

SEPTEMBER 1977

45p

TELEVISION

SERVICING·VIDEO·CONSTRUCTION·COLOUR·DEVELOPMENTS

one~chip touch tuner

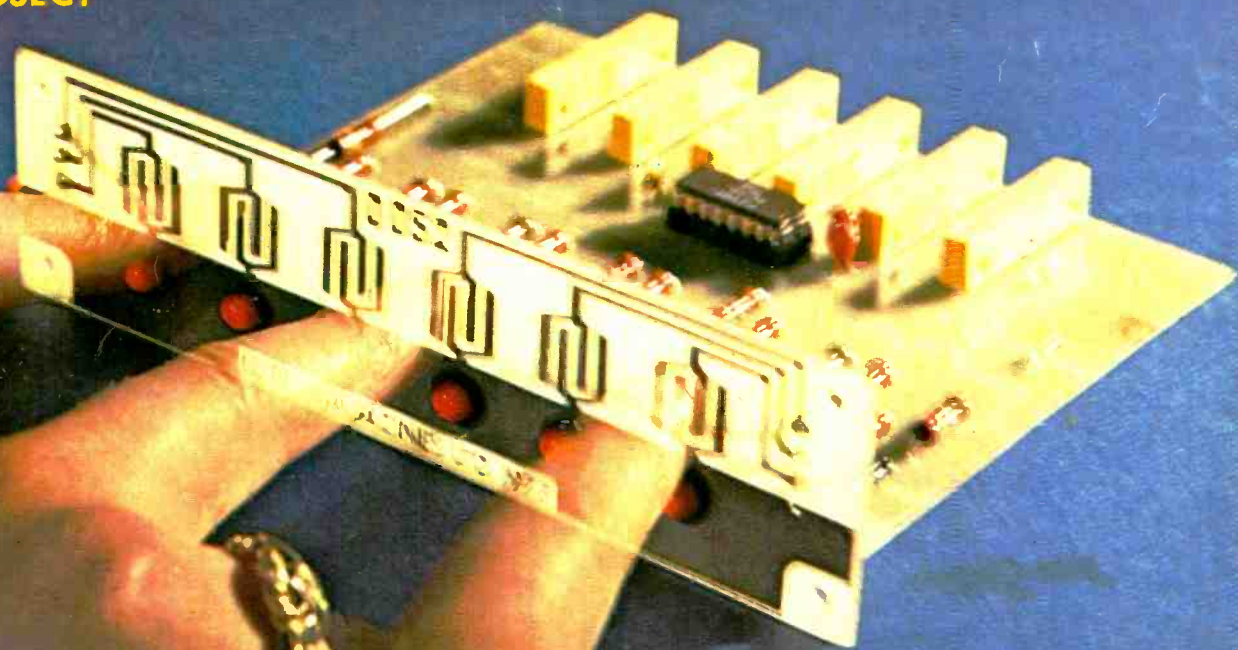

Also:~

VCR Receiver Conversion

IC Burst~Gate Pulse Generator

Servicing Pye Hybrid Colour Sets

MANOR SUPPLIES

COLOUR BAR GENERATOR

plus CROSS HATCH KIT (Mk. 4)

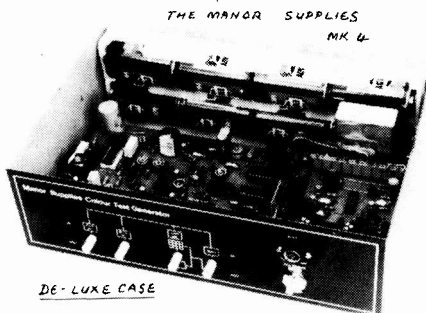

DE-LUXE CASE

- ★ Output at UHF, applied to receiver aerial socket.
- ★ In addition to colour bars, all R-Y, B-Y and Lum. Combinations.
- ★ Plus cross hatch grey scale, peak white and black levels.
- ★ Push button controls, small, compact battery operated.
- ★ Simple design, only five i.c.s. On colour bar P.C.B.

PRICE OF MK4 COLOUR BAR & CROSS HATCH KIT £35.00 + 8% VAT + £1.00 P/Packing.

CASES, ALUMINIUM £1.80, DE-LUXE £4.80, BATT. HOLDERS 78p. ADD 8% VAT TO ALL PRICES.

ALSO THE MK3 COLOUR BAR GENERATOR KIT FOR ADDITION TO MANOR SUPPLIES CROSS HATCH UNITS. £25.00 + £1.00 p.p. CASE EXTRA £1.40. BATT. HOLDERS 78p. ADD 8% VAT TO ALL PRICES.

- ★★ Kits include drilled P.C. board, with full circuit data, assembly and setting up instructions.
- ★★ All special parts such as coils and modulator supplied complete and tested, ready for use.
- ★★ Designed to professional standards.
- ★★ Demonstration models at 172 West End Lane
- ★★ Every kit fully guaranteed.

ALSO NOW AVAILABLE

MK4 DE LUXE (BATTERY) BUILT & TESTED £58.00 + 8% VAT + £1.20 P/Packing.

ALTERNATIVE MAINS SUPPLY KIT £5.78 + 8% VAT + 65p P/P. VHF MODULATOR (CHI to 4) FOR OVERSEAS £3.50. INFORMATION ON VIDEO TAKE-OFF FOR C.C.T.V.

MANOR SUPPLIES TELETEXT 77 KIT (incl TEXAS DECODER). Full facilities in colour. External unit. AE input to set. Write or call for further information. See working demonstration model!

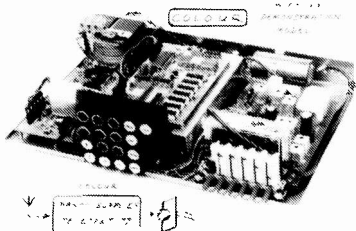

CALLERS WELCOME AT SHOP PREMISES.

MANOR SUPPLIES

172 WEST END LANE, LONDON, N.W.6.
(Near W. Hampstead Tube Station (Bakerloo Line).)

Tel: 01-794 8751.

Mail Order:-

64, GOLDERS MANOR DRIVE, London, N.W.11.

COLOUR, UHF & TELEVISION SPARES

TELETEXT 77, MANOR SUPPLIES NEW "EASY TO ASSEMBLE" KIT, INCL. TEXAS DECODER, AERIAL INPUT, COLOUR, MIXED T.V. PROGRAMME & TELETEXT, NEWSFLASH, UPDATE, AND MANY SPECIAL FEATURES NOT FOUND IN OTHER UNITS. DEMONSTRATION MODEL IN OPERATION AT 172 WEST END LANE, N.W.6. CALL OR WRITE FOR FURTHER INFORMATION. CROSS HATCH UNIT KIT, AERIAL INPUT TYPE, INCL. T.V. SYNC AND UHF MODULATOR, BATTERY OPERATED. ALSO GIVES PEAK WHITE & BLACK LEVELS. CAN BE USED FOR ANY SET (£11.00 + 45p. pp.* COMPLETE TESTED UNITS, READY FOR USE (DE-LUXE CASE) £18.00 p.p. 90p.* ADDITIONAL GREY SCALE KIT £2.90 p.p. 30p.*

"NEW TYPE" UHF SIGNAL STRENGTH METER KIT £18.00 p.p. 90p.* (VHF VERSION £18.80 p.p. 90p*). CRT TESTER & REACTIVATOR PROJECT FULL KIT £18.00 p.p. £1.30*

"TELEVISION" COLOUR SET PROJECT. MARK II DEMONSTRATION MODEL WITH LATEST IMPROVEMENTS. WORKING AND ON VIEW, LISTS AVAILABLE.

"TELEVISION" PROJECT CROSS HATCH KIT £3.60 p.p. 20p.*

VIDEO PRE-AMP MOD. KIT (Oct. '75 Article) £1.20 p.p. 20p.

SPECIAL OFFER I.F. Panel, leading British maker, similar design to "Television" panel. Now in use as alternative inc. circuit and connection data, checked and tested on colour £12.80 p.p. 95p. Also DECODER panel checked and tested on colour, full details, £16.80 p.p. 95p.

"FIVE in ONE" PANEL replaces Tuner IF, Decoder, RGB, and sound boards of original project. Tested on colour, with all data. £30.00 p.p. £1.20. MAINS TRANSFORMER 280W for "T.V." Colour Set £11.50 p.p. £1.50. TRIPLER £6.00 p.p. 75p, ERIE FOCUS £2.20, p.p. 30p, NEW AUDIO UNIT £2.60 p.p. 30p. Original packs still available. List on Request.

STABILISER UNITS, "add on" kit for either 40V or 20V, £2.80 p.p. 35p.

GEC 2040 Surpl Panels, ex-rental, Decoder £5.00, T.B. £5.00 p.p. 90p.

BRC 3000 Surplus/Salv Panels, Decoder £7.50, Video £7.50 p.p. 90p.

DECCA Colour T.V. Thyristor Power Supply, HT, LT etc. £3.80 p.p. 95p.

BUSH CTV25 Power Supply Unit £3.20 p.p. £1.50.

PYE 697 Line T.B. P.C.B. for spares, £1.50 p.p. £1.00.

MULLARD AT1023/5 convergence yoke. New £2.50 p.p. 75p.

DLIE delay line. New 90p p.p. 40p. AT1025/06 blue lat. 75p p.p. 30p.

PHILIPS G6 single standard convergence panel, incl. 16 controls, switches etc., and circuits £3.75 p.p. 85p, or incl. yoke, £5.00. PHILIPS G8 panels for spares, decoder £2.50 p.p. 85p.

VARICAP, Mullard ELC1043 UHF tuner £4.50, ELC1043/05 £5.50, G.I. type equiv. 1043/05 £3.50 p.p. 30p. UHF & VHF salvaged varicap tuners £1.50. Control units, 3PSN £1.25, 4PSN £1.80, 5PSN £2.30. Special offer 6PSN £1.00, 7PSN £1.80 p.p. 25p. TAA 550 50p p.p. 15p.

VARICAP VHF PHILIPS £3.80, ELC1042 £4.80, p.p. 30p, ELC1042 on PYE P.C.B. £5.40, Plug in 6 posn. control unit £2.50 p.p. 65p.

VARICAP UHF/VHF ELC 2000S £12.50 p.p. £2.50

UHF/625 Tuners, many different types in stock. Lists available. UHF tuners transist. incl. s/m drive, indicator £3.85; 6 posn. or 4 posn. push-button £4.20 p.p. 85p. Integrated tuners BUSH, DECCA, PYE 40 6 posn. £4.50 p.p. £1.20. AE ISOL 30p p.p. 20p.

TRANSISTORISED 625 IE for T.V., sound tested (as featured in Practical Wireless, Nov. '75). £6.80 p.p. 65p.

PHILIPS 625 I.F. Panel incl. oct 50p p.p. 50p.

TURRET TUNERS, KB "Featherlight" VC11, Philips 170 series, GEC 2010 £2.50, GEC 2018, 2019, 2038, 2039 5 position £4.20 p.p. 85p.

TBA 400 I.C.s. 480, 530, 540, £2.20, 550, 560, 920 £3.20 p.p. 15p.

HELICAL POTS, 100K. 4 for £1.20 p.p. 20p.

BRC 1500 Mains Droppers, two for 90p p.p. 50p.

LINE OUTPUT TRANSFORMERS. New guar. p.p. 85p.

BUSH 105 to 186SS, etc. £6.40

DECCA DR1, 2, 3, 121/123, 20/24, etc. £6.40

DECCA MS2000, 2400 £5.80

FERG., HMV, MARCONI,

ULTRA 850, 900, 950 Mk. 1 £7.30

950II, 1400, 1500, 1590 £5.90

GEC 2000, 2047 series, etc. £6.20

INDESIT 20/24EGB £6.40

ITT/KB VC2 to 53, 100, 200, 300 £6.20

MURPHY 849 to 2417, etc. £6.40

PHILIPS 19TG121 to 19TG156 £4.80

PHILIPS 19TG170, 210, 300 £6.20

PYE 11U, 368, 169, 769 series £6.20

PYE 40, 67 series (36 to 55) £3.80

PAM, INVICTA, EKCO,

FERRANTI equivalents as above.

SOBELL 1000 series £6.20

STELLA 1043/2149 £6.20

SPECIAL OFFERS

BUSH TV53/86, 95/99 ... £1.00

EKCO 380 to 390 £1.00

EKCO 407/417 £1.00

FERR. 1084/1092 £1.00

FERG. 506 to 546 £1.00

GEC 448/452 £2.50

KB VCI, VCII (003) £2.80

P/SCOTT 733 to 738 £1.00

REG 10-6, 10-17 etc. £1.00

SOBELL 195/282/8 £2.50

MANY OTHERS STILL AVAILABLE

COLOUR LOPTS p.p. £1.00.

BUSH 182 to 1122 etc. £7.60

MURPHY Equivalents £7.60

DECCA "Bradford"

(state Model No. etc) ... £7.80

GEC 2028, 2040 £9.20

PYE 691, 693, 697 £15.80

THORN 8500 £8.80

THORN 850 Time Base Panel, Dual Standard 50p p.p. 80p.
MULLARD Scan Coils Type AT1030 for all standard mono 110° models, Philips, Stella, Pye, Ekco, Ferranti, Invicta £2.00 p.p. 85p.

PHILIPS G8 Tripler (1174) £6.00 p.p. 75p. Others available.

6-3V CRT Boost Transformers £2.90 p.p. 75p., Auto type £1.80 p.p. 45p.

CALLERS WELCOME AT SHOP PREMISES

THOUSANDS OF ADDITIONAL ITEMS AVAILABLE NOT NORMALLY ADVERTISED

MANOR SUPPLIES

172 WEST END LANE, LONDON, N.W.6.

(Near W. Hampstead tube stn: 28, 59 159 Bus Routes) 01-794 8751

Mail Order: 64 GOLDERS MANOR DRIVE, LONDON N.W.11.

PLEASE ADD 12½% VAT TO PRICES (EXCEPT * 8%)

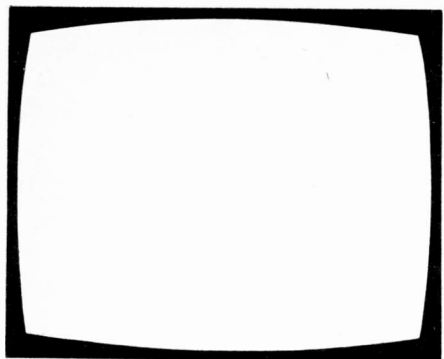

TELEVISION

September
1977

Vol. 27, No. 11
Issue 323

COPYRIGHT

© IPC Magazines Limited, 1977. Copyright in all drawings, photographs and articles published in *Television* is fully protected and reproduction or imitation in whole or in part is expressly forbidden. All reasonable precautions are taken by *Television* to ensure that the advice and data given to readers are reliable. We cannot however guarantee it and we cannot accept legal responsibility for it. Prices are those current as we go to press.

CORRESPONDENCE

All correspondence regarding advertisements should be addressed to the Advertisement Manager, "Television", Fleetway House, Farringdon Street, London EC4A 4AD. All other correspondence should be addressed to the Editor, "Television", Fleetway House, Farringdon Street, London EC4A 4AD.

BINDERS AND INDEXES

Binders (£2.10) and Indexes (45p) can be supplied by the Post Sales Department, IPC Magazines Ltd., Lavington House, 25 Lavington Street, London SE1 0PF. Prices include postage and VAT. In the case of overseas orders add 60p to cover despatch and postage.

BACK NUMBERS

Some back issues, mostly those published during the last two years, are available from our Post Sales Department (address above) at 70p inclusive of postage and packing to both home and overseas destinations.

QUERIES

We regret that we cannot answer technical queries over the telephone nor supply service sheets. We will endeavour to assist readers who have queries relating to articles published in *Television*, but we cannot offer advice on modifications to our published designs nor comment on alternative ways of using them. All correspondents expecting a reply should enclose a stamped addressed envelope.

Requests for advice in dealing with servicing problems should be directed to our Queries Service. For details see our regular feature "Your Problems Solved".

this month

- 567 ICs in the TV Environment**
- 568 Teletopics**
News, comment and developments
- 570 A Day in the Life of . . .** *by Les Lawry-Johns*
A day's business in that famous Superstore somewhere in S.E. England.
- 574 Receiver Conversion for VCR Use** *by John de Rivaz, B.Sc. (Eng.)*
Most TV sets give poor performance with VCRs because of the long time-constant of the flywheel line sync circuit. The solution presented here is to add a TBA920 timebase i.c. which is specifically designed for VCR or off-air use.
- 575 Letter**
- 576 Developments in Switch-Mode Power Supplies, Part 2** *by E. Trundle*
Two further approaches to providing regulation are described, along with suggested servicing procedures.
- 577 Readers' Printed Board Service**
- 579 Next Month in Television**
- 583 IC Burst Gate Pulse Generator** *by William Riggs, B.Sc. (Hons.)*
The use of a simple monostable multivibrator i.c. provides accurate burst gating with simple adjustment.
- 584 Service Notebook** *by G. R. Wilding*
Notes on faults and how to tackle them.
- 586 One-Chip Touch-Tuning System** *by Luke Theodossiou*
An exceptionally easy method of converting a set's tuning to an all-electronic method.
- 590 Servicing Pye Hybrid Colour Receivers** *by Andy Denham*
A comprehensive run-down on stock faults experienced on the Pye 691, 693 and 697 chassis.
- 594 The "TV" Teletext Decoder, Part 7** *by Steve A. Money, T.Eng. (C.E.I.)*
Constructing the mother board, the u.h.f. modulator and the switching control board.
- 600 Long-Distance Television** *by Roger Bunney*
Reports on DX reception and conditions, and news from abroad.
- 603 Introducing the Philips G11 Chassis, Part 2** *by A. G. Priestley, B.Sc.*
An account of the choice of circuitry for use in the chassis.
- 608 Your Problems Solved**
- 609 Test Case 177**

OUR NEXT ISSUE DATED OCTOBER WILL BE
PUBLISHED ON SEPTEMBER 19

THE FINEST
LIST OF BOOKS
AVAILABLE
FOR SERVICE
ENGINEERS



Newnes Tape

Latest
Title

Recorder Servicing Manual

JOHN
GARDNER

2nd Edition Vols. 1 & 2

Volume 1

CONTENTS: INTRODUCTION – Test equipment, Performance tests, The Dolby system, Notes on dimensions.

SERVICE DATA SECTIONS

Alba, Beocord, Elizabethan, Ferguson, Ferrograph, Fidelity, Grundig, ITT, Kenwood, Marconiphone, Philips, Sanyo, Sony, Tandberg, Uher.

INDEX TO MODELS

224 pages · £7.80

Volume 2

CONTENTS: INTRODUCTION – Test equipment, Performance tests, The Dolby system, Notes on dimensions.

SERVICE DATA SECTIONS

Akai, Amerex, Elizabethan, Ferguson, Grundig, Hitachi, ITT, Marconiphone, National Panasonic, Philips, Saba, Sanyo, Sharp, Sony, Tandberg, Teleton, Yamaha.

INDEX TO MODELS

224 pages · £7.80

OTHER BOOKS FOR SERVICE ENGINEERS

Colour Television Servicing— 2nd Edition

Gordon J. King

328 pages £6.50

Newnes Colour TV Servicing Manual

Gordon J. King

Volume 1

238 pages £6.40

Volume 2

240 pages £6.40

Volume 3

240 pages £7.80

Practical Aerial Handbook— 2nd Edition

Gordon J. King

232 pages £5.50

Radio, TV & Audio Technical Reference Book

S. W. Amos

1152 pages £24.00

Servicing With The Oscillo- scope—2nd Edition

Gordon J. King

256 pages £4.95

Television Engineer's Pocket Book—6th Edition

P. J. McGoldrick

380 pages £4.45

Television Servicing Hand- book—3rd Edition

Gordon J. King

358 pages £5.20



Order now from your local bookseller or:
NEWNES-BUTTERWORTHS
Borough Green, Sevenoaks, Kent TN15 8PH

For those
who
appreciate Quality...

a complete electronic kit
The Forgestone 400
high quality
colour television receiver

**SUPERB PICTURE QUALITY TOGETHER WITH
PROVEN RELIABILITY**

- 9 integrated circuits
- Thick film resistor units
- Ready-built and aligned IF module
- Glass epoxy printed circuit panels
- High quality components
- Fully isolated power supply
- Plugs and sockets for easy panel removal
- Each module kit available separately
- Full technical construction manual
- LT supply regulator

The isolated chassis makes the receiver ideal for the addition of Teletext decoders, remote controls etc. Please send stamp for further details of these quality products.

Forgestone Colour Developments Limited

Ketteringham, Wymondham, Norfolk, NR18 9RY, U.K.

Telephone: Norwich 810453 (STD 0603)



MAIL ORDER – Barclaycard & Access accepted

Learn to understand
electronics
for your hobbies

1. Lerna-Kit course

Step by step, we take you through all the fundamentals of electronics and show you how easily the subject can be mastered.

- (1) BUILD AN OSCILLOSCOPE.
- (2) READ, DRAW AND UNDERSTAND CIRCUIT DIAGRAMS.
- (3) CARRY OUT OVER 40 EXPERIMENTS ON BASIC ELECTRONIC CIRCUITS AND SEE HOW THEY WORK.

2. Become a Radio-Amateur

Learn how to become a radio-amateur in contact with the wide world. We give skilled preparation for the G.P.O. licence.

FREE!

Brochure, without obligation to:

**BRITISH NATIONAL RADIO &
ELECTRONICS SCHOOL**

P.O. BOX 156, JERSEY, CHANNEL ISLANDS.

NAME _____

ADDRESS _____

BLOCK CAPS

TAG PLEASE

TRANSISTORS, ETC.		Type	Price (£)	Type	Price (£)	Type	Price (£)	Type	Price (£)	Type	Price (£)	Type	Price (£)	Type	Price (£)	Type	Price (£)		
AC107	0.48	AF149	0.45	BC159*	0.14	BC301	0.35	BD136	0.46	BDY20	1.07	BF259	0.81	BY55	10.48	OC42	0.55	2N1893	0.40
AC117	0.38	AF178	0.75	BC160	0.78	BC303	0.60	BD137	0.48	BF115	0.30	BF262	0.64	BRV56	10.44	OC44	0.34	2N2102	0.51
AC126	0.36	AF179	0.78	BC161	0.80	BC307A & B		BD138	0.52	BF117	0.45	BF263	0.62	BT106	1.50	OC45	0.32	2N221A	0.50
AC127	0.40	AF180	0.75	BC167B	0.15			BD139	0.55	BF120	0.55	BF270	0.47	BT109	1.99	OC71	0.73	2N222A	0.52
AC128	0.35	AF181	0.72	BC168B	0.14	BC308 & A	0.17	BD140	0.59	BF121	0.85	BF271	0.57	BT116	1.45	OC72	0.73	2N2369A*	0.44
AC128K	0.35	AF186	0.99	BC169C	0.15	BC309*	0.17	BD144	2.24	BF123	0.58	BF273	0.33	BT119	5.18	OC81	0.53	2N2484	0.55
AC141	0.35	AF202	0.27	BC170*	0.15	BC317*	0.22	BD145	0.75	BF125	0.55	BF274	10.34	BU102	2.85	OCB1D	0.57	2N2466	0.75
AC141K	0.35	AF239	0.60	BC171*	0.15	BC318C	0.23	BD157	0.51	BF127	0.68	BF333	0.67	BU105	1.95	OC139	0.76	2N2696	1.30
AC142	0.34	AF240	1.40	BC172*	0.14	BC319C	0.26	BD160	1.65	BF137F	0.78	BF336	0.43	BU105/02	1.95	OC140	0.80	2N2904*	0.42
AC142K	0.39	AF279S	0.91	BC173*	0.22	BC320	0.28	BD163	0.67	BF152	0.19	BF337	0.46	BU108	3.15	OC170	0.34	2N2905*	0.33
AC151	0.31	AL100	1.10	BC174A & B		BC322	0.24	BD177	0.58	BF157	0.32	BF338	0.58	BU126	2.18	OC171	0.34	2N2926G	10.15
AC152	0.34	AL103	1.13			BC323	0.68	BD178	0.59	BF158	0.25	BF355	0.52	BU133	1.77	ON236A	0.72	2N2926Q	10.14
AC153	0.42	AU103	2.10	BC176	0.22	BC327	0.23	BD181	1.04	BF159	0.27	BF362	10.62	MU204	2.02	R2008B	2.25	2N2926Y	10.14
AC153K	0.43	AU107	1.90	BC177*	0.20	BC328	0.23	BD182	0.90	BF160	0.22	BF363	10.62	MU205	2.24	R2010B	2.65	2N2955	1.12
AC154	0.31	AU110	1.90	BC178*	0.22	BC337	0.24	BD183	1.18	BF161	0.45	BF457	0.68	MU206	2.97	TIC44	10.29	2N3053	0.25
AC176	0.42	AU113	2.40	BC179*	0.28	BC338	0.19	BD184	1.43	BF162	0.65	BF458	0.84	MU208	3.15	TIC46	10.44	2N3054	0.62
AC178	0.42	BC107	0.16	BC181*	0.14	BC347A*	0.17	BD187	0.61	BF163	0.65	BF459	0.91	BUY77	2.50	TIP29A	0.49	2N3055	0.70
AC187	0.48	BC108*	0.15	BC182*	0.14	BC348A & B		BD188	0.65	BF164	0.95	BF459	10.16	BUY78	2.65	TIP30A	0.58	2N3072	10.19
AC187K	0.45	BC109*	0.17	BC183*	0.14	BC349A & B		BD201	1.15	BF166	0.38	BF594	0.16	BUY79	2.85	TIP31A	0.62	2N3073	10.18
AC188	0.42	BC114	10.20	BC184*	0.14			BD202	1.50	BF167	0.52	BF597	10.17	D40N1	0.64	TIP32A	0.67	2N3074	10.18
AC188K	0.42	BC115	10.21	BC184*	0.14			BD202	1.50	BF173	0.30	BF639	0.33	I1222	0.47	TIP33A	0.99	2N3077	1.85
AC193K	0.48	BC116*	0.21	BC184*	0.14	BC350A*	0.20	BD222	0.78	BF177	0.36	BF640	0.29	E5024	10.19	TIP34A	1.73	2N3077	1.92
AC194K	0.52	BC117	10.20	BC186	0.25	BC351A*	0.18	BD225	0.91	BF178	0.38	BF641	0.29	GET872	0.46	TIP41A	0.80	2N3072	2.90
ACY17	1.20	BC118	10.17	BC187	0.27	BC352A*	0.18	BD232	2.20	BF179	0.42	BF660	0.35	MC140	10.36	TIP42A	0.91	2N3819	10.35
ACY19	0.95	BC119	0.32	BC192	0.56	BC360	0.24	BD233	0.52	BF180	0.36	BF661	0.35	MJE341	0.72	TIP3055	0.67	2N3866	1.72
ACY28	0.98	BC125*	0.22	BC207*	0.14	BC377	0.22	BD234	0.75	BF181	0.35	BF662	0.28	MJE371	0.79	TIS73	1.36	2N3904	10.24
ACY39	2.02	BC126	10.24	BC208	0.12	BC441	0.59	BD235	0.69	BF182	0.44	BF679	0.36	MJE520	0.85	TIS90	10.23	2N4032	0.57
AD140	0.68	BC132	10.17	BC212*	0.17	BC461	0.78	BD236	0.62	BF183	0.52	BF680	0.32	MJE521	0.95	TIS91	10.25	2N4058	10.18
AD142	0.69	BC134	10.20	BC212L*	0.17	BC477	0.20	BD237	0.69	BF184	0.31	BF681	0.32	MJE521	1.20	ZTX108	10.13	2N4291	10.27
AD143	0.71	BC135	10.19	BC213*	0.16	BC478	0.19	BD238	0.70	BF185	0.28	BF681	0.32	MJE521	1.20	ZTX108	10.13	2N4392	2.84
AD149	0.86	BC136	10.20	BC214*	0.17	BC479	0.19	BD253	2.58	BF194*	10.12	BF682	0.32	MJE521	1.20	ZTX108	10.13	2N4392	2.84
AD161	0.65	BC137	10.20	BC214*	0.17	BC547*	0.13	BD410	1.65	BF195*	10.11	BFW11	0.66	MJE521	1.20	ZTX108	10.13	2N4392	2.84
AD162	0.70	BC138	10.30	BC214*	0.17	BC548*	0.12	BD437	0.98	BF196	10.14	BFW30	2.17	MJE521	1.20	ZTX108	10.13	2N4392	2.84
AF114	0.35	BC140	0.90	BC237*	0.15	BC549*	0.15	BD438	1.17	BF197	10.15	BFW59	10.19	MPE102	10.40	ZTX300	10.16	2N4921	0.61
AF115	0.35	BC141	0.95	BC238*	0.16	BC550	0.15	BD517	0.41	BF198	10.29	BFW60	10.20	MPSA56	10.31	ZTX304	10.24	2N5060	10.32
AF116	0.41	BC142	0.29	BC239C	0.23	BC555*	0.14	BD518	0.43	BF199	10.29	BFW90	0.28	MPSA56	10.31	ZTX304	10.24	2N5060	10.32
AF117	0.32	BC143	0.33	BC252A*	0.27	BC557*	0.14	BD519	0.88	BF200	0.65	BFW90	0.28	MPSA56	10.31	ZTX304	10.24	2N5060	10.32
AF118	0.98	BC147*	10.12	BC252B*	0.27	BC558*	0.13	BD520	0.88	BF201	0.65	BFW90	0.28	MPSA56	10.31	ZTX304	10.24	2N5060	10.32
AF121	0.50	BC148*	10.11	BC253B	0.38	BC559*	0.15	BD520	0.88	BF202	0.65	BFW90	0.28	MPSA56	10.31	ZTX304	10.24	2N5060	10.32
AF124	0.38	BC149*	10.13	BC253B	0.38	BC559*	0.15	BD520	0.88	BF203	0.65	BFW90	0.28	MPSA56	10.31	ZTX304	10.24	2N5060	10.32
AF125	0.38	BC152	10.25	BC253B	0.38	BC559*	0.15	BD520	0.88	BF204	0.65	BFW90	0.28	MPSA56	10.31	ZTX304	10.24	2N5060	10.32
AF126	0.38	BC153	10.20	BC253B	0.38	BC559*	0.15	BD520	0.88	BF205	0.65	BFW90	0.28	MPSA56	10.31	ZTX304	10.24	2N5060	10.32
AF127	0.45	BC154	10.20	BC253B	0.38	BC559*	0.15	BD520	0.88	BF206	0.65	BFW90	0.28	MPSA56	10.31	ZTX304	10.24	2N5060	10.32
AF139	0.48	BC157*	10.13	BC262A*	0.26	BC559*	0.15	BD520	0.88	BF207	0.65	BFW90	0.28	MPSA56	10.31	ZTX304	10.24	2N5060	10.32
AF147	0.52	BC158*	10.12	BC262B*	0.26	BC559*	0.15	BD520	0.88	BF208	0.65	BFW90	0.28	MPSA56	10.31	ZTX304	10.24	2N5060	10.32
				BC263B*	0.26	BC559*	0.15	BD520	0.88	BF209	0.65	BFW90	0.28	MPSA56	10.31	ZTX304	10.24	2N5060	10.32
				BC267	0.16	BC559*	0.15	BD520	0.88	BF210	0.65	BFW90	0.28	MPSA56	10.31	ZTX304	10.24	2N5060	10.32
				BC268C	0.14	BC559*	0.15	BD520	0.88	BF211	0.65	BFW90	0.28	MPSA56	10.31	ZTX304	10.24	2N5060	10.32
				BC294	0.37	BC559*	0.15	BD520	0.88	BF212	0.65	BFW90	0.28	MPSA56	10.31	ZTX304	10.24	2N5060	10.32
				BC300	0.80	BC559*	0.15	BD520	0.88	BF213	0.65	BFW90	0.28	MPSA56	10.31	ZTX304	10.24	2N5060	10.32
				BC309	0.80	BC559*	0.15	BD520	0.88	BF214	0.65	BFW90	0.28	MPSA56	10.31	ZTX304	10.24	2N5060	10.32
				BC309	0.80	BC559*	0.15	BD520	0.88	BF215	0.65	BFW90	0.28	MPSA56	10.31	ZTX304	10.24	2N5060	10.32
				BC309	0.80	BC559*	0.15	BD520	0.88	BF216	0.65	BFW90	0.28	MPSA56	10.31	ZTX304	10.24	2N5060	10.32
				BC309	0.80	BC559*	0.15	BD520	0.88	BF217	0.65	BFW90	0.28	MPSA56	10.31	ZTX304	10.24	2N5060	10.32
				BC309	0.80	BC559*	0.15	BD520	0.88	BF218	0.65	BFW90	0.28	MPSA56	10.31	ZTX304	10.24	2N5060	10.32
				BC309	0.80	BC559*	0.15	BD520	0.88	BF219	0.65	BFW90	0.28	MPSA56	10.31	ZTX304	10.24	2N5060	10.32
				BC309	0.80	BC559*	0.15	BD520	0.88	BF220	0.65	BFW90	0.28	MPSA56	10.31	ZTX304	10.24	2N5060	10.32
				BC309	0.80	BC559*	0.15	BD520	0.88	BF221	0.65	BFW90	0.28	MPSA56	10.31	ZTX304	10.24	2N5060	10.32
				BC309	0.80	BC559*	0.15	BD520	0.88	BF222	0.65	BFW90	0.28	MPSA56	10.31	ZTX304	10.24	2N5060	10.32
				BC309	0.80	BC559*	0.15	BD520	0.88	BF223	0.65	BFW90	0.28	MPSA56	10.31	ZTX304	10.24	2N5060	10.32
				BC309	0.80	BC559*	0.15	BD520	0.88	BF224	0.65	BFW90	0.28	MPSA56	10.31	ZTX304	10.24	2N5060	10.32
				BC309	0.80	BC559*	0.15	BD520	0.88	BF225	0.65	BFW90	0.28	MPSA56	10.31	ZTX304	10.24	2N5060	10.32
				BC309	0.80	BC559*	0.15	BD520	0.88	BF226	0.65								

TELEVISION TUBE SHOP

NEW TUBES AT CUT PRICES

A28-14W Equivalent.....	£17.95
A31-410W.....	£16.95
AW59-91/CME2303.....	£15.50
CME1201/A31-18W.....	£13.50
CME1220/A31-120W.....	£15.95
CME1420/A34-100W.....	£16.50
CME1520/A38-160W.....	£17.50
CME1602/A40-12W.....	£13.50
CME1713/A44-120.....	£17.50
CME1906/A47-13W.....	£12.50
CME2013/A50-120.....	£17.95
CME2306/A59-13W.....	£14.50
CME2313/A59-23W.....	£18.95
CME2413/A61-120W.....	£18.95

SPECIAL OFFER
FOR K.B. FEATHERLITE VC11
TSD282/217..... £7.50

JAPANESE etc. TUBES

9AGP4 Equivalent.....	£17.50
190AB4.....	£15.00
190CB4.....	£15.00
230ADB4.....	£15.95
230DB4/CT468.....	£15.95
CT507.....	£17.50
240AB4A.....	£15.95
310DMB4/DGB4.....	£19.00
310DWB4/DJB4.....	£19.00
310EUB4.....	£19.50
310EYB4.....	£16.50
310FXB4 Equivalent.....	£15.95
310GNB4A.....	£25.19
340AB4.....	£19.50
340AYB4.....	£22.00
340CB4.....	£19.95
340RB4.....	£19.95
340AHB4.....	£24.50

ALL TUBES GUARANTEED 12 MONTHS

CARRIAGE:

Mono £1.50. Colour £2.50
N. Ireland £4.00

ADD VAT TO ALL PRICES

TELEVISION TUBE SHOP

52 BATTERSEA BRIDGE RD.,
LONDON, SW11. Tel. 228 6859

WE GIVE GREEN SHIELD STAMPS

PHILIP H. BEARMAN

(VALVE SPECIALISTS)

SUPPLIERS TO
H.M. GOVT. Etc.

NEW valves by Mullard, Mazda, Telefunken, Tungram, etc.

"QUALITY" BRANDED VALVES ONLY CARRY THE 90 DAY GUARANTEE, SEE OUR LISTS.

IMMEDIATE POSTAL DESPATCH LISTS S.A.E. DISCOUNT PRICES INCLUDING 6% ALLOWANCE IN LIEU OF GUARANTEE

PRICES FROM AUGUST 1977 INCL. 12½% VAT

DY86/7 50p	GY501 £1.30	PCF802 75p	PL36 95p	U25 60p	30P12 75p
DY802 55p	PC86 85p	PCF805 £1.45	PL84 70p	U26 60p	30PL1 £1.40
ECC81 45p	PC88 85p	PCF808 £1.45	PL504 £1.20	6F23 60p	30PL13 £1.00
ECC82 45p	PC97 75p	PCZ200 £1.25	PL508 £1.35	6F28 92p	30PL14 £1.20
ECL80 70p	PCC84 35p	PCL82 60p	PL509 £2.20	20P4 75p	30PL15 £1.10
EF80 50p	PCC89 60p	PCL83 75p	PL802 £2.10	30C1 60p	Etc., Etc.
EF183 70p	PCC189 60p	PCL84 65p	PY81/83 50p	30C17 80p	
EF184 70p	PCF80 60p	PCL85 } 80p	PY800 60p	30FL1 £1.00	BY 100/127 etc.
EH90 75p	PCF86 65p	PCL805 } 80p	PY801 60p	30FL2 £1.00	all 20p each
EY51 80p	PCF200 £1.25	PD500 £3.25	PY500 £1.35	30L15 75p	with 10W
EY86/7 45p	PCF801 65p	PFL200 85p	PY500A £1.35	30L17 75p	resistor.

(Correct at time of going to press)

MINIMUM ORDER 75p!

ENQUIRIES
WELCOMED
ON OUR
VAST
RANGE

TELEPHONE
ENQUIRIES
WELCOMED.

NOTE.
Any excess paid
will be refunded.

SEND SAE FOR
COLOUR & MONO
TRIPLER LIST.
ALSO LATEST
COMPONENT LIST.

HUNDREDS OF OTHER TYPES AVAILABLE, VAST STOCKS.

See separate Component, CRT and Transistor List. Many obsolete types available.

SAE with enquiries please. Please verify current prices due to inflation etc.

Overseas Post @ Cost.

U.K. Post 12p per valve under £15.00 (max. 75p) but

2p extra larger valves (ADDITIONAL VALVES 7p)

(Adjacent to Post Office) 6 & 8 POTTERS RD., NEW BARNET

STOP PRESS PC92/66, PCL200.

PL95, PL519 available!

Also EY500A, EL509 etc.

HERTS. Tel: 449/1934-5 (Robophone on 449/1934)

also 441/2541

(CLOSED 12.30-2 p.m. DAILY. OPEN SAT. A.M. ONLY)

EMO - EUROSONIC - GRUNDIG - TELETON + ALL BRITISH MAKES ETC, ETC. ● ALL SPARES READILY AVAILABLE ● PANEL REPAIR SERVICE

EXAMPLES

Thorn 1500 Smoother	£2.18
Philips E8 Smoother	1.95
Thorn 8500 Dropper	0.72
R.R.I. 141 Dropper	0.70
Philips 210 Dropper	0.60
BF258 0.38	BU126 1.95
BYX10 0.12	OA90 0.07
IN414S 0.03	B2Y88 0.12
Pye 691 Tripler	5.25
Korting Tripler	7.02
PCL85 0.69	PY500 1.21
DY802 0.44	PL504 0.87

+ VAT 12½% + 25p P & P
Orders Over £15 Free

ALMOST ANY T.V. COMPONENT SUPPLIED
By return "off the shelf" e.g. LOPTX - EHT trays
- droppers - OSC coils - switches - cans - smoothers
- transistors - diodes - I.C.'s, etc, etc.

IF YOU REQUIRE ANY TV
COMPONENT YOU CAN BE 95%
SURE WE CAN SUPPLY BY
RETURN.

IF YOU'RE WAITING FOR SPARES -
RING NOW!

FREE
SERVICE
CATALOGUE
EMO CIRCUIT

Send 25p to cover
post & packing

TELEPART (WTON) THE TELECENTRE, WORCESTER ST., WOLVERHAMPTON (0902) 772293

SOUTHERN VALVE COMPANY

Upper Floor, 8 Potters Road, New Barnet, Herts.

Telephone: 01-440/8641.

MAIL ORDER ONLY

MINIMUM ORDER 65p

ALL NEW & BOXED, "QUALITY" BRANDED VALVES

GUARANTEED 3 MONTHS. BVA ETC. (TUNGSRAM ETC.).

6% ALLOWED IN LIEU OF GUARANTEE!

ALREADY DEDUCTED FROM OUR PRICES!

NOTE:
PLEASE VERIFY
CURRENT PRICES.

Correct only
at time of
going to press.

Some leading makes available.

VAT invoices issued on request.

AZ31 80p	ECL82 48p	EL509 £2.75	PCC85 44p	PCL82 40p	PL84 48p
DY86/7 49p	ECL83 68p	EM84 50p	PCC88 62p	PCL83 63p	PL500 } 90p
DY802 50p	ECL86 60p	EY51 50p	PCC89 50p	PCL84 48p	PL504 } 90p
EB91 18p	EF80 33p	EY86/7 38p	PCC189 53p	PCL85 } 62p	PL508 } 92p
ECC81 36p	EF85 38p	EY500A £1.60	PCF80 41p	PCL805 } 62p	PL509 £2.10
ECC82 36p	EF86 52p	EZ80 40p	PCF82 45p	PCL86 50p	PL519 £2.80
ECC83 36p	EF89 39p	EZ81 40p	PCF86 58p	PCL200 £1.40	PL802 £2.45
ECC85 40p	EF183 42p	GY501 £1.10	PCF200 £1.20	PD500 £3.25	PY33 50p
ECC88 50p	EF184 42p	GZ30 70p	PCF801 50p	PFL200 73p	PY81/3 40p
ECH42 80p	EH90 56p	PC86 63p	PCF802 57p	PL36 70p	PY88 50p
ECH81 44p	EL34 £1.10	PC88 63p	PCF805 £1.45	PL81 50p	PY800 50p
ECH83 82p	EL41 70p	PC97 70p	PCF806 75p	PL81A 55p	PY801 50p
ECH84 58p	EL84 39p	PC900 50p	PCF808 £1.45	PL82 35p	PY500 } £1.33
ECL80 52p	EL90/1 47p	PCC84 35p	PCZ200 85p	PL83 50p	PY500A } etc., etc.

One valve post. 12p, each extra valve 6p. MAX 75p. LISTS & ENQUIRIES, S.A.E. PLEASE!

Large valves 2p. each extra.

ALL PRICES INCLUDE VAT @ 12½%

ENQUIRIES WELCOMED FROM
TRADE & RETAIL (same prices)

PHILIP H. BEARMAN

6 & 8 POTTERS ROAD, NEW BARNET, HERTS. Tel: 01-449 1934/5

NEW COLOUR TUBES

New tubes, fully tested

NEW MONO TUBES

Carriage £3.00

Carriage £1.50

EXPORT ENQUIRIES WELCOMED	A44/271X.....	£55.00
	A49/191X }.....	£60.00
	A49/192X }.....	£60.00
PRICES CORRECT	A51/110X }.....	£65.00
	A51/110X }.....	£65.00
AT TIME OF GOING TO PRESS	A56/120X.....	£65.00
	A63/11X.....	£75.00
	A63/200X.....	£75.00
	A66/120X.....	£82.50
SHORT SEA JOURNEY EXTRA.	A67/120X.....	£89.50
	A67/150X.....	£89.50

SPECIAL NOTE

NEW MONO

TUBES AVAILABLE

A31/410W.....	£18.00*
CME1220/A31.120.....	£18.00*
CME1420/A34.120.....	£19.50†
CME1520/A38.160.....	£21.00*
CME1713/A44.120.....	£21.00*
CME1913/A47.26WR.....	£21.00*

Limited stocks

2 year guarantee

MAZDA, TOSHIBA, USA, ETC.

OTHERS AVAILABLE SHORTLY.

* £1 less | year

† £2 less | g'tee

MW31/74.....	£3.00
14" except 110°.....	£5.00
12"/14" 110°. Prices as per centre column.	
A47/14W.....	£11.50
A50/120WR.....	£18.00
A61/120WR.....	£21.00

Others often available.
£1 less for one year guarantee.

Mostly two year guarantee.

SAE with enquiries please.

NOTE:

All prices subject to alteration due to market fluctuations and inflation.

110° prices usually as above. £5 allowed on old colour tube.

Occasionally seconds available cheaper, enquiries welcomed.

VAT included in all quoted prices at 12½%.

Prices include VAT.

TV LINE OUTPUT TRANSFORMERS

ALL MAKES SUPPLIED PROMPTLY by our
RETURN OF POST MAIL ORDER SERVICE

All Mono Lopts at the one price

£6.20 TRADE

£6.75 RETAIL (V.A.T. INCLUDED AT 12½%)
Postage and Packing 70p

Except

BUSH MODELS TV53 to TV101.
EKCO MODELS TC208 to TV417.
FERGUSON MODELS 305 to 438, 506 to 546.
FERRANTI MODELS 1084 to 1092.

HMV MODELS 1876 to 1878, 1890 to 1896, FR 20.
MURPHY MODELS V280 to V330, V420, V440, 653X to 789 OIL-FILLED.
REGENTONE MODELS 10-4 to 10-21, 1718, R2, R3, 191, 192.
RGD 519-621, 710, 711.

ALL AT £2.81 + 70p P & P

All Lopts NEW and GUARANTEED for SIX MONTHS

E. J. PAPWORTH AND SON Ltd.,
80 MERTON HIGH ST., LONDON, S.W.19

01-540 3955

BENTLEY ACOUSTIC CORPORATION LTD.

The Old Police Station, Gloucester Road, LITTLEHAMPTON, Sussex.
PHONE 6743

ALL PRICES INCLUSIVE OF V.A.T. AT 12½%. NOTHING EXTRA TO PAY

OA2 0.85	6DE7 0.90	30C15 0.77	ECC88 0.72	EZ80 0.35	PY81 0.50
OB2 0.40	6DT6A 0.85	30C17 0.77	ECC807 2.80	EZ81 0.40	PY82 0.40
1B3GT 0.55	6E5 1.00	30F5 0.70	ECF80 0.60	GY501 0.95	PY88 0.60
2D21 0.55	6EW6 0.85	30L15 0.75	ECF82 0.50	GZ32 0.60	PY500A1.35
5C68 0.75	6F1 0.80	30L17 0.70	ECF86 0.80	GZ34 1.55	PY800 0.50
5R4GY 1.00	6F18 0.60	30P12 0.74	ECH42 0.71	HN309 1.70	PY801 0.50
5U4G 1.00	6F23 0.65	30P19 0.90	ECH81 0.40	KT66 3.00	PZ30 0.50
5V4G 0.60	6F28 0.74	30PL1 1.00	ECH83 0.50	KT88 6.75	QQV03/10
5Y3GT 0.65	6GH8A 0.80	30PL13 1.00	ECH84 0.50	P61 0.60	QV06/20
5Z3 1.00	6GK5 0.75	30PL14 1.29	ECL80 0.45	PC86 0.62	R10 6.50
5Z4G 0.48	6GU7 0.90	85A2 0.75	ECL82 0.50	PC88 0.62	R19 0.75
6/30L2 0.79	6H6GT 0.30	150B2 1.00	ECL83 0.74	PC92 0.55	UABC80
6AC7 0.55	6J5GT 0.65	807 1.10	ECL86 0.64	PC97 0.75	
6AG7 0.60	6J6 0.35	5763 1.65	EF22 1.00	PC900 0.40	
6AH6 0.70	6JU8A 0.90	AZ31 0.60	EF40 0.78	PCC84 0.39	0.45
6AK5 0.45	6K7G 0.35	AZ41 0.50	EF41 0.75	PCC85 0.47	UAF42 0.70
6AM8A 0.70	6K8G 0.50	DY51 2.00	EF80 0.29	PCC89 0.49	UBC41 0.50
6AN8 0.70	6L6GC 0.85	DY86/7 0.45	EF83 1.25	PCC189.052	UBC81 0.55
6AQ5 0.68	6L7(M) 1.50	EY802 5.00	EF85 0.36	PCF80 0.50	UBF80 0.50
6AR5 0.80	6N7GT 0.70	EY80C 5.00	EF86 0.50	PCF82 0.45	UBF89 0.39
6AT6 0.50	6Q7G 0.50	E88CC 1.20	EF89 0.42	PCF86 0.57	UC92 0.50
6AU6 0.40	6Q7GT 0.50	E180F 1.15	EF91 0.50	PCF200 1.35	UC85 0.45
6AV6 0.50	6SA7 0.55	E188CC2.50	EF92 0.50	PCF201 1.00	UCF80 0.80
6AW8A 0.84	6SG7 0.55	EAS0 0.40	EF183 0.42	PCF801 0.49	UCH42 0.71
6AX4 0.75	6V6G 0.50	EABC80 0.40	EF184 0.42	PCF802 0.54	UCH81 0.50
6BA6 0.40	6X4 0.45		EH90 0.45	PCF805 2.25	UCL82 0.55
6BC8 0.90	6X5GT 0.45	EAF42 0.70	EL34 1.25	PCF806 0.53	UCL83 0.57
6BE6 0.40	9D7 0.70	EAF801 0.75	EL41 0.57	PCH2001.00	UF41 0.70
6BH6 0.70	10C2 0.70	EB34 0.30	EL81 0.70	PCL82 0.54	UF42 0.80
6BI6 0.65	10DE7 0.80	EB91 0.20	EL84 0.35	PCL83 0.49	UF80 0.40
6BK7A 0.85	10F1 0.67	ECB41 0.75	EL95 0.67	PCL84 0.46	UF85 0.50
6BN8 1.00	10F18 0.65	ECB81 0.45	EL360 1.80	PCL86 0.65	UF89 0.52
6BQ7A 0.60	10P13 0.80	EBF80 0.40	EL506 1.20	PCL805 0.60	UL41 0.70
6BR7 1.00	10P14 2.50	EBF83 0.45	EL509 2.50	PFL200 0.70	UL84 0.54
6BR8 1.25	12AT6 0.45	EBF89 0.40	EM80 0.55	PL36 0.60	UM80 0.60
6BW6 1.70	12AU6 0.50	EC86 0.84	EM81 0.60	PL81A 0.53	UY41 0.50
6BW7 0.65	12AV6 0.60	EC88 0.84	EM84 0.45	PL82 0.37	UY85 0.35
6BZ6 0.60	12BA6 0.50	EC92 0.55	EM87 1.10	PL83 0.45	U19 4.00
6C4 0.50	12BE6 0.55	ECC33 2.00	EY51 0.45	PL84 0.50	U25 0.71
6CB6A 0.50	12BH7 0.55	ECC35 2.00	EY81 0.45	PL84 0.50	U26 0.60
6CD6G 1.60	12BY7 0.85	ECC40 0.90	EY83 0.60	PL504 0.90	U191 0.50
6CG8A 0.90	19AQ5 0.65	ECC81 0.34	EY87/6 0.37	PL508 1.30	U404 0.75
6CL6 0.75	19G6 6.50	ECC82 0.34	EY88 0.55	PL509 2.20	U801 0.80
6CL8A 0.95	19H1 4.00	ECC83 0.34	EY500 1.45	PL519 2.80	VR105 0.50
6CM7 1.00	20P1 1.00	ECC84 0.35	EZ40 0.52	PY33/2 0.50	VR150 0.75
6CU5 0.90	20P4 0.84	ECC85 0.39	EZ41 0.52	PY80 0.50	X41 1.00

All goods are unused and boxed, and subject to the standard guarantee. Terms of business: Cash or cheque with order only. Despatch charges: Orders below £25, add 50p extra per order. Orders over £25 post free. Same day despatch. Terms of business available on request. Any parcel insured against damage in transit for only 5p extra per parcel. Many other types in stock. Please enclose S.A.E. with any enquiries. Special offer of EF50 VALVES, SOILED, BUT NEW AND TESTED £1 EACH.

CATRONICS FOR THE BEST VALUE IN COMPONENTS FOR THE TELEVISION TELETEXT DECODER

Kits are now available from CATRONICS LTD. for this project, all backed by CATRONICS exclusive Four Star Service.



Our kits contain all components required for the specific unit, INCLUDING A REPRINT OF THE ORIGINAL ARTICLE, plus the PCB as indicated.

Kit	Incl. PCB	Less PCB	P & P
POWER SUPPLY UNIT	£26.75	£23.80	£1.00
INPUT LOGIC CARD	£25.85	£16.05	20p
MEMORY CARD	£30.80	£22.90	20p
7 sockets for 2102 i.c.s — extra £1.60			
DISPLAY CARD	£34.65	£26.65	20p
MOTHER CARD etc. (excl. mod.)	—	£24.50	25p
MODULATOR Pre-aligned and tested	—	£17.00	20p

TUNER, SWITCHES, CABINET AND ALL OTHER PARTS ALSO AVAILABLE — SEND FOR FULL PRICE LIST.

Components also available separately:

BY213 — 70p, BY288 zeners — 13p, 1A Bridge Rectifier — 40p, 10,000 mfd 16V capacitor — £2.75, Heatsink — 30p, Illuminated Mains Switch — £1.40, Fuse and holder — 52p, Mains Transformer — £6.25 (+ £1.00 p&p), 7805 — £1.50, 7812 — £1.50, 2102 — £2.65, 74S262N — £17.00 7400 series i.c.s see Price List for details.

ALL THESE PRICES INCLUDE V.A.T.
Please add minimum of 20p P & P

Catronics COMMUNICATIONS HOUSE,
20, WALLINGTON SQUARE,
WALLINGTON, SURREY, SM6 8RG.
Telephone: 01-669 6700

EX-EQUIPMENT SPARES

MONO TUBES	MONO TUNERS	MONO LOPTS	MONO PANELS	MISC. S/Output Trans.
(tested) 19" Rimguard £4.50 23" Rimguard £6.00 20" Rimguard £6.00 24" Rimguard £7.50 + £2.50 p.p.	6 - button integrated all at £6.50 U.H.F. P/Button D/S £4.50 U.H.F. P/Button S/S £6.50 Rotary £3.00 + £1. p.p.	All D/Standard Lopts at £4.00 + £1. p.p. All S/Standard at £4.00 + £1. p.p.	i.e. Philips, Bush etc. £3.50 + £1 p.p. Quotations for complete S/Hand chassis if required. (Diff prices)	F/Output Trans. £1 + VAT + £1 P&P Scancoils £1.50 + VAT + £1. P&P. Other spares available. please write or phone for details.

VALVES (MONO & COLOUR)

PCL82 0.10	PCF802 0.10	PCC86 0.10	EY86/7 0.10	30PL1 0.10	PL509 0.50
PCL83 0.10	PCF805 0.10	PC97 0.10	EY8/7 0.10	30PL13/4 0.10	PY500 0.50
PCL84 0.10	PCF806 0.10	PC900 0.10	DY802 0.10	30P12 0.10	PD500 0.50
PCL85 0.10	PCF808 0.25	EF80 0.10	PY800/1 0.10	30FL1/2 0.25	GY501 .050
PCL86 0.10	PCF80 0.10	EF85 0.10	PL36 0.25	ECC82 0.10	PL802 0.50
PFL200 0.10	PCC189 0.10	EF183 0.10	PL504 0.25	ECC81 0.10	PL508 0.50
PCF801 0.10	PCC86 0.10	EF184 0.10	PL81 0.10	ECH81 0.10	PCH200 0.50
30C1 0.10	30C15 0.10	6BW7 0.10	6/30L2 0.10	ECL80 0.10	PCF200 0.50
30C17 0.10	30C18 0.10	ECC85 0.10	U26 0.10	ECL82 0.10	CEY51 0.15
PL83 0.10	PL84 0.10	EH90 0.10			

Please note there is 25p p.p. per order

D/STANDARD COLOUR SPARE PANELS

	IF	LUM	CHROMA	EHT	REG	CON	S/OUTPUT	POWER	L/TB	F/TB
Bush/Murphy	6.50	6.50	6.50	-	-	6.50	1.50	6.50	-	-
GEC/Sobell	6.50	7.50	-	-	-	6.50	-	-	-	7.50
Philips	6.50	9.50	-	-	-	7.50	-	-	-	6.50
Decca	6.50	12.50	12.50	-	-	6.50	2.00	8.00	-	6.00
							(19" only)			
Thorn 2000	6.50	7.50	7.50	6.50	6.50	7.00	-	8.00	9.50	6.50
Pye	7.50	7.50	9.50	-	-	6.50	-	-	-	4.00
Baird	6.50	8.50	8.50	-	-	6.50	-	-	-	6.00

Postage & Packing £1.25

S/STANDARD COLOUR SPARE PANELS

	IF	LUM	CHROMA	VIDEO	CON	POWER	L/TB	F/TB
Bush 184	9.50	-	20.00	-	8.00	6.00	20.00	-
GEC Hybrid	9.50	9.50	15.00	-	6.00	-	-	12.00
Philips G6 S/S	9.50	-	15.00	-	9.00	-	-	10.00
Thorn 3000	10.00	9.00	18.00	10.00	6.00	20.00	20.00	10.00
Pye 691/693	15.00	7.50	18.00	-	15.00	-	8.00	7.50
Thorn 3500	10.00	9.00	18.00	10.00	10.00	20.00	20.50	10.00

Korting and other foreign panels available on request.

Postage & Packing £1.25

COLOUR TUBES

19"	18.00
19" A49.192	£20
20"	20.00
22"	25.00
25"	18.00
26"	32.00

Plus P & P £3.

COLOUR TUNERS

Bush	6.50
GEC	6.50
Philips G6S/S	6.50
Thorn 3000	6.50 (£8 new)
Pye 691/697	7.50
Some new tuners in stock can supply on request. Many Foreign Tuners also available on request. Plus P & P £1	

COLOUR LOPTS

Most lopts available from £7.00. Both British & Foreign makes. Please ring or write.
P & P per lopt £1

MISC.

S/Output transformer from £1.50
F/Output from £1.25
Scancoils from £5.00
P & P £1
Other spares available on request.

CABINETS

Many British & Foreign cabinets available. Please state.
Speakers, masks, etc., available on request. Please phone or write.

T.V.'s (MONO)

Rotaries	
GEC	5.00
Thorn 950	5.00
K.B. Trans-tuners	5.00
Pye	5.00
etc.	

P/Button

Thorn 1400	9.00
Bush 161	9.00
Baird	9.00
Philips 210	9.00
Pye	9.00
etc.	

P/Button

20"	24"
Bush	11.00
GEC	11.00
Philips	11.00
Pye	11.00
etc.	

S/Standard

20"	24"
Bush	15.00
GEC	15.00
Philips	15.00
Pye	15.00
Thorn	15.00
etc.	

COLOUR T.V.'s

D/S Colour

19", 25" from £30
i.e. GEC, Bush
Philips, Baird
etc.,

S/S Colour

19", 20", 22",
24" from £50
Working from
£65
includes many makes
as well
as foreign models.

REDUCTION ON QUANTITIES

WHY NOT TRY OUR EXPRESS MAIL ORDER ON ANY OF THE ITEMS LISTED.
PLEASE ADD 12½% V.A.T. TO ALL ITEMS AND OVERSEAS AT COST. CASH WITH ALL ORDERS.

BRIARWOOD TELEVISION LTD.
Legram Mills, Summerville Road, Bradford, West Yorkshire BD7 1NS Tel (0274) 22046.

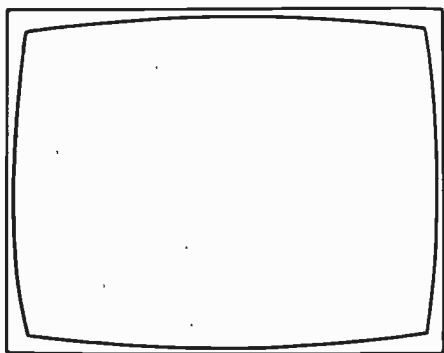

TELEVISION

ASSISTANT EDITOR

John A. Reddihough

TECHNICAL EDITOR

Luke Theodossiou

ART EDITOR

Peter Metalli

ADVERTS MANAGER

Roy Smith 01-634 4383

CLASSIFIED ADVERTS

Colin R. Brown 01-261 5762

ICs in the TV Environment

If you're involved with industrial electronics, the inside of today's television set may appear to be an awfully old-fashioned mess. Instead of neat rows of i.c.s, all sorts of different components and devices are crammed on to boards that don't look quite large enough. If you're an outsider you may feel that the TV industry is dreadfully behind other sections of the electronics industry. After all, we were actually using valves in new sets until quite recently, while despite the fact that the first i.c.s started appearing in TV chassis back in 1968 – an a.f.c. chip in the Baird 710 colour chassis, and the TAA570 inter-carrier sound chip in the GEC Series One monochrome chassis – the day of the all i.c. TV set still seems far off. In fact i.c.s are at present being rejected in many TV applications where you might expect to find them, because they don't provide the performance that can be achieved for the same cost using discrete circuitry.

If this seems puzzling, one has to recall that the electrical environment inside a TV cabinet is rather different from the conditions in say a computer. That 20-25kV is never far away and inclined to flashover; hefty sawtooth deflection currents rattle round the place, producing all-pervading fields and with flyback pulses in the kV range that are used for this, that and the other purposes; your video output stage(s) are swinging away over a 100V or so at up to 5MHz, with rich harmonics coming from here and from all those switch-mode circuits; you've vast gain to handle, and some massive feedback loops. Not really the ideal set up for those highly sensitive little black lozenges that are much happier switching away over levels of 3-4V.

It's surprising really that i.c.s have gone as far as they have in TV sets. Though you may say that a field output stage is little more than a glorified audio circuit, still the power involved is considerable and one has to raise one's hat to devices such as the TDA1170 and the TDA2600. These seem to be as far as the i.c. can go for the present in taking over TV receiver circuit functions. For the foreseeable future it looks as if advances will consist of more sophisticated devices to carry out the present operations performed by i.c.s, with a certain amount of merging into larger chips – RCA for example have an interesting one-chip PAL decoder.

The problems of designing i.c.s for TV receiver use are formidable. Quite a number of promising looking devices have been announced by the ever hopeful i.c. manufacturers, tried out by TV setmakers, and subsequently abandoned. One interesting device at present is already on its sixth design mask! It seems that with i.c.s you either strike lucky at an early stage, get involved in a very lengthy development programme, or give up.

There is a lot that happens between the announcement of a "new generation" of TV i.c.s by Texas, Motorola, Mullard or SGS and their appearance in production chassis. It was assumed at one time that the semiconductor makers would take over the design of domestic electronic equipment. But the knockabout world of everyday domestic use, and especially the TV set's innards, means that a great deal of development work remains with the setmakers' engineers in order to produce products that can be relied upon to work satisfactorily under varying conditions and lend themselves to economic production. Sophisticated industrial electronic equipment is often operated in a controlled environment: the consumer setmaker has to remember that his "transistor" may spend much of its life operating on the plate rack over the gas oven! When it comes to the selection of i.c.s for use in TV chassis you can't afford to make mistakes. If there's the slightest doubt, a new i.c., however appealing it may seem to be in offering sophisticated performance with next to no peripheral components, must be left severely alone. Hence the fact that TV setmakers pick and use, using a mixture of i.c.s from different ranges to the chagrin of the semiconductor manufacturers.

ICs have long since dominated the intercarrier sound department, but don't seem to offer much advantage on the audio side. The decoder is now the province of the i.c., but at i.f. the relative advantages of i.c.s and discrete strips seem to be in balance. Line oscillator and flywheel sync arrangements seem to be very happy in i.c. form, though hardly economic in monochrome sets. Elsewhere there'll be more i.c.s associated with tuning arrangements and remote control, but it looks as if receiver design is now set for a while, and still a far remove from the average neat logic circuit.

Teletopics

VCRs

At the recent Radio and Television trade shows Grundig were showing their new VCR4000 videocassette recorder. This will be the first machine to appear on the UK market using the new Philips "long play" (130 minute) VCR system. It's expected that an initial delivery of 500 units will be supplied to dealers during October. Grundig insist that dealers handling these machines have trained service staff, and are holding a series of courses for this purpose. Both Grundig and Philips anticipate a boom in VCR sales next year. The Philips N1700 130-minute machine is expected to be available in the UK from next January. Philips comment that their six week advertising campaign for the current N1502 machine earlier this year was a great success, "tremendously increasing" public awareness of video-cassette recording. Stock was sold out within three weeks, and at the time of writing they've yet to catch up with the orders then placed. Production of the 60-minute N1502 series is to continue alongside the N1700, but the machines will not be compatible. A switchable-system machine is considered to be too expensive a proposition.

The service call rate for the N1502 is around 1.7 a year, and Philips aim to reduce this to 0.9 with the N1700, which will have a guaranteed head life of 1,000 hours.

Meanwhile, just to thoroughly confuse the scene, yet another VCR system has been announced – and a very interesting and totally different one at that. This is being developed by BASF AG in Germany and Bell and Howell in the USA. It's based on the Linear Video Recording (there's another set of initials for you to have to remember, LVR) system which BASF has designed. The aim is to have the machine on the market in time for Christmas 1979, at a highly competitive price.

BASF have achieved a high information packing density, the 120 minute LVR cassette being only 28 per cent the size of the Philips cassette and 21 per cent the size of the current Sony cassette. The basic LVR configuration is shown in the accompanying diagram. While current VCR systems employ a relatively slow tape speed, with the head rotating as well in order to increase the effective head-tape speed to that required for recording video signals, the LVR system has a stationary head and the comparatively fast tape speed

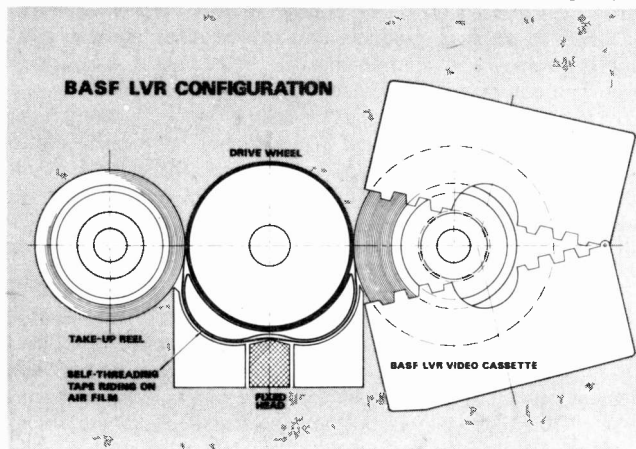

Schematic diagram of the BASF LVR VCR system.

of 3 meters/second. The chromium dioxide tape moves forward and backwards and carries 28 tracks. It's driven by a single motor. The low tape consumption – 2.4m²/h – means that tape cost should work out at the competitive figure of around £10 per playing hour at today's prices.

The machine will be aimed at the amateur market, the small size of the cassette, low tape consumption, relatively simple mechanism and sophisticated electronics offering great potential for miniaturisation. It's suggested that the tape transport system could be integrated in a video camera, giving advantages such as on the spot replay and simple recording of the original sound. The LVR system also offers economical high-quality duplicating; the 28 tracks of vision and sound signals can be duplicated from the master tape using a multiple head at a ratio of 1:1 without the need to reverse the tape.

EXHIBITIONS

The seventh International Broadcasting Convention, IBC 78, will be held in London on September 25-29th, 1978. The venue is to be the new Wembley Conference Centre, instead of Grosvenor House where five of the past six IBCs have been held. The record number of 2,600 delegates from 51 countries attended the last IBC in 1976 – the convention is held biennially.

The British Amateur Television Club is organising a slow-scan television Convention which will be held at the University of Aston, Birmingham, on Saturday November 19th, 1977, from 1000 to 1730 hours. There will be lectures in the afternoon and free car parking is available. Non club members are welcome, and the admission charge will be 50p. For further details and a map send a stamp for return postage to Mike Crampton, G8DLX, 16 Percival Road, Rugby, Warwickshire CV22 5JS.

The Video Tradex 77 International Exhibition and Conference, sponsored by the trade magazine *Video and Audio Visual Review*, will be held at the Heathrow Hotel, London Airport, on November 22-25th, 1977. Full support has been announced by Sony, Philips, BASF, Grundig, Thorn, Rank and Hitachi Denshi. For further information write to Video and Audio Visual Review, Link House, Dingwall Avenue, Croydon CR9 2TA.

BBC'S TV NOISE REDUCTION SYSTEM

The BBC has developed and is currently testing a digital signal processing system designed to reduce the amount of noise present on transmitted pictures. Such noise can arise from many sources in normal studio operations – the use of multi-generation videotape, long transmission links, standards conversion, and film grain structure for example – and in outside broadcasts where cameras are used under poor lighting conditions, particularly with electronic news gathering. The BBC's noise reduction system is understood to be the first to be successfully used with PAL colour signals, and involved some formidable problems in its development. The equipment has been successfully used in recent trials on both BBC-1 and BBC-2, using a wide variety of programme material. Over a period of ten days

about 14 hours of live and recorded programmes were processed, including a Silver Jubilee concert which was transmitted live from the Albert Hall under difficult lighting conditions. Work has now started on an automatic version for full operational use, following the trials with the manually controlled prototype equipment.

The system uses a picture store in a recirculating mode so that a number of successive pictures can be added. As a result noise, which is random, is reduced by the integrating action, while the wanted picture detail is reinforced relative to the noise. Two problems arise in that integration of successive pictures containing areas with rapid movement leads to smearing of the moving objects, while due to the eight-field sequence of the PAL colour subcarrier this would be reduced along with the noise. The BBC report that both problems have been overcome and are the subject of patent applications.

TRANSMITTER OPENINGS

The following relay stations are now in operation:

Glenluce (South West Scotland) BBC-1 channel 58, ITV (Border Television) channel 61, BBC-2 channel 64. Receiving aerial group C/D.

Millom (Cumbria) BBC-1 channel 22, ITV (Granada Television) channel 25, BBC-2 channel 28. Receiving aerial group A.

Wrexham-Rhos (Clwyd) BBC Wales channel 39, HTV Wales channel 67. Because of the wider than usual channel spacing a group E or other wideband aerial will be required. Due to the shortage of channel frequencies in the Wrexham area, the station cannot transmit BBC-2.

Ystalyfera (West Glamorgan) HTV Wales channel 49. Receiving aerial group B.

All these transmissions are vertically polarised.

GAS RADIO

What? Well yes, the North Eastern Gas Board is looking for a gas-powered radio set to add to its collection – the biggest in Britain – of old gas appliances. It's also looking for a gas-powered vacuum cleaner. The gas-powered radio set was produced by a firm in Bingley, Yorkshire, in 1939, but due to the outbreak of war it does not seem to have gone into full production. It had some eighty 3in. long by ½in. wide porcelain cylinders, in each of which a gas flame heated a thermocouple in order to produce an electrical output. In case you're thinking what on earth for, one must remember that in those days the gas and electricity suppliers were battling with each other to achieve all-gas or all-electric homes. According to the *Gas Salesman* magazine the set would help to warm the house and help the industry counter "the specious claims of electrical salesmen who paint alluring pictures of the 'all-mains' wireless" . . .

WIDEBAND AMPLIFIER

SGS-ATES have announced a two-stage wideband v.h.f./u.h.f. amplifier covering 40-860MHz. The amplifier, type SH221, employs thick-film technology. It requires a 24V supply, and provides a gain of 16dB with a noise figure of 5dB.

NEW CHASSIS

Some late news from the recent Radio and Television trade shows. The new Rank colour TV chassis, which is hinged and has fully pluggable panels, is known as the T20 and is designed around the 20AX tube. Features include a switch-

mode power supply circuit with short- and open-circuit safeguards and crowbar over-voltage protection, cooler running line and field output circuits, and switchable a.f.c. operated by the tuner door flap. The range consists of the 20in. Model BC6248, 22in. Model 6348 and 26in. Model 6448, all of which are supplied with an ultrasonic remote control unit giving sequential channel change and sound muting.

Pye's new Studio Colour range of receivers also features the 20AX tube. It incorporates the Philips G11 chassis, which is now being produced at Pye's Lowestoft TV plant as well as at Croydon.

Two new colour sets introduced by ITT, the CD651 and CD751 – 22 and 26in. models respectively – have a unique remote control system which is an integral part of the set. The idea is that the remote control unit will operate either outside the set or when fitted in its housing in the set.

A feature of the new Bush monochrome portable Model BM6514 is the use of rotary tuning with a varicap tuner – as in Thorn's new 1690/1691 series. The Rank Arena Model AC6333 television receiver, which incorporates a Teletext decoder, is now available to dealers throughout the UK, following initial market evaluation in the London area. Though Rank do not quote recommended prices, they comment that sets should be available "at a price below £800".

SET DELIVERIES

Whilst the good news is that colour set deliveries during the first four months of 1977 were 21 per cent higher than during the corresponding period last year, concern is being expressed over the increased percentage of imported sets – up from 13 to 23 per cent. Monochrome set deliveries were 8 per cent higher over the period, with a large jump of 21 per cent in April. The Japanese share of the market has risen from around 10 per cent to 17 per cent, which is seen as a threat to the Anglo-Japanese understanding on imports.

VALVE GUARANTEES

HRS are now giving guarantees on Mazda, Mullard and Tungram valves supplied by them. Valves leaving their stores have a yellow transfer on them and any valves returned for replacement must have this label. In the case of Mazda and Mullard valves the guarantee is for three months and the valves must be no older than six months from the date stamped on the valve. Tungram valves have a twelve month guarantee. HRS operate from Electron House, Meriden Street, Birmingham B5 5LR, telephone 021-643 0705/6.

SOFT-FLASH

Soft-flash, a new development from Mullard in colour c.r.t. technology, is to be introduced in their 20AX in-line gun c.r.t.s. The aim of the technique is to provide improved receiver reliability, with simplified flashover protection circuitry and possible component savings. The technique involves the use of a new internal conductive coating containing iron oxide. This has high electrical resistance, but because of the tube geometry the resistance of the e.h.t. reservoir capacitor (the tube glass plus the internal and external conductive coatings) is little increased. The effective resistance to flashover currents flowing from the internal conductive coating through the gun structure is increased to about 400Ω however. As a result, the transient energy reaching the external circuitry is reduced by a factor of at least ten.

A Day in the Life of . . .

Les Lawry-Johns

07.30 Open eyes. Think about coming day. Close eyes.

07.45 Open eyes. See cat sitting by bed waiting to be fed. Get up. Kick cat and visit bathroom. Dress and proceed downstairs preceded by cat. Say good morning to dog. Pick up morning paper and final rates demand plus a letter from the editor asking if we would like him to send us a new ribbon for our typewriter because he can't understand half of what we write and the half he can understand doesn't make sense anyway so would we like a typist as well?

07.50 Feed cat. Put on kettle and take dog for walk across road on yonder green. Throw sticks for dog. Find sticks for dog. Say good morning to passers by. Wish we had put on wellies as feet are soaking wet.

08.00 Return for breakfast. Say good morning to most beautiful girl in the world (who will read this). Read paper, at the same time listening to most beautiful girl talking about something or other. Go to toilet: read final rates demand.

08.45 Open for business. First job, fit regunned tube in 24in. monochrome Philips set. Correction. Try to fit tube, but cannot undo nuts holding old tube. Box spanner wrong size. Succeed with pliers, injuring hand. Complain to most beautiful girl who says "You should have let me do it".

09.00 Test Philips set. Goes into lines after five minutes. Change ECC82 line oscillator valve to cure.

09.05 Sell razor adaptor to man from Australia who says that things seem upside down here.

09.10 Try to ring Mullard Limited about colour tube worn out after three years by woman who leaves set on from early morning till late at night for company (tube insured for four years). Fail to get Mullard Limited. Phone out of order. Go next door to ring 151 and speak to nice engineer.

09.15 Two ladies carry in colour set, GEC Model C2111. Complaint: blows 3·15A mains fuse once per week but present trouble is no sound this time after replacing 3·15A fuse. Male member of family arrives and fills in gaps in story. Brother-in-law has serviced set up to present but never found reason for 3·15A fuse failing. Brother-in-law has gone to New Zealand, leaving good supply of fuses. Picture apparently pulsates prior to fuse failing.

Investigation reveals that the 24V line 60Ω wirewound resistor R603 (see Fig. 1) by the side of the line output stage has sprung open, thus removing the supply to the audio amplifier i.c. No shorts, no reason. Solder up resistor. Switch on. E.H.T. rustles up. Sound o.k., but no picture. Brilliance has been turned down! Turn up, picture o.k.

Now stop and think for a moment. If R603 springs open, it is overloaded. What by? The audio i.c.? Unlikely. When they go they go (they don't come back). The 24V zener? Well yes but. What else? The picture pulsates. What does that mean? Varying in size and brightness, i.e. the h.t. supply is fluctuating. What else? The 3·15A supply fuse fails regularly, apparently without cause. Add this lot up. There is a sudden rise in voltage which normally blows the fuse and can open the 24V supply because the zener is trying to cope with the sudden rise in voltage. Who's to

blame? What's his name? Thyristor. That's it, the BT106. Take out the centre supply panel, remove the BT106 and fit another. No more trouble to date.

10.00 Involved tussle with a Hitachi car radio which in the first place had only required a loudspeaker but has now burnt out the tracks to the output transformer secondary and the output transformer secondary winding to boot. Make up and fit a suitable transformer with revised secondary output to speaker, and advise customer to recheck wiring in 24V lorry supply so that the 12V used for the radio comes from the battery nearest earth and not the 12V to 24V one as one side of the speaker connects to radio earth which may not be the vehicle earth and the speaker may be running to earth and this is not good. Sort that out.

10.30 Dog takes duster from under counter and wants to play. Avo falls to floor, exit dog. Female half says we shouldn't take our nasty temper out on the dog just because the sets won't go right. Beautiful girl no longer beautiful. From now on just she. She's made a cup of coffee: Not a bad girl really.

10.40 Bush Model CTV194. Big flash from power panel on switching on. 8TH2 (mains input thermistor) doesn't look good. Fit new one. Switch on. No flash but no results as there is no l.t. supply. Output from bridge o.k., but is not present at filter resistors at top of panel. Remove panel (again) and trace crack across track coming up from bridge. Repair and try again. O.K. except for hum bar. Tighten screws securing panel, no hum bar.

Sudden bright spark from right side panel, smoke from transductor 6T3 (see Fig. 2). Fit new transductor. Picture now only a couple of inches high, with bright line top and bottom. Check this, that and the other, only to find eventually that there was a dead spot on 6RV4 which is just above the transductor. A slight touch restored normal scan.

11.05 Spend some time showing on paper how to provide two coaxial outlets from one aerial to gentleman who could not or would not understand whilst his two unruly children tear place to pieces chasing cat and dog.

11.30 Gentleman leaves, taking reluctant offspring, having purchased one coaxial plug.

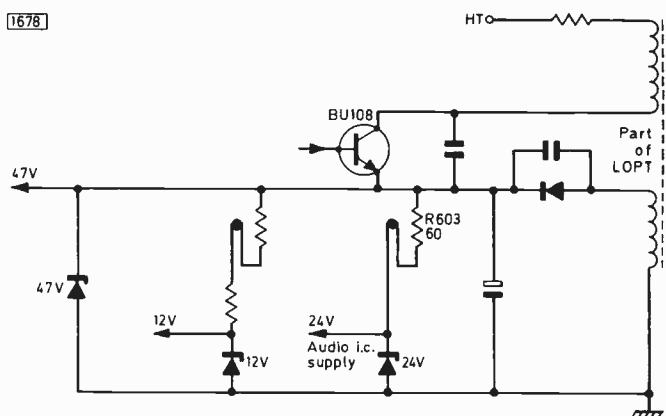

Fig. 1: What kept blowing the mains fuse, and made R603 go open-circuit? GEC Model C2111.



LINE OUTPUT TRANSFORMERS

All items new and guaranteed

MONO TRANSFORMER £7.00ea

(No Extra for Carriage)

VAT @ 12½%

86p

DISCOUNT FOR TRADE.

TOTAL

£7.86

BUSH TV102C TV128 TV183 or D TV103 or D TV134 TV183S TV105 or D TV135 or R TV183SS TV105R TV138 or R TV185S TV106 TV139 TV186 or D TV107 TV141 TV186S TV108 TV145 TV186SS TV109 TV148 TV191D TV112C TV161 TV191S TV113 TV165 TV193D TV115 or C TV166 TV193S TV115R TV171 TV198 TV118 TV175 TV307 TV123 TV176 TV313 TV124 TV178 TV315 TV125 or U TV181 or S				DECCA DR1 DM35 DR123 DR2 DM36 DR202 DM3 DM39 DR303 DR3 DR41 DR404 DR20 DM45 DR505 DR21 DR49 DR606 DR23 DM55 666TV-SRG DR24 DM56 77TV-SRG DR29 DR61 MS1700 DR30 DR71 MS2000 DR31 DR95 MS2001 DR32 DR100 MS2400 DR33 DR101 MS2401 DR34 DR121 MS2404 DR122 MS2420				MURPHY V843 all models to V979 V153 V159 V173 V179 V1910 V1913 V1914 V2014 or S V2015D V2015S V2015SS V2016S V2017S V2019 V2023 V2027 V2310 V2311C V2414D V2415D V2415S V2415SS V2416D V2416S V2417S V2419 V2423				PHILIPS 17TG100u 19TG170a... 21TG106u 17TG102u all models to 21TG107u 17TG106u 19TG179a 21TG109u 17TG200u G19T210a 23TG111a... 17TG300u G19T211a all models to 17TG320u G19T212a 23TG164a G19T314a G19T215a 19TG108u... G20T230a... 23TG170a... all models to all models to all models to 19TG164a G20T328 23TG176a 21TG100u G24T230a... 21TG102u G24T310							
BAIRD 600 628 662 674 602 630 663 675 604 632 664 676 606 640 665 677 608 642 666 681 610 644 667 682 612 646 668 683 622 648 669 685 624 652 671 687 625 653 672 688 626 661 673				GEC BT454 BT455 BT455DST 2000DST... all models to 2044 2047... all models to 2084 2104 or/1 2105 or/1				KB-ITT By Chassis: VC1 VC52 VC2 VC52/1 VC3 VC100 VC4 VC100/2 VC11 VC200 VC51 VC300 Or quote model No.				INDESIT 20EGB 24EGB				EMO WINDING			
PLEASE QUOTE PART NO. NORMALLY FOUND ON TX. BASE PLATE 4133, 4123, 4140 OR 00062.				SOBEL ST196 or DS ST19 ST290 ST297 1000DS... all models to 1102				THORN GROUP Ferguson, H.M.V., Marconi, Ultra. By Chassis:- 800, 850, 900, 950/1, 950/2, 950/3, 960, 970, 980, 981, 1400, 1500, 1500(24"), 1580, 1590, 1591, 1592, 1600, 1612, 1613. Or quote model No.											

Tidman Mail Order Ltd.,
 236 Sandycombe Road,
 Richmond, Surrey.

MON-FRI 9 am to 12.30 pm.
 1.30 pm to 4.30 pm.
 SAT 10 am to 12 noon.

Approx. 1 mile from Kew Bridge.
 Phone: 01-948 3702

Hamond Components (Midland) Ltd.,

416, Moseley Road,
 Birmingham B12 9AX.

MON-FRI 9 am to 1 pm.
 2 pm to 5.30 pm.

Phone: 021-440 6144.

Contact your nearest depot for service by-return. Callers welcome. Please phone before calling.

COLOUR TV LINE OUTPUT TRANSFORMERS E.H.T. RECTIFIER TRAYS (Prices on application)

RADIO AND TV SPARES ALL COMPONENTS BRAND NEW. CASH WITH ORDER ONLY. P & P 35np. ALL PRICES INCLUDE VAT. AT 12½%				MAIL ORDER ONLY. NO CALLERS.				PHD COMPONENTS DEPT 3, UNIT 7, CENTENARY ESTATE, JEFFERIES ROAD, ENFIELD, MIDDX. 01-805 4060. TELEX 261295.							
MULTISECTION CAPACITORS <i>Description</i> 400.400/350 3.00 200.200-150.50/300 2.50 1000-2000/35 80p 600/300 1.90 600/250 1.55 200-300/350 2.05 1000-1000/40 1.00 2500-2500/30 1.30 300-300/300 2.25 200-200.75-25/350 2.40 100-300-100-16/275 1.60 150-100-100-100-150/320 2.60 150-150-100/350 1.50 175-100-100 2.35 220/100 32p 2500-2500/63 1.70 700/200 1.30 400/350 1.55				DROPPER SECTIONS 16p each MAINS DROPPERS Pye 11062 75p Pye 11009 1.20 BRC Mono 1400 80p BRC Mono 1500 75p BRC Colour 3000/3500 75p BRC Colour 8000 75p BRC Colour 8500 75p Phillips G8 50p Phillips 210 (with link) 55p Phillips 210 65p RRI Mono 141 75p RRI Mono 161 80p GEC 27840 75p GEC 2000 75p Phillips G9 35p				DIODES AA113 14p OA85 11p BA102-24p BAX13 5p AA116 14p OA90 6p BA130 35p BAX16 6p AA117 14p OA91 6p BA145 16p BAY38 10p AA119 8p OA95 6p BA148 16p IN418 4p AA119 8p OA95 6p BA154 12p BY206 30p OA47 6p OA202 11p BA155 15p OA79 6p BA100 14p BA164 17p				INTEGRATED CIRCUITS MC1307P 1.50 SL901B 5.00 MC1310P 2.50 SL917B 7.00 TAA350 1.90 SN76003ND 1.70 TAA550 50p SN76013N 1.80 TAA630S 4.00 SN76013N07 1.80 TBA120S 1.50 SN76013ND 1.60 TBA120S0.150 SN76023N 1.85 TBA520Q 3.00 SN76023ND 1.60 TBA530Q 2.50 SN76033N 2.75 TBA540Q 3.00 SN76665N 2.50 TBA550Q 4.00 CA3065 2.50 TBA560C0.400 MC1358P 2.50 TBA750Q 2.20 MC1327P 2.00 TBA800 1.60 MC1327PQ 2.50 TBA920Q 4.00 MC1330P 1.50 TBA990Q 4.00 MC1351P 1.20 SN76003N 2.75 MC1352P 1.60			
TRANSISTORS AC107 33p AF124 23p BC142 29p BC237 15p BF118 25p BF274 15p AC126 23p AF125 23p BC143 34p BC238 11p BF121 24p BF336 34p AC127 30p AF125 23p BC147 12p BC251A 16p BF152 30p BF337 34p AC12701 50p AF127 23p BC148 11p BC301 32p BF154 30p BF338 34p AC128 23p AF139 34p BC149 13p BC303 59p BF157 30p BF458 59p AC12801 50p AF178 53p BC153 19p BC307 11p BF158 24p BFX29 29p AC141 24p AF179 55p BC154 19p BC308 9p BF163 24p BFX84 24p AC141K 40p AF180 53p BC157 14p BC327 12p BF167 24p BFX85 25p AC142 24p AF181 49p BC158 12p BC328 12p BF173 24p BFX88 23p AC142K 25p AF186 39p BC159 14p BC337 15p BF177 29p BFX89 30p AC153 23p AF239 39p BC171 14p BC547 12p BF178 32p BFX90 30p AC176 24p AL102 1.05 BC172 13p BD115 64p BF179 32p BFX50 22p AC17601 50p AU107 1.05 BC178 21p BD116 60p BF180 34p BFX51 22p AC187 23p AU110 1.85 BC181 10p BD124 79p BF181 32p BFX52 22p AC187K 24p AU113 2.20 BC182L 10p BD131 44p BF182 43p BU105/01 1.90 AC188 24p BC107 10p BC182LB 10p BD132 49p BF183 43p BU105/02 2.50 AC188K 40p BC108 10p BC183L 10p BD133 49p BF184 25p BU105/04 1.90 AC193K 29p BC109 10p BC183LB 10p BD134 49p BF185 25p BU108 3.00 AC194K 31p BC113 12p BC184L 10p BD135 39p BF194 14p BU126 2.90 AD140 45p BC114 19p BC186 24p BD136 45p BF195 14p BU204 1.90 AD142 50p BC115 19p BC187 26p BD137 47p BF196 14p BU205 1.90 AD143 50p BC116 19p BC203 15p BD138 49p BF197 14p BU206 1.90 AD145 50p BC117 19p BC204 15p BD139 80p BF198 14p BU208 3.00 AD149 1.00 BC118 28p BC205 15p BD144 2.10 BF199 24p MJE340 65p AD161 45p BC119 28p BC206 15p BD155 74p BF200 34p MJE520 80p AD162 45p BC125 21p BC207 15p BD157 74p BF200 34p AF126 1.10 AF114 50p BC126 19p BC208 11p BD183 55p BF200 34p MJE3055 73p AF115 23p BC136 19p BC209 15p BD235 74p BF240 19p MPSU05 65p AF116 23p BC137 19p BC212L 11p BD237 74p BF241 21p MPSU55 1.25 AF117 19p BC138 19p BC213L 11p BD238 74p BF256LC 44p R2008B 3.00 AF118 48p BC139 19p BC214L 11p BDX32 2.50 BF257 48p R2009 3.00 BDX11 19p BC225 15p BDX32 2.50 BF258 65p R2010B 3.00 BDX15 19p BF271 15p T131A 60p BF273 15p T132A 60p				REPLACEMENT COMPONENTS Aerial Isolators 1.00 each Lopt'Korting 10.00 each BRC 3500 Cutouts 1.60 each											
VALVES DY86/87 50p PCL82 75p DY802 50p PCL84 1.00 ECC82 50p PCL85 90p EF80 45p PFL200 85p EF183 46p PL36 90p EF184 46p PL84 70p EH90 90p PL504 1.20 PCC89 1.20 PL508 2.00 PCC189 1.60 PL509 3.00 PCF80 75p PL519 3.00 PCF86 1.50 PY500A 1.90 PCF801 60p PY800 65p PCF802 1.50 PL802 4.00				EHT TRIPLERS (Priced each) BRC950 2.65 Pye CT205 5.50 BRC1400 2.65 Pye 731 8.25 BRC1500 (17") 2.65 Decca 2030 6.60 BRC1500 (24") 3.00 GEC 2028 7.10 BRC3500 6.60 GEC 2110 7.10 BRC8000 2.90 ITT CVC5 6.60 BRC8500 5.50 RRI 111/174 10.00 BRC9000 7.75 RRI AB23 7.70 Decca CS190 7.10 Korting 90° 7.10 Phillips G8 7.30 Tanberg 7.10											

Technical Training in Radio, Television and Electronics

Start training TODAY and make sure you are qualified to take advantage of the many opportunities open to trained people. ICS can further your technical knowledge and provide the specialist training so essential to success.

ICS, the world's most experienced home study college has helped thousands of people to move up into higher paid jobs - and they can do the same for you.

Fill in the coupon below and find out how!

There is a wide range of courses to choose from, including:

City and Guilds Certificates:-

Telecommunications Technicians,
Radio, TV and Electronics Technicians,
Electrical Installation Work,
Technical Communications,
Radio Amateur,
MPT General Radio Communications Certificate.

Diploma Courses:-

Electronic Engineering,
Electrical Engineering,
Computer Engineering,
Radio, TV, Audio Engineering, Servicing and Maintenance. (inc. Colour TV)
New Self-Build Radio Courses with Free Kits.

Colour TV Servicing

Technicians trained in TV Servicing are in constant demand. Learn all the techniques you need to service Colour and Mono TV sets through new home study courses which are approved by a leading manufacturer.

The ICS Guarantee

If you are studying for an examination, ICS will guarantee coaching until you are successful - at no extra cost.

POST OR PHONE TODAY FOR FREE BOOKLET

I am interested in.....

Name.....

Address.....

Phone No:.....

ICS International Correspondence Schools,
Dept. 801K, Intertext House,
LONDON SW8 4UJ. Tel 622 9911 (all hours)

ARE YOU IN THE DARK?..
..ABOUT OUR



COLOUR T.V. PANEL EXCHANGE REPAIR SERVICE

FULL RANGE OF

THORN · RBM · PHILIPS
PYE · INVICTA · GEC
DECCA

90 DAY GUARANTEE ON ALL REPAIRS
SAME DAY POSTAL SERVICE

We employ a large skilled Staff, who utilise some of the most sophisticated Test equipment available, inclusive of AUTOMATIC FAULT FINDING COMPUTERS together with specially designed SERVICING JIGS which in short means to you:-

HIGH QUALITY REPAIRS - AT LOW COST



ONE OFF
OR



100 OFF · NO ORDER TOO
LARGE OR SMALL

SEND FOR PRICE LIST

SEND FOR CATALOGUE
BLOCK DISCOUNTS FOR TRADE CONTRACTS

Campbell Electronics Ltd.

Factory Unit E5, Halesfield 23, Telford, Shropshire TF7 4QX
Telephone: Telford (0952) 584373 Ext. 2. Telex 35191 Chamcon

ORCHARD ELECTRONICS

SERVICE SECOND TO NONE - TRY US AND SEE

SUPPLIERS TO U.K.A.E.A., D.D.E., UNIVERSITIES, ETC.

ARE YOU GETTING THE BEST SERVICE?

TRANSISTORS	£ p	I/C LINEAR	7409	0.23	7495	0.74
BU108	2.50	709 (T099)	7410	0.18	7496	0.90
BU126	2.50	709 18 PIN DIU	7411	0.24	74107	0.30
BU208	3.00	741 18 PIN DIU	7412	0.28	74121	0.38
25C1172	3.00	AV-5-1224	7413	0.38	74123	0.49
AU113	1.72	CA314	7414	0.72	74141	0.80
MJE340	0.76	LM301AN	7416	0.38	74145	1.15
AF139	0.34	LM309K	7417	0.20	74151	0.94
AF239	0.46	LM324	7420	0.18	74174	1.20
BC109	0.12	LM380/SL60745	7421	0.36	74180	1.20
BC148	0.09	LM381N	7422	0.22	74190	1.60
BC300	0.35	LM723	7423	0.34	74191	2.10
R2010B	3.00	LM3900N	7425	0.34	74192	1.60
BY126	0.18	MC1310	7426	0.36		
BY127	0.18	MC1327	7427	0.32		
BY133	0.20	MC1330P	7428	0.50		
BY154	0.40	MC1350P	7430	0.18		
1N914	0.05	NE555	7432	0.28		
1N4148	0.05	NE566	7433	0.33		
BAX16	0.06	NE567	7437	0.42		
0A47	0.09	SN76003N	7438	0.30		
1N4004	0.08	SN76013ND	7440	0.18		
1N4007	0.11	SN78013N	7441	0.85		
		SN76023N	7442	0.68		
		SN76023ND	7443	1.00		
		SN78033N	7444	1.00		
		SN76650	7445	0.90		
		TA4550	0.60*	1.30		
		TBA120ASQ	1.30*	7447	0.98	
		TBA480Q	1.25*			
		TBA520Q	1.70*			
		TBA530Q	1.90*			
		TBA540Q	1.90*			
		TBA550Q	3.40*			
		TBA560CQ	2.30*			
		TBA641	2.55*			
		TBA750	1.90*			
		TBA900Q	1.35*			
		TBA810SQ	1.45*			
		TBA820Q	1.20*			
		TBA920Q	2.80*			
		TBA990Q	2.50*			
		TCA270Q	2.20*			
		ZM414	1.40*			
		Z513UC	8.50*			
		TTL DIGITAL				
		7400	0.15			
		7401	0.20			
		7402	0.18			
		7403	0.18			
		7404	0.23			
		ELC 1043/05	7492	0.55		
		VARICAP TUNER	7493	0.55		
		£5.00	7494	0.85		
		LED T1 209/0.125"	0.2"			
		Red	20p			
		Green	29p			
		Clips for above	3p			
		RESISTORS 1 1/2p each				
		One-third WATT E12 (5%)				
		1ohm-10m ohm.				
		POTENTIOMETERS				
		Lin/Log				
		5K. 10K. 25K. 50K. 100K. 250K.				
		500K. 1M. 2M. 25p each.				

POST AND PACKING 25p.
VAT + ADD 12 1/2% REST 8%
DISCOUNTS £5 5% £10 =
7 1/2% £15 = 10%.

ORCHARD ELECTRONICS
FLINT HOUSE, HIGH ST., WALLINGFORD
OXON. 0491 35529

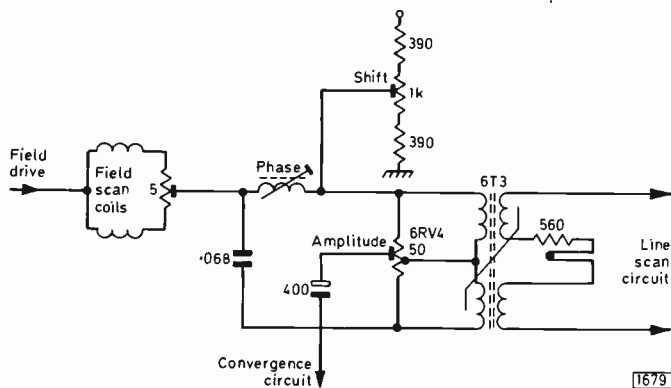

Fig. 2: Bush Model CTV194. The transducer 6T3 went up in smoke, then 6RV4 caused nasty things.

11.35 GPO engineer calls to check phone. Fault on external line. Climbs up pole to fix. Phone Mullard Limited.

11.40 Dismantle car radio. Replace fairy light used as dial lamp. Check output and find driver transformer open-circuit. Fit new driver transformer, using half a reel of desoldering braid as there doesn't seem to be a shortage of solder in Hong Kong. Assemble radio and test. Assorted whistles on medium wave, normal for this type of set.

12.00 Dismantle Ferguson 3816 portable. L.T. fuse blown. Check all circuits, no shorts. Fit new fuse and switch on. L.T. voltage 15V instead of 11.5V. Tube lights up like light bulb. Check regulator transistors VT21 and VT22 and all associated components. No fault. Set regulator to produce 5V at base of feedback transistor VT22. L.T. line now normal, with tube heater nice and dull. Surprise: picture is good black and white, no sign of strain. Question. Good picture at correct voltage means that the incorrect voltage could not have been present very long. Why the sudden rise with no apparent cause? Decide to put the set on soak test and keep an eye on the glow of the tube heater.

13.00 She shouts out "come and get lunch". Lunch only interrupted three times by phone making up for lost time.

14.00 Nice chap brings in old Bush (second set) v.h.f. only model. Find faulty PY800 in no time but on test reception is terrible. Spend much time checking tuner, valves, voltages etc. She says it might be aerial trouble. Send her away. Find v.h.f. aerial has not been plugged in to wall socket for some time. Lovely pictures on old set now that I have traced trouble.

15.00 Nip out to attend to outside calls. First an Ekco colour set (Pye 691 chassis) with no picture. Short from PY500 to chassis. Partially slide out right side unit and remove side cover of line output transformer. Snip lead of 0.47µF boost capacitor to prove it shorted, which it is. Could have been 100kΩ feed resistor to first anode controls damaged (down to zero) by shorted 0.1µF decoupler, but not this time. Replace boost capacitor and reassemble side panel. Switch on but no h.t. supply. H.T. surge limiting resistor at top of panel open-circuit, with thermistor looking a bit dicky. Replace both. PY500 none the worse for wear. Grey scale not nice. Set up and wrap up job.

15.30 Call to see set we had lately serviced, fitting new line output transformer and tube. Complaint, hum with a kinked picture - Bush Model TV161. Nasty hum, curved verticals. Check main electrolytic, earth tag (lower one with braiding) loose on rivet. Nip with wire cutters to improve contact instead of bashing with chisel (no chisel). No charge.

15.45 Call at back-to-front house. Rear of house facing road, or rather drive. Open garage with four vehicles. Pick way through garage, Land Rover, Daimler, Cortina and something else to get to back door. Apparently front door never used. Ushered through to large lounge with french windows at end looking out at front of house over garden with large swimming pool looking green and inviting. Sliding doors at side of lounge open to second lounge where family is watching second colour set. Set to be attended is a large Dynatron in Queen Anne housing. Hope it has Pye 697 chassis (familiar), but having removed twenty thousand screws from rear cover find it to be almost new with 725 chassis (modified 731) which has vertical panels and of course is all solid state.

Trouble is wrong colours. Difficult to see exactly what's wrong since grey scale is a mile out. Turn down colour and set up first anode controls on dark background. Grey scale now good, but turning up colour produces only bright red and green. Talk to self. If grey scale is o.k., blue drive must be present at blue amplifier. Check voltages just the same. O.K. This probably means that the drive from the preceding TBA530 matrix i.c. is also o.k., but as it's a plug-in one and we happen to have a spare with us it's a matter of seconds to replace it. No change. This confirms our fear. Blue drive o.k., so trouble must be lack of B-Y somewhere around the demodulator/PAL switch i.c. TBA990Q. Sorry, we don't have one with us (having searched untidy tool box and found little plastic boxes with every other i.c. you can mention). Check effect of red, green and blue level controls. Red sets up red, green sets up green, blue adjusts brightness . . . No circuit with us, and memory rapidly deteriorating to blind panic.

Refit two thousand screws in rear cover whilst chorus from family demands father make tea whilst they watch horse racing. He makes tea as he is not interested in horse racing as he is a bookie. I tell him I will call again when I have learnt a little more about my job and have a TBA990 and have had a look at the circuit. He says don't worry because the picture looks quite nice and they have the other set and he is going out to his villa in Spain anyway and will ring me when they come back. Would I like a cup of tea? I say no, so we have a brandy each before I pick my way out the back of the house to the front and return to shop where several people are waiting to shout at me for not being there when I was wanted.

17.00 Beginning to feel jaded. Check up on 725 circuit and come to conclusion that the TBA990 could well be at fault if only one or two other components can be proved o.k. Search through i.c.s but no sign of wanted one.

Repair Fidelity radio with no a.m., removing dial drum to get at suspect BF194. Replace BF194 and reassemble set so that we can return it to its owner who happens to be the landlord of the pub we are going to visit that evening.

17.30 Call it a day. Tidy up. Wash and brush up. Take dog for walk. Throw sticks for dog. Find sticks for dog. Deliver radio to pub at 18.30.

22.00 Watch News at Ten and notice light areas toward top at each side of tube (new set), due to Teletext off top of screen being reflected back by bulb of tube on to screen. Decide to do something about it later. Go to bed and remember all the things that should have been done before effect of whisky in black coffee taken with supper and News at Ten have effect on top of beer taken earlier with landlord of pub causes drowsy or is it drowsy, or drowsie or something . . .

Receiver Conversion for VCR Use

John de Rivaz, B.Sc. (Eng.)

Flywheel line sync has been the order of the day in TV sets for a good many years – since the adoption of negative vision modulation for the 625-line system used in the UK. With this system, the sync pulses are positive-going, as are electrical interference pulses. In order to provide good noise immunity therefore, a flywheel sync circuit with a long time-constant is used to synchronise the line oscillator. As a result, the line timebase operates steadily in the presence of interference. The transmitted sync pulses remain stable, so the system works well.

Sync Requirements for VCR Operation

When a set is to be operated with a VCR however the situation is different. Due to the inevitable deficiencies of the tape transport system, there are phase variations in the sync signal. Unless the set's line timebase can follow these, it will not be able to produce a steady display from the VCR's output signal.

Early TV sets, i.e. 405-line only ones, generally employed direct line sync, the line sync pulses being fed directly to the line oscillator to synchronise it. This is ideal for use with a VCR, but since the sets available to us are designed primarily for off-air use we find them incorporating flywheel line sync. There is an answer, to alter the time-constant of the flywheel sync circuit, speeding it up for VCR operation. Problems can nevertheless arise when an attempt is made to adapt a flywheel sync circuit in this way.

The first video recorder to be marketed was the Wesgrove VKR500, which used direct recording on to a $\frac{1}{4}$ in. tape travelling at 120in./sec. This is faster than the rewind speeds of many audio recorders, and the machine used 12in. spools.... It was only really suitable for enthusiasts to experiment with, being beyond the average person's capability to operate. The Wesgrove VKR500 was available in kit form, and the instruction manual recommended that a small capacitor be connected between the anode of the sync separator and that of the line oscillator "so as to introduce some direct sync". This crude modification would not have worked on most sets because, to reduce drift, sinewave line oscillators have been in general use for many years, and the phase of the sinewave bears no direct relationship to the phase of the line sync pulses. An experiment was performed, adding a monostable multivibrator in order to place the pulse required for direct sync in the correct phase: this was not very successful however.

The TBA920 Line Oscillator IC

By the time the first VCRs appeared on the market however, things called integrated circuits were appearing for use in television sets. With these, circuit complexity does not add to production costs so long as it can be contained within the chip. The TBA920 line timebase chip was first reported in these pages in the October 1972 issue (page 534). It's a Mullard device, and since Mullard is a part of Philips, the VCR people, it contained circuitry to deal with the problem of off-air/VCR line synchronisation once and

for all. It's not a cheap i.c., but the VCR performance obtained by adding it makes its use well worth while.

Typical Receiver Conversion

The following notes describe how it was successfully incorporated in a set (Bush Model CTV184S) fitted with the Rank A823 chassis. Much the same approach could be used with other chassis however.

When the VCR's signal was first applied to the unmodified set there was considerable line pulling at the top of the picture, while if there was the slightest problem with any of the cassettes it was impossible to lock the picture at all. An enquiry was made to Rank, and the suggestion came back to reduce the flywheel sync time-constant by changing 5C13 from 6,800pF to 680pF and 5C12 from 0.1 μ F to 0.01 μ F. The Philips service organisation suggested that no modification was normally required with these sets however. We decided to play safe and go for a TBA920.

When the set's manual and the Mullard i.c. data were consulted it was seen that there were two small points of incompatibility. The set's timebase l.t. rail is 20V instead of 12V, while the i.c. does not incorporate provision for overvoltage protection (this is in the line oscillator circuit in the A823 chassis). Fortunately the video input is of the correct polarity however, while the line output transformer provides reference pulses of either polarity.

The original circuit used in the A823, and the TBA920 circuit and its connections to the original, are shown in Fig. 1. During the initial experiments both circuits were left in operation, without the i.c.'s output being connected, and also without the new overvoltage circuit. An oscilloscope was then used to check that the i.c.'s output to the base of the line driver stage 5VT7 was similar in phase and duration to that provided by the original circuit. Final connection was made only after checking this.

Overvoltage Protection

The new overvoltage circuit operates on similar principles to the original one. Should the h.t. line rise excessively, neon 5N1 will conduct. The added BC184L transistor will conduct in turn, switching on the thyristor which then removes the power supply to the i.c. As a result, the line timebase shuts down, removing the e.h.t. The 100 Ω resistor in series with the overvoltage thyristor must be a 4W type so that it will not catch fire should the thyristor conduct. It should also be positioned so that it does not set anything else on fire if it has to dissipate its 4W!

Lock-in Range

When the circuit was first connected it was found that the lock-in range was insufficient and that the hold control needed frequent adjustment. Another i.c. was tried with no improvement. It was found that there was no trouble when operating with a VCR, so the circuit connected to pin 10 was investigated. It was eventually found that adding a

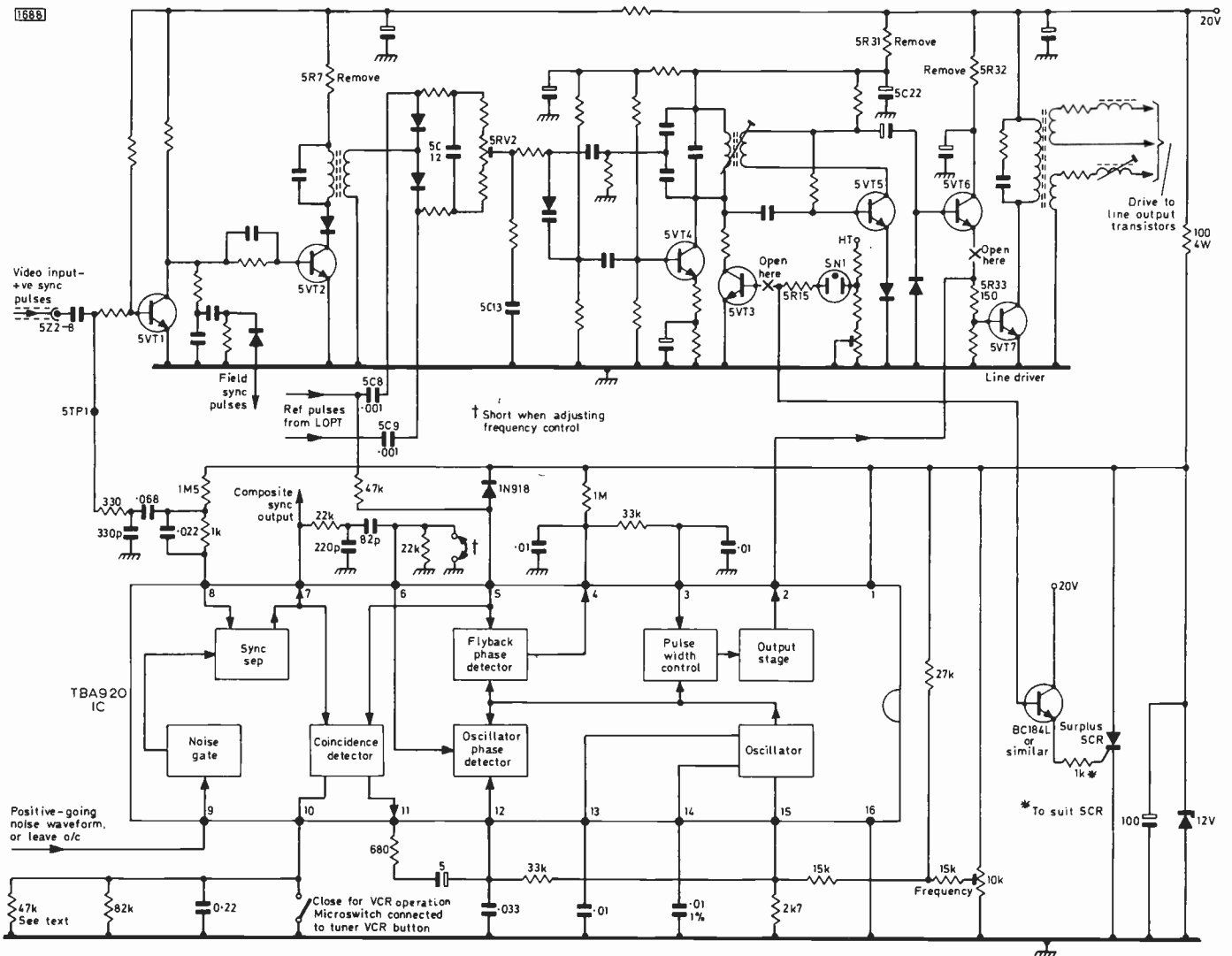

Fig. 1: Modifications to the Rank A823 chassis (A803 scan drive panel), incorporating a TBA920 line generator i.c. to provide reliable sync performance when used with a VCR. Note that the 100Ω resistor feeding the 12V zener diode must be a 4W type, in case the crowbar thyristor operates to remove the 12V supply and shut down the line timebase in the event of excessive h.t. voltage. 5VT2-5VT6 become redundant once the TBA920 circuit has been added.

47kΩ resistor in parallel with the recommended 82kΩ resistor cleared the fault.

Operation on Rewind

If the VCR has been modified according to the article in the May 1977 issue, or otherwise, to give video on rewind it will be found that a receiver fitted with a TBA920 will give better results. Lock is lost eventually however. I have resisted the temptation to improve the gain by modifying the circuit connected to pin 15 of the i.c., since the set may be damaged if run at a frequency too far removed from that intended by the designers. Lock is lost when the tape is moving fast, so for searching purposes it may help to modify the VCR by adding a switchable resistor in series with the drive motor. I've not tried this however, and suspect that there may be problems in finding a place within the VCR to mount a component which would dissipate quite a lot of heat. The later N1502 VCR uses d.c. motors, so speed control on rewind should prove to be an easier proposition. It's expected that the N1700 when it comes along will also have d.c. motors.

Mechanical Details

The new circuit is sufficiently small to be built on a piece

of Veroboard which can be supported on stiff wires on the main timebase board in the receiver. A microswitch was added to the tuner, actuated by the button used to select VCR operation. This microswitch shorts pin 10 of the i.c. to chassis. Connection to any old point on the chassis was not tried: a pair of wires was run right back to the i.c. board. For users in an area of good reception, pin 10 could be wired to chassis permanently with no ill effects. The circuit has been in use now for over a year, and has given no problems.

Letter: Tandberg CTV1

I was interested in the article on the Tandberg CTV1 colour chassis, having had considerable experience of these sets. One fault that's happened to us quite often is sound but no raster, with the heater line open-circuit due to the ECH84 line oscillator valve. But simply fitting a new ECH84 can lead to the same trouble the following day, since the basic cause is intermittent heater-cathode shorting in the PY500A. So the drill is, if the heaters are out due to the ECH84, change the PY500A as well. — K. Cummins (Southampton).

Developments in Switch-Mode Power Supplies

WE ended Part 1 (July) by taking a look at the varied power supply circuits used in the current range of Sony colour receivers. Before going on to consider the problems of fault-finding in switch-mode power supply circuits we'll consider a couple of power supply arrangements used in current UK produced colour chassis, the ITT CVC20 and its derivatives (already the CVC20/2, CVC20/3, CVC30 and CVC32) and the RRI Z718 chassis. The latter does not have a regulated h.t. supply, but is nevertheless stabilised and will enable us to look at an entirely different approach to the problem.

THE MULLARD APPROACH

As component manufacturers Mullard make available to setmakers designs using their components. In the case of a switch-mode power supply for use in TV receivers the circuit consists of a BU126 chopper transistor controlled by a sophisticated i.c., the TDA2640. The circuit was adopted by ITT for use in their CVC20 chassis, whose design evolution regular readers will recall was described in the December 1976 issue.

The TDA2640 contains no less than 80 transistors, and performs all the functions required of a conventional switch-mode control circuit. In the CVC20 chassis it carries out the following functions: output voltage stabilisation; synchronisation at line rate; over-current protection; over-voltage protection; soft starting; low mains voltage protection.

TDA2640 Operation

A block diagram of the i.c., which is housed in a conventional 16-lead DIL package, is shown in Fig. 9. The heart of the device is the oscillator, whose free-running frequency is determined by the components connected to pins 3, 4 and 5. The heavy line in the diagram is the primary path through the device, and following this we next come to the pulse-width modulator, where the duty cycle of the output waveform is varied to carry out the stabilising function. The modulated squarewave then passes through the output stage, appearing at pin 6 as a 12V peak-to-peak rectangular waveform.

A reference voltage is supplied to pin 9, while pin 10 is supplied from the slider of the "set h.t." control via which the feedback is applied. These two potentials are compared in the comparator block, whose output determines the duty cycle of the drive waveform at pin 6. This completes the basic stabilisation loop, which holds the h.t. line steady against load and mains voltage variations.

Protection and Soft-Start

The blocks in the lower half of Fig. 9 are concerned with the secondary, but very important, functions of protection and

safety. On the left, a sample of the output voltage, potted down, is applied to pin 8, while a voltage proportional to the output load current goes in at pin 11 or 12. Both the over-voltage and the over-current protection circuits feed the starting/cut-out block, which acts on the pulse-width modulator. If either the voltage or current to the load become excessive, the drive signal is deleted altogether. This removes the overload of course, and the starting circuit block then provides a so called soft-start by gradually increasing the duty cycle so that a slow build-up of output voltage takes place. If the overload is still present, the cycle will repeat, only to cut-out and soft-start again.

This trip and reset sequence does not go on indefinitely however: the counting circuit on the right switches the i.c. off altogether after a number of resets, determined by the value of the capacitor hung on pin 15. In the CVC20 chassis a 10 μ F capacitor provides for four or five cycles before shutdown, so that momentary overloads don't switch the set off. A useful aid to diagnosis is the presence of about 6V at this pin when the counting circuit has cut the power supply off.

The final block in the bottom right-hand corner is probably never used in normal circumstances: it's there to prevent disaster if the feedback loop fails. In any ordinary stabilised power supply, or indeed any closed loop, if the feedback (sampling) signal disappears the system will go to full gain in an attempt to restore the missing input. In the case of an a.g.c. loop in an i.f. amplifier there is no problem, but in a power supply unit the h.t. would rise dangerously, wreaking havoc elsewhere in the circuit. The loop fault protection block ensures that immediate shutdown results if the feedback voltage to pin 10 drops to zero as a result of an open or shorted feedback loop.

Other Features

The i.c. also contains facilities for remote on-off switching (not used in this chassis). The internal oscillator can be synchronised by an external signal applied to pin 2 if the timing components on pins 3-5 are chosen to give a slightly higher free-running frequency. This facility is used in television applications, but the chip will free-run happily (at about 18kHz in the present case) to assist diagnosis when no synchronising signal is present. At switch-on, the starting circuit produces its gradual increase of duty-cycle so that h.t. builds up relatively slowly, avoiding surges and their attendant risk of damage.

A final protection facility is embodied in the i.c. If the supply voltage to pin 1 falls below two-thirds of normal (i.e. to 8V) the output duty-cycle is reduced. This prevents destruction of the chopper transistor owing to high current inrush if the mains supply is momentarily interrupted (with the on-off switch perhaps). Without this protection, the i.c. would switch to maximum duty-cycle in an attempt to maintain the falling output (h.t.) line voltage, and a high current could flow at the instant of mains voltage resump-

Fig. 9: Block diagram of the TDA2640 i.c. The remote switch-off facility is not used in the ITT CVC20 chassis.

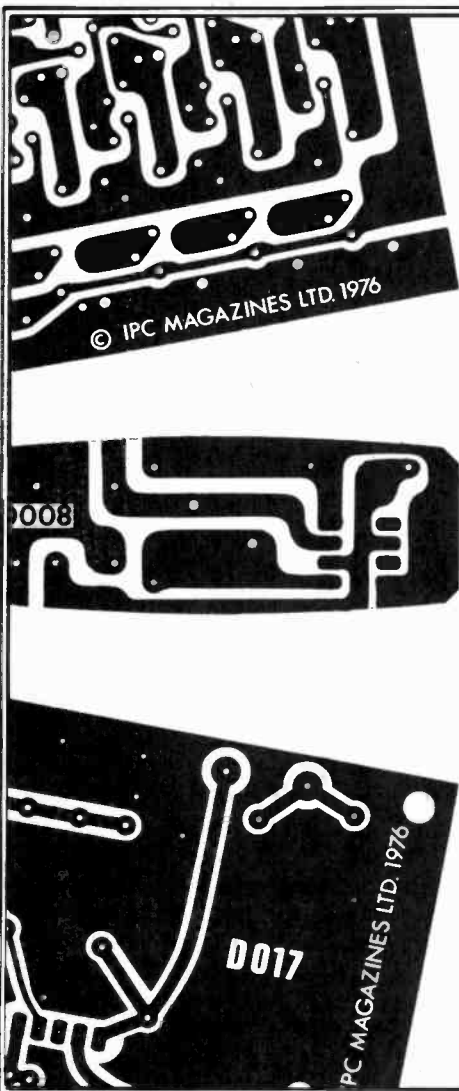
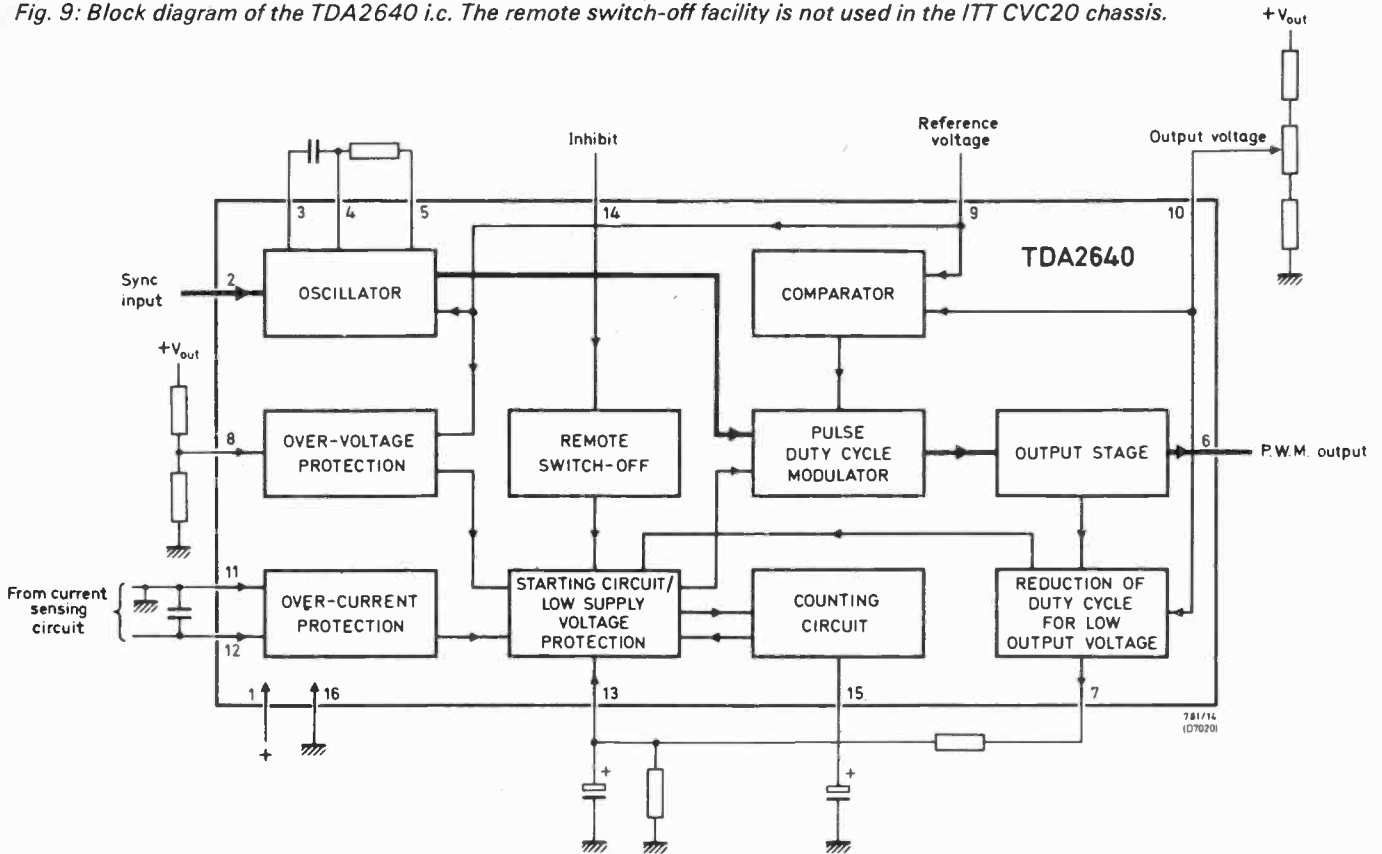

TELEVISION READERS PCB SERVICE

Issue	Project	Ref. no.	Price
April/May 1976	Video Effects Generator	DN0799A	£4.25
April/May 1976	Video Effects Generator-Fader only	DN0780A	£1.58
July 1976	Opto-coupled Audio Extractor	D001	£1.35
November 1976	Ultrasonic Remote Control	D007/D008	£2.95 per set
December 1976	IC Sound Circuits for the Constructor	D009	£1.25
		D017	£1.25
Jan/Feb/March 1977	TV Pattern Generator	{ D018 + u.h.f. mod. board }	£3.90 per set
March 1977	Teletext Decoder Power Supply	D022	£2.95
May 1977	Teletext Decoder Input Logic	D011	£9.80
May 1977	Single-chip SPG	D030	£3.00
June 1977	Wideband Signal Injector	D031	£0.65
June 1977	Teletext Decoder Memory	D012	£7.90
July/Aug 1977	Teletext Decoder Display	D013	£8.00
July/Aug 1977	TV Games in Colour	D034	£3.80
August 1977	Logic State Checker	D038	£1.50
September 1977	Teletext Decoder Switch Board	D021	£1.25
September 1977	Teletext Decoder Mother Board	D027	£4.00
September 1977	Touch Tuning System	D051/D052	£4.00 per set

All boards are epoxy glassfibre and are supplied ready drilled and roller-tinned. Any correspondence concerning this service must be addressed to READERS' PCB SERVICES LTD. and not to the Editorial offices.

To:- Readers' PCB Services Ltd. (TV), P.O. Box 11, Worksop, Notts.

Please supply p.c.b.(s) as indicated below:

Issue	Project	Ref.	Price

Prices include VAT and post and packing. Remittance with order please.

NAME _____
 ADDRESS _____
 Post Code _____

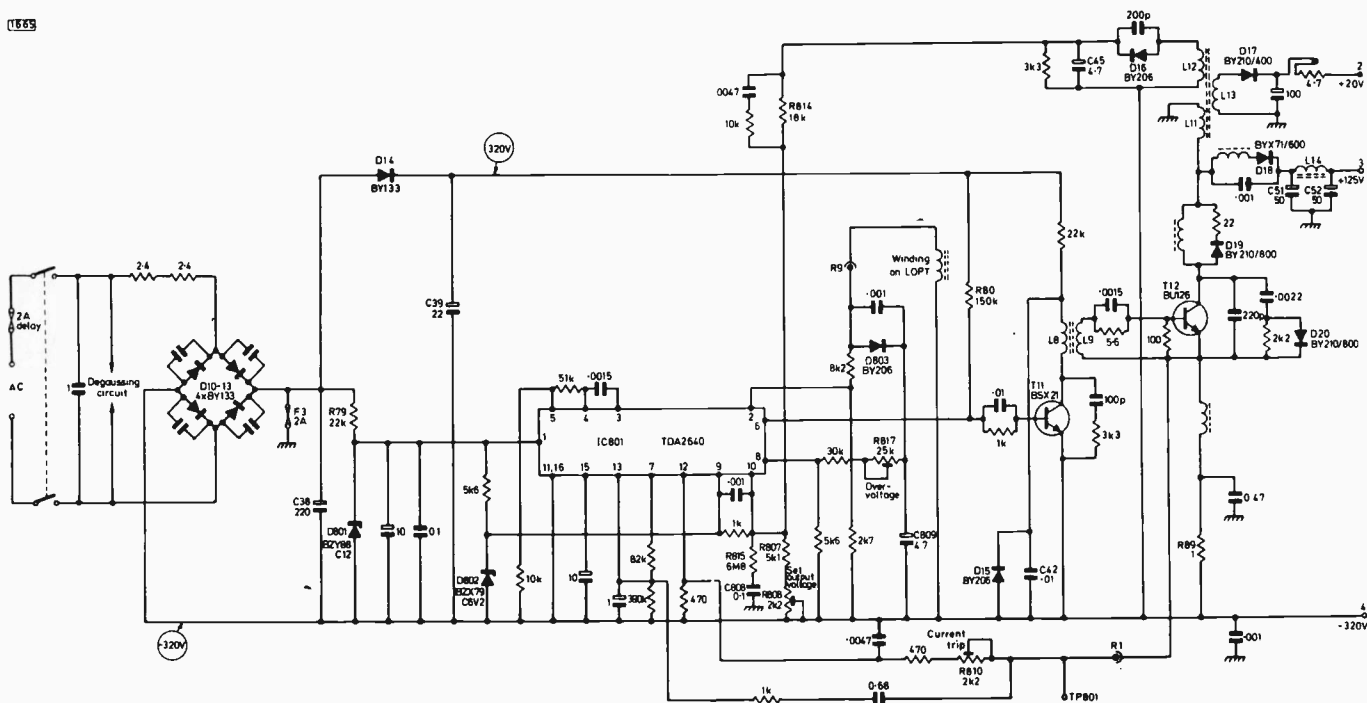

Fig. 10: The switch-mode power supply circuit used in the ITT CVC20 chassis. All overload protection is built into the i.c.

tion. Normal operation is resumed when the voltage at pin 1 exceeds 8V.

Complete Circuit

The TDA2640 is a remarkable design, and virtually fool-proof in its operation. Let's look at its role in the CVC20's power circuit supply – see Fig. 10. The mains input is applied to the bridge D10-D13, whose positive output is connected via F3 to chassis. After smoothing (C38) a negative h.t. rail of -320V appears at point 4. This forms the "earth" rail for the power supply, and means that the receiver chassis is 320V positive with respect to the common negative return rail for the power supply – a point to be borne in mind when servicing! The 12V supply for the i.c. is provided by the zener diode D801 and R79.

Pulses from the line output transformer come in at pin R9 and synchronise the i.c.'s internal oscillator via i.c. pin 2. The same waveform is rectified by D803 and smoothed by C809, the resulting d.c. voltage being an accurate indication of the e.h.t. voltage applied to the tube. This then is our over-volts trip, and R817 is adjusted so that the i.c. protection comes into operation when the e.h.t. exceeds 28kV. The i.c.'s output at pin 6 is applied via the chopper driver T11 to the base of the chopper proper (eh?) T12.

Driver and Output Stages

The circuitry of T11 and T12 can be likened to the driver and output stages in a conventional line timebase. Considered in this way, the set-up has a familiar look about it. In fact the power supply output choke/transformer L11-L13 is physically similar to a line output transformer. T11 is powered from the +320V line (receiver chassis earth line) via D14/C39 and is decoupled by C42. The presence of L and C here could give rise to spurious ringing, so D15 is included to clamp down any overshoot.

The main operating difference between this chopper output stage and a line scan circuit is that an energy-recovery device is not required to clamp the back-end of the inductor to earth, as the top-end of L11 is earthed. This partially explains why

the power supply circuit is referred to the -320V rail. D18 rectifies the waveform appearing across L11, the filter network C51, L14, C52 providing the 125V h.t. rail to power most of the receiver (via the line output stage). There are several auxiliary components around the output stage: these take no part in the basic circuit operation, but optimise the working conditions of T12 and provide protection for this device.

Auxiliary Output and Feedback

There are two secondary windings on the chopper output transformer. L13 provides a 20V rail for the sound output stage, and the output from L12 is half-wave rectified by D16 and smoothed by C45 to provide a voltage feedback for the duty-cycle control stage within the i.c. This voltage is proportional to the potential on the 125V line, and is applied via the potential divider R814/807/808 to pin 10 of the i.c. This feedback voltage is compared with the fixed 6.2V reference from D802 at pin 9 to achieve stabilisation, with R808 setting the operating point for the correct 125V output from the circuit. Pin 10 of the i.c. also receives a small 50Hz ripple voltage from the roughly-smoothed mains input via R815 and C808. This ripple is of phase and amplitude such as to cancel the 50Hz hum in the system.

Over-current Protection

The 1Ω current-sensing resistor R89 is in series with the output transistor's emitter. The voltage developed across it thus reflects the load imposed on the chopper stage by the receiver. Excessive current results in pin 12 of the i.c. being driven above the 700mV or so threshold level for the protection circuit, and R810 is set so that shutdown occurs when the peak current in T12 exceeds 3A. This represents about 150% of the normal load level. The control is difficult to set up in that it's not easy to simulate current overload conditions dynamically: we have to disconnect pin R1 of the module and apply an external source of 3V to TP801. R810 can then be adjusted until the protection circuit just operates. It's hoped that the setting-up procedures will be revised and simplified at some time in the future.

in next month's issue

TELEVISION

The Television MONOCHROME PORTABLE

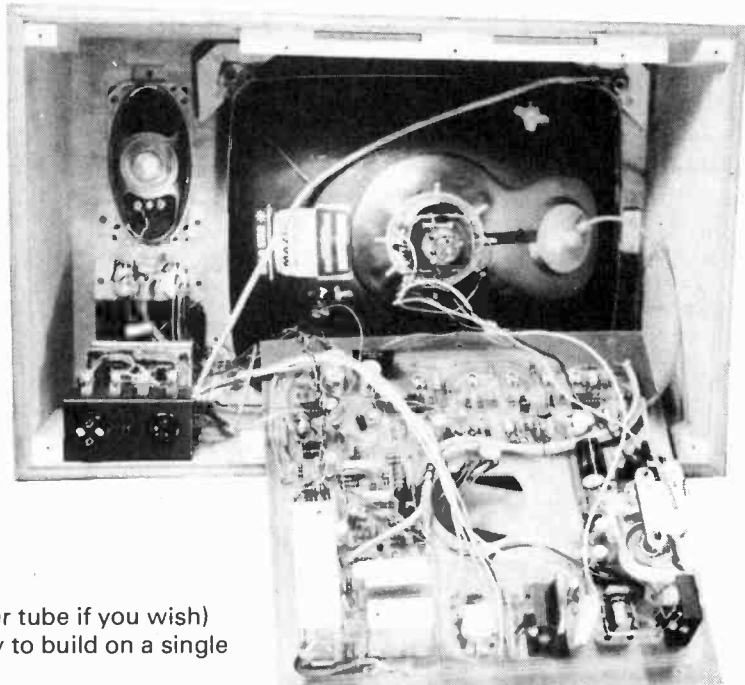

A good quality 15in. (you can use a smaller tube if you wish) mains/battery monochrome portable. Easy to build on a single PCB from readily available components.

● BEGINNERS START HERE

The start of a new series which is intended to present in a very practical way the principles of tackling and repairing faulty television receivers.

● THE RANK Z718 CHASSIS

John Coombes reports on the common faults to which this interesting in-line gun tube chassis colour is prone.

PLUS ALL THE REGULAR FEATURES

Order your Copy on form below:

TO.....
(Name of Newsagent)

Please reserve/deliver the OCTOBER issue of TELEVISION (45p), on sale September 19th, and continue every month until further notice.

NAME.....

ADDRESS.....

.....

.....

RRI Z718 CHASSIS

The Rank Z718 chassis does not have a switch-mode power supply at all. We are including it here because it represents a totally different approach to the problem of h.t. stabilisation at reasonable cost. The idea is to have a simple non-regulated power unit providing 260V output and to stabilise the line output stage internally (shades of valve days!). Virtually all the other circuits in the receiver are powered from the line output transformer.

A skeleton circuit is shown in Fig. 11. The mains voltage is rectified by the bridge 7D1-4, whose d.c. output feeds the choke input filter 7L1/C2/R1/C1 to give a reasonably ripple-free 260V output across 7C1. The line output stage is of the balanced type, similar to that in the ITT CVC20 chassis, but designed to operate from the unusually high

voltage of 260V. The two-transistor balanced stage ensures that the necessarily high flyback voltages are symmetrical about earth for both the scan coils and the output transistors, thus avoiding insulation problems. It's probably true that most of the pennies saved in the power supply have been spent on the line output stage, with a very special transformer and a high count of peripheral components, many of which have been omitted from Fig. 11.

Stabilisation

As in most new designs, a diode modulator provides EW raster correction. This ingenious concept was fully described in the November 1974 issue. The modulator enables the width to be varied both statically and at field rate without upsetting the harmonic tuning or the e.h.t.

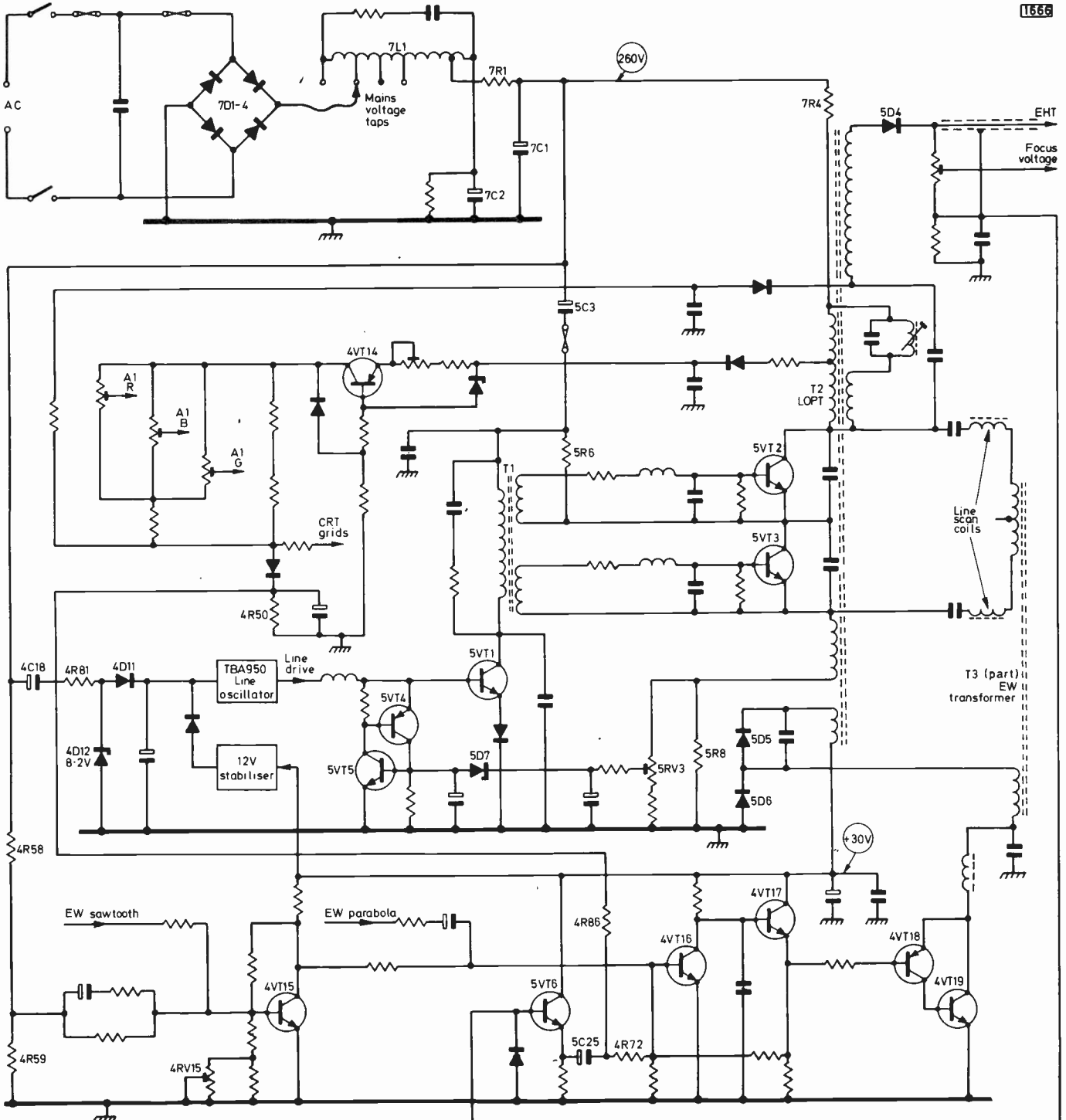

Fig. 11: In contrast, the power supply/line output stage circuitry used in the Rank Z718 chassis.

voltage. This is done by varying the bias applied to a transistor, in this case 4VT19.

The transistors 4VT15-4VT19 form a multistage direct-coupled amplifier. Sawtooth and parabolic waveforms at field rate are fed to the bases of 4VT15 and 4VT16 respectively for raster correction, while picture width is governed by the d.c. conditions in the amplifier, set by 4RV15.

As the base current of 4VT15 determines the width, this is a convenient point at which to introduce width stabilisation. A sample of the 260V h.t. line, potted down by 4R58 and 4R59, is applied to 4VT15's base. If the 260V line falls due to mains voltage or receiver load variations, 4VT15's base and collector currents will also fall and the d.c. amplifier will increase the width via the diode modulator, compensating for the fall in width due to the lower h.t. voltage.

Half-wave rectification by 5D4 provides the e.h.t. from a 21kV overwinding on the line output transformer. The leakage inductance is tuned, as in valve practice, to the fifth harmonic of the effective flyback frequency. A moment's thought will confirm that the e.h.t. is not stabilised by the system described so far, and although the usual effects of poor e.h.t. regulation are eliminated by the width stabilisation loop, further compensation is provided in the form of a current feed to 4VT16's base via 4R86 from the first-anode voltage stabiliser. This current is directly proportional to beam current. Finally, short-term variations in e.h.t. voltage are picked up on the outer screen of the final-anode lead and amplified by 5VT6, after which they are a.c. coupled into 4VT16's base via 5C25 and 4R72.

Start-up Feeds

In normal operation the line oscillator i.c. is powered from the 30V line which is derived from the line output transformer, while the line driver draws its h.t. from the centre of the line output stage via 5R6. At switch-on neither of these supplies is available, so the 260V line has to be used to get the show on the road. This is achieved for the oscillator chip by the charging current of 4C18, the resulting voltage being clamped to 8.2V by 4D12, which is isolated by 4D11 once normal running conditions are established. 5C3 charges at switch-on to momentarily power the line driver stage. When a fault is present it's necessary to override both these functions – details later.

Overload Protection

As might be expected, the protection circuit in this chassis revolves around the line timebase rather than the power unit: there is little to go wrong in the power supply, and the line output transformer is the source of all the supply lines in the receiver other than that for the RGB output stages. Overload conditions then are likely to take the form of heavy damping of the transformer. This is reflected in the total current flowing through the line output transistors to earth through 5R8. The voltage across this component is proportional to the current flowing through it, and a sample is taken via the preset 5RV3 and applied to the zener diode 5D7. The potentiometer is set so that the zener voltage of 5D7 is exceeded during overload. Under these circumstances the zener diode conducts, and the thyristor-configuration pair 5VT4 and 5VT5 latch on, shorting the line drive to earth and switching off the set. Once the supply lines have collapsed, the receiver will remain quiescent until the set is switched off for a few seconds, then on again to energise the self-start circuits.

We have strayed a little from our switch-mode theme in

describing this unusual and interesting design: if ever a line timebase was maid-of-all-work, this must vie with the Thorn 9000 chassis for the honour. We remember an editorial in these pages some time ago in which the leader writer opined that a dead set would probably become the most difficult fault to trace before long – sir, with the Z718 chassis that day has arrived!

SERVICING

In a previous article on this subject (October 1975) we advocated the use of a variac (variable autotransformer). With this, the mains input to a receiver can be gradually increased from zero while conditions in the power supply circuit and on the supply lines are monitored. We have seen 10A variacs offered for as little as £10 – this equals the cost of three chopper or line output transistors, and the variac could repay its cost on one repair job alone! A variac is thus becoming almost indispensable for servicing switch-mode power supplies. One word of warning: at switch-on the device takes a heavy initial surge current from the mains, and this is sufficient to blow the 2A or 3A anti-surge fuse usually fitted to a 500W isolating transformer. Raw mains has to be used therefore, and this introduces a shock hazard in nearly all current designs. When the variac is no longer needed then, change to the isolated mains supply before continuing with service work or setting up.

Since we have touched on safety matters, a word about field calls. The regular field technician may well have emitted a hollow laugh at the above talk of variacs and isolating transformers as he is unlikely to have the benefit of either – or indeed a rubber mat! If the floor is of wood or concrete, it is a good idea to borrow the hearthrug or something similar to stand on and to accommodate any test gear. The latter should not be earthed, and a leakage test between the mains input and exposed metalwork from time to time is a wise precaution.

Cold Meter Checks

Whether or not a variac is used, it is a sound idea to make cold checks on all semiconductors and other relevant components where a power supply circuit is in trouble. The Avo on the ohms range is all that's required, and this will indicate shorted and open junctions, but more important reverse leakage. Most silicon devices show no perceptible reverse current, though some power transistors can, even when in good condition – if in doubt, compare with a new one. Many manufacturers are sufficiently aware of the "close switch to destroy" syndrome to publish a cold resistance table for their circuits. These are invaluable in service work.

Simulation

Where circuit design allows, a useful technique is to power the chopper drive circuitry with the d.c. input to the chopper itself disconnected. This allows waveforms and some d.c. measurements to be taken, but the fact that the chopper's d.c. output is missing will upset the mark-space ratio of the drive waveform – the duty cycle will go to maximum. In the circuits we have described, the Sony 18in. and 20in. receivers and the ITT CVC20 chassis are amenable to this technique – for the KV1810UB, a 19V supply is required, positive to the power supply unit board pin 17, negative to earth; the KV2000UB calls for 21V across C612; while in the CVC20 removal of F3 is all that's necessary.

As the KV1810UB is by far the most vulnerable, we will dwell on it a little longer. Assuming that the semiconductors (including the line output GCS) have been checked cold and replaced as necessary, and the 19V line powered, a small dark raster should put in an appearance at a mains input from the variac of about 80V. If so, the chances are that all is well.

When examining the chopper drive waveforms during this simulation, correct amplitude and fast rise and fall times are the main points to check. In designs such as the CVC20, one of the few things that can destroy the chopper transistor is incorrect drive. In early production, there was a tendency for R80 (150k Ω) to develop a fault, distorting the drive waveform. If T12 should fail, this component and the diodes D19 and D20 should be checked.

Defeating the Kick-Start

A difficult situation arises when, as is often the case, a kick-start circuit is present and nothing happens at switch-on. On average about one second is available for diagnosis, and this usually isn't long enough! An externally-applied voltage as specified above is usually required to get the line generator going, but the Rank Z718 poses a problem in that the line driver requires a high voltage supply in addition to the low voltage required for the TBA950 line oscillator.

The answer here is to temporarily wire a 5.6k Ω 5W wire-wound resistor across 4C18, and another across 5C3 to feed 5VT1. This will enable the line output stage to be driven. If the set still refuses to function, chances are that the protection circuitry has come into operation, in which case 5D7 must be disconnected. This is inviting fireworks, and a current limiting resistor should be inserted in series with 7R4 (for details, see page 650 of the October 1976 issue). As we have stressed before, overload protection devices should not be overridden, and this is the only example we can think of where it is necessary to do so. Risk is minimised by the insertion of the limiting resistor however.

Pulse Sampling

Many switch-mode power supply circuits incorporate safety circuits which operate on the sample-and-pulse principle – the overload protection department shuts down the power supply momentarily, after which power is restored. If the overload remains the power supply cuts off again and so on. The result is that the whole set pulses at a rate depending on the severity of the fault, usually about 1Hz or so. If the fault is in the line scan/e.h.t. section, no picture will be present but “plops” will be heard from the speaker to indicate what is happening, or a voltmeter connected to the h.t. line will fluctuate wildly.

The problem then is to decide where the trouble lies, and an important initial clue is given by merely observing the symptoms. If the sound and picture are present on each pulse cycle, either the power supply is out of adjustment or an over voltage is present to trip it. In the latter case, the h.t. line voltage will rise to slightly more than the specified figure on each cycle, and the answer lies in the power unit itself – start by winding down the “set h.t.” preset.

If the set is showing few signs of life, with the power supply tripping and a low h.t. voltage, excessive current is indicated. Check the current consumption of each stage in turn, starting with those most vulnerable, like the line output stage. There is usually no need to break the circuit to monitor the current as there is usually a convenient series resistor present, the voltage across which is proportional to

the current flowing – even with the reduced h.t. more current than normal will flow in the faulty stage on each trip cycle.

An ordinary multimeter is a poor tool for this job, since the damping of the movement gives misleading readings under pulsed conditions. A digital meter is utterly useless! The scope is ideal for this application, and for preference should be d.c. coupled. If no series resistor is present, a 1 Ω resistor can be pressed into service so that a scope with a basic sensitivity of 10mV will indicate currents from 10mA upwards (100mA if the \div 10 probe is used).

If the line output stage is the guilty party, as is usually the case, remove the pulse input to the tripler, then the a.c. blocking choke in the shift circuit, the scan coils, the c.r.t. first anode supply rectifier and so on. Unless the line output transformer has failed, at some stage the tripping will stop, indicating that the excess load has been removed.

Dummy Loads

Where the line timebase and the power supply are independent, the load can be disconnected and a dummy load made of firebar elements substituted. This eliminates the risk of damaging the signal or timebase circuits by current or voltage overload. Table 1 gives some guidance as

Table 1: Dummy load resistors.

H.T. Voltage	Resistor value
60V	40 Ω
110-130V	Small screen sets, 300 Ω Large screen sets, 200 Ω
160-180V	350 Ω
200V	550 Ω

to resistance values required for colour receivers. We stress that this is very much a rule-of-thumb guide, as many factors are involved, but if the power unit can produce its rated voltage into these loads, it is likely to be OK.

THE FUTURE

It's difficult to forecast how power supply circuit design will progress, especially from outside the manufacturing industry. Some setmakers such as Decca, Pye and Bang and Olufsen are sticking to the simpler thyristor type of supply, with full-wave bridge rectifiers and big hot dropper resistors, but the future seems to lie with either the integration of line scan and power supply functions as embodied, in different ways, in the Thorn 9000 and Rank Z718 designs, or in i.c. technology. Certainly we haven't come to the end of the road.

One feature we can hope to look forward to is a return to an earthed chassis, which would be a boon to the trade and offer greater safety to the consumer. An isolated switch-mode power supply is possible with devices such as the TDA2640 and in other circuits where a “converter transformer” is used to supply the receiver h.t. lines. The idea is that full-wave rectification of the mains is carried out, but the converter transformer has the additional function of mains isolation, so that while the power supply components are at mains voltage (an encapsulated block, perhaps?) the secondary of the output transformer is earthed. At present, we are told, the stumbling blocks are cost and BEAB requirements, but there is a definite trend towards this on the Continent, and as fully paid-up (!) members of the Common Market, we might well see this idea come to fruition in the UK. ■

IC Burst Gate Pulse Generator

William Riggs, B.Sc.(Hons.)

THE author constructed a version of the *Television* colour receiver incorporating the i.f./decoder panel from the Pye 697 chassis. This gave good performance generally, but the colour locking was edgy at times, with a tendency for colour change or complete break up to occur, particularly when there were highly saturated blues or greens near the left-hand side of the screen.

The problem was in the timing of the burst gating pulse. Unless this pulse occurs at the correct time, the effect of the burst is lost or diminished, with consequent impairment of the colour sync. Fig. 1(a) shows the position of the burst signal, on the back porch of the line sync pulse. The job of the burst gating pulse is to turn on the burst channel in the decoder while the burst is present. Colour receivers use either the line sync pulse or the line flyback pulse to initiate this action, but as these don't coincide with the burst some method of obtaining a delayed pulse from the line sync or line flyback pulse is required. In Pye hybrid chassis, such as the 697, the negative-going line sync pulse is applied to a tuned circuit (L28, see Fig. 2) which produces a positive-going overswing. This is used as the gating pulse. The problem confronting the author was that the lack of an oscilloscope made it impossible to make the necessary checks around this part of the circuit to cure the problem.

1680

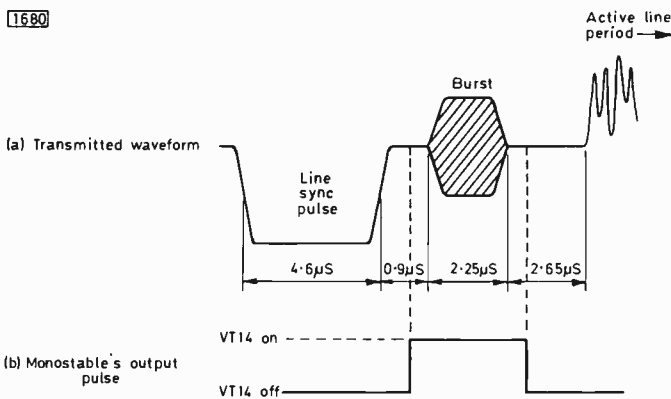

Fig. 1: (a) The position of the burst signal on the back porch of the line sync pulse. (b) The pulse provided by the i.c. monostable multivibrator for burst gating.

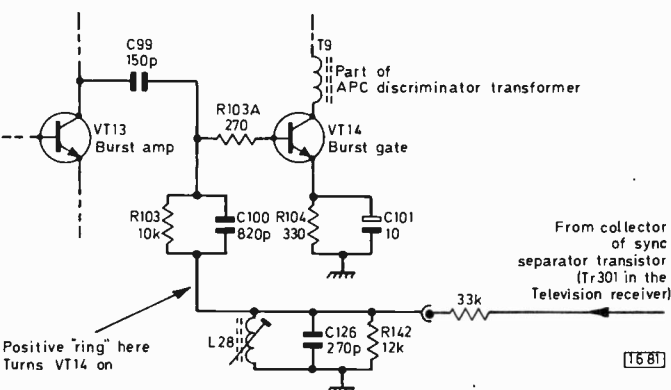

Fig. 2: The original burst gate circuit used in the Pye 697 chassis.

★ Components list

R1	1.8kΩ	C1	1,000pF polyester
R2	33kΩ	C2	0.0022µF 400V polyester
R3	3.3kΩ	C3	0.1µF disc ceramic
R4	6.8kΩ	D1	BA148
All	1/4W	D2	BZY88 C4V7
R5	680Ω 1W	IC1	SN74121
VR1	4.7kΩ		

It was decided therefore to adopt a different approach. This is more elaborate, but is ideal for the constructor with limited equipment. The solution adopted was to use the line sync pulse to trigger a simple i.c. monostable multivibrator. The delayed pulse thus produced is suitable to switch on the burst gating transistor VT14. By using timing components in the monostable circuit to give a "one shot" pulse just long enough to encompass the period of the transmitted burst, the gating transistor can be turned on during this period and then turned smartly off for the rest of the line scan.

An SN74121 TTL monostable multivibrator was chosen as its logic 1 and 0 output levels of typically 3.3V and 0.3V are suitable for turning VT14 on and off, and also because few other components are needed. The circuit is shown in Fig. 3. The monostable IC1 is triggered by the line sync pulses which previously operated the ringing circuit, i.e. the line sync pulses appearing at the collector of Tr301 on the timebase board. The track from L28 on the Pye panel to R103/C100 in the base circuit of the burst gating transistor is cut, the monostable's Q output now feeding these components. The timing components are C1, R1 and VR1. D1 protects the Schmitt triggered input to the monostable.

The circuit can be built on a tiny piece of Veroboard and mounted on the printed circuit board in place of L28.

The circuit's one variable resistor can be accurately set by simply watching the screen: increase the resistance of VR1, and hence the monostable's Q output pulse period, until the burst only is being applied to the base of VT14 and thence to the a.p.c. circuit. Proper, locked colour information will then be present on the screen. If the monostable's Q output pulse is set to too long a duration, picture chrominance information will reach and upset the a.p.c. system.

The use of this circuit has completely eliminated the problem of incorrect burst gating and colour break up. It could also be used in the original *Television* colour receiver design and in other discrete component decoders where the problem has to be dealt with by an enthusiast who has limited facilities.

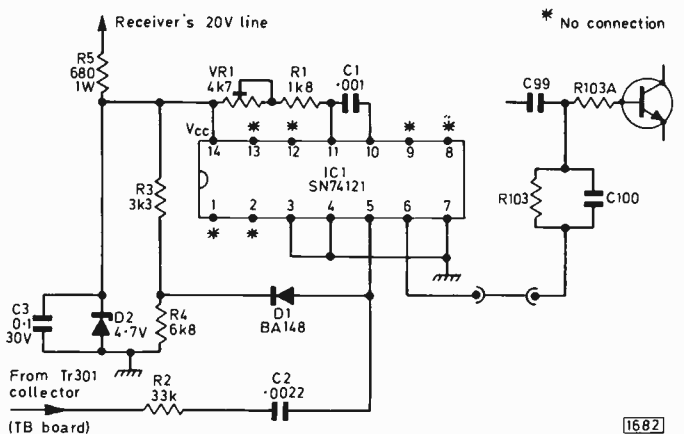

Fig. 3: The circuit of the i.c. monostable burst gate pulse generator, and its connections.

Service Notebook

G.R. WILDING

Rank A823 Chassis

We were called to see a single-standard Bush colour receiver fitted with the original A823 chassis. There was a good black and white picture, but not the slightest suggestion of colour. The rather unusual colour-killer circuitry is shown in Fig. 1. As an obvious first step we checked the voltage at TP4, the collector of the colour-killer transistor 3VT1. This was found to be at the monochrome level of 14V instead of the colour level of 0.1V – i.e. 3VT1 saturated. Clearly 3VT1 was not being switched on.

The colour-killer action is provided by diodes 3D2 and 3D5 which are connected in series in the chroma signal path. With 3VT1 non-conducting, the current flow via 3D1, 3R4, 3R6 and 3R5 results in sufficient positive voltage at the cathodes of 3D2 and 3D5 to keep them reverse biased, thus making the chroma signal path open-circuit. On a colour transmission, provided the reference subcarrier is being generated in the decoder this will be rectified by 3D15, switching 3VT11 on. The voltage (17.3V) then developed across 3R72 provides the PAL switch phasing action and also turns on the colour-killer transistor 3VT1. Since its collector voltage then drops to 0.1V, the reverse bias on diodes 3D2 and 3D5 is removed.

The next step was to check back to TP14, the collector of 3VT11, where the voltage on colour reception was found to be correct at 17.3V. The most likely causes of the trouble were a leak in the electrolytic 3C4 or the colour-killer transistor being defective. The electrolytic was found to be in order, the fault turning out to be due to a collector-base open-circuit in 3VT1. A new transistor restored normal operation and after resetting 3RV7 and tweaking one or two of the convergence presets a very good picture was obtained.

In another of these receivers the complaint was quite good line lock but weak field lock. Attention was first directed to the timebase panel, where the diode in series between the sync separator and the field oscillator was replaced. This made no difference, neither did a new BRY39 field oscillator s.c.s., while the electrolytics in this area all turned out to be up to standard. A 'scope check then

revealed that the sync pulse output at the collector of the sync separator transistor was mis-shapen, and it was also discovered that reducing the contrast control setting gave improved field lock. This suggested a fault on the i.f. panel, so we tried an old stock fault in this section, replacing the 125 μ F electrolytic 2C37 in the a.g.c. circuit. On replacing this, first class field locking was obtained.

We have often found poor field lock with normal or near normal line lock to be due to a fault in the video, luminance or i.f. circuits, particularly in 625-line/u.h.f. receivers. Since the sync pulse represents 100% modulation on this system, a fault in these areas will cause sync pulse distortion. On 405-line receivers the most common cause of weak field lock due to a fault in the i.f. circuit was slug drift, especially in older sets where the cores were locked by means of rubber string. The resulting mis-shapen response curve and restricted bandwidth distorted the sync pulse waveform.

Multiple Faults

A dual-standard ITT/KB monochrome set gave a good picture apart from progressive cramping towards the bottom of the picture, with the bottom few lines so compressed that they appeared as a single thick line. A new PCL805 field timebase valve made no improvement, so it seemed likely that the fault was due to incorrect biasing of the output stage – probably due to either the cathode bias resistor or its shunt electrolytic having decreased in value. Unless the output pentode has sufficient bias, the positive-going sawtooth waveform which is applied to its control grid will drive it to zero bias, and thus grid current, before the bottom of the scan is reached. The 390 Ω cathode bias resistor looked all right, but as the voltage across it was only 12V instead of 19V we decided to check the resistance reading across it. This turned out to be 270 Ω , so a replacement was fitted. The results were exactly the same however, so it seemed that the shunt electrolytic had a considerable leak. On snipping it out and checking it, its value was found to be ample but its resistance read only 1k Ω following the charge-up swing. A new electrolytic restored a perfectly shaped raster – but we then found that at high volume levels the picture shimmered in a horizontal direction.

The usual cause of this is a reduced value h.t. smoothing capacitor, as a result of which audio gets into the timebase and/or the signal amplifying stages. We turned the set upside down to gain access to the main electrolytics, but on switching on again the set was dead, with no heater circuit continuity across the mains lead. Wobbling the PL36 line output valve in its holder seemed to restore continuity, and on closer examination we found that we were really wobbling the valve's glass envelope in its bakelite base! On disconnecting its anode cap the envelope complete with all pins came away cleanly. We could have soldered them back quite easily, but we then found that the heater was now open-circuit. I've known the bakelite bases of these and other octal based valves become loose from the glass,

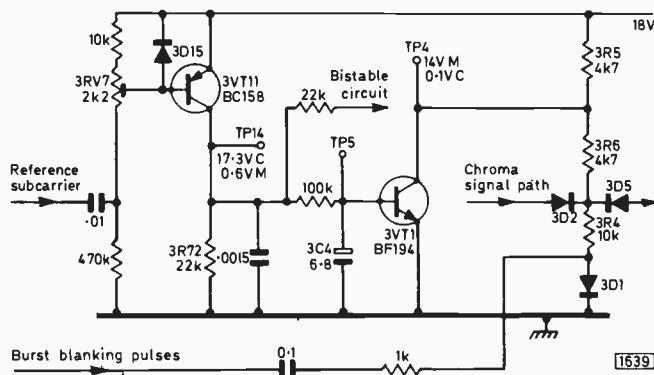

Fig. 1: Colour-killer circuit, Rank A823 chassis.

putting a strain on the connections and maybe breaking one, but have never before seen the whole envelope come away so cleanly.

A replacement valve removed all traces of the sound-on-vision effect, which had clearly been due to sound vibrations varying the pin contact.

No Sound or Raster

There was neither sound nor raster on a colour set fitted with the ITT CVC9 hybrid chassis, and the 630mA fuse in series with the main (275V) h.t. line was found to be open-circuit. There was no short across the h.t. rail, and the boost capacitor (C310, 0.47 μ F) which frequently breaks down in these sets was found to be in order. After looking around for any signs of component overheating without success the only thing to do was to replace the fuse, switch on and await developments.

Ample h.t. soon appeared at the anode of the PL509 line output valve, via the PY500A boost diode, but no real suggestion of an arc could be obtained while the anode took on a distinctly rosy glow after a very short while. The first move was naturally to try another PCF802 line oscillator valve, but the symptoms remained the same. Suspicions then fell on some of the capacitors in this stage – C291, C294 and C295 in particular – since these have been known to cause intermittent or complete loss of line oscillation. We decided to check voltages first however, in case there was an open-circuit feed resistor, but on switching on again after raising the bottom hinged chassis the line output stage became operational, giving a normal picture.

Probing and slight chassis flexing showed that there appeared to be a dry-joint somewhere near the PL509. The control grid valveholder connection was checked first, but proved to be o.k. Our next thought was the grid coupling capacitor C301, and on applying the soldering iron to one of its leads the component came away, leaving the complete leadout wire still in the panel. We then noticed that the capacitor's two leadout wires had been severely bent during panel wiring, in order to fit the relevant holes, and that one had fractured but been held in contact by the capacitor's encapsulation. A replacement restored normal results.

The fault reminded me of a Pye Continental which had performed faultlessly for many years, then when switched on one day had given a loud bang and shattered the mains fuse. On inspection it was found that the contact-cooled rectifier – remember them? – had been so mounted that one of its tags just cleared by a hair's breadth the hole in the chassis to accommodate it. Possibly due to an excessive surge at switch on, or slight tag movement, the mains had been able to arc across and rupture the fuse.

Set Tripping

There was neither raster nor sound on a German-made ITT Model FT110 colour set. All the fuses were found to be intact, but on lowering the bottom-hinged chassis faint clicking sounds at about half minute intervals could be heard. We'd been called to adjust this and other FT110 sets before, but it was the first time we'd been confronted with complete failure to give any results. These sets have an overload protection circuit which when confronted with an overload trips at 400ms intervals. It seemed certain that the clicking noises must be due to the operation of this circuit, and probably slight movement of a transformer core.

There was no evidence of any component overheating, so as our suspicions were naturally directed at the line output

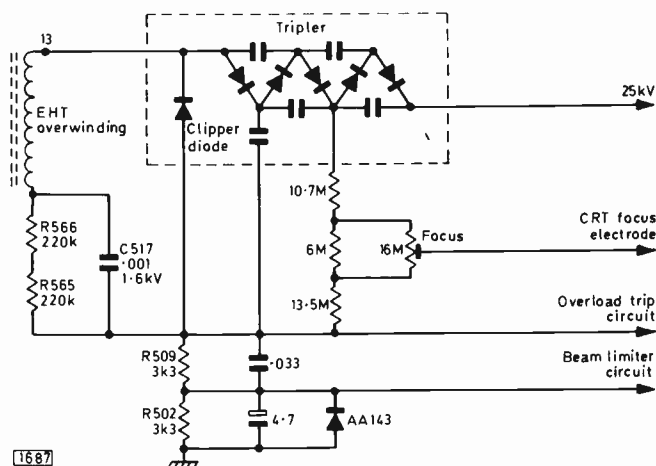

Fig. 2: E.H.T. circuit, ITT FT110 chassis.

stage our first move was to make a resistance check between the line output transformer overwinding tag (13) feeding the e.h.t. tripler and chassis. The reading was only about 7k Ω either way (R502 plus R509, see Fig.2), whereas when the clipper diode in the tripler is reverse biased the reading should have been in the region of 0.5M Ω (R566/565/509/502). Obviously the next move was to disconnect the tripler, but the readings remained the same. It was then clear that C517 must be short-circuit. On removing it a tiny raised "pip" was noticed on its casing, clearly indicating that a severe sparkover had occurred internally, possibly due to a breakdown in the tripler. Replacing C517, and the tripler for good measure, restored normal results. Since then we've heard that other service engineers hereabouts have come across the same fault, C517 going short-circuit and operating the overload protection circuit. The capacitor is mounted on the line output transformer, close to one edge near R565/R566.

Weak, Distorted Sound

There was a perfect picture on a Thorn portable fitted with the 1591 chassis, but the sound was weak and distorted. The nature of the distortion suggested that the quadrature coil associated with the TBA120A intercarrier sound i.c. was out of adjustment, rather than a fault in the audio stages or the i.c. itself. Readjusting the coil produced a considerable improvement, but the tuning was particularly flat. The tuning capacitor shunting the coil (C65, 150pF) was naturally the first suspect, and on removing the can it was found to be dry-jointed. A touch with the soldering iron, then a further readjustment of the coil, restored the sound volume and quality to normal.

Excessive Brightness

The problem with a Thorn colour set fitted with the 8000 chassis was excessive and completely uncontrollable brightness, both the main and preset brightness controls having no real affect. The emitters of the R, G and B output transistors in this chassis are returned to chassis via VT121, which is termed the brightness voltage source transistor. Attention was naturally turned to this stage therefore, and the base voltage was found to be less than 1V instead of 6-7V. The base is decoupled by an electrolytic (C190, 1 μ F), and on disconnecting it and checking a heavy leak was found. Replacing it restored normal brightness control action.

One-chip touch tuning system

Luke Theodossiou

There are quite a number of sets in use which are equipped with varicap tuners, but utilise a mechanical station selecting assembly comprising a set of potentiometers which set the required voltage for the corresponding station, whilst actual station selection is performed by interlocked switches. It is a fairly common occurrence that either the potentiometers or the switches fail, giving rise to tuning drift or making station selection impossible. The unit to be described in this article effectively eliminates the mechanical shortcomings of the switches by replacing them with electronic ones, whilst the potentiometers used are high quality cermet multiturn trimmers.

Principles

A touch tuning system has several functions to perform. First of all it has to sense the impedance of a finger across two contacts. A memory is then used to remember the last selection made, whilst a display facility indicates the selected channel. Another important function of the system is that it must realise when a new selection has been made and cancel all previous selections.

A number of different systems exist which satisfy these requirements and several have already appeared in sets, notably of Continental origins. The most elegant way, at least in the author's opinion, is the single-chip method. This approach results in the least possible number of peripheral components and when used to replace mechanical units it has the additional advantage of being powered directly from the existing 33V varicap rail.

Apart from straightforward channel selection and indication, devices similar to the Plessey ML232B which is used in this particular instance, can offer band selection, a stepping mode for remote control, sound muting and disabling the a.f.c. during the selection process.

Advantages of MOS

MOS i.c.s are ideal for this application primarily due to their high input impedance – necessary if finger impedance is used to trigger the input circuits of the device. In addition, a higher order of integration is possible with MOS technology so that all requirements may be realised with a single i.c. Other important features of this family are high

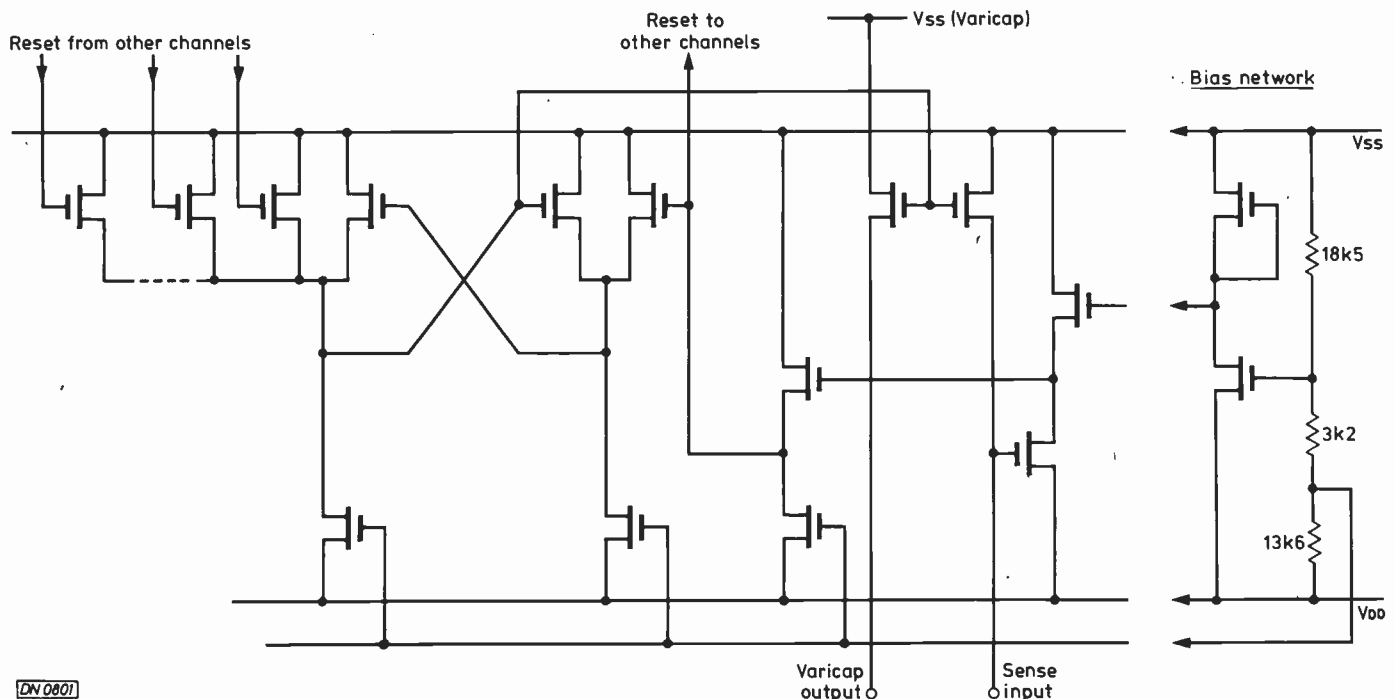

DN 0801

Fig. 1: Representative circuit diagram of the touch sensing, latching and output configuration of this family of i.c.s.

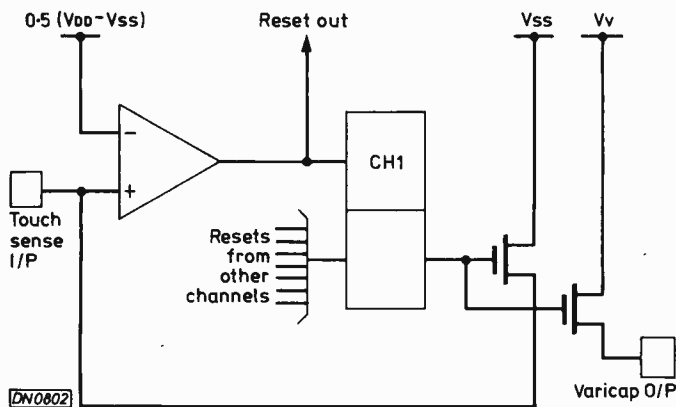

Fig. 2: Simplified circuit of the input arrangement.

noise immunity (to avoid false triggering) and a low supply current requirement.

The basic touch sensing, latching and output configuration is shown in Fig. 1. A simplified representation of the input circuit is shown in Fig. 2. A voltage comparator with a threshold voltage of $0.5(V_{DD} - V_{SS})$ is used to set the channel bistable memory and reset all other channels. One output transistor then enables the varicap output line for tuning, while another holds the input at VSS and drives the channel indicator. The varicap output lines are separated from the rest of the device, thus preventing any interference with the tuning voltage regulation. The 'on' resistance of the varicap outputs is under 100Ω .

Using I.e.d. indicators

This range of i.c.s is generally used in conjunction with neon indicators. These require a relatively high voltage for striking and the usual arrangement is to derive this voltage from the mains by rectification. This is clearly undesirable from a safety point of view and what is more, it complicates connections that have to be made to the main chassis. The use of I.e.d.s as indicators overcomes these problems by using the varicap supply itself to power them. Fig. 3 shows a low voltage sensing circuit with an I.e.d. to provide indication. Around 5mA may be drawn from the input of the i.c. which is sufficient to ensure a reasonable light output from the I.e.d. The diode in series with the I.e.d. supplements the reverse leakage characteristics of the I.e.d. In the absence of this diode, the reverse leakage current of the I.e.d. may be sufficient to cause false triggering. The potential divider arrangement comprising the 1k, 1k2 and

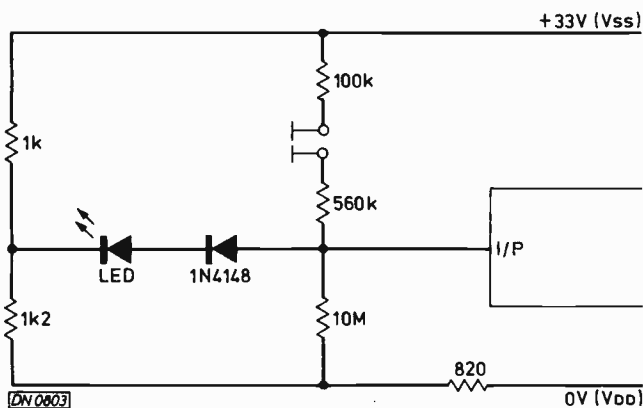

Fig. 3: Circuit showing the application of I.e.d.s as channel indicators.

820Ω resistors provides a voltage offset which increases the sensitivity of the circuit.

Output arrangement

The output circuit to the potentiometers is very simple. When a particular channel is selected, the output device is switched on thereby connecting the corresponding potentiometer to the varicap supply line. The diodes in series with each of the wipers allow the potentiometer settings to be independent of each other. The earthy ends of the potentiometers are returned to ground via a forward biased diode which provides temperature compensation.

The complete circuit diagram is shown in Fig. 4. When power is first applied, the offset provided by the additional resistor on channel 1 causes this channel to be selected in preference to any other. This is desirable since it ensures that the unit always selects a specific channel as opposed to random selection on switch-on as would otherwise occur.

Construction

The unit is built on two purpose-designed p.c.b.s. The i.c. and its peripheral components are mounted on the main p.c.b. whilst the touch plates are part of the other p.c.b. which also accommodates the I.e.d. indicators. No difficulty should be experienced in construction. It is advisable that an i.c. socket is used for IC1, and that all components are soldered into the board and the unit checked against the layout and the circuit for any possible errors before the i.c. is inserted or power applied. When inserting the i.c. it is essential that some precautions are taken, since the high input impedance of the device renders it prone to permanent damage through build-up of static charges which are in excess of the device's maximum input limits. Firstly, avoid touching the pins. All equipment must be earthed (this applies to soldering irons if any soldering is to take place after the i.c. has been inserted). The devices do have some internal protection but this assumes that the i.c. is connected to the circuit. On the whole these i.c.s are quite robust, but there is a lot to be said for taking some precautions to avoid rather expensive experiences!

The I.e.d.s are simply snapped into place on the other p.c.b. on their mounting collars and then the retaining bushes are pushed on from the back as far as they will go. The leads from the I.e.d.s are then soldered through onto the main p.c.b. and the touch plate connections are made by

BACK NUMBERS

A back numbers service is now being operated by our Post Sales Department. Back issues of *Television* can be supplied at 70p, inclusive of postage and packing.

Orders should be sent to:
Post Sales Department,
IPC Magazines Ltd.,
Lavington House,
25 Lavington Street,
London SE1 0PF.

Make cheques and POs payable to IPC Magazines Ltd.

Note that stocks of back issues are limited – consisting mainly of issues dated 1976 and 1977. Where an issue is not available the remittance will be refunded.

Fig. 5: Copper track detail of the p.c.b.

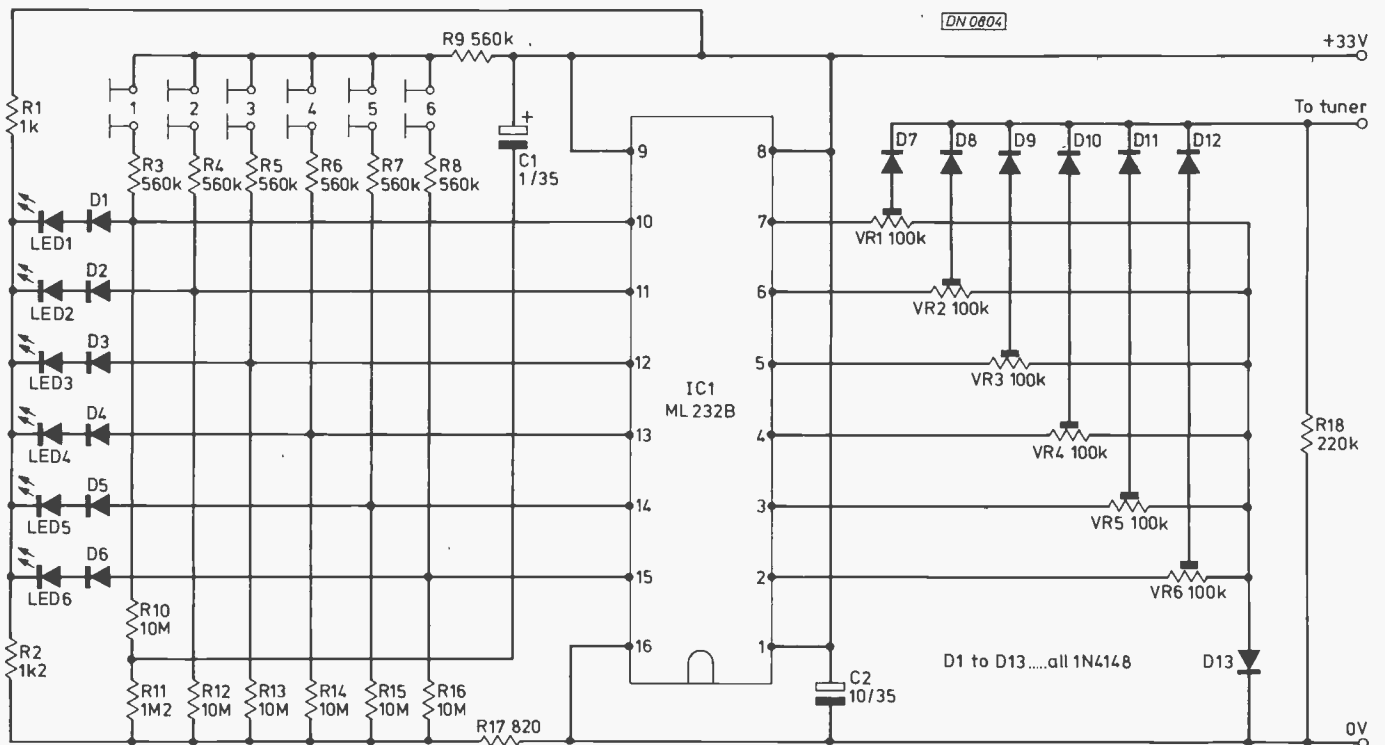
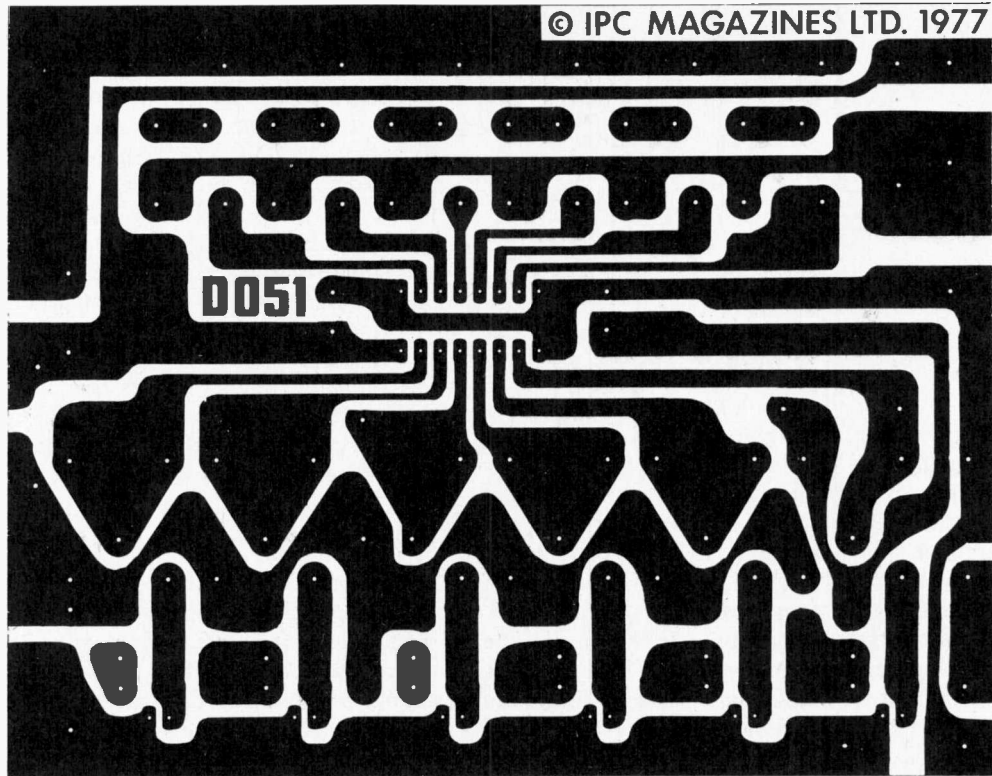

Fig. 4: Complete circuit diagram of the unit.

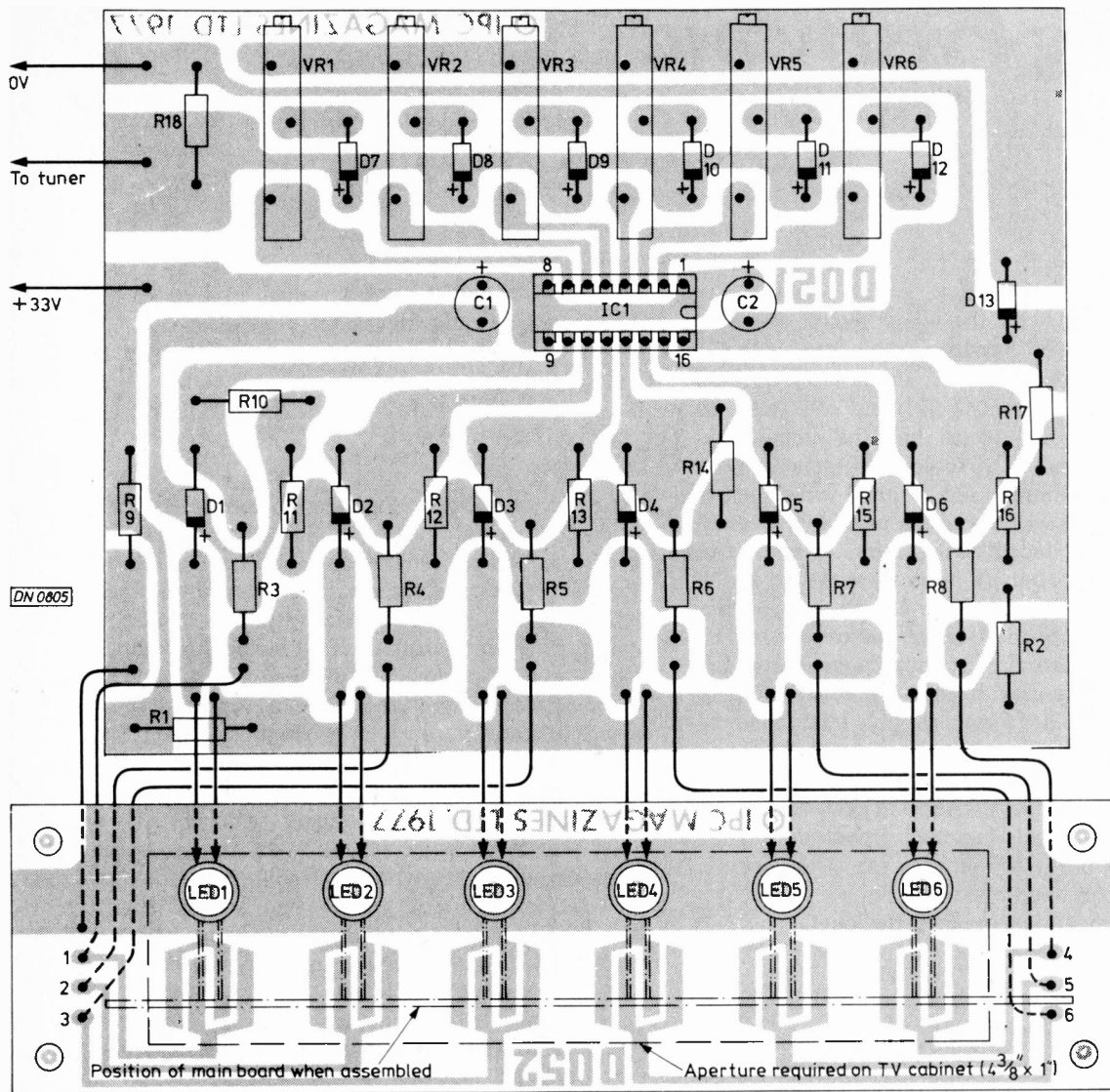

Fig. 6: Component layout diagram, also showing method of interconnecting the two boards.

★ Components list

Resistors: all $\frac{1}{4}$ W 5% carbon film

- R1 1k
- R2 1k2
- R3-R9 560k
- R10 10M
- R11 1M2
- R12-R16 10M
- R17 820 Ω
- R18 220k
- VR1-VR6 100k linear 20 turn cermet presets $1\frac{1}{2}$ in.

Capacitors:

- C1 1 μ 35V tantalum bead
- C2 10 μ 35V tantalum bead

Semiconductors:

- D1-D13 1N4148
- LED1-LED6 0.2in. red l.e.d. with panel clip
- IC1 ML232B (available from Best Electronics (Slough) Ltd, Unit 4, Farnburn Avenue, Slough, Bucks SL1 4XU - price £5.27 including postage, packing and VAT).

Miscellaneous:

- P.c.b.s reference D051 and D052 (available from Readers' PCB Services Ltd. (TV), P.O. Box 11, Worksop, Notts.)

soldering some sleeved tinned copper wire links from one board to the other. This method of construction leads to a fairly rigid assembly which is self supporting.

The unit is fitted into a TV set by cutting a rectangular aperture which allows the touch plates and l.e.d.s to show through. The touch plate p.c.b. is then mounted into position and secured by four self-tapping screws. Obviously the best place for the cutout is the space presently occupied by the mechanical channel selector. The touch tuning assembly may be mounted either horizontally or vertically.

Power supply considerations

The prototype unit drew just over 4mA from the supply and this will have to be allowed for otherwise there is a risk that the standing current through the 33V regulator (such as the ZTK33 or TAA550) is not sufficient to ensure stabilisation. The important thing to remember is that the resistor in series with the varicap voltage stabiliser allows sufficient current to pass so that the regulator is supplied with something in the region of 4mA - this is in addition to the current consumed by the unit. The simple application of Ohm's law should suffice. Should any tuning drift be experienced in use, then after rechecking calculations, it is worthwhile to actually measure the current and adjust the value of the dropper resistor if necessary. The author is grateful to Plessey Semiconductors Ltd. for their advice and assistance. ■

Servicing Pye Hybrid Colour Chassis

A. Denham

THIS article is concerned with the many sets in the Pye, Ekco, Invicta, Dynatron and Ferranti ranges fitted with the Pye group's hybrid colour chassis. There were various versions of the chassis – the 691, 693 and 697, also an earlier dual-standard version which had the same basic decoder, field timebase and CDA (colour-difference amplifier) boards. Earlier versions used a hand-wired power supply/line output stage assembly and a mechanical tuner. Varicap tuning was introduced with the 693 chassis, and the next development was to use a printed panel with an i.c. (SN76013N), also carrying the front control panel components, as an alternative to the Mullard audio module. The power supply/line timebase circuitry was then rearranged on a vertical printed board with edge connectors. There were minor changes to the sound supply, later changed back again. The earlier mains transformer was replaced, new fixing holes sometimes being required. The intercarrier sound i.c. was changed from a TAA350 in early sets to the later TBA480Q. The early side-mounted convergence panel is electrically compatible with the later top-of-the-cabinet type, but the lead lengths and brackets vary.

So much for modifications, now to the faults you can expect.

Sound/Control Panel Assembly

Early sound/control panel assemblies suffered little, sound faults usually being due to one or other of the output transistors (AC128/AC176) in the module or the speaker, which seems to be very prone to cone rubbing. It's a 12 Ω type: don't use a lower impedance one, especially in sets fitted with an audio i.c., as it will do the output stage a nasty turn. A common cause of no sound on some sets is the 1N4002 rectifier and its 400 μ F reservoir capacitor on the power supply/line timebase board. In other sets the power supply for the audio circuit is derived from the negative side of the l.t. bridge rectifier. There's a peculiar reversible electrolytic, C201, 12.5 μ F 25V, in the brightness control circuit. This can be responsible for low brilliance or brilliance fluctuations. Generally however the panel gives little bother, the only attention required being perhaps to clean the volume control.

Tuners

The mechanical tuner is fairly reliable, usually giving trouble only after an electrical storm (replace the r.f. amplifier transistor). The varicap tuner is either a Philips type or a Mullard ELC 1043. It can be responsible for drift, but far more often the trouble is due to the TAA550 tuning voltage stabiliser i.c. or its feed resistor(s). The tuning head used with the varicap tuner is troublesome, tending to cause noisy or intermittent operation or no results. Inability to change stations can be the microswitch on the rear earth bar not shorting the a.f.c. out. Repair of the heads if they break is usually impossible, and the last price I had was astronomical. Noisy operation, provided the r.f. amplifier

transistor is all right (check for 0.7V base-emitter bias), is usually due to a dry-joint in the tuner, but can also be a faulty aerial socket.

IF Strip

Low contrast, a very watery picture and poor sync can be due to one or other of the i.f. amplifier transistors. I've found that the easiest way to check for transistor action is to monitor the collector voltage while shorting the base and emitter of the transistor under test. This should result in a rise in the collector voltage. This method does not affect the a.g.c. – due to spurious pickup you can get readings of 2-3V at the base and 0V at the emitter, as the a.g.c. acts when the base is touched, particularly the first i.f. transistor.

No sync or luminance but chroma present is usually the second phase splitter transistor (VT6, BF194). If necessary, check the electrolytic (C36, 50 μ F) which couples the signal to its base. Weak or no sync is a very common problem and is usually due to the sync separator's base bias resistor R33 (4.7M Ω) increasing in value. The transistor itself (BC107, later BC147 – VT7) can also be the cause however as, less often, can its base-emitter junction protection diode D3 (OA47, BA145 or 1N4148).

Fluttering when the cabinet is tapped is frequently caused by the earth soldering around the print being broken. Clean the board well and use a high-wattage iron to sweat the frame back to the board. Work quickly with the iron hot to avoid lifting the print. Similar effects occur when the a.f.c. can is dry-jointed.

Caption buzz can sometimes be cleared by adjusting the quadrature coil (L19) associated with the intercarrier sound i.c. Otherwise the chip itself may have to be replaced. Low volume can be due to the tuning capacitor (C76) across the quadrature coil being open-circuit.

Dark bars across the picture, more severe at the top, can be caused by ringing in the a.g.c. circuit: the culprit is the 50 μ F electrolytic C46A.

Keep all leads in their original positions, well away from the CDA region. Otherwise you may get severe patterning.

Colour Faults

The decoder is straightforward: no expensive chips lie in wait. Early versions used the large Mullard delay line, later ones the slim, short type. All panels are compatible, from the first dual-standard sets to the final production run.

To override the colour killer, connect a 27k Ω resistor from the 15V rail (cathode of the 15V zener diode D38) to the anode of D21 (TP21). If a colour signal is present, the voltage at this point should be 3V (without the 27k Ω resistor): if this voltage is not present the colour killer is operating – overriding it with the 27k Ω resistor will give some indication of the fault, i.e. still no colour, either the first chroma amplifier is faulty or the reference signal is not present; coloured bands, reference oscillator unlocked due

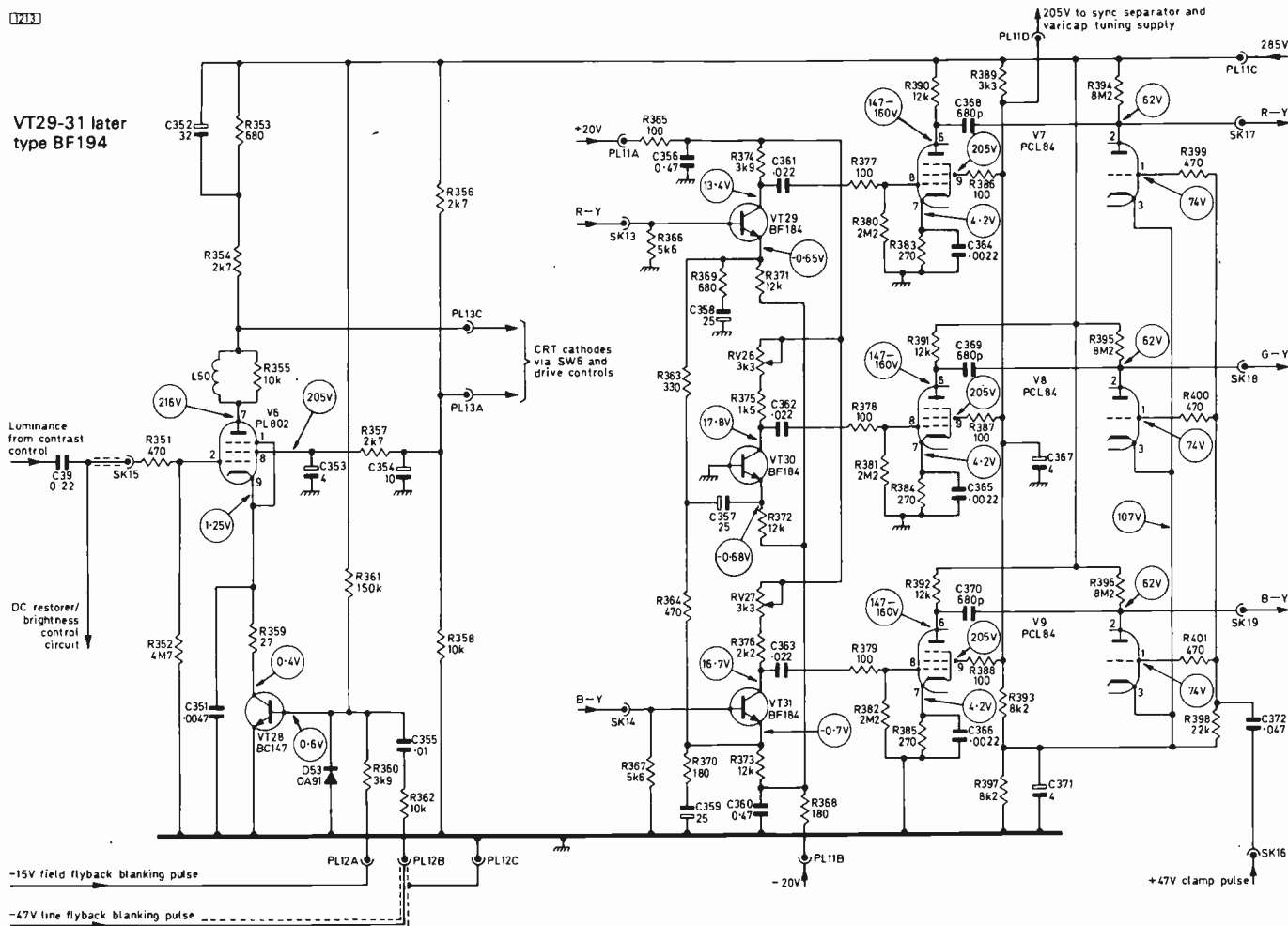

Fig. 1: Circuit of the CDA panel (C39 is on the control panel). There were minor component value differences in earlier versions.

to no burst signal or a fault in the d.c. amplifier between the burst detector and the reference oscillator; no ident, check the ident amplifier etc. If the 3V bias is present but there's no colour, examine the second chroma amplifier/delay line driver. On one occasion I had no colour due to the printed connectors on the line output board being faulty, removing the 15V supply to the decoder.

No colour can also be due to a fault on the CDA panel however. The screen grids of the three colour-difference output pentodes are supplied via a common resistor, R389. Check whether the screen grid voltages are present therefore. Quite likely the resistor will be o.k., the cause of the trouble lying in broken print or a dry-joint. The resistor also supplies the sync separator on the i.f. board, so sync may be lost; and on later versions with a varicap tuner the resistor supplies the feed to the tuning line, with the result of noise only if the supply is not present.

To set the reference oscillator, override the colour killer and remove the burst by shorting TP3 to chassis. Set RV10 for almost locked colour, then remove the short and the 27kΩ resistor.

I've found few decoder troubles that could be called common, except for a tendency for the d.c. amplifier VT15 to go giving no colour – often intermittently.

The CDA Panel

On the CDA panel (see Fig. 1) reside the colour-difference signal preamplifier transistors (VT29/30/31, type BF194), the flyback blanking transistor (VT28, BC147), the three PCL84 colour-difference output pentodes/triode clamps, and the PL802 luminance output pentode. Here the

problems start, mainly due to the heat generated by the valves and their associated high-wattage resistors. This leads to many dry-joints and to cracks in the rather poor print as the board flexes with constant heating and cooling.

The most common trouble I've had is the 12kΩ colour-difference output pentode anode load resistors R390/1/2 going dry or open-circuit. This gives a shading effect of the colour concerned from left to right, similar to a purity fault but with very defined boundaries. Other causes of this sort of trouble are bad earthing between the board and the main chassis, and a defective flyback blanking transistor. The electrolytics C367 and C371 can be responsible for the impression of impurity.

No luminance is frequently no more than a duff PL802, though the blanking transistor VT28 and R353 (680Ω) in the anode circuit can be responsible for a weak picture. Be careful when checking the voltages around the BC147: if it's o.k., shorting its base and collector in the limited space will rapidly terminate its life.

There is a simple field check that can be made on a suspect CDA panel. Since all three PCL84s are supposed to do the same thing, ergo all three should have the same voltages. The clamp triodes will always record low anode voltages on any meter other than an electronic one as the load resistors R394/5/6 are 8.2MΩ. These high-value resistors tend to increase in value, reducing the voltage at the appropriate c.r.t. grid and thus decreasing the amount of the colour concerned in the display.

Lack of brightness can be due to several things; mainly the PL802 losing emission. If its screen grid decoupler C353 is leaky the screen grid voltage will fall and R357 will cook. We've already mentioned R389 in connection

with no colour. Note however that it forms part of a potential divider chain along with R393 and R397, the junction of these two latter resistors providing the clamp voltage for the cathodes of the triode clamps. They thus have a profound affect on the brightness should they change value or go open-circuit. Say R397 goes high: the clamp voltage then rises and the effect can be uncontrollable brightness with flyback lines. If R393 goes high or open-circuit the opposite effect occurs, lack of brightness.

Colour casts are not necessarily due to a fault on the CDA panel. Check the c.r.t. first anode voltages, since the 1.5M Ω resistors in series with the first anode presets tend to increase in value.

Lack of one of the colour-difference signals can be due to the appropriate colour-difference preamplifier transistor failing. Note however that their emitters are biased from the -20V rail. Should C358 or C359 become leaky or short-circuit therefore the bias is removed or reduced with consequent reduction or removal of the B-Y or R-Y signal.

It's now officially recommended to fit stand-off valveholders on this panel to reduce the effects of excessive heating.

Field Timebase

The first thing to note about the field timebase is that it is connected between + and -20V rails. Failure of one or the other will still leave some field scan therefore though much reduced. There is also a zener diode stabilised 20V rail which supplies the field charging capacitors via the height control. If the zener is faulty the height falls in sympathy. Check for 20V at plug B7, then move over to the power supply section and check D52 (BZY94C20 or BZX61C20).

The output transistors VT26/27, both type BD124, cause their share of problems, ranging from foldover to total field collapse. On one occasion I was caused much grief when both turned out to be leaky, giving lack of height. If you can't get BD124s, use TIP31As, GD124s, SP8385s etc, with one insulating bush from the originals.

D45 (OA47) between the field oscillator and the charging circuit can cause a peculiar fold up of the picture, as can the bootstrap capacitor C256 (250 μ F).

C255 (160 μ F) is connected between the + and -20V rails: check it in the event of picture rolling with the hold control at the end of its travel.

If you have no field scan after carrying out servicing near the tube base, check the set white switch on the base panel.

Power Supplies

The usual BY127 h.t. rectifier (D49) fuse blowing antics occur. If it's not the BY127, check the 0.2 μ F mains filter capacitor C301. The heater circuit is not protected in the event of the heater rectifier diode D48 (BY126) going short-circuit. So in the event of the heaters being excessively bright check D48 and provide protection by adding a 1N4004 diode from the anode of D48 to chassis, cathode of the 1N4004 to chassis. In the event of D48 going short-circuit the 1N4004 will conduct, blowing the 2.5A mains fuse.

A most peculiar fault condition appears when the h.t. line reservoir/filter electrolytics C306/C315 go open-circuit. A rolling triangle of defocussed light is displayed on the screen, the h.t. falls to 120V and the first time I had this one it took hours to find the cause. Hum bars are usually due to one or more of the l.t. smoothing electrolytics. When it's

necessary to replace the BY164 l.t. bridge rectifier I find that four 1N4002 diodes connected as a bridge are more satisfactory. Later mains transformers have an internal thermal fuse: this doesn't seem to prevent them failing . . .

Convergence

The convergence assembly seems to have few vices apart from the usual noisy potentiometers. If difficulty is experienced, check the operation of the presets and then if necessary the AC128 clamp transistors and the electrolytics. There is one common stock fault however, the pin-cushion amplitude control RV41 which is under rated. When it fails the result is bright white lines across the top of the screen. It can be replaced with a fixed 12 Ω resistor.

I've had to replace the convergence yoke on several occasions due to the blue coils having burnt out. This can be expensive. To overcome this I've on a couple of occasions used a complete assembly from an old Philips G6 chassis.

Line Timebase

Which brings us finally to the line timebase, where quite a lot of things can occur.

Lack of brightness after some time is caused by the line output valve drawing excessive current. As a result, it operates the beam limiter which monitors its cathode voltage. Replacement of the PL509 usually cures this.

No e.h.t. with overheating in the line output stage is usually the PCF802 line oscillator valve or C213 (1 μ F) or C210 (4 μ F) in the line oscillator circuit. These electrolytics can also be responsible for weak line hold, while C213 can cause a bright vertical band down the centre of the screen. Staying with the line oscillator, a very common cause of poor or no line lock is the reference pulse feedback resistor R203 (47k Ω , 1W) falling in value. It sometimes destroys the flywheel sync discriminator diodes D40/D41 in the process. These can also be responsible for line sync problems on their own, as can one or two other things. C215 (16 μ F) for example, which smooths the supply to the line oscillator, and R210 (100k Ω) in series with the hold control - it falls to quite a low value, in fact it can fall so low that there is inadequate drive to the PL509 and the brilliance level falls due to the beam limiter circuit coming into operation. The polystyrene capacitor C211 can cause sync problems, sometimes intermittent, or kill the oscillator, and another suspect is C212. Another thing which can stop oscillation is R208 going open circuit.

Before passing on to the output stage, a word about the drive waveform shaping capacitor C214. When defective, this can cause insufficient width plus vertical cramping at the centre of the screen.

Lack of width points to the PL509, PY500A, R223 and R224. C217 is also not beyond suspicion, especially where the width fluctuates.

The dreaded smoke from the line output stage is nearly always the line output transformer or the tripler, but can also be the harmonic tuning capacitor C219 (170pF, 8kV). This last fault will result in the PY500A glowing red hot since it's then connected between the h.t. rail and chassis. Similar symptoms, i.e. no e.h.t. with the PY500A upset, occur when C224 goes short-circuit, burning up R227 (0.1 μ F 1kV and 100k Ω 1W respectively). The PL509's screen grid feed resistor R231 (2.7k Ω , 5W) may suffer under any of these conditions, as it may when the PY500A goes kaput. You must have heard it: "Well, the picture went

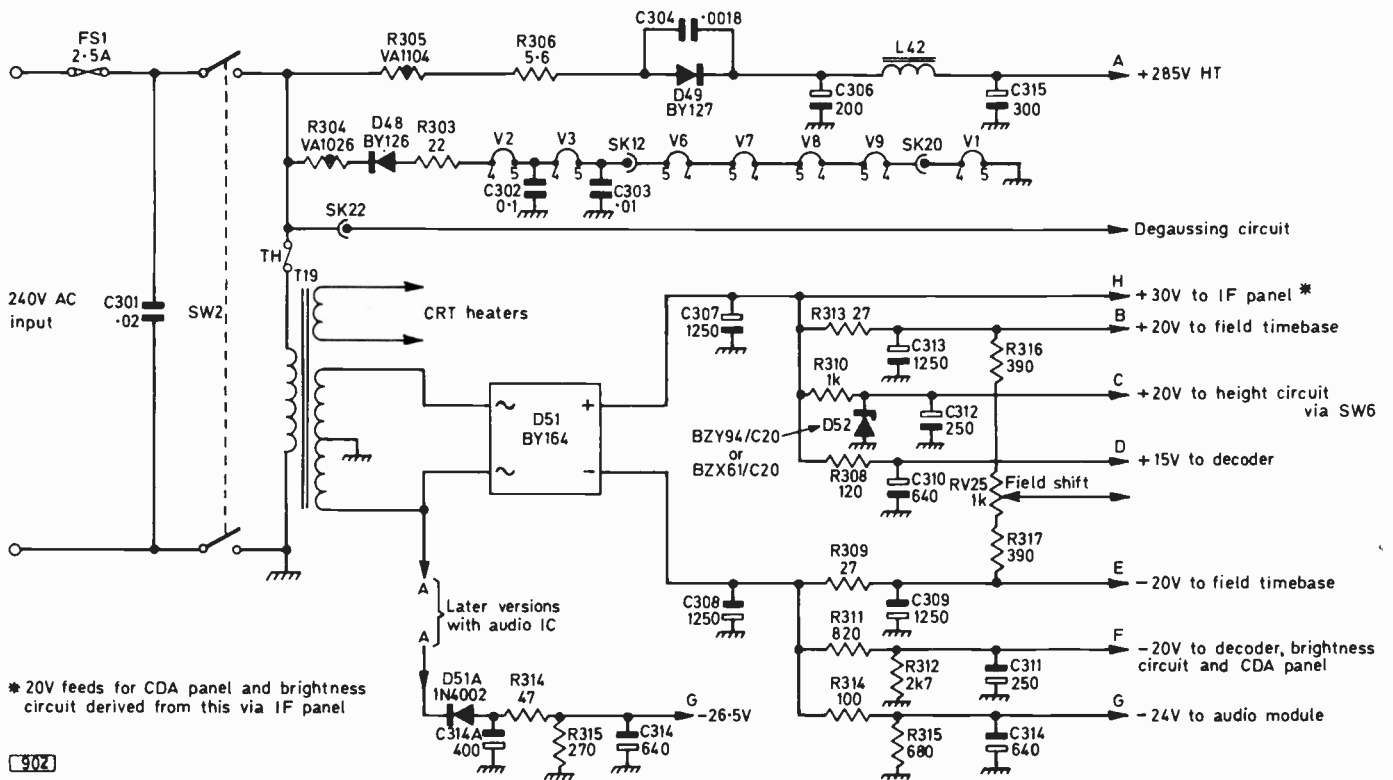

Fig. 2: The power supply circuit. In later versions C301 is 0.2μF, R306 3.3Ω, R303 and D48 are transposed and the heater chain is as follows: V2, V3, SK20, V9, V8, V7, V6, SK12, V1, chassis. Thermal fuse TH is incorporated with the later mains transformer. Note alternative audio supply circuits.

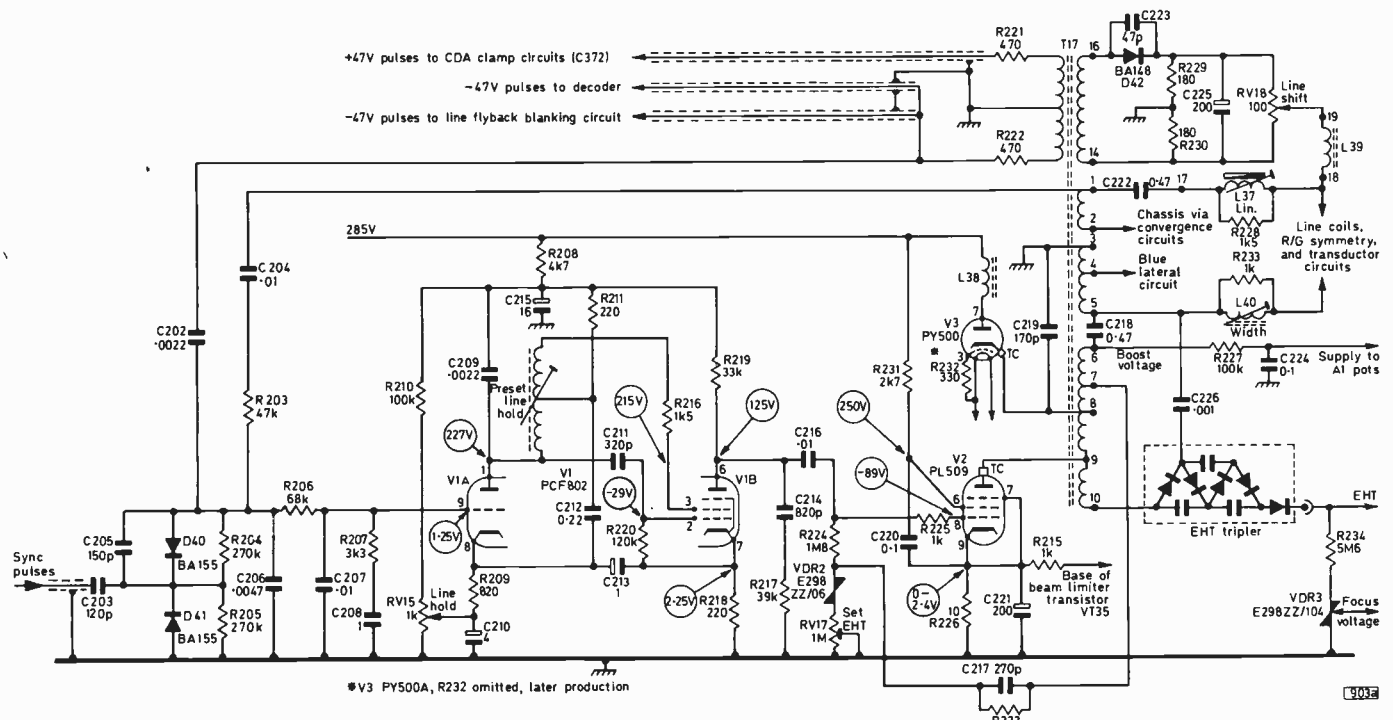

Fig. 3: Line timebase circuit. In some sets C219 is 180pF and is connected between tags 8 and 1 of T17. Also RV18 is centre-tapped, with R229/R230 omitted.

off, but we listened to Coronation Street. Smell? Well yes I suppose it did, but the kids . . .”

Two more capacitors in the line output stage cause trouble. The boost capacitor C218, and C226 which though external to the e.h.t. tray is the reservoir for the first stage in the tripler. Either can go short-circuit, in both cases upsetting the PY500A for the same reason that C219 does. C226 also makes the e.h.t. tray suffer, so that this will also require replacement. When C219, C218, C224 or C226 go

short-circuit it's usual to find the mains fuse blown.

What else is there? Oh yes, in early sets striations on the left-hand side of the picture were common due to the line linearity coil damping resistor R228 (1.5kΩ) decomposing. A special type was fitted in later sets. Finally focusing. If it drifts, replace R234 (5.6MΩ) which is in the focus assembly. If the focus is very poor, check the focus assembly (VDR3) which is prone to mechanical troubles, for example a cracked element or poor slider contact. ■

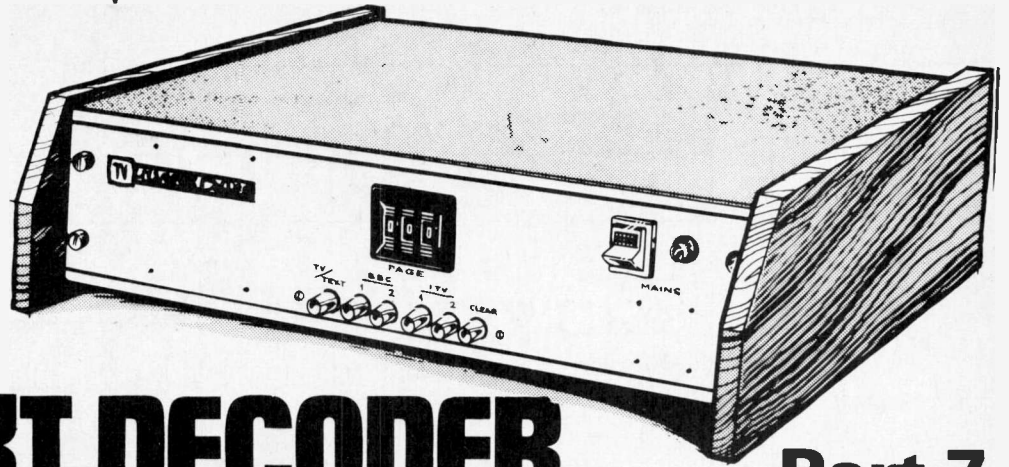

TELETEXT DECODER

Part 7

Steve A. MONEY T. Eng.(CEI)

WE had originally planned to deal with the receiver and data recovery sections of the decoder unit this month. Some of the components used in the receiver section are newly developed devices which have only recently been put into production. However, as setmakers normally get priority in the supply of such new components it seems likely that when this issue appears one or two of the components needed for the receiver section may not be readily available. Steps are in hand to remedy this situation but in order that readers should not be held up for lack of components the description of the receiver and data recovery sections of the decoder has been held over until next month, by which time the component supply position should have been resolved. In the meantime we shall deal with the remaining ancillary circuits and the mother board.

Channel and Function Switches

A small sub-board mounted behind the front panel of the decoder unit carries the channel selection switches and tuning controls together with two switches used to control the teletext functions.

The circuit diagram for this board is shown in Fig. 1, whilst Fig. 2 shows the layout of the printed circuit board.

Multiturn potentiometers are used for the adjustment of

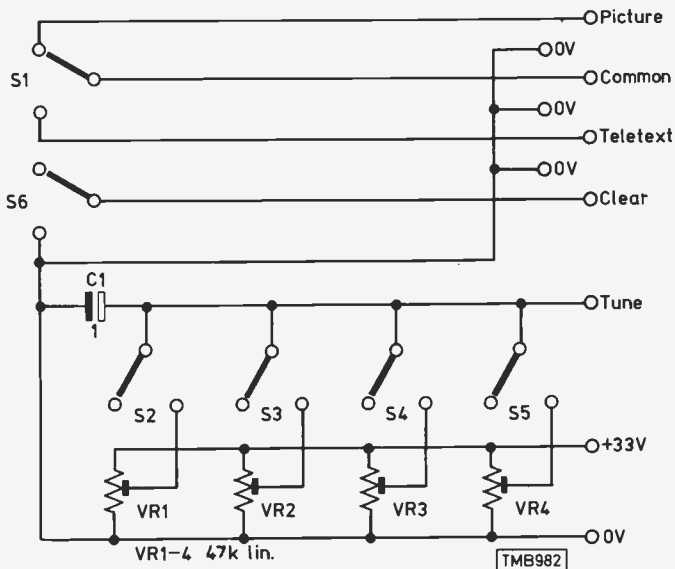

Fig. 1: Circuit diagram of channel and function switching arrangements carried out on p.c.b. D021.

tuning voltage on each channel, giving smooth tuning control and good stability in operation. The four switch banks used for channel selection are mechanically linked so that when a new channel is selected the other switches are automatically cancelled.

For TV/Text selection a separate latched switch is used to select either the normal picture signal or the dot pattern text signal and route it to the video input point on the u.h.f. modulator.

Page Clear is controlled by a momentary action push-to-

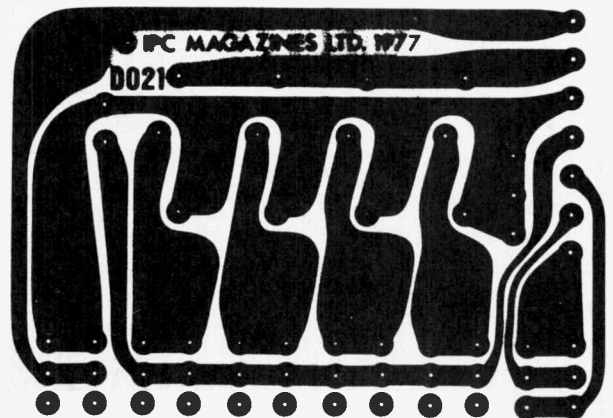

Fig. 2a: Track detail of p.c.b. D021, the switching board.

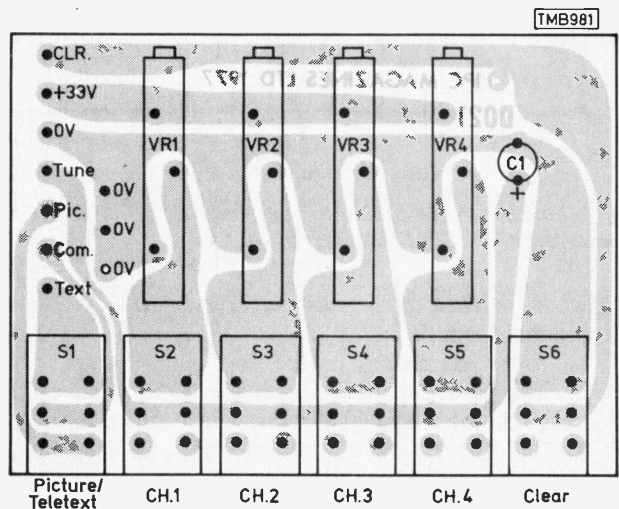

Fig. 2b: Component layout for the switching board.

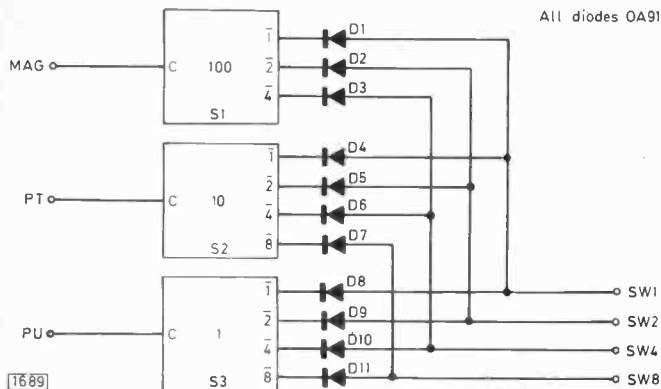

Fig. 3: Page selection switch circuit.

make switch. When this switch makes, it triggers the Clear Page logic on the input logic board and causes any text on the screen to be erased ready for a new page to be displayed.

Page Selection Switches

For page selection the required switch circuits are shown in Figure 3. Here the switch assembly consists of three banks of binary coded decimal (BCD) thumbwheel type switches mounted side by side between two end-cheeks. On the front of the switch a number between 0 and 9 appears to indicate which position is selected and the binary code corresponding to that number is set up on four output pins as a combination of made and open contacts corresponding to '1's and '0's respectively. It is important that the switches used should have inverted logic outputs where '0' is represented by a closed contact and '1' by an open contact.

The switches specified do in fact provide for both normal and inverted logic outputs. The contacts for inverted logic are marked as 1, 2, 4 and 8 on the connection strip at the back of each switch bank.

The four BCD outputs from the three banks of the page select switch are fed in parallel via four wires to the input logic card. Each bank of the switch is selected in turn by one of three timing pulses from the input logic. When the timing pulse occurs it connects the wiper of the selected switch bank to '0' at the same time as the corresponding page address data from the received signal is decoded by the input logic. The received data is then compared with the code from the selected switch bank as part of the page recognition process. The 'hundreds' bank of the switch is selected by the MAG pulse from the input logic which occurs when the magazine code is received. Similarly pulses PT and PU from the input logic are used to select the 'tens' and 'units' switch banks respectively.

As each switch bank has a common wiper for all four of its BCD output lines, there would be a problem with interaction between switch banks if the BCD outputs of the three switches were wired directly in parallel. To overcome this, a diode network is used from the outputs of the three switches. The diodes allow signals from the bank that is selected to pass through to the common output bus whilst the unselected switch banks are effectively isolated by reverse biased diodes. The diodes can be mounted from the back of the switch and the four common bus points can be anchored to a short length of tag strip which will also carry the four wires that feed signals to the input logic card.

Mother Board

To simplify the interwiring between the three logic cards and the receiver card, a printed circuit mother board is

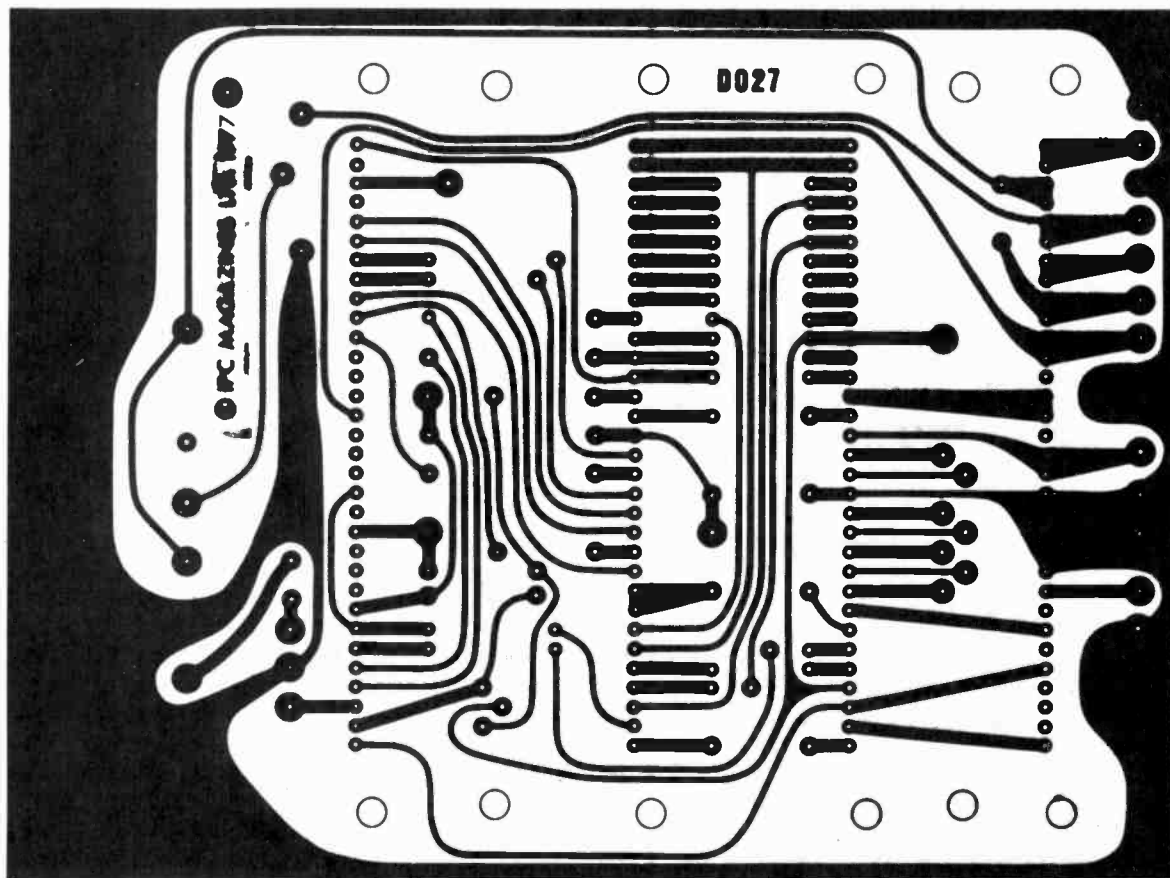

Fig. 4a: Track detail of the mother board.

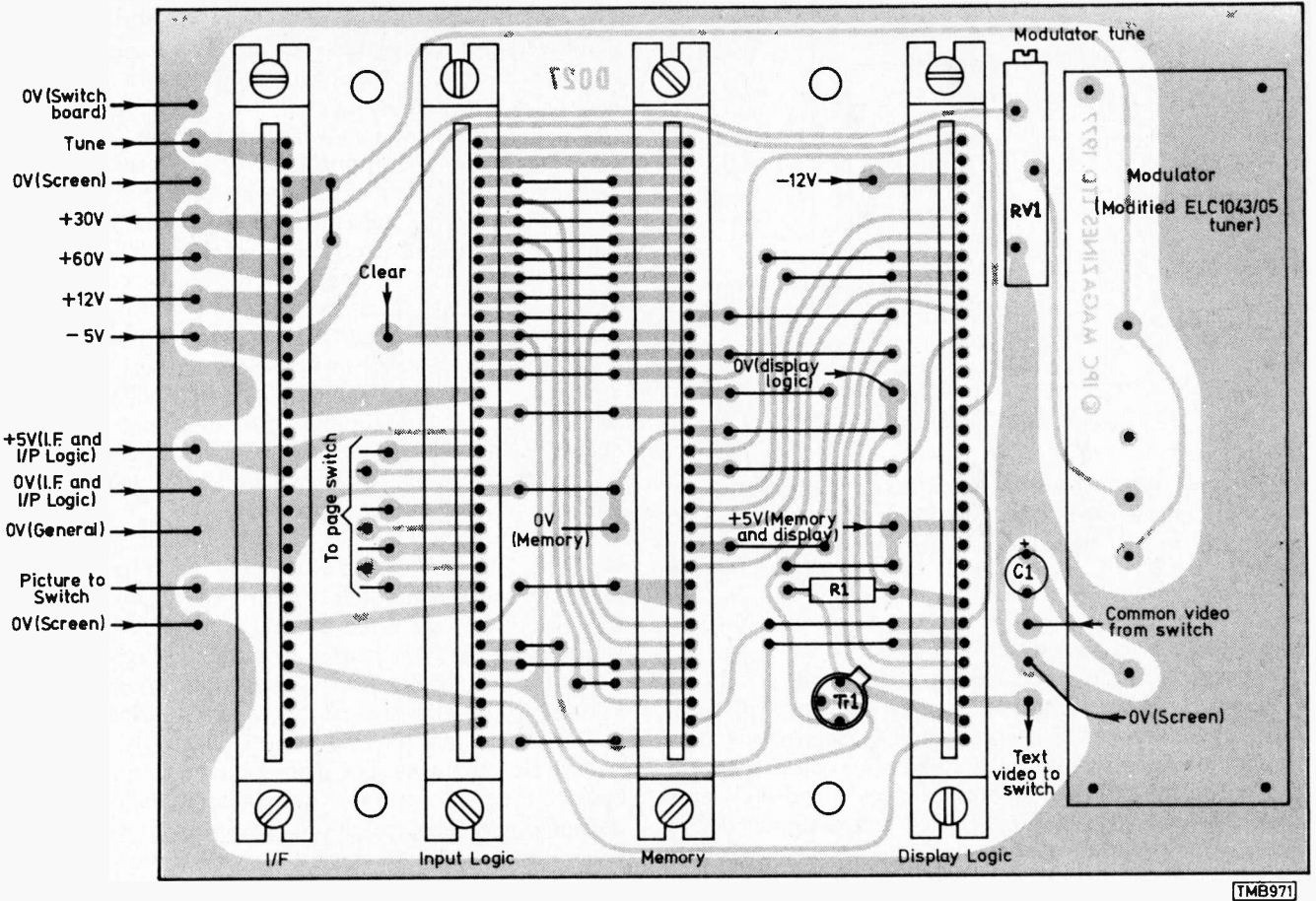

Fig. 4b: Component layout for the mother board.

used. The layout of this mother board is shown in Fig. 4. To avoid the need for having a double sided printed circuit board a number of short wire links need to be inserted into this board as shown in Fig. 4b. These links can be made with either insulated or bare single core wire.

Transistor Tr1 acts as a buffer stage for the synchronising pulses to the display p.c.b. This buffer stage is needed because the logic gate producing the synchronising pulses in the input board cannot drive all of the logic loads that are present in the rest of the system.

A coupling capacitor for the video input to the u.h.f. modulator is also included on the mother board since it is difficult to fit this inside the modulator unit itself.

The 32-way edge connector sockets should be fixed to the mother board by using nuts and bolts through the fixing feet at each end and then soldered in to the track pattern. Care is needed here to avoid solder bridges between adjacent pads.

UHF Modulator

In order to produce a signal suitable for direct injection into the aerial socket of a normal television receiver we shall have to modulate the picture or text signals onto a u.h.f. carrier, set to one of the unused local channels.

Although a simple single transistor modulator is likely to be adequate for reproducing the text display it can be difficult to achieve good reproduction of a colour picture using such an arrangement.

Experiments were carried out on a modified u.h.f. tuner of the ELC1043/05 type and this was found to be entirely satisfactory for the purpose. Details of this modification were originally described in the April 1975 issue of *Television* and reprinted in the April 1977 issue of *Practical Wireless*.

The modification makes use of the mixer/oscillator stage to generate the basic u.h.f. carrier signal.

In simple modulators where the oscillator stage itself is modulated, trouble is usually experienced with frequency modulation, harmonic generation and non-linear modulation characteristics. In this modulator circuit the two original r.f. amplifier stages are used as buffer amplifiers between the oscillator and the output. Modulation is achieved by applying the video signal to the a.g.c. control line of the first r.f. amplifier stage thus varying its gain and giving a modulated output with linear characteristics for video levels of up to 1 volt peak-to-peak amplitude.

Fig. 5 shows the circuit diagram of the ELC1043 tuner and details of the modifications required. In the ELC1043/05 different transistor types are fitted and the circuit board layout is different but the required modifications are the same. Let us now go through the circuit changes in more detail.

Firstly the 470Ω resistor in series with the a.g.c. input pin is reduced to 47Ω. In order to increase the bandwidth of the a.g.c. control circuit to cope with the video signals, the feedthrough decoupling capacitor at the a.g.c. input pin should be removed and replaced by a simple feedthrough insulating bush.

Next, the output from the second r.f. stage must be isolated from the oscillator/mixer stage of the tuner. To complete isolation of these two coils, a short wire link can be joined across the earth pads on each side of the broken link so that the wire bridge acts as a screen between the two separated parts of L11 and L12. R.f. output is now taken from the open end of L11 via a coaxial cable out of the tuner unit. This cable can be fed out through the unused hole next to the 12V supply pin for the oscillator stage.

DN 0787

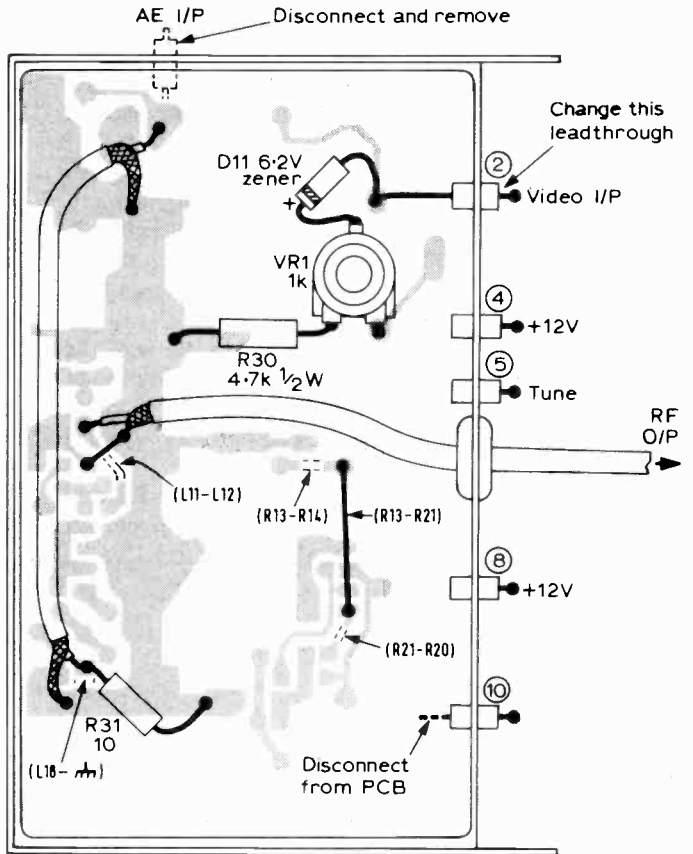
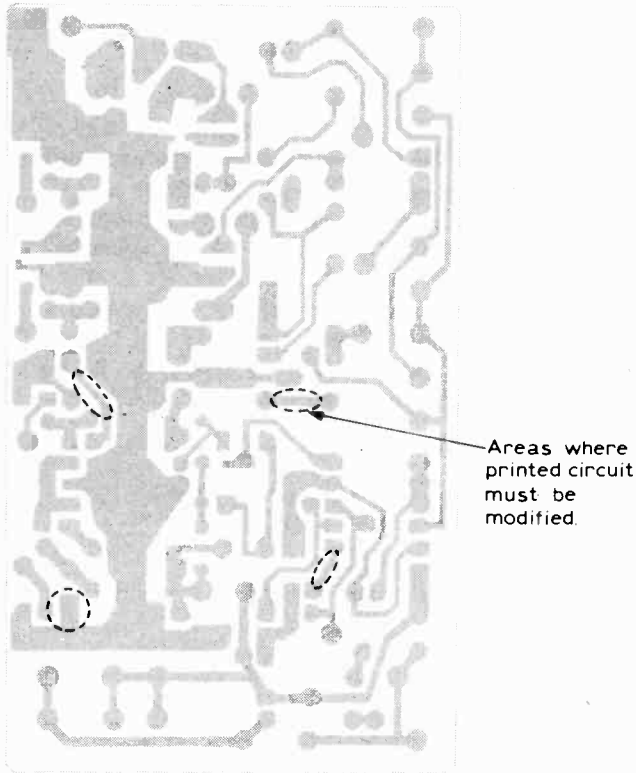

Fig. 5: Layout of the printed board and modification details for the ELC1043/05. The left-hand drawing shows the print before modification. The right-hand drawing shows track and components to be removed in broken line, links and components to be added in full line. Links should be made in 16 or 18 swg tinned copper wire, formed to stand clear of the board.

DN 0788

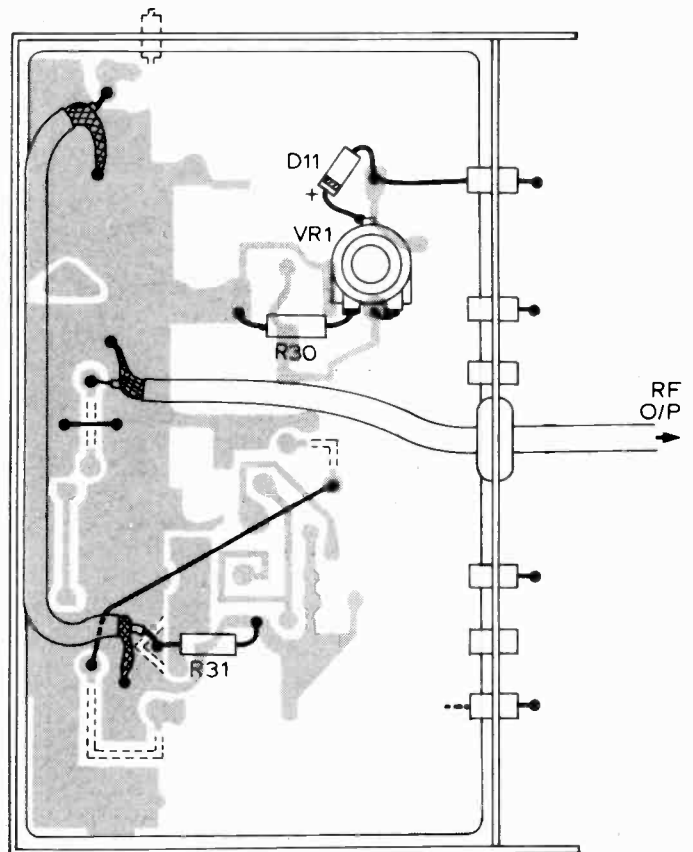
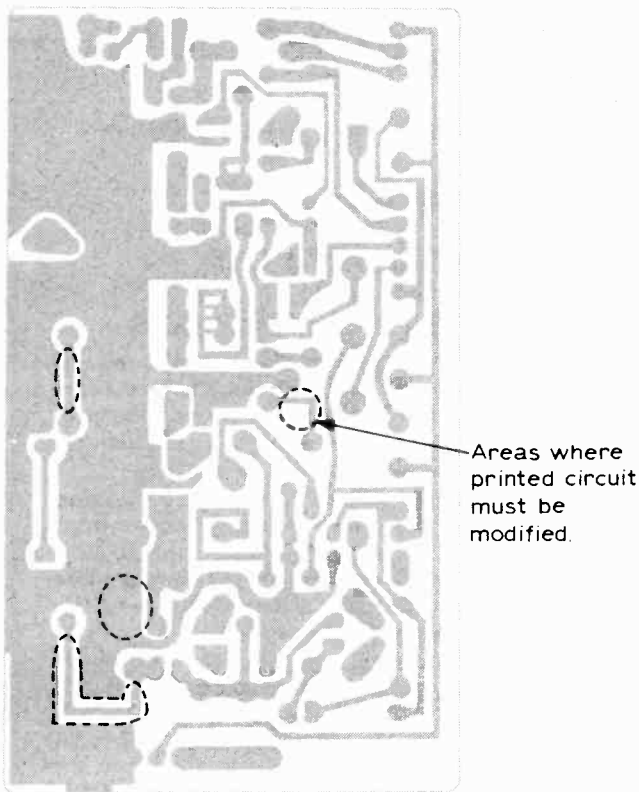

Fig. 6: Layout of the printed board and modification details for the ELC1043. Refer to the caption to Fig. 5 for further details. External connections are identical for both versions of the tuner.

This hole will need to be opened up with a reamer to allow the cable to pass through. Care has to be taken here to avoid damaging the circuit board in the tuner unit when opening out this hole. The cable needs to be about 15 inches long since it has to run from the modulator to the back of the cabinet.

Next, one end of L18 must be disconnected from earth and the signal from this point is fed back to the aerial input point on the circuit via a short length of coaxial cable. A 10Ω resistor must also be connected from the open end of L18 to earth. The original aerial input wire should be disconnected from the printed circuit board.

To ensure that the oscillator tuning will track with the tuning of the r.f. stages the control voltage originally fed to D3 is now arranged to feed D4 instead. This involves disconnecting R20 and R14 whilst the end of R21 is joined to the wiper of R13.

The zener diode D5 and potentiometer chain VR1 and R30 should be installed inside the tuner unit. This part of

the circuit is used to maintain correct black level to give a stable picture signal.

A multi-turn potentiometer mounted on the mother board provides the tuning voltage for the varactor diodes in the modified unit.

Alignment

Assuming the tuner is already prealigned the settings of R5 and R11 need not be touched. To bring the oscillator into line with the r.f. stages set the tuning voltage to 13V and tune in the signal on a television receiver. Now adjust the setting of R13 to produce maximum signal which will be indicated by minimum snow on the receiver.

For those constructors who do not wish to modify a tuner unit we understand that ready modified and aligned units will be available from Catronics Ltd., Communications House, Wallington Square, Wallington, Surrey.

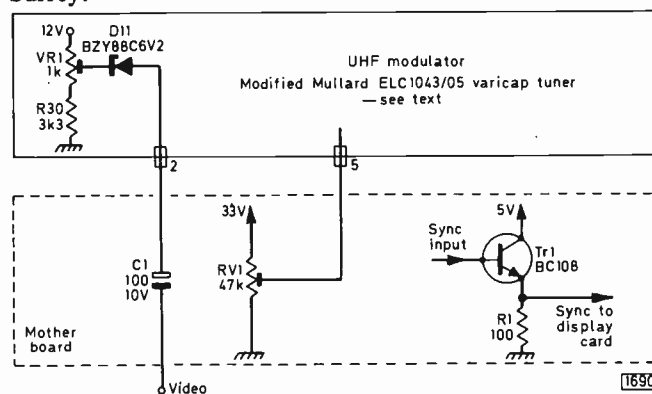

Fig. 7: Circuit diagram of miscellaneous components and interconnections found on the mother board.

★ Components list

Switching panel

- RV1-RV4 47k cermet multi-turn 1¼ in.
 S1-S6 Push button assembly, available from Catronics Ltd., Communications House, Wallington Square, Wallington, Surrey.
 C1 1μF 35V tantalum bead
 P.c.b. DO21, available from Readers' PCB Services

Mother board

- RV1 47k cermet multi-turn 1¼ in.
 Tr1 BC108
 R1 100Ω
 C1 100μF 10V tantalum bead
 SK1-SK4 32-way 0.1 in. single sided edge connector sockets (p.c.b. mounting type).
 P.c.b. DO27, available from Readers' PCB Services

Page Switching

- S1-S3 Subminiature thumbwheel BCD switches (RS Components type 338-399 with a pair of mounting cheeks type 338-406. These items are available through Doram Electronics Ltd, P.O. Box TR8, Wellington Road Industrial Estate, Leeds LS12 2UF).

- D1-D11 OA91

Modulator

- VR1 1k miniature horizontal preset
 R32 47Ω
 R31 10Ω
 R30 3k3
 D11 BZY88 C6V2
- } all ¼W ±5% carbon film

KEEP YOUR COPIES OF

Television

CLEAN AND TIDY

IN THE TV EASI-BINDER

The Easi-Binder holds twelve issues and is attractively bound in black with the title blocked in gold on the spine together with the current (or last) volume number and year. For any previous volume a set of gold transfer figures will be supplied.

Due to the change in size during Vol. 25 a large capacity binder is available to take 16 copies from July 1975 to October 1976 (Vols. 25 and 26) and a separate binder is required for the eight smaller copies of Vol. 25. Later volumes revert to 12 magazines per binder.

When ordering please state the year and volume required, and your name and address in BLOCK LETTERS.

Priced at £2.10 including UK post and VAT, TELEVISION Easi-Binders are available from the Post Sales Dept., IPC MAGAZINES LIMITED, Lavington House, 25 Lavington Street, London SE1 0PF. Overseas post 60p extra.

ON SALE SEPT. 2ND.

NEXT MONTH IN...

practical WIRELESS

A FREE POCKET MAGNIFIER

Now! You can avoid disappointing results with that new project by checking for dry joints and solder bridges on your printed circuit boards with our FREE Pocket Magnifier. Inspect your handiwork in detail. There's a dozen other uses for this handy gadget.

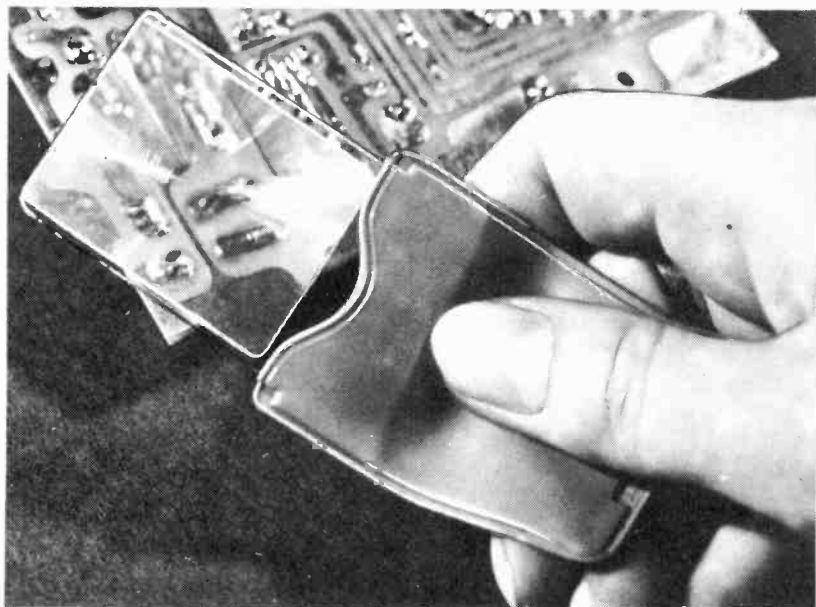

ALSO

SOLO SUPERMIND

Losing a few friends through boredom seems to be a hazard of some current "logical" games. October PW features SOLO SUPERMIND, which not only makes the "codemaker" redundant, but permits you to set and break your own codes. Simple circuitry, using readily available transistors disposes of the need for expensive "chips". It's effective, engaging, and cheap to build.

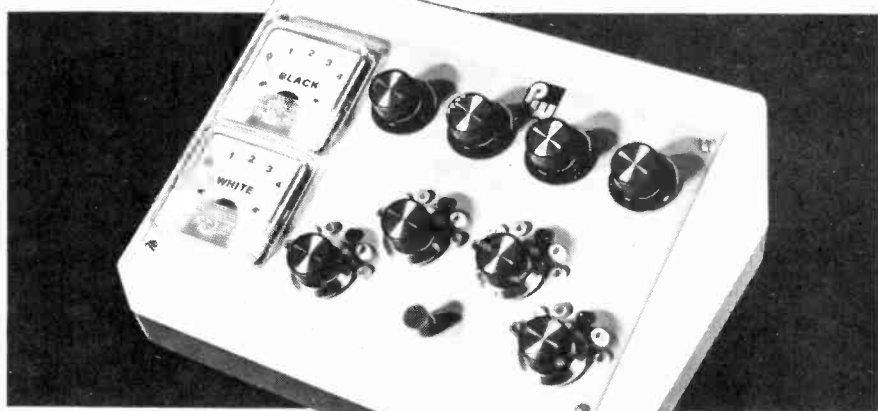

and:

Audio Level Indicator
Inexpensive Sine~Square Wave Generator

● SEE THE NEW-STYLE, LARGER PW ●

LONG-DISTANCE TELEVISION

ROGER BUNNEY

LAST month I was bemoaning the prevailing lack of signals and suggested that things had surely to change soon. Well, they have! From the end of May, Sporadic E propagation has been extremely active – one enthusiast described the situation as “pure bedlam”! Very few days during June have been without such signals, and on some days there has been SpE from 0600 through until 2400, the signals ceasing only due to the transmitters being switched off. In such conditions careful lookout has to be maintained for the really rare signal, and indeed several enthusiasts have been very fortunate.

Nigeria Received in UK!

Hugh Cocks (Devon) experienced a period of reception that can only be described as incredible. David Martin (North Dorset) also experienced some of this. On May 28th Hugh noticed a football match on ch. E3, both teams being dark skinned and with a caption indicating the scores and “second half”. At 1855 the caption NTV was observed, with globes (see accompanying photograph), and then the dark skinned footballers. At times the signal was very clear, and four Africans could be seen seated at a table in traditional head dress etc. The signal was jammed at 1920 BST by RTVE (Spain).

The story continues on the following Tuesday (May 31st) when a ch. E3 signal was again observed, with the NTV caption at 1835, this time relatively clear. These signals were also received by David Martin at Shaftesbury. The



Nigerian television (NTV) channel E3 station identification slide received at Shaftesbury, North Dorset, by David Martin on May 31st.

signals again faded at 1920, and during the period there were very strong Arabic harmonics, presumably via a single hop from North Africa. The other lettering in the accompanying photograph is Channel 3 and apparently a 4 or a 9. The transmitter identifications are at the bottom, possibly Ajankote and Ibadan.

There is more to the story however. The following day produced more spectacular reception from 1615-1845, with the Retma card on ch. E3 followed by programmes from 1630-1845 and then the Retma card again. At 1845 there were Retma cards on chs. E3 and E4, then two programmes of African origin on ch. E3. Channel E2 was dead at the time, but very strong Arabic harmonics were present.

I'm sure that all enthusiasts will wish to join me in congratulating Hugh and David on this quite remarkable reception, which I feel must be something of a record. Previous definite receptions from Africa have been few – Ian Beckett (Buckingham) received Ghana at good strength some years ago, and in the mid sixties Graham Deaves (Norwich) received Nigeria.

Other Rare Signals Seen

The enthralling events above tend to overshadow the more usual SpE reception this season, but the current period has certainly been a good one. Many rare signals have been seen. Jordan ch. E3 for example has been received by Clive Athowe and Ray Davies (Norwich), Hugh Cocks, David Martin and several others. Our Leeds friends have received the RTP ch. E4 station on the Azores and a mystery E4 signal, a Retma card with the grey scales blacked out. It's thought that this may have come from the Syrian Hassake transmitter (95kW e.r.p.). Just before Mike Allmark received this card Kevin Jackson received captions with Arabic script, indicating that reception conditions to the south east were favourable.

At times the maximum usable frequency of the Sporadic E openings has passed through Band II into the l.f. parts of Band III. George Ridgewell (Harold Wood) reports suspected reception of RTVE ch. E6, and Hugh Cocks noted SpE at up to 162MHz on June 14th.

European Reception

As a result of the good conditions we have news of several interesting sightings of European signals. RUV (Iceland) was seen with the PM5544 test pattern and a new identification – RUV at the top and ISLAND at the bottom. We now have many reports of RTP (Portugal) using the Fubk test pattern with RTP 1 identification. That old favourite the Telefunken T05 test card is again in use,

by JRT Beograd (Yugoslavia). The elusive RTS (Albania) ch. IC signal was received on the 14th by Keith Hamer (Derby) – the clock is at BST plus one hour.

Reception at Romsey

My own results reflect the very active conditions, though (as usual) I seem to have been elsewhere when anything truly outstanding appeared in the UK. I missed the first two appearances of Nigeria by only minutes – so I'm getting gradually closer! Finland ch. E2 has been well received with the Fubk pattern carrying the identification YLE HLKI. Even the difficult RAI (Italy) ch. IC presented itself on the 25th. NRK (Norway) gave a welcome variation of transmitter identifications on the PM5544 pattern – Melthus ch. E2 seems to be the pattern most often received. There seems to be no predominant direction for SpE reception this year, signals from most countries abounding from short through to long hops. Switzerland, normally a rare visitor, has been quite frequent here in South Hampshire.

There was a lift in tropospheric reception during the 16th-21st, with signals mainly from the Low Countries and West Germany in Band III and at u.h.f. As I write these lines at 2100 on the 27th RTVE is jamming chs. E2-4 inclusive! Sufficient to say that the same number of pages have been used in the log over the last twenty days as during the whole period from January through to May. Long may the signals reign!

Foreign News Items

Portugal: It's understood that RTP (Portugal) is not planning colour for some years, due to lack of funds. The current monochrome equipment frequently breaks down, due mainly to age.

Austria: ORF TV transmissions from a South Tyrol German language relay, beamed into Italy, recently ceased. Upon investigation it was found that the transmitting equipment had been stolen!

Italy: Transmissions to Italy of "pirate" programmes from transmitters on its borders continue. Of the 100 or so private TV companies operating in Italy, it seems that many have minimal equipment and studio facilities, the output tending to consist of films of doubtful content. Two such companies are operating from rooms in Rome's Hilton Hotel, with low power.

USSR: The Baku, Azerbaijan TV transmitter is to be given increased coverage shortly as a result of a 310 meter mast now under construction. Baku ch. R3 has been received in the UK.

Afghanistan: It's hoped that the new TV centre at Kabul will begin transmissions towards the end of 1977, and be fully operational by mid-1978. The transmitter is atop Mt. Asmai and will radiate with PAL colour from the start. Further links will extend the service into the more remote parts of the country by 1980. Japan is giving technical help and a loan to enable TV to get under way.

Satellites: NHK (Tokyo) hopes to commence direct-to-home satellite tests in the 12GHz band during 1978. There will be two channels (NTSC colour), each with 100W output, capable of giving nationwide coverage from a synchronous orbit at 110° East. The Ekran satellite is

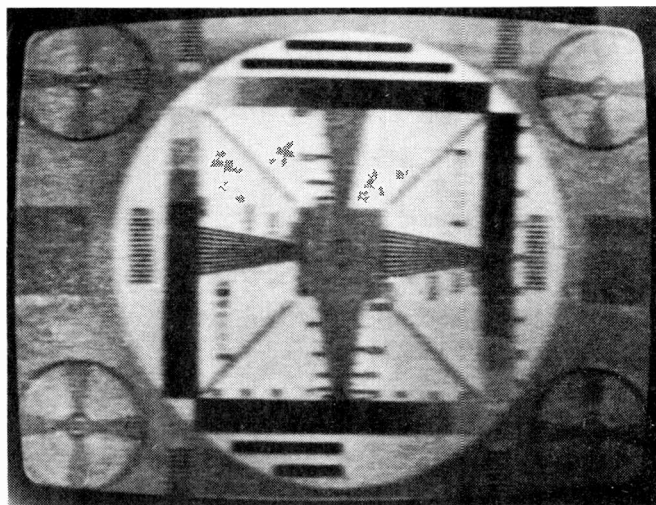

The RMA 1946 test card used by Bombay, channel E4, received in Abu Dhabi by Alan Latham.

giving increased coverage in the northern parts of the USSR. Over 60% of Yakut Republic and much of the western Polar regions can now take network television from Ekran – its output is at 714MHz. A Norwegian report suggests that within five years Sweden may be enjoying five channel TV via the Norsat satellite.

From Our Correspondents . . .

Many letters have arrived this month, mainly as a result of the really excellent and prolonged reception conditions. An established enthusiast has written to us for the first time, Ray Davies of Norwich. His equipment consists of a 50 foot steel mast with XG21K and MBM46 arrays for u.h.f. (both with 6030 Labgear amplifiers), a Band III array with Teleng masthead amplifier, and for Band I a three-element ch. E4 aerial with lower down a three-element ch. R1 array. Ray has had very good results these past weeks and also received the ch. E2 mystery signal I received in April, consisting of a dark skinned announcer, programmes and commercials. Ray has also received Jordan ch.E3 recently. His receiver incidentally is a Grundig Model 5010, with a 5.5MHz sound module added allowing switching to either 5.5 or 6MHz sound.

Andrew Emmerson (Faversham) has been very active recently, using for v.h.f. an Antiference MH308 export array (wideband Band I/III) with an integral masthead Wolsey wideband amplifier. Andrew has a hinged 30 foot steel scaffold pole, bracketed to the house and hinged at the base. It's erected with a rope and pulley. At u.h.f. he's using a Vorta VP91 multiple-element array, which by all accounts is working well.

Leslie Hetesi, our Hungarian contact, has reported reception from Iran and Egypt! An E2 transmitter at Shiraz radiates a frequency scale, an identification slide with eagle to the left and Arabic script to the right and bottom of the screen. Programmes start at 0600 and 1430 GMT. Egypt is using the Retma card on Port Said ch. E3 with colour bars at times. The identification slide is a large eagle and Arabic script at the top, followed by shots of a fortress. Programmes start at 0800 and 1500 GMT.

Report from the Gulf

Alan Latham has sent us new information on Arab stations in the Gulf area.

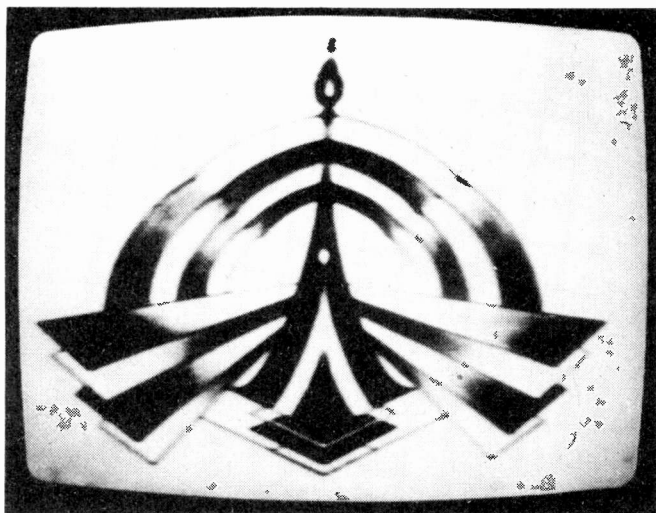

The Karachi, Pakistan identification slide, received by Alan Latham (ch. E4).

Ch. E2 Dubai (UAE) operates in monochrome with approximately 10kW e.r.p. There are frequency bars at 1400 and programmes at 1430 GMT. The first shot is the UAE flag, with the national anthem and the face of the president faded into the centre of the flag. Transmissions end at 2000 GMT. Programmes are mainly Arabic but at times American films with Arabic sub-titles. As with all Islamic countries there are frequent calls to prayer and shots of the Koran. No VITS and no commercials.

Ch. E3 Ras Al Khaima (UAE) also uses system B with PAL colour and approximately 1kW e.r.p. Timings are similar to Dubai, with a similar opening. Colour bars are the usual test pattern. Programmes consist mainly of movies with no announcers or adverts. A jamming signal is present except on the Koran and test pattern. This jammer is at about 2MHz h.f. of the vision carrier and "converters" are sold by the station to remove it (thus obtaining revenue!). No VITS and poor timebase stability (line).

Ch. A2 Dhahran, 525 lines system M NTSC, is operated by Aramco for its employees and uses the American Bulls Eye test card. Opening is at 1300 GMT on test card, with programmes at 1330. The Saudi flag is shown at 1330, but with no Koran or other religious scripts. Programme content is mainly American movies and videotapes. Cutdown is after 2000 GMT.

The ch. E4 Bahrain station, using system B PAL colour,



Bahrain channel E4 station identification, photograph from Alan Latham.

is well received. It opens at 1300 with colour bars, programmes starting at 1330. The flag, national anthem and president's shot follow. Cutdown is after 2000 GMT. Programmes are both Arabic and American films, with news in Arabic and English. Technically and production-wise this is the best station in the Gulf. VITS are used.

Alan receives Iran on chs. E3, 4, system B but SECAM. Colour bars and the EBU bar (less circle) are used and VITS are present on all output. Transmissions start with the anthem and the Shah's picture. All programmes are in Farsee.

Bombay uses system B on ch. E4 with the RMA 1946 test card, going on to programmes at approximately 1230 GMT. Karachi ch. E4 uses system B PAL with distinctive colour bars and pattern.

Ch. E2 Dubai uses a very distinctive pulse and bar at times, with a thin vertical line and square (white) on a black background. The Bahrain ch. E4 outlet often transmits a quick succession of patterns such as pulse and bar, grey scale, sawtooth etc. before the colour bars. Incidentally, Friday's transmission times are very random and subject to variation. Apparently the local paper ran a leading article saying that it wouldn't list Abu Dhabi TV programme timings unless they transmitted what they said they would! Alan has kindly offered to help any enthusiast requiring assistance with identification of suspected Arabic material.

Malaysian Television Reviewed

In view of the repeated reception of various Malaysian transmitters in Australia and the proposed start of PAL colour operation in the not too distant future the following brief notes on television in the Malaysian states may be of interest.

There are two programme networks in the Malaysian peninsula and in the states of Sabah and Sarawak, the programmes to the latter being relayed via satellite. Transmissions started towards the end of 1963, from a 10kW e.r.p., ch. E10 transmitter at the capital, Kuala Lumpur. Further transmitters were opened in 1964, while the Kuala Lumpur transmitter was changed to 100kW on ch. E5. In 1966 a start was made on constructing a comprehensive microwave network to link the main towns. Television in Sabah started in December 1971, and following the construction of a satellite terminal (mid-1975) Sabah was directly linked to the main network.

A considerable proportion of the programme output is produced at a custom built TV centre at Angkasapuri, Kuala Lumpur, with the output going via underground coaxial lines to the main telecommunications switching centre at Bukit Nanas for routing to the various transmitters and the satellite terminal at Kuantan.

There are several language groups within the states, and programmes (particularly news) can be transmitted in the main national Bahasa Malaysian or in English, Mandarin Chinese, Tamil or Indian. Imported films are rarely dubbed, but carry sub-titles in Bahasa Malaysian.

The signals generally received in Australia come from G. Sempah (112kW e.r.p., ch. E2) and Johore Bahru (100kW e.r.p., ch. E3). There have been no reports so far of reception of the lower power ch. E2 outlets in the Central Highlands.

Network three is transmitted in Sabah and Sarawak, the comprehensive service there including a 10kW ch. E2 transmitter at Limbang, Sarawak and a 10kW ch. E2 transmitter at Pendalaman, Sabah.

The test pattern? You guessed it, the Philips PM5544.

Philips G11 Chassis

A. G. Priestley, B.Sc.

THE previous article described the engineering philosophy on which the overall design of the G11 chassis is based, and some of the features of the development programme. With this in mind we can consider the problems involved in choosing the electrical circuits and in dividing them amongst the printed board assemblies. First of all, what factors formed the basis of the electrical design philosophy?

The starting point was probably the decision to use the Mullard 110° 20AX colour display tube. This tube with the associated deflection yoke has an inherently self-converging action, only minor correction being needed to take manufacturing tolerances into account. This leads to major simplification in the circuitry and the preset adjustments required on the production line. A further advantage is that a very slim cabinet can be used, and this brings us to the next point. The levels of heat dissipation typical of older colour receiver designs would have caused rather high temperatures in the slim cabinets proposed by the stylists, a situation which would not have been compatible with the high degree of reliability that was required. It was considered important therefore to use more efficient circuits wherever a significant temperature reduction could be achieved.

The next factor was the decision to use well established circuits wherever practicable, and to avoid some of the new and exotic ones which present difficulties to the service engineer and show little benefit in terms of cost and performance. It is worth pointing out that design continuity contributes towards greater reliability, since the lessons of the past are the engineering capital of the future, and can be used to great advantage.

Each printed board had to be of a convenient size and as functionally complete and independent as possible. This simplifies all stages of assembly, alignment and testing, and provides built-in flexibility. It enables any assembly to be subsequently updated without destroying the principle of interchangeability of units for easy servicing. When new integrated circuits or design techniques come along they can be incorporated in the G11, if they confer substantial advantages, without undue disruption to service procedures and spares stocking policy.

There were other factors influencing the choice of circuits of course. All engineers, whether individually or as a team, have their preferences for particular circuit techniques, based on their own judgment and past experience. Also, Philips have very large international resources in terms of design and production of nearly all types of components – both active and passive. There are also applications and research laboratories that serve the whole company. Obviously, well established in-house techniques and components are often preferred to less well known ones from outside which have not been subjected to the same depth of investigation and testing.

Printed Board Assemblies

The problem here was first how to divide the circuits into functional units, and secondly how to divide the available printed board area into separate assemblies matched to circuit needs both in size and location within the cabinet. This

jigsaw puzzle involved a lot of thought. Suffice it to say that in the end a satisfactory arrangement was achieved – see Fig. 1.

This is jumping ahead somewhat because a complete circuit diagram obviously had to be drawn up before this process could be carried out. It enables us to describe the contents of each printed board however whilst considering how each circuit came to be chosen.

It will be seen from Fig. 1 that the circuit has been divided up into the following units: power supply; line scanning; r.f., i.f. and sound; decoder; timebase; mains input; c.r.t. base; convergence tolerance correction; customer controls. We'll describe each in turn, bearing in mind that it's not possible here to give full details and circuit diagrams. It is hoped to provide a more complete description of certain key features at a later date.

The Power Supply

A stabilised power supply was considered essential for the G11, and design studies showed that a thyristor controlled circuit had advantages over other types available. It also made good use of a large amount of previous design experience.

A full-wave 100Hz circuit was adopted in order to avoid drawing d.c. from the mains supply, but it differs in some interesting respects from typical circuits of this kind. As mentioned earlier it was considered important to reduce heat dissipation, so it was decided to use active filtering and to omit the resistor which limits the current surge at switch on. Both these factors required the use of a "slow-start" circuit to reduce the size of the charging current pulses into the reservoir capacitor immediately after switch on to amplitudes comparable to those during normal operation. This had the advantage of reducing the electrical stress on several important components to levels well below those typical of many thyristor controlled circuits.

In order to ensure reliable operation of the slow-start circuit under all conditions it was necessary to adopt a two thyristor bridge configuration. This is shown diagrammatically in Fig. 2. The slow-start and voltage control circuit are of conventional type, but an inhibit circuit has been added. This

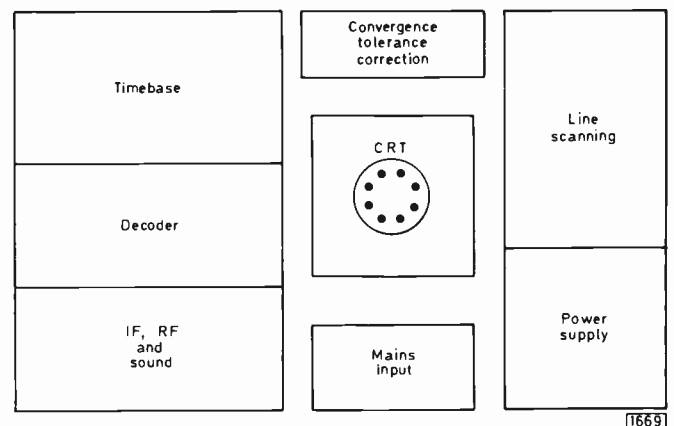

Fig. 1: Functions of the G11's printed circuit boards, viewed from the rear of the receiver.

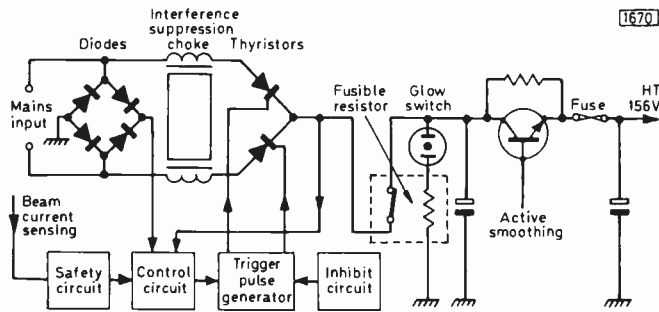

Fig. 2: An unconventional type of thyristor stabilised power supply is used.

positively prevents spurious triggering of the thyristors at wrong phases of the mains input waveform. Spurious triggering can be caused in a variety of ways, including very large voltage transient spikes on the mains supply – exceeding 1,000V peak. The result can be that the reservoir capacitor is charged to the peak of the mains waveform at up to 370V instead of about 160V. This inevitably leads to overstressing and the failure of several semiconductors. The inhibit circuit prevents this.

Early types of thyristor have been known to fail, going short-circuit with the result that the reservoir capacitor receives an excessive charge. This type of failure is almost unknown with the new types of thyristor used in the G11, but in compliance with the safety requirements of BS415 a crowbar circuit has been connected across the reservoir capacitor. It consists of a neon glow switch and a fusible resistor, and is an improvement on earlier versions of this technique because it is immune to short duration voltage overloads and so cannot operate spuriously.

Again in compliance with BS415, a further safety circuit has been incorporated to inhibit the power supply and reduce the h.t. to a low level if a fault condition causes excessive e.h.t. beam current.

Although the basic mode of operation of this twin thyristor power supply is quite straightforward and should not pose any undue difficulties to service engineers, it is in fact the result of a very large amount of detailed design work. All sorts of electrical hazards such as c.r.t. flashover, voltage spikes on the mains input, fault conditions of all kinds, and unexpected circuit interactions have been investigated in depth and rendered harmless. It is hoped to describe some of this work in detail at a later date, as it constitutes a fascinating electronic detective story.

Signal Circuits

The r.f./i.f./sound board accepts the aerial input and provides the following outputs: chrominance subcarrier and luminance to the decoder; video to the sync separator; a.f.c. to the tuning circuits; and audio drive to the loudspeaker.

A block diagram of the circuitry is shown in Fig. 3, and it will be seen that the tuner is the new Mullard U322. It combines a good noise factor – typically 7dB – with good signal handling capability. It should therefore give a good account of itself under noisy conditions in fringe areas whilst also having good immunity to cross-modulation when used close to a transmitter.

The tuner is followed by a block filter which provides most of the i.f. selectivity. Extensive use was made of computer aided design techniques and this helped to achieve a good group delay response. This means that all signal components, of whatever frequency, are delayed by approximately the same amount in their passage through the i.f. circuits. The amplitude response has been carefully matched to the vestigial

sideband transmitter characteristics and the combination of these two factors, which are not easy to achieve together, has resulted in a good overall i.f. response and hence a high standard of picture quality. It is expected that engineers will notice an improvement compared with the G8.

The block filter is followed by three stages of wideband gain with a.g.c. applied to the middle stage. It is controlled by a potentiometer which is preset to transfer the a.g.c. action to the tuner at signal levels above 3mV. This gives the best compromise between noise performance and signal handling capability.

The i.f. gain section is followed by a TCA270 synchronous detector i.c. which also provides the a.f.c. and a.g.c. voltages. This i.c. was chosen for its good performance as a detector and for its high-gain a.f.c. action which maintains accurate r.f. tuning. Two video outputs are available. One feeds the sync separator on the timebase board whilst the other has the appropriate filters and transistor buffer stages to provide the 6MHz intercarrier sound, chrominance subcarrier and luminance signals.

An important design point is that all tuned circuits in the receiver – except for the quadrature coil in the f.m. sound detector circuit – are contained in screened units and are independent of the external circuit. It should not be necessary therefore to realign any circuit in the field unless the units themselves are being serviced. Replacement units can be fitted at any time without further adjustment.

The 6MHz intercarrier sound and audio output circuits are similar to those used in the G8. An improved version of the TBA750, the TBA750A, provides f.m. detection and d.c. volume control action. A discrete output stage using two BD131 transistors is retained but has been upgraded to give approximately 3W output from a 25Ω loudspeaker. An i.c. output stage was investigated but found to give no overall advantage. The well established circuit was therefore preferred.

It will be noted that the luminance delay line is mounted on the i.f. board. This was done for two reasons. The delay time is a function of the i.f. bandpass characteristics (for a given chrominance bandwidth), so the strip can be updated at any time, and a new delay line used if necessary, without affecting the interchangeability of the boards – both old and new. The location of the line at the bottom edge of the board reduces the possibility of unwanted pickup from other circuits. A moulded cover has been fitted to prevent damage during handling.

A very stable 12V line is a great asset in signal circuits, particularly in the low-level decoder areas. It's generated on the i.f. board by an overload protected high-gain TDA1412 i.c. stabiliser. This is supplied with a 17V feed from the line output transformer, and this voltage has been carefully chosen to cater for normal production tolerances whilst minimising the heat dissipated in the stabilisation process.

The Decoder

Engineers familiar with the G8 will recognise quite a lot of the circuitry mounted on this board. The same TBA560C and TBA540 i.c.s are used because, once again, there were no alternatives which offered sufficient advantages to offset the benefits conferred by familiarity in terms of circuit techniques, reliability, and ease of servicing.

The TBA560C is a luminance and chrominance control combination and is housed in a screened unit. This prevents unwanted interference currents from the all pervading magnetic fields generated by the deflection yoke and line output transformer being induced in the sensitive input circuits. It also saves considerable space and enables the

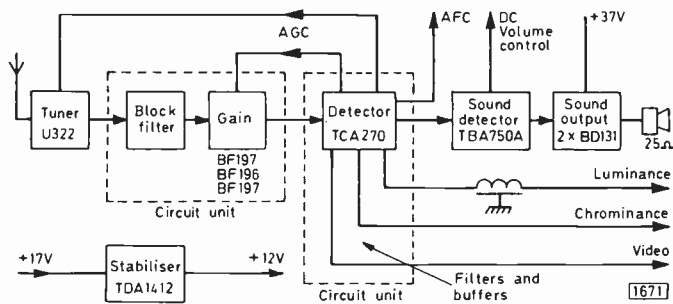

Fig. 3: Block diagram of the r.f., i.f. and sound circuits.

complete decoder to be accommodated on a board of convenient size. The i.c. and its peripheral circuits provide d.c. control of brightness and contrast, it clamps the luminance signal to the correct black level and incorporates flyback blanking.

The chrominance signal passes through a bandpass filter to exclude luminance signal components and is then gain controlled to reduce unwanted changes in subcarrier amplitude. This is followed by burst take-off and blanking, a d.c. saturation control, and sufficient gain to feed a discrete driver stage for the DL60 chrominance delay line.

The TBA540 receives the burst signal and with the aid of an a.p.c. loop and an external crystal generates the phase-locked reference carrier. It also provides colour-killer bias and ident outputs.

The output of the delay line has a very simple matrix circuit providing U and V inputs to the demodulators. At this point the circuit differs from that used in the G8 because synchronous demodulation and PAL switching are carried out in a TCA800 integrated circuit. This i.c. also matrixes the luminance signal with the three colour-difference signals to give low-level RGB outputs. These have a very accurately controlled black level, as a result of a high-gain clamp circuit in each of the three channels.

The TCA800 was chosen for the G11 because the peripheral component count is much smaller than in the equivalent circuits of the G8, giving a useful saving in complexity and space. It's followed by three simple RGB output stages using BF458 transistors operating at relatively low gain. The simplicity of these circuits is in fact deceptive. The requirements are that the three RGB stages should track very accurately with each other over a long period of time, and that their frequency responses should be matched to within ± 1 dB over the whole passband.

Accurate tracking of the d.c. levels is achieved by mounting all three transistors on a common heatsink to achieve good thermal bonding. Thus differences in transistor junction temperatures are greatly reduced, and this prevents significant changes in the base-emitter voltages which would cause variations of the collector voltages and hence poor tracking between the three stages. Variation in collector load resistances would have the same effect; this difficulty has been

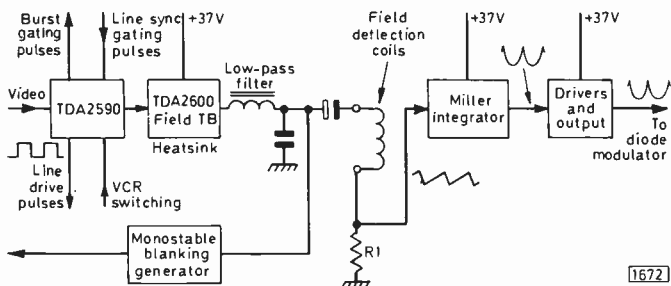

Fig. 4: The operations carried out on the timebase board.

overcome by using good quality power resistors which are conservatively rated and mounted upright on a common bracket to promote good cooling. Prolonged life tests on these output stages have shown that the stability and tracking performance are very good.

The physical construction of these circuits plays an important part in establishing the amount of stray capacitance present at the collector of each stage, and hence the frequency response. One of the last items in the design procedure was to match the frequency responses very carefully and to give them a high frequency roll-off to reduce the radiation of high order harmonics to other circuits.

Timebase Board

The circuit functions carried out on the timebase board are shown in Fig. 4. Two i.c.s which are probably unfamiliar to many engineers are used, the TDA2590 and the TDA2600. The TDA2590 is a sync separator and line oscillator combination which can be regarded as a third generation version of a well established type.

The input consists of video from the TCA270 vision detector, and the sync is separated in a noise-gated circuit from which the field sync is immediately available as positive-going 11V pulses. The line sync is a fairly complex process however, resulting in accurate triggering of the line output transistor.

The line oscillator is synchronised via the usual phase-locked loop, incorporating a coincidence detector and flywheel filter together with an additional coincidence detector. Thus as an additional operation, the phase of the oscillator is compared directly with that of the incoming sync pulse and any error corrected. The oscillator drives a trigger pulse generator, and an output stage in the i.c. provides adequate base current for the usual line driver circuit. The finishing touch is provided by a line flyback pulse whose phase is compared with that of the oscillator: again any error is corrected.

The result of all this is that any change in the instant of the line output transistor's switch off, caused for example by changes of loading such as a sudden variation of e.h.t. beam current, is corrected by reference back to the phase of the oscillator, this in turn being compared with the timing of the sync pulse. This process reduces line displacements caused by sudden changes of picture information. The phase of the picture relative to the raster can be adjusted by a preset potentiometer.

Additional features are the generation of an accurately timed burst gating pulse for the decoder, and a facility for d.c. switching the flywheel filter to provide a shorter time-constant for VCR operation.

The TDA2600 is a field oscillator and output i.c. synchronised directly by the output of the TDA2590. It was chosen for use in the G11 because it operates in class D, which greatly reduces the power dissipation. In fact it is only about 4.2W for full scanning, and this can be handled comfortably by the i.c. and its associated heatsink. A description of the circuit was given in *Teletopics* in the January 1977 issue, but a brief summary may be helpful.

The field oscillator's sawtooth output is converted into a train of pulses which have a repetition rate of about 150kHz. They are of constant amplitude but vary in width (see Fig. 5). This in effect is pulse width modulation, the width of each pulse being a measure of the amplitude of the sawtooth at that particular instant. The train of pulses is used to drive the field output stage, so it will be clear that at any instant the output transistors in the i.c. are either turned off or are hard on, i.e. bottomed. This class D operation results in very low collector

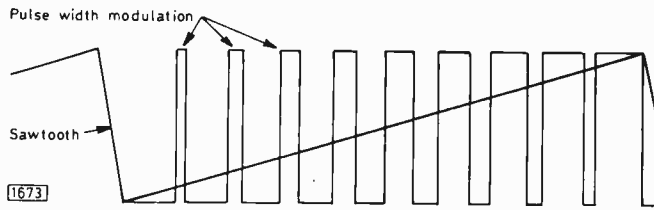

Fig. 5: A sawtooth waveform can be converted into pulse width modulation, and subsequently recovered by integration, using a low-pass filter. The advantage is that the output devices operate in class D, switched on and off by the pulses, the dissipation being greatly reduced.

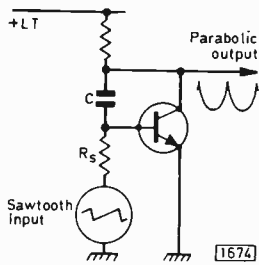

Fig. 6: The basic Miller integrator. The transistor greatly increases the effective capacitance of C which, with R_s , forms an integrating circuit, producing a parabolic output from the sawtooth input.

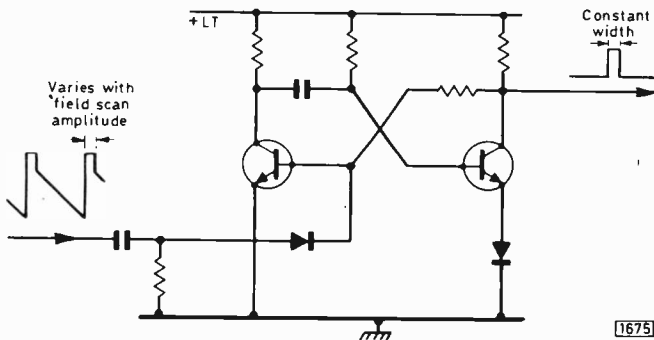

Fig. 7: The use of a monostable multivibrator in the field flyback blanking circuit gives precise timing of the duration of the blanking pulse.

dissipation — only the switching losses. A low-pass filter after the i.c. integrates the current pulses to give the normal sawtooth scanning current required.

A sawtooth voltage proportional to this current is developed across R_1 and is applied to a Miller integrator which, in its basic form, is shown in Fig. 6. The sawtooth drive to the base of the transistor produces a sawtooth collector current in the capacitor, and this provides positive feedback via R_s . The voltage across C is therefore the time integral of the current, and results in an almost pure parabolic output voltage at the collector. This waveform is amplified by driver and output stages and is used to load the diode modulator on the line scanning board in order to provide full EW correction of the raster shape and also control of picture width.

In these days of Teletext transmissions it is necessary to have very accurate control of field flyback blanking in order to ensure that the bright-up caused by the two lines of data transmission near the top of the picture is suppressed. The monostable circuit shown in Fig. 7 is used to generate an accurately timed blanking pulse and is triggered by the field flyback waveform.

Line Scanning

In the early stages of the development programme some unconventional circuits combining the power supply and stabilised line scanning were considered. After lengthy investigations it was decided that these new circuits offered no overall advantages in performance, cost or simplification. Indeed, it was anticipated that the complex techniques used in

such circuits would pose difficult problems to busy service engineers, who do not always have modern test equipment available, so the temptation to innovate was resisted. It was also reasoned that a large board carrying the whole power supply and line output stage would be too cumbersome and complicated, and in addition there was no sensible way of dividing it into two separate assemblies. A circuit based on conventional techniques, using the new and much improved BU208A transistor, was adopted instead.

The line scanning board carries the whole of the line output stage and the associated circuits therefore, and is functionally complete and independent. The inputs consist of 156V h.t. and a low-level, synchronised drive pulse supplied to the base of an orthodox driver stage. This in turn drives the BU208A which operates as a switch in series with the line output transformer, connected across the stabilised h.t. line.

The basic mode of operation of the transformer will be familiar to engineers but it has two important and interesting features. First, it incorporates a diode-split overwind to generate the e.h.t. This was described in the February 1977 issue of *Television*. To summarise briefly, the overwind is a four layer winding, each layer being the full available width of the core window (allowing for insulation clearance). Each layer has its own diode rectifier, and the flyback pulse ripple is smoothed by the interlayer self-capacitance. The technology required to mass produce this overwind is impressive, even formidable, but extensive testing and field experience shows it to be more reliable than a tripler.

The other feature of the transformer is the use of a high-level diode modulator — see Fig. 8. The principle of operation is similar to that of the better known low-level type currently used by a number of setmakers in 110° delta-gun c.r.t. chassis, but it's simpler in configuration and does not need a large l.t. load (or indeed any load at all) in order to keep the lower diode conducting. The sharing of the scan and flyback currents between the two diodes is a little complex, and a description is outside the scope of the present article. It's hoped to return to this at a later date.

The diode modulator is driven by the parabolic waveform generated in the field timebase as described earlier. Thus the EW raster shape and amplitude are easily controllable by means of preset potentiometers.

Another interesting departure from previous practice is the absence of harmonic tuning. This is not practicable with an

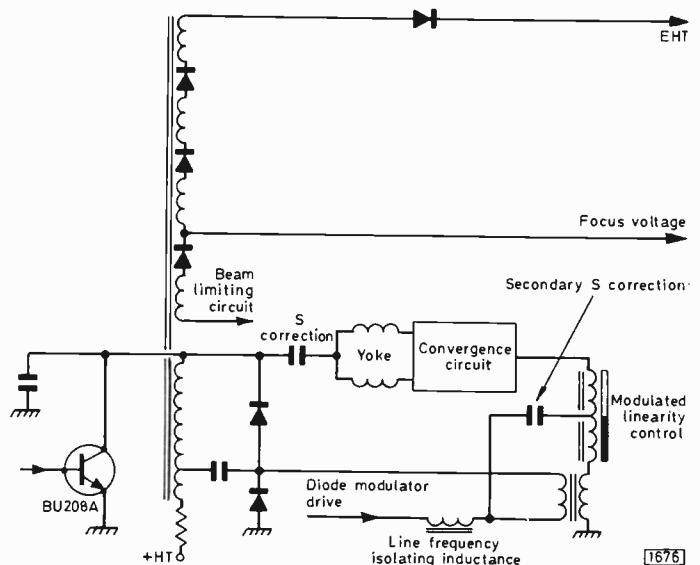

Fig. 8: Simplified circuit of the line output stage, showing the diode-split line output transformer and the new high-level EW diode modulator.

overwind having high self-capacitance, and is in any case rendered unnecessary by incorporating very tight coupling between the primary and the overwind. This is achieved by interconnecting a coupling winding placed under the overwind with one forming part of the primary.

L.T. supplies of 37V and 17V and a supplementary h.t. voltage for the RGB output stages are generated by normal scan rectification, in which the diodes conduct throughout the forward scan to give good voltage regulation. Boost h.t. for the c.r.t. first anodes is obtained by rectifying the flyback pulse at the collector of the BU208A.

The last important point is the focus voltage. This is conveniently obtained from the first layer of the diode-split overwind, at about 6.5kV, without further processing. The c.r.t. needs a d.c. focus voltage of about 4.5kV, and this is produced by a thick-film potential divider specially designed to meet the needs of the G11. This unit ensures a very stable focus voltage, and the spindle projects through the board for easy access.

The CRT Board

This board is mounted on a new c.r.t. socket specially designed for the G11 to suit the dimensional characteristics of the 20AX display tube. It has built-in sparkgaps for each pin except that connected to the focus electrode. Formed metal sparkgaps are entirely satisfactory at up to 2kV, but are prone to corona discharge at higher voltages. At best this results in a change of focus quality due to the voltage drop caused by the corona current flowing through the high source impedance. At the worst the corona causes sufficient ionisation for an arc to develop, with consequent risk of overheating and a possible fire hazard in addition to circuit damage. The focus sparkgap is therefore of printed/pierced construction on the printed board.

The other feature of interest here is that the three first anode potentiometers required for grey-scale tracking are mounted on this board for easy access and to save interconnecting leads. The potentiometers and their associated gun switches form a single unit in a plastics housing, complete with operating thumb wheels and levers. This unit has also been specially designed for the G11, to a very tight specification, to ensure that the voltages appearing at the sliders of the potentiometers not only have a very high degree of stability but also track together. Approximately 500V is applied across the potentiometers, and the outputs at the sliders track to within $\pm 1V$ over several thousand hours of life testing. This helps to ensure good grey-scale tracking in the dark areas of the picture.

The term "specially designed" seems to have cropped up several times in these two articles. The fact of the matter is that whenever a component of suitable quality or function was not available on the open market, the production scale of the G11 justified commissioning a new product. This was always procured based on a specification very carefully tailored to the needs of the circuit and the mechanical requirements.

Convergence Tolerance Correction

One glance at this board illustrates much more clearly than words do just how much complexity has been saved by the use of the 20AX system compared with its 110° delta gunned equivalents. The circuits are so easy to adjust that there is not much to be said.

Bearing in mind that the fundamental misconvergence of the 20AX system is only a small fraction of that inherent in a delta gun tube, and that the tolerance correction circuits are

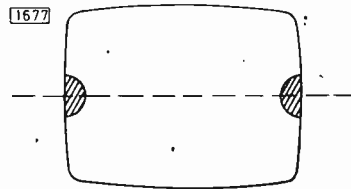

Fig. 9: When adjusting the purity, aim for symmetrical impurity in the areas shown; at the sides, before making the final adjustment of the yoke position. Ignore impurity in other parts of the picture.

operated solely by stabilised scanning currents, it's unlikely that under normal circumstances the controls will need resetting in the field. They should be regarded as factory preset adjustments.

Purity, Convergence and Focus

Experience at the time of writing shows that the 20AX system is capable of very good purity and convergence and that these are easy to adjust. There are one or two hints and tips, however, which are not immediately obvious and which may be of help to engineers.

Take purity. The first step is to set up the picture properly and then get the convergence approximately correct. It does not have to be exact. Now switch off and leave the receiver to cool for a quarter of an hour. Step two consists of displaying a white raster, either from a pattern generator or by disconnecting the aerial and the luminance signal flying lead link on the decoder board. Turn off the blue and green guns by operating the gun switches on the c.r.t. board. Set the red raster to a *medium/low* brightness level to avoid heating the shadowmask.

Step three – turn the yoke position lever to slide the yoke as far forward as possible. Then operate the two-pole purity magnets in conjunction with sliding the yoke backwards – if necessary – to get the situation shown in Fig. 9. A further small backward movement of the yoke, and possibly a touch on the purity magnet, will give perfect purity and the most central position of the raster. *Keep the yoke as far forward as possible*, because this ensures that the maximum margin is available to compensate for expansion of the shadowmask when it gets heated by high beam currents.

If you cannot get good purity with the yoke in its forward position, start again, but this time with the yoke as far back as possible. When you have achieved good purity, go on sliding the yoke forward until the purity just begins to deteriorate, then ease it back a fraction to get correct purity again. Always finish with the yoke as far forward as you can.

The next point concerns static convergence. This is adjusted by two multipole ring magnets on the tube neck – one for red/blue and the other for green on red/blue. Always adjust the static convergence as accurately as possible. The reason for this reminder is that any static error at the centre of the screen results in a corresponding error *twice as large* at the edges of the picture area. For best results the static convergence should be adjusted only after the receiver has been switched on for one-two hours at a fairly high beam current. This enables electrostatic charges in the area of the tube neck and gun assembly to become stabilised, and this condition will be rapidly re-established on each subsequent switch on.

Finally, focusing. This should always be adjusted at fairly high beam currents, and the object is to obtain optimum focusing of vertical lines about half way between the centre of the screen and the two outer edges of the picture, on the horizontal centre line. This gives best overall spot quality. ■

Your PROBLEMS solved

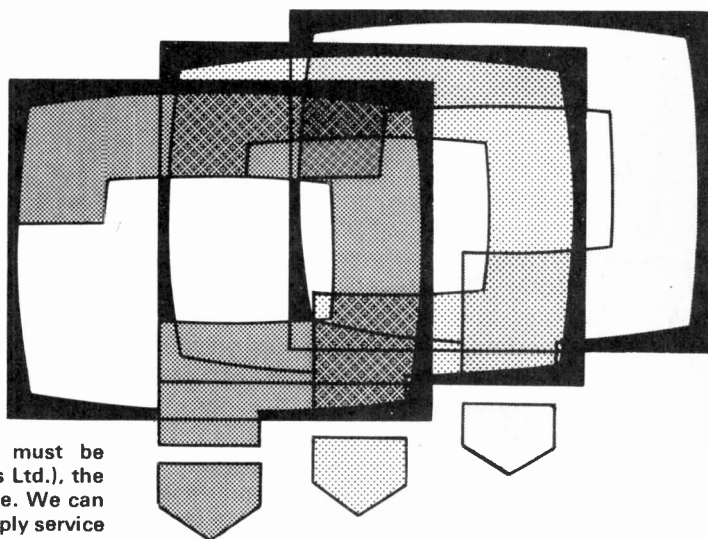

Requests for advice in dealing with servicing problems must be accompanied by a 50p postal order (made out to IPC Magazines Ltd.), the query coupon from page 610 and a stamped addressed envelope. We can deal with only one query at a time. We regret that we cannot supply service sheets nor answer queries over the telephone.

THORN 3500 CHASSIS

The picture is good when the set is switched on. After a few seconds however the blue flashes and is gone. Sometimes it will return in half an hour, sometimes in a couple of hours, and it always starts flashing when it's about to return.

The fault is in either the c.r.t., or the feed to its blue first anode or cathode – the other gun electrodes are all connected in common. Interchange the green and blue wires from the video board to the c.r.t. cathodes, and watch in black and white. If the fault is the same, suspect the c.r.t. or the blue first anode feed circuit – check the switch, the potentiometer and the decoupler, also the spark gap. If the green picture now flashes, check the blue video drive control R273, the blue output transistor VT215, and C231 and W208 in the blue clamp circuit.

DECCA GYPSY

I obtained one of the 15in. versions of this model. It was not working and L22 in the feed to the line output stage seemed to have been overheating while oversize fuses were fitted. After tests I replaced the AU113 line output transistor and the AD143 series regulator transistor and fitted the correct fuses, then switched on. The set started to function, including the c.r.t., but after about ten seconds the l.t. fuse blew. On replacing this there was hum from the loudspeaker but the input voltage was only 6V and L22 got hot. The c.r.t. did not light. L22 was disconnected and the input voltage rose to 23V, with the c.r.t. heater lighting but R68 in the supply to the audio output stage getting hot. R69 which shunts the regulator transistor does not get hot and is in order.

Leave L22 open-circuit while you make the following tests. Check the regulator transistor and its driver Tr12 for leakage, and adjust VR10 for 11.3V at the tube heater. Check the line output transistor again, and the AY102 boost diode D14. You will also have to check the other diodes in the line output stage – the AY105K efficiency diode D13, the focus/first anode supply rectifier D16 (1N4004), and the 120V rectifier D15 (ITT2002) and its 10 μ F reservoir capacitor C101.

TELPRO TRISTAR 671

Right from new this set has had an overlay of fine herringbone patterning which changes character as the fine tuning

is adjusted. It's always present, though it seems worse just after switching on. The tuner has been changed and the aerial checked on other sets. The patterning is much more noticeable on saturated red areas. The effect is worse when the colour control is turned up, though it's still slightly noticeable on monochrome. Recently a "scratchy" kind of interference has developed on ITV sound. It can be cured by fine tuning, but the position for least patterning produces the scratching noise which, incidentally, is not present when the screen is blank.

You are suffering from subcarrier dot patterning, 1.5MHz sound/chroma beat, and a misaligned cosound (33.5MHz) trap! If wobulator alignment of the i.f. strip and the rejectors cannot be carried out, a replacement i.f. panel is the only cure. These sets are similar to the Decca 30 series and were sold through Trident outlets.

GEC HYBRID COLOUR CHASSIS

The picture on this set has a pink cast. This improves after some hours, but all light areas remain tinted. The PCL84 colour-difference output valves have been replaced and their 12k Ω load resistors are within tolerance. Attempts to remove the cast by reducing the setting of the red first anode preset control only makes green or blue more prominent. Reducing the c.r.t. drive setting doesn't help either.

Check R612 (22M Ω) which is connected from the red first anode to chassis, then if necessary check the coupling components in the R-Y clamp circuit – C415 (0.002 μ F) and R417 (8.2M Ω).

GRUNDIG 6011

There is excessive field jittering on this set, with bent verticals and horizontals. The field timebase board has been checked, but everything there seems to be o.k.

If both the horizontal and vertical scans are affected, with critical field hold, the sync separator (in the TBA920 i.c.) is not working properly. Check Di403 (OA91) and R408 (3.3M Ω) in the video input circuit to the i.c. If the fault persists, carefully check the settings of the a.g.c., beam limiter and preset contrast and brightness controls as described in the manual. These adjustments are critical. If this does not cure the problem, check the voltages around the i.c. and if necessary replace it. If the field jitter is still present, replace the field sync pulse amplifier transistor Tr445 (BC238) and the unijunction field oscillator transistor Tr451 (BSV57B or E5429).

PHILIPS 210 CHASSIS

There is occasional line pulling on this set. It occurs – sometimes – when two immediately adjacent contrasting picture elements are present – not always white and black. It can start in the centre of the screen as well as at the end of a line, and is confined to the top four-five inches of the screen. It's not frequent, and whole programmes can pass without it occurring, even though the contrast conditions which can trigger it are present. The aerial is OK and the PFL200 video/sync separator valve and the two ECC82 valves in the line generator circuit have been changed. The voltages in these areas are all correct and the electrolytics have been changed. The sync separator screen grid feed resistor has been changed to 330k Ω as recommended by Philips, making the fault less frequent. In all other respects the set's performance is good.

It should be routine with line sync faults in this chassis to check the value of R2144 (27k Ω) to pin 6 (anode) of the first ECC82 (V2003). Check the video coupling capacitor C2046 to the PFL200, and the associated d.c. restorer diode X2194. We suspect the operating conditions of the video amplifier, but the a.g.c. circuit should not be above suspicion – in particular check C2075 (2.5 μ F) and ensure that there is a 4 μ F capacitor across R3483 in the a.g.c. inverter stage (assuming that a germanium transistor tuner is used).

DECCA 30 SERIES

We've had many of these sets exhibiting the following fault: wavy vertical lines at the top third of the picture. Some new sets have had this problem when unpacked.

We are surprised to hear that the problem occurs with new sets since we've not heard of this difficulty before. It could be that the trouble is a transmission or propagation problem in your area, to which these sets are over sensitive. You could try experimenting with the flywheel sync time-constant capacitors. First increase the value of the main filter capacitor C422, then try experimenting with the values of the anti-hunt network components R435/C421.

TELETON VX1110

The problem with this small-screen portable colour set is lack of brightness. Even with the contrast and brightness controls flat out the brightness level is too low. The valves in the line output stage have been changed without this making any improvement.

The third video amplifier valve V1 is low emission and will have to be replaced in order to restore correct c.r.t. cathode voltages. The valve is type 10GK6 and if necessary can be obtained from the maker's service department.

RANK A774 CHASSIS

The problem was sound perfect but no raster. On drawing a spark from the top cap of the line output valve a raster appeared plus perfect picture, the same thing then happening every time I switched the set off and later on again. After cleaning around the line output transformer I now get a raster every time on switching on but the picture has gone. The c.r.t. base voltages seem to be correct.

Drawing a spark from the top cap of the PL504 could well have sealed a poor connection in the vicinity of the line output transformer – or the PL504 valve base, as the pins do not always make good contact with the print. In doing so however you've probably administered a deadly blow to the video output transistor 2VT6 (BF178 or equivalent).

RANK A823B

The picture at switch on is exceedingly dull, and can barely be seen in a dark room. After a time – anything from a quarter of an hour to a couple of hours – the overall brightness increases and the set can be watched comfortably in a normally lit room. Just before the brightness increases, it appears to pulse for a short time. Even when the brightness has increased, the range of adjustment is not as great as one would expect. Adjusting the contrast control at switch on does not affect the dim display. The red, green and blue rasters described in the grey-scale tracking procedure given in the manual cannot be achieved under any circumstances. The focus is good at all brightness levels, and the e.h.t. stable at 25kV. The brightness pulse inverter transistor 3VT10 has been replaced and the voltages around the two i.c.s on the decoder/RGB drive panel have been checked. The only incorrect voltage found was at pin 5 of the SL917A. This was high at 1.3–1.5V instead of 0.26–0.34V.

The trouble does seem to lie in the brightness pulse inverter/brightness control section since a fault here will affect the voltage on pin 5 of the SL917A i.c. – the pulse appearing at the collector of 3VT10 is fed to pin 5 of the SL917A to trigger the ident stage in the i.c. Make sure that the voltages around 3VT10 are correct. Then check the brightness pulse feed. The pulse is derived from the line output stage and is fed to the clamps in the RGB channels as well as to 3VT10. It's clipped by 8D4 and 8D5, and coupled via 8R16 and 8C11 which caused trouble in early sets in this series. It's possible that the tube has lost emission however. An efficient and simple booster for colour or monochrome tubes was described in the May 1974 issue and has been found to work very well – though the 3.6k Ω , 1W resistor should be very much higher in value, say 330k Ω .

THORN 8000 CHASSIS

The trouble is three vertical dotted lines on the left-hand side of the screen. Adjusting the set–e.h.t. control increases or decreases the number of lines, which can be removed completely by decreasing the e.h.t. – at the cost of lack of width. I've tried tightening the line output transformer assembly.

Remove the two screws securing the focus unit to the chassis: if this removes the dots, replace the focus unit. If it doesn't, replace the e.h.t. rectifier (on front centre). If this doesn't remove the discharge, don't blame us, you'll need the rectifier later anyway! It will then be necessary to look at the line output transformer, as there may be some discharge taking place between the windings.

PYE HYBRID COLOUR CHASSIS

The fault consists of purple streaks extending to the right of light areas, captions, etc. The effect is reduced by lowering the contrast control setting, and is present on both colour and monochrome.

This is a common failing on these sets, and can be due to several causes. It's normally due to bad earthing on the CDA panel (on the left-hand side, carrying the PL802 and three PCL84 valves). Ensure that the earthing clips are making properly, then check the PL802's control grid leak resistor (R352 4.7M Ω , from pin 2 to chassis). Also check the 16 μ F capacitor C127 which decouples the sliders of the contrast and colour controls. Earth the screen of the white plug which connects the luminance signal to the CDA panel.

GEC 2114 JUNIOR FINELINE

The trouble with this portable is that the field timebase cannot be locked, and there is severe pulling at the right- and left-hand edges of the raster.

The trouble could well be due to a defective bridge rectifier, D402, assuming it is present on mains operation only. If not, check D201 (OA91) and C201 in the feed to the sync separator transistor, and the interlace diode D202 (BA128). If C201 is $1\mu\text{F}$, change it to $0.1\mu\text{F}$.



Each month we provide an interesting case of television servicing to exercise your ingenuity. These are not trick questions but are based on actual practical faults.

After many years of trouble-free operation an HMV Model 2701 was admitted to the workshop with the complaint of inaccurate colour. This model uses the Thorn 2000 dual-standard chassis, and for a number of years had been working in the 625-line mode. Workshop symptom appraisal revealed significant magenta coloration, and because this gradually cleared as the receiver warmed up the initial thought was that the picture tube was "leaky". The customer was not in a position to be able to invest in a new receiver, and our brief contained an upper expenditure limit. Owing to the receiver's age it was regarded as imprudent to recommend tube replacement.

As the tube appeared to have quite reasonable emission while our workshop was operating below capacity it was decided to let the junior technician investigate the symptom on the hopeful assumption that the tube electrodes were not to blame.

The model uses primary-colour drive to the tube cathodes, and the technician rightly concluded that a magenta tinge implies reduced, or lack of, green output. Each gun can be separately cut off by the usual R, G and B first anode switches, and to prove his theory the technician cut off the supply to the green first anode and noted barely any change in the symptom. He then restored the green gun

operation and cut off the R and B guns. This resulted in a very low intensity green raster, which became slightly brighter as the receiver was left operating.

The impression was that the emission of the green gun had virtually ceased, improving slightly with rise in temperature. Grid-cathode biasing of the guns is achieved by the three grids being connected together and maintained at approximately 30V by a supply from the brightness stabiliser circuit, the three cathodes being separately fed with the negative-going video drive signals from the appropriate output transistor.

Measurements of the biasing of the individual guns were taken, but no apparent error was here found. The set video gain and set video presets appeared to be working normally and correct primary-colour signals were being delivered by the video output stages.

The technician then moved on to another aspect of picture tube control, and here discovered the cause of the aberration. What was the most likely cause of the trouble, and why did the junior technician go the long way round to discover the fault? See next month's Television for the solution and for a further item in the Test Case series.

SOLUTION TO TEST CASE 176 (page 554 last month)

The KB Model CK500 described last month was giving the symptoms of mains supply arcing. After clearing this area of the set, the workshop technician found 50Hz pulses on the R, G and B signals. With the aerial removed, these pulses were still present at quite high, small-time amplitude, and were found to alter in rate with adjustment of the field hold control (R338f). This clearly indicated that they were being generated in the field timebase (and is the reason why the bands locked at field rate).

One or two tests in and around the field timebase (which uses a PCL805) soon exposed the trouble, which was very slight, intermittent arcing from the anode (pin 6) of the pentode section of the valve to an adjacent capacitor during the field flyback. The circuit here was tidied up, the capacitor concerned (C251f) replaced, and one or two points resoldered. Since then the receiver has been back in service for at least three months, and is apparently still performing satisfactorily.

Editorial note: Similar trouble, though not necessarily intermittent, can be caused by the field output transformer. The only cure is replacement.

QUERY COUPON

Available until 19 September 1977. One coupon, plus a 50p (inc. VAT) postal order, must accompany EACH PROBLEM sent in accordance with the notice on page 608.

TELEVISION SEPT 1977

Published on approximately the 22nd of each month by IPC Magazines Limited, Fleetway House, Farringdon Street, London EC4A 4AD. Filmsetting by Pacesetters, London SE1. Printed in England by Carlisle Web Offset, Newtown Trading Estate, Carlisle. Distributed by IPC Business Press (Sales and Distribution) Ltd., 40 Bowling Green Lane, London EC1R 0NE. Sole Agents for Australia and New Zealand - Gordon and Gotch (A/sia) Ltd.; South Africa - Central News Agency Ltd. "Television" is sold subject to the following conditions, namely that it shall not, without the written consent of the Publishers first having been given, be lent, resold, hired out or otherwise disposed of by way of Trade at more than the recommended selling price shown on the cover, excluding Eire where the selling price is subject to VAT, and that it shall not be lent, resold, hired out or otherwise disposed of in a mutilated condition or in any unauthorised cover by way of Trade or affixed to or as part of any publication or advertising, literary or pictorial matter whatsoever.

TTLs by TEXAS		60p		C-MOS ICs		OP AMPS		TBA651		BFX86/7/8		2N3053		VOLTAGE REGULATORS					
														(Plastic) Fixed					
7400	16p	74105	60p	4000	21p	1458	75p	TBA800	100p	BFX50	18p	2N3054	54p	1 Amp +ve					
7400	32p	74107	36p	4001	21p	301A	40p	TBA800	125p	BFX51	16p	2N3055	54p				1 Amp -ve		
7400	32p	74109	70p	4002	21p	3130	100p	TBA820	100p	BFY52	18p	2N3442	151p	5V	7805	130p			
7400	32p	74110	55p	4006	110p	3140	105p	TDA2020	400p	BRY39	45p	2N3702/3	14p	12V	7812	130p	12V	7912	200p
7400	48p	74111	80p	4007	22p	3900	70p	ZN414	140p	BSX19/20	20p	2N3704/5	14p	15V	7815	130p	15V	7915	200p
7401	18p	74118	90p	4009	67p	LM324N	130p	AC125	20p	BT106	140p	2N3706/7	14p	18V	7818	150p	18V	7918	200p
7402	18p	74120	95p	4011	21p	LM339N	225p	AC126/7	20p	MJ105	175p	2N3708/9	14p	24V	7824	150p	24V	7924	200p
7403	18p	74121	32p	4012	21p	709	30p	AC128	20p	BU104	315p	2N3733	320p	TELETEXT DECODER (as being featured in current issue) SPECIAL OFFER TO CONSTRUCTORS AT REDUCED PRICES:-					
7404	24p	74122	53p	4013	55p	741	25p	AC141/2	20p	MJ2955	35p	1) Power Supply Unit kit	£19.00 inc.						
7404H	40p	74123	73p	4014	110p	747	70p	AC176	20p	MJ3040	45p	2) Input Logic Card kit	£14.25 inc.						
7405	25p	74125	70p	4015	120p	748	40p	AC187/8	20p	MJE2450	130p	3) Memory Board kit	£20.20 inc.						
7406	45p	74126	76p	4016	54p	Linear ICs		AC187K	25p	MJE3055	97p	Above kits contain all the components as listed in each article except P.C.Bs.							
7407	45p	74128	90p	4017	110p	AY-1-0212		AD188K	25p	MPF102/3	40p								
7408	25p	74132	76p	4018	120p	CA302BA	112p	AD149	58p	MPSA06	37p	DISPLAY CARD KIT All Resistors, Presets and Capacitors							
7409	27p	74136	81p	4019	54p	CA3048	85p	AD114/5	22p	MPSA12	61p				3 - OA90	1 - 7402	1 - 7490		
7410	18p	74141	85p	4020	95p	CA3053	75p	AF116/7	22p	MPSA56	37p	1 - 74165	1 - 7400	1 - 74121					
7410H	30p	74142	300p	4022	100p	CA3080	97p	AF124	36p	MPSU06	37p	1 - SN74S262N	1 - 7408	1 - 74123					
7411	28p	74145	90p	4023	21p	CA3089E	250p	AF129	43p	MPSU56	98p	Mains	£6	1 - 74153	1 - 7404	2 - 74177			
7412	28p	74147	275p	4024	75p	CA3090AQ	500p	AF239	48p	OC28	79p	Transformer	130p	3 - 7474	1 - 7492	20 - Soldercon			
7413	36p	74148	173p	4025	21p	LM318N	175p	BC107/B	10p	OC35/36	79p	7812	130p	2 - 7412	1 - 7473	Pins			
7414	96p	74150	135p	4027	81p	LM380	115p	BC108/B	10p	OC71	25p	2102 RAM	220p	Complete Kit as above £25.00 inc. ALL ICs BY TEXAS INSTRUMENTS All First Grade Branded Products Only					
7416	35p	74151	77p	4028	152p	LM381	190p	BC109/C	11p	R2008B	225p	16 pin Skt	14p						
7417	40p	74153	92p	4029	120p	LM381	190p	BC115/7	11p	R2008B	225p	OA90	9p						
7420	18p	74154	164p	4029	120p	LM381	190p	BC115/7	11p	R2008B	225p	X887	£18						
7421	43p	74155	97p	4030	59p	LM381	190p	BC115/7	11p	R2008B	225p	Soldercon	100/75p						
7422	27p	74156	97p	4040	130p	LM381	190p	BC115/7	11p	R2008B	225p	VAT INCLUSIVE PRICES							
7423	36p	74156	97p	4040	130p	LM381	190p	BC115/7	11p	R2008B	225p				MAIL ORDER ONLY				
7423	36p	74156	97p	4040	130p	LM381	190p	BC115/7	11p	R2008B	225p	Add 25p P. & P.							
7425	33p	74158	160p	4042	90p	LM381	190p	BC115/7	11p	R2008B	225p				Govt., Colleges orders accepted				
7427	40p	74159	220p	4046	150p	LM381	190p	BC115/7	11p	R2008B	225p	TECHNOMATIC LIMITED							
7430	18p	74160	120p	4047	110p	LM381	190p	BC115/7	11p	R2008B	225p				Tel. 01-204 4333				
7432	34p	74161	120p	4049	68p	LM381	190p	BC115/7	11p	R2008B	225p	54 Sandhurst Road, London NW9.							
7437	37p	74162	120p	4050	54p	LM381	190p	BC115/7	11p	R2008B	225p				Telex: 922800				
7438	37p	74163	120p	4055	140p	LM381	190p	BC115/7	11p	R2008B	225p								
7440	18p	74164	130p	4055	120p	LM381	190p	BC115/7	11p	R2008B	225p								
7441	85p	74165	150p	4056	145p	LM381	190p	BC115/7	11p	R2008B	225p								
7442	75p	74166	136p	4060	120p	LM381	190p	BC115/7	11p	R2008B	225p								
7443	130p	74167	340p	4069	40p	LM381	190p	BC115/7	11p	R2008B	225p								
7444	130p	74170	250p	4071	29p	LM381	190p	BC115/7	11p	R2008B	225p								
7445	108p	74173	160p	4072	29p	LM381	190p	BC115/7	11p	R2008B	225p								
7446	108p	74174	130p	4081	25p	LM381	190p	BC115/7	11p	R2008B	225p								
7447	90p	74175	92p	4082	29p	LM381	190p	BC115/7	11p	R2008B	225p								
7448	90p	74176	130p	4093	95p	LM381	190p	BC115/7	11p	R2008B	225p								
7450	18p	74177	130p	4510	142p	LM381	190p	BC115/7	11p	R2008B	225p								
7451	18p	74180	118p	4511	160p	LM381	190p	BC115/7	11p	R2008B	225p								
7453	18p	74181	324p	4516	140p	LM381	190p	BC115/7	11p	R2008B	225p								
7454	18p	74182	88p	4518	140p	LM381	190p	BC115/7	11p	R2008B	225p								
7460	20p	74185	144p	4528	130p	LM381	190p	BC115/7	11p	R2008B	225p								
7470	32p	74186	995p	4553	575p	LM381	190p	BC115/7	11p	R2008B	225p								
7472	32p	74190	155p	MEMORY		LM381	190p	BC115/7	11p	R2008B	225p								
7473	36p	74191	160p	RAM		LM381	190p	BC115/7	11p	R2008B	225p								
7474	37p	74192	130p	2102-2	270p	LM381	190p	BC115/7	11p	R2008B	225p								
7475	48p	74193	130p	2112-2	470p	LM381	190p	BC115/7	11p	R2008B	225p								
7476	37p	74194	130p	ROM		LM381	190p	BC115/7	11p	R2008B	225p								
7480	54p	74195	104p	RO3-2513	850p	LM381	190p	BC115/7	11p	R2008B	225p								
7481	108p	74196	130p	74S262N	1650p	LM381	190p	BC115/7	11p	R2008B	225p								
7482	85p	74197	130p	Branded devices		LM381	190p	BC115/7	11p	R2008B	225p								
7483	95p	74198	214p	from RCA		LM381	190p	BC115/7	11p	R2008B	225p								
7484	103p	74199	214p	Texas, Motorola,		LM381	190p	BC115/7	11p	R2008B	225p								
7485	130p	74221	175p	Mullard, etc.		LM381	190p	BC115/7	11p	R2008B	225p								
7486	36p	74251	151p			LM381	190p	BC115/7	11p	R2008B	225p								
7489	340p	74265	97p			LM381	190p	BC115/7	11p	R2008B	225p								
7490	43p	74278	314p			LM381	190p	BC115/7	11p	R2008B	225p								
7491	90p	74279	151p			LM381	190p	BC115/7	11p	R2008B	225p								
7492	55p	74283	205p			LM381	190p	BC115/7	11p	R2008B	225p								
7493	43p	74290	162p			LM381	190p	BC115/7	11p	R2008B	225p								
7494	96p	74293	162p			LM381	190p	BC115/7	11p	R2008B	225p								
7495	75p	74298	216p			LM381	190p	BC115/7	11p	R2008B	225p								
7496	90p	74305	162p			LM381	190p	BC115/7	11p	R2008B	225p								
7497	340p	74366	162p			LM381	190p	BC115/7	11p	R2008B	225p								
74100	116p	74390	216p			LM381	190p	BC115/7	11p	R2008B	225p								
74104	60p	74393	243p			LM381	190p	BC115/7	11p	R2008B	225p								

TELEVISION ELECTRONIC DISTRIBUTION (SPARES) LTD.

412a Hanworth Road, Hounslow, Middlesex
Telephone: 01-572 4668

PANEL REPAIR/EXCHANGE SERVICE

THORN 2000 Series, 3000/3500 Series, 8000/8500 Series.

GEC Solid State 2110 Series.

PHILIPS G8

RBM A802/823

VERY COMPETITIVE PRICES. 3 MONTHS' WARRANTY FROM DATE OF OUR INVOICE. SINGLE AND BULK PRICES ON APPLICATION. 48 HOUR SERVICE WHEREVER POSSIBLE. ALSO VERY COMPREHENSIVE RANGE OF MULLARD TV COMPONENTS, INTEGRATED CIRCUITS, TRANSISTORS, DIODES, THYRISTORS, TRIPLERS. CATALOGUE AVAILABLE ON REQUEST.

TV Crosshatch & Pattern Generator

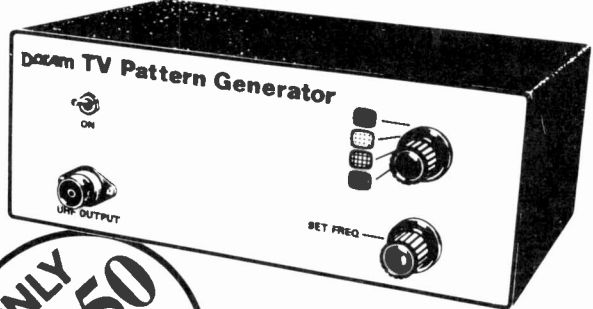

ONLY £34.50 + 8% VAT
ORDER CODE 60-660-2

Built Tested and Guaranteed

or in D.J.Y. kit form £23.95 + 8% VAT
ORDER CODE 60-661-9

Only requires connection to UHF aerial socket and to the mains. The generator has its own pulse generator and UHF modulator producing fully interlaced scan, 625 lines. Frequency is adjusted using visual display on TV screen to lock line and frame sync. Select Blank raster, dots, greyscale or crosshatch to set static and dynamic convergence, geometry, focus, beam limiting, black level clamp etc. etc.

Allow 28 days delivery
Doram Overseas orders—add 15% for p & p. All items offered for sale subject to the terms of business as set out in Doram Edition 4 catalogue. Why not send for this FREE catalogue (enclosing 20p & p) containing over 3000 components and 35 kits? The comprehensive Doram range offers everything for the home constructor from simple resistors to complete L.S.I., despatched via our speedy mail service.

An Electrocomponents Group Company

Get a great deal from Marshall's

A. MARSHALL (LONDON) LTD. Dept: TV
LONDON - 40-42 Cricklewood Broadway, NW2 3ET
Tel: 01-452 0161/2 Telex: 21492
GLASGOW - 85 West Regent St., G2 2QD. Tel: 041-332 4133
BRISTOL - 1 Straits Parade, Fishponds Rd., BS16 2LX. Tel: 0272 654201
Call in and see us 9-5.30 Mon.-Fri., 9-5.00 Sat. Trade & export enquiries welcome
NEW CATALOGUE 77
2nd edition for Autumn with over 8,000 line items. Plenty of new products and ideas.
35p post paid (25p to callers).

Our range covers over 8,000 items. The largest selection in Britain.

TOP 200 IC's TTL LINEARS

CA3018	0.81	LM380N-8	0.90	LM1845N	1.35	SN76008KE	2.50	TAA320A	1.15
CA3018A	1.08	LM380N14	0.98	LM1846N	1.80	SN78013N	1.70	TAA350A	2.48
CA3020	1.78	LM381AN	2.45	LM3900N	0.75	SN78013ND	1.57	TAA521	1.00
CA3020A	2.28	LM381N	1.80	LM3909N	0.68	SN78018KE	2.50	TAA550	0.80
CA3021	2.18	LM382N	1.25	MC1303L	1.47	SN78023N	1.50	TAA560	1.60
CA3022	1.83	LM384N	1.45	MC1304P	1.85	SN78023NO	1.57	TAA570	2.30
CA3023	1.78	LM386N	0.80	MC1305P	1.85	SN78023NO	1.57	TAA611B	1.85
CA3036	0.97	LM387N	1.05	MC1308P	1.00	SN78023NO	1.57	TAA621	2.15
CA3041	1.49	LM388N	1.00	MC1310P	1.91	SN78110N	1.46	TAA661A	1.32
CA3042	1.49	LM388N	1.00	MC1311P	1.99	SN78115N	1.87	TAA661B	1.32
CA3043	2.01	LM555CH	0.48	MC1327P	1.54	SN78116N	2.08	TAA700	3.91
CA3044	1.84	LM585CN	1.30	MC1350P	0.75	SN78131N	1.30	TAA930A	1.00
CA3046	0.89	LM701C	2.80	MC1351P	1.20	SN78226N	1.94	TAA930B	1.05
CA3048	2.23	LM702A	2.00	MC1352P	0.97	SN78227N	1.51	TAD100	1.95
CA3052	1.82	LM702C	0.75	MC1357P	1.45	SN78228N	1.75	TBA120	0.65
CA3064	1.84	LM703LN	1.05	MC1414L	1.20	SN78530N	0.91	TBA231	1.20
CA3085	1.74	LM709	0.85	MC1430P	2.28	SN78532N	1.50	TBA400	1.50
CA3086	3.02	LM709-8	0.45	MC1431P	3.00	SN78533N	1.30	TBA500	2.21
CA3067	3.13	LM709-14	0.45	MC1433G	3.00	SN78544N	1.44	TBA5000	2.30
CA3088	3.46	LM711CN	0.55	MC1435G	1.80	SN78545N	2.09	TBA510	2.21
CA3070	2.49	LM726	5.38	MC1437L	1.80	SN78546N	1.44	TBA510Q	2.30
CA3071	2.31	LM726CN	1.45	MC1438R	1.46	SN78550-2	0.41	TBA520	2.21
CA3072	2.37	LM741C	0.85	MC1439G	1.45	SN78552-2	0.85	TBA520Q	2.30
CA3075	1.88	LM741C-8	0.40	MC1455G	1.55	SN78570N	2.08	TBA530	1.98
CA3078	1.93	LM741C-14	0.50	MC1456G	2.20	SN78570N	2.08	TBA530Q	2.07
CA3086	0.51	LM747CN	0.90	MC1495L	4.70	SN78580N	1.10	TBA540	2.21
CA3088F	1.59	LM748-8	0.50	MC1498G	1.10	SN78680N	0.60	TBA550	3.13
CA3089E	2.52	LM748-14	0.50	MC1529G	0.50	SN78686N	0.92	TBA560CC	3.22
CA3090D	3.80	LM1303N	1.47	MC1530G	0.50	SL414A	2.35	TBA570	1.29
LM301AH	0.67	LM1304N	1.85	MC1531G	0.50	SL415	2.50	TBA818	2.50
LM301-8	0.44	LM1305N	1.85	MC1553G	0.50	SL610C	2.35	TBA700	1.50
LM308H	1.82	LM1307N	1.10	MC1545L	5.75	SL611C	2.35	TBA720AQ	2.32
LM308N	1.17	LM1351N	1.20	MC1545L	8.75	SL620C	3.50	TBA750	1.98
LM370N	3.00	LM1310N	1.91	MC1550G	0.80	SL621C	3.50	TBA820	1.03
LM371H	2.25	LM1458N	0.91	MC1552G	0.40	SL623C	5.75	TBA820	2.80
LM372N	2.19	LM1490N	0.91	MC1553G	0.40	SL630C	2.35	TBA841B	1.82
LM373N	2.25	LM1800N	1.76	MC1590G	3.75	SL840C	4.00	TCA180B	1.81
LM374N	2.25	LM1800N	1.92	SAS560	2.50	SL841C	4.00	TCA280A	1.30
LM377N	1.75	LM1820N	1.10	SAS570	2.50	SL701C	2.00	TCA290A	3.13
LM378N	2.25	LM1841N	1.75	SN78001N	1.57	TAA263	1.25	TCA740	2.76
LM379S	3.95	LM1828N	1.75	SN78003N	2.55	TAA300	1.89	TCA800	3.13

THIS IS JUST A SMALL SELECTION FROM OUR RANGE - PLEASE ENQUIRE FOR TYPES NOT LISTED

Prices correct @ 11 July 1977, but please add VAT. Postage & packing 40p.

TELEVISION TELETEXT DECODER

We can supply from stock complete kits of parts -

POWER SUPPLY EXCLUDING TRANSFORMER AND P.C. BOARD £12.50 + 65p P&P + 8% VAT.

INPUT LOGIC CARD UNIT EXCLUDING P.C. BOARD £15.50 + 50p P&P + 8% VAT.

MEMORY CARD KIT £32.00 + 60p P&P + 8% VAT.

DISPLAY CARD KIT £18.50 + 40p P&P + 8% VAT.

TV GAMES IN COLOUR - as featured in the July issue of this magazine. We can now offer complete kits of parts excluding the P.C. Boards at £35.00 delivered including VAT and p&p. Alternatively sets of TV Games Chips only, at £17.00 per set delivered including VAT and p&p.

We also carry a comprehensive range of transistors, diodes, bridges, thyristors, diacs, opto components, all kinds of integrated circuits, capacitors, resistors, plugs and sockets. ALL MANUFACTURERS BRANDED PRODUCTS.

VALVE BARGAINS

ANY 5-64p, 10-£1.10, 50-£5.00. YOUR CHOICE FROM THE LIST BELOW:

ECC82, EF80, EF183, EF184, EH90, PCF80, PCF802, PCL82, PCL84, PCL85, PCL86, PCL805, PL504, PY81/800, PY88, 30PL14, 6F28, PFL200.

COLOUR VALVES - PL508, PL509, PL519, PY500/A. ALL TESTED, 35p EACH.

TELEVISION AERIAL SPLITTERS, 2 WAY. INSIDE TYPE. £1.50 (ONE AERIAL TWO TV's).

PRESS BUTTON UHF TUNERS - 4 BUTTON TRANSISTOR - BRITISH MADE - £2.50 EACH.

AERIAL BOOSTERS

AERIAL BOOSTERS CAN PRODUCE REMARKABLE IMPROVEMENTS ON THE PICTURE AND SOUND, IN FRINGE OR DIFFICULT AREAS.

B11 - FOR THE STEREO AND STANDARD VHF/FM RADIO.

B12 - FOR THE OLDER VHF TELEVISION - PLEASE STATE CHANNEL NUMBERS.

B45 - FOR MONO OR COLOUR THIS COVERS THE COMPLETE UHF TELEVISION BAND.

ALL BOOSTERS ARE COMPLETE WITH BATTERY WITH CO-AX PLUGS & SOCKETS. NEXT TO THE SET FITTING £4.20.

COLOUR T.V.'s UNTESTED

Most Dual-standard; R.B.M., Philips G6, Decca, Pye, etc., from £25 + VAT.

Single-standard from £35 + VAT. Most makes available.

Monochrome from £3 + VAT. 'Square screen' from £6 + VAT. Circuit Diagrams available most sets £1 extra.

All working sets demonstrated. All untested sets can be fully inspected before purchase.

Ring or send s.a.e. for current prices and stock.

Usually scrap sets of many makes available from £10 + VAT.

Fresh stock of Castor Stands just in!

West Midlands TV Trade Sales

1532 Pershore Road (Main A441)

Stirchley, Birmingham, B30 2NW

(Phone 021-458 2208)

Open all day Mon, Tues, Thurs, Fri, Sat. Half day Wed.

TV's TV's TV's

We are the largest stockists in the south of Ireland of clean used T.V. sets.

BUSH - PHILIPS - FERGUSON

Mono D/S from £15.00 each

Colour from £110.00 each

Transistor Radios from £8.00 each

Visit our warehouse and see for yourself.

Fresh Stocks Weekly.

T.V. WHOLESALE DISTRIBUTORS LTD.

E.D.I. HOUSE,

Kylemore Park West Industrial Estate,

Dublin 10. Tel. 364139.

LOOK!

Phone: LUTON,
BEDS. 38716

OPPORTUNITIES TRADE SALES

START AT £25 INC. VAT!!

FOR D/S COLOUR TV's

G.E.C., Philips, Murphy, Decca, Ferguson

S/S COLOUR TV's

Philips, G.E.C., Telefunken, Decca, Ferguson

FROM £40 INC. VAT!!

MONO TV's, all makes from
£5 INC. VAT

SQUARE SCREEN, all models
£12 INC. VAT!!

Deliveries arranged if necessary.

**HUNDREDS OF SETS EACH WEEK TO BE
DISPOSED OF AT GIVE-AWAY PRICES.**

LUTON 38716

9.30-6.00 p.m. Weekdays
10.30-1.00 p.m. Sundays

TV'S! TV'S! TV'S!

'A' Price is good working order

'B' Price is complete but unserviced with tested tube

	'A'	'B'
Philips 25" G6 D/STD	£36.00	£20.00
GEC 19/25" D/STD	£40.00	£24.00
GEC 19" S/STD	£56.00	£40.00
GEC 22" S/STD	£72.00	£56.00
Thorn 3000 25" S/STD	£80.00	£64.00

ALL ABOVE PLUS £8 DELIVERY AND PLUS VAT.
100's OF COLOUR TV'S OFF THE PILE FROM £20.00.

Always a good selection of modern and older C.T.V. panels and scrap chassis cabinets, mono tubes etc. etc.

AGENT FOR TOP QUALITY MERCURY UHF SET TOP MULTIBAND AERIALS, BOXES OF 25 FOR £45. DEL. & VAT INC., OR SEND £2.75 FOR SAMPLE.

SQUARE SCREEN MONO

MOST MODELS AVAILABLE i.e., GEC, DECCA FROM £8.00, PHILIPS, PYE, THORN, BUSH FROM £10.00.

HUNDREDS OF 19"/23" MONO TV'S

to pick from at giveaway prices

i.e. Pye, Olympic, Philips 210, Thorn 1400 from £5.00.

All prices plus VAT

EXTRA SPECIAL OFFERS!

Philips 22" Single STD Colour TV's. Models 511, 512. Good working order with repolished cabinets. Singles at £64.00. Threes at £60.00 each. (Singles delivery and VAT inc. at £81.00 C.W.O.)

20"/24" GEC or Decca Mono TV's. Good working order. Singles at £16.00. Threes at £12.00 each. Singles delivery and VAT inc. at £24.00.

Please write for quotation on any set or spares.

Quantity discounts. Callers Welcome. Deliveries arranged.



SOUTHERN	SOUTHERN	NORTHERN	SCOTLAND
Unit 4A, Bulwark Industrial Estate, Chepstow, Nr. Bristol. Tel. Chepstow (02912) 6652	Watling Street, Hockcliffe (3 miles north of Dunstable on A5). Tel. Hock- cliffe (052521) 768	Thornbury Roundabout, Leeds Road, Bradford 3. Tel. (0274) 665670	Peacock Cross Industrial Estate, Burnbank Road, Hamilton. Tel. (06982) 29511

Transistor Devices Limited

Suite E, Georgian House, Trinity Street, Dorchester

C-MOS, SSS, TTL, NSC

TYPE	PRICE (p)	TYPE	PRICE (p)	TYPE	PRICE (p)	TYPE	PRICE (p)
4000	20	7400	15	7472	29	74147	248
4001	20	7401	17	7473	33	74148	157
4002	20	7402	17	7474	34	74150	140
4006	114	7403	17	7475	44	74151	70
4007	20	7404	22	7476	34	74153	83
4008	99	7405	22	7480	49	74154	148
4009	62	7406	41	7481	98	74155	88
4010	62	7407	41	7482	77	74156	88
4011	20	7408	23	7483	86	74157	87
4012	20	7409	25	7484	93	74158	154
4013	51	7410	17	7485	117	74159	198
4014	107	7411	26	7484	33	74160	108
4015	114	7412	26	7489	306	74161	108
4016	51	7413	35	7490	39	74162	108
4017	114	7414	88	7491	73	74163	108
4019	62	7416	32	7492	50	74164	107
4020	132	7417	36	7493	39	74165	135
4021	114	7420	17	7494	87	74166	123
4022	113	7421	39	7495	68	74167	306
4023	20	7422	25	7496	81	74170	225
4024	104	7423	33	7497	306	74173	144
4025	20	7425	30	74100	105	74174	113
4027	60	7427	36	74104	54	74175	83
4028	95	7430	17	74105	54	74176	113
4029	123	7432	31	74107	33	74177	113
4030	48	7437	34	74109	87	74180	107
4041	84	7438	34	74110	50	74181	292
4042	93	7440	17	74111	72	74182	80
4043	89	7441	77	74116	198	74185	130
4044	89	7442	68	74118	81	74186	896
4046	140	7443	117	74120	127	74190	140
4049	53	7444	117	74121	29	74191	144
4050	53	7445	98	74122	48	74192	117
4060	140	7446	98	74123	66	74193	117
4069	23	7447	81	74125	63	74194	117
4071	23	7448	81	74126	69	74195	87
4072	23	7450	18	74128	81	74196	117
4510	123	7451	18	74132	69	74197	117
4511	137	7453	18	74136	73	74198	193
4516	123	7454	18	74141	77	74199	193
4518	123	7460	18	74142	270		
4520	123	7470	29	74145	81		

LEDS & DISPLAYS

TYPE	DESCRIPTION	PRICE	TYPE	COLOUR	SIZE	PRICE
1787	.5"C.A.O 9	130	209A	Red	T-1	20
1788	.5"C.C.O 9	130	229R	Red	T-1 1/2	21
1780	.4"C.C.O 9	275	229G	Grn	T-1 1/2	30
	Double	275	229Y	Ylw	T-1 1/2	40
1790	.4"C.A.O 9	275	233R	Red	T-1	22
	Double	275	233G	Grn	T-1	32
			233Y	Ylw	T-1	42

MICROS & MEMORIES

DESCRIPTION	PRICE	DESCRIPTION	PRICE
KIM 1 - microcomputer with keyboard, LED display	04 13.70	MCS 6502	16.28
FULL MANUALS WITH UNIT	05 13.70		03 13.70
TTY, AUDIO TAPE INTERFACES	06 13.70		04 13.70
£185	12 16.28		05 13.70
MANUALS ONLY £10.50 set	13 13.70		14 13.70
	14 13.70		15 13.70
	15 13.70		02A 24.65
	02A 24.65		03A 20.45
	03A 20.45		04A 20.45
	04A 20.45		05A 20.45
	05A 20.45		06A 20.45
	12A 24.65		13A 20.45
	13A 20.45		14A 20.45
	14A 20.45		15A 20.45
	20 7.21		22 9.25
	22 9.25		30-004 18.14
	30-004 18.14		30-005
	30-005		or 6553 11.85
	or 6553 11.85		32 13.95
	32 13.95		6102 2.70
	6102 2.70		6111 2.70

DPM

DPM - 999 with 0.3"
100mv FSD 100 MΩ/I/P
DIFF I/P

CMR 70dB at DC 7 5V supply
Limited quantity avail. £25.

MISCELLANEOUS BARGAINS!

"Only while stocks last"

E304 Siliconix FET	21	40349 VI RCA	100
MJE 2955	80	BC317B - 10 for	150
BC 173C - 10 for	100	40361	25
741 DIL	22	40362	25
1710	30	BD139	30
72709	30	BD140	30
2N5295	30	1S920 - 20 for	100
LM309K	100		

UM4 COLOUR-BOOSTER · M4 VHF BOOSTER · FM2 VHF RADIO BOOSTER

These units produce remarkable improvements in colour and picture quality in fringe or difficult areas with significant reduction in noise (snow).

High gain - very low noise. Fitted fly lead - installed in seconds. Highest quality components.

WHITE PLASTIC CASE 3 1/4 x 3 1/4 x 1 1/2 FELT BASE

CHANNELS Group A, Red Code	21-33	BATTERY MODEL	£7-75
FOR UHF: Group B, YELLOW Code	39-51	SELF CONTAINED	} inc. VAT & Postage
Group C-D, Green Code	52-68	MAINS	

When ordering M4 unit please specify band and channel.

Nominal gain 16-18 dB both bands

TERMS: ADD 8% (or current rate) VAT to total. All orders under £10 add postage and packing 25p. Orders over £25 (for components only) - 10% discount. Mail order only but trade enquiries welcomed. If goods not available for despatch in 7 days, cash automatically refunded. Delivery by post in U.K. so allow time for delivery even on same day despatch. Export charged at cost. Please quote journal.

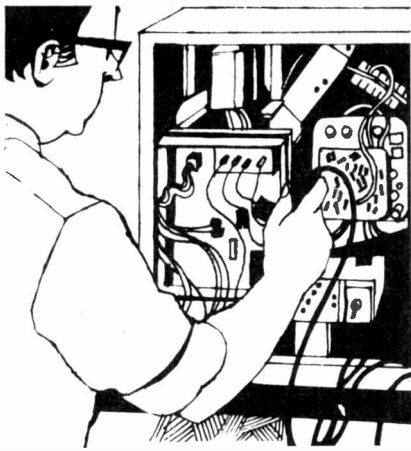

SETS & COMPONENTS

VALVE LIST

ALL VALVES FULLY TESTED

Five valves or over postage paid
Under five valves postage 6p each

DY86/87	15p	PC900	8p	PCL85/805	20p
EB91	12p	PCC84	8p	PL36	20p
ECC82	10p	PCC85	20p	PL504	25p
ECL80	8p	PCC89	8p	PY32/33	15p
EF80	8p	PCC189	8p	PY81/800	15p
EF85	8p	PCC805	15p	PY801	20p
EF183	10p	PCF80	8p	U191	15p
EF184	10p	PCF86	15p	6F23	15p
EH90	13p	PCF805	20p	6/30L2	15p
EY86/87	13p	PCL82	15p	30F5	10p
PC86	15p	PCL83	15p	30FL1	20p
PC88	15p	PCL84	15p	30PL14	15p

AND MANY MORE AVAILABLE

S. W. ELECTRONICS

114 Burnley Road, Rawtenstall, Rossendale, Lancs.

200 NEW RESISTORS, well assorted. $\frac{1}{4}$ -2 Watts. Carbon-Hi-Stab Oxide, etc. £1.50 post free. Whitsam Electrical, 33 Drayton Green Road, London W13.

BARRON ELECTRICAL WHOLESALE IN IRELAND NOW OFFER TV'S TV'S

Thorn 950's, 1400's, Pye 169's 368 from £14. Colour - Bush, Philips, Pye from £100. Bulk discounts available.

STOCKISTS OF COMPONENTS, Valves, Resistors, Capacitors, Transistors. SAVANA Regunned CRT's, 2 year Guarantee. THIS MONTH'S SPECIAL - PCL85 at 50p.

BBC Aerials. Our famous 18 ELEMENT now only £9.00. Also the 103 ELEMENT STAAL, Channels 21-28 High Gain Boosters stocked. Anything to do with TV's contact us. Personal Callers Welcome. Send S.A.E. for price lists.

57 RIVERVIEW ESTATE,
GLASHEEN, CORK, IRELAND.
Phone No. 021-45465.

ELECTRONIC Devices and Semiconductors. Components for this months projects. S.A.E. Lists. NKM, 32, Seaside, Eastbourne, Sussex. Telephone 32921.

VALVES

Radio - T.V. - Industrial - Transmitting

We dispatch valves to all parts of the world by return of post. Air or Sea mail. 2,700 types in stock, 1930 to 1976. Obsolete types a speciality. List 20p. Quotation S.A.E. Open to callers Monday to Saturday 9.30 a.m. to 5.00 p.m., closed Wednesday 1.00 p.m. We wish to purchase all types of new and boxed valves.

COX RADIO (SUSSEX) LTD., Dept. PT.,
The Parade, East Wittering, Sussex, PO20 8BN.
Tel: West Wittering 2023 (STD Code 024366).

TURN YOUR SURPLUS capacitors, transistors, etc. into cash. Contact Coles-Harding & Co., 103 South Brink, Wisbech, Cambs. 0945-4188. Immediate settlement.

SMALL ADS

The prepaid rate for classified advertisements is 13 pence per word (minimum 12 words), box number 40p extra. Semi-display setting £7.00 per single column inch (2.5cm). All cheques, postal orders, etc., to be made payable to Television, and crossed "Lloyds Bank Ltd". Treasury notes should always be sent registered post. Advertisements, together with remittance, should be sent to the Classified Advertisement Manager, Television, Room 2337, IPC Magazines Limited, King's Reach Tower, Stamford St., London, SE1 9LS. (Telephone 01-261 5846).

CONDITIONS OF ACCEPTANCE OF CLASSIFIED ADVERTISEMENTS

1. Advertisements are accepted subject to the conditions appearing on our current advertisement rate card and on the express understanding that the Advertiser warrants that the advertisement does not contravene any Act of Parliament nor is it an infringement of the British Code of Advertising Practice.
2. The publishers reserve the right to refuse or withdraw any advertisement.
3. Although every care is taken, the Publishers shall not be liable for clerical or printers' errors or their consequences.

BRC 2000, 3000, 3500, 8000, 8500.
Philips G8, Pye 691, 697, 713.
Bush Murphy 802, 823.
Panel Repair/Exchange Singles or Bulk.

MODULAR ELECTRONICS
160 Brabazon Road, Hounslow, TW5 9LP.
Telephone 01-897 0976.

POLYESTER CAPACITORS. Price per 100 including postage C280 - 0.01, 0.022, 0.033, 0.068 £2.25; 0.22 £2.50; 0.33 £3.50; 0.47 £4.00. C281 - 0.01, 0.015, 0.33, 0.47 £2.25. B. Malloy, 66 Woodvale Avenue, Belfast BT13 3EX.

TELEVISIONS

Colour & Monochrome

Dual and Single Standard. Ex-Rental & Part Exchange. Working & Non-Working.

COLOUR from £40.00
MONO from £2.00

All sets are complete.

Tubes and Aerials supplied.

FOX TV CO.

80 Merton High St, London SW19.
01-540 9553.

EX RENTAL TV

19" UHF 625 £4.50
23" UHF 625 £6.00
Colour from £40.00

EDWARDS & SONS
103 Goldhawk Road, London W12
Tel: 01-743 6996

COLOUR TV's £60-£150. All makes, some as new. The TV Exchange Centre, 60 Golborne Road, Kensington, London W10. 01-969 3722.

VALVE BARGAINS

ANY 1-12p, 5-60p, 10-£1.00, 50-£4.50

ECC82, ECH84, EH90, DY86/7, EF80, EF183, EF184, PC86, PC88, PCF80, PCF802, PCL82, PCL84, PCL85/805, PCL86, PY81, PY800, PY88, PL36, PL504, 6F28, 30PL14.

COLOUR VALVES 30p EACH
PY500/A, PL508, PL509.

Postage & Packing 25p, no VAT

VELCO ELECTRONICS

9 Mandeville Terrace, Hawkshaw, Via Bury, Lancs.

SURPLUS STOCK

COLOUR TUBES used form£10
S/S COLOUR TUBES new from£25
S/S P.I.L COLOUR TUBES new from£25
PORTABLE TUBES Mono Available
CABINETS, COLOUR, MONO, from£2
S/S COLOUR SETS MURPHY from£60
S/S & D/S MONO, from£5

RING:- JEFFRIES 01-845 2036.

MAINS DROPPERS

37-31-97-26-168Ω 50p.
25-35-97-59-30Ω 50p.
14-26-97-160Ω 50p.
14-26-97-173Ω 50p.
15-19-20-70-63-28-63Ω 50p.

Post free. C.W.O.

Durham Supplies
367 Kensington Street, Bradford, 8, Yorkshire

ELECTRONICALLY TESTED TV VALVES

DY86/7	15p	PC88	15p	PCL86	20p
ECC82	15p	PC97	15p	PCL805/85	20p
EF183	15p	PCF802	15p	PL504	20p
EF184	15p	PCL82	12p	PL36	15p
PC86	15p	PCL84	15p	U26	20p

SPECIAL OFFER - 12 PCL805/85 £2.50 post free

COLOUR TV'S

PL509	45p	PL508	40p	PY500/A	40p
-------	-----	-------	-----	---------	-----

Many others available, please send list of types required with s.a.e. for quotation. All valves subject to availability. P. & P. 11p first valve, thereafter 7p each, max. 90p. Orders over £12 post free.

Mail order only.

L. & D. COMPONENTS LTD.

71 WESTBURY AVE., LONDON N22 6SA

COLOUR TV'S

Many working for disposal, trade only. All sizes and makes available. Mono sets also available.

INGERTONE (LONDON)

24 Dames Road, Forest Gate, London E7.

Tel: 01-555 5569.

INGERTONE (BRISTOL)

28 St. Thomas St., Bristol 1.

Tel: 0272-211179 (50663)

4lbs BRAND-NEW COMPONENTS! Transistors, Diodes, Wire-wound/Carbon Resistors, Volume Controls, Presets, Electrolytic/Silver-Mica/Polyester/Polystyrene Capacitors Etc. Well assorted. £5. Inclusive. Milward, 369 Alum Rock Road, Birmingham B8 3DR.

SHEFFIELD PANEL REPAIRS

Offer you a High Speed Repair and Return Service on all BRC Colour Panels.

30 Hollybank Drive, Sheffield, S12 2BT.

FOR DETAILS RING
(0742) 745168.

WANTED

TURN YOUR Surplus components into cash. Phone 0491-35529 (Oxon).

WANTED NEW Valves, transistors, L.Cs, amplifiers, receivers, televisions (anything useful) any quantity. Stan Willetts, 37 High Street, West Bromwich. Tel: 021-553 0186.

WANTED - New Valves, Transistors. Top prices, popular types. Kensington Supplies (A) 367 Kensington Street, Bradford 8, Yorkshire.

NEW VALVES and CRT's required. PCL805, PL504, PL509, PY500A etc. Cash waiting. Bearman, 6/8 Potters Road, New Barnet, Herts. Tel: 01-449 1934/5.

BOOKS & PUBLICATIONS

SIMPLIFIED TV REPAIRS. Full repair instructions individual British sets £4.50. request free circuit diagram. Stamp brings details unique TV Publications. (Auset) 76 Church Street, Larkhall, Lanarkshire.

**SERVICE SHEETS. SERVICE MANUALS
PRACTICAL AND TECHNICAL BOOKS**

COVERING COLOUR & MONO TELEVISIONS, RADIOS, RECORD PLAYERS, TAPE RECORDERS, ETC.

SERVICE SHEETS 75p PLUS S.A.E. SERVICE SHEET CATALOGUE 50p

BOOKS

PRICES INCLUDE POSTAGE U.K. ONLY

SOLID STATE COLOUR TELEVISION CIRCUITS by G. R. Wilding	£6.20
NEWNES COLOUR TELEVISION SERVICING MANUAL by G. J. King. Vol. 1	£8.60
NEWNES COLOUR TELEVISION SERVICING MANUAL by G. J. King. Vol. 2	£8.60
NEWNES COLOUR TELEVISION SERVICING MANUAL by G. J. King. Vol. 3	£8.60
COLOUR TELEVISION SERVICING by G. J. King. 2nd Edition	£7.30
COLOUR TELEVISION THEORY by G. H. Hutson	£6.80
COLOUR TELEVISION PICTURE FAULTS by K. J. Bohlman	£2.90
COLOUR TV WITH REFERENCE TO THE PAL SYSTEM by G. N. Patchett	£5.70
MAZDA BOOK OF PAL RECEIVER SERVICING by D. J. Seal	£5.60
TELEVISION (COLOUR & MONOCHROME) Part 3 by G. N. Patchett	£4.35
TELEVISION SERVICING HANDBOOK by G. J. King. 3rd Edition	£6.10
BEGINNERS' GUIDE TO TELEVISION by G. J. King. 5th Edition	£2.65
BEGINNERS' GUIDE TO COLOUR TELEVISION by G. J. King. 2nd Edition	£2.65
CATHODE-RAY OSCILLOSCOPE AND ITS USES by G. N. Patchett	£4.00
SERVICING WITH THE OSCILLOSCOPE by G. J. King. 2nd Edition	£5.35
TOWERS' INTERNATIONAL TRANSISTOR SELECTOR. Revised Edition	£5.25

(SEND LARGE S.A.E. FOR FREE BOOK LISTS)

WE STOCK NEW AND SECONDHAND EDITIONS OF "RADIO AND TELEVISION SERVICING" BOOKS.
FROM VOLUME ONE UP TO 1976-77 EDITION. PRICES ON REQUEST.

BACK ISSUES OF FOLLOWING MAGAZINES AVAILABLE. CURRENT PRICE PLUS 25p POSTAGE PER COPY.
P. WIRELESS, P. ELECTRONICS, E. ELECTRONICS, TELEVISION, R. CONSTRUCTOR, ELECTRONICS TODAY, ELEKTOR.

BELL'S TELEVISION SERVICES

190, KINGS ROAD, HARROGATE, N. YORKSHIRE. TEL. HARROGATE (STD 0423) 55885

OPEN TO CALLERS DAILY 9.00 a.m. TO 5.00 p.m. PLEASE INCLUDE AN S.A.E. WITH ENQUIRIES

COLOUR TV MANUALS

COVERING FOLLOWING MAKES

ALBA, BRC, BUSH, DECCA, GEC, DEFIANT, MARCONI, EKCO, PYE, FERGUSON, DYNATRON, NATIONAL, HITACHI, INVICTA, ITT/KB, RGD, GRUNDIG, SOBELL, STELLA, SONY, MURPHY, PHILIPS, HMV, ULTRA.

PLEASE SEND S.A.E. FOR QUOTATION

"COMPREHENSIVE TV REPAIR MANUALS"

by McCourt. In 7 Volumes

These unique Books save time and money on repairs and cover most British Colour & Mono sets. Price £4.00 per volume plus 45p POST, or complete 7 volumes for only £27.00 POST FREE. SEND FOR FREE LEAFLET.

**LARGE SUPPLIERS OF SERVICE SHEETS
AND COLOUR MANUALS**

TV, RADIO, TUNERS, TAPE RECORDERS, RECORD PLAYERS, TRANSISTORS, STEREOGRAMS, RADIOGRAMS. ALL AT 75p EACH EXCEPT COLOUR & CAR RADIOS.

PLEASE STATE IF CIRCUIT WILL DO, IF SERVICE SHEET NOT IN STOCK. LARGE S.A.E. WITH ALL ENQUIRIES & ORDERS OTHERWISE CANNOT BE ATTENDED TO. UNCROSSED P.O.'s OR CROSSED P.O.'s RETURNED IF SERVICE SHEETS ARE NOT AVAILABLE. ALL SERVICE MEN, PLEASE NOTE, WE OPERATE A SAME DAY RETURN SERVICE, ALL CLAIMS OF NON-DELIVERY SHOULD BE MADE WITHIN SEVEN DAYS. NO OVERSEAS MAIL PLEASE. MAIL ORDER ONLY OR 'PHONE 01-458 4882. FREE TV FAULT TRACING CHART OR TV LIST ON REQUEST WITH ORDER.

C. CARANNA, 71 BEAUFORT PARK, LONDON, NW11 6BX.

NO CALLERS PLEASE

SERVICE SHEETS, Radio, TV, etc., 10,000 models. Catalogue 24p plus S.A.E. with orders-enquiries. Telray, 154 Brook Street, Preston, PR1 7HP.

SERVICE SHEETS for Radio, Television, Tape Recorders, Stereo etc. With free fault-finding guide, from 50p and S.A.E. Catalogue 25p and S.A.E. Hamilton Radio, 47 Bohemia Road, St. Leonards, Sussex.

MISCELLANEOUS

BEC CABINETS H. M. ELECTRONICS (TV.1.)
275a Fulwood Rd
Broomhill
Sheffield
S10 3BD.

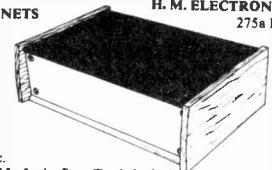

Suitable for all projects
Amps: P.A.:
Decoders etc.
Please send 15p for leaflets: Trade invited

SERVICE SHEETS - COLOUR TV SERVICE MANUALS

Service Sheets for Mono TV, Radios, Record Players and Tape Recorders 75p.

Please send large Stamped Addressed Envelope.

We can supply manuals for most makes of Colour Television Receivers by return Post.

B.R.C. PYE EKCO PHILIPS ITT/KB SONY G.E.C. HITACHI BAIRD ULTRA INVICTA FERGUSON H.M.V. MARCONI AND MANY MORE. LET US QUOTE YOU.

Please send a Stamped Addressed Envelope for a prompt reply.

COMPREHENSIVE TV REPAIR MANUALS BY J. McCOURT

Mono Volumes 1, 2, 3 and 4. Colour Volumes 2, 3 and 4.

A must for the repair man, loaded with faults and cures, all at £4.00 each plus 40p post.

Build yourself "The Colour TV Signal Injector", manual £1.45. Manual with printed circuit £2.30 post paid.

The McCourt circuit diagram manuals Mono and Colour. Send S.A.E. for full details.

Export enquiries welcome. International Reply Coupon please.

G. T. TECHNICAL INFORMATION SERVICE

10 DRYDEN CHAMBERS, 119 OXFORD ST., LONDON W1R 1PA

MAIL ORDER ONLY

LADDERS

ALUMINIUM Roof Crawlers. Sizes 12ft - 24ft. Also make aluminium ext. up to 62½ft. Leaflets. The Ladder Centre (TEL) Halesfield (1) Telford. Tel: 586644. Callers Welcome.

FOR SALE

Colour Televisions From £25.00 VAT inc.
D/S Mono From £4.00 VAT inc.
S/S Square Screens From £12.00 VAT inc.

VISIT OUR WAREHOUSE AND SEE FOR YOURSELF,
WE HAVE 4 DELIVERIES OF FRESH STOCK WEEKLY.

TELECARE

BRITAIN'S LARGEST USED T.V. DISTRIBUTOR.
Unit B.1, Eley Road, Eley Estate,
Edmonton, London N18.
Tel: 01-807 5908/9 807 5900.

EDUCATIONAL

TELEVISION TRAINING

12 MONTHS' full-time course in Radio & TV for beginners. (GCE - or equivalent - in Maths. and English.)

26 WEEKS' full-time course in Mono & Colour TV. (Basic electronics knowledge essential.)

13 WEEKS' full-time course in Colour TV. (Mono TV knowledge essential.)

These courses incorporate a high percentage of practical training.

NEXT SESSION starts on September 12th.

PROSPECTUS FROM:
London Electronics College, Dept. TT9,
20 Penywern Road, London SW5 9SU.
Tel. 01-373 8721.

BETTER JOB! BETTER PAY!

GET QUALIFIED WITH ICS IN:
COLOUR & MONO TV SERVICING
COLOUR & MONO TV ENGINEERING
COLOUR & MONO TV MAINTENANCE
PLUS: Telecommunications, radio, electronics, electrical engineering, technical communications, radio communications, etc., etc.,

NEW: Self-build radio courses with free kits

Train in your own home, in your own time with ICS, the world's most experienced home study college.

RETURN THIS COUPON TODAY
FOR FREE BROCHURE!

ICS Int Correspondence Schools
BOOK Intertext House Stewarts Rd
London SW8 4UJ Tel: 01-622 9911

Name

Address

B.R.C. 25 inch, 2000 Colour Television. Working but requires attention. £45. Buyer collects. 051-426 1395 evenings.

C.E.D. Signal strength meter. Good working order. As reviewed by this magazine May 1975. Also B1 Pre Pak cross hatch generator. Best offer secures. Box No. 136.

TELEVISION PROJECT 22" Receiver complete. Aligned needs tidying and setting up, £45. Basildon 0268 3546.

VARIOUS LABGEAR AERIAL AMPLIFIERS and accessories for sale, suitable for DX-TV, brand new and unused. S.A.E. for details. G. Smith, 17 Collingham Gardens, Derby DE3 4FS.

PLEASE
MENTION
TELEVISION
WHEN
REPLYING
TO
ADVERTISEMENTS

COLOUR TUBES STANDARD TUBES METAL BAND TUBES TWIN PANEL TUBES

Rebuilt with new Electron Guns to British Standard 415/1972.

SUFFOLK TUBES LIMITED
214, PURLEY WAY
CROYDON, SURREY
01-686 7951

Britain's Largest Independent
TV Tube Rebuilder

REBUILT TUBES!

YOU'RE SAFE WHEN YOU
BUY FROM RE-VIEW!

HERE IS WHAT YOU PAY:

MONO	
19"	£10.00
23"	£12.00
RIMBAND & TWIN PANEL	
16", 17", 19"	£10.00
20"	£12.00
23"	£14.00
24"	£15.00

Carriage £2.70 inc. V.A.T.

COLOUR	
17", 18", 19"	£31.00
20"	£32.00
22"	£34.00
25"	£36.00
26"	£40.00

Exchange Basis £5 Deposit Returnable
Old Tube.

(carriage-ins. £3.25 inc. V.A.T.)

Guarantee 1 year

Cash or cheque with order,
or cash on delivery

Add 12½% V.A.T. to all orders

INQUIRIES S.A.E. PLEASE

RE-VIEW ELECTRONIC TUBES
237 LONDON ROAD,
WEST CROYDON, SURREY
Tel: 01-689 7735

A Quick Service At The Right Price

DON'T MISS IT!

To Reveal More
 Just Call In,
 Write, Or Phone
 For Our Price List

SIDS Components

AND THERE'S PLENTY MORE

FROM SOMEONE WHO KNOWS WHAT YOUR AFTER!

THIS MONTH

AND EVERY MONTH!

OUR

Stock Range Includes

RR1 - AB23 Series
 Ceramic Cases VTM Type 63p

TV Replacement Mains Droppers

MANUFACTURER	CHASSIS	MAKERS CODE	VALUES	SIDS ORDER CODE	SIDS PRICE EACH (p)
T.C.E.	1400	06E5.016	128R+16R+1K7+116R+462R+126R	C121	85
		06E5.018	350R+20R+148R+1K5+317R	C113	63
	3000/3500	00E5.071	6R+1R+100R	C105	53
		90E5.006	56R+1K+47R+12R	D123	59
PHILIPS	210	50S01	30R+125R+2K85	D112	49
		50S11	118R+148R+L00P	D108	41
	8000	50B11	47R	C103	24
		50B32	2R2+68R	C102	39
P.V.E.	725	PL11062	27R+56R	D106	44
		PL10064			
G.E.C.	2018	27840	8R+15R+17R+70R+63R+188R	DS114	55
R.R.I.	TV161	AP48928	250R+14R+156R	D109	39
POWER WIREWOUND RESISTORS - DROPPER SECTIONS					
OVAL SECTIONS 25mm x 25mm x 7mm					
WATTAGE 12W					
ORDER CODE F104/VALUE REQUIRED					
VALUES 4R7 7R5 10R 12R 15R 18R					
22R 24R 27R 33R 39R 47R					
51R 56R 68R 75R 82R 100R					
120R 150R 180R 200R 220R					
PRICE	0.25p EACH				

Valves
Diodes
EHT Trays
Fuses
Multi Section Capacitors
Integrated Circuits
Resistors

SemiConductors

TYPE	PRICE (p)										
AC 107	28	BC 113	12	BC 213	15	BF 160	30	BRY 52	33		
AC 126	27	BC 114	15	BC 213L	13	BF 167	26	BT 106	120		
AC 127	22	BC 115	16	BC 214	13	BF 173	24	BT 108	132		
AC 128	17	BC 116	16	BC 214L	13	BF 178	30	BT 116	120		
AC 128K	33	BC 116A	30	BC 237	15	BF 179	32	BU 105/02	190		
AC 141	27	BC 117	17	BC 238	12	BF 180	33	BU 108	200		
AC 141K	37	BC 118	17	BC 301	30	BF 181	32	BU 126	165		
AC 142	20	BC 119	28	BC 303	31	BF 182	35	BU 204	160		
AC 142K	33	BC 125	16	BC 327	20	BF 183	34	BU 205	160		
AC 151	31	BC 125B	18	BC 328	12	BF 184	30	BU 206	210		
AC 154	20	BC 126	15	BC 337	15	BF 185	28	BU 208	245		
AC 155	20	BC 132	15	BC 338	18	BF 186	36	BU 208/02	264		
AC 156	31	BC 135	18	BC 546	14	BF 194	12	BUY 69B	275		
AC 176	24	BC 136	18	BC 547	12	BF 195	12	BUY 69A	300		
AC 176K	38	BC 137	15	BC 548	10	BF 196	12	E 1222	42		
AC 187	22	BC 138	20	BC 549	12	BF 197	13	MJE 340	44		
AC 187K	40	BC 139	24	BC 550	15	BF 197A	18	MJE 520	50		
AC 188	27	BC 140	38	BC 557	14	BF 198	19	2N 696	25		
AC 188K	42	BC 141	26	BC 558	13	BF 199	20	2N 706	16		
AC 193K	40	BC 142	24	BCY 72	20	BF 200	30	2N 3053	22		
AC 194K	39	BC 143	24	BD 115	60	BF 218	56	2N 3054	72		
AD 140	78	BC 147	12	BD 116	60	BF 224	30	2N 3055	60		
AD 142	74	BC 147A	12	BD 124	70	BF 240	20	2N 3702	16		
AD 143	72	BC 147B	12	BD 131	44	BF 241	20	2N 3703	12		
AD 149	79	BC 148	10	BD 132	46	BF 257	30	2N 3704	12		
AD 161	50	BC 149	12	BD 133	48	BF 258	32	2N 3705	11		
AD 161/162PR	125	BC 153	15	BD 135	34	BF 259	28	2N 3706	11		
AD 162	55	BC 154	15	BD 136	35	BF 336	34	2N 3819	25		
AF 114	35	BC 157	13	BD 137	37	BF 337	34	2N 5293	60		
AF 115	26	BC 158	12	BD 138	38	BF 338	34	2N 5294	52		
AF 116	26	BC 159	12	BD 139	42	BF 355	45	2N 5295	60		
AF 117	26	BC 160	40	BD 140	46	BF 457	60	2N 5296	50		
AF 118	65	BC 161	14	BD 144	190	BF 458	60	2N 5297	60		
AF 124	36	BC 171	14	BD 160	140	BF 459	42	2N 5298	36		
AF 125	36	BC 172	13	BD 161	80	BFT 42	41	2N 5496	60		
AF 126	36	BC 173	15	BD 182	85	BFT 43	30	OC 71	29		
AF 127	36	BC 178	17	BD 183	68	BFX 29	29	OC 72	38		
AF 139	44	BC 178B	21	BD 184	100	BFX 24	24	R 2008B	200		
AF 178	66	BC 179	18	BD 222	60	BFX 85	30	R 2010B	190		
AF 180	70	BC 182	14	BD 225	60	BFX 86	28	RCA 16334	100		
AF 181	70	BC 182L	11	BD 232	70	BFX 88	25	RCA 16335	100		
AF 239	50	BC 183L	10	BD 233	50	BFY 50	20	S 2802	200		
AF 240	22	BC 184	13	BD 234	55	BFY 51	22	S 6080	320		
AL 102	120	BC 186	24	BD 235	95	BFY 52	20	A KIT			
AL 103	144	BC 187	24	BD 236	58	BFY 90	78	TIP 31A/			
AU 107	165	BC 204	15	BD 237	58	BR 100	26	2N 5298	36		
AU 110	190	BC 212	13	BD 238	55	BR 101	36	TIP 32A	38		
AU 113	130	BC 212L	11	BDX 32	230	BRC 443	90	TIP 61A	44		
BC 107	12			B DY 20	100	BRY 39	38	TIP 42A	48		
BC 107B	15			BF 115	30			TIS 91	19		
BC 108	14			BF 123	35			2SC 1172A	300		
BC 109	14			BF 152	20			2SC 643A	140		
BC 109C	15			BF 158	20			4.43MHZ Crystal	120		

SIDS Components

FAST, RELIABLE AND COMPETITIVE

Cash with all orders - Add 12½% VAT. Minimum Order £2.00 - No postal or packing charge.

SIDS full stock + price list available - Just telephone 061.480.8244 or write to - SIDS (Electronic Components) Ltd. 251, Wellington Road South, Stockport, Cheshire.

3500 Thorn Triplers £3.50	TIP112 25p	VHF Varicap Units	BA159 10p
LP1193/1Mallard £2.50	TIP115 25p	New £2.50	BY184 25p
TK25KC15BL £1.50	TIP117 25p	VHF Varicap Units	TAA550 30p
Ex/Panel	100 Mixed Electrolytics	New. 49.00-219.00 MHZ	TBA510 £1.00
TS2511TBQ £1.50	1000 MFD to 4 MFD £2.50	£1.50	TBA480Q £1.00
TS2511TCE £3.00	120 Mixed Pack of	Reject VHF Varicap	TBA550Q £1.50
TS2511TCF £3.00	Electrolytics & Paper	Units 50p	TBA720A £1.50
TS2511TBH £3.00	Condensers £1.20	AE Isolating Socket &	TBA790B131 £1.00
TS2511TBS £3.00	100 Green Polyester	Lead 45p	TBA800 95p
1730 Decca £3.00	Condensers	6 Position 12.5k	TBA920 £2.00
Mains Droppers	Mixed Values £2.00	V/Resistors Units for	TAA700 £2.00
69R + 61R 20p	.1 MFD 2000v 15p	Varicap 50p	TBA530Q £1.00
147R + 260R 20p	.1 MFD 1000v 8p	EHT Rectifiers Sticks	TBA550 £2.00
Thorn Mains Droppers	.01 MFD 1000v EACH	Used in Triplers	SN76544N 50p
6R + 1R + 100R 35p	.047 MFD 1000v	x80/150 12p	SN76640N £1.00
Thorn Mains On/Off	.47 MFD 630v	CSD118xMH EACH	SAA570 50p
Switches 15p	.0047 MFD 1000v	CSD118xPA 15p	TBA120A 50p
Thorn 2000 & 3000	.47 MFD 1000v 15p	3 Off G770/HU37	TCA270Q £2.00
Series Hearing Aid	200+200+100M 325v 40p	Silicone 15p	TCA270SQ £2.00
External Loudspeaker	470+470M 250v 40p	Bridge Rectifiers	Star Aerial Amps
Unit £2.00	100+200M 325v 30p	1A 100v 20p	CHANNEL B+C EACH
Focus Unit 3500 Thorn £1.00	200+200+100+32M 350v 70p	2A 100v 25p	TV18 40p
4 Push Button Unit	150+200+200M 300v 50p	W005M 20p	TV20 50p
UHF Thorn £3.50	800M 250v 20p	BY127 10p	Rectifier Sticks & Lead
D.P. Audio Switch 7½p	600M 300v £1.00	IN4007 20 for £1.00	BU105 £1.00
4 Push Button Unit for	400M 400v £1.00	IN4005 20 for £1.00	BU105/04 £1.50
Varicap £1.00	800+800M 250v 60p	BYX94 1200v 1 Amp.	BU205 £1.90
7 Push Button Unit for	200+100+100+50M 300v 45p	15 for £1.00	BU208 £2.00
Varicap £1.50	200+100+100M 350v 70p	BB105 Varicap Diodes	2N3055 45p
RIZ243619 Replacement	200+200+150+50 £1.00	BA182 12 for £1.00	BRCD1603
for ELC 1043	100M 450v 25p	BYX55/350 10p	Thorn 80p
UHF Varicap new £2.50	47M 450v 25p	BY210/400 5p	BD138 20p
BF127 BC350	680M 100v 25p	BY206 15p	BD254 20p
BF264 BF178	6800M 40v 35p	BT106 95p	Audio O/P Trans.
BF180 BF121	100M 350v 20p	BT116 95p	RCA16572 40p
BF181 BF257	22M 350v 20p	12 Kv Diodes 2M/A 30p	RCA16573 PAIR
BF182 BF137	33000 10v 30p	18 Kv BYF3123 Silicone 30p	BU105 Ex. Panel 50p
BF300 BC161	15000 40v 50p	180PF 8Kv 10M 350v	BU206 Ex. Panel EACH
ACT28 BF185	220M 10v 5p	1000PF 10Kv 100M 50v	5A-300 25p
2N2222 10p	2.2M 100v 5p	1200PF 10Kv 330M 10v	TIC106 Thyristors EACH
2N3566 10p	22M 100v 5p	1000PF 12Kv 330M 25v	RCA40506 Thyristors 50p
BC198 10p	4.7M 100v 5p	160M 25v 330M 35v	BC108 7p
2N1305 30p	Plessey Green Condensers	220M 25v 330M 50v	BC194 7p
MJE2021 15p	6800M 16v	1000M 16v 330M 63v	BC188 10p
SJE5451 15p	2200M 16v	220M 35v 470M 25v	BC149C 7p
90V 80V 5A NPN	1000M 10v	220M 40v 470M 35v	Aerial Amp Power
PNP	3000M 16v	220M 50v 470M 40v	Supplies 15 volts £1.50
1N5349 Diode 10p	330M 100v	470M 25v 10p	
12v Z/Diodes EACH	4700M 10v	22M 315v EACH	
Multard UHF T/Units £1.50	1000M 63v		
300 Mixed Condensers £1.50	1500M 25v		
300 Mixed Resistors £1.50	1000M 10v		
30 Pre-Sets 50p	1500M 40v		
100 W/W Resistors £1.50	1000M 25v		
40 Mixed Pots £1.50	6800M 63v		
20 Slider Pots £1.50	1500M 50v		
	4700M 16v		
	1000M 16v		
	100M 63v		

SENDZ COMPONENTS

2 WOOD GRANGE CLOSE,
THORPE BAY, ESSEX.

Reg. Office only -
No personal callers. Thank you.
Free Postage applies in U.K. only.

PLEASE ADD 12½% VAT