

TELEVISION

20p

SERVICING · CONSTRUCTION · COLOUR · DEVELOPMENTS

JUNE
1973



and:

TACKLING FIELD FAILURE

REVERSE & FORWARD AGC

SERVICING THE BRC 1580 CHASSIS

BENTLEY ACOUSTIC CORPORATION LTD.

7a GLOUCESTER ROAD, LITTLEHAMPTON, SUSSEX
All prices inclusive of V.A.T. Telephone 6743

0A2	0.30	6AQ5	0.21	6F18	0.45	7AN7	0.27	19H1	2.00	35Z5GT	30	CV63	0.53	EB84	0.20	EP83	0.54	GZ33	0.70	PCF87	0.74	PY301	0.67	U012	0.30
0B2	0.30	6AR6	0.20	6F23	0.65	7B6	0.58	20D1	0.49	50R3	0.35	CY4C	0.53	EP91	0.10	EP85	0.26	GT74	0.47	PCF200	0.67	PY302	0.31	U11	0.38
0Z4	0.25	6AR6	1.00	6F24	0.68	7B7	0.32	20D4	1.05	50C5	0.32	CY31	0.29	EB41	0.48	EP86	0.27	GZ37	0.67	PCF800	0.55	PY801	0.31	UY85	0.23
1A3	0.23	6AT6	0.18	6F25	0.51	7F8	0.88	20F2	0.65	50C6G2	17	D63	0.20	EB81	0.29	EP89	0.23	HABC80	44	PCF801	28	PZ30	0.48	U10	0.45
1A5	0.25	6AU6	0.19	6F28	0.60	7H7	0.28	20L1	0.98	50EH5	0.55	DAC22	0.33	EB90	0.18	EP91	0.17	HL23DD	40	PCF802	37	QQV03/10	1.20	U12/14	0.38
1A7GT	0.32	6AV6	0.28	6F32	0.15	7R7	0.65	20P1	0.50	50L6GT	45	DAP91	0.20	EB91	0.28	EP92	0.28	HL41DD	98	PCF805	69		1.20	U16	0.75
1B3GT	0.35	6AV8A	0.54	6GH8A	0.50	7V7	0.25	20P3	0.76	72	0.33	DAP90	0.30	EBF80	0.30	EP97	0.55	HL42DD	98	PCF806	55	Q875/20	0.83	U17	0.35
1D5	0.38	6AX4	0.39	6CK3	0.50	7Y4	0.60	20P4	0.89	85A2	0.43	DAP90	0.30	EBF83	0.38	EP98	0.65	HN309	140	PCF808	66	Q895/10	49	U18/20	0.75
1D6	0.48	6B8G	0.13	6CU7	0.50	7Z4	0.50	20P5	1.00	85A3	0.40	DAP90	0.30	EBF89	0.26	EP98	0.25	HL23DD	40	PCF809	62	Q8150/15		U19	1.75
1G6	0.30	6BA6	0.19	6H6GT	0.15	9BWB	0.55	25AG	0.29	90AG	3.38	DD4	0.53	EBL21	0.60	EP184	0.27	HVR2A	53	PCF882	0.29		0.63	U22	0.39
1H5GT	0.33	6BC8	0.50	6J5G	0.19	9D7	0.78	25L6G	0.20	90AV	3.38	DF91	0.14	EB82	0.19	EL83	0.38	KT2	0.25	PCF883	0.54	QV04/7	63	U25	0.72
1L4	0.13	6BE6	0.20	6J5GT	0.29	10C2	0.49	25V5	0.38	90CC	1.70	DF96	0.34	EB83	0.21	EL83	0.40	KT2	0.25	PCF884	0.32	R11	0.98	U26	0.64
1L5	0.30	6BG6G	1.05	6J6	0.18	10DE7	0.50	25V5G	0.43	90CV	1.68	DH76	0.28	EB84	0.28	EL86	0.38	KT81	2.00	PCF885	0.40	R16	1.75	U31	0.30
1LN5	0.40	6BH6	0.43	6J7G	0.24	10P1	0.75	25Z4G	0.28	90C1	0.59	DH77	0.18	EB85	0.32	EL91	0.25	KT44	1.00	PCF886	0.80	R20	0.64	U45	0.78
1N3GT	0.37	6B46	0.39	6J7(M)	0.38	10P9	0.45	25Z5	0.40	150H2	0.58	DH81	0.58	EB86	0.40	EL91	0.25	KT44	1.00	PCF887	0.80	R20	0.64	U45	0.78
1N5	0.26	6BK7A	0.50	6J8A	0.10	10P18	0.55	25Z6GT	0.43	301	1.00	DH81	0.58	EB87	0.40	EL91	0.25	KT44	1.00	PCF888	0.80	R20	0.64	U45	0.78
1B4	0.22	6BQ5	0.21	6K7G	0.12	10LD11	0.53	28D7	0.34	302	0.93	DK32	0.32	EB88	0.35	EL96	0.49	KTW63	50	PCF889	0.80	R20	0.64	U45	0.78
1B5	0.20	6BQ7A	0.38	6K8G	0.33	10P13	0.54	30A5	0.44	303	0.75	DK91	0.26	EB89	0.48	EL96	0.49	KTW63	50	PCF890	0.80	R20	0.64	U45	0.78
1U4	0.29	6BR7	0.79	6L1	0.98	10P14	1.08	30C1	0.26	305	0.83	DK92	0.49	EB90	0.21	EL96	0.49	KTW63	50	PCF891	0.80	R20	0.64	U45	0.78
1U5	0.48	6BR8	0.63	6L6GT	0.50	12A6	1.08	30C15	0.55	306	0.85	DK96	0.43	EB91	0.21	EL96	0.49	KTW63	50	PCF892	0.80	R20	0.64	U45	0.78
2D21	0.35	6BR7	1.25	6L7	0.38	12AC6	0.40	30C17	0.74	807	0.59	DL33	0.35	EB92	0.25	EL96	0.49	KTW63	50	PCF893	0.80	R20	0.64	U45	0.78
2K5	0.50	6BW6	0.72	6L12	0.32	12AD6	0.40	30C18	0.89	1821	1.53	DL36	0.35	EB93	0.25	EL96	0.49	KTW63	50	PCF894	0.80	R20	0.64	U45	0.78
3A4	0.25	6BW7	0.50	6L18	0.44	12AE6	0.48	30P3	0.61	4083X	0.55	DL32	0.23	EB94	0.25	EL96	0.49	KTW63	50	PCF895	0.80	R20	0.64	U45	0.78
3B7	0.25	6BZ6	0.31	6L19	1.38	12AT6	0.55	30P4	0.58	5702	0.80	DM70	0.30	EB95	0.25	EL96	0.49	KTW63	50	PCF896	0.80	R20	0.64	U45	0.78
3D6	0.19	6C4	0.28	6LD12	0.28	12AT7	0.16	30P12	0.75	6060	0.30	DM71	0.50	EB96	0.25	EL96	0.49	KTW63	50	PCF897	0.80	R20	0.64	U45	0.78
3Q4	0.38	6C6	0.19	6LD20	0.48	12AU6	0.21	30P13	0.67	7193	0.53	DW4500	38	EB97	0.25	EL96	0.49	KTW63	50	PCF898	0.80	R20	0.64	U45	0.78
3Q5GT	0.35	6C9	0.73	6N7GT	0.48	12AU7	0.21	30P14	0.67	7475	0.70	DW4500	38	EB98	0.25	EL96	0.49	KTW63	50	PCF899	0.80	R20	0.64	U45	0.78
384	0.23	6C12	0.25	6P15	0.21	12AV6	0.28	30P14	0.66	A1834	1.00	DY802	0.22	EB99	0.25	EL96	0.49	KTW63	50	PCF900	0.80	R20	0.64	U45	0.78
40B6	0.50	6C17	0.63	6P28	0.59	12AX1	0.21	30L1	0.27	A2134	0.98	DY802	0.22	EB99	0.25	EL96	0.49	KTW63	50	PCF901	0.80	R20	0.64	U45	0.78
5G8	0.50	6CB6A	0.26	6Q7E	0.35	12H16	0.30	30L15	0.55	A3042	0.75	DY802	0.22	EB99	0.25	EL96	0.49	KTW63	50	PCF902	0.80	R20	0.64	U45	0.78
5R4GY	0.53	6CDBG	1.08	6Q7(M)	0.43	12BE6	0.30	30L17	0.65	AC2PEN	0.98	DY802	0.22	EB99	0.25	EL96	0.49	KTW63	50	PCF903	0.80	R20	0.64	U45	0.78
5T4	0.30	6CGL6A	0.50	6Q7GT	0.43	12BH7	0.27	30P4MR	95	0.98	EB80C	0.60	ECL83	0.52	EZ40	0.40	PC884	0.27	PL504/500		U42	0.60	U133	0.35	
5U4G	0.30	6C6	0.43	6R7	0.55	12J5GT	0.30	30P12	0.69	AC6PEN	38	EB2CC	0.40	ECL84	0.54	EZ41	0.40	PC885	0.24		0.60	U42	0.60	U133	0.35
5V4G	0.33	6C18A	0.50	6R7G	0.35	12J7GT	0.33	30P16	0.28	AC2PEN	7	EB180	0.90	ECL85	0.54	EZ80	0.19	PC888	0.39	PL508	0.90	U42	0.60	U133	0.35
5Y3GT	0.30	6CM7	0.50	6SA7	0.35	12K5	0.50	30P19		DI	0.98	EB180C	1.00	ECL86	0.33	EZ81	0.20	PC890	0.42	PL820	0.75	U42	0.60	U133	0.35
3Z3	0.45	6CV5	0.30	6S7GT	0.33	12K7GT	0.34	30P4	0.65	ACPEN7	50	EB180	0.90	ECL87	0.33	EZ81	0.20	PC890	0.42	PL820	0.75	U42	0.60	U133	0.35
5Z4G	0.33	6CV4	0.63	6S7G	0.32	12K7GT	0.28	30P11	0.57	ACPEN7	50	EB180	0.90	ECL88	0.33	EZ81	0.20	PC890	0.42	PL820	0.75	U42	0.60	U133	0.35
5Z4GT	0.38	6D3	0.38	6S8H7	0.53	12S4GT	0.30	30P12	0.29	ACTH1	50	EA57	0.27	EP22	0.63	EP40	0.49	PC806	0.65	PY80	0.23	U184	0.28	N66	0.33
6/30L2	0.53	6D6	0.15	6S8J7	0.35	12S7G	0.35	30P13	0.80	ACTP	0.98	EAC80	0.28	EP41	0.58	EP41	0.58	PC806	0.65	PY80	0.23	U184	0.28	N66	0.33
6A8G	0.33	6DE7	0.50	6S8K7GT	0.23	12S8G7	0.23	30P14	0.80	AL69	0.78	EAC91	0.28	EP42	0.33	EP42	0.33	PC806	0.65	PY80	0.23	U184	0.28	N66	0.33
6AC7	0.13	6DT6A	0.50	6S8Q7GT	0.38	12S8H7	0.15	30P15	0.87	ARP3	0.35	EAC92	0.48	EP43	0.75	EP43	0.75	PC806	0.65	PY80	0.23	U184	0.28	N66	0.33
6AG5	0.25	6EW6	0.55	6U4GT	0.60	12S8J7	0.33	355/51	0.63	ATP4	0.40	EAF80	1.50	EP80	0.21	GZ32	0.39	PC866	0.44	PY88	0.31	U19	0.40	Z549	0.66
6AH6	0.50	6E5	0.55	6U7G	0.53	12S8K7	0.24	35A3	0.48	AZ1	0.40	EAF80	1.50	EP80	0.21	GZ32	0.39	PC866	0.44	PY88	0.31	U19	0.40	Z549	0.66
6AJ5	0.75	6F1	0.59	6V8G	0.17	12S8Q7GT	0.50	35A3	0.75	AZ1	0.40	EAF80	1.50	EP80	0.21	GZ32	0.39	PC866	0.44	PY88	0.31	U19	0.40	Z549	0.66
6AK5	0.25	6F6	0.83	6V6GT	0.27	14H7	0.48	35D5	0.70	AZ41	0.46	EAF80	1.50	EP80	0.21	GZ32	0.39	PC866	0.44	PY88	0.31	U19	0.40	Z549	0.66
6AK6	0.30	6F6G	0.35	6X4	0.20	14S7	0.75	35L6GT	0.42	B36	0.33	EAF80	1.50	EP80	0.21	GZ32	0.39	PC866	0.44	PY88	0.31	U19	0.40	Z549	0.66
6AM6	0.17	6F13	0.33	6X5GT	0.25	15A3	0.24	35V4	0.23	B319	0.27	EAF80	1.50	EP80	0.21	GZ32	0.39	PC866	0.44	PY88	0.31	U19	0.40	Z549	0.66
6AM8A	0.50	6F14	0.40	6V6G	0.55	19BG6G	0.80	35Z3	0.50	CL33	0.90	EAF80	1.50	EP80	0.21	GZ32	0.39	PC866	0.44	PY88	0.31	U19	0.40	Z549	0.66
6AN8	0.48	6F15	0.65	6Y7G	0.63	19C6	0.50	35Z4GT	0.24	CV6	0.53	EAF80	1.50	EP80	0.21	GZ32	0.39	PC866	0.44	PY88	0.31	U19	0.40	Z549	0.66

Beginner's Guide to Colour Television — 2nd Edition

Gordon J. King RTEchEng, MIPRE, FSRE, MRTS, FISTC. The reader is guided through the principles of NTSC and PAL to an understanding of the method of operation of the PAL system from aerial to display tube. The author, who is noted for his crisp and lucid style, has completely revised this edition which will be of immense value to all who wish to understand how television works.

1973 208 pp., illustrated 0 408 00101 1 £1.95

Elements of Linear Microcircuits

T. D. Towers MBE, MA, BSc, MIERE Based on a series of articles written for *Wireless World*, the book gives practical guidance on the commercially available linear microcircuit devices, and on the handling of these sensitive circuits within an assembly. The emphasis throughout is on applications.

1973 116 pp., illustrated 0 592 00077 X £2.80

Television Engineers' Pocket Book — 6th Edition

Revised by P. J. McGoldrick CEng, MIEE, MSMPTE Extensively revised and updated, the sixth edition of this popular book provides an essential summary of all the basic facts, circuit techniques and technical data normally required for servicing either colour or monochrome receivers.

1973 376 pp., illustrated 0 408 00102 X £2.50

Obtainable through any bookseller or from the publisher

INTEGRATED CIRCUITS A. MARSHALL & SON (LONDON) LTD.,

SEMICONDUCTOR SPECIALISTS

28 CRICKLEWOOD BROADWAY, LONDON, N.W.2

Telephone: 01-452 0161/2 Telex: 21492 Cable: Coninst London
NEW LOW PRICES LARGEST RANGE BRAND NEW FULLY GUARANTEED



We Supply
COMPLETE KITS for the following units:

Television Kit No. 1 **£8.02**

PAL Decoder

Television Kit No. 4 **£7.87**

I.F. Strip

Television Kit No. 8 **£6.35**

R.G.B. Board

Television Kit No. 10 **£7.15**

Time-Base

No increase in prices!!

STOP PRESS:

New catalogue available at 15p.

100-watt Guitar Amplifier—complete kit
with case and all components **£23.50**

"SCORPIO"

Capacitor discharge ignition system (as published in
Practical Electronics, Nov. 1971).

COMPLETE KIT **£10.00** P. & P. 50p.

We Stock Full Range of:

Motorola consumer I.C.s

RCA Cos-Mos

Signetics popular I.C.s



**ALL PRICES EXCLUSIVE
OF V.A.T.**

SOUTHEND ELECTRONICS

DELAY LINES

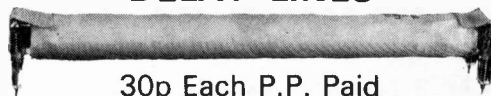

30p Each P.P. Paid

COLOUR 25 KV TRIPLERS

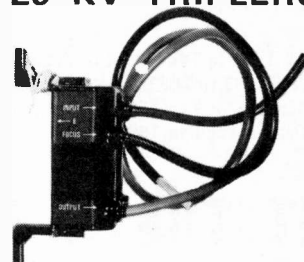

£1.65 P.P. Paid

CONVERGENCE PANEL & YOKE

£5.00 P.P. Paid

TRANSISTOR U.H.F. SIX PUSH BUTTON TUNER UNITS

£4.50 P.P. Paid

V.H.F., U.H.F. £3.50 Each P.P. Paid
No Push Button

200 + 200 + 100 +
32 MFD 275V

£1.00 P.P. Paid

100 W/W MIXED RESISTORS

£1.00 P.P. Paid

250 MIXED RESISTORS

£1.00 P.P. Paid

200 MIXED CONDENSERS

£1.00 P.P. Paid

40 MIXED POTS

£1.00 P.P. Paid

All prices include V.A.T.

SOUTHEND ELECTRONICS

240 Rayleigh Road,
Eastwood,
Leigh-on-Sea,
Essex.

Phone: Southend 521363

TV LINE OUTPUT TRANSFORMERS

ALL MAKES SUPPLIED PROMPTLY by our
RETURN OF POST MAIL ORDER SERVICE

All Lopts at the one price

£4.40 TRADE £4.95 RETAIL (INCLUDING V.A.T.)

Except

BUSH MODELS TV53 to TV67 TV94 to TV101
EKCO MODELS TC208 to TC335, TV407 to TV417
FERGUSON MODELS 405 to 438, 506 to 546.
FERRANTI MODELS 1084 to 1092.

Post and Packing 28p COD 33p

HMV MODELS 1876 to 1878, 1890 to 1896, FR 20.
MURPHY MODELS 653X to 789 OIL-FILLED
REGENTONE MODELS 10-4 to 10-21, 1718, R2, R3, 191, 192.
RGD 519-621, 710, 711.

ALL AT £2.75 + 28p P&P

EHT TRAYS SUPPLIED – MONO & COL.

All Lopts NEW and GUARANTEED for SIX MONTHS

E. J. PAPWORTH AND SON Ltd.,
80, MERTON HIGH ST., LONDON, S.W.19

01-540 3955
01-540 3513

COLOUR TV

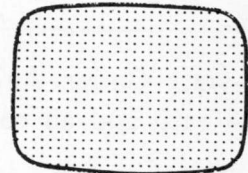
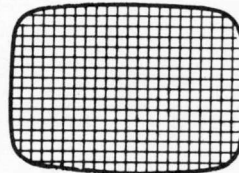
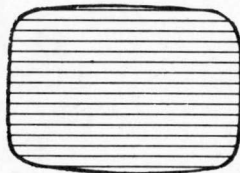
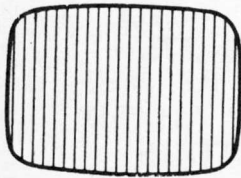

CROSS HATCH GENERATOR

Complete kit for Cross Hatch
Generator as described in
"TELEVISION"
September issue

£3.50

COMPLETE KIT POST PAID

The only way to obtain 100%
convergence of colour guns
in any colour TV

Please send me the free
BI-PRE-PAK Catalogue
Please send me kits of parts
for Cross Hatch Generator
I enclose cheque/P.O./M.O.
for
Name _____
Address _____

BI-PRE-PAK LTD

DEPT. G. 222-224 WEST ROAD, WESTCLIFF-ON-SEA, ESSEX.
TELEPHONE: SOUTHEND (0702) 46344

Reg. No. 820919

PADGETTS RADIO STORES

OLD TOWN HALL, LIVERSEDGE,
YORKS. WF15 6PQ.

Tel.: Heckmondwike 4285

The TV Graveyard of the North, as seen on TV Telewrecks. Close to the Motorway. Call in and see us. Plenty of Free Parking Space. Established 1935.

Would you like a good 19" PYE 405 line 13-Channel TV Set? Working well, with a Good Cabinet. If so, send £4.95 plus £1.50 carriage and insurance, and receive the Bargain of Your Life! Money Back Guarantee.

Special Offer of TV Sets, complete but untested. 12-Channel TV Sets 17" £1.00, 19" £3.00. Carriage & insurance on any set £1.50

We are Breaking-up the following TV Sets:

Ferguson Model 506T; Bush TV75, TV85, TV95, TV105; PYE 11U 13U Series; MURPHY V310, V410, V500; PHILIPS 1768U, 17TG100; Thorn 850 Range. Please send s.a.e. with your query.

EX TV SPEAKERS—all 3 Ohm 2½ Watts: 7 x 4", 6 x 4", 8 x 2½" 25p each. Post on any Speaker 10p.

RECLAIMED TV TUBES: AW43/80, £1.50; AW43/88 £1.50; MW43/69 £1.00. Many other types in stock. Carriage and insurance on any Tube £1.50.

TOP QUALITY TAPE: Reel to Reel 5" ST. 44p; 5" LP. 50p; 7" ST. 60p; 7" LP. 75p. Tapes, Cassette Types: C60 30p; C90 40p; C120 50p. Post on any tape 10p.

EX EQUIPMENT VALVES. All tested on our Mullard Valve Tester before despatch. 3 Months Guarantee on all valves. Single Valves Post 3p; Over, Post Paid.

ARP12	5p	EF183	20p	PL83	10p	U191	20p
EB91	4p	EF184	20p	PL33	17p	6BW7	12p
EF80	8p	PCF80	5p	PL36	17p	6F23	20p
EBF89	15p	PCC84	5p	PY81	10p	20P1	15p
ECC81	12p	PCL82	12p	PY800	17p	20P3	12p
ECC82	12p	PCL83	15p	PY801	17p	30F5	12p
EF91	4p	PCL84	15p	PY82	10p	30FL1	20p
EY86	20p	PL82	10p	PY33	20p		

Add V.A.T. at the STANDARD RATE AFTER APRIL 1st on all goods, including Carriage.

COLOUR, UHF AND TELEVISION SPARES

"TELEVISION" Constructor's Colour Set, Demonstration Model now working and on view at 172 West End Lane, N.W.6. Call, phone, or write for up to date information, colour lists. SCAN PACK No. 21. Philips/Mullard or Plessey Scan Coils, Convergence Yoke, Blue Lateral, complete set for £10-60 p.p. 40p. PRINTED CIRCUIT BOARDS. Convergence, 3 for £2-75, T.B. £1-25, Decoder £1-25, I.F. amp £1-25 p.p. 30p, R.G.B. 65p, Varicap Panels 65p p.p. 15p, Power Supply £1-65 p.p. 30p. PACKS (incl. p.p.). No. 2 £4-90, No. 5 95p, No. 9 43p, No. 12 30p, No. 13 34p, No. 14 £9-75, No. 15 £2-25, No. 16 £10-95, No. 17 £2-65, No. 19 £2-30, No. 21 £11.00, No. 22 £2-30. C.R.T. Base 30p, C.R.T. Shields £2-05 p.p. 55p, Varicap ELC1043 £4-50, TAA550 62p, AE Isolpanel 30p.

MAINS TRANSFORMER for Colour Receiver, guaranteed to give correct outputs under actual load conditions, plus additional 6-3V C.R.T. heater tapping £9-50 p.p. 50p.

C.R.T. HEATER TRANSFORMERS 6-3V 1 amp £1-10 p.p. 25p.

SPECIAL OFFER IF panel, leading British maker, similar design to "Television" panel, includes TAA350, lum. delay line AFC generator, etc., incl. circuit, £8-90 p.p. 35p.

G.E.C. Colour decoder panels (for parts) incl. DL20, crystal and approx. 50% of resistors. Conds., diodes, transist., etc. for "Television" decoder £3-50 p.p. 30p.

PHILIPS G6 single standard convergence control panel, incl. 16 controls, switches etc. and circuits £5-00 p.p. 30p.

PHILIPS G8 decoder panel part complete incl. I/C £2-50 I.F. Panel part/compl incl. modules £2-50 p.p. 30p.

BUSH CTV25 timebase units, line frame, E.H.T. surplus £4-50 p.p. 80p.

VARICAP/VARACTOR ELC 1043 UHF tuner (for "Television" colour receiver) £4-50. VHF Varicap tuners for band 1 & 3 £2-85, Varicap tuners salvaged £1-50 p.p. 25p.

UHF 625 kits and tuners. Lists available at reduced prices. UHF tuners, transistd. £3-10; incl. s/m drive, indicator £3-85; 6 position pushbutton £4-95, UHF/VHF transistd. tuner, latest type, incl. circuit £3-25. Cyldon valve type £1-50 p.p. 30p.

MURPHY 600/700 series UHF conversion kits in cabinet plinth assembly, can be used as separate UHF receiver £7.50 p.p. 50p.

SOBELL/GEC Dual 405/625 IF amp and o/p chassis incl. circuit £1-50 p.p. 30p PHILIPS 625 IF panel incl. cct £1 p.p. 30p.

FIREBALL TUNERS Fern., HMV, Marconi. New £1.90 p.p. 25p. TURRET TUNERS. KB "Featherlight" VC11, Philips 170 series, GEC 2010 £2-50. AB Dual Stand. Suit. Ferguson, Baird, KB, etc. 75p. Cyldon C 75p, Pve 110/510-Pam, Invicta, Miniature, increm. £1-95, Peto Scott 960, Decca 95/606 £1-50 p.p. 30p.

LINE OUTPUT TRANSFORMERS. Popular types available, brand new replacements, fully guar. A selection which can be supplied p.p. 30p. C.O.D. 28p.

MURPHY 849, 939, 153 2417S £4-90
PHILIPS 1768/2168, 1796/2196 £4-90
PHILIPS 17TG/100 Range £4-40

STELLA 1011/1029 ... 4-30
PHILIPS 19TG111/12 ... £4-40
PHILIPS 19TG121 to 156 ... £4-90
PHILIPS 19TG170, 210 series £4-90
BUSH TV92, 93, 105 to 186SS £4-90
EKCO 221 to 394, FERRANTI 1001 to 1065 ... £4-30
EKCO, FERR 418, 1093 etc. £4-30
DECCA DR95, 101/606, DR1, 2, 3, 121/123, 20/24, 2000 ... £4-70
FERG 305 to 436, 606 to 727 £4-30
FERG, HMV, MARCONI, ULTRA, PHILCO 3600, 2600, 4600, 6600, 1100 series, Jell pot £4-70
KB VC1 to VC11 ... £4-40
MARCONI VT157 to 172 ... £4-30
GEC 302 to 456, 2000 series £4-90
HMV 1865/9, 1870/6, 1910/1924 £4-30
PYE 17/21, 17/S, 110 to 510 700, 830, 1, 2, 3, 11U to 64 £4-30
PAM, INVICTA equiv. LOPTS to above PYE ... £4-30
SOBELL 195/282/1000 series ... £4-90
ULTRA 1770 to 2384 ... £4-30

SPECIAL OFFERS
BUSH TV53/86... £1-75
BUSH TV95/99... £2-50
EKCO 380 to 390 £2-50
EKCO 407/417 ... £2-50
FERR 1057 to 1068 £2-50
FERR. 1084/1092 £2-50
FERG. 506 to 546 £1-50
HMV 1890 to 1896 £1-50
P/SCOTT 1419 to 1725,733 to 738 £1-75
REG. 10-6, 10-17 £2-50
REG 191/2, 17-18 £2-50
RGD 519 606, 610, 612, 619, 620, 711 ... £2-50
PHILCO 1010/21 £2-25

LOPT Inserts p.p. 17p
KB NF70, OV30, PV40, PVP20, QV10, 20, 30 ... £1-95
KB/RGD VCII ... £2-75
Featherlight ... £2-75
KB/RGD VC1-9 ... £1-95
PHILCO 1030/50 ... £1-95
PHILIPS 17TG100 range ... £1-95

LOPT Inserts p.p. 17p
KB NF70, OV30, PV40, PVP20, QV10, 20, 30 ... £1-95
KB/RGD VCII ... £2-75
Featherlight ... £2-75
KB/RGD VC1-9 ... £1-95
PHILCO 1030/50 ... £1-95
PHILIPS 17TG100 range ... £1-95

LOPT Inserts p.p. 17p
KB NF70, OV30, PV40, PVP20, QV10, 20, 30 ... £1-95
KB/RGD VCII ... £2-75
Featherlight ... £2-75
KB/RGD VC1-9 ... £1-95
PHILCO 1030/50 ... £1-95
PHILIPS 17TG100 range ... £1-95

LOPT Inserts p.p. 17p
KB NF70, OV30, PV40, PVP20, QV10, 20, 30 ... £1-95
KB/RGD VCII ... £2-75
Featherlight ... £2-75
KB/RGD VC1-9 ... £1-95
PHILCO 1030/50 ... £1-95
PHILIPS 17TG100 range ... £1-95

LOPT Inserts p.p. 17p
KB NF70, OV30, PV40, PVP20, QV10, 20, 30 ... £1-95
KB/RGD VCII ... £2-75
Featherlight ... £2-75
KB/RGD VC1-9 ... £1-95
PHILCO 1030/50 ... £1-95
PHILIPS 17TG100 range ... £1-95

LOPT Inserts p.p. 17p
KB NF70, OV30, PV40, PVP20, QV10, 20, 30 ... £1-95
KB/RGD VCII ... £2-75
Featherlight ... £2-75
KB/RGD VC1-9 ... £1-95
PHILCO 1030/50 ... £1-95
PHILIPS 17TG100 range ... £1-95

LOPT Inserts p.p. 17p
KB NF70, OV30, PV40, PVP20, QV10, 20, 30 ... £1-95
KB/RGD VCII ... £2-75
Featherlight ... £2-75
KB/RGD VC1-9 ... £1-95
PHILCO 1030/50 ... £1-95
PHILIPS 17TG100 range ... £1-95

LOPT Inserts p.p. 17p
KB NF70, OV30, PV40, PVP20, QV10, 20, 30 ... £1-95
KB/RGD VCII ... £2-75
Featherlight ... £2-75
KB/RGD VC1-9 ... £1-95
PHILCO 1030/50 ... £1-95
PHILIPS 17TG100 range ... £1-95

LOPT Inserts p.p. 17p
KB NF70, OV30, PV40, PVP20, QV10, 20, 30 ... £1-95
KB/RGD VCII ... £2-75
Featherlight ... £2-75
KB/RGD VC1-9 ... £1-95
PHILCO 1030/50 ... £1-95
PHILIPS 17TG100 range ... £1-95

LOPT Inserts p.p. 17p
KB NF70, OV30, PV40, PVP20, QV10, 20, 30 ... £1-95
KB/RGD VCII ... £2-75
Featherlight ... £2-75
KB/RGD VC1-9 ... £1-95
PHILCO 1030/50 ... £1-95
PHILIPS 17TG100 range ... £1-95

LOPT Inserts p.p. 17p
KB NF70, OV30, PV40, PVP20, QV10, 20, 30 ... £1-95
KB/RGD VCII ... £2-75
Featherlight ... £2-75
KB/RGD VC1-9 ... £1-95
PHILCO 1030/50 ... £1-95
PHILIPS 17TG100 range ... £1-95

LOPT Inserts p.p. 17p
KB NF70, OV30, PV40, PVP20, QV10, 20, 30 ... £1-95
KB/RGD VCII ... £2-75
Featherlight ... £2-75
KB/RGD VC1-9 ... £1-95
PHILCO 1030/50 ... £1-95
PHILIPS 17TG100 range ... £1-95

LOPT Inserts p.p. 17p
KB NF70, OV30, PV40, PVP20, QV10, 20, 30 ... £1-95
KB/RGD VCII ... £2-75
Featherlight ... £2-75
KB/RGD VC1-9 ... £1-95
PHILCO 1030/50 ... £1-95
PHILIPS 17TG100 range ... £1-95

LOPT Inserts p.p. 17p
KB NF70, OV30, PV40, PVP20, QV10, 20, 30 ... £1-95
KB/RGD VCII ... £2-75
Featherlight ... £2-75
KB/RGD VC1-9 ... £1-95
PHILCO 1030/50 ... £1-95
PHILIPS 17TG100 range ... £1-95

LOPT Inserts p.p. 17p
KB NF70, OV30, PV40, PVP20, QV10, 20, 30 ... £1-95
KB/RGD VCII ... £2-75
Featherlight ... £2-75
KB/RGD VC1-9 ... £1-95
PHILCO 1030/50 ... £1-95
PHILIPS 17TG100 range ... £1-95

REBUILT TUBES!

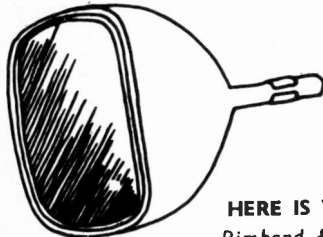

YOU'RE
SAFE
WHEN YOU
BUY FROM
RE-VIEW!

HERE IS WHAT YOU PAY:

	Mono	Rimband & Twin Panel	Colour
15-17"	£4-75	19" £6-50	19" £22-50
19"	£5-00	23" £8-50	22" £25-00
21"	£6-00	24" £9-50	25" £27-50
23"	£7-00		26" £29-00

Exchange Basis

Carriage 75p (carriage-ins. £1-50)

Cash or cheque with order, or cash on delivery
Guarantee 1 year

- ★ Each tube is rebuilt with a completely new gun assembly and the correct voltage heater.
- ★ Each tube comes to you with a guarantee card covering it for Mono Tubes, two years against all but breakage.
- ★ Each tube is insured on the journey.
- ★ Each tube is rebuilt with experience and know-how. We were amongst the very first to pioneer the technique of rebuilding television tubes.

RE-VIEW ELECTRONIC TUBES

237 London Road, West Croydon, Surrey
Tel. 01-689 7735

MANOR SUPPLIES

172 WEST END LANE, LONDON, N.W.6
(Near W. Hampstead tube stn; 28, 59, 159 Bus Routes) 01-794 8751
Mail Order: 64 GOLDERS MANOR DRIVE,
LONDON, N.W.11

Service Engineers



WHEREVER YOU ARE FOR BY
RETURN DESPATCH. WILLOW
VALE IS AS NEAR AS YOUR
PHONE....



STOCKISTS OF GENUINE MANUFACTURERS SPARES FOR:-

RANK BUSH MURPHY LTD. C.E.S. LTD. PYE.
PHILIPS INVICTA. PAM. EKCO. FERRANTI.
BRITISH RADIO CORPORATION. FERGUSON.
ULTRA. MARCONI. HIS MASTERS VOICE.

STOCKISTS OF "TELEPART" SPARES FOR:-

DECCA. K.B. GEC. SOBELL. MASTERADIO.
R.G.D. etc.

*LINE OUTPUT TRANSFORMERS
EHT RECTIFIER TRAYS
SCAN COIL ASSEMBLIES
FRAME AND SOUND OUTPUTS
DROPPER SECTIONS*

MONOCHROME & COLOUR



HUGH RANGE OF:-

ENTERTAINMENT VALVES up to 48% DISCOUNT TRANSISTORS AND INTEGRATED CIRCUITS

COMPONENTS. CAPS. RESISTORS. V/CONTROLS. PRESETS.
VALVE BASES. SLIDERS. A/E PANELS. BIAS and SMOOTHING
ELECTROLYTICS. etc.

CATHODE RAY TUBES. NEW and REBUILT. MONO and
COLOUR FROM TVETTE TO 26" COLOUR. ALL TYPES.

METERS AND TEST EQUIPMENT. Servisol, Electrolube,
Multicore, Service Tools.

FOR "BY RETURN" SERVICE CONTACT
THE SPECIALIST WHOLESALERS:-

willow vale electronics ltd

4&5 THE BROADWAY, HANWELL, LONDON W7

or

74 MAXWELLTON RD, PAISLEY, RENFREW

or

42 WEST END, STREET, SOMERSET

I would like a free copy of your catalogue

NAME

ADDRESS

P.T.

HOT LINES: LONDON 01 -567 5400
GLASGOW 041-887 4949
SOMERSET 045-84 2597

NO RETAIL ENQUIRIES
SEND FOR FREE COPY OF OUR 64-PAGE CATALOGUE
STRICTLY WHOLESALE ONLY

TELEVISION

SERVICING · CONSTRUCTION · COLOUR · DEVELOPMENTS

VOL 23 No 8
ISSUE 272

JUNE 1973

LET'S BE REALISTIC

Most of us are so concerned with the day-to-day requirements of providing working receivers for BBC and ITV that we perhaps take for granted the back-room politics that decide on TV systems and reception techniques.

Receiver designers operate within the confinements set by the policy makers who advise the Minister for Posts and Telecommunications. On what sources of information do these advisers rely? They are usually representatives of the broadcasting organisations and professional bodies: one could argue therefore that some public representation should be included as a counterbalance.

The present intention is to change transmission from v.h.f. to u.h.f. by roughly 1985. Subsequent developments could be from microwave link to satellite with wired distribution networks to individual homes. It will be possible we are told to provide by the 1980s a national wired TV distribution network with six channels for 96% of the population of the UK at a cost of some £500 million. A 24-channel network would cost £1,500 million and take twenty years to complete. Even by today's standards these are enormous sums.

We are all in favour of progress, but gain the impression that there is little sense of proportion in some of these suggestions. The reception of satellite transmissions is expected to cost, when picked up by the individual householder via a dish aerial, some £80 per installation—the alternative solution being the cable one, with central receiving stations and distribution by wire at lower frequencies to conventional receivers in individual houses.

Such estimates are in our opinion optimistic. It is by now commonplace that high technology can be extremely costly—though we must admit that broadcasting has not to date been an offender in this respect. Nevertheless the estimates mentioned make us worry—and they don't even seem to take into account the disruption to local amenities that going over to cable would entail.

Progress in broadcasting tends to come quite quickly, but if the prolonged use of 405 lines and the medium wave band is anything to go by we fancy most UK viewers would say "is it all really necessary?" The deciding factor is likely to be hard cash.

M. A. COLWELL—*Editor*

THIS MONTH

Teletopics	342
The New Colour Tube	<i>by John Neate</i> 344
Fault Finding Guide—4: Field Timebase, BRC 850 chassis	<i>by John Law</i> 348
Reverse and Forward AGC	<i>by K. T. Wilson</i> 350
Tackling Field Failure	<i>by D. W. James</i> 353
TV Test Report: Nombrex Model 43 RC Bridge	<i>by E. M. Bristol</i> 354
The TELEVISION Colour Receiver—Part 15— Mounting the Modules	356
Servicing Television Receivers—BRC 1580 Chassis	<i>by L. Lawry-Johns</i> 358
Single-Tube Colour Cameras	<i>by I. R. Sinclair</i> 362
Service Notebook	<i>by G. R. Wilding</i> 364
Letters	367
Renovating the Rentals—Part 14—BRC 2000 Chassis, Decoder and IF Strip	<i>by Caleb Bradley, B.Sc.</i> 368
Unusual Contrast/AGC Circuit	<i>by H. K. Hills</i> 371
Long-Distance Television	<i>by Roger Bunney</i> 372
Your Problems Solved	375
Test Case 126	377

THE NEXT ISSUE DATED JULY WILL BE PUBLISHED JUNE 18

Cover: We are indebted to RCA for the fine shot of the new Thorn/RCA precision in-line colour tube featured on our cover this month. The photograph clearly shows the precision toroid deflection yoke and the static convergence magnets. As can be seen there are far fewer neck components—and far fewer adjustments therefore—than are required with a conventional shadowmask tube.

TELETOPICS



TIMETABLE FOR THE FUTURE

THE Television Advisory Committee's report for 1972 gives a clear picture of the way in which things are likely to develop over the next few years. Production of dual-standard receivers is scheduled to cease in 1975—there will then be some one million 405-line only and four-and-a-half million dual-standard sets still in use. The committee says there is no certainty that 405-line only sets will be repairable after 1975: we know of the readers of one magazine however who are likely to find ways! Spares for dual-standard models are to cease in 1983. The result of all this is that sets capable of 405-line operation will be increasingly difficult to obtain after 1975 even though a goodly number of viewers are likely to need them still, while by 1985 it will be very difficult to keep any 405-line capable receivers going.

405-line transmissions are likely to be receivable by very few viewers come 1985 therefore and the broadcasting authorities will probably then be phasing them out. The present aim is to complete the three-channel u.h.f. service coverage as soon as possible after 1980. This seems likely to reach some 98% of the population by then, requiring supplementation by other means if the Band I coverage of 99.5% of the population is to be achieved.

By the time that problem becomes urgent television broadcasting via satellite may be a feasible solution, particularly if the transmissions use f.m. for the video signal since this reduces the transmission power required. The UK is likely to be assigned four channels for satellite TV transmissions, each giving national coverage. The transmissions would be in Band VI (11.7-12.5GHz) and the Committee estimates that a suitable s.h.f. front-end plus dish aerial would cost about £80—communal reception with wired distribution might prove to be a more economical way of going about providing s.h.f. reception however. The Committee's conclusion on this subject is that satellite TV broadcasting in the UK could become technically feasible on an experimental basis in the 1980s if the necessary development work is put in hand now.

There seem to be no definite plans about the use of Bands I and III once the 405-line system has been phased out. Satellite transmissions and developments in wired distribution techniques could by then make any thought of resuming TV transmissions in these Bands rather pointless.

Developments in wired distribution are particularly relevant in view of the PO's work on integrating wideband radio and TV distribution with the

telephone service. It is exactly a year ago now since we reported on this page on the proposals for the first such network in the UK at the new city of Milton Keynes in North Buckinghamshire. Housing developments in Washington (Co. Durham), Irvine (Ayrshire), Cragavon (N. Ireland) and Braclá (S. Wales) are also now being equipped with this system which the PO expects to extend to over 200,000 houses over the next 20 years.

UHF TRANSMITTER OPENINGS

The past month has seen commencement of transmissions from one main u.h.f. station and a number of relay stations. The main station is the IBA's high-power transmitter at **Beacon Hill**, South Devon. This carries Westward Television programmes on channel 60 (aerial group C, horizontal polarisation). The maximum e.r.p. is 100kW. Relay stations opened are as follows:

Bacup (Lancashire) IBA carrying Granada programmes on channel 43 (aerial group E).

Blaenavon (Monmouthshire) BBC-Wales on channel 57, BBC-2 on channel 63 (aerial group C).

Lethanhill (Ayrshire) IBA carrying STV programmes on channel 60 (aerial group C).

Nottingham BBC-1 channel 21, IBA (ATV programmes) channel 24, BBC-2 channel 27 (aerial group A).

Rhymney (South Wales) IBA carrying HTV Wales programmes on channel 60 (aerial group C).

West Runton (Norfolk) IBA carrying Anglia programmes on channel 23 (aerial group A).

Whitby (Yorkshire) BBC-1 channel 55, BBC-2 channel 62 (aerial group C).

All these relay transmissions are vertically polarised.

COLOUR SERVICING

Rediffusion's Head of Television Servicing Department B. A. Barnard makes some interesting observations on the impact of colour on domestic receiver servicing in the latest (March/April) issue of *The Royal Television Society Journal*. He has commented in their pages before on the subject: this time his comments are based on his Company's experiences over four years in dealing with the practical problems of colour servicing. We find the following quote of particular interest: "The colour television receiver has become a reasonably reliable service proposition. When catastrophic failures occur these are not always associated with the purely colour part of the receiver—too often they are associated

with the same old bogies we had with monochrome, such as power supplies, channel tuners, sound amplifiers, bad joints. Indeed I sometimes have the impression that our excellent design engineers have poured all their talents into designing decoders and convergence circuits, perhaps taking the reliability of the run-of-the-mill components for granted". We find this a relief in one way: at least it suggests that colour does not mean the advent of an era of obscure one-off faults—and indeed our talks with those in the trade have suggested that with colour we're still confronted by and large with fairly predictable stock faults. In fact a large number of colour set faults are the result of simple supply voltage failures of one sort or another that can be dealt with using just a multimeter.

B. A. Barnard adds that with four years' hindsight the problem of colour servicing in the field is undoubtedly best solved by the use of exchange, plug-in modules. Module interconnections—mostly now by means of plugs and sockets—have not turned out to be the problem some feared, and by analysis of faults reported it is possible to make an accurate assessment of the modules that need to be carried in the field and those that can be held in small numbers in the service department. A point about the use of modules is the effect of VAT which is likely to make it much more worthwhile to service faulty modules locally rather than to return them to the setmaker for attention.

Colour servicing in the UK seems to have got started remarkably smoothly. The main worries at present concern the problems that i.c. decoders will bring and, later, 110° deflection circuits.

NEW TV SETS

ITT have introduced a mains-battery portable in their RGD range: the Rapier 12 is fitted with a 12in. tube and uses the VC300 chassis. The recommended price is £69.50. A new 22in. colour model has been added to the Invicta range: the CT7053 is fitted with the Pye group 697 chassis and has the suggested price of £272. KSM have introduced a 20in. colour model featuring touch-sensitive tuning: this has the recommended price of £224.40 including VAT. Address is KSM Electronics (Televisions) Ltd., Unit 9-11 Houghton Regis Trading Estate, Houghton Regis, Dunstable, Beds.

THICK-FILM HYBRID TV SUBASSEMBLY

The introduction of an alternative field timebase/sound panel (type PC324) for the BRC/TCE 3500 colour chassis brings with it for the first time in the UK the use of a thick-film hybrid subassembly (circuit reference TF401). The new panel is completely interchangeable with the standard one and the setting up procedures are the same. The TF401 subassembly replaces the discrete component field oscillator and driver stages in the standard board.

The TF401 thick-film hybrid subassembly consists of a ceramic substrate on which a pattern of conductors and resistors is deposited in thick-film form. Modern production techniques are used to deposit the conductors and resistors, including power laser scanning which enables the resistors to be trimmed to 5% tolerances. Discrete capacitors and semiconductor devices are then added and the complete

package encapsulated to provide protection against contamination and damage. One advantage of using thick-film components is the good heatsink performance due to the high thermal conductivity of the ceramic substrate (equivalent to mild steel). A further advantage in using the subassembly is that fault-finding is simplified. A solder sucker should always be used when it is necessary to replace the device—the connections are via eleven lead-out wires.

It seems likely that for applications such as this thick-film hybrid subassemblies could have advantages over the other likely development, the use of silicon i.c.s, at least in the immediate future.

REPAIRS AND VAT

R. Thomson, vice-president of the RTRA, commented recently that the introduction of VAT coupled with recent pay awards will make many electrical repairs no longer worth while. "Many repairs will no longer be viable and we shall be a step nearer the American system of consigning an article to the dustbin when it goes wrong" he suggested. To us it looks like increased demands for the efforts of the kitchen table merchants. It is one of the ironies of VAT that it will drive business away from dealers towards the DIY brigade. Most dealers have not exactly fallen over themselves in the past to help the customer who turns up with something faulty, but it is debatable whether such a move is appropriate at a time when there are growing efforts to improve the standards and safety of electrical equipment.

SHOW COMMENTS

At the IEEE Exhibition in New York earlier this year Sony showed a colour projection system which is now on sale in the US for \$3,045. The projection unit uses a high-brightness Trinitron tube and the screen has a diagonal dimension of 50in. Sony were also showing a single-tube colour camera fitted with their Trinicon pickup tube. This employs a striped screen together with a beam-indexing system. Toshiba showed a two-tube colour camera fitted with their Chalnicon pickup tube. A system in which video stills are recorded on a standard chromium dioxide C60 tape cassette was shown by Panasonic who have managed to record two video channels each with associated stereo sound tracks on the ¼in. tape. The tape was playing at 1½in./sec., each video field occupying 6.75in. of tape to give a display time of 3.6sec. The minimum field repetition rate is also 3.6sec. of course and the field can be frozen by operating a pause control. It's an achievement to have put vision on audio tape but we can't see any great demand for a system that seems to be limited to still frames. Panasonic themselves say they have no plans at present to develop the system commercially.

At the Paris Components Show Mullard were showing a line output stage for use with 110° colour tubes. A single BU208 transistor is used with an AT2063 line output transformer and LP1174/40 e.h.t. tripler producing 25kV.

At the 1973 Inter Navex Exhibition (organised by the National Committee for Audio Visual Aids in Education) in July we are promised three-dimensional colour television with stereophonic sound.

THE NEW COLOUR TUBE

JOHN NEATE

THE new colour picture tube introduced in the UK by Thorn and developed in the US by RCA has an abundance of novel features designed to make it easier to operate and perhaps cheaper to produce. It arrives in an aura of snappy abbreviations such as PST ("precision static toroid") and ITC ("integral tube components") but the proud inventors for some reason insist on giving its full name, Precision In-Line System, the full treatment on each appearance. It seems inevitable that others will have no such inhibitions, so we shall draw comparisons between the new PI tube, the standard shadowmask tube and the Sony Trinitron. These are the only colour display devices in or near large scale production at present.

Over twenty years have passed since RCA introduced the shadowmask cathode-ray tube, the first colour television display device to be mass produced. For most of this time it has remained the only colour picture tube available and it is now produced under licence to the inventors by many manufacturers all over the world. Detail improvements have been made of course but the basic scheme has remained unchanged: three electron guns in a triangular (or "delta") formation, a shadowmask etched with a pattern of tiny holes and a corresponding array of red, green and blue phosphor dots on the screen.

In the last few years the Sony Trinitron has appeared and soon established itself as a display device for use in the small screen portable receivers for which it was designed. The three electron guns in this tube are closely spaced side by side in a horizontal plane. The "shadowmask" contains vertical slits instead of holes and the screen is composed of vertical phosphor stripes in a red-green-blue sequence.

Need for Dynamic Convergence

Both these tubes require dynamic convergence correction because although the three beams can be easily adjusted to meet at a common point at the centre of the screen they no longer converge when deflected. The type of misconvergence pattern produced in a delta gun tube is shown in Fig. 1(a) while that produced by the Trinitron is shown in

Fig. 1(b). The errors in the first case can be seen to be a complex mixture of horizontal and vertical shifts. The Trinitron misconvergence occurs only in the horizontal direction: also the errors are in practice smaller because the electron beams are closer together. For both these reasons convergence correction is a much simpler process in the Trinitron. Further advantages of the Trinitron are increased brightness and the elimination of moiré interference patterns due to the dot structure of the delta gun phosphor screen.

It was not to be expected that RCA would rest on their twenty year old laurels and they have now introduced their own colour picture tube aimed at the portable (i.e. smaller screen) receiver market. In some ways it resembles the Trinitron but one very important difference is that it is designed so that *no* dynamic convergence adjustment is needed.

Like the Trinitron, the new tube uses three "in-line" electron guns mounted in a horizontal plane. This immediately confines convergence problems to horizontal shift. The effect of deflecting the three beams horizontally by a *uniform* magnetic field can be seen in Fig. 2. The deflected beams converge at a common point *before* the screen is reached and are diverging therefore at the screen.

Effect of Astigmatic Field

The designer of the deflection coils for a picture tube has as one of his aims the elimination of deflection defocusing of the electron beam, i.e. the tendency of the beam to become progressively defocused as the deflection angle increases. In a colour tube this effect produces "over-convergence". It is possible however by adjusting the position of the turns of the coil round its former to produce an astigmatic field so that the deflected beam is always focused to a vertical line instead of a spot. This is illustrated in Fig. 3. In this diagram the circles represent the diameter of a "fat" beam of electrons reducing in diameter as it is brought to a focus at the screen.

Now the three guns of the PI tube can be imagined to lie on the horizontal diameter of the gun plane circle as shown in Fig. 4. Following the paths of the electrons from the same points indicated in Fig. 3 it is found that the electrons all converge to the *centre* of the vertical line of focus at the screen. So in this particular case the astigmatic field has the effect of automatically converging the three in-line beams to a common point—instead of the line focus that would be obtained with one large diameter beam. This is the principle on which the PI tube relies to achieve self convergence. Trying to make the principle work with conventional techniques of manufacturing and mounting scan coils and electron guns would be difficult if not impossible. To produce a field which gives exactly the right correction implies very precise alignment of the non-uniform scanning field with the electron beams and precise construction of the scan coil assembly. The word "precision" in the name of this new tube is not a product of the marketing man's imagination: it is an engineering necessity.

PST Yoke

The scan coil assembly used is shown in Fig. 5 and is called a "precision static toroid" (PST). The

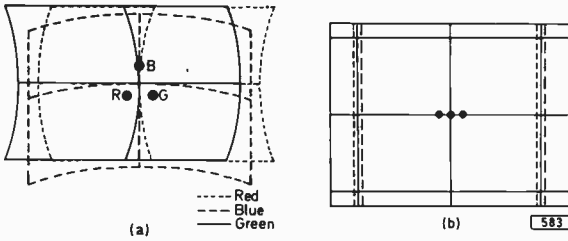

Fig. 1: (a) Basic misconvergence pattern of a delta gun shadowmask tube. (b) Basic Sony Trinitron convergence errors.

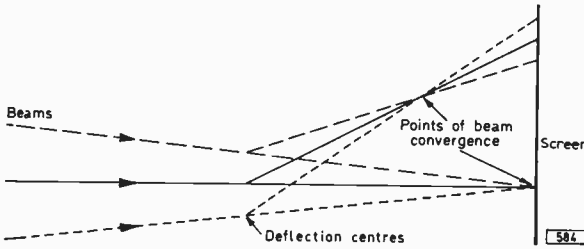

Fig. 2: Three in-line electron beams, viewed from above, when deflected by a uniform magnetic field.

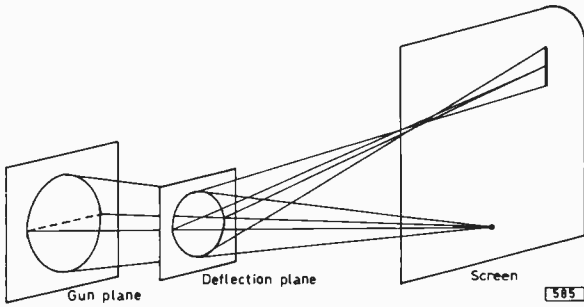

Fig. 3: A circular beam deflected by an astigmatic field is brought to a line focus at the screen.

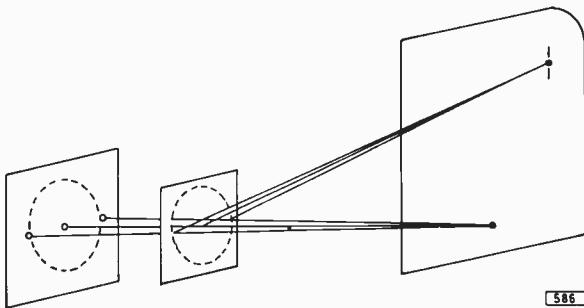

Fig. 4: Three beams on the horizontal axis of the fat beam shown in Fig. 3 are always converged by the astigmatic deflection field.

position of each turn is defined by placing it in slots in moulded plastic rings which are cemented to each end of the core, the distribution of turns around the core being designed to give the required non-uniform horizontal deflection field. It has been found that this form of construction gives extremely con-

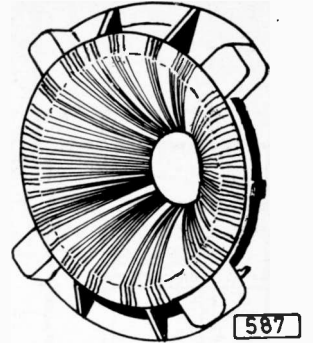

Fig. 5: The precision static toroid deflection yoke which produces the required astigmatic deflection field.

sistent results. Typical PST figures for Thorn 16/18in. tubes are: line coil inductance 0.158mH (parallel) or 0.632mH (series connected); for the series connected field coils the resistance is 2.2Ω .

Effect of Misalignment

If the deflecting field strength applied to each beam is different the position of the scan coil assembly must be critical since movement of this in the plane perpendicular to the axis of the tube will alter the field strength at the deflection centre of each beam. The effect of such a movement is shown in Fig. 6. In (a) the scan coil has been moved to the right of its correct position (as seen by the viewer). The blue beam is now passing through a stronger field so the blue raster is expanded relative to red. The green raster is correspondingly reduced in size. Clearly the lateral position of the scan coil must be adjusted to equalise the size of the three rasters. If the scan coil is moved vertically the effect is to rotate the blue and green rasters relative to red as shown for example in Fig. 6(b). Again, very careful adjustment of the position of the scan coil assembly is seen to be necessary so that the field is symmetrical about the axis of the three beams. The sensitivity of these adjustments is such that the visible change in convergence is about equal to the scan coil movement.

At this point it may seem that the designers have only eliminated one tedious adjustment (dynamic convergence) by replacing it with another (critical lateral and vertical shift of the scan coils). The basic idea of the PI tube however is that the scan coil assembly is treated as part of the tube assembly. It is fixed in its optimum position on the tube at the factory and no further adjustment is required or possible. The scan coil may be separated from the tube only by heating it sufficiently to soften the thermoplastic cement which normally locks it in

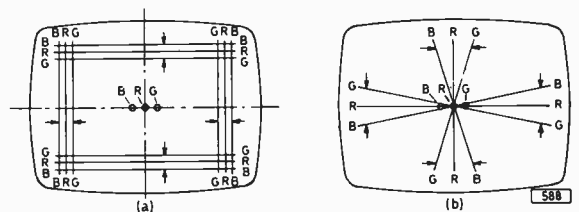

Fig. 6: (a) Convergence effect (shown by arrows) as the yoke is moved horizontally to the left from a misplaced position to the right. (b) Convergence effect as the yoke is moved vertically upwards.

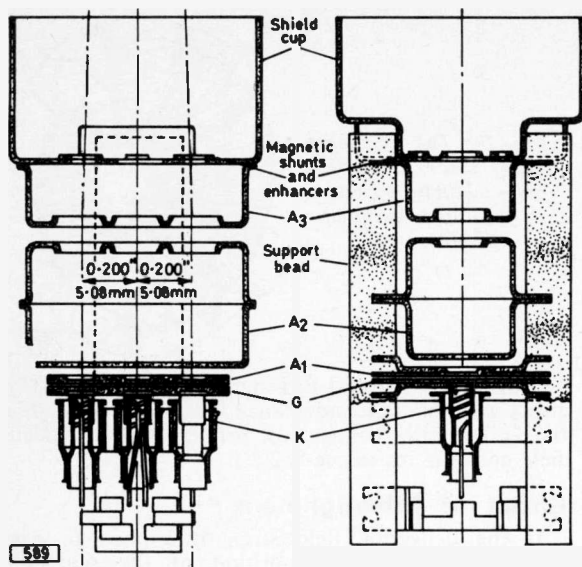

Fig. 7: Cross-section of the precision in-line gun assembly.

position. If a tube is replaced the PST will be automatically replaced with it.

In-Line Electron Guns

The spacing of the three beams must also be defined with precision. The design figure is only 0.200in. and this helps to minimise any tendency of the three beams to misconverge. The beams must also lie in an exactly horizontal plane if the self convergence is to be effective. These requirements are met by forming the three "grids" from a single piece of flat (or "planar") metal punched with three accurately located holes which determine the relative position of the three beams at this point with a tolerance of less than 0.25%. This grid electrode can be seen in the cross-section drawing in Fig. 7. In circuit terms of course this means that the three grids are at a common potential so that the tube cannot be used with grid drive or colour-difference drive.

The remaining electrodes accelerate and focus the electrons, the beams initially following parallel paths. The separation of the apertures in the A3 electrode is slightly increased however: this has the effect of bending the outer beams towards the axis, thus providing most of the static convergence. Fine adjustment is provided by a magnetic field system which is described later. The angular deflection needed for this is less than one degree.

Fig. 7 shows that the beams remain in parallel

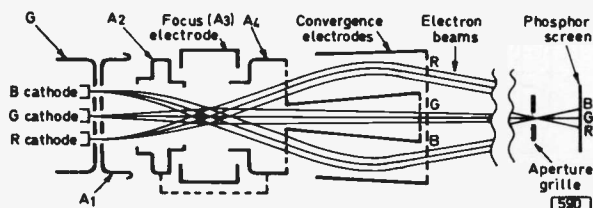

Fig. 8: Electron beam trajectories in the 13in. Sony Trinitron tube.

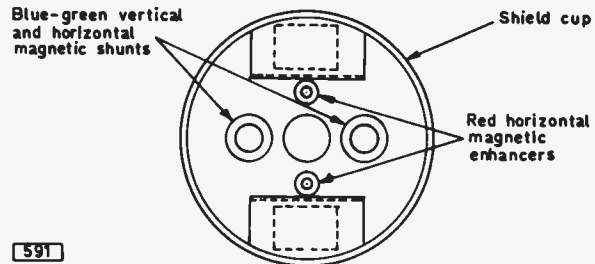

Fig. 9: Front view of the precision in-line electron gun, showing the positions of the magnetic shunts and enhancers.

paths as they pass through the focus field. This makes an interesting comparison with the Trinitron. In the latter tube the in-line beams cross over at the centre of the focus field (see Fig. 8) so that each beam passes through the centre of a relatively large diameter electrode system. This is claimed to reduce aberrations that would otherwise spoil the focus of the outer beams. Since there is only one focus electrode system for all three beams this "large diameter" gun fits into a tube neck whose diameter is 29mm.—the familiar 90° delta gun tube has a neck diameter of 36.5mm. As it happens the neck diameter of the new PI tube turns out to be the same as that of the Trinitron, 29mm. The smaller the neck diameter the less the scan power required for a given angular deflection.

Magnetic Shunts and Enhancers

One other novel feature of the electron gun design should be mentioned. Four magnetic rings are mounted on the A3 electrode as shown in Figs. 7 and 9. These act in rather the same way as a partial magnetic screen. Some of the deflection field is diverted through the material of the rings, reducing the field strength within the ring and modifying the field pattern in the vicinity of the ring.

The effect on the rasters is that the blue and green magnetic shunts reduce the size of the rasters produced by these beams while the red magnetic enhancers increase the width only of the red raster. All this is designed to ensure that the centre beam lands between the outer beams at all points on the screen. The makers claim that in a colour tube convergence errors of the red beam are the most noticeable (agreed?) and for this reason they have associated the centre beam with the red phosphor. This again invites comparison with the Trinitron whose centre beam is directed to the green phosphor because it has the best focus and the green primary signal makes the greatest contribution to the high-definition luminance component of the picture.

Shadowmask

The horizontal in-line arrangement of the electron guns in the PI tube means that as in the Trinitron the apertures in the shadowmask could be vertical slits associated with vertical phosphor stripes on the screen. If this is done however the mask can be curved in only the horizontal direction. The designers of the PI tube wanted to follow delta gun tube practice, using a mask with spherical curvature

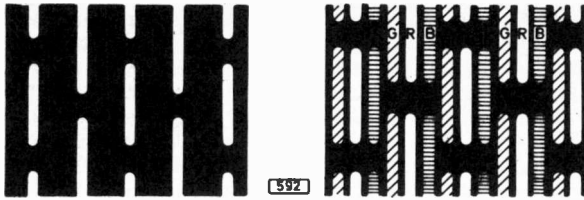

Fig. 10 (left): Arrangement of the slit-shaped apertures in the mask.

Fig. 11 (right): Impression of what is seen close up on the tube screen when the phosphor stripes are energized by the electron beams.

matching that of a similarly curved screen. The necessary mechanical rigidity to make this possible is obtained by using a compromise between holes and full-length vertical slits as shown in Fig. 10: this shows—much enlarged of course—the vertically elongated holes in the mask. The horizontal crossties allow the mask to be given slight spherical curvature. The all important “transparency” of the mask can be estimated from this diagram (that is the proportion of the mask area through which electrons can pass and reach the screen so as to contribute to the picture brightness). It appears to be about 16%, a similar figure to that for modern delta gun tubes and rather less than the 20% claimed for the Trinitron.

Screen

As phosphor stripes are used the whole screen can be covered with phosphor with no wasted areas as there are between the phosphor dots on a conventional shadowmask tube. It is not possible to energise the whole of this area however because of the crossties in the mask and because to ensure good colour

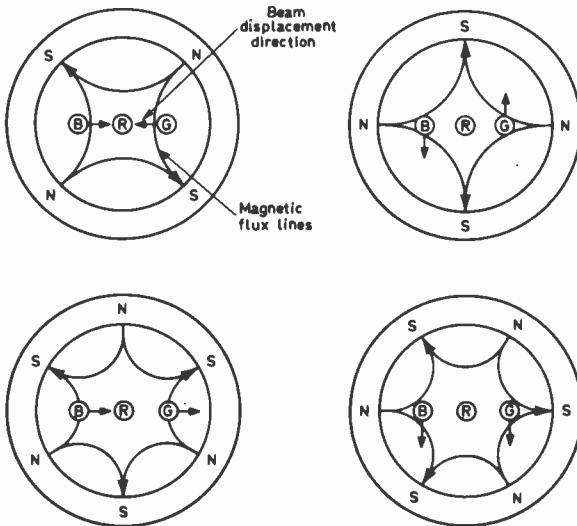

Fig. 12 (above): A four-pole field moves the outer (blue and green) beams in opposite directions.

Fig. 13 (below): A six-pole field moves the outer beams in the same direction.



Fig. 14: Comparison of the new tube with its integral deflection yoke on the left and on the right a conventional delta gun shadowmask tube. Note that it is common US practice to mount the convergence controls on the deflection/convergence assembly with standard delta gun shadowmask tubes.

purity it is necessary to make the image of the slit slightly less than the width of the phosphor stripe. An idea of the appearance of the screen close up in a “white” area of the picture is shown in Fig. 11: each slit in the mask is reproduced on the screen in the three primary colours as the three beams pass through it from different directions to land on their respective phosphor stripes.

Each stripe is 0.0108in. wide, so any one colour stripe is repeated at 0.0324in. pitch. Even on the smallest (16in.) diagonal tube this permits almost the full horizontal resolution to be displayed, with corresponding improvement in the 18 and 20in. tubes which use the same stripe spacing and therefore have more stripes across the width of the picture. A striped screen structure sets no limit to the vertical resolution of course.

Static Convergence and Colour Purity Adjustment

Even now the list of novel features of the PI tube is not quite exhausted. The arrangements for adjusting colour purity are conventional although only a horizontal shift is required. But the static convergence adjustment is provided by an ingenious magnetic field pattern provided by permanent magnets requiring no internal pole pieces. The magnets are mounted in four plastic rings. In one pair of these rings the magnets are arranged to provide a four-pole field as shown in Fig. 12. The field is zero at the centre of the ring so the centre (red) beam is not affected. The blue and green beams are shifted in opposite directions and the magnitude and direction of this shift is controlled by rotating the rings in the same way as is done for colour purity adjustment with a delta gun tube. That is, rotation of the rings in the same direction varies the direction of shift while turning the rings in opposite directions varies the amount of the shift.

In the second pair of rings each ring provides a

—continued on page 355

FAULT FINDING GUIDE

4

John Law

FIELD TIMEBASE BRC/THORN 850 CHASSIS

THE single-valve field oscillator and output stage using a PCL85/PCL805 triode-pentode is common to almost all current monochrome television receivers that still use valves. An example of this type was dealt with in Part 1 of this series (Thorn/BRC 900/950 field timebase). An earlier Thorn design is found in a number of Ferguson, HMV, Marconiphone, DER and Ultra receivers and uses two valves in the field timebase circuit—the triode section of a 6-30L2 plus a PCL85. This circuit is used in the well known 850 series dual-standard chassis. Apart from its use in Thorn brand receivers the chassis frequently turns up in the workshop in other makes of set—for example the popular Decca DR61—and comes in a wide variety of cabinets.

Chassis Identification

The 850 chassis is built in two tiers. The vision and sound i.f. and output stages plus the sync separator occupy the upper panel while the timebases and power circuits are on the lower panel. The leads are usually sufficiently long to enable the chassis to be withdrawn far enough from the cabinet to enable service work to be carried out.

Circuit Description

The complete field timebase circuit is shown in Fig. 1. The circuit consists of a two-triode (V7B and V13A) cross-coupled multivibrator and pentode output stage (V13B). The multivibrator is astable and is synchronised by the negative-going sync pulses applied to V7B grid. V7B is normally con-

ducting and V13A non-conducting so that the field charging capacitor C116 charges from the boost rail via R146 and the height control R145 to provide the positive-going sawtooth which drives the output stage. When a negative-going sync pulse appears at V7B grid this valve cuts off and by multivibrator action V13A conducts heavily, discharging C116 to provide the flyback. As the multivibrator is astable the conditions soon reverse with V13A once again cut off, V7B conducting and C116 charging to provide the next field.

Note that on 625 lines the boost feed to the height control is equalised by S2C which then introduces R185 from this point to chassis. Z3 stabilises the voltage to the height control. The field output transformer T4 is mounted on the left-hand side upright of the chassis frame, above the main smoothing pack. The thermistor X2 in series with the scan coils and the output transformer secondary stabilises the field height as the coils and set warm up in use. Feedback via C118, R151, R152 and C119 to the junction of the output pentode grid leak resistor R148 and grid stopper R149 is used to control the linearity.

For field flyback blanking, pulses are taken from the output transformer secondary via R115 to the junction of C94 and C95 in the c.r.t. grid circuit: being of high negative-going amplitude they push the c.r.t. into beam current cut off. These components will be found on the lower panel to the left behind the smoothing pack. Line sync pulses tapped from the junction of R88 and R136 are used for the line flyback blanking.

Common Faults

Some 850 chassis coming into the workshop for servicing still have the original PCL85 in position. This is clearly the first suspect. Apart from valve-caused troubles due to low emission, interelectrode leaks and intermittent faults resulting from corroded pins or sockets, changed value resistors are a common source of trouble. Check for example whether the height control is set at maximum. If the boost voltage (508V on 405 lines, 650V on 625 lines, measured at the boost capacitor C89) is normal but the picture fails to fill the screen then R146 has probably increased in value from its nominal 680k Ω . Should the picture just fill the screen replace this resistor as the increase in its value will continue to grow.

The 22k Ω $\frac{1}{2}$ W anode load resistor R138 of the 6-30L2 half of the field oscillator should always be checked for value. This component is tucked away behind V7B in a hot section of the chassis with little ventilation and tends to increase in value over the years. Replace it with one rated at 1W and you can forget it.

Field Roll

Field roll with the hold control at the end of its track can often be cured by replacing the valve alone. A change of valve will alter the position of the hold control but this may be masking the true fault. Spend a few more minutes checking the anode feed resistors and R116 in series with the field hold control; change them all if in doubt as the fault may reappear a few weeks later as the faulty resistor

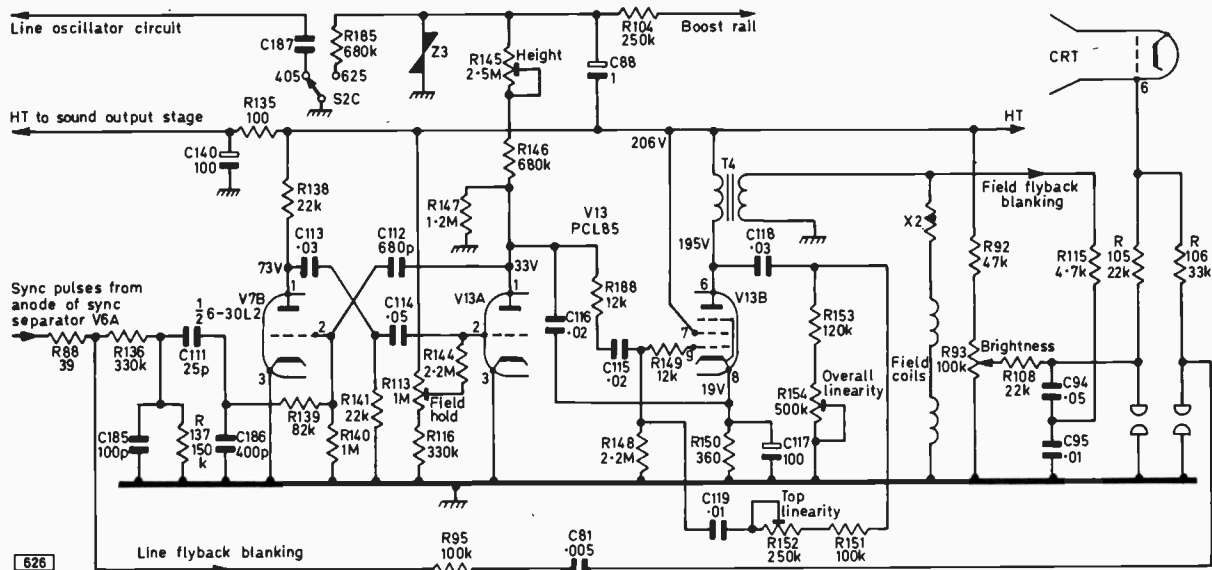

Fig. 1: The field timebase circuit used in the Thorn/BRC 850 dual-standard chassis employs separate generator and output stages. A very similar circuit was used in earlier convertible and 405-line only chassis.

changes value further. A second probably unpaid service call costs a lot more in money and lost commendations than a handful of resistors.

Another cause of field roll is R144, the 2.2M Ω grid resistor of V13A. This too can change value. The trouble can also arise through C113 or C114 being leaky.

Linearity

Generally speaking good picture linearity is dependent on maintaining the relative values of resistance and impedance in the two limbs of the linearity network—R153, R154 to chassis, and R151 etc. to V13B grid. Small changes in balance can be countered by adjusting the linearity controls but larger variations require value checking. A leak in C119 for example is a known cause of bottom compression.

The most common cause of bottom compression however is the output stage cathode decoupling electrolytic C117. A quick test is to parallel it with another 100 μ F capacitor: if the field rises to normal C117 has dried out. Note that the normal bias voltage is 19V and C117 is rated at 25V: a heater-cathode short in the PCL85 can raise the bias voltage above 25V and this in time will damage C117. While attending to this part of the circuit the value of the bias resistor R150 should be checked.

Failure of the field charging capacitor C116 will also cause bottom compression since if this capacitor is leaky a positive bias from the triode anode is applied to the pentode cathode. If C116 loses capacitance the result is the same.

The preset linearity controls sometimes give trouble, particularly on older sets. A spot of Servisol can work wonders here but it is preferable sometimes to change the components. They are relatively inexpensive and replacement may save trouble later.

Jitter

Preset potentiometers can cause field jumping or

jitter which is also often caused by a defective valve. A more serious cause of this trouble, particularly on the bottom few lines of the raster, is failure of the field output transformer T4.

Field Collapse

Failure of the field output transformer can also result in complete field collapse or its reduction to a narrow wavy line. Transformer replacement is the only cure. An occasional cause of field failure requiring less drastic action is a faulty field amplitude stabilising thermistor (X2): this is tucked away on the scan coils on the tube neck.

Complete field collapse to a narrow line can be the result of failure of the oscillator section of the timebase. Oscillation is sustained by the cross-coupling capacitors C113 and C114 from V7B anode to V13A grid and C112 from V13A anode to V7B grid: failure of any of these capacitors can stop oscillation and collapse the field. A defect in either of the triodes can also kill oscillation. The symptoms in one case were normal picture on switch-on followed some time later by foldover at the bottom of the raster and field collapse a minute or so after. Meter tests showed the coupling capacitors "normal" but substituting C112 eventually cured the fault.

Examine the Output Valve

In conclusion when a field timebase repair has been carried out if the valve has not been replaced examine it carefully in a good light. If it looks "burnt" in patches change it. In time a valve with excessive current flow will over-run and lower the value of its cathode bias resistor—conversely a low-value cathode bias resistor will cause excessive current and shorten the life of the valve. This of course applies to any field timebase circuit.

NEXT: BUSH TV141 SERIES RECEIVER UNIT

REVERSE & FORWARD

AGC

K. T. WILSON

WITH valve tuners and i.f. strips automatic gain control (a.g.c.) is a relatively simple matter. In radio receivers a negative voltage whose amplitude is proportional to the carrier amplitude is obtained from the detector, smoothed to remove both r.f. and modulation and then used to control the gain of the controlled stage(s): thus increased carrier amplitude results in the controlled stage(s) operating at decreased gain so that the input to the detector does not vary so greatly as the input to the receiver. Such a simple approach is not possible with a television receiver because of the d.c. nature of the vision transmission. On 405 lines it is the usual practice to use an a.g.c. voltage proportional to the mean video level—the so-called mean-level system—or alternatively to use a gated system which samples the signal when it is at a set level—in practice during the sync pulse back porch period when the signal is at black level—though gated systems have not been used for many years on 405 lines. On 625 lines a simple solution is to use a peak detector to measure the sync pulse amplitude since this represents maximum transmitter output on the 625-line system. For automatic chrominance control in colour receivers the control potential is based on the amplitude of the bursts or the ident waveform.

Variations in signal strength can arise from several causes, the most obvious being the inevitable change when tuning to another station. The most disturbing form of change is signal fading caused by signal interference when signals from the transmitter arrive at the receiver via different paths. This interference can cause fading or reinforcement depending on the phase relationship between the signals—the phase difference between them usually changes continuously. With radio signals below about 30MHz the problem is usually caused by one of the signal

paths being a reflection from the ionosphere: higher frequency signals are more severely affected by aircraft—the well known “aircraft flutter”.

The Variable- μ Valve

Where valves are used the a.g.c. potential is applied to a type of valve, the variable- μ type, designed for the purpose. In these valves the control grid winding is wound with a pitch (the spacing between adjacent wires) which varies from a small value at one end of the winding (see Fig. 1) to a large value at the other. The idea is that the sections with fine pitch have closer control over the flow of electrons through the grid and also cut off at a smaller negative bias voltage than the sections with a coarser pitch. When the small-pitch sections are cut off operation of the valve is left controlled by the less sensitive coarse-pitch sections and the amplification is thus reduced. The a.g.c. characteristic—i.e. the change of amplification with variation in bias—can be designed into the valve to suit particular applications.

Transistor AGC

The very different characteristics of transistors made new thinking on the subject of a.g.c. necessary in order to evolve a.g.c. techniques that suited the new devices. One problem which became more urgent was that of avoiding overloading of the r.f. or i.f. stages by large signals: this was always less of a problem with valves because valves are inherently less liable to overloading—the grid current flowing in an overloaded valve tends to bias back the grid if the grid resistor is of fairly large value—and because the amplification factor of a valve is less than the *comparable* figure for a transistor.

Reverse AGC Technique

One method of a.g.c. that can be applied to almost any transistor is *reverse a.g.c.* This technique consists of varying the bias point of the transistor so that the emitter current changes with very little change in the collector-to-emitter voltage (V_{ce}). A typical load line for a transistor using reverse a.g.c. is shown in Fig. 3. The resistive portion of the load must be very small so that the variation in base bias current causes the necessary variation in emitter-collector current without large changes in collector voltage. The load to *signal* currents is still high of course, being the impedance of the collector tuned circuit.

The transistor characteristic that makes this reverse control technique possible is the decrease in *forward transfer admittance* (the transistor equiva-

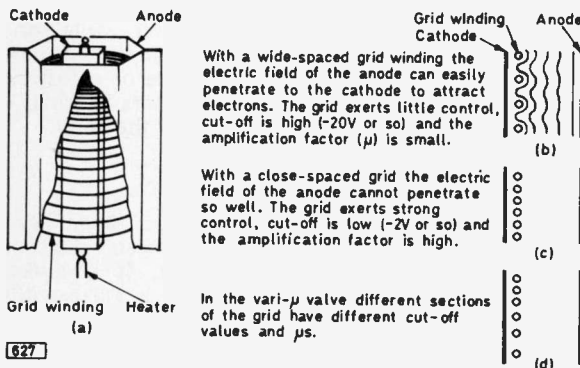

Fig. 1: Variable- μ valves designed for use with a.g.c. have a grid wound with the space between turns altering along the length of the winding.

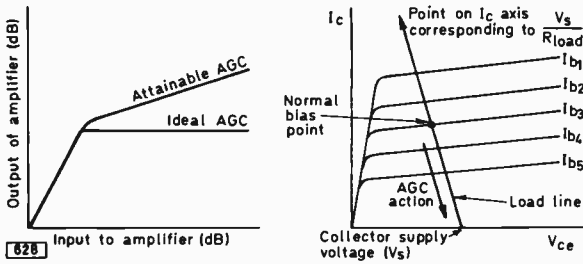

Fig. 2 (left): A.G.C. characteristics: ideally the output would not vary beyond a set level but in practice we settle for a slower change of output power compared to the increase in input power.

Fig. 3 (right): Reverse a.g.c.: the resistor is used with a small d.c. load, usually the resistance of an i.f. coil plus a small decoupling resistance. Application of the a.g.c. voltage lowers the collector and base currents and raises V_{ce} very slightly.

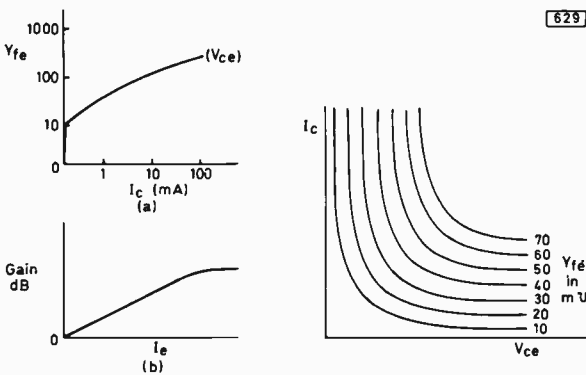

Fig. 4 (left): (a) Forward transfer admittance (current out/voltage in) plotted against I_c —this is the characteristic used for reverse a.g.c. Note that a different curve is obtained at different values of V_{ce} , which is why a low d.c. load must be used. (b) Typical graph of gain against I_e , showing how closely the a.g.c. graph approaches the ideal (Fig. 2).

Fig. 5 (right): Lines of constant Y_{fe} plotted on an I_c/V_{ce} graph for a normal transistor at low frequency.

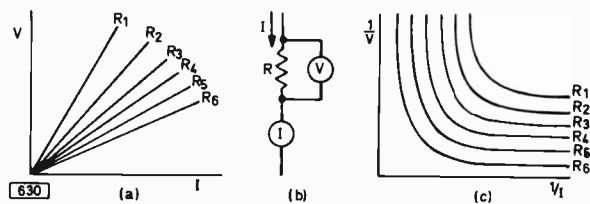

Fig. 6: (a) The relation between V and I in a resistance is represented by straight lines in the usual graph. (b) Equivalent circuit. (c) If we use reciprocal values the graphs of constant resistance look very like the Y_{fe} graph.

lent to mutual conductance in a valve) when a transistor's emitter current is decreased. Forward transfer admittance is the ratio of emitter-collector current to emitter-base voltage and is one measure of

the gain of a transistor stage. A typical plot of forward transfer admittance (Y_{fe}) against collector current (I_c) for a common emitter stage is shown in Fig. 4(a): it can be seen from this that a decrease in emitter (collector) current from 10mA to almost zero causes a change in Y_{fe} from just over 100 to around 10. Such a change in current can be produced by a small change in the base bias current so control is fairly sensitive. The typical shape of the gain/emitter current curve is shown in Fig. 4(b). At low emitter currents the graph approximates to a straight line, giving good control: at high currents the control is less effective and the gain varies much less for a tenfold change of emitter current.

Forward AGC Technique

The use of forward a.g.c. depends on an entirely different and less well known transistor characteristic which can be emphasised by suitable transistor design. This is the "high-frequency knee" characteristic which is noticeably present only in transistors whose base regions are suitably arranged.

If we plot lines of constant Y_{fe} on a graph of collector current (I_c) against collector-emitter voltage (V_{ce}) these lines should with a conventional transistor be of the form known as the rectangular hyperbola (see Fig. 5). These lines simply express the normal relation between Y_{fe} , I_c and V_{ce} and are comparable to the straight line which expresses the relationship between resistance, voltage and current in a set of resistors—see Fig. 6(a). The difference in shape is due to the fact that we are looking at a quality (Y_{fe}) which is the inverse of resistance. If we plotted the inverse quantities instead of voltage and current we would also get a rectangular hyperbola as shown in Fig. 6(c).

In suitably made transistors Y_{fe} can be made to vary at high currents and high frequencies to the shape shown in Fig. 7 where the lines are closer in shape to parabolas. If we draw a load line cutting across these curves we see that an increase of collector current can cause a decrease of Y_{fe} and thus gain, and that less current change is needed if we can arrange that the voltage V_{ce} drops fairly sharply as well. Note that the reverse is also true so that this characteristic can also be used to provide reverse a.g.c. at lower collector currents and higher V_{ce} .

The sort of load line used with a stage to which forward a.g.c. is applied is shown in Fig. 8: a comparatively high d.c. load resistance is required. This

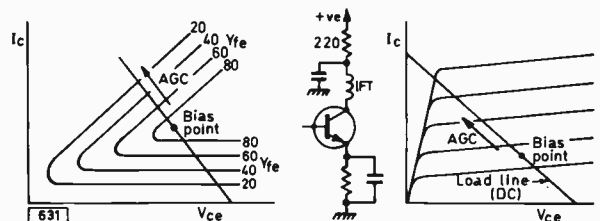

Fig. 7 (left): The high-frequency knee—in suitably designed transistors the graph of I_c/V_{ce} for constant gain can at high frequencies be made this shape. As I_c is increased and V_{ce} reduced from the bias point the load line intersects lower values of Y_{fe} .

Fig. 8 (right): Forward a.g.c. operation.

NEXT MONTH IN

TELEVISION

RENOVATING THE PHILIPS G6 CHASSIS

Continuing his series on renovating and fault finding in ex-rental colour chassis Caleb Bradley starts to work next month on the first Philips chassis. We've plenty of tricks to tell you on this one.

DC RESTORATION CIRCUIT

Many single-standard monochrome chassis have a perfectly stable vision signal at the detector but then lose the black level through a.c. coupling in the video section. Keith Cummins has developed a circuit to give d.c. restoration at the c.r.t. cathode however. Development was undertaken using the popular BRC 1500 chassis but the circuit could be adapted for other chassis.

WORKSHOP HINTS

Vivian Capel turns his attention to tuning capacitor gangs, both radio and TV receiver types, describing the fault conditions that arise and methods of dealing with them.

COLOUR RECEIVER INSIGHT

Much insight into colour can be obtained by examining the wide variety of circuitry used in different chassis. Next month we take a look at the Korting 51763 series which incorporates many novel features including an unusual ident stage and tube protection in the event of field collapse.

FAULT FINDING GUIDE

Next month John Law switches his attention to a typical i.f. panel (Bush TV141/Murphy V159 series) and describes the faults that arise and trouble-shooting procedures to be adopted in this part of the receiver.

PLUS ALL THE REGULAR FEATURES

ORDER YOUR COPY ON THE FORM BELOW

TO
(Name of Newsagent)

Please reserve/deliver the JULY issue of TELEVISION (20p), on sale JUNE 18, and continue every month until further notice.

NAME

ADDRESS

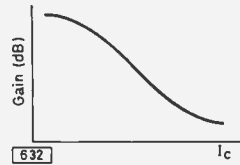

Fig. 9 (left): Forward a.g.c. curve.

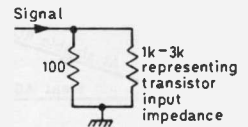

Fig. 10 (right): Addition of parallel resistances: $1/R_{total} = (1/R_1) + (1/R_2)$. Thus with 100Ω and $1k\Omega$ the total resistance is 90.9Ω while with 100Ω and $3k\Omega$ the total resistance is roughly 97Ω : the input impedance has changed by only some 6Ω in spite of a change of $2k\Omega$ in the transistor's input impedance.

is usually provided by means of a decoupled resistor in series with the "dead" end of the i.f. transformer or other tuning arrangement in the collector circuit—a typical value is 220Ω . The control curve shape is shown in Fig. 9: it can be seen that control is good over the middle range of collector current but is less linear at low and high collector currents.

The most important points about forward a.g.c. are that it can be applied only to suitable transistors and to stages amplifying high-frequency signals (since the change of shape of the Yfe curve takes place only at high frequencies). Such controlled stages are found mainly in TV sets therefore and in f.m.-only radio receivers.

The most desirable feature of forward a.g.c. is that a much greater range of signal strengths can be catered for within the same distortion limits, since the lowering of gain of the controlled stage is accompanied by an increase of collector current: unlike the reverse-controlled stage there is no risk of a strong signal causing the stage to cut off thus causing serious distortion and loss of sync.

Since large changes of input and output impedance occur in a forward-controlled transistor stage (this is true to some extent also of reverse a.g.c. stages) some precautions are necessary against detuning when the a.g.c. voltage is applied. The precautions take the form of ensuring that the controlled transistor is coupled to admittances at its output and input that swamp any change in the transistor's characteristics: this means of course sacrificing some of the gain the stage would provide when working between matched impedances. For example a low impedance (high admittance) in parallel with the input will cause the total impedance to change very little if the transistor's input impedance changes, because of the law of parallel addition (see Fig. 10): similarly a high impedance in series with the transistor's input will keep the input current constant despite changes in the transistor's input impedance. These impedances refer of course to signal frequency and not to d.c. bias.

Servicing

From the servicing viewpoint the thing to remember is that with an npn transistor a positive-going control potential is required to reduce the gain with forward a.g.c., while a negative-going potential is required to reduce the gain with reverse a.g.c.; with a pnp transistor a negative-going control potential is required for forward a.g.c. and a positive-going control potential for reverse a.g.c. ■

tackling FIELD FAILURE

D.W. JAMES

THE symptom "no field scan"—i.e. a horizontal white line across the screen—accounts for a large proportion of service calls. About eighty per cent of these calls can usually be dealt with in the customer's home by simply replacing the field output valve—generally a PCL85 or PCL805. The remaining twenty per cent of such calls will whittle out the "valve jockey" from the competent service engineer.

When faced with this fault it is first necessary to determine whether the fault is the result of failure of the field timebase to oscillate or failure of the output stage to amplify. This can be done in several ways—we are assuming that an oscilloscope is not part of the service equipment carried for outside service work. The field timebase has two basic features that the service engineer can exploit to his advantage. First as the field generator operates at

50Hz it is or can be made audible. Secondly there are many points on the chassis of a television receiver where an independent 50Hz source of suitable amplitude is available and can be used for field timebase testing.

Listening to the Oscillator

Fig. 1 shows the bare essentials of a PCL85/PCL805 field timebase. When the timebase is oscillating 50Hz should be audible at the points marked A, B, C and D. The easiest way of doing this is to use a stethoscope type headset (of the type often used with dictating machines). Each lead to the ear-phone section should first be isolated (in the d.c. sense) by means of a suitable isolating capacitor—0.1 μ F capacitors rated at 600V d.c. work satisfactorily. One lead can be left connected to chassis and the other soldered to a metal probe which can be applied to suitable monitoring points. This then enables the oscillator output to be heard: assuming that it is operating a low-frequency buzz will be audible in the headset. It is sometimes possible to trace the fault to a particular component with this set-up—by tracing systematically until the l.f. buzz disappears.

An alternative way of making the field timebase audible is to make use of the television set's audio amplifier. One end of a lead incorporating an isolating capacitor is connected to the centre tag on the volume control, the other being connected to a probe which is applied to the monitoring points in the field timebase. This time of course the buzz is audible in the set's loudspeaker.

Check for Amplification

These two approaches establish whether the circuit is oscillating. It is just as simple to establish whether or not the output stage is providing amplification.

The technique this time is to inject a 50Hz signal at the field output valve input circuit. If the scan then opens out the fault is in the oscillator section while if it does not the valve is failing to amplify. A signal of suitable amplitude and frequency is generally available anywhere along the heater chain—assuming that the heaters are a.c. fed. As Fig. 2 shows the simplest course is to use an 0.1 μ F capacitor to inject 50Hz from the heater pins—4 or 5—of the PCL85/PCL805 at its control grid—pin 9. If the output pentode section is functioning correctly the scan will then open out. Although the waveform is not the correct shape—nevertheless sufficient indication will be had as to the basic cause of the fault.

In many sets however the heater chain is not a.c. fed. Nevertheless a suitable signal can be obtained from a convenient point in the a.c. section of the power supply circuit. To make sure that the signal applied is not excessive use a coupling capacitor of comparatively low value, for example 0.001 μ F which has a reactance at 50Hz of approximately 3.2M Ω .

As in all electronic servicing it is most important first to diagnose in which stage the fault lies then to narrow down the suspects to a particular component in that stage: an obvious statement perhaps but one that is not always adhered to. ■

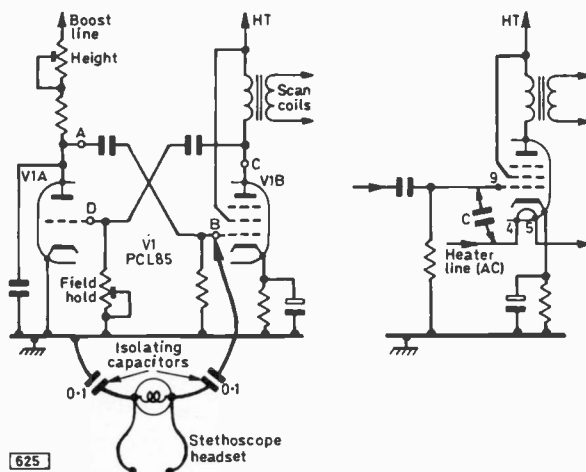

Fig. 1 (left): The basic essentials of a PCL85/PCL805 field oscillator/output stage—linearity feedback not shown. The 50Hz field signal should be audible on a stethoscope headset at points A, B, C and D: alternatively a capacitor feed from any of these points to the centre tag of the volume control will produce an output from the set's loudspeaker if the circuit is oscillating.

Fig. 2 (right): Simplified field output stage showing injection of the 50Hz signal in an a.c. fed heater chain at the control grid of the pentode section of the valve via capacitor C.

TV TEST REPORT

E. M. BRISTOL

NOMBREX MODEL 43 RC BRIDGE

A RESISTANCE/CAPACITANCE test bridge is a useful piece of equipment which should find a place in both the professional service department and amateur workshop. The resistance ranges are perhaps not quite so necessary these days, as extended resistance ranges are to be found in the majority of multirange meters which are easier to use than a bridge—in many cases meters also give both higher and lower readings than can be obtained with most bridges.

It is the facility for direct capacitance measurement that gives the RC bridge its usefulness. With the essential works for a capacitance bridge however little extra is needed to provide resistance measurement as well so one can treat this as a bonus which can be used to give a "second opinion" if one is dubious about the resistance readings obtained on the regular multimeter.

Nombrex have for some years produced a range of test equipment at competitive prices yet with the facilities and specifications of much more expensive instruments. They have done this by cutting out unnecessary frills and using transistors throughout so that dry batteries can be used for power—thereby cutting out the expense of mains power supply circuits.

I had a practical example of this recently when trying to obtain a low distortion audio generator for equipment specification checks. Many of those offered at not inconsiderable cost turned out to be no better and in some cases not as good as the inexpensive little Nombrex generator I have used for some years.

Ranges

To return to RC bridges however the Nombrex 43 has three resistance ranges—1 Ω -10k Ω (centre scale 100 Ω), 100 Ω -1M Ω (centre scale 10k Ω) and 10k Ω to 100M Ω (centre scale 1M Ω)—and three capacitance ranges—1pF-0.01 μ F (centre scale 100pF), 100pF-1 μ F (centre scale 0.01 μ F) and 0.01 μ F-100 μ F (centre scale 1 μ F).

Now this is rather curious. The maker's brochure gives the resistance limits as 10 Ω -10M Ω while the instruction leaflet specifies 5 Ω as the lowest limit and 100M Ω the highest. In fact it is as stated above

1 Ω -100M Ω . Similarly the brochure gives the capacitance limits as 10pF-10 μ F and the leaflet says 5pF-100 μ F while in fact it is 1pF-100 μ F. I wondered how many people had been discouraged from purchasing one of these bridges because the range specified was too restricted.

The greatest accuracy of course is at the centre of the scale where the calibration is spot on. At other parts of the scale the error increases—about halfway between centre and one limit it was found to be 4% but as the scale approaches the limits the error increases appreciably. Measuring 16 Ω for example showed an 8% error, 8 Ω 10% and 4 Ω 20%. At scale extreme there was a 50% error at one end and 30% at the other. This is probably why the specification gives more restricted limits, quoting those that provide reasonable accuracy. Some idea of value can be obtained at range limits however and compensation made if the amount of error is known. Most readings anyway will be measured away from the scale ends. The only criticism I have to make about the ranges is that 100 μ F is rather low for a modern bridge: with transistor equipment capacitances up to and over 1000 μ F are increasingly common.

Leakage Test

The range switch at the top left-hand side of the control panel also includes an "off" position and a capacitor leakage test position. For this latter purpose an output from the oscillator transformer is rectified to produce about 125V d.c. which is applied via a neon lamp and series limiting resistor to the capacitor under test. The actual voltage applied to the capacitor depends of course on the leakage current since this produces a voltage drop across the series resistor. Low-voltage electrolytic capacitors which might show a high leakage initially cause a compensating reduction of voltage to approximately their voltage rating: thus any working voltage capacitor can be tested safely. Leakages which occur at higher voltages only, as can happen with certain types of capacitor, will not of course show up. Non-electrolytics normally have very low leakage so that the full 125V will be applied to them by the bridge. As they are usually rated at over 125V however they can be safely tested.

Leakage is indicated by the neon flashing. The

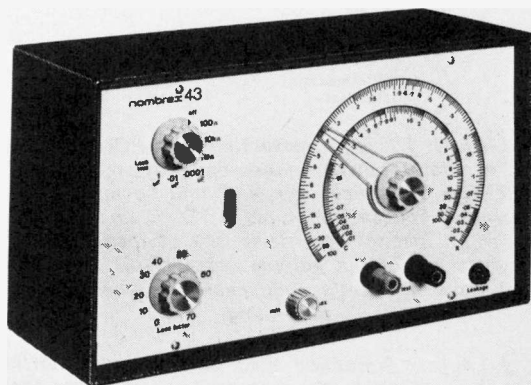

Nombrex Model 43 RC bridge.

rate of flashing depends on the capacitor's value, its voltage rating and the leakage. The leakage has the greatest effect though, a high leakage producing rapid flashing. With really bad leaks the neon remains alight.

Null Indication

Null indication, showing that the bridge is balanced, is displayed by means of a luminescent tube which has a blue keyhole pattern similar to that of the modulation indicators used on early tape recorders. H.T. for the tube is obtained from the 125V d.c. line and the heater supply from a winding on the oscillator transformer. The tube is set back behind a slot in the panel so that it is masked from light falling on the instrument at an angle. The illumination is bright and can be clearly seen even in daylight. Adjustments are made for minimum illumination.

The bridge has a built-in transistor amplifier with a gain control mounted on the panel. This can be adjusted to give the best null indication: over most of the range a setting of about two thirds works well and little adjustment is needed. On the lower values however full gain is often needed.

Loss Factor

The other control is labelled "loss factor" and gives the power factor of larger value capacitors. It is calibrated from 0 to 70 and is operative on the highest capacitance range only. It must be adjusted alternately with the main balance control to give the sharpest null indication whereupon the power factor can be read off directly from the scale.

Use

Balance is obtained in the usual manner by adjusting the control calibrated with resistance and capacitance values. There are two scales, giving 270° indication. The outer one with a scale length of 9in. is the resistance scale and the inner one with a scale length of 7in. the capacitance scale. The scale markings are bold and clear with main divisions and subdivisions. A clear plastic pointer with centre black hair-line is directly driven by the adjustment knob.

The terminals for connecting the component under test are of the screw type with hollow posts for inserting plugs if required. They are coloured red and black and the polarity must be observed when testing electrolytics. One point I noted with approval is that the terminals are just an inch apart: This enables wire-ended components that have been taken from equipment and thus had their wires cropped short to be directly connected to the posts. A fault I have found with some bridges is that the terminals are too far apart so that such components cannot be connected without extending one of the wires.

The supply voltage is provided by a 9V PP4 battery from which there is a drain of 20mA. There is a jack socket at the rear of the case into which an external 9V supply can be plugged if wished. A bridge rarely gets continuous use in the workshop however and over a period of many months test use the original PP4 maintained its voltage and only dropped to 8.5V on load. Thus unless heavy use is

envisaged the internal battery should suffice. It is securely mounted in a large clip on the inside of a panel which can be quickly removed from the back of the case by undoing two screws.

The case measures 9½ x 5½ x 4in. and is strongly made of steel with a blue hammer-effect finish. The grey control panel is recessed into the front of the instrument.

Results

In use the bridge performed very well, giving clear and quick indications. As with all bridges the null is sometimes not so easy to obtain if the component being tested is faulty—for example a capacitor with a bad leak—and at the limits of the scale. With some measurements brilliance variation could be obtained at parts of the scale other than the true one. These were only slight however and would not be mistaken for the real null point. One would only notice them if ranging to find the value of an unknown component: usually the value is approximately known and the appropriate range and part of the scale selected.

At £17.33 (including VAT) the bridge is very good value, doing most of what more expensive bridges do. My only reservation is the 100μF upper capacitance limit. The makers are Nombrex (1969) Ltd, Estuary House, Exmouth, Devon. Post and packing is 35p extra per instrument.

THE NEW COLOUR TUBE

—continued from page 347

six-pole field as shown in Fig. 13. Again the centre beam is unaffected while the outer beams are now moved in the *same* direction. The two rings of each pair make it possible to vary the amount and direction of shift. Adjustment of static convergence requires the rotation of four magnetic rings therefore. The rings can be easily identified in the photograph of the PI tube shown alongside its more venerable relative in Fig. 14. They are spaced well away from the PST and are made of barium ferrite which has a permeability of about one. The deflection field is not distorted therefore by the presence of the convergence magnets.

Tube Sizes

The PI tube is not regarded by its designers as a replacement for the delta gun shadowmask tube for picture sizes above 20in. but rather as a strong competitor for use in the portable receiver market. The initial plans are to produce it in 16, 18 and 20in. sizes. The 20in. PI tube is about two inches shorter than the 90° delta gun tube. This difference can be clearly seen in Fig. 14 which also shows that the in-line electron gun assembly (in front of the tube) is significantly shorter than that used in the delta gun design. The 16in. PI tube has an overall length of 14.2in. which makes an interesting comparison with the *twelve* inch Trinitron tube whose overall length is slightly greater at 14.4in. For a tube intended for use in portable receivers it is also noteworthy that the new Thorn/RCA tube in the 20in. size is nearly three pounds lighter than its delta gun counterpart (with the scanning and convergence components included in the comparison). ■

THE 'TELEVISION' COLOUR RECEIVER

PART 15

MOUNTING THE MODULES

It is important that the modules in the colour receiver are easily accessible for maintenance purposes. For this reason the majority of the units can be "run out" from the cabinet so that access is gained to both sides. The basic layout of the units in the receiver's cabinet is shown in Fig. 1. Before going more fully into this some essential tasks need to be completed on the cabinet itself.

Further Cabinet Work

The first of these jobs is to cut out two apertures in the control panel struts in the correct position to hold the tuner control unit. This involves cutting two small square holes using the control unit and the push-button holes already made as a template. The unit can then be fixed with two self-tapping screws.

A plate—preferably metal—should be cut to take the user control potentiometers and the mains switch (Component-Pack 23). This plate should be about 5½in. wide and 5in. high. Drill five 10mm. holes in the plate, positioned using the original template for the receiver cabinet front panel. The potentiometers and mains switch are mounted on this panel and then offered up to the front panel. Screw the plate to the vertical struts in the cabinet.

To obtain the full aperture required for the loudspeaker the struts should be carved slightly adjacent to the slits in the front panel (see Fig. 3). A Stanley knife is ideal for this job. The loudspeaker can then be screwed up against the struts. To improve the appearance from the front of the cabinet a loudspeaker grille can be placed between the loudspeaker

and the struts. This is not an essential however. Note that a *ceramic magnet* loudspeaker must *not* be used in the receiver. The unit offered in Component-Pack 23 is a ferrite magnet loudspeaker with more than adequate quality for the receiver.

The Convergence Drawer

An error was unfortunately made over the depth of the convergence drawer when describing the cabinet construction. The clearance left should have been 2½in. instead of 2in. The drawer should therefore be mounted ½in. lower than the cladding on the sides of the cabinet. The nominal depth of the convergence drawer need be only 7in. to gain access to all the components. The construction of the drawer and its runners is shown in Fig. 4. The catch shown in Fig. 5 prevents the drawer being pulled too far out. Suitable plastic "drops" can be purchased but are a little difficult to obtain: the simple bolt in a block of wood shown performs the same job.

Module Mounting System

The following modules are mounted on runners: tuner/preamplifier; i.f. module; decoder module; timebase board; RGB output module. The arrangement used for this purpose is shown in Fig. 6. Hard-board mounts are fixed to each of the mounting points on the modules, the mounts being on the copper side. It is suggested that nylon bolts are used for this. The mounts are designed to run in the slots of runners fixed in the cabinet. The copper side of each module is towards the cabinet wall of course.

To use the runner system small wooden platforms must be built up in the cabinet and the runners then mounted on these platforms. In each case the runners should be blocked off at the distant ends and the length of the runners should be no more than ½in. longer than the module concerned. Make the start of each runner about ½in. from the back of the cabinet. The wooden platforms should be glued on to the internal walls of the cabinet before attaching the runners. This method of fixing is quite strong enough to hold even the heaviest of the modules. The correct orientation of each board is indicated in the general layout (Fig. 1) by identifying a principle component on each.

In the prototype the audio module was secured to the vertical struts beside the loudspeaker itself. Only two of the four mounting holes were used.

The power supply is mounted at the rear of the

Table 1: Components List

Component—Pack 23

R601	5kΩ	Saturation (colour) control
R602	25kΩ	Contrast control
R603	500kΩ	Brightness control
R604	250kΩ	Volume control
All potentiometers linear except for R604 which is logarithmic.		
S601	Rotary double-pole mains switch (4A)	
LS601	12-15Ω 8 x 5in. ferrite loudspeaker	
Five control knobs.		

Suppliers

Pack 23	East Cornwall Components, PO Box 4, Saltash, Cornwall, PL12 4EY. Cost: £3.58 including postage and VAT.
---------	---

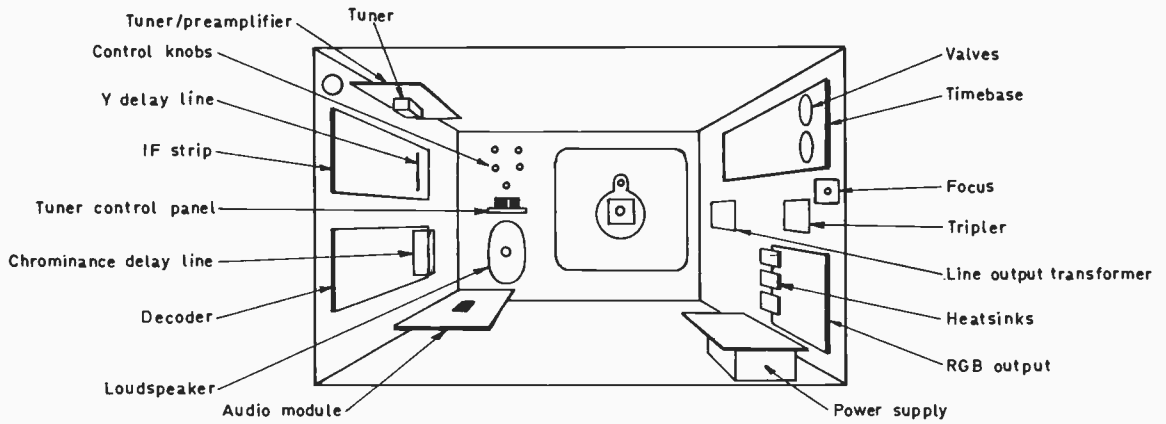

Fig. 1 Relative positions of modules in the Colour Receiver (fisheye view from rear)

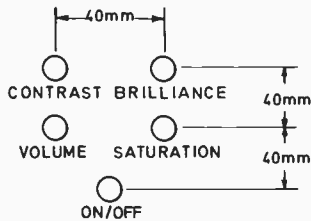

Fig. 2 Front view of position of 'domestic' controls

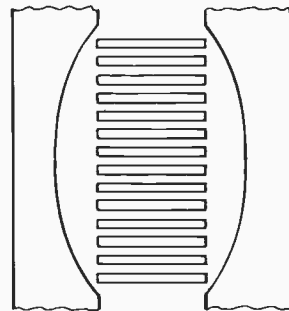

Fig. 3 Carved slats for loudspeaker mounting

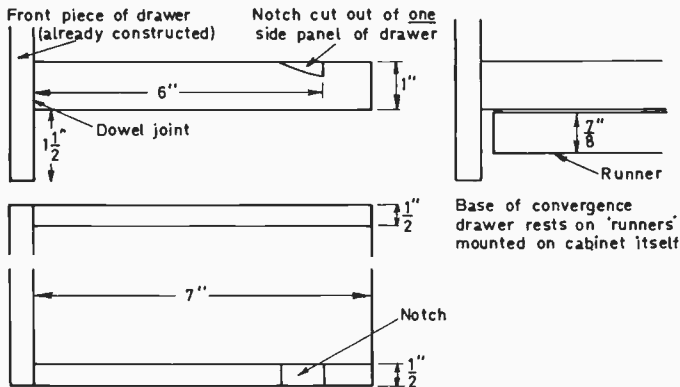

Fig. 4 Convergence drawer

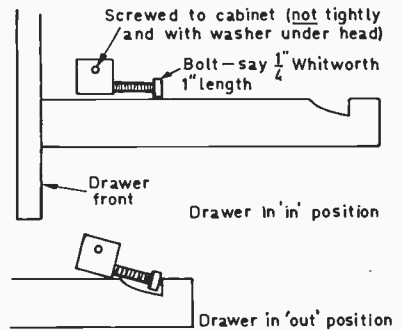

Fig. 5 Convergence drawer catch

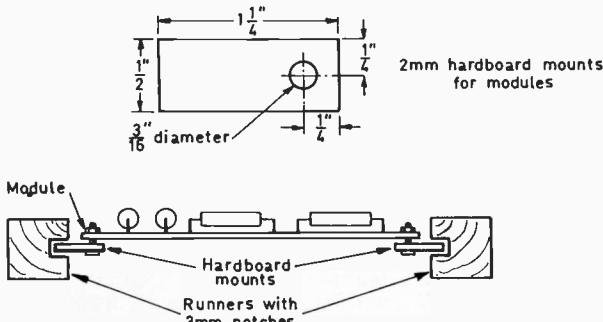
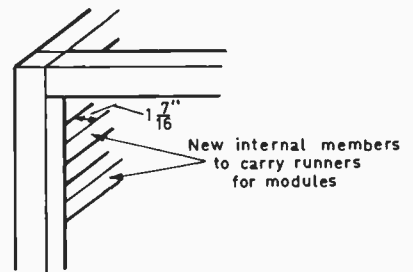
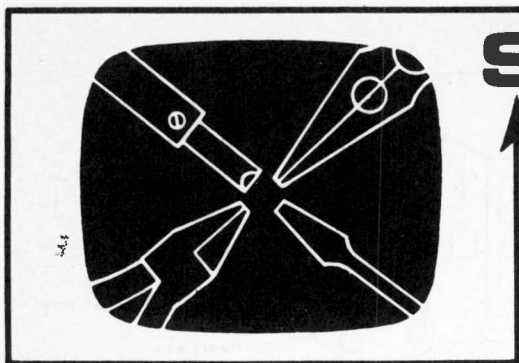

Fig. 6 Module mounting system





SERVICING television receivers

L. LAWRY-JOHNS

BRC 1580 CHASSIS

THE Ferguson 3805 and Marconiphone 4805 are mains-operated portables using the hybrid (i.e. with valves and transistors) BRC 1580 chassis. This distinguishes them from the later 1590 series which although of similar appearance uses an all-transistor circuit suitable for mains or battery operation. The 1580 chassis is designed for use on u.h.f. only and has a four push-button tuner (type T20) similar to that used in later versions of the 1400 series. Two transistors are used in the tuner and nine on the main panel with five valves. Whilst the supply for the video amplifier and sync separator transistors is derived from the 180V HT2 line the rest of the transistors depend for their supply upon the field output valve cathode circuit.

The cabinet shell is secured by two screws at the rear and two underneath. It is essential when replacing this shell to locate the rear control spindles in line with the holes and to feed the mains lead through so that no loop is left inside.

Power Supply Circuitry

The mains input passes via the on/off switch to fuse F1 which is rated at 1.6A. If this fuse is found to have failed examine its appearance to see whether it has gently melted or blown violently. If it has come to a violent end a complete short probably exists and an ohmmeter should be used to check this before replacing the fuse. If the meter shows no direct short suspect the mains filter capacitor C87 (0.1 μ F 300V a.c. working) as this loves to play games. Snip one end and try again with a new fuse.

If a direct short is recorded again check this capacitor by disconnecting one lead. If the short is still present check the h.t. rectifier W9 (BY127) and its shunt capacitor C88 (C84 is less likely to give trouble but you never know). A direct short is unlikely to be elsewhere except in C99 (the reservoir electrolytic) and this doesn't happen very often. All other h.t. circuits have series resistors which will show on the meter.

There is no dropper or series diode in the heater circuit. Instead a capacitor of 4.23 μ F (C85) is used in series with the valve heaters to produce a wattless voltage drop. In the unlikely event of this capacitor developing a fault it must be replaced by the exact type.

The d.c. output from W9 through the surge limiter R127 charges C99 to something like 295V which is then smoothed by the various resistor-capacitor combinations to give the HT1, HT2, HT3 etc.

supplies. Faulty smoothing will cause the usual symptoms of curved edges with rising and falling field linearity variations and perhaps a degree of hum on the sound.

The smoothing resistors are mainly on the rear left side and like most wire-wounds have a habit of becoming open-circuit as a result of internal failure. We can thus be presented with one part of the set suddenly refusing to work through lack of h.t. It is a peculiar fact that so far most cases of field collapse in sets serviced by the writer have been due to the h.t. supply resistor R135 being open-circuit and not to a faulty PCL805. R135 is of course the 1.4k Ω smoothing resistor for the HT4 supply. It is mounted horizontally on the left side but there is no reason why an upstanding resistor should not be fitted provided it is of adequate wattage and has sufficient clearance.

Field Timebase

Having said that we must hasten to add that if there is only a white line across the screen denoting field collapse the supply resistor will not be at fault if there is still sound. To clarify this it can be seen from the circuit that the main transistor supply is derived from the cathode circuit of the PCL805: thus if there is a fault which stops emission in the pentode section or no supply to pins 6 or 7 the transistors will be rendered inoperative and there can be no sound or vision signals.

In the majority of cases a faulty PCL805 causes total field collapse due to a fault in the triode section, leaving the output pentode section working from an emission point of view and thus maintaining the supply to the transistors. If there is sound therefore the supply resistor must be in order and a white line across the screen will denote a fault either in the PCL805 itself, the supply to the triode from the boost line (where the 1 μ F smoothing capacitor C71 is the main culprit), an open-circuit height control or some other oscillator component.

Electrolytics

Whilst the large smoothing capacitors are of normal reliability the same cannot be said of the smaller types. We have mentioned C71 which often causes field collapse but this is not the only troublesome one. The field output stage decoupler C80 (160 μ F) can become open-circuit at the drop of a hat thus causing severe loss of height—more pro-

Single-Tube

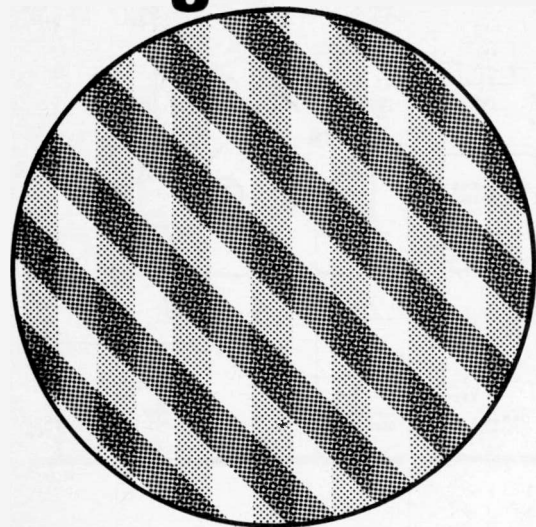

Colour Cameras

I. R. SINCLAIR

A COLOUR television system drawback that has existed since the earliest experimental systems were devised is that at least three camera pickup tubes are required. This has not restricted colour broadcasting to any great extent because the finances are available to cover the costs. For closed-circuit and small studio use however the cost and bulk of three-tube colour cameras have ensured the continuation of black and white television.

Basic Camera Requirements

In any colour television system there must be at least three camera outputs which provide signals proportional to the amplitude of each of the three primary colours present in the picture and can be combined to give a luminance (black and white) signal. The actual camera output for use with standard equipment need be only the luminance signal plus two colour (or colour-difference) signals since the third colour signal can be obtained by suitably processing the luminance and the other two colour signals.

In a camera using one pickup tube for luminance and two others for the primary colours the light passing through the camera lens must be split so that a black and white picture is focused on to the luminance tube, a red picture on the red tube and a blue picture on the blue tube—assuming that red and blue are the primaries used. Splitting the input in this way is quite a complicated optical process which is carried out by prisms and dichroic filters. The prisms split the light beams, changing their directions, while the dichroic filters extract the colours needed for the primary-colour pickup tubes.

In practice to split off the light so that only the red and blue portions of the spectrum pass is wasteful while the low signal level in the tubes would result in poor signal-to-noise ratios. For this reason inverse signals are used—for example yellow which is white minus blue and cyan which is white minus red—for blue and red pickup tubes respectively.

All this is complex and the three tubes must be carefully matched. The scans of each tube must be arranged so that they all cover the same picture area and each tube scan must be linear to the same degree. In addition the grey scales of the tubes must track well and ideally the lag of each tube must balance so that moving objects do not leave coloured trails. These are formidable requirements which have been resolved to an acceptable degree only by expensive means.

Beam Indexing

It would be intolerable if a colour receiver had to rely on optically combining the output from three c.r.t.s—though this has been done for projection TV. The shadowmask tube, in which separate electron beams are guided so that they strike only the appropriate colour phosphors on the screen, provides a solution. The mind boggles however at the thought of applying a similar arrangement to a vidicon pickup tube. The beam-indexing colour c.r.t. principle is applicable however. The three primary-colour phosphors in such tubes are laid as vertical stripes on the face of the tube. An unmodulated electron beam scanning across the stripes will generate amounts of coloured light output which will result in a grey to white display—assuming phosphors of equal light output efficiency. If the beam is modulated so that it is cut off while it crosses the green and blue stripes the tube output will be a red display. Thus if the beam modulation and scanning are synchronised any desired colour at any part of the screen can be produced. Synchronisation is achieved by deriving from the beam a reference (index) signal which indicates its position relative to the colour phosphor stripes. This signal can then be used to control the modulation applied to the beam at any instant.

Since beam-indexing colour display tubes first began to look feasible manufacturers have been examining the possibility of a beam-indexing vidicon pickup tube in which coloured layers on the faceplate would result in signal outputs proportional to the strength of each primary colour in sequence. The indexing problems are difficult though easier than those of a receiver display tube because of the better scan linearity of a small pickup tube. There has been something of a clamp-down recently on information, suggesting that some success may have been achieved.

RCA Spectraplex Tube

Meanwhile however a colour pickup tube capable of generating a complete colour signal has been developed and is now available commercially: it is the RCA Spectraplex (an RCA trade mark) tube.

Imagine a vidicon faceplate divided into stripes alternately clear and two primary colours. As the beam scans over the stripes the amplitude of the

nounced at the bottom. The 64 μ F video coupler (C32) may suddenly decide to withdraw its labour thus causing a nice blank raster with no picture information or at the most a very weak picture with little or no sync, the sound continuing merrily with no alteration since the sound and a.g.c. drive are taken off from the video driver stage VT5. Fortunately C80 and C32 nearly always become open-circuit so it is a matter of moments to shunt another capacitor across the suspect to prove the point, the exact capacitance not being very important for the purposes of a quick test though the polarity must of course be observed.

Line Timebase

The line timebase is quite nice and (speaking for myself) doesn't give much trouble. It consists of a flywheel sync discriminator (W3, W4 etc.) with reference pulses fed back via the integrating resistor R45 from winding B-C on the line output transformer, a valve multivibrator (V1, ECC82), line output valve (PL81A) and efficiency diode (PY801) working the line output transformer with its various services including a two-stick e.h.t. tray which provides the 10.5kV required by the tube.

As well as providing a reference pulse for the flywheel line sync discriminator, winding B-C on the transformer also does two other jobs: it provides line blanking pulses for the c.r.t. grid via R125, and via C55 reduced-amplitude (due to the potential divider R131, R132 and R133) pulses to gate the a.g.c. amplifier VT8.

The width circuit is the conventional BRC type with a 100pF high-voltage ceramic capacitor (C92) feeding flyback pulses to a v.d.r. (Z2) to produce a bias which is backed off by the width control. This circuit can be the source of several fault conditions. The most obvious and damaging is when C92 shorts. This cooks up the v.d.r. (Z2) and can damage the panel. The v.d.r. can survive a severe overload but should replacement be necessary a type E298ZZ/05 should be used. If the panel has suffered, a certain amount of cutting away may have to be done and the new capacitor mounted in a raised position (which is no bad thing). No fault symptoms need be given for this type of disaster of course but other defects in the circuit can produce symptoms which may puzzle the less hardened.

The symptoms in one instance can be described as corrugated verticals and in another as a wasp-waisted picture (or raster). Perhaps the more clinically minded would term the latter effect as hour glass or egg timer (I don't care, the middle comes in anyway). These symptoms denote a high resistance in the grid circuit of the line output valve and the search need only be directed to R139 (2.2M Ω) and R141 (1.8M Ω). The former will produce the wasp waist, the latter the corrugated effect. Check these items and the width control and you should be home and dry, except perhaps for a crack in the panel.

When a margin appears down the left side with a white line down the edge don't try to remove it with the width control or by valve replacement, just replace the S-correction capacitor C90 (0.1 μ F) which will be found to have shorted.

Lack of width is usually due to either the PL81A

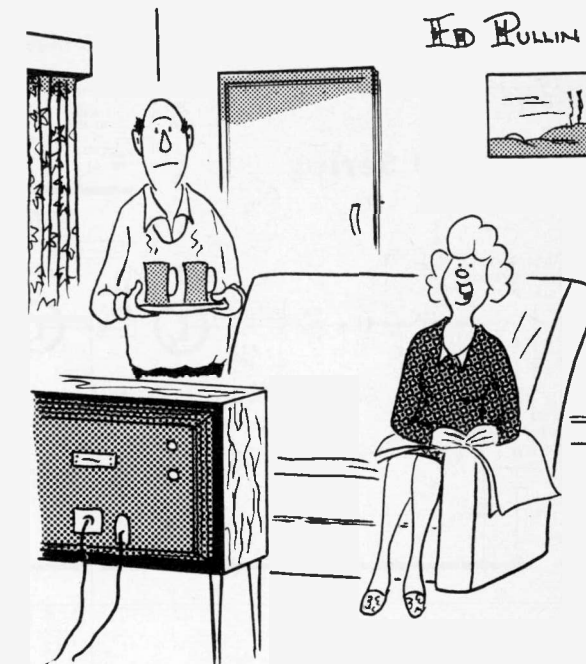

"You missed the bit where she stepped stark naked out of the bath."

or the PY801 getting tired but the width control itself and its series resistor R143 should not be above suspicion. If the PL81A is at fault and is a fairly recent replacement check the ECC82 and C96 either of which can be guilty of delivering insufficient line drive.

It is also essential to check the position of the closed-loop sleeve on the tube neck. Some previous attention to the deflection coils may have resulted in the sleeve being moved too far into the coils. There should be about 5mm. between the coils clamp and the plastic moulding on the sleeve (if it hasn't been pulled off).

In cases of no picture and no e.h.t. remove the top cap of the PY801 and try again. If e.h.t. appears (albeit low) replace the boost reservoir capacitor C95. If there is no change check the valves and line drive etc. If the PL81A is overheating suspect the ECC82 or lack of h.t. at HT2. The latter condition can result from R30 or R31 being at fault, possibly caused by a short in C36. Check the ECC82 voltages at pins 1 and 6, the line drive at the PL81A control grid and take it from there (whatever is missing, low or high). C51 can go short-circuit, opening fusible resistor R126. If the PL81A is not hot check its screen feed resistor R137 (2.2k Ω) which may well be open-circuit if cool or shorted to chassis by C94 if overheated. If all these points are in order—valves, components, drive etc.—and there is still no e.h.t. the suspect must be the line output transformer but first make sure that R144 and R145 which are in series with C103 across the e.h.t. overwinding are not overheating due to C103 shorting. These components form an anti-ring damping circuit and can be disconnected for test purposes.

CONTINUED NEXT MONTH—Circuit Over Page

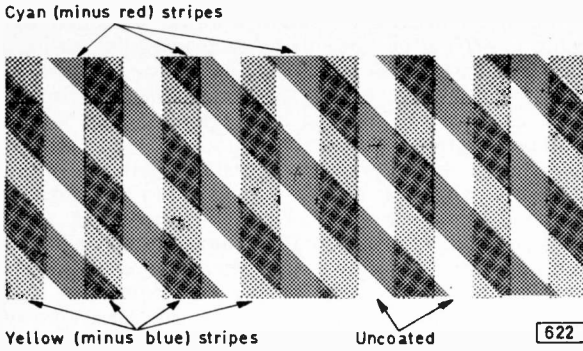

Fig. 1: Stripe pattern used on the faceplate of RCA's Spectraplex tube. The stripes are laid on the tube's faceplate with a pitch of approximately 48 millionths of an inch. As the beam scans the target a complex signal is generated consisting of a low-frequency luminance component plus two h.f. carriers which are modulated by the two colour signals.

electrical signal generated will vary since the amount of light passing through the clear stripes will be greater than the amount passing through either of the sets of colour stripes. The signal amplitude will fluctuate therefore at the rate at which the beam passes from the clear to the coloured stripes. This fluctuation makes it possible to extract a signal from the beam without any indexing system since the fluctuating signal is at a high frequency. If the number of stripes is sufficiently large the signal will be at a high enough frequency to be filtered out from the lower frequency luminance signal. What is more the high-frequency signal will be of an amplitude which depends on the difference between the luminance signal amplitude and the amplitude of one of the primary colours: to put it in a more familiar way, the high-frequency signal will be modulated by a colour signal which represents the difference between the luminance and a primary colour.

Distinguishing the Primaries

We still have the problem however of distinguishing between the two primary colours. A simple modification to the system as outlined so far makes it possible to do just this. If the pitch of one set of colour stripes is different from that of the other, the two sets will produce different carrier frequencies each modulated with its own colour information. In this way a single pickup tube can generate a

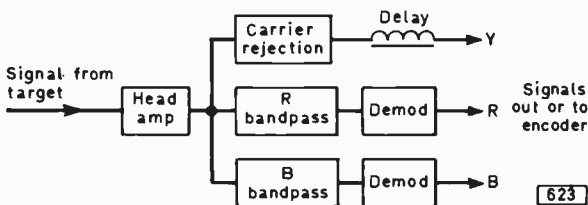

Fig. 2: Block diagram showing the way in which the signal obtained from the target of the Spectraplex tube is processed in order to separate the Y, R and B signals. The Y channel is wideband and the two colour channels narrowband.

luminance and two colour signals which can be easily sorted out in the camera circuitry and delivered as separate signals or as a composite PAL signal as required.

The Faceplate

The technical difficulties have been very considerable. Because of the way in which the vidicon faceplate is coated with photoconductive material (see *Practical Television* August 1968) attempts to coat coloured stripes directly on the inside of the faceplate—the most logical place for them—have not to date been very successful. Striping on the outside of the faceplate is easier but the stripes required are so narrow that the passage of light from the outside of the faceplate to the inside is enough to cause some overlapping of the coloured rays.

The Spectraplex vidicon has overcome these difficulties sufficiently to enable it to be manufactured on a production rather than a development basis. Taking the last problem first, the colour filter stripes consist of dichroic stripes on a faceplate which is fibre optic rather than glass of conventional construction. The fibre optic construction ensures that light which has passed through any of the stripes is guided to the corresponding part of the vidicon target with no scattering, thus resolving the difficulty of using external colour filtering.

Colour Stripes

The colour stripes used are yellow (white minus blue) and cyan (white minus red) and both are laid at a spacing of 530 line pairs per inch of target scan. So that lines of equal spacing generate different carrier frequencies the cyan stripes are 45° to the yellow stripes as shown in Fig. 1. As the beam scans the target, carriers are generated which at NTSC scanning speeds on the 525-line system are 5MHz for the vertical yellow stripes and 3.5MHz ($5 \sin 45^\circ$) for the diagonal cyan stripes. These colour stripes are laid with a pitch of some 48 millionths of an inch and it is a good measure of how far we have come in production techniques that such an array can be produced reliably. The Spectraplex is in other respects a fairly conventional vidicon, except that rather higher voltages are used for beam formation as we shall see later.

Camera Circuitry

The camera circuitry used with the Spectraplex vidicon is conventional as far as the scan and voltage supply portions are concerned. The signal processing portions are rather different of course and are outlined in block diagram form in Fig. 2. The luminance signal is wideband and if full use is to be made of the resolution capabilities of the tube the head amplifier should have a bandwidth extending to 9MHz (-3dB down). To avoid strong components at the stripe frequencies notch filters at 3.5MHz and 5MHz (in the 525-line system) must be used in the luminance channel. In addition since the luminance amplifier is wideband the Y signal travels faster through it than the narrowband colour signals do through their amplifiers and must therefore be

—continued on page 367

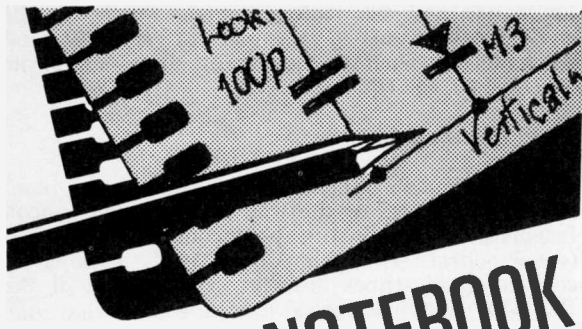

SERVICE NOTEBOOK

G. R. WILDING

Dark Pictures

Even with the brilliance control fully advanced a KB model fitted with the STC-ITT VC2 chassis gave a very dark picture. The usual cause of this is excessive c.r.t. cathode voltage or insufficient grid voltage, the tube being over biased as a result. Where the video pentode is d.c. coupled to the tube cathode the first suspicion would be that the video pentode is not passing normal anode current—probably due to excessive bias—its anode voltage and thus the tube cathode voltage being kept too high. In the VC2 chassis however the video pentode is a.c. coupled to the tube. There was no point therefore in trying a new video pentode so the first step taken was to short the tube grid and cathode base connections with a screwdriver blade. The effect of this of course is to remove all tube bias—normally a considerable negative voltage—and the result should be a brilliant raster. The brilliance was still poor however so it was clear that either the tube was defective or there was inadequate first anode voltage.

Tests showed that there was only about 80V instead of 530V at the first anode but, surprisingly, a resistance test failed to show any sign of a leak from this point to chassis—zero or low tube first anode voltage is normally caused by a leaky or short-circuit decoupling capacitor. Following general practice the d.c. supply to the tube first anode—also to the focus control—is via a high-value resistor from the boost h.t. rail. In this chassis the resistor is R156, 680k Ω . The boost voltage was found to be normal but on connecting the meter, switched to a high-voltage range, across R156 the brilliance was restored to normal, confirming that R156 was high-resistance. After replacing this resistor the focus also improved since there had previously been no h.t. to the focus control potentiometer.

While inability to reach full brilliance is generally caused by incorrect tube d.c. voltages—due to changed value resistors—the opposite condition—inability to kill the raster—is, though it too can be caused by changed resistor values, more often due to internal leakage within the tube. If the leak is from the first anode the resulting increased drain from the boost rail is sometimes sufficient to reduce picture height—since the field oscillator triode is always fed from this point in modern receivers.

Complete failure to obtain a raster although the e.h.t. is present can be due to excessive tube cathode voltage, insufficient grid voltage, zero first anode voltage or a short across the heater. If therefore the c.r.t. cathode can be seen to be glowing, first anode voltage is present and shorting the grid and cathode together fails to produce a raster then unless the e.h.t. is a.c. instead of d.c.—due to an anode-cathode short in the e.h.t. rectifier—the tube must have an internal disconnection. A shorted e.h.t. rectifier is shown up when the sparks that can be drawn from the tube anode connector and the e.h.t. rectifier anode are much the same and is also indicated by the persistent sparking that occurs between the aquadag coating of the tube and the earthing springs as the a.c. charges the total circuit capacitance.

Blue Tinting

Blue tinting on the picture was the problem with a set fitted with the BRC 3000 chassis. Since the tinting became more marked as the colour control was advanced it was clear that the fault was a decoder one. We first checked the four diodes in the U (B-Y) demodulator circuit, then the two burst blanking diodes W316 and W317 (see Fig. 1). These were all OK so as the colour lock was perfect we decided to concentrate on the chrominance signal channel. There are two stages here, the chrominance amplifier VT309 and the delay line driver VT310, but all voltages were correct. The problem was beginning to look decidedly awkward but we decided to take a look at the voltages on the polarity splitter transistor VT308—and found the collector voltage low at 22V instead of 27.5V. This transistor provides antiphase pulses to drive the burst blanking circuit and also provides, from its emitter, the burst gating pulses for the burst channel. The collector load resistor R357 was found to be within tolerance so our suspicion was directed to the miniature coupling electrolytic C337. On disconnecting this the collector voltage of VT308 returned to normal and a resistance test then confirmed a substantial leak through it. On replacing C337 the blue tinting completely disappeared.

AGC Fault

A KB model fitted with the ITT CVC5 chassis produced a good colour picture with sound the normal time after switching on, but both then disappeared within seconds leaving an unmodulated raster. It seemed probable that an a.g.c. fault was causing one or more of the transistors in the tuner or i.f. strip to stop giving signal amplification. The a.g.c. system used in this chassis (see Fig. 2) is unusual in that the negative a.g.c. voltage developed by the gated a.g.c. generator stage T41 is first applied to the second i.f. transistor T16 as a *reverse* a.g.c. potential and is then applied from the collector of T16 to the base circuit of the first i.f. transistor T15 as a *forward* a.g.c. potential. The second i.f. transistor thus also acts as a d.c. amplifier/inverter for the a.g.c. to the first i.f. stage.

Gating pulses from the line output transformer are applied to the collector of T41 which only conducts when a gate pulse arrives. The gating pulses coincide

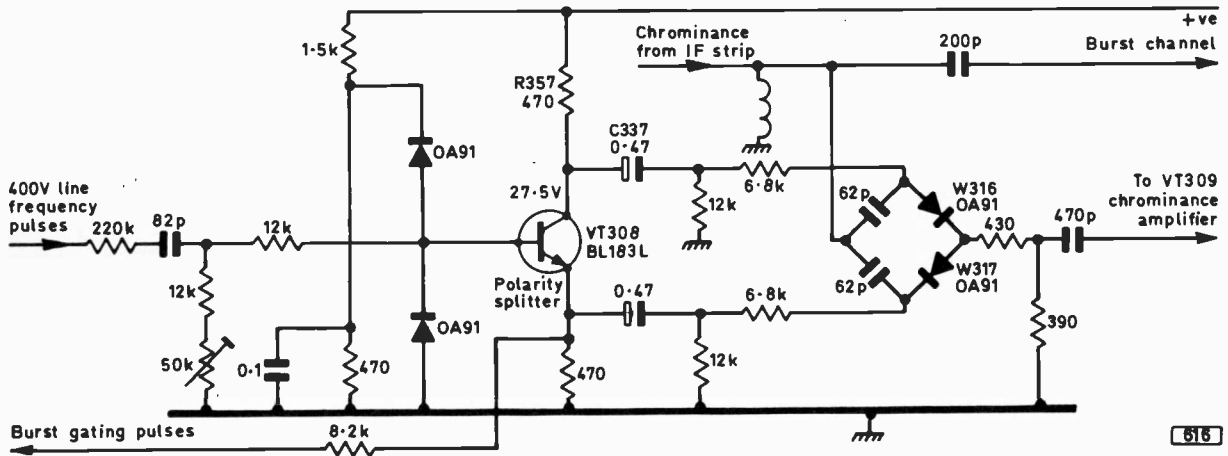

Fig. 1: Blue tinting on a model fitted with the BRC 3000 chassis was found to be due to C337 being faulty.

with the sync pulses in the luminance signal applied to its base. When the gate pulse arrives therefore T41 conducts to an extent determined by the amplitude of the sync pulse at its base, charging C235 to a mean negative potential which depends on the signal strength (as measured by the sync pulse amplitude). As the signal strength and thus the sync pulse amplitude increase so T41 conducts more heavily during the times when it is gated on and its mean collector voltage increases negatively. This negative-going potential reduces the conduction of the second i.f. transistor whose collector voltage thus increases positively, this positive voltage increase then giving forward a.g.c. action at the base of the first i.f. transistor. The increase in T16's collector voltage is from 8.5V under no-signal conditions to 15V on a strong signal.

Our first move was to check the voltage across the a.g.c. smoothing capacitor C114. This should be about $-1.1V$ on a strong signal. Immediately we contacted the test prod to this point however normal picture and sound were restored, clearly indicating

that there was excessive voltage at this capacitor. Further tests then showed that the a.g.c. transistor T41 had broken down, resulting in the second i.f. transistor T16 being almost cut-off whilst the first i.f. transistor T15 was driven to saturation—thereby preventing normal amplification.

Printed Circuit Tracks

The complaint with a Bush Model TV141 was "small picture". This turned out to be due to the field hold control having no effect so that the picture could only be locked with the height control at about half the normal setting. One side of the field hold control in these receivers is linked via a 220k Ω resistor to the grid of the triode section of the PCL85 field timebase valve while the other end is taken directly to the cathode of the pentode section. Voltage checks showed that there was no voltage at the control though the normal 14V was present at the pentode cathode. The two points are linked by a strip of printed circuit track and although this

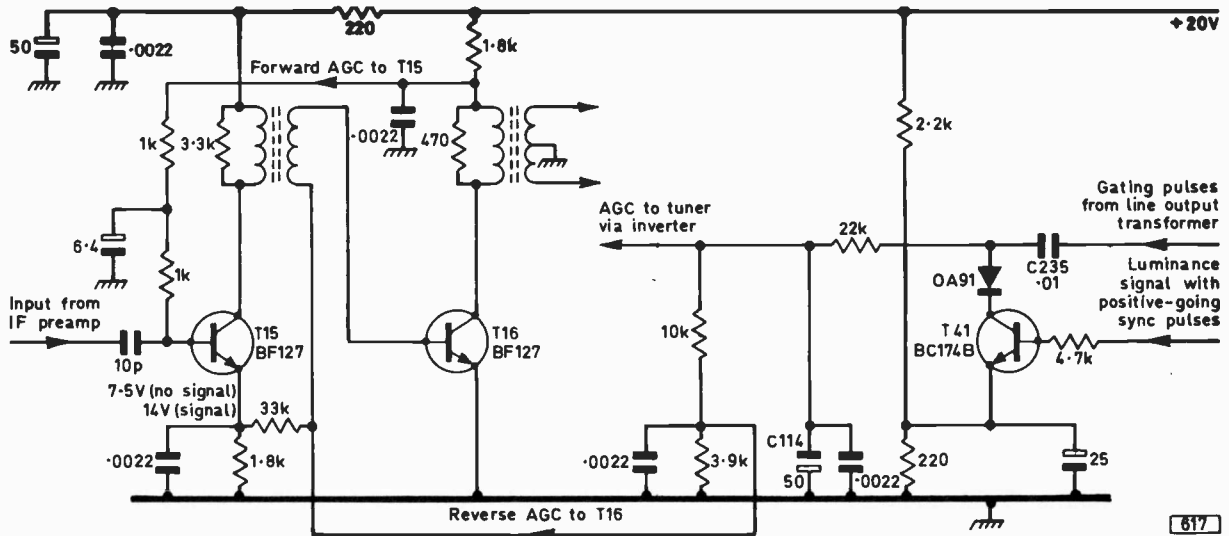

Fig. 2: A.G.C. circuit used in the ITT CVC5 colour chassis. The main a.g.c. action occurs in T15.

looked as new it was found on test to be completely open-circuit. On soldering a jumper lead across the strip normal field hold and height were obtained.

The point to watch therefore when servicing sets using printed boards is that if a specific voltage should be present at a particular component the voltage check is made at that component. Correct voltage at a point directly feeding the component via a strip of track does not imply that the voltage necessarily reaches the component even if, as in the example above, the track looks perfect and just as it left the factory. It's not always easy of course to measure voltages applied to small components except from the track side of the panel where exact identification of the component can be difficult. Resistors with insulated metal end caps usually give the greatest difficulty since the lead-out connections are right beneath them: with such components the best procedure is to scrape paint off the end caps rather than trying to locate the connection points on the other side of the panel.

Field Collapse

Field collapse—a horizontal line across the screen—was the complaint with a Bush Model TV181S single-standard receiver. Replacing the PCL805 field timebase valve had no effect but as rocking the valve in its holder resulted in vertical movement of the horizontal line it was clear that the pentode section of the valve was passing current. This implied that the output transformer, scan coils and cathode bias resistor were OK and that voltage was being applied to the pentode screen grid—simple tests like this are invaluable in reducing the number of fault suspects.

The triode and pentode sections of the valve are capacitively cross-coupled to each other in the usual multivibrator arrangement. Thus the cause of the field collapse was in the triode circuit or one of the cross-couplings. The triode anode voltage was found to be somewhat lower than the correct 130V, which was only to be expected since when an oscillator is not oscillating the absence of self-produced grid bias results in a higher than normal anode current and a proportionately greater voltage across its anode resistors. It was noticed that when the test prod was applied or removed there was a distinct

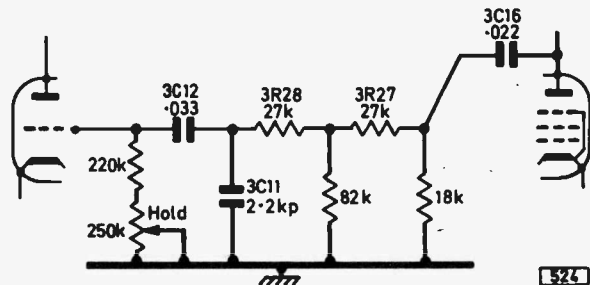

Fig. 3: Field collapse in a single-standard Bush model was due to failure of the field generator to oscillate. The cause was 3C11 in the multivibrator cross-coupling circuit being short-circuit.

though small movement of the horizontal line: thus the coupling between the triode anode and the pentode grid appeared to be sufficient to give oscillation. The most likely cause of the field collapse therefore was a break in the feedback circuit between the pentode anode and the triode grid.

The most likely suspect was 3C16 (Fig. 3) but shunting an equivalent across it failed to restore the scan. This left the possibility that 3R27, 3R28 or 3C12 were open-circuit or 3C11 short-circuit. The pulse voltage developed across 3C11 and applied via 3C12 to the triode grid is normally in excess of 225V: thus failure of 3C11 was a distinct possibility. A resistance test confirmed that this was the case and after fitting a replacement and adjusting the linearity controls a perfect test card was obtained.

UHF Fade

Picture fade on u.h.f. a short time after switching on is very often due to a slightly soft PFL200 video valve. In a couple of cases encountered recently however the fade—unlike that caused by a faulty PFL200—was accompanied by a severe increase in background noise. The sets used valve u.h.f. tuners so suspicion immediately centred on the PC88 r.f. amplifier valve. In both cases however the cause was the PC86 frequency changer valve.

TO BE CONTINUED

COLOUR RECEIVER PROJECT

—continued from pages 356/7

cabinet on the horizontal member: it should be not less than 9in. from the right-hand side to allow full clearance of the RGB module and to prevent possible interaction between the timebase board and the power unit. A small frame has to be built up to take the power supply transformer: two of the securing bolts are then on the existing rear horizontal member and two on the new member attached alongside.

Use the modules themselves as templates for the woodwork necessary to mount them.

Line Output Transformer

A fairly substantial gap should be left between the runners for the timebase and RGB modules on

the right-hand side—say about 5in. A fairly accurately cut length of wood of about this width should then be glued and pinned from the front to the rear members horizontally: this is to take the line output transformer and the tripler. Mount these securely on this new member—the transformer orientation is of no consequence. The tripler should be mounted with its leads upwards. Mount the focus unit adjacent to this new member, with the control knob protruding rearwards.

Next month we shall be giving the line output transformer connections and the connections between the units—also the preferred method of making these. There are several components still to be specified mounted on the line output transformer. The author has been abroad on business for some time this month and on returning has moved house—for these reasons it is not possible to proceed further at present.

CONTINUED NEXT MONTH

LETTERS

VHF TUNER TROUBLES

I've had the same v.h.f. tuner trouble that Chas. E. Miller described in his article on "the lemon". Two cases which come to mind gave (a) some but poor v.h.f. reception and (b) no v.h.f. reception at all. In case (a) a click was heard after about a quarter of an hour and v.h.f. was then OK. Like Chas. E. Miller I cleaned the biscuit contacts, checked voltages, tried new valves, etc. without any improvement. Yet everything seemed to be in order. Finally I decided to close the contacts in the mixer/oscillator valve-holder so as to grip the valve pins more firmly: this was done by forcing the point of a stout darning needle between the ceramic and the valve pin holders. In both cases this treatment restored perfect reception. For good measure I gave each socket in the holder a touch of "Kontakt 60" switch cleaner and while I was at it did the r.f. amplifier base as well. A point worth noting is that they were ceramic holders. Case (a) was dealt with a couple

of years ago and reception is still good. The other case is more recent but is OK so far. I hope this information may be of help to other readers confronted with such a problem.—S. P. Hill (Preston, Lancs.).

BRC 8000 CHASSIS

With reference to your comments on IBC-72 in the March issue I would like to point out that the reliability of a 22kV e.h.t. overwinding on the line output transformer could never be claimed to be equal to that of an overwinding operating at 8.5kV provided similar methods of manufacture, encapsulation and termination are employed. The improvement in reliability in the 8000 chassis is based on the consideration that the performance with the 22kV overwinding plus the silicon rectifiers and the manufacturing methods employed should compare very favourably with that of an e.h.t. system using a tripler. This takes into account the use of a transformer manufactured with silicon encapsulation and the probability of failure of two rectifiers in series compared with the five rectifiers plus four capacitors normally used in a tripler assembly.—A. Martinez, C. Eng., F.I.E.R.E., Chief Engineer, British Radio Corporation (Bradford) Ltd.

SINGLE-TUBE COLOUR CAMERAS

—continued from page 363

delayed. The luminance amplifier is thus conventional except for the carrier traps and the delay line.

The signal from the head amplifier also passes to the two chrominance channels. Each of these incorporates a bandpass tuned amplifier, working at 3.5MHz in the case of the red amplifier and at 5MHz in the case of the blue amplifier. Note that since the output of these amplifiers is a signal modulated by the difference between the stripe colour and white the signal obtained from the cyan stripes is red and the signal from the yellow stripes blue. In each channel a detector extracts the colour signal from the modulated signal so that separate red and blue signals are fed out of the camera or encoded as desired. The bandwidth of the colour amplifiers is ± 0.5 MHz.

Camera Design Problems

The problems of camera design are mainly concerned with maintaining sweep linearity and focus. If the sweep speed varies the carrier frequencies generated by the colour stripes will also vary and since the tuning of the colour amplifiers is fixed the bandwidth of the colour signals will be altered. It has been calculated that a 1% error in the position of the beam will cause the colour bandwidth to drop to half. The beam focus must be maintained during scanning since the beam must be able to resolve the stripes: any change in beam focus will cause a large change in modulation depth resulting in colour shading. For this reason the voltages at which the tube is operated are unusually high, with about 1kV on the mesh and around 600V on the wall anode. Because of losses in the fibre-optic faceplate

the tube output is low and a good low-noise pre-amplifier must be used to amplify the $0.3\mu\text{A}$ output signal from the target.

Conclusion

The problems have not been solved to the extent that the Spectraplex is likely to drive out the three-tube camera from studio use. Colour shading remains a problem, and there is a cost limit to the use of better scanning coil assemblies. The stripe pattern on the tube causes problems when scenes containing vertical stripes or stripes near 45° are televised since these set up coarse beat patterns with the striping. This can be overcome, at the expense of reduced colour and luminance bandwidth, by slight defocusing: there is also a possibility of reducing the effect optically by a form of low-stop filter. Fortunately there is one bright spot, target lag is not so critical as it is in a three-tube camera.

Another odd effect is caused by the notches in the luminance response where the carrier frequencies have been filtered out: the picture has little resolution at these frequencies so that some objects are almost invisible. This could possibly be overcome by some form of carrier cancellation on alternate lines, but the expense hardly seems worth while.

All in all the Spectraplex is a remarkable achievement which enables colour pictures to be obtained from a camera of size that can be readily hand held. For CCTV work or for small studios it brings colour working down to a price competitive with black and white, thus giving another impetus to the colour bandwagon. Further development work on single-tube colour cameras, including the development of the beam-indexing tube mentioned earlier, is certainly taking place at this time and developments are expected from Sony and Shibaden as well as from RCA. ■

RENOVATING the RENTALS

14 BRC 2000 CHASSIS

CALEB BRADLEY B Sc

DECODER AND I F STRIP

In this final instalment on the BRC 2000 chassis we shall deal mainly with the i.f. strip and the decoder. These are pretty reliable boards so to conserve space in the magazine we are giving block diagrams which should enable readers to find their way around these areas rather than complete circuits—sections of the circuit where we have experienced trouble are shown however.

Decoder

The decoder (Fig. 11) is reasonably conventional, using well known PAL switch, bistable, bridge chrominance synchronous demodulator (the burst detector is also of the bridge type) and crystal-controlled reference oscillator with varicap reactance control circuits. The only unusual features are: (a) the a.c.c. potential is obtained by rectifying the ident instead of the burst signal; (b) the elaborate pulse circuitry employed; (c) the use in the earlier version of the decoder (type 131) of a resistor chrominance matrixing circuit with a post delay line amplifier to make good the loss introduced by the line (type DL1) in the delayed signal path to the matrix. In the later type 231 decoder which uses a DL1E delay line the matrixing is done in the usual way by coils within the delay line housing, the loss in the delayed signal path being made up in the standard manner by driving the delay line from the collector of the driver stage while the undelayed signal is tapped from the emitter of this stage. The output from the colour-killer rectifier W18 is also used to bring into circuit on colour the 4.43MHz subcarrier rejector in the luminance channel: a switching transistor (VT2 in Fig. 3, March issue) is used to enable the rejector.

Pulse Circuitry

A positive-going 30V pulse from the line time-base is fed in at EC7/8 to the pulse clipper stage VT7. A proportion of the negative-going pulse appearing at the collector of this stage is used as a triggering pulse for the bistable; a positive-going pulse is taken from the emitter of this stage to the pulse mixer/clipper stage VT10 in the bistable switching phase control circuitry. In addition the collector of VT7 is d.c. coupled to the base of VT6 which provides anti-phase pulses (positive- and negative-going at its collector and emitter respectively) to drive the balanced double-diode chrominance blanking circuit (W16, W17). VT7, VT6 and the blanking circuit are shown in Fig. 12: the pulses from VT6 cut off the blanking diodes W16 and W17 during the sync pulse back porch period of each line when the burst is present. The positive-going pulses at VT6 collector are also coupled via

the integrating circuit R34, C5 and R2 to the base of the burst gate VT1 to switch it on during the burst period.

For ident synchronisation one of the bistable transistors (VT11) is driven by a pulse which appears on every other line. This is obtained as follows. The sinewave output from the ident amplifier is squared by W7/VT9 and applied along with the positive-going pulses from VT7 emitter to the pulse mixer/clipper stage VT10. This slices the waveform to produce a series of negative-going pulses which appear on alternate lines and synchronise the bistable by ensuring that VT11 is switched off on the correct lines.

Faults

The later type 231 board tends to produce grainier colour. The reference oscillator seems to drift with age so that it is sometimes necessary to trim the set oscillator frequency control R15 to bring it back into lock and restore colour. A more serious cause of lost colour is when C29 (Fig. 12) and/or C27 are leaky: this upsets the chrominance blanking circuit and the burst gate VT1.

The viewer colour (saturation) control becomes noisy and unpleasant to use: switch cleaner cures this. Noisy boards can be improved by changing VT13 and VT14 (BF115) to type BF167 and VT15 (BC107) to type BC109.

A case of bad blinds was traced to one of the diodes W10/W11 (type OA47) in the PAL switch circuit having become high resistance: replacement with a new matched pair completely cured the fault.

Convergence Board

The convergence board is clearly labelled. The usual trouble here is deteriorated tracks on the 625 R/G amplitude (R26 10 Ω), 625 blue amplitude (R27 20 Ω) and 625 blue tilt (R23 20 Ω) controls—these potentiometers can also burn out after some years of use. The blue radial convergence coils have been known to melt. The R-G horizontal lines are a little harder to converge than usual since the controls concerned are rather interdependent. Good results can be achieved with patience however.

Automatic Degaussing

The automatic degaussing circuit is shown in Fig. 13. The weak points here are the large disc v.d.r. Z1 (OE5-112) which goes open-circuit and the carbon resistor R1 which should be replaced with a wire-wound one. Degaussing occurs at switch-on and whenever the line system is changed since a new cold

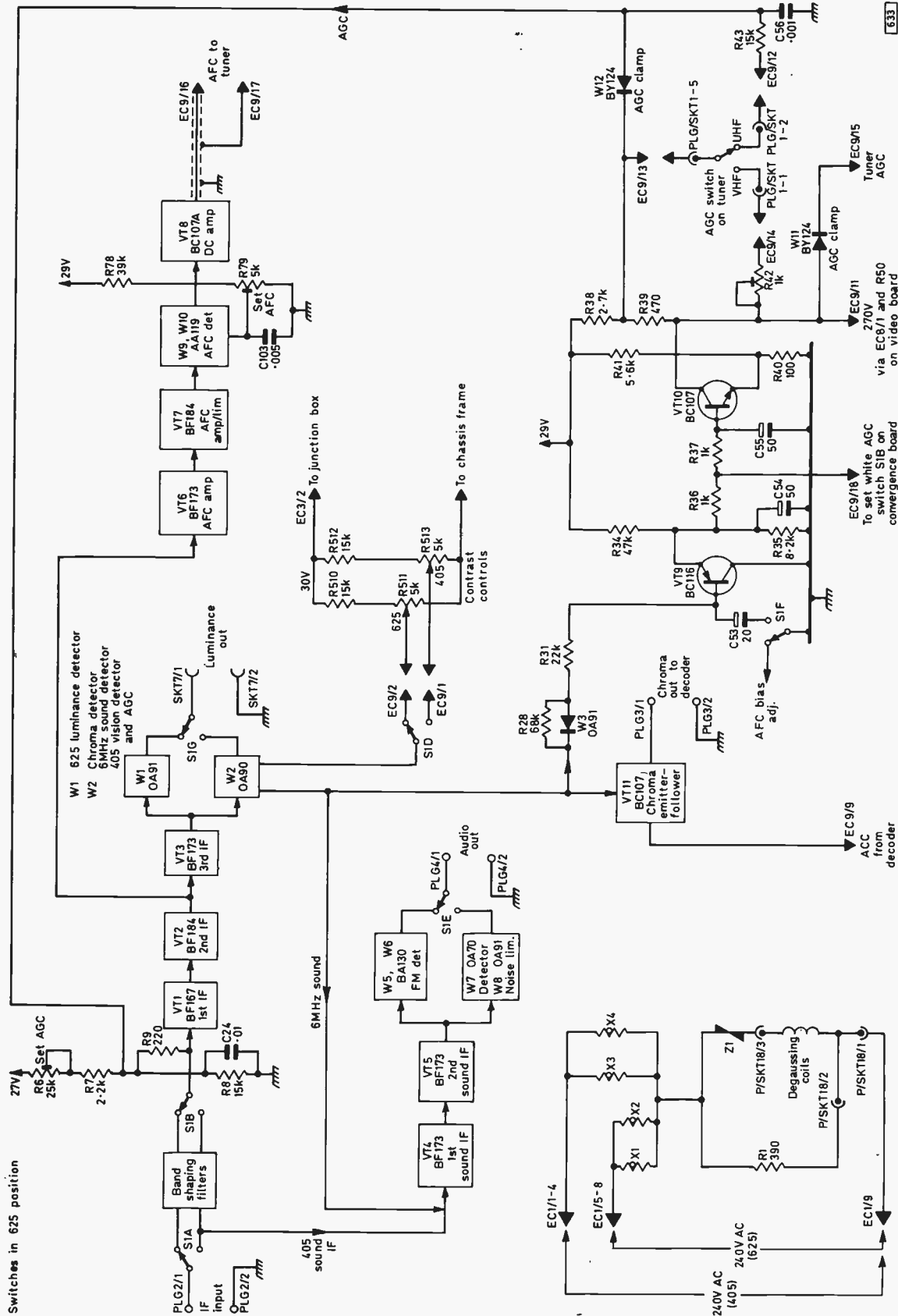

633

Fig. 13 (bottom left): The automatic degaussing circuit. Fig. 14 (above): Block diagram of the i.f. strip.

bottom of the tuner falls to bits.

If there is buzz on 625 lines trim the 6MHz discriminator coil L33: it is easy to find since it lines up with a U-shaped cutout in the lower chassis member. A curious cause of lost 625 sound is C65 and C71 touching: these small tubular ceramics are mounted close together at the bottom centre of the board.

Automatic frequency control of the tuner local oscillator is provided on u.h.f. only for stable colour reception. A precise means of tuning each station button is for 13V a.f.c. voltage at pin 16 of EC9 (or VT8 case): do not disturb the set a.f.c. control R79: it is preset to give this voltage with no signal input.

The set a.g.c. control R6 can be set for a slightly over-contrasty picture with the viewer contrast control at maximum. The a.g.c. preset R42 affects the

relative tuner/i.f. strip a.g.c. on v.h.f. If too far clockwise there may be a "step" in the contrast range with weak signals; if too far anticlockwise the picture may be grainy even on strong signals.

Noisy chrominance can be improved by replacing VT11 (BC107) with a BC109.

Conclusion

We have covered quite a few faults on this chassis in the last few articles. It is only fair to add that the chassis has proved on the whole to be remarkably reliable. At least two very regular contributors to the magazine have models fitted with this chassis and have reported that very little trouble has been experienced over a long period of time.

UNUSUAL CONTRAST/ AGC CIRCUIT

H. K. Hills

An unusual contrast control/a.g.c. circuit is used in the Decca MS2001 series of hybrid, single-standard monochrome models—see Fig. 1. The video preamplifier Tr5 is connected in the common-emitter mode to drive the video output pentode and the a.g.c. amplifier Tr6, but acts as an emitter-follower to provide, via the ceramic filter X1, the 6MHz signal for the intercarrier sound channel. The detector D1 provides a positive-going output (negative-going vision) across its load resistor R28. L10/C30 provide 41.5MHz adjacent sound rejection while L11, L12 and L13 with C31 and C35 filter out the intermediate and other unwanted frequencies. The contrast control VR27 sets the bias on the video preamplifier, forming with R25 and R26 a potentiometer across the l.t. rail and chassis. The video output from Tr5 collector is a.c. coupled to the video output pentode (which has a d.c. restorer diode in its grid circuit) and d.c. coupled to the base of the pnp a.g.c. amplifier stage Tr6—hence VR27 sets the bias on this stage as well.

Tr6 emitter is fed from the potential divider R34/R38 and as on weak signals a higher voltage is

applied to its base from Tr5 collector it is then non-conducting. Under these conditions the first i.f. amplifier is biased for maximum gain by the potential divider R37/R36. As signal strength increases, the negative-going sync pulses at Tr5 collector will be of sufficient amplitude to drive Tr6 into conduction. C37 receives a charge as a result of the pulse conduction of Tr6 and the increased voltage at the junction R36/R37 increases the forward bias applied to the i.f. amplifier, reducing its gain through forward a.g.c. action. The value of C37 determines the time-constant of the a.g.c. system while the value of R35, through which C37 charges when Tr6 conducts, determines the charging time-constant. The point at which Tr6 draws collector current during the sync pulses is determined by the mean collector voltage of Tr5: this of course is regulated by the bias on Tr5 set by the contrast control.

As in so many single-standard monochrome receivers a.g.c. is not applied to the tuner unit, the front-end gain being adjusted by a preset potentiometer. The three programmes on u.h.f. come from the same station so variations in signal strength should be negligible. Such gain controls are normally adjusted for greatest gain consistent with complete freedom from cross modulation. If in areas of exceptionally high signal strength cross modulation is still experienced with the gain control set to minimum an attenuator must be fitted in the aerial lead.

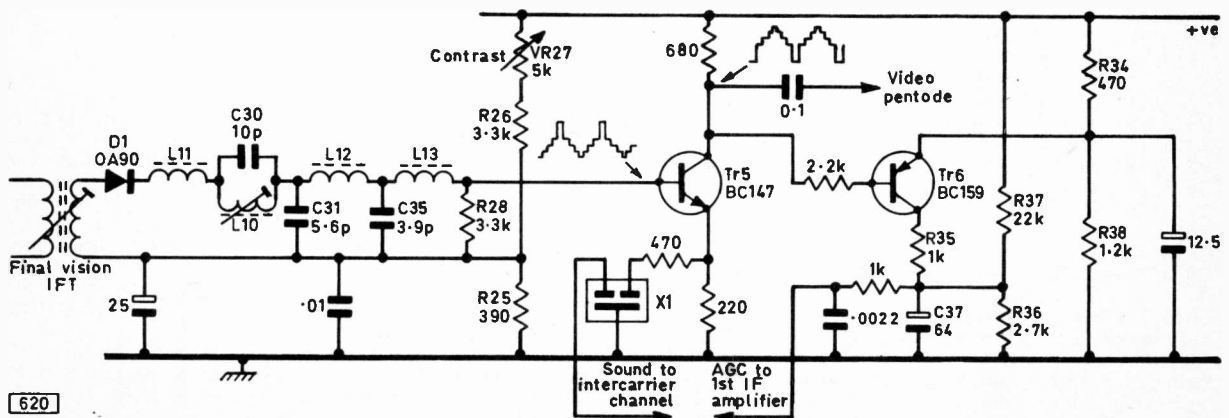

Fig. 1: The contrast/a.g.c. circuit used in the Decca Models MS1700, MS2001 and MS2401.

LONG-DISTANCE TELEVISION

ROGER BUNNEY

THE outstanding event of March was undoubtedly the enhanced spell of tropospheric propagation caused by a virtually stationary high-pressure area which lasted for over two weeks and apart from good reception conditions brought a very fine spell of weather. In this part of the country reception was confined mainly to Northern and Central French v.h.f./u.h.f. transmitters but for those parts more favourably situated the Low Countries and West Germany were well received at v.h.f./u.h.f. There has also been an encouraging increase in Sporadic E reception, which is to be expected at this time of the year. From the reception so far experienced I feel we can speculate to some extent about what the main SpE season will be like. Reception generally has tended towards medium to long skip and the Scandinavian countries have been favoured so far—indeed we have already confirmed reception of Finland chs.E2 and E3 with high signal levels (March 24th, 2200 onwards). In the circumstances I feel the prediction can be made that the forthcoming SpE season will if anything be better than last year, with a tendency for long skip signals particularly towards the East and North East. My own log for the period at this valley location is as follows:

- 3/3/73 DFF (East Germany) ch.E4; NRK (Norway) E3—both MS (meteor shower/scatter); BRT (Belgium) E2; NOS (Holland) E4—both trop. Also various ORTF (France) v.h.f./u.h.f. Northern French stations, via trop.
- 4/3/73 WG (West Germany) E2 (MS); BRT E2 (trop); also ORTF trop including Nantes E29 and Limoges E50.
- 5/3/73 SR (Sweden) E2; NRK E2—both MS; BRT E2—trop.
- 6/3/73 BRT E2—trop.
- 7/3/73 BRT E2; NOS E4—both trop.
- 8/3/73 BRT E2; NOS E4; also ORTF v.h.f./u.h.f.—all trop.
- 9/3/73 SR E2—MS.
- 10/3/73 BRT E2; ORTF v.h.f./u.h.f.—all trop.
- 11/3/73 BRT E2; NOS E4; ORTF v.h.f./u.h.f. trop—this day was particularly active.
- 12/3/73 NRK E3; SR E2—both MS; BRT E2—trop.
- 13/3/73 TVP (Poland) R1—MS; BRT E2, 8, 10—trop.
- 14, 16/3/73 BRT E2 and ORTF trop.
- 17/3/73 USSR R1—SpE; BRT E2—trop.
- 18/3/73 WG E2—SpE; BRT E2; NOS E4—trop.
- 19/3/73 BRT E2; NOS E4—trop.
- 20/3/73 BRT E2; ORTF u.h.f.—all trop.
- 22/3/73 DFF E4—MS.
- 23/3/73 BRT E2; ORTF u.h.f.—all trop.
- 24/3/73 BRT E2; NOS E4—trop.
- 25/3/73 SR E2—MS; BRT E2—trop.
- 26/3/73 BRT E2—trop.
- 27/3/73 WG E2; CST (Czechoslovakia) R1—both SpE; BRT E2 and ORTF u.h.f. including Paris E22.
- 28/3/73 BRT E2—trop.
- 29/3/73 BRT E2; NOS E4—trop; also various ORTF u.h.f. stations.
- 30/3/73 BRT E2—trop.

Sporadic E was noted on the 11th (ch.E4), 17th identified as USSR, 19th unidentified but suspected of being of Scandinavian origin, 24th unidentified mid-day but evening identified as Sweden (Finland was received as well on E2 and E3 by Graham Deaves, Norwich) and 27th identified on test pattern as West Germany and Czechoslovakia. Our congratulations to Ian Beckett

(Buckingham) for presenting a really excellent log; of particular note were his two new ORTF u.h.f. stations received on February 11th. Following the recent inclusion of the RTP (Portugal) transmission times Antonio Carvalho (Porto) adds that the times given for test transmissions are not rigid but vary somewhat. Apparently the u.h.f. test card is at times radiated on Saturdays.

We have received a letter from the RSGB following our mention of aircraft scatter propagation and the articles in the November and December 1966 issues of the *RSGB Bulletin* on this subject. If anybody has difficulty in obtaining copies of the two articles the RSGB (35 Doughty Street, London WC1N 2AE) are prepared to supply photocopies at £1.00 per set including postage. They also draw attention to *Radio Communication* December 1970, January and February 1971 in which the series "Flare Spot" also dealt with aircraft reflection.

With some dismay we must report that according to the 1973 World Radio/TV Handbook the Turkish Television network which for some time had a high-power Band I network projected now lists this as projected for Band III. This does reduce our chances somewhat via SpE (!) but for the record we detail the latest information—Diyarbakir E9; Izmir E10; Bursa E6; Erzurum E6; Kars E9 (all 100kW e.r.p.); Edirne E9; Eşkisehir E7; Adana E6; Gaziantep E10; Van E7; Trabzon E9; Samsun E7 (all 30kW e.r.p.). We are featuring the TRT information in this month's Data Panel.

Following the recent trumpet blowing activities by yours truly, reference the Baku reception, a repeat performance is now called for! On May 24th last RUV (Iceland) was received on ch.E2 (fortunately another vigilant DX enthusiast in Dorset also noted it). Suspecting that a high-power transmitter was in use the EBU station supplements were awaited to confirm this. The most recent states however that the only E2 transmitter then in operation transferred on December 5th to ch.E11. There are now no ch.E2 transmitters in operation. The transmitter in question is located at Hvalfjoerdur and on "May 24th last operated with 20 watts—it is now on ch.E11 with 600W. It does illustrate the signals that can be propagated via Sporadic E—can there still be hope for the Istanbul University transmitter on ch.E4 with 50 watts??!"

News Items

Austria: The Osterreichischer Rundfunk (ORF) is currently constructing a vast new studio centre at Vienna. This will house all technical and production facilities for both networks (ORF-1 and ORF-2). It is due for completion in 1974 and will be known as ORF Zentrum Wien. Both networks "went colour" in January 1973.

Albania: Michele Dolci reports that Albania transmits on Italian channel C. using system B, and *not* ch.R3. Test transmissions are 1800-1830 (CET 1 assume); 1800-1815 test card marked 011, 1815-1830 type 101 (see Data Panel 14, September 1972).

Monte Carlo: Michele Dolci also tells us that he has now found detailed information on the projected (and rumoured!) high-power transmissions in Italy. He is at present stationed in the area near the mountain Les Marguareis in North West Italy near Cuneo. The transmitter is ready and tests have been carried out between

DATA PANEL 23—2nd series

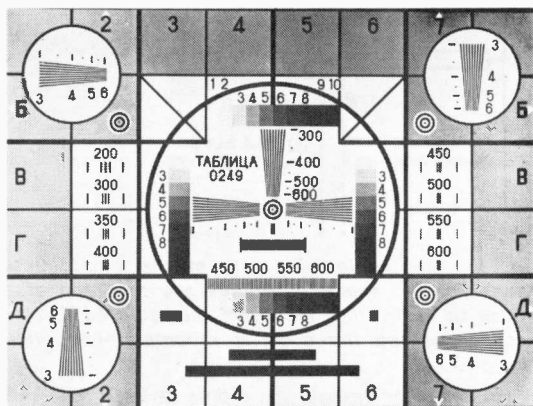

USSR test card (Televidenie Sovetskogo Sojuza—TSS).



Intervision caption—a programme with this slide would indicate origin in East Germany.

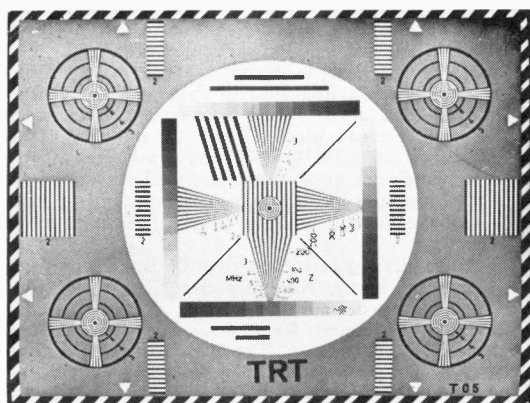

Turkish test card (Turkiye Radyo Televizyon Kurumu—TRT).



Turkish station identification slide.

Photographs courtesy TRT Ankara and TSS Moscow.

ch.E35 and E39 but apparently RAI (Radio Televisione Italiana) have "built a shield in front of the radiating tower" making reception in the projected area rather difficult. The transmitter is not on the air at present but it is hoped that broadcasts will commence in summer 1973.

Libya: Rumours abound concerning a possible ch.E4 transmitter operating in Libya. For our part we have contacted EMI Ltd, who supplied much of the technical equipment for the network. They tell us that phase 1 included Benghazi E5 and Tripoli E6 which opened at the end of 1968 (both Band III). They understand however that a small system started transmitting from Sebha (I assume Sebha Oasis which is in central Libya and surrounded by desert) in October 1971 using a low-power transmitter of French manufacture ex Tripoli Trade Fair—the channel used by the transmitter is not known. We have received no reply as yet from the authorities in Libya about the situation.

TV Book

Although commenting on books is not the purpose of this column I feel an exception can be made in the case

of *The Universal Eye* by Timothy Green, published by the Bodley Head at £2.75. I located this in the local library and found it extremely interesting. It is basically an account of television throughout the five continents, written in an informative and informal manner. The author has visited the stations and writes on the types of programmes, the political and financial aspects of the operations and the various technical aspects. I found of special interest the account of Eurovision, Intervision and TV activities in the Middle East—here mention is made of the propaganda side of things and how tropospheric ducting—common in the area—affects programming.

Latest EBU Listings

Luxembourg: Dudelange CLT-1 ch.E21 1000kW horizontal.

Sweden: Gaellivare Sr-2 ch.E33 up to 1000kW from 100kW horizontal.

East Germany (GDR): Saupsdorf E23, Piesau E24, Weissenschirmback E25, Tanna E29, Teichrdeda E30, Burkhardtswalde E31, Albrechts E36, Herzogswalde E37, Jena-Landgraf E38, all horizontal

polarisation. I suspect that most if not all these are relays but no detailed information has been included.

The EBU also advised that their annual transmitter list and supplements will be appearing in future in September. To this end all subscribers will receive three extra supplements this year to take them up to September and to edition 18.

From our Correspondents

A very full post bag this month and with the rather lengthy column this time we can unfortunately devote only a few lines to letters. Dieter Scheiba of Brussels (our photographic expert) clears up for us the query we raised in the March column about the FUBK test card. FUBK is an abbreviation from *Funkbetriebskommission*, a working group concerned with broadcasting and including the Deutsche Bundespost (Post Office), certain radio organisations and industry. This group approved the FUBK pattern which was prepared by the Institut für Rundfunktechnik in Munich and Fernseh GmbH of Darmstadt. Dieter also advises that the "ARD Stern" identification is radiated when a station connects with the ARD Centre.

The ORTF-3 identification slide that seems to 'be radiated for most of the time actually commences with a series of moving and changing circles which eventually stabilise to the well-known pattern recently illustrated.

W. Williamson (Shetland) has written about Aurora phenomena on the 21st, 22nd and 23rd February. He says that very poor quality vision was noted and considerable difficulty was experienced in locking the image—he finds that the best method is to set the controls to the known locking and tuning position and stand well back: from time to time vision will lock in for a few seconds. He noted that a non-flywheel sync receiver was better than a flywheel sync one due to the long time-constant of the flywheel sync action. Signals were noted on programme around 2000.

Dave Bunyan (Sittingbourne) has written describing his considerable success with tropospherics. Of particular interest are his comments on signal ducting—particularly with Brocken ch.E34 DFF. At the time of this reception no signals from nearer u.h.f. stations in the same path were present. The DFF signal was rather weak although with slow fading. Dave has just constructed a varicap-tuned aerial amplifier for Band I using a BF180—he mentions that an f.e.t. version is on the stocks and we look forward to details of this in due course.

For the Beginner

Having covered propagation and receiver requirements we must deal next with the all-important aerial system. Since the Sporadic E season is now upon us it seems relevant to deal initially with Band I systems. Signal strengths encountered with SpE range from very weak to exceedingly strong and certainly the beginner to the DX-TV hobby is recommended to start with this type of reception. The aerials required can be simple—often single dipoles will suffice.

The main problem with using single dipoles is that of bandwidth—we have to cover the range 48.25MHz (ch.E2 vision) to 62.25MHz (ch.E4 vision) or if sound is required from the latter channel to 67.75MHz. A single dipole using the normal $\frac{1}{2}$ in. outside diameter elements will have insufficient bandwidth—approximately 5MHz for $\frac{1}{2}$ in. o.d. We need three dipoles therefore for efficient coverage of ch.E2–E4 vision frequencies inclusive, bearing in mind that the performance of a single dipole falls sharply h.f. of its cut frequency whereas it falls rather less sharply l.f.

Since the polar diagram of a horizontal single dipole at its resonant frequency resembles a figure-of-eight, with the two main pick-up lobes at right angles to the axis of the dipole elements, we must either (a) erect two dipoles at right angles to give omnidirectional coverage

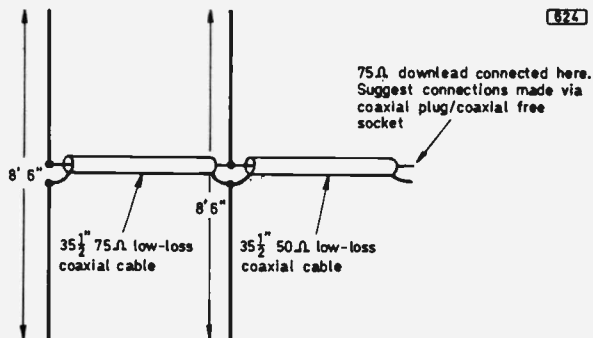

Fig. 1: An "exploded" view of the omnidirectional Band I array: the two dipoles are mounted at right angles to each other to obtain the required directional coverage and the array is mounted horizontally.

or (b) be able to rotate the dipole through 90°. In both cases the bandwidth restriction must be taken into account. The reason for mounting the dipole(s) horizontally is that this matches the majority of Continental transmissions (although there is often a polarisation shift with SpE propagation) and in addition this tends to reduce interference from high-power Band I UK transmissions which are usually vertically polarised.

An extremely simple Band I array with omnidirectional coverage was featured in *Practical Television* July 1969. The basic information is repeated here in case a copy cannot be obtained. The array (see Fig. 1) is cut to resonance at 55MHz but has been found to give reasonable performance over the ch.E2–3 vision frequencies. It solves the problem of rotation and is certainly ideal for the person unable to erect elaborate outside arrays.

An alternative solution to overall Band I coverage is the wideband array. Basically this uses three resonant elements cut to certain frequencies within the required bandwidth. Wideband Band I arrays were covered in the May 1972 *Television*. There is no reason why semi-wideband arrays should not be constructed and a working guideline is: (a) l.f.(48–55MHz), a reflector cut to 48MHz and dipole cut to 54MHz; (b) h.f.(56–63MHz) a reflector cut to 56MHz and dipole cut to 62MHz. In both cases quarter-wave reflector spacing should be used and a formula for finding the element lengths in ft. is $468/\text{frequency in MHz}$.

We must not forget that chs.R3, R4, R5 and IC are at times propagated via SpE: aerial construction for these frequencies follows the same lines as above.

To digress for a moment, Band II (TV) coverage is now simplified by using a wideband v.h.f. to u.h.f. converter which converts the 40–230MHz spectrum to approximately ch.E33–56. The u.h.f. tuner is then used to tune over the v.h.f. spectrum.

In view of the signal strengths encountered with SpE Band I reception aerial height is of less importance than with tropospheric reception. As a general rule it is wise if possible to clear local obstructions and the aerial should certainly be at least 20ft from local ground level. A relatively cheap way to reach this height is with a 20ft alloy scaffold pole: with swivel coupler, a putlock and other scaffolding clamps a cheap mast can be made that can be hinged upwards and allows quick and easy access to the aerial system. Although cable losses at Band I are quite low it is wise to use the best quality low-loss coaxial cable.

Suitable Band I aerial insulators for $\frac{1}{2}$ in. o.d. elements can be obtained from S. A. Collard Ltd., Wetherby Road, Osmaston Park Industrial Estate, Derby DE2 8JQ. X insulators with central bolt fixing (type A/1028) are 55p, X insulators with integral mast clamp (type A/1029) 70p and dipole insulators with central bolt fitting (type A/1025) 45p. These prices include postage but not VAT.

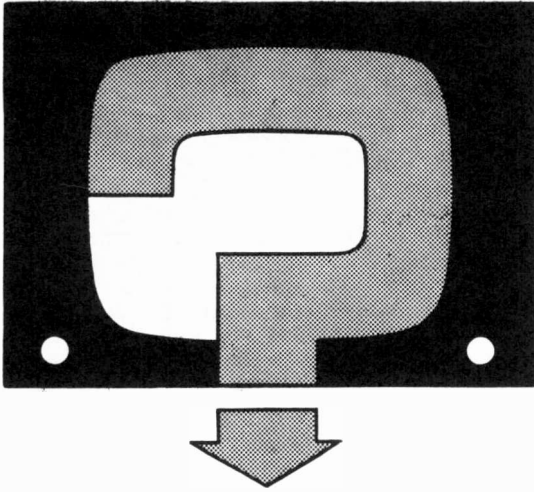

YOUR PROBLEMS SOLVED

★ Requests for advice in dealing with servicing problems must be accompanied by an 11p postal order (made out to IPC Magazines Ltd.), the query coupon from page 377 and a stamped, addressed envelope. We can deal with only one query at a time. We regret that we cannot supply service sheets or answer queries over the telephone.

INVICTA 7019U

The fault with this set is reduced width on 625 lines only, with some foldover on the left-hand side. The PL36 line output valve and the two width/e.h.t. presets R111 and R112 have been replaced.—R. Spurling (Gravesend).

The components to check are the PY800 efficiency diode and the 625-line scan correction network components C100, L38 and R118. It is always a good idea on these receivers (Pye 11U series) to replace the coupling capacitor C87 (0.01 μ F) between the PCL84 line oscillator (V14 triode section) and the PL36 as this gives quite a bit of trouble although it is not likely to be responsible for the fault condition you describe.

FERGUSON 3659

There is a ragged vertical white line 1-2in. wide at the centre of the screen. Increasing the brightness control setting makes it worse. Sometimes the picture information disappears but can be restored by reducing the brightness. The trouble is worse on Band I than on Band III, the set operating satisfactorily on u.h.f. There doesn't appear to be any damage in the e.h.t. tray and a new PL504 line output valve has made no improvement.—L. Hopkinson (Manchester).

There could be more than one reason for the interference on 405 lines. An inefficient aerial placed near the set could cause just this trouble, perhaps aggravated by inefficient bonding between the v.h.f. tuner body and the main chassis member. Check these items and then replace the 405 line linearity correction capacitors C106 (600pF 2kV) and C108 (0.3 μ F).

McMICHAEL MT762

When the set is switched on the picture is good but the sound very distorted (the set operates on 405 lines only, not having been converted to 625). After a short time the picture is lost, leaving a white horizontal line across the screen. When the set has been off for a while the picture is restored on switching on again.—J. Rivington (Sutton).

The distorted 405 sound should direct attention first to the 4.7M Ω resistor which applies positive bias

to the anode of the sound noise limiter diode: this resistor can change value. If this is not the source of the trouble the PCL84 audio output valve and its associated components—in the grid and cathode circuit—will have to be checked. The field collapse is due to a fault in the PCL85 circuit. Once again, check the valve and its operating conditions. A faulty capacitor is quite likely to be the source of the trouble.

KB KV003

The picture on both v.h.f. and u.h.f. is well-defined but on v.h.f. the contrast control is quite ineffective. On u.h.f. it is only partially effective.—A. Dalton (Haverfordwest).

If the contrast is at a high level check the PC97 r.f. amplifier valve in the v.h.f. tuner. If it is at a low level check the 4.7M Ω resistor in series with the 405/625 contrast controls switch contacts, the M1 a.g.c. clamp diode and the 10M Ω resistor in series with the slider of the a.g.c. preset control. (STC/ITT VC52 chassis.)

BUSH TV186S

Both picture and sound are perfect on the BBC-1 and -2 channels but on the IBA channel the picture is snowy, dark and hardly viewable.—E. Roberts (Sunderland).

If you are sure that you are tuning to the correct IBA channel—it is only a turn of the button away from BBC-1—then there must be a fault on the tuning gang in the tuner. If you remove the tuner cover you will see that the only difference between the channels is that the vanes of the tuning capacitors mesh farther in on ITV—the vanes are then almost fully closed. One of the moving vanes may be touching one of the stator vanes at this point—most likely at the aerial or next compartment since the fact that there is some slight reception proves that the oscillator is working. You may require a bright light and a magnifying glass, also perhaps a thin sliver of paper, to prove that the gap is not closed when adjusting the vanes.

FERGUSON 3607

The width suddenly closed in an inch at each side, with loss of brightness. The line timebase valves were replaced, also the output pentode screen feed resistor, but with no improvement. The width and brightness were restored when a meter on its 600V range was touched on the line output pentode control grid; also a 90pF capacitor connected across C131 in the line output pentode control grid circuit restores normal working, but replacing C131 makes no difference. There is also, on 625 lines only, slight fold-over on the left-hand side of the picture.—R. Beech (Islington).

The width trouble is obviously due to a fault in the e.h.t. stabilisation circuit connected to the grid of the line output pentode. We presume the 1M Ω width control itself is intact: if so check R98 (330k Ω) in series with it, R100 (1.8M Ω) in series with its slider, the v.d.r. Z1 and R101 (2.2M Ω) which links these components to the PL36 grid circuit. The left side foldover denotes a fault—or maladjustment—in the flywheel sync circuit. Check the setting of the 625-line horizontal lock preset R52, the flywheel d.c. amplifier V6B and the associated components back to the flywheel sync diodes. (Thorn 800/850 chassis.)

BUSH TV141

The set operates correctly on 625 lines. On 405 lines however the picture is steady until someone speaks which results in sound-on-vision (waves across the picture).—J. Butler (Leeds).

First ensure that the pushbuttons are correctly set and that the contrast is not too high: then adjust the core of 2L9 to clear the sound-on-vision, preferably on a constant tuning note. If necessary replace the vision i.f. amplifier valve 2V3 (EF184), having ensured first that the a.g.c. delay control 2RV1 has not been set too high.

REGENTONE 193

This convertible set is at present fitted with a v.h.f. tuner only and has come in for repair suffering from loss of signals. We have had difficulty getting any data on this set.—H. Illingworth (Ripon).

The set is fitted with the Plessey convertible chassis which is the same as that used in the Defiant 9A43 series. It incorporates a Fireball v.h.f. tuner. A frequent trouble with this was that the i.f. output coil—connected to the anode (pin 6) of the PCF80 frequency changer—becomes open-circuit due to corrosion on the fine wire to the valve base pin.

KB QV20/1

There is excessive width which is compressed at each side. The line output stage valves have been replaced, also various resistors.—J. Stannings (Redditch).

The fault appears to be associated with the deflection coils. The first move should be to check the setting of the width/linearity sleeve which is mounted beneath the coils: there should be about $\frac{1}{4}$ in. protruding at the rear with the gap at one side. Then check the S-correction components L66 and C60 (0.1 μ F) in series with the coils.

MURPHY CV2212

The set may be on for several hours before the sound goes slightly distorted and then fades away: if the tuner button is slightly retuned at this point the sound can be brought back but soon fades away altogether and cannot then be brought back by altering the tuning, only by switching off the set. The fault occurs with the set back on or off and very randomly so far as time is concerned. The audio output stage has been thoroughly checked and appears to be OK—all voltages are normal. The tuner has been changed without making any difference.—A. Street (Chesterfield).

We feel that the trouble is in the TAA350 inter-carrier sound i.c. The only true test is to replace it but we find that this nearly always cures the trouble.

INVICTA 7039

For a period of time there has been arcing around the EY86 e.h.t. rectifier. This is eliminated if the brightness control setting is increased. Various insulating materials have been tried without success.—T. Holden (Wolverhampton).

The only permanent cure for this condition is replacement of the EY86 valveholder since the insulation of this has become impaired.

BUSH TV145

There is an occasional loss of field hold on this set. The hold control can be adjusted during the times when the field is unstable but the setting is extremely critical—slight movement either way and the instability returns.—G. Glowry (Dawlish).

We suspect the field interlace diode which is part of the block half way up the right side. This is the part marked MR3, with a 2.2M Ω resistor wired across it. Fit a separate diode such as an OA81 or similar. Check the PCL85 field timebase valve and its connections.

DEFIANT 9A50

The problem with this set is low video gain and we would appreciate any clues that might enable us to solve this problem.—R. Hinton (Keighley).

The PCL84 might need replacement but before doing this check the 10k Ω and 8k Ω series-connected bias stabilising resistors next to it. These regularly change value, upsetting the valve's working conditions. The cathode voltage (pin 7) should be 4.5V on 405 lines and about 30V on 625 lines—these are the only readings that need be checked if the resistors just mentioned are in order.

HMV 2629

Even with the width control right over there is a gap of about 1 in. at each side of the screen. The PL504 line output valve appears to be OK and the height is normal.—J. Butterford (Chepstow).

The PL504 may look OK but should nevertheless be checked—also the PY801 boost diode. Then check the width circuit resistors—suspects here are R131, R133 and R130—and the S-correction capacitors, C98 on 625 lines and C99 on 405 lines. (BRC 950 chassis.)

EKCO T434

There is an odd intermittent fault on this set. We originally got occasional cramping or line pairing across the middle of the screen—on both standards—but this trouble has cleared itself. Now on switching on there is no field scan at all but on adjusting the field hold control to either end of its track the scan opens out and the picture can be locked normally at track centre. The set then functions perfectly until switched off. The field timebase valves have been replaced and all voltages are correct while the fault is present. The only clue is that the trouble is cleared by unlocking the field hold.—T. Fielding (Ilford).

The trouble sounds like a faulty capacitor. The field hold control R87 in these models is connected across h.t. and chassis (with R86 75k Ω on the h.t. side). The slider goes via a 1.5M Ω resistor R85 to the grid of one section of the field multivibrator and this is cross-coupled to the other section via C79 (0.01 μ F). The first suspect is C79: then if necessary check R86 and R85, also the action of R87. Common field troubles with these models (Pye 11U series) are the 1.2M Ω resistor in series with the height control and the thermistor in the scan coils (check by shorting out).

ITT/KB CVC2 CHASSIS

After about 10 minutes the picture shrinks at the bottom by about two to three inches, with what looks like a slight foldover at the bottom edge of the raster. The PL508 field output valve and its cathode bias resistor—which looked slightly cooked—have been replaced without however curing the fault.—E. Dickinson (Dartford).

The trouble seems to be in the biasing of the PL508 and as the cathode resistor has been replaced we suggest you check the drive coupling capacitor Cf35 and the linearity feedback capacitor Cf39. Either of these two components could be leaky thus causing the fault condition.

QUERIES COUPON

This coupon is available until June 18, 1973, and must accompany all Queries sent in accordance with the notice on page 375. Don't forget the 11p (inc. VAT) postal order!

TELEVISION JUNE 1973

it be corrected? See next month's TELEVISION for the solution and for a further item in the Test Case series.

SOLUTION TO TEST CASE 125
(Page 331 last month)

In spite of the fact that the line output valve was well up in emission the fault was nevertheless due to it as subsequent replacement proved. Some line output valves develop a tendency towards a curious kind of electron oscillation called Barkhausen oscillation (after its discoverer) or sometimes BK oscillation.

This oscillation does not affect the normal operation of the line timebase, but being at a high frequency is radiated either at the fundamental frequency or at some other frequency due to it mixing with other signals in the receiver. It is then picked up by the aerial or tuner circuits. As it is modulated at line frequency it produces a vertical line of interference on the picture as described last month. It is rich in harmonics and can affect more than one channel therefore but at reduced intensity as the channel number is increased. It rarely affects the u.h.f. channels.

The problem is aggravated by incorrect aerial input matching or by the use of a set-top or indoor aerial and is sometimes modified by the presence of a magnetic field close to the line output valve. Indeed in some early receivers a magnet was fitted on the line output valve to minimise the effect.

TEST CASE

126

Each month we provide an interesting case of television servicing to exercise your ingenuity. These are not trick questions but are based on actual practical faults.

? A Pye CT70 dual-standard colour receiver worked perfectly on sound but although the picture was present the definition on all three u.h.f. channels was "oversharp", resulting in slight ringing effects (sparkle) and sound-chrominance beat patterning.

The definition could be modified by adjusting the tuner press-buttons in the usual way: under-tuning reduced the definition and deleted the colour while over-tuning emphasised the sound-chrominance beat pattern. It was impossible to obtain the correct tuning point.

The receiver has an a.f.c. cut-out button and by depressing this while turning a button the correct tuning point could be obtained. As soon as the a.f.c. cut-out button was released however the symptoms immediately reappeared.

What was the cause of this fault and how can

TELEVISION CLASSIFIED ADVERTISEMENTS

The pre-paid rate for classified advertisements is 6p a word (minimum 12 words), box number 20p extra. Semi-display setting £3.50 per single column inch. All cheques, postal orders, etc., to be made payable to TELEVISION and crossed "Lloyds Bank Ltd." Treasury notes should always be sent *registered post*. Advertisements, together with remittance, should be sent to the Classified Advertisement Manager, TELEVISION IPC Magazines Ltd., Fleetway House, Farringdon Street, London, EC4A 4AD, for insertion in the next available issue.

SERVICE SHEETS

SERVICE SHEETS MANUALS BOOKS

SERVICE SHEETS 30p plus S.A.E. ★ SERVICE SHEET CATALOGUE 20p
OVER 12,000 SERVICE SHEETS & MANUALS IN STOCK ON COLOUR/MONO TELEVISIONS
RADIOS, RADIOGRAMS, T/RECORDERS, R/PLAYERS, ETC. S.A.E. WITH ENQUIRIES

NEW BOOKS & PUBLICATIONS	PRICE
HOW TO MAKE WALKIE-TALKIES for licensed operation by T.D. Zedd.....	£0.40
NEWNES COLOUR TELEVISION SERVICING MANUAL by G.J. King. 240 pages....	£4.90
TV TECHNICIANS BENCH MANUAL by G.R. Wilding. 187 pages. 127 Illustrations..	£2.50
TV FAULT FINDING BOOK by Data Publications Ltd. 405/625 Edition. 124 pages....	£0.50
BEGINNERS GUIDE TO TELEVISION by G.J. King. 5th Edition. 212 pages.....	£1.60
COLOUR TELEVISION SERVICING by G.J. King. 332 pages. Illustrated.....	£4.40
COLOUR TELEVISION PICTURE FAULTS by K.J. Bohlman. Illustrated in colour....	£2.50
COLOUR TELEVISION With Particular Reference To The PAL System by Patchett...	£3.00
MAZDA BOOK OF PAL RECEIVER SERVICING by D.J. Seal. 288 pages.....	£3.80
TELEVISION SERVICING HANDBOOK by G.J. King. 3rd Edition. 358 pages.....	£3.80
INTRODUCTION TO VIDEO RECORDING by W. Oliver. 128 pages. Illustrated.....	£1.50
VIDEO RECORDING: Record & Replay Systems by G. White. 216 pages.....	£3.25
TRANSISTOR SUBSTITUTION HANDBOOK by H.W. Sams. 12th Edition. 176 pages..	£1.40
UNDERSTANDING TELEVISION by J.R. Davies. 405/625/Colour Edition. 512 pages	£2.10

Special Offer. 1972 Edition of WORLD RADIO-TV HANDBOOK £1.50 post free, usually £2.80.

NEWNES RADIO & TELEVISION SERVICING books bought & sold (all years) Good prices paid

Send large S.A.E. for FREE booklets and book pamphlets on Radio, Television & Electronics
NOTE. Postage on all books is now 5p up to £1.00. Orders over £1.00 POST FREE. (UK only)

BELL'S TELEVISION SERVICES

ALBERT PLACE, HARROGATE, YORKSHIRE. Telephone 0423-86844

A.L.S. SERVICE SHEET SERVICE

OUR STOCKS NOW COVER OVER 10,000 MAKES AND MODELS

1973 list covering mono and colour—TV,
Radio, Tape, Record Players, etc. List price 25p, plus SAE.

Service Sheets—Service price 30p plus LARGE SAE.

Manuals for many makes. Enquiries welcome but please—a SAE.

Always state make, model number and whether TV, radio, tape, etc.

1973 COMPREHENSIVE COLOUR TELEVISION MANUAL

By McCourt. £2.00 including post and packing.

Money refund if dissatisfied.

We can also supply Manuals for many sets, including Colour TVs by such makers as Bush, B.R.C., Murphy, Ferguson, H.M.V., Decca, Sony, Hitachi, Sanyo, etc. Prices on Request.

NEW SERVICE SHEETS, Magazines and Newsletter. SAE brings details and free sample.

BARGAIN CORNER

Metal box containing Heavy Duty 12V 2PCO Relay OC35 (type) transistor and other components (originally fluid level control unit) price 50p.

MAIL ORDER ONLY

A.L.S.

21c Dryden Chambers, 119 Oxford Street, London W1R 1PB

WANTED

NEW BVA valves of popular types, PCL805, PY800/1, PL504, etc. Cash waiting. Bearman, 6 Potters Road, New Barnet, 449/1934-5.

SERVICE SHEETS purchased. HAMILTON RADIO, 47 Bohemia Road, St. Leonards, Sussex.

BOOKS AND PUBLICATIONS

DIGITAL COMPUTER LOGIC and Electronics. Four volume self-instructional course. £2.95 including p. & p. Money back assurance.—Cambridge Learning (IT), 8a Rose Crescent, Cambridge.

LARGE SUPPLIER of SERVICE SHEETS

(TV, RADIO, TAPE RECORDERS, RECORD PLAYERS, TRANSISTORS, STEREOGRAMS, RADIOGRAMS, CAR RADIOS)

Only 40p each.

PLEASE ENCLOSE LARGE S.A.E. WITH ALL ENQUIRIES AND ORDERS.

Otherwise cannot be attended to.

(Uncrossed P.O.'s please, original returned if service sheets not available)

C. CARANNA

71 BEAUFORT PARK,
LONDON, N.W.11

We have the largest supplies of Service Sheets (strictly by return of post). Please state make and model number alternative.

Free TV fault tracing chart or TV list on request with order.

MAIL ORDER ONLY
or Phone 01-458 4882.

SERVICE SHEETS

(1925-1973) for Radios, Televisions, Transistors, Radiograms, Car Radios, Tape Recorders, Record Players, etc. with

FREE FAULT FINDING GUIDE

PRICES FROM 5p

Over 10,000 models available.
Catalogue 15p + SAE

Please send stamped addressed envelope with all orders and enquiries.

Hamilton Radio

47 Bohemia Road, St. Leonards,
Sussex. Telephone Hastings 29066.

SERVICE SHEETS, Radio, TV etc. 8,000 models. Catalogue 15p. S.A.E. enquiries, Telray, 11 Maudland Bank, Preston.

AERIALS

BAINES for High Frequency Aerials.
UHF Multibeams by J. Beam
MBM 10, £2.20 MBM 18, £2.90
MBM 30, £3.90 MBM 46, £6.00
MBM 70, £11.00

VHF FM Aerials
Dipole £1.40 FM/H £2.00 FM3 £3.00
FM45 £5.55 FM65 £7.80

Masthead Pre-amps
Single Stage £6.00 Two-Stage £8.00
Wideband £7.00

Accessories: SAE for full list.
Co-ax. 5p Low-loss 9p
Prices do not include VAT. 10% must be added to all orders.

11 Dale Cres., Tupton, Chesterfield S42 6DR

**GENUINE FULL SIZE
18 element TV aerial**
as used by leading
TV companies

ITV, BBC 1
& 2 B/W &
Colour. Guaranteed Perfect
Picture. Save ££. We
supply this genuine U.H.F. aerial
for only £2.20, can
be fitted outside or
inside. Quality made,
technically advanced
design. Precision grid
reflector eliminates ghost-
ing. Complete with clamp,
instructions, advice.
Money Back Refund.
Wall/Caravan Bracket 25p
Low Loss Cable 10p per yard. Plug
8p & FREE with order maps &
channel reference of all Radio & TV Trans-
mitters. Send direct to Dept.
218 Mansfield Rd., Nottingham.

£2.20
incl. VAT
+ 35p carriage

IMPERIAL TRADING (AERIALS) LTD.
the quality Aerial Specialists

U.H.F. (625) 18 ELEMENT T.V. AERIALS
As used by Leading Companies
Receives BBC1, BBC2, ITV
black and white or
colour. Can be used
inside or outside.
Complete with
mounting
bracket.

+ VAT 19p
£1.90 plus
34p p.p.

Please state your
nearest transmitting
station.
Low Loss UHF Coaxial 10p yard
Coaxial Plugs 10p each
Callers Welcome C.W.O.
DAMON ELECTRONICS
118/120 Arkwright St., Nottingham
Tel. 0602-865688

Direct from the
Manufacturers
U.H.F. AERIALS
EASY ASSEMBLY KITS
10 Element **SAVE**
£1.25 **40%**
ON FULL PRICE
14 Element 18 Element
£1.50 **£1.75**

Mast clamp optional extra.
Ready assembled add 20p,
allow 35p carriage and packing.
Please state which channels or group.
TRADE SUPPLIED, SEND FOR LIST
APEX AERIALS T.V.
ALBAN WORKS, MARY ST
JOHNSTONE, RENFREWSHIRE

SETS & COMPONENTS

Top 20 Plus Tested T.V. Valves.

PL504	18p	PCL84	10p
PC86	15p	PCL82	10p
PC88	15p	PFL200	10p
PL36	15p	ECC82	10p
PCL805/85	15p	EH90	10p

Colour Valves Fully Tested.

PL509	30p	PD500	30p
PL508	30p	GY501	30p
PY500/A	30p	PL802	30p

Many others available including
Mazda types.

P. & P. 4p per valve, over 12 24p
per valve, orders over £3 post free.

Prompt service.
S.A.E. for free list.

L. & D. Components Ltd.,
71 Westbury Ave, London N22 6SA.
Tel. 01-888 2701.

TV'S COLOUR TV'S

Reserviced. Perfect working order.
Repolished.

19in DECCA	£110
19in. GEC 2028	£115
19in. THORN 2000	£120
25in. DECCA	£125
25in. RBM PHILIPS	£130
25in. THORN 2000	£135

One month comprehensive written
guarantee. These are cash and collect
prices. Delivery quotations by phone.

MONO U.H.F.

Fabulous TVs. No rubbish, from
good source. Repolished cabinets.
Many working. Recent transistorised
models, including:

BUSH TV 148 U, TV 166, TV 176	
PHILIPS style 70 and 210	
PYE & EKCO 868 chassis	
THORN 950 1400, GEC Concorde	
FROM £12 EACH	

Valve u.h.f. models include:

BUSH push-button, THORNE 850,	
SOBELL 1000, etc.	FROM £5

U.H.F. TUNERS

For FERGUSON 850, 900 chassis but
adaptable for most D/STD chassis
£2.50 each, c.w.o. postage included.
Send s.a.e. for lists of Tubes, TVs,
Valves, etc. For England:

**TRADE DISPOSALS, 1043 Leeds Rd.,
Bradford. Tel: Bradford 665670**

For Scotland:

**TRADE DISPOSALS, Unit 5, Peacock
Cross INDUSTRIAL ESTATE, 32
Burnbank Road, Hamilton.
Tel: Hamilton 29511/2**

TRANSISTORISED UHF TUNERS

6 assorted £15.50 (incl. p. & p.)

BARGAIN T.V.'s

Slim Line

23" 3 channel with UHF tuner	£9.00
19" 3 channel with UHF tuner	£8.00
23" 2 channel	£5.00
19" 2 channel	£3.50

All sets working. Personal callers
welcome.

Carriage can be arranged.

Open Fridays - Mondays inclusive.

SUNDAYS: 1.30-4.0 p.m.
and by appointment.

PLASGWYN

WAREHOUSE,

Caernarvon Road, Fourcrosses,
Pwllheli, Caernarvonshire.

Tel.: Pwllheli 2800.

For quality Hi-Fi Equipment, records and
Colour Television, Visit
HANSPAL'S AUDIONICS

488 Lady Margaret, Southall, 01-578
2258; 54 St. Anns Road, Harrow, 01-
863 3400. 24 hours Autophone Service.
Marantz, Pioneer, Sansui, Akai, Rotel,
Nikko, Lux, Telefunken, Sony, Sanyo,
Tandberg, Hitachi, Grundig, Scan-Dyna,
KEF, TEAC, National, Quad, Tele-
funken, Hitachi, Sony and Grundig
Colour T.V. Always in stock.

Up to 5 years Colour Tube guaranteed
and 1 year Free Servicing and Labour.
Late evening: Friday until 7.00 p.m.
EXCELLENT CREDIT FACILITIES

COMPONENTS GALORE. Pack of 500
mixed components manufacturers sur-
plus plus once used. Pack includes
resistors, capacitors, transistors, diodes,
I.C., gang, pots, etc. Tremendous
value. Send £1 plus 10p P. & P. C.W.O.
to Caledonian Components, Fosterton
Firs, Strathore Road, Thornton, Fife.

CHEAPER T.V. SETS

405-19" /23"	50p to £2.50
D/S-19" /23"	£2.50 to £6
625-19" /24"	£4.00 upwards

Thousands of T.V. sets always in
stock. Colour also available. Mon/
Sat. 9.00 to 5.30.

WORKING SETS AVAILABLE TO ORDER

Enquiries to:—
**Premier Warehouse, Bridge Works,
East Farleigh, Maidstone.**

EX RENTAL TELEVISION

Slimline Dual Standard with

U.H.F. Tuners. Complete—Untested

19" THORN 850	£4
19" COSSOR 962	£6
19" K.B. VV	£8
23" THORN 850	£10
23" K.B. VV	£12

Collect or Send £2.00 p.p.

162 Kettering Road, Northampton.

90 Tavistock Street, Bedford.

1000 COMPONENTS—£3

Ideal mixtures for service engineers,
etc., containing carbon, carbon film,
metal oxide and a few wirewound
resistors, 1, 2, 5%, ½, ¼, 1, 2W
types. Also ceramic, mica, paper,
electrolytic, polystyrene capacitors. At
least 1000 components £3 + 30p post.

GREENWELD (T1)

24 Goodhart Way, W. Wickham, Kent

£90 COLOUR TV £135

- ★ Fully Serviced
- ★ Accurate Decoder Set Up
- ★ Attractive Cabinets

Also:—

23" UHF Mono. Working. £10

Telephone: 01-845 2036

EX-RENTALS

**ALL SETS complete with UHF
Tuners, many working:—**

19" BBC2 Sets at £3

23" BBC2 Sets at £7

Working Sets to Order.

All Sets Re-polished. Calls Only.

TV DISPOSALS, The Grove, Bristol
Tel: Bristol 290239

EX RENTAL TV'S BARGAIN

23" 3 Channel with U.H.F. Tuner
£7.50

19" & 25" Colour from £60.00

19" 3 Channel with U.H.F. Tuner
£4.50

19" 2 Channel £1.00

All sets complete. Callers only.

EDWARDS & SONS

103 Goldhawk Road, London W.12.

COLOUR TV BARGAINS

Working Colour Sets from £80.
Various makes available of 19" and
25" with good tubes. Non-working
sets supplied at lower prices. S.A.E.
for details.

THE TV CENTRE

83 Upper Aughton Road,

Southport, Lancs.

Telephone Southport 68695

TRANSISTORS (For THORN 2000)

R2008 output transistor.
R2010 chopper transistor.
Singles £1 each inc. p. & pkg.
Any twelve for £10 inc. p. & pkg.
C.w.o. to:—

TRADE DISPOSALS (T/O)
1043 Leeds Road, Bradford 3.

COLOUR COLOUR COLOUR

19in. & 25in. Colour Televisions
DECCA, BUSH, BRC, PHILIPS etc.
19" Working £100 25" Working £140
11" Portables £80
All Good Tubes. Tested before
Despatch. Delivery can be arranged
Non-Workers — From £80
S.A.E. Details Please.
T.E.S.T., P.O. Box 1, Kirkham,
Preston PR4 2RS

U.H.F. TV TUNER SERVICE
Your Tuner SERVICED and RE-
ALIGNED to original standards—
£3.25 post free c.w.o. Guaranteed
three months. Send complete tuner
to:—

COLORTUNE, 77 Stanley Road,
Hornchurch, Essex
(Trade Enquiries Invited)
Tel.: Hornchurch 45562

TOP PRICES PAID
for new valves, popular
TV & Radio Types

KENSINGTON SUPPLIES
(A), 367 Kensington Street
Bradford 8, Yorks

AVOs and all types of meters repaired.
Postal service. Free estimates. Guaranteed.
— Instrumentation Services, 23
Hallam Road, Clevedon, Somerset.

150 NEW Capacitors/Resistors/Silicon
Diodes. Electrolytic. Mica, Ceramic.
Carbon. Oxide etc. £1 Post Free.
Whitsam Electrical, 33 Drayton Green
Road, London. W.13.

LADDERS

LADDERS, 24ft., £9.80, carr. 80p.
Phone 029-93-5222, order C.O.D. (Dept
PTT), Home Sales Ladder Centre,
Baldwin Road, Stourport, Worcs. Callers
welcome.

PHILIP H. BEARMAN

(VALVE SPECIALISTS) SUPPLIERS TO
H.M. GOVT. Etc.

NEW valves by Mullard, Mazda, Telefunken etc.,

IMMEDIATE POSTAL DESPATCH, LISTS S.A.E., DISCOUNT PRICE
PRICES FROM 1.4.1973 (INCL. V.A.T.)

DY86/7	33p	PC88	61p	PCL86	53p	6/30L2	80p	30PL13	95p
DY802	37p	PCF80	43p	PL36	70p	6BW7	66p	30PL15	95p
EB91	23p	PCF86	53p	PL81	62p	6CD6	88p	etc.	etc.
ECC81	40p	PCF801	53p	PL84	53p	6F23	85p		
ECC82	37p	PCF802	55p	PL500/4	70p	6F28	60p		
ECL80	43p	PCF805	73p	PY81	40p	20L1	88p		
EF80	37p	PCF808	70p	PY800	40p	20P4	88p		
EF183	49p	PCL82	41p	PY801	40p	30C15	84p		
EF184	49p	PCL83	53p	U25	80p	30FL1/2	60p		
EH90	46p	PCL84	49p	U26	80p	30L15	84p		
EY51	60p	PCL85	53p	U191	80p	30L17	84p		
EY86/7	33p	PCL805 (non		U193	40p	30P12	84p		
GZ34	63p	BVA)	44p	U251	83p	30PL1	66p		
PC86	61p								

NOTE:
PRICES ARE
TO NEAREST
NEW PENNY.
QUANTITY
PRICES ARE
LOWER.

BY100-127 with
10W res. 16pl

POST FREE OVER £3, BELOW THIS add 3p per valve

Large PCF80 30p. Sorry, no 10C1, X78, X79 or 12AH8.

See separate Component, CRT and Transistor Lists. Many obsolete types available.

(Adjacent to Post Office) **6 POTTERS RD., NEW BARNET**
HERTS. Tel: 449/1934-5 any time.

Local Agents: **MANOR SUPPLIES, 172 WEST END LANE, LONDON NW6**
Tel: 794/8751. (Near West Hampstead Tube Station)

MUST GO!

**NEW BOXED
VALVES
GUARANTEED**

Cheapest

Available

Anywhere

QQV03/10

PCC 84 **25p**

EBF 80 EACH
plus
5p p. & p.

ECC 40 OVER 2
POST

PCF 808 FREE

PC 86

PC 88 **25p**

PY 82 EACH
plus
5p p. & p.

PL 84 OVER 2
POST

EBF 89 FREE

ECL 80

6F 23

6AK5

ECC 91

EF 92 **25p**

PC 97 EACH
plus
5p p. & p.

PCF 201 OVER 2
POST

PC 95 FREE

PL 81

PCC 805

PCF 806

SEND PO, CHEQUE or MO to:

50 PC 86 } **£20**
50 PC 88 }

OUR BOX OF 100 ASSORTED

T.V. VALVES ONLY £12.00 + 50p p.p.

SOUTHERN MACHINE SERVICES

DEPT 285 MORLAND ROAD
PT CROYDON, SURREY, CRO 6HE

Telephone 01-653 4863
or 01-656 0374

EDUCATIONAL

FULL TIME COURSES IN ELECTRONICS AND TELEVISION. These are nine month courses, starting September 1973 leading to City & Guilds certificates. Extensive laboratory work is included, and there are, in most cases, no fees for those under 18 at enrolment. Full details from: Section 272, Electrical and Electronic Engineering Department, Southall College of Technology, Beaconsfield Road, Southall, Middx.

ENGINEERS—Get a technical certificate. Postal courses in Engineering, Electronics, Radio, T.V., Computers, Draughtsmanship, Building, etc. Free book from: BIET (Dept. ZC BTW 18), Aldermaston Court, Reading, RG7 4PF. Accredited by CACC.

COLOUR T.V. SERVICING

Be ready for the coming Colour TV boom. Learn the techniques of servicing colour TV sets through new home-study courses specially prepared for the practical TV technician, and approved by leading manufacturer.

Full details from ICS, (D.750M2), Intertext House, London SW8.

U.H.F. TV AERIALS

Suitable for Colour and Monochrome Reception

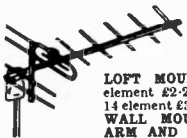

All U.H.F. aerials now fitted with tilting bracket and 4 element reflector.

LOFT MOUNTING ARRAYS. 7 element £2-25. 11 element £2-75. 14 element £3-25. 18 element £3-75. **WALL MOUNTING c/w WALL ARM AND BRACKET.** 7 element £3-25. 11 element £3-75. 14 element £4-25. 18 element £4-75. **CHIMNEY MOUNTING ARRAYS c/w MAST AND LASHING KIT.** 7 element £4. 11 element £4-50. 14 element £4-75. 18 element £5-25. **MAST MOUNTING arrays only.** 7 element £2-25. 11 element £2-75. 14 element £3-25. 18 element £3-75. Complete assembly instructions with every aerial. **LOW LOSS** coaxial cable 9p yd. **KING TELE-BOOSTERS** from £3-75. **LAGGEAR** all band V.H.F.-U.H.F.-F.M. radio mains operated preamps £7-50. State clearly channel number required on all orders. P.p. on all aerials 50p. Accs. 15p. C.W.O. Min. C.O.D. charge 25p.

BBC-ITV-FM AERIALS
BBC (band 1) Wall S/D £2. **LOFT** inverted 'T' £1-25. **EXTERNAL 'H'** array only £3. **ITV** (band 3) 5 element loft array £2-50. 7 element £3. **COMBINED BBC-ITV** loft 1+5 £2-75. 1+7 £3-50. **WALL AND CHIMNEY UNITS ALSO AVAILABLE.** Pre-amps from £3-75. **COMBINED U.H.F.-V.H.F.** aerials 1+5+9 £4. 1+5+14 £4-50. 1+7+14 £5. **FM RADIO** loft S/D £1. 3 element £3-25. 4 element £3-50. Standard coaxial plug 9p. Coaxial cable 5p yd. Outlet box 30p. P.p. on all aerials 50p. Accs. 30p. C.W.O. Min. C.O.D. charge 25p. Send 5p for fully illustrated lists.

CALLERS WELCOMED
OPEN ALL DAY SATURDAY

K.V.A. ELECTRONICS

40-41 Monarch Parade
London Road, Mitcham, Surrey
01-648 4884



COLOUR TELEVISION TRAINING

11 WEEKS' COURSE for men with Mono experience. Hours 2 p.m. to 5 p.m. Monday to Friday. Next course commences Sept. Prospectus from: London Electronics College, Dept. T.6, 20 Penywern Road, London, SW5 9SU. Tel. 01-373 8721.

MISCELLANEOUS

ALUMINIUM SHEET to individual sizes or in standard packs, 3p stamp for details. Ramar Constructor Services, 29 Shelbourne Road, Stratford on Avon, Warks.

PRACTICAL TELEVISION, rare opportunity. Copies September 1961 to 1973 complete, some P.W.s. Offers. Hewitt, 25 Whincroft Way, Belfast.

rebuilt T.V. tubes for men of vision

Current types			
17"	£4.00	21"	£5.00
19"	£4.00	23"	£5.00

Panorama & Ringuard types

19"	£6.00	23"	£8.00
-----	-------	-----	-------

Twin panel 19" £7.50

Cash or P.O. with order, no C.O.D. Carriage 50p in England, Scotland, Wales. Add 75p for carriage Northern Ireland. For all enquiries please send S.A.E. Each tube fitted with new electron gun assembly. Fully guaranteed for two years against any fault except breakage.

k.s.t. Ltd.

Providence Mills, Viaduct St., Stanningly,
Nr. Leeds, Yorks. Tel. Pudsey 78177

Build the Mullard C.C.T.V. Camera Kits are now available with comprehensive construction manual (also available separately at 76½p) Send 5" x 7" S.A.E. for details to
CROFTON ELECTRONICS
15/17 Cambridge Road, Kingston-on-Thames, Surrey KT1 3NG

AERIAL BOOSTERS—£3.25

We make three types of Aerial Boosters: B45—UHF 625, B12—VHF 405, B11—VHF RADIO

VALVE BARGAINS

Any 5—50p, 10—75p, 50—£3.30:—ECC82, ECL80, EB91, EBF89, EF80, EF85, EF183, EF184, EY86, PCC84, PCC89, PCC189, PC97, PCF80, PCF86, PCF805, PCF808, PCL82, PCL83, PCL84, PCL85, PFL200, PL36, PL81, PL504, PY33, PY82, PY800, PY801, 30L15, EH90.

19" UHF/VHF (BBC2)—£6.00

Thorn-850 or Pye, with set of spare valves. Carriage £2.00 (Untested).

100 MIXED RESISTORS—65p

½ to 2 watt—10 ohms to above 1m-ohms (our choice) 100 mixed Capacitors up to 500MFD—£1.10 (our choice).

BARGAIN PARTS

Transistor UHF Tuners—£2.00. 500K-ohms V/C with Switch—20p. 50 mixed Tuner Valves—£2.25. Brand New Transistors BF115, BF173, BC171, BC153, BC135, BC113, BC117, BC115, BA102, BA129. All 10p each. All prices include V.A.T. p. & p. 10p per order. Money back refund. S.A.E. for leaflets.

ELECTRONIC MAILORDER (BURY) LTD.

62 Bridge St., Ramsbottom, Bury, Lancs. Tel. Rams 3036

SOUTHERN VALVE CO. P.O. Box 144 BARNET, HERTS.

All new and boxed, Mazda & Mullard wherever possible. Lists see. Mail order only

AZ31	62p	EY86/7	35p	PL38	90p	U193	31p	30P19	70p
DY86/7	34p	EZ40/1	40p	PL81	45p	U404	40p	30PL1	60p
DY802	40p	EZ80	35p	PL81A	48p	U801	90p	30PL13	75p
EB91	15p	EZ81	25p	PL82	37p	Y3	35p	30PL14	80p
ECC81	34p	GY501	75p	PL83	45p	Z4	35p	30PL15	80p
ECC82	25p	GZ30	40p	PL84	45p	6/30L2	60p	30P4MR	88p
ECC83	25p	PC86	46p	PL500	58p	6AT6	30p	35W4	35p
ECC85	36p	PC88	46p	PL504	58p	6BV7	30p	50CD6G	£1.25
ECC88	45p	PC97	38p	PL508	70p	6CD6G	80p		
ECH42	34p	PC900	35p	PL509	£1.40	6F24/5	60p		etc. etc.
ECH81	34p	PC834	33p	PL802	85p	6F28	80p		
ECH84	50p	PCC85	35p	PL805	78p	6K7/8	35p		
ECL80	40p	PCC88	60p	PY32/3	47p	6V6	35p		The above types,
ECL82	45p	PCC89	45p	PY81	31p	6X4	30p		and many others,
ECL83	57p	PCC189	48p	PY88	33p	6X5	35p		are in stock at
ECL86	40p	PCF80(L)	28p	PY800	31p	9D7	40p		time of going to
EF80	24p	PCF80(Br)	38p	PY801	31p	10C2	75p		press.
EF85	36p	PCF82	50p	PY500	80p	10F1	45p		These are new
EF86	50p	PCF86	48p	UBF89	35p	10P13	70p		low e r prices.
EF89	30p	PCF200	45p	UCC85	40p	12BA6	40p		assuming V.A.T.
EF183	32p	PCF801	48p	UCH42	50p	20L1	80p		at 10%.
EF184	32p	PCF802	45p	UCH81	40p	20P3	80p		Transistor lists
EH90	45p	PCF805	55p	UCL82	40p	20P4	80p		s.a.e.
EL34	54p	FCF806	55p	UCL83	55p	20P5	95p		All valves new
EL41	50p	PCF808	50p	UF41	50p	30C1	38p		and boxed but
EL42	47p	PCH200	55p	UF85	35p	30C15	70p		we cannot always
EL84	30p	PCL82	32p	UF89	35p	30C18	55p		guarantee any
EL86	38p	PCL83	45p	UL41	55p	30F5	75p		specific make.
EL90/1	40p	PCL84	32p	UL84	42p	30FL1	50p		Postage: 3p per
EL95	40p	PCL85	40p	UY41	35p	30FL2	50p		valve / post free
EM34	99p	PCL805	40p	UY85	30p	30L1	33p		over £3.00.
EM80/1	40p	PCL86	32p	U25	62p	30L15	75p		
EM84	40p	PFL200	55p	U26	60p	30L17	70p		
EY51	45p	PL36	52p	U191	60p	30P12	70p		

Tel. (Office):
440 8641

<p>Branded TTL I.C.'s</p> <table border="0"> <tr><td>7400 23p</td><td>7475 55p</td><td>7410 34p</td></tr> <tr><td>7413 29p</td><td>7476 48p</td><td>7411 40p</td></tr> <tr><td>7430 29p</td><td>7480 79p</td><td>7412 38p</td></tr> <tr><td>7472 48p</td><td>7482 79p</td><td>7413 55p</td></tr> <tr><td>7474 48p</td><td>7483 79p</td><td>7414 55p</td></tr> </table> <p>I.C. Sockets Dual-in-line or Zig-Zag 14 and 16 pin Our Price 1p per pin.</p>	7400 23p	7475 55p	7410 34p	7413 29p	7476 48p	7411 40p	7430 29p	7480 79p	7412 38p	7472 48p	7482 79p	7413 55p	7474 48p	7483 79p	7414 55p	<p>VDR's & Thermistors</p> <table border="0"> <tr><td>A15B 75p</td><td>GL23 £1.00</td><td>VA1005 15p</td></tr> <tr><td>CZ1 15p</td><td>R53 £1.32</td><td>VA1026 13p</td></tr> <tr><td>CZ4 13p</td><td>R54 £1.46</td><td>VA1033 13p</td></tr> <tr><td>CZ13A 13p</td><td></td><td>VA1040 10p</td></tr> <tr><td>E298 ED/A258 10p</td><td></td><td>VA1053 10p</td></tr> <tr><td>E298 ZZ/08 10p</td><td></td><td>VA1055 10p</td></tr> <tr><td>GL16 £1</td><td></td><td>VA1034 10p</td></tr> </table>	A15B 75p	GL23 £1.00	VA1005 15p	CZ1 15p	R53 £1.32	VA1026 13p	CZ4 13p	R54 £1.46	VA1033 13p	CZ13A 13p		VA1040 10p	E298 ED/A258 10p		VA1053 10p	E298 ZZ/08 10p		VA1055 10p	GL16 £1		VA1034 10p	<p>Potentiometers</p> <table border="0"> <tr><td>5KΩ</td><td>50KΩ</td><td>500KΩ</td></tr> <tr><td>10KΩ</td><td>100KΩ</td><td>1MΩ</td></tr> <tr><td>25KΩ</td><td>250KΩ</td><td>2MΩ</td></tr> </table> <p>log or lin less switch (& 1KΩ lin) 12p log or lin with switch 24p dual less switch 40p dual with switch 10K, 100K & 1M log only 52p 10K log -10K antilog less switch 40p</p>	5KΩ	50KΩ	500KΩ	10KΩ	100KΩ	1MΩ	25KΩ	250KΩ	2MΩ	<p>Capacitors</p> <p>Ceramic - plate 63V (C333)</p> <table border="0"> <tr><td>1.8pf</td><td>8.2pf</td><td>33pf</td><td>120pf</td></tr> <tr><td>2.2pf</td><td>10pf</td><td>39pf</td><td>150pf</td></tr> <tr><td>3.3pf</td><td>12pf</td><td>47pf</td><td>180pf</td></tr> <tr><td>3.9pf</td><td>15pf</td><td>56pf</td><td>220pf</td></tr> <tr><td>4.7pf</td><td>18pf</td><td>68pf</td><td>270pf</td></tr> <tr><td>5.6pf</td><td>22pf</td><td>82pf</td><td>330pf</td></tr> <tr><td>6.8pf</td><td>27pf</td><td>100pf</td><td></td></tr> </table> <p>all 5p. each</p> <p>mylar film 100V</p> <table border="0"> <tr><td>1000pf</td><td>2p</td><td>-01μF</td><td>3p</td><td>-068μF</td><td>4p</td></tr> <tr><td>2000pf</td><td>2p</td><td>-02μF</td><td>3p</td><td>-1μF</td><td>4p</td></tr> <tr><td>5000pf</td><td>2p</td><td>-04μF</td><td>3p</td><td>-2μF</td><td>5p</td></tr> <tr><td></td><td></td><td>-05μF</td><td>3p</td><td></td><td></td></tr> </table> <p>metallised polyester 250V (C280)</p> <table border="0"> <tr><td>-01μF</td><td>3p</td><td>-068μF</td><td>3p</td><td>-47μF</td><td>8p</td></tr> <tr><td>-015μF</td><td>3p</td><td>-1μF</td><td>4p</td><td>-68μF</td><td>11p</td></tr> <tr><td>-022μF</td><td>3p</td><td>-1.5μF</td><td>4p</td><td>-1μF</td><td>13p</td></tr> <tr><td>-033μF</td><td>3p</td><td>-2.2μF</td><td>5p</td><td>-1.5μF</td><td>20p</td></tr> <tr><td>-047μF</td><td>3p</td><td>-3.3μF</td><td>6p</td><td>-2.2μF</td><td>24p</td></tr> </table> <p>metallised polyester 400V (C281)</p> <table border="0"> <tr><td>-01μF</td><td>4p</td><td>-047μF</td><td>6p</td><td>-22μF</td><td>10p</td></tr> <tr><td>-015μF</td><td>4p</td><td>-068μF</td><td>6p</td><td>-33μF</td><td>14p</td></tr> <tr><td>-022μF</td><td>4p</td><td>-1μF</td><td>7p</td><td>-47μF</td><td>15p</td></tr> <tr><td>-033μF</td><td>5p</td><td>-1.5μF</td><td>8p</td><td></td><td></td></tr> </table> <p>mixed dielectric 600V</p> <table border="0"> <tr><td>-01μF</td><td>7p</td><td>-047μF</td><td>7p</td><td>-22μF</td><td>16p</td></tr> <tr><td>-022μF</td><td>7p</td><td>-068μF</td><td>8p</td><td>-47μF</td><td>24p</td></tr> <tr><td>-033μF</td><td>7p</td><td>-1μF</td><td>8p</td><td>-1μF</td><td>33p</td></tr> </table> <p>mixed dielectric 1000V</p> <table border="0"> <tr><td>1000pf</td><td>6p</td><td>6800pf</td><td>9p</td><td>-1μF</td><td>12p</td></tr> <tr><td>2200pf</td><td>6p</td><td>-01μF</td><td>9p</td><td>-22μF</td><td>22p</td></tr> <tr><td>3300pf</td><td>6p</td><td>-022μF</td><td>9p</td><td>-47μF</td><td>30p</td></tr> <tr><td>4700pf</td><td>6p</td><td>-047μF</td><td>12p</td><td></td><td></td></tr> </table> <p>Ceramic 12KV.d.c. 8KV.d.c. HI-K 750V.</p> <table border="0"> <tr><td>10pf</td><td>9p</td><td>200pf</td><td>9p</td><td>1000pf</td><td>5p</td></tr> <tr><td>15pf</td><td>9p</td><td>220pf</td><td>9p</td><td>1500pf</td><td>5p</td></tr> <tr><td>22pf</td><td>9p</td><td>250pf</td><td>9p</td><td>2000pf</td><td>5p</td></tr> <tr><td>68pf</td><td>9p</td><td>270pf</td><td>9p</td><td>3000pf</td><td>5p</td></tr> <tr><td>82pf</td><td>9p</td><td>300pf</td><td>9p</td><td>5000pf</td><td>5p</td></tr> <tr><td>100pf</td><td>9p</td><td>750V DISC</td><td>10,000pf</td><td>5p</td><td></td></tr> <tr><td>120pf</td><td>9p</td><td>470pf</td><td>5p</td><td>feed-</td><td></td></tr> <tr><td>140pf</td><td>9p</td><td>1000pf</td><td>5p</td><td>through</td><td></td></tr> <tr><td>150pf</td><td>9p</td><td>5000pf</td><td>5p</td><td></td><td></td></tr> <tr><td>180pf</td><td>9p</td><td>10,000pf</td><td>5p</td><td>1000pf</td><td>5p</td></tr> </table>	1.8pf	8.2pf	33pf	120pf	2.2pf	10pf	39pf	150pf	3.3pf	12pf	47pf	180pf	3.9pf	15pf	56pf	220pf	4.7pf	18pf	68pf	270pf	5.6pf	22pf	82pf	330pf	6.8pf	27pf	100pf		1000pf	2p	-01μF	3p	-068μF	4p	2000pf	2p	-02μF	3p	-1μF	4p	5000pf	2p	-04μF	3p	-2μF	5p			-05μF	3p			-01μF	3p	-068μF	3p	-47μF	8p	-015μF	3p	-1μF	4p	-68μF	11p	-022μF	3p	-1.5μF	4p	-1μF	13p	-033μF	3p	-2.2μF	5p	-1.5μF	20p	-047μF	3p	-3.3μF	6p	-2.2μF	24p	-01μF	4p	-047μF	6p	-22μF	10p	-015μF	4p	-068μF	6p	-33μF	14p	-022μF	4p	-1μF	7p	-47μF	15p	-033μF	5p	-1.5μF	8p			-01μF	7p	-047μF	7p	-22μF	16p	-022μF	7p	-068μF	8p	-47μF	24p	-033μF	7p	-1μF	8p	-1μF	33p	1000pf	6p	6800pf	9p	-1μF	12p	2200pf	6p	-01μF	9p	-22μF	22p	3300pf	6p	-022μF	9p	-47μF	30p	4700pf	6p	-047μF	12p			10pf	9p	200pf	9p	1000pf	5p	15pf	9p	220pf	9p	1500pf	5p	22pf	9p	250pf	9p	2000pf	5p	68pf	9p	270pf	9p	3000pf	5p	82pf	9p	300pf	9p	5000pf	5p	100pf	9p	750V DISC	10,000pf	5p		120pf	9p	470pf	5p	feed-		140pf	9p	1000pf	5p	through		150pf	9p	5000pf	5p			180pf	9p	10,000pf	5p	1000pf	5p
7400 23p	7475 55p	7410 34p																																																																																																																																																																																																																																																														
7413 29p	7476 48p	7411 40p																																																																																																																																																																																																																																																														
7430 29p	7480 79p	7412 38p																																																																																																																																																																																																																																																														
7472 48p	7482 79p	7413 55p																																																																																																																																																																																																																																																														
7474 48p	7483 79p	7414 55p																																																																																																																																																																																																																																																														
A15B 75p	GL23 £1.00	VA1005 15p																																																																																																																																																																																																																																																														
CZ1 15p	R53 £1.32	VA1026 13p																																																																																																																																																																																																																																																														
CZ4 13p	R54 £1.46	VA1033 13p																																																																																																																																																																																																																																																														
CZ13A 13p		VA1040 10p																																																																																																																																																																																																																																																														
E298 ED/A258 10p		VA1053 10p																																																																																																																																																																																																																																																														
E298 ZZ/08 10p		VA1055 10p																																																																																																																																																																																																																																																														
GL16 £1		VA1034 10p																																																																																																																																																																																																																																																														
5KΩ	50KΩ	500KΩ																																																																																																																																																																																																																																																														
10KΩ	100KΩ	1MΩ																																																																																																																																																																																																																																																														
25KΩ	250KΩ	2MΩ																																																																																																																																																																																																																																																														
1.8pf	8.2pf	33pf	120pf																																																																																																																																																																																																																																																													
2.2pf	10pf	39pf	150pf																																																																																																																																																																																																																																																													
3.3pf	12pf	47pf	180pf																																																																																																																																																																																																																																																													
3.9pf	15pf	56pf	220pf																																																																																																																																																																																																																																																													
4.7pf	18pf	68pf	270pf																																																																																																																																																																																																																																																													
5.6pf	22pf	82pf	330pf																																																																																																																																																																																																																																																													
6.8pf	27pf	100pf																																																																																																																																																																																																																																																														
1000pf	2p	-01μF	3p	-068μF	4p																																																																																																																																																																																																																																																											
2000pf	2p	-02μF	3p	-1μF	4p																																																																																																																																																																																																																																																											
5000pf	2p	-04μF	3p	-2μF	5p																																																																																																																																																																																																																																																											
		-05μF	3p																																																																																																																																																																																																																																																													
-01μF	3p	-068μF	3p	-47μF	8p																																																																																																																																																																																																																																																											
-015μF	3p	-1μF	4p	-68μF	11p																																																																																																																																																																																																																																																											
-022μF	3p	-1.5μF	4p	-1μF	13p																																																																																																																																																																																																																																																											
-033μF	3p	-2.2μF	5p	-1.5μF	20p																																																																																																																																																																																																																																																											
-047μF	3p	-3.3μF	6p	-2.2μF	24p																																																																																																																																																																																																																																																											
-01μF	4p	-047μF	6p	-22μF	10p																																																																																																																																																																																																																																																											
-015μF	4p	-068μF	6p	-33μF	14p																																																																																																																																																																																																																																																											
-022μF	4p	-1μF	7p	-47μF	15p																																																																																																																																																																																																																																																											
-033μF	5p	-1.5μF	8p																																																																																																																																																																																																																																																													
-01μF	7p	-047μF	7p	-22μF	16p																																																																																																																																																																																																																																																											
-022μF	7p	-068μF	8p	-47μF	24p																																																																																																																																																																																																																																																											
-033μF	7p	-1μF	8p	-1μF	33p																																																																																																																																																																																																																																																											
1000pf	6p	6800pf	9p	-1μF	12p																																																																																																																																																																																																																																																											
2200pf	6p	-01μF	9p	-22μF	22p																																																																																																																																																																																																																																																											
3300pf	6p	-022μF	9p	-47μF	30p																																																																																																																																																																																																																																																											
4700pf	6p	-047μF	12p																																																																																																																																																																																																																																																													
10pf	9p	200pf	9p	1000pf	5p																																																																																																																																																																																																																																																											
15pf	9p	220pf	9p	1500pf	5p																																																																																																																																																																																																																																																											
22pf	9p	250pf	9p	2000pf	5p																																																																																																																																																																																																																																																											
68pf	9p	270pf	9p	3000pf	5p																																																																																																																																																																																																																																																											
82pf	9p	300pf	9p	5000pf	5p																																																																																																																																																																																																																																																											
100pf	9p	750V DISC	10,000pf	5p																																																																																																																																																																																																																																																												
120pf	9p	470pf	5p	feed-																																																																																																																																																																																																																																																												
140pf	9p	1000pf	5p	through																																																																																																																																																																																																																																																												
150pf	9p	5000pf	5p																																																																																																																																																																																																																																																													
180pf	9p	10,000pf	5p	1000pf	5p																																																																																																																																																																																																																																																											
<p>Transistors</p> <table border="0"> <tr><td>AC128 15p</td><td>BC172 18p</td><td>BF184 25p</td></tr> <tr><td>AC176 15p</td><td>BD115 67p</td><td>BF185 25p</td></tr> <tr><td>AF139 23p</td><td>BD124 £1.01</td><td>BF194 15p</td></tr> <tr><td>AF239 30p</td><td>BD131 70p</td><td>BF195 15p</td></tr> <tr><td>BC107 10p</td><td>BD132 70p</td><td>BF196 15p</td></tr> <tr><td>BC108 10p</td><td>BD131/2M.F.£1.48</td><td>BF197 15p</td></tr> <tr><td>BC109 10p</td><td>BF115 25p</td><td>BF272 53p</td></tr> <tr><td>BC147 10p</td><td>BF167 20p</td><td>BFY50 24p</td></tr> <tr><td>BC148 10p</td><td>BF173 20p</td><td>BRY39 38p</td></tr> <tr><td>BC149 10p</td><td>BF180 25p</td><td>BSX21 28p</td></tr> <tr><td>BC171 21p</td><td>BF181 30p</td><td>BU105 £2</td></tr> </table>	AC128 15p	BC172 18p	BF184 25p	AC176 15p	BD115 67p	BF185 25p	AF139 23p	BD124 £1.01	BF194 15p	AF239 30p	BD131 70p	BF195 15p	BC107 10p	BD132 70p	BF196 15p	BC108 10p	BD131/2M.F.£1.48	BF197 15p	BC109 10p	BF115 25p	BF272 53p	BC147 10p	BF167 20p	BFY50 24p	BC148 10p	BF173 20p	BRY39 38p	BC149 10p	BF180 25p	BSX21 28p	BC171 21p	BF181 30p	BU105 £2	<p>Resistors</p> <p>½ watt 5% Carbon Film - low noise Hi-Steels</p> <p>All E24 values 1p each plus p. & 7p for up to 50 Resistors and a further 2p for each additional 50. Deduct 33½% for 100 of one type or 25% for mixed orders over £1 in value.</p> <p>1 W 10% Carbon Composition 3p each 2 W 10% Carbon Composition 6p each 2 ½ W 5% Wire wound 9p each 5 W Wire wound 9p each 10 W Wire wound 10p each plus p. & p. 7p for up to 25 resistors plus 1p for each additional 25.</p>	<p>TV Electrolytics</p> <table border="0"> <tr><td>1 : 2 : 4 : 8μF</td><td>450V</td><td>14p</td><td>32μF</td><td>450V</td><td>20p</td></tr> <tr><td>16μF</td><td>450V</td><td>15p</td><td>50μF</td><td>350V</td><td>20p</td></tr> <tr><td>8 - 8μF:</td><td>450 V.W</td><td>18p</td><td>32 - 32μF:</td><td>350 V.W</td><td>25p</td></tr> <tr><td>8 - 16μF:</td><td>450 V.W</td><td>20p</td><td>32 - 32μF:</td><td>450 V.W</td><td>43p</td></tr> <tr><td>16 - 16μF:</td><td>450 V.W</td><td>25p</td><td>50 - 50μF:</td><td>350 V.W</td><td>35p</td></tr> </table> <p>16 - 100 - 100 - 300μF: 275 V.W £1.23 32 - 100 - 125 - 200μF: 275 V.W £1.23 32 - 100 - 200 - 200μF: 300 V.W £1.23 100 - 100 - 100 - 150 - 150μF: 320 V.W £1.66 175 (400V) - 100 - 100μF: 350 V.W £1.66 60 - 100 - 200μF: 300 V.W 75p 100 - 200μF: 275 V.W 75p 100 - 200 - 200μF: 300 V.W £1.15 100 - 400μF: 275 V.W £1.15 200μF: 275 V.W. 50p 300 + 300μF: 300 V.W £1.90</p>	1 : 2 : 4 : 8μF	450V	14p	32μF	450V	20p	16μF	450V	15p	50μF	350V	20p	8 - 8μF:	450 V.W	18p	32 - 32μF:	350 V.W	25p	8 - 16μF:	450 V.W	20p	32 - 32μF:	450 V.W	43p	16 - 16μF:	450 V.W	25p	50 - 50μF:	350 V.W	35p	<p>Eliminators</p> <table border="0"> <tr><td>9 volt (or 20mA (PP3))</td><td>£1.25</td></tr> <tr><td>6 volt (or 50mA)</td><td>£1.50</td></tr> <tr><td>9 volt (or 50mA)</td><td>£2.50</td></tr> <tr><td>6 - 8 volt, 50mA</td><td>£2.50</td></tr> <tr><td>9 - 9 volt, 50mA</td><td>£2.50</td></tr> <tr><td>7½ volt for cassette recorders</td><td>£2.00</td></tr> <tr><td>6.7½ or 9 volt</td><td>£3.00</td></tr> <tr><td>3, 4½, 6, 7½, 9, 12 or 500mA Car Battery Converter fully stabilised to provide 6, 7½ or 9 volts (p. & p. 15p on all types)</td><td>£4.99</td></tr> </table>	9 volt (or 20mA (PP3))	£1.25	6 volt (or 50mA)	£1.50	9 volt (or 50mA)	£2.50	6 - 8 volt, 50mA	£2.50	9 - 9 volt, 50mA	£2.50	7½ volt for cassette recorders	£2.00	6.7½ or 9 volt	£3.00	3, 4½, 6, 7½, 9, 12 or 500mA Car Battery Converter fully stabilised to provide 6, 7½ or 9 volts (p. & p. 15p on all types)	£4.99																																																																																																																																																																														
AC128 15p	BC172 18p	BF184 25p																																																																																																																																																																																																																																																														
AC176 15p	BD115 67p	BF185 25p																																																																																																																																																																																																																																																														
AF139 23p	BD124 £1.01	BF194 15p																																																																																																																																																																																																																																																														
AF239 30p	BD131 70p	BF195 15p																																																																																																																																																																																																																																																														
BC107 10p	BD132 70p	BF196 15p																																																																																																																																																																																																																																																														
BC108 10p	BD131/2M.F.£1.48	BF197 15p																																																																																																																																																																																																																																																														
BC109 10p	BF115 25p	BF272 53p																																																																																																																																																																																																																																																														
BC147 10p	BF167 20p	BFY50 24p																																																																																																																																																																																																																																																														
BC148 10p	BF173 20p	BRY39 38p																																																																																																																																																																																																																																																														
BC149 10p	BF180 25p	BSX21 28p																																																																																																																																																																																																																																																														
BC171 21p	BF181 30p	BU105 £2																																																																																																																																																																																																																																																														
1 : 2 : 4 : 8μF	450V	14p	32μF	450V	20p																																																																																																																																																																																																																																																											
16μF	450V	15p	50μF	350V	20p																																																																																																																																																																																																																																																											
8 - 8μF:	450 V.W	18p	32 - 32μF:	350 V.W	25p																																																																																																																																																																																																																																																											
8 - 16μF:	450 V.W	20p	32 - 32μF:	450 V.W	43p																																																																																																																																																																																																																																																											
16 - 16μF:	450 V.W	25p	50 - 50μF:	350 V.W	35p																																																																																																																																																																																																																																																											
9 volt (or 20mA (PP3))	£1.25																																																																																																																																																																																																																																																															
6 volt (or 50mA)	£1.50																																																																																																																																																																																																																																																															
9 volt (or 50mA)	£2.50																																																																																																																																																																																																																																																															
6 - 8 volt, 50mA	£2.50																																																																																																																																																																																																																																																															
9 - 9 volt, 50mA	£2.50																																																																																																																																																																																																																																																															
7½ volt for cassette recorders	£2.00																																																																																																																																																																																																																																																															
6.7½ or 9 volt	£3.00																																																																																																																																																																																																																																																															
3, 4½, 6, 7½, 9, 12 or 500mA Car Battery Converter fully stabilised to provide 6, 7½ or 9 volts (p. & p. 15p on all types)	£4.99																																																																																																																																																																																																																																																															
<p>Diodes & Rectifiers</p> <table border="0"> <tr><td>AA119 9p</td><td>BA156 15p</td><td>BY176 £1.50</td></tr> <tr><td>AA120 9p</td><td>BA243 56p</td><td>BY182 £1.50</td></tr> <tr><td>AA129 9p</td><td>OA47 10p</td><td>BY250 23p</td></tr> <tr><td>BA102 25p</td><td>OA79 9p</td><td>IN4001 7p</td></tr> <tr><td>BA115 17p</td><td>OA90 7p</td><td>IN4002 7p</td></tr> <tr><td>BA130 10p</td><td>OA91 7p</td><td>IN4003 8p</td></tr> <tr><td>BA148 10p</td><td>CA200 10p</td><td>IN4004 8p</td></tr> <tr><td>BA148 20p</td><td>BY100 15p</td><td>IN4005 10p</td></tr> <tr><td>BA154 13p</td><td>BY126 15p</td><td>IN4006 12p</td></tr> <tr><td>BA155 14p</td><td>BY127 15p</td><td>IN4007 15p</td></tr> </table>	AA119 9p	BA156 15p	BY176 £1.50	AA120 9p	BA243 56p	BY182 £1.50	AA129 9p	OA47 10p	BY250 23p	BA102 25p	OA79 9p	IN4001 7p	BA115 17p	OA90 7p	IN4002 7p	BA130 10p	OA91 7p	IN4003 8p	BA148 10p	CA200 10p	IN4004 8p	BA148 20p	BY100 15p	IN4005 10p	BA154 13p	BY126 15p	IN4006 12p	BA155 14p	BY127 15p	IN4007 15p	<p>Power Sections</p> <p>ohms</p> <table border="0"> <tr><td>7, 9, 10, 12, 14, 17, 5, 20</td><td>or 700mA 20p</td></tr> <tr><td>22, 25, 28, 30, 33, 36</td><td>or 700mA 25p</td></tr> <tr><td>40, 47, 52, 56, 60, 63, 66</td><td>or 300mA 20p</td></tr> <tr><td>75, 87, 100, 120, 140, 160</td><td>or 300mA 25p</td></tr> <tr><td>180, 200, 220, 250, 270</td><td>or 300mA 25p</td></tr> <tr><td>300, 350, 400, 470, 560</td><td>or 120 mA 20p</td></tr> <tr><td>726</td><td>or 150mA 25p</td></tr> <tr><td>1KΩ</td><td>or 100mA 20p</td></tr> <tr><td>2KΩ</td><td>or 70mA 25p</td></tr> </table> <p>plus p. & p. 7p per section.</p>	7, 9, 10, 12, 14, 17, 5, 20	or 700mA 20p	22, 25, 28, 30, 33, 36	or 700mA 25p	40, 47, 52, 56, 60, 63, 66	or 300mA 20p	75, 87, 100, 120, 140, 160	or 300mA 25p	180, 200, 220, 250, 270	or 300mA 25p	300, 350, 400, 470, 560	or 120 mA 20p	726	or 150mA 25p	1KΩ	or 100mA 20p	2KΩ	or 70mA 25p	<p>Presets</p> <table border="0"> <tr><td>Vertical or Horizontal</td><td></td></tr> <tr><td>0-1 watt 5p</td><td>0-25 watt 7p</td></tr> <tr><td>100 1K</td><td>10K 100K 1M</td></tr> <tr><td>250 2.5K</td><td>25K 250K 2.5M</td></tr> <tr><td>500 5K</td><td>50K 500K 5M</td></tr> </table>	Vertical or Horizontal		0-1 watt 5p	0-25 watt 7p	100 1K	10K 100K 1M	250 2.5K	25K 250K 2.5M	500 5K	50K 500K 5M	<p>Mains Droppers</p> <table border="0"> <tr><td>(1) 37Ω - 31Ω - 97Ω - 26Ω - 168Ω</td><td>50p</td></tr> <tr><td>(2) 14Ω - 26Ω - 97Ω - 173Ω</td><td>50p</td></tr> <tr><td>(3) 30Ω - 125Ω - 2.85KΩ</td><td>50p</td></tr> </table> <p>plus p. & p. 7p per dropper.</p>	(1) 37Ω - 31Ω - 97Ω - 26Ω - 168Ω	50p	(2) 14Ω - 26Ω - 97Ω - 173Ω	50p	(3) 30Ω - 125Ω - 2.85KΩ	50p																																																																																																																																																																																													
AA119 9p	BA156 15p	BY176 £1.50																																																																																																																																																																																																																																																														
AA120 9p	BA243 56p	BY182 £1.50																																																																																																																																																																																																																																																														
AA129 9p	OA47 10p	BY250 23p																																																																																																																																																																																																																																																														
BA102 25p	OA79 9p	IN4001 7p																																																																																																																																																																																																																																																														
BA115 17p	OA90 7p	IN4002 7p																																																																																																																																																																																																																																																														
BA130 10p	OA91 7p	IN4003 8p																																																																																																																																																																																																																																																														
BA148 10p	CA200 10p	IN4004 8p																																																																																																																																																																																																																																																														
BA148 20p	BY100 15p	IN4005 10p																																																																																																																																																																																																																																																														
BA154 13p	BY126 15p	IN4006 12p																																																																																																																																																																																																																																																														
BA155 14p	BY127 15p	IN4007 15p																																																																																																																																																																																																																																																														
7, 9, 10, 12, 14, 17, 5, 20	or 700mA 20p																																																																																																																																																																																																																																																															
22, 25, 28, 30, 33, 36	or 700mA 25p																																																																																																																																																																																																																																																															
40, 47, 52, 56, 60, 63, 66	or 300mA 20p																																																																																																																																																																																																																																																															
75, 87, 100, 120, 140, 160	or 300mA 25p																																																																																																																																																																																																																																																															
180, 200, 220, 250, 270	or 300mA 25p																																																																																																																																																																																																																																																															
300, 350, 400, 470, 560	or 120 mA 20p																																																																																																																																																																																																																																																															
726	or 150mA 25p																																																																																																																																																																																																																																																															
1KΩ	or 100mA 20p																																																																																																																																																																																																																																																															
2KΩ	or 70mA 25p																																																																																																																																																																																																																																																															
Vertical or Horizontal																																																																																																																																																																																																																																																																
0-1 watt 5p	0-25 watt 7p																																																																																																																																																																																																																																																															
100 1K	10K 100K 1M																																																																																																																																																																																																																																																															
250 2.5K	25K 250K 2.5M																																																																																																																																																																																																																																																															
500 5K	50K 500K 5M																																																																																																																																																																																																																																																															
(1) 37Ω - 31Ω - 97Ω - 26Ω - 168Ω	50p																																																																																																																																																																																																																																																															
(2) 14Ω - 26Ω - 97Ω - 173Ω	50p																																																																																																																																																																																																																																																															
(3) 30Ω - 125Ω - 2.85KΩ	50p																																																																																																																																																																																																																																																															
<p>EHT Rectifier Trays</p> <p>(5 stick version) for BRC Chassis i.e. Ferguson, Ultra, Marconiphone & HMV - 950 Mk II, 960, 970 & 1400 chassis Our Price £3.50 plus p. & p. 2p</p>	<p>Mains Droppers</p> <p>(1) 37Ω - 31Ω - 97Ω - 26Ω - 168Ω 50p (2) 14Ω - 26Ω - 97Ω - 173Ω 50p (3) 30Ω - 125Ω - 2.85KΩ 50p plus p. & p. 7p per dropper.</p>	<p>Presets</p> <table border="0"> <tr><td>Vertical or Horizontal</td><td></td></tr> <tr><td>0-1 watt 5p</td><td>0-25 watt 7p</td></tr> <tr><td>100 1K</td><td>10K 100K 1M</td></tr> <tr><td>250 2.5K</td><td>25K 250K 2.5M</td></tr> <tr><td>500 5K</td><td>50K 500K 5M</td></tr> </table>	Vertical or Horizontal		0-1 watt 5p	0-25 watt 7p	100 1K	10K 100K 1M	250 2.5K	25K 250K 2.5M	500 5K	50K 500K 5M	<p>MAIL ORDERS: Where no p. & p. charge is shown, a minimum of 7p applies, p. & p. on overseas orders is charged at cost. ADDRESS TO: TV Component Dept. 56, Fortis Green Road, London, N10 3HN. Telephone: 01-853 3705</p>																																																																																																																																																																																																																																																			
Vertical or Horizontal																																																																																																																																																																																																																																																																
0-1 watt 5p	0-25 watt 7p																																																																																																																																																																																																																																																															
100 1K	10K 100K 1M																																																																																																																																																																																																																																																															
250 2.5K	25K 250K 2.5M																																																																																																																																																																																																																																																															
500 5K	50K 500K 5M																																																																																																																																																																																																																																																															

CHROMASONIC electronics

PLEASE ADD V.A.T.

LAWSON BRAND NEW TELEVISION TUBES

SPECIFICATION: The Lawson range of new television tubes are designed to give superb performance, coupled with maximum reliability and very long life. All tubes are the products of Britain's major C.R.T. manufacturers, and each tube is an exact replacement. Tubes are produced to the original specifications but incorporate the very latest design improvements such as: High Brightness Maximum Contrast Silver Activated Screens, Micro-Fine Aluminising, Precision Aligned Gun Jigging, together with Ultra Hard R.F. High Vacuum Techniques.



DIRECT REPLACEMENTS FOR MULLARD-MAZDA BRIMAR GEC, ETC.

A47-11W	MW43-69	C21/KM	CME2302	7601A
A47-13W	MW43-80	C23/7A	CME2303	7701A
A47-14W	MW52/20	C23/10	CME2305	A50-120W/R
A47-17W	AW47-97	C23/AK	CME2306	MW36/24
A47-18W	AW59-90	CME1601	CME2308	MW36/44
A47-26W	AW59-91	CME1602	CRM172	CRM141
A59-11W	CI7/1A	CME1702	CRM173	
A59-12W	CI7/5A	CME1703	CRM211	
A59-13W	CI7/7A	CME1705	23SP4	
A59-14W	CI7/AA	CME1706	171K	
A59-15W	CI7/AF	CME1901	172K	
A59-14W	CI7/FM	CME1902	173K	
AW43-80	CI7/5M	CME1903	212K	
AW43-88	CI9/10AP	CME1905	7405A	
AW43-89	CI9/AK	CME1906	7406A	
AW47-90	C21/1A	CME1908	7502A	
AW47-91	C21/7A	CME2104	7503A	
MW43-64	C21/AF	CME2301	7504A	

REBUILT TUBES

LAWSON "RED LABEL" CRTS are particularly useful where cost is a vital factor, such as in older sets or rental use. Lawson "Red Label" CRTs are completely rebuilt from selected glass, direct replacements and guaranteed for two years.

	New Tubes £	Red Label £	Colour Tubes old glass not required
14"	3-85	—	—
17"	6-87	5-47	19" £43-45
19"	7-97	5-77	—
21"	9-35	7-65	22" £47-85
23"	10-70	7-97	—
19" Twin Panel	11-28	9-07	25" £52-25
23" Twin Panel	17-05	10-72	—
16" Panorama	9-35	—	26" £54-45
19" Panorama	10-32	7-65	—
20" Panorama	11-55	—	carr. £1-65
23" Panorama	13-15	9-63	—

LAWSON TUBES

18 CHURCHDOWN ROAD,
MALVERN, WORCS.
Malvern 2100

2 YEARS' GUARANTEE FULL TUBE FITTING INSTRUCTIONS

Tubes are despatched day of order by passenger train, road or goods taking far too long for customers satisfaction.

Carriage/Insurance: 14"-19" 68p. 20"-23" 82p
All the above prices include V.A.T.

A NEW COLOUR TUBE



Unveiling the TOSHIBA 20 inch SUPERSQUARE

- * For constructing colour TV
- * For service (update old 19" colour sets)
- * 1½ years guarantee

BRAND NEW—only £42.50 (add £1 carriage)

Features: Latest rare earth and sulphide phosphors for brilliance.

Easy modern push-through mounting.

Fits standard scan/converg. coils (90° shadowmask type).

Cutout, etc., Also 19" size data free! £41.50 new



R-B.T Vision Services
82 North Lane, East Preston, Sussex.

CUT PRICE T.V. AERIALS

U.H.F. Aerialite supreme (fringe model) £5.50; Set Top 6 ele. £1.60, 10 ele. £1.50, 18 ele. £2.00; J. Beam MBM30 £3.80, MBM46 £5.50.

STEREO RADIO 2 ele. £2.50, 3 ele. £4.00, 4 ele. £4.40, 6 ele. £6.80.

COAX. CABLE Low loss random lengths, 2 yds.—12 yds., 5p yd.; cut lengths 8p yd., standard cable 5p yd.

AMPLIFIERS: Pye/Labgear. Distribution 6+2 outlets £16.20, 1 outlet £10.50; Mast head/power unit £8.50. Set back batt. op. £3.75.

ACCESSORIES: Coax plug 9p, surface socket 30p, flush socket 50p, line connector 14p, Diplexers v.h.f. band 1/3 50p, u.h.f. gp. A/B-CD or A-B/CD 75p, splitters 90p, plastic tape 24 yds. x ¼" 25p, cable clips 7mm 30p 100, 5mm 25p 100.

LASHING EQUIPMENT: Universal clamps 45p, lash kit 1"—1½" masts £1.00, wall-mounting bracket 75p, loft-mounting kit 55p. Please add 10% V.A.T. to all items. Please state ch. gp. clearly.

P.+ P.: Aerials 50p; other items 30p. C.W.O. to:

H. A. ELECTRIC
Dept. P.T.
2 & 4 BARDEN LANE
BURNLEY, LANCs.

TELEVISION TUBE SHOP

BRAND NEW TUBES AT
REDUCED PRICES

A28-14W (A28-13W) ...	£12.75
A31-18W	£12.50
A47-11W	£9.95
A47-13W	£12.50
A47-14W	£8.25
A47-26W	£10.75
A50-120WR	£12.50
A59-11W	£12.95
A-59-13W	£13.50*
A59-15W	£9.95
A59-23W	£14.75
A61-120WR	£16.50
AW43-80	£6.95
AW43-88, 43-89	£6.75
AW47-90, 47-91	£7.50
AW53-80	£7.50*
AW53-88, 53-89	£8.25
AW59-90, 59-91	£9.00
CME1201	£12.50
CME1601	£10.50
CME1602	£12.00
CME1705	£7.75
CME1713/A44-120	£14.50
CME1901, 1903	£7.50
CME1906	£12.50
CME1908	£7.75
CME2013	£12.50
CME2101, 2104	£8.25
CME2301, 2302, 2303	£9.00
CME2305	£14.75
CME2306	£13.50*
CME2308	£9.95
CME2413R	£16.50
MW43-69	£6.75
MW43-80	£6.75
MW53-20, 53-80	£7.50
TSD217, TSD282	£14.00†
13BP4 (Crystal 13)	£14.00†
190AB4	£9.25
230DB4	£11.25

* These types are fully rebuilt.

† Rebuilt tubes also, at £7.00 plus carriage and old bulb.

COLOUR TUBES	NEW	R/B
	£	£
A49-15X	35	-
A49-120X	45	-
A56-120X	72	48
A61-15X	78	52
A63-11X	-	52
A66-120X	82	55
A67-120X	85	-

SPECIAL OFFER TO EXPERIMENTERS
New 90° Colour Tubes 19", Suitable for "Television" T.V., Unprotected £25.

Add Carriage and Insurance: Mono-chrome 75p, Colour £1.50.

TELEVISION TUBE SHOP

48 BATTERSEA BRIDGE ROAD
LONDON, S.W.11. BAT 6859
WE GIVE GREEN SHIELD STAMPS

COLOUR T.V.

19" £125 25" £160

Completely overhauled. (Not to be confused with 'workers'.) Variety of makes and models available, cash'n'carry discounts given where possible.

MONOCHROME

UHF SINGLE-STANDARD 19" T.V.'s completely refurbished with pushbutton UHF tuner, etc. Can be seen working at our Langley showroom. £28.50 (carr. £2.50). (Also some requiring attention £20).

UHF—working and overhauled BBC2 T.V.'s £20, carr. £2. State if VHF operation required.

VHF—available cheap!

PUSH-BUTTON type UHF transistorised tuners BRAND NEW untested £5, inc. carr.

T.V. STANDS



To suit: DECCA
CTV19/25 BUSH

CTV25 series

THORN 2000, 3000

PYE CT70 etc. etc.

ALL MONOCHROME

and COLOUR SETS—Slim, attractive

yet robust stands—crafted in

selected woods—double dowel-

led joints for strength—the finish-

ing touch to any set. Send £3.25

50p carr. and state length and depth

of set. Supplied 'in the white' or

stained and polished to your order at no

extra charge.

All prices include V.A.T.

SUMKIS, 7 High Street, Langley,

Warley, Worcs.

(Near turn-off No. 2, M5 Motorway)

Trade enquiries welcome.

REBUILT COLOUR TUBES

19" £22.50	22" £25.00
25" £27.00	26" £28.00

Exchange prices: Tubes supplied without exchange glass at extra cost, subject to availability.

Colour Tubes demonstrated to callers.
Carriage extra
all types.

New RCA Type A49-15X: £30.00

Full range of rebuilt mono tubes available, Standard, Rimband and Twin Panel

* Complete new gun fitted to every tube.

* 2 years' guarantee mono-chrome, 1 year colour.

* 15 years' experience in tube rebuilding.

* Trade enquiries welcomed.

N.G.T. ELECTRONICS LTD.
(Nu Gun Teletubes)

22-24, Anerley Station Road,
London S.E.20.

Telephone: 01-778 9178.

PHILIP H. BEARMAN, 6 POTTERS RD., NEW BARNET, HERTS.

One of the finest range of new and makers rebuilt tubes in the country; every tube is tested before it leaves the premises. Delivery usually ex stock and sent securely packed daily. Commonwealth deliveries arranged.

FOR EXAMPLE: NEW TUBES TWO-YEAR GUARANTEE

CME1702, AW43-80, CRM173, MW43-80, SE17/70 (£5.50)
CRM172, AW43-88, AW43-89, CME1705, CME1703 17" £6.46

CME1903, CME1902, CME1901, AW47-90, AW47-91,
A47-14W, C19AH 19" £7.56

CME2101, AW53-88, AW53-89, CRM211, CRM212,
MW53-20, MW53-80, CME2104 21" £8.66

CME2303, CME2301, AW59-90, AW59-91
A59-15W, CME2308 23" £10.45

(NOTE new SE17/70 will replace MW43/69 with mods.)

Makers Rebuilt Tubes:

CME1908 } £6.05	CME2308 } £8.25
" 1903 }	" 2303 }
AW47-91 } £6.05	AW59/91 } £8.25
A47-14W }	A59/15W }

MAKERS COLOUR TUBES

4 YEAR GUARANTEE

19" A49.11X, A49.191X	£53.90
20" A51.110X 90%	£55.00
22" A55.14X, A56.120X	£58.30
25" A63.11X, use A63.200X	£62.70
26" A67.120X, A66.120X	£64.90

USUALLY EX STOCK EXCEPT A66.120X (short supply)

PLUS
£1.50 Cge.
packing and
breakage insurance

NOTE: Above prices from 1st April 1973 include 10% V.A.T.

Cge. (including
insurance
Mono)

NEW TUBES (1601 as available)

*TSD282 (TSD217)	£13.75
A28-14W (Mullard)	£12.10
MW31-74	£3.30
TSD290/CME1201	£10.78
A31/120W-CME1220	£10.78
*13BP4	£15.40
MW36/24 & 44	£5.23
CME1602	£11.00
CME1713	£13.20
CME1906	£12.10
A47-13W }	
A47-11W & 26W	£9.35
A50-120W/CME2013	£11.55
†CME2306 }	
A59-13W }	£16.50
A59-11W & 25 or 23W	£12.65
CME2413/A61, 120W	£14.30

carriage up to 17" 55p.

* Two Year Guarantee Except TSD282 and 13BP4 1 year.

NOTE: A47-11W and A59-11W makers rebuilds sometimes available at £1.00 off new prices.

† Rebuilt T/Panel (£13.20 (when available))

Telephone enquiries welcomed.
MONO QUALITY DISCOUNTS IN CERTAIN CASES

OPEN SATURDAY MORNINGS
CLOSED THURSDAY AFTERNOONS

10% V.A.T. HAS
BEEN INCLUDED
FROM 1/4/1973!

RIMBAND & TWIN PANELS
COMPLETE WITH BSI
415/1972 (implosion safety)

ALL SEA
JOURNEYS
50p EXTRA

EIRE E2
EXTRA FOR
CUSTOMS
CLEARANCE

TELEPHONE: 01-449 1934/5. ALL ENQUIRIES SAE PLEASE

COLOUR TUBES STANDARD TUBES METAL BAND TUBES TWIN PANEL TUBES

Rebuilt with new Electron
Guns to British Standard
415/1/1967.

SUFFOLK TUBES LIMITED

261 CHURCH ROAD
MITCHAM, SURREY CR4 3BH
01-640 3133/4/5

Britain's Largest Independent
TV Tube Rebuilder

THE NEW UM4 "COLOURBOOSTER" UHF/625 LINE

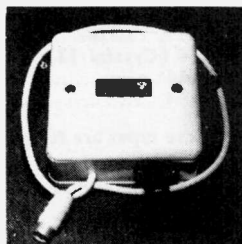

CAN PRODUCE
REMARKABLE
IMPROVEMENTS IN
COLOUR AND
PICTURE QUALITY
IN FRINGE OR
DIFFICULT AREAS
WITH SIGNIFICANT
REDUCTION IN
NOISE (SNOW).

HIGH GAIN—VERY LOW NOISE
FITTED FLY LEAD—INSTALLED IN SECONDS
HIGHEST QUALITY COMPONENTS
IVORY PLASTIC CASE 3½ x 3½ x 1½ CORK BASE
CHANNELS: Group A, Red code 21-33
Group B, Yellow code 39-51
Group C-D, Green code 52-68

EQUALLY SUITABLE FOR BLACK AND WHITE
Also the M4 DUAL BAND VHF UNIT
BOOSTS ALL BAND III and ANY SPECIFIED
BAND I CHANNEL SIMULTANEOUSLY
NOMINAL GAIN 16-18 DB BOTH BANDS

PRICES BOTH TYPES:

Battery model £4.17 Mains version £6.50
Including VAT. Postage 9p

TRANSISTOR DEVICES LIMITED
6 ORCHARD GARDENS, TEIGNMOUTH, DEVON
Telephone: Teignmouth 4757

WITWORTH TRANSFORMERS

TV Line out-put transformers (Discounts to Trade)

ALL ONE PRICE £5.17 EACH V.A.T. & CARRIAGE PAID

ALBA	
T1090	TI 1435
T1095	TD1420
T1135	TD1435
T1195	TD1824
T1235	TS 1320
T1395	TS 1724

BAIRD			
600	628	662	674
602	630	663	675
604	632	664	676
606	640	665	677
608	642	666	681
610	644	667	682
612	646	668	683
622	648	669	685
624	652	671	687
625	653	672	688
626	661	673	

Please quote part No. normally found on tx. base plate; 4121, 4123, 4140 or 4142.

COSSOR		
CT1700u	CT1975a	CT1962-77*
CT1910a	CT1976a	CT1954-77*
CT1911u	CT2100u	CT1964-78*
CT1921a	CT2310a	
CT1922a	CT2311a	
CT1935a	CT2321a	
CT1937a	CT2331a	
CT1938a	CT2332a	
CT1972a	CT2373a	
CT1973a	CT2375a	
CT1974a	CT2378a	

*Two types fitted one has pitch o/w, the other has plastic moulded overwind—please state which type required as they are not interchangeable.

BUSH	
TU versions	
TV75 or C	TV125
TV76 or C	TV125U
TV77	TV128
TV78	TV134
TV79	TV135
TV83	TV135R
TV84	TV138
TV85	TV138R
TV86	TV139
	TV141
	TV145
	TV148
	TV161
	TV165
	TV166
	TV171
	TV175
	TV176
	TV178

	TV91	TV105 or D
	TV92	TV106 or D or R
	TV93	TV106
	TV94	TV107
	TV95 or C	TV108
	TV96 or C	TV109
	TV97	TV112C
	TV98C	TV111
	TV99 or C	TV115 or C or R
	TV100C	TV118
	TV101C	TV123
	TV102C	TV124
	TV103 or D	
	TV104 or D or R	
	TV106	
	TV107	
	TV108	
	TV109	
	TV112C	
	TV111	
	TV115 or C or R	
	TV118	
	TV123	
	TV124	

From model TV123 to TV139 there have been two types of transformer fitted. One has pitch overwind, the other has plastic moulded overwind. Please state which type required as they are not interchangeable.

KB		
PVP20	QV30 (90°)	VW90
VW05	QV30FM (110°)	MV100/1
KV001	QV30-1	QF100
KV002	30	PV100
KV005	NV40	KV101
KV006	NF60	KV105
RV10	RV60	KV107
Q15	WV50	115
TV15	XV60	117
O17	NF70 or FM	119
QV20	PV70	KT400A
VW20-1	QV70	
RV20	RV70	KT405A
TV20	VV70	by chassis No.—
VW20	VW70	VC1 VC4 VC52
QVP20	VW75	VC2 VC5 VC53
QV30	QF80	VC3 VC51 VC100

SV20	KV055	KV136
SV30	056	138
SV042	065	155
SV048	066	156
SV054	113	165
SV142	114	166
SV143	124	
SV148	125	
MV818	126	
MV819	127	
MV903	134	

MURPHY		
V310	V430	V520
V310A	V430C	V530
V310AD	V430D	V530C
V310AL	V430K	V530D
V310CA	V440	V539
V320	V440D	V540
V330 or D	V440K	V540D
V330F or L	V470	V649D
V410	V480	TM2 Chassis
V410C	V490	V843*
V410K	V500	V849*
V420	V510	V873*
V420K	V519	V787

*Two types fitted. One has pitch overwind, the other has plastic moulded overwind. Please state which type required as they are not interchangeable.

FERGUSON, ULTRA, MARCONI, H.M.V. (BRC. Jellypots). ALL MODELS IN STOCK.

E.H.T. RECTIFIER TRAYS			
Suitable for: FERGUSON, ULTRA, MARCONI, H.M.V.			
Series	Series	Series	1500 Series
850	950 MKII	980	3 stick £3.52 each
900	960	981	5 stick £4.29 each
911	970	982	
950 MKI	1400		
£3.52 each	£4.29 each	£3.52 each	When ordering, model number and series must be quoted.

FIXING: Direct BRC replacement, will clip into existing transformer.

PYE	
1	
2	
3 or u	

I1u Series	
12u	State Pt. No. required—
13u	AL21003 or 772494
14u	
15u	
20u	

SP17	62
21f or uf	63
22uf	64
23uf	68
24uf	75
31uf	76
35uf	77
36	80
37	81
40f	83
48	84
49	85
53	86
58	95
59	96
60	
61	

PV110	State Pt. No. required—
V110	771980 or 772013

V210 or A	
V220	
V410 or A	State Pt. No. required—
V420A	771927 or 771920
V40A	
V510	
V530	

V200 or LB	
V300s	
V310 or s	
V400	
V600	
V620	
V630	

V700 or A or D	
V710 or A or D	State Pt. No. required—
VB30A or D or LBA	772444 or 771935

PHILLIPS		
1768u		19TG122a
1792u	Exchange	19TG123a
1796u	Units	19TG125a
2168u		19TG133a
2192u		19TG142a
2196		19TG148a
		19TG152a
		19TG153a
		19TG154a
		19TG155a
		19TG156a
		19TG158a
		19TG164a
		19TG170a
		19TG171a
		19TG172a
		19TG173a
		19TG175a
		19TG176a
		19TG177a

17TG100	
17TG102	
17TG106	
17TG200	
17TG306	
19TG108u	
19TG111a	
19TG112u	
19TG114u	
19TG116u	
19TG121a	
19TG178	
19TG179	

21TG100u	G19T210	G23T210
21TG102u	G19T211	G23T211
21TG106u	G19T212	G23T212
21TG109u	G19T213	G24T230
23TG107u	G19T214	G24T232
23TG111a	G19T215	G24T236
23TG113a	G20T230	G24T238
23TG121a	G20T232	G24T300
23TG122a	G20T236	G24T301
23TG131a	G20T238	G24T302
23TG142a	G20T300	G24T306
23TG152a	G20T301	G24T307
23TG153a	G20T302	G24T307
23TG156a	G20T306	G24T308
23TG164a	G20T307	
23TG170a	G20T308	
23TG171a		
23TG173a		
23TG175a		
23TG176a		
23FG632		

ALL MAKES OF COLOUR TRANSFORMERS IN STOCK

GECC									
BT302	BT314	BT321	BT336	BT449	2000	2015	2022	2043	2064
BT303	BT315	BT322	BT337	BT450	2001	2017	2023	2044	2065
BT304	BT316	BT324	BT342	BT451	2010	2018	2032	2047	2066
BT305	BT318	BT326	BT346	BT452	2012	2019	2033	2048	2082
BT308	BT319	BT328	BT347	BT455	2013	2020	2038	2063	2083
BT312	BT320	BT329	BT448	BT456	2014	2021	2039		

DECCA			
DR20	DR34	DR71	DR505
DR21	DM35	DR95	DR606
DR23	DM36	DR100	666TV-SRG
DR24	DM39C	DR101	777TV-SRG
DR29	DR41	DR121	
DR30	DM45	DR122	MS1700
DR30	DR49C	DR123	MS2000
DR31	DM55	DR202	MS2001
DR32	DM56	DR303	MS2400
DR33	DR61	DR404	MS2401

SOBELL			
T24	ST284 or ds	1010dst	1033
SC24	ST285 or ds	1012	1038
TPS173	ST286 or ds	1013	1039
TPS180	ST287 or ds	1014	1047
ST195 or ds	ST288ds	1018	1048
ST196 or ds	ST290ds	1019	1057
ST197ds	ST291ds	1020	1058
ST297ds	1021	1063	
T278	1000ds	1022	1064
ST282	1002ds	1023	1065
ST283	1005ds	1032	1066

EKCO			
TC403	TC437	TS13	531
404	T442	514	T532
406	T500	515	533
T418	TC501	520	535
TC419	T502	521	536
T420	503	524	540
TC421	504	525	541
T422	505	526	
433	506	527	
434	510	528	
TC435	511	529	
T436	512	530	

FERRANTI				
1075	TC1122	1163	1155	1175
1080	1123	1164	TC1157	1176
1081	1124	1165	1158	T1181
1082	1125	T1174	1159	T1182
1083	TC1126	T1175	TC1160	T1185
1093	1137	TC1135	1162	T1186
1094	T1154	1136	1163	
1095	T1155	1137	T1164	
1096	1157	1138	T1165	
1097	1159	1140	1173	
1121	1160	T1154	1174	

SPECIAL
L.O.P. Transformer as specified for "Television" Colour Set only.
£5.17 ea. V.A.T. & Carriage Paid

Every item listed stocked. Many newer and older models in stock. S.A.E. for quotation For by-return service contact your nearest depot.

Tidman Mail Order Ltd., Dept. NA.
236 Sandycombe Road,
Richmond, Surrey.
London: 01-948 3702 or 01-940 8146

Hamond Components (Midland) Ltd., Dept. NA.
89 Meriden Street,
Birmingham 5.
Birmingham: 021-643 2148

