

# TELEVISION

20p

JUNE  
1971

SERVICING · CONSTRUCTION · COLOUR · DEVELOPMENTS

NEW SERIES

## BASIC CIRCUITS FOR THE CONSTRUCTOR

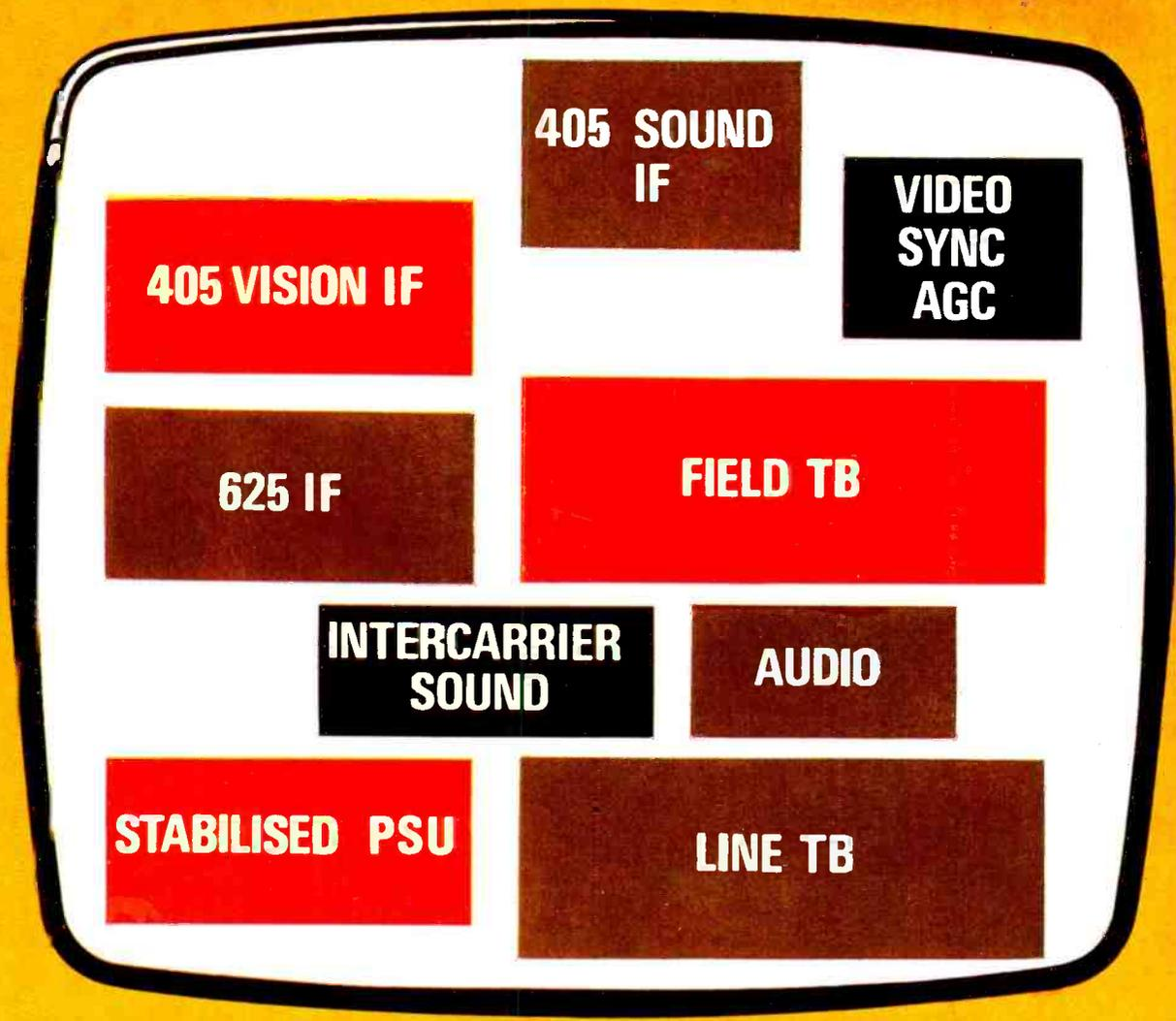

ALSO: ADDING AFC • TEST REPORT 1  
THE FAM COLOUR SYSTEM

# STEPHENS

**ELECTRONICS,  
P.O. BOX 26,  
AYLESBURY, BUCKS.**

**SEND S.A.E. FOR LISTS  
GUARANTEE  
Satisfaction or money  
refunded.**

## GUARANTEED VALVES BY THE LEADING MANUFACTURERS BY RETURN SERVICE 1 YEAR GUARANTEE ON OWN BRAND, 3 MONTHS' ON OTHERS

AZ31	50p	ECF80/2	47p	EL803	85p	PC85	42p	FY83	50p	UL41	57p	6A85	32p	6E47	35p	68K7	32p	12BE8	32p	30PL1	77p
AZ50	80p	ECF86	55p	EL821	55p	PC88	70p	FY88	41p	UL84	55p	6A86	32p	6E48	35p	68L7GT	32p	12BH7	32p	30PL13	90p
CBL1	80p	ECH35	67p	EL180	75p	PC89	61p	PY500	£1.00	UM80/4	45p	6A85	35p	6F1	70p	68N7GT	30p	12BY7	50p	30PL14	85p
CBL31	80p	ECH42	60p	EM34	80p	PC189	61p	PZ30	80p	UY41	40p	6A87G	80p	6F8	40p	68Q7	40p	12K5	50p	35A3	50p
CY31	35p	ECH81	51p	EM71	62p	PCF85	51p	QQU02-622-10	UY85	34p	6A76	45p	6F6G	25p	68R7	37p	12K7GT	35p	35A5	55p	
DAF91	41p	ECH83	40p	EM80	40p	PCF82	52p	QQU03-19	UY85	34p	6A76	45p	6F6G	25p	68R7	37p	12K7GT	35p	35B5	65p	
DAF96	41p	ECH84	47p	EM81	42p	PCF84	47p	U26	75p	6A76	45p	6F6G	25p	68R7	37p	12K7GT	35p	35C5	65p		
DF91	45p	ECL80	40p	EM84	37p	PCF86	61p	QV03-12	85p	U191	72p	6A8A	47p	6F13	35p	128G7	35p	35D5	65p		
DF96	45p	ECL82	40p	EM87	55p	PCF200/1	81p	R19	85p	U193	41p	6BE8	60p	6F14	60p	6V6GT	32p	128H7	25p	35L6GT	47p
DK91	57p	ECL83	57p	EN91	32p	PCF801	61p	R20	75p	U301	85p	6BH6	42p	6F15	55p	6X4	25p	128J7	25p	35W4	25p
DK96	57p	ECL86	49p	EY10	40p	PCF802	61p	SU2150A	75p	W29	55p	6B76	42p	6F18	40p	6X5GT	27p	128K7	40p	35Z3	55p
DL92	37p	ECL8600		EY80	45p	PCF805	85p	T21	£2.40	W759	£1.22	6BK7A	50p	6F22	32p	6X8	50p	128L7GT	40p	35Z4G	25p
DL94	37p	ECL86		EY81	40p	PCF806	61p	T22	£2.50	OA2	32p	6BL8	35p	6F23	27p	6V6G	80p	128M7GT	40p	35Z5GT	37p
DL96	40p	EF39	£2.10	EY83	55p	PCF808	67p	U18/20	67p	OA3	45p	6BN6	52p	6F24	67p	7Y4	60p	128Q7	40p	30A5	65p
DM70	32p	EF80	40p	EY86	40p	PCH200	70p	U20	67p	OB2	32p	6BN6	40p	6F25	75p	9BW6	42p	128R7	32p	50B5	35p
DY86/7	40p	EF83	50p	EY87	42p	PCL82	51p	U25	75p	OC3	50p	6BQ5	25p	6F26	35p	10C2	50p	1487	80p	60C5	35p
DY802	42p	EF85	41p	EY88	42p	PCL83	61p	U26	75p	OC3	50p	6BR7	75p	6F28	70p	10D1	40p	20D1	45p	60L6GT	40p
E55L	£2.75	EF86	60p	EZ35	27p	PCL84	51p	U31	45p	OD3	32p	6BR8	85p	6F29	32p	10D2	40p	20L1	£1.00	83A1	90p
E88CC	40p	EF89	40p	EZ40	45p	PCL85	52p	U37	£1.50	Q44	40p	6BW6	82p	6F30	35p	10F1	80p	20P1	50p	85A2	37p
E130L	£4.50	EF91	42p	EY11	45p	PCL86	51p	U50	30p	384	35p	6BW7	60p	6F34	47p	10F9	50p	20P3	60p	90A0	£2.40
E180F	35p	EF92	50p	EZ80	27p	P1600	£1.52	U52	30p	3V4	40p	6B3S	22p	6J5GT	40p	10P18	40p	30P4	£1.00	90C4	60p
EABC80	52p	EF93	47p	EZ81	27p	PFL200	74p	U76	25p	6R4GY	55p	6B26	32p	6J7	42p	10L1	40p	20P5	£1.00	90CU	£1.25
EAF42	50p	EF94	77p	EZ90	25p	PL36	94p	U78	25p	6U4G	30p	6C4	30p	6KGGT	50p	10LD11	55p	25C5	45p	807	47p
EBC33	55p	EF95	62p	OS10C	£5.00	PL38	90p	U91	75p	6U4GB	37p	6CGT	35p	6K7	32p	10P13	55p	25L6GT	37p	81A	£1.50
EBC41	47p	EF183	50p	GY501	80p	PL81	61p	U201	35p	6V4G	40p	6CD6G	£1.40	6K8G	30p	10P14	£1.00	25Z4G	30p	812A	£3.25
EBC81	32p	EF184	35p	GZ30	37p	PL81A	62p	U281	40p	6Y3GT	30p	6CA4	27p	6K23	50p	10ZAB5	50p	25Z6GT	50p	813	£3.75
EBC90	47p	E280F	£2.10	GZ31	30p	PL82	36p	U282	45p	6B7	45p	6C25	50p	6K25	75p	12AC6	37p	30A3	40p	866A	70p
EF80	40p	EF80	£1.00	GZ32	47p	PL83	51p	U301	57p	6ZAGT	40p	6C8C	27p	646GT	40p	12AD6	37p	30A3	40p	866A	70p
EF83	40p	EF804	£1.00	GZ33	80p	PL84	41p	U403	50p	6R30L2	75p	6CD6GA	£1.15	6L7	32p	12AD6	37p	30C15	75p	5642	60p
EF89	40p	EF811	75p	GZ34	55p	PL500	82p	U404	37p	6AB4	32p	6C07	45p	6L18	30p	12A15	40p	30C17	80p	6080	£1.37
EB91	20p	EL34	52p	HK90	32p	PL504	85p	U801	£1.00	6AF4A	47p	6CH6	55p	6LD20	32p	12AQ5	40p	30C18	75p	6146	£1.50
EC33	50p	EL36	47p	HL92	35p	PL505	£1.45	U802	52p	6AG7	37p	6CL6	50p	6NTGT	35p	12AT6	25p	30F5	85p	6146B	£3.37
EC88	60p	EL41	55p	HL94	40p	PL508	£1.00	UBP89	40p	6AH6	50p	6CW4	62p	6P1	60p	12AU6	75p	30FL2	92p	6267	32p
EC88/5	42p	EL91	25p	KT81	£1.37	PL509	£1.54	UBC41	49p	6AV5	40p	6CV5	45p	6P25	£1.05	12AV6	30p	30FL2	92p	6267	32p
EC90	30p	EL81	50p	K788	£1.66	PL802	88p	UC85	46p	6AK5	60p	6CV7	60p	6P28	62p	12AV6	30p	30FL13	50p	6390	£1.25
EC92	32p	EL83	41p	N78	£1.05	PL805	86p	UCH42	89p	6AK6	57p	6D3	40p	6Q7	37p	12AV7	45p	30FL14	77p	6639	£2.10
EC93	47p	EL85	42p	PABC80	40p	PY33	62p	UCH81	54p	6AL3	42p	6DC6	67p	6R7G	35p	12AX7	30p	30L1	45p	7199	75p
EC98	40p	EL86	42p	PC86/8	51p	PY80	32p	UCH82	51p	6L5	16p	6DK6	60p	6S4	55p	12AY7	67p	30L15	35p	7360	£1.80
ECC82/3	42p	EL90	32p	PC95	38p	PY81	41p	UCL83	61p	6AM5	25p	6DQ6G	80p	6S4A	55p	12BA4	50p	30L17	85p	7586	£1.25
ECC84/5	42p	EL91	25p	PC97	41p	PY80	41p	U41/2	55p	6AM6	22p	6D84	75p	6S47	37p	12BA6	32p	30P12	80p	9002	32p
ECC88	50p	EL95	85p	PC97	41p	PY80	41p	UB80/5	37p	6A85	32p	6EA8	50p	6S67	32p	12BA6	32p	30P18	35p	9002	32p
E88CC	62p	EL360	£1.15	PC884	46p	PY82	35p	UR89	41p	6A6G	50p	6E47	32p	6S77	37p	12BA7	32p	30P19	75p	9003	50p

### CATHODE RAY TUBES

New and Budget tubes made by the leading manufacturers. Guaranteed for 2 years. In the event of failure under guarantee, replacement is made without the usual time wasting forms.

Type	New	Budget	Type	New	Budget
	£	£		£	£
MW30-20		£4.50	A50-120W/R	CME2013	£10.95
MW30-21		£4.50	AW53-80		£3.93
MW43-69Z	CRM171	£4.82	AW63-88	CME2101	£3.93
	CRM172	£6.80	AW59-90		£6.25
	CRM173	£6.80	AW69-91	CME2303	£9.58
MW43-80Z	CME1702	£4.82	A59-15W	CME2301	£7.20
	CME1703	£4.82		CME2302	
	CME1706	£4.82	A59-11W	CME2303	£9.58
	C17AA	£6.80	A59-13W	CME2306	£13.05
	C17AF	£6.80	A59-16W	CME2306	£13.05
	CME1705	£6.80	A59-23W	CME2305	£12.80
AW43-88		£4.82	A59-23W/R		£10.80
AW47-90	A47 14W	£5.95	A61-120W/R	CME2413	£13.50
AW47-91	CME1901	£5.95	A65-11W	CME2501	£16.50
AW47 14W	CME1902	£5.95			
	CME1903	£5.95	<b>COLOUR TUBES</b>		
	C19AH	£5.95	A49-191X	19 inch	£52.50
147 13W	CME1906	£10.27	A86-120X	22 inch	£57.50
A47-11W	CME1905	£8.86	A63-11X	25 inch	£62.50
A47-26W	CME1903	£8.86	<b>PORTABLE SET TUBES</b>		
A47-26W/R	CME1913R	£9.33	TSD21		£11.50
			TSD282		£11.50
			A28-14W		£9.10
					Not supplied
					£7.75
					£8.00

A discount of 10% is also given for the purchase of 3 or more tubes at any one time. All types of tubes in stock. Carriage and insurance 75p anywhere in Britain.

### TRANSISTORISED UHF TUNER UNITS NEW AND GUARANTEED FOR 3 MONTHS

Complete with Aerial Socket and wires for Radio and Allied TV sets but can be used for most makes. Continuous Tuning, £4.50; Push Button, £5.00.

### SERVICE AIDS

Switch Cleaner, 55p; Switch Cleaner with Lubricant, 55p; Freeza 62p. P. & p. 7p per item.

### PLUGS

Standard Plugs	19p	Co-Axial Plugs	Belling Lee (or similar type)	61p
Standard Sockets	12p	Add 2p per doz. p. & p.		
<b>LINE OUTPUT TRANSFORMERS</b>				
G.E.C. BT454	£4.75	G.E.C. 2028		£4.75
G.E.C. BT456	£4.75	G.E.C. 2041		£4.75
G.E.C. 2010	£4.75	G.E.C. 2000 Series		
G.E.C. 2013	£4.75	Philips 19TG		£4.75
G.E.C. 2014	£4.75	Pye Mod. 36		£4.75
G.E.C. 2018	£4.75	Pye Mod. 40		£4.75
G.E.C. 2043	£4.75	Thorn 800-850		£4.75
G.E.C. 2048	£4.75			

### STYLI—BRITISH MANUFACTURED

Single Tip "S"	13p	Double Tip "S"	33p
Single Tip "D" <th>37p</th> <th>Double Tip "D"</th> <th>47p</th>	37p	Double Tip "D"	47p

"S" = Sapphire "D" = Diamond

## CARTRIDGES

A006	Inc. P.T. each	B.B.R.	Inc. P.T. each	ROSETTE	Inc. P.T. each		
GP79	£0.66	X3M	8/8	£1.20	106	8/8	80p
GP91-18c	£1.06	X3H	8/8	£1.20	106	8/8	80p
GP91-28c	£1.06	X3M	8/8	£1.20	DC400	8/8	70p
GP91-35c	£1.06	X3H	8/8	£1.20	DC400C	8/8	70p
Suitable to replace TC3		X3M	8/8	£1.11	105	D/8	£1.11
GP92	£1.24	X35H	8/8	£1.11	106	D/8	£1.11
GP93-1	£1.24	X35M	D/8	£1.99	DC400	D/8	84p
GP94-1	£1.24	X35H	D/8	£1.99	DC400C	D/8	84p
GP94-5	£1.80	XAN	D/8	£1.99			
GP95	£1.94	GOLDRING					
GP96	£1.97	850		£5.25	80TONE		
		G900		£7.35	8TA	D/8	£1.25
		G900E		£15.00	9TA	D/8	£1.79
AC05	1-10	8000 Super E		£19.50	9TACHC	D/8	£1.79</

# LAWSON BRAND NEW TELEVISION TUBES



**SPECIFICATION:** The Lawson range of new television tubes are designed to give superb performance, coupled with maximum reliability and very long life. All tubes are the products of Britain's major C.R.T. manufacturers, and each tube is an exact replacement. Tubes are produced to the original specifications but incorporate the very latest design improvements such as: High Brightness Maximum Contrast Silver Activated Screens, Micro-Fine Aluminising, Precision Aligned Gun Jigging, together with Ultra Hard R.F. High Vacuum Techniques.

## DIRECT REPLACEMENTS FOR MULLARD-MAZDA BRIMAR GEC, ETC.

A21-11W (P)	AW47-91 (M)	C19/AK (M)	CME1902 (M)	173K (M)
A28-14W	MW43-64 (M)	C21/1A (M)	CME1903 (M)	212K (M)
A31-18W (P)	MW43-69 (M)	C21/7A (M)	CME1905	7205A (M)
A47-11W (P)	MW43-80 (M)	C21/AA (M)	CME1906	7405A (M)
A47-13W (T)	MW52/20 (M)	C21/AF (M)	CME1908	7406A (M)
A47-14W (M)	MW53/80 (M)	C21/KM (M)	CME2101	7502A (M)
A47-17W (P)	AW47-97 (M)	C21/SM (M)	CME2104 (M)	7503A (M)
A47-18W (P)	AW53-80 (M)	C23/7A (M)	CME2301 (M)	7504A (M)
A47-26W (P)	AW53-88 (M)	C23/10 (M)	CME2302 (M)	7601A (M)
A59-11W (P)	AW53-89 (M)	C23/AK (M)	CME2303 (M)	7701A (M)
A59-12W (P)	AW59-90 (M)	CME1101 (P)	CME2305 (P)	CRM121 (M)
A59-13W (T)	AW59-91 (M)	CME1201 (P)	CME2306 (T)	MW31-74 (M)
A59-14W (T)	C17/1A (M)	CME1402 (M)	CME2308 (M)	A50-120W/R (P)
A59-15W (M)	C17/5A (M)	CME1601 (P)	CRM172 (M)	
A59-14W (T)	C17/7A (M)	CME1602 (P)	CRM173 (M)	
AW36-80 (M)	C17/AA (M)	CME1702 (M)	CRM212 (M)	
AW43-80 (A)	C17/AF (M)	CME1703 (M)	CRM211 (M)	
AW43-88 (M)	C17/FM (M)	CME1705 (M)	23SP4 (M)	
AW43-89 (M)	C17/5M (M)	CME1706 (M)	171K (M)	
AW47190 (M)	C19/110AP (T)	CME1901 (M)	172K (M)	

## REBUILT TUBES

**LAWSON "RED LABEL" CRTS** are particularly useful where cost is a vital factor, such as in older sets or rental use. Lawson "Red Label" CRTS are completely rebuilt from selected glass, are direct replacements and guaranteed for two years.

	Brand New Tubes	Red Label Rebuilt	Carr. Ins.
CME 1601	£8-50	£4-25	12" - 19" } 62p
17"	£6-25	£4-87	
19"	£7-25	£5-25	
21"	£8-50	£6-87	20" - 23" } 75p
23"	£9-75	£7-25	
19" Twin Panel	£10-25		
23" Twin Panel	£15-50		
19" Panorama	£9-38		
20" Panorama	£9-50		
23" Panorama	£11-95		

**LAWSON TUBES**  
18 CHURCHDOWN ROAD,  
MALVERN, WORCS.  
Malvern 2100

**2 YEARS' GUARANTEE**  
**FULL TUBE FITTING**  
**INSTRUCTIONS**

Tubes are despatched passenger train, road or goods taking far too long for customer satisfaction.

# FAULT LOCATION

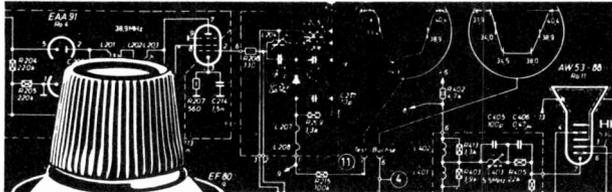

## KONTAKT "Cold Spray 75"

For rapid and effective fault location.

Non-toxic, non-inflammable, Cold Spray 75 is a chemically inert coolant capable of producing temperatures of down to -42 centigrade. It can also be used to prevent heat damage during soldering processes, for the rapid freezing of small articles for biological and technical purposes and the prompt location of hairline cracks and other faults in temperature dependent components.

Other Kontakt products:

Kontakt 60 and Kontakt 61 for relay contact cleaning; Plastic Spray 70, transparent protective lacquer; Insulating Spray 72; Kontakt WL, Spray Wash; Antistatic Spray 100, Antistatic agent for plastics; Politur 80, Polish and cleaner; Fluid 101, Dehydrating Fluid.

Details from U.K. distributors:

**Special Products Distributors Ltd.**

81 Piccadilly, London, W.1.

Tel. 01-629 9556



## BUILD YOURSELF A CCTV CAMERA with the NEW BEUKIT

The kit includes all parts necessary to make a fully operational camera, complete with instruction manual.

**Price £45.50 only**  
(excluding tube)

Optional extras: Vidicon from £5, RF kit £3.75, lenses, tripods, test, etc.

Send s.a.e. for further details:

**Beulah Electronics (1970) Ltd.**

P.O. Box 234, Shepperton, Middx.

# WILLOW VALE ELECTRONICS LIMITED

The Service Department Wholesalers

Compare our prices

e.g. NEW 19" C.R.T's . . . OUR PRICE £7.95 Plus 65p carriage

Please note: Components are sold in packs, quantities per pack are shown under each heading. Prices are per piece of each value.

TUBULAR CAPACITORS (5's)		
.001	400v.	£0.04
.0022	600v.	£0.04
.0033	600/1500v.	£0.04
.0047	600/1500v.	£0.04
.01	400v.	£0.04
.022	600v.	£0.05
.033	600v.	£0.05
.047	600v.	£0.05
.1	600v.	£0.05
.22	600v.	£0.10
.47	600v.	£0.14
.01	1000v.	£0.06
.022	1000v.	£0.06
.047	1000v.	£0.09
.1	1000v.	£0.09
.22	1000v.	£0.14
.47	1000v.	£0.19
.001	1500v.	£0.08

BIAS ELECTROLYTICS (5's)		
25mfd	25v.	£0.07
50mfd	25v.	£0.08
100mfd	25v.	£0.10
250mfd	25v.	£0.15
500mfd	25v.	£0.19
1000mfd	12v.	£0.30
1000mfd	30v.	£0.30
2000mfd	25v.	£0.35
2500mfd	30v.	£0.45
3000mfd	30v.	£0.47
5000mfd	30v.	£0.55
25mfd	50v.	£0.08
50mfd	50v.	£0.10
100mfd	50v.	£0.13
250mfd	50v.	£0.18
500mfd	50v.	£0.24
2000mfd	50v.	£0.47
2500mfd	50v.	£0.55

WIRE-WOUND RESISTORS (5's)		
10 watt rating, suitable for mains dropper sections.		
1	Ohm	£0.09
10	Ohms	£0.09
13	"	£0.09
25	"	£0.09
33	"	£0.09
50	"	£0.09
87	"	£0.09
100	"	£0.09
150	"	£0.09
220	"	£0.09
330	"	£0.09
1K	"	£0.09
2.2K	"	£0.09
3.3K	"	£0.09
4.7K	"	£0.09

SMOOTHING ELECTROLYTICS		
Wire ended, 450v. working.		
1mfd		£0.07
2mfd		£0.08
4mfd		£0.11
8mfd		£0.13
16mfd		£0.16
32mfd		£0.23
50mfd		£0.25
8/8mfd		£0.19
8/16mfd		£0.25
16/16mfd		£0.26
16/32mfd		£0.27
32/32mfd		£0.27
50/50mfd		£0.42
50/50/50mfd		£0.52

PULSE CERAMICS (5's) 12KV		
100pf	22pf	£0.06
120pf	47pf	£0.06
180pf	68pf	£0.06
250pf		£0.06

Tubular type for use in Scan correction circuits and Line Outputs.

CANNED ELECTROLYTICS		
100/200mfd		£0.63
100/400mfd		£0.83
200/200mfd		£0.85
200/200/100mfd		£0.95
200/400/32mfd		£0.95
100/300/100/16		£0.95
100/400/32mfd		£0.95
100/400/64/16		£1.07

CERAMICS (6's)		
500pf	22pf	£0.03
680pf	47pf	£0.03
820pf	68pf	£0.03
1000pf	100pf	£0.03
1500pf	120pf	£0.03
3000pf	180pf	£0.03
5000pf		£0.03

SKELETON PRE-SETS (5's)		
25K	Vertical	£0.07
50K	"	£0.07
100K	"	£0.07
250K	"	£0.07
500K	"	£0.07
1 meg	"	£0.07
2 meg	"	£0.07
500K	Horizontal	£0.07
680V	"	£0.07
1 meg	"	£0.07

SUB-MINIATURE ELECTROLYTICS (5's)		
1mfd	18v.	£0.09
2mfd	18v.	£0.09
4mfd	18v.	£0.09
5mfd	18v.	£0.09
8mfd	18v.	£0.09
10mfd	18v.	£0.09
16mfd	18v.	£0.09
25mfd	18v.	£0.09
32mfd	18v.	£0.09
50mfd	18v.	£0.09
100mfd	18v.	£0.09
200mfd	18v.	£0.09

RADIO/TV GLASS FUSES	
1 amp, 1.5 amp, 2 amp, 3 amp.	£0.15
Per dozen	

MAINS FUSES	
2 amp, 3 amp, 5 amp, 13 amp.	£0.25
Per dozen	

TERMINAL STRIPS	
2 amp	£0.12
5 amp	£0.14
15 amp	£0.29

THERMISTORS (5's)	
Miniature	£0.08
TH1	£0.13

RECTIFIERS Silicon Mains (5's)	
Westinghouse S10AR2	£0.33
BY127 Mullard	£0.26
BY327	£0.25

**CARBON FILM RESISTORS**  
 1/2 watt, 1 watt and 2 watt.  
 The following values are packed in cartons of six of each value.

CONTACT COOLED FULL WAVE	
75ma	£0.60
100ma	£0.70
150ma	£0.86

10	ohm	1.2K	150K
12	"	1.5K	180K
15	"	1.8K	220K
18	"	2.2K	270K
22	"	2.7K	330K
27	"	3.3K	390K
33	"	3.9K	430K
39	"	4.3K	470K
43	"	4.7K	560K
47	"	5.6K	680K
56	"	6.8K	820K
68	"	8.2K	1M
82	"	10K	1.2M
100	"	12K	1.5M
120	"	15K	1.8M
150	"	18K	2.2M
180	"	22K	2.7M
220	"	27K	3.3M
270	"	33K	3.9M
330	"	39K	4.3M
390	"	43K	4.7M
430	"	47K	5.6M
470	"	56K	6.8M
560	"	68K	8.2M
680	"	82K	10M
820	"	100K	12M
1K	"	120K	15M

CO-AXIAL PLUGS	
Bakelite top	£0.04
Egen metal	£0.08
Single point (car radio)	£0.10

SLIDER PRE-SETS (3's)	
100K	£0.08
1 Meg	£0.08
2.2 Meg	£0.08

JACK PLUGS	
Chrome standard	£0.20
Standard	£0.15
3.5mm. metal	£0.15

DIN PLUGS (2's)	
3-pin	£0.10
5-pin	£0.11
Sockets	£0.06

All the above values are available in both 1/2 watt, 1 watt and 2 watt versions.  
 \*Special for Philips TV's:  
 8.2M 2-watt, 23p per pack.  
 Price 1/2 watt -10, 1 watt -13, 2 watt -23

DOUBLE DIODE RECTIFIERS (5's)	
Bush/Murphy/BRC, etc.	
Line/frame timebases etc.	
3 leg	£0.31
4 leg	£0.31
5 leg	£0.31

VOLUME CONTROLS	
Standard spindle with flat.	
Double pole switch	£0.25
Without switch	£0.19
(One per pack)	
5K, 10K, 25K, 50K, 100K, 250K, 500K,	
1 meg, 2 meg.	

MOBILE STORES VANS IN LONDON, WEST COUNTRY, WALES AND SCOTLAND

RECORD PLAYER CARTRIDGES		SERVISOL AND ELECTROLUBE PRODUCTS (Nett trade)		REPLACEMENT STYLI	
ACOS: GP67/2g. High gain general purpose Mono	£0.83	Servisol aerosol can	£0.63 nett	TC8	£0.23
GP91/3C. Stereo-compatible replacement	£1.10	Electrolube 2AX aerosol	£0.70 nett	GCB	£0.23
GP91/3SC. High gain version of above	£1.10	Servisol Freezit	£0.47 nett		
GP94/1SS. Stereo cartridge	£1.89	Electrolube No. 1 Snorkel	£0.90 nett		
GENERAL PURPOSE REPLACEMENT FOR TC8's etc.		Electrolube 2GX Grease	£0.42 nett		
High gain, plenty of output (Jap.)	£0.99	Servisol Aero-Clene for tape heads	£0.53 nett		
Stereo version	£1.89	Servisol Aero-Duster	£0.53 nett		

## REBUILT AND NEW TUBES—TWO YEARS' GUARANTEE

REBUILT	BRAND NEW	A FEW SAMPLE TYPES, REMEMBER WE STOCK EVERY TUBE
17" @ £5.95	£6.50	CME1702, AW43-80, CRM173, MW43-80, MW43-69*, CRM172*, AW43-88, AW43-89, CME1705, CME1703, C17AF, C17SM, etc.
19" @ £5.95	£7.95	CME1903, CME1902, CME1901, AW47-90, AW47-91, A47-14W, C19AH, C19AF, C19A.
21" @ £7.95	£9.90	CME2101, AW53-88, AW53-89, CRM211*, CRM212*, MW53-20*, MW53-80*.
23" @ £7.95	£10.80	CME2303, CME2301, AW59-90, AW59-91.
<b>COLOUR TUBES IN STOCK. PRICES ON APPLICATION</b>		<b>*NEW ONLY. NO REBUILDS</b>
<b>ALL PRICES ARE NETT</b>		
TWIN PANELS 19" CME1906 A47-13W } ON APPLICATION		23" CME2306 A59/13W } ON APPLICATION

**HOT-LINE ORDERS**  
Tel: 01-567 5400/2971  
TRADE ONLY

EVERY TUBE IN STOCK INCLUDING 12", 16" PORTABLES, PANORAMA & RIMGUARDS. TERMS: CASH WITH ORDER. CARRIAGE ANYWHERE IN GT. BRITAIN 65p per Tube

### RADIO AND TELEVISION VALVES SMALL SELECTION

British made valves normally supplied. EVERY TYPE IN STOCK

DY86/7	EY86/7	PCL86
DY802	EZ80	PD500
EABC80	EZ81	PFL200
EB91	EZ90	PL36
EBC90	GZ34	PL81
EBF80	GY501	PL81A
EBF89	PC86	PL82
ECC81	PC88	PL83
ECC82	PC97	PL84
ECC83	PC900	PL302
ECC804	PCC84	PL504
ECH81	PCC88	PL508
ECH84	PCC89	PL509
ECL80	PCC189	PY33
ECL82	PCC806	PY81
ECL83	PCF80	PY800
ECL84	PCF86	PY801
ECL86	PCF87	PY82
EF80	PCF801	PY83
EF85	PCF802	PY500
EF86	PCF805	UABC80
EF89	PCF806	UCH81
EF183	PCF808	UCL82
EF184	PCL82	UCL83
EH90	PCL83	UL41
EL34	PCL84	UL84
EY51	PCL85	UY85

**VALVE DISCOUNTS**  
42% ORDERS UP TO £50  
50% ORDERS OVER £50

ALL MAZDA/BRIMAR TYPES IN STOCK.

### TRADE & SERVICE ENGINEERS ONLY SUPPLIED

Cash with order. 10% MAY BE DEDUCTED FROM THE ADVERTISED PRICES EXCEPT FOR NETT ITEMS, C.O.D., OR TUBES

All orders must exceed £5.00 in value otherwise postage and packing will be charged at 25p per invoice. Components must be ordered in multiples as packed.

**COMPREHENSIVE CATALOGUE** listing valves, tubes, L.O.P.T.'s components, transistors, including HUGE VALVE EQUIVALENTS LIST. 15p in loose stamps, please.

## L.O.P.T.'s

LINE OUTPUT  
TRANSFORMERS

ALL MAKES SUPPLIED

L.O.P.T.'s ONLY AVAILABLE  
FROM LONDON DEPOT

**EXCHANGE UNITS AND  
NEW REPLACEMENTS**

EVERY MAKE SUPPLIED  
(EXCEPT MURPHY OIL-FILLED)

REWIND SERVICE FOR  
OBSOLETE MODELS

FRAME OUTPUT, SOUND OUTPUT AND  
MAINS TRANSFORMERS REWOUND

REMEMBER . . . We are the Service department Wholesalers and supply only the Service Engineers' requirements and can therefore carry large stocks, and also we know and understand your problems regarding getting the right spares QUICKLY and the RIGHT PRICE.  
HOT-LINE ORDERS: LONDON 01-567 5400-2971. 01-579-3582. SOMERSET 045-84-2597

**4 & 5 THE BROADWAY, HANWELL, LONDON, W.7**

Telephones: 01-567 5400    01-567 2971    01-579 3582

**42 WEST END, STREET, SOMERSET 045-84 2597**



# I'D RATHER HAVE A MINITEST™

The SEI MINITEST has made a remarkable impact in the pocket-sized multi-range meter market, by making itself a firm favourite with discerning people in the industry. Let's look into the reasons why.

First, the appearance. Diminutive, neat, wipe-clean cyclac case with shock and magnetic field proof steel liner. Controls are simple and easy to use.

Second, the range. The Minitest measures a.c. and d.c. voltages d.c. current and resistance over 20 ranges to a sensitivity of 20,000 and 2,000 ohms per volt d.c. and a.c. respectively.

Third, high voltage probes. These extend the range to 25 or 30kV d.c.

Little wonder the Minitest is preferred!

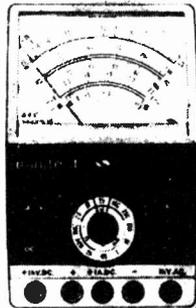

**SALFORD ELECTRICAL INSTRUMENTS LTD**  
 Peel Works, Barton Lane, Eccles, Manchester M30 0HL  
 Telephone 061-789 5081 Telex 667711  
 A Member Company of GEC Electrical Components Ltd.



## VALVES SAME DAY SERVICE NEW! TESTED! GUARANTEED!

**SETS** 1R5, 1B5, 1T4, 3B4, 3V4, DAF91, DF91, DK91, DL92, DL94  
 Set of 4 for £1.02. DAF96, DF96, DK96, DL96, 4 for £1.46.

1R5	-88	30C1	-30	DL94	-37	EM80	-41	PCL83	-60	UABC80	-35
1B5	-21	30C15	-63	DL96	-38	EM81	-41	PCL84	-37	UAF42	-61
1T4	-16	30C17	-90	DY86	-26	EM84	-33	PCL85	-45	UBC41	-52
3B4	-28	30C18	-67	DY87	-28	EM87	-37	PCL86	-41	UPF80	-34
3V4	-37	30F5	-78	EABC80	-32	EY51	-36	PCL88	-72	UPF89	-33
5U4G	-26	30FL1	-63	EAF42	-50	EY86	-32	PCL800	-77	UCB4	-35
5V4G	-37	30FL12	-78	EB91	-11	EZ40	-43	PENA4	-48	UCC85	-38
5Y3GT	-30	30FL14	-72	EBC33	-40	EZ41	-43	PEN36C	-70	UCF80	-36
5Z4G	-37	30LL1	-32	EBC41	-54	EZ80	-32	PFL200	-53	UCH42	-63
6J30L2	-53	30L15	-62	EBC90	-22	EZ81	-34	PL36	-46	UCH81	-32
6AL5	-11	30L17	-73	EBF80	-33	GZ30	-87	PL81	-46	UCL82	-35
6AM6	-13	30P4	-65	EBF89	-31	GZ32	-43	PL81A	-61	UCL83	-55
6AQ5	-26	30P12	-77	ECC81	-18	GZ34	-50	PL82	-33	UP41	-56
6AT6	-22	30P19	-65	ECC82	-23	KT41	-77	PL83	-55	UP89	-33
6AU6	-22	30P11	-63	ECC83	-35	KT61	-55	PL84	-33	ZL41	-60
6BA6	-22	30PL13	-85	ECC85	-28	KT66	-63	PL500	-65	UL44	£1.00
6BE6	-23	30PL14	-70	ECC804	-60	LN319	-53	PL504	-37	UL54	-35
6BL6	-42	30PL15	-90	ECF80	-30	LN329	-72	PL508	£1.17	UM84	-22
6BW7	-60	35L6GT	-43	ECF82	-30	LN339	-63	PM84	-37	UY41	-41
6CD9G	£1.10	35W4	-28	ECH35	-30	N78	-87	PX25	£1.17	UY85	-28
6F14	-45	36Z4GT	-25	ECH42	-63	P61	-50	PY32	-55	VP4B	-77
6F23	-71	807	-45	ECH81	-29	PABC80	-35	PY33	-55	Z77	-29
6F25	-62	6063	-63	ECH83	-41	PC86	-51	FY81	-27	Transistors	-
6K7G	-12	AC/VP2	-77	ECH84	-37	PC88	-37	AC107	-17		
6K8G	-17	AZ31	-55	ECL80	-35	PC96	-42	PY83	-25	AC1297	-13
6P28	-90	B349	-65	ECL82	-33	PC97	-40	PY88	-35	AD140	-37
68L7GT	-27	B729	-62	ECL86	-40	PC900	-37	PY800	-37	AF115	-90
6V6G	-22	CCH35	-67	EF39	-23	PCC84	-32	PY801	-37	AF116	-80
6V6GT	-32	CL33	-93	EF41	-60	PCC85	-30	R19	-32	AF117	-90
6X4	-23	CY31	-32	EF80	-24	PCC86	-42	R20	-65	AF118	-45
6X5GT	-22	DAC32	-38	EF85	-31	PCC89	-47	U25	-63	AF125	-17
10P13	-60	DAF91	-21	EF86	-31	PCC189	-51	U36	-65	AF127	-17
12AHR	£2.25	DAF96	-30	EF89	-26	PCC805	-65	U47	-65	OC26	-25
12A7T	-18	DF33	-38	EF91	-13	PCF80	-30	U49	-65	OC44	-12
12A06	-23	DF91	-16	EF163	-29	PCF82	-32	U50	-39	OC45	-12
12A07	-23	DF96	-36	EF184	-32	PCF86	-47	U52	-31	OC71	-12
12A7	-23	DH77	-22	EH90	-42	PCF800	-37	U78	-24	OC72	-12
19BG6G	-87	DK32	-37	EL33	-55	PCF801	-33	U191	-63	OC75	-12
20F2	-87	DK91	-22	EL34	-49	PCF802	-45	U193	-42	OC81	-12
20P3	-85	DK92	-42	EL41	-55	PCF805	-67	U251	-72	OC81D	-12
20P4	-92	DK96	-38	EL84	-24	PCF806	-80	U301	-52	OC82	-12
25L6GT	-25	DL35	-35	EL90	-26	PCF808	-72	U329	-72	OC82D	-12
25U4GT	-57	DL92	-26	EL500	-82	PCL82	-36	U801	-98	OC170	-32

## READERS RADIO

85 TORQUAY GARDENS, REDBRIDGE, ILFORD, ESSEX. Tel. 01-550 7441

Postage on 1 valve 5p, on 2 or more valves 3p per valve extra.  
 Any Parcel Insured against Damage in Transit 3p extra.

## REBUILT TUBES!

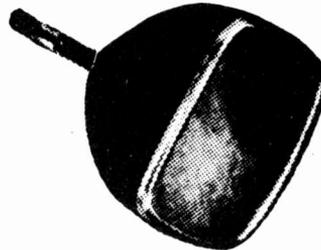

YOU'RE  
 SAFE  
 WHEN YOU  
 BUY FROM  
 RE-VIEW!

### HERE IS WHAT YOU PAY:

12in.	..	..	£4-75	19in.	..	..	£5-87
14in.	..	..	£5-00	21in.	..	..	£7-25
15in.	..	..	£5-25	23in.	..	..	£8-50
17in.	..	..	£5-25	19in. Twin Panel	..	..	£7-50
				23in. Twin Panel	..	..	£10

Cash or cheque with order, or cash on delivery

### OLD TUBES PURCHASED

#### Discount for Trade

- ★ Each tube is rebuilt with a completely new gun assembly and the correct voltage heater.
- ★ Each tube comes to you with a guarantee card covering it for two years against all but breakage.
- ★ Each tube is delivered free anywhere in the U.K. and insured on the journey.
- ★ Each tube is rebuilt with experience and know-how. We were amongst the very first to pioneer the technique of rebuilding television tubes.

### RE-VIEW ELECTRONIC TUBES

237 London Road, West Croydon, Surrey  
 Tel. 01-689/7735

# TELEVISION

SERVICING · CONSTRUCTION · COLOUR · DEVELOPMENTS

VOL 21 No 8  
ISSUE 248

JUNE 1971

## OUTLOOK UNSETTLED

IT is usually a pleasant experience to have an eminent authority confirm one's views—especially when the original views expressed were in the form of a prediction or warning. The sort of feeling, one assumes, of Madame Osiris when her misty manifestations in the crystal ball actually prove to be true.

The present writer however gets no joy from a recent reminder of his leader in the December 1967 issue. Headed "Industry in Danger," it pointed out that the UK had already lost a large proportion of the transistor radio market, warned that audio products were following suit and posed the question "How long before *all* such products are imported?" How long in fact before we ended up importing TV sets as well now that we are hitched to the 625-line system?

The flashback was caused by Dr. F. E. Jones, managing director of Mullard Ltd., who while addressing American industrialists in New York recently noted that the production of electronic devices and equipment is being progressively taken over by low-cost labour countries at the expense of high-cost labour countries. He cited industry as shrugging off the fact that 80% of radio sets sold in the UK are imported on the grounds that the demand for monochrome and now colour TV receivers is of greater significance. But now even the market for TV receivers is being slowly taken over by imports—and there's nothing left to take its place!

Pressing on relentlessly Dr. Jones stressed that of the home market of 30 million receiving valves in the UK last year 15 million were imported. In the field of semi-conductors 58% of the 1970 sales were imported and with i.c.s the import figure was as high as 74% of the total market!

Another voice recently raised was that of John Bowes, chairman of the British Radio Cabinet Manufacturers' Association, who pointed out that during 1970 some 150,000 monochrome and 35,000 colour TV sets were imported into the UK.

As Dr. Jones explained the problem is not one of relative technological efficiency for the performance figures (sales per employee, pretax profits per employee etc.) are very close between such comparable giants as RCA and Matsushita. But the wage rates are less than one-fifth for Matsushita. And there are many countries where the labour costs are much lower still.

We do not pretend to know the answers to the problems besetting the UK television industry. But our crystal ball indicates that the situation is in danger of becoming more critical in the future.

W. N. STEVENS, *Editor*

## THIS MONTH

Teletopics	342
Basic Circuits for the Constructor—1 405-Line Vision IF Amplifier <i>by J. W. Thompson</i>	344
Colour Receiver APC Loops <i>by S. George</i>	348
TV Test Report <i>by E. M. Bristol</i>	350
Direct-Reading Analogue/Digital Frequency Meter—Part 2 <i>by Martin L. Michaelis, M.A.</i>	351
The FAM Colour System <i>by Paul Silverhay</i>	357
Adding Automatic Frequency Control <i>by T. Snowball</i>	360
Service Notebook <i>by G. R. Wilding</i>	364
Colour Receiver Circuits—Colour-Difference Preamplifiers <i>by Gordon J. King</i>	366
Servicing Television Receivers—Philips Style 70 series cont. <i>by L. Lawry-Johns</i>	369
Dynamic TV Pictures	371
DX-TV	372
Points from the Post	373
Your Problems Solved	374
Test Case 102	378

THE NEXT ISSUE DATED JULY  
WILL BE PUBLISHED JUNE 22

We deeply regret having to record the death of our DX correspondent Charles Norman Rafarel. An Appreciation by Roger Bunney appears on page 372.

# TELETOPICS



## GOING DIGITAL

Nearly two and a half years ago in our January 1969 issue we reported on the BBC's work on the use of digital techniques for TV sound signal distribution—the sound-on-sync system. In this system the original sound signal is converted into a digital one and the pulses representing the digital signal are inserted into the line sync pulse period of the television waveform. This period of course does not otherwise carry any modulation. In this way the need for a separate sound distribution network is avoided while appreciable improvement in the quality of the sound signal is achieved. The signal is converted to digital form at the transmitting end of the distribution network and converted back to a sound signal at the reception end.

The BBC is now working on the extension of the use of digital techniques to video waveforms and demonstrated recently the use of these techniques in an experimental 625-405 line standards converter (a similar converter has been developed by the ITA's Experimental and Development Department). All programme material is now originated in 625-line form and converted down to 405 lines for the v.h.f. system. It is likely that the 405-line system will continue in use long beyond the useful life of the present generation of standards converters and for this reason the BBC's Research and Designs Departments are carrying out a programme of work aimed at providing a replacement converter with good performance and reliability at reasonable cost. Since the present converters were designed considerable progress has been made in the application of digital

techniques to TV signals and it has therefore been decided that the new form of converter will process the signal after it has been converted to digital form.

The basic technique used in these digital systems is to sample the original video or sound signal at regular and extremely rapid intervals—for example in the sound-on-sync system the sound signal is sampled twice each line, or at a rate of 31,250 times per second in the 625-line system—and to convert these samples into digital form. The digital form used is the binary system in which there are only two signal conditions, 0 and 1. 0 is represented by the absence of a pulse and 1 by its presence. Thus a ten-digit signal—as used in the sound-on-sync system—would take the form of a group of pulses indicating for example 0101100110, i.e. a group of 0s and 1s totalling ten, the different possible combinations of 0s and 1s representing different levels of signal amplitude. Now since every sample of the original signal is separately described by a sequence of pulses it follows that the digital signal varies much more rapidly than the original signal. As on the other hand there are only two possible signal levels in the digital signal while the original signal can vary gradually through a given range of levels depending on its amplitude, the digital signal is much more resistant to interference and to variations in the characteristics of the transmission network than the original signal. Moreover a digital signal can be reconstituted substantially without error after being subject to moderate amounts of interference and distortion. The price of this advantage is the increased bandwidth necessary to convey the more

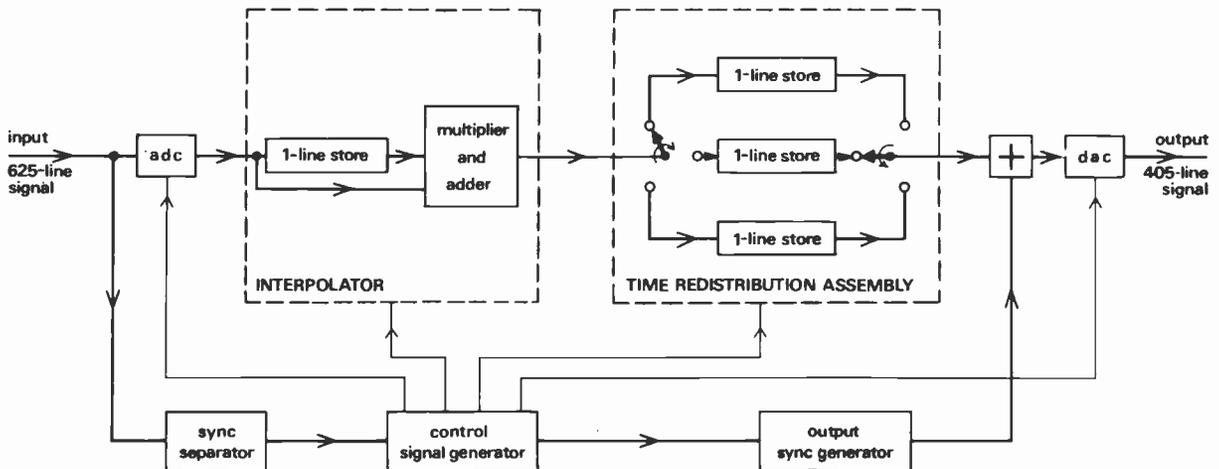

Fig. 1: Block diagram of the BBC's experimental digital line-store standards converter. Box adc is the analogue-to-digital converter and dac the digital-to-analogue converter.



rapid variations of the digital signal.

The BBC's experimental digital line-store standards converter is shown in block schematic form in Fig. 1. It will be seen that the incoming signal is first fed to an analogue-to-digital converter which converts the conventional "analogue" input into digital form while at the output it is converted back again to a conventional signal by the digital-to-analogue converter (the term analogue is used because conventional electronic signals are analogues of the actual light level or sound pressure waveform). Thus the conversion processes undertaken in the converter are carried out with the signal in digital form.

There are two main processes involved in 625-405 line conversion, interpolation and time redistribution. The 625-line input is first modified by the interpolator which derives 405 completely new lines of video information from the incoming 625-line information. This is done in such a way that each of the 405 new lines derived carries information corresponding to the scanning of the scene by a 405-line raster pattern: the process consists of combining the signals from two (in the experimental converter) or more successive input lines in accordance with the relative positions of corresponding lines in 625- and 405-line raster patterns, assuming the rasters to be superimposed. The 405 lines thus derived are however still of the same time duration as the original 625 lines so that there are gaps in the waveform which in consequence must be stretched. This is where the time redistribution process comes in, the 405 lines provided by the interpolator being individually adjusted in duration in this part of the converter so as to occupy the correct time intervals set by the 405-line scanning standard. This time redistributing process is effected by an arrangement of electrical stores. These use computer memory techniques and in the experimental converter the stores consist of assemblies of m.o.s. shift registers.

The experimental digital line-store converter samples the incoming 625-line signal at the rate of 11 million samples per second (11MHz). The amplitude of each sample is converted into an eight-digit binary number by the analogue-to-digital converter: this gives 256 different possible levels, i.e. with an eight-digit code each sample may be represented by one of 256 different binary digital numbers. (The ITA's converter samples the input at three times the colour subcarrier frequency, i.e. 13.3MHz.)

The process of interpolation is carried out using a digital store with a capacity corresponding to the information contained in one input line and a high-speed multiplier and adder which accepts two eight-digit numbers (one direct and one from the store), multiplies each by a suitable three-digit number and adds the resulting products (this binary arithmetic can reasonably be regarded as fast as the eight-digit numbers occur at the rate of 11 million per second!).

The time-redistribution process is carried out using an assembly of stores each of which again have a capacity corresponding to one input line. Each wanted line from the interpolator is loaded into one of the redistributing stores at a rate corresponding to 625-line scanning. Shortly after a store has been loaded it is emptied, but this time at a rate corresponding to the 405-line scanning standard. With a suitable number of stores and a suitable switching arrangement the stores are loaded and emptied in sequence so that all the wanted lines are

suitably processed in the correct order.

Ancillary circuits provide sync pulses for the 405-line standard, again in digital form. These are added to the digital signals from the time-redistributing stores and the combined digit stream is then converted back to a conventional analogue TV signal.

The BBC says that a considerable amount of work remains to be done before the design of an operational digital line-store standards converter is finalised, but the demonstration we saw was most impressive and an insight into the lines along which TV technology is now developing. Sometime in the future we may see the video signal converted to digital form in the camera before gamma correction and colour signal processing take place and remain in this form right up to the transmitter. The advantage would lie in maintaining the quality of the signal throughout the broadcast network. The effects of interference and circuit drifts would be largely eliminated and equipment line-up and adjustment rendered almost entirely unnecessary.

Another area in which significant advantages are likely to result from digital working is in TV recording. Digital TV recordings would be similar in form to the data recordings now used in computers but would need to have considerably higher transfer rates and storage densities.

Our hats off to the BBC for demonstrating that the technologies of digital storage and calculation are now capable of dealing with broadcast-quality TV signals.

## SET NEWS

Chairman of the British Radio Cabinet Manufacturers' Association John Bowes has warned UK radio and TV setmakers not to be complacent in the face of growing imports. He reported that of a total of 150,000 monochrome receivers imported in 1970, 100,000 came from the Far East while in addition 35,000 colour sets were imported from the Continent. Mr Bowes points as a warning to the US market where one colour set in every three is Japanese. These figures are indeed alarming and must wake up UK TV setmakers if their market is not to go the way of the transistor portable radio market.

**Hitachi** are launching their PAL colour models at their May trade show after which there is to be full-scale distribution. Sample sets to familiarise engineers have been about for a while and one was on show briefly at the Ideal Home Exhibition in March. There are 15, 17 and 19in. models.

Italian **Indesit** monochrome receivers may be introduced on the UK market following a test run earlier this year when 1,000 sets were brought in. The model is a single-standard 24in. one intended to sell at £83.43.

Three new sets have been announced by UK setmakers. From BRC comes the **Ferguson** 12in. single-standard portable Model 3805, called the Courier, at £58.60. This mains-only model is housed in a plastics case, features push-button tuning and has an adjustable loop aerial connected by flying leads. It is fitted with a new BRC chassis, the 1580 hybrid chassis, and weighs 16½lb. From **Dynatron** come two 26in. colour models. The CTV7 Marlborough is a console model with period styling at £410 and the CTV8 Narvic a consolette at £359 with teak finish and £363 with walnut finish.

# BASIC CIRCUITS FOR THE CONSTRUCTOR



THIS is the first in a series of articles describing the construction of the basic circuit blocks which comprise a monochrome television receiver. The circuits are original and unless otherwise stated designed from first principles. With a little ingenuity the more advanced constructor should be able to put together a television set of very high quality tailored to suit his own individual requirements. Fig. 1 shows in block schematic form the entire circuitry. The series should also be of interest to the beginner as a fair amount of general information will be given.

The circuit this month is a transistorised vision i.f. amplifier (Fig. 2) suitable for the British 405-line standard. In some ways transistors are not very well suited to this application; they have low gain compared to valves and a very high internal feedback capacitance (150 millipF for a BF167 transistor compared to 5.5 millipF for an EF184 valve). They are, on the other hand, less noisy, dissipate far less heat and have an indefinitely long life. With careful design their disadvantages can be made relatively unimportant.

Before going any further a summary of the 405-line system might be useful to anyone whose theory needs brushing up. A British 405-line transmitter radiates at v.h.f. a single-sideband vision carrier and a sound carrier of much narrower bandwidth at a frequency 3.5MHz lower than the vision carrier. The tuner unit in a receiver amplifies the aerial signal and converts the frequencies to standard i.f.s of 34.65MHz vision and 38.15MHz sound. The basic frequency response requirements of a vision i.f. amplifier for this system are that it should have a 6dB bandwidth of 3.0MHz and that it should be capable of com-

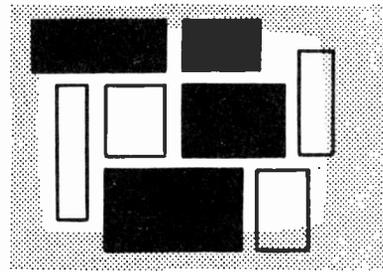

J.W. THOMPSON

pletely "notching out" the sound carrier to prevent sound bars appearing on the picture. In addition notch rejection of the adjacent lower channel sound (33.15MHz) and adjacent upper channel vision (39.65MHz) may be required. Ample provision for this is made in the circuit.

## Circuit Description

As can be seen in Fig. 2 three common-emitter i.f. amplifier transistors are used. The i.f. output from the v.h.f. tuner is coupled via C11 to the input filtering circuitry: L11 provides rejection at 33.15MHz, L12 passes the 38.15MHz sound signal to the sound i.f. amplifier, L13 provides very efficient notch rejection of the sound carrier while L14 may, if necessary, be tuned to 39.65MHz to reject adjacent upper channel vision.

Tr11 has variable gain and couples the vision i.f. signal to the following stage by a conventional double-tuned transformer. Correct impedance match-

Note: All relays shown in '625' position

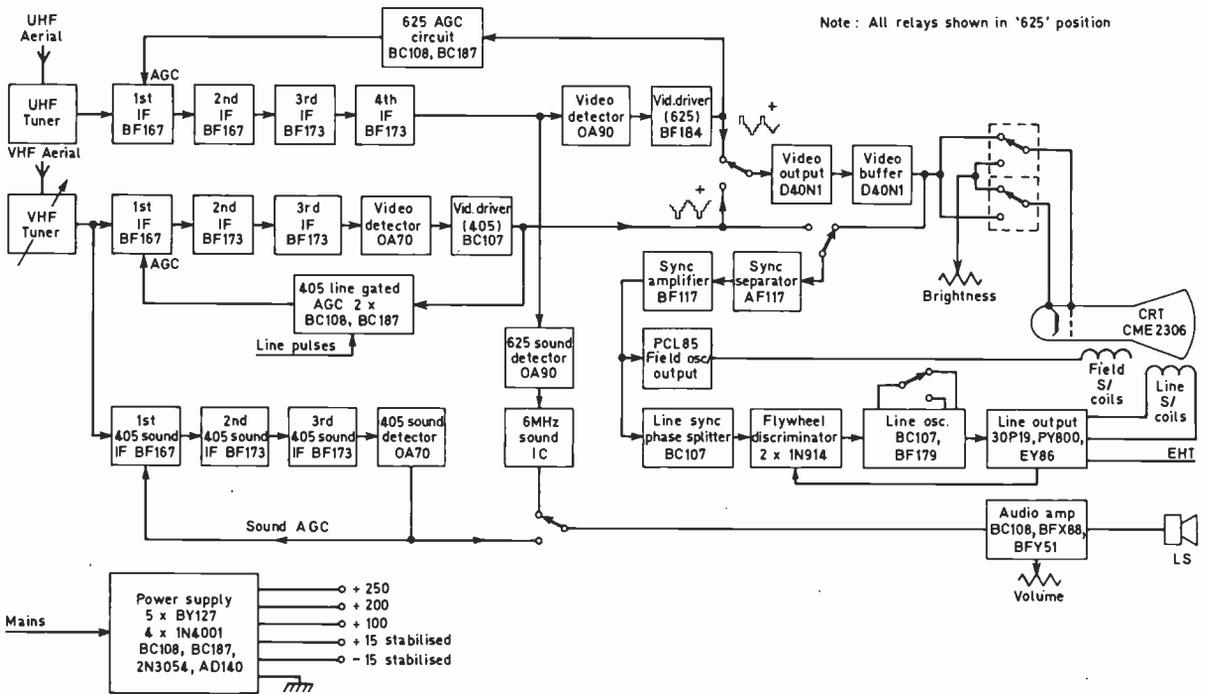

Fig. 1: Simplified block diagram of the complete project.

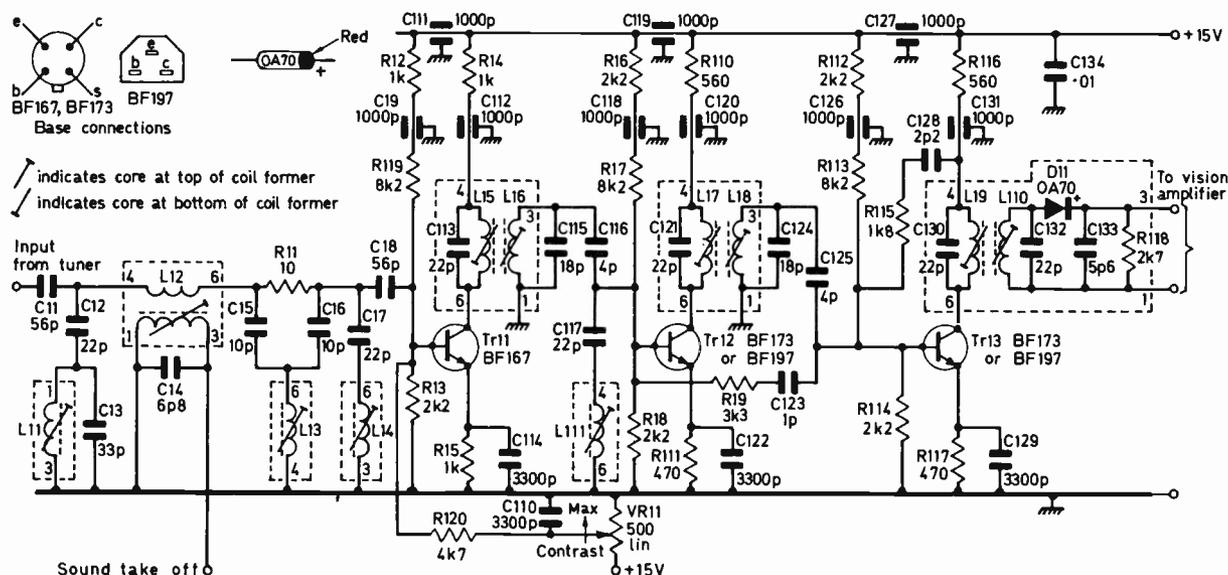

Fig. 2: Circuit diagram of the 405-line standard vision i.f. amplifier.

ing into Tr12 is achieved by the combination of C116 and the input capacitance Cbe (about 45pF) of Tr12. Additional sound rejection is provided by L111. Tr12 is effectively unilateralised (i.e. the capacitive and resistive components of internal feedback balanced out) by the series combination of R19 and C123, ensuring complete stability. Tr13 is the i.f. output transistor and is also unilateralised but by a slightly different method (R115, C128). The final double-tuned transformer (L19, L110) couples the signal to the detector D11. A detected vision signal of at least 3V peak-to-peak is present between pins 1 and 3 of the final i.f. transformer.

A brief word concerning the numbering of components: the first digit signifies the number of the circuit in which the component appears. R118 for example is in circuit 1 while R318 is in circuit 3. This will simplify cross-references between subsequent circuits in the series.

### Construction

The overall size of the metal chassis used will depend on the number of circuits to be built on it and the reader would be well advised to wait until the end of the series before making this decision.

## ★ components list

### Resistors:

R11	10Ω	R14	1kΩ	R17	8.2kΩ	R110	560Ω	R113	8.2kΩ	R116	560Ω	R119	8.2kΩ
R12	1kΩ	R15	1kΩ	R18	2.2kΩ	R111	470Ω	R114	2.2kΩ	R117	470Ω	R120	4.7kΩ
R13	2.2kΩ	R16	2.2kΩ	R19	3.3kΩ	R112	2.2kΩ	R115	1.8kΩ	R118	2.7kΩ	VR11	500Ω lin.

### Capacitors:

C11	56pF 5% SM	C111	1,000pF F	C121	22pF 5% SM*	C131	1,000pF F
C12	22pF 5% SM	C112	1,000pF F	C122	3,300pF 160V 10% P	C132	22pF 5% SM*
C13	33pF 5% SM	C113	22pF 5% SM*	C123	1pF 5% SM	C133	5.6pF 5% SM*
C14	6.8pF 5% SM	C114	3,300pF 160V 10% P	C124	18pF 5% SM	C134	0.01μF 160V 10% P
C15	10pF 5% SM	C115	18pF 5% SM	C125	4pF (3.9pF) C	C ceramic; F feedthrough;	
C16	10pF 5% SM	C116	4pF (3.9pF) C	C126	1,000pF F	P, polyester; SM, silver-mica;	
C17	22pF 5% SM	C117	22pF 5% SM	C127	1,000pF F	* Side-mounting printed-	
C18	56pF 5% SM	C118	1,000pF F	C128	2.2pF 5% SM	circuit type.	
C19	1,000pF F	C119	1,000pF F	C129	3,300pF 160V 10% P		
C110	3,300pF P	C120	1,000pF F	C130	22pF 5% SM*		

### Semiconductors:

Tr11	BF167	Tr12	BF173 or BF197	Tr13	BF173 or BF197	D11	OA70
------	-------	------	----------------	------	----------------	-----	------

### Miscellaneous:

9 Aladdin coil formers,  $1\frac{7}{8} \times \frac{1}{4}$  in. (CR14)  
 8 screening cans (CR15)  
 11 Hexagonal dust cores, 6 × 12.7 mm. (Z81A)  
 Tube non-hardening core locking compound (ZA39A)

Nylon leadthrough tag (Z149)  
 Trimming tool (TL33A)  
 Numbers in brackets are Home Radio catalogue numbers.

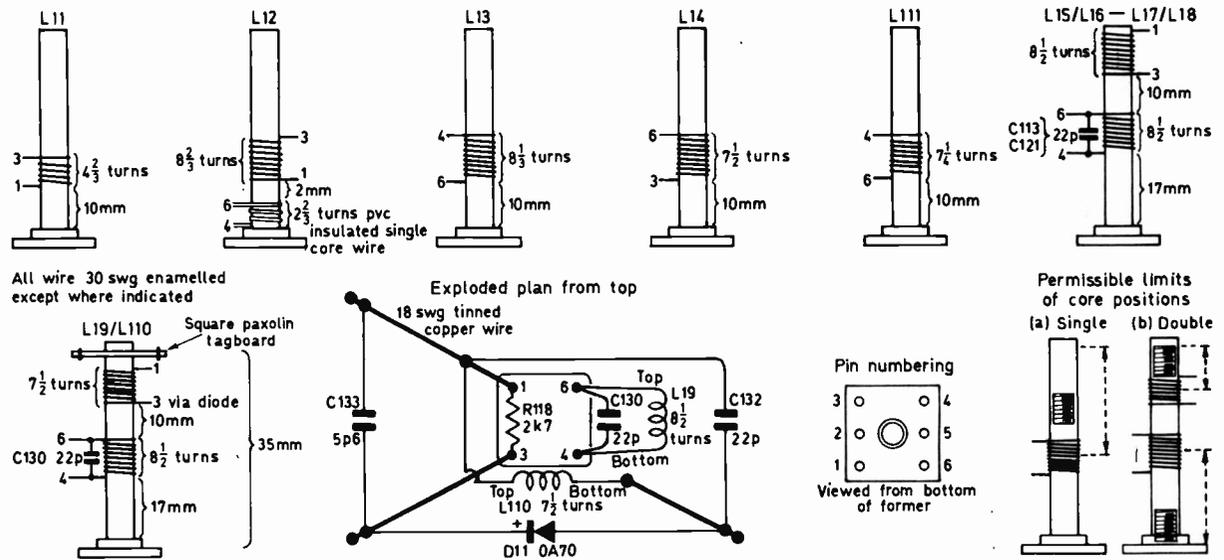

Fig. 3: Coil winding details. Coils wound clockwise looking from top of former.

The metal must be easy to solder: brass or mild steel would be suitable, of gauge 16 or 18 s.w.g. A layout plan for circuit 1 is shown in Fig. 4 and this must be followed closely for optimum stability. Two soldering irons will be required, one of about 15W power and the other about 50W for heavy soldering to the chassis.

### Winding the Coils

The most difficult part of all is winding the coils. The windings must be evenly wound and secured to the former with wax or polystyrene cement. Wind the coil, spread liberally with the selected fixing compound and hold patiently until the latter has set. Strip the enamel from the ends of the wire and solder into the pins at the base of the former as detailed in Fig. 3. Any additional tuning capacitance (e.g. C113) must be soldered with short leads across the relevant pins. The dotted lines surrounding each coil in the circuit diagram indicate exactly which components (if any) should be mounted inside the coil screening can.

The i.f. output transformer (L19, L110) is a special case and requires explanation. Many readers will have stripped down old television i.f. amplifiers and will probably recall seeing i.f. transformers with a square paxolin tagboard fitted towards the top of the coil former, often with four heavy gauge wires leading down to the base. The principle here is the same except that there are only three heavy gauge wires. These go from pin 1 to the tagboard, from pin 3 to the tagboard and from the tagboard to half way down the coil former immediately above pin 4. Obtain a suitable square tagboard from an old i.f. amplifier or make one if necessary, and wire up as shown approximately in Fig. 3. *Do not damage the diode by overheating when soldering.* There should be plenty of room for all the components. As a final precaution against short-circuits to the can, wrap the entire coil assembly in waxed paper.

The coil dust cores have a hexagonal centre hole and will require a special trimming tool. To minimise tuning drift they should all be coated in core locking compound which is obtainable from Home Radio Ltd.

Returning to the chassis,  $\frac{7}{32}$ in. holes should be drilled for pins 1, 3, 4 and 6 of the coils and two  $\frac{1}{4}$ in. holes for the 6BA coil mounting bolts. The core trimming hole corresponding to the centre of each coil former is optional as both cores, being hexagonal, can be adjusted from the top of the coil.

### Feedthrough Capacitors

Considerable use was made in the prototype of ceramic leadthrough capacitors (e.g. C19) and nylon leadthrough tags. One of the latter is shown in Fig. 4 at the tuner input point. Any leadthrough tag may be used (nylon, p.t.f.e. or ceramic) but it must not possess a self-capacitance to chassis greater than 5pF. The transistors may be put in after all major soldered connections to the chassis have been made and provided reasonable care is taken it is unlikely that they will be damaged by heat. Further information on fitting feedthrough capacitors was given on page 16 of the October, 1970, issue.

### Testing and Alignment

When the wiring has been completed it is advisable before connecting a power supply to measure the resistance between the +15 volt line and the chassis. If there is a dead short check the leadthrough capacitors very carefully. Otherwise it is reasonably safe to connect a power supply which, for test purposes, may be a 9V and a 6V battery in series. Measure the voltages from each transistor emitter to chassis: any voltage between 1.5 and 3.0V is satisfactory. Each transistor base voltage should be about 0.6V more positive than the emitter voltage and if it is very different from this the offending transistor should be replaced.

If these measurements are satisfactory disconnect the power supply and temporarily solder pin 1 of the i.f. output transformer to chassis. Connect a voltmeter on its 0.5V range (or a 10,000 $\Omega$ /voltmeter on the 0.1mA range) between pin 3 of the i.f. output transformer and chassis. In addition to the meter a 3,300pF capacitor should be temporarily connected between pins 1 and 3: do not forget to remove this

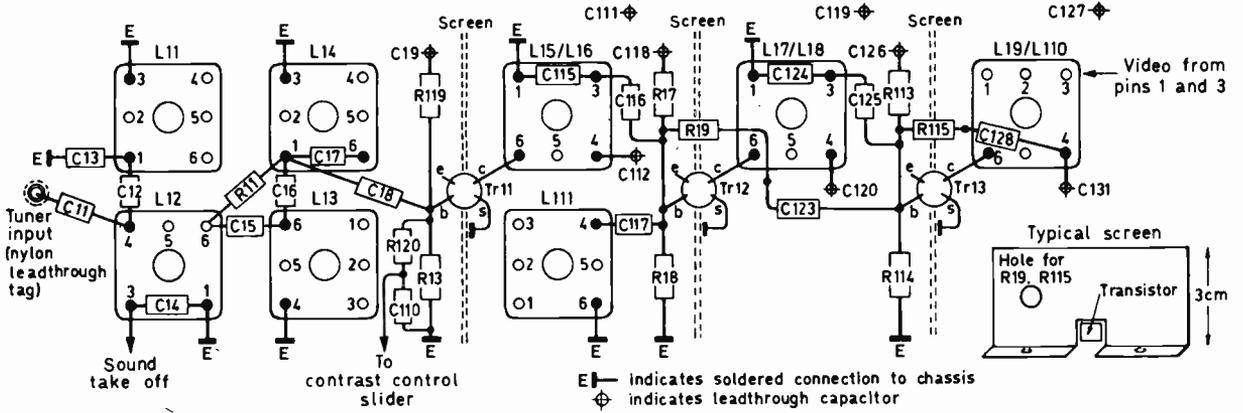

Fig. 4: Recommended layout (underside). The emitter resistors and capacitors have been omitted for clarity. R12, R14, R16, R10, R112 and R116 are mounted on the topside. Connect C111, C119 and C127 together to form the positive i.t. rail and connect C134 from this to chassis.

capacitor when the alignment is complete.

The contrast control should initially be set for maximum gain then during the final stages readjusted so that the overall i.f. gain is reduced by a factor of 10 (i.e. -20dB).

On reconnecting the power supply the meter should not move appreciably: if the needle hits the end-stop violently the amplifier is unstable. In this event detune some of the transformer cores slightly until the meter returns to zero. If this fails it is likely that the wiring is defective in some way. This should not occur and indeed it was impossible to make the prototype amplifier oscillate with any combination of coil settings.

If all has gone well so far it is time to set up the signal generator which need not be particularly elaborate: a Nombrex Model 31 will be more than adequate. Set the cores of all single-tuned coils to the top of each coil can and the upper and lower cores of double-tuned coils to top and bottom of each coil can respectively. Inject a strong 36.0MHz signal at the base of Tr13 and peak L19 and L110 for maximum meter indication. Reduce the signal generator output level as necessary to prevent the meter from going off the scale. Move the generator to the base of Tr12 and peak L17 and L18. Finally inject the signal at the tuner input point and peak L15 and L16 as nearly as possible.

Disconnect the generator and make up a loosely coupled input coil on a standard Aladdin former as

follows: secondary 2 turns of single-core p.v.c. insulated wire connected with short leads between the tuner input point and chassis; primary 4 turns of the same wire connected to the signal generator via a short coaxial lead and free to slide along the coil former towards the secondary winding. Switch on the signal generator again and move the sliding winding along the former until the meter shows at least 1/4 full-scale deflection. Make sure that all the i.f. transformers are correctly peaked at 36MHz and then slightly detune some of the cores to spread the response. Check that the response has been spread by altering the signal generator frequency.

The tuning should now be spread until the meter shows at least some indication between 33 and 40MHz but there is no need yet to aim for a flat response. Tune L11 for minimum output at 33.15MHz and L13 for minimum at 38.15MHz. Slight adjustment of the number of turns on these coils may be necessary in order to obtain the correct rejection point. In areas of very strong signal it will be necessary to tune L111 for minimum output at 38.15MHz and in areas where an appreciable signal exists on the adjacent upper channel L14 should be tuned for minimum output at 39.65MHz. Under normal reception conditions leave the cores of these two coils at the tops of their cans or remove them completely.

The cores of the double-tuned i.f. transformers should now be tuned to obtain the response shown in Fig. 5. The points marked -6dB at 34.65 and 37.65MHz are those at which the output voltage should be exactly half its value along the flat top of the response curve. Try not to be discouraged if this procedure takes several hours. With a wobulator and oscilloscope it would take a matter of a few minutes but it is assumed that these instruments will not be available in the average reader's workshop. The top of the response curve should be as flat as possible or ringing may occur on the picture at certain vision frequencies. When a v.h.f. tuner is ultimately connected to the i.f. amplifier the mixer output coil on the tuner should be adjusted for best picture definition on a test card consistent with good sound.

Circuit 2 next month will deal with a British 625-line i.f. amplifier.

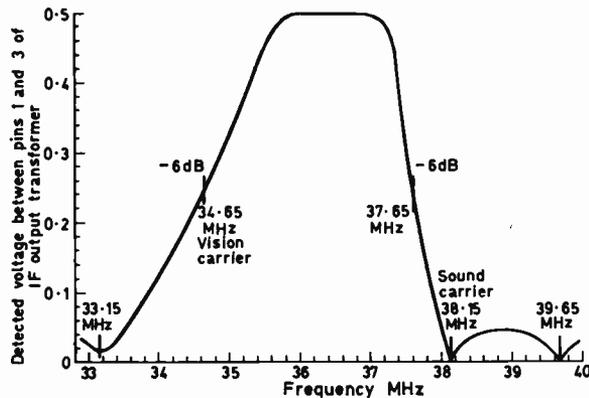

Fig. 5: Response curve, 405-line vision i.f. strip.

TO BE CONTINUED



# Colour Receiver APC LOOPS

S. GEORGE

THE detected vision or luminance signal is either positive- or negative-going depending on which way round the detector diode is connected. At the c.r.t. cathode the signal is negative-going, driving the tube from cut-off—black level—towards peak white. With the chroma signal the position is different. The colour-difference signals produced by demodulating the chroma signal are required to supplement the luminance signal, increasing or decreasing as required by the picture being transmitted the red, green and blue beams of the shadowmask tube. Thus the chroma detectors have to produce outputs varying not only in amplitude but in polarity as well. Clearly simple diode envelope detectors will not suffice: the detectors used must be able to give either a negative- or positive-going output and for this reason synchronous detectors are used.

### **Synchronising the Reference Signal**

Synchronous detectors require not only a signal input but a reference subcarrier input as well and for this reason a local reference oscillator or subcarrier regenerator (suppressed subcarrier transmission being used for the chroma signal) is required in a colour receiver decoder. To obtain correct colour signals the local reference oscillator must be synchronised to the transmitter subcarrier oscillator. This is a vital feature in a colour receiver and for this reason the reference oscillator is incorporated in an a.p.c. (automatic phase control) loop under the control of the transmitted colour sync signal—the 10 cycles burst of subcarrier transmitted during the back porch of the line sync pulse. One chassis—the Rank-Bush-Murphy single-standard one—uses a somewhat different approach, making use of the burst signal as the local reference signal by feeding it to a high- $Q$  narrow-band crystal filter circuit which rings at the subcarrier frequency throughout each line. However, to return to the more usual arrangement.

The reference signal fed to the synchronous detectors must be identical in phase and frequency with the suppressed subcarrier and while the crystal oscillators used stay right on frequency nevertheless even the slightest tendency towards phase shift must be prevented. In this article we shall examine a typical complete a.p.c. loop of the type widely used to attain this essential phase control, taking as our example the circuit used in the Pye single-standard chassis (the 691 chassis).

Before proceeding further however it may be as well to clear up two important points that are apt to be overlooked about the colour bursts. First, to ensure correct R-Y switching in a PAL receiver the colour burst alternates  $45^\circ$  each side of the -B-Y phase

position on successive lines, raising the question how does the reference oscillator lock to this line-by-line switched signal. The answer is that the a.p.c. loop locks to the average phase of this alternating signal, i.e. to -B-Y, ignoring the rapidly alternating  $\pm R-Y$  component of the burst signal. Secondly the phase of the oscillator is actually in quadrature with the colour burst, its lag or lead depending on the immediate circuitry (whichever it is can of course be reversed simply by transposing coil or transformer connections). This is because the reference oscillator is arranged to be in phase with the R-Y signal. The reference signal then passes through a  $90^\circ$  phase shifter before being fed to the B-Y synchronous detector (it will be recalled that the R-Y and B-Y components of the chroma signal are  $90^\circ$  out of phase with each other).

### **Burst Channel**

To return however to the Pye a.p.c. circuit shown in Fig. 1. The first stage shown, Tr1, is not part of the a.p.c. loop itself but is included so as to take in the burst channel which feeds the a.p.c. discriminator circuit. Tr1 is a conventional common-emitter amplifier stage which is fed with the chroma signal from the collector circuit of the first chroma amplifier. R1, R2 provide forward bias and the chroma signal, centred at 4.43MHz, appears amplified across L1 in its collector circuit. To minimise the input capacitance of the stage the emitter circuit is only partially decoupled.

Tr2, the burst gate, can be regarded as the first stage in the a.p.c. loop. There is no fixed forward bias to this stage which is switched on only momentarily during the colour burst period by positive-going pulses from transformer T1. These pulses are actually overswings instigated by the negative-going line sync pulses fed from the sync separator to this transformer. Whilst the sync pulses themselves represent an almost ideal, regularly occurring gating pulse they end of course just before the actual colour burst. Hence the use of the ringing transformer T1 which produces positive-going overswings—the correct polarity to bias Tr2 on—of sufficient duration to comfortably span the 2.5 $\mu$ sec burst period. In this way only pure burst signal is developed across T2 for feeding to the a.p.c. loop discriminator diodes D1 and D2 and the a.c.c. rectifier D3.

### **Automatic Chrominance Control**

To digress slightly, the a.c.c. rectifier provides a negative-going output to yield an automatic chroma control reverse bias potential related to the strength of



# TV TEST REPORT

E. M. BRISTOL

## ANTEX DESOLDERING IRONS

THERE are seven desoldering instruments manufactured by Antex Ltd.: four 25W (ESS) types for 24, 115, 220 and 240V respectively and three 18W (GSS) types for 115, 220 and 240V. The GSS types are miniature models for very small work such as hearing aids and subminiature assemblies while the ESS types are for normal workshop use. The subject of this report is the ESS 240V model.

The instrument is similar in appearance to the normal Antex soldering irons but with additional equipment for performing the desoldering operation. A nylon air tube is supported along the length of the handle by a bracket at the front and a rubber grommet at the rear with a control-valve assembly at the front. This valve consists of a finger push-button mounted so that it can be operated by the forefinger. The bracket also supports the solder trough and acts as a stand for the iron. At the front the air way curves downward through the hollow bit and then out the opposite side to a hole in the lid of the solder trough. The nylon air tube is about 6ft. long—as is the three-core mains cable—and is supplied complete with a set of adaptors to enable the tube to be connected to a workshop air line. If this is not available—and few workshops are so equipped—a footpump can be supplied to provide the air pressure.

Unlike most desoldering instruments this one operates by pressure rather than suction, the force of the air pressure across the end of the hollow bit producing suction by the venturi principle. This obviates the possibility of foreign matter being sucked into the airways and valve and thus eliminates

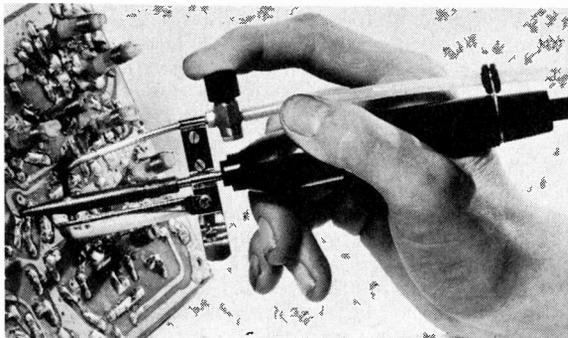

The Antex ESS desoldering iron in use.

the need for the elaborate filtering arrangements used to prevent this on suction instruments.

The bit gently tapers to a 4mm. diameter circular flat section in the centre of which is a 2mm. diameter air vent. The choice of size for the air vent is not an easy one for manufacturers of desoldering irons: if it is too large the suction is reduced and effective removal of solder inhibited while if it is too small it will not fit over terminal posts and tags in the printed circuit. The dimensions chosen by Antex for their iron seem just about right for the majority of printed circuit work.

The solder trough needs occasional emptying. This can be done quite easily as both the trough and its cover are hinged by a single screw on the main assembly support. It needs only slight pressure to swing them both downwards so that the cover can be pulled up and the solder emptied. To prevent solder adhering to the stainless steel trough the makers recommend smearing a little oil or grease over the inside.

### Use

The instrument sits very well in the hand and because of its lightness causes no fatigue during long periods of use. The best position to use it (see photo) is with the air line passing over the top of the handle, the instrument being held between the thumb and the side of the second finger with the first finger on the control valve. The printed board can be in almost any position but the easiest working position is vertical or nearly so. The lightness of the tool is almost a disadvantage as when the iron is stood on the workbench there is a tendency for the weight of the air line and mains cable to pull it off. The most stable parking position is right at the edge of the bench where the instrument can make good three-point contact by standing on the two legs of the supporting bracket and the rear of the handle, the air line and mains cable hanging directly over the edge.

When used with a workshop air line the iron is effective and simple to use. When used with the footpump however it is not quite so easy—as in fact is the case with all irons that use a pump. The pump must be positioned in just the right place, preferably secured to the floor in some way. When using the iron one's eyes and attention are obviously on the work and one's foot has to search for and operate the pump by feel. It is easy to push the pump over on its side if it is not secure, especially as quite a vigorous push is needed to build up enough pressure to create the necessary suction in the bit.

Various combinations of control valve and footpump operation were tried. Best results were obtained by operating the footpump with the valve still in the closed position to enable pressure to be built up in the tube and airways. Suddenly opening the valve while continuing the footstroke then gives a violent rush of air and good suction at the bit. Workshops that do a fair amount of desoldering but are not equipped with an air line might find a compressed air bottle that can be recharged at the local garage a good alternative to the pump.

One noteworthy feature of the iron is its quick warming-up time. It will melt solder in a minute and a half and within two minutes is ready for desoldering. The price of all the models is £4.67 or £5.65 complete with pump.

**NEXT: PICARD DESOLDERING PUMP**



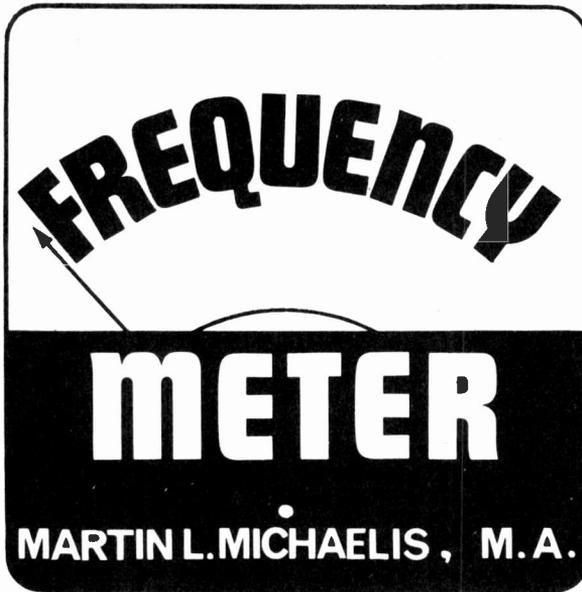

# FREQUENCY METER

MARTIN L. MICHAELIS, M.A.

## PART 2

THE input stage Tr1 of the amplifier section is a voltage amplifier with a number of safety features. The gain control VR1 gives adequate response for frequencies up to well above the design limit of 100kHz. R1 limits the charge surge current into C1 for input voltages grossly in excess of the set trigger level or for large d.c. components accompanying small a.c. components of an input signal. Any voltage up to at least 100V sum of d.c. and peak a.c. components may be connected to P1 with any settings of the controls without damage. D1 and D2 prevent excessive voltages reaching Tr1 while R5 prevents instability.

Tr2 phase splitter stage is d.c.-coupled to Tr1 collector and provides antiphase amplified replicas of the input waveform across its equal collector and emitter resistors. The oscilloscope signal output is taken from the emitter via preset potential divider VR3 to the inverting input of the operational amplifier IC1. As we have two phase-inverting stages between P1 and P3 the oscilloscope signal has the same polarity as the input signal. IC1 is an MC1709CG used in a circuit operating in the same manner as described in the i.c. preamplifier article (November, 1970, and January, 1971). Its gain is determined by the ratio of R46 to R44. VR3 is adjusted during setting up so that the gain from P1 to P3 is exactly 20. This figure provides the same deflection sensitivity of the Videoscope MV3 oscilloscope when P3 is connected directly to its Y input and the signal probe to P1 as when the signal probe is connected directly to the Y input of this oscilloscope. This is true for any other oscilloscope with a standard  $1M\Omega$ , 40pF Y input and standard  $10M\Omega$ , 4pF signal probe. For signals fed directly to P1 the path P1 to P3 behaves as a straightforward preamplifier with a gain of 20.

The only new feature of the operational amplifier circuit IC1 compared to the circuits described in the i.c. preamplifier article is the use of R44 and R45 to feed two signals to  $\bar{I}P$ . This is the algebraic adding function of the operational amplifier. Due to the heavy negative feedback from OP to  $\bar{I}P$  the latter point behaves as a virtual earth and any number of

input signals may be connected to it via respective gain-determining series resistors without any mutual interference. Thus the output waveform of this arrangement is the linear algebraic sum of all the input waveforms. This sum consists of the added waveforms weighted by the gain factors determined by the respective series resistors. The second waveform injected via R45 consists of the final output pulses of the amplifier chain. By virtue of the linear algebraic addition these simply sit on the signal waveform without in any way otherwise affecting or distorting the latter. They mark the exact features or time points of the signal waveform at which the pulse univibrator fires.

## Pulsing Circuits

The purpose of the pulsing circuits Tr3 to Tr6 is to produce an accurate squarewave with steep flanks irrespective of the frequency or waveform of the input signal. Tr3 is an emitter-follower which reproduces the waveform taken from VR2 slider with much lower impedance at its emitter so that C15 is rapidly charged to the peak negative amplitude. Consequently the entire peak-to-peak amplitude of the waveform appears with positive polarity across R20. This is the d.c. restorer function of D3 in conjunction with C15. The track of VR2 is connected via blocking capacitors between the collector and emitter of the phase splitter Tr2. This is in effect a bridge circuit which is balanced when VR2 slider is set to mid-track. There is then no signal present at the slider. Opposite polarity signals are obtained on opposite sides of the track centre, with increasing amplitudes as the ends of the track are approached.

Tr4 to Tr6 form a Schmitt trigger circuit which must always take up one of two stable states. In the resting state with no input signal Tr4 and Tr5 are cut off because there is then no base bias to make them cut on. Tr6 however is conducting to saturation, being turned on hard by R22. The voltage drop across Tr6 is negligible in this state so that the entire supply voltage is dropped across R23 and R24 in series. The portion dropped across R23 plus the two silicon thresholds of about 0.6V each for Tr4 and Tr5 is the minimum positive voltage which must be applied to Tr4 base to make Tr4 and Tr5 cut on. When this threshold voltage is exceeded Tr5 commences to draw current through R22. The voltage at Tr6 emitter and consequently the voltage drop across R23 then suddenly decrease, Tr4 and Tr5 suddenly cutting on even harder. The effect is cumulative so that in fact the circuit trips over extremely rapidly to its other stable state, with Tr4 and Tr5 conducting and Tr6 cut right off. This state persists as long as the signal waveform excursion at Tr4 base remains above the trip threshold. By converse action the circuit trips back to its resting state as soon as the signal waveform at Tr4 base drops below the threshold again.

It is quite immaterial how rapidly or how slowly the signal waveform crosses the threshold or at what frequency. The Schmitt trigger circuit trips over in the same extremely rapid manner in every case. The output at Tr6 emitter is a virtually perfect square-wave: in the resting state with Tr6 cut on its emitter rests at nearly the collector supply voltage level while in the tripped state with Tr6 cut off its emitter is only about 1V above chassis potential.

By virtue of the positive d.c. restorer function of

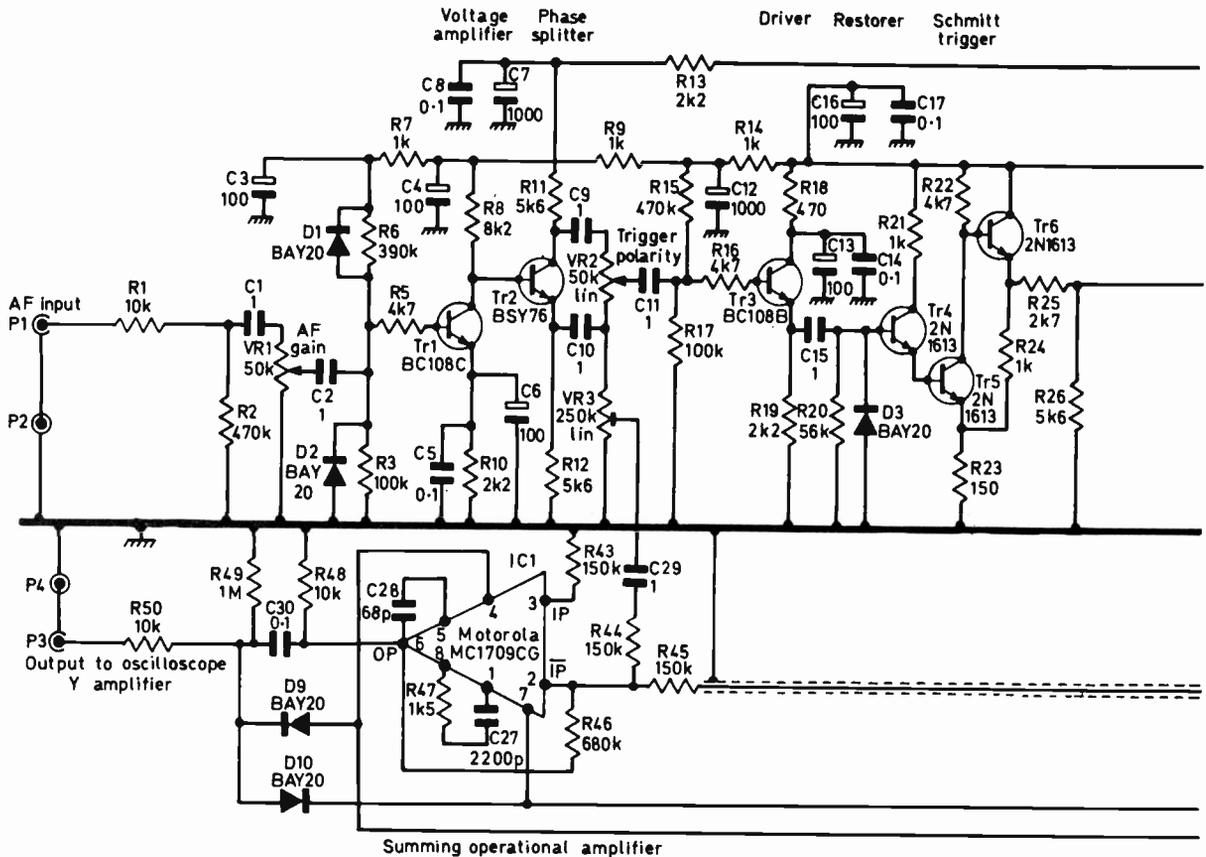

D3 and C15 the tripped state persists for a certain phase angle around the positive peak of the signal waveform at Tr3 emitter, and this may be chosen to be the positive or the negative peak region of the input waveform by moving VR2 to the appropriate side of the track centre position.

Since the bridge is balanced and there is no signal at all with VR2 slider in its centre setting it is necessary to move the slider a certain critical distance to either side in order to obtain a signal amplitude sufficient to fire the Schmitt trigger at all. In the critical setting the Schmitt trigger produces extremely brief square pulses because it only briefly trips coincidentally with the positive or negative peak of the signal waveform. If VR2 is turned farther towards the respective end of the track the Schmitt trigger trips progressively lower down the signal waveform and the square pulses it produces broaden symmetrically about the respective peaks of the input waveform. In this manner it is possible to choose a trigger point anywhere within the positive and negative waveform peak regions, giving accurate conversion to a steady squarewave frequency even with complex waveforms such as video signals with sync pulses in which the video content may be continuously changing. This is a conventional sync separator function but is more versatile in applying to all manner of other waveforms too.

### Q-pulse Generator Circuits

Thus negative-going square pulses are produced at Tr6 emitter. The flanks of these pulses are always very sharp and independent of the signal in-

put waveform but the *duration* of the pulses depends upon the trigger level setting and the input signal frequency. For proper operation of the frequency counters we require pulses of uniform shape and duration, the latter short enough to suit the highest designed for operating frequency. A repetition frequency of 100kHz implies a pulse width of 10 $\mu$ sec with zero gaps. The actual width has been chosen to be about 6 $\mu$ sec.

These pulses are produced by the pulse univibrator Tr8, Tr9 which is triggered via Tr7 from the output of the Schmitt trigger. The positive-going flanks of the square pulse from Tr6 emitter are passed via C18 and the diodes D4 and D6 to Tr7 base and thus appear at low impedance across VR5 to trigger the pulse univibrator. The negative flanks are blocked by D4, any fraction nevertheless leaking past D4 by stray capacitance being shorted out by D5. The potential tapped from VR4 is used to cancel the silicon thresholds of the diode network while VR5 sets the optimum trigger sensitivity of Tr8 and Tr9 for stable operation at all intended frequencies. Note that it is the positive-going flank of the negative-going square pulse at Tr6 emitter which fires the pulse univibrator Tr8, Tr9 so that the counting pulse is produced not when the Schmitt trigger trips but when it drops back to the resting state. This means that the counting pulses which are displayed on the input waveform by the adding action of IC1 always appear after the signal waveform peak, when the waveform drops below the threshold level on its return to the zero line.

Tr8 and Tr9 form another type of threshold trigger

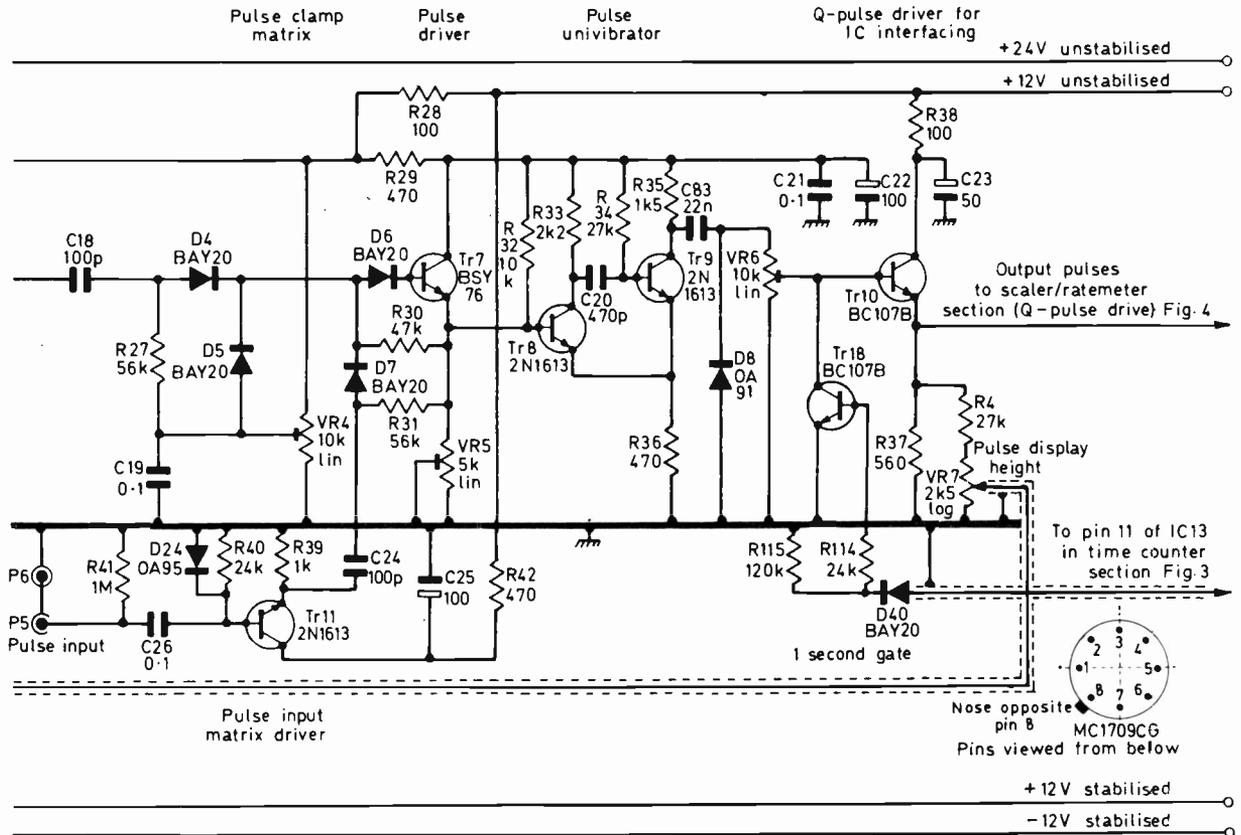

Fig. 2: Circuit diagram of the amplifier section of the frequency meter.

circuit with two stable states. Normally Tr8 is resting cut off because VR5 is adjusted so that the base bias voltage is just insufficient to cut it on. A slight positive rise across VR5 injected from Tr7 suffices to cut Tr8 on. A cumulative action then takes place, cutting off Tr9 and cutting Tr8 hard on by virtue of the multivibrator coupling C20, R34 and the common emitter resistor R36. When C20 has discharged via R34, i.e. after a definite time determined by the values of C20 and R34, the circuit suddenly reverts to the stable state with Tr8 cut off again and Tr9 conducting hard. This time interval has been made about  $6\mu\text{sec}$ . Since Tr9 is cut off for this brief period and is conducting hard at all other times a positive pulse of about  $6\mu\text{sec}$  duration appears at Tr9 collector.

C83 and D8 form another positive d.c. restorer, to make this pulse train entirely positive-going from the zero line irrespective of frequency. Otherwise the base line would gradually sag below the zero line as frequency increased, leading to very erratic triggering of the frequency counter section at higher frequencies.

The correct pulse amplitude for operating the frequency counter section is established by VR6 during setting up. Tr10 is simply an emitter-follower to provide the amplitude-adjusted output pulses at very low source impedance. The full amplitude is fed straight from Tr10 emitter to the frequency counting section and a suitable fraction is applied to the track of the marker amplitude potentiometer VR7. Since the positive pulses here are fed to the

inverting input  $\bar{P}$  of IC1 the marker pulses appear negative at the oscilloscope output P3. Thus the counting trigger points of the signal waveform appear as very narrow downward spikes on the oscillogram. Their amplitude is independently adjustable — to vanishing point if desired — with VR7 on the front panel.

### One-second Gate

Tr18 is normally cut off so that in the continuous counting mode it has no effect. In the intermittent counting mode a symmetrical positive-going square-wave with 2sec. repetition period is fed from the time counter section to the anode of D40. This cuts Tr18 on for alternate seconds. Pulse counting stops during these seconds because Tr18 then short-circuits the amplifier output pulses to chassis at the slider of VR6.

### Pulse Input Stage

Waveforms which are already sharply pulsed may be fed to the pulse input socket P5. D24 and C26 form a positive d.c. restorer so that the waveform becomes entirely positive-going at the base of the emitter-follower Tr11 which effects impedance step-down. By virtue of the d.c. restorer action positive or negative pulsed waveforms cut Tr11 on equally well. C24 and R31 differentiate the pulse waveform, producing a series of alternate positive and negative spikes. Only the positive spikes pass through D7 and

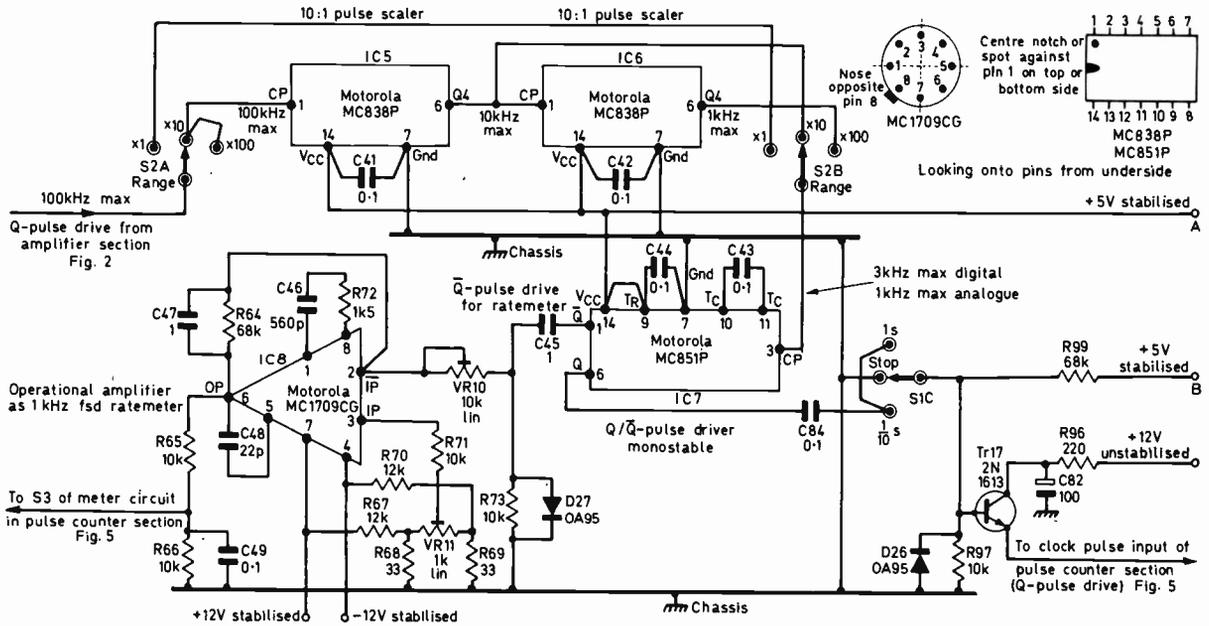

Fig. 4: Circuit diagram of the pulse scaler and ratemeter sections.

any portion of the negative spikes which pass D7 via stray capacitance is again shorted out to chassis via D5 and C19. The positive spikes on the other hand proceed via D6 and Tr7 to trigger the pulse univibrator in the same way as positive spikes arriving from the a.f. amplifier and pulser section via D4.

The trigger threshold at P5 is nominally 5V pulse amplitude. The actual trigger level measured was found to be 3.5V pulse amplitude in the prototype. This is determined by the silicon thresholds of Tr11, D7, D6 and Tr7 in series and the setting of VR5. It is quite sharp, so the pulse input may be used for pulse amplitude discriminator functions. If greater sensitivity is required the i.c. preamplifier described in a previous article may be connected between the signal source and the pulse input P5. The circuitry around Tr11 has been designed to suit the i.c. preamplifier so that correct functioning is obtained in all gain settings of the i.c. preamplifier. The maximum i.c. preamplifier gain setting is 200 making the nominal pulse waveform trigger threshold 25mV (actual trigger threshold less than 20mV) in the most sensitive setting. A sensitive preamplifier has not been incorporated in the present design because in many applications it would lead to hum trouble with erratic triggering. With its self-contained battery circuit the i.c. preamplifier is completely free from such troubles and gives accurate triggering here even with pulse waveforms in the millivolt range.

The rise time of a positive-going flank of the waveform applied to the pulse input P5 must be equal to or shorter than 10 $\mu$ sec for the required threshold amplitude of 3.5V. Waveforms which do not contain a positive-going flank with at least this steepness and amplitude are unacceptable at P5 and produce no response there. These waveforms must be fed to the a.f. input P1.

### Scaler/Ratemeter Section

The range switch S2 (see Fig. 4) feeds the Q-pulses from the amplifier section either straight through to

the clock pulse input CP of the monostable IC7 or to this same point via one or both of the 10:1 pulse scalers IC5 and IC6. Before describing the circuit action we will briefly recapitulate the input-output terminology for these digital i.c.s. CP is the abbreviation used to indicate a clock pulse input and Q is the general symbol for an output. We write Q if the output normally rests in the low state (logical 0, voltage less than +1V) and goes to the high state (logical 1, voltage greater than +3.5V) when a signal is present. For the converse case we write  $\bar{Q}$ . Q and  $\bar{Q}$  are complimentary and many devices provide both. This is the digital circuit equivalent of a push-pull output in an analogue circuit. If several Q and/or  $\bar{Q}$  outputs are present in a device they are numbered in succession. The 10:1 pulse scalers used possess Q1, Q2, Q3 and Q4 outputs. The states of the Qs change each time the input CP drops from the high to the low state. There is no response to a change at CP from the low to the high state. Thus a "count" is produced at the end of a Q-pulse (base line low state, pulse high state) or at the start of a  $\bar{Q}$ -pulse (base line high state, pulse low state). Tr10 in the amplifier section produces Q-pulses so that IC5 or IC7 respond on the flank at the end of each such pulse.

### 10:1 Pulse Scaler

Table 1 shows the truth table for this digital integrated circuit (MC838P). The initial state is assumed to be the one with all Qs in the low state. The successive lines of the truth table show the states of the Qs after the specified numbers of Q-pulses have been fed to the input CP. Only Q4 is actually used on IC5 and IC6. We see in the truth table that Q4 remains low (0) until the eighth Q-pulse has been fed to CP when it goes high (1). It remains high when the ninth Q-pulse arrives but returns to 0 at the end of the tenth Q-pulse. All the other Qs as well are then 0 so that the initial state exists once again after 10 Q-pulses have arrived.

It is the transition from high to low at the end of

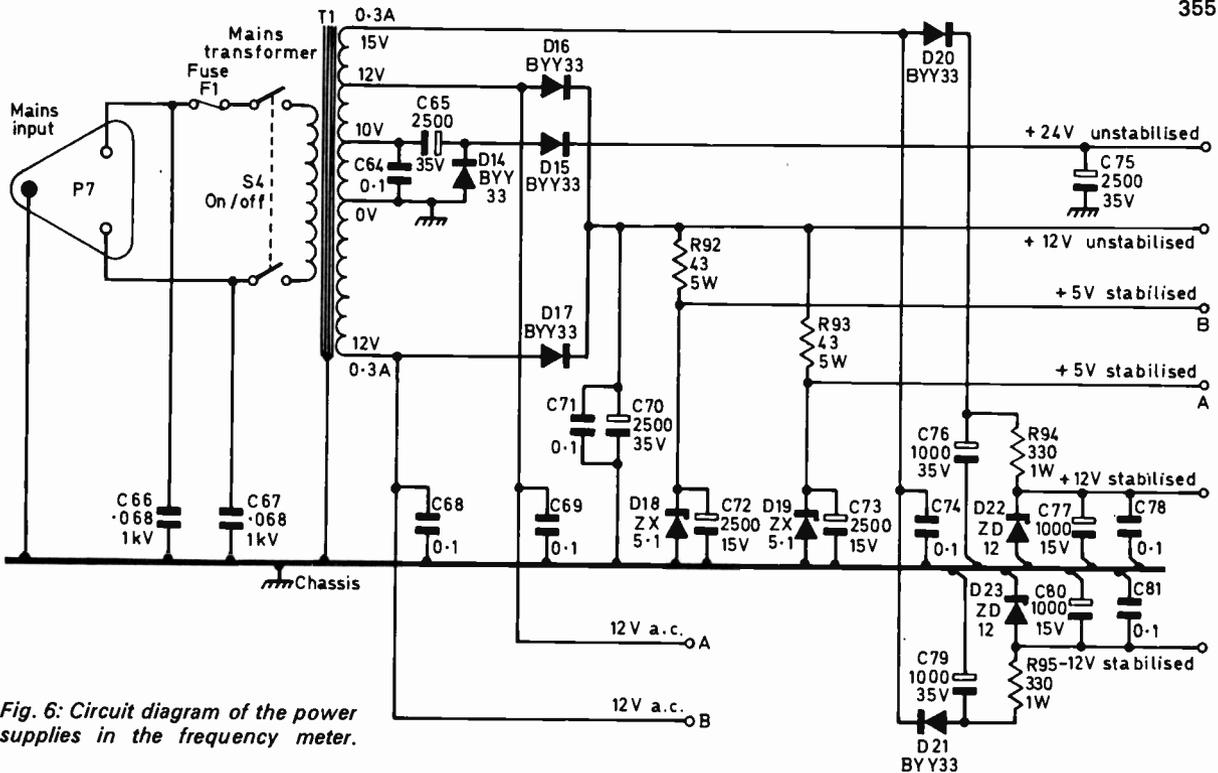

Fig. 6: Circuit diagram of the power supplies in the frequency meter.

a Q-pulse which gives a response at a CP, so Q4 of IC5 is strapped straight through to CP of IC6. By the same action the transition at Q4 of IC6 from 1 to 0 takes place on every *tenth* 1 to 0 transition of IC6 CP. This is Q4 of IC5 and thus corresponds to every *hundredth* 1 to 0 transition of IC5 CP which is the end of every hundredth Q-pulse from the amplifier section.

Any desired number of 10:1 pulse scalers may be connected in cascade in this manner to scale down by any required power of ten. There is no problem of instability because the signal levels are not being amplified. Thus neither decoupling chains nor special coupling circuits are required. Q4 and CP of successive stages are directly connected along the entire chain but the connections must be kept very short because the pulse flanks lie in the v.h.f. range. A common power supply rail is sufficient, without decoupling chain, allowing about 30mA for each

Table 1 : Truth table for 10:1 pulse scaler

No. at CP	Q1	Q2	Q3	Q4
Initial State	0	0	0	0
1	1	0	0	0
2	0	1	0	0
3	1	1	0	0
4	0	0	1	0
5	1	0	1	0
6	0	1	1	0
7	1	1	1	0
8	0	0	0	1
9	1	0	0	1
10	0	0	0	0*

\* Initial state once again.

The tenth pulse at CP causes Q4 transition from 1 to 0. It is thus able to produce a response at CP of the next stage.

stage. An 0.1µF bypass capacitor is desirable between the power supply and ground pins directly at each i.c. package, e.g. C41 and C42 on IC5 and IC6.

### Q and Q̄ Pulse Driver Monostable

It is evident from the truth table of the 10:1 pulse scaler that none of the Qs provide pulse outputs. All these outputs are so-called *step functions*. The input signals change the outputs between the high and low states, these states being held indefinitely until further signals arrive which may in principle take infinite time. A pulse of course is a change of state followed by a reversal of that change of state after a time *t* called the pulse width.

It was the function of the pulse univibrator Tr8, Tr9 in the amplifier section to produce pulses from the trigger signals and essentially the same purpose is fulfilled by the Q/Q̄-pulse driver monostable IC7 in the scaler/ratemeter section. The high to low transition step at IC7 CP causes its Q and Q̄ outputs to change state for a pulse width time determined by the external capacitor C43 after which Q and Q̄ return of their own accord to their resting states. Thus the waveforms at Q and Q̄ are true square pulses. C43 is connected across the pins marked TC, i.e. time-constant.

### The Ratemeter

IC8 is yet another application of our familiar type MC1709CG operational amplifier, this time as a pulse ratemeter. This is a circuit giving a d.c. output voltage linearly proportional to the repetition rate (frequency) of a train of uniform input pulses fed to it. This operation is called integration and is essentially the same as smoothing the output of a rectifier in a power supply circuit. The pulses must first

**NEXT MONTH IN**

# TELEVISION

## THE COMING OF COLOUR

Just 20 years ago next month the first public demonstrations of compatible colour television were given in the New York area. This was really the beginning of colour TV as we know it today and was the culmination of one of the most intensive development programmes in the history of electronics. Starting next month we shall be tracing the course of this unique technological history. As the story unfolds those readers who have not yet boned up on colour basics will be given an opportunity to do so—in the context of this fascinating story of technological achievement.

## SERVICING TRANSISTOR IF STRIPS

Most chassis today used transistorised i.f. strips and the fault-finding techniques necessary with them differ somewhat from the well-established procedures used with valved i.f. strips. A detailed examination of the approach required, together with a component function and fault guide chart, will be given.

## ECONOMY UHF TV

Most people probably still view the v.h.f. TV transmissions. However with three programmes on u.h.f. in an increasing number of areas there's a move to u.h.f. reception. Many ex-rental dual-standard models are now coming on the secondhand market and present a good opportunity to change to u.h.f. reception economically. Caleb Bradley comments on this subject and describes the action necessary with a particular readily-available ex-rental chassis.

## SERVICING TV RECEIVERS

The next chassis we shall be covering is the GEC/Sobell 2012/1012 hybrid series.

## PLUS ALL THE REGULAR FEATURES

**ORDER YOUR COPY ON THE FORM BELOW**

TO.....  
(Name of Newsagent)

*Please reserve/deliver the JULY issue of TELEVISION (20p), on sale JUNE 22, and continue every month until further notice.*

NAME.....

ADDRESS.....

be rectified, i.e. made to have entirely one polarity with respect to a base line clamped to zero volts. The d.c. restorer D27 and C45 provides this condition. The integrator itself behaves as a large capacitor: each unipolar pulse pumps a certain charge into this capacitor so that the total charge is proportional to the number of pulses. At the same time a resistor in parallel with the capacitor drains the charge away within a certain time so that in the steady state the voltage to which the capacitor rests charged is proportional to the number of pulses arriving within the discharge time, i.e. it is proportional to the frequency.

In our circuit we require negative-going input pulses because these are fed to  $\overline{IP}$  of IC8, polarity inversion thus occurring in this stage, and we require a positive d.c. voltage at OP for the meter circuit. The correct polarity pulses are available at  $\overline{Q}$  of IC7 and are d.c. restored to be entirely negative-going with respect to zero across R73.

For the duration of each pulse VR10 passes a certain definite current into IC8  $\overline{IP}$  thus transferring a certain charge to this point. The large-value capacitor C47 is used in parallel with the feedback resistor R64 of the operational amplifier. By ordinary Miller effect the function is exactly the same as if C47 was not present but instead a capacitor  $A$  times as large was connected directly between  $\overline{IP}$  and chassis, where  $A$  is the closed-loop gain of the operational amplifier. The "Miller capacitor" at  $\overline{IP}$  is the smoothing capacitor and VR10 the smoothing resistor for the integrator circuit considered in analogy to a power smoothing circuit.

The offset is balanced in the normal manner with VR11 so that the output voltage is exactly zero when no input pulses are present. VR10 is then adjusted to give exactly full-scale deflection for a  $\overline{Q}$ -pulse frequency of 1kHz from IC7. The value of C43 has been chosen to make the  $\overline{Q}$ -pulses about 300 $\mu$ sec long. Thus the maximum possible  $\overline{Q}$ -pulse frequency is about 3kHz giving a very large safety margin as far as the ratemeter is concerned. With one 10:1 scaler in circuit the ratemeter reads 0 to 10kHz and with both 10:1 scalers in circuit it reads 0 to 100kHz. In all cases the actual  $\overline{Q}$ -pulse range from IC7 is 0 to 1kHz for zero to full-scale meter reading. The decimal ratios of the ranges are effected automatically by the scalers and thus adjustment of VR10 on any range is correct for all ranges.

## Digital Counter Driver

The  $\overline{Q}$ -pulse output of IC7 is used to drive the digital counter section. The start/stop switch is incorporated here. In the stop setting Tr17 base is connected to chassis by S1C. In the count settings (1/10s or 1s) C84 and D26 form a positive d.c. restorer for proper  $\overline{Q}$ -pulse drive of Tr17 which steps down the impedance to the low value required for driving the frequency counter chain.

*Figures 3 and 5, the time and frequency counter circuits, will appear next month along with the circuit description of these sections of the frequency meter. Because of the rather specialised nature of this particular feature and the shortage of space in the magazine at present it is not proposed to publish detailed layout diagrams. These are however available on request.*

**CONTINUED NEXT MONTH**

# THE FAM COLOUR SYSTEM



PAUL SILVERHAY

FREQUENCY-AMPLITUDE modulation (f.a.m.) appears to be a conflict of terms: normally if you want to amplitude modulate a signal you try to prevent any frequency modulation and vice versa. F.A.M. is however a complete process rather than a type of modulator and at one time was a contender in the European colour standards battle, following NTSC, PAL and SECAM. The system is a development by the German research group I.R.T. (Institut für Rundfunktechnik) and one of the major uses to which it is now being put is as a colour converter for low-cost videotape recorders. Equipment for this purpose is being produced by Ampex (Gt. Britain) and Vitronic of W. Germany.

Bandwidth is not normally a limiting factor in recording colour on a low-cost recorder. If a machine has a bandwidth of say 3.5MHz, it would be a relatively simple job to take a PAL signal and modify its standards so as to have a colour subcarrier at say 2.8MHz. This would give acceptable results for closed-circuit use even though the luminance bandwidth would have to be restricted to about 2MHz.

A more important limitation is the stability of the machine—the head-to-tape speed stability and the effectiveness of the servo systems. Efficient servo systems are not cheap and this has in practice meant that, although an acceptable monochrome recorder can be purchased for £300, more than four times this price is required for a machine with sufficient stability for colour. This is still low-cost in comparison with broadcast-standard videotape equipment but for the majority of users—educational, industrial and private—£1,000 or more is considered to be high-cost. The f.a.m. system has the advantage that it is much more insensitive to these stability variations than other colour-coding systems because with f.a.m. the subcarrier modulation itself is not especially sensitive.

The basic system used by Ampex and Vitronic in their f.a.m. colour adaptors is based on videotape recorders which have a bandwidth limit ( $-3\text{dB}$ ) of about 3.5MHz. This is the system we will describe here. The complete equipment consists of a f.a.m. coder whose output is fed to the recorder and a f.a.m. decoder which is used on replay to obtain normal colour signals from the recorder.

## FAM Signal Encoding

The basic encoding process is shown in block diagram form in Fig. 1. There are two basic input signal conditions. The first is that shown fully in Fig. 1, with studio signals from for example a camera: the signals here will consist of R, G and B inputs. The other condition is for recording off-air, when luminance and colour-difference signals would be obtained from a colour receiver: these inputs would be inserted after the matrix which changes any RGB inputs into the same signal form.

The luminance (Y) signal is then bandwidth restricted by a low-pass filter with a  $-3\text{dB}$  point at 2MHz and a  $-6\text{dB}$  point at 2.8MHz. The two colour-difference signals are also bandwidth restricted by low-pass filters with  $-3\text{dB}$  points at 0.7MHz and  $-6\text{dB}$  points at 1MHz.

The R-Y signal is used—after filtering and pre-emphasis—to frequency modulate a carrier at 2.65MHz. With this centre frequency ( $f_c$ ) the deviation for full-amplitude colour bars is  $\pm 500\text{kHz}$  (i.e.  $\pm \Delta f_c$ ). The equivalent V signal amplitude fed into the modulator for full-amplitude colour bars is 0.49V. As with any f.m. system, noise is produced which is of a triangular nature—increasing at the higher modulating frequencies. Pre-emphasis is applied to the signal before modulation to maintain the same noise factor for all input levels.

This f.m. signal with its centre frequency of 2.65MHz is then used as the carrier in an amplitude modulator. This is fed with the U signal as the modulating information. Whether or not R-Y information is present on the colour signal, the output of the frequency modulator will be constant in amplitude at 0.3V. This therefore will also be the output from the amplitude modulator if B-Y information is not present. The maximum amplitude for the U signal entering the amplitude modulator for full-amplitude colour bars is 0.63V. The output from the stage for this input would be from  $-0.16\text{V}$  to  $+0.76\text{V}$  which corresponds to a modulation depth of 153%. This gross amount of overmodulation is not permissible however because the subcarrier output from the modulator in this case falls to zero. In practice the average value of the B-Y signal is unlikely to cause half this modulation depth—i.e. 77%—giving amplitude swings at the output of the modulator of 0.07 to 0.53V.

It is preferable to increase the subcarrier amplitude rather than to reduce it and for most colour pictures B-Y has average negative values. The input is therefore phase reversed to  $-(B-Y)$  to achieve a general increase in subcarrier amplitude when the modulation takes place.

The R-Y signal is chosen for the frequency modu-

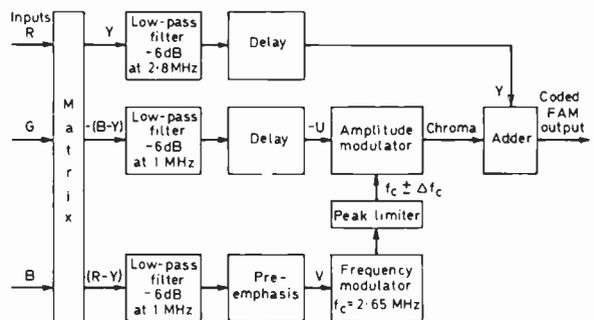

Fig. 1: FAM encoder block diagram.

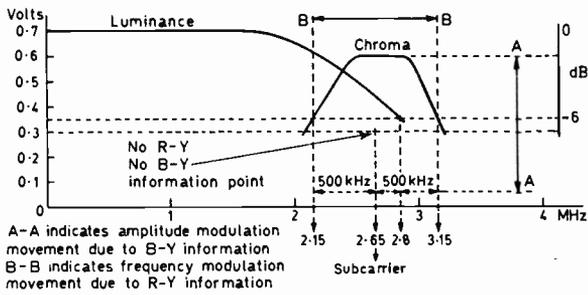

Fig. 2: FAM system parameters—signal bandwidths and amplitudes.

lation process rather than the B-Y signal because f.m. is more insensitive to amplitude variations in the system. As the R-Y signal contributes most to the total picture luminance (for average pictures) it is chosen for this f.m. treatment.

The combined modulation output from the amplitude modulator consists then of R-Y signals frequency modulating a subcarrier at 2.65MHz, this subcarrier itself being amplitude modulated by the B-Y signal. In the absence of B-Y and R-Y signals the output will be an 0.3V 2.65MHz sinewave. With R-Y present the amplitude will remain constant but the frequency will vary with the amplitude of the R-Y signal with a maximum deviation of  $\pm 500\text{kHz}$  either side of the subcarrier frequency. With B-Y information also present the amplitude of the subcarrier will vary between the limits we indicated before.

The modulator output is then added to the bandwidth restricted luminance signal of 0.7V to form the composite f.a.m. output.

**FAM Signal Bandwidth**

Taking account of the factors given before, the maximum limits of the coded f.a.m. signal are given in Fig. 2. This response shows that the absolute maximum bandwidth of the signal is about 3.15MHz and that the maximum amplitude of the chroma approaches the maximum amplitude of the luminance, therefore giving similar noise performances. There is the obvious possibility of some crossover of information between the luminance and chroma signals above 2MHz, but because of the f.m. used and the decreasing luminance signal content at these frequencies the effects are not very annoying on the majority of pictures. The interference that does occur shows as subcarrier patterning on some colour areas—particularly cyan, yellow and green. The patterning is an uneven movement and can therefore be annoying on large colour areas. To prevent this the

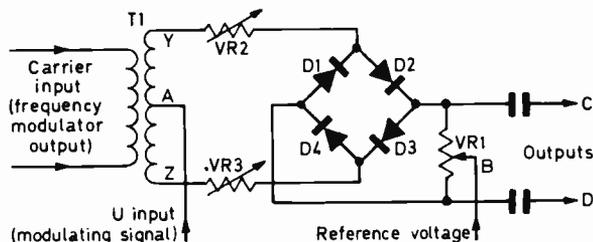
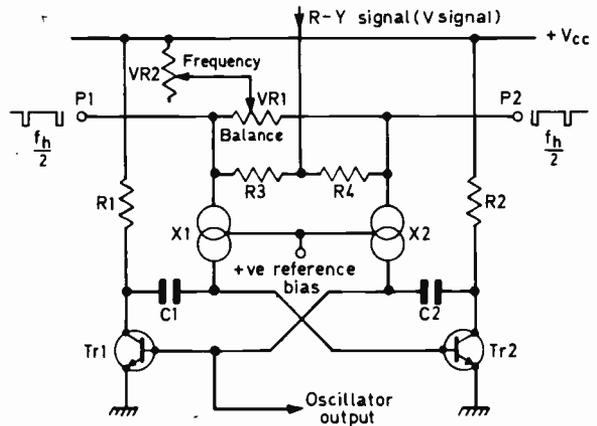

Fig. 3: The amplitude modulator circuit.



subcarrier oscillator is locked with a 180 degree change in phase on alternate lines. This reduces the structure of the patterning because the spectrum of the subcarrier consists mainly of odd multiples of half-line frequency (just as in NTSC).

It can be seen then that the bandwidth of the f.a.m. signal—with the chosen parameters—is suitable for use with a low-cost v.t.r. having a -3dB point at say 3.5MHz. Reasonable performance could also be obtained from a v.t.r. with a 3MHz bandwidth.

**Amplitude Modulator**

Most of the circuits used to fill the blocks of Fig. 1 are quite conventional. Of particular interest though are the two modulators. The amplitude modulator is of balanced diode ring formation as shown in Fig. 3. The U modulating signal input is effectively connected between A and B. The carrier (the frequency modulated V signal) appears across the secondary of T1, out of phase at each end of the winding. When the carrier is positive at Y and negative at Z diodes D2 and D3 conduct and as the bridge formed by these diodes and T1 secondary is then of very low impedance point C rises to the modulating voltage (across A-B). During the following half-cycle of carrier diodes D1 and D4 conduct and point D rises to the modulating voltage. If the outputs at C and D are taken to the inputs of a difference amplifier (see for example Fig. 3, page 536, September, 1969) the output from this will be a peak-to-peak voltage of twice the modulating signal switched at the carrier rate—i.e. an amplitude modulated signal. The small reference voltage of about 0.2V at B sets up the modulating conditions so that blanking level on the U signals corresponds to zero modulation. VR1, VR2 and VR3 allow accurate adjustment of the balance of the circuit.

**Frequency Modulator**

The frequency modulator used is slightly more sophisticated. Its basic element is a free-running multivibrator. The frequency of this kind of circuit can be adjusted by a d.c. potential so that an a.c. signal applied in its place can produce frequency modulation. The centre frequency will not however be very stable and as a result a moving subcarrier structure will appear on the colour picture. This is particularly disturbing because of its uneven, restless motion. The answer to this problem is to stop the



Fig. 4 (left): Circuit diagram of the frequency modulator.

Fig. 5 (right): Block diagram of a f.a.m. decoder.

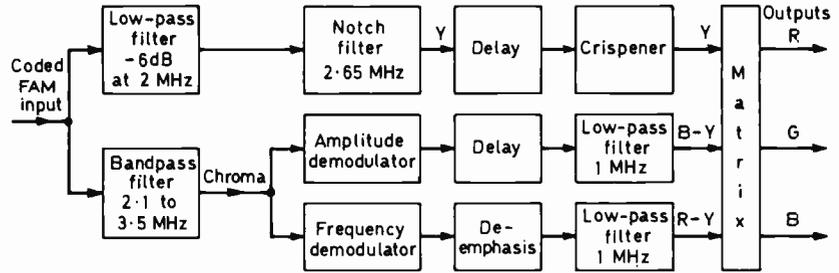

multivibrator during line and field blanking periods and to restart it when wanted in the desired phase. This also prevents the subcarrier appearing on the line sync pulses of the system output. The best condition is to restart the oscillator 180 degrees out of phase with the preceding line. Both the stop and start functions can be achieved by means of line pulses. The arrangement is shown in Fig. 4.

Tr1 and Tr2 are the active multivibrator elements. X1 and X2 are shown as constant-current sources—in the practical circuit they are transistors performing this function—supplying current to the charging capacitors C1 and C2 and therefore affecting the frequency of operation. With no R-Y signal present the centre frequency of the oscillator is determined by the reference bias on X1 and X2 and the d.c. supplied from VR2 ("set centre frequency") from the voltage rail. VR1 balances the two halves of the circuit accurately to combat inequalities due to component tolerances. The appearance of the R-Y(v) signal at the centre point of R3 and R4 then alters the oscillator frequency in sympathy with its amplitude—i.e. frequency modulation is obtained. The R-Y signal has already been passed through an amplifier with pre-emphasis applied at h.f. as with any process using f.m., in order to reduce the effects of triangular f.m. noise. The circuit used for this is a standard RC filter.

Two trains of negative-going pulses are applied to P1 and P2. Their repetition rate is at half-line frequency and the two trains are offset by one line to each other—i.e. one pulse occurs at P1, another a line period later at P2 and another line period later a further pulse occurs at P1. The pulses counteract the positive potentials at the junction of X1, R3 and X2, R4 stopping the multivibrator. When a pulse finishes the multivibrator is biased to oscillate again. The action on alternate sides makes the oscillator start 180 degrees out of phase on alternate lines, reducing the residual subcarrier appearance at the decoder output

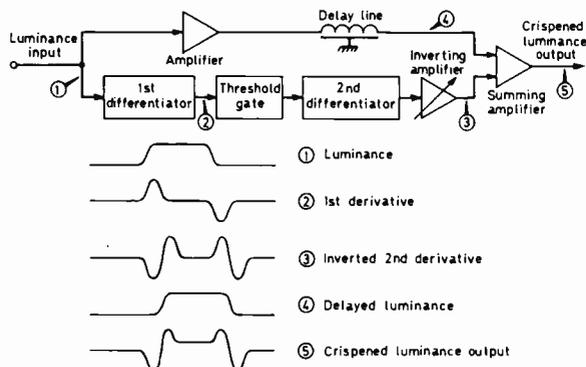

Fig. 6: Luminance crispening—block diagram and waveforms.

to a locked fine dot pattern of low visibility and annoyance.

The oscillator output is taken to the amplitude modulator (Fig. 1) via a diode peak limiter which eliminates any amplitude modulation caused by the f.m. process.

### The Decoding Process

With very little addition the decoding process is the reverse of the coding system—see Fig. 5. From the modulated signal the subcarrier and its components are stripped off using a bandpass filter with  $-6\text{dB}$  points of 2.1 and 3.5MHz. This chroma signal is applied to both an amplitude and a frequency demodulator. The frequency demodulator is followed by the de-emphasis circuit necessary to restore a linear frequency response. The amplitude demodulator, an envelope detector, is insensitive to frequency changes while the frequency demodulator is insensitive to amplitude changes. The outputs are therefore pure B-Y and R-Y. 1MHz filters are inserted in each output to remove spurious signals outside the necessary bandwidth and this includes h.f. noise.

As in any colour system the subcarrier must be removed in the luminance chain. Whereas in PAL and NTSC the subcarrier is of constant frequency and therefore easily removed by a notch filter, in f.a.m. the subcarrier is effectively varying from  $2.65\text{MHz} \pm 500\text{kHz}$ . For adequate subcarrier suppression and therefore minimum visibility on coloured areas of the picture at least 9dB of attenuation should be present at the lowest frequency point ( $2.15\text{MHz}$ ) with somewhat more attenuation at the more frequently occurring subcarrier frequencies (i.e. around 2.65MHz).

Two possibilities for this subcarrier suppression come to mind. The first is a low-pass filter with a sharp cut-off at about 2.1MHz. This would give the necessary attenuation but the luminance signal would almost certainly ring. A low-pass filter with a less sharp cut-off would prevent such overshoots being developed but insufficient rejection would be given around the subcarrier centre frequency. The solution is to use this latter filter but with a notch filter follow-it centred at 2.65 MHz.

Compared to a standard PAL or NTSC signal the most obvious deterioration in picture quality is the restricted luminance bandwidth. This also results in a lower picture brightness because there is less luminance energy. The "crispener" circuit seeks to re-establish some of this lost resolution and brightness. This can be done by enhancing the existing waveform edges in the luminance signal. A block diagram of the arrangement is shown in Fig. 6 and the waveforms which might be expected are shown

—continued on page 363

PUSH-BUTTON tuning on u.h.f. while being very convenient often leaves a margin of mistuning, especially after some wear and tear has occurred on the mechanism. Even dial tuning can lead to errors due to the difficulty many people experience in judging the correct point. Oscillator drift due to temperature changes can also cause mistuning. Automatic frequency control (a.f.c.) will correct all these faults.

The vision carrier when the set is correctly tuned on u.h.f. is at 39.5MHz as it passes down the i.f. strip. Thus if at the end of the i.f. strip a discriminator tuned circuit is incorporated centred on 39.5MHz the discriminator output will be zero at 39.5MHz and will move positively one side of 39.5MHz and negatively the other as the tuning drifts. This response is shown in Fig. 1.

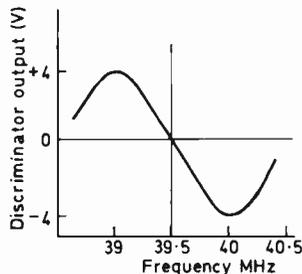

Fig. 1: Showing how the discriminator output varies with frequency. At the centre frequency—39.5MHz—its output is zero.

If the tuning is not correct then the discriminator output is not zero and if this output is applied to change the reverse bias on a tuning diode mounted in the oscillator section of the u.h.f. tuner it will correct most of the error. Tuning, varicap or varactor diodes—to give them a few of their names—are junction diodes normally operated with reverse bias but not sufficient to bias them into the breakdown region in which zener diodes operate. The greater the reverse bias the lower their capacitance: a typical curve, for the Mullard BB105 or STC BA141 tuning diode, is shown in Fig. 2.

All diodes exhibit this basic type of characteristic but special diodes have to be used for u.h.f. because they must not introduce any excessive loss into the tuned circuits they control. In other words, just as a coil has to have a good  $Q$  so does a varicap diode. Normally, we don't worry about the  $Q$  of a capacitor as it is usually very good. However, a tuning diode is not a true capacitor. It has, for example, leakage current so the  $Q$  of the diode is a factor which has to be considered. The diode manufacturer however will have considered these points and if you buy a diode specified for u.h.f. use you will have no trouble. These points have been mentioned to clear up any misunderstandings and to show why any old diode won't do.

### Basic AFC System

To return to our TV set, if the oscillator frequency is too high then the vision carrier frequency will also be too high and in the simple arrangement shown in Fig. 3 the discriminator will give a negative signal to decrease the bias on the tuning diode thus increasing its capacitance and in turn reducing the oscillator frequency and correcting the error. Note that in this diagram the reverse bias on the diode is applied to its cathode. It is therefore positive with respect to ground so that a negative signal from the discriminator will reduce the positive voltage on the diode thus reducing its bias and increasing its capacitance. In

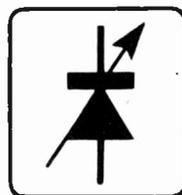

# ADDING AUTOMATIC

this arrangement the diode is biased somewhere near the mid-point of its characteristic by the positive d.c. bias fed into one side of the discriminator. The discriminator thus adds to or subtracts from this d.c. bias.

### AFC Loop Gain

The amount by which the error is reduced depends on the gain of the circuit. An estimate of the gain required must first be made by guessing how much error is likely to be given by your push-buttons or hand tuning: 1MHz would be an outside figure as a tuning error of that magnitude would produce a very bad picture of low definition in one direction and badly broken up in the other. This error should be reduced to about 100kHz to be really unnoticeable, indicating a required gain of ten.

In fitting a.f.c. to an existing set some measurements should be done as an experiment before finally deciding on the circuit gain. The first thing to do is

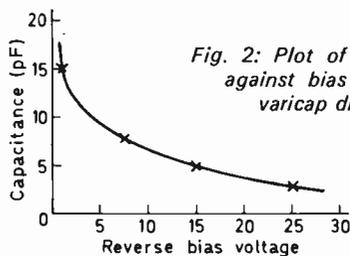

Fig. 2: Plot of capacitance variation against bias voltage for a typical varicap diode.

to add the suggested discriminator to the i.f. strip. As the circuit (Fig. 4) shows a Foster-Seeley type discriminator is used and with the coils specified and the driver circuit shown it should give  $\pm 4V$  for  $\pm 0.5MHz$  input variation.

### Circuit Description

The driver stage Tr1 takes a small sample signal from the i.f. strip but this should be large enough to drive Tr1 into saturation. That is to say Tr1 is a limiter stage so that the signal amplitude applied to the discriminator coil L2 stays constant over the nor-

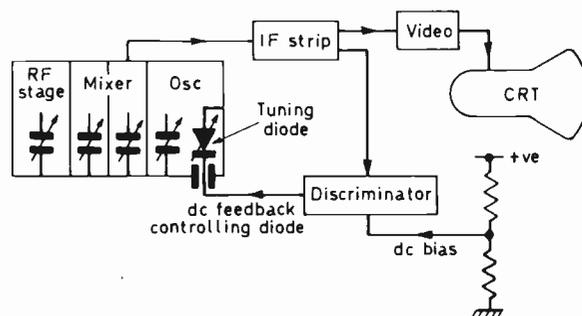

Fig. 3: Simple discriminator feeding a varicap tuning diode in the u.h.f. tuner.

# FREQUENCY CONTROL

## T. SNOWBALL

mal range of signal levels. Tr1 is biased at approximately 7mA which, according to the original report ("Simple a.f.c. system for 625-line TV receivers" by P. Bissmire, *Mullard Technical Communications*, March, 1970), gives the best limiting performance. C1, R14 and R3 damp the stage to prevent oscillation. C2 decouples the power feed and should be close to the circuit. The coil former and can are the normal ones used for TV sets and so should be easily obtainable: the former diameter is 5mm. and length 40mm. and winding details are given in Fig. 5.

### Setting up the Discriminator

Setting up the discriminator is much easier if a signal generator is available. The collector coil L1 is set to 39.5MHz. This is not easy to do using the discriminator diodes as detectors and an alternative way is to rig up a temporary detector fed from a small capacitor of 2-3pF connected to the BF194 collector. The secondary coil L2 is adjusted for 0V output at 39.5MHz across C7, with a smooth transition to peaks of equal and opposite amplitude at 39 and 40MHz. If the primary L1 is not on frequency at 39.5MHz then the peaks of the secondary will not be equal either in amplitude or frequency spacing from the 0V point.

If a signal generator is not available the TV set itself can be used but more care is necessary to ensure that the discriminator is set up correctly. First of all the test card must be used to set up correctly the tuning of the TV set. The discriminator then has to be connected to the set. For valve i.f. strips the method shown in Fig. 4 is suggested. The addition

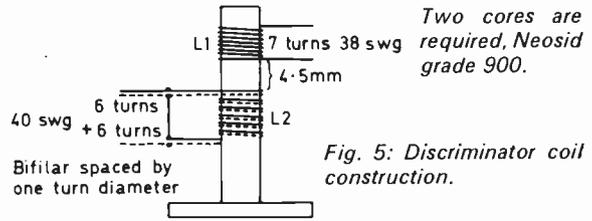

of the coupling capacitor C13 will of course slightly shift the i.f. response of the set. This must be corrected first by adjusting the core of the transformer to which C13 is connected until as viewed on test card the set is correctly aligned once more.

Having done this the next step is to adjust L2 for 0V output. Then, by swinging the u.h.f. tuner, the output can be made to move positive and negative as in Fig. 1 with adjustments made to L1 to ensure equal amplitude peaks evenly spaced about the position of correct tuning—which of course must be made 0V by checking L2. As L1 and L2 interact somewhat this must be done carefully and slowly. It is easy to see that a signal generator is the best method of setting up.

### Connecting to the IF Strip

If the discriminator is set up using a signal generator then on connecting it to the i.f. strip the point just mentioned about readjusting the TV set's final i.f. coil is of course still valid. The value of the coupling capacitor C13 should be kept low to reduce the effect of added capacitance on the i.f. transformer but must be big enough to drive the transistor well into limiting in order to keep the discriminator output constant for varying gain level in the i.f. strip, changes of contrast and a.g.c. action. The way to go about this is to start with a small capacitor of 1 to 2pF and at a given output, say 2V, alter the contrast control setting: over a reasonable range the discriminator output should stay 2V. If this is not so a larger coupling capacitor can be tried remembering always to cancel out the effect on the set's i.f. strip by retuning the

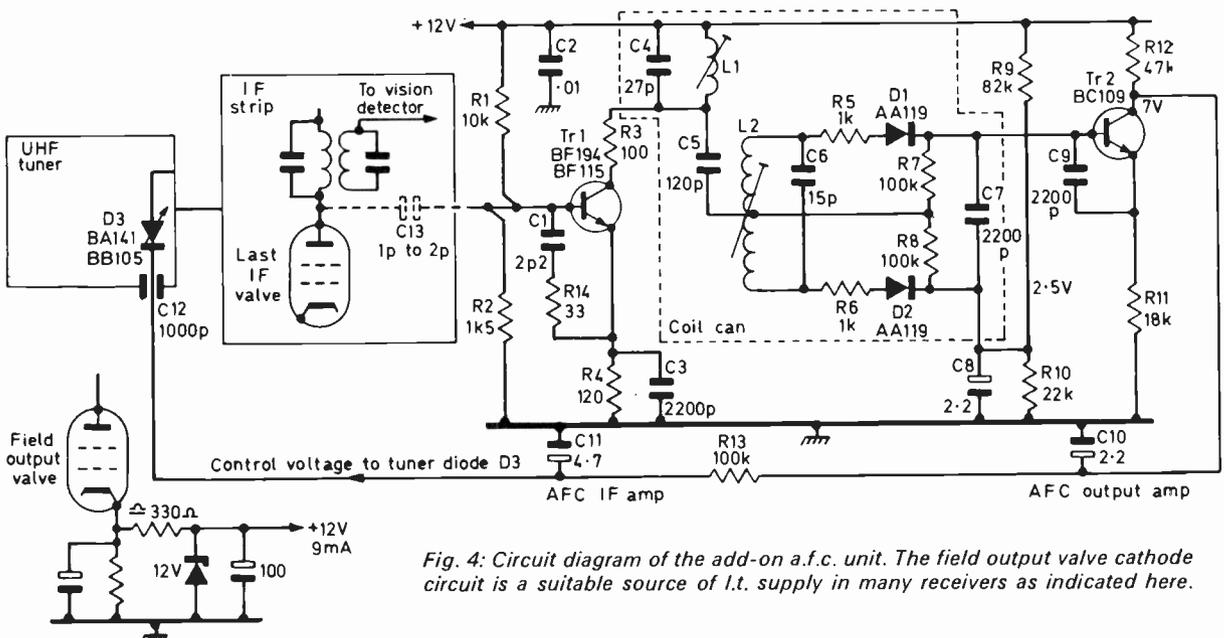

Fig. 4: Circuit diagram of the add-on a.f.c. unit. The field output valve cathode circuit is a suitable source of i.t. supply in many receivers as indicated here.

i.f. transformer core.

If the i.f. strip is transistorised then the voltage levels will be smaller and larger values of C13 needed. A slightly different input circuit can be tried as indicated in Fig. 6—assuming that the detector diode connection is available. Alternatively, for example, in the Constructor's TV set last year by Keith Cummins the original i.f. strip used has a 6.8pF capacitor

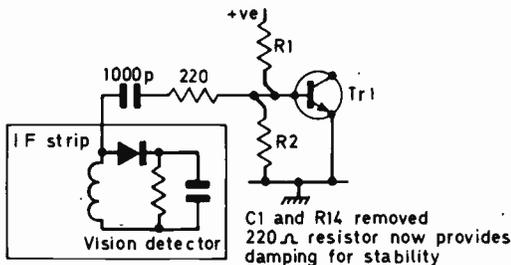

Fig. 6: Alternative coupling from a low-impedance, low-voltage point in an i.f. strip.

(C25, Fig. 2, Page 25, October, 1970, TELEVISION) which is normally connected to earth on 625 lines. This could, of course, be used as the coupling capacitor C13 in this article. In his later i.f. strip (September, 1970, page 554) the coupling could come from Tr4 collector or the junction of D1 and D2 on L6 using the circuit suggested in Fig. 6.

### Tuning Diode Adjustment

The next thing to do is to set up the operation of the tuning diode. As all tuners are different the author can only describe how he fitted up his own set but the basic idea can be applied to any tuner. The tuned circuits in u.h.f. tuners consist of small resonant cavities tuned by small tuning capacitors. The diode must be coupled into the oscillator section in such fashion as to give a useful tuning range but not sufficient to impair the oscillator operation. It was not found to be very critical.

Figure 7 shows the usual layout of a cavity. It can be seen that the tuning capacitors are connected from the top or live end of the "coils" and it appeared best to do the same with the tuning diode. An earthing point near the dead end of the tuned circuit was first found and a feedthrough capacitor fitted (after drilling a suitable hole) near the live end. The diode was mounted by its leads and correct control was obtained by bending the diode nearer to or away from the tuning line. Bias the diode for these tests with a

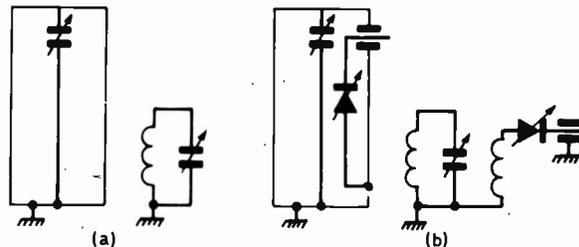

Fig. 7: Cavity tuned circuit mechanical layout and electrical equivalent, (a) without and (b) with tuning diode.

potentiometer which takes the diode over its working range—0 to 25V for the STC BA141.

Set the push-buttons or dial of the set to the correct position for a station. Then on putting the diode in the cavity the tuning will change due to the diode, stray capacitance and stray wiring. The situation will be that even with the diode at minimum capacitance it will be impossible to retune the oscillator: some capacitance must be lost. As a check swing the tuning capacitors to prove that the oscillator operation has not been upset. Then reset the tuning to the correct position and remove capacitance by either turning out the trimming capacitor which is usually present or in the limit by bending out the vanes of the oscillator tuning capacitor.

The magnitude of the effect the diode has on the tuning of the set is not too critical. A change of plus or minus 1MHz for example will cause a loss of definition, quite noticeable on the test card when the oscillator frequency is low but when it is 1MHz high the picture will break up due to sound channel patterning. So if this state is reached with anything between  $\pm 1V$  and  $\pm 5V$  on the diode all will be well. Obviously the  $\pm 1V$  case should be aimed for as it increases the gain of the a.f.c. loop.

While the diode is being set up a high-sensitivity test meter ( $20,000\Omega/V$ ) used to read the discriminator output will also show the oscillator frequency shift because the discriminator described will give approximately  $\pm 4V$  for  $\pm 0.5MHz$  shift. So in the final stages of setting up the diode its frequency versus voltage characteristic can be quite accurately determined.

As a final touch the trimming capacitors should be set to give correct tuning as checked on the test card with a voltage of 7V on a tuning diode type BA141. This voltage will vary with different types of diode but will always be about one-third of the maximum voltage allowed on the diode. The reason for the choice of this voltage is to allow equal swings of

## ★ components list

R1	10k $\Omega$	R13	100k $\Omega$
R2	1.5k $\Omega$	R14	33 $\Omega$
R3	100 $\Omega$	All	$\frac{1}{10}W$ or greater.
R4	120 $\Omega$		* Values depend on gain required through a.f.c. system.
R5	1k $\Omega$		
R6	1k $\Omega$		
R7	100k $\Omega$		
R8	100k $\Omega$		
R9	82k $\Omega$ *		
R10	22k $\Omega$ *		
R11	18k $\Omega$ *		
R12	47k $\Omega$ *		

### Capacitors:

C1	2.2pF	ceramic
C2	0.01 $\mu F$	paper or ceramic
C3	2200pF	ceramic
C4	27pF	silver mica or polystyrene
C5	120pF	silver mica or polystyrene
C6	15pF	silver mica or polystyrene
C7	2200pF	ceramic
C8	2.2 $\mu F$	electrolytic
C9	2200pF	ceramic
C10	2.2 $\mu F$	electrolytic
C11	4.7 $\mu F$	electrolytic
C12	1000pF	feedthrough
C13	1.2pF	ceramic—see text

### Semiconductors:

Tr1	BF194 or BF115
Tr2	BC108 or BC109
D1, D2	AA119 or OA47
D3	BA141 or BB105

frequency either side of the chosen tuning point—the diode capacitance (see Fig. 2) and frequency shift do not change linearly with voltage so that half voltage is not the correct centre point.

### Setting the Gain

The system is now ready for its gain to be measured. As mentioned above a test meter can be used to measure the frequency change caused by the diode voltage. If, for example,  $\pm 0.5V$  on the diode causes  $\pm 2V$  from the discriminator this indicates a gain of four or a frequency change of  $\pm 0.25MHz$ . We mentioned earlier a desirable gain of 10. So in this case an extra gain of 2.5 is required. This could possibly be arranged by readjusting the diode coupling on the tuner to make it more sensitive but it is much easier to provide some gain by using an extra transistor between the discriminator and the tuning diode. In the circuit suggested (Fig. 4) an overall gain of 10 is achieved with a d.c. amplifier (Tr2) having a gain of 2.5.

The amplifier should use a high-gain low-current transistor such as a BC109 or BC108. With such a transistor a collector current of  $100\mu A$  will be produced with a very low base current which will not affect the output voltage of the discriminator. Its collector, which is connected to the diode, should be set at +7V and a filter used to smooth the output and remove pick-up. As  $100\mu A$  is chosen as a suitable collector current then with a 12V supply 5V must be dropped across the collector resistor R12 making it  $47k\Omega$ , a preferred value. The emitter resistor for a gain of 2.5 will then be  $47/2.5 = 18k\Omega$  preferred value where  $gain = Rc/Re$ . This makes the emitter voltage 1.8V and allowing a base-emitter voltage of 0.7V the base bias voltage must be about 2.5V. This is provided by R9 and R10 and may be adjusted

to get Tr2 collector to +7V without any signal fed into the discriminator.

The final setting-up consists of checking that the output is in the correct sense to reduce the tuning error, remembering that the addition of an amplifier will invert the signal and require reversal of the discriminator connections.

### AFC/Manual Switch

An a.f.c./manual switch will be found desirable. The easiest way of going about this appears to be to short-circuit the a.f.c. amplifier base to ground: this sets the discriminator output to zero and the amplifier output to the diode to +7V. The push-buttons can then be set for a correct picture after which opening the switch brings the a.f.c. into action. The wire to Tr1 base must be kept very short so that if on a dial-tuned set it is found that the a.f.c. must be disabled each time a different station is tuned in, then as long leads would be needed to a panel switch it is suggested that instead the collector of Tr2 is switched out of circuit and the tuning diode connected to a potential divider providing +7V.

Other constructional points include making sure that all i.f. signal leads are kept very short. The circuit should be attached to the i.f. strip with this point in mind.

### Power Supply

The supply to the unit should obviously not drift to any great extent. A useful supply point is the cathode of the field output valve which is usually about 15-17V. Using a 12V zener diode (see Fig. 4) the supply can be made very stable. Otherwise rectification some way up the heater chain with smoothing and again a zener diode will be suitable. ■

## THE FAM COLOUR SYSTEM

—continued from page 359

beneath. The luminance is assumed to be a pulse with slow edges (1). The first differentiator produces a pulse at each edge with the same rise time as the original (2). Each of the edges of this differentiated waveform produce a further pulse at the output of the second differentiator and the resulting waveform is inverted in an amplifier (3). A second signal path has meanwhile delayed the original luminance pulse (4) and these two signals are added in the summing amplifier to produce the output waveform (5). This is effectively a crispened signal because the edges of the pulse change in amplitude considerably more than the original over the same time—i.e. the rise time is faster. The amount of crispening introduced can be controlled by altering the gain of the inverting amplifier in the differentiating chain, thereby changing the proportion of this chain's signal appearing on the output. The delay time in the main path must be carefully chosen for maximum effectiveness.

One of the big disadvantages of this type of correction and any similar techniques is that noise is inevitably added to the signal. The effect of this can be reduced by the introduction of the threshold gate in the secondary chain. This consists of a pair of diode, capacitance-resistance chains which allow only the tips of the pulses through and therefore stop any datum line noise. There is still noise left on the pulse tips, of course, but this has relatively less effect. A

secondary advantage of this gate is that the pulse widths are reduced making the correction a little more effective.

We have examined f.a.m. in its application as a low-cost colour v.t.r. system assuming a usable recorder bandwidth of 3.5MHz. Vitronic also manufacture f.a.m. units for use on lower bandwidth recorders of 3MHz and 2MHz and the corresponding frequencies of the subcarrier etc. are changed accordingly. Vitronic also manufacture a version which enables a PAL input signal to be handled and which gives a PAL output signal. These variations enable the equipment to be used with a large number of 0.5in. and 1in. videotape recorders and in a number of systems. The Vitronic equipment has been seen operating with a Sony v.t.r. over a long period and the results have been most acceptable.

It would be a mistake however to assume that f.a.m. has only this type of application. Perhaps one of the future developments will be its use as *the* standard for colour in closed-circuit television. The advantages are low capital outlay coupled with a reasonable performance, the small bandwidths involved enabling existing monochrome equipment such as vision mixers and distribution equipment to be retained. It should be noted that to mix between f.a.m. sources would require the subcarrier frequency to be derived from a common point and fed to all sources and the present coders would require a small amount of modification. ■

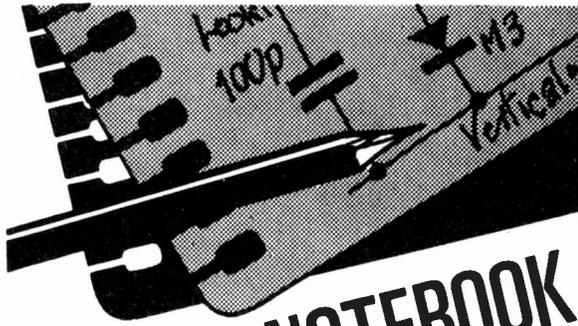

# SERVICE NOTEBOOK

## G. R. WILDING

### Thorn 16in. Portables

A portable model fitted with the 16in. version of the Thorn 950 chassis was completely dead and on removing the back we found that although the cartridge fuse was intact the fusible link R147 (see Fig. 1) at the top of the chassis was open. On resoldering the link and checking across the mains plug we found no continuity and it seemed that a dropper resistor section or valve heater must be open-circuit. This portable receiver is closely based on the standard 950 chassis but after looking around the closely packed cabinet we failed to see any droppers. The unusual value— $4.33\mu\text{F}$ —of the large canned capacitor mounted near the fusible link however obviously indicated that it had a special purpose and by following through the circuitry we found that it is employed as a capacitive dropper in the heater circuit. A check with the service sheet confirmed this and we realised that after resoldering the open fusible link we had been looking for a non-existent fault. On then plugging in we obtained normal reception.

As this heater circuit is so unusual however and as there are thousands of these excellent receivers in use it is worthwhile describing the arrangement in case you come across a model fitted with this chassis. It will be noticed that the solenoids operating the system switch are energised only briefly, during system changeover, and that if misuse results in an overload current opening the fusible resistor R147—as occurred in our case—the mains supply will be completely removed from the receiver. Seven valve heaters plus the c.r.t. heater are in the series circuit with the dropper capacitor C121, the remaining four heaters being shunted across resistors R153 and R152 in series with the neutral mains connection to chassis.

The heater current through V7, V3, V6 and V5 will therefore be that of the receiver's h.t. demand and as this is in excess of the 300mA they require R153 is factory adjusted to bypass—with R152—the excess. The total shunt impedance of these valve heaters and resistors forms part of the h.t. smoothing arrangements—in the negative lead—most of the series smoothing being effected by R138 and R151 in the positive h.t. lead.

In this heater circuit arrangement there is no "wasted" electrical energy to unnecessarily raise the cabinet temperature—always a problem with valved TV portables. R153 should not normally require readjustment, but it must be emphasised that if V3, V5, V6 or V7 are withdrawn while the set is on or if one of the heaters goes open-circuit, R152 and R153 will pass the total h.t. demand and will be grossly overloaded and reduce the rail h.t. Similarly if an h.t. short develops in the receiver it will cause excessive heater current through these valves so that if one of them is found with an open-circuit heater it is wise to check that its failure was not due to this cause.

Should an intermittent h.t. short or other fault make it desirable not to energise these four valve heaters the makers recommend connecting a  $140\Omega$ , 12W resistor from chassis to the C120-C112 negative connections, leaving out one of the valves. The set will then show a normal raster but without vision or sound.

If it becomes necessary to readjust R153 the correct procedure is to remove the lead from tag 24A on the printed circuit panel (junction V3 and V7 heaters) and connect a milliammeter in series. With the controls set for a normal picture adjust the slider of R153 for 300mA.

The 960Z and 960Y versions of this portable use a more orthodox arrangement with a conduction-cooled mains dropper clamped to the chassis to serve as a form of heat sink and a choke for series smoothing. Other versions use a silicon diode (BY101) dropper for the heater chain.

Note the connection of the heater decoupler C107 to the cathode of the video amplifier: excessive heater current will lead to a shaded raster drawing attention to this condition.

### Intermittent Loss of Vision

THE customer's complaint was intermittent loss of vision. On switching on a picture appeared but disappeared almost immediately. After removing the back and lowering the bottom hinged chassis we found that tapping the PCL84 video output pentode would intermittently restore the picture.

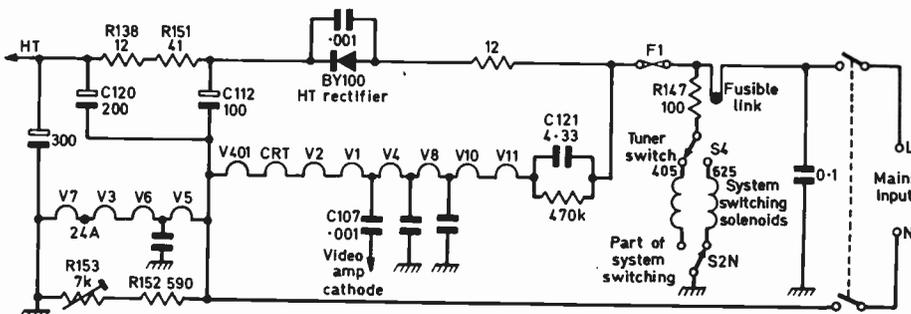

Fig. 1: Heater supply circuit used in some versions of the Thorn 950 chassis in 16 in. portable sets to minimise heat dissipation in the cabinet. C121 acts as a capacitive dropper in series with the heater chain. Note that mains neutral is not connected directly to chassis.

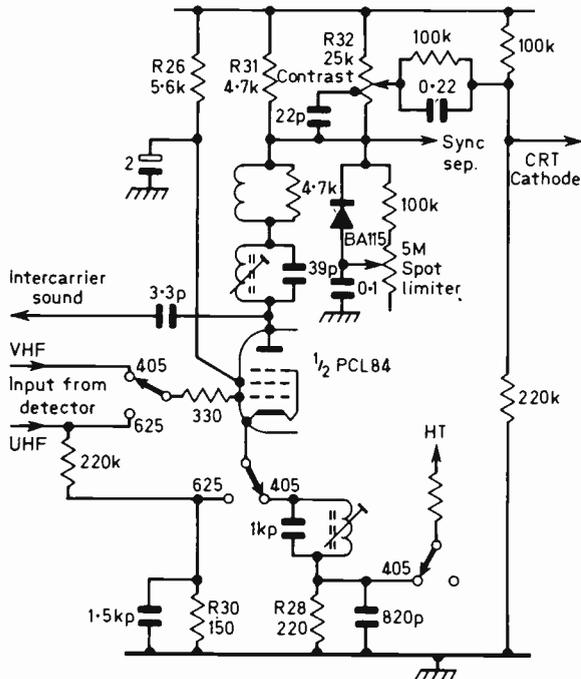

Fig. 2: The video output stage used in the Ekco T433 series. After replacing the PCL84 and R26—the latter being burnt out by an intermittent short-circuit in the original valve—the 405 contrast was well below standard and the preset sensitivity control had to be turned back from its original maximum setting.

We also noticed that the 5.6kΩ screen feed resistor R26—mounted close to the valvholder—was badly discoloured and on applying light pressure it completely disintegrated. Obviously—and as frequently occurs—the PCL84 had developed an intermittent short-circuit.

No other resistor or component around the valvholder was discoloured or showed signs of heat damage so we replaced the 5.6kΩ resistor and the PCL84 and tried again. A tolerable picture appeared but it was found necessary to reduce the setting of the chassis-mounted contrast control to obtain optimum contrast, whereas originally the owner could fully advance the control to obtain a really black-and-white picture.

On checking voltages we found that the screen potential was down to about 165V on 405—it should have been 200V—while the anode voltage was also well below normal. We then noticed that both the newly fitted screen feed resistor and the anode load resistor R31 were overheating, the almost certain cause being insufficient grid bias due to valve reduction in the cathode resistor. On changing over to 625 and thereby switching cathode resistor R28 out and R30 into circuit, the anode and screen feed resistors stopped overheating and the voltages were restored to the correct 625 figures.

Cathode resistors are usually mounted close to their associated valves—as we had expected when looking for other burnt resistors near R26—but in this particular series the video amplifier ones are mounted some distance away—just under the system switch to facilitate bias change. R28 was only

slightly discoloured but when the blade of a small screwdriver was levered underneath it crumbled easily, a sure sign of its having been over-run. We replaced it with a 220Ω ¼W type and on switching on again were able to fully advance the contrast control to obtain a really well contrasted picture.

The reason for the contrast peaking before the original maximum setting was that as a result of inadequate bias strong positive-going signals from the detector diode were driving the pentode into the grid current region.

The most common shorts in video pentodes are from the screen to the control grid and from the screen to cathode and if sustained will completely burn up and easily identify all the components passing the excessive current. If only an occasional flashover has occurred (and also in old, well-used sets that have not had this complaint) it is always best to check such resistor values as even small changes can greatly impair the contrast range. Many tubes have been considered past their useful life when in fact the video stage has been cramping or limiting the output amplitude.

Low-emission video pentodes can result in the picture seeming to fade into the background raster as the contrast is increased. This is because of their restricted working grid base. Any input in excess of a certain low figure drives the valve to saturation and irrespective of input signal amplitude the anode voltage can only fall by a fixed limited amount.

TO BE CONTINUED

## COLOUR RECEIVER APC LOOPS

—continued from page 349

achieved, the chroma channel conducting only when a colour transmission is present. At other times it is cut off so that spurious signals in the chroma pass-band do not interfere with the black-and-white display.

### Fault-finding

Although the a.p.c. loop operates in an entirely different way to signal amplifying circuits nevertheless fault location in a.p.c. loops is no more difficult and although scope observations are extremely helpful voltage checks alone will in most cases identify the defective stage.

In practice most colour sync faults are due to mis-adjustment of the preset controls. This means that either the oscillator's operating point is placed outside the pull-in range of the a.p.c. loop or the burst gate fails to correctly and cleanly pass just the bursts from the chroma signal applied to the stage. There will of course be no colour if the reference oscillator is not working.

It must also be remembered that in many receivers the burst gating is done by pulses taken from the line output stage instead of by a pulse instigated by the transmitted line sync pulse. In such cases if the line hold control is not set exactly right there can be unstable colour sync or even no colour at all.

If the colour burst signal does not reach the discriminator there will be no ident signal and therefore no turn-on bias for the colour-killer controlled stage in the chroma channel and in consequence no colour.

# COLOUR RECEIVER CIRCUITS

## COLOUR-DIFFERENCE PREAMPLIFIERS

GORDON J. KING

We have so far investigated the circuits leading from the aerial input through the front-ends, the i.f. stages and second detectors (as distinct from the synchronous detectors of the colour decoder) to the cathodes of the picture tube via the Y or luminance stages. In other words we have covered all those signal circuits which are involved in the production of a monochrome display or the "brightness" of a colour display.

The Y signal is responsible for the *detail* of a colour display; in fact it is this signal which provides *all* the information required for a monochrome picture. Colour is added to the monochrome detail separately, and the definition of the colour information is only about one-fifth that of the luminance. This means that the colour is added rather boldly to the luminance detail. It is the job of the colour decoder to process the colour information carried by the composite aerial signal in such a way as to secure three new signals, called *colour-difference signals*.

At the camera three primary-colour signals corresponding to the saturation of the red, green and blue scanned elements of the scene are obtained. The Y signal is derived from these three signals by addition and it has been discovered that the Y signal is nicely balanced (corresponding to the video signal which would be expected from a monochrome camera when scanning a colour scene) when it consists of 30% red signal, 59% green signal and 11% blue signal. The colour camera thus delivers the Y signal composed as above plus red, green and blue signals.

The Y signal is fed to the transmitter in a similar manner to the video signal of a monochrome system (which is why we can run our monochrome sets from it). A colour transmitter however has to handle the colour signals as well and these cannot be multiplexed with the Y signal as they stand because for one thing there is insufficient vision channel bandwidth and for another the composite signal must be usable by a monochrome set. The multiplex signal actually transmitted must therefore be carried within the bandwidth of an ordinary 625-line channel.

### Colour-difference Signals

The problem is solved by producing colour-difference signals; that is by subtracting the Y signal separately from each primary colour signal thereby obtaining R-Y, G-Y and B-Y signals. A bonus of this scheme is that colour-difference signals occur only when there is colour in the scene. If the scene is in monochrome (no colour) then only the Y signal is produced.

Another very useful feature of the scheme is that the G-Y signal can be obtained by matrixing the R-Y and B-Y signals in the receiver so that we need transmit only the R-Y and B-Y signals along

with the Y signal. This eases transmission and bandwidth problems. The two colour-difference signals along with the Y signal and the sync pulses are "multiplexed" to form a complex signal which is modulated on to the vision carrier. It is the job of the receiver to sort this lot out.

We have already seen how the Y signal is sorted out but are not yet ready to investigate the circuits which sort out the colour information. What we must do first is to look at the circuits which handle the R-Y and B-Y signals emanating from the colour decoder, the circuits which produce the G-Y signal and then follow the three signal paths to the grids of the colour picture tube. To do this therefore we must for the present take it for granted that the colour decoder produces R-Y and B-Y colour-difference signals.

### Colour-difference Drive

It is best to look at the picture tube end of the colour-difference channels first of all to get some idea of how the three primary-colour signals are derived by the tube guns. Fig. 1 shows the basic arrangement. Here the Y signal is applied to all three cathodes while the R-Y, G-Y and B-Y colour-difference signals are applied separately to the grids of the red, green and blue guns. Each gun therefore is fed with a combination of the appropriate colour-difference signal and the Y signal. This is the system known as colour-difference drive.

The Y signal is ordinary video and is negative-going as shown at (a) in Fig. 2 (for the colour-bar test-pattern waveform). The colour-difference signals are also now at video frequency as distinct from the V and U chroma signals—since they are derived by the decoder synchronous detectors from the chroma signal delivered by the second detector. The R-Y, G-Y and B-Y signals, which can swing positive and negative, are shown respectively at (b), (c) and (d) in Fig. 2.

### CRT Primary-colour Matrixing

Now assuming that the tube grids are clamped to a d.c. level a Y signal going increasingly negative progressively turns on more beam current at the three

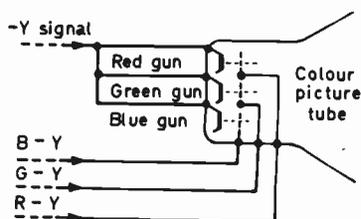

Fig. 1: Showing how with colour-difference drive the c.r.t. guns add the Y signal to the colour-difference signals to obtain the three primary-colour signals. -Y at the cathodes equals +Y at the grids.



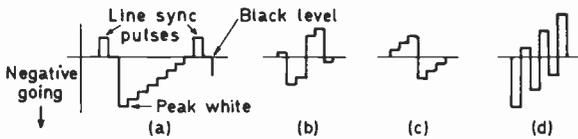

Fig. 2: Signal waveforms: (a)  $-Y$ , (b)  $R-Y$ , (c)  $G-Y$  and (d)  $B-Y$ .

guns, resulting in an overall raster of increasing brightness. If a grid goes positive then the corresponding colour will become brighter but if it goes negative the colour intensity reduces. In other words since a negative-going signal at the cathode of a gun brightens the appropriate colour while a negative- or positive-going signal at the grid adds to or subtracts from this brightness each gun acts as a matrix neatly adding or subtracting the luminance and the appropriate colour-difference signal. This action of course restores the original primary-colour signal.

The signals shown in Fig. 2 correspond to the standard colour bars. Now it is possible though a bit time consuming to plot the four signals in  $Y$  and  $X$  axes scale and then add (a) to (b), (c) and (d) separately to discover what the primary-colour signals look like. A better way is to feed a standard colour-bar signal into a receiver and to view each primary-colour signal across its associated gun on the screen of an oscilloscope.

Excluding the horizontal steps at black level and peak white on the signal at (a) we find that there are six intermediate ones. These correspond to the yellow, cyan, green, magenta, red and blue colour bars displayed on the screen of the picture tube from left to right. The horizontal steps can be better seen in the  $Y$  signal oscillogram in Fig. 3 but here the electronics have caused the waveform to be displayed the opposite way round. Starting from the sync pulse top left we have the black step then we go down to peak white via the blue, red, magenta, green, cyan and yellow steps. The peak white step is not fully resolved in this oscillogram.

**Primary-colour Signals**

Each colour-difference signal—(b), (c) and (d) in Fig. 2—will also be seen to have a total of six horizontal steps. These correspond to the colour bars in the order of picture tube display. If we feel like it we can add or subtract—as they swing both positive

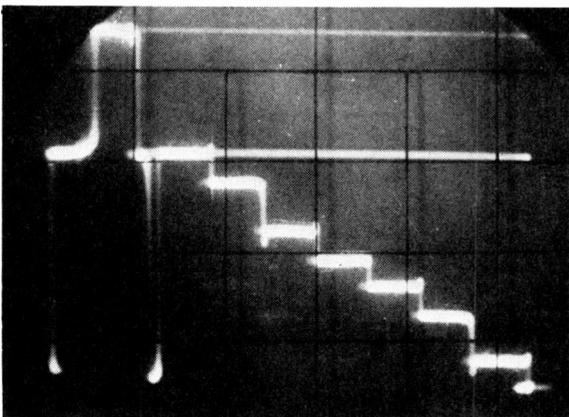
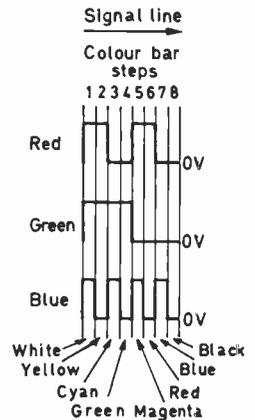

Fig. 3: Oscillogram of the  $Y$  signal (see text about the mirror image effect).

Fig. 4: When the  $-Y$  signal—(a) in Fig. 2—is separately added to the colour-difference signals—(b), (c) and (d) in Fig. 2—we get the three primary-colour signals shown here (for the colour-bar test signal). The eight intervals or steps of the  $-Y$  signal corresponding to the standard colour bars are identified here from white through to black across the screen from left to right.



and negative in polarity—the colour-difference signal steps and the luminance signal steps and in this way resolve the separate primary-colour signals.

The primary-colour signals will come out as drawn in Fig. 4, each of the same amplitude since the saturation of the standard colour bars is consistent and almost 100% over the colours. Eight steps, including the black and white ones, are identified making it possible to see exactly how the three beams combine to give the colours. Starting at the white step we see that all the guns are active, the three colours red, green and blue thus combining to produce white light. On the yellow step the red and green guns are active, red and green light producing in combination yellow light, the complementary of blue which is cut off on this bar. On the cyan step the blue and green guns are active, blue and green light producing cyan light the complementary of red which on this bar is cut off. On the green step only the green gun is active, producing a green display of primary colour. The same principles hold for the other colour bars through to black when of course all guns are cut off.

Colour pictures of course are produced by a wide range of variations in the strengths and combinations of the three primary colours over the screen area, the colour at each picture element being dictated by the colour-difference signals present. All the time the  $Y$  signal is giving all the detail in brightness and definition.

**Colour-difference Channel**

Now let us look at a block diagram of the colour-difference channels (Fig. 5). As with the luminance amplifier each channel consists of a preamplifier and an output stage. The preamplifier is commonly transistorised while in many receivers the output stage uses a valve. The synchronous detectors supply  $R-Y$  and  $B-Y$  signals only and as mentioned earlier the  $G-Y$  signal must be created from these two signals. It is probably best to see how this is done by looking at a fairly typical colour-difference preamplifier

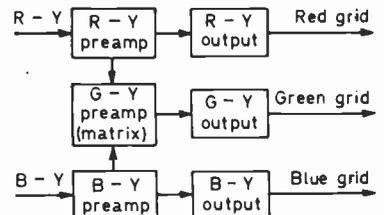

Fig. 5: Block diagram of a colour-difference pre-amplifier channel and  $G-Y$  matrix.

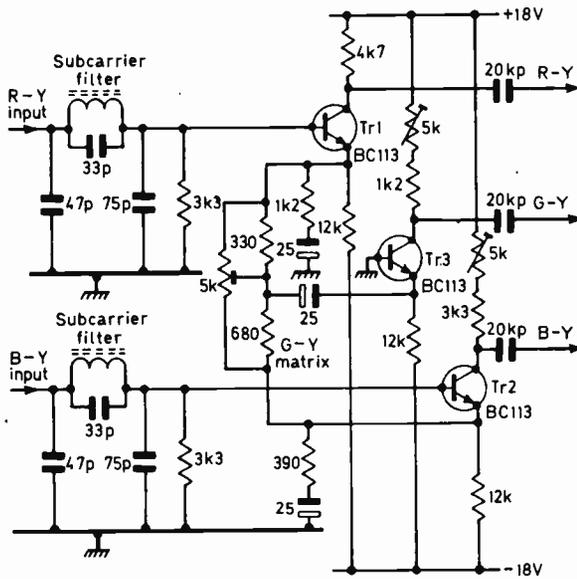

Fig. 6: Circuit of a representative colour-difference preamplifier channel with G-Y matrix.

circuit. In Fig. 6 Tr1 is the R-Y preamplifier, Tr2 the B-Y preamplifier and Tr3 the G-Y preamplifier. The bases of Tr1 and Tr2 receive the R-Y and B-Y signals respectively from the synchronous detectors via low-pass filter circuits which eliminate residual chroma signal.

From the point of view of the R-Y and B-Y signals transistors Tr1 and Tr2 are both in the common-emitter mode. However the emitters also deliver signals and it is these that are matrixed to produce the G-Y signal. The matrix network consists of the 5k $\Omega$  potentiometer and associated fixed resistors whose junction feeds signal via the 25 $\mu$ F electrolytic to the emitter of the G-Y preamplifier Tr3. This transistor is arranged in the common-base mode so that its output will be in phase with the R-Y and B-Y signals at the collectors of Tr1 and Tr2. Thus we have R-Y, G-Y and B-Y signals at the collectors of the three transistors and these are communicated to the output valves. Before we go on to this however let's see how the G-Y signal is produced by matrixing the R-Y and B-Y signals.

### Recreating the G-Y Signal

It will be recalled that the Y signal is brewed from  $0.3R + 0.59G + 0.11B$ . To simplify we'll round off the figures to  $0.3R + 0.6G + 0.1B$  which is near enough for our purpose. R, G and B correspond to the red, green and blue primary-colour signals and the percentages are given in terms of decimals: thus 0.3R simply means 30% red signal.

If we subtract Y from both sides of  $Y = 0.3R + 0.6G + 0.1B$  we get  $0 = 0.3(R-Y) + 0.6(G-Y) + 0.1(B-Y)$ . We are interested in extracting G-Y so we can change the expression round (noting the change of signs) to give  $0.6(G-Y) = 0.3(R-Y) - 0.1(B-Y)$ . Now dividing this out by 0.6 (to get rid of the 0.6 in front of the (G-Y)) we end up with  $G-Y = 1/2(R-Y) - 1/6(B-Y)$ . Sometimes the G-Y signal is expressed as  $0.51(R-Y) - 0.19(B-Y)$ , which is pretty well the same thing. If we are

interested in obtaining a  $-(G-Y)$  signal then the expression is merely changed to  $1/2(R-Y) + 1/6(B-Y)$ .

However one looks at it therefore the matrix merely accepts R-Y and B-Y signals from the appropriate preamplifiers or associated circuitry and adds or subtracts one to or from the other in the approximate ratios of 1/2 and 1/6, whether addition or subtraction is carried out depending on the drive phase requirements. Some chassis, notably the Rank-Bush-Murphy single-standard one, use part of an integrated circuit for handling the G-Y matrixing.

In Fig. 6 the R-Y and B-Y signals are of the correct phase for matrixing at the emitters of transistors Tr1 and Tr2. The colour-difference output signals from the preamplifiers (Fig. 6) must be negative-going since we get a phase-reversal in each colour-difference output valve and require positive-going drive signals at the picture tube grids. Now since Tr3 is in the common-base mode the signal at its collector is of the same phase as the signal applied to its emitter, which means that the matrix must yield a  $-(G-Y)$  signal. The matrix thus adds the R-Y and B-Y signals in the ratios already mentioned.

### Preamplifier Circuitry

The preamplifier transistors have gains such that 500mV peak-to-peak full-drive signals from the synchronous detectors are boosted to several volts for application to the grids of the colour-difference output valves. An equal-luminance drive system requires different drive voltages for the different colours. The preamplifier outputs can be adjusted to secure the required conditions by the preset resistors in the collectors of Tr2 and Tr3.

The correct form of the G-Y signal is obtained by regulating the 5k $\Omega$  preset potentiometer of the matrix circuit. There are various ways of making the adjustment for optimum results. One is by using the standard colour bars as transmitted or as produced by a colour-bar generator, the adjustment being made for the best green display. This can introduce complications however, especially when the drive presets are wrong. As this subject is somewhat involved and requires more knowledge of the colour-difference output stages we will leave it until next month.

### Signal Weighting

One final point. The V and U chroma signals are "weighted", i.e. reduced in amplitude by set amounts, at the transmitter to avoid over-modulation. The correct levels are restored in the colour-difference preamplifier stages by presetting the gains of the R-Y and B-Y preamplifiers. This is the reason for the different values (1.2k $\Omega$  and 390 $\Omega$ ) of the a.c. coupled bias resistors in Tr1 and Tr2 emitter circuits.

CONTINUED NEXT MONTH

## NEW FROM ANTEX

Antex have introduced a new soldering kit, the SK2, which consists of a 240V 15W miniature soldering iron fitted with  $\frac{1}{8}$ in. bit, two spare bits  $\frac{1}{16}$ in. and  $\frac{3}{32}$ in., coil of cored solder, heat sink, 1A fuse and their booklet *How to Solder*. The recommended price (UK) is £2.40. Antex, Mayflower House, Plymouth, Devon.

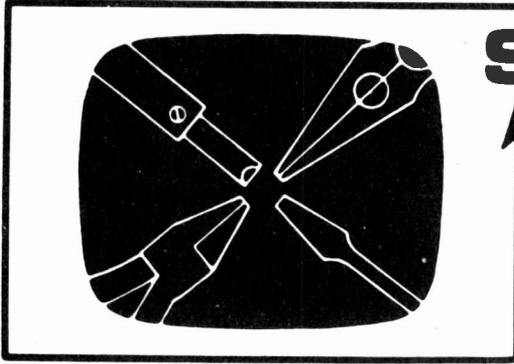

# SERVICING television receivers

L. LAWRY-JOHN'S

PHILIPS STYLE 70 SERIES—cont.

## Field Timebase

Undoubtedly the weak link here is the PCL85 (PCL805). Whatever queer things are happening to the height and vertical stability (top or bottom compression, rolling, jittering or just no field scan at all—white line across the centre etc.) change this valve first. Try two, the first one may not be too good although it is new. Then check the bias resistors to make sure first that they are there and secondly that they are of the correct value. They are R443 and R444, both 560Ω.

Having checked the valve and the resistors observe the resulting picture. If it is sadly lacking height with severe bottom compression check C425 which may be open-circuit. Shunting another 100μF electrolytic across it is a quick check. This is easy of course.

What isn't so easy is when one is faced with top compression which does not respond to valve changing, resistor checks or adjustments. Check all the resistors and capacitors in the linearity circuit from L107 (transformer linearity winding) back to pin 9 of the PCL85 base. You may find a faulty one, usually C422 or R440.

There are however times when all is in order here but the top distortion remains. Yes, you're right, it's the transformer which has a faulty winding. A temporary part remedy is to hook up an 0.01μF (1kV) capacitor from the pin 6 end of the winding L106 to R437 and disconnect L107. This is not wholly satis-

factory and a new transformer should be obtained as soon as possible.

Now here is another naughty one. If there is no field scan and all voltages appear to be in order (including pin 6 to prove the transformer) and a hum check to pin 9 does not open out the raster at all consider the possibility of an open-circuit in the field deflection coils.

Disconnect one side of the coils (so you don't read through the transformer secondary) and check the continuity with an ohmmeter. If there is no reading check the fine wire connections and then face up to fact that the coils are at fault and that a new set is called for. If coils are fitted which are not of the same make as the original don't be dismayed if the resulting picture is reversed with the writing appearing as though viewed through a mirror or (and!) upside down. We can't all get the connections right the first time.

## Reduced Height

It is often the case that the height of the picture has reduced evenly top and bottom with the height control at its maximum. In this case check from pin 1 across resistor R446 which should record 1.5MΩ. This resistor tends to hide behind the height control but there is no reason why a replacement should not be wired on the print side if this is more convenient.

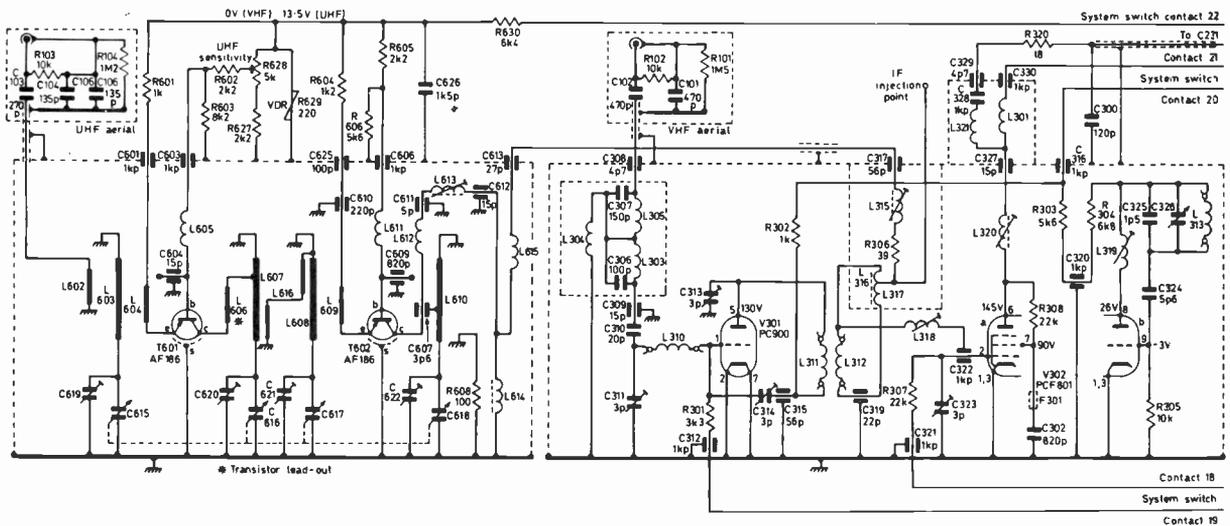

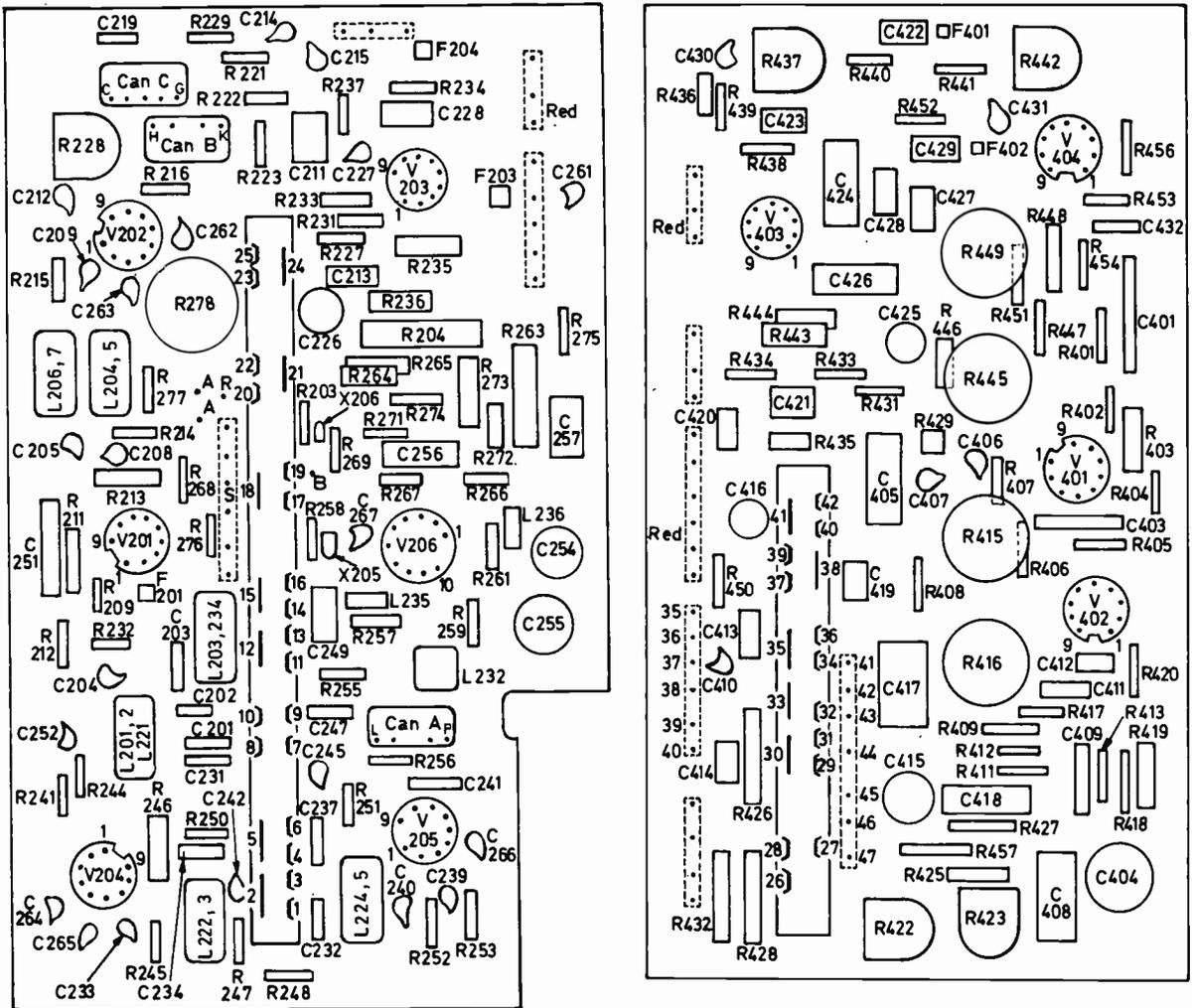

Fig. 3: Layout of the i.f. and timebase printed panels.

If this resistor is found to be in order check R428 and ensure that C414 has not shorted to the h.t. line.

### Field Hold

Resistor R447 tends to change value on occasions resulting in the hold control being at the end of its travel. This one is in a fairly exposed position just to the right and between the height and hold controls. If this resistor is in order don't overlook the EF80 V404. We tend to regard these valves as everlasting but they can play tricks on occasions causing field hold troubles and indeed no scan at all. It is after all half the field oscillator. This all assumes that the PCL85 has been checked as we said at the outset.

### Line Hold

Reverting to the line timebase a frequent source of trouble is a defective ECC82 valve. There are two of these. V402 is the oscillator and failure of this one results in complete stopping of the timebase and overheating of the output valve. Loss of emission causes the line speed to rise and vary. This however is a symptom which could also be caused by a defective

V401—as well as the more usual loss of line sync generally caused by this valve. By loss of sync we mean inability to lock the picture in a horizontal sense, the picture bending off and streaming away one moment then hovering about the screen and dissolving into lines the next.

### Video Stage

If we appear to have spent a lot of time discussing timebase faults it is because this is where the majority of the trouble occurs. We now turn to the video and sync separator stages, coupling these together since they are closely related, both operations being carried out by the same valve V206 (PFL200).

Let's kick off here with a fault which has puzzled many. The symptoms are that the picture is perfectly normal when the contrast is kept down but as it is advanced to produce a more black-and-white picture the sync is impaired with line pulling and rolling and the detail is smeared. Quite clearly the operation of the sync separator is being upset by the contrast control and a look at the circuit will show that the contrast control which is at a positive potential is closely coupled to the sync separator control grid. This must

not be allowed to become positive and is prevented from doing so by the diode X206 (BA115). If this diode is open-circuit it can no longer conduct and stop the line from becoming positive. The usual back-to-front reading can be made with an ohmmeter without disconnecting the diode: if the diode is open-circuit a high reading will be obtained both ways.

A similar set of conditions arises when (if) C257 leaks but here the contrast control would not be the determining factor.

### Excessive Brightness

If the picture is inclined to be overlight and lacking in correct contrast first check the PFL200. This tends to draw grid current—particularly on 625—and was a very common fault some time ago. It was recommended that the 625-line grid-coupling components be changed to reduce the chances of this happening. Capacitor C429 was changed to 0.1 $\mu$ F and the grid leak R258 reduced to around 220k $\Omega$ . Improvements in the design of the valve have rendered this change unnecessary of late and the trouble is now far less common. However the PFL200 is still the chief suspect when weak contrast and a light picture are the symptoms exhibited.

A weaker than normal picture, this time accompanied by poor sync, is often caused by a faulty electrolytic capacitor in the video stage. Both C255 (20 $\mu$ F) and C254 (250 $\mu$ F) should be checked, remembering that C255 is at h.t. potential. A 16 $\mu$ F or 32 $\mu$ F electrolytic rated at 275V or over can be used in this position.

### DC Restorer

If on 625 lines the general background level seems to vary, giving dark scenes an overall grey effect, check the BA115 diode X205. This can become open-circuit in the same way as the diode in the contrast circuit.

### IF Circuits

Generally the only trouble experienced in the vision and sound i.f. strips is when a short develops in a valve, particularly the EF184. This results in R256 burning out and tends to direct suspicion to the decoupler C241 which could well in fact be at fault. Usually however it is the EF184 which is responsible.

The other defects are of a more general nature—poor switch contact, dry-joints in or at the base of the i.f. coil cans etc.—but it is difficult to itemise or describe the precise nature of these symptoms.

The alignment of the 625 sound i.f. coils seems to alter as time goes by but great care must be used in altering the core settings and this should be avoided if possible.

### Audio Stages

Now and again trouble is experienced in the PCL82 sound stage. Usually the valve itself runs into grid current and either damages the bias resistor R235 or causes the 100 $\Omega$  h.t. feed resistor R236 to drop off. The value of the bias resistor is 470 $\Omega$  and this value should be checked whenever it is found necessary to replace the PCL82. R234 may occasionally go high to cause distortion on a strong signal but it is usually the valve itself which causes all signals to be distorted.

### Tuner Units

A transistorised tuner is used for u.h.f. reception and this rarely gives trouble except from a mechanical point of view. If signals are suddenly lost when a button is depressed and no other button will receive a signal it is likely that the teeth of the quadrant have become disengaged from the cog and the spring has pulled it completely away.

Variation of signal strength, fading etc. are most likely to be due to poor contact in the two-pin plug and socket which connects the output of the v.h.f. tuner to the i.f. panel left side. Moving this rubber-covered plug will quickly confirm this. Note that this is the output of the v.h.f. tuner but that this defect will be common to both standards. To explain this, the output of the u.h.f. tuner is taken to the v.h.f. tuner for further amplification and therefore the i.f. output of the v.h.f. tuner is common to both standards.

It is the v.h.f. tuner which is likely to give trouble if the set is used on 405 lines or relay. These troubles are mainly due to poor contact between the biscuit studs and the spring bank and should respond to the usual cleaning. The awkward one is when the fine tuner plunger shaft snaps making tuning of the v.h.f. signals impossible. This fault and the action necessary to renew the core were fully described in our December, 1968 and January, 1969 issues.

**NEXT MONTH: GEC/SOBELL 2012/1012 SERIES**

### DYNAMIC TV PICTURES

In using the circuit featured in our April issue (page 254) it has been found that with the wide diversity of i.f. strips and video output valves encountered it is often necessary to increase the maximum signal output from the transistor stage.

This can be done by reducing the value of R2, the lowest value permissible being set by the voltage rating of the transistor used — BFY51 in the prototype. The BFY51 has a maximum collector voltage rating of 30V and with this transistor this is the limit which must not be exceeded when there is no signal input. Norman McLeod writes that he has used as low a value as 15k $\Omega$  for R2 and that with this value the voltage across C5, C6 and C7 never rises much above 10-20V except when changing channel. He also comments that a 47 $\Omega$  grid stopper can be added in series with V1 grid but that this should not be necessary as the stage is quite stable.

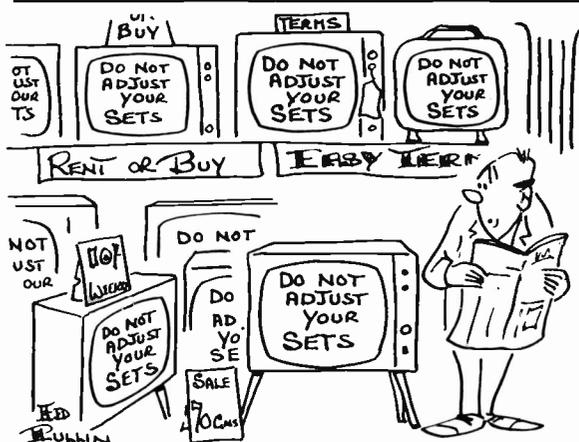

# DX-TV

ON Sunday, 14th March, 1971, in the late afternoon, Charles Norman Rafarel passed peacefully away. His death came as a tremendous shock to us all, and he will be sadly missed. Those who knew Charlie personally—and he had many friends—will remember him as a very active and enthusiastic figure. His love of television dated back to the 1930s when he constructed a mechanical scanning televisor—which worked. Within recent years this machine was presented to the ORTF museum in Paris. Following the last war and in the 1950s his interests were in long-distance television reception, but towards the end of the fifties he became well known for his short-wave listening on the Amateur Bands.

His old love, television, caught up with him again in 1960 and at Parkstone near Poole he commenced experiments into the daily reception of Caen ch.F2. In due course a Bush Model TV62 was modified for DX use and his television horizons expanded. With the excellent Sporadic E conditions of those days he became absorbed with TV-DX. Undaunted by the collapse of two 50ft. masts, a lattice mast taller and magnificent indeed arose from his garden. Our photograph illustrates this and underlines his enthusiasm for this hobby.

In September, 1963, the first DX-TV column appeared in PRACTICAL TELEVISION, giving news and information for the followers of this passtime. It quickly grew in popularity with letters arriving from DXers all over the world. In May, 1966, Charlie was taken ill. Fortunately he recovered to almost his former self and at this time he moved to a different

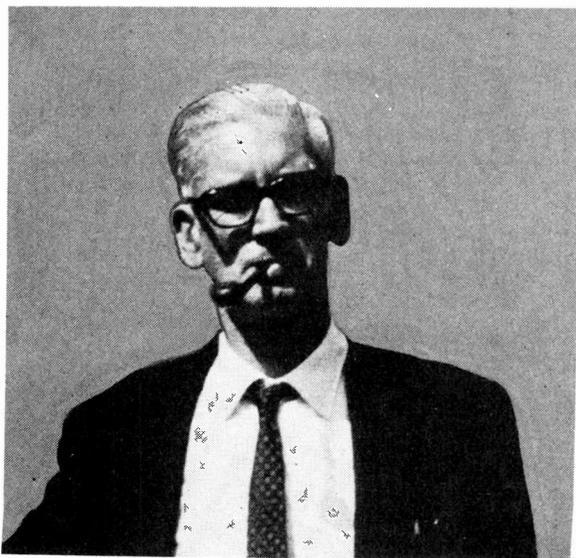

Charles Norman Rafarel

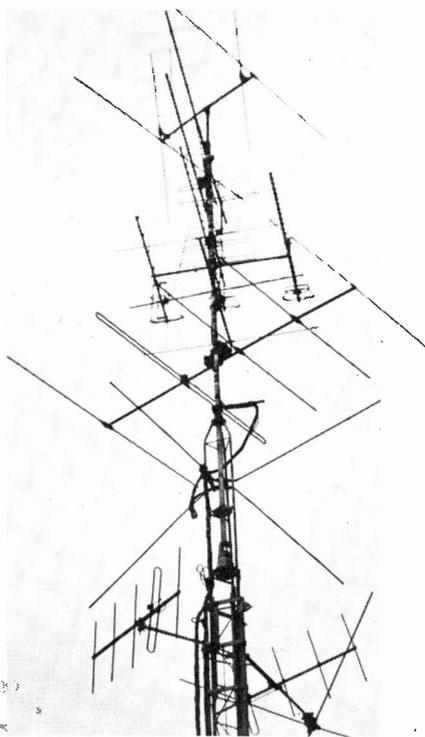

Charles's aerial installation at Bournemouth.

location in Bournemouth. More recently he travelled widely in Europe including behind the Iron Curtain. Only months ago a colour receiver was installed at his home; he was as always anxious to experiment further with his great love, TV-DX.

Charlie did much to increase interest in TV-DX. He was always willing to help anyone in the various problems which are encountered. Today in Britain TV-DX is a thriving hobby and most of this is due to Charlie. He will be sadly missed.

We would like to extend to his wife Maisie our sincere condolences in her sad and unexpected loss.

Rest in peace, Charlie.

Roger.

THE DX-TV column will resume its normal presentation and layout next month but under the new heading *Long-Distance Television*. A run-down of the month's reception will be given, news from enthusiasts and extracts from their letters will be maintained together with notes on the opening of new transmitters and other news from the Continent and indeed the world. It is hoped to commence within the next two months a new series of "data panels" showing the latest test patterns and cards from all countries in the European Broadcasting area. This will include North African and Middle Eastern countries. We will include the latter first to make the series as comprehensive as possible, secondly so that they are known in the event of one of these countries opening up in Band I and also for the assistance of our readers overseas. Very occasionally we will have as separate articles items on subjects such as preamplifiers, etc. suitable for DX use. For example towards the end of the year I hope to present information on wideband aerials for Band I.

We are always pleased to hear from readers of

their reception and experiences and will be delighted to assist with their problems be they of programme identification or queries about equipment and aerial installations. If news comes to hand of changes in test cards, transmitters and so on please let us know in order that we can inform other enthusiasts. For example Doug Bowers of Saltash writes to advise us of changes with the Norwegian test card. We will also be pleased to hear from our many overseas readers: let us know about your reception—especially if unusual types of propagation are experienced.

At the time of his death Charlie was working on a pamphlet giving information on various aspects of DX-TV. I intend to continue and finish this project but there is likely to be some delay. So please understand and be patient whilst certain problems at this end are sorted out.

### MARCH REPORT

Now a quick run over the news of the last month—March. It was generally rather quiet with the usual short bursts of m.s. and Sp.E. On the 3rd, 4th and 5th there were sustained Sp.E signals into Eastern Europe; rather surprisingly these openings occurred at around the same local time each day—at 1730-1830.

3/3/71 USSR R1.  
4/3/71 Unidentified R1.  
5/3/71 USSR R1, Czechoslovakia R1, Unidentified R2.

The 12th and 13th showed an improvement in Trop with various Northern French stations and NOS Holland E4.

At around this time of the year Sp.E tends to increase compared with the winter months' quiet conditions. During the first half of the 1960s a good Sp.E season started typically with a mid-April opening and then the real season opening towards the middle of May. During recent years however these April openings have been lacking and the seasons themselves have left much to be desired. By the time you read this we should be in a position to know if we are to have a good season. Certainly with the falling sunspot figures it would appear that our chances are better. Let's hope so.

### NEWS IN BRIEF

New transmitters in operation:

**Belgium:** Wavre ch. 25, 1000kW horizontal (BRT).  
Wavre ch. 28, 1000kW horizontal (RTB).  
**Iceland:** Hafell ch. E7, 440kW horizontal.  
(This might just be possible for Scottish DXers via Trop and during an Aurora.)  
**Portugal:** Porto ch. 41, 300kW horizontal (RTP 2).  
Montejunto ch. 46, 200kW horizontal (RTP 2).  
**Sweden:** Kiruna ch. 29, 1000kW horizontal.  
Gaellivare ch. 33, 100kW horizontal.  
Aange ch. 42, 250kW horizontal.  
Lycksele ch. 45, 1000kW horizontal.  
Sollefteaa ch. 46, 1000kW horizontal.  
All 2nd chain.

The sound e.r.p. of all Swedish transmitters was reduced from 20% to 10% from 15th November, 1970.

**Finland:** We have heard that Finland Helsinki ch. 24 is now off the air. It was apparently used for training engineering staff and closed 31st December last.

Jyvaskyla ch. 25 is now transmitting, e.r.p. not known at present.

Our good friend Sepp J. Pirhonen in Finland has

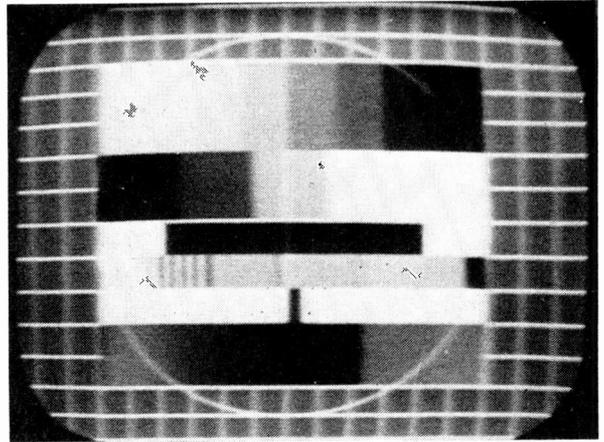

*The electronic test card now used by Finland.*

sent us useful information. Apparently the test card has changed to a new electronic type and is radiated daily at 0700-1200 GMT with the exceptions of Tuesday, Thursday and Saturday. On these days between 1000-1145 various patterns and slides are shown. The new card is similar to that shown here except that it carries the identification YLEISRADIO in white letters in the central black rectangle and that the TV2 network omits the circle. Usually the TV2 E2 transmitter at Tampere is off the air from 1st June to approximately mid-August and we must I think assume that the same will happen this year. This still leaves a number of TV1 transmitters in Band I fortunately. (Note that W. Germany also uses variations of this card.)

Charlie's last column gave interesting details of Albania. One slight correction however: the transmissions are being received on R6 and are manifesting themselves as interference on the local RA1 transmitter. If anyone has information on Albania we would appreciate hearing about any TV activity there.

Unfortunately the sunspot details from the Swiss Solar Observatory were held up in the postal dispute and are only just beginning to trickle through. The January list gave smoothed predicted counts for May of 75, June 73 and July 71. Being somewhat below last year's count at this time this augurs well for the forthcoming season.

If space next month permits I will give a brief survey of F2 activity over the past winter, both of European and reception farther afield.

*Roger Bunney.*

### POINTS FROM THE POST

Reader D. Fowler of 18A Udney Park Road, Teddington, Middx, will be emigrating at the end of the year and wishes to dispose of the "625-line Receiver for the Constructor" he has built and also back copies of the magazine. Anyone interested should send him a stamped, addressed envelope for details.

Another reader has bought a Channel TV wave-form generator, type T2, serial No. 43490. The original firm is no longer in business and he requires a circuit diagram. Let us know if you can help.

R. L. Smith of 8 Hillside, Oswestry, Salop, wants to contact anyone who has made up a field sequential colour converter system.

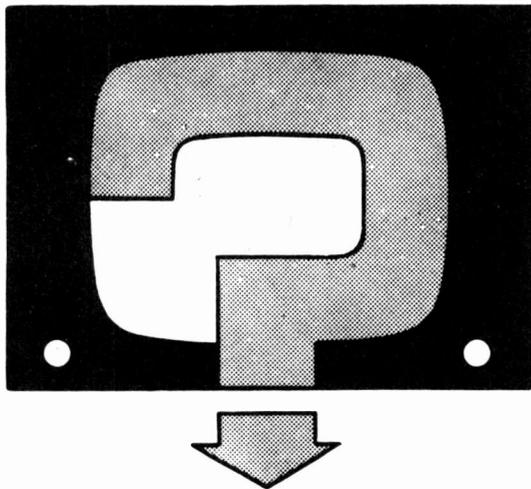

# YOUR PROBLEMS SOLVED

★ Requests for advice in dealing with servicing problems must be accompanied by a 10p postal order (made out to IPC Magazines Ltd.) the query coupon from page 378 and a stamped, addressed envelope. We can deal with only one query at a time. We regret that we cannot supply service sheets or answer queries over the telephone.

## PHILCO 5600

Two resistors in the circuit near the PCL84 video output valve are badly overheating. These are numbered R76 and R77 on the board but unfortunately I cannot obtain a service sheet for this model—G. Lee (Colne).

This model was fitted with the same chassis as the Ferguson 3600 group of models. R76, the stabilising resistor connected between screen and cathode, is  $47\text{ k}\Omega$  while R77 picture quality control in the cathode circuit is  $100\Omega$ . The PCL84 may need replacement and we suggest you check the voltages in this stage, cathode 6V screen grid 175V and anode 110V. If the valve has to be replaced you might also find it necessary to replace the OA70 vision detector diode W3 inside can L36-L37.

## INVICTA 7007

The picture is a narrow strip about 2in. wide across the centre of the screen. All manual controls have been adjusted without improving matters. The field timebase printed panel is mounted at the top right-hand side close to the e.h.t. connection on the tube and the capacitors on it are all blackened. A  $16+16+16\mu\text{F}$  capacitor close to the panel appears to be faulty with a white discharge to chassis.—E. Hopecraft (Swansea).

The appearance of the paper type capacitors is quite normal and the fact that they are blackened does not affect their efficiency. You may find if there is a fault present that one or two of them are leaky. However you should first replace the PCL85 field timebase valve which is the principal offender here. Then check the voltages at its base. The weeping electrolytics you mention should be replaced at an early date.

## HMV 2635

This receiver has poor line linearity when switched to 625 lines with compression at the centre of the test card. On 405 lines the field and line linearity are good. All timebase valves have been renewed.—A. Boyd (Cheam).

Check C98 ( $0.1\mu\text{F}$ ) the S-correction capacitor on 625 lines. This however may not be at fault and the boost reservoir capacitor C101 ( $0.22\mu\text{F}$ ) should also be checked together with the adjustment of the line drive control.

## MARCONIPHONE 4609

The picture has developed a constant downwards roll which cannot be overcome by adjusting the vertical hold control which is over to its full range. The field timebase valve has been replaced without improving matters. Otherwise the picture is normal.—F. Stephens (Evesham).

Check the value of the  $22\text{ k}\Omega$  resistor R138 behind the 6-30L2 (V7) valve at the front centre of the lower deck. This resistor, the anode load of one section of the field multivibrator, should be replaced with a  $22\text{ k}\Omega$  1W type. Also check the resistors—R144, R116—associated with the hold control.

## GEC 2019

The fault is line pulling to the left on whites. The vision definition is impaired suggesting that the trouble lies in the video stage rather than the sync separator. The vertical and horizontal locking is very good even with the contrast turned down to minimum. The EF183, EF184 and PFL200 have been renewed and all voltages seem to be correct.—L. Bradshaw (Rugby).

Pulling on whites is not a fault which normally affects these models so we would suggest you first look for some possible external cause of the trouble such as ghosting from the aerial. If everything seems OK check the sync coupling capacitor C104 ( $0.22\mu\text{F}$ ).

## FERGUSON FR19

For about an hour after switching on the picture fades. It can be brought to full brilliance by changing the channel switch to another position and back again but fades away again after a minute or two. The tuner switch contacts have been cleaned and the PCC89 replaced with no improvement.—F. Bilson (Grantham).

It is not easy to localise a fault of this type. Although the tuner contacts have been cleaned the trouble could still be in this area due, for example, to a poor contact on a valveholder or a dry-joint. There is no reason why the fault should be confined to the tuner, however, and it would perhaps be useful to probe around the i.f. panel valves and capacitors to see if the fault can be provoked by a disturbance in a particular area.



## NEW LINE OUTPUT TRANSFORMERS

**ALBA** 655, 656, 717, 721 £3-75. 890-895, 1090, 1135, 1195, 1235, 1395, 1435 £5-90.  
**BAIRD.** Prices on request. From model 600 quote part no. normally found on TX base plate.  
**BUSH** TV53 to TUG69 £2-00. TV91 to TV139 £4-75. (From Model TV123 an alternative Square Tag Panel was fitted on Main Bobbin, please state if required.) TV141 to TV176 Rewind £4-50.  
**COSSOR** 904 to 957 Rewind £4-50. CT1700U to CT2378A £5-90.  
**DECCA** DM1, DM3C (90°), DM4C (70°), DR1, DR2, DR121 £4-50.  
**DEFIANT** 7P20 to 7609. Prices on request.  
**DYNATRON** TV30, TV35, TV36, TV37, TV38, TV39, TV40, TV41, etc. £4-00.  
**EKCO** T231, T284, TC267, T283, T293, T311, T326, T327, T330, TMB272, T344, T344F, T345, TP347, T348, T348F, TC347, TC349, TC356, T368, T370, TC369, T371, T372, TP373, TC374, T377A, T393, T394, 433, 434, 435, 436, 437 all at £4-00. 503, 504, 505, 506 £4-75.  
**FERGUSON** 306T, 308T, 406T, 408T, 416, 436, 438, 506, 508, 516, 518, 536, 546, 604, 606, 608, 616, 619, 636, 646, 648, 725, 726, 727, 3600, 3601, 3602, 3604, 3611, 3612, 3614, 3617, 3618, 3619, 3620, 3621, 3622, 3623, 3624, 3625, 3626, 3627 3629 £4-00. Jelly Pots, please state colour: red, black or white.  
**FERRANTI** T1001, T1002, T1002/1, T1004, T1005, T1023, T1024, T1027, T1027F, TP1026, T1071, T1072, T1121, TC1122, TC1124, T1125, TC1126 £4-00. 1154, 1155 £4-75.  
**G.E.C.** BT302, BT342 £3-50. BT454DST-456DST, 2010, 2013, 2014, 2012, 2000DS, 2001DS, 2002DS £4-25.  
**H.M.V.** 1865, 1869, 1870, 1872, 1874, 1876, 1890, 1892, 1894, 1896 £4-00.  
**KB** OV30, NF70, NV40, PV40, QV10, QV30, RV10, RV20, RV30, PVP20 £4-50. Featherlight £4-50. Chassis No. VC1-VC2-VC3-VC4 £4-50.  
**MASTERADIO** 4013 DST, D500 DST, D507 DST £4-25.  
**MARCONI** VT153, VT155, VT156, VT157, VT159, VT161, VT163, VT165, VT170, 4611, 4800, 4801, 4803, 4615 £4-00.  
**PAM** 600S to 822F £4-00.  
**PETO SCOTT.** Prices on request.  
**PHILCO** 1019, 1020, 2021 £4-13. 1029, 1030, 1035, 1036, 1040, 1050, 1060 £4-13.  
**PHILIPS** 11TG190 to 24T301 £5-90. 1768U to 2196U Rewind £4-75 (old unit required).  
**PILOT** PT450, 452, 455, 650, PT651, P60A, P61 £4-00.  
**PYE** V200, V400, 200LB, 210, 220, 300F, 300S, 310, 210S, 410, 510, 530, 600, 620, 630, 700 A or D, 710 A or D, 830 A or D or LBA £4-00. 11U Series. 11U-P/NO, AL21003, 21F to 61. Part Nos. must be given when ordering Pye LOPTS £4-00.  
**REGENTONE** 197-198, 298, TV402, TV401, TV501, TV502 £4-50.  
**R.G.D.** 626, 627, 628, 726, RV202, RV302 £4-50.  
**SOBELL** 1000DS, 1002DS, 1005DS, 1010DST, 1012, 1013, 1014, 1018, 1019, 1020, 1021, 1032, 1033, 1038, 1039 £4-25.  
**STELLA** T1011U to 2149A £5-90.  
**ULTRA** 1770, 2170, 1772, 1782, 1771, 1771, 1775, 2175, 1774, 2174, 1773, 2137, 1980c, 1984c, 100c, 200c, 2380, 2384, 1984, 1985, 1986, 1980, 1980a, 1780, 2180, 2181, 2183, 2182, 1871, 1783, 6600, 6625, 6626, 6628, 6632, 6642 etc. £4-00.  
 We can rewind most LOPT £4-75.

*Post and Package 26p. C.O.D. 30p extra.*

### LINE OUTPUT TRANSFORMER INSERTS ONLY

**BUSH** TV92-TV93, TV94-TV95-TV96-TV97, TV98, TV100, TV101, TV103, TV104, TV105, TV106, TV108, TV109, TV110, TV113, TV115, TV115R, TV115c, 123, 125, 128 £2-75. Complete with heater windings. TV75, TV85 £2-75.  
**DECCA** DR95, DR101, DR202, DR303, DR404, DR505, DR606 £2-75.  
**EMERSON** E700, E701, E704, E707, E709, E710, E711, Portarama £2-00.  
**FERGUSON** 204T, 205T, 206T, 214T, 235T, 236T, 244T, 245T, 246T £2-00.  
**FERRANTI** 14T2, 14Tc, 14T3F, 14T4, 14T4F, 14T5, 14T6, 17K3, 17K3F, 17T3, 17T3F, 17K4F, 17K6, 17SK6, 17T4, 17T4F, 17T5, 17T6, 21K6, 21K6V £2-00.  
**INVICTA** T118, T119, T120 £2-50.  
**KB** PV40, MV100, OF100, PV100, NV40, NF70, OV30, QV10, QV30 £2-00 pair.  
**PETO SCOTT** 1416, 1418, 1419, 1422, 1423, 1716, 1719, 1720, 1722, 1723, 1724, 1725 £1-48.  
**PYE** V4, VT7, CTM4, TCM7 £2-50.  
**REGENTONE** 10-4, 10-6, 1021, 17-18, 10-12 £2-00. T176, TT7, 191, 192 £2-00.  
**R.G.D.** Deep 17, The 17, 590, 600, 606, 611, 710, 723 £2-00.  
 Guarantee. Post and Package 26p. C.O.D. 30p extra.

### NEW REPLACEMENT L/OP/TX

**MURPHY** £5-90 26p P.P.  
 V310 TO 789

#### REPLACEMENT DROPPERS

Philips Type 30+125+2-85 63p. P.P. 7p.  
 Ferguson, H.M.V., Marconi, Ultra 800 & 850 Series (Convertible) 37+31+97+26+168. 63p. P.P. 7p  
 As above 85 series (Dual Standard) 14+26+97+173 63p each. P.P. 7p

#### HIGH VOLTAGE PULSE CERAMICS

10, 15, 22, 33, 68, 82, 100, 120, 140, 155, 180, 220, 250pf. 9p. P.P. 3p

#### T.V. CANNED ELECTROLYTICS

64-100. 450v. £1-23 each. P.P. 17p  
 100-200. 275v. £1-10 each. P.P. 17p

#### T.V. CANNED ELECTROLYTICS

100-200. 350v. £1-23 each. P.P.	150-100-100-100-150
100-200-60. 17p	320v. £2-05 each. P.P. 17p
300v. £1-23 each. P.P. 17p	200. 350v. 95p each. P.P. 17p
100-300-100-16. 17p	200-200-100.
275v. £1-50 each. P.P. 17p	350v. £1-93 each. P.P. 17p
100-400-275v. £1-15 each. P.P.	300-300. 300v. £2-00 each. P.P.
17p	17p
100-400-16. 17p	125+200+100+32-275v. £1-40
275v. £1-50 each. P.P. 17p	400+400-350v. £2-30

#### POWER RESISTOR SECTIONS

These wirewound sections enable you to build up any Mains Dropper to your requirements. A central 2BA hole is provided for mounting.

Ohms 7, 9, 10, 12, 14, 17-5, 20. All at -7A .. .. .	21p each
Ohms 22, 25, 28, 30, 33, 36. All at -7A .. .. .	26p each
Ohms 40, 47, 52, 56, 60, 63, 66, 75, 87, 100 at -3A .. .. .	21p each
Ohms 120, 140, 160, 180, 200, 220, 250, 270 at -3A .. .. .	26p each
Ohms 300, 350, 400, 470, 560, all at 12A .. .. .	21p each
Ohms 726 at -15A .. .. .	26p each
K Ohms, 1 K ohm at -1A .. .. .	21p each
K Ohms, 2 (-07A) .. .. .	26p each

Postage each section 3p

**WE CAN STILL SUPPLY PARTS FOR THE CONSTRUCTOR  
 625 RECEIVER. S.A.E. FOR REQUIREMENTS**

CALLERS WELCOME. But to avoid disappointment please phone to check that the items you require are in stock.  
 All new components inserts are guaranteed for three months from the date of invoice subject to the breakdown being due to faulty manufacture or materials. S.A.E. all enquiries.

**Dept. "R" D. & B. TELEVISION (Wimbledon) LTD. 80 MERTON HIGH STREET, S.W.19  
 01-540 3513 01-540 3955**

# BENTLEY ACOUSTIC CORPORATION LTD.

38 CHALCOT ROAD, CHALK FARM, LONDON, N.W.1  
THE VALVE SPECIALISTS Telephone 01-722 9090

0A2	0.30	6BH6	0.43	6R7G	0.35	12AV6	0.28	30PL14	1.763	0.50	DK91	0.28	EL32	0.18	IW3	0.38	PCL82	0.37	QV04/7	0.83	UY41	0.38	
0B2	0.30	6B36	0.43	6SA7G	0.35	12AX7	0.28	30PL12	0.37	1D	0.98	DK92	0.43	EL34	0.53	IW4/350	0.38	PCL83	0.50	R10	0.75	UY85	0.29
0Z4	0.23	6BQ5	0.24	6SA7M	0.35	12AY7	0.48	30PL1	0.32	7193	0.53	DK96	0.37	EL37	0.87	IW4/500	0.55	PCL84	0.38	R11	0.85	UY1	0.45
1A3	0.23	6BQ7A	0.38	6SC7GT	0.38	12BA6	0.30	30PL15	0.48	7475	0.70	DL33	0.35	EL40	0.40			PCL85/85	0.35	R16	1.75	UZ14	0.38
1A5	0.25	6B7	0.79			12BE5	0.30	30PL17	0.78	A1834	1.00	DL36		EL42	0.53					R17	0.85	U16	0.75
1A7GT	0.37	6BR8	0.43	6BG7	0.35	12BH7	0.33	30P4MR	0.78	A2134	0.98	DL34	0.32	EL81	0.50	KT2	0.25	PCL86	0.43	R18	0.50	U17	0.35
1D5	0.35	6B87	1.25	6BH7	0.53	12C1	0.45		0.98	A3042	0.75	DL36	0.32	EL83	0.38	KT8	1.75	PCL88	0.75	R19	0.33	U18/20	0.75
1D6	0.45	6BV6	0.72	6BJ7	0.35	12CT0T	0.33	30P12	0.89	AC044	1.18	DM70	0.30	EL84	0.24	KT41	0.98	PEN43	0.35	R20	0.59	U19	1.73
1F1D1	0.35	6B87	0.72	6BK8GT	0.35	12K5	0.50	30P19/30P4	AC2/PEN	DM31	0.38	ECH21	0.63	EL85	0.40	KT44	1.00	PEN45	0.35	R32	0.59	U2	0.39
1H6	0.30	6B26	0.33			12K7GT	0.23		0.89	DW4/300				EL86	0.40	KT63	0.35		0.75	RG1/240A		U26	0.59
1H5GT	0.35	6C6	0.39	6SQ7GT	0.34			30PL1	0.89	AC2/PEN				EL88	0.40	KT66	0.83	PEN46	0.30	R34	1.38	U31	0.30
1L4	0.13	6C9	0.73			12Q7GT	0.38	30PL12	0.37	AC2/PEN				EL89	0.40	KT74	0.93	PEN48	0.30	R35	0.33	U33	0.30
1LD5	0.30	6CD6G	1.15	6U4GT	0.60			30PL13	0.75	AC2/PEN				EL90	0.40	KT76	0.83		0.98	SP42	0.75	U33	1.50
1LN5	0.40	6C6	0.38	6U7G	0.53			30PL14	0.75		0.38	DY867	0.28	EL91	0.23	KT88	1.70	PEN49	0.98	SP61	0.33	U35	0.30
1N5GT	0.39	6C6L	0.43	6V6G	0.18			30PL15	0.98	AC/PEN(7)				EL92	0.35	KT88	1.70			SP42	0.75	U35	1.50
1R5	0.28	6CW4	0.63	6V6GT	0.33	12RC7	0.35	35A3	0.50	AC/TH1				EL93	0.35	KT88	1.70	PEN49	0.98	SP61	0.33	U35	0.30
1R4	0.24	6D6	0.15	6X4	0.22	12RG7	0.23	35A6	0.75	AC/TH1				EL94	0.35	KT88	1.70			SP42	0.75	U35	1.50
1R5	0.22	6E1	0.63	6X3GT	0.25	12RH7	0.15	35D5	0.70	AC/CTP				EL95	0.35	KT88	1.70			SP42	0.75	U35	1.50
1U4	0.29	6F6	0.43	6V6G	0.55	12S17	0.23	35L0GT						EL96	0.35	KT88	1.70			SP42	0.75	U35	1.50
1U5	0.48	6F6G	0.25	6V7G	0.63	12SK7	0.24		0.44	AL60	0.78	E83F	1.20	EL97	0.35	KT88	1.70			SP42	0.75	U35	1.50
2D21	0.35	6F13	0.33	7B6	0.58	12SQ7GT		35W4	0.23	ARP3	0.35	E1148	0.53	EL98	0.35	KT88	1.70			SP42	0.75	U35	1.50
3A4	0.20	6F14	0.75	7B7	0.35			35Z2	0.50	ATP4	0.12	EA50	1.18	EL99	0.35	KT88	1.70			SP42	0.75	U35	1.50
3A5	1.00	6F15	0.65	7C6	0.30	14H7	0.48	35Z4GT		AZ1	0.48	EA76	0.88	EL100	0.35	KT88	1.70			SP42	0.75	U35	1.50
3B7	0.25	6F18	0.45	7F8	0.88	14H7	1.15		0.24	AZ1	0.48	EA76	0.88	EL101	0.35	KT88	1.70			SP42	0.75	U35	1.50
3D6	0.18	6P23	0.72	7H7	0.28	15A05	0.24	35Z5GT		B31	0.35	E180F	0.95	EL102	0.35	KT88	1.70			SP42	0.75	U35	1.50
3Q4	0.38	6P24	0.68	7K7	0.65	19H1	2.00		0.30	B319	0.32	E1F42	0.50	EL103	0.35	KT88	1.70			SP42	0.75	U35	1.50
3Q5GT	0.35	6P25	0.65	7J7	0.25	20D1	0.65	50B3	0.35	CL33	0.98	E1B34	0.53	EL104	0.35	KT88	1.70			SP42	0.75	U35	1.50
384	0.28	6P28	0.70	7Z4	0.50	20I4	1.05	50C5	0.32	CL33	0.98	E1B34	0.53	EL105	0.35	KT88	1.70			SP42	0.75	U35	1.50
3V4	0.32	6F32	0.16	9B3W6		50P2	0.70	50CD6G		CV6	0.53	E1B91	1.12	EL106	0.35	KT88	1.70			SP42	0.75	U35	1.50
3V4GY	0.53	6HGT	0.15	9J7	0.78	20L1	0.98		2.17	CY31	0.38	E1BC4	0.48	EL107	0.35	KT88	1.70			SP42	0.75	U35	1.50
3V4G	0.38	6J5G	0.19	10C1	1.25	20P1	0.85	50L6GT		CY31	0.38	E1BC4	0.48	EL108	0.35	KT88	1.70			SP42	0.75	U35	1.50
3V3GT	0.28	6J5GT	0.28	10C2	0.50	20P3	0.90		0.45	D83	0.25	E1BC1	0.32	EL109	0.35	KT88	1.70			SP42	0.75	U35	1.50
5Z3	0.45	6J6	0.18	10D1	0.50	20P4	0.93		0.72	D77	0.12	E1BC9	0.30	EL110	0.35	KT88	1.70			SP42	0.75	U35	1.50
5Z4G	0.35	6J7G	0.24	10D2	0.75	20P5	1.00	85A2	0.43	DAC32	0.35	E1B21	0.30	EL111	0.35	KT88	1.70			SP42	0.75	U35	1.50
6B10L2	0.58	6J7GT	0.38	10F1	0.75	25A6G	0.29	85A3	0.40	DAP91	0.22	E1B28	0.40	EL112	0.35	KT88	1.70			SP42	0.75	U35	1.50
6A8G	0.33	6K7G	0.10	10F9	0.45	25L6G	0.29	90A3	3.38	HAF96	0.35	E1B29	0.32	EL113	0.35	KT88	1.70			SP42	0.75	U35	1.50
6A7G	0.15	6K7GT	0.23	10F18	0.35	25Y5	0.38	90A4	3.38	HCC30	1.00	E1B21	0.30	EL114	0.35	KT88	1.70			SP42	0.75	U35	1.50
6A9B	0.25	6K8G	0.39	10L11	0.53	25Y3G	0.43	90A5	1.70	DD7	0.53	E1B28	0.40	EL115	0.35	KT88	1.70			SP42	0.75	U35	1.50
6AK5	0.25	6L1	0.98	10L13	0.65	25Z1G	0.30	90C9	1.68	DF33	0.33	E1C74	0.50	EL116	0.35	KT88	1.70			SP42	0.75	U35	1.50
6AK6	0.30	6L6GT	0.39	10P14	1.10	25Z5	0.40	90C1	0.90	DF91	0.14	E1C86	0.63	EL117	0.35	KT88	1.70			SP42	0.75	U35	1.50
6AM6	0.17	6L7GT	0.63	10P18	0.33	25Z6G	0.43	150B2	0.58	DF96	0.35	E1C86	0.63	EL118	0.35	KT88	1.70			SP42	0.75	U35	1.50
6AQ5	0.28	6L18	0.45	12A6	0.63	30C1	0.30	150C2	0.30	DF97	0.63			EL119	0.35	KT88	1.70			SP42	0.75	U35	1.50
6AR6	1.00	6L19	1.38	12AC6	0.40	30C15	0.65	301	1.00	DH63	0.30			EL120	0.35	KT88	1.70			SP42	0.75	U35	1.50
6AT6	0.20	6L20	0.48	12A16	0.40	30C17	0.80	302	0.83	DH76	0.28			EL121	0.35	KT88	1.70			SP42	0.75	U35	1.50
6AU6	0.25	6N7GT	0.40	12A26	0.48	30C18	0.84	303	0.75	DH77	0.20			EL122	0.35	KT88	1.70			SP42	0.75	U35	1.50
6AV6	0.30	6P28	1.25	12A76	0.23	30F5	0.80	305	0.83	DH81	0.58			EL123	0.35	KT88	1.70			SP42	0.75	U35	1.50
6B8G	0.13	6Q7	0.43	12A77	0.19	30FL1	0.84	306	0.65	DH107	0.90			EL124	0.35	KT88	1.70			SP42	0.75	U35	1.50
6BA6	0.23	6Q7G	0.30	12A16	0.24	30FL2	0.75	807	0.59	DK32	0.37			EL125	0.35	KT88	1.70			SP42	0.75	U35	1.50
6BE6	0.24	6R7	0.55	12A17	0.23	30FL12	0.80	1821	0.53	DK40	0.57			EL126	0.35	KT88	1.70			SP42	0.75	U35	1.50

All valves are unused, boxed, and subject to the standard 90-day guarantee. Terms of business:— Cash or cheque with order only. Post/packing 0.03 per item, subject to a minimum of 0.08. Orders over 5.00 post/packing free. Same day despatch by first class mail. Any parcel insured against damage in transit for only 0.03 extra per order. Complete catalogue with conditions of sale price 0.07 post paid. CALLERS WELCOME! We do not handle seconds nor rejects, which are often described as "New and Tested" but have a limited and unreliable life. No enquiries answered unless S.A.E. is enclosed for a reply.

## Learn at home... First Class Radio and TV Courses



After brief, intensely interesting study—undertaken at home in your spare time—YOU can secure a recognised qualification or extend your knowledge of Radio and TV. Let us show you how. **FREE GUIDE**  
The New Free Guide contains 120 pages of information of the greatest importance to both the amateur and the man employed in the radio industry. Chambers College provides first rate postal courses for Radio Amateurs' Exam., R.T.E.B. Servicing Cert., C. & C. Telecoms., A.M.S.E. (Elec.). Guide also gives details of range of certificate courses in Radio/TV Servicing, Electronics and other branches of engineering, together with particulars of our remarkable terms of Satisfaction or refund of fee  
**Write now for your copy of this valuable publication. It may well prove to be the turning point in your career.**  
Founded 1885 Over 150,000 successes  
**CHAMBERS COLLEGE**  
(Incorp. National Inst. of Engineering)  
(Dept. 244V) Aldermaston Court, Reading, RG7 4PF

## NEW RANGE U.H.F. - TV - AERIALS

All U.H.F. aerials now fitted with tilting bracket and 4 element grid reflector.  
**Loft Mounting Arrays:** 7 element, £22.25; 11 element, £2.62; 14 element, £2.00; 18 element, £3.50. **Wall Mounting with Cranked Arm:** 7 element, £3.25; 11 element, £3.75; 14 element, £4.12; 18 element, £4.50. **Chimney Mounting Arrays, Complete:** 7 element, £4.11 element, £4.37; 14 element, £4.75; 18 element, £5.25. **Complete assembly instructions with every aerial.** Low loss coaxial cable, 81p yd. King Teleboosters-Labgear U.H.F. Boosters from £3.75. **Belling Lee "Concord" all Band V.H.F./U.H.F. mains operated pre-amplifier, £7.50.** State clearly channel number required on all orders. P.P. Aerials, 40p; accessories, 15p. C.W.O. or C.O.D.

## BBC - ITV - FM AERIALS

**BBC** (Band 1): Loft, £1.25; wall S.D., £1.62; 'H' array, £3.00. **ITV** (Band 3): 5 element loft array, £2.25; 7 element, £2.75; wall mounting, 5 element, £3.25. **Combined BBC** (Band 1 & 3): wall mounting 1+3, £3.75; wall mounting 1+3, £3.87; chimney mounting 1+3, £4.50. Pre-amplifier from £3.75. **Combined BBC ITV BBC2 Aerials:** 1+3+9, £4.00; 1+3+4+14, £4.50. Available loft only.

**FM Radio:** Loft S.D. 97p; 'H', £1.62; 3 element array, £2.87. Standard coaxial cable, 5p yd. Coax plugs, 8p. Outlet boxes, 30p. Diplexer crossover boxes, 87p. P.P. Aerials, 40p; accessories, 15p. C.W.O. or C.O.D. (min. C.O.D. charge 17p). 5p for fully illustrated lists. CALLERS WELCOME!  
**OPEN ALL DAY SATURDAY.**

**K.V.A. ELECTRONICS (Dept. P.T.)**  
40-41 Monarch Parade  
London Road, Mitcham, Surrey  
01-648 4884

## Vary the strength of your lighting with a DIMMASWITCH

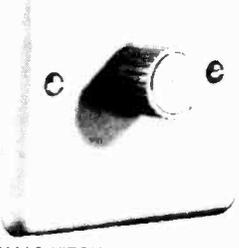

The DIMMASWITCH is an attractive and efficient dimmer unit which fits in place of the normal light switch and is connected up in exactly the same way. The ivory mounting plate of the DIMMASWITCH matches modern electric fittings. The bright chrome control knob activates an on-off switch and controls 40-600 watts of all lights except fluorescents at mains voltages from 200-250V, 50 Hz. The DIMMASWITCH has built-in radio interference suppression. Price: £3.20 plus 10p post and packing. Kit Form: £2.70 plus 10p post and packing. Please send C.W.O. to:—

**DEXTER & COMPANY**  
3 ULVER HOUSE, 19 KING STREET, CHESTER CH1 2AH. Tel: 0244-25883

As supplied to H.M. Government Departments, Hospitals, Local Authorities, etc.

**EKCO T419**

The picture exhibits a plastic effect, the whites having very little definition unless turned low which gives faces a glassy look. The video amplifier valve PCL84 has been replaced but very little improvement obtained.—F. Dudley (Birmingham).

You will probably find that the screen and cathode resistors in the video amplifier stage have changed value. These are R26 5.6k $\Omega$  and R28 220 $\Omega$ . If these are faulty check also the control grid stopper resistor R27 (330 $\Omega$ ) and the vision detector diode V7 (CG64H).

**MARCONIPHONE 4621**

There is cogging on the picture the extent depending on the setting—which is on the critical side—of the line hold control. One of the flywheel sync diodes has been replaced with another diode which is not an exact replacement—making the cogging worse.—T. Marshall (Solihull).

It is essential that the flywheel discriminator diodes are replaced with the correct type—either the original type or one with precisely the same ratings. Also both diodes must be replaced at the same time as the circuit must be balanced. The latest replacements quoted are type BA153/1 but you should find the BA144 a suitable replacement which is easier to obtain.

**GEC BT318**

The raster is present but there is no sound or vision—only a rumbling sound from the speaker. The h.t. rectifier, tuner and audio output valves have been replaced.—J. Dance (Bury).

Examine the rear of the coaxial socket on the i.f. board into which the output plug from the tuner connects: the track from the socket to the first i.f. transformer often cracks. Also check the common i.f. stage valve and voltages.

**PYE 40F**

The set works well on 405 lines but when switched to 625 the width decreases by about 1½ in. on each side even with the width control set to maximum. The valves in the line timebase have been changed without improving matters and all voltages are correct. In all other respects the u.h.f. picture is good.—R. Irwin (Windsor).

Check the coupling capacitor C111 (0.47 $\mu$ F) to the line output valve and the width stabilisation v.d.r. R148 in its grid circuit.

**BUSH TV171**

When the set is first switched on the field slips from the top to the bottom. On adjusting the hold control the picture will lock for a few seconds then starts to slip again. Then a sequence sets up, the picture locking for a few seconds and then slipping for a few seconds and so on. The PCL85 and PFL200 have been replaced, also SR302.—G. Thornton (Birmingham).

The trouble could be caused by a faulty electrolytic—check the capacitor C46 (100 $\mu$ F) which smooths the h.t. supply to the field timebase. Also check the electrolytics associated with the PFL200—8 and 10 $\mu$ F. Then check the front-to-back ratio of the interlace diode 3MR3.

**ALBA T655**

There is trouble in the line output and e.h.t. supplies. The boost voltage was low but this was put right by fitting a new boost reservoir capacitor. Now if either the contrast or brilliance are increased the boost voltage drops to about 300V, the width decreases, the line whistle changes and the e.h.t. rectifier heater goes dead and then glows green. The line output valve screen voltage is 160V instead of 140V but the screen resistor has been checked and is correct. The c.r.t. cathode voltage drops to about 50V when receiving a signal. There is also severe arcing from the EY86 top cap to chassis which can only be stopped by increasing the contrast or brilliance control settings. The valves in the line output stage and many other components have been replaced and a new c.r.t. tried.—G. Carter (Bournemouth).

The basic cause of the boost and e.h.t. voltages dropping as the brilliance is advanced is lack of drive to the line output valve, so the line oscillator stage (V10 ECL80) must be thoroughly checked including the coupling capacitor (C47 0.01 $\mu$ F) to the line output valve. Once this trouble has been cleared you will experience worse discharge from the EY86. This is a matter of improving the insulation. Try a good application of silicon rubber (Radiospares tube) around the discharge point.

**DEFIANT 901**

The picture is very pale on ITV and there is so much snow on BBC-1 that it cannot be discerned properly. On ITV the picture comes on bright with a click and half-an-hour later it goes pale again.—G. Dorset (Frome).

The trouble, or at least some of it, appears to be in the system switching on the left side panel. Check the contacts and clean. Also check the PFL200 video amplifier valve and ensure that there is good contact with its valveholder. Check the associated components by disturbing gently to locate any poor connections. Check the tuner unit contacts and ensure that the BBC-1 aerial is up to specification.

**PYE V210**

The picture has very little contrast and is reduced in width by 1 to 1½ inches on each side of the screen. The PL81 is glowing red hot but a replacement makes no difference. I checked the grid circuit in case it was running unbiased and found approximately -24V here. The other valves in the line output stage have been replaced but the fault persists.—J. Manningfield (Chichester).

The cause of the trouble is the 2.2k $\Omega$  feed resistor to the screen of the line output valve becoming low in value. Replace it using a 5W wirewound type.

**PETO SCOTT 235**

There is bad foldover at the top of the picture and the pulse and bar test pattern appears almost halfway down the screen. Several valves including the field timebase one have been replaced in order to improve the performance of the set.—P. Wainwright (Bromley).

This model was particularly prone to linearity troubles. The linearity controls and the capacitors in the linearity network will have to be carefully checked and any defective ones replaced.

**BAIRD 663**

There is an intermittent fault on 625 lines. When the set is first switched on the set works perfectly for five minutes or so. The hold then slips and the picture is reduced in height to four-five inches. This is accompanied by a loud hum on sound and at times motor-boating. If the set is left on it will right itself in time while if the contrast is turned down to minimum the fault disappears completely. On 405 the hold does not slip but the hum is present on sound. All valves have been checked.—J. Read (London SW16).

There appear to be two faults on the receiver. The first is almost certainly the failure of one section of the h.t. smoothing and this should be corrected first. Check C190 and C191. The second problem is probably the common one on this range of models, dirty or loose contacts on the rather complex standards changeover system. If yours is an early model this is achieved with a cable linkage the movement of which should be checked.

**TEST CARD COLOUR BAR**

Can you tell me how the colour bars on the top of test card F can be shifted down the screen without putting out the convergence?—R. George (Bromwich).

It is usually possible to move the raster down enough to resolve the colour bar by means of the

vertical shift control. This will not affect the convergence at all. Alternatively you could shrink the height. This will misconverge the raster slightly but immediate correction will be obtained when the height is expanded again.

**PYE 11U**

There is lack of width, marginal on 405 but  $\frac{1}{2}$  in. each side on 625, and this is not affected by the "set e.h.t." controls. Also the raster is distorted at the top left of the picture with a flyback line present there while the picture tends to be trapezium shaped. The line oscillator and output valves have been changed.—A. Richards (Clerkenwell).

For the width fault check the line feed capacitor C87 (10k $\mu$ F) which may have changed value. Your distorted raster is due to the deflection coils themselves. Try moving the raster correction magnets M3 and M4 if they are of the adjustable type.

**QUERIES COUPON**

This coupon is available until June 22, 1971, and must accompany all Queries sent in accordance with the notice on page 374. Don't forget the 10p postal order!

TELEVISION, JUNE, 1971

**TEST CASE****102**

Each month we provide an interesting case television servicing to exercise your ingenuity. These are not trick questions but are based on actual practical faults.

? A Ferguson 2000 series all-transistor receiver was investigated by the field engineer for apparent grey-scale mistracking. On the colour bars or the contrast wedges of Test Card F with the colour control turned right down the white display was normal, but as the bars or wedges progressed through the greys to black there appeared increasing evidence of a green hue, becoming bright green on the final grey bar or wedge, with black normal. The field engineer found that the normal grey-scale tracking procedure failed to cure the trouble and as a consequence suspected a fault in the tracking of the green gun.

With the receiver in the workshop it was discovered that the fault symptom was somewhat intermittent and that it was hardly apparent at all on colour pictures (i.e. when the colour control was advanced). On a monochrome picture the green had a "flaring" tendency, not unlike the symptom on monochrome

sets with poor low-frequency response characteristics. The degree of green "flaring" could be altered significantly by adjustment to the contrast and brightness controls.

Although the workshop engineer realised that a defective picture tube might well cause such a symptom, he decided first to investigate elsewhere in the set and as it turned out his efforts were well rewarded. What part of the set would be most likely to produce a symptom of this kind? See next month's TELEVISION for the solution to this fault and a further item in the Test Case series.

**SOLUTION TO TEST CASE 101**

Page 331 (last month)

It was found that the unusual symptom of the picture height altering with adjustment of the brightness control was accompanied by a change in the boost voltage which fell as the brightness control was advanced and the picture height reduced. The boost voltage feed to the c.r.t. first anode was disconnected and it was then found that the potential at the feed point remained constant over the entire range of brightness control.

This was a fair indication of insulation breakdown between the tube gun electrodes. Subsequent tests proved that when the tube was warm a low-resistance path developed between the first anode and control grid. This resulted in the boost potential being bypassed progressively as the brightness control was turned down, the height being affected since the field timebase generator is energised from the boost potential.

T.V. TUBES "VIDEOCHROME" T.V. TUBES  
FOR BRILLIANCE & DEFINITION



COMPARE  
OUR  
PRICES

17" £5-00  
19" £5-50  
21" £7-00  
23" £7-50

19" PANORAMA £6-25  
23" PANORAMA £8-25

CASH OR CHEQUE WITH ORDER

TRADE SUPPLIED  
ALL TUBES PRECISION REBUILT AT OUR OWN  
FACTORY BY SKILLED CRAFTSMEN ● EACH TUBE  
BENCH AND SET TESTED TO A VERY HIGH  
STANDARD BEFORE DESPATCH

2 YEARS GUARANTEE ● FREE  
DELIVERY ANYWHERE IN THE U.K.

**VIDEOCHROME TUBES LTD.**  
25 BELLEVUE AVENUE  
RAMSGATE, KENT. Tel. THANET 52914

# DON'T BE CAUGHT OUT!

Colour television is already here, but 1971 is a big year for colour television with a number of single standard colour sets coming on to the market, engineers with a knowledge of colour television will obviously be in great demand.

## SO DON'T DELAY

We have developed a colour television course geared for the service engineer which will enable him to tackle any problem in colour television.

The course consists of 10 lessons on colour mixing, Pal colour system, colour receivers, decoders, IF circuits, time-bases, convergence, waveforms, set-up procedures, test equipment, fault finding, typical circuits. Fee for complete course 10 gns. Write for details without obligation to:

**DAYLIN ELECTRONICS**  
(Dept. A) 1a Avebury Road  
SOUTHEND-ON-SEA

BI-PAK Semiconductors now offer you the largest and most popular range of I.C.s. available at these EXCLUSIVE LOW PRICES. TTL, Digital 74N Series fully coded, brand new. Dual in-line plastic 14 and 16 pin packages.

BI-PAK Order No.	Description	Price and qty. prices		
		1-24	25-99	100 up
BP00 7400N	Quad 2-Input NAND GATE	23p	20p	15p
BP01 7410N	Quad 2-Input NAND GATE—OPEN COLLECTOR	23p	20p	15p
BP04 7404N	HEX INVERTER	23p	20p	15p
BP10 7410N	Triple 3-Input NAND GATE	23p	20p	15p
BP20 7420N	Dual 4-Input NAND GATE	23p	20p	15p
BP30 7430N	Single 8-Input NAND GATE	23p	20p	15p
BP40 7440N	Dual 4-Input BUFFER GATE	23p	20p	15p
BP41 7441N	BCD to decimal decoder and N.I.T. Driver	87p	77p	67p
BP42 7442N	BCD to decimal decode (TTL O/P)	87p	77p	67p
BP50 7450N	Dual 2-Input AND/OR/NOT GATE expandable	23p	20p	15p
BP53 7453N	Single 8-Input AND/OR/NOT GATE—expandable	23p	20p	15p
BP60 7460N	Dual 4-Input—expandable	23p	20p	15p
BP70 7470N	Single JK Flip-Flop—edge triggered	35p	32p	29p
BP72 7472N	Single Master Slave JK Flip-Flop	35p	32p	29p
BP73 7473N	Dual Master Slave JK Flip-Flop	43p	40p	37p
BP74 7474N	Dual D Flip-Flop	43p	40p	37p
BP75 7475N	Quad Bistable Latch	47p	45p	43p
BP76 7476N	Dual Master Slave Flip-Flop with preset and clear	47p	45p	43p
BP83 7483N	Four Bit Binary Adder	87p	77p	67p
BP90 7490N	BCD Decade Counter	87p	77p	67p
BP92 7492N	Divide by 12 4 Bit binary counter	87p	77p	67p
BP93 7493N	Divide by 16 4 Bit binary counter	87p	77p	67p
BP94 7494N	Dual Entry 4 Bit Shift Register	87p	77p	67p
BP95 7495N	4 Bit Up-Down Shift Register	87p	77p	67p
BP96 7496N	5 Bit Shift Register	£1-10	£1-00	90p

Data is available for the above Series of I.C.s. in booklet form, price 13p each.

### LINEAR I.C.'s

Type No.	Case Leads	Description	Price		
			1-24	25-99	100
BP 201C - SL201C	TO-5 8	G.P. Amp	63p	53p	45p
BP 701C - SL701C	TO-5 8	OP. Amp	63p	53p	45p
BP 702C - SL702C	TO-5 8	OP. Amp Direct O/P	63p	53p	45p
BP 702C - 72702	D.I.L. 14	G.P. OP. Amp (Wide Board)	53p	45p	40p
BP 709 - 72709	D.I.L. 14	High OP. Amp	53p	45p	40p
BP 709P - uA709C	TO-5 8	High Gain OP. Amp	53p	45p	40p
BP 741 - 72741	D.I.L. 14	High Gain OP. Amp (Protected)	75p	60p	50p
uA 703C - uA703C	TO-5 6	R.F. IF Amp	43p	35p	27p
TAA 263	TO-72 4	A.F. Amp	70p	60p	55p
TAA 293	TO-74 10	G.P. Amp	90p	75p	70p

### TTL INTEGRATED CIRCUITS

Manufacturers' "Full outs"—out of spec. devices including functional units and part function but classed as out of spec. from the manufacturers' very rigid specifications. Ideal for learning about I.C.s. and experimental work.

Pak No.	Pak No.	Pak No.
UIC00 = 12 x 7400N 50p	UIC42 = 5 x 7450N 50p	UIC80 = 5 x 7480N 50p
UIC01 = 12 x 7401N 50p	UIC50 = 12 x 7450N 50p	UIC82 = 5 x 7482N 50p
UIC02 = 12 x 7402N 50p	UIC51 = 12 x 7451N 50p	UIC83 = 5 x 7483N 50p
UIC03 = 12 x 7403N 50p	UIC60 = 12 x 7460N 50p	UIC86 = 5 x 7486N 50p
UIC04 = 12 x 7404N 50p	UIC70 = 8 x 7470N 50p	UIC90 = 5 x 7490N 50p
UIC05 = 12 x 7405N 50p	UIC72 = 8 x 7472N 50p	UIC92 = 5 x 7492N 50p
UIC10 = 12 x 7410N 50p	UIC73 = 8 x 7473N 50p	UIC93 = 5 x 7493N 50p
UIC20 = 12 x 7420N 50p	UIC74 = 8 x 7474N 50p	UIC94 = 5 x 7494N 50p
UIC40 = 12 x 7440N 50p	UIC75 = 8 x 7475N 50p	UIC95 = 5 x 7495N 50p
UIC41 = 5 x 7441AN 50p	UIC76 = 8 x 7476N 50p	UIC96 = 5 x 7496N 50p

UICX1 = 25 x Ass'd 74's £1-50  
Packs cannot be split but 20 assorted pieces (our mix) is available as Pak UICX1. Every Pack carries our BI-PAK. Satisfaction or money back GUARANTEE.

**DTL (Diode Transistor Logic) INTEGRATED CIRCUITS** manufacturers' "Fall outs"—out of spec. devices including functional units and part functional but classed as out of spec. from the manufacturers' very rigid specifications. Ideal for learning about I.C.s. and experimental work.

Pak No.	Pak No.
UIC930 = 12 x uA 930 ..... 50p	UIC948 = 8 x uA 948 ..... 50p
UIC932 = 12 x uA 932 ..... 50p	UIC951 = 5 x uA 951 ..... 50p
UIC933 = 12 x uA 933 ..... 50p	UIC961 = 12 x uA 961 ..... 50p
UIC935 = 12 x uA 935 ..... 50p	UIC9093 = 5 x uA 9093 ..... 50p
UIC936 = 12 x uA 936 ..... 50p	UIC9094 = 5 x uA 9094 ..... 50p
UIC944 = 12 x uA 944 ..... 50p	UIC9097 = 5 x uA 9097 ..... 50p
UIC945 = 8 x uA 945 ..... 50p	UIC9099 = 5 x uA 9099 ..... 50p
UIC946 = 12 x uA 946 ..... 50p	UIC x 925 Assorted 930 Series £1-30

Packs cannot be split but 25 Assorted Pieces (our mix) is available as Pak UICX9. Every Pak carries our BI-PAK. Satisfaction or money back guarantee. Data Booklet available for the BP930 Series, PRICE 13p.

RTL MICROLOGIC CIRCUITS	Price each		
	1-24	25-99	100 up
Epoxy TO-5 case			
uL900 Buffer	35p	33p	27p
uL914 Dual 2i/p gate	35p	33p	27p
uL923 JK flip-flop	50p	47p	45p

Data and Circuits Booklet for I.C.'s. Price 7p.

Dual-in-Line Low Profile Sockets	
14 and 16 Lead Socket for use with Dual-in-Line Integrated Circuits.	
Order No.	Price each
	1-24 25-99 100 up
TSO 14 pin type..	30p 27p 25p
TSO 16 pin type..	35p 32p 30p

ALL PRICES QUOTED IN NEW PENCE  
Please send all orders direct to our warehouse and despatch department.

**BI-PAK SEMICONDUCTORS**  
P.O. BOX 6, WARE, HERTS.

Postage and packing add 7p. Overseas add extra for Airmail. Minimum order, 50p. Cash with order please. Giro No. 388-7006.

# TELEVISION CLASSIFIED ADVERTISEMENTS

The pre-paid rate for classified advertisements is 4p a word (minimum 12 words), box number 7½p extra. Semi-display setting £2.50 per single column inch. All cheques, postal orders, etc., to be made payable to TELEVISION and crossed "Lloyds Bank Ltd." Treasury notes should always be sent *registered post*. Advertisements, together with remittance, should be sent to the Classified Advertisement Manager, TELEVISION IPC Magazines Ltd., Fleetway House, Farringdon Street, London, EC4A 4AD, for insertion in the next available issue.

## EDUCATIONAL

### TRAIN FOR SUCCESS WITH ICS

Study at home for a progressive post in Radio, TV and Electronics. Expert tuition for City & Guilds (Telecoms Techn's Cert. and Radio Amateurs') R.T.E.B., etc. Many non-exam courses incl. Colour TV Servicing, Numerical control & Computers. Also self-build kit courses—valve and transistor.

Write for *FREE prospectus* and find out how ICS can help you in your career.

ICS, DEPT. 560, INTERTEXT  
HOUSE, STEWARTS ROAD,  
LONDON S.W.8.

**ENGINEERS**—get a technical certificate. Exam and Certificate Postal Courses in all branches of Engineering, Electronics, Radio and TV. Computers, Draughts, Building, etc. Write for helpful *FREE BOOK*: BIET (Dept. 171K), Aldermaston Court, Reading, RG7 4PF.

**BECOME** "Technically Qualified" in your spare time, guaranteed certificate and exam Home Study courses in Radio, TV, servicing and maintenance, R.T.E.B., City & Guilds, etc., highly informative *FREE Guide*.—Chambers College (Dept. 858K), Aldermaston Court, Reading, RG7 4PF.

**RADIO AND TV Exams and Courses** by Britain's finest home study School, Coaching for Brit.I.R.E., City and Guilds Amateur's Licence, R.T.E.B., P.M.G. Certificate, etc. Free brochure from British National Radio School, Russel Street, Reading.

**MEN!** You can earn £50 p.w. Learn Computer Operating. Send for *FREE brochure*—London Computer Operators Training Centre, C98 Oxford House, 9-15 Oxford Street, London, W.1.

## LADDERS

**VARNISHED TIMBER LADDERS** from manufacturer, *LOWEST PRICES* anywhere: 15½ ft ext. £6.20; 17 ft ext. £6.50; 20 ft ext. £7; 21½ ft ext. £7.75; 24½ ft ext. £8.90; 29 ft ext. £10.25; 31½ ft triple ext. £12.25; 36 ft triple ext. £16. Carr. 80p. Free Lists. Also Aluminium Ext. and Loft Ladders. **CALLERS WELCOME.** Dept. PTT, HOME SALES, BALDWIN ROAD, STOURPORT, WORCS. Phone 02-993 2574/5222. Placing order on C.O.D.

## WANTED

**CASH PAID** for New Valves. Payment by return. **WILLOW VALE ELECTRONICS**, 4 The Broadway, Hanwell, London. W.7. 01-567 5400/2971.

**SERVICE SHEETS** purchased, **HAMILTON RADIO**, 54 London Road, Bexhill.

## WANTED (continued)

**WANTED!** New valves especially TV types. Cash waiting. Bearman, 6 Potters Road, New Barnet, Herts. Tel. 449/1934.

**TOP PRICES PAID**  
for new valves, popular  
TV & Radio Types  
**KENSINGTON SUPPLIES**  
(A), 367 Kensington Street  
Bradford 8, Yorks

**WANTED** Wobulator Heath Kit Model HFW1 or other modern non-mechanical sweep type. Box No. 88.

## FOR SALE

**625/405 VHF/UHF IF Panels**, B.R.C. 850 series. Ideal for components, IF transformers and switching, P/C Valve bases or repairs to this Thorn receiver. £1.75 each plus 2½p p.p. **WILLOW VALE**, 4 The Broadway, Hanwell, W.7.

**PRACTICAL TELEVISION** books 1960 to 1970 inclusive, £8. Parry, 25 Longfellow St., Liverpool 8.

**NEWNES R. & TV Servicing**, Vols. 1/1v & 65/66; old copies PT, PW, WW & Rad. Cons. Beveridge, 26 Durham St., Monifieth, Dundee.

**NEWNES Radio Servicing**, 11 vols. to 1961, £10. Stacks of Service Sheets, Murphy books, Radio Retailing sheets and 80 others, £5; 100 Practical Televisions from 1953, £3. Stanmore, Middlesex. Tel. 954 3418.

**FOR SALE.** Philips 25" colour TV. Dual standard, two years old, offers. Replies to R. Wood, 40 Ashville Gardens, Pellon, Halifax, Yorks.

**MARCONI** Signal Generator T.F. 801A, £30 o.n.o. Hunter, 58 West St., Bedminster, Bristol 666066.

## MISCELLANEOUS

**RECORD TV** sound using our loud-speaker isolating transformer. Provides safe connection to recorder. Instructions included. 70p plus 10p P&P. **Crowborough Electronics (P.T.)**, Eridge Road, Crowborough, Sussex.

## SERVICE SHEETS

## SERVICE SHEETS (continued)

### SERVICE SHEETS

(1925-1971) for Radios, Televisions, Transistors, Radiograms, Car Radios, Tape Recorders, Record Players, etc. By return post with

### FREE FAULT FINDING GUIDE PRICES FROM 5p

Over 8,000 models available.  
Catalogue 13p.

Please send stamped addressed envelope with all orders and enquiries.

### Hamilton Radio

54 London Road, Bexhill, Sussex

**SERVICE SHEETS** with Free Fault Finding Chart, 23p. S.A.E. Lesmar, 15 Conholt Rd., Andover, Hants. (Mail only).

## LARGE SUPPLIER of SERVICE SHEETS

(TV, RADIO, TAPE RECORDERS, RECORD PLAYERS, TRANSISTORS, STEREOGRAMS, RADIOGRAMS, CAR RADIOS)

Only 25p each. Manuals from 50p

**PLEASE ENCLOSE LARGE S.A.E. WITH ALL ENQUIRIES AND ORDERS.**

Otherwise cannot be attended to.

(Uncrossed P.O.'s please, original returned if service sheets not available.)

## C. CARANNA 71 BEAUFORT PARK, LONDON, N.W.11

We have the largest supplies of Service Sheets (strictly by return of post). Please state make and model number alternative.

Free TV fault tracing chart or TV list on request with order.

MAIL ORDER ONLY

## Service Sheets & Manuals

LARGE RANGE OF MODELS AVAILABLE FOR RADIO, TELEVISION, TAPE RECORDERS, R/PLAYERS, ETC. FROM 25p EACH — S.A.E. WITH ENQUIRIES PLEASE — 1971 LISTS ARE AVAILABLE 13p.

MULLARD TRANSISTOR AUDIO AND RADIO CIRCUITS	PRICE £1 - 63p	} Post free
T.V. FAULT FINDING BOOK by DATA PUBLICATIONS LTD.	.. 55p	
MULLARD VALVE & SEMI CONDUCTOR DATA BOOK	.. 23p	
MAZDA VALVE & PICTURE TUBE DATA BOOKLET	.. 23p	
BRIMAR VALVES & TELE TUBE DATA LIST	.. 20p	
RESISTOR COLOUR CODE INDICATOR DISC	.. 13p	

Sets of Brand New Valves supplied for most makes of Radio T.V. etc. Prices on request.

**BELL'S TELEVISION SERVICES**  
Albert Place Harrogate Yorkshire Tel 0423-88844

## SERVICE SHEETS (continued)

## TRADER SERVICE SHEETS

30p each plus postage

We can supply Trader Service Sheets for most makes and types of Radios, Tape Recorders and Televisions—Manuals for some.

Cheques and open P.O.s returned if sheets not available.

## OAKFIELD ENTERPRISES

LIMITED

29 CHURCH ROAD,  
TUNBRIDGE WELLS, KENT

Make	Model	Radio/TV

1971 List now available at 10p plus postage

If list is required indicate with X

From.....

Address.....

enclose remittance of.....  
(and a stamped addressed envelope)  
s.a.e. with enquiries please  
**MAIL ORDER ONLY (May T)**

**RADIO, TELEVISION**, over 3,000 models. **JOHN GILBERT TELEVISION**, 1b Shepherds Bush Road, London, W.6. SHE 8441.

**SERVICE SHEETS**, Radio, TV, etc. 8,000 models. List 10p. S.A.E. enquiries. **TELRAY**, 11 Maudland Bank, Preston.

## AERIALS

## AERIALS

**UHF**: Set Tops £2-10, Outside: 9 ele £1-25, 10 ele £1-90, 11 ele £2-50, 12 ele £2-55, 18 ele £3-25, 20 ele £3-50. Multi-beam 46 and Supremes £5-50.

All aerials supplied with clamps.

**ANTIGHOST**: Troubleshooters / Log-beams £5.

**FM/VHF**: H £2-25, 3 ele £3-25, 4 ele £3-75. Stereo 6 ele £6.

Motorized Units: Semi Auto £20, Auto £25.

All Aerials by either, "AERIALITE", J BEAM, ANTIFERANCE, PREMIER, MAXVIEW.

**ACCESSORIES**: Sockets, Plugs, Dips, Splitters, Masts, Lashings, etc., etc.

**EAGLE LOGS**

All that's best in Electronics: Head-phones, Amps, Speakers, Meters, etc. Send 25p for Catalogue.

**COAXIALE**: Standard 100 Mtrs. £4-50. Low Loss £7, or per Mtr.

State channels for all TV Aerials/Amps. FM state wide band or channelized. **TERMS**: CWO, COD, P & P 32½p. Send 2½p stamps for lists. Callers Welcome.

## JEFFRIES SERVICES

31 Hambrook St., Portsmouth. Tel. 28354

## AERIALS (continued)

## BAKER AND BAINES UHF AERIALS

**BBC and ITV 625 Colour**  
10 ele 2-10; 14 ele 2-35; 18 ele 3-25; 22 ele 3-75

**BBC 405 Aerials**  
Dipole 1-75; 1/4 aerial 2-15; H aerial 2-40; 3 element 5-20; 4 element 6-90.

**ITA 405 Aerials**  
5 element 1-50; 8 element 2-70; 11 element 3-30; double 5, 8 and 11 arrays available on request.

**Combined BBC-ITA 405 Aerials**  
Dipole plus 5 2-70; Dipole plus 8 3-10; H plus 5 4-10; X plus 5 4-50. Loft special Dipole plus 5 2-10.

Diplexers, Triplexers, Matched Diplexers UHF/VHF. Poles, Lashings, Clamps, Couplers etc., Coax .06 and .11. Postage paid inland on aerials. Please state channel required when ordering. SEA will bring full lists.

11 Dale Cres., Tupton, Chesterfield

## SETS &amp; COMPONENTS

**EX N.E.V. C.C.T.V.** Camera and Monitor Circuits, S.A.E. for list. **LOWE**, 29 Vanner Point, Hackney, London, E.9 5AX.

**NEW!** Continuous range High-Gain Pre-Amplifier 40-900 mHz. Television, Radio, Stereo all bands including colour! Precision made in neat case. Fixed in seconds, no modifications, aerial connection only. Suberg value at £7-75p. Post paid to anywhere in U.K. S.A.E. for Leaflet. **Johnsons (Radio)**, St. Martin's Gate, Worcester.

**120 NEW ASSORTED** Capacitors, Electrolytic, Mica, etc., and Resistors, ¼/20W, 85p. Post Free. **Whitsam Electrical**, 33 Drayton Green Road, London, W.13.

## WITWORTH TRANSFORMERS LTD.

Dept. P.T., 236 SANDYCOMBE ROAD.

RICHMOND.

SURREY.

Telephone: 01-940 8146. 9 a.m. till 5 p.m.

## TELEVISION LINE OUTPUT TRANSFORMERS

PRACTICALLY ANY MAKE OR MODEL SUPPLIED OR REWOUND

**EKCO, FERRANTI, DYNATRON** Replacement cases £1-00 each, please state model.

S.A.E. for return of post quotation. **TERMS**: Cash with order or C.O.D., please add 20p for postage.

C.O.D. orders will be charged 30p extra. Transformers fully guaranteed. (98)

## AERIAL BOOSTERS £2-95 EACH

We make four types of transistorized aerial pre-amplifiers. These take only seconds to install.

1. L45 625 TELEVISION (U.H.F.).

2. L12 405 TELEVISION (V.H.F.).

Please state channel numbers.

3. L11 V.H.F. F.M. RADIO.

4. L10 WIDEBAND RADIO.

This covers M/W and S/W to 20 MHz.

## PRICE EACH

L45, L12 and L11 £2-95; L10 £1-95.

S.A.E. FOR DETAILS

MONEY BACK GUARANTEE

P. &amp; P. 10p

## VALVE BARGAINS

Any 1-10p, 5-45p, 10-70p.

EB91, EBF89, ECC82, EY86, ECL80, EF80, EF85, EF183, EF184, PCC84, PCC89, PCC189, PC97, PCF80, PCF86, PCF800, PCL82, PC97, PCL84, PCL85, PL36, PL81, PL83, PY32, PY33, PY81, PY82, PY800, PY801, 30FL1, 30F5, 30L15, 30C15, 6F23, 6-30LZ.

TESTED, WITH 3 MONTH GUARANTEE VALVES 20p EACH

BY100 TYPE RECTIFIERS with Surge-resistor on bracket, 12½p each.

## T.V. SPARES

**OIL FILLED MURPHY LOFT's** U26 type. Model number not known. £1.25 each plus 25p p.p.

**BAIRD FERGUSON V.H.F. TUNERS**. Uses PC97 and 30C18 valves. Fits 620 to 650 series models, complete with all coils, supplied less valves, £1.75 each plus 25p p.p.

**BARGAIN PARCEL TRANSFORMERS** 5 mixed frame output, sound output, chokes, driver transformers. Must be value at £2-50 plus 30p p.p.

**FERGUSON/EKCO PLUG IN MAINS LEADS**. Moulded two-pin connector type. 6 for £2.50 plus 25p p.p.

**LATE G.E.C./SOBELL 625 405**, etc. Dual Standard 405/625 I.F. Panels, complete with switching for direct replacement in this popular Radio and Allied receiver. £1.75 plus 25p p.p. Fits all 1000 and 2000 series.

**TIMEBASE PANELS** to fit Sobell 195, 282, 283, 284, 285, 286, 287, 288 (and DS models), McMichael MT762, 763, 765, P405. Complete and new for direct replacement, £1.75 each plus 25p p.p.

**V.H.F. ROTARY TUNER UNITS** to fit McMichael, Sobell, G.E.C. 1000 series. New and unused, £1.75 each plus 25p p.p.

**MULLARD COLOUR SCAN COILS**. Complete with plug in leads. £5.50 each plus 25p p.p.

**FERGUSON 800/850 series TIMEBASE PANELS**, complete and unused in original packing. £2.25 each, plus 25p p.p.

Terms. Cash with order or C.O.D. 27½p extra. S.A.E. all enquiries. Catalogue of valves, CRT's, LOPT's, components, etc., 20p.

## WILLOW VALE ELECTRONICS LTD.

4 & 5 The Broadway  
Hanwell, London, W.7

Tel: 01-567 2971 and 5400

01-579 3582

Terms cash with order or C.O.D. 27½p extra  
S.A.E. all enquiries. Catalogue 20p

## SPARES

available from second-hand TVs. Transformers, Valves, etc. S.A.E. your enquiries. Complete 19-in. TVs, untested, from £5 plus £1-50 carriage.

LINAVALLE RADIO LTD.,

48 Hoe St., London, E.17.

01-520-7546.

**TELEVISION SPARES**. All makes and models, new and used. Send S.A.E. for your enquiries. Used Tested Valves 20p each, postage 2½p. Thriftys, Green Lane Farm, Green Lane, Chessington, Surrey.

## VELCO ELECTRONICS

62 Bridge Street, Ramsbottom, Bury, Lancs. Tel. 3036

## TELEVISION TUBE SHOP

BRAND NEW TUBES AT  
REDUCED PRICES

A28-14W (A28-13W)	£11-75
A31-18W	£12-50
A47-11W	£9-95
A47-13W	£12-50
A47-14W	£7-75
A47-26W	£10-75
A50-120WR	£12-50
A59-11W	£12-95
A59-13W	£13-50*
A59-15W	£9-95
A59-16W	£13-50*
A59-23W	£14-75
A61-120WR	£16-00
AW21-11	£10-50†
AW36-20	£5-75
AW36-80	£5-75
AW43-80	£6-50
AW43-88, 43-89	£6-75
AW47-90, 47-91	£7-50
AW53-80	£7-50*
AW53-88, 53-89	£8-25
AW59-90, 59-91	£9-00
C17LM, 17PM, 17SM	£6-50
CME1101	£12-00
CME1201	£12-50
CME1402	£5-75
CME1601	£10-50
CME1602	£12-00
CME1702, 1703	£6-75
CME1705	£7-75
CME1901, 1903	£7-50
CME1906	£12-50
CME1908	£7-75
CME2013	£12-50
CME2101, 2104	£8-25
CME2301, 2302	£9-00
CME2305	£14-75
CME2306	£13-50*
CME2308	£9-95
CME2413R	£16-50
CRM93	£5-50*
CRM124	£5-50
CRM141, CRM142	£5-50
CRM171, CRM172	£6-50
CRM211, CRM212	£7-50*
MW36-24, 36-44	£5-50
MW43-69	£6-75
MW43-80	£6-75
MW53-20, 53-80	£7-5*
TSD217, TSD282	£14-00†
13BP4 (Crystal 13)	£14-00†

†Rebuilt tubes also, at £7-00

\*These types are FULLY rebuilt.

ALL TUBES ARE TESTED AND GUARANTEED FOR A MINIMUM OF 12 MONTHS

ADD 75p FOR CARRIAGE AND INSURANCE

COLOUR TUBES

19 in. and 22 in. having slight marks or scratches at £35 each.

## TELEVISION TUBE SHOP

48 BATTERSEA BRIDGE ROAD,  
LONDON, S.W.11. BAT 6859

WE GIVE GREEN SHIELD  
STAMPS

## SETS & COMPONENTS (continued)

NEW MOSTLY BVA VALVES! Huge range by post service well known to the trade. Brief list of television types herewith, full list S.A.E. All types ex stock!

DY86/7	43p	PCF86	63p	PY82	50p	20L1	95p
EB91	25p	PCF801/2	62p	PY800/1	50p	20P4	£1-00
ECC82	42p	PCF805	87p	R19	85p	30C15	90p
ECL80	50p	PCF808	85p	U25	95p	30C17	95p
EF80	42p	PCL82	51p	U26	95p	30F5	95p
EF85	45p	PCL83(S)	60p	U37	75p	30FL1 & 2	65p
EF183/4	57p	PCL84	60p	U191	90p	30L15	95p
EH90	55p	PCL805/85	57p	U193	48p	30L17	90p
EY51	60p	PCL86	66p	U251	95p	30P12	95p
EY86/7	43p	PL36/8	87p	U301	90p	30PL1	90p
PC86 & 8	75p	PL81	80p	U801	£1-25	30P4MR	£1-25
PC97	45p	PL83	85p	6/30L2	90p	30P19	87p
PC900	55p	PL84	65p	6AT6	55p	30PL13	£1-00
PCC84	50p	PL500	90p	6BW7	82p	30PL14/5	£1-10
PCC89	62p	PL504	90p	6CD6G	95p	etc., etc.	
PCF80	52p	PY81	50p	6F23	95p	<b>Trade prices</b>	

POST FREE OVER £3-00, 2½p PER VALVE BELOW £3-00

LATEST NEW BY100/127 type silicon rectifier 15p, 33Ω res 5p!

Large bulb Imported PCF80 32p! Note. Ask for separate component and transistor lists.

**LOOK! Nearly every type in stock now!!**

## NEW TELEVISION TUBES!

TWO YEAR FULL REPLACEMENT GUARANTEE

SEE THE DIFFERENCE A NEW TUBE CAN MAKE TO YOUR VIEWING—LATEST SCREENING TECHNIQUES INCLUDING TINTED SCREENS ON MOST 19" and 23" TYPES

Large stocks by British leading manufacturers, why buy cheap rebuilds. Two year warranty!

COLOUR! FOUR (yes 4) years guarantee: 19" £49-00; 22" £53; 25" £57. Enquiries welcomed.

Special offer! 19" mono rebuilds, 2 year guarantee £5-50! 23" £7-50

12" £3-00 (not 110°) 20" Mullard 14" to 16" (not 110°) £4-75

17" £5-87 A50/120W £10-50

19" mono tubes—all £6-87. Carriage all 60p. All 21" mono tubes—£7-87

23" mono tubes £9-50. Carriage 75p, also 24" and 25" available.

Prices on application.

RIMBANDS, 19" £8-50; 23" £11-50 } Carriage

TWIN PANELS, 19" & 23" £10-12 & £15-00 } 75p

Bulk enquiries welcomed. GIRO 34.361.4006

## PHILIP H. BEARMAN

(Suppliers to H.M. Govt. etc.)

**6 POTTERS ROAD, NEW BARNET, HERTS.**

Closed Thurs. & Sat. afternoons

TEL. 01-449/1934 & 1935

(Adjacent to Post Office)

(Robophone)

NEW VALVES. Radio/Television 1930/1954. Send S.A.E. stating type required and equivalent if known. Wakely, IOB Coombe Road, New Malden, Surrey.

BRAND NEW Thorn 625 IF units complete with valves as in constructors 625 set. £3 each inc. P&P. Rathbone (Radio), 58 Cumberland Road, Urmston, Manchester.

## SOUTHERN VALVE COMPANY (Valve specialists)

44 Earls Court Road, London, W.8

ALL valves boxed and brand new, some BVA! Send s.a.e. for free lists.

DY87	37p	PC868	50p	PCL805	44p	U193	35p	30L17	75p
DY802	45p	PC97	40p	PCL86	37p	U251	62p	30P12	70p
EB91	15p	PCF80	32p	PL36	52p	6/30L2	60p	30PL1	60p
ECC81	37p	PCF86	52p	PL81	46p	6BW7	60p	30P4MR	95p
ECC82	30p	PCF801	50p	PL84	55p	6CD6G	90p	30P19	70p
ECL80	40p	PCF802	50p	PL500/4	65p	6F23	75p	30PL13	75p
EF80	27p	PCF805	50p	PY81	35p	6F28	48p	30PL14	75p
EF183	37p	PCF808	60p	PY800	35p	20L1	85p	etc., etc.	
EF184	37p	PCL82	37p	PY801	35p	20P4	90p		
EH90	45p	PCL83(s)	50p	U25	65p	30C15	70p		
EY51	50p	PCL84	37p	U26	60p	30FL12	75p		
EY86/7	37p	PCL85	44p	U191	65p	30L15	75p		

NOTE  
BY100/BY127  
equiv only 20p  
with resistor.

Post free £2-00 and over. Mail order only.

[932



## £5 TELEVISIONS £5

Delivered anywhere in Great Britain

17" 12 channel. Complete & tested. Good working order

Carriage and ins. £1

17" Untested TVs 12 channel. £1:50 Carriage £1. All makes

## TUBES! TUBES!

Guaranteed 6 months

17" (43/88 only).....	£1.50
19" All makes.....	£2.00
23".....	£2.50
19" Bonded.....	£3.50
23" Bonded.....	£4.50

Plus 50p carriage

**SPEAKERS** PM 3 ohm perfect ex-T.V. (minimum order two) 5" round, 8" by 2" rectangular, 6" by oval—12 1/2 each. Add 7 1/2p per speaker postage and packing.

## VALVES EX EQUIPMENT

EB91 5p	EF184 12 1/2p	PCF86 17 1/2p	PCL86 17 1/2p
EBF89 12 1/2p	EY86 17 1/2p	PC84 7 1/2p	PCL83 12 1/2p
ECC82 12 1/2p	30PL13 20p	PCF80 7 1/2p	PL36 22 1/2p
EC180 7 1/2p	630LZ 12 1/2p	PCC89 12 1/2p	PL81 17 1/2p
EF80 12 1/2p	30L15 12 1/2p	PCL85 22 1/2p	PY81 15p
EF85 12 1/2p	30P4 12 1/2p	PCL84 17 1/2p	PY800 15p
EF183 12 1/2p	PC97 17 1/2p	PCL82 17 1/2p	PY82 7 1/2p
PY33 22 1/2p	U191 17 1/2p	6F23 17 1/2p	30PLI 22 1/2p
30P12 20p	30F5 11p		

On two valves or more 5p postage & packing.

**UHF TUNERS** TO SUIT FERGUSON 850 900 CHASSIS £2:50 p. & 50p

Dept. T.S.

## THORNBURY TRADE DISPOSALS

Thornbury Roundabout, Leeds Rd., Bradford. Tel. 665670

## SETS & COMPONENTS (continued)

**TOP 20 TV Valves**, 10p; PL504, PL36, PY33, 15p, P&P 4p per valve, over 12 valves post free. Guaranteed tested ex-equipment, individually boxed. Resistors and capacitors all values and sizes. Leading manufacturers components and hi-fi equipment, 10% or more off. 13A plugs, 12p. Mains fuses, 20p for 10. Tools, etc., P&P extra on all items. Trade enquiries welcome, discount for quantity. S.A.E. for list. L & D Components Ltd., 71 Westbury Avenue, Wood Green, N.22. 01-888 2701.

## TOWERBY LTD

For Line Outputs and Deflector Coils

We have the Country's largest stock of Manufacturer's Original (or Authorised Replacement) Line Output Transformers for many "difficult" makes, including Ambassador, Baird, Cossor, Decca, Dynatron, Ekco, Ferguson, G.E.C., H.M.V., K.B., Masteradio, Peto-Scott, Philips, Regentone, RGD, Sobell, Ultra, etc. Also deflector coils; output and oscillator transformers, inc. Alba, Bush, Murphy. Examples, L.O.P.T. Murphy 350.410/540/659/759, £7 35; Bush, TV80, TV95, TV96, £7 35; Cossor 950, £3 87; Ferguson 306/308, £3 97; Philips 1768U L.O.P.T. assembly, £4 75; Ultra 1984-200c, £5 06. Rewind most L.O.P.T.s, £4 50.

### SPECIAL OFFER

Ekco improved type for Models T221, 231, 310, all at £2 25; Ferranti 14T4 series inserts, £1 25. Philco 1019/1021, £2 62; Terms: C.W.O. or C.O.D. (17p), post-packing 30p; 2 or more L.O.P.T.s post packing free. All enquiries answered but regret no lists available. Same day delivery on most types.

## TOWERBY LTD

MAIL ORDER DIVISION OF T.C.S. LTD.  
70 STREATHAM HILL, LONDON, SW2  
Tel.: 01-674 2185.

**LARGE** quantities of used TV spares for most models, 1952-64. Lofts, Tuners IF Strips, Time Base Panels Scan Coils, Frame Transformers, Knobs, cabinet Trim, etc. New manufacturers replacement parts, can be supplied, for more modern sets on receipt of an order deposit. S.A.E. for quotations. C.W.O. to TV Dismantlers, Foxhole, Whitstone, Holsworthy, Devon.

## VALVES, VALVES, VALVES

Any ten of your choice 72 1/2p, post 5p. 100 £5:50, post paid.

EF85, EF80, EB91, EBF89, ECL80, EF183, EY86, PCF80, PCC84, PL36, PY81, PCL82, PCL83, PCC89, PY33, PY82, PY800, PY801, PY88, PCL84, 30F5, 6BW7, PY801.

### BOB'S,

2 St. James Street, Rawtenstall  
Rossendale, Lancs.  
Mail order ONLY.

## R & R RADIO

51 Burnley Road, Rawtenstall  
Rossendale, Lancs

Tel.: Rossendale 3152

### TESTED VALVES— 3 MONTHS' GUARANTEE

EBF80 15p	PCC84 15p	PY800 17 1/2p
EBF89 17 1/2p	PCF80 15p	PY801 17 1/2p
ECC82 15p	PCL82 20p	U191 22 1/2p
ECL80 15p	PL36 25p	30C15 25p
EF80 10p	PY33 25p	PCF86 25p
EF85 15p	PY81 17 1/2p	PCL85 25p
EY86 20p	PY82 15p	PCL84 25p

Copper Laminate Board, for etching, 1p per sq.in. Double sided 1 1/2p per sq.in. Any size cut, min. order 50p plus 10% P. & P.

Postage on Valves: one valve 4p, up to 6 2 1/2p, over 6 post paid.

## NEW VALVES!

Guaranteed and Tested

24-HOUR SERVICE

1R5	-27 DF91	-16 EF91	-12 PFL200	-54
1R5	-21 DF96	-35 EF183	-59 PL36	-49
1T4	-16 DK61	-37 EF184	-50 PL81	-46
3B4	-88 DK92	-41 EL33	-54 PL82	-31
3V4	-37 DK96	-37 EL84	-24 PL83	-34
5Y3GT	-87 DL92	-28 EY51	-35 PL84	-31
6Y30L2	-57 DL94	-37 EY86	-31 PL500	-64
6AQ5	-25 DL96	-37 EZ80	-22 PL504	-65
6BW7	-57 DY86	-26 EZ81	-23 PY32	-54
6F1	-80 DY87	-26 GZ37	-70 PY33	-54
6F23	-70 EABC80	-31 KT61	-54 PY81	-26
6F25	-80 EB91	-11 KT66	-82 PY82	-26
25L6GT	-22 EBC33	-38 N78	-85 PY800	-35
30C15	-62 EBF89	-30 PC86	-49 PY801	-35
30C18	-88 ECC11	-17 PC88	-49 R19	-31
30F5	-78 ECC82	-20 PC97	-39 U25	-68
30FL1	-62 ECC83	-23 PC900	-35 U26	-59
30FL14	-70 ECF80	-28 PCC84	-31 U191	-80
30L15	-60 ECF82	-28 PCC89	-46 U251	-70
30L17	-71 ECH35	-27 PCC189	-50 U329	-70
30P4	-60 ECH81	-25 PCF80	-29 UBF89	-31
30P19	-80 ECL80	-45 PCF86	-45 UOC83	-36
30PL1	-81 ECL82	-31 PCF801	-32 UCH81	-32
30PL13	-77 ECL86	-37 PCF802	-44 UCL82	-34
30PL14	-87 ECF39	-22 PCF805	-63 UCL83	-49
OCH35	-65 EF80	-24 PCL82	-33 UFB89	-30
DAF91	-21 EF85	-28 PCL84	-35 UL84	-32
DAF86	-35 EF86	-31 PCL85	-42 UY85	-27
DCC90	-80 EF89	-24 PCL86	-40 Z77	-18

Postage on 1 valve 5p, on 2 or more valves 3p per valve extra. Any parcel insured against damage in transit 3p extra. Office address, no callers.

## GERALD BERNARD

83, OSBALDESTON ROAD  
STOKE NEWINGTON,  
LONDON, N.16

## NEW TELEVISION TUBES

FULLY GUARANTEED

### STANDARD TUBES — 2 YEAR GUARANTEE

17" £5-90	21" £8-00
19" £6-90	23" £9-25

### PANORAMA TUBES

19" £ 9-75	20" £12-00
23" £12-25	24" £15-00

### COLOUR TUBES — 4 YEAR GUARANTEE

19" £57-50	25" £68-50
22" £63-50	

### FULL RANGE OF REBUILDS FROM £4-00

Carriage FREE in our van area. Otherwise add 75p for Black and White tubes, £1:50 for Colour tubes.

### VALVES

6 month guarantee all TV types British made—VERY LOW PRICES. We also supply Stylii, Cartridges, Microphones, Record Changers, etc.

SEND FOR FULL LISTS

## VACUONICS LTD.

Newtown St. • Cradley Heath • Warley • Worcs.  
Tel: Cradley Heath 69138 FOR SERVICE

**STEPHENS**ELECTRONICS,  
P.O. BOX 26,  
AYLESBURY, BUCKS.SEND S.A.E. FOR LISTS  
GUARANTEE  
Satisfaction or money  
refunded.**MAGNETIC RECORDING TAPE  
FINEST QUALITY  
PACKED IN LIBRARY PLASTIC PACKS**

POLYESTER			POLYESTER		
Length	Spool Size in.	Price	Length	Spool Size in.	Price
<b>Standard Play</b>			900 ft.	5	70p
600 ft.	5	50p	1200 ft.	5½	85p
850 ft.	5½	63p	1800 ft.	7	100p
1200 ft.	7	70p	<b>Double Play</b>		
<b>Long Play</b>			1200 ft.	5	88p
210 ft.	3	28p	1800 ft.	5½	110p
450 ft.	4	18p	2400 ft.	7	130p

**EMPTY TAPE REELS**

3 in.	8p
4 in.	9p
5 in.	11p
5½ in.	13p
7 in.	14p

**CASSETTES**

Boxed in Plastic Library Packs	
C60	53p
C90	63p
C120	83p
P & P 8p on all orders.	

**BRAND NEW 20 in. KB TELEVISIONS £59-50**, Carriage plus INS. £1-50. **EX RENTALS BBC1**  
ITA BBC2 PYE Models 20 UF Bush 125. 19" & 25" **£17-50** Each. Carriage and Insurance **£1-50**.

**STEPHENS**ELECTRONICS,  
P.O. BOX 26, AYLESBURY, BUCKS.SEND S.A.E. FOR LISTS GUARANTEE  
Satisfaction or money refunded**REBUILT  
TELEVISION TUBES****STANDARD TYPES:**

19".....£5-00	21".....£6-50
19".....£5-50	23".....£7-50

**'PANORAMA' & 'RIMGUARD' TYPES:**

19".....£7-00	23".....£9-00
---------------	---------------

**TWIN PANEL or BONDED FACE TYPES:**

19".....£7-50	23".....£10-00
---------------	----------------

- ★ Complete new gun fitted to every tube.
- ★ Two years' guarantee.
- ★ **Free delivery** by our own transport within 25 miles of London. Over this distance 75p extra for carriage and insurance.

We have been rebuilding tubes for the past 12 years and can supply any type including 11", 12", 13", 16", etc. and colour tubes. Trade enquiries invited.

**N.G.T. ELECTRONICS LTD.,**  
**22 Anerley Station Road,**  
**London, S.E.20**  
**Telephone: 01-778 9178**

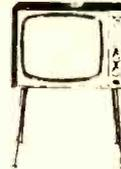
**EX RENTAL TV's**

19" —	£29-95
23" —	£39-95

All Channels 405/625  
**2 Years Guarantee.**  
Free List by return.

17" Slim line TV's £11-95, 19" Slim line TV's £15-95. Guaranteed 2 years. Send for List. Carr. & Ins. all sets £1-95. Daily demonstrations to personal shoppers.

**TEAK HI-FI STEREO CABINETS £14-95**

Brand New 44" wide X 16" deep X 18" high with Legs. A superb piece of furniture. Carr. £1-00.

**PRESS BUTTON SWITCHING UNITS.** 4 Banks 17p. 6 Banks 27p P. & P. 5p.

Transistor Radio Cases: 25p each.  
Size 9½" X 6¼" X 3½" P. & P. 15p  
**SPEAKERS** 50p 25 8Ω BRAND  
NEW. P. & P. 5p.

**TRANSISTORS Post Free**

AC 126	AF 179	OC 81
AC 128	OC 44	OC 83D
AF 114	OC 45	
AF 117	OC 71	15p each

**POTENTIOMETERS 23p each**

Double & Switched	500 KΩ/500 KΩ	3½" shaft
Double & Switched	500 KΩ/100 KΩ	2" shaft
Double & Switched	1 MEG/100 KΩ	1½" shaft

Post. & Pack. 5p.—4 for 10p

**KNOBS 100,000 to clear (Brand New)**

100 assorted Radio & T.V. knobs 50p.  
Postage 10p. (If you require sets 2 to 6 just ask)

**DUKE & CO. (LONDON) LTD.**

421/3 Romford Road, Manor Park, E.12  
Phone 01-478 6001-2-3 Stamp for Free List

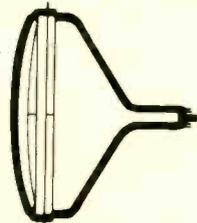
**TV TUBES REBUILT  
GUARANTEED 2 YEARS**

14"—£3-95, 17" & 19"—£5-95,  
21" & 23"—£6-45.

Exchanged Bowls. Carr. 53p.

# 19" TV's

Ex Rental Television sets as they come.  
Fair sets at fair prices.

## TRADE ONLY

Telephone or call

**WILLOW VALE ELECTRONICS LTD**  
Wholesalers to the Service Engineer

**42 WEST END, STREET,  
SOMERSET**

Tel: 045-84 2597

## 2 NEW "TELEBOOSTERS"

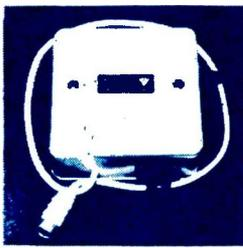

**THE M4  
DUAL BAND  
V.H.F. UNIT**

**KING . . .**

the name you  
can depend on.

- \* Boosts all Band III and any specified Band I Channel simultaneously.
  - \* Still higher gain . . . nominally 17-18 d.B. both Bands.
  - \* Very low noise third generation passivated transistor.
  - \* Fitted fly lead . . . installed in seconds.
  - \* Quality Case 3 1/4" x 3 1/4" x 1 1/2" Cork base.
- Specify Band I channel when ordering.

**THE NEW UM4 UHF "COLOURBOOSTER"**  
Channels: Group "A" Red Spot. "B" Yellow Spot, "C" Green Spot. Prices: Both types—£3.75 Battery Model OR £5.87 Self Contained Mains Model.  
P/P 13p

**TRANSISTOR DEVICES LIMITED**  
Bridge House, NEWTON ABBOT, Devon.  
*Literature on request.*

## UHF. COLOUR AND TELEVISION SPARES

**COLOUR PLESSEY SCAN COILS** £5.75 p.p. 35p. **CONVERGENCE COILS** £3.80 p.p. 25p. **BLUE LATERAL** £1.25 p.p. 9p. or Complete Set £10 p.p. 50p. **MULLARD TYPE SCAN COILS** £3.50 p.p. 35p. **CONVERGENCE COILS** £2.75 p.p. 25p. **LUMINANCE/CHROMINANCE PANEL** £1 p.p. 25p. **INTEGRATED TRANSISTORISED DECODER UNIT** (including EHT and FOCUS ASSEMBLY) £4.50 p.p. 35p. (Shop customers only. assortment Colour Panels of various makes). **ALSO COLOUR TV CAMERA UNITS.**

**COLOUR TV MONITOR PANELS** Designed to highest BBC standards. PAL filter & delay £6.00. Chrominance £8.00. Luminance £4.50. Encoded Video Input £2.50 pp 25p.

**UHF 625 conversion kits and tuners** available at reduced prices. Lists available.

**UHF Integrated transistd.** 6 position push button tuners, leading British makers surplus £4.50 p.p. 35p. Transistd. IF panels (salvaged) £2.50 p.p. 25p.

**MURPHY 600/700 series UHF conversion kits** in cabinet plinth assembly can be used as separate UHF receiver £7.50 p.p. 50p. 625 IF amplifier incl. 5 valves and circuit £3 p.p. 35p.

**SOBELL/GEC Dual 405/625 IF amp and o/p chassis** incl. circuit £1.50 p.p. 30p. **ULTRA 1980 C to 2384 625 IF amp & switch** incl. circuit £1.50 p.p. 30p. **PHILIPS 625 D/C IF panel** incl. circuit data £1.95 p.p. 30p.

**UHF tuners transistd.** incl. S/M drive or push button £5.25 p.p. 25p.

**EKCO/FERRANTI UHF tuner kit**, incl. valves, slow motion drive, knobs, leads, aerial panel £5.50 p.p. 30p.

**TV SIGNAL BOOSTER UNITS** Latest **PYE/LABGEAR** all station UHF/VHF transistd. "Set back" mains operated £5.90 UHF Masthead £4.25. Power Unit £3.25 pp. 25p.

**FIREBALL TUNERS** Ferg., HMV, Marconi. New £1.90, others salvaged 90p p.p. 25p.

**PUSH BUTTON** Plessey. Ekco. Ferranti £1.50 pp. 25p.

**TURRET TUNERS** Pye 11u (export type) 75p, AB Dual Standard Suitable Ferguson, Baird, KB etc. 75p, Cydon C 75p, Ferguson MT7 £2.75, GEC 2018/9 £4.50 pp. 25p. Large selection channel coils.

**LINE OUTPUT TRANSFORMERS.** Popular types available, brand new replacements, fully guar. A selection which can be supplied p.p. 25p. C.O.D. 25p.

**MURPHY 470 to 530 (oilfilled)** . . . £3.75

**PHILIPS 17TG100 Range** . . . £3.50

**STELLA 1011/1029** . . . £4.00

**PHILIPS 1GTG111/12** . . . £4.50

121 to 155 . . . £4.50

**PHILIPS 19TG170, 210 series** . . . £4.50

**BUSH TV53 to 69 £2, 95 to 135** £4.50

**EKCO 221 to 331 (U25 or U26 types)** . . . £3.50

**FERRANTI 1001/19 (U25 or U26)** £3.50

**EKCO 342 to 394, FERRANTI 1021 to 1065** . . . £3.75

**EKCO, FERRANTI 418, 1093 etc.** £3.50

**DECCA DM17, 3, 4 (70) DR95, 101/606** . . . £3.95

**FERG 305 to 436, 505 to 727** . . . £3.75

**FERG, HMV, MARCONI, ULTRA, PHILCO 3600, 2600, 4600, 6600, 1100, Jellypot** . . . £3.75

**KB QU 20, PVP20, VCI to VC11** £4.00

**MARCONI VT157 to 172** . . . £3.75

**GEC 302 to 346, £2.50, 448 to 452** £3.25

**GEC 454/6, 2000 series** . . . £4.50

**HMV 1865/9, 1870/6, 1890/1024** £3.75

**PYE CTM/CW series (printed circuit) 17/21, 17/S, 110 to 510, 700, 830, 11U to 40F** . . . £3.50

**PAM, INVICTA equiv. LOPTS to above PYE** . . . £3.50

**PETO SCOTT 1419 to 1725** £1.75, 733 to 738 . . . £2.50

**SOBELL/McMICHAEL TPS 173, 180, T23, 24, 178, 278, SC24, 270, MP17, 18, M72, M74** . . . £2.50

**TPS 781, 279, SC34, 370, MP27, M75 76, 93** . . . £3.25

**195, 282 to 288, 762, 763** . . . £3.25

**SOBELL 196/7, 1000 series** . . . £4.50

**PHILCO 1010 to 1021** . . . £2.25

**ULTRA 1770 to 2834** . . . £3.75

**PRACTICAL TV 625 RECEIVER** Integrated push button transistorised tuner . . . £4.50 p.p. 25p

Transistorised IF panel . . . £4.75 p.p. 25p

850 line output transformer . . . £3.75 p.p. 25p

850 held output transformer . . . £1.62 p.p. 15p

850 scan coils . . . £3.90 p.p. 25p

(p.p. on complete set of 5 items 50p)

**VALVE BASES** B9D for PL500 series and colour 121p p.p. 5p

**SPECIAL OFFER** Leading British makers surplus 625 single standard 625 TV chassis, latest design, almost complete, includes transistorised IF stages, frame and line time bases, transformers, etc., incl. circuit £8.65 p.p. 50p.

## MANOR SUPPLIES

172 WEST END LANE, LONDON, N.W.6

(Near W. Hampstead tube stn.; 28, 59, 159 Bus Routes) 01-794 8751

MAIL ORDER: 64 GOLDERS MANOR DRIVE, LONDON, N.W.11

# In just 2 minutes, find out how you can qualify for promotion or a better job in Engineering . . .

That's how long it will take you to fill in the coupon below. Mail it to B.I.E.T. and we'll send you full details and a free book. B.I.E.T. has successfully trained *thousands* of men at home – equipped them for higher pay and better, more interesting jobs. We can do as much for YOU. A low-cost B.I.E.T. Home Study Course gets results fast – makes learning easier and something you look forward to. There are no books to buy and you can pay-as-you-learn on 'SATISFACTION – OR REFUND OF FEE' terms. If you'd like to know how just a few hours a week of your spare time, doing something constructive and enjoyable, could put you out in front, post the coupon today. No obligation.

## WHICH SUBJECT WOULD INTEREST YOU?

### Mechanical

A.M.S.E. (Mech.)  
Inst. of Engineers  
Mechanical Eng.  
Maintenance Eng.  
Welding  
General Diesel Eng.  
Sheet Metal Work  
Eng. Inspection  
Eng. Metallurgy  
C. & G. Eng. Crafts  
C. & G. Fabrication

### Draughtsmanship

A.M.I.E.D.  
Gen. Draughtsmanship  
Die & Press Tools  
Elec. Draughtsmanship  
Jig & Tool Design  
Design of Elec. Machines  
Technical Drawing  
Building

### Electrical & Electronic

A.M.S.E. (Elec.)  
C. & G. Elec. Eng.  
General Elec. Eng.  
Installations & Wiring  
Electrical Maths.  
Electrical Science  
Computer Electronics  
Electronic Eng.

### Radio & Telecomms.

C. & G. Telecomms.  
C. & G. Radio Servicing  
Radio Amateurs' Exam.  
Radio Operators' Cert.  
Radio & TV Engineering  
Radio Servicing  
Practical Television  
TV Servicing  
Colour TV  
Practical Radio & Electronics (with kit)

### Auto & Aero

A.M.I.M.I.  
MAA/IMI Diploma  
C. & G. Auto Eng.  
General Auto Eng.  
Motor Mechanics  
A.R.B. Certs.  
Gen. Aero Eng.

### Management & Production

Computer Programming  
Inst. of Marketing  
A.C.W.A.  
Works Management  
Work Study  
Production Eng.  
Storekeeping  
Estimating  
Personnel Management  
Quality Control  
Electronic Data Processing  
Numerical Control  
Planning Engineering  
Materials Handling  
Operational Research  
Metrication

### Constructional

A.M.S.E. (Civ.)  
C. & G. Structural  
Road Engineering  
Civil Engineering  
Building  
Air Conditioning  
Heating & Ventilating  
Carpentry & Joinery  
Clerk of Works  
Building Drawing  
Surveying  
Painting and Decorating.  
Architecture  
Builders' Quantities

### General

C.E.I.  
Petroleum Tech.  
Practical Maths.  
Refrigerator Servicing  
Rubber Technology  
Sales Engineer  
Timber Trade  
Farm Science  
Agricultural Eng.  
General Plastics

### General Certificate of Education

Choose from 42 'O' and 'A' Level subjects including:  
English  
Chemistry  
General Science  
Geology  
Physics  
Mathematics  
Technical Drawing  
French  
German  
Russian  
Spanish  
Biology  
B.I.E.T. and its associated schools have recorded well over 10,000 G.C.E. successes at 'O' and 'A' level.

WE COVER A WIDE RANGE OF TECHNICAL AND PROFESSIONAL EXAMINATIONS.

Over 3,000 of our Students have obtained City & Guilds Certificates. Thousands of other exam successes.

## THEY DID IT—SO COULD YOU

"My income has almost trebled . . . my life is fuller and happier." – Case History G/321.

"In addition to having my salary doubled, my future is assured." – Case History H/493.

"A turning point in my career – you have almost doubled my standard of living." – Case History K/662.

"Completing your Course meant going from a job I detested to a job I love." – Case History B/461.

## FIND OUT FOR YOURSELF

These letters – and there are many more on file at Aldermaston Court – speak of the rewards that come to the man who has given himself the specialised know-how employers seek. There's no surer way of getting ahead or of opening up new opportunities for yourself. It will cost you a stamp to find out how we can help you.

# Free!

Why not do the thing that really interests you? Without losing a day's pay, you could quietly turn yourself into something of an expert. Complete the coupon (or write if you prefer not to cut the page). We'll send you full details and a FREE illustrated book. No obligation and nobody will call on you . . . but it could be the best thing you ever did.

## BRITISH INSTITUTE OF ENGINEERING TECHNOLOGY

Dept D257 Aldermaston Court, Reading RG7 4PF.

(Write if you prefer not to cut this page)



# BIET

## POST THIS COUPON TODAY

To: B.I.E.T., Dept D257 Aldermaston Court, Reading RG7 4PF  
Please send me book and details of your Courses in

Name..... Age.....

Address.....

Occupation.....