

PRACTICAL

TELEVISION

3/0

JULY
1969

Start of New Series...

**WAVEFORMS IN
COLOUR TV
RECEIVERS**

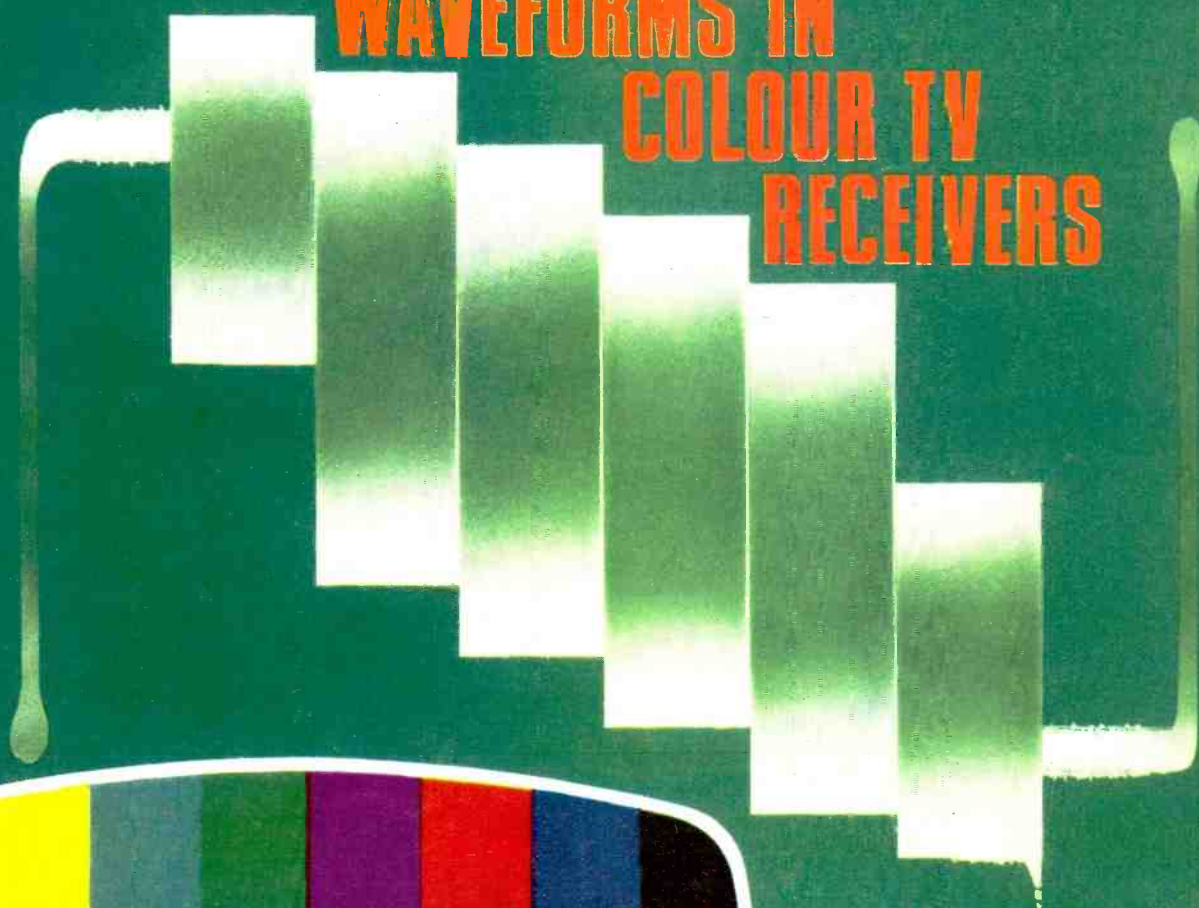

**also
inside**
**CORNER
REFLECTOR
UHF
LOFT
AERIAL**

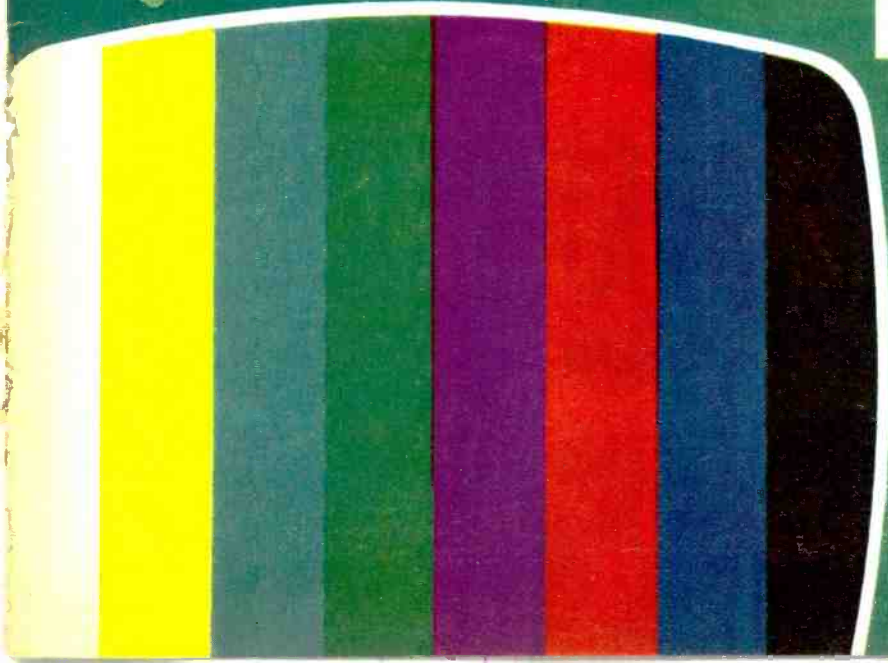

BENTLEY ACOUSTIC CORPORATION LTD.

38 CHALCOT ROAD, CHALK FARM, LONDON, N.W.1
THE VALVE SPECIALISTS Telephone PRIMROSE 9090

SAVE POSTAL COSTS! CASH AND CARRY BY CALLERS WELCOME

OA2	5/9	6AU6	5/6	6LD20	8/6	12AD6	6/6	30C15	13/6	5763	10/6	DK91	5/6
OB2	6/9	6AV6	5/6	6N7GT	8/6	12AE9	7/6	30C17	12/6	6060	5/6	DK92	7/6
OZ4	4/3	6B9G	2/6	6P1	12/6	12AT6	4/6	30C18	8/9	7193	10/6	DK96	7/6
IA3	4/6	6BA6	4/6	6P25	12/6	12AT7	3/9	30P15	15/6	7475	4/6	DL33	6/6
IA5	5/3	6BE6	4/6	6P26	12/6	12AU6	6/6	30P14	12/6	A1834	20/6	DL35	4/6
LA7GT	7/6	6BH6	7/6	6P28	25/6	12AU7	4/6	30FL12	16/6	A2134	10/6	DL39	4/6
IC5	4/9	6BJ6	6/6	6Q7G	6/6	12AV6	5/6	30FL14	12/6	A3042	15/6	DL94	5/6
ID5	6/9	6BQ3	4/6	6Q7	8/6	12AX7	4/6	30L1	6/6	AC2PEN	19/6	DL96	7/6
ID9	9/6	6BQ7A	7/6	6R7G	7/6	12AY7	9/9	30L15	13/9	AC3PEN	19/6	DL97	7/6
IFB1	6/6	6BK7	6/6	6R7	11/6	12BA6	6/6	30L17	13/6	DD	19/6	DM70	6/6
IFD9	9/6	6BR8	8/6	6SA7GT	7/6	12B56	5/9	30P12	13/6	AC/CPEN	4/9	DM71	7/6
IO6	6/6	6B87	16/6	6SCTGT	6/6	12EL	17/6	30P4MR	12/6	AC/CPEN	4/9	DM72	7/6
IH5GT	7/6	6BW6	12/6	6S7G	6/6	12J7GT	6/6	30P12	13/6	AC/CPEN	4/9	DM73	7/6
IL4	2/6	6BW7	11/6	6SH7	3/6	12K5	10/6	30P19	12/6	AC/CPEN	4/9	DM74	7/6
ILD5	5/6	6C4	2/9	6SJ7	6/6	12K7GT	5/9	30P19	12/6	AC/CPEN	4/9	DM75	7/6
ILN5	8/6	6C6	3/9	6SK7	4/6	12KRGT	7/6	30P11	15/6	AC/CPEN	4/9	DM76	7/6
IN5GT	7/6	6C9	11/6	6SN7GT	4/6	12Q7GT	4/6	30P13	15/6	AC/TH1	10/6	DM77	7/6
IR5	4/9	6CD6G	19/6	6S7GT	5/6	12SA7GT	12/6	30P14	15/6	AC/TH1	10/6	DM78	7/6
IR4	7/9	6CH6	6/6	6U4GT	12/6	12SA7GT	12/6	30P15	15/6	AC/TH1	10/6	DM79	7/6
IR5	3/9	6D3	7/6	6U7G	7/6	12SC7	4/6	35A5	5/6	AC/IVP2	10/6	DM80	7/6
IU4	5/9	6D6	3/6	6V6G	3/6	12SG7	3/6	35L6:3T	8/6	ATP4	2/3	EA50	10/6
IU5	6/9	6F1	8/9	6V6GT	6/6	12SH7	3/6	35W4	4/6	AZ1	8/6	EA76	13/6
2P21	5/6	6F6	12/6	6X4	3/6	12SJ7	4/6	35Z3	10/6	AZ31	8/9	EABCO	6/6
3A4	3/6	6F9G	4/6	6X5GT	5/6	12SK7	4/9	35Z4GT	4/9	AZ41	7/6	EAC91	3/6
3A5	10/6	6G12	3/6	6Y7G	12/6	12SQ7GT	7/6	35Z5GT	6/6	B163	10/6	EAF42	5/9
3B7	3/9	6G13	3/6	7B6	10/6	12TA7	16/6	35Z6	10/6	B331	7/6	EAF42	5/9
3D6	3/9	6F15	9/6	7B7	7/6	14H7	1/6	50C5	6/3	CV6	10/6	EB41	4/6
3Q4	6/6	6F18	7/6	7C6	6/6	14H7	15/6	50C6	6/3	CY1C	10/6	EB91	2/3
3Q5GT	6/6	6F23	13/6	7H7	5/6	18	12/6	50C6G41	6/6	CY31	7/6	EB92	2/3
3H4	4/9	6F24	11/9	7R7	12/6	19	10/6	50L6GT	6/6	D63	5/6	EB93	2/3
3V4	5/6	6F28	10/6	787	20/6	19AQ5	4/9	72	6/6	D77	2/3	EB94	2/3
3R4GY	8/6	6F92	3/6	7V7	5/6	20A1	13/6	85A2	8/6	DAC32	7/6	EB95	2/3
3U4G	8/6	6G9G	2/6	7Y4	6/6	20D3	20/6	90AG	6/6	DAP91	3/9	EB96	2/3
5V4G	7/6	6H6GT	1/9	8RW6	7/6	20P3	13/6	90AV	6/6	DAP96	6/6	EBF80	6/6
5Y3GT	5/6	6J5G	3/9	9D7	9/6	20P4	13/6	90CCG	34/6	DDC90	10/6	EBF83	6/6
5Z3	8/6	6J6	3/9	10C1	12/6	20P1	17/6	90CV	33/6	DD4	10/6	EBF89	3/9
5Z4G	6/9	6J7G	4/9	10C2	10/6	20P3	18/6	90D1	18/6	DDT4	8/3	EBF91	3/9
6/30L2	12/6	6J7GT	6/6	10D1	8/6	20P4	13/6	150B2	14/6	DF33	7/9	EBF92	3/9
6A8G	5/6	6K6GT	5/6	10D2	14/6	20P5	18/6	150C2	5/9	DF91	2/9	EBF93	3/9
6AC7	3/6	6K7G	7/6	10F1	15/6	25A5G	7/6	301	20/6	DF96	6/6	EC70	4/6
6AK5	4/6	6K7GT	4/6	10F2	15/6	25V5	6/6	302	18/6	DF97	10/6	EC79	4/6
6AK6	6/6	6K8GT	7/6	10F18	7/6	25V5	6/6	303	15/6	DH63	6/6	EC79	4/6
6AL5	2/3	6L1	19/6	10LD11	10/6	25V5G	8/6	305	16/6	DH76	4/6	EC79	4/6
6AM6	3/3	6L6GT	7/9	10P13	13/6	25Z4G	6/6	306	13/6	DH77	4/6	EC79	4/6
6AQ5	4/9	6L7GT	12/6	10P14	12/6	25Z5	7/6	307	11/9	DH81	10/9	EC79	4/6
6AR8	20/6	6L18	5/6	12A6	8/6	26Z6G	8/6	308	2/6	DK32	7/6	EC79	4/6
6AT6	4/6	6L19	19/6	12AC6	7/6	30C1	6/6	1281	10/6	DK40	10/6	EC79	4/6

EC86	10/3	EF98	10/6	HL42D18	10/6	PCF84	8/6	QS150/15	UY41	6/9
EC92	6/6	EF183	6/6	HN309	27/4	PCF86	9/6	UY85	5/6	
ECC31	15/6	EF184	6/6	HVR2	8/9	PCF801	7/6	U10	9/6	
ECC32	4/6	EH90	6/6	HVR2A	8/9	PCF802	9/6	R10	15/6	
EF93	29/1	EL32	3/6	IWS	5/6	PCF805	8/9	R11	19/6	
ECC34	29/6	EL33	12/6	IV4350	15/6	PCF806	11/6	R16	34/11	
ECC40	9/6	EL34	9/6	IV4500	6/6	PCF808/12/6		R18	10/6	
ECC81	3/9	EL35	10/6	KB3C3	20/5	PCL81	9/6	R18	9/6	
ECC82	4/6	EL37	17/3	KT2	5/6	PCL82	7/6	R19	6/6	
ECC83	4/6	EL41	9/3	KT8	3/6	PCL83	9/6	R20	11/9	
ECC84	5/6	EL42	9/9	KT32	5/6	PCL84	7/6	R52	7/6	
ECC85	5/6	EL43	8/6	KT41	19/6	PCL85	8/3	SP4	7/6	
ECC88	7/6	EL83	6/9	KT41	20/6	PCF86	11/6	SP4	12/6	
ECC189	9/6	EL84	4/6	KT41	12/6	PCL88	15/6	TR1	17/6	
ECC190	12/6	EL85	7/6	KT63	4/6	PCN45	7/6	TD14	8/3	
ECC807	27/6	EL86	8/6	KT66	17/3	PEN45DD		TH4B	10/6	
ECF80	6/6	EL91	2/6	KT74	12/6			TH233	7/6	
ECF82	6/6	EL95	5/6	KT76	7/6	PEN46	4/6	TP2620	8/9	
ECF86	9/6	EM71	14/6	KT88	29/6	PEN	15/6	UABCO	5/9	
ECF86A	9/6	EM80	5/9	KTW61	10/6	PEN	15/6	UAF42	9/6	
		EM81	6/9	KTW63	5/9	PEN	15/6	UB41	6/6	
ECH21	12/6	EM84	6/6	KTW63	5/9	PEN	15/6	UB41	6/6	
ECH33	22/6	EM85	11/6	KTZ41	6/6			UBC81	7/6	
ECH35	5/9	EM87	7/3	L63	3/9	PFL20012/6		UBF80	5/9	
ECH42	10/6	EY51	6/9	LN152	6/6	PL33	19/6	UBF89	6/9	
ECH81	5/9	EY81	7/6	LN309	9/6	PL39	9/6	UBL21	9/6	
ECH83	8/6	EY83	8/3	LN319	15/6	PL81	7/3	UC92	5/6	
ECH84	7/6	EY84	7/6	LN319	15/6	PL81A	13/6	UC92	5/6	
ECL80	6/6	EY86	6/6	ML229	6/6	PL82	6/6	UC93	6/6	
ECL82	6/6	EY87	6/6	MH4014/9		PL83	6/6	UC94	7/6	
ECL83	9/6	EY88	7/6	MHD4	8/3	PL84	6/3	UC94	7/6	
ECL84	12/6	EY91	3/6	MHL1	12/6	PL302	12/6	UC94	7/6	
ECL85	11/6	EY95	5/6	MHL6	7/6	PL500	12/6	UC94	7/6	
ECL86	8/6	EY90	3/3	MHL6	6/6	PL504	12/6	UC94	7/6	
ECL87	8/6	EY90	3/3	MHL6	6/6	PL509	23/9	UC94	7/6	
ECL88	8/6	EY90	3/3	MHL6	6/6	PL509	23/9	UC94	7/6	
ECL89	8/6	EY90	3/3	MHL6	6/6	PL509	23/9	UC94	7/6	
ECL90	8/6	EY90	3/3	MHL6	6/6	PL509	23/9	UC94	7/6	
ECL91	8/6	EY90	3/3	MHL6	6/6	PL509	23/9	UC94	7/6	
ECL92	8/6	EY90	3/3	MHL6	6/6	PL509	23/9	UC94	7/6	
ECL93	8/6	EY90	3/3	MHL6	6/6	PL509	23/9	UC94	7/6	
ECL94	8/6	EY90	3/3	MHL6	6/6	PL509	23/9	UC94	7/6	
ECL95	8/6	EY90	3/3	MHL6	6/6	PL509	23/9	UC94	7/6	
ECL96	8/6	EY90	3/3	MHL6	6/6	PL509	23/9	UC94	7/6	
ECL97	8/6	EY90	3/3	MHL6	6/6	PL509	23/9	UC94	7/6	
ECL98	8/6	EY90	3/3	MHL6	6/6	PL509	23/9	UC94	7/6	
ECL99	8/6	EY90	3/3	MHL6	6/6	PL509	23/9	UC94	7/6	
ECL100	8/6	EY90	3/3	MHL6	6/6	PL509	23/9	UC94	7/6	

All goods are new and subject to the standard 90-day guarantee. We do not handle manufacturers' seconds, nor rejects, which are often described as "new and tested" but have a limited and unreliable life. Business hours Mon.-Fri. 9.30-5.30 p.m. Saturdays 9.1-5 p.m.
Terms of business. Cash with order only. Post/packing 6d. per item. Orders over £5 post/packing free. All orders cleared on day of receipt. Any parcel insured against damage in transit for only 6d. extra. Complete catalogue of valves, transistors and components with conditions of sale, price 10d. post. No enquiries answered unless 8 A.E. enclosed for reply.

T.V. TUBES "VIDEOCHROME" T.V. TUBES FOR BRILLIANCE & DEFINITION



CASH OR CHEQUE WITH ORDER

COMPARE OUR PRICES

- 17"—£4-15-0
- 19"—£5-5-0
- 21"—£6-10-0
- 23"—£7-10-0

TRADE SUPPLIED

ALL TUBES PRECISION REBUILT AT OUR OWN FACTORY BY SKILLED CRAFTSMEN WHO HAVE BEEN REBUILDING TUBES FOR OVER 10 YEARS. EACH TUBE BENCH AND SET TESTED TO A VERY HIGH STANDARD BEFORE DISPATCH

PRICES FOR TWIN PANEL TUBES AVAILABLE ON REQUEST

2 YEARS GUARANTEE FREE DELIVERY ANYWHERE IN THE U.K.

VIDEOCHROME TUBES LTD.
25 BELLEVUE AVENUE,
RAMSGATE, KENT. Tel. THANET 52914

17in.—£11.10.0 TWO-YEAR GUARANTEE 19in. SLIMLINE SOBEL—24 Gns. EX-RENTAL TELEVISIONS

FREE ILLUSTRATED LIST OF TELEVISIONS

17"—19"—21"—23" WIDE RANGE OF MODELS SIZES AND PRICES DEMONSTRATIONS DAILY

TWO-YEAR GUARANTEED TUBES 100% REGUNDED

Slim Line Tubes 110" 17" and 19" 99/6, 21" and 23" 119/6.
Normal Tubes 70" and 90" 17" 89/6, 21" 109/6, 14" and other sizes 69/6.

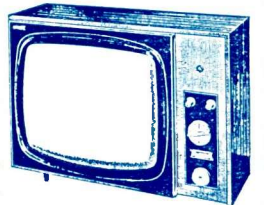

COCKTAIL/STEREOGRAM CABINET £25

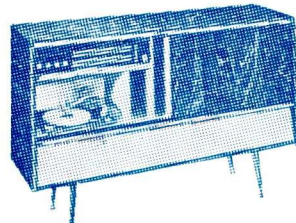

Polished walnut veneer with elegant glass fronted cocktail compartment, padded. Position for two 10in. elliptical speakers. Record storage space. Height 35 1/2in. width 5 1/2in., depth 14 1/2in. Legs 1/2in. extra.

Speakers 6/6: 2"—75Ω, 2 1/2"—35Ω. P. & P. 2/6. Acos Mics. 35/6. Standard: Stick Mic. 2gns. P. & P. 3/6. Asstd. Condensers: 10/- for 50. P. & P. 7/6. Asstd. Resistors: 10/- for 50. P. & P. 4/6. Asstd. Controls: 10/- for 25. P. & P. 7/6. Transistors: Mullard matched output kit 9/- OC81D—2 OC81's. P. & P. FREE.

Ferrite Rods 3/6: 6"— 1/2" complete with LW/MW Coils. P. & P. FREE. TRANSISTOR CASES 19/6. Cloth covered, many colours. Size 9 1/2" x 6 1/2" x 3 1/2" P. & P. 4/6. Similar cases in plastic 7/6.
TRANSISTOR RECORD PLAYER CABINETS 19/6. Dim. 11" x 14 1/2" x 5 1/2". P. & P. 7/6.

SINGLE PLAYER CABINETS 19/6. P. & P. 7/6.
STRIP LIGHT TUBES 3/9 each. 11" (2

ARE YOU READY FOR COLOUR TV?

SINGLE STANDARD—'69 !
 THAT MEANS MORE SALES, MORE SERVICE WORK AND
 MORE ENGINEERS !!!

DO YOU QUALIFY ? *Our correspondence school has proved of immense value to hundreds of engineers in England and abroad. Don't be left out.*

Colour television is now here and engineers with a working knowledge of colour television theory are in great demand and short supply. Do you know the meaning of "burst gating", "APC", "synchronous detectors", "ACC", "colour centre", "Hanover blinds", etc., etc.? Do you know that there are three different types of delay line for de-luxe PAL decoding?—or that the delay line may in fact disappear completely when the inevitable simple PAL receiver appears on the market? The last thing we wish to do is make colour television sound difficult—this is not so.

HOWEVER, KNOWLEDGE IS ESSENTIAL

The course consists of 10 lessons on colour mixing, the PAL colour system, colour receivers, decoders, IF circuits, time-bases, convergence waveforms, set-up procedures, test equipment, fault finding, typical circuits, etc., etc.

This course is designed for engineers who will be called upon to service colour television receivers within the coming months.

Expert guidance throughout the course. Test questions with each lesson. Model answers supplied. Terms available. Certificates awarded.

Fee for the complete course 10 guineas.

**DON'T DELAY
 POST COUPON NOW!**

To: DAYLIN ELECTRONICS LIMITED,
 32 PARKSTONE DRIVE,
 SOUTHEND-ON-SEA, ESSEX.

Please send, without obligation, details of your colour television course.

NAME

ADDRESS

"NORTH STAR"

LOOK NORTH FOR QUALITY AND
 RELIABILITY

Fully rebuilt television tubes—all types

Two years guarantee

Look North—buy "North Star"

9", 12", 14", 17"	£5. 0.0
16", 19"	£6. 0.0
21"	£7. 2.6
23"	£7.10.0
19" Panorama	£9. 0.0
23" Panorama	£12. 0.0
25" Panorama	£16. 0.0
*19" Twin Panel	£10.10.0
*23" Twin Panel	£13.10.0

*NB Twin Panel tubes cannot be successfully rebuilt to our stringent standards—these types therefore are brand new

Carriage and Insurance 10/-

TERMS

Cash or Cheque with order—state tube type required

Two Years Guarantee

"NORTH STAR" TUBE SUPPLY Co.,

P.O. Box 17, "HIGH RIGG",

CARR BANK, OTLEY, YORKSHIRE

VALVES SAME DAY SERVICE NEW! TESTED! GUARANTEED!

SETS 1R5, 1R5, 1T4, 384 3V4, DAF91, DF91, DK91, DL92, DL94.
 Set of 4 for 1R5, DAF96, DF96, DK96, DL96, 4 for 2R6.

OZ4	4/6	20L1	16/-	DK96	7/-	EL41	10/6	PCL85	9/-	UBF89	6/9
1A7GT	7/6	20P3	11/9	DL35	5/-	EL84	4/9	PCL86	8/6	UC92	5/-
1H5GT	7/3	20P4	18/6	DL92	5/9	EL90	5/-	PEN A4	12/6	UCC84	7/9
1N5GT	7/9	25L6GT	5/-	DL94	6/-	EL500	12/6	PEN36C15/-		UCC85	6/9
1R5	5/9	25V4GT	11/6	DL96	7/-	EM80	5/9	PFL20012/6		UCF80	8/3
1S5	4/3	30C1	6/6	DY86	5/9	EM81	6/9	PL36	9/9	UCH42	9/9
1T4	2/9	30C15	13/-	DY87	5/9	EM84	6/6	PL81	7/3	UCH81	6/9
384	5/9	30C17	16/-	EABC80	6/6	EM87	7/6	PL82	7/-	UCL82	7/3
3V4	6/-	30C18	11/6	EAF42	8/9	EY51	7/3	PL83	7/-	UCL83	11/6
3U4G	4/6	30F5	16/-	EB91	2/3	EY86	6/6	PL84	6/6	UF41	10/6
5Y3GT	5/9	30FL1	13/9	EBC33	3/3	EZ40	7/6	PL500	13/-	UF85	6/9
5Z4G	7/6	30PL12	14/6	EBC41	8/3	EZ41	7/6	PL504	13/6	UF89	6/9
6J0L2	12/6	30PL14	12/-	EBF89	6/3	EZ80	4/6	PL508	23/6	UL41	10/6
6AL5	2/3	30L1	6/6	EBF89	6/3	EZ81	4/9	PL802	14/6	UL44	20/-
6AM6	3/6	30L15	14/-	ECC81	4/9	GZ32	8/9	PM84	7/9	UL84	7/9
6AQ5	4/9	30L17	15/6	ECC82	4/9	GZ34	9/9	PX25	10/6	UM84	7/-
6AT6	4/9	30P4	12/-	ECC83	7/-	KT81	8/9	PY31	5/6	UY41	8/3
6AU6	4/6	30P12	13/9	ECC84	5/6	KT86	16/-	PY32	10/-	UY85	6/9
6BA8	4/6	30P19	12/-	ECC85	5/9	ME140015/-		PY33	10/-	VP4B	10/-
6BE6	4/9	30PL1	13/9	ECC804	12/6	N78	14/9	PY81	5/3	VP1321	21/-
6BJ6	7/-	30PL3	15/6	ECC80	7/-	PABC80	7/-	PY82	5/3	Z77	3/6
6BW6	13/-	30PL4	15/6	ECCF2	6/9	PC86	10/3	PY83	5/9	Transistors	
6F13	3/6	35L6GT	8/-	ECH35	6/-	PC88	10/3	PY88	6/3	AC107	3/6
6F14	9/-	35W4	4/6	ECH42	10/6	PC96	8/6	PY900	7/6	AC125	2/-
6F23	14/3	35Z4GT	5/-	ECH81	6/9	PC97	8/6	PY901	6/9	AD140	7/6
6K7G	2/6	6063	12/6	ECH84	7/6	PC900	8/-	R19	6/6	AF115	3/6
6KR6	4/3	AC/VP2	10/-	ECL80	6/9	PCC84	6/6	R20	12/6	AF116	3/6
6L18	6/-	AZ31	9/-	ECL82	6/9	PCC85	6/6	TH21C	9/9	AF117	3/3
6V6GT	6/6	B729	12/6	ECL83	9/9	PCC88	9/9	U25	13/-	AF124	7/6
6X4	4/3	CCR35	10/-	ECL86	8/3	PCF89	10/6	U26	12/-	AF125	6/6
6X5GT	5/9	CL33	18/6	ECH37A	6/6	PCF89	10/6	U47	13/6	AF126	7/6
7B7	7/-	CY31	6/9	EF39	4/9	PCF80	6/6	U49	13/6	AF127	3/6
7C6	6/9	DAC32	7/3	EF41	10/9	PCF82	6/6	U52	4/6	OC26	5/9
7Y4	6/6	DAF91	4/3	EF80	4/9	PCF86	9/6	U78	4/3	OC44	2/3
10P13	15/6	DAF96	6/6	EF85	6/-	PCF200	13/6	U191	12/6	OC45	2/3
12AH8	33/-	DF33	7/9	EF86	6/3	PCF800	13/6	U301	13/6	OC71	2/6
12AT7	4/9	DF91	2/9	EF89	5/3	PCF81	6/9	U801	19/6	OC72	2/6
12AU6	4/9	DF96	6/6	EF91	3/6	PCF802	9/6	UABC80	6/9	OC75	2/6
12AU7	4/9	DH77	4/-	EF183	6/-	PCF805	11/6	UAF42	9/6	OC81	2/3
12AX7	4/9	DH81	10/9	EF184	5/6	PCF808	12/-	UB41	6/6	OC81D	2/3
12K8GT	7/-	DK32	7/6	EH90	6/3	PCL82	7/-	UBC41	8/6	OC82	2/3
19B6GT	17/6	DK91	5/9	EL33	8/9	PCL83	9/9	UBC81	7/-	OC82D	2/6
20F2	13/6	DK92	9/3	EL34	10/3	PCL84	7/6	UBF80	6/-	OC170	2/6

READERS RADIO

85 TORQUAY GARDENS, REDBRIDGE, ILFORD,
 ESSEX. Tel. 01-550 7441

Postage on 1 valve 9d. extra. On 2 valves or more, postage 6d. per valve extra. Any Parcel Insured against Damage in Transit 6d. extra.

HIRING CCTV EQUIPMENT?

TV CAMERAS:	Plumbicon & Vidicon
VTR MACHINES:	Helical scan 1" & 3/4"
PICTURE MONITORS:	5 1/2" - 25" screens
LENSES:	5.7 mm to 1,000 mm
ZOOMS:	4:1, 10:1 & 20:1
CAMERA ACCESSORIES:	Tripods, heads, dolleys & cranes
TV VIEWFINDERS:	For film cameras
SOUND RECORDERS:	Nagra, Uher, etc.
SOUND ACCESSORIES:	Condenser, rifle & radio microphones, Fisher booms, etc.
LIGHTING:	Colortran, Lowell, Mole Richardson, Battery portable
RADIO TELEPHONES:	Walkie talkies to 25 watt Master
VT SERVICE:	Off air recording, tape duplication, copying, viewing
SOUND SERVICES:	Recording, dubbing & transfer
FILM SERVICES:	16 & 35 mm cameras & projectors
CAMERA CARS:	With front, roof & rear platforms
HELICOPTERS:	Alouette II Astazou, Bell 47G4A
EDITING FACILITIES:	Music & Effects libraries, Cutting rooms, Viewing theatre
TECHNICIANS:	As required

**DAY & NIGHT
WORLD WIDE SERVICE**



SAMCINE HOUSE
303 Cricklewood
Broadway,
London, N.W.2
Phone: 01-452 8090
Telex: 21430
Cables: SAMCINE
London

BRAND NEW LINE OUTPUT TRANSFORMERS

ALBA 655, 565, 77/6.
DYNATRON TV30, TV35 48/6, TV36 70/-.
EKCO T231, T284, TC267, T283, T293, T311, T326, T327, T330 48/6. TMB272 68/6. T344, T344F, T345, TP347, T348, T348F, TC347, TC349, TC356, T368, T370, TC369, T371, T372, TP373, TC374, T377A, T380, T380F, T381, T382, TC386, T393, T394, all at 70/-.
FERGUSON 306T, 308T 48/6 each. 406T, 408T, 416, 436, 438, 506, 508, 516, 518, 536, 546, 604, 606, 608, 616, 619, 636, 646, 648, 725, 726, 727, 3600, 3601, 3602, 3604, 3611, 3612, 3614, 3617, 3618, 3619, 3620, 3621, 3622, 3623, 3624, 3625, 3626, 3627, 3629 65/-.
FERRANTI T1001, T1002, T1002/1, T1004, T1005 48/6. T1023, T1024, T1027, T1027F, TP1026, T1057, T1057F, T1058, T1061, T1063, T1063F, T1068, T1068F, T1071, T1072 70/-.
G.E.C. BT302, BT304 62/6.
H.M.V. 1865, 1869 48/6. 1870, 1872, 1874, 1876, 1890, 1892, 1894, 1896 65/-.
PILOT PT450, 452, 455, 650, PT651, P60A, P61 82/6.
PHILCO 1962, 1967, 1967M, 1019, 1020, 2021 82/6. 1029, 1030, 1035, 1036, 1040, 1050, 1060 82/6.
PYE V200, V400, 200LB, 210, 220, 300F, 300S, 310, 210S, 410 60/-.
Please state part No.
ULTRA 1770, 2170, 1772, 1782, 2172, 1771, 2171, 1775, 2175, 1774, 2174, 1773, 2137, 1980c, 1984c, 100c, 200c, 2380, 2384, 1984, 1985, 1986, 1980, 1980a, 1780, 2180, 2181, 2183, 2182, 1871, 1783 78/-.

Guarantee. Post and Package 4/6. C.O.D. 6/-.
All new components inserts are guaranteed for three months from the date of invoice subject to the breakdown being due to faulty manufacture or materials.

D. & B. TELEVISION (Wimbledon) LTD.
80 MERTON HIGH STREET, S.W.19
01-540 3513 01-540 3955

Your Practical Wireless line-up for July

- ★ A.C./D.C. METER
a sensitive multirange transistorised voltmeter for measuring A.C. and D.C. voltages
- ★ READY CALIBRATED SIGNAL GENERATOR
- ★ INTEGRATED CIRCUIT AUDIO FREQUENCY SIGNAL INJECTOR
- ★ DIRECTIONAL MICROPHONE
- ★ MINI METRONOME
and all your regular features in

**PRACTICAL
WIRELESS** 3/-

July issue NOW ON SALE

PRACTICAL TELEVISION

VOL 19 No 10
ISSUE 226

JULY 1969

TV JOINS FILMS AT "FILM 69"

"EXPORT or die!" could well have been in the mind of someone who started making films specifically for the small television world market of twenty years ago. Those were early days, when only a few countries possessed the new-fangled amenity of television.

It is over twenty years ago that the BBC took the plunge in joint ventures with outside production companies to make films specifically for television broadcasting. They had to be simple in story-line yet with "meaty" plots; full of action but with plenty of close-ups; of good continuity but punctuated with skilled cutting; and with endings which did in fact end.

The British film production industry has had its ups and downs for many years, but with a decided up when it participated in films made specifically for television. These films, together with films for the cinema, are now important exports.

The world superiority of British colour television is now universally acclaimed. This professional superiority is due partly to the magnificent efforts of the BBC, spurred on by the barrage of potential competition from 15 independent television companies and, may it be said, from the major cinema film studios which have also now attained advanced technical developments. The ready exchange of technical information between all these world-revenue-producing sources has become a civilised form of technological integration, deserving greater fiscal encouragement.

Alas! Our present government is continuing the process of killing the geese that lay the golden export eggs, with corporation tax, levies, s.e.t., star-stranglehold (deterrent) tax, and dozens of other ways of extracting money from professional show-business people. Some of the money will no doubt be used to gratify the whims of amateurish do-gooder Ministers who, however, with their civil service advisers would be better occupied in studying and encouraging the British film and television industries (including equipment manufacturers) to expand efforts in overseas markets and to recognise the export opportunities now before them. Technical progress can be achieved with healthy competition and this is the splendid objective of the international event, "FILM 69", which involves both films and television.

W. N. STEVENS, *Editor*.

THIS MONTH

Teletopics	436
Waveforms in Colour Receivers— Part 1	by Gordon J. King 438
ACC for CCTV	by K. T. Wilson 442
DX-TV	by Charles Rafarel 445
Film Sound on Magnetic Stripes	by Baynham Honri 446
The PTV Videoscope—Part 4	by Martin L. Michaelis, M.A. 451
Early TV Camera Tubes—Part 2	by I. R. Sinclair 454
A Corner Reflector UHF Loft Aerial	by Keith E. G. Pitt, B.Sc. 456
Band I Omnidirectional DX Aerial	by Roger Bunney 457
Servicing Television Receivers— Bush/Murphy TV125/V849 series cont.	by L. Lawry-Johns 459
Inside TV Today—Part 18— Documentaries	by M. D. Benedict 462
Field Linearity Faults	by J. B. Willmott 466
Underneath the Dipole	by Iconos 468
The Decca Professional 23 TV Receiver	by H. K. Hills 470
Your Problems Solved	474
Test Case 80	476

**THE NEXT ISSUE DATED AUGUST WILL BE
PUBLISHED JULY 18**

TELETOPICS



FIFTY-SIX YEARS ON!



Photo by courtesy of M.G.M.

The name Samuelson has been established in the UK film production industry since 1913 and is now the largest film and TV equipment rental business in the world, with headquarters at Cricklewood, London. Samuelson's own research department is able to supply photographic filters, graduated or otherwise and to any special requirement, a unique service which is in world-wide use. Not only can Samuelson's supply almost any type of film or TV equipment—they can also provide the crews to operate the equipment. High equipment capital costs have increased the demand for this type of service. Specialised vehicles for filming are available, and also the helicopter shown above in use during the production of *Alfred the Great*.

Anthony Samuelson won the joint first prize in the light aircraft class in the *Daily Mail* Transatlantic Air Race.

ITA RELAY STATION AT ABERGAVENNY

The new ITA low-power television transmitting relay station at Abergavenny, Monmouthshire was officially taken into service on April 23rd. The station will relay on Channel 11 the Harlech Television programme for Wales from the ITA station at St. Hilary (Channel 7).

It is estimated that about

29,500 people live within the service area of the new relay station which will serve mainly viewers in Abergavenny, Crickhowell, Gilwern and Brynmawr.

The Abergavenny station will transmit horizontally polarised signals and for optimum reception viewers should use a Channel 11 aerial with horizontal rod elements.

The maximum e.r.p. is 100W vision and 25W sound.

ITA AND BBC-1 COLOUR

The present aim is to start transmission of ITA and BBC-1 u.h.f. colour on November 15th, in the London area. The service will be extended to other regions as soon as possible and it is expected that 40% of the public will be able to receive the ITA and BBC-1 on u.h.f. by the end of the year.

STATE OF THE MARKET

The downward trend reflected in the December figures for radio and television receiver deliveries to the home trade has continued into January and February of this year according to the Economic and Statistical Division of the British Radio Equipment Manufacturers' Association.

Colour television estimates at 15,000 for the first two months of the year show 6,000 less than for the same period last year and although monochrome receivers at 271,000 give a 1.5% increase over the two months the February figure of 121,000 is 29,000 less than either January or December.

AMATEUR TV CONGRESS

An International Congress of Amateur Television organised by the Club Français de Télévision d'Amateur was held on Saturday 19th and Sunday 20th April in the Salle des Sports at Armentières in Northern France. This highly successful event was attended by over 300 amateurs.

WIRING COLOUR CODE

We would like to remind readers of the new three-core flexible cable colour code that takes effect from July 1st: it's now *brown live, blue neutral and yellow-and-green earth*.

THE NEW SETS

Most of the setmakers have now announced models featuring the new tube sizes, 20 and 24in. Single-standard sets are also now beginning to appear at the Trade Shows.

From **Rank - Bush - Murphy** come the TV183D (20in.) and TV186D (24in.) Bush models; and the V2015D (20in.) and V2415D (24in.) Murphy models. No prices have been announced so far. Also from Murphy is the V2314DD "Exclusive Circles," a luxury-presentation 23in. model at £105 17s. 2.

The **Alba** 20in. Model TD1420 features an integrated tuner. The Thorn/BRC 1400 chassis with 20in. tube is featured in the **Ultra** Model 6658, priced at £75 18s.

GEC 20 and 24in. models are the 2063 and 2064 at 76 and 83gns. respectively. GEC/Radio & Allied are also showing to the trade single-standard monochrome and colour sets under the GEC and Sobell brands.

Decca announce four single-standard colour sets, the CS190 (19in.), CS2200 (22in.), CS2500 and CS2501 (both 25in.). Prices are not yet available. New Decca dual-standard monochrome sets are the 20in. DR21 at £82 19s. and the 24in. DR24 at £92 8s.

NEW BRC COLOUR CHASSIS

A series of two-day courses for engineers is being conducted by British Radio Corporation (Thorn Group) to introduce the forthcoming 3000 series all-transistor single-standard colour chassis.

KB AND RGD SPARES

The name of the service organisation for the KB and RGD brands, previously Combined Radio and Television Services Ltd., has been changed to ITT Consumer Products Services Ltd.

BATC CHAIRMAN

Gordon Sharpley, G6LEE/T, has been elected to the position of Chairman of the British Amateur Television Club.

BBC RELAY STATIONS

The BBC-2 Halifax relay station is now transmitting on Ch.27 (aerial Group A), vertical polarisation; Ffestiniog BBC Wales (and v.h.f. radio) station is transmitting on Ch.5, with horizontal polarisation.

SANDY HEATH BBC-2 TRANSMITTER

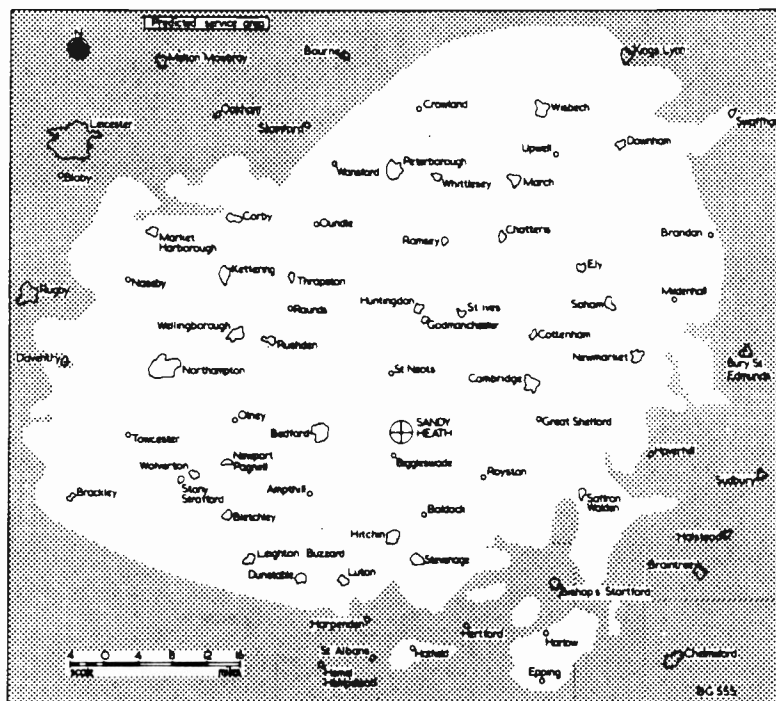

The expected service area of the Sandy Heath station is indicated above. The station will transmit on Channel 27 with maximum vision e.r.p. of 750kW. Use of Group A receiving aerial installed for horizontally polarised transmissions. The other u.h.f. channels assigned to the station are 21, 24 and 31.

FORESIGHT OF THINGS TO COME

An indication of future trends in TV set design is given by component developments revealed by Mullard at the International London Electronics Components Show. These included five new integrated circuits for use in TV receivers; a new line output transistor with highest-ever collector-base voltage rating; a thyristor power unit for monochrome and colour receivers; new push-through 19 and 25in. ColourScreen picture tubes; tuner units using variable-capacitance diodes for tuning; a new 24in. Supersquare monochrome tube, type A61-120W/R, with push-through presentation; a new chrominance delay line for PAL decoders; and new combined deflection and convergence units for 19, 22 and 25in. ColourScreen tubes.

The integrated circuits are type TAA570, which fulfils the intercarrier sound i.f. and detector functions, with quadrature detector, audio pre-amplifier and optional facility of a d.c.-operated remote volume control; the TAA550 voltage reference source, which provides a stabilised 33V supply for a varicap diode tuner unit; type TAA700 central signal processor, a jungle circuit comprising a video preamplifier, a.g.c. detector and amplifier for the i.f. stages, a delay network for the tuner a.g.c., noise gate, sync separator, automatic line sync and field sync pulse separator; the development type 1630M colour demodulator incorporating the synchronous detectors, G-Y matrix, PAL switch and bistable circuits, in two versions, one to drive colour-difference output transistors and the other to drive the TAA470 which incorporates an R, G, B matrix; and the just-mentioned TAA470 R, G, B matrix unit which provides outputs to drive separate red, green and blue transistor amplifiers.

The new line output transistor is the BU105 with a $\frac{1}{2}$ cb rating of 1.5kV and a current rating of 2.5A. For a colour receiver two BU105s can be used in series, with the 0.5A required at stabilised voltage obtained from the mains via a thyristor circuit.

waveforms in **COLOUR** receivers

PART 1

GORDON J. KING

THIS NEW series is about the diverse signals that are for ever active in colour television sets. In spite of their deceptively passive appearance, all classes of sound and vision receiving equipment are literally alive with signals of various kinds. Even the smallest transistor radio handles at least five different signals when it is working correctly—the modulated carrier-wave, local oscillator, modulated i.f., the audio signal and the d.c. produced by the rectifying action of the detector and a.g.c. diodes on the i.f. signal. Monochrome television sets deal with many more signals than this, including the numerous component signals comprising the composite vision signal, parts of which serve to synchronise the timebase generators and activate the vision blanking circuits during the synchronising periods.

Colour sets abound with almost three times as many signals; some of them are the same as those found in monochrome sets, and some of them are entirely different. It is proposed to trace the signals all the way from the colour camera to the shadowmask picture tube and to discuss them as we go along the vision chain. We shall not be concerned particularly with the accompanying sound signals, but we shall certainly be investigating the timebase signals and their admixtures active in the dynamic convergence departments.

To acquire a proper understanding of the working of the PAL colour television system—and, indeed, to be really successful in the servicing of colour sets—it is essential to be knowledgeable with respect to the signals present in the various parts of the system. If our job is to service colour sets, then during the course of this activity we shall often have to resolve the signals to waveform traces on the screen of an oscilloscope—an essential instrument for the servicing of colour sets. Fundamentally a signal constitutes a repetitive change in potential—not uncommonly swinging plus and minus, like a sine-wave—with time. Thus by making the spot of light on the screen of the oscilloscope (scope for short) deflect vertically to record the potential change (amplitude) and simultaneously horizontally to record time, the nature of the signal is accurately traced out by the spot of light. And since the spot of light moves faster than our eyes can discern at any instant we get the impression of trace continuity, sustained by the fact that the trace repeats rapidly over its entire waveform due to the synchronising action of the scope.

How Signals Are Displayed

Although this is not meant to be an article to describe the working and applications of the scope it is rather important at the outset to get one or two

points perfectly clear to save having to concentrate on them when we are dealing with actual signal displays. First, the vertical and horizontal deflections of the spot of light are usually measured in centimetres by means of a graticule scribed in centimetre squares, possibly with millimetre subdivisions, placed at the front of the screen. This, in fact, calibrates the scope, in conjunction with the circuits and controls which move the spot horizontally (the timebase) and vertically. With waveforms in colour set service manuals the spot deflection distance vertically (amplitude) is given as so many volts (or fractions of a volt) per centimetre while the horizontal scale of the trace is measured in terms of *velocity* and is thus given in seconds (usually fractions thereof) per centimetre.

Signal Amplitude

In this respect, let us study the waveform displays in Fig. 1. At (a) we have a simple pulse waveform (field sync) which, from its base line in the middle of the graticule, rises to a peak of almost 2cm. Now if the scope is set to say 0.3V/cm, then the peak value of the waveform (from its base line) would be close to 0.5V. Fig. 1 (b) shows two partially superimposed waveforms with the larger of the two having a *peak-to-peak* amplitude of 1cm. If the scope is set to 10V/cm, then the p-p amplitude of that waveform would of course be 10V. However if it happened to be a pure sinewave its r.m.s. value would be equal to 0.707 *times* its peak value—that is, 0.707 *times* 5V, or 3.535V. Fig. 1 (c) shows a near sinewave signal with a p-p amplitude of 4.5V since the scope is set to 1V/cm. The peak value is half the p-p value which is 2.25V, making its r.m.s. value 1.59V. A more complex waveform is shown at (d). This has a peak-to-peak value of 5cm, representing a p-p amplitude of 0.5V with the scope set to 0.1V/cm.

Many scopes have a switched input attenuator calibrated in volts/centimetre so that when a signal is fed into the Y terminal (that connected to the vertical amplifier) the spot is deflected vertically over a distance accurately corresponding to the setting of the attenuator. Thus with the attenuator set to say 3V/cm, one can be certain that an input signal with an overall amplitude of 3V will result in a 1cm, vertical deflection (6V giving a 2cm, deflection and so on). A calibration terminal carrying sine or squarewave signal of known amplitude is not an uncommon feature on the better class scopes, allowing the vertical deflection periodically to be checked against the attenuator setting.

It must be realised of course that the spot on the screen deflects in direct proportion to the amplitude of the signal at any instant, irrespective of its

Radio & Television Servicing

POPULAR MODELS FROM 1969 RIGHT BACK TO 1965

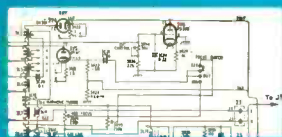

Circuit Diagrams



Block Diagrams

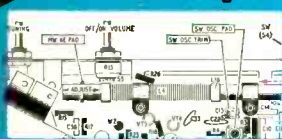

Component Layout Diagrams



Printed Panel Diagrams

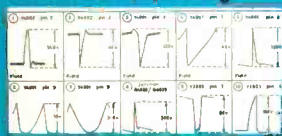

Waveform Graphs

Servicing data for all these makes

COLOUR TELEVISION (148 PAGES)—
Baird, B.R.C., Bush, G.E.C., Murphy,
Philips, Sobell, Stella.

**MONO TV, RADIOS, RADIOGRAMS,
CAR RADIOS, RECORD REPRODUCERS,
TAPE RECORDERS—**

Aiwa, Alba, Baird, Beogram, Beolit, Bush,
Carousel, Corsor, Dansette, Decca,
Defiant, Dynaport, Dynatron, Eddystone,
Ekco, Elizabethan, Ever Ready, Ferguson,
Ferranti, Fidelity, G.E.C., Grundig,
H.M.V., Kolster-Brandes, Hitachi, Invicta,
McMichael, Marconiphone, Masteradio,
Motorola, Murphy, National, Newmatic,
Pam, Perdio, Peto-Scott, Philips,
Portadyne, Pye, Radiomobile, R.G.D.,
Regentone, Roberts' Radio, Sanyo, Sharp,
Smith's Radiomobile, Sobell, S.T.C., Sony,
Standard, Stella, Stereosound, Teletron,
Thorn, Trans Arena, Ultra, Van Der Molen
World Radio.

Plus recent developments in Radio & TV

Electronic Video-Recording and Reproduction—
EVR system, Radio Receivers—Car radios,
Stereo Multiplex reception, Capacitance Diode
Tuning, Colour Television Test Equipment—
Crossshat Generator, Degaussing Coil, E.H.T.
Meter, Colour Bar Generator, Cathode Ray
Oscilloscope.

**2,180 PAGES, 2,657 CIRCUITS,
COMPONENT LAYOUT DIAGRAMS,
PRINTED PANEL DIAGRAMS,
TABLES AND WAVEFORM GRAPHS**

Complete panel on right, fold and post

See it FREE

Complete section below,
fold along A to A turning this
section under. Then fold
across at B and C and tuck
B into C so reply-paid
section shows. Post today.

Please tick (✓) here
The address on left is
(✓) your property
Rented Unfurnished
Furnished Temporary
If you are under 21 your father must fill up this section.
Name (BLOCK LETTERS) _____
Address _____
County _____
Occupation _____
Signature _____
Mrs. _____
Miss _____

Full Name (BLOCK LETTERS) _____
Address _____
County _____
Occupation _____
Signature _____
Mrs. _____
Miss _____

Please send **RADIO & TV SERVICING—1965/69**
Models in 4 volumes without obligation to buy if you
accept my application. I will return the books in 8
days or post—
Tick (✓) Full cash price of £16, or
here 20/- deposit and 16 monthly
payments of 20/- paying £17 in all.

Also send me on 7 days trial **ELECTRICAL
ENGINEER'S REFERENCE BOOK**. Price shown left
For Eire and N.I. send cash price with coupon.
Elsewhere overseas send cash price plus 20/- post,
packing and insurance.

Postage
will be
paid by
Buckingham
Press Ltd

No postage
stamp
necessary if
posted in
Gt. Britain or
Northern
Ireland

BUSINESS REPLY SERVICE
Licence No. OF. 381/1

BUCKINGHAM PRESS LTD.,
18-19 WARREN STREET,
LONDON, W.1

Tick coupon above to examine
**Electrical Engineer's
Reference
Book**

**JUST OUT
NEW 12th
EDITION**

Over 2,000 Pages
More than 2,400
Diagrams, Photo-
graphs and Tables

A comprehensive reference work
on modern theory, practice, equip-
ment and latest developments
written by 75 leading experts.
Main Sections include—
Theory and Calculations, Power
Station Practice, Cables and
Wires, Lighting, Heating Lifts,
Motors, Wiring and Installation,
Applied Electronics, Automatic
Control, Computers, Latest I.E.E.
Reg. requirements, Education,
Training, City & Guilds, etc.

If kept after free trial, 12/- dep.,
then 9 monthly payments of
14/- paying £6.18s. (inc. post
and packing) in all. Cash in
8 days £6.12s. (inc. post and
packing).

RV4/EERB/3990B

Here's money-making repair data for over 1,000 Popular Models

FROM 1969 RIGHT
BACK TO 1965

Radio & TV Servicing

This big 2,180-page Repair Library will help you to speed up repair work—create good will

See for yourself the wealth of time-saving and money-making information in RADIO & TV SERVICING. It provides all the CIRCUITS, REPAIR DATA and VITAL INFORMATION for servicing over 1,000 popular 1965-1969 TV's, Radios, Radiograms, Car Radios, Record Players and Tape Recorders—including COLOUR TV. 47 aspects of Colour TV are covered—instructions for installing receivers, the explanation of new terms, adjustments on purity, Colour balance, Static convergence, Dynamic convergence, etc. The many circuits, component layout diagrams, tables, printed panel and block diagrams in the colour section are invaluable to the service engineer and make this repair library well worth owning. See this Big Library of repair data FREE FOR A WEEK without obligation to buy. Simply complete coupon overleaf and POST TODAY—No stamp required.

THE
ONLY
WORK
OF ITS
KIND

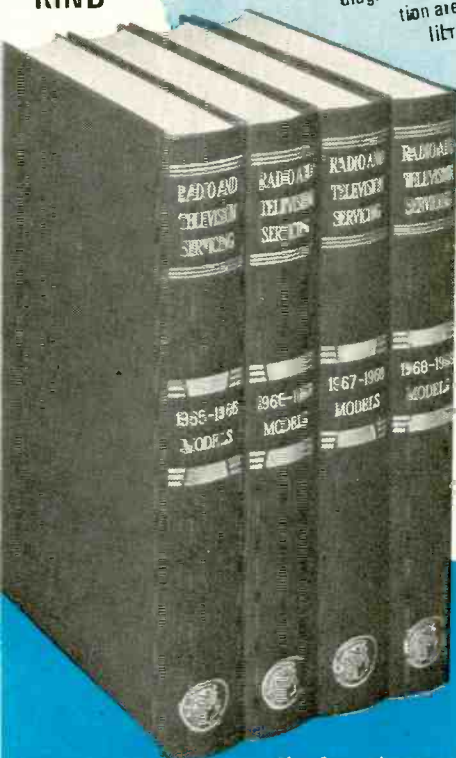

Handsomely bound
in maroon and gold

■ 69 LEADING MAKES COVERED

All you need from *Alba* to *Decca*, from *Ferguson* to *Sanyo* — Full list shown overleaf

TELEVISIONS including 148 pages on

COLOUR TV

- RADIOS ● RADIOGRAMS
- CAR RADIOS ● RECORD PLAYERS
- TAPE RECORDERS

Send no money—it's yours by
post on a week's

FREE TRIAL

Complete and post this reply-paid coupon today—see overleaf

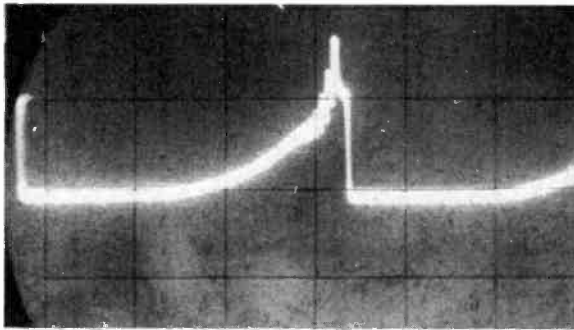

(a)

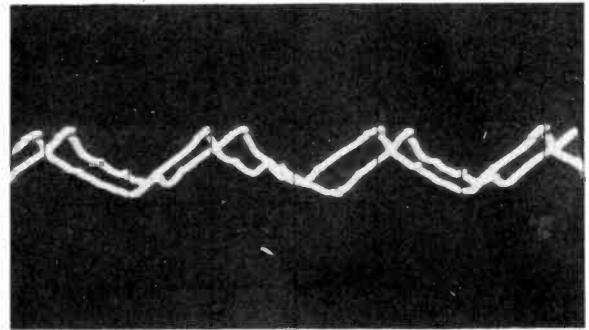

(b)

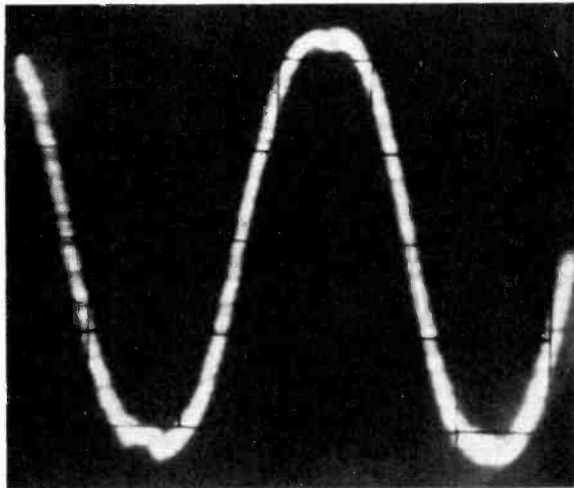

(c)

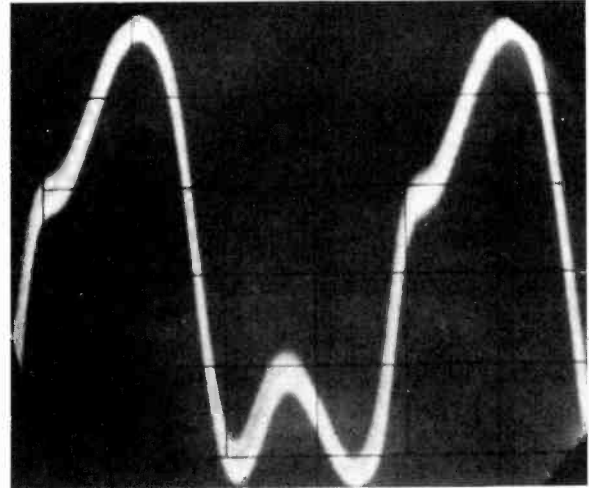

(d)

Fig. 1: These waveforms are described in the text in terms of amplitude and time.

character. A sinewave signal is thus recorded in terms of p-p amplitude, since one half cycle goes positive and the other half-cycle negative, relative to the base or datum line (see Fig. 2). Similarly, an *overall* amplitude is recorded when the signal is of a pulse nature, as (a) in Fig. 1. This differs significantly from the measurement of signals with a moving-coil type of instrument where the read-out calibration is usually based on the r.m.s. value of a sinewave signal.

Sweep Frequency

So much then for the vertical aspects of a signal display. Horizontally the display is controlled by the scope's timebase, which is rather like the timebase generators of TV sets themselves. That is a sawtooth voltage wave makes the spot deflect linearly from the left to the right of the screen and then return to its starting point again very swiftly (giving the flyback or retrace as it is called) to make the same trace all over again; and so it goes on as long as the timebase is working. The speed or velocity at which the spot makes its trace from left to right across the screen is governed by the repetition frequency of the timebase, and there are usually two controls to adjust this parameter, one a switched control and the other a fine, variable control. The switched control provides a coarse adjustment of sweep, as it is called, and this is calibrated in seconds,

milliseconds or microseconds per centimetre of screen swept, while the variable control gives a fair range of sweep adjustment either side of the switched velocity.

Let us suppose that the sweep is set to 10msec/cm. to achieve the display shown in Fig. 1(a), meaning that a distance of 2cm. is traversed by the spot from the time that the signal just starts to rise from the base line to the time that it falls rapidly to the base line again after having traced out the nature of the signal. The complete cycle of signal thus takes a period of 20msec which is a fiftieth of a second or 50Hz. In this connection it is note-

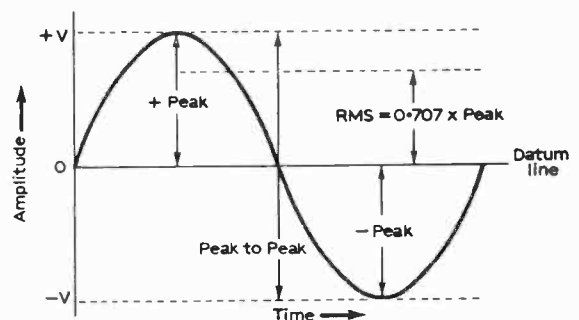

Fig. 2: Basic parameters of a sinewave.

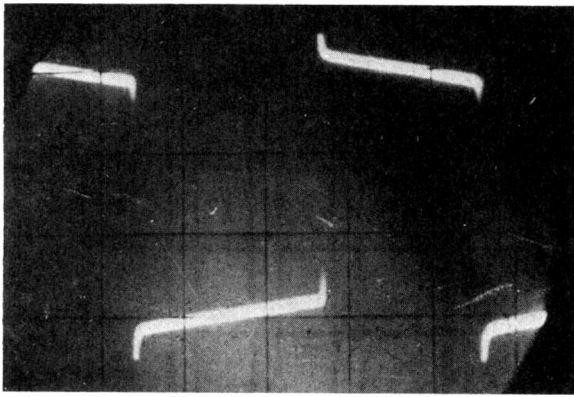

Fig. 3: Squarewave display.

worthy that the time in seconds taken by a complete cycle of signal is the reciprocal of the frequency. For instance a 2Hz signal takes half a second (500msec) to complete; a 10Hz signal takes 100msec and so forth. Time in msec or μ sec is derived respectively by dividing 1,000 or 1,000,000 by the signal frequency in Hz.

In the squarewave display shown in Fig. 3 the top and bottom flats of the signal each occupy a distance of about 2cm; thus with the scope's velocity

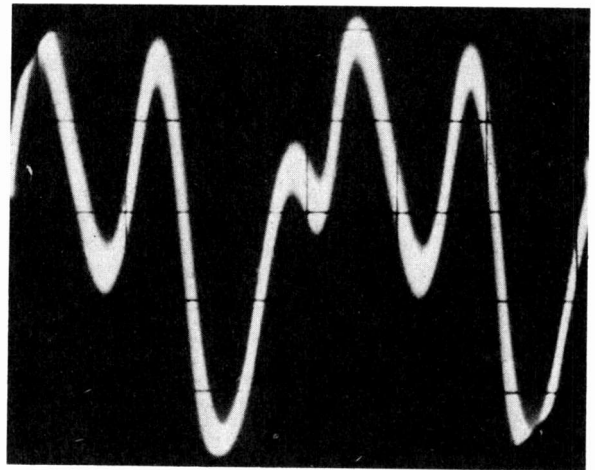

Fig. 4: Complex waveform.

controls adjusted for a sweep of say 3msec/cm. the two half-cycles of waveform together take about 12msec (4 times 3msec) working out to a shade over 83Hz in terms of squarewave repetition frequency ($1,000/12 \approx 83$). When it is required to obtain an approximation of sinewave frequency by this method the distance in cm. occupied by a com-

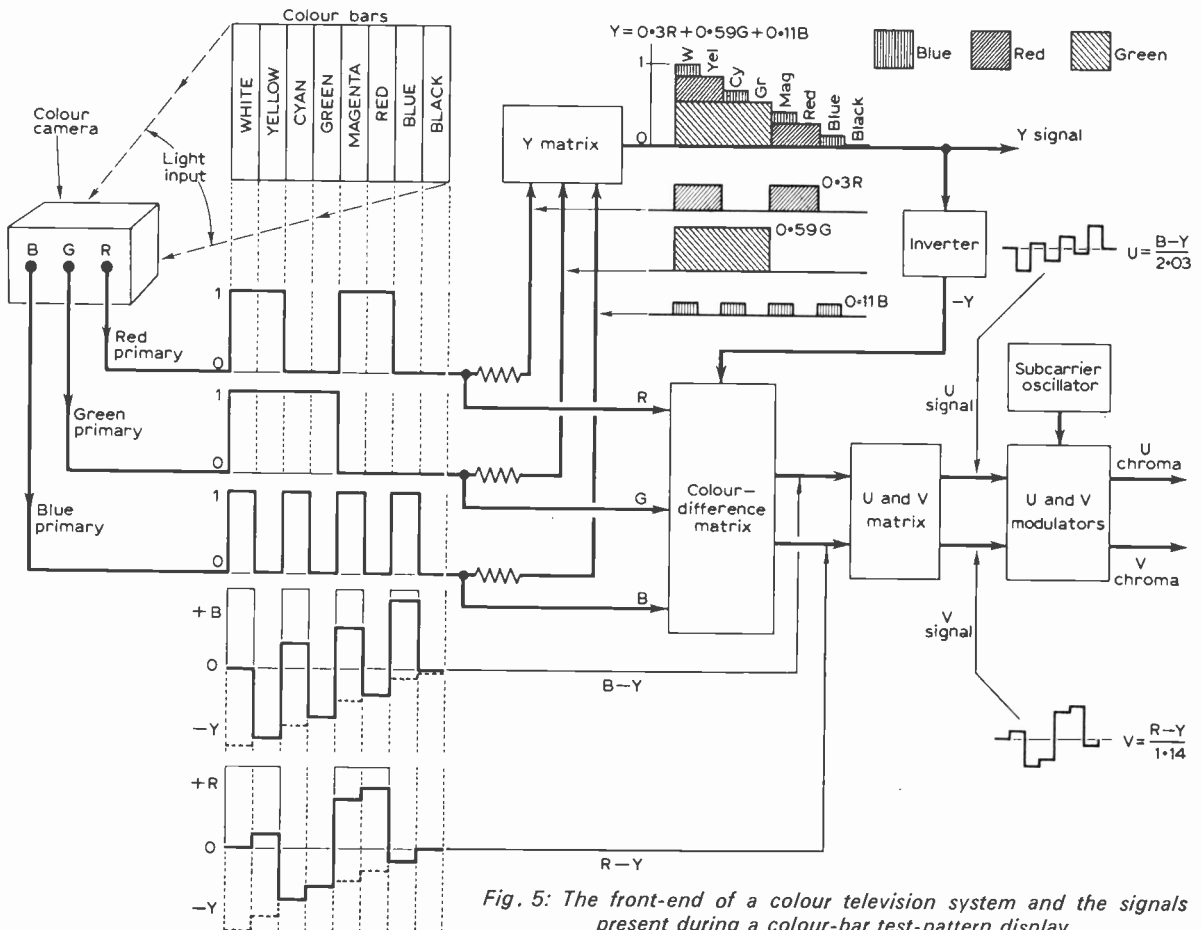

Fig. 5: The front-end of a colour television system and the signals present during a colour-bar test-pattern display.

plete cycle of signal must be taken into account. In Fig. 1(c) for example a complete cycle occupies 4cm, so if this display is obtained with a sweep of 5msec/cm. the cycle takes exactly 20msec, working out to 50Hz. That is all there is to it! A few complications can arise, however, when we meet signals like that shown in Fig. 4; but again by calculating the time taken by each component signal making up the whole, the frequency of each component signal can be worked out if this happens to be the fundamental exercise in hand, which is unlikely.

To summarise, then, any signal can be displayed in terms of two scales, one showing amplitude in vertical direction, called the *Y axis*, and the other time (or frequency) in the horizontal direction, called the *X axis*. All scopes feature *Y* terminals, *Y* amplifiers, *Y* shift and so on to process the display in the *Y* or vertical direction. The timebase built into the scope deals usually with the *X* or horizontal deflection, as we have seen, although it is not uncommon to find a separate *X* terminal either to feed out the timebase signal (for sync purposes) or for feeding in a signal from an external source for providing triggered horizontal deflection.

Scope Requirements for Colour Servicing

For colour television work our scope should be accurately calibrated in the *Y* direction from at least 300V/cm. to 0.1V/cm. because many of the signal measurements made in colour sets have to be compared accurately in amplitude with the waveforms corresponding to normal working given in the maker's service manual. The scope should also have a sweep range extending from at least 100msec/cm. to 1µsec/cm., controlled by a ten- or eleven-position rotary switch for coarse adjustment and a variable control for fine adjustment. A desirable feature on scopes for colour work is the so-called *X expansion control*. This allows a waveform display to be opened up or expanded over its *X axis* so as to reveal otherwise hidden minor signal components of a composite waveform. This control is basically achieved by an *X* amplifier which has the effect of increasing the sweep velocity some ten times or so (depending on its setting) above that set by the sweep control itself. Thus a scope with a top fixed sweep of say 1µsec/cm. would have its effective sweep increased to 0.1µsec/cm. by ten-times *X* expansion.

Because video signals—both monochrome and colour—carry components corresponding to fairly high frequencies the *Y* channel of the scope should have a bandwidth of at least 6MHz. Indeed as the subcarrier in colour sets is about 4.43MHz the scope must at least resolve this; and just as important the high-frequency components of fast-occurring video signals must also be retained to avoid distortion of the waveform display so that the *Y* channel must respond to these just as well as it responds to the lower fundamental frequencies of say the line and field timebase signals and the sync pulses.

Many of the signals possess squarewave characteristics, meaning that they embody a multiplicity of harmonically-related signals to quite high orders, and the *Y* channel must amplify these without

altering their phase relationship or distorting them in any way. It is for this reason that some colour set servicing manuals recommend the use of a low-capacitance probe when picking up the video signals in vulnerable, high-impedance stages of the set. Such a probe ensures that the higher-order harmonic components of the video signals are not attenuated by hand-capacitance or *Y*-channel coupling-lead capacitance. However I have found from experience that provided the *Y* signal-leads are kept as short as possible and—where screening is necessary to avoid hum or line timebase signal pickup—low-capacitance screened leads are adopted, a low-capacitance testing probe is not essential for the majority of signal observations. Detector-type scope couplers however are sometimes needed to obtain the display signal from the set without interfering with its normal working, but these will be considered later in the series when we come to more specialised scope applications.

Colour Camera Signals

To conclude this first article of the series let us have a look at the signals created at the camera end of the colour TV chain. Fig. 5 shows a three-tube colour camera scanning the standard colour-bar pattern (white, yellow, cyan, green, magenta, red, blue and black) and the associated signal waveforms thereby produced. Each of the three tubes in the camera is set up to respond separately—yet in perfect registration with the others—to the scene being televised, one receiving its light input through a red filter, the second through a green filter and the third through a blue filter. In this way the scene is analysed in terms of the three additive primary colours (an addition of these three *additive primaries* giving white light) present. Thus the red-filtered camera tube produces a red primary signal while the green and blue primary signals are produced likewise by the green- and blue-filtered tubes.

Primary-colour Signals

The three primary-colour signals resulting from the standard colour-bar pattern are in the form of rectangular waveforms as shown on the red, green and blue primary feeds in Fig. 5. The main points to note at the moment are that red output occurs on the white, yellow, magenta and red bars; that green output occurs on the white, yellow, cyan and green bars; and that blue output occurs on the white, cyan, magenta and blue bars.

The red, green and blue camera tubes each give an output when the corresponding primary-colour bar is present as would be expected since the filters in front of the tubes pass light of these colours, the red filter being really a "red-pass filter" and likewise with the green and blue filters. Primary-colour outputs are also obtained on the white bar since white light is an integration (by our eyes) of at least the lights of the three primary colours. We get a red primary-signal output on yellow and magenta because red plus green equals yellow and red plus blue equals magenta; a green primary-signal output is obtained on yellow and cyan because red plus green equals yellow and blue plus green equals cyan; while a blue primary signal is obtained on cyan

—continued on page 473

AGC for CCTV

K.T.WILSON

IN STUDIO applications the automatic control of picture contrast is neither necessary nor desirable since the video mixer must alter the contrast of each camera's picture to suit the requirements of the producer. Closed circuit TV equipment however must frequently work unattended or with comparatively unskilled operators, often under more varied lighting than is encountered in studio service or even on outside broadcast work.

If CCTV cameras used image orthicon pickup tubes the provision of automatic contrast control (a.c.c.) would be a matter of considerable difficulty for the designer, requiring a set of variable gain stages in the video amplifier with all the complications of bandwidth which would arise. Using a vidicon, however, a.c.c. can be achieved by varying the voltage applied across the vidicon's target. To see how this affects contrast we must first take a look at the function of the vidicon target.

Vidicon Operation

Figure 1 shows a magnified cross-section of the target region of a vidicon. The faceplate is glass of optical quality, ground flat (the ground blanks alone cost about 25/- before polishing) and sealed by a film of the soft metal indium to the tubing which forms the body of the vidicon. The inside surface of this faceplate is coated with a layer of material, usually tin oxide, which is both transparent and electrically conducting so that a voltage can be applied to the target.

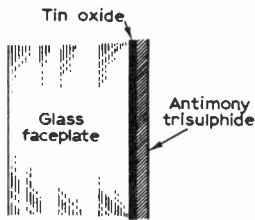

Fig. 1: The vidicon target.

Deposited on top of this layer is the target coating itself, a thin layer of the photoconductive material antimony trisulphide. This last operation is extremely critical and must be done by condensing the vapour of the chemical on to the faceplate. Since the presence of air causes the antimony trisulphide

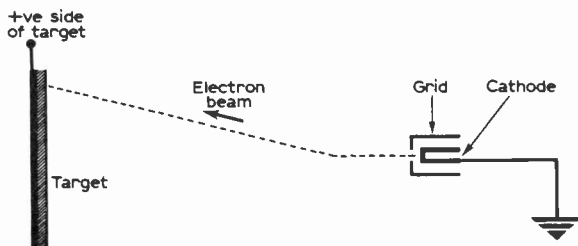

Fig. 2: How the electron beam earths the antimony trisulphide layer.

to change to the trioxide, which is useless, the condensation operation must be done with no air surrounding either the faceplate or the hot antimony trisulphide which provides the vapour. Usually the reaction is carried out in a jar filled with the expensive and rare gas argon.

In operation the antimony trisulphide surface of the target is scanned by the electron beam (Fig. 2) and this has the effect of "connecting" the target surface to the cathode of the tube, the electron beam acting as a connection just as surely as a piece of wire. Imagine now that a positive voltage is applied to the faceplate side of the target layer via the transparent conducting layer on the faceplate. If the target behaved as a pure resistance one would expect the same voltage to appear on the other side of the target when the electron beam is not scanning; but the target layer behaves just as much as a capacitor as a resistor, having one common conducting plate, the faceplate, and one "moving plate", the electron beam. Figure 3 shows an equivalent circuit which

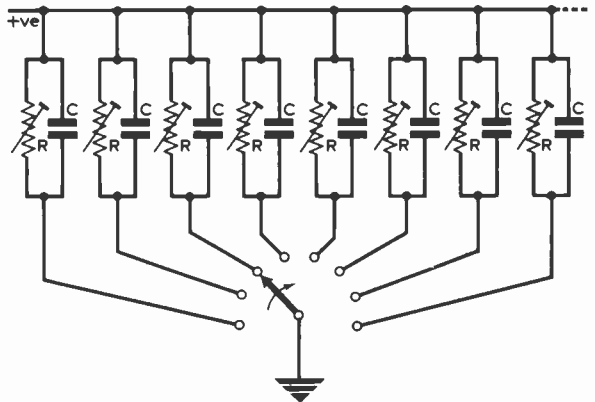

Fig. 3: Equivalent circuit of the action of scanning the vidicon target.

behaves in a way very similar to a portion of a vidicon target. As each capacitor has its free plate earthed by the switch (doing the work of the beam) it charges. When the switch moves on, each capacitor discharges so that the voltages on the plates equalise, but this takes some time due to the resistance R across each capacitor. If the resistors are varied the charging time will change, and if the capacitors are switched at regular intervals which are less than their charging time then the voltage on each free plate will vary according to the value of the charging resistor (Fig. 4).

In a vidicon with the switching done by the beam the resistance of the target at any point is controlled

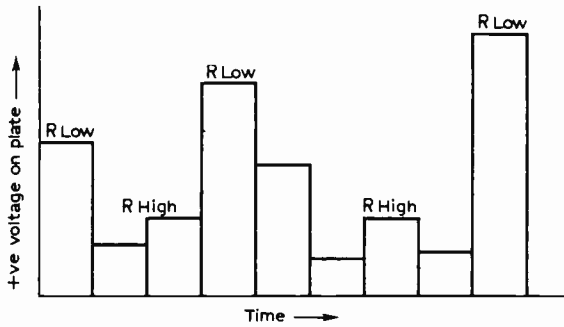

Fig. 4: Video signal stored on capacitor plates.

by the amount of light reaching it. Thus with the target scanned at 50 fields per second and a time-constant for the target greater than 20msec the voltage which any part of the target reaches will depend on two factors, (1) the amount of light reaching the target at that point and (2) the voltage to which the other side of the target is set.

An increase in either of these factors will increase the contrast of the video signal; for the video signal is taken from the target and consists of the current which the beam passes to discharge the target. If the faceplate side of the target is at a high voltage, the peak whites will reach a high voltage and the discharge current will be correspondingly high, assuming the beam to be of high enough current density to cope.

This is the means by which automatic target control can be achieved, for if at some voltage setting of the target the light input causes too great a video voltage (too high contrast) then reducing the target voltage will automatically reduce this video output, since the target charges more slowly when the voltage is lowered. There is of course a limit to the control which can be exercised in this way; if the peak light input is too high the resistance of the target in these regions will be so low that the target will charge up completely and the whites will merge with the greys.

Applying the Control Potential

In principle all that is involved in target control is to produce a steady voltage proportional to the video output and to use this to bias the target back from its usual positive setting. There are however some snags. The first snag concerns sampling the video signal. When the video signal is taken from the target it resembles a finished video signal apart from having no sync pulses. There is no signal during flyback since the vidicon beam is then blanked off, except for traces of pulses picked up at the target, and in most cases this portion of the waveform is set to black level before the automatic contrast voltage is taken. Thus if the output voltage is taken without modification the control voltage is never really proportional to contrast because of the time spent at black level. The process of sampling the video signal must therefore include a gating circuit so that only the video during the line period is used.

The second snag concerns the conversion to d.c. If a video signal is rectified and the output smoothed and only lightly loaded the steady voltage obtained is proportional to the peak of the waveform. The contrast control will then be set by the brightest part of the input signal. Thus when a scene is

viewed which contains one very bright spot the contrast will set to that spot and any detail in the rest of the picture will be lost in the black level. On the other hand if the output of the rectifier is fed into a small load (low time-constant) the d.c. output is proportional to average signal value and detail will then be lost in the white regions of the signal. A compromise between these two is thus necessary and the time-constant of the rectifier circuit must be carefully adjusted to ensure satisfactory operation on a variety of different signals.

Thirdly the smoothing of the rectified, sampled video signal must be sufficient to prevent ripple reaching the target since this would be amplified through the video amplifier. As this is a negative feedback arrangement oscillation should be caused only if the phase is shifted appreciably but this is highly likely due to all the time-constants involved.

Control Techniques

The simplest possible method of automatic target control and one which is particularly suited to amateur CCTV is shown in Fig. 5. Here the target is fed from a high d.c. voltage through a high-value resistor R1. The load resistor for the target is R2 with C1 used for decoupling. As the average signal current increases due to a bright scene the voltage across R1 increases and hence the target voltage is lowered.

A more widely used method is to rectify the video signal, amplify the d.c. signal thus produced and feed this to the target. Figure 6 shows a circuit used in the GEC-AEI camera type VCT2. The inverted video signal from an amplifier is fed to diode D1 by capacitor C1 and is d.c. restored so that the tip of the video signal is at the voltage set by VR1. D2 then rectifies the

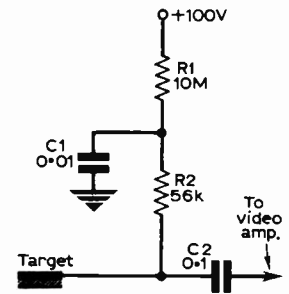

Fig. 5: The simplest form of automatic target control

sync pulses and feeds the d.c. to the base of Tr1. The d.c. appearing at the collector of Tr1 is used to control the target voltage. The catching diode in the collector circuit of Tr1 ensures that neither collector nor target voltage rises above +80V. Tr1 must of course be capable of withstanding a collector-emitter voltage of this size. This

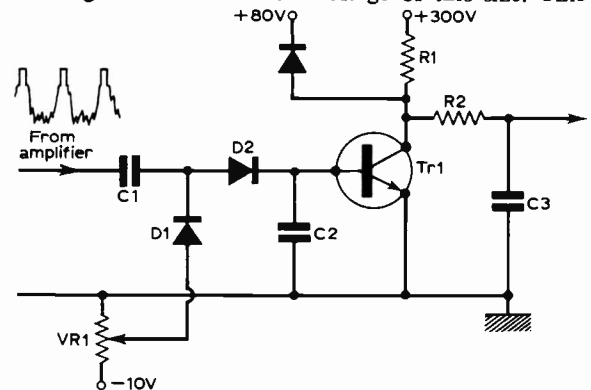

Fig. 6: Basic a.c.c. circuit used in the GEC-AEI type VCT2 camera.

DX TV

A MONTHLY FEATURE FOR DX ENTHUSIASTS

MAY is with us as I write and that should mean we should have the long awaited SpE openings. I am glad to say that there are signs of increased activity at long last although the build-up that I had hoped for during the rest of April did not materialise and the early improvement was not maintained. In fact for the greater part of April SpE conditions were extremely poor, even worse than February. From the 6th to 27th, apart from the 19th, there were only short bursts of Czechoslovakia and the USSR on R1, Yugoslavia on E4 and Austria on E2a, in all just about the worst month I have had to report in many years.

However things improved very considerably at the end of the month and the beginning of May (see below) so I am going to risk a further prediction, that May will be good. SpE log period 5/4/69 to 4/5/69:

- 5/4/69 Czechoslovakia R1.
- 6/4/69 to 27/4/69 short bursts as above.
- 19/4/69 Czechoslovakia R1 and Austria E2a (very good).
- 28/4/69 West Germany E2 and mystery test card E2 (see below).
- 30/4/69 Czechoslovakia R1, USSR, Poland R1, Austria E2a.
- 1/5/69 Czechoslovakia R1, USSR R1, Sweden E2 (two stations), Yugoslavia E4 and Italy IB.
- 2/5/69 USSR R1, Norway E2 (two stations) and E3.
- 3/5/69 Czechoslovakia R1 and Sweden E4.

The Trops during the above period were in general just as bad.

Big and heartening news from Roger Bunney about Iceland again, even better than last time. All we want is a few decent SpE openings and we should be able to get a "new" country. Just in passing I would note that the skip distances involved are just about the same as to RAI Mte Cammarata Sicily on Ch.1A, and we all know what a good one that is. Here are the new Icelandic ones:— Stykkisholmur E3 90kW horizontal; Skalafell E4 300kW horizontal; Hafell E7 10kW horizontal.

The E3 station is situated near the NW corner of the island and the E4 station in the SW corner covering Reykjavik. Both of them should be almost certainties for us!

Norway Greipstad E2 is now up to 30kW horizontal. Portugal Ch.25 420kW is now carrying RTP2 second chain: this is a correction by EBU—it was listed at RTP1. Other new ones are Switzerland Ch.33 25kW horizontal (for optimists!) and West Germany Pharrkirchen Ch.27 250kW horizontal (location 12E-48N).

The following is the latest France second chain u.h.f. list (high power): Ch.21 Brest, Lille, Toulouse Pic du Midi, Gex and Mulhouse; Ch.22 Paris and Niort; Ch.23 Marseilles and Mezières; Ch.24 Troyes; Ch.25 Caen; Ch.26 Bourges, Neuvy and Chambéry; Ch.28 Clermont Ferrand and St Raphael; Ch.29 Nancy and Nantes; Ch.33 Rouen; Ch.34 Metz; Ch.41 Besançon; Ch.43 Le Havre; Ch.45 Rennes; Ch.46 Rheims; Ch.56 Vannes and Strasbourg; Ch.58 Carcassonne. Medium power possibles are Ch.57 Boulogne and Ch.59 Cherbourg. Just for the record the only ones in the above list not yet claimed by DXers here are Gex, Mulhouse, Chambéry, St Raphael, Amiens, and Carcassonne!

Just to add to the general despondency about conditions I feel that I ought to quote a USA article about SpE. Reporting on the corelationship between sun-spot maximum and SpE, at the last maximum 11 years ago results were similar to the current ones, that is a decrease in SpE to be followed by an increase towards the sun-spot minimum. If this theory is correct this year will be poor again and after this there should be a steady increase peaking in 1973-4-5. So this year may be no better than last but next year should show a significant improvement. I hope that the theory will be proved wrong this time but we can only wait and see. Even if things are not better we should at least have something to see and maybe a chance of some new countries as well.

Roger Bunney reports weak short duration reception at intervals of a test card on E2. This appears as a small dark centre circle (similar to Test Card D) and with dark corner circles on a darkish background. My own was a different test card also on E2 on 28/4/69. This was a square electronic (West German type) pattern but with a wide black bar below it. This looks like a West German one but from what station I just do not know. Did any other DXer see either of these? If so we would like your comments to try and sort out what they were.

Not exactly a mystery, the Swedish test card has been seen with a black band across the centre; this presumably carries the details of the accompanying music which was given in the bar at the bottom on the older type of card.

In the hope of better things to come soon I have, since the last article, been getting further organised. Thanks to the generosity of our old friend Roger Bunney I have inherited one of his five-stage Band I broadband preamplifiers with about 28dB gain at low noise level. It goes like a bomb so the present gear here has, I feel, never been better for SpE. I hope soon to produce something really spectacular, perhaps even a new country or two!

Doug Bowers of Saltash reports an interesting event over Easter. He received the Swiss Caption on Ch.1A Italy and says he thinks that this was an RAI relay from Switzerland. We fully agree with his suggestion so this is a point worth noting in view of the close proximity of channels E3 and 1A.

FILM SOUND ON.....

MAGNETIC STRIPES

.....BAYNHAM HONRI

It is hands across the sea to the S.M.P.T.E. (Society of Motion Picture and Television Engineers) of the USA from the British Kinematograph Sound and Television Society when they meet at "Film '69".

"Film '69" is a good title for a film convention, even if there are strong electronic overtones in the papers and exhibition. It so happens that the motion picture and cinema industry has been in existence for about sixty-nine years. During that three score years and nine it has progressed from the embryonic miracle of projecting a (soundless) flickering picture on a tiny sheet to the modern presentations with huge screens and multitudes of loud-speakers.

The Brighton Mob

In Britain the film production industry started off in 1900 in a very small way, in London and Brighton, until the USA Edison Trust practically cornered the world market from 1908 to 1912. Staged film productions in rudimentary film studios then practically ceased during the 1914-18 European war and there was subsequently little hope for Britain to compete with the USA in the now large world market for silent pictures able to carry subtitles in any written language. British prospects were almost hopeless until the Cinematograph Films Act of 1927 was piloted through the House of Commons by the then Sir Philip Cunliffe Lister. This enforced a quota of British films to be distributed by renters and shown at cinemas in Britain. In a pamphlet the British Film Institute mistakenly awarded somebody else in Parliament (guess who!) the credit for putting British films on the map!

Lean Years

The American film industry was also experiencing lean years, however, and major film producers were straining for technical gimmicks as well as stars to attract audiences. Attempts were made to add sound to picture production and Warner Brothers were the first of the major film companies to achieve success, using initially synchronised discs for the sound, running at 33½ r.p.m. Film industry engineers followed up with photographic sound on film, first on separate film, synchronised, but followed immediately with variable density or variable width optical sound track alongside the picture. This was as long ago as 1928 and bears a close relation to the technical development likely to commence in 1969 and referred to later in this article.

British film production continued on a reduced scale during the last war, but it was not until after the war that colour motion pictures improved and began to be accepted by audiences and—what is more—came to be expected. Technicolor (with three-

strip 35mm. negatives in their cameras) paved the way then in 1949, just as three-strip monochrome colour separations are now used in 1969 by Technicolor for television with enormous success in transferring colour recorded on videotape to 35mm. or 16mm. colour film prints, valuable products for export to television studios all over the world. Vidronics led the way but now competitors are in the field.

The Search for a Technical Gimmick

Colour films were accepted and liked but did not fill the box office; black-and-white movies lost face and slowly descended to being B class pictures. The colour of horses and mid-west open spaces helped but didn't provide the desired box-office smash. American front office executives once more turned to their technical men, members of the S.M.P.T.E. A gleam of hope came when stereoscopic pictures and 3D were introduced, requiring the spectators to wear polarised or colour-separated spectacles to sort out two pictures on the screen from two projectors, one intended for the left eye and one for the right. By this means it was possible to give the impression that there was a Lion in your Lap, as promised in the ballyhoo. Needless to say the success of this technical gimmick was ephemeral.

In about 1951 came the next slump. More hunting for more technical gimmicks led eventually to the rediscovery of an ultra-wide picture format of 2.66:1 (compared to the normal "Academy" ratio of 1.37:1), invented by Prof. Chretien, a Frenchman,

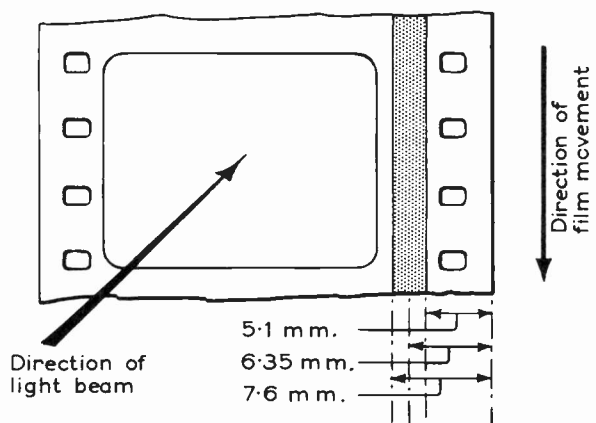
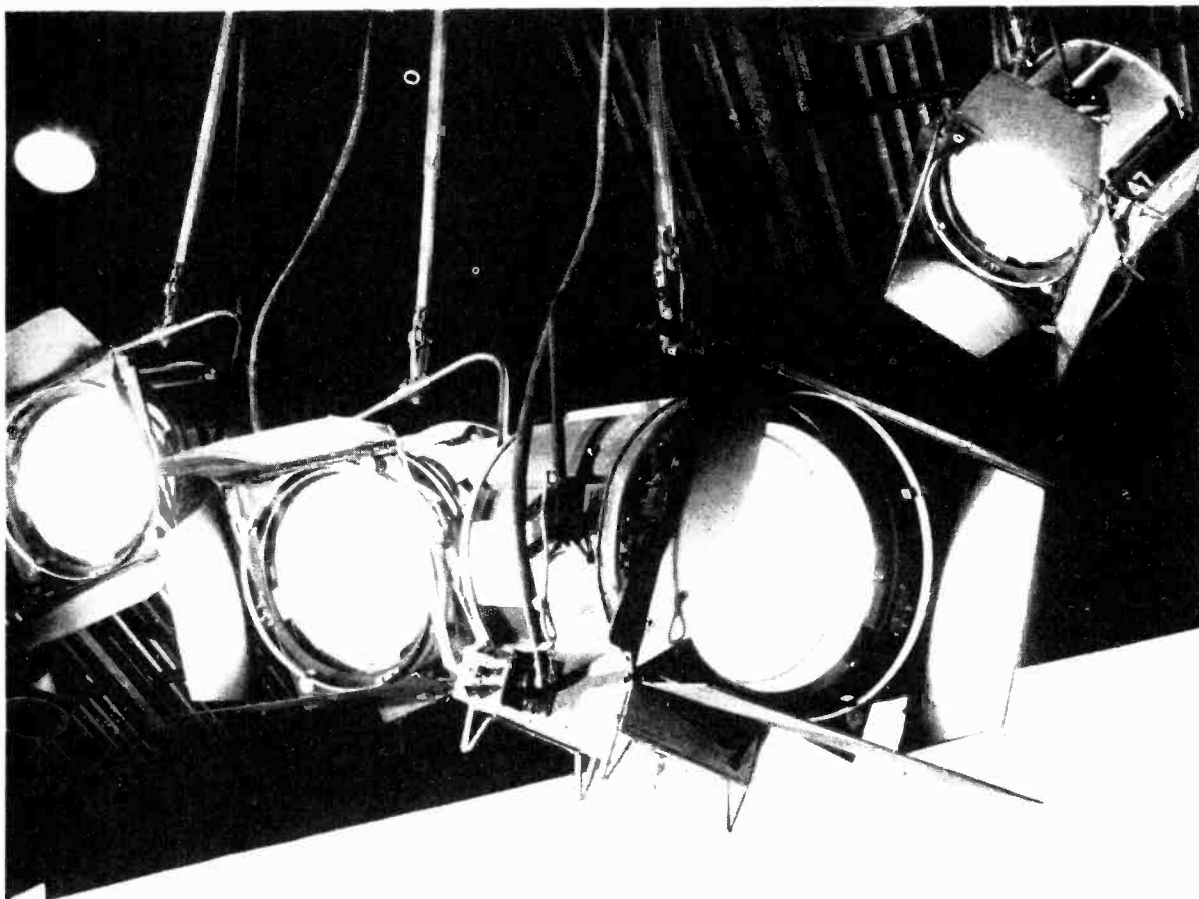

Fig. 1: Position and size of the magnetic stripe as specified in the DIN 15582 standard for a single magnetic stripe on 35mm. film. The width of the replay head is 2.2mm., the width of the record head is 2.6mm. and the width of the erase head 2.8mm. First published in January 1963. The film is shown above looking from the emulsion side.



See the latest stages of TV Development at Pinewood.

You've already applauded the dual-purpose J & K stages. They've helped improve both the quality and efficiency of your television productions. And soon you'll be able to be in production on dual-purpose L & M. The latest stages of development at Pinewood.

Pinewood have invested hundreds of thousands of pounds to meet your television requirements. Experts consulted experts to find out what was needed. And then went to work. One of the results being Area 6. A new dubbing studio geared exclusively to television productions.

Currently under construction at Pinewood is the finest sound centre you've ever heard of. Incorporating a six track stereo dubbing centre with up to 48 sound channels. Another sound effects and post synching studio. Plus the modernisation of their 35 mm production area which includes all the latest equipment. There's a lot of people at Pinewood doing a lot of work on your behalf.

film69 Welcome to Pinewood this week.

Nothing is too much trouble at Pinewood



THE RANK ORGANISATION FILM PRODUCTION DIVISION

Pinewood Studios, Iver Heath, Bucks. Telephone: Iver 700. Cables: Jarpro, Iver Heath. Telex: 84505.

LEE ELECTRIC (LIGHTING) LIMITED

FILM AND

TELEVISION

LIGHTING

**1-7 ALDERSON STREET
LONDON W10**

**• KENSAL ROAD
• Phone: 01-969 3621**

an anamorphic optical contraction/expansion system which stretched the picture very wide. Twentieth Century-Fox's engineers quickly improved the methods of photographing and projecting this format, which they called *CinemaScope*, and with smaller perforations on 35mm. prints they were able to introduce three magnetic sound tracks for stereophonic effects. The magnetic tracks were striped on to these release prints, the sound having to be transferred from master magnetic tracks on a one-off basis, which was a highly expensive operation. The extra costs were quickly reduced by returning to the long established single photographic sound tracks and standard size perforations. The picture format was then reduced to 2.35:1, which was less of a letterbox shape but still very effectively wide. Lack of height to the picture was restricted, due to poor sight lines. This occurred when the top of the picture was cut off by the front of the cinema's circle—as seen from the back rows of the stalls. Occupants in those back rows *do* want to see the picture, sometimes!

Stereo Restrictions

Though of extremely good quality the use of stereophonic sound was rather a mixed blessing. When stereo sound films were edited together from various angles, the stereo dialogue coming from left to right, with reverse camera angles sometimes reversing rapidly the right to the left sound dialogue, it became disturbing. Gradually, dialogue tracks were almost wholly reproduced on the centre loudspeakers from their corresponding sound track, leaving the other tracks for music and sound effects, and genuine stereo dialogue recording in the studio was abandoned. Extra sounds from auditorium loudspeakers had become positively objectionable and were mainly discontinued. By using a single magnetic sound track in the exact position as an optical sound track better quality sound could be achieved. What is more the sound could be erased and a different language could be dubbed on. This method was not received enthusiastically at that time, however, because optical track processing had been improved.

The DIN Standard

In January 1963 the German industrial standards organisation (Deutsche Industrie Norm) published the DIN 15582 standard for a single magnetic stripe for sound on 35mm. film, exactly coinciding with the position of the long-standing photographic (optical) track. The film would have normal sized perforations and the play-off position would be 28 frames behind the relative picture (as compared with 20 frames in front used on optical track). It was therefore possible for film projectors or telecine to have magnetic sound play-off fitted without interfering with the existing optical sound pick-ups. The original German single track was based upon the magnetic track being inlaid on the release print. Later it was realised that if a magnetic stripe was added to a copy of a film with optical sound a balancing stripe on the other edge would be required.

In this manner a film print could start its life with an optical dialogue sound track. If not damaged, a DIN magnetic stripe could be applied upon which a different language could be dubbed. If still usable

this language could be erased and dialogue in another tongue could be substituted—and so on ad infinitum (if the copy is still usable). With colour 35mm. prints costing hundreds of pounds this seemed to be a logical development. But it would of course be necessary to fit the essential DIN magnetic play-offs on the film projectors before the step could be made. Which was to be done first—DIN sound striping and sound transfer or the DIN magnetic play-off? Another case of which was first—the chicken or the egg?

Procrastinating over DIN

There was a hold-up in DIN progress in Britain over a lengthy period of time, particularly in the cinema film side. Many theatres had been fitted in 1953 with magnetic play-offs for the original CinemaScope three-track magnetic stereophonic sound and had been unable to make use of them for years because the highly expensive prints (with magnetic sound) were no longer available! Naturally the film exhibitors didn't want to scrap their veteran 1953 play-offs. But the BBC, ITA and fifteen Independent Television Companies decided to adopt the DIN system and a joint technical meeting agreed to this in January 1966.

The film interests and the television interests both attempted to obtain a standard at the British Standards Institution (BSI) but the film side tried to restrict the DIN system to *television only*. After a most extraordinary period of delay by the BSI, in which committee minutes of a March meeting were not circulated until December (fortunately of the same year), both the standards were adopted, the DIN standard being *not* restricted to television only and therefore available for the cinema.

The BSI

The activities of the British Standards Institution have come under pressure, appropriately, from the Committee of Enquiry on Pressure Vessels. The BSI's own journal printed an extract of their report: "*The Committee argues that BSI works too slowly, is indecisive, takes too much account of minority views and tries too hard to harmonize national and international standards.*" National technical standards are always inclined to be boring and especially so if there are only two speeds of action: "*slow*" and "*stop*". Yet the American Standards Association, the N.A.R.B., and the German DIN seem to be more go-ahead; and the Russian organisation is technically logical and what is more carries out with speed decisions reached—often following the lead of the USA with alacrity! The International Standards Organisation, with delegates from almost every country in the world using film, accepted the controversial DIN magnetic system.

Dubbing

The expansion of the market for films for television stations has been growing steadily, now covering several countries that are involved (or about to be involved) in colour television. Some organisations and countries use 625 lines, 50 fields (with PAL or SECAM systems), others the American NTSC system which usually operates on 525 lines, 60 fields. This restricts the international interchange of videotape-recorded television programmes. However, all

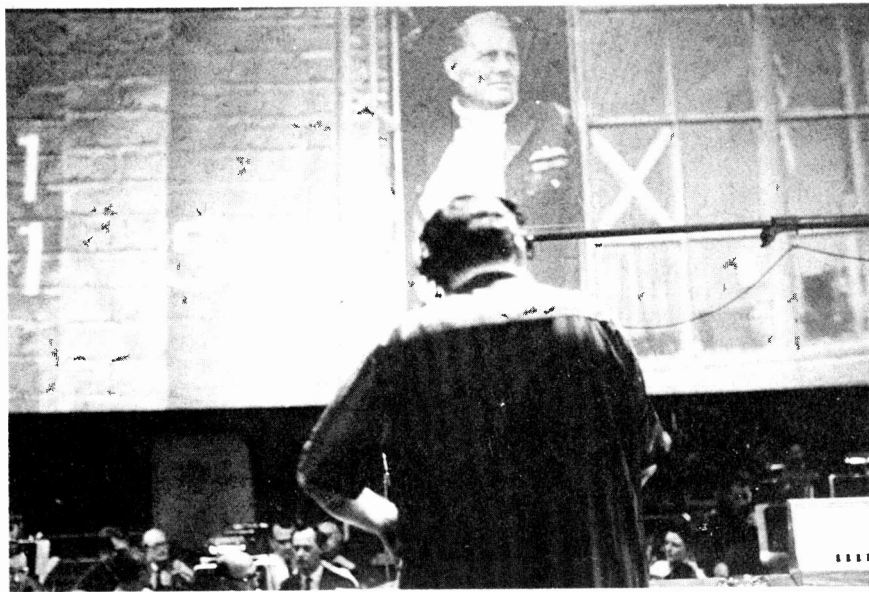

At the Anvil company's music scoring stage, Denham. Malcolm Arnold conducting the orchestra to coincide with a sequence in the film "The Battle of Britain." The film is projected on to a screen behind the orchestra, facing the conductor, to enable him to key music and film together. Photo by Courtesy of Spitfire Productions Ltd.

television organisations use 35mm. and/or 16mm. film, monochrome or colour. Big networks in the USA and elsewhere use 35mm. film (with optical tracks) for class A programme features and 16mm. film for news and other magazine features, the latter with optical or magnetic sound. Countries with different languages sometimes make use of overlaid subtitles, others dub locally the local tongue on to separate synchronised sound tracks. But the international step forward will be when organisations such as the BBC and the ITV companies are able to supply foreign versions with dialogue in German or Spanish or French or Swahili or what-have-you.

Foreign Language Dubbing

A great deal of foreign language dubbing has been carried out for years in England and France. In London the De Lane Lea company has specialised in this field for many years and is able to carry out efficiently the translation and recording of exactly the right words to fit the mouths of the actors or, a much easier job, to substitute foreign versions of commentaries and "voices off". Quite amazing feats of idiomatic vernacular in drama have been achieved by loop systems, prompting machines, variable-speed records and other lingual legerdemain. There is no one particular way of doing this kind of job, but experts know the right way, playing by ear! The new language dialogue tracks are then recorded magnetically with separate music and effects tracks added, resulting in a foreign, say Spanish, master track. This has special synchronising marks on it. The Spanish master track can then be dubbed on to a magnetic striped print of the picture on 16mm. or 35mm. film, as required. Later it can be erased and another language substituted.

High-speed Reversing

Dubbing often requires many sound tracks: dialogue, sound effects, sound loops, music, effects, etc. A few years ago the "rock and roll" projection system was evolved for *reversing* the picture film and the many sound film tracks to avoid having to

rewind them and relace them. This reversal is usually at normal speed, same as forward. The BBC has now in operation four sets of the high-speed German Keller dubbing equipment in London and one in Scotland. This system uses a television monitor (monochrome) for picture interlocked with four (or more) sound play-offs for 35mm. or 16mm. sound film, optical or magnetic. This can be reversed at double or four times the forward speed and stays locked. Developments are now proceeding in Holland, the USA and Britain for special cinema projectors which will rock and roll in reverse at four or even six times the usual forward speed. There are many organisations in London which cater for dubbing sound effects and music, or for recording music sessions on tape or film. The Anvil company has a huge music scoring stage at the old Denham studios, capable of coping with the largest symphony orchestras (as well as the smallest pop groups) apart from its complicated sound dubbing plant, multiple-track film or tape recorders, reverberation devices, etc. An expanding Sound Business!

Pathé, Warwick, Kay, Anglo, United, TVR and other independent recording companies are in specialist sound recording whose customers in the television field now exceed the number dealing with films. All the major film studios at ABPC and at MGM Elstree; Pinewood, Iver Heath; Twickenham Studios and Shepperton have very extensive sound dubbing facilities. Television studios at Teddington (Thames), ATV (Boreham Wood), London Weekend (Wembley) are equally well-equipped, and like most of the provincial companies and the BBC use the Mellotron sound effects generators to speed up operations in an efficient manner. Now most of them will soon be able to cope with polyglot language on the DIN system. Carry on, Gunga Din! ■

BINDERS AND INDEX

Don't let your copies of PRACTICAL TELEVISION become torn and dirty: hard-cover binders are now available for the new page-size at 14s. 6d. from:

BINDING SECTION,
IPC MAGAZINES, LTD.,
SOUTHAMPTON STREET,
LONDON, W.C.1.

Indexes to Vol. 18, 1967-8, are also available at 1s. 6d.

These prices include post and packing.

VIDEOSCOPE



MV3

MARTIN L. MICHAELIS, M. A.

PART 4

THE timebase stroke was seen to be produced by partial discharge of a positively charged timing capacitor, and a timebase conventionally runs from left to right on the screen. Thus when the timebase output is replaced by an external signal source for horizontal deflection positive comes at the left and negative at the right of the screen. This is unfortunate in being the opposite to the normal graphical quadrant depiction, but it was considered inappropriate to invest further outlay in order to effect polarity inversion when switching over from the timebase to an external signal.

All other deflection functions should appear in accordance with the conventional graphical depiction. Thus the vertical display must appear such that a positive-going change at P1 deflects the spot upwards, and a negative-going one downwards. If the converse is found to be the case interchange the connections to pins 6 and 7 of the c.r.t. Similarly if the timebase runs from right to left interchange the connections to pins 9 and 10 of the c.r.t. The sense of the timebase can be checked by connecting a capacitor of several microfarads temporarily between V4 pin 8 and chassis so that the timebase runs really slowly and the movement of the spot can be observed.

Having got the deflection polarities right next check the shift controls VR3 and VR6. Clockwise rotation of VR3 should move the trace downwards, and clockwise rotation of VR6 should move it to the right. The converse is irritating and confusing in use. If the shift controls are found to function in the incorrect sense, reverse the connections to the ends of the tracks.

If the horizontal and vertical deflections are found to be interchanged, and assuming the c.r.t. connections at pins 6, 7, 9 and 10 have not been confused, then the c.r.t. has not been positioned correctly as shown in Fig. 9 and it must be turned through a right angle. Note that the c.r.t. base mounting screws on the rear panel run in slot arcs to permit small adjustment of the c.r.t. orientation so that the timebase trace is quite parallel with the screen graticule. Make this adjustment carefully, switching off and allowing time for the h.t. and e.h.t. capacitors to discharge before making each adjustment of the c.r.t. position.

ADJUSTING THE CRT VOLTAGES

If necessary select a better value for R39 such that VR5 just gives a control range from beam cut-

off to maximum usable brightness (trace halo just not commencing). If necessary distribute the same total value of R37 and R38 differently to make the best focus setting fall close to the mid-track setting of VR4.

Now switch to external X-input and apply no signals so that a spot is obtained on the screen. Bring this spot to the exact centre of the screen with the shift controls and focus it as well as possible with VR4, setting VR5 to the greatest intensity still not giving a halo ring round the spot. Be quick with this adjustment to avoid burning the screen. Now adjust VR13 until the optimum focus setting with VR4 gives the smallest possible spot, not an ellipse of least aberration. Next switch on the timebase again and if necessary select a better value for R41

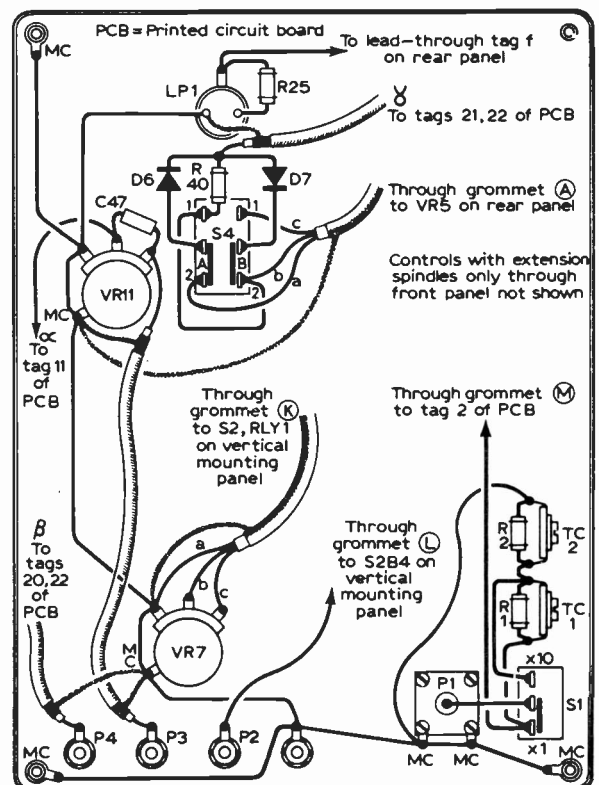

Fig. 8: Wiring on rear of front panel.

such that the optimum focus setting does not change with the setting of the intensity control VR5. Finally correct the adjustment of VR13 again if necessary.

The c.r.t. is now correctly adjusted. For all steps of these adjustments which required the timebase the d.c. restorer polarity switch should have been set to the blanking position.

Y-AMPLIFIER ALIGNMENT

Apply a 5 kHz square-wave from a signal generator or makeshift multivibrator directly to P1 at a level of several volts peak-to-peak. Adjust the timebase to display this squarewave on the c.r.t. The appearance will in general be as indicated in Fig. 11 (a) or (c). With S1 set to the $\times 10$ position adjust TC1 until the proper display Fig. 11 (b) is observed. If the overshoot shown in Fig. 11 (a) persists even at minimum setting of TC1 select a slightly larger value of C2 and try again. On the other hand if the correct display is obtained with TC1 near maximum, or the rounded form of Fig. 11 (c) persists even at maximum setting, select a smaller value for C2 or remove C2 entirely.

Now switch S1 to the position $\times 1$ and interpose the probe (Fig. 10) between P1 and the same 5 kHz squarewave source. Adjust the trimmer in the probe until the correct display Fig. 11 (b) is once again obtained. If necessary add a 3pF fixed capacitor in series (persistent overshoot) or parallel (persistent

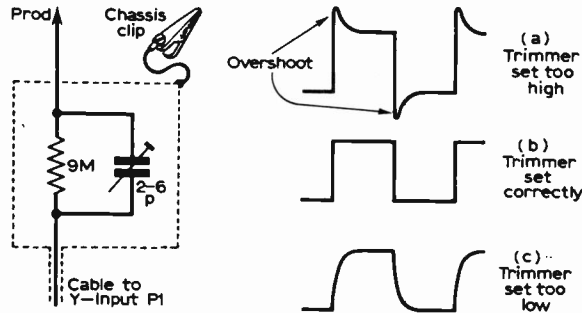

Fig. 10: Signal probe (10:1). Fig. 11: Alignment waveforms.

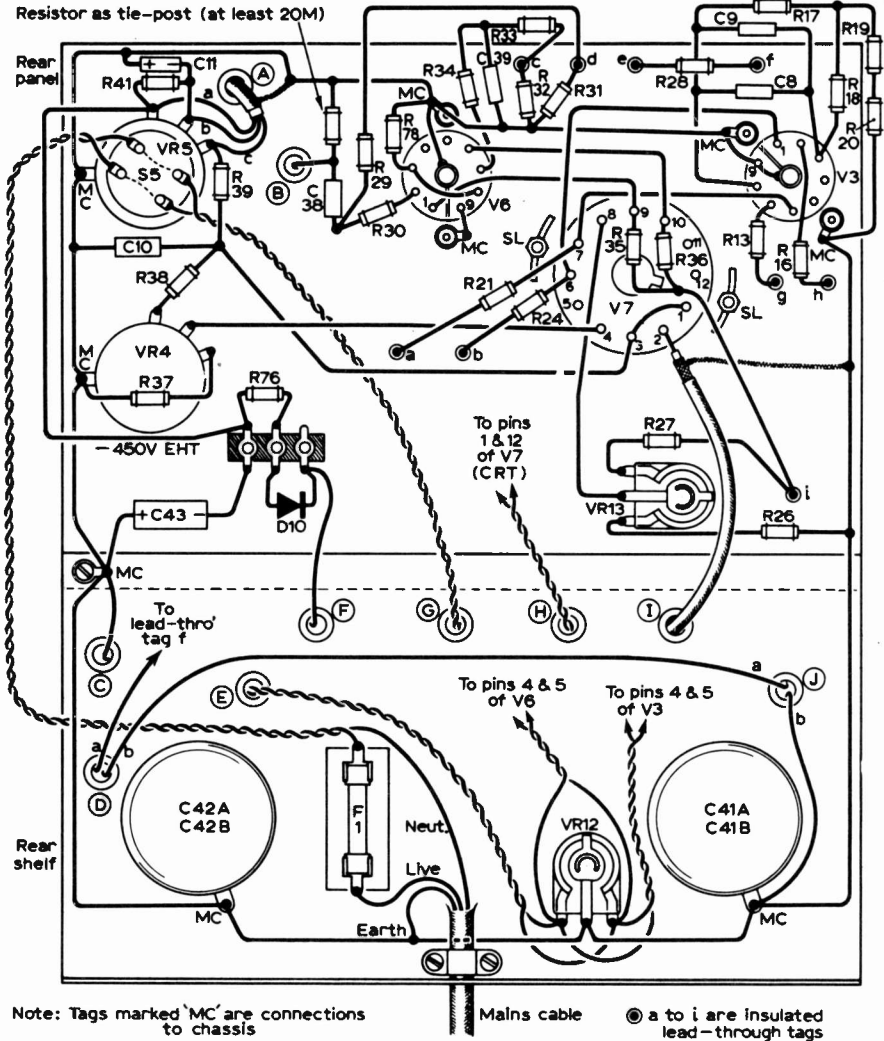

Fig. 9: Wiring of rear panel and shelf. Note: C11 is shown connected in correct polarity, i.e. positive to chassis, above; it is shown incorrectly in the main circuit diagram, Fig. 2 in the April issue.

rounding) with the trimmer in the probe to bring the balance point within the control range of the trimmer. If this still fails to find a balance point, reduce the length of probe cable or use a type with lower self-capacitance.

When the adjustment is correct switch to the $\times 10$ setting of S1 and maintaining the probe turn up VR2 to restore the display amplitude. Now adjust TC2 to obtain the correct display once again. If necessary connect small fixed capacitors in parallel with TC2 to obtain a balance point within its control range.

Check by repeating the entire sequence of adjustments of TC1, probe trimmer and TC2 again, making small readjustments where necessary. Do not depart from the described order for the first and second rounds of adjustments.

The input attenuator is now correctly aligned and the continuation of level frequency response from the audio range into the supersonic range ensured. It remains to align for high radio frequencies near the

passband limit. First of all correct the gain calibration. Feed a signal of known peak-to-peak amplitude, e.g. at mains frequency, into the amplifier and adjust VR1 for correct display amplitude according to the calibration described previously. If this is not possible select a different value for R20. This correction if necessary must precede the r.f. alignment because the latter is also effected in the cathode circuit of V3 by selecting the cross-capacitance value C9. For this purpose feed in a signal from a short-wave r.f. signal generator connected to P1 and select C9 so that the response is as level as possible in the region from 3 to 5MHz whilst preserving reasonable gain up to about 7MHz.

The entire Y-amplifier is now correctly aligned. The horizontal deflection amplifier does not require alignment.

TIMEBASE ALIGNMENT

Adjust VR8 to obtain a timebase trace 5cm. long. Using a time-spotting signal from a signal generator (preferably squarewave but sinewave is also usable) fed to the intensity-modulation input, check that the respective settings of S3 give a timebase duration of $10^1 \dots 10^5 \mu\text{sec}$ with VR10 always at maximum resistance. If necessary pad the capacitor values on S3 accordingly.

SYNC & HORIZONTAL GAIN CONTROL

Switch to external X-input and feed the same 5kHz squarewave signal as used for Y-amplifier alignment to P2. Do not connect any Y-signal. The display will be two disconnected horizontal trace sections each containing a bright spot. Select a value for C46 such that this display resolves into two spots at a setting of VR7 between quarter and half track and at maximum setting.

FLYBACK BLANKING ADJUSTMENT

With the specified prototype values for C32 and C34 in position select C27 for optimum blanking accuracy at the highest timebase speeds, with alternate adjustments of VR9 at the lowest timebase speeds.

INTENSITY-MODULATION AMPLIFIER

Now feed the 5kHz squarewave signal to P3 and select C47 so that the division of the timebase trace into bright and dark sections is as sharp and uniform as possible for all settings of VR11, in both the bright-up and the blanking settings of the d.c. restorer switch. In particular minimise any unevenness in the brilliance of the bright sections.

If there are two distinctly optimum settings of VR11, one of which is necessarily at full gain, aim to make the other fall at about quarter to half track setting of VR11. If this can be achieved with a value of C47 which gives unacceptably poor sectioning of the trace at other settings of VR11, nevertheless retain this value for C47 and correct the performance at other settings by selection of C32 and C34, changing the values of these capacitors in equal proportions (approximately). Then recheck C47.

Finally if C32 and C34 have been modified considerably recheck the flyback blanking alignment of

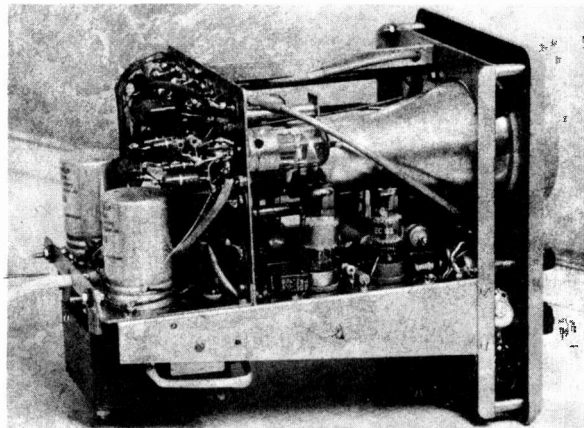

Right-side view of completed unit with case removed.

C27 (fastest timebase speeds) and VR9 (slowest timebase speeds).

POWER SUPPLIES

After completing construction the voltages specified for the salient points of all stages should be checked with a good meter. In particular R72 must be selected to obtain the specified voltage at C41a under the conditions specified in Fig. 3. Since the timebase is very sensitive to slight hum via the sync amplifier the latter requires an extremely well smoothed collector supply. The nominal voltage of the winding on T1 for this supply is not critical and need not be 60V. A suitable winding can be added, or an existing third heater winding modified, or a small auxiliary transformer may be used. The alternative of taking a larger value and wattage for R77 and returning this resistor to one of the main h.t. smoothing capacitors led to poorer sync stability on account of ripple injection, but this may work in other cases according to the characteristics of the mains transformer and electrolytics used.

It is advisable to check the voltages at the specified points of all circuits before and after alignment. Slight discrepancies are likely but any wide departures indicate a fault. In particular if attempts to align the instrument according to the detailed instructions given above fail to produce the desired response a check of the d.c. voltages present at the points specified in Fig. 3 will help to locate the faulty or incorrectly wired component quickly. If trouble is encountered in setting the c.r.t. operating conditions check the voltages at the c.r.t. gun electrodes and compare with Fig. 3 to locate the discrepancy.

It is permissible to employ a mains transformer possessing only a single 350V winding rated for the full h.t. current of 80mA. An h.t. bridge rectifier is then required grounding neither end of the transformer winding but instead the negative d.c. output of the bridge rectifier. The negative e.h.t. potential for the c.r.t. must then be obtained from a separate low-current 350V winding, one end of which is connected to chassis and the other to the half-wave rectifier. Some transformers sold for oscilloscopes are of this kind with two separate untapped high voltage secondary windings, one for low current and one for high current. These may not be connected in a full-wave rectifier circuit as shown in Fig. 3. Do not apply significantly larger voltages than those specified to the c.r.t. ■

PART 2

EARLY TV CAMERA TUBES

ALTHOUGH the Emitron was used successfully in studio broadcasts where high lighting intensities could compensate for its low sensitivity the Emitron design team thought that a considerable improvement could be obtained if the two tasks of storage and photoemission could be separated. Out of this idea came the Super-Emitron, the tube used for televising the Coronation of November, 1937.

The Super-Emitron

Figure 6 shows the working principles of the Super-Emitron. Basically the same bulb and gun system is used, but the window portion has been replaced with a length of tube with a window sealed at the far end and a silvered mica disc 60mm. (2.36in.) in diameter supported just inside the window and connected to a terminal. This mica disc is made into a photocathode by deposition of caesium, but the caesium is kept away from the mosaic as far as possible by heating the main bulb. Around the short neck of the photocathode section is a focusing coil so that the electrons leaving the photocathode are focused on to the mosaic target. The electron image is magnified about four times in this process. The mosaic may be plain aggregated silver, aggregated aluminium or even plain mica.

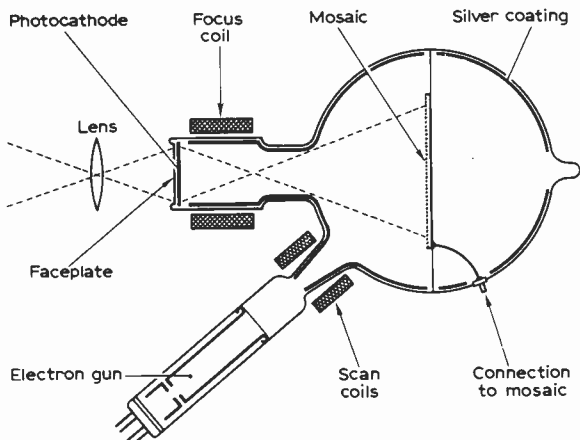

Fig. 6: Construction of the Super-Emitron tube.

The voltages applied to the electrodes of the Super-Emitron are identical to those used for the Emitron except that the photocathode terminal requires a -400V supply and the focus coil a supply of stabilised current which can be varied for best focus. The focus coil must be carefully screened from the scan coils fitted around the neck of the gun otherwise the image will be defocused by the scanning fields.

In action photoelectrons from the photocathode strike the mosaic target causing positive charging by secondary emission. Current flows from the photocathode as long as it is exposed and not merely

I. R. SINCLAIR

when the beam is scanning one particular area, and the secondaries can leave the target for a larger area around the scanning beam than was the case in the Emitron. Because the photocathode is a continuous layer instead of a series of islands, and because the photocathode can now be coated with caesium for maximum efficiency, the photocathode efficiency is very much higher. The photocathode efficiency of the Emitron was limited by its small effective area and by the facts that the amount of caesium must be limited to avoid electrical leakage between islands and that the photosensitivity cannot readily be monitored since there is no direct electrical connection to the mosaic.

When the photoelectrons strike the target near the region of the beam secondary electrons are emitted and collected by regions which have just been scanned. There is some signal gain here because the ratio of secondary electrons emitted to primary electrons landing is high. There is also longer storage because the secondaries arise out of a primary beam of 400V and have more energy so that they can leave an area larger than in the case of the Emitron.

For these reasons the sensitivity of the Super-Emitron is some 15 times higher than that of the Emitron and there are several other advantages. Since the photocathode is now much closer to the window than in the case of the Emitron lenses of much shorter back focal length are required; and because of the higher sensitivity smaller lens apertures can be used or, alternatively, scenes of much lower illumination can be televised.

The Super-Emitron and its USA counterpart the Super-Icoscope were in regular use for both studio and outside broadcast work on both sides of the Atlantic until replaced in this country by the CPS Emitron and in the USA by the orthicon. Super-Emitrons were used for some studio applications until fairly recently.

The CPS Emitron

This tube arose from an idea put forward during the development of the Emitron for an Emitron with a transparent target which could have a gun in line with the target instead of at an angle. In addition the advantages of scanning with a very low-speed electron beam from a cathode only a volt or so lower than the mosaic had been demonstrated by the American researchers Rose and Weimer in their work on the orthicon.

Figure 7 shows the CPS Emitron in outline and the arrangement of the target. The target consists of a thin sheet of glass (0.003in. thick and 2.6in. diameter) supported close to the flat endplate of the

tube. On the side of the target facing the endplate the target is coated with a transparent conducting material (tin oxide, as used in the vidicon) and on the other side is formed a photocathode of the trialkali type (antimony, with caesium, sodium and potassium). Close to the target is mounted a collector mesh of copper, the stabilising mesh, which is run at about 10V positive to the gun cathode. The photocathode is formed while the tube is being evacuated by evaporating the constituent elements from sources placed in side tubes attached to the neck of the CPS Emitron: thus the photocathode is of mosaic form due to the shadowing effect of the mesh on the target. Overall tube dimensions were about 15in. long and $3\frac{1}{2}$ in. maximum diameter.

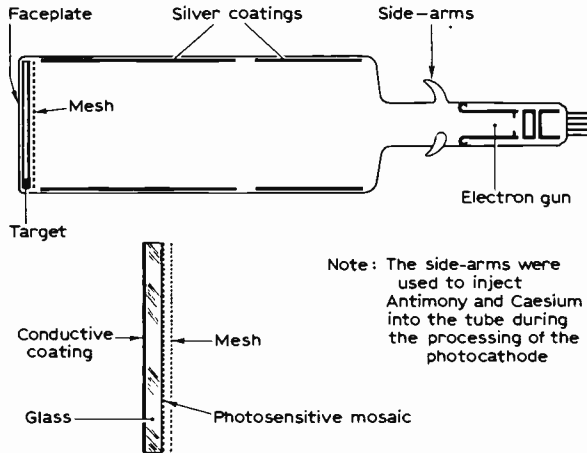

Fig. 7: Outline of the CPS Emitron (above) with details of the target shown below.

The gun cathode is earthed, the target conducting layer set at +1.5V via a load resistor and the mesh set at +10V. When areas of the photocathode are illuminated electrons are liberated from the photocathode which then becomes positively charged in the illuminated areas. The liberated electrons are collected by the stabilising mesh. The scanning beam strikes the target at low speed, because of the low-voltage difference, and reduces the voltage at all points of the photocathode mosaic to approximately earth potential. In doing so current flows and causes a video signal to appear in the load resistor connected to the conducting layer on the opposite side of the target. This method of signal generation is strikingly similar to the operation of the vidicon except that the charging of the target is carried out by photoemission and not by photoconduction.

To ensure that the video signal does not contain spurious signals and that charging conditions are the same all over the target, two precautions must be taken. One is that *ions*, negative particles formed by the collision of beam electrons with gas or caesium vapour in the tube, must not reach the target; the other is that the beam should always strike the target travelling in a direction at right angles to the target, and this implies that the beam must be deflected twice in its path from gun cathode to target (Fig. 8).

The removal of ions is effected by an ion trap mesh which is held at a voltage 10V above the voltage of the final anode of the gun. Since the lightest ions are 1,900 times as heavy as an electron they travel much more slowly and are attracted to

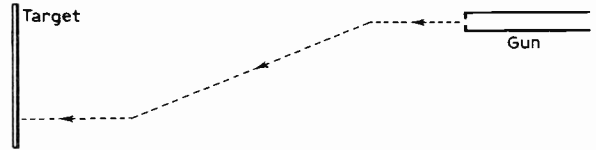

Fig. 8: Path of the beam in the CPS Emitron.

the mesh whereas the fast electrons simply pass on to the target. The "orthogonal landing" condition (for the beam approaching the target at right angles) is achieved in several steps. First, the beam from the gun is made to emerge exactly on the axis of the tube, despite any gun misalignment, by a pair of small deflector coils, called alignment coils, carrying d.c. Then after deflection of the beam by the deflector coils the beam is forced to move parallel to the axis of the tube by the combined effect of a decelerator electrode near the target and the two meshes (ion trap mesh and stabiliser mesh).

CPS Emitron Features

The CPS Emitron was greatly superior to the earlier Emitrons and still has some points of advantage compared to later tubes. The target is charged and discharged from the same side, as with the earlier Emitrons, but the photoelectrons are collected all the time and not merely when the beam is near so that there is complete field storage, causing the CPS Emitron to be much more sensitive than the Super-Emitron although there is no gain due to secondary emission.

Since the charging and discharging of the target is carried out on the one side the conductivity of the target is immaterial provided that it is low and the tube can be operated as soon as the gun cathode has warmed up. The image orthicon tubes currently in use require a long (20 minutes) warm up because their operation depends on the conductivity of the target (see PRACTICAL TV, July 1967). The signal current of the CPS Emitron is greatest in regions of greatest illumination, unlike the earlier Emitrons and the current image orthicons, so that noise is maximum in white areas and minimum in dark areas—an ideal arrangement since noise in a video signal is much less visible in illuminated areas. In addition the noise of the electron beam does not affect the noise of the signal output because the electron beam is used only as a switching means and does not carry signal (unlike the beam of the image orthicon).

The history of the development of camera tubes has been marked by considerable improvements in sensitivity and increases in complexity which reached a peak in the image orthicon. There appears to be a trend now to a greater simplicity of operating principles (although not of manufacturing technique) coupled with the same standards of sensitivity and resolution. The forerunners of this trend are the Philips Plumbicon tube (see PRACTICAL TV, September 1967) and the very similar E.E.V. "Leddicon", and the Westinghouse matrix of photosensitive integrated circuit switches used in the moon-landing TV equipment may very well be the next step.

The author wishes to acknowledge the kind help of EMI Ltd. and of Professor McGee of Imperial College in the preparation of this article; also to Mr. Mather and Mr. Stallwood of EMI Publicity Department who were so extremely helpful in the provision of historic photographs.

A CORNER REFLECTOR

UHF

LOFT AERIAL

Keith E. G. PITT, B.Sc

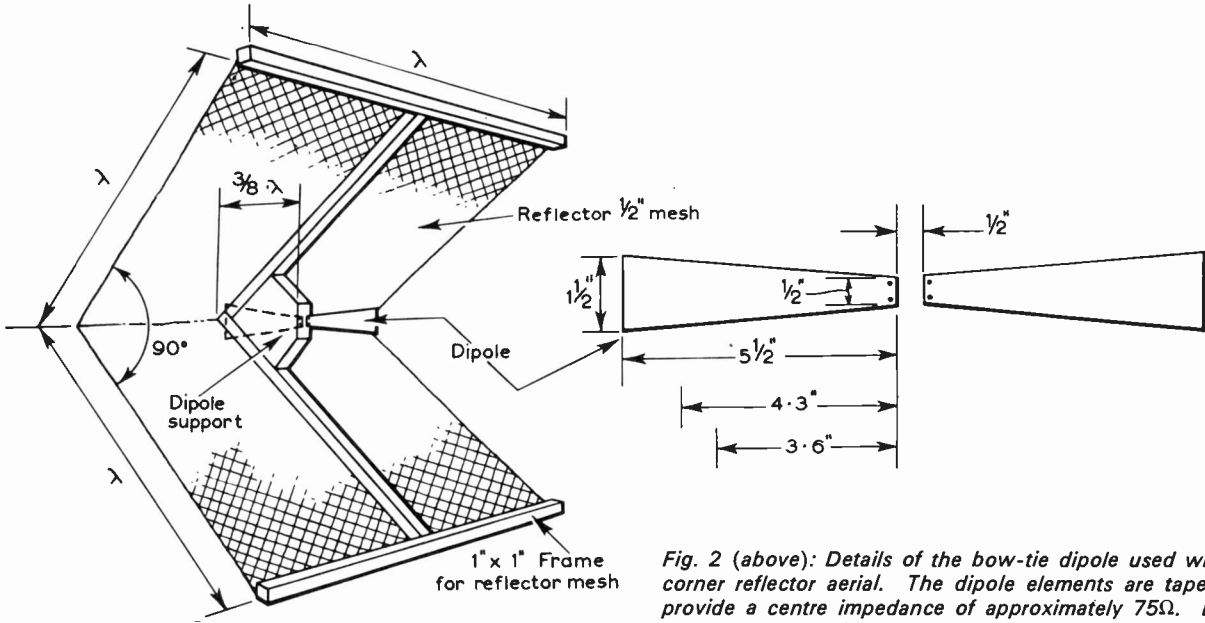

Fig. 2 (above): Details of the bow-tie dipole used with the corner reflector aerial. The dipole elements are tapered to provide a centre impedance of approximately 75Ω. Length depends on channel group.

THE physical dimensions of aerials for use on the u.h.f. band are very much smaller than at v.h.f. The ratio of wavelengths between channel 1 and the top end of Band V is approximately 20:1. For this reason complex arrays, impractical on the lower bands, are readily obtainable for use on the u.h.f. bands. This is important because the actual signal transfer to a set is related to the total length of aerial rod in use. Thus the shortness of the element rods for Band IV and V use has to be made up by increasing the gain of the aerial.

Considerable absorption of u.h.f. signals occurs in roofing materials—signals may be reduced by up to two thirds in some cases—and the BBC and ITA u.h.f. coverage is planned on the basis of outside aerials mounted at least 30ft. above the ground being used. In certain favourable positions, however, it may be possible to obtain adequate results using a loft aerial, while some people may be forced by circumstances to use indoor aerial arrays. The u.h.f. corner reflector aerial described here has been used very successfully in a wide range of locations in three versions to suit the appropriate channel groups.

Corner Reflector Aerial

A corner reflector has a gain similar to that of a 9-12 element Yagi array. It has good ghost rejection properties, good front-to-back ratio and is con-

siderably cheaper and easier to make than the more commonly used Yagi. It consists (Fig. 1) of a reflector measuring 2 × 1 wavelengths and bent at 90°

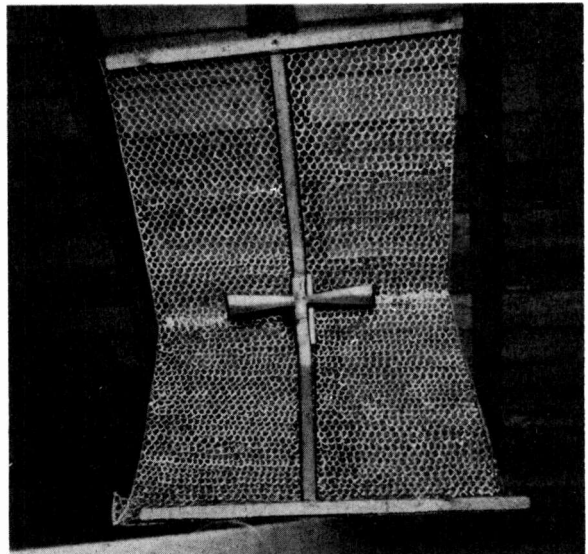

The author's loft-mounted prototype.

in the middle to give two areas each one wavelength square at right angles to each other. The dipole, tapered for matching purposes, is mounted on a support bisecting the angle between the two halves of the reflector and at a distance of about $\frac{1}{2}$ wavelength from the corner.

Construction

The version shown in the photograph uses $\frac{1}{2}$ in. mesh wire netting for the reflector, mounted on a wooden frame, with a sheetmetal dipole to which the coaxial cable is soldered. To minimise losses it is essential to use low-loss coaxial cable. The reflector could be made of sheet metal or aluminium baking foil on a wooden or hardboard base. However it was found experimentally that the replacement of the $\frac{1}{2}$ in. mesh by foil gave no visible improvement in the reception of channel 56 from Dover at a range of 70 miles. The dimensions for the versions for the three channel groups are given in Table 1.

The construction is shown in Figs. 1 and 2. The framework for the reflector may be made from lin. square wood strips nailed together as in Fig. 1 and the dipole support is a square with one corner removed. The foil dipole is screwed or tacked on to the flat part of this block while the mesh is stapled

Table 1: Aerial Dimensions

Element	Channels		
	21-34	39-50	51-68
Overall reflector	4ft. x 2ft.	3ft. x 1ft. 6in.	2ft. 6in. x 1ft. 3in.
Dipole, each half	5 $\frac{1}{2}$ in.	4.3in.	3.6in.
Spacing	7 $\frac{1}{2}$ in.	5 $\frac{1}{2}$ in.	4 $\frac{1}{2}$ in.

..... and a

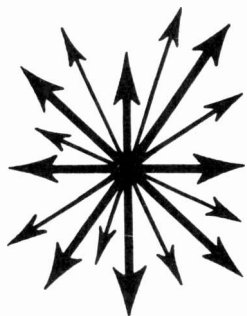

BAND I OMNIDIRECTIONAL DX AERIAL

ROGER BUNNEY

A FEW years ago an aerial was required for meteor shower work on Band I having an omnidirectional response pattern and at the same time giving a reasonable performance over the channels E2, E3 and E4 (approximately 48-68MHz). An array was constructed using crossed dipoles and this performed well on the various meteor shower openings. At the same time it occurred to the author that it may perform equally well during Sporadic E openings so the aerial was retained for the duration of the season. Since then this aerial has been constructed by a number of long-distance enthusiasts, both as a main and as a standby aerial, and reports on its performance have been most encouraging. For the benefit of other DXers who are unable to erect

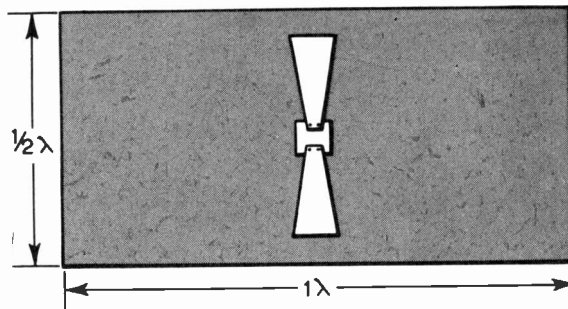

Fig. 3: A simplified version that may be used in areas of exceptional signal strength.

to the frame as shown in the photograph.

As shown in Fig. 2 the dipole is cut from tinplate or copper foil (or any suitable solderable sheet). The basic taper for all three sizes is the same and the appropriate length is cut off for the required channels.

In many situations a corner reflector provides a perfectly adequate signal for black-and-white reception. For colour, however, it is essential to have high signal strength at the set and if at all possible indoor aerials should be avoided except in areas of the highest signal strength.

In areas of exceptional signal strength an even simpler aerial is effective for black-and-white reception. This consists of the tapered dipole mounted at the same distance as before in front of a flat metal or mesh reflector one wavelength long by half a wavelength wide as shown in Fig. 3. It would, however, be false economy to attempt to use it for colour. ■

large multi-element arrays and for the beginner requiring an efficient yet small array details are given in this short article on the construction of this aerial.

Basically the aerial consists of two dipoles mounted at right angles, phased and matched into a 75Ω unbalanced output. The system is resonant on 55MHz, giving coverage on Ch. E3 and its neighbours, Ch. E2 and E4. Theoretically the latter two channels lie outside the bandwidth of this array, but in practice these channels have been well received both via Sporadic E and Tropospheric reflection.

The elements are of $\frac{1}{2}$ in. alloy tubing, the overall dimensions of the array being given in Fig. 1. The dipoles are mounted horizontally and at right angles to each other, either using separate Band I aerial

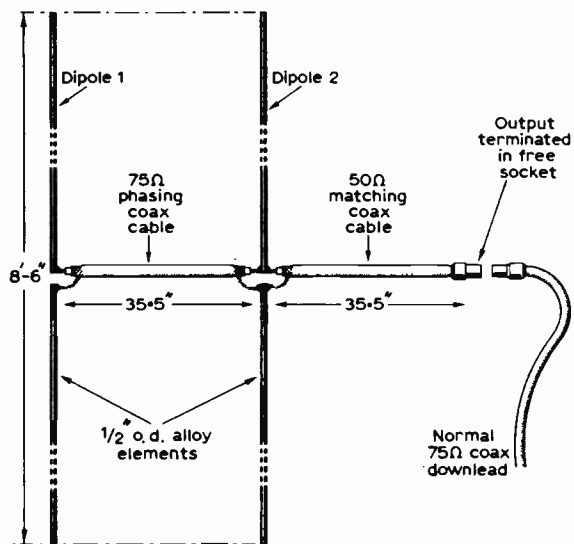

Fig. 1: "Exploded" view of the dipole X-array.

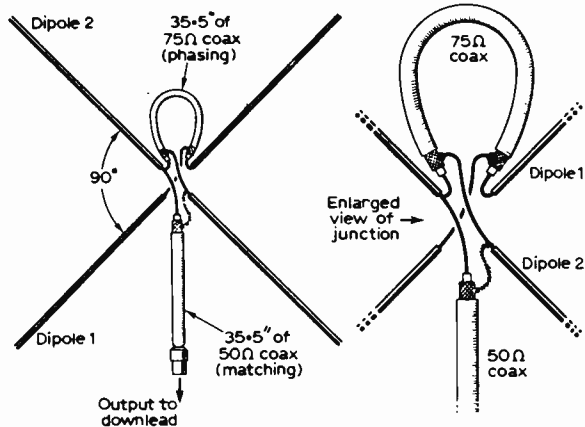
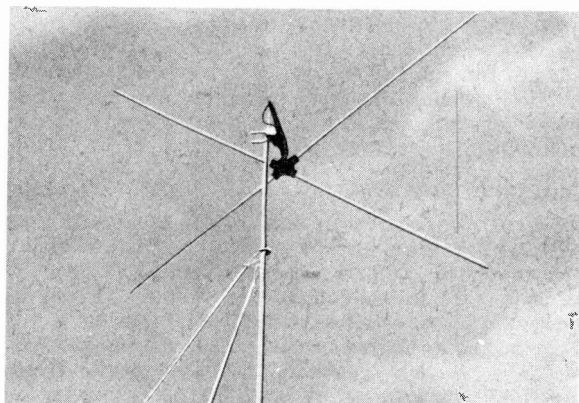

Fig. 2: Left, the assembly; right, wiring details.

insulators or preferably an X-insulator such as the Antiference Antex type. If an X-insulator is used it is most important to obtain one that will allow the dipoles to be mounted at right angles for the desired omnidirectional response to be obtained. The Antex type used by the author was found to be most convenient for the phasing and matching cable connections.

The phasing harness of 35½in. 75Ω coaxial cable was soldered to tags on the connecting lugs inside the insulator. Two holes were drilled through the bottom of the insulator to allow the cable to be fed out from one dipole, looped and taped to the supporting insulator boom, and then taken back through the other hole and soldered to the other dipole connections. The matching section of 35½in. 50Ω coaxial cable was soldered to one of the dipole terminations and fed out through the hole which would feed the normal coaxial cable on a conventional domestic installation, through the mast tubing.

In my installation the mast has been cut down to approximately 1ft. which allows the 50Ω coaxial matching cable to emerge for connection to the con-



Photograph of the author's omnidirectional array.

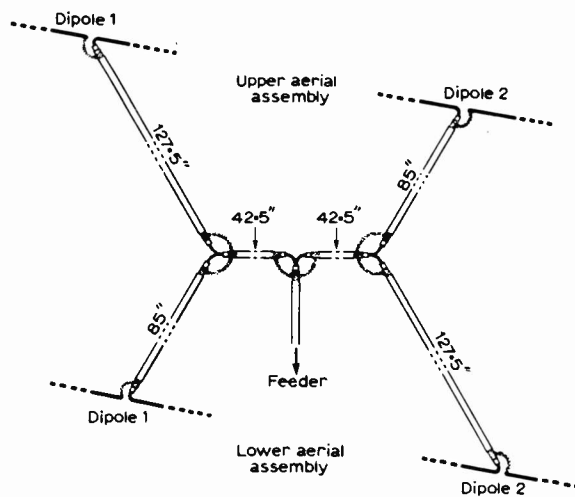

Fig. 3: Matching and phasing harness for stacking two omnidirectional X-arrays. All cable is 75Ω cellular coaxial. All connections must be taped and soldered.

ventional download. This short mast also allows the array to be clamped to a vertical mast, allowing this omni-X array to be horizontally mounted.

The phasing cable must be of the low-loss type cable with a solid single conductor. The 50Ω matching section must also be of good quality and I found it convenient to terminate the end of this section with a Belling and Lee free coaxial socket (catalogue reference L734/J/AC), allowing any coaxial feeder with a coaxial plug to be used as a download. It is strongly recommended that low-loss feeder should be used, as indeed it should for all feeder cable for DX use.

Before screwing the cover on to the insulator (if the Antex type is used) check that all connections are correct, that no whiskers of screening wire are shorting out the feeder, and apply a slight smear of petroleum jelly to all tags to prevent electrolytic corrosion and any ingress of moisture into the insulator and connecting cables.

For increased gain, especially on weak Tropospheric signals, two such aerial assemblies may be

—continued on page 472

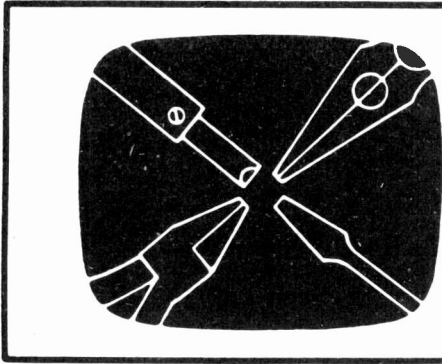

SERVICING television receivers

L. LAWRY-JOHN'S

BUSH/MURPHY TV125/V849 SERIES—cont.

The function of the mains input components should be clearly understood. The thermistor 3TH2 is in series with the supply to the h.t. as well as the heater circuit. It is not surprising therefore that it tends to fail more often than those used purely in a heater circuit. Its type should be noted (CZ19). Later models reversed the positions of 3TH2 and 3R58 and this modification should be carried out to avoid further trouble. It means that the thermistor is then in the heater circuit only and 3R58 becomes the main surge limiter (this then being the primary suspect when the receiver is inoperative). See Modifications.

Note also that the mains adjustment droppers are two separate groups. The three tag one is the heater circuit adjustment and therefore carries a.c., whereas the five section one is on the output side (d.c.) of the rectifier. It is not unusual for one of these sections to become open-circuit thereby preventing the h.t. reaching the smoothing block or making the valve heater chain open-circuit. Incidentally, the heater fuse should be 500mA and not 350mA.

Line Timebase

The line output valve is a PL36 and can give rise to several fault symptoms, lack of width being the most common. Its glass can crack which means that the valve does not light up at all although the others do. It always pays to check the PL36 and its screen feed resistor to pin 4, the green 2.2k Ω wirewound on the right-side tag strip.

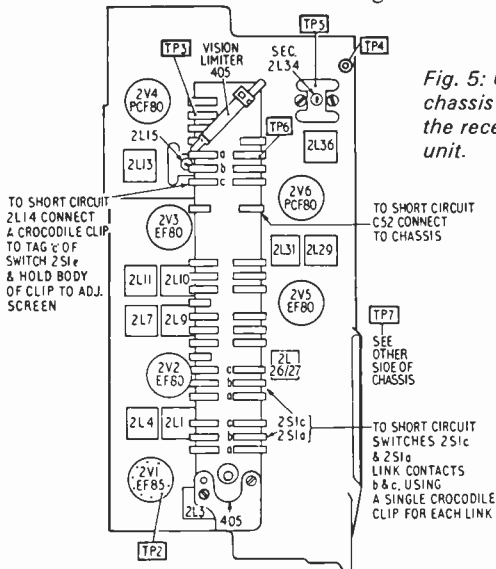

Fig. 5: Under chassis view of the receiver unit.

The boost diode is or should be a PY88 which has a 30V heater. The use of a PY81-PY800 as a replacement means a 13V rise in the heater supply; make sure the voltage selector is set to 240-250V.

The e.h.t. rectifier is a DY86/87. If the line timebase is working but this valve is not heating up it may well have an open-circuit heater but this is not necessarily so as corrosion on the pins or in the socket can stop it working. It is sometimes necessary to remove the base socket and link pins 1, 4, 6 and 9 together with one wire and pins 2, 5 and 8 with another in order to obtain good contact (or replace the base).

The line output stage is often rendered inoperative not because of a fault in the output stage itself but because of trouble in the line oscillator or flywheel sync circuits. The line oscillator is PCF80 3V3 further up the right side associated with the preset hold compression trimmer. This trimmer itself can give rise to an inoperative line timebase condition which may be intermittent. An exploratory adjustment can sometimes be rewarding and may restore line drive if the plates have been shorting in one position of the screw.

More often however it is the PCF80 which will be found at fault, either causing loss of line hold or no line drive at all. The discriminator diodes 3MR1 and 3MR2 (Z33/PC9000 or 9999) should receive their quota of attention as these can be responsible for complete loss of picture (line oscillator inoperative) as well as weak sync or varying hold settings.

Field Timebase

The other PCF80 on the right side (3V1) functions as the sync separator (pentode) and part field oscillator (triode). The diodes 3MR3 and 3MR4 are the filter (interlace) rectifiers (Z35/PC317) whose function is to clean up the sync pulses applied to the field oscillator. The PCL85 works as the other half of the oscillator (triode) and the output (pentode).

The usual troubles affecting this stage are bottom compression and, less common, top foldover. The latter condition is most often caused by a faulty top linearity preset control 3RV9 (250k Ω) although the high-voltage capacitors (yellow) of 0.022 μ F and 0.1 μ F should be checked. Usually however the PCL85 will be found responsible for most fault conditions, whether the symptoms be complete loss of scan (a single white line across the centre of the screen), bottom compression, loss of hold etc.

The cathode bias of a field output valve is very critical if an even scan is to be achieved. It is not generally realised that the value of the bias resistor

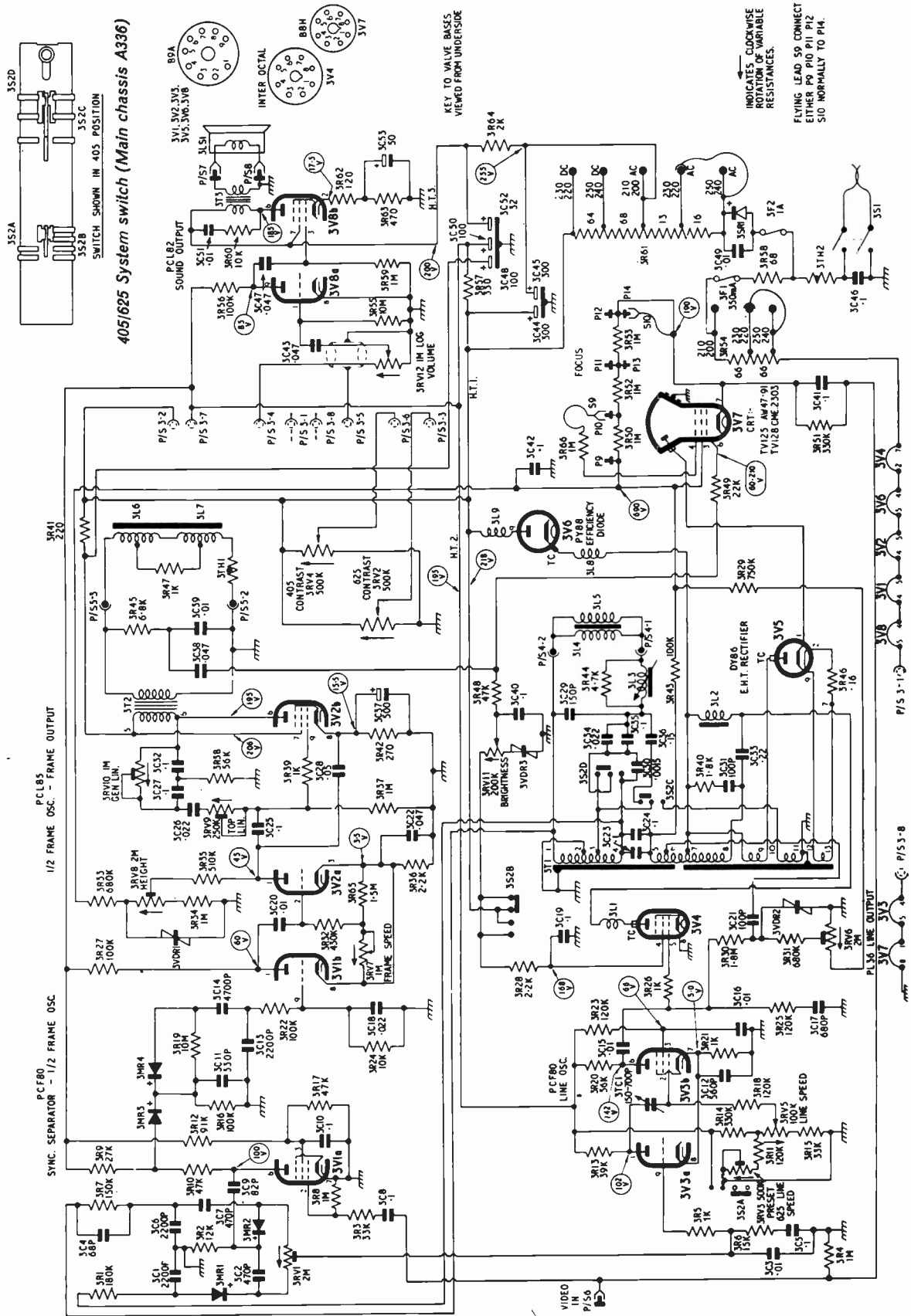

Fig. 6: Circuit diagram of the main chassis Type A336 used on the Bush/Murphy TV125/V849 series of receivers.

must be maintained within close tolerance in order to obtain even spacing of the lines from top to bottom.

Whilst the resistor fitted in these sets is of quite generous size, larger than in some other makes, it can still be damaged by a heavy flow of current through the PCL85. The value (270 Ω) should be checked whenever it is suspected that it has been called upon to pass excessive current due to a faulty valve or a leaky capacitor. The bias capacitor is much better known for its effect on the field scan, its influence, particularly on the lower half, being quite drastic.

Hum

A ripple voltage in the sound stages is immediately identified by the annoying 50Hz hum. A similar ripple in the field timebase however seems to be less readily identifiable. This trouble is far more noticeable now than it used to be (when the transmitters were locked to the mains), and more so on earlier sets than on these, whose smoothing circuits are more efficient. However an undulating raster, where the line spacing is constantly varying in a rhythmic manner, can occur and should direct attention to the PCL85 valve. The electrolytics should be checked if the effect is not due to the valve. Such faults can only enter the timebase or any other part of the circuit through the heater or the h.t. supply.

The Sound Circuits

These stages do not normally give much trouble but when it does occur it will most often be found in the PCL82 stage. This valve is inverted and is roughly in line with the brilliance control, making the base very accessible for voltage readings and component changes when necessary. Crackling and dry-joint noises are usually an indication that the PCL82 pins are not making good contact in the socket. Cleaning the valve pins is about all that is needed.

Distorted sound on all channels would suggest that the valve is defective or that 3C47 (0.047 μ F) is leaky. This would be evidenced by a higher than 17.5V reading at pin 2. Distortion on strong signals more than on weak ones would suggest a high resistor in the limiter stage: check 2R50 3.3M Ω .

Voltage Conditions

The readings on the circuits were measured with 225V a.c. mains input and no signal, using a 20,000 Ω /volt meter. Contrast controls set to minimum. E.H.T. 15.5kV; total main chassis h.t. current 190mA; receiver unit h.t. current 76mA.

Main Chassis Modifications

3R3 changed to 15k Ω ; 3C54 0.1 μ F added between 3VR5 slider and chassis; 3C55 0.01 μ F and 3R67 430k Ω added between c.r.t. pin 6 and the junction C29, P/S4-2; 3C56 33pF added in parallel with 3R49; 3R68 2.2k Ω added in screen feed to 3V8b; 3R1 changed to 43k Ω and connected to tag 3 instead of tag 4 of 3T1; 3R58 changed to 10 Ω and transposed with 3TH2; 3C34 changed to 0.12 μ F and 3C35 deleted.

For notes on the later Bush TV135R and RU series (valved, not the hybrid versions) see the October and November 1967 issues.

NEXT MONTH IN

Practical TELEVISION

VOLTAGE ANALYSER

A handy and simple-to-build item for the constructor. Enables voltages at parts of the chassis difficult to reach to be speedily checked.

TRANSISTORS IN TIMEBASES

The timebase sections of the receiver have not so far yielded to the transistor. In this new series the problems of using transistors in this field will be outlined and the present position described, starting with sync separator stages.

DX TV PREAMP

Now the DX season is with us enthusiasts will find this high-gain preamp of great help. Full details along with a simple noise generator to assist with alignment.

FAULT FINDING IN LINE OSCILLATOR STAGES

A detailed look at current line generator circuits with details of common faults and their cure.

SERVICING TV RECEIVERS

In answer to many requests next month we start on the Thorn 850 chassis.

PLUS ALL THE REGULAR FEATURES

ORDER YOUR COPY ON THE FORM BELOW

TO.....
(Name of Newsagent)

Please reserve/deliver the AUGUST issue of PRACTICAL TELEVISION (3/-), on sale JULY 18th, and continue every month until further notice.

NAME

ADDRESS.....



PART 18 M. D. BENEDICT MAKING DOCUMENTARIES

DOCUMENTARIES and programmes providing information or education use a very different technique to that described in the May issue for drama productions. For a start the budget and facilities will frequently be much smaller. Often the subject matter will dictate the approach needed and it may be arranged that right from the outset filming will be used entirely. Starting with a brief from the Head of Department the producer sorts out the basic line of the programme. What approach, how long it will run, and how it can be broken down into each weekly programme.

Staff are selected—a director if the producer cannot direct or has not enough time to do so, production assistants or researchers, the production secretary (or P.A.). Particularly important in such programmes are the researchers and production assistants who are responsible for the donkey work of finding out facts, figures, film and photographs and hammering these into a script ready for the director. Often a great deal of time is taken selecting the right bits of film from 25 or more major film libraries in this country or from any other special source that can be discovered. In addition they will have to edit the film, deal with some of the filming, and handle many of the administrative arrangements, both inside and outside the broadcasting organisation. All arrangements for transport, accommodation, and facilities have to be made for the film unit and production team whilst filming at whatever place the director decides is necessary for the subject.

Presentation

It is not common for the pure documentary to have a presenter but many schools and adult education programmes feature a regular presenter who appears in both a film and in the studio. Assuming no presenter is used and the programme is to be entirely on film, once filming is complete or enough library film has been obtained it is simply a matter of assembling the film in the cutting room, laying sound effects and combining special effects and music at a dubbing session. Any commentary is added from a dubbing studio at this stage. The work print and negative go to the laboratories to make the show print, which is then stored with the mixed sound track ready for transmission.

Where studio sequences are needed then the approach is somewhat different. Usually the presenter will be required and at an early stage the producer must decide on using a professional presenter or an expert on the subject of the programme. Naturally the latter course is somewhat risky as appearing before the cameras and presenting a programme are not as easy as they look, even with such aids as Autocue or Teleprompter.

Prompting

These devices are basically a machine for displaying rolls of paper on which the script is typed out, using a very large typeface. Movement is effected by a controlled motor. Several rolls can be controlled from one master machine and sprocket holes ensure that each roll is in sync with the master roll and moves at the same pace. For some applications a sheet of glass is placed at an angle across the camera lens and this reflects an image of the rolls, and hence the script, to the person in front of the camera. However the camera looks straight through the glass at the artist. Hence the presenter can look straight at the camera lens and read his script at the same time.

Unfortunately many people working with such devices go glassy-eyed and give an unnatural performance without glancing away from the camera at all. In general these devices are very useful and many artists use them with great success. It would be completely impossible for a presenter of many magazine or current affairs programmes to learn all the scripts, often available only a few hours before. With documentary programmes a great deal of factual information is present in the script so often a performer uses Autocue or Teleprompter devices as a reminder, enabling him to improve his performance. Fewer, more expert performers use "idiot cards" with cues into telecine or videotape sequences. To enable the P.A. or director to run the telecine or videotape machine, the exact wording of the introduction would have to be fixed.

The Script

After selection of the presenter, work on the script proceeds. Again a choice must be made between

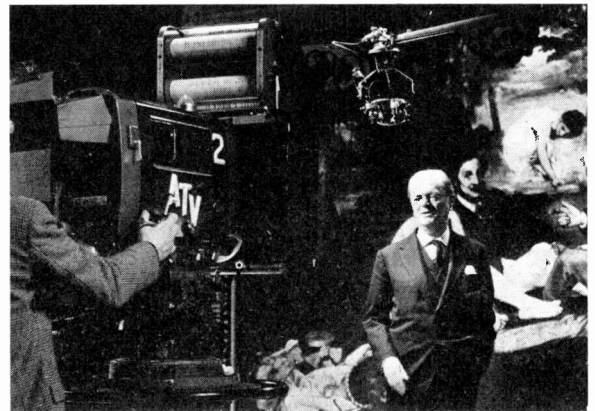

Teleprompter mounted on a camera: the rolls of large typescript are above the camera but the reflection appears across the camera lens when this is viewed by the presenter from the front.
ATV photograph

View (right) of the Thames TV Studio 1 at Teddington showing the use of MR Duolights with wide-angle lenses for the tricky problem of cyclorama lighting. Thames TV photograph

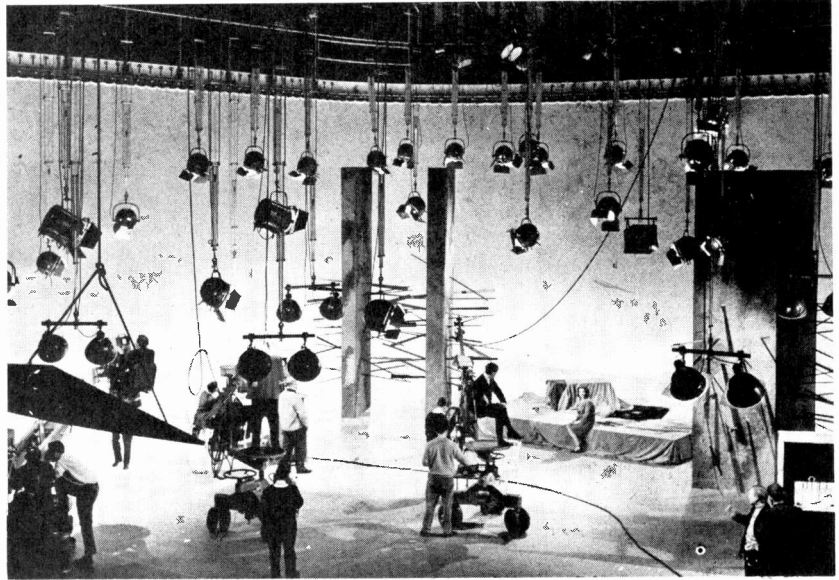

using an expert to write the script and then adapting it for the television medium, or using researchers or production assistants to prepare the script, having investigated the subject very closely. When an expert is presenting the programme it is usual to use his assistance for preparation of the script as well as writing the final version in his own words.

The Director

Finally the script has been prepared, the film selected and edited, photographs chosen and copyright cleared, and all is ready for the director, who almost always takes some part in the preparatory work. He can add his camera shots to the script, these usually being very simple shots with only the occasional cut away to a specific demonstration, slides or other visual aids. Once in the studio work proceeds much as with a play, although since videotape editing may be restricted in comparison to high-budget dramas, breaks and mistakes cannot be tolerated.

Outside Broadcasts

One type of programme in which no mistakes can be corrected is the outside broadcast. Complex as these are by themselves, imagine the situation if up to four or five outside broadcasts are going on simultaneously—and being combined into one programme, for this happens on both BBC-1 and ITV every Saturday afternoon in the *Grandstand* and *World of Sport* programmes.

Planning Sports Coverage

Planning for these starts often up to a year before when the dates of sporting fixtures are decided. Some events such as the test matches are an automatic choice for *Grandstand*. Not only is there an outside broadcast unit already at the ground covering play on Thursday and Friday, but often BBC-2 will carry a continuous coverage of the match. Other events fall into place with similar ease—horse racing is pretty well divided up with BBC having contracts with some courses and ITV with others. Events such as motor racing, athletics, swimming have to earn their places and are included to balance the programme. Sometimes special events are laid on by the BBC or programme companies. Many motor sports fall into this category, including rallycross, scrambling and the occasional driving test and autopoint contest. Such events are used by the planners to inject interest into Saturdays when the choice of events may be somewhat limited. They are usually arranged by an existing club or organisation on behalf of the programme company, using the financial guarantee offered by television. However these events are

perfectly genuine as most enthusiasts in them are only too pleased to see more coverage of events featuring their favourite sport.

Deploying Equipment

Thus for each weekend the executive producer or editor of the programme may have four to five events available. Next comes the most difficult part—deploying the facilities and equipment. An outside broadcast unit capable of giving the correct coverage without squandering facilities unnecessarily must be allocated to each event. The director appointed to the event by the producer has his own ideas of what is essential and naturally some take priority. With horse racing, which gets the biggest bite of the cherry, it is not uncommon to use extra cameras and radio cameras and the roving eyes to give greater coverage of the course. Special events, the Olympics, certain International Rugby or Football matches (the Football Association usually do not allow live coverage of matches) or Athletic matches may be allowed to take priority.

Horse racing cannot be recorded and replayed later as punters at home must be allowed to place their bets before the race. Even major events in motor racing (which is one of the most popular specialist sports) are often ignored or barely covered in order to cover the four or five horse races transmitted in full, from paddock to unsaddling enclosure.

Other facilities like stop frame video-disk recorders are allocated as decided by the editor should any conflict occur. Not just programmes such as *Grandstand* and *World of Sport* need to be considered; both channels may cover a football match for transmission the following day or in the evening. Normal coverage of concerts and other special events has to be considered and it is often necessary to call in the regional units or the small companies' outside broadcast equipment, even though this means moving out of their own territory.

Booking Lines

After this it is necessary to book the lines, a job which may be well nigh impossible at first sight.



MOLE-RICHARDSON [ENGLAND] LTD.

for professional lighting rental

Mole-Richardson (England) Limited

Chase Road,
London, N.W.10.

Tel: 965 6834

Telex: 22127

Night: PINNER 7814
467 5986
25 57395

Mole-Richardson (England) Limited

Old Road,
Cheadle,
Cheshire.

Tel: 061-428 8214

Night: 061-748 9595

Arc Lamps, Incandescents, Colortran, Quartz Iodine, Bulbs, Carbons, Filters, Cranes, Booms, Wind Machines, Fog Machines, Molevators, Hydraulic Stands, Dollies, Tracks, Specialised equipment of every kind, full range of mobile silenced generators, experienced studio and location electricians. Period hire by negotiation.

AUSTRIA	—1130 Auhofstrabe 204, Vienna— Tel: 82.81.12
FRANCE	—105 Ave Aristide Briand, F-94-Cachan— Tel: 655 20 02
GERMANY	—Hofangerstrasse 78, Munich 8— Tel: 401827
GREECE	—112 Leoforos Kifissias, Halandri, Athens— Tel: 683870
IRELAND	—67a, Pembroke Lane, Ballsbridge, Co. Dublin—Tel: 689 679
ITALY	—Via de Velodromo 70, 00179-Rome— Tel: 783827
SPAIN	—Gustavo Fernandez Balbuena 13, Madrid 2 —Tel: 4157254
SOUTH AFRICA	—Lone Hill Studios, Bryanston, Johannesburg—Tel: 40-1643

MOLE-RICHARDSON

An International Organisation

LAWSON BRAND NEW TELEVISION TUBES



SPECIFICATION: The Lawson range of new television tubes are designed to give superb performance, coupled with maximum reliability and very long life. All tubes are the products of Britain's major C.R.T. manufacturers, and each tube is an exact replacement. Tubes are produced to the original specifications but incorporate the very latest design improvements such as: High Brightness Maximum Contrast Silver Activated Screens, Micro-Fine Aluminising, Precision Aligned Gun Jigging, together with Ultra Hard R.F. High Vacuum Techniques.

DIRECT REPLACEMENTS FOR MULLARD-MAZDA BRIMAR GEC, ETC.

A47-11W (P)	MW53/20	T914	CME1901	21C2P4
A47-13W (T)	MW53/80	C19/10A	CME1902	21DKP4
A47-14W	AW-47-97	C19/10AP (T)	CME1903	23SP4
A47-17W (P)	AW-53-80	C19/AK	CME1905	171K
A47-18W (P)	AW53-88	C21/1A	CRM1906 (T)	172K
A59-11W (P)	AW53-89	C21/7A	CME1908	173K
A59-12W (P)	AW59-90	C21/AA	CME2101	212K
A59-13W (T)	AW59-91	C21/AF	CME2104	7205A
A59-14W (T)	C17/1A	C21/KM	CME2301	7405A
A59-15W	C17/4A	C21/SM	CME2302	7406A
A59-16W (T)	C17/5A	C21/TM	CME2303	7502A
AW36-80	C17/7A	C23/7A	CME2305 (P)	7503A
AW43-80	C17/AA	C23/10A	CME2306 (T)	7504A
AW43-88	C17/AF	C23/AK	CME2308	7601A
AW43-89	C17/FM	C23/AKT (T)	CRM173	7701A
AW47-90	C17/HM	CME1402	CRM212	CRM121
AW47-91	C17/SM	CME1702	CRM211	MW31-74
MW43-69	MW/53-80	CME1703	17ARP4	
MW43-64	T908	CME1705	17ASP4	
MW43-80	T911	CME1706	17AYP4	

FOR YOUR INFORMATION

Experience of supplying CRTs over many years has shown us that when a customer requires a new CRT he means **Immediately**. We at Lawsons are geared to give a by-return service. Tubes are sent fully insured by passenger train.

12" Types	£4.10.0
14" Types	£4.10.0
17" Types	£5.19.0
19" Types	£6.19.0
21" Types	£7.15.0
23" Types	£9.10.0
19" Panorama	£8.10.0 (P)
23" Panorama	£11.10.0 (P)
19" Twin Panel	£9.17.6 (T)
23" Twin Panel	£12.10.0 (T)

Carriage & Insurance 10/-

LAWSON TUBES

STATION ESTATE, MALVERN

Offices

18 CHURCHDOWN ROAD,
MALVERN, WORCS. MALVERN 2100

2 YEARS' FULL REPLACEMENT GUARANTEE

Complete tube fitting instructions are supplied with each tube.

In theory every outside broadcast should be fed to the studio for the whole time that action occurs. Many events can be videotape recorded at the studio centre so that any events can be swiftly replayed to the studio. However, the lines may not be available all the time so that compromises are made. One such compromise occurs in the arranged programmes such as Autocross, where the action only takes place whilst the outside broadcast is being transmitted. After the central studio cuts away to another sport from another outside broadcast all action ceases on the course until the outside broadcast is transmitted again. If too much delay is envisaged, the first few events are transmitted live, latter events are recorded and the recording is played back at a convenient time in the programme. Such techniques free either lines or a videotape recorder and allow a switch to another outside broadcast to come in on the same vision line. It really pushed the Post Office manager to squeeze a few more vision circuits out of the trunk telephone system.

Preparations for Broadcasting

All the normal procedures for outside broadcasts are dealt with; such as permission to use the site and facilities, which are completed in the agreement drawn up with the organising body for the sport. Large sums of money are paid out by the BBC and ITV companies for the spectacular outside broadcasts, since the planners use popular items to build up the audience to last right through the evening. On the other hand, the organisers fear that televising a popular event will ruin their attendance figures; the Football Association, for example, insists that in general football matches be recorded and transmitted well after the match is over, either late night on Saturday evening or on a Sunday afternoon. Minority interest sports have little to worry about and welcome the large sum of money that television pays.

During the week or so before the programme the producer arranges schedules and checks progress. The commentators and link men research their facts and figures. Charts and captions are prepared, although horse racing results are usually dealt with by freelance artists who paint the captions at a remarkable speed, filling all the details in as they are fed from specialist news services which telephone direct from the race course. Depending on the nature of each event, the outside broadcast unit arrives one or two days before and sets up the cameras and microphones. Each director has his brief from the executive producer or editor regarding the coverage and how it will be fitted into the complete programme.

In the central studio the sets are prepared, usually showing editorial staff writing and typing out the news as it comes in straight off the teleprinters, which may themselves be featured for the results. The key performer is the link man or presenter who introduces each item and passes on news and comments to keep the viewer informed. Usually he will wear a hearing aid radio receiver and radio microphone, so that he can move around freely yet can hear instructions from the studio director. Besides the normal talkback, "switched talkback" is used which operates only when a switch is depressed. This allows the studio director to speak directly to the link man or other directors in each outside broadcast

unit only when important instructions are needed. Link men and outside broadcast directors can then work without the distraction of hearing studio talkback all the time.

Executive Producer

In charge of all this is the editor or executive producer. He will contact the directors in the outside broadcast unit, usually by telephone, as well as being in touch with an assistant in the videotape recording area. Thus he can judge where the action is and which is the best time to join a given event. Recordings are controlled by a member of the team whose responsibility it is to select the starting points of any sequence, arrange for it to be cued up on this point when required, inform the editor of the duration of the sequence and to arrange that any action continuing to occur is recorded on another machine.

Inserting Recordings

When a recording is being played into the programme the link man and director agree on a given word or phrase and the director runs the recording when this phrase is used. A verbal countdown from the P.A. using her stopwatch can be heard by the link man and he simply stops talking at the zero to the sequence. If he cannot wear a hearing aid or is too far away on an outside broadcast the stage manager or floor manager indicates the ten-second rundown by holding up his fingers and thumbs on the countdown from the P.A.'s stopwatch. He stands alongside the camera and the link man can see exactly how many seconds are left over for talking by the number of digits in sight. Again he stops talking at the zero and the studio takes the recording.

Programme Timing

Complicated sums by the editor and the P.A. ensure that the programme runs to time without excessive padding by the link man or commentators on the outside broadcast. Although the timings for each event may look fine in theory it rarely works out like that and it is often necessary to revise the timetable and the timings of each event. Some, like horse racing, cannot be altered so it is often necessary for the editor to make an agonising decision to leave an event in the closing stages rather than run on too long and miss the horses in the paddock. Someone is certain to be offended whatever occurs. Fortunately for the ITV, the commercials can come more or less anywhere and so the normal cue dot procedure is used to indicate each break.

Finally the closing music is played, often at a fixed time, to be faded up when the link man stops talking and the programme goes off the air. But even then all is not over because the highlights of some events are transferred to film and kept in the library for use in the mid-week sports programmes. Editing on the Match of the Day or the Big Match proceeds ready for the transmission in a few hours time and the rest sit back to contemplate the next programme, at the best the following Saturday and at the worst a bank holiday programme the following Monday.

If that sounds hectic then consider Television News, the subject of the next article in this series.

TO BE CONTINUED

FIELD LINEARITY

J. B. WILLMOTT



A COMMON fault in TV receivers, particularly after an extended period of use, is poor field scan linearity. It is quite surprising how many viewers are prepared to tolerate this fault condition and cheerfully watch a screen which presents people with large heads and foreshortened legs or vice versa and rolling titles which appear to have letters which expand or contract as they travel up or down the screen.

Usually the first symptom to develop as a set ages is lack of height (i.e. there is an unfilled gap at the top or bottom—or both—of the screen) and to counteract this the field height control is adjusted. Almost inevitably this results in noticeable stretching or cramping of the picture at either the top or bottom, and a slight adjustment of the field linearity control is called for to correct this. Eventually, there comes a time when it is no longer possible to fill the screen vertically yet maintain linearity, and it is at this stage that some more positive treatment is necessary.

FIELD TIMEBASE CIRCUITS

Let us first of all consider the type of circuit used to produce the field scan in a TV receiver. As the field frequency is 50Hz the field output stage bears a strong similarity to an audio output stage. It is thus the general practice to employ a pentode valve coupled to the low-impedance field scanning coils by means of a matching field output transformer. The field output stage is required to give a linear sawtooth output similar to that shown in Fig. 1. However it is extremely difficult to design a

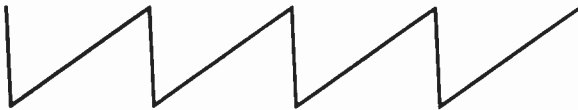

Fig. 1: Idealised waveform required for linear field scanning in a television receiver.

field output stage whose output is completely linear and in any case the preceding field oscillator stage frequently introduces some distortion of the field scanning stroke. Divergences in component tolerances and operating voltages in individual receivers from the same production run also make it essential that a range of adjustments to the operating conditions of the field scanning circuits is available in each receiver.

Various methods of height and linearity control are in use. A means of adjusting the amplitude of the drive to the control grid of the output stage is included to enable the height to be adjusted and

in addition a means of linearising the scan is provided by adjusting the bias conditions of the output stage or by various negative feedback arrangements. Two representative circuits are shown in Figs. 2 and 3 to indicate typical practice.

So far so good. But having discovered how a linear field scan is obtained what conclusion should one arrive at when no amount of juggling with the field height and field linearity controls will produce a linear scan which fills the screen?

FIELD OUTPUT STAGE FAULTS

The first and most probable suspect is the field output valve itself. Loss of gain after a considerable period of use is only to be expected and this of course results in loss of height. Advancing the height control, i.e. increasing the grid drive to the output stage, tends to aggravate matters from the linearity viewpoint as the already failing output valve is driven further into distortion. Therefore the first action should be to test the efficiency of the output valve by substitution with a known good valve of the same type. But before doing this it is as well to ensure that the main h.t. line of the receiver is up to standard. Normally this should be in the 180-210V region. Obviously lack of h.t. voltage will reduce the scanning power of the field output valve and as these valves are frequently worked close to the limit of their power handling capabilities any reduction in h.t. voltage is made immediately apparent by loss of height. The h.t. to the generator stage should also be checked since in many models this is derived from the boost h.t. line.

If the h.t. voltage is satisfactory, and after fitting a new field output valve adjustment of the height and linearity controls still does not produce a satisfactorily linear picture, one must look to the other components in the circuit. First under suspicion should be the cathode bypass capacitor in the output stage. This is normally a high-value electrolytic (e.g. 250 μ F in Fig. 2 and 500 μ F in Fig. 3) and it is common for these to lose their efficiency with age. They may either dry up leading to loss of capacitance (in which case an unwanted degree of negative voltage feedback will occur, leading to reduced scan); or internal leakage will result in insufficient bias voltage for correct operation of the valve. Here again substitution is the quickest and best test. Check the cathode bias resistor as well.

Another cause of nonlinearity is leakage in the interval coupling capacitor between the anode of the oscillator stage and the grid of the field amplifier. A leakage even of several megohms here is sufficient to completely upset the bias voltage conditions in the

Fig. 2: Typical field timebase circuit using a single triode-pentode valve. This circuit is used in the McMichael Model MP20. The basic scanning waveform is generated by the charge and discharge of the scan charging capacitor. This charges via the 470k Ω resistor and height control when the triode section of the valve is cut-off to give the forward scanning waveform. The pentode section of the valve in addition to amplifying the waveform acts with the triode section as a multivibrator. When the triode section conducts the scan charging capacitor discharges rapidly to provide the flyback portion of the scanning waveform. In more recent models the scan charging capacitor is charged from the boost rail to give a more linear scan.

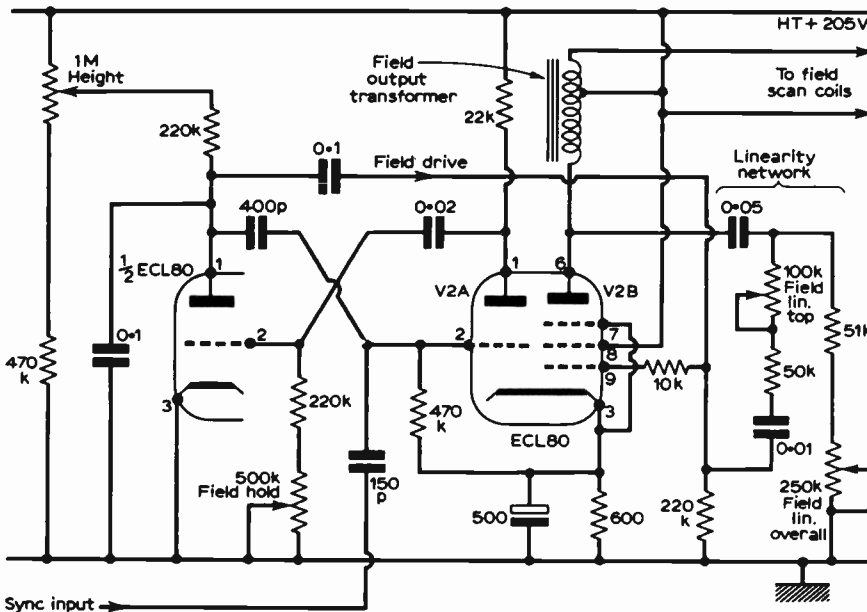
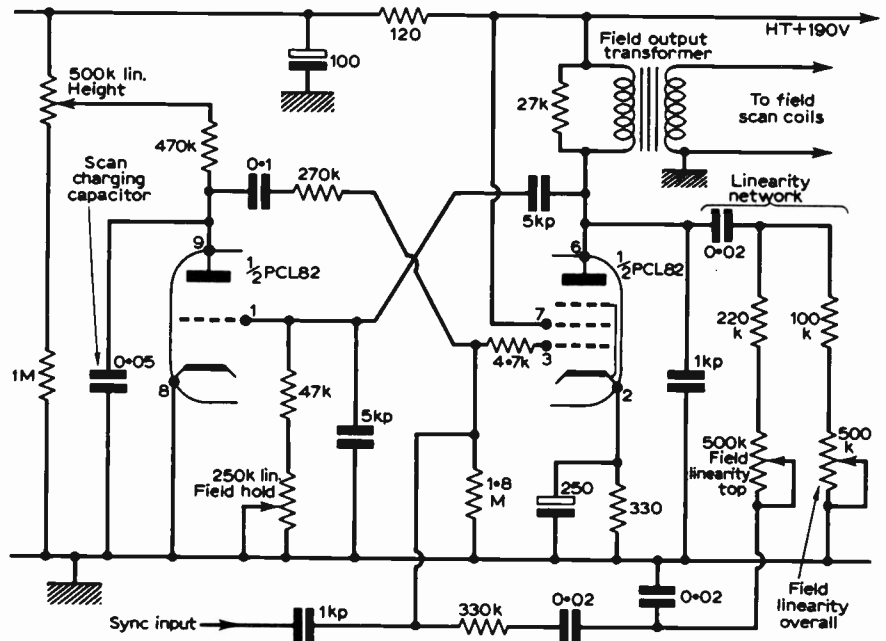

output valve with severe results in the form of distorted output. A really first-class coupling capacitor is a must in this position, so if in doubt change it for a new component.

If the fault still persists attention must next be paid to the linearising (i.e. frequency correction) networks. First under suspicion are the variable controls themselves. Any irregularity in the tracks of the height or linearity controls will have serious effects. As a first move it is a good plan to clean the tracks and rotors with a proprietary brand of cleaner. Checking the smoothness of operation by moving the control with an ohmmeter connected between the rotor and one end of the track should also be tried as this will quickly show up any irregular or open-circuit control.

If the controls are found to be in good order or

have been replaced and yet the fault still persists, the values of all resistors in the output and oscillator stages should be checked. Particular attention should be paid to high-value resistors (220k Ω and over) as these tend to go high resistance or even open-circuit with age. Obviously any of the capacitors associated with the stages are also suspect and should be tested by substitution one at a time.

If after all the foregoing checks and substitutions the fault is still present the field output transformer must come under suspicion. A complete open-circuit of either the primary or secondary windings results in collapse of the field scan, but shorting turns or leakage between the windings and the core (and hence the receiver chassis) causes distortion rather than complete loss of output. A frequent failure is that

—continued on page 473

Fig. 3 (left): In this field timebase circuit, used in the Decca DM1, DM3, DM4, DM5 series, the generator and output stages are separate. The two triode valve sections form a multivibrator, with the pentode section driving the field scan coils via an autotransformer. The field linearity circuit is of the same type as that used in the previous example, comprising a negative feedback network connected between the anode and control grid of the output pentode. The linearity controls are incorporated in this feedback loop and determine the precise correction applied to the scanning waveform. It is the general practice in current models to connect the "earthy" end of the scan charging capacitor to the cathode of the output pentode.

UNDERNEATH THE DIPOLE

RECENTLY *The Siegfried Idyll*, based on the romantic period of Richard Wagner's colourful life, was presented on colour television with magnificent exterior scenes by (and on) the lake at Tribschen, near Lucerne. Beautiful photography by Ken Westbury, fine direction of acting by Anthony Wilkinson and superb settings all contributed their share to the success of this television biography.

A point of technical interest is that it was photographed on 16mm. film, processed and printed by Denham Laboratories for the BBC. Fast-sensitivity film stock was used for the interior scenes, many of which were shot on foreign location. Exteriors were shot almost entirely in and around the lakes in Bavaria, using less sensitive and finer grain colour negative. Many of the scenes were breath-taking in their beauty. Ken Westbury was a one-time "focus-puller" on the famous Ealing film comedies under Gordon Dines B.S.C., then Head of Ealing Studio camera department. Ken is now one of the two cameramen survivors at the BBC Film Studios, Ealing, from the Sir Michael Balcon/Ealing régime. The other gifted survivor of the "Balcon mob" is A. A. (Tubby) Englander, whose immaculate photography of the world-touring Sir Kenneth Clark's art series *Civilisation* has also set engineers thinking. Do we need 35mm. colour film when such good work can be achieved with the much less expensive 16mm. negative or reversal colour film?

ITCA

The name of the Independent Television Companies Association (ITCA) indicates exactly what it is—a confederation to safeguard the interests of all programme companies appointed by the Independent Television Authority. This concerns not only matters of front office policy but personnel employed, legal and copyright matters and engineering problems, including standardisation of techniques. From the very start of independent television in Britain the engineering side has been regarded as being of paramount importance. Technical committees (and subcommittees) have been active ever since. The collaboration with the film production industry has grown closer over the years, even to the extent of the main technical committee having a meeting in the Board Room of a film studio.

This happened a few weeks ago when chief engineers (or their deputies) from each of the ITV companies held a technical meeting in the graciously

panelled board room of Pinewood Studios, under the chairmanship of J. Stuart Sansome, M.I.E.R.E. (chief engineer of Thames Television). The committee later made a tour of the studios including the famous J and K dual-purpose stages and the almost completed L and M stages, built in record time but with great skill and craftsmanship.

TV SERIES POPULARITY

It is not easy to achieve high TV-ratings for individual plays of half-an-hour or fifty-minute duration without considerable ballyhoo in the national press and programme magazines. Or with interpolated three-minute trailers of the forthcoming attractions. With a serial, a series with "resident" cast, or even a series of entirely separate plays under a common title (like "Armchair Theatre") goodwill can be built up week-by-week. That is why *Coronation Street*, *Dr. Finlay's Casebook*, *The Troubleshooters* and *The Borderers* have made such a good impression. They retain their viewing public and will continue to do so providing they keep to the basic story-line and cast formula, making (with great discretion) slight changes only occasionally. The viewing public often detect and dislike major style changes; but they tire of the monotony of exactly the same style and shape every week.

A BUILDING CHRONICLE

Here is the quite remarkable date sheet and schedule which was achieved in the construction and equipping of a pair of dual-purpose (film or television) stages at Pinewood Studios: (a) Arrival of building permits, Friday 29th November 1968. (b) Cutting the first sod, Sunday 1st December 1968. (c) Three main concrete foundation rafts started on 3rd January 1969. (d) Steel structure construction commenced on 15th January 1969. (e) High-quality brickwork cladding started on 20th January 1969. (f) Mansard roof and television lighting grid of stage L was completed on 31st March, to be followed three weeks later by stage M and then by control rooms, dressing rooms, etc. (g) Stage L was seen by members of the ITCA Technical Committee on



J. Stuart Sansome, M.I.E.R.E., in the chair at the recent meeting of the ITCA Technical Committee at Pinewood Studios. Note the essential reading on his left-hand side!

30th April 1969. The Stage was then almost full of sets for the first film to be shot there, starting on 14th May, a big feature film for the cinema, *David Copperfield*.

These dates were achieved after one of the worst winters ever for rain, snow and frost. This was good going as well as good bricklaying. The cost of the whole two-stage production complex will be £600,000, completely equipped down to pens and pencils on the secretaries' desks!

The logical layout of the premises, the concrete raft concept and other methods of avoiding structure-borne interference noises, the silent ventilation and the time-and-motion departmental plans seemed to evolve naturally. This was due to teamwork headed by Pinewood's technically minded managing director E. A. R. Herren, chief engineer Tommy Knight, consultant Baynham Honri, architect Michael Brown (of Doric Ltd.) and Bill Brown for the main building contractors, Specialist Builders. The faith of this team and their confidence in the superiority of brick cladding to steel work frames (with sound insulation between) was clearly proved. Planning for the future was also kept in mind and even lintels were built into walls to allow for extra accommodation and facilities in the future.

Compare this kind of planning and building to the £8,000,000 National Theatre proposed on the South Bank: it makes you think! But then this new pair of production stages was planned and built by professionals in showbusiness, not by arty-crafty amateurish do-gooders. This is indeed a "Matcham Reconnaissance" of good sense in good building.

FILM AND TELEVISION'S TOGETHERNESS

There are times when it is difficult to detect when BBC or ITV companies are putting out programmes on tape or on film, whether black-and-white or colour. The matching is excellent, even in balancing the colours of one shot on tape with the next shot on film. Sometimes the end product turns out to be on film prints, with VTR sequences retransferred to film which is carefully graded throughout at the film processing laboratory. The existence of a 35mm. photographic film negative is of great value for the export trade, but release prints for the insatiable international television market may want programmes on 35mm. film or 16mm. film, with English dialogue or with their own language dubbed on. Film has certain advantages for dubbing and cutting, as the rival British television organisations have discovered.

A skilled film editor can work at lightning speed, cutting together with great precision many different shots of a dramatic sequence, overlapping and counterpointing separate dialogue sound tracks, cut-in shots, picture inserts and "voices off". He uses a multiple film synchroniser, an editing machine and a non-magnetic pair of scissors. A

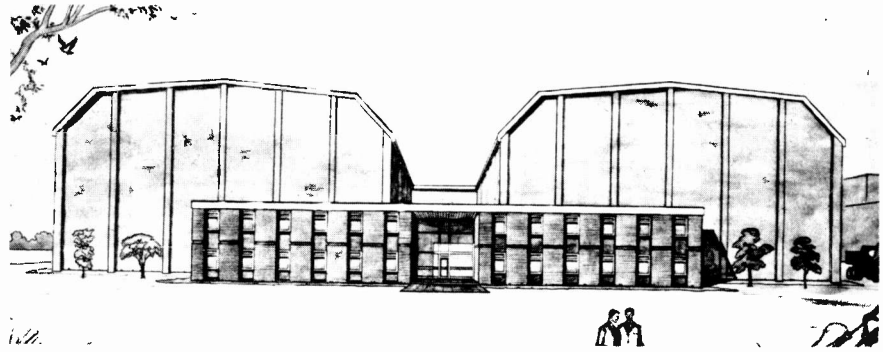

Artist's impression of the new dual-purpose L and M stages at Pinewood Studios.

skilled videotape editor has to go about his work in quite a different way, more difficult because he can't see the pictures on the tape, restricted by invisible syncs and frames and relying on complex (and expensive) detecting and guillotine instruments. Use of A and B TVR machines, cutting from one to the other and transferring the output to a third machine, can be adopted of course. But it involves a colossal amount of capital equipment. Television-film editors prefer continuous motion-film editing machines such as those made by Evershed, Steenbeck, Keller, Rigby and Acmade. Traditional film studio editing machines with intermittent-motion mechanisms tend to damage and scratch films, particularly when they have just arrived from the processing laboratory and are still "green", which means slightly damp.

There has been an astonishing expansion in the hiring facilities demanded by television and film producers for stage use, sports and even news items. At one time there was only an occasional call for the hire of mobile generators for lighting or for the hire of luminaires. Now, with the coming increase of colour film and videotape programmes for BBC-1, the ITV companies and of course BBC-2, there are seven or eight companies providing equipment for hire. Simultaneously the major film studios have called for more equipment hire facilities for film spectaculars as well as for films for television. The Lee Brothers have established a hiring centre near Paddington station, Lee Electrics (Lighting) Ltd., which now owns about 80 vehicles, devoted to mobile lighting generators and a very wide range of lighting luminaires including everything from the new lightweight "brute" carbon arcs to the comparatively featherweight incandescent and halogen type fittings.

The hire of equipment and the people who have to operate it proceeds steadily. The main difficulty, with so many television channels, is to hire the scriptwriters, producers and directors who have the right technical training, now essential for the new art. There are too few of these. The engineers have a much better idea of the artistic so-called "creative" side of the profession than some of the non-technical kinkies who try to invade the electronic profession.

Iconos

the DECCA 'PROFESSIONAL 23' TV RECEIVER

H. K. HILLS

NOT much attention has been paid by TV receiver manufacturers to producing the visual equivalent of a hi-fi radio, in striking contrast to the bewildering array of grams, tuner units, amplifiers and speakers offered to the high fidelity market. However the Decca company with a long history of making hi-fi sound equipment offer a TV receiver bristling with technical innovations and expressly designed to take full advantage of the high quality of picture and sound now transmitted. Two years were spent developing this particular model, the Professional 23.

Power Supplies

All power supplies are taken from a multi-wound isolating transformer to BS415 specification. This ensures that the chassis is neutral so that it is perfectly safe to run leads in and out of the receiver, and in fact there are sockets provided for feeding the a.f. output to a hi-fi amplifier or tape recorder and for hearing-aid devices. In addition if required outputs for a videotape recorder and/or socket for a TV camera can be provided.

The integrated tuner, i.f., video and all sound stages are transistorised using the latest silicon planar types, valves being employed in the timebase circuits and for the sync separator. The valve h.t. supply is provided by a full-wave bridge rectifier circuit, and the transistor i.t. supply by two separate full-wave circuits to minimise hum level and possible intercoupling between the supplied stages.

The absence of dropper resistors in the heater circuit greatly assists in the cool running of the receiver, increasing component reliability and reducing the overall power consumption to only 115 watts.

As the chassis is electrically neutral and fitted with an implosion-proof c.r.t. the manufacturers can supply the receiver without cabinet for building into a separate unit or shelf assembly.

For improved focus and to minimise deflection defocusing the e.h.t. is maintained at 20kV, a v.d.r. width stabiliser ensuring constant picture scan for a $\pm 10V$ variation in mains voltage.

Raster Linearity

Considerable attention was paid to reducing geometric scan distortion to a minimum and by careful design and employing close-tolerance components it has been found possible to maintain the sides, top and bottom of Test Card D parallel to within $\frac{1}{32}$ in. in contrast to the deviation in ordinary receivers of from $\frac{1}{2}$ to $\frac{3}{4}$ in. Also no square on Test Card D will vary in size by more than 15% from any other square.

As with width, the height is stabilised and will remain constant within a mains voltage variation of $\pm 10V$ while interlace will be no less than 45-55 over 50% of the entire vertical hold range.

Resolution

The minimum standard for picture definition on 405 is clear resolution of the 2.5MHz bars, and on 625 clear resolution of the 4.5MHz bars, with minimum ringing and overshoot and negligible streaking on both systems. This naturally entails an extremely high standard of alignment, and to ensure complete freedom from unwanted frequencies and adjacent channel interference a very efficient rejector system is used. The circuitry linking the integrated tuner to the separate vision and sound i.f. stages, which includes these multiple rejectors, is shown in Fig. 1. Overall a rejection of better than 40dB to i.f. image and adjacent channel signals is achieved.

On v.h.f. the unwanted frequencies are at 33.15MHz (adjacent channel sound) and 39.65MHz (adjacent channel vision), but on u.h.f. the adjacent channel sound is at 41.5MHz while the cosound i.f. signal at 33.5MHz must be sufficiently depressed to prevent the sound i.f. amplitude rising above the minimum vision i.f. amplitude to prevent vision buzz on the intercarrier sound system. It will be seen (Fig. 1) that apart from the v.h.f. sound i.f. take-off coil L4 there are two traps at this frequency, L5 a rejector in series with the signal feed to the vision i.f. amplifier and L6 an acceptor shunted across the circuit.

Gain

The transistor video output stage (see Fig. 2) will provide not less than 120V peak-to-peak drive to the c.r.t. with an input of 1V from the v.h.f./u.h.f. detector. This is obtained with a signal input at the aerial of $10\mu V$ on Bands I and III and $12\mu V$ on Bands IV and V. The Professional is thus a sensitive receiver with noise figures better than 5.5dB on Band I, 7.5dB on Band III and only 13.5dB on both u.h.f. bands. In areas where a very strong 405 signal is received, BBC or ITA, use of button 6 on the integrated tuner will switch in a local/distance control which can be used to attenuate the input signal to the required level.

Sound System

The sound circuits will give up to 3W with no more than 5% harmonic distortion from a complementary push-pull output stage. The entire sound stage being solid state, sound appears immediately

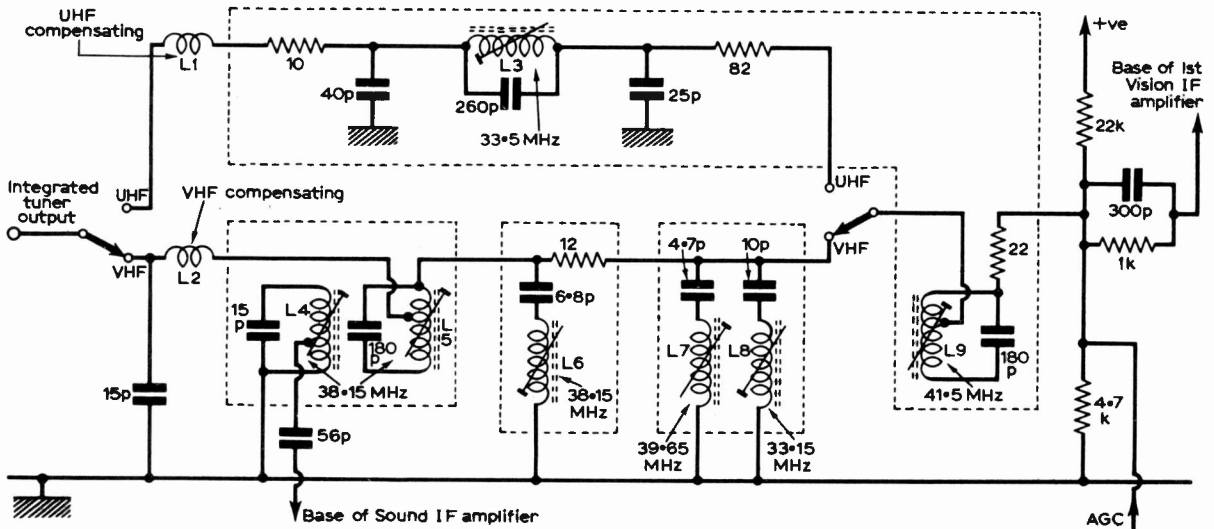

Fig. 1: Circuits linking the integrated tuner and the first i.f. stage. On u.h.f. L3 maintains correct cosound channel amplitude with L9 the adjacent sound channel rejector. On v.h.f. L4 is the sound take-off coil with L5 and L6 cosound rejectors, L7 adjacent vision channel rejection and L8 adjacent sound channel rejection.

the receiver is switched on and the provision of a separate mains switch enables the volume to be preset to any level.

Video Circuits

Unusually in a hybrid model the video circuit is fully transistorised, employing a phase-splitter as first stage (Fig. 2) from which the output on u.h.f. is tapped from the collector and on v.h.f. from the emitter. Use of a transistor in this fashion, which is not confined to Decca receivers, has the very great advantage that a single vision detector diode can be used with no system switching. Diode detectors, being non-linear devices, are extremely susceptible to producing unwanted beat signals: the simpler the associated circuitry and more effective the screening the less risk of background patterning from this cause. In addition the reduction in stray capacitance resulting from the elimination of system switching

from the detector is advantageous in maintaining h.f. response.

The detector gives a positive-going output so that the phase-splitter emitter output is also positive-going while the collector output is in the opposite phase. The 6MHz u.h.f. sound signal is tapped directly from the collector of the phase-splitter while a 6MHz rejector in the base lead to the video driver ensures that there is no breakthrough at this frequency to the output stage. The phase-splitter thus serves as a most convenient way of obtaining video drive of the correct polarity on both systems, while its base serves as a convenient take-off point for the signal input to the gated a.g.c. system.

The BC118 video driver matches the differing impedance of the phase-splitter output on both systems to the low input impedance of the BD119 common-emitter output stage. Direct coupling to the c.r.t. cathode is via a peaking coil and 1.2k Ω resistor, the peaking coil also providing protection of the

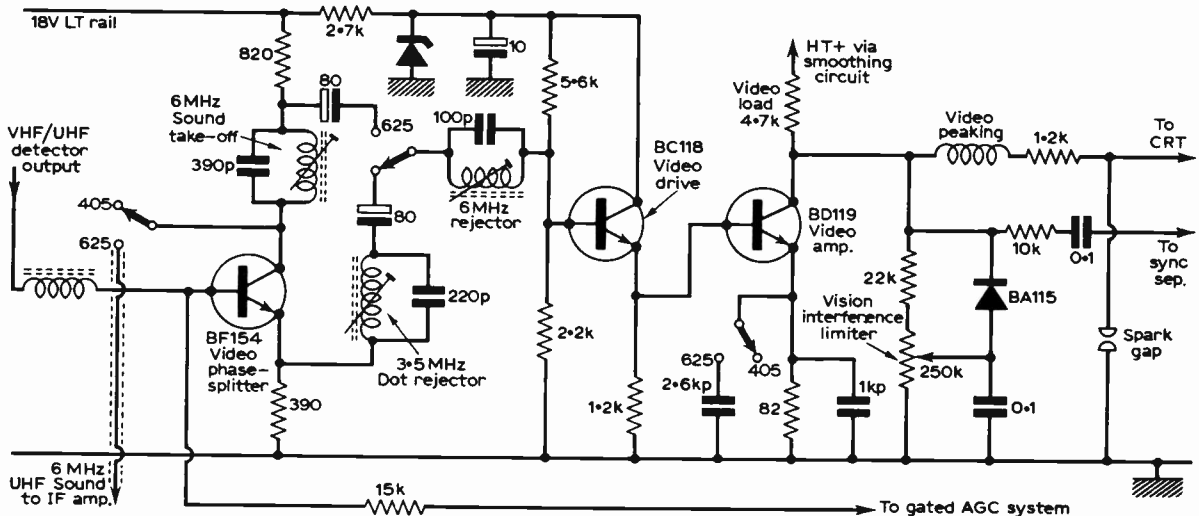

Fig. 2: Three-stage video amplifier with direct drive from output transistor to c.r.t. to eliminate caption streaking.

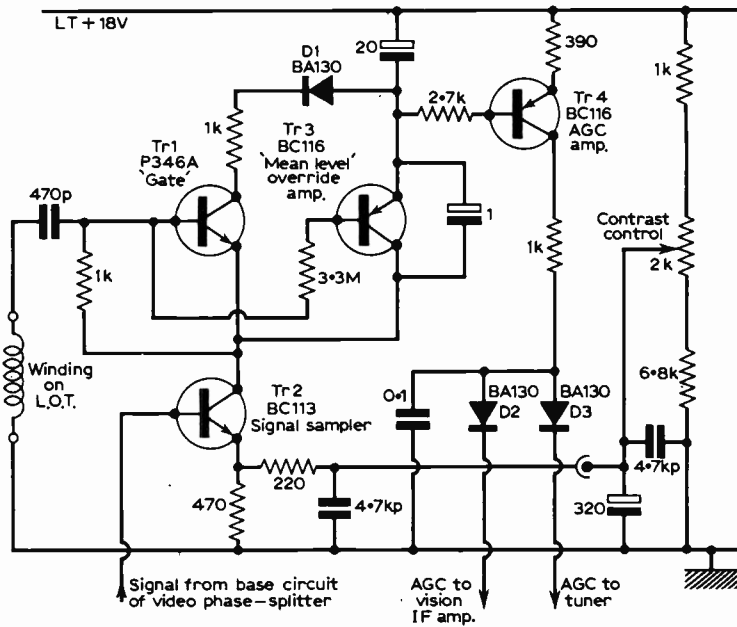

Fig. 3: The complete gated a.g.c. system used in the Professional 23. Tr1 is gated on by a positive pulse from a winding on the line output transformer during the back porch of the sync pulse period.

output transistor against possible flashovers in the tube. Additional emitter bypass capacitance is switched in on 625, while the BA115 diode is arranged as a conventional interference limiter. To enable the transistor output stage to fully drive the tube its collector is fed from an h.t. point resulting in a no-signal standing voltage of 140V.

AGC System

The a.g.c. system is a gated one, that is the level of a.g.c. applied to the vision i.f. and tuner r.f. amplifier stages is not dependent on the mean level of the signal but on the amplitude of the 5–8µsec back-porch period of the signal waveform which is a true measure of signal strength. Although such systems are much more complicated than conventional mean-level systems they have the great advantage that as the a.g.c. is independent of picture content the contrast ratio remains at transmitted levels and is not artificially increased or decreased during dominantly dark or bright scenes.

As shown in Fig. 2 the input to the transistor phase-splitter is also tapped off and fed to the a.g.c. system as the control drive, and this feed can be seen in Fig. 3 applied to the base of the first transistor in the a.g.c. system—the signal sampler. This transistor Tr2 is in series with Tr1 the gating transistor. The gating action of Tr1 is a result of it having virtually no base bias; it conducts only during the back-porch period when a positive line pulse is fed to it from a winding on the lone output transformer to switch it on. When this happens the signal sampled by Tr2 is applied via Tr1 and D1 to the a.g.c. amplifier Tr4. The signal at the base of Tr4 is thus dependent on signal amplitude during the back-porch period.

Tr4 provides a.g.c. to the vision i.f. and tuner stages and to start with is held non-conductive till a signal is received from the signal sampler when the resulting potential change at the gate transistor (Tr1) collector will cause Tr4 to conduct proportionally to signal strength, thus applying a positive a.g.c.

potential to the controlled stages via diodes D2 and D3. The 20µF capacitor connected from Tr4 base to the l.t. rail charges to the control potential and maintains Tr4 conduction at the correct level between successive pulse periods. Normally therefore Tr4 could be viewed as a comparatively low-value variable conductor between the positive l.t. and the a.g.c. rails whose conductivity is increased by increasing signal strength to place a higher proportion of the l.t. potential across the a.g.c. rail and chassis.

Under abnormal conditions when the line timebase is not operating during tuning or system change Tr3 the mean-level override amplifier conducts and applies mean-level a.g.c. to the controlled stages.

Contrast control is provided by a 2kΩ potentiometer which applies a variable positive voltage to the emitter of the signal sampler (Tr2). An increase in this applied potential reduces the effective or net value of the positive signal fed to the base of Tr2 from the video phase-splitter stage.

From all angles the Decca Professional 23 is a particularly fine instrument and justly deserves the maker's claim that it gives the highest quality of sound and picture ever achieved in a television receiver. ■

OMNIDIRECTIONAL DX AERIAL

—continued from page 458

stacked. In this case no 50Ω cable need be used and a matching and phasing harness may be constructed as in Fig. 3. Both arrays should be mounted horizontally and stacked with a spacing of 11ft. or as near to this spacing as one can allow, bearing in mind mast loading etc. The cable used for matching and phasing with this stacked array is the 75Ω low-loss cellular type.

Before erection it is worthwhile to check that the array is connected correctly. An ohmmeter check across the free socket should produce an open-circuit reading. If a low reading is obtained a screen connection has been crossed with an inner conductor somewhere in the assembly.

Readers overseas may also find this array of interest and a matching transformer could be incorporated at the output of the matching harness to allow 300Ω balanced ribbon feeder to be used instead of 75Ω coaxial. Belling and Lee manufacture such a balun transformer type L1635.

The accompanying photograph illustrates this aerial in use at the author's location and the author wishes to express his thanks to Mr. V. R. Hartopp, Director, J-Beam Aerials Ltd., Rothersthorpe Crescent, Northampton for his kind help and assistance with this project. ■

WAVEFORMS IN COLOUR RECEIVERS

—continued from page 441

and magenta because green plus *blue* equals cyan and red plus *blue* equals magenta.

Yellow, cyan and magenta are called complementary colours because when a primary colour is subtracted from white the resulting colour must be yellow, cyan or magenta. For example yellow is the complement of blue since yellow is obtained by subtracting blue from white light (resulting in red plus green equals yellow). Similarly, cyan is the complement of red and magenta the complement of green.

Luminance Signal

Referring back to Fig. 5 it will be seen that the primary-colour signals are all of the same amplitude, signified as unity in the drawing. After leaving the camera outputs however the three primary-colour signals are modified in amplitude and then added to give the Y or luminance signal. The Y signal, which is the same as the video signal in monochrome television and is required to give compatible transmission, is produced by the addition of 30% of the red primary signal, 59% of the green primary signal and 11% of the blue primary signal, these proportions corresponding to the non-linear sensitivity of the human eye to light of different frequencies, i.e. different colours. The signals are accurately added in the Y matrix and the Y output is adjusted to give the required amplitude on the white step, again shown as unity (1) in Fig. 5.

It is noteworthy that the "stepped" nature of the Y colour-bar pattern signal stems directly from the addition of the level-adjusted red, green and blue primary-colour signals as shown. Since the amplitude of each one of these signals has been reduced from the camera-output unity value in the ratios of 0.3R, 0.59G and 0.11B it follows that the white step of the Y signal on the colour-bar pattern will have an amplitude of unity (i.e. $0.3 + 0.59 + 0.11 = 1$). The other steps down from white will have Y amplitudes of 0.89 yellow, 0.7 cyan, 0.59 green, 0.41 magenta, 0.3 red, 0.11 blue and, of course, zero black.

Colour-difference Signals

For transmission we use the Y and two colour-difference signals instead of the three primary-colour signals direct. The colour-difference signals are obtained by subtracting the Y signal separately from the red and blue primary-colour signals, giving R-Y and B-Y. The third colour-difference signal, G-Y, is not transmitted but is reconstituted at the set by matrixing the red and blue colour-difference signals, as we shall see later.

A colour-difference matrix is used at the transmitting end for deriving the colour-difference signals as Fig. 5 shows. The lower waveforms in column with the colour bars on the left of Fig. 5 (below the primary-colour signals) show the form of the colour-difference signals on the colour-bar pattern. As can be seen the B-Y signal is derived from the blue primary-colour rectangular waves (positive-going) and the stepped Y waveform (negative-going). These two components are drawn in

faint lines while the actual resulting B-Y signal waveform is drawn in heavy line. The same scheme has been adopted to illustrate the formation of the R-Y signal.

U and V Signals

Now sadly very few texts make clear the distinction between the colour-difference signals themselves and the U and V signals actually transmitted. The U signal is a weighted version of the B-Y signal while the V signal is a weighted version of the R-Y signal. We can remember which way round they are because *blue* rhymes with *U*! Weighting in this connection means that the colour-difference signals are reduced in amplitude to avoid over-modulating the transmitter when the composite (colour-encoded) signals are applied to the u.h.f. carrier wave (more will be said about this next month). The U signal is equal to $(B-Y)/2.03$ and the V signal to $(R-Y)/1.14$.

TO BE CONTINUED

FIELD LINEARITY FAULTS

—continued from page 467

leakage occurs after the receiver has been in use for some while and is thus thoroughly warmed up, at which stage the field scan reduces in amplitude. Replacement of the field output transformer is the only cure, but it is essential that an exact replacement component is obtained if at all possible; replacing a field output transformer with one of another type would probably introduce a whole range of amplitude and frequency distortion which no amount of juggling with controls or circuit values will remedy.

MODIFYING OUTPUT STAGES

The more experienced constructors working on the older (one might almost say vintage) models which so frequently occupy their time and ingenuity may like to consider replacing the original field output valve with one of a more modern type. Frequently the original design drove the field output valve to the limits of its power handling capabilities to secure a full scan so that substituting a valve of greater efficiency will enable greater scanning power to be obtained from the same drive and h.t. voltage. For example the writer has on several occasions successfully used an EL84 valve as a field output stage. This of course involved removing the heater chain connections to the field output valve holder and supplying the EL84 heater from a separate 6.3V heater transformer mounted inside the TV receiver cabinet.

Where the field output valve is part of a dual valve with a common cathode such as the ECL80 in Fig. 3 this substitution is more difficult as the triode section here forms part of the multivibrator field oscillator circuit. Where the substitution is practicable however and suitable component values for bias resistor and negative feedback circuitry are used it will be found possible to obtain much improved field scan linearity at quite a low setting of the height control, thus leaving plenty of gain in hand for future ageing of the valve. A modification of this nature should not be attempted lightly since many patient hours of experiment with resistor and capacitor values may be needed before a satisfactory scan is obtained. ■

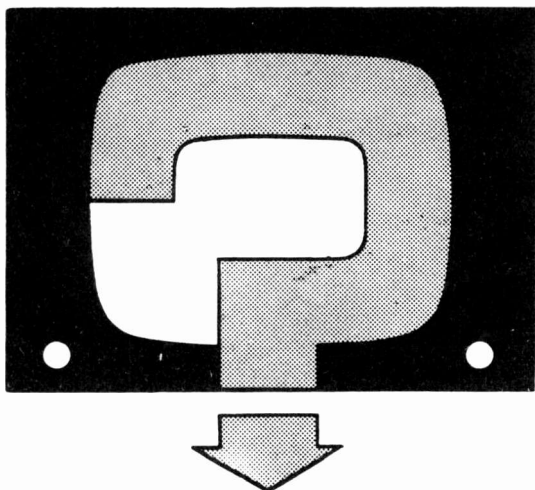

YOUR PROBLEMS SOLVED

Whilst we are always pleased to assist readers with their technical difficulties, we regret that we are unable to supply service data or provide instructions for modifying equipment. We cannot supply alternative details for constructional articles which appear in these pages. WE CANNOT UNDERTAKE TO ANSWER QUERIES OVER THE TELEPHONE. The coupon from page 476 must be attached to all queries, and a stamped and addressed envelope must be enclosed.

FERGUSON 3618

The trouble started with a line across the screen about $\frac{1}{2}$ in. deep. After trying the valves for good connection in their sockets the picture opened out but was very dark and about three inches smaller all round. If the brightness and contrast controls are adjusted the picture becomes larger then fades.

I have tried the set with different valves but the fault persists. The sound meanwhile is perfect on all channels.—R. Widdowson (Essex).

Check the h.t. voltage. This should be not less than 200V at the normal h.t. line. If the h.t. is in order check the PL36 (30P19) the PY81 and associated supplies.

KB NEW QUEEN

The BBC and ITV vision are both good but there is no sound on either channel.—C. Stewart (Surrey).

Check the sound i.f. amplifier. Also check the 0.001 μ F decoupling capacitor.

MASTERADIO 4003DST

On switching to BBC-2 the picture is very poor, fuzzy and lacking in contrast. After some minutes it suddenly rights itself to a very good picture. Twice I have replaced the two valves in the 625 tuner which gave a good improvement for a short while.—R. Rimmer (Lancashire).

Check the system switch operation and clean the contacts if necessary. Check the u.h.f. aerial socket and connections to and from the u.h.f. tuner unit. You will then have to make up your mind whether to strip the tuner down to locate the fault or purchase an exchange tuner.

PYE CT70 COLOUR RECEIVER

It is felt that an aerial preamplifier would help when using this receiver as there is noise on the picture. Also there are on the left side of the screen light vertical bars. These are very heavy on the extreme left and become much lighter towards the centre of the screen, finally disappearing completely. Could you suggest whether a set-end preamp would suffice instead of an aerial-end one and the means of eliminating the vertical bars?—D. Wakeham (Sussex).

Since you are on the edge of the service area a masthead preamplifier should prove more beneficial. It is important to measure field strengths on u.h.f.

and a suitable meter should be standard equipment at your dealer's. The CT70 when working correctly will give noise-free pictures at 1mV, begin to show snow at about 500 μ V and lose colour altogether around 100 μ V.

The striations on the left side of the picture suggest a line timebase fault (try the linearity choke).

PHILIPS 502 COLOUR RECEIVER

There is a very good colour picture and sound but there is a grey mist about 2 in. wide across the screen which sometimes moves up and sometimes moves down the screen and occasionally stays still. This fault only appears on 625 black-and-white and colour.—P. Read (Essex).

The asynchronous nature of the fault you describe suggests mains hum in the luminance stages. The luminance amplifier should be checked for heater-cathode leakage. Also check the main and secondary smoothing capacitors for insufficient capacitance.

REGENTONE 191

This receiver is working well except for expansion and contraction which spoils viewing. This variation is most noticeable when the set is first switched on and gradually reduces in severity as time goes on, but it does not stop altogether. The line is perfectly steady.—E. Groom (Essex).

We would advise you to replace the main smoothing capacitor.

ULTRA 6700 (BRC 2000 SERIES COLOUR CHASSIS)

This set has a buzz on sound on BBC-2 which varies with picture content. The buzz is also made louder as the contrast is increased. This is probably vision-on-sound. Can you tell me if there is a vision trap that I can try to adjust?—C. White (Hertfordshire).

The only adjustments which you could alter to improve your 625 sound are the 6MHz strip L30, L32 and L33 on the i.f. board at the bottom left viewed from the rear. Make sure that the 4 μ F ratio detector capacitor C84 is efficient.

Care should be taken as most adjustments are interdependent and high pulse voltages are distributed around the chassis at points other than the 25kV e.h.t. section.

BUSH TV24

Originally this set worked all right but the picture took a long time to appear. The set was then stored for a period of six months. When tried after this time the raster refused to appear at all. I renewed the EY51 e.h.t. valve but this made no difference. The sound is quite good but not as loud as it was before the six-month storage period.

I held a screwdriver close to the e.h.t. anode on the tube until it nearly touched and there was hardly any spark at all.—E. Rambow (Middlesbrough).

The e.h.t. is quite low (about 8-9kV) and will not give the more vigorous spark of more up-to-date receivers. A more reliable indication is given by observing whether the EY51 lights up (clean envelope). In any case the tube appears to be of very low emission.

PHILCO 1030

The picture is compressed at the bottom and there is bad foldover. I have renewed the PCL85 and several resistors and capacitors. Both the field blocking transformer and line output transformer seem to be in order.—A. Hopkins (Dorset).

The field distortion could be caused by an electrical leak in the capacitor on the control grid of the field output valve. However if most of the smaller components are in good order check the heater current in the set, for low current (as small a reduction as 50mA) can give the effect mentioned without any other apparent shortcomings. Low current can stem from (a) incorrect mains tapping or (b) a faulty thermistor. Check the field output valve cathode decoupling electrolytic.

GEC 4003DST

After running for a while this set develops a loud hissing noise and the picture reduces to half height with much interference. On switching off for a minute then switching on again the set behaves perfectly for 15 minutes or longer then there is a repeat of the original fault.—J. Thompson (Northumberland).

You should try to locate the source of the hissing noise. This may be from the upper-left e.h.t. section or possibly from the deflection coils on the tube neck. If the noise is from the tube neck area, try withdrawing the closed loop sleeve from the deflection coils as there may be a discharge from the coils to the sleeve at one particular point.

BUSH TV83

Could you please give details of how to boost the tube in this set. Also details of how to fit a new tube.—D. Cunlon (Newcastle upon Tyne).

The tube cannot be successfully boosted by the application of extra heater current except for a very brief period. To do this wire a 5k Ω 10W resistor from the fuse holder to the active heater pin of the c.r.t. base.

To replace the tube, remove the chassis complete with tube. Remove the ion trap magnet, beam shift magnet and base connector. Remove the e.h.t. connection and release the front clamping band. Release the deflection coils clamp and carefully withdraw the tube.

DECCA DM55

Occasionally the picture collapses to a narrow band in the centre of the tube about $\frac{1}{2}$ in. wide. Soon after it expands again to a full picture. It does this approximately 8 to 10 times then the picture remains normal for about an hour. I have renewed the PL84 which had a short in it but when the above symptoms occur a blue flame can be seen running up inside this valve.—R. Hardyman (Hampshire).

You should check the h.t. to the anode of the PL84 when the fault is occurring. If the voltage falls suspect a faulty field output transformer. If however it rises check the field deflection coils.

BUSH TV24C

Upon warming up, when the brightness control on the front panel is turned up from the no-picture position a normal picture appears. A very slight touch of the brightness control and the screen goes almost white and a hazy picture appears in the background. The control gives an almost switch-like action.—H. Chamberlain (Nottinghamshire).

You should replace the brilliance control in order to obtain a smooth action. If the brilliance is not at fault check the associated components and the tube for shorts.

HMV 1890

There is a picture but it is rather weak and the contrast control has no effect at all. The distant/local control has no effect either. The horizontal synchronisation is unstable but I assume this may be the effect of a weak video signal. The contrast potentiometer appears to be in good working order and the output from it is approximately 180V to zero. There is 1V or so on the cathode of V3 and the anode and screen voltages appear reasonable.—E. Tarry (Nottingham).

If the weak picture is ragged and grainy check the tuner unit valves. If it is smooth but weak check the OA70 diode detector, the PCL84 video amplifier and associated resistors, also the cathode circuit 50 μ F capacitor.

TUBE REPLACEMENTS

Could you state whether a C17AF Brimar tube could be used as a direct replacement for a Mullard AW43-88 without any modification for heater voltage etc. Also could one of the twin-panel tubes be used as a replacement for the Mullard AW43-88 in a 17in. Decca DM45C?—J. Wallbank (Cheshire).

The C17AF may be used in place of an AW43-88 with no modifications.

A twin-panel tube is supplied with mounting lugs at the corners. These would not coincide with the fixings on the DM45C due to the necessity for a larger aperture and the different shape of the 19in. tube.

SOBELL T191

The picture is 2in. short at the bottom of the raster. I have replaced the ECC82 and the PCL82.—A. Glass (Newcastle upon Tyne).

We advise you to replace the 250 μ F electrolytic capacitor (25V working) which decouples pin 2 of the PCL82. Check the bias resistor (330 Ω).

GEC BT336

The picture seems to be all on the left-hand side of the screen. There is a thick black line down the right-hand side and the width controls are at maximum. I have tried substituting valves to no avail.—D. Cowley (Liverpool).

Immediately behind the deflection coils is a clamp holding an offset round magnet. Rotate the clamp to the side and then rotate the magnet to move the picture in the required direction.

Check the h.t. voltage and replace the rectifier if it is found to be necessary.

INVICTA 7007

When switched on from cold sparking takes place at the base of the EY86 but after about ten minutes this stops gradually and for the remainder of the evening's viewing no more is heard. To obtain this condition the brilliance has to be turned up more than is necessary and if the contrast control is moved to balance the highlights sparking occurs again at intervals of a few seconds.

The EY86 has been replaced and the line output transformer and tube base covered with the recommended grease, but this annoying crackling still takes place.—A. Mason (Staffordshire).

We presume that the EY86 base and cover are new. We also presume that the connections at the base of the EY86 have not been resoldered leaving protruding ends and edges. It is also necessary to rule out the possibility of a somewhat humid atmosphere since this tends to promote arcing until the heat of the receiver dries it out thoroughly.

If you are satisfied on these counts check width and voltages, line drive to the PL36, boost line voltage (which should be 650V) and the capacitor C111 (68pF).

FERGUSON 406T

There is at least a 1in. margin at each side of the picture and two flyback lines can be seen at the top of the screen. A reasonably bright vertical strip on the left-hand side of the picture is followed by alternate dark and light strips each approximately 1in. wide for the remainder of the picture.

Also the size and shape of the picture alter slightly when either the brightness or the contrast controls are used.—S. Barnard (Middlesex).

You should replace the 1.5k Ω resistor across the width coil. Check the PL36 and PY32 (PY33) valves. Adjust the top linearity preset control.

BUSH TV66

Would it be possible to replace the two rectifier valves (PY82) with a BY100 silicon rectifier?—D. Goodwin (Shropshire).

We would advise you to adhere to the PY82 valves as the rectifiers in this set. The use of BY100 or similar silicon diodes will possibly result in excessive surge voltages which in an older-type receiver such as this can cause premature breakdown in many components.

QUERIES COUPON

This coupon is available until July 18, 1969, and must accompany all Queries sent in accordance with the notice on page 474.

PRACTICAL TELEVISION, JULY 1969

TEST CASE



80

Each month we provide an interesting case of television servicing to exercise your ingenuity. These are not trick questions but are based on actual practical faults.

? A Ferguson set converted to work on the Rediffusion system (by using a so-called "inverter") gave fair performance to start with but after several months a significant flare had developed on the picture (with black-after-white and vice versa), and this was often accompanied by bad patterns and impaired definition.

On the Rediffusion system the inverter frequency-changes the incoming h.f. vision signals to v.h.f. ones acceptable to the ordinary type of off-air set, and directs the audio sound signals supplied by the Rediffusion system to the loudspeaker in the set, leaving the set's audio section redundant and its output loaded across a 5 Ω resistor. Thus any possible faults

in the set's sound channel cannot be detected.

It was decided therefore to check the set on a friend's normal aerial system, and after retuning the front end to match this sort of input again the symptom was severe patterning and no sound at all! What was the most likely cause of the trouble? See next month's PRACTICAL TELEVISION for the answer.

SOLUTION TO TEST CASE 79

Page 380 (last month)

Of recent years it has been the practice of some setmakers to include a voltage-dependent resistor (v.d.r.) in series with the brightness control for various reasons, including regulation and switch-off spot suppression. Such a v.d.r. is used in the Cossor set mentioned last month and has the habit of going high-resistance. This tends to make it impossible to reduce the positive potential to the tube grid sufficiently to bias it off completely, and this is just what was happening. Replacing the component cleared the trouble.

The experimenter should of course have made tests not only at the tube cathode but also at the grid, ensuring that the biasing circuit, which includes the brightness control, pulls the bias well negative (grid to cathode) with the brightness control fully retarded.

Practical Television Classified Advertisements

The pre-paid rate for classified advertisements is 4/- per line (minimum order 12/-), box number 1/- extra. Semi-display setting £2 10s. 0d. per single column inch. All cheques, postal orders, etc., to be made payable to PRACTICAL TELEVISION and crossed "Lloyds Bank Ltd." Treasury notes should always be sent *registered post*. Advertisements, together with remittance, should be sent to the Classified Advertisement Manager, PRACTICAL TELEVISION IPC Magazines Ltd., Fleetway House, Farringdon Street, London, EC4, for insertion in the next available issue.

TECHNICAL TRAINING

CITY & GUILDS (electrical, etc.) on "Satisfaction or Refund of Fee" terms. Thousands of passes. For details of modern courses in all branches of electrical engineering, electronics, radio, TV, automation, etc., send for 132-page handbook—FREE. B.I.E.T. (Dept. 173K), Aldermaston Court, Aldermaston, Berks.

EDUCATIONAL

CORRESPONDENCE & PRACTICAL COLOUR TELEVISION COURSES by Electronic & Colour Television Training Limited. Recommended by leading manufacturers and approved by Training Board. For full details write or phone 45, Walton Road, East Molesey, Surrey. 01-979 5553.

BECOME "Technically Qualified" in your spare time, guaranteed diploma and exam. Home-study courses in radio, TV servicing and maintenance. T.T.E.B. City and Guilds, etc., highly informative 120-page Guide—FREE. CHAMBERS COLLEGE (Dept. 858K), 148 Holborn, London, E.C.1

TV and RADIO, A.M.I.E.R.E., City & Guilds, R.T.E.B., Certs., etc. on "Satisfaction or Refund of Fee" terms. Thousands of passes. For full details of exams and home training courses (including practical equipment) in all branches of Radio, TV, Electronics, etc., write for 132-page Handbook—FREE. Please state subject. BRITISH INSTITUTE OF ENGINEERING TECHNOLOGY (Dept. 172K), Aldermaston Court, Aldermaston, Berks.

TRAIN FOR SUCCESS WITH ICS

Study at home for a progressive post in Radio, TV and Electronics. Expert tuition for City & Guilds (Telecoms Techn's Cert. and Radio Amateurs') R.T.E.B., etc. Many non-exam courses incl. Closed circuit TV, Numerical control & Computers. Also self-build kit courses—valve and transistor.

Write for FREE prospectus and find out how ICS can help you in your career.

ICS, INTERTEXT HOUSE,
STEWARTS ROAD, LONDON, SW8.

SITUATIONS VACANT

RADIO AND TV Exams and Courses by Britain's finest home study School, Coaching for Brit.I.R.E., City and Guilds Amateur's Licence, R.T.E.B., P.M.G. Certificate etc. Free brochure from British National Radio School, Russell Street, Reading.

SITUATIONS VACANT

(continued)

ENGINEERS. A TECHNICAL CERTIFICATE or qualification will bring you security and much better pay. Elem. and adv. private postal courses for C. Eng., A.M.I.E.R.E., A.M.S.E. (Mech. & Elec.), City & Guilds, A.M.I.M.I., A.I.O.B., and G.C.E. Exams. Diploma courses in all branches of Engineering—Mech., Elec., Auto, Electronics, Radio, Computers, Draughts, Buildings, etc. For full details write for FREE 132 page guide: BRITISH INSTITUTE OF ENGINEERING TECHNOLOGY, (Dept. 171K), Aldermaston Court, Aldermaston, Berks.

SERVICE SHEETS

SERVICE SHEETS. Radio, T.V., 5,000 models. List 1/6 S.A.E. enquiries. TEL-RAY, 11 Maudland Bank, Preston.

BY 100s, 3/9 each; 3 for 10/-, with Free Surge Resistors, Lesmar, 15 Conholt Road, Andover, Hants.

SERVICE SHEETS (1925-1969) for Televisions, Radios, Transistors, Tape Recorders, Record Players, etc., by return post, with Free Fault-Finding Guide. Prices from 1/-. Over 8,000 models available. Please send S.A.E. with all orders/enquiries. Hamilton Radio, 54 London Road, Bexhill, Sussex.

LARGE SUPPLIER OF SERVICE SHEETS

(T.V., RADIO, TAPE RECORDERS, RECORD PLAYERS, TRANSISTORS, STEREOGRAMS, RADIOGRAMS)

FREE. Fault Tracing Guide or TV list on request.

Only 5/- each, plus large S.A.E. (Uncrossed P.O.s please, returned if service sheets not available.)

C. CARANNA
71 BEAUFORT PARK
LONDON, N.W.11

We have the largest supplies of Service Sheets (strictly by return of post). Please state make and model number/alternative.

Mail order only.

SERVICE SHEETS with Free Fault Finding Chart, 4/6d. S.A.E. Lesmar, 15 Conholt Rd., Andover, Hants. (Mail only.)

SERVICE SHEETS

(continued)

RADIO, TELEVISION over 3,000 models. JOHN GILBERT TELEVISION, 1b Shepherds Bush Road, London W.6. SHE 8441.

MISCELLANEOUS

UFO DETECTOR CIRCUITS, data, 10s. (refundable). Paraphysical Laboratory (UFO Observatory), Downton, Wilts.

FOR SALE

VALVE CARTONS at keen prices. Send 1/- for sample and list. J. & A. BOX-MAKERS, 75a Godwin Street, Bradford 1.

FOR SALE

MICRO-WAVE TELEVISION TRANSMITTER & RECEIVER.
Pye 7003. Complete.
Fully maintained. Reasonable price.
Enquiries to The Principal,
Didsbury College of Education,
Wilmslow Road, Manchester,
M20 8RR.

TOP TRADE DISCOUNTS FOR

All

COMPONENTS

VALVES

TUBES

TRANSISTORS

L.O.P.T's

Free Trade Catalogue
Engineers & Service Dealers Only

**WILLOW VALE,
THE SERVICE DEPT.
WHOLESALE,**

4 The Broadway, Hanwell,
London, W.7

01-567 5400/2971

WANTED

DAMAGED AVO Meters, Models 7 and 8. Also damaged Meggers, any quantity, send for packing instructions. HUGGETTS Ltd. 2/4 Pawsons Road, West Croydon.

SERVICE SHEETS purchased, HAMILTON RADIO, 54 London Road, Bexhill.

NEW VALVES WANTED. Popular TV and Radio types. Best cash price by return. DURHAM SUPPLIES, 367A Kensington Street, Bradford 8, Yorkshire.

WANTED*(continued)*

WANTED. L.O.P.T. for Murphy TV, model V250A. L. H. Whitmore, 35 Croft Drive, Moreton, Wirral, Cheshire.

NEW popular valves wanted, loose or boxed. Cash by return. Weatherby's 18 Dutton Road, Blackpool, Lancs.

ULTRA TV slimline 21/70 (1959) I.F. printed panel and tuner or complete set. 9 Manhood Lane, Sidlesham, Chichester, Sussex.

WANTED—Popular Brand New Valves—R.H.S., Stamford House, 538 Great Horton Road, Bradford 7.

WANTED new valves, television, radiograms, transistors, etc. STAN WILLETTS 37 High Street, West Bromwich, Staffs. Tel: WES 0186.

AERIALS**TV AERIALS**

Band I, H. Mast Fitting	£2 0 0
Band III, 5 Ele Mast Fitting ..	£1 12 0
Band I/III, 5/D and 4-Array ..	£1 17 6
Band IV, 10 Ele Array	£1 12 6
Band IV, 18 Ele Array	£2 18 6

Lashing Kits from 10/-; Poles, Co-ax 10d., Grade "A" 1/6. Plugs 9d.

C.W.O., S.A.E. for list.

P. & P. 7/6.

TELEINDUSTRIES LTD.

BREAKSPEAR ROAD, RUISLIP, Middx.

BAKER & BAINES

for Television and F.M. Aerials

Examples of prices: F.M. dipole 21/-, H 38/-, BBC dipole 30/-, X 38/-, H 42/-, 3 ele 89/-, ITA 3 ele 26/-, 5 ele 34/-, 8 ele 47/6, 11 ele 57/6, combined BBC/ITA 1 + 5 45/-, H + 5 69/-, X + 5 75/-, BBC 8 ele 29/-, 14 ele 37/-, 18 ele 54/-, 22 ele 63/-.

All types generally available including accessories—prices include mounting clamps and postage.

11 DALE CRESCENT,
NEW TUPTON, CHESTERFIELD.

SETS & COMPONENTS**SETS & COMPONENTS***(continued)***R & R RADIO**

51 Burnley Road, Rawtenstall

Rossendale, Lancs

Tel.: Rossendale 3152

VALVES BOXED, TESTED & GUARANTEED

EBC41 4/6	PCC84 3/-	PY82 3/-
EBF80 3/-	PCF80 3/-	U191 4/6
EBF89 3/6	PCF82 3/6	6F23 5/-
ECC82 3/-	PCL82 4/-	30F5 2/6
ECC83 4/-	PCL83 4/-	30L15 5/-
ECL80 3/-	PCL84 5/-	30P12 4/6
EF80 1/6	PL36 5/-	30C15 5/-
EF85 3/-	PL81 4/-	50CD6 7/6
EF183 3/6	PL82 4/6	
EY86 4/-	PL83 4/-	
EL41 5/-	PY33 5/-	
EZ40 4/6	PY81 3/6	
	PY800 3/6	

POST ONE VALVE 9d. TWO TO SIX 6d.
OVER SIX POST PAID.

BARGAIN PARCELS

ANY 1—2/-, 5—9/-, 10—14/- 100—110/-

FROM THE LIST BELOW

EBF80, EBF89, EB91, ECC82, ECC83, EF80, EF85, EF183, EF184, EY86, ECL80, PCC84, PCF80, PCF82, PCL82, PCL83, PCL84, PL36, PL81, PL82, PL83, PY32, PY33, PY81, PY82, PY800, U26, U191, 6F23, 6-30L2, 30F5, 30L15, 30FL1, 30P12, 30P4.

MANY OTHER TYPES IN STOCK

P. & P. 1/-

BY100 TYPE RECTIFIERS WITH SURGE
RESISTORS ON TAG STRIPS 2/6 ea.

VELCO ELECTRONICS

62 Bridge St., Ramsbottom, via Bury,
Lancs.

150 NEW ASSORTED Capacitors, Resistors, Silvered Mica, Ceramic, etc. Carbon, Hystab, Vitreous 1/2-20 watt, 12/6. Post Free. WHITSAM ELECTRICAL, 33 Drayton Green Road, West Ealing, London, W.13.

SETS & COMPONENTS*(continued)***TELEVISION TUBE SHOP**

ALL THE LATEST NEW TUBES
AT REDUCED PRICES

A28-14W	£11. 0.0
A47-11W	£9.19.6
A47-13W	£11.15.0
A47-14W	£7.12.6
A59-11W	£12.19.6
A59-13W	£14.15.0
A59-15W	£9.10.0
A59-16W	£14.15.0
AW21-II	£10.10.0
AW36-20, 21	£5.12.6
AW36-80	£5. 7.6
AW43-80	£6. 7.6
AW43-88, 43-89	£6.12.6
AW47-90, 91	£7.10.0
AW53-80	£8.17.6
AW53-88, 53-89	£8. 5.0
AW59-90, 59-91	£8.15.0
C17BM, FM, HM	£6. 7.6
C17LM, PM, SM	£6.12.6
C21HM, SM, TM	£8.17.6
CME1201	£12.10.0
CME1101	£11.19.6
CME1601	£10. 5.0
CME1702, 1703	£6.12.6
CME1705	£7. 7.0
CME1901, 1903	£7.10.0
CME2101, 2104	£8. 5.0
CME2301, 2302	£8.15.0
CME2306	£14.15.0
CRM93	£5.10.0
CRM124	£5.10.0
CRM141, 2, 3, 4	£5. 2.6
CRM171, 2, 3	£6. 7.6
CRM211, 212	£8.17.6
MW36-24, 44	£5. 2.6
MW43-64, 69	£6. 7.6
MW43-80	£6. 7.6
MW53-20	£8.17.6
MW53-80	£8.17.6
7405A	£6.12.6
TSD217, 282	£11.10.0

All tubes tested before despatch and guaranteed for 12 months.

Re-processed tubes also available at reduced prices.

CARRIAGE 10/- via B.R.S. or 15/- via passenger train. Add 2/6 for Comprehensive insurance.

Midland Stockists:—

Amateur Electronics,
518/520 Alum Rock Road,
Birmingham 8

TELEVISION TUBE SHOP

48 BATTERSEA BRIDGE ROAD
LONDON, S.W.11. BAT 6859

WE GIVE GREEN SHIELD
STAMPS

LOOK! Nearly every type in stock now !!**NEW TELEVISION TUBES!**

TWO YEAR FULL REPLACEMENT GUARANTEE

SEE THE DIFFERENCE A NEW TUBE CAN MAKE TO YOUR VIEWING—
LATEST SCREENING TECHNIQUES INCLUDING TINTED SCREENS ON
19" & 23" TYPES

Large stocks by Cathodeon & other leading manufacturers so why buy ordinary rebuilds? Some Colour tubes available!

12" £2 10 0 (not 110°) 14" to 16" (not 110°) £4 15 0
17" £5 15 6 19" 1901 & 19AH £7 10 0

Other 19" mono tubes—all £6 17 6. Carriage all 12/- . All 21" mono tubes—£7 15 0, 23" mono tubes £9 10 0. Carriage 15/-.

RIMBALDS, 19" £8 10 0; 23" £11 10 0 Carriage
TWIN PANELS, 19" £9 17 6; 23" £12 10 0 20/-

Bulk enquiries welcomed, special terms.

PHILIP H. BEARMAN

(Suppliers to H.M. Govt. etc.)

6 POTTERS ROAD, NEW BARNET, HERTS.

Closed Thurs & Sat afternoons TEL. 449/1934 & 7873 (Robophone)

SETS & COMPONENTS (continued)

TELEVISION TUBES

Large stocks of television tubes, London's leading wholesale suppliers, all tubes complete with guarantee card. By return despatch. Terms: Cash with order, s.a.e. all enquiries.

14in. types. AW36/20, AW36/21, AW36/80, MW36/24, CRM141, CRM144, CME1402 etc.	£4 17 6
17in. types. MW43/80, AW43/80, CRM173, CME1702, MW43/69, CRM172, AW43/88, AW43/89, CME1703, CME1705 etc.	£4 17 6
19in. types. AW47/90, AW47/91, CME1901, CME1903, CME1902, C19AH	£4 19 6
21in. types. AW53/88, AW53/89, CME2101, CME2303	£6 12 0
MW53/80, AW53/80, MW53/20, CRM211/2	£8 18 10
23in. types. AW59/90, AW59/91, CME2301, CME2303	£6 12 0
23in. Twin Panel. CME2306, A59-16W	£13 1 0
23in. Panorama. A59/11W etc.	£12 0 0
19in. Twin Panel. A47-13W, CME1906 etc.	£10 1 0
19in. Panorama. A47/11W etc.	£9 0 0

We stock all types of tubes. Carriage and Packing 12/6d. per British Road Services. Large stocks of valves, transistors, components, L.O.P.T.'s. Electrolube, Servisol switch cleaner, Multicore solder. Service Tools.

WILLOW VALE ELECTRONICS LTD.

The Service Dept. Wholesalers, 4, The Broadway, Hanwell, London, W.7. Tel: 01-567 2971/5400
FREE CATALOGUE—TRADE ONLY. S.A.E. Please.

NEW BVA VALVES! Huge range by return postal service well known to the trade. Brief list of television types herewith, full list s.a.e.

DY86/7	8/-	PCF80	10/3	PL504	17/-	6BW7	13/9	30PL13	18/6
EB91	5/-	PCF86	12/3	PY81	8/3	6CD6G	28/-	30PL14	18/6
ECC82	8/6	PCF801/2	12/3	PY82	7/-	6F23	15/6	etc., etc.	
ECL80	8/-	PCF805	13/-	PY800/1	8/3	20L1	19/6	SPECIAL BARGAINS	
EF80	8/-	PCF808	13/6	R19	13/-	20P4	20/-	(mostly imported)	
EF85	8/3	PCL82	10/3	U25	15/-	30C15	13/9	ECC82	5/-
EF183/4	11/3	PCL83	12/3	U26	15/-	30C17	15/9	EF80	5/-
EH90	10/3	PCL84	10/3	U37	15/-	30F5	16/6	EY86	7/-
EY51	7/6	PCL85	10/6	U191	14/6	30FL1	12/9	PCC84	6/6
EY86/7	7/9	PCL86	10/3	U193	8/3	30L15	15/3	PCC89	9/6
PC86/8	10/3	PL36/8	12/9	U251	17/3	30L17	14/6	PCF80	6/6
PC97	8/3	PL81	10/3	U301	17/-	30P12	15/6	PCL82	6/9
PC900	10/3	PL83	10/3	U801	24/-	30PL1	12/9	PY81	5/9
PCC84	9/3	PL84	8/3	6/30L2	15/6	30P4MR	20/-	PY800	6/6
PCC89	12/3	PL500	16/6	6AT6	9/9	30P19	12/9	PY801	6/6

POST FREE OVER £3—LATEST ENCAPSULATED BY 100 & 33 ohm res, 4/-!

SEE SEPARATE
TUBE LIST etc.

PHILIP H. BEARMAN

CALLERS
WELCOME

Tel. 449/1934 & 7873
(Robophone)

(Suppliers to HM Govt. etc.)

Closed Thursday &
Saturday afternoons

6 Potters Road, New Barnet, Herts.

BY 100 TYPE 6 for 10/-
RECTIFIERS
SUPER SILICON

TV etc., 1200 PIV, 800 MA 5/- or complete with instructions, resistor, condenser 6/6, 400 PIV. HW 6 amp 6/-, 200 PIV. HW 6 amp 6/-, CONTACT COOLED, 14RA1282/FC101 7/6, EC1 12/6, EC2 12/6, 30v. 250mA FW 7/6, 250v. 100mA FW Grundig 12/6, FC116 7/6 FIN TYPES.

Equivs. for RM4 7/6, 14A97 13/6, 14A86 7/6, 14A100 10/6, RM3 3/-, CHARGER RECT. FW 12 volt 1A 5/-, 2A 7/-, 4 amp 10/6, CHARGER TRANSFORMER 4 amp 12/6/2 volt 21/6. Plus 3/- P. & P.

LINE O.P. TRANS: All 30/- each. Corsor 948, KB Queen, Peto Scott 1920, 1726, 1729, 1730, Murphy V350 and V230, Philips 1446U/45 and 1746U/45 with EY51. MULTIMETERS from 32/-.

Stamped envelope for full latest selection and bargain offers in CHEAP METERS, RADIOS, BABY ALARMS, INTERCOMS, WALKIE-TALKIES, SINCLAIR & EAGLE. Under £1 P. & P. 6d., £1 to £3 1/6d. C.O.D. 3/6d. extra.

MAIL ORDER ONLY

DURHAM SUPPLIES
367 KENSINGTON ST., BRADFORD 8, YORKS.

BOB'S BARGAINS. 10 assorted your choice 14/6. 100 assorted £5-10-0. PC F80 PCC84 PL81 PL36 PY81 PCL82 PCL83 EF85 U91 U301 30F5 30P12 PY33 PY32 PY82 EB91 ECL80 ECC82 EBF80 EBF89 6BW7. The following valves only at 12/6 per doz. EF80 EY86. All valves tested. 3 BY100 type rec. with surge res. 9/- p. & p. 6d. New 25k ohm w.w. controls 2/- p. & p. 6d. EKCO U25 type plastic l.o.p.t. housings 12/6 p. & p. 2/-.

Mail Order Only. 2 St. James St., Rawtenstall, Rossendale, Lancs.

BARGAIN PARCELS

10—13/-, 20—24/-, 100—£5 FROM
THE FOLLOWING LIST:—

ECC82, ECL80, EBF89, EF80, EF85, EF91, EB91, EY86, PCC84, PCF80, PCL82, PCL83, PL36, PL81, PL82, PL83, PY33, PY81, PY82, 6-30L2, 30FL1, 30F5, 10F1.

S. ASHWORTH

9 MANDEVILLE TERRACE,
HAWKSHAW, VIA BURY, LANCS.

**WITWORTH
TRANSFORMERS LTD.**

Dept. P.T., 26 All Saints Road,
North Kensington, W.11

Telephone: 01-229 9071. 9 a.m. till 5 p.m.

**TELEVISION LINE
OUTPUT
TRANSFORMERS**

PRACTICALLY ANY MAKE OR MODEL
SUPPLIED OR REWOUND

EKCO, FERRANTI, DYNATRON
Replacement cases 16/- each, please state model.

S.A.E. for return of post quotation.
TERMS: Cash with order or C.O.D., please add 4s. for postage.

C.O.D. orders will be charged 6s.
Transformers fully guaranteed. (98)

**THIS MONTH'S SCOOP
PORTABLE T.V. KIT**

Ex-Perdio, comprising:—

CABINET, complete.

C. R. TUBE, fitted.

SCAN COILS for above.

KNOBS & CONTROLS

Tube is Mullard AW 21-II,
(Retail price £12-0-0)
with slight mark, but fully
guaranteed.

all for

£9 - 19 - 6d.

Carriage & Insurance 20/-

TELEVISION TUBE SHOP
48, Battersea Bridge Rd, S.W.11

SETS & COMPONENTS

(continued)

TOWERBY LTD

For Line Outputs and Deflector Coils

We have the Country's largest stock of Manufacturer's Original (or Authorised Replacement) Line Output Transformers for many "difficult" makes, including Ambassador, Baird, Cossor, Decca, Dynatron, Ekco, Ferguson, G.E.C., H.M.V., K.B., Masteradio, Pato-Scott, Philips, Regentone, RGD, Sobell, Ultra, etc. Also deflector coils output and oscillator transformers, inc. Alba, Bush, Murphy. Examples, L.O.P.T. Murphy 310/350/410/540/659/759, 117/-; Bush TV80 117/- TV22 & 24, 78/6; Cossor 950 77/6; Ferguson 306/308 79/6; Philips 1768U L.O.P.T. assembly 122/6; Ultra 1984-200C 101/3.

Rewind most L.O.P.T. 90/-.

SPECIAL OFFER

Ekco improved type for Models T221, 231, 310 all at 45/-; Ferranti 14T4 series inserts 25/-; Philco 1019/1021 52/6. Terms: C.W.O. or C.O.D. (3/6). R.G.D. Sobell, 6/-, 2 or more L.O.P.T.s post/packing free.

All enquiries answered but regret no lists available. Same day delivery on most types.

TOWERBY LTD

MAIL ORDER DIVISION OF T.C.S. LTD.
70 STREATHAM HILL, LONDON, SW2.
Tel: 01-674 2185.

EX N.E.V. C.C.T.V. Camera and Monitor Circuits, S.A.E. for list. LOWE, 35 Hensley Point, Hackney, London, E.9.

PADGETTS RADIO STORE

OLD TOWN HALL,
LIVERSEDGE, YORKS.

Telephone: Cleckheaton 8866

Indicator Unit Type 26. Size 12x9x9in. with outer case, fitted with 2jin. C.R.T. type CV1326, 9 E7G valves, clean condition, but not tested. 32/8, P/p 10/-

New 12in. Speakers with built-in Tweeter, 3 ohm or 15 ohm—6 watt max, 28/8. Post paid.

Tube Unit 116A Complete with VCR97 tube Mu-metal, screen and EF95 valves good condition but not tested 22/8, Carriage 10/-.

Perspex Implosion Screens. Removed from TV sets 14in. and 17in., 6 for 12/-, Post paid.

Speaker output. Transformer removed from TV. 3 ohm. Secondary 5 for 10/-, Post paid.

Reclaimed TV Tubes with six months' guarantee 17in. types AW43/88, AW43/80, 40/-, MW 43/69 30/- 14in. types, 17/-, All tubes 12/- carriage.

Speakers removed from TV Sets. All PM and 3 ohms and 8x2in., 6/8. Post and packing 3/6.

6in Round, 3/-, P/p 3/-, 6 for 24/-, post paid.

8x4in. 3/-, P/p 3/-, 6 for 24/- post paid.

7x4in., 5/-, P/p 3/-, 6 for 34/- post paid.

5in. Round, 3/-, P/p 3/-, 6 for 24/- post paid.

Slot Speakers, 8x2 1/2in., 5/-, P/p 3/-, 6 for 30/- post paid.

24 Way Plug and Socket. Ex units 1/8, P/p 1/-, 12 for 14/- post paid.

Untested. Pye K.B., R.G.O. Ekco 17in. TV sets. Bush 17in. TV sets, 50/- each, carriage 15/-. Passenger train, double rate.

VALVE LIST

Ex. Equipment, 3 months' guarantee

Single Valves Post 7d., over 3 Valves p. & p. paid.

10F1, EB91, EF50, PY82, PZ30, 20F3. All at 10/- per dozen, post paid.

ARP12	1/8	PCL83	5/-	6BW7	2/8
EB91	9d.	PL36	5/-	6K7	1/8
EF85	3/-	PL61	4/-	6U4	5/-
EBF80	3/-	PY33	5/-	6V6	1/8
ECC81	3/-	PY33	5/-	6P28	5/-
ECC82	3/-	PY81	1/8	10P13	2/8
ECC83	4/-	PY82	1/8	185BT	8/8
EF50	1/-	PZ30	5/-	20D1	2/-
EF91	9d.	U191	5/-	30P1	5/-
EY31	2/8	U281	5/-	20P3	2/8
EY86	5/-	U282	5/-	30PL1	5/-
KT36	5/-	U301	5/-	30P12	5/-
PCC84	2/-	U329	5/-	30F5	2/8
PCF80	2/-	U251	5/-	30FL1	5/-
PCL82	4/-	6B8	1/8	6/30L2	5/-

NEW VALVES

Guaranteed Set Tested
24 HOUR SERVICE

1R5	5/6	ECH85	5/6	PCL83	8/0
1R5	4/8	ECH42	10/6	PCL84	7/-
1T4	2/0	ECH81	5/9	PCL85	8/9
384	5/9	ECL80	6/3	PCL86	8/3
3V4	5/9	ECL82	6/3	PFL200	11/0
6AQ5	4/6	ECL86	7/8	PL86	9/3
6L13	6/-	EF7A	6/-	PL81	7/-
90C18	11/-	EF89	4/6	PL82	6/9
30FL1	18/6	EF80	4/9	PL83	6/9
30FL12	14/3	EF85	5/9	PL84	6/3
30FL14	11/9	EF86	6/3	PL500	12/9
30P4	11/8	EF89	4/8	PL504	13/3
30P19	11/8	EF183	6/9	PY32	10/-
80P11	18/6	EF184	5/3	PY33	10/-
OCB35	9/9	EH90	6/-	PY81	5/-
CL33	17/6	EL33	8/2	PY82	5/-
DAC82	6/9	EL41	10/3	PY83	5/3
DAP91	4/3	EL84	4/9	PY88	6/-
DAP96	6/3	EY51	7/8	PY800	7/3
DF83	7/8	EY86	5/9	PY801	6/8
DF91	3/0	EZ80	3/0	R19	6/3
DF96	6/3	EZ81	4/6	U26	12/9
DK32	6/9	KT61	8/3	U26	11/6
DK91	5/6	KT66	16/9	U191	12/3
DK96	6/6	N78	14/8	UA3C80	6/6
DL45	4/6	FABC80	4/9	UBC41	8/3
DL92	5/9	PC86	10/3	UBF89	6/3
DL94	5/9	PC88	10/3	UCC84	7/9
DL96	6/9	PC97	7/9	UCC85	6/8
DY86	5/3	PC900	7/6	UCF80	8/-
DY87	5/3	PC984	6/3	UCE42	10/6
EAC380	5/9	PC989	9/9	UCR81	7/-
EBC41	8/-	PCC189	11/8	UCL82	6/9
EBF80	6/-	PCF80	6/6	UF41	10/6
EBF89	5/9	PCF82	6/8	UF89	6/6
ECC81	4/6	PCF801	6/6	UL41	10/3
ECC82	4/-	PCF806	11/-	UL84	6/9
ECC83	4/9	PCF808	11/9	UY41	7/9
ECC85	5/6	PCL82	6/9	UY85	5/3

Postage on 1 valve 9d. extra. On 2 valves or more, postage 6d. per valve extra. All parcels insured against damage in transit 6d. extra. Office address, no callers.

GERALD BERNARD

83 OSBALDESTON ROAD
STOKE NEWINGTON
LONDON, N.16

TRADER SERVICE SHEETS

5/- each plus postage

We can supply Trader Service Sheets for most makes and types of Radios, Tape Recorders and Televisions—Manuals for some.

Cheques and open P.O.s returned if sheets not available.

OAKFIELD ENTERPRISES

LIMITED

30 CRAVEN STREET, STRAND
LONDON WC2

Make	Model	Radio/TV

1969 List now available at 2/- plus postage

If list is required indicate with X

From
Address
.....
.....
enclose remittance of
(and a stamped addressed envelope)
s.a.e. with enquiries please
MAIL ORDER ONLY (July PT)

**Learn at home...
First Class Radio
and TV Courses**



After brief, intensely interesting study—undertaken at home in your spare time—YOU can secure a recognised qualification or extend your knowledge of Radio and TV. Let us show you how.

FREE GUIDE

The New Free Guide contains 120 pages of information of the greatest importance to both the amateur and the man employed in the radio industry. Chambers College provides first rate postal courses for Radio Amateurs' Exam., R.T.E.B. Servicing Cert., C. & C. Telecoms., A.M.I.E.R.E. Guide also gives details of range of certificate courses in Radio/TV Servicing, Electronics and other branches of engineering, together with particulars of our remarkable terms of Satisfaction or refund of fee

Write now for your copy of this valuable publication. It may well prove to be the turning point in your career.

FOUNDED 1925 Over 150,000 successes
CHAMBERS COLLEGE
(Incorp. National Inst. of Engineering)
(Dept. 844V) 148 Holborn, London, E.C.1.

NEW RANGE BBC 2 AERIALS

All U.H.F. aerials now fitted with tilting bracket and 4 element grid reflectors.
Loft Mounting Arrays, 7 element, 37/6. 11 element, 45/-, 14 element, 52/6. 18 element, 60/-, Wall Mounting with Cranked Arm, 7 element, 60/-, 11 element, 67/-, 14 element, 75/-, 18 element, 82/6. Mast Mounting with 2in. clamp, 7 element, 42/6. 11 element, 55/-, 14 element, 62/-, 18 element, 70/-, Chimney Mounting Arrays, Complete, 7 element, 72/6. 11 element, 80/-, 14 element, 87/6. 18 element, 95/-, Complete assembly instructions with every unit. Low Loss Cable, 1/6 yd. U.H.F. Preamps from 75/-, State clearly channel number required on all orders.

BBC-ITV AERIALS



BBC (Band 1), Telescopic loft, 25/-, External S/D, 30/-, "H", £2.15.0. ITV (Band 3), 3 element loft array, 30/-, 5 element, 40/-, 7 element, 50/-, Wall mounting, 3 element, 47/6, 5 element, 52/6.
Combined BBC / ITV Loft 1+3, 40/-, 1+5, 50/-, 1+7, 60/-, Wall Mounting 1+3, 57/6, 1+5, 67/6. Chimney 1+3, 67/6, 1+5, 75/-, VHF transistor preamps, 75/-

COMBINED BBC1 - ITV - BBC2 AERIALS, 1+3+9, 70/-, 1+5+9, 80/-, 1+5+14, 90/-, 1+7+14, 100/-, Loft mounting only. F.M. (Band 2), Loft S/D, 15/-, "H", 32/6, 3 element, 55/-, External units available. Co-ax cable, 8d. yd. Co-ax plugs, 1/4. Outlet boxes, 5/-, Diplexer Crossover Boxes, 13/6. C.W.O. or C.O.D. P. & P. 6/-. Send 6d. stamps for illustrated lists.

Callers welcomed. Open all day Saturdays.

K.V.A. ELECTRONICS (Dept.P.T.)
40-41 Monarch Parade, London Rd., Mitcham, Surrey. 01-648 4884.

REBUILT TUBES!

You're safe when you buy from
RE-VIEW!



- ★ Each tube is rebuilt with a completely new gun assembly and the correct voltage heater.
- ★ Each tube comes to you with a guarantee card covering it for two years against all but breakage.
- ★ Each tube is delivered **free** anywhere in the U.K. and insured on the journey.
- ★ Each tube is rebuilt with experience and know-how. We were amongst the very first to pioneer the technique of rebuilding television tubes.

HERE IS WHAT YOU PAY:

12in.	£4.15.0
14in.	£5. 0.0
15in.	£5. 5.0
17in.	£5. 5.0
19in.	£5.15.0
21in.	£7. 5.0

Cash or cheque with order, or cash on delivery

Discount for Trade

Old Tubes Purchased

RE-VIEW ELECTRONIC TUBES

237 LONDON ROAD, WEST CROYDON, SURREY. Tel. 01-689 7735

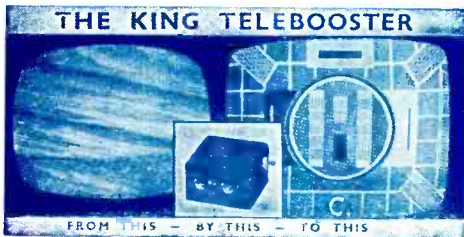

THE ORIGINAL VHF DUAL BAND TUNABLE PRE-AMPLIFIER

Still the best of its kind available. Latest low-noise transistor and printed circuit. Boosts Band I and II simultaneously without switching. Two amplifiers in one. Can produce good viewing out of almost nothing in fringe areas. Ideal for DX work. Guaranteed gain: Minimum 18dB Band I. 14dB Band III. Channels: Red spot: Band I, 1, 2 and 3, all Band III. Yellow spot, Band 1, 3, 4 and 5, all Band 3. Power: Self-contained 9v PP4 battery, 17mA. Plastic case 3 1/2 x 3 1/2 x 2 in. brown, with cork base. Retail price, £3.15.6. Complete with battery OR self-contained mains version, retail price £5.17.6. Specify channels, one Band I, one Band III.

THE KING UHF TELEBOOSTER FOR BBC2

Unique design, employing quarter-wave cavity, resonator for 100% stability, printed circuit for reliability, with the very latest third generation low-noise transistor. Tunable. Covers channels 21-68. Plastic case 3 1/2 x 3 1/2 x 2 in. brown, with cork base. Retail price £4.17.6, complete with battery OR self-contained mains model, £6.15.0.

Sole manufacturers:

TRANSISTOR DEVICES LTD.
BRIDGE HOUSE, NEWTON ABBOT, Devon
Tel. 2457 *Send for literature*

BBC2 KITS AND TELEVISION SPARES

UHF/625. Modify your set to BBC2. 1955 to 1963 models covered. Selection of manufacturers conversion kits and tuners at reduced prices. Lists available.

SPECIAL OFFERS: Leading Brit. maker dual 405/625 transistd. 6 postn. push button tuners £5-5-0. 405/625 transistd. 1F panels £2-15-0 incl. circuits, p.p. 4/6.
SOBELL/GEC dual 405/625 1F amp. and o/p chassis incl. circuit 42/6. **ULTRA** 1980C to 2384 625 1F amp. chassis and switch incl. circuits 25/-, p.p. 4/6.
UHF TUNERS. Transistd. incl. circuit, 50/-. **PYE/EKCO** valve type 55/- **EKCO/FERRANTI.** 4 position push button valve type £5-10-0. p.p. 4/6.
TV SIGNAL BOOSTER UNITS. Sens. gain all stations. **PYE/LABGEAR** trans'd BNC/ITA or UHF Battery "plug in", 75/-, UHF Mains "plug in", 97/6. UHF Masthead 35/-. Post free.
FIREBALL TUNERS. Used/good condition 30/-. **PUSH BUTTON TUNERS.** For Sobell 290, RGD 612, 619, REG 17/18, 192. Used/good condition 30/-. **TURRET TUNERS.** New **PYE** 13 ch. CTM range incremental incl. valves 35/-. **CYLDON C** 20/-. **EKCO** 283/330 25/-, p.p. 4/6. Many others available. Large selection channel coils.

LINE OUTPUT TRANSFS. Popular types available, brand new exact replacements fully guar. A selection which can be supplied, p.p. 4/6, C.O.D. 3/6.

PHILIPS 17TG100 range, STELLA 1011/1029	70/-	LOFT Inserts p.p. 2/-	
EKCO 221 to 331 (U25 types)	42/6	Alba 655, 658	35/-
FERRANTI 1001 to 1011 (U25 types)	42/6	Bush TV32, 36, 43	45/-
EKCO/FERRANTI (U26 types) 709/909	55/6	Bush TV53 to 69	30/-
EKCO 342 to 394, FERRANTI 1021 to 1068	75/-	Cossor 933 to 950	35/-
ENCO/FERRANTI 418, 1093, etc.	62/6	Ekco TP305	38/6
DECCA DM1, 2, 17; DM3C , DM4C (70°)	73/6	Emerson 703 range	35/-
FERG 305 to 436, 42/8; 505 to 727	55/6	Ferguson 203 to 248	35/-
FERG. HMV. MARCONI. ULTRA. PHILCO	55/-	Ferranti 1474 to 1775	20/-
3600, 2600, 4600, 6600, 1100 ranges Jellypot	45/6	KB NF70, OV30, PV40	35/-
KB QV120, QV20/1, 30/1, RV10, 20, 30, SV20	20/-	PVP20. QV10, 20 30	35/-
KB LPT50, 60, 100, MV10, 50, 60	55/-	KB/RGD Featherlight	50/-
MARCONI. VT157, 159, 160, 161, 163, 164	55/-	KB/RGD WV05/627	35/-
GEC 302 to 320, 62/6; later models	78/6	PETO SCOTT 733/738	35/-
HMV 865/875, 1870/84, 42/6; 1800 to 1924	55/-	Philco 1961 1919 to 1060	35/-
PYE VT17, GS17, CSM17, CV17, 17/21,	62/6	Philips 17TG100 range	35/-
17/8, 110 to 510, 700 A/D, 11U 12U, 15U ect.	62/6	Pye VT4, VT7	42/6
PAM. INVICTA equiv. LOFTS to above Pye	62/6	RGD D17, 590 to 619	35/-
PETO SCOTT 1419 to 1725	35/-	RGD 10-4, 10-17 to 192	35/-
SOBELL/McMICH. TP8174, 180, T23, 24, 178	45/6	Ultra 1770 1780 range	35/-
278, 8024, 270, NP17, 18, M72, 74	65/6	SCAN COILS. Frame O/P, frame/line osc. trans. mains dropper, controls, etc.	
TP8 784, T279, 8034, 370, MP27, M75, 76, 93	65/6	NEW SCAN COILS 110° types surplus special offer, PYE. EKCO. ULTRA. K.B.	
PHILCO 1110 to 1021 45/-, 1029 to 1000	55/6	PILOT. MURPHY. 30/-, p/p 4/6. FRAME O/A TRANSF. SOBELL. 17/6	
ULTRA 1770 to 2384, PILOT PT 150 to 630	62/6	p.p. 4/6.	

ENQUIRIES invited, quotations given, C.O.D. despatch available.
MANOR SUPPLIES
 64 GOLDERS MANOR DRIVE, LONDON, N.W.11
 Callers: 599b HIGH ROAD (nr. Granville Road) N. Finchley N.12.
 HILL 9118 (01-445 9118).

VALUABLE NEW HANDBOOK FREE TO AMBITIOUS ENGINEERS

Have you had your copy of "Engineering Opportunities"?

The new edition of "ENGINEERING OPPORTUNITIES" is now available—without charge—to all who are anxious for a worthwhile post in Engineering. Frank, informative and completely up to date, the new "ENGINEERING OPPORTUNITIES" should be in the hands of every person engaged in any branch of the Engineering industry, irrespective of age, experience or training.

On 'SATISFACTION or REFUND of FEE' terms

This remarkable book gives details of examinations and courses in every branch of Engineering, Building, etc., outlines the openings available and describes our Special Appointments Department.

WHICH OF THESE IS YOUR PET SUBJECT ?

TELEVISION ENG.
Advanced Television Eng.—
Gen. Television Eng.—Tele-
vision Servicing and Main-
tenance.

ELECTRONIC ENG.
Advanced Electronic Eng.—
Gen. Electronic Eng.—
Applied Electronics—
Practical Electronics—
Radar Tech.—Frequency
Modulation—Transistors.

MECHANICAL ENG.
Advanced Mechanical Eng.—
Gen. Mechanical Eng.—
Maintenance Eng.—Diesel
Eng.—Press Tool Design—
Sheet Metal Work—
Welding—Eng. Pattern
Making—Inspection—
Draughtsmanship—
Metallurgy—
Production Eng.

RADIO ENG.
Advanced Radio—Gen.
Radio—Radio Servicing—
Telecommunications—
Sound Recording—Auto-
mation—Practical Radio—
Radio Amateurs' Exam.

ELECTRICAL ENG.
Advanced Electrical Eng.—
Gen. Electrical Eng.—
Installations—Draughts-
manship—Illuminating
Eng.—Refrigeration—
Elem. Electrical Science—
Electrical Supply—Mining
Electrical Eng.

CIVIL ENG.
Advanced Civil Eng.—
Municipal Eng.—Structural
Eng.—Sanitary Eng.—
Road Eng.—Hydraulics—
Mining—Water Supply—
Petrol Tech.

WE HAVE A WIDE RANGE OF COURSES IN OTHER SUBJECTS INCLUDING CHEMICAL ENG., AERO ENG., MANAGEMENT, INSTRUMENT TECHNOLOGY, WORKS STUDY, MATHEMATICS, ETC.

Which qualification would increase your earning power?
B.Sc. (Eng.), A.M.S.E., C.Eng., A.M.I.E.R.E., R.T.E.B., A.M.I.P.E.,
A.M.I.M.I., A.M.I.E.D., A.R.I.B.A., A.I.O.B., P.M.G., A.R.I.C.S., M.R.S.H.,
A.M.I.Mun.E., CITY & GUILDS, GEN., CERT. OF EDUCATION, ETC.

British Institute of Engineering Technology
445A ALDERMASTON COURT, ALDERMASTON, BERKSHIRE

THIS BOOK TELLS YOU

- ★ HOW to get a better paid, more interesting job.
- ★ HOW to qualify for rapid promotion.
- ★ HOW to put some letters after your name and become a key man . . . quickly and easily.
- ★ HOW to benefit from our free Advisory and Appointment Dept.
- ★ HOW you can take advantage of the chances you are now missing.
- ★ HOW, irrespective of your age, education or experience, YOU can succeed in any branch of Engineering.

164 PAGES OF EXPERT CAREER-GUIDANCE

<p>PRACTICAL EQUIPMENT</p> <p>Basic Practical and Theoretic Course for beginners in T.V., Radio, Electronics Etc. A.M.I.E.R.E. City & Guilds Radio Amateurs' Exam. R.T.E.B. Certificate P.M.G. Certificate Practical Radio Television & Radio Servicing Practical Electronics Electronics Engineering Automation</p>	<p>INCLUDING TOOLS</p> <p>The specialist Electronics Division of B.I.E.T. NOW offers you a real laboratory training at home with practical equipment. Ask for details.</p> <p>B.I.E.T.</p>
---	--



You are bound to benefit from reading "ENGINEERING OPPORTUNITIES", and you should send for your copy now FREE and without obligation.

POST COUPON

TO B.I.E.T. 445A ALDERMASTON COURT, ALDERMASTON, BERKSHIRE.
Please send me a FREE copy of "ENGINEERING OPPORTUNITIES." I am interested in (state subject, exam., or career).

NAME

ADDRESS

WRITE IF YOU PREFER NOT TO CUT THIS PAGE

THE B.I.E.T. IS THE LEADING INSTITUTE OF ITS KIND IN THE WORLD