

YBA Harper

Practical TELEVISION

OCTOBER 1967

2/-

**video
tape
recording**



**new series
starts now**



17in.—£11.10.0
3 Star Guarantee
 ★ Tube ★ Valves
 ★ Components Carr. 30/-

TWO-YEAR GUARANTEE
EX-RENTAL TELEVISIONS

COCKTAIL/STEREOGRAM CABINET £25

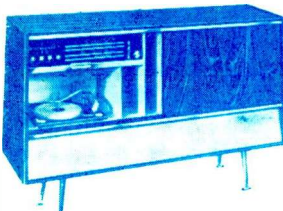

Polished walnut veneer with elegant glass fronted cocktail compartment, padded position for two 10in. elliptical speakers. Record storage space. Height 35½in., Width 52½in., Depth 14½in. Legs 1 gn. extra. **Other models. Send for free list.**

TAPE RECORDER CABINETS 49/6. Dia. 16" x 12½" x 7½". Red and Grey. Cut out for BSR deck. P. & P. 7/6.

TRANSISTOR CASES 19/6. Cloth covered many colours. Size 9½" x 6½" x 3½". P. & P. 4/6. Similar cases in plastic 7/6.

SINGLE PLAYER CABINETS 19/6. P. & P. 7/6.

TV TURRET TUNERS, 2/6. New, less valves. Slim models 5/-. Press button models 19/6. P. & P. 4/6.

FREE ILLUSTRATED LIST OF TELEVISIONS
 17"–19"–21"–23"
WIDE RANGE OF MODELS
SIZES AND PRICES
DEMONSTRATIONS DAILY

TWO-YEAR GUARANTEED TUBES 100% REGUNNED
 14in.—89/6 17in.—89/6
 21in. and all **SLIMLINE TUBES 99/6**
 Exchanged Bowls Carr. 10/6

EX MAINTENANCE TESTED TUBES
 17in.—35/- 14in.—15/-
 Carr. 5/- (not slimline)

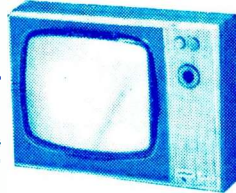

DUKE & CO. (LONDON) LTD.
 621/3 Romford Road, E.12 (Parking space) ILF 6001-2-3

BI-PRE-PAK LTD
 222-224 WEST ROAD, WESTCLIFF-ON-SEA, ESSEX
 PHONE: SOUTHEND (OS02) 46344

NEW FROM THE U.S.A.
"TEXAS" Integrated Circuits

SN7360	Quadruple 2 Input NAND/Nor Gate.	19/6
SN7430	8 Input Positive NAND Gate.	21/6
SN7302	Dual J-K Flip-Flop with Preset.	35/-

F.E.T.'s Field Effect Transistors

2N3822	'N' Channel 4-Lead	15/-
--------	--------------------	------

TRANSISTORS PRICE

AF114	4/-
AF115	3/-
AF116	3/-
AF117	4/-
AF118	3/6
AF119	3/6
AF178	10/-
BS395A	5/-
OC22	5/-
OC23	10/-
OC25	8/-
OC26	5/-
OC28	5/-
OC35	5/-
OC41	5/6
OC42	2/6
OC71	2/6
OC72	2/6
OC73	2/6
OC81	5/6
OC81D	2/6
OC83	4/6
OC139	2/6
OC140	5/6
OC170	3/6
OC171	4/6
OC200	5/6
OC201	8/6
2G39A	4/-
2N397	5/6
2N706	5/6
2N 1302 or 3	4/6
2N 1304 or 5	5/6
2N 1306 or 7	6/6
2N 1308 or 9	8/6

FANTASTIC! BARGAINS OF THE YEAR

★ OC45	1F transistor	1/9
★ OC44	Osc. transistor	1/11
★ OA9	Equal to OA5	2/-
★ OC36	Power transistor (better than OC35)	7/6

GENUINE TRANSISTORS NOT REMAKES

No.	PRE-PAKS	PRICE
A1.	6—Silicon rectifiers BY100 type	20/-
A2.	10—Relays mixed types and voltages	20/-
A3.	20—Mixed marked and tested trans.	20/-
B1.	50—Unmarked, untested, trans., new	10/-
B52.	30—Trans., new tested, but unmarked	10/-

● ALL OUR SEMICONDUCTORS HAVE A WRITTEN GUARANTEE ●

Send for our FREE lists and catalogue of all our products. Check your own equivalents with our free substitution chart.

FIRST EVER LOGIC KITS. Learn for yourself how computers work, even make one for yourself. Full instructions for a noughts and crosses machine, binary counters, timers, etc. L1 5 gns. L2 10 gns. No need to purchase both kits, you can start with L2, which incorporates L1. DETAILS FREE.

NO CONNECTION WITH ANY OTHER FIRM. MINIMUM ORDER 10/-. CASH WITH ORDER PLEASE, add 1/- post and packing. OVERSEAS ADD EXTRA FOR AIRMAIL.

KITS HAVE NEVER LOOKED THIS GOOD BEFORE

A FULL-FEATURE VTVM FOR THE SERIOUS ENTHUSIAST

Plus a 0-5V scale for transistor servicing

Kits have never looked this good before, never had such a professional finish because Knightkits have never been widely available in the U.K. Now they are—from Electronics.

The KG 625 Vacuum Tube Voltmeter kit costs £28.19.6d. and is just one example of the high-quality range of test equipment—scopes, signal generators, multimeters, power packs etc. that are covered in the FREE 70-page Knightkit brochure. We put the quality in—you build it up. It's instructive and kit building saves you money.

All kits are fully guaranteed and available on credit terms if required.

Knightkit doesn't only mean test gear, but Hi-Fi and photographic equipment, and electronic car tuning kits as well. In fact there's a Knightkit for every interest.

Features of the KG 625 6in. 200µA meter; movement shorted in "off" position; fluorescent knife-edge pointer; pre-aged bridge valve and matched triode section; separate colour scales; direct reading peak-to-peak a.c. volts; gimbal bracket mounting; supplied with battery and test probe. R.F. demodulator and probe also available as accessories.

Use the coupon on the right to get the rest of the facts on the complete Knightkit range.

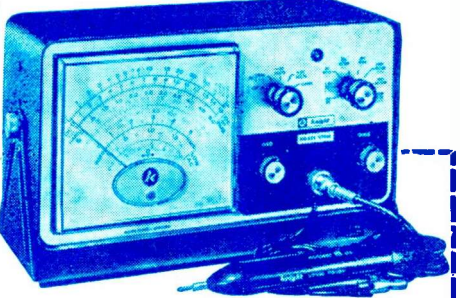

I am interested in the KG 625 VTVM and should like to read further details in your FREE brochure K3.
 Send to Electronics (Prop. STC) Limited, Edinburgh Way, Harlow, Essex.

NAME _____

ADDRESS _____



knight-kit by **electronics**
 Quality Built-in Built-up by you

AN IMPORTANT ANNOUNCEMENT TO THE MANY THOUSANDS WHO HAVE BOUGHT AND WILL BUY

The COMMON CORE Series

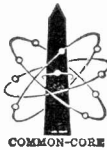

there is now added

THE 'NUMBERS GAME'

Play it with TRAINER-TESTER Response Sheet No. E3 and the eleven ADJUNCTIVE PROGRAMMING SUPPLEMENTS TO

basic electricity and basic electronics

Full details and prices will be sent on application to

THE TECHNICAL PRESS LTD

112 WESTBOURNE GROVE, LONDON, W.2

★ Incidentally BASIC TELEVISION part 1 is now ready (see below) ★

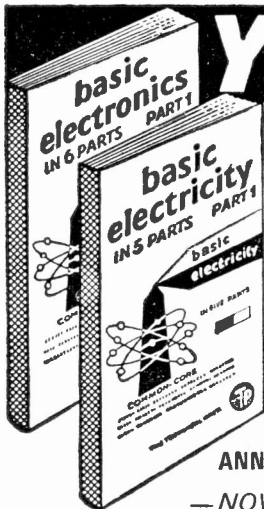

YOURS FREE FOR 7 DAYS

The New 'Picture-Book' way of learning BASIC ELECTRICITY (5 vols.) BASIC ELECTRONICS (6 vols.)

You'll find it easy to learn with this outstandingly successful new pictorial method—the essential facts are explained in the simplest language, one at a time; and each is illustrated by an accurate cartoon-type drawing.

The books are based on the latest research into simplified learning techniques. This has proved that the Pictorial Approach to learning is the quickest and soundest way of gaining mastery over these subjects.

SPECIAL ANNOUNCEMENT

—NOW READY—

BASIC TELEVISION Pt. 1. Price 22/- inc. postage

Complete in two parts, publication date of Pt. 2 to be announced later. Available on 7 days free trial, see coupon.

TO SELRAY BOOK CO. 60 HAYES HILL, HAYES, BROMLEY, KENT

Please send me Without Obligation to Purchase, one of the above sets on 7 Days Free Trial. I will either return set, carriage paid, in good condition within 7 days or send the following amounts. Basic Electricity 70/-. Cash price or Down Payment of 10/- followed by 4 fortnightly payments of 15/- each. Basic Electronics 82/-. Cash 17/6 or Down Payment of 15/- followed by 5 fortnightly payments of 15/- each. This offer applies to U.K. only. Overseas customers cash with order.

Tick set required (only ONE set allowed on free trial).

- BASIC ELECTRICITY 70/-
BASIC ELECTRONIC CIRCUITS 40/-
BASIC INDUSTRIAL ELECTRICITY 40/-
BASIC SYNCHROS & SERVOMECHANISMS 38/-
BASIC TELEVISION PART 1 22/-
BASIC ELECTRONICS 82/-
All prices include postage

Signature..... (If under 21, signature of parent or guardian)

NAME..... BLOCK LETTERS BELOW

FULL POSTAL ADDRESS.....

POST NOW FOR THIS OFFER!!

This is the latest list of Line Output Transformers and Inserts from D & B Television

NOW UNDER NEW MANAGEMENT

ALBA Prices on request.
BUSH TV53, TV56, TV57, TUG58, TUG59, M59, TV63, TV66, TV67. Inserts 27/6. Other types rewind at 70/-.

DECCA DM3, Exchange unit 70/-.
EKCO TC208, TC209, TC209/1, T221 to 331. Complete L.O.P.T. 40/-, TMB272 48/6, T344, T344F, T348, T348F, T356, TC312, T313, T313F T335 58/6.

EMERSON E700, E701, E704, E707, E708, E709, E710, E711, Portarama, Inserts 35/-.

FERGUSON 306, 308 40/-, 204 to 246, Inserts 30/-.
FERRANTI 14T2 to 14T5, 17K3 to 17SK4, Inserts 35/-, T1001, T1002, T1002/1, T1004, T1005, T1021, T1011 40/-, T1012, T1023, T1034, T1022 58/6.

K.B. PV40, MV100/1, OF100, PV100, NV40, NF70, OV30, QV10, QV30, Inserts only 45/- pair. All other types rewind 70/-.

PETO SCOTT TV1416, TV1419, TV1716, TV1719, TV1720, TV1722, TV1725, TV1418, TV1726, Inserts only 32/6.

PYE V4, V7, VT4, VT7, CTM4, CTM7, Insert only 40/-, V200, V400, V210 55/-, Other types prices on request.

PILOT V110, 117U, Inserts only 30/-.
REGENTONE T14, 10-6, 10-4, 10-17, 10-21, Inserts only 30/-, T176, 191, 192, T21FM, Inserts only 45/-, Deep 17, THE17, T21, 600, 590, Inserts only 35/-.

SOBELL T25, T280, 193, SC24, SC34, SC370, T279, TPS186, Rewinds only 70/-.

All the above L.O.P.T. can be rewound at 70/-.

ULTRA 1984, 1984C, 200C. Rewind only 70/-.

1967 REVISED VALVE LIST

CBL31	14/-	EF184	6/3	PL83	6/6
DAF91	4/3	EL84	4/2	PL84	6/6
DAF96	6/3	EM81	6/9	PL500	13/6
DF91	3/-	EY51	6/10	PY33	8/6
DF92	3/-	EY86	6/3	PY81	6/-
DF96	6/11	EZ81	4/11	PY82	5/6
DK92	7/9	PC86	10/9	PY800	6/-
DK96	6/9	PC88	10/9	PY801	6/-
DL94	5/9	PC97	7/3	UABC80	5/3
DY87	6/3	PCC84	5/6	UCH81	6/3
EABC80	6/3	PCC89	10/-	UCL82	7/-
EB91	3/-	PC189	10/10	U25	12/3
EB90	4/3	PCF80	6/2	U26	12/3
EBF89	6/6	PCF82	7/7	30C15	11/3
ECC82	4/9	PCF86	7/9	30F5	9/9
ECH42	9/3	PCL82	7/-	30FL1	13/9
ECH81	5/-	PCL83	8/6	30L15	14/9
ECL80	6/9	PCL84	7/6	30P12	8/11
ECL82	6/3	PCL85	8/11	30P19	12/9
EF80	4/9	PFL200	13/6	30PL1	14/9
EF85	6/3	PL36	10/6	30PL13	14/9
EF183	6/-	PL81	7/6	30C18	10/-

All Line Output Transformers, Inserts and Valves are new and are fully guaranteed for 3 months. C.O.D. 5/- extra. Return of Post service. S.A.E. all enquiries. Post and packing 4/6.

D. & B. TELEVISION (Wimbledon) LTD

131 KINGSTON ROAD, WIMBLEDON, 01 540 3513 S.W.19 01 540 3955

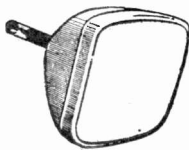

"SABRINA"

STILL WELL IN FRONT

COMPLETELY REBUILT C.R. TUBES ALL TYPES

12" now	..	£5. 0.0	} For Single Tubes
14" to 17" now	..	£5.10.0	
19" now	..	£6.15.0	
21" now	..	£8. 0.0	

ALL C.W.O.—TRADE SUPPLIED

Special Bonus Scheme for Service Engineers—Reducing to:

12"—87/6; 14"/17"—97/6; 21"—147/6

FREE Pass. transit & Ins. anywhere in British Isles or N. Ireland (12 months' guarantee).

ALSO FULL RANGE OF VALVES (Guaranteed 12 months)

SABRINA C.R. TUBE CO.

Electron Works, 50 North Bar BANBURY, OXON Telephone 2390

VALVES SAME DAY SERVICE
 NEW! TESTED! GUARANTEED!

SETS 1R5, 1R6, 1T4, 3R4, 8V4, DAF91, DF91, DK91, DL92, DL94, DL96, 4 for 16/8, DAF96, DF96, DK96, DL96, 4 for 24/6.

1A7GT	7/6	7B7	7/-	DAC82	7/8	ECL80	6/1-	PC980	7/9	TH21C	11/6
1H8GT	7/3	7C5	12/-	DAF91	3/9	ECL82	6/3	PCC84	5/6	U25	11/6
1N8GT	7/9	7C6	8/9	DAF96	6/-	ECL86	7/9	PC989	9/9	U26	11/6
1R5	5/8	7H7	5/8	DC990	7/-	EF89	3/9	PCC189	8/6	U47	17/6
1R5	4/9	7Y4	6/9	DC93	7/8	EF41	9/8	PCF80	6/6	U49	13/6
1R5	3/9	10P1	9/9	DF91	2/8	EF80	4/9	PCF82	6/-	U52	4/6
1T4	2/9	10P18	10/6	DF96	6/-	EF85	5/-	PCF86	9/-	U78	3/6
3A4	7/-	12AT7	3/9	DB77	4/-	EF86	6/3	PCF800	10/6	U191	11/6
30X5	5/6	12AU6	4/9	DH81	12/8	EF89	5/-	PF801	8/9	U301	13/-
354	4/9	12AU7	4/9	DK82	7/8	EF91	3/6	PC8402	8/6	U801	18/-
3V4	5/8	12AX7	4/9	DR81	3/8	EF92	3/3	PCF805	9/9	UABC80	5/6
5U4G	4/6	12XNGT	7/6	DK92	8/-	EF97	7/8	PCF808	11/6	UAF42	7/9
5V4G	7/9	20P2	11/6	DK96	6/8	EF183	6/9	PCF80811/3	UB41	8/6	
6Y3GT	5/-	20L1	14/8	DL33	6/9	EF184	5/9	PCL82	6/9	UCB41	6/9
5Z4G	7/6	20P1	9/-	D135	5/-	EH90	8/6	PCL83	8/6	UBF80	5/6
6B0L2	11/9	20P3	14/9	DL92	4/9	EL33	6/6	PCL84	7/-	UBF89	6/9
6AL5	2/3	20P4	17/-	DL94	5/8	EL41	8/6	PCL85	8/6	UBL21	9/-
6AM6	3/6	25U4T	11/6	DL96	6/-	EL84	4/9	PCL86	8/6	UC92	5/-
6AQ5	4/9	30A15	11/6	DY86	5/9	EL90	5/-	PEN A4	8/9	UCC84	7/9
6AT9	4/-	30C17	12/8	DY87	5/9	EL95	5/-	PEN30C15/8	UCC85	8/6	
6C86	6/6	30L17	13/6	EF80	7/-	EY86	6/6	PFL200	13/6	UCF80	8/3
6B0E4	4/3	30F5	12/8	EA42	8/6	EM81	6/9	PL36	9/-	UCH21	9/3
6B0G6	15/-	30FL1	13/9	EB91	2/3	EM84	6/3	PL81	6/9	UCH42	8/9
6B0J6	8/9	30FL14	12/6	EB93	7/8	EM87	6/6	PL82	6/8	UCH81	6/9
6B0W6	7/3	30L15	12/-	EB41	8/-	EY81	6/3	PL88	8/3	UCL82	7/-
6C86	6/6	30L17	13/6	EF80	7/-	EY86	6/6	PL84	6/8	UCL85	8/9
6F1	7/9	30P4	18/-	EF89	5/9	EZ40	6/9	PL500	13/6	UF41	8/-
6FL3	3/6	30P12	11/-	ECC81	3/9	EZ41	6/9	PX25	7/9	UF80	7/-
6FL4	9/-	30P19	12/-	ECC82	4/9	EZ80	4/6	PY32	8/8	UF89	5/9
6P23	12/6	30P11	14/6	ECC83	7/-	EZ81	4/6	PY33	8/6	UL41	8/9
6K74	1/6	30P13	14/6	ECC84	6/8	GZ32	9/-	PY80	5/3	UL44	20/-
6K84	4/3	30P14	14/6	ECC85	5/6	KT81	6/6	PY81	5/3	UL84	8/-
6K8GT	7/8	33L6GT	7/6	ECF80	7/-	KT81	12/-	PY82	5/-	UY21	8/9
6L18	8/-	35W4	4/6	ECF82	6/9	N18	5/6	PY88	5/9	UY41	5/8
6V6G	3/6	35Z4GT	4/6	ECF86	9/-	N78	14/9	PY88	7/8	UY85	4/9
6V6GT	6/6	3603	12/6	ECF85	6/-	N108	13/6	PY800	6/-	VP4B	10/6
6X4	3/6	4Z91	9/-	ECF82	6/-	PC86	5/9	PY801	6/-	VP321	21/-
6X3GT	5/9	B36	4/9	ECF81	5/3	PC88	8/-	R19	7/-	W7	3/3
7B6	10/8	B729	12/6	ECF84	6/6	PC97	5/9	R26	12/9	Z77	3/6

READERS RADIO

85 TORQUAY GARDENS, REDBRIDGE ILFORD, ESSEX. 01-550 7441

Postage on 1 valve 9d. extra. On 2 valves or more 6d. per valve extra. Any parcel insured against damage in transit 6d. extra.

Practical Television

INTERIM PERIOD

OCTOBER
VOL. 18

1967
No. 1
issue 205

LAST month we posed the question of where are the colour sets. Well, we saw *some* of them during our Baedeker tour of London hotels which housed the recent series of trade exhibitions (described elsewhere in this issue).

An impression gathered was that colour TV was not always given the expected brass band treatment. Moreover, it seems more than likely that the BBC, too, is playing the colour scene very coolly during this launch period.

The reasons could be that manufacturers, due to capital risk in setting up production lines, the dangers of over-production and the technical complexity of the final product, would prefer to phase in production on a slowly rising scale rather than go all out for maximum initial impact. Such reasons may be economically sound, even essential, but the viewing public will not have their interest kindled, nor their confidence gained, when sets are in such short supply that most dealers do not yet seem to have either the initiative or the ability to obtain demonstration models from the makers.

But even though colour is so very slow in making headway at the moment, it *could* really get under way when enough sets roll off the assembly lines, when the BBC starts the full service and when the industry generally is *seen* to be enthusiastic. In this interim period, however, most service technicians have availed themselves of training courses organised by set makers and institutions and have studied articles in this and other technical journals. But very few have actually been faced with a genuine faulty receiver—yet!

In the event, colour servicing may not be so daunting, for detailed analysis will often be unnecessary. Makers are building their sets on the unit panel principle, enabling the substitution technique to be used to restore operation. And one will not need much new test equipment, apart from a cross hatch generator (even without colour facilities), a degaussing device and something to measure up to 25kV.

We will, in due season, carry articles on colour servicing. In the meantime, brush up your theory and try not to feel *too* alarmed at the prospect of circuits with up to 80 semiconductors and valves!

W. N. STEVENS, Editor.

THIS MONTH

Teletopics	4
Video Tape Recording—Part 1 <i>by H. W. Hellyer</i>	6
TV at the Shows	11
DX-TV <i>by Charles Rafaret</i>	14
A Look at Transistor TV Circuits—Part II <i>by S. George</i>	15
Inside TV Today—Part II <i>by M. D. Benedict</i>	18
Indoor Aerial for Bands I and III <i>by G. Darling</i>	24
Servicing Television Receivers —Bush TV 135/Murphy V929 Series <i>by L. Lawry-Johns</i>	26
Underneath the Dipole <i>by Iconos</i>	29
Letters to the Editor	31
Colour is Coming!—Part V <i>by A. G. Priestley</i>	33
Your Problems Solved	41
Test Case—59	43

THE NEXT ISSUE DATED NOVEMBER
WILL BE PUBLISHED ON OCTOBER 20

TELETOPICS

DID GREAT BRITAIN INVENT TELEVISION ?



ONE of four new postage stamps intended to illustrate British discoveries depicts a television like that used in the early experiments by John Logie Baird. There is, however, controversy as to whether or not Britain invented TV. Mr. Clive Abbott, the stamp designer, said that his research had raised serious doubts about the authenticity of television being a British invention. The Post Office have admitted removing the name of Baird from the stamp so that it will not cause any historical controversy.

According to *Encyclopaedia Britannica*: "The basic principle of translating light into its electrical counterpart was discovered in 1873 by an English telegrapher, May.

"But the first crude television system was first put to use in 1923 when J. L. Baird in England and C. F. Jenkins in the United States demonstrated the transmission of crude black and white silhouettes in motion."

We would be interested to hear from readers if they have any observations to make on this matter.

BBC-1 and ITV DUPLICATION

PLANS have now been made for the duplication of the BBC-1 and ITA transmissions on bands IV and V as a colour/monochrome service and it is intended that the system, to give approximately 80% coverage, will be completed by late 1971.

BBC and ITA broadcasts will be from the same transmitting sites throughout the country. The intention is that all programmes will be originated using 625-lines, the existing v.h.f. transmitters putting out 405-line pictures converted from the original 625 signals.

WILTS. RELAY STATION

THE BBC has placed contracts for the erection of the 150ft. aerial tower and the building for the BBC-2 television relay station at Salisbury, Wilts. The aerial tower is to be designed, supplied and erected by the J. L. Eve Construction Company Limited, of Morden, Surrey. The building will be erected by J. T. Parsons and Son Limited, of Salisbury. The Salisbury station will transmit BBC-2 including colour on Channel 63, and is expected to be brought into service early next year.

It will bring the BBC-2 television programmes within reach of some 47,000 people living in Salisbury, Wilton and the immediately adjoining areas.

ELECTRONICS BRING CANADA AND FRANCE TOGETHER

DESPITE the rumpus between the Canadian and French Governments, both countries are in perfect agreement about the usefulness of participating in the 1968 Electrical Engineers Exhibition at Earls Court, London, taking place from 27th March to 3rd April, 1968.

The French Government has decided to participate in the International Exhibition and has taken up 300 square metres of floor space. This is the first time France has decided to take part in the Exhibition.

Canada too has now taken up about 300 square metres.

THE Marconi Company recently announced the introduction of a new range of high definition displays, designed to help designers and other users to communicate easily and directly with computers. This new "electronic sketch-pad" provides a simple and direct method of discussing a problem with a computer, in the terms of the problem itself, rather than in a computer "language".

This photograph shows a Marconi engineer using a light pen with one of the prototype display units. The very high definition of the lines on the cathode-ray-tube face can be clearly seen. Each line can be defined by the use of the light pen, and a vector generator used to produce the actual straight line.

Information from the sketch can then be passed directly into the computer, and the light pen used to add to or amend the sketch, or to indicate a particular point on it to the computer.

ELECTRONIC SKETCH-PAD



STOCKHOLM'S TELECOMMUNICATION TOWER

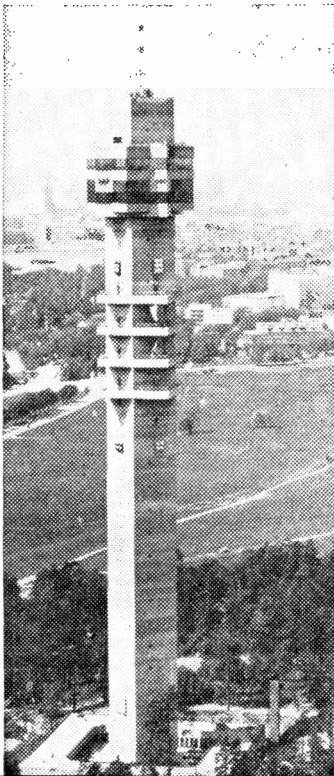

Pictured above, is the Stockholm Telecommunication Tower, which is the Swedish equivalent of our G.P.O. Tower. The photograph shows the different aerials sited on the tower.

We would like to convey our thanks to Mr. Mats Wahlin of The Stockholm Tourist Association for sending us this picture and also for providing us with information which we will be using in an article on the Telecommunication Tower, in a future issue.

Mazda Colour Tubes Guarantee

A four year guarantee is now available to the customer by the payment of an additional sum at the time the colour receiver is purchased.

For the 25in. colour picture tube, the cost to the dealer is £6 10s. and the company recommends that the customer should pay £8 for this facility. This ensures, for the purchaser, free replacement tubes in the 4 year period from the date of installation.

PROFESSIONAL CAMERAS AT MANCHESTER UNIVERSITY

EMI Electronics have been awarded contracts to supply closed circuit television equipment to Manchester University and Padgate College of Education.

The Manchester University scheme will employ three EMI Type 201 vidicon cameras and is believed to be the first educational television system at a university to use professional broadcast cameras. Space has been planned on the control desk for two further cameras, one of which will be used for telecine.

The installation includes vision mixing and switching equipment and video tape recorders. The separate sound control desk incorporates an eight-channel sound mixer, audio tape and disc playing facilities.

Padgate College of Education will be using two of EMI's latest camera channels, Type BC920, and a Type 9A camera. The BC920 is a semi-professional turret camera, designed by EMI especially for educational and similar small studio installations. Padgate plan to distribute programmes via a v.h.f. system.

EMI have also supplied Type 201 vidicon cameras to Rediffusion, main contractors, for the Hull City School Scheme.

"NEWS FILM OF THE YEAR" COMPETITION

DISTRIBUTION of entry forms for this year's "Television News Film of the Year" Competition, sponsored by the Rank Organisation, is well under way. Judging is not until November, but this early start ensures that cameramen have plenty of time to select their best work.

Last year's contest attracted a record entry and the organisers are hoping for even bigger numbers this year.

The rules remain unchanged and the main prize will again be the Rank Organisation Trophy plus 100 guineas.

Judging will be on November 14th, 15th and 16th.

Awards will be presented on Wednesday, December 13th, at the Royal Lancaster, Hyde Park, W.2, when the winning films will be screened.

"Home Sweet Home" Colour TV Demonstrations



THE ground floor showroom of the new Radio Rentals Colour Centre at 467 Oxford Street, London W.1. The basement has been designed to enable the public to view colour television in typical home surroundings.



VIDEO TAPE RECORDING

PART 1

H.W.HELLYER

VIDEO TAPE recording is another of those developments that one may be surprised to learn has actually been with us for a decade now. Recent events, however, notably the marketing of a machine that comes within the pockets of serious semi-professionals, have brought the subject once again into prominence. This is therefore as good a time as any to answer the questions that tape recording enthusiasts are asking about the new equipment, such as: Why is such a high speed necessary? What limits the quality of the recorded picture? Why use frequency modulation to put the video signal on tape? What sort of camera is used? How do we synchronise the picture? Is compatible recording possible? What about head wear, etc? Can we record direct from TV? and Can we play back through any set or must a special monitor be used?

The principle of video tape recording is simply to store the electrical signals which produce the picture on a cathode-ray tube by using them instead to modulate a magnetic tape, thus making a magnetic pattern in the oxide coating of the tape which can be replayed later to produce a replica of the original picture scanned by the camera. There are a number of reasons why we cannot do this in exactly the same way as we deal with audio signals; reasons which cause a studio type video tape machine as used in broadcasting studios to cost in the region of ten thousand pounds.

This is actually much the same as the cost of the first video tape machines between the years of 1956, when the Ampex Corporation of Redwood City, USA launched the first really practical model at the April NAB Convention, and 1958, when other companies developed machines and the professional field, at least, began to widen. It was still to be some time, however, before domestic machines became a practical proposition.

Historical outline

At that first launching, on the historic date of April 14th 1956, Ampex gained orders totalling over 1½ million pounds and broadcasting studios all over the world struggled to equip themselves with this alternative to expensive film recording—even though those first studio-tailored systems cost more than £25,000 each.

In November 1956 a CBS programme, *Douglas Edwards with the news*, was originated at New York City, recorded at Hollywood TV city and later the same night replayed for the west coast. The time difference problem that besets network operators in a country as vast as the USA had been overcome. There were many snags—the Ampex VR1000, good though it was, had limitations that impaired picture quality, but research had been going on since 1952 and the snags

were gradually ironed out. Today's drawbacks are more those of cost and facilities available than picture quality compared with the direct original programme—but that is another story.

The field of video recording widened rapidly, from the obvious application of studio broadcast work to medicine, education, government and industry, and it is now considered by some authorities that the use of video tape recording is roughly fifty-fifty divided between broadcast and closed-circuit applications. With the growth of domestic video tape recording, this ratio should swing still further towards closed-circuit use and the price continue to fall gradually.

The first two Ampex VR1000 video tape recorders to be delivered to Europe were employed by Rediffusion (then Associated Rediffusion of London) in 1958. These 405-line, 50c/s machines came into use in June of that year, chalking up another notable British first. The company now operates six video tape recorders, the originals having already logged up some 8,000 recording hours prior to the changeover to more modern types last year. Some 90 per cent of programme material is now taped, and broadcasting engineers often defy us to tell the difference between live and taped material.

In 1958 Ampex also brought out their first colour television unit. This was for NTSC standards, and it was still some time before the VTR 2000 high-band machine became available for 625-line colour programmes. Ampex claim that this machine is capable of producing "third generation" tape copies comparable with the original. The introduction of this machine was less than two years ago, and since then research has been more concerned with closed-circuit TV and the development of a machine for domestic use. Undoubtedly the advent of helical scan was the factor that made the latter innovation possible. Which brings us to the first important question: What is helical scan? And its corollary, why is it an advantage over linear scanning and what are the limiting factors?

Limiting factors in magnetic recording

The principal limiting factor in any magnetic recording system is the bandwidth of the signal that can be effectively recorded and reproduced. Audio signals, which range from zero (i.e., d.c.) to as much as 20,000c/s, can be handled by passing a tape linearly across a magnetic recording head having a gap of a little over a thousandth of an inch width. This is not the place to go into the theory of magnetic recording; suffice it to say that the varying magnetic field produced across the

record head gap by the signals fed to the coils in the head causes flux variations which magnetise the tape oxide in a pattern that is proportional to the original signal. The pattern can be considered as a number of small magnets whose length depends on the wavelength of the flux variation, or, more immediately obvious, on the frequency of the signal. Thus with a constant tape speed the higher frequencies will have a shorter wavelength than the lower frequencies. Looking at it another way, in a given time, more "magnets" will be formed in the tape oxide by the higher notes recorded.

The upper limit is determined by several factors. First, the gap width for playback must be small enough to "scan" the smallest of these magnet formations. If the magnet of one cycle is smaller than the gap, it will not be defined—upper frequencies will be lost. Next, the shortness of the magnets can itself lead to loss of definition, for the magnets tend to demagnetise themselves by their actual shortness. And, finally, the high frequency bias which is necessary to overcome part of the non-linearity of the recording process tends to reduce the effectiveness of the higher frequencies.

Tape speeds

Part of the answer to the problems of limitation so far discussed is to speed up the travel of the tape past the head. This gives, in effect, longer magnet lengths on the tape for the same recorded frequency. Thus higher frequencies can be handled when the tape is transported at a higher speed. Normal recording speeds are $3\frac{1}{2}$ and $7\frac{1}{2}$ in./sec., giving a useful frequency range with head gaps of 0.00012 in. of up to 15,000 c/s. Slower speeds are also employed, usually sub-multiples of the foregoing, $1\frac{1}{2}$ or $\frac{1}{2}$ in./sec., and some of the more recent cassetted audio machines have odd speeds such as 2 in./sec.; and quite good results are obtained at such speeds by the use of finely machined heads and improved quality tape. At the higher end of the normal speed range, professional machines employ 15 and 30 in./sec. speeds of tape transport to further extend the frequency response. But the limitation occurs at around 20,000 c/s., and the advantage of the higher speeds is usually that special heads can be used which wear less quickly, while maintaining the high frequency response.

So, for audio signals, we can say that a bandwidth of 20kc/s is about the limit, and that this can be handled by a tape travelling linearly past the head at 15 in./sec. But for recording and replaying television signals the bandwidth we need to be able to record in order to reproduce the finest details is more like 3Mc/s for 405-line signals and over 4Mc/s for a 625-line signal.

Even if we accept some degradation in picture quality, and allow the horizontal resolution to be impaired by limiting the bandwidth to 2.5Mc/s, a tape would have to travel at about 200 in./sec. past a head with a $2\mu\text{m}$ gap to achieve anything like a good "top-end" response.

There are several reasons why this is not a practical proposition. First, the playing time is severely limited by the amount of tape that would be needed. A half-hour programme would take

30,000ft. of tape at this speed. When we consider that a quadruple play tape (about the finest in domestic use at present) of about 10,000ft. occupies a reel $10\frac{1}{2}$ in. in diameter, it can be seen that the spool size is one limiting factor. Another is the mechanical system; quite complicated braking would be needed for reels of the weight we are discussing, and motors would have to be much more powerful than at present while maintaining their regularity and precision.

A further consideration is the difficulty in keeping the tape in intimate contact with the surface of the recording or playback head while reducing wear—the friction at the speed we are discussing would be fearsome. But perhaps the least obvious difficulty is that which would give the greatest trouble. This is the need to provide equalisation over the very wide bandwidth.

Equalisation and bias

Equalisation is the tailoring of the response of the playback amplifier to give a characteristic with a falling treble at an even rate of 6dB per octave to allow for the rising response of the signal voltage at the playback head. But this is under ideal conditions: in practice, such things as head losses, which become quite severe at higher frequencies and would be formidable at the high speed envisaged, make the equalisation curve a complicated proposition. Distortion results. High frequencies are also the deciding factor when we consider the bias that is necessary to make recording possible. For a number of reasons, this bias frequency has to be four times or more the frequency of the highest signal to be recorded. At audio frequencies, this brings the bias to about 60kc/s and even there we have problems with r.f. heating effects and self-erasure due to the h.f. bias frequencies. These problems are greatly multiplied when we come up to the regions of video frequencies.

One partial solution is the employment of cross-field biasing. A separate bias head is used, its gap applied to the tape on the reverse (i.e. polished) side and at a point slightly in advance of the recording head. The tape becomes pre-magnetised so that the recording signal is outside the range of the bias signal and this reduces high frequency losses. This system, widely used by Akai, and lately in some Tandberg tape recorders in the audio field, is the basis of the Akai video tape recorder, which has a linear tape speed of 30 in./sec. and a useful bandwidth of 1Mc/s.

1Mc/s is hardly enough for studio quality resolution, but there are several ways this can be increased without the need of whipping the tape past the heads at impossible speeds. Nevertheless, the blind alley of increased bandwidth with special circuits and a limited tape speed was followed by several early makers of video recording machines.

Early UK video tape recorders

As long ago as 1964 a British video tape recorder was ready for the domestic market, but for business reasons that cannot be detailed here was not produced. Telecan used normal $\frac{1}{4}$ in. recording tape

with two video and two audio tracks and a speed of 120in./sec., with 10½in. spools. It was the brain-child of two British engineers, Norman Rutherford and Michael Turner.

A year after the frustrated Telcan, a similar machine appeared on the market, this time in a kit form to be marketed for £97 10s. The firm behind this venture was Wesgrove Electronics Ltd. The recording system, using standard ½in. tape, was simultaneous half-track video and sound, the latter being on an f.m. carrier to prevent interaction, running past fixed heads at a speed of 150in./sec. Triple play tape was employed, giving about a half-hour of programme time for the rather large spools (11½in.).

The reduction of this machine to its bare necessities meant sacrificing the fast rewind function, and for respooling it was necessary to invert the reels and wind free of heads and guides. Speed change for 90, 120 or 150in./sec. was by interchanging capstans, and drive was by belt from a 1/10h.p. motor.

A frequency range of 2Mc/s was stated at the 90in./sec. speed but permanent magnet erasure had to be used and d.c. bias was fed to the heads with the synchronising pulses when recording. The video waveform was extracted from a normal receiver and passed through a head driver unit, while the sync pulses were differentiated and, on replay, a pre-amplifier and integrator with sync re-insertion completed the basic set-up, the reproduced signal being applied again to the unmodified video stage of a normal receiver.

Transverse scan system

Professional recording engineers had long since realised that the limitations in bandwidth could not be improved by making linear speed faster and faster. One solution was to improve the relative tape-to-head speed by moving the head also, and a method that was costly but very effective had been in use for some time by recording studios. This was the transverse scan method. By mounting four heads on the periphery of a drum rotating with its axis in line with the tape travel, i.e. diameter at right angles to tape travel, and passing the tape at 15in./sec. an effective tape velocity of some 1,500in./sec. could be realised.

Because of the movement of the tape and the relative arc of the recording heads, the actual track scanned across the tape is not exactly at right angles to the tape travel, but has a slight right-to-left slope. In the Ampex system, two edge tracks were employed at the top for servo control pulses and the audio signal and the remainder of the track width was scanned by the four-head disc. A switching arrangement transferred the signal to the active head at each appropriate moment. The intimate contact of the tape with the head, now made a greater problem by the transverse head movement, is obtained by a vacuum-pump arrangement. An air pump attached to the head guide extracts air from the space between the tape and guide, i.e. acts as a sucker to the polished side of the tape, and forms it to the shape of the head travel arc.

Naturally, this "cupping" method is expensive, and makes a lot of demands on tape quality. Moreover, the price of top-quality tape being so high,

operators were not keen to chop it about, and a compromise system between tape-hungry but bandwidth-limited linear scan and wide-tape transverse scan had to come. Helical scan was the answer.

Helical scan system

Three main helical scan systems have been developed and some of the prime features of each will be discussed. But we are more concerned, in this short series of articles, to look at the special problems that video recording poses, and to discuss the kinds of circuitry used to overcome these problems.

The three systems we shall consider here are the Ampex, Sony and Philips video recorders. Each has its individual peculiarities. Only the Sony system has thus far admitted there may be a demand for such a device on the domestic market and has tailored its price accordingly. Doubtless, by the time this appears in print rival concerns will have trimmed their sails to compete. For example, the Ikegami video recorder is currently entering the British market at £800 (plus £190 or so for the camera, which has, unfortunately, a fixed lens system). Its four-head helical-scan system is again non-standard, using tape ½in. wide at a speed of 9in./sec. A bandwidth of 2.2Mc/s is claimed and with 7in. spools it runs for 65 minutes per track.

A single-head helical-scan system was adopted by both Ampex and Philips but, despite superficial similarities, these two firms have between them widened the variations in the field of video recording almost as much as have the rival cassette systems in the audio market.

Heads

There are certain advantages to a single-head system that may have influenced Ampex to revert from the two-head design of the VR1500 to the single-head design employed in the VR6000 and similar models. In the first place, no two video heads have exactly the same characteristics, which means that rather complex limiting circuits are needed to level the response of each head to obtain a linear composite signal. We shall see more of this when we come to the Sony circuitry. Moreover, the material of which the head is made, however good, is subject to wear, and there is no guarantee that the heads will wear at the same rate. Irregular head wear can become rather obvious in patchy reproduction. Philips overcame the basic problem with a single-head ferrite system, Ampex use complicated circuitry to compensate, but Sony have come up with a head which is a wafer of crystal that does not wear at the comparatively high rate of ferrite heads.

Video recording heads are expensive. The Philips types cost some £25 and no doubt the Ampex ones would knock a sizeable hole in anyone's pocket. But we must remember that development costs have been immense. Philips tell us that they have laid out some two million pounds on the research behind their beautifully neat EL3400 head.

One of the "dirty words" in electronics is *compatibility*. The TV engineer understands it to mean that a receiver capable of picking up colour broadcasts shall also do justice to black and white programmes. The audio engineer is concerned that a tape recorded on one machine will replay on another without the need for tone control adjustment. But in the video tape world the word is much more restricted. With so many different systems and standards to consider, it is as much as can be done to make compatibility mean that a tape made on a machine of a certain type shall be replayable on another machine of the same type. Even this apparently obvious limitation is something of a triumph in video tape! My own experiments in the field have shown that it is possible, by juggling with the three basic elements of the system, i.e. camera, tape recorder and monitor, to obtain results so widely different with the same piece of tape that any attempt at diagnosis must be qualified by the knowledge that true compatibility is still a hopeful dream. But these are early days. . .

Ampex system

Returning to the systems to be described, however, the Ampex single-head systems are based on 1in. tape, with 3,000ft. of 1.4 mil thickness on 9 $\frac{3}{4}$ in. diameter reels. Figure 1 shows the layout of the helican scan system. Note the two capstan guides, which are mounted on a common shaft. These are rubber covered to maintain a good friction contact between tape and capstan without the need for pinch wheels, rollers or belts. (Surprisingly, the last device is reported as a recent innovation, providing a more constant tape drive than the conventional roller and capstan method.)

In the Ampex system, the single head rotates within the wrap of the tape, the whole upper half of the drum turning so that the tape "floats" on an air cushion. The relative head-to-tape speed

for a 50c/s system is 833in./sec. (1,000in./sec. at 60c/s). The drum in this model is of 5.3in. diameter and the tape wrap describes a nearly complete helix.

Helical scanning

The operative word is "nearly". Helical scan systems are arranged to give sufficient coverage of tape surface to record a single field with every rotation of the head. But the period of each rotation during which the head is out of contact with the tape represents the loss of a few lines of picture information. The helix is not complete, and even the staggered head system of the Sony video tape recorder is not a complete field scan, as we shall see. Two-head systems can be arranged so that one head is contacting the tape in the correct position before the other leaves it, but this needs a good deal of complicated switching, therefore increasing costs. The battle, nowadays, is to simplify video tape recording systems; switching has therefore to be reduced.

Direction of tape travel is from left to right, and after leaving the feed spool, at the left, the tape passes a tensioning arm. This device is part of the compatibility arrangement, being a virtual fixed guide during recording, but acting as a variable tension arm during replay to allow for differences between tapes. The guide system is also variable, opening to give easy threading clearance for loading and unloading the tape, then closing inward to achieve a closer helical wrap.

Full track erase is prior to the tape entering the drum and on some versions the control track is recorded at this point along the upper edge of the tape. After leaving the drum, i.e. after video scanning, the audio track is recorded along the lower edge, a narrow track being erased for this purpose. To prevent interaction between tracks, the erase band is slightly wider than the recorded track, dimensions being as shown in Fig. 1b. In some models the control track is recorded at the same stage as the audio track.

With this particular machine, a wide range of facilities is included to allow its use on any of the existing TV systems. Thus four basic line standards and two field standards can be catered for. The relative playing time varies with the different standards because the relationship between scanning speed and tape speed is altered in each case. This is to ensure that the sync pulses match properly on adjacent scans. Thus while when 625-line recording the tape speed is 9.45in./sec. and the playing time 62 minutes, on 405-lines the tape speed is 10.42in./sec. and the playing time is reduced to 56 minutes. A control is provided to adjust the video head exactly to a pre-recorded track to reduce noise problems during replay.

Other special features on this machine are the ability to record a single audio track on the tape, without affecting existing video or sync signals, and the method of halting the tape while allowing the video head to continue rotating, thus scanning a single field. As, however, there must be some slight difference between the scanning angle in this mode and the slight curvature when moving (the *dynamic scanning angle*, to give it the proper name), the reproduced picture is not as clear as

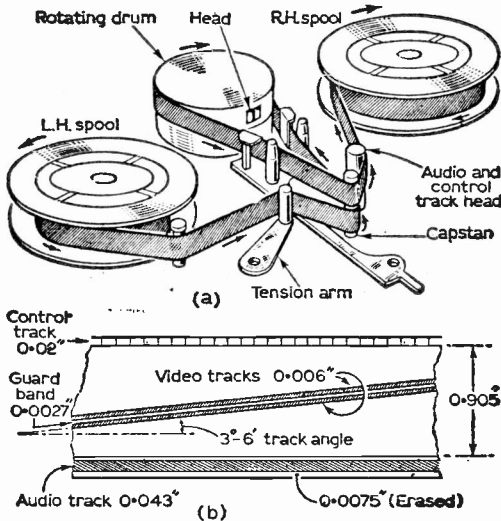

Fig. 1: Ampex mechanical system and track dimensions.

that from the moving tape. Sports followers who watched the "freeze" shots when goals were scored (or interesting fouls took place!) during last year's football jamboree will have noticed this peculiarity, even with the more elaborate studio equipment.

The application of the control pulses and the way these operate to maintain the drum speed, etc. will be discussed in greater detail later. For the present, let us take a brief look at the mechanics of the rival systems.

Philips system

It will immediately be noticed that the Philips system (Fig. 2) appears to be very similar. Most obvious differences are the levels of the tape around the drum, the different direction of head rotation and the take-up spool threading. There are many other changes. The tape width is 1in. as before, but tape speed is 7½in./sec. An 8in. spool with 1,800ft. of tape gives a playing time of 45 minutes. Again, the rotation of the head follows the field scanning period, so that the rotation is 50 per second, each scan of the head across the tape recording one field. Actually, the length of each "wipe" of the head across the tape is some 47cm., and it is inevitable that a few lines are lost as the head exits from one end of its scan before starting the next, but the synchronising is so arranged that the lines lost are those just before the flyback, i.e. the ones that would normally be at

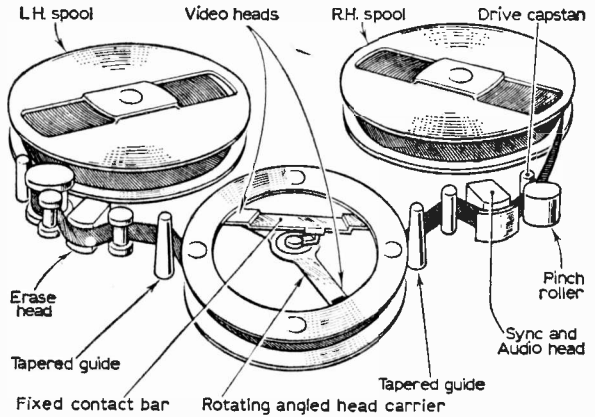

Fig. 3: Basic layout, Sony model 2000

the very bottom of the picture.

This is arranged so that the complete field pulse is recorded and the succeeding field then follows with no break in recording, to aid synchronising. Again, there are some interesting synchronising features which will have to be omitted at this point, while we finally take a brief look at the Sony system.

Sony system

Observant readers will have noticed that in the above references to "fields" being scanned we mentioned a head rotation of 50 times a second. This means that while the head helically scans the tape in the time of one complete field, the number of lines recorded in this time will be half those appearing in one complete interlaced picture of two fields. In the Philips machine, the head-to-tape velocity of 906in./sec. gave a virtual bandwidth of 2.5Mc/s.

Sony have a different way again of achieving the bandwidth necessary for good pictures. A two-head system is used, with the heads on a staggered arm; the helical scanning is similar to the previously described systems, with one of the heads doing the recording. The tape travels at 7½in./sec., but the head rotation is 25 times a second. Using ½in. tape and again with the control track at the top and audio track at the bottom, this ingenious system records every other field and then plays this back twice by switching in the second head to reproduce each recorded field nearly twice in each rotation of the head assembly. This is not quite true picture reproduction, but the ultimate effect is a bandwidth better than 1.8Mc/s and a picture of quite good quality. In view of the remarkable reduction in price and retention of many of the good video recorder features of the expensive machines this model, the Sony 2000, can justly be described as a technical breakthrough. We shall look at it in some detail in following articles.

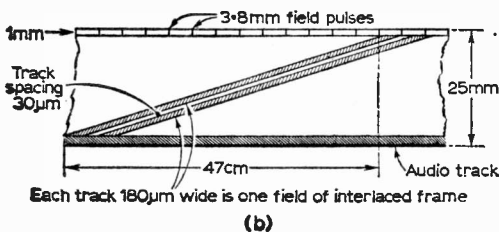
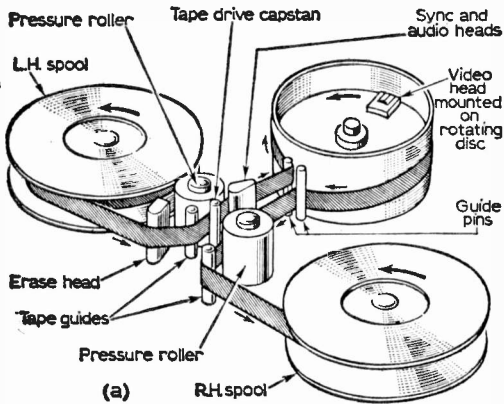

Fig. 2: Details of the Peto Scott video tape recorder.

To be continued

TV AT THE SHOWS

REPORT FROM THE "PRACTICAL TELEVISION" TEAM OF THE LATEST RECEIVERS AND TRENDS SEEN AT THE TRADE SHOWS DURING THE PERIOD OF AUGUST 20-25TH

AS one would expect, the main feature at this year's London trade shows was colour TV, and it was fascinating to see dealers crowding round all available colour receivers. The magic of colour TV may be judged by the fact that nearly all of them soon became absorbed in the films being shown, and forgot they were supposed to be assessing the quality of the receivers and the pictures produced.

DISPLAYS

Some manufacturers seemed bent on an overwhelming display; Bush had dozens of colour sets operating next to one another and the intended effect was certainly created. Other makers were content to show sets in "domestic" settings and had just one or two different models operating. Both approaches have their merits: when many sets are operating, the unavoidable differences in colour rendering are accentuated, but the total effect remains impressive; with only one or two sets operating, it is difficult for everyone to see, and in any case, a demonstration in a hotel is not the same as viewing a set at home.

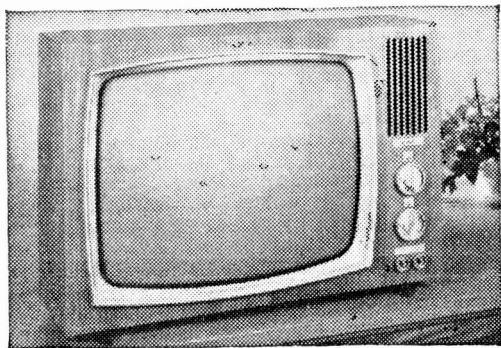

G.E.C. MODEL 2023 — 23" TV

The 2023 is a 23" television in a teak cabinet with silver trim and controls. Its main features are implosion-free tube that eliminates the need for a separate screen guard. A transistorised continuously tunable U.H.F. tuner for peak performance. Forward facing high sensitivity loudspeaker for perfect clarity and a new all programme 5 position V.H.F. tuner for adjacent channelling and instant station selection. All components are mounted at the base of the receiver for a cooler running longer life. Whole chassis slides clear of cabinet whilst remaining in circuit for instant servicing.

The c.r.t.'s employed in the current colour sets are of the shadow-mask type and made by Mazda or Mullard. The popular size is 25in. and this will seem large to those who find 23in. tubes rather too big for home use. The truth is that a 25in. c.r.t. is not too big, even in a small room, if a 625-line programme is being viewed, and results are even better when the programme is in colour. With 405-line pictures, however, results in small rooms are likely to be poorer, with the scanning lines easily visible.

19in. SETS

G.E.C. showed their 19in. colour set which is currently in production and sells at about £260. This is the only 19in. set actually being produced, but Decca were showing one (about 300 gns.) and the Pye group is also planning a 19in. receiver for release next year.

Alba announced a colour set—it is a 25in. model and has a hybrid circuit with push-button tuning, a visual tuning-meter, automatic demagnetising, and a push-button tone control. The price has yet to be announced.

The "automatic demagnetising" which is included on most of the sets helps to eliminate one item which is frequently mentioned in the folk-lore of colour TV. The shadow-mask c.r.t. (which has been dealt with in the September 1967 issue of PRACTICAL TELEVISION) can give very inferior results if the shadow-mask or the metal band round the tube becomes magnetised. In modern receivers, the bowl of the tube is surrounded with a shield of magnetic material and a coil wound on to the shield. The coil is then fed with alternating current of a suitable magnitude each time the receiver is switched on. The circuit supplying the current often uses thermistors and is designed to ensure that a surge of current takes place on switching on, the current flow gradually decaying until what remains may be neglected. The decaying current demagnetises the c.r.t. in the same way that tapes are demagnetised or erased on a tape recorder, or indeed, on a bulk eraser. The Thorn receivers demagnetise the c.r.t. when line standards are changed too, two thermistor circuits being used.

LOWEST PRICE

Baird seem to have many more models than their competitors and also claim to be marketing the lowest priced 25in. model—the 701 in Melamine-finished teak or walnut veneers. The chassis of the Baird model is in sections like most colour

sets, with printed panels for decoder, timebases, convergence, i.f. section, power supply, and tube-base components. The u.h.f. tuner is transistorised and the v.h.f. tuner valved. The receiver is mainly transistorised, but stages such as the sound output, colour-difference amplifiers, and timebases use valves.

Colour sets were also shown by the Thorn group. Their all-transistor chassis was mentioned in our July issue, with further technical information in our September issue.

IMPORTED SETS

One imported colour set was seen and this was a 25in. model from Nordmende. It is expected to retail at about £330. Another imported set announced recently is the S.S.C. Luxor "Colorama" 25in. colour TV, priced at 305 gns. This receiver is for 625-line operation only, and will therefore be limited to BBC-2 reception at present.

Dynatron's Queen-Anne-style colour set is currently in production and priced at 349 gns. The CTVICH in Chippendale-style will be in production in December and also be 349 gns. A third model, the CTV2, will be a Scandinavian-style console with tambour doors and finished in teak veneers. The price has yet to be announced, and production will start in February next year.

The S.T.C. group, which includes KB and RGD, seemed to be the only one with no colour TV in current production. However, a colour set was exhibited and featured front-access to the convergence controls.

The Pye group colour sets all have a suggested price of 312 gns.—the brand-names involved are Pye, Ekco, Ferranti, and Invicta—and the sets have 25in. c.r.t.s.

Philips have three 25in. colour sets and were showing them at Harrogate during the period of the London shows. The models are the 500, 501

and 502 and they are priced at 295 gns., 325 gns. and 305 gns. respectively.

CABINETS

The screen-size of colour sets has meant a return to the large cabinets common not too many years ago. A contributing factor is the increased amount of circuitry which has to be accommodated compared with monochrome sets. The big cabinets permit better sound quality, more room for servicing, and give a "solid" appearance, of value (in keeping with their price).

The circuitry for colour reception must of necessity be better than that generally employed for monochrome sets; the vision characteristic must be flatter and more carefully defined; the sound rejection must be very good; the tuner must drift hardly at all; and an a.g.c. system of the gated type is an advantage. This latter fact has caused difficulties in design owing to the necessity for standards-changing from 625 lines to 405 lines. The a.g.c. system must produce a control-potential dependent on the level of signal being received, and the content of the picture must not influence the control-potential; this requirement is easier on 625 than 405.

FORECAST

The general view obtained from talking to designers of colour sets is that the need for standard-changing results in one compromise after another in the design of the sets. Though the results obtained on both standards are usually excellent, the 625-line pictures are better and not only because the system is inherently better. This leads us to make the forecast that British manufacturers will soon be bringing out colour sets purely for use on 625-line reception. After all, it seems rather pointless to invest in a colour set and use it for most, or even half, of the time viewing monochrome signals on Bands I or III. The design of a set for u.h.f. reception only should bring economies in components and circuitry and result in colour reception being that much less expensive. Whether or not our forecast comes true remains to be seen.

Another point in favour of such a radical change in colour receiver design is that monochrome programmes are better when viewed on a monochrome set, particularly 405-line programmes. The current fashion is to have two TV sets (at least) and the idea of having one for colour and one for monochrome seems a good one. A provincial dealer told us that when any of his rental customers change to colour, they will be invited to continue to rent their existing monochrome set, but at a much reduced rental.

TEST EQUIPMENT

The introduction of colour TV has meant the appearance of new test equipment on the market. Rank Bush Murphy now have available an e.h.t. voltmeter, an i.f. sweep generator, a u.h.f. signal-strength meter, a demagnetising coil, and a cross-hatch generator. A demagnetising coil is often a necessity when installing a colour set and is used to demagnetise the tube and any surrounding

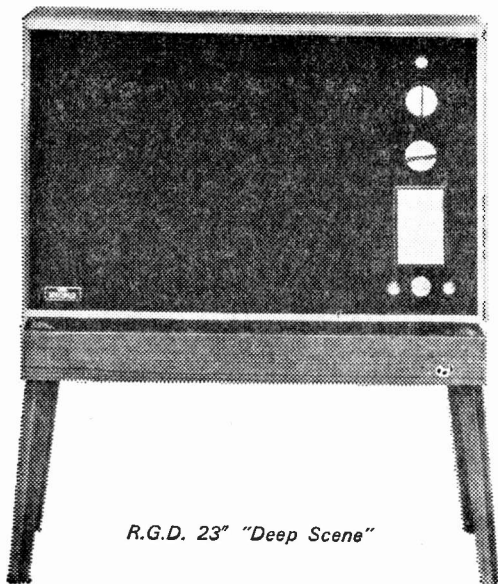

R.G.D. 23 "Deep Scene"

objects—such coils are often called “degaussing” coils, for no apparent or good reason. A cross-hatch generator is another requirement when setting up a colour set, and provides a grid of white lines on a black background for use when adjusting the convergence of the receiver. The number of lines is normally variable to suit the engineer using the instrument, and most generators can also give white dots instead of a cross-hatch. The output is generally r.f. suitable for feeding into the aerial sockets of the receiver (checks must be carried out on 405 and 625).

Labgear also had a number of items on show including a transistorised portable signal-strength meter for Bands I, III, IV and V. It operates from two PP6 batteries and reads from 25µV to 10mV, or higher if attenuators are used. Labgear also had a pattern generator for use when setting up colour sets (or black-and-white sets, if required, of course). The generator provides horizontal lines, vertical lines, cross-hatch, or dots, and the output is at r.f.

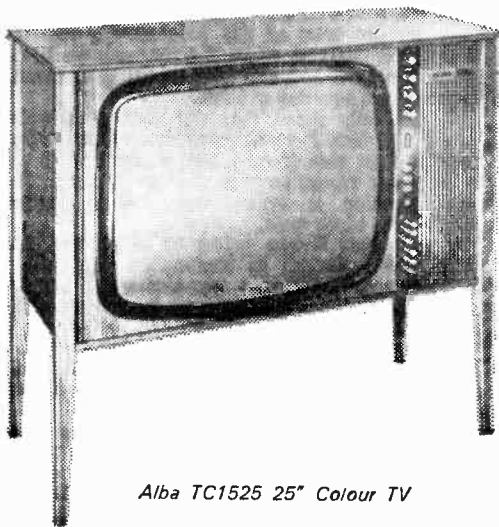

Alba TC1525 25" Colour TV

AMPLIFIERS

Other items from Labgear were a wide-band preamplifier for Bands I and III, and three for u.h.f., one being designed for mast-head mounting and giving 14dB gain. Power is fed via the down-lead and mains supply—units are available.

MONOCHROME SETS

So far as black-and-white receivers are concerned, there seemed to be a welcome interest in the quality of the picture, an interest which has been lacking in recent years. For example, Decca announced the “Professional” 23in. Receiver which has a recommended retail price of 125 gns. This set has a number of unusual features all of which are aimed at obtaining the best results from the transmitted signals. As is well known, most television receivers contain compromises somewhere

—continued on page 44

NEXT MONTH IN

Practical TELEVISION

Co-Channel Interference

In this country, to ensure that reception of BBC1 and ITV transmissions are satisfactory for the majority of viewers, a large number of TV stations are required. Because the number of channels however are limited, it is necessary for more than one station to work on the same channel number. The problem will also become quite acute as further u.h.f. channels are exploited. Due to directional aerial systems and siting of TV transmitters this problem is largely overcome—however due to other factors, co-channel interference will become more of a problem in the very near future. Methods of combating this type of interference and its effects on reception are illustrated. A filter to reduce this interference will shortly be available to dealers throughout the country, and brief details of this unit are given.

Helical Aerial

On the Continent the helical aerial is widely used for u.h.f. TV reception. Although its design is unusual it is claimed to be quite efficient. The construction is well within the capabilities of the average amateur, and is mainly intended for indoor use. Nevertheless, there is no reason why to improve performance an outdoor version cannot be constructed.

Plus —

Part 6—Colour is Coming—More about Video Tape Recording—Video Stages in Transistor Receivers—and all the regular features.

ORDER YOUR COPY ON THE FORM BELOW

TO.....
(Name of Newsagent)

Please reserve/deliver the NOVEMBER issue of PRACTICAL TELEVISION (2/-), on sale October 20th and continue every month until further notice.

NAME

ADDRESS.....

DXW

A MONTHLY FEATURE
FOR DX ENTHUSIASTS

by Charles Rafarel

NOT quite such good conditions this time and neither S.P.E. nor tropospheric openings have been maintained at such high levels.

There has, however, been some reasonable activity, although on several days there was an almost complete absence of any signals at all. And although there is still of course plenty of time for the current S.P.E. season to improve I have a feeling that 1967 will not be as good as previous years.

The tropospherics have been fairly good at times, but the rainy days of early August certainly "damped-down" reception in all bands, including u.h.f.

There was an unusual example of S.P.E. propagation on 22/7/67, when on E2 channel at 11.44 I suddenly received a very short duration 625 line positive picture which could only be B.R.T. Ruiselede, Belgium! The distance is only about 200 miles, and the reception was typical of S.P.E., and as such must rate as the shortest skip ever for me. Some time ago you may recall R. Bunney and myself reported R.T.B. Liège, Belgium via S.P.E. as being exceptional, but this skip is much shorter. Here is the S.P.E. reception report for the period 15/7/67 to 18/8/67:

15—16/7/67. Spain E2, 3, and 4, Portugal E3, Italy IA.

17/7/67. Sweden E2, and 3.

18/7/67. Poland R1, Czech. R1, and 2, Spain E3, and 4.

19/7/67. Poland R1, and R2, Czech. R1, and R2, Switzerland E3, W. Germany E4, Yugoslavia E4, Austria E2a, Norway E2, Italy IA, and IB, Corsica Bastia F2.

20/7/67. Italy IA, and IB. Spain E2, and E3.

22/7/67. Belgium E2 (very short skip). Austria E2a, and E4, Spain E2, and 4, Hungary R1, W. Germany E3, Italy IA, and IB.

28/7/67. USSR R2.

29/7/67. Czech. R1.

30/7/67. Spain E3.

31/7/67. W. Germany E2, and 3, Italy IA, Yugoslavia E3, and 4.

1/8/67. USSR R1, Spain E2, and 4.

2/8/67. Spain E2, 3, and 4, Czech. R1.

3/8/67. Czech. R1, and 2, W. Germany E4.

4/8/67. Spain E2, 3, and 4, Italy IA.

5/8/67. Czech. R1.

7/8/67. Italy IA, and IB, Yugoslavia E4, W. Germany E4, and Portugal E3.

8/8/67. Czech. R1.

10/8/67. Czech. R1, Sweden E2.

12/8/67. Czech. R1. Spain E2.

13/8/67. Spain E2, 3, and 4.

14/8/67. Spain E2.

15/8/67. Sweden E2, 3, and 4, W. Germany E2, and ? Finland E2 (for first time 1967.) W. Germany E2, USSR R1.

16/8/67. USSR R1, Czech. R1, Poland R2, and Spain E3.

18/8/67. Czech. R1.

NEWS

First of all a correction about the usual muddle over the Test Cards (Retma type) for Poland and Hungary. D. Kelly reports reception of the card on R1 and R2, followed on R2 by the T.V.P. Warsaw caption, at the start of the programme, and the card definitely carried white figures with no break between the card and the start of the programme with clock, and opening caption.

This can only mean that the card with white figures is in fact Poland, notwithstanding earlier comments that this looked like Hungary. In the light of better reception this year as evidence, the present position is Poland with white figures, Hungary with black ones.

My wife and I are going to Bratislava and Budapest plus Zagreb in September next and I hope (language difficulties permitting) to extract news from all these TV services, and particularly Budapest *re* Test Cards.

Mr. Bowers reports with others, the use of a relief map of the Canary Islands, behind the local news reader on Azana E3, this is a help in identification.

Another "exotic"? R. Bunney notes reception on E2 on 12/8/67 at 18.56 of "a coloured announcer in a white coat", it was a very short duration signal, and although we have no precise idea of its origin, it certainly does make one think in terms of Africa.

He also gives the latest news on sun-spot activity. At the end of May the count was quite high, but June was well below the predicted figure (in fact only 60). Predictions are as follows: Aug. 90, Sept. 92, Oct. 94, Nov. 96, rising to 100 in Jan. 1968, so we might well get some very interesting F2 DX in Dec.-Jan. next.

Mr. Bunney also reports reception of ORTF2 Vannes Ch. 56, so this looks like a chance for u.h.f. DXers in the South.

READERS' REPORTS

C. R. Dykes of Bexleyheath has presented us with a very full log including Italy, Spain, USSR, Hungary, W. Germany, Austria, and Czechoslovakia, and what I would suggest was his best "catch"—Corsica Bastia F2.

D. Kelly of Castlewellan, N.I., has been doing well and the latest list covers Spain, Portugal, Italy, Czechoslovakia, Belgium, W. Germany,

—continued on page 32

TRANSISTOR TV CIRCUITS

S. GEORGE

THE use of transistorised i.f. stages represents a logical step towards the completely transistorised receiver, and while the use of transistors involves the inclusion of an additional stage or stages compared to valved i.f. circuits in order to achieve sufficient gain, a number of hybrid models using transistors for all stages up to the audio and video stages have been marketed. Transistorised television i.f. strips generally employ three vision i.f. stages and a further couple of sound only i.f. stages, with the sound take-off on 405 after the second vision i.f. amplifier whilst the sound signal passes through the complete vision i.f. strip on 625. In the vision i.f. strip the final stage is wideband tuned, but stagger tuning may be employed in the initial vision i.f. stages.

I.F. Circuit design

As with valved circuits, i.f. circuit design has to take many and often conflicting requirements into account. It will usually require an overall gain of at least 75dB from tuner output to vision detector to supply the latter with several volts of video signal; it will also require a bandwidth of 3.5Mc/s on 405 and 6Mc/s on 625, trap circuits to reject adjacent channel signals on v.h.f. and u.h.f., and circuits to extract the respective sound signals for further amplification on both systems. Additionally, at least one stage must be controllable by an a.g.c. voltage without sensibly altering the overall response curve.

Finally, most transistors for use at i.f. need neutralisation to prevent any tendency to instability through internal feedback, though it is claimed that this is not necessary with the latest epitaxial planar types.

A great deal of research has gone into the development of transistors especially suited to these stringent television requirements, and Mullard's TVistor range for example includes types for both high and low signal levels in both the vision and sound channels.

The first transistor in vision i.f. strips is invariably used in conjunction with a.g.c., and must therefore have a high maximum gain smoothly variable down to a low value without substantially altering circuit response. The second i.f. transistor, though not automatic gain controlled, will also need to have high gain, and is usually of the same type as that used in the first stage, either an AF181 where germanium pnp transistors are used or a BF164 where silicon npn transistors are used. The third and final vision i.f. stage requires a different type able to handle the greatly increased

signal level at this point and is generally an AF179 or BF159 for pnp or npn line-ups respectively.

Forward A.G.C.

For maximum gain, the transistors are used in the common emitter mode, and forward a.g.c. is applied to the first stage. With forward a.g.c. an increase in signal strength produces an a.g.c. bias that increases the collector current of the controlled stage, and reduces its gain. To achieve this end a resistor is connected in series with the controlled transistor's collector, generally about 390 Ω , to progressively decrease collector voltage as the current rises.

Transistor sound i.f. amplifiers, on the other hand, do not need the wide gain control characteristics of vision types. The AF115 transistor is used in the sound i.f. stages of receivers using pnp transistors and the BF158 or BF159 where npn line-ups are employed. Two stages are invariably used and, as with the vision strip, a.g.c. is only applied to the first stage, but in this case either forward or the conventional reverse type of a.g.c. may be employed.

Application of A.G.C.

As with transistor radio receivers, the application of a.g.c. presents more problems to the set designer than where valves are used. The latter, being purely voltage operated, impose no loading on the a.g.c. circuit, but a.g.c. bias for transistors involves a small power outlay which must be provided by the receiver itself.

In transistor radio design, it is common practice to use a single automatic gain controlled i.f. stage but to have in addition an overload diode which augments the a.g.c. range by conducting on very strong signals, loading one of the i.f. transformer windings, and thus reducing gain. In some designs a transistor detector instead of the usual diode is used and the amplification it provides is made use of in the a.g.c. supply circuit.

Amplified A.G.C.

However, with television transistor circuits a rather different approach is made. As power supply is plentiful, the a.g.c. potential is invariably amplified by a separate one or two stage transistor

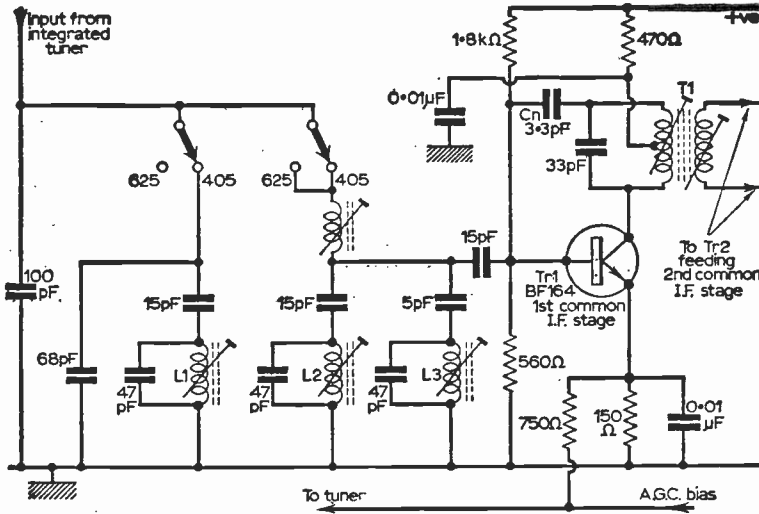
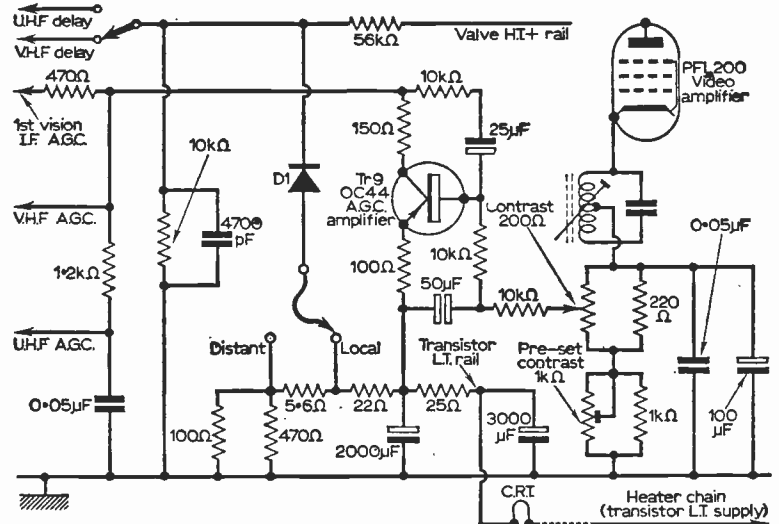

Fig. 4 (left): First common i.f. stage in the Pye 40F hybrid television model, using a silicon npn transistor. L2 and L3 shape the response on both systems, with L1 introduced in addition by switching on 405 to modify the response. Cn provides neutralisation. The a.g.c. voltage from a transistor a.g.c. amplifier controls Tr1 emitter potential and thereby its effective base bias, the 470Ω collector resistor providing the forward a.g.c. action.

Fig. 5 (right): Transistor a.g.c. amplifier stage used in G.E.C./Sobell hybrid models. As the input to the video amplifier increases, so does its cathode voltage reducing Tr9 collector current and thereby the a.g.c. line voltage. Reducing the a.g.c. bias applied to the emitters of the controlled stages increases the current through them thus reducing their gain through forward a.g.c. action. Emitters of the r.f. amplifier transistors are fed via a 56kΩ resistor from the valve h.t. rail until the a.g.c. bias reduces to about 12V when D1 clamps their supply to the transistor l.t. rail.



amplifier to give a really wide range of control without loading the a.g.c. source.

As a typical example, the single transistor a.g.c. amplifier stage used in the G.E.C. 2012/Sobell 1012 models is shown in Fig. 5.

In these receivers, the coupling from the video detector to the grid of the video amplifier is d.c. on 405 but a.c. on 625, when an additional diode is brought into circuit to provide a d.c. component in the same sense as that of the 405 signal so that the video valve current rises on both systems with increasing signal strength. The video amplifier cathode voltage is therefore a function of vision signal strength.

In the cathode lead of this valve are two series connected controls, a 1kΩ variable resistor which acts as a pre-set contrast control, and a 200Ω potentiometer, the main contrast control, which is

arranged so that its slider determines the bias applied to the transistor a.g.c. amplifier Tr9. Thus the base potential of this transistor, which ultimately determines the sensitivity of the receiver, is the result of (a) the contrast control setting and (b) anode current of the video amplifier, which is dependent on signal strength.

The emitter of the a.g.c. transistor is connected to the transistor power supply point of maximum l.t., approximately 12V positive to chassis. A 150Ω resistor links the collector to the a.g.c. rail, to which are returned the bases of the first i.f. and the u.h.f. and v.h.f. r.f. amplifiers.

On no-signal and with contrast control setting at maximum the a.g.c. transistor base voltage will be that of the video amplifier cathode, i.e. 14V. It will thus be "bottomed", i.e. fully conducting, so that saturation current will result in the collector

potential being virtually that of the emitter; in practice these are 14.3V and 14.4V respectively. As the input signal increases, however, the video amplifier cathode voltage similarly rises increasing Tr9 base voltage positively and thus reducing its collector current. The a.g.c. rail voltage is thus reduced (made more negative) and the current in the controlled transistors increases to lower gain as previously explained.

Tracing A.G.C. circuits

Television a.g.c. circuits tend to be difficult to follow through since not only is forward a.g.c. bias used in place of the better known reverse a.g.c. bias but a.g.c. voltages referred to as reducing, or increasing, are made with reference to chassis, but depending on the type of transistor, circuit connection, and point of control (base or emitter) can appear to the transistor as being of opposite sign. Then in hybrid circuits where the chassis is the negative side of the supply for both the valves and the transistors it is the practice with pnp transistors to draw them "upside down" so that at first sight the collector and emitter circuitry appears transposed.

Further, some models, notably Pye/Ekco, use npn transistors, and while their supply polarity requirements fit in well with established valve practice, i.e. with emitters (cathodes) returned to chassis and collectors (anodes) fed from a positive l.t. rail drawn at the top of the diagram, it necessitates a mental readjustment to absorb the reversal of polarities involved in the a.g.c. action.

Delayed A.G.C.

The arrangements made to delay the a.g.c. voltage to the r.f. amplifiers are also often unusual and easily overlooked.

In the G.E.C./Sobell chassis the emitters of the gain controlled r.f. amplifier transistors in both the v.h.f. and u.h.f. tuners are fed from the main valve h.t. rail via a 56k resistor which in effect swamps the internal resistance of these transistors so that for small reductions in a.g.c. bias their collector current and therefore gain remains substantially constant. With the transistor supply taken from such a high resistance source, variations in transistor characteristics brought about by bias changes have little effect on collector current since they produce only marginal changes in total circuit impedance, and the transistor can therefore be regarded as being fed from a constant current source. However, when the a.g.c. voltage drops to below 12V, from a maximum of approximately 14V, a clamp diode (D1 in Fig. 5) conducts and clamps the r.f. amplifiers' emitters to the 12V transistor l.t. supply rail. If the a.g.c. voltage applied to the bases falls further, the resulting increase in collector current reduces gain as it does in the case of the first i.f. amplifier.

In other words, the r.f. amplifier transistors are supplied from the h.t. rail via a high value resistor during times of maximum sensitivity, and are then generally unaffected by a.g.c. bias changes,

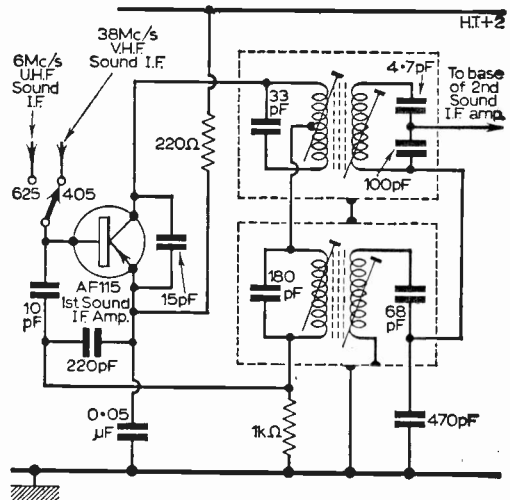

Fig. 6: First sound only i.f. amplifier in the fully transistorised Philips TVette model. Although the 405 and 625 sound i.f. transformers are series connected, the wide difference in the frequencies obviates the need for circuit switching on system change. Note the use of series connected tuning capacitors to provide correct impedance matching to the following stage.

but are clamped to the low impedance l.t. rail when signal strength is high, and are then subject to normal gain variation with varying a.g.c. This is a major change in circuit operation that may be easily overlooked from a quick circuit inspection.

As a further refinement, a local/distance tapping selects two different voltages at which the clamping diode conducts to tie the r.f. amplifiers' emitters to the transistor l.t. rail.

A basically similar a.g.c. arrangement is used in many Pye/Ekco hybrid models, although in these receivers a two stage transistor a.g.c. amplifier is used, with the initial positive-going drive to the base of the a.g.c. transistor obtained from a diode which also functions as the first detector of the 6Mc/s sound signal.

Sound A.G.C.

As the v.h.f. sound signal is amplified by the gain controlled common i.f. stage, there is no need for a further wide degree of control, so that a simple non-amplified system is satisfactory. These follow conventional practice as found in radio receivers, but a refinement used in some Pye/Ekco and Bush/Murphy hybrid models is well worth mention. In these the a.g.c. potential is taken from the positive-going output of the 405 sound detector, has its a.c. component filtered out, the remaining d.c. component being fed to the grid of the triode a.f. amplifier in addition to the usual a.f. signal. Increasing signal strength increases the triode's anode current, and the smoothed d.c. potential developed across the valve's cathode resistor, rising with signal strength, is then fed back to the first sound i.f. transistor as base bias.

To be continued

INSIDE TV TODAY

PART 2 M. D. BENEDICT

JUST as the heart of the television set is its display tube, the heart of the television camera is its pick-up tube. Three types of tube are used at present: the Image Orthicon, the Vidicon, and its successor, the Plumbicon.

Image Orthicon

The Image Orthicon is a highly developed, extremely complicated but basically stable pick-up tube (Fig. 1). An image of the scene is focused on the "photo cathode" part of the tube. This is an image intensifier section in which electrons are knocked off the photo cathode by the light falling on it. As these spiral away from the photo cathode, coils focus an "electron image" of the original scene on the target. Electrons forming this image knock more electrons off the target, a process called secondary emission, and these are collected by the target mesh, leaving a positive "charge image" on the target.

At the other end of the Image Orthicon, an electron gun fires a stream of electrons along the tube towards the target. From this, large focus and scan coils form this stream into a beam which is used to scan the target. The target is made of very thin glass and its temperature is held constant by a heater and a cooling fan controlled by thermostats.

Current from the charge image leaks through the target to the back face where it is neutralised by the scan-

ning beam. Due to the extreme thinness of the target, the charge reaches the back surface before it has enough time to leak sideways and reduce definition.

In fact, only the electrons needed to restore the target potential at the points where the charged image has changed the target potential actually land. Remaining electrons return towards the gun. The focus and scan coils ensure that this return beam follows the same path as the scanning beam until a "persuader" electrode around the gun deflects these electrons on to the material surrounding the electron gun, which forms the first stage of an electron multiplier.

When an electron strikes many types of material it knocks off several more electrons. By placing several adjacent electrodes at increasing potentials it is possible for one electron to knock several more of the electrons off the first electrode. These are attracted to the next electrode by its higher potential and knock off many more electrons.

This method of electron multiplication allows very high gains to be achieved and so the electron multiplier is incorporated within the image orthicon tube to amplify the very low level of beam modulation representing the signal. From the anode of the electron multiplier the signal current is fed through the latter's load and thence to the head amplifier.

The Vidicon

Fortunately the Vidicon tube (Fig. 2) is much simpler in principle. As for the Image Orthicon, focusing and scan coils control the electrons from an electron gun and form a beam which scans the target. This target is made of a material which changes its resistance in proportion to the light falling on it. Tin oxide, in a layer so thin that it is transparent, is deposited on the front surface of the target and this is biased, the rear surface of the target discharging to the tin oxide layer in the areas of low resistance. As before, the scanning beam restores the rear surface of the target to its original

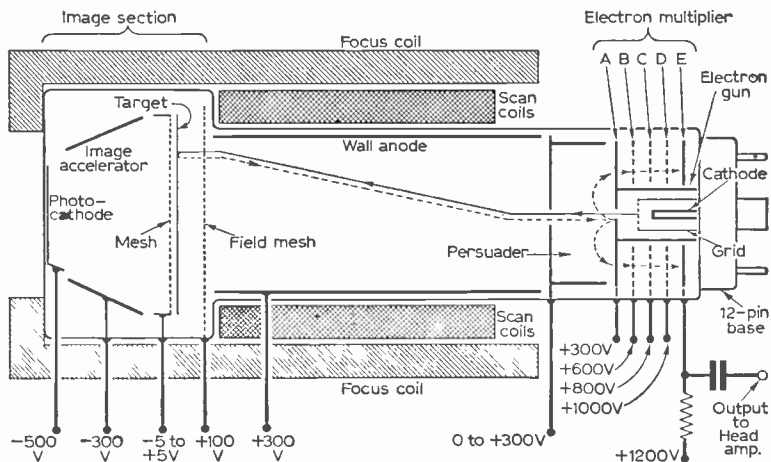

Key to electron multiplier.....A_1st dynode and gun anode B_2nd dynode C_3rd dynode D_4th dynode E_Anode

Fig. 1: The Image Orthicon camera tube. 3 and 4½ in. types differ slightly in detail.

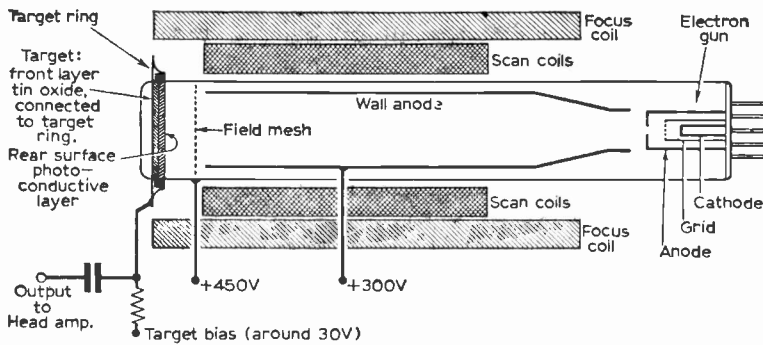

Fig. 2: The Vidicon photoconductive camera tube (the Plumbicon is similar in principle, but has a different target structure).

potential, causing a small pulse of current to flow, proportional to the resistance of the point scanned, hence the light falling on it.

The Plumbicon

Similar in principle and in construction, although slightly larger, is the Plumbicon, which uses lead oxide as the photoconductive material. Such materials have been tried for several years, but after a few hours use, targets would break up and give a crazed appearance, and it is only recently that manufacturing techniques have been developed to overcome this defect.

The Plumbicon tubes, then, consist of the thin layer of tin oxide backed by lead oxide to form a 3-layer device equivalent to a P-I-N diode. Doping of the rear surface, as used in producing all semiconductor devices, gives a P type characterisation, whilst the tin oxide layer gives N type characterisation; in the middle the target lead oxide is pure or intrinsic (I). As with a Vidicon, bias is applied, and the device acts like a reverse biased diode. Light reaching the I layer of the target releases electrons, which flow to the tin oxide part of the target.

Removal of electrons leaves the target positive until scanned by the beam, which restores its potential and causes a slight current to flow, proportional to the charge lost by electrons flowing to the target, which is proportional to the incident light. Thus the effect is similar to the Vidicon tube, although the cause is different.

Camera Tube Troubles

Compared with the Image Orthicon, the Vidicon is very simple, both in principle and operation. However, it needs much more light if the picture quality is to approach that of the Image Orthicon. As the Vidicon target bias is increased, so is the output signal, so that pictures can be resolved in very low light conditions.

Unfortunately, in these conditions pictures tend to lag; in other words, bright images take some time to disappear even after the camera has been panned away, and bright moving objects train in the direction of the movement. Lagging is due to a slow change in the resistance of the photocon-

ductive layer at low light levels and to incomplete re-charging of the rear surface of the target by the beam, which takes several fields to complete.

A second fault apparent in low light conditions is unevenness or shading of dark areas caused by variations in the photoconductive layer. This latter defect is not apparent in the Plumbicon to any appreciable extent, as the reverse bias of the diode when no light is present gives a very low reverse or "dark" current. The

Image Orthicons are not perfect by any means—they are large and cumbersome and inherently complex. Image Orthicons tend to be noisy or grainy and suffer from uneven "background" with spurious shading and unevenness.

Noise is due to the small charge in the target and the amount of amplification needed. Moving the target nearer to the layer reduces this effect but sensitivity is reduced as well and vibration of

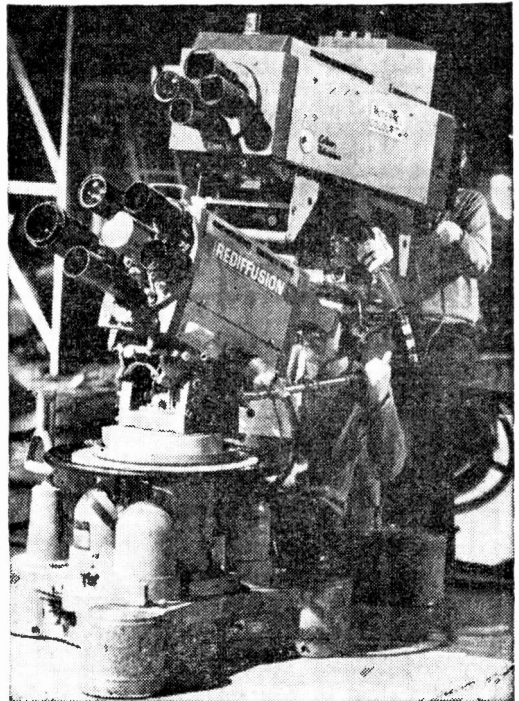

Gas pedestals carrying an E.M.I. Image Orthicon and a Marconi 3 Image Orthicon tubed colour camera during a simultaneous recording on British 405-line standard and American 525-line standard in colour. The vast size of the colour camera is apparent. Rediffusion photo.

the target and the mesh would modulate the camera with any external noise such as loud music. This effect is similar in appearance to sound-on-vision seen on a misaligned home receiver.

A different solution is achieved by increasing the target area. Early Image Orthicon tubes were 3in. in target diameter and this was later increased to 4½in., the present standard size. This increase also reduces the many effects of unusual electron redistribution in the image section. White areas surrounded by a black halo, and two or more images of a bright object against a dark background are examples of this fault. In fact, various target mesh to target distance arc manufactured for different purposes, such as standards conversion and outside broadcasts.

Other effects are spots, marks and shading on the background, due to the various electrodes in the beam's path, particularly the first electrode of the electron multiplier. Such effects are rarely noticed when displaying normal pictures but evenly illuminated scenes show them up. If left on a particular scene, the tube will retain an image of this scene burnt into the target so automatic movement of the image at a very slow rate is used: called orbiting, this varies the shift of the scans, but adds complexity to the channels.

About the only defect of the Plumbicon is a tendency to red insensitivity, making lips appear to be too dark. Surprisingly, this is not a problem with Plumbicon colour cameras. As may be gathered, the Plumbicon is the tube of the future. At present, only Philips produce these tubes in quantity but other manufacturers expect to have them in production soon.

Except for the tube, television cameras are basically similar, although circuit techniques vary. From

all these types of tube, the signal is fed to a head amplifier.

The output of a Vidicon tube is about 0.3µA and that of an Image Orthicon is about 15µA/V from a high source impedance. If a high value of load resistor is used, high frequency losses due to the capacitance of the connector from the tube output to the head amplifier will become too great to compensate without noise. If too low a load is used, the output is too low. Most designs of head amplifier use a load included in a feedback loop, the actual value being a compromise.

After amplification, high frequency boost is applied to give equalisation for the high frequency losses mentioned, then a low output impedance stage is used to feed the vision down the camera cable. All these functions are performed by the head amplifier. Naturally, the head amplifier is mounted close to the output point of the tube.

Beside the tube, the scan coils and its head amplifier, the camera contains only a line scan generator and a viewfinder, and a few smaller clamps. To keep down the weight and size of the camera only those items which have to be near the tube are mounted in the camera.

External Equipment

Connected by the camera cable is the rest of the control equipment mounted on a rack. Consisting of the remainder of the signal processing chain, certain pulse processing and scan generators, this equipment is normally called the Camera Control Unit, or C.C.U. As can be seen in Fig. 3, the signal reaching the C.C.U. from the head amplifier

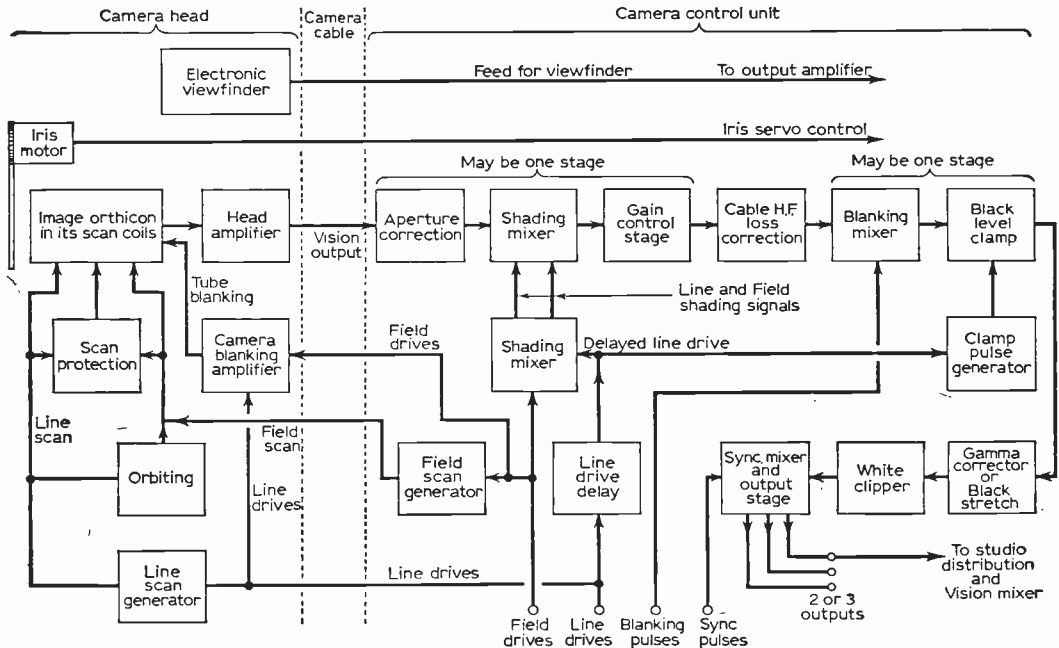

Fig. 3: Block schematic of an Image Orthicon camera and its control circuits.

via the cable is corrected by a special h.f. boost stage to give correction for the size of the scanning spot. Shading signals to correct for shading inherent with the Image Orthicon tube are added and gain controls are also applied. All these functions may be combined within one stage.

H.F. losses in the cable are corrected by yet another h.f. boost circuit, whose control is coupled to the line drive delay unit so all cable length compensation is switched together, usually in lengths of 100ft. To stabilise the vision signal a clamp stage operates to bring the signal to the correct "brightness", or lift as set by the lift control; at the same stage system blanking is applied to clean up the signal during the flyback period before the syncs are added. Gamma control distorts the signal by stretching the black parts of the picture, a requirement for Image Orthicon channels as the output of these tubes is not proportional to the light input in the correct manner for transmission.

Finally, the signal is clipped so that excursions above the standard one volt of video signal are clipped off and do not affect the transmission chain, before feeding to the output amplifier where sync pulses are added to give the complete video signal.

All the camera scans are driven by pulses from a central sync pulse generator along with blanking and sync pulses. Pulses called line and field drives operate their respective scan generators, the field scan generator being in the C.C.U. with the line scan circuit at the camera. The drives are mixed and used to blank the tube during flyback so that the output then corresponds to black level. At the black level clamp this potential is stabilised to a particular potential, eliminating the effects of a.c. coupling in the channel.

Blanking pulses suppress the signal for a period before and after line and field syncs to allow monitors and receivers to fly back and provide a stable black level around the picture edges. This is added at the black level clamp and it is essential that the tube blanking lies within the system blanking or the whole purpose is lost. With long camera cables, the line drive would not have enough time to travel to the camera and return as the camera tube blanking in the video waveform and still be within system blanking, unless the line drive were advanced in timing.

Pulse generators for O.B.s allow up to 2,000ft. of camera cable to be used between the camera head and its C.C.U. A switched delay unit gauged to the cable h.f. loss corrector allows waveforms such as shading and clamp pulses, which are derived from the drives, to be delayed by the same amount as the cable delay. Such waveforms process the signal and must be in sync. In some early cameras, drives were sent up to the camera head and returned back down the cable to provide the delay, but ordinary delay networks are now used.

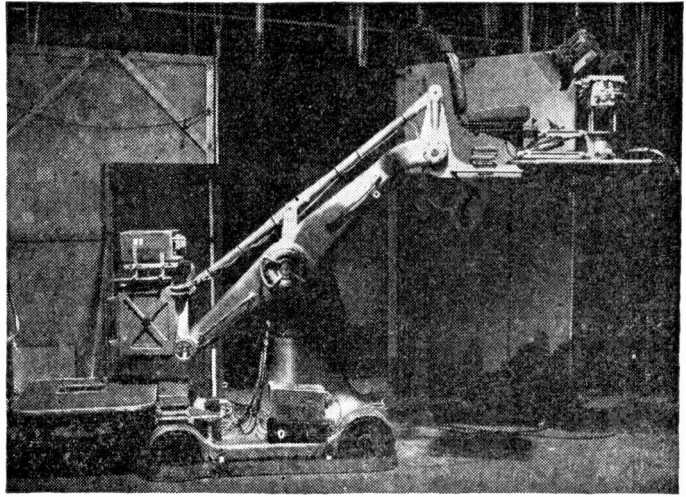

Mole Richardson camera crane. The base is electrically propelled. Note ABC TV photo.

An orbiting generator moves the scanned area of the tube to avoid sticking of stationary images. If the scans should fail the beam would damage the tube by burning the target, so a special protection circuit cuts off the beam if the scans should fail. An electronic viewfinder is provided by a small monitor set built into the camera.

At the C.C.U. most modern cameras remote almost all of the controls to a special engineering control panel, which may carry the 35-odd potentiometers and 11 switches that are used to line up an Image Orthicon channel. Control of some functions are switched to a second operational panel under the control of the Vision Control operator.

Operating a Camera

Operation of a television camera is nowadays divided into three parts; firstly the studio engineers switch on the cameras after they have been rigged and the cables connected, then they retire for coffee! This is not laziness or greed on the engineers' part, but is to allow the cameras to warm up.

As a rule apparatus as complex as a camera channel takes up to half an hour to settle down but with Image Orthicons the tube must be heated till the target is the correct temperature, and then cooled to stop it overheating. With the target too cold, pictures stick and "burn in", as the charge is taking too long to leak through the target, too hot and the definition of the pictures deteriorates as the charges leak sideways, hence the careful control of target temperature.

After warming up, the channel is checked by passing a sawtooth test signal through the vision chain, starting at the head amplifier. Gain controls can be set to give the correct amplification at each stage to minimise amplifier noise.

Image Orthicons are then un-capped, or Vidicons exposed, the electron beam current increased so the target is scanned and the target bias adjusted to

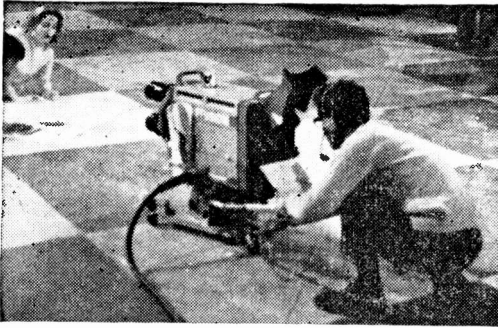

The creeper, a very low camera mounting for low-angle shots.
Rediffusion photo.

give a picture. Test cards or special slides are used so that various focus controls can be set up. Adjustment of the scanned area to fit a mask on the faceplate of the tube gives an exact and consistent method of setting the aspect ratio and the scan dimensions. Several other adjustments are made to an Image Orthicon channel but many controls are interdependent requiring considerable skill and experience to obtain the optimum results.

Many of the defects discussed earlier can be minimised by careful adjustments and compromises. Thus if beam focus is adjusted for absolute maximum definition, the beam scans the electron gun assembly and this appears in focus. Just a slight defocus of beam hardly reduces definition but puts the surface and its marking almost completely out of focus so that it is no longer objectionable. Many such adjustments are necessary and it requires great skill to line an Image Orthicon to give its best pictures.

Setting up

When complete, the camera is exposed to a standard test slide or caption. Adjustment of exposure is very critical as the Image Orthicon has a non-linear input/output characteristic. Image Orthicons tend to crush the white parts of the picture and less signal is received from the highlights than would be expected. Far from being a disadvantage, this non-linearity is welcome, as it partly compensates for the display tube characteristics and helps to limit the effect of very bright objects, reflections and flares from jewellery.

Sometimes black stretching is applied to give a similar characteristic in the black parts of the picture. Exactly when this white crushing occurs is very critical when it comes to adjusting the cameras. In fact, it is such that a certain amount of crushing occurs and all cameras in the studio should be adjusted to give a similar characteristic. This is not always possible with a device as complex as the Image Orthicon.

Vidicon cameras are much simpler to set up, as are Plumbicon cameras, and a complete line-up takes only a few minutes.

After the engineering line-up, control is switched to the simplified control panel carrying only those controls needed for operational adjustments.

Rehearsals can then start. At the camera end of the cable, the cameraman has a list of the shots he is required to offer. "Framing", or adjustment of the position of items within the picture, is achieved by movement of a "panning handle" to point the camera from side to side (panning) or up and down (tilting).

Lenses

A turret of four lenses, each of different focal length, can be rotated to bring each lens in front of the tube to give the effect of different distances from the subject. Rotation of the turret is achieved by a handle on the side or the back of the camera. Usually a special non-linear gearing is used to move the lens quickly and quietly to the next position and align it in the correct position in front of the tube. Close-ups are provided by a long focal length lens, wide shots by short focal length lenses.

Zoom lenses are now in common use, the most popular types being power operated over a range of 10:1. Controls for these operate on a rate of zoom principle, using a twist grip to control the speed of zoom. Speed control allows a much smoother mode of control which allows the cameraman to zoom slowly in without a trace of jerkiness yet, by turning the twist grip further, the lens can be zoomed out at full speed. As well as this control, the cameraman can select four pre-set positions on the range of zoom, allowing him to set up a given shot with a given width of view very quickly.

Movement of the tube and its scan coils on a carriage is used to effect the focusing of fixed length lenses and usually requires adjustment when the lens is changed. Focusing of a zoom lens is controlled by movement of a lens element within the zoom lens itself, the tube focus mechanism being left as set up.

When the camera is moved on its mounting in towards the subject, or tracking in as it is called, adjustment of focus is also required, as in any change of camera-to-subject distance. The focus handle is mounted on the side of the camera. A zoom differs from the track as the perspective alters to give a flat, foreshortened scene when zoomed in tight.

Outside broadcasts often show horses or racing cars apparently moving at a snail's pace towards the camera, completely spoiling any impression of speed. Test matches with grossly foreshortened pictures are also often seen. Such effects are a result of using telephoto lenses where it is impossible to move the cameras in close enough to the subjects, and a zoom lens zoomed in suffers similarly.

Camera Mountings

Most camera mountings used in the studio have wheels or castors to enable the camera to be moved from set to set, also allowing the camera to be moved in towards the subject. The simplest camera mounting is the tripod often seen with the legs fitted into a framework base which is carried by castors. Various developments of the tripod idea incorporating an adjustment for height and steering

all wheels together with a tiller system have been developed.

Probably the most flexible mounting in use today is the gas pedestal. Featuring steering of all wheels by a ring and a tiller, or one wheel by tiller alone, and smooth adjustment of height with the weight of the camera counter-balanced by compressed nitrogen, it can be accurately tracked or elevated by the camera alone, yet, with its small base area, it can move into the most confined spaces to give shots from the most unlikely places without delay. Ring steering of the tiller and counter-balancing allows the cameraman to manoeuvre the camera to any position and elevate the camera with one hand, whilst the other pans the camera.

Two men are required to operate the simpler camera cranes. Operated hydraulically, these typically consist of a base which can be driven and steered in the normal manner or can be crabbed (moved sideways). From the base extends a jib which carries the camera and cameraman, allowing elevation or lowering as desired. Camera and cameraman are carried on a platform with the pan and tilt head fixed to a vertical post at the centre of the platform.

Panning through 360deg. is facilitated by allowing the cameraman's seat to rotate on the same axis as the camera. Such a mounting allows more complicated tracking and elevations than the pedestal, but at the expense of size and manoeuvrability. Another crane in common use is the Mole Crane featuring a jib which can be swung from side to side as well as up and down, and is operated by three people.

Occasionally huge cranes are hired for spectacular aerial shots and may require six or even

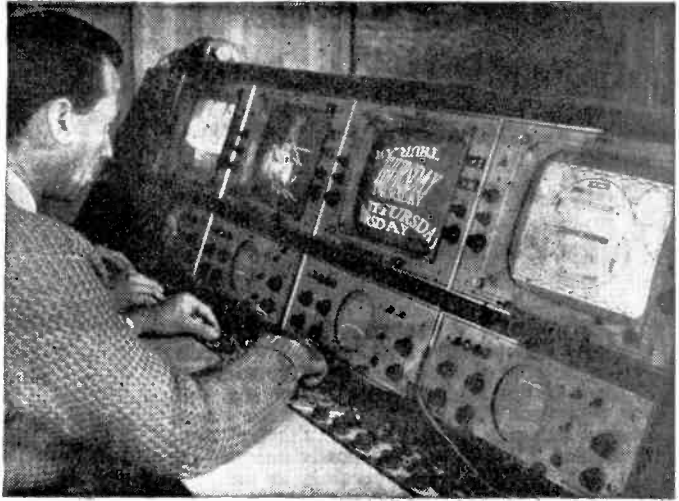

Camera line up; the engineering control panel.

Rediffusion photo.

eight people to track the crane and swing the jib, which may be 40ft. long. On the other hand, low angle shots can be obtained from a special mounting called a creeper.

Production

Clipped to his camera, each cameraman has a shot card prepared by the production team indicating each shot by a number and a description. As the required shot approaches, the cameraman presents the shot as required by the director at rehearsals. He hears the director's instructions (called talkback) in his earphones and can talk to the vision controller who may relay his comments to the production team.

If the camera is mounted on a crane the cameraman can whisper instructions via an intercom or give special hand signals to guide the crane crew. Naturally, close teamwork is required for smooth results so small monitors may be strapped to the crane to enable the crew to adjust their camera's position as the performers move.

At the far end of the camera cable the third function concerning camera operation takes place. Sitting at a desk containing all the operational controls, facing a bank of preview monitors displaying all the camera outputs, is the vision controller. His function is to match the pictures from each camera on the same scene so that facial tones, for example, do not change when a different shot is taken.

Matching of cameras requires very careful matching of the tube and gamma control characteristics during the engineering line-up. Image Orthicons being extremely complex tubes having varying characteristics, it requires great skill to set up six different Image Orthicon cameras so that they all match each other.

In this country there are three main manufac-

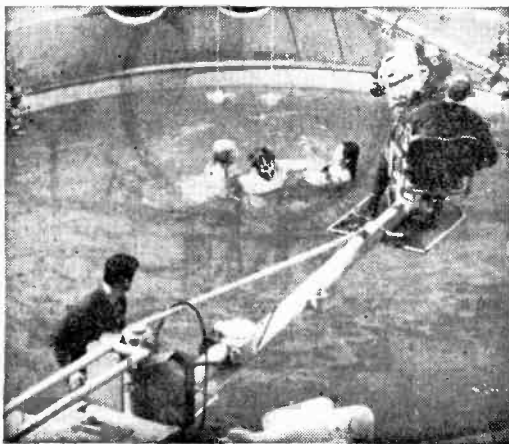

A huge camera crane specially hired for the occasion. ABC TV photo.

—continued on page 28

The author describes the construction and installation of a combined aerial for BBC-1 and ITV, that may be fitted in the loft, or mounted adjacent to the TV receiver.

MANY readers of PRACTICAL TELEVISION will have constructed their own TV aerials, possibly to designs that have appeared in past issues of this magazine. The author has, after much experimentation, come up with the design published herewith. Although the "simpler" types of combined TV aerials are normally intended for "local area" reception, this aerial is in use in a "fringe area" and giving quite good results.

With careful attention to mechanical details and construction excellent results should be obtained. It is suitable either for set-top, or attic mounting using 75 ohm low loss (semi air-spaced) coaxial cable. The photograph shows the prototype in which fixed (not telescopic) horizontal elements were used. These consisted of 17in. lengths of $\frac{1}{8}$ in. dia. aluminium tubing. These may be used if the constructor so desires, but the type of telescopic aerial stocked by many radio component stockists (these are usually $\frac{1}{8}$ in. diameter at the base) were used in the final design. Three are required and each should be capable of extending to at least 19in.

The two semi-circular elements of $\frac{1}{8}$ in. dia. aluminium rod should be fashioned exactly as shown in Fig. 1, bearing in mind the middle and lower section spacing. The ends are flattened, either by using a metal vice, or careful use of a hammer. Holes of $\frac{3}{16}$ in. diameter are then drilled where shown in the diagram.

The trio of telescopic aerials too, are flattened at their ends, and $\frac{3}{16}$ in. holes are also drilled in these, and then bolted in their respective positions—one on each side of the upper paxolin strip and one to the lower section. The whole is then bolted or screwed to the base unit. This can either be of paxolin, or if this is not available, a suitable piece of wood could be used. This should be approximately 9in. long and have a 2 x 2in. cross section.

The underside of the base unit should be covered with a piece of felt or other suitable material if the intention is to stand the aerial on the set top.

Metalwork

Suitable L type metal brackets, as shown in Fig. 1 may either be made up, or obtained from a local hardware shop.

If the constructor is unable to obtain these items locally, it is suggested that they may be made as follows: obtain four 3in. lengths of hard brass or other metal strip with a thickness of at least 18s.w.g. The width can be approximately $\frac{1}{2}$ in.—

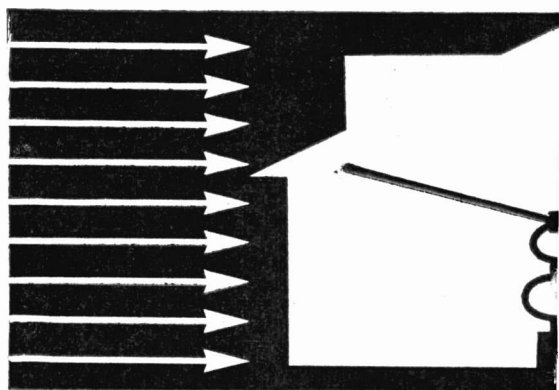

INDOOR AERIAL

G. DA

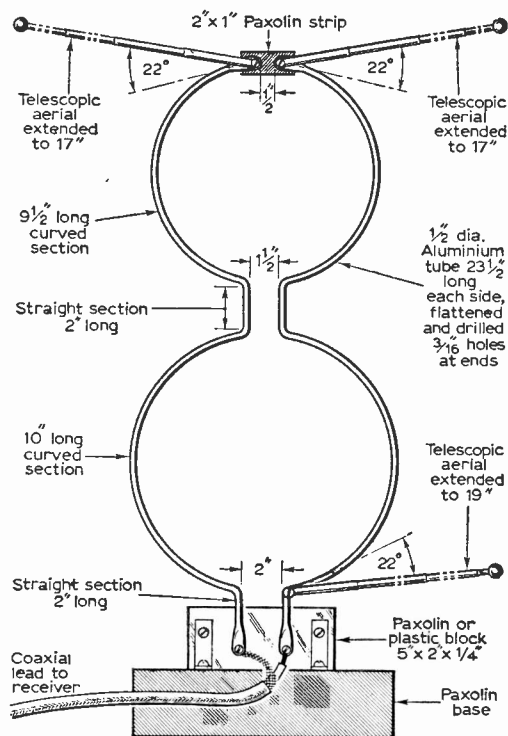
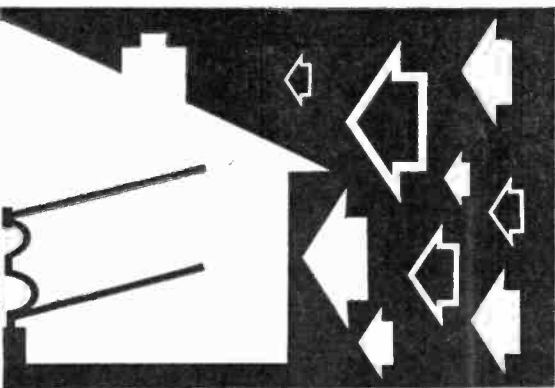

Fig. 1: The drawing above gives all the major dimensions for the combined indoor aerial. Note the use of telescopic horizontal sections.



FOR BANDS I & III

RLING

it should not be narrower. Each strip is then drilled to take either 4 or 2BA bolts. When drilling, use the "first off" as a template for the other three strips to ensure that all the holes come in exactly the same place. One hole drilled towards each end, should be sufficient.

Place the drilled strips in a metal vice and bend to form an L shaped foot. Stand the lower paxolin section on the base unit, and mark or scribe the hole positions for the L brackets. Drill the paxolin

sections carefully, this is best carried out by laying them on a wooden block or by clamping them together in the vice.

Coaxial cable is attached as shown and the far end fitted with a suitable coaxial plug, and the aerial is ready for use. It is not important to which side of the aerial the inner conductor or braid is terminated. Good electrical and mechanical connections are very important. It is suggested that suitable solder tags are used under the heads of the bolts, and the coaxial cable soldered to these. This cable should preferably be of the semi air-spaced variety—especially if the aerial is to be loft mounted, and may be of any length (within reason).

Optimum results

Correct orientation of the aerial is necessary for optimum results and this should provide no difficulty.

If the aerial is to be positioned, on top of the receiver, adjustment is quite simple. This also applies to loft mounting (it can simply be stood on the floor of the loft when finally adjusted, and left—no fixing should be necessary).

Switch to the ITV channel and extend the horizontal aerial elements to approximately 17 inches. Rotate the aerial slowly for maximum picture, adjusting the contrast control as necessary. Maximum contrast should coincide with maximum sound, but do not worry if there is some slight deviation. The angle of the horizontal elements, set at 22°, was found by experiment, in the author's location, to be satisfactory for optimum reception on BBC-1.

Obviously other settings may be obtained which may give better results—but check sound and vision and adjust for a satisfactory balance.

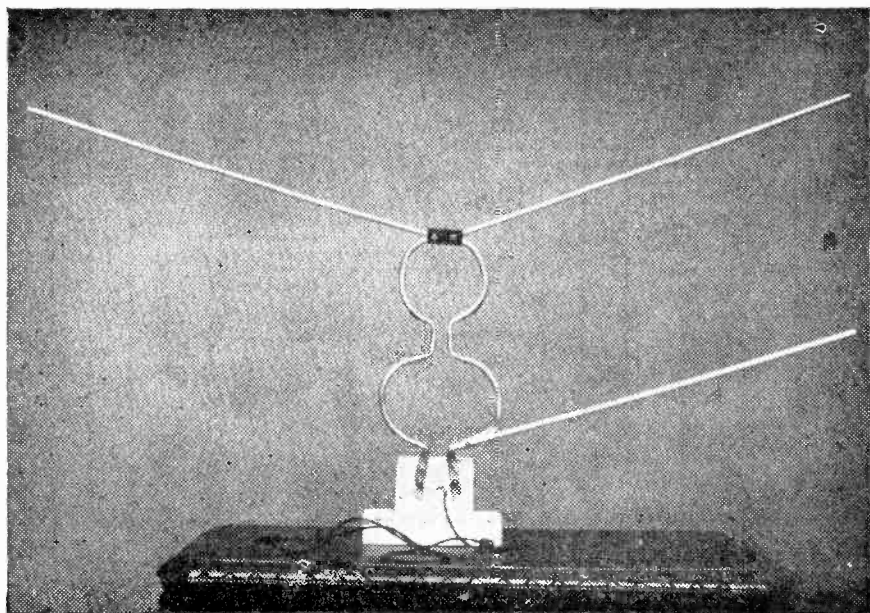

Photograph shows the author's original prototype, this was before the telescopic horizontal elements were fitted

Servicing TELEVISION Receivers

No. 139 - BUSH TV135/MURPHY V929 series

by L. Lawry-Johns

THIS series includes the Bush models TV135R and RU, TV138R and RU, Murphy models V923, V923U, V929 and V929U. They are dual standard with 19in. or 23in. tubes.

Push button tuners are fitted. Bush models may have type A506 or A514 (valve) or type A520, A527 or A528 (transistorised) u.h.f. tuners. 19in. Murphy models are fitted with A507 or A515 (valve) or A522 (transistorised) u.h.f. tuners, while 23in. Murphy models are fitted with A544 (valve) or A522 (transistorised) u.h.f. tuners. Because of mounting differences the units cannot be interchanged. V.H.F. tuner unit type A490 uses a PC900 and a PCF806.

The v.h.f. tuner is normally set with two buttons adjusted for any Band I channel and the other two for any Band III channel. This arrangement can be changed if desired to provide any combination of channels in Band I or III.

To revise the switching, remove the tuner unit from the cabinet (see later dismantling instructions) remove the cover by pressing in the end, lifting slightly and disengaging the other end. Slacken the P.K. screw securing the switch actuating tab to the rocker bar. Reposition the tab downward if Band III is required or upward if the button is to tune over Band I.

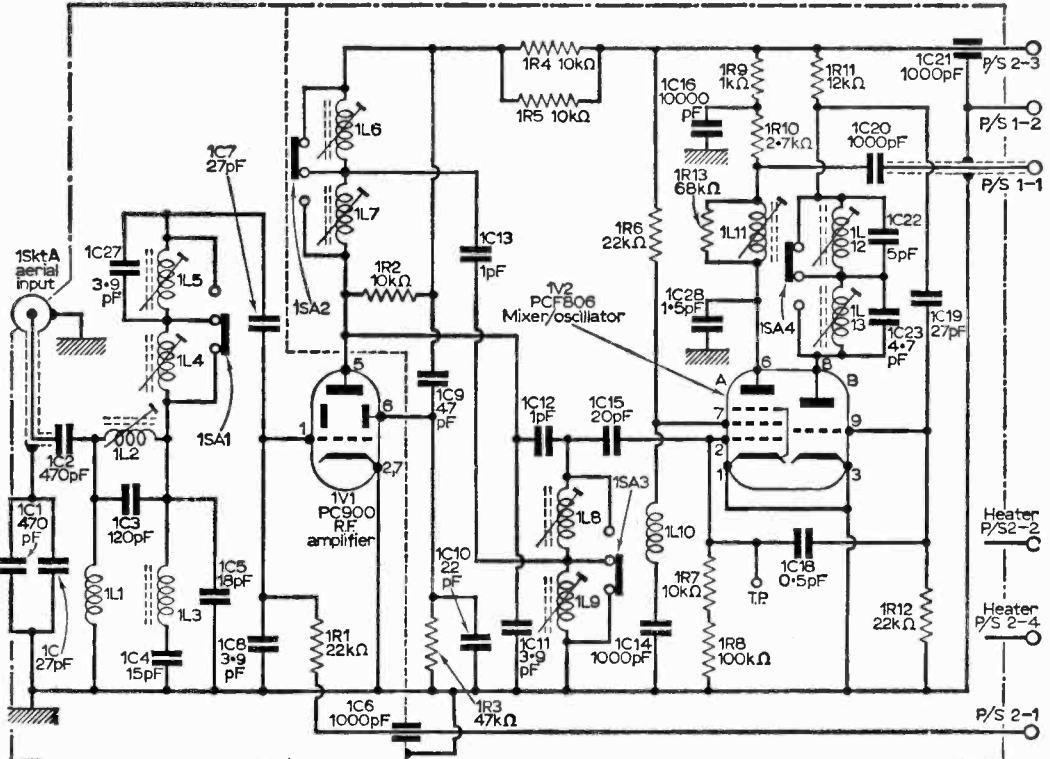

Fig. 1: Circuit diagram of the v.h.f. tuner unit.

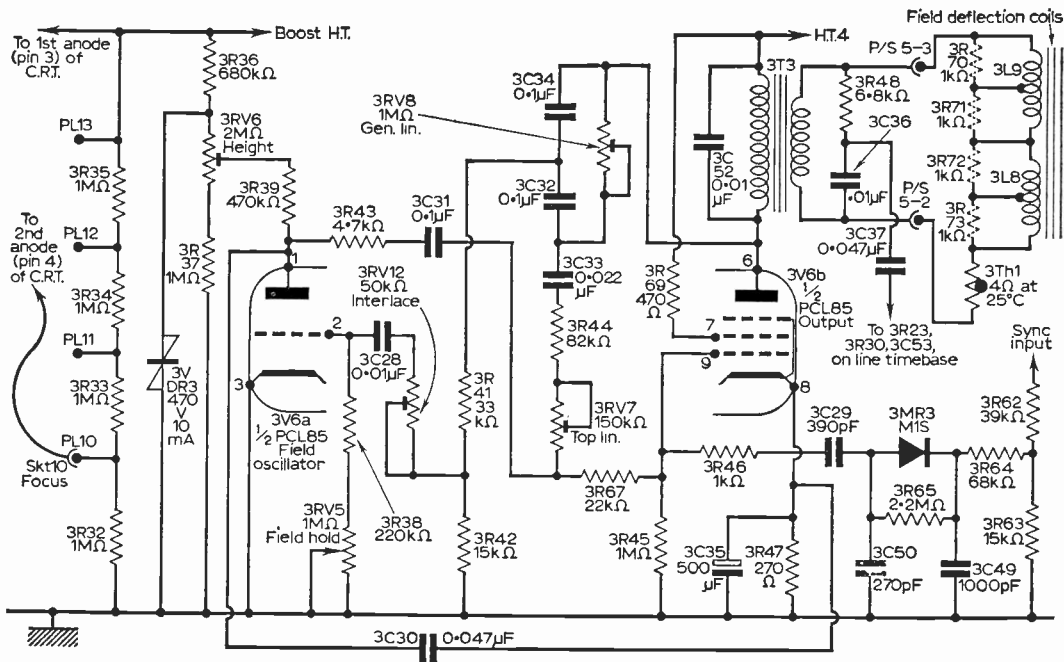

Fig. 2: Circuit of the self-oscillating field timebase used in this series of models.

Oscillator adjustment

To adjust the tuning of a particular button, press it in to select the desired channel, then pull it out to engage the spline on the tuning spindle. Rotate for optimum reception and then press in to disengage the spindle.

When the button will not engage the spindle, i.e., the tuning is unaffected when the above procedure is followed, examine the button itself (remove tuner) as the engaging slots may have been worn away.

Fractured oscillator core

Quite often it may be found that the buttons are partially or wholly inoperative, sometimes tuning when set on one channel but being hopelessly out of line when next operated.

This is nearly always due to the plastic core being broken inside the coil former. This core carries a number of brass sleeves which tune the coils as it moves inside the former.

Various dodges may occur to the repairer to keep the core operative whilst a replacement is being obtained, e.g., spring loading the rear (open) end to keep the core pressed at the fracture.

Replacing the core may appear rather difficult but in fact it is quite easy if it is remembered that the tuner is in two main parts which may be separated by taking out the P.K. screws at each side. This exposes the end of the core.

V.H.F. tuner removal

Remove the power and i.f. plugs from their

sockets on the receiver unit and release the large hexagon bolt securing the tuner unit bracket support to the cabinet.

Withdraw backward to disengage front locating lugs. At this point the buttons will probably fall off.

U.H.F. tuner removal

Similar to above but two bolts are used at the rear which should only be slackened, not removed.

Trouble spot

Intermittent reception with or without a snow-storm is most often due to incorrect operation of the standards switch. Cleaning (and very slight adjustment if really necessary) will generally overcome this trouble. Also check the plugs and sockets on the receiver panel.

Special features

These receivers do not use a mains dropper, the large tapped resistor at the rear is the voltage selector and consists of two 47Ω sections only. The voltage at these sections is d.c., obtained from a BY101 silicon diode (3SR2) which of course only conducts on half cycles, thus effectively lowering the voltage available to the heater line since there is no reservoir capacitor (to fill in the troughs).

This is a very neat way of obtaining the required heater current, but there are two points which require comment. A voltmeter will not read the true voltage. For example, at a convenient point say the tube heater pins where the correct voltage

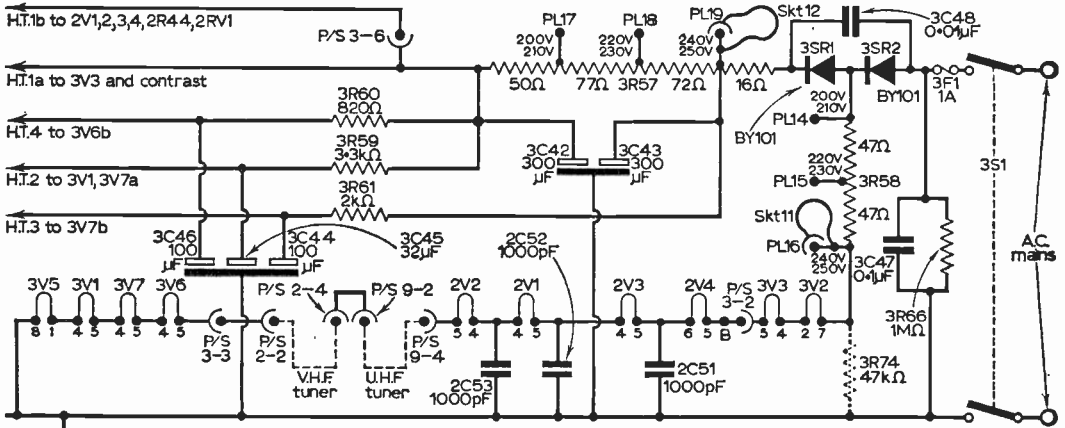

Fig. 3: Power supply circuits. HT1 234V; HT2 216V; HT3 212V; HT4 191V (405 measurements). HT1 223V; HT2 199V; HT3 210V; HT4 181V (625 measurements).

drop is 6.3V from pin 1 to chassis (pin 8 is chassis), only 4V will be recorded. The whole heater chain (junction 3V2 pin 7 and 3R58) will record 98.8V. This means that the indicated voltage on a meter is two-thirds or 66% of the true voltage.

The second point is perhaps more important; we say perhaps because of the built-in safety precaution which immediately calls attention to a condition which could otherwise cause extensive premature wear and damage.

We have mentioned that the effect of putting a diode in series with the heater line is to drop the voltage available to the valve heaters. Obviously, then, if this diode shorts the voltage will immediately rise causing a much heavier flow of current along the chain, overrunning the valves and tubes which might not be noticed by the viewer. "Our picture's much brighter than next door's mum," may be the only comment.

To call attention to this possible fault condition a resistor 2R38 feeds the screen of the sync separator from the heater line at PS/3 where it feeds 2V4 pin 5. Thus when the heater line suddenly becomes a.c. the sync separator is upset and picture becomes unlockable thus necessitating the attention of an engineer who will immediately notice the overrun valve heaters (we hope).

A resistor 3R74 is also included to limit the voltage rise when and if a valve heater should become o/c or if a valve is removed with the receiver on. Always switch the set off before removing a valve or disconnecting the c.r.t. base socket.

H.T. supply

Before leaving the subject of mains supply we should point out that from an h.t. point of view there are two silicon diodes in series, the heater supply being taken from the junction of the two.

Both rectifiers are type BY101 and whilst BY100s may be used if desired it is stressed that two must be used and the original circuit adhered to in order to maintain correct heater line voltage. The capacitor 3C48 is also necessary to absorb

transient peaks. The output of 3SR1 is surge limited by a 16Ω section of 3R57 with 3C43 acting as the reservoir capacitor.

The smoothing is by various resistor-capacitor combinations, the main electrolytics being in a double 300μF can with a triple can nearby, 100 + 32 + 100μF.

Voltage and current data

The following measurements were taken with 225V a.c. mains input, no signal and the contrast control set to minimum. U.H.F. tuner unit total current 26mA (A506,7), 23mA (A514,5,44). V.H.F. tuner h.t. line 195V, total current 34mA, 1V2A screen grid 132V, 1V1 cathode current 15mA, 1V2A cathode current 11mA, 1V2B cathode current 8mA.

to be continued

INSIDE TV TODAY *continued from page 23*

turers of broadcast quality cameras: EMI, Marconi and Pye; with Philips producing colour and monochrome Plumbicon cameras. Marconi and Pye built cameras using the 3in. Image Orthicon as developed in America but soon the limitations of this tube became apparent so that Marconi developed the 4½in. Image Orthicon and have refined it until they have actually sold 4½in. Image Orthicon cameras to the USA.

EMI entered late but not behind the others, along with broadcast Vidicon to match those made by Pye and Marconi. Now Marconi and EMI offer colour Plumbicons although Marconi have sold colour cameras using three of the 3in. tubes.

(The first part of this series was incorrectly credited to a reader, Mr. A. F. Cameron. We apologise to the rightful author M. D. Benedict for this error!)

To be continued

GOVERNMENT *White Papers* are rarely whiter-than-white, especially when they have anything to do with radio, TV, newspapers, films and the theatre. They are often like the heavy clouds which portend parliamentary legislation, leading to more restriction, more inspection, more taxation and more jobs for the boys. The white papers are usually metaphorically and politically tinted, not necessarily influenced by the government in power. The voluble dislike of commercial television by some members of the Pilkington Committee, for instance, has had regrettable effects on television as a whole, as we all know.

National film school

Now it is the turn of the film industry to be subjected to a government committee — the Lloyd Committee—with the following terms of reference:—

“To consider the need for a National Film School and to advise, if necessary, on the objects and size of such a School, its possible location and form of organisation and the means by which it might be financed.”

The Lloyd Committee was appointed in October 1965 and has just completed its report, a white paper with a green cover, presented by the Department of Education and Science. It is a fact that the film production industry, which deals with artistic product, is basically highly technical, and one would expect the report to be down-to-earth and practical. Though the intentions were admirable, the Committee contained no known engineers or technicians and consequently tended to deal with artistic problems of a past age rather than plans for the future. Nevertheless, its report seemed to exude that “culture” of doubtful quality which is fashionable today.

Pay up! Pay up! Pay up!

The amount of negative film photographed for television is now at least ten times as much as that used making films for the cinema, both on 35mm. or 16mm. film. The number of cinemas is declining. The tech-

UNDER NEATH



THE DIPOLE

niques of television and cinema film making are getting closer and closer together. The Lloyd Committee have reported that the capital outlay for land and buildings for a film school in a site in Central London will cost £600,000 and the initial equipment £200,000. Notwithstanding the rapid progress made in some British film studios in the last four years, the Lloyd concept appears to relate more to filmmaking of twenty years ago than to the latest techniques. The Lloyd Committee's attention to the cultural importance of the Royal College of Art, the Slade School, the London School of Film Technique and other educational bodies fills one with apprehension. The declining standards of some of the dramatic schools is, indeed frightening, not only on account of the poor diction of their students, but because of sloppy production, down-beat off-colour plays and other shortcomings. They are not all beatniks, however. The Bristol

drama group is the best I've seen to date.

Down the kitchen sink

On a back page of the Lloyd Report several societies are credited with offering advice, including the British Kinematograph Sound and Television Society—an organisation which has long taken interest in training by the provision of special tutorial lectures fee-paying courses and articles in its journals. “Credits” are important. On inquiry of the BKSTS as to the contribution by that society to the Lloyd Report, I was told that its sole participation was a letter from the Society's Chairman to the Lloyd Committee's Secretary stating that if a film school was to be built, it should be in London; that it should be of benefit to technicians in film and allied industries and that suitable technical training would be accessible to candidates wanting to enter the film industry.

That, believe it or not, was the sole communication from BKSTS on the subject. If the Lloyd Committee's recommendation for a National Film School is carried out along the lines now suggested, without technical advice, one can anticipate teething troubles. Will there be thousands of pounds pouring down the cultural kitchen sink, paid for by hard-pressed cinema exhibitors or equally hard-pressed taxpayers?

Arty-crafty

As for the so-called creative side of a National film school, is this the type of trend-setting talk we can expect? The following was actually printed in a programme of a students' performance:—

“It is cruelty that cements matter together, cruelty that moulds the features of the world. Good is always on the outer face but the face within is evil, evil which will eventually be reduced, but at the supreme instant when everything that was form will be on the point of returning to chaos.”

This was part of the description in the programme of *A spurt of Blood*, a playlet produced by the students of the Royal College of Art recently. On the same evening they presented *The Gas Heart*, described as:—

“Aortaorb cometobe nipplebog

pebbletongue bladdercloud crag-plasma bonevapour sandvalve bouelcanyon ethernerve . . ."

The "credits" of this masterpiece included a "designer of sets and pneumatics", in addition to a projectionist and a choreographer.

If this is the type of "culture" they propose for the National Film School, then the sooner engineers take charge, the better.

Colour Processing

Processing of black-and-white film plays an important part in all television areas, at both BBC and ITV studios, large and small. News and magazine items in black and white are speedily processed and then cut and edited in negative form. On telecine, the negative film is turned into a positive picture by phase reversal.

The editing machines in TV studios usually of the continuous motion type, such as those made in Britain by Rigby, Acmade and Editola or the continental ones from Steenbeck and Prevost. The Moviola, Acmiola and other types with intermittent sprockets are easier to thread up. These are more popular in film studios, where positive prints are used for editing and a few scratches don't seem to matter.

Now we come to colour processing, at present carried out in large commercial film laboratories, such as Technicolor, Denham, Humphries and Kays, who develop and print 35mm. and 16mm. and even 8mm. The "road show" 70mm. prints are also made at Technicolor. Television studios will use 16mm. film for colour news, utilising colour reversal stock for their "local" programmes plus 35mm. for big features.

The BBC have just taken delivery at Alexandra Palace of the new colour processing machine (for the Kodak ME 4 system), supplied by Photomex (London) Ltd., who already have a large number of orders in hand. Processing colour, especially reversal, is of course much more complicated than b. and w., requiring about 12 baths and other treatment. Newman and Guardia, of Harlow, Essex, makers of many types of automatic processing equipment, are also about to complete tests on a 16mm. colour film processing machine

suitable for London and regional television stations. It is interesting to note that British-made black-and-white film processing plant is used in large numbers of television studio centres all over the world and it rather looks as though the success of these two British made equipments will be similarly repeated on colour television.

Colour burst

Transmitter link equipment, camera equipment, control equipment, telecine equipment—all colour (or almost all colour) is the policy and the order placed with Marconi's Wireless Telegraph Company by the Yorkshire Television Network. Sixteen of the new model V11 Marconi colour cameras will be delivered to the YTN studio centre in Kirkstall Road, Leeds, which will contain a large (4 camera) studio, a medium (2 camera) studio and a presentation (one camera) studio, plus two outside broadcast (4 cameras each) trucks. There will also be three Marconi colour telecine equipments for 35mm. and 16mm. films plus slides. The cost of all this up-to-date-than-to-date equipment will be £650,000 and is the largest single order of TV studio equipment ever placed in this country.

Society's problem

At a time in history when man seems intent on harming his neighbour and himself; when television is rooted in society as the medium for purveying news and views—news of what, and the views of who?

The juxtaposition of horrific news items and syrupy soap operas—this is when the truly moving programme can really sear into the viewers mind. Such programme was *So many Children* written and produced by John Pett, a bulwark of Westward Television but almost unknown nationally. His programme dwelt on the problem of mentally handicapped children, and in particular with those 62 pupils at the Downham Junior Training Centre at Plymstock, near Plymouth. For too long there has

been a veil drawn over the devoted and patient work, and of the great advances made in the care of the retarded — and of teaching the parents to cope. The greatest tragedy is that there are not enough Downhams and schools like Downham to do the job.

With their "Emmy Award" for *Wyvern at War* safe at their Plymouth headquarters Westward seem to have a formula for documentary TV—linking video tape with filmed sequences; what a pity that the regional stations have insufficient budgets for shooting in colour for world wide sale to the countries where colour TV is real TV! Director David Scott, and the camera team of Gerry Ewens, David Howarth and Trevor Mathews turned in a first-class job. But we must also thank the ITCA for networking such a programme at a peak time.

A play within a play, or a film within a film have always had an appeal to me, and when the playwright is a film director and the TV play is about a "cinema verite" documentary about a film director known to everyone as "R. G."—then I watch for technical knowhow. Wolf Rilla wrote the play for the *Love Story* series, and John Gregson reproduced a typical fictional film director — complete with his own projector, studio lamps, and canvas chair with his name on it "R. G. Bishop". But these were cardboard characters which the actors tried hard to animate—I kept thinking of that Peter Cook and Dudley Moore "send up" of the epic that never was in one of their series. I bet John Gregson was glad he didn't have to shave his head and wear a monocle!

Johnny Morris can put his personality on any programme, whether it's Hammy going up the riverbank, or viewing the Niagara Falls in a monk-like mackintosh habit from under the falls. His comment that his original intention was to stay an hour at the falls, and instead stayed two days was true to life, rather than the "from our own correspondent" style when the commentator is flying from one airfield to another.

Icons



LETTERS TO THE EDITOR

625 LINES IN 405 CHANNELS

SIR,—Mr. Hopkins' novel ideas about the anatomy and physiology of the eye are not borne out by the facts (PRACTICAL TELEVISION, May and June). To suggest that the perception of flicker has anything to do with the push-pull action of the iris muscles is inaccurate and an insult to the refined data processing that goes on in the retina and visual areas of the brain. For anyone interested in this fascinating area of biological computation I will be happy to recommend some simple accounts of the latest thoughts on the matter.

His proposals for improved television scanning standards are interesting, and should be noted by anyone designing a television system from scratch. It is easy, though, to "be wise after the event", and the prospects of changing even this country's standard is remote. Apart from the initial muddle such a change would cause, the cost would surely prevent its being carried out. The gas industry is finding how difficult it is to change from one standard (Town gas) to another (North Sea gas) even with small areas of the country. A national television change would therefore seem impossible.

—J. MELLERIO, PH.D. (Department of Physiological Optics, Institute of Ophthalmology).

The Author replies:

Several enquiries or comments have been made, some by correspondence and some in these columns, regarding the optical and physiological information contained in the above article. Readers unfamiliar with the relation between visual optics and television may welcome some clarification of similar questions which may have arisen.

The diagram of the eye in Part 1, is greatly simplified, as I stated, for easy explanation of its reception of a television picture. The two iris muscles actually have a complex structure, but they "push" the pupil smaller (by dilation) as I explained. Flicker does not activate the iris; a light flash activates the retina, which then signals (via the optic nerve) for protection by a reduced pupil. Slow pulsations of light and dark make the iris try to admit a comfortable light level, but its slow "push-pull" is unpleasant; at about 50 flashes (field sweeps) the pupil settles to a stationary aperture which satisfies the visual demand.

The retina, receiving a steadily repeated image of the traced picture, retains each image for about 1/15 second before fading commences. The cinema would still project only 16 film pictures to the screen each second if the original sound-track had been compact enough to insert in the relative frame of the "silent" film. There was no flicker in 1928; it was eliminated by flashing each stationary frame three times to the screen.

If you check scanning spot size, as suggested, by closing up the lines, and find less than one-third of your screen is left unscanned, you must

SPECIAL NOTE: Will readers please note that we are unable to supply Service Sheets or Circuits of ex-Government apparatus, or of proprietary makes of commercial receivers. We regret that we are also unable to publish letters from readers seeking a source of supply of such apparatus.

The Editor does not necessarily agree with the opinions expressed by his correspondents.

be getting a hazy picture; either the spot is out of focus or your e.h.t. is down.

"Triple-interlacing" has been condemned in the past as showing "line crawl"; this and other unwanted optical effects such as the familiar "patterning" and "moiré" are seen because the traced lines are seen individually. The lines are visible because they are separated; close them up and unwanted effects cannot appear.

"Three-field scanning" implies that each traced field fills one-third of the screen, using the present "twin-interlace" spot which covers only two-thirds of the screen by two field sweeps as we have proved. How else, other than by three fields, can a really complete TV picture be formed, with definition balanced in both dimensions to achieve the highest pictorial quality?—A. O. HOPKINS (Worthing, Sussex).

COLOUR TRANSMISSIONS

SIR,—Prior to the construction of some of the Pal decoder circuits I have been attempting to observe the 4.43Mc/s colour burst on the present local colour transmissions. For this purpose I am using a 625 converter unit and an oscilloscope with 6Mc/s bandwidth. The i.f. bandwidth has been flattened, using your recently described wobulator, to the required limits. I am surprised to find that no visual evidence can be seen on the oscillograph of the burst signal, although the line sync pulse and back porch is extremely clear. Whilst appreciating that a clear 90° wide sine wave is unlikely, I rather expected a hazy outline. I have checked the oscilloscope and it resolves 5Mc/s easily.

Have you any comments to make on this experiment?—JOHN F. CANNELL (Maidenhead, Hants).

[Since the i.f. bandwidth has been increased to the required extent, the detector (or video amplifier) output will contain 4.4 Mc/s components if any exist in the signal. Since the line sync pulse is "extremely clear" it may be assumed that rise- and fall-times are not degraded in the oscilloscope amplifier, whose bandwidth must therefore be of the order of 1 or 2Mc/s at a minimum. Hence, either

- some intermediate signal amplifier (between receiver output and scope input) has bandwidth less than 4.43Mc/s, or
- the receiver output contains no component at 4.43Mc/s.

Since neither of these appears to be the case, it appears that there is some fault in observation. I suggest the following consideration.

- If a whole line is displayed—about 60μs—each cycle of a signal at 4.43Mc/s occupies about 1/200 of the line as displayed; or, on a 3-inch tube face, 0.015 inches. It could be

missed, if there is any appreciable jitter. Great care will be needed in synchronising, and I would hazard a guess that unless a signal/noise ratio of at least 26dB (voltage) exists, the colour-burst will not be seen.

- (b) Try synchronising the displayed line with a 4.43Mc/s signal from a suitable signal generator—I presume the 'scope in use has provision for external sync.
- (c) In any case, it is possible that the sync pulses as transmitted are not accurate to about 20 to 50 nanoseconds, nor is the initiation of the colour-burst so accurate as this. Should this be the case, apparent jitter may well be occurring and if greater than about 1/10 of 1% may readily obscure the 4.43Mc/s display.

I regret the rather vague figures but I have no access to my text books at the moment—however, the above may help.—D.R.B.

THE FIRST OF MANY

SIR,—I am fortunate in having every issue of PRACTICAL TELEVISION except the very first—that is, April 1950. As you may remember, that issue became out of print within a few hours of publication on March 24, 1950 (your editorial, May 1950). If any other readers would care to sell me a copy of this magazine, I should be very grateful to him or her.

I would also like to mention that I would be pleased to lend any copies to any readers for as long as they wish, providing that they return them in the condition in which they were lent.—A. G. FOSTER (44 Warwick Road, Luton, Bedfordshire).

PTV SUPERVISOR

SIR,—I would be grateful if any reader could lend me the third blueprint for the P.T.V. Supervisor together with the relevant literature.—A. PEARSON (148 Portman Street, Middlesbrough, Yorkshire).

DX-TV

—continued from page 14

Austria, Norway, USSR, Yugoslavia, Poland, and perhaps best of all Finland E3 (card Marked TV1).

Graham Deaves of Hichin is another DXer who has been complaining with some justification about the confusing mass of J.R.T. Yugoslav test cards and patterns. We agree there has been no improvement here and have now seen J.R.T. using the E.B.U. card with Zagreb in white letters on it, so that is still another version! Graham has been maintaining his reputation with W. Germany, Canary Is., Italy, and Hungary under the recent difficult conditions.

Ian Rose of Blackburn is going to be disappointed. Our note of last month about his possible Amman, Jordan E3 reception has produced other replies saying firstly Amman is not yet in service, and secondly the Amman caption was probably part of a R.A.I. Italy newsreel on Ch. IA, in connection with the recent Middle East troubles.

COLOUR AND MONOCHROME PATTERN GENERATOR

Labgear Ltd., Cromwell Road, Cambridge, announce their Pattern Generator type E5180 which is specifically designed to provide facilities for the installation and adjustment of colour receivers. It gives the necessary patterns to enable correct convergence of red, green and blue beams on the colour tube. Being fully transistorised and battery-operated, there is no trace of hum, and it is fully stabilised against battery voltage variation. An on/off indicator lamp is provided and a slow motion drive for r.f. tuning.

Operation is on 405/625 lines, Channels 6-13 and 26-52 (for A, B and C channel groups). The patterns generated are: dot pattern, used for static convergence of a colour receiver. Crosshatch pattern, used for dynamic convergence. Vertical bars, used for horizontal linearity adjustment and horizontal lines, used for vertical linearity adjustment. Price is £75 net.

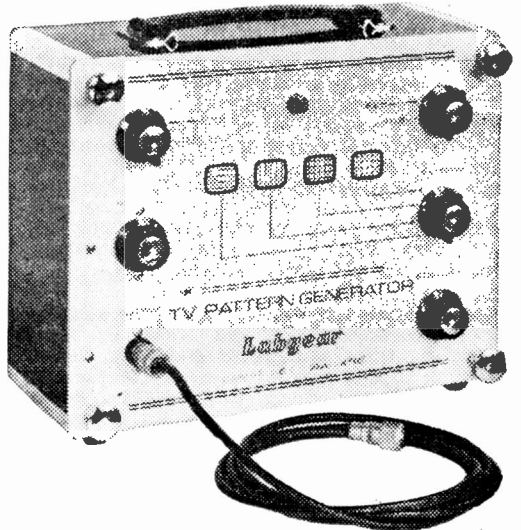

Integrated Test Oscillator

by A. J. McEvoy

PRACTICAL TELEVISION
AUGUST 1967

Messrs. Ferranti Ltd., Gem Hill, Chadderton, Lancashire, have informed us that the ZSS54A is only available on a 4-6 week delivery basis at a cost of 102/- each. They are however, able to offer a much cheaper alternative from stock. This is the ZSS134A which costs 62/6d. and fulfills the same requirements.

COLOUR IS COMING!

A SHORT BASIC COURSE ON COLOUR TV FOR
THE TECHNICIAN AND AMATEUR ENTHUSIAST

by A. G. PRIESTLEY

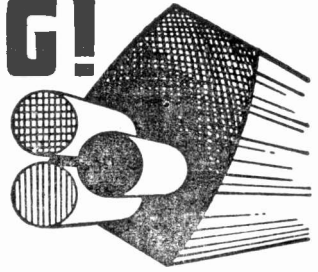

PART 5 — DECODING PAL

THE term *decoding* refers to the process of extracting the colour information from the combined R—Y and B—Y chrominance signals picked up by the receiver. In its strict sense it is simply another from of detection, but it is convenient to talk of a “PAL decoder”, meaning the whole group of circuits which accept the chrominance signals, process them, and provide R—Y, B—Y and G—Y colour-difference output signals at amplitudes of up to 200V peak-to-peak for driving the grids of the three guns in the colour c.r.t. It is a completely self-contained part of the receiver circuitry and is often manufactured as an independent assembly—usually on a printed circuit board. It is also the only part of a receiver which is given over wholly to colour.

INPUT AND OUTPUT WAVEFORMS

Before we start to consider colour signal processing let us be quite clear what sort of signal appears at the input of the decoder, and what sort of drive voltages we shall expect from the colour-difference outputs. Fig. 17 shows a chrominance waveform after it has been removed from the vision carrier. It corresponds to the standard BBC colour bar test pattern and will commonly be at an amplitude of a fraction of a volt. Notice the burst signal transmitted during the back porch interval of the waveform. This consists of about 10c/s of unmodulated chroma subcarrier.

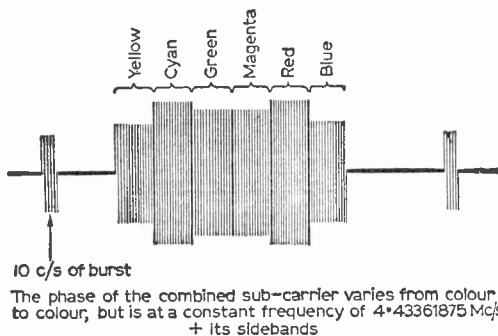

Fig. 17: Chrominance subcarrier representing the standard colour bar test pattern.

It should at this point be mentioned that suppressed carrier transmission is used for the chroma signals. With this technique the subcarrier is suppressed at the modulator stage in the transmitter, only the sidebands, which contain the actual B—Y and R—Y information, being passed on to the output stages of the transmitter for transmission via the aerial system. To simplify matters, however, we shall in this section in referring to the chroma signals refer to the chroma subcarrier as if it were transmitted along with the chroma sidebands.

In our discussion of the transmitted signal we saw that the phase of the subcarrier at any instant in time is a measure of the hue, while the amplitude of the subcarrier tells us the saturation—i.e. how much of a particular hue or colour is being transmitted. So during any particular colour bar in the BBC colour bar test pattern the phase and amplitude of the subcarrier is constant, but as soon as the next bar comes along the phase changes because the hue changes.

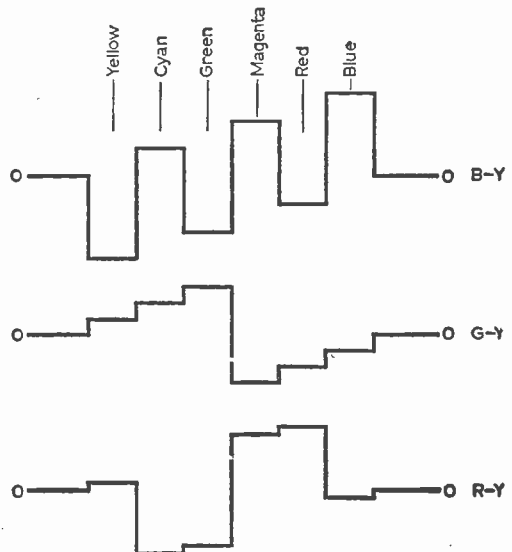

Fig. 18: Colour-difference output signals for the standard colour bar test pattern.

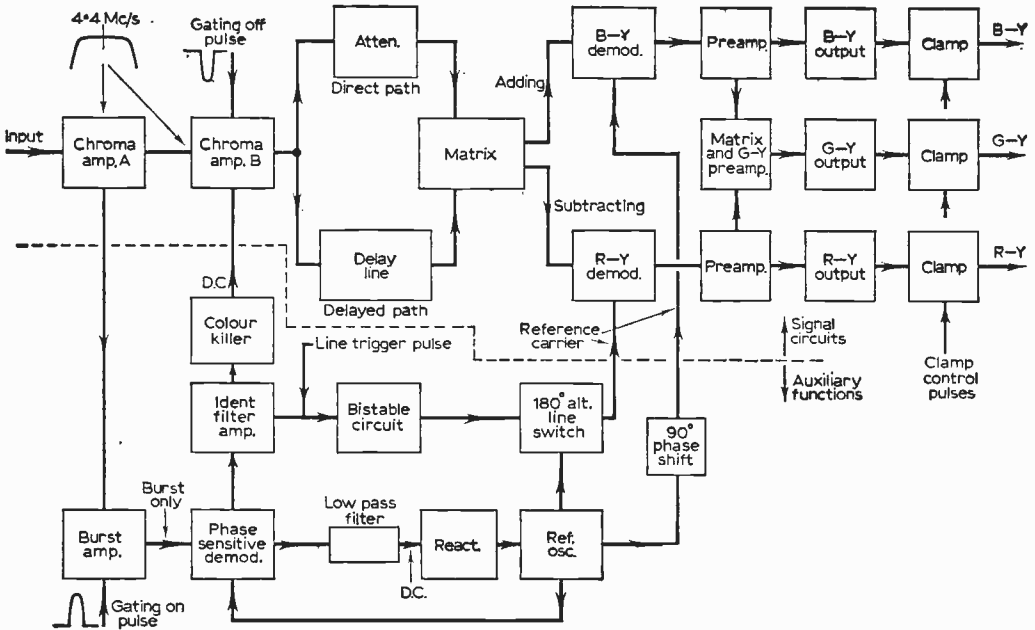

Fig. 19: Block diagram of a typical PAL decoder.

R—Y, B—Y and G—Y colour difference outputs from the decoder for the various bars in the BBC colour bar test pattern are shown in Fig. 18.

BASIC PAL DECODER

A typical PAL decoder contains quite a large number of separate circuit functions but these can conveniently be split up into two groups. One group of circuits carries the actual chrominance signals, whilst the other comprises a number of auxiliary functions most of which are concerned with providing a reference carrier of correct phase to enable the chrominance information to be extracted by the chroma demodulators. Fig. 19 is a block diagram showing the operations carried out on the signal between the input and output of the decoder. Let us follow the path of the signal and discuss the functions of each group of circuits in turn. Afterwards we will consider the auxiliary circuits and see what part they play in the complete decoder.

CHROMINANCE AMPLIFIERS

The first block on our diagram is a tuned amplifier. More commonly this will consist of two bandpass stages (A and B) each tuned to a centre frequency of 4.4Mc/s and with a bandwidth of about ± 1.0 Mc/s. The amplitude response is shown inserted in Fig. 19. The bandwidth is wide enough to include all the worthwhile sideband information carrying the colour detail.

In some decoders the first stage is gain controlled and so a d.c. bias will be fed in from the

chrominance a.g.c. circuits, now commonly known as a.c.c. (automatic chrominance control) circuits. We will consider this in more detail later.

The second stage is gated by means of a pulse derived from the line flyback pulse. This cuts the stage off during the flyback period so that the burst signal is not passed on to following stages. The burst signal, if not removed at this point, could otherwise interfere with the colour reproduction.

DELAY LINE

There are several different techniques of chrominance signal processing but the commonest one, which we are considering here, uses a delay line. The purpose of the line is to delay, or store up, the signal for a period of time equal to one scanning line. As a result of this we have at the input to the matrix at any given instant the picture information being received together with the corresponding information for the same point along the preceding line, i.e. the point immediately above it in the picture. This enables an averaging process to be carried out in the matrix (or mixer) which causes certain hue errors to be cancelled.

A typical delay line is illustrated in Fig. 20. This is of the folded type such as is currently manufactured by Mullards. It consists of a block of glass fitted with two electroacoustic transducers. If an electrical impulse is fed to one of the transducers it is converted into an acoustic impulse (or sound wave) which then travels through the glass, bounces back off the end of the line, is picked up by the second transducer, and converted back again into an electrical impulse. The output

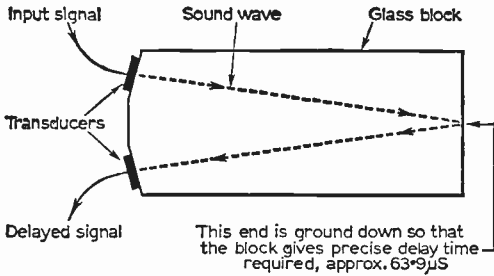

Fig. 20: A folded glass delay line.

impulse is delayed by the time taken for the sound wave to travel down the block of glass and back again. The time interval is therefore determined by the characteristics of the glass and by the length of the block, and each line can be ground very accurately to a predetermined delay time. The type of glass used has to be carefully chosen so that the delay does not vary significantly with change of temperature. The delay time is approximately $63.9\mu\text{S}$ (one line of a 625-line picture).

MATRIXING

Matrixing means mixing—adding or subtracting. It usually consists of a resistive network and has two separate inputs. One input comes from the delay line and consists of the chrominance subcarrier signal which has been stored up for one line. The other input comes straight from the chrominance amplifier via an attenuator to compensate for the loss in the delay line. We therefore have the chrominance information from the current line together with the corresponding information from the previous line: both at exactly the same amplitude. These signals can be processed together because in practice the information is remarkably similar from line to line.

In the matrix we add these two signals as one operation, and we subtract them as another. This gives us two new subcarriers of constant phase in place of the single combined subcarrier of variable phase. One has an amplitude proportional to the $R-Y$ signal, and the other proportional to $B-Y$. Note once again that we are no longer interested in the precise phase of either carrier. Now let us see how this comes about—it is much more simple than it sounds.

Figure 21(a) shows the combined chrominance subcarrier and how it is derived from the original individual $R-Y$ and $B-Y$ modulated carriers for two successive lines of the picture, both having the same hue. (See "Transmitting Colour", PRACTICAL TELEVISION, August 1967.) This is the information that is arriving at the matrix. Fig. 21(b) shows what happens when we add these signals. The result is a carrier of the same phase as the original $B-Y$ carrier, but twice its amplitude. Similarly if we subtract them we get a resultant carrier equal to $2(R-Y)$.

So we now have two separate subcarrier outputs from the matrix: one $R-Y$ and one $B-Y$. All we have to do is to measure their amplitude and polarity. Note that the colour-difference signals can

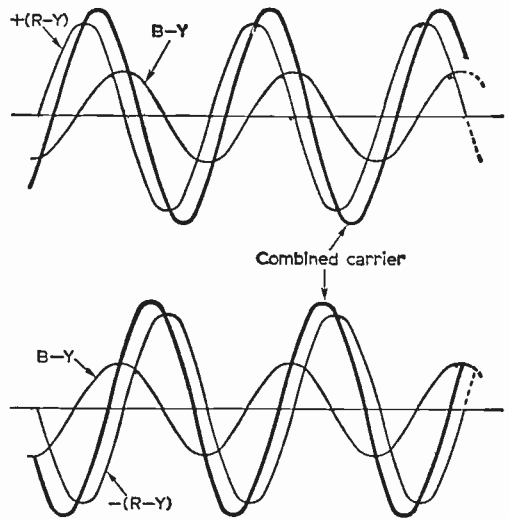

Fig. 21(a): Combined chrominance subcarrier for alternate lines of the picture (same hue).

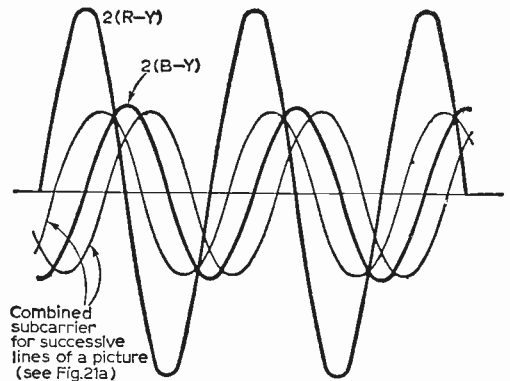

Fig. 21(b): The matrix adds the subcarriers from two successive lines to give $2(B-Y)$ and subtracts them to give $2(R-Y)$.

be either positive or negative, and here is the rub. Because we need to know their polarity as well as their amplitude we cannot use ordinary amplitude detection with a single diode: we have to use *synchronous detection* instead.

MATRIX VECTOR DIAGRAMS

Some people think best in terms of vector diagrams, so before going on to consider synchronous detection let us re-draw the matrixing process in another way. Instead of drawing several cycles of several sinewaves we draw arrows representing the height of each sinewave. We can then plot the arrows on a circle of 360° (one cycle) in positions which represent the phase angles between the signals. We know that the $R-Y$ signal leads the $B-Y$ signal by 90° (because of the quadrature

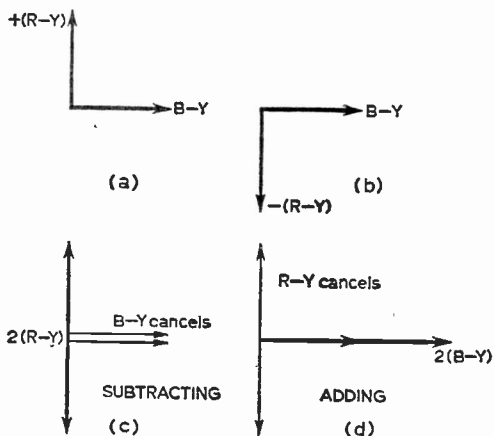

Fig. 22: Vector diagrams of the matrixing operation, which gives outputs of $2(B-Y)$ and $2(R-Y)$.

modulation technique used), and so this leads to Fig. 22. In (a) we show the signal transmitted on, say, line 1. In (b) we show the signal of line 2. Fig. 22 (c) and (d) shows how outputs of $2(R-Y)$ and $2(B-Y)$ are obtained when the signals are added and subtracted in the matrix.

If the combined subcarrier is delayed due to defects in propagation or through any other cause, a phase change is introduced which in the NTSC system causes hue errors. In delay line PAL however the phase error is cancelled and does not cause any change in hue but results in desaturation instead, because the resultant $R-Y$ and $B-Y$ signals from the matrix are slightly too small: this is illustrated in Fig. 23.

SYNCHRONOUS DETECTION

A colour television receiver contains only a few basic circuit techniques which are not found in a normal black-and-white receiver. However, of these few undoubtedly the most important is the chrominance demodulator. Its function is to extract the $R-Y$ and $B-Y$ colour-difference signals from the two subcarriers which have been separated out by the matrix, and to do this we need two separate demodulators in parallel.

In a normal vision detector we use a diode feeding an RC load combination whose time constant is chosen so that the voltage across RC follows the peaks of the carrier and gives the carrier "envelope". This is the signal that was originally modulated on to the carrier.

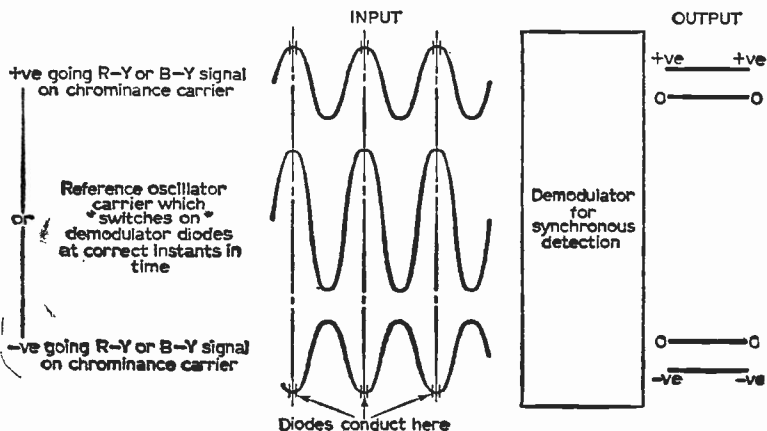

Fig. 24: Showing how synchronous detection "inspects" a chrominance carrier and determines its amplitude and the polarity of the modulated information.

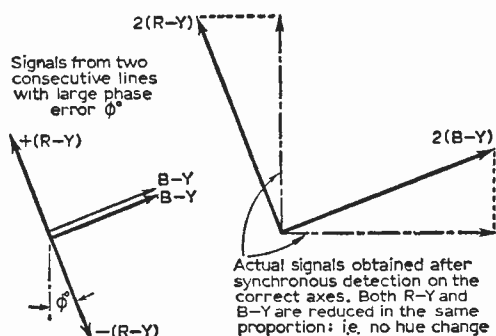

Fig. 23: Showing how phase errors in the signal caused by propagation defects are compensated in the PAL system after signal matrixing and synchronous detection.

A colour demodulator however uses the principle of synchronous detection whereby the circuit is switched on (or gated) for brief periods so that it inspects the incoming carrier at a precisely controlled instant during each cycle. This process is illustrated in Fig. 24, and you will notice that the demodulator is gated on by a reference carrier at the same frequency but of constant amplitude and phase. This new carrier is generated in the decoder by a local reference oscillator controlled by the burst waveform on the back porch of the transmitted signal. In delay line PAL the phase of the reference carrier is adjusted so that it gates on the demodulators at the peaks of the two chrominance subcarriers. We therefore get from the demodulators a voltage output equal to the height of the carrier, and of a polarity which depends upon whether the peak of the carrier was positive or negative at the instant of inspection. See Fig. 24 again.

This inspection process can be carried out very accurately, and in another technique of PAL decoding known as simple PAL the combined subcarrier is inspected simultaneously by two

demodulators. The demodulators are gated at carefully chosen instants in time on the flanks of the sinewave in such a way that pure R—Y and B—Y outputs are obtained. In the absence of a delay line no electronic averaging is carried out and the decoder, although appreciably cheaper to construct, is not as good. A certain amount of visual averaging takes place on viewing the screen of the c.r.t., however, and this helps to cancel hue errors though very accurate decoder alignment is required if certain other defects are to be avoided.

Just by way of an example Fig. 25 shows the commonly used type of four-diode bridge demodulator with typical waveforms.

Let us sum up this part of the discussion. From the matrix we get two separate subcarriers. The amplitude of one subcarrier is proportional to the R—Y signal, and the amplitude of the other is proportional to the B—Y signal. As a result of the delay line and matrix operations we are no longer interested in phase because we have split up the combined transmitted subcarrier of variable phase into two separate ones of constant phases. These two subcarriers are fed to two demodulators which are gated on for a brief instant at the peaks of the sinewaves. From the demodulators we get R—Y and B—Y signal voltages.

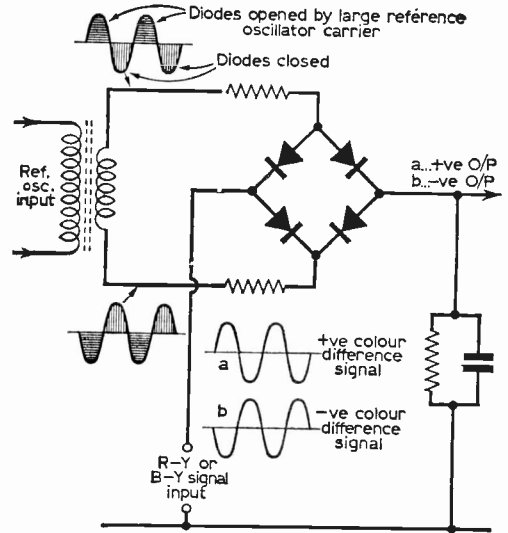

Fig. 25: Four-diode bridge demodulator, a commonly used synchronous detector circuit.

demodulators a reference carrier of the same frequency as the signal, but of constant phase, to use as a timing device so that we can switch on the demodulators at the right instant during each cycle. The reference carrier is obtained from a local oscillator (usually crystal controlled) in the decoder, its frequency and phase being controlled by the transmitted burst signal. The burst signal must therefore be extracted and processed.

Figure 19 shows the basic operations that have to be carried out on the burst signal in order to obtain a control voltage for the reference oscillator. The complete chrominance waveform, centred at 4.43Mc/s, is applied to the burst amplifier, which is gated by a pulse derived from the line flyback or line sync so that the amplifier only conducts during the time when the burst occurs. Thus an output is obtained which consists only of ten cycles of burst sinewave amplified to a high level and without any chrominance information at all.

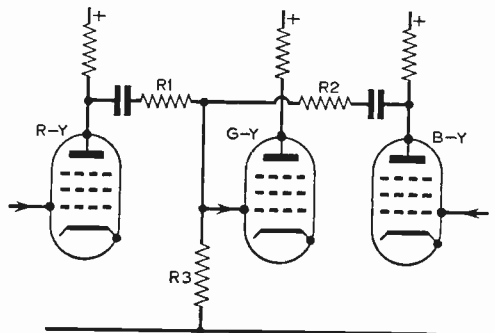

Fig. 26: Simple resistive matrixing, showing how the G—Y colour-difference signal is obtained by adding suitable proportions of the R—Y and B—Y colour-difference signals determined by the valves of R1, R2 and R3.

COLOUR-DIFFERENCE OUTPUTS

Before we can feed the colour-difference signals to the grids of the shadow mask tube we have to do four things. Firstly we have to ensure that the R—Y and B—Y signals are of the correct amplitude relative to each other. Before transmission B—Y is compressed by a factor of 2.03 and R—Y by 1.14. This is done in order to avoid overloading the transmitter, and so the appropriate gain correction must be built into the decoder.

The next operation is to mix the right proportions of $-(R-Y)$ and $-(B-Y)$ to get $(G-Y)$. Fig. 26 shows a simple resistive matrix for performing this operation.

Then all three colour-difference signals are amplified from a level of about one volt at the decoder to a maximum of about two hundred volts peak to peak ready to feed to the c.r.t. Now up to this point the chrominance signals have been a.c. coupled throughout, and so the mean level of the signal will depend upon the picture contents. Thus the actual voltage at any instant will depend not only upon the signal being transmitted at that instant, but also upon the whole picture content of the scene. This will cause quite serious hue errors in any picture with large areas of one colour. The answer is to clamp the a.c. coupled signals so that during the blanking period each colour-difference signal is tied down to a predetermined d.c. voltage. This is done by means of diode, triode or transistor clamp circuits gated on during the blanking period by line flyback pulses. The block diagram of Fig. 19 shows a typical arrangement of colour-difference preamplifier, output and clamp stages.

THE BURST SIGNAL

We have seen that in order to carry out synchronous detection it is necessary to feed to the

If we now apply this burst signal to a phase-sensitive detector of similar type as used for detecting the colour difference signals, and also feed a part of the reference oscillator output to this detector, we can obtain a control potential to control the frequency and phase of the reference oscillator.

Because of the R—Y signal phase reversal on alternate lines in the PAL system, at the output of the phase sensitive detector a sinewave output at 7.8kc/s (half line frequency) also appears.

The output of the phase sensitive detector is used for three important functions. Firstly, it is used to control the local reference oscillator so that its output always has the correct frequency and phase for feeding to the chrominance demodulators. Secondly, its 7.8kc/s sinewave output is used to control the triggering of the switch which inverts the R—Y colour-difference signal from line to line in sympathy with the transmitter so that it is always +(R—Y) at the c.r.t. Finally, it may be used to operate the colour killer stage and as a source of a.c.c. potential. We will consider these three functions in turn.

A.P.C. LOOP

The a.p.c. loop (automatic phase control) consists of a phase sensitive detector feeding a control voltage to a reactance stage (generally a varicap diode) which in turn controls the crystal controlled reference oscillator. This oscillator supplies a reference carrier back to the demodulator to enable it to detect the transmitted burst signal. See Fig. 19. The whole process is precisely analogous to an ordinary flywheel line sync system such as you find in black-and-white receivers.

Suppose that the frequency and phase of the oscillator is exactly in step with the burst. No control voltage is fed to the reactance stage, and so the oscillator is running free. But if the phase of the oscillator changes by even a few degrees a chain reaction starts up: the demodulator output changes; the flywheel filter converts this to a positive or negative d.c. control voltage; this is applied to the reactance stage; the reactance stage alters the capacitance across the oscillator tuned circuit (the crystal); the oscillator frequency starts to change; the phase returns to being in step with the burst again; the demodulator output returns to normal; the oscillator and a.p.c. loop are in equilibrium and the chain reaction stops.

The output of the reference oscillator is therefore completely controlled by the transmitted burst signal.

PAL SWITCHING

In our discussion of the chrominance demodulators we did not mention PAL switching because this would have complicated the issue. Nevertheless it is a vital part of the decoder.

We have seen that during transmission the R—Y signal is inverted on alternate lines, and this is used by the delay line and matrix circuits to obtain the separate R—Y and B—Y carriers of constant phase and substantially free of hue errors. Now when we demodulate the R—Y carrier we must invert the

phase of the reference carrier from the local oscillator by 180° on alternate lines in sympathy with the transmission. If this is not done the c.r.t. will receive +(R—Y), -(R—Y), +(R—Y) etc., and alternate lines will have the complementary hue instead of the correct one.

The usual technique of PAL switching is to trigger a bistable circuit with line flyback pulses so that a squarewave output is obtained at line rate. See Fig. 19. This squarewave is then used to gate a circuit which inverts the reference carrier signal fed to the R—Y synchronous detector on a line to line basis. However, it is necessary to ensure that the inverting operation is in step with the transmission. This is achieved by feeding the 7.8kc/s sinewave output from the burst demodulator via an *ident filter* to the bistable circuit to control its triggering (the 7.8kc/s sinewave is alternating at half line frequency). If the bistable is out of step the 7.8kc/s sinewave blocks the line flyback pulses until the correct time has arrived for the bistable circuit to change from one condition (it is a two-state circuit) to the other. The 7.8kc/s sinewave is termed the "ident signal" since it is used to identify the lines transmitted with R—Y signal phase reversal. It is extracted by means of a high-Q tuned circuit, amplified and used for this and other purposes, as we shall see.

COLOUR KILLER STAGE

If the chrominance signal circuits are left on when a monochrome signal is received no coherent colour would appear on the picture because none is being transmitted. Obviously. But electrical noise, or high frequency sidebands of the luminance signal, may enter and be processed in the decoder as though in fact they were colour information, producing coloured effects on the picture. To prevent this happening a colour killer circuit is normally included.

These circuits can be operated in several different ways, but the principle is the same. The colour killer applies a bias to some point in the chrominance signal chain to render it non-conductive on monochrome reception so that no colour can then appear on the c.r.t. The stage that is cut off must be after the point at which the burst signal is extracted. If a particular transmission contains colour information a burst signal will be present also, and this will be detected in the burst demodulator to give the 7.8kc/s sinewave ident signal. This can thus be smoothed and applied to the colour killer circuit as a bias to switch it on, lifting off the bias fed to the chrominance signal stage to make it non-conductive. This is therefore enabled to conduct, and colour appears on the screen. If no colour is being transmitted, no burst signal is present, and the colour killer circuit keeps the chrominance signal stage cut off. Alternatively the ident signal may be used when present as a bias voltage, after smoothing, to make the gated chroma stage conduct.

CHROMINANCE A.G.C.

Our block diagram of a decoder, Fig. 19, does not show any a.c.c. circuit because this is not an

essential feature. Some commercial receivers will have it, and others will not. However, if we add a second burst demodulator operating along the B—Y axis, and integrate the output, we can obtain a d.c. voltage proportional to the height of the burst signal which is in turn proportional to the amplitude of the complete chrominance signal. If this d.c. is applied in the appropriate polarity to a chrominance amplifier normal a.g.c. action can be obtained. Alternatively the amplitude of the ident signal can be used, after smoothing, as the source of a.c.c. potential.

OTHER DECODING TECHNIQUES

In this article our discussion has been confined almost entirely to delay line PAL (or PAL_M as it is often called) for two reasons. In the first place it is likely to be the commonest form of PAL decoding technique used in the first generation of colour receivers to appear on the British market. Secondly, it illustrates clearly the basic operations that have to be carried out in order to convert the chrominance subcarrier into the three colour-difference voltages of large amplitude which drive the grids of the c.r.t. We have also made passing reference to simple PAL (PAL_S) which is not a very satisfactory technique and is unlikely to be found in general use.

It should be borne in mind, however, that there are other forms of PAL decoding based on the locked oscillator principle, and these may be encountered in some commercial receivers. They are likely to find more general acceptance in second generation designs. The signal circuits of Fig. 19 remain largely unchanged, but the auxiliary circuits differ considerably although their basic function remains the same—namely to produce a reference carrier to feed to the demodulators to enable synchronous detection to be carried out.

The basic idea is that the R—Y and B—Y subcarrier outputs from the matrix are of *constant phase*, but their polarity at any given instant can differ by 180° in each case, depending upon the signal modulation. These subcarriers can be processed and used to trigger continuously either one or two oscillators, known as *locked oscillators*. The polarity of these oscillators can be controlled at the beginning of each line by the normal burst

signal. Depending upon the way the technique is used, the a.p.c. loop becomes redundant and even the ident, bistable and R—Y switching circuits as well. Of course a number of additional circuits have to be added, but the expensive oscillator crystal is discarded and a number of fairly critical alignment operations are avoided. One important advantage of these new techniques is that a reference carrier is produced which is not controlled in phase by the burst signal, which occurs only for a brief period once each line, but is related all the time to the phase of the subcarriers. If the phase of the subcarriers changes, due for instance to peculiarities of propagation conditions, the reference carrier will change in sympathy. This means that certain defects due to slight errors in synchronous detection are reduced, and the decoder is more "robust".

Space does not permit an adequate description of locked oscillator techniques, but once the basic principles of PAL_M are understood other forms of decoding should not present undue difficulty.

Another variation which has already been introduced in practice is to carry out further signal matrixing in the output stages so that the drive voltages are fed to the cathodes of the shadow mask c.r.t. only, as in monochrome television, instead of to the grids and cathodes ("BRC Colour Sets", PRACTICAL TELEVISION, September 1967). This means that instead of feeding the luminance and three separate colour-difference signals to the c.r.t., the picture tube drive consists of the true R, G and B signals.

NTSC DECODING

Readers who are familiar with NTSC system will have noticed that it has a great deal in common with PAL. In point of fact PAL is basically NTSC, but with certain important modifications. If the delay line, matrix, bistable circuit and R—Y switch of Fig. 19 are removed, we are left with an NTSC decoder operating on R—Y and B—Y axes. It only needs a few minor changes to enable it to operate on an NTSC transmission. Conversely an NTSC decoder can be modified fairly readily by the addition of extra circuits for use on PAL.

To be continued

PRACTICAL WIRELESS

FREE

ALL-PURPOSE DATA-RULE

- ★ Instant conversion factors
- ★ Components tolerances
- ★ Parallel resistor chart
- ★ Normal mathematical slide rule functions.
- ★ 17 Scales
- ★ LCF ABAC
- ★ Decibels

TRANSISTORISED CAR RADIO

Full details of how to build a solid state car radio.

MAINS INTERCOM

Uses the mains wiring to pipe audio all round the house. Just tap off where you want it. Full circuitry and details.

SIMPLE 2 METRE CONVERTER

Easy-to-build converter to allow reception on the two metre amateur band. Output is at 4-6Mc/s.

PRACTICAL ELECTRONICS

FREE

6 INCH 33 $\frac{1}{3}$ RPM RECORD

"ELECTRONIC SOUNDS & EFFECTS"

plus special article

ELECTRONIC MUSIC TECHNIQUES

construct

1-2 KILOWATT THYRISTOR CONTROLLER

ON SALE NOW

LAWSON BRAND NEW CATHODE RAY TUBES

The rapidly increasing demand for a complete range of new tubes of the very highest quality is now being met by the new Lawson "CENTURY 99" range of television tubes.



SPECIFICATION:

The new "Century 99" range of C.R.T.s are the products of Britain's premier C.R.T. manufacturers. All types are exact replacements, manufactured to the original specification but incorporating the very latest design improvements to give superb performance, coupled with maximum reliability and very long life

"Century 99" C.R.T.s, available as direct replacements for the following makes and types

MULLARD		MAZDA		BRIMAR		EMISCOPE & EMITRON		GEC & COSSOR also ENGLISH ELECTRIC	
MW43/69	AW36-80	CRM121	CME1901	C12FM	C17SM				141K
MW43/64	AW36-21	CRM123	CME1902	C14M	C19/7A		4/14		171K
MW36/24		CRM122	CME1903	C14GM	C19/16A		4/15G		172K
MW31/74		CRM124	CME2101	C14HM	C19/10AD		5/2		173K
MW31/16	Twin Panel	CRM141	CME2104	C14JM	C19AK		5/2T		212K
MW43/30	Types	CRM142	CME2301	C14LM	C19AK		5/3		7102A
MW36/44	A47-13W	CRM143	CME2302	C17A	C21A		5/3T		7201A
MW53/80	A59-16W	CRM144	CME2303	C17A	C21AA		14KP4		7203A
MW53/20	A59-13W	CRM153		C17A	C21AM		17ARP4		7204A
MW43/43		CRM172	Twin Panel	C17A	C21NM		17ASP4		7204A
AW59-91		CRM173	Types	C17AE	C21SM		17AY4		7401A
AW59-90		CRM211	CME1906	C17AF	C21SM		21CJP4		7405A
AW53-89		CRM212	CME2306	C17BM	C21YM		SE14/70		7406A
AW53-28		CME141		C17FM	C23-7A		SE17/70		7501A
AW53-80		CME1402		C17GM	C23-7A				7502A
AW47-90		CME1402		C17HM	C23AG				7503A
AW43-89		CME1703		C17JM	C23AK				7504A
AW43-88		CME1705		C17LM					7601A
AW43-80		CME1706		C17PM					7701A

- 12" .. £4.10.0
- 14" .. £5.10.0
- 17" .. £5.19.0
- 19" .. £6.19.0
- 21" .. £7.15.0

Terms: C.W.O.
Carr. and Ins. 10/-

2 YEARS' FULL REPLACEMENT GUARANTEE

Complete fitting instructions supplied

LAWSON TUBES

STATION ESTATE, MALVERN. Offices

18 CHURCHDOWN ROAD, MALVERN, WORCS. MALVERN 2100

BENTLEY ACoustic CORPORATION LTD.

38 CHALCOT ROAD, LONDON, N.W.1 Tel. Primrose 9090

Nearest tube Chalk Farm SPECIALISTS IN NEW VALVES AND TRANSISTORS All goods advertised are in stock

0A2	6/1	12AU6	4/8	50C5	5/9	6BK11	7/3	EF50	4/6	EY88	7/6	PC085	6/9	PY81	5/-	UB41	10/6	X66	7/6	BFY52	5/1	UC30	8/-
0B2	6/1	12AV6	5/9	50L6GT	6/1	EB0N1	6/3	EF83	9/6	EY91	3/1	PC088	10/6	PY82	5/-	UBC41	6/6	X78	28/2	BF163	4/-	UC35	10/-
0Z4GT	4/3	12BA6	5/-	72	6/6	EBF50	5/9	EF85	4/6	EZ40	6/-	PC089	9/9	PY83	5/6	UBC81	6/6	X79	40/9	BY100	3/6	UC36	10/-
1D8	9/8	12BE6	5/3	85A2	8/6	EBF53	7/-	EF86	6/3	EZ41	6/6	PC089	8/3	PY88	7/8	UBF80	5/6	Y63	6/6	BY212	7/6	UC38	12/6
1K5	4/9	12BH7	6/-	90A1	6/7	EBF59	5/9	EF89	4/9	EZ80	3/9	PCF80	6/3	PY800	6/1	UBF89	5/9	Transistors		BY213	7/6	UC41	5/-
185	3/3	12CF7	6/6	90AV	6/7	EBL21	10/3	EF91	3/3	EZ81	4/3	PCF82	6/-	PY801	6/-	UBL21	9/-	and diodes		BY234	4/-	UC44	3/-
1T4	2/6	12CG1	6/-	90C1	16/-	EC70	4/9	EF95	4/9	EZ34	10/-	PCF85	8/-	QV03/10	UC084	8/-	AC107	3/6	GET1103	4/6	UC46	3/-	
2X2	3/-	20D1	10/-	90C9	33/6	EC92	6/6	EF97	8/-	EZ37	14/6	PCF801	8/6	30T	UC085	6/6	AC126	2/6	GET1113	5/-	UC65	22/6	
3A5	8/-	20D4	20/5	150B2	14/6	EC331	15/6	EF98	8/-	HAB080	9/3	PCF82	9/6	UY04/7	UC089	8/3	AC127	2/6	GET1161/2	2/-	UC68	25/-	
3Q5GT	6/6	20E2	11/6	807	11/9	EC040	9/6	EF133	6/3	HL41D	19/6	PCF865	9/6	R10	15/-	UC181	9/-	AC128	2/6	GET1115	7/6	UC70	3/-
384	4/9	30L1	13/-	5753	10/-	EC081	3/6	EF184	5/9	HL22D	19/6	PCF806	11/8	R17	17/6	UC182	9/-	AC128	2/6	GET1119	7/6	UC71	2/6
3Y4	5/6	20L1	17/6	6090	6/-	EC082	4/6	EF204	2/5	HL42D	19/6	PCF81	9/-	R18	9/6	UC181	6/-	AD140	10/6	GET57312/6	UC72	2/6	
584GY	8/9	20P3	15/-	7475	2/6	EC083	4/6	EF290	7/6	HN309	26/6	PCF82	6/3	R19	6/6	UC182	7/-	AD149	10/6	GET58712/6	UC73	18/-	
5U4G	4/9	20P4	16/-	AC2PEN		EC084	5/6	EK32	5/9	HVR2	8/9	PCF83	8/6	S130	25/-	UC183	8/9	AF127	18/-	GET5873	5/-	UC74	8/-
5V4G	8/-	20P5	16/-	DD	19/6	EC085	5/6	EL32	3/1	HVRC2A	9/8	PCF84	7/-	S161	2/-	UF41	7/9	AF114	4/-	GET5887	7/6	UC75	3/-
5Y3GT	5/-	25L8	4/9	AC8PEN	4/9	EC088	7/-	EL33	12/-	KTR3C	19/6	PCF85	8/3	TH233	6/9	UF42	4/9	AF115	3/-	GET5889	7/6	UC76	3/-
5Z3	7/6	25V6G	8/6	AZ31	7/6	EC091	3/-	EL34	9/6	KT36	29/1	PCF86	8/-	TY86F11/10	UF89	6/9	AF116	3/-	GET5890	7/6	UC77	4/-	
5Z4G	7/6	25Z4G	6/3	AZ41	6/6	EC089	9/-	EL36	8/9	KT41	19/6	PEN45	7/-	U10	9/-	UF85	7/3	AF117	4/-	GET5896	7/6	UC78	3/-
6A8	7/6	25Z6GT	8/6	836	4/9	ECF80	7/6	EL41	8/-	KT44	5/9	PEN45DD	U12/14	7/6	UF86	9/-	AF118	3/-	GET5897	7/6	UC79	8/-	
6AC7	3/-	30C15	10/6	CB11	19/6	ECF82	6/9	EL42	7/6	NT61	12/-	U16	15/-	UF89	5/6	AF119	3/-	GET5898	7/6	UC81	2/3		
6A47	5/9	30C17	11/6	CL33	19/6	ECF86	8/6	EL43	6/9	KT66	16/6	PEN383	9/6	U19	40/6	UF84	5/6	AF127	3/6	GET5899	7/6	UC82	2/3
6A45	4/9	30C18	9/6	CY21	6/6	ECF84	2/6	EL44	8/6	KT78	27/6	PEN453DD	U22	5/9	UM4	17/6	AF120	3/6	GEX66	15/-	UC82D	2/6	
6A78	3/9	30C19	7/6	DAP96	6/-	ECF81	9/6	EL45	7/6	KTW61	4/3	19/6	U25	11/6	UM80	5/1	AF126	3/6	OA70	3/-	UC83	3/-	
6A06	5/6	30FL1	13/-	DF96	15/-	ECF85	6/-	EL46	8/6	KTW92	12/6	DFL20013/6	U36	8/6	U8	18/6	AF122	5/-	OA79	5/6	UC84	3/-	
6A06	5/6	30FL12	13/-	DF96	6/-	ECH42	8/9	EL47	2/6	KTW53	4/-	FL33	9/-	U31	6/1	UY1N	19/6	ASV29	10/-	OA81	2/6	UC123	4/6
6BA6	4/6	30FL13	6/-	DF97	10/-	ECF81	5/-	EL49	5/-	MH14	7/6	PL36	9/-	U33	13/6	UY21	9/-	BA115	2/8	OA95	2/6	UC169	4/6
6BE6	4/3	30FL14	11/-	DK40	10/6	ECF84	12/-	EL50	5/-	MH16	12/6	PL38	19/9	U35	16/6	UY41	5/6	BA129	2/6	OA182	3/6	UC170	2/6
6BE6	6/6	30L17	12/-	DK96	6/6	ECF80	6/-	EM71	14/-	MU12/14/4	6/-	PL41	6/9	U37	34/11	UY85	4/9	BA130	2/6	OA202	2/6	UC171	4/6
6B36	7/6	30P4	11/8	DL72	15/-	ECL82	6/3	EM80	5/9	N37	23/3	PL31A	6/9	U45	15/6	V14	14/6	BCY10	5/-	OA221	7/6	UC172	4/6
6BQ7A	7/6	30P4MR		DM70	6/6	ECF83	9/-	EM81	8/9	N78	38/4	PL32	6/9	U46	4/6	VP4B	11/-	BCY12	5/6	OC19	25/-	UC200	6/6
6BR7	9/-			DM71	9/9	ECL85	11/-	EM85	11/9	PACB08	7/6	PL34	6/3	U51	9/-	VR105	5/-	BCY33	5/-	OC22	5/-	UCP17	27/6
6B88	8/6	30P12	9/-	DM72	9/9	ECL83	9/-	EM84	6/-	N108	26/7	PL33	6/-	U191	10/6	VR150	5/-	BCY34	5/-	OC23	7/6	UDP12	15/6
6BW6	7/6	30P19	10/-	DY87	5/9	ECL86	7/9	EM87	6/6	P61	2/6	PL500	13/6	U282	12/3	WU111	6/-	BCY38	5/-	OC25	7/6	MAT100	7/9
6BW7	5/-	30P19	12/9	ES00C	33/-	ECL800		EY51	5/6	P086	8/6	PM84	9/3	U301	12/6	W107	10/6	BCY39	5/-	OC26	5/6	MAT101	8/6
6C9	10/9	30PL13	13/3	ES0F	24/-			EY81	7/-	P088	8/6	PM84	9/3	U31	14/6	W229	19/6	BFY50	5/6	OC28	5/6	MAT120	7/9
6CD6G	19/6	30PL14	13/3	ES3F	24/-			EY84	9/-	PC97	5/9	PY32	6/6	U4020	8/-	X41	10/-	BFY51	5/6	OC29	16/6	MAT121	8/6
6L19	19/-	30PL15	13/6	ES8C	12/6			EY86	5/9	PC900	8/6	PY33	8/6	UABC80	5/3								
10P13	12/-	35L6GT	6/3	E180F	17/6	EF37A	7/-	EY87	5/9	PC084	5/6	PY80	5/-	UAAF2	7/9								
10P14	13/-	35W4	4/6	E180C80	5/9	EF39	5/-																
12AC6	8/-	35Z3	10/6	EAF42	7/6	EF40	8/9																
12AD6	9/-	35Z4GT	4/6	E181	4/9	EF41	8/-																
12AE6	7/6	35Z5GT	5/6	E181	2/6	EF42	3/6																
12AT6	4/6	50B5	3/3	EB3C3	6/-	EF50	2/6																

We require for prompt cash settlement all types of valves, loose or boxed, but MUST be new. Orders made by return.

Terms of business:—Cash with order only. No C.O.D. Postage/Packing 6d. per item. Orders over £5 post free. Any parcel insured against damage in transit for only 6d. extra. All orders despatched on day of receipt. Callers welcome to the shop. Mon.—Fri. 9 a.m.—5.30 p.m. Sat. 9 a.m.—1 p.m.

All goods are new first quality brands only and subject to makers' full guarantee. We do not handle manufacturers' seconds or rejects which are often described as "new and tested" but which have a limited and unreliable life. Complete catalogue of over 1000 valves actually in stock with resistors, condensers, transformers, microphones, speakers, metal rectifiers with terms of business, 6d. post free.

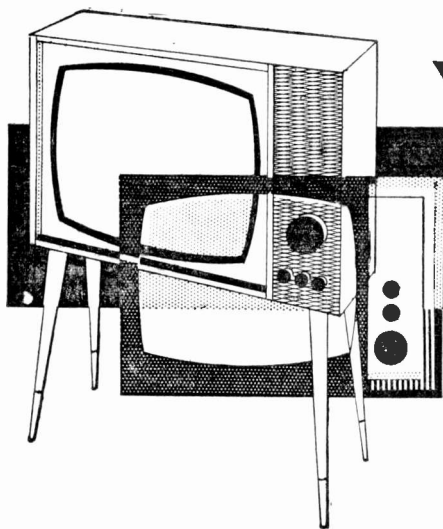

Your Problems Solved

Whilst we are always pleased to assist readers with their technical difficulties, we regret that we are unable to supply diagrams or provide instructions for modifying surplus equipment. We cannot supply alternative details for constructional articles which appear in these pages. WE CANNOT UNDERTAKE TO ANSWER QUERIES OVER THE TELEPHONE. The coupon from page 43 must be attached to all queries, and a stamped and addressed envelope must be enclosed.

K-B VV20

At times, the sound will suddenly go low both on BBC and ITV and on moving the channel switch, the sound comes back.—K. Flindie (Atherton).

The trouble is due to a poor connection in the sound strip. Quite likely in one of the audio circuit coupling capacitors. Disturb these components and re-solder all suspect components.

K-B VV30

The service sheet I have calls for a e.h.t. rectifier R20 but I find the one in the set is a U26. I wish to change the valve, the reason being a variation of size as the brilliance is advanced.

I would also like to improve the focus as this seems slightly out.—E. Stilgoe (Sheffield, 13).

Either a U26 or R20 valve may be used as an e.h.t. rectifier. Check the value of the focus control which may possibly have changed. Also check the video amplifier.

SOBELL 1005DST

The sound on this set is good on BBC-2 and ITV but on BBC-1 it is very poor. Could you also say how the chassis can be removed from the cabinet.—W. Goodg (Bromley, Kent).

Two types of v.h.f. have been fitted to this set. One is a small turret type and the other, the Sobell semi-incremental M96512. However in both types the oscillator coil core is adjusted through the front of the tuner with the switch knob and fine tuner knob removed. Adjust for maximum BBC-1 sound.

FERGUSON 317T

There are multiple images (line) which cannot be locked by the control in any position. Also, the sound output transformer appears to overheat.—S. R. Woodcock (London, N.10).

Check V17, V18 and V19, all on the upper right

side (EF80, ECC81 and EB91). Check associated components if necessary, particularly the 0.01 μ F capacitors (2) associated with the right side oscillator-phasing transformer.

Also check the sound output PCL82.

BUSH TV56

There is a buzzing noise on BBC-1 which cannot be tuned out with the fine tuner. This fault is not present on ITV.—R. Main (London, S.E.4).

First ensure the left side plug is in the "local" position. Then install an aerial attenuator to reduce the signal input.

MASTERADIO TE7T3

This set suffers from lack of width, distorted sound, a motor-like sound in the speaker with the volume turned right down and bad focusing.—J. Bayley (Hertfordshire).

We advise you to check the main electrolytic capacitors and the h.t. rectifier. You would not go far wrong if you were to replace both these units.

PYE V210

Both sound and vision went off. On inspection I found that the bottom part of the mains dropper had burned out together with the fuse. I replaced the burnt part of the dropper with a wirewound resistor—value 47 Ω —switched the set on again and exactly the same damage resulted.—W. Denholm (Edinburgh).

The trouble could be caused by a faulty h.t. rectifier or its 1800pF limiting capacitor, which is wired from the a.c. end to the chassis. Before replacing, check that the h.t. line has not developed a short, by progressively disconnecting main electrolytic capacitors in turn.

FERGUSON 3600

I have recently purchased this second-hand set which is fitted with a 405/625 selector switch and a "U" on the station selector switch.

What components do I need to convert this set to BBC-2 and how much will it cost?—A. Keith (Hamilton).

The only provision for u.h.f. reception is that the line timebase is switched. This means that in addition to a u.h.f. tuner and switch linkage etc. a complete i.f. panel must be fitted. There is no easy way of carrying out this modification. The cost, depending on the source of supply will vary from about £5 to £10.

FERRANTI T1134

The picture jerks up and down intermittently. This fault occurs on both standards and appears to be in the field circuits. The jerking takes place over the whole screen area but it is usually worse at the bottom. The field oscillator valve (PCL85) was replaced to cure a field linearity fault but this had no effect on the above-mentioned fault.—R. N. Bates (London, S.W.16).

Check the 200 μ F electrolytic C74 in the cathode circuit of the PCL85, and the vertical linearity control R79 (270k Ω). Also check V11 (PCF80).

HMV 1826A

There is no vision or sound, but all the valves light up except the EY51. When the set is first switched on, there is a hum from the speaker which increases in volume and the PY81 valve gets overheated. I have replaced the PY81 but this has made no difference.—J. McGuire (Staffordshire).

The sound should return when the top cap of the PY81 is removed. The fact that this valve overheats indicates that it is being overloaded. Check the N152 (PL81) and associated components.

COSSOR 933

Within minutes of the picture coming on, the fuse blows. Just before this happens the picture cramps at the top and bottom.—W. C. Wright (Liverpool, 21).

The commonest cause of the fuse blowing in this receiver, is a defective PY82 (17Z3) h.t. rectifier valve. Alternative causes are defects in the line output and efficiency diode stages.

DECCA DM35

When this set is switched on, I get an upside-down picture about 2in. in on the screen. I have replaced valves PCL84, ECL80 and PL84 but this has made no difference.—J. Medley (Yorkshire).

We would advise you to check the 0.5 μ F, 0.33 μ F, 0.22 μ F and 0.047 μ F capacitors in the PL84 circuit and ensure the cathode resistor of this valve is over 300 Ω .

MURPHY V430

I wish to receive BBC-1 on Channel 12 from Winter Hill. Can I re-wind the existing coils to do this?—H. Barwell (Blackpool, Lancashire).

We have no coil-winding details for adapting your Channel 2 coils to receive transmissions from Winter Hill. Since replacement coils are relatively inexpensive and readily available to Murphy dealers, we would advise you to try and obtain a correct set, which can be placed in either of the two vacant positions.

BAIRD 472

The fault consists of a series of horizontal lines, slightly angled when the brilliance is advanced to maximum. When the brilliance is normal, these lines change to a series of vertical dots, situated to the left-hand side of the screen.—M. McGill (Bristol, 6).

Trace the circuit from pin 2 of the c.r.t. back to the field flyback capacitor and check this component.

DECCA DM4C

The picture has become expanded on the left-hand side and severely cramped on the right side with about 2in. showing a "doubling effect".—F. Whitlock (Ashted, Surrey).

Check the PL81 valve and the components associated with the line output transformer. Also check the line deflection coils if necessary.

BUSH TV56

Sound and vision drift apart when away from a strong signal source. The picture is reasonable and the sound is good otherwise.

I have had the valves tested and although at least five of them were weak, I am not certain that they all want changing.—E. Carvill (Barrow-in-Furness).

Check the setting of the left-side local-distant plug and place in the "distant" position. Replace the PCC84 valve on the tuner unit.

SOBELL MP20

This set has lack of gain and the picture is closed in from the sides by about 2in.—H. Watkins (Birmingham, 14).

Check the large PY32 rectifier, using a PY33 for replacement. Check PL81 and PCC89 valves if necessary. The PL81 is line output and the PCC89 is on the tuner.

PAM 600

When I first switched this set on, the sound on both Channels 1 and 9 was perfect and remained so on Channel 9. If I switched to Channel 1, after about half an hour, the sound was distorted and there was a "rushing" noise which spread all round the dial of the fine tuner.

I have replaced the sound valve, PCL82 but

this has made no difference. As this fault does not appear on ITV, could it be that the BBC oscillator coil needs re-tuning?—W. Porter (Gravesend, Kent).

It would appear that the BBC oscillator coil core is out of alignment but it is possible that the decoupling to the tuner or i.f. stages is inadequate. Check aerial socket.

BUSH TV77

There is a constant hum from this receiver, sounding similar to a dynamo working. The picture remains perfect.—H. Ashworth (Bury, Lancashire).

One of the electrolytics in the smoothing circuit could be at fault, but we are more inclined to suspect one of the sound valves—left side—of heater/cathode leakage. Check the PCL82 (upper left) in particular.

ALBA T766

The first symptom was complete breakdown, with no sound or vision and no heaters glowing. I replaced the PY81 and the sound returned, but there was no raster.

Whilst testing C73 from pin 9 of the PY81, it exploded. This was replaced and the raster returned but was only 6in. wide in the centre of the screen and was very dull.—M. Hart (Havant, Hampshire).

Check the 1.8k Ω resistor to pin 8 of the PL81. Check the width control and V9 (ECC82).

QUERIES COUPON

This coupon is available until OCTOBER 20th, 1967, and must accompany all Queries sent in accordance with the notice on page 41.

PRACTICAL TELEVISION OCTOBER, 1967

TEST CASE -59

Each month we provide an interesting case of television servicing to exercise your ingenuity. These are not trick questions, but are based on actual practical faults.

? The original trouble with an Ultra Model 66-40 was lack of raster, testing subsequently revealing lack of e.h.t. voltage (e.h.t. rectifier heater out) and a slight curl of smoke emanating from somewhere in the line output transformer. The technician in charge of the repair replaced the line output transformer. This restored normal working with no apparent distortion on the line scan or width cramping, and the set was returned to the owner.

Two weeks later the set was returned to the workshop with the same lack of raster symptom. Further testing indicated lack of e.h.t. and smoke, just as previously. The transformer was again replaced, but this time the line timebase circuits were checked in detail before the set was sent back to the customer. The technician spotted something that could have been responsible for both failures. What could it have been? See next month's PRACTICAL TELEVISION for the solution, and for a further Test Case.

SOLUTION TO TEST CASE 58

Page 572 (last month)

The smoking resistor in the h.t. feed to the line output stage led to the technician suspecting a very heavy line output stage current. This was proved by a current test in the line output valve cathode, and also by the fact that the screen grid electrode in the valve appeared to be glowing

red hot. The valve, too, was very much hotter than normal.

As the grid bias to the line output valve in the set in question is supplied mainly by the drive waveform from the line generator stage, the technician correctly concluded that something was amiss with the generator, and tests, first with a high resistance d.c. voltmeter connected between the output valve control grid and chassis, showed a very slight positive potential instead of a negative one—produced normally by the grid/cathode of the valve acting as a rectifier to the drive waveform.

Testing with an oscilloscope confirmed lack of line drive under which condition the line output valve is unbiased, the cathode current then running very high, sufficient to cause overheating of the feed resistor. Incidentally, it is also possible in some cases to check the line drive with an a.c. voltmeter. But caution must be used in this instance since some a.c. voltmeters are insensitive to 10,125c/s and 15,625c/s frequencies, and others are of insufficient impedance (on a.c.) to avoid heavy loading on the drive and coupling circuits. It is for this reason that a d.c. bias test is recommended, remembering that the resistance of a testmeter switched to d.c. voltage is usually well in advance of the impedance on a.c. volts, and that the a.c. response of the meter is immaterial on d.c.

Further tests in the line generator stage brought to light a high resistance winding on the line blocking oscillator transformer. This transformer was replaced and the fault cleared.

TV AT THE SHOWS

—continued from page 13

in the circuit; this is due to the need to keep prices down in order to make sure the sets sell. Now, Decca apparently take the view that many people will be willing to pay rather more than the usual for a black-and-white set provided that the results from it are excellent.

In the "Professional", close limits are set to the permissible distortions of scanning linearity and picture shape. The chassis is fully isolated from the mains supply and it is therefore safe to connect external equipment to the receiver. In fact, the set is fitted with an output socket for feeding a tape recorder or hi-fi amplifier, and there is also a socket for use with a hearing-aid. An extra unit will be available if required to enable the set to feed a video tape recorder and to allow the output from a TV camera to be fed into the set.

SOUND

The sound-output stage included in the receiver is transistorised and of the push-pull type with complementary output and driver stages. The maximum output is 3W from the 8 x 5in. loud-speaker. A tone control is also included—a very unusual item on a TV set.

The vision a.g.c. system is of the gated type, sampling the video waveform once every line. This is a system encountered on too few receivers since the mean-level system is easier to design and cheaper to produce. The main merit of gated a.g.c. is that the a.g.c. potential produced depends purely on the level of signal being picked up by the aerial, and not on the content of the picture being displayed. With the mean-level system, a dark picture (on 405) produces less a.g.c. potential and the gain of the set is therefore automatically "turned up", resulting in dark scenes being made brighter than they should be. Leading film-makers have often complained that their efforts with cameras, on night-time scenes in particular, count for nothing when the films are seen on TV. Also, of course, bright scenes tend to come out dimmer than they should.

The mean-level system gives better results on 625, but the gated system is to be preferred, nevertheless.

BLACK LEVEL

It is not only the a.g.c. system which has a bearing on the distortion of the brightness of the picture; the links between the video detector and the c.r.t. also influence results. Another manufacturer drawing attention to the question of picture quality is Bush. The new Bush sets feature black-level clamping—this results in better rendering of light and dark in a picture, and improvements are likely on contrasty pictures such as white captions on a black background.

In these days of colour TV, the introduction of coloured black-and-white sets by Murphy was very interesting. Of course, it is the cabinets which are coloured, not the pictures. The sets are a continuation of the Acoustic De Luxe range, and are

available in vivid colours named Revolution Red, Outrageous Orange, Smooth Blue, Serene Green, Quite White, and Dramatic Black. The finish is stated to be resistant to chipping and staining and to have a surface like lacquer. These sets should go down well in modern homes since the trend generally seems to be towards bright colours. As well as the "painted" finishes, cabinets in teak and rosewood are also available. The model-number is V1913, and the prices are 71 gns for teak finish, 72 gns for "painted" cabinets, and 73 gns for rosewood.

A new Bermuda model from Ultra, 6648, introduces a new style—the loudspeaker and controls are mounted on a panel above the c.r.t. The panel slopes slightly backwards and is reminiscent of a car dashboard!

HIDDEN TUBE

KB and RGD showed a 23in. version of the "Deep Scene" TV—the 19in. model was released in July. This set has a flat panel of black Oroglas at the front through which the controls and loud-speaker grille protrude. When the set is switched off, the face of the c.r.t. cannot be seen and this certainly gives an unusual appearance to the sets—very useful if you do not like the "stare" of a black c.r.t. This idea reminds one of the dark-tinted implosion shields used by another manufacturer in the early days of TV—the main idea then was to improve the contrast of the picture rather than to alter the appearance of the set. When light fell on to the set, if it were reflected from the screen, it had to pass through the tinted material twice, and was therefore considerably attenuated. However, the light from the screen passed through the implosion shield once only, and suffered little loss. Thus, the picture was improved.

Another maker preoccupied with quality is Dynatron. Their new range includes seven new sets with 3W output stages for the sound feeding loudspeakers in "acoustic chambers". These sets have tone controls too. The prices range from 100 gns. for the "Norseman" TV95 with 23in. c.r.t. to the 25in. "Marlborough" in Queen Anne or Chippendale styles at 157 gns. A remote-control unit is supplied with six models, but not with the "Norseman" TV. Dynatron also showed a 25in. dual-standard TV set combined with a stereo radiogram having 25W output. This unit is finished in teak and is known as the "Emperor" TRG12—the price is 263 gns.

TRENDS

The general impression gained at this year's shows is of concern with quality of picture and sound. It is interesting to reflect that most of the ideas were employed as standard in the early days of TV but were eliminated on the grounds of cost as the years went by. Makers seemed to think, with some justification, that all viewers wanted from a receiver was a very contrasty picture which moved. It is now evident that the public in general—not just the technically minded—is realising that it is possible to obtain much better pictures than they have been used to, especially on u.h.f. It is to be hoped that the trend towards better pictures and sound continues. ■

BIG-VALUE ISSUE FOR HANDYMEN!

FREE!

Nailing and Wood Panelling Slide Guide

Packed with at-a-glance reference for the right Nails and Panelling for every job.

FREE!

2-way Porch Construction Chart

Full how-to-build instructions for Porches at Front and Side Entrances.

EXTRA!

**12 Page Supplement
IMPROVE THE VALUE OF YOUR HOUSE**

Including detailed advice from top building society experts... how to rewire your house... how to add central heating.

EXTRA!

Fold-out Data Sheets

For Bricks and Building Blocks

Damp-Proofing Wall Tiles

Thermal Insulation.

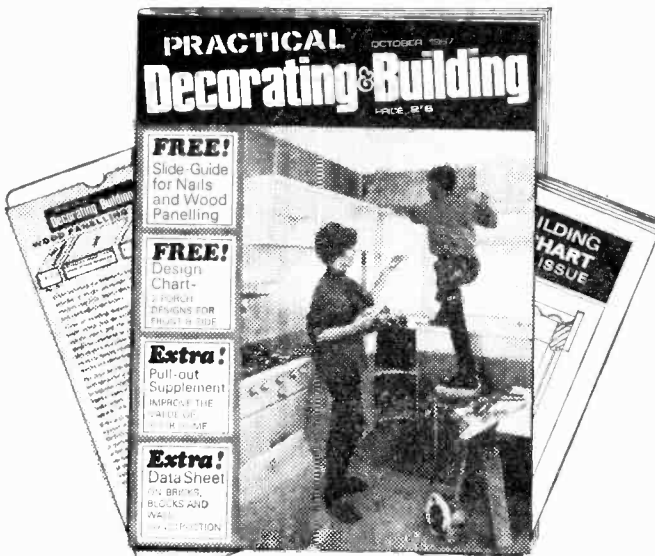

**PRACTICAL
Decorating & Building**

October Issue 2/6
Don't risk missing it!
Get yours today!

SETS & COMPONENTS

150 NEW ASSORTED Capacitors, Resistors, Silvered Mica, Ceramic, etc. Carbon, Hystab, Vitreous, 1-20 watt, 12/6. Post Free. WHITSAM ELECTRICAL, 18 Woodrow Close, Perivale, Middlesex.

STOP

FULLY GUARANTEED L.O.P.T. REWINDING SERVICE

A few of the types are listed below:-

- BUSH TV 53-66.
- K.B.P.V.P.20, etc.
- PHILIPS 1768U, 17TG100U, etc. All at 50/-

NEW FROM STOCK

- U25 Type ECKO, state model. PYE 200-400.
- FERGUSON 306-328 305-307 All at 45/-
- FERGUSON 406, 408, 416, 436, 438
- S.A.E. Enquiries P. & P. 4/-, C.O.D. 6/-

WITWORTH TRANSFORMERS Ltd.
26 All Saints Road, North Kensington
W.11 Telephone: 01-229-9071

OLYMPIC II TV. S.A.E. for itemised price list. AJAX ELECTRONICS, 18a Rumbold Road, Fulham, S.W.6.

BARGAIN PARCELS

Any 10 Valves 14/-, Any 50, 60/- from the list below
PCF80, PCC84, PL82, PCL82, PCL83, PL81, PL36, PY32, PY82, PY81, EF80, EF85, EB91, ECL80, EY86, ECC82, 30P4, 30FL1, 30F5, 6-30L2.

All Valves will be replaced if faulty within six weeks if sent with another order. P. & P. 2/-

3-BY100 Type Rectifiers with Surge Resistors 10/- 50 Television Fuses 5/-

VELCO ELECTRONICS

49 Bridge St. Ramsbottom, nr. Bury, Lancs.

GUARANTEED IDEAL for ANY RECORDER

TAPE World Famous make. PRICES SLASHED. APPROX. HALF PRICE!

By enormous purchase we can offer you fully tensilised Polyester/Mylar and P.V.C. tapes of identical Hi-Fi wave range recording characteristics as top grade tapes. Quality control manufacture. Not substandard in any way. TRY ONE for YOURSELF. They are TRULY WORTH A FEW MORE COPPERS.

STANDARD PLAY		DOUBLE PLAY	
3" 150'	2/3	3" 300'	4/-
4" 300'	4/6	4" 600'	8/-
5" 600'	7/6	5" 1200'	15/-
5 1/2" 900'	10/6	5 1/2" 1800'	19/6
7" 1200'	13/6	7" 2400'	27/-
LONG PLAY		TRIPLE PLAY	
3" 225'	2/9	4" 900'	13/-
4" 450'	5/6	5" 1800'	25/-
5" 900'	10/6	5 1/2" 2400'	34/-
5 1/2" 1200'	13/-	7" 3600'	44/-
7" 1800'	18/6	QUADRUPE PLAY	
		3" 600'	8/-

Postage 1/- per reel.
Post free and less 5% on three.
Trade and quantity enquiries welcomed.

TECHNICAL TRADING CO.
All Mail Orders to Brighton please.
Devonian Court, Park Crescent
Place, Brighton. 689722 67606
350/352 Fratton Road, Portsmouth 22034
72 East Street, Southampton 25851
132 Montague Street, Worthing 2638

RATES: 4/- per line or part thereof, average five words to line, minimum 2 lines, Box No. 1/- extra. Advertisements must be prepaid and addressed to Advertisement Manager, "Practical Television", 15/17, Long Acre, London W.C.2.

SETS & COMPONENTS

(continued)

BOB'S BETTER BARGAINS. Any 10 valves 14/6 post paid. Refunded in full if not satisfactory. PCF80, PCC84, PL81, PY81, PL36, PCL83, EF80, U191, EY86, U301, 30F5, EF85, PY32, PY82, EB91, 30PL1, 30FL1, 30P4, ECL80. T.V. legs, set of four with plates 5/-, post 3/6. Mail Order only. GREEN, 2 St James Street, Rawtenstall, Rossendale, Lancs.

T.C.S. LTD.

FOR LINE OUTPUTS AND DEFLECTOR COILS

We have the Country's largest stock of Manufacturers' Original (or Authorised Replacement) Line Output Transformers for many "difficult" makes, including Ambassador, Baird, Cossor, Ecko, GEC, HMV, KB Masteradio, Peto-Scott, Philips, Regentone, RGD, Sobell, Ultra, etc. Also deflector coils, output and oscillator transformers, inc. Aliba, Bush, Murphy Examples, L.O.P.T.s: Murphy 280, 89/6; 310/350/410/540/659/759, 99/6; Bush TV53, 79/6; 80, 95/-.

SPECIAL OFFER:

Ecko improved type for Model T221 at 42/6, T231 at 45/-; T310 at 47/6.

Terms: C.W.O. or C.O.D. (3/6). Post/packing 5/-, 2 or more L.O.P.T.s Post/packing Free.

All enquiries answered but regret no lists available. Same day delivery on most types.

T.C.S. LTD.

28 BROCKLEY CROSS, LONDON SE4

Tel. TIDeway 5394

EX N.E.V. C.C.T.V. Camera and Monitor Circuits. S.A.E. for list. LOWE, 62 Brownwood Road, London, N.4.

R. & R. RADIO & T.V. SERVICE

Salvage Valves	Good Emission Guaranteed	
EF80 1/6	30P4 6/-	PL84 8/-
EF184 5/-	EB91 1/-	PL82 4/6
ECL80 4/6	EF85 5/-	PL36 5/-
30F5 5/-	6BW7 4/-	PC284 4/-
PCP50 4/-	EY86 4/-	PY81 3/6
U191 5/-	30P12 5/-	PY33 6/-

Speakers Ex T.V. 5 inch Rnd 3/6, 6x 4 3/6, Post 2/6. 8 inch Rnd 6/- Post 4/6 for one or two. BY100 and equiv. with 10 watt res 5/6 post paid. Ecko line O/P Trans. U26 type 85/-, U25 type 27/6. Push button tuners, req valves type 30L15 and 30C15 rectangular buttons, 27/6 post paid.

Postage on valves 6d. Three and over post paid. S.A.E. with all enquiries.

51 Burnley Road,
Rawtenstall, Rossendale,
Lancs.

TELEVISION TUBE SHOP

THE

NEW TUBE Specialists

A47-13W	£12.10.0
A59-13W	£15.10.0
AW36-20, 21	£5.12.6
AW36-80	£5. 7.6
AW43-80	£6. 7.6
AW43-88, 43-89	£6.12.6
AW47-90, 91	£7.10.0
AW53-80	£7.12.6
AW53-88, 53-89	£7.17.6
AW59-90, 59-91	£9.10.0
C14B M, F M	£5.15.0
C17B M, F M, H M	£6. 7.6
C17L M, P M, S M	£6.12.6
C21H M, S M, T M	£7.17.6
CME1402	£5.17.6
CME1702, 1703	£6.12.6
CME1705	£7. 7.0
CME1901, 1903	£7.10.0
CME2101, 2104	£7.17.0
CME2306	£15. 0.0
CRM93	£5.10.0
CRM124	£5.10.0
CRM141, 2, 3, 4	£5.17.6
CRM152	£5.10.0
CRM153	£3.19.6
CRM171, 2, 3	£6. 7.6
CRM211, 212	£8.17.6
MW31-16, 74	£5.10.0
MW36-24, 44	£5. 2.6
MW43-64, 69	£6. 7.6
MW43-80	£6. 7.6
MW53-20	£8.17.6
MW53-80	£8.17.6
14KP4A, 141K	£5.12.6
171K, 172K, 173K	£6. 7.6
7201A, 7203A	£5.12.6
7204A	£5.10.0
7401A	£6.7.6
7405A	£6.12.6

Manufacturers' Reprocessed Tubes available at £1 each less than the above prices.

All tubes tested before despatch and guaranteed for 12 months.

CARRIAGE 10/-, via B.R.S. or 15/- via passenger train. Add 2/6 for Comprehensive Insurance.

* Reprocessed tubes only of this type at present.

Midland Stockists:-

Amateur Electronics Co.,
240 Lichfield Road, Aston,
Birmingham.

TELEVISION TUBE SHOP

48 BATTERSEA BRIDGE ROAD
LONDON S.W.11. BAT 6859

JUST SOUTH OF THE BRIDGE
OPEN SATURDAY UNTIL 4 p.m.

SETS & COMPONENTS

(continued)

BRAND NEW TELEVISION TUBES — 2 YEAR GUARANTEE!

(CATHODEON AND OTHER LEADING MANUFACTURERS)

We hold large stocks of top quality tubes. why buy ordinary rebuilds? Some rebuilds available, 19in. upwards at 21/- off quoted prices, 12 months warranty. Colour, rimbands, etc. available. Lists. Rimband types, 19in. £8.10.0; 23in. £11.0.0.

CRM121, 2, 3 & 4; MW31-16, MW31-74; C12FM; 121K, C12/1, etc.	£3 0 0
AW36-80; MW36-24, 36-44; CRM143, 4; CME1402; C14BM; C14FM, MW41/1, etc.	£4 0 0
CRM143, CRM144; £4.0.0 CRM141, 2; CRM151, 2, 3; 15EP4, etc. C17BM, SE14/70, AW36-20, 36-21.	£4 15 0
AW43-80, 43-88, 43-89; MW43-64, 43-69; MW43-80; CRM171, 2, 3, 4; C17FM; CME1703, 5; C17AF; C17SM	£5 15 6
AW47-90; AW47-91; CME1902; CME1903, etc.	£6 17 6
C19AH; CME1901; AW53-88, 9; CME2101, 4; AW53-80; MW53-20; MW53-80; CRM211, 2, etc.	£7 10 0
19in. Twin Panels A47-13W; CME1906, £9.17.6 23in. Twin Panels A59-13W, CME2306	£12 10 0

(Carriage 15/-)

(Carriage 25/-)

CARRIAGE AND INSURANCE. Up to 19in. 12/-, 21in. upwards 15/-, Twin Panels (see above). Lists, s.a.e. please.

SOME OLD TUBES WANTED, 17" UPWARDS

PHILIP H. BEARMAN, 6 Potters Road, New Barnet, Herts. Tel: BAR 1934/7873 (Robophone)

CLOSED Thursday & Saturday afternoons **LISTS BRITISH VALVES!**

TV SPARES, all makes, all sets. SAE/Quote, EKCO/Ferr. Plastic Housings 15/- each. Car/House Alarm Kits 25/- each. Transistor Car Radios with fittings kit £8.10 std. Push Button £11.10 comp. Band Radar Detectors for car £13.10 comp. 8 x 30 Binoculars in hide case £7.10; 10/50 £10. Please add P.P. 5/-. Open Sats. All new goods. KING'S, 8 Cray Parade, Main Road, St. Paul's Cray, Kent. Tel: ORPINGTON 30566.

WANTED
(continued)

PROJECTION TV RECEIVER WANTED: any make; working or not; particulars to Box 53.

SERVICE SHEETS purchased. HAMILTON RADIO, 54 London Road, Bexhill, Sussex.

FOR SALE

RECTIFIERS

SILICON TV 6/- or complete with instr., resistor-condenser 7/6.

Rectifiers—Contact Cooled
14RA1282/FC101 18/6; 18RD2281/FC124FW 18/6; EC1 12/8; EC2 12/6; FC116 7/6; 14RA/1285 (FC31) see Silicon.

Rectifiers—Fin Types
Equivs. for RM4 9/6; RM5 17/6; 14A97 13/6; 14A86 10/6; EK2 17/6; EK6 17/6; 14A949 19/-; LW15 19/-; LW7 19/-; 14A100 19/-; 14A989 10/-; FW12V-1A 5/-; 2A 7/-; 4A 10/6.

MULTIMETERS from 32/-
Stamped envelope for full latest selection and bargain offers in cheap meters, Radios, Baby Alarms, Inter-coms and Walkie-Talkies.

Line O.P. Trans; all 30/- each
Murphy V350 and V230, Cossor 948, Philips 1446 U/45 and 1746 U/45 with EY51.
Under £1 P. & P. 6d. Over £1 Post Free. NO C.O.D.

DURHAM SUPPLIES

175 DURHAM ROAD, BRADFORD 8, YORKS.

S/H Radio & Television books, 89 Carlyon Ave., South Harrow, Middx. 422-5185.

100 VALVES

100 mixed television valves our choice 25/-, P. & P. 5/-.

M. Ashworth, 9 Mandeville Terrace, Hawkshaw, Bury, Lancs.

VALVE CARTONS at keen prices. Send 1/- for sample and list. J. & A. BOX-MAKERS, 75a Godwin Street, Bradford 1.

SERVICE SHEETS

SERVICE SHEETS, Radio TV, 5,000 models. List 1/6. S.A.E. enquiries. TEL-RAY, 11 Maudland Bank, Preston.

SERVICE SHEETS
(continued)

SERVICE SHEETS

For all makes of Radio, Television, Tape Recorders, 1925-1966. Prices from 1/-. Catalogue of 6,000 models, 2/6. Free fault-finding guide with all Service Sheets. Please send Stamped Addressed Envelope with all orders and enquiries.

HAMILTON RADIO
54 London Road, Bexhill, Sussex

SERVICE SHEETS

4/- each, plus postage

We have the largest supply of Service Sheets for all makes and types of Radios and Televisions, etc. in the country (speedy service). To obtain the Service Sheet you require please complete the attached coupon:

Name:
Address:

To: S.P. DISTRIBUTORS
35/36 Great Marlborough Street
London, W.1

Please supply Service Sheets for the following:

Make:
Model No. Radio/TV
Make:
Model No. Radio/TV
Make:
Model No. Radio/TV

I also require new 1967 List of Service Sheets at 1/6 plus postage.
(please delete items not applicable)

enclose remittance of
(which includes postage)
MAIL ORDERS ONLY (Oct. PT.)

THIS MONTH'S SCOOP!
HUGE PURCHASE
NEW BRIMAR C17AF BOXED
17", 110", 0-3A Short neck
Can replace AW43-88, CME1705 etc.
£3-19-6
TELEVISION TUBE SHOP
48 BATTERSEA BRIDGE ROAD, SW11

TUBES, AERIALS, VALVES

U.H.F. aerials. Bands I, II & III aerials. U.H.F. transistorised boosters. I.T.V. boosters. Regunned TV tubes, Valves, etc. New and second-hand TV sets, Transistor Radios and all types of Electrical Appliances. Quotations without obligation. Coaxial cable, fluorescent light fittings, all at special prices to the trade and Home Engineers. S.A.E. for list.

G. A. STRANGE

BROADFIELD, NORTH WRAXHALL, nr. Chippenham, Wilts. Tel. Marchfield 236

WANTED

NEW VALVES WANTED. Popular TV and Radio Types. Best cash price by return. **DURHAM SUPPLIES, 175 Durham Road, Bradford 8, Yorkshire.**

WANTED—Popular Brand New Valves—R.H.S., Stamford House, 538 Great Horton Road, Bradford 7.

DAMAGED AVO METERS WANTED. Models 7 and 8. Any condition. Any quantity. **HUGGETTS LTD., 2-4 Pawson's Road, West Croydon.** Send for packing instructions.

WANTED—Volumes of Radio and Television Servicing, 1958-1967. Telephone—Sedbergh (Yorks.) 540.

SERVICE SHEETS
(continued)

SERVICE SHEETS with free fault finding chart 3/-. S.A.E. LESMAR, 17 New Street, Andover, Hants.

AERIALS

TV AERIALS

- Band I. H. Mast Fitting £1 15 0
 - Band III. 5 Ele Mast Fitting £1 10 0
 - Band I/III. S/D and 4-Array £1 15 0
 - Band IV. 9 Ele Array £1 10 0
 - Band IV. 18 Ele Array £2 18 6
- Lashing Kits from 10/-; Poles, Co-ax 8d., Grade "A" 1/4. Plugs 6d.
P. & P. 4/6. C.W.O., S.A.E. for list.

TELEINDUSTRIES LTD.

BREAKSPEAR ROAD, RUISLIP, Middlesex

EDUCATIONAL

TV and Radio, City & Guilds, R.T.E.B. Certs., etc. on "Satisfaction or Refund of Fee" terms. Thousands of passes. For full details of exams and home training Courses (including practical equipment) in all branches of Radio, T.V., Electronics, etc. write for 132-page Handbook—FREE. Please state subject. **BRITISH INSTITUTE OF ENGINEERING TECHNOLOGY** (Dept. 172K), Aldermaston Court, Aldermaston, Berks.

BECOME "Technically Qualified" in your spare time, guaranteed diploma and exam. home-study courses in radio, T.V. servicing and maintenance. T.T.E.B., City and Guilds. etc.: highly informative 120-page Guide—FREE. **CHAMBERS COLLEGE** (Dept. 858K), 148 Holborn, London, E.C.1.

NEW RANGE BBC 2 AERIALS

All U.H.F. aerials now fitted with tilting bracket and 4 element grid reflectors. **Loft Mounting Arrays**, 7 element, 35/-. 11 element, 42/6. 14 element, 50/-. 18 element, 57/6. **Wall Mounting with Cranked Arm**, 7 element, 60/-. 11 element, 67/-. 14 element, 75/-. 18 element, 82/6. **Mast Mounting with 2in. clamp**, 7 element, 42/6. 11 element, 55/-. 14 element, 62/-. 18 element, 70/-. **Chimney Mounting Arrays**, Complete, 7 element, 72/6. 11 element, 80/-. 14 element, 87/6. 18 element, 95/-. Complete assembly instructions with every unit. **Low Loss Cable**, 1/6 yd. **C.H.F. Preamps** from 75/-. State clearly channel number required on all orders.

BBC - ITV AERIALS



BBC (Band D. Telescopic), 10, 21/-. External S/D, 30/-. "H" £2.10.0. **ITV** (Band 3), 3 element loit array, 25/-. 5 element, 35/-. 7 element, 45/-. **Wall mounting**, 3 element, 35/-. 5 element, 45/-. **Combined BBC/ITV**, Loft 1+3, 41/3; 1+5, 48/9; 1+7, 58/9; **Wall mounting** 1+3, 56/3; 1+5, 63/9; **Chimney** 1+3, 63/9; 1+5, 71/3. **VHF** Transistor preamps, 75/-. **COMBINED BBC - ITV - BBC2 AERIALS** 1+3+9, 70/-. 1+5+9, 80/-. 1+5+14, 90/-. 1+7+14, 100/-. Special leaflet available. **F.M.** (Band 3), Loft S/D, 12/6. "H", 30/-. 3 element, 52/6. External units available. Co-ax cable, 8d. yd. Co-ax plugs, 1/3. Outlet boxes, 4/6. **Duplexer Crossover Boxes**, 12/6. C.W.O. or C.O.D. P. & P. 5/-. Send 6d. stamps for illustrated lists.

K.V.A. ELECTRONICS (Dept. P.T.)
27 Central Parade, New Addington
Surrey (CRO-04B)
LUDGE HILL 2366

SITUATIONS VACANT

RADIO AND TV Exams and Courses by Britain's finest home study School. Coaching from Brit.I.R.E., City and Guilds Amateur's Licence, R.T.E.B., P.M.G. Certificate etc. Free brochure from **Brush National Radio School**, Russell Street, Reading.

ALDERMASTON COURT POSTAL TRAINING for B.Sc. (Eng.) Part 1, A.M.I.E.R.E., A.M.S.E., City and Guilds, pay and security as Technician or Technologist. Thousands of Passes. For details of Exams and Courses in all branches of Engineering, Buildings, Electronics, etc. (including latest information on C.Eng.), write for 132-page Handbook—FREE. Please state interest. **BRITISH INSTITUTE OF ENGINEERING TECHNOLOGY** (Dept. 171K), Aldermaston Court, Aldermaston, Berks.

TECHNICAL TRAINING

CITY & GUILDS (electrical, etc.) on "Satisfaction or Refund of Fee" terms. Thousands of passes. For details of modern courses in all branches of electrical engineering, electronics, radio, T.V., automation, etc., send for 132-page handbook—FREE. B.I.E.T. (Dept. 173K) Aldermaston Court, Aldermaston, Berks.

PADGETTS RADIO STORE

OLD TOWN HALL, LIVERSEDGE, YORKS.
Telephone: Cleckheaton 2866

Speakers Removed from TV Sets. All 3 ohm PM and perfect 6 x 4in. and 6in. round 3/-, post 2/9. Six for 22/-, post paid 7 x 4in. 5/-. post 2/9. Six for 34/-, post paid. 8in. round 6/6, post 3/6.
New 12in. Speakers with Built-in Tweeter, 28/6, post paid. 3 or 15 ohm Coil.

VALVE LIST

Ex Equipment, 3 months' guarantee 10F1, EP80, EB91, ECL80, EF50, PY82, PZ30, 20P3. All at 10/- per doz. Post paid. Single valves post 7d.

ARP12 1/6	PL36 5/-	185BT 8/6
BB91 8d.	PL81 4/-	20D1 3/6
EBF80 3/-	PY33 5/-	20L1 5/-
ECC81 3/-	PY8 1/6	20P1 2/6
ECC82 3/-	PY82 1/6	20P3 2/6
ECC83 4/-	PZ30 5/-	20P4 4/6
ECL80 1/6	U25 5/-	5U4G 4/6
EF50 1/-	U191 5/-	6B6 1/8
EP80 1/6	U281 5/-	6K7 1/9
EF91 9d.	U282 5/-	6K25 5/6
FL36 5/-	U301 5/-	6P25 5/6
EY86 5/-	U329 5/-	6U4 5/-
KT88 5/-	U251 5/-	6V6 1/9
PCC84 2/-	U801 8/6	6P28 5/-
PCF80 2/-	10C2 5/-	EY51 2/6
PCL82 4/-	10P13 2/6	

NEW VALVES EX UNITS

1T4, 2/-; 1L4, 2/-; 1A3, 2/6; 1S5, 2/6; 12AT7, 3/-; 3A4, 2/6; EP91, 2/-; EB91, 1/3; EL91, 2/-; U08, 4/-; GSNT, 2/6; 10P13, 4/-; box of 50 ARP 12 Valves, 22/-, post paid.

New Boxed TV Tubes, 14in. MW36/44, 40/-, Carriage 10/-. 12 months' guarantee.

90 degree Tubes, Twelve months' guarantee. Slight glass fault, 30/- and 50/- Carriage 10/-.

Sync Unit, BC993B, tube 3in. 3EP1 2t tuning meter. 16 valves. Clean condition, 30/-, Carriage 10/-. Complete with case.

Display Unit, 2, SFP7 tubes, 2 6H6 valves. Complete with case. Clean condition, 12/6. Carriage 10/-.

Reclaimed Tubes, Six months' guarantee. AW4380, 40/-, MW4380, 30/-, MW4368, 30/-, CRM12, 30/-, CRM142, 17/-. 12in. Tubes, 10/-, 17in. Tubes, perfect but without guarantee, 17/-. Carriage on any Tube in G.B., 10/-.

Ex Washing Machine Motors, Fully guaranteed. Single phase 1 h.p., 26/-, Sixth h.p., 15/- Plus carriage 10/-.

Our new Walk Round Room is now open. Full of Surplus Bargains. Also our Special Department, nothing over six-pence.

NEW VALVES

Guaranteed Set Tested 24 HOUR SERVICE

- 1R5, 1S5, 1T4, 3S4, 3V4, DAF91, DF91, DK91, DL92, DL94, SET OF 4, 16/9.
- DAF86, DF96, DK96, DL96, SET OF 4, 23/6.
- 1R5 5/- ECC85 5/3 PCL84 7/-
- 1S5 3/9 ECH35 5/9 PCL85 8/3
- 1T4 2/9 ECH42 8/9 PFL200 12/6
- 3S4 4/3 ECH81 5/3 PL36 8/-
- 3V4 5/6 ECH84 6/3 PL81 6/9
- 6F1 6/3 ECL80 5/9 PL82 6/9
- 6L18 6/- ECL82 6/- PL83 5/11
- 10F1 9/6 ECC86 7/6 PL84 6/-
- 10P13 10/3 EF39 3/6 PL500 12/6
- 12K8GT 7/- EF80 4/9 PY32 8/6
- 20P2 11/3 EF85 5/- PY33 8/6
- 30P1 8/9 EF86 6/- PY81 5/-
- 30P4 11/6 EF89 4/9 PY82 4/9
- 30P19 11/6 EF183 6/- PY83 5/3
- DAC32 6/9 EF184 5/6 PY800 5/11
- DAF91 3/9 EL33 6/3 PY301 5/11
- DAF90 5/11 EL41 R19 6/6
- DF33 7/6 EL84 4/6 U25 11/-
- DF91 2/9 EY51 5/11 U26 11/-
- DP96 5/11 EY86 5/9 U191 11/6
- DK32 7/- EY80 6/6 UABC80 4/6
- DK91 5/6 EZ80 4/6 UAF42 6/11
- DK96 6/3 EZ81 4/6 UBC41 6/6
- DL33 6/6 GZ32 8/9 UBF89 5/9
- DL35 4/9 KT61 6/3 UCC84 7/9
- DL92 4/3 N78 14/6 UCC85 6/-
- DL94 5/6 PC86 7/9 UCF30 4/6
- DL96 5/11 PC88 7/9 UCH42 8/6
- DY86 5/6 PC97 5/9 UCH81 5/9
- DY87 5/6 PC900 7/6 UCL82 6/9
- EABC80 5/6 PCC84 5/3 UCL83 8/6
- EBE41 7/9 PCC89 6/9 UP41 7/9
- EBF80 5/9 PCF89 8/3 UP89 5/6
- EBF89 5/9 PCF80 6/3 UL41 8/6
- ECC81 3/9 PCF82 5/9 UL84 6/-
- ECC82 4/6 PCL82 6/3 UY41 5/3
- ECC83 5/6 PCL83 8/3 UY85 4/9

Postage on 1 valve 9d. extra. On 2 valves or more, postage 6d. per valve extra. Any parcel insured against damage in transit 6d. extra.

Office address no callers.

GERALD BERNARD
83 OSBALDESTON ROAD
STOKE NEWINGTON
LONDON N.16

FIRST-CLASS RADIO AND T.V. COURSES... GET A CERTIFICATE!

After brief, intensely interesting study—undertaken at home in your spare time—YOU can secure a recognised qualification or extend your knowledge of Radio and TV. Let us show you how.

FREE GUIDE

The New Free Guide contains 120 pages of information of the greatest importance to both the amateur and the man employed in the radio industry. Chambers College provides first rate postal courses for Radio Amateurs' Exam., R.T.E.B. Servicing Cert., C. & C. Telecoms., A.M.I.E.R.E. Guide also gives details of range of diploma courses in Radio/TV Servicing, Electronics and other branches of engineering, together with particulars of our remarkable terms of

Satisfaction or refund of fee

Write now for your copy of this invaluable publication. It may well prove to be the turning point in your career.

FOUNDED 1885—OVER 150,000 SUCCESSSES

CHAMBERS COLLEGE

(Incorp. National Inst. of Engineering)
(Dept. 84V), 148 HOLBORN
LONDON, E.C.1

REBUILT TUBES!

*You're safe when you buy from
RE-VIEW!*

- ★ Each tube is rebuilt with a completely new gun assembly and the correct voltage heater.
- ★ Each tube comes to you with a guarantee card covering it for two years against all but breakage.
- ★ Each tube is delivered **free** anywhere in the U.K. and insured on the journey.
- ★ Each tube is rebuilt with experience and know-how. We were amongst the very first to pioneer the technique of rebuilding television tubes.



**HERE IS WHAT YOU
PAY:**

12in.	£4.15.0
14in.	£5. 0.0
15in.	£5. 5.0
17in.	£5. 5.0
19in.	£5.15.0
21in.	£7. 5.0

*Cash or cheque with
order, or cash on delivery*

Discount for Trade

Old Tubes Purchased

RE-VIEW ELECTRONIC TUBES

237 LONDON ROAD, WEST CROYDON,
SURREY. Tel. THOrnton Heath 7735

BBC2, TV, RADIO & TAPE REC. SPARES

UHF/625. Modify your set to BBC2. 1965 to 1963 models covered. Selection of new manufacturers conversion kits and tuners at reduced prices. List available.

SPECIAL OFFERS: FERGUSON 625 IF amp. chassis. NEW, incl. 6 valves 39/8 (less valves, 19/6). Circuit and Instr. 3/6, p/p 4/6. PHILIPS 625 conversion kit, incl. tuner, IF amp., valves, circuits etc. £4.18.6, p/p 6/- GEC/SOBELL dual 405/625 IF amp. and output chassis, NEW 38/6, p/p 4/6.

UHF TUNERS. NEW, with valves, 30/-.

TV SIGNAL BOOSTER UNITS. Sens. gain all stations. PYE/LABGEAR trans'd. BBC/ITTA or UHF Battery "plug in", 75/-, UHF Mains "plug in", 87/6, UHF Masthead 105/-, Post free.

FIREBALL TUNERS. New or Man. tested. Ferguson, H.M.V., Marconi 92/6, Philco, Ultra, Emerson, etc. 75/-, Quantity used/good condition 30/-, P/P 4/6.

PUSH BUTTON TUNERS. Used/good condition for Sobell 280, RGD 612, 619, REG 17/18, 199 30/-, P/P 4/6.

TURRET TUNERS. New, Cyldon C, 38 Mc/s 20/-, KB 16 Mc/s, KB MV/F 38 Mc/s 10/-, P/P 4/6. Many others available. Tech. repl. service for Pye, Ferg., Sobell, Philips, Stella, GEC, McMich. etc. Large selection channel coils.

CRTs. Rebuilt, guar. 17in. 70", 90" 85/-; 17, 19in, 110", 105/-, Callers only.

LINE OUTPUT TRANSFS. Popular types available, brand new exact replacements fully guar. A selection which can be supplied:—

PHILIPS 1768/177G, STELLA 8617/1017	88/8	LOPT Inserts p/p 2/-.	
EKCO 221 to 331 (U25 types)	42/6	Bush TV32, 36, 43	45/-
FERRANTI 1001 to 1011 (U25 types)	42/6	Bush TV53 to 69	30/-
EKCO/FERRANTI (U26 types) 70"/90"	58/6	Cosmor 930 to 950	35/-
EKCO 344, FERRANTI 1023 range	72/6	Emerson 700 range	35/-
DECCA DM1, 2, 17; DMSC, DMAC (70")	78/6	Ferguson 203 to 246	35/-
FERG 305, 306, 308, 42/6; 406, 506 range	58/6	Ferranti 14T3 to 17T6	35/-
FERG, HMV, MARCONI, ULTRA 3600, 2600, 4600, 6600, range	59/6	KB MV100/L, NF70, OV30, PVE20 etc.	35/-
KB H/F60 to MV60, 20/-; QV20/1, RV20 range	30/-	Peto Scott 1419 to 1724	30/-
MARCONI, VT157, 158, 160, 164	35/6	Philco 1981, 1010 to 106035/-	35/-
GEC 1252, 1748, 2745 range 58/6 later models	72/6	Philips 17TG 100 range	35/-
HMV 1865, 1869, 42/6; 1870/6, 1890/6	68/6	Pye VT4, VT7	42/6
PYE V14, VT17 CTM17, 17/21, 110 to 510	62/6	RGD D17, 590 to 619	35/-
PAM, INVICTA equip. LOPTS to above Pye	62/6	Reg 10-4 to 10-17	35/-
SOBELL TFB180, SC24, SC270 range	72/6		

Also ALBA, BUBE, COSSOR, MCMICHAEL, MURPHY, ULTRA, etc. Postage and Packing for Lincs. 4/6, C.O.D. 3/6 extra.

SCAN COILS. Frame o/p frame coil, trans., width/linearity coils, sound o/p trans., mains droppers, control knobs, dust vol., controls, line coil, trans. resistors, condensers, etc.

TAPE REC/CHANGER. Drive Belts, Heads Pinch Wheels, Idlers, Motors for most British (incl. WALTER) and Continental.

SALVAGED COMPONENTS. Large selection for popular models, clean, serviceable condition, tubes, transformers, etc. ENQUIRIES invited, quotations given. C.O.D. despatch available.

MANOR SUPPLIES
64 GOLDERS MANOR DRIVE, LONDON, N.W.11
(Callers: 5896, HIGH ROAD (nr. Granville Road), N. Finchley, N.12)
HIL 9118 (DAY) SPE 4032 (EVO)

COLOUR TELEVISION SCHOOL

DAYLIN ELECTRONICS ANNOUNCE A
CORRESPONDENCE COURSE IN THE THEORY
AND PRACTICE OF COLOUR TELEVISION

A series of 10 lessons dealing in detail with:—

Colour mixing, the PAL colour system, colour receivers, decoders, IF circuits, time-bases, convergence, waveforms, set-up procedures, test equipment, fault finding, typical circuits. This course is designed for engineers who will be called upon to service colour television receivers within the next four months. Expert guidance throughout the course. Test questions with each lesson. Model answers supplied. Terms available. Certificates awarded.

Fee for the complete course 10 guineas.

To: DAYLIN ELECTRONICS LIMITED
32 PARKSTONE DRIVE
SOUTHEND-ON-SEA, ESSEX

Please send, without obligation, details of your colour television course.

NAME

ADDRESS

VALUABLE NEW HANDBOOK **FREE** TO AMBITIOUS **ENGINEERS**

Have you had *your* copy of "Engineering Opportunities"?

The new edition of "ENGINEERING OPPORTUNITIES" is now available—without charge—to all who are anxious for a worthwhile post in Engineering. Frank, informative and completely up to date, the new "ENGINEERING OPPORTUNITIES" should be in the hands of every person engaged in any branch of the Engineering industry, irrespective of age, experience or training.

On 'SATISFACTION OR REFUND OF FEE' terms

This remarkable book gives details of examinations and courses in every branch of Engineering, Building, etc., outlines the openings available and describes our Special Appointments Department.

WHICH OF THESE IS YOUR PET SUBJECT?

TELEVISION ENG.

Advanced Television Eng.—
Gen. Television Eng.—*Television Servicing and Maintenance.*

ELECTRONIC ENG.

Advanced Electronic Eng.—
Gen. Electronic Eng.—
*Applied Electronics—
Practical Electronics—
Radar Tech—Frequency
Modulation—Transistors.*

MECHANICAL ENG.

Advanced Mechanical Eng.—
Gen. Mechanical Eng.—
*Maintenance Eng.—Diesel
Eng.—Press Tool Design—
Sheet Metal Work—
Welding—Eng. Pattern
Making—Inspection—
Draughtsmanship—
Metallurgy—
Production Eng.*

WE HAVE A WIDE RANGE OF COURSES IN OTHER SUBJECTS INCLUDING CHEMICAL ENG., AERO ENG., MANAGEMENT, INSTRUMENT TECHNOLOGY, WORK STUDY, MATHEMATICS, ETC.

WHICH QUALIFICATION WOULD INCREASE YOUR EARNING POWER?

A.M.I.E.R.E., A.M.I.Mech.E., A.M.S.E., A.M.I.C.E., B.Sc., A.M.I.P.E., A.M.I.M.I., A.R.I.B.A., A.I.O.B., A.M.I.Chem.E., A.R.I.C.S., M.R.S.H., A.M.I.E.D., A.M.I.Mun.E., C.ENG., CITY & GUILDS, GEN. CERT. OF EDUCATION, ETC.

BRITISH INSTITUTE OF ENGINEERING TECHNOLOGY

445A ALDERMASTON COURT, ALDERMASTON, Berks

THIS BOOK TELLS YOU

- ★ HOW to get a better paid, more interesting job.
- ★ HOW to qualify for rapid promotion.
- ★ HOW to put some letters after your name and become a key man . . . quickly and easily.
- ★ HOW to benefit from our free Advisory and Appointments Dept.
- ★ HOW you can take advantage of the chances you are now missing.
- ★ HOW, irrespective of your age, education or experience, YOU can succeed in any branch of Engineering.

132 PAGES OF EXPERT CAREER - GUIDANCE

PRACTICAL EQUIPMENT

Basic Practical and Theoretic Courses for beginners in TV, Radio, Electronics, etc., A.M.I.E.R.E. City & Guilds, Radio Amateurs' Exam, R.T.E.B. Certificate P.M.G. Certificate Practical Radio Television & Radio Servicing Practical Electronics Electronics Engineering Automation

INCLUDING TOOLS

The Specialist Electronics Division of B.I.E.T. NOW offers you a real laboratory training at home with practical equipment. Ask for details.

B.I.E.T.

You are bound to benefit from reading "ENGINEERING OPPORTUNITIES", send for your copy *now*—FREE and without obligation.



POST COUPON NOW!

To B.I.E.T., 445A Aldermaston Court 3d. stamp if posted in
Aldermaston, Berkshire an unsealed envelope

Please send me a FREE copy of "ENGINEERING OPPORTUNITIES". I am interested in (state subject, exam., or career).

NAME

ADDRESS

WRITE IF YOU PREFER NOT TO CUT THIS PAGE

THE B.I.E.T. IS THE LEADING INSTITUTE OF ITS KIND IN THE WORLD