

Practical TELEVISION

FEBRUARY 1966

2/-

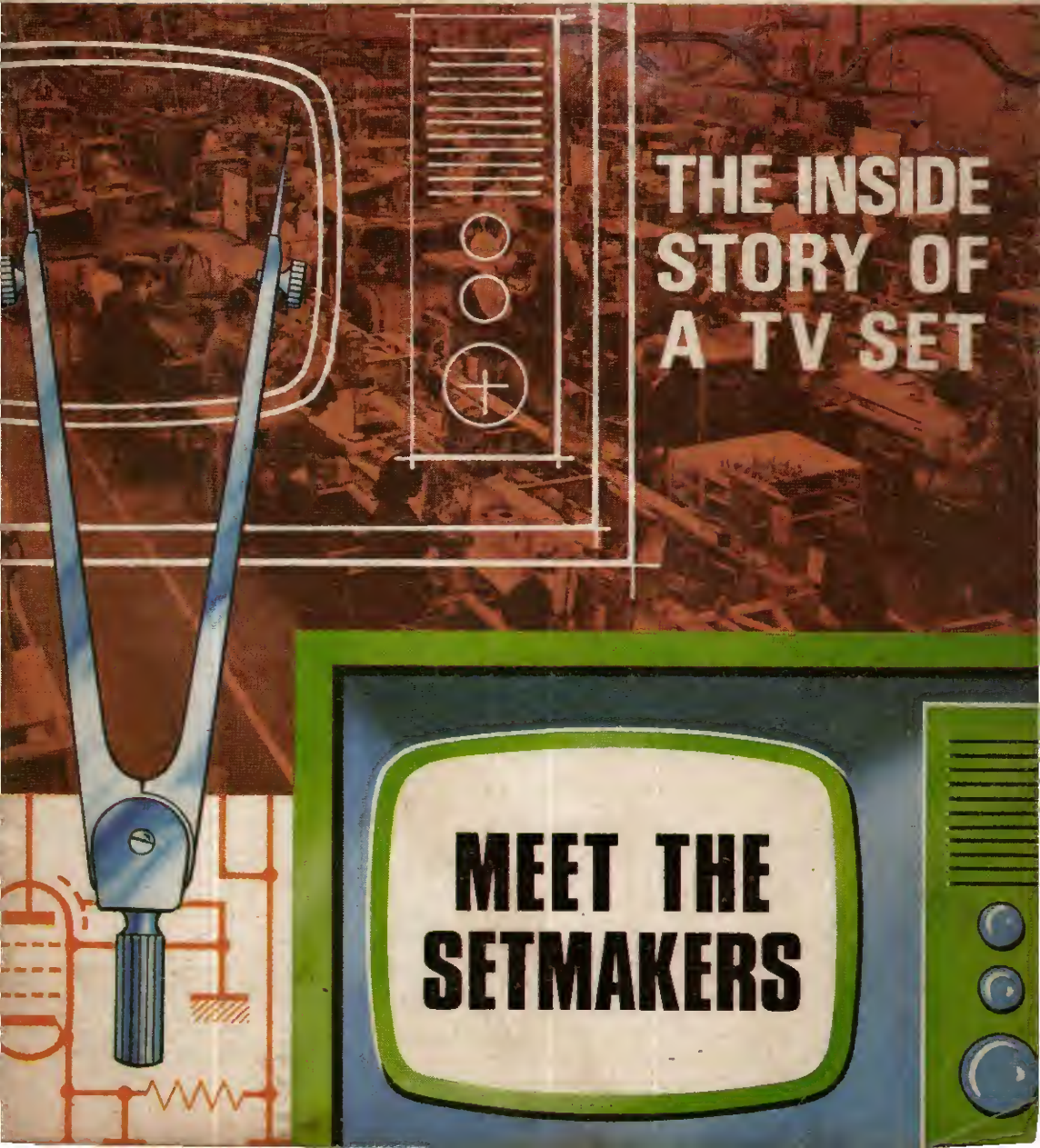

THE INSIDE
STORY OF
A TV SET

MEET THE
SETMAKERS



"SABRINA" STILL WELL IN FRONT

STOP FIDDLING WITH KNOBS . . . ABSOLUTELY UNNECESSARY . . . Our Automatic Regulator ensures constant voltage on TV, even with Mains of 180/265 v. YES, we know it's wonderful. "Have a heart for your Valves and Tube."

S.A.E. details. *Conditional Free Trial.*

COMPLETELY REBUILT C.R. TUBES ALL TYPES

| | | |
|-----------------------|---------|--------------------------|
| 12" now | £5. 0.0 | } For Single Tubes |
| 14" to 17" now | £5.10.0 | |
| 19" now | £6.15.0 | |
| 21" now | £8. 0.0 | |

ALL C.W.O.—TRADE SUPPLIED

Special Bonus Scheme for Service Engineers—Reducing to:

12"—87/6; 14"/17"—97/6; 21"—147/6
FREE Pass. transit & Ins. anywhere in British
Isles or N. Ireland (12 months' guarantee).

ALSO FULL RANGE OF VALVES
(Guaranteed 12 months)

SABRINA C.R. TUBE CO.

Electron Works, North Bar
BANBURY, OXON
Telephone 2390

ADCOLA

(Regd. Trade Mark)

SOLDERING EQUIPMENT

DESIGNED FOR ALL RADIO ENGINEERS



APPLY CATALOGUES:—
ADCOLA PRODUCTS LTD.

ADCOLA HOUSE,
GAUDEN ROAD,
LONDON, S.W.4.

TELEPHONE: MACAULAY 4272 & 3101
TELEGRAMS: SOLJOINT, LONDON, S.W.4.

FREE TO AMBITIOUS ENGINEERS

— THE LATEST EDITION OF ENGINEERING OPPORTUNITIES

Have you sent for your copy?

ENGINEERING OPPORTUNITIES is a highly informative 156-page guide to the best paid engineering posts. It tells you how you can quickly prepare at home for a recognised engineering qualification and outlines a wonderful range of modern Home Study Courses in all branches of Engineering. This unique book also gives full details of the Practical Radio & Electronic Courses, administered by our Specialist Electronics Training Division—the B.I.E.T. School of Electronics, explains the benefits of our Employment Dept. and shows you how to qualify for five years promotion in one year.

SATISFACTION OR REFUND OF FEE.

Whatever your age or experience, you cannot afford to miss reading this famous book. If you are earning less than £30 a week, send for your copy of "ENGINEERING OPPORTUNITIES" today—FREE.

BRITISH INSTITUTE OF ENGINEERING
TECHNOLOGY

(Dept. 30/B), 29 Wright's Lane, London, W.8

WHICH IS YOUR PET SUBJECT?

Mechanical Eng.,
Electrical Eng.,
Civil Engineering,
Radio Engineering,
Automobile Eng.,
Aeronautical Eng.,
Production Eng.,
Building, Plastics,
Draftsmanship,
Television, etc.

GET SOME LETTERS AFTER YOUR NAME!

A.M.I.Mech.E.
A.M.I.C.E.
A.M.I.Prod.E.
A.M.I.M.I.
A.I.O.B.
E.Sc.
A.M.I.E.R.E.
City & Guilds
Gen. Cert. of Education
Etc., etc.

PRACTICAL EQUIPMENT

Basic Practical and Theoretical Courses for Beginners in Radio, T.V., Electronics Etc., A.M.I.E.R.E., City & Guilds
Radio Amateur's Exam
R.T.E.B. Certificate
P.M.O. Certificate
Practical Radio
Radio & Television Servicing
Practical Electronics
Electronics Engineering
Automation

INCLUDING TOOLS!

The specialist Electronics Division of B.I.E.T. NOW offers you a real laboratory training at home with practical equipment. Ask for details

B.I.E.T.
SCHOOL OF
ELECTRONICS



POST COUPON NOW!

- Please send me your FREE 156-page "ENGINEERING OPPORTUNITIES" (Write if you prefer not to cut page)
- NAME
- ADDRESS
-
-
- SUBJECT OR EXAM THAT INTERESTS ME..... 30/B.

THE B.I.E.T. IS THE LEADING INSTITUTE OF ITS KIND IN THE WORLD

B. & B. TELEVISION (WIMBLEDON) LTD.

131 KINGSTON ROAD · SOUTH WIMBLEDON · London SW19

Telephone: CHerrywood 3955 and 3513

LINE OUTPUT TRANSFORMERS

ALBA—655, 721, 766, 866, all at 82/- each.
BEEHIVEN—B106, B109, B208. Inserts only at 30/- each.
BUSH—TV38, TV56, TV57, TV68, M59, TV69, TV82, TV63, TV66, TV67, TV69, M59. Inserts only 30/- each.
ALL BUSH TRANSFORMERS OBTAINABLE. PRICES ON REQUEST.
COSSOR—R17A, R30, 931, 933, 934, 935, 937, 938, 939A, 939FA, all at 85/- each. 940, 942, 942A, 943, 944, 945, 949, 949B, 945, all at 56/6 each. 949, 950, all at 80/- each.

DECCA—DM1, DM2/C, DM3/DM4, DM4/C, DM5, DM14, 444, 555 all at 88/- each. DM35, DM45, DM55, DM56, all at 83/6 each.
 DM21C, DM221, at 76/- each. DM22C, SKOT7656, 9ROTU777, at 79/6 each. DR19, DR19C, DR29C, DR39C, DR39C, all at 79/6 each. DR41, DR32, DR34, DR41, all at 85/- each. DR41, DR41 at 72/6 each. DR95, DR100, DR101, DR202, DR303, DR404, DR565, DR006, all at 82/- each.

DYNATRON—TV30, TV35, at 50/- each.
ALL MODELS AVAILABLE. PRICES ON REQUEST.
EKO—TC205, TC209, TC209A, T221, T231, T231F, T240, TC267, TC267/1, TC267C, TC268, T283, T294, T291, T310, TGC316, T326, T327, T330, T330F, T331, all at 50/- each.
 TMB272, T344, T344F, T348, T348F, T356, TC312, T313, T313F, T355, all at 85/- each.

FROM THIS MODEL ONWARDS TOO NUMEROUS TO LIST. ALL TYPES 72/- each.

EMERSON—E700, E701, E704, E707, E708, E709, E7010, E711, Portofino. These are supplied as an insert all at 30/- each.
FERROSON—45T, 454T, at 85/- each. 103T, 105T, 115T, 135T, 142T, 145T, 145T, all at 82/6 each.
 990T, 991T, 992T, 993T, 994T, 995T, 996T, 997T, 998T, all at 27/6 each. 998T, 999T, at 27/6 each. 305T, 307T, 315T, 317T, all at 65/- each. 309T, 309T, at 52/6 each. 406T, 406T, 416T, 416T, 436T, 436T, all at 85/- each.
 405T, 407T, at 85/- each. 506T, 508T, 516T, 518T, 536T, 536T, 546T at 85/- each. 505T, 507T, at 85/- each.
 604T, 606T, 608T, 616T, 618T, 636T, 646T, all at 65/- each.
 648T, 729T, at 85/- each. 726T, 737T at 72/- each.
 3600, 3601, at 89/6 each. 3622, 3624, 3611, 3514, 3014, at 88/6 each. 3617, 3618, 3619, 3620, 3621, 3622, Thorn 850 series, all at 72/6 each. 3623, 3624, 3625, 3626, 3627, 3629, Thorn 900 series, all at 82/- each.

FERRANTI—14T3, 14T3, 14T3F, 14T4, 14T5, 17K3, 17K3F, 17T3, 17T3F, 17K4, 17K5, 17K4F, 17K6, 17K6F, 17T4, 17T4F, 17T5, 17T5F, 17K4F, 17K5F. These are supplied as inserts all at 30/- each.
 T1001, T1002, T1002/1, T1004, T1005, T1021, T1011, all at 50/- each. T1012, T1023, T1034, T1034, all at 85/- each.

G.E.C.—BT302, BT303, BT304, BT306, all at 72/- each. BT312, BT314, BT315, BT316, BT319, all at 72/- each.
 BT320, BT321, BT322, BT324, BT326, BT328, BT329, all at 72/- each. BT448, BT449, BT450, BT451, BT452, all at 30/6 each.

ALL DUAL STANDARD MODELS CAN BE OBTAINED TO ORDER.

H.M.V.—1865, 1869, at 50/- each.
 1870, 1871, 1872, 1873, 1874, 1875, 1876, all at 52/6 each.
 1890, 1892, 1894, 1896, all at 65/- each.

INVICTA. ALL MODELS AVAILABLE. PRICES ON REQUEST.
KOLSTER-BRANDS—N70, OV30, OV30FM, OF100, PV70, PV70FM, PV100 all at 95/- each.
 OV30/1, PV40, PV100/1, PV20, PV20/1, QV20, QV30, all at 115/6 each. QV70, QV70FM, QV100, QV120, RV10, RV20, RV60, all at 105/6 each. RV20FM, RV30, RV30FM, RV70, RV80, SV20, TV15, TV20, TV30, all at 85/- each.

MARCONI—TV156, VT157, at 52/6 each.
MARTEADIO—All models available Rewind, at £3,10.0.
MURPHY—V270, V280, V290CA, V290, at 90/- each.
 V310, V310A, V320, V330, V350, at 72/- each.
 V410, V420, V430, V470, V480, V490, V500, V510, V519, V520, V530, V530C, V530D, V540, V540D, all at 90/- each.
 V640D, V659, V659A, at 72/- each.

McMICHAE—M22T, M23NFC, M71T, M72T, M72NFC, MP14, MP14DL, MP17, at 72/6 each. M74NFC, M74T, M247NFC, MP18, MP19, at 74/6 ea. M75T, M76NFC, M82NFC, M793, M763T, M793, MP20, MP27, MP29, at 76/- ea. M77NFC, M84NFC, M190TG, M794, MT762, MT763, at 76/- ea. MT762DS, MT762DS-T, MT763DS, MT763DS-T, MT765, MT765DS, MT765DS-T, at 82/- each.

PAM—All models available prices on request.

PETG SCOTT—148A, TR16, 178A, TV1416, T1419, TV1716, TV1719, TV1720, TV1722, TV1723, TV1734, TV1418, TV1726. Inserts at 30/- each. TV1730, TV1731, at 72/- each.

PYE—V4, V7, V7, V7, at 72/6. V14, V14C, at 52/6 each. V17, V21, at 82/6 each. V110, V110, at 69/6 each. V200, V300, at 82/6 each. V230, V210, V220, at 63/- each. V300, V310, V310F, V310F, at 52/6 each. V410, V500, at 68/- each. V510, V500A, at 72/- each. V700, V830A, at 72/- each.
 CMT4, CMT4F, CMT178, CMT17T, and 211n. Models at 72/6 each. CM17, CM17, LB172F, 17CDL, at 82/6 each.
 CT158S, CT158VS, 17S, 17Z1S, at 86/- each.
 RT17, RT17SP, at 58/6 each. SP17, SP17LB, 52/6 each.
ALL DUAL STANDARD MODELS PRICES ON REQUEST.

PILOT—All models Rewind at £3,10.0 each.

PORTADYNE—All models Rewind at £3,10.0 each.

PHILCO—1000 1100, 1020 at 72/6 each. 1015, 1021, 1023, at 76/- each. 1030, 1035, 1040, 1050, 1055, 1058, at 78/- each. 1100, 1105, 1110 at 72/6 each.

REGENTONE—T14 10-3, 10-4, 10-17, 10-21. Inserts only at 80/- each.

ROBELL—T32, T33, T17, T17, T33, T33, T33, T33, T33, at 72/6 ea. SC24, SC27, T34, T34, T37, T37, T37, T37, T37, at 75/6 each. SC34, SC37, T36, T192, T193, T279, T290, T293, TP57D, TP57E, at 70/- each.

ULTRA—1453, VF1453, V1500, V1752, V1752, V1700, V1762, at 42/6 ea. W1702, V1763, V1763, V2150, V2152, 2160, at 42/6 ea.
 V1770, V1771, V1772, V1773, V1774, V1775, V2170, V2171, at 52/6 each. V1772, V1773, V2174, V2175, V2175, at 52/6 each.
 V1780, V1781, V1782, V1783, at 75/- each. V1950, V1994, V1995, V1996, at 75/- each. V2380, V2384 at 80/- each.

ALL BRAND NEW VALVES GUARANTEED 3 MONTHS

POSTAGE & PACKING ON VALVES 6d. EACH

| | | | | | | | | | | | | | |
|--------|------|--------|------|--------|------|--------|------|-------|------|-------|------|-------|------|
| AZ31 | 10/6 | ECC84 | 7/8 | EM55 | 10/- | PCF80d | 10/- | UCC84 | 8/10 | U193 | 7/- | 10P14 | 11/- |
| DAF91 | 7/10 | ECC85 | 7/4 | EY31 | 7/- | PCL82 | 8/4 | UCC85 | 7/4 | U251 | 11/8 | 20P2 | 11/- |
| DAF96 | 7/10 | ECCF80 | 8/6 | EY36 | 7/- | PCL83 | 8/8 | UCF80 | 8/4 | U281 | 12/6 | 20L1 | 12/6 |
| D91 | 6/6 | ECC85 | 18/- | EZ40 | 5/6 | PCL84 | 8/8 | UCH49 | 8/8 | U282 | 13/9 | 20P3 | 15/- |
| DF92 | 6/6 | ECH82 | 8/6 | EZ41 | 5/6 | PCL85 | 8/8 | UCH81 | 7/8 | U301 | 13/9 | 20F1 | 12/- |
| DF96 | 7/10 | ECH81 | 7/- | EZ50 | 5/6 | PCL86 | 8/8 | UCL82 | 8/8 | U303 | 14/- | 20F2 | 13/- |
| DK91 | 7/10 | ECL80 | 7/4 | EZ51 | 5/6 | PL36 | 10/- | UCL83 | 10/8 | U305 | 14/- | 20P5 | 13/- |
| DK92 | 7/10 | ECL82 | 8/8 | EZ59 | 5/- | PL81 | 8/4 | EL41 | 7/8 | 6F1 | 9/8 | SCC15 | 9/6 |
| DK94 | 7/10 | ECL84 | 10/6 | GZ52 | 11/- | PL82 | 8/4 | EL42 | 8/4 | 6F1 | 9/8 | SCC17 | 11/6 |
| DL92 | 6/8 | ECCL80 | 8/5 | GZ54 | 11/- | PL83 | 8/4 | EL43 | 7/8 | 6F13 | 12/3 | SCC18 | 10/- |
| DL94 | 6/8 | EF80 | 7/2 | HBCC90 | 6/4 | PL84 | 7/- | EL44 | 15/- | 6F15 | 12/6 | SCF5 | 10/6 |
| DL96 | 6/8 | EF85 | 7/- | PABC80 | 7/6 | PL80 | 14/- | EL45 | 7/8 | 6F15 | 12/6 | SCF11 | 10/6 |
| DY86 | 7/- | EF86 | 5/4 | PC86 | 9/10 | PY33 | 9/8 | EL46 | 10/6 | 6F23 | 10/6 | SCF14 | 10/6 |
| DY87 | 7/- | EF88 | 9/8 | PC88 | 9/10 | PL82 | 8/4 | EL47 | 8/8 | 6F24 | 10/6 | SCF15 | 10/6 |
| EABCO6 | 7/6 | EP91 | 11/- | PC97 | 7/6 | PY81 | 7/- | EL48 | 9/8 | 6F25 | 9/8 | SCF18 | 10/6 |
| EAF42 | 8/6 | EP92 | 9/- | PC98 | 7/4 | PY82 | 5/6 | EL49 | 5/8 | 6F25 | 9/8 | SCF19 | 10/6 |
| EB91 | 4/3 | EP18 | 9/8 | PC98S | 7/4 | PY83 | 9/8 | EL53 | 5/8 | 6L1 | 15/8 | SCF15 | 13/8 |
| EC33 | 11/2 | EL33 | 10/6 | PC88 | 12/6 | PY88 | 8/- | EL54 | 5/6 | 6L18 | 12/6 | SCF17 | 11/6 |
| EC41 | 7/2 | EL32 | 9/8 | PC98 | 10/6 | PY80 | 8/2 | EL55 | 5/8 | 6L1 | 15/8 | SCF12 | 9/6 |
| EC81 | 6/6 | EL36 | 8/8 | PCF149 | 10/6 | PY81 | 7/- | EL56 | 7/8 | 6L12 | 12/- | SCF4 | 12/- |
| EBF80 | 7/- | EL41 | 8/- | PCF90 | 8/4 | UABC80 | 7/- | EL57 | 7/8 | 10F1 | 8/6 | SCF19 | 12/- |
| EBF89 | 7/- | EL43 | 9/4 | PCF92 | 9/4 | UC41 | 7/- | EL58 | 10/8 | 10F9 | 8/- | SCF11 | 12/6 |
| EC81 | 7/4 | EM53 | 7/6 | PCF80 | 10/- | UC81 | 7/- | EL59 | 10/8 | 10F18 | 8/- | SCF13 | 12/6 |
| EC82 | 7/4 | EM51 | 8/8 | PCF801 | 10/- | URF80 | 7/- | EL59 | 10/8 | 10F18 | 8/- | SCF13 | 12/6 |
| EC83 | 7/4 | EM54 | 8/8 | PCF802 | 10/- | URF89 | 7/- | EL59 | 9/8 | 10P13 | 12/6 | SCF14 | 11/8 |

We are open 9 a.m. to 6 p.m. Monday, Tuesday, Thursday and Saturday—9 a.m. to 7 p.m. Friday. Closed all day Wednesday.

SERVICE SHEETS. TELEVISION !! ALL MAKES AND MODELS 4/-, P. & P. 4d.

IMPROVED

Modern styling in light grey with legible black engraving.

Constructed to withstand adverse climatic conditions.

Ever ready case, including leads, prods and clips.

Improved internal assemblies.

Re-styled scale plate for easy rapid reading. 2 basic scales, each 2.5 inches in length.

New standards of accuracy, using an individual calibrated scale plate d.c. ranges 2.25% f.s.d., a.c. ranges 2.75% f.s.d.

Available accessories include a 2500V d.c. multiplier and 5, 10 and 25A shunts for d.c. current measurement.



Mk 4

MULTIMINOR

STANDARDS OF ACCURACY AND RELIABILITY

The Mk. 4 MULTIMINOR is the latest version of this famous Avo instrument and supersedes all previous models. It is styled on modern lines, with new high standards of accuracy, improved internal assemblies, and incorporating panclimatic properties.

The instrument is supplied in an attractive black carrying case, which also houses a pair of leads with interchangeable prods and clips, and an instruction booklet. It is packed in an attractive display carton. Robust real leather cases are available, if required, in two sizes, one to take the instrument with leads, clips and prods, and the other to house these and also a high voltage multiplier and a d.c. shunt.

D.C. Current: 100µA f.s.d. —1A f.s.d. in 5 ranges
A.C. Voltage: 10V f.s.d. —1,000 f.s.d. in 5 ranges
D.C. Voltage: 2.5V f.s.d. —1,000 f.s.d. in 6 ranges.
D.C. Millivolt range: 0 —100mV f.s.d.
RESISTANCE: 0-2MΩ in 2 ranges using 1.5V cell
SENSITIVITY: 10,000Ω/V on d.c. Voltage ranges.
 1,000Ω/V on a.c. Voltage ranges.

● For full details of this great pocket size instrument, write for descriptive leaflet.

Avo are now operating a new nett Price List. Full details on request.

AVOCET HOUSE - 92-96 VAUXHALL BRIDGE ROAD - LONDON, S.W.1 - Tel: VICtoria 3404



AVO LTD

MM17

EX-RENTAL TELEVISION

14 in. £7.10.0
 17 in. £11.10.0

12 months 3 star Guarantee
 ★Tubes★Valves★Components

COLOURED FREE LIST

Channels for all areas
 Demonstrations daily from Large Selection

Personal collection or insured
 Carr. 14in. 20/-; 17in. 30/-.



EX-MAINTENANCE TESTED TUBES

17in.—35/- 14in.—15/-
 Most makes and types available,
 Guaranteed good picture. Carriage 5/- extra.

ONE YEAR GUARANTEED TUBES

21 in. 69/6
 17 in. 79/6
 15,14 59/6
 12 in.



100% REGUNDED
 Add 10/- or old tube.
 All 110°—99/6 plus
 30/- refundable on
 old tube, Carr. 10/6,
 14in. Slimline 17 &
 19 in. — overseas
 postage 30/-

VALVES £1 per 100. Assorted TV and Radio.
 Surplus ex-plant dismantled receivers. Post 4/0.
 Send for list.

CONDENSERS 10/- per 100. New Assorted Electrolytics and p.F.s. P.P. 2/8.

RESISTORS 5/- per 100. New. Mostly High Stabs. Assorted. P.P. 2/8. Overseas 3/6.

SPEAKERS 7/0 6in., 8in., 7 x 4in., 8 x 3in. Ex-mid. Salvage. P.P. 2/3. Overseas 4/-.

DUKE & CO. (LONDON) LTD.

621/3 Romford Road, Manor Park, E.12
 Liverpool St.—Manor Pk.—10 mins.
 Phone: U.Ford 600/1/2/3. Stamp for Free List

AERIAL BARGAINS

Latest 6 array combined all channels:
 Loft 89/6; Outdoor 48/6. P.P. 4/6.
 BBC/UEF 6 element pencil 89/6;
 6 element add on extension 11/-.
 P.P. 2/6.

A complete basic course on television... now in a new 3rd edition including colour and 625 line television—

A BEGINNER'S GUIDE TO TELEVISION

AN ELEMENTARY COURSE IN 17. LESSONS

The modern miracle of television is here explained in a series of seventeen lessons. Written in non-technical language which the veriest beginner can understand, the reader is taken by easy stages through every aspect of TV transmission and reception. A further lesson has been added on the conversion of 405 to 625 line pictures. It is a companion volume to the "Beginner's Guide To Radio", a best seller which has already sold over 75,000 copies.

Contents Scanning and Persistence of Vision. The Cathode-Ray Tube Explained. The Timebase Interlocking—Frequency Bands—The Receiving and Transmitting Systems. The Aerial. Tracing the Signals through the Receiver. The Video Section. The Television Camera Explained. The Tuning Signal, Test Card C, and Tracing Faults. Early Systems of Scanning. Colour Television. The N.T.S.C. System—Tricolour Tubes Explained. More About Colour TV Tubes and Receivers. Telecine—Video Tape and Electronic Recording. Stereoscopic Television. From 405 to 625 lines. Technical Terms.

FROM ALL BOOKSELLERS

Only 8s. 6d.
ORDER TODAY

... or, in case of difficulty 9s. 6d.
 by post from George Newnes Ltd.,
 Tower House, Southampton St.,
 London, W.C.2.

NEWNES

Practical Television

IT ALL DEPENDS

THE Television Act 1964 empowered the Independent Television Authority to assume a more direct role in the setting of advertisement standards and vested in it the duty and power to exclude any advertisement that could reasonably be called misleading.

Accordingly, the ITA drew up a Code of Standards and Practice and organised a staff to examine scripts and films of commercials before acceptance for broadcasting. The ITA Annual Report states that 7,500 scripts were dealt with last year and only one in four could be appraised without some degree of special investigation. In the event, some 20% required amendment to bring them into line with the Code of Standards.

The reaction of many impartial viewers could well be, judging from what we see on the screen, to speculate on what the offending commercials were like before purification.

In the Code it is given that "The general principle which will govern all television advertising is that it should be legal, clean, honest and truthful". Well, now. A lot of viewers (if clean, honest and truthful) would probably agree that many commercials do not exactly aspire to such lofty specifications.

How, for instance, does the ITA reconcile with the Code, those phoney "demonstrations"? Not every viewer is aware of the various ingenious artifices used to obtain certain effects. But, perhaps, film studio tricks are exempt from the general principles?

And the scripts, despite "rigorous examinations", often include statements and innuendos which, to us at least, would not stand up to a rigid interpretation of the guiding principles of the Code. Possibly this is a malaise common to other forms of advertising but in TV, which harnesses both visual and sound "messages", the impact is greater.

Furthermore, the Code lays down that "Audible matter in advertisements must not be excessively noisy or strident." Obviously, it all depends on the interpretation of what is excessive, no less than what is capable of being misleading.

FEBRUARY 1966

VOL. 16 185

THIS MONTH

| | |
|---|-----|
| Teletopics | 196 |
| Meet the Setmakers <i>by P. Westland</i> | 198 |
| "Laying the Ghost" <i>by G. W. Nixon</i> | 202 |
| Faulty Capacitors <i>by F. A. Grindthorpe</i> | 203 |
| Scope from a TV Chassis <i>by C. Doran</i> | 207 |
| First Time Tests—Part 6: IF Amplifiers, Tuners and Aerials <i>by H. W. Hellyer</i> | 211 |
| Triodes in Modern TV Design <i>by G. R. Wilding</i> | 216 |
| Towards Better TV Reception: Part 2 <i>by Gordon J. King</i> | 219 |
| DX-TV <i>by Charles Rafarel</i> | 223 |
| SECAM for Colour Videotapes <i>by K. T. Wilson</i> | 225 |
| Servicing Television Receivers The Bush TV99 <i>by L. Lawry-Johns</i> | 227 |
| Underneath the Dipole <i>by Iconos</i> | 230 |
| Your Problems Solved | 232 |
| Test Case—39 | 236 |

**OUR NEXT ISSUE DATED MARCH
WILL BE PUBLISHED ON FEB. 24th**

TELETOPICS

MARCONI TV FOR UNIVERSITY

THE largest single educational television system yet planned in Britain, has been ordered from The Marconi Company for the new first year science building at Edinburgh University. No less than nine fully automatic television cameras and 51 receivers will be installed, with a comprehensive control room and wired vision and sound distribution network linking lecture theatres and viewing rooms throughout this partly completed building.

The nine cameras and their associated sound channels will be connected to a central Control Room, from which up to three different programmes can be distributed simultaneously to selected viewing rooms throughout the building. Apart from the size of the scheme, a feature of this system will be the comprehensive control facilities. A lecturer will be able to control the programme channel selection and volume from a single point, close to his desk, for all receivers in the room.

The cameras used in this system will be the new Marconi V322 series, designed specifically for educational television. Each camera is fully automatic in operation, being able to cater for a full range of lighting conditions without attention from an operator. In normal use, the ON/OFF switch is the only electronic control that need be touched.

Four of the cameras will be mounted on lightweight tripods fitted with wheels for mobile use. These cameras will be the studio version type V322B fitted with integral electronic viewfinder.

The other five cameras type V322A will be permanently mounted in the lecturer's bench in selected lecture theatres. These cameras do not incorporate the viewfinder. Each camera will be mounted behind a screen and will be used either as electronic blackboards, or for document transmission. A monitor will be installed next to each of the fixed camera positions.

The complete system has been engineered into this new building at the planning stage. The vision and sound wired distribution system has been designed and will be installed by Rediffusion Limited, who will also provide the receivers.

TALLEST TOWER IN EUROPE

WORK on a 1,180ft. television tower has started in East Berlin. The constructors claim that the tower, almost twice the height of the recently completed G.P.O. tower in London's Howland Street, will range among "the tallest buildings in Europe, if not the world", and will be "considerably higher than the Eiffel tower".

The project, which is to be completed by 1968, provides for a restaurant and an observation platform at a height of 600ft.

The height proposed for the East Berlin tower compares with a total height of 620ft. for the London G.P.O. tower (including 40ft. for television aerials). The revolving restaurant of the G.P.O. tower is placed at a height of 550ft. The Eiffel tower of Paris has a total height of 1,033ft. (including 15ft. for transmitter installations).

PW AND PTV FILMSHOW

CAXTON HALL, S.W.1 on FEB 4th, 1966. — See page 224 of this issue.

SEARCHING BY TELEVISION

A TINY snake-like television camera which can see round bends has been developed by Pye Laboratories Ltd., for use in the complicated pipeline networks of many major industries.

This articulated pipe inspection camera, the smallest of its type in the world, is only 2½ in. in diameter. The entire length of the camera, its amplifier and lighting system is 28 in. It has been specially designed for small bore pipe inspection and will save time and cost in industries throughout the world, including oil refineries, chemical plants, power stations, gasworks and shipping companies.

Pipe inspection and maintenance has been an acute problem in industry because long lengths of pipe have so far had to be physically disconnected for periodic checks and repairs. The unique construction of this new Pye camera will help overcome these problems by enabling continuous lengths of up to 1,000ft. to be inspected.

The camera itself is articulated so that it can pass easily round bends in piping. It consists of two sections, a tube assembly and amplifier unit joined by a flexible metal coupling. An articulated optical assembly with built-in lighting is fitted to the front end of the tube assembly. The camera is lightweight, completely waterproof, costs £1,850 complete with control and monitor unit.

The photograph shows the articulated television camera being lowered down the ventilation pipe of a double-bottomed tank on board the Union Castle liner the "Reina del Mar" at Southampton.



NEW MARGONI COLOUR TELEVISION CAMERA

AN entirely new, fully transistorised, colour television camera, the Mark VII, has been introduced by The Marconi Company. This camera, which uses four plumbicon pick-up tubes, represents a significant advance in stability of operation.

It is in fact sufficiently stable for "hands-off" operation from a simple control panel mounted in a studio suite. The use of plumbicon tubes has made it possible to design a comparatively small and light camera which is easy to handle and simple to use.

The camera can be switched to either the 525-line or 625-line standards and will provide signals suitable for coding to any of the systems that have been proposed—NTSC, PAL or SECAM.

The camera itself is shown in the photograph.

Four plumbicon camera tubes are employed in this camera. Three of these are used to produce signals corresponding to the three primary colours, red, green and blue, while the fourth tube gives a normal black-and-white, or luminance signal. This signal ensures that the final output of the camera is fully compatible—it can be picked up by a normal monochrome receiver, to give a good black and white picture.

The use of a separate camera tube for the "luminance" channel, greatly reduces the dependence of the colour picture on extremely accurate registration of the pictures from the three colour tubes. The definition of the final colour picture is dominated by the single luminance channel.

An important feature of the Mark VII camera, particularly in outside broadcast work, is its ability to operate with a camera cable up to 2,000ft. in length. A unique phase locking system ensures that signals are accurately synchronised with the drive and blanking pulses, irrespective of the length of camera cable and of temperature variations.

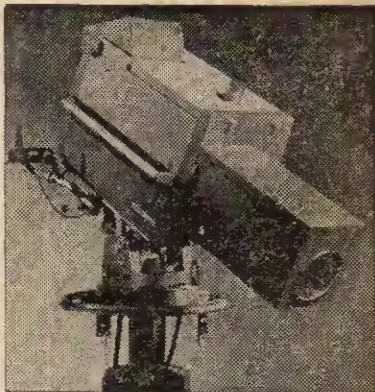

TV SURVEILLANCE IN PRISON

PYE closed-circuit television has been planned and installed as a modern addition to H.M. Prisons recently completed at Blundeston in Suffolk. The object of the installation is general surveillance of the corridors on to which prison cells open.

Inside a cell block, at the junction of three corridors meeting at right-angles, a reinforced housing has been built into the ceiling. Three port-hole windows in this encasement face out upon the corridors. A "Sentinel" camera head mounted on a panning unit is fitted inside the housing and this can be remotely-controlled to view any selected corridor.

A control and monitoring console is positioned in the guard-room. The three camera heads are controlled by a camera switching unit, which is used by the operator to select any one of three cameras. A three-position switch on the control panel at the top operates the panning motor of the selected camera which is then orientated to one of the three viewing positions. The pictures are displayed on a general purpose 14in. video monitor.

A BRITISH "FIRST" IN EUROPE

PYE TVT LTD., of Cambridge, England, have been awarded a contract by the Swiss Post and Telegraph Administration for the supply and installation of two 10 kilowatt u.h.f. television transmitters. The transmitters will be part of the expansion of the Swiss Television Service.

The order was placed after technical discussions between representatives of the Swiss PTA and Pye TVT Ltd., in Berne and its value is in the region of £100,000.

This is the first order ever obtained by Britain for the supply of u.h.f. television transmitters to Europe and is the first u.h.f. television transmitter to be purchased by Swiss PTA. The equipment will be installed at Mount Rigi in central Switzerland.

MOSCOW COLOUR TV BROADCAST TO PARIS

A SUCCESSFUL experimental colour TV broadcast from Moscow to Paris was carried out for the first time on November 29 by means of a *Molniya-1* artificial earth satellite.

The telecast was carried out under the Franco-Soviet agreement on co-operation in colour television. The colour programme was telecast according to the SECAM system.

From the Moscow TV station the signal of the television programme was transmitted to a ground point in the USSR and then to the *Molniya* sputnik. From the sputnik the signal was picked up by a ground point in France, whence it was directed via a relay-line to Paris and relayed by the Butte-Chaumont colour television transmitter. The telecasting of a varied colour programme continued for about one hour.

Despite the complexity of the communication line, the quality of the received colour images was on the whole good.

STOP PRESS!

We have just received news of yet another colour TV system! This one, called NIR, seems to be a Russian marriage between SECAM and PAL. We hope to have fuller details next month.

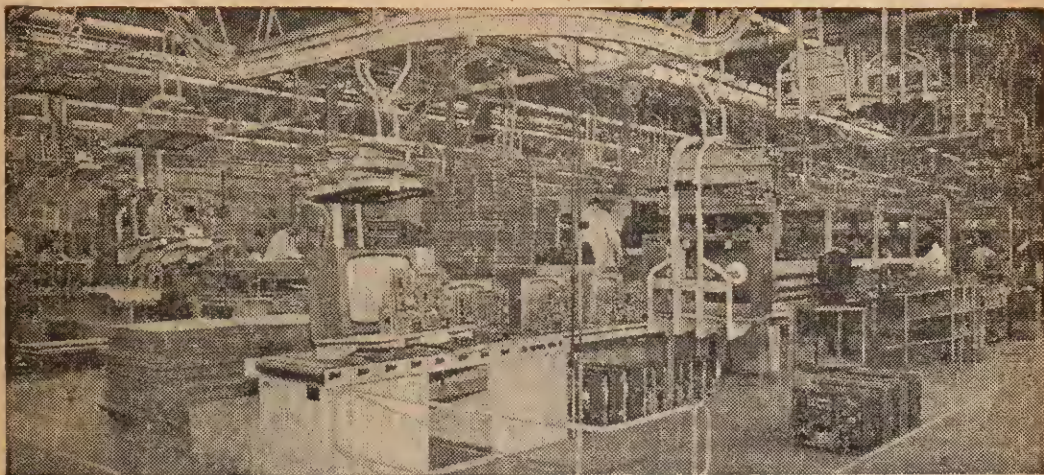

MEET THE SETMAKERS

PART I: SETTING THE SCENE

P. WESTLAND

THIS is a story about the setmakers. The men who, year after year, design and produce the hundreds of thousands of television receivers that give so much enjoyment in nearly every home in the country. More especially it is a story about how a new TV is born. We are going to follow it behind the scenes right from the very beginning.

We shall meet it first as a small dot on a large and complicated chart hanging on the wall of the sales manager's office. We shall watch this dot assume an identity of its own, as ideas develop and form a shadowy outline of the TV-to-be. Gradually the ideas will crystallize, until the point is reached where a complete written specification can be drawn up. This is the brief to which the design department will work.

Then we will follow the new receiver through all stages of its design—electrical, mechanical, and styling—until the first prototype models are built. We shall take one home to test it under normal domestic viewing conditions, and then do field tests at a deserted and windswept spot high up on the South Downs, in a smoke laden back street in the Potteries, or a score of other places.

When all the modifications have been made, and the design finally proved, we shall follow its progress through all the phases of pre-production activity until it finally appears on the factory floor. We shall meet it again in various stages of assembly on the production line, and will see how trimming, testing, inspection, and quality control are carried out. There will be production problems, too, which will have to be overcome if we are to achieve our aim of delivering a near perfect receiver to the stores, ready for despatch to our customers.

This, then, is the skeleton of our plot: now meet the players.



The Organisation

The players of our story are the individuals, sections, laboratories, departments, and groups that, taken together, form the organisation of our setmaker. You are shortly going to be introduced to many of them because their names will be constantly flickering through these pages, and without knowing a little about them, and how they fit into the overall pattern of events, our story will not come to life. For instance, what sort of men are the "Setfathers", and what does an Estimator estimate?

Organisation is of vital importance because, without it, it would not be possible to carry out the basic purpose of a setmaker—namely to sell receivers. In order to do this he must first manufacture products of the right design, at the right time, the right price, and the right quality. He must then back this up with an efficient sales department. The whole process of designing, producing and selling a new design of TV involves a high degree of individual ability, and close co-operation between a large number of different departments. In other words good organisation. Any weak link in the chain means that the design may be commercially obsolete before it is produced; of poor performance; too expensive to sell at a profit, or of such poor quality that the manufacturer loses his reputation and customer goodwill.

There is no single form of organisation that will give the best results, and probably every setmaker in this country has a different approach to the matter. The organisation used will depend upon the amount of emphasis placed upon quality of design and manufacture, as opposed to speed in getting the new TV into production, and numerous other factors of this kind. In many cases the organisation has its roots way back somewhere in the firm's history. Again, it is not always possible to obtain staff who will fit into a preconceived pattern, and so often the organisation has to be tailored to make the best use of the individual staff available.

Having made the obvious point that most setmakers manage their affairs differently, let us not worry too much about the names of departments, or their exact areas of responsibility and chain of command. Instead we will take a hypothetical setmaker, typical of most but not to be identified with any particular existing company, and list the various departments that are likely to be found in it, and the basic functions that they have to perform. We will start at the commercial end of the business and then work our way steadily towards the production line.



Sales

The main purpose of a sales department is, of course, to sell, although there is another very important aspect of its activities that we shall be considering later. Our typical setmaker will employ quite a large number of sales staff, and they will tend to be split into two groups. The larger one will consist of representatives scattered about all over the country who have the job of calling upon dealers and booking orders. Another important part of their job is to act as a liaison between the dealer and the set maker so that information of all kinds—both advice and criticism—can flow freely in both directions. The other group will consist of a very few senior staff who will visit the big bulk buyers, such as chain stores, and negotiate the large contracts. The sales department will also employ a veritable army of staff, and perhaps a computer as well, to handle the flood of paperwork in connection with these incoming orders. Invoices will have to be sent out, and instructions issued to the stores to despatch the appropriate goods to each buyer.

In addition to the actual sales staff there are a number of very important auxiliary departments and services which act as the supporting cast. These include Market research, publicity, accountants, dealer promotion, and perhaps a press office or P.R.O., and a customer advice service. Sometimes the latter is handled by the service department. Other important services are obtained from outside specialists such as advertising and photographic agencies, together with a few tame printers.

The market research people keep their finger on the public pulse and are able to give very useful advice about how the market is developing, and

what the customer wants. This enables the sales department to provide the right product in the right price range to suit each particular section of the community. Conversely it also helps to prevent the unfortunate possibility of making a lot of receivers that no-one wants to buy. This must surely be the sales manager's recurrent nightmare!

Part of the advice given will be in the form of long range forecasting. They will estimate, for example, the total industry sales for the year after next, and the company's share of the kitty. This helps the sales department to plan its production programme well in advance of requirements. It is upon the accuracy of these forecasts that the financial success of the company often depends.



Publicity and Advertising

The publicity department is likely to be responsible for organising the national advertising, and the design, printing, and distribution of leaflets and brochures under the overall control of the sales manager and top management. It will probably also have the job of arranging displays at, for instance, the Earls Court Radio Show and other exhibitions. It will have its own tame printers, and specialist contractors for display stands and other promotional material.

The Accountants

The chief accountant and his staff provide the usual figures of profit and loss, but they also give very valuable advice as to which individual sectors of the overall operation are providing the profits, and which the losses. The chief accountant may very well point out, for example, that half the sales expenses are incurred by a part of the selling operation that is only providing a small proportion of the orders. This is very valuable advice to the sales manager, and can result in a much more efficient sales effort with a consequent lowering of prices, if competition is keen.

Dealer Promotion

Our typical setmaker will have a dealer promotion group who advise and help dealers to run their businesses more efficiently. Help will be given in the form of material for window displays, and advice on adopting up-to-date techniques of accountancy, stock control, service and spares organisation, and local advertising. Whilst this obviously helps the dealer, it should not be forgotten that it also benefits the customer, because in the first place he will get better service, and in the long run a cheaper product due to the increased efficiency of the distribution network.

The Advertising Agency

Our agency will be retained by the setmaker to handle all the problems in connection with national advertising. It will draw up a plan of campaign

within the budget allocated for advertising purposes, to be approved by the sales manager and top management, then put this into effect. It will be centred upon some theme such as, for example, "good value for money", which has been agreed upon during the course of numerous discussions between the various parties concerned.

The agency employs a large staff of studio artists, writers, photographers, etc., to produce the illustrations and designs for the promotional material. It is a very specialist business, and calls for great skill if advertisements are to be produced which will attract the public's interest and attention in favour of our setmaker's receivers, in preference to the products of some other setmaker which, let's face it, look very much the same. Fig. 1 is a simplified diagram of the sort of sales department that we have been discussing, but it should be borne in mind that in most cases the organisation will be much more complex in its detailed make-up. However it serves to show the scale of the enterprise, and some of the more important functions involved.

Now at this stage you may be tempted to ask what all this has to do with the actual birth of a new TV. The point is that the only people who can fairly be given the responsibility for commissioning a new product, and indeed are the only people qualified to do so, are the sales manager and his staff. After all, they will be responsible for selling it. Later on when we start drawing up the specification of the new receiver it will be the sales department who will be the instigators. Naturally they will have advice freely available from the design department, stylists, production departments, the market research group and others, but it will be the sales department who will have the final say.

The work of the factory and its associated departments can be split up into three separate but interdependent groups of activity. Design, preparations for production, and the production process itself. There are also a number of services which support the whole operation.



Design and Production

The function of this department is basically to design the receiver so that it is tailor-made for the factory that is going to produce it, and to specify every last detail of it in the form of engineering drawings. The department will probably consist of a TV design lab.; a components design lab.; a mechanical design office; perhaps a separate drawing office; a documentation office; a styling section; a model shop; stores, and the usual secretarial staff. Some setmakers expect their TV development

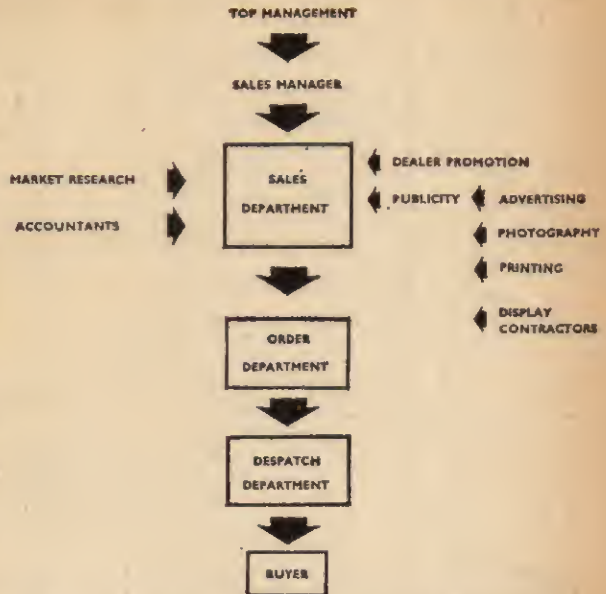

Fig. 1—Simplified diagram of a setmaker's sales department.

engineers to design their own coils and transformers, which are then made up by a coil winding section. A separate components design lab. is not then needed. The model shop produces hand made components of anything from simple right angled brackets in sheet steel to delicately made switch mechanisms. The documentation office keeps the original transparency of all drawings, and issues prints on request from any other department.

Preparing for Production

The complete design of our TV leaves the design department in the form of hundreds of engineering drawings, and a few hand made prototype models. The factory then has the task of trimming this into a fully fledged manufacturing process which can be put into operation on the assembly lines by a certain date. Almost every department in the factory will be involved in these preparations. Strictly speaking, the design department has done its job when it issues the drawings, and certainly its main efforts will be directed towards its next job, but in practice it will continue to give advice and answer queries from other departments, and also tidy up any loose ends.

The department responsible for getting ready for production, which we will call the production engineering department, will almost certainly contain a planning section which will co-ordinate all the activities. They will draw up a master plan, showing all the functions that have to be carried out, and the target date for each one. If the whole operation was not carried out to a strict timetable, it would not be possible to start production on the required date, and chaos would be the inevitable result.

The next most important group is the setfathers department. (A fascinating name, isn't it?) It has

the task of breaking down the design into detailed and carefully planned stages of assembly which can be put into operation as a complete assembly process on the factory floor. It will also be involved in the choice of jigs and other assembly aids, and will specify such details as lead lengths. In general it will be responsible for the details of what each assembly operator does.

Another section of the production engineering department will investigate suitable techniques for mechanising individual operations, and may well design its own machines for doing so. For example, it would study the problems involved in dip soldering printed panels, and then design a machine to do this automatically under carefully controlled conditions. Another aspect of its duties is to choose or investigate the cheapest method of doing any particular function.

The Production Department

Obviously the most important member of this part of the organisation is the factory floor where the assembly lines are laid out. All the individual items, components, and sub-assemblies are fed into it, and completed, tested, and packed receivers come out of it as the result of a long series of complex operations. The main assembly department is backed up by a number of specialist groups. Amongst these is a sub-assembly department, a cabinet assembly department, coil winding shop, machine shop, perhaps a plating shop and a paint spraying shop, and a separate department for producing printed panels. Apart from these there will be a highly organised stores feeding all materials to the main assembly and sub-assembly areas, and a section that inspects incoming raw materials, components and other supplies. If any of the forming tools are made by the setmaker, there will also be a tool design department working in close co-operation with the production engineering department.

Another very important group is the testgear laboratory. Its main function is to design and produce, or in some cases buy, the right sort of testgear in sufficient quantity to enable all the necessary testing to be carried out on the production line. It will also have to generate picture test patterns which can be piped all round the factory, in addition to supplying the assembly lines.

The types of receivers being made at any given time, the quantities, and timing, will be co-ordinated by a planning section, who will be in close touch with the sales department in order to make sure that their requirements are being fulfilled. The detailed co-ordination of the production control department who organise incoming supplies of all materials and components, and control the throughput of all the various items through all the departments involved in production processes. At the head of the whole production operation lies the purchasing department. Their job is to make sure during

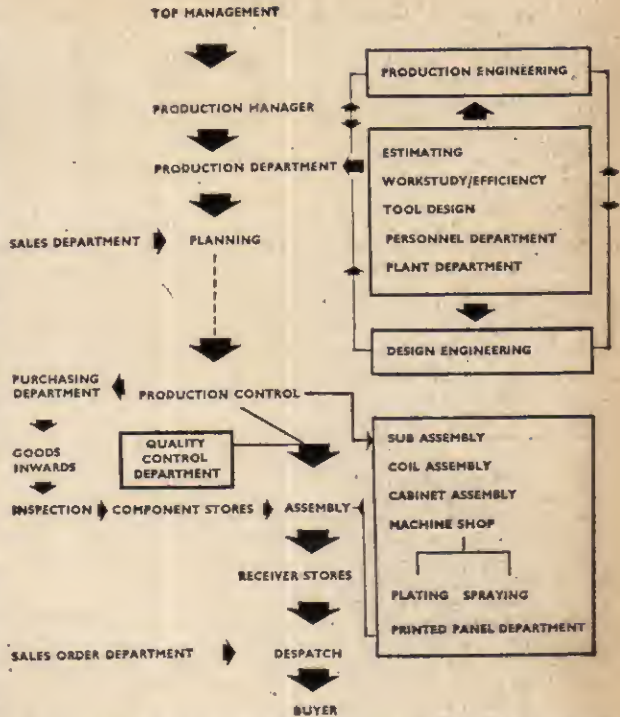
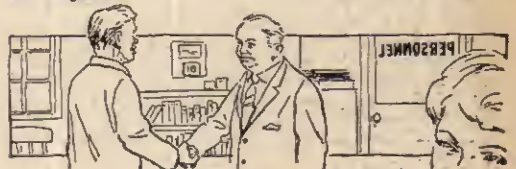

Fig. 2—Diagram of a production department, showing how it is served by the rest of the factory.

the preparation stage that every single item can be obtained at a satisfactory price, and then to negotiate contracts for production quantities when these are required.



Other Departments

All three phases of design, preparation, and production are supported by other departments who either give technical aid, or else form part of the complex community that constitutes a factory.

On the technical side there will be the estimating department who will work out the actual cost of an item, a process, or a complete receiver if it exists; or will give an estimated cost of any item or process that is proposed. This department is of tremendous help to almost every other department in the factory, since costs, and cost comparisons, are of the very essence of engineering.

The plant department is responsible for the care of the whole factory building, and the upkeep of many of its services. Many skilled electricians,

—continued on page 231

"LAYING THE GHOST"

by G. W. Nixon

THE universally adopted system for 405-line picture scanning is that known as "Twin Interlace", consisting of two fields each comprising $202\frac{1}{2}$ lines. Two field scans constitute one picture which occupies a period of $1/25$ sec., i.e. 0.04sec. From this fact it is an easy matter to calculate the period of time for one line in microseconds:

$$\frac{0.04 \times 10^6}{405} = 98.77 \text{ microseconds } (\mu \text{ sec.}) \dots\dots \text{I.}$$

This data will figure later subsequent to the following measures.

If a large-scale ordnance survey or accurate map is available showing an area enveloping transmitting and receiving stations an approximate position of the offending reflector(s) can be assessed. The larger the scale the greater the accuracy.

Take a sheet of transparent paper, place over the survey and indicate with a cross the exact position of transmitter and receiver. Draw a straight line through these crosses which will represent the direct signal.

Measure the distance between these stations and convert to basic scale of survey. This dimension we may identify as distance "X".

Temporarily transfer the paper to a flat surface and attach by driving a large ordinary pin through each cross into the surface beneath. Ensure that the pins are secure and to one of these attach about 24in. of fine twine which is sufficiently strong and does not lengthen a great deal under tension. Raise the twine to the underside of pin head.

Place this preparatory work aside and now concentrate upon the visible signals on the television screen. Ascertain the picture control knob and reduce the width until the extremities of the scanning

lines are distinguishable. We may identify this overall width as "W". This procedure will compress all signals, direct and indirect proportionately and will in no way detract from the accuracy of the operation.

Fig. 1 illustrates a screen with compressed picture width "W" with a direct signal trace "a" and a weaker indirect trace "b" lagging behind by period "w".

The period of lag "w" may be calculated as a ratio of the full width "W" which occupies 98.77 microseconds as quoted earlier.

$$\text{Lag in } \mu\text{S} = \frac{w \times 98.77}{W} \dots\dots \text{II.}$$

"W" and "w" are measured on the tube screen with any convenient rule but the basic units must be the same for both dimensions. Equation II represents the additional period necessary for the reflected signal to arrive at the receiver.

Since the velocity of radio waves in free space is equal to 186,108 miles per second the velocity per microsecond can be easily obtained dividing by 1,000,000, i.e. 10^6

$$\text{Miles per } \mu\text{S} = \frac{186108}{10^6} = 0.186108 \dots\dots \text{III.}$$

The mileage in excess of the direct signal is now obtained by solving the product of equations II and III.

$$\begin{aligned} \text{Excess mileage} &= \frac{98.77 \times w}{W} \times 0.186108 \\ &= \frac{18.38w}{W} \dots\dots \text{IV} \end{aligned}$$

to the nearest two decimals.

The distance travelled by the reflected signal is the total of equation IV and dimension "X" scaled earlier from the survey.

$$\text{Total distance in miles} = \frac{18.38w}{W} + "X" \dots\dots \text{V.}$$

We now return to complete the preparatory work by attaching the reverse end of the twine to the remaining pin in such a manner that the free twine measures a length equivalent to equation V.

The stock of a narrow pencil should now be placed lightly against the twine, Fig. 2a, and, commencing at one end of the common centre line, proceed to describe half an elliptical path.

Repeat for the remaining half. Fig. 2b indicates the manner in which this is carried out and the ultimate appearance of the cartography.

The elliptical envelope is theoretically composed of an infinite number of continuously variable paired

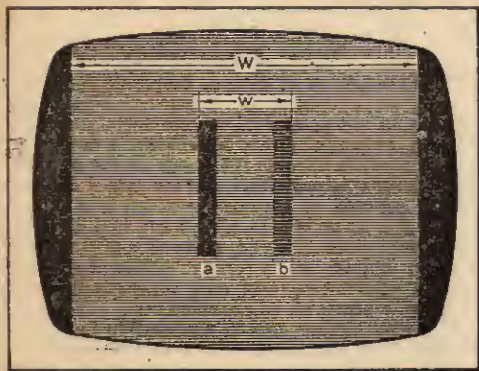

Fig. 1—Screen with compressed picture width.

—continued on page 206

FAULTY CAPACITORS

— THEIR EFFECT IN TV RECEIVERS —

F. A. GRINDTHORPE

THE capacitors which generally give trouble in TV receivers may roughly be classified into three groups: smoothing, decoupling and coupling. Tuning capacitors whether variable or fixed do not often give trouble and will not be considered in this article.

Smoothing capacitors are usually electrolytic but in low-current circuits, such as a.g.c. systems, paper capacitors of $0.5\mu\text{F}$, $0.25\mu\text{F}$ or $0.1\mu\text{F}$ are often found working in conjunction with high-value smoothing resistors of $470\text{k}\Omega$, $1\text{M}\Omega$ or more. Decoupling capacitors are used to keep voltages steady at points where variation could cause interaction or feedback. In low-frequency circuits these may be electrolytic but in r.f. or i.f. stages may be as low as 80pF or thereabouts, ceramic or small paper types (the former being more generally encountered). Coupling capacitors may be about $0.01\mu\text{F}$ in audio (sound) circuits but where the frequency is always low, in the field (frame) circuits, for example, values of $0.5\mu\text{F}$ are often found. These are usually paper types but ceramic capacitors of $0.01\mu\text{F}$ to $0.03\mu\text{F}$ are often used in audio circuits.

Electrolytic Smoothing Capacitors

It is usual to find large capacity electrolytic capacitors in the h.t. smoothing circuit, one can often containing two or more sections. A typical

can may be a $100+200\mu\text{F}$ 275V working. Invariably the $100\mu\text{F}$ section is used as a reservoir capacitor whose function is to partly fill in the supply gaps left by the action of the half-wave rectifier. As an a.c. supply changes direction at a rate of 50 cycles per second and the rectifier will only pass current in one direction it is obvious that the output of the rectifier, although unidirectional (d.c.), will consist of "hills and valleys". The reservoir capacitor charges up during the "hills" and discharges as the rectifier stops conducting to fill in the "valleys". It necessarily follows therefore that if the reservoir capacitor dries up and becomes a virtually chargeless component the h.t. voltage available will fall drastically. A normal 220V at this point falls to something like 140V or less, causing a complete loss of picture due to the line timebase being unable to operate or a very small picture giving the impression of a low-emission rectifier. The amount of hum or ripple would depend upon the amount of capacity at the other (smoothed) end of the smoothing choke or smoothing resistors.

Although the term "dries up" was used to describe the non-operating condition this is not necessarily the cause of the fault. An open-circuit connection in the capacitor often occurs and usually the fault is referred to as "an open-circuited reservoir" or "OC electrolytic". The larger

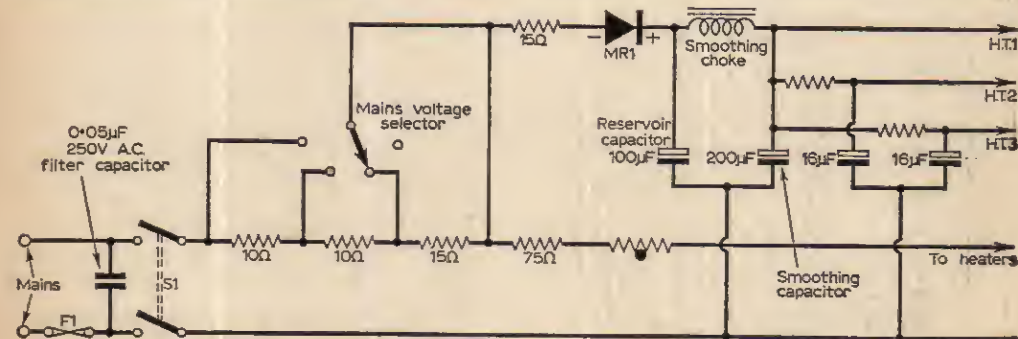

Fig. 1—Position of the main electrolytics and mains filter capacitor in a typical receiver.

capacity "smoother" section, which may be $200\mu\text{F}$ as already quoted, can be any larger value up to $500\mu\text{F}$. The larger values are usually employed where wire-wound resistors are used in place of a heavier and more expensive smoothing choke. Should this section become "OC" the usual result is a loud hum on the sound, severely curved edges to the picture with the curved sections shaded dark and light. Complete loss of synchronism may also result. We say "usually" and "may" because various sections of the circuit may be separately smoothed or decoupled by fairly high value electrolytics which would minimise the effect in that circuit.

Decoupling Capacitors

Decoupling capacitors differ widely in their type and application. Used in r.f. (tuner) and i.f. stages they usually have a value of $0.001\mu\text{F}$ ($1,000\text{pF}$) or thereabouts. Their purpose is to divorce one part of the circuit from another to prevent interaction. An open-circuit decoupling capacitor at one end of an h.t. feed line may cause severe sound-on-vision and/or vision-on-sound or possibly complete loss of signals even though there is another and good capacitor at the other end and there is no resistor (as such) to cause an unwanted coupling. The small voltage drop along the supply lead or through the chassis or printed track itself can cause these effects. One or two examples of actual faults encountered would perhaps illustrate these and similar effects.

Example 1. K-B 17in. RV30. Complaint: Normal picture and sound for first few minutes and then the screen becomes overall brilliant, no picture and severe loss of sound. Fault traced to a faulty connection between the $2,200\text{pF}$ decoupling capacitor from pin 8 of the 9D7 common i.f. amplifier and chassis. Resoldering the connections cleared the fault.

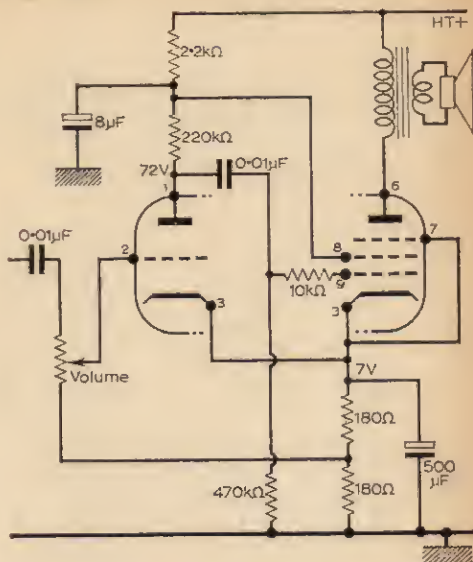

Fig. 3—The audio stage of a typical receiver.

Example 2. Pye VT17. Complaint: No vision signals, raster normal, sound normal. As this is a very common fault no time was lost in bridging a $0.001\mu\text{F}$ capacitor across the existing one in the screened compartment. Actually wired pin 8 of final vision i.f. amplifier EF80 to chassis. A replacement restored normal conditions. It is worthy of mention that whereas the decoupling capacitor of the earlier i.f. stages are of the ceramic type the ones which give trouble in the final vision and sound i.f. stages are of paper type. Open-circuit decoupling capacitors were often responsible for severe loss or complete loss of sound in earlier Marconi, HMV, K-B, RGD and Regentone models to name but a few. Bridging with a known good capacitor usually restores normal conditions but it must be borne in mind that the connections must be direct and the leads kept very short.

It will also be noted that we are only dealing with the effects of open-circuit decoupling capacitors. A shorted capacitor in an h.t. circuit usually calls attention to itself by burning out its supply resistor. There are many other applications for decoupling capacitors. In sound and field output circuits an electrolytic is wired across the cathode bias resistor to reduce current (negative) feedback and the value of such a capacitor can be anything

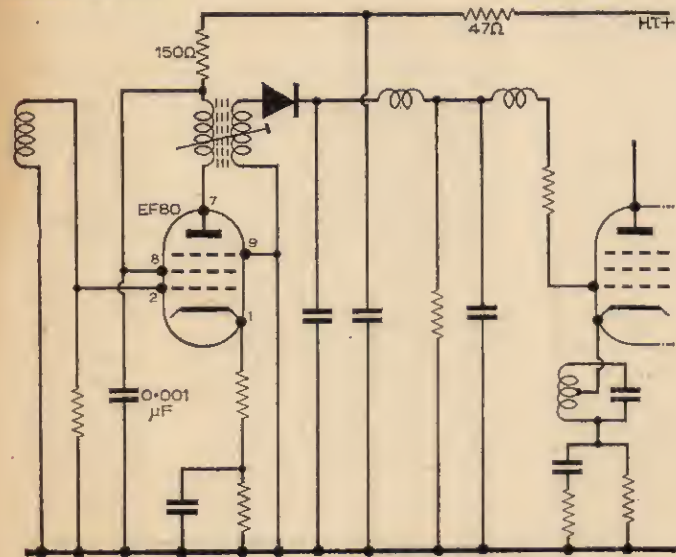

Fig. 2: The final vision i.f. stage of the Pye VT17.

from $50\mu\text{F}$ to $500\mu\text{F}$. An open-circuit capacitor in this position will result in loss of volume in an audio circuit and loss of height, particularly at the bottom of the picture in a field (frame) output circuit.

There are complications to this, however. For example, an audio circuit may consist of a triode pentode such as an ECL80. The triode is used as an audio amplifier, the pentode as the output stage. The common cathode is pin 3 and the bias is sometimes provided by two resistors with the grid of the triode returned to the junction. An electrolytic is wired from pin 3 to chassis. If this capacitor becomes open circuited feedback is introduced in a positive sense from the pentode to the triode and the result is a loud howl. Where there is a connection between the cathode of the audio amplifier to the cathode of the output this point should be kept in mind. Electrolytics are often used to separately smooth and decouple the h.t. supply to the audio stages and an o.c. capacitor in this position can not only give rise to the expected effects, loss of volume, hum, interaction, etc., but also to a strong vision-on-sound buzz, varying with the picture content. This was particularly the case in some earlier K-B receivers.

Still on the subject of electrolytics, it is often the case that sub-h.t. lines are decoupled by separate sections of a single can-type capacitor. For example, a $32+32\mu\text{F}$ may be used for h.t. decoupling to the audio and field timebase circuits. These sections may retain their capacity but leakage between the sections can give rise to strong interaction, causing a loud buzz on the sound and disturbance of the field scan in sympathy with the sound modulation. The effect can be most disturbing where a triple section can, say $16+16+16\mu\text{F}$, is employed. Disconnecting each section and using separate wire-ended capacitors for test purposes may seem untidy but is the best way of clearing uncertainty. Always observe voltage ratings.

Coupling Capacitors

We will consider here the effect of leaking as well as open-circuited or loss of capacity.

As previously stated, coupling capacitors in audio circuits usually have a capacity of about $0.01\mu\text{F}$. The usual trouble experienced with these small paper types is leakage. The idea is to pass variations of voltage or signals but block any steady or standing d.c. In the case of the previously mentioned triode-pentode the triode anode may have an operating voltage of, say, 100V. The signal voltage developed across the anode load resistor must be communicated to the pentode control grid, which is normally held at chassis potential in order to be negative in respect to the positively biased cathode. A capacitor therefore connects from the triode anode to the pentode control grid circuit. Leakage through this capacitor will cause the control grid to go positive, leading to heavy pentode current, upsetting its normal operating curve and introducing severe audio distortion. The output valve may appear overheated, the cathode voltage will be high. The best way to quickly check the capacitor without disconnecting it is to

note what happens to the cathode voltage of the pentode when the anode of the triode is shortened to chassis. This will, of course, remove the voltage from the triode anode end of the capacitor and, if the capacitor is at fault, will cause the pentode cathode voltage to fall to normal. If the voltage does not fall the output valve itself is at fault and should be replaced. Although any capacitor can leak some tend to leak or short completely more often than others. Without naming any specific make the writer is always wary of equipment which uses oval-shaped black capacitors not made in this country. These have given a considerable amount of trouble in some quality stereo amplifiers, radio-gram chassis, tape recorders and dictaphones. It is distressing to find three out of four ECL82 valves on a good quality R/G chassis glowing red-hot and probably ruined by leaky coupling capacitors.

Now let us consider leaky capacitors in TV timebases. Quite often the picture on a TV receiver exhibits severe distortion at the bottom of the picture, this being folded over to form a bright band with inverted images. Although this is often caused by the output valve running into grid current the coupling capacitor should always be suspect, and the same remarks in reference to the audio output voltages apply here. A slight twist to this theme, however, is where the coupling capacitor is taken not from a positive source but from a negative, i.e. the oscillator grid-circuit. The Cossor 948 series used to exhibit the symptoms of severe distortion in the centre, the foldover being across the middle, although the lower part was also distorted, as indeed was the top, and the field hold was erratic. The $0.25\mu\text{F}$ coupling capacitor was invariably at fault.

It is in the line timebase that the most confusing symptoms can occur. Taking a concrete example

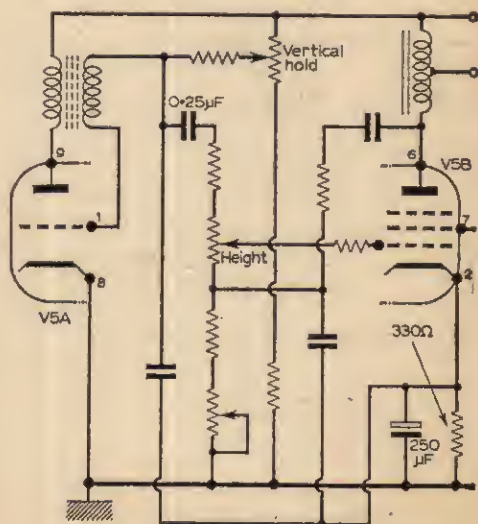

Fig. 4—Part of Cossor 948 field timebase.

Let us consider the case of a Ferguson 306T. Quite obviously leakage through the $0.001\mu\text{F}$ coupling capacitor will cause severe overheating in the PL81, probably stopping the timebase altogether, but in fact this does not happen often and the PL81 itself is more often at fault with screen-to-grid leakage. However, it often happens that the symptoms are of lack of width and poor e.h.t. Replacement of the PL81 may appear to rectify the fault but observation may show that it is still overheating. Our old friend the screen resistor ($2.2\text{k}\Omega$) is usually suspected (quite rightly) but may be found quite innocent. The $0.001\mu\text{F}$ is checked for leakage but has none. The 800pF and the PCF80 are likewise free of guilt and the $47\text{k}\Omega$ resistor is in order. What has happened is that the $0.001\mu\text{F}$ has lost capacity and a test capacitor bridged across it will immediately restore normal conditions. The overheating and rapid deterioration of the PL81 is due to lack of drive from the oscillator to the PL81 control grid.

Voltage Ratings

Whenever a capacitor is replaced the voltage rating marked on the original must be observed. For example, a $2\mu\text{F}$ electrolytic used in the boost line of a receiver may be rated at 450V or 500V. In some cases two $8\mu\text{F}$ are wired in series. It is no use using a replacement of the same capacity if the voltage rating is lower. A capacitor rated at 350V will have an extremely short life and may ruin the efficiency diode and possibly the rectifier (h.t.) as well. Another pitfall for the unwary is the mains filter capacitor, often a $0.05\mu\text{F}$ wired at some point across the mains input. This may be

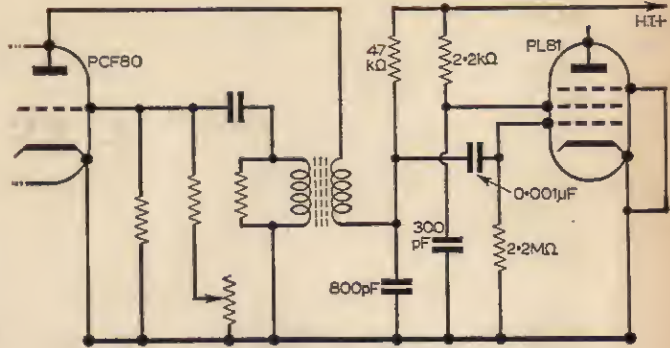

Fig. 5—Part of Ferguson 306T line timebase.

marked $0.05\mu\text{F}$ 250V a.c.

Readers often ask why a replacement rated at 350V or 500V blows out. A replacement which is only marked with a d.c. voltage rating should be at least 750V or 1,000V. Capacitors with an a.c. rating are particularly made with mains peak voltages in mind and are marked with an r.m.s. value. Similar remarks apply to capacitors used in the line output stage where ceramic types of 6kV (6,000V) or more are common. This may appear obvious but what may not be quite so obvious is that the field (frame) output stage generates quite high peak voltages, which is why a voltage dependent resistor is often wired across the field output transformer primary winding. Capacitors used in this circuit must be adequately rated.

An audio output circuit is just as capable of producing high peak voltages, particularly if the loudspeaker is removed, leaving the transformers unloaded. This can cause the tone correction capacitor to short and/or the output transformer to break down.

LAYING THE GHOST

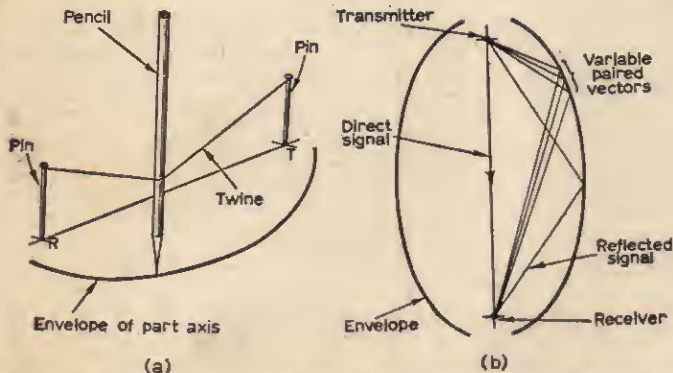

Fig. 2—(a) Method of describing elliptical path. (b) The ultimate appearance of the cartography.

—continued from page 202

vectors whose combined magnitude will always remain constant and equivalent to V.

Remove the pins and twine and superimpose the transparent paper upon the survey relating the crosses with their respective stations. A search may now be carried out upon this elliptical path to ascertain the offending reflector.

Repeat the whole operation for additional "ghosts".

This operation is in no way a solution for the removal of their origin but most aerials fitted with additional directors (thereby reducing the acceptance angle) may be intelligently rotated to remove or at least reduce the unwanted signals.

SCOPE

by G. Doran

FROM A TV CHASSIS

The author describes the conversion of a popular 14in. TV receiver to an oscilloscope, with the timebase covering 200 c/s to 30 kc/s.

HAVING built the "Audio Amp" from a TV chassis, as described in the August P.T., readers may well be at a loss as to what to do with the remainder of the chassis, tube, etc. The writer has just completed the conversion of a Ferguson 992T receiver to an oscilloscope, and some readers may like to try the design. The oscilloscope does not use the part of the chassis required for the audio amp and, provided that the tube supports are replaced by suitable brackets, the "de-amped" chassis may be used.

A 14in. receiver was chosen for conversion because the oscilloscope was intended primarily for demonstrations at the writer's school. The design could easily be adapted to use a 9in. tube, however.

The oscilloscope uses valves reclaimed from the chassis (although an extra PL81 is required (see below). Components from the receiver may also be used, but, in the writer's experience, second-hand paper capacitors tend to have suffered changes in value. New capacitors are therefore recommended where the value may be critical (e.g. timebase capacitors).

It must be appreciated that the remarks below apply mainly to the Ferguson 992T SCH E and that differences must be expected in the other models mentioned in the Audio Amp article, including different schedules (A and B) of the 992T.

Clearing the Chassis

Remove the tuner, if fitted, and all valves except the EY51. Withdraw the chassis from the cabinet. The tube may be removed, if desired, applying only gentle pressure if it tends to stick. The writer did not remove the tube, which consequently had some near misses from a 4lb. weight used to stabilise the chassis when on its side. So perhaps removal is desirable!

Remove the small Band I tuner chassis on the left of the top of the chassis as viewed from the front. This is held by four p.k. screws. Saw off the vertical aerial socket bracket, and remove all

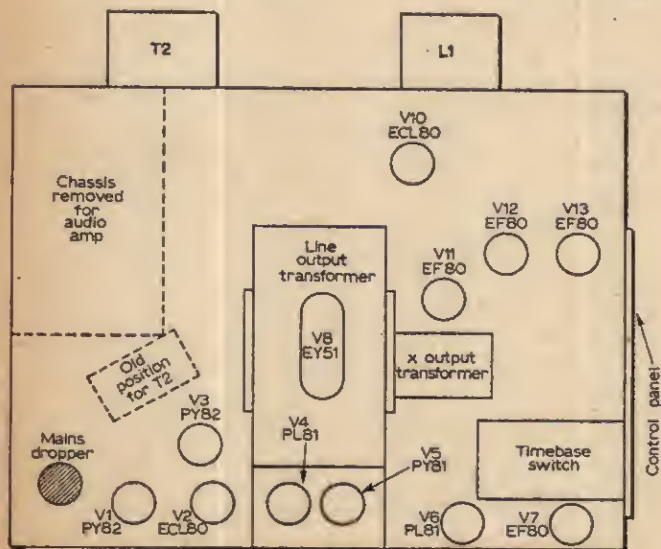

Fig. 1—Chassis layout—showing positions of major components.

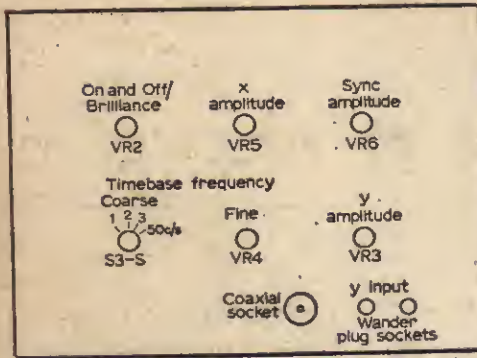

Fig. 2—The control panel which is bolted to the left-hand side of the chassis.

components, including i.f. cans, from this chassis. Replace it the other way round, i.e. with the valveholders towards the back of the main chassis. Now remove all i.f. cans from the main chassis. These are held by spring clips, and are easily removed after unsoldering the connections below the chassis. One of these cans contains a germanium diode (OA60 or OA70). Unsolder this carefully using pliers as a heat shunt. Put the diode aside; it will be required later.

Now remove all wiring, except to the line oscillator and output stages and to the power stage (see below for circuits). Brown leads to the valveholders (heaters) may be retained, although the valves may be connected in a different order later.

Remove the field output transformer and fix it to the chassis in place of the loudspeaker output transformer (see Fig. 1). A new fixing hole will have to be drilled if this part of the chassis has been cut away. A new lead to the field scan coils will have to be fitted. This should be a piece of co-axial, with the outer braiding connected to chassis, to reduce dangers of feedback to the amplifier. The two $1k\Omega$ resistors attached to the scan coils should be retained.

Control Panel

The writer used a formica panel drilled with six holes to take potentiometers and timebase switch (see Fig. 2). The panel was bolted to the left-hand side of the chassis as shown in Fig. 1.

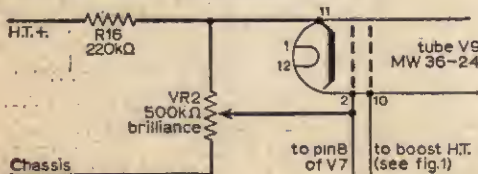

Fig. 4—Tube supply circuit. If a pentode tube is used connect the second anode to the cathode.

Power Supplies

The original power supply circuit may be altered (provided, of course, that the smoothing capacitors have not been cannibalised to make a microphone pre-amplifier). The circuit of the power section of the 992T is shown in Fig. 3, for servicing purposes, and also for those readers who may inadvertently cut the wrong lead!

The total heater voltage is similar to that of the original receiver and the same dropper may be used. To reduce hum pick-up to a minimum, the heater of V13 (Y amplifier input) was put at the chassis end of the heater chain. This was followed by the c.r.t., the remaining valves being connected in the order shown in Fig. 3. Provided that the above points are remembered, the heaters may be connected in any convenient order. PL81 and PY81 may be at the live end of the chain because of their high heater/cathode insulation. The mains switch (S1 and S2) is ganged to the brilliance control (VR2).

Since this oscilloscope uses a mains connected chassis it would be highly desirable that a mains isolation transformer should be used. This should be capable of taking 1.5A. Failing this, care should be taken that the chassis is connected to the neutral

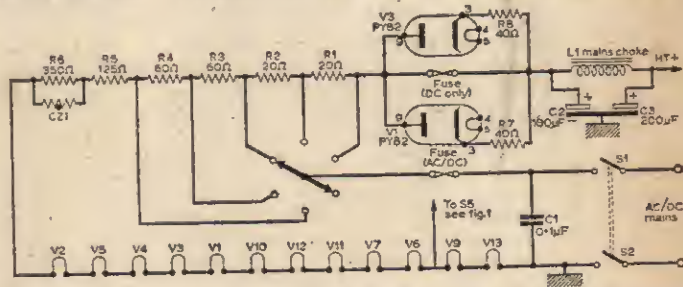

Fig. 3—Power unit circuit (Ferguson 992T). S1 and S2 ganged with brilliance control (VR2).

side of the mains, particularly if a two-pin plug is used. Indication could be given by connecting a neon bulb with one plate to the chassis and the other to a metal point on the cabinet (e.g. a screw). If the oscilloscope is incorrectly plugged in, the neon will light on earthing this point by touching.

If an isolating transformer is not used, very great care must be taken when using the oscilloscope with a.c./d.c. apparatus.

Tube Supplies

The e.h.t. is obtained as described below. The brilliance control circuit is shown in Fig. 4. Note that if the tube has been removed, the ion trap magnet will have to be reset when the tube is replaced. To do this, ensure that the arrow on the magnet is pointing to the front of the tube. With the brilliance control turned full up, slide the magnet along the neck, rotating if necessary, until a spot is obtained on the screen. Adjust for maximum brilliance and clamp the magnet (not too tightly or the tube will be under strain and likely to implode).

The brilliance control should always be turned

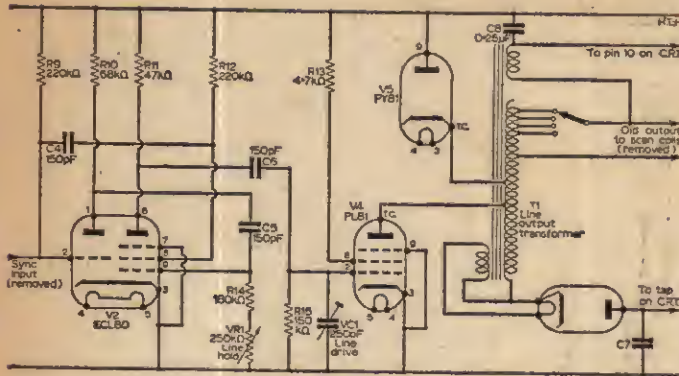

Fig. 5—(above) Modified e.h.t. generator. C7 is capacitor between inner and outer tube coatings.

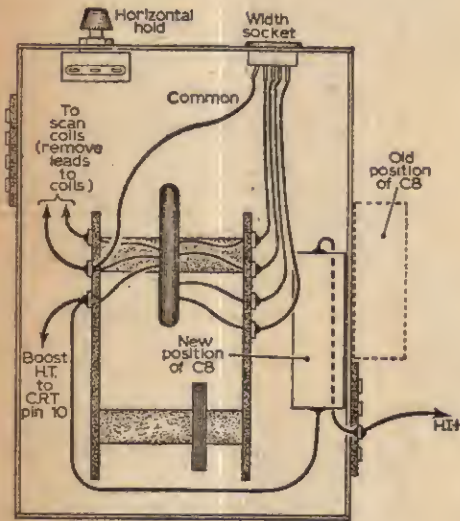
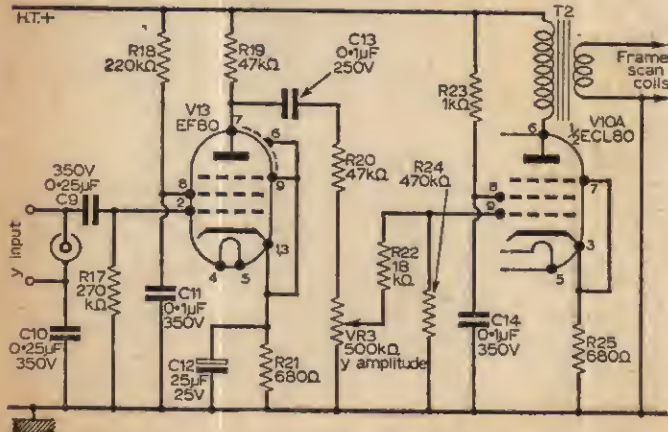

Fig. 6—(left) Line output transformer.

Fig. 7—(below) The circuit of the Y amplifier.



down as low as possible when the instrument is in use, to avoid burning the screen.

Power for the first anode is obtained from the boost voltage at the line output transformer (see Figs. 5 and 6).

Fly-back blanking is provided by connecting the c.r.t. grid (pin 10) to the screen (pin 8) of the timebase oscillator valve, V7 (see Fig. 8).

E.H.T.

The e.h.t. for the tube is obtained from the boost voltage. The circuit for the 992T is given in Fig. 5. Since this receiver uses an auto-transformer output, no load was found necessary in place of the line scan coils. In another receiver a 30Ω 10W resistor may have to be connected in place of the scan coils. A glance at the circuit will show that the width control plug must remain in position. The line-hold control now serves to put the oscillator frequency above the audible range and so reduce annoyance to the user.

A 0.25μF paper capacitor is mounted outside the e.h.t. transformer box, as shown in Fig. 6. Remove this and mount it inside the box. Taking care that it does not touch any of the connections to the l.o.p.t. Connect it as before, one end to h.t.+ on the tag-board on the outside of the transformer box, and the other to the third connector away from the valves on the left underside of the l.o.p.t. The lead from this point originally connected to the tag-board is to be used later. (See Fig. 4.) Connections from the l.o.p.t. to the scan coils (including the linearity magnet and assembly) should now be removed to leave two free leads to the coils.

Y Amplifier

The circuit of the amplifier is shown in Fig. 7. The layout is not critical except that R22 should be fixed close to pin 9 of V10, as it is a grid stopper. The output valve is the pentode half of an ECL80, the triode portion being unused. The output transformer, T2, is the field output transformer from the receiver.

Since this oscilloscope performer uses a mains connected chassis, if an isolation transformer

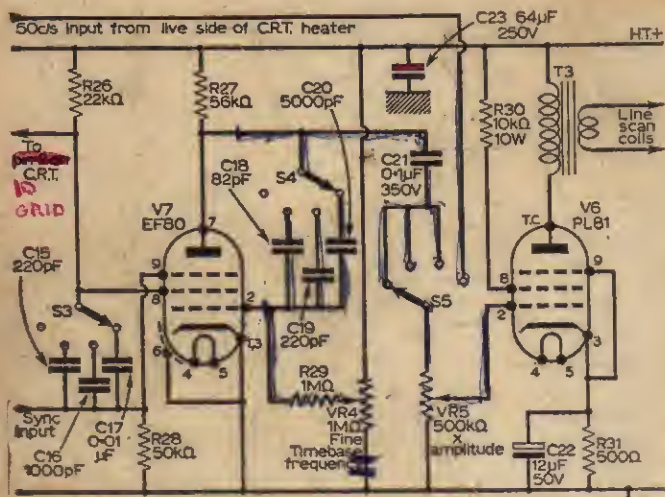

Fig. 8—The timebase circuit (standard transitron-Miller oscillator). S3, S4 and S5 are ganged.

is not employed, the capacitors C9 and C10 must be included to offer some protection to the user. The writer is by no means fully satisfied with this arrangement and, where circumstances permit, it would be desirable to use a low ratio intervalve transformer to isolate the input terminals.

Timebase

The timebase (Fig. 8) is a standard transitron-Miller oscillator as described in previous articles in this magazine (August to November 1963). Over the frequency range available, the layout is not critical. The timebase is built up on the small tuner chassis mentioned above.

The writer used a 3-pole, 4-way switch from the junk box for S3, S4 and S5. For ease in mounting the components, the rotor of a second switch wafer

withstand the high voltages expected. The line scan coils are designed for operation at high voltages with respect to chassis and need not be connected to chassis. This will remove the risk of primary-secondary sparking in the transformer. C23 was included in the circuit to remove timebase hum from the h.t. line. It should be connected as close as possible to the timebase circuitry.

Synchronisation

The transitron-Miller timebase is synchronised by positive-going pulses at the suppressor grid. Sync is obtained from the Y amplifier output (Fig. 9). This circuit was originally published in October 1963 P.T.

C24 and R32 are mounted on the Y output transformer, and a co-axial lead carries the signal to V12. R33 is a grid-stopper and is connected close to the grid (pin 2) of V12. D1 is the diode obtained from the receiver. This is normally glass-cased and the point contact can be seen. The diode should be connected with the "cat's whisker" end to chassis.

The Cabinet

Modifications to the cabinet will depend on the receiver used. The writer covered the loudspeaker grille and holes for control knobs with hardboard. A suitable hole was cut in the side for the control panel. The hole originally placed for the tuner knobs presented some problems at first, but was eventually disguised as a ventilation hole by covering with gauze! Note that if the inside of the cabinet is screened with metal foil the gauze should not touch the screening.

Finally a stout carrying handle was fitted to the top of the cabinet—an oscilloscope has to be more portable than a television set! Why not use a console model with castors?

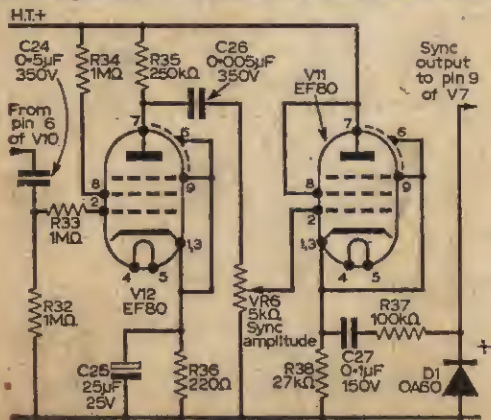

Fig. 9—Synchronising amplifier circuit.



TESTS

PART 6

By H. W. Hellyer

IF AMPLIFIERS, TUNERS AND AERIALS

MANY of the problems that can arise from faults in intermediate and radio frequency circuits of television receivers have been touched upon in the previous articles of this series. Thus far, we have been considering either the complete absence of any signal or the presence of a distorted signal. The distortion in the cases we have looked at has been caused by trouble in what the purists will kick me for calling "the display circuits". We must now turn to the two alternatives again; no signal at all, or a signal that is for some reason impaired.

Any practising television engineer will confirm that the condition of "no signal" is the easier to tackle. Some of the disturbance tests that can be made were described previously. The i.f. stages can be checked for "life" by scratching on the grid pins of successive stages, commencing at the output end, using either a neon tester or ohmmeter probe as the disturbing source. This will give interfering pulses that show as noise in the sound output and flashes on the screen that prove—to some extent—the health of the vision amplifiers.

Fortunately, the construction of the television receiver helps us to make an early diagnosis. (We are talking of the 405-line set unless otherwise stated.) Sound and vision circuits separate after the tuner, or after a common i.f. amplifier stage, and unless there are two separate faults we can go straight to the "front end" of the set to chase a "no signal" condition.

But first, we must consider the i.f. stages themselves, and imagine either poor sound or poor vision, with the output sections, detectors, etc., tested in the way described in the previous two articles.

I.F. Stages

The sound i.f. circuits do not normally give us much difficulty. Most readers will have had the experience of being able to pull in a sound signal even where a vision modulation was quite impossible on the cathode ray tube. Without going into the reasons for this, in a purely practical article, we can take advantage of the fact in our tests. One example is the condition of "no signal", with some healthy interference pulses coming through from the aerial, or the tuner (see below). By swinging the tuning beyond its normal point, it should be possible to hear the vision signal. This is not an Irishism. After all, both sound and vision are no more than electrical impulses, and the effect of tuning the vision signal through the sound i.f. band is quite unmistakable: a loud buzz. The counterpart, sound-on-vision, is also an obvious symptom; the picture quivers and may even break up entirely, in sympathy with sound impulses. Speech is the best input with which to test the set when adjusting to remove s-o-v.

There are two conditions which can cause the symptom. First, the obvious mistuning which allows the vision pass-band to encroach on the sound i.f. The answer is to retune the oscillator and regain the separation that is needed. (See Fig. 19.)

Second, maladjustment of the tuned circuits employed to reject sound frequencies from the vision amplifiers. These take many forms, and some idea of the particular circuits used is necessary before any attempt is made to retune. Very often, the tuned circuits are coupled in such a way that critical setting of one particular core should be made before the rest of the alignment procedure. Until this is done, any retuning of i.f. transformers is largely a waste of time. Because the sound channel bandwidth is relatively narrow, rejection of vision from the sound circuits is not so important, and accurate tuning is relied upon to keep the vision from the sound channel. Therefore, alignment procedure usually entails preliminary tuning of the sound circuits and the sound traps in the vision circuits before the vision channel is aligned.

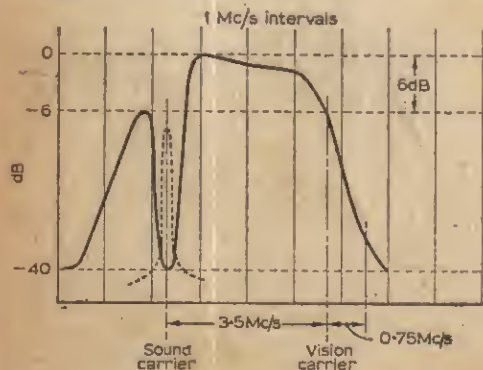

Fig. 19—Typical vision response curve of 405-line receiver. Sound carrier shown dotted, not in proportion.

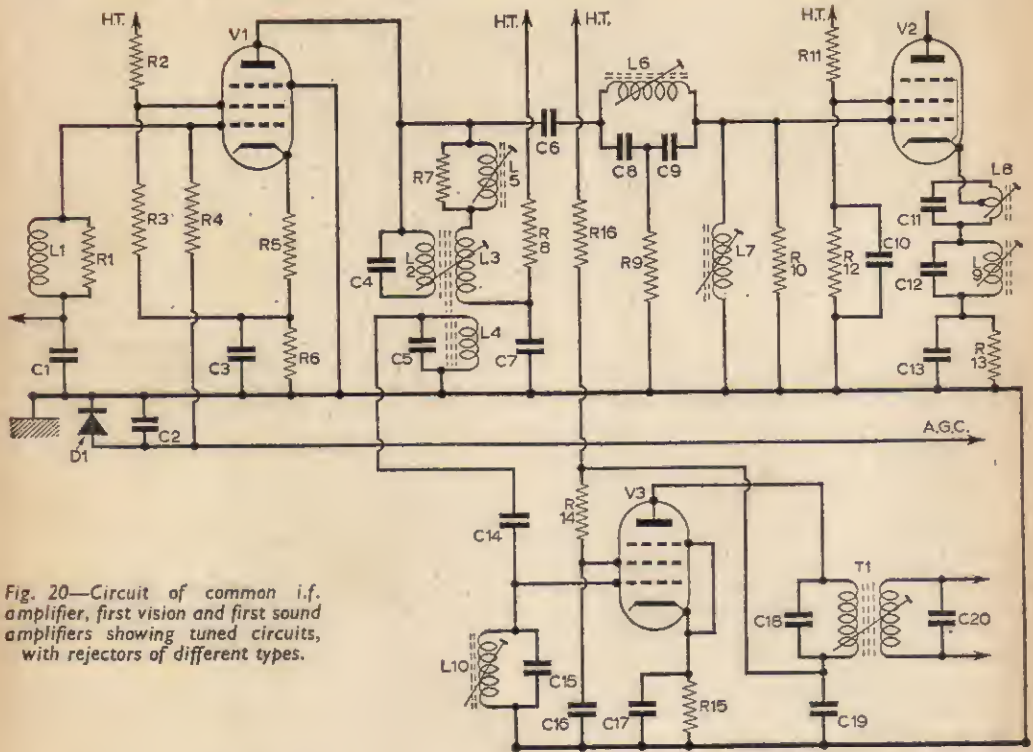

Fig. 20—Circuit of common i.f. amplifier, first vision and first sound amplifiers showing tuned circuits, with rejectors of different types.

But we are in a different position—we are making first-time tests to determine fault sources in a set that, it is presumed, has been correctly tuned. We must first check the possibility of instability or overloading which can cause somewhat similar symptoms to sound-on-vision or vision-on-sound. The first, most obvious and important test is to establish the real seat of the trouble; i.e., swing the tuning so that the oscillator is more toward the vision end of the pass-band. If the fault is s-o-v, the symptoms will diminish. They may not disappear altogether, however far we tune, especially if the cause is an open-circuited capacitor across a vision tuning circuit.

The clue to this kind of fault, causing s-o-v, is that retuning the oscillator toward the correct position, and then away from the vision channel, brings vision buzz much sooner than normal. This is because the vision channel has spread beyond its correct limits due to the flattening of the tuning. Other faults that can cause this are leaky interstage capacitors, where this form of coupling is used in addition to the i.f. transformer circuit, usually in conjunction with a rejector circuit, and leaky a.g.c. decouplers which effectively damp the grid circuit. As these problems generally have side effects, and give additional clues, patient tracing on the lines already indicated should resolve them.

Some idea of the various trap circuits that may be used can be gained from a study of Fig. 20. This is a composite circuit with V1 the common vision and

sound amplifier, V2 the first vision i.f. valve and V3 the first sound i.f. valve. The sound rejectors in this circuit are L6 and its associated "bridge-T network" between the bandpass transformer whose primary is L5 and secondary L7; and L8, C11 in the cathode circuit of the vision i.f. amplifier V2. In addition, the tuning of L2, C4 is critical for sound take-off, as is the closed-loop circuit of L4, C5 which selects the narrow sound band and passes it to L10, tuned by C15.

The other rejector circuit L9, C12 will be tuned to the adjacent channel. In a circuit of this nature, exact tuning of the various coils is essential for good response and for separation of sound and vision. Peaking-up to improve a poor signal can be a very touchy business, often resulting in good output on one channel and almost impossible vision and sound on another. A signal generator and information on the tuning procedure is needed to achieve any sort of success. This does not prevent us from making a logical series of "mistuning tests" to ensure that the circuits are actually doing their job. The method is to tune in the signal, as accurately as possible on more than one channel, preferably in Bands I and III, identify the coupling circuits and test for correct tuning. This can be done by slightly de-tuning each coil separately, noting the effect, and the amount of movement needed to produce the effect, and then returning the core to its original position. The best way of doing this is by pencilling guide marks on the coil screens, or, in the case of

hexagonal-cored slugs, making a table of the exact amount of rotation of the trimmer tool. This is an extremely laborious way of doing things, and a few minutes with a signal generator—or even less time with wobulator and oscilloscope—can produce much more effective and reliable results. However, needs must when a lack of equipment drives.

Altering the setting of slugs may not seem to make a great deal of difference. Fig. 19 shows that the vision i.f. pass-band is quite wide, and to achieve this it is necessary to stagger-tune the coupled circuits. In Fig. 20, for example, while the primary L5 may be tuned to the nominal intermediate frequency of 35Mc/s, the secondary L7 will probably be peaked at around 37Mc/s. The important thing in making these first-time tests is to recognise the general style of the circuit and consider the possible faults than can affect both the stage gain and the response.

Stage gain is most easily checked by applying a signal generator at the appropriate frequency to the output then the input of a stage, noting the attenuation required to produce the same results. But a disturbance test can also tell us something—1,000pF capacitor bypassing a stage should effectively reduce the gain by the amount of the stage gain of that stage—if it does not, attention can be focussed more keenly on that exact portion of the circuit. Static tests, voltage drop across cathode resistors, voltages at electrodes, bypassing of decouplers, etc., can also tell us much about a stage without actually referring to the maker's data. It is surprising how often a drastic alteration in conditions can be made by the simple expedient of bypassing a faulty decoupling capacitor. Instability of amplifying stages, due to open-circuited decouplers, has been mentioned before, when video stages were being considered. But just as probable as an "open" capacitor is one that is leaky or has simply changed in value. A little gentle probing with a plastic knitting needle can sometimes provoke an intermittent connection, or reveal a dry joint. Heating to the fault-inducing temperature, by close application of a soldering iron, or temporarily raising the ambient temperature by covering up the receiver, or a section of it, will reveal the heat-induced intermittent fault.

Tuner Troubles

Many of these first-time tests are largely a matter of common-sense. They are the normal stock-in-trade of the practising television engineer. Much the same thing can be said of the procedure used to locate faults in tuner units—although here, because of the higher frequencies employed, discrepancies from original design can have more alarming symptoms.

Again, considerable time can be saved by a knowledge of the kind of fault that usually occurs. The two common faults can be summarised as (1) no oscillation, and (2) low gain. Valve failure is the most likely cause, accentuated by the higher frequencies, where any deterioration in valve efficiency has a greater effect. Substitution is the first test. Valve voltages are not always a helpful guide to operating conditions—unless drastically different from those specified. But the h.t. voltages to the

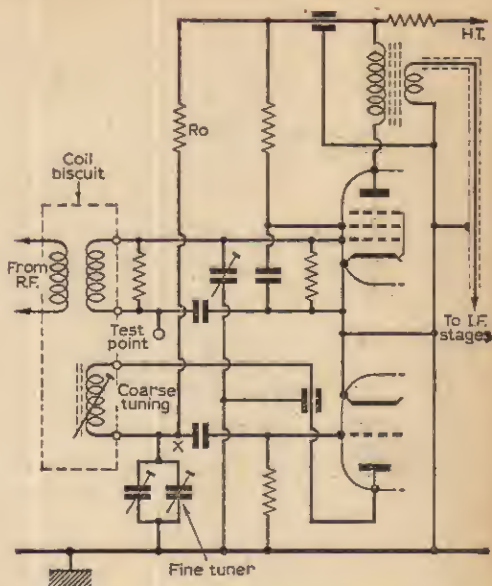

Fig. 21—Typical oscillator stage of tuner unit. Note decoupling by feed-through capacitors. The value of R_o is around $4.7k\Omega$ — $10k\Omega$ when a PCF80 is used as frequency changer.

vital points of the tuner unit should be checked. A slight drop in h.t. may be sufficient to cause oscillation to cease, or affect the signal-to-noise ratio of the amplifying sections and result in an impaired signal. In a circuit such as Fig. 21, the oscillator anode load resistor R_o , is often a 2 watt component, and where a carbon type is used overheating can cause an increase in its resistive value, and a consequent drop in anode volts, leading to loss of oscillation. Replacement should always be with a component of adequate rating, to keep the heat dissipation down. It should be mounted in as nearly as practically the same place as the original and lead-out wires should be cut as short as possible.

Testing for "no oscillation" should include a first-time test of this h.t. resistor, but it must be remembered that its failure may have been caused originally by valve breakdown, or even a short-circuited bypass capacitor. If the resistor has burned out, it would be most foolhardy to replace it without also replacing the oscillator/mixer valve, and checking for capacitor short-circuits. Another small point to note is that a capacitor can be apparently normal when tested with an ohmmeter, but may break down at its rated voltage. As the set warms up and current passes, keep the meter probe on the junction point (X in Fig. 21) and be ready to switch off if the voltage suddenly falls below the normal oscillator anode figure. A common cause of this kind of failure is a crack in the ceramic of a lead-through capacitor. In emergency, this can be substituted by a component of similar value and small size, with its insulated lead wired through the hole.

The voltage at the anode of an oscillator will

normally rise when oscillation ceases. But application of the test probe to the triode, anode or to the anode end of Ro, will kill oscillations anyway, and this test must either be made with a very high resistance meter presenting a suitable impedance to the circuit or by measuring volts drop across the resistor, which may be less convenient. The easiest way to "kill" the oscillator is to shunt the grid to chassis, and this is best done by using a 0.1- μ F capacitor between chassis and the lead-out connection of the fine tuner. Do not make a direct short-circuit as the fine tuner will often be at h.t. potential, depending on the type of circuit used.

Mechanical Faults

Most of the foregoing details have been concerned with the older type of turret tuner. There are many variations even of this basic design and several versions of the slide selector and push-button, continuous tuned unit have been produced. This is not the place to discuss the mechanical and electrical peculiarities of tuners, though any practising television engineer will confirm that they are painfully prevalent. However, it should always be kept in mind when making preliminary tests that the mechanical factors have a direct bearing on electrical efficiency. Poor contacts, erratic springs and rocker arms, loose printed circuit boards, insecure components—all these can cause intermittent or permanent loss of oscillation or poor signals.

A useful trick when a signal generator is available is to feed a spurious signal into the tuner unit at the test point, beating this with the incoming signal to produce the necessary i.f. This is general practice in radio testing but not so convenient for checking the TV receiver. A quick test of the mixer stage can be made by touching on the test point with a screwdriver blade held in the fingers. This should cause a pronounced noise signal to be heard and sometimes displayed. If the oscillator is working but far off frequency, rotating the fine tuner should alter the nature of this noise. Occasionally a spurious signal in the v.h.f. range may be picked up and Morse signals are not unusual. One or two experiments with a signal injected to the test point, which is generally in the grid circuit of the mixer section, as in Fig. 21, will soon reveal the conditions that may be expected with and without the oscillator operating.

If the oscillator is working but it is suspected that it may be at the wrong frequency it will be necessary to alter the coarse tuning. In the older types of tuner unit, and also in many of the recent versions, this is done by alteration of the position of a brass or iron-dust slug in the oscillator coil. Care must be taken when doing this as a clumsy movement of the trimming tool can wreck a coil or crack an iron-dust slug. Removing the coil biscuit is not always such an easy task and repairing a split coil former is seldom effective. Perhaps the most usual trouble is inadvertent loss of the slug by screwing it beyond the thread (or the spring wire which takes the place of a thread with many brass core types) and allowing the slug to slide deep into the former. Rather than poking from the free end or removing any other slug

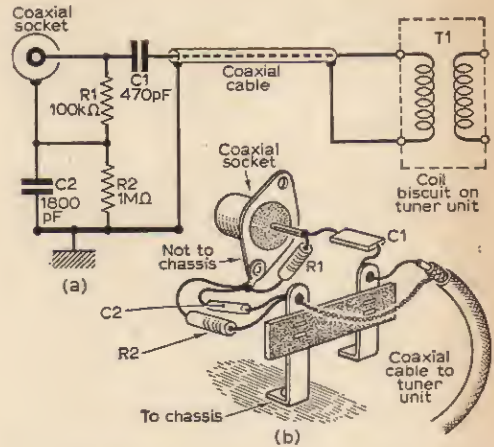

Fig. 22—Aerial input circuit. a: Theoretical and, b: Practical. Note coaxial socket skirt is not bonded to chassis.

which may be fitted in the common former, removal can be made by applying a spot of Bostik or wax from some convenient capacitor to the end of a fine-bladed screwdriver, inserting this gently until it meets the slug and as gently withdrawing. A little patience pays dividends when dealing with these mishaps.

When retuning or when tuning to locate the errant signal as a first test, remember that insertion of a brass core into the coil lowers its inductance and thus increases the resonant frequency. If two or more channels can be pulled in by coarse tuning, as is common with Band III reception in many sites, this small point can help identify them, even when both stations are transmitting an identical signal. As the sound i.f. is higher than the vision i.f. with a standard receiver the oscillator frequency will be higher than the incoming carrier. As a brass core is screwed in, first the buzz of the vision carrier will be heard, then the sound will pull in and finally the vision display should appear. Further movement inwards will tune away from the sound, through the vision, until the picture breaks up and modulation disappears altogether. With an iron-dust core insertion increases inductance and oscillator frequency and the opposite sequence applies.

This presupposes a signal reaching the mixer from the aerial via the r.f. stage or stages. Again valve weakness is the first possibility, followed by h.t. failure. Again breakdown of the feed resistor is a possibility and can be caused by a cracked feed-through capacitor or a faulty valve. The "scratch" technique can be used to trace signals through this section of the set, remembering that a good sound and vision interference signal will be obtained only when the circuits are in tune. Trace from the input connection to the tuner unit to the aerial socket and do not overlook the possibility of a short-circuit or a poor connection in the isolating network at the aerial

socket (see Fig. 22). If the set has been operated "wrong way round", with chassis live, and the aerial connection has been at any time short-circuited to chassis it is likely that one or both of the small resistors will have been damaged.

Aerial Assemblies:

Finally we come to the aerial and its feeder. Pages could be written on aerial characteristics and construction but from our point of view all that is necessary is to determine whether the aerial is providing the receiver with the required signal and, if not, why not. We are assuming at this stage that the set has previously functioned satisfactorily but has now deteriorated or given up the ghost. Continuity tests of the aerial will not be conclusive: a folded dipole will present us with an apparent short-circuit and an ordinary dipole with an apparent open-circuit. But we can test at the receiver end for short circuits by visual inspection of the plug and by separating the feeder inner and outer, inserting the inner into the centre pin of the socket and tuning the set over its known strongest channel. This should give us at least a sound signal and perhaps some degree of modulation. If this is lost when the plug is again connected and inserted we can assume that a short-circuit exists, probably at the masthead. A visual inspection of the feeder will reveal any strained or chafed sections. Danger points are sharp angles where the feeder crosses guttering or window and door ledges.

The quality of some coaxial cable leaves much to be desired and an open-circuited inner can be caused by continual flexing or a run that is too taut. In areas of fairly high signal strength the result may be a signal that varies in level and has all the symptoms of a mismatch—patterning or smearing. The quickest test is to grasp the feeder in the hand, noting any alteration in picture level or quality. A correctly matched feeder should behave as if it were not there—it is simply a link between the aerial and the set; moving it or grasping it in the way described should make no difference. If it does there is a mismatch which may be due to an open-circuited feeder, a poor aerial joint, an aerial with elements missing or a break in the circuit feeding the first stage of the receiver. In this respect the connecting cable, isolating components and primary of T1 (Fig. 22) are a continuation of the aerial feeder.

Where Band I and Band III aerials are combined in a splitter box another possibility of fault exists and further tests have to be made. If this part of the assembly is suspected disconnect the inners of the coaxial connections (see Fig. 23) and temporarily make a direct circuit of each. It needs only a damp track or a stray whisker of wire to rob the set of the few microvolts that are reaching it.

Before leaving the subject it may be as well to remind readers that aerials are by no means the everlasting erections that so many users seem to take for granted. The corrosive atmosphere in which we live attacks even the best quality aerial—and not all are of the best quality. Oxidisation of the metal, a tendency of aluminium to crystallise where clamped and rusting of steel bolts are a few

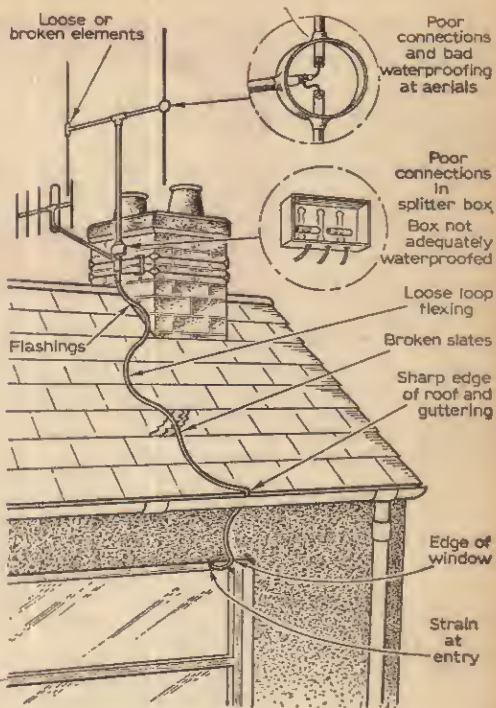

Fig. 23—Typical aerial assembly, showing danger points as discussed in text.

of the possible hazards. Loose joints caused by strain after constant wind pressure and loss of signal due to dampness within the connecting box are other prime defects. These may not come within our terms of reference as "first-time tests" but they are at least first-time suspects when the receiver has been proved to be in order.

These notes are not a comprehensive servicing guide. At all times the author has tried to bear in mind the man on his own with little more than the basic tools and the minimum of test gear. If they have provided a few ideas and pointed the way to some short cuts the series of articles will have served the purpose for which they were written.

PRACTICAL TELEVISION BINDERS

The Practical Television Easi-binder is designed to hold normally 12 issues. Please state volume number required otherwise a blank cover will be sent. The price is 11s. 6d. inclusive of postage.

Order your binder from: Binding Department, George Newnes Ltd., Tower House, Southampton Street, London, W.C.2.

Owing to an oversight, the October, November, December 1965 and January 1966 issues were classified as "Volume 15", whereas of course, Volume 16 started with the October 1965 issue.



G. R. WILDING

WHILE triodes and duo-triodes still continue to be far superior to pentodes as r.f. amplifiers on v.h.f. and u.h.f. bands, current TV design shows increasing use of these basic valves in a variety of new uses. For instance, additional to their normal employment as a.f. amplifiers and t.b. oscillators, triodes are used in modern receivers as Sync Separators, Reactance Loads, Cathode Followers, Line Sync Comparators, Field Sync Amplifiers and d.c. Amplifiers. Undoubtedly the widespread popularity of a.g.c. line circuits in the dual-standard models has done much to stimulate their use, while the need to keep circuitry as simple as possible has encouraged designers to more fully utilise the triode sections of the very many triode-pentodes available.

Sync Separators

To take the Sync Separators first. These operate in exactly the same way as the more usual pentode types, with the values of grid feed capacitor and grid leak determining the operating bias of the valve, and with this negative voltage being fed back as the mean level a.g.c. voltage to the controlled i.f. and r.f. valves.

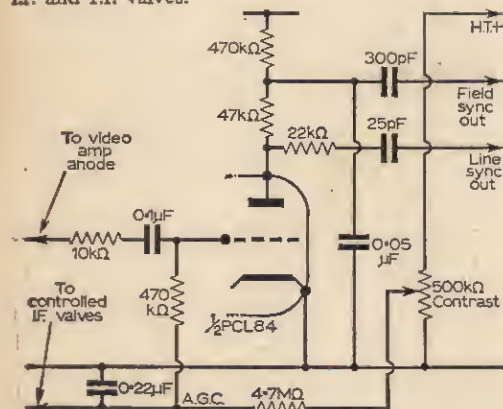

Fig. 1—Triode sync separator and mean-level a.g.c. voltage source used in many McMichael/Sobell receivers. 10kΩ grid input resistor prevents valve input capacity from loading video anode circuit and reducing definition.

Two typical arrangements are shown in Figs. 1 and 2, the former being the McMichael/Sobell system and the latter employed in many Pye/Inivicta models.

Possibly the most interesting and unusual

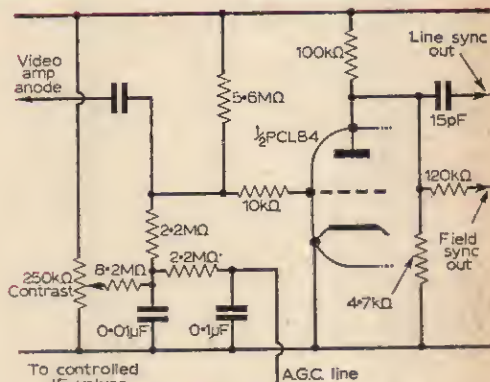

Fig. 2—Triode sync separator and a.g.c. voltage source used in many Pye/Inivicta receivers. Note slight positive bias via 5.6 MΩ resistor to the h.t. rail.

employment of a triode as a reactance valve is to be seen in the STC VC2 chassis, used in many K-B, Regentone and RGD chassises. The pentode section of a PCF802 is used as a sine wave line generator, with one winding of the transformer being in series with the h.t. supply to the screen and the other winding being shunted across the triode section. As the varying negative or positive control voltage from the discriminator is applied to the triode, its varying capacitive reactance then tunes the transformer winding up or down to maintain the correct oscillation frequency. Carefully chosen resistor and capacitor values in the anode circuit of the pentode then shapes the sine wave oscillation to the necessary saw-tooth waveform, while a 0.22μF capacity feeds the PL302 line output pentode in the conventional manner.

A completely different approach to the problem of keeping the line oscillator on frequency is used in some Ferguson/HMV/Coscor models which incorporate a quite conventional blocking transformer system. As usual the circuit is preceded by a duo-diode discriminator to provide the required oscillator control voltage, as shown in Fig. 3. One diode is fed with the line sync pulses developed by the sync separator and the other is fed with a sample of the line oscillation taken from an additional small winding on the line output transformer via an integrator. Should both voltages be equal, indicating that line frequency and sync pluses are co-incident, cancellation will occur, but if line frequency varies

ROADS MODERN TV DESIGN

above or below the sync pulse frequency, a positive or negative correction voltage will be developed to be fed back to the line generator.

This voltage will only be quite small and to ensure that it is adequate to control the valve, an additional PFC80 triode is used to boost its potential before it is fed to the grid circuit. Naturally this valve must be directly coupled and as it is handling zero frequency has no cathode by-pass capacitor.

A somewhat similar d.c. amplifier is used in some Ekco dual-standard receivers as seen in Fig. 4, but unusually the line sync pulses are fed in via a small iron-cored transformer instead of by the normal small capacitor. The output is fed as before to the grid of the blocking oscillator via a couple of high value resistors and thus swings its bias up or down if its generated frequency tends to move one way or another.

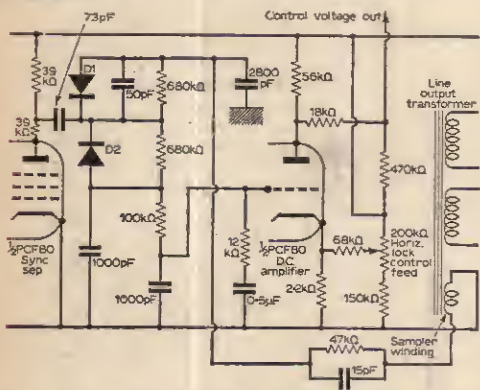

Fig. 3—Triode d.c. amplifier (Ferguson/HMV/Cassor) to amplify fly-wheel line oscillator control voltage obtained from D1/D2 discriminator before feeding to grid of line generator.

Amplified Field Sync

Although many current models incorporate these and other fly-wheel a.f.c. circuits, some makers are now including a triode to amplify the field sync pulses.

As is well known, the integrated field sync pulse train presents a far from ideal shape for positive time-base firing and in the past many designs have appeared to sharpen and/or amplify the leading edge so that triggering becomes as regular as possible. This train comprises 840μSec pulses spaced 10μSec. apart and on being fed to the inte-

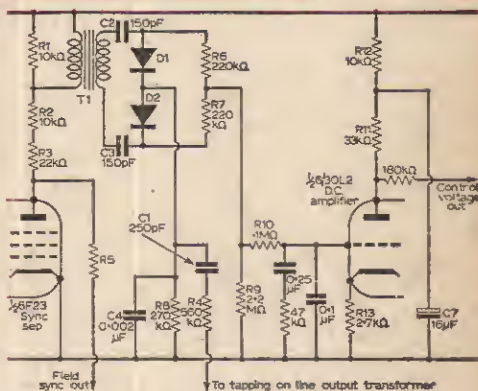

Fig. 4—Triode d.c. amplifier (Ekco, amplifies D1/D2 discriminator voltage to control line generator. Transformer T1 injects line sync pulses and C1/R4 injects line 'samples' into the circuit. When line speed is correct D1/D2 outputs cancel, otherwise a negative or positive voltage is developed.

grating capacitor produces the usual serrated edge, slowly rising waveform.

However in some current K-B and Regentone receivers, a triode both amplifies and shapes this pulse train so that the field time-base tends to fire early in its duration, when the wave-form is most nearly vertical so that succeeding frames will all fire at virtually the same spot. This ensures good interlace and complete freedom from any tendency to "jitter".

The system is shown in Fig. 5 and it will be seen that the PCL84 triode used is cathode coupled (to maintain the correct sync phase), and has its grid earthed. D.c. level is maintained by feeding the cathode via a purely resistive network from the sync separator anode, and the high value anode load resistor gives substantial gain.

Another very popular use for triodes in current TV design is as a cathode-follower linked to the normal pentode video amplifier, and a typical and classically simple example is shown in Fig. 6. As cathode-followers fail to effect any voltage amplification, in fact the output/input ratio is slightly less than unity, they would appear at first sight to serve no useful purpose. However their value lies in their



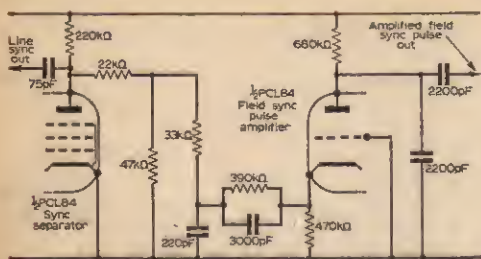

Fig. 5—Triode field sync pulse amplifier. (K-B/Regentone). By using grounded-grid arrangement phase of sync pulse is unchanged after amplification while direct cathode coupling maintains d.c. level.

ability to permit the use of much higher anode load to the pentode, thus proportionately increasing the stage gain since pentode amplification closely approximates to $G_m \times R$ load. In a cathode-follower circuit, the pentode load is shunted with only the small input capacity of the triode, whereas normally it is shunted with the cathode/heater capacity of the tube (always considerable), the input capacity of the sync separator and the wiring capacities leading up to the tube base. Being freed of these capacities enables a much higher value of load resistor to be used while preserving the overall response curve, and in the example shown, the load resistor is 10kΩ instead of the more usual 5-6kΩ employed by the pentode-only v.f. stage.

Transfer of the tube and sync separator feeds to the cathode load of the triode has relatively little effect at this point, due to the output of the cathode-follower being constant over a wide variation in cathode impedance.

Interference Suppression

In the past there have been many triode interference suppressing systems which inverted the phase of the noise pulse so that a black spot was produced by such interference instead of the more noticeable white spot. However, the introduction of negative modulation on u.h.f. transmissions which

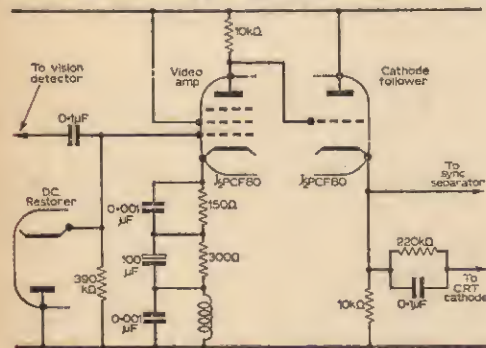

Fig. 6—Triode cathode-follower (Decca). Video stage used to free pentode anode circuit from tube and sync separator input capacities, thus permitting use of higher value anode loads and obtaining greater gain.

naturally produces such an effect, together with the need to reduce system change-over circuitry as much as possible has removed them from current designs. Practically all a.g.c. circuits today use the "mean level" negative voltage derived from the grid of the sync separator as the control voltage but in some Defiant models the a.g.c. voltage is produced and amplified by a separate triode.

The circuit is shown in Fig. 7, and it will be seen that the PCL84 triode used is cathode fed from the anode of the pentode video amplifier section. The anode is pulsed with a small voltage tapped from the line output transformer via a 0.001μF capacitor to provide conduction on the positive peaks of the waveform while MR1 gives the usual delay to the a.g.c. voltage supplied to the PCC89.

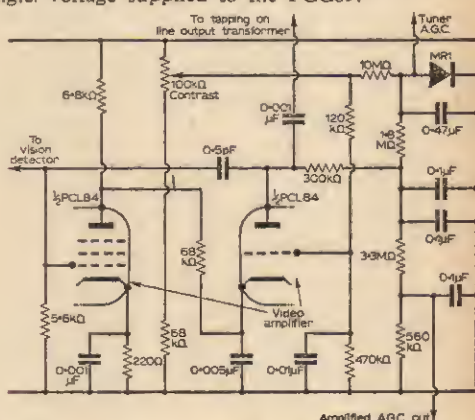

Fig. 7—Triode a.g.c. amplifier (Defiant). Amplitude of negative-going video feed to cathode and setting of 100kΩ contrast control determine amplified a.g.c. output. Anode potential of triode is obtained from positive peaks of line waveform fed in via 0.001μF capacitor from tapping on line output transformer.

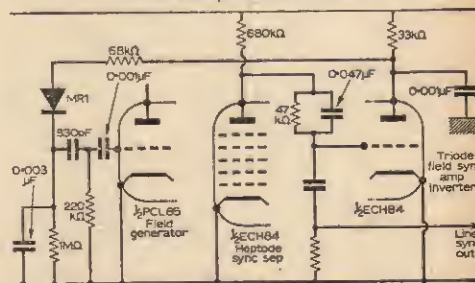

Fig. 8—Triode field sync amplifier/inverter (Defiant). To preserve the essential d.c. level, direct coupling is used throughout, grid feed producing the required 180° phase change at the anode.

In the same series of receivers there is a triode field sync pulse amplifier, but unlike other types mentioned, this one also inverts the pulse for feeding to the grid of the field multivibrator. To provide the inversion the input to the triode is via the grid with the output taken from the anode. Fig. 8 shows the arrangement and it will be seen that the d.c. level is maintained at all points by direct coupling. ■

TOWARDS BETTER TV RECEPTION

Part Two of a Series

LAST month we dealt mainly with television reception on the v.h.f. channels. We shall now concentrate a little while on the u.h.f. channels. U.h.f. television has now been going long enough in the London and Birmingham areas to allow us to get some idea of what's what. Straight away we can say that the u.h.f. signals fail to spread as far from a station as v.h.f. signals. They are also more easily screened. We knew this would happen, of course, and we know that to secure countrywide u.h.f. television many more u.h.f. transmitters will be required than the existing v.h.f. ones.

The problem is aggravated as we saw last month by the increase in noise signal as the channel number is increased. However, it was shown that the new transistor u.h.f. tuners will partly solve this problem.

Another aggravating factor is the increase in attenuation in the coaxial downlead with increase in frequency of the signal. Indeed an ordinary length of downlead may have twice the attenuation to the u.h.f. signals relative to the v.h.f. signals. This in itself means that for the best reception of BBC-2 lower-loss cable should be used from the u.h.f. aerial than that from the v.h.f. aerials. Special low-loss u.h.f. downlead is now readily available.

DOUBLE AERIAL SOCKETS

Dual-standard sets have two aerial sockets, one for the v.h.f. downlead coming from the BBC-1 and ITV-1 aerials (often via a diplexer as we saw last month) and the other for the u.h.f. downlead coming from the BBC-2 aerial. The separate socket for the BBC-2 aerial downlead is useful, for it means that extra special attention can be given to the u.h.f. aerial system without interfering with the existing v.h.f. aerials. Thus a viewer changing his old 405-line-only set for a new dual-standard model needs only to have installed a separate u.h.f. aerial system, the existing v.h.f. aerial system being used as before for the reception of the 405-line programmes.

In many BBC-2 areas it is necessary to pay detailed attention to the u.h.f. aerial system to secure reception equal to that on the v.h.f. channels. Very unsatisfactory results are obtained by the use of a makeshift or inferior u.h.f. aerial system and by failure to orientate the u.h.f. aerial

for maximum signal pick-up to give the best signal/noise performance. There are areas, however, unfortunately some quite near a station, where the u.h.f. reception is very much below the standard of that of the v.h.f. channels in spite of particular attention being paid to the u.h.f. aerial system. The general symptoms are those of excessive picture grain (i.e. poor signal/noise ratio) and weak field and line holds, especially the former.

In these locations it is often possible, where the dual-standard set features a valve u.h.f. tuner, to achieve a substantial improvement in signal/noise ratio by the use of a transistor aerial amplifier or booster as these devices are now often called.

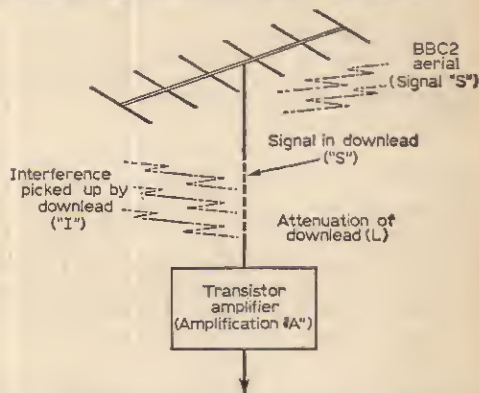

Fig. 7—With the aerial amplifier mounted at the set-end of the downlead interference picked up on the downlead is amplified along with the signal.

It will be remembered that last month we saw how transistors can improve the noise performance of a tuner over valves. The noise performance of a TV set is governed mainly by the amount of noise that the first valve in the tuner produces. The frequency changer, of course, also produces quite a bit of noise, but this is outweighed more than that of the r.f. valve since the signal applied to the frequency changer from the r.f. valve is considerably stronger than that applied to the r.f. valve from the aerial.

Theoretically, therefore, the total noise contains noise of each stage, but it can be shown mathematically that noise of each stage does, not

add directly but it adds in a square law. This article is not meant to be highly technical but the square law effect means simply that most of the noise is usually contributed by the first stage, that is the stage to which the aerial or input signal is applied.

Thus if we put a low-noise transistor amplifier in front of a valve tuner we can expect an improvement in the overall noise performance, resulting in a better signal/noise ratio. Let us suppose that we put such an amplifier at the set end of the u.h.f. downlead as shown in Fig. 7. Let us suppose also that the equivalent noise signal at the amplifier input is $3\mu\text{V}$ as against the noise signal at the input of the tuner (i.e. u.h.f. aerial terminal of the set) which, say, is $6\mu\text{V}$.

Now if the u.h.f. signal at the end of the downlead is, say, $300\mu\text{V}$, a signal/noise ratio of $300/6$ (i.e. 50 to 1) would be attained by connecting the downlead direct to the set and quite a bit of picture noise (grain) would be present. However, by connecting via the low-noise transistor amplifier the signal/noise ratio would be improved and from first principles the ratio would be $300/3$ or 100 to 1, meaning insignificant noise on the picture.

The improvement in signal/noise ratio is not so great as this simple example implies since we have failed to take into account the noise signal of the tuner. Nevertheless, even when the tuner noise is taken into account, the low-noise transistor amplifier provides a worthwhile improvement in overall noise performance.

MAST-HEAD AMPLIFICATION

It is obvious that we could secure an even better signal/noise ratio by locating the low-noise transistor amplifier at the aerial end of the downlead. This is because the downlead attenuates the aerial signal. Thus in the case of Fig. 7 the signal actually applied to the amplifier is the aerial signal S divided by the attenuation ratio of the downlead L . If L is 2 to 1 (i.e. 6dB) then the aerial signal S is twice the strength of the signal applied to the amplifier. Therefore by transferring the amplifier to the aerial end of the downlead, using the same signal values as the previous example, the amplifier receives $600\mu\text{V}$ of signal (as distinct from the $300\mu\text{V}$ of the previous example), meaning now that the signal/noise ratio at the amplifier is increased to $600/3$ or 200 to 1. Theoretically picture noise would not exist under this condition but in practice the tuner noise is added in a square law as we have seen, so the overall signal/noise ratio is not so good as the simple calculations show. Nevertheless the signal/noise ratio overall is better than what it is with the amplifier located at the set end of the downlead. Whether the possible improvement is worth the trouble of mounting the amplifier at the aerial end of the downlead depends upon the available aerial signal.

If the signal is very weak and the set particularly noisy, aerial mounting is well worth considering. On the other hand, if just a little improvement in signal/noise ratio is required, the less complicated set-end mounting will suffice.

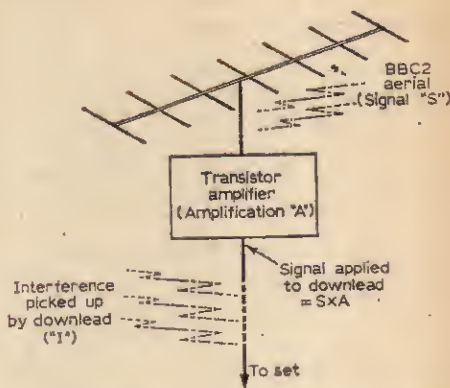

Fig. 8—Signal/noise ratio improvement is attained by mounting the amplifier close to the aerial. There is also an improvement in signal/interference ratio.

There is another aspect relating to the position of the amplifier on the downlead, which is one of interference. Referring to Fig. 7 again we see that any interference I picked up on the downlead is fed to the amplifier and amplified on arrival at the set. Thus the signal/interference ratio in this case is S/I . With S at $600\mu\text{V}$ and I at $10\mu\text{V}$ the signal/interference ratio is $600/10$ or 60 to 1. The amplifier will amplify both S and I by the same amount, so the signal/interference ratio will be the same at the input to the set.

Where the amplifier is by the aerial, however, we see that by reference to Fig. 8 any interference picked up by the downlead is not amplified. The signal/interference ratio here, therefore, is $S \times A/I$ where A is the times gain of the amplifier. If the gain, say, is four times, then the signal/interference ratio is $600 \times 4/10$, using the same signal and interference values as before. This works out to 240 to 1, which is a substantial improvement over the set-end mounted system.

In practice, though, the improvement may not be anywhere near as great as this calculation shows, for two reasons. One is that a correctly matched downlead of good quality, low-loss coaxial cable picks up considerably less interference than the aerial itself. This means that if interference is going to be picked up the aerial will pick it up in vast majority rather than the downlead. The other reason is that the u.h.f. system is not particularly troubled with ordinary impulsive interference pick-up as was explained in last month's article.

From the interference aspect it seems as though the aerial-mounted amplifier, so far as u.h.f. is concerned, shows its main advantage when the downlead may pick up a large amount of stray r.f. signal from a nearby radio station to which the aerial proper may not particularly respond. Under this condition the interfering r.f. signal induced into the downlead and applied to the amplifier may give rise to cross-modulation troubles, to which transistors are more prone than valves. This would not happen to such a great degree with the

amplifier mounted close to the aerial with little length of cable between its input and the aerial. So much then for the positioning of a low-noise transistor u.h.f. amplifier. But what about powering?

Amplifiers designed for set-end application are often self-powered from a small internal battery. Provided the amplifier is switched off when the set is switched off the battery has several months of useful life, since the transistor requires only about 1mA to work it properly. Set-end amplifiers are also being designed with a small, internal mains power supply. These are more expensive than the battery models, of course, but once they are connected they can be left. Some makes have a special type of mains transformer with a current primary winding. This winding is simply connected in series with the mains lead of the set so that when the set is switched the amplifier is simultaneously switched (see Fig. 9).

Amplifiers designed for aerial mounting are in waterproof cases and are powered from the set end of the downlead through the coaxial downlead. The downlead is filtered in such a way that the signal comes down from the aerial amplifier to the set and from a small power unit, mains or battery operated, the current for the transistor is sent up the downlead. This method of powering has been dealt with in past issues of *Practical Television* and will not be further investigated in this series.

To sum up then it seems as though better BBC-2 reception is possible in weak and screened signal areas by taking advantage of the low-noise feature of a transistor and mounting an amplifier containing such a transistor either near the set or near the aerial, depending upon the prevailing conditions. It is essential nevertheless always to ensure that the u.h.f. aerial is sited and orientated for the best possible signal pick-up unaided.

What has been said about u.h.f. signal boost applies also to the v.h.f. channels and set-end and aerial amplifiers are available for the v.h.f. channels in Bands I and III. Let us now see what special precautions should be taken with regard to siting and adjustment of the u.h.f. aerial.

U.H.F. AERIAL SYSTEM

The trend is—and always will be—that the u.h.f. aerial system is installed as a secondary item to the existing v.h.f. aerial system. This is really bad, for it implies—and generally means—that the best site is already taken by the v.h.f. aerial system and that the u.h.f. aerial has to take second place. This is one of the reasons for poor BBC-2 reception in some areas, even those reasonably close to the station.

One often finds the u.h.f. aerial mounted well below the v.h.f. aerials on a common mast as shown in Fig. 10. While this arrangement picks up some sort of u.h.f. signal one is greatly inhibited in that the aerial is below the maximum available height and that it is close to the large chunks of v.h.f. metalwork. It nevertheless has the advantage that the u.h.f. aerial is easily added simply by clamping it on the existing pole.

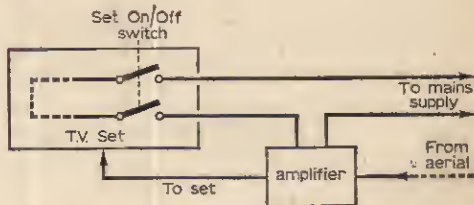

Fig. 9—A mains-powered transistor amplifier can be controlled by the set's on/off switch if the mains transformer in the amplifier has a "current" winding.

If at all possible it is far better to mount the u.h.f. aerial on a pole of its own clear of metalwork and the existing v.h.f. aerials. U.h.f. aerials are susceptible to other bits of metal nearby, the metal absorbing signal from the u.h.f. aerial, and as they are generally far more directional than the existing v.h.f. aerials a simple method should be available to permit accurate orientation on the signal. This is not easily possible when the aerial is clamped on the pole of an existing aerial system as shown in Fig. 10.

If there is not room for both v.h.f. and u.h.f. aerials on the chimney stack or other mounting the possibility of bringing the v.h.f. aerials into the attic should be investigated so as to give clear outside space for the much more critical u.h.f. aerial.

When the u.h.f. aerial is mounted on the top of a mast or pole it should be remembered that the narrow beam width of a directional array can result in serious picture flutter effects due to wobbling of the aerial system in the wind. This is aggravated by a tall, slender pole which is made top-heavy by the aerial. The solution to this problem is to ensure that the mast or pole is of adequate diameter and rigidity to remain stable in relation to the weight and size of the aerial under reasonably windy conditions. Excessive wobble and the resulting picture flutter can prove more disconcerting than a noisy picture resulting from a mounting such as that in Fig. 10. Where a really

lofty u.h.f. aerial system is demanded the mast or pole should be stabilised by the use of support wires.

The type of aerial array required for good reception will depend upon the very local signal strength conditions. Unfortunately at u.h.f. it is not sufficient to em-

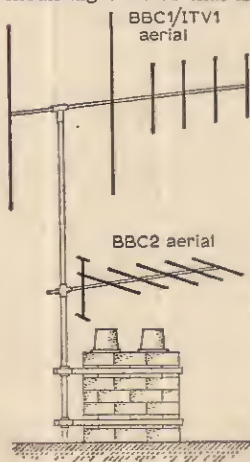

Fig. 10—The u.h.f. aerial is very often mounted below the v.h.f. aerials, as this diagram shows. The text reveals why this is not always the best position for the aerial.

ploy an aerial similar to that used by a near neighbour, even though the neighbouring u.h.f. viewer may be getting good receptions. This is because the signal field can rise and fall extremely unpredictably in built-up areas, meaning that at one roof the signal may be at peak while at the next roof the signal may be at a very low level in a "trough". Probing around the roof area for the best signal is required in many cases to change a poor BBC-2 picture to equal the strength and quality of that of BBC-1, especially in built-up areas towards the inner fringe of the station.

On the other hand, one may be placed in a zone of very strong BBC-2 signal. In this case a simple attic or outdoor aerial serves quite well, and in very good reception areas a simple set-top u.h.f. aerial may be all that is required for good, noise-free pictures, depending upon the noise performance of the u.h.f. tuner.

CURIOUS EFFECT

Normally, though, it is the other way round, the BBC-2 picture being in trouble. One case recently investigated by the author showed a very noisy—barely viewable—BBC-2 picture with the u.h.f. aerial plugged into the set, while with the aerial removed the BBC-2 picture was far better! It was eventually discovered that the v.h.f. aerial system as well as the u.h.f. aerial was picking up BBC-2 signal and that due to some intercoupling between the two input signals the signal in one aerial was partially cancelling the signal in the other. Hence the improvement with the u.h.f. aerial disconnected. Similar effects can occur should the u.h.f. downlead pick up excessive signal as well as the aerial itself. This latter can happen due to bad matching at either the u.h.f. aerial or u.h.f. tuner. Ensure that the downlead is of the best quality and that no fault can be found at the aerial and aerial plug connections. If the BBC-2 picture is extremely noisy in spite of the set being supplied with a fairly strong signal have the dealer replace the u.h.f. tuner, for this is probably where the trouble lies, especially if the same aerial works a friend's or neighbour's set without undue noise.

Part 3 follows next month

PRACTICAL WIRELESS MARCH

★ SIMPLE PROXIMITY ALARM

For use as a house burglar alarm. Built-in protection prevents alarm sounding when occupier returns to premises.

★ MOBILE TRANSMITTER

Solid state mobile transmitter. Complete with self-contained modulator to provide 10W fully modulated on 160m "ham" band.

★ SWITCH TUNED SUPERHET

Modern circuitry using miniature range valves. Push-button station selection avoids band-hunting.

On Sale 3rd February Price 2/-

NEXT MONTH IN Practical TELEVISION

INTEGRATED TUNERS

Recent developments have brought about many changes in "front end" TV design. This article deals with the latest "all band" transistor tuners now being fitted to some current dual standard receivers.

SOUND CHANNEL PROBLEMS

Television audio troubles discussed, with particular emphasis on noise and/or impulse limiters.

FAULTY RESISTORS

Examines the effects of faulty carbon, wire-wound and variable resistors in TV receivers.

ALSO:

Meet the Setmakers; Towards Better TV Reception; Servicing Television Receivers; DX-TV; and a wide range of other features.

Practical TELEVISION

Order Your Copy on the Form Below

(Name of Newsagent)

To _____

Please reserve/deliver the March issue of
PRACTICAL TELEVISION (2/-), on sale
February 24th, and continue until further notice.

Name _____

Address _____

by Charles Rafarel

DX-TV

TV DX-ers are often asked by the layman: "What is DX-TV?" And at the moment many of us are asking ourselves the same question! It must have been a pleasant dream of spring and early summer!

But before you are tempted to lower that 40ft aerial array to see if the coaxial feeder is still connected consider that in all the years I have been DX-ing, conditions for both Sporadic E and Tropospheric propagation have never, never been so poor as between mid-November to mid-December, and only in the last day or so Tropospheric reception has improved a little.

The expected reduction in Sporadic E signals is normally offset by a marked improvement in Tropospheric ones. This year Tropospheric openings came in very early (mid-September) but did not stay. Continual waves of atmospheric depression, coupled with high winds and snow in some parts of the country, have made the Tropospheric take an unprecedented "hammering". I hope that by the time that you read these words things have improved.

CONDITIONS

Period 20/11/65-15/12/65, Sporadic E: There have been a number of very short duration openings at about 0830 GMT from East Europe, USSR and Czechoslovakia, but that is all.

During the present DX "lull" I would like to crave the indulgence of established DX-ers and try and clear up one or two problems of would-be DX-ers and beginners. We have had lots of letters asking what it is all about and for the benefit of newcomers here is a brief summary.

Briefly there are three types of propagation which apply under suitable atmospheric conditions and enable us to receive TV signals at great distances.

(1) "Sporadic E" reception (possible between 500-2,000 miles) is due to reflection of the receivable signal from ionised clouds floating in the upper atmosphere. Signals are often very strong but often suffer from rapid fading and changes of "skip-distance", i.e. reception of USSR can fade out and be replaced by a signal from, say, Poland at a shorter distance.

This type of propagation usually occurs during the period May to September, particularly during periods of unsettled weather, but it can occur at times throughout the year.

(2) "Tropospheric" propagation is possible from anything up to 800 miles and is due to

refraction (i.e. the bending of the signal to more nearly follow the earth's curvature instead of leaving tangentially at the horizon).

Still air with layers at different temperatures are needed for this refraction and the received signals are steadier than those received via Sporadic E and are usually of longer duration. These conditions can occur throughout the year but are usually best in autumn and early winter and particularly during fog.

(3) F2 Layer reflections only occur at or near sunspot maximum (i.e. 1967-68) but offer the possibility of reception at very great distances up to as far as 12,000 miles.

Receivers. Continental TV standards differ from British but most British TV sets can be converted with varying degrees of success for Continental reception. Write to me giving details of your present set and we will advise you as to its possible conversion. We will also be pleased to answer any specific questions that anyone wishes to raise on DX-TV principles and techniques.

NEWS

Two items of news received here via ORTF French TV:

(1) Toulouse Pic du Midi, Ch.21, is now in service. Power is 2,000kW, the greatest in France. This station has the highest altitude in Europe and the largest service area, so in spite of the distance it may well be a "possible".

(2) Rennes St. Pern, Ch.45, 1,000kW, goes into service at the end of 1965 or at the latest in January, 1966. Southern DX-ers please note.

Frank Smales (Pontefract) has had some excellent reception, including the following (channels in brackets): U.H.F., Munster (21), Wuppertal (22), Aachen (24), Dortmund (25), Niebull (60) for West Germany; Lille (27), Bourges (26) for France; Lopik (27) for Holland; plus several unidentified stations. Band III, Sonderjaelland (E7), Denmark; Bergen (E9), Norway; Heidelberg (E7), Donnersberg (E10) and Bamberg (E11) for West Germany; Bourges (F9) and Le Havre (F7 very low power) for France.

D. Boniface (Ripon) is back again with new successes: Sonderjaelland (E7), Sydjaelland (E6) and Westjaelland (E10) for Denmark; Smilde (E6), Holland; Bergen (E9), Norway; Goteborg (E9) and Borlange (E10) for Sweden; Cologne (E11), West Germany; Brest (F8), Lille (F8a) and Cherbourg (F12) for France; plus Wavre (E10), Belgium.

E. Baker (Whitley Bay) reports good reception from RAI, Chs. IA, and IB, Udliberg (E3), Switzerland; Kreuzberg (E3), West Germany; Stockholm (E4), Sweden; Warsaw (R2), Poland; and Bremen (E2) as a Tropospheric West German. He has also had Markelo (E7), Holland, and Vestjaelland (E10), Denmark, and he is making a start on u.h.f.

DATA PANEL-6

SOVIET TV



Test Card: As photo except that the word "МОСКВА" 1; is now omitted. Channels R1 and R2 are often well received here, and at times reception is also possible on Channels R3 and R4 in Band II.

Stations: Since the same Test Card is used by all stations, precise station identification is not possible from the Test Card, but if a station name is seen before the start of a regional programme this can probably be taken as a means of identification. Note that these names are in Russian script, so if in doubt copy what you see and send it to us for deciphering. The "likely" stations for reception here are:

- Ch. R1. Moscow, Minsk, Leningrad, and Lvov.
- Ch. R2. Tallin, and Kiev.
- Ch. R3. Kharkov.
- Ch. R4. Kaliningrad or Vilnius.

Programme Times: Test Card. Weekdays (except Monday) 08.00 to 14.00 G.M.T.

Sundays 11.00 to 14.00 G.M.T.

Programmes. Weekdays 15.00 to 22.00 G.M.T.

Sundays 11.00 to 22.00 G.M.T. except for test card as above.

These details, which are official, are given by courtesy of the Soviet TV Authority.

SOMETHING FOR EVERYONE IN PRACTICAL ELECTRONICS

PORTABLE RATEMETER
COMPACT POWER UNIT
VIBRATO UNIT

plus
RADIO CONTROL OF MODELS

FEBRUARY ISSUE
Now on Sale Price 2/6

PRACTICAL WIRELESS AND TELEVISION FILMSHOW

LAST CHANCE FOR FREE FILMSHOW TICKETS!

The date of the Filmshow is 4th February, 1966, and it is to be held at Caxton Hall, Caxton Street, Westminster, London, S.W.1, starting at 7.30 p.m. sharp.

The films to be shown are "Electromagnetic Waves, Part 2" and "Thin Film Microcircuits". The illustrated talk will be on "Transistor Topics", and will be given by Mr. Ian Nicholson of Mullard Ltd. In the chair will be Mr. W. N. Stevens, Editor of "Practical Wireless" and "Practical Television".

Refreshments will be provided during the interval. Applications for free tickets should be made to FILMSHOW, "Practical Wireless", Tower House, Southampton Street, London, W.C.2 and NOT to Caxton Hall. A stamped addressed envelope must be enclosed.

FIELD CIRCUITS ANALYSED

It is regretted that due to circumstances beyond our control, Field Circuits Analysed has had to be held over until next month.

SECAM

FOR COLOUR VIDEOTAPES

Although it seems likely that the broadcast system to be adopted in the UK will be PAL, there is a strong possibility that SECAM will be used extensively as a system for videotapes.

by K. T. WILSON

CONSIDERING the controversy which presently rages about the respective merits of the NTSC and SECAM colour TV systems, two recent advances in the use of the SECAM signal have received rather less attention than they should. In USA, the CBS television network announced that they intended to buy several SECAM translators to convert NTSC signals to SECAM for tape recording purposes and back again for re-broadcasting. The Japanese Broadcasting Corporation also announced that, following on a programme of research into the SECAM type of signal which had begun in 1957, it intended to use the SECAM signal internally in broadcasting stations, although, of course, the transmitted signal would continue at the moment to use the NTSC signal.

These decisions have probably done more to advance the "cause" of SECAM than the much-publicised meeting at Vienna, for the major "political" reason for this country's strong allegiance to the NTSC system is that so many of our programmes are of American origin; we exchange more taped material with the USA than with any other country. This argument falls a little flat if the USA tapes happen to be recorded on the SECAM system.

Transmitting Standards

On the face of it, any switch of *transmitting* standards from NTSC to SECAM either in the USA or in Japan seems a little unlikely, yet we must not forget that, even in this boom year for colour TV, the size of audience which would have to change from NTSC to SECAM is smaller than the audience which the BBC expected to change to 625 lines, and the compulsions to change would be very much greater, even if NTSC and SECAM transmissions could be run simultaneously for some time. Let it not be forgotten that the USA has on one previous occasion started a colour TV service and then scrapped it in favour of a better system.

What is it, however, about tape recording colour TV which makes the use of the SECAM system so attractive? To answer this we must examine both the NTSC and the SECAM systems in detail and decide what limitations their use would impose on a videotape recorder.

Videotape

A typical videotape recorder, the Ampex, uses a tape speed of 15 inches per second. There are four video heads arranged so as to scan across the tape. The drum carrying these heads is about two inches in diameter and rotates at a speed of 240 in./sec. (14,400 r.p.m.) across the tape. The head-to-tape speed is therefore about 500 in./sec. We have two speeds to keep constant in this arrangement; the tape speed and the head speed. For monochrome television it is sufficient that these speeds be kept steady to within 0.05%, which is quite a formidable requirement. For colour the requirements are very much more stringent. The American standards for the NTSC signal specify that the frequency of the subcarrier should be maintained within $\pm 0.0003\%$ with a maximum rate of change which must not exceed 0.1 cycles-per-second per second. Also, to prevent detectable shifts in hue, the phase of the subcarrier should not shift more than five degrees from the beginning of one picture line to the beginning of the next. The stability figure which has been given as suitable for monochrome would amount to a phase error which could be as large as 72° , and no smaller than 36° at the frequency of the subcarrier used in the 525 line system. To record the NTSC signal satisfactorily therefore requires a reduction of tape position errors of about fourteen times.

Head Response

In addition to this, errors will arise due to the slightly differing response of each of the four heads. If each head has a different response at the subcarrier frequency, then stripes with different degrees of colour saturation appear on the picture. If the responses are even allowed to differ near cutoff, the resulting phase distortion causes colour banding.

The contact between the tape and the head is also more critical. In monochrome use, such variation causes the cutoff frequency to jitter, and hence the phase of high frequency signals jitters; this is of very little importance in monochrome work. In colour, this jitter affects the phase of the subcarrier and thus the hue is distorted at various positions of the scan.

Every one of these objections can be overcome

by the use of more sophisticated recording techniques, as used in the latest Ampex Colour Videotapes, which are an object lesson in precision engineering, both mechanical and electrical. The rotational stability of the tape and heads is ensured by using servo-feedback techniques, comparing the recorded subcarrier against a highly stable locally-generated source. The mechanical requirements for the servo-motors are very strict; fortunately the need for such motors in other fields has made them available. The heads are specially selected for characteristics as near identical as is possible, and their outputs are passed into equalising circuits to make the residual differences even less. The tape is kept in perfect contact with the head by such methods as blowing compressed air on the opposite side of the tape or by having a large number of small holes drilled through the heads and using a vacuum to retain the tape to the heads.

Such refined methods cost money, and this is precisely the reason which makes the use of the SECAM signal for videotape recording so attractive. The SECAM system, instead of modulating the subcarrier in amplitude and phase simultaneously with both colour difference signals, uses only one colour difference signal at a time, frequency modulated on to the subcarrier. At the receiver, both colour difference signals are reconstituted by combining the direct received signal with the signal received exactly one line ago which has been passed through a delay line. Since the hue of the received picture is no longer critically dependent on the phase of the subcarrier, and since the amplitude of the subcarrier is of little importance, it might be expected that tape recording of the SECAM signal would be very much easier than recording the NTSC signal. This is indeed the case; so much easier, in fact, that a normal monochrome videotape machine is quite adequate. Let us examine the advantages of the SECAM signal in detail.

When the SECAM signal is fed into a system with a poor high frequency response, the monochrome part of the signal shows the usual deterioration in resolution. However, since the colour subcarrier is frequency modulated and its amplitude limited at the receiver, no chromaticity change should be observable unless the attenuation of the signal becomes very severe. In fact a change in amplitude of some 20dB is hardly noticeable. This is strikingly superior to the behaviour of the NTSC signal in similar circumstances.

We have already seen what tolerance must be placed on tape speed fluctuations to record NTSC signals with some degree of success, a figure of 0.004% will be taken as representative of the stability achieved (compare this with the quoted figures for domestic tape recorders of around 1% at a tape speed of $7\frac{1}{2}$ in/sec.).

SECAM Superiority

To illustrate the superiority of the SECAM signal in this respect, consider the effect of a variation in speed of 0.1%. In the SECAM signal being used by the Japanese Broadcasting Corporation, the subcarrier is at the NTSC American Standard frequency of 3.5Mc/s. If the speed of the tape changes by 0.1% then the frequency of the sub-

carrier will also change by 0.1%, which is a deviation of 3.5Kc/s. Since the maximum peak-to-peak deviation of the subcarrier in this system is 1Mc/s, the unwanted signal is 47dB down on peak Chroma signal and the colour shift is negligible. As far as the differences from one head to another are concerned, these differences have as little effect on the SECAM signal as any other small amplitude changes, that is negligible.

Granted that there are considerable technical advantages in the use of SECAM for videotape recording of colour television, is the conversion worth while economically? The answer to this question must be an unqualified "Yes"; otherwise the very cost-conscious American TV networks would never consider the idea. Every TV station has, of necessity, at least one monochrome videotape recorder; many stations will have a large number. To scrap or convert *each* of these or even a fraction of them, to colour use will involve the expenditure of some \$50,000. For a station with several videotape machines, this sum would buy a suitable converter for NTSC to SECAM and back and leave a handsome amount left over for general improvements. For the single videotape station (which would hardly be in the market for colour anyhow) the saving would not be so impressive at once, but the long-term saving of using a well-tryed, "rugged" type of monochrome videotape instead of the delicate and rather short-lived colour videotape would make it well worth while.

Signal Conversion

Lastly a brief look at the methods used for signal conversion. Starting with the NTSC signal, part of the signal is passed through a low-pass-filter, and in this part an index pulse is inserted. This index pulse indicates at the reconverter the order of the colour difference sequential signals. The rest of the signal, the portion containing the subcarrier, is fed through a band-pass-filter to a synchronous detector which changes its reference phase by 90° each line. This detector therefore detects the colour difference signals alternately, and these signals are then frequency modulated on to a subcarrier which is then added to the monochrome signal to give the complete SECAM signal for recording.

The reverse conversion is more complex. The monochrome signal is again split off by a low-pass filter. The Chroma signal, after passing through a band-pass filter, is changed in frequency so that the one-line delay may be carried out on a conveniently high frequency for a quartz crystal delay line. The frequency used in the Japanese system is 30Mc/s. The frequency-modulated 30Mc/s signal is passed through an amplitude limiter and into the one-line delay circuit. Two identical gating circuits accept the signals from both the amplitude limiter directly and from the delay line. As the gates are opened and closed by pulses which are exactly in phase opposition, each gate passes only one colour-difference signal, and these signals are demodulated (remember that they exist at this stage as frequency modulated 30Mc/s signals) separately and added to each other and to the monochrome signal in a final mixer to give the NTSC composite signal. ■

Servicing TELEVISION Receivers

No. 121 The Bush TV99

by L. Lawry-Johns

THE TV99 is a 21in. table model intended for use in service areas. The TV99c is the console version. There are many similar models in the 17in. range, some having "fringe" specification with a more complicated circuit. Much of the material of this article can be used in conjunction with these models, particularly in respect of the tuner unit and time bases, mechanical handling etc. First introduced in 1959 this range was continued well into the next year with various modifications and differences in layout and cabinet presentation.

Handling

The chassis, tube, etc., is conveniently removed in one piece except for the loudspeaker as in earlier designs and no trouble should be experienced in removing and replacing. There are one or two points to watch however, and the following notes may help to avoid some pitfalls.

In the first place use a flat soft surface on which to work. Remove the rear cover of the receiver. Turn it on its side and remove the small front bottom cover. This exposes the two screws which secure the front panel. Slacken these screws but don't take them out. Withdraw the panel. Unscrew the four chassis retaining screws. Turn the receiver up and remove the nuts of the plates at the two upper corners. Remove the loudspeaker leads from the upper left audio output transformer. The chassis can now be withdrawn but it may be stuck at the front to the mask. Use a little care at this point gradually exerting the necessary pull to allow the "unsticking" process to go all round as it will, given time.

Most servicing can be carried out without any further stripping down but it is sometimes necessary to remove the tube.

Tube Removal

Remove the tube base socket and the deflection coils plugs (P102 & P103) from their sockets. Loosen the clamp screw and carefully ease the assembly from the tube neck. The linearity sleeve should come off without trouble but make sure that this is not damaged and that it goes back exactly as found. Movement in and out of the deflection coil varies the width and linearity and its proper positioning is essential. Next unclip the e.h.t. connector from the side of the tube—observing the usual precautions—and slacken the clamp band enough to allow the c.r.t. to be withdrawn from the assembly. Do not handle the tube by the neck at all.

The Left Side I.F. Unit

It is rarely necessary to remove this unit completely. The two screws on the right side of this unit, when released, allow the unit to be swung open and the components inspected and replaced if necessary. The two screws on the left should only be loosened, not removed.

Some Common Faults—the Tuner

One of the most common troubles encountered is poor contact and inconsistent push button selector. It is not sufficient to clean and lubricate the actual contact surfaces as quite a lot of the trouble can be due to the spindles not travelling freely when the buttons are pressed. The spindles should be lubricated to ensure free movement and to ensure the same amount of travel each time the buttons are depressed. This can be done quite easily but, of course, the lid of the tuner must be pulled off to gain access to the switch contacts. Now there is one trouble which can be a little awkward to locate in this and other types of tuner more recently encountered. The symptoms can cause a little head scratching particularly on some receivers (not these) where the tuner unit is not so accessible. The symptoms can be loss of one channel or the other completely, leaving the other very weak with poor sound. Of course, the tuner unit valves and the common i.f. stages must first be checked, but if this produces no result a voltage check on the frequency changer valve base may well reveal absence of response at C2. In the case of a PCF80

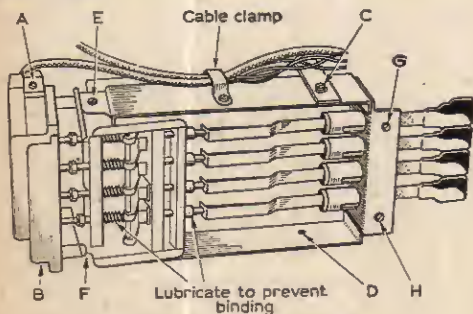

Fig. 1—Tuner mechanism details.

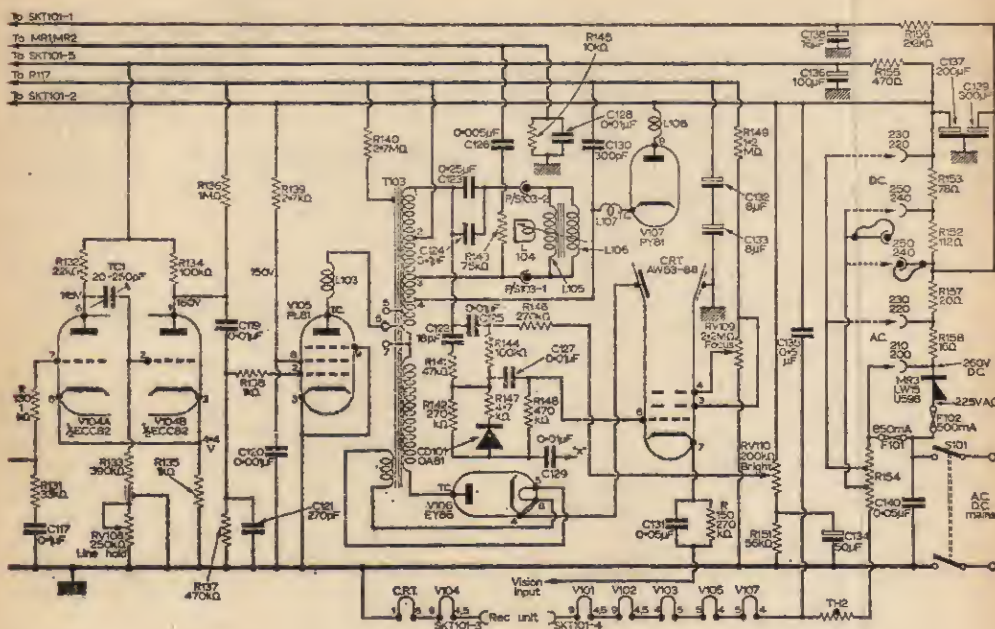

Fig. 2—Circuit of the main chassis.

this is pin 3. The feed resistor will be found defective. Whilst this could be caused by a shorted decoupling capacitor to chassis this is not often the case, and a replacement resistor is usually all that is required. The replacement should occupy the same position as the original in order to avoid detuning or instability. It is emphasised that in most cases such a fault is due to a defective aerial or connection, a faulty valve, improper tuning or

switch contact. Note that the r.f. amplifier V201 is a 30L15. The use of a PCC84 in this position will result in loss of gain.

No H.T.

A fault which will almost certainly be encountered with these receivers is absence of h.t. although all valves light normally—except the EY86 which is not easily seen anyway. This could,

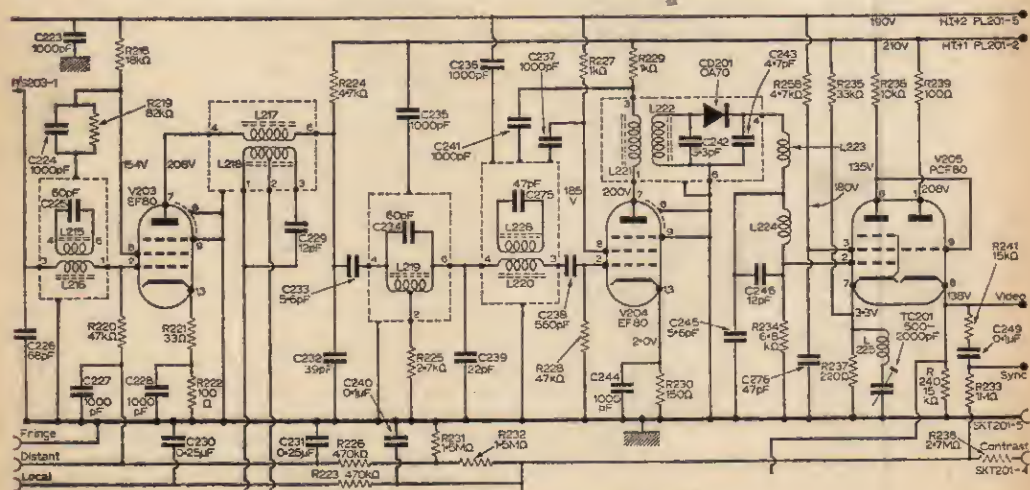

Fig. 3—Vision and sound i.f. strip.

of course, be due to an open circuit fuse F102 which is in the supply to the LW15 metal rectifier. If, however, the fuse is intact and a.c. is found at the rectifier, the cause of the trouble will almost certainly be found behind the voltage selector panel where a number of resistors are wired. A clue as to which is at fault can be obtained by taking a d.c. voltage reading at the output end of the rectifier. If this voltage is very low R157 or R158 will be found at fault as an open circuit here prevents the resistor capacitor C139 being used. If, however the output is high, say over 260V, one of the higher value resistors in the smoothing circuit will be found at fault, say R152 or R153. A quick test is to short each across in turn to see which restores near normal conditions. A better method is to leave the set switched off and check each resistor with an ohmmeter. The circuit shows which resistor is connected across which tags and no trouble should be experienced in obtaining the correct value if it is no longer discernible on the resistor itself.

Failing Rectifier

After a period of use the rectifier tends to deteriorate leading to low voltage output. This results in a small picture. The d.c. output of the rectifier should be some 20—30V more than the a.c. input. If the output is low the rectifier should be changed, using, if desired, a silicon diode in series with a 15Ω wire wound resistor. These two items can be wired between the end plates of the rectifier leaving

this connected. Remember that the resistor will run quite warm and the connection must be made with this in mind, leaving plenty of room between the diode and the resistor. Before leaving the subject of the h.t. supply a word about the fuse itself (F102) will not be out of order. This must be of the anti-surge type as the current passing at the moment of switch on is quite high due to the charging of the reservoir capacitor.

Dark Picture

Sometimes it is found that the brilliance has to be fully advanced before any sort of picture is resolved. Then it overcontrasted only the highlights being visible. A voltage check at pin 3 of the c.r.t. base may show the first anode voltage to be low even taking into consideration the shunting effect of the meter. A glance at the circuit shows that pin 3 is fed from the junction of R149 and RV109. The voltage at pin 3 therefore depends upon the relative values of these two resistors. R149 is not likely to change and will invariably be found at its correct 1.2MΩ. However, RV109 is the 2MΩ focus element and this does tend to fall in value taking the first anode voltage down with it. A quick check is to disconnect one end of the focus element and wire a 2.2MΩ resistor in its place. The focus control is not absolutely essential and pin 4 (focus electrode) can be fed from pin 3, pin 7 or pin 1, whichever gives the best focus.

To be continued

BOOK REVIEW

The Technique of the Television Cameraman
by Peter Jones, published by London Focal Press Ltd.,
243 pp., price 42 -.

THIS is a book about "the glory boys", the men who are in the front line of television technical operations, "driving" the cameras.

The fact that there are many other technical occupations in a TV studio which are just as important does not diminish the high proportion of applications for positions as trainee television cameramen.

In this book Peter Jones commences by describing the personal qualities necessary for achieving success, quite apart from a knowledge of electronics. They read like the preliminary assessment of the human qualities needed by fighter pilots: keenness, youth, physical condition, picture sense, technical knowledge, a hard worker, a good mixer, a sense of responsibility and self-discipline—in that order. It sounds as though it is a hard life—and that is what it is!

This book is not a treatise on electronics, circuitry and their advanced complex non-linear mathematics. It is a *vade-mecum* of the practical side of this strenuous job, added to which is an appreciation of the many other technical activities in a television studio: the sound balancer and boom operator, the floor manager, the racks operator and teleciné, the lighting supervisor, the vision mixer and—last but not least, the director.

The author deals with equipment used on the studio floors by the TV cameraman: the pedestal, the pathfinder dolly, the crane, the intercom, tic-tac signals, the focusing (and de-focusing), the tracking—and the artistic appreciation of the contribution they make, and the speed at which decisions have to be made.

The application of television techniques to the making of films specifically for television is a growing industry, because of the expansion of the world TV market, for which the motion picture film is a world currency. The techniques discussed in this book should be of special interest to film technicians who are now faced with using their film cameras in a new and frightening manner at Pinewood and Elstree studios. They will have to meet the challenge half-way, at least, between the speed and efficiency of a television studio (which turns out about thirty minutes per day per stage) compared with the laborious and glorious craftsmanship of a film studio (average end product two minutes thirty seconds per day per stage). But we must all bear in mind the closer tolerances required for a big screen in a cinema are equivalent to a bandwidth of about 25Mc/s compared with about 2.5Mc/s by the time a picture arrives on the viewer's own TV set.

It is a valuable work of reference not only for would-be TV cameramen, but cameramen who have been in this business for years. It is difficult for a highly professional technician to achieve this particular literary approach when describing the complex human and technical parameters involved—but Peter Jones has done it. In so doing he has written a classic.—*Iconos*

UNDER NEATH



THE DIPOLE

TOP of the Bill, top of the Pops, top of the TAM-ratings and top of the Gallup and N.O.P. polls! These are all targets aimed at by participants in show business and in politics, in a democratic country such as ours. Scientifically observed assessments are made in different ways by all of the poll organisations—which are feverishly read by the people behind the scenes, including those who plan and produce the TV programmes, political or otherwise. So far as “goggle box” is concerned, the Television Audience Measurement’s weekly volume of information is a comprehensive evaluation of public interest and advertising values of all the ITV companies’ programmes set alongside the BBC-1 and BBC-2 presentations.

BBC-2

At the moment, BBC-2 on u.h.f. has a poor showing, to say the least. But this situation will

change when colour television arrives. In the meantime, show business talk about the TAM figures of the Royal Variety Performance continues to be a conversation piece weeks and weeks after November 14th, 1965. You can’t get away from the high-tide figures achieved on this occasion by each ITV company from 69 to 80 on TAM ratings. Did anybody bother to switch on to BBC-1 or BBC-2 while the Royal affair was in progress?

When the Royal Performance was on the air, the BBC touched new low levels in the London area with BBC-1 at 10 and BBC-2 barely on the scale, varying from zero to 1. Yet both of these BBC programmes carried first-class material, with the film *The Red Shoes* on BBC-1 and *The World of George Orwell* on BBC-2. One has to bear in mind that there are still only just over one million viewers in the London area with 625-line sets, of which only 640,000 are able or willing to receive the poor and uneven signals from the transmitter. London will require about fifteen medium and low power transmitters to boost the signals in the same area so splendidly served by BBC-1. Many of them haven’t even bothered to put up BBC-2 aerials. You and I will have to pay for the enormous costs of these transmitters by way of higher and higher (and higher) licence fees plus professionally installed expensive aerials. Remember that a bad aerial site may be only a couple of feet away from a good one. The only way of locating this optimum position is by probing the air, with the aid of a kind of fire-escape ladder device, waving the wand to find that desired vantage-point.

Royal Variety Performance

That November 14th show is still discussed; in some cases the variety acts are subjected to unfavourable comments. Some turns were obviously untalented. You could see that as they walked on the stage, groping for their microphone or microphone stands. Nevertheless some of the youngsters who were properly trained presented their acts with professional expertise. There were also a number of highly talented and brilliant performers who failed to make the

grade, mainly because of poor script material. I refer to Spike Milligan, Peter Sellers, Arthur Haynes, Peter Cook, Dudley Moore and Max Bygraves.

These are all personalities of importance, gifted and able to give a good show at all times. At all times? Surely the Royal occasion warrants the peak of performance which necessitates also the peak of the material they use. Opinions differ as they have during continuous arguments and opinions expressed in railway compartments, pubs and clubs. Reference to any of these star actors has been made in sorrow rather than enthusiasm. As for those, hitherto almost unseen and who made top grade from the moment they walked on the Palladium stage, I particularly refer to Hope and Keen, a double act with a brilliant trombone finish; Neville King, a new-stone ventriloquist; and Frank Ifield, Shirley Bassey (with the magnificent backing of Alyn Ainsworth and his orchestra), Ken Dodd and Lilly Yokoi, a cycling act (with charm and skill) were all enchanting. It was a great evening for everyone except the script writers, who must have been saving up their inspirations for the pantomime or summer seasons.

Mellotron

Never in my experience has a sound play-off device been so enthusiastically welcomed in television or films as Mellotron, the kind-of-sort-of computer supplier of sound effects. BBC studios, ABC-TV Teddington studios, Associated Television, the Film Producers’ Guild, Elstree Studios, an Italian film studio and others have ordered these remarkable keyboard operated devices.

They say that if you stand outside the Leicester Square Tube station long enough everyone in show business will pass by. So far as the television business is concerned it is possible to stand around in the Mellotronics showroom near Oxford Circus to see dozens and dozens of technicians, producers, managing directors and others.

Careless Talk

It is said that psychiatrists start forming their first assess-

LAWSON BRAND NEW CATHODE RAY TUBES



The rapidly increasing demand for a complete range of new tubes of the very highest quality is now being met by the new Lawson "CENTURY 99" range of television tubes.

SPECIFICATION:

The new "Century 99" range of C.R.T.s are the products of Britain's premier C.R.T. manufacturers. All types are exact replacements, manufactured to the original specification, but incorporating the very latest design improvements to give superb performance, coupled with maximum reliability and very long life.

"Century 99" C.R.T.s, available as direct replacements for the following makes and types

| MULLARD | MAZDA | BRIMAR | EMISCOPE & EMITRON | GEC and COSSOR Also ENGLISH ELECTRIC |
|---------|---------|--------|--------------------|---|
| MW43/69 | CRM121 | C12FM | E1/4 | 141K |
| MW43/64 | CRM123 | C14FM | 4/15 | 171K |
| MW36/24 | CRM122 | C14GM | 4/15G | 172K |
| MW31/74 | CRM124 | C14HM | 5/2 | 173K |
| MW31/16 | CRM141 | C14IM | 5/2T | 212K |
| MW43/80 | CRM142 | C14LM | 5/3 | 6901A |
| MW36/44 | CRM143 | C14PM | 5/3T | 7102A |
| MW53/80 | CRM144 | C171A | 14KP4 | 7201A |
| MW53/20 | CRM152B | C174A | 17ARP4 | 7203A |
| MW43/43 | CRM153 | C175A | 17ASP4 | 7204A |
| MW41/1 | CRM171 | C177A | 17AYP4 | 7205A |
| AW59-91 | CRM172 | C17AA | 21CJP4 | 7401A |
| AW59-90 | CRM173 | C17AF | SE14/70 | 7405A |
| AW53-89 | CRM211 | C17BM | SE17/70 | 7406A |
| AW53-88 | CRM212 | C17FM | | 7501A |
| AW53-80 | CME141 | C17GM | | 7502A |
| AW47-91 | CME1402 | C17HM | | 7503A |
| AW47-90 | CME1702 | C17JM | | 7504A |
| AW43-89 | CME1703 | C17LM | | 7601A |
| AW43-88 | CME1705 | C17PM | | 7701A |

| | | |
|---------|---------|-----------------------|
| 12" ... | £4.10.0 | Terms: |
| 14" ... | £5.10.0 | C.W.O. |
| 17" ... | £5.19.0 | C.O.D. |
| 19"-21" | £7.15.0 | Carr. and Ins. 8/6 |

DOUBLE GUARANTEE
All tubes fully guaranteed for 12 months and are supplied with a full money back guarantee if you are not delighted with their performance. Complete fitting instructions supplied

LAWSON TUBES
STATION ESTATE, MALVERN,
Offices and Enquiries:
2 PEACHFIELD CLOSE,
MALVERN WELLS,
MALVERN 2100

LASKY'S

FANTASTIC NEW YEAR OFFER

PORTABLE TV SCOOP!

WE ARE PROUD TO BE FIRST AGAIN WITH THIS OUTSTANDING "USE ANYWHERE" 405/625 LINE MAINS/ BATTERY PORTABLE TV BY FAMOUS BRITISH MANUFACTURER AT ALMOST HALF ORIGINAL LIST PRICE !!

SUPER QUALITY FEATURES:

- Fully transistorised ● Receives BBC1/BBC2 and all ITV stations ● Operates on 200/250V. A.C. Mains and internal rechargeable batteries (charger is built into set) and external 12V. D.C. supply (car battery) ● 8 1/2 in. Mullard Radiant Tube ● 5 in. P.M. speaker
- Wood cabinet covered in washable material, with strong carrying handle—front fascia in high quality two-tone plastic ● U.H.F. tuner with extra fine tuning control for 625 line channels. ● Fitted with fully directional telescopic aerial for 405 line stations ● Sockets provided for external U.H.F. and V.H.F. aerials ● Dimensions: 11 x 14 x 11 in.—weight 24 1/2 lb ● All usual TV controls fitted—complete operating instructions included.

Each receiver is fully tested before sale.
The makers list price for this remarkable set was 83 gns.

Lasky's Price 49 Gns.

Due to the inherent fragility of TV receivers we would prefer not to send these sets by carrier, but if required we will send by Express Passenger Train Parcels Service at a cost of £4 including packing and insurance to any address in the U.K.

207 EDGWARE RD, LONDON, W.2 Tel: PAD 3271

33 TOTTENHAM CT. RD., LONDON, W.1. Tel: MU5 2605

Both open all day Saturday. Early closing Thursday.



Optional extras: Plug-in 625 line aerial 7/6. Set of rechargeable batteries (listed at £5.4.0) 4 guinea.

152/3 FLEET STREET, LONDON, E.C.4 Tel: FLt. 2653

Open all day Thursday. Early closing Saturday.
Mail orders to 3-15 Cavel. St, London, E.1. Tel: STt 4621 2

CRT'S

Rebuilt

- RESCREENED
- RE-ALUMINISED

Regular buyers of Suffolk and Midland Tubes have learnt to rely on their outstanding quality. Every Tube guaranteed 12 months with proved performance and Reliability.

PRICES FROM £4.10.0 EACH
The largest independent rebuilders in the U.K.

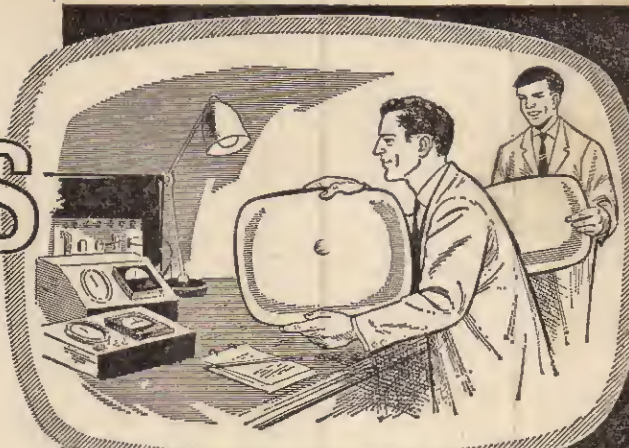

SUFFOLK TUBES LTD

1/3 UPPER RICHMOND ROAD
PUTNEY LONDON S.W.15
Tel: Vandyke 4304/5267

MIDLAND TUBES LTD

477/483 OLDHAM ROAD
MANCHESTER 10
Tel: Collyhurst 4412

BENTLEY ACOUSTIC CORPORATION LTD.

THE NEW VALVE SPECIALISTS

38 CHALCOT RD, LONDON, N.W.1

MULLARD BY100 MIDGET SILICON RECTIFIERS

ESPECIAL OFFER
Mullard POF801 valves
85 per dozen post free

Nearest tube
Chalk Farm

All goods
advertised are
in stock

Primrose
9090

Output 250v. at 1 amp.
No larger than a shirt button
6/8 each

| | | | | | | | | | | | | | | | | | | | | | | | |
|--------|------|--------|------|--------|------|----------|------|--------|------|-------|------|--------|------|---------|------|---------|------|--------|------|-------|------|--------|------|
| 0A3 | 5/9 | 6CW4 | 24/- | 10P13 | 12/- | 30PL13 | 9/6 | DL96 | 6/8 | ECH81 | 5/9 | EL95 | 5/- | KTW62 | 5/9 | PL61 | 8/9 | U22 | 5/8 | UF85 | 6/9 | OAS1 | 3/8 |
| 0B2 | 6/- | 8D3 | 9/8 | 10P14 | 11/8 | 35C5 | 6/8 | DM70 | 5/- | ECH83 | 6/8 | ELL50 | 15/6 | KTW63 | 5/6 | PL62 | 5/3 | U25 | 8/6 | UF86 | 9/8 | 0AZ310 | 7/8 |
| 0Z4GT | 4/8 | 6F1 | 9/8 | 12AC6 | 8/8 | 85L6GT | 6/- | DM71 | 9/9 | ECH34 | 9/8 | EM34 | 11/8 | MHD4 | 7/6 | PL63 | 6/- | U26 | 7/6 | UF89 | 6/8 | GC13 | 25/- |
| 1D4 | 9/8 | 6F13 | 3/8 | 12AD6 | 9/8 | 35W4 | 6/- | DY36 | 6/8 | ECL80 | 5/8 | EM71 | 15/6 | MHLD612 | 6/6 | PL64 | 6/3 | U31 | 6/6 | UL41 | 7/8 | OC22 | 23/- |
| 1E5 | 4/- | 6E2 | 9/8 | 12AE6 | 3/8 | 35W4 | 15/6 | DY87 | 7/8 | ECL82 | 6/8 | EM80 | 6/8 | MU12/14 | 4/8 | PL60 | 15/9 | U38 | 13/6 | UL54 | 5/6 | OC25 | 12/- |
| 1E5 | 8/6 | 6E24 | 10/8 | 12AH8 | 10/9 | 35Z4GT | 4/6 | ESOF | 24/- | ECL85 | 10/- | EM81 | 7/- | N77 | 10/6 | PM84 | 9/3 | U36 | 16/8 | UL4 | 17/6 | OC26 | 8/- |
| 1E4 | 2/8 | 6J7G | 4/6 | 12AT8 | 4/6 | 35Z5GT | 4/6 | ESSF | 24/- | ECL86 | 8/- | EM84 | 9/- | N78 | 20/- | PM84 | 8/- | U37 | 20/- | UL84 | 17/6 | OC28 | 25/- |
| 2D2L | 5/- | 6K7G | 1/8 | 12AU8 | 5/9 | 50B5 | 6/8 | ESSK | 13/6 | EP22 | 6/8 | EM85 | 8/8 | N109 | 26/2 | PM84 | 6/9 | U45 | 15/6 | UL80 | 8/3 | OC29 | 16/8 |
| 2E3 | 8/- | 6K8G | 3/8 | 12AV8 | 5/9 | 50C5 | 6/- | EISOF | 19/8 | EP36 | 3/6 | EM87 | 7/6 | PABC80 | 5/9 | PM82 | 8/9 | U76 | 4/6 | UL6 | 11/- | OC33 | 9/8 |
| 3A5 | 6/9 | 6K82TM | 9/- | 12BA8 | 5/3 | 50L6GT | 6/- | E1A50 | 1/8 | EP37A | 7/- | EN31 | 10/- | PM81 | 2/6 | PM82 | 8/9 | U191 | 9/6 | UL8 | 14/- | OC38 | 21/8 |
| 30Q5GT | 9/9 | 6K26 | 24/- | 12BE6 | 4/9 | 72 | 6/6 | EABCS0 | 6/8 | EP39 | 5/- | EV51 | 5/6 | PC86 | 9/9 | PM80 | 4/9 | U261 | 9/9 | ULY1 | 10/3 | OC41 | 3/8 |
| 3B4 | 4/9 | 6L6GT | 7/8 | 12BH7 | 8/8 | 86A2 | 6/9 | EAF42 | 7/8 | EP40 | 8/9 | EV81 | 7/8 | PC88 | 9/9 | PM81 | 5/- | U262 | 12/8 | ULY2 | 9/9 | OC44 | 4/9 |
| 3E4 | 5/9 | 6L7GT | 6/8 | 12C7GT | 7/8 | 90AG | 6/78 | EB24 | 1/- | EP41 | 4/6 | EV83 | 9/8 | PC89 | 6/9 | PM82 | 4/9 | U301 | 11/- | UL41 | 5/9 | OC45 | 3/8 |
| 5R4GY | 9/8 | 6L8 | 10/- | 12C85 | 10/- | 90V | 6/78 | EB41 | 4/9 | EP42 | 3/9 | EV84 | 9/8 | PC97 | 6/9 | PM83 | 5/6 | U404 | 6/- | UL85 | 4/9 | OC55 | 22/8 |
| 5U4G | 4/9 | 6LD20 | 6/6 | 19AQ6 | 7/3 | 90C1 | 16/- | EB91 | 2/3 | EP60 | 2/6 | EV80 | 5/6 | PCCS4 | 5/6 | PM83 | 7/8 | U801 | 15/- | VP4 | 14/6 | OC58 | 25/- |
| 5V4G | 8/- | 6P23 | 11/8 | 20D1 | 10/- | 90C6 | 42/- | EB33 | 3/9 | EP90 | 4/8 | EV88 | 8/9 | PCCS8 | 6/9 | PM80 | 5/8 | U802 | 6/8 | VP4B | 12/- | OC70 | 9/8 |
| 5Y3GT | 4/9 | 6P27G | 4/3 | 20P2 | 11/8 | 90C7 | 42/- | EB34 | 6/9 | EP93 | 9/9 | EV91 | 9/9 | PCCS8 | 10/6 | PM80 | 7/8 | U803 | 6/8 | VP4C | 15/6 | OC71 | 8/8 |
| 5Z3 | 6/8 | 6E7G | 5/8 | 20L1 | 12/- | 180B2 | 16/6 | EB31 | 6/8 | EP95 | 4/8 | EV42 | 8/8 | PCCS8 | 10/6 | PM80 | 7/8 | U804 | 6/8 | VP4D | 15/6 | OC72 | 8/8 |
| 6Z4G | 7/8 | 6R7GT | 4/6 | 20P1 | 12/8 | 807 | 11/8 | EBF50 | 5/9 | EP86 | 6/8 | EZ41 | 6/8 | PCCS8 | 9/9 | QV03/10 | 10/- | UB1 | 10/6 | VP107 | 10/8 | OC73 | 19/- |
| 6A3 | 5/9 | 6S17GT | 4/9 | 20P3 | 12/8 | 3763 | 7/8 | EBF53 | 7/8 | EP89 | 4/8 | EZ90 | 3/9 | PCCF9 | 6/6 | UB1 | 10/6 | VP108 | 10/8 | VP108 | 10/8 | OC74 | 8/8 |
| 6AC7 | 3/8 | 6S27GT | 4/8 | 20P4 | 13/8 | 7475 | 2/6 | EBF59 | 5/8 | EP91 | 3/8 | EZ81 | 4/8 | PCCF2 | 6/6 | QV04/7 | 7/8 | UB1 | 10/6 | VP109 | 10/8 | OC75 | 8/8 |
| 6AG7 | 5/9 | 6U4GT | 8/8 | 20P5 | 11/8 | ACCPEN | 4/8 | EB121 | 10/8 | EP92 | 2/6 | EZ33 | 14/6 | PCF84 | 8/6 | R10 | 15/6 | UBF90 | 3/8 | VP109 | 7/8 | OC76 | 8/8 |
| 6AQ6 | 5/8 | 6V6 | 6/8 | 25L6 | 4/8 | AZ21 | 9/8 | ECS8 | 12/9 | EP95 | 4/8 | EZ34 | 10/8 | PCF86 | 8/3 | R17 | 17/6 | UBF99 | 6/8 | VP109 | 26/2 | OC77 | 12/- |
| 6AT6 | 2/8 | 6X4 | 3/8 | 25Z4G | 6/6 | AZ41 | 6/8 | EC70 | 4/9 | EP97 | 10/- | EZ37 | 14/6 | PCF801 | 9/9 | R18 | 9/6 | UB121 | 10/8 | VP109 | 27/- | OC78 | 8/8 |
| 6A7G | 5/8 | 6X5GT | 6/3 | 25Z6GT | 6/6 | B36 | 4/9 | EC92 | 6/6 | EP98 | 9/9 | IABC90 | 9/3 | PCF802 | 9/9 | R19 | 9/6 | UCB2 | 6/8 | VP109 | 27/- | OC81 | 4/- |
| 6A78 | 5/8 | 630L3 | 9/9 | 30C15 | 10/- | CB11 | 12/- | EC031 | 3/8 | EP189 | 7/3 | IA1DD | 12/6 | PCF805 | 9/9 | EL90 | 22/8 | UCCS4 | 8/- | VP109 | 27/- | OC81D | 4/- |
| 6BA5 | 4/8 | 756 | 12/8 | 30C17 | 11/8 | CL33 | 12/8 | EC040 | 7/- | EP184 | 6/6 | IA2DD | 12/6 | PCF806 | 12/6 | SP41 | 8/9 | UCCS5 | 6/8 | VP109 | 27/- | OC82 | 10/- |
| 6BE6 | 4/8 | 757 | 9/6 | 30C18 | 9/8 | CY31 | 5/9 | EC081 | 3/8 | EP190 | 9/8 | IA2ED | 12/6 | PCF807 | 12/6 | SP41 | 8/9 | UCCS6 | 6/8 | VP109 | 27/- | OC83 | 10/- |
| 6BH6 | 5/8 | 7C5 | 3/- | 30P3 | 7/3 | DAF96 | 6/- | EC082 | 4/8 | EK32 | 5/9 | IA2ED | 12/6 | PCF808 | 12/6 | SP41 | 8/9 | UCCS7 | 6/8 | VP109 | 27/- | OC84 | 10/- |
| 6B76 | 5/8 | 7C5 | 6/8 | 30FL1 | 9/8 | DD41 | 10/6 | EC083 | 4/8 | EK32 | 5/9 | HN369 | 25/8 | PCF809 | 12/6 | SP41 | 8/9 | UCCS8 | 6/8 | VP109 | 27/- | OC85 | 10/- |
| 6BZ4 | 7/8 | 7E7 | 5/9 | 30L13 | 10/8 | DP66 | 15/- | EC084 | 5/8 | EL33 | 6/8 | HYR2 | 8/9 | PCF810 | 12/6 | SP41 | 8/9 | UCCS9 | 6/8 | VP109 | 27/- | OC86 | 10/- |
| 6BZ7 | 9/8 | 7E7 | 12/8 | 30L17 | 11/8 | DP96 | 6/- | EC085 | 5/9 | EL34 | 9/9 | HYR2A | 8/9 | PCF811 | 12/6 | SP41 | 8/9 | UCCS10 | 6/8 | VP109 | 27/- | OC87 | 10/- |
| 6BR8 | 8/- | 7X4 | 5/8 | 30P4 | 12/8 | DP97 | 10/- | EC088 | 8/9 | EL36 | 8/9 | KT33C | 8/- | PEN43 | 7/9 | U10 | 8/9 | UC183 | 8/9 | VP109 | 27/- | OC88 | 10/- |
| 6BW6 | 7/8 | 9B3W | 9/6 | 30P13 | 7/8 | DH101 | 25/- | EC091 | 3/8 | EL41 | 7/- | KT36 | 28/8 | PEN45DD | 12/6 | U12A | 7/8 | VP109 | 27/- | VP109 | 27/- | OC89 | 10/- |
| 6BW7 | 5/8 | 10C1 | 8/9 | 30P19 | 12/8 | DH107/11 | 11/8 | EC099 | 11/8 | EL42 | 7/9 | KT41 | 6/8 | PEN48 | 4/9 | U16 | 15/6 | VP109 | 27/- | VP109 | 27/- | OC90 | 10/- |
| 6C9 | 10/9 | 10C2 | 12/8 | 30FL1 | 9/8 | DK92 | 8/- | EC093 | 7/8 | EL41 | 8/8 | KT44 | 8/- | PEN48 | 4/9 | U18 | 15/6 | VP109 | 27/- | VP109 | 27/- | OC91 | 10/- |
| 6CDBG | 18/- | 10F1 | 10/- | 30FL13 | 10/8 | DK96 | 8/8 | EC092 | 6/8 | EL38 | 6/9 | KT61 | 9/8 | PEN48 | 4/9 | U18 | 15/6 | VP109 | 27/- | VP109 | 27/- | OC92 | 10/- |
| 6CDB6 | 6/8 | 10D11 | 9/8 | 30FL14 | 11/8 | DL72 | 15/- | EC094 | 10/- | EL43 | 4/6 | KT63 | 8/9 | PEN48 | 4/9 | U18 | 15/6 | VP109 | 27/- | VP109 | 27/- | OC93 | 10/- |
| | | | | | | | | EC091 | 10/- | EL46 | 7/6 | KT63 | 12/3 | PL33 | 9/9 | U18 | 15/6 | VP109 | 27/- | VP109 | 27/- | OC94 | 10/- |
| | | | | | | | | EC093 | 6/- | EL46 | 7/6 | KT63 | 12/3 | PL33 | 9/9 | U18 | 15/6 | VP109 | 27/- | VP109 | 27/- | OC95 | 10/- |
| | | | | | | | | EC094 | 8/- | EL41 | 8/8 | KT44 | 8/- | PL36 | 9/9 | U18 | 15/6 | VP109 | 27/- | VP109 | 27/- | OC96 | 10/- |
| | | | | | | | | EC094 | 8/- | EL41 | 8/8 | KT44 | 8/- | PL36 | 9/9 | U18 | 15/6 | VP109 | 27/- | VP109 | 27/- | OC97 | 10/- |

Terms of business—Cash with order only—No C.O.D.
Postage/Packing 6d. per item. Orders over £5 post free.
Any parcel insured against damage in transit for only 6d. extra. All orders despatched on day of receipt. Callers welcome.
8.00am—7.30pm—5.00pm. Sat. 9.00am—1.00pm.

We require for prompt cash settlement all types of valves, loose or boxed, but MUST be new. Offers made by return.

All goods are new first quality brands only and subject to makers' full guarantee. We do not handle manufacturers' seconds or rejects which are often described as "new and tested" but which have a limited and unreliable life. Complete catalogue of over 1000 valves actually in stock with resistors, condensers, transformers, microphones, speakers, metal rectifiers with terms of business, 6d. post free.

SERVICE SHEETS

SERVICE SHEETS (75,000) 4/- each. Callers welcome. **ALWAYS OPEN.** 5 South Street, Oakenshaw, Bradford.

SERVICE SHEETS, Radio, TV, 5,000 models. List 1/-. S.A.E. enquiries. **TELRAY**, 11 Maudland Bk., Preston.

EX N.E.V., C.C.T.V. Camera and Monitor Circuits. S.A.E. for list. **LOWE**, 62 Brownswood Road, London, N.4.

SERVICE SHEETS

For all makes of Radio and Television—1925-1965. Prices from 1/-.

Fee fault-finding guide with all Service Sheets. Please send S.A.E. with enquiries. Catalogue of 6,000 models, 1/6.

All types of modern and obsolete valves. Radio and TV Books. S.A.E. lists enquiries.

HAMILTON RADIO

Western Road, St. Leonards, Sussex.

STATE MODEL No. Radio 1/6, TV 3/-. S.A.E., **DARWIN**, 19 George Street, St. Helens, Lancs.

SERVICE SHEETS, also Current and Obsolete Valves for sale. **JOHN GILBERT TELEVISION**, 1b Shepherd's Bush Road, London, W.6. Tel. SHE8441. Nr Goldhawk Rd. Station.

SERVICE SHEETS

4/- each, plus postage

We have the largest supply of Service Sheets for all makes and types of Radios, Televisions, Tape Recorders, etc. in the country (speedy service).

To obtain the Service Sheet you require, please complete the attached coupon:

Name:

Address:

.....

.....

To: **S.P. DISTRIBUTORS**

44 Old Bond St., London, W.1

Please supply Service Sheets for the following:

Make:

Model No..... Radio/TV

Make:

Model No..... Radio/TV

Make:

Model No..... Radio/TV

New 1966 List now available.

I also require list of Service Sheets at 1/6.

(please delete items not applicable)

enclose remittance of

MAIL ORDERS ONLY (Feb PT.)

RATES: 4/- per line or part thereof, average five words to line. minimum 5 lines. Box No. 1/- extra. Advertisements must be prepaid and addressed to Advertisement Manager, "Practical Television", Tower House, Southampton Street, London W.C.2.

SETS & COMPONENTS

"HEATHKITS" can now be seen in London and purchased on H.P. Free brochure. **DIRECT TV REPLACEMENTS LTD.**, 126 Hamilton Road, West Norwood S.E.27. GIPSY HILL 6166.

STOP

FULLY GUARANTEED L.O.P.T. REWINDS

We can rewind ALL makes except Oil Filled or Fully Encased type. A few of the types are listed below.

ALL AT 50/-

PHILIPS 1768 to 17TG100 etc.
STELLA 8617 to 1007 etc.
Above types should be sent complete.
PYE V4 to 700 etc.
Also Frame Output Transformer Rewinds.
S.A.E. Enquiries P & P 4/-. C.O.D. 6/-

WITWORTH TRANSFORMERS Ltd.
26 All Saints Road, North Kensington
W.11 Telephone: BAY 9071

CONVERT ANY TV SET into an Oscilloscope. Instructions and diagrams 12/6. **REDMOND**, 42 Deanclose, Portslade, Sussex.

R. & R. RADIO & TV SERVICE

44 MARKET STREET

BACUP, Lancs. Telephone: 465

| | | | | | |
|--------|------|--------|-----|-------|-----|
| 6F13 | 4/6 | PY32 | 6/- | 30P12 | 5/- |
| 6K25 | 10/- | 6F15 | 5/- | 6L18 | 4/6 |
| 6/30L2 | 5/- | 6U4gt | 5/- | 98W6 | 5/- |
| EBF80 | 5/- | EB91 | 1/- | 6F1 | 2/6 |
| EF91 | 2/6 | EBF89 | 5/- | EF80 | 1/6 |
| ECC82 | 4/- | EF85 | 5/- | ECL80 | 4/- |
| 20P3 | 5/- | EY86 | 4/- | 30F5 | 6/- |
| 30PL1 | 5/- | 20P4 | 7/6 | PL36 | 7/6 |
| PCC84 | 4/- | PL38 | 6/- | PL82 | 4/- |
| PCL83 | 5/- | PCF80 | 4/- | PY83 | 5/- |
| PL83 | 4/- | PL81 | 5/- | U301 | 6/- |
| PZ30 | 5/- | PY81 | 3/6 | 10P13 | 5/6 |
| 10F1 | 1/- | U801 | 7/6 | 20F2 | 5/6 |
| 10P14 | 5/- | 10LD11 | 5/- | 20P5 | 6/6 |
| 20D1 | 2/- | 20L1 | 5/- | 30P4 | 7/6 |
| 30FL1 | 6/6 | 20P1 | 6/6 | PY82 | 5/- |

Post 6d. per valve. Three or more post free. Ex used Equip.

Turret Tuners ex TV as removed, 8/-, post 2/9.

Line output transformers, scan coils, etc. State make and model No. with all enquiries.

Fireball Tuners, as removed 14/6. Post 2/9.

Metal Rectifiers, finned type 5/- plus 8d. p. & p.

Ecco Line output shrouds, 8/- incl. post.

TV Transistor pre-amps, Band 1, 2 and 3. £3.17.6, post paid.

Model B45, covering any ten channels in Band 4 or 5, £4.5.0, post paid. State clearly the channel you require.

TELEVISION TUBE SHOP

The

NEW TUBE Specialists

| | |
|------------------|---------|
| AW36-20, 21 | £5.12.6 |
| AW36-80 | £5. 7.6 |
| AW43-80 | £6. 7.6 |
| AW43-88, 43-89 | £6.12.6 |
| AW47-90, 91 | £7.10.0 |
| AW53-80 | £7.12.6 |
| AW53-88, 53-89 | £7.17.6 |
| AW59-90, 59-91 | £9.10.0 |
| C14BM, FM | £5.15.0 |
| C178M, FM, HM | £6. 7.6 |
| C17LM, FM, SM | £6.12.6 |
| C21 HM, SM, TM | £7.17.6 |
| CME1402 | £5.17.6 |
| CME1702, 1703 | £6.12.6 |
| CME1705 | £7. 7.0 |
| CME1901, 1903 | £7.10.0 |
| CME2101 | £8. 7.6 |
| CRM93 | £5.10.0 |
| CRM124 | £5.10.0 |
| CRM141, 2, 3, 4 | £5.17.6 |
| CRM152, 153 | £4. 0.0 |
| CRM171, 2, 3 | £6. 7.6 |
| CRM211, 212 | £7.17.6 |
| MW6-2 | £6.17.6 |
| MW22-16 | £5. 2.6 |
| MW31-16, 74 | £4.17.6 |
| MW36-24, 44 | £5. 2.6 |
| MW43-64, 69 | £6. 7.6 |
| MW43-80 | £6. 7.6 |
| MW53-20 | £7.12.6 |
| MW53-80 | £7.12.6 |
| T901A | £6.12.6 |
| 14KP4A, 141K | £5.12.6 |
| 171K, 172K, 173K | £6. 7.6 |
| 6901A | £6.19.6 |
| 7201A, 7230A | £5.12.6 |
| 7204A | £5.10.0 |
| 7401A | £6. 7.6 |
| 7405A | £6.12.6 |

Manufacturers' Reprocessed Tubes available at £1 each less than the above prices.

All tubes tested before despatch and guaranteed for 12 months.

CARRIAGE 10/-, via B.R.S. or 15/- via passenger train. Add 2/6 for Comprehensive Insurance.

TERMS £2 down (plus carriage balance £1 per month).

Midland Stockists:—

Amateur Electronics Co.
240 Lichfield Road, Aston,
Birmingham.

TELEVISION TUBE SHOP

48 BATTERSEA BRIDGE ROAD
LONDON S.W.11. BAT 6859

JUST SOUTH OF THE BRIDGE
OPEN SATURDAY UNTIL 4 p.m.

SETS & COMPONENTS

(Continued)

THIS MONTH'S SCOOP!

To clear

NEW CRM153 MAZDA

£3.19.6 plus carriage

TELEVISION TUBE SHOP
48 Battersea Bridge Road, S.W.11

OLYMPIC II TV. S.A.E. for itemised price list. AJAX ELECTRONICS, 13a Rumbold Road, Fulham, S.W.6.

BRAND NEW TUBES, Year's g'teel
CRM124, MW31/74, etc. ... 50/-
AW36/80, CME1402 ... 60/-
AY43/80, 88, MW43/69, etc. ... 115/6
AY47/91, 1, CME1901, 2, 3 ... 140/-
Also 21in., 23in. twin panels. Cge extra.
P. BEARMAN, 6 Potters Road,
New Barnet, Herts.
Tel: BAR 1934/7873

STOP

FULLY GUARANTEED LINE OUTPUT TRANSFORMERS

NEW FROM STOCK

EKCO U26 TYPES—state model }
PYE 200 and 400 ... } **55/-**

EKCO U25 TYPES—state model }
FERGUSON 306-308 ... } **45/-**
GEC 3743-8426 Etc. ... }
HMV 1865-1869 ... }

We manufacture all types of Transformers.
Post & Packing 4/- S.A.E. all enquiries

WITWORTH TRANSFORMERS LTD.

26 All Saints Road, North Kensington,
W.11. Telephone: BAY 9071

GUARANTEED Ideal for any recorder.

TAPE

World Famous make.
PRICES FLASHED
APPROX. HALF PRICE!

By enormous purchase we can offer you fully
tensified Polyester/Mylar and P.V.C. tapes of
Identical Hi-Fi wide range recording
characteristics as top grade tapes. Quality
control manufacture. Not standard in any
way. TRY one for YOURSELF. They are
TRULY WORTH A FEW MORE COPPERS.

| STANDARD PLAY | | DOUBLE PLAY | |
|---------------|------------|-------------|------------|
| 3" | 150' 2/3 | 3" | 300' 4/- |
| 4" | 300' 4/6 | 4" | 600' 8/- |
| 5" | 600' 7/6 | 5" | 1200' 15/- |
| 5 1/2" | 900' 10/6 | 5 1/2" | 1800' 21/- |
| 7 1/2" | 1200' 13/6 | 7 1/2" | 2400' 27/- |

| LONG PLAY | | TRIPLE PLAY | |
|-----------|------------|-----------------|------------|
| 3" | 225' 2/9 | 4" | 900' 13/- |
| 4" | 450' 5/6 | 5" | 1800' 25/- |
| 5" | 900' 10/6 | 5 1/2" | 2400' 34/- |
| 5 1/2" | 1200' 13/- | 7 1/2" | 3600' 44/- |
| 7 1/2" | 1800' 18/6 | QUADRUPLER PLAY | |
| | | 3" | 600' 8/- |

Postage 1/- per reel.

Past free and less 5% on three.

Trade and quantity enquiries welcomed.

TECHNICAL TRADING CO.

All Mail Orders to Brighton please. **67999**
11/12 North Road, Brighton
350/352 Fraddon Road, Portsmouth 22034
72 East Street, Southampton 25851

SETS & COMPONENTS

(Continued)

TV SPARES, fully guarant'd. Makers' parts. Telephone orders sent same day C.O.D. Line O.P. Trans., Murphy V240/250, 70/6; V270/280, 89/6; Ekco T311, 330, 221, 231, 327 series and Pye VT4, etc., all 62/6. Most types stocked. Send S.A.E. for quote. Add 4/- p.p. Ekco/Ferr. Plastic Hsgs., 151-7, KINGS (ORPINGTON) LTD., 8 Cray Parade, Main Road, St. Paul's Cray, Kent. Orpington 30566.

TUBES, AERIALS, VALVES

U.H.F. aerials, Bands I, II & III aerials. U.H.F. transistorised boosters. I.T.V. boosters, Regulated T.V. tubes, Valves, etc. New and second-hand T.V. sets, Transistor Radios and all types of Electrical Appliances. Quotations without obligation. Coaxial cable, fluorescent light fittings, all at special prices to the trade and Home Paraders. S.A.E. for list.

G. A. STRANGE

BRADFORD, NORTH WRAXHALL,
nr. Chippenham, Wilts. Tel. Marshfield 236

A.1 POST FREE BARGAINS

Stock clearance of reclaimed valves

| | | | | |
|-------|-----------|-----------|------------|-----|
| B86 | 3/- PCL82 | 4/- UP49 | 1/9 10C1 | 7/- |
| EB41 | 1/9 PCL83 | 3/8 UCH42 | 5/- 10C2 | 3/8 |
| EB91 | 9d. PEN46 | 1/9 UL46 | 5/8 10P13 | 3/9 |
| EF80 | 3/8 PL33 | 2/8 263 | 3/- 10P14 | 3/9 |
| EC32 | 2/6 PL32 | 2/- 266 | 3/8 12A17 | 5/- |
| EP80 | 4/8 PL33 | 2/- 3P1 | 1/- 20D1 | 1/9 |
| ECL80 | 1/8 PY31 | 1/8 6P13 | 2/8 20F3 | 4/3 |
| ER42 | 2/9 PY32 | 4/8 6P14 | 2/8 20P1 | 2/6 |
| EP80 | 9d. PY80 | 1/8 6P15 | 3/- 20E3 | 3/6 |
| EP85 | 4/8 PY81 | 1/9 6L1 | 3/9 30F5 | 4/6 |
| EL42 | 4/8 PY82 | 1/8 6L18 | 3/- 30F11 | 3/9 |
| KT30C | 2/8 PZ30 | 1/8 6L19 | 12/8 30P11 | 3/9 |
| KT38 | 3/8 T41 | 4/8 6LD20 | 4/8 30P12 | 3/9 |
| KT61 | 2/8 U31 | 2/8 6N7 | 7/- 185ET | 7/6 |
| LF3 | 2/- U31 | 3/8 6P26 | 2/8 PCC84 | 4/- |
| N37 | 3/- U39 | 3/8 6P28 | 4/8 KTW63 | 2/6 |
| PCF80 | 2/- UB41 | 3/8 6S0L2 | 2/8 KTZ63 | 3/6 |

EF80 5/- doz. ECL80 12/- doz. PCF80 18/- doz.
EB91 5/- doz. FY82 12/- doz. PL8 19/- doz.

A.1 RADIO COMPONENTS

41 The Borough, Canterbury, Kent

NEW MULLARD BY100!

WITH 25 ohm Resistor ... 6s/-!
ALSO New EF80, PCF805, PC97,
PCF801, etc. 5/- 1 NEV 12in. tubes 50/-!

M/S E. JOHNSON

12 Pank Avenue, New Barnet,
Herts. (Mail Only)

TWO OUTSTANDING INTRODUCTIONS★

★ TO THE FAMOUS 'KING' RANGE

★ THE KING TWIN TELEBOOSTER
operates two TV Receivers simultane-
ously from one aerial, separate Bands,
or both on the same channel.
Only 24.7.6. inc. battery and p.p.
★ MAINS OPERATED UNITS
On/off controlled by receiver switch.
The Original VHF TELEBOOSTER (dual band)
Still the Best. 23.19.0 incl. batt. & p.p.
Mains version. 28. 0.0 incl. p.p.
★ THE KING UHF TELEBOOSTER for BBC
Unique design. 25. 0.0 incl. batt. & p.p.
★ THE KING VHF/FM RADIO BOOSTER
(all Band II) 28.18.0 incl. batt. & p.p.
Mains version. 28. 0.0 inc. p.p.
Co-axial lead, moulded terminations, 5/6 extra.
Send S.A.E. for full details, and when ordering
please state channel/s to be boosted on BBC
and/or ITA.
All models obtainable direct from the S.P.
Manufacturers:

TRANSISTOR DEVICES LTD., Dept. P.T.
Bridge House, Newton Abbot, Devon. Tel: 2457.

SETS & COMPONENTS

(Continued)

DIRECT TV REPLACEMENTS LTD., largest stockists of TV components in the U.K. Line Output Transformers, Frame Output Transformers, Deflector Coils for most makes. Official sole suppliers for many set makers. Same Day Despatch Service. Terms: C.O.D. or C.W.O. Send S.A.E. for quotes. Day and Night Telephone: Gipsy Hill 6166. 126 Hamilton Road, West Norwood.

FOR SALE

VALVE CARTONS at keen prices. Send 1/- for sample and list. J. & A. BOXMAKERS, 75a Godwin Street, Bradford 1.

500 TELEVISIONS, not working, from 5/-. Callers only. 39 Whitehorse Lane, E.1. Opposite Stepney Green Station.

HAMMERITE

HAMMER PATTERN BRUSH PAINT FOR PANELS AND BOXES
★ THE PATTERN IS IN THE TIN ★
ALL YOU DO IS BRUSH IT ON!

2 1/2 lbs. 3/6 1 gallon 55/-
1 pint 7/6 1 gallon 55/-
1 pint 15/- (sent by road)

Carriage: Orders up to 5/-, 9d.; up to 10/-, 1/9; 15/- and over 2/9.

Colours: Blue, Silver or Metallic Black.
Return of post service 30s. to Fri.
From your component shop or direct from the manufacturer:

FINNIGAN SPECIALTY PAINTS (PT)
Minsky Square, Stockfield, Northumberland.
Phone: Stockfield 2280

METAL RECTIFIERS

RECTIFIERS—CONTACT COILED
14RA1282 (FC101) type 250 v. 250 mA 13/6;
ECL 13/-; FC116, 7/6; 14RA1283 (PC31) see Silcon.

RECTIFIERS—FIN TYPES
Equivs. for RMI 13/6; RME 17/6; 14A899 18/6;
14A80 10/8; 14A87 11/6; EKK 15/-; EKK 15-1;
14A949 19/-; LW15 19/-; LW7 18/-; 14A100 18/-;
FW127 1A 5/-; 2A 7/-; 4A 10/6.

SILICON TV 6/- or with instr. resistor-condenser, 7/6.

MULTIMETERS from 38/-.
Stamped envelope for full latest selection and
bargain offers in cheap meters, Radios, Baby Alarms,
Inter-coms and Walkie-Talkies.
Under £1 P. & P. 6d. over 21 Post Free.
NO C.O.D.

DURHAM SUPPLIES

175 DURHAM ROAD BRADFORD 8 YORKSHIRE

WANTED

NEW VALVES WANTED . . . EY51,
EY86, PL81, PCC84, PCF80, PCL82,
PCL83, PY81, R19, 30P19, U25, etc.
Best cash prices by return. DURHAM
SUPPLIES, 175 Durham Road, Bradford
8, Yorks.

SERVICE SHEETS purchased.
HAMILTON RADIO, Western Road,
St. Leonards, Sussex.

URGENTLY WANTED: New, modern
Valves, Transistors, Radios, Cameras,
Tape Recorders and Tapes, Watches,
Tools, any quantity. S. N. WILLETTS,
16 New Street, West Bromwich,
Staffs., Tel. 2392.

DAMAGED AVO METERS WANTED.
Models 7 and 8. Any condition. Any
quantity. HUGGETT'S LTD., 2-4
Pawson's Road, West Croydon.

A PROMPT CASH OFFER for your
surplus brand new Valves and Trans-
istors. R.H.S., Beverley House,
Mannville Terrace, Bradford 7.

MISCELLANEOUS

How to use standard G.P.O. type telephones in a two way system with fully automatic ringing. May be used up to 5 miles apart, requires only standard twin lead from Auto-Unit. Easy to construct. Details and circuit 6/6 inc. post.

Build a low cost three to five line fully automatic telephone system ideal to rent or sell to schools factories, offices etc. Uses standard G.P.O. type telephones, full details, diagrams and instructions 15/6 inc. postage.

PARTRIDGE TECHNICAL PUBLICATIONS

Dept. T,
21-25 Hart Road, Thundersley, Essex.

SITUATIONS VACANT

RADIO AND TV Exams, and Courses by Britain's finest home-study School. Coaching for Brit.I.R.E., City and Guilds Amateur's Licence, R.T.E.B., P.M.C. Certificate, etc. Free brochure from British National Radio School, Russell Street, Reading.

EDUCATIONAL

TV AND RADIO—A.M.I.E.R.E., City and Guilds, R.T.E.B. Cert., etc. on "Satisfaction or Refund of Fee" terms. Thousands of passes. For details of exams, and home training courses (including practical apparatus) in all branches of Radio, TV and Electronics write for 156-page handbook—FREE. B.I.E.T. (Dept. 172K), 29 Wrights Lane, London, W.8.

A.M.I.Mech.E., A.M.I.E.R.E., City and Guilds, G.C.E., etc. Become a Technician or Technologist for high pay and security. Thousands of passes. For details of exams, and courses in all branches of Engineering, Building, Electronics, etc., write for 156-page handbook—FREE. B.I.E.T. (Dept. 171K), 29 Wrights Lane, London, W.8.

TECHNICAL TRAINING

CITY AND GUILDS (Electrical, etc.) on "Satisfaction or Refund of Fee" terms. Thousands of passes. For details of modern courses in all branches of Electrical Engineering, Electronics, Radio, TV, Automation, etc., send for 156-page handbook—FREE. B.I.E.T. (Dept. 173K), 29 Wrights Lane, London, W.8.

KEY BOOK paper backs

HI-FI AND AUDIO

by A. T. Collins
Modern Designs for the Amateur Constructor. High Sensitivity Amplifier. Two-valve Pre-amp and Equaliser. Mains Gramophone Amplifier. Output Transformers and Loudspeakers, etc.

SIMPLE RADIO CIRCUITS

by A. T. Collins
A Complete "Build Your Own Radio" Guide. Simple Mains Short Wave Receiver, Medium Wave Transistor Receiver, Dual Wave One-valve, etc.

3s. 6d. each from All Booksellers or, in case of difficulty, 4s. each by post from George Newnes Ltd., Tower House, Southampton Street, London, W.C.2.

PADGETTS RADIO STORE
OLD TOWN HALL
LIVERSEGE, YORKS.

Telephone: Cleethorpe 2806

Special Offer. Brand New Boxed TV Tubes, MW43/69, 65/-. MW36/24, 37/6. 90 Degree Tubes with slight glass fault 37/- each. New JAP earpieces complete with lead and plug, 3 or 5mm., 1/11 post or 20/- per dozen.

Reclaimed Tubes, Six month's guarantee. AW43/80, 30/-. MW43/80, 30/-. MW43/69, 30/-. CRM172, 30/-. CRM142, 17/-. 12 inch tubes, 10/-. 17 inch tubes perfect but without guarantee, 17/- each. Carriage on any tube in G.B., 10/-.

Scope tube removed from units, DG7-S, 2.5in., perfect condition, 30/-. Post 4/6. New JAP earpieces complete with lead and plug, 3 or 5mm., 1/11 post or 20/- per dozen.

New Transistors, OC72, 2/-; CV425, 10d.; CV43, 10d.; CV442, 10d. New Diodes, top grade, no duds, 3/- doz. post paid.

New 12in. Speakers with built-in tweeter, 3 or 15 ohms, 28/6. Post paid.

Perfect Speakers ex. equipment, 10in. round, 10/-; Post 3/-; 8in. round, 8/-; Post 3/-; 7 x 4in., 5/-; Post 2/-; 6 x 4in., 3/-; Post 2/-; Six for 20/-; Post paid 8 in. round, 3/-; Post 2/-; Philips 5in. round, 5/-; Post 2/-; New Indicator Unit, CAT 400, complete with two tubes, type VCRX383 and VCR298 plus 21 small valves, relays removed, 57/- or less valves 32/-, carriage 10/-. Sorry no details on the unit.

Bush 12in. TV G.C.13 channel TV. Complete and tested with good tube only wants cleaning, 55/-, carriage 10/-, G.B.

VALVE LIST

| Ex equipment | 3 months' guarantee | 3 months' guarantee |
|--------------|-------------------------|---------------------|
| EL91 1/6 | 90P1 4/ | PCC84 4/- |
| EL80 2/- | 20P4 8/6 | PCL82 5/- |
| EL84 5/ | U801 8/6 | PCL86 5/ |
| ECC81 3/- | U81 5/- | PL38 5/- |
| ECC82 3/- | U2M1, CAT 400, complete | 12AT7 3/- |
| EY51 2/6 | U292 5/- | 6CH6 1/6 |
| EY85 5/- | KT36 5/- | R19 3/6 |
| EBF80 4/6 | 6V6GT 4/- | ARP12 1/6 |
| EB91 8d. | 6B3 1/6 | 50 for 2/- |
| ECC33 4/6 | 6X4 5/ | 807 5/ |
| EL38 5/ | 6P25 3/6 | EF50 1/- |
| EF91 9d. | 6U4 5/- | Doz. 6/- |
| 6F1 1/- | FX33 6/- | EF80 1/6 |
| 6F1 1/- | FX30 3/- | Doz. 10/- |
| 6F15 6/ | FX81 3/- | 6K7 1/3 |
| 10C2 5/ | PL38 8/6 | Doz. 10/- |
| 10F1 1/- | PL81 4/- | 6V8 1/9 |
| 10F13 1/- | PL82 3/- | Doz. 18/- |
| 10F14 1/- | PL83 3/- | 6KE 1/9 |
| 20D1 5/ | FX82 3/- | Doz. 18/- |
| 20L1 5/ | PCF80 4/- | U25 5/- |
| 20P3 4/- | PZ30 5/- | |

All valves post paid

ALUMINIUM, LIGHT ALLOYS
BRASS, COPPER, BRONZE
STAINLESS STEEL

IN ROD, BAR, SHEET, TUBE, STRIP
WIRE, ANGLE, CHANNEL, TEE

3,000 STANDARD STOCK SIZES

H. ROLLET & CO. LTD.

HOWIE STREET, S.W.11
BATtersea 7872

Branches at Liverpool, Manchester,
Birmingham, Leeds, Glasgow.

No quantity too small

Please mention
"Practical Television"
when replying to
Advertisements

A SUCCESSFUL CAREER IN
ELECTRONICS, RADIO AND
TV CAN NOW BE YOURS
AT VERY LITTLE COST!

NEW. No. 500 RADIO AND
TELEVISION COURSE 75/-

Here at last is your opportunity to own a most complete course at a very modest cost! This expanded course which now includes television as well as radio repair training could get you started on a white new career!

The Radio Section of the course was ORIGINALLY DEVELOPED BY THE RADIO TECHNICAL INSTITUTE, while the Television Servicing Course has formed the basis of instruction provided by one of the world's largest television and electronics firms!

Compare lesson by lesson with some courses costing ten times as much! You save because you receive all the lessons at one time and are not required to purchase equipment you may not need.

The lessons are crystal clear, practical, easy to master and use. Early lessons make fundamentals clear even to the beginner, while other lessons will give you the practical know-how of an expert!

The new 500 Radio & Television Course consists of 352 large quarto size pages of instruction, hundreds of illustrations. We positively guarantee that you will be delighted or your money refunded!

NEW. No. 600 RADIO-TELEVISION
ELECTRONICS COURSE 85/-

This is really big value to home training. Similar in details to the above courses excepting that you get an extra 56 pages of instruction making a total of 408 quarto size pages. Hundreds of illustrations. Includes all the usual subjects plus Radio Transmitter Circuits, Electronic Test Equipment, Thyristor Tubes, Inter-Communicators, Sound Level Meters, Servicing Printed Circuits and many more similar items. This course could be your first step into the fascinating world of electronics!

No. 400. ELECTRONICS COURSE 45/-

A complete home-study course of 35 lessons. Consists of 216 large quarto size pages of instruction. Comes complete with instructor's notes and test questions. This is a modern course that teaches without resorting to comic strip methods... Thousands of readers of this magazine have taken this course and enjoyed every minute of it... Why not you? Clip this coupon for your free trial offer now!

UNCONDITIONALLY GUARANTEED TO
GIVE COMPLETE SATISFACTION

Any course not satisfactory may be returned within 10 days post-paid for full refund or credit of the purchase price.

IF YOU SEND CASH WITH ORDER WE WILL INCLUDE A FREE BOOK worth 4/6 to 7/- if bought separately. By sending cash you reduce book-keeping and other costs which we pass back to you. But you must include cash at the time of order to get this special offer!

***** FREE TRIAL OFFER *****

PAY ONLY 5/- per week if you wish.

TO: SIM-TECH TECHNICAL BOOKS DEPT. F.3. Gale's Mill, West End, Southampton, Hants.

Please send the courses I have circled.
No. 500 No. 600 No. 400
If not delighted I may return any book post-paid without further obligation on my part. Otherwise I will pay cash price or 5/- weekly (10/- fortnightly) commencing not later than 10 days after delivery. I am over 21 years of age. (If under 21 parents should place order).

I enclose cash to the sum of £
I understand you will refund this money if I am not 100% satisfied and I return the book within 10 days.

Please send me the free book(s) I have ticked.
 Oscilloscope Book Electronic Gadgets Book
 Transistor Book Radio Instrument Book

Name

Address

REBUILT TUBES!

You're safe when you buy from
RE-VIEW!

- ★ Each tube is rebuilt with a completely new gun assembly and the correct voltage heater.
- ★ Each tube comes to you with a guarantee card covering it for a year against all but breakage.
- ★ Each tube is delivered free anywhere in the U.K. and insured on the journey.
- ★ Each tube is rebuilt with experience and know-how. We were amongst the very first to pioneer the technique of rebuilding television tubes.

RE-VIEW ELECTRONIC TUBES

237 LONDON ROAD, WEST CROYDON,
SURREY. Tel. THORnton Heath 7735

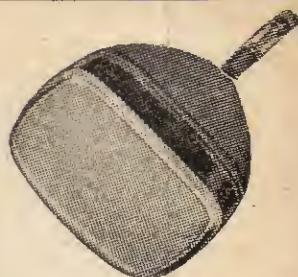

HERE IS WHAT YOU
PAY:

| | |
|-----------|-------------|
| 12in. ... | ... £4.15.0 |
| 14in. ... | ... £5. 0.0 |
| 15in. ... | ... £5. 5.0 |
| 17in. ... | ... £5. 5.0 |
| 19in. ... | ... £5.15.0 |
| 21in. ... | ... £7. 5.0 |

Cash or cheque with
order, or cash on delivery

—Discount for Trade—

Old Tubes Purchased

BBC2 (625 LINE) TV AERIALS



Wash Mounting Arrays, 8 element 45/-; wide spaced high gain, 11 element 55/-; 14 element 62/8. Wall Mounting with Cranked Arm, 9 element 60/-; wide spaced, high gain, 11 element 67/8; 14 element 75/-. Chimney Arrays Complete, 9 element 72/-; wide spaced high gain, 11 element 80/-; 14 element 87/8. Loft Arrays, 7 element 32/8; wide spaced high gain, 11 element, with Tiltting Arm, 62/8; 14 element 70/-. All high gain units have special Multi-rod Reflector. Low loss co-axial cable 1/6 per yard. UHF transistor pre-amps from 75/-.

BBC · ITV · F.M. AERIALS



B.B.C. (Band 1). Tele-scope loft 21/-. External S/D 30/-.
I.T.V. (Band 3). 3 Element loft array 25/-, 5 element 35/-. Wall mounting. 3 element 35/-. 5 element 45/-.
Combined B.B.C./I.T.V. Loft 1+3, 41/8; 1+5 49/9; Wall mounting 1+3 56/8; 1+5, 63/9; Chimney 1+3, 63/9; 1+5 71/3.
VHF transistor pre-amps from 75/-.

F.M. (Band 2). Loft S/D 12/8. "H" 30/- 3 element, 52/6. External units available. Co-ax cable 8d. yd., Co-ax plugs, 1/8. Outlet boxes 4/6. Diplexer Crossover Boxes, 12/6. C.W.G. or C.O.D. P. & P. 4/6. Send 6d. stamps for illustrated lists.

K.V.A. ELECTRONICS (Dept.P.T.)
27½ Central Parade, New Addington,
Surrey. LOD 2266

NEW VALVES!

Guaranteed Set Tested
24 HOUR SERVICE

1R5, 1S5, 1T4, 3S4, 3V4, DAF91, DF91, DK91,
DF32, DL94. SET OF 4, 14/-.
DAF96, DF98, DK96, DL96. SET OF 4, 23/8.

| | | | | | |
|--------|------|-------|------|--------|------|
| 1R5 | 4/- | EB91 | 1/9 | PL38 | 3/8 |
| 1S5 | 3/3 | EBC41 | 6/3 | PL31 | 6/8 |
| 1T4 | 1/9 | EBF80 | 5/9 | PL82 | 5/- |
| 3S4 | 4/3 | EBF89 | 5/9 | PL83 | 5/11 |
| 3V4 | 5/3 | ECC81 | 3/8 | PL84 | 6/- |
| 6K7G | 1/3 | ECC82 | 4/6 | PY32 | 3/4 |
| 6K8G | 3/3 | ECC83 | 4/6 | PY33 | 3/6 |
| 6Q7G | 5/6 | ECC85 | 5/8 | PY80 | 4/9 |
| 6V6G | 3/- | ECF32 | 5/9 | PY31 | 5/- |
| 10C2 | 11/- | ECH35 | 5/9 | PY82 | 4/9 |
| 20L1 | 11/- | ECH42 | 7/9 | PY83 | 5/3 |
| 20P3 | 10/6 | ECH41 | 5/6 | PY300 | 5/11 |
| 20P4 | 13/- | ECL80 | 5/11 | U25 | 3/- |
| 20P5 | 11/8 | ECL82 | 6/6 | U26 | 3/8 |
| 30FL1 | 9/3 | ECL86 | 8/- | U191 | 9/6 |
| 30L15 | 9/9 | EF39 | 3/6 | U301 | 10/6 |
| 30PL13 | 10/- | EF41 | 5/9 | U801 | 14/9 |
| 35L6GT | 5/8 | EF80 | 4/8 | UABC80 | 5/- |
| CL33 | 3/6 | EF85 | 4/6 | UAF42 | 6/11 |
| DAC32 | 6/9 | EF86 | 6/6 | UBC41 | 6/- |
| DAF91 | 3/3 | EF89 | 4/3 | UBF80 | 5/8 |
| DAF96 | 5/11 | EF91 | 2/9 | UBF89 | 5/9 |
| DF33 | 7/6 | EL41 | 7/6 | UCC84 | 7/11 |
| DF91 | 1/9 | EL84 | 4/6 | UCC85 | 6/9 |
| DF96 | 5/11 | EY51 | 5/11 | UCF80 | 3/3 |
| DK32 | 7/- | EY88 | 5/6 | UCH42 | 7/- |
| DK91 | 4/- | EZ49 | 5/6 | UCB1 | 6/- |
| DK92 | 7/9 | EZ90 | 3/9 | UCL82 | 9/9 |
| DK96 | 6/3 | EZ81 | 4/3 | UCL83 | 9/9 |
| DL33 | 6/6 | PCC84 | 5/6 | UF41 | 6/6 |
| DL35 | 4/9 | PCC89 | 8/6 | UF89 | 5/6 |
| DL82 | 4/3 | PCF80 | 9/8 | UL41 | 7/- |
| DL94 | 3/- | PCF82 | 5/9 | UL84 | 5/9 |
| DL96 | 5/11 | PCF85 | 8/- | UY41 | 3/11 |
| EY88 | 6/3 | PCL82 | 6/3 | UY85 | 4/9 |
| EY87 | 6/3 | PCL83 | 8/8 | W77 | 2/- |
| EASCB8 | 5/8 | PCL84 | 7/8 | Z77 | 2/9 |

Postage on 1 valve 8d. extra. On 2 valves or more, postage 6d. per valve extra. Any parcel insured against damage in transit 8d. extra.

Office address, no callers.

GERALD BERNARD

83 OSBALDESTON ROAD
STOKE NEWINGTON
LONDON N.16

FIRST-CLASS RADIO AND T/V COURSES... GET A CERTIFICATE!

After brief, interesting study
—undertaken at home in your spare
time—**YOU** can secure a recognised
qualification or extend your knowledge
of Radio and TV. Let us show you how.

FREE GUIDE

The New Free Guide contains 120 pages of information of the greatest importance to both the amateur and the man employed in the radio industry. Chambers College provides first rate postal courses for Radio Amateurs' Exam., R.T.E.B. Servicing Cert., C. & C. Telecoms., A.M.I.E.R.E. Guide also gives details of range of diploma courses in Radio/TV Servicing, Electronics and other branches of engineering, together with particulars of our remarkable terms of

Satisfaction or refund of fee
Write now for your copy of this invaluable publication. It may well prove to be the turning point in your career.

**FOUNDED 1885—OVER
150,000 SUCCESSSES**

CHAMBERS COLLEGE
(Incorp. National Inst. of Engineering)
(Dept. 844Y), 148 HOLBORN
LONDON, E.C.1

VALVES SAME DAY SERVICE

NEW! TESTED! GUARANTEED!

SETS 1B5, 1B5, 1T4, 8B4, 8V4 DAF91, DF91, DK91, DL92, DL94, Set of 4 for 15/-, 1A P96, DF99, DK99, DL99, 4 for 24/6.

| | | | | | | |
|------------|------------|-------------|-------------|----------------|------------|------|
| 1A7GT | 7/8 7B7 | 7/9 85A2 | 8/9 80C83 | 7/- GZ83 | 12/6 TH283 | 6/6 |
| 1H5GT | 7/8 7C5 | 7/9 00A8 | 12/6 80C84 | 6/8 GZ37 | 8/9 TY287 | 10/9 |
| 1N4GT | 7/9 70C | 6/9 A231 | 8/8 80C85 | 5/6 KT61 | 6/6 U25 | 8/8 |
| 1L5 | 4/8 7H7 | 4/9 B36 | 4/6 80F90 | 7/6 MU14 | 4/- U26 | 3/9 |
| 1B4 | 4/8 7Y4 | 5/- CL38 | 6/8 80F93 | 5/- N15 | 6/6 U37 | 8/6 |
| 1B5E | 3/6 8B4W | 6/8 CY1 | 12/6 80F96 | 10/9 PC37 | 8/9 U38 | 8/6 |
| 1T4 | 1/8 10C2 | 1/6 DLAC93 | 7/8 ECH35 | 8/- PCC84 | 6/6 U54 | 3/9 |
| 8A5 | 6/9 10P1 | 9/9 DAF91 | 3/9 ECH42 | 3/8 PCC89 | 9/6 U78 | 3/6 |
| 8Q4 | 5/8 10LD13 | 7/6 DAF96 | 6/- ECH61 | 6/- PCC189 | 9/- U191 | 9/9 |
| 8B4 | 4/8 12A77 | 3/8 DCC90 | 6/9 ECL80 | 6/8 PCF80 | 6/8 U301 | 10/9 |
| 8V4 | 5/8 12A70 | 4/9 DFB38 | 7/9 ECL92 | 6/8 PCF82 | 9/- U301 | 15/- |
| 9T4G | 4/6 12A77 | 4/9 DFB1 | 1/9 ECL96 | 3/8 PCF84 | 8/- UABC80 | 6/9 |
| 8Y3GT | 4/11 12A77 | 4/9 DFB6 | 6/- EP30 | 3/8 PCF86 | 8/8 UAF43 | 7/9 |
| 8Z40/GT8/9 | 12K7GT | 3/8 DH76 | 3/8 EF41 | 6/8 PCF800 | 8/- UBC41 | 6/9 |
| 8Z612 | 8/9 12K8GT | 8/8 DH77 | 4/- EP80 | 4/9 PCL82 | 6/8 UBC81 | 6/8 |
| 8AL6 | 2/- 19Q7GT | 8/9 D183 | 12/6 EFS8 | 6/- PCL85 | 6/6 UBF90 | 8/- |
| 8AME | 2/9 19D6G | 5/9 DK92 | 6/9 EP86 | 6/8 PCL84 | 8/8 UBF90 | 5/9 |
| 8AQ8 | 4/8 20L1 | 11/8 DK90 | 4/9 EP89 | 4/8 PCL85 | 8/- UCC84 | 3/- |
| 8AT8 | 4/- 20P3 | 10/8 DK92 | 8/- EP91 | 2/9 PCL86 | 8/8 UCC85 | 6/8 |
| 8BA0 | 4/8 20P4 | 13/8 DK96 | 6/8 EP92 | 2/- PESA4 | 6/8 UCF90 | 8/8 |
| 8BE6 | 4/8 20P5 | 11/8 DLS8 | 6/8 EP97 | 7/6 P2838 | 9/8 UCH91 | 9/9 |
| 8BH0 | 5/- 21A6GT | 4/8 DL85 | 5/- EF183 | 6/8 PEN36C15/- | UCH81 | 8/8 |
| 8BJ0 | 5/8 20U4GT | 11/8 DL92 | 4/9 EL33 | 8/8 PFL30017/6 | UCH82 | 7/3 |
| 8HW8 | 7/9 2524G | 6/8 DL94 | 5/8 EL38 | 11/8 FL86 | 9/9 UCL93 | 9/3 |
| 8CH6 | 6/8 30C16 | 8/- DL98 | 6/- EL41 | 7/3 FL81 | 8/9 UFL41 | 8/8 |
| 8CE6 | 6/8 30C23 | 8/8 D186 | 6/9 EL42 | 8/8 FL82 | 6/8 UFL42 | 4/8 |
| 8F14 | 9/- 30P11 | 9/8 DY87 | 6/8 EL90 | 4/9 FL83 | 6/8 UFL80 | 3/- |
| 8F23 | 9/- 30L16 | 10/8 EABC80 | 9/- EL95 | 5/- PL84 | 6/8 UFL89 | 5/9 |
| 8K7G | 1/8 30L17 | 12/- EAF49 | 7/8 EM90 | 5/9 PL600 | 14/- UL41 | 7/8 |
| 8K8G | 4/8 30P4 | 13/8 EB41 | 4/- EM81 | 7/3 PL801 | 7/6 UL44 | 15/- |
| 8K9GT | 7/6 30P12 | 7/8 EB41 | 7/6 EM84 | 5/8 FX33 | 7/6 UL45 | 8/8 |
| 8P28 | 9/8 30P19 | 13/8 EBC33 | 6/- EM97 | 6/8 PY82 | 8/9 UL84 | 6/9 |
| 8Q7G | 5/8 30P11 | 8/8 EBC41 | 6/8 EY51 | 6/3 PY83 | 8/9 UY41 | 4/9 |
| 98L7GT | 4/8 30P11 | 10/8 ERF80 | 6/- EY86 | 6/3 PY86 | 5/8 UY85 | 4/9 |
| 8V40 | 5/8 30P14 | 11/- ERF83 | 7/8 E240 | 6/3 PY81 | 6/3 VY4B | 11/- |
| 8V8GT | 5/8 30L16 | 8/8 ERF89 | 6/8 E241 | 6/3 PY82 | 6/- W76 | 3/6 |
| 8X4 | 3/8 35W4 | 4/6 EY40 | 6/8 E260 | 4/- PY83 | 6/9 W77 | 2/- |
| 8X5GT | 6/8 38Z4GT | 4/6 EOC81 | 3/9 E281 | 4/8 PY800 | 6/8 X79 | 24/6 |
| 7B6 | 10/8 88K4 | 8/8 EOC83 | 4/8 FW4/800 | 6/8 TH21C | 9/6 Z77 | 2/8 |

Practical, authoritative and inexpensive



BEGINNER'S GUIDE TO ELECTRIC WIRING

by J. H. M. Sykes, Assoc.I.E.E.

Covers the complete design and layout of electrical installations likely to be needed especially on domestic premises. Written from the point of view of an electrical engineer. All recent advances in the field are covered, including the ring circuit and off-peak storage heating systems. Among the other aspects of installation practice dealt with are: outdoor wiring, cupboard door switches, connections to under-floor electric heating installations, connections to warm air central heating and air conditioning plant, dimmers, burglar alarm circuits, baby alarm circuits, and electricity in the greenhouse and the garden.

160 pages 81 line diagrams
only 15s.

FROM ALL BOOKSELLERS

... or, in case of difficulty, 16s. by post from George Newnes Ltd., Tower House, Southampton Street, London, W.C.2.

To say this book is very good value would be inadequate in its field it is first class.

ELECTRICAL AND RADIO TRADING
NEWNES

READERS RADIO

24 COLBERG PLACE, STAMFORD HILL LONDON N.16. STA 4587 & 85 TORQUAY GARDENS REDBRIDGE, ILFORD ESSEX. CRE 7441

Postage on 1 valve 6d. extra. On 2 valves or more postage 6d. per valve extra. Any Parcel Insured against Damage in Transit 6d. extra.

BBC2, TV, RADIO & TAPE REC. SPARES

UHF.625/BBC2. Modify your set to BBC2. 1955 to 1963 models covered. Manufacturers' tuners, IF panels, etc. Send for free lists. SPECIAL OFFER. Complete Pye/Ekco UHF conversion kits:—tuner, transistorised IF and T.B. panel, fittings, circuit, etc. New in manufacturers cartons. Normally 18 Gns. Our Price £8.10.0, post 3/6. Can be used to convert all makes of receivers.

TRANSISTORISED UHF TUNERS new, £7.15.0, post 3/6. TV SIGNAL BOOSTER UNITS. Sensational gain all stations, trans., plug-in types, LABGEAR (Pye) BBC1/ITA or BBC2 75/-, PERDIO BBC2 70/-, LABGEAR (Pye) MATHED 105/-. Post free. CRTs. Rebuilt, new guns, fully guaranteed 12 months. Mullard, Mazda 14", 17" £45.0; 21" £6.10.0, 110" 20/- extra. Carriage 15/-. LINE OUTPUT TRANSFS. Popular types available, brand new exact replacements fully guar. A selection which can be supplied:—

| | |
|--|------|
| PHILIPS 1768 etc., STELLA 8617 etc. | 98/6 |
| EKCO 221 to 331 (U25) types | 45/- |
| FERRANTI 1001 to 1011 (U25 types) | 42/6 |
| EKCO/FERRANTI (U26/perspex types) | 42/6 |
| FERGUSON 406 to 606 etc. 74/6; 306, 308 | 42/6 |
| MARCONI VT157, 158, 160, 161 etc. | 42/6 |
| PHILCO 1000, 1010, 1019, 1020, 1030 etc. | 42/6 |
| KB Royal Star PVP20, QVP20 | 32/6 |
| HMV 1840 to 1854, 68/-; 1865 to 1869 | 42/6 |
| 1870, 1890, 1910, 1920, etc. | 42/6 |
| SOBELL TS17, 346, 486/6; other models | 72/6 |
| PAM, INVICTA all models | 66/6 |
| PYE all types available V4 to V700 etc. | 66/6 |

| |
|----------------------------|
| ALSO L.O.T.s Available for |
| Alba Peto |
| Cosmor Scott |
| Decca Pilot |
| G.E.C. R.G.D. |
| K.E. Dynatron |
| Ultra Recentra |
| Emerson, Etc. |
| McMichael |

Postage and Packing for above L.O.T.s 3/6. C.O.D. 2/6 extra. SCAN COILS. Frame o/p frame osc. transf., width/linearity coils, sound o/p transf., mains droppers, control knobs, dual vol., controls, line osc. transf., resistors, condensers, etc.

TUNER UNITS. Fireball, Pye Miniature, incremental, turrets, channel coils, technical replacements service available.

TAPE REC/CHANGER. Drive Belts, Heads, Pinch Wheels, Idlers, Motors for most British (incl. WALTER) and Continental.

SALVAGED COMPONENTS. Large selection for popular models, clean, serviceable condition, turrets, transformers, etc. ENQUIRIES invited, quotations given. C.O.D. despatch available.

MANOR SUPPLIES

64 GOLDERS MANOR DRIVE, LONDON, N.W.11 (Callers: 589b, HIGH ROAD (nr. Granville Rd), N. Finchley N.12). Open all week incl. Sat., HIL 9118 (Day) SPE 4032 (Evg.).

Just published . . . a comprehensive guide for all interested in — or concerned with — transistors . . .



TRANSISTOR POCKET BOOK

by **R. G. Hibberd**
B.Sc., N.I.E.E., Sen.M.I.E.E.E.

This addition to Newnes' series of technical pocket books provides a comprehensive guide to the characteristics and use of the various types of transistor that have come into use in recent years. It is based on the junction transistor, fully taking into account the latest varieties including the epitaxial planar, field effect, metal-oxide silicon and thin film types.

Early chapters describe the principles of operation, transistor characteristics, equivalent circuits and parameters and establishing suitable d.c. operating conditions. A chapter is included on the manufacture of transistors, so that the effect of the basic methods of fabrication and types of junction on transistor characteristics is clearly understood. The operation and characteristics of associated semiconductor devices used in conjunction with transistors, such as the junction rectifier, silicon controlled rectifier, zener diode, tunnel diode, varactor diode and phototransistor are also described. Low level, high power and high frequency amplification; oscillator, switch and d.c. amplifier circuits; radio receivers and power supply arrangements are all covered in separate chapters, practical circuits complete with transistor types and component values being included for these various applications. The book also includes notes on handling and testing transistors, and a chapter on solid state circuit techniques.

Fully Covers Historical Introduction; Basic Principles; Transistor Characteristics; Transistor Technology; Associated Semiconductor Devices; Transistor Equivalent Circuits and Parameters; D.C. Operating Conditions; Low Level Low Frequency Amplifiers; High Power Audio Amplifiers; High Frequency Amplifiers; Transistor Oscillators; Transistor Radio Receivers; The Transistor as a Switch; D.C. Amplifiers; Power Supplies; Use and Handling of Transistors; Solid Circuit Techniques; Recent Developments.

**MAKE SURE
OF YOUR
COPY
NOW!**

312 pages
220 illustrations
7 tables

only 25s. from
ALL BOOKSELLERS
or complete this coupon and post today

Published by
NEWNES

SEND NO MONEY NOW!

To ODHAMS BOOKS DEPT. SF.330,
Basted, Sevenoaks, Kent

Without obligation reserve me "TRANSISTOR
POCKET BOOK" and send special invoice with
100% Satisfaction or No Charge Guarantee.

BLOCK LETTERS BELOW

NAME

Full Postal Address

.....