

Practical TELEVISION

APRIL 1964

2/-

VISION ON
SOUND C

625 IS HERE!



PART TWO

**Aerial
Designs
for**



BBC 2

Fringevision Ltd

ELCOT LANE MARLBOROUGH · WILTS

TELEPHONE: 657 and 658



WIDE BAND UHF AERIALS for BBC2 now and ITV 2

FIVE STAR QUALITY AERIALS

★ Anodised elements for protection. ★ Modern plastic moulding techniques used for convector reflector and parasitic elements giving longer life. ★ Staggered spaced elements for maximum performance with all channel band width. ★ Multi-element reflector giving high back to front ratio ★ Maximum efficiency of matching by using laboratory developed collector plate—without any other matching device.

Model	Description	Gain DB	B F Ratio DB	Retail Price
UF H3	3-ELEMENT, HEAD ONLY with CLAMP	7.0	18.0	31/6
UF H5	5-ELEMENT, HEAD ONLY with CLAMP	8.25	19.5	36/6
UF H7	7-ELEMENT, HEAD ONLY with CLAMP	10.5	24.5	41/-
UF H10	10-ELEMENT, HEAD ONLY with CLAMP	12.5	26.0	47/-
UF H12	12-ELEMENT, HEAD ONLY with CLAMP	13.5	28.0	51/-
UF H14	14-ELEMENT, HEAD ONLY with CLAMP	15.0	29.0	55/-
UF H18	18-ELEMENT, HEAD ONLY with CLAMP	16.25	30.0	70/-
UF H22	22-ELEMENT, HEAD ONLY with CLAMP	17.0	31.0	85/-

PLEASE STATE LARGE OR SMALL CLAMP REQUIRED

FOR THE AMATEURS RADIO STATION

Illustrated

$\frac{1}{8}$ inch detachable bit soldering instrument
List No. 70

Combined Protective Unit with Wiper Abrasion Pad and Solder Reel
List No. 700

Apply SALES & SERVICE

ADCOLA

(Regd. Trade Mark)

ADCOLA HOUSE
GAUDEN ROAD
LONDON, S.W.4

Telephones:
MACaulay 4272 & 3101

Telegrams:
"SOLJOINT, LONDON S.W.4"



British & Foreign
Patents, Registered
Designs, etc.

VACUUM
ELECTRONIC
LIMITED

KEEPS YOU IN THE PICTURE

WITH THE
FINEST REBUILT CATHODE RAY TUBES

12 MONTHS
GUARANTEE

12"-14" £4.15.0

15"-17" £5.5.0

21" £7.15.0

15/-

CASH WITH ORDER OR
PRO FORMA, ADD 12/6 FOR
CARRIAGE AND INSURANCE.

ALLOWED
ON RECEIPT
OF OLD
TUBE

DELIVERY FREE IN LONDON AREA

WRITE PHONE OR CALL
VACUUM ELECTRONIC LTD.

35, SACKVILLE STREET
LONDON, W.1
REGENT 6404 (5 lines)

D. & B. TELEVISION (WIMBLEDON) LTD.

131 KINGSTON ROAD, SOUTH WIMBLEDON, LONDON, S.W.19. 'Phone: CHerrywood 3955

"COMPARE OUR SERVICE WITH ANY OTHER"

For the finest service in the Country. We are open from 9 a.m. to 6 p.m.—1 p.m. on Wednesdays. For any information or problems you have, call or phone, we are always pleased to help. Line output and Scan Coil specialists.

EXAMPLE OF LINE OUTPUT TRANSFORMERS FROM OUR STOCKS.

ALBA—T301, T304, T394, T484, T494, T504, TR1974, TR9974 at 49/7	MASTERADIO—All types can be rewound, some can be supplied on our Exchange Unit Plan.	81/-
T312 Rewind. at 75/-	McMICHAEL—M14T, M17T, M17LC	81/9
T321, T324, T424, T524, T524PM, at 44/9	M31T, M211LC, M22C, M23HFC, M72T, M77HFC	81/9
T331, MT341, T352, MT362, T431, T432, MT441, MT442, at 51/9	All types available, earlier Models, Rewind or Exchange Units.	81/9
T641, T644, T724PM, T744PM. at 70/10	MURPHY—240-250	78/8
T655, T669, T717 at 57/9	V270, V280	82/-
BEETHOVEN—R106, R109, R204 at 57/9	V310, V330, V350, V470 to V540 inclusive	82/-
BUSH—TV32, TV33, TU634A, T36, TV36, TUG36, TV36/C, TUG36/C, TV43, TV53, TV56, TV57, TUG58, M59, TUG59, TV62, TV63, TV66, TV67. Rewind or Exchange Unit at 70/-	V410, V420	87/9
TUG68, M69, TUG69. Rewind or Exchange Unit at 128/-	All spares available. Prices on request, S.A.E.	87/9
TV80 at 103/9	PAM—908, 909, 932, 953, 958	57/9
TV85 at 103/9	754, 764, 785C	63/9
TV75 Rewind Only	501, 501A, 501F, 517, 517A, 517C, 517F, 521, 531CA, 521CF, 521F, 560P	67/6
COSSOR—R17A, 930, 931, 933, 934, 935, 937, 938, 938A, 939FA, 940, 942, 942A, 943, 944, 946 at 63/-	With INVICITA, PAM or PYE spares please state serial number and maker's part number.	67/6
945, 945B, 949 at 64/-	PETO SCOTT—14SA, TR16, 17SA, TV1416, T1418, T1419, TV1716, TV1719, TV1720. These are supplied as inserts only at 38/6	
DECCA—DM1, DM2/C, DM3, DM4, DM4/C, DM5, DM14, DM17, 444, 555, DM55 at 72/8	PHILCO—1000, 1010	91/5
DM35, DM45, DM21/C, DMG21, DM22/C at 74/8	1013	92/6
DEFIANT—all Rewinds only	1021, 1023	91/5
DEKATRON—All early models Rewinds TV35, TV30 at 52/8	1800, 1810	91/5
EKCO—TK208, TK209, TK3091, T221, T231, T234F, T240, T227, TC267A, T283, T284, T295, T311, TGC316, T326, T327, T330, T330F, T331, TCC337 at 52/8	1900, 1911, 1968, 2100, 2161	72/3
TMB272, T344, T344F, T345, T348F, T350 at 68/6	1962M, 1967, 1967M	47/6
TC312, T313, T313F, T335 at 73/9	All Philco spares are available, some being exchange units, some are rewinds (older models). Please send S.A.E. for quotation on any not listed.	65/6
EMERSON—E700, E701, E704, E708, Port O Rama, E707, E709, E740, E711. These are supplied as an exchange unit at 52/8	PILOT—CV76, TV76, CV77, CV84, TV84, CV84/12, TV82/12, DV87, CV87, TV87, DDC87/12, CV87/12, TV87/12. These are supplied as inserts only	44/-
ENGLISH ELECTRIC—All these components are rewind only, S/Coils and line output, although some we can do on exchange unit basis.	TV94, DDC97, TV97. These are supplied as inserts only	44/-
FERGUSON—45T 454T at 85/5	110F, 111, 117, TV107	63/11
103T, 105T, 113T, 135T, 142T, 143T, 145T, 990T, 991T, 992T, 993T at 66/9	All other types available, prices on request.	
994T, 995T, 996T, 997T, 998T at 66/9	PORTADYNE—All types are rewind only	70/-
988T, 989T at 52/8	PYE—V14, V14C, V4, V4A, V7, V7	52/8
203T, 204T, 205T, 206T, 214T, 235T, 236T, 244T, 246T at 68/9	Luxury 17 series	66/-
302T, 307T, 313T, 317T at 91/5	ITP01, CS17, CS17C, CS17F, CS17CF, CTM17F, CTM17S, CM17T, CW17, CW17C, CW17CF, CW17F	66/-
306T, 308T at 57/9	CTM17S, CW17S, CW17S	67/8
408T, 408T, 416T, 436T, 438T, 405T, 407T at 91/5	CTM21S, CW21S, CT158F	67/6
500 Series 504T at 91/5	CTM21, CTM21C, CTM21F, VT21, VT21C	72/8
FERRANT—14T2, 14T3, 14T3F, 14T4, 14T4F, 14T5, 14T6, 17K3, 17K3F, 17T3, 17T3F, 17K4, 17K4F, 17K5, 17K4K, 17K4KF, 17K6, 17K6F, 17K6S, 17K6K, 17T4, 17T4F, 17T5, 17T6. These are supplied as inserts only	V200, V200LB, V410, PV110, V300S, V300F, V310S, V310F, V210, V210LB, V220, V230, V410, V430, V510, V730, V600A	72/8
20741, 21K6, 21K6V, 22K3, 24K4. These are rewinds or exchange units.	V700 P/No. 782740	42/9
T1001, T1002, T1002/1, T1004, T1005, T1011 at 52/8	V700 P/No. 716374 or V700 P/No. 782643	61/9
T1012, T1023, T1024, T1027 at 66/-	V700A P/No. 782740	42/9
G.E.C.—BT1251, BT1252, BT1252A, BT1746, BT1748, BT2250, BT2745, BT2745R, BT2747, BT4743, BT3248, BT3347, BT3348, BT3643, BT643R, BT8245, BT8246, BT8640. All these are supplied on Exchange Unit basis	V700LBA P/No. 716374	42/9
BT8742, BT1136, BT1334, BT2154, BT2155, BT8149, BT8248 at 80/-	V820A, V830LBA, V710A	59/9
1829, 1829A at 67/6	TT1	42/9
1840, 1841, 1842, 1843, 1844, 1845, 1846, 1847, 1848 at 67/6	BT260A, V700D, 710D, 830D, Model 1, Model 2, Model 11, Model 13	59/9
1865, 1869 at 67/6	Other Pye spares quotation on request, S.A.E. please. When ordering Pye spares please state model No. and serial No. also state if printed or wired circuit.	
1870, 1871, 1872, 1873, 1874, 1875, 1876 at 91/5	RAYMOND—All S/Coils and line outputs are rewind only.	
INVICITA—T118, T119, T120 at 57/9	REGENTONE—All early models rewind or exchange unit.	
T122, T126 at 61/9	T14 10-6 (or rewind at 70/-)	114/-
T123, T124, T125, T133, T134 at 64/6	10-4 and 1017 supplied as insert	38/6
287, 2378F, 437 at 88/-	R.G.D.—DEEP17PME, 17TME21 rewind only	
537, 538, 539 at 61/5	710, 611, 610	114/-
With INVICITA, PAM or PYE spares please state serial number and maker's part number.	SOBELL—T817, T347	81/-
KOLSTER BRANDES—All types available, some of these are rewinds.	T21, T21C, T211C, T22	87/9
PVP20, PVP30 Royal Star at 106/9	T11, T11C, T129	81/9
QV10R, QU20, QU30 at 97/3	T141, SC34, SC34, SC270, SC370	66/-
PV40 at 102/-	ULTRA—V814, V815, V817, V915, V917. These are exchange units	97/8
QVP20, QVP30 at 104/3	14-53, VP14-53, V15-60, V1750, VRI752, V1753, V1760, VRI762	63/6
PV100, PV100/1 at 121/8	WR1762, V1763, V1764, V21-50, V21-52, V21-60	80/9
MARCONI—All types available, some are rewinds.	V17-80, V17-81, V17-82, V17-83	72/6
68 series, VTC84DA, VCL153 at 67/6	V19-80, V19-84, V19-85	81/3
VT153, VT155, VT156 at 52/8	V23-80, V23-84	70/-
VT157, VT158, VT159, VT160 at 91/5	All S/Coils can be supplied on the above Ultra range.	

This list of line outputs is the most comprehensive and up-to-date yet published by anyone, if you do not see what you require we may still hold this in our stocks, or if not we can rewind it for you . . . Send S.A.E. all enquiries, and remember . . . All goods if in stock will be despatched the same day.

THE ABOVE LISTED ITEMS ARE BRAND NEW & SUBJECT TO 3 MONTHS GUARANTEE
OUR STREAMLINED RE-WIND SERVICE IS NOW ONLY 7 DAYS

Send S.A.E. for free list of valves, and quality re-built CRT's at bargain prices

TERMS: C.W.O. or C.O.D., Postage on all L.O.P.T.S and S/Coils, 3/-. C.O.D., 5/-.

NEW, Revised, Enlarged Edition!

RADIO, TELEVISION & ELECTRICAL REPAIRS

AMAZING 'KNOW HOW' BOOK
Brings You RIGHT UP TO DATE!

576
PAGES
OVER
470
ILLUSTRATIONS

JUST OFF THE PRESS—this essential handbook for the enthusiast, handyman or professional repairer is packed with detailed information and easy-to-follow instructions on how to service radio and TV sets (including all-transistor and U.H.F. circuits), audio equipment and domestic appliances of every kind. Shows every step in fault tracing and the use of modern test gear, from simple meters to complex oscilloscopes. Also provides practical guidance on household electrical installation work. 576 pages. Over 470 illustrations. Mammoth value—Special De Luxe Edition, superbly bound in leathercloth, 50/-, or on easy terms: 13/- down and 3 monthly instalments of 14/- (55/-).



HUNDREDS OF NEW ILLUSTRATIONS! REVISED
CONTENTS COVER LATEST TECHNICAL DEVELOPMENTS!

U.H.F. TELEVISION

Here are basic circuits and full instructions to enable you to service modern sets—get perfect 625-line reception.

Getting the best from RADIO AND TV SETS

How to make adjustments and repairs in order to get the best possible performance from any set.

All you need to know about DOMESTIC INSTALLATIONS



Learn from these helpful pages how to carry out modifications and extensions—with efficiency and safety! Complete guidance on lighting and power circuits, practical wiring work, safety regulations, cables, earthing, fuses, etc.

Also includes Fluorescent Lighting, Thermostats and Time Switches.

WATER HEATING

All you should know about the various types of water heaters and how to install them and keep them in perfect working order.

How to service FIRES and SPACE HEATERS.

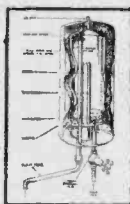

HOW TO MAINTAIN AND REPAIR DOMESTIC APPLIANCES

From irons, toasters, hair driers, etc., to cookers, washing machines and refrigerators. Also covers the repair and rewinding of small motors.

SPECIAL SECTION ON COLOUR TELEVISION

Explains clearly and concisely the principles of prospective colour-transmission systems.

TRACKING DOWN TROUBLE

This grand book is invaluable for tracing faults in radio and TV sets (both valve and transistor circuits). Deals fully with tools and bench work—shows how to make the best use of test instruments. Tells everything you want to know—from how to carry out preliminary tests to how to align tuned circuits.

Servicing DOMESTIC AUDIO EQUIPMENT

How to locate and rectify faults in hi-fi equipment (mono or stereo), record players, tape recorders, etc.

ACT NOW!

Simply complete form, indicating method of payment preferred, and post in a 2½d. stamped, unsealed envelope. Offer applies in the U.K. and Eire only. Hurry! Make sure of your copy.

ONE GREAT VOLUME covers:

Current, Voltage and Resistance. Coils, Capacitors and Tuning. Valves, Tubes and Transistors. Radio Components. Receiver Design Principles. Transistor-Radio Circuits. Valve-Radio Circuits. Valve-Television Circuits. Transistor-Television Circuits. Colour-Television Systems. Audio Amplifier Circuits. Audio Equipment and Gramophones. Tape Recorders. Radio and Television Aerials. Tools and Bench Work. Test Instruments and Their Use. Fault Tracing and Circuit Testing. Alignment of Tuned Circuits. Television Fault Tracing. Interference Suppression. Domestic Power Supply Circuits. Electrical Wiring Work. Fluorescent Lighting. Thermostats and Time Switches. Motor Repair and Rewinding. Small Appliances. Space- and Water-Heaters. Electric Cookers. Washing, Drying and Ironing Machines. Electric Refrigerators. Suction Cleaners and Floor Polishers.

SEND NO MONEY NOW!

To: Dept. H.F.35, Othlams Books Ltd., Basted, Sevenoaks, Kent.

WITHOUT OBLIGATION reserve me "Radio, Television and Electrical Repairs" and send Special Invoice with "Full Satisfaction or No Charge" Guarantee.

Tick method of payment preferred: CASH TERMS
BLOCK LETTERS BELOW

NAME

Full Postal ADDRESS

H.F.35/April '64

Practical Television

AND TELEVISION TIMES

VOL. 14, No. 163, APRIL, 1964

Editorial and Advertisement
Offices:

PRACTICAL TELEVISION

George Newnes Ltd., Tower House
Southampton Street, W.C.2.

© George Newnes Ltd., 1964

Phone: Temple Bar 4363.

Telegrams: Newnes, Rand, London.

SUBSCRIPTION RATE

including postage for one year
To any part of the World £1.9.0

Contents

	Page
Editorial	291
Teletopics	292
Aerial Design for BBC-2	294
A Flying-Spot Transparency Scanner	297
Servicing Television Receivers ...	301
Underneath the Dipole	304
Slow Running Timebases	306
A Sound/Vision Transmitter	309
Changing Cathode Ray Tubes... ..	312
On the Air	316
Books Reviewed	318
110° Scanning Circuits	319
DX-TV	322
Your Problems Solved	323
Test Case	328
Letters to the Editor	331

The Editor will be pleased to consider articles of a practical nature suitable for publication in "Practical Television". Such articles should be written on one side of the paper only, and should contain the name and address of the sender. Whilst the Editor does not hold himself responsible for the manuscripts, every effort will be made to return them if a stamped and addressed envelope is enclosed. All correspondence intended for the Editor should be addressed to The Editor, "Practical Television", George Newnes Ltd., Tower House, Southampton Street, London, W.C.2.

Due to the rapid progress in the design of radio and television apparatus and to our efforts to keep our readers in touch with the latest developments, we give no warranty that apparatus described in our columns is not the subject of letters patent.

Copyright in all drawings, photographs and articles published in "Practical Television" is specifically reserved throughout the countries signatory to the Berne Convention and the U.S.A. Reproductions or imitations of any of these are therefore expressly forbidden.

625 IS HERE!

IN a week or two, the test transmissions from the BBC u.h.f. transmitter at Crystal Palace will give way to the first regular programmes. April 20th is D-Day for BBC-2, a day which will take its place as a milestone in the history of television, along with other notable events of the past. For BBC-2 opens a new chapter in the development of TV in this country.

The Crystal Palace station will serve about 10 million people in London and the Home Counties and is the predecessor of a chain of stations which, ultimately, will cater for virtually the entire population. Other high power stations expected to go on the air next year will cover the Midlands, Central Scotland, South Wales, Lancashire, South Yorkshire, Northern Ireland, the Isle of Wight and N.E. England. Nine more high power stations scheduled for 1966 will bring BBC-2 to around 75% of the population. A large number of "fill-in" stations, necessary due to the nature of u.h.f. propagation, will complete the coverage, by 1969 it is hoped.

To the experimenter, the advent of BBC-2 is a welcome innovation, bringing a challenge and an incentive. The techniques of u.h.f. propagation and reception will be new to many and will present new problems, both on the constructional and servicing side—apart from the question of aerials and test gear.

But the adoption of u.h.f. broadcasting is not simply a matter of changing the carrier frequency and the number of lines in the horizontal scanning circuit. We are now faced with the unfamiliarity of a whole new system of transmission and reception. The days of the 405-line v.h.f. system are numbered. A new order appears before us.

But in the preoccupation with personal technical matters, it is very easy to forget the massive operation which has been necessary to launch the new service from the "other side of the picture".

In a comparatively short time, the BBC has had to alter existing studios to handle both 405 and 625 standards, to build and equip entirely new studios, to install much new technical equipment and convert existing equipment, to recruit new staff—producers, designers, cameramen, sound engineers, script writers, make-up personnel, vision mixers, secretaries, etc. A gigantic task, demanding "crash" action.

Vintage viewers will recall the early post-war days of television, when hearing that programmes from BBC-2 will be restricted in duration from 7 or 7.30 to around 10.30. To some, these were halcyon days. Was this because with limited time, the question was not what to put on but what to leave out? Apart from a considerable increase in transmission time, the intervening years have seen the arrival of an alternative programme and, consequent upon this, a preoccupation with competition and audience rating figures.

We hope that BBC-2 does not inherit the same outlook.

Our next issue dated May will be published on April 22nd.

TELETOPICS

Packed Audience at Practical Television Film Show

THIS year's PRACTICAL WIRELESS and PRACTICAL TELEVISION Film Show, held on January 31st at Westminster's Caxton Hall, attracted more

people than ever before. In the audience were readers from as far away as Southampton and Coalville, many of whom, no doubt, were prompted to attend by the

subject of the first half of the programme—an illustrated talk by Mr. I. Nicholson of Mullard Limited, on colour and u.h.f. television. This, of course, proved of especial interest to the PRACTICAL TELEVISION readers among the audience.

The audience also had the opportunity this year, of hearing for the first time the Editor of P.W. and P.T., Mr. W. N. Stevens, speak from the chair.

Re-assembling in the hall after a break for refreshments, the audience was entertained during the second half of the evening's programme, by a Mullard film on the use and applications of ultrasonics. The meeting ended with Mr. Nicholson replying to questions from the audience on various subjects, but mostly on colour and u.h.f. TV.

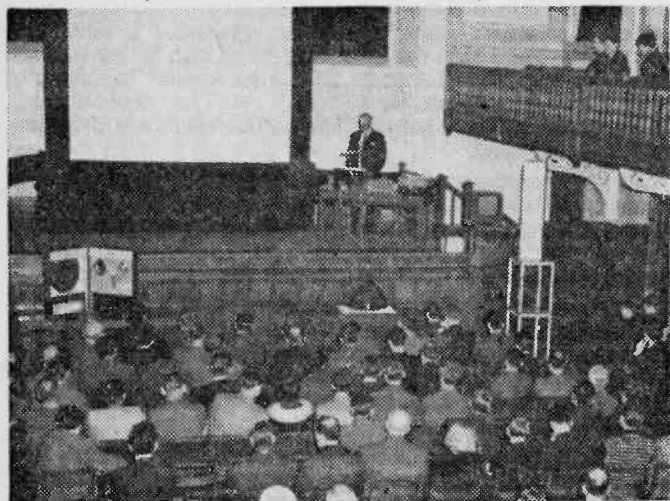

The Film Show audience listens to Mr. I. Nicholson of Mullards.

BOAC EXPERIMENT WITH CCTV

CLOSED circuit television has been introduced by the British Overseas Airways Corporation at London Airport on an experimental basis, to convey BOAC flight information from the Station Duty Room to television monitors in various departments of the building. As new information about each flight arrives, it is written on an illuminated panel in front of a camera, which then carries the information over the CCTV link to the monitors.

The system was built and installed by Epsilon Industries Limited, and if it proves a success, it will be extended to some twenty departments of BOAC.

MORE U.H.F. AERIAL INSTALLATIONS

FOLLOWING the announcement that the Marconi Company Limited had been awarded the contracts to supply u.h.f. aerials for the Wenvoe and Sutton Coldfield Stations of the BBC (see Teletopics last month), the same firm announces further contracts to supply and install transmitting aerials at three more stations in the network to provide BBC-2 coverage of the whole country. Two of the aerials are to be installed at the Corporation's Rowridge (Isle of Wight) and Pontop Pike (N.E. England) stations, and the third will be mounted on the ITA mast at the Authority's Black Hill (Scotland) station. The aerial to be installed at the latter station will be similar to that being used at the Crystal Palace transmitter. The two other aerials will follow the form of construction used at the Wenvoe and Sutton Coldfield transmitters, that is, dipoles mounted inside fibre-glass cylinders.

To make room for the u.h.f. aerial on the Pontop Pike mast, the existing Band I BBC aerial is to be dismantled and a new one mounted lower down. EMI Electronics Limited has received the order for the aerial which, once installed, will be put into service overnight at the same time as transmissions from the original one cease, so that there will be no interruption in the service.

"Fill-in" Stations for BBC-2

DESPITE the fact that a man living in Warwickshire, Mr J. S. J. Griffiths, manager of a branch of Radio Rentals Limited in Shirley, Solihull—has received BBC-2 trade test transmissions from the Crystal Palace station, a reception survey of the service area of the London transmitter has revealed that, as predicted, there are a number of "shadow" areas where the u.h.f. signals are obstructed by hills and other such obstacles, making it impossible for many viewers in these areas to receive satisfactory pictures.

To overcome this problem, the BBC proposes to build "fill-in" stations in the four main shadow areas which have been found to exist in Reigate, Tunbridge Wells, Guildford and Hertford. These stations, which are expected to begin service about the middle of 1965, will of course, operate on channels other than the channel 33 of the main Crystal Palace station.

Although other fill-in stations will be necessary to serve smaller shadow areas which will still exist, plans of these cannot be announced until reception in the service area is further investigated.

Anglesey's New Relay Station

ON March 9th the BBC brought into service a new television relay station on the island of Anglesey, to provide the town of Holyhead with satisfactory transmissions of the new BBC Television Service for Wales. A new station was necessary because the other transmitter in Anglesey—at Llanddona—has only a restricted radiated power which meant an inadequate service for viewers in Holyhead.

Transmissions from the station are on channel 4 (vision 61.75Mc/s, sound 58.25Mc/s) with horizontal polarisation.

Flying-spot Scanners for TV Company

AS a further step toward converting its Southampton studio centre to 625-line operation, Southern Television has ordered more flying-spot film scanners from Rank Cintel. The order includes both 16mm and 35mm scanners, along with a specially designed control desk. Increasing numbers of commercials from Southern's two transmitters have made extra flying-spot equipment necessary for the many test marketing campaigns carried out in the area.

O.B. Unit at Winter Olympics

TELEVISION coverage for the American Broadcasting Company of this year's Winter Olympics, held recently at Innsbruck, Austria, was provided by the European TV production company, InterTel A.G. To carry out this undertaking, InterTel hired a comprehensive television outside broadcast unit from the Marconi Company Limited. This unit comprised an operating crew of 24 engineers and technicians and four vehicles in which the cameras and equipments were carried from Marconi's headquarters in Chelmsford, Essex, to Innsbruck.

The outside broadcast vehicle itself is notable for its ability to carry no less than eight black-and-white television cameras, which InterTel used in conjunction with two more cameras, linked to the van by microwave radio links, to provide the necessary coverage.

Full vision mixing facilities for ten cameras thus became available to the production company, along with sound mixing facilities for up to 16 microphone channels.

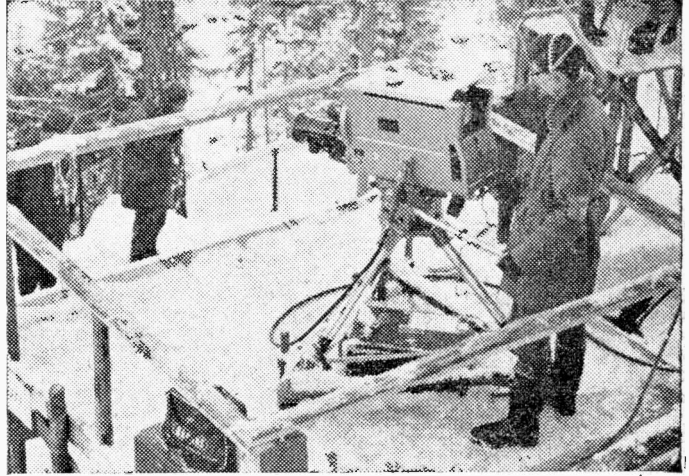

A Marconi camera in position at the Olympic bobsleigh run in Innsbruck.

SIX NEW ITA STATIONS

SIX new ITA transmitting stations are to be equipped by the Marconi Company Limited, under a contract announced recently. The stations are to be established in areas not adequately covered by existing transmitters and will operate automatically and unattended.

Three new stations at Caithness, Central Berkshire and Bedford, will be equipped with four translators (type BD.368) and four 500W amplifiers (type BD.377) and all ancillary equipment; while the other three—at Dundee, Scarborough and the Isle of Man—will have dual translators and dual 500W amplifiers, plus ancillaries.

The new station at Caithness is to have a mast, a Band III aerial and feeder system supplied by EMI Electronics Limited under a separate contract placed by the Independent Television Authority. Although at first only the channel 8 ITA service will be transmitted from Caithness, space will be left available at the top of the mast for a u.h.f. cantilevered aerial capable of transmitting up to 4 u.h.f. programmes, to cover future requirements.

The 750ft. high triangular lattice steel mast will be erected by British Insulated Callender's Construction Company Limited,

AERIAL DESIGN FOR BBC 2

By K. Royal

PART 2

IN the first part of this article we investigated the more theoretical aspects of u.h.f. aerials. This second part deals with the practical side. Armed with all the technical details of element lengths, spacing and so forth, the experimenter will now want to try his hand at constructing a practical aerial for mounting on the chimney or in the attic.

Mechanically, an outside aerial needs to be more rugged than its attic-mounted counterpart, though technically there is not a lot of difference between them. At this early juncture, however, a point should be made of the fact that at frequencies corresponding to Bands IV and V the signals passing through the roof of a house are weakened or attenuated several times more than signals of the v.h.f. channels, and this applies more when the roof is damp or wet.

The u.h.f. attenuation is least when the roof is perfectly dry and when the signal arrives at right-angles to the roof surface. The worst possible condition for an attic aerial is the centre of a terrace block with the signal passing along the length of the building! It is just not worth considering an attic aerial in such a case.

Neither should attic aerials be considered if there happens to be a lot of foil or metal in the roof space. Sometimes a metal foil material is employed for heat insulation, and this can really play havoc with attic-mounted u.h.f. aerials.

OUTSIDE AERIALS PREFERABLE

Generally speaking, the best possible outside aerial should be used in all areas other than those in a very high signal field. Note that even close to the transmitter outside aerials may be needed to get rid of ghosts or to overcome some local screening problem.

Set-top aerials and other types of aerials installed in the same room as the receiver are not very satisfactory at ultra-high frequencies, and recent reports have been received of signal variations due to the movement of knives and forks when viewing-room aerials have been used. This, of course, is not surprising when it is considered that an average fork is approaching a halfwave length of the London u.h.f. channel (channel 33).

Greater liberties can be taken with the v.h.f. aerials, and in cases where a roof or chimney stack is cluttered with such arrays, an attempt should be made to bring them indoors (in the attic), thereby making room for the more critical u.h.f. arrays. If the v.h.f. signals fall too much by this technique, a pre-amp such as the Telebooster can be employed to restore the strength.

BUILDING AN ATTIC AERIAL

In the last article a few practical details of the Yagi aerial were given and it is now proposed to provide more constructional details of this and other type of aerials suitable for the u.h.f. channels.

For attic use, the mechanics of aerials are greatly simplified and a hardwood cross boom is perfectly satisfactory. The small dimensions of the elements and the fact that the u.h.f. transmissions are horizontally polarised are other features which make attic-mounted aerials a good proposition (always provided the conditions permit their use as emphasised above).

The general disposition of the aerial elements in a Yagi array for channel 33, and the essential dimensions are given in Fig. 9.

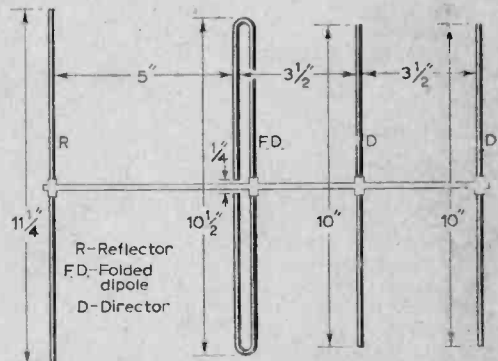

Fig. 9—Lengths and spacing details of aerial elements for channel 33. All elements are made from $\frac{1}{4}$ in. diameter copper tube.

Fig. 10 shows how a length of hardwood batten can be arranged to act as the cross boom to secure the elements. Small staples, or metal "U" clamps held in position by wood screws, can be employed to hold the elements at the pre-calculated points along the length of the batten. A length of 1 in. by 1/2 in. batten is suitable, but the wood should be thoroughly dry and of good quality.

An alternative arrangement is shown in Fig. 11. Here the boom is made of a piece of 1 in. by 1 in. wood and holes are drilled to accommodate the elements. The diameter of the holes must be such that the elements are a tight fit when pushed through the boom.

For attic use, the elements can be made of $\frac{1}{4}$ in. diameter copper tube. This is readily available from

garages and is easy to work with, even if machining facilities are not available.

The biggest problem is in stretching the tube to straighten it so that it can be cut accurately to the element lengths. When it is purchased it is rather kinky and coiled since it is usually unrolled. However, clamping one end in a vice and pulling one's weight against it solves the problem, but care should be taken to ensure that the vice itself is adequately secured, also the tube between the clamps.

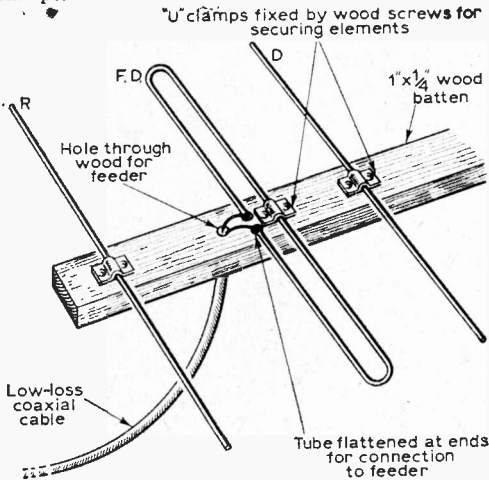

Fig. 10—Practical diagram showing how the elements of an attic type u.h.f. aerial may be secured to a 1 in x 1/4 in. wooden batten.

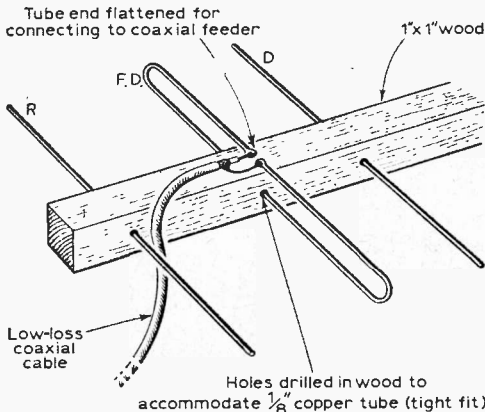

Fig. 11—An alternative method of fixing the elements by drilling through a 1 in x 1 in. cross boom.

MAKING THE FOLDED DIPOLE

The dipole fold is achieved by shaping round the handle of a broom, but extra special attention should be paid to the dimension of the dipole, having in mind that the length is from the centre of the bend at one end along one side, to the centre of the bend at the other end. (See Fig. 6 in last month's article.)

It is best to waste a short length of tube for the dipole by making the open ends overlap. The

correct distance of about 1/4 in. between the open ends is then easy to obtain, after which the ends should be hammered flat for making the coaxial connections, and for screwing to the cross boom.

Soldered connections to the inner and outer coaxial conductors are desirable, but before this is done the elements should be thoroughly polished with a mild abrasive. The polishing should, in fact, take place before the elements are mounted on the boom.

After mounting, a final polish should be given and then the elements should be given a couple of coats of the special type of transparent varnish of the kind that is sold to prevent discolouration of polished brass and copper. Note that this substance is highly inflammable and should be applied in a well ventilated room clear of open flames. The first coat must be dry before the second coat is applied.

The flat ends of the dipole should not be coated, of course, before soldering the coaxial cable.

Last month it was mentioned that instead of a rod or a series of rods the reflector can consist of a sheet of metal mesh. Dimensionally, the reflector should be at least 1 wavelength by 1 wavelength. A suitable material is expanded aluminium of the kind that is often employed for loudspeaker grilles. This is easily fixed to the end of the wooden boom, as shown in Fig. 12. The dimensions given in this diagram relate to channel 33.

"BOW-TIE" AERIAL

Another attic type aerial suitable for the u.h.f. channels is the so-called "bow-tie" or "batwing" dipole used extensively in the U.S.A. and in Europe. Fig. 13 gives all the measurements and constructional details for building this aerial.

The reflector is designed for a 60° angle and this is initially established by the critical face dimension of the wooden dipole support. Stability of the reflector at the correct angle is then achieved by the wooden supports at the rear. The distance of the "bow-tie" type of dipole from the corner of

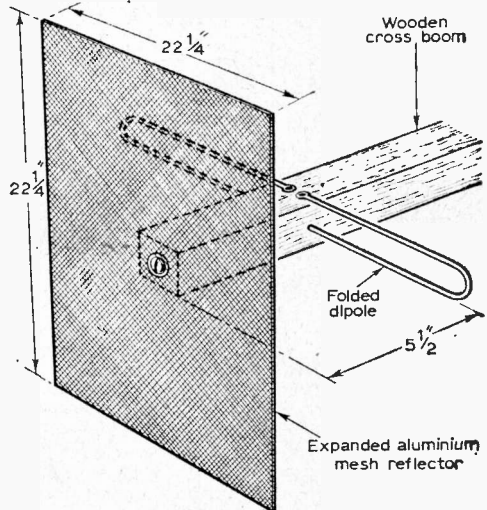

Fig. 12—Expanded aluminium can make a useful reflector and is easily screwed on to the end of the cross boom as this drawing shows.

the reflector is rather critical, as this establishes the gain and the dipole impedance. It will be seen that the dimension also has a bearing on the reflector angle.

The reflector proper can be made of expanded aluminium or of sheet aluminium, the latter being more rigid and the former probably calling for some form of outside wooden framework.

Any type of dipole can be experimented with, but that shown is rather interesting. It is made of flat aluminium of an overall length of $10\frac{1}{2}$ in., which allows for a $\frac{1}{2}$ in. spacing between the two half sections. The narrow ends are $\frac{1}{2}$ in. wide and the outside ends 2 in. wide. The necessary bandwidth is achieved by virtue of the unusual shape of the dipole.

(The length of the bow-tie dipole is basically that of a conventional rod type, but as the width (or diameter) is increased, the length should be correspondingly decreased. It will be remembered that increasing the width or diameter of a dipole increases the bandwidth.)

An ordinary $10\frac{1}{2}$ in. (overall) rod dipole can be used almost equally as well, but a fold is not necessary for impedance matching provided the spacing of the reflector from the corner of the reflector is as per the drawing Fig. 13.

This type of aerial has a very high gain and front-to-back ratio, and is ideal for the attic mounting, provided it is not "looking" along the length of a terrace block of houses.

OUTDOOR AERIALS

Aerials for outdoor erection follow the same general principles as described for attic types, but greater stability to withstand the weather is essential. Moreover, high gain u.h.f. arrays are extremely directional, which means that picture flutter could be bothersome if the aerial vibrates or moves with the wind.

For outdoor arrays, the special components available to aerial constructors should be employed, for these days it is hardly worth while machining special rods, insulators, brackets and so forth as they are so easily obtainable to almost any requirement.

There is little doubt that the greatest scope for the experimenter lies in the design of attic-mounted arrays, such as have been dealt with in detail here.

As a final thought, it is as well to check with the house insurance before mounting home-made aerials on chimney stacks.

CABLES FOR U.H.F.

Normal coaxial cable is likely to prove unsatisfactory for Bands IV and V. At higher frequencies transmission losses in cables are increased and cause serious falling-off in signal strength. The importance of using suitable coaxial cable for aerial

downloads especially in low signal strength "fringe" areas cannot be overstressed.

Special cables have been designed by several manufacturers for Band IV and Band V applications. These cables have larger inner conductors and improved polythene insulation to reduce the rate of attenuation at ultra high frequencies.

Details of typical cables are given below. These cables have an impedance of 75Ω . The first two types are suitable for general use under good conditions. The third and fourth types should always be used in fringe areas or wherever there are difficult reception conditions.

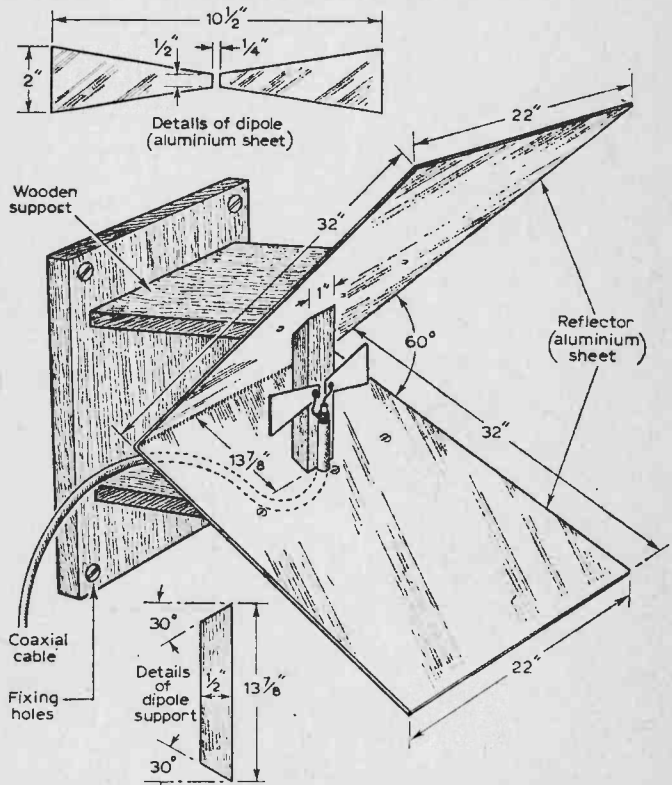

Fig. 13—Constructional details of a "bow-tie" corner reflector type of u.h.f. aerial for attic installation.

Make and type	Inner conductor diameter	Overall diameter	Attenuation dB/100ft. at 600Mc/s
Aerialite: Super Aeraxial 499	0.048in.	0.219in.	5.5
BICC: T3278	0.048in.	0.3in.	5.5
Aerialite: Super Aeraxial 500	0.056in.	0.252in.	4.5
BICC: T3279	0.056in.	0.33in.	4.5

All these cables are suitable for use with standard connectors.

Modulation

Because of the very low power involved anode modulation is used. The r.f. oscillator is built round, a version of the well-known Hartley circuit and the modulating signal is applied to the anode by way of C42 and the r.f. choke L2. (It is not within the scope of this article to go into the full implications of transmitter modulation. Suffice to say that in anode modulation the modulating voltage at the anode causes the anode voltage to rise and fall, causing the amplitude of the generated r.f. signal to vary in sympathy; a modulated r.f. signal is thus produced.)

Positive sync pulses from the anode circuit of the blanking amplifier are taken to V15A and appear as amplified negative pulses at the anode of the valve. These pulses pass through C41 and are

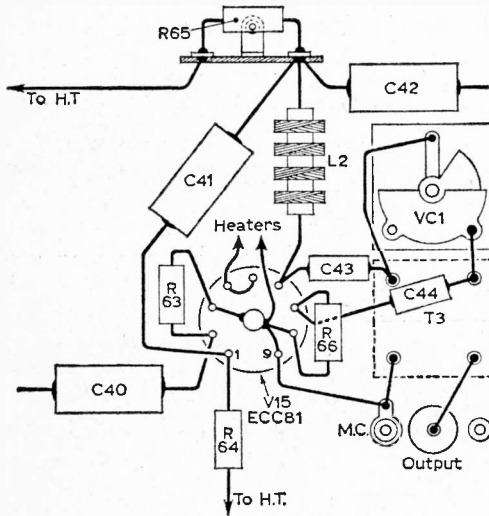

Fig. 25—Wiring diagram of the circuit shown in Fig. 24.

mixed with the video signal at the oscillator anode. The r.f. signal, modulated by the mixed video and sync waveforms, appears at the primary of T3 and the secondary of this coil couples the unit to the monitor set.

Construction

The oscillator circuit should be well screened to prevent unwanted r.f. radiation. The oscillatory circuit of C43, C44, VC1 and T1 should be wired in to be as close as possible to the valve base, and because of the simplicity of the circuit this should not be difficult.

The connection to T1 secondary should be made by a short length of coaxial cable taken to a screened coaxial output socket.

T3 is wound on a dust-cored Aladdin former of 7/8 in. diameter, the whole coil being totally enclosed in a screening can. The primary of the coil consists of seven turns of 22s.w.g. enamelled wire close wound. The secondary is wound over this coil, using two turns of thin insulated wire; any thin

p.v.c. or similarly insulated "hook-up" wire can be used.

The rest of the circuitry is in no way critical and any reasonable layout may be adopted. A suggested arrangement is given in the wiring diagram in Fig. 25.

Testing

With C42 disconnected it should be possible to detect sync signals at V15B anode, using the headphone circuit of Fig. 18. If no signal is heard check the circuit around V15A. When this test has been satisfactorily completed reconnect C42 and disconnect C41, when the video signal should be heard on testing at pin 6 on the valveholder. If both circuits are functioning satisfactorily reconnect C41.

The output should be connected to the monitor set by a short length of coaxial cable and VC1 adjusted so that about half capacitance is in circuit. Switch the monitor receiver to an unused channel in Band I. (It is assumed that the monitor set is a standard multi channel receiver with all channel coils fitted for Band I. If this is not the case then

Test Voltages	
H.T. voltage	350V
Anode voltage	40V
Measured with a 20,000Ω/V meter.	

the extra channel "biscuit" will have to be fitted first before the test is carried out.) The dust core of T3 is now adjusted until the monitor screen brightens generally, and when the point of maximum brightness is reached the core of T3 should be sealed in place.

The circuit is now set up and ready for final testing and alignment.

ALIGNMENT AND FINAL TESTING

Make up the shape of a cross, using insulation tape or similar opaque material, and stick this figure on to the middle of the scanner tube face. (The dimensions of the cross are relatively unimportant but in the original the arms of the cross were 1 1/2 in. long by 1/2 in. wide.) Set the shift amplitude controls on the scanner timebase so that the area covered by the scanner trace is placed squarely behind the cross with a little overlap (say 1/2 to 1 in.) around the ends of the arm.

Switch on the monitor set and allow it to warm up for about 20min. The picture displayed on the monitor screen will in all probability be rather jumbled with a great deal of line tear and frame roll. When the monitor has fully warmed up set the blanking level control VR9 about halfway along its track and adjust the timebase "hold" controls until a steady, single raster is produced. It is suggested that the line hold VR4 should be set first as the frame hold VR6 is more easily set with a stable line lock. If it is difficult to obtain a satisfactory lock the blanking level control should be reset to find a position where full lock can be obtained.

Set the video gain controls VR8 and VR12 on the scanner to minimum output and adjust the brightness control on the monitor set so that the trace is only just visible. Place the phototube in front of the scanner unit with the cathode of the cell some 6 to 9in. away from the scanner tube face. Increase the scanner tube brightness control VR2 to its maximum and focus the tube (VR1) to obtain the finest possible trace.

Turn up the video gain controls to maximum and on doing so a picture should be resolved on the monitor set. If this picture is negative—that is to say, the cross appears white on a dark background—the negative/positive control on the video amplifier (see Fig. 16) should be switched to its alternative position, when the correct black cross on a white background should be displayed.

The video controls are now varied to produce the best available picture and the blanking level control set to give the most satisfactory compromise between good synchronisation and minimum obtrusiveness of the flyback lines.

It will be found that if the final display seems a little squashed a reduction in height of the scanner trace will elongate the displayed picture (VR6 and VR7) and a similar situation prevails for the width controls (VR4 and VR5). It is not possible to detail all the combinations and permutations obtainable with the controls and it is best left to the constructor to find these out for himself by experiment. With a little experience it is possible to resolve an extremely satisfactory picture.

If all has gone well a steady, good-definition picture has been obtained of the cross, having the same dimensional relationship as the original (although not necessarily being of the same size). The cross should now be removed and a transparency substituted, ensuring that this material is in close contact with the tube face.

It will be found that the scanner tube to photocell distance has an effect on the picture definition and when the best position has been found the phototube unit should be fixed in position. Precautions must be taken to ensure that stray light is not picked up by the photocell as this will spoil the final picture, so some device must be used to exclude unwanted light. In the original shutters were placed either side of the slit in the metal screen around the photomultiplier and these worked extremely well.

The purpose of the variable capacitor VC1 in the r.f. circuit (Fig. 24) is to take care of any drift in the r.f. sections of the monitor or transmitter. It will almost certainly be found that VC1 will have to be adjusted slightly every two or three hours to compensate for this drift.

This completes the construction of the Flying Spot Scanner and the unit, properly constructed, should give very satisfactory results and it is hoped that in building the unit the reader will have come to a better understanding of the principles which underly the transmission and reception of television pictures.

**FIRST TIME
EVER!**



PRACTICAL MOTORIST ANNUAL 1964

128-Page Guide to Better Motoring at Less Cost

SPECIAL SECTIONS INCLUDE:

TOOLS AND HOW TO USE THEM Basic tool kit - the right files hammers, drill's and measuring instruments.

CAR KNOW-HOW Interpreting specifications, suspension layout, understanding gear ratios, choosing the right oils, balanced braking.

REPAIR, MAINTENANCE, OVERHAUL Running in - routine maintenance - top and bottom overhauls - fuel system check - overhauling hydraulics, etc., etc.

TUNING MADE EASY Hotting up the family saloon - improvements without expense - keeping up performance - tuning - testing.

ELECTRICS Survey of car electrics and lighting - ignition check know-how - lights and the law.

DRIVING TECHNIQUES How to be a better driver - how to teach a learner.

SELECTED ROAD TESTS Selected P.M. appraisals of popular models.

Demand will be tremendous
TO MAKE SURE
OF YOUR COPY **ORDER NOW!**

Please reserve/
deliver my copy
of the Practical
Motorist
Annual 1964
(2/6), on sale
March 20th.

TO
(Name of Newsagent)

NAME

ADDRESS

SERVICING TELEVISION RECEIVERS

No. 100: K.B. QV20/1, QV70 and QV30/1

By L. Lawry-Johns

THE QV20/1 and 30/1 models have 17in. tubes and are table models. The QV20/1 and QV20/1/F are known as the "Queen", the difference being in the type of tuner unit fitted. The latter has a "Fireball" whilst all other models have a standard Brayhead.

The QV30/1 is known as the "Queen De Luxe" and has front push buttons for on/off and tone control.

The QV70 is a 21in. model with legs. The chosen name for this is the "Kolstar". This also has the push-button controls.

Two further models, the RV20 and RV60, use a basically similar circuit but have a different layout to suit a slimmer cabinet and there are several differences which this article does not cover.

The models which are covered may use a PCC84 or a PCC89 as an r.f. amplifier on the tuner unit

and, contrary to widely-held belief, the latter cannot be satisfactorily used in place of the former. If extra gain is desired from a tuner unit using a PCC84 fit a Mazda 30L15 and retrim the top studs on a Band III test card.

H.T. Rectifier

All models use a contact cooled rectifier bolted on the outside of the right side of the chassis, and whilst this position is an improvement inasmuch as it provides better ventilation, this type of rectifier is prone to efficiency loss. Replacement with a silicon diode such as the BY100 may be considered, bearing in mind the usual precautions to be observed when using this type of low-loss rectifier.

A series resistor of some 25-30Ω wire wound must be included in series with the rectifier and a

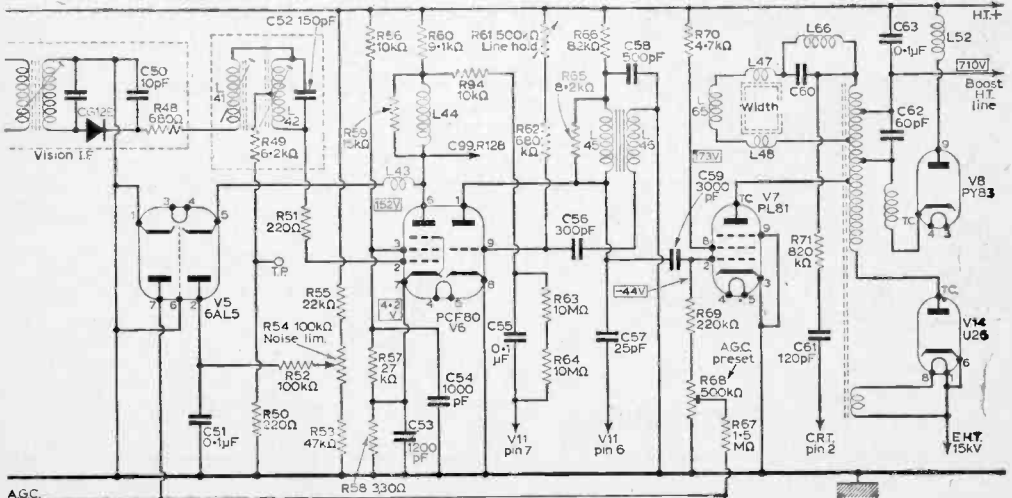

Fig. 1—The video and line timebase circuit.

high-voltage (1kV) 0.005 μ F or 0.01 μ F capacitor wired from the rectifier to chassis or across the rectifier to shunt peak transient voltages which could otherwise cause the rectifier to break down.

Symptoms of a Failing Rectifier

Low h.t. voltage due to a failing metal rectifier can give rise to various symptoms as the voltage drop increases. At first, lack of width with some bottom compression is noticed and then large variations of picture size with loss of focus and complete picture failure when the brilliance is advanced, may manifest themselves. If the width is adequate at low brilliance level, the U26 e.h.t.

render the receiver inoperative but still allow the valve heaters to function. Therefore if the receiver seems completely dead, i.e. no sound from the loudspeaker of any kind and no sign of life from the timebases but the valves all light up, it may be assumed that (a) the fuse has failed, (b) that the rectifier has become open-circuited internally (and this does happen), or (c) that a dropper section is o.c., R139, R140 or R141.

Any of these defects or a combination of them can be caused by an h.t. short, perhaps in the rectifier itself. Quite often the heat generated in the rectifier distorts the insulation, causing one of the contact tabs to touch the metal body. This in itself can be confusing, since once the rectifier cools

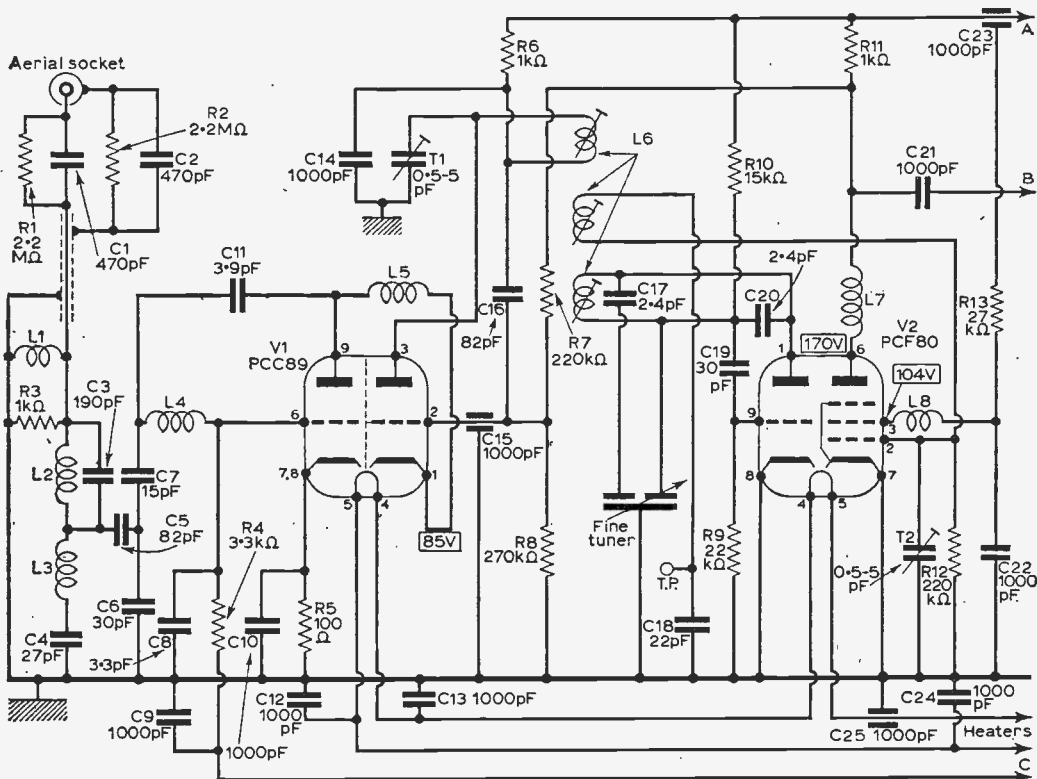

Fig. 2—The circuit of the Brayhead tuner, as fitted on some later models.

rectifier can be reasonably suspected, but if the picture lacks width and to a degree, height, at low brilliance level, it is the h.t. voltage which should first be suspected and checked. This voltage should not be much under 220V.

Fuse

One fuse is fitted and this is a 750mA delay type wired in series with the d.c. input to the h.t. rectifier. It is not associated with the heater circuit. This has certain implications which may not be wholly appreciated.

The obvious point is that failure of the fuse will

off the tab may not touch and no short will be found or will occur again until the rectifier has had time to heat up again. This can be avoided by examining the tabs and their proximity to the metal body.

Another point to note is that a short in the heater chain will not cause the fuse to blow, and if the heater chain is dead there is no point in checking the fuse. Check the mains to the mains dropper with a meter or a neon, check both ends of R135 and, if a clear indication is shown, immediately check the PY83, which is most likely to be suffering from an open-circuited heater which, incidentally, may first be caused by a heater-cathode short in

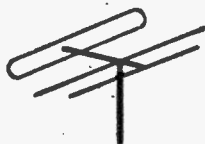

A MONTHLY COMMENTARY

Underneath the Dipole

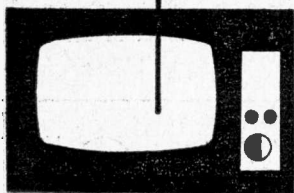

BY ICONOS

THE BBC had a loss of a million of viewers' TV sets during the last few months — until Tuesday's "Steptoe and Son" programmes topped the TAM-rating. It is not surprising that the entertainment of these programmes has almost doubled the number of viewers compared with response to the contemporary, uncheerful and "kitchen sink" TV plays. Both the BBC and the ITA programme producers have been influenced by the vague theatrical productions which appeal only to the small and specialised audiences in London cinemas and theatres. Unpleasant stories which are without endings, have a distasteful appeal to the general television public. The well-balanced script, production and technical values of "Steptoe and Son" have given a first-class backing to the splendid performances of Harry H. Corbett and Wilfred Brambell. Cockney humour is not quite so popular in Scotland and in North-east England as in the South, and possibly the dialect cannot always be fully appreciated in U.S.A. and elsewhere. However, Cockney accents have been successfully understood in the big American cities in "My Fair Lady", "Blitz" and "Oliver" which have led to a steady increase in the import of British-made films and TV plays.

World Currency of TV Programmes

There are now hundreds of TV stations all over the world whose

programmes are mainly obtained by 35 or 16mm film, using television equipment. Prints of the films are compatible for stations operating on 405 or 625 lines (on 50 cycles) or 525 lines (on 60 cycles). The American networks have promoted a large proportion of their TV plays, series, spectaculars or musicals by direct photography on black-and-white film amounting to about 80%. A similar policy has been introduced in various European countries and in Russia. On the other hand, production of equivalent staged material in England, both by the BBC and ITA, has been mainly recorded on magnetic video tape on 405 lines. In order to export it to other countries, transfers are made by photographing on a motion picture camera film, from high quality monitors. The BBC have been particularly successful in obtaining reasonable quality film prints and in the last twelve months have sold no less than 6,400 programmes to 105 countries—about twice the number sold the previous year. The four ITV major programme companies have also exported many programme items by transferring sound and vision from magnetic tape to film. Generally speaking, the technical qualities of directly photographed TV film is superior to film which is transferred from tape, and in addition it enables much more flexible editing and extra shots to be carried out. For example, the BBC's import from America of the "Dick Powell Theatre" series is a good example of visual and sound quality which was superior to other items on the same evening—a BBC Tuesday! For colour television, the American networks produce about 94% of the staged material on film. All of these trends have been expanded in the studios of Hollywood, both black-and-white and colour film production being expanded

for television in place of the cinemas. There are about ten studios in West Germany which have followed the same policy with great success. The application of production controls of three or four motion picture cameras, along the same line as TV cameras, has arisen to the achievement of about 20 minutes of play per day per stage, compared with about 30 minutes per day using TV cameras live or for video tape. On the other hand, traditional methods of film production in studios, including lighting, rehearsing and the use of single cameras, reduces the output per stage per day to less than three minutes of finished and edited film!

Dubbing in Foreign Languages

In the ordinary way, the German films for cinemas and television have been restricted by the language in other countries. Translations of the dialogue are often printed in text over the lower part of the picture or alternatively by the dubbing of appropriate voices to synchronise with the original actors. The same methods have been used when English TV films have been dubbed into the foreign language required. There are methods of recording of vocal dubbing, using loops of film sound track and picture, but one of the most ingenious systems has been devised by De Lane Lea's in London, in which the wave-form of the original sound is synchronised with the written words which are screened before the actors. With this method, English dialogue was applied to the Danish TV film, "The Boy who Loves Horses" for the BBC-TV and was in very good synchronisation. So far as the dubbing of foreign languages is concerned, vocal translations are much more satisfactory on domestic TV sets than the small sub-titles which

are sometimes difficult to read, particularly when the lettering becomes cluttered out by the background or is obscured by the frame.

Charles Dickens

A hundred years ago there must have been more than a hundred theatres or so in all parts of England presenting the classics of Shakespeare, Sheridan, Goldsmith and Dickens. Charles Dickens enthused about the stage versions of his books which appeared in London theatres and in some cases he took part in the stage management of shows until he died in 1870. If he lived today, he would take great interest in the revival of many of his plays on television, films and modern theatres. The BBC's TV serial "*Martin Chuzzlewit*" was a first-rate production, scripted by Constance Cox, in which Richard Pearson gave a brilliant performance of Pecksniff, admirably supported by Anna Middleton and Rosalind Knight as Mercy and Charity, his daughters, and Barry Jones as Old Martin. Other

Dickens stories such as "*The Old Curiosity Shop*", "*Pickwick*", "*Nickleby*" and "*Oliver Twist*" are classics which should attract a large number of viewers, whether presented as plays or as musicals. A good many biographies of Charles Dickens have been written since his death, but the full account of his autobiography can be detected in his writings. His imagination, humour, love and charity for the poor and oppressed made him a great story-teller.

Symphony Orchestras

The first time the BBC experimentally transmitted stereophonic transmissions of symphony orchestras was in 1926, when two large and heavy moving coil microphones were installed in the Manchester Free Trade Hall in front of the Hallé Orchestra. One of the microphones was connected with the BBC network of medium wave stations and the other with the long-wave transmission from 5XX, Daventry. By the use of two sound receivers connected with stereophonic

headphones in a number of radio enthusiasts' and BBC engineers homes, the impact of the orchestra was most impressive. Little progress has been made since then with stereo on radio or TV in Britain, though during the last few years there have been great developments in stereo discs for radiograms and multiple magnetic sound tracks for cinema films. The presentation of monophonic sound of symphony orchestras on television is somewhat dull, though the sound balancers at the studios use multiple microphone set-ups and mix skilfully from microphones which are reasonably near to active musicians. Television presentation of classical symphony orchestra music is more successful with certain conductors, performers who are pianists, violinists or cellists in concertos. Their magnetic personalities make a great contribution to the enjoyment of these concerts. Sir Malcolm Sargent is one of the few conductors whose direction is convincing to the orchestras and elegant in gestures and appearance for viewers.

COLOUR CONFERENCE

CCIR Defer Decision

THE Sub-group of CCIR Study Group XI under the Chairmanship of Mr. Erik Esping, Engineer-in-Chief of the Royal Board of Swedish Telecommunications, which has been discussing in London the problems involved in the choice of standards for public colour television services in the European Broadcasting Area, has just concluded. The meetings have been attended by delegations from the Administrations of 19 countries. In addition, representatives of 13 recognised private operating agencies, experts from four industrial organisations and observers from two international organisations also attended.

The Sub-Group had before it considerable evidence of trials and experiments undertaken by Administrations and by members of the European Broadcasting Union and by the Radio industry. These results covered all aspects of a public colour television service—the design of studio equipment—magnetic tape recorders—radio transmitters—problems of propagation—and receivers. The delegates also had the opportunity to participate in a number of demonstrations of the three systems, N.T.S.C., SECAM and PAL.

Nevertheless, many countries do not yet consider that sufficient work has been done to enable a definite choice of system for Europe to be made. Certain delegations expressed the view that the technical evidence of the work undertaken to date

on the N.T.S.C., SECAM and PAL systems—coupled with the operating experience of ten years of the N.T.S.C. system in the U.S.A.—should have allowed a decision to be given at this point in time but most of the delegations, however, felt it preferable to wait until the next meeting of CCIR Study Group XI to be held in Vienna in the spring of 1965 to make a final review and to reach a final recommendation. 25th February, '64.

Commenting on the above CCIR communiqué on the London meeting, a Post Office spokesman said:

"The view of United Kingdom experts, as endorsed by the Television Advisory Committee, is that, taking all factors into account, the N.T.S.C. system is better than the other two systems. The United Kingdom delegation at the CCIR meeting, therefore, pressed for its adoption. However, the majority of the European Administrations represented at the meeting felt they needed time for further study of the problem.

"The future policy to be adopted in this country will now be reviewed in the light of these discussions; the Television Advisory Committee, on which the broadcasting authorities, the radio industry and Government Departments are represented, are to meet in March to formulate their advice to the Postmaster General."

Slow Running TIMEBASES

By
C. P. Finn

READERS who have watched the television medical programmes will no doubt have seen the electrocardioscopes, which show the waveform of the patient's pulse. The timebase in such an apparatus is designed to run at approximately one cycle per second, for the range of the human pulse is about 50—100 cycles per *minute*. This article describes how a simple timebase may be built to imitate such machines, although it does suffer from some small disadvantages.

The system uses in fact two oscillators; one is a sawtooth oscillator, the output of which is applied to the x-plates of an oscilloscope in the usual way, and in fact can be the internal timebase of the

oscilloscope itself. The second oscillator is made to run *almost* in sync with the first, and its output is fed to the grid of the 'scope. Thus it can be seen that the trace will be blanked except for the duration of the peak pulses on the grid, and since these run almost in sync with the x-scan, the spot will appear to scan at a frequency which is equal to the *difference* between the two oscillators. The "beat" frequency should be that of the y-signal, and can be so adjusted by controlling the speed of one oscillator with respect to the other.

The frequency is controllable from 0—10c/s approximately: above this speed, the spot begins to break up into a series of dashes.

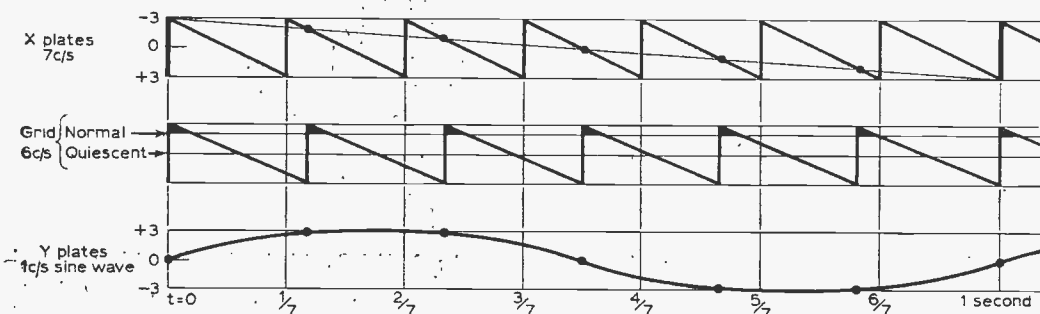

Fig. 1—Illustrating how a 1c/s y-signal is derived from two oscillators running at 7 and 6c/s respectively.

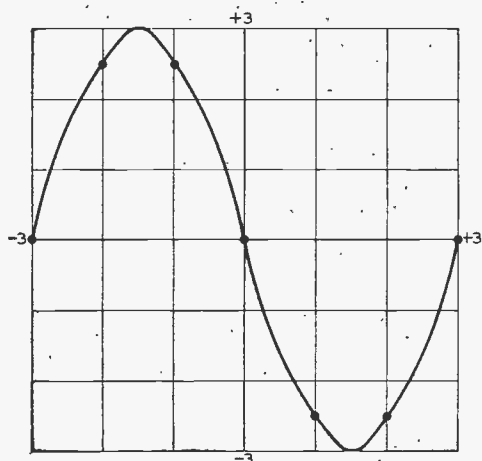

Fig. 2—Display of the combined x and y traces.

Best Speeds

The *actual* speeds of the oscillators must of necessity be something of a compromise, since at low frequencies the trace degenerates into a line of dots which is difficult to interpret accurately; and at high frequencies, the beat frequency is obviously difficult to control. (It is clearly easier to maintain two oscillators at, say 50 and 51c/s than at, say, 5,000 and 5,001c/s), and so the best pair of frequencies must be found by trial.

The development of the trace can be seen from the diagrams in Fig. 1. These illustrate how the oscillators are run at 7c/s and 6c/s respectively to display a y-signal consisting of a sine wave of frequency 1c/s. In Fig. 2, the combined x and y traces are shown. In practice much higher oscillator speeds would be used and the figure is diagrammatic only, serving merely to illustrate the principle.

The waveform of the second oscillator deserves some consideration, and the author used a sawtooth generator identical to the oscilloscope timebase.

—continued on page 315

IMPROVED

Modern styling in light grey with legible black engraving.

Constructed to withstand adverse climatic conditions.

Ever ready case, including leads, prods and clips.

Improved internal assemblies.

Re-styled scale plate for easy rapid reading. 2 basic scales, each 2.5 inches in length.

New standards of accuracy, using an individual calibrated scale plate d.c. ranges 2.25% f.s.d. a.c. ranges 2.75% f.s.d.

Available accessories include a 2500V d.c. multiplier and 5, 10 and 25A shunts for d.c. current measurement.



Mk 4

MULTIMINOR

ACCURACY AND RELIABILITY

The Mk. 4 MULTIMINOR is an entirely new version of this famous Avo instrument and supersedes all previous models. It is styled on modern lines, with new high standards of accuracy, improved internal assemblies, and incorporating pneumatic properties.

The Instrument is supplied in an attractive black carrying case, which also houses a pair of leads with interchangeable prods and clips, and an instruction booklet. It is packed in an attractive display carton. Robust real leather cases are available, if required, in two sizes, one to take the instrument with leads, clips and prods, and the other to house these and also a high voltage multiplier and a d.c. shunt.

D.C. Current: 100µA f.s.d. —A f.s.d. in 5 ranges
 A.C. Voltage: 10V f.s.d. —1,000 f.s.d. in 5 ranges
 D.C. Voltage: 2.5V f.s.d. —1,000 f.s.d. in 6 ranges
 D.C. Millivolt range: 0 —100mV f.s.d.

Resistance: 0.2 MΩ in 2 ranges using 1.5V cell.
 Sensitivity: 10,000Ω/V on d.c. Voltage ranges.
 1,000Ω/V on a.c. Voltage ranges.

● For full details of this great new pocket-size instrument, write for descriptive leaflet.

AVO LTD AVOCET HOUSE - 92-96 VAUXHALL BRIDGE ROAD - LONDON, S.W.1 - VICTORIA 3404 (12 lines) **M** GROUP

NM17



17" £11.10.0

14" £ 7.10.0

12 months' Full Written Guarantee

Channels for all areas.

Demonstrations daily in our Shop. Personal collection

Carr. 14in., 20", 17in., 30".

TV EXTRAS

AERIALS 25/-. Indoor combined. Complete with 12ft. co-ax. and plug. P. & P 2/6

AERIALS 35/6. Loft Combined BBC with 3 element ITA universal fitting. P. & P. 3/6.

LEGS—35/6. Complete with fittings for any set.

Co-ax Cable 6d. per yard. Plugs 1/3 ea.

PERSONAL CALLERS

T.V.s 5/-. Type 38 Sets 15/-.

Large Transmitting Valves 5/-.

Tape and Player Cabinets 5/-.

Telephone Multi-line and dials systems 25/-.

Tubes various: 2in. to 6in. short or long persistence, some electrostatic, Brit. and U.S.A. from 5/-.

VALVES 9d. each 40—£1.

Thousands of Valves available. P.P. on 1 - 4 6d., 12 1/6.

Phone ILford 6001/2/3

SPEAKERS 7/9 ea. 6in. 8in. 7in. x 4in. Money back guaranteed. Enquire for other sizes Ex. mfd. salvage. P.P. 2/3.

SPARES

Condensers. 100, 10/- . New Assorted electrolytics & P.F.s. Resistances 100—5/- . Ass. sizes, watts, grades.

TELEPHONE 15/6 HANDSETS pair

G.P.O. standard pattern. House to Workshop, garage, inter-office, etc. Works off any small battery. P. & P. 4/6.

TELEVISION TUBES

REGUNDED

Guaranteed 1 Year. Ins. and Carr. 10/6

Add 10/- refundable on OLD TUBE.

15, 14, 59/6

(110° Tubes in stock) 12 in.

15/- EX-MAINTENANCE TESTED TUBES

Satisfaction Guaranteed. 36/24, 14KP4, 141, 121, 31/74, and others. Carr. 5/-.

Stamp For Free List

DUKE & CO. (LONDON) LTD.

621/3 Romford Road, Manor Park, E.12

Liverpool St.—Manor Pk.—10 mins.

LARGE REDUCTIONS IN PRICES OF COMPONENTS FOR OLDER MODELS

VAST SELECTION OF TV REPLACEMENT COMPONENTS FOR ALL MODELS!

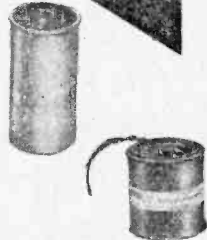

ALWAYS OBTAINABLE FROM STOCK: Time Base Components, Standard 405/625 & 625 Line Output Transformers. Chemicals for Servicing, Capacitors, Resistors, Rectifiers, Test Equipment, etc. etc. Retail enquiries S.A.E., Trade enquiries on headed paper.

See the D.T.V. Range I.E.A. Exhibition Stand No. N.197

Order on SAME DAY SERVICE

direct TV FROM **Replacements LTD**

Dept. PT126, Hamilton Road, West Norwood, London, S.E.27
 Telephone: GIPsy Hill 6166. P.B.X.

BENTLEY ACOUSTIC CORPORATION LTD.

EXPRESS SERVICE!!!

C.O.D. ORDERS RECEIVED BY 3.30 P.M. EITHER BY LETTER, PHONE OR WIRE, DESPATCHED SAME AFTERNOON

THE NEW VALVE SPECIALISTS 38 CHALCOT RD., LONDON, N.W.1

Nearest tube Chalk Farm All goods advertised are in stock Primrose 9090

MULLARD BY100 MIDGET SILICON RECTIFIERS Output 250v. at 1 amp. No larger than a shirt button! 7/6 each.

OAZ2	4/6	6BW6	6/9	6BW6	9/6	30FL12	11/2	DAP90	5/9	ECC84	5/9	EL34	8/6	KT38C	4/-	PRN45	7/-	U10	9/-	UCL82	7/9	OA73	3/-
OB2	6/-	6BW7	5/-	9117	7/6	30L15	9/6	D141	12/3	ECC85	6/3	EL36	9/8	KT36	29/1	PEN45DD	U12/14	7/6	UCL83	8/6	OA79	3/-	
OZAGT	4/3	8A9	10/9	10C1	9/3	30P14	12/3	D198	18/-	ECC88	10/-	EL41	7/3	KT41	7/6	U16	15/-	U14	6/9	OA81	3/-		
1C5	6/3	6C196	18/-	10C2	12/3	30P12	7/6	D196	5/9	ECC91	3/1	EL42	7/6	KT44	5/-	PEN46	4/3	U19	48/6	U142	7/9	OC19	25/-
1D5	9/6	6C116	5/-	10P1	10/-	30P19	12/3	D197	10/-	ECC189	11/6	EL81	8/3	KT61	6/9	PEN383	U22	5/9	U180	6/3	OC22	23/-	
1R5	4/-	6C14	24/-	10L11	9/6	30PL1	8/6	DH101	25/-	ECC180	6/1	EL83	6/9	KT63	3/9	U103	U24	12/6	U185	6/9	OC26	25/-	
1S5	5/6	6D3	9/6	10P13	11/6	30PL3	9/6	DH107	16/11	ECC182	6/3	EL84	4/9	KT66	12/3	PL33	9/-	U25	8/6	U186	9/-	OC28	12/6
1T4	2/3	6E1	9/6	10P14	11/6	30PL14	12/6	DK92	6/9	ECC186	11/6	EL85	7/6	KT68	28/-	PL36	8/-	U26	7/6	U189	6/9	OC29	25/6
2D2L	5/6	6P13	4/9	12AC6	8/6	35C	8/3	DK96	6/3	ECC121	9/6	EL86	7/3	KT61	4/9	PL38	16/-	U31	6/9	U141	6/9	OC35	13/-
3A4	3/9	6P23	9/-	12AD6	9/6	35L6GT	6/9	D168	15/-	EOH35	6/3	EL91	2/6	KT62	5/6	PL81	6/9	U33	12/6	U144	23/3	OC36	21/6
3A5	6/9	6P25	14/9	12AE6	8/-	35W4	4/9	DL72	15/-	ECH42	7/6	EL95	5/6	KTW63	5/6	PL82	5/3	U35	16/6	U146	8/6	OC41	8/-
3Q5GT	7/-	6T7G	4/6	12AH7	5/-	35Z3	10/4	DL76	5/9	EOH81	5/9	EL360	27/-	MH1D612	PL83	5/3	U37	29/-	U184	8/6	OC44	8/3	
384	4/6	6K73	1/3	12AW8	9/-	35Z4GT	4/6	DM79	5/9	ECH83	6/6	EL259	16/8	MKT4	17/6	PL84	5/6	U43	15/6	U14	15/2	OC45	8/-
3V4	5/3	6K84	3/3	12AT6	4/6	35Z5GT	7/9	DM71	9/9	ECH184	9/6	EL282	18/6	MUL14	14/6	PL500	15/9	U76	4/6	UM34	18/10	OC55	22/6
5R4GY	8/6	6K23	24/-	12AU6	5/9	50B5	6/6	DY86	7/6	ECL80	6/-	EL90	20/5	MX40	8/3	PM84	9/3	U191	9/6	UM80	8/3	OC86	25/-
5T44	4/6	6L1	10/-	12AV6	6/9	50C5	6/6	EO9F	24/-	ECL82	7/-	EM4	17/9	S37	23/3	PX4	9/3	U251	9/-	U16	9/6	OC70	6/6
5V45	7/6	6L6G	6/6	12BA6	5/9	50L6GT	6/3	EO9F3	9/6	EM34	11/6	N78	20/-	PY31	6/-	U282	12/3	U18	11/6	OC71	3/6		
5Y3GT	4/3	6L7HT	4/6	12BP6	4/9	55K10	14/6	EO9CC	10/-	ECL86	8/9	EM71	13/6	N108	26/2	PY32	8/6	U301	11/3	UY1N	10/3	OC72	8/-
6Z2	7/-	6L8	10/-	12BH7	6/9	72	6/6	E180F	19/6	E196	3/3	EM80	6/3	PY33	8/9	U304	6/-	U321	8/-	OC73	16/-		
5Z4G	7/-	6L120	5/6	12K5	10/-	85A2	8/6	EA50	1/6	E197A	3/9	EM81	7/-	PABC80	6/9	PY30	5/-	U801	16/3	UY41	4/6	OC74	8/-
6A7	8/9	6P28	11/6	19AQ3	7/3	90AG	6/7/6	EABC80	5/6	E199	3/9	EM84	6/9	PC86	10/3	PY31	5/6	U4020	6/9	U85	5/-	OC75	8/-
6A8	5/9	6Q74	4/6	19H1	6/-	90AV	6/7/6	EAF42	6/9	EP40	8/9	EM85	8/9	PC88	14/7	PY82	4/9	U48C80	5/-	VP4	14/6	OC76	8/6
6AC7	3/-	6K71	5/9	20I1	10/-	90C1	16/-	EB34	1/9	EP41	6/9	EM87	15/2	PC95	11/8	PY83	5/9	UAF42	7/-	VR105	5/6	OC77	12/-
6AG7	5/9	6L4GT	8/6	20E2	11/6	90C4	42/-	EB41	4/9	EP42	4/9	EY61	5/9	PC97	7/6	PY88	7/9	UBA1	10/6	VR180	4/9	OC78	8/6
6AQ5	5/9	6V6G	3/9	20L1	12/6	90C6	42/-	EB41	2/6	EP43	5/-	EY81	7/3	PC94	5/6	PY800	6/6	UB41	6/3	W107	10/6	OC81	4/6
6AT6	3/9	6X4	3/9	20P1	12/6	150R2	16/6	EBC33	8/6	EP40	3/9	EY88	9/3	PC85	6/9	PY801	7/-	UBC81	8/9	W29	17/6	OC8D	4/6
6AU6	5/3	6X3	4/6	20P3	12/-	185BT	34/11	EB44	6/6	EP83	9/9	EY84	9/6	PC88	10/6	R10	26/6	UBF90	5/9	X41	15/-	OC82	10/-
6AV6	5/6	630L2	8/3	20T4	13/6	869A	12/6	EBBC81	5/9	EP85	4/9	EY86	5/9	PC89	7/9	R17	17/6	UBP89	6/9	X66	13/3	OC83	6/6
6RA6	4/6	7B6	12/6	20T5	12/3	5735	7/6	EBF80	5/6	EP86	6/-	EY88	8/9	PC180	10/6	R18	9/6	UBC21	8/9	N78	20/6	OC84	8/-
6RE6	4/9	7C7	7/-	25Z4G	6/6	7475	2/9	EBF83	7/3	EP89	4/9	EZ10	5/6	PCF80	5/6	R19	6/6	UC92	6/3	N79	27/-	OC170	6/6
6B46G	13/6	7B3	7/-	25Z5G	7/9	A36PEN	4/9	EBF89	6/9	EP91	3/-	EZ11	6/-	PCF82	6/3	SP41	2/-	UCC84	8/9	N63	5/-	OC71	9/-
6RH6	5/3	7C6	6/9	27A1	23/3	AZ31	6/6	EBL21	8/-	EP92	2/6	EZ20	4/-	PCF84	8/9	SP61	2/-	UCC85	6/3	Z66	7/3	OCPT1	17/6
6R16	5/6	717	5/9	28C5	9/-	AZ41	6/6	EC70	4/9	EP95	4/9	EZ21	4/9	PCF86	7/9	SP25	27/2	UCF80	8/9	Transistors	MAT100	7/9	
6BQ7A	7/6	7K7	12/6	30C13	10/6	B36	4/9	EC81	27/6	EP97	11/8	EZ23	17/6	PCF80	17/6	T41	9/-	UCH21	8/3	and diodes	MAT101	8/6	
6R7	8/8	787	14/6	30C3	5/9	C33	11/6	EC92	6/6	EP98	10/-	EZ24	10/-	PCF82	6/6	TY233	6/9	UCH42	7/-	AF117	5/8	MAT120	7/9
6BR3	8/-	7X4	5/-	30FL1	9/3	CV31	5/9	EC34	21/7	EP143	14/6	EZ27	14/6	PCF83	7/6	TY86F	11/8	UCH81	6/6	OA70	3/-	MAT121	8/6

Terms of business.—Cash with order or C.O.D. only. Postage 6d. per item. Orders over £3.00 free. C.O.D. 3/6 extra. Any parcel insured against damage in transit for only 6d. extra. All orders despatched on day of receipt. Callers welcome Mon.—Fri. 8.30-5.30, Sat., 8.30-1 p.m.

We require for prompt cash settlement all types of valves, loose or boxed, but MUST be new. Offers made by return.

All goods are new, first quality brands only, and subject to makers' full guarantee. We do not handle manufacturers' seconds or rejects, which are often described as "new and tested" but which have a limited and unreliable life. Complete catalogue of over 1000 valves actually in stock, with resistors, condensers, transformers, microphones, speakers, metal rectifiers with terms of business, 6d. post free.

"WAVE GUIDE AERIALS"

Manufacturers of TV Radio and Ham Transmitting Antennae wish to offer examples from their range of products. For the amateur enthusiast and the Do-it-yourself type.

NOW IN PRODUCTION COMPLETE RANGE U.H.F. AERIALS

	£ s. d.		£ s. d.
3 Element BBC Folded Dipole, Channel 1, with a Double Five Channel 9 ITA, complete with all clamps ...	7 10 0	D.6 Element outdoor fixing with Universal mast clamp ...	2 1 0
or Double Eight Element ITA ...	8 10 0	D.11 element outdoor fixing with Universal mast clamp ...	2 17 6
Mast Equipment per your specification extra ...	1 10 0	Loft Mounting attachment for these Aerials ...	6 6
S/D5 Combined BBC, ITA Loft Aerial ...	2 13 6	Double 11 Super Fringe Aerial ...	6 5 0
S/D5 Combined BBC, ITA Outdoor Aerial, wall mounting, complete ...	4 13 0	Double 18 Extreme Fringe Aerial ...	10 0 0
H & 7 combined BBC, ITA with chimney lashing equipment ...	12 9	Diplexer for combining U.H.F. BBC/ITA into one cable ...	12 6
BBC Loft Aerial ...	1 10 0	Coax Cable semi low loss, 7d. per yard; super low loss 1/2d. per yard.	
5 Element ITA Aerial for attaching to existing mast ...	1 6 0	Cross over boxes for combining separate BBC and ITA Aerials, 9/6d.	
5 Element ITA Loft Aerial ...	4 0 0	Please send 6d. stamp for full list of aerials and accessories. Terms C.W.O. orders over £4 post and packing free.	
Double 5 ITA Super Fringe outdoor Aerial ...	5 0 0		
Double 6 ITA Super Fringe Outdoor Aerial ...			

PLEASE STATE CHANNELS REQUIRED WHEN ORDERING

WAVE GUIDE AERIALS LIMITED
DICKER MILL, HERTFORD.

for 70cm ham band A Switchable SOUND/VISION TRANSMITTER

CAUTION

Before r.f. transmission of pictures can be contemplated, the operator will require an Amateur Television Licence. This licence can be obtained by a British subject who has passed the Radio Amateur's Examination. No morse test is required. For further particulars on this subject write to the Radio Services Dept., General Post Office, Headquarters Building, St. Martins-le-Grand, London, E.C.1.

By B. W. Smith, G3LG/JT

This is a low power transmitter suitable for the newly licensed TV ham. The input to the final stage is 25W.

The G.P.O. licensing conditions require amateur TV stations to transmit their call signs by c.w. or phone as well as by the video signal, although not necessarily simultaneously. Therefore the equipment to be described in this present series has been designed for sound or vision operation. The mode of operation is selected by a sound/vision switch.

CONTINUED FROM PAGE 250 OF THE MARCH ISSUE

FIG. 3 shows a plan view of the main r.f. and sound modulator chassis from the valve (top) side. This chassis has a standard small 15in. rack front panel, and the front view is shown in Fig. 4.

The exact fixing positions for the main components are shown in these two diagrams, however as already mentioned this layout does not necessarily have to be maintained although rearrangement of the r.f. section would be unwise.

The anode coils of V1A and V1B are self-supporting and are mounted on their respective capacitors VC1 and VC2, underneath the chassis at right-angles to each other. All leads should be as short as possible and the components should be as near the correct connection points to minimise lead inductance.

The anode coil of V2 is mounted above the chassis directly on the tuning capacitor VC3. The connecting leads are taken through two separate holes to the valve base using short lengths of 18s.w.g. copper wire.

Fig. 3 shows the method of mounting V3, the valve lies horizontal and parallel with the front panel on top of the chassis. The mounting plate is spaced away from the valve base so that it lines up with the r.f. shield plate in the QQV03/20A valve itself. The B7A valve base of V3 is a special p.t.f.e. type which has very low r.f. losses.

Details of the mounting plate are given in Fig. 5. The grid coil L5 is self-supporting and is mounted to couple to L4. There should be about $\frac{1}{2}$ in. separation between the coil turns of L4 and L5.

The grid resistor R43 and the screen resistor R15 are connected via insulated feedthroughs to the underside of the chassis. The heater feed of V3 is also connected through the chassis, but using a feedthrough capacitor C20. The cathode of V3 is connected to earth using a short length of copper braiding to provide a substantial low impedance earth.

Stages V2 and V3 are completely screened by an

aluminium panel $3\frac{1}{2}$ in. high, shown in Fig. 3. This screen is necessary to prevent r.f. losses from the output stage and also to minimise 144Mc/s radiation from V2.

MAKING THE RESONANT LINES

The L6 lines are made from $3\frac{1}{2}$ in. lengths, $\frac{1}{8}$ in. outside diameter thin walled brass tubing. These two tubes are connected together at one end by an $\frac{1}{8}$ in. x $\frac{1}{8}$ in. brass strip so that the lines are parallel to each other and have a centre to centre spacing of 14mm (same spacing as the valve anode pins).

The method of connecting to the valve pins is shown in Fig. 6. The lines have two slots opposite one another sawn to a depth of $\frac{1}{8}$ in. Fitted into these slots are two shaped pieces of 28s.w.g. phosphor bronze, see Fig. 6. The advantage of these connectors is that free play is allowed for sideways and longitudinal movement, while maintaining good electrical and thermal conductivity. The connections to VC4 are made by two lengths of copper braiding about 1in. long. These connections are made adjustable by making $\frac{1}{2}$ in. phosphor bronze clips which can slide along the L6 lines. These clips should be initially set at about 1in. from shorted end of L6. C10 is a feedthrough capacitor coupling the 300V h.t. to L6 line through R16, and the lines are in fact supported at the end by R16.

The output coupling loop L7 is tightly coupled to L6 and can rest on L6, overlapping from the short circuit end of L6 by about 1in.

The video r.f. probe is partly built around the aerial socket; keeping the leads short, the following components should be mounted here, R55, R56, R57, C29 and D4. The remainder of the circuit is mounted near V11 valveholder (Fig. 8).

The layout of the sound modulator is not critical at all, the only points to watch are input leads which should be screened. The anode leads of V6 and V7 to the transformer T1 and from the transformer to the tripler will also need to be screened.

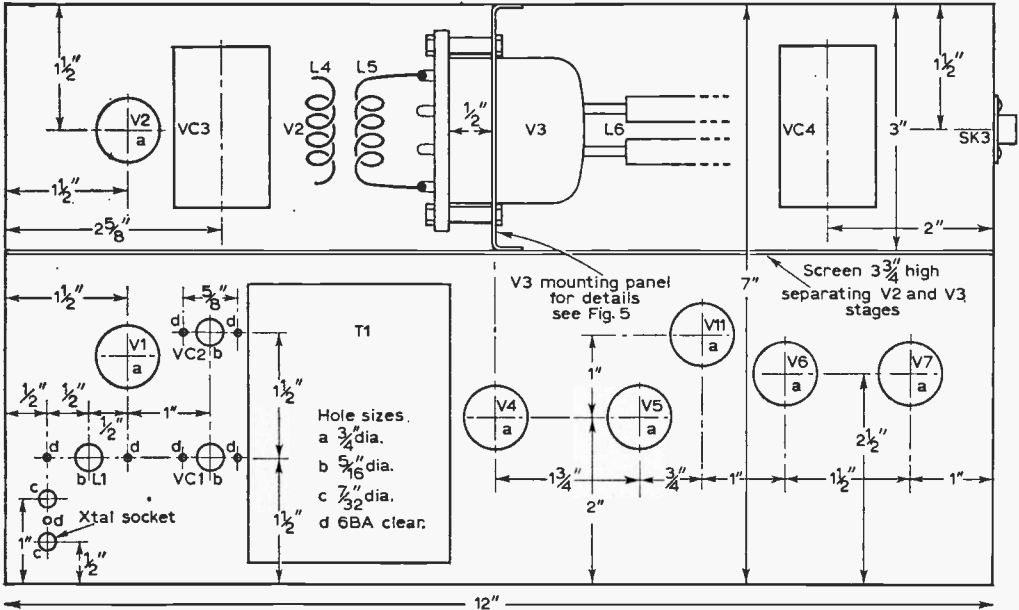
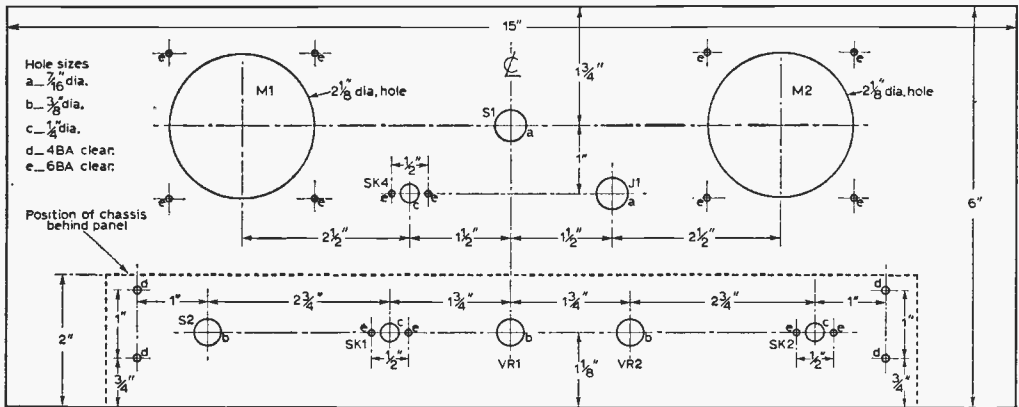

Fig. 3 (above)—A plan view of the main r.f. and sound modulator chassis.

Fig. 4 (below)—Front panel drilling dimensions.



The modulation changeover relay should be mounted under the chassis and placed to minimise video modulator lead length from the modulator input socket.

The power unit plug from the power unit PL1, the power output SK5 to the vision modulator, and the coaxial socket SK9 for connecting the vision modulator output to the transmitter, are all mounted on the back of the transmitter chassis. The power input plug on the transmitter (PL1) will need to have at least six connectors. The power output socket to the vision modulator (SK5) will need at least four connectors.

The vision modulator is built on a separate chassis which is mounted on a 15in. x 3in. front

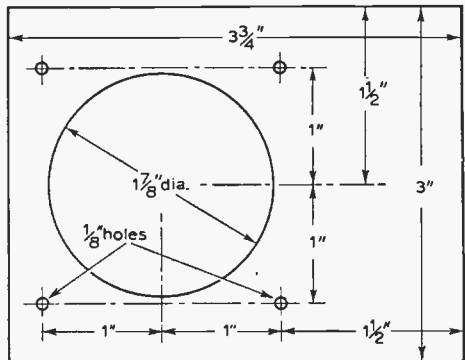

Fig. 5 (right)—V3 mounting panel details.

panel and mounted in the same 15in. rack as the transmitter. The only components fitted on this front panel are the two potentiometers VR3 and VR4 and the vision bridging sockets SK6 and SK7. VR4 can be a preset potentiometer. The circuit layout is not critical, but the leads to VR3 should be kept as short as possible. The three valves will have to be mounted on their sides to fit into the 3in. high space. A power connection plug PL2 is fitted on the back and will require at least four connectors, power being obtained from the transmitter unit.

A coaxial socket (SK8) is connected to the vision modulator out-

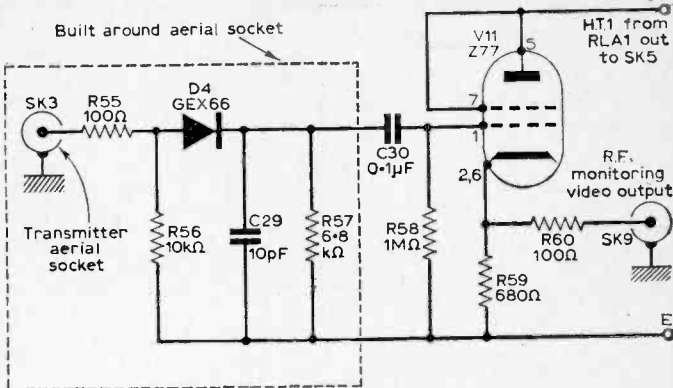

Fig. 8—The video r.f. probe circuit.

put and is coupled to the transmitter vision modulator input socket by means of a single un-screened p.v.c. covered wire; coaxial cable must not be used for this purpose.

A complete description has not been included of the power unit (Fig. 7), but standard practice can be followed here.

The writer has used two identical h.t. supplies, one for the r.f. section and a separate one for the modulators. Because the vision modulator takes less current than the sound modulator, the modulator h.t. rises when transmitting vision; this is quite in order and allows heavier video modulation to be used. The transmitter and sound modulator valves have 12V heaters, while those in the separate vision modulator are 6V types.

Fig. 6 (left)—Construction of the L6 quarter-wave resonant lines.

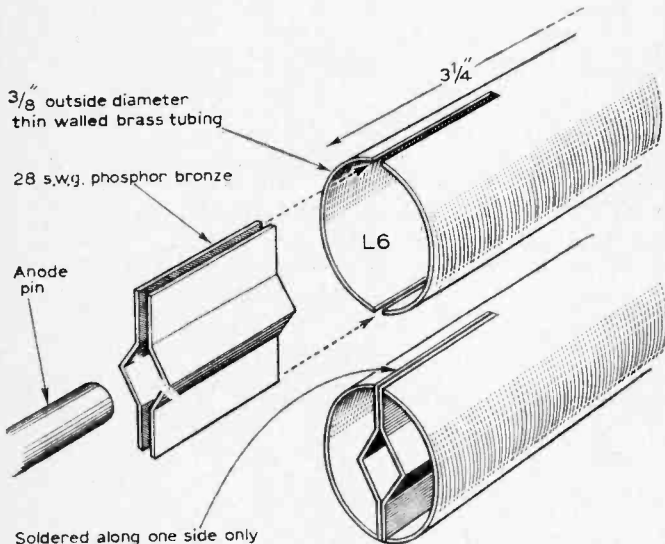
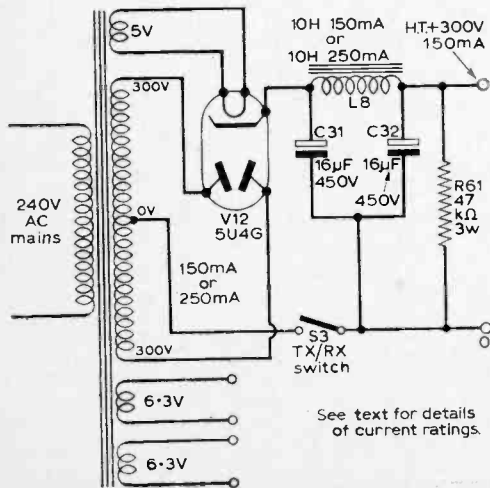

Fig. 7 (left)—A suitable power unit. See text for details of current ratings.



POWER REQUIREMENTS	
L.T. 12.6V	2.5A—transmitter and sound modulator.
6.3V	1.7A—vision modulator.
H.T.(1) switched	{ 300V 100mA—sound modulator.
	{ 350V 50mA—vision modulator.
H.T.(2)	300V 150mA—r.f. section.

One h.t. supply could be used for transmitting but a 300V transformer supplying 250mA does not seem to be an easily obtained item. Fig. 7 shows a circuit of one of the supplies. The 12V supply is obtained by connecting the two 6.3V windings in series, the 6.3V point is used to feed the video valve heaters. An on/off switch is incorporated in the a.c. side of the h.t. supply and is used as a Tx/Rx switch. This switch must be included in both h.t. supplies otherwise the screen V3 could be overloaded under vision modulation operation.

CONTINUED NEXT MONTH

THIS FIRST ARTICLE OF A NEW SERIES PROVIDES SOME GENERAL DATA ON THE LATEST TUBES AND ON THE SETS IN

WHICH THEY ARE USED. FUTURE ARTICLES WILL DEAL WITH SPECIFIC MAKES OF SETS.

CHANGING

RAY

SOME four years have elapsed since the conclusion of the last series of articles dealing with the practical problems that arise when changing cathode ray tubes. In the interim new generations of sets have evolved, and new types of c.r. tubes have been introduced to work in them. Nearly all these tubes have a 110° scanning angle, and a much shorter pentode or hexode gun. A new base, type B8H is invariably fitted, and our old friend the ion trap magnet has vanished, we hope for good.

The "Slimline" receivers made possible by these new tubes normally incorporate a vertical printed chassis, through the centre of which the neck of the tube (complete with scanning coils) protrudes.

Focusing.

Electrostatic focusing is employed with these tubes. The focus electrode (pin 4) derives its voltage either from a potentiometer between boosted h.t. and chassis, or by means of a short lead which is tapped around the various tube electrodes and h.t. until an optimum voltage point is found.

Although focusing is more uniform over the screen and less critical in its setting than in the case of the magnetic type, the initial setting of the focus may be difficult to make, in fact on some scenes the adjustments may appear to make little difference at all.

If possible use that rare bird—the test card, or a still scene, and turn the controls so that the picture is brighter than you would normally have it. It should then be possible to adjust focus for the sharpest resolution of the white parts of the picture.

Handling

Much that has been written before about handling tubes holds good for the slimline range. Remove them from the carton as indicated—usually from the bottom. Some tubes have the faceplate protected by tissue, and a foam rubber band around the bowl as additional cushioning. This should not be fitted into the set with the tube. A plastic pin protector is frequently found over the base pins, and this is best left in situ until the tube has been fitted into the set.

Never pick up tubes by the neck alone, but

support them from beneath with one hand whilst steadying the neck with the other. If the tube is a 21in. or 23in. variety try and obtain some assistance, and wear protective goggles.

These large tubes are extremely heavy (especially at the faceplate end) and awkward to handle. Modern factory skill has enabled the maker to achieve a higher vacuum, and at the same time produce a flatter faced, more rectangular tube. As mentioned in the first series, the further from the spherical shape that a tube is made, the more likely it is to be subject to abnormal stresses and to fracture. *Plainly put—the new tubes are more likely to burst with careless handling than the old ones. If they do, the implosion will be more violent.*

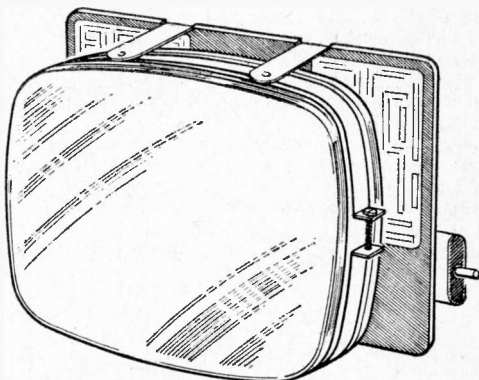

Fig. 1—A typical chassis arrangement, with the tube held around the bowl by a clamping band.

Removing the Tube

Before removing an old tube, its e.h.t. cavity connector should be discharged more than once whilst it is still in the set, as shocks from the cavity during removal can be disconcerting. If the tube has to be traded for a glass allowance against its replacement, take care of the faceplate by protecting it with a soft cloth, or with the square of tissue provided with the new tube. Some rebuilding firms will not accept old glass if the faceplate is badly scratched.

An example of 110° tube fitted in a slimline chassis is shown in Fig. 1, and the method

CATHODE RAY TUBES

By H. Peters

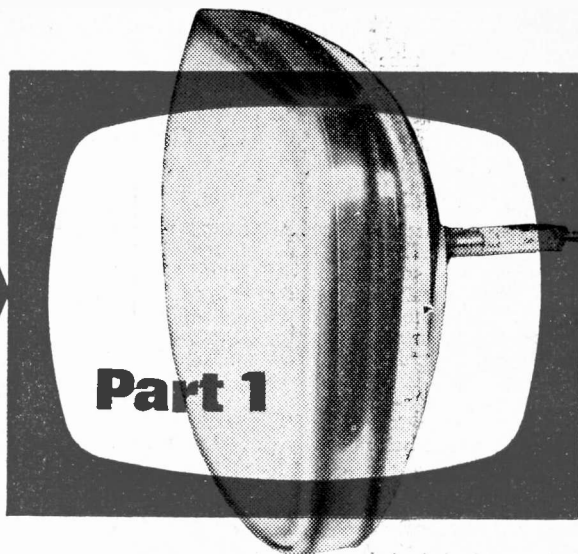

employed in changing it is typical of the majority of receivers in the age group under review.

First the c.h.t. connector is removed, and the cavity discharged to chassis. This is normally not as easy as it sounds since the anode is nearly always inaccessibly placed, and protected by a polythene skirt. The simplest way is to slide a long screwdriver through the skirt until the blade rests flat between the lip of the connector and the tube face. If the screwdriver is then twisted through 90° the connector will be released (Fig. 2). If it is stuck, play safe, and renew the whole c.h.t. lead rather than risk imploding the tube.

Next turn your attention to the base connector which should slide off quite easily. If leverage has to be applied this should be done gently, and should the whole assembly be stuck together with wax melted from adjacent components, warm oil will usually soften the wax up in a few minutes.

Be careful with the wiring to the base connector, as thinner wiring is used in the modern sets, and the plastic insulation may be brittle with heat and age.

It is now the turn of the scan coil assembly which is invariably clamped to the tube neck by a brass collar, which should be slackened off. Depending upon the set, the scancoils will either be loosely clamped to the chassis, or else merely pushed up the tube neck, and held there by the aforementioned brass collar.

In the latter case, it is normally wise to allow the coils to travel forward with the tube as it comes out to the extent of the scancoil connecting wires. It is then usually possible to rest the edge of the tube bowl on the bench whilst the coils are slowly eased back along the neck.

Mark the top of the coils with crayon if this is not obvious. If you forgot to mark the top of the coils, it is usually possible to refit them correctly by inspection, as the top surface will have attracted more dust than the underside.

The scancoils themselves are today a fairly standard component, and a typical example is given in Fig. 3. At the front are two small bar magnets to correct pincushioning, or barrel distortion. Sometimes these are fixed by the maker and cemented into position, but in our illustration they are shown adjustable by bending and twisting until an optimum setting is reached.

Picture Centring Machines

Picture positioning is adjusted by turning the two small centring rings behind the scancoils. These are rotated singly, together, or in opposition depending upon the movement required. The rings are, in fact, two weak magnets polarised across their diameter. Being metal, they have the same effect as a short-circuited turn across the scancoils, reduce their efficiency. A recent development has been to make these rings of a flexible plastic material which is non-conductive, and which does not therefore damp down the scancoils. The rings are much smaller than those fitted some years ago, and as high peak voltages are present at the scancoil terminals, it is usual to find a small hole or slot punched in the adjusting tab to enable a screwdriver to be used to make the adjustment.

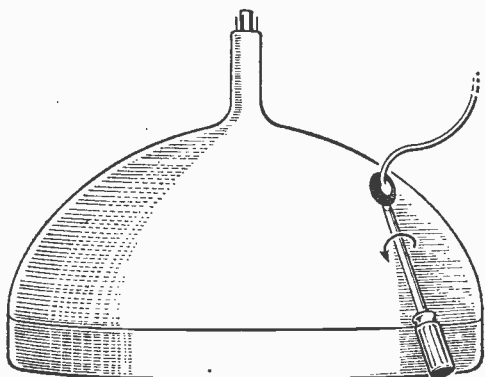

Fig. 2—The method for removing an obstinate anode cavity connector.

Clamping Band

Reverting to the tube itself, the final operation in dismantling is the slackening off of the clamping band around the tube bowl. Before doing this it is expedient to measure the distance from the face of the tube perpendicular to the front of the clamping band, as this in some sets is the only means of ensuring that the replacement tube has been fitted in the correct position.

If the tube is installed too far forward, it will grind against the safety glass and produce a small white spot that cannot be removed. Fitted too far back, the airtight seal may not be effective and the space between the tube face and the safety glass will become dusty in a very short while.

Between the clamping band and the tube bowl, it is customary to find a plastic belt which acts as a cushion, and also as a dust excluder, and when the clamping band is undone and the tube withdrawn forward, this plastic belt normally comes away with the tube.

Cleaning up

Having reached the halfway stage in changing the tube, a thorough clean-up of the chassis, using a dusting brush, is advocated. At the same time, the inside of the cabinet should be cleaned out, and the safety glass polished on both sides. This will help to prevent dust from falling down to settle on the front of the screen just as the set is finally being boxed up.

Fitting the New Tube

When the new tube is fitted, make sure that all the insulating washers in the scancoil assembly have been refitted correctly, and that the coils are fully forward on the neck of the tube. Clamp them up finger tight, and replace the base connector and e.h.t. connector. If the latter is in a tight corner, it is easier to press it home when the tube is only halfway in.

Some readers will notice that in their set, the e.h.t. lead appears to be much too long, and that the slack has been taken up in the form of a loosely tied loop. This is, in fact, a small choke introduced to help reduce line timebase radiation.

Once the tube is fitted and clamped up, there remains only three adjustments to perform, namely focus and picture position, which have already been discussed, and picture tilt which is straightened by rotating the scancoils slightly around the tube neck. *Do not make this adjustment by hand with the set running.*

Boosting

Although the writer has not had so much success in the fitting of boost transformers to 110° tubes as he did with the earlier types during the "Golden Age of TV", sometimes a useful purpose can be served by doing so.

The procedure is the same for all sets. The existing heater wires to pins 1 and 8 of the tube are disconnected, joined together, and taped back, and in the case of 12V tubes, the heater part of the

mains dropper is set 10V higher to compensate for the absence of the tube from the chain.

A low capacity cathode ray tube transformer of the correct voltage, and which incorporates a "boost" tapping is fitted, with its boosted secondary connected to the heater pins of the cathode ray tube base connector. Mains for the boost transformer is obtained from the set side of the "on-off" switch.

It should be noted that this procedure only applies to a.c.-d.c. sets used on a.c. mains. One or two early receivers, such as the first Pye P110 portables, use a 6.3V/0.6A tube fed from a small transformer. These sets are marked "a.c. only" on the back, and should not be boosted in this way.

Types of Tube

With the advent of the 110° tube, a measure of uniformity is to be found between tubes of various makes.

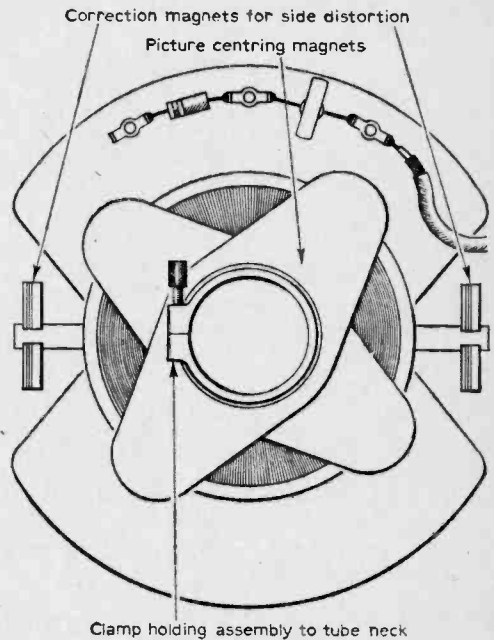

Fig. 3—A typical 110° scancoil assembly.

Originally the slimline tube was available as a 17in. or 21in. screen. Since then improvements in production technique have enabled the 17in. tube to become a 19in., with a flatter face and sharper corners, and the 21in. has in turn given way to the 23in. tube.

About the time of the changeover from 17in. to 19in. the industry went through its short-lived "Portable Set" phase, and to assist the "quart" sized chassis to be shoe-horned into the "pint-pot" sized cabinet, we were given the "short neck" tubes. These tubes have a shorter gun assembly than the standard tube, and are not readily

TABLE I

TYPES OF TUBE AVAILABLE

Tube	Heater Volts (all 0-3A)	B8H Base Pins	NOTES (All Aluminised and Aquadag)
17 inch			
MULLARD			
AW 43/88	6-3V	1	
AW 43/89	6-3V	2	Short Neck.
MAZDA			
CME 1703	12-6V	1	
CME 1705	12-6V	1	Short Neck.
19 inch			
MULLARD			
AW 47/90	6-3V	1	CME 1902 (Equivalent).
AW 47/91	6-3V	1	CME 1903 (Equivalent).
AW 47/10	6-3V	1	Twin Panel Tube.
MAZDA			
CME 1901	12-6V	1	
CME 1902	6-3V	1	AW 47/90 (Equivalent)
CME 1903	6-3V	1	AW 47/91 (Equivalent)
CME 1906	6-3V	1	Twin Panel Tube.
21 inch			
MULLARD			
AW 53/88	6-3V	1	
AW 53/89	6-3V	2	Short Neck Tube.
MAZDA			
CME 2101	12-6V	1	
CME 2104	12-6V	2	Short Neck.
23 inch			
MULLARD			
AW 59/90	6-3V	1	CME 2302, C23AK (Equivalent)
AW 59/91	6-3V	1	CME 2303 (Equivalent)
AW 59/10	6-3V	1	Twin Panel Tube.
MAZDA			
CME 2303	6-3V	1	AW 59/91 (Equivalent)
CME 2306	6-3V	1	Twin Panel Tube.

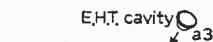
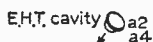

Pin details of B8H tube valholders.

interchangeable with their longer necked counterparts.

Bonded Implosion Guard

The latest development is the bonded implosion guard or "twin panel" tube. These tubes are standard 19in. or 23in. types fitted with a bonded perspex implosion guard. These are mounted by means of clamps over plastic lugs at the corners, and in many cases the tube is held to the wooden case by this means rather than to the chassis.

It is hoped to include changing instructions on some of these types in a later article of this series, but it is sufficient to emphasise now that a tube with a bonded guard should never be replaced by a tube without one. Likewise, the plastic lugs should never be drilled to mount the tube.

Set Types

Unfortunately the simplification of tube types and style has been offset by an increase in the number of receiver types issued annually. As an example, the Ekco range (which will be covered in our next article) begins in 1959 with just over six receivers. The index of "Radio and Television Servicing" for the current 1962-63 season lists no less than twenty-nine different models for the same manufacturer.

Each subsequent article in this series will include

SLOW RUNNING TIMEBASES

—continued from page 306

The peaks of this waveform are quite sharp, but no doubt other types would suit, e.g. a sharply differentiated square-wave.

The second oscilloscope should be powered from a supply other than the oscilloscope external power socket—the author has found that use of this socket more often results in complete sync of the two oscillators, resulting in a loss of x-scan.

Alternative Arrangements

With higher frequencies on the y-plate, the display will break up. A different type of display can be arranged in this case, by running the *internal timebase* (rather than the "beat" frequency) in

an index in which the reader will find the set of his choice listed against a basic type. Then by turning to the basic type mentioned, he should be able to replace his own tube by using the instructions therein, modifying them a little to cope with any small differences he may discover in his own cabinet.

sync with the y-signal. The external oscillator speed can then be varied independently of the y-signal frequency, and will produce a spot which runs up and down the trace as the speed of the external oscillator is varied. This all rounds rather complicated, but with the apparatus in front of him, the constructor should have no difficulty.

Incidentally, to display traces at low frequencies, it helps to have a long persistence tube, and it is of course essential to have a direct-coupled amplifier; this means direct coupled from the tube plates right back to the transducer at the input. The other requirement is that the grid voltage can be set well negative in quiescent conditions, so that only the peaks of the applied waveform at the grid bring it up to normal voltage and illuminate the trace. ■

ON THE AIR

Amateur Band Topics

JOHN E. TANNER DESCRIBES HIS STATION

AMATEUR television station G3NDT/T was located in Bristol up to March of last year when it was moved to Harrow, the present location. It is since moving to the London area that the station has been most active, working in conjunction with the other stations in the area, and occasionally with the more remote stations when propagation conditions permit.

In common with almost every other amateur television station, transmissions take place in the 70cm amateur band, usually towards the high frequency end of the band to avoid interference to other sound stations.

Since the station was first licensed in November 1958 the equipment in use has grown from a simple flying spot scanner and a two watt (6J6) transmitter, to the present set-up which consists of an image orthicon camera to provide live camera pictures and a monoscope camera for test card "C"—useful to save running up the big camera for test transmissions.

Either of these picture sources can be fed into the transmitter which uses a 4X150A valve as the final amplifier and operates at the maximum permitted power level. At the moment a rather small aerial system is in use but plans are in hand to enlarge this soon.

On the receiving side a transistor pre-amplifier heads a re-tuned commercial u.h.f. tuner which in turn feeds into a 17in. Pye television set. A second 14in. TV set has been modified to take video signals instead of r.f., and this receiver is coupled either to the input to the transmitter, or to a probe to check the picture as transmitted.

The heart of the station is the synchronising pulse generator as this operates all the vision equipment. It is built to a circuit published in CQ-TV, the Journal of the British Amateur Television Club, and will operate on 405/525/625 lines, although it takes some time to change standard.

G3NDT/T operates on 405 lines most of the time, but plans are in hand to change everything to

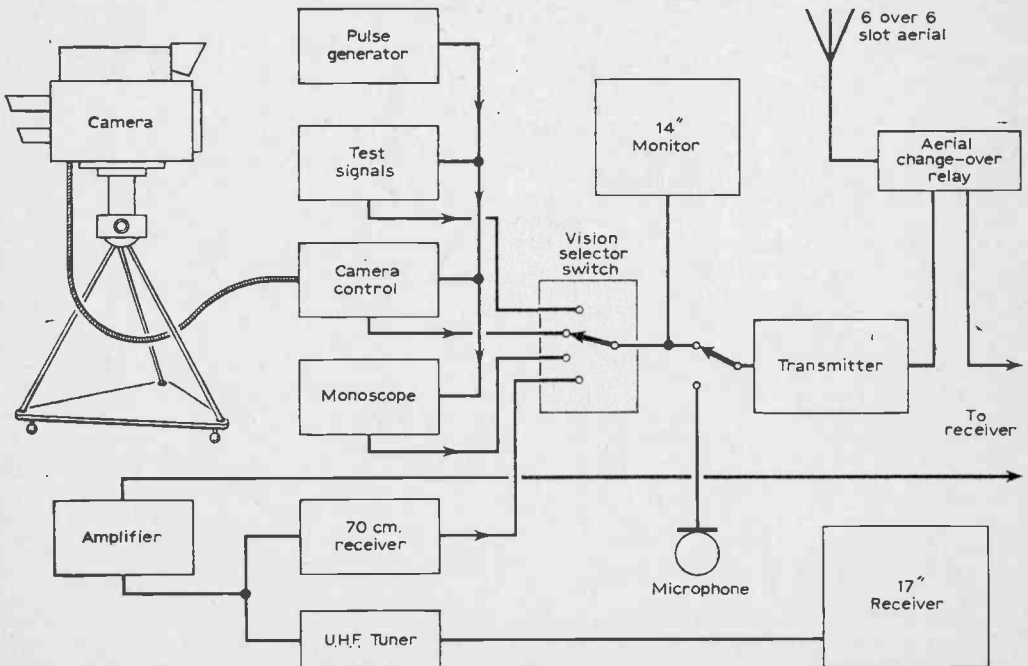

Fig. 1—A block diagram of amateur television station G3NDT/T.

625 to bring the transmissions into line with the new u.h.f. television service, as it seems likely that many of the receivers can be re-tuned to cover the amateur band as well as covering the new BBC channel.

The block diagram of Fig. 7 shows the basic set-up of the station.

One facility of interest is the ability to relay other amateur television signals. By receiving a signal at the low end of the band the transmitter and receiver can be operated together and an incoming signal re-transmitted at the high end of the band—in fact amateur television pictures have been sent from Ely to London passing through two other stations on the way. Up to now the transmissions have been of vision or sound only and no attempt has been made to transmit sound and vision together, although the low power transmitter used occasionally for mobile or "Roving Eye" television may be used for this.

A few more technical details of the equipment may be of interest.

PULSE GENERATOR: Four step dividers using multivibrator switches count down from

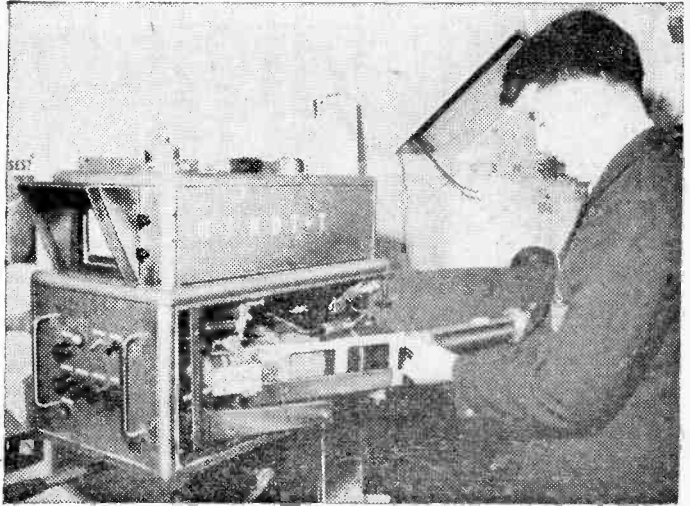

The author makes an inspection of his camera.

pulses are used to "drive" the cameras, the sync and blanking used to process the signals before transmission. The outputs are all negative going at 2V into 75Ω. The whole unit is in a portable case complete with power supply.

CAMERA: The image orthicon camera tube requires a strong, long focus field and this implies large amounts of scanning power. Accordingly the camera is built with the scan generators built-in to save the problem of trying to feed high power scanning currents along a camera cable. This means that the camera is rather large, but on the other hand a viewfinder can be built in without making it look out of proportion. The line and field scan generators are built on small sub-chassis which can be removed for servicing, or operated on flexible leads. Each scan generator carries a protection circuit which cuts off the beam in the image orthicon in the event of failure of the scanning currents. The two generators are "driven" by the line and field drive pulses, and should the pulse generator fail the scans stop—hence the need for protection circuits.

Also in the camera is the focus current stabiliser and the head amplifier for the vision signal. High voltage for the tube (1kV approximately) is obtained from the line scanning circuit, although some of the voltages are fed to the camera from the control unit which simply takes the raw signal from the camera and "processes" it by clamping, blanking, aperture correcting, black and white clipping and finally adding synchronising signals



The author's test card carrying his callsign.

twice line frequency to field frequency (50c/s)—this is compared with the mains and any error signal used to control the master oscillator—the system is therefore locked to the mains.

Suitable trigger signals are taken from the counter chain to time the output waveform generators which provide line and field frequency drive pulses, mixed line and field synchronising pulses, and mixed line and field blanking pulses. The drive

BOOKS REVIEWED

COLOUR TELEVISION EXPLAINED

By W. A. Holm; published by Philips Technical Library, U.K. and Eire distributors: Cleaver-Hume Press Ltd., 10-15 St. Martin's Street, London, W.C.2. 110 pages, 6in. x 8in., 52 illustrations (8 pages with 4-colour illustrations). Price 20s.

THIS is a welcome addition to available literature on a subject for which there will be increasing demand for information. It is written on the assumption that its readers will mainly consist of technicians, engineers and keen amateurs; in other words it assumes a knowledge of the technicalities of monochrome television and can thus dispose of the need for digressions into explanation of fundamental principles. The treatment is basically non-mathematical.

The book is divided into four main sections—Fundamental Theory (of Colour), Colour Television Pickup Equipment, Reproduction Systems, and the Transmission System. The first chapter includes a very good explanation of the nature of colour, which should provide anyone with a real understanding of fundamental colour theory—essential if the electronics of colour TV are to be fully grasped.

The main object of this book is to present the theoretical bases of all aspects of colour television and to this end, very little circuitry is provided—block diagrams and waveforms, etc., serving to illustrate the subject matter discussed. In this way a lot of ground is covered and we get a compact book stripped of superfluities and full of basic, essential data. The book is enhanced by the various illustrations in colour (including that of a colour triangle) which have been used sparingly but effectively.

This book obviously fills a gap in current literature and can be recommended to all who take more than a casual interest in the technicalities of colour television.—*W.N.S.*

UNDERSTANDING TELEVISION

By J. R. Davies; published by Data Publications Ltd. 504 pages, 6in. x 9in., 299 diagrams. Price 37s. 6d.

THIS is a comprehensive volume covering all aspects of television reception. Wide in scope, it explains not only current practice in this country but gives details, whenever pertinent, of alternative standards and circuit techniques employed in other countries. Some attention is given to the newly introduced 625-line service on u.h.f., and an introduction to colour is included.

The treatment is entirely non mathematical and should be well suited to anyone who has a reasonable knowledge of radio theory. The text is profusely illustrated with diagrams and explanatory captions succinctly hammer home the relevant points—a valuable supplementary to the main text.

It is clear that the author is quite familiar with the manufacturing side of television engineering; this book conjures up the practical atmosphere of the production floor rather than the generally aloof atmosphere of the laboratory. Realities of commercial production are ever to the fore; thus the reader is made aware how a compromise is often necessary in some particular of circuit design in order to minimise other shortcomings and to enable economies to be effected in the ultimate cost of the receiver. Frequently a close look is taken at the actual processes involved in the manufacture of a particular component.

The painstaking care with which the text has been compiled can be exemplified by the attention that has been accorded matters of historic interest. For example, in the chapter devoted to the Cathode Ray Tube, the evolution from the original cone-shaped tube with circular screen to the present 110° deflection tube with rectangular screen is described. These references to progress in television design and production techniques lead naturally to the detailed discussion of present day practice in the U.K. or elsewhere.

The first chapter discusses very fully the character of the television signal, not only the domestic 405-line system, but the 525-, 625- and 819-line systems at present used in various parts of the world. The cathode ray tube is the subject of the second chapter. From Chapter 3 (The Receiver R.F. Stages) to Chapter 11 (Power Supply Circuits), each section of the television receiver is explored, the "unusual" circuits are broken down to their elements and their function carefully explained. Wherever appropriate, mention is made of circuit differences for 405-, 525-, 625- and 819-line operation.

Receiving aerials are covered in chapter 12, an introduction to colour television is given in chapter 13, while an appendix gives concise information regarding tuners for u.h.f. reception.—*F.E.B.*

RADIO, TELEVISION, INDUSTRIAL TUBE, DIODE AND TRANSISTOR EQUIVALENTS MANUAL

By B. B. Babani; published by Bernards (Publishers) Ltd. 208 pages. Price 9s. 6d.

A USEFUL pocket size reference book listing more than 20,000 types of semiconductor, thermionic valves and cathode ray tubes.

The contents include: commercial valve and semiconductor types and equivalents; C.V., British Service and U.S.A. Service valve types with commercial equivalents; television tubes with suggested replacements and modification details where necessary.

110° Scanning Circuits

BY G. K. FAIRFIELD

IN recent years the increase in scanning angle to 110 deg. has presented the circuit designer with the problem of where to obtain the increase in scanning power necessary to cover this wider angle. The problem is most acute in the line scan circuit, although a simple solution for the frame scan circuit is by no means easy to achieve. In this first article it is hoped to show how these difficulties are being tackled for the line circuit and to suggest practical methods which the reader may wish to try out for himself.

"Tuned Transformer" Line Scanning

A common feature of a badly-designed line scanning circuit is the pronounced resonance of the leakage reactance of the transformer with its stray capacitance. This occurs at a frequency of about 100kc/s and results in a series of alternate vertical light and dark bands which are most prominent at the left-hand side of the screen.

Many methods of suppressing this "ringing" effect are used and in most modern receivers the effect is rarely discernible. These suppression methods all have one feature in common, however—they abstract energy from the transformer by damping and so lead to loss of circuit efficiency. It is this loss of efficiency that has been seized upon by the circuit designer as a source of the extra energy required for 110 deg. scanning. The ringing effect is, in fact, turned to good advantage and is used to increase the scanning current required.

In principle the method consists of "tuning" the transformer leakage reactance such that it is capable of resonating simultaneously at only certain frequencies which have a definite numerical relationship with each other.

Fig. 1 shows a simplified equivalent circuit for a line scanning circuit where:

L1=Equivalent inductance of transformer windings and coupled scanning coils.

L2=Leakage inductance of the e.h.t. overwind coil.

C1=Equivalent lumped capacitance of transformer windings, scanning coils, valves, wiring, etc.

C2=Self-capacitance of e.h.t. overwind coil.

C3=Capacitance of e.h.t. rectifying diode plus wiring capacitance.

Now if we make the natural resonant frequency of the leakage branch L2, C2, to be a certain multiple of the main transformer resonance L1, C1, then the resonant voltage of the leakage inductance circuit can be made zero at the end of the flyback period. This results in zero energy stored in the leakage inductance at this point in time and the ringing cannot therefore continue during the scanning period.

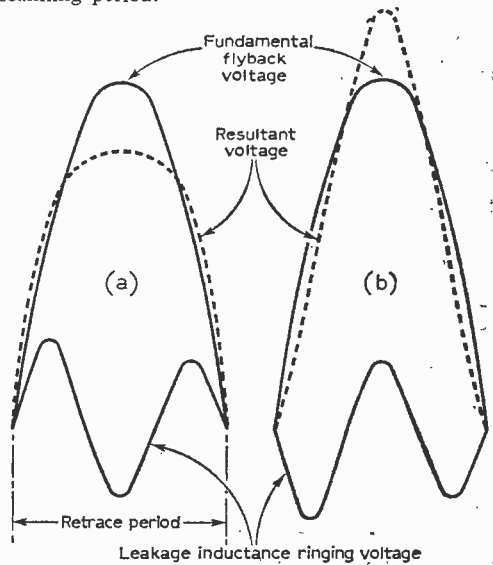

Fig. 2—Effect of tuning e.h.t. winding; (a) at anode of line output valve, (b) at anode of e.h.t. rectifier.

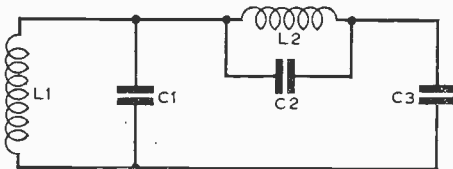

Fig. 1—Line scan equivalent circuit.

The minimum ringing condition exists for more than one ratio of resonant frequencies. One of these will be found to be 2.7 (ideally fundamental and third harmonic) and another 4.4 (ideally fundamental and fifth harmonic).

In Fig. 2 is shown the condition where the ratio of 2.7 has been chosen. The resonance during the flyback period due to L1, C1 and the leakage resources due to L2, C2, are shown separately, and their combined effects, as far as the total trans-

former flux is concerned, are shown by the dotted lines for two points on the line scanning auto-transformer.

Two results are immediately apparent from this tuning method. The peak voltage at the anode of the line output valve is reduced and the peak voltage at the anode of the e.h.t. rectifier diode is increased. This allows the output valve and boosting-diode valve to operate under less stringent conditions and gives more e.h.t. for the wide-angled cathode ray tube. In addition, of course, the effects of ringing are now absent from the screen and the increase in flux energy circulating within the transformer core allows us to obtain the additional scan required for 110 deg. working.

Practical Considerations

Turning now to practical considerations, in order to reduce the normal resonance frequency of the leakage reactance (usually in the range 50 to 150kc/s) to a smaller multiple of the fundamental

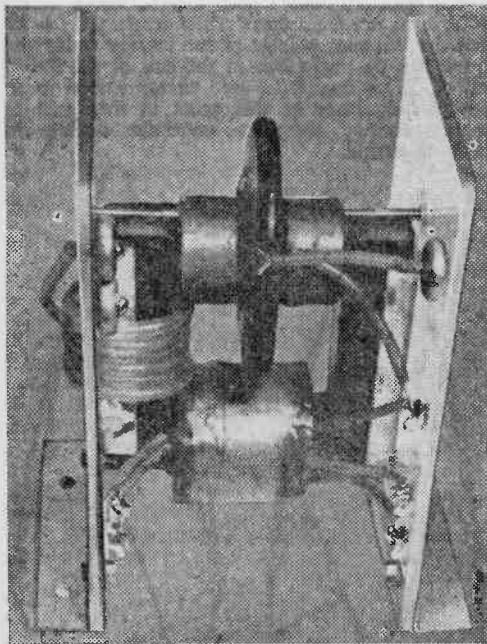

Fig. 3—An experimental 'tuner transformer' line scanning transformer.

transformer resonance (10kc/s) it is necessary to modify the transformer to give the higher leakage reactance required.

Most modern line scanning transformers take advantage of the reduced losses inherent in the use of ferrite materials for the transformer core, and a double-U form of core construction is normally adopted. With this arrangement it is relatively simple to obtain a high leakage reactance by placing the e.h.t. overwind on one limb of the transformer and the remaining windings on the opposite limb as shown in Fig. 3. This will result in a very low coupling coefficient for the e.h.t. overwind and hence a large leakage reactance.

Variation of this leakage reactance can be brought about by introducing a controlled coupling between the two windings as indicated by the circuit diagram of Fig. 4. The link-coupled coils L3 and L4 each consist of a small winding fairly tightly coupled to the main windings L1 and L2 respectively.

This method can be tried fairly simply on any existing design of scanning transformer. Winding

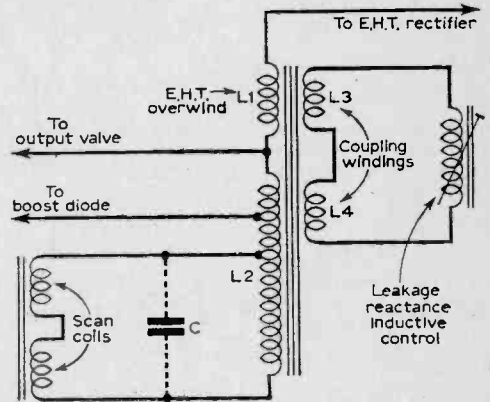

Fig. 4—Transformer arrangement to obtain controlled leakage inductance.

details are given on the following page and the theoretical diagram is given in Fig. 5. Care must be taken to provide good insulation between the core, the coupling winding L4 and the e.h.t. overwind. Several layers of 0.005in. polythene tape are used for this purpose.

The adjustable inductance used for controlling the amount of leakage inductance can be similar in design to that used for linearity control in which a

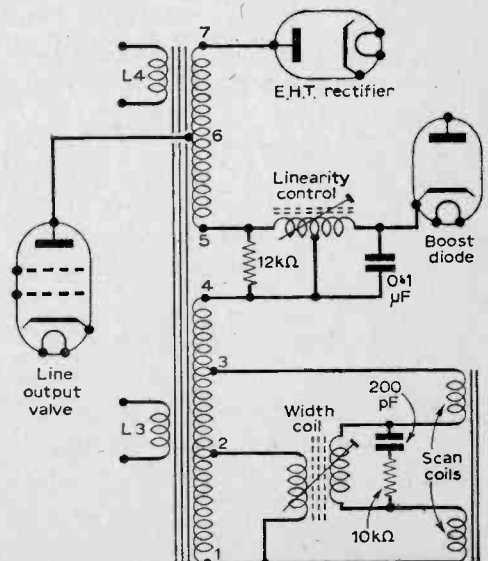

Fig. 5—The theoretical circuit diagram.

ferrite slug slides in and out of a solenoid. A suitable design is given in Fig. 6.

A Second Method

A second method of achieving resonance control which may or may not be applicable to any given design is described below.

The transformer is wound with the e.h.t. over-wind on a separate limb as previously suggested. The resonant frequency of the leakage reactance is accepted and the *main* transformer resonance is adjusted until the correct ratio between the two is obtained.

This is carried out by adjusting the value of a capacitor, C (Fig. 4), which is tapped at a convenient point across the transformer winding. This could be across the scanning coil connections, where a capacitance value of about 300 to 500pF

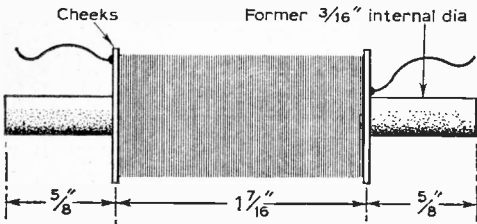

Winding details—870 turns pilewound of 0.0124" enam. copper wire
 Ferrite core—1" x 1/8" dia.
 Fig. 6—Inductive control solenoid.

will be required. Adjustment is carried out until ring-free conditions are observed on the c.r.t. screen.

If a meter is connected to monitor the e.h.t. produced at the same time it will be noticed that this ring-free condition will be found to coincide with a peak in the e.h.t. produced. The addition of this capacitor will generally reduce the peak potential developed across the transformer. What is looked for will be a sudden increase in the mean value of the e.h.t. superimposed upon a gradual reduction in the mean value as the value of C is increased.

If the necessary flyback of C is found to be too large it will give rise to a lengthy flyback period,

On The Air

—continued from page 317

before presenting at the output a signal, positive going, of one volt into 75Ω.

Mechanically the camera is based on a framework made of Imlok. This is divided into two halves, one half takes the electronics, the other is made light-proof and carries the camera tube and its associated coil assembly—the whole lot mounted on a slide system for focusing. The viewfinder is mounted on top of the camera framework and is a completely self contained 7in. monitor apart from h.t. supply. The complete camera plus viewfinder takes about 800mA of h.t. current at 270V, and this is supplied from an electronically regulated power unit.

TRANSMITTER: This is a simple unit starting with an 8.075Mc/s or similar crystal which is multiplied up to 144Mc/s in a small drive strip.

WINDING DETAILS

Windings 1-2	28 turns	} All .0124in. dia. enam. wire
" 2-3	252 "	
" 3-4	348 "	
" 5-6	180 "	
" L3 and L4	24 turns, .0124in. dia. enam. wire	

Windings 1-6 are layer wound on a 7/8in. dia. insulated former with .003in. paper interleaving every layer.

Winding L3 is wound over windings 1-6 with .005in. polythene strip insulation between these two windings.

Winding L4 is wound over several layers of .005in. polythene strip on a second former 7/8in. dia. mounted on opposite transformer limb. Before winding 6-7 is placed on L4, several layers of .005in. polythene strip is wound on top of L4 as insulation.

Winding 6-7 1,000 turns of .0048in. enam. and single-silk wire wavewound 1/8in. wide using gears:-

A	B	C	D	E	F
42	31	36	48	80	40

Ferrite core: Mullard type FX1036.

so that part of the picture will be "folded over" and appear in the flyback trace. The solution here is to redesign the e.h.t. overwinding to have a similar self-capacitance. This can often be achieved by selecting suitable gear ratios on the wave-winding machine to give a larger number of "crossovers" per turn of the coil and result in a more open weave.

This second method is largely experimental and it is emphasised that the capacitor C must be able to withstand the peak potential that appears across the scanning coils during the flyback. A peak potential of several thousand volts may be present across the capacitor, so that continuous variation of the capacitance value may be difficult to achieve. Fortunately the value required is not critical and a selection from a half a dozen fixed values will usually allow the correct value to be determined.

Having increased the line scan current by one of the methods suggested above it now remains to increase the frame scan current by a suitable value. How this may be achieved will form the subject of the next article.

The 12W of power at 144Mc/s is fed to a QQVO6-40a tripler which in turn feeds the 4X150A final amplifier. Modulation for both sound and vision is applied to the control grid of the 4X150A, and a simple protection circuit is included in the G2 supply to protect the valve in the event of a fault condition removing anode volts, in which case the valve would be destroyed very quickly. The anode draws 150mA at 1,000V for a peak white signal (150W). Due to the small size of the 4X150A, a blower system is essential—in fact the valve can destroy itself with only heater volts applied if the blower is not working—and an air duct runs through the transmitter to keep the penultimate and final stages cool.

No regular schedule of transmissions is arranged, but G3NDT/T is usually on the air on Saturday evenings and Sunday mornings when an amateur television, "net" is arranged with G3OUO/T, G30PB/T and other stations in the area.

A MONTHLY FEATURE
FOR DX ENTHUSIASTS

by Charles Rafarel

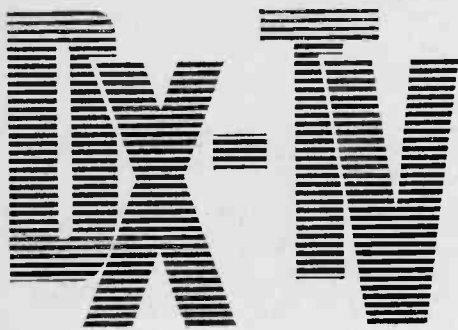

HERE are a few more tips on station identification, as there is nothing more infuriating for the DXer than to receive a beautiful picture without having any idea where it came from.

RTF France

Paris, Eiffel Tower (Channel F8A) carries at times the normal test card with the single word "Paris" at the bottom of the centre square. This special card is only used occasionally but when seen it is proof of the reception of the Eiffel Tower transmitter. (No other transmitter uses it.)

The RTF promise of regional names on Test Cards has not yet been carried out, although I have noted, on one isolated occasion, the use of a map of Western France on the Caen test card, in place of the usual statue in the centre.

Switzerland

All test cards are basically the same for transmissions originating from the French, German or Italian speaking regions of the TV service. There is, however, one important feature on all test cards, often overlooked by DX viewers because it is not easily noticed, particularly on weak or noisy pictures.

On the right hand side of the centre circle there is a small square containing a "letter" corresponding to the exact transmitter; i.e. "U" = Uetliberg, "D" = La Dôle, etc.

USSR

Very rarely the Russian 0249 type of test card carries the name of the transmitter and when it does is positive identification of its location. The word may be at the top, centre or bottom of the card and will be in Russian characters (Moscow will be "Mocba", etc.).

If you receive any of this type of card and care to send us an exact copy of the lettering we will be pleased to identify the station for you.

Sound and Vision Simultaneous Reception

With reference to RTF 819-line signals, we have recently received a very interesting letter from Mr. W. N. Burrige of Totnes, giving his solution to the problem of reception of sound and vision from France.

The sound-to-vision separation on French channels is approximately 11Mc/s, and although

the sound is a.m. for Bands I and III, the use of a standard British 405-line set will not enable us to receive sound and vision together.

The simplest solution is to use another TV set for the sound channel, a somewhat "bulky" arrangement of apparatus. Mr. Burrige's solution is as follows:— By using a standard 405-line receiver, and a suitable Band I aerial, he receives the Caen RTF sound signal on 41.25Mc/s (i.e. Band I channel B1 adjacent to BBC London on 41.50Mc/s).

When the sound is tuned in on 41.25Mc/s the tuner is automatically set for the receiver to accept a vision frequency of 44.75 (i.e. 41.25 + 3.5Mc/s). There is, of course, no RTF station on 44.75Mc/s, but if we search for "possibles" in Band III we note from Mr. Burrige's location that he can receive Rennes-Pern on F5 channel with a vision signal on 164Mc/s.

By employing a second aerial resonant on 164Mc/s he feeds this vision signal to a transistorised frequency converter, and by beating the 164Mc/s signal with a local oscillator at 208.75Mc/s, a resultant "i.f." of 44.75Mc/s is produced, which in turn is fed via a suitable coupling coil to the main set input at 44.75Mc/s.

This ingenious system will work excellently, but there is one small objection. At times (admittedly not very frequently) RTF stations carry their own regional programmes. This presents no further problems when Caen and Rennes stations (both Tele Ouest Regional Transmitters) are used, but for viewers in other parts of the country the use of, say, Caen for sound and Lille for vision will give rise to a curious situation when sound and picture do not agree because the programmes differ!

An alternative solution is the one I use, that is to disconnect the sound i.f. strip of the 405-line set at the "take off" point from the first common sound/vision i.f. stage and to connect a second tuner (incremental type) to the sound i.f. strip and to tune the sound channel separately.

This works well, but just two points should be noted:—the exclusion of the common first i.f. sound/vision from the sound circuit results in some drop in sound sensitivity, this can be largely overcome by employing EF184 valves in place of the more usual EF80 type in the sound i.f. strip.

Secondly the sound-only tuner produces a fundamental frequency and harmonics which can be troublesome on some vision channels. Where necessary, appropriate "evasive" action can be taken by detuning the tuner to another channel.

—continued on page 332



Your Problems Solved

Whilst we are always pleased to assist readers with their technical difficulties, we regret that we are unable to supply diagrams or provide instructions for modifying surplus equipment. We cannot supply alternative details for constructional articles which appear in these pages. **WE CANNOT UNDER-TAKE TO ANSWER QUERIES OVER THE TELEPHONE.** The coupon from p. 328 must be attached to all Queries, and a stamped and addressed envelope must be enclosed.

ALBA T717

On BBC, sound is only just audible with the controls at maximum. A certain amount of hum also is present on the sound. ITA sound, although considerably better than BBC, is definitely below normal.

This set has also developed a video fault which requires the contrast control to be set at maximum at all times to receive a satisfactory picture.

I suspect these faults originate in the turret tuner.—M. J. Lovell (Southend-on-Sea, Essex).

The cause of the faults described could be in the tuner, but equally, misalignment of the sound and vision i.f. channels could be responsible. The hum on sound is probably due to vision signal breakthrough into the sound channel, and this is invariably caused by misalignment of the sound i.f. channel.

If the trimmers have been altered recently, then suspect misalignment. Also check the aerial system and, if necessary, the tuner valves for emission.

PUSH TV24A

When first switched on the picture fills the screen as normal, but gaps at either side of the picture soon begin to develop. After about five minutes these gaps are at least 2in. wide.

I have replaced the PY82, the PL81, the PY81 and the EY81. I have also changed the width control, VR7. None of these measures, however, have effected a cure.—F. T. Howe (Saffron Walden, Essex).

It is surprising that replacement of the PL81 and the PY82 did not right the fault as these are most often the cause of the symptoms described. However, if you are sure that the new valves are in order, you will have to check the 3.3k Ω screen dropping resistor, the 0.1 μ F boost line capacitor and the 80pF 6kV tubular capacitor from the PY81

to the width control (on the transformer panel, being the right hand one of the two).

EKCO T283

Two vertical bars of light divide the screen—which lacks illumination—into three sections.

There seems to be insufficient e.h.t. at the anode of the U25.

I have replaced the 30P4 and substituted the line oscillator valve without tracing the fault.—G. Laidlan (Shildon, Co. Durham).

These symptoms are caused either by a faulty U191 or to a faulty boost capacitor. This is the 0.5 μ F component below the chassis near the line output transformer vent hole.

FERGUSON 506T

The picture on this set is stretched at the top of the screen. Also, a gap has appeared at the bottom of the screen which varies in depth to a maximum of 2in. Adjusting the height control to correct this latter fault only worsens the stretching.—R. Allen (Hayes, Middlesex).

Check the frame output PCL82 (V13) and its 390 Ω bias resistor and 100 μ F bias electrolytic. This valve is next to the PY32 on the lower deck and the two other components (R124 and C96) are behind these two valves.

FERRANTI 1325

There is no sound or vision, only a white streak across the screen. I can obtain a good purple spark from the e.h.t. valve but the spark at the tube anode is very weak.

I have tested all the valves without tracing the fault.—R. C. Allen (London, S.E.2).

The trouble is in the line timebase and we would

advise you to check the line scanning coils and their shunt components which are a 5-6k Ω resistor and a 500pF capacitor in series.

Check also the width coil.

DEFIANT T172

The fault in this receiver appears on ITA only. Sometimes the set works correctly for maybe one, or even two hours, but then the picture begins to pull across the screen from right to left. It is impossible to straighten the picture with the line hold control or fine tuner.

Although the BBC picture is normal, this is with the line hold almost at its limit.—J McDonald (Blackhill, Co. Durham).

We would advise you to change the 6/30L2 valve which is situated virtually in the centre of the chassis.

PHILIPS 1400A

The contrast, brightness and focus controls have to be set at minimum to obtain a reasonable picture and even then the focus changes with every camera change. The latter fault can be dealt with partially by adjustment of the contrast control.

The e.h.t. unit in this set was replaced recently.—M. W. G. Bennett (Epsom, Surrey).

The trouble would appear to be in the e.h.t. unit, but as this is a recent replacement we would suggest you check the PL38 driver and ECL80 oscillator valves and associated components, particularly the high value resistors associated with the latter valve.

BUSH TV75

The picture has reduced in size and has become square shaped. This condition leaves a black border around the picture.

When the brilliance control is advanced, the picture enlarges and goes out of focus.—A. J. Astell (Bristol, 3).

Check the h.t. voltage output of the LW15 metal rectifier. If this is under 190V, change it. If it is 190V or more, check the PL81 valve inside the screened section and the ECC82 above it.

McMICHAEL M71T

Occasionally the brilliance of the screen decreases to such an extent that the picture disappears. At these times the voltage on the grid of the tube increases. Sometimes when this fault occurs the EY51, which is new, glows blue.

I have checked the brilliance control and all the capacitors and resistors in its associated circuit. I have also tested all the valves.—G. F. Winter (Belfast, 14).

If the tube grid voltage varies, even though the voltage applied to the grid from the brightness control is constant, then there is little doubt that the tube is at fault. However, check the capacitor connected to the grid for insulation resistance.

SOBELL T175

When first switched on the picture rolls up or down and adjustment of the vertical hold control is necessary to lock the picture. During an evening's viewing the fault will recur and adjustment is again necessary.

I have replaced the two ECL80's, V14 and V15.—R. Saunders (Rainhill, Liverpool).

Test the components which are connected between the sync separator valve and the frame oscillator, for your remarks indicate that the frame sync pulses are attenuated due to a component fault. Also check the OA61 interlace filter diode on pin 1 circuit of the ECL80 frame valve.

FERGUSON 636T

Neither picture nor sound were present on this set (although there was a raster and a hum in the loudspeaker) and so I attempted to bring in a signal by adjusting L7 in the tuner unit, but with no success. Further investigations revealed that the resistor R242 in the tuner h.t. feed was charred and so I replaced it. Signal strength was then restored but while adjusting the coils in the tuner unit I must have shorted L4 as R8 burned out. I replaced this resistor and also C14 but when I switched the set on to receive a picture, R8 once again burned out. The next time I replaced it, I first switched on when all stations had closed and everything functioned normally. However, when once more I switched on during a transmission, the resistor burned out again.—C. Woolley (Crawley, Sussex).

Check the capacitor connected to the other end of the resistor (i.e. not the h.t. end) for this may have an intermittent fault. Another case is an intermittent short in the associated tuner valve.

EKCO T161

One of the two resistors to the base of the U801 in this receiver short circuited and as a result this valve burned out. I renewed both the valve and the resistors but now, although all the valves light and there is no obvious fault, the set is completely dead; no sound, no raster and no e.h.t. I conclude that there is no h.t. but I cannot trace a fuse in the h.t. line.—H. H. Williamson (Formby, Liverpool).

There is no separate h.t. fuse on this receiver and we suggest you check around the main electrolytic capacitors and especially the h.t. smoothing choke next to them, below chassis.

COSSOR 950

The picture and sound on channel 1 both faded gradually from this receiver so that now there is no picture and only very faint sound.

Reception on channel 9 is perfect.

I have changed both valves in the tuner unit without improving matters.—D. McKenty (London, S.E.1).

This fault suggests a faulty set of BBC coils and we would advise you to replace them. These are easily fitted by removing the bottom cover of the tuner.

AN AETI PRODUCT

Anatomy of a Superior Soldering Iron

The Solon range of electric soldering irons includes 15 and 25 watt models for radio, TV and electronic equipment; 65 watt models for household and workshop use. Larger models up to 240 watt also available.

Select a SOLON

TRADE MARK

Used in industry for over 30 years
Obtainable from your usual radio or electrical supplier



6 ft. flexible lead with cord grip

Heats up from cold in 2 1/2 mins.

Will give a lifetime of service

25 watt model for radio work

Heat concentrated in bit

13/40E

Better, Brighter Picture Tubes

BRAND NEW THROUGHOUT
excepting glass

12in. ...	£4.10.0	14in. ...	£5. 5.0
15-17in. ...	£5.15.0	21in. ...	£7.15.0

New Silver Screen and Aluminising. All makes Mullard, Mazda, Emiscope, Cossor, Brimar, Emitron, etc.

REBUILT MULLARD AND MAZDA TUBES

12in. ...	£3. 0.0	14in. ...	£4. 0.0
15-17in. ...	£4.10.0	21in. ...	£6.10.0

All Tubes Fully GUARANTEED 12 MONTHS. Dispatch same day. Cash with Order. Carriage and Insurance 10/-.

S.T.S. Ltd.

35 POUND STREET, CARSHALTON, SURREY

Telephone: WALLINGTON 9665

GUARANTEED LINE OUTPUT TRANSFORMERS

FREE POST AND PACKING except C.O.D. 5/-

5/- ALLOWANCE ON YOUR OLD L.O.P.T. IF SENT WHEN ORDERING REPLACEMENT L.O.P.T.

ALBA —T301, T304, T394, T484, T494, T504, TR1974, TR9874	1 at 46/-
T312 Rewind	1 at 75/-
T321, T324, T424, T524, T524FM	1 at 44/9
T331, MT341, T352, MT362, T431, T432, MT441, MT442	1 at 51/9
T641, T644, T724FM, T744FM	1 at 70/10
T655, T909, T717	1 at 57/9
BUSH —TV32, TV33, TUG34A, T36, TV36, TUG36, TV36/c, TUG39/c, TV43, TV53, TV58, TV57, TUG58, M59, TUG59, TV62, TV63, TV66, TV67, TUG68, M69, TUG69	1 at 70/-
Rewind	1 at 120/-
TV80	1 at 103/9
TV85	
COSSOR —R17A, 930, 931, 933, 934, 935, 937, 938, 939A, 939FA, 940, 942, 942A, 943, 944, 946	1 at 80/-
945, 945B, 949	1 at 63/6
DECCA —DM, DM2/C, DM3, DM4, DM4/C, DM5, DM14, DM17, 444, 555, DM55	1 at 72/6
DM35, DM45, DM21/C, DMG21, DM22/C	1 at 74/6
DEFIANT —All Rewinds only	
EKCO —TC206, TU209, T209/1, T221, T231, T231F, T249, TC267, TC267/1, T283, T284, T293, T311, TCG316, T326, T327, T330, T330F, T331, TCG337	1 at 50/-
TMB272, T344, T344F, T349, T349F, T356	1 at 69/-
TC312, T313, T313F, T335	1 at 73/9
EMERSON —E700, E701, E704, E708, Port O'rama E707, E709, E710, E711	1 at 50/-
FERGUSON —43T, 454T	1 at 95/5
988T, 989T	1 at 52/6
23T, 204T, 205T, 206T, 214T, 235T, 236T, 244T, 246T	1 at 89/9
267T, 305T, 315T, 317T	1 at 91/5
306T, 308T	1 at 57/9
406T, 408T, 416T, 436T, 438T, 405T, 407T, 500, Series 604T	1 at 91/5
FERRANTI —14T2, 14T3, 14T3F, 14T4, 14T4F, 14T5, 14T6, 17K3, 17K3F, 1773, 1773F, 17K4, 17K4F, 17K5, 17SK4, 17SK4F, 17K6, 17SK6, 17K6G, 17T4, 17T4F, 17T5, 17T6, These are Re-winds. 20T4D, 21K6, 21K6V, 22K3, 24K4, T1001, T1002, T1002/1, T004, T1005, T1011	1 at 52/6
T1012, T1023, T1024, T1027	1 at 66/-
G.E.C. —BT1251, BT1252, BT1252A, BT1746, BT1748, BT2230, BT2745, BT2745R, BT2747, BT4743, BT5248, BT5347, BT5348, BT5643, BT5643R, BT8245, BT8246, BT8640	1 at 70/-
All these are supplied Re-wind.	
BT8742, BT1156, BT1354, BT2154, BT2155, BT8149, BT8248	1 at 67/-
H.M.V. —1824, 1824A, 1824B, 1825, 1826, 1826A, 1827, 1827A, 1829, 1829A, 1840, 1841, 1842, 1843, 1844, 1845, 1846, 1847, 1848	1 at 67/6
1865, 1869	1 at 57/9
1870, 1871, 1872, 1873, 1874, 1875, 1876	1 at 91/5
INVICTA —T118, T119, T120	1 at 57/9
T122, T123	1 at 61/9
T123, T124, T125, T133, T134	1 at 64/6
237, 237SF, 437	1 at 66/-
537, 538, 539	1 at 61/5
With INVICTA, PAM or PYE spares please state serial number and makers part number.	
KOLSTER BRANDES —all types available, some of these are re-winds.	
PV220, PV30, Royal Star	1 at 106/9
QV10R, QU20, QU30	1 at 97/3
PV40	1 at 102/-
QVP20, QVP30	1 at 104/3
PV100, PV100/1	1 at 121/6
MARCONI —All types available, some are re-winds 69 series.	
VRC84DA, VC153	1 at 67/6
VT153, VT155, VT156	1 at 52/6
VT157, VT158, VT159, VT160	1 at 91/5
MASTERADIO —All types can be re-wound.	
PILOT —CV78, TV76, CV77, CV84, TV84, CV84/12, TV84/12, DDC/87, CV87, TV87, DDC87/12, CV87/12, TV87/12	
Re-wind.	
110F, 111, 117, TV107	1 at 63/11
All other types available, prices on request.	
PYE —V4, V74, V7, V77	1 at 52/6
All other models available.	
REGENTONE —All early models re-wind.	
T11, 10-6 (or re-wind at 70/-)	1 at 114/-
R.G.D. —DEFITIME, 17TME21, Re-wind only.	
710, 611, 610	1 at 114/-
SOBELL —TS17, T347, T171, T171C, T172	1 at 81/-
T21, T21C, T21LC, T22, TPS147, T178	1 at 87/9
T181, SC34, SC24, SC270, SC370	1 at 66/-
ULTRA —V814, V815, V817, V915, V917	1 at 97/6
14-38, VP14-53, V15-50, V1750, VR1752, V1753, V1760, VR1762	1 at 69/6
WR162, V1763, V1764, V21-50, V21-52, V21-60	1 at 80/9
V17-70, V17-71, V17-72, V17-73, V17-74, V17-75	1 at 80/-
V17-80, V17-81, V17-82, V17-83	1 at 72/6
V19-80, V19-84, V19-85	1 at 81/3
V23-80, V23-84	1 at 70/-

SATISFACTION GUARANTEED. RETURN POST SERVICE SUBJECT TO STOCK.

Rewind Service 7 Days. Trade Supplied. S.A.E. all enquiries.

WITWORTH T.V. SERVICE

32a All Saints Road, London, W.11.

Tel: PARK 9972.

Open all day MON-SAT Inc.

HERE'S A LOW COST WAY TO GET INTO T.V. SERVICING FAST!

If you are a man who wants to get ahead in television, you will probably be interested in this new revolutionary type television training programme now being introduced for the first time.

Knowing that early success will usually spur a man on to greater achievement you learn how to make the easiest T.V. repairs first. These are the easiest T.V. repairs are the ones most often found on service calls, you are ready to make money right after the first lesson. Then as you progress you will discover how to handle every kind of trouble found in all makes of T.V. set!

Here for example are some of the items covered in the course:

1. Simple adjustments to correct poor pictures.
2. Circuit faults indicated by a poor pattern.
3. Finding bad valves by observing picture faults.
4. Antenna principles and practices.
5. Facts about the T.V. signal to help you in repair work.
6. All about Cathode Ray tubes.
7. How to tell what is at fault.
8. Explanation of television circuits.
9. U.H.F. converters and tuners.
10. Television test equipment and alignment.
11. Advanced trouble shooting by picture analysis.

This is a real home study course that has been bound into one giant 8 x 11 in., 192 page manual to reduce cost.

Compares favourably with some courses costing very much more! By creating a mass market through large volume sales and eliminating individual letter writing we are able to pass on these savings directly to you!

The course features over 325 different line drawings, circuits, servicing charts and illustrations to simplify the text and make your study more enjoyable. Soon you will be well on your way to becoming a first-class television repair technician!

YOU TAKE NO CHANCES WHEN YOU DEAL WITH SIM-TECH

You must be convinced that this is the best value you have ever seen in television training, otherwise you can return the course (or have your money refunded if sent with order) after you have examined it in your own home for a period of seven full days.

The price? Only 36/- per course, plus postage and packing, 1/6.

Free 71-page book on Television Faults will be included if you send cash with order.

FREE TRIAL OFFER

Terms only 5/- per week if you wish.

To SIM-TECH BOOK COMPANY Dept. AT.5
West End, Southampton, Hants.

Please send your Television Course for a full seven days' free trial. If not delighted I may return the course post-paid without further obligation on my part. Otherwise I will pay cash price of 37/6 or 5/- weekly until 37/6 plus 2/6 service charge, total 40/- is paid.

Tick here if enclosing full price of 37/6. (Same 7-day money back guarantee). NOTE: Customers who send cash with order get in addition a 71-page book on TELEVISION FAULTS. Overseas customers please send full amount (including Ireland).

Name

Address

City..... County.....

96 pages of factual tabulated data ... should be on the workbench of every serious constructor and service man

"PRACTICAL WIRELESS"

RADIO and TELEVISION REFERENCE DATA

Compiled by J. P. Hawker

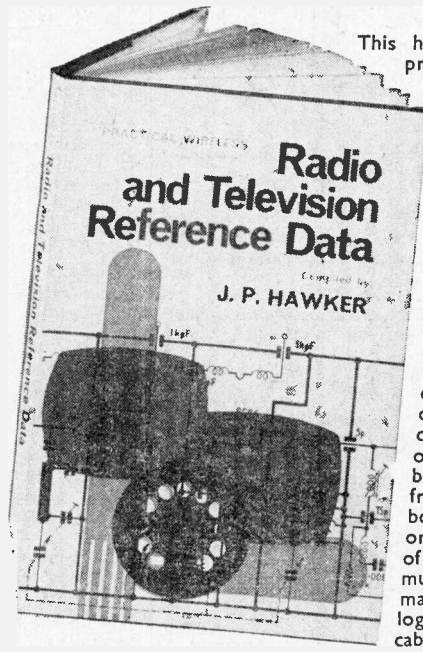

This handy book provides the practical reference data that radio and television servicemen, radio constructors, enthusiasts and amateurs always need. It has been compiled with the day-to-day requirements of servicemen particularly in mind. Contents include: full details of colour codes; a comprehensive collection of practical, everyday formulae for calculating the values of biasing components, potential dividers, etc.; aerial dimensions; a quick frequency-wavelength conversion table; full lists of radio and television, broadcasting stations and frequencies; common symbols and abbreviations; notes on Amateur radio and a list of call-sign prefixes; communication receiver I.F.s; mathematical data including logarithm tables; wire and cable data; battery equivalents;

and a full and up-to-date listing of valve, transistor and cathode-ray tube pin connections, bases, ratings and equivalents, including CV types

order here

Please send me by return.....copy/copies of

P.W. RADIO AND TELEVISION REFERENCE DATA

10s. 6d. each (11s. 6d. by post)

**10s. 6d.
FROM
ALL
BOOK
SELLERS**

Name

Address

... or, in case of difficulty use this handy order form TODAY

Simply complete this order and post with cheque/postal order for 11s. 6d. per copy to GEORGE NEWNES LTD., Tower House, Southampton Street, London, W.C.2.

PT 4/64

NE...IES

ULTRA 17-70

Recently I lost the picture on this set but after replacing R32, C35 and X1 the picture returned, only reduced in width and height, leaving a border approximately 1in. all round.

I have renewed V12, V7, V6 and V9 but have not found a cure for this fault.—H. Mott (Bexley, Kent).

You should check the h.t. voltage and if this is very much under 190 to 200V, change the h.t. metal rectifier.

If the h.t. voltage is not low, check the boost line voltage and associated capacitors.

EKCO TC209

Whilst the right-hand half of the picture on this set is excellent, the left-hand portion is obscured by a shadow. This shadow is darkest at the extreme left of the screen.

Advancing the brightness control produces a smudgy and hazy area on the left-hand side of the screen with the right-hand side naturally becoming too bright.—A. Knight (Cefn Coed, Glamorgan-shire).

Check the 200 μ F section of the main smoothing capacitor and also the 0.001 μ F frame flyback suppression capacitor below the chassis near the main smoothing capacitor.

PETO SCOTT 1725

Recently the raster jumped, suddenly, to the right-hand side of the screen leaving only about a quarter of the raster visible. The part visible was very ragged.

I checked by substitution the PCF80, PCL82, ECC82, PCL83 and EB89 valves, and now the raster has returned to its correct position but remains "jumpy" and pulls to both the right and left of the screen. Also it is now somewhat enlarged, and the picture has the appearance of being behind a set of bars.

Finally, the h.t. pin 6 of V15 (PCL82) and on one end of the frame output transformer reads 250V against 165V.—H. Wilkes (Southampton).

The line patterns could indicate some form of outside r.f. interference. If the trouble is on one channel only, this possibility should be investigated. If both channels are affected, check the frame timebase, for the symptoms indicate that the frame amplifier is taking insufficient current. The frame valve could be low emission.

PYE 177

I can get no picture on this set and there is no e.h.t. This condition was preceded by the gradual lengthening of the warming up time and the appearance of lines across the screen.

Now when the set is switched on, the PL81 gets very hot.

I have changed the EY86.—J. Cocker (Burslem, Staffordshire).

Check the PCF80 line oscillator valve which is just in front of the mains selector plug.

FERGUSON 546T

For some time now periodic adjustment of the vertical hold control has been necessary to stop the picture rolling. Recently, however, another fault has developed. Approximately 15 minutes after being switched on from cold, the picture suddenly disappears completely, leaving a good raster and sound.

If I switch the set off and on again after about half an hour, a perfect picture is received (apart from the occasional roll) for a further 15 minutes.

Most of the valves (including the tuner valves) have been changed without clearing the fault.—D. Jennings (London, E.3).

We advise you to check the PCL84 video amplifier (if this valve is not among those already changed) and the coils to the left of this valve: open wound chokes.

Then check the OA70 crystal diode inside the coil cap near the coils and rear edge, which is smaller than the other three.

McMICHAEL M76

After being on for half-an-hour or so, this set develops frame judder. I managed to cure this by replacing the PCL85 but only temporarily as the fault returned in a few days.

I have also renewed the PCL85 cathode capacitor but have not cured the fault.—J. Macpherson (Peebles).

Whilst we are sure the effect is caused by a faulty capacitor it is difficult to say which one it will turn out to be. We would suggest you replace C57 (0.01 μ F) and C53 (0.2 μ F) in the first instance.

MURPHY V410

Sound has recently failed on the BBC channel on this receiver, leaving a humming noise. On ITA the sound remains perfect with the picture on both channels remaining correct.

Both tuner valves, V1 and V2, are new and in working order and the sound i.f. (V9) and a.f. amplifier and output (V10) valves have been checked by substitution.—R. K. Deakin (Stretford, Lancashire).

This fault is a frequent offender. We advise you to replace the 0.001 μ F capacitor decoupling the screen grid of the sound i.f. stage on top of the chassis. The present capacitor is a brown one with rounded ends and must be changed for a good quality Hunts W99 type.

FERGUSON 305T

When I obtained this set second-hand, the resistor R84 had burned out. This I replaced and on switching on, everything at first appeared normal. After about 20 minutes, however, the auto transformer (T3) burned out.

I replaced this component but now, after the receiver has been working for about half-an-hour, the picture starts to move across the screen from

right to left until line lock is completely lost.—
A. J. Williams (Kingstone, Herefordshire).

Replace the 0.01 μ F capacitors across the windings of the line oscillator/discriminator transformer and check that the windings are securely cemented to the former when the can is removed for capacitor replacement. Afterwards, set the two cores according to the service sheet instructions.

BUSH TV24

The left-hand side of the picture on this receiver is constantly brighter than the remainder of the screen. When viewing the screen with no signal present, the bright area extends two inches in from the left-hand edge where it finishes in a definite line.—S. Darnell (London, W.6).

Check the 2.2k Ω resistor associated with the width coil, the 0.1 μ F capacitor decoupling pin 10 of the c.r.t. (first anode supply, pin 4 on earlier tubes) and the setting of the line drive preset capacitor under the main deck.

EKCO T415/F

There is a permanent "buzz" on the sound which comes on as the picture appears after the set is first switched on. This is present on all channels including u.h.f. and cannot be reduced by use of the "anti-buzz" control on 625-line working. Operation of the volume control does not affect the buzz.

Another sound fault on this set occurs whenever a light switch is operated. When this happens, a flash appears across the screen, a loud click is heard from the loudspeaker and the sound level generally becomes very loud. After a while the sound returns to its normal level.—D. J. Mundy (Richmond, Surrey).

The first fault may be due to frame timebase pick-up on the lead from the sound output valve anode to the sound output transformer. This lead should be screened.

Volume variations are usually caused by a faulty 25 μ F electrolytic in the cathode circuit of the sound output valve.

TEST CASE -17

Each month we provide an interesting case of television servicing to exercise your ingenuity. These are not trick questions, but are based on actual practical faults.

? The main symptom on a five-year-old receiver was sound-on-vision and no manipulation of the fine tuning control could clear it. It was also observed however, that slight vision-on-sound was present and that the sound-on-vision cleared completely when the volume was turned right down.

Having come up against similar trouble of this kind before, the experimenter replaced the frame timebase valve, thinking that this was microphonic and that the fault was being caused by sound vibrations from the loudspeaker modulating the electron stream of the valve. The trouble persisted.

What are other causes of this effect and what component is usually to blame?

See next month's PRACTICAL TELEVISION for the answer and for another Test Case.

SOLUTION TO TEST CASE 16 (Page 284, last month)

The symptoms last month were those of a very bad mismatch on the aerial downlead. Such would indicate either a short-circuit in the coaxial cable or an open- or short-circuit at the dipole connection or, in the case of individually coupled aerials, trouble in the diplexer or at its terminals.

The signal getting to the receiver was obviously very weak, which would mean that very little grid

bias was getting back to the controlled valves from the vision a.g.c. system, thereby causing the set to work at full gain. Under this condition, even a slight input circuit mismatch would tend to aggravate instability, which was the reason for the "ringing" tendency.

The varying signals on moving the downlead at the rear of the set were caused mainly by the downlead itself picking up signal direct, the degree of pick-up being dependent, of course, on the orientation of the lead in relation to the direction of the transmitter and the polarisation of the signal.

Under normal conditions a downlead will not pick up signal direct, but resulting from a mismatch a length of coaxial cable can, in fact, be turned into a reasonably efficient aerial. This is the cause of indifferent reception on some aerial systems which are not ideally matched both at the aerial and at the set. The aerial cable picks up some signal, as does the aerial proper. Now if these two signals arrive at the set out of phase with each other, then the weaker signal will subtract from the stronger and the net signal applied to the set will be somewhat less than the aerial signal.

QUERIES COUPON

This coupon is available until APRIL 22nd, 1964, and must accompany all Queries sent in accordance with the notice on page 323.

PRACTICAL TELEVISION, APRIL, 1964

LAWSON

BRITAIN'S CATHODE RAY TUBE SPECIALISTS

OUR PRODUCTS

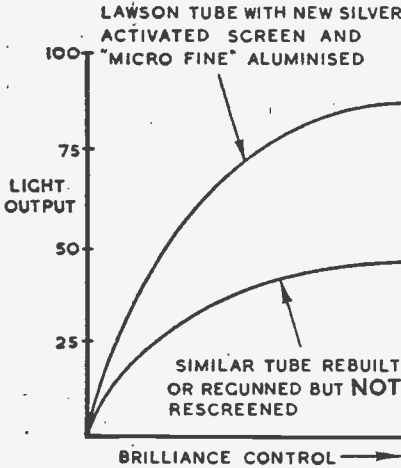
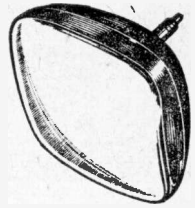

LAWSON TUBES are the Products of the Commonwealth's largest cathode ray tube manufacturers. All tubes are designed to give very much improved performance in all TVs (especially older sets). Their new high resolution electron guns by Mullard, Mazda, GEC, Cossor etc. (suitable for 625 or 405 lines) give crisp, needle sharp definition and focus. Brilliant new silver activated screens ensure much improved brightness and contrast. Exclusive "Micro Fine" controlled thickness aluminising gives 50% more light output. Silicon vacuum pumping plus depth formed cathodes ensure very long life. Each tube is 100% BRAND NEW (glass excepted), and guaranteed an exact replacement for the original.

OUR SERVICE

THE LAWSON CRT organisation is specially designed to give a world wide CRT service from the largest stocks of all types of CRT's in Britain. We can supply the EXACT tube you require by return, it matters not if you live at No. 10, the Outer Hebrides or far away New Zealand, or if you want 1 tube or 1,000, our long experience, vast stocks and special CRT containers ensure rapid and safe delivery anywhere.

C.O.D. or C.W.O. Carr. and Ins. 7/6.
12" .. £4.10.0 10/- If old tube returned.
14" .. £5. 5.0
15"-17" £5.15.0
19"-21" £7.10.0
 12 MONTHS' FULL REPLACEMENT GUARANTEE AND FITTING INSTRUCTIONS WITH EVERY TUBE.

LAWSON TUBES 2 PEACHFIELD CLOSE, MALVERN, WORCS. Malvern 2100

VALVES SAME DAY SERVICE NEW! TESTED! GUARANTEED!

SETS 1R5, 1S5, 1T4, 3S4, 3V4, DAF91, DF91, DK91, DL92, DL94 .. Set of 4 for 15/-
 DAF96, DF96, DK96, DL96 4 for 23/6

1A7GT 8/-	6SL7GT 5/8	CY1 12/6	ECL80 6/3	PCC89 8/-	U50 4/6
1D5 6/6	6SN7GT 3/9	DAC32 8/3	ECL82 7/-	PCF80 5/9	U78 3/9
1H5GT 8/3	6U4GT 9/6	DAF91 3/9	ECL85 9/-	PCF82 6/9	U91 9/3
1N5GT 8/-	6V6G 3/9	DAF96 6/9	EF39 3/9	PCF84 8/-	U281 3/6
1R5 4/9	6V8GT 6/6	DCC90 6/9	EF41 6/6	PCF86 8/-	U282 11/9
1S5 3/9	6X4 3/6	DF33 8/-	EF42 4/6	PCF86B 14/-	U281 9/-
1T4 2/6	6X5GT 5/6	DF91 2/6	EF80 4/3	PCL82 7/3	U04 5/9
1U5 5/-	7B7 8/-	DF96 6/-	EF85 5/6	PCL83 8/-	U01 15/9
3A5 6/9	7C5 7/9	DH76 3/6	EF86 6/3	PCL84 6/6	UABC80 5/9
3Q4 5/3	7C6 7/6	DH77 3/9	EF89 4/-	PCL85 8/6	UAF42 8/-
3S4 4/9	7H7 5/9	DK32 8/-	EF91 2/6	PEN4DD 19/6	UBC41 5/3
3V4 5/6	7S7 12/9	DK91 4/9	EP82 2/6	PENB4 17/6	IBC81 7/3
5U4G 4/6	7Y4 5/-	DK92 6/9	EL33 7/6	PENB4 17/6	UBF80 6/-
5Y3GT 5/-	10C2 12/3	DK96 6/6	EL41 7/3	PEN38C 8/-	UBF89 6/9
5Z4G 7/-	10F9 10/9	DL33 7/3	EL42 7/9	PEN38C 9/6	UBL21 9/9
6A9G 5/6	12A7G 4/3	DL35 6/9	EL84 4/9	PL38 8/9	UCS9 5/6
6A1.5 2/-	12A7T 3/9	DL92 4/9	EM34 6/9	PL81 7/6	UCCS8 6/9
6A05 6/-	12A7U 4/9	DL94 5/6	EM80 6/9	PL82 5/6	UCR80 8/6
6A7E 3/9	12A7X 4/9	DL96 6/-	EM81 7/9	PL83 5/6	UCH42 7/6
6BA6 6/-	12K7GT 4/3	EABC80 5/3	EM84 8/3	PL84 5/9	UCH86 6/6
6BE6 5/3	12K8GT 8/9	EAF42 8/-	EM87 8/9	PL85 9/-	UCL82 8/-
6BC6G 12/6	12Q7GT 4/3	EB31 2/-	EY51 6/-	PX25 7/9	UCL83 9/-
6BH6 5/-	19BG6G 13/6	EBC33 5/-	EY84 7/9	PY32 9/-	UF41 7/3
6BJ6 5/6	20F2 1/6	EBC41 7/3	EY86 5/6	PY33 9/-	UF42 4/9
6CD6G 28/6	20P4 13/-	EBC81 5/9	EZ40 5/6	PY80 5/3	UF39 6/3
6F1 5/6	20F6 14/9	EBF90 5/6	EZ41 7/6	PY81 5/9	UL41 7/-
6F13 4/9	25LGT 5/9	EBF83 7/9	EZ60 4/6	PY82 4/9	UL44 15/6
6F14 9/1	25U4GT 10/6	EBF89 6/-	EZ81 4/6	PY83 5/9	UL46 8/6
6F15 6/6	30FL1 9/-	EBL21 8/6	EZ82 5/6	PY88 7/9	UL84 6/3
6KTG 1/6	30L15 8/6	ECC40 7/3	KT32 5/-	R17 15/-	U07 6/9
6KTGT 4/-	30PL1 9/-	ECC41 3/9	KT61 7/6	TD44 7/9	UY21 7/9
6K9G 4/3	30PL13 9/6	ECC82 4/9	KT63 3/9	TH2C 9/6	UY41 4/9
6K8GT 7/9	30PL14 12/3	ECC83 7/-	KTW61 4/9	TH233 5/9	UY85 5/-
6L6G 5/9	35A5 14/-	ECC84 6/3	MU14 5/6	U22 6/-	VP41 4/9
6LD20 5/3	35L6GT 7/9	ECC85 6/3	MX40 8/9	U24 12/-	VP321 15/-
6P2E 6/6	35Z4GT 4/11	ECF90 6/3	N18 5/6	U25 8/6	W77 2/6
6P2E 9/6	AZ31 6/6	ECF92 6/3	PC05 9/-	U26 8/6	W76 2/6
6Q7G 4/9	B36 4/6	ECH35 8/-	PC87 7/6	U37 17/-	X03 5/6
6Q7GT 7/9	CCR35 12/3	ECH42 8/3	PCC84 6/9	U47 8/6	X109 17/6
6TGT 9/6	CL33 9/6	ECH81 6/-	PCC85 6/9		

FIRST-CLASS RADIO AND T/V COURSES... GET A CERTIFICATE!

After brief, intensely interesting study—undertaken at home in your spare time—YOU can secure a recognised qualification or extend your knowledge of Radio and T.V. Let us show you how.

FREE GUIDE

The New Free Guide contains 120 pages of information of the greatest importance to both the amateur and the man employed in the radio industry. Chambers College provides first rate postal courses for Radio Amateurs' Exam., R.T.E.B. Servicing Cert., C. & C. Telecoms., Grad. Brit. I.R.E. Guide also gives details of range of diploma courses in Radio/T.V. Servicing, Electronics and other branches of engineering, together with particulars of our remarkable Guarantee of

SUCCESS OR NO FEE
 Write now for your copy of this invaluable publication. It may well prove to be the turning point in your career.

FOUNDED 1885—OVER 150,000 SUCCESSES

CHAMBERS COLLEGE
 (Incorp. National Inst. of Engineering)
 (Dept. 462), 148 HOLBORN
 LONDON, E.C.1

READERS RADIO
 24 COLBERG PLACE, STAMFORD HILL
 LONDON N.16 STA. 4587

Post 6d. per valve extra.
 Any Parcel Insured Against Damage in Transit 6d. extra.
 Any C.O.D. Parcel 4/3 extra.



LETTERS TO THE EDITOR

TELEVISION DEAF-AID IMPROVEMENTS

SIR,—The article on a Television Deaf-aid in your December '63 issue, was of interest to me because, at the time, I happened to be making a device on similar lines for a friend who had been using his deaf-aid to listen to television sound. There are two modifications to Mr. Royal's circuit which I have found invaluable and would like to pass on to other readers.

The article concerns, of course, those who find themselves afflicted with what is known as "h.f. deafness" which comes with advancing years. This is to say, their auditory sensitivity begins to fall off at about 2kc/s, and does so very rapidly above 3kc/s. Deaf-aids have a rising frequency characteristic which is designed to counteract this impairment, since it is these higher audio frequencies which make an essential contribution to the intelligibility of speech. Correction on these lines is made more difficult in all the television receivers I have examined, by the filter circuit which is connected across the primary of the speaker transformer. Whether this circuit element (a capacitor and resistor in series) is included merely by custom, or with the specific purpose of covering up the deficiencies of the sound reproduction system of the modern receiver, is an interesting speculation. In any case I suggest that the first step in helping the hard-of-hearing is to sever this shunt circuit.

The other point concerns "mixed audiences". If, as was the case in my experience, one listener has a hearing deficiency, while the others have not, it is useful to provide both parties with independent volume controls.

This can be accomplished quite simply by connecting a 250Ω variable resistor in series with the speech coil of the loudspeaker. The volume control on the receiver can then be left at maximum and the two parties can adjust their individual controls to suit.

Mr. Royal's opening paragraph puts the case against the use of an unmodified deaf-aid in a nutshell and his "belt and braces" approach to the safety aspect is to be commended. I think he will agree however, that this latter suggestion of mine does not present a very serious hazard, provided the precaution he shows in Fig. 2 of his article is observed.—**DR. G. W. SUTTON** (Cranleigh, Surrey).

OBSERVATIONS OF A SERVICEMAN

SIR,—With reference to the article in your March issue entitled "Starting a Radio and Television Repair Business", would you or Mr. Ford care to furnish readers with a list of radio wholesalers who, according to Mr. Ford's article, are prepared to supply the kitchen table brigade with components,

SPECIAL NOTE: Will readers please note that we are unable to supply Service Sheets or Circuits of ex-Government apparatus, or of proprietary makes of commercial receivers. We regret that we are also unable to publish letters from readers seeking a source of supply of such apparatus.

The Editor does not necessarily agree with the opinions expressed by his correspondents.

so that I and many of your advertisers would know where *not* to order supplies in future?

Also, does Mr. Ford really consider that the public is prepared to pay 15s. an hour—as he suggests it is—while the serviceman makes countless calls to distributors because he carries inadequate stocks? Finally I would like to ask how long insurance stamps have been a "deductable expense"?—**DAVID BUSHELL** (Leeds 6).

WEST GERMANY TEST CARDS AND TV SOUND

SIR,—With reference to the West German test card illustrated on page 129 of the December 1963 issue of PRACTICAL TELEVISION, it may be of interest to the DX-enthusiasts amongst your readers, to know that this is used by *all* West German TV transmitters at different times, thus including the stations named by Mr. Rafarel in the caption. It is used most frequently by the transmitters radiating the programmes of the new second network which has been in service for just under a year, and which has its central administration and studios in Mainz where I live, so that it is, so as to speak, my "local" test card.

Another point of interest about this test card is that it is not produced by televising a picture of it, but is generated entirely electronically with transistorised oscillators in a compact unit which was developed by Messrs. Fernseh GmbH, Darmstadt, West Germany. The background of light squares and the entire composite circular section are all produced in this manner and, being independent of scan geometry at the generator, are exceedingly accurate as transmitted.

In the same issue of P.T., ICONOS, in the opening paragraph of Underneath the Dipole, raises the problem of poor loudspeaker arrangements employed in many modern TV receivers. I would suggest that the improved arrangement outlined therein (to incorporate a switch and extension speaker sockets) is at most only half way to providing the necessary solution.

The following arrangement is one which I have used for over a year on the Continent, where the superb quality of the CCIR-standard sound transmissions accentuates this problem.

The internal speaker of the set should be inspected and replaced by a better quality one if necessary, wired as previously. No switch is fitted, just a pair of extension loudspeaker sockets in parallel with the speech coil of the internal speaker. Assuming a table model receiver is concerned, a special table can be built for the receiver in the

—continued on next page

—continued from the previous page

form of a large bass reflex cabinet, with a good quality speaker in it, together with a high-fidelity amplifier giving some 6 to 10W output. The input circuit of this amplifier is fed from the extension speaker terminals, thus drawing no audio power away from the internal speaker. The large speaker then radiates sound strictly forwards from just below the receiver, whereas the built-in speaker of the set should, preferably, radiate from the cabinet side.

This arrangement gives results which have to be heard to be believed, and has the important feature of an increase of available audio power as well as speaker improvement.

Hence my observation that a poor loudspeaker is only half the trouble in domestic sets; the power output is all too often quite inadequate for really good sound reproduction, even with the best speakers. The fact that CCIR has been going for many years on the Continent, yet most domestic sets sold here suffer just as much from inadequate speakers and audio power as ICONOS complains of in British-made receivers, suggests that matters will probably be not much better with u.h.f. transmissions in the U.K. (I have seen sets here with nothing more than a miniature speaker without baffle, slung in the sub-chassis wiring and radiating—or trying to radiate—sound through the ventilation holes between the underside of the set and the tabletop!)—MARTIN L. MICHAELIS (Mainz, West Germany).

DX-TV

—continued from page 322

At times our chosen RTF sound and vision transmitters may even suffer, but we can overcome this by slightly altering the sound i.f. frequency, so that a "new" setting of the sound tuner is required. But even so, this system is very versatile, as any sound channel can be married to any vision channel, which helps when conditions are erratic and some RTF stations are coming in better than others.

625-Line Conversion

Many readers have been asking for conversion details for the use of the Bush TV 53-62 range of sets for 625-line negative reception. Consequently an article is being prepared and will appear as soon as possible.

NEWS

On u.h.f., RTF Lyons is understood to be already in operation. Channel details are not yet available, but if you see a third RTF on u.h.f., it is probably this one.

U.H.F. DX still continues to make the running and several amateurs' logs now show well into the "Teens" for numbers of stations logged.

Remember we are always delighted to hear of your results on Bands I, III and u.h.f.

JUST OUT!

PRACTICAL HOUSEHOLDER

SPRING ANNUAL 1964



AN UP-TO-THE MINUTE GUIDE TO IMPROVEMENTS IN THE HOME

SPECIAL SECTIONS ON:

Exterior Improvements, Interior Decoration,
Modernisation, Kitchens, Concreting and
Brickwork, Furniture and Woodworking,
Garden Furniture, Home Workshop.

2/6 from all Newsagents and Bookstalls

BIG DEMAND! HURRY FOR YOURS!

TELEVISION, TAPE RECORDER AND RADIO COMPONENTS SUPPLIED

LINE OUTPUT TRANSFORMERS. All popular types available brand new, exact replacements, fully guaranteed. A selection which can be supplied:

PHILIPS 1768 to 17TG100 etc., STELLA 8617 to 1007 etc.	90/-	ALSO L.O.T.s Available for
EKKO 221 to 331 etc. (U25 types)	55/-	Alba Pam
FERRANTI T1001 to T1023 etc. (U25 types)	55/-	Bush Pilot
EKKO/FERRANTI (U26 types)	62/6	Dossor R.G.D.
FERGUSON 406 to 606 etc. 67/6	306, 308	Deca Regent.
PHILCO 1000, 1010 etc. MARCONI VT157 etc.	67/6	G.E.C. Sobell
PYE V4, V7, V14, VT17, CTM17, etc.	58/6	K.B. Ultra
HMV 1840 to 1854 60/-	1865 to 1869	Invicta Murphy
1870, 1890, etc.	67/6	

Postage and Packing for above L.O.T.s 3/6. C.O.D. 2/6 extra.

★ Also available for all sets ★

SCAN COILS. Frame output transformers, line and frame oscillator trans., width/linearity coils, sound output trans., mains trans., control knobs, dual vol. controls, etc.

TUNER UNITS. Fireball, incremental and turret types—replacement service available. 10, 16, 38 Mc/s.	
U.H.F. Tuners, I.F. Panels, etc. for new BBC 2 station.	
C.R.T.—Rebuilt with new guns by long established Nat. Co. Guaranteed 12 months.	
MULLARD, MAZDA, BRIMAR, EMISCOPE 14in.	£4 7 6
MULLARD, MAZDA, BRIMAR, EMISCOPE 17in.	£4 10 0
MULLARD, MAZDA, BRIMAR, 21in.	£6 10 0

TAPE RECORDER CHANGER SPARES. Drive belts, heads, pulleys, motors, styli, etc., for most British and some foreign makes.

STANDARD COMPONENTS. Resistors, Capacitors, Electrolytics, Drive Cord, Pilot Lamps, Vol. Controls, Presets, Ion Traps, Rectifiers, etc.

SALVAGED COMPONENTS. Large selection available including tuner units, loudspeakers, transformers, valves, etc.

Your enquiries invited, prices by return; or prompt despatch C.O.D.

MANOR SUPPLIES 64 GOLDERS MANOR DRIVE, LONDON, N.W.11 SPE 4032 (EVNG) (CALLERS, 589B HIGH ROAD, N. FINCHLEY, N.12. HIL 9118)

PADGETT'S RADIO STORES

OLD TOWN HALL, KNOWLER HILL LIVERSEDGE, YORKS.

Telephone: Cleckheaton 2866

New Boxed Tube Unit Type 7301. With two E762, three EF81, five 6J6, two CV4025, one 6V8GT. Also Tube Type VCRX283 with metal screen. Fitted with dimmer unit and lamps Part 7302. A fine unit for only 45/- Carr. B.R.S. 8/-. No details on this unit.

Reclaimed tubes. Six months' guarantee. 14in. CRM 1-2. MW 36/24.4. AW 36/21; also 12in. Mullard, 17/-, Carriage 7/6. 17in. tubes. CRM 171-172, MW 43/64-69. 30/-, Carriage 7/6.

ARMY SET TYPE 19. Complete sets 32/-. Less Transmitter valves 30/-. Less valves for spares, but with 500 micro-amp meter. 12/6. Used, but have no dry rot, all untested. Carr. B.R.S. on any set 10/-.

P.M. Speakers, Guaranteed ex T.V. sets. 6in. round, 6 x 4in. Rola and Plessey, Philips 6in. round, all at 3/- each. Post 2/-, 6 for 20/-, post paid. **Coolumans** 7 x 4in., 5/-, post 2/-. 8in. round, 6/-, post 2/-.

Valves Removed from T.V. sets. Tested on a Mullard Valve Tester and are 100% as new. Three months' unconditional guarantee. **POST FREE.**

ECL80	2/-	10P14	5/-	PL33	4/-
ECC82	3/-	20D1	3/-	PL38	5/-
EY301	2/6	20L1	5/-	PY80	5/-
E3F80	4/6	20P39	5/-	PY81	4/-
LB9	8d.	20P4	8/6	PY82	5/-
EP81	9d.	20P1	5/-	PCF80	4/6
6SN7	2/6	U801	8/6	PCC84	4/6
6P1	1/-	U281	5/-	B36	4/-
6P1	5/-	U282	5/-	N37	5/-
6W5	5/-	U329	5/-	6U4	5/-
6LD20	5/-	KT36	5/-	6P25	3/6
10C2	5/-	PL81	5/-	6T25	5/-
10F1	1/-	PL82	5/-	6P23	3/-
10P13	5/-	PL93	5/-	P230	5/-

EP80 1/6, or 10/- per doz. Grade II EP80 for test purposes 4/- per doz.

New Valves Ex Units. POST FREE. 8K7 1/6, doz. 12/-, 8K8 2/6, doz. 22/-, 6V6 2/6, doz. 22/-, 807 U.S.A. 6/-, PP3/250 (P.X4) 5/-, AC2PEN (PEN4) 2/6, 5U4 3/-, 6SM7 3/-, 6V8GT 4/6, EF81 1/6, EL91 1/6, 6P6 2/-, 24 5/6, 5Y4 4/6, 6X5 4/6, EF50 1/-, 6/- doz. ARP12 1/6, 8 for 5/6, box of 50 19/-, KT66 8/-, ARP22 2/-, ART4 2/-, APP37 2/-, AR8 2/-, IT4 2/-, 954 new boxed 1/3.

13 Channel T.V. Sets. 14in. untested 30/- Carr. 10/-, 17in. sets untested, 50/-, Carr. 10/-. Well packed, sent at owner's risk.

New Reclaimed Slim Line 90 Tubes. (Seconds) small pin head mark on glass. Perfect picture otherwise. Fully guaranteed 39/-. Carriage and ins. B.R.S. 7/6.

TV Tubes. Completely Rebuilt and Refaced. 12 months guarantee. Sizes up to 17in. Special trade price of 75/- Carr. and ins. 17/6.

Personal Ear Phone. 2/11. Post Free.

RES/CAP. BRIDGE 39/6

Checks all types of resistors, condensers 6 RANGES

Built in 1 hour. Direct reading.

READY CALIBRATED

Stamp for details of this and other kits.

RADIO MAIL (Dept. VW)

Raleigh Mews, Raleigh Street, Nottingham

B.B.C.2 (625 LINE) TV AERIALS

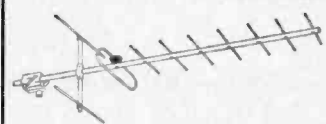

EXTERNAL MAST MOUNTING ARRAYS

5 element, 39/6; 9 element, 45/-, WALL MOUNTING; 51/6; 9 element, 60/-, CHIMNEY ARRAYS with LASHINGS, etc. 5 element, 63/6; 9 element, 72/-, LOFT ARRAYS. 3 element, 24/-, 7 element, 32/6. Also available for Window Fixing, 2/6 extra. Co-ax. Plugs, 1/3. Low Loss Co-axial Cable, 1/6 yd.

BBC · ITV · F.M. AERIALS

B.B.C. (BAND 1). Telescopic loft, 21/-. External S/D 30/-.

I.T.V. (BAND 3). 3 Element loft array, 25/-, 5 Element, 35/-, Wall mounting, 3 Element, 35/-, 5 Element, 45/-.

COMBINED B.B.C./I.T.V. Loft 1+3, 41/3; 1+5, 48/6. Wall mounting 1+3, 56/3; 1+5, 63/6. Chimney 1+3, 63/6; 1+5, 71/3.

F.M. (BAND 2). Loft S/D, 12/6. "H". 30/-, 3 Element, 52/6. External units available. Coax. cable 8d. yd. Coax. plugs 1/3. Outlet Boxes 4/6. Diplexer Crossover Boxes 12/6. C.W.O. or C.O.D. P.P. 3/-. Send 6d. stamps for illustrated lists.

K.V.A. ELECTRONICS (Dept. P.T.) 3B, Godstone Road, Kenley, Surrey. CRO. 2527

HAVE YOU EVER SEEN T.V. TROUBLES?

That is "Pin-Point T.V. Troubles in 10 minutes" we mean! Thousands of *Practical Television* readers already own and use "T.V. Troubles" every day. Designed for use by amateur or expert, this amazingly practical manual shows you how to find the trouble in any T.V. circuit FAST!

A simple cross-index tells you where you'll find cause of trouble, handy check charts then help you accurately locate the EXACT trouble spot! You will eliminate hours of aggravation, cut out waste time, because this new Coyne system will help you get right down to the heart of the trouble in minutes.

Over 700 trouble spots are covered in the 340 cross-index pages. Included are 50 time saving check charts as well as 200 diagrams and photos together with explanations of circuits and designs.

YOU CAN USE THIS BOOK RIGHT ON THE JOB—NO NEED TO MEMORISE!

This Pin-Point Book was designed especially for on-the-job trouble shooting. You simply turn to the indexed section, locate the circuit description and check-charts, and in minutes you have the trouble spot located and ready for repair.

NO COMPLICATED THEORY OR MATHEMATICS. Just practical circuit description, service methods and troubleshooting techniques to help you make faster t.v. repairs.

EVEN AN EXPERT CAN SAVE TIME BY USING "T.V. TROUBLES"

Here is a way to reduce "thinking time".

All the logical reasons for each problem are stated in black and white—you use your skill to take it from there!

Don't miss out any longer. Time wasted now locating t.v. faults could be saved by quick reference to this lightning fast t.v. problem answer book. Send for your trial copy now then when you decide to keep it (as we are sure you will), pay only 5/- per week until completed.

The price? Only 39/6 plus postage 1/6
FREE ELECTRONIC DATA HAND-BOOK WITH EVERY ORDER

IRONCLAD GUARANTEE

This book must be able to earn you more than its cost within two weeks or your money refunded!

Free 88 page oscilloscope book will be included if you send cash with order.

FREE TRIAL OFFER!

TERMS ONLY 5/- PER WEEK!

To SIM-TECH TECHNICAL BOOKS Dept. WX2.

West End, Southampton, Hants.

Please send "T.V. Troubles" for a full seven days' free trial. If not delighted I may return the manual, post paid without further obligation on my part. Otherwise I will pay cash or 5/- weekly until paid.

Tick here if enclosing full price of 41/- (which includes 1/6 postage). You get free Oscilloscope Book. Name 7-day money back guarantee. Overseas customers please send full amount (including Ireland).

Name

Address

.....

.....

City..... County.....

TELEVISION TECHNICIANS LINE OUTPUT TRANSFORMERS

SCAN COILS, ETC.

LABORATORY TESTED

ALBA: T301, T304, T394, T484, T494, etc.	46/8
BUSH: TV11A, 11B, 12A, 12B, TVG12A, etc.	44/-
TVG26, TV32, TV33, TVG34, TVG34A, T36, TV36, TVG36, TV36C, TVG36C, TV43	88/8
TV53, TV56, TV57, TV58, TV62, TV63, TV65, TV67, etc.	94/-
TV80 with EY31	109/-
COSSOR: 930 and T931, 933-4-5, 937, 938A, and F, 939 and A and F	81/8
943T, 940-945, 949, 945B 954F, 947, 949	85/8
DECCA: D17 and C	69/8
DMI, DM2C, DM3, DM4/C	74/-
DM5, DM14, DM17, 44, 555	74/-
DEFIANT: TR1453, TR1753	58/8
DYNAMOR: EKCO: T893, TC8102, T8105, TS115, TRC124, TC138, TS188, TS193	54/-
TRC139, TC140, T141, TV142	78/8
T101, TC162, T164, T165, etc.	78/8
TC208, TV209, T231, T221, T231F, T248, T283, T284, T293, etc.	58/8
FERGUSON: 103T, 105T, 113T, 135T, 145T 941T-953T inclusive	65/8
961T-997T inclusive	68/8
30ET, 30ET	64/-
FERRANTI: 14T3, 14T3F, 13TA 17K3 and F, 17T3 and F	47/8
17K4 and F, 178K4 and F	47/8
17T4 and F	47/8
14T5, 178K5, 17K5	47/8
G.E.C.: BT1251, BT1252, BT1746, BT1748, BT4643, BT5147, BT5246-48	88/8
BT4743	48/8
BT5348-BT5643R inclusive	48/8
and 88/8	
H.M.V.: 1824 and 1 to 1831 inclusive 1840, 1841, 1842-1848	66/8
All models available.	66/8
INVICTA: T118, T119, T120	54/-
All other models available.	
K.B.: LFT50, LVT50, LFT60, MV60	108/8
All models available.	
MARCONI: All models available.	
MASTERADIO: Most models in stock.	
MICHOEAL: Most models in stock.	
MURPHY: V200, V202U	58/-
V240, V250	94/8
PETO SCOTT, PHILCO: Most models in stock.	
PAM: 908, 909, 952, 953, 958	54/-
PHILIPS: 1768U, 2168U	104/-
119V, 1200V	74/-
122GU, 1236V, 1238V	74/-
114UF, 114UM, 115U	74/-
1437U, 1446U	74/-
Most models in stock.	
PILOT: Most models in stock.	
PYE: CTM4, FV4C, FV4COL	54/-
V4, VT4, V7, VT7	54/-
LV30, FV1, FV1C	68/8
CM17F, CTM17F, CW17	68/8
CW17G, CW17GP, CW17F, etc.	68/8
Most models in stock.	
RAYMOND: Most models in stock.	
REGENTONE: All models available.	
R.G.D.: 9017T, 7017, C54, etc.	58/8
Most models in stock.	
SOBELL: T817, T346	64/-
Most models in stock.	
STELLA: ST3721U	104/-
ST8917U, ST8621U	104/-
ST8917U	104/-
ST8614U, ST86417U	74/-
ST89314U	74/-
ULTRA: 86 series, 185 series, with U25, etc., complete	78/8
Most models in stock.	
VIDOR: CN4217-CN4291 inclusive	64/-
Post and Packing 3/6. C.W.O. Only	
Also: Used O.P. Txns., Scan Coils, etc.	
ALL GUARANTEED 90 DAYS	
(All enquiries S.A.E.)	

WYNDSOR TELEVISION TECHNICAL DIVISION

ST: ALBANS RD., BARNET, HERTS.
BAR 1769

RATES: 4/- per line or part thereof, average five words to line, minimum 3 lines, Box No. 1/- extra. Advertisement must be prepaid and addressed to Advertisement Manager, "Practical Television", Tower House, Southampton St., London, W.C.2.

SETS & COMPONENTS

DIRECT TV REPLACEMENTS LTD., largest stockists of TV components in the U.K. Line Output transformers, Frame Output transformers, Deflector Coils for most makes. Official sole suppliers for many set makers. Same Day Despatch Service Terms. C.O.D. or C.W.O. Send S.A.E. for quote. Day and night telephone: GIPSY Hill 6166, 126 Hamilton Road, West Norwood, SE27.

FLYING SPOT SCANNER Test Card Transparencies, 3/6 including P.P. Sets of 1-3Mc/s bars plus grey scale to make camera test card 2/6. Complete test cards 3/6. WOOD, 79 Cotham Brow, Bristol 6.

TUBES · AERIALS · VALVES

U.H.F. aerials, Bands I, II & III aerials. U.H.F. transistorised boosters, I.T.V. boosters, Returned T.V. tubes, Valves, etc. New and second-hand T.V. sets, Transistor Radios and all types of Electrical Appliances. Quotations without obligation. Co-axial cable, fluorescent light fittings, all at special prices to the trade and Home Engineers. S.A.E. for list.

G. A. STRANGE

BROADFIELD, NORTH WRAXHALL, nr. Chippenham, Wilts. Tel. Marshfield 236

EXCEPTIONAL VALUE: Picture tubes, brand new, Mazda 191n., CME 1901, Mullard 191n., AW47-90/91, £4/10/-; Mullard 191n., AW59/90, £6/10/-; carriage (insured) paid. 12 months guarantee. Note: All brand new. We also supply most other sizes completely equipped at £4/17/6, guaranteed 12 months. TOMLINS, 156 Lewisham Way, New Cross, SE14. TID 3657.

R. & R. RADIO & TV SERVICE

44 MARKET STREET, BACUP, LANCs.
Telephone 465

SPEAKERS. Ex T.V. in good working order, all sizes, 3 ohm, 6 x 4in., 7 x 4in., 6in. round, 8in. round, 7/6 each. P.P. 2/3. **Sound Output transformers,** 3/6, P.P. 1/-. **Turret tuners,** most makes available, 8/-, post 2/-.

Fireball tuners, 12/6, post 2/-. As available, query first. 13 channel tuners complete with sound and vision strip, on one chassis size, 6in. wide, 3in. high, 14in. front to rear, 38Mc/s I.F., less valves, otherwise working, 30/-, post 3/-.

SALVAGE VALVES All Tested before dispatch

EF90	1/6	PCF80	4/-	20L1	5/-
ECL30	3/-	PCC84	4/-	10F1	2/6
ECC82	3/-	PL81	5/-	6P14	5/-
ECC83	3/-	FY81	3/6	6F15	5/-
EF91	2/6	30P4	7/-	10P13	5/6
30F5	7/6	20P4	6/6	10P14	5/-

Many more types available, s.a.e.

Most types of transformers available at bargain prices, state set model number with enquiries.

Terms C.W.O.

Single valves 6d. post, 6 or more post free. ALL GOODS SOLD SUBJECT TO SATISFACTION OR MONEY REFUNDED.

TELEVISION TUBE SHOP

We have the following

Unused, Guaranteed Tubes

in Stock now

AW36-20, 21	£5. 2.6
AW36-80	£5. 7.6
AW43-80, 88	£6. 7.6
AW43-89	£6.12.6
AW47-90, 91	£7.10.0
AW53-80	£7.12.6
AW53-88	£7.17.6
C148M, FM	£5. 5.0
C178M, FM, HM	£6. 7.6
C171M, PM, SM	£6.12.6
C21 HM, SM, TM	£7.17.6
CME1402	£5. 7.6
CME1702, 1703.	£6.12.6
CME1705	£7. 7.0
CME2101	£8. 7.6
CRM93	£4. 2.6
CRM124	£4.12.6
CRM141, 2, 3, 4	£5. 7.6
CRM152, 153	£5.17.6
CRM171, 2, 3	£6. 7.6
CRM211, 212	£7.17.6
MW6-2	£6.17.6
MW22-16	£4. 2.6
MW31-16, 74	£4. 2.6
MW36-24, 44	£5. 2.6
MW41-1	£6.12.6
MW43-64, 69	£6. 7.6
MW43-80	£6. 7.6
MW53-20	£7.12.6
MW53-80	£7.12.6
7901A	£6.12.6
14KP4A, 141K	£5. 2.6
171K, 172K, 173K	£6. 7.6
6901A	£6.12.6
7201A, 7203A	£5. 2.6
7204A	£5. 5.0
7401A	£6. 7.6
7405A	£6.12.6

All tubes tested before despatch and guaranteed 12 months.

CARRIAGE 7/6, via B.R.S. or 12/6 via passenger train.

TERMS £2 down (plus carriage) balance £1 per month.

Midland Stockists:—
Amateur Electronics Co.
240 Lichfield Road, Aston,
Birmingham.

Shop Soiled Tubes (unused)

(Subject to Availability)

14in. CRM141, 2 67/6. Others 57/6
17in. CRM171, MW43-69, 43-64,
75/- Plus Carriage. Guaranteed
for 12 months.

TELEVISION TUBE SHOP

48 BATTERSEA BRIDGE ROAD
LONDON, S.W.11. BAT 6859
South of the Bridge. Open Sats.
until 4 p.m.

SALVAGED VALVES TESTED ON A MULLARD HIGH SPEED VALVE TESTER

AC11	2/6
B36	2/6
B329	4/-
D1	2/6
D68	2/6
D77	2/6
DAF91	4/-
DD4	2/6
DD41	2/6
DD4L	2/6
DF91	4/-
DH77	4/-
DK91	4/-
EA50	1/3
EB94	1/3
EB41	1/3
EB338	2/6
EBC41	2/6
ECC33	2/6
ECC81	4/-
ECC92	4/-
ECL80	4/-
EF50	1/3
EF80	2/6
EL13	1/3
KT330	1/3
KT81	2/6
KT241	2/6
LB3	2/6
N368	1/3
N329	4/-
N339	4/-
N369	4/-
N379	4/-
PC81	3/6
PC91	2/6
PC044	5/-
PCF80	5/-
PCL29	4/-
PCL59	4/-
PEN45	2/6
PEN46	2/6
PL33	4/-
PL81	5/-
PL82	4/-
PL83	4/-
PL84	4/-
PY31	4/-
PY81	4/-
PY80	2/6
SP4	1/3
SP42	2/6
SP61	1/3
U31	4/-
U351	4/-
U39	4/-
UF42	2/6
VP4	4/-
W77	2/6
Z68	2/6
Z68	2/6
Z77	1/3
Z90	1/3
Z719	2/6
4TP8	2/6
8AL5	2/6
6A316	1/3
6BW7	4/-
6BX6	2/6
6C6	4/-
6D6	4/-
6F12	1/3
6F18	1/3
6J8	2/6
6J7	2/6
6P26	2/6
6P28	2/6
8D3	1/3
9D6	2/6
10P1	4/-
10P13	4/-
10P14	2/6
12BH7	4/-
20F2	4/-
20F1	2/6
20P3	4/-
20P5	4/-
23L6	2/6
30C1	5/-
30C15	5/-
30L1	5/-
30PL1	4/-
30PL18	4/-
32	2/6
43	2/6
49	2/6
807	2/6

EXAMPLES
FULL CATALOGUE 9d.
VALVE HOLDERS
American Octal ... 5/- doz.
Noval ... 8d. each

RESISTORS
Card of 4W Resistors, 72 values covering complete 10% range. 24/- per card.
Full range of separate Resistors, Condensers, etc.

VARIABLE CONDENSERS
3-50pF concentric trimmers 3/- doz.

GEO CRTS (SALVAGED) SPECIAL OFFER
12in. G.E.C. 7102 ... 10/- ea.
Personal Callers Only

30 Mc/s, 16 Mc/s, 10 Mc/s INCREMENTAL OR TURRET TUNERS
LESS VALVES, EX-RECEIVERS 12/6.

We can often supply for the actual set you want the tuning to fit. But cannot guarantee what channels are fitted.

TRANSFORMERS
CET Boost Transformers, 2V, 4V, 6V, 10V, 13V. State which required ... 12/6 ea.
Heavy Duty Output Transformers, 8 ratios from 13:1 to 43:1 ... 25/- ea.
Miniature Output Trans., 3/9 ea.
Standard Output Transformers, Multi-match ... 10/- ea.
Transformer Driver: 1:1 CT 10/- ea.
2:5:1 CT 12/6 ea.
Transistor Output: 6:0:1 CT 10/- ea.
9:2:1 CT 10/- ea.
Microphone Transformers, ratio 65:1 ... 35/- ea.

I.F. TRANSFORMERS
Standard 465 kc/s ... 12/6 per pair
Midget 465 kc/s ... 18/- per pair

AUTO TRANSFORMERS
250W ... 87/6 ea.
100W ... 27/6 ea.
50W ... 20/- ea.

TRANSISTORISED FAULT FINDER
Enables faults to be located quickly. Consists of a two-transistor, multi-vibrator in a box. Complete with battery. 32/6

CRYSTALS
GENUINE MULLARD, Bored.
OA6 6/- OAN1 3/-
OA70 3/- OAN5 3/-
OA79 3/- OAN9 3/6

TRANSISTORS
OC16W 48/- OC72 8/-
OC19 48/- OC76 8/-
OC26 25/- OC78 8/-
OC44 11/- OC78 8/-
OC45 10/- OC81 8/-
OC70 6/6 OC82 18/-
OC71 6/6 OC170 17/6

TERMS: C.W.O. or C.O.D.
Orders under £1. P. & P. 1/3.
Open till 11 p.m. most days.

3d. stamp for list or 9d. for full catalogue
Dept. PTA

SETS & COMPONENTS
(continued)

EKCO—FERRANTI L.O.T.s
U25 Type
PERSPEX HOUSINGS to suit above 16/- each. Post Free.
Quantity Prices: 6 at £4; 12 at £7.5s.
BOYLAN ELECTRONICS
Church St., Warrenpoint, N. Ireland

"HEATHKITS" can now be seen in London and purchased on H.P. Free Brochure. DIRECT TV REPLACEMENTS LTD., 120 Hamilton Road, West Norwood, SE27. GIPsy Hill 6166.

TUBES! Rescreened, realuminised!
70", 90", 110" £4.15.0, carriage 12/6. Also BRAND NEW £5.15.6! All famous makes. Years g'tee, NO just regunned tubes sold!
NEW BOXED VALVES! 12 months' guarantee.
BY100, EY51, EY26, ECL80, PY800 ... 7/-
EF86, EF183-4, PCC84, DK91, DK96 ... 7/6
PL81, U.25, PCF80, U.91, PCL82 ... 9/-
FREE lists—valves/tubes/transformers.

Return of post service.
P. BEARMAN, 43 Leicester Road, New Barnet, Herts. BAR 1934 (Any time)

TV SPARES

Fully Guaranteed Makers Parts.
Telephone orders sent same day.
Line Output Transformers.

a—Maker's Correct Parts;
b—Cheaper Replacement Part
Eko T221, 231, 311, 284, TC208, T310, T331 T327, TU209, T248, TC267 and Ferranti T1001-5, b—52/6; a—62/6. 14T3-6, 38/6.
Murphy V240/250, 62/6; V270/280, 79/6.
Pye V4/7, UT4/7 and Pam 906-53. 52/6.
H.M.V. 1840-9, 2805-5902, only 62/6.
Bush TV53, b—69/6; a—79/6; TV24C, TV80 etc., b—79/6; a—89/6. Philips 1768U 92/6; 1114-5, 1437-46, 89/6.
Masteradio T917, T977, T409-12 etc., 75/-
Alba T301, 304, 394, 484, 494, 497/6.
Cossor 930-8, 58/6; Ferg. 992-8, 62/6; Baird P2014/7, 2114/7, 59/6.

L.O.P.T.s. FOR ANY MAKE and Model supplied. USED trans., often available, ask for quote. SCAN COILS.
Eko T221, T231, etc. Pye VT4-7, both 50/-
Used 14in. ex-Rental 13 Ch. sets: Pye/Ferg./Sobell, 10/- each. MIN Lots of 20. Lots of 6 for £5. (25/-; 625 LOP 90/-.
Please state clearly whether Maker's correct part (a) or cheaper replacement part (b) required. Ekco-Ferranti plastic housing available. 15/- each.

Free Insurance and Quantity discounts Callers Welcome. Open all day Saturdays
Terms: C.W.O. or C.O.D. Post & Pack 4/-

TELEVISION CONSUMER SERVICES LIMITED

Post Orders to:
8 CRAY PARADE, MAIN ROAD
ST. PAUL'S CRAY, KENT
Tel.: Orpington 30566.

Callers to:
112 CAMBERWELL ROAD, S.E.5.
After business hours, Phone: RODNEY 7917 (Autophone)

SETS & COMPONENTS
(continued)

FLYING SPOT SCANNER, 93"A. Photomultipliers with base 35/-, post free. Govt. Surplus, but guaranteed perfect. RULEMAN, 86 Tamworth St., Manchester 15.

FOR SALE

VALVE CARTONS at keen prices. Send 1/- for sample and list. J. & A. BOXMAKERS, 75a Godwin Street, Bradford 1.

EXCEPTIONAL TRANSISTOR Portable Tape Recorders, value £5/19/6, complete with crystal microphone, earphone, spools, tape, batteries, instructions, presentation box (extra tapes, 100ft. 4/6), ideal gift. £5/19/6. Satisfaction guaranteed. Postage packing 2/6. TOMLINS, 156 Lewisham Way, New Cross, SE14.

1,000 TELEVISIONS, all makes, from £3 working, 10/- not. Callers only 9 till 6, including Sats. 39 Whitehorse Lane, Stepney, London.

A COMPLETE PORTABLE RADIO (Peto-Scott Model B.P.41) for less than the cost of the 4 valves included—DK91, DF91, DAF91, DL92. Uses 90 V. and 1½ V. batteries. A SNIP AT 39/6 (P. & P.). ACT FAST—THEY WON'T LAST LONG.

E. S. C.

25 Christleton Road, Chester, Ches.

20,000 Variable resistors for sale. 500,000 ohms carbon type (6,500). Standard size and spindle 6 ohms wirewound miniature (13,000). Standard spindle Diameter of Pot 8in. Miscellaneous Wirewound miniature, 100 ohms, 60 ohms & 500 ohms. (500) 9d. each or proposition considered for job lots. Surplus Mullard high speed valve testers—complete with cards. In good condition 435 each. ELECTRONIC TRADING CO., Briggate House, 13/14 Albion Place, Leeds 1, Yorkshire.

VALVE TESTERS VT5 new. £12. Exchanges. R. C. MOLINEUX, Lowfield Heath, Crawley.

TELEVISIONS: Large quantity of trade-in televisions available for sale. Mostly working. Sizes up to 39in. From £2 each. Call, write or phone SUTTON RADIO 29, Church Road, Tunbridge Wells, Kent. Phone 30523.

METAL RECTIFIERS

RECTIFIERS—CONTACT COOLED
14RA1282 (PC101) type 250 v., 250 mA 13/6;
12RA1288 (PC31) type 250 v., 300 mA 17/6;
350 mA 19/6; ECU 13/-; F0118, 7/6.

RECTIFIERS—FIN TYPES
Equivs. for 1R4 250 v., 250 mA. 13/6; RMs 250 v., 300 mA. 17/6; 1A4895 400 mA. 13/6; 1A486 16/8; 1A497 19/-; 1A4100 22/6; 1A4949, 20/-; LW7 17/6; LW15 20/-; EK6 20/-.

MULTIMETERS from 39/6. Stamped envelope for full latest selection and bargain offers. Under £1 P. & P. 8d., over £1 Post Free. NO C.O.D.

DURHAM SUPPLIES

175 Durham Road, Bradford 8, Yorkshire

(Continued on next page)

Arion Television
Maxted Road, S.E.15 NEW X 7152

FOR SALE
(continued)

TAKE YOUR PICK **2/6**
ANY PACK FOR:-

NEW - ASSORTED - COMPONENTS (Pref Values)

- | | |
|----------------------------|---------------------|
| 30 Carbon Resistors | 35 Springs |
| 8 Trimmers, Stamp type | 12 Knobs Rad/TV |
| 15 Ceramic Condensers | 15 Tag Strips |
| 250 Sleeves & Grommets | 10 Valve Holders |
| 350 sq. in. Insulating Etl | 16 Socket panels |
| 24 Clamps & Brackets | 15 Coil Formers |
| 4 Equipment Handles | 8 R.F. Chokes |
| 8 Water S/w Biscuits | 3 Potentiometers |
| 3 Add-on D/P Switches | 16 Valve Top Caps |
| 3 Dropper Resistors | 60ft. Sleeving |
| 340 sq.in. Kerline Cloth | 7 Metalpack cond |
| 13 Paper Tube Conds | 3 L/S OP Sw Skts |
| 72 Self Tap Screws | 27 Conl Clips |
| 12 Mica Condensers | 75 Felt Washers |
| 1 Gram Mounting Kit | 10 Fuscholders |
| 1 HD Carbon Brushes | 40 Mounted Tags |
| 10 Diodes (Rejects) | 12 Equipment Feet |
| 6 BT/9 Valve Cans | 10 Pins |
| 45ft Prestic Compound | 6 T.V. Coils |
| 3 2s 2-pla. sw Sockets | 45 Can Cleats |
| 6 Sub-mini Trimmers | 15 Psh/Btn Knobs |
| 24 Loudspeaker Gauzes | 2 Wafer Switches |
| 12 Anti-vibration Mounts | 1 Slider Switch |
| 500 sq.in. Almn. Foil | 6 Motorcar Bulbs |
| 60 Nuts/ Bolts/ Washers | 7 Printed Circuits |
| 3 Electrolytic Conds | 1 Twin Ion Trap |
| 3 Block Paper Conds | 10 SES Lamphires |
| 1 T.V. Tuner Chassis | 24 sq.in. Felt Tape |
| 1 1/2 Wave Rectifier | |
| 1 Plastering Trowel | |

New & Used Ex Govt. Equipment, etc.

Pulse Generator No. 2, E18, Modulator No. 28, #11, Test Set Mic/Receiver No. 4, #27, 4 Valve Modulators, 1/8, AC/DC Power Units, 11/-, No. 19 Control Units, 5/-, Dimmers, 7/6, 7 TV Pots, 7/6, Mrobo Generators, 30/-, 15a Man Switches, 7/8, 6v 6-pin Vibrators, 7/9, 6v 40ah Accumulators, 25/-, Wide-Band Amplifiers, 30/-, Radio Cabinets, 19/-, F90 Valves, 1/8. Regret all V/Voltmeters SOLD Large range of Radar Equipment to callers only. Please add small amount P. & P. Cat. 1/-, List S.A.E. FREE—Foreign Stamps if requested with orders. (See advts in W/W, P/W, etc. for other lines.)

ALBATROSS ENGINEERING CO.
Dept. FT4, 78-80 HIGH STREET, GOSBERTON SPALDING, Lincs. (Tel. Gos 468)

WANTED

WANTED: Service Sheets. No quantity too large, highest prices paid. SULTAN RADIO, 29 Church Road, Tunbridge Wells, Kent.

NEW VALVES WANTED . . . EY51, EY86, PL81, PCC84, PCF80, PCL82, PCL83, PY81, R19, 30P19, U25 etc. Best cash prices by return. DURHAM SUPPLIERS, 175 Durham Road, Bradford 8, Yorks.

A PROMPT CASH OFFER for your surplus brand new Valves and Transistors. R.H.S., Beverley House, Manville Terrace, Bradford 7.

SERVICE SHEETS purchased. HAMILTON RADIO, Western Road, St. Leonards, Sussex.

MISCELLANEOUS

CCTV OWN SCANNING COILS

Details only 6/6 post free of scanning and focus coils for closed circuit television cameras. Simple jig winding. Formers use easily obtained materials. Send 6/6 to: **HARRIS** 66 Walliscote Rd., Weston-super-Mare Post orders ONLY

BOOKS & PUBLICATIONS

FIND TV SET TROUBLES IN MINUTES from that great book *The Principles of TV Receiver Servicing*. 10/6 all book houses and radio wholesalers. If not in stock from Dept. C Secretary, 32 Kidmore Road, Caversham, Reading, Berks.

SERVICE SHEETS

S.E.S. SERVICE SHEETS for all TV Radio, including Transistors, Tape Recorders, Units, Amplifiers, Record Players and Autochangers, etc., also various domestic appliances. List 1/- S.A.E. Mail orders only. SUN ELECTRIC SERVICES, 38 St. Georges Road, Hastings.

SERVICE SHEETS. Radio and TV 4/- each. List 2/- . All orders dispatched on day received. Also Manuals for sale and hire. S.A.E. please. SULTAN RADIO, 29 Church Road, Tunbridge Wells, Kent.

SERVICE SHEETS (30,000) 8/- each with S.A.E. DARWIN, 19 George St., St. Helens, Lancashire.

SERVICE SHEETS, Radio TV, 5,000 models. List 1/-, S.A.E. inquiries: TELRAY, 11 Maudland Bk., Preston.

SERVICE SHEETS, also Current and Obsolete Valves for sale. JOHN GILBERT TELEVISION, 1b Shepherd's Bush Road, London W6. Tel: SHE 8441. Nr Goldhawk Rd. Station.

SERVICE SHEETS

4/- each, plus postage.

We have the largest supply of Service Sheets for all makes and types of Radios, Televisions, Tape Recorders, etc. in the country, and can supply by return of post.

To obtain the Service Sheet you require, please complete the attached coupon:

From: _____
Name: _____

Address: _____

To: S.P. DISTRIBUTORS

44 Old Bond St., London, W.1
Please supply Service Sheets for the following:

- Make: _____ Model No.: _____ Radio/TV
Make: _____ Model No.: _____ Radio/TV
Make: _____ Model No.: _____ Radio/TV
Make: _____ Model No.: _____ Radio/TV

I also require list of Service Sheets at 1/6.

I also require list of Manuals at 1/- (please delete items not applicable)

I enclose remittance of _____
MAIL ORDERS ONLY

SERVICE SHEETS

(continued)

SERVICE SHEETS

For all makes of Radio and Television—1925—1963. Prices from 1/- . Free fault-finding guide with all Service Sheets. Please send S.A.E. with enquiries. Catalogue of 6,000 models, 1/6. Special offer of 125 Radio/TV Sheets covering many popular models, 2/1-. All types of modern and obsolete valves. Radio and TV books. S.A.E. lists/enquiries.

HAMILTON RADIO

Western Road, St. Leonards, Sussex.

EDUCATIONAL

THE INCORPORATED PRACTITIONERS in Radio & Electronics (I.P.R.E.) Ltd., Membership Conditions booklet 1/- . Sample copy of I.P.R.E. official Journal 2/- post free. Dept. C Secretary, 32 Kidmore Road, Caversham, Reading, Berks.

SITUATIONS VACANT

RADIO & TV Exams and Courses by Britain's finest home study School. Coaching for Brit., I.R.E.; City and Guilds Amateur's Licence; R.T.E.B.; P.M.G. Cert., etc. FREE BROCHURE from British National Radio School, Russell Street, Reading.

BUSINESS OPPORTUNITIES

IF YOU ARE a self employed TV Service Engineer wishing to increase your profits by at least 25% and receive free technical information, send s.a.e. for details to BOX No. 38.

NEW VALVES!

Guaranteed Set Tested 24-HOUR SERVICE

1R5, 1S5, 1T4, 354, 3V4, DAF91, DF91, DK91, DL92, DL94, SET of 4, 14/-, DAF96, DF96, DK96, DL96. SET of 4, 22/-

0A2	4/-	DL25	6/-	PCF82	6/-
1D5	4/9	DL92	4/3	PCL82	6/3
1R5	3/9	DL94	5/-	PCL83	7/9
1S5	3/3	DL96	5/6	PCL84	6/6
1T4	2/3	EB91	2/-	PL36	7/9
3S4	4/3	EB41	6/3	PL81	6/6
3V4	5/-	EBF80	5/3	PL82	5/-
5Y3GT	4/3	EBL21	7/9	PL83	5/-
5Z4C	6/9	ECC40	6/9	PL84	5/3
6K7G	1/3	ECC81	3/3	PY31	6/-
6K8G	3/-	ECC82	4/6	PY32	8/6
6Q7G	4/3	ECC83	4/6	PY33	8/6
6U7G	6/6	ECC84	5/6	PY80	4/9
6V9G	3/6	ECC85	6/-	PY81	5/-
6X5GT	5/-	FCF80	5/9	PY82	4/9
12K7GT	3/3	ECF82	5/9	PY83	5/6
12K8GT	8/6	ECH42	7/3	U25	8/-
12Q7GT	3/3	ECH81	5/3	U26	7/9
12SN7GT	6/6	ECL90	5/6	UABC80	5/-
25L6G	4/9	EF41	3/6	UAF42	6/9
35L6GT	5/6	EF80	3/9	UBF80	5/6
35Z4GT	4/6	EF85	4/9	UCC85	6/-
85A2	6/6	EF86	5/9	UCH42	6/9
CL33	8/6	EF89	4/9	UCH81	6/3
DA32	7/9	EF41	2/6	UCL82	7/6
DAF91	3/3	EL41	4/6	UCL83	8/-
DAF96	5/6	EL94	4/6	UF41	6/3
DF33	7/6	EY51	5/6	UF43	6/3
DF91	2/3	EY86	5/6	UF89	5/9
DF96	5/6	EZ40	5/-	UL41	6/6
DH77	3/6	EZ80	3/9	UL84	5/9
DK32	7/6	EZ81	3/9	UL89	11/-
DK91	3/9	MU14	4/3	UY21	7/6
DK92	6/9	PCB84	5/6	UY41	4/3
DK98	6/-	PCC89	7/6	UY85	4/9
DL33	6/9	PCF80	5/3		

Postage 6d. per valve extra. Any Parcel Insured Against Damage in Transit 6d. extra. Any C.O.D. Parcel 4/3 extra. Office address, no callers.

GERALD BERNARD

83 OSBALDESTON ROAD, STOKE NEWINGTON, LONDON, N.16

REBUILT TUBES!

*You're safe when you buy from
RE-VIEW!*

- ★ Each tube is rebuilt with a completely new gun assembly and the correct voltage heater.
- ★ Each tube comes to you with a guarantee card covering it for a year against all but breakage.
- ★ Each tube is delivered free anywhere in the U.K. and insured on the journey.
- ★ Each tube is rebuilt with experience and know-how. We were amongst the very first to pioneer the technique of rebuilding television tubes.

RE-VIEW ELECTRONIC TUBES

385 LONDON ROAD, WEST CROYDON,
SURREY. Tel. THOrnton Heath 7735

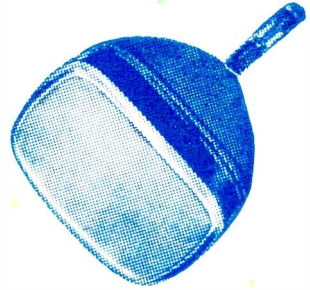

HERE IS WHAT YOU PAY:

12in.	£4.10.0
14in.	£4.15.0
15in.	£5. 0.0
17in.	£5. 0.0
21in.	£7. 0.0

Cash or cheque with order, or cash on delivery

—Discount for Trade—

FREE TO AMBITIOUS ENGINEERS

— THE LATEST EDITION OF ENGINEERING OPPORTUNITIES

Have you sent for your copy?

ENGINEERING OPPORTUNITIES is a highly informative 156-page guide to the best paid engineering posts. It tells you how you can quickly prepare at home for a recognised engineering qualification and outlines a wonderful range of modern Home Study Courses in all branches of Engineering. This unique book also gives full details of the Practical Radio & Electronics Courses, administered by our Specialist Electronics Training Division—the B.I.E.T. School of Electronics, explains the benefits of our Employment Dept. and shows you how to qualify for five years promotion in one year.

**We definitely Guarantee
"NO PASS — NO FEE"**

Whatever your age or experience, you cannot afford to miss reading this famous book. If you are earning less than £25 a week, send for your copy of "ENGINEERING OPPORTUNITIES" today—FREE.

WHICH IS YOUR PET SUBJECT?

Mechanical Eng.,
Electrical Eng.,
Civil Engineering,
Radio Engineering,
Automobile Eng.,
Aeronautical Eng.,
Production Eng.,
Building, Plastics,
Draughtsmanship,
Television, etc.

GET SOME LETTERS AFTER YOUR NAME!

A.M.I.Mech.E.
A.M.I.C.E.
A.M.I.Prod.E.
A.M.I.M.I.
A.I.O.B.

B.Sc.
A.M.Brit.I.R.E.
City & Guilds
Gen. Cert. of Education
Etc., etc.

PRACTICAL EQUIPMENT

Basic Practical and Theoretic Courses for beginners in Radio, T.V., Electronics, Etc., A.M.Brit.I.R.E. City & Guilds Radio Amateurs' Exam. R.T.E.B. Certificate P.M.G. Certificate Practical Radio Radio & Television Servicing Practical Electronics Electronics Engineering Automation

INCLUDING TOOLS!

The specialist Electronics Division of B.I.E.T. NOW offers you a real laboratory training at home with practical equipment. Ask for details

B.I.E.T. SCHOOL OF ELECTRONICS



POST COUPON NOW!

Please send me your FREE 156-page "ENGINEERING OPPORTUNITIES" (Write if you prefer not to cut page)

NAME

ADDRESS

SUBJECT OR EXAM THAT INTERESTS ME (SE/20).

BRITISH INSTITUTE OF ENGINEERING TECHNOLOGY

(Dept. SE/20), 29 Wright's Lane, London, W.8

THE B.I.E.T. IS THE LEADING ORGANISATION OF ITS KIND IN THE WORLD

REBUILT AND RESCREENED CATHODE RAY TUBES

Complete with all new components excepting glass

FOR QUALITY, RELIABILITY AND SERVICE BUY FROM BRITAIN'S
LARGEST GROUP OF INDEPENDENT MANUFACTURERS OF REBUILT
CATHODE RAY TUBES

SUFFOLK TUBES LIMITED
1/3 UPPER RICHMOND ROAD
PUTNEY, S.W.15.
Tel: Vandyke 4304/5267

MIDLAND TUBES LIMITED
477/483 OLDHAM ROAD
MANCHESTER, 10.
Tel: Collyhurst 4412

VIDIO REPLACEMENTS LTD
25 ADDINGTON SQUARE
CAMBERWELL, S.E.5
Tel: Rodney 7550/7559

ALL TYPES -
12 MONTHS' GUARANTEE

KEEN PRICES -

PROMPT DELIVERY
WRITE FOR BROCHURE

Cuttriss Ltd.
Westminster House
Frederick Street
Birmingham
Telephone: Central 3221/2/3

Lawsons Ltd.
36 Cornhill
Bury St. Edmunds, Suffolk
Tel: Bury St. Edmunds 3304

J. H. Sunderland
11 Clements Street
Rochdale, Lancs.
Tel: Rochdale 48484

Wizard Productions
16 Withy Grove
Manchester
Tel: Dea 2772

Radiovision (New Forest) Ltd.
The Croft
Burley, Hants.
Tel: Burley 2128

M. & G. Trade Services
23 Boscombe Grove Road
Bournemouth, Hants.
Tel: Bournemouth 37184

Chester Radio
11 City Road
Chester
Tel: Chester 24727

Taylor's
162 Eastney Road
Milton, Portsmouth
Tel: Portsmouth 35000

Millards Southern Rentals
3 High Street
Aldershot, Hants.
Tel: Aldershot 20408

Lucketts of Banbury
57a/58a High Street
Banbury, Oxon
Tel: Banbury 2813

Electrical Marketing Co. Ltd.
12a College Square North
Belfast 1
Tel: Belfast 33340

R.E.D. Ltd.
Waltham Street
Crewe
Tel: Crewe 4364

Fylde Television Services
460 Talbot Road
Blackpool
Tel: Blackpool 31159

R. Watson
Leathern Bottel
Wavenden, Woburn Sands, Bucks
Tel: Woburn Sands 2027

J. Wildbore Ltd.
6/12 Peter Street
Oldham
Tel: Mai 4475

T. Barratt & Co. Ltd.
Mill Street
Sutton Coldfield
Tel: Sutton Coldfield 1192/3

G. M. Carlow Ltd.
3 Hurst Green Road
Bentley Heath, Solihull
Tel: Knowle 2742

Cotton T.V. Service Ltd.
63/65 Oundle Road
Peterborough
Tel: Peterborough 2169