

FAULT-FINDING-A.G.C. SYSTEMS

Practical Television '13

AUGUST 1957

AND TELEVISION TIMES

EDITOR: F.J. CAMM



The Zoom Lens

PREMIER RADIO COMPANY

OPEN TILL
6 P.M. SATURDAYS

(Regd.) B. H. MORRIS & CO. (RADIO) LTD

(Dept. P.T.8) 207, EDGWARE ROAD, LONDON, W.2

Telephone :
AMBASSADOR 4033
PADDDINGTON 3271

Build these PREMIER TELEVISORS
from **£27.9.4**

SEND 21d. STAMP
FOR OUR 1957
CATALOGUE



SPENCER-WEST TYPE 80 CONVERTER

£6.5.0



- * B.B.C. or Commercial Programmes at the touch of a switch.
- * Built-in power supply for 200/250 v. A.C.
- * Size 6½ in. x 4 in. x 3½ in. wide.
- * Guaranteed for 12 months.

SPENCER-WEST PATTERNING REMOVAL UNIT TYPE 54. Works with any Band 3 converter unit and completely removes patterning caused by Band 1 breakthrough. Price **25/-** plus 1/6 pkg. & carr.

OR WITH THE NEW TURRET
TUNER £33.7.11

PLUS COST OF C.R.T.



These Televisors use a double wound main transformer which gives you complete safety from contact with the mains supply when handling the chassis or controls.

MAY BE EASILY BUILT IN 5 SEPARATE UNITS
FULL CONSTRUCTION DETAILS AVAILABLE. INSTRUCTION BOOK 3/6 POST FREE INCLUDES BOTH DESIGNS

CONSOLE CABINETS with full length doors for 14in., 16in. and 17in. tubes. PRICE £14.14.0. H.P. Terms : Deposit £7.7.6 and 9 monthly payments of 18/6. **CONSOLE CABINETS**, half door, still available at £12.12.0. H.P. Terms : Deposit £6.6.0 and 8 monthly payments of 18/3. On above cabinets add 21/- for pkg. and carr.

WHY buy surplus or reconditioned tubes when these Fully Guaranteed Wide Angle Tubes are available? The latest type 17in. Rectangular Tube MW43/64 by Telefunken at £17 (inc. tax) post and packing 21/- extra.

TELEVISION TUBES

| | | | | | |
|---------|-----|-----|---------------|---------------|---------------|
| MULLARD | ... | ... | 12in. £6.10.0 | 14in. £7.0.0 | 17in. £8.10.0 |
| COSSOR | ... | ... | 12in. £6.10.0 | 14in. £6.10.0 | 17in. £8.10.0 |
| EMITRON | ... | ... | 12in. £6.10.0 | 14in. £7.0.0 | 17in. £8.10.0 |

MULLARD. 12in. now 6 weeks delivery. All other types ex-stock.

MONTHLY CLEARANCE REDUCTIONS

| | | | | |
|-----------|-----|--------------------------|--------------------------|--------------|
| MAZDA | ... | 14in. £5.10.0 | 15in. £6.10.0 | 17in. £7.0.0 |
| MULLARD | ... | 16in. Metal Cone £5.10.0 | 17in. Metal Cone £6.10.0 | |
| CATHODEON | ... | 14in. £6.0.0 | | 17in. £7.0.0 |

All Tubes plus 12/6 carriage and insurance.

SIX MONTHS' GUARANTEE

Terms to the Trade.

RE-VIEW (LONDON) LTD.

81, HIGH STREET . . . MERTON S.W.19

Telephone : CHERRYWOOD 3255

Wanted!

QUALIFIED MEN AND WOMEN

Industry & Commerce offer their best posts to those with the necessary qualifications—such posts that will bring personal satisfaction, happiness, good money and security. As part of a modern industrial organisation, we have skilled knowledge of what is required in industry to-day and the best means of training personnel for its present day and future requirements. We specialise also in teaching for hobbies, new interests or part-time occupations in any of the subjects listed below. Make your own choice and write to us to-day for further information. There is no obligation of any kind.



The E.M.I. Factor's at Hayes, England.

PERSONAL & INDIVIDUAL TRAINING IN—

- | | | | |
|---------------------------------------|--------------------------|------------------|---------------------|
| Accountancy | Customs Officer | Languages | Refrigeration |
| Advertising | Draughtsmanship | Management | Sales Management |
| Aeronautical Eng. | Economics | Maintenance Eng. | Sanitary |
| A.R.B. Licences | Electrical Eng. | Mathematics | Engineering |
| Art (Fashion, Illustrating, Humorous) | Electrical Installations | M.C.A. Licences | Salesmanship |
| Automobile Eng. | Electronics | Mechanical Eng. | Secretaryship |
| Banking | Electronic | Metallurgy | Shorthand & Typing |
| Book-keeping | Draughtsmanship | Motor Eng. | Short Story Writing |
| Building | Eng. Drawing | Painting & | Short Wave Radio |
| Business | Export | Decorating | Sound Recording |
| Management | Heating & | Photography | & Reproduction |
| Carpentry | Ventilation Eng. | P.M.G. Certs. | Telecommuni- |
| Chemistry | High Speed | Police | cations |
| City & Guilds | Oil Engines | Production Eng. | Television |
| Exams | Industrial Admin. | Production | Time & Motion |
| Civil Service | Jig & Tool Design | Planning | Study |
| Commercial | Journalism | Radar | Tracing |
| Commercial | | Radio Amateurs | Welding |
| Art & Drawing | | (C&G) Licence | Workshop Practice |
| | | Radio & Tele- | Works M'gement |
| | | vision Servicing | and many others |

Also courses for GENERAL CERTIFICATE OF EDUCATION, A.M.I.H.&V.E., A.M.S.E., A.M.Brit.I.R.E., A.M.I.Mech.E., A.M.I.E.D., A.M.I.M.I., A.F.R.Ae.S., A.M.I.P.E., A.M.I.I.A., A.C.C.A., A.C.I.S., A.C.C.S., A.C.W.A., City & Guilds Examinations, R.T.E.B. Serv. Cert., R.S.A. Certificates, etc.

NEW! Courses with PRACTICAL EQUIPMENT

in RADIO · TELEVISION · MECHANICS
CHEMISTRY · ELECTRICITY
DRAUGHTSMANSHIP · PHOTOGRAPHY etc., etc.

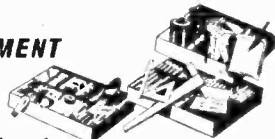

COURSES FROM 15/- PER MONTH

POST THIS TODAY

FREE

E.M.I. INSTITUTES, Dept. 138K, London, W.4.

NAME _____ AGE _____
(if under 21)

ADDRESS _____

Subject(s) with/without equipment _____

AUG./57 We shall not worry you with personal visits

BLOCK CAPS PLEASE

IC 92

EMI INSTITUTES

- Part of "His Master's Voice", Marconiphone, etc. etc.

BRIMAR 6BQ7A

The Brimar 6BQ7A is a double triode consisting of two independent high slope sections with similar characteristics. The valve is particularly useful as a cascode R.F. amplifier for television receivers and also as a combined oscillator and mixer for frequency modulation receivers. It can, of course, be used wherever high slope triodes are required, and features low interaction between the sections as an internal screen is provided which is brought out to a separate base pin.

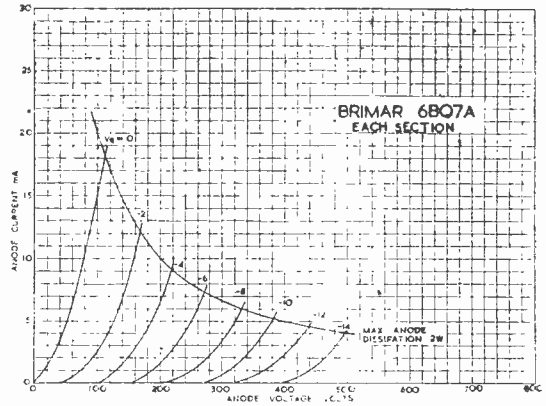

TYPICAL CHARACTERISTICS

| | |
|---|-------------------|
| Heater voltage..... | 6.3 volts |
| Heater current..... | 0.4 amp |
| Anode voltage..... | 150 volts |
| Cathode bias resistor..... | 220 ohms |
| Anode current..... | .9 mA |
| Mutual conductance..... | 6.4 mA/V |
| Amplification factor..... | 39 |
| Anode resistance..... | 6,100 ohms |
| Grid cut-off voltage ($I_{g1} = 10 \mu A$)..... | —10 volts approx. |

Write to the Publicity Department for a data sheet.

Standard Telephones and Cables Limited **FOOTSCRAY SIDCUP KENT** Footscray 3333

SUMMER SALE

LOOK! 17in. T.V. CHASSIS £19.19.6



17in. Rectangular tube on adapted chassis. Any or all channels. The TURRET TUNER can be added later as an extra at our special price, to chassis clients, 50/- . Valve line-up (5 valves): 6SN7G 6P25, EY51 and 2-6D2's. Others: 6L18, EL38 and 7-6F1's. These may be on YOUR shelf. Chassis size 11 1/2in. x 14 1/2in. x 11in. 12 months guarantee on the rectangular

tube, 3 months guarantee on the valves and chassis. All complete and working on any channel 1-5, but less valves. With 5 of the valves, £21.19.6. Complete with all valves, £25.19.6. Ins., Carr. (incl. tube), 25/- . Please state B.B.C. channel (and I.T.A. channel if TURRET TUNER required).

17" 12 MONTHS GUARANTEE ON 14" £7.10.0. RECTANGULAR T.V. TUBES £5.10.0

We are now able to offer this wonderful guarantee. 6 months full replacement, 6 months progressive. Made possible only by the improved high quality of our tubes. Ins., Carr. on all tubes, 15/6. N.B.—All tubes are C.W.O. As a SPECIAL OFFER we can now supply 14in., 15in. and 16in. round type tubes with three months guarantee, £5. C.W.O. only. Ins., Carr., 15/6.

12in. T.V. TUBES, £6

Shortage may cause delay. Phone first, we may have alternative and can tell you delay, if any.

T.V. TUBES, 30/-.

With cathode to heater shorts, or with burns, 15/- . Please enquire. Give type and size required, Carr. extra.

Open SATURDAY all day. Send for FREE catalogue. Liverpool Street Station to Manor Park—10 minutes.

14in. T.V. CHASSIS, TUBE & SPEAKER £13.19.6.

FAMOUS TURRET TUNER FITTED 50/- EXTRA.

Complete with 14in. round tube and speaker. Modified ready working. Fully guaranteed for three months. Less valves. These are demonstrated in our shops for your inspection. You can convert later if you wish to a 17in. rectangular tube. With 5 of the valves, £15.19.6. Complete with all valves, £19.19.6. Ins., Carr. (incl. tube), 25/- . I.F.s 10.5-14 Mc/s. Please state B.B.C. channel (and I.T.A. channel if TURRET TUNER required).

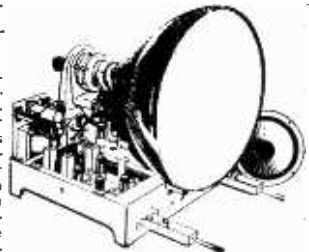

ARGOSY PUSH-PULL RADIOGRAM CHASSIS, 139/6

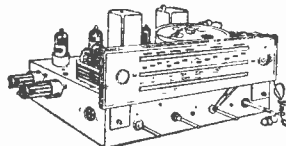

5-valve latest models. 3 w/band and gram. switched. Over 10 watts output. Full-tone range. 4 knob controls. Size 12in. x 7 1/2in. x 7 1/2in. Less valves. Ins., Carr., 5/6. Drawings 3/6 or FREE with order.

POPULAR RADIO OR RADIOGRAM CHASSIS 39/9

3 w/band and gram. s/het. 5 valve International Octal. Ideal table gram, but still giving high quality output. 4 knob controls. 8in. P.M. speaker. 7/9 extra. Set of knobs, 2/- . Chassis size 12in. x 6in. x 9in. Less valves. Ins., Carr. 4/6.



DUKE & CO. (P.T.) 621/3, Romford Rd., Manor Park, London, E.12 GRA 6677-8-2791



Practical Television



& TELEVISION TIMES

Editor : F. J. CAMM

Vol. 8 No. 85

EVERY MONTH

AUGUST, 1957

Editorial and Advertisement Offices :
PRACTICAL TELEVISION
George Newnes, Ltd., Tower House,
Southampton Street, Strand, W.C.2.
Phone : Temple Bar 4363.
Telegrams : Newnes, Rand, London.
Registered at the G.P.O. for trans-
mission by Canadian Magazine Post.

SUBSCRIPTION RATES

including postage for one year

Inland - - 17s. 6d. per annum
Abroad - - 16s. 6d. per annum
Canada - - - 16s. per annum

CONTENTS :

| | Page |
|--|------|
| Aerials and Devices... | 4 |
| Starting a Service Depart- ment—Part III | 6 |
| Silver Plating for the Ex- perimenter | 7 |
| Fault Finding on A.G.C. Systems—Part II | 9 |
| Servicing Television Receivers Sobell TS17 and T346 | 11 |
| Aerial Matching and Mis- matching | 15 |
| Faults with Focus | 17 |
| Some Obscure Faults | 18 |
| Beginner's Guide to Television | 21 |
| The Zoom Lens | 23 |
| Converting the 3807 | 26 |
| Telenews | 27 |
| New Telecine Equipment | 31 |
| News From the Trade | 32 |
| Underneath the Dipole | 35 |
| Correspondence | 39 |
| Your Problems Solved | 43 |

The Editor will be pleased to consider articles of a practical nature suitable for publication in "Practical Television." Such articles should be written on one side of the paper only, and should contain the name and address of the sender. Whilst the Editor does not hold himself responsible for manuscripts, every effort will be made to return them if a stamped and addressed envelope is enclosed. All correspondence intended for the Editor should be addressed to: The Editor, "Practical Television," George Newnes, Ltd., Tower House, Southampton Street, Strand, W.C.2.

Owing to the rapid progress in the design of radio apparatus and to our efforts to keep our readers in touch with the latest developments, we give no warranty that apparatus described in our columns is not the subject of letters patent.

Copyright in all drawings, photographs and articles published in "Practical Television" is specifically reserved throughout the countries signatory to the Berne Convention and the U.S.A. Reproductions or imitations of any of these are therefore expressly forbidden.

TELEVISIONS

SUBSCRIPTION TELEVISION

A MOVE is afoot in America to introduce subscription television. Under the proposed system, set owners would buy or rent unscramblers that would permit reception of motion pictures and other shows. Subscription television needs at present Government approval. It is said that the Federal Communications Commission is in favour of Pay-as-you-see TV on a trial basis. The programmes would be received by all sets but with the sound and picture scrambled and the viewer would have to purchase an unscrambler. Under another system payment would be made annually, depending on the number of programmes seen. An attachment to the TV set would keep count of such programmes.

SCOTTISH RADIO AND TELEVISION EXHIBITION

JUST under 65,000 people passed the turnstiles during the 10-day run of the Scottish Radio and Television Exhibition. This averages 6,500 a day. This must give the exhibition organisers, as well as the exhibitors, some anxiety because, on such a low gate, it can hardly be considered a paying proposition, either to the organisers or to the exhibitors. There are many over the Border who cannot afford the time to travel to the Earls Court Show, and many Northern Englishmen in a similar predicament. Yet exhibitions which have been staged in the provinces at a sort of halfway mark have never been successful. We wonder whether such exhibitions are now worth while.

DABBLING ?

A TRADER protests that there are many amateurs who make a profitable sideline of servicing TV and radio receivers, and he thinks they are ruining the trade. He forgets, however, that these amateurs are far more skilled than some radio dealers, and it is understandable that in a district where the dealers are known to make heavy charges for unsatisfactory and unskilled work, the skilled and knowledgeable amateur is often called in. His charges are reasonable and his work satisfactory. It is rather ironic that many of these loquacious dealers who write glibly about dabbling ruining the trade originally started in business themselves as dabblers. This dealer also forgets that there is plenty of dabbling undertaken by those owning radio and TV shops who also sell perambulators, bicycles and other lines.

THE RADIO SHOW

THE Radio Show this year takes place at Earls Court from August 24th to September 7th. Make a note of our Stand—No. 117—on the ground floor, where all readers will be welcome.—F. J. C.

Our next issue, dated September, will be published on August 22nd.

SOME sets are fitted with two input sockets, one for Band I, the other for Band III. The more modern type is fitted with two sockets, one for TV and the other for Band II V.H.F., whilst some use the same socket for all three bands. We will give some simple methods to overcome the use of elaborate aerial assemblies. We will start with a simple device for matching; these are known commercially as crossovers, duplexers, splitters, etc., but are for matching and separating two inputs to feed one

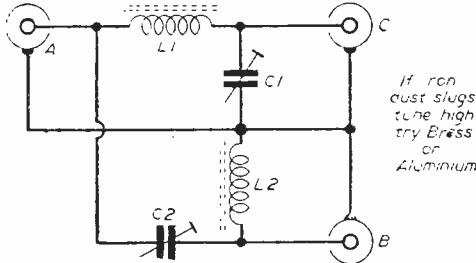

Fig. 1.—Simple aerial matching circuit. L1 consists of 9 turns of 20 s.w.g. $\frac{1}{16}$ in. diameter spaced one turn; L2 consists of 7 turns of 20 s.w.g. $\frac{1}{16}$ in. diameter spaced one turn; C1, C2 are 0.30 pF concentric trimmers. L1 and L2 are wound on Aladdin formers tuned by slugs. C1 and C2 would then become 10.15 pF Ceramic. The turns are spaced to tune to the required wavelength.

input or to feed two inputs from a combined aerial. Fig. 1 shows the arrangement. If we connect the input from a combined Band I and III aerial we get two outputs from "B" and "C," the aerial being connected to "A," or we can take two inputs from separate aeriels Band I and Band III to "B" and "C." We then get from "A" an input to a set that has one socket for two bands. This device works

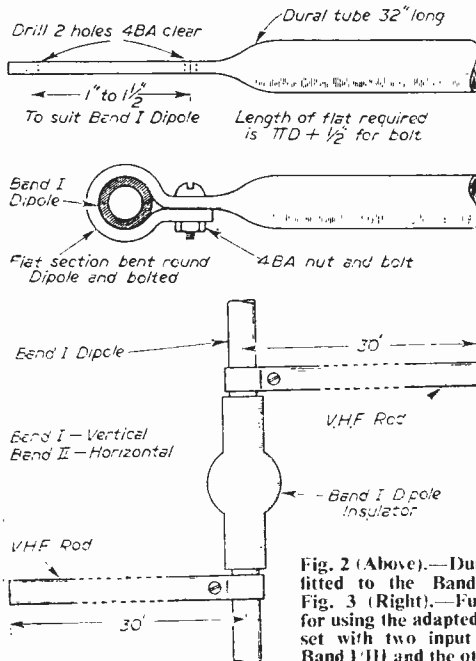

Fig. 2 (Above).—Duralumin rods fitted to the Band I dipoles. Fig. 3 (Right).—Further device for using the adapted aeriels on a set with two input sockets for Band I/III and the other for F.M.

SOME USEFUL

METHODS OF AVOIDING ELABORATE

successfully both ways. The unit is simply constructed and is preferably screened in a box. For maximum gain and for minimum interference, the slugs in the coils should be set for the optimum position, or if the coils are not slugged, the condensers tuned for this position. The turns of the coils can also be space tuned. For long runs of coaxial, in a strong signal area, two units may be used to advantage.

For reception of Band II signals in a strong signal area, this would be O.K. from a Band I aerial. However, there is one answer for the combined set, and that is to fit on to the Band I dipoles two dural rods, each 2ft. 6in. long; these are simply made and fitted (Fig. 2). In this we flatten two of the rods at the ends, bend them around the dipoles and bolt them on to the dipoles, giving them a coat of protecting paint after fitting.

Fig. 3 shows another device for using one of these adapted aeriels with a set that has two input sockets, one for Band I/III, the other for F.M. We use a bakelite lighting junction box and this splits up the combined input from the aerial and there are two outputs, one to TV socket, the other to the F.M. socket; the resistors are $\frac{1}{2}$ watt carbon.

Connection 1 is the conductor from the aerial.

Connection 2 is the TV output.

Connection 3 is the common braiding in screening connection.

Connection 4 is the F.M./V.H.F. output.

Band III is related to Band I. As an example, Band I Channel 4, and Band III Channel 8.

We see here clearly this relationship as a halfwave dipole on Channel I is one and one-third wavelength on Channel 8.

In an area of good signal strength we should not require an aerial for Band III reception as the wavelength is related. Possibly we should get some patterning from one or other station, but this can be removed by using a tuned filter or Spencer West pattern remover.

We could fit one of the V.H.F. aeriels as described previously, and cover Bands I, II and III with one aerial, making the assembly and

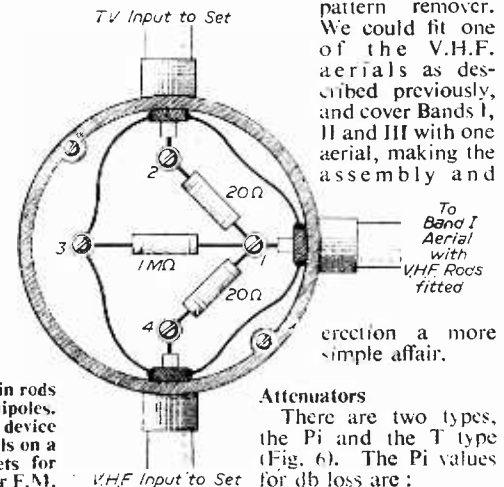

Attenuators

There are two types, the Pi and the T type (Fig. 6). The Pi values for db loss are:

AERIAL DEVICES

AERIAL ASSEMBLIES By J. Brown

| Attenuation | R ₁ | Values in Ω R ₂ | R ₃ |
|-------------|----------------|-------------------------------|----------------|
| 10db | 150 | 100 | 100 |
| 20db | 470 | 100 | 100 |
| 30db | 1.5k | 80Ω | 80Ω |
| 40db | 3.3k | 80Ω | 80Ω |
| 50db | 10k | 100Ω | 100Ω |

The balanced feeder attenuators are as below. First, there is the variable type. In this we can attenuate both independent of each other (Fig. 4). Fig. 5 shows the combined attenuator which, as with

| To attenuate | Values in Ω | |
|--------------|-------------|-----|
| | ABCD | E |
| 10db | 35Ω | 50Ω |
| 20db | 65Ω | 15Ω |
| 30db | 100Ω | 1Ω |

the previously mentioned matching device, can be used two ways, for two inputs and one output, or one input and two outputs. We also have the Pi attenuator for both coaxial and for balanced feeders. There is also the problem of working more than one set from the same input. This can be done by 1/2 watt resistors again and can be made to work satisfactorily. The value of the required resistor can be found roughly by the following formulae:

$$R = \frac{\text{Impedance of the aerial}}{\frac{N-1}{N+1}}$$

Where the number of outlets is N.

E.g., if we require three outlets (Fig. 7) we get, if the impedance of the aerial is 75 ohms,

$$R = \frac{75}{\frac{2-1}{2+1}} = \frac{75}{\frac{1}{3}} = 25 \text{ ohms}$$

Where the aerial comes in to the set a neon between the conductor of the coaxial and earth is an assistance for lightning, also will remove any static.

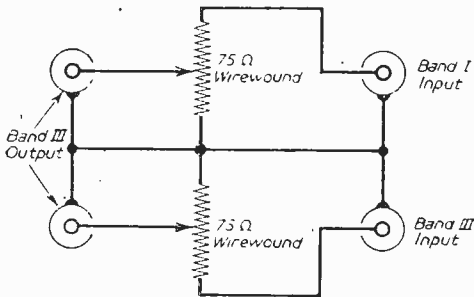

Fig. 4.—Variable type feeder attenuator.

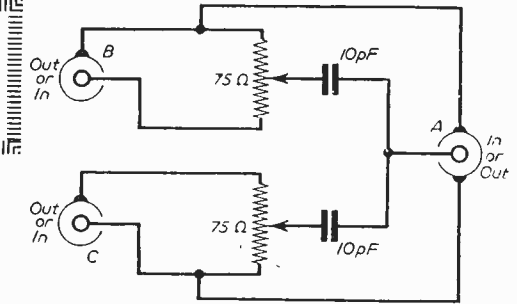

Fig. 5.—Combined Band I and Band III aerial fed in at A. We get Band I out of B with variable attenuation and Band III out of C. Separate Band I and Band III aerials fed in at B and C.

If across the dipoles connection inside the box we fit a 2 K or 3 K resistor, we can at any time test the aerial feeder for continuity. This test, however, does not apply to aerials with folded dipoles.

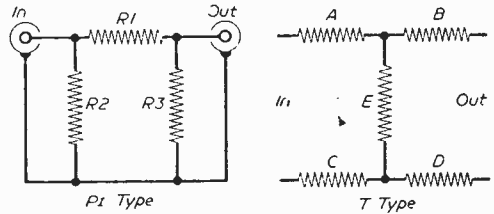

Fig. 6.—Circuits for the Pi and T type attenuators.

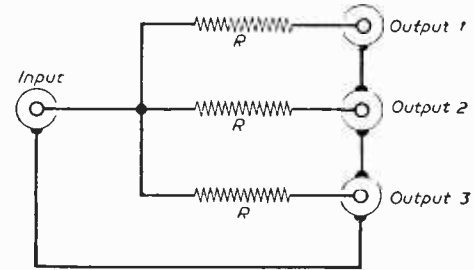

Fig. 7.—Method of working more than one set from the same input.

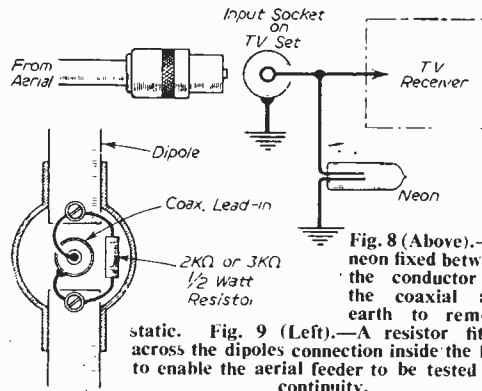

Fig. 8 (Above).—A neon fixed between the conductor of the coaxial and earth to remove static. Fig. 9 (Left).—A resistor fitted across the dipoles connection inside the box to enable the aerial feeder to be tested for continuity.

Starting a Service Department

NOTES BY A SERVICE ENGINEER
(Concluded from page 517 June issue)

SO far I have only dealt with the service department itself, but there must always be a certain amount of service to be done outside the department. On a request for service being received, the following data should be ascertained. The make and model number of set, the nature of the complaint, when it will be convenient to send an engineer, and if he considers it necessary, will the customer allow the set to come in for service. A good point here is to have a set available for loan to a customer, should the set have to be kept for more than a couple of days.

Making the Call

A service engineer paying a service call should be properly equipped with the necessary tools, valves, spares and instruments. He should also have service data on the set. It is always advisable to send an experienced man on outside service work. Many dealers send out boys or trainees, who know very little about TV. This is not very wise, as people are very critical nowadays, and when they see someone messing around with their set, who apparently knows very little about it, they are inclined to call the deal off.

Checking the Set

On arriving on the job the engineer should first of all check the make and type and make a note of the service number of the set. This latter is for records in the service department, and is also of assistance as some makers have modifications of a type after a certain serial number. The mains voltage of the house should be checked and notice taken of the voltage setting on the set itself. This can be important because quite a few causes of poor hold and lack of width are due to low mains voltage. The set should then be switched on and checked over as far as possible, paying special regard to the complaint. If the trouble is located and does not necessitate the chassis being removed from the cabinet, it should be rectified if possible. In nearly all cases where it means the removal of the chassis, I advise that the set go to the service department.

There are very few houses where it is convenient or practicable to work on a chassis. The light is generally insufficient and in most cases it means working on the floor. One cannot do a thorough job under these circumstances. Many do this, I know, but I have seen during many years' service work quite a few of these sets repaired under these conditions returned for further service. In all these cases it was due to the work carried out in these unsuitable conditions. Another point is that a job

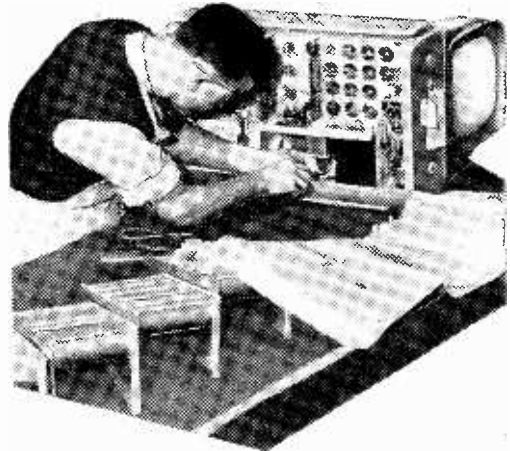

like this done in a customer's house will probably take twice as long as if it had been done in the service department.

On the other hand, if it is only a minor replacement (resistor or condenser) underneath the chassis and the customer does not want the set to go away, it should of course be done. A point to be watched is that a customer may offer you a table to work on. If it is a polished top, see that it is covered with some thick material (paper or table cloth is of no use), before placing chassis thereon. Movement of a chassis on a polished top will leave scratches. One doesn't want a bill in for re-polishing after an engineer's visit. A square of green baize carried in the engineer's tool bag is handy for this.

During the engineer's visit, a quick check over of the aerial system is very necessary. Innumerable faults that customers complain of are due to either an inadequate or inefficient aerial system. If any major changes are required here, I do not advise that it be done on this service call. It should be made a separate job.

It is advisable, for the purposes of records and charging, for the service engineer to have a proper job sheet for each outside job. These job sheets should have on them the customer's name and address, the make and type of set, with a position for the serial number to be filled in. There should be columns for time arriving and time leaving, nature of complaint, cause and cure. There should also be a place for the customer to sign, stating that the job was completed to his satisfaction. The back of the job sheet could be used for costing purposes.

Instruments, Tools and Spares

The service engineer should carry in his tool case the following:

- Multirange meter.
- Range of valves according to set and complaint.
- Resistors and capacitors.
- Small soldering iron with adaptors for various fittings and solder holder for soldering iron (prevents burning of carpets, etc.).
- Trimming Tools.
- Pliers.
- Screwdrivers.
- Service data for set.
- Any other components that nature of complaint seems to call for.

SILVER PLATING FOR THE EXPERIMENTER



AVOIDING LOSSES IN CONDUCTORS

By D. R. Bowman

It is widely known that when high-frequency current flows along a conductor the surface only is effective in conducting the electricity. This "skin effect" becomes increasingly important as the frequency rises, so that whereas at 100 kc/s or less the main body of a conductor plays its full part, yet at 20 Mc/s and upwards it is the surface skin only which affects conductivity.

This phenomenon has several important results. First of all, Litz wire is of considerable use for the lower radio frequencies—say up to 3 or 4 Mc/s. At higher frequencies it is actually disadvantageous compared with bare wire; partly because of the capacitance from strand to strand of wire, partly because the electric field of the current undergoes its changes within the substance of the insulation of the strands and so gives rise to quite serious losses.

Secondly, screening (by non-magnetic metal shields) is effective because an incident changing electromagnetic wave induces currents in the metal

soldered and is very resistant to corrosion by the atmosphere. Copper is less expensive, but its surface rapidly acquires a poorly conducting layer of copper oxide, which interferes with its effectiveness as a screen. Tinned copper wire is quite a poor conductor, relatively, at frequencies of over 40 Mc/s. Aluminium is a "difficult" metal for soldering, and normally is so much trouble that the amateur uses nuts and bolts and soldering tags. Tinplate for screening is not unknown, but at high-frequency is only of inferior performance.

To get the best of all worlds the usual method for high-class professional work is to use a silver plating on conductors carrying high-frequency currents. The amateur can also use this technique with a minimum of trouble and with very simple apparatus.

Materials required are as follows. They are all easily obtained in any town and in very many country places as well.

Scrap Silver—the present market price is from 6/- to 7/- an ounce; an ounce will last a lifetime. See that it is hallmarked. Silver coinage will not do, and it is illegal to use it, anyway.

Silver Nitrate—this is much more expensive, but can be prepared as described later. About 1 dram will be needed.

Potassium Cyanide—or sodium cyanide. ½ oz. will be needed, or a little over. This can be obtained from a chemist, but the poison book will have to be signed and the chemist can only supply it if you are known to him. It is an extremely dangerous poison.

Nitric Acid—1 oz. concentrated (in glass stoppered bottles).

Hydrochloric Acid—1 oz. concentrated (in glass stoppered bottles).

Detergent—any household type will do.

L.T. Battery, 1½ volts—of the kind used for portable wireless sets, but the bigger it is the longer it will last.

The container is ideally a large glass tank, but polythene domestic utensils are very handy. In any case, the size of dish will have to be decided

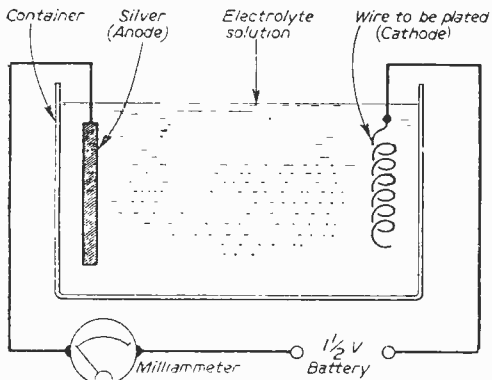

Arrangement of the silver plating bath.

of the screen, and their effect is to create a field which is equal and opposite to the incident field. (Readers will remember this as "Lenz's Law.") If the material of the screen is not a good conductor, only reduced screening effect will occur. For high-frequency use, screen material should therefore be of first-class conductivity.

In decreasing order of effectiveness, both as a wire conductor and as screening material, are silver, copper, aluminium and tin. If silver were cheap it would be much used because it is easily

in the light of the size of the article to be plated. Assuming a coil of 20 gauge tinned copper wire is to be plated, or a small under-chassis screen made of tinfoil, a domestic Pyrex dish will be about right. This will need about a pint of solution.

The Solutions

First proceed to make up the electrotype solution by dissolving the silver nitrate in an ounce or two of warm water. Then dissolve the cyanide in about 4oz. of water. Add the cyanide solution to the silver nitrate a little at a time.

A white curdy precipitate will form at first, but adding more cyanide little by little will result in this substance dissolving again. When just enough has been added to make a clear liquid, add a few spoonful more of the cyanide solution. The remaining cyanide solution should be thrown down the lavatory immediately—two flushings will get rid of it safely. The electrolyte solution is decidedly less dangerous, but is still very poisonous. Make up the electrolyte to a pint by adding water. Keep this in a tightly screwed or corked bottle clearly labelled POISON, and keep well away from food and out of the reach of children.

Referring to the diagram, it will be seen that the effect of plating is to be gained by passing current through the solution. Silver is deposited on the article connected to the negative pole of the battery, while silver is dissolved away from the piece of silver attached to the positive of the battery. The electrolyte solution thus retains its properties and does not get used up. It will last almost indefinitely.

The silver plating will only adhere firmly to the object if the latter is perfectly clean. First scrub the article well in hot detergent, and if necessary use emery cloth and metal polish first to get a clean metal surface. Then ensure that this is chemically clean by immersing in acid solution for a time. For this purpose the acids mentioned in the list of materials are diluted with water; make up to about 4oz. of solution. They may be used as follows:

Dilute nitric acid cleans tinned copper wire (10 mins.-15 mins. immersion strips off the tin), brass rod or threaded rod; thin brass or copper sheeting for screening—almost anything.

Dilute hydrochloric acid cleans aluminium; copper or brass on pickling for 24 hours; tinfoil.

Cleanliness

When the article has been cleaned in this way it must not be touched by hand again. Use a wire soldered to an edge, or clean forceps. Wash well under the tap and connect up to the prepared apparatus. Adjust the current flowing until 10-30 milliamps flow; this may be done by a variable resistor or by varying the distance between the silver anode and the article. If too heavy a current is passed, the silver will be deposited as a black powder, which does not adhere. When properly arranged—and it is extremely easy to do—excellent results are obtained, the silver being deposited in a creamy shining layer (not a mirror). It may be burnished, if a mirror finish is required, by rubbing with a piece of hard calico, or a plastic knitting needle. No diffi-

culty is experienced at all—provided the article to be plated is absolutely clean.

Aluminium

If aluminium is to be plated, use hydrochloric acid for cleaning. The attack of the acid on the metal is rapid and spectacular, but must be allowed to go on until the surface of the aluminium is completely etched away. Silver will deposit on it beautifully, but it will still not solder afterwards—the silver plate allows oxygen to pass through and this soon forms a skin underneath the plating of aluminium oxide. Using copper sulphate solution (1oz. to a pint of water) as electrolyte, a preliminary copper plate can be put on to it, but it needs to be a very heavy plate for good soldering results afterwards.

A little experimenting will soon give the knack needed. The amateur's transmitting coils and V.H.F. coils for receivers, under-chassis screens, and even complete chassis themselves, will not only look professional but will give their best results. It will not be long before the ladies of the house come along armed with spoons, forks, vases and so on to be refurbished.

Since silver nitrate is so expensive, it can be more cheaply made by dissolving a little scrap silver in some concentrated nitric acid. Stand the bottle or tube containing them in warm water. When no more silver is dissolved, even on heating gently, add some water, pour off, and make up with cyanide as described earlier. Because there will be acid left unused, this *must* be done in the open air, great care being taken not to breathe even a trace of the gas that will be given off. Rather more cyanide will have to be used.

Warning

The acids used for cleaning, even when dilute, are very corrosive. They should be kept in glass-stoppered or polythene stoppered bottles. If any gets on the hands wash with plenty of water. If any splashes on the clothes, apply household ammonia liberally.

There is, however, no real danger in using these chemicals provided the following points are always kept in mind.

- (a) Take your time.
- (b) Have everything labelled.
- (c) Preserve cleanliness.
- (d) Keep children out of the way.
- (e) Take your time.
- (f) Keep everything away from food.
- (g) Remember the apparatus is for plating, not eating.
- (h) Work on a plastic table top or in a deep sink.
- (j) Take your time.

A NEW HANDBOOK AMPLIFIERS: DESIGN & CONSTRUCTION

By F. J. CAMM
17/6, Post 18/-

Containing Designs for Radio, Gramophone, Tape-Deck,
P.A. Amplifiers, with a special chapter on D.C. Amplifiers.

From **GEORGE NEWNES, LTD.**
Tower House, Southampton Street, Strand, W.C.2

Fault Finding on A.G.C. Systems

HOW TO LOCATE TROUBLES IN CIRCUITS WHICH ARE PICTURE CONTROLLED

By F. E. Apps

(Continued from page 563, July issue)

IN the previous article I showed how A.G.C. was obtained but, as stated, these methods are not suitable to the system of television used here. The sync pulses occur at zero modulation, whatever the carrier amplitude, and so cannot be used as in the methods mentioned in Part I. Therefore, it is necessary to find another point where there is a steady voltage for a steady signal strength. If we take black level as a constant, it will be found to be 30 per cent. of peak white. This is also the height of the sync pulses, and is always a steady value, irrespective of modulation. To connect this standard to an A.G.C. line we have to arrange that it is connected immediately after each line pulse. This means some method of switching.

A valve is placed in the circuit which is switched or keyed by the flyback. The pulse makes the valve conduct and thus connects the video output signal with the A.G.C. line. In Fig. 1 a typical circuit is shown. The action is as follows: The video signal is taken from the cathode of V3, the video amplifier, and passed to the anode of V3, which is a diode whose diode load is R1, approximately 2.2 MΩ. It will be noticed that when this diode conducts, the cathodes of the video amplifier and V2 are practically joined. Further, the cathode of V3 is connected to the secondary of the line output transformer. When a line flyback occurs, a pulse is placed on V3 cathode, causing it to conduct for the period of the pulse. Thus, during this pulse the video amplifier and V2 are joined, and the cathode of V2 is negative at that moment, due to this negative pulse. This produces an amplified negative pulse in the anode circuit of V2. The pulse from the anode of V2 is passed to the cathode of V1 and causes it to conduct. It will be

noticed that V1 is biased to cut-off point by a tapping off a bleeder circuit. The output from V1 is smoothed and passed by a decoupling network to the A.G.C. line.

It will be seen that should there be any change in level of signal at the video amplifier, it will cause a change in the cathode potential of V2 when V3 conducts. Should signal strength decrease, the cathode of the video amplifier will be less negative, and the pulse at V2 cathode will therefore be less, resulting in a lower output from V2 and a decrease in bias on the A.G.C. line. If the signal increases in strength the reverse action will take place. The gain of V2 and the size of the pulse for a given strength of signal will be governed by the contrast control which is in the grid circuit of V2.

It will be observed that the A.G.C. cannot act until the pulses arrive from the line output transformer to trigger V3. This means that until the A.G.C. operates the valves controlled by A.G.C. will be running without bias and so overload valves and components. To prevent this a safety circuit is employed which consists of a crystal diode coupled between video amplifier grid and the line output valve cathode. When the line output stage is not working this diode holds the video amplifier grid at chassis potential. When the line stage starts working the cathode volts bias off the diode and releases the video amplifier grid.

Fault Finding on this Method

Any fault occurring in this A.G.C. system will affect the I.F. controlled valves. The grids will be grounded and no signals will result. An oscilloscope is very useful here and, if applied to point B, video

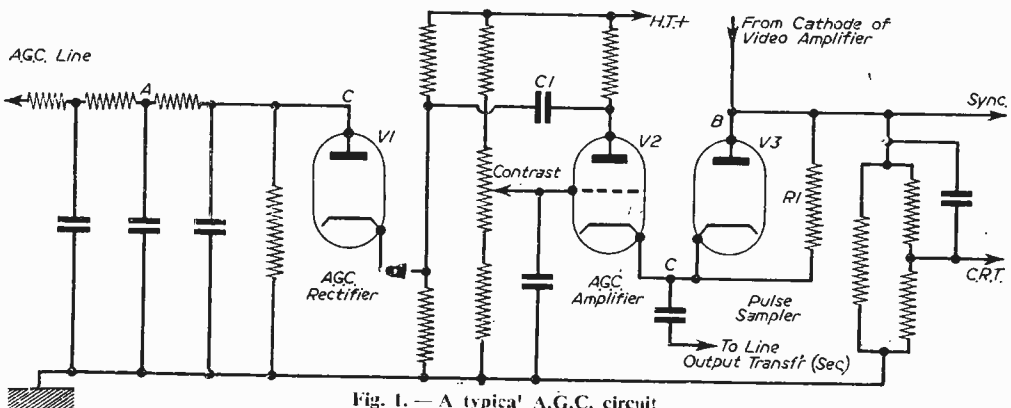

Fig. 1. — A typical A.G.C. circuit

SERVICING (VALUES)

Fig. 1.—Sound Circuit.

R68—1 m Ω .
 R70—270 Ω .
 R71—150 K Ω .
 R72—47 K Ω .
 R73—560 Ω .
 R74—68 K Ω .
 R75—1 K Ω .
 R76—3.3 K Ω .
 R78—560 Ω .
 R79—560 Ω .
 R80—100 K Ω .
 R81—470 Ω .
 R82—1 M Ω .
 R84—4.7 M Ω .
 R85—22 K Ω .

C53—50 pF.
 C54—.1 μ F.
 C55—.005 μ F.
 C56—.005 μ F.
 C57—.005 μ F.
 C58—5 pF.
 C59—30 pF.
 C60—5 pF.
 C61—100 pF.
 C62—.01 μ F.
 C63—24—18 μ F.
 C64—100 μ F 12 v.
 C65—.01 μ F.
 C66—.001 μ F.
 C67—.005 μ F.

Fig. 2.—Vision Det. and Vision Amp.

R37—1.5 M Ω .
 R38—1.5 M Ω .
 R39—560 K Ω .
 R40—15 K Ω .
 R41—6.8 K Ω .
 R42—470 Ω .
 R43—47 K Ω .
 R44—15 K Ω .
 R45—6.8 K Ω .
 R46—47 K Ω .
 R47—120 K Ω .
 R48—10 K Ω .
 R50—220 K Ω .
 R51—100 K Ω .

C38—5 pF.
 C39—.1 μ F.
 C40—80 pF.
 C41—.1 μ F.
 C42—.25 μ F.

Fig. 5.—Power Supply

R116—A 25 Ω 10 w.
 B 20 Ω 9 w.
 C 33 Ω 3 w.
 D 190 Ω 23 w.
 R117—35 Ω , 5 w.
 C97—A 100 μ F.
 B 200 μ F.
 C98—.1 μ F.
 C99—.01 μ F.

Fig. 4.—Frame Time Base.

R91—333 K Ω .
 R92—2.2 meg.
 R93—1 meg.
 R94—47 K Ω .
 R95—47 K Ω .
 R96—820 K Ω .
 R97—220 K Ω .
 R98—39 K Ω .
 R99—820 Ω .
 R100—10 K Ω .
 R101—1.8 meg.
 R102—220 K Ω .
 R103—22 K Ω .
 R104—27 K Ω .
 R105—470 K Ω .
 R106—22 K Ω .
 R107—470 Ω .
 R108—470 Ω .

C73—.001 μ F.
 C74—.05 μ F.
 C75—.5 μ F.
 C76—.03 μ F.
 C77—.003 μ F.
 C78—.05 μ F.
 C79—100 μ F, 12 v.
 C80—.1 μ F.
 C81—.1 μ F.
 C82—.003 μ F.
 C83—.1 μ F.
 C87—30 pF, 2 Kv.

Fig. 3.—Line Time Base.

R20—8.2 K Ω .
 R21—10 K Ω .
 R22—470 K Ω .
 R23—4.7 meg.
 R48—10 K Ω .
 R49—4.7 meg.
 R52—2.2 M.
 R53—.15 M.
 R54—33 K Ω .
 R55—68 K Ω .
 R56—330 K Ω .
 R57—100 K Ω .
 R58—150 K Ω .
 R59—39 K Ω .
 R60—470 K Ω .
 R61—1 K Ω .
 R62—8.2 K Ω .
 R114—3.3 K Ω .
 R115—100 K Ω .

C29—.005 μ F.
 C30—.1 μ F.
 C31—.1 μ F.
 C41—.1 μ F.
 C43—.1 μ F.
 C44—10 pF.
 C45—100 pF.
 C46—.01 μ F.
 C47—100 pF, 3 Kv.
 C88—.008 μ F.
 C89—200 pF.
 C90—.1 μ F.
 C91—.1 μ F.

panel is slid out. When removing the chassis, move it to the right and pass through the control panel as it is withdrawn.

The viewing window of the TS17 is removed from the front by slackening the two screws which hold the small metal clips in position. These hold the glass in position and once they are removed the plate can be lifted out and down for cleaning purposes.

Removal of the C.R.T. from the chassis is equally simple. Once the chassis is removed, unscrew the two bolts holding the metal band round the screen end of the tube, remove the tube base socket and ion trap magnet and loosen the scanning coils on the tube neck. Remove the tube from the front, taking care not to impose any strain on the tube neck in doing so. Remember that gentle handling and patience accomplish far more than brute strength and, invariably—regret. When replacing the chassis, ensure that all valves are properly seated. It seems that the left side front EF80 always manages to become tilted resulting in a complete lack of sound and vision signals and this can be very exasperating until it is realised what is wrong, especially when the customer is watching and passing helpful remarks such as, "Perhaps it's because you haven't got the back on."

Before replacing the bottom panel, remember to check upon the frame scan since the frame linearity control is located beneath the chassis. For the benefit

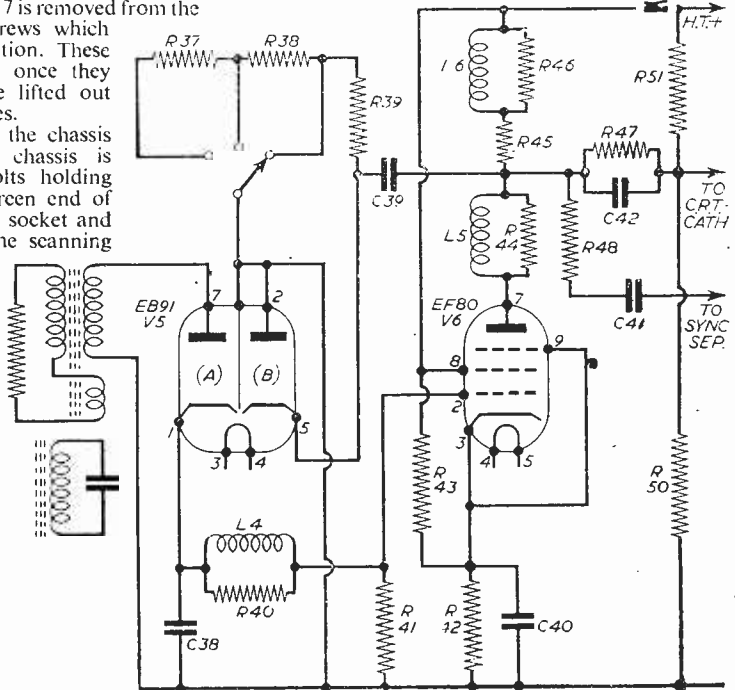

Fig. 2.—Vision detector and video amplifier.

of those readers who are not so well acquainted with the terms used, the control referred to expands and contracts the upper part of the picture only, thus if the scanning lines are unduly compressed or extended at the top (causing normal people to become "egg heads") adjustment to this control is necessary, the height control being used to complete the picture if necessary; final positioning of the picture on the screen being effected by the picture shift lever mounted just in front of the focus magnet. When it is desired to fit new coil strips in the tuner unit, this being necessary when a channel not already catered for is required, say Channel 10 on a receiver already fitted with coils for 8 and 9, it is necessary to remove the bottom inspection cover and the screening cover of the tuner. The turret is then accessible and the strips may be clipped into the desired position.

When this has been done, replace the cover, set switch to the new channel, set the fine tuner to the mid position and adjust the oscillator core for maximum sound. To adjust this core, the switch selector and fine tuner knobs should be removed and a fairly long trimming tool, say a plastic or bone knitting needle with a shaped end to fit the slot of the core, should be inserted into the exposed hole. The hole is visible when the knobs are in position but the tool would enter at an angle and thus it is really necessary to take off at least the outer ring, the switch knob being replaced to make for easier selection of the channels. Tuning should be carried out with the sensitivity retarded to give as weak a signal as can

be reliably tuned. This is to prevent the automatic gain control circuit "flattening" the sound peak as the tuning slug is rotated.

Circuit Description

The tuner unit is of the conventional cascade type employing a PCC84 and a PCF80; so many diagrams and descriptions of this type of tuner have been given in past issues that it is not considered necessary to go into any circuit detail. The I.F. output of this unit is 19.5 Mc/s sound and 16 Mc/s vision, and is applied to the common I.F. amplifier V3 control grid via L1. The A.G.C. bias is applied to this grid.

The anode circuit of V3 contains the vision I.F. transformer T1 and the sound pick-off coil L2, the latter being connected to the control grid of the V8 EBF80 sound I.F. amplifier. This valve contains two diodes, one of which functions as the sound detector and A.V.C. and the other as the vision A.G.C. clamp. This latter diode prevents the A.G.C. line becoming positive under any conditions, for instance, due to a fault in the sync separator circuit.

The band pass vision I.F. transformer couples the signal to the control grid of V4, this valve being normally biased by the cathode resistor and shunt capacitor.

The output of V4 is applied to the vision detector V5A via a further set of band pass coils T2, a sound rejector being contained in the same can (L3).

The V5 EB91 functions as a conventional detector (a) and limiter (b). The detector diode, pins 7 (anode)

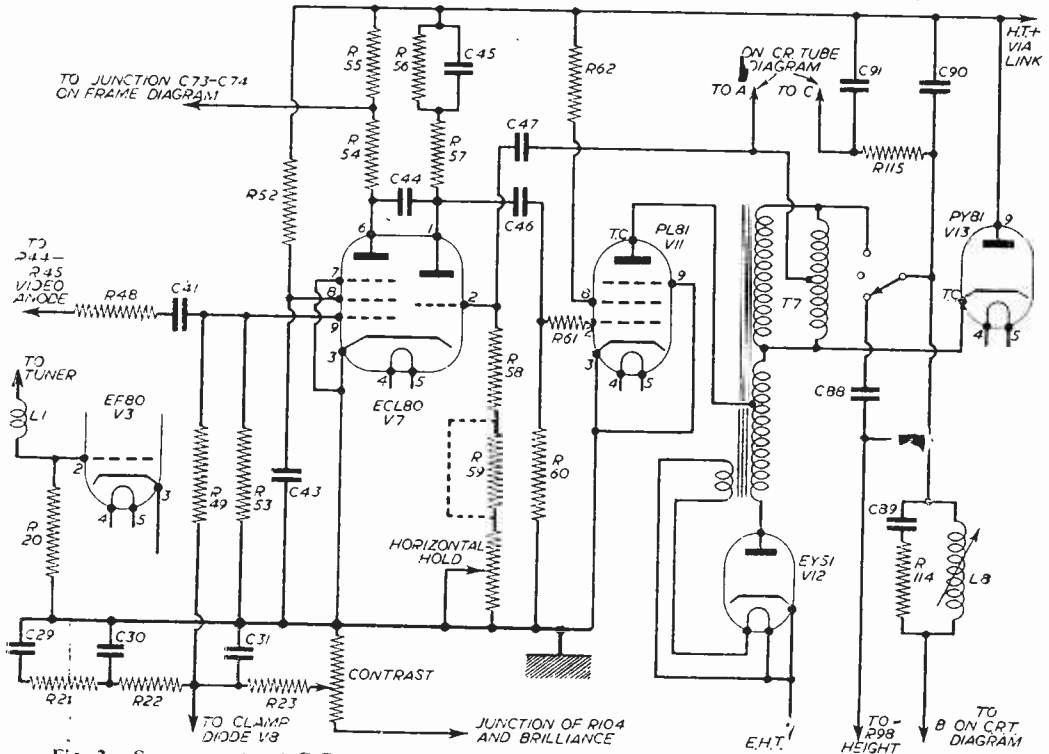

Fig. 3.—Sync separator A.G.C. and line time base. In connection with 17, the centre terminal of the adjacent switch should be joined to it.

and 1 (cathode), is connected as shown in the diagram, with the cathode coupled to the video amplifier control grid via a video choke wound on a 15 KΩ resistor. The cathode of the video amplifier V6 is taken to chassis via the bias resistor R42, the constant current characteristic being improved by R43, a 47 KΩ resistor wired from H.T. to the cathode (pin 3). This maintains a steady flow of current through R42.

The anode of V6 is coupled to the C.R.T. cathode, the sync separator control grid and the vision limiter as shown in the diagram, via a capacitor to the limiter, via a resistor in series with a capacitor to the sync separator and via a resistor in parallel with a capacitor to the C.R.T.

The V5B limiter incorporates in its circuit a three position switch to give varying degrees of peak white cut-off.

The Sound Circuit

The 19.5 Mc/s I.F. output appearing at the anode of V8 is transformer (T3) coupled to the sound detector diode, the rectified output of which is fed to the volume control and after smoothing to the control grid of V8 for A.V.C. purposes.

The term automatic volume control is used to prevent confusion with the automatic picture control, here referred to as A.G.C. Here again, A.G.C. (automatic gain control) is used in preference to A.P.C. which in other types of receivers could refer to yet another circuit. Thus in this article at least,

A.V.C.—sound control circuit, A.G.C.—vision control circuit, also affecting sound. The slider of the volume control is coupled via a capacitor to pin 2 of the PCL83 (V9) which is the triode control grid. The anode of this section is connected to the sound noise limiter rectifier MR1 and thence to the pentode control grid (pin 9) via a further capacitor. The output of the pentode anode is coupled via the sound output transformer to the speaker, fixed tone compensation being effected by a .005 μF capacitor in series with a 22 KΩ resistor, connected from the anode of the PCL83 pentode section to the main H.T. line. The H.T. supply to the PCL83 is decoupled as shown in the diagram by two 560 ohm resistors and a 24 × 8 μF capacitor. Negative feedback is derived from the transformer secondary and applied to the lower end of the volume control via a 3.3 KΩ resistor. The feedback applied is actually developed across the 560 ohm resistor wired from this junction to chassis.

Sync Separator and A.G.C.

The anode of the video amplifier is coupled to the sync separator control grid (pin 9 of V7 ECL80) via a 10 KΩ resistor and a .1 μF capacitor. The grid leak to chassis is a 1.5 MΩ resistor and, as well as biasing the valve, the negative voltage developed across it is applied via a 4.7 MΩ resistor to the A.G.C. network as the control bias for V3. The setting of the contrast control determines the level at which the control circuit starts to operate.

(To be concluded)

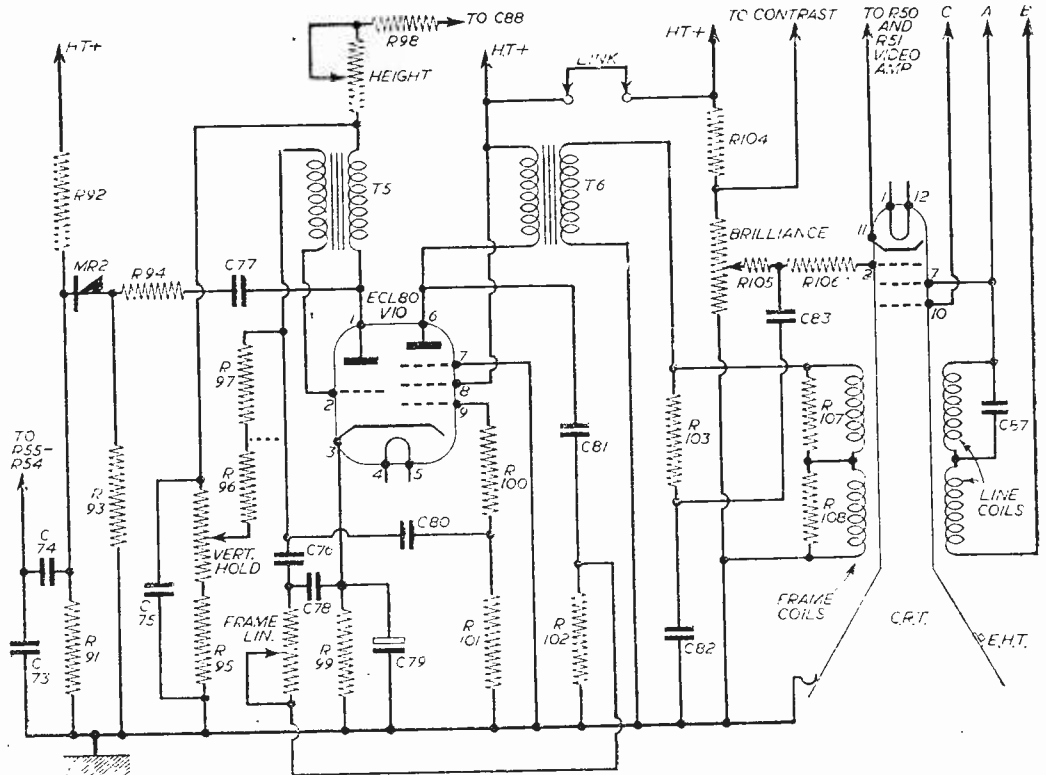

Fig. 4.—Frame time base and C.R.T. circuit.

Aerial Matching and Mismatching

HOW IT AFFECTS RECEPTION IN "FRINGE" AND LOW SIGNAL STRENGTH AREAS

By A. F. E. Sonn

HAVING run across, of late, many cases of complaints of poor reception, especially in "fringe" and low signal strength areas, where the trouble has been due to mismatching of the aerial to the television set, it is perhaps appropriate that an article should be written to explain, without a lot of technicalities, the necessity for correct matching, if the best possible reception is desired.

Aerials

A television receiver requires an aerial that is more efficient than that required for an ordinary radio receiver. It is essential that the maximum signal strength be developed in the aerial, the signal is only received from one source, and that the aerial is positioned well away from an interference source. Moreover, a television aerial is self resonant, has

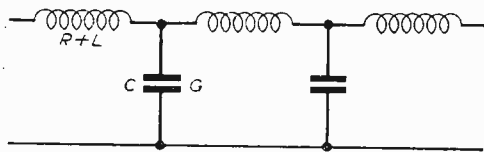

Where R = Resistance L = Inductance C = Capacity and G = Conductance

Fig. 1.—A transmission line represented as a circuit.

marked directional properties and has to be erected according to whether the polarisation of the signal transmitted is vertical or horizontal. It is also necessary that it should be erected as high as possible, in order to obtain the maximum signal developed in the aerial.

Types of Aerials and Their Impedance

When an aerial is erected for a television receiver it is necessary to know the impedance of the aerial. Table I gives a list of typical aerials as used for television reception, with their impedances. It will be noticed that except for the folded dipole on its own, the impedances range from 40 to 70 ohms. As the impedance drops only slightly on the aerials with reflectors and directors, and as this is made up by increased gain, the aerials can be taken as 70Ω aerials without fear of serious mismatching, and loss of signal. As mentioned in paragraph two, the television aerial is self resonant and therefore has to be of certain dimensions. Also, if reflectors and directors are to be used, the distance between them must be regulated. Table II gives dimensions for aerials for all channels.

Transmission Lines

Generally there are three types of transmission line from aerial to set, used in television. They are :

- (a) Balanced twin feeder.
- (b) Solid coaxial.
- (c) Air-spaced coaxial.

Now these transmission lines have different impedances. A transmission line may be represented as a circuit as in Fig. 1. A transmission line is a means of transferring the signal from the aerial to the television receiver, with as low a loss as possible. This loss will only be low if the impedance of the line matches the terminal load impedance, i.e., the input impedance of the television receiver. If the line

| Type | Impedance |
|---|-----------|
| Ordinary Single Dipole H-Type | 70Ω |
| H-Type | 60Ω |
| Folded Dipole | 250/300Ω |
| Folded Dipole with Reflector and Director | 60Ω |
| Folded Dipole with Reflector and up to five Directors | 40/50Ω |

impedance varies from the terminal load impedance, then a reflected wave is set up in the line, which is superimposed on the original wave. This in turn sets up standing waves along the line. This causes losses and the way to eliminate them is to see that the impedance of the line is equal to, or is as near as possible equal to the terminal load impedance. Now the impedances of these three types of transmission line are as follows :

- (a) Balanced twin feeder, 300 ohms.
- (b) Solid coaxial, 50-80 ohms.
- (c) Air-spaced coaxial, 40-50 ohms.

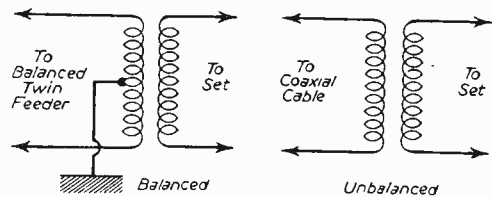

Fig. 2.—Balanced and unbalanced aerial input.

Now should the impedance of these transmission lines differ from the input impedance of the television receiver, what is called "mismatching" occurs and loss of signal strength is entailed. For instance, should a receiver be made for 300 ohm balanced input and it is fed from a 75-ohm coaxial transmission line, then serious mismatching can occur. In fringe and low signal strength areas, it may be found that losses are so great that very poor reception or even no reception would occur.

In areas of strong signal strength, a certain amount of mismatching will probably not be noticed as there is so much signal to play with that the sensitivity or contrast controls can cope with this loss. However, in fringe or low signal strength areas, it is advisable

| Channel | Aerial 1 | Reflector 2 | Director 3 | Spacing | |
|---------|----------|-------------|------------|---------|--------|
| | | | | 1 to 2 | 1 to 3 |
| 1 | 10' 7" | 11' 1" | 10' | 5' 7" | 3' 4" |
| 2 | 9' 3" | 9' 9" | 8' 8" | 4' 10" | 2' 11" |
| 3 | 8' 5" | 8' 11" | 7' 11" | 4' 5" | 2' 8" |
| 4 | 7' 8" | 8' 1" | 7' 3" | 4' 1" | 2' 5" |
| 5 | 7' 1" | 7' 6" | 6' 8" | 3' 9" | 2' 3" |
| 6 & 7 | 31 1/2" | 33" | 29 1/2" | 16 1/2" | 9 1/2" |
| 8 & 9 | 29 1/2" | 31 1/2" | 27 3/4" | 15 3/8" | 9 1/4" |
| 10-11 | 28 1/2" | 29 3/4" | 26 3/4" | 14 3/8" | 8 1/2" |
| 12-13 | 26 3/4" | 28 3/8" | 25 1/2" | 14" | 8 3/8" |
| Band 4 | 11 1/2" | 12 1/2" | 11" | 6 1/2" | 3 3/8" |

to use the makers' instructions as regards the input impedance and match this with the transmission line, as even a small loss may mean the difference between good and indifferent reception.

Matching Transformer

It is very necessary that a television receiver, even in areas of good signal strength, should have the

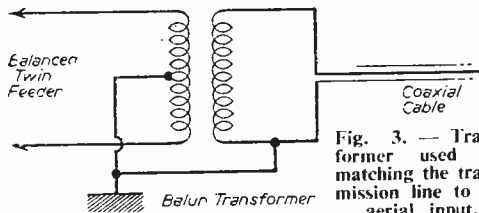
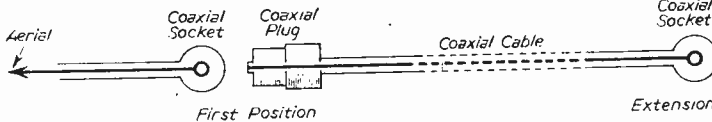

Fig. 3.—Transformer used for matching the transmission line to the aerial input.

correct type of transmission line connected to it. Some receivers have a balanced aerial input and others an unbalanced one. See Fig. 2. It has already been stated that balanced twin feeder has an impedance of 300 ohms whereas coaxial cable is about 70



Plug in extension coax, when extension point is required. Use small length of coax. with plugs from set to socket.

Fig. 4.—How to overcome disturbance to reception by people passing near the extension.

ohms. Serious mismatching can therefore occur here if the wrong type of transmission line is connected to the wrong aerial input. To overcome this, however, matching transformers can be obtained which will do the job of matching. An example of this is shown in Fig. 3. This transformer can be used either way round, for connected a 70 ohm feeder to a 300 ohm balanced input or vice versa. This type of transformer can be made up by yourself and should be in a screened box. The number of turns for primary and secondary depend upon impedances. Trial and error methods are best. Turns need be closely coupled and will vary according to whether you are using Channels 1 to 5 or the higher frequency ones 6 to 13. Of course, on the 6 to 13 channels turns will be few.

Other Causes of Mismatching

Cases have arisen where an extra aerial point has been added to an aerial system and mismatching has occurred. If, for instance, two positions for the television set have been arranged and the set is connected to the extended position, then if the coaxial has just been paralleled off, reception will be O.K. On the other hand, if the television set is connected to the first position and the second left open, then mismatching will take place and poor or even no reception will take place. This is due to the fact that the signal travels along the extension cable and when it reaches an unmatched

termination it will be reflected back to the first position. Here, the reflected signal would tend to cancel out the original signal. When using the first position also, the extension would be acting as a

Fig. 5.—Resistors used to obtain the same terminal impedance at each receiver point.

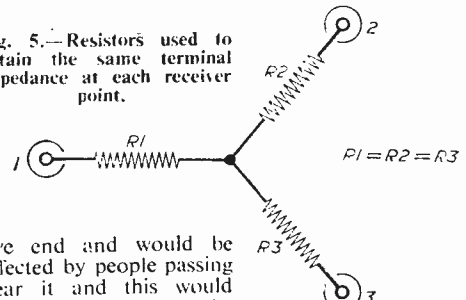

live end and would be affected by people passing near it and this would cause disturbance to the reception. To overcome this see Fig. 4.

More Than One Receiver on Aerial

Occasions may occur when two or more receivers are required to work from the same aerial. Here mismatching can occur unless the transmission line is run so that the same terminal impedance is at each receiver point.

In this case resistors are used, which should be non-inductive. An arrangement is shown in Fig. 5. Value of resistors will be as under for various impedance lines and numbers of receivers.

| Receivers | 50Ω | 70Ω |
|-----------|-----|-----|
| 2 | 17 | 22 |
| 3 | 25 | 35 |
| 4 | 30 | 42 |

Matching Stubs

This is a method of altering the impedance of a line for matching purposes. These are generally short lengths of coaxial joined to the feeder. The length has to be accurate for correct matching and outside a laboratory can only be done by trial and error methods. In multi array aerials this matching is already done by the makers and the stubs are generally in the cross arm of the aerial.

(To be continued)

FAULTS WITH FOCUS

SOME PRACTICAL ADVICE ON FAULTS AND CURES

By L. J. Sonn

IN a cathode ray tube the electronic beam from the cathode has to be focused on to the screen to give a good picture. In all systems used at present this focusing is done either magnetically, electro-magnetically or electrostatically.

Focusing is achieved in a cathode ray tube in a way very similar to the focusing of light rays in an optical system (see Fig. 1).

The first lens system in a C.R.T. consists of the cathode, the grid and the first anode, and the second lens system consists of the focusing device and the second anode.

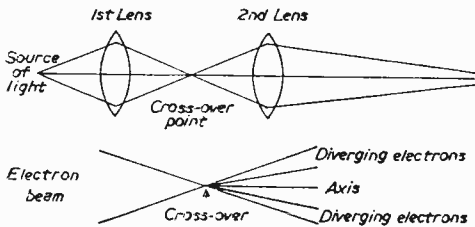

Fig. 1. (above) and Fig. 2.—Principles of focusing.

Action of Focusing

When the electronic beam leaves the cathode it will come to a focus (at the cross-over point) due to the bending or curvature of the lines. This bending is caused by the action of the first anode and the amount of bend will depend upon the distance between the anode and the grid. This cross-over point may be considered to be (for the purpose of focus) the starting point of the electron beam. Now, electrons leaving the cross-over point are not all parallel to the axis of the tube. Some are leaving at small angles to the axis (see Fig. 1). To bring these back to meet at another point on the axis the second lens system is required. In all cathode ray tubes the first lens system is the same and it is only the second lens system that changes according to whether the tube is magnetically, electro-magnetically or electrostatically focused.

Magnetic Focus

In a tube thus focused the electron beam leaving the cross-over point will, if they leave at small angles to axis, come under the magnetic field of the focus magnet. Now this field is at right angles to the resulting force of the electrons and this will cause them to move in a circular path. The electrons also, however, are speeding forward up the gun of the tube and consequently they will assume a helical path (see Fig 3), and come back to the axis. Now the position where they arrive back at the axis will depend upon the strength of the magnetic field, and the forward velocity. Thus it is possible by varying the position of the focusing magnet, one is able to arrange for this electron beam to

focus on the screen. It should be noticed that the velocity of the beam affects the focus point, so that if the E.H.T. on second anode is low or volts on first anode, focusing may be very difficult or even impossible.

Electro-magnetic

In electro-magnetic focusing the principles are very similar. The electro-magnetic field is at right angles to the beam and exerts a force on the divergent electrons, twisting them back to the axis. In this case the electro-magnetic field is generally controlled by a potentiometer, thus altering its effect on the beam. If trouble is met with on this type of focus, check the control first for open circuit or intermittent operation and also the coil for resistance value with the maker's figures.

Electrostatic Focusing

This type of focusing is now being adopted by tube manufacturers. With this type the focus magnet with its problems of adjustment and mounting are abolished. A small potentiometer

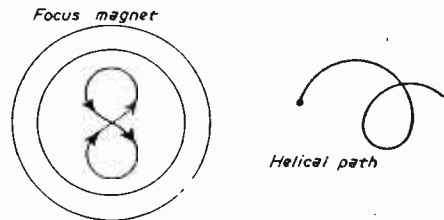

Fig. 3.—The helical path of the electrons.

control can be fitted to the set to control the focusing, but as this adjustment is not often required this control is omitted by some makers. When this is done, the method is then called "auto focus" (see Fig 4).

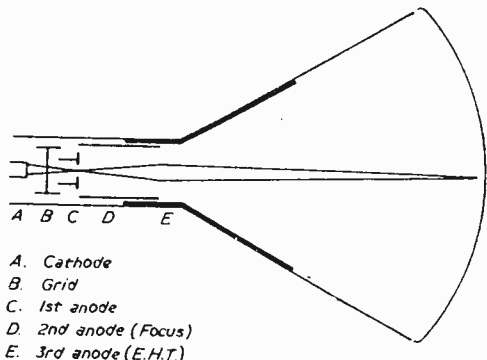

Fig. 4.—The auto-focus system.

(Continued on page 47)

Some Obscure Faults

A SERVICE ENGINEER GIVES DETAILS OF SOME TRICKY AND UNUSUAL TROUBLES

AMONGST the many faults that can occur in a television set there are some that can be, at times, difficult to locate. In this article a few instances are given that were at the time not self-evident. It is apparent, of course, that to readers who have already run across any of these faults they are not obscure, but to others they may be of assistance, at some time or another.

Poor Frame Hold

In this case valves and all components were checked and found to be O.K. The set had been previously serviced and, in doing so, wiring had been disturbed. It was found that wiring of the frame circuit was very close to heater circuit of other valves. Apparently, induced voltage from this heater circuit was sufficient to upset the "synch" of the frame circuit and prevent locking. Movement of these leads cured the trouble.

EHT Failure

In this case the EHT rectifier had developed an open circuit filament within a very short period. A poor valve was suspected. This was replaced but it went again within a short period. It was then found that the type of EHT rectifier being used was a 1.4 volt type although the set was originally designed for a 2-volt type. A short length of resistance wire had been inserted in the filament leads to reduce this voltage to 1.4 volts. After a short period, however, this resistance wire, owing to faulty insulation, shorted out, thus putting 2 volts on to the filament and causing the valve to fail in a little while.

Complete Failure at Periods

In this instance the barretter was blowing. This indicated a short on the heater line. All valves were removed and tested for periods on a valve tester. All were or appeared to be O.K. The trouble turned out to be the half-wave rectifier. In the set itself these valves were mounted horizontally, but when checked on a valve tester they were vertical. Thus, on a tester they were O.K., but when placed horizontally in the set, and after getting well heated, electrode sag occurred, causing shorting and the barretter to blow.

Recurrent Sound on Vision

Continual alteration of the sound rejector trimming condenser was necessary to remove fault. This was due to the fact that someone had sealed this condenser with wax, and as this condenser was close to valves some of the wax melted with the heat and percolated into the trimmer causing alteration of capacity. Clearing this wax away rectified the trouble.

Reduced Brightness

This is not always due to a low emission tube. In a case the writer came across the fault was due to wrong positioning of the ion trap. This apparently had been done to cure focus trouble. All that was required was a fresh positioning of the focus coil and then resetting of the ion trap.

New C.R.T. Troubles

When new tubes are fitted to some of the older type of 12in. sets it will be found that the round-faced type of tube is no longer available. The flat faced type is supplied in lieu.

In many cases it will be found that line distortion, especially to the left of the picture, is then apparent. This is because the deflection coils are incorrect for this tube. There is no satisfactory method of correcting this. New coils suitable for the flat-faced tube are necessary.

Enlarged Picture

This fault is peculiar in its effects. When the brightness control is turned up the picture expands in all directions. This is, in most cases, not a fault on the C.R.T. itself, but merely low EHT. Changing the EHT rectifier will cure this trouble in most cases.

Negative Picture

There can be several reasons for a television receiver showing a negative picture. The most common are a faulty C.R.T., or too strong a signal (often due to contrast control). However, in the case in question, it was not due to either of these, but a fault in the A.P.C. network, causing zero bias to be placed on all A.P.C. controlled valves.

Vertical Foldover

Normally this is due to a fault between the frame oscillator and the frame output valve. It can be a leaky coupling condenser or an alteration in the valve of the grid leak. In the case in question however, it was due to an open circuited bias condenser of the frame amplifier.

Loss of Height

In this case all the usual tests were carried out. Oscillator and amplifier valves and circuits were correct. Frame output transformer resistance values were correct, according to service sheet. However, it turned out to be the transformer which apparently developed shorted turns on load. Replacing this cured the trouble.

Aerial Troubles

The faults that can arise through faulty aerial systems are multitudinous: The writer has found that trial and error are the only methods to employ to trace them.

NEWNES RADIO ENGINEER'S VEST POCKET BOOK

By F. J. CAMM

6/-, or by post 6/4

Obtainable from booksellers, or by post from
George Newnes, Ltd. (Book Dept.), Tower House,
Southampton Street, Strand, W.C.2.

SUMMER SALE!

Finest Battery Portable

Ferrite rod aerials, low consumption valves, superhet circuit with A.V.C., ready-built and aligned chassis, if required, beautiful two-tone cabinet covered with I.C.I. Rexine and Tygan. Guaranteed results on long and medium waves anywhere. All parts, including speaker and cabinet. Price is £7.15.0 complete or £1.15.0 deposit and 7 monthly payments of £1. post and ins. 3.6. ready-built chassis 30/- extra. Data 1/6.

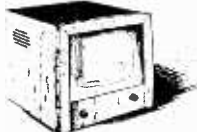

14" T.V. Cabinet

14in. T.V. cabinet of the latest styling—beautifully veneered and polished—limited quantity—sale price 17.6 each. Carriage and packing 1.6 extra.

Transistor Receiver 19/6



Makes ideal bedroom radio, uses one transistor and one crystal diode. Complete less case 19.6. case 5/- extra, post and ins. 1/6.

Crystal Microphone

Miniature crystal type has high gain and is suitable for all purposes—tape recorders—amplifiers. Price 4.9, post and ins. 9d.

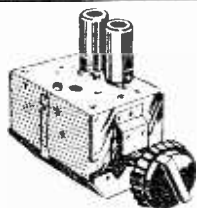

**THIS MONTH'S SNIP
Turret Tuner**

Brand new stock, not surplus, with coils for Band I and III complete with valves PCC84 and PCF89—1.F. Output, 39.38 Mc/s with instructions and circuit diagram, 79.6. With knobs 3.6 extra, post and insurance 2.6.

The Skysearcher

This is a 3-valve set useful as an educational set for beginners, also makes a fine second set for the bedroom, workshop, etc. All parts, less cabinet, chassis and speaker, 19.6. Post and ins. 2.6. Data free with parts or available separately 1.6. 3-valve battery version also available at the same price.

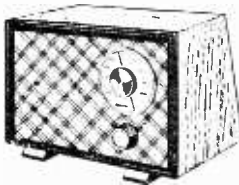

Save £2-10-0



The Cleveland Band III converter is one of the best on the market and literally thousands are in use all over Britain. Original price, £7.10.0. Sale price £4.19.6. carriage and insurance 5/-.

Connecting Wire



PVC covered copper wire in 100ft. coils most colours. Sale price 2.6 per coil of 5 coils 10/-, post free.

Electric Blanket Element 15/-

We are offering an out-of-season bargain—14 yards of waterproof electric blanket element, enough to make a full size blanket. Normally we sell at 20/-. Sale price is only 15/-, post free, complete with illustrated data.

ELECTRONIC PRECISION EQUIPMENT, LTD.

Post orders, Dept. 5, Sutton Road, Eastbourne

266, London Road, Croydon. Phone: CR0 6558
42-46, Windmill Hill, Roydon, Middx. Phone: RU1S 11P 5780
152-3, Fleet Street, E.C.4. Phone: FLEET 2833
29 Strand Green Rd., Finchley Pk., N.4. Phone: ANChway 1049
248, Kilburn High Road, Kilburn. Phone: MAtda Vale 4921

VALVES • SAME DAY SERVICE

All Guaranteed New and Boxed

1.4V. midget. 1R5, 1S5, 1T4, 1U3, 2S4, 2AF91, DF91, DK91, DL2. DL94: ANY 4 for 27.6.

| | | | | | | | | | |
|-------|------|--------|------|--------|------|--------|------|--------|------|
| 1A7GT | 12.6 | 6L18 | 13/- | D1 | 3/- | EF39 | 6/- | PCL82 | 12.6 |
| 1CSGT | 15.0 | 907GT | 9.6 | D77 | 6.6 | EF40 | 12.6 | PCL83 | 12.6 |
| 1HSGT | 11/- | 6SNTGT | 7.6 | DAC32 | 11/- | RF41 | 9.6 | PEN46 | 6.6 |
| 1NSGT | 11/- | 6U4GT | 12.6 | DAF96 | 8.6 | PF42 | 12/- | PL36 | 18.6 |
| 1R5 | 8.6 | 6V8GT | 7.6 | DCC90 | 7/- | EF50 | 8.6 | PL38 | 22.6 |
| 1S5 | 7.8 | 6V8GT | 7.6 | DF33 | 11/- | EF80 | 8.6 | PL81 | 11.8 |
| 1T4 | 7.3 | 6X4 | 7/- | DF96 | 8.6 | EF85 | 7.6 | PL82 | 9/- |
| 3Q4 | 9/- | 8X5GT | 6.6 | DH76 | 8.6 | EF86 | 12.6 | PL83 | 10.6 |
| 3Q5GT | 9.6 | 7B8 | 9.9 | DH77 | 8.6 | EF89 | 10/- | PY80 | 8/- |
| 3S4 | 7.6 | 7B7 | 8/- | DK32 | 12.6 | EF91 | 6.6 | PY81 | 8/- |
| 3V4 | 8.6 | 7C5 | 8/- | DK92 | 8/- | PF92 | 5.6 | PY82 | 7/- |
| 5U4G | 8/- | 7C6 | 8/- | DK96 | 8.6 | EL32 | 8.6 | PY83 | 9.6 |
| 5Y3GT | 7.6 | 7H7 | 9/- | DL33 | 15.6 | EL38 | 22.6 | PZ30 | 18/- |
| 6AB6 | 7.6 | 7Y4 | 8/- | DL96 | 8.6 | EL42 | 11/- | SP61 | 3.6 |
| 6AK5 | 4.6 | 10C2 | 13/- | DM70 | 8.6 | EL83 | 9.6 | U25 | 11.6 |
| 6AL5 | 6.6 | 10F1 | 15/- | EA50 | 2/- | EM34 | 10/- | U50 | 7.0 |
| 6AM5 | 5/- | 12AH8 | 10.6 | EABC80 | 9/- | EM38 | 10/- | U76 | 5/- |
| 6AM6 | 6/- | 12AT7 | 8.6 | EAC91 | 8/- | EV51 | 10.6 | L78 | 7/- |
| 6AQ5 | 7.6 | 12AU7 | 7/- | EAF42 | 10.6 | EV85 | 9.6 | UABC80 | 11.6 |
| 6AT6 | 8.6 | 12AX7 | 9/- | EB91 | 6.6 | EL240 | 8.6 | UAF42 | 10.6 |
| 6BA6 | 7.6 | 12J7GT | 11/- | EBC33 | 7.6 | E241 | 10.6 | UBC41 | 8.6 |
| 6BE6 | 7.6 | 12K7GT | 8.6 | EBC41 | 10.6 | E240 | 8.6 | UBF80 | 8.6 |
| 6B16 | 7/- | 12KGT | 14/- | EBF80 | 9.6 | E241 | 10/- | UCH42 | 10.3 |
| 6BRT | 11/- | 12Q7GT | 3.6 | EBF89 | 9.6 | FW4500 | 12.6 | UF41 | 9.6 |
| 6BW6 | 7.6 | 12Z3 | 7.6 | ECC81 | 8.6 | GPC32 | 12.6 | UF80 | 10.6 |
| 6BX6 | 7.6 | 14S7 | 13.6 | ECC82 | 7/- | KT33C | 10/- | UL41 | 10.6 |
| 6CH6 | 7/- | 25L6GT | 9/- | ECC83 | 9/- | KT44 | 6.6 | UL84 | 11.6 |
| 6F1 | 15/- | 25Z4G | 9.6 | ECC84 | 10.6 | KT63 | 6.6 | UY21 | 15.6 |
| 6F8G | 6.6 | 25Z6GT | 9.6 | ECC85 | 9.6 | KTW61 | 8.6 | UY41 | 8.6 |
| 6F12 | 6/- | 35L6GT | 9.6 | ECC80 | 12.6 | MU14 | 8.6 | UY83 | 10.6 |
| 6F13 | 14.9 | 35Z2C | 8.6 | ECC82 | 11/- | N78 | 12.6 | VP41 | 7.6 |
| 6F15 | 14.9 | 35ZACT | 8.6 | ECC85 | 9.6 | P61 | 3.6 | W76 | 8.6 |
| 6J6 | 5.6 | 35Z5GT | 9/- | ECH42 | 10/- | PCC84 | 8.6 | W77 | 5.6 |
| 6K7C | 4.6 | 50L8GT | 8.6 | ECH81 | 8/- | PCF80 | 8.9 | X79 | 12.6 |
| 6K7CT | 6.6 | 8.9 | 8.6 | EL83 | 8.6 | PCF82 | 11.6 | Y63 | 6.6 |
| 6R8C | 7.9 | B33 | 19.6 | EF37A | 9/- | PC182 | 11.6 | Z77 | 6.6 |
| 6R8GT | 9.6 | | | | | | | | |

Postage 5d. per valve extra.

READERS RADIO

24, COLBERG PLACE, STAMFORD HILL, LONDON, N.16 STA. 4587

MULLARD TAPE AMPLIFIERS

We stock all the components for the Amplifiers as described in the Mullard Tape Recording Booklet.

RESISTOR KITS. LAB. All fixed and variable resistors as specified. Model A, 33/3. Model B, 31/9.

CONDENSER KITS. Model A, 33/-, Model B, 35/-, These kits are made up for the Brenell and Collaro Decks. If Lane or Truvox Decks are being used this must be stated when ordering.

OUTPUT TRANSFORMERS. G.1son OP767, 25/6. Elstenz OT/3, 21/-, Partridge SVO/1, 60/-.

ELCOM PLUGS AND SOCKETS. FO4 Chassis Plug, 3/6. S04T Flex Socket, 5/3.

IGRANIC JACK SOCKETS. P71, 3/4. P72, 3/10. Eulgin jack Plugs to fit, 3/-.

BELLING LEE PLUGS AND SOCKETS. Speaker Sockets. L316 Red and Black, 1/- each. L378 Plugs to fit, 10d. each. Co-Ax Socket L734S, 1/-, L604S, 1/3. L734 Plugs to fit, 1/3 each.

McMURDO VALVE HOLDERS. BM9, U, 10d. XM9, UC1, 1/7. XM9, UG1, 2/3.

SWITCHES. Set of three for Model A, 32/6. One Switch for Model B, 16.6.

BULGIN TAG BOARDS. C120, 1/3. C125, 2/3.

EQUALISER PLUG AND SOCKET. Plugs, 2/3 each. Socket, 6d.

CERAMIC STAND OFF PILLAR. 1/- each.

OSCILLATOR COILS. Brenell, 8/-, Truvox TR98, 6/9.

CHASSIS. Denco. Fully drilled. Model A, 31/6. Model B, 31.6.

VALVES. EF86—Mullard, 24/4; Alternative, 15/-, ECC82—Mullard, 19/6; Alternative, 10/-, EM81—Mullard, 18/1. EL84—Mullard, 16/-; Alternative, 12/-, OA71 Diode, 6/-.

KNOBS.—Bulgin K370, 1/6 each. EM81 ESCUTCHEON, 2/6.

SUNDRIES KIT. Contains all nuts, bolts, tags, wire, flex solder, etc., 8/-.

FULLY DETAILED LIST is available free upon request. This gives prices for complete kits and details of Power Unit Components.

WATTS RADIO

8, Apple Market, Kingston-on-Thames, Surrey Telephone: KINGston 4292

A Beginner's Guide to Television

STEREOSCOPIC
TELEVISION

By F. J. Camm

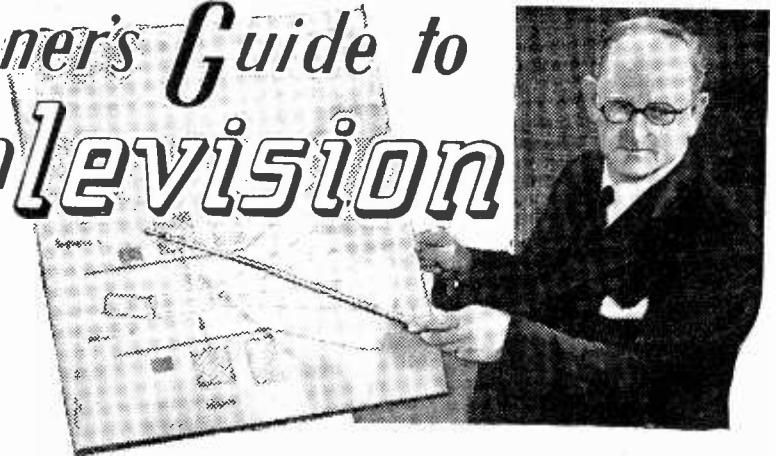

I HAVE already dealt with the general principles of colour television which is still a possibility, but not of the immediate future; it will certainly be some years before it is introduced. Stereoscopic or three-dimensional television, which has been the subject of considerable experiment over a number of years, is also a very remote possibility if we are to avoid the wearing of special glasses. It is, however, interesting to review the position of the technique to-day. In the early experiments by Baird the monochrome television image was transmitted after scanning it in a succession of lines, and in the colour process three such pictures were transmitted, one red, one blue and one green, the three blending to give an image in colour. Stereoscopy was obtained by transmitting two images corresponding to a stereoscopic pair and viewing them at the receiving end through a stereoscope. Baird showed a 12ft. colour picture to a cinema audience in 1936, the pictures being transmitted from the Crystal Palace by radio. This was followed in 1939 by a demonstration of colour television using a cathode-ray tube as we do to-day.

Nothing further was done with stereoscopy until 1942 when Baird commenced experiments with high definition stereoscopic image in colour.

The first experiment was applied to his 600-line, two-colour apparatus. The red image was really a view of the scene from a slightly different angle from the blue, so that the red and blue images constituted a stereoscopic pair, the receiving screen being viewed through glasses fitted with red and blue filters as in an anaglyph process. This, while simple, had the disadvantage that it was necessary to wear glasses, and that, as the colour phenomenon was used to effect the change-over from right to the left eye, neither the colours nor the stereoscopy could ever be properly rendered.

Frame Frequency

So far, the object in mind had been to produce a system capable of being transmitted through the

existing channels available to the BBC, but in an endeavour to obtain as perfect a result as possible it was decided to produce an entirely experimental apparatus regardless of existing practical limitations. In the apparatus demonstrated, the frame frequency had been increased from 50 per second to 150 per second, the scanning altered to a field of 100 lines interlaced five times to give a 500-line picture, successive 100-line frames being coloured green, red and blue. At the transmitter a cathode-ray tube is used in conjunction with photo-electric cells, the moving light spot being projected upon the scene transmitted. In front of the projecting lens a mirror device, consisting of four mirrors at right-angles, split the emergent light beam into two paths separated by a space equal to the separation of the human eye. By means of a revolving shutter, the scene is scanned by each beam alternatively, so that images corresponding to the right and left eye are transmitted in rapid sequence. Before passing through the shutter disc the light passes through a rotating disc with blue, red and green filters.

Thus superimposed red, blue and green pictures blend to give a picture with full natural colours and transmitted for left and right eye alternately.

Pairs of Images

At the receiver the coloured stereoscopic pairs of images are reproduced in sequence and projected upon a field lens, alternate halves of the projecting lens being exposed by means of a rotating shutter, the image of the shutter being projected upon the eye of the viewer so that his left and right eyes are presented alternately with the left and right images, the combined effect being a stereoscopic image in full natural colours.

Stereoscopic television is an entirely British achievement, it has been shown nowhere but in England, but this was the first time that stereoscopic television in colour had been achieved.

Hitherto, coloured television has been accomplished by the use of rotating discs used in conjunction with cathode-ray tubes. In a later Baird apparatus the rotating discs were eliminated

and the coloured television images produced entirely by electro-optical means.

Images corresponding to the primary colours blue, red and green (or blue-green and orange-red, where a two-filter process is employed) are reproduced side by side in sequence on the fluorescent screen of the cathode-ray tube at the receiver. Lenses with their optical centres on perpendiculars through the centres of each of the three images, and at a distance from the images equal to the focal length of the lenses, project parallel beams on to a large lens separated from the receiving screen by a distance equal to its focal length. The pictures are thus caused to overlap on the screen.

Two-filter, 600 Line

Demonstrations were given on receivers adapted to receive a 600 line, two-filter transmission (blue-

green and orange-red). The two images corresponding to the blue-green and orange-red components appeared in sequence one above the other on the flat face of a 10in. projector-type cathode-ray tube operating at 26,000 volts. In the lens system, single lenses were employed (owing to the difficulty of obtaining special lenses at the time of the demonstration), and this entailed a certain loss of optical efficiency; the actual aperture has, nevertheless, the large value of approximately 3.5. Proper registering of the two pictures presented several initial difficulties, as great accuracy is necessary, but these experimental problems were finally solved and very accurate registration was obtainable. The system is, of course, equally applicable to the transmitter, but a revolving disc was still employed, the same transmitter being used both for the old-type colour disc and a new discless type.

TECHNICAL TERMS

(Continued from page 561, July issue.)

Vacuum

A space from which all matter has been removed.

There is, of course, no such thing as a perfect vacuum. Nevertheless, the degree of vacuum obtained by modern methods in some of the electrical tubes used in connection with television working is extremely high, the residual gaseous pressure in many such tubes being reduced to approximately one hundred-millionth of the normal atmospheric pressure.

Electrical tubes in which the degree of vacuum is very high are termed "hard" tubes; those whose vacuum is of a lower order are called "soft" tubes.

In many instances the vacuum of an electric tube or bulb is deliberately lowered by the introduction of a small quantity of an inert gas such as neon or nitrogen. These constitute the "gas-filled" tubes and lamps.

The most perfect degree of vacuum so far obtained was one in which it was estimated that no less than 99,999,999,990 per cent. of the air existing within an electric tube had been removed.

Velocity Modulation

A method of modulating the output current of a television transmitter by means of which the scanning spot moves quickly over the dark portions of the picture to be televised and slowly over the bright parts of the picture. Velocity modulation, or variable-speed scanning, is only applicable to cathode-ray systems of television.

Velocity of Light

Light rays do not travel from point to point instantaneously. Their rate of travel, however, is so enormous that for any distance on the earth's surface normal observation is unable to detect any appreciable

time-interval between the transmission of a light ray and its reception.

It has been shown, however, by several different methods that light travels through space with a speed of approximately 186,282 miles per second. This speed was determined by the N.P.L. in 1950.

Video

Television term signifying picture or vision, as distinct from sound (audio).

Wobulation

Variation of the oscillator frequency over a band of frequencies.

Wobbulator

A servicing instrument consisting basically of a signal generator. A cathode-ray tube is used as an indicator, and a mechanical or electrical arrangement is used to "wobble" or swing the frequency to which the generator is adjusted. In some instruments the degree of swing may be adjusted. The instrument shows on the indicating tube the response curve of tuned circuits and it is used to adjust television receivers.

X-Plates

Name applied to the pair of deflecting plates in a cathode-ray tube, the application of a voltage across which, owing to its deflection of the cathode-ray stream, causes the line of light set up by the Y-plates to be extended at right-angles, thus producing a pattern or configuration upon the fluorescent screen of the tube.

Y-Plates

Name given to the pair of deflecting plates in a cathode-ray tube, the application of a potential across which, owing to the resulting deflection of the cathode-ray beam, causes the light spot on the fluorescent screen of the tube to be spread out into a line.

The Entirely New 12th Edition of The Famous Standard Work

THE PRACTICAL WIRELESS ENCYCLOPÆDIA

By F. J. GAMM

Considerably enlarged, amplified and entirely re-written and re-illustrated. Complete Television Section, with theoretical and constructional data.

All the facts, figures, and constructional data of Radio and Television—Definition, Terms—Units—Principles, Circuits, etc.

Over 300,000 copies sold Price 21/- or 22/- by post from:

GEORGE NEWNES, LTD., Tower House, Southampton Street, Strand, W.C.2.

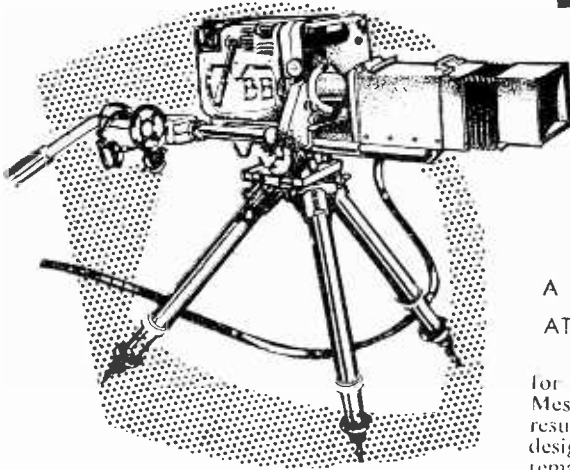

THE ZOOM LENS

A DESCRIPTION OF THE VARIABLE-FOCUS
ATTACHMENT FOR THE TELEVISION CAMERA

UNDOUBTEDLY one of the most useful accessories on the transmitting side of TV is the zoom lens. When it was first introduced a great fuss was made of it, and as with many "new toys" its use was overdone. Nowadays it is used so skilfully that it is probable that the majority of viewers do not realise that it is in action. They have become so used to the changing viewpoint that in addition to not being aware that it is in use they are also unaware that more than one camera is being used. The name "Zoom" is rather unfortunate, as one associates it with a sudden rush, either forward or backward, whereas the movement can be performed very slowly.

What is the zoom lens? Practically every amateur photographer knows that the lens has to be situated a certain distance from the plate or film (which will be the negative) and this distance depends upon the size of the lens and other factors. The same principle applies to the TV camera, which is, after all, acting in the same way as a camera and instead of a plate or film, a special C.R. tube device is provided. Now when focused on a certain object, if the opening for the lens is rather large, all objects nearer or farther away than the object being viewed will be blurred or "out of focus." To bring to a sharp focus objects farther away the lens must be moved nearer to the plate or C.R. tube, and when it is closer the lens has to be moved farther away from it. On many cameras used for TV a set of lenses of varying focal length are used and mounted on what is known as a "turret." This has to be turned bodily, and if a transmission is left on when such a camera is at work the image jumps from one size to another with a not very pleasing effect.

Unfortunately, these very high quality lenses do not consist merely of one glass, but two or more in a set, and their position relative to each other is critical. Therefore, it is not possible merely to slide one forward, as at the same time its components must also be moved a certain critical distance.

A Dr. H. H. Hopkins worked on this problem

for years whilst in the research department of Messrs. W. Watson & Sons, and his labours have resulted in a fully-corrected optical system, the design of which is such that the aberrations remain fully corrected through the complete range of focal length, which is from 3in. to 15in. for Model 75/6.7 and 6in. to 30in. for Model 75/13.4. In addition, the position of the focal plane is absolutely steady, so that once the object is correctly focused it remains in focus through the whole Zoom-range. This means that two of the main disadvantages of varifocal lenses have been eliminated. The field is flat and the picture quality equals that of high-class camera objectives of standard types.

Front cell focusing is provided for near objects. The closest distance which can be focused is 10ft. 6in. from the front of the lens. When once focused correctly, no matter what its distance, an object remains steadily in focus when zooming.

Owing to the physical limitations of lens diameters the highest apertures available through the whole range are as follows:

Model 75/6.7—from 3in. to 15in. focal length, maximum aperture is $f/6.3$. The aperture $f/3.0$ is available for 3in. to 6.75in. focal length. If the aperture is set at $f/3.0$ and the lens zoomed from 3in. focal length past the 6.75in. focal length position, the aperture decreases, linearly, reaching $f/6.3$ at 15in. focal length.

Dissector window and focal
length scale on this side

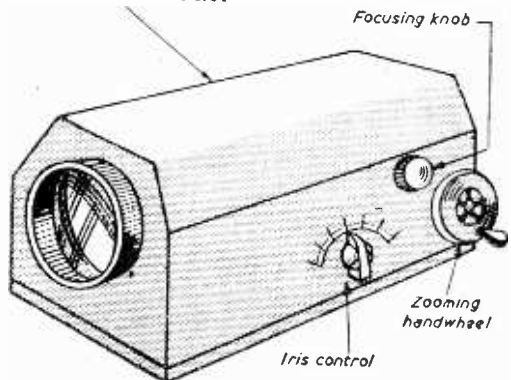

Fig. 1.—A general view of the zoom lens.

Model 75/13.4—from 6in. to 30in. focal length. maximum aperture is $f/12.5$. The aperture $f/6.0$ is available from 6in. to 13.5in. focal length. If the aperture is set at $f/6.0$ and the lens zoomed from 6in. focal length past the 13.5in. focal length position, the aperture decreases linearly, reaching $f/12.5$ at 30in. focal length.

With the above restrictions the relative aperture when once set remains constant when zooming.

Some types of photocathode used in television cameras have a relatively large size with respect to 35 mm. film. For this reason the Watson 5:1

of the image as the scattered light is reduced at the same time. The light transmission of the Watson 5:1 Zoom Lens thus compares very favourably with standard camera lenses.

Since the Watson 5:1 Zoom Lens has in effect an infinite number of focal lengths, it enables the correct focal length to be chosen so that exact framing of a scene is simply and easily carried out. (This is also of importance where back projection techniques are employed.)

Mechanical

Kinematic principles of suspension have been applied throughout the construction, and ball bearings play an important part in minimising friction and ensuring rigidity.

Lenses. (Fig. 2)

The five lenses of the complete system are mounted in individual cells, four of which are equipped with adjustments for obtaining initial accurate centring, spacing, and aligning of the optical path.

Lens Trolleys (Fig. 3)

The two inner lenses are mounted on trolleys, each supported by three rollers running on ground steel rods, which are located and secured on to the base. The two rollers on one side of each trolley are vee-shaped, and locate the trolley directionally on one rod, while the remaining roller, on the opposite side, is plain and serves only to support the trolley. These rollers are fitted with miniature ball bearings. The trolleys are constrained against the steel rods by a further roller on each side, bearing on the underside of the rods. These rollers are equipped with an adjustment to regulate the contact friction: Thus, with the minimum of friction, a completely free travel in one direction only is permitted.

Carriage

The carriage which carries the cams for controlling the lens separations is supported by rollers on ground steel rods located in accurately machined seatings in the base. The carriage is

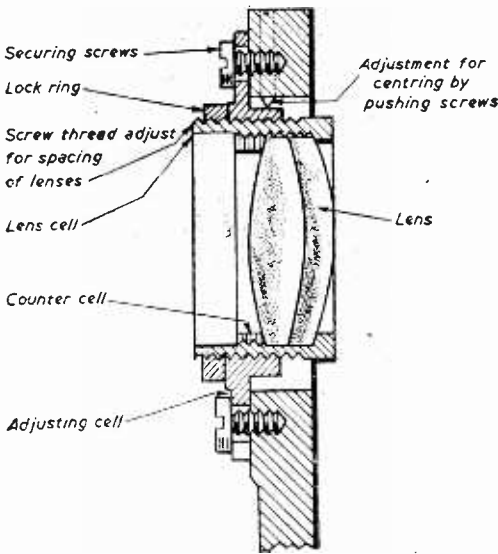

Fig. 2.—Details of one of the lens mounts.

Zoom Lens has been given rather a large image diameter. The maximum field size is greatly in excess of most needs, but, in common with standard camera lenses, the central definition is slightly better than that of the extreme edge, so that any reduction in the size of the image used yields a slightly better picture, though the actual improvement in practice is small.

The large zoom ratio of 5:1 means that in terms of area the field of view may be varied in the ratio 25:1. This enormous variation is achieved smoothly and continuously.

The optical system consists of ten lens elements cemented in pairs to form five doublets. These five doublets are arranged to form an afocal (telescopic) system of variable power, together with a camera lens. The afocal part of the system is symmetrical in the mean position, and the variation in power is achieved by differential displacement of the two middle components of this part of the system.

The Watson 5:1 Zoom Lens is noteworthy in that it has only five components, with ten air-glass surfaces. (This compares favourably with fixed focal length triplet lenses having three components and six air-glass surfaces.) All air-glass surfaces in the lens are specially coated (bloomed) to reduce loss of light by reflection at these surfaces. This results in an increase in the contrast

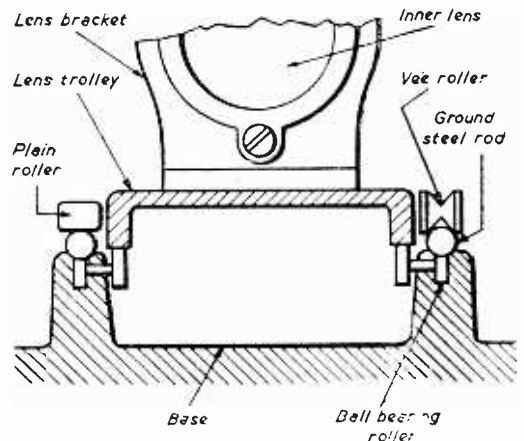

Fig. 3.—Details of the mounting of the lens trolley.

constrained against the steel rods by a powerful spring which operates against rollers on the underside of the base. In addition to constraining the carriage on to the rods, the spring provides effective protection to the carriage and its fittings against sudden shock.

Differential Movement

Differential movement of the two inner lenses is provided by two identical plate cams which operate against ball bearing followers attached to the underside of the lens trolleys.

The cams are provided with inner rims parallel with their outside contours, and spring-operated rollers press against these. The reaction of the springs on the lens trolleys holds the cam followers firmly against the outer edges of the cams.

The design of this spring loading mechanism is such that the compression of the springs remains constant, thus combining the accuracy of plate cams with the positive action usually associated with tracked cams.

The cams are mounted on the main carriage on ball-bearing arbors. On the underside of the carriage helical gears are attached to the cam arbors. These gears mesh with racks secured to the base. Thus, as the carriage moves the cams rotate, causing displacement of the lens trolleys, carrying the inner lenses.

After initial adjustment the gears are pinned to, and become integral with, the cam arbors.

Zooming (Fig. 4)

The Zoom effect is produced by transporting the main carriage from one position to another, when the necessary differential movement to the lens trolleys is superimposed through the racks, gears and cams as described above.

Movement of the main carriage is by a non-slip band drive arranged parallel with one side of

the carriage. The steel band is driven by a toothed wheel on a shaft mounted in ball bearings, bringing the operating spindle out on the side, at the rear of the main case. The steel band is attached to a block on the main carriage in such a way that while linear motion is transmitted, without loss, the block is free to take up its own alignment relative to the carriage.

A scale on the carriage is visible through a window on the side of the case, and indicates the

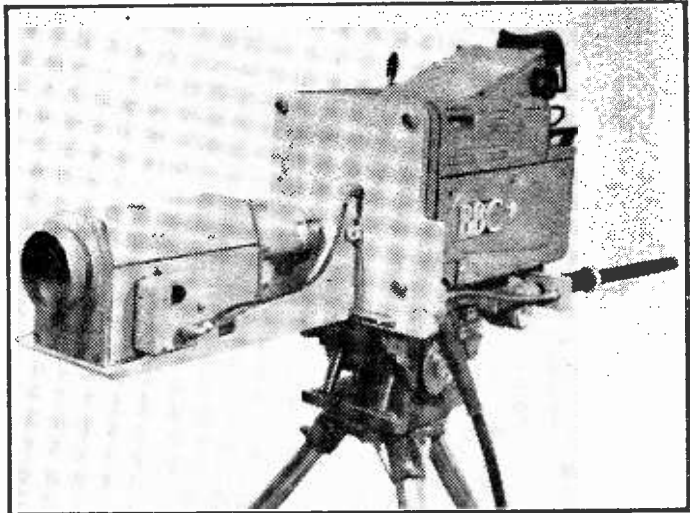

A 5 : 1 zoom lens fitted to a Marconi Mk. III camera.

focal length obtaining at any position of the Zooming range.

Focusing

Focusing is by movement of the front lens. The bracket carrying the lens cell slides on a central steel rod located on the front and rear walls, the focusing movement being controlled by a handwheel on the side, at the rear of the main case.

Motorised Operation

The three controls, i.e., zooming, iris aperture and focusing, are designed in such a manner that motorising could, if desired, be accomplished with a minimum of interference to the zoom lens. The control knobs, or wheels, described above are fitted to shafts which protrude from the side of the case. Thus, removal of these control knobs will expose the shaft for subsequent motorising.

Other Makes

All the above information was supplied by W. Watson & Sons, Ltd., who supply the lens direct to the camera manufacturers. Accordingly the details are applicable to the two models mentioned only. However, the general principles still hold good for another type of zoom lens supplied to another camera manufacturer and in use by the BBC. These lenses are made by Taylor, Taylor & Hobson, but no specific details are available concerning these.

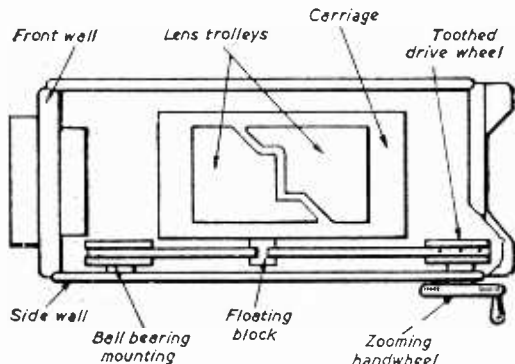
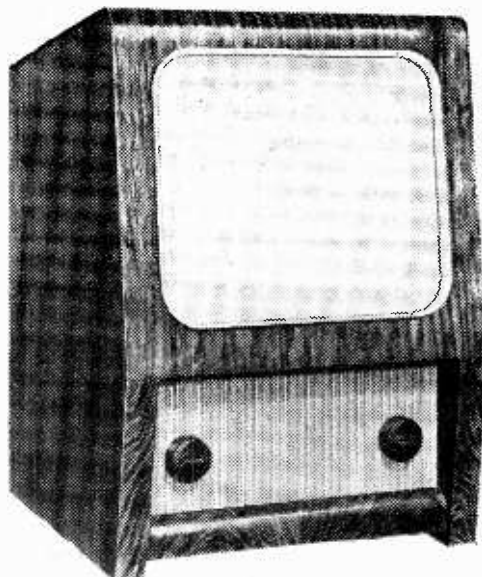

Fig. 4.—How the zoom action is effected.



H.M.V. model 1807

THERE are many of these receivers still giving good service, and they can be cheaply converted to give 12-channel reception together with improved performance. The turret tuner advertised by various firms in this magazine (price 99s. 6d., plus postage and knobs), giving an I.F. output of 33-38 Mc's was used by the writer with very good results.

The 3807 has an I.F. of 34 Mc/s vision and 37.5 Mc/s sound, and so the tuner unit needs no modification. Mounting brackets for the tuner will have to be made, heavy gauge aluminium being ideal. The tuner is fitted just above the R.F. strip. As there is little room to spare careful measurement is necessary before drilling holes in the cabinet. Make sure no metal parts are exposed to the operator.

Electrical Installation

First remove V1 (Z77) and V2 (X78). Viewed from the back of the set these are fifth and fourth valves respectively on the left-hand side of R.F. chassis. Connect pin 3 to pin 4 on V1 valve base. Cut away coaxial lead from V1 stage at grommet on chassis. Remove aerial input panel. Remove all connections to pins 1, 2, 3, 6 and 7 from V2 valve base. (The 100 K from pin 1 and 22 K from pin 6 should be removed from set.)

From pin 1 of V2 base, connect 100Ω resistor to chassis, also connect a 12in. length of coaxial cable from pin 1 to chassis (inner to pin 1) and pass through chassis grommet.

Connect pin 2 of V2 to pin 2 of V1 base. Connect .001 μF condenser from pin 2 of V2 to chassis; this can be the condenser which was removed from pin 1 of V2. Connect pin 7 of V2 to the junction of the 470Ω resistor and .001 μF condenser in V2 anode circuit (anode, pins).

Connect pin 6 of V2 to chassis. Fit V1 (Z77) to V2 base; V1 base is not used.

Converting the 3807 to 12-channel Reception

By Simons

THIS CONVERSION ALSO APPLIES TO H.M.V. RECEIVERS 3808, 3815, 3811, INCLUDING THE LONDON AND MIDLAND MODELS, i.e., 1807, 2807, ETC., AND MARCONIPHONE EQUIVALENTS

Turret Tuner

From the turret tuner there are four leads and a short length of coaxial cable. Connect the heater leads between pin 3 of V2 and chassis. Connect the gain control, A.G.C. and chassis lead to receiver chassis.

Connect the H.T. lead to pin 7 of V1. Connect coaxial lead to coaxial lead (from pin 1 of V2) with a coaxial plug and socket. A circuit diagram of the tuner is provided and leads are colour coded; these should be checked as the writer found an error in this coding. Fit the tuner unit to cabinet.

Cut a piece of Paxolin to the size of the receiver

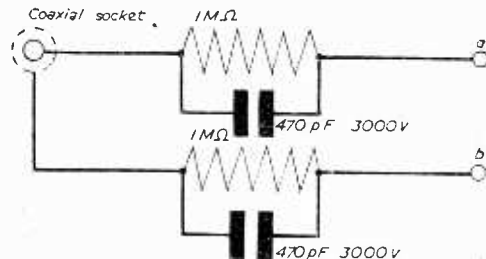

Fig. 1.—Input network for the tuner.

aerial input panel and on it fit a coaxial socket and isolating condensers (Fig. 1).

From (a) and (b) connect 10in. coaxial cable and join to aerial input of turret tuner, which are two lugs on top of tuner chassis; one lug is joined to tuner chassis, so good isolation is necessary. Do not use original aerial panel.

Connect mains to set and check heater current; adjust ballast resistor if necessary. The set can now be tested. If signal is too strong on either band a 50 K wirewound potentiometer can be fitted between gain-control lead from tuner and chassis.

The original Contrast control now operates on V2, which is an extra vision and sound I.F. stage.

REFRESHER COURSE IN MATHEMATICS

8/6. by post 8/10. 4th Edition.

By F. J. CAMM

From: GEORGE NEWNES, LTD.
Tower House, Southampton Street, Strand, W.C.2

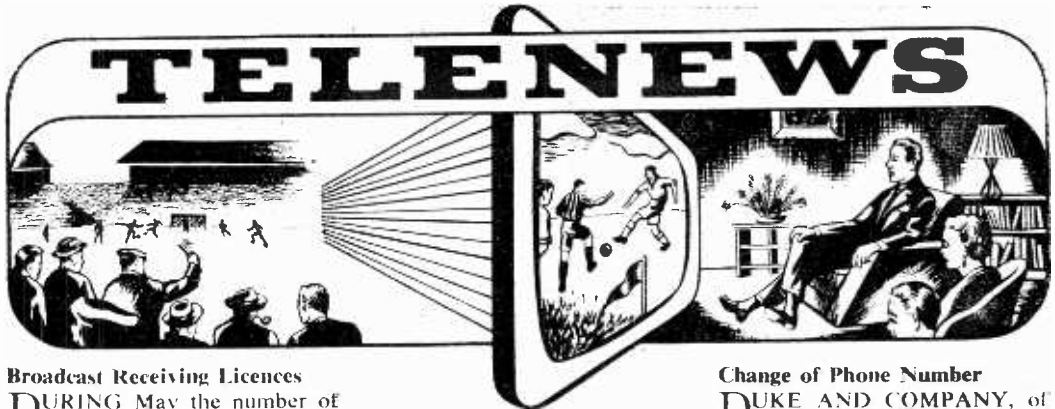

Broadcast Receiving Licences

DURING May the number of television licences increased by 68,390.

14,583,256 broadcast receiving licences, including 7,118,698 for television and 312,528 for radio sets fitted in cars, were current in Great Britain and Northern Ireland at the end of May, 1957. For analysis see following page.

First Television Bus

THE world's first television bus recently took part in the Cambridge week celebrations which took place in Holland in June. The bus was fitted out by Pye Limited as a complete television studio and viewing room, passengers on the top deck being able to watch on a television screen, entertainment relayed from the studio on the lower deck. The idea opens up a new field of application and permits its use in aircraft, small ships or large road vehicles. The camera, a modified version of the standard industrial camera has been modified for use on 24 volts D.C. without a rotary converter, and makes use of the bus's own 24-volt batteries. A practical application of this idea would be to have a camera installed on the platform of a bus so that the driver with the aid of a monitor screen in his cab could watch passengers alighting from and boarding the vehicle.

New BBC V.H.F. Station at Llangollen

THE BBC announces that a new V.H.F. sound broadcasting station for North-East Wales will be built on a site 1,800ft. above sea level at Cynry-Brain, near Llangollen, and some eight miles west of

Wrexham. The station will be known as Llangollen. Building work will start as soon as possible, and it is expected that the station will be completed by the autumn of next year.

Llangollen will be the fourth BBC V.H.F. sound broadcasting station to be built in Wales and will serve some 270,000 people in the Principality. This will bring the coverage of the V.H.F. service in Wales up to 90 per cent. of the total population. The area served will include Wrexham, the whole of Flintshire, most of Denbighshire, and parts of the counties of Merioneth and Montgomery. The station will also be well received in most of Cheshire and Shropshire.

Change of Phone Number

DUKE AND COMPANY, of 621, Romford Road, London, E.12, announce that their new telephone number is ILFord 6001-3.

P.T. and P.W. at the Show

MAKE a note of our stand number 117 on the ground floor where all readers will be welcome to discuss technical problems.

Congratulations

CONGRATULATIONS to Air Commodore A. V. Harvey, C.B.E., M.P., whose name appeared in the Queen's Birthday Honours List, he becomes a Knight Bachelor. Mr. A. J. Smith becomes an M.B.E. and Mr. Sydney J. Wrigglesworth becomes an O.B.E.



The Radio Bus. Passengers viewing a programme. See paragraph on this page.

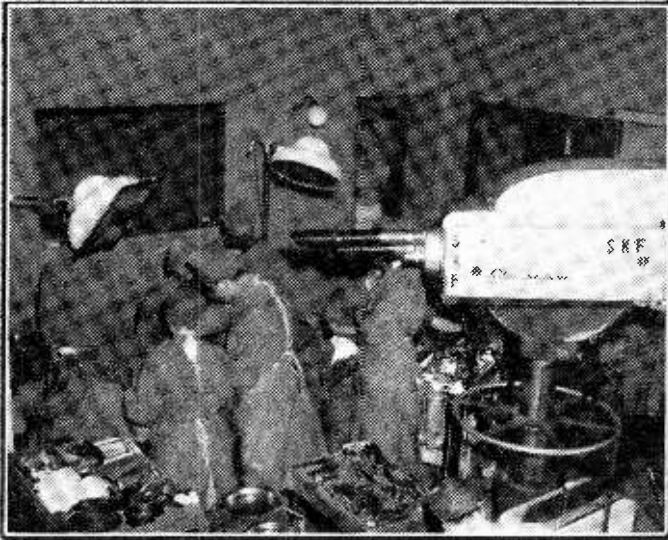

Doctors watching operation in colour on a TV screen during a closed circuit demonstration at St. Bartholomew's Hospital recently. It was dealt with on page 566, July issue.

Colour TV in U.S.A.

AN analysis of manufacturers' programmes for the new season in the U.S.A. indicates that colour TV is farther away than ever. Black and white TV sets are being manufactured in larger numbers and there are signs that the recent decline in demand caused by the expectation that colour TV was imminent has been arrested. Only one company, the Radio Corporation of America, continues to state that colour TV will make a big showing this year.

TV Comes of Age

IT was on August 26th, 1936, that the first high definition television service was radiated from the Radio Show, then known as Radio Olympia. Thus TV has now come of age and at the 24th National Show at Earls Court which takes place this year, from Wednesday, August 28th, to Saturday, September 7th, the 21st birthday will be celebrated. Some of those who took part in the first BBC broadcast will appear in anniversary programmes reminding viewers that Great Britain was the pioneer in TV, as in most other branches of radio and electronics. The BBC will operate from a large studio, specially constructed for the Exhibition.

Commercial TV at the Show

COMMERCIAL TV will for the first time play a major part in the Exhibition, the Independent programme companies, pooling their resources, to give from their own arena, performances by their stars, practically non stop for ten hours daily.

Other Show News

MORE than 100 manufacturers, including all the leading makers of radio and television sets and sound reproducing and recording equipment, will show their latest models.

Many new designs of television receivers will be seen, including more portable or transportable sets, and radio sets will include transistorised models only a little more than 2lb. in weight.

The Radio Industry Council, organisers of the Exhibition, will demonstrate in full public view the simultaneous control of two different television programmes. Technicians, programme officers and announcers will be seen at work behind glass walls.

The Royal Air Force and the General Post Office are among exhibitors. The Exhibition is to be opened by Lord Brabazon, H.M. the Queen is Patron.

Music Trade Exhibition

THE second Music Trade Exhibition will be held at Park Lane House, 45, Park Lane, London, W.1, on September 24th.

More than 60 per cent. I.T.A.

THE proportion of television homes able to receive independent television in the London, Midlands and Northern I.T.A. areas increased by 12 per cent. during the last six months. Television Audience Measurement Limited stated recently.

T.A.M. adds that more than 60 per cent.—3,330,000—of all television homes in the three I.T.A. areas are now receiving independent television compared with 48 per cent. six months ago.

Over 11,400,000 viewers can now watch I.T.V.

TELEVISION RECEIVING LICENCES

STATEMENT showing the approximate number of Television Receiving Licences in force at the end of May, 1957, in respect of stations situated within the various Postal Regions of England, Wales, Scotland and Northern Ireland.

| REGION | SOUND | TELEVISION | TOTAL |
|----------------------------------|-----------|------------|------------|
| London Postal | 1,157,195 | 1,482,138 | 2,639,334 |
| Home Counties | 1,164,653 | 846,125 | 2,010,775 |
| Midland | 887,845 | 1,176,463 | 2,064,309 |
| North Eastern | 1,166,253 | 1,117,542 | 2,283,792 |
| North Western | 864,771 | 1,015,241 | 1,880,012 |
| South Western | 734,694 | 522,158 | 1,256,852 |
| Wales and Border Counties | 462,925 | 399,218 | 862,143 |
| Total England and Wales | 6,438,332 | 6,558,885 | 12,997,217 |
| Scotland | 832,810 | 493,244 | 1,326,054 |
| Northern Ireland | 193,416 | 66,569 | 259,985 |
| Grand Total | 7,464,558 | 7,118,698 | 14,583,256 |

NEW! THE PRACTICAL WAY

of learning **RADIO • TELEVISION • ELECTRONICS**
AMATEUR S.W. RADIO • MECHANICS • PHOTOGRAPHY • CARPENTRY, Etc. Etc.

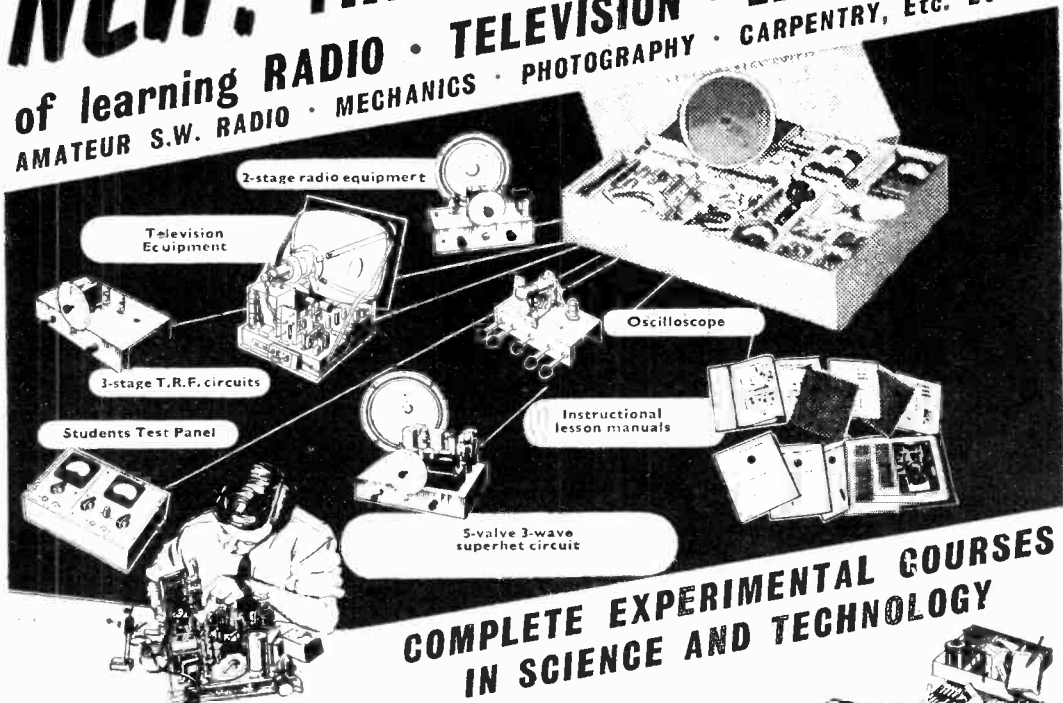

COMPLETE EXPERIMENTAL COURSES IN SCIENCE AND TECHNOLOGY

NEW... completely up-to-date methods of giving instruction in a wide range of technical subjects specially designed and arranged for self-study at home under the skilled guidance of our teaching staff.

NEW... experimental outfits and lesson manuals are despatched on enrolment and remain the student's property. A tutor is allotted to each student for personal and individual tuition throughout the course. In the case of radio and television, specially prepared components are supplied which teach the basic electronic circuits (amplifiers, oscillators, detectors, etc.) and lead, by easy stages, to the complete design and servicing of modern commercial radio and television receivers.

If you are studying for an examination, wanting a new hobby or interest, commencing a career in industry or running your own full-time or part-time business, these practical courses are ideal and may be yours for moderate cost. Send off the coupon to-day for a free Brochure and full details. There is no obligation whatsoever.

SUBJECTS INCLUDE—
RADIO • SHORT WAVE RADIO
TELEVISION • MECHANICS • CHEMISTRY
PHOTOGRAPHY • ELECTRICITY • WOODWORK
ELECTRICAL WIRING • DRAUGHTSMANSHIP
ART, etc.

The only Home Study
College run by
a World-wide
industrial
organisation.



EMI INSTITUTES

COURSES FROM 15/- PER MONTH

FILL IN COUPON FOR **FREE PROSPECTUS**

E.M.I. INSTITUTES Dept. 138X, London, W. 4

NAME _____ AGE (if under 21) _____

ADDRESS _____

BLOCK CAPS PLEASE

I am interested in the following subject(s) with/without equipment _____

AUG. 57 We shall not worry you with personal visits

- Part of "His Master's Voice", Marconiophone, etc. etc.

TRANSISTORS

JUNCTION TYPE P-N-P

(British Manufacture)

RED-SPOT 800 Kcs Audio Frequency..... 10-
 BLUE-SPOT 1.5 Mc's Mixer and Frequency Changer... 15-
 WHITE-SPOT 2.5 Mc's R.F. and I.F. Amp..... 20-

All Transistors are Tested and Guaranteed.
 N.B. The Red-Spot is similar to Mullard OC71.

Superseding The Popular
 "Pre-Selected Transistor-Seven"
 The New
"TRANSISTOR-8"

Push-Pull Portable Superhet
 Can be built for **£11/10/-**

This Portable 8 Transistor Superhet is tunable for both Medium and Long Waves and is comparable in performance to any equivalent Commercial Transistor Set. Simplified construction enables this set to be built easily and quickly into an attractive lightweight cabinet supplied.

TEN STAR FEATURES

- ★ 8 Specially Selected Transistors
- ★ 250 Milliwatts Output Push-Pull
- ★ Medium and Long Waves
- ★ Internal Ferrite Rod Aerial
- ★ 7 x 4 Elliptical High Resistance Speaker
- ★ Drilled Plastic Chassis 8) x 2 1/2 in.
- ★ Point to Point wiring and practical layout
- ★ Economical. Powered by 7 1/2 v. battery
- ★ Highly sensitive
- ★ Attractive lightweight contemporary case

N.B. Pair of OC72's supplied at additional cost of 40/-

Call and hear demonstration model.

We can supply all three items including Cabinet for **£11/10/-**. All parts sold separately.

Send for circuit diagrams, assembly data, illustrations and instructions, and full shipping list, 1/6.

"EAVESDROPPER"

THREE TRANSISTOR POCKET RADIO
 (No Aerial or Earth required)

Pre-selected to receive the Light and Home Stations. Total cost, as specified including Transistors, Transformers, Coils, Condensers and Battery, etc., with circuit and plastic case.

All items sold separately. **77/6** POST FREE
 With single phone, 82/6. With Acos Mike, 90-/. With Min. Hearing Aid, 92/6.

THE TELETRON "COMPANION"

THREE TRANSISTOR POCKET RECEIVER
 MEDIUM AND LONG WAVES. NO AERIAL OR EARTH
 Tuned R.F. Circuit. Ardente Transformers. 3 Transistors.
 Drilled Plastic Chassis and Cabinet size 4 1/2 x 3 1/2 in., and all Components. Balanced Armature Output. Total cost

89/6

ALL PARTS SOLD SEPARATELY

TRANSISTOR PUSH-PULL AUDIO AMPLIFIER

(200 MILLIWATTS OUTPUT)

Build this Push-Pull Amplifier which is ideal for Crystal or Magnetic Pick-up Amplification, Baby Alarm, Microphone Amplifier, etc. Powered by 6-volt Dry Battery lasting for 3 months. Complete Kit of Parts including 4 Transistors and all Components with Circuit (Less Speaker), **24/10/-**.

TRANSISTOR SIGNAL TRACER

Complete Kit with 2 Transistors, Components, Phones with Circuit and plastic case. **42/6**.

TRANSISTOR SQUARE WAVE GENERATOR

Complete Kit with 2 Transistors, Components, Circuit and plastic case. **25/-**.

DIODES

B.T.H. GERMANIUM 1/6
 MULLARD OA7A..... 2/6
 IN21..... 3/6
 IN22, IN23, IN21A..... 5-

"HOMELIGHT" 2 TRANSISTOR PERSONAL PORTABLE

No Aerial or Earth Required
 Pre-selected 2 Station Receiver

We can supply all components including 2 Transistors, Diode, Resistors, Condensers, Miniature Hearing Aid and Plastic Case, size 4 1/2 x 2 1/2 x 1 1/2, and 1 1/2 v. Battery. FOR 55-/. All items sold separately.

AMAZING OFFER

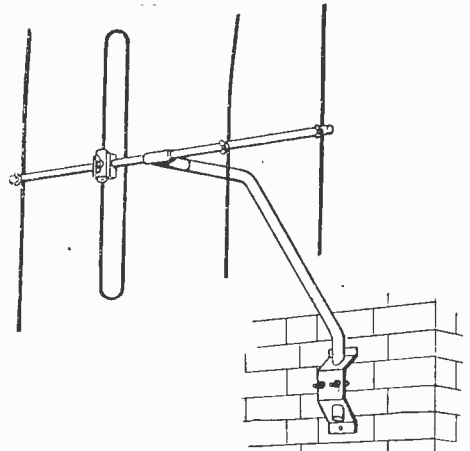

This powerful 4-element, pre-assembled, wide-spaced, Band III beam aerial by a leading manufacturer. Supplied complete with cranked pole and wall fixing bracket, can also be loft mounted. Lined at 55/6.

Our price, Brand New, in maker's sealed carton, **39/6**.

Identical to above complete with full chimney lashing kit, **46/6**. Limited number of 4-element aerials, head only, **25/-**. Terms: Cash with order or C.O.D. All 2/- extra P. & P. Mail order only.

G. C. EQUIPMENT CO., LTD.
 2, PARK ROW, LEEDS, I.

GUARANTEED VALVES

| | | | | | | | |
|--------|------|-------|------|----------|------|-------|------|
| CV6 | 1/6 | EL33 | 15/- | VR116 | 6/- | 6R7 | 8/6 |
| DET19 | 1/6 | EL41 | 10/- | VR150/30 | 7/6 | 6SA7 | 8/- |
| DET25 | 5/- | EL42 | 10/- | VU111 | 2/- | 6SH7 | 5/- |
| DF91 | 7/6 | EL81 | 10/6 | X85 | 10/- | 6SJ7 | 7/6 |
| DF92 | 7/6 | EL90 | 7/- | OZ4A | 6/6 | 6SK7 | 7/6 |
| DL92 | 7/6 | EL91 | 8/6 | 1L4 | 7/6 | 6X4 | 6/6 |
| DL93 | 7/6 | EM80 | 13/- | 1T4 | 7/6 | 6SN7 | 7/6 |
| DL95 | 7/6 | EN91 | 7/6 | 1Q5 | 8/6 | 6SS7 | 5/- |
| EA50 | 1/- | EY51 | 11/6 | IU5 | 7/6 | 6T8 | 9/- |
| EABC80 | 9/- | EZ35 | 8/- | 2C94 | 2/6 | 6V6 | 7/6 |
| EB94 | 2/6 | EZ40 | 8/- | 2D21 | 7/6 | 6X4 | 7/6 |
| EB91 | 6/- | EZ80 | 5/6 | 2X2 | 4/- | 8D2 | 4/6 |
| EBC33 | 9/- | FC13C | 4/6 | 3A4 | 7/6 | 9D2 | 4/6 |
| EBF90 | 9/- | HL13C | 4/6 | 3Q4 | 7/6 | 12A6 | 7/6 |
| ECC83 | 7/6 | H83 | 7/6 | 4D1 | 4/6 | 12AH9 | 10/- |
| ECC35 | 7/6 | KT33C | 8/6 | 5U4 | 8/- | 12AT7 | 7/6 |
| ECC81 | 7/6 | KT44 | 10/- | 5Z4 | 8/6 | 12AU7 | 9/- |
| ECC82 | 9/- | KTW61 | 7/6 | 6AG5 | 6/6 | 12AX7 | 9/- |
| ECC83 | 9/- | KTW63 | 7/6 | 6AK5 | 6/6 | 12H6 | 2/6 |
| ECC84 | 11/- | PL38 | 20/- | 6AL5 | 6/6 | 12J5 | 5/- |
| ECH35 | 10/- | PL81 | 10/6 | 6AM5 | 7/6 | 12K7 | 7/6 |
| ECH81 | 9/- | PL82 | 10/6 | 6AQ5 | 7/- | 12K7 | 7/6 |
| ECH42 | 10/- | PY80 | 9/- | 6AT6 | 8/- | 12K8 | 17/6 |
| ECP82 | 11/- | PY81 | 8/6 | 6AU6 | 7/- | 12X7 | 7/6 |
| ECL80 | 9/- | PY82 | 8/6 | 6BE6 | 8/- | 12SC7 | 7/6 |
| EC52 | 5/- | PCF80 | 9/6 | 6BA6 | 8/6 | 12SG7 | 5/- |
| EC54 | 5/- | PCF82 | 10/- | 6BC5 | 6/6 | 12SH7 | 5/- |
| EC90 | 6/- | PC81 | 10/- | 6BH6 | 7/6 | 12SJ7 | 7/6 |
| EF26 | 6/- | PC84 | 11/6 | 6BR7 | 8/6 | 12SK7 | 5/- |
| EF37A | 10/- | PC182 | 10/- | 6BS7 | 8/6 | 15D2 | 5/- |
| EF39 | 8/- | PEN45 | 8/6 | 6BW6 | 8/6 | 35L6 | 9/- |
| EF41 | 10/- | R61 | 5/- | 6BX6 | 8/6 | 35Z4 | 8/6 |
| EF42 | 10/- | R62 | 15/- | 6B9 | 5/- | 45 | 6/6 |
| EF50 | 5/- | RK34 | 3/6 | 6C3 | 6/- | 58 | 5/- |
| EF54 | 7/6 | RL37 | 5/- | 6F32 | 5/- | 76 | 5/- |
| EF55 | 9/- | SP13C | 4/6 | 6F33 | 7/6 | 85A2 | 9/- |
| EF69 | 8/6 | SP41 | 5/- | 6G6 | 5/- | 90C1 | 7/6 |
| EF85 | 10/6 | SP61 | 5/- | 6HG | 2/6 | 807 | 6/6 |
| EF91 | 7/6 | U801 | 50/- | 6J5 | 8/6 | 825 | 40/- |
| EF92 | 5/6 | TT11 | 4/- | 6J7 | 7/6 | 832 | 30/- |
| EF94 | 7/- | UBC41 | 10/- | 6K7 | 5/6 | 954 | 5/- |
| EF95 | 6/6 | UF41 | 10/- | 6K8 | 8/6 | 955 | 5/- |
| EF96 | 6/6 | UB3 | 20/- | 6L5 | 10/- | 7193 | 3/- |
| EK32 | 6/6 | UL46 | 10/- | 6N7 | 7/6 | 8012 | 6/6 |
| EK90 | 8/- | UY41 | 8/- | 6P28 | 20/- | 9001 | 5/- |
| LL32 | 6/6 | VP13C | 4/6 | 6Q7 | 8/6 | 9003 | 5/- |

Post & Packing 6d. Free over £1. C.O.D. 2/6 extra.

LAWRENCE ELECTRONICS

150, CHIPSTEAD VALLEY ROAD, COULSDON, SURREY.
 UPLANDS 9075. Personal callers preferably on Saturdays.

HENRY'S RADIO LTD.

5 HARROW ROAD, EDGWARE ROAD, LONDON, W.2
 TEL.: PADDINGTON 1008-9.

New Telecine Equipment

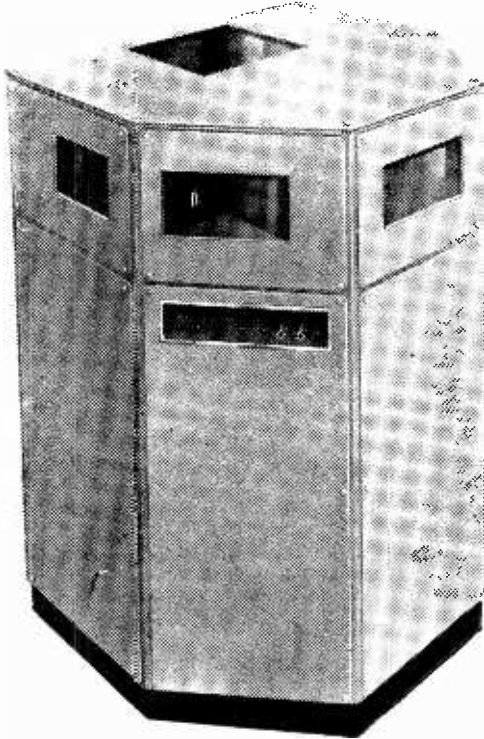

This picture shows the Multiplexer used in the Marconi Type BD.844 Vidicon Telecine Camera Channel. It consists of a six-sided cabinet 5ft. high, designed to accept the light beams of normal film and slide projectors at the standard optical height of 48 inches.

THE 1in. diameter Vidicon pick-up tube has been developed to such an extent that it provides a completely adequate source of video signals when used with film equipments, and after laboratory development the Marconi Company have produced their Type BD.844 Vidicon Telecine Camera Channel based on it.

One of the great advantages of using a camera tube over the Flying Spot technique for telecine work is that several projectors can be multiplexed on to a single camera tube, very much in the same way that film slide projectors are integrated to provide a continuous performance in the cinema. In the past the majority of these optical multiplexers have used either semi-silvered mirrors or very thin "pellicules" to mix the light beams, but the former invariably give a second reflection from the un-silvered surface while pellicules suffer from extreme fragility.

With the problems of colour television in mind, Marconi's have produced a design of optical multiplexer which uses only front-surface-silvered mirrors, which therefore cannot produce second reflections and which can be made extremely robust and stable. A further advantage of these mirrors is that they can be made sufficiently large to ensure that definition and registration problems are minimised.

Yet another important asset of the Marconi

Multiplexer is its ability to provide a local optical preview of what is in the gate of the next projector to come into operation. The operator is thus always sure that his "next channel" contains the right material; the provision of this facility removes what has hitherto been one of the biggest objections to multiplexing - that of not knowing that a mistake has been made until it is too late.

The Marconi BD.844 Multiplexer consists of a six-sided cabinet standing approximately 5ft. high and is designed to accept the light beams of any normal film and slide projectors at the standard optical centre height of 48 inches from the ground. It contains all the necessary relays for actuating the moving mirrors, the action being such as to produce the effect of a "wipe" of approximately three frames only, when changing from one source to another.

Should it be considered necessary to superimpose two sources, a new type of mixing mirror can be fitted which has a second reflection of less than 1 per cent. and a very high optical efficiency. Primarily designed for colour television operation, this mixing mirror represents an important advance in optical coating techniques.

The Multiplexer has inputs for a maximum of four projectors which will generally be two film and one or two slide, but an additional lens system can be added to view standard 9in. x 12in. caption cards or opaque displays of the same dimensions. Thus the telecine equipment can be used to show small animated displays or products mounted on a turntable.

The Marconi BD.844 Vidicon Telecine Camera Channel consists of the small vidicon camera itself, rack mounted processing and deflection chassis, power supplies and a camera control unit.

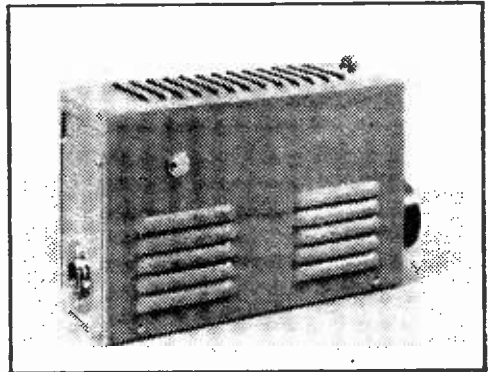

This photograph shows the Vidicon Telecine Camera used in the Marconi Type BD.844 Vidicon Telecine Camera Channel. This is a new design in which the video signals are obtained by a 1in. Vidicon tube instead of by the conventional Flying Spot technique. One of the advantages of the system is that several projectors can be multiplexed onto a single camera tube. The camera itself is a simple compact unit containing the Vidicon pick-up tube, its deflection yoke, a signal pre-amplifier and a blanking amplifier and clipper.

News From the Trade

NEW MARCONIPHONE TV RECEIVER

AN attractive new 14in. table television receiver—Model VT150—is announced by the Marconiphone Co., Ltd.

Incorporating the new aluminised Emiscope electrostatic-focus tube, its outstanding picture features are exceptionally high brightness; extremely good definition; precise focusing; freedom from spot distortion. The inherently high standard of picture quality is further enhanced by the tinted screen and special non-reflecting tube mask.

Notable circuit features include 13-channel incremental inductance tuning unit with coils for instantaneous tuning to all Band I and Band III



The Marconi VT150.

channels; very high sensitivity, giving excellent reception even in difficult areas; "sync. cancelled" A.G.C. system on vision to counteract signal fading and aircraft "flutter" and to provide automatic compensation for differences in signal strength between Band I and Band III transmissions; adjustable "black spotter" interference limiter; tunable input filter to combat diathermy and similar interference.

On sound a high quality output is provided by the advanced circuit design in conjunction with a high-efficiency front-facing elliptical speaker of special design. An efficient automatic suppressor circuit deals with interference.

Both main and secondary controls are conveniently located, the former at the front and the latter at the side of the compact cabinet, which is beautifully styled in polished wood with walnut veneered front.

Operation is from mains voltages of 195-255 volts, either D.C. or 50 c/s A.C. The price of the Marconiphone Model VT150 is 66 guineas (tax



paid).—The Marconiphone Co., Ltd., Hayes, Middlesex, England.

TV REPLACEMENTS HANDBOOK

DIRECT TV REPLACEMENTS have just issued a new handbook. It contains the most complete list of TV components and as such is a valuable guide to engineers when estimating for repairs.

The many illustrations simplify identification of components. A chart illustrates slider controls, the diagrams being actual size, and a special Baird line output chart has been compiled by Direct TV Replacements and included in this present edition.

Service hints and modifications have been included in the technical section. With each copy a new type pre-paid order form, listing the most popular items is enclosed.

This handbook will be sent to any bona fide dealer requesting it, and as it is such an asset to engineers, a personal copy may be obtained for 1s. post free.—Direct TV Replacements, 134-136, Lewisham Way, New Cross, S.E.14.

GUARANTEED COMPONENTS

THE Radio Components Specialist, 337, Whitehorse Road, S. Croydon, has sent us a copy of the guarantee which they supply with all their goods. This makes it clear that all goods are guaranteed against faulty workmanship, electrical and mechanical faults, except in the case of misuse, for a period of 12 months from the date of invoice. Although the company's decision in all cases must be final, the customer will be given the benefit of any doubt. Faulty goods will be either repaired, exchanged free of charge or credited and their cost refunded. Valves are guaranteed for a period of three months.

PRACTICAL WIRELESS AUGUST ISSUE NOW ON SALE PRICE 1/3

Making an F.M. Feeder Unit from the popular RF27 unit forms the main constructional feature in our companion paper now on sale. The article deals with the main features of the conversion, and the RF27 unit is now readily available from most dealers in ex-Government equipment.

A Midget 4-valve Portable is also described in a complete article and this utilises the DA series of Midget Mullard valves.

Interesting experiments in the field of Stereophonic Recording are also given in the issue, together with the circuits and switching arrangements used.

Making an Output Indicator, a Mains T.R.F. Short Waver and a Simple Test Probe, are three other interesting constructional features, whilst the issue also contains the completion of the articles on Car Radio and an Amateur Communications Receiver.

The issue includes all the usual features.

325 NEW MODELS

1956-1957

INCLUDING LATEST RADIO SHOW SETS

NEWNES

Radio and Television Servicing

A CERTAIN MONEY-MAKER IN ONE HANDY VOLUME

START building your library of radio and television data with Newnes latest volume—RADIO AND TELEVISION SERVICING (1956-57). Covering a total of 325 popular new models it provides all the data necessary to keep these newer sets working and customers happy and satisfied. Radio service mechanics who are profiting from these yearly volumes of *new models* know their value in £ s. d. and snap them up as soon as they are published! There is a copy for you to examine *freely and without obligation* if you apply AT ONCE.

325 MODELS • 624 PAGES

Examine it—Use it

FREE FOR 7 DAYS

Without Obligation

Presented with every copy

This HANDY ENLARGER

Just what you need to follow intricate circuits easily—stand it on any diagram and it enlarges every detail. Magnifies small print, too. There is one for you FREE and post paid on retaining Newnes RADIO AND T.V. SERVICING after examination.

Boxed and with Lens Polisher



ACT-NOW! NOTHING TO PAY FOR 7 DAYS' EXAMINATION

TELEVISION

MODELS BY

Alba, Ambassador, Baird, Banner, Beethoven, Bush, Champion, Cossor, Decca, Defiant, Ekco, English Electric, Ferguson, Ferranti, G.E.C., H.M.V., Invicta, K-B, Marconiophone, Masteradio, Murphy, Peto Scott, Philco, Philips, Pilot, Portadyne, Pye, R.G.D., Sobell, Stella, Ultra, Vidor.

RADIO

MODELS BY

Ambassador, Armstrong, Berec, Bush, Champion, Cossor, Eddystone, Ekco, Ever Ready, Ferguson, Ferranti, G.E.C., Grundig, H.M.V., Invicta, K-B, McCarthy, Marconiophone, Masteradio, Motorola, Murphy, Pam, Philco, Philips, Pilot, Portadyne, Pye, Pye Telecommunications (Car Radios), Radiomobile, Regentone, R.G.D., Roberts' Radio, Sobell, Stella, Ultra, Vidor, Webcor.

ALSO RECENT DEVELOPMENTS—INCLUDING

Repair of Printed Circuit Models . Transistors . Servicing of Transistor Circuits . Band III Conversion . Aerials . V.H.F./F.M. Receivers.

HURRY ! ACT TO-DAY—THERE WILL BE NO REPRINT

George Newnes, Ltd., 66-69, Great Queen Street, London, W.C.99.

Send me the 1956-1957 Volume of Newnes *Radio and Television Servicing*. I will either return it in 8 days or send 12s. 6d. deposit 8 days after delivery, and you will then send the *Handy Enlarger*. Thereafter I will send 10s. 0d. monthly paying £2 12s. 6d. in all. Cash price in 8 days £2 10s.

Name

Address

Occupation

Signature

(Parent's Signature if under 21.)

Place X where it applies

| | |
|---------------------|--------------------------|
| HouseOWNER | <input type="checkbox"/> |
| Householder | <input type="checkbox"/> |
| Living with Parents | <input type="checkbox"/> |
| Lodging Address | <input type="checkbox"/> |

R4U

LASKY'S RADIO

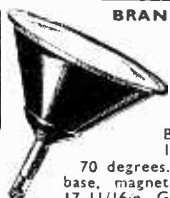

BRAND NEW AND PERFECT
16" METAL CONE C.R.T.
AT ENORMOUS
PRICE-SAVING

SPECIAL OFFER OF
BAND I-III
TURRET TUNERS

Covering Channels 8.4 or 1.9 with provision for 10 more coil sets. 2 Mazda valves: 30L1 cascade r.f. amp., 30C1 triode/pentode f.c. I.F. output 16-19 Mc/s, easily modified to other outputs. Complete with power supplies for 200-250 v. A.C., valves, knob and circuit diagram.
LASKY'S PRICE £5.17.6
 Post 3/6.
 Price without power unit, 99/6.

SPECIAL OFFER OF
VALRADIO
12-CHANNEL TUNERS

Limited quantity only. Type TP16FS. Brand new and unused. Covers all channels Bands I and III. 2 valves: PCC84 and PCF80, series heaters, I.F. output 16-20 Mc/s. Complete with valves, dials, knobs and full instructions. Listed at £6.
LASKY'S PRICE 84/-
 Post 3/6.

Brief specification : 6.3 v. heater, Ion trap, 14 kV. E.H.T. wide angle 70 degrees, standard 39 mm. neck, duodecal base, magnetic focus and deflection. Length 17 11/16in. Gives large black and white picture 11 x 14in. Unused in original cartons. **GUARANTEED BY US FOR 3 MONTHS.** Full data, connections and suggested time bases supplied with every Tube.

LISTED AT £23.9.10. LASKY'S PRICE £8.9.6
 Carr. & Insur. 22/6 extra.
 Masks, Anti-Corona, Bases and Ion Traps available.

Just Arrived! Too late to illustrate

BBC & ITA 17" TV CHASSIS

By well-known manufacturer. For A.C./D.C. mains. Brand new and unused, complete with 21 valves, 12-channel Turret Tuning with coils for all channels, Band I and channels 8 & 9 Band III, with provision for 5 further channels. I.F. 33-38 Mc/s. 17in. Mullard dark screen C.R.T. 43/64. All main controls through front of chassis. Overall dimensions including C.R.T., 17" wide, 15" deep, 18" high. Very limited quantity and will be sold out very quickly. Secure yours now!

TODAY'S £60 LASKY'S PRICE £37/10

Complete with all valves and C.R.T.
 For personal callers only.

MAKER'S SURPLUS
COMPONENT BARGAINS

- WIDE ANGLE 39 mm. Line E.H.T. trans., Ferro-cube core, 9-16 kV..... 25/-
- Scanning Coils, low imp. line and frame..... 25/-
- Ferro-cube cored Scanning Coils and Line Output Trans., 10-15 kV. EY51 winding Line Trans. Complete with circuit diagram, the pair..... 50/-
- Frame Output Transformer Scanning Coils low imp. line and frame..... 17/6
- Frame or line block osc. transformer..... 4/6
- Focus Magnets Ferro-rod P.M. Focus Magnets, Iron Cored..... 19/6
- Duomag Focallisers..... 22/6
- 300 m/a Smoothing chokes 15/-
- Electromagnetic focus coil, with combined scan coils 25/-

STANDARD 35 mm.

- Line Output Transformers, No. E.H.T..... 12/6
- Line Output Transformers, 6.9 kV. E.H.T. and 6.3 v. winding, Ferro-cube..... 19/6
- Scanning coils, Low Imp. line, and frame..... 12/6
- Ditto by Igranic..... 14/9
- Frame or line blocking oscillator transformer..... 4/6
- Frame output transformer..... 7/6
- Focus Magnets, Without Vernier..... 12/6
- With Vernier..... 17/6
- Focus coils, Electromag..... 12/6
- 200 m/a Smoothing Chokes..... 10/6

LASKY'S (HARROW ROAD) LTD.

Open All Day Saturday. Early Closing, Thurs. Mail Orders to Harrow Rd. 42, TOTENHAM COURT ROAD, W.1. 370, HARROW ROAD, PADDINGTON, W.9. Telephone: MUScum 2805. LADbrock 4075 and CUNning 1 cm 318.

FOR VALVES
GUARANTEED ALL TESTED BEFORE DISPATCH

| | | | | | |
|-------|------|-------|------|-------|------|
| 0Z4 | 5/6 | GAT6 | 8/6 | 6L18 | 11/6 |
| 1A7 | 12/6 | 6DB6 | 4/- | 6L66 | 9/- |
| 1C2 | 9/6 | 6BA6 | 7/6 | 6N7 | 7/- |
| 1J6 | 7/9 | 6BE6 | 9/- | 6X7GT | 8/- |
| 1BGT | 10/6 | | | 6X7CT | 8/- |
| 114 | 6/6 | 6BJ6 | 9/- | 6AG7 | 7/6 |
| 1N5 | 10/6 | 6BR7 | 11/6 | 6BH7 | 6/- |
| 1R5 | 8/- | 6BR7 | 13/- | 6BK7 | 6/- |
| 1S4 | 10/6 | 6BW6 | 8/- | 6BL7 | 6/- |
| 1S5 | 7/6 | 6BW7 | 10/- | 6BN7 | 7/- |
| 1T4 | 7/6 | 6C4 | 7/6 | 6B07 | 9/6 |
| 2X2 | 4/6 | 6C5GT | 6/6 | 6U4GT | 14/- |
| 3Q4 | 9/6 | 6C6 | 5/- | 6U30 | 8/6 |
| 3Q5 | 9/6 | 6C91 | 10/6 | 6U5 | 8/6 |
| 3B1 | 8/6 | 6C10 | 7/6 | 6U76 | 8/6 |
| 3Y4 | 9/6 | 6D6 | 5/- | 6U6 | 7/- |
| 42 | 8/- | 6F1 | 13/6 | 6V6GT | 7/6 |
| 3R4G | 9/6 | 6F6C | 7/6 | 6X4 | 7/6 |
| 514G | 8/- | 6F6M | 7/6 | 6X50 | 7/6 |
| 5Y34 | 8/- | 6F13 | 14/- | 6X3CT | 7/6 |
| 5Y6GT | 8/- | 6F15 | 14/- | 6X31T | 7/6 |
| 6Z4G | 10/6 | 6G6R | 4/6 | 7B7 | 8/6 |
| 6A7 | 13/6 | 6J6 | 2/6 | 7C7 | 8/- |
| 6A8G | 10/6 | 6J6G | 5/- | 7G6 | 8/- |
| 6A7 | 6/6 | 6J3M | 6/6 | 7H7 | 9/- |
| 6A15 | 6/6 | 6J6 | 6/6 | 7K7 | 9/- |
| 6A85 | 6/6 | 6J7 | 6/- | 7Q7 | 9/- |
| 6A87 | 6/6 | 6K6GT | 7/- | 7S7 | 9/6 |
| 6A17 | 9/6 | 6K7G | 5/9 | 7Y4 | 8/6 |
| 6A15 | 6/6 | 6KM | 6/9 | 75 | 11/6 |
| 6A86 | 9/6 | 6K8G | 6/9 | 77 | 8/- |
| 6A15 | 7/6 | 6K8GT | 9/6 | 80 | 8/6 |

| | | | | | |
|--------|------|---------|------|---------|------|
| 807 | 6/6 | 5W4 | 9/- | EL22 | 8/6 |
| 912 | 3/9 | 3Z4GT | 8/6 | EL41 | 10/6 |
| 9001 | 5/6 | 5Z5 | 9/- | EL42 | 11/6 |
| 9003 | 5/6 | 5BL6GT | 8/6 | EL48 | 11/- |
| 9004 | 5/6 | 1ZB7 | 4/- | EL51 | 13/- |
| 9006 | 5/6 | 2161DT | 5/- | EM34 | 11/- |
| 954 | 2/- | 216VPT | 5/- | EM80 | 11/- |
| 955 | 4/9 | ACUPEN | | EY51 | 11/6 |
| 956 | 3/6 | | | EY86 | 12/- |
| 10F1 | 13/6 | ATP4 | 3/6 | EY91 | 6/- |
| 12A6 | 6/6 | DAP6 | 10/6 | EZ40 | 10/- |
| 12AH8 | 11/6 | DP96 | 10/6 | EZ50 | 10/- |
| 12AT6 | 10/6 | DH7M | 9/- | EZ30 | 9/- |
| 12A7 | 7/6 | DK96 | 10/6 | EL148 | 2/- |
| 12A7 | 9/6 | DL96 | 10/6 | GZ32 | 12/6 |
| 12AX7 | 10/- | DM70 | 8/6 | H30 | 5/- |
| 12BA6 | 9/- | LAIR 50 | | HN200 | 13/6 |
| 12BE5 | 10/- | | | HL92 | 12/6 |
| 12BH7 | 11/- | EA 91 | 7/6 | KB22 | 8/- |
| 12C8 | 7/6 | KAF42 | 12/6 | KF25 | 8/6 |
| 12D5 | 4/6 | EB41 | 9/- | KL25 | 8/6 |
| 12E7 | 10/6 | EB41 | 10/- | KT2 | 5/- |
| 12K7 | 9/6 | EBP80 | 11/- | KT21 | 4/6 |
| 12K8 | 13/6 | EC91 | 9/6 | KT33 | 10/- |
| 12M7 | 9/6 | EC784 | 12/6 | KT66 | 15/- |
| 12M7 | 7/6 | EC85 | 10/- | KTW62 | 1/- |
| 12SH7 | 5/6 | EC91 | 8/- | | |
| 12S47 | 8/- | ECF80 | 14/6 | | |
| 12SK7 | 6/- | ECF82 | 15/- | KRW63 | 8/6 |
| 12S47 | 10/6 | EC785 | 11/6 | KT51 | 6/6 |
| 12M7 | 6/6 | ECM42 | 11/6 | LP26 | 5/- |
| 1487 | 13/6 | ECM41 | 10/6 | MH4 | 7/6 |
| 15192 | 7/9 | EC180 | 10/6 | N78 | 12/6 |
| 20P3 | 12/6 | EC182 | 13/6 | P61 | 3/9 |
| 20F5 | 11/6 | EF80 | 7/6 | PF22 | 8/6 |
| 22L6GT | 10/6 | EF22 | 8/6 | P215 | 3/11 |
| 25V5G | 9/9 | EF40 | 12/- | PEN44 | 15/6 |
| 25Z40 | 9/- | EP41 | 11/- | PEN25 | 5/6 |
| 25Z5 | 9/- | EP45 | 12/- | PEN34 | 7/- |
| 25Z6GT | 9/6 | EP66 | 12/6 | PEN220A | |
| 20F5 | 12/6 | EP89 | 12/6 | | |
| 30F11 | 12/6 | EP92 | 8/6 | PCCS4 | 4/- |
| 33L6GT | 9/6 | EP95 | 12/6 | PCF80 | 11/- |

| | | | | | |
|--------|-----|----------|------|--------|------|
| VR32 | 6/6 | VR91 | VP41 | 8/6 | |
| (EP30) | 6/6 | (LF50) | 4/- | V870 | 3/9 |
| VR34 | | VR91 | | VF52 | |
| (EB34) | 2/- | (8V1) | 7/- | (LF52) | 6/6 |
| VR35 | | (EA50) | 1/6 | VF29 | |
| (EP35) | 7/6 | VR103 | 30 | (MT12) | 14/- |
| VR36 | | | | | |
| VR37 | | VR116 | 6/6 | | 8/9 |
| (EC32) | 8/- | VR136 | 5/6 | VT11 | 2/6 |
| VR38 | | VR156 | 5/6 | W77 | 8/6 |
| VR39 | | VR150/30 | | X65 | 10/6 |
| VR40 | | VR66 | 8/- | X79 | 11/6 |
| (P61) | 3/9 | VR21 | 2/9 | Y239 | 12/6 |

TRANSISTORS RED SPOT 10/- each. BLUE SPOT 15/- each. PACKING AND POSTAGE 6d. per valve. SAME DAY SERVICE.

| | | |
|---|-----|--|
| PUBLICATIONS, ETC. | | TV Fault Finder. —Promously illus with photographs taken from a TV screen, price 5/- |
| No. 128. How to make aerials for T.V. (Bands I and 3) and V.H.F. (Band 2) | 2/6 | The Everstopper. —A miniature transistor receiver for local station reception, price 1/6 |
| No. 109. A comprehensive valve guide, Book No. 1... | 5/- | Frequency Modulation Tuner Unit. —For fringe and local area reception, price 2/- (Please include 4d. postage per copy.) |
| No. 121. A comprehensive valve guide, Book No. 2... | 5/- | Collaro Rim Drive Electric Gramophone Unit, Model 3 551. Bites pickup STU1010... 1" spaced £8.19.8 each. Postage 3/-. |
| No. 128. Practical Transistors and Transistor Circuit | 3/6 | |
| No. 140. T.V. Servicing for Beginners | 4/6 | |
| No. 142. Modern T.V. Circuitry and General Fault Finding Guide | 4/6 | |

All these and many other interesting radio and TV components are listed in our **CURRENT CATALOGUE** which is available to you now. Send 1/- in stamps for your copy.

ALPHA RADIO SUPPLY CO.

103 LEEDS TERRACE
 WINTOUN STREET
LEEDS 7

TERMS : Cash with order or C.O.D. Postage and Packing charges extra, as follows: Orders value 10/- add 1/-; 20/- add 1/6; 40/- add 2/-; £5 add 3/- unless otherwise stated. Minimum C.O.D. fee and postage 3/-. All single valves postage 6d. Personal shoppers Monday-Friday 9 a.m. to 5 p.m.

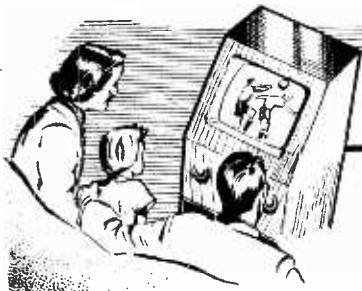

UNDERNEATH THE DIPOLE

TELEVISION PICK-UPS AND REFLECTIONS

By Iconos

A GREAT many years ago, the overgrown fishing village of Blackpool startled other seaside resorts by advertising its attractions. The town grew; its council became a corporation and continued the advertising tradition, plastering hoardings all over the country with posters of the great Tower, accompanied with catch phrases about the benefits of Blackpool's breezes. The town became a borough and the advertising account grew year by year, as did the popularity of the resort, until it has now reached the unique position of having thousands of pounds of free advertising thrust upon it. Television, for instance, has been giving Blackpool a good boost over several years; but this summer it will be getting the biggest boost ever.

SHOW TOWN OF THE NORTH

DURING the next few weeks the BBC alone will be relaying large parts of programmes from many Blackpool shows. They have already negotiated with all but one of the many theatre managements in the town, and as a result Ruby Murray, Ken Platt, Vic Oliver, Albert Burdon, Ann Shelton, Hylda Baker, Jill Day and many other top-line artistes will be seen in shows from all three piers, the Palace, the Hippodrome, the Queens and the Derby Baths. Not to be outdone, the I.T.V. companies will follow up with special spectacular shows and variety from the Winter Gardens and Tower. With their fingers on the pulses of their Yorkshire audiences, A.B.C.-TV and Granada will also pay regular visits to Morecambe, the west coast resort that attracts so many people from Yorkshire. I suppose that most of the seaside resorts on both east and west coasts will have brief moments on TV screens, but there is no doubt that, as usual, Blackpool will have the lion's share. It is not to be wondered at,

really. In the summer season there is a bigger theatrical population (particularly, of variety and concert party artistes) in the Blackpool district than there is in London. As a matter of fact, a good many of them—and their agents—have made their homes within sight of the Blackpool Tower.

BLACKPOOL IRONMONGERY

I HAVE been told that the only attraction in Blackpool which does not run at a comfortable profit is the actual steel structure of the Tower itself. The prosperous Tower company has many other eggs in its basket of entertainment, however, and can afford to keep this gigantic piece of ironmongery in good order. Imagine Blackpool without a tower! The board of directors would turn pale. There was a suggestion, many years ago, that the tower would be an ideal site for a television transmitter, with aerial array designed to radiate in a landward direction. The intention was to have this centre of entertainment and show business on the doorstep of the transmitting station, thereby eliminating heavy costs for long co-axial cables to a transmitter near Manchester. However, the

present sites of the BBC and I.T.A. transmitters in Lancashire and Yorkshire are far higher than the 520ft. Blackpool Tower, the cost of long co-axial or radio link relays has come down, and the picture quality losses are relatively negligible. Blackpool's season is a long one, extending into the autumn with the help of the magnificent illuminations. This is one of the few places where the theatre managers can't complain of the evils of television competition. They are highly in favour of as much free advertising as possible.

PROGRESS IN LANCASHIRE

LANCASHIRE as a whole seems to be very much television-struck just now. Commercial television has made its mark, and the success of the Granada TV network's activities has encouraged that organisation to extend its space and facilities at the Granada Television Centre in Manchester. Fortunately, there is ample clear space adjoining the existing premises in Quay Street and here will shortly be built what is claimed will be the biggest television studio in Britain, with stage space of 94,000 sq. ft. Three of the walls will have glass wall panels, one of

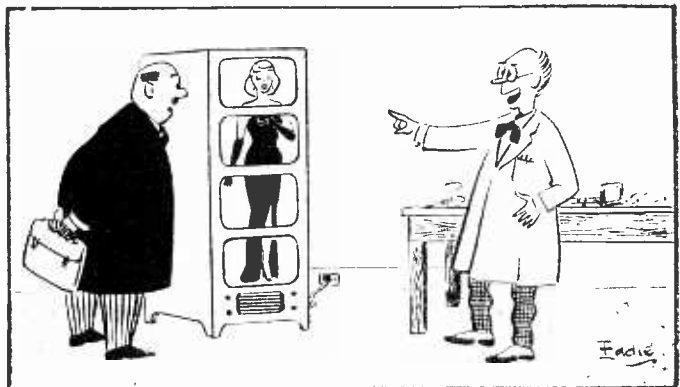

Prof. Boffin: "At last! Full length TV."

them 94ft. long and 7ft. high. to enable visitors to watch all television activities during rehearsals or actual shows.

A special "tour" for visitors is planned. From the entrance hall they will pass upstairs into a modern cafeteria lounge, with double glass windows looking out into the stage; audiences of up to 350 can be comfortably seated here to watch the shows. Sound and picture will be reproduced on a number of monitor sets installed in strategic positions. The visitors will then continue the tour and watch engineers at work in the vision apparatus room; the producers directing the action in the Vision Control Room and the sound engineers at their dials in the Sound Control Room. The new stage will require additional ancillary premises. These will comprise 23 new dressing-rooms, crowd rooms, a band room, prop rooms and so forth, the plans of which have now been submitted to the Manchester City Corporation and which have been designed by Ralph Tubbs who prepared the plans for the Dome of Discovery at the Festival of Britain. For some months the Granada network have been overtaking the capacity of their original premises and have had to make frequent use of the A.B.C.-TV's Capitol TV Theatre at Didsbury during the weekdays.

T.W.W. STUDIOS

ALLIED with Granada TV network—so far as interchange of programmes is concerned—is Television, Wales and West, Ltd., with studios now being built on a one-acre site in Cardiff called Pontcanna Farm. In this case, the large stage will measure 80ft. x 60ft. with a smaller stage adjoining together with control rooms, telecine room, dressing-rooms, scene dock and workshops. The premises will be entirely new, but the original farmhouse will be retained for offices or other purposes. Equipment is being supplied by Marconi, Cinema Television, Pye and E.M.I.—all of the latest type. The studio layout and organisation is planned for a "readiness date" of 25th November, though there is some doubt at the moment that the I.T.A. transmitter will be ready by then. There has been a hold-up in approval of the siting of the transmitter mast at St. Hilary, and there is a possibility that an alternative site will have to be

found. Mr. Chapman Walker, T.W.W.'s managing director, has stated that 7½ hours of programmes each week will originate from their Cardiff studios or its associated outside television camera equipment. A large proportion of the balance will be taken from the Granada Network, during the seven day a week operations of T.W.W. Mr. Chapman Walker is anticipating that at least 250,000 TV sets will be capable of receiving the Cardiff transmissions on the opening day, which number will rapidly build up to over a million.

FIRST HAND

THIS first-class documentary series became nostalgic recently when Paul Johnstone devoted over half an hour to Brooklands, the famous motor racing track at Weybridge, now disused. This was a very well scripted mixture of interviews, old films and old still photographs of this wonderful racing track, interspersed with "live" transmission from the studio of several cars which covered themselves with glory on the track many years ago and which still glistened in the studio lights. The interviews with Lord Brabazon, Oliver Bertram, Capt. Eyston and Key Petric were snappily carried out by Peter West, and the film sequences of various races at Brooklands were well selected and full of the exciting atmosphere of the great days of Brooklands, almost including the pungent smell of Castrol "R" lubricant which most of the cars used. I particularly enjoyed seeing the enormous "Chitty, Chitty, Bang-Bang," the colossus of the track, and the Napier-Railton special. Another BBC-TV documentary feature of a mechanical

type, but nevertheless of wide appeal, was the visit to the Tal-y-Lyn narrow gauge railway. I hope that both will be repeated in the not-too-distant future, like the Shell Le Mans racing film was.

SERIES PROGRAMMES

NEXT to the domestic comedy series, such as the "Burns and Allen Show" and "I Love Lucy," the American dramas of the wild west gain in popularity. These American TV films are very professionally made and are full of action to please kids of all ages. Shortly we will be seeing "Wells Fargo," a series dealing with the famous organisation of mail carriers across America in its wildest and woolliest days before railways. It is difficult to think of British equivalents to these fast-moving subjects. So far, the most successful have been period pieces, such as "Robin Hood" and "Sir Lancelot." I suppose the British equivalent to "Wells Fargo" would be a hotbed-up history of the early days of Pickford's or Carter Paterson! A move in modern style is A.B.C.-TV's "Electrode 93" from Birmingham, which is being sent out live from the Television Theatre at Aston. Other subjects that occur to me as possibilities for series treatment are adventures of Sherlock Holmes, mysteries of Fu Manchu, George Pearson's sensational "Ultus, the Man From the Dead," "Zigomar," "Protea," and the Nat Gould horse racing stories. Most of these have had successful appearances on stage or screen, apart from publication in book or serial form. With the greatest respect to the successful "Robin Hood" series, we should give costume drama a rest—excluding, of course, "Robin Hood" itself!

SCOTTISH TELEVISION

FURTHER recognition of the importance of a standard meter research service to the television industry has been given by a contract concluded between Television Audience Measurement Limited, Scottish Television Limited, the company which will bring independent television to Scotland, and the Institute of Practitioners in Advertising.

The contract provides for TAM to supply audience data to Scottish Television Limited similar to that which it supplies to members of the recently formed Television Audience Research Ad-

visory Committee (ABC TV, AR, ATV and the IPA) and for Scottish Television to become a full member of this Committee.

With the incorporation of Scottish Television as a member of TARAC, the value of TAM's contract with the television industry has been considerably increased. Already providing audience data to programme contractors covering all existing ITV areas, TAM will thus maintain a similar position when the transmitter serving the Scottish ITV area opens on August 31.

C.R.T. ISOLATION TRANSFORMER

Type A. Low leakage windings. Ratio 1:1:2.5 giving a 2 1/2% boost on secondary. 2 v., 10.6; 4 v., 10.6; 6.3 v., 10.6; 10.8 v., 10.6; 13.3 v., 10.6.

Type B. Mains input 220-250 volts. Multi-tap Output 2, 4, 6.3, 8, 10 and 13 volts. Input has two taps which increase output volts by 25% and 50% respectively. Low capacity, suitable for most Cathode Ray Tubes. With Tag Panel, 21" x 6 1/2".

Type C. Low capacity wound transformer for use with 2 1/2 volt Tubes with fitting chassis. Input 220-250 volts. Output 2-2 1/2, 2-3 volts of 2 amps. With Tag Panel, 17 1/2" x 6 1/2". NOTE. It is essential to use mains primary types with T.V. receivers having series-connected heaters.

TRIMMERS Ceramic. 30, 50, 70 pf., 80, 100 pf., 150 pf., 1.8; 250 pf., 1.0; 500 pf., 750 pf., 1.9.

RESISTORS. All values. 10 ohms to 10 meg. 1/4, 1/2, 1, 2, 5, 10, 20, 50, 100, 250, 500, 1,000, 2,000, 5,000, 10,000, 20,000, 50,000, 100,000, 250,000, 500,000, 1,000,000, 2,000,000, 5,000,000, 10,000,000.

HIGH STABILITY. 1/2, 1, 2, 5, 10, 20, 50, 100, 250, 500, 1,000, 2,000, 5,000, 10,000, 20,000, 50,000, 100,000, 250,000, 500,000, 1,000,000, 2,000,000, 5,000,000, 10,000,000.

WIRE-WOUND RESISTORS 13 100 ohms to 10,000 ohms 1/2, 1, 2, 5, 10, 20, 50, 100, 250, 500, 1,000, 2,000, 5,000, 10,000, 20,000, 50,000, 100,000, 250,000, 500,000, 1,000,000, 2,000,000, 5,000,000, 10,000,000.

15,000 ohms—50,000 ohms, 5 v., 1.9; 10 v., 2.3.

12.6 PURETONE RECORDING TAPE

1,200 ft. on standard 7" Plastic reels. Spools 5" metal, 1 1/2", 7" plastic, 4 3/4".

FERROVOICE 1,200ft. Plastic Tape 25-SCOTCH BOY 1,200ft. Plastic Tape 27-

U.P. TRANSFORMERS.

Multi-tap, post-impul., 6.8. Miniature, 28.1 v. 4.4. L.F. CHOKE 10 H. 40. 90. 150. 250. 500. 1,000. 2,000. 5,000. 10,000. 20,000. 50,000. 100,000. 250,000. 500,000. 1,000,000. 2,000,000. 5,000,000. 10,000,000.

MAINS TRANS. 250-0-250, 50 mA., 2 v., 1.9; 4 v., 4.4; 6 v., 6.8; 8 v., 9.2; 10 v., 11.6; 15 v., 17.4; 20 v., 23.2; 25 v., 29.0; 30 v., 34.8; 40 v., 46.4; 50 v., 58.0; 60 v., 69.6; 70 v., 81.2; 80 v., 92.8; 100 v., 117.6; 150 v., 176.4; 200 v., 235.2; 250 v., 294.0; 300 v., 352.8; 400 v., 470.4; 500 v., 588.0; 600 v., 705.6; 750 v., 882.0; 1,000 v., 1,176.0; 1,500 v., 1,764.0; 2,000 v., 2,352.0; 2,500 v., 2,940.0; 3,000 v., 3,528.0; 4,000 v., 4,704.0; 5,000 v., 5,880.0; 6,000 v., 7,056.0; 7,500 v., 8,820.0; 10,000 v., 11,760.0; 15,000 v., 17,640.0; 20,000 v., 23,520.0; 25,000 v., 29,400.0; 30,000 v., 35,280.0; 40,000 v., 47,040.0; 50,000 v., 58,800.0; 60,000 v., 70,560.0; 75,000 v., 88,200.0; 100,000 v., 117,600.0; 150,000 v., 176,400.0; 200,000 v., 235,200.0; 250,000 v., 294,000.0; 300,000 v., 352,800.0; 400,000 v., 470,400.0; 500,000 v., 588,000.0; 600,000 v., 705,600.0; 750,000 v., 882,000.0; 1,000,000 v., 1,176,000.0; 1,500,000 v., 1,764,000.0; 2,000,000 v., 2,352,000.0; 2,500,000 v., 2,940,000.0; 3,000,000 v., 3,528,000.0; 4,000,000 v., 4,704,000.0; 5,000,000 v., 5,880,000.0; 6,000,000 v., 7,056,000.0; 7,500,000 v., 8,820,000.0; 10,000,000 v., 11,760,000.0; 15,000,000 v., 17,640,000.0; 20,000,000 v., 23,520,000.0; 25,000,000 v., 29,400,000.0; 30,000,000 v., 35,280,000.0; 40,000,000 v., 47,040,000.0; 50,000,000 v., 58,800,000.0; 60,000,000 v., 70,560,000.0; 75,000,000 v., 88,200,000.0; 100,000,000 v., 117,600,000.0; 150,000,000 v., 176,400,000.0; 200,000,000 v., 235,200,000.0; 250,000,000 v., 294,000,000.0; 300,000,000 v., 352,800,000.0; 400,000,000 v., 470,400,000.0; 500,000,000 v., 588,000,000.0; 600,000,000 v., 705,600,000.0; 750,000,000 v., 882,000,000.0; 1,000,000,000 v., 1,176,000,000.0; 1,500,000,000 v., 1,764,000,000.0; 2,000,000,000 v., 2,352,000,000.0; 2,500,000,000 v., 2,940,000,000.0; 3,000,000,000 v., 3,528,000,000.0; 4,000,000,000 v., 4,704,000,000.0; 5,000,000,000 v., 5,880,000,000.0; 6,000,000,000 v., 7,056,000,000.0; 7,500,000,000 v., 8,820,000,000.0; 10,000,000,000 v., 11,760,000,000.0; 15,000,000,000 v., 17,640,000,000.0; 20,000,000,000 v., 23,520,000,000.0; 25,000,000,000 v., 29,400,000,000.0; 30,000,000,000 v., 35,280,000,000.0; 40,000,000,000 v., 47,040,000,000.0; 50,000,000,000 v., 58,800,000,000.0; 60,000,000,000 v., 70,560,000,000.0; 75,000,000,000 v., 88,200,000,000.0; 100,000,000,000 v., 117,600,000,000.0; 150,000,000,000 v., 176,400,000,000.0; 200,000,000,000 v., 235,200,000,000.0; 250,000,000,000 v., 294,000,000,000.0; 300,000,000,000 v., 352,800,000,000.0; 400,000,000,000 v., 470,400,000,000.0; 500,000,000,000 v., 588,000,000,000.0; 600,000,000,000 v., 705,600,000,000.0; 750,000,000,000 v., 882,000,000,000.0; 1,000,000,000,000 v., 1,176,000,000,000.0; 1,500,000,000,000 v., 1,764,000,000,000.0; 2,000,000,000,000 v., 2,352,000,000,000.0; 2,500,000,000,000 v., 2,940,000,000,000.0; 3,000,000,000,000 v., 3,528,000,000,000.0; 4,000,000,000,000 v., 4,704,000,000,000.0; 5,000,000,000,000 v., 5,880,000,000,000.0; 6,000,000,000,000 v., 7,056,000,000,000.0; 7,500,000,000,000 v., 8,820,000,000,000.0; 10,000,000,000,000 v., 11,760,000,000,000.0; 15,000,000,000,000 v., 17,640,000,000,000.0; 20,000,000,000,000 v., 23,520,000,000,000.0; 25,000,000,000,000 v., 29,400,000,000,000.0; 30,000,000,000,000 v., 35,280,000,000,000.0; 40,000,000,000,000 v., 47,040,000,000,000.0; 50,000,000,000,000 v., 58,800,000,000,000.0; 60,000,000,000,000 v., 70,560,000,000,000.0; 75,000,000,000,000 v., 88,200,000,000,000.0; 100,000,000,000,000 v., 117,600,000,000,000.0; 150,000,000,000,000 v., 176,400,000,000,000.0; 200,000,000,000,000 v., 235,200,000,000,000.0; 250,000,000,000,000 v., 294,000,000,000,000.0; 300,000,000,000,000 v., 352,800,000,000,000.0; 400,000,000,000,000 v., 470,400,000,000,000.0; 500,000,000,000,000 v., 588,000,000,000,000.0; 600,000,000,000,000 v., 705,600,000,000,000.0; 750,000,000,000,000 v., 882,000,000,000,000.0; 1,000,000,000,000,000 v., 1,176,000,000,000,000.0; 1,500,000,000,000,000 v., 1,764,000,000,000,000.0; 2,000,000,000,000,000 v., 2,352,000,000,000,000.0; 2,500,000,000,000,000 v., 2,940,000,000,000,000.0; 3,000,000,000,000,000 v., 3,528,000,000,000,000.0; 4,000,000,000,000,000 v., 4,704,000,000,000,000.0; 5,000,000,000,000,000 v., 5,880,000,000,000,000.0; 6,000,000,000,000,000 v., 7,056,000,000,000,000.0; 7,500,000,000,000,000 v., 8,820,000,000,000,000.0; 10,000,000,000,000,000 v., 11,760,000,000,000,000.0; 15,000,000,000,000,000 v., 17,640,000,000,000,000.0; 20,000,000,000,000,000 v., 23,520,000,000,000,000.0; 25,000,000,000,000,000 v., 29,400,000,000,000,000.0; 30,000,000,000,000,000 v., 35,280,000,000,000,000.0; 40,000,000,000,000,000 v., 47,040,000,000,000,000.0; 50,000,000,000,000,000 v., 58,800,000,000,000,000.0; 60,000,000,000,000,000 v., 70,560,000,000,000,000.0; 75,000,000,000,000,000 v., 88,200,000,000,000,000.0; 100,000,000,000,000,000 v., 117,600,000,000,000,000.0; 150,000,000,000,000,000 v., 176,400,000,000,000,000.0; 200,000,000,000,000,000 v., 235,200,000,000,000,000.0; 250,000,000,000,000,000 v., 294,000,000,000,000,000.0; 300,000,000,000,000,000 v., 352,800,000,000,000,000.0; 400,000,000,000,000,000 v., 470,400,000,000,000,000.0; 500,000,000,000,000,000 v., 588,000,000,000,000,000.0; 600,000,000,000,000,000 v., 705,600,000,000,000,000.0; 750,000,000,000,000,000 v., 882,000,000,000,000,000.0; 1,000,000,000,000,000,000 v., 1,176,000,000,000,000,000.0; 1,500,000,000,000,000,000 v., 1,764,000,000,000,000,000.0; 2,000,000,000,000,000,000 v., 2,352,000,000,000,000,000.0; 2,500,000,000,000,000,000 v., 2,940,000,000,000,000,000.0; 3,000,000,000,000,000,000 v., 3,528,000,000,000,000,000.0; 4,000,000,000,000,000,000 v., 4,704,000,000,000,000,000.0; 5,000,000,000,000,000,000 v., 5,880,000,000,000,000,000.0; 6,000,000,000,000,000,000 v., 7,056,000,000,000,000,000.0; 7,500,000,000,000,000,000 v., 8,820,000,000,000,000,000.0; 10,000,000,000,000,000,000 v., 11,760,000,000,000,000,000.0; 15,000,000,000,000,000,000 v., 17,640,000,000,000,000,000.0; 20,000,000,000,000,000,000 v., 23,520,000,000,000,000,000.0; 25,000,000,000,000,000,000 v., 29,400,000,000,000,000,000.0; 30,000,000,000,000,000,000 v., 35,280,000,000,000,000,000.0; 40,000,000,000,000,000,000 v., 47,040,000,000,000,000,000.0; 50,000,000,000,000,000,000 v., 58,800,000,000,000,000,000.0; 60,000,000,000,000,000,000 v., 70,560,000,000,000,000,000.0; 75,000,000,000,000,000,000 v., 88,200,000,000,000,000,000.0; 100,000,000,000,000,000,000 v., 117,600,000,000,000,000,000.0; 150,000,000,000,000,000,000 v., 176,400,000,000,000,000,000.0; 200,000,000,000,000,000,000 v., 235,200,000,000,000,000,000.0; 250,000,000,000,000,000,000 v., 294,000,000,000,000,000,000.0; 300,000,000,000,000,000,000 v., 352,800,000,000,000,000,000.0; 400,000,000,000,000,000,000 v., 470,400,000,000,000,000,000.0; 500,000,000,000,000,000,000 v., 588,000,000,000,000,000,000.0; 600,000,000,000,000,000,000 v., 705,600,000,000,000,000,000.0; 750,000,000,000,000,000,000 v., 882,000,000,000,000,000,000.0; 1,000,000,000,000,000,000,000 v., 1,176,000,000,000,000,000,000.0; 1,500,000,000,000,000,000,000 v., 1,764,000,000,000,000,000,000.0; 2,000,000,000,000,000,000,000 v., 2,352,000,000,000,000,000,000.0; 2,500,000,000,000,000,000,000 v., 2,940,000,000,000,000,000,000.0; 3,000,000,000,000,000,000,000 v., 3,528,000,000,000,000,000,000.0; 4,000,000,000,000,000,000,000 v., 4,704,000,000,000,000,000,000.0; 5,000,000,000,000,000,000,000 v., 5,880,000,000,000,000,000,000.0; 6,000,000,000,000,000,000,000 v., 7,056,000,000,000,000,000,000.0; 7,500,000,000,000,000,000,000 v., 8,820,000,000,000,000,000,000.0; 10,000,000,000,000,000,000,000 v., 11,760,000,000,000,000,000,000.0; 15,000,000,000,000,000,000,000 v., 17,640,000,000,000,000,000,000.0; 20,000,000,000,000,000,000,000 v., 23,520,000,000,000,000,000,000.0; 25,000,000,000,000,000,000,000 v., 29,400,000,000,000,000,000,000.0; 30,000,000,000,000,000,000,000 v., 35,280,000,000,000,000,000,000.0; 40,000,000,000,000,000,000,000 v., 47,040,000,000,000,000,000,000.0; 50,000,000,000,000,000,000,000 v., 58,800,000,000,000,000,000,000.0; 60,000,000,000,000,000,000,000 v., 70,560,000,000,000,000,000,000.0; 75,000,000,000,000,000,000,000 v., 88,200,000,000,000,000,000,000.0; 100,000,000,000,000,000,000,000 v., 117,600,000,000,000,000,000,000.0; 150,000,000,000,000,000,000,000 v., 176,400,000,000,000,000,000,000.0; 200,000,000,000,000,000,000,000 v., 235,200,000,000,000,000,000,000.0; 250,000,000,000,000,000,000,000 v., 294,000,000,000,000,000,000,000.0; 300,000,000,000,000,000,000,000 v., 352,800,000,000,000,000,000,000.0; 400,000,000,000,000,000,000,000 v., 470,400,000,000,000,000,000,000.0; 500,000,000,000,000,000,000,000 v., 588,000,000,000,000,000,000,000.0; 600,000,000,000,000,000,000,000 v., 705,600,000,000,000,000,000,000.0; 750,000,000,000,000,000,000,000 v., 882,000,000,000,000,000,000,000.0; 1,000,000,000,000,000,000,000,000 v., 1,176,000,000,000,000,000,000,000.0; 1,500,000,000,000,000,000,000,000 v., 1,764,000,000,000,000,000,000,000.0; 2,000,000,000,000,000,000,000,000 v., 2,352,000,000,000,000,000,000,000.0; 2,500,000,000,000,000,000,000,000 v., 2,940,000,000,000,000,000,000,000.0; 3,000,000,000,000,000,000,000,000 v., 3,528,000,000,000,000,000,000,000.0; 4,000,000,000,000,000,000,000,000 v., 4,704,000,000,000,000,000,000,000.0; 5,000,000,000,000,000,000,000,000 v., 5,880,000,000,000,000,000,000,000.0; 6,000,000,000,000,000,000,000,000 v., 7,056,000,000,000,000,000,000,000.0; 7,500,000,000,000,000,000,000,000 v., 8,820,000,000,000,000,000,000,000.0; 10,000,000,000,000,000,000,000,000 v., 11,760,000,000,000,000,000,000,000.0; 15,000,000,000,000,000,000,000,000 v., 17,640,000,000,000,000,000,000,000.0; 20,000,000,000,000,000,000,000,000 v., 23,520,000,000,000,000,000,000,000.0; 25,000,000,000,000,000,000,000,000 v., 29,400,000,000,000,000,000,000,000.0; 30,000,000,000,000,000,000,000,000 v., 35,280,000,000,000,000,000,000,000.0; 40,000,000,000,000,000,000,000,000 v., 47,040,000,000,000,000,000,000,000.0; 50,000,000,000,000,000,000,000,000 v., 58,800,000,000,000,000,000,000,000.0; 60,000,000,000,000,000,000,000,000 v., 70,560,000,000,000,000,000,000,000.0; 75,000,000,000,000,000,000,000,000 v., 88,200,000,000,000,000,000,000,000.0; 100,000,000,000,000,000,000,000,000 v., 117,600,000,000,000,000,000,000,000.0; 150,000,000,000,000,000,000,000,000 v., 176,400,000,000,000,000,000,000,000.0; 200,000,000,000,000,000,000,000,000 v., 235,200,000,000,000,000,000,000,000.0; 250,000,000,000,000,000,000,000,000 v., 294,000,000,000,000,000,000,000,000.0; 300,000,000,000,000,000,000,000,000 v., 352,800,000,000,000,000,000,000,000.0; 400,000,000,000,000,000,000,000,000 v., 470,400,000,000,000,000,000,000,000.0; 500,000,000,000,000,000,000,000,000 v., 588,000,000,000,000,000,000,000,000.0; 600,000,000,000,000,000,000,000,000 v., 705,600,000,000,000,000,000,000,000.0; 750,000,000,000,000,000,000,000,000 v., 882,000,000,000,000,000,000,000,000.0; 1,000,000,000,000,000,000,000,000,000 v., 1,176,000,000,000,000,000,000,000,000.0; 1,500,000,000,000,000,000,000,000,000 v., 1,764,000,000,000,000,000,000,000,000.0; 2

BAND 3 T.V. CONVERTERS

12 months' guarantee. 1/6 extra C.O.D.

For all I.T.A. stations and all sets except Philips (see next column).

State B.B.C. Pattern rejector fitted. All fully wired, aligned and ready for use. All with power pack, knobs, aerial switching, metal rectifier and 2 valves ECC81. Direct switching from B.B.C. to I.T.A. Fine tuning on front. No drift.

DON'T FIDDLE at the back of your set, our converters have rubber feet to stand on top where you can reach.

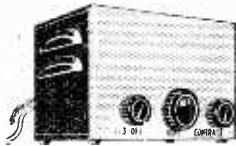

£4.7.6 (p. & p. 2/6)

With metal cabinet as illustrated. Stove enamel grey hammer finish.

Or Walnut cabinet,

£4.17.6. Lizard Rexine, £4.12.6 (p. & p. 2/6).

Or chassis, i.e., less cabinet, £4 (p. & p. 2/6).

Variable attenuator, 7/6 (p. & p. 1/-).

Aerial Splitter, 8/- (p. & p. 1/-).

Band III Aerials, mast mounting: Carr. Paid
3-element, 27/-; 5-element, 35/-; 8-element, 55/-.

Low-loss Co-axial, 8d. yard.

Tinted Perspex Screens (by I.C.I.).

14½ in. by 11 in., 6/6. Carr. paid.

Our aerials are suitable for loft mounting.

Watch for our new Bristol address.

THE CONVERTER PEOPLE — GLADSTONE RADIO

82B, HIGH STREET, CAMBERLEY, SURREY.

OPEN SATS. TO 5 p.m.

HERE IT IS

A SUPERB "ADD-ON" CONVERTER

Designed and made by a world-famous organisation regardless of expense. Tunable over the whole of Band I and Band III to give one Band I and two Band III stations at the turn of the switch. Acts as Two-valve Pre-amplifier on Band I. Valves PCC84 and PCF.80. No drift. In Moulded Bakelite Cabinet, 8½ in. x 4½ in. x 6 in. high. With full operating instructions. Built-in Power Pack added by us. Separate gain controls for I.T.A. and B.B.C. Not recommended for T.R.F. receivers, owing to danger of re-radiation by receiver.



£5.5.0 (plus 2/6 p. & p.) C.O.D. 1/6 extra.

CONVERTER available for Philips' receivers in the above bakelite case, complete with built-in power pack, at £5. 5. 0 plus 2/6 p. & p. C.O.D. 1/6 extra. All converters by return of post; aerials by rail.

A CHEAPER YET EFFICIENT BAND III CONVERTER in Walnut Cabinet, size 9 in. x 6 in. x 5½ in. Available at £4.7.6 (p. & p. 2/6, 1/6 C.O.D.)

Chassis by another well-known T.V. manufacturer and incorporates Power Pack. Valves PCC84 and ECC81. Direct switching I.T.A. to B.B.C.



CHASSIS

Let us supply the chassis for your set. We are specialists in this field and actual makers of aluminium chassis. Supplied either plain or with the large and awkward holes already drilled.

UNDRILLED ALUMINIUM CHASSIS

| 4 sides 1½ in. deep | 2 sides 2 in. deep |
|--------------------------|--------------------------|
| Welded Corners | 7 in. x 4 in., 3/- ea. |
| 7 in. x 4 in., 4/3 ea. | 9 in. x 6 in., 4/- ea. |
| 9 in. x 6 in., 5/6 ea. | 11 in. x 7 in., 4/9 ea. |
| 11 in. x 7 in., 6/6 ea. | 13 in. x 9 in., 6/- ea. |
| 13 in. x 9 in., 7/9 ea. | 14 in. x 11 in., 7/6 ea. |
| 14 in. x 11 in., 9/- ea. | 16 in. x 14 in., 9/6 ea. |

Send sketch of your requirements for prices by return to:—

Oliver & Randall Ltd.
53 Perry Hill, London, S.E.6

EDDY'S (Nottm.) LTD.

(DEPT. P.T.)

172 ALFRETON ROAD, NOTTINGHAM

THIS MONTH'S SPECIAL OFFERS

CAR RADIO AERIALS 26/11. Postage 1/6 each. Brand new, best quality chrome. Please state side or wing fitting. Co-ax lead with terminals for above 4/- extra.
MU-METAL SCREENING CANS for mike transformers. 5/6 each. 6d. extra post.
RECORDING TAPE. 1,200ft. reels. Good quality. 9/11 each. Postage 1/- each.

Any parcel insured against damage in transit 6d. EXTRA.

NEW AND GUARANTEED

VALVES

| | | | |
|--------------|-------------|------------|---|
| AZ1 12/11 | EF91 7/11 | UBC41 8/11 | Postage and Packing 6d. per valve extra, over £2 FREE |
| CY31 12/11 | EL32 5/11 | UF42 13/6 | 6X4 6/11 |
| DAF96 9/6 | EL84 10/3 | UL41 9/11 | 6SK7 4/11 |
| DF96 9/6 | EY51 9/6 | UL84 9/6 | 6U4GT13/11 |
| DK96 9/6 | EY86 10/3 | UY41 7/11 | 12AH8 10/6 |
| DL96 9/6 | EZ80 8/3 | VUIH 1/6 | 12J7GT 9/6 |
| DM70 7/11 | EZ81 9/11 | IR5 7/6 | 12K7G 8/11 |
| EABC80 7/6 | GZ32 12/6 | IS5 7/3 | 12Q7G 9/6 |
| EB91 6/11 | MS-PEN(7) | IT4 7/3 | 12SJ7 7/11 |
| ECC83 8/3 | 9/6 | 3V4 8/6 | 12SK7 5/11 |
| ECC84 10/11 | MSP41(7) | 5Z4G 8/3 | 12SH7 5/6 |
| ECC85 9/- | 9/6 | 5Y3GT 7/6 | 1457 12/11 |
| ECH35 9/ | MU14 8/11 | 6AT6 7/11 | 19AQ5 11/6 |
| ECH42 9/11 | PCC84 10/11 | 6BA6 7/3 | 25Z4G 8/11 |
| ECH81 8/11 | PCF80 9/11 | 6B6 7/11 | 35A5 10/6 |
| ECL80 8/11 | PCL83 11/9 | 6BMG 3/6 | 35Z4G 8/3 |
| EF39 5/11 | PL2 8/11 | 6188 3/11 | 35W4 8/11 |
| EF40 10/11 | PL3 11/6 | 6K7G 2/11 | 80 1/6 |
| EF41 9/6 | PY80 8/11 | 6K8G 9/6 | 955 3/11 |
| EF50(R) 6/11 | PY81 8/3 | 6Q7G 8/3 | 956 2/6 |
| EF80 8/3 | PY82 8/3 | 6V6GT 5/11 | 958 3/11 |
| EF85 10/6 | UBF80 9/6 | 6V6M 7/11 | 807 3/11 |
| EF89 9/6 | | | |

C.O.D. & C.W.O. ONLY. NO LISTS. TRADE ENQUIRIES INVITED.

CORRESPONDENCE

The Editor does not necessarily agree with the opinions expressed by his correspondents. All letters must be accompanied by the name and address of the sender (not necessarily for publication).

TRANSISTORISED TIMEBASE

SIR.—With reference to your article on the Television Society's Exhibition (May, 1957), you give a circuit and text for the transistorised timebase unit by the G.E.C. which, I think, requires correction. V3, in the line timebase section, is shown, and described as a P-N-P transistor, when, in fact, it should be a N-P-N type. Perhaps this mistake has arisen from someone misinterpreting the circuit symbols for the two different types of transistors, in which case it should give added strength to the argument for standardised symbols for transistors. Another point about the circuit concerns the resistor from the collector of V2, the frame sync. separator and clipper. Should this be a 22 k Ω and not a 15 k Ω resistor as shown?

Getting back to transistors in general, what about an article by one of your expert writers describing the exact functions of transistors? We all know how thermionic valves do their work, with the function of each electrode, but transistors seem to be an unknown quantity to most people.—GORDON WHITLEY (Rotherham).
[Such an article has already appeared.—ED.]

COLOUR TELEVISION

SIR.—In a recent editorial you referred to the chaos which is being caused in America by a too premature introduction of colour television. This not only spoils the sale of standard monochrome receivers but it also had a disastrous effect on the sales of ordinary broadcast receivers. I know people in this country are deferring scrapping old-fashioned 9-inch TV receivers because they fear that whatever set they now buy will be rendered obsolete very soon by the introduction of colour TV. As a dealer I am glad to note that you are campaigning against the commonly held belief that colour TV is imminent. When it does come viewers will be able to receive the programmes in monochrome as at present. For my own part, having witnessed most of the colour TV demonstrations I think it has a long way to go before it has reached a standard comparable to colour films. It would be a great mistake for manufacturers to go into production in colour TV at the present state of its development. Baird made the fatal mistake of marketing his crude Nipkow disc machine without, he it noted, giving any credit to the real inventor—Paul Nipkow) before even that was ready. Thousands of these machines were sold which failed to receive pictures and caused dealers no end of trouble. We were, of course, all very new to TV in those days, but in many cases when the firms' service engineers were called in they too failed to achieve any results. There was always the stock excuse of fringe areas, screening, steel buildings, etc.

One more point. Is the British public really waiting for colour TV? I understand that such

sets at present are extremely troublesome and they are certainly likely to be very costly.—J. E. SILLIE (Paisley).

DABBLE AMATEURS

SIR.—Amateurs are more and more tending to encroach upon the livelihood of the recognised dealer. In my district I am expected to supply spares at trade prices to customers who claim that they wish to carry out their own repairs. Their calls, however, are far too frequent for this to be true and I have evidence that they are really spending their evenings as travelling servicemen and, of course, greatly undercutting prices. I do not in any case grant trade discount and charge full retail prices, but these amateurs are still able to quote below my prices because they have not the overheads of rates, taxes, staff, etc., to meet.

I know that in some districts so-called professional servicemen have brought our trade into disrepute through their extortionate charges and utter incompetence, but in general the trade is insisting upon a high standard of ability and the charlatans are dying out. It really is too much, however, when a customer comes in with a set and asks me to line it up because he has not the necessary apparatus. One customer even asked if he might be allowed to use my test gear! He had not even bought the spares from me.

I realise, of course, that many of your readers are extremely knowledgeable and know as much, if not more than, some radio dealers. Armed with the service data which you regularly publish and with the assistance of your explanatory articles they are well able to carry out most of the major repairs. My solution to the problem is that local dealers should themselves employ these part-time workers in the evenings even though they prefer to work at home. They would call at the dealers for work and be paid an agreed fee when the set had been returned and had passed an acceptance test. Dealers find it difficult to obtain skilled staff. Most of them are in arrears with their work and cannot give prompt service, and this might provide an easy solution to the labour problem.—ANTI-DABBLER (London E.2).

SUPERVISOR SERVICE DATA

SIR.—Many of your readers residing in my district have built your very successful Supervisor. Indeed, I built one myself and showed it in my shop window, offering to help local readers who had encountered difficulties in construction. Could you publish service data for this receiver for the benefit of dealers

SPECIAL NOTE

Will readers please note that we are unable to supply Service Sheets or Circuits of ex-government apparatus, or of proprietary makes of commercial receivers. We regret that we are also unable to publish letters from readers seeking a source of supply of such apparatus.

who are often called upon to service the Supervisor?

I am not one who is opposed to home-constructed receivers, and indeed a local radio club meets once a week in my workshop and I allow them the use of my equipment for a nominal charge per week provided they do not undertake private servicing. I have found this arrangement pays handsomely, for the members have recommended me, and I have sold a large number of receivers as a result and greatly increased my clientele. Yours is the only journal of real value to the keen television viewer, and I happen to know, although it is produced for members of the public, that large numbers of dealers also take it. I have my copies on file in one of your loose binders and with the indexes to each volume I find the issues most useful, especially when I strike an obscure fault.—DEALER (Hemel Hempstead).

RHOMBIC AERIALS

SIR,—*Re Rhombic TV Aerials* (July issue), the rhombic shown is horizontally polarised (as American TV radiations are) and thus is of use in this country except where the required transmission is horizontally polarised.

To use it for the majority of our transmissions, the rhombic would have to be stood up on end, with the obtuse angles at top and bottom. Owing to the height required, especially for Band I frequencies, it is then not a very practical proposition.

A better arrangement is the half-rhombic in such cases, where only the two top legs are needed, supported by a mast at its apex. Terminating resistance is then 300Ω and matching can be effected by Q-bars at the "receiver" end. The ends of the aerial can be brought down to ground level, though for convenience the Q-bars can be mounted on short wooden posts.

I have used such an aerial myself in the days of "A.P." when signal strength here was very low—of the order of a few μ V only. The half-rhombic produced far more signal than a 4-element Yagi array, and the front/back ratio was far superior. Passing cars produced little more than a momentary "burp" as they passed the house.

In my case the Q-bars were two 5ft. 6in. lengths of $\frac{3}{4}$ in. water-pipe, mounted on stand-off insulators. At the end to which the co-ax was terminated they were spaced $\frac{1}{4}$ in. apart, and the other ends were opened out to produce the maximum signal strength. This distance was about 6in. The top bar was joined to the aerial wire, the lower bar being connected to an earth spike. The two legs of the wire were three wavelengths long (about 66ft. each leg) at 43mc/s. The mast was 52ft. high, and the spread at the bottom of the aerial was about 90ft. This aerial, good though it was, had to be abandoned due to stray earth currents from the trolley-bus system causing random noise.—W. E. THOMPSON (St. Leonards).

THE PRE-WAR P.T.

SIR.—How many of your present readers were also readers of your earlier essay into the field of television journalism—*Practical Tele-*

vision and Short Wave Review, the first issue of which was published in September, 1934, and which ran until November, 1935? I have all of the issues and shall retain them for historical purposes as they contain everything one wishes to know about the early days of television and disc machines, mirror drums, mirror screws, etc. I spent a small fortune experimenting with those crude devices but I do not regret it. The journal was then of course ahead of its time and it suspended publication.—E. J. S. (Dorking).

BAIRD AND TV

SIR,—It is quite true as you state that Baird was not responsible for inventing high definition television and it is equally true that he was not responsible for inventing the disc machine which is now defunct. I was stupid enough to buy one of these machines at a time when thirty-line transmissions were taking place; it was only on very rare occasions that I got a very hazy picture. The machine itself had obviously not been designed by anyone having the slightest knowledge of engineering. It was crude in the extreme. It seemed to me that it had been designed and made by an amateur, instead of being handed over to skilled engineers to be modified for mass production. As a fact it did television a great amount of harm at that time, because members of the public who asked their friends how the set was working, were informed that it was a flop and seldom worked. Some even used harsher terms. How a company could market such a device, I do not know. But it must have put off a lot of would-be customers. It is my view that Baird was experimenting for his own amusement with Nipkow's disc, a financier saw it and Baird had not the courage because of his Scottish vanity to admit that it was a crib.—H. D. Lewisham.

[Baird did not of course invent anything to do with modern television and very little in connection with low definition television, and it is right that in the interests of historical accuracy, and before history gives the credit to Baird as they have with Dunlop and others, that the facts should be widely known. On the other hand it is only fair that credit should be given to Baird for arousing interest in the subject and setting trained minds to work. There is nothing in television to-day for which credit should be given to Baird.—ED.]

BOOKS FOR TV ENTHUSIASTS

TELEVISION PRINCIPLES AND PRACTICE by F. J. Camm. 2nd edition. 25s. or 26s. by post.

PRACTICAL TELEVISION CIRCUITS by F. J. Camm. 15s. or 16s. by post.

BUILDING THE "PRACTICAL TELEVISION" RECEIVER by F. J. Camm. 3s. 6d. or 4s. by post.

From all newsagents or
from The Book Department.

GEORGE NEWNES LTD.,
Tower House, Strand, W.C.2.

Presenting the new HOMELAB range of SIGNAL GENERATORS

TYPE 2

100 kc/s. to 100 Mc/s CW or 400~ modulation. Audio signal for amplifier tests PRICE : £4.10.0d., p. & p. 5/-

TYPE 12

100 kc/s. to 130 Mc/s. Sine and square wave modulation at 1,000~. Sine or square wave signal for amplifier tests PRICE £8.10.0d., p. & p. 5/-

TYPE 20

An AM/FM signal generator covering all modern radio and TV requirements up to 240 Mc/s PRICE £15.15.0d., p. & p. 5/-

Send stamp for full details of above, and also our Mullard FM Tuner complete with power supply PRICE : £12.0.0d.

HOMELAB INSTRUMENTS LIMITED

615-617, HIGH ROAD, LEYTON, LONDON, E.10

Telephone : LEYtonstone 6851

BENTLEY ACOUSTIC CORPORATION LTD.

EXPRESS SERVICE :

G.O.D. ORDERS RECEIVED BY 3.30 P.M. EITHER BY LETTER, PHONE, OR WIRE, DESPATCHED SAME AFTERNOON.

THE VALVE SPECIALISTS

38, CHALCOT RD., LONDON, N.W.1

FRImrose 9090

FOR ONLY 6d. EXTRA PER ORDER WE WILL INSURE YOUR VALVES AGAINST DAMAGE IN TRANSIT. ALL UNSURED PARCELS AT CUSTOMERS' RISK.

| | | | | | | | | | | | | | | | | | | | | | | | | |
|------|--------|------|------|---------|-------|-------|--------|---------|--------|---------|-------|-------|-------|----------|-------|-------|-------|---------|---------|-------|-------|----------|-------|----|
| 62A | 6-5AC7 | 6.6 | 6F13 | 13-6177 | 8.6 | 12H1M | 3- | 352A0T | 8- | B320 | 10.6 | 1E191 | 6.6 | 1E191 | 9- | KTW63 | 8- | Q121 | 7- | 1L46 | 15- | | | |
| 1A3 | 3-6A45 | 6.6 | 6F16 | 9.6 | 6V66 | 7- | 12350T | 4- | 352A0T | 8.6 | 1L523 | 7.6 | 1E192 | 15- | 1E192 | 6.6 | KTZ41 | 6- | Q121B | 12.6 | 1L54 | 11.6 | | |
| 1A7 | 6-6A45 | 12.6 | 6F17 | 12.6 | 6V66T | 7- | 12350T | 11- | 41MP | 12.6 | 6V623 | 6.6 | 1E193 | 7.6 | 1E193 | 5.6 | KTZ63 | 10.6 | Q125 | 6.6 | 1L9 | 8.6 | | |
| 1A9 | 12.6 | 6A45 | 8- | 6F22 | 10.6 | 6N4 | 7- | 12K70T | 8.6 | 41MTL | 7.6 | 6V625 | 6.6 | 1E194 | 10- | 1E141 | 10.6 | 1A6 | 6- | Q1510 | 15 | 1L41 | 8.6 | |
| 1D6 | 10.6 | 6A45 | 5- | 6F23 | 12.6 | 6N50T | 6.6 | 12K80T | 11.4 | 3005 | 12.6 | 6V63 | 10.6 | 1E195 | 9.6 | 1E142 | 11- | 1M14 | 7- | 10.6 | 1L55 | 10.6 | | |
| 1H5 | 11- | 6A45 | 7.6 | 6G6 | 8.6 | 6Z41 | 12.6 | 12Q70T | 8.6 | 501.60T | 8.6 | 6V85 | 12.6 | 1E196 | 9.6 | 1E181 | 15- | 1M14 | 7.6 | 1R12 | 14- | 1L597 | 5- | |
| 1L1 | 6.6 | 6A45 | 6.6 | 6H63 | 2.6 | 6Z5 | 12.6 | 12R37 | 8.6 | 57 | 8.6 | 6V271 | 10.6 | 1E197 | 5.6 | 1E181 | 10.6 | 1M1.106 | | 5.06 | 12.7 | 1L58492A | 13.6 | |
| 1L15 | 5- | 6A45 | 5- | 6H6M | 3.6 | 6Z60 | 12.6 | 12R37 | 7.6 | 58 | 8.6 | 6V425 | 30- | 1E198 | 4- | 1E181 | 5- | 12.6 | 1M1.106 | | 15 | 1L58492A | 15.6 | |
| 1L23 | 5- | 6A46 | 9- | 6H69 | 5- | 7A7 | 12.6 | 12R67 | 7.6 | 61ET | 12.6 | 1D1 | 3- | 1E199 | 15- | 1E183 | 10- | 1M16 | 6.6 | 1P41 | 3.6 | 1L594 | 6.6 | |
| 1N2 | 11- | 6A45 | 7.6 | 6H65T | 5.6 | 7A7 | 8- | 12R17 | 5.6 | 61ST | 15- | 1D42 | 10.6 | 1E202 | 10.6 | 1E180 | 10.6 | 1M14 | 8.6 | 1P42 | 12.6 | 1L594 | 15- | |
| 1R5 | 8.6 | 6A48 | 10- | 6H67M | 6- | 7C5 | 8- | 12R37 | 8.6 | 72 | 4.6 | 1D63 | 5- | 1E203 | 8.6 | 1E151 | 10.6 | 1N109 | 10.6 | 1P41 | 3.6 | 1L597 | 7- | |
| 1S5 | 7.6 | 6A46 | 8.6 | 6H66 | 5.6 | 7C6 | 8- | 12R37 | 6.6 | 77 | 8- | 1D77 | 6.6 | 1E205 | 8.6 | 1E156 | 10.6 | 1O13 | 9- | 1H30T | 25- | 1L593 | 6.6 | |
| 1T4 | 7- | 6B34 | 6- | 6H73 | 6- | 7H7 | 8- | 12R07 | 8.6 | 78 | 8.6 | 1E472 | 11- | 1E209 | 15- | 1E155 | 6.6 | 1O13 | 8- | 1P22 | 10.6 | 1L591 | 8.6 | |
| 1T5 | 7- | 6B37 | 10.6 | 6H73T | 9.6 | 7H7 | 9- | 12R07 | 8.6 | 80 | 8.6 | 1E474 | 7.6 | 1E208 | 8.6 | 1E156 | 6.6 | 1P41 | 3.6 | 1L59 | 12- | 1L593 | 12.6 | |
| 2A2 | 12.6 | 6B36 | 6.6 | 6H74 | 5- | 7A7 | 8.6 | 12136 | 7.6 | 83 | 8.6 | 1E476 | 9.6 | 1E202 | 7.6 | 1E141 | 10.6 | 1P40 | 1.22 | 7.6 | 1L594 | 5- | | |
| 2C26 | 4- | 6B3M | 4.6 | 6K47 | 6- | 7Y4 | 8- | 12Y4 | 10.6 | 85A2 | 15- | 1D630 | 7- | 1E208 | 8.6 | 1E15 | 15- | 1.25 | 13.6 | 1L591 | 5- | | | |
| 2D13 | 7.6 | 6B34 | 7.6 | 6K48 | 8- | 8D3 | 9- | 11R7 | 10.6 | 150R2 | 15- | 1D63 | 11- | 1E208 | 10- | 1E151 | 10- | 1P41 | 8- | 1L59 | 9- | 1L597 | 8.6 | |
| 2X2 | 4.6 | 6B36 | 7.6 | 6K50T | 11- | 9D2 | 3- | 1487 | 14- | 210LF | 3- | 1D91 | 7.6 | 1E208 | 9.6 | 1E150 | 12.6 | 1P41 | 8- | 1L59 | 9- | 1L597 | 8.6 | |
| 3A4 | 7- | 6B36 | 8- | 6L13 | 10- | 10C3 | 15- | 11H1 | 10- | 807 | 6.6 | 1E483 | 6.6 | 1E209 | 5.6 | 1E152 | 12.6 | 1P40 | 7- | 1L59 | 8- | 1L591 | 12.6 | |
| 3A5 | 7- | 6B37 | 11.6 | 6L13 | 9- | 10C2 | 12- | 250H1 | 12- | 806A | 12.6 | 1D163 | 8.6 | 1E209 | 12.6 | 1E152 | 14- | 1P42 | 11.6 | 1L59 | 8- | 1L591 | 10- | |
| 3B7 | 6.6 | 6B36 | 6.6 | 6L17M | 8- | 10C1 | 15- | 20H1 | 13.6 | 88A | 10.6 | 1D176 | 8.6 | 1E152 | 12.6 | 1E150 | 5.6 | 1P42 | 12.6 | 1L59 | 7- | 1L591 | 11.6 | |
| 3D6 | 5- | 6B37 | 10- | 6L15 | 13- | 10C9 | 11.6 | 25H1.6 | 9- | 906 | 3- | 1D177 | 8.6 | 1E155 | 9.6 | 1E150 | 12.6 | 1P42 | 12.6 | 1L59 | 15- | 1L597M | 14- | |
| 3E4 | 9- | 6B36 | 10- | 6N7 | 8- | 10D8 | 11.6 | 25Z13 | 9- | 1203 | 7- | 1D182 | 12.6 | 1E152 | 10- | 1E150 | 10.6 | 1P40 | 1.22 | 15- | 1L79 | 12.6 | | |
| 3E5T | 9.6 | 6B37 | 8.6 | 6Q74 | 8.6 | 10D13 | 8.6 | 25Z5 | 10.6 | 1023 | 12.6 | 1D181 | 9.6 | 1E151 | 8.6 | 1E152 | 10.6 | 1P41 | 2.5 | 1.304 | 8.6 | 1L591.3 | 4- | |
| 3F1 | 8- | 6C3 | 7- | 6Q74T | 9- | 10D13 | 17.6 | 25Z09T | 8.6 | 1203 | 12.6 | 1D182 | 10- | 1E150 | 9.6 | 1E141 | 7.6 | 1P41 | 12.6 | 1L59 | 10.6 | 1L591 | 6.6 | |
| 3A1 | 8- | 6C3 | 6.6 | 6R74 | 8.6 | 11Z4 | 15- | 27- | 7.6 | 1193 | 5- | 1D186 | 9.6 | 1E15 | 10.6 | 1E141 | 7.6 | 1P41 | 12.6 | 1L59 | 10.6 | 1L591 | 6.6 | |
| 3A4 | 8- | 6C6 | 6.6 | 6R47 | 8.6 | 12A6 | 8.6 | 2D7 | 7- | 17475 | 7.6 | 1D12 | 15- | 1E156 | 4.6 | 12.6 | 1P41 | 13.6 | 1L59 | 10.6 | 1L591 | 4- | | |
| 3A4 | 12.6 | 6C6 | 8- | 6R67 | 8.6 | 12A17 | 8- | 30 | 7.6 | 1903 | 5.6 | 1D133 | 9.6 | 1E157A | 9- | 1L59 | 12.6 | 1P41 | 12.6 | 1L59 | 10.6 | 1L591 | 4- | |
| 3A1 | 10- | 6C9 | 12.6 | 6S17 | 8- | 12A18 | 10.6 | 30C1 | 12.6 | 1903 | 5.6 | 1D132 | 8- | 1E156 | 6- | 1L59 | 12.6 | 1P41 | 12.6 | 1L59 | 10.6 | 1L591 | 4- | |
| 3A3 | 7.6 | 6C9 | 10.6 | 6S17 | 8- | 12A19 | 10.6 | 30C5 | 12.6 | 1903 | 6- | 1D131 | 9- | 1E156 | 12.6 | 1E15 | 8.6 | 1P41 | 12.6 | 1L59 | 10.6 | 1L591 | 4- | |
| 3A4 | 10- | 6C9 | 7.6 | 6S17 | 5.6 | 12A17 | 8.6 | 30E11 | 12.6 | 1903PEN | 6.6 | 1D136 | 9.6 | 1E151 | 8.6 | 1E152 | 4- | 1L59 | 10.6 | 1L591 | 10.6 | 1L591 | 4- | |
| 3Z2 | 12.6 | 6D16 | 6.6 | 6H74T | 8- | 12A17 | 7.6 | 80H14 | 12.6 | 6.6 | 1D130 | 10.6 | 1E152 | 12.6 | 1E15 | 10.6 | 1P41 | 12.6 | 1L59 | 10.6 | 1L591 | 10.6 | 1L591 | 4- |
| 3Z13 | 10- | 6F1 | 15- | 6S85T | 7.6 | 12A17 | 9- | 30P12 | 13.8 | AV 11L | 10.6 | 1D170 | 8.6 | 1E156A | 7- | KT44 | 7- | 1P41 | 9- | 1L59 | 11.6 | 266 | 20- | |
| 3A5 | 10- | 6C9 | 6.6 | 6S87 | 7.6 | 12B36 | 9- | 31 | 7.6 | 11D | 15- | 1L50 | 2- | 1E150.15 | 5- | KT63 | 6.6 | 1P41 | 9- | 1L59 | 11.6 | 277 | 9- | |
| 3A17 | 8- | 6F5 | 10.6 | 6L14C | 14- | 12B36 | 10- | 33A 15M | AC194 | 8- | EA70 | 9.6 | 1E151 | 5- | KT61 | 6.6 | 1P42 | 7.6 | 1P40 | 10.6 | 274 | 12.6 | | |
| 3A18 | 10- | 6F12 | 9- | 6L36 | 7.6 | 12C1 | 30- | 35M | 30- | AL69 | 10- | EA870 | 7.6 | 1E153 | 10.6 | KT62 | 8- | 1P41 | 10- | 279 | 12.6 | | | |
| | | | | | | | | 35M | 12.6 | AP1 | 7.6 | EA91 | 9- | 1E150 | 8.6 | | | | | | | | | |
| | | | | | | | | 35A0 | 11- | APP4 | 3.6 | EA12 | 10.6 | 1E155 | 7.6 | | | | | | | | | |
| | | | | | | | | 35L0T | 9- | AZ1 | 12.6 | EB11 | 2- | 1E150 | 12.6 | | | | | | | | | |
| | | | | | | | | 35Z3 | 10.6 | B509 | 9- | 1L41 | 8.6 | 1E150 | 10- | | | | | | | | | |

Terms of business: Cash with order or C.O.D. only. Orders value £5 or more sent post free. Prices below £2 higher and 6d. per valve. C.O.D. orders, including post and packing 7/- We are open for personal shoppers. (Mon-Fri, 10am-6pm, Sat. 10am-5pm)

Please enquire for any valve, germanium diode, or transistor not listed. 2'd. stamp, please, or phone.

All valves new, box, lot, and subject to makers' guarantee. First rate goods only, no seconds or rejects. All orders received by post despatched same day A.M. for free delivery, but with full terms on back of order.

RADIO SUPPLY CO. (LEEDS) LTD.

Dept. N.
32, THE CALLS, LEEDS 2.

Post Terms C.W.O. or C.O.D. NO C.O.D. under £1. Postage 1/9 extra under £2. 2/9 under £5. Open to callers 9 a.m. to 5.30 p.m. Sats. until 1 p.m. S.A.E. with enquiries, please. Full list 6d.; Trade list 5d.

R.S.C. TRANSFORMERS

Fully Guaranteed.
Interleaved and Impregnated.
Primaries 200-230-250 v. 50 c/s screened
TOP SHROUDED DROP THROUGH
250-0-250 v 70 ma, 6.3 v 2a, 5 v 2a ... 18/9
350-0-350 v 80 ma, 6.3 v 2a, 5 v 2a ... 19/9
250-0-250 v 100 ma, 6.3 v 4a, 5 v 3a ... 23/9
350-0-350 v 100 ma, 6.3 v 4a, 5 v 3a ... 23/9
350-0-350 v 150 ma, 6.3 v 4a, 5 v 3a ... 29/9

FULLY SHROUDED UPRIGHT
250-0-250 v 60 ma, 6.3 v 2 a, 5 v 2 a
Midget type, 2 1/2-3 in. ... 17/9
250-0-250 v 100 ma, 6.3 v 4a, 5 v 2a ... 26/9
250-0-250 v 100 ma, 6.3 v 6 a, 5 v 3 a
for R1335 Conversion ... 31/-
300-0-300 v 100 ma, 6.3 v 4a, 5 v 3a ... 23/9
350-0-350 v 100 ma, 6.3 v 4a, 5 v 3a ... 23/9
350-0-350 v 150 ma, 6.3 v 4a, 0.4 v 3a ... 33/9
425-0-425 v 200 ma, 6.3 v 4 a, C.T. 6.3 v
4 a, C.T. 5 v 3 a ... 49/9

FILAMENT TRANSFORMERS
All with 200-250 v 50 c/s Primaries: 6.3 v
1.5 a, 5/9; 6.3 v 2 a, 7/6; 0-4-6.3 v 2 a, 7/9;
12 v 1a, 7/11; 6.3 v 3a, 8/11; 6.3 v 6 a, 17/9.
CHARGER TRANSFORMERS
200-250 v 0-9-15 v 1 a, 11/9; 0-9-15 v 3a, 16/9;
0-9-15 v 5 a, 19/9; 0-9-15 v 6 a, 22/9.

OUTPUT TRANSFORMERS
Standard Pentode 5,000 to 3 ohms ... 4/9
Small Pentode 5,000 to 3 ohms ... 3/9
P.I.L.T. TRANSFORMERS 200-230-250 v.
2,500 v 5 ma, 2-0-2 v 1.1 a, 2-0-2 v 1.1 a
for VCR97, VCR517 ... 36/6

SMOOTHING CHOKES
250 ma 5 h 50 ohms ... 11/9
100 ma 10 h 250 ohms ... 8/9
80 ma 10 h 350 ohms ... 5/8
60 ma 10 h 400 ohms ... 4/11

SELENIUM METAL RECTIFIERS
G.E.C. 300 v 250 ma, 12/9; 120 v 40 ma, 3/9;
6.12 v 1 a F.W., 4/11; 240 v 50 ma, 4/11;
6.12 v 2 a F.W., 3/6; 6.12 v 4 a, 14/9; 250 v
80 ma, 7/9; 6.12 v 6 a F.W., 19/9; 6.12 v
10 a, 25/9; 6.12 v 15 a, 35/9.

BATTERY SET CONVERTER KIT
All parts for converting any normal type
of Battery Receiver to A.C. mains 200-250 v
50 c/s. Supplies 120 v, 90 v or 60 v at 40 ma.
Fully smoothed and fully smoothed L.T.
of 2v at 0.4 a to 1 a. Price including circuit
49/9. Or ready for use, 9/9 extra.

**ALL DRY RECEIVER BATTERY
ELIMINATOR KIT**—All parts for the
construction of a unit (metal-case
5 1/4-2 in.) to supply Battery Portable
receivers requiring 90 v and 1.5 v. Fully
smoothed. From 200-250 v 50 c/s mains.
Price, inc. point-to-point wiring
diagrams, 39/9. Or ready for use, 46/9.

**EX-GOVT. DOUBLE WOUND STEP
UP/STEP DOWN TRANSFORMER**
10-0-100-200-220-240 v to 5-0-75-115-135 v
or REVERSE. 80/100 watts. Only 11/3,
plus 2/9 post.

EX-GOVT. CASES. Well ventilated black
crackle finished, undrilled cover. Size 14
x 10 x 8 in. high. IDEAL FOR BATTERY
CHARGER OR INSTRUMENT CASE.
OR COVER COULD BE USED FOR
AMPLIFIER. Only 9/9, plus 2/9 postage.
Size 13 1/2 x 8 1/2 x 6 1/2 in., with undrilled perforated
cover finished stoved grey enamel.
7/9, plus 2/9 post.

EX-GOVT. VALVES (NEW)

| | | | | | |
|-------|-----|-------|------|------|------|
| 1T4 | 7/9 | 6KT7 | 3/9 | 6AT5 | 7/9 |
| 1S5 | 7/9 | 6X5GT | 7/9 | EB91 | 8/9 |
| 3S4 | 8/9 | 6L6G | 11/9 | EF9 | 8/9 |
| 6K9C | 9/9 | 807 | 7/9 | EF36 | 4/9 |
| 6S9GT | 9/9 | 12A6 | 7/9 | EL32 | 4/9 |
| EF39 | 5/9 | 15D2 | 4/9 | EL91 | 5/9 |
| 6V6GT | 8/9 | 25Z4G | 9/9 | KT63 | 11/9 |
| 6U6G | 3/9 | MH4 | 4/9 | SP61 | 2/9 |

EX-GOVT. UNIT RDFI.—Brand new,
cartoned. Complete with 14 valves,
including 5Z4G. Also mains trans, L.F.
choke, rectifier, etc., etc. Only 29/8,
Carr. 7/9.

SMALL POTTED MAINS TRANSF.
Removed from New ex-Govt. units.
Primary 0-200-230-250 v Secs 250-0-
250 v 60 ma, 6.3 v 2 a, 5 v 2 a. **11/9**
Size 31 x 41 x 3 in.

CO-AXIAL CABLE 1 in.
75 ohms 14 36 ... 8d. yd.
Twinned screened Feeder ... 11d. 3d.

EX-GOVT. SMOOTHING CHOKES.—
100 ma 5 h 100 ohms Tropicalised ... 3/11
150 ma 6-10 h 150 ohms ... 6/9
150 ma 10 h 150 ohms ... 11/9
250 ma 5 h 50 ohms ... 12/9

E.H.T. SMOOTHERS
.02 mfd. 5,000 v Cans (ex-Govt.), 2/11.

BATTERY CHARGER KITS.—Consist-
ing of attractive Blue Hammer Case,
Transformer, T.W. Rectifier, Fuse, Fuse
Holder, Tag Strip Grommets and Circuits.
For mains input 200-230-250 v 50 c/s, 6 v 2 a,
25/9; 6 v or 12 v 2 a, 31/6; 6 v or 12 v 4 a,
35/9. Any type assembled and tested for
6/9 extra.

**R.S.C. 6 v or 12 v
BATTERY CHARGER**
For normal A.C. mains
input 200-230-250 v 50 c/s.
Selector panel for 6 v or
12 v charging. Variable
charge rate of up to 4
AMPS. Fused, and with
meter. Well ventilated
case with attractive
hammer finish. Guarant-
eed for 12 months.
75/-, Carr. 3/6.



TV CABINETS
Handsome well-constructed with walnut
vener finish. Size 18 in. high, 20 in. wide,
19 in. deep. Size of aperture 17 in. 19 in.
Fitted Doors. For 15 in. or 17 in. Tube.
Limited number at only
Plus 7/6 carr. **79/6**

BATTERY CHARGERS.—For mains
200-250 v 50 c/s. Output for charging 6 v or
12 v at 1 amp. In strong metal case. Only
25/9. Above can also be used for electric
train power supply.

St. Mary's Electronics

Radio — Television — Components

18, PRAED STREET, LONDON, W.2

Telephone: AMBassador 9795

T/V TUBES

| | | | | |
|-------------|--------|--------|--------|--------|
| | 12 in. | 14 in. | 15 in. | 17 in. |
| MULLARD ... | £5 | £6 | £6.10 | £7 |
| MAZDA ... | £5 | £6 | £6.10 | £7 |
| EMITRON ... | £4.10 | £6 | — | £7 |

Also various other makes of tubes in stock. Terms
3 months' Guarantee. C.W.O. P/P, Ins., 10/-.

12 in. Mazda Rebuilt Tubes £9 inclusive P/P. 6
months' Guarantee.

Special terms to the trade.

All makes of Valves supplied to the trade.
All types New Tubes on Credit Terms.

We also have a large selection of
TELEVISIONS, all working. 12 in. S/het Set
£14; 5 Channel £18.10. Carr. paid.

Write, phone or call letting us know your require-
ments. We will be pleased to assist you.

Please enclose payment with order.

TECHNICAL TRADING CO.

ATTRACTIVE 14 in. TABLE T.V. CABINETS. Size 17 in. x
19 in. x 6 in. complete with mask and glass, 7 1/4 front speaker
baffle, 29/-, post 6/-.

3 in. 15-OHM SPEAKERS, ex new equipment, smallish magnet,
9/6.

WIDE ANGLE FOCUSING MAGNET ASSEMBLIES, centring
control, complete, 9/6. Ditto, latest twin magnet type, 12/6.

13 CHANNEL CONVERTERS, famous make, complete PCC94,
PCF80, beaut. bakelite cabinet, adjustable all I.F. freqs.,
tunable all channels, no extra coils required. £3/15/-.

GERMANIUM CRYSTAL DIODES, famous make, tested,
general purpose, polarity marked, 10d., p. & p. 3d., 8/6 doz.

T.V. COILS consisting double slugged 1 in. formers in standard
small square cans, easily rewound as required. 6d. each.

T.V. SMOOTHING CHOKES. Compact 5 H. 250 m.A., 4 - each.

I.F. TRANSISTORS, junction type P.N.P., latest stock
6/- each!

P.N.P. TRANSISTORS, junction type P.N.P., latest stock,
11/- each!

100 + 200 MFD. ELECTROLYTICS. 275 v.w. standard cans,
5/- each.

B9G AMPHENOL VALVEHOLDERS WITH SCREEN. EF80
size, 1/- each.

Note: All the above equipment is (excepting the first item) unused
and in guaranteed condition. Full cash refund will be made if
not completely satisfied.

ALL VALVES AS ADVERTISED LAST MONTH AVAILABLE,
subject to being unsold, e.g. 5U4G 8/6, 6K7GT 5/6, 6SNTGT 5/9,
6V6GT 6/-, 12AU7 7/-, ECL93 8/6, EF9 2/6, EF89 8/-, EY61 10/-, etc.,
etc.

S.A.E. FOR FREE LIST

Giving 400 attractive lines at clearance prices.

EX-GOVERNMENT EQUIPMENT.—Commencing August 1st
we are opening our store situated at the junction of Green Road
and Summer Street, Southsea, on Saturdays only for the retail
disposal of a very large range of units, valves, components, fittings,
etc., etc.

Postage 1 - in £1 (in £1 Speakers Trans.). Min. 6d. No C.O.D.
10 000 OTHER BARGAINS TO CALLERS AT:—

350/352 FRATTON ROAD, PORTSMOUTH



Whilst we are always pleased to assist readers with their technical difficulties, we regret that we are unable to supply diagrams or provide instructions for modifying surplus equipment. We cannot supply alternative details for constructional articles which appear in these pages. WE CANNOT UNDERTAKE TO ANSWER QUERIES OVER THE TELEPHONE. The coupon from p. 47 must be attached to all Queries, and if a postal reply is required a stamped and addressed envelope must be enclosed.

BUSH TV 43

This was a very good set until I started experimenting with a slot aerial and now I seem to have upset the set somehow. The trouble is this: Faces are darker than they ought to be, so when I advance the brightness control the picture closes in and distorts. Contrast control acts the same way. Some evenings the pictures are good, more often they are not. I am using a folded dipole for I.T.A. for BBC a dipole which was quite O.K. until this happened. Sound O.K. Will you please tell me what is wrong?—W. F. Goode (Wednesbury).

Unless you have made adjustments within the receiver, we feel that the trouble described is caused either by mismatch in the aerial system or a signal which is weaker than that previously obtained by way of the conventional dipole and to which the comparison is made. In this event, you may find it desirable to revert back to the dipole. On the other hand, a greater signal may be picked up on the slot, in which case an attenuator may be required to restore optimum balance.

KB MV30

The symptoms are dim or negative picture. On test card C the vertical contrast wedge, which should show five quite distinct changes in contrast, only shows four, this being due, I think, to the fact that if I turn up the brightness the picture shrinks and the circle on text card C becomes egg-shaped, the whole picture, of course, being blurred or out of focus. If I keep the brilliance low I can receive a picture which I would term as being negative. I think the fault is caused by low EHT but would like your opinion on this. Could you also tell me how the chassis is removed from the cabinet? Operation of the contrast causes similar symptoms except that shrinkage of picture is from top to bottom; operation of brightness causes shrinkage left to right.—R. Rutherford (Nr. Glasgow).

A low emission EHT rectifier valve would probably cause similar symptoms to those described in your letter, though in this case it is unlikely that the picture would turn negative at low brightness levels. We feel that a low-emission picture tube is responsible

for your trouble. Also check the condition of the GD3 vision detector germanium diode.

The chassis can be removed from the cabinet as follows: After removing the back from the cabinet, unscrew the bar-type control knobs and pull off the rim-type knobs. Unplug the loudspeaker leads from the output transformer at the rear of the chassis, remove the chassis fixing screws at the rear of the chassis and carefully withdraw the chassis from the cabinet, taking care to avoid knocking the picture tube.

PYE FV1

The set is running on 230 volts D.C. mains. A ripple of 600 cycles is present. The set works quite well but in the picture there are six places where the lines are slightly wider than elsewhere, giving a slight black bar effect; the lines run down slowly showing interlace is not perfect, but the black bars remain stationary. Can you tell me where I should look for the trouble, to cure it?—J. Holmes (E.14).

Check the H.T. smoothing and filtering circuits. If the 600 cycles ripple is of excessive amplitude on the supply voltage you may find it necessary to increase the efficiency of the filter circuits with respect to this frequency.

Streaking or "flaring" is usually caused by a poor high-frequency response in the vision channel or over amplification of the low-frequency components of the vision signal. A rising high-frequency response generally leads to "ringing" and black-after-white effects. The trouble generally lies in the tuned circuits themselves, and realignment is often called for. However, the use of the incorrect time-constant in the video coupling network or cathode circuit of detector or video stages has the same effect.

MULLARD 684/15

I would be much obliged if you can help me find the cause of my television picture going dark and then bright every now and then. Now the picture has closed up to $\frac{1}{2}$ in.—C. W. Sinclair (Dagenham).

If the picture has collapsed horizontally and the narrow picture mentioned in your letter appears vertically on the screen, suspect breakdown either in the line scanning coils or in the line output transformer. Also check the condition of the line timebase valve and associated components.

G.E.C. BT4640

This is tuned for Channel 1. I have tried to convert same to Channel 2 by taking a turn off coils L1, L2, L5 and L6, still obtaining no results.

As far as I can test, no faults with this set apart from being wrongly channelled.

According to your book, "Some Practical TV Circuits," only coils 1 to 6 differ by one turn each for the different channels.

I have G.E.C. service data sheet for model BT4640 (replacing bulletin No. 128), which gives conversion details from Channel 1 to 4.

Apparently coils L3, L4 and L7 (by the way I read it) have no connection with Channel 1 circuit. Consequently I haven't interfered with them; should I do so?—K. Cawood (Hull).

Later versions of the model mentioned feature extra coil sections on the aerial, R.F. and oscillator coils for changing from Channel 1 to Channel 4 or

vice versa. Unfortunately, no facilities are available for changing to other channels. However, by following along the lines you have already adopted, little difficulty should be experienced in getting the set to work on Channel 2, although the extra coil sections mentioned above should not be disturbed. We would suggest that you restore the oscillator coil to normal and, if necessary, add a 5 pF capacitor in parallel with the oscillator tuning trimmer in order to get the oscillator to cover the frequency required for Channel 2.

EKCO TRC139

Just recently the contrast has fallen off a bit; with the contrast control on full the picture is not as clear as it should be; it is almost impossible to see picture in the daylight.

After the set has been working for about 30 minutes the picture narrows down from top and bottom until the picture is a narrow band about an inch wide across the screen.

Adjusting the picture height control will not bring it back, the only remedy is switching the set off until it cools down.

The raster is good and plenty of brightness, and the picture comes through very soon after switching on. Please will you tell me which valve or component to suspect to cure this fault? The tube now in use is about 12 months old.—C. Brook (Tunbridge Wells).

Although the possibility of a faulty tube cannot be ruled out it seems unlikely from your description. Lack of contrast on this model is usually traced to dirty valve pins, which a "waggle" of the valve will reveal, or to faulty decoupling which can be checked by a small condenser on a flylead. The SP41 (or SP61) valves can also give a lot of trouble and your picture shrinkage is probably due to a falling off of the one used for frame output. This is the middle valve of three just below and right of the scan-coils. As the video amplifier is one of these valves, this can also be checked in your search for lack of contrast. It is the valve nearest the aerial socket.

EKCO T161B

About three months ago I noticed the picture was very poor at first and improved in about 20 to 30 minutes, but lately it has worsened and now nothing can be recognised and increasing the brightness or contrast control makes the screen go blank as if the set were switched off.

I took this to be the C.R.T. going and so I purchased one (not new), but on fitting I found no improvement on the old one. Is it possible some other component is at fault and causing this trouble?—K. W. Hill (Bristol).

The most likely cause of your trouble, if you are sure that your new tube is beyond suspicion, is the soldered-in U25 rectifier valve which can produce similar symptoms. If your picture swells up at the point where the contrast or brightness control starts to cut it out this valve is almost certainly the trouble.

When replacing, round off the solder neatly on your joints to prevent corona, and discharge the EHT condenser before working on the set.

Other valves which could give similar trouble are the 20P1 and the U801.

PYE VTA

I have a Pye type VTA just fitted with a new tube. When it is on there is a black line at the bottom $\frac{3}{4}$ in. broad.

I have tried, when the signal is on in the mornings, to enlarge the picture by means of the two screws at the back of set, but this only elongates and distorts the picture.

Occasionally it fills out itself, but always goes back again. I have no maintenance schedule so I would be very grateful if you could advise me what is wrong.—Robert McDonald (Saltcoats).

A new frame output valve type PL82 will almost certainly cure your trouble. This valve is located behind the black line output can and supported by a pillar and clip.

To obtain easy access, remove the two screws on the rear flange of the chassis and withdraw it to the extent of the leads, after unscrewing the aerial panel.

MURPHY V200

The EHT winding of the line transformer (oil filled) was arcing over inside and the picture was jumping. I obtained a new one which is open type. The H.T. on the transformer is 200 +. The valve is an output PL38. I enclose fitting instructions supplied with the transformer. The heater does not heat up (new valve EY51) and very little voltage at the anode. The line appears to be working as the whistle is there. I have also fitted a new oscillator transformer. I returned the new line transformer to the makers and they say it is in order. Would you kindly give fitting instructions.—J. Lock (S.E.23).

Apart from a fault in the wiring the most likely trouble is the PL38 valve which may have been damaged by the fault in your old transformer. Another possibility is a fault in the reclaim rectifier circuit where the chief suspects are the U281 valve and the 8 μ F condenser (which is wired positive to chassis).

If this stage is working properly, *minus* 43 volts will be present at the cathode (pin 8) of the PL38. Check also that your EHT rectifier is in fact an EY51 and not a U25 as previously.

PYE B18T

I wish to fit an isolating transformer owing to a cathode or heater short in the tube. Could you please inform me whether I need a mains type 6.3 volt or ordinary 1-1 ratio and could you please advise as to fixing mains type if this is necessary?—C. R. Spain (S.E.6.)

The Pye B18T is an A.C./D.C. receiver and will require a mains type transformer.

Connect the mains side of it between chassis and the 230 volt tapping of the mains voltage selector, and connect the 6.3 volt side to the heater pins of the tube, having previously removed the existing wiring and connecting a 15 ohm wirewound 3 watt resistor as ballast across the heater wires in place of the tube. It is advisable to mount the transformer on the woodwork over 6in. away from the tube and connect the 6.3 volt winding by short free-spaced leads.

(Continued on page 47)

SETS & COMPONENTS

BRAND NEW RF.26 27, 27/6 (postage 2/6); RF.26 or 27, used, damaged dials, 15/-; Metal Rectifiers, 750v 80mA, 7/6; 500v 300mA, 10/-; 240v 30mA, 3/6; 1,000v 30mA, 7/6; 6v 13A, 25/-; 120v 2A, Bridge, 30/-; R1155 S.M. Tuning Drives, "N" type, brand new, 10/6. Chokes, L.F. Ferranti, 10H, 120mA, screened, 7/6; 162v, 200mA, 8/6; 5H, 130mA, 4/6; "C" type, 10H, 300mA, 12/6. Switches, wafers, 1 pole, 6 way, 1 bank, 1p., 11w., 1b., 1p., 8w., 1b., 1p., 3w., 3b., 2p., 3w., 2b., 4p., 2w., 1b., 1p., 6p., 5b., 1p., 6w., 2b., 2/6; 1p., 11w., 2b., 6p., 2w., 4b., 3/6. Stud type, 1p., 9w., 2b., 4/6. Winkler-Painton type, IP24W 2B, 7/6. Transformers, "C" core, 230v m. outputs, 315-0-315v 60 mA, 5v, 25v, 6.3v, 150v, 25 (p.p.), 3-1; 285 315v, 350mA, 7/6; 90/850v, 480mA, 40/- (curr. 7/6). Potentiometers, w. wound, 26k, 3.1in. dia., ceramic, 4/6. P.E. Elbows or Sockets, 6d. each. P.F. Chokes, RX type, 1/6. Indicator Units, similar type 6, brand new, with VCR97 and 6 valves, 30/- (curr. 6/-). Responder, ZC8931, with valves, good condition, 190/230mcs., 20/- (curr. 7/6). Potentiometers, range 20k to 1 meg., 3in. spindle, 10/- (curr. 7/6). Plugs, Sockets, 6 or 8 way, pair 1/6. List and enquiries, s.a.c., please! Terms, c.w.o. Postage extra. Immediate despatch, W. A. BENSON, 136, Rathbone Road, Liverpool, 15.

GUARANTEED TELEVISION, 12in. 5-Channel models, first-class picture, £26 each, carriage paid. THE GRAMOPHONE SHOP, 19-21, Brockley Rise, London, S.E.23.

LARGE NUMBER of 12in. BBC Band I Sets in good working order to clear at £8 each; 13 channel at £25. CCW., 12, Dockhead, S.E.1. (BER 3756.)

CATHODE RAW TUBES, used, but in good working order, and with 3 months' guarantee. All 12in. to 17in. Mazda, Mullard and Emitron types at £4/10- each, plus 13/6 carriage. Orders and enquiries by letter only to: BHP DISTRIBUTORS, 379, Staines Road, Hounslow, Middlesex.

TELEVISION, 12in., 5 channel, tunable anywhere, models for £25 each, carriage paid; guaranteed perfect. RYAN ELECTRICS, 134, Acre Lane, Brixton, London, S.W.2. (BRI 4533.)

ELESTRADIO—Dual Wave Coil 2/6 with circuit, ditto, plus Reaction 4/Tuning Condenser 3/10. Crystal Diode 1/6, tested 4 Transistor Set Circuit 1/3. All Transistor Components stocked. Post free, 18, Broadlands Av., Keynsham, Somerset.

5-CHANNEL TELEVISIONS: 12in. screen Ferguson 988, Ekco 161, etc., £25 each. A good selection of 12in. T.V. (London), 100% condition, from £15; 9in. from £7. Also 12in. T.V. Slight faults, from £7, 9in. from £4. TYLER TELEVISION, 63, Lee High Rd., Lewisham, S.E.13. (LEE 5979.)

LOUDSPEAKERS repaired promptly. MODEL LOUDSPEAKER SERVICE, Bullington Rd., Oxford.

TELEVISIONS, NEEDING ATTENTION, 9in., 10in. models £4/10- each, 12in. models £6/6- each, 15in. models and Philips Projection models £11/10- each; immediate despatch; carriage paid. BARKERS, 325, Brockley Road, S.E.4. (TID 6752.)

TELEVISION, 10in., London models, good working order, £7 each, carriage paid. RYAN ELECTRICS, 134, Acre Lane, Brixton, London, S.W.2. (BRI 4533.)

DIPOLE INSULATORS, 1in. hood, 1in. elements, suitable T.V. or F.M. Dipoles, 5/- P.O. with order. C. & H., 2A, Mona Street, Liverpool, 7.

RATES: 4/- per line or part thereof, average five words to line, minimum 2 lines. Box No. 1 - extra. Advertisements must be prepaid and addressed to Advertisement Manager, "Practical Television," Tower House, Southampton St., Strand, London, W.C.2.

AERIALITE CONVERTIBLES (McMichael). Band 3 converters, McMichael 6 to 13, in-built beautiful walnut tables; original price £18/18 - now £6/15/-; carriage paid; maker's guarantee. TOMLINS, 127, Brockley Rise, Forest Hill, S.E.23. (FOR 5497.)

T.V. AND TUBE BARGAIN, 9in. £3/10- (12in., 14in., 15in., 16in., 17in., £5 each). Over 100 second-hand T.V.s in stock, cheapest in London. Trade enquiries welcomed. Phone: LADORKE 1734. Call: C. EDWARDS, 1070, Harrow Rd., N.W.10.

TELEVISIONS, 9in. models £7/10/-, 12in. models £13/10/-, 12in. 5-Channel models £19/10- each; all working; carriage paid. Send for list. TOMLINS, 127, Brockley Rise, Forest Hill, S.E.23. (FOR 5497.)

I.T.V. CONVERTERS from £3/19 6. Self-contained, guaranteed, H.P. without fuss. Aerials from 14/6. Trade enquiries invited. G. A. STRANGE, Dept. P., North Wraxall, Chippenham, Wilts.

FILTERS (Mains) Receivers, appliances, 15/-; (Aerial), I.F., H.P. pattern, 21/-; Taxis, Police, 144 mcs. 25/-; Postage 1/- in £. Details: A. W. BUSH, 63, Lynton Rd., Acton, London, W.3.

AERIALS direct from manufacturers. F.M. Indoor Dipole with mast and base, 12/6; H ditto, 22/6; Outdoor Dipole with chimney lashings, 37/6; H ditto, £3/5/-; T.V. 5 Element Band III, channels 8-10, finest quality, with 3ft. cranked mast and universal clip, 45/-; with lashings 57/6. Best value in England. Trade supplied. Coaxial Cable, best only, 9d. yard. Aerial list for s.a.c. Illustrated parts list with all technical data, etc., 1/-. All goods post free. Write for details. SKYLINE WORKS, Burnshall Rd., Coventry. (Tel.: 66418.)

SITUATIONS VACANT

ROLLS-ROYCE

DERBY

have vacancies for

ELECTRONIC TECHNICIANS

who have completed military service, to operate and maintain recording equipment used for Aero Engine Development. Good knowledge of basic principles of electronics necessary. Applicants accepted for these posts will be required to work alternate morning and afternoon shifts. The posts carry a salary of £600 per year upwards, according to age and experience, together with additional payment for overtime and shift work. This is an excellent opportunity for men wishing to undertake varied and interesting work in an expanding section of the civil aero engine industry. Interviews can be arranged at any time, including evenings or Saturday morning, expenses paid. Apply:

The Manager (T.1), Technical Administration, Rolls-Royce Limited, Derby.

FOR SALE

MAKING YOUR OWN? Telescopes, Enlargers, Binoculars, Microscopes, Projectors, or, in fact, anything that needs lenses. Then get our booklets "How to Use Ext-Gov. Lenses & Prisms, Nos. 1 & 2 - price 2/6 ea. Also our stereo book, "3-D Without Viewers," price 7/6. Comprehensive list of lenses, optical, radio and scientific gear free for s.a.c. H. W. ENGLISH, Rayleigh Road, Hutton, Brentwood, Essex.

EFFICIENT AERIALS. Test new way with Aerial Current Meter. Guaranteed. HOBLEY, 109, The Drive, Wellesborough.

SUPERIONIC SUNLAMPS, listed £7/10/-; 80/-; S.A.E. SCIENTIFIC PRODUCTS CO., Cleveleys, Lancs.

LINEAR AMPLIFIERS with pre-amp. A.C. mains, complete, guaranteed, £12/12/-. Electric Blankets, washable, no interference, single £3/16/-, double £4/6/4, guaranteed. Postage 1/- in £. A. W. BUSH, 63, Lynton Rd., W.3.

"ALBA" I.T.A. Converter, £4. 9d. Birchfield Rd., Redditch, Worcs.

WANTED

ALL TYPES OF VALVES REQUIRED for cash. State quantity and condition. RADIO FACILITIES LTD., 38, Chalcot Road, N.W.1. (PRIMrose 9096.)

WANTED, Valves EY51, 6CH6, 10F1, PL81, KT61, 6F1, FW4/500, 20D2, 20F2, 10P14. Prompt cash. WM. CARVIS LTD., 103, North St., Leeds, 7.

WANTED, H.M.V. 1206 (3806) Circuit, KT61, 266. WELY, 22, Wellington Rd., Birkenhead.

WORK WANTED

METALWORK - Chassis, Panels, etc. to your own specification. AVON, 10, Pottery Lane, London, W.11.

SERVICE SHEETS

SERVICE MANUALS/SHEETS, Tel/ Radio for hire, sale and wanted. S.A.E. enquiries, W. J. GILBERT (P.T.), 24, Frithville Gardens, London, W.12.

SERVICE SHEETS, Radio, T.V., 5,000 models. Lists 1/-. S.A.E. enquiries. TELRAY, 11, Maudland Bk., Preston.

EDUCATIONAL

INCORPORATED Practical Radio Engineers home study courses of Radio and TV Engineering are recognised by the trade as outstanding and authoritative. Moderate fees to a limited number of students only. Syllabus of Instructional Text is free; "The Practical Radio Engineer" Journal, sample copy 2/-, 6,000 Alignment Peaks for Superhets, 5/9. Membership and Entry Conditions booklet 1/-. All post free from the SECRETARY, I.P.R.E., 20, Fairfield Road, London, N.8.

BUILD YOUR OWN T.V. and learn about its operation, maintenance and servicing. Qualified engineer-tutor available while you are learning and building. Free Brochure from E.M.I. INSTITUTES, Dept. PT58, London, W.4. (Associated with H.M.V.)

FREE! Brochure giving details of Home Study Training in Radio, Television and all branches of Electronics. Courses for the Hobby Enthusiast or for those aiming at the A.M.Brit. I.R.E. City and Guilds, R.T.E.B., and other professional examinations. Train with college operated by Britain's largest Electronics organisation. Moderate Fees. Write to E.M.I. INSTITUTES, Dept. PT28, London, W.4.

BAND III CONVERTOR for ANY SET in ANY AREA

This unit has been widely used since I.T.A. Transmissions began to convert all types of sets, Superhet and T.R.F., to receive on Band III.

Unlike many other convertors this unit is small enough to be fitted inside your cabinet, enabling the job to appear finished and perfectly safe for all to use.

The wiring is simple to follow, and alignment is not difficult.

- * IT will convert any set, any age, T.R.F. or Superhet.
- * IT includes station switching.
- * IT provides pre-set contrast balancing.
- * IT uses only one aerial input for both bands.
- * IT provides manual tuning on Band III.
- * IT is totally screened.
- * IT completely rejects unwanted signals.
- * IT requires no additional power supply where either 6.3 v. or .3 amp. heater line is available.

| | |
|---|---------|
| CONVERTOR wired and aligned with fitting instructions | £3 10 6 |
| KIT complete in every detail, less knobs | £2 10 6 |
| KNOBs each | 1 0 |
| CIRCUIT and instructions in detail (free with kit) | 1 6 |
| KITS made up by customers checked and aligned, including post | 12 6 |

When ordering please state present B.B.C. Station and I.T.A. Orders over £2 post free.

C. & G. KITS

285, LOWER ADDISCOMBE ROAD,
ADDISCOMBE, CROYDON, SURREY

Phone: ADDiscombe 5252

TRANSFORMERS

We supply all types, and if we haven't got it we can usually make to specification. Mains transformers, Line output, Frame oscillator, Line oscillator, Speaker output, C.R.T. Transformers with boost tap, isolating transformers, etc., etc. Electrolytic condensers all T.V. types. Volume, tone and contrast controls. Electronic equipment of every description. S.A.E. please with all enquiries.

HOWORTH

51 POLLARD LANE, BRADFORD, 2, YORKS
Tel. 37030



QUALITY TELEVISION COMPONENTS

SCANNING COILS, 6/10 kV. and 13/15 kV., R.F., E.H.T. UNITS, E.H.T. and OUTPUT TRANSFORMERS, LINE FLYBACK E.H.T. UNITS.

COIL KITS FOR "P.T." BAND III CONVERTERS

Write for illustrated list (Publication 75)

HAYNES RADIO Ltd., Queensway, Enfield, Middlesex.

COVENTRY RADIO

Component Specialists
since 1925

We have now trebled the size of our premises in order to supply a larger range of Components, Amplifiers and Hi-Fi Equipment

Send your enquiries to:
189-191 Dunstable Road,
Luton, Beds.

New Telephone No.:
LUTON 7388-9

OPPORTUNITIES IN TELEVISION

144 pages

Free!



Television offers unlimited scope to the technically qualified. Details of the easiest way to study for A.M. Brit. I.R.E., R.T.E.B. Cert., City and Guilds, Television, Television Servicing, Sound Film Projection, Radio Diploma Courses, etc., are given in our 148-page Handbook "ENGINEERING OPPORTUNITIES" which also explains the benefits of our Appointments Dept.

**We Guarantee
"NO PASS—NO FEE"**

If you are earning less than £18 a week you must read this enlightening book.

Send for your copy NOW—FREE and without obligation.

WRITE TO-DAY!

British Institute of Engineering Technology
237, College House,
29-31, Wright's Lane,
Kensington, W.8.

BIET

NEW-MAX ELECTRONICS LTD.

For London's finest bargains in electronic television and radio equipment.

T.V.'s 500 SETS

500 P.P. repossessed T.V. sets—always in stock. All makes and sizes. At remarkably low prices. For example:

12" 5 channel £29.00
14" 432.10.0
17" 442.10.0

(Postage & Packing 25/- extra)

All popular makes in stock. All fully guaranteed in perfect working order. Also spares and test equipment.

C.R. TUBES

Reclaimed and guaranteed Cathode Ray Tubes. 14in. £5 ; 15in. £7.10.0 ; 17in. £7.10.0. P. & P. 10/-

C.R.M. £2 also MULLARD M.W. 2/16. Both carry 4 month guarantee. £8 p. & p. 10/-

CHASSIS

IMPERIAL MAJOR
AM/FM Radiogram Chassis L.W., M.W., S.W. & F.M. Size 20 x 10 x 6in. high. Piano key selector, ferrite rod directional aerial. Base & Treble control. 3 speakers for stereophonic sound. £25. p.p. 10/- extra.

FRUSTRATED EXPORT ORDER
COLLARO RC 54

3 speed automatic record changer with High fidelity £7.17.6 p. & p. studio pick-up. 10/-

Orders and Callers to:
NEW-MAX ELECTRONICS LTD.
220, Edgware Road, London, W.2.

PAD 5807

REGENTONE

I have a rectifier breakdown on the H.T. half-wave rectifier of my Regentone set. I have replaced the 64- μ F condenser, and also replaced the rectifier for a 14A 100 Westinghouse which is the rectifier specified for the set but which has (unlike the one taken out) three connections which I assume are two input (common) connections and one output. The replacement of these two components, however, has not cured the fault. There is still the possibility of breaking down the new rectifier, if power remained on for a period of time. Could you suggest what may be causing this, and the best method to test without danger to the rectifier?—F. Sharratt (Stoke).

We would advise you that the rectifier should be connected with the *outer plates strapped* and connected to the D.C. output point; i.e., the smoothing choke and 64 μ F capacitor. The centre contact of the rectifier is the A.C. input connection. If with these connections made, overloading is still experienced, check remaining electrolytics and disconnect each sub H.T. line in turn to isolate the section which has the shorted component. We cannot say which section may be at fault and some degree of logical tracing will have to be employed.

PHILCO 1251L

The set has been working for 18 months with cathode heater short tube MW3116. The EHT collapsed and have fitted tube guaranteed second MW31-16 which I know to be perfect having tested it in another set. I have Ferguson service sheet for 968T which I think is the same. The line output appears to be working all right as I can hear the line whistle from the PL38 output valve, but can get only a very small spark from the EY51 heater anode to the tube. I get an illumination on the tube when setting brilliance control, but not as a raster as the EHT is missing. Have tested all three EGL80 valves and also valves in vision and sound compartments; all O.K. on test meter. These valves are about three years old and could be faulty, which might not show on valve tester.

Have checked L24 line amplitude, replaced G38.0.02 μ F to line 8 frame coils. Should be very pleased if you could give me a few details where to look for this elusive fault. The only test gear I have is an A.C.-D.C. volt meter.—D. Saffin (S.E.9).

The fact that the tube works in another set does not mean that it will do so in yours. However, a few simple tests should establish the cause of the fault and the following procedure should be adopted. With set working, note whether EY51 heats up. If it does not remove C.R.T. anode cap to check for internal short in tube. If with the lead removed from the anode EHT returns and the EY51 lights up, the tube is at fault with a grid to cathode fault. This may not show up in another receiver if the first anode voltage is lower.

If, however, conditions are unchanged, remove the single wire end of the EY51 from the solder cup. If now the heater lights up the LO transformer is at fault. If no results are obtained check PL38 screen dropping resistor and PY31 μ .5 F capacitor, the latter for leakage.

ARGOSY TV1412N

Which valves should I check in my Argosy TV1412N for complete absence of picture raster, etc? Unable to obtain any suggestion of a picture.—K. Morton (Roby).

This receiver employs a Plessey MK11 chassis as described in the July, 1956 issue of PRACTICAL TELEVISION (and in the June, 1954) "Serving TV Receivers." We would advise you to check the 6F13 valves. Since you do not mention the sound at all we are unable to "narrow down the field" of likely possibilities. The likelihood of the tube developing a heater-cathode short should be borne in mind.

FAULTS WITH FOCUS

(Continued from page 17)

Faults on Focus

Do not always think it is the fault of focus magnet or focus coil that causes poor focus. There can be other reasons. For instance unused permanent magnet focusing trouble may be due to low EHT voltage or if a tetrode C.R.T. is used it can be the voltage of the first anode. Otherwise it can be a faulty cathode ray tube. The writer has met quite a few cases where the ion trap has been moved to correct focus. This is useless and also dangerous to tube as an incorrectly set ion trap can cause ion burns on screen. It should be understood that as the ion trap is fitted to gun before the cross-over point of electron beam, it cannot affect focus.

Setting of Focus

Correct focus should if possible be set up on the test card. The I.M.C.'s bars should be even. It can be set up roughly on a raster, when endeavour should be made to get the lines thin and even. An incorrectly set focus coil can also cause displacement of picture, either vertically or horizontally. Some of the earlier sets, besides have a permanent magnet focus coil which is adjustable, have also a further focus control. This is in most cases a control on the grid circuit of the line output valve. This varies the grid/cathode capacity of the valve, so altering the line flyback shape, thus altering the EHT voltage.

QUERIES COUPON

This coupon is available until AUGUST 21st, 1957 and must accompany all Queries sent in accord with the notice on page 43.

PRACTICAL TELEVISION, AUGUST, 1957

**A SPENCER-WEST
BAND III CONVERTER
FOR £6.5.0**

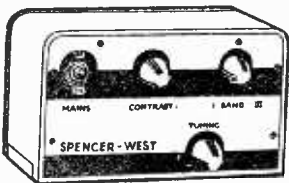

The Type 80 with printed circuits, panel controls for Band switch and fine tuning and a performance which ensures enthusiastic satisfaction. Handsomely designed and finished to stand on your receiver with its self-contained power supply it just plugs straight in.

Full descriptive leaflet on request.

SPENCER - WEST LTD.,
Quay Works, Great Yarmouth,
Norfolk.

Phones : Works 4794 : Sales 3009
Grams : Spencer-West, Great Yarmouth.

**FIRST-CLASS
TELEVISION and
RADIO COURSES . . .**

GET A CERTIFICATE!

After brief, intensely interesting study—undertaken at home in your spare time—**YOU** can secure your professional qualification or learn Servicing and Theory. Let us show you how!

- **FREE GUIDE**
- The New Free Guide contains 132 pages of information of the greatest importance to those seeking such success compelling qualifications as
- **A.M.Brit.I.R.E., City and Guide Final Radio, P.M.G. Radio Amateurs' Exams., Gen. Cert. of Educ., London B.Sc. (Eng.), A. M. I. P. E., A.M.I.Mech.E., Draughtsmanship (all branches),** etc., together with particulars of our remarkable Guarantee of
- **SUCCESS OR NO FEE**
- Write now for your copy of this invaluable publication. It may well prove to be the turning point in your career.
- **FOUNDED 1885—OVER**
- **150,000 SUCCESSES**

**NATIONAL INSTITUTE OF
ENGINEERING**
(Dept. 462), 148, HOLBORN,
LONDON, E.C.1.

**UNDERSTANDING
HI-FI CIRCUITS**

23 - Postage 1/-
by **NORMAN H. CROWHURST**

- **TV.—IT'S A CINCH.** By E. Ainsberg. 23s. 0d. Postage 9d.
- **TELEVISION EXPLAINED.** By W. E. Miller. 12s. 6d. Postage 9d.
- **V.H.F. HANDBOOK.** By W. I. Orr and H. G. Johnson. 24s. 0d. Postage 9d.
- **TELEVISION RECEIVING EQUIPMENT.** By W. T. Cocking. 30s. 0d. Postage 1s.
- **RAPID TV. REPAIR.** By G. W. Heath. 23s. 0d. Postage 9d.
- **THE RADIO AMATEUR'S HANDBOOK.** By A.R.R.L., 1957. 32s. 6d. Postage 1/6.
- **RADIO VALVE DATA.** Compiled by "W.W." Price 5s. 0d. Postage 6d.

The MODERN BOOK CO.
BRITAIN'S LARGEST STOCKISTS
of British and American Technical Books
Write or call for our 1957 catalogue
**19-23, PRAED STREET,
LONDON, W.2**
Phone : PADDington 4185
Open 6 days 9-6 p.m.

DISC CERAMIC CAPACITORS

The modern decoupling capacitor. Midget size, non-inductive with excellent dielectric insulation. Ideal for T.V., etc., 500 v. D.C. (300 v. A.C.) working : 470 pF. .001 pF. .002 pF. .003 pF. .005 pF. Each 9d. Minimum postage 6d. on orders under £3.

Holiday Closing :

We shall be closed August 17-24 inclusive.

**SOUTHERN RADIO &
ELECTRICAL SUPPLIES**
SORAD WORKS, REDLYNCH,
SALISBURY

Telephone : Downton 207.

Air-Spaced Coaxial Cable. New. 75.80 ohms 9d. yd., 70/- per 100 yds. Meters, 500 microamps. F.S.D. 2in. Dial, marked 15,600 v., 15-T.V. Tables, 20in. x 20in. x 24in. high. Walnut finished. 72 6. Extension Speakers, complete with volume control in Walnut finished cabinet. New. 6in., 40/- 8in., 50/-

SPEAKERS. 3in., 18/- 5in., 18 6/- 6in., 18 - 8in., 19 6/- 7in. x 4in., 16 - 12in., 15 wats by Baker. 50w. 5WTL L.P. or STD. Types B.S.R., S.E., S.K., S.B., 5 6
T.V. AERIALS. Band III, 3-El. 28 6/- 5-El. 38 6/- 8-El. 58 6/- Band I, S Diode, 30 - "H." 77 6/- "X." 74 6. Coax. Plug, 1 - Taylor Monrother Meter, AC/DC, volts, amps, ohms—complete with leads. 70/-
Ion-Trap Magnets, 5/- Car Aerials, Chrome, 37 6. Volume Controls, L/S, 2 - D.P. 4,4 : 1 mag., 8/P, 2-9. Instrument Soldering Irons, 230 volt with spare bit, 24 - Rectifiers, R.M.4, 15/10 : R.M.3, 7 6 : R.M.2, 5 6 : R.M.1, 4 6. **Elstone 013,** for Mullard's watt amplifier, 21/-.

GUARANTEED VALUES

| | | | | | | |
|------|-------------|------|-----------|------|-------|------|
| 07A | 5/- 6U7 | 6 6 | ECL8010 6 | E280 | 7 6 | |
| 1A5 | 3- 6RW5 | 6 6 | EC8211 6 | EF30 | 9 6 | |
| 1LN5 | 3- 6AT6 | 7 6 | EC8311 6 | FCR1 | 9 6 | |
| 1LD5 | 3- 12SJ7 | 6/- | EF86 | 14 6 | UCH42 | 8 6 |
| 1A7 | 13/10 12AU7 | 9/- | EY31 | 9 6 | UBC11 | 8/- |
| 1R5 | 8 6 12K7 | 11/- | EY86 | 14 6 | UI 41 | 10/- |
| 1T4 | 7- 25L5 | 7/- | PC8110 6 | U78 | 7 6 | |
| 185 | 7 6 6X8 | 9/- | PC8211 6 | U78 | 7 6 | |
| 2X2 | 4- 6S17 | 6 6 | EL01 | 6 6 | 6BC6 | 19 6 |
| 3D6 | 2 6 7R7 | 6 6 | DL96 | 7 6 | DK06 | 9/- |
| 5Y3 | 3- TP25 | 6 6 | EL81 | 9/- | DH149 | 10/- |
| 5Z1 | 3- EL32 | 4 6 | PY82 | 7 6 | W145 | 9 6 |
| 6CD6 | 19 6 B36 | 17 6 | EZ40 | 7 6 | U25 | 14 6 |

Terms : C.W.O. or C.O.D. Minimum C.O.D. charge 3/- Postage and Packing under £1, 1 3; £2, 1 6; £3, 1 9; £1, post free. Valves, 6d. per valve.

MAIL ORDER ONLY.

ELECTRO-SERVICES & Co.
221 BATTERSEA PARK ROAD,
LONDON, S.W.11. MA6 8155

**ALUMINIUM, LIGHT ALLOYS,
BRASS, COPPER, BRONZE,**

IN ROD, BAR, SHEET, TUBE, STRIP
WIRE, ANGLE, CHANNEL, TEE

3000 STANDARD STOCK SIZES

H. ROLLET & CO., LTD.

6, CHESHAM PLACE, LONDON, S.W.1.
SLOane. 3463

Works :

36, ROSEBERY AVE., LONDON, E.C.1.

Branches at Liverpool, Manchester,
Birmingham, Leeds.
"No Quantity too Small"

**TELEVISION COMPONENT
SERVICE**

Replacement components available for
the popular home constructor designs.
Catalogue available on request.

J. T. FILMER 82, Dartford Road,
Dartford, Kent.
Tel. : Dartford 4057

OSMOR CONVERTERS

ALL CHANNELS

Simple, efficient for all TV (including TRF), Guaranteed no break-through of Band for re-radiation. Approx. 1 hr. to build. Will convert any Band III channel to any Band I channel. AC or AC DC. Kit, £3.5.0. Ready wired, £4.0.0. Post free. Terms : C.W.O. Post orders only. **THE ELECTRONIC SUPPLY CO.** 29, Leigh Rd., Highbury, London, N.5

BAND III AERIALS OR FITTINGS

Whether you are contemplating the construction of a Band III aerial or purchasing one complete it will be well worth your while to write to us who, as manufacturers, can offer you real

VALUE FOR MONEY

THE FOLLOWING IS A CROSS SECTION OF ITEMS TAKEN FROM OUR NEW COMPREHENSIVE CATALOGUE.

- * 10 Element Band III Aerial, 77/6.
- * 8 Element Band III Aerial, 62/6.
- * 6 Element Band III Aerial, 47/6.

FITTINGS

- * Universal Band III Clamp-on Fitting.
- * Band III Insulator, complete with folded dipole.
- * Director and Reflector Rod Holders for Bands I, II, and III.
- * Straight and Cranked Masts (all sizes).
- * Chimney and Wall Brackets. Alloy Tubing, etc. etc.

Send 1/- P.O. for the NEW MULTI-PAGE illustrated Catalogue (together with element and boom measurements (all Bands) to help the constructor) to :

FRINGEVISION LTD. MARLBOROUGH, WILTS.
Phone 657/8

ARTHURS HAVE IT!

LARGE STOCKS OF VALVES and C.R.T.s. METERS, Avo, Advance, Taylor and Philips Service Pattern Generators. Oscillosopes, Cossor and Philips. AMPLIFIERS, Leak, Trix & Quad. GRAM UNITS, Garrard & Collaro. Collaro TRANSCRIPTION UNIT 2010PX.

LOUDSPEAKERS, Goodmans, Wharfedale, WB, Tannoy and leading makes. PICK-UPS and STYLII of most makes. TAPE RECORDERS, Grundig, Philips, Truvox, Playtime & Ferrograph.

LATEST VALVE MANUALS

Mullard, 10/6 ; Osram & Brimar No. 6, 5/- each ; Osram Part 2, 10/-.

Postage 9d. each extra.
PARTICULARS ON REQUEST.
Terms C.O.D. OR CASH with order.

Arthurs
Est. 1919

PROPS: ARTHUR GRAY, LTD.

OUR ONLY ADDRESS : Gray House,
150-152 Charing Cross Road, London, W.C.2

TELEGRAMS—"TELEGRAY, WESTCENT, LONDON."
CABLES—"TELEGRAY," LONDON.

SIGNAL GENERATOR

Coverage 120 Kcs-220 Kcs, 300 Kcs-900 Kcs, 900 Kcs-2.75 Mc.s, 2.75 Mc.s-8.5 Mc.s, 8 Mc.s-28 Mc.s, 16 Mc.s-56 Mc.s, 24 Mc.s-84 Mc.s. Metal case 10in. x 6in. x 4in. Size of scale, 6 1/2 x 3 1/2in. 2 valves and rectifier. A.C. mains 230-250 v. Internal modulation of 400 c.p.s. to a depth of 30 per cent., modulated or unmodulated R.F. output continuously variable 100 milli-volts. C.W. and mod. switch, variable A.F. output and moving coil output meter. Grey hammer finished case and white panel. Accuracy plus or minus 2%. £4.19.6 or 34/- deposit and 3 monthly payments 25/- P. & P. 4/6 extra.

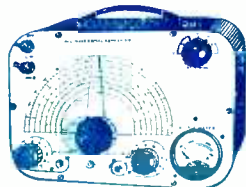

SIGNAL & PATTERN GENERATOR

Coverage 7 Mc.s-210 Mc.s in five bands, all on fundamentals, slow-motion tuning, audio output, 8 vertical and horizontal bars, logarithmic scale. In grey hammer finished case with carrying handle. Accuracy ± 1%. A.C. mains 200-250 v.

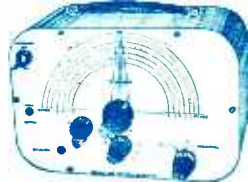

£6.19.6. Or £3 deposit and P. & P. 5/6. 3 payments of 30/-

COMMERCIAL TELEVISION CONVERTER SUITABLE ANY T.V. EXCEPT PHILIPS

ALL CHANNELS

NO ALTERATIONS TO SET
Complete with built-in power supply, 230-250 v. A.C. mains. Crackle finish case 5 1/2in. long, 3 1/2in. wide, 3 1/2in. high. Incorporating rain control and band switch. Illustrated with cover removed.

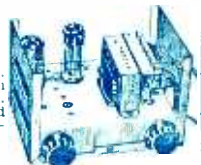

£3.19.6 Plus P. & P. 2/6.



AC/DC MULTI-METER KIT

Comprising 2in. moving coil meter, scale calibrated in AC DC volts, ohms and milli-amps. Voltage range AC DC 0-10, 0-100 and 0-500. Milli-amps 0-10, 0-100. Ohms 0-1,000 and 0-10,000. Front panel, range switch, wire-wound pot. for ohms zero setting, two toggle switches, resistors and meter rectifier. In grey hammer finish case. 19/6 Plus P. & P. 1/6.

Point to point wiring diagram 1/-, free with kit.

4 VALVE ALL-DRY SUPERHET PORTABLE KIT

incorporating Ferrite rod aerial Medium and long waves. In grey leatherette. Size 9in. x 7in. x 6in. Valve line-up : 1T4, 1R5, 18S, 3V4. Complete kit of parts (less batteries).

£5.19.6 Plus Post & Packing 3/6



COMpletely BUILT PORTABLE AMPLIFIER approx. size 6 1/2in. x 2 1/2in. incorporating 2 valves, contact-cooled metal rectifier, bass and treble hfc controls. Plus double wound mains transformer 230-250 v. 39/6 P. & P. 3/6. 6 1/2in. P.M. SPEAKER & O.P. TRANSFORMER, if purchased with the above 18/6. Plus P. & P. 1/6.

COLLARO 4-SPEED AUTOMATIC CHANGER

Model 156 (suitable for use with above amplifier). A.C. mains, 200-250 v., turnover crystal head. £8.19.6 Plus P. & P. 5/6. Brand new, fully guaranteed.

RADIO & T.V. COMPONENTS (Acton) LTD.
23, HIGH STREET, ACTON, LONDON, W.3
GOODS NOT DESPATCHED OUTSIDE U.K.

performance assurance

with

COSSOR

**printed
circuits**

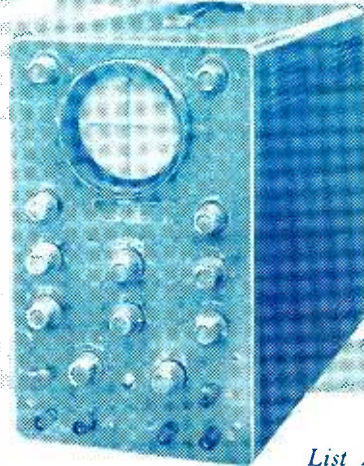

**MODEL 1045K
KIT OSCILLOSCOPE**

List Price
£36.13.4

A new single-beam Oscilloscope in Kit form of equal value to the professional engineer or amateur alike is available in Model 1045K. Providing an amplifier of wide bandwidth and high sensitivity and a variable time base with X expansion, this instrument will satisfy, economically, the Laboratory's or Works' need for a general-purpose oscilloscope.

The use of printed circuit techniques has made possible the inclusion in this Kit of circuit boards which, by their innate accuracy of wiring and layout, assure the attainment of the design specification. The assembly of the instrument requires no skill other than that needed to use a soldering iron. Each step in the construction is covered clearly in the profusely illustrated, 53-page Manual whilst the work provides a valuable exercise for the student of electronic equipment.

Write for descriptive brochures and prices of available Kit instruments to :

COSSOR INSTRUMENTS LIMITED

The Instrument Company of the Cossor Group

COSSOR HOUSE · HIGHBURY GROVE · LONDON N.5.

Telephone: CANonbury 1234 (33 lines). Telegrams: Cossor, Norphone, London. Cables: Cossor, London

712