

TEST CARD "C" EXPLAINED

Practical Television '53

OCTOBER 1956

AND TELEVISION TIMES

EDITOR: F.J. CAMM



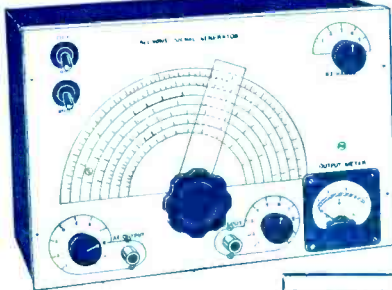

**COMPLETELY BUILT
SIGNAL GENERATOR**

Completely built Signal Generator, coverage 120 Kc.s-320 Kc.s, 300 Kc.s-900 Kc.s, 500 Kc.s-2.75 Mc.s, 2.75 Mc.s-8.5 Mc.s, 8 Mc.s-28 Mc.s, 10 Mc.s-56 Mc.s, 24 Mc.s-84 Mc.s. Metal case 10 x 6 1/2 x 4 1/2 in. Size of scale 6 1/2 x 3 1/2 in. 2 valves and rectifier. A.C. mains 230-250 v. Internal modulation of 400 c.p.s. to a depth of 30 per cent., modulated or unmodulated R.F. output continuously variable 100 millivolts. C.W. and mod. switch, variable A.F. output and moving coil output meter. Black crackle-finish case and white panel. Accuracy plus or minus 2%. **£4.19.6** or 34/- deposit and 3 monthly payments 25/-. P. & P. 4/6 extra.

**COMMERCIAL
TELEVISION
CONVERTER**

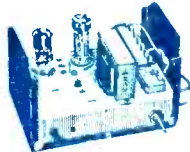

Illustrated with cover removed
SUITABLE ANY T.V.
using lower side band
No Alterations To Set
£3.19.6
Plus Post
& Pkgs. 2/6

Complete with built-in power supply. 230-250 v. A.C. mains. Crackle finish case 5 1/2 in. long, 3 1/2 in. wide, 4 1/2 in. high. Incorporating gain control and band switch.
Less power supply **£2.19.6** P. & P. 2/6

BOTH GENERATORS GUARANTEED FOR 12 MONTHS

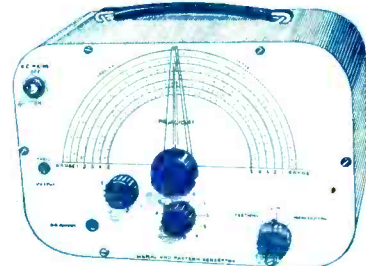

**SIGNAL & PATTERN
GENERATOR**

Coverage 7.6 Mc.s-210 Mc.s in five bands, all on fundamentals, slow-motion tuning, audio output, 8 vertical and horizontal bars, logging scale. In grey hammer finished case with carrying handle.
P. & P. 5/6

Accuracy ± 1%. A.C. mains 200-250 v. Or **£6.19.6** £3 deposit, P. & P. 5/6 and 3 payments of 30/-
Line or Frame Oscillator Blocking Transformers, 4/6 each. **Smoothing Choke**, 250 mA. 5 henry, 8/6; 250 mA. 10 henry, 10/6.
Wide Angle P.M. Focus Unit, vernier adj., state tube, 15/-.
P.M. Focus Unit for Mullard tubes with vernier adjustment, 15/-.

Ion Traps for Mullard or English Electric tubes, 5/- Post paid.
T.V. Coils, moulded former, iron cored, wound for rewinding purposes only. All-can 1 1/2 in. x 1 in., 1/- each; 2 iron-cores All-can, 2 1/2 in. x 1 in., 1/6 each. These coil formers are suitable for the Prac. T.V. Converter.

Doublier, 001 10kV. working, 3/6.
Primaries 200-250 v., P. & P. 2/-
300-0-300, 100 mA. 6 v. 3 amp., 5 v. 2 amp., 22/6.
Drop thro' 350-0-350 v. 70 mA. 6 v. 2.5 amp., 5 v. 2 amp., 14/6.
Drop thro' 250-0-250 v. 80 mA. 6 v. 3 amp., 5 v. 2 amp., 14/6.
280-0-280, drop through, 80 mA. 6 v. 3 amp., 5 v. 2 amp., 14/6.

**3-speed
TRANSCRIPTION MOTOR
BY FAMOUS MANUFACTURER**

Complete Kit of parts comprising accurately balanced precision made, heavy turntable with rubber mat, large constant speed condenser start motor, base plate. Can be assembled in half an hour.
A.C. Mains 200/250 v. Fully guaranteed **£6.19.6**
Parts sold separately. Post Paid.

BAND III CONVERTER KIT

Comprising 5 channel tuner, mains transformer, metal rectifier, electrolytic, 2 valves, 12AT7 and 6F80, and all necessary components for A.C. mains operation. Complete with conversion data.
£2.5.0 P. & P. 2/6.

Three-speed automatic changer by B.S.R. MONARCH, current model. Will take 7 in., 10 in., or 12 in. records mixed. Turnover crystal head. Cream finish. BRAND NEW.
VERY LIMITED QUANTITY.
A.C. Mains 200/250, **£7.15.0**, P. & P. 3/6.

**GARRARD RC/110
3-SPEED
AUTOMATIC CHANGER**

10 Records, 7 in., 10 in. or 12 in. mixed, turn-over crystal head, BRAND NEW. A.C. Mains. 100/250 v.



LIST PRICE £14.10.0.
£7.19.6
P. & P. 3/6.

Drop thro' 270-0-270 60 mA. 6 v. 3 amp., 11/6.
250 v. 350 mA. 6.4 v. 4 a., twice 2 v. 2 a., 19/6.
Semi-shrouded drop-through 380-0-380 120 mA., 6.3 v. 3 amp., 5 v. 2 amp., 25/-.

Auto Trans. Input 200/250 H.T. 500 v., 250 mA., 6 v. 4 a., twice 2 v. 2 a., 19/6.
Auto Trans. Input 200/250 H.T. 350 v. 350 mA., Separate L.T. 6.3 v. 7 a., 6.3 v. 11 amp., 5 v. 3 amp., 25/- P. & P. 3/-.

Heater Transformer, Pri. 230/250 v. 6 v. 11 amp., 6/-.
350-0-350 75 mA., 6.3 v. 3 a. tap, 4 v. 6.3 v. 1 a., 18/6.
500-0-500 125 mA., 4 v. C.T. 4 a., 4 v. C.T. 4 a., 4 v. C.T. 2.5 a., 27/6.
500-0-500 250 mA., 4 v. C.T. 5 a., 4 v. C.T. 5 a., 4 v. C.T. 4 a., 39/6.
Chassis mounting or drop thro', Pri 110/250 v. Sec. 350-0-350 250 mA., 6.3 v. 7 amp., 6.3 v. 0.5 amp., 5 v. C.T. 0.5 amp., 4 v. 4 amp., 32/6. P. & P. 3/6.

P.M. Speakers, closed field, 3 ohm speech coil 12 in., 25/-; 10 in., 25/-; 8 in., 20/6; 6 in., 18/6; 5 in., 18/6. P. & P. 2/- each extra.
1,200 ft. High Impedance recording tape on aluminium spool, 12/6 post paid.

Valve Holders, moulded octal Mazda and loctal, 7d. each. Faxolin, octal Mazda and loctal, 4d. each. Moulded BTG, 98A and 99A, 7d. each.

Where cost and packing charge is not stated, please add 1/6 up to 10/-, 2/- up to £1 and 2/6 up to £2. All enquiries S.A.E. Lists 5d. each.

Line and F.H.T. Transformer, 9kv. Ferrocarr core, EY51 heater winding, complete with scan coils and frame output transformer and line and width control. 35/- P. & P. 3/-.

As above but complete with line and frame blocking transformers, 4 henry 250 mA. choke, 100 mfd. and 150 mfd. 350 wkg., 380 mA. A.C. ripple. **£2.9.6**, P. & P. 3/-.

Standard wave-change Switches, 4-pole 3-way; 5-pole 3-way; 3-pole 3-way, 1/9 each; 9-pole 3-way, 3/6; Miniature type, long spindle, 4-pole 3-way and 4-pole 2-way, 2/6 each, 2-pole 11-way twin wafer, 5/-; 1-pole 12-way, 5/- P. & P. 3d.

USED metal rectifier, 250 v. 150 mA., 6/6.

Combined 12 in. Mask and Escutcheon perspex. New aspect, edged in brown. Fits on front of cabinet. 12/6. As above for 15 in. tubes, 17/6.

Polishing Attachment for electric drills. 1 in. spindle, chromium plated 5 in. brush, 3 polishing cloths and one sheepskin mop mounted on a 3 in. rubber cup. 12/6. P. & P. 1/6. Spare sheepskin mops, 2/6 each.

RADIO & T.V. COMPONENTS (ACTON) LTD.
23 HIGH STREET, ACTON, LONDON, W.3

OSMOR VARIABLE Band I ATTENUATOR

Balances reception of ITA and BBC in all areas and avoids constant adjustment of controls. The Osmor is the only variable attenuator that will reduce the signal exactly to the required level. Easily Fitted—just plug in. Reduction ratios variable 2-1 to 10-1. An Essential with all types of Band III Converters. 10/- plus 9d. p. & p. From your Dealer—or direct.



BAND I FILTER

Rejects BBC from ITA aerial and improves picture. Suitable for all makes. Fitted in 2 minutes. 10/- plus 6d. p. & p. including instructions.

ITA CONVERTERS LONDON · LICHFIELD · MANCHESTER

A very efficient Band III Converter for all TV sets of any age (including TRF). Approximately one hour to build! Guaranteed no breakthrough of Band I. Will convert any Band III Channel to any Band I Channel. Station switching. A.C. or A.C./D.C. Size 4 1/4 in. x 2 1/2 in. x 3 in. Circuits, Wiring Diagrams and full constructional information, ready to fit inside your TV cabinet.

Complete Kit **65/-** Completely wired **80/-**
Both plus 2/- post and packing.

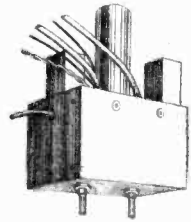

FREE We keep right up to date in building the latest circuits published in "Practical Wireless," "Wireless World" and "Radio Constructor" and we stock the components specified. Send 7d. in stamps for circuits, fully descriptive literature together with coil and coilpack leaflets, component lists, chassis drawings and templates.

ITA Band III CONVERTER KIT

Complete with all components, including power unit, for construction of an efficient Band III converter. Nothing else to buy. Circuit, wiring diagram, chassis templates and complete instructions, **£6.19.0.**

plus 2,6 p. & p.

OSMOR RADIO PRODUCTS LTD. 418 Brighton Road, South Croydon, Surrey. Croydon 5148-9

Dept. PT3.

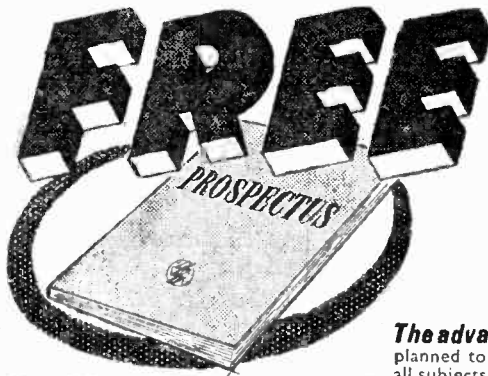

POST THE COUPON TODAY FOR OUR BROCHURE ON THE LATEST METHODS OF HOME TRAINING FOR OVER 150 CAREERS & HOBBIES

PRIVATE AND INDIVIDUAL TUITION IN YOUR OWN HOME

City and Guilds Grouped Certificates In Telecommunications: A.M.Brit.I.R.E. Examination, Radio Amateur's Licence, Radio and Television Servicing Certificates, General Radio and Television Courses; Radar, Sound Recording, etc. Also Courses in all other branches of Engineering and Commerce.

The advantages of E.M.I. training. ★ The teaching methods are planned to meet modern industrial requirements. ★ We offer training in all subjects which provide lucrative jobs or interesting hobbies. ★ A tutor is personally allotted by name to ensure private and individual tuition. ★ Free advice covering all aspects of training is given to students before and after enrolling with us.

Equipment supplied upon enrolment and remains your property.

Courses from **15/- per month**

POST THIS COUPON TODAY

Send without obligation your FREE book:
E.M.I. INSTITUTES, Dept. 138K,
43 Grove Park Road, London, W.4.

NAME _____

ADDRESS _____

10 50
SUBJECT(S) OF INTEREST _____

IC.38F.

NEW LEARN THE PRACTICAL WAY. COURSES WITH EQUIPMENT

With many of our courses we supply actual equipment thus combining theory and practice in the correct educational sequence. Courses include: Radio, Television, Electronics, Draughtsmanship, Carpentry, Photography, and Commercial Art, etc.

EMI INSTITUTES

The only Postal College which is part of a world-wide Industrial Organisation.

BRIMAR

TRIPLE-TESTED

Transistors

save space power & weight

Types TP1 & TP2

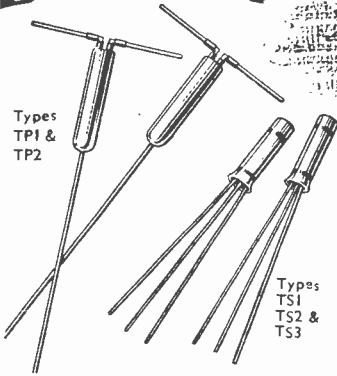

Types TS1, TS2 & TS3



Types TJ1, TJ2 & TJ3

These long-life transistors in your circuits will save space and power and incidentally save weight. Exhaustive tests by our unique triple-test process have proved their reliability over a long period.

Their small size and low consumption permit the design of light, compact equipment and, since the cases are of metal, there is little danger of accidental fracture.

The BRIMAR TP1 and TP2 are point contact n type, germanium transistors. Type TP1 may be used in control and switching circuits at frequencies up to 100 Kc/s and will work consistently and reliably within this range. Type TP2 may be used as an amplifier or oscillator at frequencies up to 2 Mc/s. Collector dissipation 150 mW max. at 20° C. The BRIMAR TS1, TS2 and TS3 are p.n.p. alloyed junction transistors intended for use in low frequency applications up to 500 Kc/s. These transistors are fully hermetically sealed. They are thus immune from the effects of humidity and noxious atmospheric conditions. The collector dissipation of these types is 50 mW at 20° C. The TJ1, TJ2 and TJ3 are similar to the TS1, TS2 and TS3, but have a collector dissipation of 200 mW at 20° C. and are somewhat larger in size.

Send for data sheets of these transistors to

Standard Telephones and Cables Limited FOOTSCRAY, SIDCUP, KENT Footscray 3333

LASKY'S RADIO

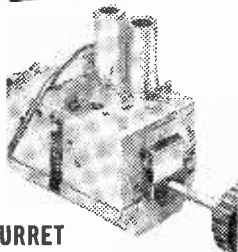

TURRET "TELETUNER"

Complete with 12 coil sets. Covers all Channels Band I and III, London and Birmingham. Valves used : PCC84, R.F. double triode, cascade R.F. amplifier, PCF80, triode pentode t.c. and mixer. I.F. output 33-38 Mcs, easily modified to other I.F. outputs. With full instructions and circuit diagram. **99/6.** Post 26. Knobs, 3/6.

Biggest Bargain Ever Offered in TV Cathode Ray Tubes!



BRAND NEW, PERFECT 16" METAL CONE C.R.T.

A big new purchase of these Tubes enables us to still further reduce our price. Brief specification : 6.3 v. heater. Ion trap, 14 kv. E.H.T. wide angle 70 degrees, standard 38 mm. neck, duodecal base, magnetic focus and deflection. Length 17 11/16in. Gives large black and white picture 11 x 14in. Unused and in 3 MONTHS. **GUARANTEED BY US FOR** gested time bases supplied with every Tube.

LISTED AT £23.9.10. LASKY'S PRICE £8.9.6.

Carr. & Insur. 22/6 extra. Masks, Anti-Corona, Bases and Ion Traps available.

AMAZING OFFER OF FIRST CLASS TAPE RECORDERS!

The famous High Fidelity "CONCERTONE" 2-spd., 7 1/2 and 3 1/2 in. per sec. Wearite heads, fast forward and rewind, 3.4 watts output. **LASKY'S PRICE 33gns.** List-4 at £50.8.0. complete with 1,200 ft. Emi-tape, take-up Spool and Microphone. Carr. & Insur. 21/- extra. Full details on request.

MAKERS' SURPLUS COMPONENT BARGAINS!

WIDE ANGLE 38 mm.	
Line E.H.T. trans. Ferro-cube core, 9-16 kv.....	25/-
Scanning Coils, low imp. line and frame.....	25/-
Ferro-cube cored Scanning Coils and Line Output Trans. 10-15 kv. EY51 winding Line Trans. incorporates width and linearity control. Complete with circuit diagram, the pair.....	50/-
Frame Output Transformer Scanning Coils low imp. line and frame.....	6/6
Frame or line block osc. transformer.....	17/6
Focus Magnets Ferro-cube P.M. Focus Magnets, Iron Cored.....	4/6
Duomag Focallisers.....	19/6
300 m.a. Smoothing chokes Electromagnetic focus coil, with combined scan coils.....	19/6
22/6	25/-
STANDARD 35 mm.	
Line Output Transformers. No E.H.T.....	12/6
Line Output Transformers 6.9 kv. E.H.T. and 6.3 v. winding. Ferro-cube.....	12/6
Scanning coils. Low imp. line and frame.....	14/6
Ditto by Iron.....	14/6
Frame or line blocking oscillator transformer ...	4/6
Frame output transformer Focus Magnets :	7/6
Without Vernier.....	12/6
With Vernier.....	17/6
Focus coils, Electromag.....	12/6
200 m.a. Smoothing Chokes	10/6

LASKY'S (HARROW ROAD) LTD.

Both Addresses Open All Day Saturday. Early Closing, Thursday.

42, TOTTENHAM COURT ROAD, W.1. Telephone : MUSEum 2605.

370, HARROW ROAD, PADDINGTON, W.9. LADBroke 4075 and CUNningham 1978.

All Mail Orders to Harrow Road, please SEND FOR OUR NEW LIST enclosing 3d. in stamps



Practical Television



& TELEVISION TIMES

Editor : F. J. CANN

Editorial and Advertisement Offices : "Practical Television," George Newnes, Ltd., Tower House, Southampton Street, Strand, W.C.2. 'Phone : Temple Bar 4363. Telegrams : Newnes, Rand, London.
Registered at the G.P.O. for transmission by Canadian Magazine Post.

Vol. 7 No. 75

EVERY MONTH

OCTOBER, 1956

TelevIEWS

TV AT THE SHOW

THE Radio Show this year provided no surprises and from many points of view was extremely disappointing. Whereas a few years ago manufacturers vied with one another to produce novel designs and to prove that their sets were better than their competitors, this year there was a bleak standardisation which almost invited members of the public, when they required to buy a television set, to go into the nearest dealers and ask for a TV set without specifying the make. For they mostly looked alike, and apart from the fact that most makers have standardised on 17in. tubes, there was little distinction between this year's models and the previous one.

It was surprising that so few manufacturers made use of transistors, but we understand that this is entirely due to production difficulties, one well-known firm who manufacture transistors turning out only 250 a week. Perhaps next year transistors and printed circuits will be more in evidence.

The very excellent side shows provided by the BBC and others were the main attractions which drew the crowds. The stall-holders have mixed feelings about this. There are those who think that these shows lure away potential customers, whilst others think that but for the side shows the attendances would be much less. The credit squeeze and other factors, it must be admitted, have made this a difficult marketing year for manufacturers, and they have not encouraged manufacturers to embark upon new designs. Perhaps the time has come when these national shows should be held biennially.

As in previous years, air conditioning, catering, and seating accommodation (or lack of it!) left much to be desired.

TV AERIALS

THE Post Office states that out of 95,000 complaints concerning interference, investigations show that in one year over 15,000 were found to be due to inefficient aerials. In the early days of radio we became accustomed to

the vast amount of weird aerial arrays all claimed to give better signal strength and in these comparatively early days of TV a similar state of affairs exists. There is, however, greater justification for this diversity of aerial practice, because reception conditions even in two adjacent houses can be vastly different, and often experiments are necessary in order to obtain the required signal strength. The situation is complicated because at present we need three aerials, one for BBC TV, one for ITV and another for V.H.F. (sound). We may shortly require a fourth, when the shorter wavelengths come into operation. There must be a solution to this problem, for if the attitude of certain landlords is persisted in many tenants will be deprived of the benefits of all but one form of TV entertainment. A number of people, however, are able satisfactorily to receive BBC and commercial television on indoor aerials. The cost of a television aerial is a not inconsiderable item and in these days of tight purses the need for a number of them is not in the best interests of trade.

THE PROGRAMMES

ANOTHER factor which is in need of considerable improvement is the quality of the programme material. Much of it is moronic, particularly those programmes which make use of interviews and bringing nonentities to the screen. During show week the programmes reached a new low, although the technical excellence was on a very high level.

The general standard and routing of the exhibition was a great improvement on last year, and the signpost indicating the avenues upon which particular stand numbers could be found was a marked improvement.

INDEX TO VOLUME 6

THE index to volume 6, comprising issues dated June, 1955, to July, 1956 (12 issues), are now available for 1s. 3d., by post from the publisher, George Newnes, Ltd., Tower House, Southampton Street, Strand, W.C.2. Owing to the printing dispute we did not publish issues dated March, 1956, and April, 1956. — F. J. C.

The 'Scope as an Aid in Receiver Alignment

* * * * * By G. J. King * * * * *

MOST readers are by now aware that it is much more satisfactory to be able to observe the effect of a trimmer adjustment on a response curve displayed on the screen of a C.R.T. than having to rely on the limited information given by an indication on an output meter at various spot frequencies. In the latter respect, however, a curve based on the output meter indication at various frequencies may be produced if desired, but this is surely a tedious process and one that cannot be performed each time a trimmer is altered.

More TV set makers are now providing alignment instructions embracing the use of a wobblator and oscilloscope. Some are even providing two sets of instructions, one relating to the 'scope method and the other to the spot frequency method where a signal generator and output meter are used.

The connection of the 'scope and wobblator for TV alignment has been explained in these pages on many occasions. So far as the vision section of a TV receiver is concerned, however, the "Y" 'scope voltage is picked up either from across the vision detector load resistor or from across the output of the video amplifier valve. In the latter instance it is often more convenient to take the connection direct from the appropriate pin (cathode or grid, depending on how the tube is modulated) on the picture tube.

A Frequency Marker

When making trimmer adjustments in a vision channel while observing the response curve on the C.R.T. it is essential to know the precise frequency corresponding along the width of the curve. To aid in this respect a signal from an accurately calibrated signal generator is applied to the receiver under test together with the normal wobblated signal. This additional signal gives a little burst of R.F. at a point on the response curve corresponding to the frequency of the signal (see Fig. 1).

Clearly, then, the frequency at any significant point on the response curve can be determined simply by

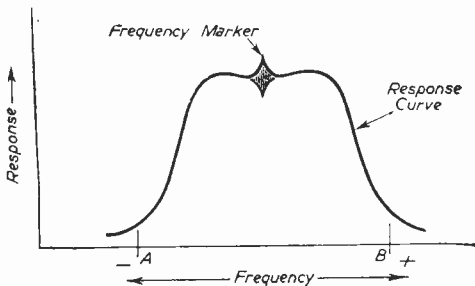

Fig. 1.—Showing the formation of a frequency marker on a response curve.

adjusting the tuning of the marker generator until the burst of R.F. (generally known as a marker pip) is at the required point on the curve, and then reading the frequency on the scale of the generator. As the frequency of the marker generator is swung from, say, the frequency corresponding to point A on Fig. 1 to the frequency corresponding to point B, the frequency marker will appear at point A, slide up the curve, along the top and then down the other side and disappear at point B. A means is thus available of accurately determining the width of the curve in terms of frequency.

Some wobblators designed for TV use have a terminal available for injecting into them a marker frequency. If an instrument of this kind is not available, however, it is quite a simple matter to inject the two frequencies simultaneously into the receiver by using a network such as that shown at Fig. 2.

If it is found that the frequency marker extends considerably over a large area of the response curve and hides important contours of the curve, the marker can be sharpened up considerably by connecting a 0.001 μ F capacitor across the "Y" and earth terminals of the 'scope.

The diagram at Fig. 3 shows how the 'scope, wobblator and marker generator should be connected to a TV receiver.

A Calibrated Graticule

Particularly during the operation of TV alignment, it is often necessary to know the relative amplitude of the displayed response curve at various points along the trace. For example, when aligning normal receivers it is general practice to arrange the alignment of the I.F. stages so that the response at the nominal vision carrier frequency is 6 dbs down.

A calibrated graticule which can easily be fixed in front of the C.R.T. screen is a considerable aid in this respect. Such a device can be made quite easily by

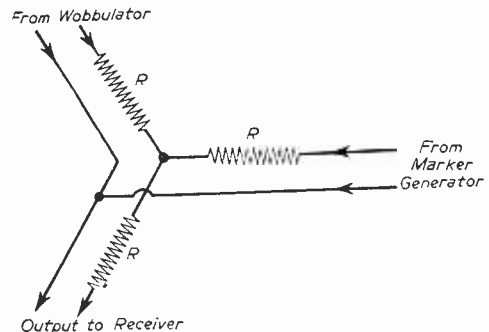

Fig. 2.—A network suitable for injecting two signals simultaneously into a receiver.

scribing a piece of Perspex as shown at Fig. 4. The size of the Perspex should be such that it fully covers the front of the tube; some commercially produced 'scopes have sliders at the front of the instrument for taking a graticule of this kind, but if such a feature is not available little difficulty should be presented in fixing the graticule by some other means.

If the deflection amplifier is fairly linear, the horizontal db lines may be marked off as percentages of response amplitude as follows: 3 db 70 per cent.; 6 db 50 per cent.; and 20 db 10 per cent.

Method of Alignment

Full alignment procedure cannot be given in this article, as the alignment procedure varies considerably between receivers. As has been intimated previously in various articles, optimum results are attainable only

is not registered on the curve. What happens is that the curve dips correctly as the rejectors are tuned towards the sound frequency, but from a certain point and up to the point of optimum rejection no further dip is indicated.

After adjusting the rejectors it is general practice to align the sound section of the receiver. This can be done by employing the 'scope and wobulator method, as detailed some time ago in these pages. The more popular method, however, simply involves connecting the "Y" terminal of the 'scope across the sound detector load resistor, applying a modulated signal at the sound I.F. to the control grid of the first valve, which is common to both sound and vision (as when adjusting the rejectors), and adjusting the appropriate trimmers in the sound channel for maximum amplitude trace, after setting the timebase frequency at about 50 c.p.s.

Using the arrangement as illustrated at Fig. 3, it is general practice next to connect the wobulator output to the signal grid of the final vision I.F. valve. The wobulator is adjusted to provide a frequency sweep in the region of plus or minus 4 Mc/s relative to the nominal vision I.F., or as stipulated in the alignment instructions. With the timebase running between 12 c.p.s. and 50 c.p.s. the trimmers appropriate to the final vision I.F. valve should be adjusted, aiming for a curve something like that shown at Fig. 5(b)—it should be noted that this is for a single sideband vision characteristic.

The output of the wobulator is then transferred to the signal grids of the preceding vision I.F. valves in turn, working back to the first valve in line, and adjusting the tuned circuits relating to the valve which is in receipt of the wobulator signal, curves after the style of those at Fig. 5(c) and (d) should be resolved.

The I.F. transformer in the anode circuit of the frequency changer (or mixer) valve should be adjusted to produce a curve something like that at Fig. 5(e), when the wobulator signal is applied to the signal grid of the valve concerned.

In cases corresponding to displays (b) to (e) it will be observed that the I.F. corresponding to the carrier is

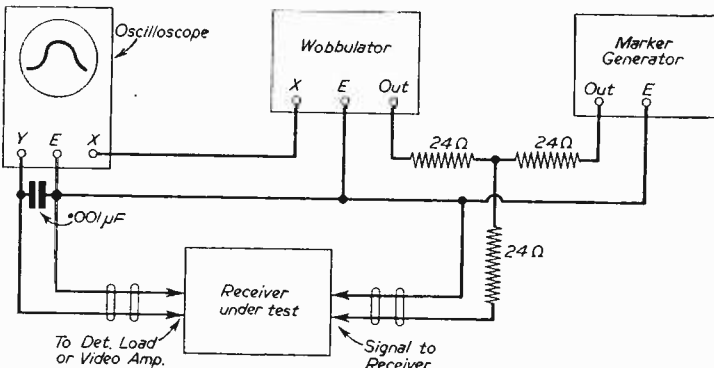

Fig. 3.—A block diagram showing how the 'scope, wobulator and marker generator should be connected to a TV receiver.

if the procedure given in the maker's instructions is closely followed. This applies to service engineers as well as experimenters, for although a picture will undoubtedly be obtained by employing the "guess and adjust" method, the operation can never be considered conclusive, and one is always tempted to readjust here and readjust there, always aiming for something a little better! Of course, if the instructions are really unobtainable then this course has to be adopted.

Even when employing the visual method of alignment it is always best to adjust the sound rejectors first by applying a spot frequency equal to the sound I.F. and setting the associated tuned circuits for minimum output from the vision channel. The 'scope may be used as an output indicator in this case by connecting the "Y" terminal across the diode load resistor as for wobulator alignment, using a modulated input signal and adjusting for minimum amplitude trace, with the timebase running at about 50 c.p.s.

Although a frequency marker can readily be produced at the sound rejection frequency on a displayed vision response curve, as shown at Fig. 5(a), it is necessary to tune the rejectors with a signal considerably larger than that obtained from the wobulator to provide a response display. If it is endeavoured to adjust the rejectors, therefore, while observing the vision response curve (i.e., adjusting for maximum dip at the sound rejection frequency), one often finds that the optimum point of rejection

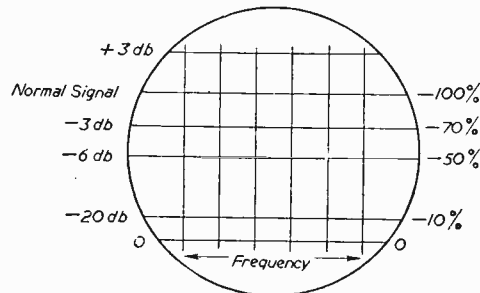

Fig. 4.—A suitable piece of Perspex scribed to form a graticule, as shown, considerably eases visual alignment of TV receivers.

approximately 6 db (50 per cent.) down the right-hand side of the curve, as indicated by the frequency marker. This, of course, indicates that the I.F. stages are tuned and adjusted to have a single sideband characteristic. Moreover, as the arrows indicate a rising frequency from the right to the left of the response curves, it will be seen that the nominal I.F. falls on the lower sideband of the curve.

Oscillator Frequency

It is worth while bearing in mind that this I.F. scale will be produced only on receivers whose local oscillator frequency is higher than the carrier frequency; on sets of this kind the sound channel I.F. is always higher than the vision I.F. A mirror image of the overall vision characteristic is thus presented in the vision I.F. channel. When the wobulator signal is applied to the aerial terminals, or injected before the frequency changer, the frequency scale of the displayed overall response curve will, of course, show a rising frequency from left to right.

Using a 'Scope

As many readers have shown interest in the use of the 'scope, but are uncertain of the best methods of using it, a short series of articles commences in this issue on page 116 dealing with this particular aspect.

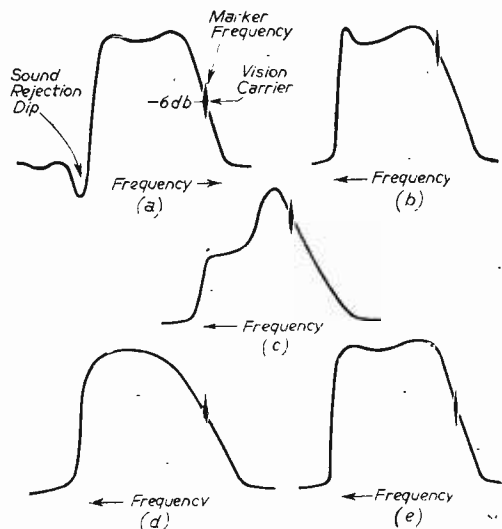

Fig. 5.—Response curves obtained during the process of TV alignment.

Pictures in Colour

THE following is an extract from a speech by Mr. B. J. Edwards, Technical Director of Pye, Ltd., to the Radar Association, dealing with methods of producing TV in colour.

"Twenty-one years after Baird's first demonstration, Pye, Ltd., gave the first demonstration in Great Britain at the Radio Show, Olympia, in 1949. For this occasion we used the sequential system operating on 405 lines under closed-circuit conditions, and this was followed by similar demonstrations in a number of Continental countries.

"In 1953, on the occasion of the Coronation, we gave a full-scale demonstration of the sequential type of colour television using a U.H.F. transmitter to transmit to a number of receiving points in the London area. This was the first full-scale colour transmission in Europe, and indicated the very great value of the addition of colour in a spectacle such as the Coronation.

"Whilst it was evident that extremely good colour pictures could be produced by means of the sequential system, it was equally obvious that the band-width requirement, which was approximately three times that of black and white picture transmission, would render the system impractical for broadcast purposes, since the space in the ether for transmission of this band-width is not available in that part of the frequency spectrum where it is economic to transmit and receive.

"America, with her vastly greater number of viewers and television stations, was the first country to realise this, and by force of circumstance had to set her scientists and technicians a problem of providing a colour transmission system capable of being transmitted over the existing television network, and capable of being received in black and white on existing television receivers. . . .

"It is interesting that the American public, despite

the fact that colour transmissions and colour receivers have been available now for the past year, have not bought television receivers in anything like the quantity the manufacturers envisaged. I think there are two reasons for this: one, as I mentioned earlier, that from an entertainment point of view, colour adds little to a picture, and therefore the public made no special demand for colour, and the other reason which, taken in conjunction with what I have just said, probably provides the whole answer, and that is that the cost of the receiver is just too high.

C.R. Tubes

"The most expensive component in a colour television receiver is the cathode ray tube, which at the moment costs approximately seven times that of a corresponding-sized black-and-white tube. In addition, this tube demands more complicated and costly circuits than a black-and-white receiver, and this accounts for the price difference.

"The only colour tube in reasonable production at the moment is the R.C.A. colour tube, and this, whilst a monument to man's ingenuity, is an intrinsically complicated and expensive tube. There is no doubt that R.C.A. are working on simplified versions of this tube, but I feel that fundamentally it is wrong and must be supplanted by a simpler, cheaper tube in the near future. Another tube that has been demonstrated in America, which is the Lawrence tube, is a less costly tube to manufacture, but does not produce as good a picture as the R.C.A. tube.

"A third tube that has been recently demonstrated is that made by Philco, which is known as a beam indexing tube, and this is in my opinion the tube of the future. It should be easy to make, install and operate, and when certain circuit problems have been worked out should enable a considerably cheaper television receiver to be made.

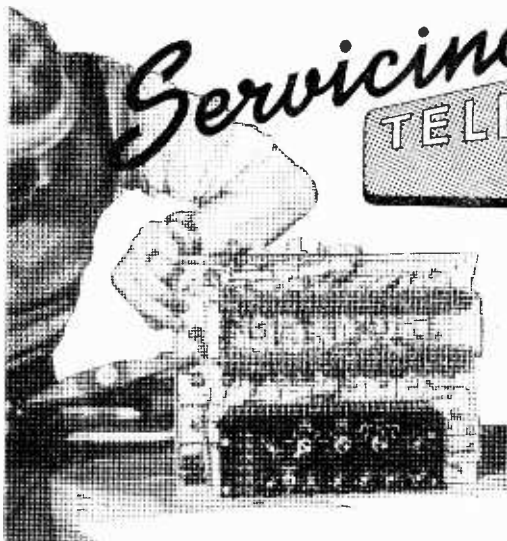

Servicing TELEVISION RECEIVERS

No. 23.—THE G.E.C. BT5147

By L. Lawry-Johns

THESE notes may be used with reference to the associated models BT4544, BT5543, BT6542, BT5246, BT4643, BT5642 and BT6641. Various differences occur, of course, such as the tube type fitted, and some differences in the circuit of the fringe models BT5246, BT4643 and BT5642 may be noticed from the description and the diagrams.

The BT5147 which is the subject of this article is a table model employing a Mullard MW36-24 tube. The BT4544 and BT4643 are the console and console with doors versions.

These are 16-valve superhet receivers, suitable for connection to A.C. or D.C. mains of 200-250 volts. Tunable to any of the five BBC channels in Band I, they are readily converted for dual band use by the G.E.C. BT204 for the BT5147 and the BT203 for the console versions.

The method of fitting the converters is quite simple provided the instructions are understood and followed, and it is not proposed to deal with this subject in the present article.

Reference to the diagram showing the top view of the R.F. chassis shows that all the valves are of the Z77 type with the exception of the sound detector and A.F. amplifier, which is a DH77. There is no valve diode in the vision strip—detection being by a crystal diode (GEX35). V1, V2 and V3 are common to both sound and vision and in the event of sound and vision failure, a blank raster still being controlled by the brilliance to indicate the functioning of the rest of the set, these valves and associated components should be suspected. V4 is the vision I.F. amplifier and V5 the video. The fault of "sound, no picture," but brilliance operating, should direct attention to V4 and the crystal diode circuits. A fault in the V5 stage usually affects the brilliance, since the cathode of the C.R.T. is fed from the video amplifier anode. To clarify this, the normal anode voltage of V5 is 160 volts with a current of 6.6 mA passing. Should the emission of the valve fall the current will reduce, thus causing the voltage drop across the load resistors (two 12 K $\frac{1}{4}$ watt in parallel) to reduce correspondingly. Therefore, the anode voltage rises nearer to that of the H.T. line, causing the C.R.T.

cathode-grid difference of potential to become greater. This gives the same effect as reducing the brilliance control except that the contrast of the picture also falls with, perhaps, a loss of picture hold. This applies to the majority of receivers where the C.R.T. is cathode modulated from the video amplifier anode circuit. A poor picture when the sound is good, with weak sync, often indicates a faulty GEX35 crystal diode when both V4 and V5 are proved good. The crystal is mounted between the V4 and V5 valve bases—roughly midway.

No Sound

No sound, but with a hum from the speaker upon rotation of the volume control, indicates a fault on the R.F. chassis, and if the vision appears in order the V9, V10 stages are normally in need of inspection.

The DH77 does seem prone to sudden failure which, of course, results in complete loss of sound signals. On the other hand, distorted and probably low sound should immediately point attention to the 10 M Ω resistor associated with the crystal diode sound noise limiter. The crystal is adjacent to the underside of the octal socket to the left of V10. The resistor is close by, coloured brown, black, blue. Normally, this resistor increases in value to an extent where it is practically open circuit, thus restricting the operation of the diode. If, however, the resistor is not responsible, check the crystal itself (GBX34) and then the 220 K Ω DH77 anode load resistor which is very close to the crystal. This resistor is coloured red, red, yellow.

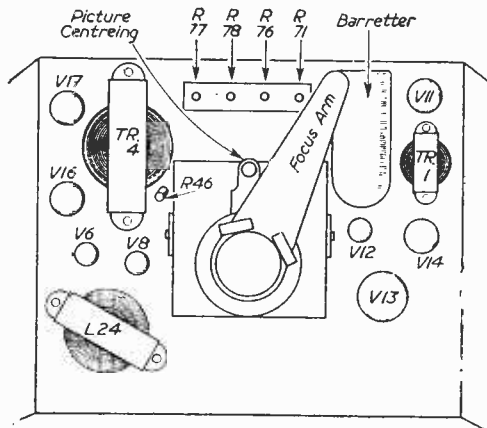

Fig. 1.—Rear view of main chassis; R.F. unit and tube removed for clarity.

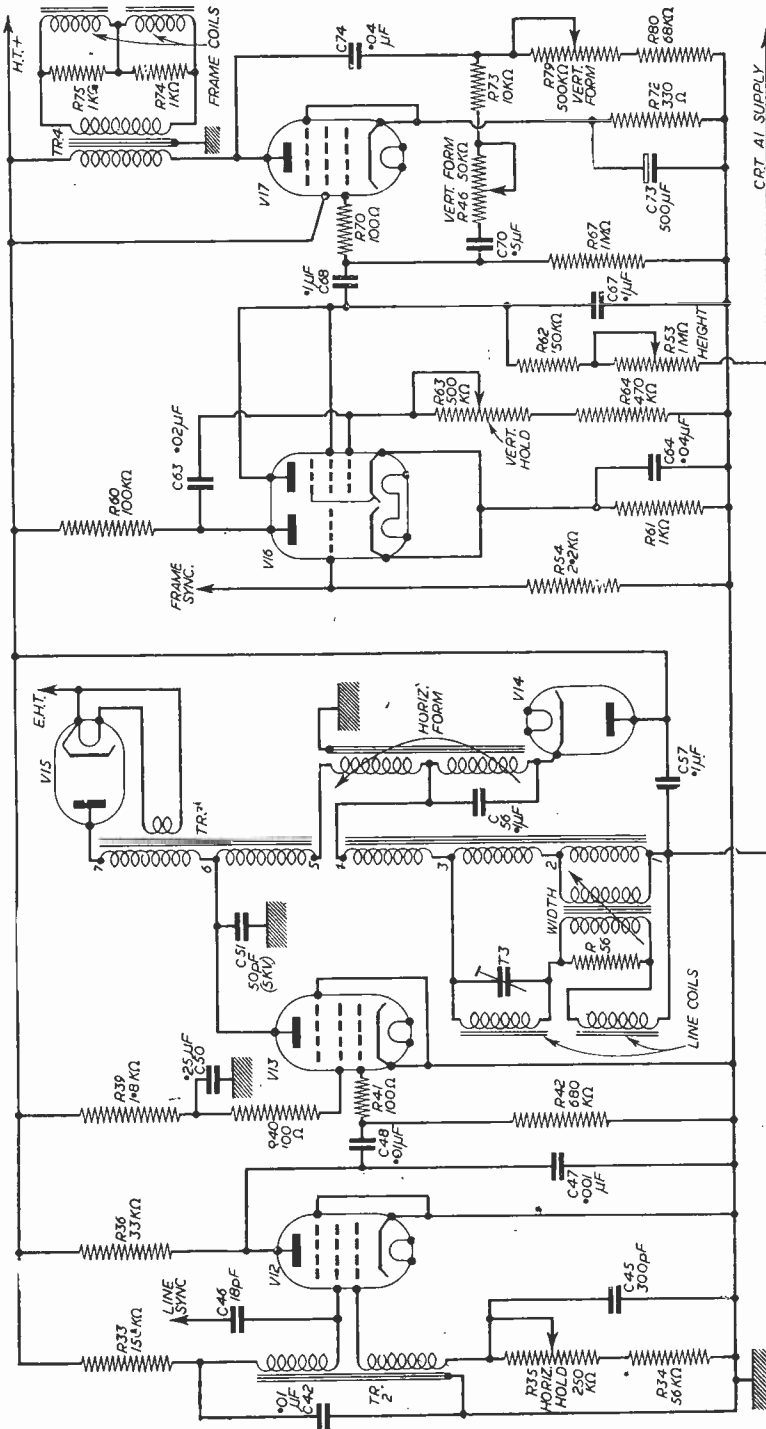

Fig. 3.—Line and frame timebases.

The sound output valve is V11 PL82; in the event of doubt, this may be interchanged with V17, whereupon the frame scan will exhibit abnormal operation if V11 is defective as well as the sound fault clearing.

Noise Limiter, Vision

A D77 on the main chassis (V6) carries out the function of noise limiter diode (V6a) and interlace diode (V6b). For the moment only V6a need be considered. It was mentioned earlier that the C.R.T. is fed from the V5 anode. The actual connection is to the left side of the R.F. chassis and this is marked X on the layout diagram.

As well as being the C.R.T. cathode feed, this also feeds the noise limiter cathode (pin one on V6 valvebase). The anode of this section of the valve is pin seven which connects to the slider of the noise limiter control. In the event of a heater-to-cathode leak in the diode a heavy A.C. ripple will be superimposed upon the C.R.T. cathode. This results in wide black and white bars across the raster. In some cases the top half of the raster only appears as white and the lower half is completely blacked out or vice versa.

C.R.T. Circuit and Faults

The tube is fairly trouble free in service, but is prone to cathode-grid shorts, which were fully dealt with in an earlier article in this series (Further Notes On Cathode Ray Tubes) and heater partial shorts, which were also mentioned in the article. The MW36-24 is a tetrode tube and is used in this receiver with an EHT voltage of 13 kv. An ion trap

magnet is fitted on the tube neck and the only position for this is that which gives maximum brilliance. Some small movement can be made to remove corner shadow, but only if the brilliance is not affected. The first anode voltage (tag 10 of the tube base) is slightly in excess of 400 volts when the receiver is working normally. The cathode voltage (tag 11) should be 160 approximately, whilst the grid voltage at tag two should vary from this figure down to zero as the brilliance is retarded. When the grid voltage approaches that of the cathode some distortion of the raster is to be expected since the heavy beam current taken by the tube tends to overload the U25 EHT rectifier and line output stage.

Some readers appear to be under the impression that the picture size should not vary under high brilliance conditions. It is desirable that the picture size and focus should remain constant over the entire brilliance range. Unfortunately, however, the source of EHT power is essentially a high impedance one. The regulation is, therefore, inherently poor, so that as the tube current increases, the supply voltage falls, and the efficiency of the line output stage diminishes. This explains why the presence of an

internal short in the tube causes the symptom of no EHT, and why EHT brushing is likely to occur when the brilliance is at minimum, this being the condition when the EHT is at its highest (no load).

Thus some degree of distortion is to be expected at high brilliance level and is a normal condition. On the other hand, if the picture distorts and fails upon normal operation of the brilliance control, and bright scenes such as the weather chart tend to cause the picture to "blow out" and disappear, the U25 EHT rectifier should be immediately suspected. Therefore, some tolerance and plain common sense should always be used when testing and criticising the performance of a receiver employing EHT derived from the line output stage.

The Line Timebase

A Z77 (V12) is used as the line oscillator in a conventional blocking circuit, the output of which is coupled to the KT36 (V13) control grid. Now this valve (V13) depends upon the line drive from V12 for its bias. In the event of V12 failing, or some component associated with V12 causing it to cease

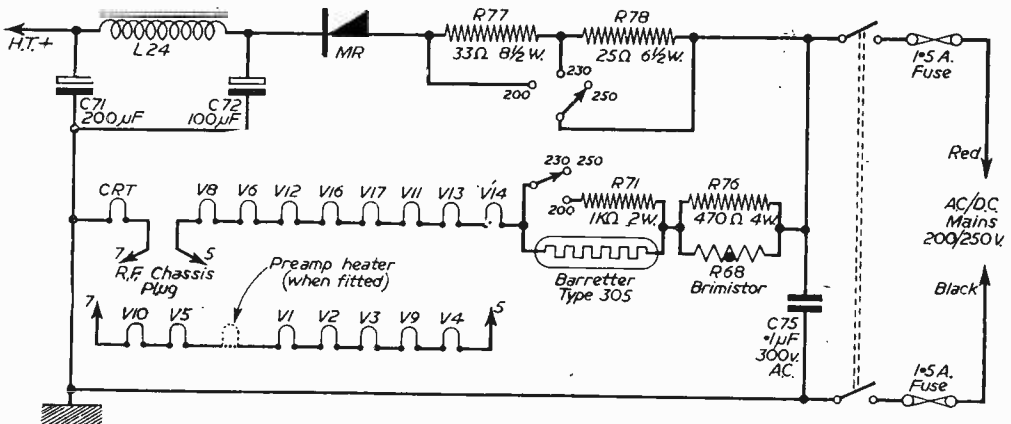

Fig. 4.—Mains supply circuit.

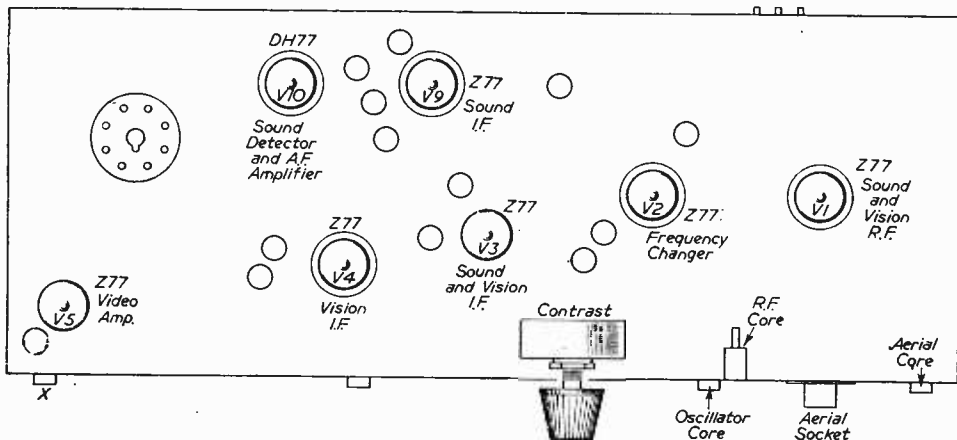

Fig. 2.—Top view of chassis.

operating, the KT36 will be left without bias and the current through it will rise to a high level, thereby endangering the valve and its associated components, especially the screen dropping resistor R39 (1.8 K), which may become overheated, causing a variation in value. Therefore, if upon the symptom of "no picture, no line timebase whistle," etc., the KT36 appears to be overheating check V12.

If this is in order, check the KT36 itself. If the timebase now resumes operation, but the picture width is insufficient, check R39, which may have gone high in value.

On the other hand, if the KT36 still draws excess current R39 may have decreased in value. Either is likely, and a new KT36 is not likely to last long if R39 has decreased much in value.

The line output transformer is fairly reliable in operation, but a misleading symptom is often caused by C51 (50 pF 5 kV) shorting to chassis. This immediately stops the line timebase and causes V14 to become red hot. This in turn causes, in a few cases, the U329 to develop a heater-to-cathode short. This defect often occurs without a component failure causing it; but in any case the symptoms are unmistakable. Upon removal of the rear cover it may be observed that the Barretter lamp is glowing brightly and that no valve heaters are visible. As the first valve in the heater chain is the U329 it is not difficult to see that a defect in this valve would divert the heater current from the remaining valves, thus causing the Barretter to overheat and probably fail if the receiver is not quickly switched off. In a typical case of this a receiver was examined and the Barretter was found to be defective, thus preventing any current reaching the valve heaters.

A new Barretter was fitted and the set switched on. The Barretter glowed normally and then settled down as the valve heaters became visible. After a few moments, however, the valve heaters dimmed and the Barretter started to glow abnormally. The set was hurriedly switched off to prevent further "losses" and the U329 was replaced after a meter check had revealed that no short circuits were present. Upon switching on normal working was maintained and the Barretter behaved normally.

EHT Circuit

The overwind on the line output transformer is applied to the anode of V15 (U25) EHT rectifier. This valve is mounted behind the KT36 valve base and the cabinet must be removed from the base plate to gain access to it. This is a simple operation and will be described later. The U25 heater is fed from another winding upon the line output transformer which supplies the nominal two volts required under normal working conditions.

The EHT voltage for the tube anode is derived from this point. There is no separate EHT capacitor as the conductive coating of the tube forms, with the internal anode coating, sufficient smoothing capacity at line frequency. As stated, the EHT voltage under normal working conditions is some 13 kV.

Frame Timebase

An LN309 (V16) is connected as a cathode coupled multivibrator, the pentode section of the valve being connected as a triode. In the event of unreliable frame timebase operation or a total collapse, as evidenced by a thin horizontal white line, the LN309 should always be suspected first. Poor height should

direct attention to V17 (PL82), the LN309 and its anode load resistors, R60 and R62. Cramping at the bottom of the picture or raster should direct attention to, first, the PL82, then, if the cramping is severe with loss of picture height, C73. Then inspect the components in the vertical form circuits, C70, C74, etc., and also C68 coupling capacitor. A frequent fault is that of the LN309 developing a heater-to-cathode short. The symptoms are no picture, no sound and a slight wisp of smoke rising from the V16 valve base. This is from the 1 K cathode resistor. This quickly decreases in value, causing the majority of the valve heaters to become extinguished and the Barretter to glow brighter.

Valves 11, 13, 14 and 17 will remain heated, glowing more brightly than is normal.

It is not sufficient to replace only the LN309; the 1 K resistor (R61) must also be inspected and replaced in most cases.

Hints on Handling

As the main chassis is vertical the bottom of the cabinet is not removable. A large amount of servicing can be carried out by simply removing the rear cover. To do this, remove the five fixing screws, pull the back rearwards until the flanges clear the sides of the cabinet; spring the side pieces outwards to clear the side controls, then tilt the back to clear the top of the cabinet and withdraw to the rear and upwards.

To gain access to the rear of the valve bases, the U25, metal rectifier, etc., remove the back cover as above, pull off the two side knobs, and unscrew the two large screws from underneath the baseboard, one each side, towards the rear. Slide the cabinet forwards about half an inch to a stop.

Lift off the cabinet; the speaker leads are long enough to permit free access if the cabinet is turned back to front and placed at the side of the receiver.

The following information may be of assistance in various ways:

The Brimistor is a CZ1A. The Barretter a type 305. The volume control on-off switch is a 500 K Ω —double pole. The brightness is a 100 K Ω , vertical hold 500 K Ω , horizontal hold 250 K Ω , contrast 5 K w.w., I.F. vision 35.6 Mc/s, sound 37.6 Mc/s. Fuses: two 1.5 A. G.E.C. cartridge type RK201658. Resistance of line output transformer windings: 1-2: 0.18 Ω , 2-3: 4.3 Ω , 3-4: 5.8 Ω , 5-6: 3.6 Ω 6-7: 24,000 Ω , see Fig. 3.

The normal H.T. voltage is 200 at 230 mA. The boosted H.T. voltage at C57 is approximately 420. Where insufficient width is experienced on low voltage D.C. mains, the metal rectifier may be shorted out to avoid the volts drop across it, but when this is done great care must be taken to see that the mains leads are correctly wired, i.e., red positive, black negative.

To clarify this, if the metal rectifier is to be shorted by placing a lead between its two ends, the polarity of the mains supply must be first ascertained and the mains lead connected accordingly to the supply socket.

THE SUPERHET MANUAL

5th Impression

By F. J. CAMM

7/6, by post 7/10

From

GEORGE NEWNES, LTD.,

Tower House, Southampton Street, Strand, W.C.2.

A TELEVISION TABLE

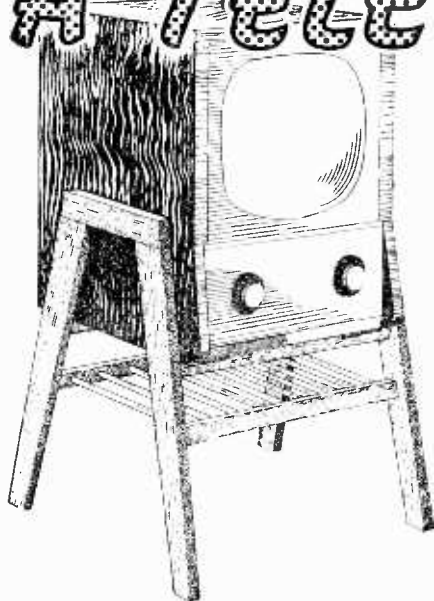

MAKING A CONTEMPORARY DESIGN FOR A TABLE MODEL RECEIVER
By D. K. Wright

tion of the design and the features underlying it. The set was to be supported at a desired level, firmly but without excessive timber in the construction. The appearance was to be one of lightness and in modern treatment and, if possible, some facility for the housing of books such as the "Radio Times" was to be provided—again to avoid heaviness and dust-retaining shelves. The solution was finally found surprisingly easy and without any need for elaborate carpentry. Only ordinary domestic tools are required, namely a saw, plane, brace and bit, and screwdriver. Ready-planed timber is available in most districts and the only part of the suggested design which may prove difficult is the shaped legs. As depicted these

MANY viewers prefer the table type of receiver to the console, and in the majority of cases this is placed on some kind of small table in a corner. In these days of contemporary furnishings this does not give an altogether modern appearance, and something more in keeping is called for. Certain manufacturers have realised this and are now supplying ready-made stands for their table models either as an integral part of

the design or to be purchased separately. I had a rather old table model which I did not wish to part with as it had given such yeoman service, and this was generally kept on a table. Unfortunately the particular model was rather larger than its modern counterpart and the table raised the picture to a level above that which experience had shown to be necessary. I, therefore, set out thinking how to house the set to preserve a modern appearance, and at the same time lower the screen to a more convenient angle. The solution is depicted in the artist's impression at the head of this page.

Design

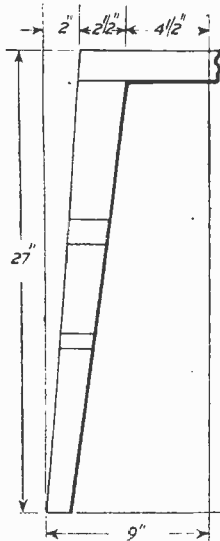

Fig. 1—Detail of the legs. First of all a rough descrip-

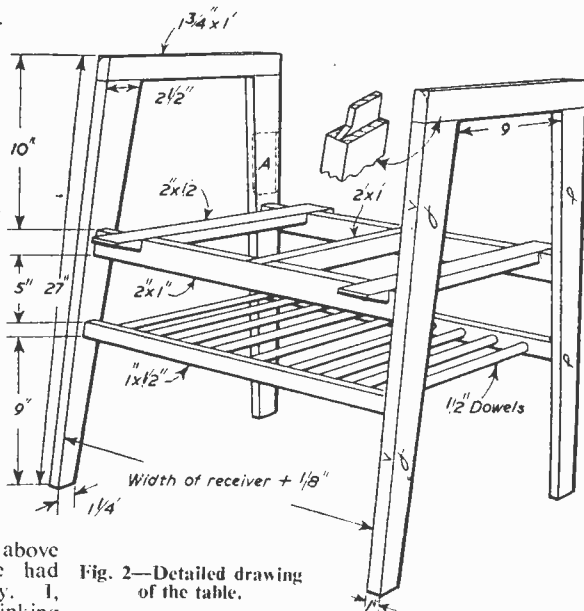

Fig. 2—Detailed drawing of the table.

are tapered which will call for cutting and subsequent planing, but this may be avoided by using material which is parallel throughout its length. This will to some extent detract from the more modern appearance given by the tapered legs. They are not difficult to make and it is only necessary to run a line from the top to the bottom, retaining the measurements shown, and then cut along the line, and if you possess one of the modern power bench saws the cut may be made

in a matter of minutes to all four legs. Plane and sandpaper the cut as the two rear legs expose the cut edge to the front. It is possible to cut two legs from one piece of timber if you choose a piece 3in. in width. The sloping line will then cut for two legs, although the overall length would have to be greater than 2ft. 6ins. so that the narrow end could be preserved. Points such as these depend upon your carpentry experience and ability, and the single shaped leg is the simplest. In addition to the 2½in. strips needed for the legs you will also need some 2in. by 1in., some 1in. by ½in., some 1½in. by 1in., some 2in. by ½in. and a quantity of ½in. dowelling.

Construction

Full details are given in Fig. 2, and the only tricky part shown is the tenon which I used for the leg tops. I deemed this necessary in the interests of rigidity, and it would well repay any constructor

to follow this feature. To assist in accuracy the individual parts may be drawn out full size on some shelf-covering white paper or wallpaper, and the cut pieces then tested for accuracy on the drawings. Note that the height of the supporting shelf will be governed by the particular receiver which is to be used, and also that the width of the stand is the other main controlling dimension. Should one of the receivers with side knobs be used it may be necessary to slot or otherwise modify the upper cross piece on the legs, but this will be left to the individual—bearing in mind that the receiver will have to be capable of being removed.

It should be unnecessary to give any other instructions and the finish and similar details are left to personal preferences. There is no reason, for instance, why the bookshelf should not be omitted or even made in slightly different form. The main thing is the general overall design of the legs and method of supporting the table model.

New Pye Underwater Camera

PYE LIMITED announce that they have produced a new hand-held underwater television camera which will enable divers to be effectively supervised from above water. It will be the smallest and cheapest underwater TV camera yet to be produced.

With the new camera, instead of having to rely on a diver's report, a number of expert observers may view the underwater scene displayed on large-screen picture monitors. A record of the picture reproduced on the monitor screen is easily made by photographic means, which obviates the difficulty of taking photographs under water. The equipment will find many applications in salvage operations, submarine engineering, marine biology and oceanography.

The camera is intended for operation down to a depth of 250 feet, but to provide an adequate safety margin the container has been designed to withstand a water pressure of 220 lbs. per square inch, corresponding to a depth of 500ft. The unit is buoyant in water and weighs 38 lbs. in air.

Normally, the spherical camera is fitted with two handles held in position by means of two clamping rings. When not required the handles can be removed and replaced by weights or lamps so that the unit can be used without the assistance of a diver. An output socket is provided for the connection of lamps or an underwater loudspeaker.

The equipment consists of a spherical-shaped camera unit, 12in. in diameter, and a picture monitor and camera control unit which may be on board ship or at any other convenient location above water. All camera adjustments are carried out from the control position, the only concern of the diver being to position the camera correctly.

The container for the camera unit consists of two Duralinox hemispheres held together entirely by external air or water pressure to form a sphere 12in. in diameter. The action of forcing the two halves together by means of a simple hand tool pushes air through a release valve and creates low internal pressure.

The electronic details of the equipment are similar to those of Pye industrial television. The camera, control unit and monitor comprise a complete closed circuit television system capable of providing a high definition picture.

Lime Grove—Studio "D"

THE first of the new Emitron cameras at Lime Grove was brought into service in August when the programme "Nom-de-Plume" was transmitted from Studio "D."

The pick-up tubes in these cameras are similar in principle to the former C.P.S. type, but an additional mesh on the scanning side of the mosaic greatly reduces the tendency to instability caused by excessive high-light brilliance. The tubes can accept an illumination of ten times the normal peak-white value without instability, and even when instability does set in, it is confined to the area immediately surrounding the point of excess brilliance. The former tendency for the instability to spread over the entire mosaic (causing the effect sometimes known as "peeling off") has been eliminated.

The fundamental sensitivity of the new tubes is approximately the same as the C.P.S. type, but their greater resistance to instability enables them to be worked with twice the previous signal current, giving higher signal-to-noise ratio and an increase in the acceptable contrast ratio.

The normal control of lighting within the camera is by a continuously variable neutral density filter which is remotely controlled. This makes it possible to work with a fixed lens aperture and therefore to maintain a constant depth of field under varying lighting conditions. The use of this filter, together with the increased working signal current, will require some increase in studio lighting for a given aperture. On the other hand the increased flexibility of choice of scenery and wardrobe (resulting from the increased contrast range) will be an advantage.

The absence of any shading controls, together with the provision of remote control for the neutral density filter, means that the normal operational control of each camera channel requires only three knobs—"Light," "Lift" and "Gamma."

While the studio has been out of service a new "inlay" equipment (which enables special scenic effects to be produced electronically) has been installed in the Vision Control Room. The flying-spot raster in this equipment is in the centre of a large desk, with almost completely unobstructed access in all directions. This should make the operator's task of placing the necessary masking devices in position a great deal easier.

A Beginner's Guide to Television

A NEW SERIES

7.—THE TUNING SIGNAL,
TEST CARD C, AND
TRACING FAULTS

By F. J. Camm

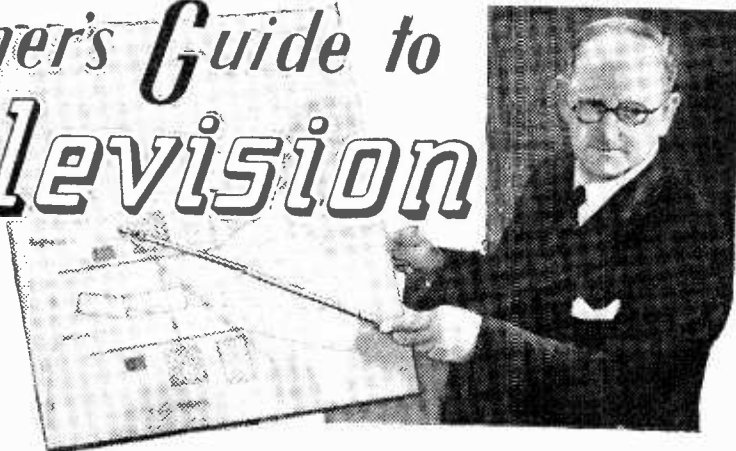

At the commencement of each TV programme a standard tuning signal is radiated, and it is illustrated in Fig. 29. It is intended as a guide to receiver adjustment, so that this can be carried out before the actual programme commences. The controls should be adjusted so that the central ring is circular and the segments around the circle should appear as depicted. This will ensure correct values of black and white, and correct linearity, and the Brilliance and Contrast controls should be set so that the various tones are as illustrated. In general, the Contrast control will govern the lighter shades, and the Brilliance control the lower shades. This tuning signal is used to check the performance of the receiver, but it must also be remembered that it will also indicate defects in the transmission itself, such as ghost images.

The controls on television receivers vary according to make, and so it is impossible to give specific instructions. In general, the controls which set the Brightness and Contrast are the most important and they are inter-related. If this adjustment is not correct, the brightness of the picture will change in accordance with the intensity and position of the high lights in the studio.

The BBC recommends that the receiver should be switched on 15 minutes before the start of the programmes so that the circuits may have enough time to reach their normal working temperature. Next, turn the Contrast and Brightness controls fully down, then turn the Brightness control slowly up until a very faint glow is just visible on the screen. Next, turn it down slightly until the glow just vanishes. Now turn the Contrast control up until the topmost shapes on each side of the circle on the

tuning card are white, and the shapes below them are light grey. Then, readjust the Brightness control so that the bottom shapes are black and those above them dark grey. Make a slight adjustment to the Contrast control to get the best contrast between the white and pale grey shapes.

Finally, adjust the Focus control to give the clearest definition to the vertical lines in the centre of the circle. On modern sets there are only two controls, and the major adjustments have been carried out by the makers.

Test Card C

A special test pattern is included in the morning television transmissions on weekdays, and at certain other convenient times, and it is shown in Fig. 30. It is designed to give an immediate indication of the performance of the whole transmitting and

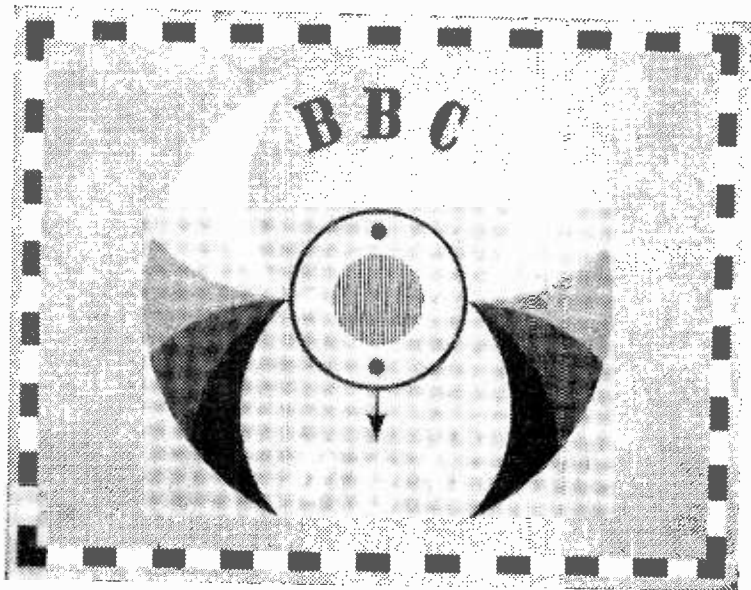

Fig. 29.—The new BBC tuning signal.

receiving chain. As the performance of the transmitting equipment is maintained in accordance with agreed standards, during the normal periods of radiation for test purposes, Test Card C serves as a check on propagation and the performance of the receiving apparatus.

The card, which bears the identification letter C, incorporates a number of patterns each designed to assess one particular characteristic, and they are listed as follows :

Aspect Ratio

Concentric black and white circles surrounding the 5-frequency gratings will appear truly circular when the width and height of the picture are adjusted to the standard aspect ratio of 4 : 3.

Resolution and Bandwidth

Within the circles there are two groups of frequency gratings, each consisting of five gratings having black and white stripes corresponding to fundamental frequencies of 1.0, 1.5, 2.0, 2.5, and 3.0 Mc/s. In the left-hand group the 1.0 Mc/s grating is at the top, the frequency increasing towards the bottom, and in the right-hand group the order is reversed. The response of the whole system is required to be uniform to 2.7 Mc/s, so that the 2.5 Mc/s gratings should be clearly reproduced, but the 3 Mc/s gratings may be blurred. The picture must just fill the viewing aperture during the test, with the black and white border visible.

Contrast

A 5-step contrast wedge appears in the centre of the test card. The top square is white, corresponding to 100 per cent. modulation, and the lowest square is black, corresponding to 30 per cent. modulation. The three intermediate squares should be reproduced as pale, middle and dark grey.

Scanning Linearity

The background of the test card is a middle grey, bearing a graticule of white lines. The areas enclosed between the lines should be reproduced in all parts of the picture as equal squares.

Synchronisation Separation

The border consists of alternate black and white rectangles, which facilitate recognising interference between the picture signals and synchronisation.

Low-frequency Response

A black rectangle within a white rectangle

is provided at the top and in a perfect system it would be reproduced as a rectangle of uniform blackness on a clean white background. At present, imperfections in the transmitting system result in a slight streaking at the right-hand side of the black area, even with a perfect receiver, but by experience it is possible to judge whether the reproduction is abnormal.

Reflections

Reflections, which may occur in propagation or in the receiving installation, are indicated by two single vertical bars, which should be reproduced without positive or negative images at their right-hand sides. The width of these bars represents a pulse of 0.25 μ s.

Uniformity of Focus

These are four diagonally-disposed areas of black and white stripes corresponding to a fundamental frequency of about 1 Mc/s, and all four should be resolved uniformly throughout.

The size of the tuning signal and of test Card C will, of course, vary according to the size of tube. Each must completely fill the screen.

Of course, troubles develop in course of time, and readjustments are usually carried out by the dealer who is agent for that particular make of receiver. When a new receiver is installed all that it should be necessary to do is turn on the picture. Just as one would turn up the sound volume on a normal broadcasting receiver. In course of time, however, valve deterioration takes place, or components may vary in value. These will call for additional adjustments and these adjustments are made by resetting the pre-set controls at the back of the receiver.

Some of the elementary defects can be corrected

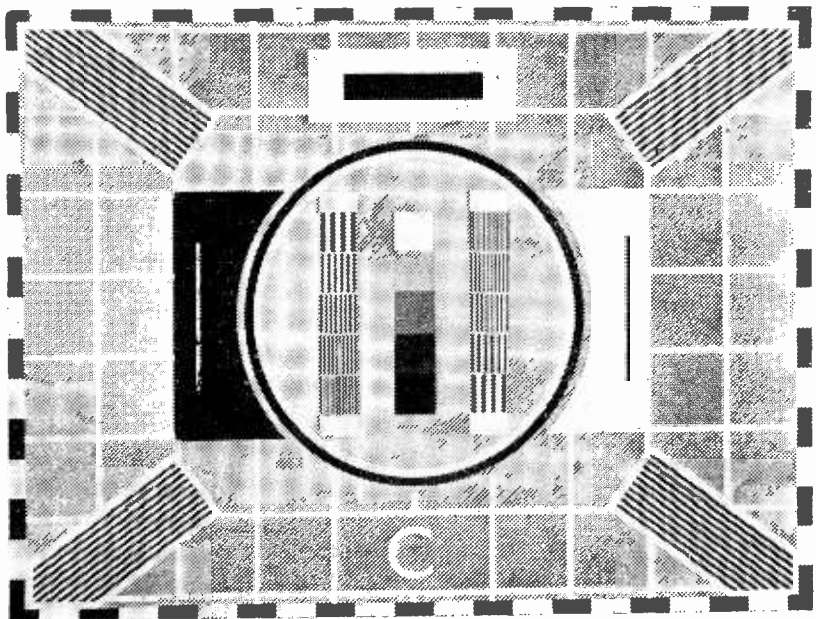

Fig. 30.—Test Card C, which is transmitted by both the BBC and I.T.A.

by use of a simple system, but for regular servicing a very expensive and comprehensive range of instruments is required, and these include an oscilloscope, an all-purpose test meter for measuring the A.C. and D.C. voltages, and a special meter for measuring EHT, with readings up to 25 kW. This is the voltage used in most projection receivers. A valve tester, and a capacity bridge are other instruments which are necessary.

As I have already said, however, a simple universal or general-purpose meter will suffice for simple adjustments. It must cover D.C. voltages up to 500, A.C. voltages up to 250, and a low reading scale for testing heater circuits. The EHT voltages can be calculated without direct measurement.

Common Faults

We have seen that the cathode-ray tube is fed from the timebases in such manner that even without a signal a rectangular area of light known as the picture area and of the correct aspect ratio of 4 : 3 appears on the end of the tube. We have seen that

this area of light is modulated by the output from a visual receiver, and so produces a picture. The loudspeaker is fed from the sound receiver to produce the speech of music. From this it can be deduced that if there is a raster (picture area) and a signal is obtainable from a loudspeaker, the fault lies in the vision or video part of the receiver. On the other hand, a picture, unaccompanied by sound indicates that the sound receiver is faulty, and absence of picture or raster with a sound signal indicates trouble either in the tube or in the timebases.

The horizontal and vertical timebases are independent, and it is extremely unlikely that both will fail together, and thus absence of raster will indicate a fault in the tube or in the power supply to both timebases. A horizontal line only on the tube indicates failure of the frame timebase, and a vertical line indicates failure of the line timebase.

Once the functions of the receiver are understood, irrespective of make or design, a little reasoning will quickly indicate the path of the circuit in which to look for faults. *(To be continued.)*

I.T.A. Results in the Midlands

DATA produced by the Nielsen Television Index shows that the potential audience able to receive I.T.A. transmissions in the Manchester area is 428,000 households (as at August 2nd, 1956). This is an increase of 75 per cent. over the available audience when the I.T.A. transmitter opened in May. This audience is continuing to grow.

A study of the viewing habits in the Manchester area during this first quarter shows that the average I.T.A./BBC household has been viewing 3.9 hours per day Monday to Friday, 4.4 hours per day Saturday/Sunday, and 4.0 hours per day Monday to Sunday on average.

cent. share. Viewing to the Birmingham I.T.A. station accounts for 7 per cent. of the Saturday/Sunday viewing.

Monday to Sunday Manchester I.T.A. station transmissions averaged 55 per cent. share of viewing. The BBC averaged 37 per cent. share. Viewing to the Birmingham I.T.A. station averaged 8 per cent. share of the Monday/Sunday viewing.

The tables on the left show the average percentage of households viewing during evening transmissions.

An analysis of the top ten programmes in each week since the opening of the I.T.A. transmitter shows that the following programmes have appeared most frequently in the top ten.

	Manchester I.T.A. per cent.	BBC per cent.	Total* per cent.	
7- 8 p.m.	33	20	58	} Mon.-Fri.
8- 9 p.m.	41	27	73	
9-10 p.m.	43	25	74	
10-11 p.m.	31	18	53	} Sat. and Sun.
7- 8 p.m.	32	14	48	
8- 9 p.m.	45	24	74	
9-10 p.m.	42	29	75	} Mon.-Sun.
10-11 p.m.	38	18	59	
7- 8 p.m.	33	18	55	
8- 9 p.m.	42	26	74	} Mon.-Sun.
9-10 p.m.	43	26	74	
10-11 p.m.	33	18	55	

* NOTE.—Homes tuned to the Birmingham I.T.A. station are included in this total.

Monday to Friday Granada transmissions have had an average share of 54 per cent. of this viewing. The BBC has had 38 per cent. share. It will be noted that viewing to the BBC and the Manchester I.T.A. station does not account for all the viewing in the Manchester area. This is because of the overlap between the Birmingham and Manchester I.T.A. areas which enables certain homes in the Manchester area to receive transmissions from the Birmingham I.T.A. station. Viewing to the Birmingham I.T.A. station accounts for 8 per cent. of the Monday to Friday viewing.

Saturday/Sunday ABCTV transmissions averaged 57 per cent. share of viewing. The BBC had 36 per

1st	Sunday Night at The Palladium/Blackpool	ABC	11 times
2nd	{	ABC Playhouse	} 6 times
		Jack Jackson Show	
		TV Theatre	
		Gun Law	
6th	{	Dragnet	} 5 times
		My Wildest Dream	
8th	{	64,000 Question	} 4 times
		Douglas Fairbanks Presents	
		Val Parnell's Startime	
		Make Up Your Mind	

Of all programmes appearing in the top ten ratings 77 per cent. were transmitted by the I.T.A. of which 65 per cent. were Granada programmes and 35 per cent. ABCTV.

Of the total number of appearances in the top ten ratings Granada obtained 56 per cent., ABC 32 per cent. and BBC 12 per cent.

During the first three months nearly 6,000 commercials have been delivered through the Manchester I.T.A. station, 72 per cent. of these being put out by Granada and 28 per cent. by ABCTV. Of the Granada commercials 18 per cent. were of seven seconds duration, 43 per cent. 15 seconds, 21 per cent. 30 seconds and 13 per cent. 60 seconds.

Of the ABCTV commercials 18 per cent. were of seven seconds duration, 36 per cent. 15 seconds, 26 per cent. 30 seconds and 18 per cent. 60 seconds.

HOW TO USE AN OSCILLOSCOPE

HOW TO UNDERSTAND AND EMPLOY THIS VALUABLE
SERVICING ACCESSORY

By J. Hillman

On the right is the 'scope which was described in our May and June issues.

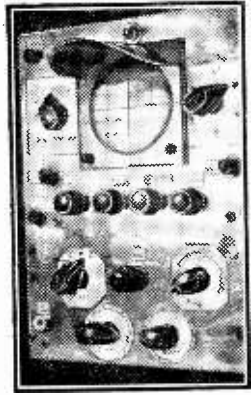

Introduction

ON looking through numerous books on oscilloscopes I could find very little on how to operate them, especially in regard to TV and radio servicing. Most of the books assume one knows how to operate the oscilloscope, and the purpose of this short series of articles is to give the necessary information so that anyone who has never used an oscilloscope before can operate it. The oscilloscope I use was described by me in the May and June issues of this magazine, but the tests described can be carried out with any oscilloscope though the traces may be slightly different due to the different sensitivity of the oscilloscope used.

Operation

Before making any test with an oscilloscope make sure that the leads you are using do not alter the trace, and there should be a straight line on the screen with no leads connected to it. This should still be a straight line with one end of the leads connected to the oscilloscope and the other end not connected to anything. First switch on and set the following controls, with no leads connected to oscilloscope, beam sw. on; beam blanking sw. to hard; coarse frequency sw. to 1 (i.e., slowest speed); sync sw. to int.; X amp. sw. to int.; Y amp. sw. to high; sync control min.; fine frequency control halfway; Y amp. control near min.; X amp. control halfway; now advance brilliance control until a trace appears on the screen. This should be a straight line.

Centre this line by moving Y and X shift controls. The length of the line can now be altered by moving X amp. control. The line will probably be blurred and thick, but by operating the focus control it can be made thin and clear. One point to notice is that

the line cannot be focused all along its length due to the curvature of the tube. If the centre part is in focus, then the sides are out of focus and vice versa. Having obtained a straight line, the Y amp. control can now be advanced to maximum, and the line should still be straight. Any waviness in this line will be due to the Y amplifier picking up hum. At the very slowest speeds of the timebase it is very difficult to eliminate hum entirely, but so long as the line is reasonably straight this will not interfere with the working of the oscilloscope. However, the straighter this line the more efficient is the oscilloscope.

Tests

Having seen how the various controls affect the trace it is now time to carry out a few tests. For all these tests the controls are set as follows: Sync sw. to int.; X amp. sw. to int.; beam blanking sw. to hard; beam sw. to on when trace is required. Keep brilliance control just high enough to see trace clearly and use focus control to give sharp outline. Coarse frequency sw. to 1; Y amp. high; Y amp. control to 3 (all variable controls having 10 divisions); X amp. to 4; connect a lead from Y to 50 cycle test; sync control min.; adjust fine frequency control until a trace, as shown in Fig. 2, appears, and advance sync control until trace is stationary. Timebase is now running at 50 cycles per second, and this setting can be noted for future reference. Without altering control settings adjust fine frequency to show trace (Fig. 2). This is 25 cycles per second, then trace (Fig. 3) 16.6 c.p.s. and trace (Fig. 4) 12.5 c.p.s. Note that as frequency gets lower the trace will be rather jumpy in the vertical plane, even though it remains locked and stationary. At intermediate frequencies the trace will appear as a number of loops and traces, and by counting the number of loops and dividing

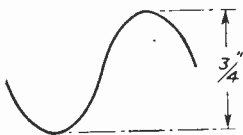

Fig. 1



Fig. 2

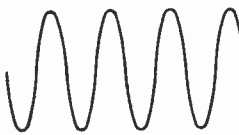

Fig. 3

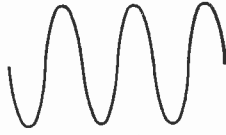

Fig. 4

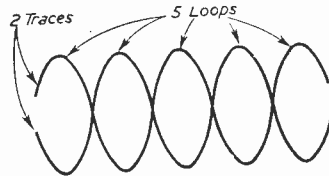

Fig. 5



Fig. 6

Figs. 1 to 6. —Various waveforms as they are depicted on the tube with variation of the sync and other controls.

by the number of traces the ratio between the frequency of the Y and X inputs is obtained. Thus in Fig. 5 there are five loops and two traces, and ratio is $F_y = \frac{5}{2}$. Therefore $F_x = \frac{2 \times F_y}{5}$, i.e., $F_x = \frac{2 \times 50}{5} = 20$ c.p.s. Where F_y is frequency of Y input, in this case mains frequency 50 c.p.s. and F_x is frequency of timebase. Formula for finding timebase frequency is therefore $F_x = \frac{F_y \times \text{number of traces}}{\text{number of loops}}$. Now adjust controls until trace Fig. 6 appears, and it will be seen that there are two traces and two half loops, and the ratio is therefore 2:1, and frequency $F_x = \frac{50 \times 2}{1} = 100$ c.p.s.

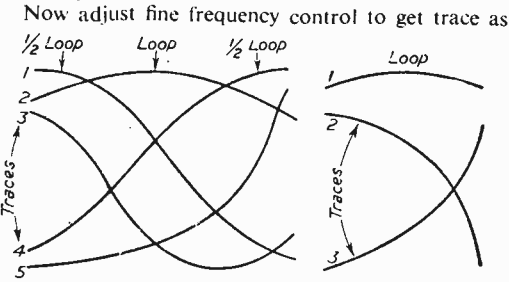

Figs. 7 and 8.—Curves for calculating frequency as explained here.

Fig. 7. In this there are one loop and two halves, making two loops and five traces. Then $F_x = \frac{50 \times 5}{2} = 125$ c.p.s. Similarly, Fig. 8 gives 150 c.p.s., and Fig. 9 gives 175 c.p.s. As these intermediate frequencies are not easy to recognise, it is best always to return to a trace that you know for certain, such as 25 c.p.s., 50 c.p.s., 100 c.p.s., to check whether the trace is above or below this frequency. All the above tests were carried out using the mains frequency as a standard, but any standard frequency can be used and the curves shown will still be obtained. Suppose we used a standard frequency of 1,000 c.p.s., obtained from an audio oscillator, and inject it into Y output socket, joining their common earth leads together. Then, if Fig. 1 trace is obtained at a certain setting of the fine frequency control, the timebase frequency is the same as the standard one, i.e., 1,000 c.p.s. For, say, Fig. 7, where we have two loops and five traces, then using the formula $F_x = \frac{F_y \times \text{number of traces}}{\text{number of loops}}$, then $F_x = \frac{1,000 \times 5}{2} = 2,500$ c.p.s. Where F_x = Speed

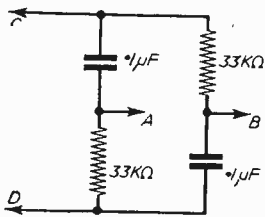

Fig. 10

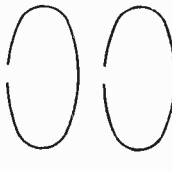

Fig. 11

Fig. 12

Figs. 10, 11 and 12.—A circuit for obtaining circular traces and two examples.

of timebase and F_y = Speed of standard frequency. Another method that is used is a circular trace. First, make up the circuit as Fig. 10. Connect Y out to point A; X ext. to point B; 50~ test to C and earth socket to D. Beam blanking hard; X amp. max.; Y amp. high; Y amp. near max.; range sw.1; X switch ext.; sync off; adjust fine frequency until trace Fig. 11 appears. This is a circle or ellipse with a gap in it and the speed of the timebase is 50 c.p.s. Similarly, trace Fig. 12 has two gaps and the frequency is 100 c.p.s. Now switch to beam blanking

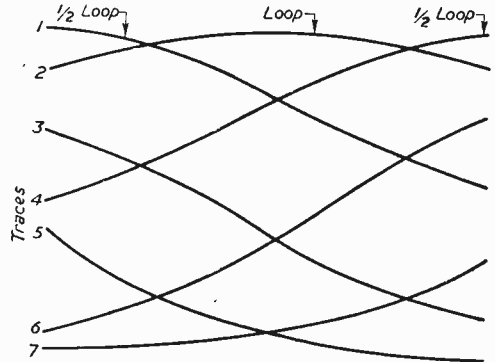

Fig. 9.—The traces from a 175 c.p.s. frequency.

soft and where gaps are in the trace it will brighten up and this makes them easier to see when checking higher frequencies. Simply count the number of bright spots and multiply them by 50 c.p.s. In this case, or, if you use a higher standard frequency, then multiply by that frequency. Incidentally, if you use a higher or lower frequency as a standard, then the values shown in Fig. 10 will need to be altered. The resistor should always equal the reactance of the condenser at the frequency used. The reactance of a condenser varies according to the frequency, and this value can be found from a book of tables or from the formula, one divided by $[6.283 \times \text{frequency in cycles per second} \times \text{capacity of condenser in farads}]$, remembering that a microfarad is one millionth of a farad.

Comparisons

To compare two frequencies, say, 50~ mains and signal generator L.F. signal output, set up as follows: X ext. to B; earth to D; Y out to A; beam blanking switch to grid mod.; sw. to ext.; sync sw. to ext.; Y amp. sw. high; Y amp. control max.; X amp.

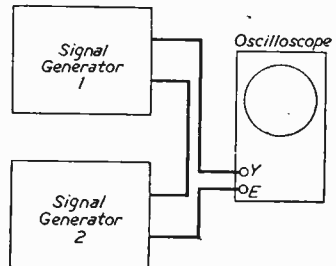

Fig. 14

Figs. 13 and 14.—A further trace and diagram of hook-up for obtaining a check on the instrument.

control max.; 50~ test socket connected to point C (Fig. 10); grid mod. socket to signal generator L.F. socket E of signal generator to E of oscilloscope. Trace will now appear, as in Fig. 13, and number of spaces in this case was 11, giving a frequency of 550 c.p.s. Note that as the gain control of the signal generator is altered so does the frequency, so that if at any time you are using the L.F. output of the signal generator as a standard frequency always check the frequency against the mains frequency, using this method, and do not alter the setting of the gain control on signal generator. To summarise, if you connect the known frequency across C and D (Fig. 10), and the unknown frequency across grid mod. and earth, then count the number of spaces in the circular trace and multiply this number by the known frequency; the answer gives the unknown frequency.

To Check Accuracy of Signal Generator Using Another Signal Generator

Connect up, as in Fig. 14. Set X sw. to int.; Coarse freq. range 1; beam blanking hard; sync sw. int.; Y

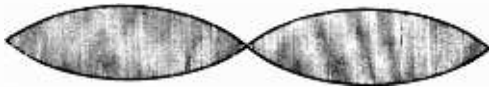

Fig. 15.—Traces from the time generators shown in Fig. 14.

amp. sw. high, X amp. 4; fine frequency 6. Set signal generators 1 and 2 at 100 kc/s and adjust signal generator 2 until envelope trace is as in Fig. 15. when the two generators are now working at the same

frequency. It will depend on the setting of fine frequency control as to the number of envelopes seen, but so long as the envelopes are clear and stationary the two generators are at same frequency. Both instruments were at 1 volt output each, and some idea of the traces given is shown in Fig. 16. Trace A was obtained at 600 kc/s; B at 1,500 kc/s, C at 10 Mc/s, and at either side of this frequency the trace would thicken. The limit at which the trace could be checked was 15 Mc/s. The maximum range of the timebase of this oscilloscope was 650 kc/s, which was on range 5 with fine frequency at maximum. This gave a trace of one cycle of the 650 kc/s fre-

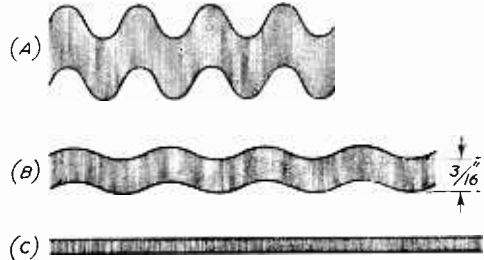

Fig. 16.—Traces obtained from the set-up in Fig. 14.

quency with an input of 1 volt from the avo signal generator and trace was 3/16in. high with Y amp. at max.

In the next article we will show how to measure the sensitivity of the oscilloscope, how to see sound waves, phase displacement, traces obtained in TV and radio servicing. (To be continued)

Television Licences Analysis

AT the end of June, 1956, there were 5,922,020 television licences in force throughout the country, an increase of 182,427 over the figures at the end of March. The increases were as follows:—

England (excluding Monmouthshire), from 5,087,506 to 5,241,433.

Wales and Monmouthshire, from 261,729 to 269,424.

Scotland, from 348,152 to 365,646.

Northern Ireland, from 42,206 to 45,517.

London Postal Districts

The number of licences increased from 658,212 to 674,361. The south-eastern district had the highest number of licences with 141,629 followed by the eastern district with 138,912 and the northern district with 119,641.

Wales

Of the Welsh counties, Glamorganshire had the largest number of licences with 150,012 and of the towns, Cardiff headed the list with 54,565, followed by Newport with 44,148.

Scotland

Glasgow led in Scotland with 114,263, followed by Edinburgh with 48,950.

Northern Ireland

Belfast had 37,919 licences.

There are 60 towns and districts throughout the country where the number of television licences exceed those of sound—31 in and around London, 7 in the north-west, 4 in the north-east and 18 in the Midlands.

BBC Television Centre

THE BBC announces that a contract has been awarded to Higgs and Hill Ltd. for the erection of the superstructure of the main block at the Television Centre, Wood Lane, W.12, upon foundations constructed by George Wimpey and Co., Ltd., who were awarded the contract for that work last November. The retaining walls now constructed by them to receive the superstructure contain an area of approximately 3½ acres—nearly twice the area covered by St. Paul's Cathedral.

This next stage in the development of the BBC's Television Centre covers the erection of a circular building around a central courtyard. The building will have a high multi-storey inner ring—basement to seventh floor—which will contain dressing rooms and technical areas in the lower storeys and office accommodation on the upper floors. Radiating from this ring will be the studios, of which four of the seven provided for will be completed initially. Two of these will be 100ft. by 80ft. by 35ft. high, and two will be 70ft. by 50 ft. by 25ft. high, each with its ancillary accommodation. Around the outer periphery of the studios there will be an enclosed runway for transporting scenery. Between two of the studios there will be a multi-storey "wedge" in which there will be accommodation for the central control and apparatus rooms, and the telecine and presentation suites. Under the central courtyard there will be telerecording rooms.

The contract requires the construction of the first operational unit by the end of 1959—with a view to it being in service in 1960.



**FOR VALVES
GUARANTEED
ALL TESTED
BEFORE
DESPATCH**

0Z4	5/6	617G	7/6	EF80	10/-	
1A3	3/6	6V6G	8/-	EF22	8/6	
1A5GT	6/-	6V6GT	7/6	CL80	10/6	
1A7	11/6	6X4	7/6	EF41	11/6	
1C2	9/6	6X5GT	7/6	EF66	12/6	
1C5GT	9/6	6X5GT	7/6	EF89	12/6	
1H5GT	10/6	7B6	9/6	EL2	12/6	
1L1	6/6	7B7	8/6	EL32	6/6	
6L5	5/-	7C5	8/-	EL41	10/6	
1N5	10/6	7C6	8/-	EL42	11/6	
1R5	8/-	7H7	9/-	EL94	11/-	
8E4	9/9	7Q7	9/6	EM34	10/-	
1R5	7/6	7R7	9/6	EM80	11/-	
1U3	7/6	7T4	8/6	EY51	11/6	
1U5	7/6	7T6	10/6	EY80	12/-	
2X2	4/6	7T	8/-	EY91	8/-	
3A4	7/-	80	8/6	EZ40	10/-	
3D6	5/-	807	8/6	EZ41	11/-	
3Q4	8/6	8D2	2/9	EZ80	10/-	
3Q5	8/6	9D2	3/9	E1148	2/-	
2R4	7/6	9001	5/6	PW4-500	10/-	
3V4	8/6	9003	5/6	GZ32	12/6	
4D4	3/-	9004	5/6	H30	5/-	
42	8/-	9006	5/6	HL2	3/-	
9R46Y	9/6	954	2/-	HL1320	4/-	
8F40	8/-	955	4/9	HL23DD	8/-	
5Y2G	8/-	956	8/6	KL35	8/6	
5Y3GT	8/-	10C1	12/6	KT2	5/-	
5Z4G	8/9	10C2	10/6	KT3C	10/-	
6A7	11/6	10F1	11/-	KT61	13/-	
6AG	10/6	10F9	11/6	KT66	12/-	
6AC7	6/6	10P13	11/6	KT69	7/-	
6A15	6/6	10P14	13/6	KT69B	6/6	
6AK5	6/6	12A6	9/6	KTZ41	6/6	
6A15	6/6	12AH7	8/-	LP220	6/9	
6AM5	5/-	12AT7	9/-	M8/P29	5/-	
6AM6	7/6	12AT7	9/6	P61	3/9	
6AQ5	7/6	12AX7	10/-	P215	5/-	
6AT6	8/6	12BF6	10/-	PEN25	5/-	
6B8	4/-	12C8	7/-	PEN46	7/-	
6B46	7/6	12H6	3/-	PEN220A	4/-	
6B56	8/-	12J5	4/6	PC084	10/-	
6BW6	8/6	12K7	9/6	PCF80	9/-	
6BW7	10/6	12K8	11/-	PCF82	12/6	
6C4	7/6	12K8	11/-	PCL83	12/6	
6C5GT	6/6	12Q7	9/6	PL81	12/6	
6C6	6/6	12QC7	2/6	PL82	10/-	
6C8	10/6	12RG7	7/6	PL83	12/-	
6CH6	7/6	12RH7	5/6	PP25	5/-	
6D6	6/6	12RJ7	8/-	PX25	13/6	
6F1	12/6	12NK7	6/-	PY80	10/-	
6F6G	7/6	12MQ7	8/6	PY81	10/-	
6F6M	7/6	12NR7	7/6	PY82	8/-	
6F13	14/6	15D2	5/-	R19	13/6	
6F14	12/6	20D1	10/6	SP229	6/9	
6F15	14/-	20F2	13/6	U10	9/-	
6G6G	4/6	20F1	12/6	U22	8/-	
6H6	2/6	25L6GT	9/6	U25	13/6	
6L5G	5/-	25L6GT	10/-	U403	4/-	
6L5GT	5/6	25V5	9/6	U404	11/6	
6J5M	6/6	25V5G	9/9	UAF42	11/6	
6J6	6/-	25Z4G	9/-	UB41	8/-	
8A7G	8/-	25Z6GT	9/6	UB41	10/-	
8B6G	7/-	35L0GT	9/-	UBC42	11/-	
8K7G	8/9	33W4	9/-	UP41	11/6	
8K7M	6/9	35Z4GT	8/6	UL41	11/-	
8K8	8/9	35Z5	9/-	UY41	10/-	
8K8-T	8/6	50L6GT	8/6	VR21	3/-	
6L6G	9/-	ACU/PEN	8/6	VR32 (EF39)	VP22	8/6
6L7	7/6	4T4	5/-	V870	3/-	
6L7	7/-	DH73M	10/-	VT02 (EL29)	VT02	8/6
6Q7GT	9/-	EAB80	10/-	2/-	VT501	6/-
8R47GT	8/-	EAF42	12/6	VR55 (EB33)	VT39	8/6
8R47	7/6	EB41	9/-	VR56 (EP36)	UM17(14)	8/9
8R47	6/-	EB41	10/-	VR54 (U12) 9/-	VR54 (U12) 9/-	8/6
8R47	8/-	EBP80	11/-	VR57 (EK32)	VT111	2/6
8R47	6/-	EC91	9/6	VI126A	3/-	
8R47	8/-	EC984	12/6	W61	8/-	
8R47	8/-	EC985	10/6	W77	8/6	
8R47	9/3	EC989	14/6	X65	10/-	
8R47	6/-	EC982	15/-	X96	11/6	
6L4GT	15/-	EC155	11/6	X79	11/6	
6L54	8/6	EC142	10/6	Y68	11/6	
6L5	8/6	EC181	11/-	Y68	17/6	

Packing and Postage 6d. per valve. SAME DAY SERVICE

ARE YOU BUILDING THIS POPULAR KIT ?

Modern Portable. A.C./D.C. Mains/Battery Receiver. Four valves, DK96, DL96, etc. 2 Waveband Superhet. In an attractive Lizard Grey Case, size 8 1/2 in. x 8 1/2 in. x 4 1/2 in. Full Kit of Parts down to last nut and bolt.



£9.9.0

Or if you prefer you can build the battery version first for £7/17/6 and add the mains components later. Post extra on Kit 3/-.

Full Circuit Diagram, Shopping List, and Point-to-Point Wiring Diagram, 2/6.

MAINS TRANSFORMERS—3-way Mounting Type

MT1:
Primary: 200-220-240 v. Secondaries: 250-0-250 v. 50 ma 0.5-3 v. 4 amp. 0-4 v. 2 amp.
Both tapped at 4 v. each 18/3

MT2:
Primary: 200-220-240 v. Secondaries: 350-0-350 v. 50 ma 0.5-3 v. 4 amp. 0-5 v. 2 amp.
Both tapped at 4 v. each 18/6

MT3:
Primary: 200-220-240 v. Secondary: 50 v. 2 amps. Taps at 3 v., 4 v., 6 v., 8 v., 9 v., 10 v., 15 v., 18 v., 20 v., 24 v. each 18/6
Please add 2/- per transformer post and packing.

SPECIAL OFFER

Indicator Unit Type 6 with Tube, Less Valves. Many useful Components 17.6. Carriage Paid. Antiference Aerial Type C194 Indoor ... with full instructions, etc. 13/3 each. Carriage Paid.

Aerialite Band III Aerials 5 element, 702 x 1/4. An array with universal lin-2in. mast-head bracket, suitable channels 8, 9 and 10. Price 41/-, carriage 4/6.
Aerialite Coaxial outlet boxes at 4/6 each.
Aerialite Coaxial plugs and sockets at 1/1 each.
Transformers T1134H, 25/- each. Transformers T1134H, 37/- each. Transformers T1154 in rough condition, 15/- each.
Carriage and postage on above Transformers 18 12/6.
Meters 0-100 in a.c. panel mounting, 7/6 each.
Meters 0-5 amp. R.F. panel mounting, 7/6 ea.

CRT ISOLATION TRANSFORMERS

NR9A 2 v.; NR9B 4 v.; NR9C 6.3 v.; NR2D 10.5 v.; NR9E 13.5v. Price 10/6 each, all for use on receivers with own transformer.
NR14 Input 230/240 v., output 2-24-21-21-3 volts at 2 amps. 17/6 each.
NR12 Input 220/240 v. Multi output 0-2-4-6-3-7-3-10-13 volts 25% and 50% BOOST, 21/- each.
NR15 Input 220/240 v. Output 6.3 v. with 25% and 50% BOOST. Price 17/6 each

OUR ILLUSTRATED CATALOGUE IS NOW AVAILABLE
Send 6d. in stamps for your copy.

LOUD SPEAKERS

All PM Types less Transformers

5in. Types by Elac, Electrona, Celestion, etc.	Each	17/3
6 1/2in. Types by Goodmans, Rola, R. & A.	18/6	
8in. Types by Goodmans, Plessey, R. & A.	19/6	
10in. Types by R. & A., Celestion, etc.	25/6	
6 1/2in. Water Speaker by Truvox, suitable for Car Radio, etc.	20/-	
12in. Plessey Lightweight	35/-	
Elliptical Speakers, Goodmans, 4in. x 7in.	19/6	



OUTPUT TRANSFORMERS

Multi Ratio Type, each	6/6
Midget for 384 Output, each	4/6
Standard 5,000 ohms, each	4/6
Standard 19,000 ohms, each	4/6

CHARGER RECTIFIERS—All Full Wave

12 volt 1 amp., each	5/3
12 volt 2 amp., each	8/6
12 volt 3 amp., each	13/3

WHEN ORDERING PLEASE QUOTE DEPT. "PT."

TERMS: Cash with order or C.O.D. Postage and Packing charges extra, as follows: Orders value 10/- add 1/-; 20/- add 1/6; 40/- add 2/-; £5 add 3/- unless otherwise stated. Minimum C.O.D. fee and postage 3/-. All single valves postage 6d.

MAIL ORDER ONLY



**5/6 VINCES CHAMBERS
VICTORIA SQUARE
LEEDS 1.**

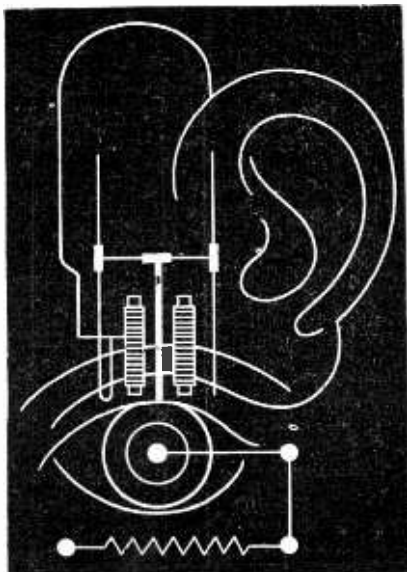

SMITH'S FOR TECHNICAL BOOKS

Books on radio theory, practice and maintenance for the beginner and books on new developments in circuit design, new components, methods of application, and the established text books can be obtained through your local Smith's shop or book-stall. Books not in stock at the branch can be quickly obtained from Head Office.

★ *Your stationery and printed matter can also be supplied through our local branch.*

W. H. SMITH & SON

FOR BOOKS ON ELECTRONICS

Head Office: STRAND HOUSE, LONDON, W.C.2

BAND III T.V. CONVERTER

12 months' guarantee all items.

FOR I.T.A. LONDON, BIRMINGHAM, MANCHESTER, YORKS, GLASGOW. For superhet or T.R.F. State B.E.C. station. Fully wired with power pack, aerial switching, tested and ready for use.

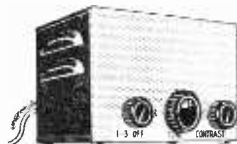

£4-10-0

Post Free

C.O.D. fee 1/6 extra

with valves EF91 and 12AT7 (ECC81) and metal rectifier. NO ALTERATION TO YOUR SET. OR in walnut cabinet, 3 knobs, 2 valves 12AT7, and metal rectifier, £5. (C.O.D. 1/6.) OR in chassis form with power pack, £4.2.6. BAND I aerials: Telerection "X" with pole and lashing, 55/-. "H" aerial with lashing, 50 -. Co-axial cable, 7d. yd. Low loss, 9d.

Filter eliminating Band I pattern on I.T.A., 8/-, 1,000 pf, 2,000 pf, 3,000 pf ceramics, 4/6 doz. 0.5 pf, 3.3, 4.7, 6.8, 20, 22, 30, 35 pf, 4/- doz. Part 7-v. T.V. strip by famous mnfr. (over 50 ceramics and resistors) with drawing, 10/-.

GLADSTONE RADIO
P.O. BOX 8, CAMBERLEY, SURREY

VIDEO ELECTRONICS (LONDON) LTD. (Dept. P.T.)

Head Office : 27, Bacon Street, London, E.1.

Works : 16/22, Bacon Street, E.1.

Telephones : Bishopsgate 0419/0410.

T.V. Tubes (17in. £8, 14in. £6, 12in. £5, etc.)

Cheap, reliable high grade seconds and reconditioned C.R.T.s, as supplied to the trade and leading Television Insurance Companies, prices from £3.

Valves

Send at once for our useful list of cheap valves which will save money, we are the cheapest in the trade.

Condensers

Electrolytics, bias, coupling, etc., etc., at give-away prices. All types stocked.

Resistors

A fine stock of these at very low prices.

T.V. & Radio Cabinets

A few 17in. Table cabinets, new, ex famous manufacturer, and about 500 very handsome radio cabinets.

Send for stock list of speakers, valves, components and T.V. and Radio Spares.

All our goods are guaranteed.

Selenium Rectifiers in Power Supply Circuits

SOME USEFUL NOTES ABOUT A POPULAR COMPONENT

By W. J. Burbidge, A.M.I.P.R.E.

THERE are many uses for which the selenium rectifier is suitable, in fact, wherever a valve rectifier is normally fitted, a selenium rectifier can be used and often with no small advantage. They provide a simple, compact and, not least, an economical form of alternating current rectification.

Several types are available giving outputs varying from 30 mA up to approximately 300 mA for use in television receivers, power amplifiers, etc. The low current types are very useful in providing the H.T. for television converters, pre-amplifiers and so forth, in fact, for any equipment where a compact and convenient form of H.T. supply is required.

The use of this type of rectifier presents little problem, but there is one precaution which must be observed if long life is to be expected, and that is to

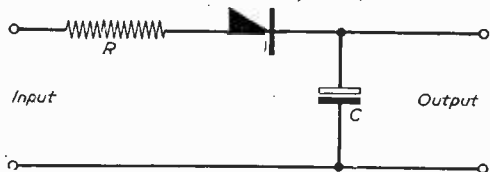

Fig. 1.—The half-wave circuit.

ensure adequate cooling. This is particularly important in the case of the low current rectifiers. The rectifiers are adequately provided with cooling fins to dissipate the heat generated by them, but the air reaching the fins should be cool, not air which has been heated by the valves and other components in the equipment. This point must be watched in the case of pre-amplifiers of the completely enclosed type. The maximum temperature to which the rectifier is allowed to rise must never exceed 75 deg. C. The rectifiers must always be mounted with the fins vertical.

There are many advantages to be gained by using selenium rectifiers, first and foremost being that no heater supply, with its wastage of power and heat, is required. Another feature of them is their mechanical strength. There are no delicate parts at all and so they are ideal for applications in mobile equipment where severe vibration may occur. Also there is no limit to the size of reservoir capacitor which may be fitted, thus by using a very large value capacitor of, say, 50 or 100 μ F, H.T. voltage regulation and smoothing is greatly improved. The voltage drop across the rectifier is less than with a valve rectifier and so the D.C. voltage is higher.

The half-wave rectification circuit, Fig. 1, is often preferred when using selenium rectifiers and the last-mentioned advantage enables us to use a large value reservoir capacitor, C, to offset the effect of the larger ripple voltage present in half-wave rectification circuits as compared to the full-wave or bi-phase half-wave circuit. The 30, 60, 100 and 120 mA

selenium rectifiers are suitable for a maximum applied R.M.S. voltage of 125, but in applications where a higher voltage is required, two or more rectifiers may be fitted in series. Care must be taken that the applied R.M.S. voltage does not exceed 125 multiplied by the number of units fitted.

The purpose of R in Fig. 1 is to limit the peak current, particularly when switching on. With the large values of capacitance used for the reservoir capacitor, the initial charging of this component causes a high peak current to flow. This peak current can cause "ageing" of the rectifier to take place, but

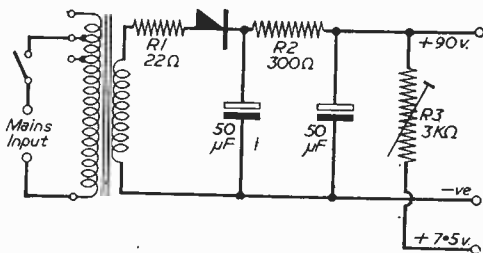

Fig. 2.—Circuit of a complete power supply, using the half-wave rectifier.

R, although small, effectively reduces this current thus minimising any ageing which might otherwise occur. A typical value for R is 22 ohms in a single rectifier circuit, this value being doubled when two rectifiers in series are used.

The 120 mA selenium rectifier may be used to form part of a very compact power unit for converting battery portable apparatus of the series filament type, using low consumption valves of the DK, DF, DAF and DL96 range, normally using a 90-volt H.T. battery and a 7.5-volt L.T. battery, to mains use. A practical circuit is shown in Fig. 2.

The mains transformer, T1, secondary gives an output of 125 volts R.M.S. which is applied through the limiter resistor, R1, to the selenium rectifier. On load, the D.C. output is approximately 130 volts,

(Concluded on page 144)

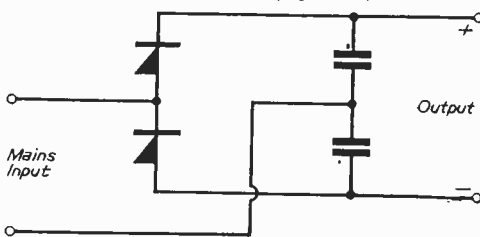

Fig. 3.—The basic circuit for a voltage doubler.

TV Distribution at the Radio Show

SOME INTERESTING DETAILS OF THE NETWORK WHICH WAS USED AT EARLS COURT

QUITE a number of visitors to our Stand at the Radio Show enquired about the pictures which were demonstrated on the various stands and apparently it was not realised that the distribution of the TV signals to the exhibitors' stands at both Band I and Band III frequencies is a very difficult proposition. The work was carried out by the E.M.I. organisation, and in view of the interest expressed we give the following details of the set-up which is used for such purposes.

The number of television points comprised in the distribution system varies from year to year, but is usually estimated at approximately 400, and when one realises that each exhibitor expects—as he is entitled to expect—constant, high-quality reception throughout the entire period of display, without dislocation or interference, for every one of his operating models, it will be appreciated that its successful achievement is no mean task.

More Than Eight Miles of Cable

The network starts from the transmitters in the R.I.C. Control Room, which is itself unique in that it is the only TV Control Room in existence that handles two separate TV programmes from a variety of sources simultaneously, and is in continuous operation for 12 hours a day. From there 16 main trunk cables, some 30 ft. above the ground floor, traverse the entire length of the great hall, and from these main trunks are tapped the feeder lines supplying the stands and demonstration rooms. The system involves over *eight miles* of co-axial cable.

Each of these main trunk cables and their associated feeders carry both BBC and I.T.A. programmes at Channel 4 and Channel 11 carrier frequencies respectively to groups of television receivers, all capable of multi-channel selection. Because of the cable losses at the different carrier frequencies, the line and differential voltages must be carefully calculated and corrected where necessary.

The entrance of the feeders into the ultra-modern structures of the stands must be made as unobtrusive as possible, and exhibitors are committed to confining the number of receivers in operation to the number of points initially requested and provided for in the network. Observation is maintained during the course of the exhibition to ensure that no "piracy" occurs and that all receivers are operating correctly.

The transmitters, which are specially designed and built by E.M.I. for the Exhibition, consist of two separate racks of equipment—one for Band I and one for Band III. Each rack incorporates four transmitters—two for vision and two for sound (one of each pair being a stand-by), and measured approximately 8ft. 9in. wide, 6ft. 2in. high and 2ft. 2in. deep and weighs over a ton.

Wide Variety of Programmes

Incoming programmes may be received from aerials at Channel I and Channel 9 frequencies, or they may be received at video and audio frequencies by cable from remote studios, or from cameras and microphones at various places within the exhibition, or from combinations of these sources. Signals

received at television frequencies are de-modulated to give video and audio signals to modulate the transmitters.

Because of the possibility of interference from unwanted pickup of Channel I and Channel 9 signals on the distribution cables, the signals are distributed throughout the exhibition on Channels 4 and 11 respectively.

The separate outputs of the four transmitters are combined into a single complex signal for distribution over the network. This is achieved by means of special mixing equipment contained in the rear portions of the end bays of the two racks.

The control panels on each rack provide great diversity and flexibility of switching so that, in addition to the switching functions already described, the monitor speakers, the picture monitors and the waveform monitors can be applied to any appropriate incoming source of signal so that these can be checked before being passed into the main equipment. All this is done without interfering in any way with the outgoing programmes.

Altogether some 460 valves are in operation in the two racks, and the total power consumption is of the order of 6 kilowatts.

Technical Details of the Equipment

The general construction uses the enclosed type of cabinet, with the actual apparatus built on to panels and mounted on runners. Any panel can be withdrawn from the front and remains supported on the runners for easy inspection and service. An adequate system of ventilation and air extraction is incorporated to remove the quite considerable heat generated in the cabinets.

The detailed layout of the equipment is as follows:—

Each rack consists of five bays, both similar in layout and equipment.

In the first bay are three TV receivers covering all Bands I and III Channels. They are specially designed and built for this work and have separate outputs for video and audio frequencies.

They are used to receive BBC and I.T.A. transmissions respectively, and to monitor the R.F. output of the E.M.I. transmitters.

The lower three panels are: (a) a patching panel to connect any of the three receivers to suitable aerials and to route the outputs of the receivers to the control panel described later; (b) A Pattern Generator and Wedge Generator for test purposes, available for use on either rack (that is, on the Band I or Band III equipment) by switching; (c) power supplies for the above two generators.

The second bay carries (a) the Vision Monitor for checking the picture received from any video input or the video output of any of the three receivers; (b) an oscilloscope for checking the level and the waveform of the audio signals and the audio frequency response of the equipment; (c) power supplies for the vision and sound transmitters housed in the fifth bay.

The centre bay carries the control equipment. At the top are various indicators, including two

(Concluded on page 128)

An INFINITE Resistance VOLT METER

By A. M. St. CLAIR

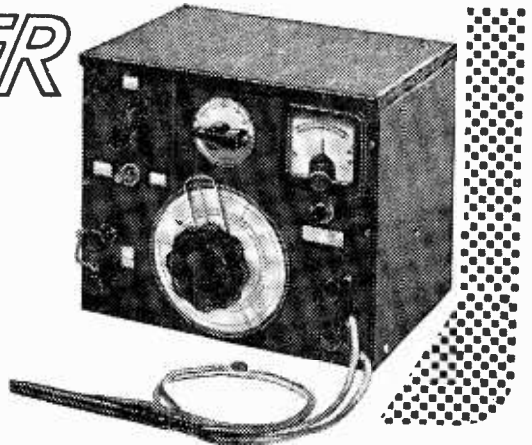

EVERY radio man knows those irritating-to-measure voltages which are reduced, sometimes almost to vanishing point, by the application of even a "high resistance" meter. There are, of course, formulae for the correction of such reduced readings; but as long as there are non-linear elements in the circuit—valves, for example—they cannot be relied upon to give correct answers. The solution is, of course, to use an infinite resistance voltmeter. The electrostatic voltmeter has virtually infinite resistance, but even if we do not mind its bad scale-shape, its sluggishness and its lack of robustness, we are likely to find the price strongly against it. The instrument to be described has, properly used, true infinite resistance, an open scale, and is far from costly.

One of the standard laboratory methods of measuring voltage, the "potentiometer method," consists of a device for opposing the voltage to be measured with an equal and opposite voltage, and obtaining a reading of the voltage required to do this. Since, in this method, no current is drawn from the source under measurement, it "sees" the measuring instrument as an infinite impedance. The apparatus normally comprises a uniform wire, evenly stretched

we are using a 100 volt battery, to make R_1 100 k Ω would draw 1 mA., and it would then dissipate 0.1 watts ($I = E/R$, $W = I^2R$). R_2 is a "stopper" and should be embodied in the end of a prod, as will be described later. If we apply the prods to the voltage being measured, and adjust the slider of R_1 until no current is registered on the milliammeter, then we know that the voltage on the slider is exactly equal to the voltage on the upper prod. This is read off on the voltmeter and, since no current is being drawn from the apparatus under test, we have a correct infinite resistance reading.

If you wish to achieve this result with a single meter, you may proceed as follows: First, ascertain the resistance of the meter on the volts range on which you are going to use it. (For example, a 200 ohms-per-volt meter on the 100 volt range is $200 \times 100 = 20,000$ ohms.) Obtain a resistance of this value and connect it in place of the voltmeter in Fig. 1. Adjust for zero current as before. Now remove the meter from its current-reading position, switch to volts, and connect it in place of the resistance which has been "dummying" for it. These steps are shown in Fig. 2(a and b). Since you are now measuring a voltage to which you are no longer connected, nobody can complain that you are upsetting circuit conditions!

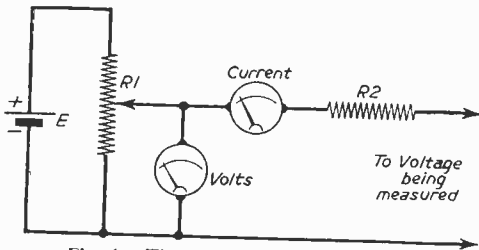

Fig. 1.—The potentiometer principle.

over a long graduated scale, and a slider actuated by means of a vernier screw mechanism. Not very convenient for the amateur lab., and not particularly cheap, either. But here are two methods of achieving the desired result rather more simply and with sufficient accuracy for our purposes.

In Fig. 1 we have a battery of voltage E , which must be higher than the voltage to be measured, connected across a potentiometer R_1 . The only restrictions on the value of R_1 are that it should be of high enough wattage to stand the applied voltage E , and as low in resistance as is compatible with a reasonable drain on the battery. For example, if

Practical Arrangement

For those who wish to build these principles into

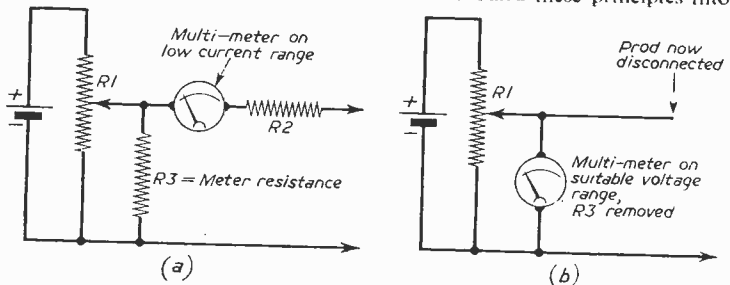

Fig. 2.—Potentiometer, using a multi-range meter.

a permanent instrument, instead of setting up a "hook-up" each time the need arises, details are given in Figs. 3 and 4. The circuit of Fig. 3 is fundamentally the same as that of Fig. 1, but certain refinements have been incorporated for convenience in use. The simple potentiometer has been augmented by a bank of switched resistances, to effect multi-range working. The ranges suggested are 0-50 volts, 50-100 volts, 100-150 volts, 150-200 volts and 200-250 volts. Note that the ranges do not start from zero each time; this means that a difference of one volt is as big on the top range, and therefore as easy to read, as it is on the lowest. This is due to the method of range-switching adopted, which also ensures that the current drain on the internal source is constant and that the same calibrating point can be used for all ranges.

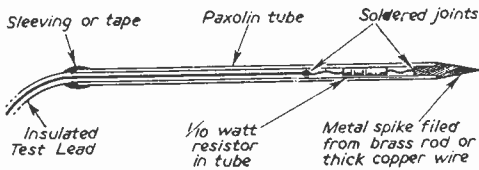

Fig. 5.—How to make the test prods

The functions of the components are as follows: R4 is the calibration control. It is used to adjust the current through the main potentiometer so that the voltage across the latter shall at all times be equal to the range coverage, namely, 50 volts. R2 is the main potentiometer, corresponding to R1 in Fig. 1. R1 in Fig. 3 is the meter shunt, which can be disconnected by means of S3, a normally closed push-button. R3 is an isolator or "stopper," of which more later. S1 is the "Calibrate—Read" switch. In the "Read" position the instrument is available for use as a voltmeter; in the "Calibrate" position the meter M is placed in series with the battery feed, enabling R4 to be adjusted to the correct value. S2 is the range and on-off switch.

R4 is an ordinary 50 k. carbon pot. R2 is a linear 50 k. pot, preferably wire-wound, but necessarily of good quality and construction. S2 is an ordinary two-pole six-position wafer switch, and the resistances

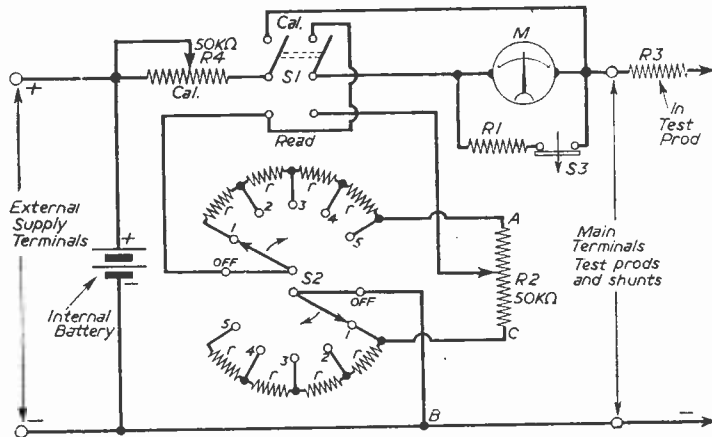

Fig. 3.—Theoretical circuit of the meter.

"r" are tenth-watt 47 k., soldered direct to the switch tags. By making them slightly smaller in value than R2 we ensure that each range overlaps slightly those above and below it, at the expense of a slightly reduced overall coverage. If the resistances were all perfectly accurate the ranges would become 0-50, 47-97, 94-144, 141-191, 188-238. S1 is a normal double-pole double throw toggle switch. M is the best meter you can afford to use; centre-zero is desirable, but not essential. Mine is a 100-0-100 microamp 2in. square, but anything up to a 1 milliamp movement should serve. The better the meter the more sensitive the indication of zero current, and therefore of the true infinite resistance condition. If you use a 1 milliamp meter you can omit R1 and S3. Otherwise R1 is a shunt to make the meter read 1 milliamp so long as the button of S3 is not pressed. Make this as accurately as possible, for although the accuracy of the instrument does not depend upon it, the accuracy of the 50 volt range coverage does. (If this appears contradictory, you will see what I mean when we come to the setting up procedure.)

The panel layout suggested in Fig. 4 is not in any way essential; it is that which I have adopted, and I have found it convenient. R2 is fitted with a large knob to the underside of which is screwed a strip of Perspex 3in. x 3in. x 1/16in.; a hairline is

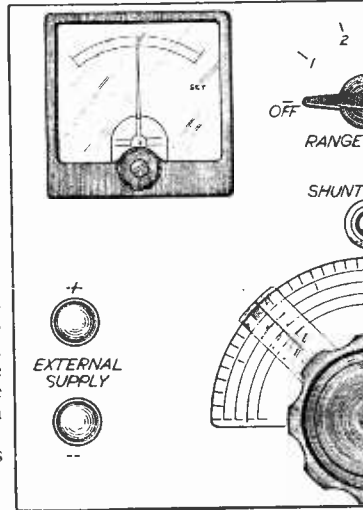
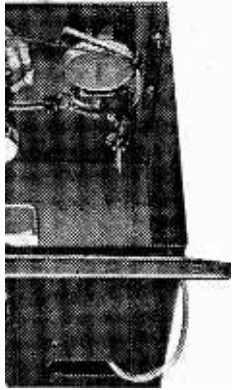

Fig. 4.—Panel layout. The dial will, of course,

scribed down the centre of this cursor, top and bottom, to avoid parallax in the readings. One then takes the reading obtained when both lines are seen to coincide. The dial is made of good cartridge paper marked in indian ink during setting up and protected after marking by clear copal varnish. The internal wiring is straightforward, and may be point-to-point or in beautiful right-angles at the whim of the constructor. R3 is not in the instrument case but in the prod. A suitable value for general use is 47 k., wattage unimportant. It is desirable to make up three prods, however, one having the 47 k. just men-



View of t



interior

tioned, one with 1,000 ohms and one with 10 megohms. The special uses of the last will soon become apparent. A suitable form for the test prods is shown in Fig. 5. As for the battery of Fig. 3, any source of 250-280 volts D.C. may be used. I use an ordinary unstabilised power pack on the bench and three midget 90 volt batteries when portability is desired. The current consumption is precisely 1 milliamp. It is often possible to make use of the H.T. from the apparatus under test; under these circumstances voltages can be measured only with reference to chassis.

Operation

Here is the procedure for using the instrument. Set the "range" switch to the required range. Put the "Read - Calibrate" switch in the "Calibrate" position. Adjust the "Calibrate" control until the meter indicates 1 mA.

(This point should be clearly marked on the meter scale, preferably in red.) Switch the "Read - Calibrate" switch to "Read." Apply the prods across the points where the measurement is to be made, as for an ordinary voltmeter. Turn the main dial until the meter indicates zero current, pressing the shunt button to obtain final adjustment. The pointer of the main dial now indicates the true voltage.

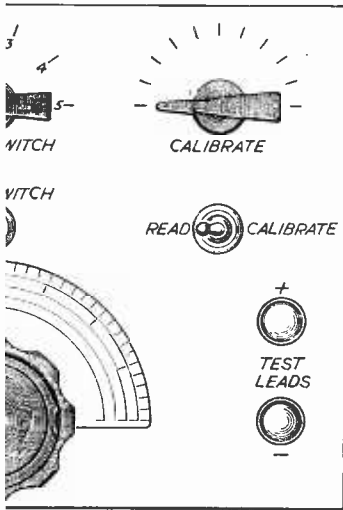

be drawn to suit R2, i.e., 180° or 270°.

It remains only to show how the main dial itself is calibrated; the initial setting up. There are two methods. We may do it by theory or by checking against known voltages. The theoretical method is perfectly satisfactory so long as R2 is a really good, accurate component and the 1 mA marking on the meter is true. Five semicircles are drawn with suitable radii on the dial, one for each range, together with radial lines corresponding with the ends of the pointer travel. The range switch is set to position 1, and the resistance between points A and C (Fig. 3) is measured. This figure, which is the resistance of R2

(probably not exactly 50 k) gives the voltage span of every range, at the rate of 1,000 ohms per volt, i.e., if it is 49.3 k, each range will cover exactly 49.3 volts. Mark this figure at the top end of range 1. Turn to range 2 and measure the resistance between B and C. This figure corresponds to the bottom of range 2. If it is 46.8 k then we mark 46.8 v at the beginning of range 2 and 46.8- 49.3, i.e., 96.1 v at the top. Still reading between B and C, repeat for the other ranges. Mark the intermediate voltages by dividing the

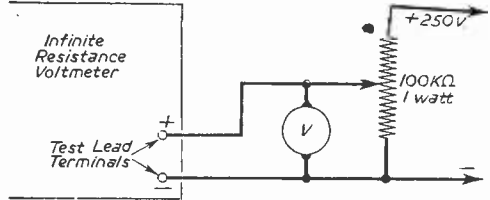

Fig. 6.—One calibration method.

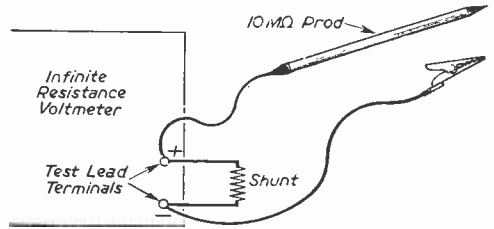

Fig. 7.—A range multiplier.

scales evenly. If you are content to neglect the odd fractions of a volt, and in practice they are claiming a higher accuracy than we are likely to be entitled to, then it is sufficient to divide the outer scale only and to obtain the divisions on the others by drawing radii, since each scale covers the same range in volts. You can simplify things still further by purchasing R2 and the four resistances on the lower half of S2 (Fig. 3) as 1 per cent. tolerance components. You

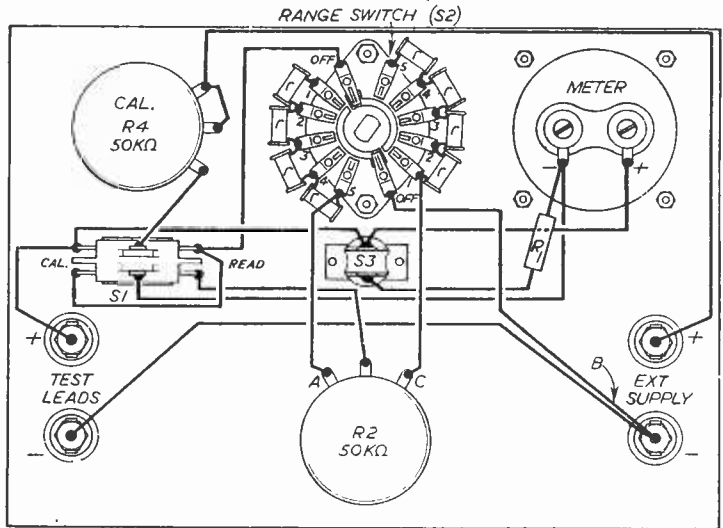

Fig. 8.— Practical wiring diagram of the instrument.

then know in advance that the five resistance readings will be 50 k, 47 k, 94 k, 141 k and 188 k and can prepare your dial accordingly.

Calibration

The second method is quicker and easier, but requires an accurate voltmeter against which to calibrate the infinite resistance instrument. It consists, in effect, of setting up a second, temporary infinite-resistance meter. The circuit is shown in Fig. 6. The potentiometer in this diagram is varied to give suitable voltages as read on the ordinary voltmeter, and the infinite resistance instrument is adjusted at each voltage for zero current indication. The voltage then shown on the ordinary meter is entered on the scale of the infinite resistance meter directly under the hair-lines of the cursor on the appropriate range. Before marking any point on the scale it is advisable to switch to "Calibrate" for a moment, to make sure that the current through the main potentiometer is still standing at 1 mA. If this second method of calibration is adopted, the instrument will be accurate independently of the accuracy of the 1 mA mark on the face of the built-in zero-current meter, but the range covered in any one setting of the "Range" switch, since it is equal to the voltage developed across the main potentiometer, is directly proportional to the accuracy of this mark. This fact can, indeed, be used to correct for small inaccuracies of resistance in the main potentiometer.

Test Prods

Finally, a word about the prods. Since the instrument possesses infinite resistance when properly adjusted, no amount of series resistance in the leads will affect the readings. This is in contrast to the behaviour of a conventional voltmeter, in which series resistance is used to extend the range. The effect of the two lower resistance prods is to isolate the voltage under measurement from the capacity of the instrument, and of its user, without affecting the accuracy of the readings. Too much resistance, however, causes the indication of zero current to become vague. Hence, use the 47 k prod wherever possible, otherwise try the 1,000 ohm one.

The 10 megohm prod is used as a range multiplier, by the device of connecting shunts across the main terminals of the instrument. See Fig. 7. In conjunction with a 10 megohm shunt all ranges are doubled: a 2.5 megohm shunt will multiply them by 5, and so on. Used in this way the instrument is no longer infinite resistance, of course, but its resistance is always over 10 megohms, which is good enough for many purposes.

The instrument described is, of course, suitable for D.C. voltages only. Its use, however, need not be confined to the "vanishing voltages" for whose measurement it was specifically designed; it is suitable for the measurement of any D.C. voltage within its range.

I.T.A. Statement on the £750,000

THE Independent Television Authority has learnt with dismay of the Government's decision that none of the £750,000 provided in the Television Act for the support of balancing programmes can be made available to it.

The setting aside of a maximum sum of £750,000 each year from the rapidly increasing yield of the licence fees for the support of such programmes was an integral part of the arrangements approved by Parliament and embodied in the Television Act in 1954, and has always been regarded by the Authority as crucial to the proper discharge of its duties in this field.

So completely did it seem to be accepted that the money would be available, if the Authority judged it necessary, that the Treasury began deducting this additional £750,000 from the licence fees in the financial year 1955-56, and the deduction is continuing this year. The Treasury has now received, during the last sixteen months, a million pounds under this arrangement. Requests for this grant were made in November 1955, and repeated during the following eight months. It was only on July 31st that the Authority was informed that no money at all would be passed on to it.

Meanwhile the gross yield of the licence fees has risen in 1955-56 to £11,500,000, an increase of over £3,000,000. These licence fees were swollen by payments from over a million and a half families in Band III homes (over a quarter of all viewers) who spend more than three-fifths of their viewing time watching I.T.A. programmes.

The Authority is conscious, and its view is shared by the programme companies, that the present programmes, although extremely popular, do not contain a sufficient number of programmes of information

and discussion, or of plays and performances of lasting value. For this the explanation is the very simple one that such programmes, whether transmitted by the Authority or the BBC, do not attract relatively large audiences, despite their national value. The possibility that this situation would arise was clearly foreseen during the debates on the Television Bill, and it was precisely in order to make such programmes possible that the £750,000 provision was included in Section II of the Act.

The BBC does not find itself in this difficulty, as its rising income is guaranteed whatever the size of its audience. The Authority and the programme companies are, however, very much in this difficulty, and are apparently to be left unable to respond, as they would wish, to the preferences of large and important minorities.

This is not a situation which the Authority can accept without feeling that it is failing in one of its main duties, whatever degree of success it may have achieved in the discharge of others. It is, of course, aware that the provision of the £750,000 is not automatic under the terms of the Act but depends upon the agreement of the Treasury and the Postmaster General. It did not at any time enter into its calculations that this agreement would be withheld.

The Authority appreciated that the Government might reasonably take the view that the payment of the full sum should be deferred while the country's present financial difficulties continue, and so made it clear that it would for the present rest content with the payment of only a small part of the sum so that at least a start could be made in the provision of balancing programmes, and in token of the acceptance of principle that independent television, if it is to grow to its proper stature, should not be dependent on advertising revenue alone. Even this modest proposal has been rejected.

Battery Operated TV

HINTS FOR THE COUNTRY DWELLER AND OTHERS WHO HAVE NO MAINS FACILITIES

By F. G. Rayer

THE operation of a TV receiver from an accumulator supply is a relatively straightforward matter, but experience shows that some initial difficulty in obtaining satisfactory results is by no means unusual. Such battery operation is, of course, quite pointless when mains are available, but nevertheless has a certain field of utility. "Portable" equipment can be powered from a car battery, while in rural houses with low-voltage lighting plants, there is no alternative to the use of some type of battery circuit.

A number of methods exist, each with particular advantages. The rotary transformer is simplest, but draws rather a heavy current in some circuits. A vibrator is much more economical, but produces R.F. hash difficult to suppress. Whether or not the receiver is to be used on mains will also govern the method adopted.

The direct operation of an A.C./D.C. type receiver from a rotary transformer of sufficiently large rating has much to recommend it when circumstances permit. No changes whatever are required to the receiver, which may be plugged into convertor unit or mains, as required. Connections for this method of operation are shown in Fig. 1.

It is essential that a rotary transformer of correct rating be used, and a large model will be required, since the output also has to provide heater current. For example, assume that the receiver consumes 60 watts, then a 200 v. to 250 v. rotary with this output rating is required. The mains-voltage selector of the receiver is adjusted to suit the transformer output voltage, if this differs from the local mains voltage.

The input voltage of the rotary is also chosen to suit the supply available, usually being 12 v. for "portable" use, or 24 v. to 30 v. for domestic low-voltage plants. It is necessary to bear in mind that the current consumption will be quite high. When running, it is likely to be around 8 to 15 amps., according to battery voltage and receiver, with an initial starting current of up to 20 amps. or more. For successful operation, the input voltage to the

rotary must be maintained. A large accumulator, well charged and in good condition, is thus essential. With domestic plants, the load can be relieved by running the engine generator when the rotary is in action.

To avoid unnecessary interference, the rotary unit is best kept clear of the receiver. Connecting plugs should be marked, or non-reversible, so that the receiver cannot be connected in the wrong polarity when operated from the D.C. output of the convertor unit. If interference is observed, suppressor chokes may be inserted in the output leads from the rotary, which may need screening. It should in any case be enclosed, to reduce noise. Further by-pass condensers from input leads to earth may also prove necessary to keep down interference.

It is possible to operate an A.C. type receiver from a convertor giving an A.C. output, but this is not easy to arrange, as both output voltage and frequency are liable to fluctuation, with resultant deterioration in reception.

H.T. Only

In home-constructed receivers of suitable type, where the heater circuit can be separated and operated directly from a source of low voltage, the load upon the rotary transformer will be very greatly reduced. If heaters and rotary may both be run from the same accumulator, as in Fig. 2, the arrangement is particularly simple. The large type of transformer required in Fig. 1 is no longer necessary, as the output only needs to provide a suitable H.T. current.

The 6.3 v. type of valve is very suitable for operation from a 6 v. accumulator; or may be wired in pairs (dissimilarity of current rating, if any, being met by parallel resistors) for 12 v. operation. The current required from the battery can be found by adding consumption of the rotary and all heaters operated from this circuit.

Reasonable care to avoid interference is necessary, with by-pass condensers from heater and H.T. circuits

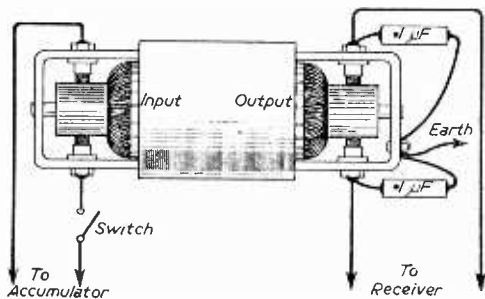

Fig. 1.—Operating an unmodified A.C./D.C. receiver.

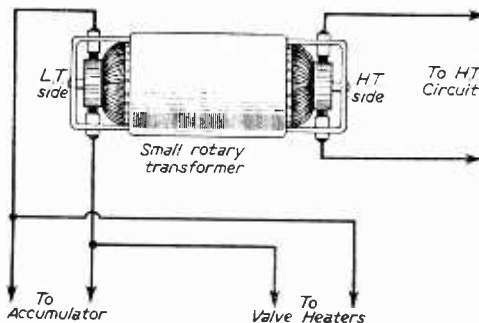

Fig. 2.—Circuit for H.T. only.

to earth. If the rotary sparks excessively this may be caused by worn or dirty brushes or commutator. If so, attention to this may well remove the interference, and such a fault should certainly be corrected if present.

Vibrator H.T.

A vibrator can provide a fairly economical and

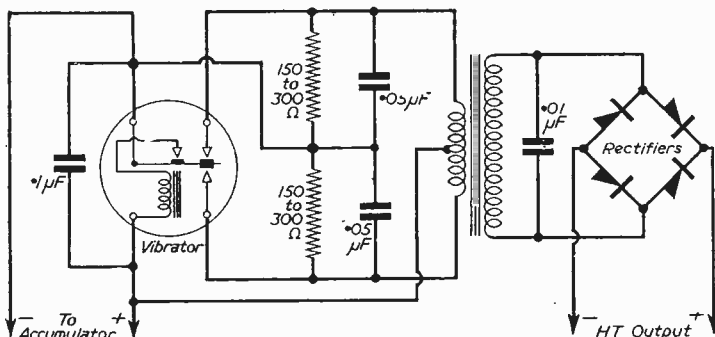

Fig. 3.—A vibrator H.T. supply.

reasonably quiet means of obtaining H.T., but is very prone to cause interference. In operation, it throws upon the accumulator a load which alternates in degree continuously, and which may produce a low-pitched hum or buzz. Even when this is avoided, the continuous sparking produces forms of R.F. interference often difficult to suppress. For this reason, the self-rectifying (synchronous) type is best

avoided, as sparking at the rectifying contacts may be a source of trouble, and will be avoided with a valve or metal rectifier.

Fig. 3 shows a typical vibrator circuit, a metal rectifier being employed to avoid further load on the battery. The small condensers shown are primarily R.F. by-pass components. To reduce low-frequency buzz, a capacity of $100\mu\text{F}$ or more may be found beneficial, in parallel with the accumulator circuit. The whole equipment needs to be screened and earthed, with suppressor condensers inside, and possibly suppressor chokes in the leads where they emerge to accumulator and H.T. circuit. Indeed, without full care it will probably be found that interference is very troublesome and difficult to eliminate.

If necessary, suppressor chokes may be added between vibrator contacts and transformer primary, with further condensers of $.05\mu\text{F}$ or $.1\mu\text{F}$ to earth line. It must not be overlooked that R.F. interference can readily travel along the accumulator leads, thereby entering the receiver, and that the H.T. output may not, therefore, be responsible for trouble of this kind.

When circumstances permit, the rotary transformer will be found less troublesome in terms of interference, since it forms a steady load, which a vibrator does not.

TV DISTRIBUTION AT THE RADIO SHOW

(Concluded from page 122)

oscilloscopes for continuous observation of the vision and audio waveforms going out to the network, and meters showing the outputs of the vision and sound transmitters.

The main control panel carries 84 push-buttons and 16 other controls. All the video and audio switching is done on this panel, which includes the master level controls of the vision and sound transmitters.

Below is the mains intake, with Variacs for precise voltage control, fuses and power distribution equipment.

The fourth bay carries the Monitor speaker, the Vision Monitor and a Waveform Monitor, for monitoring and checking any of the inputs and outputs as required, while the Waveform Monitor is also used to check the waveform and levels of the Vision Modulator sections of the vision transmitters. At the bottom of this bay are the power supplies for the vision and sound transmitters in the next bay.

The fifth bay in each rack carries two vision and two sound transmitters and modulators—one of each being a stand-by.

The vision and sound transmission frequencies are respectively 61.75 and 58.25 Mc/s for BBC programmes, and 204.75 and 201.25 Mc/s for I.T.A. programmes. All frequencies are crystal controlled to ± 0.005 per cent.

At the rear of this bay is the equipment for combining the vision and sound transmissions, and splitting the outputs to feed the main trunk lines of the distribution network.

PRACTICAL WIRELESS NOW ON SALE

OCTOBER ISSUE
PRICE 1s. 3d.

The current issue of our companion paper, "Practical Wireless," now on sale, has as its main constructional feature an article on building an A.C. Straight 3/4. This is a simple receiver, ideal for the beginner, as it utilises a commercially-made chassis and plastic cabinet, and as it is not a superhet, there are no problems of alignment. The finished receiver has a commercial appearance and it would form an ideal set for the kitchen or bedroom as an addition to a standard domestic receiver, or could itself replace an old set in the home. It is simple and inexpensive to build, and the article is complete in this issue.

Another interesting constructional feature deals with a voice-operated relay arrangement in which the particular instrument described in this issue forms a Baby Alarm. There are, of course, a number of other applications for this type of apparatus, such as the audio control of a tape recorder, transmitter, etc.

A novel new type of Speaker Enclosure forms the subject of another constructional article, and this gives full dimensions and instructions for a cabinet to improve the bass and treble response. It is designed for two speakers.

Further notes are given on the Experimental Power Pack, Adding a Transistor Stage and modifying the R.1155, whilst the issue also contains a Review of Principal Exhibits at the Radio Show.

BAND III CONVERTER.

Coil kit by TELETRON, with circuit and wiring details, etc. For use with TRF or Superhet TV Receivers. ONLY 12/-.
Drilled chassis 3/-. Instruction leaflet only, 6d.

INDICATOR UNIT TYPE 6.—Contains VCR 97 tube with mu-metal screen, 4 valves EF50 and 2 of EB34, valveholders, CRT holder, condensers, resistors, etc. NEW CONDITION. ONLY 39/6 (carriage, etc., 7/6).

AMPLIFIER TYPE 223A or 208A.—As described in July, 1955, issue of *Practical Television*, for making a TV CONVERTER. Complete with 2 valves EF50. ONLY 10/- (post, etc., 2/-).

PYE 45 MC/S.I.F. STRIPS.—Ready-made for London Vision Channel. Complete with 6 valves EF50 and 1 of EA50, and details of very slight mods. required. BRAND NEW. ONLY 49/6 (post, etc., 2/6).

I.F. STRIP 194.—Another easily modified strip for T.V. Complete with 6 valves SP61, 1 of EA50, and 1 of EF36; also mod. data. ONLY 29/6 (post, etc., 2/6).

RECEIVER UNIT 150.—Contains 4 valves, 1 each EF50, EA50, SP61, RL37 and 21 v. Selector switch. ONLY 7/6 (post, etc., 2/-).

R.F. UNITS TYPE 26.—Complete with 2 valves EF54 and 1 of EC52, this is the variable tuning unit covering 65-50 mc/s (6-5 metres). BRAND NEW IN MAKER'S CARTONS. ONLY 27/6.

POCKET VOLTMETERS.—Read 0-15 and 0-300 v. A.C. or D.C. BRAND NEW. ONLY 18/6.

COMMAND RECEIVERS.—Huge purchase from the Air Ministry. These famous compact American receivers which can be used for a variety of purposes are offered at ridiculously low prices while stocks last. Complete with six metal type valves, one each of 12K8, 12SR7, 12A6 and 3 of 12SQ7, in aluminium case, size 11in. x 6in. x 5in. Used, but in good condition. Choice of models, BC 455 (6-9 Mc/s), 25/-, BC454 (3-6 Mc/s), 27/6, BC 453 (190-550 kc/s), 59/6, and a few of the 1.5-3 Mc/s model 65/-. (Postage on all models 3/-).

COLLINS TRANSMITTERS.—The renowned American TCS models covering 1.5-12 Mc/s in 3 bands. Complete with 7 valves, employing 2 of 1625 in P.A. stage, one of 1625 in each of buffer and modulator stages and 3 of 12A6 in oscillator stage. Provision for O.F.O. or crystal control for 4 Xtal positions. Incorporates plate and aerial current meters. In Brand New Condition. ONLY £12.10.0 (Carriage, etc., 15/-).

COLLINS RECEIVERS.—Matches the above transmitter and is exactly the same size, 11in. x 13in. x 11in. Has 7 valves, 1 each of 12SA7, and 12SQ7, 2 of 12A6, and 3 of 12SK7. Also has provision for Xtal control. A really terrific receiver for the serious operator. In Brand New Condition. ONLY £8.10.0. (Carriage, etc., 15/-).
OR THE TRANSMITTER AND THE RECEIVER TOGETHER, £20.0.0. (Plus Carriage, as above).

L.T. HEAVY DUTY TRANSFORMER.—Ex Admiralty. Has 3 separate windings of 5V-0-5V, at 5 amps, and by using combinations will give various voltages at high current. BRAND NEW. ONLY 29/6 (post, etc., 2/8).

MODEL MAKERS MOTOR.—Reversible poles. ONLY 2 1/2in. long and 1 1/2in. diameter, with 1in. long spindle. Will operate on 4, 6, 12 or 24 volts D.C. ONLY 10/6 (post, etc., 1/-).

TRANSFORMERS.—Manufactured to our specifications and fully guaranteed. Normal Primaries. 425-0-425 v. 200 ma. 6.3 v. 4 a., 6.3 v. 4 a., 5 v. 3 a., ONLY 65/-; 250 v. 0-250 v. 100 ma., 6.3 v. 6 a., 5 v. 3 a., ONLY 37/6; 350 v. 0-350 v., 180 ma., 6.3 v. 5 a., 5 v. 3 a., ONLY 37/6; 250-0-250 v. 60 ma., 6.3 v. 3 a., 5 v. 2 a., ONLY 21/-. The above are full shrouded, upright mounting. 5.5 kv. E.H.T. with 2 windings of 2 v. 1 a. ONLY 79/6; 7 kv. E.H.T. with 4 v. 1 a. ONLY 59/6. PLEASE ADD 2/- POSTAGE FOR EACH TRANSFORMER.

E.H.T. TRANSFORMER FOR VCR97 TUBE.—2500 v. 5 ma., 2-0-2 v. 1.1 a. 2-0-2 v. 2 a., 42/6 (postage 2/-).

SPEAKERS.—P.M. 6 1/2in. less trans. 19/6; 8in., less trans. 16/6.

CHOKES.—10H 60 mA., 4/-; 5H 200 mA., 7/6 (post 1/-).

Open until 1 p.m. Saturdays, we are 2 mins. from High Holborn (Chancery Lane Station) 5 mins. by bus from King's Cross. Cash with order, please, and print name and address clearly. Include postage and carriage on all items.

U.E.I. CORPN. THE RADIO CORNER, 138, GRAY'S INN ROAD, LONDON, W.C.1 (Phone TERMINUS 7937).

COMMERCIAL TV FOR YOUR VIEWMASTER

All parts in stock.



Reprint of all articles from "P.T." giving full conversion data, etc. Price 3/6.

Ready work modification coil set, 20/-.

3 station tuner, coils and screens, 30/-.

Switch kit, fine tuner, coil mounts, 27/-.

T.C.C. Condensers

1 pF CC1255, 3 pF SCPS, 5 pF SCPT, 10 pF SCPB, all at 1/- ea.

1,000 pF CTH310 (3 required), 1/3 ea.

1,000 pF CC1605 (10 required), 1/9 ea.

3 pF CC164N and 9 pF CC159N, 3/- ea.

CI30 and C366 printed circuits, 12/- pair.

Special B9A valveholders, 1/4 ea.

COMPLETE T.C.C. KIT AS LISTED ABOVE, £13.0.

VALVES, PCC84 and PCF80, 10/6 ea.

TRANSFORMER. Special 16 volt, 10/6.

RESISTORS. Complete set for tuner, 5/-.

PRE-SET GAIN Controls. 5 K (3 required), 3/3 ea.

Coaxial plug, 1/3. Coaxial socket, 1/3.

Set of specified drills for printed circuit, 10/-.

HOME RADIO (MITCHAM) LTD.

187, LONDON ROAD, MITCHAM, SURREY.

Telephone: MITcham 3282.

TECHNICAL TRADING CO.

F.M. RECEIVERS, ex-Manuf., 6 latest Mullard valves, horizontal tuning scale, elliptical speaker, beaut. styled cabinet, boxed with circuit. Listed £20, our price, 21/-, carriage paid.

SPECIAL BARGAIN 12 V. 4 AMP RECTS. 9/6 EA., 25 Doz. Iron Selenium, Pull Wires, heavy construction. No. 19 WALKIE-TALKIES, 59/-.

RESPONDER RECEIVERS.—Ideal T.V./F.M. use, all new. Type 7, 9 valves, VR137, VR136, SP61, EA50, 39/-, carr. 4/-; Type P25.—10 valves VU120, 5Z4, 826A, SP61, EC52, EA50, 55/-, carr. 6/-; Type B, 15 valves, Magic Eye, 5Z4, GP11, VR135, VR137, EA50, P61, beautiful 200/250 v. C.C. Power Pack, £4.15, carr. 7/6.

10 FIVE CHANNEL COILS.—3 R.F.s, tunable, 7 I.F.s, and rejectors, famous make, new, 9/-; **TELEVISION CHASSIS.**—Stamped for B9A holes and standard components, 4/8, post 1/6; **29-WAY TAG PANELS.**—small type, 1/-; **2-WAY CARTRIDGE FUSEHOLDERS.**—6d.; **TUBE SUPPORTS.**—1 1/2in. front under, 9d.; **TUBE BATHING SPRINGS,** phosphor-bronze, 6d.

WIDE ANGLE TRANSFORMER KITS boxed, consisting: (a) Line Transformer 14 Kv., ceramic base, EY51 mounting, ferric oxide core, 17/6 with instructions. (b) Frame Transformer, large efficient for ECL50, 9/6.

(c) 250 ma 7 H Smoothing Chokes, 3 way mounting, 7/6. **COMPLETE KIT AS ABOVE,** ship Price for 3 items, 30/-.

Width Coils and Linearity Coils, to match above, 4/- ea.

ION TRAP MAGNETS.—Best quality, 3/6. **ALADDIN FORMERS.** 1 1/2in. with slug, 4/- doz. **VISONCON COND'S.**—002 mfd., 18 Kv., 4/9.

DEFLECTION COILS.—Standard 35 mm. iron cored, 9/6. **5 CHANNEL TUNERS.**—Complete chassis, famous make, for PCF80 and PCX84 (10 valve), 12/6. **BOWLER HATS, 1/-.** **FOCUS MAGNET HANDLES.** 6d. **LOUDSPEAKERS.**—Top makes, 7 x 4 elliptical, 17/6; 6 1/2in. P.M., 12/6; 8in. P.M., 12/6. Ditto, ex. EQPT, 7/6. **THERO MIKES.**—British, boxed, 2/6. Single LR earphones with headband, 2/6.

also, latest designs, 14in., 12/-; 17in., 22/6; ditto with mask and glass 14in., 29/-; 17in., 39/-; all 7/6 carr. **COSSOR D.B. SCOPES,** 18.

WIREWOUND PRE-SET POTS.—500 Ω, 1 K, 2.5 K, 5 K, 10 K, 20 K, 25 K, 50 K, 2/- ea. **MARCONI VALVE VOLTMETERS,** 110.

AMPHENOL HOLDERS.—Octal, Mazda, Novak, B7C, B9A, 8/- doz. B9C W/screen, 12/6. Tube Holders, Octal, 6d. **Duoedral, 1/-.**

MEG. OBLOCK POTS D.P. SWITCH.—3 1/2in. spindle, small type, 3/6. Ditto, 1in. spindle, 2/6. **DST.100, 14 VALVE, 6 W. COMMUNICATION RECEIVERS,** 218.

INDICATORS, TYPE 96.—16 valves, VCR97. **1-2 WATT RESISTANCES,** our assortment.—4.7 Ω—1m Ω, 2/- doz., 10-100, AVO VOLT TESTERS, Ex. cond., transit case, 29.

MIDGET CERAMIC CONDENSERS.—10, 20, 50, 100, 1,000, 5,000, 8/- doz. Midget 16-16 350 v., 3/-; Midget 8 x 250 v., 1/-; Midget 100 mfd., 6 v., 1/-; 60-100 250 v., 6/-; **ORGANIXONE RADIOGRAM CHASSIS,** 28.

F.M. CHASSIS.—Drilled 6 valve receiver, hammersmith finish, 1 1/2. **CHASSIS.**—6 x 4 x 1 1/2, 2.9, 6 x 4 1/2 x 2 1/2, 8 x 5 x 2 1/2, 8 x 6 x 2 1/2, 4.9.

350/352, FRATTON ROAD, PORTSMOUTH

PORTSMOUTH'S RADIO, T.V. AND TOOL SHOP

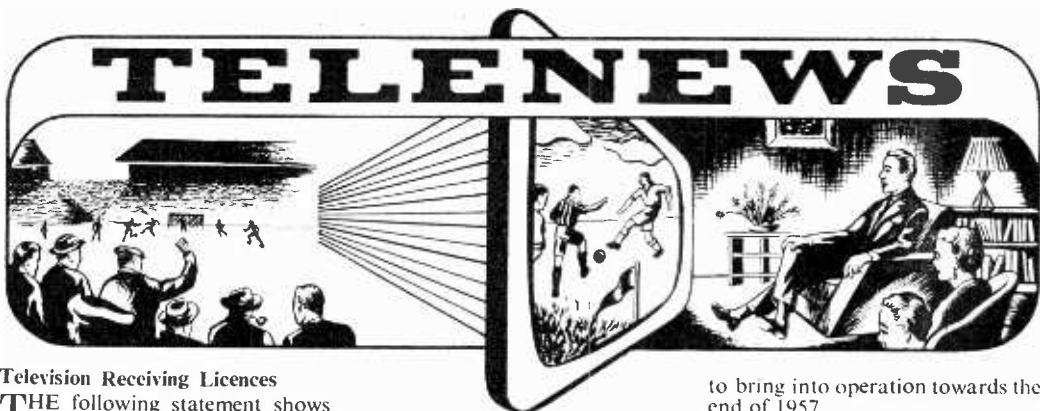

Television Receiving Licences

THE following statement shows the approximate number of Television Receiving Licences in force at the end of July, 1956, in respect of receiving stations situated within the various Postal Regions of England, Wales, Scotland and Northern Ireland.

Region	Total
London Postal	1,334,471
Home Counties	688,164
Midland	1,030,027
North Eastern	911,785
North Western	859,072
South Western	405,608
Wales and Border Counties ...	333,694
Total England and Wales ...	5,562,821
Scotland	370,457
Northern Ireland	46,232
Grand Total	5,979,510

Airborne TV for Reconnaissance

THE Philco Corporation, of Philadelphia, announced recently that it has developed an airborne TV system which may be used by the U.S. Air Force for its reconnaissance jet planes. The system will provide ground control points with a picture of troop movements or terrain and makes it possible to transmit a TV picture, not only from near ground level but also from the stratosphere, beyond reach of anti-aircraft gunfire.

Unlike those systems which have been used commercially to relay TV signals from one ground point to another, via a slow-circling plane, the new airborne reconnaissance system is a complete, self-contained broadcasting station. It is so compact that it may be carried in a single-seat aircraft.

To cover a wide area, two unmanned TV cameras are used in the plane. Signals from the plane are transmitted to a ground control point where they are picked up by a receiver. At ground control, the picture may be instantaneously photographed on 35mm. film, pro-

cessed in less than a minute, and then immediately projected on theatre-size screens or relayed to other locations. Live pickups from slower-moving aircraft may also be observed on standard fine-line monitors.

The company has overcome the inherent difficulties of obtaining a clear, sharp picture from aircraft travelling at supersonic speeds by developing a unique transmitter circuitry and method of transmitting a high-quality picture. The picture obtained is as good as ordinary TV. It is now possible to slow, or stop, TV pictures taken at high speeds without blurring ground movement. Data, such as time and position, may also be automatically printed on the film.

I.T.A. Station in South Wales

THE Independent Television Authority has been giving careful consideration to the selection of a site for its new station to serve South Wales and the areas to the east and south of the Bristol Channel. It has now decided to locate the station in the Wenvoe area. Sites on the south side of the Bristol Channel have been considered, but have been rejected on technical grounds.

About 3,000,000 people should be served by the new transmitter, which the Authority hope

to bring into operation towards the end of 1957.

The Authority will be advertising shortly for applications for the contract to supply the programmes which will be broadcast by this transmitter.

Durham TV Traffic Control

DURING August Durham became the first city in Great Britain to use television for traffic control. Due to the narrowness of certain streets it is very difficult to ensure a steady flow of traffic through the market-place, and jams became frequent. By installing two television cameras of the commercial type, one attached to a lamp-post in one street and another cited in a first-floor window of another street, a closed circuit relay to the pointsman in the market-place enables a steady



The television control point in Durham. See story above.

view of both streets to be seen. In this way the traffic lights may be suitably controlled and the congestion considerably reduced.

Radio Show for Glasgow

THE Radio Industry Council, organisation of all sections of the radio manufacturing industry announces that it will hold a Scottish Radio and Television Exhibition at the Kelvin Hall, Glasgow, in Mid-May, 1957.

It is expected that all the leading manufacturers of radio and television receivers will exhibit and there will also be exhibits of the latest high-fidelity sound equipment and of valves and components.

The BBC has promised its full co-operation.

The only previous exhibitions held in Scotland by the radio manufacturers were at Kelvin Hall in 1933, 1934 and 1935.

London Base for Television Index

HEADQUARTERS for British Nielsen Television Index have been established in London at Stockleigh House, 99, Park Lane, W.1 Telephone: MAYfair 4528/4529/4530; Telegrams: Nielindex Audley; Cables: Nielindex.

From this office Graham R. Dowson, the Nielsen company's director in charge of NTI, will direct the operation and development of Nielsen audience research activities. Day-to-day sales and client servicing—under William S. MacDonald—will also be based on the Park Lane office. TV Field administration and Production operations remain at the company's main offices in Oxford.

The establishment of the London office is part of the Nielsen Company's plan to provide maximum assistance to its Television Index clients in the interpretation and effective use of audience-research findings.

The London office will soon be available on Tellex, installation of which is currently in hand.

Drama Script Editor

GEORGE F. KERR, a Lancashire man, born in St. Helens and brought up in Southport, has been appointed script editor for A.B.C. TV's new Drama Department, now being set up by drama supervisor Dennis Vance. Mr. Kerr's appointment will, however, leave him time to continue the writing which has brought him many successes in recent years.

At the beginning of 1955 Mr. Kerr joined Towers of London Productions as script editor, and was responsible for many of the scripts in the "TV Playhouse" and "Theatre Royal" series.

I.T.A. Midlands Transmitter at Lichfield

ADDITIONAL sound and vision transmitting equipment is now installed at the Authority's Lichfield transmitter. This is available as a stand-by in the event of breakdown. Moreover, when certain ancillary equipment has been installed early in the autumn, the authority will then be able to give

V.H.F. (F.M.) transmissions of the Home, Light and Third programmes.

Miniature TV

A MINIATURE TV camera and transmitter which, combined, weigh only 19 lb., and with a range of over a mile, were recently announced by the Radio Corporation of America. Batteries can operate the camera and transmitter for about 5 hours.

BBC's Crystal Palace Aerial

WORK on the erection of the first part of the permanent aerial at the Crystal Palace trans-

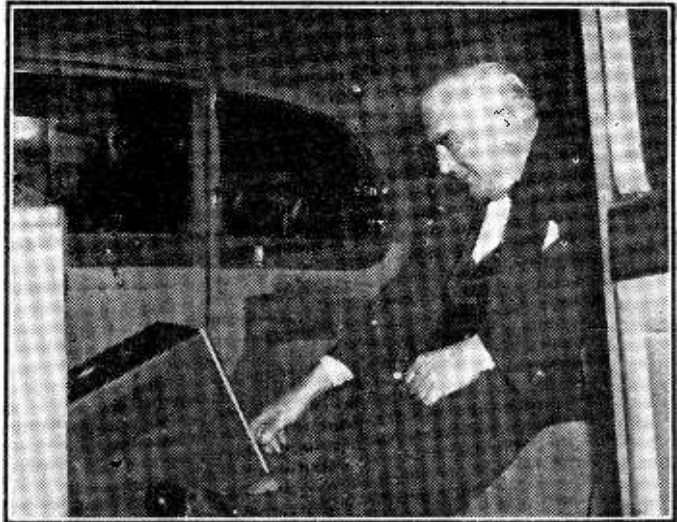

Mr. Menzies, the Australian Prime Minister, had a television receiver fitted to his car whilst he was here for the Suez talks. This was so that he could follow the Test Match during his journeys.

effect to its intention of raising the regular power of this transmitter from 50 to 200 kW effective radiated power.

New BBC Station for Londonderry

THE BBC announces the purchase of a site some 570ft. above sea level on Sherriffs Mountain, near Londonderry, Northern Ireland, for the Londonderry television transmitting station.

The new station is expected to be ready for service by the end of 1957. It will serve an area including Londonderry, Strabane, Limavady, Dungiven and Newton Stewart, bringing the BBC Television Service within reach of more than 130,000 additional people in Northern Ireland.

The site will also be suitable for

mitting station is making good progress. The new aerial is mounted at a height of 400ft. at the top of the support tower which forms the lower part of the permanent mast. It will therefore be twice as high as the present temporary aerial and, in addition, it will have greater horizontal directivity. The overall result will be an increase in the effective radiated power from 60 kW to 120 kW. The resulting increase in the strength of signal will be most noticeable on the fringes of the service area.

Preparatory work is also in hand for the completion of this aerial by the addition of a further section above the support tower; this work is expected to be completed in the late summer of 1957.

12in. TV. CABINET—15/-

We are offering these at the most more than the cost of the plywood they contain. If not wanted for T.V. many useful items can be made — record storage cabinet, H.F. loudspeaker case, book case, etc., etc.

Price 15/-, carriage 3/6.



"SNIPERSCOPE"

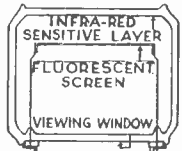

"Cats eye" used for seeing in the dark. Will work burglar alarms, counting circuits, smoke detectors and the hundred and one other devices as will the simpler type of photo cell. Price 5/- each. Post and ins. 1/-. Data will be supplied with cells if requested.

WESTINGHOUSE (U.S.A.) METERS



All flush mounting type, outside diameter of face 3 1/2 in.

0-500 v. D.C.	25/-
0-1.5 kV D.C. external multiplier supplied	35/-
0-2.5 kV D.C. external multiplier supplied	35/-
0-15 v. A.C. moving iron	30/-
0-1 mA.	35/-
0-50 mA.	25/-
0-100 mA.	25/-
0-150 mA.	25/-
0-250 mA.	25/-
0-500 mA.	25/-



CONNECTING WIRE

P.V.C. covered in 100ft.coils—20 a coil or four coils different colours, 10/- post free.

W.D. CIRCUIT DETAILS

Diagrams and other information extracted from official manuals. All 1/6 per copy, 12 for 1/5. American Set-76 receiver Vice Sheets
 A.1134 R23-ARC5
 BC.348 R1116/A
 BC.312 RA-1B
 R.105A AR80D
 B.C.342 AN APA-1
 RA-1B 78
 R-208 76
 R-1155 R.T.18
 R-1124A CAY-36-AAM-
 R-132A R-131 RADAR
 R-1147 A.S.B.-3
 R-1224A Indicator 62A
 R-1082 Indicator
 T-1355 A.S.B.3
 B.C.1206-A/B Indicator 62
 B-455-A (or -B) Indicator 6K
 B-454-A (or -B) R.F. unit 24
 B-453-A (or-B) R.F. unit 26
 Transmitter R.F. unit 25
 TH154 R.F. unit 27
 Fifty-eight Wireless set No. 19
 walkie talkie 19
 Frequency Demobbed
 meter B.C.221 valves
 R.109

PRODUCTION INCREASED—CIRCUIT IMPROVED—PRICE REDUCED

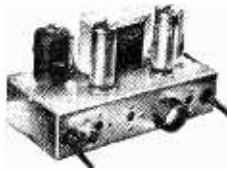

To-day's best value in Band III converters suitable for your T.V. or money refunded. Complete ready to operate. 49 6 non-mains, or 69 6 mains, post and insurance, 3/6.

T.R.F. CONVERTOR

New this month is a converter for T.R.F. Set View-mastor-Electronic Engineering, etc. Small models to the T.V. are necessary as this must be turned into a superhit to stop re-radiating. Price complete with two valves £6.10.0 assembled—ready Oct. Nov.

THE UNI—T.V.

Undoubtedly the most up-to-date television for the home constructor. You can build all or only part and the set when finished will be equal to a factory-made equivalent. What other constructor T.V. has all these features?



- ★ Made up units if required.
 - ★ All miniature valves.
 - ★ Metal rectifier.
 - ★ No expensive transformers.
 - ★ 13-channel circuitry.
 - ★ Multi-vibrator time bases.
 - ★ Ferrux cube, E.H.T. and scan coils.
 - ★ 34/37 Mc/s I.F.
 - ★ Suitable for any modern 12, 14 or 17" tube.
 - ★ Modern contemporary cabinet if required.
- The building cost (less tube) is only £29.10.0, plus 10-carriage and insurance. All parts guaranteed 12 months. Full information and data free with parts or available separately price 3/6.

THE "CRISPIAN" PORTABLE RADIO



A 4-valve truly portable battery set with very many good features as follows: Ferrite rod aerials. Low consumption valves, superhit circuit with A.V.C. ready - built and aligned chassis if required, beautiful two-tone cabinet covered with I.C.I. Rexine and Tygan. Guaranteed results on long and medium waves anywhere.

All parts, including speaker and cabinet, are available separately or if all ordered together the price is £7.15 complete, post and ins. 3/6, ready-built chassis 30/- extra. Instruction booklet free with parts or available separately price 1/6.

THE REALITE



This is a complete fluorescent, fitting, stove enamelled white with starter and ballast all ready to install. Price 29/6, plus 4/6 carriage and packing. 40-watt tube, 10/-, no extra for packing if ordered with fittings.

CROYDON BRANCH OPENING

We have taken the Lease of 286, London Road, Croydon, and hope to open this month.

ELECTRONIC PRECISION EQUIPMENT, LTD.

Post orders should be addressed to E.P.E., LTD., Dept. 5, Sutton Road, Eastbourne.

Personal shoppers to one of these addresses please.
 42-46, Windmill Hill, 152-3, Fleet Street, 29, Strand Green Rd., 249, Kibbourn High
 Ruislip, Middx. E.C.4. Finsbury Park, N.4. Road, Kibbourn.
 Phone: RU1SLIP 5790 Phone: FLEET 2833 Phone: ARCHWAY 1049 Road, Kibbourn.
 Half day, Wednesday. Half day, Saturday. Half day, Thursday. MAIDA VALE 4921.

THE SKYSEARCHER

An all mains set for 19/6



This is a 2-valve plus-metal rectifier set useful as an educational set for beginners, also makes a fine second set for the bedroom, workshop, etc. All parts, less cabinet, chassis and speaker, 19/6. Post & ins. 2/6. Data free with parts or available separately 1/6.

THERMOSTATS

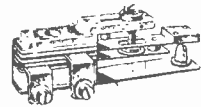

Useful for the control of appliances such as converters, blimpots, vulcanisers, hot plates, etc. Adjustable to operate over the temperature range 50-550 deg. F. 11 amp. 3/6; 5 amp. 8/6; 2 amp. QMB. 5/6; 5 amp. QMB. 15/-.



MULLARD AMPLIFIER "510"

A Quality Amplifier designed by Mullard. Power output exceeds 10 watts. Frequency response almost flat from 10 to 20,000 C.P.S. For use with the Acoas Hi G and other good pick-ups. Made up and ready to work is £12 10/- or 95/- deposit plus 10/- carriage and insurance.

MAINS-MINI

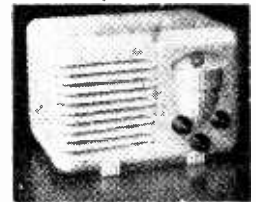

Uses high-efficiency coils, covers long and medium wavebands and fits into the neat white or brown bakelite cabinet—limited quantity only. All the parts, including cabinet, valves, in fact, everything, £4 10/- plus 3/6 post. Constructional data, free with the parts, or available separately 1/6.

RADIO SUPPLY CO. (LEEDS) LTD.

Post Terms C.W.O. or C.O.D. NO C.O.D. under £1. Postage 1/- extra under 10/-; 1/6 extra under £1.; 2/- under £3. Open to callers 9 a.m. to 5.30 p.m. Sats. until 1 p.m. S.A.E. with enquiries, please. Full list 6d.; Trade list 5d.

R.S.C. TRANSFORMERS

Fully Guaranteed. Interleaved and Impregnated.

Primaries 200-230-250 v 50 c/s screened

TOP SHROUDED DROP THROUGH

230-0-230 v 70 ma, 6.3 v 2 a, 5 v 2 a	16 9
350-0-350 v 80 ma, 6.3 v 2 a, 5 v 2 a	18 9
250-0-250 v 100 ma, 6.3 v 4 a, 5 v 3 a	23 9
350-0-350 v 100 ma, 6.3 v 4 a, 5 v 3 a	23 9
350-0-350 v 150 ma, 6.3 v 4 a, 5 v 3 a	28 9

FLY SHROUDED UPRIGHT

250-0-250 v 60 ma, 6.3 v 2 a, 5 v 2 a	
Midjet type, 2i-3-3in.	17 6
250-0-250 v 100 ma, 6.3 v 4 a, 5 v 3 a	26 9
250-0-250 v 100 ma, 6.3 v 6 a, 5 v 3 a	

For R1335 Conversion.

300-0-300 v 100 ma, 6.3 v 4 a, 5 v 3 a	26 9
350-0-350 v 100 ma, 6.3 v 4 a, 5 v 3 a	23 9
350-0-350 v 150 ma, 6.3 v 4 a, 0-4.5 v 2 a	31 6

125-0-125 v 200 ma, 6.3 v 4 a, C.T. 6.3 v 4 a, C.T., 5 v 3 a

FILAMENT TRANSFORMERS

All with 200-250 v 50 c/s Primaries:	6.3 v 1.5 a, 5 9; 6.3 v 2 a, 7 6; 0-4.6-3 v 2 a, 7 9; 12 v 1 a, 7 11; 6.3 v 3 a, 8 11; 6.3 v 6 a, 17 9.
--------------------------------------	---

CHARGER TRANSFORMERS

200-250 v 0-9-15 v 1 a, 11 9; 0-9-15 v 3 a, 16 9; 0-9-15 v 5 a, 19 9; 0-9-15 v 6 a, 22 9.

OUTPUT TRANSFORMERS

Standard Pentode 5,000 to 3 ohms	4 9
Small Pentode 5,000 to 3 ohms	3 9

E.H.T. TRANSFORMERS 200-230-250 v

2,500 v 5 ma, 2-0-2 v 1.1 a, 2-0-2 v 1.1 a	
For VCB57, VCB55	36 6

SMOOTHING CHOKES

250 ma 5 h 50 ohms	11 9
100 ma 10 h 250 ohms	8 9
80 ma 10 h 350 ohms	5 6
60 ma 10 h 400 ohms	4 11

SELENIUM METAL RECTIFIERS

G.E.C. 300 v 250 ma, 12 9; 130 v 40 ma, 12 9; 6.3 v 1 a F.W., 5 9; 240 v 50 ma, 5 9; 6.12 v 2 a F.W., 8 9; 6.12 v 4 a, 16 9; 250 v 80 ma, 7 9; 6.12 v 6 a F.W., 19 9; 6.12 v 10 a, 29 9.
--

BATTERY SET CONVERTER KIT

All parts for converting any normal type of Battery Receiver to A.C. mains 230-250 v 50 c/s. Supplies 120 v 90 v or 90 v at 40 ma. Fully smoothed and fully smoothed I.T. of 2 v at 0.4 a to 1 a. Price including circuit 49 9. Or ready for use, 9/9 extra.

ALL DRY RECEIVER BATTERY ELIMINATOR KIT.

All parts for the construction of a unit (metal-case 6i-4i-2in.) to supply Battery Portable receivers requiring 90 v and 15 v. Fully smoothed. From 200-250 v 50 c/s mains. Price, inc. point-to-point wiring diagrams, 39 9. Or assembled and tested at 46 9.

R.S.C. TAI HIGH QUALITY TAPE DECK AMPLIFIER.

For ALL Tape Decks with High Impedance. Playback and Erase Heads, such as Lane, Truvox. Adjustment to type of deck made by alteration of a resistor. For A.C. Mains 230-250 v 50 c/s. Positive compensated identification of recording level given by Magic Eye. Recording facilities for 15 7i or 3in. per sec. Automatic equalisation at the turn of a knob. Linear frequency response of .3db, 50-11,000 c.p.s. Negative feedback equalisation. Minimum microphons and hum. High output with completely effective erasure and distortion reproduction. Sensitivity is 15 millivolts so that any kind of crystal microphone is suitable. Provision is made for feeding a P.A. amplifier. Unit can also be used as a gram-amplifier requiring input of 0.75 v R.M.S. Carriazo 7.6. Illustrated leaflet 6d.

EX-GOVT. UNIT RDEL.

Brand new, cartoned. Complete with 14 valves, including 5Z4G. Also mains trans. L.F. choke, rectifier, etc., etc. Only 28 9. Carr. 7 9.

Dept. N, 32, THE CALLS, LEEDS 2.

SMALL POTTED MAINS TRANSF.

Removed from New Ex-Govt. units Primary 0-200-230-250 v Secs 250-0-250 v 60 ma, 6.3 v 2 a, 5 v 2 a. 11/9

CO-AXIAL CABLE 2in.

75 ohms 1436	8d.	3d.
Twin-screened Feeder	11d.	3d.
EX-GOVT. SMOOTHING CHOKES		
100 ma 10 h 250 ohms Tropicalised	3 11	
150 ma 6-10 h 150 ohms	6 9	
150 ma 10 h 150 ohms	11 9	
250 ma 5 h 50 ohms	11 9	

F.H.T. SMOOTHERS

5 mid 2,500 v Blocks (ex-Govt.), 2 11.

BATTERY CHARGER KITS.

Consisting of attractive Green Crackle Case. Transformer, F.W. Rectifier, Fuse, Fuseholder, Tag strip, Grommets and Circuits. For mains input 230-250 v 50 c/s, 6 v 2 a, 49 9. Or 6 v or 12 v, 2 a, 31 6 or 12 v, 4 a, 49 9. Any type assembled and tested for 6 9 extra.

R.S.C. 6 v or 12 v BATTERY CHARGER

For normal A.C. mains input 200-230-250 v 50 c/s. Selector panel for 6 v or 12 v charging. Variable charge rate of up to 4 AMPS. Fused, and with meter. Well ventilated case with attractive hammer finish. Guaranteed for 12 months. 69 6. Carr. 3 6.

T.V. CABINETS

Handsome well-constructed with walnut veneer finish. Size 18in. high, 20in. wide, 13in. deep. Size of aperture 17in. 13in. Pitted Doors. For 15in. or 17in. Tube. Limited number at only 79/6

BATTERY CHARGERS.

For mains 200-250 v 50 c/s. Output for charging 6 v or 12 v at 1 amp. In strong metal case. Only 25 9. Above can also be used for electric train power supply.



RADIO & RADIOGRAM CHASSIS

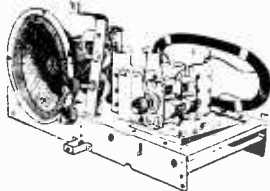

3 w band & gram. Extra speaker sockets, 5 valves international octal. Built-in portable aerial. 4 knob control. A.C. or universal optional. Less valves (see our cheap list). 8 P.M. speaker 7 9 with order. Set of knobs 2/- (when speaker is fitted). Carr. 4 6.

39/6

RADIOGRAM CHASSIS 29/9

Including 8" speaker, dial and knobs. 5-valve set 3 wave band, a.c. mains. Complete, tested, guaranteed. Less valves. P. & p. 4 6.

8" P.M. SPEAKERS. 8 9. Guaranteed std - 2-5 ohms, good makes. Post 1 9.

T.V. MASKS. 3 9. New rubber for 12in. tubes. Post 1 3.

T.V. MASKS. 1 8. Soiled, need washing. fit 12in. tube. Post 1 3.

T.V. CHASSIS UNITS.

TIME BASES. 10 d. Containing scanning coil, focus unit, line trans., etc. Drawing free with unit. Carr. 2 6.

SOUND & VISION STRIP. 27 6. S hot. Complete sound and vision strip. 10 valve holders (EF91, etc.), less valves. Drawing FREE with unit. Post 2 6.

POWER PACK. 29 9. 5 K.V. E.H.T. 325 v., 250 ma. Smoothed H.T. heaters. 6 v. 5 amp., 4 v. 5 amp., 4 v. 5 amp. Carr. 4 6.

POWER PACK & AMP. 22 6. Output stage 6V6 with O.P. Trans. 3 ohms matching Choke. Smoothed H.T. 350 v. 250 ma. 6.3 v. at 5 amp., 22 v. at 3 amp., 6.3 v. at 4 amp., and 4 v. centre tapped. Ins. & carr. 5/6.

POWER PACK & AMP. 22 6. Output stage. Pen 45. O.P. trans., Choke, Smoothed H.T. 325 v. at 250 ma. 4 v. at 5 amp., 6.3 v. at 5 amp., 4 v. at 5 amp. centre tapped. Less valves. Ins. & carr. 5 6.

at 5 amp., 4 v. at 5 amp. centre tapped. Less valves. Ins. & carr. 5 6.

Remember SATURDAY open all day.

Telephone: GRA 6677



VIEW MASTER CONVERTER

All items for the View Master Converter as described in "Practical Television" can be supplied from stock. Full details are given in our special list which is available free upon request.

COIL SET AND METAL PARTS. Denco. Includes a ready wound set of coils, switch screens and metal cover. 30/-.

SWITCH ASSEMBLY. Denco. Complete switch with fine tuner and coil platforms. 27/-.

CONDENSER AND PRINTED CIRCUIT KIT. TCC. Contains all the condensers, printed circuit and valve holders. 43/-.

RESISTOR KIT. We make up this kit with the specified LAB resistors. All labelled with value and position. 8/-.

GAIN CONTROLS. Colvern CLR901 5,000 ohms. Three required. 3/3 each. Panel for mounting three controls, 1/-.

VALVE SCREENS. Carr Fastner. Skirt and screen. Two required. 1/3 each.

CO-AXIAL PLUG AND SOCKET. Belling Lee. L604S Socket. 1/3. L734P Plug. 1/3.

SOLDER. Ersin Multicore. Special for printed circuits. 2/6.

VALVES. Mullard PCC84 24/4. Surplus 13/6.

Mullard PCF80 25/9. Surplus 13/6.

Knob. Pointed knob for switch. 1/-.

SUNDRIES KIT. Contains all nuts and bolts, flex, wire co-axial cable, copper foil and spring wire. 8/-.

COMPLETE KITS. All above items supplied at one time.

KIT A. With new Mullard valves. £9.40. Credit Terms: Deposit £1.6 9 and seven monthly payments of £1.6 9.

KIT B. With surplus valves. £8.20. Credit Terms: Deposit £1.40 and seven monthly payments of £1.40.

PLEASE NOTE. These kits do not include the items needed for conversion of the View Master Sound/Vision Chassis. We can supply the chassis conversion kit for £2.00. Full details in our list.

SET OF TWIST DRILLS. Complete set of the correct size twist drill for drilling the Printed Circuit Panel. 10/-.

WATTS RADIO

8 Apple Market, Kingston-on-Thames, Surrey.

Telephone: KINGSTON 4099.

A Band I/Band III Switch

DETAILS OF A HOME-MADE COMPONENT AS USED IN THE EF50 CONVERTER

By R. Shatwell

ON the opening of the Winter Hill transmissions the writer hurriedly assembled a simple converter and the need for a station switch soon evidenced itself. Changing the set aerial lead, although simple, was considered rather crude and amateurish.

Very little information on commercially made switches for this purpose could be found, but the essentials are obviously low capacity, self-cleaning contacts, with facilities for earthing the unwanted signal. A search of the spares box brought to light a 10 pF variable condenser, and this produced a switch providing all these essentials and also screens between each section. Any similar type condenser can, with the use of gummed paper strip, some phosphor bronze for contacts, and a piece of thin paxolin, be similarly converted.

This switch, incidentally is the one depicted in the diagram (Fig. 2) of the EF50 Converter which was described in last month's issue.

The Essentials

The diagrams show the essentials. Fig. 1 is the condenser used, Fig. 2 the converted switch. Fig. 3 is simply to show the fitting together of the various parts. Obviously, only one contact strip is actually visible at each plate, but two are shown as this shows the earthing action more clearly. Fig. 2 omits parts 5 and 6 for clarity.

The sequence of operations in conversion is as follows: Dimensions will be to suit the condenser being used. The numbers quoted are to assist identification in the various drawings.

Construction

First remove the shaft with the moving plates attached, and remove all the moving plates from the shaft 1. With gummed paper strip build up this shaft to approx. $\frac{1}{16}$ in. diameter. Next remove alternate fixed plates. Four fixed plates are needed with about $\frac{1}{16}$ in. space between each. Build up the spaces on the rods 2 to $\frac{3}{16}$ in. diameter, with the paper strip cut to the correct width. Three spaces each side should be so treated. Now cut the T-piece 3 from thin tin plate, length to suit shaft and width of $\frac{3}{16}$ in. cross-piece sufficient to encircle the built-up shaft. Bend about the shaft with the $\frac{1}{16}$ in. tongue lying along the shaft. The circling of the shaft should be such that a butt joint is made. This is soldered and cleaned smooth with a fine file.

At points on the shaft coinciding with the position of the fixed plates build up with $\frac{1}{16}$ in. gummed paper strip to $\frac{1}{16}$ in. diameter. Before this make certain that the fitted piece 3 is completely isolated from the shaft. When the four points have been built up the shaft is completed and contains the circular ring as the output and the other two sections for Band I and Band III contact points. At a position 180 deg. from the tongue in these two sections file the build-up away to expose the shaft as an earth contact. From $\frac{1}{16}$ in. wide strips of thin phosphor bronze or springy

brass cut three of the clips 4 and fit to the rods, one per section, between the fixed plates on alternate sides.

The two pieces 5 are then cut from $\frac{1}{16}$ in. paxolin. The sawcuts are $\frac{1}{16}$ in. deep and to slide tightly on to the fixed plates. The slots are $\frac{1}{16}$ in. wide and deep to hold the clip contacts firmly in place. Two 18 s.w.g. wire clips 6 hold the assembly securely, one at each end of the paxolin strips. The switch is now ready for use. No locators have been fitted, and

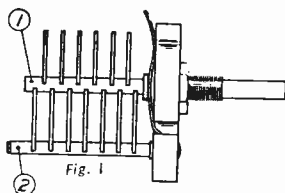

Fig. 1

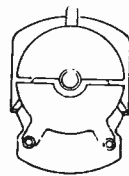

Fig. 3

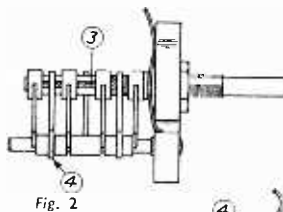

Fig. 2



Details of the various parts of the switch

in use it can be rotated in either direction. The earthing of the unwanted signal is the deciding factor on correct setting and is evidenced by the disappearance of the patterning caused by the unwanted signal.

Connecting up

Wiring should be by coaxial, the outer sheaths being divided and taken to the fixed plates at each side of the contact used, thus shielding each contact strip from the remainder.

Tests in use have been unable to trace any breakthrough due to the switch, but obviously it will do nothing to mitigate breakthrough prior to the switch, which is a matter for rejectors and screening.

"PRACTICAL TELEVISION CIRCUITS"

288 pages, 156 illustrations

15/- net or 15/6 by post from :

GEO. NEWNES LTD.

Tower House, Southampton Street, Strand, W.C.2

CORRESPONDENCE

The Editor does not necessarily agree with the opinions expressed by his correspondents. All letters must be accompanied by the name and address of the sender (not necessarily for publication).

I.T.A. SOUND QUALITY

SIR.—My attention has been drawn to a letter in your July issue under the above reference. Whilst I am in entire agreement with Mr. Dowling regarding the shouting and fair-ground announcements of some of the advertisers, I also feel that something should be done about the bad quality when films are transmitted. This trouble occurs also on the BBC channel, and in many cases there is a constant hum and noise in the background, and that it is the film or projector is obvious because when the picture stops for the commercial, so does the noise, only to return when the picture is resumed. Could it be due to the fact that they are old American films which have been badly worn or defaced, or is it just bad technique? Incidentally, to return to the main criticism of Mr. Dowling, I have fitted a remote volume control only to my set (which is home-made) and for the majority of the advertisements I turn the volume off. Some of these adverts. are clever and very musical, catching the eye as well as the ear, but others are simply ridiculous and bring the makers of the product into ridicule.—G. J. STEBBING (Barnet).

AERIAL DESIGN

SIR.—I wonder if any of your experts could supply actual constructional data for combined aerials of *unorthodox* type. I remember some years ago the chicken-wire netting aerial of the slot type, which did not follow any known principles, but worked. Then before that we had the "X" aerial which was found highly efficient, and then rules and formulae governing its function were produced. Surely, the experts have not packed up at this? What about Band III novelities? I have seen in some American magazines the "bow tie" and wire netting reflector types on these very high frequencies, and being *really* an experimenter I would very much like to try out any new ideas such as these. I still use the netting slot aerial for Band I with a home-made Band III aerial, and it would be nice to dispense with both and put in something small but just as efficient.—H. G. BURTON (N.W.5).

A READER'S SUGGESTION

SIR.—In your July issue a reader suggests a twin filament tube to avoid costly repayment. I wonder this idea has not been adopted. Years before the war I designed a similar idea, in which a filament shaped like a letter M was used, the lower part of the central "V" section being anchored and made one connection, whilst the other connection was taken from the bottom of either of the uprights. Coupled with this suggestion was one that the anode should be formed as a succession of tapers—with a tapped filament, thereby providing a variable- μ valve. The suggestion was put up to one of the large companies, but was turned down, and shortly afterwards a valve did appear on the market with the switched filament idea to replace a burnt-out section.—L. WEALD (N.W.)

COLOUR AND DEFINITION

SIR.—There is a most interesting argument laid on in Mr. Presslow's letter in the September issue. Surely there is a very sound argument for both sides of this question. Colour, in my opinion, will provide what is missing in the way of definition with the present line structure, and I feel that a coloured picture will give much more satisfaction, even if the bandwidth as well as the "lineage" is less than at present. Of course, after some months of such a picture one would become critical as now with the present system and want improvements, but, so far as I see it, colour is much more important than bringing up the lines. After all, our engineers knew about the higher definition when they started and there must be a good reason why they stuck to 405 lines and not anything higher.—R. EDWARDS (N.9).

TV RECORDING

SIR.—Thinking recently about the recording of radio programmes directly on to tape without the use of a microphone, I was wondering if the same system could be used to record television picture signals (including sync. pulses, etc.). The programmes would be transmitted on closed circuit to a tape recorder which would record the signals and could later replay them when required. This would provide a simpler method of recording programme material as well as improving on the quality of present film repeats.

I should be glad to know if the method is in use.—G. SMITH (Thornton Heath).

STRANGE SIGNAL PICK-UP

SIR.—Perhaps you could hazard a guess as to the reason of the following phenomenon.

A friend of mine who built himself a Band III television converter was trimming same when, for some reason, he says he received quite plainly the "speaking clock." At first I did not believe him but eventually I was convinced he was speaking the truth and not "pulling my leg." He says it was quite distinct but superimposed on the sound.

I asked him had he a telephone and the answer was no. The nearest telephone was some distance away on the other side of the street.—ANTHONY MAGUIRE (Birkenhead).

RECEPTION ON WOBBULATOR

SIR.—I thought perhaps you would be interested in the following strange behaviour of the wobulator which was described in your September issue. We had already made up the scope recently described and decided that the wobulator would be a worthwhile addition. It was finished, checked over, and then connected to the scope. We switched on, and as soon as it had warmed up adjusted the calibrator and were surprised to see on the scope tube the Band III pictures. In fact it makes a splendid Band III converter.—G. BURNS (Surbiton).

BAND 3 T/V CONVERTER—185 Mc/s - 199 Mc/s

Suitable for London, Birmingham and Northern Transmissions

£2-5-0 post free.

A highly successful unit (W/World circuit), incorporating variable oscillator tuning, Midget BVA valves, etc. Chassis size 7 x 4 x 2 1/2 in. Thousands already in use. Suitable for most types of T V sets. TRF or Superhet. Kit of parts 45/- . Blueprint 1/6, Power pack kit 30/- . Switch kit (Band 1—Band 3 Ae switching).

6-6 All Post Free. Wiring and aligning of above 20 - extra. Full range of Band 3 aerials in stock. Adaptors from 7.6 per set. Indoor dipoles, 6/6. Outdoor with cable 13/9. Band 1—Band 3 crossover filter unit, 7/6. Variable attenuators 6 db—36 db, 7/6. BBC Break-through Filter, suitable for BBC pattern rejection, 8/6.

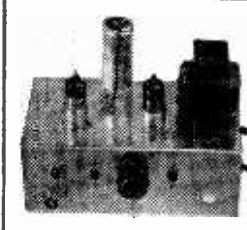

Volume Controls

Log. ratios, 10,000 ohms - 2 Megohms. Long spindle etc. 1 year guarantee. Midget Elliott type. No. S.A.S.P. Sw. D.P.S.W. 3/- 4/- 4/0 Linear Ratio, 10,000 ohms - 2 Meg ohms. Less switch, 4/- each. Coax plugs, 12. Coax sockets 1/- . Couplers 1/3. Outlet boxes, 4/6.

80 ohm COAX CABLE

STANDARD 1/4 in. diam. Polythene insulated. GRADE "A" ONLY. 8d. yd. SPECIAL - Semi-air spaced polythene. 80 ohm. Coax 1/4 in. diam. Stranded core. Losses cut 50%. 9d. yd.

TWIN FEEDER, 80 ohms. 6d. yd. 300 ohms. 8d. yd. TWIN SCREEN FEEDER, 80 ohms. 1/3 yd. 50 OHM COAX CABLE 8d. per yd. 1/4 in. dia. TRIMMERS, Ceramic, 4 pf. - 70 pf. 8d. 100 pf. 150 pf. 1/3; 250 pf. 1/6; 400 pf. 1/9. PHILIPS Beelieve Type - 2 to 8 pf. or 3 to 30 pf., 1/3 each. RESISTORS - Pref. values 10 ohms in megohms. CARBON WIRE WOUND 20% Type. 1 w. 3d. 1 w. 5d. 1 w. 6d. 2 w. 9d. 10% Type. 1 w. 9d. 5% Type. 1 w. 1/- 1% Hi-Stab. 1 w. 2/- WIRE-WOUND POTS. Pre-set Min. T.V. Type. Knurled Slotted Knob. All values 25 ohms to 50 K., 3/- ea. 50 K., 4/- . Ditto Carbon Track 50 K. to 2 Meg., 3/- . CONDENSERS. - mica or S. mica. All pref. values. 3 pf. to 600 pf., 6d. ea. Ceramic types, 2.2 pf. - 5,000 pf. as available, 8d. each. Tubulars, 450 v., Hums and T.C.C., 0.005, .001, .005, .01 and 1.50 v., 9d., .02, .05, 1.500 v. Hums, T.C.C., 2/- . 25 Hums, 1/6. 5 Hums, 1/9. 1.500 v. T.C.C. (insulex), 3/6. .001 6 kv. T.C.C., 5/6. .001 20 kv. T.C.C., 9/6.

SILVER MICA CONDENSERS - 10% 5 pf. to 500 pf., 1/- . 600 pf. to 3,000 pf., 1/3. 1% 1.5 pf. to 500 pf., 1/9. 515 pf. to 5,000 pf., 2/- . STANDARD 3 WAVEBAND COIL PACK. Size 2 1/2 x 2 1/2 x 1 1/2 in. depth, 4 pos. Switching. Long. Mel. Short. Grain. Dust-core coils prealigned for 415 kc/s I.F. Complete with trimmer, ready to use. A very sensitive and efficient Coil Pack. Manufacturer's Surplus. Bargain Offer, 27/6. ALUMINIUM CHASSIS - 18 s.w.g. Plain, undrilled. Iridged 4 sides and riveted corners lattice finish holes. Strong and soundly constructed with 2 1/2 in. sides. 7 in. x 6 in., 4/8; 9 in. x 6 in., 5/9; 11 in. x 7 in., 6/9; 13 in. x 8 in., 8/6; 14 in. x 8 in., 10/6; and 18 in. x 16 in., 3/0. SPECIAL OFFER. - Goodmans 12 in. P.M. Speaker Audiom 60. Brand new, boxed and gar. FEW ONLY. 54/10/-. Carr. 3/6. BRIMSTONS. - CZ1 for 3A heater chains, 3/6. CZ2 for 15 A., or 2A. 2/6. CZ3 (Pilot Lamp), 1/6. COPPER ENAMEL WIRE. - 1 lb. 14 to 26 s.w.g., 2/- . 22 to 28 s.w.g., 2/8; 30 to 40 s.w.g., 3/6. SWITCH CLEANER Fluid. - 10 oz. tin 8/9.

3 TONE AMPLIFIER
With variable Tone and Volume controls. 3 Midget BVA valves. 4 watts output. Neg. feedback. Chassis isolated from Mains. A.C. 200, 250 v. A quality amplifier at an economical price. PRICE £3.19.6. Carr. 2/6. Wired and tested, 15/- extra. Circuit and instr., 1/6. free with kit.

ALL WAVE RADIOGRAM CHASSIS 3 WAVEBANDS, 5 VALVES LATEST MIDGET M.W. 200 m. - 550 m. BVA
L.W. 800 m. - 2,000 m. SERIES Brand new and gar. A.C. 200 250 v. 4 pos. A.C. sw. short-medium-long-grain. P.I. socket. High Q dist core coils. Latest circuit technique, delayed AVC and neg. feedback. O.P. 4 watts. Chassis size 13 1/2 x 5 1/2 x 2 1/2 in. Dial 100 x 4 1/2 in. Hor. or vert. station names. Walnut or ivory knobs to choice. Aligned and calibrated ready for use. Sensitivity and Quality at Low Cost. Double wound mains trans. BARGAIN £9.15.0 Carr. and ins., 4/6. PRICE £9.15.0 or 10 in. speakers to match, from 21/6.

7 Valve De Luxe, push-pull version 7 watts output, £12.10.0. Carr. & ins., 5/-
BARGAIN VALUE IN AUTO CHANGERS
3 speed auto change mixers for 7 in., 10 in., & 12 in. records. Lightweight Mat. Pl. with turnover. Duo-point sapphire stylus for Hi-Fi reproduction. Latest models - Modern styling. All brand new, boxed and gar. A.C. 200/250 v. only. PLEASER, £8 10 0. B&H 40NARH1, 81 c/s. GARRARD R010, £8 19 6. COLLARO R034, £10/10/-. All suitable for above Radiogram chassis.

QUALITY FLUORESCENT FITTINGS
Ideal for home or workshop. 4ft., 220-250 v., complete with tube, ballast unit, etc., ready for use. Famous manufacturer's surplus offered at approx. half price. Starter switch type, 42/-. Quick start type, 47/6. Carr. and ins., 7/6 ea. FEW ONLY NOW LEFT.

NEW VALVES GUARANTEED ALL BOXED
1R3, 1Y47/6/D1AF90 8/- EC181 12/6/EZ20 10/- 1R5, 1R4 7/6/D1R96 9/- EC180 12/6/EZ20 11/- 2R4, 3V4 8/4/DK96 9/- EF41 10/6/MC14 9/6 6A4 8/6/DL96 9/- EF50 10/- PCU84 12/6 6AT6 8/6/EA50 2/- EF50 PCP80 12/6 6CH6 10/6/EB94 7/6 Equip. 5/6 PCP82 12/6 6HM8 8/6/EB41 10/6 EP80 10/6 PC183 12/6 6K7 6/6/EB33 8/6/EP85 10/6 PL1 12/6 6K8 8/6/EB33 8/6/EP86 13/6 PL2 10/6 6Q7 8/6/EB34 13/6/EP89 10/6 PLS3 12/6 6N87 8/6/EB35 13/6/EP91 8/6 PY80 11/6 6V6 7/6/EP89 12/6 PL41 11/6 PY81 12/6 6X4 8/6/EB32 13/6/EL84 12/6 PY82 10/- 6X5 8/6/EB42 10/6 EY31 12/6 PY25 12/6 and hundreds of others at Bargain Prices. SPECIAL PRICE PER SET 1R3, 1Y4, 1R5 and 3R4 or 3V4 ... 27/6 6K8, 6K7, 6Q7, 6V6, 3Z4 or 6X5 ... 35/- SPEAKER FRET - Expanded Bronze, anodised metal 8 in. x 8 in., 2/3; 12 in. x 8 in., 3/-; 12 in. x 12 in., 4/3; 12 in. x 16 in., 6/-; 24 in. x 12 in., 8/6 etc.

ELECTROLYTICS ALL TYPES NEW STOCK
25, 25 v. 50 12 v. 1/9 50, 50 v. 4 500 v. 2/- 8 + 8 450 v. T.C.C., 4/6 100 25 v. 2 450 v. 2/- 8 + 16 450 v. Hums 5/6 4 450 v. B.E.C., 2/3 16 + 16 8750 v. 5/6 8 500 v. Dnb., 2/6 16 + 16 450 v. T.C.C., 5/6 8 8 500 v. Dnb., 4/6 16 + 25 500 v. B.E.C., 5/6 8 16 450 v. T.C.C., 5/- 22 450 v. Dnb., 4 10 150 v. B.E.C., 3/6 32 22 450 v. T.C.C., 6/6 16 500 v. Dnb. 4 - 60 350 v. T.C.C., 6/6 16 16 450 v. T.C.C., 5/6 60 100 375 v. 12/6 32 500 v. Dnb. 4 - 100 200 275 v. 12/6 50 150 350 v. B.E.C., 6/6 6,000 mfd. 6 v. 3/9

SENTERLOCK RECTIFIERS. E.H.T. TYPE FLY-BACK VOLTAGES - K2525 2 kv. 4/2; K3, 3 kv. 6/-; K3-6 +, 3 kv. 6/6; K3-50, 4 kv. 7/3; K3/100 8 kv., 12/6; MAINS TYPE. RM1, 125 v., 60 ma., 4/-; RM2, 100 ma., 4/9; RM3, 120 ma., 6/9; RM4 type, 250 v., 275 ma., 16/-.

ENGRAVED CONTROL KNOBS for 7 in. Spindle. 1 1/2 in. diam. Walnut or Ivory. Gold filled. 16 Standard engravings, 1/6 ea. Plain knobs to match above, 1/11. 16d. ea. 1 1/2 in. dia., 8d. ea. Walnut or Ivory, 12 in. 1+ ea. 1 in. 9d. ea. Pointer Knobs. Black with White Line, 9d.

WEARITE "P" TYPE COILS. All ranges, 1 to 7, 2.6 ea. Osamor Q Series Coils. Slug tuned. All ranges from 3/8. Full range popular Coil Packs.

I.F. TRANSFORMERS - 465 kc/s
Brand new ex-manufacturer's midgeet I.F.T. size 2 1/2 x 1 in. x 2 in. dust core tuning. Lotz wound coils. High Q. Bargain offer, 7/6 pair.

MAINS TRANSFORMERS - Made in our own Workshops to Top Grade spec. Fully interlocked and impregnated. RADIO AND AMPLIFIER TYPE. - 250 v., 60 ma. F.W. sec. 5 v. or 6.2 v. 1/4 rect. 6.3 v. 2.5 A. set Htrs. 21 v. etc. C.R.T. HTR. ISOLATION TYPE. - low leakage with or without 25% sec. boost voltage. Ratio 1 : 1 or 1.25 : 2, 10/6; 4 v., 10/6; 6.3 v., 12/3; 12.5 v., 10/6. Ditto with mains primaries 200/250 v., 12/6. Specials to order.

L.F. CHOKES. - 10 H. 65 ma., 5/-; 15 H. 100 ma., 10/6; 30 H. 120 ma., 10/6; 20 H. 150 ma., 16/6; 250 ohm, 10/6; 500 ohm, 10/6. Paper type, good quality, 1.2000, 12/6. Reels only, 3/8, 3 in. 4 3 TWIN GANG TUNING CONDENSERS. - 375 pf. Midget, 6/6; 400 pf. ditto, with dust cover and trimmers, 8/6. .0005 mfd. Standard size with feet, 8/6.

TYGON FRET (Murry's pattern). - 12 in. x 12 in., 2/-; 12 in. x 18 in., 3/-; 12 in. x 24 in., 3/4/- etc., etc.

F.M. TUNER-UNIT (87 mc/s - 105 mc/s by Jason.) - As tested and approved by Radio Constructor. Complete Kit of parts to build this modern highly successful unit, drilled chassis and C. R. dial, coils and cans. 4 BVA miniature valves and all components, etc., for only £6.10.0 post free. SUPERIOR TV PLUG GLASS DIAL. - Calibrated in Mc/s and edge lit by 2 pilot lamps, 12/6 extra. Illustrated handbook with full details, 2/- post free.

TRS RADIO COMPONENT SPECIALISTS (Est. 1946)

70 BRIGSTOCK ROAD, THORNTON HEATH, SURREY (THO 2188)

50 yards Thornton Heath Station.

Listed above are only a few items from our very large stock.

HOURS: 9 a.m. - 6 p.m., 1 p.m. Wed.

Terms: C.W.O. or C.O.D. Kindly make cheques, P.O.s, etc., payable to T.R.S. Post Packing up to 3/6. 7/3, 11b, 11j, 31b, 1/6, 51b, 2/-, 151b, 3/6.



Unfailingly fresh

Tobacco at its best. Player's Medium Navy Cut is once again supplied in the familiar pocket tin, vacuum sealed, which means that absolute freshness is retained and enjoyment assured whenever you buy it.

2 oz. tin 9/7d.

PLAYER'S MEDIUM NAVY CUT TOBACCO



To open, simply
remove small
rubber seal.

'The choice for a lifetime'

[NCT 94M]

HANNEY of BATH offers:—

ERIE RESISTORS, all values from 10Ω to 10MΩ. Type 9 (4 watt) 6d. ; Type 8 (1 watt), 8d. 10 watt Silertex wire-wound resistors, all values 10Ω to 10 KΩ, 2/- each.

SILVER MICA CONDENSERS, top quality, close tolerance (up to 33 pF ± 1 pF, from 33 pF up - 1%), 1.5 pF to 300 pF, 1/- each ; 316 pF to 815 pF, 1/3 each ; 1,000, 1,500, 1,800 and 5,000 pF, 2/- each.

SILVER CERAMIC CONDENSERS, 3 pF to 500 pF, 1/- each. Hi-K Midret ceramicons, 500, 620, 1,000, 1,500, 2,200, 3,000, 5,000 and 10,000 pF., 1/- each.

COILS, Osmor "Q." full range, 4/- each ; Weymouth "H" type, full range, 3/9 each ; Weymouth CT2W2 coils, TRF, 10/3 pr. ; Denco Type "C" TRF, 9/- pr. ; REP Crystal set coils, 2/6 ; Single TRF, 4/- ; Matched pr. TRF, 8/- ; Denco 465 Kcs. midret I.F.s, 12/- pr. ; Weymouth, ditto, 15/- pr.

COILPACKS, Osmor Type HO, 50 5 ; H.F. stage for HO, 31/- ; Osmor TRF (L. and M.W. only), 42/- ; Denco CP.3 370 and CP.3500, 44 9 each ; CP.4L and CP.4M, 35/- each ; CP.4L, G and CP.4M G, 43 5 each.

FERRITE ROD AERIALS, M. and L.W., 12 6 each by Denco, REP and Teletron.

TRANSISTORS, MULLARD OC.50, OC.51, OC.72, 30/- each ; OC.70, 21/- ; OC.71, 24/- ; BRIFARE, 3X100N, 3X101N and 3X300N, 40/- each ; 3X301N, 45/- ; 3X302N, 50/-.

GERMANIUM DIODES, BRIMAR GD3, GD4 and GD5, 7 6 each. MULLARD OA70, 5/-, OA71, 6/- ; G.E.C. GEX34 and GEX35, 4/- each.

METAL RECTIFIERS, Full range of the popular types of Westinghouse and Brimar available.

ALL COMPONENTS AND PRICED PARTS LIST ARE AVAILABLE for :

Osmar 912 AMPLIFIER, Passive Unit and Pre-Amplifier, MULLARD 510, 20 watt, 3 watt Amplifiers and Pre-Amplifiers, MULLARD, OSRAM, WIRELESS WORLD, DENCO and TSL, F.M. UNITS, HIWAYMAN, VIEWMASTER, V-MASTER 3 STATION TUNER CONVERTER, TELEKING, MAGNAVIEW, etc., etc. Send 2/d. stamp for lists required. Please add sufficient postage to orders under £3.

L. F. HANNEY

77, LOWER BRISTOL ROAD, BATH

Tel. : 3811



QUALITY TELEVISION COMPONENTS

SCANNING COILS, 6/10 kv. R.F., E.H.T. UNITS, E.H.T. and OUTPUT TRANSFORMERS, LINE FLY-BACK E.H.T. UNITS.

COIL KITS FOR "P.T." BAND III CONVERTERS

Write for illustrated list (Publication 75)

HAYNES Radio Ltd., Queensway, Enfield, Middlesex.

NEW-MAX ELECTRONICS LTD.

220, Edgware Rd., London, W.2 Tel. PAD. 5607

Come and visit us. The largest Electronic Bargains Store in London. We have 500 Reprocessed T.V.s, all sizes always in stock, also Radio Sets, Radiograms. Reclaimed and guaranteed C.R. Tubes, 12in. £5, 14in. £6 10/-, 15in. £7 10/-, 17in. £8 - -, p. and p. 10/- ; Tubes with Heater Cathode Short, 14in. £3 10/-, 15in. £4 10/-, 17in. £5 - -, p. and p. 10/- . Surplus Valves, Components and Test Equipment, etc., etc. Also available all types and makes of new C.R. Tubes at list prices. Part exchanges welcomed!

SPECIAL OFFER

Projection T.V. Unit. Complete optical projection box with focus and frame coil, usual cost £30 our price £6 - - incl. p. and p. Any set can be converted to large screen T.V. with this unit by increasing E.H.T. (to approx. 15-20 kv).

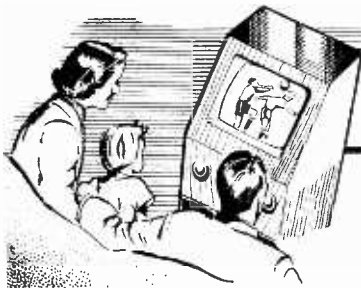

UNDERNEATH THE DIPOLE

TELEVISION PICK-UPS AND REFLECTIONS

By Icons

A PEER SPEAKS

LORD LUCAS of Chilworth, champion of the authors' and composers' rights in the House of Lords debate on the Copyright Bill, attacked the I.T.A. in a speech at a luncheon of the Performing Right Society recently. "Good music is going off the commercial TV screen," he said, "and what have we in its place? Alleged humour which starts as mediocrity, gets to vulgarity and on all too many occasions has already reached obscenity." Strong words, these, but there's some truth in them. Commenting upon the popular methods used to put classical music over on television, he said: "Their ideas of production generally result in showing artists performing in every posture except standing on their heads." Truth in that, too, but how dull it would be to listen to a TV orchestral concert with a static long-shot of the orchestra on the screen. Finally, the angry peer attacked television itself: "Television is turning the nation into a glassy-eyed community of crystal gazers." His startled audience of members of the Performing Right Society were able to console themselves that the popularity of this particular kind of crystal gazing has yielded them a rich harvest of performing right royalties.

THE MUSICAL HORIZON

THE noble lord is entitled to his opinions, but I am of the opinion that popular taste for music on TV will steadily improve. At the moment, it is only natural that the best known classics and works which might be termed hackneyed occupy a large part of screen-time devoted to music. Musical orchestrations of a very high standard are often heard in the lighter programmes, particularly in those shows which feature ballet items. I would even suggest that many contemporary

high-brow musical works, indigestible in themselves, prove acceptable when accompanied by an interesting visual image on the screen. Perhaps the musical horizon isn't quite so black as Lord Lucas painted it.

PICTURES ON TAPE

A STARTLING development has occurred in the technique of recording television pictures on magnetic tape. The Ampex Corporation of America have demonstrated their Videotape recorder, a machine in which good picture recordings have been achieved at the remarkably low tape speed of only 15in. per second. Hitherto, in order to obtain a 4 megacycle response needed for good quality tape recording of a picture, a speed of about 2,000in. a second has been required. This would mean that a 14in. diameter reel of magnetic tape would only record about half a minute of picture—which is hardly a practical proposition. With the new Ampex machine, a

tape 2in. wide is used and the magnetic pattern is recorded transversely across the tape instead of longitudinally, as with conventional tape recordings. Four magnetic heads on a rotating drum scan the tape transversely at high speed in such a way that one head is always in contact with the tape. The sound accompanying the picture is recorded in the normal way, longitudinally, on one edge of the same magnetic tape. The machine was designed especially for television programme relay, so that New York live TV programmes could be sent by coaxial cable, recorded and stored, to be transmitted from Los Angeles and West Coast stations two or three hours later. It is said that both NBC and CBS networks have ordered a number of these new Ampex picture recorders, which, it is claimed, give much better quality pictures than the usual photographic tele-recorder or "Kinescope," as they call it in America. I haven't yet heard of any similar type of picture

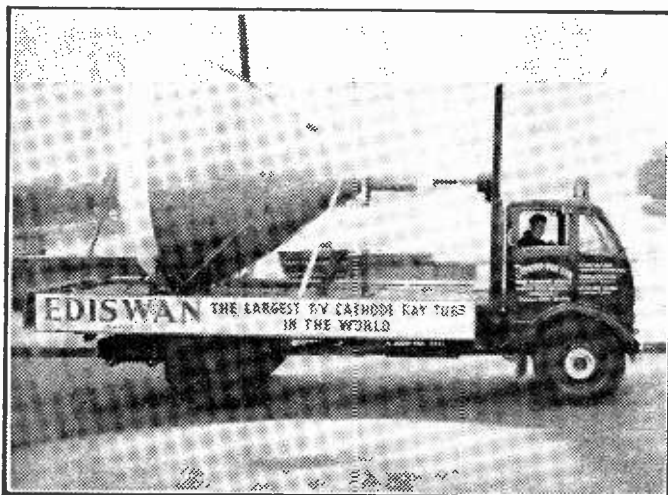

The "Largest Tube in the World" on its way to the Radio Show. It was, of course, a dummy, made from Flexiglass.

magnetic tape recorder being developed in England. The manufacturers seem to have concentrated on photographic recorders and reproducers, which, when correctly operated, have achieved a very high standard indeed.

GOOD MUSIC

Is good music a failure on TV? The public polls and private TV audience research organisations say it is. Hence, the steady reduction of programme time on I.T.A. transmissions devoted to music. Obviously, advertisers do not want to buy time for their commercials during periods when a large proportion of viewers has turned over to the BBC or gone out to the cinema. It is a great pity that this tendency is accepted by both commercial and BBC programme planners, though the

Maurice Elvey comment on pictures and picture personalities, past and present. I find Maurice Elvey's dips into the past quite fascinating and it is interesting to see how well some of the very old pictures stand up to the test of time, technically and otherwise. A good example recently transmitted was the excerpt from *Soldiers of the King* with Cicely Courtneidge playing mother and daughter in a theatrical scene. As regards the presentation of selections from modern films, I feel that it is a mistake to cut both sides of CinemaScope aspect ratio pictures in order to make the image fill the television screen. This sometimes results in principal characters near the sides of the picture being partially cut out. Much better to cut top and bottom of the picture

Theatre, Walham Green; and the Viking Studios, Kensington. The other extensions are on the way. The Viking Studios, formerly used as a film studios for second feature and documentary films, has been in use for over a year as a training school for television technicians by Marconi's Wireless Telegraph Company. Fully fitted with TV cameras and telecording equipment, it is admirably arranged for this purpose, having a stage space of about 2,000 sq. ft. and excellent lighting equipment. Recently it has been used for a number of live transmissions by AR-TV during weekdays and at the week-ends by A-TV, and also, for specially filmed TV material for the Jack Hylton Organisation. I think we shall hear a lot more about this beautifully fitted up little television centre in the near future, when the training school is able to give more time over to the actual programmes. It seems a tiny little place compared with Lime Grove Studios, but the results obtained are first class.

WEMBLEY—THE H.Q.

THE announcement of the centralisation of facilities by AR-TV at Wembley and the consequent discontinuance of operations at their studios at Television House, Kingsway, and at the Granville Theatre, was not unexpected. This will mean that a large number of staff and quite a lot of equipment will become redundant. The concentration of activities at Wembley will result in great economies and reduce the enormous weekly loss that has been increased during the last few months. Losses were expected, of course, until commercial television was fully established. But what had not been realised was the amount of live TV it was possible to put through a comparatively small plant. Ideas and planning had been based upon experience of the vast resources of the BBC and of the huge American networks. A-TV, ABC-TV and Granada have demonstrated that it is possible to get by with a much more concentrated organisation and facilities. Nevertheless, it is unlikely the equipment and studio space will be scrapped. It will go into mothball treatment, ready for use at reasonably short notice.



An O.B. camera with zoom lens in action during a recent relay of the British Oxygen Plant.

BBC does occasionally produce some excellent musical programmes of a more serious type. After all, television is a composite of visual images allied to speech, sound effects and music, in varying proportions, and it would seem right that the high quality of sound reproduction on the TV channels should be used more for what is termed "good music."

PICTURE PARADE

ONE of the smoothest presentations of any of the current series put out by the BBC is Alan Sleath's *Picture Parade* in which Peter Haigh, Derek Bond and

and reproduce the elongated CinemaScope shape.

CO-AXIAL FEEDERS

THE web of co-axial cables laid by the Post Office for commercial television contractors increases almost week by week. There is hardly a part of London which is not fairly close to a terminal point. In the north-east, Highbury and Wood Green Empire are hooked up to A-TV headquarters, and I understand that a further extension is being made to the Hackney Empire. Television House is connected to Wembley Studios; Granville

Index for Vol. 6—Now Ready
PRICE 1/3 by post

NEW!

EXPERIMENTAL KITS
in Radio, T.V. etc.

LEARN THE PRACTICAL WAY

Specially prepared sets of radio parts from which we teach you, in your own home, the working of fundamental electronic circuits and bring you easily to the point when you can construct and service radio sets. Whether you are a student for an examination; starting a new hobby; intent upon a career in industry; or running your own business — these Practical Courses are intended for YOU — and may be yours at a Very Moderate Cost.

EASY TERMS FROM 15/- A MONTH
With these outfits, which you receive upon enrolment, you are instructed how to build basic Electronic Circuits (Amplifiers, Oscillators, Power Units, etc.) leading to complete Radio and Television Receiver Testing and Servicing.

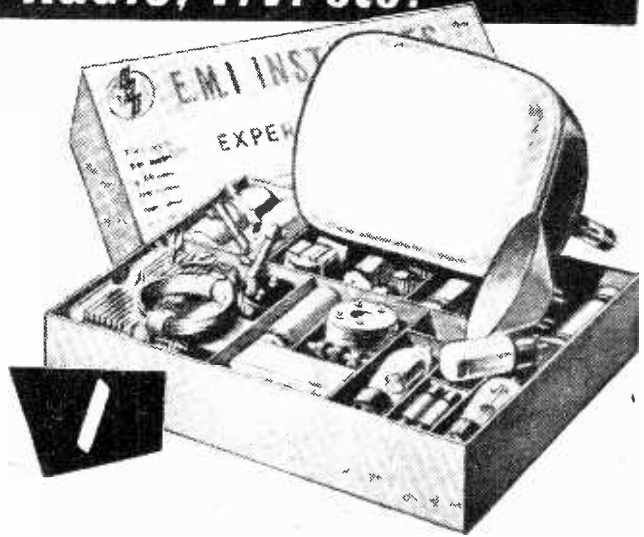

TELEVISION — With this equipment you are instructed in the design, construction, servicing and testing of a modern high quality Television Receiver.

ALL EQUIPMENT SUPPLIED IMMEDIATELY AND REMAINS YOUR PROPERTY

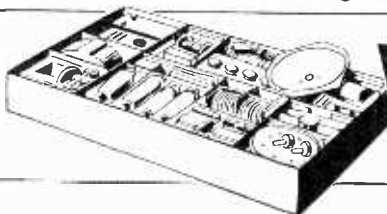

BEGINNER'S RADIO OUTFITS

— For carrying out basic practical work in Radio and Electronics, from first principles and leading to the design and building of simple Receivers.

ADVANCED RADIO OUTFITS

— With this equipment, you are instructed in the design, construction, testing and servicing of a complete modern T.R.F. and Superhet Radio Receiver.

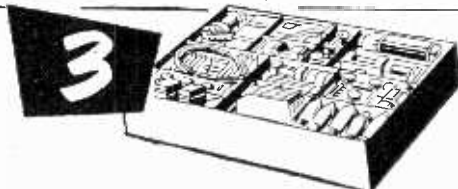

OTHER COURSES WITH OUTFITS INCLUDE:

**MECHANICS • ELECTRICITY
CHEMISTRY • PHOTOGRAPHY
CARPENTRY**

**ALSO DRAUGHTSMANSHIP • COMMERCIAL ART
AMATEUR S.W. RADIO • LANGUAGES • ETC.**

POST THIS COUPON TODAY

Please send me your **FREE** book on Practical Courses: I am interested in Television , Radio: Beginners , Advanced .

Other subjects (Please indicate Item(s) required)

To: E.M.I. INSTITUTES, Dept. 138x, Grove Park Road, London, W.4.

NAME _____

ADDRESS _____



OCT

E.M.I. INSTITUTES

The only Postal College which is part of a world-wide Industrial Organisation

1355 RECEIVER
Complete with 11 valves.
8 SP61, 5U4G, VU120, VR92.
As specified for "Inexpensive Television." In absolute new condition. 27/6. Carr. 5/-.

R.F. UNITS
RF24 complete with valves, 10/-.
RF25 complete with valves, 12/6.
RF26 complete with valves, 25/-.
Brand new. Carr. 2/6.

MINIATURE I.F. STRIP TYPE "373" 9-72 MEG.
Brand new miniature I.F. Strip size 10 1/2 in. x 2 1/2 in. x 3/16 in. high. Valve line-up: 2-EF92, 3-EF91 and EB91. With circuit.
1/2 in. (less valves) 7/6.
P. & P. 1/6.
This I.F. Strip is part of above equipment.

U.S.A. INDICATOR UNIT BC929A
Complete with 3BP1 C/R tube and screen. 7 valves 2-6SN7GT, 2-6HG8T, 6G6, 2X2, 6X5G, volume controls, condensers, etc. Ideal for portable "scope". In black crackle case size 1 1/2 in. x 9 in. x 9 in.
BRAND NEW. 65/- carr. FREE.

TR 1198 TRANSMITTER
Transmitter section comprising EL32, EF50, VT501, Relay, etc., 12/6. P.P. 2/6.
COMPLETE T.R.A. AND MIXER RECEIVER with 24 v. power-pack in original transit case. 57/6. P.P. 5/-.

TRANSISTORS

JUNCTION TYPE (Red Spot) OFFERED AT LESS THAN HALF-PRICE

Designed for A.F. application up to 800 kc/s and is suitable for use in Radio Control, Signal Tracers, Local Station Receivers, Oscillators, Transistor Voltmeters, Microphone Pre-Amplifiers, etc.

10/-

(Tested and complete with Data and Circuits)

N.B.—These transistors may be used in place of Mullard OC71 or similar Transistors.

R.F. TRANSISTORS (Blue-Spot), 1.6 Mc/s, 15/- each.

BUILD THE "TELETRON" TRANSISTOR SUPERHET

Complete Kit of Parts with 4 Transistors and 3in. Speaker, I.F.T.'s, 2-gang miniature cond. V/C Ferrite Rod, Cond. and Res. 28/10/0

"TELETRON" Transistor Superhet with Push-Pull Output, 8 Transistors, 6 x 4 Elliptical Speaker, I.F.T.'s, 2-gang miniature cond. V/C Ferrite Rod, Cond. and Res. 28/10/0

£9/0/0

(Call and hear Demonstration Models working.)

MINIATURE COMPONENTS FOR TRANSISTOR CIRCUITS

- Fortiphone sub-miniature inter-valve P.P. each Trans. 12/6
- Fortiphone min. inter-valve P.P. Trans. 15/-
- Fortiphone miniature output push-pull Trans. 15/-
- J.B. 2-gang 375 P.P. miniature condenser Miniature W/W 1K V/Controls 2/6
- On/Off Slide Switch..... 1/6
- Ferrite Rod, double wound 10/-
- Teleton miniature oscillator coils and I.F.T.'s coils 315 kc/s 6/6

CRYSTAL MICROPHONE INSERTS

Ideal for Tape Recording, Gramophone Amplifier, etc. Very sensitive. Guaranteed and Tested. 5/- (ex-units) or 8/6 Brand new and boxed.

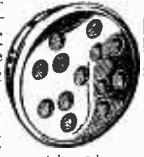

62A INDICATOR UNIT
Containing VCR57 with Mu-Metal Screen. 21 Valves: 12-EF50, 4-SP61, 3-EA50, 2-EB94, Plus Pots, Switches, H.V. Cond., Resistors, Muirhead S/M Dial. Double Deck Chassis and Crystal.
BRAND NEW ORIGINAL CASES. 67/6. Carr. 7/6.

INDICATOR UNIT TYPE 182A
Unit contains VCR517 Cathode Ray Gm. tube, complete with Mu-Metal screen, 3-EF50, 4SP61 and 1-5U4G valves, 9 wirewound volume controls and quantity of resistors and condensers. Offered BRAND NEW (less relay) at 67/6. Plus 7/6 carr. "Radio-Constructor" scope circuit included.

GARRARD 3-SPEED MIXER AUTO-CHANGER Model RC110
A.C. 200/250. List price £14/13/-, Brand New 27/19/6, P.P. 3/6.

HENRY'S

(RADIO LTD.)

5, HARROW ROAD, PADDINGTON, LONDON, W.2. TEL.: PADDINGTON 1008-9, 0401

ARTHURS HAVE IT!

LARGE STOCKS OF VALVES AND C.R.T.'S.

AVO METERS IN STOCK			
Avo Model 7	—	—	£19 10 0
Avo Model 8	—	—	23 10 0
Electronic Test Unit	—	—	27 10 0
Electronic Test Meter	—	—	40 0 0
AC/DC Minor	—	—	12 0 0
* Cassor Oscilloscopes Model 1052	—	—	104 0 0
	—	—	120 0 0

Full range Taylors Meters. List on request.

LEAK Pick-up Arm	—	—	2 15 0
	—	P.T.	1 3 1
.. Long Play or Standard Heads With Diamond Stylus	—	—	5 15 0
	—	P.T.	2 8 4
.. Matching Transformer	—	—	1 15 0

Leaflets on Request
JASON AF/FM Tuner, complete with valves and automatic frequency control, also cascade input — £28 13 0

LATEST VALVE MANUALS
MULLARD, 10/6, OSRAM & BRIMAR No. 6, 5/- each, OSRAM Part 2, 10/-, Post 9d. each extra.
TRANSFORMER for 200/230 v., 37/6.

Terms: C.O.D. OR CASH with order and subject to price alterations and being unsold.

Est. 1919

Arthurs

PROPS: ARTHUR GRAY, LTD.
OUR ONLY ADDRESS: Gray House
150-152 Charing Cross Road, London, W.C.2
TEMPLE Bar 5833/4 and 4765
TELEGRAMS—"TELEGRAY, WESTCENT, LONDON."
CABLES—"TELEGRAY, LONDON."

"You can rely on US" for ...

ALL RADIO and ELECTRONIC COMPONENTS

One of Britain's Largest Stockists of all Leading Makes: Hunts, T.C.C., Haynes, Allen, Denco, Osrom, Weymouth, Morganite Bulgin, Belling Lee, Teleton, R.E.P., Scotch Boy, Ellison, Elstone, Partridge, Wynall, Westinghouse, S.T.C., AVO, Taylor, Goodmans, J.B. Wharfedale, Wearite, Acos, etc.

Suppliers to: Ministries, Development Laboratories, Education Authorities, etc.

Some of the more difficult parts you may not be able to acquire:

- Tapped Vol. Control, Linear C.T. 1/2 mg., 1 mg., 7/6. Linear 1/2 mg., 1 mg., 6/6. Post 6d.
- 2 High Stab. 1/2 w. Resistors. 2% Range. 100Ω to 2 meg., 1/6 each. 1% Silver Micas up to 100 pf. 1/-, 280 pf., 1/2. 500 pf., 1/4. 1,000-5,000, 2/6. Post 6d.
- Teleton Band III Converter—Punched Chassis, 4/-, Post 6d. Set of Coils and Circuit, 15/-.
- Band III Loft Aerials, 30/- plus 2/- carriage.

Thousands of Valves, Condensers, Resistors—Can We Help You?

MULLARD 510 and GEC 912 all specified parts and lists available.

Catalogue, Book Lists, S.A.E.

RADIO SERVICING CO.,

82, SOUTH EALING ROAD, LONDON, W.5.

Tel.: EAL 5737. Next Sth. Ealing Tube, 65 Bus. 1 p.m. Wed.



Whilst we are always pleased to assist readers with their technical difficulties, we regret that we are unable to supply diagrams or provide instructions for modifying surplus equipment. We cannot supply alternative details for constructional articles which appear in these pages. WE CANNOT UNDERTAKE TO ANSWER QUERIES OVER THE TELEPHONE. The coupon from p. 147 must be attached to all Queries, and if a postal reply is required a stamped and addressed envelope must be enclosed.

MARCONIPHONE VC59A

Thanks to your servicing series of July, 1955, I was able to locate the drop in H.T. through a faulty N152 (PL81) which restored the picture and other defects. One fault outstanding is lack of sound. There is a suspicion of sound barely distinct with the volume control fully advanced and very badly distorted. I have replaced the various Z152 valves, neglecting the D152 detector as the picture is satisfactory.

Could you please give me some guidance where to locate this fault?—D. C. Downes (Stonehouse).

If the serial number of your receiver is over H17/6200 check sound detector crystal diode XLI wired in the secondary circuit of the final sound I.F. transformer. Also check W1 noise limiter diode and associated $1\text{ M}\Omega$ resistor. Also check all coils for continuity, i.e., both I.F. sound transformers. If the serial number is lower than that indicated, check ZD152 valve and anode circuit, including the $4\ \mu\text{F}$ capacitor. Also noise limiter and $1\text{ M}\Omega$ resistor as before. Finally check $.1\ \mu\text{F}$ feeding volume control for leakage and capacity.

FERGUSON MODEL 10ST

Please advise on following faults on above model TV:

1. Picture unsteady horizontally on both Channels 1 and 9. The frame hold is steady.
2. After the set has been on some time picture moves to the right, leaving $\frac{1}{2}$ in. to 1 in. gap between picture edge and escutcheon. Cramping is not present when this happens. The picture can be made to fill the frame by use of line hold, but this is not correct use of this control and line lock check by removing and replacing aerial gives locked picture immediately.
3. The set has hitherto worked perfectly on indoor aerials, simple dipole for Channel 1 and dipole with one reflector and two directors on Channel 9. Construction information gathered from your publications, of course!—T. W. Leary (Cambridge).

On the left side of the tube as viewed from the rear are two EF80 valves. The second one should be changed with a valve which is known to be absolutely

steady on emission. This is the line control valve.

When the valve is replaced the picture should be locked by the controls on the weakest possible signal, or, better still, follow the information given on this subject in the "Servicing TV Receivers" article which dealt with the Ferguson 991T (Feb. '56).

G.E.C. 12in. MODEL.

The tube of my set, which is a 12in. G.E.C. model, has worn out. All I can get is a faint raster. I have just started to get your monthly magazine, "Practical Television," which mentions reactivating tubes, details of which are printed in earlier issues. Unable to obtain these I was wondering if you could explain to me how to reactivate my tube—K. Dawson (Manchester).

The general method of increasing the tube emission, temporarily that is, is to employ a transformer which supplies a higher voltage to the tube heater. The exact transformer type and method of connection depend upon the type of tube and the model number of the receiver. We will give you full details of the necessary work if you will let us have the model number of the set. This is marked upon the rear cover and will be BT—.

BUSH TV24

I built your P.T. Converter some months ago, and it has proved very successful, but each time I change from BBC to I.T.A. I have to alter the tuning control at the back of the set. Is there any way in which I can eliminate this? Can you help me at all?—R. Thompson (S.E.3).

Set up the receiver for Band I operation and carefully adjust the tuning control and associated aerial and R.F. cores for optimum results. Connect the Band III converter and allow sufficient time to warm up properly. Adjust the oscillator of the converter for compromise between I.T.A. sound and vision and secure optimum balance with the aerial and R.F. tuning. You may also find it necessary to adjust the I.F. transformer tuning. This should be done without disturbing the receiver's tuning in any way.

EKCO T141

I have an Ekco T141 12in. TV and I am fitting a CRM123 tube. The EHT is approximately 7 kV. I would like to get the maximum results from this tube, which operates at 10 kV. Would, in your opinion, the enclosed circuit of a boost EHT taken from a back number of "Practical Television" be satisfactory, or could you suggest any other method?—L. Engelen (Belfast).

The circuit shown will undoubtedly give an EHT boost, but since the line amplifier in your model is working at maximum under normal conditions the modification will severely impair the EHT regulation and make it difficult to obtain full width.

PYE VT4

My set has given good service for two years, but has now developed the following fault: two white lines (parallel) appear horizontally across the picture, which is badly distorted vertically. Do you think that the valve ECC82 is the cause of the trouble?—F. W. Jaques (Birmingham).

The ECC82 frame timebase valve often causes this effect if it becomes faulty or alters in characteristics.

We feel that it would be well worth your while to check this valve before delving too deeply into the circuit.

McMICHAEL MODEL

I have the following fault on my McMichael No. 512.

There appears to be a "foldback" on the lower half of the picture which will not react to the picture height control. The fault appears to be on the video output valve, which is an EF91. (This is necessitated by the heater circuit being in series, and this appears to be the only B7G based valve at .3 amps. which is suitable).—A. W. Gaddes (Sutton).

We do not understand your remarks concerning the EF91 video output valve. This has no bearing upon the frame timebase and thus cannot be responsible for the compression of the lower part of the frame scan.

You should substitute the ECC82 valve (12AU7), frame timebase oscillator and output valve, and if this does not clear the condition replace the 50 μ F cathode bias capacitor.

EKCO TC138

When first switched on the picture and sound keep going off and on for about eight or nine times before it finally settles down, and also when I turn the contrast up the sound is very distorted. This is very awkward and I have to have the picture pretty dim in order to follow the sound.—J. Jones (Ealing).

You will no doubt find that the intermittent vision and sound is due to a poor contact between the pins and socket of one of the first two valves (right side far end as viewed from rear). The valves should be rocked in their sockets to ascertain which is responsible and the valve pins should then be cleaned before replacement. The sound distortion is no doubt due to a high value resistor in the sound noise limiter circuit increasing in value. This would be concerned with the right side 6D2, which is behind the 6P25. The effect of this is to restrict the operation of the diode as the resistor is wired from the H.T. line to the anode of the limiter.

ULTRA V710

I have an Ultra V710 and I get just a blank screen and plenty of volume on sound. An electrical friend of mine spent several hours on it and has apparently got all the trimmers of the screened coils and I.F. transformers out of alignment.

As I am a complete novice I would like you to inform me of the correct way to use these trimmers.—F. E. Portland (S.E.15).

As viewed from the rear, on the left side of the chassis is a row of valves, the nearest one being a 6D2. Behind this is a 6F1. The components associated with this valve should be checked and you will probably find that the 1.8 K Ω anode/screen decoupling resistor is open circuit, thus preventing any H.T. voltage reaching these electrodes. This could be due to a defect in the associated .01 μ F decoupling capacitor which is wired from the resistor to chassis. If the sound is in order only the coil cores associated in front and behind this valve may require adjustment. Once a picture is received the left side coil cores may be adjusted on test card C for best vision and sound response. We base this reply upon the assumption that a "blank screen" means that brilliance may be varied but with no picture.

TESTING DIODES

I would be pleased to know if a diode rectifier such as CG12E or CG6E, as fitted in vision strips of television receivers, can be tested with a 1,000 O.P.V meter, as I have been told they can be wrecked. I have a Ferranti small meter that is 1 mA FSD and would be pleased if you could say what I should do as one of these costs 7s. 6d. I feel that some advice on the matter would save any undue expense.—V. J. D. Smith (Surrey).

Germanium diodes suspected of a fault in a TV receiver are best checked by substitution. A rough check is available by the simple application of an ohmmeter, as you suggest, and no damage will result by using a 1,000-ohms/volt instrument for the purpose. The forward resistance will be found to vary between specimens and between different types of diode, but generally, if it is low compared with the reverse resistance, then the diode should at least give some indication of life in the circuit.

DEFIANT

I have a Defiant 9in. TV; it is about five years old and has developed a loud hum and the talking is "quacky," and a dark bar covers the top half of the screen. Now and again it rights itself, on and off like Morse; the hum is louder with the aerial in. I substituted a 16 \times 16 μ F condenser in place of the original 8 \times 16 μ F power pack, but it made no difference. I have not got a circuit diagram, so I am at a loss to know what could cause it. I changed over the T41s, also Pen45s, but there was no change.—J. Davis (Bootle).

If you are sure that the electrolytic smoothing capacitors are all in good condition, then the trouble is probably caused by an intermittent heater-to-cathode short in one of the valves common to both sound and vision. Sometimes gently tapping the valves in turn reveals the one which is responsible by causing a show or correction of the effect. Check for poor soldered connection in the H.T. circuits.

SELENIUM RECTIFIERS IN POWER SUPPLY CIRCUITS

(Concluded from p. 121)
this being dropped by the resistor, R2, to 90 volts. R2 and C2 form the smoothing components. The current required for the valve heaters is drawn from the H.T. supply via R3, this resistor being used to reduce the voltage to the required 7.5 volts. R3 is of the cement coated type of 5 watts rating and fitted with a metal strap, this being adjusted to give the correct voltage. The use of the double-wound mains transformer provides complete safety when the unit is fitted to receivers which have metal facias in contact with the chassis.

Other applications where the selenium rectifier may be with advantage are as follows: for rectification of low voltage A.C. for bias purposes, for voltage doublers, for energising loudspeaker field coils where the speaker is remote from the main amplifier and for numerous applications in test apparatus.

Fig. 3 shows the basic circuit for a voltage doubler. This gives full-wave rectification and is very useful where large voltage is required for operating a constant load. It is essential that the load is fairly constant as the regulation with this circuit is poor. The working voltage of C3 and C4 must be at least 1.414 times the A.C. voltage, R.M.S. applied. Typical values for C3 and C4 are 8 μ F or 16 μ F.

SPEAKERS, new, 8in., in round metal, grey, case, with on/off switch, 27/6 (post 3/-). Dipole Insulators, Perspex, for in- rods, 3/6. Brand new Command Receivers, 1.5-3 mc/s, with 6 valves, 55/- (post 3/-). Vibrapacks: Mallory 12v to 250v, 80 ma, synch., reversible, 18/6; Jeff Travers 12v to 150v, 30 ma, synch., smoothed, 15/6; 12v to 110v, 30 ma, stabilised, 12/6 (p.p. 3/- each). RXS.112/114 (TR1987), with 3.EF91, 2/EL91, 5 gang tuner, new 37/6; Circuit 1/-. Suppressors, radio interference, ex-A.M., 5/6 (post 2/-). Brand new Units, Types R.F. 26 or 27, 27/6 (postage 2/6); R.F. 24, R.F. 25, soiled, 10/6. Dynamotors, Edystone, 12v to 190v, 75 ma, cased, 15/- (post 3/-); 11v to 300v, 200 ma, cased, 15/- (carr. 8/6). Throat Mics, U.S.A., new, 2/6. Metal Rectifiers, 600v, 30 ma, 6/-; 500v, 500 ma, 10/6; 1,000v, 30 ma, 7/6. I.F. Amplifier 178, 13.0 mc/s, with valves, 15/6 (postage 2/6 each). Relays, 6v, 2 break, 1/6. I.F.T.s, 10/13 mc/s, canned, new, 1/3. R155 Coilpacks, new, 12/6; used, 9/6. Chokes, L.F. Ferranti, 10H, 150 ma, screened, 7/6; 10H, 200 ma, 8/6; 5H, 200 ma, 5/6. R1355 I.F. Strips only, complete, new, with valves, 25/-; less valves, 12/6 (post 2/6). Toggle Switches, new, metal DPST, 2/-. Wafer Switches, 1 pole, 11 way, 2 bank, 3/6; 6 p., 2 w., 4 b.; 2 p., 3 w., 2 b.; 1 p., 6 w., 5 b., 2/6; 4 p., 2 w., 1 b., 1/3. List, and enquiries, s.a.c. please. Terms: C.W.O. Postage extra. Immediate despatch. Callers and post: W. A. BENSON (WW), 136, Rathbone Rd., Liverpool, 15.

THE NEW COLLARO AUTOMATIC, twin track, 3-speed-Tape Deck (no amplifier), is available at PHOTO-OPTIX (LONDON) LTD., The Tape Recorder Specialists, at 19 Gns., 73-75, Praed St., London, W.2. (PAD 2891.)

1,000'S OF SERVICE SHEETS, sale or hire. Stamp with enquiries. New 60-page Catalogue of Radio and T.V. Spares now in preparation. Demand may exceed supply. Reserve your copy at once. 1/- P.O. M. FOY, 6, Wykebeck Gardens, Leeds, 9.

MASSIVE CONSOLE, Radio/Television, 1210A, Cossor, w.o., Service Sheet, £18, 39, Jellicoe Avenue, Gravesend, Kent.

VALRADIO I.T.V. CONVERTERS, surplus to requirements, new, £4, complete. POOLE BROS., 63A, Shireland Road, Smethwick, 40.

EDDY'S SURPLUS STORES, 172, Alfreton Rd., Nottingham. 6/5, 2/11; 6KT, 2/11; 6V6GT, 5/11; 1T4, 7/11; VU11, 1/6; p. and p. 9d. each; 1154 Transmitters, 29/11, p. and p. 10/-; BC929 Indicators, 59/6, p. and p. 10/-, C.W.O. only.

T.C.R.C.
POSTAL COURSES
RADIO TELEVISION MATHEMATICS
Backed by 23 years' success
Write for free booklet "T"
T/C RADIO COLLEGE
DUART HOUSE, ASHLEY ROAD,
NEW MILTON, HANTS.

RATES: 4/- per line or part thereof, average 60 words to line, minimum 2 lines, Box No. 1, extra. Advertisements must be prepaid and addressed to Advertisement Manager, "Practical Television," Tower House, Southampton St., Strand, London, W.C.2.

TAN IN 24 HOURS.—Super-tonic Sunray Lamps, ultra-violet infra-red combined; automatic exposure; controlled emission; all mains; listed £7/10/-, our price 80/-, S.A.E. brochure Dept. 16. **SCIENTIFIC PRODUCTS**, Cleveleys, Lancs.

BAND III CONVERSION easily carried out with Spencer-West Type 66 printed circuit Converter. Price, complete with valves and change-over switch, £4. **SPENCER-WEST LTD.**, Quay Works, Great Yarmouth.

CAR CIGARETTE LIGHTERS, 6 or 12 volt, 7/6, post free. **WHITSAM ELECTRICAL PRODUCTS**, 18, Woodrow Close, Perivale, Middlesex.

SERVICE SHEETS, T.V. and Radio, over 2,000 models, sale or hire. Valves and Components, S.A.E. with enquiries. W. J. GILBERT, 24, Frithville Gardens, London, W.12.

B.S.R. MONARCH 3-speed auto-change units; new in maker's sealed carton; guarantee; complete with instructions, template, suspension springs, £9/15/1, carriage paid; immediate delivery. **TOMLINS**, 127, Brockley Rise, Forest Hill, S.E.23.

TELEVISION, 9in. models, £6/10/-; 12in. models, £15; all makes; working; carriage paid. **TOMLINS**, 127, Brockley Rise, Forest Hill, S.E.23.

DIRECT T/V REPLACEMENTS offer the most complete Handbook of T/V Components and Rewinds, price 1/-, T/V Components, for all kit sets in stock. "Nuray" heater booster isolator for 2-volt C.R.T.s, just plugs in, 27/6, plus 2/- packing and postage. 134-136, Lewisham Wav. S.E.14. (TIDeway 3696-2330.)

TELEVISION AND RADIO BAR-GAINS.—12in. 5 Channel, £18/10/-; 12in. London Station, £12/10/-; 9in. London Station, £7/10/-. All guaranteed. Phone LAD 1734, call 1970. Harrow Rd., N.W.10.

LOUDSPEAKERS repaired promptly. **MODEL LOUDSPEAKER SERVICE**, Bullington Rd., Oxford.

SEVERAL EARLY MODELS 9in. Television, complete and mostly working, £5/5/- each; carriage paid. **TOMLINS**, 127, Brockley Rise, Forest Hill, S.E.23. (FOR 5497.)

MAKING YOUR OWN? Telescopes, Enlargers, Binoculars, Microscopes, Projectors, or, in fact, anything that needs lenses. Then get our booklets "How to Use Ex-Gov. Lenses & Prisms," Nos. 1 & 2, price 2/6 ea. Also our stereo book, "2-D Without Viewers," price 7/6. Comprehensive list of lenses, optical, radio and scientific gear free for s.a.c. H. W. ENGLISH, Rayleigh Road, Hutton, Brentwood, Essex.

GUARANTEED TELEVISION, 12in. models, first-class picture, 5-channel, £30 each, carriage paid. **THE GRAMOPHONE SHOP**, 19-21, Brockley Rise, Forest Hill, S.E.23.

ENGRAVING.—Amateurs and trade surplus can be undertaken by getting in touch with A. G. ENGRAVING, now at 292, Earlsfield Road, London, S.W.18. (Tel.: BAT 9897.) (Engravers to well-known makers of Electronic Equipment used by the Aircraft industry. A.W.R.E., etc.)

TELEVISION, 12in., 5 channel, tunable anywhere models, £28 each, carriage paid; guaranteed perfect. **RYAN**, 4, Ewelme Road, Forest Hill, London, S.E.23.

TELEVISION INTERFERENCE. Receiver Filters, High-Pass E.5027, 30/-; Low-Pass E.5031, 39/-; Composite Band I/III, 49/6; Transmitter Filter E.5043-60dB, 1kW, £6. **LABGEAR (CAMBRIDGE) LTD.**, Willow Place, Cambridge.

WANTED

WANTED, Valves 6F13, 6F15, 6U4 EY51, 5Z4, ECL80, KT61, 25A6, etc.; prompt cash. **WM. CARVIS LTD.**, 103, North Street, Leeds, 7.

ALL TYPES OF VALVES REQUIRED for cash. State quantity and condition. **RADIO FACILITIES LTD.**, 38, Chalcot Road, N.W.1. (PR1mrose 9090.)

SITUATIONS VACANT

TECHNICAL AUTHORS required for the preparation of technical handbooks and sales literature for T.V. transmitting and receiving equipment. Should have sound electronic background preferably with T.V. experience, and be able to write in clear, concise English accurate descriptions of complex equipment. **DRAUGHTSMEN** also required for circuits and diagrams in connection with the above. Please apply in writing to **CHIEF ENGINEER**, Eye Limited, Cambridge, quoting "TP."

EDUCATIONAL

BUILD YOUR OWN TV and learn about its operation, maintenance and servicing. Qualified engineer-tutor available while you are learning and building. Free brochure from **E.M.I. INSTITUTES**, Dept. P.T.58, London, W.4. (Associated with H.M.V.)

INCORPORATED Practical Radio Engineers home study courses of Radio and TV Engineering are recognised by the trade as outstanding and authoritative. Moderate fees to a limited number of students only. Syllabus of Instructional Text is free. "The Practical Radio Engineer" journal, sample copy 2/-. 3,000 Alignment Peaks for Superhets, 5/9. Membership and Entry Conditions booklet 1/-. All post free from the **SECRETARY**, I.P.R.E., 20, Fairfield Road, London, N.8.

THE ROYAL NEW ZEALAND AIR FORCE

HAS VACANCIES FOR **BRITISH EX-SERVICEMEN** in the following trades:

Radio Mechanics
Radar Mechanics

Commencing pay between £10.8.2 per week and £17.1.3 per week according to previous experience. Ages between 21 and 40, married or single. This is an opportunity to start a new life in New Zealand with excellent conditions of service and free passage. Limited vacancies also exist in other trade groups. Write for full information to:—

The Royal New Zealand Air Force Headquarters
(Dept. P.T.)
ADLPHI BUILDING
JOHN ADAM STREET, LONDON, W.C.2

News From the Trade

SPENCER-WEST CONVERTER

THE ordinary type of converter often proves disappointing, due to the differences between the strength of the Band I and the Band III signals. In the Spencer-West converter illustrated below this difficulty has been overcome in a very ingenious manner. Instead of the normal cascade first-stage in the converter operating on Band III only, it is also applied to the Band I signals, and two normal R.F. gain controls are included in the stage. In this manner one is able to adjust the gain on both Band I and Band III signals before they are passed to the set in the normal manner, and equalisation of the signals can take place before amplification by the normal receiver—acting as usual as an I.F. strip.



gain control is at the rear. The controls are identified with small theoretical symbols instead of being named, and the general finish is in gilt and grey. The overall dimensions are 9½ in. long by 7 in. deep by 3½ in. high and four small rubber feet are fitted so that it may be placed on a polished cabinet without soiling it. The price is £11 17s. 6d.—Spencer-West. Ltd., Quay Works, Gt. Yarmouth, Norfolk.

"BI-SQUARE" TELEVISION AERIAL

LABGEAR announce the introduction of the "Bi-Square"—an outstanding new long-range TV aerial, representing a big step forward in loft aerial design. Because it is out of sight, the "Bi-Square" leads the way in meeting objections to forests of outdoor aerials.

Much smaller than the ordinary Band I aerial, the "Bi-Square" will stand in any loft safely under the roof. It is delivered pre-assembled and folded up

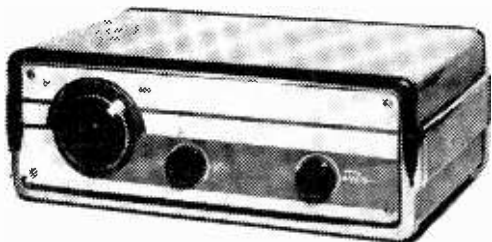

The Spencer-West type 50 converter

As might be expected, this enables the grain of the picture to be kept at a minimum as a good strong signal may be passed to the normal receiver as a result of which the receiver gain or sensitivity control may be set well back. We have had an opportunity of testing one of these units out over a long period and the results certainly justify the claims made by the makers.

The unit has two sockets at the rear to accommodate both Band I and Band III aerials and it should be stressed here that for best results these should be separate without the use of any cross-over networks or similar devices, and as good as it is possible to fit. An output lead is provided for insertion into the aerial socket of the receiver. A further useful point is that the mains plug on the receiver is inserted into a socket on the rear of the converter, and then, switching on the converter (which has its own power supply) also switches on the receiver. The left-hand control on the converter panel selects the Band I signal, then either of the present Band III signals, with a spare position. Other versions are available in which the output from the first position may be at any Band I signal—to assist in using it with a multi-channel receiver where it would be possible to tune the receiver to a Channel other than the local, to assist in the removal of patterns. The centre control is the combined on/off switch and Band III trimmer, whilst the right-hand control is the Band III gain. The Band I

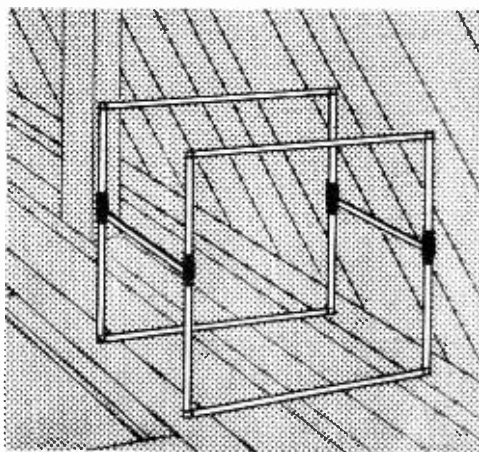

The Bi-Square loft aerial.

neatly to under 6ft. long, and it takes no more than a few minutes to assemble ready for use. No special mounting is needed.

The Bi-Square gives first-class reception up to 40-50 miles, and is for Band I only. The price is £6 10s. 0d.—Labgear (Cambridge), Ltd., Willow Place, Cambridge.

QUERIES COUPON

This coupon is available until OCTOBER, 21st, 1956, and must accompany all Queries.
PRACTICAL TELEVISION, OCTOBER, 1956.

Published on the 22nd of each month by GEORGE NEWNES, LIMITED, Tower House, Southampton Street, Strand, London, W.C.1, and printed in England by W. SPEAIGHT & SONS, Exmoor Street, London, W.10. Sole Agents for Australia and New Zealand: GORDON & GOTCH (A/asia), LTD., South Africa: CENTRAL NEWS AGENCY, LTD. Subscription rate including postage, for one year: Inland 17s. 6d., Abroad 16s. 6d. (Canada 16s.). Registered at the General Post Office for the Canadian Magazine Post.

VALVES • SAME DAY SERVICE

All Guaranteed New and Boxed

14V. midret.	1R5, 1S5, 1T4, 1U5, 3S4, DAF91,
DF91, DK91, DL92, DL94, any 4 for 27.6,	
1A7GT12/6 6U4CT	DF33 11/8 EM34 10/6
1CSG111-	14/6 DF96 7/6 EY51 10/6
1H5GT	6V6G 7.- DH77 8/6 EZ40 8.-
	11/6 6V6GT 7.- DK32 12/6 EZ41 8.-
1N5GT	16X4 7/6 DK92 8/6 EZ80 8/6
	11/6 6X5GT 6/9 D336 7/6 FW4.500 10.-
1R5	8/6 7B7 8/6 DL33 11/8
1S5	7/3 7C5 8/6 DL35 11/- GZ32 12/6
1T4	7/3 7C6 8/6 DL96 7/6 KT33C10/6
1U5	7/3 7H7 8/6 EAF42 8.- KT63 7/6
3A5	7/6 7S7 8.- EB91 6/9 MU14 8/6
3Q5GT	7Y4 8/6 EBC33 7/6 PC684 8/6
	11/6 10C1 12/6 EBC41 10/- PCF80 8/6
3S1	7/6 10F1 10/- EBF90 9/6 PCF8211-
3V4	8/6 10LD11 ECC4012/6 PEN36C
5U4G	8/6 10/6 ECC81 9.- 16.-
5Y3GT	7/9 10P14 13/6 ECC83 9/6 PEN45 16.-
6Z4G	9.- 12A7 9.- ECC91 6.- PEN46 7.-
6AK5	5.- 12A U7 8/6 ECF8013/6 PY30 14/6
6AL5	6/9 12J7GT ECF82 PL81 11/3
6AM6	7/6 9/6 14/6 PL82 9.-
6AQ5	7/8 12K7GT ECH35 11/- PL83 11/9
6AT6	8/6 12K8CT 8/6 ECH42 10.- PY90 9.-
6BA6	7/9 12K8CT 8/6 ECH42 10.- PY91 9.-
6BE6	7/6 12/6 ECH81 9.- PY82 7/9
6BW6	7/9 12Q7GT ECL8010- PZ30 18.-
6C0	10.- 8/6 EF37A U25 12/6
6F1	13.- 14S7 12.- 9.- U37 15/6
6FG	9/6 20L1 10/9 EP39 8/6 U50 7/9
6F13	13.- 20P1 16/9 EP40 12.- U78 7/6
6F15	12.- 25L6GT EF41 10.- UB41 8/9
6J6	6.- 8/6 EP42 12/6 UCH12
6J7G	7/6 25Z4G 9/6 EP50 7/6 10/3
6K7C	5.- 35L6GT EP39 9/6 UF41 9.-
6K7GT	6.- 35Z4GT 8.- EP85 8/6 UL11 10.-
6K8GT	7/9 50L6GT8/9 EP86 11/6 UU7 11/6
6K8GT	9/6 AZ1 11/6 EP91 7/6 UY31 8/6
6L18	10/6 CCH35 16/- EP92 6/6 W77 8/6
6Q7GT	9/6 DAC3211/6 EL32 6/8 X79 12/6
6SN7GT	1AD96 7/6 EL41 10/6 Y83 7/6
	7/9 DCC90 7/6 EL84 10/6 Z77 7/8

Postage 5d. per valve extra.

READERS RADIO
24, COLBERG PLACE, STAMFORD
HILL, LONDON, N.16 STA. 4587

ILLUSTRATED CATALOGUE No. 10

6d., post free (U.K. only)

56 pages, over 2,000 items, 135 photographic illustrations and technical data on brand new guaranteed components by leading manufacturers.

SOUTHERN RADIO & ELECTRICAL SUPPLIES

SORAD WORKS, REDLYNCH SALISBURY, WILTS

Telephone: Downton 207

ALUMINIUM, LIGHT ALLOYS, BRASS, COPPER, BRONZE,

IN ROD, BAR, SHEET, TUBE, STRIP, WIRE, ANGLE, CHANNEL, TEE

3000 STANDARD STOCK SIZES

H. ROLLET & CO., LTD.
6, CHESHAM PLACE, LONDON, S.W.1.
SLOane 3463

Works:
36, ROSEBERY AVE., LONDON, E.C.1.
Branches at Liverpool, Manchester, Birmingham, Leeds.

"No Quantity too Small"

FIRST-CLASS TELEVISION and RADIO COURSES

GET A CERTIFICATE!

After brief, intensely interesting study —undertaken at home in your spare time—YOU can secure your professional qualification or learn Servicing and Theory. Let us show you how!

FREE GUIDE

The New Free Guide contains 132 pages of information of the greatest importance to those seeking such success compelling qualifications as **A.M.Brit.I.R.E., City and Guilds Final Radio, P.M.G. Radio Amateurs' Exams., Gen. Cert. of Educ., London B.Sc. (Eng.), A.M.I.P.E., A.M.I.Mech.E., Draughtsmanship (all branches), etc.,** together with particulars of our remarkable Guarantee of

SUCCESS OR NO FEE

Write now for your copy of this invaluable publication. It may well prove to be the turning point in your career.

FOUNDED 1885—OVER

150,000 SUCCESSES

NATIONAL INSTITUTE OF ENGINEERING
(Dept. 462), 148, HOLBORN, LONDON, E.C.1.

"VIEWMASTER"

Printed Circuit Converter

No Patterning or Breakthrough

We can supply the complete kit of parts including valves, **£5.0.0**

Send for detailed list of this kit and others, **POST FREE.**

Set of coils for conversion of Viewmaster receiver, **£1.15.0**

AUDIO LTD.,

Tower Road, London, N.W.10

!! RECORDERS !!

We are London's largest stockist of tape recorders. All makes and types available from stock.

We also have a large quantity of used and H.P. reprocessed Guaranteed machines at Bargain Prices for the personal shopper.

Recorders bought, sold, repaired and part exchanged.

Collaro 3-speed tapdeck £20.10.0 good selection of surplus valves, speakers and components.

No Lists.

JACKSON RADIO

163, Edgware Road, London, W.2

Telephone: PAD 0537

OPEN ALL DAY SATURDAY

RADIO AND TELEVISION COMPONENTS

All parts in stock for:
Viewmaster, Soundmaster, Telemek, etc.
Easy Terms available.
21d. stamp (only) for Catalogue.

JAMES H. MARTIN & CO.
FINSTHWAITHE, NEWBY BRIDGE,
ULVERSTON, LANCs.

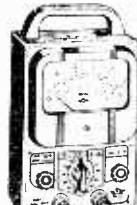

PULLIN
SERIES 100
TEST METER
AC/DC 10,000 Ω/V
21 RANGES
100μA to 1000V
COMPLETE IN CASE WITH SELF-LOCKING CLIPS AND PROTECTIVE COVER
FULLY GUARANTEED

SENT POST FREE FOR £2.10s. DEPOSIT AND NINE FURTHER MONTHLY PAYMENTS OF £1.4s. CASH PRICE £12.7s.

FRITH RADIOCRAFT LTD

69-71 CHURCH GATE LEICESTER
& 28 HIGH ST NEWPORT PAGNELL Bucks

F M and H-F I Components

DENC0 F.M. TUNER	circuits	1s. 6d.
RADIO CONST'N. F.M.	..	2s. 0d.
MULLARD AMPLIFIERS	..	3s. 6d.
G.E.C. 912 PLUS AMPLIFIER	..	4s. 0d.
G.E.C. FM PLUS TUNER	..	2s. 6d.

Separate price lists available on request to
J. T. FILMER MAYPOLE ESTATE,
BEXLEY, KENT.
Tel. Bexleyheath 7267.

OSMOR CONVERTERS

LONDON, BIRMINGHAM, MIDLANDS.
Simple, efficient for all TV (including TRF). Guaranteed no break-through of Band I or re-radiation. Approx. 1 hr. to build. Will convert any Band III channel to any Band I channel. AC or AC/DC. Kit. £3.5.0. Ready wired. £4.0.0. Post free. Terms: C.W.O. Post orders only.
THE ELECTRONIC SUPPLY CO.
29, Leigh Rd., Highbury, London, N.5

TELEVISION TUBES

MULLARD ...	12in. £6.10.0	14in. £7.0.0	17in. £8.10.0	} Ex Stock
COSSOR ...	12in. £6.10.0	14in. £7.0.0	17in. £8.10.0	
EMITRON ...	12in. £6.10.0	14in. £7.0.0	17in. £8.10.0	

MAZDA. 12in. only £6.10.0. 14 Weeks Delivery.

All Tubes plus 12/6 carriage and insurance.

SIX MONTHS' GUARANTEE

- Converter M.1.** Midlands area, high gain, own power supply, built in crossover unit £9.9.0
- Converter M.2.** Midland fringe area, own power supply £9.18.0
- Crossover Box.** Low loss 12/6

Finished in Stove Enamelled Steel Case.

Terms to the Trade

RE-VIEW (LONDON) LTD.

81, HIGH STREET : MERTON, S.W.19

Telephone : CHERRYWOOD 3255

MAKE SOUND JOINTS SIMPLY BY USING Multicore

ERSIN MULTICORE

Contains 5 cores of extra-active, non-corrosive Ersin Flux. Prevents oxidation and cleans surface oxides.

SIZE 1 CARTON

5/-

HANDYMAN'S CARTON

Suitable for 200 average joints. 6d.



HOME CONSTRUCTORS 2/6 PACK

In addition to the well-known Home Constructors Pack (containing 19ft. of 18 s.w.g. 60/40 alloy) a similar pack is now available containing 40ft. of 22 s.w.g. 60/40 alloy especially suitable for printed circuits.



Wherever precision soldering is essential, manufacturers, engineers and handymen rely on MULTICORE. There's a MULTICORE SOLDER just made for the job you have in hand. Here are some of them.

ARAX MULTICORE

FOR METAL FABRICATION

(Not wire-to-tag joints)

Contains 2 cores of Arax flux. Flux residue is easily removed with water.

SIZE 8 CARTON

5/- Handyman's Carton 6d.



BIB WIRE STRIPPER AND CUTTER

Strips insulation without nicking wire. cuts wire cleanly, splits extruded flex 3/8 each



BAND III AERIALS OR FITTINGS

Whether you are contemplating the construction of a Band III aerial or purchasing one complete it will be well worth your while to write to us who, as manufacturers, can offer you real

VALUE FOR MONEY

THE FOLLOWING IS A CROSS SECTION OF ITEMS TAKEN FROM OUR NEW COMPREHENSIVE CATALOGUE.

- * 10 Element Band III Aerial, 77/6.
- * 8 Element Band III Aerial, 62/6.
- * 6 Element Band III Aerial, 47/6.

FITTINGS

- * Universal Band III Clamp-on Fitting.
- * Band III Insulator, complete with folded dipole.
- * Director and Reflector Rod Holders for Bands I, II, and III.
- * Straight and Cranked Masts (all sizes).
- * Chimney and Wall Brackets. Alloy Tubing, etc. etc.

Send 1/- P.O. for the NEW MULTI-PAGE illustrated Catalogue (together with element and boom measurements (all Bands) to help the constructor)

to : **FRINGEVISION LTD.** MARLBOROUGH, WILTS. Phone 657/8

MULTICORE SOLDERS LTD.,

MULTICORE WORKS, HEMEL HEMPSTEAD, HERTS. (BOXMOOR 3636)

PREMIER RADIO COMPANY

(Regd.) B. H. MORRIS & CO. (RADIO) LTD.

(Dept. P.T.) 207, EDGWARE ROAD, LONDON, W.2

Telephone :
AMBASSADOR 4033
PADDINGTON 3271OPEN TILL
6 P.M. SATURDAYS

★ Band Three (Commercial)
For the Home Constructor

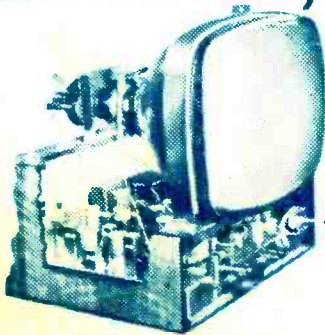

Instruction Book 3/6. Post
Free. Includes details of
both designs.



The Televisor may be constructed in 5 easy stages : (1) Vision, (2) Time Base, (3) Sound, (4) Power Pack, (5) Final Assembly. Each stage is fully covered in the Instruction Book, which includes layout, circuit diagrams and point-to-point wiring instructions. The Instruction Book also includes full details for converting existing Premier Magnetic Televisors for use with modern wide angle tubes. All components are individually priced.

THE NEW PREMIER TELEVISOR 13 CHANNEL DESIGN

SUITABLE FOR USE WITH ANY POPULAR WIDE ANGLE TUBE

DESIGN 1. Includes a Multi-Channel Tuner (Channels 1-13) continuously variable 40-100 Mc/s and 170-225 Mc/s. The Tuner is supplied wired and tested and is complete with Valves, all connecting leads and fixing brackets.
THIS DESIGN MAY BE BUILT FOR **£32. 7. 11** (plus cost of C.R.T.)

DESIGN 2. Channels 1-5, tunable from 40-68 Mc/s.
THIS DESIGN MAY BE BUILT FOR **£27. 9. 4** (plus cost of C.R.T.)

- ★ Constructors who have built Design 2 (5 Channels) may convert their Receivers to Design 1 for £6; this price includes Multi-Channel Tuner, New Vision Input Coil and full instructions.
- ★ All Coils supplied for these two Superhet Receivers are PRE-TUNED, ASSURING ACCURATE ALIGNMENT AND EXCELLENT BANDWIDTH.
- ★ Duomag permanent magnet focusing with simple picture centring adjustment.
- ★ Exceptionally good picture "hold" and interlace. ★ Noise suppression on both Sound and Vision.

2 'musts' for the home constructor

Two highly informative publications



◀ THE G.E.C. 'nine-one-two PLUS'

This publication contains step-by-step wiring instructions for this high quality Amplifier together with many additional features of exceptional interest to the Home Constructor.

PRICE **4/-** from your dealer or by post — 5d. extra — from the G.E.C. Valve and Electronics Dept.

◀ THE "FM PLUS" TUNER

The "FM PLUS" Tuner is ideal for use with the 'nine-one-two PLUS' Amplifier and the publication gives constructional details and suggested circuits for inter-station noise suppression and a "magic eye" tuning indicator.

PRICE **2/6** from your dealer or by post — 5d. extra — from the G.E.C. Valve and Electronics Dept.

THE GENERAL ELECTRIC CO. LTD. MAGNET HOUSE · KINGSWAY · LONDON · W.C.2