

• THE V.M. BAND III CONVERTER •

# Practical Television 1<sup>1</sup>/<sub>2</sub>

JANUARY 1956

AND TELEVISION TIMES

EDITOR: F.J. CAMM

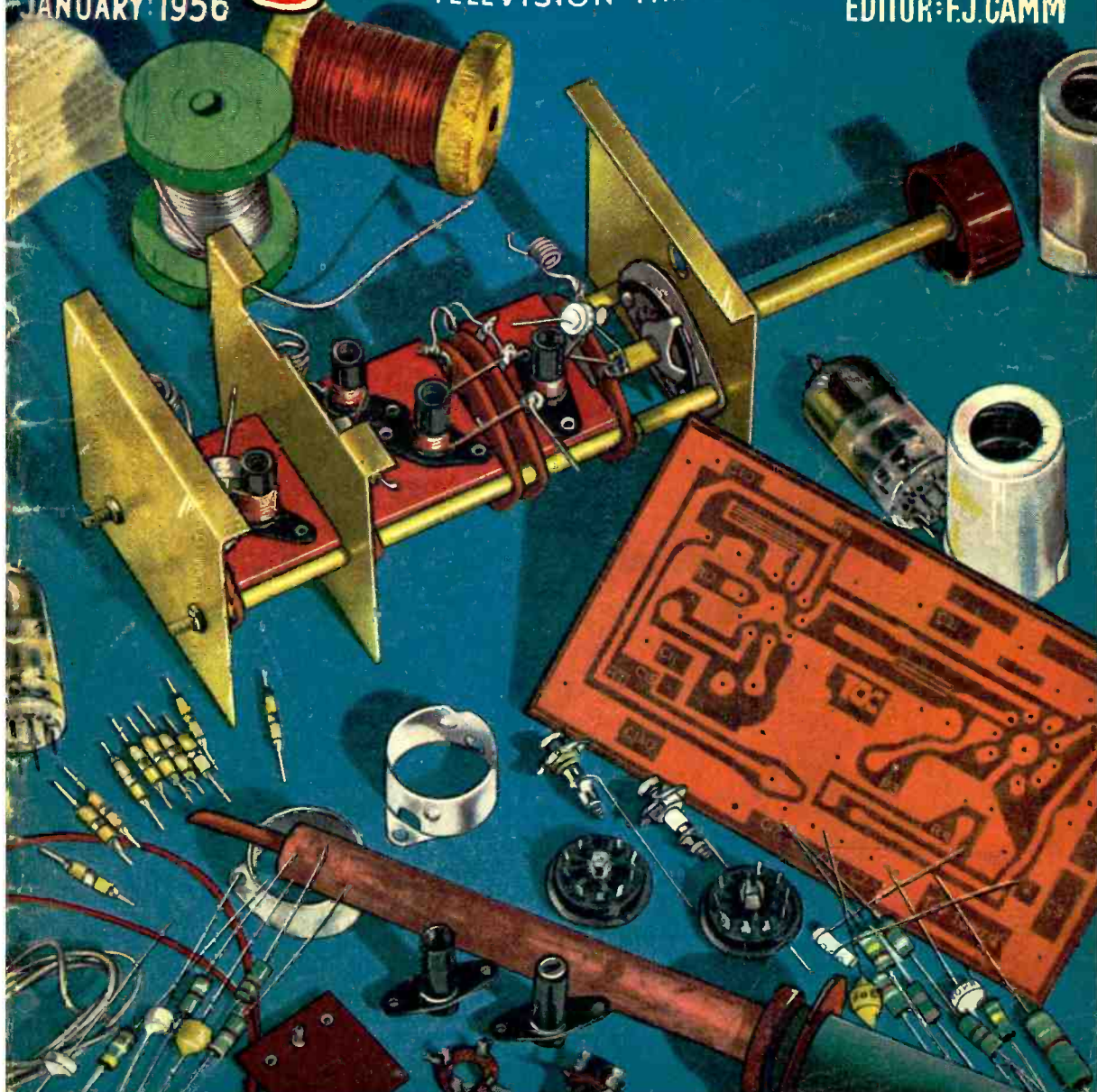

## PREMIER RADIO COMPANY

OPEN TILL  
6 P.M. SATURDAYS

(Regd.) B. H. MORRIS & CO. (RADIO) LTD

(Dept. P.T.) 207, EDGWARE ROAD, LONDON, W.2

Telephone :  
AMBASSADOR 4033  
PADDINGTON 3271

★ **Band Three (Commercial)**  
For the Home Constructor

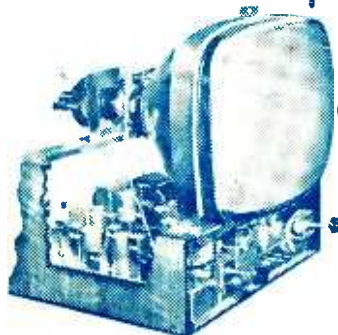

instruction Book 3/6. Post  
Free. Includes details of  
both designs.



The Televisor may be constructed in 5 easy stages : (1) Vision, (2) Time Base, (3) Sound, (4) Power Pack, (5) Final Assembly. Each stage is fully covered in the Instruction Book, which includes layout, circuit diagrams and point-to-point wiring instructions. The Instruction Book also includes full details for converting existing Premier Magnetic Televisors for use with modern wide angle tubes. All components are individually priced.

### THE NEW PREMIER TELEVISOR 13 CHANNEL DESIGN

SUITABLE FOR USE WITH ANY POPULAR WIDE ANGLE TUBE

**DESIGN 1.** Includes a Multi-Channel Tuner (Channels 1-13) continuously variable 40-100 Mc/s and 170-225 Mc/s. The Tuner is supplied wired and tested and is complete with Valves, all connecting leads and fixing brackets.  
THIS DESIGN MAY BE BUILT FOR **£34. 9. 7** (plus cost of C.R.T.)

**DESIGN 2.** Channels 1-5, tunable from 40-68 Mc/s.  
THIS DESIGN MAY BE BUILT FOR **£30** (plus cost of C.R.T.)

- ★ Constructors who have built Design 2 (5 Channels) may convert their Receivers to Design 1 for £6 : this price includes Multi-Channel Tuner, New Vision Input Coil and full instructions.
- ★ All Coils supplied for these two Superhet Receivers are PRE-TUNED, ASSURING ACCURATE ALIGNMENT AND EXCELLENT BANDWIDTH.
- ★ Duomag permanent magnet focusing with simple picture centring adjustment.
- ★ Exceptionally good picture " hold " and interlace. ★ Noise suppression on both Sound and Vision.

The



## ELECTRONIC TESTMETER

This instrument has been developed to meet the growing demand for an instrument of laboratory sensitivity built in a robust and portable form, for use in conjunction with electronic and other apparatus where it is imperative that the instrument should present a negligible loading factor upon the circuit under test.

The instrument consists basically of a balanced bridge voltmeter. It incorporates many unique features and a wide set of ranges so that in operation it is as simple to use as a normal multi-range testmeter.

The instrument gives 56 ranges of readings as follows :—

**D.C. VOLTS :** 5mV. to 250V. (Input Resistance 11.0 megohms.)  
25mV. to 10,000V. (Input Resistance 110.0 megohms.)

**D.C. CURRENT :** 0.5μA. to 1 Amp. (250mV. drop on all ranges.)

**A.C. VOLTS :** 0.1V. to 2,500V R.M.S. up to 2 Mc/s. With diode probe external 0.1V. to 250V. R.M.S. Useful measurements can be made up to 200 Mc/s. the applied voltage being limited to 105V. above 50 Mc/s.

**A.C. OUTPUT POWER :** 5mW to 5 watts in 6 different load resistances from 5 to 5,000 ohms.

**DECIBELS :** -10db. to +20db.

**CAPACITANCE :** .0001μF. to 50μF.

**RESISTANCE :** 0.2 ohm to 10 megohms.

**INSULATION :** 0.1 megohm to 1,000 megohms.



List Price :

**£40** Size 12½ins. x 9ins. x 5½ins.  
Weight : 12½lbs.

The instrument operates on A.C. mains, 100-130V. and 200-250V., 50-60c/s

Write for fully descriptive pamphlet.

The instrument is quickly set up for any of the various tests to be undertaken, a single range selector switch automatically removing from the circuit any voltages and controls which are not required for the test in question.

Sole Proprietors and Manufacturers :

**THE AUTOMATIC COIL WINDER & ELECTRICAL EQUIPMENT CO. Ltd.**

Avocet House, 92-96, Vauxhall Bridge Road, London, S.W.1

Phone : VICTORIA 3404-9

E.T.M.3

# FOR TV CONSTRUCTORS

**BAND III CONVERTER.**—For use with TRF or SUPERHET Receivers. Complete kit of parts including ready wound coils, drilled chassis, valves, wiring diagram, etc. **ONLY 49/6** (postage, etc., 1/6).

**RUNNING HOUR METERS.**—For checking running time of equipment up to 9,999 hours. Operates from normal 50 cycles mains. **BRAND NEW IN MAKER'S CARTONS. ONLY 39 6.**

**"ALL DRY" RECEIVER MAINS UNIT.**—If your battery portable uses midget 1.4 v. valves of the 154-1T4-1R5-354 series, then this will save you pounds in batteries. Delivers LT and HT from normal mains. Manufactured by "AVO" for the Ministry of Supply. Fused on mains side, and ready to work. Size 8 1/2 in. x 5 1/2 in. x 2 1/2 in. **BRAND NEW. ONLY 39 6.**

**BENDIN TRANSMITTER TA-12-C.**—A magnificent item of American equipment. Wave ranges are 300 600 kc.s., 3,000 4,800 kc.s., 4,900 7,650 kc.s., 7,650 12,000 kc.s., and 1 spot frequency on each can be selected. Valves employed are 3 of 807 and 4 of 12SK7. A superb buy at **ONLY 59 6.**

**RECEIVER 25 73.**—Part of the TR1196, this 6-valve unit makes an ideal basis for a mains operated All-wave Superhet, full modification data being supplied. Complete with valves, 2 each EF36 and EF39, and 1 each EK32 and EBC33. **BRAND NEW. ONLY 27 6.**

**MODEL MAKERS MOTOR.**—Reversible poles. Only 2 1/2 in. long and 1 1/2 in. diameter, with 1 in. long spindle. Will operate on 4, 6, 12 or 24 volts D.C. **ONLY 10 6.**

Open until 1 p.m. Saturdays, we are 2 mins. from High Holborn (Chancery Lane Station) 5 mins. by Bus from King's Cross. Cash with order, please, and print name and address clearly. Include postage or carriage on all items.

**U.E.I. CORPN.**

**100-0-100 VOLTS METERS** by Sangamo Weston, 2 1/2 in. circular, basic movement being 500-0-500 microamps. A really first-class centre zero meter for hundreds of uses. **BRAND NEW. IN MAKER'S CARTONS. ONLY 27/6.**

**WALKIE TALKIE TYPE 18.**—Covers 6.0-9.0 Mc.s. Complete with valves, microphone and headset, and transmitting and receiving units in metal case. In excellent condition. **ONLY 79 6.**

**AVOMINOR CARRYING CASES.**—Size 5 in. x 5 in. x 2 in. with long carrying strap. In high-quality leather with press stud fixing flap. Made for UNIVERSAL Avominor. **BRAND NEW. ONLY 7 6.**

**CRYSTALS.**—British Standard 2-pin 500 kc.s., 15. Miniature 200 kc.s. and 465 kc.s., 10 each.

**SPEAKERS.**—P.M. 6 in. less trans., 19 6; 8 in. less trans., 16 6; 10 in. with trans., 27 6.

**CHOKES.**—10H 60 mA., 4; 5H 200 mA., 7 6; 20H, 120 mA., 10 6.

**MU-METAL SCREEN FOR VCR97 TUBE,** etc., **ONLY 8 6.**

**CABLE—CLEARANCE OFFER OF 18 012 twin polythene.** Weatherproof, and suitable for outdoor use. 39 6 per 100 yard coil. S.A.E. for sample, trade enquiries invited.

**R.F. UNITS TYPE 26.** For use with the R.1355 or any receiver with a 6.3 v. supply. This is the variable tuning units which use 2 valves EF54 and 1 of EC52. Covers 65-50 Mc.s (5-6 metres). Complete with valves, and **BRAND NEW IN MAKER'S CARTONS. ONLY 29 6.**

**AMPLIFIER TYPE 293A, or 208A,** as described in the July issue of "Practical Television" for making a TV CONVERTER. Complete with valves. **ONLY 15 -.**

**PYE 45 Mc. I.F. STRIPS.**—The strip that is ready made for the London Vision Channel. Complete with 6 valves EF51 and 1 of EA50. **BRAND NEW. ONLY 59 6.**

**POCKET VOLTMETERS.**—Not ex-Govt. Read 0-15 v. and 0-300 v. A.C. or D.C. **BRAND NEW & UNUSED. ONLY 18 6.**

**TRANSFORMERS.**—Manufactured to our specifications and fully guaranteed. Normal Primaries, 425-0-425 v. 200 ma. 6.3 v. 4 a., 6.3 v. 4 a., 5 v. 3 a., **ONLY 65 -;** 350 v.-0-350 v. 150 ma., 6.3 v. 5 a., 6.3 v. 3 a., 5 v. 3 a., **ONLY 47 6;** 250 v.-0-250 v. 100 ma., 6.3 v. 6 a., 5 v. 3 a., **ONLY 37 6.** 350 v.-0-350 v. 150 ma., 6.3 v. 5 a., 5 v. 3 a., **ONLY 37 6.** 250-0-250 v. 60 ma., 6.3 v. 3 a., 5 v. 2 a., **ONLY 21 -.** The above are fully shrouded, upright mounting, 5.5 kv. E.H.T. with 2 windings of 2 v. 1 a., **ONLY 79 6;** 7 kv. E.H.T. with 4 v. 1 a., **ONLY 89 6.**

**THE RADIO CORNER, 138, GRAY'S INN ROAD, LONDON, W.C.1.**  
(Phone TERminus 7937.)

## LASKY'S RADIO

### 12-CHANNEL TV TUNER

Famous make. Covers Bands I and III. Complete with valves EF80 and ECC81. Ceramic valveholders, finest quality components, precision made. Switch and fine tuning. I.F. output, 20-25 Mc.s. Freq. coverage 50 87 Mc.s and 175-215 Mc.s. Supplied with full details and circuit diagram. **39/6** Post 3 6. Knob, 2 9 extra.

### TELETRON BAND III CONVERTER COIL SET

For use with T.R.F. and superhet Band I TV sets. Uses two 27T19. Circuit, wiring diagrams, alignments and full details with each **15/-** set. Post 1 6.

Complete Kit to build the Teletron Band III Converter, including chassis, condensers, valves, etc., with full instructions and diagram. **48/6** Post 1 6.

**MK. II COIL SET.** cascade 17 6. **MK. II CHASSIS** (also takes power supplies), 6 -. **OTHER TYPES OF CONVERTERS IN STOCK.**

## BAND III CONVERSION FOR ALL !

Commercial TV is in full swing from London and soon commences from Birmingham. Order NOW to avoid disappointment.



Famous Manufacturer's Turret "TELETUNER" OFFERED FOR THE FIRST TIME

Previously supplied to Set manufacturers only.

This 12 channel Tuner consists of a turret having 12 clip-in aerial and mixer coil strips.

When turret is rotated the appropriate strip locates on a contact panel providing the necessary connections to the valves and circuit. Supplied with coils for Bands I and III London and Birmingham, BBC and ITA. (4 Sets of Coils.)

This type of tuner enables you to clip in pre-aligned coils for the reception of any station not already provided for in Bands I and III, while affording maximum gain, high stability and minimum noise, which are essential in a modern tuner. I.F. output 33-38 Mc.s. Easily modified to other I.F. outputs.

Valves used: PCC81, R.F. double triode, cascade R.F. amplifier, PCP80 triode pentode i.c. and mixer. Will work with most sets. Full instructions and circuit diagram supplied. Price **99/6** Post 2 6. Knob, 3 6 extra.



### "THE UNIVERTOR"

A Band III Converter for home-constructed or factory-made Band I receivers. Uses two 6AM6, one 12AT6, one 6X4. Contains its own power supplies. Complete unit. **£8/10/-** in Cabinet. Post free

### IMMEDIATE DELIVERY, All Types, Band III Aerials

All Channels, 3-, 4-, 5- and 6-element outdoor, indoor and loft. A few examples —  
Wolsey Minor, indoor, 12 6.  
King Pin, indoor, 7 6.  
Aerialite 4-element loft, 42 6.  
Wolsey Combined Bands I III, 17 6.  
Aerialite outdoor for fitting to existing mast :3-ele., 30. : 4-ele., 36 6. 5-ele., 42 6.  
Chimney lashing and wall fitting equipment available, extra.  
Co-axial Cable, semi-airspaced, yd. 9d.  
Aeraxial, yd. 10 1/2d. 300 ohms Feeder, yd. 9d.  
Diplexes, 12 6. Wolsey Crossover Boxes, 15 -.

Open all day SAT. Half day Thurs.  
**LASKY'S (HARROW ROAD) LTD.,**  
42, TOTTENHAM COURT ROAD, W.1.  
Telephone: MUSeum 2605.  
**370, HARROW ROAD, PADDINGTON, W.9.**  
Telephone: CUttingham 1979-7214.  
All Mail Orders to Harrow Road.

Wolsey Combined Bands I III, 17 6.  
Aerialite outdoor for fitting to existing mast :3-ele., 30. : 4-ele., 36 6. 5-ele., 42 6.  
Chimney lashing and wall fitting equipment available, extra.  
Co-axial Cable, semi-airspaced, yd. 9d.  
Aeraxial, yd. 10 1/2d. 300 ohms Feeder, yd. 9d.  
Diplexes, 12 6. Wolsey Crossover Boxes, 15 -.

# Your set deserves a Mullard

## LONG=LIFE TV TUBE

If you are building a television receiver, leave nothing to chance: choose a Mullard Tube. Mullard Television Tubes owe their high reputation for performance, reliability and LONG LIFE to the unrivalled facilities for research possessed by Mullard and to the complete control of manufacture from the production of raw materials to the finished product. For practical evidence of performance and reliability, ask the people who use them.

### MULLARD LONG LIFE TUBES FOR HOME CONSTRUCTORS

MW22-16	...	...	9 inch circular screen.
MW31-74	...	...	12 inch circular grey-glass screen.
MW36-24	...	...	14 inch rectangular grey-glass screen.
MW41-1	...	...	16 inch circular screen. Metal cone.
MW43-64	...	...	17 inch rectangular grey-glass screen.

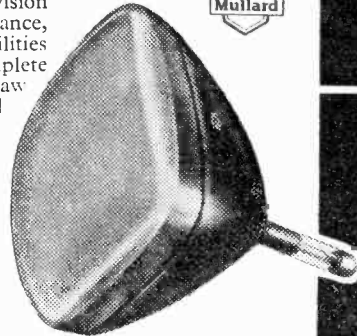

MW43-64



MW22-16



MW31-74



MW36-24

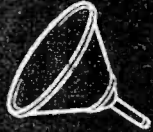

MW41-1

MVM290

MULLARD LTD · CENTURY HOUSE · SHAFESBURY AVENUE · LONDON W.C.2

## FOR THE HOME CONSTRUCTOR

# 'VIEWMASTER'

## Bands I and III Tuner, incorporating T.C.C. printed circuits

This set of parts has been specially developed for the home constructor, as specified in this issue of 'Practical Television'. It is now made available by T.C.C. to simplify assembly and eliminate possibility of errors.

### Set of Condensers and Printed Circuits for Viewmaster Tuner

1	1 pF	Type CC.125S	10	1000 pF	Type CC.160S
1	3 pF	.. SCP.5	1	5-3 pF	.. CC.164N
1	5 pF	.. SCP.7	1	3-9 pF	.. CC.159N
1	10 pF	.. SCP.8	2	—	Printed Circuits
3	1000 pF	.. CTH.310	2	—	(Types C.130 & C.366)
					B9A Valve Holders

Special price . . . £2.3.0

Order through your usual dealer

## THE TELEGRAPH CONDENSER CO. LTD

RADIO DIVISION: NORTH ACTON · LONDON · W.3 · Telephone: ACOrn 0061



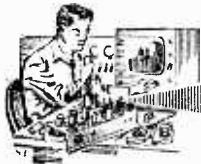

# Practical Television

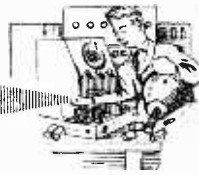

## & TELEVISION TIMES

Editor : F. J. CAMM

Editorial and Advertisement Offices : "Practical Television," George Newnes, Ltd., Tower House, Southampton Street, Strand, W.C.2. 'Phone : Temple Bar 4363. Telegrams : Newnes, Rand, London.  
Registered at the G.P.O. for transmission by Canadian Magazine Post.

Vol. 6 No. 68

EVERY MONTH

JANUARY, 1956

## TelevIEWS

### T.R.F. AND I.T.V.

UNTIL the advent of I.T.V. many receivers were designed around the standard tuned radio-frequency circuit. It is not possible to receive I.T.V. on a T.R.F. receiver satisfactorily without modification. We are publishing at present the modifications necessary for one well-known home constructor TV receiver, and together with a tuner for Band I and Band III we shall publish modification details so that it may be used with other receivers. Until I.T.V., the BBC held not only a monopoly of the programmes, but also of technical development.

### THE NEW CRYSTAL PALACE TRANSMITTER

THE new Crystal Palace transmitter which is expected to be in operation in the spring of next year will operate on a single side-band, and this will render obsolete a number of receivers for which such a system of transmission is unsuitable. As announced elsewhere in this issue, the Television Advisory Committee has informed the Postmaster-General that the best technical solution to the problem of siting television stations in the London area is a single tower to carry the aerials for all the television services of the BBC and I.T.A., and the BBC has agreed to make provisions for I.T.A. requirements on the tower now in course of erection at its new television station at Crystal Palace. Fuller technical information concerning the transmitter appears on page 352 of this issue.

### THE CRITICS CRITICISE

LADY DOCKER has informed the press that she has "banned" TV as a result of the comments of the TV critics concerning her recent appearance on I.T.V. She says that because she is not a professional performer she will not be criticised by the critics. This much-publicised lady and her husband, however, should remember that publicity is of two kinds,

favourable and adverse, and those who seek publicity must take what is coming to them. We do not imagine that viewers will be greatly perturbed at Lady Docker's decision not to appear on TV in future, and whilst we deplore the phraseology of some of the criticisms, such as the reference to Sir Bernard's Victorian side stroke, or to Lady Docker as the last of Mayfair's red hot mommas, critics have every right to criticise programmes, whether those appearing are either professional or amateur, or whether they are appearing purely for publicity purposes. No one has the right to expect critics to be entirely adulatory. In point of fact, the I.T.A. would be well advised to keep away from stunt items in their programmes. The viewer pays his money and in the main should expect to be entertained by paid professional artists.

### "A BEGINNER'S GUIDE TO TELEVISION"

WE recently concluded in our companion journal, *Practical Wireless*, a series of articles entitled "A Beginner's Guide to Radio," which has since been republished in book form at 7s. 6d. This series of articles proved most popular and the demand for back issues which could not be supplied led to the republication of the series as a volume.

The suggestion has been made by large numbers of readers that a similar series relating to television should be given in this journal, and accordingly next month the first article of a new series entitled "A Beginner's Guide to Television" will appear. The series will be entirely non-technical and fully illustrated.

More advanced readers are reminded that we publish *Television Principles and Practice* which costs 25/-, and for the constructor, *Practical Television Circuits* at 15/-. A full catalogue of all our technical publications in the fields of radio, television, electricity, engineering and model making is available free to all readers enclosing a stamped envelope. Address your enquiries to "Catalogue" care of this journal.  
—F. J. C.

# ALIGNMENT OF TV RECEIVERS

MAXIMUM PERFORMANCE IS ONLY OBTAINED WHEN A SET IS PROPERLY LINED-UP. THE PRINCIPLES ARE DEALT WITH HERE

(Concluded from page 294 December issue)

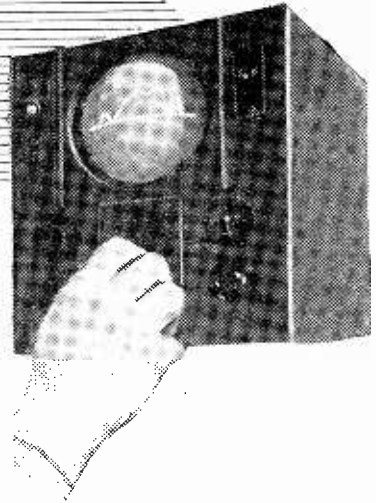

**I**N practice it is sometimes found desirable first to tune the oscillator for maximum sound, and then readjust it very slightly to strike a compromise between minimum sound interference on vision and optimum picture quality—and in some cases to minimise “ringing” on the picture.

The purpose of the pre-frequency changer stage/s is to preserve the desired responses obtained in the I.F. channels and to limit the sensitivity of the receiver to signals which are liable to fall in the spectrum which is just outside the bandwidth of the channel to which the receiver is tuned. Moreover, the R.F. circuits raise the aerial signal to a level which outweighs the “noise” generated by the frequency changer, and thus enhances the receiver’s signal-to-noise ratio.

In order to adjust the R.F. and oscillator circuits of Fig. 8, for example, the oscillator should be made active and the signal generator removed from the anode of the R.F. valve V1. The generator should now be connected to the aerial socket and tuned to the sound frequency of the channel required. In the case of Channel 4 (Sutton Coldfield) this is 58.25 Mc/s.

At this stage it is desirable to switch the receiver on and allow it time to warm up properly before adjusting the oscillator tuning, L5, for maximum sound. If it is known that the generator is not very accurate, it should be attempted to receive the sound signal on the partly aligned receiver (this very rarely presents

any difficulty), after which coupling the generator to the aerial terminals and then adjusting it to the dead-beat point so that a correction reading can be obtained.

After having set the local oscillator tuning, the image rejector, L1, should be adjusted. This circuit is installed to prevent a signal at the vision image (second channel) frequency from gaining admittance to V1. The precise frequency to which it should be tuned for this purpose depends, of course, on the relationship between the vision I.F. and oscillator frequency. So far as the circuit at Fig. 8 is concerned, however, it might well be tuned to a frequency of 95 Mc/s, but since such a circuit can tune over a relatively wide range, it is permissible to tune it to correspond to any frequency within its range at which a spurious response of the receiver might cause pattern interference.

It is best adjusted by applying a large signal to the aerial terminals at the second-channel or receiver’s spurious frequency and tuning for *minimum* indication in the video meter.

The aerial transformer and the R.F. anode coil are generally adjusted for maximum output in the video meter when a signal which is 1.5 Mc/s lower than the vision carrier frequency is applied to the aerial terminals. On a Channel 4 receiver this is 60.25 Mc/s, such a deviation from the vision carrier towards the sound carrier provides a good balance between sound and vision.

Finally, the sound and video meters should be removed, the aerial inserting in place of the generator, and the oscillator adjusted on the signal for optimum performance.

## Sensitivity and Bandwidth Measurement.

Those service engineers and experimenters who are fortunate in possessing a signal generator which features a fairly accurately calibrated attenuator, a meter which is suitable for measuring video output, and a sound output meter are in a position to determine the accuracy of the sound and vision alignment.

With television receivers, apart from measuring the sensitivity of the sound and vision channels, it is also desirable to get some knowledge of the band-

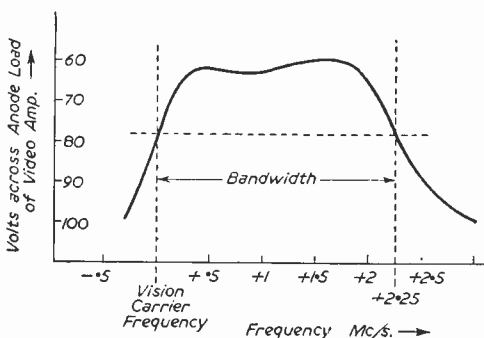

Fig. 9.—A vision response curve obtained by plotting the deviation in voltage across the video anode load resistor against small changes of frequency from the carrier frequency.

width of the vision channel, for it is this latter characteristic which determines the amount of picture detail passed by the vision channel.

Bandwidth in this respect is often defined as the difference between the vision carrier frequency and the frequency at which the response is again at the same level.

Sensitivity, on the other hand, is generally a measure of the input voltage (in microvolts) at the sound or vision carrier frequencies required to give a stipulated output.

In order to acquire a measure of the overall sensitivity of both the sound and the vision channels, the signal generator should be connected to the receiver aerial input terminals, the same as for R.F. alignment, an audio output meter or A.C. voltmeter should be properly loaded and connected in place of the loudspeaker and a D.C. voltmeter may be connected across the anode load of the video amplifier valve with the negative connection to anode—this set-up is shown in Fig. 10.

Now, when the receiver is switched on the voltage drop across the anode load resistor will be measured on the D.C. voltmeter, which, incidentally, should have a full-scale deflection of something like 100 volts (on certain receivers a higher volts range may be necessary). When a signal at vision carrier frequency is applied to the receiver aerial terminals from the generator, the voltage drop across the anode load resistor will increase as the result of an increase of current in it.

This alteration of voltage corresponds, within limits, to the signal in the vision channel, so that an increase of voltage will occur with an increase of signal from the generator. The actual voltage deviation used as a standard measure varies between receivers, but when it is taken from across the video anode load resistor a change of 10 volts often represents a standard output.

This being the case, then the signal generator attenuator is carefully adjusted until the meter reading is 10 volts above that with no input signal. The resulting input voltage—as shown on the variable attenuator—is a direct measure of the sensitivity of the vision channel. Normally, the change of voltage which is aimed at corresponds to a peak-white signal level, in which case the sensitivity can be defined as a "certain number" of microvolts necessary to drive the tube peak-white.

The sensitivity of the vision channel varies considerably between receivers, but for a modern fringe area receiver it ranges between 75 and 150  $\mu\text{V}$  at the carrier frequency. By the way, it is not desirable to modulate the signal from the generator for tests in the vision channel.

We have seen that the receiver response at the carrier frequency is some 6 dB down on a modern single sideband receiver. Therefore, as the generator frequency is increased from the carrier frequency the

apparent sensitivity of the receiver will rise, but it will start falling again as the generator frequency is advanced towards the limit of the high-frequency response of the vision channel.

Now, if we take a reading, as for the vision sensitivity test, at the carrier frequency, making sure that the applied signal is not overloading the vision channel in any way, and then slowly adjust the frequency of the generator above the carrier frequency and along the top of the vision response curve until the voltage reading falls again to correspond to that given at carrier frequency, we can get a good idea of the bandwidth of the vision channel, it being simply the difference between the vision carrier frequency and the frequency given on the generator at which the voltage across the anode load resistor again falls to the same level. On most receivers the bandwidth measured in this way is in the region of 2.25 Mc/s.

If we wish, of course, we can easily make a graph of the vision channel response by plotting the deviation in voltage across the anode load resistor against small changes of frequency from the carrier frequency (or even below it) to about 3 Mc/s above—see Fig. 9. The top of the response curve so derived should be fairly flat, but in practice it is generally found to possess a few bumps which are quite harmless provided they are not too peaky; peaky changes in response are liable to provoke considerable "ringing" or black after white.

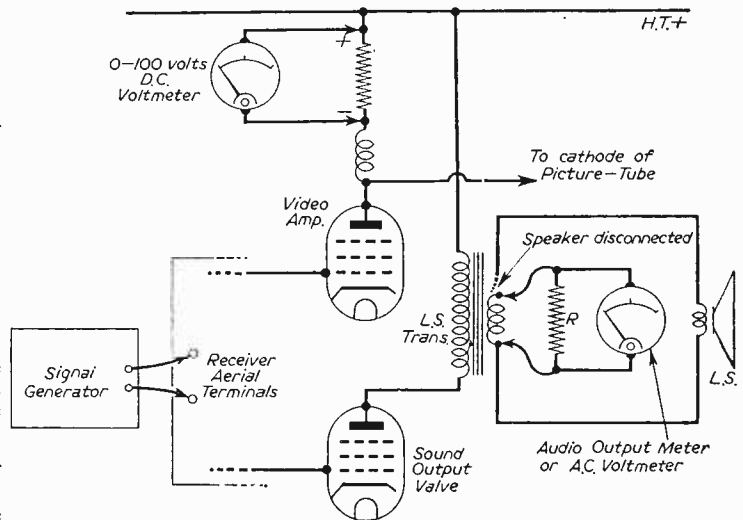

Fig. 10.—Setting up a television receiver for sensitivity and bandwidth measurements.

#### Sound Channel

The sensitivity of the sound channel is measured by disconnecting the loudspeaker and in its place connecting either a suitably loaded A.C. voltmeter or an audio output meter, and applying a modulated signal from the generator at sound carrier frequency.

Again, the reference voltage used as a standard varies between receivers, but in a lot of cases it is something in the region of 0.5 volts A.C. developed across a 5 ohm resistor. This corresponds to 50 milliwatts, which, of course, would be read directly from the scale of an audio output meter.

# A TELEVISION VIEWING LAMP

By J. Black

IT is well known that some kind of subdued lighting is an advantage while viewing a television screen. The following gives details of a television viewing lamp with adjustable brilliance which has also proved a very economical decorative lamp when the brilliance is set to a low position.

A 25 watt lamp was decided upon as the maximum and 5 steps of decreasing brilliance were arranged.

A 250 volt 25 watt lamp takes  $\frac{25}{250}$  amps equal to .1 amp or 100 milliams.

A dimmer resistance was not used due to the heat dissipated, and a choke coil was found to be much more suitable.

### The Choke Coil

The choke coil consists of a 1 1/4 in. stack of laminations as shown in Fig. 1.

The coil consists of 2,600 turns of No. 32 enamelled wire with tappings at 1,300, 1,800, 2,200 and 2,600 turns, which is the finish of the winding.

A five-point switch is wired up as shown in Fig. 2 to give control, and care should be taken that a switch with an insulated spindle is obtained in the interests of safety.

The coil bobbin is very easy to wind with a hand brace secured in a vice acting as a lathe. The tapping points should be soldered and covered with adhesive tape before continuing winding. Care must be taken that the sections are all wound in the same direction. There is ample room on the bobbin for the wire, and thin plastic wire obtainable at the popular stores should be used to make the tap leads which, of course, are only three—five leads in all including the beginning and end of the coil.

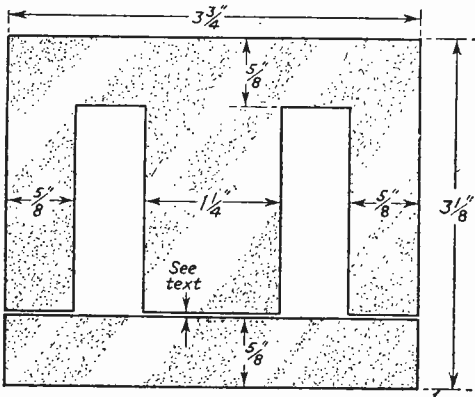
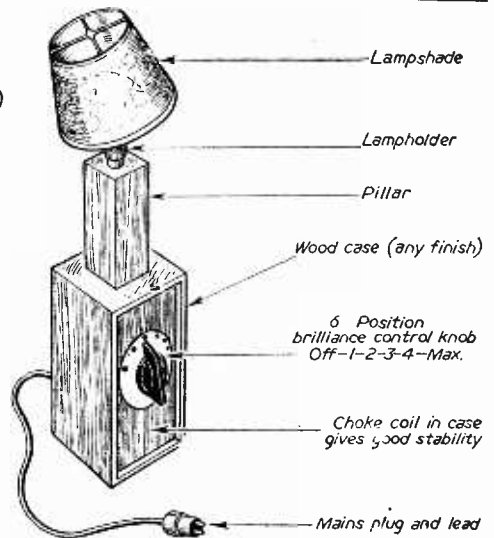

Fig. 1.—Typical iron core laminations which are used to make up the choke shown in Fig. 2.



### Cool Running

There is no heat generated by the choke coil, which operates by generating a back E.M.F., and, of course, limits the current and so the brilliance, depending upon the setting of the dimmer switch.

The finished lamp can take any desired form but a drawing of the lamp as made by the writer is in the block at the top of the page.

The minimum brilliance level of the lamp can be fixed within limits by varying the gap of the core from butt joint up to about 1/32 in. gap or slightly more.

### For A.C. Only

The lamp, of course, is only suitable for A.C. mains.

In the case of D.C., of course, it is not possible to use a transformer, and some alternative method of regulating the lamp would then become necessary. Probably the simplest method would be to use a variable resistance in the form of one of the larger types of rheostat which would carry the current passed by the particular bulb which is chosen for the lamp. The heat problem must then be considered, and, as in the case of the A.C. equipment, it must be totally enclosed to avoid the risk of shocks.

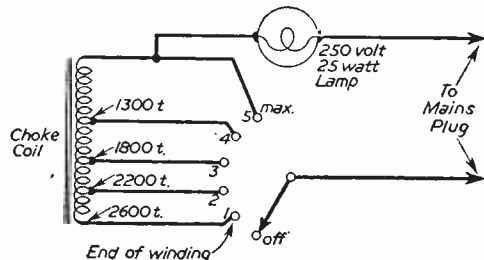

Fig. 2.—Circuit of the tapped choke which is used for controlling the brilliance of the lamp.



# CONVERTER PROBLEMS

COPING WITH PROBLEMS OF CONVERTERS FOR BAND III

By "Serviceman"

**B**ESIDES the designs which have been appearing in PRACTICAL TELEVISION, a large number of different models of converters for Band III are now available. The majority of these converters have been designed as "Add-on" units which can be connected to the television receiver.

Their principle is the conversion of Band III frequencies to those of Band I and they have been designed so that the local Band III transmitter can be received with the television receiver proper tuned to the local Band I station.

The principles of converters have been known for a long time; modern techniques and circuitry have made the production of converters fairly simple and the use of modern valves has increased their efficiency. What is lacking is data of their practical performance on the newly-opened band and some unexpected stages have arisen.

## Signal Strength

It must be fully appreciated that the signal strength in any one locality is known to be much smaller in the case of Band III transmissions than is the equivalent case for Band I.

Where the signal appears to be weak, then, the first point to examine is the aerial system rather than blame the converter for low amplification.

We cannot, at this stage, determine what type of aerial is best in any one locality. As a rather loose general guide it can be said that a dipole will not be very effective at more than 10 miles from the transmitter.

Now please do not immediately write and tell me you are living in the Outer Hebrides and are receiving a wonderful signal with a length of wetted string. In the first case I would not believe it and in the second case the reply is that there are exceptions to every rule!

Because we read that someone in Bristol is receiving the programmes it does not automatically follow that good reception should be obtained 20 miles from the transmitter. The chap at Bristol is probably living right at the top of a very big hill and has an array of 20 or more elements, while someone could be almost within viewing distance of the transmitting aerial yet could not get satisfactory results because of shadows.

Use a good aerial system if the signals show signs of weakness and erect the system as high as is practicable.

## Feeder and Matching Losses

At Band III feeder losses are much greater than exist in Band I, and where the feeder is of any length the losses are likely to be quite high. The use of a low-loss feeder from a reputable maker is worthwhile and is a principle which should always be followed.

\*As an example a loss in the feeder system of 3db would necessitate an increase of power of five times at the transmitter to produce the same results as if there was no loss.

The matching difficulty is more acute. Bad matching not only results in loss of signal strength but encourages ghost reception. It is worth while experimenting with the converter end to obtain the very best matching possible between the converter and feeder.

Where a single feeder is being used for a Band III and Band I aerial then a splitter box should be employed. For the best results a commercially produced article should be used; they are not expensive.

## Coils

The coils in the converter have been designed so as to cover the frequency of the channel in Band III which is situated locally. Because of the bandwidth of the converters, most kinds will tune in both channels by adjustment of the cores. If it is impossible to peak the tuning then try closing up or widening out the spaces between the coil turns.

The rule is that where iron-dust cores are used then the coil turns should be spaced farther apart if the core is almost out of the former, before a peak is reached. On the other hand, the coil turns should be spaced closer together if the core is fully in without the peak being reached.

Where brass cores are used the reverse is the case as insertion of the core increases the frequency to which the coil will tune.

It is wise to cement the coil turns in position with a drop of recognised coil dope which has low-loss properties.

## Frequency Drift

Final adjustment of the tuning should not be made until the converter and the televisior have been well warmed up and the tuning should not be altered once it is set. Many constructors fail to appreciate this point and retune the coils when first switching on, finding out that they have to be reset when the converter is fully warmed up.

In severe cases it may be advisable to fit a condenser with a negative temperature coefficient across the oscillator tuning coil. A Dubilier CTS 310 should prove suitable. It should be connected across the

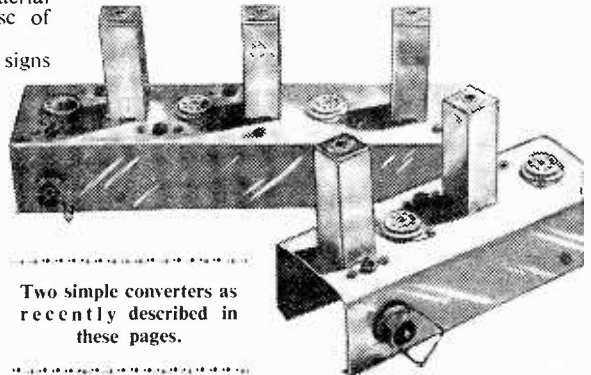

Two simple converters as recently described in these pages.

existing tuning condenser on the oscillator circuit, or across the oscillator coil if there is no tuning condenser.

### London Receiver Difficulties

The London transmitter at Alexandra Park was the first TV transmitter in the world to go into regular service. Much has been learned since this station was first opened and one rather important factor affecting us at the present time is the fact that double sideband modulation is used for the vision signal. Single sideband transmission is now the universal rule and all the other TV stations in Great Britain use single sideband.

The difficulty now arises as to the method employed by the manufacturer of a television receiver in his I.F. tuning arrangements.

Some receivers have the I.F. arranged to cover both sidebands; some have the I.F. arranged to cover the upper sideband; some have the I.F. arranged to cover the lower sideband.

Most converters are based on the principle that the sound transmitter is at a lower frequency than the

where complaints were made of the poor quality of the Band III pictures. It was found that the sensitivity of the Band III converter had been turned very low and the input to the televisior being at such a low level it was necessary to turn the contrast up to maximum. The result was the production of noise patterns on the screen.

Contrast and sensitivity should be adjusted in conjunction with each other, the ideal arrangement being equal parts of each.

It must be remembered that a converter adds considerable gain to a televisior and this must be taken into account. Where separate aerials are employed, then use a good class of aerial for the Band III transmissions, even if the signal strength is high, and fit attenuator pads in the aerial system.

Fig. 1 shows some suitable attenuators for coaxial cable and for balanced twin.

### Local Breakthrough

In places where the local Band I transmitter has a good signal strength then it has been found that the local station will break through the converter and

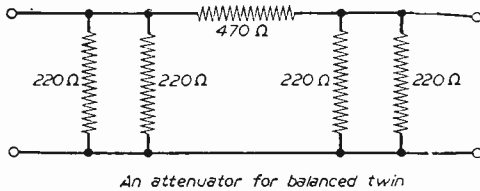

An attenuator for balanced twin

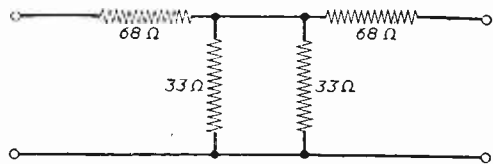

An attenuator for coaxial cable

Fig. 1.—Right, An attenuator for coaxial cable, and left, an attenuator for a balanced twin lead.

vision transmitter but the distance between the two is set by the usual channel requirements. The lower sideband of the vision signal is employed and those London receivers in which the lower sideband is employed should respond quite satisfactorily to a converter built for this standard form.

Where the London receiver is adapted for the full double sideband reception, then the picture is liable to suffer from distortion when it comes from the converter. Ideally, the vision signal should be 6db down at carrier frequency for normal sideband reception and this condition does not hold where the circuits are adjusted for the full double sidebands.

In these cases, some adjustments of the converter oscillator may enable a reasonable picture to be resolved. It is unwise to alter the oscillator in the televisior or normal reception of the Band I station may be affected.

Where the televisior is adjusted for the upper sideband then it will be rather difficult to get the converter to work. The only real solution to the problem is to re-align the vision I.F. stages so that lower sideband reception conditions are obtained.

The re-alignment procedure requires some skill and should not be attempted by the novice. Once the I.F. alignment is altered it is not a simple matter to obtain the correct alignment without the aid of a signal generator and/or wobblulator.

### Contrast and Sensitivity

Some converters are fitted with a sensitivity control and it is important that this control should be correctly set, in conjunction with the controls of the normal televisior.

To make the matter clear, a case was experienced

both programmes can be received simultaneously.

The answer to the problem is to fit wavetraps in the converter first stages, which are tuned to reject the local station.

Where T.R.F. receivers are used then it is possible for the local station to be picked up directly and the answer here is either to fully screen the vision and sound R.F. stages, or to convert to a superhet.

Five-channel tuners can be successfully used in some cases. Where the local transmitter is on, say, Band I Channel 1, then the televisior can be switched to another channel and the converter tuned to convert on that chosen channel.

### F.M. Breakthrough

It is possible for harmonics from the F.M. transmitters to break through and interfere with the picture. Careful screening and re-orientation of the aerial system may assist in these cases.

The second harmonic from the transmitters at Wrotham fall directly into Band III.

A point which must not be overlooked is the possibility of the injection of the oscillator frequency from a F.M. converter which is located nearby.

A wavetrapp at the fundamental may provide some assistance.

The gain of the mixer stage of the converter is dependent on the conversion conductance of the valve. To obtain the best results the injection voltage from the oscillator must be set to within comparatively narrow limits.

It is often worthwhile to experiment with the oscillator voltage to ensure that injection is taking place at the best possible point. Even slight variations often produce a marked increase in gain.

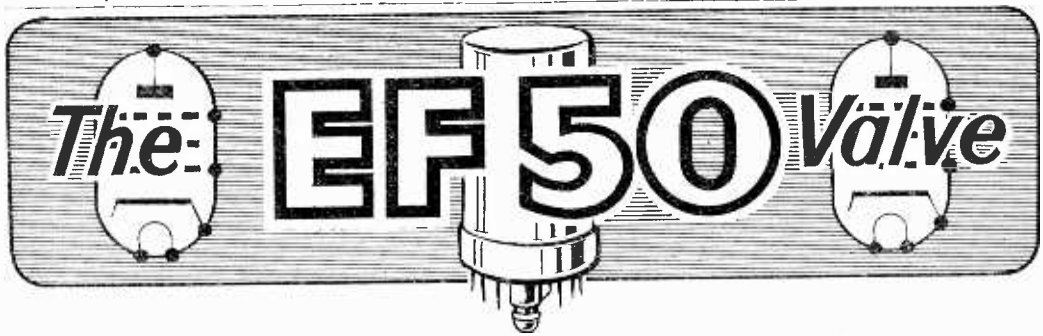

## SOME NOTES ON ITS MERITS AND FAULTS

By "Erg"

**T**HE EF50 valve is deservedly popular with the home constructor and has been used in very many television receivers including commercial models. In the commercial world it has been superseded by the miniature type which enables chassis space to be saved and greater efficiency to be attained.

During the war years the valve was used extensively in all kinds of radar equipment and this accounts for it being available in such large quantities.

The original valve was made in this country by Mullards and the ex-Government British types which are of Mullard manufacture still take some beating—even by the famed red Sylvania types.

The valve has a 6.3 volt heater, rated at 0.3 amps. The maximum anode voltage should be 250 volts and the current 10 mA. The maximum screen voltage should be 250 volts and the screen current at this rating is 3 mA.

Grid volts (negative) should be 2 volts, which gives a cathode bias resistor value of 150 ohms, approximately.

The valve has a gm of 6.5 mA per volt and an Ra of 1,000 K. The ex-Government number is VR91.

The performance of the valve is quite good up to about 100 Mc/s, though it can be used for frequencies higher than these and can handle Band III frequencies.

It should be remembered that this valve has been made by different manufacturers and it is difficult to find two valves which have perfectly identical characteristics. It is a good precaution to try different valves in a circuit which does not come up to expectations in order to obtain the optimum results.

When the EF50 was introduced it became a serious challenger to the SP61 which it has, for most practical purposes, superseded. The SP61 is not only a greedy valve as it takes 0.6 amp. heater current, but the chassis layout has to be especially designed to cater for the top-cap grid connection.

With the grid of the EF50 taken out to the base pin a much simpler form of construction can be employed.

### Bias Adjustment

Some of the EF50 valves are quite critical when it comes to the biasing arrangements. For maximum efficiency when a valve of unknown origin is being used it is a good move to make the bias variable from between 1 to 3 volts. Care must be taken not to under-bias and thus over-run the valve and a fixed resistor should be inserted in the circuit as shown in the diagram on page 346.

### Heater Resistance

It has been found that with many of the non-British types the resistance of the heater is liable to vary, being both above and below the standard. It is for this reason that it is well worth-while trying several valves in a circuit which does not appear to come up to expectations.

Another common fault is poor cathode insulation which causes the control grid to be driven positive. In such cases the life of the valve is generally short!

### Video Output Valve

The valve performs quite satisfactorily as a video output valve in standard circuits, but when used with a grid-modulated C.R.T. there is some danger of over-running the valve.

Where grid modulation is employed the output of the video valve must drive the grid of the tube in a positive direction on peak whites so as to increase the strength of the electron beam. This means that the input to the video valve must be negative-going, i.e., the whites must drive the grid in a negative direction.

Now the greater part of the incoming waveform (70 per cent.) constitutes the positive movement and so the valve must be lightly biased or the grid, being driven heavily negative, will drive the valve beyond its cut-off point. The result is that peak whites are cut and the picture lacks the brilliance of that where cathode modulation of the C.R.T. is employed.

Being lightly biased the valve will draw a heavy anode current when no picture signal is being received. The wise constructor will take out the video valve when he is experimenting with the timebase or sound section of the receiver and no signal is being received.

### Base Pins

One of the major defects of the valve would appear to be in the base pins. Trouble from poor contact between the holder and the valve is very common and there are several precautions which should be observed when using the valve.

The first and most obvious is to clean the valve pins. These valves have been in storage for a considerable time and the pins will often be found to be very dirty. It is a simple matter to clean them with emery cloth, but undue pressure should not be exerted or the glass may fracture.

It is a good idea to test the pins at this time to ensure that they are securely anchored. More than one puzzling fault has been caused by the pins

seeming sound enough but not fully secured to the internal section.

The valveholder needs careful choice. There are three main types about—the ceramic, the plastic and the paxolin. Of these the writer prefers the paxolin, which makes a good contact; some prefer the ceramic, which is quite a good holder, but undoubtedly the worst type is the plastic one, as the pins are liable to drop out when an iron is applied.

It is advisable always to use one of the retaining rings available for this class of holder.

There are two main types available, the screw type and the spring type. Of the two the latter is liable to prove the better as it grips the valve securely.

#### Stability

One complaint which is often heard about this valve is its proneness to instability. Provided the associated circuitry is in order then the main cause of instability is poor base contact and the measures mentioned in the previous paragraphs should be adopted.

Some of the valves appear temperamental in regard to the connection of the suppressor grid. In some cases an improvement will be found if this is connected to the cathode, in others it is better for the grid to be connected directly to the chassis.

It must not be forgotten that the outer metal casing is connected to the central spigot and this must be earthed. Also the internal screen is

connected to pins 5 and 8 and these, too, must be earthed.

#### Alternative to SP61

Constructors often enquire if the valve can be used in place of the SP61 (VR65 alias CV118). Where

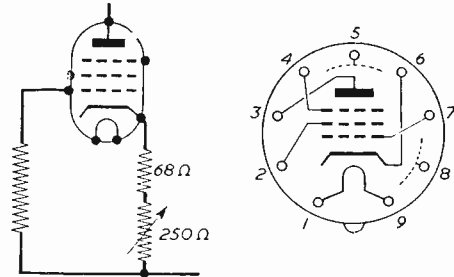

Bias arrangement and base details of the EF50.

timebase circuits are involved the answer is yes, and modification is not normally necessary.

However, in the case of tuned circuits the question of stray capacitances comes into operation. As a general rule it can be said that the valve can be used provided the constructor is prepared to experiment with the turns of the associated grid coil. It will be found that in most cases the grid coil should be reduced by one turn when an EF50 is used.

## "Animal, Vegetable or Mineral"

### Some interesting details of a Popular Programme

"ANIMAL, Vegetable, Mineral" has a new pair of hands. They are those of Elizabeth Hamilton, the London fashion model, who has joined the programme as the "lady handler" responsible for setting the objects in front of the panel of experts. Miss Hamilton is the fifth "handler" since the programme started; and she has taken over from Miss Frances Lyndall, who is now with a theatre touring company. Like her predecessors, Miss Hamilton has to handle valuable objects with the greatest of care: and it is a tribute to these assistants—as well as to the experts themselves—that only one item has been broken during the run of the programme. This was an ancient Egyptian surveying instrument, which was accidentally snapped in two while being examined by the panel. It is now repaired.

"A.V.M.," as it is called around the Lime Grove studios, is now in its fourth year, with actual performances in the sixties. Each edition begins with a green folder marked "A.V.M. Pending" in the office of producer Paul Johnstone. From this folder are taken in rotation the letters from museums challenging the experts. The producer then visits the week's challenging museum to look at the objects chosen by the museum. The day before the programme is televised the BBC sends a car to collect the objects and an attendant. All the packing and unpacking is done by museum officials, never by BBC staff. The attendant sees the objects into a strong-room at Lime Grove, where they remain until the programme is rehearsed. Needless to say, the experts do not take part in this rehearsal, which is conducted for the benefit of the camera crews, for chairman

Glyn Daniel to see the objects and for the handler to get used to them. Usually, the museum curator and a Lime Grove call-boy stand in for the panel. This rehearsal over, Dr. Daniel, the curator and the producer go off to dine at a restaurant ten minutes' ride away from the studios. There they are joined by the experts. "At this dinner," says Paul Johnstone, "the producer has to keep a keen eye on the curator to see that he doesn't let slip any piece of information that would subsequently help the panel. It did happen once." After dinner the company returns to Lime Grove with a quarter of an hour to spare before the programme goes on the air. Then, when the programme is over, the objects are put back in the strong-room and returned to the museum the next day. All collections of objects are automatically insured for £3,000. But if their value exceeds this a special insurance policy is taken out. For example, a £60,000 collection of Faberge's jewellery which formerly belonged to the Czar of Russia had to be specially insured.

Since it began, "Animal, Vegetable, Mineral" has introduced between 60 and 70 experts; and the expert with the best record of successes is, of course, Sir Mortimer Wheeler, who in the first year of the programme was beaten only by one object—a comb for removing the mud from horses' tails. "A.V.M." has been the subject of U.N.E.S.C.O. articles; librarians report that it has encouraged interest in archaeology; and museums say that the number of finds offered to them has doubled since the programme began to be televised. What was the producer's favourite moment during the programme's long run? It was the occasion when Dr. Julian Huxley was confronted with an egg. He wagered chairman Glyn Daniel £1 that it must be either a reptile's or a bird's egg. It was neither; it was a Giant Snail's egg. Dr. Huxley paid over the £1.

# BAND III AERIAL SITING

THE PROBLEM OF AVOIDING GHOSTS AND OBTAINING GOOD INPUT SIGNALS

By R. Best

**A**ERIAL siting is a relatively simple job on Band I, it being necessary in a large number of cases simply to set the aerial on a pre-determined compass bearing. This procedure is generally adequate in service areas and in near fringe areas where little interference and ghosting is experienced.

In extreme fringe areas or where ghosting and interference is troublesome, however, the task may not be quite as simple. Here it often pays either to site the aerial for maximum pick-up or for maximum signal-to-noise (and ghosting) ratio. The trouble is, of course, aggravated to a large degree where a complex multi-element array is necessary, owing to its relatively small angle of pick-up.

In cases such as these, some form of contact between the man on the roof and an operator at the receiver is most desirable, as then the array may be readily rotated for the best picture. A small ex-Government field telephone is ideal for this purpose, and is used by experimenters and installation engineers all over the country.

Now that Band III is open, and large sections of the country, for the time being anyway, are not going to be adequately provided with a first-class signal, many multi-element Band III aerials are going to be installed. These aerials, owing to their high gain and large number of elements, possess an extremely narrow angle of pick-up, considerably less than any Band I aerial of the multi-element variety.

With certain arrays of this kind it is necessary only to swing it a matter of 5 to 10 degrees to pass right across the acceptance angle and thus go from a point of minimum pick-up to a maximum pick-up and then again to a point of minimum pick-up. Even if an accurate compass bearing can be obtained at the site in relation to the transmitter, it is most difficult and in some cases almost impossible to set the aerial within such a fine tolerance.

This is particularly marked in areas of very low signal strength, where it is quite feasible to install the array by compass and then discover later that the picture is well below expectations. In a lot of cases of poor Band III pictures investigated in the fringe area by the writer, the trouble has been caused solely by inaccurate aerial siting. In some extreme cases no picture at all could be obtained until the array was rotated just a matter of degrees!

Clearly, then, something more than purely verbal contact is required between the receiver operator and the aerial rigger. A telephone can be a great help, of course, but some more definite means of setting the aerial is almost certainly going to become essential in the very near future.

## A Solution

Several experiments have been carried out by the writer in an endeavour to find a simple solution to the problem. It was first thought that the obvious solution simply involved running a length of twin cable from across the receiver's low-impedance loudspeaker tags to an A.C. voltmeter or audio output meter conveniently situated in proximity to the aerial.

This method was tried by adjusting the receiver to give a readable indication on the meter during a test-tone transmission. The aerial could undoubtedly be adjusted to provide a peak reading, but three main drawbacks were observed.

First, it was soon discovered that a steady test-tone transmission is not always available when required (this was taking the BBC transmissions as a basis, since a test-tone has been transmitted almost continually by the Belling and Lee Band III station during its period of operation on Channel 9), and it is hopeless trying to make a delicate adjustment when the meter needle is flicking to-and-fro in rhythm with any other modulation.

Secondly, it was noticed that even if the aerial was adjusted for maximum sound, this may not represent the optimum position for maximum vision. This effect, however, may have been aggravated since the aerial which was used appeared to have a wider pick-up angle at the sound frequency than at the vision frequency—though this was not proved conclusively.

Thirdly, the effect of the sound A.V.C. was most noticeable unless the input signal to the receiver was sufficiently attenuated. It may have been the A.V.C. action, of course, which was tending to emphasise effect number two. Unfortunately, the A.V.C. system on most commercial TV receivers cannot quickly be disconnected and reconnected.

If any reader wishes to try out this method for himself, care should be taken to ensure that the chassis of the receiver used is adequately isolated from the cable. Remembering that a TV aerial is usually well earthed, and that if the cable connected to the output meter is live and happens to be touched by the rigger at the same time as the aerial, the effect may be dangerous, particularly if the rigger is perched precariously on the apex of a roof.

Two good A.C. isolating capacitors should be used between the loudspeaker terminals and the cable as shown in Fig. 1, and to be on the safe side it is as well to make sure that the receiver is connected to the mains in such a way that the chassis is in contact with the neutral side, where the receiver is of the A.C./D.C. variety, bearing in mind that the loud-

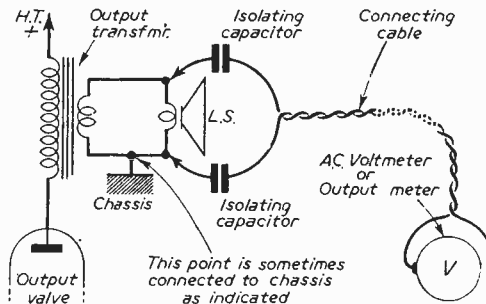

Fig. 1.—Using the sound signal.

speaker is connected direct to chassis on a large number of commercial sets.

### Using the Vision Signal

Next, it was decided to experiment by using the vision signal as a general reference. The problem, however, was that of obtaining a meter indication at

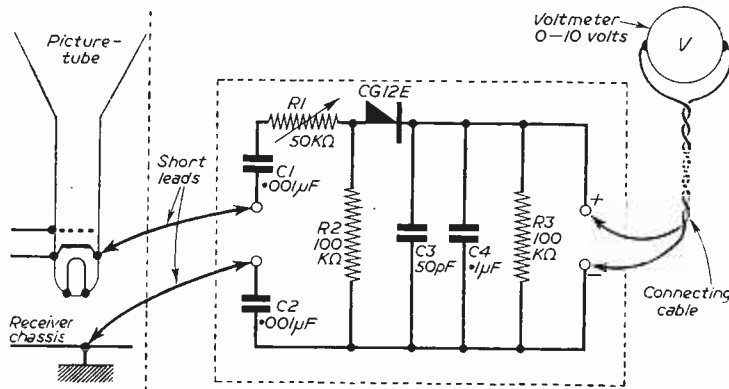

Fig. 2.—Using the vision signal.

a point well removed from the receiver without unduly disturbing the function of the video stages. This was eventually solved by building a rectifying circuit into a small box which could readily be connected between the cathode connection at the picture-tube and receiver chassis.

Provided such an arrangement is connected to the set through short leads, it has very little adverse effect on the general function of the receiver, but is capable of supplying a D.C. voltage sufficient to give a usable indication on a standard moving-coil meter.

The circuit which was finally adopted is shown in Fig. 2. From this it will be realised that the voltage developed across the load resistor R3 corresponds to an average voltage representative of the composite picture-signal and synchronising pulses. Thus, the greater the white content of the picture, the greater will be the voltage across R3.

For this reason, therefore, it is necessary to use the indicator for aerial siting purposes only during the transmission of a still picture, such as the test card. Nevertheless, the test card is radiated more frequently than the test-tone on sound, and at more convenient times—it is understood that the same will apply on Band III.

The rectifier unit makes use of a small crystal diode, and two isolating capacitors C1 and C2 are incorporated to eliminate the risk of shock. The variable resistor R1 acts as a form of sensitivity control which can be adjusted to provide the best indication on the voltmeter. A 4.7 K resistor may, if desired, be connected in series with R1, so that the video circuits of the receiver will not be subjected to excessive damping by the diode circuit when R1 is set to minimum resistance. Capacitor C4 acts as a reservoir and

also provides a certain degree of damping on the voltmeter. This is by-passed by a 50 pF non-inductive capacitor C3 to keep R.F. out of the connecting cable.

Even when used with receivers embodying A.G.C. in the vision channel a maximum can usually be obtained on the voltmeter when the aerial is accurately sited. In areas of very high signal strength, however, the vision A.G.C. may tend to flatten the peak, though this effect can nearly always be countered by the use of a suitable attenuator in the aerial lead, or by reducing the sensitivity setting on the receiver. But, as was intimated earlier, a device of this kind is of most use in areas of low signal strength.

Experiments seem to indicate that siting the aerial for maximum vision signal is much better than siting for maximum sound.

## German Radio and Television Exhibition

ON September 4th the Great German Radio, Television and Phono Exhibition came to an end, after running for ten days with great success. 238 exhibitors from the radio, television, gramophone and component parts industries had reserved a total floor area of over 45,000 square metres, and presented a display unsurpassed in its extent and detail. Numerous interesting developments in almost all fields pointed to the future, showing trade buyers and others interested that this important branch of German industry (as a whole) has reached a standard of achievement capable of holding its own against any international competition.

The exhibitors almost without exception report their sales orders as outstanding. In many cases orders resulting from the exhibition amount to the total production of the firm until spring next year. Hopes for sales of television sets were already high,

but they have been well exceeded by the actual orders received. Representative firms also all agree that this time foreign visitors have been far more interested in buying than at the previous Radio Exhibition in 1953.

The television studio of "German Television" was one of the strongest draws for the crowds. The part it played in stimulating a genuine, in many cases really spontaneous, enthusiasm for television deserves special mention.

The exhibition had over 450,000 visitors. From the point of view of the comprehensiveness of the display the floor space covered by the stands, the number of visitors, and the business transacted, it was the greatest exhibition so far of this type, and, as can be asserted without any doubt from all reports, the beginning of television in Germany on a large scale.

### REFRESHER COURSE IN MATHEMATICS

8/6, by post 8/10. 4th Edition.

By F. J. CAMM

From: GEORGE NEWNES, LTD.

Tower House, Southampton Street, Strand, W.C.2

# A Two-band Signal Input Filter

CONSTRUCTIONAL DETAILS OF A "DIPLEXER," "COMBINER" OR "SPLITTER" FOR USE WITH TWO AERIALS

**N**EARLY all modern commercial two-band television sets feature a single aerial socket which is common to both bands. Such an arrangement is ideally suited when a composite two-band aerial system is employed with a common feeder. Systems of this kind are in use mainly in districts within the service area of both stations where the local field strength due to both transmitters is relatively high. The actual aerials in these cases are coupled in such a way that an impedance match is maintained at the point of connection to the feeder, and a reasonable isolation ratio between the two frequencies involved is achieved.

optimum results. Success in this method is sometimes possible when the Band III aerial input impedance is 300 ohms as against 75 ohms on Band I, but even then the best results are not obtained. Apart from the disturbance in matching by joining two feeders in this way, we must also bear in mind that the chief

## The Problem of Feeding Two Signals to a Common Input

In districts within the secondary service area and in fringe areas it is nearly always necessary to erect separate Band I and Band III aerials in order to obtain pick-up on Band III equal to that on Band I. Excluding brand new installations, the addition of Band III means the erection of a Band III aerial independent of the existing Band I array.

Since the losses involved in carrying the higher frequency Band III signals along the feeder from the aerial to the receiver are approximately double the losses at Band I frequencies, it is always desirable to use extra low-loss feeder on the Band III system, even though standard feeder may be employed on the Band I installation. For this reason it is not good policy to make do with the existing Band I feeder to carry the signals in both bands (although this is possible as we shall see later). The most desirable method calls for the use of a separate run of feeder from the Band III aerial to the receiver.

Two feeders, one for each band, are all very well if the set is fitted with separate aerial sockets, but this is rarely the case these days. A solution, of course, lies in fitting an aerial changeover switch or in changing over the feeders when the band-switch on the set is changed. Both of these methods are inconvenient, and the latter one soon results in deterioration of the set's aerial socket.

It is not possible to join together the feeders of two aerials working at different frequencies and still obtain

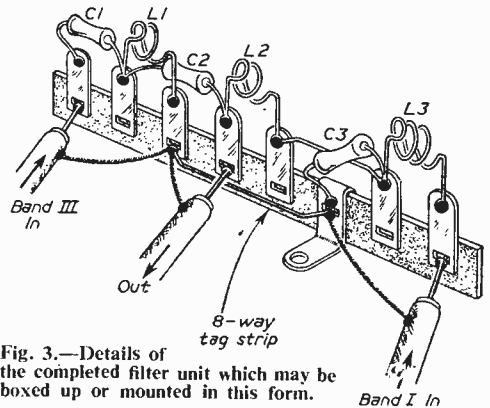

Fig. 3.—Details of the completed filter unit which may be boxed up or mounted in this form.

requirement is in isolating the high frequency and low frequency sections of the feeder, in order to avoid the high frequency signal (Band III) in one feeder shunting the low frequency signal (Band I) in the other feeder and, of course, the converse.

Avoidance of signal shunting can be achieved by combining the signals in both feeders in a double filter network. One section of the filter has a high-pass characteristic and the other section a low-pass characteristic. Now, if the Band III signals are taken to the high-pass section and the Band I signals to the low-pass section, very little attenuation will occur on the signals passing from the aerials into the filters, but considerable attenuation will be offered across the outputs of the filters to the frequencies of the signals involved. For instance, the high-pass filter should be designed to pass the Band III signals and attenuate the Band I signals, and the low-pass filter should be designed to pass the Band I signals and attenuate the Band III signals.

Filters for this purpose can take many forms / though one of the most popular and easy to work with is the "T" section kind. A high-pass "T" section is shown at Fig. 1a and a low-pass "T" section at Fig. 1b; the method of calculation is also indicated for those interested.

Fig. 2 shows a complete high-pass/low-pass filter network and the values of the capacitors. Successful networks of this nature have been made up by the author on eight-way tag strips, using one of the tags as an earthing and fixing point. The method of construction is illustrated at Fig. 3. Here it will be seen that the coils are made self supporting. Eighteen s.w.g. tinned copper wire is ideal and the coils are best formed on a rod of 1/4 in. diameter. Coils L1 and

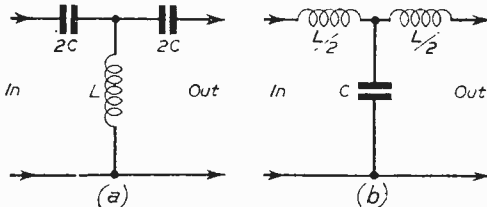

Fig. 1.

High-pass "T" section

Case (a) :  $f_c = 1/4\pi \sqrt{LC}$

$L = Ro/4\pi f_c$

$C = L/Ro^2$

Low-pass "T" section

Case (b) :  $f_c = 1/\pi \sqrt{LC}$

$L = Ro/\pi f_c$

$C = L/Ro^2$

Where  $f_c$  is the critical frequency and  $Ro$  the input and output resistance.

L.2 have two turns, and coil L.3 three turns ; the turns should be separated approximately the diameter of the wire.

It should be mentioned that commercial filter networks made in unit form are known by various names such as " Y " units, " Combining units,"

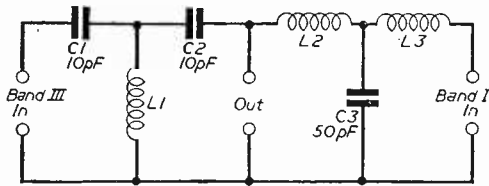

Fig. 2.—A complete high-pass/low-pass filter network for Band III and Band I frequencies.

"Diplexers" and "Splitters." Unfortunately, though, they are not readily available at the time of writing owing, no doubt, to their terrific demand at the present time. In the circumstances, therefore, the writer was compelled to manufacture his own, and since the district concerned is well in the fringe of Band III, the unit described is primarily of use at the receiver end, where two feeders are invariably at hand to be connected to a common aerial socket. The tag-strip arrangement, however, permits easy installation in the receiver cabinet well out of way of the user.

## International Children's News Service

THE BBC announces the inauguration of an International Children's Television News Service. The first edition of this News Service will be seen by children in nine countries of Western Europe early in December. The countries participating in this scheme, which originated from the BBC Children's Television Department, are France, Italy, Luxembourg, Switzerland, Belgium, Holland, Sweden, Denmark and Britain.

Each of these countries will on the first day of every month send a filmed item not less than three minutes in length to all participating countries complete with sound effects but without a spoken commentary. A written commentary will accompany the film which each receiving country will translate for "live" or dubbed transmission.

From material received each country will be free to select material from other countries to be edited by itself and presented in whatever length it prefers for transmission at periods determined by itself.

The contents of the programme will be based on real news and not merely on habits, customs or characteristic magazine type of information. The news in the programme will be about children and their individual or collective achievements. But legislative or social activities connected with, or for the benefit of, children will also be dealt with.

Items televised each month will be selected on their news value—an act of heroism performed by a child, even though it occurred three weeks previously, is essentially more newsworthy than, for example, a visit to a zoo.

Other promising fields are sport ; humane activities such as lifesaving, Junior Red Cross and welfare work.

## The Problem of Extracting Two Signals from a Common Feeder

In areas of high signal strength where a combined Band I/Band III aerial might well be in use it may be required to extract the two signals from the common feeder, either to feed to a receiver having two input sockets, or in cases where a Band III converter is used.

The filter described is quite suitable for this purpose; it is, in fact, simply used the other way round, that is the common feeder taken to the output terminals and the Band I and Band III outputs taken to the appropriate sockets on the receiver or converter.

Provided the network is built into a waterproof box it can be used at the bottom of the aerial mast or close to the aerials so that a common feeder can be used from two aerials to connect to the receiver.

It is often more economical to use two filter networks when separate Band I and Band III aerials are used together with separate aerial sockets than by employing two feeder runs, one for Band I and the other for Band III. Economy is effected particularly in cases where very long feeder runs are necessary, for then a waterproofed filter can be used close to the two aerials to combine the two signals along a common feeder, and then another can be used close to the receiver as a means of extracting the two signals for application to the appropriate aerial sockets.

## BBC Audience Research

IN the tables below the July/September quarter, 1955, is compared with the corresponding quarter of 1954.

### Television

Average level of viewing among the whole adult population of the United Kingdom (approximately 37,600,000 persons).

	% of the adult population
July/September, 1955	11.2
July/September, 1954	10.5

Average level of evening viewing among the "television public."

	% of the "television public"
July/September, 1955	30.0
July/September, 1954	36.9

The audiences of the BBC's evening television broadcasts in July/September, 1955, were larger than they were in the same quarter of 1954. Their average size was 11.2 per cent. of the adult population this year as against 10.5 per cent. last. This expansion was not, however, comparable with the expansion in the size of the "TV public" for viewers spent rather less time in viewing evening programmes. This year the typical evening broadcast was seen by 30 per cent. of the "TV public," whereas last year the corresponding figure was 36.9 per cent. Here again it seems likely that this year's good weather had its effect, for the gap between this year's figure and last year's tended to diminish as the quarter drew to its close and the hours of darkness lengthened.

It is estimated that the average size of the adult "TV public" (i.e., those living in homes where there is a television receiver) in the July/September quarter of 1955 was approximately 13,000,000 and in the same quarter of 1954 was about 10,000,000.



# Cathode-modulating the VCR97

AN EXPERIMENTER'S CIRCUIT FOR THIS CLASS OF C.R.T.

By L. B. Moore

**I**N most of the circuits which employ the VCR97 and similar tubes, grid modulation is employed. This is distinct from the normal commercial practice where the C.R.T. is almost invariably modulated by means of the cathode.

The merits and demerits of cathode versus grid modulation have been discussed before in these pages and it is not intended here to renew the discussion, but to give a simple and straightforward method whereby the amateur can try out grid modulation for himself.

In most of the circuits a phase-splitter stage is employed (often mis-termed, in this sense, a cathode follower).

A standard type of circuit is shown in Fig. 1. The output from the video valve is fed to V, the phase-splitter valve. R is made very high and the complete input circuit presents a high impedance to the video valve. For grid modulation it is preferable to have a low impedance input so as to minimise as far as possible the shunting effect on the high frequencies caused by the input capacitance of the C.R.T.

The output from the video valve is made positive-going on whites and as the polarity at the cathode of a valve is the same as that at the grid, then the correct polarity signal is available from the cathode bias resistor of the phase splitter, and direct connection to the grid can be made.

For sync separation using the standard single valve method a negative-going signal is required. The sync valve is arranged so that under static conditions no current flows through the valve. With a negative-going signal the video portion is negative, while the sync portion is positive, and the sync separator will therefore only respond to the positive sync pulses.

A negative-going signal is available at the anode of the phase splitter and this can therefore be applied to the sync valve.

If it is desired to modulate the cathode of the tube then a negative-going signal is required. If the cathode is driven in the negative direction on peak white, then this is equivalent to driving the grid of the tube in the positive direction and the net result is the same—an increase in the strength of the electron beam.

It is clear, then, that we have, at the anode of the phase splitter a signal of suitable polarity for driving the cathode of the tube.

### Brilliance Control

Unfortunately it is not quite so simple as may appear at first sight. In most cases the brilliance control is associated with the cathode and is generally tied to it in some manner. Direct connection cannot therefore be made between the two, and it is necessary to insert a blocking condenser between the two points (Fig. 2).

Another point which must not be overlooked is that the brilliance control is of comparatively low resistance, the value dependent upon the setting of the control. This would exert a direct, low-resistance shunt to the incoming waveform which would not only reduce it in value but would also cause distortion of the sync pulses by reason of the shunting effect on the output of the phase splitter.

This problem can be fairly easily overcome by inserting a "stopper" between the cathode of the tube and the brilliance control. This is shown as RS in Fig. 2.

One further point is the effect of hum. Generally it is the practice to tie the cathode of the C.R.T. to the heater to avoid hum effects. The effect can be

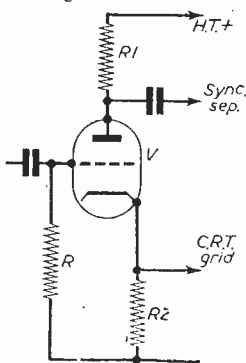

Fig. 1.—Standard phase splitter.

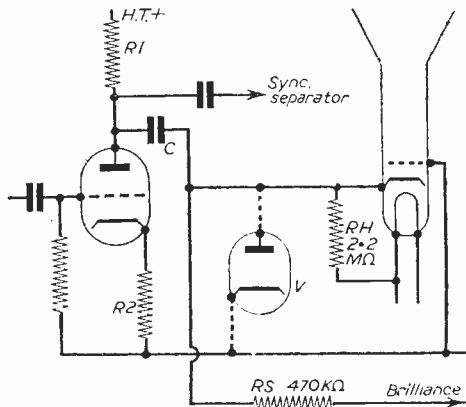

Fig. 2.—Cathode modulated C.R.T.

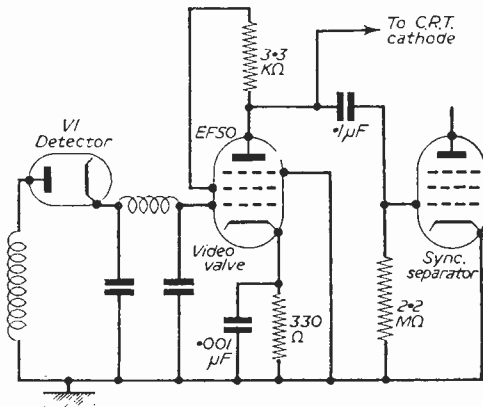

Fig. 3.—A direct-coupled circuit.

simulated by using a resistor between cathode and heater, instead of a direct connection. This is shown as RH in Fig. 2.

The coupling condenser C should be of fairly large value to ensure free passage to the low frequency part of the waveform. A figure of about 4  $\mu$ F should be the minimum and care should be taken to keep the condenser clear of the chassis, so as to avoid loss by capacitance between the condenser and the chassis.

#### The D.C. Component

The circuit so far described would function quite well, but it has one feature which may be regarded as a drawback.

The coupling condenser "C" blocks the D.C. component in *both* directions so that the D.C. component of the video signal does not reach the tube circuit.

Because of this the picture will tend to assume an overall average brilliance and there will not be sufficient difference between the blacks and whites, so far as the discerning viewer is concerned.

It has some advantage in that it forms a rough kind of automatic gain control and is often quite effective in minimising the troubles due to reflections from aircraft.

In order to obtain a correct balance, however, it is advisable to restore the D.C. component and this can be "faked" in by using a D.C. restoring diode.

It is usual to use such a diode in the input to the phase splitter, but if this method of cathode modulation is employed then a further D.C. restorer must be fitted.

A simple diode valve such as the EA50 can be inserted in the circuit as shown by the dotted lines in Fig. 2 and it will be found to be quite effective.

In cases where negative E.H.T. is employed, the diode must be carefully positioned, as it will be at E.H.T. potential. Also C must be rated at the full

E.H.T. voltage. It is better to use a D1 valve instead of the EA50 in this case, as the D1 has a 4-volt heater which can be taken directly from the heater supply for the C.R.T.

#### Direct Video Coupling

The method we have given so far involves the least modification to the existing circuit. A better method which will give the full advantages of cathode modulation is shown in Fig. 3.

This circuit follows the lines of standard commercial practice employing a direct coupling between the video output valve and the cathode of the C.R.T. The phase splitter with its accompanying D.C. restorer is eliminated and it is unnecessary to use a D.C. restorer at the grid of the C.R.T.

To modify an existing circuit it will be necessary to reverse the detector valve so that correctly phased signals are presented to the video grid. The anode and cathode of the valve are reversed as shown in the diagram.

As the input to the grid of the video valve will now be positive-going, the valve must be more heavily biased and the bias resistor must therefore be increased in value.

The output of the video valve can be coupled to the sync separator via the usual condenser and resistor arrangement.

The C.R.T. cathode is coupled directly to the anode of the video valve and the brilliance control arrangements transferred to the grid of the tube. Some modification of the component values of the bleeder network may be required.

One direct result should be an improvement in the peak whites of the picture, but ignition interference is not now automatically suppressed and if the television is operated in a busy area an interference limiter should be fitted.

## BBC Crystal Palace Transmitter

THE Television Advisory Committee has informed the Postmaster-General that the best technical solution of the problem of siting television stations in the London area is a single tower to carry the aerials for all the television services of the BBC and ITA. The BBC has accordingly agreed to make provision for the ITA's requirements on the tower now in course of erection by the BBC at its new television station at Crystal Palace. The BBC's offer has been welcomed by the General Post Office, which is responsible for approving the sites of all BBC and ITA stations, and by the ITA itself. The ITA is at present negotiating with the L.C.C. to acquire land near the base of the tower for the erection of a building to house a new television station which will replace the temporary station now in service at Croydon.

The new arrangements will involve halving the size of the BBC's Band I aerial. The top 250 feet of the tower will have to be redesigned and this will delay its completion by 18 months. It will not, therefore, be possible for the new tower to be brought into service early next year as had been planned. However, in order that the new high-power transmitter which is being installed at Crystal Palace may be brought into service as soon as possible, the BBC will erect a temporary mast and aerial, 250 ft. high.

This temporary mast and aerial system will be capable of a radiated power of 60 kilowatts instead of the 200 kilowatts which the BBC had hoped to be able to radiate initially from Crystal Palace.

The Corporation has decided to make this arrangement in order to achieve co-siting of the BBC and ITA stations in London, which has been recommended by the Television Advisory Committee as a means of giving the best reception to viewers of both services. When the new tower and aerial system in its new form come into service about May, 1957, the BBC will be able to raise the power of its transmission to 125 kilowatts. Later on a further increase to nearly 500 kilowatts, the maximum permitted by international regulations, is planned.

The ITA hopes to begin transmitting from the new tower at the Crystal Palace during 1957.

In answer to questions, a BBC spokesman said it is hoped to transfer transmission from Alexandra Palace to Crystal Palace in the spring of next year. The date will be announced later. The temporary BBC mast will be close to the permanent mast.

The BBC has exercised its option on the lease of Alexandra Palace, and will continue to use the premises for Television News and Newsreel, and other purposes.

The radiated power of 60 kilowatts from Crystal Palace compares with 34 kilowatts at present from Alexandra Palace.

# ION-TRAP C.R. TUBES

AN EXPLANATION OF THE WORKING OF THIS SPECIAL TYPE OF PICTURE TUBE

**A**S the art of television progresses so we see the old being replaced by the new as new techniques are developed and new processes invented to overcome defects.

We have seen the virtual disappearance of the 9in. C.R.T. and this is likely to be followed quite soon by the disappearance of the 12in. tube, though manufacturers are bound to retain a small amount of production for replacement purposes.

We may not all agree that the disappearance of the 12in. tube is a good thing, but one feature which no one will regret its passing is the nasty large brown stain on the screen of an otherwise perfectly good tube by reason of ion bombardment.

The cause of the stain is quite simple really; it is not practical to produce economically a tube which is a complete vacuum. There is always some trace of unwanted elements left in the evacuated tube and it is these elements which cause the brown stain.

The high velocity of the electron beam within the tube ionises the particles of gases which remain and the ions proceed on the same path towards the screen. Compared with electrons the ions are very heavy and are not deflected by the magnetic fields of the deflector coils as is the electron beam.

The result is that the heavy stream of ions proceeds

As the beam is directed to the side of the tube, so also is the stream of ions, which is thereby prevented from reaching the screen.

All that remains to be done is to redirect the electron beam to the screen by use of a magnetic field which will bend it easily but will not affect the ion stream. This is accomplished by placing a small permanent magnet on the outside of the tube.

In Fig. 1 is shown the elements of the scheme. Note that this figure is diagrammatic and is used to illustrate the principle.

Both of the methods explained have proved very effective, and ion burn is now a thing of the past, enabling the life of the tubes to be increased considerably.

## Precautions

When fitting an ion trap because of a tube replacement, etc., certain precautions must be taken to ensure that no damage is done to the tube.

It will be appreciated that if the magnet is not adjusted correctly only part of the electron beam will reach the screen and the result is just like the loss of emission. To overcome the trouble there is a tendency to increase the brilliance control and to turn up the contrast, thereby over-running the tube and shortening its life.

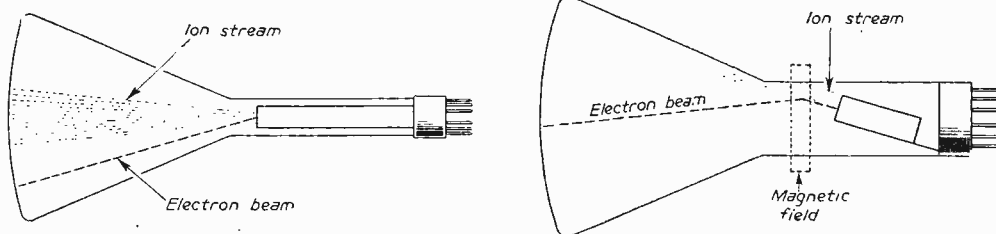

Fig. 1.—Diagram of the ordinary tube and the electron stream, with a comparison with the ion-trap tube.

towards the screen and arrives like the shot from a shot-gun spread over a definite area but always concentrated in that area.

As the electron beam is affected by the magnetic fields of the deflecting coils it is constantly on the move. If the deflecting fields fail, then the spot remains stationary and a hole will be burned on the screen.

The ion stream acts in a similar manner, though more slowly, by "burning" the active constituents of the screen and thus causing the brown stain.

## Modern Approach

The problem of ion burn has been solved by modern techniques and there are two methods in general use. The first is by coating the inside of the stream with fine particles of aluminium. By this method it is claimed that not only is the ion stream prevented from reaching the screen but also the screen brightness is improved by the virtue of the reflecting properties of the aluminium particles.

The second method is to arrange the gun structure inside the tube so that the electron beam comes out at an angle directed at the neck of the tube.

Ion traps should always be most carefully adjusted.

Under no circumstances should the ion trap magnet be adjusted in order to overcome a shadow on the screen. Shadows may be caused by incorrectly positioned deflector coils or focusing magnet and these should be adjusted first.

## Adjustment

The ion trap magnet is the last item to be placed on the neck of the tube before the valve-holder is connected. It should be positioned so that the arrow marked on the ring is upwards and the arrow points towards the screen. (Note that in some televisions, by reason of mechanical arrangements and space, the magnet is placed upside down, that is with the arrow underneath and pointing away from the screen.)

A line is usually marked on the tube showing the position which must coincide with the arrow of the magnet.

Position the magnet so it is just clear of the base of the tube.

After switching on the television and allowing a

suitable period for warming up, the brightness control should be adjusted so that the raster is just faintly visible. It may be necessary to adjust slightly the position of the magnet at this stage.

The next step is to move the magnet towards the screen, keeping the arrow in line with the marking line on the tube until maximum brightness is obtained on the raster. Reduce the brightness control until the raster is of normal brilliance and readjust the position of the magnet to obtain its maximum brightness position.

The television can now be set to receive the picture and it is preferable that a stationary picture is available such as Test Card C. Adjust brilliance and contrast normally until the picture is at its normal brightness and readjust the magnet for maximum brightness in the bright parts.

It may be found that under these conditions the

picture is not central, and if this is the case adjust the focusing magnet. If the limit of this adjustment is reached without the picture being exactly central then the ion-trap magnet can be turned very slightly in either direction provided that no decrease in brilliance of the picture is caused thereby.

The aim is to keep the brightness of the screen as high as possible and any position of the magnet which reduces that brightness is the incorrect position.

Having obtained these conditions the retaining screw on the magnet can be adjusted to fasten it in position.

Note that the magnet should be handled with great care and should not be knocked, dropped or left near other strong magnetic fields.

Note also that if a position of maximum peak brightness cannot be obtained with the magnet then it should be changed for another one.

## C.R. Tube Research

**T**HE successful production of television cathode-ray tubes on a large scale calls for continuous research into the materials and processes used in their manufacture. Some of the most intriguing problems in this field are provided by the production of the fluorescent screen. For this reason enlarged facilities, which incorporate a number of interesting new features, have recently been built at the Wembley research laboratories of The General Electric Co., Ltd., for intensive work on screening problems.

The development of 21in. and 24in. screens for future manufacture has made it necessary to increase the size and scope of the research facilities required for this work. Such extensions are now able to accommodate the larger tubes themselves and the greater sizes of the experimental batches to be processed. They will enable large scale experiments to be carried out for testing both the methods and the materials used for screening the tubes. Further work in the new laboratories is devoted to the investigation of more fundamental aspects of filming and screening processes. Among these are investigations into the increased screen efficiency, less tendency towards electron burn, improved colour characteristics, or a combination of these properties.

The principle underlying the provision of the new laboratories is that each screening process be fully proved before it is applied in the factory. The proper investigation of each detail of each process makes necessary the provision of special conditions under which every factor can be rigorously controlled.

### Atmosphere Control

During the manufacture of the screen it is vitally important that no unwanted impurities enter the cathode-ray tube bulb or the materials used for screening. As little as 1 part per million of copper, for example, can adversely affect the fluorescent properties of some powders, while even one minute particle of dust would cause a screen defect.

One of the primary considerations in designing the new screening rooms has, therefore, been the provision of a clean atmosphere. Filtered hot and cold air are brought in through two ducts and mixed to give an atmosphere of the required temperature. This degree of temperature control will enable experiments to be carried out on the effect of temperature on the various screening processes used. Later

work may also include the analysis of samples taken from the atmosphere, so that the effect of atmospheric conditions in general (including temperature, humidity and pollution) can be gauged.

Although atmospheric conditions are easily controlled in the laboratory, some of the equipment used there may be open to the atmosphere. In the factory, on the other hand, the corresponding automatic equipment used for mass production would be completely sealed and thus more independent of atmospheric conditions.

### Screening Research

The development of a new manufacturing process can be broadly divided into two parts, the technique itself and the materials to be used in it. A fluorescent screen is prepared in two stages, known respectively as screening and filming. In the former, the fluorescent powder is allowed to settle on to the inside of the glass bulb through a cushioning liquid. All excess liquid is then allowed to drain off by decanting. Since the phosphor screen at this stage has a granular structure, it is necessary to bridge the gaps by covering the powder itself with a thin skin or foil before the reflecting aluminium coating is applied by evaporation. In this process, known as filming, a thin film of an organic liquid is made to cover the phosphor in one of several ways. For example, the irregularities in the screen structure of the phosphor can be filled with water, which is then frozen. A solution of the film-forming material in a volatile solvent is then made to flow over it and the solvent removed by evaporation. After the film has completely solidified the temperature is raised, the ice melted and the resulting water dried out by evaporation.

Alternatively, in the flow filming method, after filling in the structure of the phosphor screen with water, a solution of the film-forming substance may be allowed to flow over it. The film is then dried out as before.

In yet another method, the flotation process, the film is formed on the surface of a water pool covering the screen. This is achieved by dropping a small quantity of a solution of the film-forming material, in a volatile water-insoluble solvent, on the surface of the water and allowing it to spread. When the film has set the water is syphoned off or decanted away and the film thereby deposited on the screen. Any residual water held in the screen can then be removed by evaporation through the film.

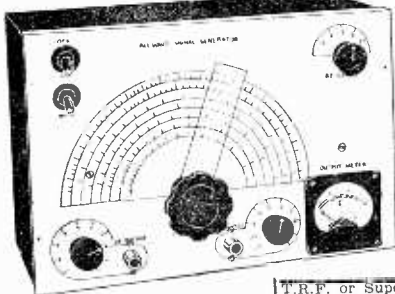

**COMPLETELY BUILT SIGNAL GENERATOR**

Completely built Signal Generator, coverage 120 Kc s-320 Kc s, 300 Kc s-900 Kc s, 900 Kc s-2.75 Mc s, 2.75 Mc s-6.5 Mc s, 8 Mc s-28 Mc s, 16 Mc s-56 Mc s, 24 Mc s-84 Mc s. Metal case 10 x 6 1/2 x 4 1/2 in. Size of scale 6 1/2 x 3 1/2 in. 2 valves and rectifier. A.C. mains 230-250 v. Internal modulation of 400 c.p.s. to a depth of 30 per cent., modulated or unmodulated R.F. output continuously variable 100 milli-volts. C.W. and mod. switch, variable A.F. output and moving coil output meter. Black crackle-finished case and white panel. Accuracy plus or minus 2%. £4.19.6 or 34/- deposit and 3 monthly payments 25/-. P. & P. 4/- extra.

**COMPLETELY BUILT T.V. CONVERTER**

for the new commercial stations, complete with 2 valves. Frequency can be set to any channel within the 136-198 Mc s band. I.F. will work into any existing T.V. receiver between 42-68 Mc s. Input arranged for 90 ohm feeder. 12F80 as I.F. amplifier, EOC81 as local oscillator and mixer. The gain of the first stage, RF amplifier 10DB. Required power supply of 200 D.C. at 25mA. 6.3 v. A.C. at 0.6 amp. Input filter ensuring freedom from unwanted signals. Simple adjustments only, no instruments required for trimming. Will work into any

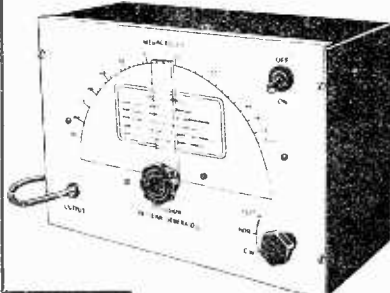

**PATTERN GENERATOR**

T.R.F. or Superhet incorporating Band switch, and wire-wound gain control. Fully screened in black crackle finished case, size 5 1/2 in. long, 3 1/2 in. wide, max. overall height 4 1/2 in. £2.19.6. P. & P. 2/6. As above with built-in power supply, £3.19.6. P. & P. 2/6. A.C. Mains 200-250 v.

**BOTH GENERATORS GUARANTEED FOR 12 MONTHS.**

**SPECIAL OFFER — VERY LIMITED QUANTITY**  
7 valve push-pull A.C. Mains 200/250 v.

**RADIOGRAM CHASSIS**

3 wave band, coverage short wave 16-50 m., medium wave 187-550 m., long wave 900-2,000 m., 4 controls, volume control on-off, tone control, tuning and wave change with gram position. Valve line up X79, W727, two DH7T's, two EL41's and EZ30. Output 7 watts. Size of chassis 16 1/2 x 7 1/2 x 2 1/2 in. Size of scale 12 1/2 x 4 1/2 in. Overall height including back plate 7 1/2 in. BRAND NEW. Fully guaranteed. £9. 19.6 P. & P. 7/6

USED 9in. TUBE, 22 14C' with ion burn, 17 8. Post paid. Used Mullard 9in. tube 22 17 and 18 ion burn. 25/- post paid.



A.C. mains 230 240 Comp. rprising choke, power-factor condenser, 2 tube holders, starter, and starter-holder. P. & P. 3/- 17.6.

20 watt A.C. or D.C. 200 250 v. Fluorescent kit, comprising trough in white stove enamel, 2 tube holders, starter, starter-holder and bar reter. P. & P. 1/6. 12 6.

Three-speed automatic changer by B.S.R. MONARCH current model. Will take 7in., 10in. or 12in. records mixed. Turnover crystal need. Cream finish. BRAND NEW. VERY LIMITED QUANTITY. A.C. Mains 200, 250. £7.15.0. P. & P. 3/-

Line and E.H.T. Transformer, 9kV. Ferronact core. EY51 heater winding, complete with scan coils and flame output transformer and line and width control. 35/-. P. & P. 3/-

As above but complete with line and frame blocking transformers, 4 henry 250 mA. choke, 100 mfd. and 150 mfd. 350 wkg., 380 mA. A.C. ripple. £2.9.6. P. & P. 3/-

Standard wave-changer 5W Helios, 4-pole 3-way; 5-pole 3-way; 3-pole 3-way, 1.9 each; 9-pole 3-way 3 6; Miniatur type, long spindle, 4-pole 3-way and 4-pole 2-way 2 6 each. 2-pole 11-way twin waler, 5/-; 1-pole 12-way 5/-. P. & P. 2d.

USED metal rectifier, 250 v. 150 mA., 6 6.

Combined 12in. Mask and E-scutech on perspex. New aspect, edged in brown. Fits on front of cabinet, 12 6. As above for 15in. tubes, 17 6.

Polishing Attachment for electric drills, 1in. spindle, chromium plated 5in. brush, 3 polishing cloths and one sheepskin mop mounted on a 3in. rubber cup. Post & pkg. 1 6. 12 6. Spare sheepskin mops, 2 6 each.

**R. & T.V. COMPONENTS (ACTON) LTD.**

23 HIGH STREET, ACTON, LONDON, W.3

40-70 Mc s direct calibration, checks frame and line time base, frequency and linearity, vision channel alignment, sound channel and sound rejection circuits and vision channel band width. Silver plated coils, black crackle-finished case 10 x 6 1/2 x 4 1/2 in. and white front panel. A.C. mains 200 250 volts. This instrument will align any T.V. receiver, accuracy plus or minus 1%. Cash price £3.19.6 or 29/- deposit and 3 monthly payments of £1. P. & P. 4/- extra.

Line or Frame Oscillator Blocking Transformers, 4 6 each. Smoothing Choke, 250 mA, 5 henry, 3 6; 250 mA, 10 henry, 10 6; Wide Angle P.M. Focus Unit, Vernier adj., state tube, 15/-; P.M. Focus Unit for Mullard tubes with vernier adjustment, 15/-.

Ion Traps for Mullard or English Electric tubes, 5/- Post paid. T.V. Grid, muller iron core, wound for re-winding purposes only. All-can 1 1/2 in., 1/- each; 2 iron-cores All-can, 2 1/2 in. x 1 in., 1 6 each. These coil formers are suitable for the Prac. T.V. Converter.

Doublier .001 10kV working, 3 6.

Primary, 200-250 v. P. & P. 2/-

300-0-300, 100 mA., 6 v. 3 amp., 5 v. 2 amp., 22 6.

Drop thro' 350-0-350 v. 70 mA., 6 v. 2.5 amp., 5 v. 2 amp., 14 6.

Drop thro' 250-0-250 v. 80 mA., 6 v. 3 amp., 5 v. 2 amp., 14 6.

280-0-280, drop through, 80 mA., 6 v. 3 amp., 5 v. 2 amp., 14 6.

Drop thro' 270-0-270 80 mA., 6 v. 3 amp., 11 6.

250 v. 350 mA., 6.3 v. 4 a., twice 2 v. 2 a. 19 6.

Semi-shrouded drop-through 390-0-390 120 mA., 6.3 v. 3 amp., 5 v. 2 amp., 25/-

Auto Trans. Input 200 250. H.T. 500 v., 250 mA., 6 v. 4 a., twice 2 v. 2 a., 19 6.

Auto Trans. Input 200 250. H.T. 350 v. 350 mA. Separate I.T. 6.3 v. 7 a., 6.3 v. 11 amp., 5 v. 3 amp., 25/- P. & P. 3/-

Heater Transformer, Pri 230 250 v. 6 v. 1 amp., 6/-

350-0-350 75 mA., 6.3 v. 3 a. tap, 4 v. 6.3 v. 1 a., 13 6.

500-0-500 125 mA., 4 v. C.T. 4 a., 4 v. C.T. 3 a., 4 v. C.T. 2.5 a., 27 6.

500-0-500 250 mA., 4 v. C.T. 5 a., 4 v. C.T. 5 a., 4 v. C.T. 4 a., 39 6.

Chassis mounting or drop-thro. Pri 110-250 v. Sect. 350-0-350 250 mA., 6.3 v. 7 amp., 6.3 v. 0.5 amp., 5 v. C.T. 0.5 amp., 4 v. 4 amp., 32 6. P. & P. 3 6.

R.F. E.H.T. Oscillator Coil, 6.9 kV with EY51 rectifier winding, and circuit diagram, 15/-

As above, but complete with 6V6, EY51 and associated resistors and condensers. Circuit diagram, 37 6.

P.M. Speakers, closed field 3 ohm speech coil, 12in., 25/-; 10in., 25/-; 8in., 20 6; 6 1/2in., 15 6; 5in., 18 6. P. & P. 2/- each extra.

Medium wave superhet in polished walnut cabinet, size 14 x 9 1/2 x 7 1/2 in., complete with valves 6K8, 6K7M, 6Q7 and 6F6, 6 1/2 in. P.M. speaker. Fully guaranteed. P. & P. 7 6. £3.15.0.

1,200 ft. High impedance recording tape on aluminium spool, 12 6 post paid.

Valve Holders, moulded octal	250 mfd., 22 v. wkg. ...	1-
Mazda and Octal, 7d, each	18 mfd., 500 wkg. ...	33
Parolin, octal, Mazda and	8 mfd., 500 v. wkg., wire ends 2 6	
Octal, 4d, each, Moulded	8 mfd., 350 v. wkg., tag ends 1 6	
H7C, B8A and B9A, 7d, each	100 150 mfd., 350 v. wkg.,	
17G and B9A moulded with	280 mA., A.C. ripple ...	4 8
screening can, 1 6 each.	100, 200 mfd., 275 wkg. ...	7 6
32 mfd., 350 wkg. ...	16' 15 mfd., 350 wkg. ...	3 3
16 24, 350 wkg. ...	50 mfd., 180 wkg. ...	1 9
4 mfd., 200 wkg. ...	65 mfd., 220 wkg. ...	1 6
10 mfd., 450 wkg. ...	8 mfd., 150 wkg. ...	1 6
16 8 mfd., 500 wkg. ...	60 1 100 mfd., 280 wkg. ...	7 6
16 16 mfd., 500 wkg. ...	50 mfd., 12 wkg. ...	11d.
16 16 mfd., 350 wkg. ...	50 mfd., 50 wkg. ...	1 9
32 32 mfd., 350 wkg. ...	Miniature wire ends	
25 mfd., 25 wkg. ...	moulded, 100 pf., 500 pf.,	
	and .001, ea. ...	7d.

\*Where cost and packing charge is not stated, please add 1 6 up to 10/-, 2/- up to £1 and 2 6 up to £2. All enquiries S.A.E. List, 5d. each.

# HENRY'S

(RADIO LTD.)

### BAND III CONVERTER UNIT

Complete Kit of Parts. Including 2-EPF0 and Chassis and Wiring Diagram. Voltage required 200 v. at 30 mA 6.3 v. 6 amps. 4B 6, plus 2 - P.P. Or assembled and tested, 67/6, plus 2- P.P. Power Supply Components. 22/-.  
The Unit Complete with Power Supply. Tested and ready to plug in. 97/6.

### "RF 26" F.M. CONVERTER UNIT 88 100 Mc/s

This well-known RF26 Unit is now adaptable for F.M. reception using 2 IF stages and separate local Oscillator and tuned by a Muirhead graduated Vernier drive. Can be converted at low cost of 62/6. Send 1/6 for 8-page Descriptive booklet containing full wiring instructions, circuits and layout diagrams.

### PYE 45 Mc/s STRIP TYPE 3583 UNITS

Size 15in. x 8in. x 2in. Complete with 45 Mc/s Pye Strip, 12 valves, 10 EF50, EB34, and EA50, volume controls and hosts of Resistors and Condensers. Sound and vision can be incorporated on this chassis with minimum space. New condition. Modification data supplied. Price 69/6. Carriage paid.

### U.S.A. INDICATOR UNIT Type BC929A

These Units are in absolutely new condition. In black crackle cabinet 14 1/2 in. x 9 in. x 9 in. Complete with 3BP1 C R Tube, Shield and Holder, 2-6SN7GT, 2 6HG6T, 1 6X5GT, 1 2X2, 1 6G6, V controls, condensers, etc. Ideal for scope. 65/-. Carr. Pd.

### CATHODE RAY TUBES (Brand New)

VCR97 (slight cut-off) 15/-  
VCR97, guaranteed full T/V Picture ... 40/-  
VCR517C, guaranteed full T/V Picture ... 35/-  
VCR139A, guaranteed T/V Picture ... 35/-  
3BP1, guaranteed full T/V Picture ... 30/-  
Carr. & packing on all tubes, 2/-.

### CRYSTAL MICROPHONE INSERTS



Ideal for tape recording and amplifiers. No matching transformer required.

### QUARTZ CRYSTALS

Type FT 243 Fundamental Frequencies  
2-Pin 1-in. Spacing  
200 TYPES IN FOLLOWING FREQUENCIES  
5675 kc/s to 8650 kc/s (in steps of 25 kc/s).  
5706 kc/s to 8340 kc/s (in steps of 33.333 kc/s).  
**BRAND NEW 10/- EACH**  
Special Price for Complete Sets of 80 or 120

Type FT 241A	54th Harmonic	2-Pin 1-in. Spacing	23.2 Mc/s.	26.1 Mc/s.
21.1 Mc/s.	23.0 "	23.4 "	26.4 "	27.0 "
21.2 "	22.8 "	24.4 "	26.0 "	27.0 "
21.4 "	22.9 "	25.0 "	26.0 "	27.0 "

Brand New & Guaranteed 7/6 ea.  
FT241A 200 kc/s ... .. 10/-  
FT241A 465 kc/s ... .. 10/-  
HOLDERS FOR CRYSTALS ... .. 1/3  
**SPECIAL PRICE FOR QUANTITIES.**

**B.S.R. 3-SPED AUTO-CHANGERS**  
These are brand new in original cartons. Plays mixed records. Cream finish. List price £16.10.0. Our Price 67/19/6.

### VALVES - VALVES - VALVES

WE HAVE OVER 50,000 AMERICAN AND ENGLISH VALVES IN STOCK AT VERY LOW PRICES. SEND 3/6 FOR 28-PAGE ILLUSTRATED CATALOGUE.

5, HARROW ROAD, PADDINGTON, LONDON, W 2

TEL.: PADDINGTON 10089/9, 0401

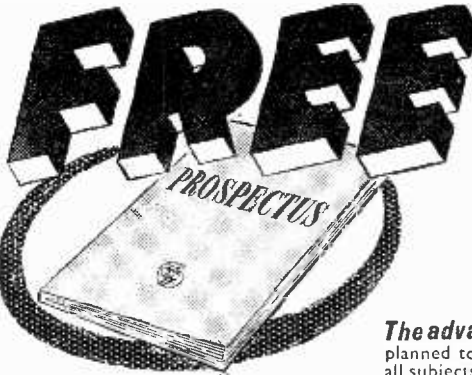

**POST THE COUPON TODAY FOR OUR BROCHURE ON THE LATEST METHODS OF HOME TRAINING FOR OVER 150 CAREERS & HOBBIES**

### PRIVATE AND INDIVIDUAL TUITION IN YOUR OWN HOME

City and Guilds Grouped Certificates in Telecommunications: A.M.Brit.I.R.E. Examination. Radio Amateur's Licence, Radio and Television Servicing Certificates, General Radio and Television Courses, Radar, Sound Recording, etc. Also Courses in all other branches of Engineering and Commerce.

**The advantages of E.M.I. training.** ★ The teaching methods are planned to meet modern industrial requirements. ★ We offer training in all subjects which provide lucrative jobs or interesting hobbies. ★ A tutor is personally allotted by name to ensure private and individual tuition. ★ Free advice covering all aspects of training is given to students before and after enrolling with us.

**Equipment supplied upon enrolment and remains your property.**

**Courses from 15/- per month**

### NEW LEARN THE PRACTICAL WAY. COURSES WITH EQUIPMENT

With many of our courses we supply actual equipment thus combining theory and practice in the correct educational sequence. Courses include: Radio, Television, Electronics, Draughtsmanship, Carpentry, Photography, and Commercial Art, etc.

# EMI INSTITUTES

The only Postal College which is part of a world-wide Industrial Organisation.

### POST THIS COUPON TODAY

Send without obligation your FREE book. E.M.I. INSTITUTES, Dept. 138K, 43 Grove Park Road, London, W.4.

NAME \_\_\_\_\_

ADDRESS \_\_\_\_\_

1/56 SUBJECT(S) OF INTEREST \_\_\_\_\_

# Aerial Feeder Design for Band III

## MATCHING DETAILS FOR COMBINED AERIAL ARRAYS

By D. H. Taylor, G3IG0

WITH the commencement of television transmissions on Band III, many amateur constructors find themselves confronted with the problems of design for VHF for the first time, and also with the installation of the more elaborate types of aerial required, in most cases, to deal with the weaker field strength of the Band III transmission. The simple two-element array of dipole and reflector, so often used on Band I, presented no difficulties, as by using almost any type of low-impedance feeder, according to the requirements of the receiver, satisfactory operation of the aerial could be assured. But in the installation of a multi-element array for Band III it is not practical merely to connect aerial to receiver by the first available length of feeder, as quite serious losses may occur by so doing. In addition the aerial system has now to provide two signals of widely different frequencies, and more problems arise when it is intended to connect both aerials to a single download. However, by the application of some simple theory to the design of the feeder system, these difficulties may easily be overcome and maximum performance of the aerials assured.

### Matching the Band III Aerial

As more directors and reflectors are added to the simple half-wave dipole to make a multi-element array, the radiation resistance at the centre of the dipole, about 80 ohms in free space, drops sharply. For a four-element array it is of the order of 6 to 8 ohms. A feeder constructed to match this impedance would have impossibly close spacing, and thus a means of increasing the radiation resistance must be found. The commonest is the so-called folded dipole, almost universally used in aerials for Band III. The folded dipole is fundamentally two half-wave dipoles in parallel, connected together at the ends, with the feed taken from the centre of one of them. If the two conductors have the same surface areas (e.g., made from the same diameter tubing), the aerial current divides equally between the two, and the radiation resistance at the feeder terminals is quadrupled. Thus the feeder impedance required to match a four-element folded dipole array is of the order of 30 ohms. If 72- or 80-ohm cable is used to the receiver a mismatch will be produced, which, although it may not be very serious, will result in increased losses from the feedline and reduced efficiency.

The simplest matching device for coaxial cable is the "quarter-wave transformer." This consists of a quarter-wavelength of coaxial line connected between the two impedances it is desired to match. If the two

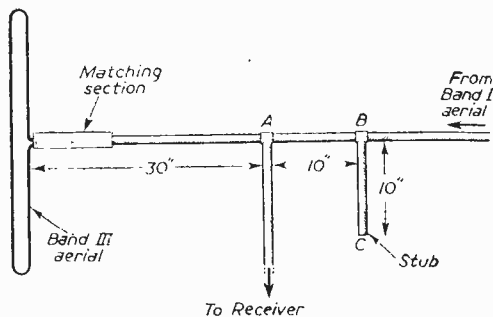

Fig. 3.—Construction of the complete feeder system for Bands I and III.

impedances are denoted by  $Z_1$  and  $Z_2$ , then the impedance of the quarter-wavelength section

$$Z_c = \sqrt{Z_1 Z_2}$$

If a section of 50-ohm cable is used it will provide a match to 31.25 ohms from 80-ohm cable, which can then be used for the download.

### The "Balun" Converter

As the outer conductor of coaxial feeder is earthed at the receiver end, the two halves of the folded dipole will not be balanced equally about their earthed centre point, resulting in distortion of the polar diagram of the aerial and pick-up from the feedline. The conversion of an unbalanced coaxial line for use with a balanced aerial termination is accomplished with a so-called "balun" (balance-to-unbalance) converter. The most practical form is known as the "quarter-wave can," and consists of an additional coaxial screen, a quarter wavelength long, placed around the existing feedline at the aerial end and connected to the outer screen of the feedline at the end farthest from the aerial (see Fig. 1). The end nearest the aerial is coincident with the end of the outer screen of the feedline, but insulated from it. The outer conductor will now effectively be earthed, and the two connected to the aerial will be able to move in antiphase with respect to earth—, with a folded dipole, its centre point.

A balun converter may easily be constructed using a length of heavy  $\frac{1}{2}$  in. coaxial cable from which the centre conductor and polythene dielectric have been removed. The braid screen and outer covering are slipped over the feedline and the end soldered to a bared section of the outer conductor of the feedline. If the converter is used with a quarter-wave matching transformer as well, it will start at the same point, and all three cables must be carefully soldered together as shown in Fig. 1. Great care must be taken not to short the inner conductor to the screens, or to distort the polythene by application of too much heat when soldering the screens themselves. The outer covering of the heavy cable can then be pulled down over the joint and trimmed at the aerial end, making sure that the two braid screens do not touch at this point. The cable ends may then be waterproofed with Bostik adhesive, or other suitable compound.

When calculating the length of a quarter-wave the "velocity factor" of the cable must be considered.

$$\text{Velocity factor} = \frac{\text{Velocity of wave in feedline}}{\text{Velocity of wave in free space}}$$

Or, for any one frequency:—

$$\text{Velocity factor} = \frac{\text{Wavelength in feedline}}{\text{Wavelength in free space}}$$

Thus, to obtain the length of a quarter-wave in a feedline, the natural quarter-wavelength must be multiplied by the velocity factor of the cable used. A round figure for polythene-spaced coaxial cables is .66. For Channel 9, a quarter-wavelength in coaxial cable is almost exactly 10in.

### The Single Download

When two feeders from two separate aerials are connected to a single line for connection to the receiver, a device must be used to prevent each aerial, with its own feeder, from interfering with the other. A Band III signal received on its aerial, when passing the junction of the feeder to the Band I aerial, must "see" an infinite impedance in the direction of the Band I aerial, and the same applies conversely to the Band I

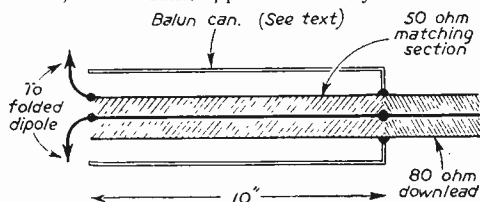

Fig. 1.—Construction of the Band III matching section.

signal. If this is not so an impedance mismatch will occur at the junction and the signal from each aerial will be mixed with a smaller signal received on the other aerial, resulting in the spoiling of the polar diagrams of both aerials. This problem is solved commercially by the use of a pair of filters incorporated in a "junction box," the filter in the Band I lead being adjusted to reject signals in Band III, and vice versa. The design and construction of such filters is not impossibly difficult for the amateur, but it is possible to effect the same result without using them by attention to the feedlines themselves.

The principle used is a familiar one at radar frequencies, where it becomes invaluable. On a resonant section of transmission line the impedance (voltage-current ratio) varies sinusoidally along the line. For a perfect line the impedance at points of no current is infinite, and where there is no voltage the impedance is zero (see Fig. 2). Thus, if the line is physically short-circuited at such a point, the operation of the line is unaffected. A quarter-wavelength away, however, the voltage is at its maximum, and there is still an infinite impedance. If any point on a feedline is physically short-circuited, thus introducing zero impedance, a quarter-wavelength away the impedance of the line will appear to be infinite to that particular frequency, and a further quarter-wavelength away it will appear to be zero again. Also, if a length of line is terminated in an open-circuit, a quarter-wavelength from the end it will appear to be short-circuited, and so on. Thus, to produce a reflected open-circuit at any selected point on a feedline, one may instead produce a short-circuit at a distance of one quarter-wavelength from it. But this short-circuit may also

be artificially produced, e.g., by connecting to the line a quarter-wavelength of feeder open-circuited at its other end. This length is called a stub. In Fig. 3, a stub is seen connected to the Band I feedline a quarter-wavelength away from the junction and a quarter-wavelength long. To a Band III signal the open-circuit at point C is reflected as a short-circuit at point B, and this short-circuit appears as an open circuit at point A, the feeder junction. Thus, a Band III signal "sees" an infinite impedance along the Band I feeder. If desired, another open quarter-wave stub may be connected a further half-wavelength along the line. This, it will be seen, will reinforce the effect of the first.

The construction of the stub is as simple as it looks. To insulate the junction of the inner conductors a short piece of polythene tubing may be used drilled through one side to take the stub and slit lengthwise through the hole to allow it to be slipped over the junction. The polythene from the cable used for the balun converter is most suitable for this purpose. The braiding should then be wrapped around the junction and carefully soldered in position. The completed stub can then be laid along the feedline, encased in a length of sleeving.

To prevent the Band III array from affecting the Band I signals the same principle is applied. Where a folded dipole is used for Band III reception, the ultimate end of the entire Band III feeder system is a short-circuit at the centre of the folded dipole. Thus, if the total length from this point to the feeder junction is made a quarter-wavelength at the Band I frequency, an infinite impedance will appear at the junction as "seen" by the Band I signal. It is sufficiently accurate to regard the velocity factor of the actual folded dipole, considered as a transmission line at Band I

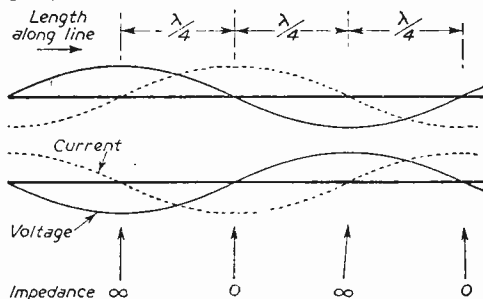

Fig. 2.—Diagram of voltage-current relationship on a transmission line.

frequency, as being unity, so that if the length round one leg of the dipole is subtracted from a natural quarter-wavelength at the Band I frequency, and the remaining length multiplied by the velocity factor of the cable used, the length of the feedline required for the Band III aerial is obtained.

### Testing

The performance of the junction system is easily tested. With the receiver tuned to Band III the signal strength is observed while the Band I feedline is disconnected from the junction, and also when it is shorted and open-circuited beyond the stub. Absolutely no variation should be seen. When tuned to Band I there should again be no change in signal strength when the Band III feeder is disconnected and reconnected at the junction.



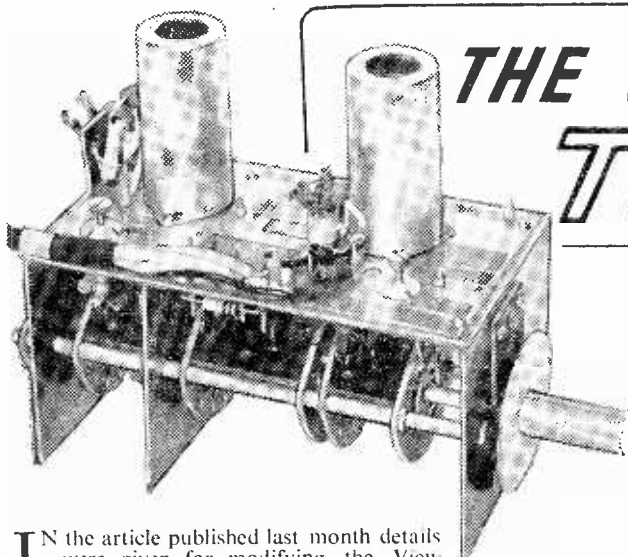

# THE V.M. TV Tuner

DETAILS OF A 3-STATION TUNER  
DESIGNED FOR THE VIEW MASTER,  
BUT WHICH MAY BE USED WITH  
OTHER RECEIVERS

**I**N the article published last month details were given for modifying the View Master Sound and Vision Receivers so as to convert them to I.F. amplifiers. The I.F.'s which were chosen were 34.65 Mc/s for the vision amplifier and 38.15 Mc/s for the sound amplifier. These are the preferred I.F.'s for commercial TV receivers, and manufacturers are gradually changing over to these figures. This article deals with the technical and assembly details of a tuner which will give a first-rate performance, is easy to build, reliable, and will give the constructor the satisfaction of having achieved what was at one time considered a most difficult task.

The design of the tuner is based on the use of a printed circuit for the main plate. This has on it the major portion of the wiring including all inter-valve connections and leads. Also printed are two small condensers of critical value. It is to the use of this printed plate that the simplicity of assembly and the reliability of performance is mainly due. In view of the new technique which has been adopted the constructor is urged to study carefully all the details relating to the assembly, so that when building it the construction details are followed closely.

The circuit arrangement follows the now accepted practice of having a double-triode valve operating as a cascode R.F. amplifier so as to give a useful gain in front of the frequency changer and thereby to give freedom from background noise. The cascode R.F. stage is followed by a triode-pentode operating as a combined oscillator-converter and this too follows present-day convention.

In designing the tuner one of the first decisions to be taken was to determine how the greatest advantage could be taken of the use of a printed circuit, as it was felt that an assembly which had to operate reliably for long periods at frequencies of the order of 200 Mc/s could not easily be assembled

by the home constructor using normal assembly methods. The arrangement which was finally arrived at was to have the printed circuit as the main plate of the tuner; on this were mounted the two valves and other small components. The switch assembly would have mounted on it some of the tuning coils and would then be coupled to the main tuning plate. Coupling together of these two units would then be sufficient to complete the tuner and it is on these lines that the design has been carried out.

A further point which required some thought was the method of channel switching which was to be used, and also how many channels were to be catered for. The majority of commercial TV receivers are usually fitted with 12 channel tuners, these being either of the turret type or the so-called incremental inductance tuner. In the turret tuner complete sets of coils tuned to the respective channels are switched into circuit, whilst in the incremental inductance tuner wafer switches are arranged to switch into circuit that amount of inductance which, with the circuit capacities, will tune to the respective channel. Both these arrangements are convenient for manufacturers who produce TV receivers in bulk and then

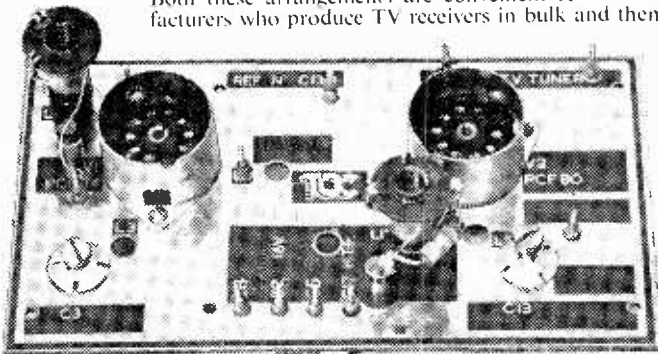

View of the top of printed panel with some components fitted in position.

despatch them to any part of the country where they may be used on any channel in Band I and possibly on either of two channels in Band III. The same necessity for a multi-channel tuner does not arise in the case of the home constructor, since he will build a receiver for his own personal use and will operate it in only one area, so that a twelve channel tuner would be unnecessarily complicated and expensive without gaining any real advantage. At the same time any tuner, if built now, should be capable of receiving not only the local Band I transmission but since it is anticipated that ultimately the BBC will also have their own alternative programme in Band III, it will be necessary for the tuner to operate on two channels in Band III. From this it is evident that the home constructor's tuner need only tune to three channels, and this being the case the incremental method of tuning is the most suitable as wafer type switches may then be employed. The Band III inductances may be wound so as to be self-

the secondary of the input transformer is connected directly in parallel with the switched input circuit of V1. On Band I, L2 is directly in parallel with L3, and since two inductances in parallel give a value of inductance lower than either of them it has become necessary for L3 to have many more turns on its former than would normally be necessary. On Band III, L2 is in parallel with L4, and since the value of L4 is itself low, there is little change in the total inductance and it be-

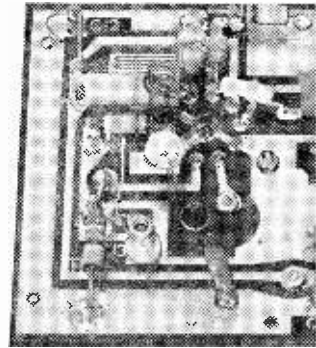

General appearance of the pa

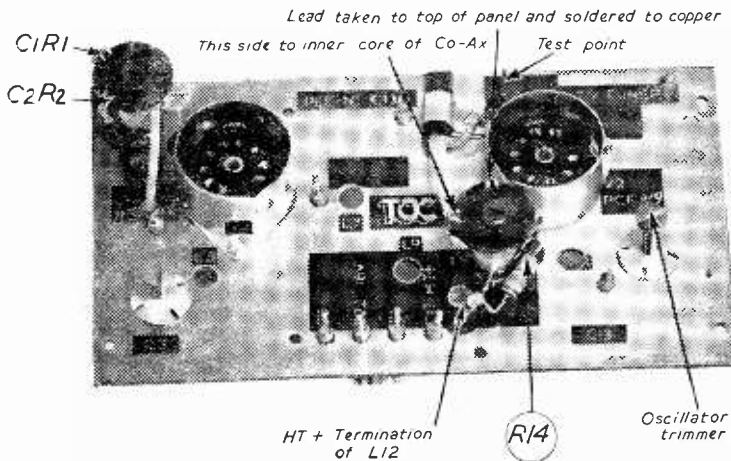

Another view of the panel with identification of components.

supporting, whilst the Band I inductances can be of conventional type and wound on small moulded formers. Summarising therefore, the design of the tuner has been based on a printed circuit top plate, which incorporates all the wiring and has printed on it two condensers of critical value. In addition there is mounted on it the majority of the components. The fully assembled printed circuit plate therefore forms a sub-assembly whilst the wafer switch which has fitted to it the four Band I coil formers forms a second sub-assembly. It is then only necessary to combine the two units to have a complete tuner, and so long as the wiring has been carried out according to the instructions it is almost certain that the tuner will operate immediately on being switched on and only alignment will be necessary before putting into service.

### Design

Dealing now with the circuit of the tuner (Fig. 1 page 363) the input has been designed for use with  $75\Omega$  coaxial feeder, this being coupled to L1 by a pair of ceramic isolating condensers each of which is by-passed by a resistor to prevent charges building up. L1 is tightly coupled to L2, this transformer acting solely to feed the incoming signal to the first tuned circuit connected to the grid of V1. It will be seen that

comes possible for L2 to be tuned and to act as a fine tuner during alignment when adjusting L4. A transformer input of the type described becomes essential when using an incremental tuner since otherwise it would become necessary for additional switch banks to be used to switch into circuit separate windings or tappings, whereas in this arrangement no additional switching is at all necessary. It will be seen from the circuit arrangement that V1, which is a double triode, operates as a cascode R.F. amplifier. The theory of the cascode R.F. amplifier has been dealt with on many occasions and it is not therefore necessary to go into this deeply. It is sufficient to say that an appreciable gain is obtained over Bands I and III whilst the use of a grounded grid triode gives a low background noise.

The input impedance of V1 is fairly high on Band I

### LIST OF

- 6 Moulded coil formers—type as previously used in View Master.
- 1 6 wafer, 3-way switch with platforms—Specialist Switches, 23, Radnor Mews, W.2.
- 2 Valve holders—B9 printed circuit type. TCC.
- 2 Valve shields—Carr Fasteners No. 76-813.
- 2 2.2 M $\Omega$  resistors Type T. LAB Resistors.
- 2 15 K $\Omega$  resistors Type T. LAB Resistors.
- 1 47 K $\Omega$  resistors Type T. LAB Resistors.
- 1 5.6 K $\Omega$  resistor. Type T. LAB Resistors.
- 1 220  $\Omega$  resistor Type T. LAB Resistors.
- 3 100 K $\Omega$  resistors Type T. LAB Resistors.
- 1 1 K $\Omega$  resistor Type T. LAB Resistors.
- 1 8.2 K $\Omega$  resistor Type T. LAB Resistors.
- 1 22 K $\Omega$  resistor Type T. LAB Resistors.
- 1 680  $\Omega$  resistor Type T. LAB Resistors.
- 1 6.8 K $\Omega$  resistor Type T. LAB Resistors.
- 1 6.8 K $\Omega$  resistor Type R. (R.15). LAB Resistors.
- 1 Condenser, 3 pF. Type SCP5. TCC.
- 1 Condenser, 5 pF. Type SCP7. TCC.

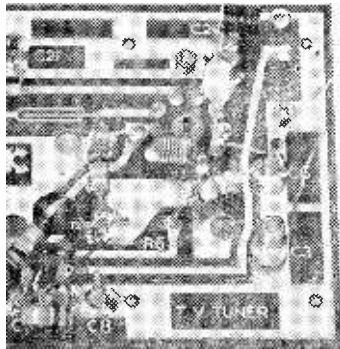

with some components in place.

require re-setting. The cathode arrangement of V1 is conventional and a variable resistor is intended to be connected in series with it to operate as a gain control. The circuit diagram does not, however, show this variable resistor in position, but this point is covered further on in the section dealing with the operation of the tuner. It is intended to have separate gain controls for each channel, these being adjusted to give a constant output when switching from Band I to Band III. At this point it should also be mentioned that it is preferable to control the gain of

and it therefore becomes necessary to reduce it so as to have adequate band width and it is for this reason that resistor R3 is connected across L3 which is the Band I tuned circuit. On Band III the input impedance is lower and additional damping is not required.

Condenser C4 with a capacity of 3 pF, together with C3 which is variable, form two arms of a bridge for balancing out the stray capacities existing in V1. Once C3 has been correctly adjusted it does not again

the I.F. amplifier rather than the gain of the tuner particularly when the signal is not too strong since then the maximum gain of the tuner is obtained and the general background noise on the picture is kept low. It will also be noted that C5 and C6 which decouple the cathode of V1 are drawn as coaxial feed-through condensers. The use of coaxial feed-through condensers becomes essential when operating at frequencies of the order of 200 Mc/s since otherwise the series inductance of conventional by-pass condensers could be sufficient to cause resonance within the wanted frequency band and thereby decoupling efficiency would be reduced, possibly with a chance of instability. The resistor R6 is merely to limit the bias and R5 to ensure that the cathode of V1 does not at any time become open as might occur if the variable resistor became faulty or was removed from the circuit.

The anode of V1 is connected to the cathode of the following triode through a small inductance whose

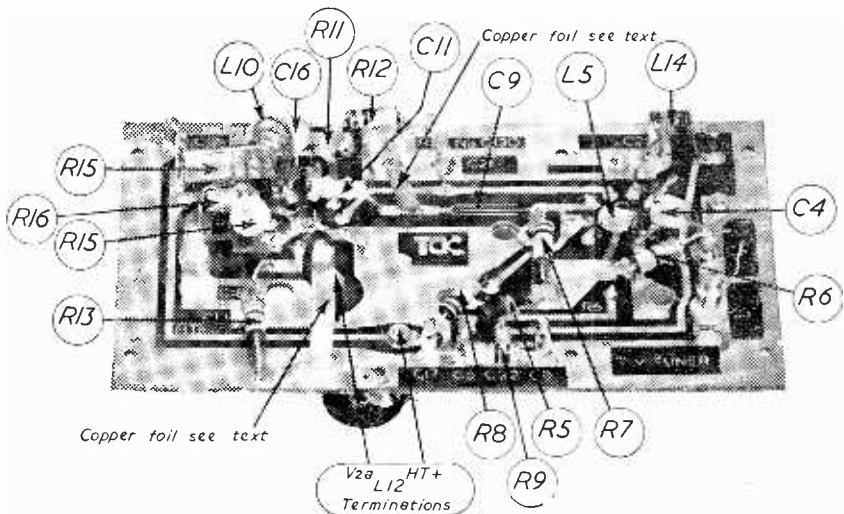

Further components are identified in this illustration.

**COMPONENTS**

- 10 Condensers, 1,000 pF lead-through Type 160S. TCC.
- 1 Condenser, 1 pF. Type 125S. TCC.
- 3 Condensers, 1,000 pF. Type CTH310. TCC.
- 1 Condenser, 10 pF. Type SCP8. TCC.
- 1 Trimmer condenser, 0.5 to 3 pF. Type CC164N. TCC.
- 1 Trimmer condenser, 3 to 9 pF. Type CC159N. TCC.
- 1 Printed circuit of TV tuner, Type C130. TCC.
- 1 Printed circuit of fine tuner plate. Type C366. TCC.
- 1 Short length of coaxial feeder.
- 1 Coax. plug.
- 1 Coax. socket.
- 1 Valve PCC 84. Mullard.
- 1 Valve PCF80. Mullard.
- Quantity of 22 or 24 gauge brass or copper for screens and cover.

value is such as to cause it to resonate above Band III. The second triode is connected in an earthed grid arrangement and is that part of the cascode circuit that gives a useful voltage gain. The bias on the upper triode is fixed by the potential divider consisting of resistors R7 and R8, though the current which flows in the two triodes is identical as they are both connected in series. It was mentioned above that the upper triode operates as an earthed grid: it should be understood that this, of course, is earthed so far as R.F. is concerned and this is done via C7.

The output of the cascode R.F. stage is taken to the primary section of an R.F. transformer which is top end capacitively coupled on Band III via an 0.5 pF condenser, this condenser being printed on the panel, whilst on Band I the coupling is mixed, there being an additional 1 pF condenser across L7 and L9, the primary and the secondary, whilst the coils themselves are spaced to give some degree of inductive coupling. The purpose of arranging the couplings in this manner is to ensure that an adequate band width is achieved on both bands, since otherwise it

would be possible to have an excessive band width with a resulting loss of gain or, alternatively, too narrow a band width giving poor definition, or a weak vision signal yet adequate sound, or even adequate vision gain with a total loss of sound. Condenser C9, the 0.5 pF coupling condenser, is printed and appears on the panel in the form of a single line conductor between two other conductors. By printing this condenser the assembly has been somewhat simplified; at the same time a critical value condenser is correctly placed in the circuit and a consistent performance is obtained. As on the input circuit to V1 it has also been found necessary to damp L9, the secondary of the transformer, by connecting a resistor of 8.2 KΩ directly across it; this resistor is actually mounted on the switch.

The R.F. intervalve coupling feeds the grid of the pentode section of V2 which operates as the mixer. This stage is conventional with the exception that the grid resistor is formed of two resistors, R11 and R12, and the junction of these is taken to the top of the printed panel and is marked as the test point.

The purpose of this test point is to enable the I.F. to be fed into the grid of this valve so as to ensure that the input circuit of the I.F. amplifier may be correctly aligned. It will be recalled that in last month's article it was recommended that when align-

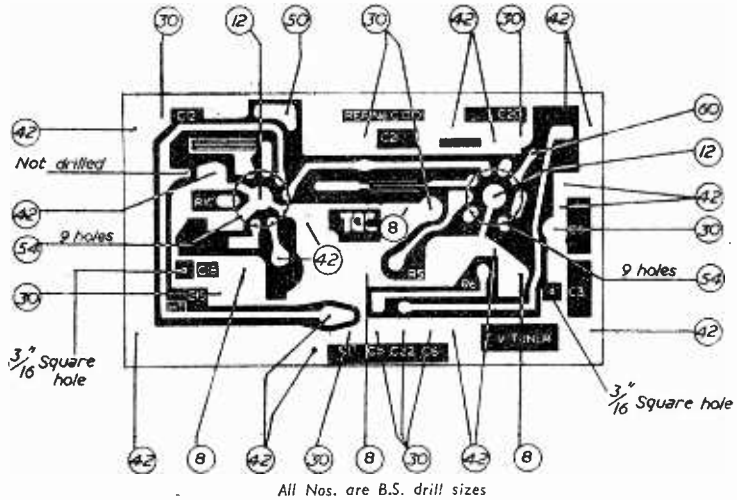

Fig. 2.—Drilling data for the printed circuit.

COIL DATA.

	Band I Channels 1 and 2	Band I Channels 3, 4 and 5	Band III Channel 9	Wire gauge
L1	1½ turns	—	—	32 s.w.g. D.S.C.
L2*	20 turns	—	—	32 s.w.g. D.S.C.
L3*	30 turns	24 turns	—	32 s.w.g. D.S.C.
L4	—	—	5 turns	18 s.w.g. enamel wound on .2in. former.
L5	8 turns	—	—	22 s.w.g. enamel wound on ¼in. former.
L6	—	—	3 turns	18 s.w.g. enamel .2in. former.
L7*	11½ turns	8½ turns	—	32 s.w.g. D.S.C.
L8	—	—	1 turn	18 s.w.g. enamel wound as loop
L9*	8½ turns	7 turns	—	32 s.w.g. D.S.C.
L10	—	—	3 turns	18 s.w.g. enamel on .2in. former.
L11*	6 turns	5 turns	—	32 s.w.g. D.S.C.
L12*	18 turns	—	—	32 s.w.g. D.S.C.
L13	1½ turns	—	—	32 s.w.g. D.S.C.
L14	10 turns	—	—	22 s.w.g. enamel wound on ¼in. former.

\* On former with adjustable iron dust core.

All Band I coils which are wound and remain on moulded coil formers use similar formers to those specified in the original View Master vision receivers. They are a little over ¼in. diameter.

All Band III coils as well as L5 and L14 are wound on formers whose diameter is specified above, then removed from the formers and made self supporting by being soldered into position.

ing the R.F. amplifier a small resistor should be connected in series with the input coil of V1 so as to permit a voltage to be developed across it and thereby fed to the grid. This, however, was only a temporary measure when aligning the I.F. amplifier on its own. When the tuner is connected to its I.F. amplifier, this resistor must of course be removed and the input from the aligning oscillator or signal generator should then be taken to the test point on the tuner. The oscillator voltage developed in the triode section of V2 is fed to the grid of the pentode via condenser C14 with a capacity of 2 pF. Advantage has been taken of the printing method to include this condenser on the panel and it will be seen that it consists of an interlinked grid, the capacity being obtained by the proximity of the adjacent conductors. By printing condenser C14 closer control can be obtained of the oscillator voltage fed to the mixer and a critical part of the assembly has been greatly simplified. The oscillator itself consists of a Colpitts arrangement with a similar method of switching to that used in the R.F. circuits. C18 is a variable ceramic trimmer intended for pre-setting of the oscillator frequency. Its range of capacity is only 0.5 to 3 pF and it is similar in appearance to C3 except that the body colour is white. C19 is the fine oscillator trimmer mounted on the front of the tuner, the moving vane being mounted concentrically with the switch spindle so as to permit easy adjustment of the oscillator frequency if necessary when switching from one channel to the other. The variation of capacity of C19 is obtained by moving a metal disc to and from a small printed panel having on it a copper disc approximately 9/32in. diameter, and connected via a wire to the oscillator circuit. The total movement of the metal disc need not exceed 1/16in., this variation being sufficient to shift the oscillator frequency by approximately 2 Mc/s.

C16 has a capacity of 5pF and is connected from the anode of the oscillator to chassis. This condenser has

a negative temperature coefficient and compensates for variations in inductance which normally occur due to an increase in temperature of the tuner when this is operating. The rise in temperature of the tuner is, of course, quite normal and occurs due to the heat generated by the valves and resistors. In addition C15 which is the grid condenser of the triode oscillator also has a negative temperature coefficient. These two condensers adequately compensate for any variations due to temperature rise and maintain the frequency of the oscillator constant over long periods. Even when switching the tuner on from cold there is no appreciable drift and the oscillator setting need not be touched for long periods. From this point of view it compares very favourably with tuners fitted in commercial TV receivers.

The I.F. output of the mixer valve is developed across L12 connected in the anode and damped by R14 to ensure that the band width is sufficient to cover the vision and sound I.F. frequencies. A low-impedance winding consisting of one and a half turns is tightly coupled to L12 and it is from this winding that a short length of coaxial feeder is taken direct to the input of the vision and sound I.F. amplifiers.

One point so far not referred to has been the fact that V1 which is a PCC84 and V2 which is a PCF80 are series connected and require 16 volts A.C. to feed the heaters. This arrangement has been preferred to that of having parallel heaters fed from a 6.3 volt source as the layout of the printed panel is very much simplified by the series connection. In addition, the valves used are more readily available than their 6.3 volt equivalents, and since in any case it would be necessary for an additional heater transformer to be obtained it was not considered at all a disadvantage to specify a 16 volt winding at 0.3 amp. rather than a 6.3 volt winding. The H.T. and the heater supplies for the tuner are taken through the printed panel by

means of the coaxial feed-through condensers and in this way all R.F. currents are kept out of the power supply leads and source. This again adds to the stability of the tuner. There is little more that need now be said about the theoretical aspect and the practical assembly can now be considered.

**Practical Details**

Dealing with the assembly of the tuner unit, it is recommended that the printed panel be assembled first and then the switch unit with the Band 1 coils. The first step in the assembly of the printed panel must be to drill carefully all the holes in the panel. The diagram on page 362 indicates the sizes of drills used for each hole. The drill centres are themselves clearly marked on the printed panel so there is little room for error, nevertheless great care should be taken to ensure that no holes are out of position or incorrect in size whether this is smaller or larger than the specified dimensions. The holes for the two trimmers are best made by first drilling, then filing to shape, taking care not to enlarge them unnecessarily. Having drilled all the holes and ascertained that all components are available, the resistors and condensers mounted on the tuner plate may then be soldered in position. At this point some recommendations on soldering will be made and the constructor is urged to take this advice. The copper foil of the printed panel is in a clean solderable condition and very readily takes up the heat from the soldering iron with the result that the solder will flow very rapidly. The soldering iron used should preferably be one of the modern types having a small diameter solder bit, approximately 3/16in. or 1/4in. diameter, whilst the solder to be used should be either No. 20 or 22 gauge resin-coated solder.

(To be continued)

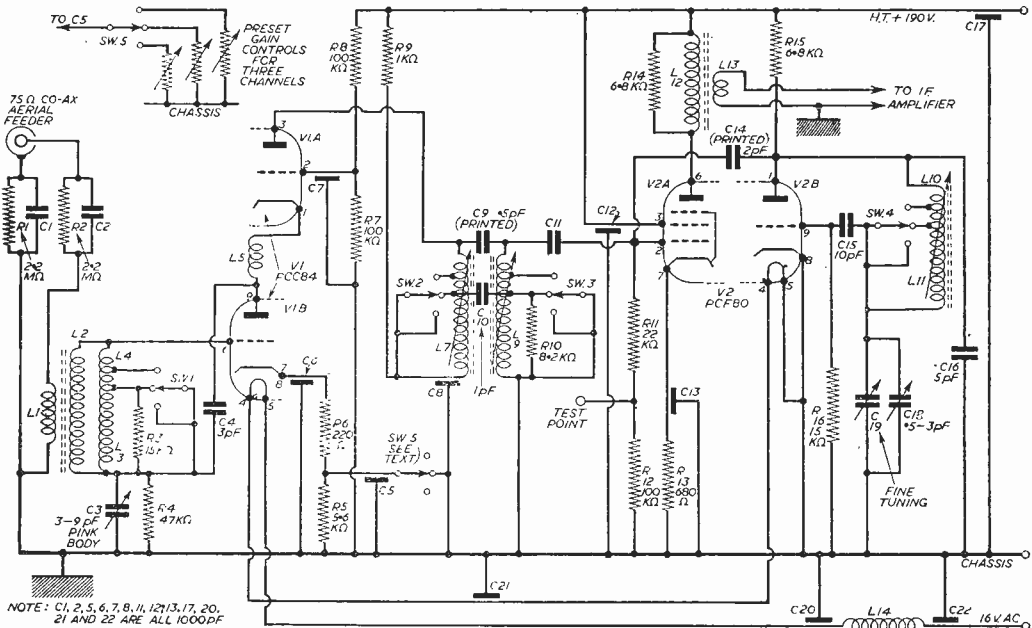

Fig. 1.—Theoretical circuit of the tuner.



## No. 16.—RECOGNISING FAULTS DUE TO DEFECTIVE CATHODE RAY TUBES

By L. Lawry-Johns

**B**Y every post letters arrive which show that a very large number of readers do not recognise the symptoms which indicate a defective cathode-ray tube.

Therefore, in place of the usual "receiver" article this will attempt to clarify the effects of tube failure and the steps which may be taken to remedy the condition, where this is possible. By far the most misunderstood effect is that due to a heater-to-cathode short or partial short. It would appear that Mazda CRM92, 121, 123, 152 and others of the two-volt range suffer from this defect more than others. Fortunately the cure is simple and the tube is 100 per cent. efficient after this has been carried out. Where most confusion arises is where the leak between the heater and cathode does not actually cause the picture to disappear, but only causes the line structure to tear. Quoting from a typical letter from a reader:

"After the set had been working for about 15 minutes a partial loss of line hold would occur which could not be corrected by any of the controls. Also the picture would tend to defocus in bands or all over. In those areas where the line hold was lost the jumbled picture would appear to be discoloured."

This was a fault which happened on an Ekco receiver.

A two-volt isolating heater transformer completely cleared the trouble and a perfect picture was regained. Now consider the same fault happening on a receiver containing a Plessey chassis such as a Regentone, Defiant, Argosy and many other well-known types of receiver. Quoting again: "The picture would suddenly start to roll and then collapse to a horizontal line: all frame timebase valves have been tested and it would appear that all components are in order."

The letter went on to say that the writer appreciated that the type of timebase employed in these receivers requires the presence of sync pulses in order to operate the multi-vibrator type of frame oscillator.

In this type of receiver chassis, Plessey Mk. I and II, the heater of the tube is decoupled to chassis by a .1 $\mu$ F capacitor. In this case, therefore, a leak between the heater and cathode caused not only the picture con-

tent to be shunted to chassis, but also the sync pulses, thereby causing the frame timebase to collapse.

We would mention, however, that a stationary horizontal white line would not result. This would indeed point to a frame timebase fault. However, when the sync pulses are prevented from reaching the timebase the raster will alternately build up and collapse in a "flip-flop" manner. If a tube defect is suspected disconnection of .1 $\mu$ F capacitor will restore the raster and the symptoms will then approach those indicated in the previous case, i.e., loss of line hold, defocused picture, etc.

Where the leak is slight the effect may be only intermittent jump or tear, the picture content appearing to be unimpaired. Other descriptions of the effect of this fault mention "bars of rippled picture," "bands of picture out of focus," "picture blurs and clears when the neck of the tube is tapped." This last is probably the most valuable pointer to the cause of the trouble.

Tapping the tube neck near the base will nearly always enable the diagnosis to be confirmed without doubt.

### Booster Transformer

A very convenient method of clearing the effect of the condition is to fit a small adaptor made by Direct TV Replacements which is termed the Nuray. This is a plug and socket attachment and as well as clearing the heater/cathode insulation failure effects it also provides means of boosting the heater voltage so as to prolong the natural tube life. More will be said of this later.

The more usual type of isolating and boosting transformer is screwed to the inside of the cabinet and consists of two separate windings. The primary is usually tapped for use from 200 to 250 volt A.C. mains.

The secondary may have the normal heater voltage taps with one or more extra points for boosting purposes.

For the benefit of those who cannot quite see the difference between using the receiver mains transformer for supplying the tube heater and a separate smaller transformer the following explanation should help to clarify the difference.

A normal mains transformer is wound purely to supply a given voltage at a given current and with due attention to adequate insulation the windings may be wound in close proximity to one another.

(Continued on page 367)

**MAKE A SOLDER GUN**

A 7-second solder gun was described in Practical Mechanics. Only two essential parts are required: (a) the transformer and (b) the push switch. These we can supply at 13/6 plus 2 post. The rest of the parts you will have in your own "junk" box. Copy of the article concerned given free with the kit.

**TRANSFORMER SNIP**

11/6

Post 2/-  
Fully shrouded — standard 280 - 0 - 280, 200-250v. primary at 60 ma. 6.3 v. at 3 amp., 5 v. at 2 amp.

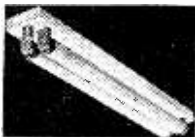

**THE TWIN 20**

This is a complete fluorescent lighting fitting. It has built-in ballast and starters — stove enamelled white and ready to work. It is an ideal unit for the kitchen, over the work-bench and in similar location. It uses two 20-watt lamps. Price, complete less tubes, 29/6, or with two tubes, 39/6. Post and insurance 5/-. Extra 20-watt tubes, 7/6 each.

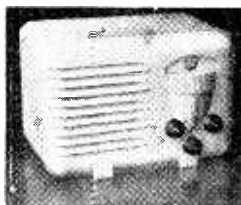

**MAINS-MINI**

Uses high-efficiency coils—covers long and medium wavebands and fits into the neat white or brown bakelite cabinet. Limited quantity only. All the parts, including cabinet, valves, in fact, everything, 24/10/-, plus 3/6 post. Constructional data free with the parts, or available separately 1/6.

**BAND III AERIAL KIT**

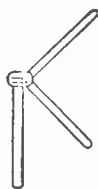

"The Folded V" was described in the July number of this magazine. We tried this and found it to be most efficient. The kit comprises alloy elements and connectors, neat plastic centre piece and saddle for mounting. 8/6 post 1/6.

**PARTS FOR CONVERTER**

Coil formers, valves, mains-transformers, etc., etc. For converters, available. Call or send for list.

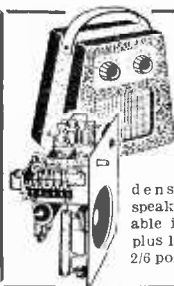

**THIS MONTH'S SNIP**  
**ALL MAINS THREE 22'6**

Build yourself a handy midget 3-valve mains receiver giving powerful loudspeaker strength of Home, Light, and many foreign stations. All component parts, including valves, coils, tuning condenser, resistors, etc., but not loudspeaker, metal chassis or cabinet (available if required) will cost you only 22/6 plus 1/6 post. Data available separately 2/6 post free.

**ADDITA—BAND III CONVERTER**

Any television receiver whether superhet or straight A.C. or A.C./D.C. home constructed or factory built, which at present will receive B.B.C. will also receive I.T.A., if this converter is added. No modifications at all are necessary to the receiver. Simply plug in the aerial leads and connect to A.C. mains. The converter is in a neat metal case with provision for fixing to the side or the back of the set. Price 28/10/-, or H.P. terms available on request if required.

**BUILD YOUR OWN CONVERTER**

You can save at least £2 on the above if you build the converter yourself. Price of all components including stove enamelled case and even transfer for the front is £3/10/- or £4/10/- if mains components also required. Data is included free with the parts or available separately price 2/6. State whether Midlands or London.



**STOP PRESS BARGAIN!**

American insert microphone. Reference No. MIC-253-A. 8/6 each.

**PRACTICAL T.V. BLUEPRINT BAND III CONVERTER**

All parts to build this most successful converter are available. Price Inc. valves, metal chassis, wound coils, etc., 59/6, post and packing 2/6. Made up 79/6.

**F.M. TUNER**



This tuner is based upon the very successful circuit published by Data Publications. We have made up models at all branches and will gladly demonstrate. Stability is extremely good and making and aligning most simple. Cost of all parts including valves, prepared metal chassis, wound coils and stove enamelled case, slow-motion drive, pointer, tuning knob, in fact everything needed is £6/12/6. Data is included free with the parts or is available separately, price 2/-. Extra for fringe area model, 2/-.

**THE CLEVELAND ORGANTONE**

5 valve 3 waveband superhet covering Long, Medium and Short waves. Osram miniature valves—low loss iron coils—permeability—tuned I.F.S.—full A.V.C.—variable negative feed-back—gram position—4 watts out-put—particularly fine tone. Chassis size 7in. x 7in. x 7in. approx. Tested in difficult areas, where exceptional results have been obtained. Price £11/10/0 or £13/6/0 despatch. Carriage, etc., 7/6.

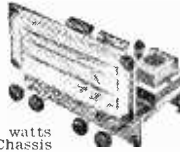

**1in. MICROMETER**

Exceptional purchase enables us to offer a 1in. precision micrometer at the very low price of 10/-. A micrometer is an essential part of an engineer's equipment. If you act quickly you can acquire one now at the remarkable low price of 10/-, post free.



**THE ELPREQ E.H.T. GENERATOR**

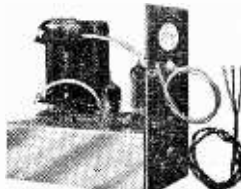

This is a made-up unit, power consumption (6.3 volt 8 amp. filament) and approx. 59 mA H.T.), contains three BVA valves. Output from 6 kV to 9 kV rectified with normal H.T. rail input but somewhat higher outputs can be obtained with higher H.T. supply. Dimensions are 6 1/2 x 4 1/2 x 7 1/2. Price 69/6, post, packing, etc., 5/-.



**MADE FOR THE JOB**

This ex-W.D. 10-valve superhet was designed to receive 200 megacycles transmission so it will require virtually no conversion to receive the commercial T.V. programmes. These contain 6 valves type 6P61, and one each 6L7, 6L6 and 6A50. Six 1P transformers 12 Mc s. band and hundreds of other useful components. Price 59/6, plus carriage and packing 7/6. These receivers are unused and perfect.

**MULTI-METER KIT**

We can now offer a kit of parts suitable for making a multi-meter to measure D.C. volts., milliamperes and ohms. Price for kit containing all the essential items including moving coil meter, metal rectifier, resistors, range selector, calibrated scale, etc., etc., is 15/-, plus 1/- post and packing.



**ELECTRONIC PRECISION EQUIPMENT, LTD.**

Post orders should be addressed to E.P.E. LTD., Dept. 5, 123 Terminus Road, Eastbourne.

Personal shoppers to one of these addresses, please:

- |  |  |  |   |
|--|--|--|---|
| 42-46, Windmill Hill, Rushing, Middlesex. Phone 2 RUSLIP 5780 Half day, Wednesday. | 152-3, Fleet Street, E.C.4. Phone 2 FLEET 2333 Half day, Saturday. | 29, Stroud Green Rd., Finsbury Park, N.4. Phone 2 AICHWAY 1049 Half day, Thursday. | 243, Kilmurn High Road, Kilmurn, MALDA Vale 1921. |
|--|--|--|---|

# Unfailingly fresh

Tobacco at its best. Player's Medium Navy Cut is once again supplied in the familiar pocket tin, vacuum sealed, which means that absolute freshness is retained and enjoyment assured whenever you buy it.

2 oz. tin 9/1d.

## PLAYER'S MEDIUM NAVY CUT TOBACCO



*'The choice for a lifetime'*

[NCT 87M]



## The Bennett College can make you an expert TV technician

**—IN YOUR OWN HOME!**

**Here's your big chance!** The Bennett College, famous the world over for its first-class postal tuition, now offers you a course in Television Servicing. Right away you can start adding to your knowledge of television repairs and maintenance, increasing your technical ability—and making a sound investment for your future.

**Studying with The Bennett College is a pleasure.** You work in your own home, as quickly — or as slowly — as you like. Your personal tutor at the College sends you your lessons — and gives you his friendly help based on years of teaching experience. The College guarantees to continue teaching you until you reach the standard you wish — and all your text-books are provided free of charge.

Send for a free prospectus today! *Just fill in the coupon opposite and post it off — The Bennett College will send you a prospectus free of charge and without obligation.*

**EXCELLENT COURSES** in the following subjects are also offered by The Bennett College. Write on your coupon the course that interests you.

- ELECTRICAL ENGINEERING
- RADIO ENGINEERING
- ELECTRICAL WIRING
- TELECOMMUNICATIONS
- POWER STATION ENGINEERING

To: THE BENNETT COLLEGE (Dept. A 55), SHEFFIELD.  
Please send me free of charge and without obligation,  
a copy of your prospectus on \_\_\_\_\_ (subject s)

NAME \_\_\_\_\_

ADDRESS \_\_\_\_\_

Age (if under 21) \_\_\_\_\_ Please write in block letters.



This is quite in order as long as the heater and cathode of the C.R.T. have no connection. If, however, a leak occurs, the picture signal and sync pulses are not only applied to the cathode, but also to the tube heater and, therefore, the heater winding of the mains transformer.

This is, of course, precisely what happens when a separate isolating transformer is fitted, but with this difference: the capacity between the windings of a normal mains transformer is considerable and therefore the effect is that of a large condenser being placed from the cathode of the C.R.T. to the A.C. mains supply and also, due to the capacity between the windings and the core of the transformer, to the chassis of the receiver. However, an isolating transformer is wound in such a way that the capacity between the primary and secondary windings is reduced to negligible proportions.

In order to reduce the capacity between the winding and the chassis to a minimum it is as well to mount these small transformers on the inside of the cabinet woodwork. If tinfoil screening is fitted a small area of this may be removed so as to permit the mounting of the transformer.

Where a resistor is fitted from the cathode of the C.R.T. to one of the heater tags the value of this may be reduced to, say, 100 ohms, or even shorted out completely. For instance, when wiring one of the heater leads to the tubeholder the wire may be continued across the 100 K resistor (on most Ekco and other receivers) to the cathode tag.

#### A.C./D.C. Models

The symptoms described and the steps taken to overcome the fault have so far been confined to A.C. models, where a transformer supplies the tube heater. It is essential to check the tube type and number so as to ensure fitting the correct isolating transformer. For instance, the heater voltage of the Emiscope TA10, as fitted in the H.M.V. 1805, is 4 volts. However, in the 1808 an Emiscope 3/16 is fitted which requires 13.3 volts. The short table given at the end of this article may help to avoid doubts about the correct heater voltages of various tubes.

Even in receivers bearing the same model numbers the same type of tube is not always fitted and it is therefore essential to check the actual tube type number before selecting a transformer.

When the tube heater is not supplied from the mains transformer and is wired in series with the valve heaters an entirely different set of symptoms is presented. Still considering the effects of a heater to cathode leak or short, the shunting capacity of the transformer so evident in the A.C. mains receivers cannot be considered; and the fact that the tube heater is either directly or indirectly connected to the chassis must be taken into consideration. Where the heater is directly wired to the chassis, i.e., when it is the last in the heater chain, a short from cathode to heater will, of course, remove the H.T. potential from the cathode and leave the grid with a positive potential. Thus, the symptom of uncontrollable brilliance is provoked. A meter reading taken at the cathode will show that there is little or no H.T. present. Quite often tapping the tube neck will clear or provoke the symptoms. It is, of course, essential to check the voltage at the video amplifier anode (in the average receiver) and the coupling components to the C.R.T. cathode to ensure that a defect in one of

them is not responsible. The voltage may be extremely low at these points, but if any doubt is felt the removal of the cathode lead from the tube base will restore normal voltage readings if the C.R.T. is responsible.

In some models the C.R.T. heater is not the last in the heater chain, and should a leak develop a large A.C. potential will modulate the cathode and the net effect of this is to produce broad black and white bars on the screen. Some care is required correctly to diagnose this fault, however, as similar effects are produced by heater/cathode insulation failure in the diode detector (if a valve is used for the purpose) and to a lesser extent in the video amplifier. Again, tapping the neck of the tube may help to identify definitely the cause of the trouble, and operation of the brilliance control will still have some effect if a valve is responsible. Where the receiver is operated from A.C. mains the use of an isolating transformer will completely clear the trouble, and when this is done the two original heater leads must be joined to complete the heater chain. This can be done by directly joining the two leads and adjusting the voltage selector tapping, say, from 230 to 240, or by joining in a resistance of the correct value and wattage. The value is arrived at by dividing the heater voltage of the C.R.T. by the heater current.

The wattage is obtained by multiplying the voltage by the current. In the case of a Mullard MW31/16 this would work out at a two watt resistor with a value of 21 ohms. If the receiver is being operated from D.C. mains a transformer cannot be fitted.

#### Tube Replacement

It would appear that the only thing which can be done, therefore, is to replace the tube. There is a

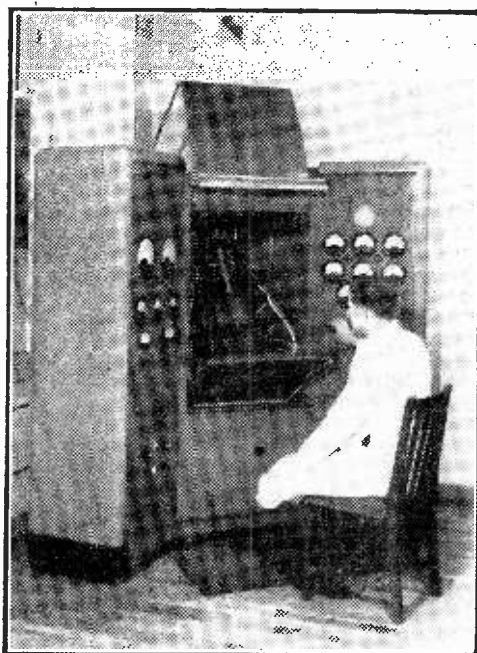

A typical commercial television picture tube tester at the Mullard Valve Service Depot in Glasgow.

temporary means of clearing the short, however, which works in quite a large number of cases. If a large value electrolytic condenser is charged from the H.T. line and discharged across the cathode and one heater tag the short will sometimes clear and the tube be rendered serviceable. This method is, of course, not worth trying where a transformer can be fitted. It is intended more as a "last ditch" operation, where the only alternative is to buy a new tube.

### Inter-electrode Leaks

Uncontrollable brilliance is not necessarily an indication of heater to cathode insulation failure. A grid to cathode short will produce the same symptoms, and in this case there is little which can be done other than to underrun the tube heater. This can be done by dropping the voltage applied to the heater by means of a series resistor, for A.C. mains receivers, or by shunting the heater with a resistor to drop the current passing through it, for A.C./D.C. receivers. Underrunning the heater is not always successful, however, and the fault may remain. Even though it does clear in some cases the emission may drop to a point where the picture has no entertainment value. A tube defect which is similar again often occurs with Mullard MW31/16 and MW31/74 tubes as well as others in the 9in. range. In this case, however, the symptoms are that the brilliance builds up to such a point that the E.H.T. supply is overloaded and the raster is lost. When first examining a receiver with this fault one is led to believe that the EY51 rectifier has failed, as a spark is available at the tube anode.

However, removing the E.H.T. clip and suspending it free from all contact immediately brings the line output stage and EY51 to life and a healthy spark is produced when the E.H.T. is tested. In this case there is very little that can be done and replacing the tube is a regrettable necessity. The brilliance does not always build up and the picture may just flash and disappear without warning.

### Low Resistance Heater

In a good many cases a C.R.T. has been pronounced "low emission" and discarded when a little close examination would have revealed that the heater was not being heated sufficiently to enable the cathode to give its full emission. This happens in A.C./D.C. receivers, and although the valves may be glowing normally the C.R.T. heater is rather dim and a voltmeter test shows that only some three or four volts are actually being dropped across the tube, where the correct reading should be 6.3. If the receiver is being worked from A.C. mains the obvious answer is to employ a separate heater transformer exactly as employed in the event of a heater/cathode short. When this is done it is wise to wire the mains to the highest voltage tapping so that the voltage applied to the heater is less than 6.3. The reason for this is because the entire heater of the tube is not in circuit. If it were the correct heater voltage would have been dropped across it when it was in the heater chain. Obviously then, if the full 6.3 volts is immediately applied, the current passing through the active section may be too great. If the heater does not light up unduly brightly the full voltage may be applied.

### Failing Emission

After a period of use the picture, which may have hitherto been bright and clear, slowly drops in brilliance and sparkle, and at a normal brilliance control setting presents a flat appearance. Increasing the control or brilliance only gives the picture a "blushed" appearance. After a time the condition worsens to a point where advancing the controls results in a "negative" picture where the blacks lighten and the whites darken. The most effective way of improving this condition is to boost the heater voltage. This immediately gives a new lease of life to the majority of tubes. Mazda tubes in particular respond very well to this treatment and the boost may be started at 10 per cent., increasing this to 25 per cent. when necessary, and then to 40 per cent., when the user should certainly have had his money's worth out of the tube.

### Ion Trap Magnets

These sometimes lose their efficiency and although they may work on a low emission tube, when a new one is fitted the picture may not be at all satisfactory. Moving the normal focus magnet may improve the picture brilliance and this often gives an indication that the ion trap is either wrongly positioned or has lost its residual magnetism. If any doubt is felt it is always worthwhile to try another magnet. A close examination of a defective magnet will sometimes show a slight crack.

### LIST OF C.R.T. TYPES

#### MAZDA

	Heater Volts	Amps	Final Anode KV	First Anode V	Base
CRM91 ...	2.0	1.4	4-6	—	M.Octal
CRM92, 92A	2.0	1.4	5-7	—	M.Octal
CRM121, 121A ...	2.0	1.4	5-7	—	M.Octal
CRM122 ...	7.3	0.3	5-8	—	M.Octal
CRM123 ...	2.0	1.4	7-10	—	M.Octal
CRM121B	2.0	1.4	7-10	—	M.Octal
CRM141* ...	12.6	0.3	8-11	300	Duodecal
CRM142* ...	12.6	0.3	10-13	300	Duodecal
CRM151 ...	2.0	1.4	10-13	—	M.Octal
CRM152A & B	2.0	1.4	10-13	—	Duodecal
CRM153* ...	12.6	0.3	11-15	300	Duodecal
CRM171* ...	12.6	0.3	12-16	300	Duodecal

#### MULLARD

	Heater Volts	Amps	Final Anode KV	First Anode V	Base
MW22-14 } & 14C	6.3	0.3	5-7	250	B8G
MW22-16* } 17 } 18 }	6.3	0.3	6-9	300	Duodecal
MW31-7	6.3	0.6	6.8	250	B8G
MW31-14 } & 14C	6.3	0.3	5-7	250	B8G
MW31-*16 } 17 } 18 } *74 }	6.3	0.3	6-9	300	Duodecal
MW36-22* } MW36-24* }	6.3	0.3	9-13	300	Duodecal
MW36-44*	6.3	0.3	10-14	300	Duodecal
MW41-1*	6.3	0.3	10-14	350	Duodecal
MW43-43*	6.3	0.3	10-14	350	Duodecal
MW43-64*	6.3	0.3	10-14	350	Duodecal

\* Ion trap magnet required.

# BAND 3 T/V CONVERTER — 186 Mc/s-196 Mc/s

£2-5-0 post free.

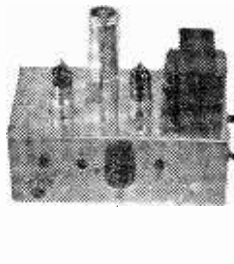

This Unit, comprising drilled chassis, 7in. x 4in. x 2½in., two miniature valves and met. rect., wound coils, res., cond., etc., is a slightly modified version of the circuit shown in *Wireless World*, May, 1954. It has proved itself highly successful—over 3,000 sets have already been sold to buyers all over England. We invite you to visit us and see it in operation for yourselves. Suitable for most types of T/V Sets, T.R.F. or Superhet. Blueprint and circuit details will be sent on application by

return of post, 1/6, post free. Supply voltages required 200-250 v., 20 mA H.T. 6.3 v. 1 A. L.T.  
Power pack components to fit chassis as illustrated, 30/- extra. Complete set wired, tested and aligned ready for use 20/- extra. Band 1, Band 3 Ae switching can now be added, switch kit, 6/6. Full range of Band 3 aerials in stock. Adaptors for 7/6 per set, dipoles—indoor 6/6, outdoor with cable 13/6. Band 1-Band 3 Cross-over filter unit, 10/6.

### Volume Controls

Midjet Edison type. Long Spindles. Guaranteed 1 year. All values 10,000 ohms to 2 Meg. ohms.  
No. S.P.S.W. D.P.S.W.  
3/- 4/- 5/9  
COAX PLUGS ... 1.2  
SOCKETS ... 1.2  
COUPLER ... 1.3  
OUTLET BOXES ... 4.6

### 80 ohm COAX CABLE

STAN-BARD ¼in. diam. Polythene Insulated. GRADE A ONLY.  
8d. yd.  
SPECIAL — Semi-air spliced polythene, 80 ohm Coax ¼in. diam. Stranded core. Losses out 500%.  
9d. yd.

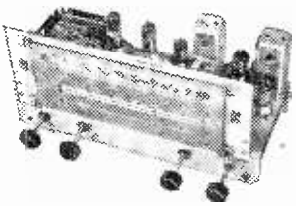

### ALL WAVE RADIOGRAM CHASSIS

THREE WAVEBANDS. FIVE VALVES.  
S.W. 20 m.—50 m. LATEST MIDGET CHASSIS 20 m.—50 m. L.W. 800 m.—2,000 m. SERIES.

### TWIN FEEDER

80 ohms, 6d. yd.; 300 ohms, 8d. yd.  
**TWIN SCREEN FEEDER**, 80 ohms, 1/- yd.  
**50 OHM COAX CABLE** 8d. per yd., ¼in. diam.  
**TRIMMERS**, Ceramic, 4 pf. 50 pf. 9d. 100 pf. 150 pf. 1/3; 250 pf. 1/6; 600 pf. 1/9. PHILIPS Beehive Type—2 to 8 pf. or 3 to 30 pf., 1/3 each.  
**RESISTORS**—Pret. values 10 ohms to megohms.

Brand New and Guaranteed. A.C. 200-250 v. Four position Wavechange Switch. Short-Medium-Long-Gran. Pick-up connections. High Q iron-die-cored coils. Latest circuit technique, delayed A.V.C. and Negative feedback. Output approx. 4 watts. (Chassis size 13 1/2 x 3 1/2 x 2 1/2in. Glass Dial—10in. x 4 1/2in. horizontal or vertical type available. lit by 2 Pilot Lamps. Four Knobs supplied. Walnut or Ivory to choice, aligned and calibrated ready for use. Chassis isolated from mains. PRICE **£9. 15. 0** Carriage and Insurance, 4/6.  
8in. or 10in. speakers to match available.

### CARBON WIRE WOUND

1 w., 9d.; 1 w., 5d.; 1 w., 6d.; 2 w., 9d.; 10% Type, 1 w., 9d.; 5% Type, 1 w., 1/-; Hi-Stab, 1 w., 2/-.  
**WIRE-WOUND POTS**. Pres-Set Min. 7 1/2 Type. Knurled Slotted Knob. All values 25 ohms to 30 K., 3/- ea. 50 K., 4/-; Ditto Carbon Track 50 K. to 2 Meg., 3/-.

### CONDENSERS

—Mica or S. Mica. All pref. values, 3 pf. to 980 pf., 6d. each. Ceramic types, 2.25-5.00 pf., as available, 9d. each. Tubulars, 450 v. 1.50 v. and T.C.C., 0.005, .001, .005, .01, .02 and 1.50 v. 9d., .05, 1.50 v. Hunts Mullard, 1/6, .25 Hunts 1/8, .25 Hunts 1/9, 1.50 v. T.C.C. (Simplex) 3/8, .001, 0.005, T.C.C. 5/8, .001, 12.5kV., T.C.C. 9/8.  
**SILVER MICA CONDENSERS**—10%. 5 pf. to 500 pf., 1/-; 600 pf. to 3,000 pf., 1/3; 1%, 1.5 pf. to 500 pf., 1/9; 5 1/2 pf. to 5,000 pf., 2/-.

## BARGAIN VALUE IN RECORD CHANGERS

Recommended for above chassis

**B.S.R. MONARCH**—Latest Model 3 sp. Auto-Change Mixer Unit. Famous Magi line, 7, 10 and 12in. Record Selector. Modern Cream Styling Dual Xtal Cartridge Stylus for Hi-Fi reproduction. Bargain price.

**£8.19.6** Carr. 4/6 Ins.

### 3 VALVE AMPLIFIER

With variable Tone and Volume controls, 3 Midjet B.V.A. valves, 4 watts output. Neg. feedback. Chassis isolated from Mains. A.C. 200/250 v. A quality amplifier at an economical price. PRICE **£3.19.6**. Carr. 2/6. Wired and tested, 15/- extra. Credit and inst. free.  
**ALUMINIUM CHASSIS**—18 s.w.g. Plain, undrilled, folded 4 sides and riveted corners lattice fixing holes. Strong and soundly constructed with 2 1/2in. sides. 7in. x 4in., 4/6; 9in. x 6in., 5/9; 11in. x 7in., 6/9; 13in. x 9in., 8/6; 14in. x 11in., 10/6; and 18in. x 16in. x 3in., 15/6.

### CARBON MIKE INSERT

—Superior quality type 2 1/2in. x 1in. Brand new and boxed only. 3/6 each.  
**BIRMISTERS**—CZ1 for 3a heater chassis, 3/6; C22 for 15 a., or 2 a., 2/6. C23 (Pilot Lamp), 1/6.  
**COPPER ENAMEL WIRE**—1 lb. 14 to 20 s.w.g., 2/-; 25 to 28 s.w.g., 2/6; 30 to 40 s.w.g., 3/6.  
**SWITCH CLEANER** Fluid, squirt sprout, 3/9 Tin.  
**TWIN GANG TUNING CONDENSERS**—375 pf. Midjet, 6/6; ditto, with dust cover and trimmers, 8/6; .0005 mil. standard size with feet, 8/6;  
**LINE COND.**—3 amp, 60 ohms per foot, 2 amp., 100 ohms per foot, 2 way, 6d. ft.; 3 way, 7d. ft.

NEW BOXED	VALVES	ALL GUARANTEED
1R5	7/6/6Q7	8/6/EP41 10/6/MU14 8/6
185	7/6/6S7	9/-/EP50 PC984 12/6
1T4	7/6/6V6	7/6/Mullard PCP80 12/6
184	7/6/6X4	8/6
284	8/-/6X5	8/-/EP50 PCP41 12/6
3V4	8/-/EA50	2/-/Equip. 5/6/PL2 10/-
316	3/6/EBCH1	EP90 10/6/PL3 12/6
5Z4	8/6	10/6/EP86 13/6/PY80 11/-
6AM6	8/6/EB91	7/6/EP91 8/6/PY81 12/6
6AT6	8/6/EP33	8/6/EL41 11/6/PY62 10/-
6CH6	10/6/EPN3	12/6/EL84 12/6/SP41 5/6
6H6M	3/6/EB42	10/6/EM80 12/6/SP61 6/6
6K7	6/6/EBL0	12/6/EV51 12/6/T22 8/6
6X8	9/-/EP39	7/6/EP40 10/-/UT5 12/6

**SPECIAL PRICE PER SET**  
1R5, 1T4, 185 and 384 or 244 ... 27/6  
6K7, 6X7, 6A7, 6V6, 5Z4 or 6X5 ... 35/-  
**SPEAKER FRET**—Expanded Bronze standard model 8in. x 8in., 3/2; 12in. x 8in., 3/-; 12in. x 12in., 4/3; 12in. x 16in., 6/-; 24in. x 12in., 8/6, etc.  
**TYGON FRET** (Murphy pattern)—12in. x 12in., 2/-; 12in. x 18in., 3/-; 12in. x 24in., 4/-; etc., etc.

### ELECTROLYTICS ALL TYPES NEW STOCK

Tubular Wire Ends	Can Types, Clips, 3d. ea.
25 25 v., 50 12 v.	1/9 S48/450 v. T.C.C. 4/6
50 50 v., 4 500 v.	2/- 8/-16/450 v. Hunts 5
100 2 1/2 v.	2/- 15/-16/25 v. T.C.C. 4/6
5 500 v., 10 250 v.	2/6 16/-16/250 v. B.E.C. 5/6
8 8 500 v., 10 250 v.	4/9 16/-16/450 v. T.C.C. 6/-
8 8 16/450 v. Hunt.	5/9 32/350 v. B.E.C. 4/-
16 450 v., B.E.C.	3/6 32/32/450 v. B.E.C. 6/6
16 500 v., 10 250 v.	4/6 60/350 v. B.E.C. 6/6
16 16/450 v. T.C.C.	5/6 60/100/250 v. 11/6
32 350 v. B.E.C.	4/6 60/250/275 v. 12/6
32 500 v., 10 250 v.	5/6 100/200/275 v. B.E.C. 11/6
32 32/450 v. B.E.C.	5/6 100/200/275 v. B.E.C. 12/6

### RECTORCEL RECTIFIERS. E.H.T. TYPE FLY-BACK VOLTAGES.

KV.25 2 KV., 4.3; KV.30 3.2 KV., 6.2; KV.45 3.6 KV., 6/6; KV.50 4 KV., 7/3; KV.100 4 KV., 12/6. **MAINS TYPE**. R.M.L. 125 v., 60 ma., 4/-; R.M.2, 100 ma., 4/8; R.M.3, 120 ma., 5/9; R.M.4, 200 v., 275 ma., 16/-.

### ENGRAVED CONTROL KNOBS

for 1½in. Spindles, 1½in. diam. Walnut or Ivory. Gold filled, 16 Standard engravings, 1/6 ea. Plain knobs to match above, 1/2in. 10d. ea., 1½in. 11d. ea. Superior Unmarked Knob with Gold Ring. Very stylish and becoming highly popular. Walnut or Ivory, 1½in., 1/- ea.; 1in. 9d. ea. Pointer Knobs, Black with White Line Ed.

### WEARITE "P" TYPE COILS.

All ranges, 1 to 7, 2/6 ea. Osron Q Series Coils. Shug tuned. All ranges from 3/6. Full range popular Coil Packs.

### REACTION COND.

—0.001, .0002, .0005 mfd., 3/6 ea.  
**MAINS DROPPERS**—silicone coated, with 2 slider clips, 15 amp., 1,500 ohms, 4/3; 2 amp., 1,000 ohms, 4/3; 3 amp., 1,000 ohms, 4/9. 25 amp. 750 ohms non-coated, 4/6.

### LOUDSPEAKERS P.M. 3 OHM.

Richard Allen, 5in., 16/6; Celest., 7in. Celest., 18/6; 7 x 7 in. Edithel, 18/6; 7in. Flac., 20/-; 10in. R. and V., 25/-; 12in. Flac., 35/-

### RECORDING TAPE.

—but. rolls, Scotch box, 30/-; competitive paper type, 12/6.

### F.M. TUNER-UNIT

(87 mc's—105 mc's) by Jason. As tested and approved by Radio Constructor. Complete kit of parts to build this modern highly successful unit, drilled chassis and J.L. coil, coils and cans, 4 BVA miniature valves and all component e.t.c. for only **£8.10.0**, post free. **SUPERIOR TYPE**—LANS. DIAL—calibrated in 30's, and also lit by 2 pilot lamps, 12/6 extra. Illustrated handbook with full details, 2/- post inc.



## TRS RADIO COMPONENT SPECIALISTS (Est. 1946)

70 BRIGSTOCK ROAD, THORNTON HEATH, SURREY (THO 2188)  
50 yards Thornton Heath Station. Buses 130A, 133, 159, 166 & 190

Listed above are only a few items from our very large stock. Send 3d. stamp today for Complete Bargain List. Hours: 9 a.m.—6 p.m., 1 p.m. Wed. OPEN ALL DAY SAT.

Terms: C.W.O. or C.O.D. Kindly make cheques, P.O.'s, etc. payable to T.R.S. Post/Packing up to 15d. 6d., 10d. 1/-, 30d. 1/6, 50d. 2/-, 100d. 2/6.



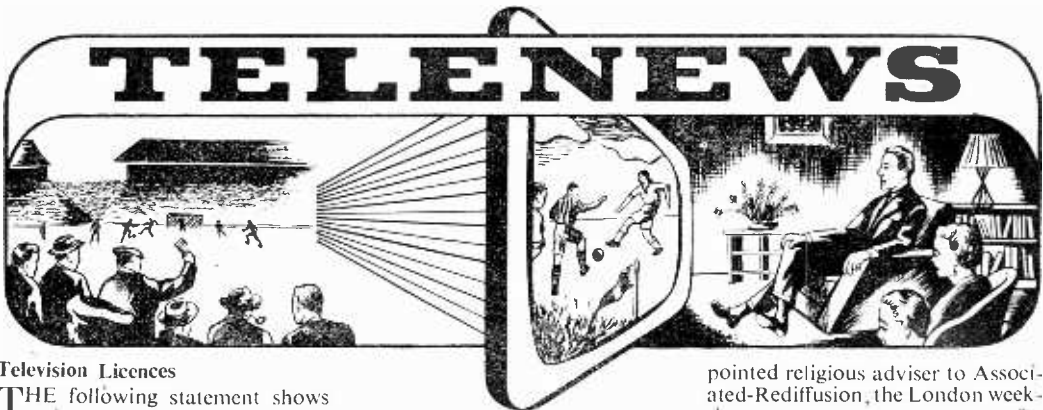

**Television Licences**

THE following statement shows the approximate number of television licences in force at the end of October, 1955, in respect of wireless receiving stations situated within the various Postal Regions of England, Wales, Scotland and Northern Ireland.

Region	Number
London Postal ... ..	1,202,131
Home Counties ... ..	568,320
Midland ... ..	900,348
North Eastern ... ..	754,669
North Western ... ..	738,849
South Western ... ..	313,049
Wales and Border Counties ... ..	279,761
<hr/>	
Total England and Wales ... ..	4,757,127
Scotland ... ..	290,792
Northern Ireland ... ..	30,342
Grand Total ... ..	5,078,262

**A Sign of the Times**

WE learn from Caughnawaga, in Canada, that Chief White Eagle of the Iroquois has placed a television aerial on top of his wigwam and enjoys good reception on his receiver inside.

**Progress in Belgium**

BELGIUM now has three television transmitters in operation: in Brussels, Liege and Antwerp. Two more outside broadcast units were acquired earlier this year.

**ITA London Transmissions**

THE Independent Television Authority announces that high power test signals are now transmitted from its station at Croydon at all periods when programmes are not being broadcast between 10 a.m. and 11 p.m. on Mondays to Fridays, and between 9.30 a.m. and 11 p.m. on Saturdays.

**Meldrum Station**

THE BBC announces the appointment of Mr. W. Balfour as engineer-in-charge of the new

television transmitting station under construction at Meldrum, Aberdeenshire. He will also continue to be responsible for the Home Service transmitting station at Redmoss and the Aberdeen studios.

Mr. Balfour joined the BBC in 1934 as an assistant maintenance engineer at the Washford transmitting station and later served at the Daventry and Westerglen transmitting stations. In 1937 he joined the superintendent engineer transmitters' department in London, where he remained until his appointment as engineer-in-charge, Aberdeen and Redmoss, in 1950.

pointed religious adviser to Associated-Rediffusion, the London week-day programme contractors for ITA. He will be responsible for the Epilogue, which closes the transmission each evening at 11 o'clock.

**Year's Best Performers**

SIXTY television producers and directors have chosen, by ballot, Virginia McKenna and Peter Cushing as the actress and actor who gave the best television performances in the year ended August. This decision was announced at the ball held by the Guild of Television Producers and Directors at the Savoy Hotel in October.

**TV for Judges**

A SUGGESTION is to be made that television be installed in the Newcastle City Mansion House. Mr. Justice Oliver and Mr. Justice

**ITA Religious Adviser**

THE REV. L. M. CHARLES EDWARDS, Vicar of St. Martin-in-the-Fields, has been ap-

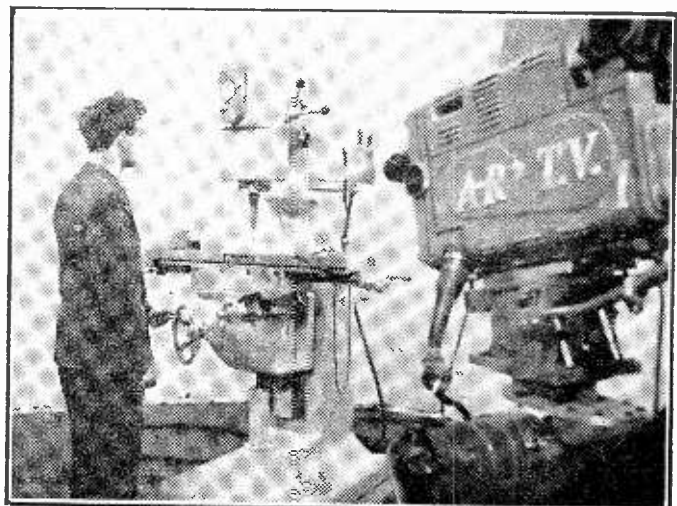

One of the television cameras focuses on one of the Mullard ultrasonic demonstrations during rehearsals for ITA "The Scientist Replies" programme. The machine is drilling a square hole in a piece of glass.

Pilcher are to be asked whether it would be considered desirable that these installations should be made.

### Zoo Film Unit

**A** PERMANENT establishment of a television and film unit is to be set up at the London Zoological Gardens. The technical resources are being provided by Granada Theatres, the contractors for the weekday transmissions in

This latter is rendered necessary because, for technical reasons, the mast has had to be built in the middle of a disused reservoir; the catwalk will carry the feeders across to the base of the mast.

Due to the unusual nature of the siting, the work involved represented a radical departure from routine. First, the water had to be drained and a number of carp

the foundations have gone in, and work on the mast is virtually complete.

For the purpose, use is being made of the Marconi mast which formerly carried the temporary aerial at Northern Ireland's television station. This aerial was recently replaced by a permanent structure, and consequently became redundant. It was dismantled by Marconi's in the record time of under three weeks.

### Council House Aerials

**A**LL new council houses to be built at Edmonton (Middlesex), it is reported, are to be fitted with inbuilt television aerials.

### Mullard in Science Programme

**I**N the second of "The Scientist Replies" programmes televised on ITA, one of the questions answered by the panel of experts related to ultrasonics. Since this subject is one of growing general interest and rapidly increasing application in science and engineering, some interesting demonstrations to show what ultrasonics is and what it can do were arranged.

With the help of Mullard Research Laboratories special equipment was set up in Associated Rediffusion Wembley Studios to give a live demonstration during the programme.

Viewers saw a square hole drilled through a piece of glass and some effects of producing ultrasonic waves in water. Another laboratory demonstration showed the heating and fatiguing effect of ultrasonic waves on metals.

Ultrasonic research in this country has been pioneered by Mullard Limited, and many other interesting applications, particularly that of cleaning, are possible. The scientific adviser to the programme is Norman MacQueen, and the panel on this date included Sir Harold Spencer Jones, the Astronomer Royal.

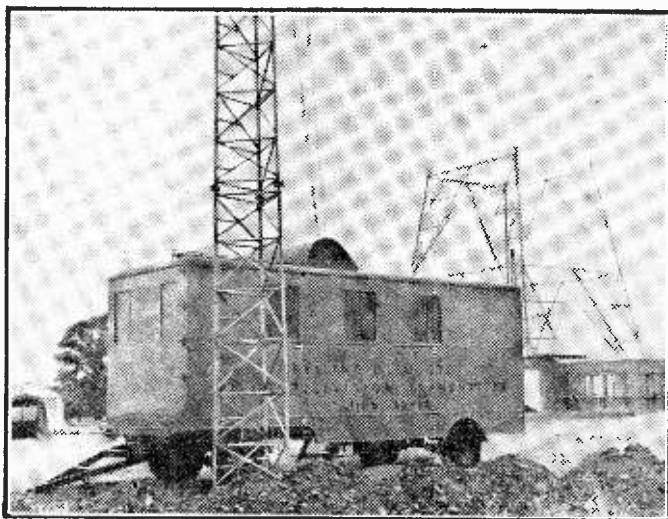

The trailer housing the "Belling-Lee" TV test transmitter on the ITA site at Lichfield. The 85 ft. mast in the foreground carries the four-bay aerial. In the background will be seen the lower sections of the 450 ft. ITA mast.

Manchester. It is claimed that the arrangement will avoid unplanned competitive television from the Zoo which might involve having the cameras of several rival organisations in the grounds.

### Crystal Palace Station

**T**HE BBC have awarded further contracts to Marconi's Wireless Telegraph Co., Ltd., for work on the Crystal Palace television station.

These call for the erection of a 250ft. mast, together with an aerial and feeder system, and for the design, construction, and installation of a special catwalk.

transferred to a pond in the Crystal Palace grounds. This done, mud to a depth of several feet was removed from an area to enable the mast foundations to be laid.

Although a rumour—subsequently disproved—of the presence of an unexploded German bomb caused a certain delay in progress,

**Our next issue, dated  
Feb., 1956, will be on sale  
on Friday, Jan. 20th.**

*The Editor will be pleased to consider articles of a practical nature suitable for publication in "Practical Television." Such articles should be written on one side of the paper only, and should contain the name and address of the sender. Whilst the Editor does not hold himself responsible for manuscripts, every effort will be made to return them if a stamped and addressed envelope is enclosed. All correspondence intended for the Editor should be addressed to: The Editor, "Practical Television," George Newnes, Ltd., Tower House, Southampton Street, Strand, W.C.2.*

*Owing to the rapid progress in the design of radio apparatus and to our efforts to keep our readers in touch with the latest developments, we give no warranty that apparatus described in our columns is not the subject of letters patent.*

*Copyright in all drawings, photographs and articles published in "Practical Television" is specifically reserved throughout the countries signatory to the Berne Convention and the U.S.A. Reproductions or imitations of any of these are therefore expressly forbidden.*

**NEW!**

# EXPERIMENTAL KITS in Radio, T.V. etc.

## LEARN THE PRACTICAL WAY

Specially prepared sets of radio parts from which we teach you, in your own home, the working of fundamental electronic circuits and bring you easily to the point when you can construct and service radio sets. Whether you are a student for an examination; starting a new hobby; intent upon a career in industry; or running your own business — these Practical Courses are intended for YOU — and may be yours at a Very Moderate Cost.

### EASY TERMS FROM 15/- A MONTH

With these outfits, which you receive upon enrolment, you are instructed how to build basic Electronic Circuits (Amplifiers, Oscillators, Power Units, etc.) leading to complete Radio and Television Receiver Testing and Servicing.



**TELEVISION**—With this equipment you are instructed in the design, construction, servicing and testing of a modern high quality Television Receiver. **ALL EQUIPMENT SUPPLIED IMMEDIATELY AND REMAINS YOUR PROPERTY**

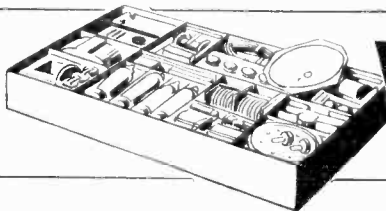

### BEGINNER'S RADIO OUTFITS

— For carrying out basic practical work in Radio and Electronics, from first principles and leading to the design and building of simple Receivers.

### ADVANCED RADIO OUTFITS

— With this equipment, you are instructed in the design, construction, testing and servicing of a complete modern T.R.F. and Superhet Radio Receiver.

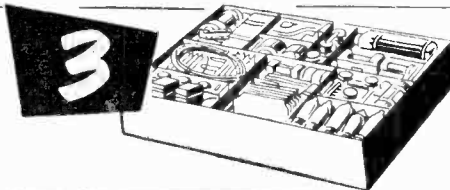

### OTHER COURSES WITH OUTFITS INCLUDE:

**MECHANICS • ELECTRICITY  
CHEMISTRY • PHOTOGRAPHY  
CARPENTRY**

**ALSO DRAUGHTSMANSHIP • COMMERCIAL ART  
AMATEUR S.W. RADIO • LANGUAGES • ETC.**

### POST THIS COUPON TODAY

Please send me your FREE book on Practical Courses: I am interested in Television , Radio: Beginners , Advanced . Other subjects

(Please indicate Item(s) required)

To: E.M.I. INSTITUTES, Dept. 138x, Grove Park Road, London, W.4.

NAME \_\_\_\_\_

ADDRESS \_\_\_\_\_

JAN.



# E.M.I. INSTITUTES

The only Postal College which is part of a world-wide Industrial Organisation

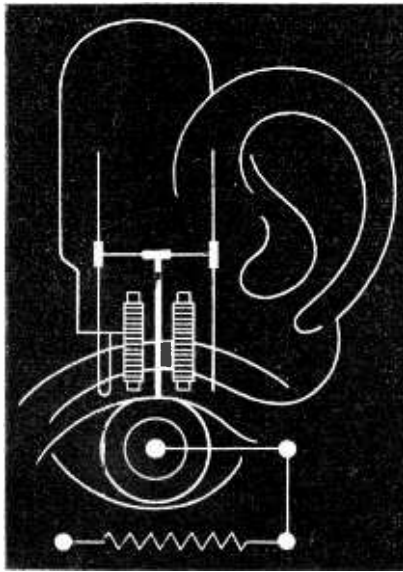

## SMITH'S FOR TECHNICAL BOOKS

Books on radio theory, practice and maintenance for the beginner and books on new developments in circuit design, new components, methods of application, and the established text books can be obtained through your local Smith's shop or book-stall. Books not in stock at the branch can be quickly obtained from Head Office.

★ Your stationery and printed matter can also be supplied through our local branch.

# W. H. SMITH & SON

FOR BOOKS ON ELECTRONICS

Head Office: STRAND HOUSE, LONDON, W.C.2

## Commercial Television

### CONVERTER KIT

Complete kit of parts including valves, ready wound coils, punched chassis, down to the last nut and bolt. Suitable T.R.F. or superhet receivers. PRICE £2 15s. 0d. Circuit details, 6d. post paid.

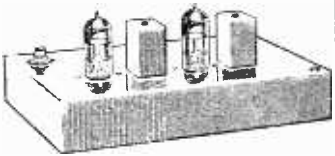

**Mk. II CASCODE CIRCUIT.** Specially suitable for fringe areas as it provides high gain and low noise level. **COMPLETE KIT, £3 1s. 6d.**

**MIDLANDS READERS**—These converters have been carefully tested on the Lichfield pilot transmissions—Build Yours Now and be ready for the start of this exciting new service.

Ready punched chassis with base screen	...	3 9
Ready punched chassis with base to accommodate converter and A.C. power pack. With screens	...	6 0
Low loss ceramic B9A valve-holders	... each	1 6
Ready wound coils Mk. I circuit	...	15 0
Ready wound coils Mk. II cascode circuit	...	17 6
Airsaced ceramic trimmers	...	1 6
Coaxial plugs, 1/3. Coaxial sockets, 1/3.	...	
<b>7pf FINE TUNER.</b> Air-spaced, ceramic, with spindle	...	2 6
<b>VALVES.</b> EF80, ECC84, ECF82, etc.	... each	10 6
<b>RESISTORS.</b> Complete set of resistors for Mk. I	...	2 6
<b>RESISTORS.</b> Complete set of resistors for Mk. II	...	3 6
<b>CONDENSERS.</b> Complete set of fixed condensers	...	4 0
<b>CONDENSERS.</b> Complete set for cascode circuit	...	7 6
Low loss air-spaced coaxial cable, 9d. per yd.	...	
Large stocks of Band III aerials, cross-over units, AddeX units, Aerial manuals, power units, etc.	...	

### HOME RADIO OF MITCHAM

187, London Road, Mitcham, Surrey. MIT. 3282.

"You can rely on Us" for . . .

## ALL RADIO and ELECTRONIC COMPONENTS

One of Britain's Largest Stockists of all Leading Makes: Hunts, T.C.C., Haynes, Allen, Denco, Osmor, Weymouth, Morganite, Bulgin, Belling Lee, Teletron, R.E.P., Scotch Boy, Ellison, Elstone, Partridge, Wynall, Westinghouse, S.T.C., AVO, Taylor, Goodmans, J.B., Wharfedale, Wearite, Acos, etc.

Suppliers to: Ministries, Development Laboratories, Education Authorities, etc.

Some of the more difficult parts you may not be able to acquire:

Tapped Vol. Controls, Linear C.T.  $\frac{1}{2}$  mg.,  $\frac{1}{4}$  mg., 1 mg., 7/6. Linear  $\frac{1}{2}$  mg.,  $\frac{1}{4}$  mg., 1 mg., 6/6. Post 6d.  
2 High Stab.  $\frac{1}{2}$  w. Resistors. 2% Range, 100Ω to 2 meg., 1/6 each. 1% Silver Micas up to 100 pf., 1/-, 280 pf., 1/2. 500 pf., 1/4. 1,000-5,000, 2/6. Post 6d.  
Teletron Band III Converter—Punched Chassis, 4/- Post 6d. Set of Coils and Circuit, 15/- Band III Loft Aerials, 30/- plus 2/- carriage.

Thousands of Valves, Condensers, Resistors—Can We Help You?

**SPECIAL OFFER.**—B.S.R. Monarch Record Changers—New, Boxed, £8.17.6. Carriage 3/-.

Catalogue, Book Lists, S.A.E.

## RADIO SERVICING CO.,

82, SOUTH EALING ROAD, LONDON, W.5

Tel.: EAL 5737. Next Sth. Ealing Tube, 65 Bus.

1 p.m. Wed.



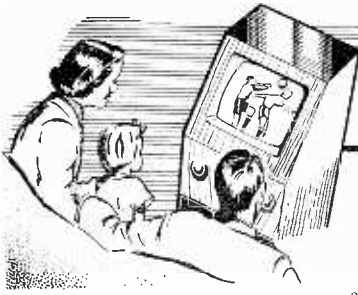

## UNDERNEATH THE DIPOLE

TELEVISION PICK-UPS AND REFLECTIONS

By Iconos

### "GISELLE"

**L**ONG shots with many dancers and busy scenery may be tolerable in light programmes to viewers with large-tube receivers, but even these lucky people must have reached for their opera glasses when Philip Bate presented Alicia Markova in Act 2 of "Giselle." The heavy backlighting (presumably representing moonlight), made the stage appear to be covered with snow, and the traditional woodland scenery overpowered the story, the dancers and the television camera. On this unfortunate occasion, the orchestral accompaniment also overpowered the voice of a woman narrator in the prologue. It must be admitted that "Giselle" is a difficult ballet for the television medium if it is presented in a form almost indistinguishable from its stage version. It should be obvious that television demands an entirely fresh approach to the matter of decor: simplicity of design by the art director is a first requirement. Let us hope that the next time Philip Bate presents the gifted Markova in a ballet, he gives us an opportunity of seeing her properly. Script, decor and continuity of most ballets, like plays, require careful adaptation for the newer medium.

### THE TELEPROMPTER

**M**ORE American TV gadgets will be seen in the studios over here shortly. The latest one is the TelePrompTer, spelt with three capital letters, which is a device for helping actors (and others) to remember their lines. The entire dialogue of a scene is written on a roll of translucent paper, 10in. wide, which is wound forward in time with the artist's delivery. The mechanism which does this is contained in a small sound-proofed box which can be attached to the front of a TV camera, a suitable position being just above the lens. Several of these TelePrompTer boxes can be operated,

simultaneously, and in synchronism, positioned on each TV camera or mounted on stands which bring them into the eyeline of the actors on the set, without being seen by the viewers. The words on the paper are illuminated from behind with just sufficient light not to cause glare and can be regulated according to the amount of light being used in the TV studio. On some American programmes, as many as 12 of these machines have been used on one set at the same time. This seems to me to be a big improvement on the off-stage blackboard or the often audible voice of an off-stage prompter. The multiplicity of the cueing machines, gets over the risk of apparent "glances off" by the actors.

### RECORDED TV SHOWS

**T**HE BBC and ITA organisations both seem to have their off-nights with film reproduction, particularly on the sound side. "Dragnet," the American series, has suffered with excessive ground noise on its sound track and many

other items have been afflicted with peculiar distortions. Perhaps our ears are becoming accustomed to the very wide range of frequencies reproduced on direct live shows or from magnetic recordings used for certain filmed items by the BBC. The use of photographic sound tracks, particularly those recordings made on the same film and in the same camera used for photographing the picture, do not stand up to a comparison with live sound. Mixing of audience reaction noise, applause and laughter is often very poor on ITA, probably due to hasty patching together by the film editors or faulty mixing in the dubbing process. Multiple track magnetic recording, as used on many CinemaScope films, will probably prove the answer to this problem of sound quality.

### BBC TELEVISION CENTRE

**T**HE BBC has now placed a contract with Messrs. George Wimpey & Co., Ltd., for the excavation and foundations of the main building to be erected at Television Centre, Wood Lane,

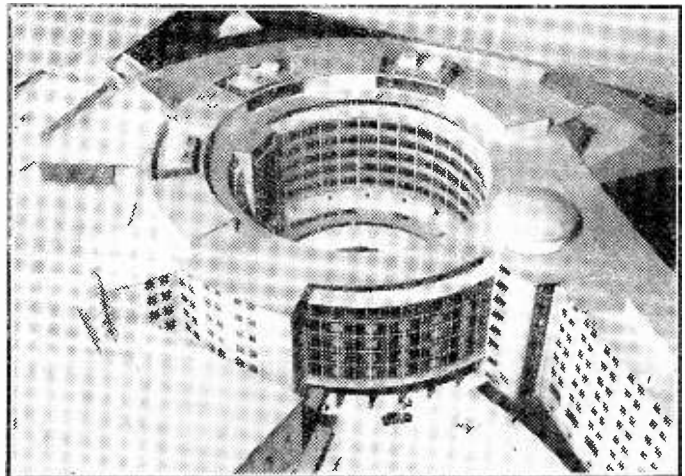

A general view of the northern aspect of the new BBC Television Centre Main Block at White City.

London. This will be the third stage in the BBC's building programme for the development of the site. It will be preliminary to the building, later, of the superstructure which will be in the form of a multi-storey "ring" building of nine floors, enclosing a court some 150ft. in diameter. In the "ring" there will be dressing-rooms, wardrobe space and engineering areas on the lower floors, with offices above. Radiating from it will be television production studios, telecine and telerecording areas, and a central control room. The outer periphery of the studios will be enclosed by a continuous runway along which scenery and properties can be conveyed to the studios from the Scenery Block, which is completed and in use. What is to be the Restaurant Block for the whole project is also in use, though at present for rehearsal rooms and offices.

The area to be enclosed by the "ring" building and buildings radiating from it will be  $3\frac{1}{2}$  acres—an area nearly twice that covered by St. Paul's Cathedral. The foundations and retaining wall of this section of the main project are to be completed by the end of September next year, when the building of the superstructure will commence to be ready for occupation in 1960. A photograph of this part of the building appears on page 375.

The quantity surveyors are Messrs. Ainsley.

#### TECHNICAL COMPARISONS

SO far, I have not read any critical evaluation of the overall technical results obtained by the three organisations—BBC, A.R.T.V. and A.T.V.—plus the joint venture, I.T. News. My own observations lead me to place the BBC an easy first in technical quality of live or filmed picture, of direct or recorded sound and of general technical consistency and slickness. I have taken the trouble to investigate a number of transmissions on systems which gave unpleasant all contrasty results on faces and found that they all originated from image-orthicon type cameras. These cameras are extremely sensitive and give a result which seems to be sharper in focus than with other types and yet they frequently have the extraordinary effect of adding ten years to the age of the actors and, unfortunately, actresses, unless the lighting has been very carefully carried out.

Similarly, I have checked up on several programmes which have been notable for a pleasant high-key quality, with excellent skin texture on close-up of actors' faces. These programmes were for the most part televised with C.P.S. Emitron cameras. No special care seems to have been taken with the lighting. What is happening? Is it a mere coincidence that in the cases I investigated the image-orthicon cameras prematurely aged the victims? Poor Chris Chataway is a good-looking young chap with sandy hair, not the haggard middle-aged man we see in I.T. News. Other well-known personalities have suffered similarly. Unless the C.T.V. technicians improve their lighting, the ladies will definitely prefer to appear before BBC cameras. Technicians tell me that the technique of lighting varies a great deal with the different types of camera they have to handle—Emitrons, Super Emitrons, Photicons, Image Orthicons, etc., etc. Optimum lighting levels vary from 300 to 400 foot candles to as low as 80 foot candles for the more sensitive types.

#### SKIN TEXTURE

BY the way, it is quite possible to simulate the bad facial quality and skin texture, as mentioned above, in ordinary still or movie photography! It can be done quite simply by using orthochromatic negative film which is not sensitive to the red end of the spectrum. Almost similar ageing or "dirty face" results can be obtained by using panchromatic negative and a green filter on the

lens. Facial blemishes, unshaven beards, wrinkles and pimples can be most successfully exaggerated by using extra-red-sensitive negative and an infra-red filter on the lens or on the lights. Alas! All of these remarkable ageing effects have been obtained regularly by the ITA companies and quite a few times by the BBC. There is a moral behind my technical criticisms. By all means let the ITA and BBC engineers use test cards and test charts for checking cameras and equipment. But let them remember that test cards do not check relative textures, reflections, specular reflections, monochrome equivalents of colours, which are the main factors which affect the reproduction of the face as regards skin texture and brightness of the eyes. Test cards merely deal with the elemental geometry of the reproduction of the picture, its sharpness and contrast. Surely we have progressed further than that! Let the engineers study a few faces through their TV cameras and manipulate lighting, filters, lenses and (yes!) diffusion discs. Diffusion discs are sometimes most effective on head close-ups and should not be ignored. Still photographers use ultra-fast film for "candid" snaps under poor lighting conditions. The result usually gives the victim the facial characteristics of a hunted criminal—until a skilful retoucher gets to work. Unfortunately, the TV faces cannot be retouched. That job has to be done by care in the use of studio lighting.

#### PRACTICAL WIRELESS JANUARY ISSUE NOW ON SALE, Price 1/-.

The January issue of our companion paper "Practical Wireless" contains, as the main constructional feature, details of a Novel C/R Bridge. This is a neat radio accessory, useful, alike to the amateur and the serviceman. It enables resistors and condensers to be tested, and the indicator is in the form of a neon lamp which to many will prove more useful than the more usual "Magic-eye." It is entirely self-contained and mains operated, and the article is complete in the issue.

Amongst the other features in this issue are the conclusion of the series on the 8-valve A.M./F.M. receiver, and the conclusion of the Car Radio articles. A further chapter in the series on Using Test Instruments deals in this issue with the measurement of Phase Shift in Amplifiers. There is also a complete article on a Novel Phase Inverter, a Receiver Analyser/Valve Tester, some reminiscences on Loudspeakers of the Past, Frame Aerials, Transmitting Topics (this month's notes being on the design of the Power Pack for the Transmitter), Voltage Stability in Power Units, and in the Servicing Series, the receiver which is dealt with is the Vidor Portable CN396.

# TELEVISION TUBES

**MULLARD — MAZDA — COSSOR — EMITRON — or equivalents.**

12in., £6.10. 14in., £7.10. 15in., £8.10. 17in., £10.

Packing and Insurance, 12/6.

**6 MONTHS' GUARANTEE.**

**LOW LOSS CROSSOVER BOX.** For inside or outside fitting. No soldering, 13/6.

**LONDON. L1 CONVERTER.** Band I-III ... .. £9. 6.0

„ Fringe Areas. L2 CONVERTER. 4 Channel Model ... .. £9. 9.0

**MIDLANDS. M1 CONVERTER.** Band I-III ... .. £9. 6.0

„ Fringe Areas. M2 CONVERTER. 4 Channel Model... .. £9. 9.0

**SOUTH COAST. S1 CONVERTER.** 4 Channel Model £9.18.0

All Converters with Built-in Power Supply. L1 and M1 also includes Crossover Box. South Coast and Fringe Areas are specially developed HIGH GAIN Models. Finished in stove enamelled steel case. Instructions for fitting enclosed. Cash with Order or C.O.D.

**REVIEW (LONDON) LTD., 14, BEYNAN ROAD, CARSHALTON, SURREY**

Phone : LIBERTY 2825.

Terms to the Trade.

## VIDEO ELECTRONICS (LONDON) LTD.

Head office : 27, Bacon Street, London, E.I.

Works : 16/22, Bacon Street, E.I.

Telephones : Bishopsgate 0419/0410.

### T.V. Tubes

Cheap, reliable high grade seconds and reconditioned C.R.T.'s, as supplied to the trade and leading Television Insurance Companies, prices from £3.

### Valves

Send at once for our useful list of cheap valves which will save money, we are the cheapest in the trade.

### Condensers

Electrolytics, bias, coupling, etc., etc., at giveaway prices. All types stocked.

### Resistors

A fine stock of these at very low prices.

### T.V. & Radio Cabinets

A few 17" Table and Console cabinets, new, ex famous manufacturer, and about 500 very handsome radio cabinets made for export.

Send for stock list of speakers, valves, components and T.V. and Radio Spares.

All our goods are guaranteed.

## HANNEY of BATH offers:—

**VIEWMASTER.**—Constructor's Envelope, 7/6 : WB.103, 42/- : WB.103A, 52/6 : WB.104, 15/6 : WB.105, 43/6 : WB.106, 25/6 : WB.107, 32/6 : WB.108, 33/3 : WB.109 1, 2 or 3, 22/6 : WB.110, 7/6 : WB.111, 5/9 : Westinghouse rectifiers : 14A86, 21/4 : 14D36, 14/4 : WX.3 and WX.6, 4/2 each : 36EHT100, 29/5 : 36EHT50, 26/1 : 36EHT45, 23/8. SenTerCel Rectifiers : K3.100, 14/8 : K3.50, 8/9 : K3.45, 8/2. Wearite Coils with L.9, 30/- : Pre-amp coils, 4/- pr. State channel.

**TELEKING.**—Constructor's Envelope, 6/- : Coils sets, 44/6 : Chassis kit, 50/- : P.C.C. kit, 47/4 3 : RM4 rectifier, 22/6 : Allen Components, L0308, 40/- : FO305, 21/- : DC300C, 33/6 : FC302, 31/- : GL16 and GL18, 7/6 each : BT3.4, 15/- : SC3 2, 21/- : AT310, 30/- : OP117, 9/-.

**P.T. SUPERVISOR.**—T.C.C. Condenser kit, £8 6 4 : Erie resistor kit, 54/4 : 5 w w pots, 26/- : 7 Erie carbon pots, 35/- : Allen coils sets, 44/6 : Allen DC 300C, 39/6 : GL.16 and GL. 18, 7/6 each : SC.312, 21/- : FC.302, 31/- : OP.117 output trans., 9/- : Denco WA FMA1, 21/- : WA L0T1, 42/- : Denco chassis kit, 51/6 : Westinghouse WX.6, 4/2 : WG4A, 7/6 : LW.7, 26/8 : English Electric polystyrene mask, 45/9 : perspex filter, 32/8 : anti-coronal ring 6/8 : Tube sheath, 6/2 : T.901 tube, inc. carriage and insurance, £23.15/- : Elac I18 ion trap, 5/-.

**MAXI-Q (Denco) F.M. FEEDER UNIT.**—Constructor's Technical Bulletin, 1/9. P. Free. Chassis set, 7/6 : Coilset, 11/9 : 10.7 Mc/s IF's 6/- each : Ratio discrim. trans., 12/6 : Phase discrim. trans., 9/-.

**SUNDRIES.**—1st Quality 70 80 ohm co-axial cable, by famous maker, stranded core, 9d. yard, 8/9 doz. yds. post paid. Pre-set controls, 3 watt wire-wound, all values, 10u to 30 K $\Omega$ , 3/- each; ditto, 1 watt carbon, all values 50 K $\Omega$  to 2 M $\Omega$ , 3/- each. Denco MTO.1 Test Oscillator, with valve, 75/- : Denco TFA.1 TV pre-amp, with valve, 29/6 : Elac ion traps, all types, 9/- : ALSO, over 100 values in close tolerance Silver Micars in stock from 1.5 Pf. to 5,000 Pf. 20,000 Erie resistors ex-stock in all preferred values and wattage.

Send S.A.E. for list. Please add 2/- postage to all orders under £3 any excess refunded.

**L. F. HANNEY**

**77 LOWER BRISTOL ROAD, BATH**

Tel: 3811

## VIEW MASTER

### Band 3 Converter

We shall be able to supply complete kits or separate components for the View Master Band 3 Converter described in Practical Television.

SEND NOW FOR OUR FULLY DETAILED PRICE LIST.

## WATTS RADIO

8, Apple Market, Kingston-on-Thames, Surrey.

Phone K1Nginston 4099

## LINE E.H.T.

### TRANSFORMERS BEWOUND

#### PROMPTLY

Our 30 years' experience of winding and wave-winding enables us to provide the finest service in the Country for all types of TELEVISION COMPONENTS. We repair or manufacture all types of transformers singly or in quantity, and welcome your enquiries.

## H. W. FORREST (TRANSFORMERS) LTD.

349 HASLUCKS GREEN ROAD, SHIRLEY, BIRMINGHAM.

Telephone: SH1 2483

### PLEASE NOTE

## Technical Trading Co.

(RADIO—TELEVISION—TOOLS)

Have now moved to more spacious premises  
at 350/352 Fratton Road, Portsmouth



17in. T.V. CABINETS. Large purchase enables us to offer new, top-grade table cabinets at keenest prices, famous 1954 model, complete mask, glass, spkr, fret, in front. (Size 19 1/2 in. H. x 18 1/2 in. W. x 18 1/2 in. D.). 39 - (carr. 6 -).

"ENSTAT" 1600. SKYROD AERIALS. Complete 2 antistatic transformers, 60ft. screened feeder, wall lashings, 30 -.

TESTED TELEVISION TUBES (No faults) 12in., £4; 14in., £6. 15in., £5; 17in., £7 10 - . Returnable in 14 days if not satisfied.

DST100 COMMUNICATION RECEIVERS. 7 bands, 10-4,000 m., B.F.O. "S" meter, vernier dial, mains transformer, 15 valves, noise limiter, etc., etc., £19 (carr. 12 6).

12 VOLT 10 20 WATT AMPLIFIERS. Complete with valves in compact grey steel case with push-pull 6L6 (or equiv.) output, cost approx. £30, good condition. £5 10 -, carr. 7 6.

ALKALINE CELLS. 40 a.h. Unused with original sealing bungs. 9 cell or 10 cell units in hardwood crates at 9 - per cell.

TECHNICAL TRADING CO.'S ORIGINAL PREMISES AT 181, LAKE RD., PORTSMOUTH WILL NOW BE OPEN ON SATURDAYS ONLY FOR THE SALE OF PART OF OUR EX-GOVERNMENT EQPT. AND (FOR CALLERS ONLY) REPAIRABLE TELEVISION SETS FROM £3 10 - !

## AERIAL FITTINGS

FOR

Band III, Band I and Radio F/M.

Our increased range of Diecast Alloy Fittings include Band III to Band I Mast Couplers, Reflector and Director Rod Holders, Insulators (both "In-line" and "H" types), Masthead Fittings, Masts and Elements, Chimney Brackets, etc., together with useful Formulæ and Hints for constructing your own aerial quickly and cheaply. Send 1/- P.O. to cover the cost of catalogue and postage to:

## FRINGEVISION LTD.

MARLBOROUGH, WILTS.

Phone: 657/8



## QUALITY TELEVISION COMPONENTS

SCANNING COILS, 6'10 kV. R.F., E.H.T. UNITS, E.H.T. and OUTPUT TRANSFORMERS, LINE FLY-BACK E.H.T. UNITS

Write for illustrated list (Publication 75)

Coil Kit of two for Aug "P.T." Band III Converter 5/-  
Kit of three 7/6. Kit of four for October Band III Converter 6/-.

**HAYNES RADIO Ltd.**, Queensway, Enfield, Middlesex.



*Whilst we are always pleased to assist readers with their technical difficulties, we regret that we are unable to supply diagrams or provide instructions for modifying surplus equipment. We cannot supply alternative details for constructional articles which appear in these pages. WE CANNOT UNDERTAKE TO ANSWER QUERIES OVER THE TELEPHONE. The coupon from p. 383 must be attached to all Queries, and if a postal reply is required a stamped and addressed envelope must be enclosed.*

#### FERGUSON 941T

I have been operating a Ferguson 941T at this address for five years without the slightest bother. Recently I installed the same set and aerial in Dulwich, where the signal is stronger. Apart from altering the tappings to suit 200 volts, and spending hours adjusting all controls, I have made no radical amendments. I am now getting pronounced sound tremors on the vision screen and am unable to get full picture height.

As I am no expert, will you please explain in the simplest possible terms the most probable cause of the trouble and the best method of rectifying it?—R. J. Hawkes (Orpington).

Adjust T1 trimmer for minimum sound interference on vision. Looking in at the rear, on the left-hand side is situated a small trimming condenser. This is mounted on its own, near the second valve. This is T1.

#### PHILIPS 3309

Frame would not lock. I changed the two ECL80s and the frame would then lock, but would not scan the screen properly. First half picture, then one small picture in centre and half one top and bottom. The picture lacks definition, except when commencing to roll; then there is a slight burst which would be quite a good picture if I could lock it but it will not. Also, could you tell the value of the horizontal hold, as the core has worked its way out of the back of control and will not return?—J. J. Durbin (King's Norton).

You should make sure that the replacement ECL80s are well up to standard. The fact that the replacements cured the original fault but caused a reduction in frame amplitude, would indicate that one or other of them is not 100 per cent. good. You should also check the condition of the small fixed resistors which are connected to the frame hold control tags. If these have altered in value they should be replaced.

We regret that we are unable to supply the value of components in your particular model.

#### VIEW MASTER—NARROW PICTURE

I have increased my E.H.T. as per booklet and am receiving a good picture except for two obvious faults. After removing 1 Megohm resistor from R46 I still get faint vertical lines. Secondly, the width of my picture is  $\frac{7}{8}$  in. short on either side of the screen, tube in use CRM121B.—George Johnson (Leeds).

If your picture is showing a slight vertical band on the left it will be necessary to slightly increase the value of R46. At the same time check that the voltages in the receiver are exactly as specified since this will affect the width of the picture. You can also connect a 220 pF condenser across the line-scanning coils, Tags L1, L2.

#### PYE VO9

I have a model VO9 Pye receiver which is now just over two years old and which until recently has given no trouble whatsoever.

Now on switching on and after the usual warming up period the picture develops a number of diagonal lines (white), and the picture starts to slip downwards, alternating between fast and slow slip. The picture itself, other than these white lines, is of first-class quality and though the lines are mostly present, occasionally disappears leaving the picture reasonably steady.

The vertical hold control has no effect on the picture, but by turning the contrast control to minimum has the effect of slowing picture slip whilst increasing contrast, speeds up picture slip.

Last evening on switching on the picture remained perfectly steady for approximately 10 minutes and showed no trace of either lines or slip.—A. R. Hebblethwaite (S.W.17).

The short diagonal lines result when the frame timebase repetition frequency is too far removed from the frame sync pulse frequency. This also results in the picture slipping vertically. Normally, the timebase frequency can be adjusted by means of the vertical hold control until it corresponds to the sync pulse frequency, the picture then falls into lock. As this cannot be achieved in your case we feel that the correct timebase frequency is outside the range of the control. This often means either that the frame oscillator valve is defective, or that one of the resistors connected to the vertical hold control has increased in value. You should check these possibilities.

#### FERGUSON 998T

My brilliance and contrast controls are working almost full out. Turning down brilliance control results in complete loss of picture. The same happens in turning down contrast. If I increase contrast control, picture turns milky before going off.

With brilliance and contrast controls carefully set my picture is very good with hardly any variation.

I would like to mention also that I have adjusted ion trap magnet for maximum brilliance.

I have an X type aerial which I constructed myself. Hoping you can help me in my problem.—A. Harris (Hythe).

If this fault has gradually developed over a period of time, it is most likely caused either by a failing picture-tube, or as the result of loss of emission of the E.H.T. rectifier valve (EY51). If, on the other hand, it occurred suddenly, you should check the vision detector and video amplifier circuits. Also ensure that the vision interference limiter control is set properly.

**G.E.C. 5145**

My TV has recently developed a fault as follows :—

The picture collapsed to a single vertical bright line down the centre of the tube which after 5 or 10 seconds faded leaving the screen blank. The set was switched off and left until the following day. When the set was switched on again it came on as usual and has been working now for some ten days with one fault. Brilliance isn't up to standard and cannot be advanced too far or it causes defocusing. Valves KT36 and U31 have been substituted, without success. Resistance No. 39 (6.8 K) on the service sheet, appears to have been overheating but still shows approximate correct value.—O. R. Cooksey (Sutton Coldfield).

The poor picture is probably due to a low emission U37 E.H.T. rectifier. The resistor was probably burned when the KT36 ceased to oscillate.

There are a number of causes for the sudden cessation of oscillation which may not occur again.

**H.M.V. 1824A**

I have a Model 1824A H.M.V. TV, the sound on which seems to be of poor quality and rather weak until the volume control is turned on almost to its full extent.

At low volume the sound is distorted and thin, at higher volumes it is harsh and without much bass. Can you suggest please what the trouble might be ?

Also, what is the control fitted to a bracket on the side of the tube mounting, and what is its correct setting please ? At the moment it is turned fully clockwise (i.e., facing back of set).—A. Holden (Highbury).

Low and distorted sound is usually due to load resistor of the sound interference limiter going "high."

The adjustment referred to is probably the line scan coils balancing capacitor. This is adjusted to remove any vertical striations which may be present on the left-hand side of the raster.

**PYE B18T**

The picture and sound were getting weak and to get them better I have had to put the brightness control and sensitivity control at the back of the set nearly up to maximum, and I was thinking that perhaps a valve is losing its emission.

If I turn down the contrast the picture breaks up, so I have that full on. I also have trouble with the valves not seating correctly, and I have to loosen the back of the set and press the valves now and again to get the sound back.

Whether it be a coincidence or not, I have a Cleveland converter for Band III ; the mains lead for this I have fixed on the output side of the auto-transformer at the back of the set, which brings my voltage up to 230, which the Pye requires.

When I put the converter on Band III, I have picture and sound for a while, sometimes half an hour, then it goes off ; the BBC is O.K. After a few minutes on the BBC I switch over and back comes Band III, only to go off again.—F. W. Garlick (S.W.15).

Looking in from the rear the first two valves nearest the front of the set, just to the rear of the contrast control, are common to both sound and vision. These EY50 valves should be tested. The valve sockets may require to have their springs tightened so as to make better contact with the valve pins.

If possible, you should substitute the valves in the converter. This is to check upon these being the cause of the ITA signals being lost after a given period.

**VIEW MASTER E.H.T.**

The sides or width of the picture keeps closing. At the same time, the top and bottom extends. This is happening at regular intervals about every two seconds. It does this immediately the picture shows on the screen, even after two hours' running it does not vary in its time.

It also goes out of focus. I have shorted out the width-control, with no result.—T. Parnahy (Royton).

From your description we suspect that a fault has developed in either the line transformer or in the E.H.T. smoothing condenser, C45. This is causing the E.H.T. to fall, and when this occurs then the picture width becomes smaller, whilst the frame becomes larger. We suggest that you closely examine all the components and wiring in this part of the receiver.

**FERRANTI T1825**

The frame hold will not lock. The picture moves down rapidly up to half way on the control ; beyond half way the picture moves up rapidly. If I advance the control to the end the bottom of the picture folds up to half way and the top half is divided into two. I have interchanged the frame timebase valves with other valves in the set, but without effect. Also, the height control has no effect on the picture. I have no data on this set. Could you please point out the frame timebase circuit and where the fault lies ?—P. B. Jones (Abertillery).

In this receiver an ECL80 valve functions as frame oscillator (the triode section) and frame amplifier (the pentode section). This valve is situated on the right-hand side of the upper chassis, directly behind the vertical form control viewing from the rear of the cabinet.

The triode section is in the form of a blocking oscillator and it is in this section that your trouble lies. If it is not caused by an increase in value of the 1.5 megohm resistor connected to the slider of the vertical hold control, then you should suspect a fault in the frame blocking oscillator transformer.

**AMBASSADOR TV/4**

After the set has been operating a while, a loud hum suddenly appears on the sound, the picture being quite unaffected. It is a very clear hum not characteristic of mains hum.

The magnitude of the hum is not affected by varying the volume control.

After a few minutes or more the hum suddenly disappears again. The hum is definitely not vision on sound, although it appears to be at frame frequency. I wonder if the fault is in the frame timebase circuit.

I should point out that at any time a slight hum is heard which varies in frequency with adjustment of the frame frequency control.

Otherwise the set is very good, giving an excellent picture.—D. P. Holmes (Sheffield).

It would appear that the sound detector and limiter 6D2 has developed a heater to cathode leak. It is mounted at the extreme front end of the receiver on the right hand side as viewed from the rear and is just to the left of the 6P25 sound output valve.

**BAND THREE UNITS** : 160/220 mcs. RFD1, 11 valves, 25/-; Responder, ZC8931, 30/-; R3170A, 13 valves, 55/-; SLC4, 15 valves, 30/-; carr. 7/6 each; R161, CV66, 2/EP54, EC52, converter to 16.5 mcs, 17/6; I.F. Amp. 178 for above, 8 valves, 22/6 (post each 2/6); improved type R1355, 37/6 (rail 7/6); R1355 I.F. strip only, new, metal condensers, 15/-, with valves, 27/6 (post 2/6); RT34/APS13, 430 mcs, 5/6. 8/6AG5, 17V105, 30 mcs, min. I.F.T.S. 65/-; R1155b, less DP valves, latest drive, 99/6 (rail 10/-); metal Rectifiers, 1kV, 30ma, 7/6; 600v, 30ma, 6/-; Rxi392A, 100/150 mcs, 13 valves, with circuit, damaged meter, 80/- (rail 10/-). Cash with order. Immediate despatch. S.A.E. for list/enquiries. W. A. BENSON, 308, Rathbone Rd., Liverpool, 13.

**RADIO UNLIMITED** offer: Band 3 Loft Aerials, 19/6; Co-ax Cable, 8/6 doz. yds.; Teltron Band 3 Coilset, 15/-; drilled Chassis, 3/9; complete Kit. incl. coils, valves, chassis, 50/-, with p/pack, 67/6; Valves, EP80, 12/6; Plessey 12in. P.M., 31/-; Elip. 7in. x 4in. P.M., 17/-; 2-valve battery Amplifier, with valves, 35/6; 2-valve + Rec. Amplifier AC or AC/DC, complete kit incl. valves, 49/6 wired 59/6. New valve list ready. Stamp, please. **RADIO UNLIMITED**, Elm Road, London, E.17 (KEY 4813); also at 50, Hoe Street, E.17 (LAR 6377).

**SERVICE SHEETS** for Hire. Radio, 1V Components, Valves, etc., supplied. Send stamp for list. M. FOY, 6, Wykebeck Gardens, Leeds, 9.

**SIMPLEX T.V.** 18 swg Chassis, with screens and valve punched, 17/6, post 1/6; fully wound Coil Sets, 15/-, post 1/-; Simplex Mains Transformer, 27/6, post 2/-; Magnetic Chassis and Screens, 22/6; 0.1 of 2.5 kV wkg.; 7/6; Rectifiers, RM3, 5.9; 3K/40, 6/-; 14-way Tag Boards, 2/-; List for other items. Lynx-wound Coil Sets, 35/-, post 1/-; C.O.P.Y. WINDINGS, Healey Lane Batley, Yorks.

**R.F. UNITS**, Types 27 or 26, 25/-; 25 or 24, 10/-; brand new with valves; post 2/6. E.W.S. CO., 69, Church Rd., Moseley, Birmingham.

**ENGRAVING**.—Amateurs and trade surplus can be undertaken by getting in touch with A. G. ENGRAVING, now at 88, Bedford Hill, London, S.W.12. Tel.: BAL 7085. (Engravers to well-known makers of Electronic Equipment used by the Aircraft industry. A.W.R.E., etc.)

**P.O. TYPE 3.000** Relays, 1,000 ohms, 3/-; EP50 Valves, as new, ex units, 3/3; s.a.e. lists. 340, Cherryhinton Road, Cambridge.

**F.M. COMPLETE KITS** from £5. BEL, Marlborough Yard, Archway, N.19. (ARC 5078).

**DIRECT T/V REPLACEMENTS** offer the most complete Handbook of T/V Components and Rewinds, price 1/-; T/V Components for all kit sets in stock. "Nuray" heater booster isolator for 2-valve C.R.T.'s, just plugs in, 27/6, plus 2/- packing and postage. 134-136, Lewisham Way, S.E.14. (TIDeway 3696-2330.)

**SIMPLEX T.V.**, needs adjusting, £12, or offers also Power Pack for R1132A Receiver. Box No. 182, c/o PRACTICAL TELEVISION.

**B.S.R. MONARCH** 3-speed auto-change units: new in maker's sealed carton; guarantee; complete with instructions, template, suspension springs, £9/15/11, carriage paid; immediate delivery. TOMLINS, 127, Brockley Rise, Forest Hill, S.E.23.

**TELEVISION**, 9in. models, £6/10/-; 12in. models, £15; all makes; working; carriage paid. TOMLINS, 127, Brockley Rise, Forest Hill, S.E.23.

**RATES**: 4/- per line or part thereof, average five words to line, minimum 2 lines, Box No. 1/- extra. Advertisements must be prepaid and addressed to Advertisement Manager, "Practical Television," Tower House, Southampton St., Strand, London, W.C.2.

**"VIEWMASTER"** valves, exact to specification, guaranteed new, and boxed, set of 12, £5/19/6; "Trio-King," complete set of 17, £8/19/6; 14v miniature: 1S5, DAF9, 1R3, DK91, 174, DF91, 3S4, DL92, DK92, any 4 for 27/6, post 1/-; all new and boxed. For individual prices and other types see displayed advert., page 384. **READERS RADIO**, 24, Colberg Place, Stamford Hill, London, N.16. (STA 4587.)

**SEVERAL EARLY MODELS** 9in. Television, complete, and mostly working, £5/5/- each; carriage paid. TOMLINS, 127, Brockley Rise, Forest Hill, S.E.23. (FOR 5497.)

**GUARANTEED TELEVISION**, 12in. models, first-class picture, 5-channel, £30 each, carriage paid. **THE GRAMOPHONE SHOP**, 19-21, Brockley Rise, Forest Hill, S.E.23.

**TV WITHOUT MAINS**.—Absolutely first-class picture, plus DC circuit for lighting; as supplied to the B.B.C. Special AC/DC "Chorehorse" Generators, self-starting, compact, and complete. AC 220/250 volts, 50/60 cycles, 250/350 watts AVC. Will run radios, vacuum cleaners, small tools, etc., £47/10/-, plus 10/- delivery. Below:

**STORAGE BATTERIES**, 12v, 75AH heavy duty, 19 plates, separate cells in hardwood cases; finest possible specification, £5/17/6, 9/6 delivery; 12v, 22AH, almost similar specification, surprisingly powerful, £2/14/-, delivery 5/6. **TEDDINGTON ENGINEERING CO. LTD.**, Dept. "C," High St., Teddington, Middx. (KINGston 1193-4.)

**LOUDSPEAKERS** repaired promptly. **MODEL LOUDSPEAKER SERVICE**, Bullington Rd., Oxford.

**PROMPT CASH** offered for your surplus brand new Valves, Loudspeakers, Components, etc. Send list and prices to R.H.S. LTD., 153, Swan Arcade, Bradford, 1.

## CASCADE TYPE T/V PRE-AMPS

NOW PROVING VERY POPULAR

Manufactured specially to suit fringe and ultra-fringe conditions. In use 140 miles north of Kirk O'Shotts (check our position) and in many other distant locations and difficult reception areas. Complete in crackled steel case with built-in power-pack 200-250 A.C.

£5/5/- P. & P. 2/-

State channel used, or send 6d. stamp for illustrated details and some interesting fringe data.

**ELECTRO-ACOUSTIC LABS.** TAIN-ROSS-SHIRE-SCOTLAND

### RADIO MECHANICS

Ferranti Limited have vacancies for Skilled Radio Mechanics, preferably with Radar experience, for a variety of work in production and research departments. Good opportunities exist especially for those who have, or are willing to study, for the City & Guilds Certificates. Please write, giving details of career to date to the Personnel Officer, Ferranti Limited, Perry Road, Edinburgh, 5, quoting Ref. RM/109.

T/V in perfect working order, all makes, many sets from £12; sets available for use any part of the country. T.V. requiring attention from £7. Send s.a.e. for lists. 13-Channel Tuners, suitable wiring into receivers, with full instructions, £6/5/-, incl. packing and postage. When ordering state make and model No. of receiver. Orders are dealt with in strict rotation. Few only. Monarch B.S.R. 3-speed Magi-disk Autochangers, new in carton, template supplied, £9/10/-, carriage paid. **HIGH STREET RADIO**, 284-6, High Street, Croydon, Surrey. (Tel.: CROYdon 8030.)

**BAND III TV CONVERTER**, complete, tested and guaranteed, in attractive case; will convert any TV TRF or Superhet; London or Birmingham. Models available, £6/15/-. Make it yourself and save money! Complete kit of parts down to last nut, bolt and screw, and comprehensive instructions, £5 5/-; Terms: Cash with order; we pay carriage; immediate despatch. **B. FRANKS**, 97, Amhurst Road, London, E.8.

**TELEVISION**.—E.P.E. 15in. walnut Console, g.w.o., £40, o.n.o., including spare coils, E.H.T. trans., valves, choke, condensers; seen working after 6 o'clock. **F. NICHOLLS**, 45, Pratt St., Camden Town, London, N.W.1.

**ALL DISTRICTS**. An opportunity exists for Television Technicians to establish a business of their own. The business can be commenced in their instance in spare-time, showing an all the year round increasing income. Write, giving particulars of age, training, test equipment, experience, to **TELEPATROL LTD.**, Federation House, Epson.

**MAKING YOUR OWN?** Telescopes, Enlargers, Binoculars, Microscopes, Projectors, or, in fact, anything that needs lenses. Then get our booklets "How to Use Ex-Gov. Lenses & Prisms," Nos. 1 & 2, price 2/6 each. Also our stereo book, "3-D Without Viewers," price 7/6. Comprehensive lists of lenses, optical, radio and scientific gear free for s.a.e. **H. W. ENGLISH**, Rayleigh Road, Hutton, Brentwood, Essex.

### SITUATIONS VACANT

The engagement of persons answering these advertisements must be made through a Local Office of the Ministry of Labour or a Scheduled Employment Agency if the applicant is a man aged 18-64, inclusive, or a woman aged 18-59, inclusive, unless he or she, or the employment, is exempt from the provisions of the Notification of Vacancies Order, 1952.

**WIREMEN REQUIRED** for model shop and production prototype wiring of electronic equipment; good rates payable according to ability and experience. Apply to **PERSONNEL OFFICER**, McMichael Radio Ltd., Wexham Road, Slough, Bucks.

### VALVES

**ALL TYPES OF VALVES REQUIRED** for cash. State quantity and condition. **RADIO FACILITIES LTD.**, 38, Chaleot Road, N.W.1. (PRImrose 9090.)

**WANTED**, Valves 6F13, 6F15, 6U4, EY51, 5Z4, ECL80, KT61, 25A6, etc. prompt cash. **WM. CARVIS LTD.**, 103, North Street, Leeds, 7.

**GUARANTEED VALVES**, boxed, PCC84, PCF80, 10P14, 6K25, U251, U25, 10/-; 6F15, 12J7GT, 10C1, 20F2, U2B2, 9/-; 10C2, EP80, ECL80, EBF80, 6F17, 20L1, 10F1, 12K8GT, 12K7GT, 1H5GT, ECC81, 3Z5, UUG, 6K8G, PY81, U281, X150, 8/6; 6SN7, PY82, 6Q7, 6V6, U2, 25Z, 7/6; W. FEWELL, 19, Mapledean Rd., Dalston, London, E.8. (CLI 7882.)

OPPORTUNITIES IN TELEVISION

144 pages

Free!

Television offers unlimited scope to the technically qualified. Details of the easiest way to study for A.M.Brit.I.R.E., R.T.E.B., Cert., City and Guilds, Television, Television Servicing, Sound Film Projection, Radio Diploma Courses, etc., are given in our 144-page Handbook "ENGINEERING OPPORTUNITIES" which also explains the benefits of our Appointments Dept.

We Guarantee "NO PASS-NO FEE"

If you are earning less than £15 a week you must read this enlightening book.

Send for your copy NOW-FREE and without obligation.

WRITE TODAY!

British Institute of Engineering Technology 237, College House, 29-31, Wriought Lane, Kensington, W.8.

BIET

THE VALVE SPECIALISTS Bentley Acoustic Corp. Ltd.

38, CHALCOT ROAD, N.W.1.

PRIImrose 9090

1st trade goods only. No seconds or rejects.

Table of vacuum tube prices with columns for tube types (e.g., 6X4, 6X5, 6Y7, etc.) and prices.

CRYSTAL DIODES. 6171, 6EX31, 608E, MP 61046, all 7/- each.

All quoted and guaranteed. Post 6d. each. Insurance (optional) 6d. per order. Shop hours 8.30 to 5.30, Sat. 1-5.30. Why not place an order for these items? Write for immediate despatch C.O.D.'s. Complete list free S.A.E.

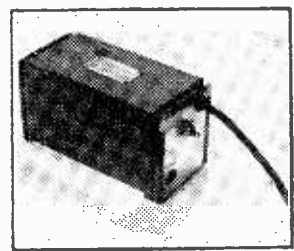

BAND III CONVERTERS

TYPE 30

For Band III reception with any type of receiver. A sensitive beautifully-designed unit completely enclosed with its own power supply. Price ... £8.5.0 complete.

TYPE 32 SWITCH UNIT

A remote control for mounting in or on the television receiver permitting switching from B.B.C. to I.T.A. programmes with the Type 30 converter unit mounted in any convenient position. Price £1.5.0 complete.

TYPE 33 CONVERTER

A sensitive low noise converter unit as the Type 30, but including remote switch panel for One Band I and Two Band III stations. Price £10.2.6 complete.

Leaflets with pleasure on request.

SPENCER WEST LTD.

Quay Works, Gt. Yarmouth.

NEW-MAX

ELECTRONICS LTD.

We have pleasure to announce the Opening of Larger Premises at 220, Edgware Road, W.2. Tel. PAD. 5607!! Come and visit us. The Largest Electronic Bargains Store in London. We have large stocks of H.P. re-possessed T.V. and Radio Sets, Radiograms, Reclaimed C.R. Tubes, Valves, Components, and Test Equipment, etc. etc. Part exchanges welcomed!! Also Wanted: Electronic Equipment of Every Description. Best Prices Given. Phone, Write or Call.

RADIO AND TELEVISION COMPONENTS

All parts in stock for: Viewmaster, Soundmaster, Telexing; etc. 2ld. stamp (only) for Catalogue. Easy Terms available.

JAMES H. MARTIN & CO. FINSTHWAYE, NEWBY BRIDGE LULVERSTON, LANCS.

LYONS RADIO LTD.

DEPT. MT.

3, Goldhawk Road,

Shepherds Bush, London, W.12.

Telephone: SHEpherds Bush 1729.

ELECTROSTATIC LOUDSPEAKERS.—Designed to reproduce the higher frequencies when connected across existing speaker systems and combine to produce that high quality reproduction essential when receiving P.M. transmissions or reproducing high quality recordings or TV sound. Type LSH75, 3 x 3 x 1 1/2 in., for outputs up to 6 watts. PRICE 12/6. Type LSH1518, 7 x 2 x 1 in., for outputs up to 12 watts. PRICE 17/6. Type LSH100, 5 x 4 x 1 in., for outputs up to 21 watts. PRICE 21/-, Full instructions with each speaker.

FLEX.—Twin flat, PVC insulated, conductor 14/36 tnd. copper. Suitable for electrical and radio work, wiring extension speakers, telephones, bells, etc. PRICE 6/6 for 25 yards, 11/6 for 50 yards, 21/- for 100 yards. Postage any qty. 1/-.

BAND III CONVERTER KITS.—Complete coil kit by Teletron Co. with circuit, point to point wiring diagram, alignment instructions, etc. Provides the basis for an efficient, easy to make, 2 valve converter, which can be relied on to give good results. For use with TRF or Superhet Band I TV Receivers. MK. 1, 2-pentode version for Service Area. PRICE 15/-, post 6d. MK. 2, Cascode, triode pentode version giving higher gain for fringe or difficult reception areas. PRICE 17/6, post 6d. Ready drilled chassis, 3/9, post 6d. Data leaflets only 3d. each, post 1 or 2, 3d.

SPARE VALVES FOR R1155.—Complete set for receiver, i.e., 1 each VR99 and V100, 3 VR100, 2 VR101. PRICE £2/6. Separately: VR99 and V100, 7/6 each; VR100, 8/6; VR101, 8/6. Post 9d. any qty.



# CORRESPONDENCE

The Editor does not necessarily agree with the opinions expressed by his correspondents. All letters must be accompanied by the name and address of the sender (not necessarily for publication).

## I.T.A. RECEPTION AND BBC INTERFERENCE

**SIR,**—The impression has been given to certain viewers that only the more modern sets are capable of receiving the I.T.A. This, of course, is wrong; any television which can receive the BBC can be fitted with a converter for the I.T.A. The main problem with single channel television is not so much receiving the I.T.A. as getting rid of breakthrough from the BBC.

For the viewers in optical range of the I.T.A. it is possible to make a very directional aerial indeed for this station; but though this will boost the signal from I.T.A. it does little or nothing to reduce the BBC interference, apart from the fact that it may be possible to have the contrast at a lower setting.

Rejector circuits built into the converter did not solve the problem. The most effective solution was the most simple as far as I was concerned. A piece of coaxial cable cut to quarter-wave I.T.A. shorted at one end, joined across the I.T.A. aerial input plug at the other, made a matching stub which acted as a dead short to the BBC, but had no effect on I.T.A. reception. To complete the job. The chassis of the converter should be made common with that of the television through a point one condenser. In odd cases it may also be necessary to put a 500 pF condenser in parallel with the point one.

The length of the matching stub in my case came to 15½ in., but it may be just as well to start with a piece about 20 in. long and chop it off ½ in. at a time till the optimum length is reached.—R. PINKNEY (Fareham).

## BAND III RECEPTION

**SIR,**—With reference to S. T. Whitwell's (N.19) letter (November issue) I also made the simple converter with the same results regarding the simple dipole, but with the H aerial as described in September issue I got a perfect picture, good sound, but I also was troubled with the BBC on sound and vision. I stumbled on a cure quite by accident. I had about a spare yard of coaxial in the Band III download lying on the floor beside the set, and with the intention of further trimming the cores to improve reception, I picked the aerial lead up off the floor and hung it on the download, out of harm's way, to prevent it being trodden on. I then found that by sliding the loop up or down the download it effected the perfect cure.—LESLIE F. KIRK (Charlton, S.E.7.)

## FAULT FINDING

**SIR,**—I should like to make a point regarding the location of faults in commercial sets. I have had a lot of experience in radio and television and recently a friend asked me to look at a television receiver which had gone wrong and which the local dealer would not touch, as it was so old. He said it was not worth the expense. I found the E.H.T. was absent and on examining the inside of the metal can housing it I found all the wax had run out. The chassis was removed and a systematic search for the trouble made. A short-circuit of the normal H.T. line was

discovered and it took a considerable time to find it. Due to the use of tag-strips in the wiring it was necessary to detach leads from one after the other, and eventually it was found that the screen resistor for the very first valve in the video strip was in contact with a fixing screw on a tag-strip. The insulation of the resistor had broken down. I am sure if I had not had considerable experience I would never have discovered the elusive fault.—G. F. R. COURTNEY (N.W.).

## COAXIAL HINT

**SIR,**—With reference to the hint in the August and November issues, I should like to make a further point. Certain coaxial has stranded inner wires, and to remove the outer plastic covering a penknife is usually employed. Unfortunately, due to the tough nature of the covering, it is quite easy to cut through one of the strands of the cable, and if this is not noticed at the time, after the end of the cable is soldered to the connector or plug, the odd end of the cut wire may make intermittent contact with the others and produce a noisy contact which is very difficult to locate. I have found that it is best to warm the insulation with a soldering iron, and then use a wire stripper which pulls off the covering without touching the wire.—G. PACKER (Edmonton).

## TWO HINTS

**SIR,**—There are two points to which I would like to draw the attention of other amateurs.

With modern tubes we have the alternative these days of aluminised screens or screens protected by ion/trap. I personally use the former as I find the assembly problems simplified. It is interesting to note, however, that if for any reason one encounters corner cutting with this type of tube, this can be corrected by slipping on an ion/trap magnet near the base of the tube and rotating suitably.

On the subject of 13 channel receivers, in which we are all interested, I had the opportunity of trying out several commercial versions, and they seem to consist of 13 fixed points with a floating trimmer for fine adjustment. On switching to any given band, it is necessary to rotate the fine trimmer until the Test Card "C" is received with the best definition. This setting is quite critical and it would seem that on switching over to another band, say Band III, the same procedure would have to be adopted. It can be seen, therefore, that these are not simply switchable receivers, and as it would be impossible to adjust the trimmer to optimum position on any ordinary picture, the result would be that reception on either or both channels would always be imperfect.—GEO. T. LAYTON (Eccles).

## QUERIES COUPON

This coupon is available until JANUARY 21st, 1956, and must accompany all Queries.  
PRACTICAL TELEVISION, JANUARY, 1956.

# VALVES

## SAME DAY SERVICE

### All Guaranteed New and Boxed

1.4V. midget, IR5, 1S5, 1S4, 1T4, 3S4, DAF91	
DF915 DK91, DL92, DL94: any 4 for 27/6	
1A7GT 6K8GT 9/6 35Z5GT 8/6 EF92 5/-	
11/6 6K25 12/3 50L6GT 8/6 EF95 10/6	
1C5GT 6LD20 9/6 80 8/6 EL38 23/9	
11/6 6P25 5/6 18BT 9/6 EL41 11/6	
1D5 11- 6P28 21/6 AZ31 10/6 EL91 5/-	
1H5GT 6Q7GT 9/6 D1 3/6 EY51 13/6	
11/6 6SN7GT DAC32 EY51 13/6	
1N5GT 8/6 11/6 EZ40 8/6	
11/6 6U4GT 18- DCC901 10/6 GZ32 15/-	
1R5 8/6 6V8GT 7/6 DF33 11/6 GZ32 15/-	
1S5 7/6 6V6GT 7/6 DH77 8/6 KT63 7/6	
1T4 7/6 36X4 7/6 DK32 11/6 MU14 9/6	
3A5 10/6 6X5GT 6/9 DK92 7/6 P61 5/6	
3Q5GT 7B7 8/6 DL33 11/6 PCF80 10/-	
11/6 7C5 8/6 EABC80 PL33 13/6	
3S4 7/6 7C8 8/6 EB91 9/6 PL38 23/9	
3V4 8/6 7H7 7/6 EB91 9/6 PL81 11/6	
5U4G 8/6 7S7 8/6 EC33 7/6 PL82 9/6	
5Y3GT 7/9 7Y4 8/6 EBC10 10/6 PL83 12/6	
5Z4G 9/- 10F1 10/- EBF90 PY80 10/-	
6AK5 6/6 10P13 10/- 10/6 PY81 10/-	
6AL5 6/9 10P14 12/6 ECC4015 6/6 PY82 8/6	
6AM5 5/- 12AT 10/- ECC81 10/- PZ30 18/-	
6AM6 7/6 12B1 10/- ECC93 10/6 T41 15/-	
6AQ5 8/- 12J7GT 9/6 ECC91 7/- U22 10/6	
6AT8 8/6 12K7GT 10/6 ECH35 U25 12/-	
6BA5 7/9 12K7GT 11/9 U35 21/6	
6BE6 6/6 ECH42 10/- U50 7/9	
6BH6 6/- 12K8GT 9/6 ECH81 10/6 U78 8/6	
6BJ6 6/- 12K8GT 9/6 ECL80 10/- U281 11/-	
6BW6 7/6 12Q7GT EF73A UBC41 9/-	
6BX6 7/6 9/6 11/6 UBF80	
6C9 8/6 12Z3 7/6 EF39 6/6 UCH42 9/6	
6FG 7/6 20F2 12/6 EF40 17/6 UCH42 9/6	
6F14 12- 20P1 10/9 EF41 10/- UF41 8/6	
6F15 13- 20P1 15/- EF50 7/6 UL41 9/9	
6J6 7/- 25L6GT EF80 10/- U8 18/-	
6J7GT 7/6 8/9 EF85 10/6 UY41 9/-	
6K7G 6/- 25Z4G 9/6 EF85 10/6 W77 5/-	
6K7GT 6/- 25L6GT 9/6 EF88 14/6 Y83 7/6	
6K8G 8/6 35Z4GT 8/6 EF91 7/6 Z77 7/6	

Postage id. per valve extra.

## READERS RADIO

24, COLBERG PLACE, STAMFORD HILL, LONDON, N.16. STA. 4587

## KNOCK-OUT PRICES!

### SECOND-HAND TV COMPONENTS

for

PYE B16T	}	9in. TUBES
PYE D18T		VALVES
PHILIPS 383a		SCAN COILS
PHILIPS 663a		TRANSFORMERS
EKCO 46		CHOKES
AND OTHERS		CABINETS, ETC.

S.A.E. FOR REPLY PLEASE.

## T. A. MADDOX

RADIO AND TV ENGINEER

HIGH ST., ORWELL, ROYSTON, HERTS

## TELEVISION COMPONENTS

in stock for the

P.T. LYNX. P.T. SUPER-VISOR, TELE-KING. VIEWMASTER. E.E. TELEVISOR and BAND III and wide angle modifications

Price lists available on request to:

J. T. FILMER, Maypole Estate, Bexley, Kent. Tel.: Bexleyheath 7267

## R.F. OSC. E.H.T. COILS

TYPE D 2-9 kV 25/-  
 TYPE D WITH RECTIFIER MOUNTED 54/-  
 TYPE F 9-14 kV 30/-  
 TYPE F WITH RECTIFIER MOUNTED 59/-  
 HAYNES LINE OUTPUT TRANSFORMERS  
 TYPE 34 WIDE ANGLE FERROXUBE 50/-  
 10-12 kV TYPE 27 WIDE ANGLE FERROX-  
 UBE WITH RECTIFIERS 26.12.5/-  
 Above Post Free. Complete with Circuit. C.W.O.  
 Post orders only.

THE WATSON WATCH CO. 29, Leigh Road, London, N.5.

## FIRST-CLASS TELEVISION and RADIO COURSES . .

### GET A CERTIFICATE!

After brief, intensely interesting study — undertaken at home in your spare time—YOU can secure your professional qualification or learn Servicing and Theory. Let us show you how!

### FREE GUIDE

The New Free Guide contains 132 pages of information of the greatest importance to those seeking such success compelling qualifications as:

- A.M.Brit.I.R.E., City and Guilds
- Final Radio, P.M.G. Radio
- Amateurs' Exams., Gen. Cert. of Educ., London B.Sc. (Eng.), A.M.I.P.E., A.M.I.Mech.E., Draughtsmanship (all branches), etc., together with particulars of our remarkable Guarantee of

**SUCCESS OR NO FEE**

Write now for your copy of this invaluable publication. It may well prove to be the turning point in your career.

### FOUNDED 1835—OVER

.....150,000 SUCCESSES.....

NATIONAL INSTITUTE OF ENGINEERING (Dept. 462), 148, HOLBORN, LONDON, E.C.1.

## COVENTRY RADIO

189, DUNSTABLE ROAD, LUTON, BEDS.

Phone: Luton 2677

The Quality Component Specialists offer you Kits of Parts for the following:—

Osram "912" Amplifier	... 3/6	Manual
Mullard 10-watt Amplifier	... 3/6	
The Coventry		
2-watt Amplifier	... 1/-	}
4-watt Amplifier	... 1/-	
6-watt Quality Amplifier	... 1/-	
The Coventry A.M. Tuner Unit	1/-	
Denco F.M. Tuner Unit	... 1/6	

Complete Component Price Lists will be supplied with each Manual.

Have you had a copy of our 1954/5 60-page illustrated Component Catalogue, price 1/- plus 3d. postage?

## THE MODERN BOOK CO.

BRITAIN'S LARGEST STOCKISTS OF British and American Technical Books

Radio Servicing Pocket Book, by E. Molloy and J. P. Hawker. 10s. 6d. Postage 4d.

Sweep and Marker Generators for Television and Radio, by B. Middleton. 20s. 0d. Postage 6d.

Probes, by Bruno Zucconi and Martin Clifford. 20s. 0d. Postage 6d.

Colour Television Fundamentals, by Milton S. Kiver. 34s. 0d. Postage 1/-.

Simple Electronic Musical Instruments for the Constructor, by A. Douglas. 5s. 0d. Postage 3d.

An F.M. Tuner Theory and Construction, by E. Adler. 5s. 0d. Postage 3d.

A Complete Catalogue Textbook and Manual on Electronic Organs, by R. L. Eby. 40s. 0d. Postage 1/-.

T.V. Fault Finding and Data Publication No. 5. 5s. 0d. Postage 3d.

Practical T.V. Aerial Manual for Bands I and III, by R. Laidlaw. 4s. 0d. Postage 3d.

Maintenance Manual, by Mullard. 10s. 6d. Postage 6d.

Telecommunications Principles, by R. N. Renton. 37s. 6d. Postage 1/-.

Radio Valve Data, by "Wireless World." 3s. 6d. Postage 3d.

Please write or call for our new 1956 catalogue.

19-23, PRAED STREET, LONDON, W.2.

Phone: PADDington 4185. Open 6 days 9-6 p.m.

## BAND III CONVERTER KIT (FOR T.R.F. OR SUPERHET)

Complete kit of parts, including: Ready Drilled Chassis, 7in. x 3in., (2) Miniature Valves, Ready Wound Coils, etc.,

£2-8-0 Postage 1/6.

(Supply voltages required: 250 v. at 20 mA., 6.3 v. at 6 a.)

FM Tuner-kit (Jason), £7-5-0, complete to the last nut and bolt. Both kits can be seen and heard at

## TELEKIT SUPPLY

104, High Street, Beckenham, Kent. (BEC 3720.)

## ALUMINIUM, LIGHT ALLOYS, BRASS, COPPER, BRONZE,

IN ROD, BAR, SHEET, TUBE, STRIP, WIRE, ANGLE, CHANNEL, TEE

3000 STANDARD STOCK SIZES

## H. ROLLET & CO., LTD.

6, CHESHAM PLACE, LONDON, S.W.1. SLOane 3463

Works:

36, ROSEBERY AVE., LONDON, E.C.1. Branches at Liverpool, Manchester, Birmingham, Leeds.

"No Quantity too Small!"

# ARTHURS HAVE IT!

**LARGE STOCKS OF VALVES AND C.R.T.s.**

**AVO METERS IN STOCK**

Avo Model 7	—	—	—	—	£19 10 0
Avo Model 8	—	—	—	—	23 10 0
Electronic Test Unit	—	—	—	—	27 10 0
Electronic Test Meter	—	—	—	—	40 0 0
AC/DC Minor	—	—	—	—	10 10 0
* Cossor Oscilloscopes Model 1052	—	—	—	—	104 0 0
" " " 1035	—	—	—	—	120 0 0

**Full range Taylors Meters. List on request.**

Leak—TL/IO Amplifier and "Point One"	—	—	—	—	—
Pre-Amplifier	—	—	—	Complete	28 7 0
F.M. Kit of parts £5 less valves. Ref. Radio Constructor, July, 1954.	—	—	—	—	—
Jason F.M. Tuner Unit and Power Pack	—	—	—	—	19 7 0
Chapman Tuning Units	—	—	—	from	16 0 0
Aerialite Band 3 Unit	—	—	—	—	9 10 0
Latest type M.C.	—	—	—	—	10 17 6

**LATEST VALVE MANUALS**

MULLARD, 10/6, OSRAM & BRIMAR No. 6, 5/- each, OSRAM Part 2, 10/- Post, 6d. each extra.

**SCOPE SOLDERING IRON. A.C./D.C. HEATING TIME: 4 v, 6 sec., 6 v, 4 sec. 39/6.**

**TRANSFORMER for 200/230 v. 37/6.**  
Terms C.O.D. OR CASH with order and subject to price alterations and being unsold

# Arthurs

Est. 1919

PROPS: ARTHUR GRAY, LTD.

**OUR ONLY ADDRESS: Gray House, 150-152 Charing Cross Road, London, W.C.2**

TE Mple Bar 5833/4 and 4765.

TELEGRAMS—"TELEGRAY, WESTCENT, LONDON."  
CABLES—"TELEGRAY, LONDON."

## Finest Soldering? Always specify ERSIN MULTICORE to be precise

Wherever precision soldering is essential, manufacturers, engineers and handymen rely on MULTICORE. There's a MULTICORE SOLDER just made for the job you have in hand. Here are some of them.

### SIZE 1 CARTON

4 specifications for radio enthusiasts.

**5/-**



### HANDYMAN'S CARTON

Sufficient for 200 average joints. **6d.**



### TAPE SOLDER

**MELTS WITH A MATCH!**  
Real tin/lead solder containing cores of Ersin Flux. Needs no soldering iron or extra flux.

**1/-**

**PER CARD**



### Bib GIFT PACK

The ideal present for any electrician or handyman—a Bib Stripper, Tape Solder and Insulated Screwdriver on a presentation card—all for **5/-**

MANUFACTURERS ARE INVITED TO

WRITE FOR DETAILS OF BULK PACKS AT BULK PRICES

## MULTICORE SOLDERS LTD.

MULTICORE WORKS, HEMEL HEMPSTEAD, HERTS (BOXMOOR 3636)

# For HIGH SPEED SOLDERING

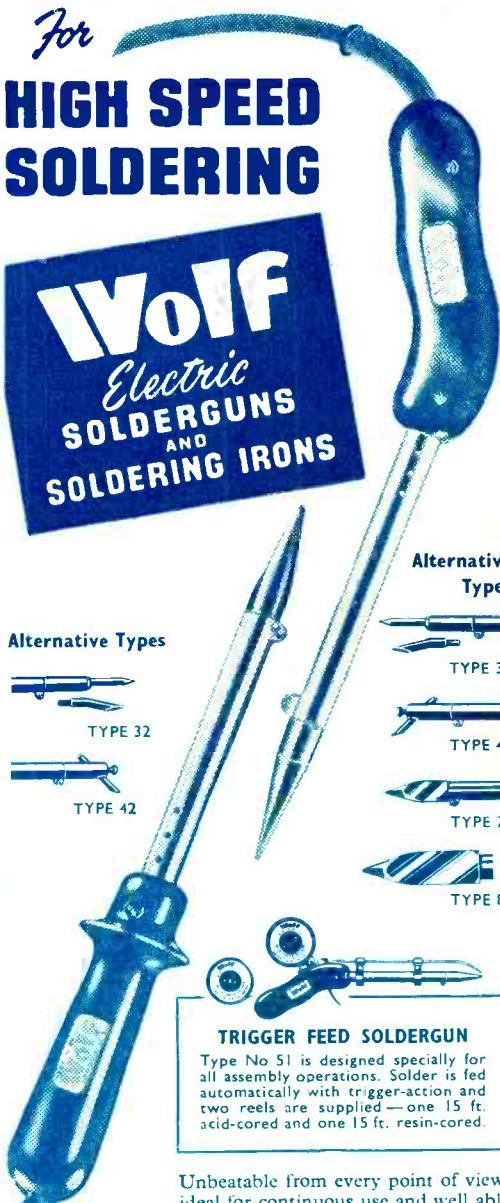
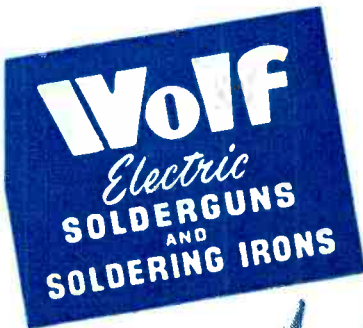

Alternative Types

Alternative Types



TYPE 32



TYPE 42



TYPE 33



TYPE 41



TYPE 71



TYPE 81

### TRIGGER FEED SOLDERGUN

Type No 51 is designed specially for all assembly operations. Solder is fed automatically with trigger-action and two reels are supplied—one 15 ft. acid-cored and one 15 ft. resin-cored.

Unbeatable from every point of view, ideal for continuous use and well able to withstand hard workshop treatment. Features include rapid constant localised heat—solid sturdy construction—low current consumption—perfect balance—absolute dependability. A type and bit for every purpose from fine instrument to heavy industrial work. Each tool includes 5 feet tough rubber 3-core cable.

Obtainable from all leading tool merchants and factors. Fully descriptive Brochure free on request.

## WOLF ELECTRIC TOOLS LIMITED

PIONEER WORKS • HANGER LANE • LONDON W.5

Telephone: PERIVALE 5631/4

Branches: Birmingham Bristol Glasgow Leeds Manchester Newcastle

