

# PRACTICAL TELEVISION

AND TELEVISION TIMES

A NEWNES PUBLICATION

1/-

EDITOR  
F. J. CANN

Vol. 2 No. 21

FEBRUARY 1952

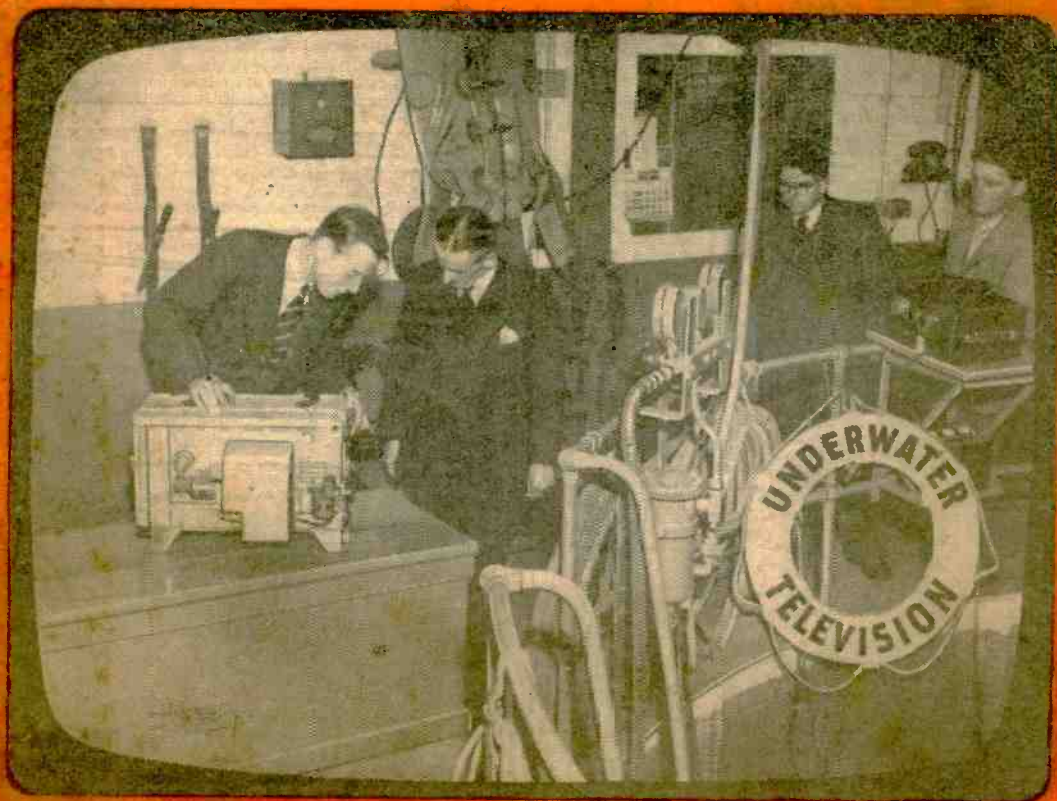

## FEATURED IN THIS ISSUE

The Video Detector  
Development of the C.R.T.  
Aerial Matching

The Uses of Tuning Slugs  
Interpreting Theoretical Diagrams  
Modifying the AN/APR-4

JAN 53 JULY 50  
AUG 53

# D. COHEN

Radio and Television Components

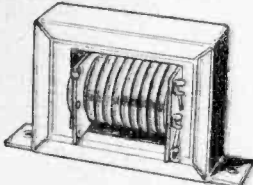

Line and E.H.T. Transformer. 5-7kV., removed from chassis, guaranteed, **12/6**

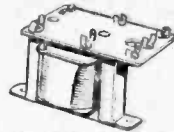

Smoothing choke 150 mA 2 Henry **3/6**

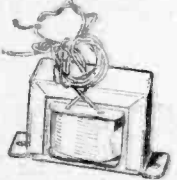

Heater transformer Pri. 230-250 volt, Sec. 2 volt 2 amp. **5/-**



Frame oscillator blocking transformer **4/6**

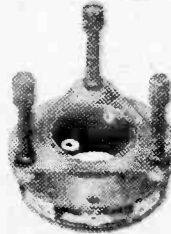

P.M. Focus Unit. Any 9in. or 12in. tube, except Mazda 12, **12/6**

P.M. Focus Unit for 12in. Mazda **15/-**

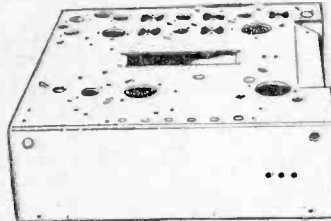

T.V. Chassis could be adapted for use with the above components. Size 9" x 9" x 3" **3/-**

The above components are a very famous T.V. manufacturer's surplus.

### MAINS TRANSFORMERS

These transformers are all famous radio manufacturers' surplus and are fully inter-leaved, impregnated and guaranteed.

- Primary 200-250 v. P. & P. on each 1/6 extra.
  - 300-0-300, 100 mA, 6 volt 3 amp., 5 volt 2 amp., 17/6.
  - 320-0-320, 120 mA, 6 volt 4 amp., 5 volt 2 amp., 25/-.
  - 250-0-250, 100 mA, 6 v. 3 amp., 4 v. 3 amp., 4 v. 3 amp., 17/6.
  - 250-0-250, 60 mA, 6 v. 4 amp. (to be used on common heater chain with 6 x 5 rectifier), 13/6.
  - 350-0-350, 150 mA, 6 v. 3 amp., 5 v. 2 amp., 27/6.
  - 280-0-280, 80 mA, 6 v. 3 amp., 4 v. 2 amp., drop-through, 14/-.
  - Drop thro', 350-0-350 v. 70 mA, 6 v. 2.5 amp., 5 v. 2 amp., 14/6.
  - Semi-shrouded, drop-thro', 280-0-280 80 mA, 4 v. 6 amp., 4 v. 2 amp., 12/6.
  - 350-0-350 v., 120 mA, 4 v. 6 amp., 4 v. 3 amp., drop-through, 21/-.
  - 350-0-350, 100 mA, 4 v. 2 amp., 4 v. 4 amp. Upright or drop-through mounting, 16/-.
- Auto-wound, could be used in the Viewmaster. H.T. 280 volt, 360 mA, 4 volt 3 amp., 4 volt 3 amp., 2 volt 3 amp., 2 volt, 3 amp., 10/- plus 1/6 post and packing.
- 9in. White rubber mask with armour-plate glass ... .. 10/-
  - 12in. Rubber mask with armour-plate glass ... .. 15/-
  - 15in. Rubber mask ... .. 15/-
  - 9in. Armour-plate glass ... .. 4/-
  - 12in. Armour-plate glass ... .. 3/-
  - 9in. Armour-plate glass ... .. 3/-
- Heater Transformer Pri. 200-250 v., 6 v. 1 1/2 amp., 6/-; 12 v. 1 1/2 amp., 6/-; P. & P. each 9d.
- R.A. 6 1/2in. closed field P.M. 12/6. Width coil 2/- post paid.

TERMS OF BUSINESS CASH WITH ORDER

DISPATCH OF GOODS WITHIN 3 DAYS FROM RECEIPT OF ORDER.

Orders under £2 add 1/6. Under £1 add 1/- post and packing.

All enquiries and lists, stamped addressed envelope

**23, HIGH STREET, ACTON, W.3.**  
(UXBRIDGE ROAD) Acorn 390h

# CLYDESDALE

Bargains in Ex-Services Radio and Electronic Equipment

## FOR INEXPENSIVE TELEVISION

INDICATOR UNIT TYPE 62 IN ORIGINAL MAKER'S CASE  
CLYDESDALE'S PRICE ONLY **£5.9.6** CARRIAGE PAID

THE "194" I.F. STRIP LESS VALVES  
CLYDESDALE'S PRICE ONLY **17/6** POST PAID

THE B1355 I.F.A.F. UNIT  
CLYDESDALE'S PRICE ONLY **67/6** CARRIAGE PAID

THE I.F. UNIT TYPE £7 IN ORIGINAL MAKER'S CARTON  
CLYDESDALE'S PRICE ONLY **63/-** POST PAID

MAINS TRANSFORMER.—Pri. tapped 200-230-250 v. A.C. Sec. 350-0-350 v. 100 mA. 6.3 v. 8 a., 5 v. 2.5 a. Price, post paid, 32 6d. ea.

I.F.T. TRANSFORMER.—Pri. tapped 200-230-250 v. A.C. Sec. 2,000 v. 5 mA., 4 v. 1 a., 4 v. 1 a. CT. Price, post paid, 32 6d. each.

MAINS TRANSFORMER (TOP QUALITY). Pri. tapped 230-250 v. A.C. Sec. 350-0-350 v. 160 mA., 6.3 v. 3 a., 6.3 v. 8 a., 5 v. 3 a. Price, post paid, 65/- each.

I.F.T. TRANSFORMER (TOP QUALITY).—Pri. tapped 230-250 v. A.C. Sec. 2,500 v. 3 mA., 4 v. 1 a., 4 v. 1 a. CT. Price, post paid, 45/- each.

Circuits for 62, B1355, I.F. 27 at 1 3d. each.

New List of Ex-Service Items No. 8 Now Ready. Price 1 6d. Price Credited on purchase of 10/- value or over.

Order direct from:

## CLYDESDALE SUPPLY CO. LTD.

2, Bridge St., Glasgow, C.5. Phone: SOUTH 270619  
Visit our Branches in Scotland, England and N. Ireland.

# The solder for all HOME TELEVISION CONSTRUCTOR SETS

Designers of television constructor sets know that the efficiency of their equipment depends on the solder used by the constructor—that's why they recommend Ersin Multicore for trouble-free, waste-free soldering. Ersin Multicore, the only solder containing three cores of extra-active, non-corrosive Ersin Flux, is obtainable from all leading radio shops. Ask for Cat. Ref. C.16018, 18 S.W.G. 60 40 High Tin Television and Radio Alloy. The size 1 Carton contains 37 feet of solder, costs 5/-.



## Ersin Multicore Solder

In case of difficulty in obtaining supplies, please write to:

MULTICORE SOLDERS LTD.,  
MELLIER HOUSE, ALBEMARLE STREET, LONDON, W.1 • R.Gent 141E

The Picture  
 can ONLY  
 be as good  
 as the  
 AERIAL—  
 be sure with

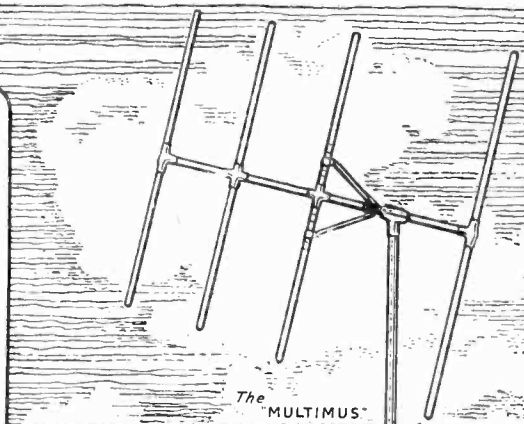

**Telerection**  
 specially for Fringe Areas  
 Antenna Works, St. Paul's  
 CHELTENHAM. Telephone Cheltenham 55960



"One of these days  
 I must insure my life!"

... then **TODAY** you must  
 read this book!



A Life Policy with The London Assurance gives a man such obvious advantages — security for his family, a capital asset when he needs money—that he is bound to see the value of. Less obvious is the fact that the sooner he takes out his Life Policy, the less it costs.

The first step is simple. Post the coupon for a copy of our free book. That's all. When

you've read it, you'll have a very clear picture of what you ought to do, and how to do it.

**AND WHAT ABOUT ACCIDENTS ?**

Among other things, "The London" can insure you against accidents—with the advantage of 15% discount on your Personal Accident Policy premiums if your life is also insured with us at normal rates. If you would like to know more about this, write YES in the margin against this paragraph and cut it out with the coupon.



THE LONDON ASSURANCE  
 1 King William St., London, E.C.4  
 Please send me your booklet  
 "How to be well Assured"

Name \_\_\_\_\_  
 Address \_\_\_\_\_

**THE LONDON ASSURANCE**

*Very good people to deal with*



## CONDENSERS

The abbreviated ranges of two popular types given here are representative of the wide variety of T.C.C. Condensers available.

### HI-K 'PEARL' CERAMICS

Capacity pF.*	Wkg. Voltage		Dimensions		Type No.
	D.C.	A.C.	Length	Dia.	
1·0	500	250	3·5 mm. to 7 mm.	5 mm. to 7 mm.	SPG I
10·0	500	250			SPG I
33·0	500	250			SPG I
150	500	250			SPG I
330	500	250			SPG I
470	500	250			SPG I

### HI-K MULTIPLE TUBULAR CERAMICS

Capacity pF.*	Wkg. Voltage		Dimensions		Type No.
	D.C.	A.C.	Length	Dia.	
2 × 500	500	250	10 mm.	4·5 mm.	2CTH 310/W
2 × 1000	500	250	10 mm.	4·5 mm.	2CTH 310/W
2 × 1500	500	250	15 mm.	4·5 mm.	2CTH 315/W
2 × 2200	500	250	22 mm.	6 mm.	2CTH 422/W
3 × 500	500	250	15 mm.	4·5 mm.	3CTH 315/W
3 × 1000	500	250	15 mm.	4·5 mm.	3CTH 315/W
3 × 2200	500	250	22 mm.	6 mm.	3CTH 422/W

\* Guaranteed not less than stated values at 25°C.

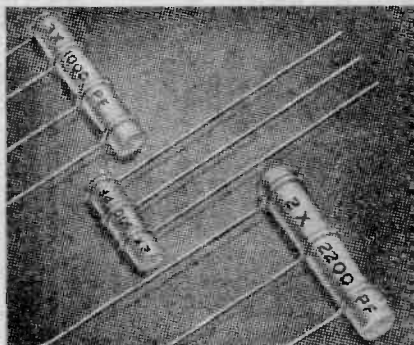
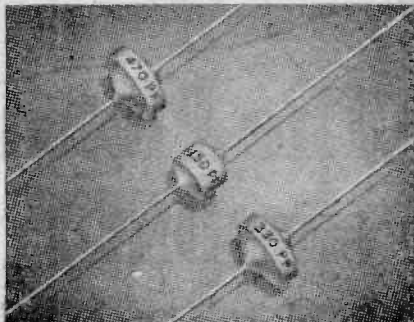

## THE TELEGRAPH CONDENSER CO. LTD.

Radio Division: North Acton, London, W.3. Tel: Acorn 0061

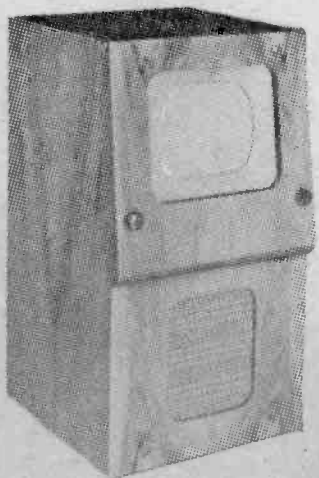

## LASKY'S RADIO

### De Luxe Television Cabinets

For 12in. cathode-ray tubes. Beautiful figured medium walnut finish, with high polish. Fitted with shelf for receiver, glass, speaker grille and fret, and castors for easy movement. Undrilled. Suitable for use

with the "Viewmaster," "Practical Television," "Practical Wireless," and "Wireless World" televisions.  
**LASKY'S PRICE £8. 10. 0** Carriage 12/6 extra.  
Outside dimensions of cabinet: 17½in. x 16½in. x 32in. high.  
Why not convert your table receiver to a console? Adaptor Frames for 9in. and 10in. C.R. tubes available.

## LASKY'S RADIO,

(Lasky's (Harrow Road) Ltd.)

\*Phone: Cunningham 1979 and 7214.

Send a 2½d. stamp with your name and address for a copy of our current Bulletin. We have large stocks of new surplus radio components, valves, transformers, etc., details of which are given in our Bulletin.

## EVERYBODY IS BUILDING THE VIEWMASTER

The television set you can build at home from standard parts. Incorporates all the latest developments. Holme Moss, Sutton Coldfield and Alexandra Palace operation. Brilliant high definition black and white picture. Superb reproduction. Uses 9in. or 12in. Cathode Ray Tube. Table or Console Model. Incorporates all the latest developments. **Television for the home constructor at its finest.** Send to-day for the CONSTRUCTION ENVELOPE, a 32-page booklet crammed with top-rate information and all the necessary data, also 8 full-size working drawings and stage by stage wiring instructions. Model "A" for use in London and Home Counties. Model "B" for use in Sutton, Coldfield Area. Model "C" for Holme Moss. Model "D" for Kirk o' Shotts.

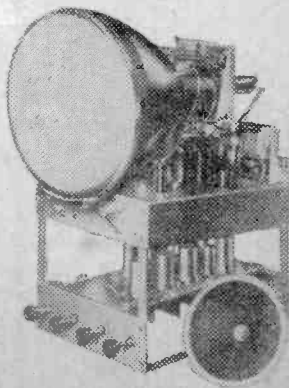

PRICE 5/-  
per copy, post free.

All components in stock and sold separately

370, HARROW ROAD, PADDINGTON,  
LONDON, W.9. (Opposite Paddington Hospital)

Hours: Mon. to Sat., 9.30 a.m. to 6 p.m. Thurs., half-day.

# PRACTICAL TELEVISION

## & "TELEVISION TIMES"

Editor: F. J. CAMM

Editorial and Advertisement Offices: "Practical Television," George Newnes, Ltd., Tower House, Southampton Street, Strand, W.C.2. Phone: Temple Bar 4383. Telegrams: Newnes, Rand, London.

Registered at the G.P.O. for transmission by Canadian Magazine Post.

Vol. 2. No. 21

EVERY MONTH

FEBRUARY, 1952

### Televiews

## FREE BLUEPRINT OF THE P.T. "ARGUS" NEXT MONTH

IT is with especial pleasure that we announce that next month every issue of this journal will contain a FREE GIFT BLUEPRINT for the construction of the P.T. "Argus," an efficient television receiver. It has always been our aim to bring television within the means of those hundreds of thousands of people who to-day, because of Purchase Tax, cannot afford to buy one of the excellent commercial receivers.

This receiver, in order to keep the price down, will make use of a 6in. tube. It will contain 21 valves plus the popular VCR97 ex-Service tube. Thousands of these tubes are being used by amateurs with great success. The total cost of the "P.T. Argus" television receiver at present market prices is just under £20, although this may vary to a small degree according to the supply position.

The design is suitable for any of the existing or proposed stations, and full coil data is included on the blueprint for winding the coils for each channel. The blueprint will, of course, include only the wiring data which most amateurs find the most difficult part of the work. The constructional data and the theoretical circuits will be included in the issue. This has enabled us to reproduce the wiring diagrams to a large scale.

On the sound side, a small 6in. speaker of a special television type is used, and this enables a panel only 13½in. high and 14in. wide to be used, the tube and speaker being mounted side by side.

In view of the paper position it is essential for PRACTICAL TELEVISION to be ordered from your newsagent. There is bound to be a great demand for next month's issue, so do it to-day!

This is the first time since 1939 that a blueprint has been included in any journal.

### ON TO THE 2,000,000!

WHEN this journal was launched in April, 1950, the total number of television licences was 285,500. In the space of 18 months that number had increased to 1,113,900, and week by week licences are increasing. When will the 2,000,000 mark be passed? But for the shortage of materials

and the increase in the Purchase Tax the end of this year might have seen the number of licences top that magic figure.

If the Chancellor of the Exchequer sees fit in April to reduce or abolish Purchase Tax, it is still possible for the 2,000,000 mark to be reached. Certainly, the Chancellor has a case for the abolition of Purchase Tax on television receivers in view of the fact that £2,000,000 of licence money is to be taken from the BBC for general revenue purposes. Quite apart from that, however, in these early days of the development of the television service, when every penny is needed to keep abreast of our foreign competitors, he should remove every possible restriction which is retarding television progress.

In America it has swept the country from one coast to another: in this country it is still regarded somewhat as the Cinderella of radiated entertainment.

The new Government may have ideas which radically differ from that of the old; we hope so. One of the surprising things is that whilst the number of television licences has increased, there has not been a corresponding diminution in ordinary broadcasting licences, which continue to increase month by month.

There are approximately 24,000,000 homes in this country housing a population of almost 50,000,000. This means that one home in two is still without a radio or television licence. The peak, therefore, has by no means yet been reached. That absorption point must be reached one day is, of course, inevitable, but it will be many years hence.

### HEALTH TALKS ON TV

SOME of the Sunday newspapers have been criticising a BBC producer because he declined to devote programme time to a talk on breathing as an aid to health. Some time ago this same producer was in trouble with the doctors because of his broadcasts on slimming for women. Perhaps this has made him cautious. We, however, support his decision for we do not believe that a talk on correct breathing would have been of interest since it is taught in every school.—F.J.C.

# The Video Detector

DESIGN AND CIRCUIT DATA OF THE VISION RECTIFIER

By "Experimenter"

WITH component values modified, the vision detector can adopt any of the forms taken by its sound counterpart. Although, invariably, the diode detector is used and for this purpose a special high-frequency diode has been developed which has a much lower impedance than the comparatively narrow-band sound diode.

A low-impedance diode is necessary in view of the much lower value load resistor needed to maintain the desired frequency response. Further, its inter-electrode capacities must also be small if reasonable rectification efficiency is to be secured. These necessary qualities, therefore, render ordinary diodes, of the type used in sound receivers, unsuitable.

Current design appears to favour the new crystal diodes; and from experiments conducted by the author their efficiency and simplicity of operation at the higher frequencies are very desirable features.

Diode detectors do not always follow conventional

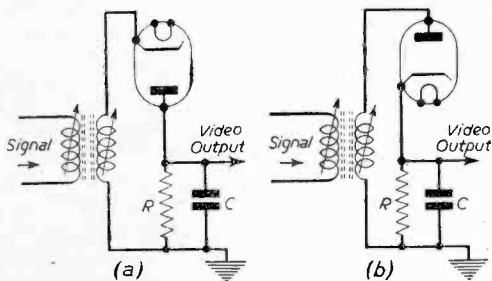

Fig. 1.—A typical detector circuit—positive output at (b), negative at (a).

practice, however, but sometimes two diodes are employed in a full-wave, or voltage-doubler circuit, each having their respective merits.

Such is the versatility of television circuitry that at least one manufacturer has adopted the lower anode bend detector principle—where a single valve performs the dual function of detection and video-frequency amplification.

### Output Phase

The video output from a single diode is usually insufficient fully to modulate the picture tube, and for this reason a video amplifier is employed. But owing to its phase-reversing effect the detector will need to deliver an output in the negative sense, for grid modulation. For cathode modulation, however, the detector output must, of course, be positive going.

A detector circuit suitable for the former function is shown at (a) Fig. 1, while the circuit at (b) is fitting for the latter condition.

### R.C. Values

The resistor-capacitor combination R.C. comprises the detector load and R.F. filter, and thus forms the time constant components of the circuit. The correct

choice of values is very important if a wide bandwidth coupled with reasonable efficiency is to be realised.

As previously intimated, however, a fairly low value for R is necessary from the bandwidth aspect. While C is frequently formed by the stray circuit capacitance alone, if a capacitor is used in conjunction it rarely exceeds 10 pF.

It will be realised, of course, that owing to the presence of C in shunt with R, attenuation of the higher video modulation frequencies is bound to ensue. The degree of attenuation may be expressed as a function of R/Xc, where Xc equals 1/2πfC. From this, the following formula has been evolved, which may be used to compute the percentage of attenuation at any frequency relative to zero:

$$(1) \dots\dots\dots 100 - \left( \frac{100}{\sqrt{1 + R^2}} \right) \frac{1}{X_c^2}$$

Usually, however, the detector stage is considered

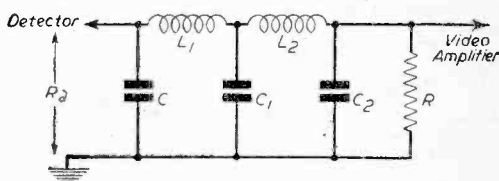

Fig. 2.—A low-pass filter.

mediocre provided the output at the highest modulation frequency does not drop to less than 90 per cent. of its zero frequency value. Thus, in order to calculate the value for R, to produce these conditions, formula (1) may be simplified to the following:

$$(2) \dots\dots\dots R \text{ equals } \frac{80}{fC}$$

Where R and C are in kilohms and pFs respectively: f denotes the highest modulation frequency in Mc/s, at which the detector output will be 10 per cent. less than that at zero frequency.

For an example, it will be instructive to consider a circuit which has a total capacitance C of 10 pF, while the highest modulation frequency is 2.7 Mc/s.

Thus, R equals  $\frac{80}{10 \times 2.7}$ , equals a little less than 3 kilohms.

Another aspect of this consideration is the fact that while the diode is conductive, its resistance Rd is in shunt with R, an effect that does not always occur. For instance, the diode conducts on peaks of the picture signal, and in so doing charges C to a value depending on the modulation depth. Should the modulation at a given instant represent peak white, C will charge to a maximum value. A sudden transition from white to a darker background, however, will momentarily render the diode non-conducting, due to the potential across C being greater than that of the instantaneous signal. Such conditions will exist until either C loses some of its charge through R, or the modulation swings towards white.

It can be said, therefore, that the high video-frequency response will be better for increasing modulation than predicted by equation (2).

**Rectification Efficiency**

Broadly speaking, to achieve high rectification efficiency ( $\eta$ ), the resistance of R should be equal to the impedance of the diode. But R is a function of

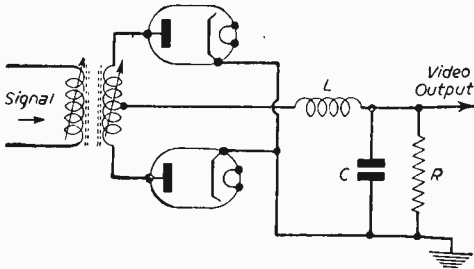

Fig. 3.—A push-pull detector with negative output.

the frequency response, which has been previously determined by calculation. The limiting factor is, therefore, the diode itself, because, although television diodes have very low impedance, they do not, in many cases, correspond to the value of R. This will, of course, reduce their efficiency for wide-band application—where  $\eta$  rarely exceeds 0.5. Often, however, the efficiency of a normal narrow-band circuit is in the region of 0.9 (where  $\eta$  equals 1 for 100 per cent. efficiency). An appreciable difference is thus noted.

From a practical consideration, this means that if the applied signal is E volts peak, C will acquire an average charge of  $\eta E$  volts.

With a view to increasing efficiency, an H.F. peaking coil is sometimes connected in series with R. This has the effect of offsetting the attenuation at the higher modulation frequencies, thereby enabling R to be increased in value. The inductance value of such a coil, for a maximally-flat response, should be equal to  $0.25 CR^2$ , and under these conditions R may be three times that required for an uncompensated circuit, for the same loss at 2.7 Mc/s.

**Low-pass Filter**

Present across C is not only the demodulated vision signal, but also quite a large R.F. voltage. Mainly this voltage is at carrier frequency, but, due to rectification, contains also components at its harmonics.

If these voltages are fed to the video amplifier stage

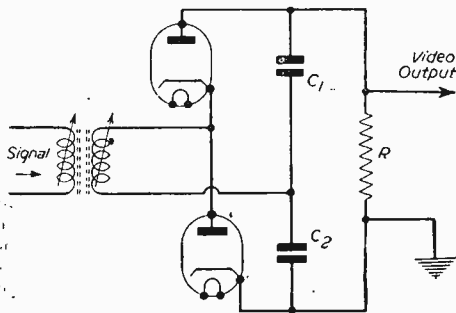

Fig. 4.—A voltage-doubler circuit for a negative-going output.

trouble would, no doubt, be experienced from instability and interference patterns on the picture, depending on a straight or superheterodyne receiver. With the former, R.F. at carrier frequency may find its way back to the input circuits, resulting in instability. While in the latter circuit, harmonics of the I.F. which fall near the carrier frequency may gain admittance via the first stage, and give rise to the very undesirable pattern effects on the picture.

To a degree, C offers a low impedance to such R.F. voltages, while attenuating the modulation frequencies relatively less. But in order to suppress completely components of the carrier frequency, a more elaborate type of R.F. filter is usually employed.

A circuit for this function is depicted in Fig. 2, and is included as the coupling link between the detector and video amplifier stage. Fundamentally, it takes the form of a low-pass filter, designed to offer high attenuation to the carrier frequency, and also, in the case of a superheterodyne, to the I.F.

By referring to Fig. 2, it will be noted that the filter input is in shunt with Rd, while the output end is loaded by R—the detector load. In practice, however, the inevitable mismatch due to these unbalanced loadings may be ignored.

The inductive elements are usually arranged to resonate at the carrier, and I.F. (approximately), and should be designed for minimum self capacitance.

C2 is quite often formed by the input capacitance of the video amplifier stage, while C and C1 are in the

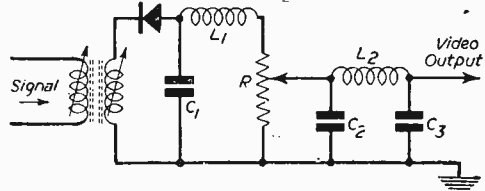

Fig. 5.—An interesting detector circuit by G.E.C.

region of 10 pF. It is worthy of note that at the modulation frequencies these capacitances are effectively in parallel, and should be so considered when computing R.

**A Push-pull Circuit**

Due to the filter, the extra capacitance across R will necessitate a reduction in its value, resulting also in a decrease of  $\eta$ .

The push-pull circuit of Fig. 3 has the advantage of a comparatively high  $\eta$ , owing to the need for less elaborate filtering. For this will obviously result in less capacity across R, which can, therefore, be increased in value for the same video response.

An advantage is created because the full-wave rectification action tends to balance out even harmonics of the I.F. or carrier frequency. For this reason a single stage inductance circuit is quite sufficient for filtering purposes, such as shown in the circuit of Fig. 3.

The input voltage required, however, is twice that of a single diode, and is obtained from a centre-tapped input transformer. It is in the designing of this transformer—which is no easy matter—where the disadvantage of this method of demodulation lies. For unless the correct degree of coupling, together with a low self-capacitance is secured, the performance of a single diode circuit may prove superior.

**A Voltage-doubler Circuit**

Another rather interesting circuit where, again, two diodes are employed, is the voltage-doubler circuit of Fig. 4. The circuit shown is arranged to provide a negative-going video output, but, if desired, a positive output may be obtained by reversing the connections to each diode. The voltage appearing across the load resistor R is equal to  $2E\theta$ , where E is the instantaneous signal voltage.

As with the single diode circuit, a fairly complex filter is necessary, but, owing to the filter capacitors C1 and C2 being in series across R, limitations to its value are less severe.

The main advantages of such a circuit may be realised in locations of high signal strength, where, under normal conditions, the video signal from the detector is not quite of sufficient magnitude to modulate fully the picture tube, without extra amplification. Or in the so-called fringe areas, where the output from a normal detector is insufficient to drive the video amplifier valve for full modulation of the picture tube.

**Crystal Diodes**

The G.E.C. germanium diode may be used, with advantage, to replace the valve in any of the foregoing circuits. It is rapidly coming to the foreground in television circuitry, owing mainly to its much lower shunt capacitance, and to the fact that it needs no heater current.

For vision detectors the low-impedance type—GEX 33—is most suitable. An interesting vision detector circuit employing a crystal diode is shown in Fig. 5. This circuit was developed by G.E.C., and is in use in their current receivers. A noteworthy point is the rather unusual method of contrast control, which utilises the diode load resistor R in the form of a variable potentiometer for this purpose.

**An Anode Bend Detector**

By employing the anode bend detection principle, which was once a very popular method for sound demodulation in midget T.R.F. receivers, a means is made available for the combined functions of detection and video amplification.

This well-known principle involves operation towards the point of anode current cut-off so that non-linearity occurs, thereby giving rectification, and is clearly illustrated by Fig. 6.

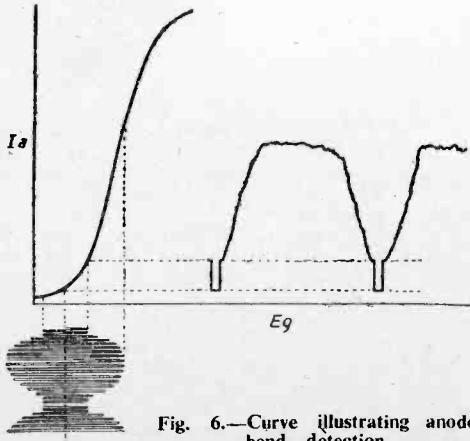

Fig. 6.—Curve illustrating anode bend detection.

An R.F. pentode operating under these conditions is used by Philips in one of their current receivers. The circuit takes a form similar to that of Fig. 7. Because the lower bend is used for rectification purposes the video output will be in a negative phase and correct for cathode modulation of the picture tube.

The main disadvantage of this system is that the full R.F. component of the vision signal is applied to the grid of the valve. Therefore, the filtering which must be performed in the anode circuit is more difficult, owing to the greater amplitude of R.F. at this point. Nevertheless, with careful screening of the filter choke and associated components, satisfactory operation is readily achieved.

Inductor L1 constitutes the filter choke, while L2 and

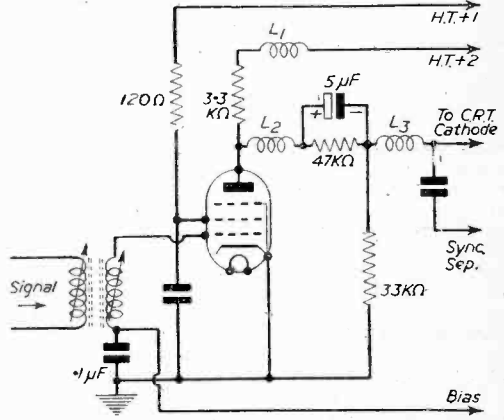

Fig. 7.—A circuit for anode bend detection.

L3 comprise the H.F. video correcting network. The valve is operated with screen and anode voltages about normal for an amplifier, but G1 is so biased that anode current is nearly at cut-off for no signal conditions.

Whilst the vision detector circuitry is relatively simple, it may be expected to give little trouble; this generally is the case. Nevertheless, some perplexing faults do occur, and a knowledge of the basic principles involved is far the best instrument for their rapid diagnosis.

FREE BLUEPRINT  
OF THE  
**P.T. 'ARGUS'**  
in Every Copy  
of  
Next Month's Issue

**ORDER YOUR  
COPY NOW!**



# Aerial Matching

USING THE CORRECT FEEDER FOR THE RECEIVER, AND HOW TO CORRECT UNBALANCE

By W. J. Delaney (G2FMY)

RECENT articles have dealt with the question of aerial design and attenuators, but although the majority of viewers are aware that aerials must be matched to the receiver the reasons are not very well known, and the question of how to match up feeder and receiver is often found to present a difficulty. Feeders between an aerial and a receiver may be designed to have a very wide range of impedance, but in modern television practice it is customary to adopt an impedance of approximately 75 ohms—which means a value somewhere between 60 and 80 ohms. Now it is possible to obtain two standard types of feeder having this impedance—the most popular being the coaxial cable, and the other the twin feeder. For newcomers it may be mentioned that coaxial is that type of wire which consists of a single or multi (twisted) wire running through the centre of a thick length of insulating material, surrounded by a plaited metallic covering. The twin feeder, on the other hand, consists of two separate lengths of wire insulated from each other and running parallel. The wires are held permanently in position by the moulding of the outer covering. The purpose of these types of feeder is, of course, to carry the signal down from the aerial and at the same time to avoid any pick-up of interference. Car ignition interference and radiation from domestic electric equipment is at its maximum below roof tops and, therefore, by erecting the aerial above the roof the signal should be "in the clear" so far as local interference is concerned, but an ordinary single, unshielded wire running down the house would pick up all the interference, and probably result in more interference than signal at the receiver end.

## How They Work

A single wire running through a screened covering will, of course, if the covering is earthed, pick up no interference, and thus the coaxial is used in this manner. The connection to the receiver must then be carried out by taking the single conducting lead to a one- or two-turn primary winding on the input coil, or even to a tapping on the coil, thereby providing an auto-transformer (Fig. 2). It will be noted that the screened outer covering is usually joined to the lower part of the dipole, although we believe that at least one manufacturer has supplied dipoles with the upper part connected to the screening and the lower to the inner wire. It will be obvious that any interference will be picked up by the earthed outer covering, and this means that the receiver end of this lead must be soundly earthed if the feeder is to be effective and the use of the standard coaxial plug and socket should take care of this.

The twin feeder, on the other hand, will pick up any interference on each of its wires, but by connecting the receiver end to each end of a small coil, and then earthing the centre of the coil, the currents in the two wires will cancel out. The oscillating signal currents will, however, be transferred to the secondary or grid winding, and as there is a risk of interference pulses also jumping across it is sometimes found that an electrostatic screen is called

for between the two windings. This type of twin feeder is known as a "balanced" feeder, whereas the coaxial is known as "unbalanced," and it will now be obvious that if the receiver is provided with an input socket connected to a tapping on the grid coil (or to a one- or two-turn coil primary winding), then it will be wrong to try and connect a twin feeder to it. The same remarks apply where the receiver has a centre-tapped or balanced input circuit and an attempt is made to connect a coaxial cable to it.

Difficulty sometimes arises where an aerial has been installed with one type of feeder to suit the particular receiver in use, and at a later date this is exchanged for a different make, and the input arrangement is of the opposite type. Fortunately, it is not a difficult matter to make a small coil which will provide a "balance to unbalance" condition, and the arrangement is shown in

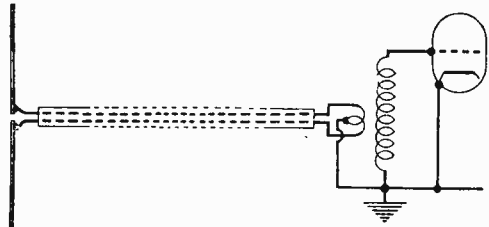

Fig. 1.—Connections for the twin feeder.

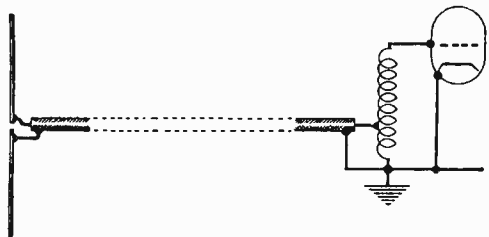

Fig. 2.—Connections for the coaxial lead.

Fig. 3—in theoretical and practical form. It will be seen that it consists merely of a standard type of coil, with a tapping point, plus a small coil at the "hot" or grid end of the coil. The standard type of Aladdin former may be used and the winding must suit the particular channel which is being used. Tapping A will be at 1 to 2 turns—and it will be found that in some circuits  $\frac{1}{2}$  or  $\frac{1}{3}$  turn will be critical—whilst the additional winding will consist of 2 to 3 turns. No centre-tap should be provided on this coil. The secondary is wound in the usual way, with turns touching, using appropriate turns according to the channel which is received in your particular locality. Over the winding a double layer of

ordinary notepaper is stuck. They dry a thin piece of paper is laid on, and on this a double ring of notepaper,  $\frac{1}{8}$  in. wide. This is also stuck, and when dry 2 turns of thin, flexible wire should be attached with Durofix or Polystyrene cement, the turns in this case being slightly spaced, and a few inches left at either end for subsequent connection. When thoroughly dry the inner separating piece of paper should be removed, and the ring carrying the 2 turns should then be just tight enough to enable it to be slid to any desired position on the tube, where it should remain without slipping—it should be a comfortable sliding fit. In use the best position is found, and then a touch of cement placed against the edge to prevent

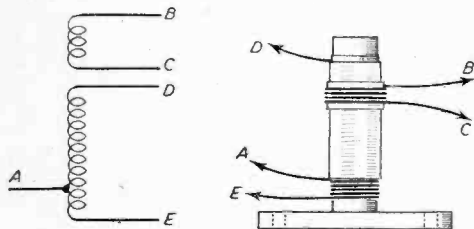

Fig. 3.—A simple matching transformer.

any subsequent movement. The main coil is, of course, tuned by means of the iron core in the usual manner. When completed it may be mounted on the chassis or, if the area is one where there is considerable local interference it may be found preferable to enclose it in a small metal box, soundly earthed. Actual connections will depend upon the manner in which this component is to be used. If, for instance, a receiver with a balanced

input is being used with a coaxial feeder, the feeder should be joined to point A and points B and C should be taken to the pair of receiver input sockets. On the other hand, if a receiver with unbalanced input is being used with twin feeder, then the ends of the feeder should be joined to points B and C, whilst point A should be joined to the input socket on the receiver. It should be unnecessary to add that any connection from this point should be carried out with coaxial in order to maintain the screening and also the matching.

#### Reason for Matching

One might argue that if interference is not bad it may not be necessary to match an aerial feeder and a receiver, and whilst this may be true in some cases there are two very good reasons why matching should be carried out where possible. First, a mismatch can give rise to reflections, in some cases much stronger than those caused by a nearby building or metal structure. What happens is that the signal travels down the feeder and on arriving at the receiver it is not all absorbed by the input circuit, and some of it is accordingly reflected back up the feeder. It is either reflected entirely at the aerial junction, or part is absorbed and some of it sent back, arriving out of phase and giving rise to a displaced image. The displacement will be quite small in the majority of cases, but although perhaps not visible as a secondary image the effect will be to "blur" the picture slightly and thus give poor definition. Thus, for maximum definition and freedom from interference the correct feeder for the receiver should be employed, and where it is not desired to go to the expense of exchanging one or the other, the little matching transformer described here may be used to assist in overcoming the mismatch.

## TV in 1952 in U.S.A.

**D**URING the past year, television established itself as such a vital force in the life of America that in 1952 it promises to be a decisive factor in the nomination and election of the President of the United States, Brig.-General David Sarnoff, chairman of the Board of the Radio Corporation of America, declared in a year-end statement issued as we go to press.

"By election day," General Sarnoff said, "there will be approximately 18 million television sets in the United States, with a potential audience of more than 60 million persons—exceeding the total population of the United States when Grover Cleveland campaigned for the presidency in 1884. For the first time, coast-to-coast network facilities will be available for the national campaigns.

"No other force, in so short a time, has ever exerted such a widespread impact on the home, on entertainment, education, politics, advertising, news and sports."

Describing television as the most effective means of mass communication known to man, he said that "therein lies its great destiny," and added:

"The power of such a medium for moulding public opinion is unprecedented. It provides an open forum in which every home has a front-row seat in the discussion of national and international problems. The leaders, as they speak, become living personalities, whose emotions and appearance are viewed directly by millions of people. This new art brings sincerity or insincerity into focus and has an intimate way of portraying the distinguishing characteristics of a natural leader.

"Television of to-day, however, is only the prelude to the television of to-morrow. It will change its format

from time to time to keep pace with new programme trends and new inventions. It is a live and flexible medium. In the process of its evolution it will develop its own art form, distinct from radio, motion pictures, stage and press. It will create and develop new entertainers and new personalities for the television screen.

"Already television has revealed its tremendous impact as an advertising medium. Based on the financial results of the first 10 months, the 1951 time billings of four TV networks and 109 stations should reach at least 250 million dollars. In 1951, for the first time, television surpassed network radio in revenue. To-day there are 15 million television sets in the United States. About 40 theatres are television-equipped."

### JOIN THE PRACTICAL GROUP

Edited by F. J. Camm

**PRACTICAL ENGINEERING, 6d.**  
Every Friday.

For Engineers, Mechanics, Designers and  
Works Managers.

**PRACTICAL MECHANICS, 1/-**  
Every Month.

Devoted to Mechanics, Science and Invention

**PRACTICAL WIRELESS, 1/-**  
Every Month.

# Servicing With the Oscilloscope

APPLICATIONS OF THE INSTRUMENT FOR RECEIVER TESTING

By Gordon J. King, A.M.I.P.R.E.

**N**OT so very long ago the cathode-ray oscilloscope was looked upon, by constructors and service engineers alike, as a box of mystery, for use in the research laboratory only.

With the coming of television, however, the general attitude towards this very versatile instrument has been severely modified. Indeed, a large number of home experimenters employ self-constructed instruments, which in most cases compare very favourably with their commercial counterparts. Furthermore, with the present trend in domestic television focused on "service," the overworked service engineer is beginning to realise the potentialities such an instrument offers in assisting with the diagnosis of illusive faults in the synchronising and time-base circuits.

It will be the aim of this article, therefore, to discuss the characteristics, merits, and application of this very useful servicing aid.

## Controls

Nearly all general purpose oscilloscopes utilise the "electrostatic type" cathode-ray tube. From this, therefore, it will be evident that for beam deflection a voltage input is needed.

The controls associated with the 'scope vary slightly according to the make and price range of the instrument, but in the main their fundamental adjustment is similar. Therefore, to render this article instructive from the beginners aspect it is proposed to consider briefly these adjustments before pursuing the subject of application.

## Focusing

Focusing of the electron beam is effected by a potentiometer controlling the voltage on the focusing electrode of the tube, which follows normal electrostatic practice. (See P.T., October, 1951.)

## Brilliance

The brilliance of the trace is controlled by a potentiometer which varies the bias on the grid of the C.R.T. Sometimes the main "on/off" switch is included in this control.

## The Time-base

For most practical applications the electron beam is made to traverse the screen of the C.R.T. in a horizontal direction, while the voltage waveform under examination deflects the beam in a vertical direction.

In order to examine, in an exact manner, a voltage waveform, the horizontal deflection of the beam must be linear; i.e., the electron beam must be deflected from left to right at a constant speed; after which it should return to its starting point in the shortest possible time.

As with television, a saw-tooth waveform is necessary for this function. Further, the T.B. generator must have external facilities for varying its repetition frequency. Usually this adjustment is in the form of two controls mounted on the main control panel. One is a "rough" adjustment, which alters the repetition frequency in multiples of 10; while the other, a "fine" adjustment, enables the T.B. repetition frequency to be varied within the limits set by the "rough" adjustment. In this way

the T.B. frequency is rendered continuously variable limited only by the type of instrument.

It should be noted at this point that for television application it is essential for the T.B. frequency to be variable between 10 to, at least, 5,000 c/s. The T.B. output is fed to the horizontal deflecting plates, sometimes referred to as the "X" plates. The majority of commercial oscilloscopes provide an external connection from the "X" plates, and thus the T.B., via a suitably engraved terminal.

## Horizontal Shift

Variation of the static bias on the horizontal deflection plates by means of a potentiometer enables the trace to be moved from left to right, or from right to left.

## Vertical Shift

In a similar manner to the horizontal shift a potentiometer controls the static bias on the vertical deflecting plates, enabling the trace to be centred vertically.

## Horizontal Input

This adjustment simply controls the horizontal deflection voltage fed to the "X" plates, and consequently the amplitude of deflection of the trace.

## Deflection Amplifier

As previously intimated the signal under examination is fed to the vertical deflector plates, or "Y" plates. Unfortunately a normal C.R.T. requires anything from 25 to 100 volts R.M.S. for "full screen deflection." Therefore, it is customary to employ a deflection amplifier when voltages of a small magnitude need to be examined.

Such an amplifier is usually embodied in the instrument case as an internal unit. The overall gain of the amplifier is adjustable by two (in most models) external controls. One control is usually in the form of a rotary switch; where the selected position multiplies the former position by 10 (a decade switch). The other control, designated "gain," "vertical input," or such, according to the type of instrument, gives a continuously variable control of amplifier gain from zero to the maximum selected by the decade switch.

It is important that the amplifier should have a substantially flat frequency response, extending, at least, from 50 to 100,000 c/s.; this is especially important if the instrument is to be used for television work. Since

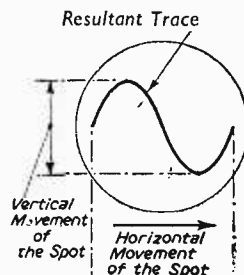

Fig. 1.—Showing how a sine-wave is traced on the screen when the T.B. frequency equals the sine wave frequency.

a poor high-frequency response seriously distorts the trace of the line sync pulses and the line scan waveform. Similarly, unless the low-frequency response is maintained distortion of the frame saw-tooth waveform will ensue, rendering the instrument useless for linearity checks. If the frequency response of the internal amplifier is not suitable, however, an external amplifier may be employed, the design of which should follow video frequency practice.

### The Trace

By connecting an alternating voltage to the "Y" plates it will now be obvious that examination of the applied waveform is possible. For the sake of completeness, however, it may be worth while to consider the action in detail.

Suppose for example, a "sample" of the 50 c/s. mains voltage is applied to the "Y" plates. The voltage rises to a maximum in the positive direction, falls to zero and rises to a maximum in the negative direction. The electron beam and thus the spot will follow this in a vertical movement across the screen of the C.R.T. At the same time, the spot is being moved across the screen in a horizontal direction at a speed determined by the repetition frequency of the T.B. The resulting waveform which will be traced on the screen is shown by Fig. 1.

It will be noted that the time taken for the spot to travel from left to right across the screen is equal to the time of one complete sine-wave. It follows, therefore, that under these conditions the frequency of the applied mains voltage is equal to the repetition frequency of the T.B. Doubling the frequency of the T.B. will result in one half-cycle of waveform only being traced on the screen. Whereas if the T.B. frequency is halved, two complete cycles will be traced. The same reasoning follows if the T.B. frequency is unchanged while the frequency of the "sample" voltage is halved or doubled. It is obvious, therefore, that the precise number of sine-waves appearing will depend on the relationship between the sine-wave frequency and the repetition frequency of the T.B. For detailed examination of a waveform it is desirable to have no more than two cycles on the screen simultaneously. Therefore, in order to examine a line saw-tooth waveform successfully, the T.B. will need to run at just a little over 5,000 c/s.

### Synchronism

As previously shown the T.B. frequency must be an exact multiple of the frequency under observation, so that after a complete number of cycles the spot flies back and commences to trace the succeeding waves immediately on top of the first.

Should the frequency of the T.B. be slightly different from that of the waveform under observation, however, the waveform will have the appearance of moving slowly across the screen.

Since it is impracticable to hold both the frequency of the T.B. and the observation signal sufficiently stable to prevent this effect, a synchronising voltage is fed to the T.B.

This is done by introducing a small ratio of the voltage under examination to the grid (in the case of a gas-filled triode) of the T.B. generator. This will have the effect of locking the T.B. frequency to that of the examination voltage, and then the variation of the T.B. frequency controls will cause a series of stationary patterns to appear.

Synchronising voltage is usually applied by connecting a link direct from the "Y" plate terminal to a terminal marked "sync input" located on the front of the

instrument. It is worthy to note, however, that for TV work the voltage for synchronising purposes is best taken from the output of the deflection amplifier. This will prevent the T.B. of the 'scope from affecting the synchronising of the television receiver.

A potentiometer is employed to control the magnitude of synchronising voltage fed to the T.B. The effect of too much sync will be to reduce the amplitude of the trace, or to reduce the number of waveforms initially traced on the screen. And for this reason the synchronising control should be adjusted in conjunction with the magnitude of the examination voltage, or "deflector amplifier" gain.

### Time-base Analysis

Many and varied are the uses to which the oscilloscope may be put in television servicing, though it is most valuable for checking the operation of the sync separating circuits and also for investigating the time-bases.

It is of assistance when employing the instrument for the latter function to have some idea of the repetition frequency of the T.B. of the 'scope. It will be possible then to acquire some indication of the frequency of the receiver's time-bases.

The T.B. frequency of the 'scope is usually adjusted empirically to suit the frequency of the waveform under examination, and as a consequence the operator can be easily misled. It is at least desirable to know when the T.B. is running at, say, 25 and 5,000 c/s., as a correctly running frame and line time-base will then show two complete cycles on the screen of the C.R.T.

The oscilloscope finds a most obvious application for rapid fault diagnosis in the line and frame time-base circuits.

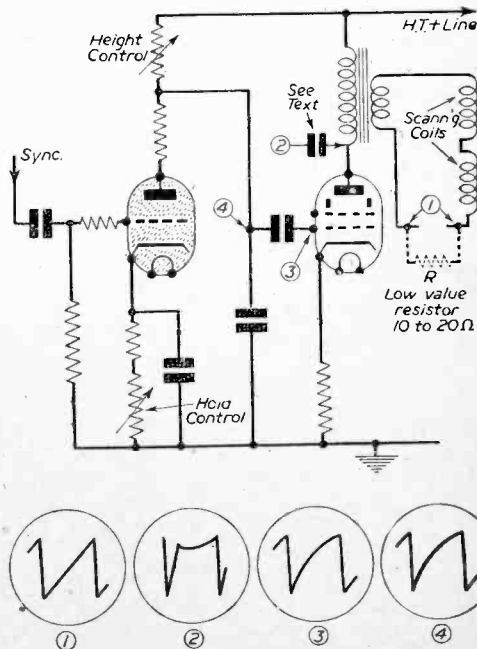

Fig. 2 (a) (top).—A typical thyratron time-base circuit showing the four test points. Fig. 2 (b) (bottom).—Showing oscillograms which may be expected from the test points indicated.

For instance, suppose the T.B. is not working, the effect of which will be indicated on the screen of the receiver by a bright vertical line, providing, of course, E.H.T. is not derived from the line flyback. Fig. 2 (a) illustrates a typical thyatron line T.B. circuit showing four positions where application of the scope may be made, whilst the oscillograms which may be expected at the points indicated are shown in Fig. 2 (b). The procedure being to work backwards through the circuit until the signal is located.

With electromagnetic deflection it may be found necessary to insert a low value resistor (R) in series with the scanning coils when making test (1). This is because the 'scope needs a voltage input, whereas the scanning coils need current. With electrostatic deflection this, of course, would not be necessary.

If the signal is present at this point and yet no frame deflection is indicated on the screen of the receiver, this can only mean that the scanning coil is short circuited, the resistor acting as a load for the output of the T.B.

If signals are present at point (2), however, and not at point (1), the secondary of the output transformer or the scanning coils are open circuited.

It should be observed that in test (2) connection from the 'scope is *not* made direct to the anode of the valve, but via a small capacitor; a crocodile clip fastened on to the insulation of the wire carrying the current will in

most cases give sufficient coupling. This precaution is necessary owing to the very large voltages which occur there on the line flyback stroke.

No signal at point (2), but signal at point (3) will indicate a fault in the output stage, where normal circuit testing should soon reveal the cause.

A signal at point (4), but not at point (3) will, obviously, indicate a faulty coupling capacitor. No signal at point (4), however, will prove the oscillator circuit faulty.

**Linearity**

From the foregoing it is easy to see how a fault in the T.B. circuit may be rapidly localised without disturbance to the wiring, or numerous unsoldering and resoldering operations. Furthermore, the waveform at the point of test is also indicated.

This can prove of great assistance when tracing for non-linearity, for unless the scanning stroke of the saw-tooth waveform is linear, distortion of the raster is bound to ensue. It should be remembered, however, that the charge or discharge curve for the "charging capacitor" in the T.B. proper is exponential and will be indicated thus on the oscillogram (see test (3) and (4), Fig. 2b). But distortion in the opposite sense is introduced in the output stage where the two distortions cancel out, leaving a linear waveform.

This effect is illustrated more fully in the oscillograms of Fig. 3b, which are those that may be expected at the indicated test points of the blocking oscillator circuit (Fig. 3a).

It will be observed from the oscillogram at test point (5) that the scanning stroke increases exponentially with time, whereas the waveform appearing at the grid of the output valve (point 3) is slightly exponential in the opposite sense. This paradox is due to a negative feed-back voltage (point 4) counteracting the original non-linearity across the charging capacitor. The slightly non-linear current built up through the output valve tends to cancel the distortion present at its grid, resulting in a linear current through the scanning coils; and thus securing a linear deflection of the beam in the C.R.T.

When the examination voltage is very small and an appreciable amount of deflection gain is used, trouble may be experienced from mains ripple, induced into the connecting leads of the 'scope. The effect of this causes the amplitude of the waveform under examination to change continuously at a rate depending on the ratio of the two frequencies. To minimise this phenomena it is desirable to employ a screened cable from the point of test to the 'scope input.

**Inefficient Interlacing**

One of the most difficult television faults to trace is that resulting in faulty interlacing. In its worst form the lines of successive frames are completely superimposed, giving the appearance of lack of focus with an apparent reduction in detail. Most faults of this nature investigated by the author have been due to the line time-base pulse reaching the frame scanning generator. And in order to procure complete freedom from this inter-reaction analysis with an oscilloscope is essential. The procedure is as follows:

Remove the aerial from the receiver and disconnect, or render inoperative the frame generator—where possible this should be done by removing the oscillator valve. Remove the E.H.T. connection from the C.R.T.

Switch on the receiver and ascertain that the line time-base generator is working correctly. Next, connect

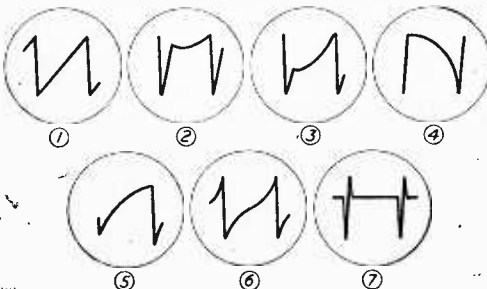
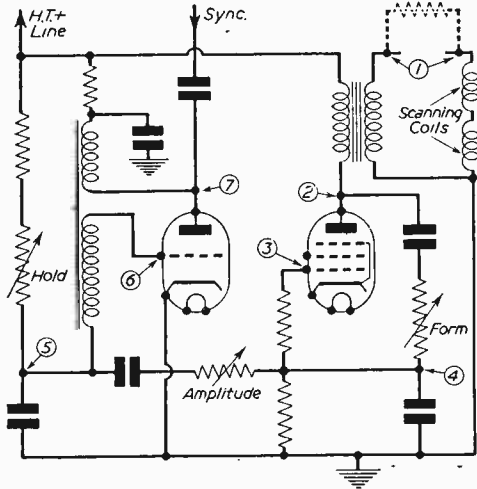

Fig. 3 (a) (top).—Circuit of blocking oscillator frame time-base, showing seven test points. Fig. 3 (b) (bottom).—The oscillograms which may be expected from the seven test points indicated above.

the 'scope to various parts of the frame generator circuit in turn—using fair amount of deflection gain. Freedom from breakthrough is indicated, of course, by no vertical deflection of the 'scope trace. In practice this condition is rarely achieved, although the magnitude of breakthrough voltage at line frequency should be very small for good interlacing.

Most of this breakthrough can be traced to unwanted coupling in the generator connecting leads. For instance, connecting wires carrying current at line frequency in close proximity to connecting leads of the frame generator. A common coupling in the H.T. line due to a faulty decoupling capacitor has been known to cause this trouble. In a badly-designed receiver, line pulses in the frame circuit may be traced via a common coupling at the sync separator circuit, especially where no buffer valve is employed, for pulse shaping, etc., between the sync separator and the frame generator. Analysis along these lines, however, soon enables the precise point of entry to be determined.

### Irregular Synchronising

Another illusive fault in the time-base circuit which presents difficulty in locating is intermittent line hold. With this fault it is usually found that the critical position for the line hold control fluctuates with picture content. The trouble is due to faulty sync separation, in most cases, and investigation with an oscilloscope will usually reveal that an appreciable amount of picture signal is reaching the line generator.

For reliable synchronising the magnitude of picture signal at the output of the sync separator valve should be unrecordable with an average 'scope.

Fig. 4 (a) depicts a sync separating and pulse shaper

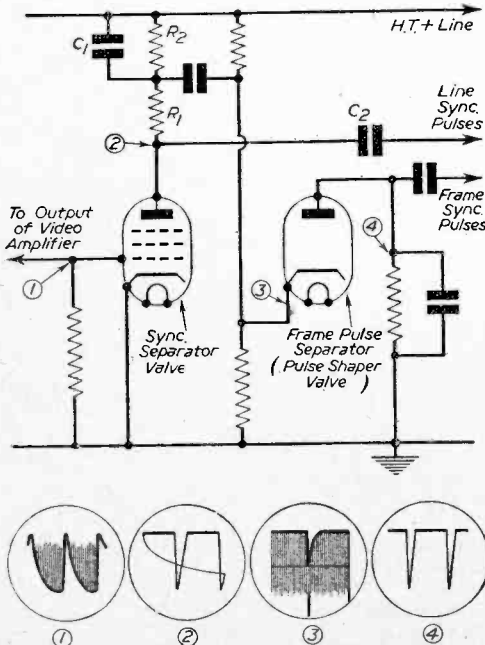

Fig. 4 (a) (top).—Sync separator and frame pulse separator circuit by G.E.C. showing four suggested oscilloscope test points. Fig. 4 (b) (bottom).—Oscillograms which may be expected at the above test points. (See text.)

circuit as employed in the current range of G.E.C. receivers, while the waveforms at approximate parts of the circuit are shown at Fig. 4 (b).

For examination of the composite picture and line sync pulses the T.B. of the 'scope should be adjusted for line frequency. Oscillogram (1) clearly indicates such a signal, showing two complete lines in the negative direction.

It should be mentioned at this point that it is desirable to disconnect the line and frame feeds to the time-bases when tracing sync pulses. This will prevent pulses originating from the time-base generators combining with the sync pulses to form erroneous oscillograms.

The output from the sync separator valve, Fig. 4 (a), is composed only of line and frame sync pulses, the picture signal being completely eliminated owing to the limiting action of the valve. The line sync pulses, however, are developed across  $R_1$  and fed via  $C_2$  to the line generator, while the frame pulses are developed across  $C_1$ ,  $R_2$ .

Oscillogram (2) illustrates the appearance of the line sync pulses, showing complete freedom from picture signal. Further, it will be noted they are inverted owing to the reversing action of the valve.

Complete frames with frame sync pulses are shown by oscillogram (3), from which it will be observed that the frame sync pulse magnitude is greater than that of the line pulses, brought about by the action of  $C_1$ ,  $R_2$ .

The function of the frame pulse separator valve is clearly indicated by oscillogram (4), where frame sync pulses only are recorded.

In conclusion, it should be mentioned that the use of an oscilloscope is a technique which only practice can master. But by its use it is surprising how much can be learnt about television time-base and synchronising circuits, resulting as a consequence in more efficient and rapid fault tracing.

It is hoped, therefore, that the foregoing notes will be of assistance to constructors and service engineers alike; and will enable them to use the oscilloscope with a better understanding.

## NEXT MONTH!

### FREE BLUEPRINT OF THE P.T. 'ARGUS'

A unit-constructed television receiver using the popular VCR 97 cathode-ray tube.

Five separate units, which are finally bolted together to form a complete receiver, facilitate construction, servicing and modification.

Total cost about £20.

**ORDER YOUR COPY NOW!**

# THE USES OF TUNING SLUGS

THE DIFFERENCES BETWEEN IRON DUST AND BRASS, AND SOME HINTS

By F. R. Pettit

**T**HE purpose of this article is to describe the functions of the H.F. coil core materials whose uses are so widespread in modern equipment. The nature and properties are first explained, and then the uses to which these properties may be put are described.

There are two main groups into which these materials may be classified (a) the brass slug and (b) the dust-iron slug.

## Brass

The brass slug consists of a small cylindrical piece of brass commonly  $\frac{1}{8}$  in. long and  $\frac{3}{16}$  in. in diameter. It can be considered as a single-turn short-circuited coil and has the effect when introduced into a coil of decreasing the effective inductance of the coil. The action is similar to the effect of placing a screening can over a coil; the de-tuning of this operation is well known to all experimenters.

## Iron

It is well known to experimenters that the presence of iron near a coil has the effect of increasing the inductance of the coil. For direct current uses the iron is generally in solid form; for audio frequency use the iron is generally laminated to reduce eddy current losses. At radio frequencies these losses are very great and the problem is overcome by further subdividing the iron into minute particles which are each insulated and bonded, finally being moulded into suitable shapes and sizes for use in coil construction. By this means the eddy current losses are reduced to negligible proportions but a substantial increase in coil inductance takes place. For a given inductance less wire is required in the construction of an "iron"-cored than an air-cored coil. Hence the H.F. resistance of the former is less, resulting in a higher Q. Dust-iron core material is produced in various grades, some being of high  $\mu$  and suitable for medium frequency use, for instance in the long- and medium-wave bands. Other grades are superior in their performance at very high frequencies but possessing lower  $\mu$ .

## Effects

With either type of material, the effect of insertion into a coil is to alter the inductance of that coil and thereby alter the frequency to which the coil tunes. A dust core increases the inductance and decreases the tuning frequency, while a brass core has the reverse effect.

## Uses

There are many applications in which the use of coil cores is more convenient than the use of tuning (or trimming) condensers. For instance, in quantity production coils may be more easily wound to specified limits when final adjustments can be made simply by adjusting the position of the coil core.

One interesting application of the iron core is the improvement in Q of frame aerials. If the number of turns in a frame aerial is reduced, and the reduction in its inductance compensated for by adding a small iron-cored coil in series, the resulting system may be capable of giving increased output and selectivity. Although

the pick-up is reduced the H.F. losses are also reduced, but by far greater amount, with careful design, so that the overall Q is increased.

A wide-range tuning unit may be constructed by fixing on a common spindle a dust slug and a brass slug separated by a distance equal to the length of the coil it is required to tune. With the dust slug fully inserted the coil inductance is increased, and with the brass slug inserted the inductance is reduced below its normal value. Two illustrations are given. For medium-wave use the coil should be long and narrow, for short-wave

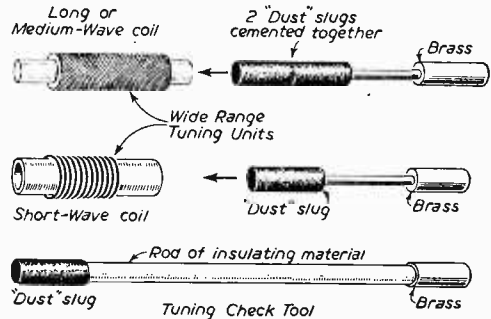

Note: Brass slugs may be either solid or hollow

## Combined slugs and a useful trimming tool.

use normal construction may be employed. The length of the slugs should approximate the length of the coil winding.

## Trimming Checker

Construction of a trimming check tool. When aligning radio receivers, much time can be saved if it is known whether to increase or decrease the tuning capacity before the trimming operation is commenced. To aid this, the following tool can be easily constructed as may be seen in the accompanying illustration. A small dust slug is fitted to one end of a short rod of insulating material and a brass slug fitted to the other end. This end should be coloured. To use the tool insert the coloured end into the tuning coil of the circuit to be adjusted. If the response improves increase the capacity of the trimming condenser. If the response is reduced a decrease should be made in the capacity of the trimming condenser. The insertion of the uncoloured end of the tuning stick has the opposite effect and an improvement in response indicates the necessity to reduce tuning capacity. To check that a coil is on tune, first insert one end of the tuning stick and then the other, noting that a reduction in response should take place whichever end is inserted.

It should be noted that the dust slug has more effect on the circuit than the brass slug.

In some cases a flexible tuning stick may be easier to use than the one described above. This may be constructed from a piece of plastic sleeving and two slugs, one being inserted in each end. A piece of the covering from television aerial cable or some similar wire is

(Concluded on page 428)

# Underwater Television

## DETAILS OF THE LATEST CAMERA DEVELOPMENTS

**T**HE use of television for purposes other than entertainment has been the subject of much research and experiment in recent months. When, last April, the Admiralty requested the help of Marconi's Wireless Telegraph Co., Ltd., in an attempt to find the *Affray* with a Marconi television camera chain, a new field of television applications was opened.

Since then the Marconi Co. have been investigating this application and have found that it promises to be of great assistance to various bodies and organisations. Its primary importance is in any type of underwater work where a diver would normally be used, and more particularly when it would be dangerous for a diver to go down.

In the majority of cases a television camera can work for far longer periods under water than could a diver; the extreme sensitivity of the Image Orthicon camera tube can be more effective and accurate than the human eye under water; the camera can go deeper than a diver; and, in matters of interpretation, it allows scientists and experts to see what is below and eliminates the discrepancies which must creep into a diver's report—the diver usually having no specialized knowledge of the flora, fauna, machinery or geological vista he is sent down to inspect.

Another very important advantage is that the television picture received on board a ship from a sunken camera can be filmed and a permanent record obtained.

So far, standard Marconi cameras similar to those used by broadcasting authorities all over the world, and used extensively by the British Broadcasting Corporation for outside television broadcasts, have been used. The versatility of these compact cameras has shown that no special design is called for, only minor modifications and additions being necessary for underwater televising.

### Additions

No modifications have yet been found necessary in order to work the cameras successfully under water. If any are found to be useful later on it is expected that they will only be of a minor nature. The additions which have been found useful in providing remote control and "indication of behaviour" facilities on board ship are:

- (a) *Remote focus control.*—This allows the camera to be focused, while submerged, by the operators on board ship and, as indication of setting is shown at the control point, it is possible to estimate the size and distance away of an object with reasonable accuracy.
- (b) *Remote iris control.*—Remote indication is again provided with this facility. The main advantage of remote iris control is that the lens aperture can be varied to obtain the best possible picture under conditions of considerable light variation. Such variations are present when an object is viewed at 20ft. distance and then the camera is moved in for a close-up view at 4ft., without varying the light intensity.
- (c) *Lighting system.*—This must be very flexible to allow of use in waters of various densities and content, and at various depths. The unit provides

eight lamps which can be controlled, in pairs, from the surface.

- (d) *Mounting facilities.*—This must also be a flexible system so that camera and lights can be set up for viewing at various angles, as well as at varying distances.
- (e) *Inclinometer.*—This gives indication, at the control point, of the unit's angle when submerged.
- (f) *Water indicator.*—Moisture within the pressure casing which houses the camera is extremely detrimental to all the equipment and this facility detects and warns the operators of any moisture entering the casing.

Later refinements will, no doubt, include a compass to show the correct orientation of the unit.

Apart from the experimental side of underwater television the Marconi equipment has already proved highly successful in the finding of the *Affray* at a depth of 280ft.

Knowledge gained on that occasion is now being put to use and a pressure casing for containing the camera is being designed and produced. These casings will have viewing windows through which the lens of the cameras will "shoot" the underwater scenes. A new type of gland has been devised for the camera cable. The cable is of special construction and is capable of being operated at depths of over 1,000ft.

(Concluded on page 416)



Engineers preparing to lower the underwater TV camera in its pressure casing, into the test tank.



# Interpreting Theoretical Diagrams

## HINTS ON PRACTICAL WIRING FOR THE BEGINNER

By "ERG"

IT is a serious thought that when a new television is first switched on twenty or more valves plus an expensive cathode-ray tube may perish!

This thought tends to make many inexperienced amateurs steer clear of television construction; they are quite happy with the normal broadcast receiver, but the complicated circuits in a television receiver appear rather frightening. It would be much easier if

but for the purpose of illustration we will examine a more or less standard input, or first stage. It is shown by itself in Fig. 1. Let us now analyse this into its main divisions: this gives us H.T. supply, filament circuit, signal input circuit, signal output circuit, and the common thread which links them all together, the earth—zero potential.

Consider the H.T. supply to the anode. First we have R1, the anode side of which is connected to an earthed capacitor. So far as R.F. is concerned this point is at zero potential, so these components (R1 and C1) can be tucked away on a convenient tag strip.

Next we have R2, C2. At first sight it may appear that we could do the same with these—but the output signal is developed across R3, and we have, therefore, a V.H.F. signal across the ends of R3, and as V.H.F. currents are very critical it is best to keep R2 close to R3.

Speaking broadly, the effect of R3 is to prevent the signal travelling farther into the H.T. supply and to pass it on to the next tuning coil. C3 is merely to prevent the H.T. being short-circuited to earth. Briefly, the signal is produced across R3 and passed on to L2. As we do not want to lose any signal on the way, these components are kept as close as possible and the length of the connecting wire reduced to a minimum.

The first golden rule, then, is to *keep the leads as short as possible.*

Anode resistors and coupling capacitors should be wired directly to the tags of the valveholders; if the lead between the component and the valveholder is  $\frac{1}{4}$  in. long it is becoming too long.

Zero potential, so far as R.F. is concerned, should appear on the screening grid. This is accomplished by R6 and C6. Once again the leads should be kept short and these components should also be wired directly to the valveholder tags.

R5, C5 and R4, C4 perform similar functions to R1, C1, and in addition reduce the H.T. voltage applied

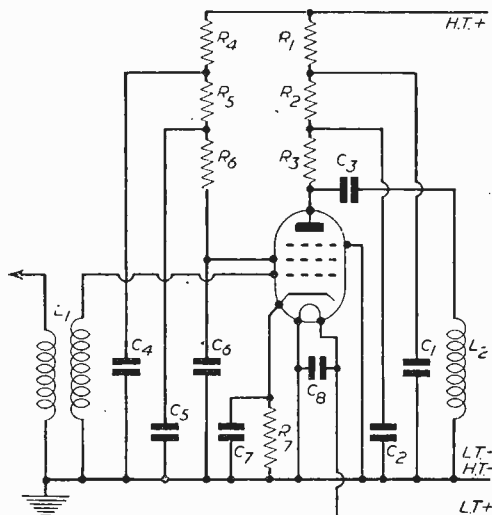

Fig. 1.—Typical R.F. stage as found in the majority of television receivers.

point-to-point wiring diagrams could be supplied, but his is not always possible, and wiring directly from a theoretical circuit which spreads across the page (and probably on to the next) seems almost an impossibility.

In actual fact the job is quite easy provided a little care is taken and the work is tackled systematically.

There need be no bar to any novice tackling the (apparently) most complicated diagram. The only qualifications required are the ability to read a theoretical circuit, a few tools, and—a pencil! Provided with these items, any of the many interesting circuits published in these pages can be constructed.

Take a look at any straight television receiver circuit. It will be seen to consist of a vision receiver comprising, say, four R.F. stages, with a diode detector and video output valve. Now this suggests an immediate division into parts: R.F. stages, detector, video stage.

A closer examination of the R.F. stages will usually reveal that they are practically duplicates of each other; we can therefore further simplify the diagram into R.F. (x 4), detector, and video stage.

The only things that these stages have in common are the H.T. supply, filament supply and earth. But for these the circuit can be treated as six individual circuits.

Now let us extract one of the R.F. stages and examine it more closely. It does not matter which one we take,

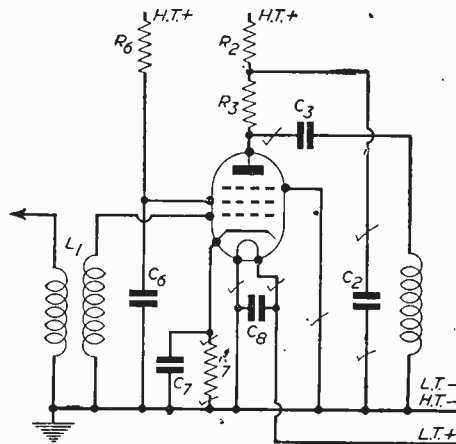

Fig. 2.—Tie off the wiring as it is completed.

at the screening grid to the figure required. They can therefore be mounted on the tag strip.

R.F. zero potential should appear at the cathode of the valve which means that here, too, the resistor R7 and capacitor C7 should be wired directly to the valveholder.

R.F. zero potential is required at the filament. One side of the filament is directly earthed and once again the lead is kept as short as possible. The other side of the filament is earthed, so far as R.F. is concerned, by means of capacitor C8, and this component should therefore be wired directly to the valveholder.

At the grid of the valve we have to ensure that none of the signal is lost and the wire here must be kept short.

Now that we have removed some of the accessories to the tag strip let us look at what we have left (Fig. 2). Not very complicated, is it? (Ignore the little ticks; we will deal with those later.) There is still one very important point to be observed: we must not allow any of the amplified signal in the anode circuit to leak back into the grid circuit or instability will result.

Here is our second golden rule: *Keep grid circuits and anode circuits clear of each other.*

This is easily accomplished by careful positioning of the components and the use of metal screens. It is common practice to erect metal screens across the valveholder to separate the two circuits.

One point to remember is that the grid circuit of V2 is part of the anode circuit of V1, and it is quite usual to include R1, C1, R2, C2 in the same screening can as C3, L2.

The practical outcome of all this is shown in Fig. 3, which gives the layout for the circuit in Fig. 1 using an EF50 valve. The rest of the R.F. circuits can be dealt with in a similar manner.

When we come to the detector and video circuits they can be split into their component parts in the same way as the first R.F. stage, and the practical layout of the components will follow the same pattern.

### Time Bases

The main points to remember here are, first to treat the circuits in the same way as the R.F. circuits (though a little more latitude can be allowed), and secondly to ensure that the line and frame time bases are kept separate from each other, to prevent any interaction between them. For example, you would not place a line oscillator transformer next door to the frame output transformer.

The golden rule for time bases, then, is to *keep the frame and line circuits clear of each other.*

### Power Supplies

The same rules apply to power packs for televisions as to any power pack, remembering that you are handling heavier currents than usual. Fitting fuses in the H.T. line is a sound precaution.

### EHT

The trend nowadays is to obtain the EHT from R.F. units or from the line fly-back circuit. Neither of these are lethal though they can give one a nasty burn. Two golden rules apply in EHT work:

*Keep the wires well insulated and well away from the chassis and other components.*

*Do not leave short ends of wire poking out from terminating tags or you will encourage corona discharges.*

### Practical Work

Here are the rules for the actual construction:

Obtain wire with different coloured sleeving.

Have all the components ready and check them with the diagram.

Use a really hot soldering-iron kept hot continuously. An iron which only just melts the solder is worse than useless.

Use a resin-cored solder.

Have the diagram in front of you together with a soft-lead pencil.

Bolt the necessary items to the chassis (terminating tags, valveholders, etc.).

Deal with each section in turn (e.g. vision receiver first, sound receiver second, and so on).

Having decided which section you are going to start

*Note: Securing nuts marked E are earthing points*

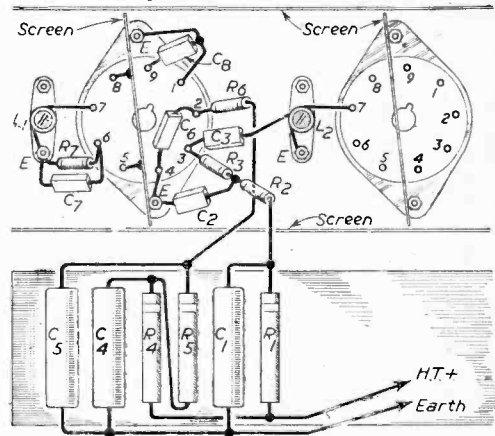

Fig. 3.—Practical interpretation of the circuit in Fig. 2.

with, commence by wiring up the filament circuits using bare wire for earths and black wire for the non-earthed sides.

Solder each wire as you go along and then you will not leave any "dry" joints.

Tick off on the diagram each wire after it has been soldered. (Note ticks in Fig. 2.)

Wire the grid circuit of the first valve with yellow-covered wire.

Now wire the anode circuit. Referring to Fig. 1, this will be R2, C2, R3, C3, L2. Use green-covered wire.

Next wire the screened grid circuit (R6, C6), using white-covered wire.

Anode decoupling components can be next with orange wire (R1, C1).

Now complete the screen decoupling components and use blue wire.

The H.T. common can now be wired, using red wire.

The cathode circuit can be wired in grey wire.

**Important.** Do not let any snippets of wire fall into the "works." If any do, then get them out straight away; don't leave the job for "presently," as presently never comes. Remember those 20 valves!

The foregoing paragraph applies also to spots of solder.

By the time you have finished, the chassis will look as pretty as a Christmas tree, but don't let that worry you; using different coloured wires will help enormously when it comes to fault tracing.

# Development of the C.R.T.

A SCIENTIFIC SERIES OF INVESTIGATIONS WHICH LED ULTIMATELY TO TELEVISION

By J. F. Stirling, M.Sc.

**M**ORE than 40 years have now elapsed since the late Mr. A. A. Campbell Swinton, F.R.S., one of the pioneer electrical physicists of this century, first suggested, in 1908, the use of cathode rays in a system of television. A year later, Boris Rosing, a Russian scientist, came forward with a somewhat similar scheme.

Although the ultimate fruition of Campbell Swinton's original idea has not come about in commercial practice until our own times, the basic notion of cathode rays is nearly a century old. In fact, cathode rays were known and had been studied long before the very nature

was made visible and, by applying a magnetic field to the cathode beam, the light-spot on the screen could be made to move about more or less at the will of the experimenter.

It was, no doubt, this particular tube which Campbell Swinton had in mind when, years later, he first made the suggestion of applying cathode rays to the solution of the then intensely difficult problem of satisfactory television reception.

## The Braun-Wehnelt Tube

About 1905, another experimenter named Wehnelt came forward with a distinct improvement on the original Braun tube. He used a hot cathode comprising an oxide-coated platinum strip which was electrically heated to redness. This increased the cathode emission, enabling a lower potential to be applied to the anode of the tube and withal producing a more brilliant spot on the screen. Wehnelt also surrounded his cathode with a cylindrical shield (the "Wehnelt cylinder") to which he applied a negative potential, which latter acted by concentrating, as it were, the emitted cathode rays into a narrow pencil or jet in which form they could more readily travel up the tube to the screen without wasteful diffusion.

It is the Braun-Wehnelt tube which forms the prototype of the modern high-definition giant cathode-ray tubes which are fitted to all present-day television receivers. In this article, however, we are to consider more the actual nature and properties of the nowadays indispensable cathode rays rather than the details of the various types of tubes in which they may be produced.

## "Radiant Matter"

For this reason, therefore, let us go back again to the beginnings of these rays, to the time when their real nature was just dawning on the more alert experimenters. The original idea of Plücker in 1859 maintaining that any electrical discharge from a cathode surface in a vacuum is, in actuality, a pure cathode-ray discharge has nothing intrinsically incorrect about it. But at that time the very nature of the electrical discharge through a vacuum space was imperfectly understood. One early experimenter with these electrical discharges (Goldstein, 1876) thought that they consisted of transverse ether

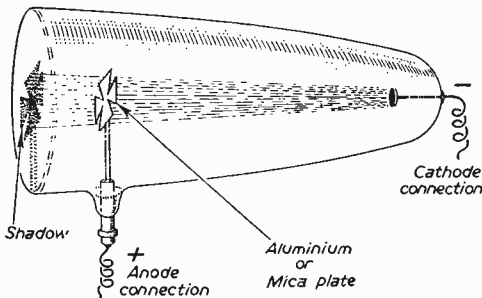

Fig. 1.—The "Maltese cross tube" showing that cathode rays are capable of casting a shadow.

of electricity and the existence of the electron had been disclosed. It was the German experimenter, Plücker, who first coined the name "cathode ray" as far back as 1859 when he was studying the discharge of electricity through various vacuous glass tubes. Originally, the name was applied to any electric discharge through a vacuous tube between a negatively-charged electrode (cathode) and a positively charged one (anode), the discharge proceeding from the cathode to the anode.

After Plücker's time, it was shown that if the degree of vacuum were sufficiently high this same cathode discharge set up a peculiar glow or fluorescence in the glass walls of the tube caused by the bombardment of the tube walls by "particles of electricity," to which the name "electrons" was most aptly applied or, rather, first suggested, by Johnston Stoney in 1890.

Another seven years elapsed before the next move was made in the realm of cathode rays. Then, in 1897, Ferdinand Braun, Professor of Physics in the University of Strasburg and a close runner-up with Marconi himself in the introduction of wireless transmission, brought out his famous electron tube. This was the first cathode-ray tube to be made. An electron stream was emitted from a cathode disc of metal within the tube. This was, under the attractive influence of a high-potential anode, directed along the tube and, after passing through a diaphragm which narrowed-down the stream of rays, it impinged on a mica screen which was coated with a brightly glowing fluorescent material—usually one of platinumcyanides of potassium, barium or magnesium. Thus, the point or area of impact with the mica screen

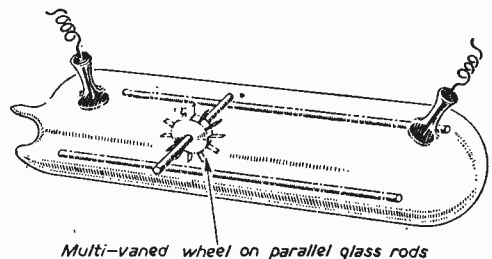

Fig. 2.—A cathode-ray "turbine" tube devised by Sir William Crookes to demonstrate the mechanical properties of cathode rays.

waves generated inside the evacuated tube. In other words, he pictured them as being high-frequency, sideways-oscillating electro-magnetic waves flung off from the powerfully energised cathode surface. The famous Sir William Crookes, who was much concerned about the rays, came to a very remarkable conclusion. To him, cathode rays consisted of a stream of electrically generated particles, but these particles were themselves neither gaseous, nor liquid, nor even solid in character. Crookes thought that he had actually hit upon an entirely new state of matter, a fourth or ultra-gaseous state which he called "radiant matter."

For a time, Crookes' "radiant matter" theory held the field, and scientific people came really to believe that every material substance known could, given the right conditions, exist in a fourth "radiant" form in addition to the traditional solid, liquid and gaseous states. But in 1897, Sir J. J. Thompson, Professor at Cambridge, advanced a view that Crookes' "radiant matter" had no actual existence and that the long-debated cathode rays were nothing more than a stream of negatively-charged particles of electricity which had been formed in the vacuum tube partly by the energisation of the atoms in the cathode surface and partly by the disintegration of the atoms of residual gas which remained in the tube.

#### Guided Missiles

This is much the modern view of cathode rays. Electrons are flung off from the cathode surface, and these knock out further electrons from the still remaining gas atoms within the tube. It is these high-speed directed electrons which, acting as guided missiles on a miniature scale, bombard the fluorescent screen at the end of the tube and, by giving up their energy, cause the fluorescent material of the screen to give a vivid momentary light-glow.

Because electrons are common to all varieties of matter, it follows (as Crookes originally pointed out) that the cathode rays are quite independent of the nature of the cathode surface from which they originate, and, also, of the variety of residual gas which still exists in the tube.

Most of the known properties of cathode rays were first elucidated by the experimenter Crookes. It was he who first observed their effect in producing light from phosphorescent substances with which they made impact. It was Sir William Crookes, also, who found that cathode rays produce heat at the surfaces on which they impinge. By positioning a piece of platinum foil in the focus of the rays, he was able to heat the foil to redness. That the receiver screen of a modern TV set does not get actually hot under the influence of the rays is consequent on the large cooling surface, which the screen exposes and on the fact that the pencil of rays in the modern receiver is never stationary on any one spot on the screen.

It was Crookes, too, who observed that cathode rays could be deflected by a magnet or by an electro-magnetic field. This fundamental observation, coupled with that concerning the production by the rays of luminous effects in certain specialised materials, must surely be held to be at the very basis of the modern system of television by cathode-ray tube methods, for which reason, Crookes, although he was little enough aware of the future import of his experiments and observations, is to be hailed as one of the earliest pioneers of television methods.

#### "Maltese Cross" Experiment

The fact that cathode rays will actually cast shadows is demonstrated by the nowadays well-known "Maltese

Cross" tube of the electrical laboratory. This almost classic experiment consists of producing cathode rays in a simple type of evacuated tube having in the path of the rays a hinged plate of aluminium or mica cut into the shape of a Maltese cross. Since the rays travel in straight lines from the cathode, a shadow of the cross is thrown on the end of the tube, but when the cross is lowered so that it now no longer interrupts the path of the rays, the part previously in shadow becomes indistinguishable from the surrounding area. This, indeed, formed the one crucial experiment by means of which Crookes correctly demonstrated the fact that cathode rays travel only in straight lines at right angles to the surface of the cathode and that they do not proceed in all directions like ordinary light from a luminous surface.

Another interesting experiment, due originally to Crookes, showed that cathode rays can exert a mechanical action. In a specially constructed horizontal cathode-ray tube a very light pair of parallel glass rails are fixed. On these a small mica-vaned wheel is free to rotate. On switching on the rays, having previously carefully

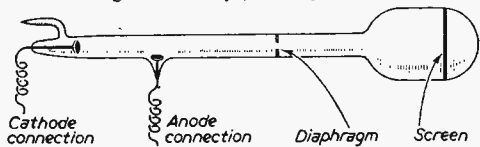

Fig. 3.—The Braun Tube of 1897. This was the first attempt at a cathode-ray tube in which a pencil of cathode rays was made to impinge on a fluorescent screen.

levelled the tube, the wheel will travel away from the cathode. On reversing the polarity of the electrodes, the wheel will now move in the opposite direction. From this experiment it is clear that the electron stream constituting the cathode rays has actual mechanical properties in that it can act with a certain degree of mechanical force in much the same manner as that shown by a simple jet of steam in causing a vaned wheel placed in its path to rotate.

#### Fundamental Property

Crookes considered that the most important character of the cathode rays was their capability of being accurately deflected when subjected to a magnetic field. He was certainly right here, for if, like their related X-rays, this had not been the case, cathode-ray television would have been quite impossible of achievement.

Cathode rays proceed at a velocity of some 20,000 miles per second, an enormous velocity, indeed, but nevertheless, one which hardly even fringes on the actual speed of light.

Perhaps, of all the electrical "rays"—X-rays apart—we have, in the cathode rays one of the most useful electrical tools which the ingenuity of scientific experimenters has ever brought to light. For in the cathode rays we are conveniently provided with an extremely fast-moving, well-nigh weightless and inertialess beam of electrons which we can control at our pleasure and with the greatest of precision by either electrical or magnetic means. Such a tool must necessarily be ultra-fruitful in its applications. It has "made" popular television on an eminently practical nation-wide commercial scale. Whether this wonder-beam memorial of Sir William Crookes, this fast-speeding weightless shaft of electrons will give rise to any more surpassing achievement than that of present-day television technique is for the future only to reveal.

# NEW WINDSOR TESTGEAR



MODEL 45B

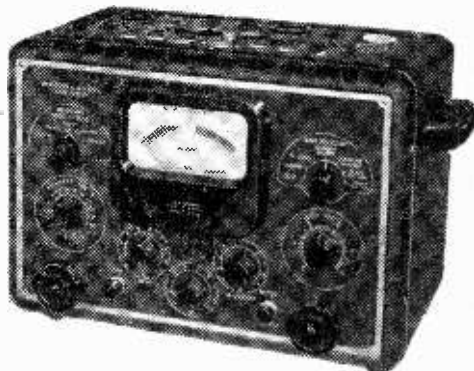

A comprehensive mutual conductance valve tester, suitable for most types of British, American and Continental receiving valves. Supplied with valve chart giving data for testing nearly 3,000 different valves. For use on A.C. Mains only.

## TESTING FACILITIES

### ★ MUTUAL CONDUCTANCE

Two ranges: 0.3 mA/V and 0.15 mA/V.

### ★ EMISSION. Rectifiers and Diodes may be tested for emission.

### ★ GAS TEST. Press-button test shows abnormal positive or negative grid current.

### ★ CATHODE LEAKAGE

Tests for Heater/Cathode insulation up to 10 megohms, with heater at operating temperature.

### ★ ELEMENT SHORTS. Short-circuits between electrodes are clearly indicated.

Please write for details and information on other WINDSOR & TAYLOR products.

**TAYLOR ELECTRICAL INSTRUMENTS LTD.**

419-424 MONTROSE AVENUE, SLOUGH, BUCKS. Phone: SLOUGH 21381

**BUILD YOUR OWN  
MODERN RECEIVER  
for  
HALF the normal cost**

*You're SURE to get it at*  
**STERN'S**  
ESTABLISHED 25 YEARS

**SOME POPULAR KITS  
and CIRCUITS for  
EASY ASSEMBLY by the  
HOME CONSTRUCTOR**

- ★ **A MIDGET 4-STATION "PRE-SET" SUPERHET. RECEIVER** for A.C. mains. Designed to receive any three stations on Medium Waveband and one on Long Wave by the turn of a Rotary Switch, no Tuning being necessary. The Complete Assembly Instructions, showing the Wiring Diagram, Component Layout, and Point to Point connections, together with a Component Price List, available for 1/9.
- ★ **A 4-VALVE T.R.F. BATTERY PORTABLE "PERSONAL" SET**, available as a Complete Kit of Parts or by purchase of the Components separately. The complete price details, including an individual Component Price List, are included in our set of Assembly Instructions, which is obtainable for 9d.
- ★ **A MIDGET 4-VALVE SUPERHET. PERSONAL SET**, covering Long and Medium Wavebands and designed for Mains or Battery operation. This receiver is designed to operate on A.C. mains or by an "All-dry" Battery; either method is selected by means of a Rotary Switch. It is so designed that the Mains Section is supplied as a separate section which may be incorporated at any time. The set, therefore, can be made either as an "All-dry" Battery Personal set or as a Midget Receiver for Combined Mains/Battery operation. The Assembly Instructions, which include Wiring Diagrams and Practical Component Layouts, are available for 1/9. This includes a separate Components Price List.
- ★ **TUNING UNITS.** A publication showing how to make three different types of Tuning Units. 1. A 1-Valve T.R.F. Unit, covering Long and Medium Wavebands. 2. A Superhet. Unit, covering S., M. and L. Wavebands. 3. A "Pre-set" Station Superhet. Unit, providing three Stations on Medium and one Station on Long Waves. The Manual, price 2/6, shows Wiring Diagrams, Practical Layouts and Component Price Lists.

- ★ **THE MIDGET A.C. MAINS 3-VALVE RECEIVER** as designed and published by "Wireless World," covering Long and Medium Wavebands. Cost of all Components to build this set is £4/17/9. A reprint of the complete Assembly Instructions, including Practical Layouts, is available for 9d.
- ★ **THE "WIRELESS WORLD" MIDGET A.C. MAINS 2-VALVE RECEIVER.** We can supply all the components including Valves and M/Coil Speaker, to build this set for £3/10/0. Reprint of the original Assembly Instructions and Circuit may be obtained for 9d.
- ★ **THE "SUMMER ALL-DRY" BATTERY PORTABLE,** as published in the June issue of "Practical Wireless." We can supply from stock all of the Components to build this Midget 3-Valve Receiver. A reprint of the complete article and circuits, including Practical Layout and Component Price List is available for 1/-.
- ★ **A COMPLETE KIT OF PARTS** to build a MIDGET "All-dry" BATTERY ELIMINATOR, giving approx. 60 volts and 1.4 volts. This eliminator is suitable for use with 4-valve Superhet. Personal Sets. It is easily and quickly assembled and is housed in a case size 4 1/2 in. x 1 1/2 in. x 3 1/2 in. Price of Complete Kit, 42/6. In addition we can offer a similar complete kit to provide approx. 90 volts and 1.4 volts. Size of assembled unit 7 in. x 2 1/2 in. x 1 1/2 in. Price 47/6.
- ★ For £6/5/0. A Complete Kit of Parts, including Drilled Chassis and Valves, to build a 6 to 8 watt PUSH-PULL AMPLIFIER for operation on A.C. Mains. Incorporates Tone Control and is suitable for use with any type of pick-up. The complete set of Assembly Circuits, including Practical Layouts, is available for 9d.

★ Send 9d. P.O. for our NEW STOCK LIST, showing many KITS OF PARTS for Sets and Battery Chargers and "hundreds" of Wireless Components. When ordering please cover cost of postage and packing.

**STERN RADIO LTD., 109 & 115, FLEET STREET, E.C.4.**

Telephone:  
CENTRAL 5814 & 2280

# T/V TECHNOLOGY



*Home Study will give you  
a fuller understanding  
of Television problems*

To the enthusiast for whom television is an absorbing interest and who wishes to understand more about it, or to those who are constructing their own sets and want complete knowledge of the theory underlying the constructional details, ICS offer a sound, practical and comprehensive course of instruction. It has given a high level of efficiency to many, who studied in their own time. What about you?

#### FOR THE ENTHUSIAST OR INTENDING T/V ENGINEER

Course 'A' provides a sound introduction to radio and television principles, deals with the principles of reception and transmission, and includes the preliminary study of Mathematics, Electrotechnics and Radio and Television.

Course 'B' offers a more comprehensive treatment of receiving equipment, deals in detail with modern principles of transmission and reception, and contains the necessary introductory instruction in mathematics, electrotechnology and radio.

The ICS also offer the following Courses in Radio :

Complete Radio Engineering  
Radio Service Engineers  
Radio Service and Sales  
Advanced Short-Wave Radio  
Elementary Electronics, Radar and Radio

And the following Radio Examinations :

British Institution of Radio Engineers  
P.M.G. Certificates for Wireless Operators  
City and Guilds Telecommunications  
Wireless Operators and Wireless Mechanics, R.A.F.

For FREE BOOKLET and full details of these highly successful courses, fill in and post the coupon below. Fees are moderate and include ALL books required.

Generous Discount to H.M. Forces.

CUT HERE  
INTERNATIONAL  
CORRESPONDENCE SCHOOLS LTD.  
(Dept. P.T.18)

International Buildings, Kingsway, London, W.C.2.

Please send booklet on subject.....

Name..... Age.....  
(BLOCK LETTERS PLEASE)

Address .....

## RADIO MAIL

4, RALEIGH STREET, NOTTINGHAM.  
MISCELLANEOUS BARGAINS, ALL POST PAID

CO-AXIAL TYPE SCREENED CABLE. Light-weight, stranded inner conductor 14/36, plastic insulation, ideal for P.A. mike leads, etc. 7d. yard, or 6½d. yd. for 12 yds. or over. EX-W.D. UNITS TYPE 9263a, 2½ins. over-all diam., ideal speaker for midget receivers, etc., new, boxed, 6/6. METER RECTIFIERS, bridge, 5 m/a., 5/-. MIDGET ACCUMULATORS, lead acid, 2 V. 7 AH, 9 plate, unspillable (not jelly), size 1½ x 4½ x 3½ ins., 9/9. THERMOSTATS, heavy contacts, 50 degs. F., plus or minus 10, 2/6. COLVERN WIRE-WOUND POTS, 25,000, 1/9. CONDENSERS, cardboard, tubular, .1 mfd., 350 v., 3d. A.F. CHOKES, for filters, etc., 3/6. I.F. TRANSFORMERS, 465 Kc/s, 1½ ins. square x 3½ ins., 6/9 pair. WAFER SWITCHES, 3-pole 6-way, 8d. PRESSED METAL BOXES, hinged lid, 6 x 9½ x 4½ ins., 4/-. CO-AX. CABLE, 3 ft lengths, 3 for 2/6. METAL RECTIFIERS, 20/30 v., 40 m/a., 2/3. FUSE BRIDGES AND HOLDERS, 15 A., 1/3. CONDENSERS, .001 mfd. moulded mica, 4d. Micamold metal cased, .1 mfd. 350 v. tubular, 10d. Ceramicons, 20 pf., 3d. EX-W.D. OSCILLATOR UNITS, 465 Kc/s, ideal for I.F. aligners, with circuit, 6/6. BELL PUSHES, bakelite, makers' boxes, 6d. CABLE GRIPS, clamp ½ in. co-ax. to "Pyc" plug, 3d. CARLISLE FUSE BOXES, 2-pole, 3-way, 15 amps., porcelain fuses, 9/6. Also 2-pole, 2-way, 15 amps., 7/6. EF50 RETAINERS, 4d. EX-GOVT. VALVES, boxed, guaranteed. SP61, 3/3. EA50, 2/3. ATP4, 3/3. 7V7, 7/6. Genuine RCA 954 UHF acorn pentodes, in makers' boxes, 4/6.

STAMP WITH ALL ENQUIRIES PLEASE

## SAVES P.T. on T.V.

Even small screens give you a BIG PICTURE when you use a Magnavista lens. That's why wise buyers see the Magnavista first—then save money on their sets!

Remember, it's optically correct, and the inside filter allows daylight viewing with a normal brilliance setting and saves overworking the tube.



### PRICES

There is a Magnavista for every set—over 18 different models from £5. 5. 0. upwards.

A PRODUCT OF METROPEX LTD.  
42a DENMARK HILL, LONDON, S.E.5.

# Getting the Best From Your Murphy Receiver

## SIMPLE RECEIVER ADJUSTMENTS

By J. H. Hum (Murphy Radio Ltd.)

**E**VEN though television sets seem to become easier to operate as fresh developments take place—commercial receivers have, as each new design comes out, fewer and fewer controls for the user to touch—there is no escaping the fact that whatever they may seem to be, they still need a good deal more “setting-up” (as the expression goes) than does a broadcast receiver. Inadequate setting-up can produce a lot of trouble and irritation.

The purpose of the notes which follow is to give setting-up information in almost wholly non-technical language.

### A First Look

An important preliminary is to ensure that the correct mains tapping is used. Murphy sets are sent out with the mains tapping at its highest setting (250 volts). If the mains voltage in your district is lower, see that the set is altered accordingly. Efficient performance depends on it.

Three main controls appear on every television set. They are: *Sound Volume* (this is often combined with the on/off switch), *Contrast*, and *Brightness*. Some sets also have a *Focus Control*, possibly even a *Tone Control*. The functions of Volume and Tone controls should already be familiar to everybody and it is not proposed to say any more about them.

In addition there is usually quite an array of “pre-sets.” *Line Hold*, *Frame Hold* (sometimes called *Horizontal and Vertical Hold*), and *Sensitivity* are those with which the salesman is most likely to be concerned, but there are often others for *Tuning*, *Picture Width*, *Picture Height*, and *Linearity*. The latter appear under a variety of names such as *Horizontal or Vertical Form*, *Lin-Lin* (short for *Line Linearity*) or *Frame Linearity*, and so on. The user should not normally require to interfere with these linearity controls, but if readjustment is necessary, then look up the appropriate sections of the service manual.

### Initial Settings

Now let us assume that a set has been connected to the mains, and a suitable aerial and feeder erected and plugged into the appropriate sockets. Before the set is switched on, turn the Contrast control to about three-quarters of its travel in a clockwise direction; the Brightness control should at first be set at its minimum (fully anti-clockwise) position. Then switch on, and allow a minute or two to warm up. In most sets it takes about twice as long for a picture to appear as it does for the sound to be heard. After a suitable interval has elapsed turn up the Brightness control until some

illumination appears on the screen. Avoid “flooding” the screen with too bright a picture, as this shortens the life of the tube.

### Line and Frame Hold (Horizontal and Vertical)

Some sort of picture should now be visible. If it is reasonably stable, further adjustment is easy, but if it is hardly recognisable, a certain amount of “juggling” may be necessary.

Let us assume for the moment that the worst seems to have happened, and the screen shows only a confused jumble of lines. First try readjusting the Line Hold control, but make a note of its position and reset it there if no improvement results. A stable picture may result with a setting, or possibly a picture which moves up or down across the screen. Leave this control in what appears to be the best position, and try adjusting the Frame Hold. It should be possible now to get a completely stable picture. Normally it will be possible to get the picture “locking” over an appreciable section of the range of both these controls midway between these limits.

### Contrast and Brightness

With Murphy sets the factory adjustment is such that this stage should be reached with little or no readjustment, and it now remains to get the best possible picture quality. This is done by adjustment of the Contrast, Brightness, and Sensitivity controls. Before proceeding to the adjustment of the Sensitivity pre-set, let us consider the difference between Contrast and Brightness, for to the uninitiated they seem very similar.

The Contrast control sets the tonal range of the

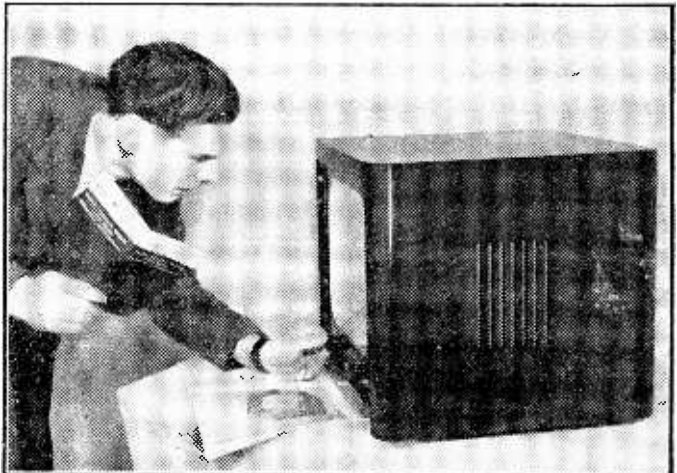

Preliminary adjustments should be made carefully—following the maker's instructions.

picture, i.e. it determines the amount of difference which will exist between the black and white parts. Too low a contrast setting will result in a picture which has neither whites nor blacks, but only a dull, flat-looking set of middle tones; or, depending on the Brightness setting, it may seem to have whites, but nothing darker than a medium grey, or perhaps deep blacks with no light parts at all.

On the other hand, increasing the Contrast setting beyond the correct point will result in a picture which becomes more and more "soot and whitewashy." Detail in shadow and highlight disappears progressively, until, if carried to an extreme, the result would be almost a silhouette.

Brightness controls the overall illumination of the picture, and must be used intelligently in conjunction with the Contrast control. Their functions, although different, are closely interconnected. As Contrast is increased, it will usually be necessary to decrease Brightness and vice versa.

### Viewing Conditions

The optimum settings depend on a variety of factors, of which the two chief are the type of picture being transmitted and the amount of light in the viewing room. As regards the latter, the more light there is the greater will be the contrast required to give a satisfactory-looking picture, which in really bright daylight is practically impossible; so see that the lighting is suitably subdued. The best viewing conditions are such as would obtain in the evening in the dim light of, say, a 60-watt table lamp placed somewhere so that it does not shine directly on the screen. Absolute darkness is not necessary or desirable.

As regards programmes, outdoor sporting events, for instance, have a tendency to appear rather lacking in contrast, while broadcasts from outside theatres and some film transmissions tend the other way. There is no doubt that the best quality pictures come from the studios, where the lighting is under absolute control. This type of transmission is to be preferred for setting-up purposes where at all possible.

### Sensitivity

Reverting to the setting-up procedure, the Sensitivity control will have a somewhat similar effect on the picture to the Contrast control. There are technical differences which we will not go into, but its function is to provide a means of compensating for the variations in signal strength which are bound to arise from differences in situation and aerial efficiency. Murphy sets are sent out with the Sensitivity control at its maximum position, and generally it will need to be turned back a little. With the Contrast control set as previously instructed (three-quarters of its travel in a clockwise direction), adjust the Sensitivity control in conjunction with Brightness to give a satisfactory picture. It should then be possible to make the necessary readjustments to suit different types of programmes with the Contrast control. It should be borne in mind at this stage that lack of contrast can arise from too high a sensitivity as well as too low, for if too powerful a signal is fed through the set, it will not be possible to get any true black on the screen.

We have left mention of the Sensitivity adjustment until this point because we wished to make it quite clear what kind of picture should be aimed for when dealing with it. With Murphy sets it will often turn out to be the first control to need attention.

### Focus

The modern tendency is to use a permanent-magnet focusing device which is set up in the factory and will probably not require any further attention. If it does, the advice of the local dealer should be enlisted. He will have the appropriate service book.

Some older sets had electro-magnets with an external control for adjusting focus sometimes incorporated as an additional refinement along with the P.M. system.

Where an external control exists it should be operated to give the best overall definition. The position which gives the sharpest horizontal lines is *not always* the best. Watch the definition in the verticals as well (the vertical bars in the test-card and tuning signal, for instance).

Any subsequent alteration of Brightness or Contrast may, on some sets, necessitate refocusing.

### Tuning

Many receivers have a pre-set Tuning control. This should be adjusted to give maximum *sound* output.

### Picture Width and Height

The adjustment of Picture Width and Picture Height controls, where they exist externally, is usually a fairly simple matter, but if they have to be moved very much it is likely that they will affect the settings of the Line and Frame Hold controls, which should be rechecked.

### Interlacing

It should be known that the television picture is composed of a number of lines (405 of them) which are "scanned" alternately, the spot then returning to the beginning of the frame and tracing out the intervening lines to form the complete picture. Now, if the spot does not return to exactly the right place, the second set of lines will not interlace properly with the first, but will be more or less superimposed upon them. This gives the picture a very "lily" appearance. Instead of 400 finely spaced lines, there are 200 rather thicker lines with much wider spacing. If the picture is interlacing properly, the lines appear more closely spaced so that at a small distance away the line structure cannot be distinguished.

Correct interlacing makes a world of difference to picture quality, and it is well worth the effort to make sure it is occurring. It is accomplished by a fairly critical adjustment of the Frame Hold control. In the comparatively wide band over which the picture will lock, there is a narrower band, usually in the centre, over which correct interlacing will take place.

These instructions have been written in general terms so that they may be applied to almost any set. Obviously, the position of the main controls and pre-sets will vary with different models. Sometimes what is a pre-set on one receiver will appear as a main control on another, and others may not appear externally at all. It is manifestly impossible to mention all the alternatives which may be encountered, but enough has been said to give an idea of general procedure.

Murphy Radio issue a booklet of operating instructions with every set. In addition, there is a wealth of information in the preliminary service notes and the subsequently issued service manuals which are sent to all dealers. The former are written for the non-technical purchaser, and should be quite easily understood by anybody. The latter are intended primarily for the more technically minded service men, but much of their contents could usefully be assimilated by the comparatively non-technical demonstrator as well.



# Modifying the AN/APR-4

HOW TO ADAPT THIS AMERICAN RADAR RECEIVER FOR TELEVISION RECEPTION

By John A. Bladon (G3FDU)

## Introduction

THE ex-U.S. army receiving equipment, AN/APR-4, has appeared in small numbers on the surplus market. It is not generally realised that this unit is easily adaptable for use in television reception. The purpose of the present article is to describe this unit and to illustrate how it may be used with slight modification as a vision receiver, or with more extensive modifications as a receiver for both sound and vision.

## Description of the Equipment

The APR-4 receiver was designed as a search receiver for investigating radio and radar signals over a range of frequencies from 38 Mc/s to 2,400 Mc/s. The equipment AN/APR-4 proper consists of a wideband intermediate frequency amplifier, a detector followed by a video amplifier, and a power unit. The I.F. amplifier is of variable bandwidth, a two-position switch giving either 4 Mc/s or 700 kc/s bandwidth at a centre frequency of 30 Mc/s. The video amplifier is designed to give amplification over the whole range from 20 c/s to 4 Mc/s. Separate outputs of I.F. at 30 Mc/s, video from a cathode follower or transformer-coupled audio at 8,000 or 600 ohms impedance are available from the front panel. The power supply operates on 80 or 115 volts A.C.

60-2,600 cycles per second, and is quite suitable for operation from 50 c/s mains through a stepdown transformer. All the units are mounted on one chassis, which has space for plug-in R.F. units, these being interchangeable to give different frequency coverages. For use as a television receiver, one of the following tuning units should be obtained:

- TN16/APR-4
- TN1/APR-1 } 38-95 Mc/s.
- TU56A }

Unfortunately these units are very scarce, but a modification of the well-known RF26 unit will be described.

## Circuit Description

The intermediate-frequency amplifier consists of five high-slope pentodes (6AC7—V-101-1/5) coupled by bandpass circuits tuned in the range 28.5-31.5 Mc/s. A.V.C. is applied to the grid of each of these valves except V-101-5, or the gain may be varied manually by switching different value resistors in the cathode returns of V-101-1 and 2 by means of the gain switch S-101. The signal input from the appropriate tuning unit is applied to the grid of the first I.F. valve V-101-1 through the 470 pF. condenser C-102-1. The reduced bandwidth of 700 kc/s is obtained by switching a sharply tuned

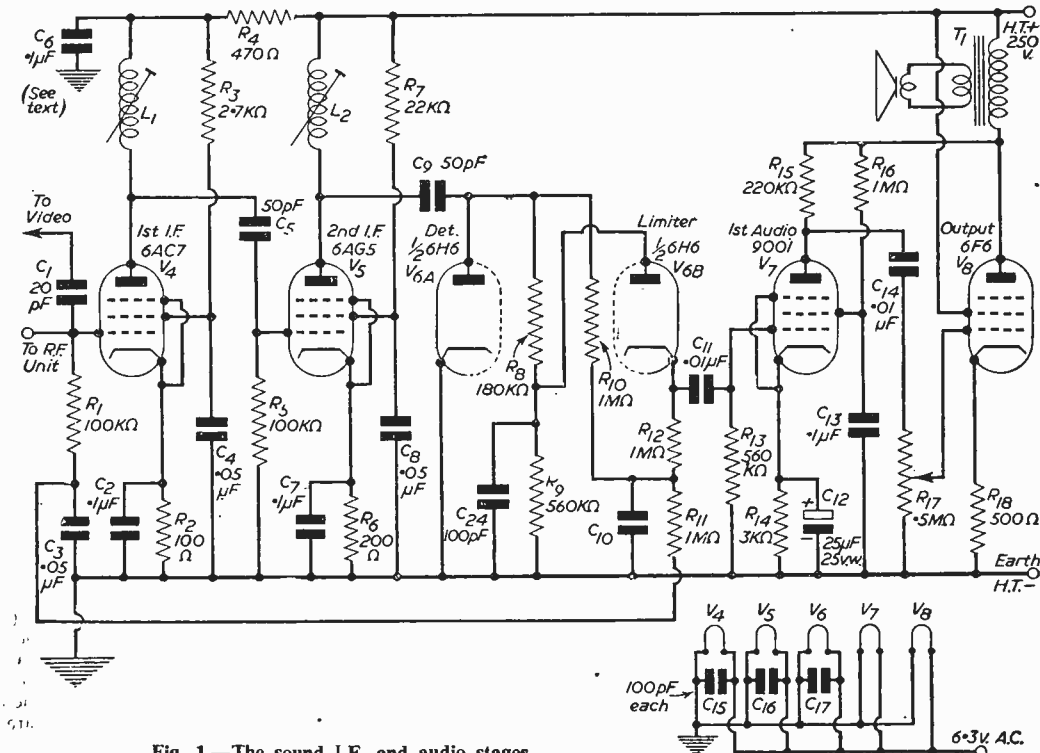

Fig. 1.—The sound I.F. and audio stages.

circuit consisting of L-104 and C-104-2 in place of the bandpass transformer T-101-4 between the last two I.F. valves. The output from the last I.F. transformer is brought out to the "Panadaptor" socket on the front panel through a 27 K $\Omega$  resistor R-119-1 and is also applied to one half of a 6H6 double diode (V-102) which acts as a detector. The I.F. component of the rectified signal is filtered out by C107 (10 pF) and L-105-2, which are made small so as not to impair the video response; the diode load R-121 (18 K $\Omega$ ) is small for the same reason. Between this resistor and the diode earth return is connected a 200-microamp meter for use as a tuning meter.

The second half of the 6H6 is used in a conventional circuit as an A.V.C. rectifier, the negative D.C. voltage at the cathode being applied to the I.F. valve grids through R-120-1.

The output across the diode load R-121 is applied via C-103-3 to the grid of the video amplifier V-101-6 (6AC7). The anode load for this valve consists of R-124-1 (220 $\Omega$ ) in series with the 15 K $\Omega$  potentiometer R-123, shunt compensation for the higher frequencies being provided by L-106 in series with R-129-2. The purpose of the inductance L-106 is to resonate with the circuit capacities to form a heavily damped rejector circuit at the higher video frequencies, thus extending the frequency range of the amplifier. For this reason also, the cathode bias resistor R-122-1 is not by-passed.

The slider of potentiometer R-123 is connected via C-106-4 to the grid of a 6AG7 (V-103), which is connected as a cathode follower to give the low-impedance video output available on the front panel. The anode of this valve is connected to the primary of an audio-transformer, the secondary of which is tapped to give

alternative audio outputs of either 8,000 or 600 ohms impedance at the front panel.

The final 6AC7 (V-101-7) is an audio-oscillator to provide tone modulation of the signal if required. Owing to the wideband nature of the amplifier and also poor oscillator frequency stability at higher frequencies, it would not be possible to obtain a good C.W. note by means of the conventional B.F.O. This stage acts as an A.F. resistance-capacity-coupled oscillator, the output being applied to the grid of I.F. valve V-101-4, thus modulating any incoming signal with an audio tone. This circuit is brought into operation by means of switch S-103, which completes the A.F. oscillator cathode circuit and at the same time puts a small positive delay voltage to the second detector valve,

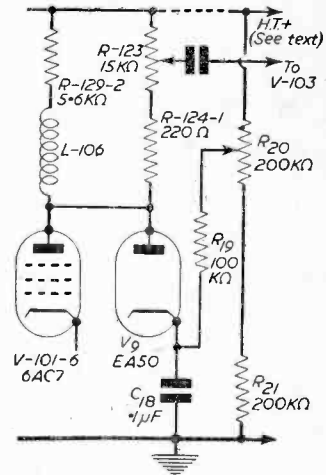

Fig. 2.—The video limiter.

this delay voltage being produced by the drop across the potentiometer formed by R-117-3 (200 K $\Omega$ ) and R-102-12 (2,700 $\Omega$ ) connected across the H.T. supply. The purpose of this delay voltage is to prevent "break through" of the A.F. modulation tone when no signal is being received.

The power supply is quite conventional, a double-tapped H.T. transformer being provided, using two 5Y3 rectifiers (V-104-1/2) and two filters to

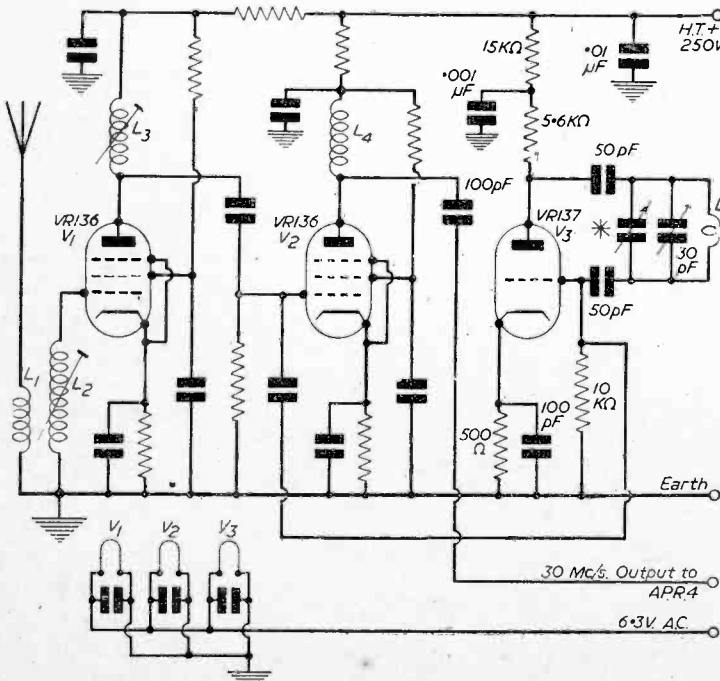

Fig. 4.—The R.F. unit. L1 is 2 turns, L2-5 turns and L3-4½ turns, all of 26 d.c.c. on a ½ in. slug-tuned former. L5 is 2 turns of 14 S.W.G. ½ in. long by ½ in. diameter.

## REFERENCES OF RESISTOR AND CONDENSER VALUES

### RESISTORS.

(All ½ W unless specified)

R101—100 K $\Omega$	R102—2,700 $\Omega$
R104—9,100 $\Omega$	R105—3,900 $\Omega$
R107—30 K $\Omega$	R108—15 K $\Omega$
R110—3,600 $\Omega$	R111—2,200 $\Omega$
R113—680 $\Omega$	R114—330 $\Omega$
R116—10 K $\Omega$	R117—220 K $\Omega$
R119—27 K $\Omega$	R120—568 K $\Omega$
R122—100 $\Omega$	R123—15 K $\Omega$
R125—2K $\Omega$ 8W	R126—38 K $\Omega$
R128—39K $\Omega$ 2W	R129—5,600 $\Omega$

### CAPACITORS

C101—3,300 pF	C102—470 pF
C104—120 pF	C105—.1 $\mu$ F
C107—15 pF	(block)
	C108—.005 $\mu$ F

### VALVES

V101—6AC7	V102—6H6
V103—6AG7	V104—5Y3

give H.T. voltages of 200 v. for the receiver proper and 250 v. for the tuning unit. Connections for the tuning unit are made by means of pins which mate with similar sockets on the unit when it is plugged into the receiver. The smoothing condensers are dual electrolytics mounted on octal bases. A heater coil surrounds one condenser,

encountered at high altitudes. At normal temperatures this heater is inoperative.

**Adapting the Receiver**

*(a) Modifying the RF26*

It is necessary to modify the existing 7 Mc/s output of the RF26 unit to give output at 30 Mc/s. This introduces the complication that if the local oscillator is operated 30 Mc/s below the signal frequency, the signal in the I.F. amplifier will be blocked by oscillator breakthrough. Hence it is necessary to operate the local oscillator 30 Mc/s higher than the required signal, i.e., at about 75 Mc/s for Alexandra Palace and at about 90 Mc/s for Sutton Coldfield. This problem is not as difficult as it may appear at first sight since the R.F. and mixer circuits are fixed tuned and do not introduce any tracking difficulties.

The tuning condensers and associated trimmers are taken out of the RF26 and plates are removed from each half of the two-gang unit, leaving three moving and four fixed vanes on each half. This is then remounted so that it is alongside the VR137, and the shaft is recoupled to the tuning drive by means of two flexible couplers and a 4in. length of  $\frac{1}{8}$ in. shafting. The oscillator is rewired as a shunt-fed Colpitts oscillator, the 3-30 pF trimmer being mounted just above the tuning condenser and L5 being soldered to the terminals of the tuning condenser. The connections to these are taken through holes in the chassis deck and wired to the valveholder tags with 14 S.W.G. wire. The R.F. circuit is rewired with L2 between grid and earth and L3 in the anode circuit, both slug-tuned and resonated with the circuit capacities. L4 is a small R.F. choke consisting of 40 turns of 34 S.W.G. enamelled wire wound on a 6,000-ohm resistor, turns

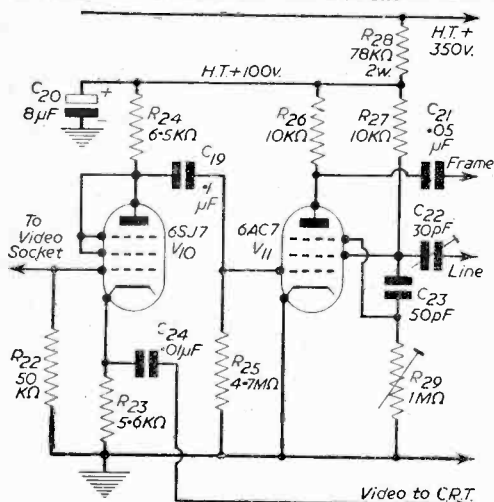

Fig. 3.—The phase-splitter and sync separator.

this being switched into the 110 v. A.C. circuit by a thermostat. The object of this is to prevent the electrolyte freezing at the very low temperatures sometimes

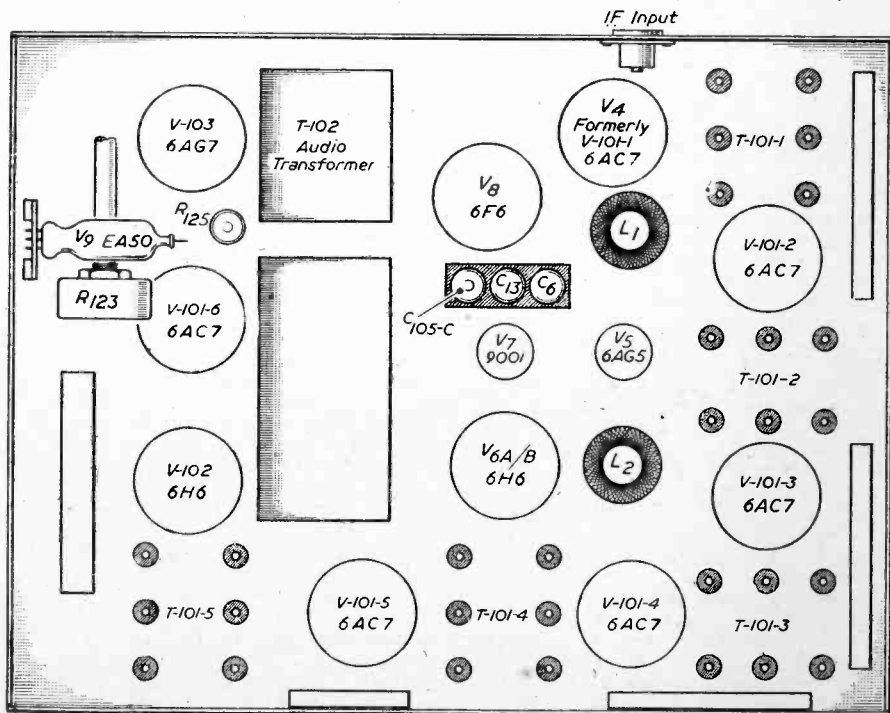

Fig. 5.—Underside of the modified AN/APR-4 I.F. unit.

**RESISTOR AND CAPACITOR VALUES**

- R103—47 $\Omega$
- R106—470 $\Omega$
- R109—5,600 $\Omega$
- R112—1,200 $\Omega$
- R115—120 $\Omega$
- R118—56 K $\Omega$
- R121—18 K $\Omega$
- R124—220 $\Omega$
- R127—12K $\Omega$  2W

- C103—1,000 pF
- C106—.01  $\mu$ F
- C109—20  $\mu$ F (block)

—6H6  
—5Y3-GT

being laid side by side. The component values are for Sutton Coldfield, all others unmarked on the diagram being the components as originally wired. In order to fit the RF26 into the space in the APR-4 receiver, it will be necessary to remove the locating rails at top and bottom of the space. The RF26 may then be held in position by drilling and tapping 4-BA holes in the front panel of the APR-4 to take the captive screws of the R.F. unit. Power supplies may be taken from a Jones socket wired to the internal connections of the receiver.

When trimming the R.F. unit, the aerial should be plugged in and with the tuning dial at about 40 deg. (maximum capacity being at zero) and the Narrow-Wide switch at Narrow, the 3-30 pF trimmer should be carefully adjusted until the sound channel is heard. The slugs in L2 and L3 should be adjusted for maximum reading on the diode meter. It will be found that the vision transmitter can be heard as a rasping noise with the tuning dial set at about 120 deg.

#### (b) Modifying the APR-4

The receiver will now be suitable for use as a receiver for the sound channel and may be tested as such. The thermostat and heater unit are not needed and may be cut out and removed from the power pack. A.V.C. is not necessary in a video receiver, and the best way to cut this out is to earth the tag of C-105-A (0.1  $\mu$ F), which will be found in the centre of the chassis, being the left-hand tag of the three-condenser block when looking at the underside of the receiver from the rear. The components associated with the A.V.C. rectifier (R-120-1, R-129-1, R-118, R-117-1/2, C-108-1, C-103-21, C-101-12) may be cut away. In order to preserve correct polarity of the video signal, connections to pins 5 and 8 of the 6H6 (V102) should be reversed. The connections at the back of the 200-microamp meter on the front panel must also be reversed. D.C. restoration for V-101-6 may be applied by removing C-106-3 (0.01  $\mu$ F) and bridging the tags. The cathode resistor of this valve must now be reduced to 47 ohms to prevent plate current cut-off on peak white signals. D.C. restoration for V-103 may be applied by wiring the grid of the 6AG7 (pin 4) to pin 4 of V-102, pin 3 of this valve being earthed. In order to reduce the standing current of V-103, the 220-ohm cathode resistor (R-124-2) should be increased to 5.6 K $\Omega$ . Video-output may now be taken from the socket on the front panel through a short length of coaxial cable direct to the phase splitter in the sync separator unit.

A receiver modified in this manner has been in use for some time at a distance of 65 miles from the transmitter. Locally, the signal is quite weak owing to the shielding effect of a 600ft. escarpment immediately to the south of the author's location. However, good signals are being received on a simple dipole aerial, V-101-1 being removed and pins 4 and 8 of that valve being bridged by a 20 pF condenser, C1, in order to reduce the overall gain of the receiver.

### Rebuilding as a Complete Receiver for Sound and Vision

#### (a) Relocation of the Video Stages

The foregoing directions will be sufficient to operate the receiver successfully for either the vision or the sound signal. There are, however, many components that are unnecessary for this use, and if these are removed and a few others moved, it is possible to make sufficient space on the chassis to accommodate a separate I.F. and audio unit for reception of the sound channel without impairing the operation of the vision receiver.

In order to do this, V-101-1 is removed and the output of the RF26 taken to tag 2 of T-101-1 via a 20 pF con-

denser. All the resistors and condensers in the cathode of the valve can be removed. The cathode circuit of V-101-2 can be taken direct from R-103-4 to the power unit tag board. The components associated with the heterotone oscillator V-101-7 may be cut away and the tag board and pillars in the centre of the chassis also taken out. This frees the connection to C-105-B and C-105-A is freed by moving the earth previously placed on the A.V.C. line to the A.V.C. end of R-102-3. The heater decoupling chokes L-106-2/5, and anode decoupling resistors R-106-4/6/8/10 are now relocated so that when the associated tag boards are removed there is a clear space about 3 $\frac{1}{2}$ in. x 5 $\frac{1}{2}$ in. in size in the centre of the chassis. C-105 remains in its former position, parts A and B being used as C6 and C13 in the sound unit. The components associated with the Narrow-Wide switch are not required and thus S-104, C-104-1/2 and L-104 may be removed and the connections from T-101-4 taken direct to V-101-4/5.

#### (b) The Sound I.F. Unit

With the local oscillator in the R.F. unit operating at 91.75 Mc/s, the video carrier I.F. is at 30 Mc/s, and the sound I.F. will appear 3.5 Mc/s higher than this, i.e., at 33.5 Mc/s. Output from the RF26 unit is taken to the grid of V4, input to the video I.F. unit being taken via C1. The anode circuit of the first sound I.F. amplifier V4 (6AC7) consists of a slug-tuned inductance L1 resonated at 33.5 Mc/s by the stray capacitances and coupled to V5 (6AG5) through C5. The second I.F. amplifier is similar to the first, the output at the anode of V5 feeding the detector V6A through C9. V6A is connected in a normal diode detector circuit with a shunt load formed by R8 and R9 in series. C24 acts as an I.F. filter in conjunction with R8, and audio output is applied to the first audio amplifier valve V7 through the series noise-limiter V6B. The negative potential developed across R9 is applied direct to the anode of this diode, the full negative potential across R8 and R9 being applied through the audio filter R10-C10 to the cathode of V6B. This potential depends on the carrier amplitude and is also used to provide a source of A.V.C. voltage via R11, whilst the potential on the anode of V6B is dependent upon the instantaneous A.F. amplitude. These are suitably proportioned so that the diode just remains conducting with audio potentials corresponding to 100 per cent. modulation of the carrier. Any noise pulse exceeding this level will cause the anode potential to fall below that of the cathode, cutting the diode off and disconnecting the detector from the audio amplifier.

The first audio stage is a high-gain pentode amplifier, valve type 9C01 being used on account of its small size. It will be noticed that the anode and screen loads of this valve are connected to the anode of the output valve. This is a simple method of applying negative voltage feedback over the final stage in order to reduce distortion. The audio gain control R17 is included in the grid of the 6F6 pentode power amplifier in order to eliminate noise due to the possible wear of the potentiometer slider. The audio transformer T1 (Fig. 1) is mounted on the speaker.

The major parts are mounted as shown in the diagram. The valveholder of V4 is rotated and refixed with pin 4 rather closer to T-101-1 than previously for convenience in mounting C1. L1 and L2, the two anode inductances, each consist of 12 turns 26 d.c.c. wire close-wound upon  $\frac{3}{8}$ in. formers—L1 was wound on the former previously carrying L-104. The screening cans around these coils were obtained from old I.F. transformers.

(To be continued.)

# From VCR97 to Magnetic-2

CONVERTING A RECEIVER FOR STANDARD TUBES

By R. Shatwell

THE alternative to the arrangement described last month for the H.T. supply, is to fit bleeder resistances, a very wasteful method of operations. It is also quite likely that the magnetising current alone of the large transformer equals or exceeds that necessary for radio operation.

The needs of an additional small power pack for radio operation can be met by a small transformer, rectifier, choke and reservoir condenser. The smoothing condenser can be common to both units without undue complication, but to go further than this raises problems out of proportion to the saving effected.

The switching necessary should, by now, be simplified considerably, and in practice only four circuits are switched, these being:

- (1) Mains to—1a. TV power transformer. 1b. Radio power transformer.
- (2) H.T. to L.F. stages to—2a. TV 250 v. line. 2b. Radio H.T. line.
- (3) 6.3 v. to L.F. stages to—3a. TV 6.3 v. line. 3b. Radio 6.3 v. line.
- (4) Audio input to L.F. stages to—4a. TV detector output. 4b. Radio detector output.

The numbers given above will be used to identify the connections in further references to them and Fig. 5 shows the diagram of these circuits. A three-way switch is shown with gram and radio muting, but the third position and S5 can be omitted if gram is not desired.

### Modifications to Television Set

These are quite simple and disturb no critical signal circuits. The L.F. stages should be carefully examined and the H.T. and 6.3 v. line isolated from the remainder of the chassis, taking care not to break the continuity to other stages. One side of the 6.3 v. line is earthed in both cases, so that only one lead need be switched. If a 4-way tagboard is mounted at a convenient point the 250 v. and 6.3 v. connections to the L.F. stages

can be anchored to two of these (2 and 3), and the TV 250 v. and 6.3 v. line (2a and 3a) to the other two. These should then be labelled or colour coded. The smoothing condenser on the TV 250 v. line should then be transferred to a convenient point and connected to (2) when it becomes common to each power pack.

The audio input to the L.F. stages is readily available at the volume control, and a two-way tagstrip should be mounted close to this. The lead from the "hot" end of the control is removed and soldered to one tag, becoming (4a). The now vacant volume control connection is taken to the other tag and becomes (4). If the mains switch is on the brilliance or volume control, it can be dispensed with in certain instances, as mentioned later. This completes all interference with existing circuits.

### Power Unit

The additional radio power pack should, in the interests of compactness, be included if possible on the TV power pack chassis. A chassis 12in. x 12in. and 1in. deep will easily take both units. The new power pack need cost no more than 25s. and either full or half-wave, metal or valve rectification is suitable.

### Switching

Several methods of switching are possible, the simplest of which is rotary, following exactly the circuit of Fig. 5. It is necessary, however, to bear in mind that mains voltages are being switched and any rotary switch must be carefully chosen. This difficulty is obviated if the mains switching is by two toggle switches actuated by arms fixed to the rotary switch spindle. The toggle switches should be of the type with a vee cut in the toggle arm, and they should be positioned so that the actuating arm, after operating them, slides free at the opposite side of the vee to operate the other one. It will be noted that no "off" position is available if a three-way rotary switch is used, and this should then be ganged with the volume control. Alternatively, a central position on the rotary switch can be used as an "off"; radio and gram being at one side of this and TV at the other. The toggle switches would be set apart by one switch position.

In cases where the power unit used for the VCR97

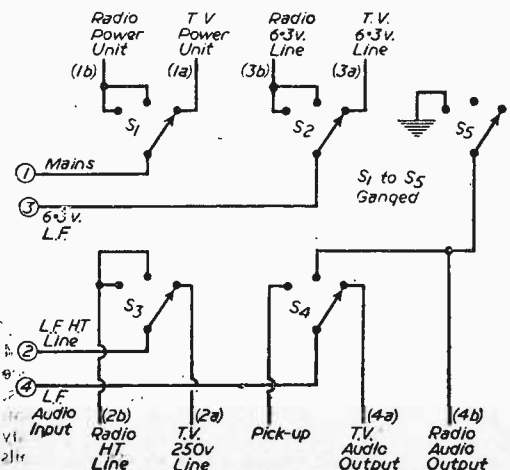

Fig. 5.—One form of switching.

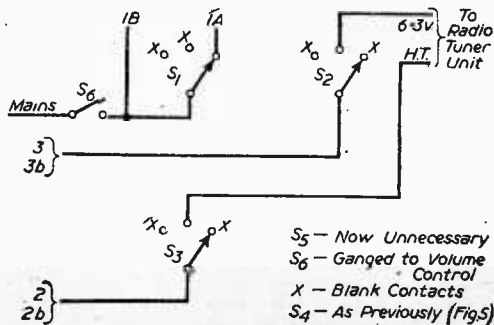

Fig. 6.—Modification for TV switching.

set is insufficient for magnetic tube operation, the auxiliary radio power unit can relieve the TV supply of the L.F. stages, the H.T. and 6.3 v. supply to these being permanently connected to this unit. S1, S2 and S3 of Fig. 5 can then be modified, as shown in Fig. 6,

vantage, since the depression of one button not only makes and breaks circuits on that button, but of the one released. In the arrangement shown no possible combination of depression of more than one, or even all buttons, can result in damage to the unit or the set.

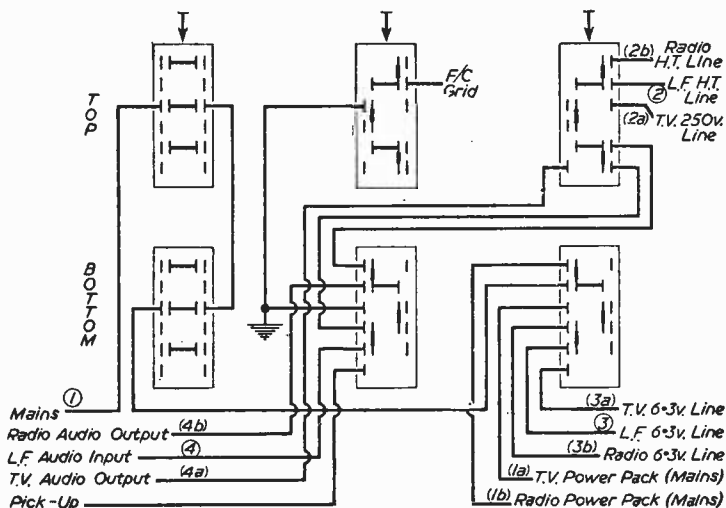

Fig. 7.—Push-button wiring arrangement.

to switch off TV power when on radio, and silence the radio tuner unit when on TV or gram. This retains the existing audio switching and makes the volume control switch the main on/off switch.

Although slightly more complicated to wire, the neatest and most efficient solution to the switching problem is a push-button unit, and this was finally adopted by the author, although doubts existed as to the ability of such a switch to withstand the high voltages involved, particularly mains. Careful choice of the contacts remote from low-potential points, and a double break in the mains lead, has resulted in trouble-free operation over a period of 12 months.

In the system adopted, four buttons are used, labelled "off," "gram," "TV" and "radio." The "off" button has no function other than breaking the mains supply. "Gram" shorts F.C. grid and radio output to earth, and connects the pickup to L.F. audio input (4). The TV switch is the heart of the unit, making all four TV circuits in the depressed position, and all radio circuits in the released position. Fig. 7 gives the wiring diagram of the unit used by the author. The use of push buttons confers an ad-

ditional safety, since the depression of one button not only makes and breaks circuits on that button, but of the one released. In the arrangement shown no possible combination of depression of more than one, or even all buttons, can result in damage to the unit or the set.

It is unlikely that a push-button unit identical with that shown will be available, but the wiring can be adapted easily to other contact arrangements. The "TV" switch is crowded because in the author's arrangement the fourth or "radio" button is actually any one of six station selection buttons. Its only function in a four-way unit would be to release the button already depressed, and if other than push-button station selection is used it could operate half the switching shown in the "TV" position.

In making connections to the switch, twin coloured braided lighting flex is useful, as it will be found that much of the wiring runs in pairs, the braiding colour identifying the pair and the red and black rubber the separate leads. Before soldering to the switch slip a 3/8 in. length of rubber or plastic sleeving over the braiding and after soldering push tag to make a sturdy and well insulated connection. Allow sufficient wire to prevent pulling and run in "cable forms" tied neatly. Length

(Continued on page 415.)

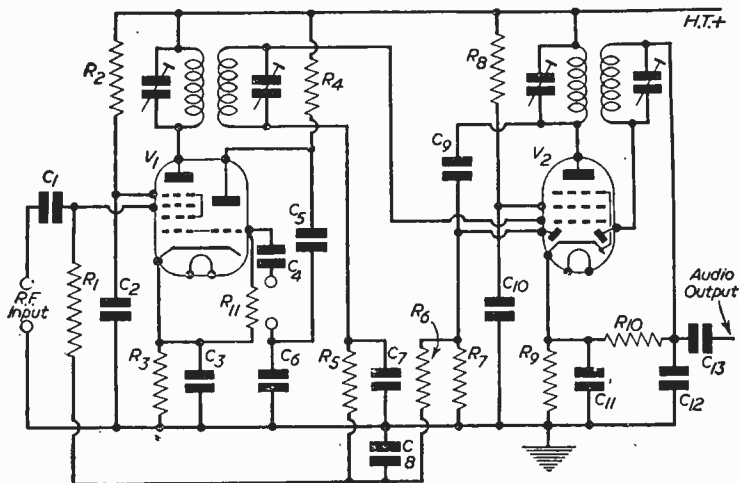

Fig. 8.—Sound receiver section.

#### COMPONENT VALUES

C1—.005 $\mu$ F.	R1, 5—5 M $\Omega$ .
C2, 3, 7, 8, 10, 11—.1 $\mu$ F.	R2, 8, 10—100 K $\Omega$ .
C4—100 pF.	R3—300 $\Omega$ .
C5—300 pF.	R4—50 K $\Omega$ .
C6—Padder (to suit coils).	R6, 7—1 M $\Omega$ .
C9, 12—50 pF.	R9—220 $\Omega$ R11—50 k $\Omega$
C13—.01 $\mu$ F.	V1—6K8. V2—6B8.

**RDFI RECEIVER.**—The unit reviewed in the October and November issues of this journal for conversion into a Television giving **SOUND AND VISION ON THE ONE CHASSIS.** Complete with 14 valves as follows: 5 of SP61, 2 of P61, 3 of EA50, and 1 each CV63, EB34, EC52, 5Z4, also the complete reprint of the above review. **ONLY 49/6** (carriage, etc., 5/-).

**194 I.F. STRIP.**—Reviewed in the October issue of this journal. A really first-class strip for TV conversion, and easily fitted into any layout, measuring only 18in. x 5in. x 5in. Ideal for constructors who have built a TV but are having trouble in the Vision or Sound sections. Complete with 6 valves SP61, 1 EA50 and 1 EF36 or EF39. **BRAND NEW, ONLY 45/-** (postage, etc., 2/6).

**"PYE" 45 Mc/s STRIP.**—The strip which is ready made for London Vision Channel. Complete with 6 valves EF50 and 1 EA50 and details of very slight mods. necessary. **ONLY 57/6** (postage, etc., 2/6).

**CHASSIS OF RECEIVER 3653.**—A wonderful "buy" for any constructor, measuring 18in. x 11 1/2in. x 3in., and although certain components have been removed, it contains 17 valveholders, 4 Pye plugs, 85 resistors, 23 tubular condensers, 40 Silver Mica condensers, trimmers, switches, etc., etc. Has front mounting panel, 11 1/2in. x 7 1/2in., and is complete in a Metal Case. In New Condition. **ONLY 15/-** (carriage, etc. 4/6).

**TRANSFORMERS.**—EHT for VCR97 TUBE with 4v. for tube heater and 4v. tapped 2v. for EHT Rectifier, 37/6. **HEAVY DUTY 350-0-350v. 160 m.a., 5v. 3a., 6.3v. 6a., 6.3v. 3a. ONLY 42/6.** **HEAVY DUTY 250-0-250v. 100 m.a., 5v. 3a., 6.3v. 6a. ONLY 32/6.** **350-0-350v. 80 m.a., 0-4-6.3v. 4a., and 0-4-5v. 2a. ONLY 18/6** (postage 1/6 per transformer).

**CHOKES.**—20h. 80-120 m.a., 9/6; 5h. 200 m.a., 6/-; 30h. 150 m.a., 12/6 (postage 1/- per choke).

**MAGNIFYING LENS for VCR97 Tube.** First-grade oil filled. **ONLY 25/-** (postage, etc., 2/-).

Cash with order, please, and print name and address clearly.

**U.E.I. CORPN., The Radio Corner,  
138, Gray's Inn Road, London, W.C.1.  
(Phone TERMINUS 7937)**

Open until 1 p.m. Saturdays. We are 2 mins. from High Holborn (Chancery Lane Stn.) or 5 mins. by bus from King's Cross.



TYPE 21

4 OTHER MODELS TO CHOOSE FROM

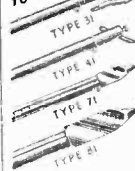

Only Wolf solderguns have all these time and money-saving advantages—

- OFF-STRAIGHT EASY-GRIP HANDLE
- PERFECT CONTROL
- LOW CURRENT CONSUMPTION
- QUICKER HEAT-UP
- MAINTAINS CORRECT HEAT
- LOCALISED HEAT
- MODELS FOR EVERY PURPOSE FROM FINE INSTRUMENT TO HEAVY INDUSTRIAL SOLDERING

**HAVE YOU TRIED AUTOMATIC SOLDERING?**

Win new efficiency and economy with Wolf Automatic Soldergun. Its automatic trigger solder-feed action and perfect balance make it indispensable to all modern assembly. TYPE 51

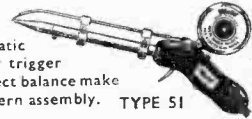

Also

**Wolf Electric SOLDERING IRONS**



For all who, for special reasons prefer the conventional straight type handle. Identical as regards elements and bits to Wolf Solderguns but with round



hard wooden handle with heat deflecting skirt.



*It pays to Solder with* **Wolf**

**ELECTRIC SOLDERGUNS & SOLDERING IRONS**

★ Obtainable from all high-class stockists and ironmongers

**WOLF ELECTRIC TOOLS LIMITED · PIONEER WORKS  
MANGER LANE · LONDON · W.5 Telephone PERIVALE 5631**

**FREE!** to those who wish to Qualify in any of these subjects



This book costs you nothing. But it offers you success in terms of your career.



- ACCOUNTANCY EXAMS ★ AVIATION—ENGINEERING AND WIRELESS ★ BOOK-KEEPING ★ CIVIL SERVICE ★ COMMERCIAL ART ★ ALL COMMERCIAL SUBJECTS ★ CIVIL ENGINEERING ★ DRAUGHTSMANSHIP ★ ELECTRICAL ENGINEERING—CITY AND GUILDS CERT. ★ GENERAL CERT. OF EDUCATION ★ HIGS, TOOLS AND FIXTURES ★ JOURNALISM ★ MATHEMATICS ★ MECHANICAL ENGINEERING—A.M.I.MECH.E., CITY AND GUILDS ★ PLASTICS ★ PRESS TOOLWORK ★ RADIO SERVICE ENGINEERING ★ RADIO (SHORT WAVE) ★ SALESMANSHIP ★ SECRETARIAL EXAMS. ★ SHORTHAND ★ SHORT TECHNICAL COURSES ★ SURVEYING ★ TELECOMMUNICATIONS ★ TELEVISION ★ WORKS MANAGEMENT.

**By Post,** specialised Tutors in these and many other subjects give individual attention to Bennett College Students. Tuition is guaranteed until you Qualify. State your subject. Send coupon for prospectus.

You can start on a Bennett Course **FOR ONLY 30/-** and 15/- monthly.

To the Governor, Dept. B-55,  
**The BENNETT COLLEGE**  
Sheffield, Eng. Send me the free book on how I can Qualify

in.....(subject)

NAME.....

ADDRESS.....

..... AGE (if under 21).....

Please Write in Block Letters.

INDICATOR UNIT TYPE 62A

Contains VCR97 and is almost identical to Unit Type 62, but is better because it contains VR91 valves instead of VRS5 valves. Limited quantity. Price £4/10/-, carriage and packing 10/- extra.

UNIT TYPE RDF.1

Plans for turning this unit into a Telesiv were given in October issue. Complete with 14 valves. Price 49/6, carriage and packing 5/-. (Reprint of plans free with chassis if required.)

194 STRIP

Also described in the October Practical Television, contains 8 valves and really does give superior results. Price 45/-, plus 2/6 postage.

EF50 in Original Cartons, guaranteed 10/6 each.

10-VALVE 11-METRE SUPERHET

Contains 6 valves type SP61 (two) and one each RL7, RL16 and EA50 six I.F. Transformers of 12 mc/s, 4 mc/s band width, and 4 hundred s of other useful components. Price 59/6, plus carriage and packing 5/-, unused and in original wrappings.

Orders are dealt with by our Ruislip depot. For prompt delivery, please to: E.P.E. Ltd. (Dept. 5), Windmill Hill, Ruislip, Middx. Include extra 2/6 under £2, 1/9 under £1.

5 WAVEBAND 7-VALVE RADIO CHASSIS

A famous set by a famous manufacturer. Undoubtedly a serious listener's receiver. Special features are H.F. stage and tuning indicator. Tunes up to 11-metre band. Price new with all valves, but less speaker, £14/9/6. Carriage and packing 15/-, partly returnable. Models available.

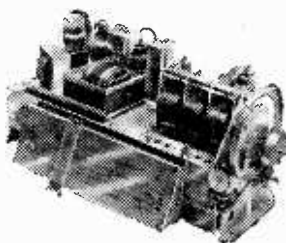

A.C. mains and Car battery

MAGNETIC TV TUBES FROM 27/6 EACH.



MAZDA, MULLARD, BRIMAR, etc.

TYPE A.—Only fault is low heater to cathode insulation. These will give perfect picture in grid-modulated circuit: 9in. price, £3/15/- each; Diagram showing how any circuit can be modified to use cathode/heater leaky tubes, 1/- post free.

TYPE B.—Have small ion burns but good cathode to heater insulation. Will be quite suitable in any type circuit: 9in. price, £2/15/- each; 12in. price, £3/15/- each.

TYPE D.—Are useful, but may have several faults. 6in. £1/7/6.

NOTE.—Callers to our Ruislip branch can see these tubes demonstrated, but whether you see it or not we guarantee a working tube. If not calling please add 7/6 each tube for packing and postage.

OTHER CATHODE RAY TUBES

Note.—All these tubes have green fluorescence.

ECF1.—6in. electrostatic. American manufacture, medium persistence, suitable for TV or scope, in original cartons. 19/6, carriage and insurance 2/6.

VCR517.—6in. electrostatic, medium persistence, suitable for TV or scope work; unused, ex new equipment, 22/6, carriage and insurance 5/-.

VCR97.—We have had a new delivery of this new famous electrostatic 6in. TV tube. These are not the cut-off type, they give a full picture, 42/6, carriage and insurance 5/-.

VCR516.—9in. magnetic tube, long persistence, which makes it rather unsuitable for TV. Price £2/10/-, postage and insurance 10/-.

RADIOGRAM CABINET



Full size console type; really well made with highly polished walnut finish. Designed to take standard type auto-change gram unit and radio chassis. You can have these at £12/10/- each which means a brand new radiogram for less than £30; for we can supply a 5-valve 3-waveband chassis at £10 (some adaptation will be necessary, of course), and gram units from £5/5/- upwards.

152-153 FLEET STREET, E.C.4, and at WINDMILL HILL, RUISLIP MANOR, MDDX.

PRECISION EQUIPMENT logo and name in a stylized font.

ALPHA RADIO SUPPLY COMPANY

5-6 VINCES CHAMBERS, VICTORIA SQUARE, LEEDS 1

MOULDED MICA CONDENSERS .0001, .0002, .0003, .0005, .0008, .0014, .0027, .001, .002, .003, .005, .01 all at 5/6

RESISTORS 1 watt sizes 350 Ohms, 30K Ohms, 40K Ohms, 50K Ohms, 100K Ohms, 1K Ohms, 10K Ohms, 250 Ohms, 33K Ohms, 47K Ohms ... 6d.

FILAMENT TRANSFORMERS Rely Two-hole Fixing, Primary 210-240v., Secondary 6.3v., 1.5a. ... 8/6

PERMANENT MAGNET FOCUS UNITS Elac. Type R17/1, for Tetrode Tubes. (Listed at 21/-, ... 12/6)

DIAL BULBS 6.3v., 15a., 15 mm. Ball Type, M.E.S., 6.3v., 3a., 10 mm. Tubular Type M.E.S. ... 8/6

SPEAKERS. All 2 to 3 ohms unless otherwise stated. Midget 3" Speaker for personal sets ... 12/9

METAL TUBULAR FIXED CONDENSERS .1 mfd. 350v. D.C., Sprague ... 7/-

VALVES Majority in Makers' Cartons—New Government surplus

Table listing various vacuum tube models and their prices, including VR91, SP61, VR119, VR116, VR118, VR117, VR130/30, VP133, OZ4, IT4, 1A5, 184, 1R5, 1S3, 1CGT, 2A3, 2X2, 3A4, 3D6, 3Q6GT, 4R, 4R2, 5U4G, 5Y3G, MHD1, 6X5GT, 6AM6, 6AL5, 6B8, 6C5G, 6C6, 6D6, 6F6M, 6H6, 6K7, 6L6, 6M7, 6N6, 6P6, 6R5, 6S5, 6T6, 6X4, 6X5, 6X6, 6Y5, 6Z5, 6Z6, 6Z7, 6Z8, 6Z9, 6Z10, 6Z11, 6Z12, 6Z13, 6Z14, 6Z15, 6Z16, 6Z17, 6Z18, 6Z19, 6Z20, 6Z21, 6Z22, 6Z23, 6Z24, 6Z25, 6Z26, 6Z27, 6Z28, 6Z29, 6Z30, 6Z31, 6Z32, 6Z33, 6Z34, 6Z35, 6Z36, 6Z37, 6Z38, 6Z39, 6Z40, 6Z41, 6Z42, 6Z43, 6Z44, 6Z45, 6Z46, 6Z47, 6Z48, 6Z49, 6Z50, 6Z51, 6Z52, 6Z53, 6Z54, 6Z55, 6Z56, 6Z57, 6Z58, 6Z59, 6Z60, 6Z61, 6Z62, 6Z63, 6Z64, 6Z65, 6Z66, 6Z67, 6Z68, 6Z69, 6Z70, 6Z71, 6Z72, 6Z73, 6Z74, 6Z75, 6Z76, 6Z77, 6Z78, 6Z79, 6Z80, 6Z81, 6Z82, 6Z83, 6Z84, 6Z85, 6Z86, 6Z87, 6Z88, 6Z89, 6Z90, 6Z91, 6Z92, 6Z93, 6Z94, 6Z95, 6Z96, 6Z97, 6Z98, 6Z99, 6Z100.

VOLUME CONTROLS Morgante 100K Ohms, 1 Meg, 1 Meg, 2 Meg, each all with Single Pole Switch ... 4/3

DIALS AND DRIVERS J.B. SL3 3-waveband with spin wheel drive, at ... 27/6

METAL RECTIFIERS L.T. 12 volt 1 amp. ... 5/-

KNOBBS.—All fit Standard 1/4in. Spindle. Brown Knobs with a small pointer, 4/- doz.

Heavy Duty Cooker Switch, 4 position, 30 amp. ... 4/6

POST ORDERS ONLY. CASH WITH ORDER. OR C.O.D. Please add 1/6 for post orders under 40/-, 1/- under 20/-, Over 40/- carriage free. Send 3d. stamp for Latest List.



of leads is of little importance. The L.F. signal leads must be of screened wire, single or twin and the plastic sleeve should be sufficient to cover the screening braid well clear of the switch unit.

**Radio**

The radio circuit decided upon is immaterial to the switching problems, but the normal receiver of moderate sensitivity can be built around a two-valve superhet circuit, providing F.C., Osc., I.F. amplifier, detector and AVC. Tuning can be manual, push-button or both. The push-button unit shown in Fig. 7 is a war-time "Premier" 10 button unit, providing originally gram, three wavebands, four M.W. stations and two L.W. stations. It is probable that a large number of these are in the hands of constructors as they were definite bargains when advertised. All but the station selector buttons were stripped of wiring, the first being unused, the shaft being bent back and the escutcheon hole used for a "radio on" indicator bulb. If a four-way unit is used, manual tuning can be incorporated, or one of the new 4-station rotary turrets would enable a very compact unit to be assembled.

Fig. 8 shows the circuit used and the whole was assembled around the push-button unit, and mounted

on one side of the screen, the volume, contrast and brilliance controls balancing the layout at the other side.

The only remaining problem is that of aerial switching if it is not desired to use separate radio and TV aerials. It must be realised that the TV aerial is only a poor radio aerial, but results superior to the "picture rail" aerial are possible with a good outdoor TV aerial. Switching is avoided by the circuit in Fig. 9, which is simple and effective and does not affect the TV circuits. The aerial coupling transformer primary is taken to chassis via a five-point instead of direct, the junction feeding the radio aerial socket via a length of coaxial. If maximum radio sensitivity is needed, of course, a normal radio aerial is to be recommended.

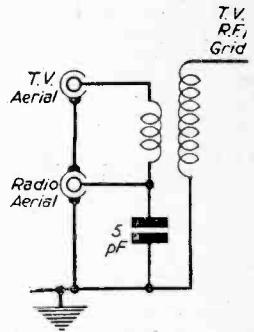

Fig. 9.—Input arrangements.

# A Slotted Indoor Aerial

FRINGE AREA RECEPTION WITHOUT AN ELABORATE OUTSIDE ARRAY

By T. F. Sowler, M.Sc.

I HAVE been experimenting with long-range television for some time now with a standard H (Sutton Coldfield to Tees-side), but with the advent of Holme Moss pictures are comparatively "on the doorstep" at 80 miles.

I was set a problem with the opening of Holme Moss which I feel sure must have faced many people in the older terraced streets of northern towns—how to put up (for my father, not myself) an aerial installation capable of consistent "fringe" reception (80 miles) at as cheap a cost as possible. The problem was further complicated by the stipulation—"it must be in the loft; the chimney is not considered safe enough for an outside array."

The problem has been solved for the ridiculously small figure of 13s. 7d., plus 5s. 6d. for twin feeder, a total of 19s. 1d. The bandwidth is ample and so far no appreciable fading has been recorded. In addition wet slates do not adversely affect reception. There must be some snags in the mysterious realms of back-to-front ratios, but so far I have not experienced them. It would appear to me that here lies a grand opportunity for experiment "on the fringe" without any large call on the pocket.

Briefly, the "slot" type of aerial was constructed and a reflector placed behind it, closely spaced, in the hope of increasing the signal, and also bringing nearer a match between the impedance of the aerial and the feeder.

**Materials required :**

	s.	d.
9 yds. of 36in. wire netting (1in. mesh) at 1s. 1d. per yd. . . . .	9	9
2 50ft. coils of stranded copper aerial wire (not insulated) at 1s. 11d. each . . . . .	3	10
<b>Total . . . . .</b>	<b>13</b>	<b>7</b>

**Construction**

First cut the roll of netting into two 4½yd. lengths and fold back the raw ends for neatness and strength. To prevent unnecessary backache drive a few nails into

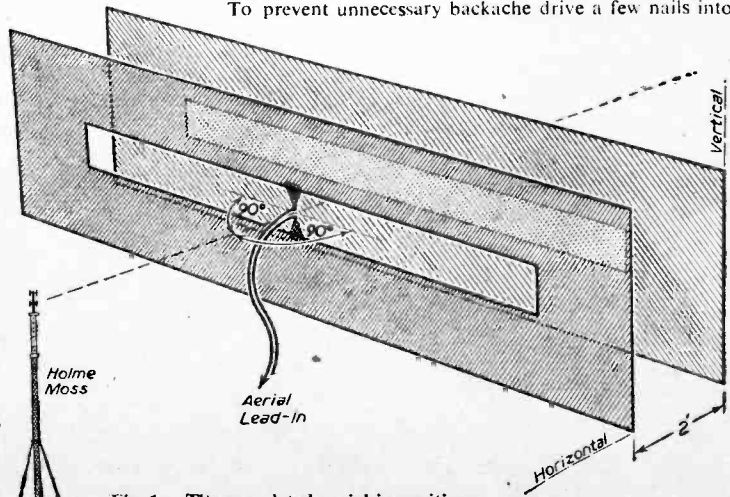

Fig. 1.—The completed aerial in position.

the fence or backyard wall at eye level and hang one length of netting on to them. (Fig. 2.)

Tie a small piece of string on to the edge of the netting to mark the half-way point (this is important), and then mark off 4ft. 7in. on either side (as in diagram). In a similar manner tie pieces of string to indicate the corners of the slot ABCD: Now run half of the stranded aerial wire through the netting, bonding as much as possible, to form the rectangle ABCD (9ft. 2in. x 8in.). With wire snips remove a 12in. portion of a raw edge to fold back for strength. When this 12in. section has been removed, tie a stout piece of string or cord (wire, insulated or not, will not do) across the slot to preserve its shape. Repeat this operation until the whole of the material in the slot has been removed. When all the raw edges have been folded back, bond the edges of the slot again with the remainder of the first coil of wire.

Now mark out a piece of copper plate (no doubt tin-plate would do) as in Fig. 2, and separate the two "delta" shaped pieces. Solder them to the centre of the wire netting with good electrical contact with the bonding wire. Their taper points will be approximately  $\frac{1}{2}$ in. apart. To these points solder the two ends of the twin feeder. (Fig. 2.)

The first half of the aerial is now complete.

The reflector is built in exactly the same way as the above except that the slot measurements are 9ft. 4in. x 8in., and there are no central taper pieces, as no electrical connection is required either to the front of the array or to the set.

### Erection

Roll up the two sections of the aerial into a roll sufficiently compact to be passed through the trapdoor

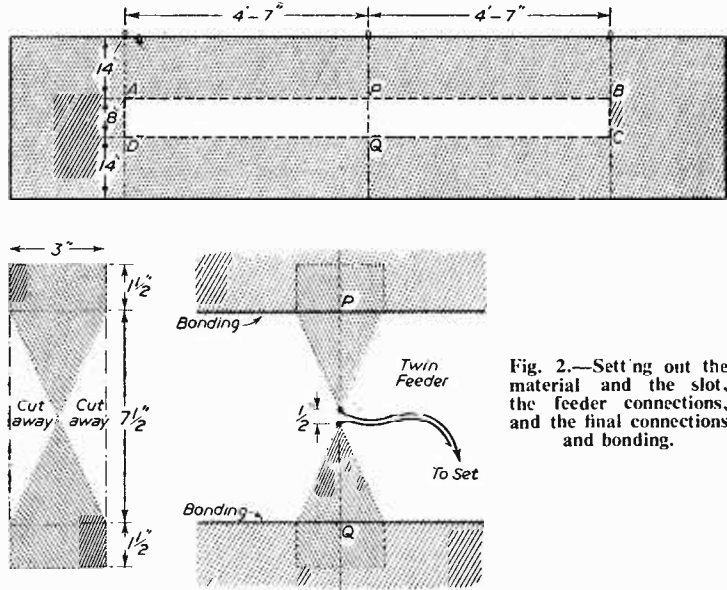

Fig. 2.—Setting out the material and the slot, the feeder connections, and the final connections and bonding.

into the loft. Great care must be taken in the setting up of the array as it is directional, and contradicts the accepted practice for other more normal arrays. There should be no difficulty if the diagram is followed and the two sections of the aerial placed about 2ft. apart. (Fig. 1.)

There is no need to insulate the aerial from joists, etc., and wire can be used to suspend it, provided always that no metal is used in the slot.

In conclusion let me say that I believe that this aerial can be considerably improved upon.

## The British Industries Fair

GREAT BRITAIN'S biggest and best-known exhibition halls, Castle Bromwich, Earls Court and Olympia, will again be used to house the British Industries Fair. It opens simultaneously in London and Birmingham on May 5th, 1952, and for the next 11 days will present to the world's buyers a display of our newest industrial products.

This will be the 31st Fair in a series which began during the first World War, and which in the past five years has enhanced its reputation to the point where a record number of nearly 20,000 overseas visitors attended in 1951.

With predominantly heavy industry shown at Castle Bromwich and consumer goods at the London sections, the B.I.F. crystallises the production of nearly 3,000 firms in 90 trade groups.

The scope of the Fair ranges all the way from plastic ash-trays (there will be 48 exhibitors of plastics, occupying nearly 13,000 sq. ft. of space) to a demonstration of the industrial uses of atomic energy. Many novelties are promised, it being the practice of many manufacturers to use the B.I.F. to launch the fruits of their research and development in the preceding year. The general public is admitted on only two days of its run.

## UNDERWATER TELEVISION

(Continued from page 398)

### Illumination

The Marconi cameras have been used at varying depths and it has been found that in certain conditions good pictures are obtained as deep as 80ft. without the aid of artificial light.

Tests made under practical conditions at sea show that artificial illumination of the object is of doubtful value when the water is clear, but many more results will have to be compiled and obtained before firm conclusions can be justified. Another interesting point shown by these sea tests is that tungsten lighting appears to give better results than either sodium or mercury vapour light.

Under test conditions some applications have already been thoroughly tried out—study of wrecks, finding of objects, and the investigation of the sea bed—and others which present themselves are the study of fish in their natural surroundings, the investigation of trawl nets under operational conditions, identification and control of oyster and scallop beds, inspection of dock gates and ships below the water line without employing divers or using dry docks, and the possibility of undertaking really deep-sea research to depths exceeding 1,000ft.

**"YOU CAN RELY ON US"**  
FOR CLEAN COMPONENTS  
AT COMPETITIVE PRICES

**VALVE DATA MANUALS**

MULLARD. 5/- MARCONI OSRAM. 5/- BRIMAR. 5/-

**VALVES**

CIC	10/-	5Z3	10/6	77	7/6
CV1141	5/-	5Z4 metal	10/6	80	10/-
DH63	12/-	6AG5	9/6	954	5/-
EA50	3/6	6AK6	8/6	955	5/-
EB41	8/6	6B8	8/-	VU111	7/6
EP30	10/6	6C4	7/6	3525	12/6
EP50	7/6	6C5m	7/6	3524et	12/6
EP54	7/6	6C5et	7/-	2525	12/6
EP91	10/6	6H6m	4/6	6BE6	12/6
EL32	8/-	6J5et	6/6	KT61	12/6
EL35	10/6	6J7G	8/-	KT41	12/6
KTW61	8/6	6K6	8/6	KT83	10/6
KT33C	16/-	6K7 metal	8/-	KT66	12/6
MS/Pen	7/6	6K7G	8/-	6J5M	7/-
N37	10/6	6L7 metal	8/6	6ACTM	8/6
Pen46	8/-	6SA7et	8/-	6BW6	15/-
PT25H	5/-	6SH7 metal	7/6	6AT5	10/6
U78	10/-	12SR7	7/6	6AC5	13/6
VU120A	4/6	12A6	7/-	S130	7/6
1Q4	8/6	12SC7	7/-	12K8	12/6
1S4	10/6	12SG7	6/-	7C5	8/6
3A4	7/6	12SK7	8/-	UB41	8/6
3Q5et	8/6	12SR7	6/6	VE115	3/6
3S4	10/6	76	6/-	807	10/6

Postage 6d. any quantity.

Thousands of valves in stock including many BVA types at List Price. Let us know your requirements and we will quote the price.

**SWITCHES.**—Rotary: 1 pole, 18 way, 2/6. 4 pole, 3 way, 4/- 3 pole, 4 way, 4/- 2 pole, 6 way, 4/- 6 pole, 3 way, 4/6.  
**SELENIUM RECTIFIERS.**—8EHT50, 22/6 8EHT45, 20/6. Type 14D36, 10/6. Type 14A86, 18/6. Type 8EHT100, 27/10. WX3, 3/5. WX6, 3/5. Meter rectifiers, midget, 5 m/a., 1/-.

**EASYBUILT CHASSIS.**—Two chassis for the Easybuilt Television, heavy gauge tinned soldered four sides, 8/6 each. EF50 3in. x 3in. screens, 6d. Ask for complete list of parts.

**SPEAKERS.**—2in. WB, 17/3. 6in. Elac, 15/- 3in. Elac, 14/3. 5in. Plessey, 14/9.

**HAYNES COMPONENTS.**—Scanning Coil Units. Type S914, S914H, S112, each, 42/- Transformer TQ135, 17/6. Choke Type LUS9F, 22/- LUS9L, 16/6. TQ132, 12/-.

**SPANNERS.**—4 B.A., 6d. Five for 2/- Box type, set of three Flat Type, 2 B.A., 4 B.A., 6 B.A., 1/-.

**FILAMENT TRANSFORMERS.**—Midget dimensions, finished in green crackle. Primary 210/240v. to 6.3 v. 1.5 a., 8/6; to 6.3 v. 3 a., 12/6; Multi purpose type for instruments, models, etc., tappings 3 v. to 30 v. at 2 amp., 24/-.

**SPEAKER TRANSFORMERS.**—Super Midget for personals, DL92 3S4, 1S4, 5/- Standard Pentode, 4/6; 60:30:90: to 1, 6/6. 30:1, 4/- Mains Pentode, Midget, 4/-.

**COLLS.**—Wearite "P" Colls, 3/- Wearite Viewmaster colls, per set, London, 20/- Midland, 25/- Holme Moss, 30/- MW/LW TRF Matched pair with circuit, 7/6. Weymouth CT3W3, 9/6 pair. CS2W2, 11/6 pair. K.O. Colls, 4/9. "H" Colls, 3/3.

**I.F. TRANSFORMERS.**—RS/GB Semi-Midget 465 kc/s, 12/6 pair. Wearite M800, 21/- pair. Weymouth P4, 15/- pair.

**FORMERS.**—Aladdin with cores, 1in., 7d.; 1in., 10d.; 1in., 9d. Cores, 1in., 3d.; 1in., 4d.

**BOOKS.**—Viewmaster Book and Circuits, 5/- London or Midland Easybuilt Television, 2/6; Portable Television, 3/-; Personal Portables, 2/6.

**MISCELLANEOUS.**—Bulkin Octal plug, 2/3. Belling-Lee Co-axial plug, 1/6. Socket 1/6. Connector, 1/6. Bulgin rotary DP Switch, 4/3. Bulgin feeder plug, 1/3. Socket, 1/3.

**ELECTROLYTICS.**—2 mfd. 350v., 1/3. 4 mfd. 350v., 1/6. 16-16 mfd. 450 v., 7/6. 8 mfd. 500 v., 3/6. 16 mfd. 450 v., 4/6. 16 mfd. 350 v., 3/6. 32 mfd. 450 v., 4/9. 8 mfd.-16 mfd. 450 v., 5/6. 8 mfd. plus 8 mfd. 500 v., 4/3. 25 mfd. 25 v., 1/8. 50 mfd. 50 v., 2/-.

**CHOKES.**—First quality Audio Chokes, high impedance, 10/6. 40 ma. Midget, 5/- 60 ma., 6/6. Smoothing chokes.

**TTC PICOPACKS, ETC.**—Picoacks, 2/6. Metalmites, 1/8. .001 mfd. 6 kv., 4/6. .001 mfd. 12 kv., 7/6. Hunts W99 .001 mfd. 1/3. .003, 1/3. .005, 1/6.

**MAINS DROPPERS.**—3 a. 800 ohm, 5/6. Midget Type, 6/3; 2 a. 950 ohm, 5/6. Midget Type, 6/3.

**LINECORD.**—3 way 2 a. 100 ohm per foot, 8d. per foot; 3 way 3 a. 60 ohm per foot, 8d. per foot.

Our No. 10 Catalogue, price 6d., Post Free.  
Postage: Over £2 free, below 10/-, 6d.; £1, 9d.; £2, 1/-.

**RADIO SERVICING CO.**  
444, WANDSWORTH ROAD, CLAPHAM,  
LONDON, S.W.8.

Telephone MCAulay 4155.  
77, 77A, 168, 169 Buses. S.R. Station: Wandsworth Road.  
Open till 6.30 p.m. 1 o'clock Wednesday.

Here is your area  
and here is your

**Aerialite**  
AERIAL

RANGE

UP TO 15 MILES

15 TO 25 MILES

25 TO 40 MILES

40 TO 60 MILES

60 MILES & OVER

**MODEL 65 "Aeradoro."** Designed for indoor skirting-board mounting. Fitted with one telescopic and one flexible arm. Can be adjusted to any channel. Complete with 5 yards of coaxial lead-in. **PRICE 32/-**  
**MODEL 65A** with 5 yards of Twin-feeder. **PRICE 32/-**  
Also **MODEL 66**, which has two flexible arms. Complete. **PRICE 25/9**  
**MODEL 66A**, with 5 yards twin-feeder. **PRICE 25/9**

**MODEL 74.** Has three fully flexible elements. High pickup properties. Trouble-free performance. Centre element has a spring tensioning device and neat connector box. All Channels. **PRICE 13/6**  
**MODEL 53** (similar to 74). Three rigid metal elements. Installed in variety of positions. All Channels. (Coaxial lead-in extra.) **PRICE 32/6**

**MODEL 57.** Single dipole for chimney stack mounting. Complete with chimney bracket, mast, lashings, etc., ready for installation. Excellent performance. **PRICE 62/6**  
**MODEL 58.** A dipole designed for wall mounting. Cranked stand-off mast similar to Model 57. **PRICE 52/6.** (58A with straight stand-off arm, 47/-) All Channels.

**MODEL 55.** An H-aerial with dipole and reflector. Forward gain 3.8 dB. Front back ratio 11.0 dB. Acceptance angle 180 deg. All Channels. Complete with a 10ft. x 2in. dural mast, brackets, lashings, etc. **PRICE £7/19/0.** Other "H" type aerials available.

**MODEL 63A.** For fringe and difficult reception areas. Folded dipole three element aerial. High gain 8.0 dB. Front/back ratio 29 dB. Acceptance angle 90 deg. All Channels. Complete with 10ft. x 2in. dural mast, brackets, lashings, etc. **PRICE £13/5/0.** With 4ft. mast, £14/2/0. Various styles of this model available.

**A NEW INDOOR AERIAL**

**MODEL 71.** A directional double folded dipole with four fully flexible elements. Easily erected in loft, attic or upper room. Highly directional characteristics. Forward gain 3.75 dB. Excellent reception at considerable distances from transmitters. Complete ready for erection to any channel specified. **PRICE 25/-.** Send 3d. stamps for FREE Illustrated Catalogue.

**AERIALITE LTD., Stalybridge, Ches.**

**VCR97 C.R. TUBES.** Brand new in original crates, guaranteed for television. 45", cart., and packing 7/6. 3 HPI C.R. TUBE complete with base and shield in holder with leads. 25/- Brand new.

**RECEIVER TYPE 25.** The receiver portion of the T/R 1196. Covers 4.3-6.7 Mc/s. and makes an ideal basis for an all-wave receiver as per *Practical Wireless*, August, 1949, issue. Complete with valves type EF36 (2), EF99 (2), EK32 and EB33. Supplied complete with necessary conversion data for home use. 35/-. New condition.

**GERMANIUM CRYSTAL DIODES.** complete with full wiring circuit and diagram. 4/6.

**METAL RECTIFIERS, S.T.C. 200,** volts 75 mA., 6/-; G.E.C. 6 volts 1 amp. 4/-. Westinghouse 12 volts 2 amps., 12/6; Pencil Type E.H.T., 600 v. 1 mA., 4/7; Pencil Type E.H.T., 1,000 v. 1 mA., 6/-; Pencil Type E.H.T., 2,400 v. 3 mA., 15/-; 12 v. 31 amps., 17/6.

**WALKIE-TALKIE CHASSIS, TYPE 46.** Complete size Valves, VP23, 1 HL20DD, QP25, TP25 & ATP4. 8 Aerial rods. I.F. Trans., etc. In new condition, less transmitting components removed, by M.O.S. 50/-.

**No. 38 "TALKIE-TALKIE" TRANS-RECEIVER.** Complete with Throat Mike, Phones, Junction Box and Aerial Rods in canvas bag. Freq. range 7.4 to 9 Mc/s. All units are as new and tested before dispatch. As supplied to Overseas Police Forces. 24/19/6. Carr. 2/6.

**VIBRATOR POWER UNITS, 2 volt.** As for Canadian 58 set. Completely smoothed, output 15 v. L.T. and 90 v. and 180 v. H.T. at 35 mA. Complete in grey metal box. Size 8 x 3 1/2 x 4 1/2 inches.

**FREQUENCY CONTROL CRYSTALS** By American G.E. Co. Octal base fixing. Following frequencies only: 3,500 kc/s., 6,200 kc/s., 8,000 kc/s., 7/6 each.

**I.F. TRANSFORMERS.** Manufacturers surplus. Iron-cored, 465 kc/s. Size 4 1/2 x 1 1/2 x 1 1/2 inches. Per pair, 8/6. **FLASSETT 3in. P.M. Speaker** with miniature 0.4Ans., 17/6. **W.B. 21in. P.M.**, 3 ohms, less trans., 15/-.



5 HARROW ROAD, LONDON, W.2

PADddington 1008/9  
0401

<b>RECORD CHANGERS</b> Collaro RC500	
with crystal pick-up ... ..	£12 3 3
Collaro RC511 with plug-in pick-up either crystal or Hi-Fidelity ... ..	£11 16 9
Collaro 3-speed changer ... ..	£12 9 9
Plug-in heads for same magnetic ... ..	£1 19 6
Plug-in heads for same crystal ... ..	£3 2 4
Hi-Fidelity high impedance ... ..	£2 6 0
Hi-Fidelity low impedance ... ..	£1 19 6

<b>MOVING COIL METERS</b> (Brand New)	
0-50 mA. square panel mounting, 2in. scale ... ..	7 6
0-40 volts square panel mounting scale ... ..	7 6
0-20 amps. square panel mounting scale ... ..	7 6
0-300 volts square panel mounting scale ... ..	12 6
0-40/120 mA. double reading round scale ... ..	12 6
0-1,500 v. electrostatic, 2 1/2in. scale round ... ..	£1 5 0
0-100 v. A.C. rectified type, 2 1/2in. scale round ... ..	£1 5 0

Send stamp for current Component List. Stamp include postage under £1

**CONTINUITY TESTER.** Manufactured by well-known manufacturer dual-scale 0-500 ohms and 100-200,000 ohms. The meter is a moving coil type operated from 4 1/2 volt battery incorporated in unit. Size 6in. x 3 1/2in. x 4 1/2in. weight 2 1/2 lb. Listed at £8/10/0. Our price, brand new, £4/4/0. P.P.

**MIDGET .0005 mfd. TWO GANG TUNING CONDENSER.** Size only 2 1/2 x 1 1/2 x 1 1/2in. Capacity guaranteed, standard length, 1in. spindle, complete with mounting bracket less trimmers, 6/6, or complete with built-in trimmers 7/6 each, plus 6d. post.

**TUNING CONDENSERS.** .0005-4 gangs, ceramic insulation, with fixing feet at 5/-. .0005-2 gangs with four push buttons, each fully adjustable at 8/6.

**EX-GOVT. VALVES, THE FOLLOWING ARE BRAND NEW:** EF50 Red Sylvanian, Original Boxes (U.S.A.), 10/-; EF50 English Types, Original boxes, 8/6. EF50 Ex-Units, Guaranteed, 6/-; At 8/6 each: EF50, EF54, EF55, CV82, EF3, EF36, EF39, EF42, EF43, EB33, 6K7GT, 6J7GT, 6L7GT, 6S7GT, 6S7JGT, 6B8GT, 6N7GT, 6J5GT, 6C5GT, 6A7GT, 6S47GT, 6S7GT, 6D6, 6C6, 6N7GT, 12SA7GT, 12SK7GT, 12SJ7GT, 12SQ7GT, 12CB, 12SR7GT, 12SH7GT, 12A8GT, 1A7GT, 12Q7GT, 7A7GT, 7C7GT, 7H7GT, 7S7GT, 7B6GT, 41ME, 955, 9002, 9003, 129A, VR150/30, 2AD7, 9D2, 4D1, 15D2, RECTIFIERS at 8/6 each: -V1111, V1233, VU120A, C24, 6X5, VU120, 5Z4, 5Z3, U50, U22, 5Y3C. At 10/- each: -6F7, AC6PEN, MU14, 6AM6, 6V8GT, 5U4C, 6Q7, 6A8U, 52, 6AG5, PEN46, 5R4, 6S17GT, 6F9J, 80. At 12/6 each: -12K8GT, 25A6G, 6K8G, KT35C, 6SN7GT, 41, 6A8, 61622 Metal. Also at 10/-: 35L6GT, 50L6GT, EA50 (VR92), 3/6; D1, 3/6; EB34, 2/6; VR65 (SP61), 5/-; RL18, 5/-; 954, 5/-; 6H6, 5/-; S130, 7/6.

**ALL DRY BATTERY VALVES.** 3V4, 1C5, 1N5GT, 1H5, 1T4, 1S5, 1R5, 1LN5GT, 1S4, 354, all at 10/- each. Also HiVAC XH at 7/6, VP23, VP2, SP2, HL23/DD, 8/6, PEN20A 6/-, P2 (Super-power) 4/-, HL2 2/6, 21SSG 6/-

# SUCCESS? -

In Radio, Television, and Electronics, there are many more top jobs than engineers qualified to fill them. Because we are part of the great E.M.I. Group we have first-hand knowledge of the needs of employers, thus our Home Study courses are authoritative and based upon modern industrial needs. Alternatively, our courses will prove equally valuable to you in furthering your hobby.

**POST THIS COUPON NOW**

E.M.I. INSTITUTES, Postal Division, Dept. 136, 43 GROVE PARK ROAD, CHISWICK, LONDON, W.4.

Please send, without obligation, your FREE BROCHURE, (if have marked the subjects which interest me)

Mechanical Eng.  Electrical Eng.  Draughtsmanship,  Radio  Production Eng.  Automobile Eng.  Aeronautical Eng.  General Cert. of Education (Matric).  Civil Service.

Also courses for A.M.I. Mech.E., A.M.I.C.E., A.M. Brit. I.R.E., A.F.R.Ae.S., CITY and GUILDS EXAMS. in Mech. Eng., Elect. Eng., Telecommunications, etc.

Other Subjects .....

NAME .....

ADDRESS .....

## GUARANTEED GOODS

For Holme Moss, Sutton Coldfield & London

**"ELECTRONIC ENGINEERING" MANUALS.**—A Modern Home Built Televisor, London edition, 2/9; Sutton Coldfield edition, 4/9; post paid. "The De Luxe Home Built Televisor & Radio Gram" (covers London and Sutton Coldfield), 6/9 post paid.

**"ELECTRONIC ENGINEERING" DRILLED CHASSIS.**—To exact specification. Vision chassis with all valveholders, screens and iron-cored coil forms, London, 24/3; Sutton Coldfield, 24/3. Sound Chassis with valveholders, screens and coil forms, London, 20/3; Sutton Coldfield, 20/3. Time Base chassis with cut outs and valveholders, 19/-. Power Pack chassis with valveholders and sockets, 26/9.

**"VIEWMASTER" CONSTRUCTOR MANUALS.**—Comprehensive manual with full constructional and operating details, photographs, and large scale plans for the construction in seven easy stages of a first-rate televisor. Available for London, Sutton Coldfield, or Holme Moss transmissions, 5/- or by post 5/6.

**"VIEWMASTER" COMPONENTS.**—Complete list of revised prices, 2/6 post paid. Whiteley: Double-deck conversion assembly, 35/-. WB103 Heater Transformer, 37/6. WB103A Heater-auto transformer, 52/6. WB104 Choke, 15/6. WB105 Special Television 5in. loudspeaker with output transformer, 32/6. WB112 Front and Rear Tube Supports, 18/9. Set of Wearite Coils: London, 20/-; Sutton Coldfield, 28/-; Holme Moss, 28/-. RF Choke, 1/9, 2/-.

**"VIEWMASTER" KITS IN STAGES.**—Holme Moss: (1) £3.2.3, (2) £2.2.9, (3) £4.19.4, (4) 8/11/4, (5) £9.19.10, (6) £6.12.9, (7) £2.13.11. Sutton Coldfield: (1) £3.3.0, (2) £2.2.9, (3) £4.18.10, (4) 8/11/4. Stages 5, 6, 7 as Holme Moss. London: (1) £3.3.6, (2) £2.1.10, (3) £4.5.9, (4) 6/7, stages 5, 6, 7 as Holme Moss prices. Kit of specified valves, £12.8.9. (Brand New, B.V.A. guaranteed.) Please include postage and packing on orders under £2.0.0.

**CATALOGUE No. 8.**—54 pages illustrated on fine art paper. Contains over 2,000 lines. Price 9d. post free.

## Southern Radio & Electrical Supplies

85 FISHERTON STREET, SALISBURY, WILTS

Telephone: Salisbury 2108.



### International Programme Exchange

**A**CCORDING to Dutch television experts, an exchange of programmes between countries in Western Europe will be possible within the next three years.

This scheme would probably include Britain, France, Germany and the Low Countries, and would be operated by repeater stations or a coaxial cable round Europe.

### Interference from Lights

**A**CCORDING to a Midlands electrical contractor, Mr. S. Dagnall, interference on television screens over the Christmas period may have been caused by the on-and-off flashing of fairy-lights on Christmas trees.

Suppressors could be fitted, but only at a cost of between 15s. to £1, and as this was not considered worth while, Mr. Dagnall refused to sell the lights.

### Cinema's Ally

**M**R. J. GOODLATTE, chief of the ABC cinema circuit, believes that the effect of television on box office takings in this country is only slight.

The small drop in cash receipts is even less noticeable in the South, he says, but is being felt more in the North, where viewing is still a novelty, although attendances are not affected at all when such attractions as "Samson and Delilah," "Hornblower" and "The Great Caruso" are being shown.

Mr. Goodlatte praises the everyday housewife and places her second only to the films themselves as the cinema's greatest ally. After a hard day at home it is she who most wants to go out for her entertainment.

### Experimenter Must Buy Licence

**M**R. JAMES R. M'CLEERY, of Londonderry, who has received pictures from the Holme Moss transmitter, has been informed by the G.P.O. that if he wishes to continue with his experiments, he must take out a £2 television licence, in spite of the fact that he is 200 miles "beyond the fringe."

*The Editor will be pleased to consider articles of a practical nature suitable for publication in "Practical Television." Such articles should be written on one side of the paper only, and should contain the name and address of the sender. Whilst the Editor does not hold himself responsible for manuscripts, every effort will be made to return them if a stamped and addressed envelope is enclosed. All correspondence intended for the Editor should be addressed to: The Editor, "Practical Television," George Newnes, Ltd., Tower House, Southampton Street, Strand, W.C.2.*

*Owing to the rapid progress in the design of wireless apparatus and to our efforts to keep our readers in touch with the latest developments, we give no warranty that apparatus described in our columns is not the subject of letters patent.*

*Copyright in all drawings, photographs and articles published in "Practical Television" is specifically reserved throughout the countries signatory to the Berne Convention and the U.S.A. Reproductions or imitations of any of these are therefore expressly forbidden.*

have been caused by the oscillator which controls the University's cyclotron, used for atomic research.

### Television Tape Recordings

**I**T was recently announced in Hollywood, California, that a method of recording television images on a magnetic tape is expected to be ready for commercial use in a few months.

This system is the result of two years of research, financed by Bing Crosby.

### Long-range Reception

**A** FEW weeks before Christmas, a householder at Arley, near Bewdley, purchased and had installed a television set, as had many of his neighbours.

Some days later, every receiver in the area failed to give a picture with the exception of the new one, which appeared to be unaffected. Electricians were called, but they too were baffled by the situation and could find no answer until a check was made with the transmitter at Sutton

### Interference Culprit

**I**NTERFERENCE on sets within half a mile of Birmingham University was finally found to



A party of top officials of the French Broadcasting Authority visited the Marconi Works on Tuesday, November 27th, 1951. They were General Marien Leschi, Directeur des Services Techniques; Monsieur Chamagne, Chef des Services des Recherches; Monsieur Guyot, Directeur des Services de la Télévision; and Monsieur D'Arcy, Technician. The illustration shows General Leschi (fourth from right) inspecting a camera control desk.

Coldfield which, they discovered, was experiencing a technical hitch.

Evidently the new set had been receiving its picture from the Holme Moss transmitter, three times as far away.

#### Kirk O'Shotts Signals

**R**EPORTS are still coming in from all over Scotland telling of "first class and very clear" reception of signals transmitted from the new station at Kirk O'Shotts.

The signal, a black cross on a white background, has been received clearly in Glasgow, Dumfries and other large districts, while in some areas the signal showed up so strongly that the sets were overloaded, although the strength was only five kilowatts.

#### Tax Off for Big Sets

**T**HE Customs and Excise have agreed to exempt from the two-thirds purchase tax all sets which project large pictures on to a screen or wall.

Screens would have to be at least 3ft. by 4ft. to warrant exemption, as a screen of this size would place a set in the cinema television class.

Should this type of receiver become popular, however, the Customs and Excise state that the situation may have to be reviewed.

Costing from £150 to £300, the sets are mainly used in hospitals and nursing homes and are being considered for use in schools when special educational programmes become available.

#### Viewing in the Clouds

**A** BRITISH firm are planning a receiver for installing in airliners, to provide entertainment for passengers.

The biggest snag would be interference from the engines.

#### Writers' School

**A** NEW department of the BBC's Staff Training Centre in London is a school for writers wishing to learn television technique to enable them to produce the necessary dialogue to make shows and programmes a success.

Producer Royston Morley was recently appointed as writing master, teaching trainees of all ages. Applications have been received from Belgium, Holland, Switzerland, Germany, Canada and Australia for places in the school.

#### Appeal from BBC

**T**HE BBC recently appealed for better behaviour from patrons at televised outside events where candid

cameras take close-ups of crowds or where commentators hold interviews with people surging in the background.

Some viewers have complained about hand-waving or face-pulling from people who know that they can be seen at home.

#### Brothers Accused

**T**WO brothers, Walter S. and Earl N. McGuire, of Shadyside, Ohio, U.S., have been charged with illegal relaying of television programmes by the Government in a Federal Grand Jury action.

They are accused of boosting signals from stations outside their area and relaying them over their own antenna to be received by people who normally are outside the range of any station.

#### Colour Recess

**A** RECENT order from the American Government has brought a halt to the broadcasting of commercial colour programmes in the United States. The order, which is being carried out to conserve scarce materials, has caused a minor disruption in some sections of the industry, particularly those making colour conversion kits and others beginning to build complete colour receivers.

#### International Meeting

**I**N W e s t Berlin, from March 3rd to 5th, an international conference on television will be held.

#### New Method of Talent Spotting

**O**NE of the chief reasons for the success of Charlton F.C. during the Christmas soccer season was the constructive, dashing display of Roy Pawson, amateur international outside-left, playing for Charlton for the first time.

Although the club had not previously seen Pawson in the flesh, he was asked to play after Charlton officials had spotted him in matches on television.

#### Broadcast Receiving Licences

**S**TATEMENT showing the approximate numbers issued during the year ended November 30th, 1951.

Region	Number
London Postal .. ..	2,363,000
Home Counties .. ..	1,661,000
Midland .. ..	1,756,000
North-eastern .. ..	1,954,000
North-western .. ..	1,645,000
South-western .. ..	1,078,000
Welsh and Border Counties .. ..	735,000
Total England and Wales	11,192,000
Scotland .. ..	1,115,000
Northern Ireland .. ..	219,000
Grand Total .. ..	12,526,000

The above table includes 1,113,900 television licences. This was a record increase of 81,950 television licences over the previous month's figure.

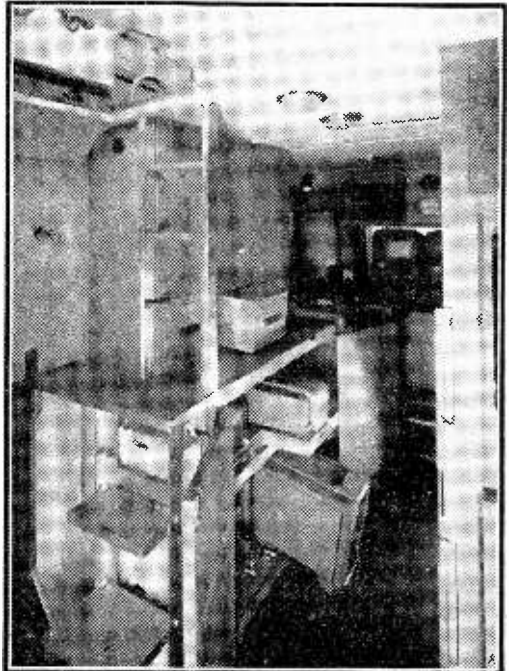

An interior view of one of the two television outside-broadcasting vehicles, designed and equipped by Marconi's Wireless Telegraph Co., Ltd., for the new Canadian television service. The illustration shows (left to right) roof ladder, cameras and viewfinders in their store cupboards and (above) lens boxes, tool storage and spares cupboards.

# PREMIER RADIO CO.

(REGD.) B. H. MORRIS & CO. (RADIO) LTD. ESTAB. 40 YEARS

This is our only address: (Dept. P.T.) 207, EDGWARE ROAD, LONDON, W.2

OPEN TILL 6 P.M. SATURDAYS

Phones: AMBASSADOR 4033 & PADDINGTON 3271/2

TERMS OF BUSINESS:—CASH WITH ORDER OR C.O.D. OVER £1. Please add 1/- for Post Orders under 10/-, 1/6 under 40/-, unless otherwise stated.

**BALANCED ARMATURE, LOW RESISTANCE HEADPHONES.** Type 1, 5/11 pair.

**BALANCED ARMATURE, LOW RESISTANCE HEADPHONES.** Type 2, 7/11 pair.

**HIGH RESISTANCE HEADPHONES,** 12/6 pair.

**LIGHT-WEIGHT HIGH RESISTANCE HEADPHONES,** 14/6 pair.

**MOVING COIL HEADPHONES,** Type 5, 8/11 pair.

**TANNOY HAND MICROPHONES,** with switch in handle, 4/11. Post and insurance 2/-.

**BRAND NEW R1155 RECEIVERS,** In original cases, complete with 10 valves, £12/10/-, 7/6 Packing and Carriage.

**BRAND NEW R1355 RECEIVERS,** In original cases, as specified for the "Inexpensive Television," complete with 11 valves, £2/15/-, 7/6 Packing and Carriage.

**TUNING CONDENSERS,** 4-Gang, .0005 mfd. Ceramic insulation, in 1 spindle, 5/-, 9-Gang, .0005 mfd., 1 spindle, 7/6.

**GERMANIUM CRYSTAL DIODES,** wire ends, midjet size. The ideal Crystal Detector, G.E.C. or B.T.H., 4/6 each.

**CRYSTAL MICROPHONE**

An entirely insulated crystal microphone which can be safely used on A.C./D.C. amplifiers. High impedance. No background noise, really natural tone. The ideal Mike for tape, wire and disc recording and sound projectors. Price 22/6.

**SPECIAL OFFER OF ADMIRALTY REFLEX-RE-ENTRANT P.A. LOUD-SPEAKERS,** v/coil 7 ohms. Matching transformers 4.5-1 and 6-1 ratios with vol. control at max. Very sensitive and directional. Single unit, 55/-. Twin units, 75/-. Carriage and packing, 5/-.



**SENSATIONAL OFFER**

The famous Dulci Midget Receiver for use on either A.C. or D.C. mains, 200-250 volt. This is a 2-waveband 4 v. Superhet Receiver covering the short waveband from 13.6 metres to 50 metres, and the medium waveband from 200-550 metres. Can be supplied in either ivory or brown bakelite cabinet. Size 7 1/2 in. length, 6 in. height, 6 1/2 in. depth.

This receiver is fully covered by the manufacturer's guarantee. Price £8/15/0, carriage paid.

**THIS OFFER CANNOT BE REPEATED.**

**NEW BABY ALARM KIT**  
A tremendously improved and re-designed version of the famous Premier Baby Alarm Kit, consisting of a Kit of Parts in Plastic Cabinet to construct a device to enable Baby's cries, or even breathing, to be heard in any selected room in the house. Consists of a 2-valve amplifier (A.C. mains-operated 200 250 volts), with a Midget Telephone used as a Microphone. A 9 in. Loudspeaker is now incorporated in the kit which together with other improvements in the design have resulted in tremendously improved sensitivity and quality of reproduction. May be left permanently connected. Extra Microphones in different colours may be used without impairing the efficiency of the Unit.

The lead from Microphone to the Unit may be up to 60 ft. in length. Complete with Valves, Circuit and Instructions. 69/6.

**PREMIER SUPERHET COILS,** 16-50, 180-550, 800-2,000 metres. Set, with circuit, 10/6.

**EX-U.S.A. U.I.F. AERIAL,** with untuned detector stage consisting of VR92 valve, etc. Brand new in carton, 5/-.  
**T.V. WHITE RUBBER MASKS (CORRECT ASPECT).** We can supply a specially designed White Rubber Mask for 6in. C.R. tubes at 8/6 each, 9in. White Masks, 9/6, 12in. White Masks, 16/11. Round or flat-faced.

**IMPORTANT ANNOUNCEMENT:** We cannot accept responsibility for, or guarantee any kit or component sold as a Premier product by firms other than ourselves. All prices quoted are those ruling at the time of submitting advertisement copy, and are subject to alteration without notice.

## Television at 200 miles

NEW MODEL SC23 TV PRE-AMPS. ALL CHANNELS



- High gain and low noise.
- Customs built to the highest standards.
- Ample bandwidth for good definition.
- Ideal for the "difficult" fringe and ultra fringe areas.
- Each pre-amp. supplied guaranteed to have been "air tested" and to have received both vision and sound at 200 miles using a standard commercial superhet. receiver.
- Models SC22 and SC23 have self-contained metal rectifier power supply, 200/250v. A.C.
- 12 months' guarantee.
- Immediate delivery.

**RETAIL PRICE LIST**

(Trade enquiries invited)

SC23, new model, £5. 5. 0.      SC22, two-stage, £8. 10. 0.  
SC21, two-stage, £6. 6. 0., requires power supply.  
SG12, TV Sig. Gen., £6. 19. 6.      PG11, Patt. Gen., £14. 0. 0.



**TELEVISION SIGNAL GENERATOR**

- Frequency range 40/70 Mc/s.
- Calibration chart for all Television Channels.
- Modulation on sound and vision optional.
- Sensitive meter fitted for use as grid dip oscillator.
- Ideal for service engineer and experimenter.
- Measures coil, aerial frequencies, etc.
- The only one of its kind on the market.
- Self-contained power supply, 200/250v. A.C.
- 12 months' guarantee.
- Immediate delivery.

**J. V. RADIO CO. 84, EMBANKMENT ROAD, PLYMOUTH.**  
Manufacturers of Television Equipment. Tel. 4737.

THE WORLD'S MOST FAMOUS WORK OF REFERENCE

# ENCYCLOPAEDIA BRITANNICA

The oldest, most honoured and widely read Encyclopaedia  
in the English language

It stands, unchallenged, as the most authoritative work of reference in the world, with over 4,000 contributors of international repute. But it is more than a great storehouse of knowledge. By keeping you up-to-date, year by year, under a unique 10-year plan, Encyclopaedia Britannica becomes an investment paying continuous dividends.

You can own the SECOND LONDON PRINTING by means of one of the simple monthly subscription methods. Send to-day for full details.

..... FILL IN AND POST TO-DAY .....

**ENCYCLOPAEDIA BRITANNICA LTD.,  
PT1, Britannica House, Dean Street, London, W.1.**

Please let me have complete details of the latest Encyclopaedia Britannica, including particulars of the Supplementary Services and the subscription methods of payment.

Name .....

Address .....

.....



TELEVISION PICK-UPS AND REFLECTIONS

# UNDERNEATH THE DIPOLE

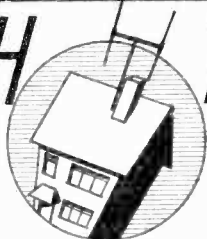

By Iconos

SUNDAY night is one of the peak viewing nights—a fact which makes it rather surprising that the plays presented on the Sabbath are repeated on another day of the week—usually on Thursdays. To cap this obvious limitation of the choice of programmes, the “long-haired boys” seem to be having rather more than their fair share of Sundays (and Thursdays). Christopher Fry, the poet and playwright, once more provided the fare considered suitable for peak-viewing periods, and his *A Sleep of Prisoners* was duly served up on Sunday night with an encore on Thursday.

WHO SAW IT?

NOW, I am perfectly willing to admit that my taste in entertainment is not highbrow and that I rarely listen to the Third Programme. Therefore, I will not comment upon a play which had so little appeal to me that I switched off after twelve minutes and spent the rest of the evening listening to *Calling All Forces* and Radio Luxembourg. During the next few days, however, I solicited the opinions of the circle of friends-and acquaintances who form my own private “galloping poll.” I struck a blank. As I have previously mentioned, there are 30 persons in this circle, including myself, and not a single one had seen the complete production of *A Sleep of Prisoners*, though a few had switched on and viewed it for a short period. Some of them had deliberately avoided viewing it, having been forewarned by the advance description in the *Radio Times*. Of those who attempted to sit it out, one person achieved 20 minutes and another about 15 minutes—but most of them gave up the struggle after a very few minutes. The “Gallopings Thirty Poll” can therefore be summarised as follows:

Viewed complete play.....	Nil
Viewed between 10 and 20 minutes of it.....	3
Switched off after less than 10 minutes.....	7
Didn't switch on at all (because it didn't appeal).....	6
Otherwise occupied.....	12
Indisposed.....	1
Went to sleep after about 5 minutes.....	1

I am not dogmatically asserting

that *A Sleep of Prisoners* was a bad play—but I am saying that it is a play which was quite unsuited to television, and obviously scared very many viewers from even switching on. Christopher Fry is, I am told, a brilliant poet whose works have filled theatres in London and New York and whose name is destined to make theatrical history. So what? Viewers cannot be forcibly made to view any more than potential cinema-goers can be press-ganged into their local “flicks.” Therefore, it would be a wise move if Mr. Barnes, head of the BBC's TV, exercised his authority and confined this ultra-Third Programme material to less important nights, with *no* repeats. Alternatively, of course, he could omit this supra-highbrow stuff altogether until an alternative service is available, otherwise there is a risk that on “long-haired” nights the TV service will degenerate into *A Sleep of Viewers*.

NORMAN WISDOM

WHAT a magnificent array of talent took part in the TV

Christmas Party. Norman Wisdom, recently returned from America (where he appeared as a guest in the Ed Sullivan programme in New York last November), proved that his particular line of comedy is well suited to TV. When he was in America, he took a trip to Hollywood for a “look around,” and amongst other things was shown a television set by Stan Laurel which gave a choice of *twelve* programmes—most of them absolutely first-rate in entertainment value. He flew back to England to play the part of “Buttons” in the pantomime *Cinderella* at Wolverhampton, with a day off for the BBC Christmas Party. With comics like Jewel and Warris, Norman Wisdom, Vic Oliver, Terry Thomas and Ethel Revnell in the party, an hilarious time was had by all. This, at any rate, was an occasion when the longed for alternative programme was unnecessary—slick production and a rapid barrage of new and old gags, which appealed alike to London, Midland and Northern viewers.

NEWSREEL PROGRESS

BEFORE the war, the BBC ran a commercial cinema newsreel. After the war, the Newsreel Association decided that they could not, in fairness to their normal customers, allow any of the commercial newsreels to be shown by the BBC. As

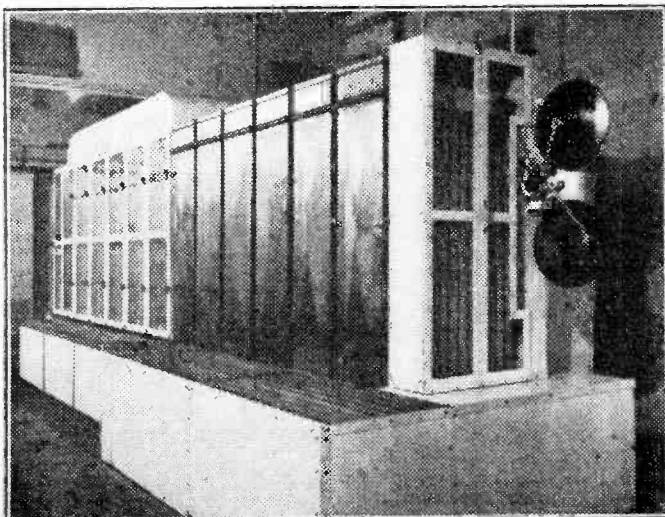

The Vinten “Spraymaster” processing machine—black and white.

the N.R.A. represented all five British newsreels (Gaumont-British News, Movietone News, Universal Newsreel, Pathé News and Paramount Newsreel) the BBC had no alternative but to organise and produce their own newsreel. For the first few months of its existence, the BBC newsreel betrayed an amateurish, hesitant make-up, and no doubt the complex organisation of this highly specialised form of news dispersion suffered from an abnormal amount of teething troubles. My comments in this column were not always kind to the producer, Philip Dorté, and his editors. However, progress was certainly made in the hard way and the modern Television Newsreel is probably better than any other TV or cinema newsreel in the world. Meeting Dorté recently, I mentioned some of the harsh criticisms I made about the editing, musical backgrounds and commentaries of these early efforts, in which every known elementary mistake seemed to have been made. I was contrite. "But you were right," he said. "I've been looking at some of our earliest issues and they look pretty grim now!" It is Dorté who is not entirely satisfied now. Having secured the initiative, he is gradually introducing newer and better techniques and improvements in organisation.

#### LABORATORY COSTS

A FEW months ago, I mentioned a high-speed automatic developing machine made by the French firm of Debrie. Now comes news of a British machine, the Vinten "Spraymaster," an elaborate affair in which the developing solution is sprayed through a large number of jets on to the film. These jets partially atomise the solution, which gives very much improved resolution to the negative in the development process. A machine on somewhat similar lines is the "Harcourt Special," another British-made processing machine. These spray development machines, one of which is illustrated, are expensive units, however, involving a capital outlay of upwards of £10,000. The equipping of a complete developing and printing laboratory does not end, however, with an automatic developing machine for dealing with negatives. There is the printing process, requiring expensive and precision-made printing machines; grading and testing equipment; a developing machine for dealing with positive prints and a complex array of plumbing, air conditioning, filtration and

the like. A modern film processing laboratory could not cost much less than £100,000—and with the present rise in prices, might cost as much as £120,000. This capital outlay is not the end, however, and a staff of at least ten persons would be required. Such a plant, though comparatively small, would be capable of dealing with many thousands of feet a day—far more than the BBC's requirements. Therefore, the obvious and desirable state of affairs which would give the BBC complete control of printing and processing, is a very expensive item to install and maintain. Sooner or later, the BBC will have their own laboratory for processing newsreels and other film items, including tele-cine recordings. But money is tight just now!

#### THEATRE SHOWS

I MUST say that I was a little impatient when I read that the

Musicians' Union and Actors' Equity were seeking to ban the televising of stage plays. One of the reasons given was that actors could not do justice to stage work before an audience and to the TV camera at the same time. The relay from the Dudley Hippodrome of *Cinderella* seemed to justify this point of view. Lighting was definitely below par and the usual limitations of working in a theatre seemed to be more accentuated than usual. The best that could be said about this show was that the show itself was good, deserving of better technical presentation on TV. The occasion was the dress rehearsal, before an invited audience. I hope that local viewers went along to see its subsequent performances at Dudley Hippodrome, thereby encouraging more theatre people to give facilities to the BBC. And I hope the BBC cover the technical snags better next time.

## Here and There

#### Appeal to Motorists

A LEAFLET containing an appeal from the Postmaster-General to motor-car owners to fit suppressors to their cars in order to reduce interference with television reception was distributed to car owners in England, Scotland and Wales who renewed their Road Fund Licences during the current renewal period.

A Post Office spokesman said that motor-cars are probably the sources of wireless interference which most frequently affect television reception. The Postmaster-General is appealing to motorists for their voluntary co-operation in fitting suppressors to their vehicles so that they and their friends will be able to enjoy clearer television reception whenever they view.

#### Televised Hearings Criticised

THE New York State Bar Association's Committee stated recently that the televising of hearings was a jeopardy to individual rights and that an atmosphere "of Kleig lights, clicking cameras, flashbulbs and microphones" could do nothing but impede the efficient running of the hearings.

#### Sport

AN announcement is expected shortly from The Television Sports Advisory Committee concerning efforts that are being made to reach some agreement over the televising of sporting events.

The committee is expected to favour the broadcasting of all forms of sport and, if necessary, to televise only parts of matches, events or meetings should promoters not favour the transmission of whole programmes—that is, the first or second half only of a football match or one period of an ice-hockey game.

Some sporting associations have had no objection in the past to the televising of complete relays—the Lawn Tennis Association and the Rugby Union, for instance—but most promoting bodies feel that though the idea may have advertising qualities, the relaying of a complete afternoon's sport would affect attendances and cash losses would be the inevitable result.

#### Viewing in Ireland

IT is understood that approximately 1,000 people in Dublin have access to a TV receiver and that reception is good.

Mr. Harry Wilson, who pioneered in producing television, says that there are 250 sets in Dublin alone and quite a few out in the country, including one owned by a resident of Mayo, who receives an excellent picture.

#### "American Menace"

IN a cable from California, U.S., where he is staying, "Wee Georgie Wood," considers television in the United States to be a "menace to the country."

## DUKE'S

**Radio and Electrical Accessories by Post**  
**COLOUR TELEVISION**—The very latest development in T.V. accessories. Glare-free and natural colour viewing is now possible with this new colour filter. Price £1. Send for illustrative leaflet. For screens of all sizes, and also works with black screens and magnifying lenses.

**T.V. LENSES**—Magnifies picture 11 times. For 8in. and 9in. screens. 55/- For 10in. and 12in. screens. 75/- Tinted for anti-glare and daylight viewing. 5/- extra. Postage 2/6.

**SALVAGE RADIO BARGAINS**—A.C. and Universal Radio-Gram Chassis, All-Wave 1952 models. Price £9/17/6. Latest pin-type midget valves. These sets were made to sell at three times this price. Satisfaction guaranteed or money refunded. A real "winner" ready to build into your own cabinet. Complete line-up of valves and other information sent by return of post.

**BESIDE RADIO**—This new 4 Valve TRF Midget Radio Kit can be built by any amateur constructor with the aid of our complete instructions, including point-to-point wiring list. For A.C. or Universal, with choice of Ivory, Green or Walnut Plastic Cabinet. Price £5/12/6. Assembled ready for use. 35/- extra. Postage 2/6.

**EXTENSION SPEAKERS**—Price 19/6. 5in. Speaker in attractive polished wooden cabinet. Miniature moving-coil "phone speaker, 1 1/2in. diameter, price 5/9. Ideal for quality microphone. Matching Trams, multi-ratio (2 to 40 ohms) and pentode for above for use either in receiver or as an extension, price 4/9. Postage 1/- per speaker.

**CONDENSORS**—Electrolytic. 16 x 16 mfd., 500 v. D.C. 4/9 ea. 12 x 12 mfd., 350 v. D.C. 4/9 ea. 8 x 8 mfd., 350 v. D.C. 3/9 ea. 8 mfd. 350 v. D.C. 2/9 ea. Bias 50 mfd. 12 v. D.C., 6d. ea.

**INSTRUMENT STORAGE CASES**—Price 3/6 ea. Brand new ex-W.D. stock, tin, laminated plywood, with steel hinges and locking device. Size 9in. x 9in. x 7 1/2in. Smaller size, price 2/6. Size 7 1/2in. x 6 1/2in. x 6in. In sheet steel with carrying straps, size 10 1/2in. x 8 1/2in. x 5 1/2in. Price 2/- Ideal for tools, fishing tackle, etc. Postage 1/6 per case.

**MICRO SWITCHES**—Price 3/6 ea. Precision made by well-known manufacturer, ex-W.D. type in perfect condition. Postage 6d.

**MOTORS**—160-250 v. A.C. or D.C., 1/16 h.p., shaft 1in. by 5/16in. dia. Made by Croydon Manufacturing Co. Price 39/6. post 2/6.

Money Back Guarantee. Cash with order or C.O.D.

Send stamp for Catalogue or Valve List to

DUKE'S, 621, Romford Rd., Manor Park, London, E.12.  
 GRA. 6877. A/c at 219, High Lane, Romford, Essex. H.E.  
 MAIL ORDER OFFICE AT 621.

## ARTHURS HAVE IT!

### LARGE VALVE STOCKS

### TEST METERS IN STOCK

#### "AVO," "TAYLOR" TEST METERS AND SIGNAL GENERATORS

Leak Point One Amplifiers	... ..	£28 7 0
Leak Pre-amplifiers	... ..	9 9 0
Leak Tuning Unit	... ..	36 17 4
Chapman Tuning Units	... ..	17 6 8
Crystal and Moving Coil Microphones.		
Decca Replacement Heads and Pickups.		
Goodman's Axiom 150 Speakers	... ..	10 5 6
Partridge Output Transformers (or Williamson Amplifiers	... ..	6 12 0
Cossor Double Beam Oscilloscope	{ 1035	85 0 0
	{ 1049	120 0 0

#### LATEST VALVE MANUALS

#### OSRAM & BRIMAR No. 4. 5/- each

#### TELEVISION SETS, WIRE AND TAPE RECORDERS ALWAYS IN STOCK

Goods offered subject to price alterations and being unsold

*Arthurs* first  
 Est. 1919  
 PROPS: ARTHUR GRAY, LTD.

OUR ONLY ADDRESS: Gray House,  
 150-152 Charing Cross Road, London, W.C.2

Temple Bar 583314 and 4765 WRITE FOR LISTS  
 TELEGRAMS—"TELEGRAY, WESTCENT, LONDON"  
 CABLES—"TELEGRAY, LONDON"

## VIEWMASTER

### LINE TRANSFORMERS

24/6 post 6d.

### SCANNING COILS

29/6 post 6d.

Trade supplied. Quotations on application.

### AUDIO LTD.,

37, HILLSIDE, STONEBRIDGE,  
 LONDON, N.W.10.



### QUALITY TELEVISION COMPONENTS

SCANNING COILS P.M. FOCUS UNITS  
 6/10 kV. R.F., E.H.T. UNITS  
 E.H.T. and OUTPUT TRANSFORMERS  
 LINE FLY-BACK E.H.T. UNITS

"TELEVISION CIRCUITS"

Third Edition, 64 pages, 2/6

**HAYNES RADIO Ltd.,** Queensway, Enfield,  
 Middlesex.

## WALTON'S OF WOLVERHAMPTON

**HEAVY DUTY 8in. EXTENSION SPEAKERS**—Brand new, in maker's sealed boxes. 25/-, plus 1/- postage.

**4,000 OHM SUPER SENSITIVE HEADPHONES**—Made by S. G. Brown and including special ear pads, and lead with Jack Plugs. Ideal for Crystal Sets. Laboratory work etc. worth 40/- NEW IN BOXES. 15/-, plus 1/- postage.

**FERRANTI A.F.3 INTERVALVE TRANSFORMERS**—3/6, plus 9d. postage.

**U.S.A. CATHODE RAY TUBES**—5 NPI, sealed crates. 15/-, plus postage 2/6.

**NUTS, BOLTS, SCREWS AND WASHERS**—Mainly B.A. sizes and approx. 1,000 items. 3/6 box, plus 1/- postage.

**RIVETS**—1/16in.-1in., mainly aluminium. 3/6 box, plus 9d. postage.

**Polyethylene DIPOLE INSULATORS**—5/- each, plus 1/6 postage.

**HOLME MOSS DIPOLE AERIALS**, complete with elements and centre insulator, 17/6 each, plus 2/6 postage.

**SUTTON COLDFIELD DIPOLE AERIALS**—15/- each, plus 2/6 postage.

Send s.a.e. for latest clearance list.

**WALTON'S WIRELESS STORES, 48, STAFFORD ST., WOLVERHAMPTON**

### NOW READY

For the

## VIEWMASTER

(KIRK o'SHOTTS)

SETS OF COILS  
 WIDTH CONTROLS  
 BOOST CHOKES  
 RF CHOKES

### OLYMPIC RADIO COMPONENTS,

COIL WINDING SPECIALISTS.

224, HORNSEY ROAD, HOLLOWAY, N.7

Phone: NORth 2914.

**GEE Bros. RADIO Ltd.**

GUARANTEED GOODS AT  
COMPETITIVE PRICES

1.50 pencil rectifiers, 400v. at  
2 m/a., 6/9.

.5 T.M.C. condensers. 3.5 K.v.  
working. 2½ in. round x 6in., 4/9.  
V.C.R.138 (ECR35), 3½ in. C.R.  
Tube (New), with mu-metal screen,  
mask and base, 40/-.

3BP1 3in. C.R. Tube. Brand new,  
25/-.

10in. Elac. P.M. L/Speakers, 3 ohm  
speech coil, 25/-.

P.M. Focus magnets for Triode or  
tetrode tubes, any type, high or  
low flux, 20/-.

90v. and 1½ v. dry batts. in good  
condition (ex-Govt.), size 7½ x 4½  
x 3½ in., 6/6.

2½ in. round 0-100 micro-ampmeter,  
scaled as 0-1,500 yds., 25/-.

Collaro 3 - speed auto-record  
changers, R.C.3511, complete with  
dual-speed crystal head, brand new,  
£15.10.0.

80 ohm ¼ in. dia. co-axial cable,  
1/- per yard.

465 Kc. I.F.T.'s standard size,  
Wearite, 10/6 pair.

300v. H.W. Selenium metal recti-  
fiers, 100 m/a., 6/9.

**GEE BROS. RADIO LTD.**  
15, Little Newport St., London,  
W.C.2. Tel.: GER. 6794/1453

**THE MODERN BOOK CO.**

**The Principles of Television Recep-  
tion**, by A. W. Keen. Price 30s. 0d.,  
postage 9d.

**Osram Valve Manual. Part One**,  
by G. E. C. Price 5s. 0d., postage 6d.

**The De Luxe Home Built Televisor  
and Radiogram**, by W. I. Flack.  
Price 6s. 6d., postage 3d.

**Television Receiving Equipment**,  
by W. T. Cocking. Price 18s. 0d.,  
postage 6d.

**Practical Wireless Encyclopaedia**,  
by F. J. Camm. Price 21s. 0d., post-  
age 9d.

**Television Explained**, by W. E. Miller.  
Price 5s. 0d., postage 4d.

**Sound Reproduction**, by G. A. Briggs.  
Price 10s. 6d., postage 6d.

**Radio Valve Data**, compiled by 'Wire-  
less World.' Price 3s. 6d., postage 3d.

**Basic Television**, by B. Grob. Price  
5s. 6d., postage 10d.

**Television and F.M. Receiver Ser-  
viceing**, by Milton S. Kiver. Price  
22s. 6d., postage 10d.

**Television Simply Explained**, by  
R. W. Hallows. Price 9s. 6d., postage  
4d.

**High Definition Television Construc-  
tion Manual**, Price 3s. 6d., postage  
2d.

**The Encyclopaedia of Radio and  
Television**, published by Odham's  
Press. Price 16s. 6d., postage 9d.

**Time Bases**, by O. S. Puckle. Price  
30s. 0d., postage 9d.

**Television Servicing Manual**, by  
E. N. Bradley. Price 4s. 6d., postage  
9d.

We have the finest selection of British  
and American Radio books in the  
Country. Complete list on application.

**19-23, PRAED STREET,  
(Dept. PT.2) LONDON, W.2.**

PADDINGTON 4185.

**G.E.C.**

**GERMANIUM  
CRYSTAL DIODES****LATEST, SMALLEST  
SUPREME CRYSTAL DETECTOR**

Midget Size, 15/16in. x 3/16in.  
Wire Ends for Easy Fixing.  
4/6 each, postage 2½d.  
Technical Details and Selected Types  
available.

**SILICON CRYSTAL VALVE**  
3/6 each, postage 2½d.  
Fixing Brackets 3d. Extra.

**COPPER INSTRUMENT WIRE**

ENAMELLED, TINNED, LITZ  
COTTON AND SILK COVERED  
Most gauges available.

B.A. SCREWS, NUTS, WASHERS.  
soldering tags, eyelets and rivets.  
EBONITE AND BAKELITE PANELS  
TUFNOL ROD, PAXOLIN TYPE  
COIL FORMERS AND TUBES  
ALL DIAMETERS.

ERIE AND DUBILIER RESISTORS.  
Latest Radio Publications  
SEND STAMP FOR LISTS  
TRADE SUPPLIED.

**POST RADIO SUPPLIES**

33, Bourne Gardens,  
London, E.4.

**VIEW MASTER****SPECIAL OFFER**

Complete set of resistors for the View Master.  
Every resistor packeted and labelled with the value  
and number.

London, 26/-. Midland and Northern, 24/9.

All View Master components are available  
separately and a fully detailed list will be sent  
upon request.

**M. WATTS & CO.,**

8, BAKER STREET, WEYBRIDGE, SURREY

**VALVES or COMPONENTS?**

—★—  
VALUE, QUALITY AND  
EXPRESS SERVICE FROM

**COVENTRY RADIO**

COMPONENT SPECIALISTS SINCE 1925

189, DUNSTABLE ROAD, LUTON. BEDS.

Phone: LUTON 2677

**"ADCOLA" SOLDERING INSTRUMENTS**

Reg. Trade Mark



Regd. Design No. 860302

(British, U.S. and Foreign Patents.)

For Wireless and Television Assembly

The advanced design of the Adcola Instruments meets the modern  
requirements of Television, Telecommunication and  
Radio Engineers.

SUPPLIES FOR ALL VOLT RANGES FROM 617 v. to 230/250v

3/16in. dia. Bit. Standard Model ... 22/6

1/4in. dia. Bit. Standard Model ... 25/-

3/16in. dia. Detachable Bit. Model ... 30/-

Sole Manufacturers

**ADCOLA PRODUCTS LIMITED**

GENERAL OFFICES AND WORKS

Cranmer Court, Clapham High Street, London, S.W.4  
(MACaulay 4272)

THE NEW 1355 CONVERSION . . . . The now famous  
self-contained TV receiver. Data for all Five TV channels,  
3/- per copy.

**MAINS TRANSFORMER**, as specified, 52/6, metal recti-  
fiers as specified, 4/6 each.

**RECEIVER TYPE 1225**. A UHF receiver, containing five  
EF50's, two EF39's, and one EB34: Chock-full of useful  
components, these are pre-tuned to four predetermined  
frequencies, and may easily be slightly modified for normal  
UHF working. 39/6 (1/6 post).

**POWER UNIT 532**. Containing 5Z4, VU120 EHT rectifier  
(5,000 v., 2 v. indirectly heated) two transformers, one  
smoothing choke, high resistance relay, 1, 2½ kV. condenser,  
two other condensers, etc., etc., complete with our 50 cps  
conversion data for EHT (approx. 1,800 v.) or H.T. (approx.  
450 v. at 50 mA), 17/6 (2/3 carriage).

**RADIO EXCHANGE CO.,**

9, CAULOWELL STREET, BEDFORD.

Phone: 5568.

## CORRESPONDENCE

The Editor does not necessarily agree with the opinions expressed by his correspondents. All letters must be accompanied by the name and address of the sender (not necessarily for publication).

### R1124 AND TV SOUND

SIR,—I have seen the above receivers advertised as being suitable for television sound.

Have any readers successfully used it for Holme Moss? If so, could details of conversion be supplied, please? The location of my address is about 14 miles south of Manchester.—W. BINNING (13, Oakfield Close, Alderley Edge, Manchester).

### "FRINGE AREA RECEPTION"

SIR,—The article in the December issue of PRACTICAL TELEVISION on the above by Bernard Barnard contains numerous errors, and I feel a few of these should be cleared up. These are listed below.

1. Fig. 2 has the switch placed so that the load is short-circuited in the H position. This is hardly what is intended, is it?

2. Fig. 3 has the secondary of the R.F. transformer connected to the mixer by one wire only.

3. Also in Fig. 3 the local oscillator requires an anode load; there is not much point in taking an output from the H.T. + line.

4. Under the heading "Distant Reception," the author refers to "horizontal pickup." This is a very queer term. It might mean anything. Why not use the proper terms, and leave the queer ones to the Americans, who do them so much better than anybody else?

5. The BBC should show some interest in these "ideas" on propagation put forward by Mr. Bernard in this section.

6. Also stated in the section "Distant Reception" is 3λ is approx. equal to 30ft. How are the programmes on 100 Mc/s band?—B. HILL-SHARDLAW (Nottingham).

[The Author makes the following comments:

(1) B.H.-S. is quite right—there is a mistake in Fig. 2. Switch should connect a resistor in and out in parallel with the anode load, thus increasing the load in the High Sensitivity position and decreasing it in the Low position.

(2) and (3). This drawing is not intended to be complete but is a sketch diagram showing the salient features of the circuit only.

(4) The phrase "horizontal pickup" means precisely what it says—normally polarised radiation received by direct ray from the transmitter. The lobes on a vertical polar diagram which indicate this pickup are usually referred to as "horizontal lobes."

(5) No comment.

(6) A half-wave element at TV frequencies is between five and six feet in length; thus three wavelengths are approximately equal to 30 feet.]

### TIME BASES

SIR,—I have been doing a considerable amount of experiment on various time bases recently and some of the information I have discovered may be of use to other readers.

The most satisfactory arrangement I have found to date consists of hard valve oscillators with the necessary oscillator transformers and output valve, transformer fed, to line and frame, somewhat in the manner of the "View Master" circuit. First, to use a 15in. aluminised

tube I have arranged voltage doubling for the E.H.T., the doubler having an alternative arrangement for connecting direct to the output valve anode instead of the transformer which gives the alternative of one-and-a-half times voltage instead of double voltage; by this means I have readily available E.H.T. of 7, 10 and 14 kV.

On the power pack I have also arranged a switch so that I can change from choke to condenser regulation of the rectifier, which effectively means that I have available either 300 or 375 volts as a supply, which in turn gives a further variation to the E.H.T. voltage available. I have found that with cathode input to the C.R.T., even with brilliance turned well down, there is more flash-back on switching off than is desirable, but by using the line amplitude control, which is effectively a variable cathode bias, in the line output valve this, turned down, cuts off E.H.T. and thus such a potentiometer with switch avoids the need to touch the brilliance and contrast controls and thus makes the set simpler for family use. Apart from this the screen resistor to the line output valve, if made from a 30 kΩ wire-wound variable, controls the E.H.T. and amplitude of line and I personally have found the amplitude goes up at a faster rate than the E.H.T., so that variation of this control acts as an aspect ratio control for fine adjustment. When it is turned up there is more E.H.T. and more line scan making the picture wider, but the increase of E.H.T. decreases the frame scan and thus makes the picture shallower. This is a very handy control for compensating mains voltage variations.

Finally, although I was expecting regulation difficulties with the methods of E.H.T. that I have used, in fact, very little difficulty has been experienced, and the variations encountered with a different degree of brilliance are certainly no more than any other normal fly-back arrangement.—G. T. LAYTON (Urmston, Lancs).

### RESIDUAL SPOT

SIR,—With reference to your answer to R. E. K. (Loughborough) re "Switching Off." Some time ago, while working with a projection receiver, the problem arose to kill the bright spot which appeared on the tube face after the main supply was switched off.

This was solved by using a four-pole on/off switch on the brilliance control, in such a manner that when the set was switched off the main smoothing condenser was placed across the grid of the tube so that the grid was held at a negative potential (thereby cutting off the tube) for several seconds, giving the E.H.T. time to die away.

In this case it was found necessary to use a 64μF condenser to give a sufficient time constant, but for other lower E.H.T. tubes a much smaller condenser would probably suffice.—D. M. BROWN (G3GMF) (Hounslow).

### "CONVERTING THE RDFI"

SIR,—I am very interested in the RDFI conversion details given in two recent issues. There are, however, one or two points which I am wondering if you would clarify for me:—

1. Is the suggested power supply meant to supply the time base as well as vision and sound? Would five henries at 200 mA. be a suitable value for the smoothing choke, and how many watts should the 2kΩ and 3kΩ resistors be?

2. Are resistors referred to in the text and lists of components half-watt rating?—J. E. BULSDON (Sidcup).

[There is a printer's error in the diagram of the power

supply, Fig. 7. A tap should be taken from the receiver side of the choke to supply the time base.

The choke mentioned would be quite suitable for the job.

The 2k $\Omega$  and 3k $\Omega$  resistors should be rated at a minimum of 10 watts. The power supply details were not dealt with more fully because of the reasons stated in the article.

All other resistors can be rated at half watt, except the anode load resistors in the time base (1 watt) and VR6, which should be 2 watt.—ED.]

### LINE TRANSFORMER

**S**IR,—No doubt other readers would be interested in some of my experiences in making television components. Not to save money, but to gain experience, I tried to wind a line output transformer. I worked out all the details on the lines of a standard mains transformer, allowed a good margin to take care of the fly-back voltages and then wound a component. I took great care with it (using a home-made winding machine) and finally connected it up. I switched on, heard the customary howl as the time-base warmed up, and then "pop," the transformer broke down. I did this no less than six times before I found the reason. My advice now is that when winding the main winding, each successive layer should be at least two turns fewer on each side, and a stoutish paper interleaving used, so that turns from one layer cannot drop down into a lower layer. This might be well known but I found that it was not simple to keep the turns in their relative layers, and I finally obtained some wax from old ex-Service mains transformers baked up on the gas-stove, and poured this into the winding before handling it too much. I have had the present transformer in use now for nine months satisfactorily.—G. H. JENKINS (Edgware).

### AERIAL SCREENING

**S**IR,—On page 341, January issue, "Erg" says that it must be ensured that there is no obstruction between transmitter and aerial. I should like to recount an experiment of mine on this subject.

I have a Q5R9 loop aerial, which stands on top of my Bush console, with a very short lead down to the chassis.

## Club Reports

### THE BRITISH TELEVISION VIEWERS' SOCIETY

Hon. Sec.: E. W. Gregg, 15, Convent Hill, Upper Norwood, S.E.19.

**MR. JOHN BENTLEY**, television, radio and film actor, addressed members of the British Television Viewers' Society at their monthly meeting at Kemard's Restaurant, Croydon, on Monday, December 3rd. He spoke on the technique of acting on television as compared with radio and film acting and explained methods of using the voice at the microphone.

Following Mr. Bentley's talk a general discussion took place, during the course of which questions on such matters as sponsored television programmes, press criticisms of television and radio programmes and script-writing were put to the speaker. Mr. Bentley was accompanied by Mr. Richard Newcombe, a vice-president of the society, who contributed in no small measure to the success of the meeting.

### LEEDS TELE-VIEWERS' SOCIETY

Secretary: Mrs. D. Wallbridge, 24, Carr Manor Parade, Leeds, 7.

**THE** Leeds Tele-viewers' Society was formed in February, 1951, by a small group of enthusiastic viewers in Leeds, because although not living in the actual reception area of the Sarton Goldfield transmitter, they had been receiving programmes from that station for some months. The idea was to get the society in being before the opening of the new transmitter at Holme Moss, when the viewing public in the area would greatly increase.

The aims of the Society are to gather together viewers for discussions on reception, programmes, interference, etc., and to have lectures at some of the meetings by representatives from the

This aerial is highly directional, and beams on transmitter from full signal to zero.

In a recent experiment I interposed a large brass plate between transmitter and loop aerial, and it had absolutely no effect on the picture strength. I moved the plate to different distances from aerial, and tried it both earthed and unearthed. Also in different positions around the aerial. All had no effect whatever.

This suggests that the transmission must not be regarded like a stream of bullets but as an electrical strain in the atmosphere, more like the pressure strain as recorded by barometer. Hence it is impossible to isolate the aerial by any plate forming what might be expected to be a shield. This may be like sound transmission in which case the mass of the panel is the important factor. I think there is a good deal of imagination at work about aerials as it is difficult to make reliable tests when working with the roof type.

It was my intention to try to screen my loop aerial from interference by fixing laminated foil on two sides, earthed, leaving a gap through which the transmission would beam. From my test it would appear that this is impossible, as the interference, like the transmission, would just pass through it.

It might be noted also that I can only beam a tuned signal and hence interference is picked up from any angle of loop.

I should like some reports on my tests.—GEORGE H. GILL (Manchester).

## THE USES OF TUNING SLUGS

(Continued from page 397.)

suitable. The slugs may readily be inserted in the sleeve if the latter is heated slightly as this renders the plastic more pliable. A tool so constructed is unbreakable.

To sum up, the use of a dust-iron core increases the inductance thereby reducing the tuning frequency of a coil, while a brass slug decreases the inductance and increases the tuning frequency. The dust core, if of the correct type to suit the frequency used, may considerably improve the coil Q, while a little consideration will show that a brass slug may reduce the Q slightly.

TV manufacturers. There is also a technical adviser to give advice to any members who are in any trouble with their reception. Parties have already been round a television factory in Yorkshire, and the Leeds studio of the BBC has been visited to see recorded programmes.

This society is in no way a trade organisation, but is run entirely for the mutual benefit of the members.

Meetings are held regularly at the Griffin Hotel, Boar Lane, Leeds, and the membership is growing every month.

It is hoped to visit the Holme Moss transmitter early in the spring of 1952, and social events have been arranged for during this winter.

### THE TELEVISION SOCIETY—LEICESTER CENTRE

**T**HE committee present the following lecture programme for the current season. The lectures cover nearly all aspects of television and are an endeavour to cater for the interests of all members. The attendances at the various lectures will be a useful guide to the committee when planning future programmes.

The vacant date and this late issue are both mainly due to the difficulty which BBC officials often experience in ascertaining their commitments until near the date of the proposed lecture. This is, of course, unavoidable, but in view of the interest of these lectures this slight inconvenience must be accepted.

February 4th, 1952—Room 104. Awaiting confirmation. Details later.

March 3rd, 1952—Room 104. Mr. H. O. Sampson, Senior Lighting Engineer, BBC Television Service: "The Technique of Television Studio Lighting."

March 31st, 1952—Room 104. Mr. R. Freeman and Mr. E. D. Groom, of Waveform, Ltd.: "The Design and Application of Television Gear."

These lectures are held at the Leicester College of Technology, The Newarke, Leicester, and commence at 7 p.m.

**BARGAINS.**—Condensers . 33/32 mfd. 350v. tub. card. 2/6; 8/500. 2/6; 50/50. 2/6; 16-8-4/500. 7/6; 10-24/350. 5/4; Variables-twin. 0005 5/4; 5/2.5kV. 3/1-. 25/2kV. 2/6; IFTS. canned. new. 10/13mcms or 7mcms (R1355). 1/6; Valveholders. English. pax. asstd. doz. 5/-; Trans. LF (for EHT 2kV). 7/6; fil. trans. 2v. 2a. 6/-; single 3/6, twin with 2-speed reduction 6/6, 4 gang 7/6, 75pf D.E. 2/-; twin 4/-, single 1/3, 50pf 1/6. Murrhead Drivers (black). 7/6. Epicyclic Drives. 1/3. Spindle Couplers. brass. concertina or insulated 9d.; Eddystone type. 1/3. Mains Droppers. 2A or 3A. 5/-; Linecord. 3A 3-way. 1/- yd. Rotary Toggles. 1/-; Williamson Amplifier Manual. 2/6. Pre-amps. type. 6048 17/6, less valves 8/6. Coifformers Pax. slugged. 2in. x 1in. 4 for 1/3. Postage extra. Ask for List with orders. W. A. BENSON, 308. Rathbone Rd., Liverpool. 13.

**TELEVISION.**—Canned 3in. x 2 1/2in. Condensers, 2 cores ea. 2/-; 4in. Polyesterene tagged, cored. 1/2; 1/16 to L18 Video Chokes 18/-. **BEL SOUND PRODUCTS CO.** (Dept. PT), Marlborough Yard, London Archway, N.19.

**VALVE BARGAINS.** 6J6. 20/-; X78. EC91. CV139. 6BA6. 15/-; 6AG5. 6SN7. 6L6. EL33. KT61. KT66. 10/-; GTIC. 807. IT4. 8/6; 1L4. 3Q4. 3A4. N18. EHC33. 7/6; 6C4. 6N7. 12A6. EL32. 6/6; 6AC7. 6Y5. 6C5. L63. S130. 5/-; EA50. 2/6. Special offer of two 1LA and one 3Q4 or 3A4 for £1. T.V. Pre-amps. with EF54, require 250v. H.T. and 6.3v. L.T. only 18/6, complete with power plug; Parmeko Chokes. 10 H. 100 ma. 90 ohms. 6/6. High-voltage Valve Holders. British or American 4-pin. 1/6. Pve Plugs and Sockets. 7/6 per doz. pairs. T.V. H.F. Chokes. wire ended. 6d. Aladdin Formers. 2d. Screened Cable. single 6d., 2-way 3d., 3-way 10d., per yd. Condensers. 100 pf. miniature moulded mica, and 1,000 pf. tubular ceramic. 3/6 doz. Volume Controls. with D.P. switch. long spindle. 10k. 50k. 1 meg. 1/2 meg. 4/-. Add 9d. orders under £1. **ELECTRAD RADIO.** 69, High St., Bellast. N. Ireland.

**PHILIPS AND MULLARD** Negative Feedback Output Transformers; special rewind service; delivery by return; year guarantee. A. McLUCKIE, 141, Lowther Street, Carlisle.

**TIME BASE.** £2. Premier electrostatic. MARSDEN, 3, Lode Lane, Solihull, Birmingham.

**T.V. COMPONENTS** for Practical Television. Viewmaster Electronic Engineering, etc.; 8 x 8 mfd. 350v. cardboard case or alum. case, 3/9; 2mm. and 4mm. Slewing. 3/ doz. yds. 4in. Polyesterene Formers. 1/0; JARVIS, 12, Chatsworth Rd., Manchester, 21.

## TELEVISION COMPONENTS

FOR THE  
"Practical Wireless"  
**VIEWMASTER AND**  
**E. E. TELEVISORS**  
IN STOCK

Price lists of specified and alternative components available on request.

Prompt Postal Service

**J. T. FILMER**

MAYPOLE ESTATE, BEXLEY, KENT  
TEL. Bexleyheath 7267

## RATES

3/- per line or part thereof  
average five words to line,  
minimum 2 lines. Box No.  
6d. extra. Advertisements  
must be prepaid and addressed  
to Advertisement Manager,  
"Practical Television," Tower  
House, Southampton St.,  
Strand, London, W.C.2.

**RADIO SUPPLY CO.**, 15 Wellington St., Leeds.—R.S.C. Mains Trans., 200-250v screened primaries. 250. 250v 70ma. 6.3v 2a. 5v 2a. midget drop-through type. 13/11; 250-0-250v 100ma. 6.3v 6a. 5v 3a. for R1355 conversion. 25/9; 350-0-350v 100ma. 6.3v 3a. 5v 2a. 21/9; 350-0-350v 150ma. 6.3v 4a. 5v 3a. 27/11; fully shrouded. 350-0-350v 250ma. 6.3v 6a. 4v 8a. 0-2-6-3v 2a. 4v 3a. for Electronic Eng. Televisor. 65/-. Closed Field P.M. Speakers. 2-3 ohms. 5in. 12/11; 6in. 14/11; 8in. Rola. 17/9. Fil. Trans. 220-240v primary. 6.3v 15a. sec. 5/9. Electrolytics. 8 mfd. 350v. 1/4; 8 mfd. 450v. 2/3; 16 mfd. 450v. 2/9; 3/3; 8-16 mfd. 21/11; 12-12 mfd. 350v. 1/3; 32-32 mfd. 350v. 6/6; 32-32 mfd. 450v. 7/6. Output Trans. standard Pentode. 5,000 ohms to 3 ohms. 3/11; push-pull. 12 watt. 6V6. 6L6. etc. to 3-5-8-15 ohms. 15/11. New boxed ex-Govt. Valves. D1. 1/3; EA50. VU120A. 954. 956. 9D2. 959. 2/9; VU133. 3/3; M5/ Pen. KT2. 4/9; 6JSGT. 12SH7Met. 12SG7Met. 5/9; 1LA4. 1N5GT. 7/7; 717A. 12A17GT. 6C5Met. 6C6. KT41. L65. 6SS7Met. 12SK7Met. 12SR7Met. 12SQ7Met. 12C8Met. 6/9; KTZ63. 6J7G. 6K7G. 6N7GT. 4SH. 7FT. 7C5. 6S7J. 6SC7. 12AGMet. 7/6; 6K6GT. EF39. 8/9; Pen. 46. VP4B. MHL D6. 5U4G. 6X5GT. IT4. 184. 9/6; 6Q7G. KT66. EB51. 5Y3G. 10/6; 6K8G. 11/9. Smoothing Chokes. Philips. 90ma. 10h. 100 ohms. 3/11. Selenium Rectifiers (ex new equip.). 230v 50ma. 120-0-120v 60ma. 4/9; 250-500v 60ma. 680v 30ma. 6/9. All goods guaranteed. Full list of bargains. Ad. C.W.O. or C.O.D. over £1. Postage 1/3 extra under £3.

**FRESH STOCK CONDENSERS.** 4/450v 2/-, 8/450v 2/6, 16/450v 3/6, 8x16 4/3, 16x16 4/6, 32x32 6/6, 8/500v 3/3, 16x500v 4/6. Orders of 12 less 10%. Leading make 6in. Speakers. 12/6; post 6d. Stamp list. D. F. STRANGE, 52, Pendlestone Rd., London. E.17.

**SPOTLESS RED** EF50 Valves. 7/6; EB91. EF91. 10/-; EF36. EF39. EK32. EL32. 7/6 ea. HVR2A. 6/6. Full range B.V.A. types in stock. Order c.o.d. Co-ax Cable. 4in. 80 ohms. 12/6 doz. yds. Non-mag. Speakers. 5in. 12/-, 8in. 14/6. V/Controls. 10F. 25K. 50K. 100K. 1/-, 1/- and 2-meg. 3/-. W/sw. 4/6. Amplion semi-midget. 4/-. SP/sw. 5/9. DP/sw. 6/6. Bargain list stamp. **RADIO UNLIMITED.** Elm Rd., London. E.17.

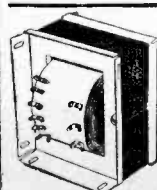

Mains Transformers  
**BRIGHT DROP THROUGH AS ILLUSTRATED.**  
Two Types Only.  
Guaranteed. 80 mA. 0-4-8.3v. 5 amp. 0-4-5v. 2 amp. No. 2. Same, but 350v. Both 16/-, post 1/6 for 1 to 3.  
**HILLFIELDS RADIO.**  
8, Burnham Road, Whitley, Coventry

**COLOUR TELEVISION.** First in the field with the new "Elpico" colour filter; installed in a matter of seconds; beautiful pastel shades with no glare and no eyestrain; supplied in all sizes; 9in. and 10in. 20/-, 12in. 21/-, 15in. 27/6; post 1/-. Order early to avoid disappointment. **RADIO UNLIMITED.** Elm Rd., London. E.17. (KEY. 4813.)

**"VIEWMASTER"** Valves, as specified; all guaranteed brand new and boxed, comprising 5 EF50. 1 KT61. 1 6P25. 1 FBC33. 1 EB91. 2 6K25. 1 6P28. set of 12. £6/9/6. New boxed, EF50. 7/6; 6AM6. EF91. 6P12. 6AL5. EB91. 6D2. 10/-; EY51. PL38. EC91. 18/6; 6C9. UCH42. 16/6; 6F15. 13/6; UO9. AZ31. 11/-; PZ30. 16/6. Miniature all-dry Battery types. 155. 1R5. IT4. 3V4. 8/9; 354. 10/-; HVR2A. EFB. KT2. 7/9; 6K7G. 6K7GT. 6/6; 9D2. 4/6. All valves guaranteed brand new and boxed. P.M. Speakers. latest types. 2 1/2in. 5in. and 6 1/2in. 12/6; 8in. 13/6. C.W.O. Post paid 20/- **READERS RADIO.** 24, Colberg Place, Stamford Hill, London. N.16.  
**GUARANTEED Valves:** 6K8G. 6Q7GT. 6SL7GT. 6SN7GT. 10/6; 6V6G. 5U4G. 807. 9/6; 25L6GT. 6X5GT. VU39. 9/-; 7C5. 7B6. 12K8. 8/6; 6G6G. 6F8G. 6J7G. 1LN5. 6/9; 12A6. 12J5GT. 12SR7. 6/6; HL2. 7193. 2/-; Special offer: 6J5GT. 4 for 15/-. Postage 6d. C.O.D. or C.W.O. List now available. S.A.E. Send us your valve requirements. **ELECTRO-SERVICES & CO.** 28, Ethelburga Street, S.W.11. (BAT. 2964.)

## EDUCATIONAL

**TELEVISION.**—The Gothic Television School, devoted exclusively to training in Television, prepares students to Brit. I.R.E. and R.T.E.B. examination standards. Correspondence course prospectus from the Secretary. **GOTHIC TELEVISION SCHOOL.** 13, North Avenue, London. W.13.

**FREE!** Brochure giving details of Home Study Training in Radio, Television and all branches Electronics. Courses for the hobby enthusiast or for those aiming at the A.M.Brit.I.R.E. City and Guilds Telecommunications. R.T.E.B. and other professional examinations. Train with the College operated by Britain's largest electronic organisation. Moderate fees. Write to E.M.I. INSTITUTES, Postal Division, Dept. PT28, 43, Grove Park Road, London. W.4. (Chiswick 4417.) (Associated with H.M.V.)

**TELEVISION** Servicing and Theoretical (postal) Courses at extremely moderate fees are available from the Institute of Practical Radio Engineers, either for study or as reading matter only. Syllabus post free from the Secretary. I.P.R.E., 20, Fairfield Road, London. N.8.

When you are planning to use  
**ALUMINIUM, LIGHT ALLOYS,  
BRASS, COPPER, BRONZE,**

remember . . . you have a  
choice of 3,000 stock sizes of  
**TUBE, ROD, BAR, SHEET, STRIP,  
WIRE, ANGLE, CHANNEL, TEE**

at  
**H. ROLLET & CO. LTD.**  
6, CHESHAM PLACE, LONDON, S.W.1

Phone: SLOane 3463  
WORKS:  
32/36, ROSEBERY AVENUE, LONDON,  
E.C.1.

KIRKBY TRADING ESTATE  
LIVERPOOL

"No Quantity too Small"

# TRADE TOPICS

## Emitron Tubes

**E**LECTRONIC TUBES LIMITED, of High Wycombe, announce that Emitron valves and Emitron cathode-ray tubes are now available to the maintenance market. Distribution is through the usual BVA channels.

The initial range consists of types of Emitron valves and tubes which are already in extensive use by various set makers and for which a regular market is thus assured. Details of the initial range will be advised at an early date. The range will be extended as required from time to time.

Display matter and literature for the use of dealers is already at hand. Further announcements about these Emitron products will be made as circumstances demand.

The managing director of Electronic Tubes Limited is Mr. Bruce Wilkinson, and the sales manager, to whom trade enquiries should be addressed, is Mr. A. J. Morley, Electronic Tubes Ltd., Kingsmead Works, High Wycombe, Bucks, England.

## Miniature Silvered Ceramics

**S**PHERE RADIO announce that they are now manufacturing miniature silvered ceramic capacitors and allied small components. This part of the business will eventually be dealt with by an associate company, "Jay Developments," now being formed.

A new factory is in course of erection in Bromford Lane, West Bromwich. This should be completed by the summer of 1952, and until that time all inquiries will be dealt with at the present address in Heath Lane.—Sphere Radio Ltd., Heath Lane, West Bromwich.

## Clydesdale Bargains

**T**HE Clydesdale current complete list No. 8 is now available. In a handy pocket size, this 180-page illustrated bargain list may be obtained by readers on receipt of a remittance for 1s. 6d.—Write to Clydesdale Supply Co., Ltd., 2, Bridge Street, Glasgow, C.5.

## V.H.F. Signal Strength Meter

**T**HE new E.M.I. signal strength meter for use at V.H.F. is now in production and is illustrated here.

This instrument, a prototype of which was seen at the National Radio Show at Earls Court, provides a ready means of measuring signal strengths in a given locality and of checking aerial output and orientation for optimum results. The signal generator, which forms an integral part of the signal strength meter, can also be used independently for the alignment of tuned circuits, etc.

The wide range of frequencies covered by the signal strength meter (40-70 Mc/s) encompasses the existing and projected high-power BBC television stations, and many other short-wave and amateur transmissions.

It is completely portable, having its own vibrator power supply, fed from an internal 2 volt accumulator. An inbuilt A.C. mains charging unit is also incorporated to enable the accumulator to be recharged when necessary.

Applications of the V.H.F. signal strength meter are many and varied. Dealers will find it of immense value in checking customers' television aerial installations; it can be used to great advantage by aerial installation contractors to determine signal strengths at various

points in a multiple installation, and by television and short-wave aerial manufacturers for the design and testing of their products.

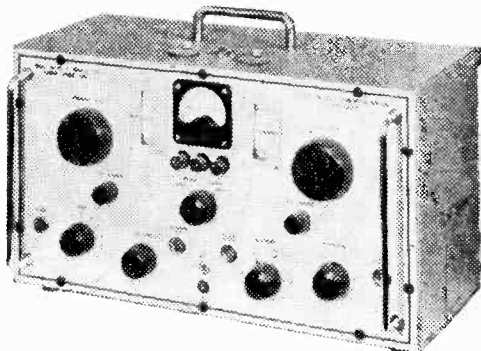

The E.M.I. signal strength meter.

The V.H.F. signal strength meter, type QD/151, is marketed by the Dealers' Service Development Division of E.M.I. Sales and Service Ltd., and is priced at £75.—E.M.I. Sales and Service Ltd., Hayes, Middx, England.

## "Color-Vision"

**A** NOVEL accessory for the television receiver has been introduced recently to provide a coloured effect on the received picture. It consists of a sheet of transparent material, having the upper part coloured blue, the lower part green and the centre red. The colours are pale and transparent, and when the screen or filter is placed in front of the tube the image is obviously coloured in three sections. On outside views the effect is most pleasing, and at times one is almost convinced that a full colour picture is being viewed. On close-ups of announcer, etc., the effect is sometimes incongruous, the speaker having blue hair and a green chin, for instance. When used over a period of time, however, it is found that the general effect is very pleasing, and considerable reduction in glare takes place, the picture being softened. We found that it was preferable to remove a "black screen" where one was fitted, and by slightly increasing contrast and brilliancy and using normal room lighting the detail was apparently improved. No doubt the device will be received with mixed views, but in our opinion it is certainly an attractive addition for some types of picture. For 9in. and 10in. tubes the cost is 21/-, and for 12in. screens, 22/6. The distributors are: J. & S. Newman Ltd., 100, Hampstead Road, London, N.W.1.

## Windsor Testmeter—Price Reduction

**W**E are informed by Taylor Instruments that Model 77A Windsor 20,000 o.p.v. testmeter has been reduced in price from £16 list to £15 list.—Taylor Electrical Instruments, Ltd., 419/424 Montrose Avenue, Slough, Bucks.

## NEW EDITION NOW READY

### "PRACTICAL WIRELESS" CIRCUITS

15th Edition

6/-, or 6/6 by post from

GEORGE NEWNES LTD.,

Tower House, Southampton Street, Strand, W.C.2



# YOUR Problems SOLVED

*Whilst we are always pleased to assist readers with their technical difficulties, we regret that we are unable to supply diagrams or provide instructions for modifying surplus equipment. We cannot supply alternative details for constructional articles which appear in these pages. WE CANNOT UNDERTAKE TO ANSWER QUERIES OVER THE TELEPHONE. If a postal reply is required a stamped and addressed envelope must be enclosed.*

## SPOT-WOBBLER

"I am thinking of investing in a 16in. tube soon, and am rather worried about the position of the line structure. We obviously do not want to get right across to the other side of the room, but wish to take full advantage of the bigger screen and get really near to it without having too much of the lines showing. Do you recommend that I consider fitting a spot-wobbler, and, if so, can you give suitable details of this?"—E. B. (Romford).

Although a spot-wobbler does break up the line structure we are not certain that it is necessary. You can obtain a very similar effect by slightly defocusing, or by using a suitable voltage on the first anode. If you adjust the latter to provide a very small spot, and your interlace is nearly perfect, obviously the lines will be clearer than if you have the same size spot but a "waver-ing" interlace or if you have a good interlace and a large spot. It is really necessary to see tubes working under these conditions and with a proper spot-wobbler to decide which you prefer in your own conditions.

## VALVE REPLACEMENT

"My commercial receiver broke down recently and when I looked inside I could see that one of the valves was not alight. I took it to a local shop and they confirmed that the heater had gone and supplied me with an exactly similar equivalent. I put this in, but now cannot get the picture to fill the screen sideways. It is all right from top to bottom and I can get the picture right beyond the mask in this direction, but when I adjust width the picture goes so far and then everything cramps up at the sides and refuses to go any further. Can this be due to the new valve, or does it indicate that something else has gone wrong?"—G. Burthor (Clapham, S.W.).

You do not state whether the valve which failed was in the line time base, but it is possible that it was part of this circuit and that the new valve, although exactly similar so far as make and reference is concerned, may have slightly different characteristics. Makers' tolerances can affect the functioning of certain parts of a television receiver, and it is possible to find that on replacing certain valves adjustments must be made to certain components to obtain the original performance, and we therefore suggest that you have the circuit examined by a service engineer who is familiar with the receiver. There is, on the other hand, the possibility that a fault had arisen due to the breakdown or partial breakdown of a component and that this had caused the original valve to fail, and continued use of the new valve may result in this also breaking down.

## BRILLIANCE ADJUSTMENT

"In carrying out some tests recently with my receiver

I have noticed that the adjustment of brilliancy affects focus. If I turn the brilliancy down so that the picture is not 'sparkling' all the scanning lines can be clearly seen, but as soon as I turn them up to get the whites really bright I can see on close inspection that the lines are defocused and run into one another. This is only in the white parts of the picture, the rest does not appear to suffer so much. Is this an indication that the bias (which is what the brilliancy controls in this set) is too much, or am I turning it up too far?"—H. Nathan (Welwyn Garden City).

Excessive E.H.T. or wrong bias can give rise to the effect mentioned, but if the receiver is a commercial model this is hardly likely to be the reason in this particular case. Poor regulation of the E.H.T. supply (often met with in R.F. E.H.T. supplies) will produce defocusing on peak whites, whilst insufficient contrast (weak signal) will also produce the effect if the brilliancy control is turned up to produce brilliant whites. Try increasing the R.F. gain—that is, turn up the contrast or sensitivity control, but if this is at maximum you may have to use a pre-amplifier to obtain a stronger signal, and then you will find that the brilliancy will not have to be turned so far to obtain a bright white. If this fails to cure the trouble you may find that the E.H.T. is low or that better regulation is necessary—perhaps a replacement of the E.H.T. rectifier is called for.

## ION TRAP MAGNET

"Can I fit a trap magnet to my present tube to avoid further spot trouble, or must I get a new tube designed for the trap? I am not quite clear how this device works but I have a fairly large flare area on my tube now and wonder if I could put off the purchase of a new tube and obtain a longer period of life by fitting one of these magnets."—B. Murray (Willesden, N.W.10).

The ion trap magnet can only be fitted to a tube which has been designed for it. In the normal tube the electrode assembly is straight and directs the electron beam on to the centre of the screen. In the later types of tube the assembly is bent and directs the beam off the screen. To bring it back on to the correct place the magnet is fitted round the neck of the tube and its position is adjusted so that the correct position of the beam is obtained. You cannot, therefore, fit the magnet to your tube and there is nothing you can do to give the tube any further extension of life. It will eventually have to be replaced. There is one point, however, which is not too clear in your query, and that concerns the actual trouble you are experiencing. You refer to a "flare area." Normally, the ion burn is a darkening of a large area, whereas a bright area in which detail is lacking can be due to the screen having been burnt off in that part of the tube face by misuse, or a variation in speed of the scan, allowing the trace to remain longer in that position and giving rise to an increased brightness.

## P. TELEVISION RECEIVER

"I am not quite clear regarding the trimming or lining-up of the Practical Television receiver and should be glad if you could enlighten me on one or two points. Are the coils close-wound, or are turns spaced. When trimmed, are the slugs supposed to be level with the top of the chassis, or should they be deep down. This means which coil, in the case of the transformers, should actually be tuned?"—G. H. Thurston (Aylesbury).

In the prototype the coils were all wound with turns touching. One or two readers have found, however, that slight spacing between turns improves signals in

their particular area and you could therefore experiment if you wished in this connection. The transformers are intended to have the winding nearest the chassis tuned, and therefore the slugs should not be inserted so that they are below chassis level, although their exact position will depend upon the position on the coil formers occupied by the windings. In other words, insert the slugs so that the thread is just engaged and then commence trimming whilst the core is being screwed in. The first resonant position is the correct one.

#### PICTURE "TEARING"

"We are on the outer fringe area and find that considerable difficulty is obtained with most receivers in the direction of line slip or picture tearing. We have obviously not had as much experience as you in the South but the symptoms to us are that the line pulses are too weak. The effect is that the slightest interference, from cars, for instance, results in the picture jumping into strips displaced sideways and jumping sideways. It is found that by adjusting the line hold control very carefully whilst the picture is tearing in this manner you can get a position where you can almost hold it but not quite. Have you any recommendations regarding this difficulty, which is not particular to any one make of receiver?"—J. Booker (S. Shields).

As a general rule, it may be said that picture tearing such as you describe is due to poor sync separation. It is necessary, in theory, to remove all picture pulses in the sync separator or limiter stage, and at the same time to separate completely the frame and line pulses. In practice, some slight trace of picture pulses is left, and in many circuits the line time base carries traces of frame pulse also. This is not serious and is not so troublesome as line and picture pulses entering the frame circuits, in which case poor interlace is the result. Unfortunately, you may find that if you increase the signal by adding pre-amplifiers, etc., you will aggravate the trouble and, therefore, we suggest you try alternative valves (of the correct type and make) in the sync separator stage, as it is often found that some function better than others. It may also be worth while to consider improving the filtering action by series grid stoppers in the separator and line oscillator stages.

#### COIL CORES

"I have been experiencing some disappointment in a home-made vision receiver, and a friend who has been in to try and assist me has told me that I have the wrong cores in the coils. These are made of brass and I must admit that the old circuit details which I had were very dilapidated and I may have been wrong in my memory as to the specification. Would you confirm, before I go to any more expense, that this can make any difference?"—G. Cackett (Wakefield).

The material from which the core is made plays a vital part in the frequency coverage, the coil in effect being modified in the following manner by the core. With an iron core the effect of inserting the core is that of adding turns to the coil, whilst when a brass core is inserted it is equivalent to taking off turns. We refer you to the article in this issue on the subject and would remind you that it is essential to use the correct core for the coil specification. As to the merits of the two systems, the final result is almost the same, although

in some circuits it will be found that better results will be obtained with a coil tuned by a brass or copper slug.

#### THE TELEVISION SOCIETY

"I have become so interested in television that I am anxious to join some society which is devoted to the subject, but I find that my local club is interested only in radio—mainly transmitting. Is there any television club which caters only for television which I could join? If so, could you let me have particulars, please?"—K. L. Deanhurst (Wellingborough).

We suggest you write to the secretary of the Television Society, G. Parr, 68, Compton Road, London, N.21, for details of membership, etc. We have no trace of any television club or society in your area.

#### NOISE

"I am getting a fairly good picture on my receiver, but it is not what might be termed 'clear.' In the background there appears to be a lot of specks moving all the time almost as though the picture was boiling. Is this a fault or is it general to long-distance reception? If it is not, can you suggest any way in which I might get rid of it?"—H. K. Lenkmann (Middlesbrough).

The trouble is apparently merely noise which makes its presence evident by a form of twinkling. Is it present on all transmissions? You may find, for instance, that when taking a studio broadcast where two or three cameras are in use, some cameras give the effect more than others, and obviously there is nothing you can do at your end to remove it. What is required is a really good, strong signal, and operating valves "all out" or with several stages of H.F. pre-amplification will give the noisy background. In your case, therefore, attention to the aerial may be the best solution, remembering that height is the most important consideration, plus the use of reflectors, etc., to concentrate all the available energy in the aerial proper.

#### USING 16in. TUBES

"I notice that the 16in. tubes are being extensively advertised, and I should like to try out one of these. I cannot find, however, any constructional data in your pages and you do not yet seem to have dealt with this type of tube. Is there any drawback to its use in my home-made receiver, or could I go ahead and get one to substitute for my present 12in. tube?"—K. Renshawe (Harrow).

You could not merely remove your 12in. tube and replace it with a 16in. model. Firstly, the neck of the larger tube has a larger diameter than the old tube and thus your present scanning coil might not fit on it. Furthermore, the new tube has a wider angle of deflection and your present scanning coils would not cover the tube. A further point is that a different focusing magnet would be needed, and to cope with the increased scanning angle a more powerful time base would have to be used. Thus, you see that a complete new unit is called for and we are hoping to publish data on a unit of this type in a subsequent issue.

#### WIRELESS COILS, CHOKES AND TRANSFORMERS

8th Edition now ready.

Price 6/- by post 6/6d.

## HOLME MOSS CONVERSION

Type AC/4 Converter unit for use with Sutton Coldfield receivers. Optimum picture detail and Sound reception without retuning or alterations. Incorporates power supply unit, R.F. stage and highly successful double mixer stage ensuring freedom from noise and correct reception of the new single side-band transmitters. Also available for Holme Moss on London type receivers. Price, complete with 5 valves, etc., 15 gns. C.O.D. if desired, or by arrangement with your own Dealer.

The AC/3 neutralized triode PRE-AMPLIFIER. A well designed and proved unit giving the best possible results for 'Fringe' and long distance viewers. Our confidence in the unit is revealed by our 7 days' approval offer. Price complete, 10 gns. C.O.D. if desired, or by arrangement through your Dealer. Illustrated leaflets and details, etc., available on request.

## SPENCER WEST

Quay Works, Gt. Yarmouth  
Telephone: Gt. Yarmouth 3009.

Pre-Amplifier Transformer. Prim. 200/250 v., Sec. 230 v. at 30 mA., 6.3 v. at 1.5/2 amps., 23/-.  
HS150. 350-0-350 at 150 mA. 6.3 v. 3 amps. C.T. 5 v. 3 amps. Half-shrouded, 30/9.  
FS43. 425-0-425 at 200 mA., 6.3 v. 4 amps. C.T., 6.3 v. 4 amps. C.T., 5 v. 3 amps. Fully shrouded, 51/-.  
FS5X. 350-0-350 v. at 250 mA., 6.3 v. 6 amps., 4 v. 8 amps., 4 v. 3 amps., 0-2-6.3 v. 2 amps. Fully shrouded, 71/6.  
FS160X. 350-0-350 v. 160 mA., 6.3 v. 6 amps., 6.3 v. 3 amps., 5 v. 3 amps. Fully shrouded, 47/6.  
FS43X. 425-0-425 v. 250 mA., 6.3 v. 6 amps., 6.3 v. 6 amps., 5 v. 3 amps. Fully shrouded, 69/-.  
FS50. 450-0-450 v. 250 mA., 6.3 v. 4 amps. C.T. 6.3 v. 2 amps. C.T. 5 v. 3 amps. Fully shrouded, 75/-.  
F36. 250-0-250 v. 100 mA. 6.3 v. C.T. 6 amps. 5 v. 3 amps. Fully shrouded, 32/6.  
FS150. 350-0-350 v. 150 mA. 6.3 v. 2 amps. C.T. 6.3 v. 2 amps. C.T. 5 v. 3 amps. Fully shrouded, 34/9.  
F30X. 300-0-300 v. 80 mA., 6.3 v. 7 amps., 5 v. 2 amps. Framed, 31/9.  
E.H.T. TRANSFORMERS. Prices on application.  
The above have inputs of 200-250 v. C.W.O. (ADD 1.3 in £ for carriage.)

## H. ASHWORTH

676, Great Horton Road, Bradford, Yorks.  
Tel.: Bradford 71916.

## NORMAN H. FIELD

68, Hurst Street, Birmingham, 5

MAIL ORDER DEPT.,

64-65, Church Lane, Wolverhampton

### CHEAPER VALVES

At 12/6: 8K56. At 10/6: X61. At 10/-: 1618. PEN46. 5Y3G/5Z4. 12SL7. 50Y/G/GT. 6SN7. 6Q7. EGC32. At 9/-: 6P7. 6P7. ARP6. 6V6G. KT9L. KT88. IT4. IS4. IR5. IS5. At 7/6: VT32. EL32. EBC31. VR55. 7H7. 77. 6K7. U77. VR150. 646/GT. 1A5/GT. 7C7. VR119. UY7G. 7C5. ARP22. TP25. OZ4. 12A6. 12AC7. VR136. At 7/-: 6BR. 6BE G. 1G6 GT. C. 6K7G. VR53. EF39. EF36. At 6/6: 6AB7. 6D6. VT24. RK34. 2C31. AR9. HL23DD. ARP12. VP23. At 5/6: 68S7. 1243. 128C7. 6C5GT. 6L7. 12J5. 6J7G. 6SH7 G. VR91. EF50. 3D6. 6SKT. TT11. VT501. At 5/-: 6J5. 12SK7. 6SK7 GT. 2A3. VU133. 2V3G. 1625. VT51. PEN20A. VR118. KT2. At 4/6: 6J5 G. 645GT. 12SH7. 12H6. VU120. At 2/6: RKR72. ARP3. 9D2. 6H6. At 3/3: VR19. 215SG. 2X2. VU111. HL2. VR21. VR88. PW9. VR65. SP41. VR85A. SP41. At 2/6: VR54. EB3. VR92. EA30. VR79. DL. At 1/9: 7193. Whilst some of the above Valves may not necessarily be new, they are all tested, Tested, and Guaranteed.

E.H.T. Transformers, 2,500 v. 5 Ma. 4 v., 2 amp. 0-2-4 v., 4 amp. 210-250 v. 50 cycles. Completely Wax Impregnated.....41/9

CHOKES, 60 ohms 200 mA., 31in. x 21in. x 2in. (For Viewmaster).....4-5.000 ohms Potentiometers, Colverna Wirewound. (Viewmaster).....2/6  
Please add something for Post. Money Back Guarantee.

Call in and ask TOM GAMBLE (64 DBL) how you can save money on your VIEWMASTER, by building his way.

## OPPORTUNITIES IN TELEVISION



144 pages  
**Free!**

Television offers unlimited scope to the technically qualified. Details of the easiest way to study for A.M.Brit.I.R.E., R.T.E.B. Cert., City and Guilds, Television, Television Servicing, Sound Film Projection, Radio Diploma Courses, etc., are given in our 144-page Handbook "ENGINEERING OPPORTUNITIES" which also explains the benefits of our Appointments Dept.

**We Guarantee "NO PASS-NO FEE"**  
If you are earning less than £14 a week you must read this enlightening book.

Send for your copy NOW—FREE and without obligation.

**WRITE TODAY!**

British Institute of Engineering Technology  
237, Stratford House,  
17-19, Stratford Place,  
London, W.1.

## BIET

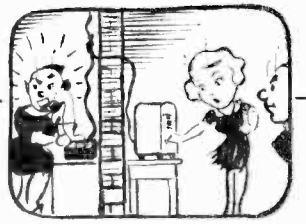

The "Fluxite Quins" at Work

Cried OO, "I really don't know  
What's wrong with our old radio.  
It's mended all right,  
Soldered tight with FLUXITE,  
But all we can hear is 'Hello'!"

See that FLUXITE is always by you—in the house—garage—workshop—wherever speedy soldering is needed. Used for over 40 years in Government works and by leading engineers and manufacturers. Of all ironmongers—in tins from 1/- upwards.

The FLUXITE GUN puts FLUXITE where you want it by a simple pressure. Price 2/6, or filled 3/6.

## FLUXITE SIMPLIFIES ALL SOLDERING

Write for Book on the Art of "SOFT" Soldering and for Leaflets on CASE-HARDENING STEEL and TEMPERING TOOLS with FLUXITE. Price 1/3d. each.  
FLUXITE Ltd., Dept. P.T.  
Bermondsey Street, London, S.E.1

## Come to the CLASSIC for

"THE CLASSIC SERVICE"  
Our Motto is  
"NOTHING IS TOO MUCH TROUBLE"

We will ship to any part of the British Isles or Abroad.

**TAPE RECORDING EQUIPMENT**  
Agents for all leading makes.

**AMPLIFIERS & HI-FI EQUIPMENT**  
Agents for: Leak, Quad, Williamson, Decca, Connoisseur, etc.

**TELEVISION COMPONENTS**  
Northern and Scottish readers write to us for details of our special offer of View Master components. Full details sent by return. Special terms available for those wishing to build their own Television receivers. Maximum stocks of valves, tubes and other accessories available for despatch by return.

Send 2jd. stamp for List, to:

**The Classic Electrical Co. Ltd.**

352-364 LOWER ADDISCOMBE RD.,  
CROYDON, SURREY.  
Tel.: ADD. 6061-2

# ADVANTAGES OF THE 'ENGLISH ELECTRIC' METAL C.R. TUBE

## I. The Face Plate

The face plate is one of the most important features of a C.R. tube, for upon the quality of the glass, its degree of curvature and the screen coating, depend the final reproduction of the picture. The use of a metal cone enables the face plate to be manufactured separately, permitting the use of glass of a very high optical quality. The curvature is slight which lessens distortion at the edges, and the picture is presented on a high efficiency white fluorescent screen. A rounded end picture  $11" \times 14\frac{3}{8}"$  is obtained by using the full screen diameter; or a rectangular picture  $10" \times 13\frac{1}{4}"$  within the minimum-useful-screen area.

### BRITISH MADE BY 'ENGLISH ELECTRIC'

Enquiries are also invited for a new 16" tube with short overall length suitable for AC/DC technique and with 6.3 volt and 0.3 amp. heater current.

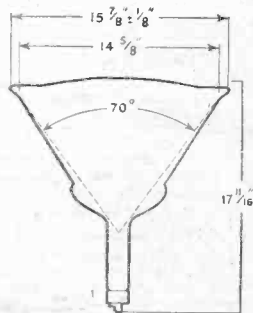

PRICE £24 · 6 · 5 Tax Paid

For full technical details and price for quantities write to:

THE ENGLISH ELECTRIC COMPANY LTD., TELEVISION DEPT., QUEENS HOUSE, KINGSWAY, LONDON, W.C.2