

**EXTRA
EVERY
MONTH!**

16 "Practical Photographer"
Page **PULL-OUT SUPPLEMENT**

13

PRACTICAL MECHANICS

EDITOR: F. J. CAMM
JULY: 1958

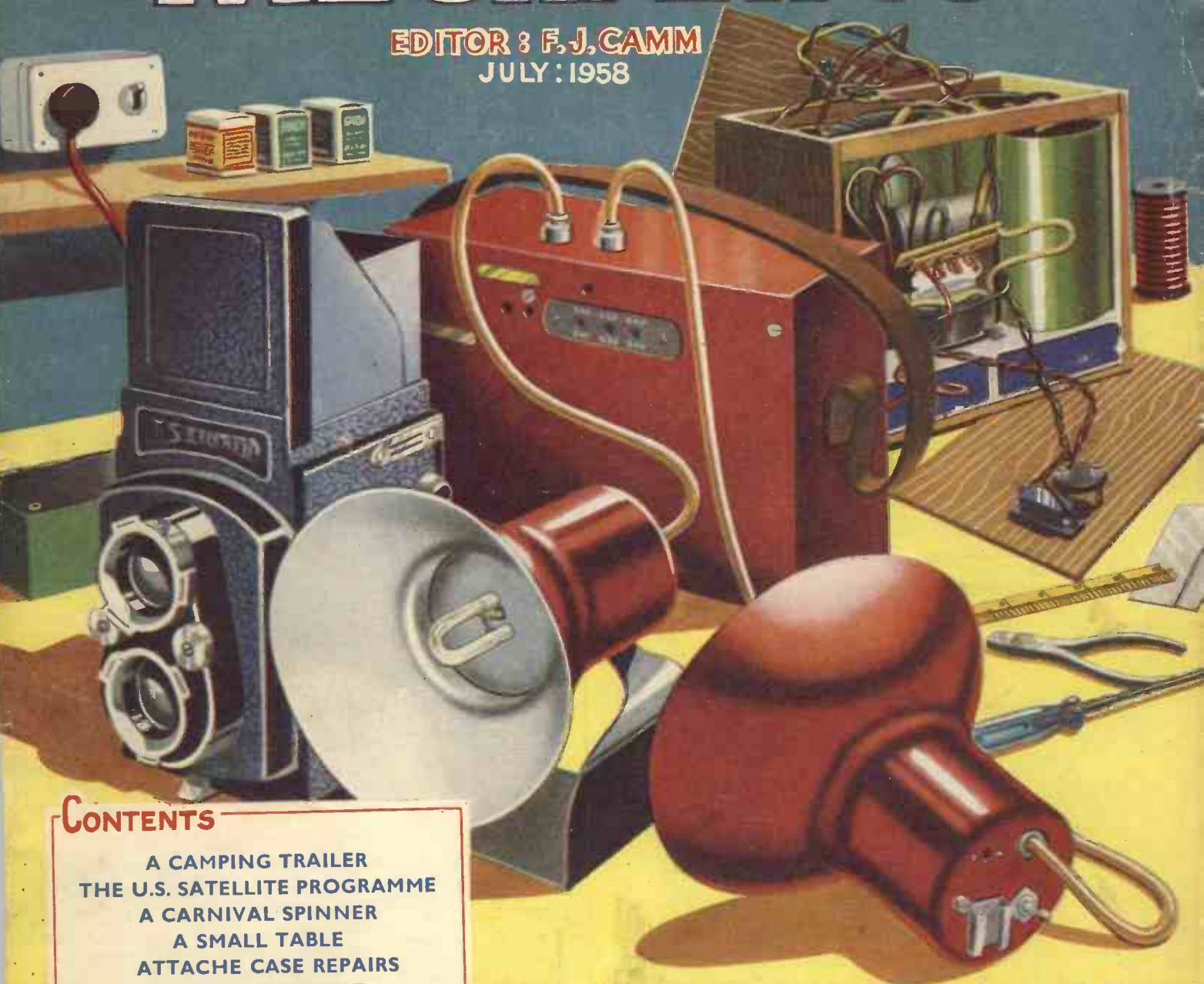

CONTENTS

- A CAMPING TRAILER
- THE U.S. SATELLITE PROGRAMME
- A CARNIVAL SPINNER
- A SMALL TABLE
- ATTACHE CASE REPAIRS
- A LIFTING MAGNET
- SPECIAL SECTION FOR JUNIORS,
ETC.

An Electronic Flash Outfit



**LOOKING FOR A
Certain SPRING?**

... compression, 18 S.W.G. x $\frac{5}{16}$ x 2", 17 coils?

Sorry, you'll never find it in that drawer of odds and ends. Why not use TERRY'S BOXES OF ASSORTED SPRINGS and put your hand on it right away?

Just the job for you experimental people—a simply unlimited variety of springs of every kind—compression, expansion, long, short, heavy, light, any gauge you want. We show some of our boxes here, but why not let us send you our fully illustrated list—post free?

No. 757.
Extra Light Compression, 1 gross Assorted, $\frac{1}{2}$ " to $\frac{3}{4}$ ", $\frac{1}{2}$ " to 2" long, 27 to 20 S.W.G. 15/- each.

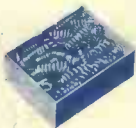

No. 388.
 $\frac{1}{2}$ gross Assorted Small Expansion Springs. $\frac{1}{2}$ " to $1\frac{1}{4}$ ", 18G to 21G. 9/6 each.



No. 758.
Fine Expansion Springs. 1 gross Assorted $\frac{1}{2}$ " to $1\frac{1}{2}$ ", $\frac{1}{2}$ " to 2" long, 27 to 20 S.W.G. 15/- each.



No. 753.
3 doz. Assorted Light Expansion $\frac{1}{2}$ " to $\frac{1}{2}$ " diam., 2" to 6" long, 22 to 18 S.W.G. 10/6 each.

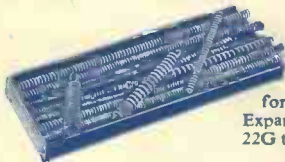

No. 1024.
20 Compression Springs 12" long, $1\frac{1}{2}$ " to $1\frac{1}{2}$ " diam., 24G to 18G, suitable for cutting into shorter lengths; and 30 Expansions $1\frac{1}{2}$ " to 12" long, $5/32$ " to $\frac{1}{2}$ " diam. 22G to 16G. 24/- each.

* Interested in Spring Design? Send for 'Spring Design and Calculations'—Post Free 12/6

**TERRY'S
ASSORTED SPRINGS**

HERBERT TERRY & SONS LIMITED · REDDITCH · WORCS.
(Makers of quality Springs, Wireforms and Presswork for over 100 years)

HT 24 A

STEEL SHELVING

72 in. HIGH
34 in. WIDE
12 in. DEEP

- Brand new—Manufactured in our own works.
- Shelves adjustable every inch.
- Heavy gauge shelves will carry 400 lbs. each.
- Stove enamelled dark green.
- 6 shelves per bay—Extra shelves 8/- each.
- Quantity discounts.

Delivered free £3 15s.
Ready for erection.

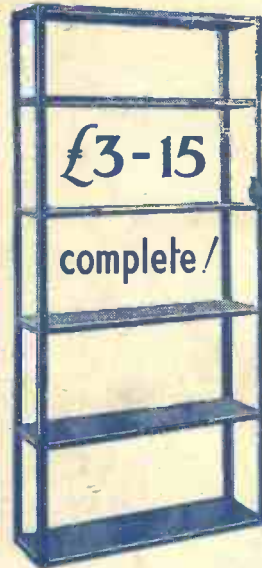

N. C. BROWN LTD.

Green Lane Wing

HEYWOOD · LANCs

—the manufacturers!

ALL OTHER SIZES available at equally keen prices.

Deliveries Free to England, Scotland and Wales.

Telephone: Heywood 69018 (3 lines)

Pupil BADGER at 55

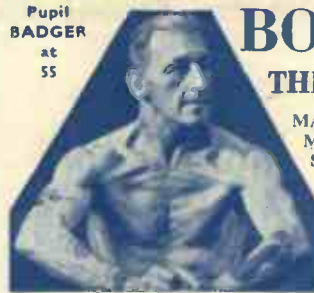

TOM BADGER

showing good muscular condition as a result of 'Maxalding Home Training.'

BODYBUILDING THE FINEST HOME HOBBY!

MAXALDING, THE WORLD'S FOREMOST METHOD OF MUSCLE BUILDING, CAN SHOW A RECORD NUMBER OF SUCCESSES IN MEN OF ALL AGES.

FIGHTING FIT AT FIFTY-FIVE

Postal Pupil TOM BADGER (left) is shown at 55 years of age. Engaged in an unhealthy occupation which necessitates the wearing of a protective respirator for 8 hours daily, Pupil Badger maintains full fitness and a high standard of muscular development.

PERSONAL POSTAL TRAINING

The unequalled success of the Maxalding courses in attaining RAPID and PERMANENT RESULTS is due to the fact that the training is arranged in accordance with individual requirements and conditions. No stereotyped or ready-prepared method can compare with genuine personal supervision for results.

FREE EXPLANATORY LITERATURE

PROFUSELY ILLUSTRATED with nearly 200 photographic reproductions of pupils from 15-65 years of age, the Brochure and Folders will be sent Without Cost or Obligation in a sealed cover free from external advertising. No further communications are sent without the request of the applicant. (6d. stamp for return postage is appreciated.)

MAXALDING (PM7), SHEPHERDSWELL, DOVER - KENT.

Please send Free literature: PM7

NAME..... AGE.....

ADDRESS





A FASCINATING HOBBY made Simple & Successful by means of this BOOK

Lampshade making can give endless fun, beautify your home and delight your friends. There are 83 practical and easy-to-follow illustrations and ideas to show you how to do it.

Published by C. Arthur Pearson Ltd., Tower House, Southampton Street, Strand, London, or obtainable from :

SAMUEL JONES & CO., LTD.

8/6



BUTTERFLY BRAND

SAMUEL JONES & CO., LTD.
Obtainable from all Booksellers or by requisition

TYZACK'S "WIZARD" TOOLKIT

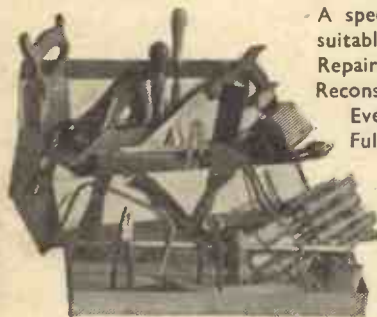

A specially selected set of Tools suitable for Furniture Making and Repairing, General Household Reconstruction & Decorating, etc. Every Tool first quality and Fully Guaranteed.

First Payment **£1-10-0**
Nine Equal Payments **£1-8-4**
CASH PRICE **£12-10-0**

CONTENTS :

- | | | |
|---|---|--------------------------|
| 22in. Handsaw. | Adjustable Iron Smooth Plane, American pattern. | Wood Rasp. |
| 8in. Tenon Saw. | 2ft. Boxwood Rule. | Joiner's Square, 6in. |
| Hammer | Nail Punch. | Bin. Level. |
| Pincers. | Carpenter's Brace, set of 3 Bits. | Hatchet. |
| Set of 4 Chisels in handsome protective plastic wallet, 1/2, 3/4, 1 in. | Beech-handled Screw-driver. | Coping Saw & six blades. |
| Footprint Wrench. | Combination Pliers, Glass-cutter. | Metal Hacksaw. |
| Bradawl. | | Wall Stripper. |
| | | Putty Knife. |

FREE WITH EACH TOOLKIT. *Handsome Cloth-bound Fully Illustrated Instruction Book.*

ALL COMPLETE IN STEEL TOOL CHEST WITH REMOVABLE TRAY. OVERALL SIZE 21" x 8" x 8".

S. TYZACK & SON LTD. Tel. : SHOREDITCH 8301.
341-345 OLD ST., LONDON, E.C.1.



INTRODUCE the "Airtrol" HARD VALVE RECEIVER

The smallest receiver in the World!



Price (inc. P. Tax) **£7.5.0**

Write for NEW illustrated list giving full technical details of all E.D. ENGINES, RADIO CONTROLS, MECHANISMS, SPARE PARTS, ACCESSORIES, ETC.

Order from your Model Shop.

Size 2 1/2" x 1 1/2" x 1 1/2" and weighs only 2 1/2 ozs. The "AIRTR0L" is the latest addition to the E.D. range of Remote Control Receivers and has been specially developed to meet the great demand for a transistor hard valve receiver with a specification producing the ultimate in Radio Control.

H.T. Supply — 22 1/2 volt battery.
Idling current—0.6 ma.
Current change—0.6 ma.
L.T. consumption—25 ma.
Hard Valve—no quench coils.
Simple tuning.
Two transistors for output and economy.
Valve life—4,000 hours.

E.D. ELECTRONIC DEVELOPMENTS (SURREY) LTD.
DEVELOPMENT ENGINEERS
PHONES: MOLESEY 6037-6038 ISLAND FARM RD. WEST MOLESEY, (SURREY) ENGLAND. GRANGE 5258 EAST MOLESEY

Training with I.C.S. THE WAY TO SUCCESS

The great and growing demand of today is for TRAINED men. Thousands more are needed, but there is no worthwhile place for the untrained.

Through I.C.S. Home Study you gain the specialised knowledge that marks you out for promotion, for SUCCESS! I.C.S. teaches you in your own time—expertly, quickly and easily. It is the world's largest and most successful correspondence school, offering courses for almost every branch of trade, industry and the professions. No books to buy.

ADVERTISING & SALESMANSHIP
Account Executives' Mail Order
Copy Writers' Advertisement Managers' Commercial Travellers' Sales Management
EXAMS: Joint Inter. A.A. & I.P.A. Finals. Inc. Sales Mngrs. Ass. United Com. Travel Association.

ARCHITECTURE & BUILDING
Drawing and Designing
Quantity Surveying
Builders' and Surveyors' Clerks
Bricklaying
Carpentry & Joinery
Construction and Steelwork
Heating and Ventilating
EXAMS: Roy. Inst. of Br. Archts. Inst. of Quant. Surveyors. Roy. Inst. of Chartered Surveyors. Inst. of Builders. Inst. of Mun. Engrs. (Bldg. Inspectors'). Inst. of Clerk of Works.

COMMERCIAL ART
Elementary Art Training
Poster Work
Sketching

COMMERCIAL TRAINING
Bookkeeping and Accountancy
Costing and Auditing
Company and Private Secretarial
EXAMS: Chartist. Inst. Secs. Corp. of Secs. Ass. of Cert. & Corp. Accts. Inst. of Cost & Works Accts. Inst. of Bookkeepers.

ELECTRONIC ENGINEERING
Industrial Electronics
Electronic Computers

CIVIL ENGINEERING
Highway Engineering
Surveying and Mapping
Structural and Concrete Engineering
EXAMS: Inst. of Civil Engineers. Inst. of Mun. Engrs. Inst. of Structural Engrs.

DRAUGHTSMANSHIP (State which Branch)
Architectural
Drawing Office Practice & Machine Design
Structural Drawing
Maths. & Machine Drawing
Woodworking Drawing

ELECTRICAL ENGINEERING
Illumination and Heating
Electricians'
EXAMS: Society of Engineers. C. & G. Cert. in Elec. Eng. Practice. C. & G. Cert. in Elec. Installations. C. & G. Cert. in Illum. Engg.

FARMING & HORTICULTURE
Arable Farming
Pig & Poultry Keeping
Livestock Rearing
Farm Machinery (Maintenance)
Flower, Vegetable & Fruit Gardening
Rock & Shrub Gardening
EXAMS: R.H.S. General.

FIRE ENGINEERING
EXAMS: Inst. of Fire Engineers. Fire Service Promotion

GENERAL CERTIFICATE OF EDUCATION
Principal Subjects at Ordinary or Advanced Level
Engineering Joint Board Preliminary

MANAGEMENT
Foremanship
Industrial Management
Business Management
Methods Engineering
EXAMS: British Inst. of Mngemt. Intermediate, Final and Certificate of Foremanship

MECHANICAL ENGINEERING
Subjects include:
Welding, Fitting, Turning, Erecting, Jig & Tool Design, Production, Draughtsmanship, Mathematics, Inspection, Diesel Engines, Diesel Electric Locomotives, Refrigeration.
EXAMS: Inst. of Mech. Engineers. Inst. of Production Engineers. Society of Engineers.

MOTOR ENGINEERING
Diesel Transport Engines
Motor Body Rebuilding
Owner Drivers'
Running and Maintenance

PHOTOGRAPHY
A basic Course including Colour Work

RADIO AND TELEVISION ENGINEERING
Service Engineers'
Television Servicing and Equipment
Practical Radio with Equipment
Radio Service & Sales
EXAMS: Br. Inst. of Radio Engrs. C. & G. Radio Servicing Cert. (R.T.E.B.), P.M.G.'s Cert. in Wireless Telegraphy. C. & G. Telecoms. Engineering. C. & G. Radio Amateurs'

WRITING FOR PROFIT
Free Lance Journalism
Short Story Writing

NEW—PRACTICAL PHOTOGRAPHY COURSE
Learn camera technique and how to produce first-class negatives and prints in monochrome or colour.

Permanent Magnets in action

The finest tool-rack you ever saw.

Make your own magnetic tool rack and keep your workshop tidy! This and many other uses of "Eclipse" magnets are shown in descriptive leaflets, available through your usual tool dealer.

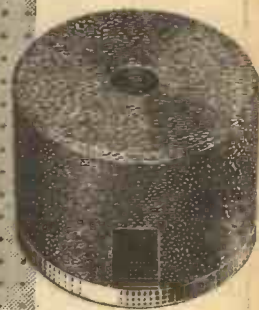
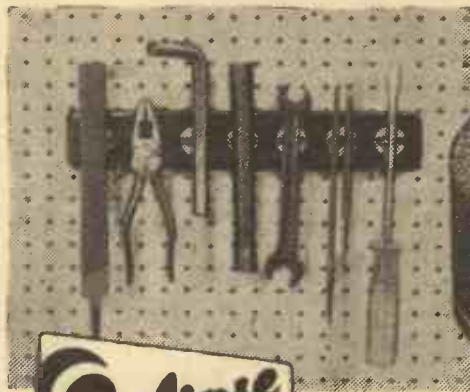

PERMANENT MAGNETS

Made by James Neill & Company, (Sheffield) Limited and obtainable from all tool distributors

PM43



it's the wise man with a THIRD HAND to-day

Nowadays, it's no laughing matter for a man who hasn't his "third hand" handy in the home, garage or workshop when tackling the inevitable repair and maintenance jobs. With a positive grip, exceeding 2,000 lbs. if required, the Mole Wrench locks on the job-in-hand, leaving both hands free—your "third hand" in fact, used as super-pliers, wrench, hand vice, clamp—whatever the job demands. Join the thousands of satisfied users—visit your Ironmonger, Motor and Motor, Cycle Accessory Dealer for

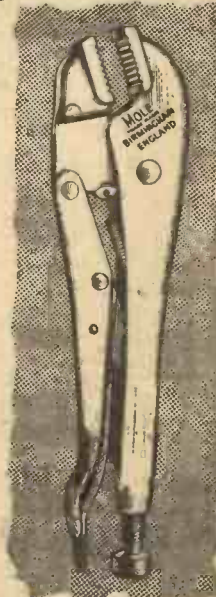

In two sizes: 7in., 12/6 and 10in., 15/-

Ask for a genuine MOLE WRENCH—look for the name on it.

If in any difficulty write to:
M. MOLE & SON LTD., BIRMINGHAM, 3.

INTERNATIONAL CORRESPONDENCE SCHOOLS

Dept. 169D, International Buildings, Kingsway, London, W.C.2.

Please send me free booklet on.....Age.....

Name..... Occupation.....
(USE BLOCK LETTERS)

Address

7/58

Addresses for Overseas Readers

Australia: 140, Elizabeth Street, Sydney. Eire: 3, North Earl Street, Dublin.
India: Lakshmi Bldg., Sir Pheroza Mehta Rd., Fort Bombay. New Zealand: 182, Wakefield Street, Wellington. N. Ireland: 26, Howard Street, Belfast.
South Africa: Dept. L., 45, Shortmarket Street, Cape Town.

INTERNATIONAL CORRESPONDENCE SCHOOLS

ON TERMS FROM MONDEX

BSR MONARCH

4-Speed Auto-changer for building into a Hi-Fi Radiogram. Brand new. As advertised. Guaranteed. Direct from B.S.R.'s factory £8.15.0 cash or 25/- dep. & 8 m. ps. of 25/- (P.P. 4/-). ALSO AVAILABLE—Amplifiers, R.G. Chassis, F.M. Tuners, Loud-speakers. Ask for lists.



BURGESS Electric BAND SAW

Fully portable. Built-in 1/10 h.p. A.C. motor, will make intricate cuts, or saw through heavy material with ease. On base-board. £19.7.8 or 40/- dep. and 8 m. ps. of 50/-.

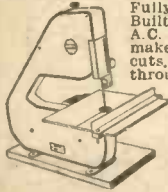

PLUG IN and SAW!

THE NEWEST ELECTRIC COPING SAW

Improved design. More powerful. Cuts up to 1" in hardwood or soft metal. Takes standard Eclipse Blades. Built-in switch. Adjustable. No TV interference. 200/250 v. A.C. With 4 blades.

52/6 cash or 10/- dep. and 5 m. ps. of 10/-.

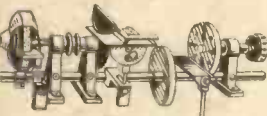

PICADOR PUP
For use with 1" power drill units, for turning, sawing, drilling, grinding, etc., with cradle. 15/- dep. & 8 m. ps. of 21/- or £8.0.0. Accessories available.

THE NEW 'B & D' D.500 DRILL

Black and Decker's very latest. Entirely re-designed power drill with helical gears and 3 geared chuck. Smart two-tone finish. Runs at 2,500 r.p.m. Built to precision standards, yet costs only £6.19.6 or from Mondex, 10/- dep. & 8 m. ps. of 18/9. Suitable for B. & D. Tools and Accessories.



WOLF QUARTER-MASTER

A brand new type of power unit of great power and adaptability. Precision engineered. Takes most Wolf Cut accessories. Unconditionally Guaranteed. £9.9.0 or 15/- dep. & 8 m. ps. of 25/-.

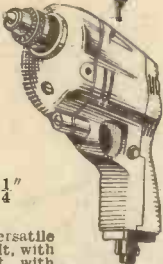

BRIDGES 'NEONIC' 1/4" POWER DRILL

Improved version of the versatile and very powerful DR2T unit, with neon indicator in circuit with motor. 15/- dep. & 8 m. ps. of 21/- or £7.19.6 cash.

TO BUILD A MODERN HOME WORKSHOP

SELECTA HOME-MASTER

Takes any standard 1" power unit or drill to enable a wider range of jobs to be carried out. 30/- dep. and 8 m. ps. of 37/8 (£14.10.0 cash).

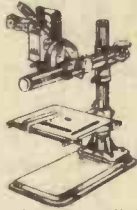

SELECTA POWER PAK

Very powerful unit for use with Home-Master. 20/- dep. and 8 m. ps. of 27/- (£10.9.6 cash). The Selecta Home-Master can also be supplied with Bridges 'Neonic' 1/4" Power Drill or Wolf Quartermaster if desired.

SELECTA 30in. LATHE

7/6 dep. and 8 m. ps. of 11/9 (£4.9.0 cash).

ACCESSORIES FOR ALL ABOVE MAKES AVAILABLE ON TERMS

NEW MONDEX CATALOGUE FREE

MONDEX PRODUCTS LTD

(Dept. PM/9), 87 Aldersgate Street, London, E.C.1

This model farm cost less than 2'6



It was made from a half-crown tin of Sankey's PYRUMA—farmhouse, barn, implement shed, walls and gate—and there was still plenty of this grand modelling material left to build many more farm features, by simple methods described in the Instruction Book (see Coupon below).

PYRUMA, plastic and ready-for-use, becomes stone hard after drying or baking, and can be painted in natural colours. For permanent modelling—

MAKE IT AND BAKE IT IN



Obtainable from your local Ironmonger or Hardwareman and many Art Material dealers. Ideal for making—

- Model Railway Buildings and Accessories. Harbours.
- Ship Models. Airport Buildings and Features.
- Houses. Bookends. Ashtrays. Animals and Figures.
- Plaques, etc.

Post this Coupon today for your Instruction Book.

CUT OFF HERE

To **J.H. SANKEY & SON LTD** Dept. P.M., Ilford, Essex

Established over a century

Please send **ILLUSTRATED INSTRUCTION BOOK** with full colour pages, on Pyruma Modelling.

Enclosed Postal Order value 6d. (not stamps).

NAME

ADDRESS

Specially for model engineers!

TALBOT BLUE LAYOUT FLUID



SIMPLIFIES MARKING OUT

- ✘ Durable, yet easily removed
- ✘ As used by many big engineering firms

Available through most engineers' merchants and model making shops

TALBOT TOOL CO LTD Telephone: B'ton 55832
'Grip' Works, ROEDALE ROAD, BRIGHTON, SUSSEX

Follow the **FLUXITE** way to Easy Soldering

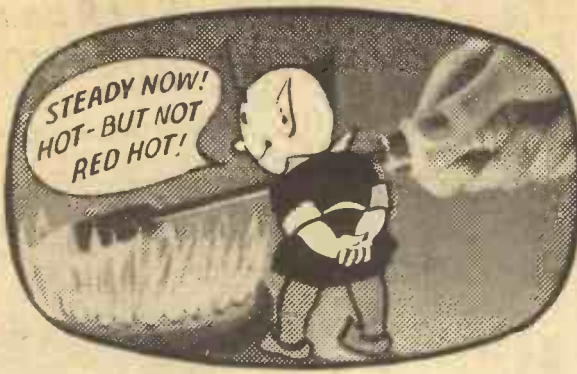

No. 3. HEATING THE BIT

A clean flame is best, such as that of a gas ring, and care must be taken not to let the bit get red hot. When the flame turns green the bit is at the right temperature.

FLUXITE is the household word for a flux that is famous throughout the world for its absolute reliability. In factory, workshop and in the home FLUXITE has become indispensable. It has no equal. It has been the choice of Government works, leading manufacturers, engineers and mechanics for over 40 years.



Fluxite Limited, Bermondsey Street, London, S.E.1

G M.53

3 MONTHS' VALUES GUARANTEE											
1F2	2/9	9D2	6/9	DK66	8/9	EL84	10/9	U22	10/9	UF41	8/9
4D1	6/9	11B3	6/9	DF66	8/9	EL81	3/9	UJ46	8/9	UF41	8/9
6AM5	3/9	12A6	8/9	EAS0	1/9	EZ40	8/9	UJ46	8/9	UJ46	8/9
6AM6	7/9	12AT7	8/9	EABC80	9/6	EZ80	8/9	U52	8/9	U52	8/9
6B7	1/9	12BE6	6/9	EAF42	8/9	FW4/500	10/9	VR65	6/9	VR65	6/9
6B8G	3/9	12K7	8/9	EB84	1/9	KTW61	5/9	VT52	6/9	VT52	6/9
6F12	7/9	12Y4	8/9	EP38	5/9	KTW63	8/9	VT501	6/9	VT501	6/9
6F14	8/9	35Z4	8/9	EBCC3	6/9	L410	1/9	VW85	1/9	VW85	1/9
6H8M	1/9	35L6	8/9	ECC81	8/9	NR41	3/9	TT11	6/9	TT11	6/9
6J5M	2/9	63SPT	2/9	ECH42	8/9	PEN45	6/9	W76	8/9	W76	8/9
6K7M	3/9	77	3/9	EF37	4/9	PEN46	6/9	W81	3/9	W81	3/9
6SJM	8/9	210VPT	5/9	EF39	3/9	PEN220A	3/9	Z77	7/9	Z77	7/9
6V6M	8/9	7193	3/9	EF42	8/9	PL22	8/9				
6P28	12/6	AR6 (2V)	1/9	EF50	2/9	PM202	1/9				
6SA7M	3/9	ARP35	3/9	EF50RED	5/9	PP225	3/9				
6SG7	3/9	CV1083	3/9	EF80	8/9	PY81	8/9	UX TYPES			
6SG7M	2/9	CV188	3/9	EF85	8/9	P61	6/9	42	3/9	42	3/9
8D2	3/9	D1	1/9	EF91	7/9	RL57	1/9	78	3/9	78	3/9
8D3	7/9	DH76	8/9	EF92	3/9	SF61	6/9	25RE	3/9	25RE	3/9

Post on valves 9d. each. 2 - on 4.
FOCUS MAGNETS. 12 0. Elac. Brand new. 38 mm. P. & P. 2.3.
FOCUS MAGNETS. 3 0. Ex-Plessey chassis. 35 mm. for triode tubes. P & P. 2.3.
T.V. MASKS. 14/9. For 17". Brand new. P. & P. 2.3.
ALLEN SCANNING COILS. 7/6. Low impedance. For 14" or 17" wide angle tubes. P. & P. 1/4.
MAINS POWER TRANSFORMER. 0 0. 350-0-350 v. 250 m/a. 6 v. heaters at 5 amp. 4 v. at 5 amp. 4 v. at 5 amp. isolated. Extra isolated winding for 2 or 4 v. Drop-through type. Prim. 200-250 v. Size : 4 1/2" x 5" x 5". P. & P. 2.3.
RESISTORS. 6d. doz. 270 ohms 1/2 watt. Ceramic. Post on 1 doz., 6d. ; on 4 doz., 1/- ; on 10 doz., 2/6.
INSULATING TAPE. 1/6. 75 ft. by 1/2 in. wide. Post on 1 9d. ; on 8 only 2/-.
SOLDER REELS. 1/6. 60-40, 3 core Ersin. 20 ft. on plastic spool. Post 6d.
O.P. TRANSFORMERS. 1/3. Salvage guaranteed. 2.5 ohms. Matching Pentode or Tetrode. Post 1/9. 20 for £1. Post 5/6.
HEADPHONES. 1/9. Single earphone and band. C-LR type. Grand bargain. Ideal for Crystal sets. extension on T.V. or radio. Post 1/6.
CO-AX CABLE. 6d. yard. Cut to any length. Good quality. Post on 20 yds., 1/8. 45/- per 100 yards. Post 3/6.
DROPPERS. 9d. each. 750 ohms, 2 amp. Post 9d. 5/- doz. Post 2/6.
CHASSIS. 1/- each. 6 or 8 valve. latest type midget valve design for A.M. or F.M. New. Cadmium plated on s.w.g. steel. 12 1/2 in. x 7 1/2 in. x 2 1/2 in. Post 1/9. 4 for 4/- Post 3/- 12 for 10/- Carr. 3/-
VOLUME CONTROLS. 1/9. 1 meg. ohm. Long spindle. New, boxed. Post 1/6.
RELAYS. 9d. (10F/1479) 150 ohms. Break 1 make 2. G.P.O. pattern. Used. Post 1/-
CONDENSERS. 9d. 32 mfd., 450 volt working. Cardboard. New. Post 1/- 12 for 7/- Post 3/6.
R.F. FILTER UNITS. 1/9. G.P.O. specifications. Beautifully made in solid brass case. Fitted with in-out switch. Simply fitted in the aerial. Has 2 stage tuning. Limited stock. Post 1/3.
VALVE SCREENING CANS. 1/- doz. Latest midget type. Aluminium 2 1/2 in. x 1 1/2 in. dia. Post 6d.
TORCH LANTERNS. 6d. each. Ex-W.D. Including 2 bulbs. Uses 800 battery. Post 1/6. 5/- doz. Post 3/-
PIANO HINGE. 1/6 pair. Chrome. New. 7 1/2 in. long, post 6d.
TELEPHONE SETS. 7/9. Ex-W.D. Wireless remote control unit. EMK11. New condition. Morse tapper, switched, jack plugs, etc. less phone. Carr. 3/6.
AM/FM TUNER UNIT. 7/9. Inc. : 2 gang. New, Ex-manufacturers. Not tested. Takes ECC85 valve (not incl.). Post 1/-.
CAR AERIALS. 6/9. Whip antennae. 50 in. long, collapsing to 11 in. 1 hole fixing. Post 1/-
GANGED CONDENSERS. 1/9. 2 or 3 gang. Salvage, guaranteed. .0005. Post 1/3.
L.F. TRANSFORMERS. 1/- Pair. 465 kc/s. Tested, guaranteed. Post 1/-
PHILLIPS CONICAL TRIMMERS. 6d. each. 5/- doz. 5-50 pF. The World's finest trimmer. Unused. Post 9d. 1/- on doz.
T.V. SLIDER CONTROLS. 9d. 10 K. and 2 K. only. wire wound. Post 6d. 4 for 2/6.
P. P. COMPONENTS LTD. 219, ILFORD LANE, ILFORD, ESSEX. Phone : ILF 0295.
 Send 3d. stamp for FREE catalogue.

M&W ENGINEERS' PRECISION & HAND TOOLS



MEASURE UP TO ANY JOB

The next time you buy tools, remember that it pays to buy good tools, tools upon whose accuracy you can rely. (M&W) tools are made from the finest material and are guaranteed to conform to British Standard Institution Specifications where they exist. The next time you buy tools ask your dealer for (M&W) Engineers Precision and Hand Tools.

Send 10d. in stamps for a copy of our catalogue, mentioning this journal.
 MOORE & WRIGHT (SHEFFIELD) LTD., 14/28, NORTON LANE, SHEFFIELD, 8

DEVELOP YOUR GREATEST ASSET

Pelmanism Will Lift You Out of the Rut

Do you find life humdrum and boring? Do you think of your job as "the same old monotonous routine"? Why remain in a groove, only half alive, when you have the latent ability which could enable you to enjoy life to the full and to "hold down" an interesting, progressive job?

Are you making the most of your greatest asset—your mind? The Pelman Institute with its unrivalled experience of over half a century will show you how to develop this invaluable asset to the fullest capacity. Pelmanism will lift you out of the rut and eliminate your feelings of Frustration and Inferiority. It will teach you how to dispel your Fears and to overcome such failings as Aimlessness and Depression.

Whatever your age, whatever your occupation, Pelmanism will change for the better your whole outlook on life.

The Course will give increased power and energy to your mind: will strengthen your Will-Power and develop your Initiative. You will find that your outlook on life will change to one of cheerfulness and optimism, and with your increased Efficiency will come Happiness, Success and Financial Betterment.

Pelmanists are not left to make the applications themselves. An experienced and sympathetic instructional staff shows them, in exact detail, how to apply the principles of Pelmanism to their own circumstances and aspirations.

Send for Free Book

The Pelman Course is fully described in "The Science of Success" which will be sent you, gratis and post free, on application to:—

PELMAN INSTITUTE
 130, Norfolk Mansions,
 Wigmore Street, London, W.1.
 WELbeck 1411

Remember—Everything you do is preceded by your attitude of mind.

HOW TO LEARN LANGUAGES

The Pelman Languages Institute teaches French, German, Spanish and Italian, without translation. Write for particulars and specimen lesson of the language that interests you, which will be sent gratis and post free.

Pelman Languages Institute,
 130, Norfolk Mansions, Wigmore St., London, W.1.

.....POST THIS COUPON TO-DAY.....

Pelman Institute,
 130, Norfolk Mansions, Wigmore Street, London, W.1.

"The Science of Success," please.

Name

Address

.....

Pelman (Overseas) Institutes: Delhi, Melbourne, Durban, Paris, Amsterdam.

EX-GOV. BARGAINS

SCT. MK. II THREE-DRAW TELESCOPES. 25 x 50. Lightweight, only 2½ lbs., with leather case and sling. Optically perfect. Sound condition. £6.10.0 each. Near new condition. £8.10.0. Spare high-power eyepieces to fit 50X or 75X; 50/- each. Triple power conversion kit to fit, giving 25X and 40X terrestrial and 60X astro, 50/- per set.

SIX POWER KIT. 25, 40, 50 and 80X terr. and 60 and 120X astro, £5 per kit. We can supply eyepieces to increase the power of most types of telescope. State type or send existing eyepiece for quotation.

TELESCOPE OBJECT LENSES. New, perfect and first grade. 45 mm. x 20in., 25/-; 45 mm. x 27in., 35/-; 50 mm. x 15in., 30/-; 75 mm. x 12in., £4; 38 mm. x 4in., 12/6; 48 mm. x 18in., 25/-. Bargain offer: 48 mm. x 18in. O.G.s, air-spaced high resolution O.G., in rusty mounts and need cleaning, 12/6 each.

EYEPIECES. Wide-angle orthoscopic. Plain mounts. New ½in., 35/-. Ditto, bloomed, 45/-; ¼in., 25/-; 1in., 25/-.

ERECTING EYEPIECES. 2X, 45/-; 4X, 50/- in focusing mount.

DIRECTORS NO. 7. Weight 6 lbs. Will set out any angle with accuracy of theodolite; 5in. dial calibrated 360 degrees with micrometer to 5 mins., with throw-out lever to geared head. Limited elev. and dep. adjustment could be adapted for levelling. With 4X optical sight. Sound condition, but not guaranteed, 35/- each. In near new condition, 55/- each.

DIRECTORS NO. 9. Weight 8 lbs. As No. 7 but with large geared head in gunnial with large bearing surface and ring contact for elec. connection and cal. E. & D. adj., also adaptable for levelling. 45/- each, or in leather case in perfect condition, £3.10.0. Geared heads only, ex No. 7, 12/6 each. Carr. 2/-. Or No. 9, 17/6 each. Carr. 2/6.

EX-GOV'T. TELESCOPES. All brass. 30X. Length 20in., dia. 2in. As new in wood case. £4.5.0 each.

ASTRO TELESCOPE KITS. Achro. O.G., 20in. x 45 mm. Paxolin tube and focusing eyepiece. £2.

TERRESTRIAL 40X KIT. As above, but with erecting eyepiece ready to mount in tube, £4.

HELIOGRAPHS. Brand new in leather case. Cost £30 each. A gift at 15/- plus 2/- post.

Our lists contain details of more than 800 USEFUL ITEMS, many unobtainable from any other source. We claim the widest variety and most complete range of Ex-Gov. Optical and Scientific Equipment in the BRITISH ISLES. Lists FREE FOR STAMPED ENVELOPE. "HOW TO USE LENSES & PRISMS." Nos. 1 and 2, 3/- each, post free.

H. W. ENGLISH

Rayleigh Rd., Hutton, Brentwood
Essex

MAINS BLOWER. 200/250 v. A.C./D.C. 1-amp., 5,000 r.p.m., consists of the motor with attached enclosed fan, and funnel intake 1½in. dia., side outlet 1½in. x 1½in. plinth base 5in. x 4½in. Finish black crackle and die cast aluminium, size overall 9in. long, 4½in. wide, 5in. high, weight 7½lb., a very superior blower, offered at a fraction of original cost, new, unused, 25/- Post 3/6.

ELECTRIC PUMPS, suitable for most liquids the popular cylindrical immersible type 2½v. at which they deliver 10-g.p.m. at 20-ft. head also give excellent performance at 12 v., new in sealed cartons, 4 ft. long, 35/- carriage 5/-.

HUGHES MOTORS, shunt wound, 12 v. 1½-amp., speed 5,000 r.p.m., reversing, size 3½ in. long, 1½ in. dia., 1½ in. shaft, weight 20 oz., a very superior motor designed for anti-radar equipment, new unused 10/-, post 1/6. £5 per doz., carriage paid, ditto fitted reduction gear, giving a final drive (1½ in. shaft) of either 320 or 160 r.p.m., state which required, 12/6, post 1/9; £6 per doz., carriage paid.



K TYPE CYLINDER LOCKS, deadlocking and theftproof, has 7 concentric tumblers instead of the usual 5 in 7, interchangeable fittings with ordinary cylinder locks, latchbolt reversible, for right or left hand doors (no need to specify), complete with 2 keys, all fittings and instruction booklet, new boxed, 5/-, post 1/6; 4 for 20/-, post paid.

REFLECTOR GUNSIGHTS by Ross, etc., consists of an optical mount which contains 4 high-grade lenses, 3 are 34 m.m. dia., bi-convex, plano-convex, concave negative, with smaller bi-convex objective, mount is in line with enclosed lamp-house, fitted reflector, rheostat and lampholder, new unused, cost £20, our price 10/-, post 1/6.

RANGEFINDERS by Barr and Stroud, 1-metre base coincidence type, a hand held instrument giving the distance of any object, from 500 to 20,000 yds. (12-miles). The 14x variable focusing right eyepiece provides two images of the object viewed, one from the right objective, the other from the left. When these two images are brought into coincidence by a thumb wheel control, the distance in yards can immediately be read in the left eyepiece. Fitted two filters and other refinements. A very superior high quality instrument, original cost £180, our price in new or near new condition, supplied in stout fibre cases £5, carriage 100m. 7/6, 200 m. 10/-, 300 m. 12/6 N.I. 20/-.

SIGHTING TELESCOPES by Ross, Taylor Hobson, etc., these high quality instruments contain four 40 m.m. dia. achromats, 2 of 3in. focal length, 2 of 3½in. focal length, also a 18 m.m. dia. image erector achromat, 4 screw fine adjustment cross gratule, length 16in., weight 7 lbs., new and boxed, 35/-, post 3/6.

GUNSIGHT TELESCOPES, has 4 lens high grade optical system with cross gratule, approx. 2x, all brass, 1½in. long, 1½in. dia., makes an ideal rifle sight, or astro telescope star marker, perfect condition, in metal cases, 20/-, post 1/9.

TELEPHONE SETS, consists of two combined microphones and receivers, which when wired up by ordinary twin flex, provides perfect 2-way communication, excellent results at 1 mile range have been reported, self-energised, no battery required, set complete, new unused 7/6, post 1/3; suitable twin 14/36 p.v.c. up to 300ft. lengths at 1d. per ft. supplied, postage each 20 ft. flex 3d. extra.

RELAYS. U.S. type, coil resistance 7,600-ohms, single make contacts, size 2½in. x 2in. x 1½in., unused and perfect, 3/6, post 9d.

TIME DELAY SWITCHES, 24 v. clockwork type by "Venner," in smart metal cases with external press wind, in addition to clockwork mechanism contains two electro-magnets, 5-pole cam-operated contacts, etc., new and boxed, 5/-, post 1/6.

SPERRY GYROSCOPES, as fitted to Direction Indicators, an exceptionally high grade, fine precision job, normally operates from vacuum supply, otherwise will operate from pressure, gimbal mounted with 360-degree circle, appear to be new unused, original cost over £20, our price 10/-, post 1/6.

Many other Bargains : send stamped, addressed envelope for lists.

MIDLAND INSTRUMENT CO., Moorpool Circle, Birmingham, 17

TEL.: HAR 1308

NEW For the ENGINEER and PRACTICAL MOTORIST

NEWNES

AUTOMOBILE ENGINEER'S REFERENCE BOOK

Consulting Editor: G. H. LANCHESTER, M.I.Mech.E., M.I.P.E., M.S.A.E. (Past President Inst. Auto. Engineers)

NOW READY! Here is the 2nd Edition of Newnes standard work of reference on design, manufacture, maintenance, and the testing of cars and commercial vehicles. Latest advances and developments in all branches are included. Packed with data, graphs, diagrams and technical information. It is a work to have on your bookshelf now—always at hand to give you important wanted data. Examine it without obligation, Free for 7 days. Post coupon to-day!

1,696 PAGES
1,066 DIAGRAMS
262 PHOTOGRAPHS
30 SECTIONS

Units of Construction. Materials. Engines. Lubrication and Lubrication Systems. Fuels and Fuel Supply Systems. Fuel Injection Equipment. Ignition Systems. Supercharging. Silencing. Radiators and Cooling. Clutches and Fluid Drives. Gearing and Gearboxes. Transmission. Brakes. Steering and Front Axles. Wheels and Tyres. Springs and Suspension Systems. Bodywork. Heating and Ventilating of Automobiles. Electrical Systems. Batteries. Dynamos. Starting Methods. Instruments and Accessories. Car Radio. Production Methods. Testing. Costing and Control. Motor Industry Research Association. Progress.

20-Page Quick-Reference Index.

NEW IN THIS 2ND EDITION

Stainless Steel for Car Trim. Dry Bearings. Developments in Gearbox Design. 8/10 Speed Gearboxes. Disc Brakes. New Automatic Transmission Systems. Safety Trailer Break-away System. Car Air Conditioning.



FREE FOR 7 DAYS

59 SPECIALISTS contribute HALF-A-MILLION WORDS

They include technicians from these world-famous companies—

AC-Delco, A.E.C., Alvis, Austin Motor Co., Bakelite, Borg & Beck, Bryce Berger, Burman, David Brown (Huddersfield), Dunlop, Ferodo, Glacier Metal, Heenan & Froude, Herbert Terry & Sons, K.L.G. Plugs, Nuffield Organization, Leyland Motors, Morris Motors—Engines Branch, Sheep-bridge Eng., Shell, Shorrock Superchargers, Skefko, Smith Motor Accessories, Smith Radiomobile, Rootes Group, S. Smith & Sons—England, Standard Motor Co., Vulcan, Vauxhall Motors, Westinghouse Brake & Signal Co., etc.

POST NOW—No Cost! No Obligation!

George Newnes, Ltd., 66-69, Great Queen St., London, W.C.99.

Send me Newnes AUTOMOBILE ENGINEER'S REFERENCE BOOK. I will either return it in 8 days or send 7s. 6d. deposit eight days after delivery, then eight monthly payments of 10s., paying 87s. 6d. in all. Cash price in eight days is 80s.

Name

Address

Occupation

Your Signature

(Or your Parent's Signature if under 21) AB17

Place X where it applies

HouseOWNER	<input type="checkbox"/>
Householder	<input type="checkbox"/>
Living with Parents	<input type="checkbox"/>
Lodging Address	<input type="checkbox"/>

VALUABLE NEW HANDBOOK FREE TO AMBITIOUS ENGINEERS

Have you had your copy of "Engineering Opportunities"?

The new edition of "ENGINEERING OPPORTUNITIES" is now available—without charge—to all who are anxious for a worthwhile post in Engineering. Frank, informative and completely up to date, the new "ENGINEERING OPPORTUNITIES" should be in the hands of every person engaged in any branch of the Engineering industry, irrespective of age, experience or training.

**We definitely Guarantee
"NO PASS—NO FEE"**

This remarkable book gives details of examinations and courses in every branch of Engineering, Building, etc., outlines the openings available and the essential requirements to quick promotion and describes the advantages of our Special Appointments Department.

WHICH OF THESE IS YOUR PET SUBJECT?

MECHANICAL ENGINEERING
Gen. Mech. Eng.—Maintenance—Draughtsmanship—Heavy Diesel—Die & Press Tool Work—Welding—Production Eng.—Fig & Tool Design—Sheet Metal Work—Works Management—Mining—Refrigeration—Metallurgy

ELECTRICAL ENGINEERING
Gen. Elec. Eng.—Elementary & Advanced Elec. Technology—Installations Draughtsmanship—Supply—Maintenance—Design—Electrical Traction—Mining Electrical Eng.—Power Station Equipment, etc.

RADIO ENGINEERING
Gen. Radio Eng.—Radio Servicing, Maintenance & Repairs—Sound Film Projection—Telegraphy—Telephony—Television—C. & G. Telecommunications

AUTOMOBILE ENGINEERING
Gen. Automobile Eng.—Motor Maintenance & Repairs—High Speed Diesel—Garage Mngment.

CIVIL ENGINEERING
Gen. Civil Eng.—Sanitary Eng.—Structural Eng.—Road Eng.—Reinforced Concrete—Geology.

BUILDING
Gen. Building—Heating & Ventilation—Architectural Draughtsmanship—Surveying—Clerk of Works—Carpentry and Joinery—Quantities—Valuations

WE HAVE A WIDE RANGE OF AERONAUTICAL COURSES AND COURSES IN FORESTRY, TIMBER TECHNOLOGY, PLASTICS, G.P.O. ENG., TEXTILE TECHNOLOGY, ETC., ETC.

One of these qualifications would increase your earning power

WHICH ONE?

A.M.I.Mech.E., A.M.I.C.E., A.M.I.P.E., B.Sc., A.M.Brit.I.R.E., A.F.R.Ae.S., A.M.I.M.J., L.I.O.B., A.R.I.B.A., A.M.I.H. & V.E., M.R.San.I., F.R.I.C.S., A.M.I.E.D., CITY & GUILDS, COMMON PRELIM., GEN. CERT. OF EDUCATION, ETC.

**THE BRITISH INSTITUTE OF
ENGINEERING TECHNOLOGY**



410A, COLLEGE HOUSE,
29-31, WRIGHT'S LANE,
KENSINGTON, W.8.

Phone: WEStern 9861

WHAT THIS BOOK TELLS YOU

- ★ HOW to get a better paid, more interesting job.
- ★ HOW to qualify for rapid promotion.
- ★ HOW to put some valuable letters after your name and become a "key-man" quickly and easily.
- ★ HOW to benefit from our free Advisory and Appointments Depts.
- ★ WHERE today's real opportunities are... and HOW you can take advantage of the chances you are now missing.
- ★ HOW, irrespective of your age, education or experience, YOU can succeed in any branch of Engineering that appeals to you.

**144 PAGES OF EXPERT
CAREER-GUIDANCE**

You are bound to benefit from reading "ENGINEERING OPPORTUNITIES," and if you are earning less than £15 a week you should send for your copy of this enlightening book now—FREE and without obligation.

POST NOW!

TO: B.I.E.T. 410A, COLLEGE HOUSE, 29-31, WRIGHT'S LANE, KENSINGTON, W.8.

Only 2d. stamp is needed if posted in an unsealed envelope.

Please send me FREE and without obligation, a copy of "ENGINEERING OPPORTUNITIES." I am interested in (state subject, exam., or career).....

NAME

ADDRESS.....

WRITE IF YOU PREFER NOT TO CUT THIS PAGE

THE B.I.E.T. IS THE LEADING INSTITUTE OF ITS KIND IN THE WORLD



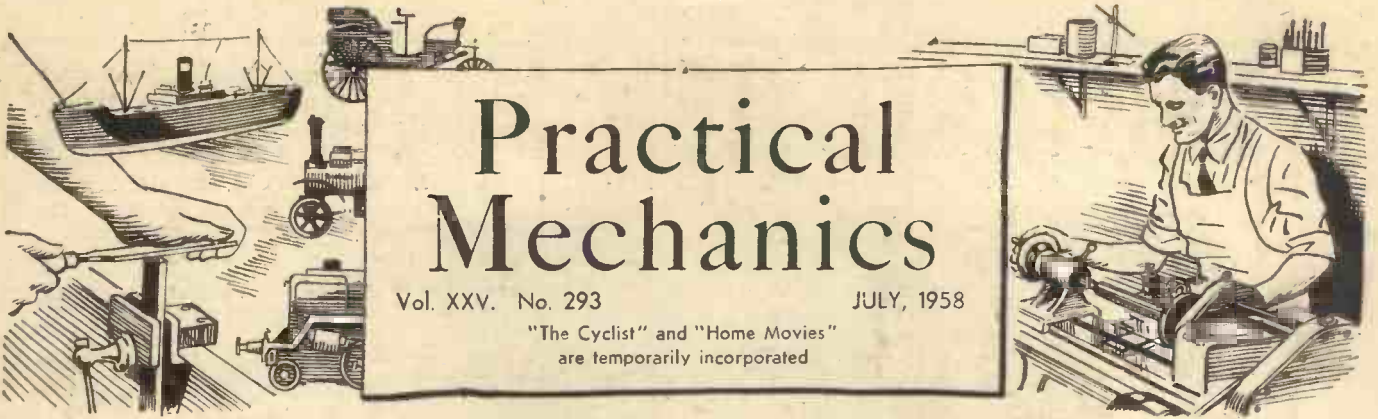

Practical Mechanics

Vol. XXV. No. 293 JULY, 1958

"The Cyclist" and "Home Movies" are temporarily incorporated

FAIR COMMENT

MINIATURE POWER VEHICLES

ONE remarkable feature of the bus strike has been the calm with which the public accepted the challenge. There has been no public outcry and members of the public resident in the affected areas, inured to transport strikes, this time took immediate steps to find alternative means of transport. Some were able to use the Underground railways, a comparative few were able to obtain lifts, but a vast number took to two wheels, either pedal or power propelled. The public in other words has taken steps to make itself independently mobile, and scooters, mopeds and motorised bicycles have sold in great numbers during the past few weeks. These handy vehicles are reasonably fast and reliable, they give weather protection to the rider and they cost very little to run, most of them doing more than one hundred miles to the gallon, some nearly 200 miles. The strike has indeed forced the individual to realise that the settlement of a strike is but a temporary affair, whether in transport or in any other sphere. The modest bicycle which costs practically nothing to run and even when used for utility purposes combines a healthy pastime has also been selling well.

The transport industry, therefore, as a result of the strike, has lost a large number of its customers who are unlikely to tolerate further the risk of inconvenience and increase in their travelling costs, for whatever claim is granted must eventually come out of the pocket of the user. The handy and reliable moped has provided a ready-made solution. These tiny vehicles came into use immediately after the war as the result of Continental development. Until British manufacturers got busy all of the machines were of Continental manufacture, but now there are several British makes. The user, apart from saving money by this fascinating form of travel, has eliminated the discomfort of bus and Underground travel. He can run to his own time schedule and is no longer the victim of strikes. The Cyclist Touring Club, as was expected, scorned them. Its secretary described them as neither fish nor flesh. They, however, are here to stay and have affected the sales of bicycles. No doubt London Transport are very concerned at this turn of events. Indeed, they warned busmen that the strike is likely to lose them custom. It is quite apparent and the facts must be faced that individuals should no longer place reliance upon archaic means of transport such as buses, trams, Underground railways and trains, and the aim should be towards making oneself completely independent of them. "With the congestion on the streets, the heyday of the bus is gone," says Sir John Elliot, chairman of London Transport. The strike, therefore, has performed one useful purpose, in demonstrating that one of the main causes of congestion is buses—not private cars.

The sales of the miniature bubble cars continue to rise, and further fortify the opinion that the travelling public intends to become independently mobile. The buses, the trams and the Underground railways have been losing millions a year for a long time, and the gradual scrapping of surface vehicles will help to lessen the burden of taxation. Buses in the not too distant future will merely be used in outlying districts.

THE "BEGINNER'S GUIDE TO TELEVISION"

OUR new handbook entitled "Beginner's Guide to Television," a companion volume to "Beginner's Guide to Radio" (now being produced also in Braille) will be published on July 19th. It is an elementary guide in fifteen lessons, and those who require a rudimentary introduction to television should study this book which costs 7s. 6d., or 8s. 3d. by post from the Book Department, address as on this page.—F. J. C.

The August issue will be published on July 31st. Order it NOW!

Editorial and Advertisement Offices
"PRACTICAL MECHANICS"
George Newnes, Ltd., Tower House,
Southampton Street, Strand, W.C.2
© George Newnes Ltd., 1958

Phone : Temple Bar 4363
Telegrams : Newnes, Rand, London

SUBSCRIPTION RATES

Including postage for one year
Inland 20s. per annum.
Abroad 18s. 6d. per annum.
Canada 18s. 6d. per annum.

Copyright in all drawings, photographs and articles published in "Practical Mechanics" is specially reserved throughout the countries signatory to the Berne Convention and the U.S.A. Reproduction or imitations of any of these are therefore expressly forbidden.

CONTENTS

	Page
Fair Comment	459
Making a Camping Trailer	460
The U.S. Satellite Programme	463
Working With Wire	465
Science Notes	466
Apparatus for Electrostatic Experiments	467
Puzzle Corner	468
A Small Table	469
An Illuminated Magnifier	470
Repairing Tents	471
A Novel Home Safe	472
Making a Fibreglass Yacht	473
A New British Interceptor	475
A Carnival Spinner	476
About Binoculars	479
Changing the Speed of D.C. Motors	480

JUNIOR SECTION

A Powerful Lifting Magnet	483
Making Rafts	484
Letters to the Editor	489
Trade Notes	490
Your Queries Answered	493

CYCLIST SECTION

What I Think	37
Detecting Wear	38

PRACTICAL PHOTOGRAPHER SUPPLEMENT

The Practical Photographer	49
Photography Abroad	50
A Table Top Tripod	51
Out of the Ordinary with Infra Red	52
Dish Developing a Film	54
Freelance Photography	55
An Electronic Flash Outfit	56
The Camera Lens	61
Camera Collections	62
Replies to Readers' Letters	63

CONTRIBUTIONS

The Editor will be pleased to consider articles of a practical nature suitable for publication in "Practical Mechanics." Such articles should be written on one side of the paper only, and should include the name and address of the sender. Whilst the Editor does not hold himself responsible for manuscripts, every effort will be made to return them if a stamped and addressed envelope is enclosed. All correspondence intended for the Editor should be addressed: The Editor, "Practical Mechanics," George Newnes, Ltd., Tower House, Southampton Street, Strand, London, W.C.2.

CAMPING EQUIPMENT

The First of a Short Series

Making a Camping Trailer

A DUAL-PURPOSE CARRIER AND COOKING ANNEXE By F. HOOK



out." It will be remembered that the front wheels of cars generally do not run parallel but are toed-in about $\frac{1}{4}$ in. to improve steering characteristics.

The Axle

First of all obtain a suitable front car axle, strip it of all unnecessary fittings and

THE trailer will form the ideal method of carrying camping gear. If the motorist is a regular week-end camper, then the trailer will be of especial benefit, as, when returning late on a Sunday night, the trailer is unhitched and the equipment is all ready for the next week-end and need not be all unpacked.

A good many of the dimensions of this trailer will be dependent on the type of axle which is used in its construction. The reader will have to visit the car-breakers' yard and look for the front axle with the two semi-elliptical springs suspension found on the old Morris Minor and similar cars. The trailer shown in the photographs was built upon a very ancient Morris axle. It was rather heavy but very robust, and the 19in. wheels made it rather higher off the ground than could be

wished for. Nevertheless, very heavy loads of gear have been carried in it many thousands of miles.

As the unladen weight of the trailer will exceed 2 cwt. it will be necessary to fit over-run brakes to the trailer in order to comply with the law. Therefore, when purchasing the axle, examine the brakes fitted to the

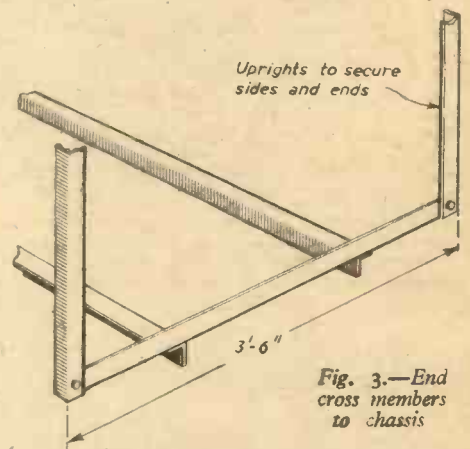

Fig. 3.—End cross members to chassis

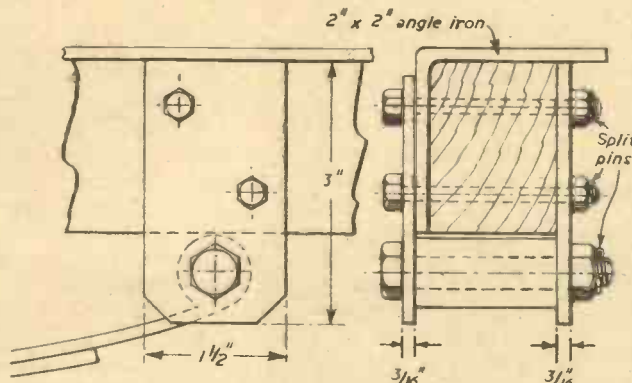

Fig. 1.—Front fixed shackle.

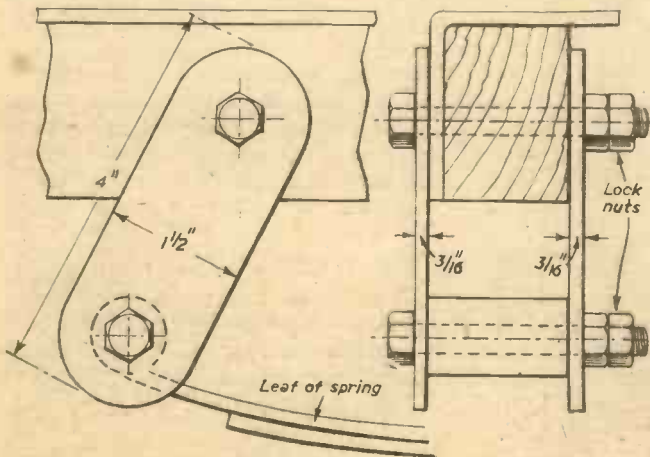

Fig. 2.—Rear shackle

wheels to see that they are in working order and may be easily adapted to work from the over-run mechanism on the towing bar.

On some axles the brake arms may be so arranged, as was the case of the author's axle, that the axle, when fitted to the trailer, ran forwards in the reverse direction to that which it did in the car to which it was originally fitted. In such a case it will be necessary to adjust the track rod connecting the two wheels so that the pair of wheels do not "toe

WHAT THE SERIES WILL COVER

TWO types of trailer will be described. Firstly, details are given of a rather larger box-type trailer with lids which rise up and form the walls of an extremely simple caravan-like structure. This will be most useful as a cooking annexe in camp or it may be used for washing purposes, etc. The 6ft.-long seat along one side of the trailer may also be pulled out to form an occasional bed if desired.

Secondly, a description is given of a very light, low loading trailer, especially useful for high-speed touring and designed to take camp gear only. It is covered with a tarpaulin or the ground sheet of the tent.

This trailer chassis can be adapted to carry the PRACTICAL MECHANICS Pram Dinghy described in our issues dated August to November, 1956. In such a case the camp equipment is carried in the dinghy.

Tent designs are very numerous, but the simple Cottage Tent is still the best seller and is ideal for family camping. Details of making such a tent in lightweight material will be given.

With transport and shelter taken care of one's thoughts turn to further camp comforts. A design will be given for a cooking unit in which one may cook in a gale without the stove blowing out. This will be followed by a design for a set of light folding table and chairs which will add greatly to camp comfort with but little extra weight.

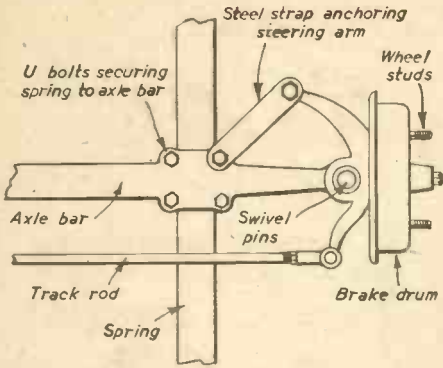

Fig. 4.—Method of anchoring the steering arm.

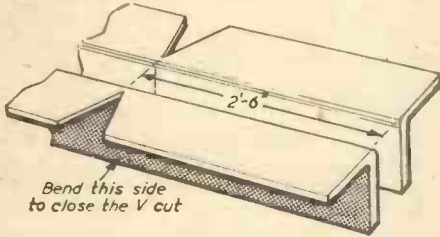

Fig. 5.—V notches in the towing bar.

note the direction in which the brake arms have to be pulled in order to apply the brakes. Then arrange in which direction the axle will move so that the brakes are applied according to the instructions in the previous paragraph.

Next, note that the ends of the springs nearest to the front end of the trailer are

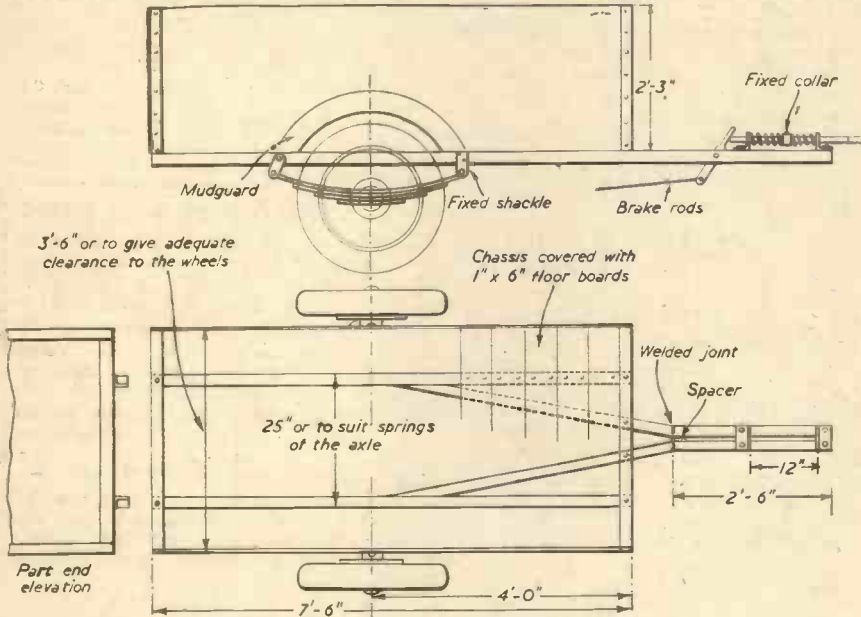

Fig. 6.—Side elevation and plan of trailer.

fixed to the chassis whereas the rear ends of the springs are fixed to a movable shackle plate to accommodate the movement of the springs when the trailer is in use.

The two main members of the chassis are made of two pieces of 2in. X 2in. angle iron each 7ft. 6in. in length. On the inside angle of these members are two lengths of timber of thickness arranged so that together with the thickness of the angle iron the width of the eye at the end of the springs is obtained. Refer to Figs. 1 and 2 which give the constructional details of the front and rear shackles.

Having bolted the shackles to the chassis members, next drill the ends to which are secured two pieces of angle iron as shown in Fig. 3. Bolt together very securely after

ascertaining that the framework is square. Note that on the backplate of one brake drum is the steering arm which is interconnected with the other wheel by the track rod. Adjust the wheels to be parallel with the chassis members and then securely fix the arm to a point on the chassis so that it cannot move. On the trailer now described, the point of anchorage was the end of one of the U-bolts securing the springs to the axle (Fig. 4).

The Towing Bar

At 2ft. 6in. from the ends of the two pieces of 7ft. 6in. long angle iron for the towing bar make a V-cut as in Fig. 5. This will enable the iron to be bent to the angle shown in Fig. 6. When the correct angle has been obtained the V-joint should be welded. It is suggested that if welding cannot be done a suitable plate could be bolted across the joint (Fig. 7).

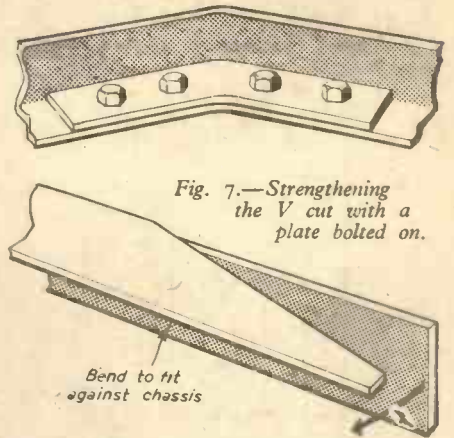

Fig. 8.—How the ends of the towing bar are cut and bent.

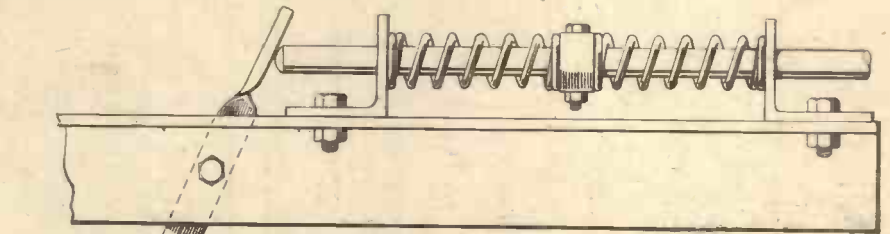

Fig. 9.—Details of the coupling.

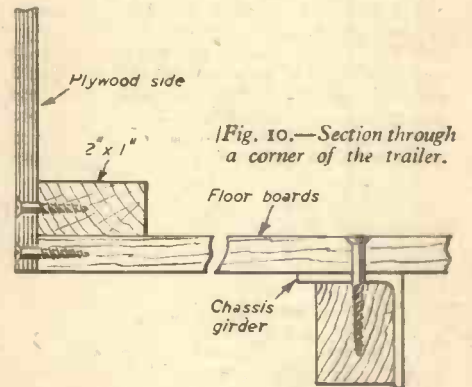

Fig. 10.—Section through a corner of the trailer.

The rear ends of these two pieces have a tapering piece sawn from the top sides of the angles to run in with the main members of the chassis. The vertical sides of the angles are then bent to fit against the chassis members to which they are subsequently bolted as in Fig. 8. Before drilling these members it is as well to hold them both in position with small G-cramps to test that the draw bar is on the centre line of the trailer. Also fit the spacer plate at the V-junction shown in Fig. 6. This spacer is



The trailer in the closed position.

Fig. 11.—A home-made jack and tailboard fixing.

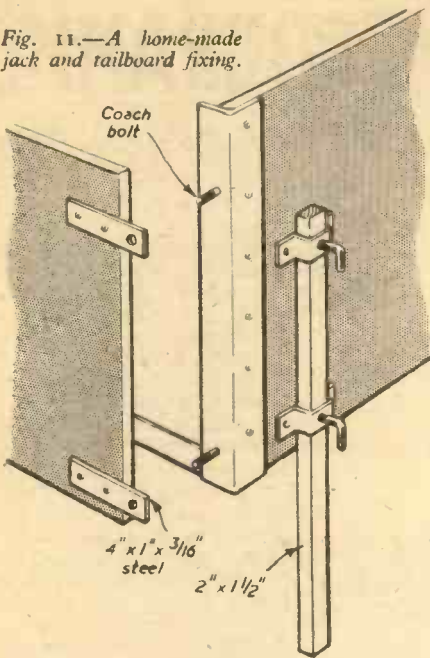

made from the same material as the brake lever. A piece of tinplate packing may be added so that the brake arm will move easily between the two pieces of angle iron.

The Coupling

Perhaps the reader who wishes to cut down metal constructional work could purchase a commercial coupling unit and fix it to the end of the draw bar.

On the other hand a simple design is shown in Fig. 9 which the reader could make for himself. Two short cross-members of 3in. x 3in. angle iron are bolted to the draw bar as shown. Two holes are drilled in them to take the coupling bar made from

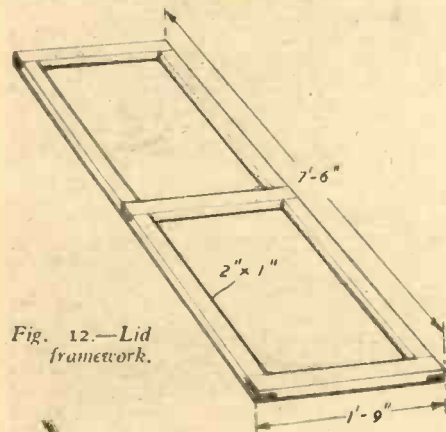

Fig. 12.—Lid framework.

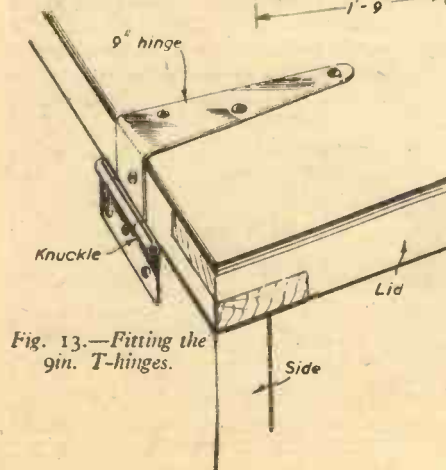

Fig. 13.—Fitting the 9in. T-hinges.

3/4in. dia. steel bar to one end of which an eye is forged to hitch to the towing bracket on the car. A collar is fixed in the centre of the space between the two pieces of angle iron to take the pull and push of the two stout springs. The collar is secured with a high tensile steel bolt. Alternatively, the collar could be welded to the coupling bar.

Experiment will be necessary with the length of the brake lever so that sufficient movement is obtained at the lower end of the lever to give full application of the brakes, having regard to the amount of movement on the top end of the lever.

Floor Boards

The chassis is now completed and can be

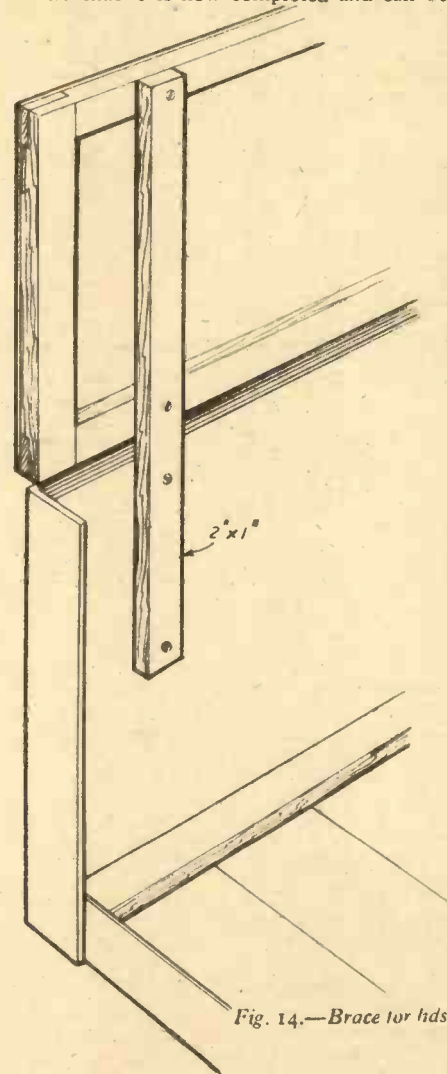

Fig. 14.—Brace for lids.

drawn behind a car in this state. Work must now proceed upon the body.

First of all prepare the timber for the floor. This is made from some 1in. x 6in. floorboards. The width of the floor is governed by the clearance between the two road wheels as shown in Fig. 6.

A wider floor space could be made overlapping the wheels as in the case of caravan construction. This would, of course, necessitate the construction of wheel arches which adds to the work. For simplicity the design shown was used.

The required number of 1in. x 6in. x 3ft. 5in. floorboards are screwed or bolted to the chassis. This will necessitate drilling through the angle iron so that the screws can take up in the wooden members secured on the underside.

Sides of the Trailer

At each end of the floor and secured to

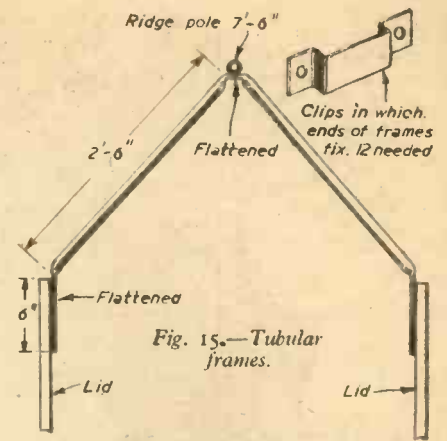

Fig. 15.—Tubular frames.

the ends of angle iron cross-members is a vertical piece of 1 1/2in. x 1 1/2in. angle iron 2ft. 3in. in length.

The sides and ends of the trailer are made from 5/16in. or 3/8in. resin-bonded plywood and bolted to these corner members. The lower edges of the sides overlap the ends of the floorboards as shown in Fig. 10 to which they are secured. Additional strength at these points can be obtained by fitting lengths of 2in. x 1in. deal.

The front end of the trailer is fixed whereas the rear end is made removable in the nature of a tailboard.

Jacking

At this juncture some thought should be given to methods of jacking the trailer. Here again, four commercial jacks could be bought and fitted. Alternatively, some simple home-made jacks can be made on the lines of those shown in Fig. 11, which

(Continued on page 474.)

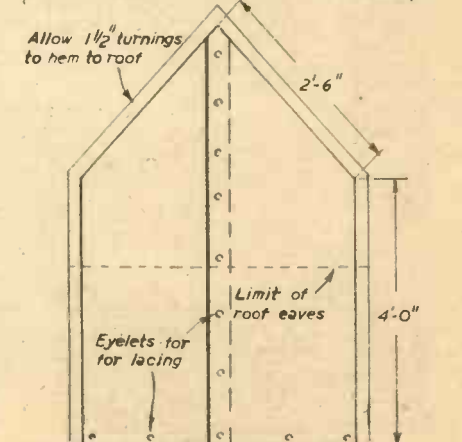
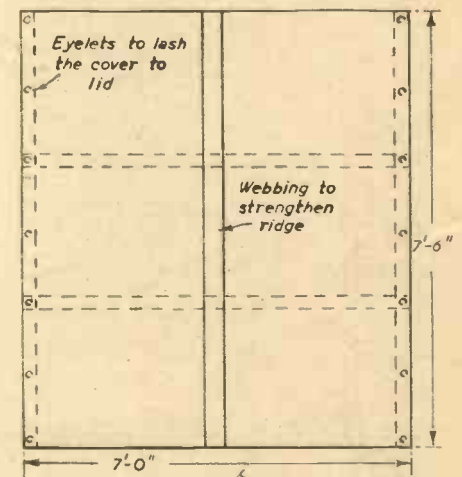

Fig. 16.—Details of the canvas covering.

THE U.S. SATELLITE PROGRAMME

Part 1—The Satellites, Details of Their Rockets, Launching and Instrumentation

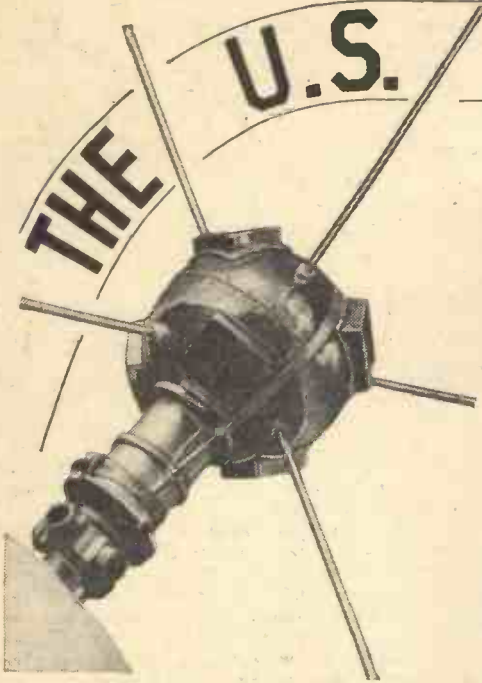

Fig. 1.—The 7in. diameter Vanguard I.

AMERICAN scientists planned to launch six fully-instrumented satellites during the International Geophysical Year and put into orbit several other "test vehicles."

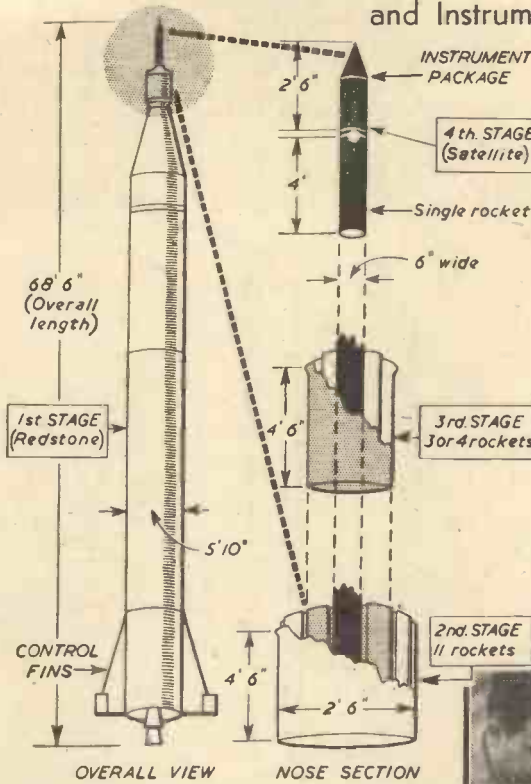

Fig. 3.—Details of the 70ft. Jupiter C launching vehicle.

propellant rockets surrounding the third stage—a triangle of three similar rockets. Directly in the centre is the fourth stage—a single solid rocket with its instrumented section extending above the lower portion of the barrel. This boosts the speed to 18,000 m.p.h. and its casing remains attached to the satellite in orbit.

The Vanguard vehicle, shown in Fig. 2 taking off to put the first test sphere (Explorer II) into orbit, is a three-stage rocket. The first two stages are guided by internal controls, but the third stage is kept to a straight flight path by spinning it about its longitudinal axis prior to firing. It is 72ft. long and has a gross weight of 22,600 lb.

The first stage is a liquid propellant rocket; the second



Fig. 5.—Vanguard I being fixed into position on top of the third-stage rocket.

By the end of March, 1958, the U.S. had three satellites in orbit, the first of these, Explorer I, being launched on January 31. The Vanguard I satellite (Explorer II) followed seven weeks later and a few days after this Explorer III was in orbit.

Explorer I (shown diagrammatically in Fig. 4) and Explorer III were rocket-shaped satellites with identical dimensions—80in. in length and 6in. in diameter. Both were launched by a Jupiter-C rocket. Explorer II was launched by a Vanguard rocket and its shape and general appearance may be seen in Fig. 1.

The Launching Vehicles

Details of the Jupiter-C rocket can be seen in Fig. 3. The first stage is a modified "Redstone" rocket modified to burn a hydrazine-based compound instead of alcohol. The three following stages are contained in a barrel-like cylinder. The second stage is a cluster of eleven solid-

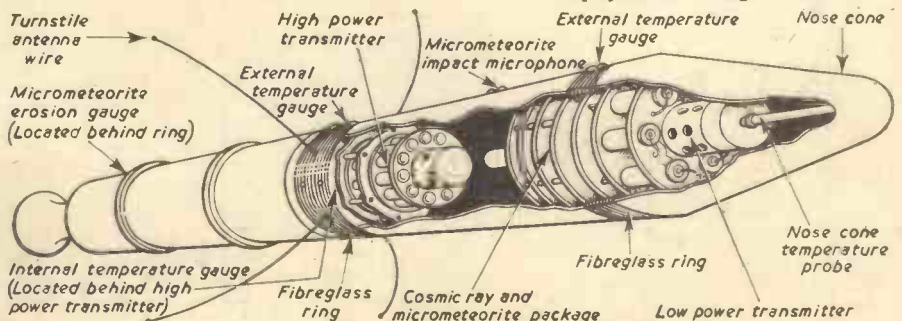

Fig. 4.—The instrument carrying section of Explorer I and the final stage rocket (rear) which went into orbit as a single unit. The antennae, fanning out from the centre section, are kept in position by the satellite's rotational spin.



Fig. 2.—The Vanguard launching vehicle as it took off to put Vanguard I into orbit.

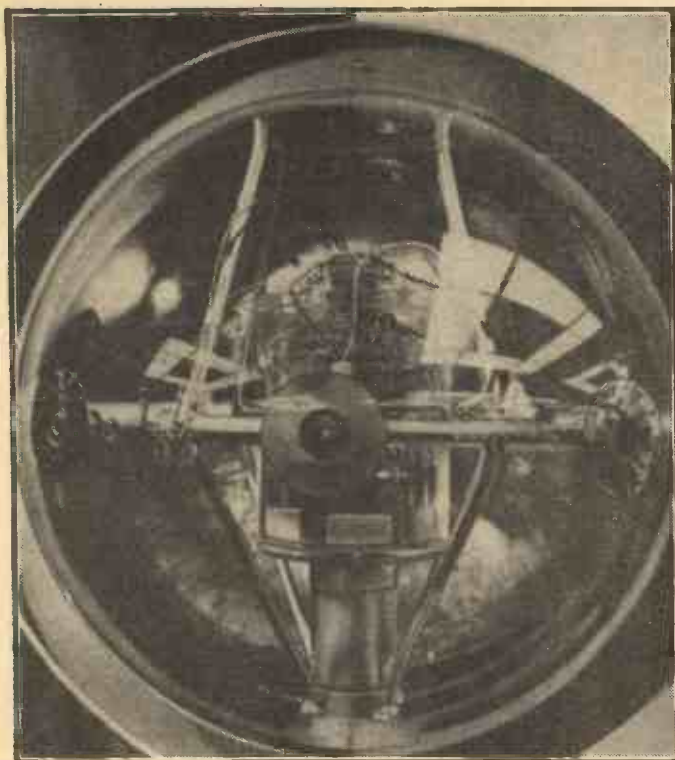

Fig. 6.—Model of the 20in. satellite. Instruments shown are: (A) Solar cell, current from which resets memory-playback unit. (B) Ion chamber which detects ultra-violet radiation. (C) Thermistor strip which measures outside skin temperature. (D) Erosion gauge. (1) The Minitrack transmitter. (2) Memory system for collisions with larger meteorite particles. (3) Telemetry coding system, feeding data from instruments to the transmitter. (4) This is below (3) and is the Lyman Alpha memory unit. (5) Meteoric collision amplifier. (6) Lyman Alpha amplifier. (7) Mercury battery power supply.

over ground receiving stations. Two hours' data—information covering a complete orbit—was transmitted in just five seconds.

The 20in. Satellite

It is proposed to launch a series of these satellites, which weigh 21lb. each and are designed to send back much more information than the previously launched test satellites.

Research in which they are planned to play a vital part includes measurement of the sun's ultra-violet radiation, determination of the arrival frequency of primary cosmic rays, measurement of the earth's magnetic field, and determination of the amount of radiation from the sun to the earth, and of solar energy reflected back from the earth. Additional information gathered will include data for the study of the changing patterns of the earth's cloud cover, surface and inside temperatures and surface erosion by meteoric dust, collisions and punctures by meteorites. Fig. 6 shows a model of the satellite and the positions of some of the instruments. Actual size can

Vanguard I Satellite

Though less than 7in. in diameter, Vanguard I carried a good deal of delicate and complex apparatus. Included in this were six tiny solar batteries, energised by the sun's rays which will keep the radio transmitter working, possibly



Fig. 9.—The complete Minitrack transmitter unit.

stage attaches to the forward end of the first stage and carries in its nose the third stage and the satellite (Fig. 5). This stage is the "brain" of the launching vehicle. The third stage is a solid-propellant rocket which delivers 2,300lb. of thrust at operating altitude. It is spun while it is in the second stage; then it separates and ignites.

Explorer I and III Satellites

Both these carried about 11lb. of instruments, designed to gather and transmit information on cosmic rays, meteorites and orbital temperatures. Explorer III had one important additional item of equipment—a tiny magnetic tape-recorder, which provided data on cosmic ray bombardment. The information was stored and released later while orbiting

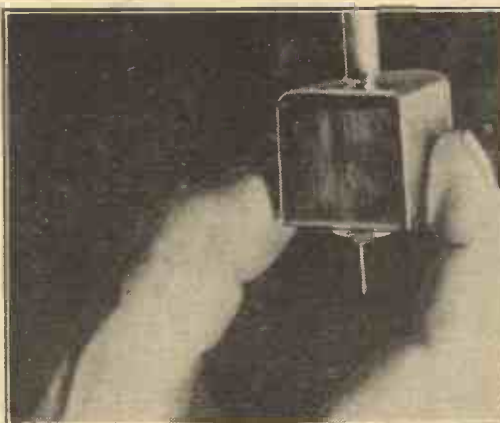

Fig. 8.—Miniature pressure-gauge which registers instantly if a meteorite punctures the satellite's shell.

be seen in Figs. 7-10. The information gathered will aid the determination of inter-Continental distances and the shape of the earth; it will tell us more about the density of the upper atmosphere, cosmic rays, X-rays and other phenomena. Improved weather forecasting, improved radio and television transmission and new discoveries in medicine, chemistry, astronomy, physics and other sciences may all be brought about by this research.

The information in this article is reproduced by kind permission of the U.S. Information Service.



Fig. 7.—Lyman Alpha memory unit which memorises and later recites data on ultra-violet ray intensity.

for years. Each solar battery is a sandwich of 18 extremely thin wafers of silicon. The negative and positive silicon wafers convert the sun's rays into electric power to feed a miniature transmitter broadcasting continuously on 108.03 Mc/s. In addition to providing tracking facilities the transmitter also reports on the sphere's inside temperature. Explorer II is expected to remain in orbit for several years. This satellite was launched as part of the "Test Sphere Programme," which is intended

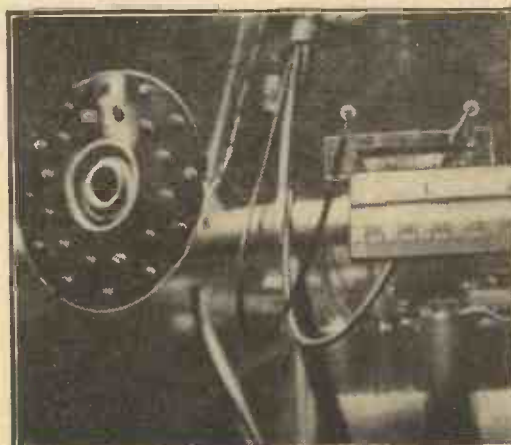
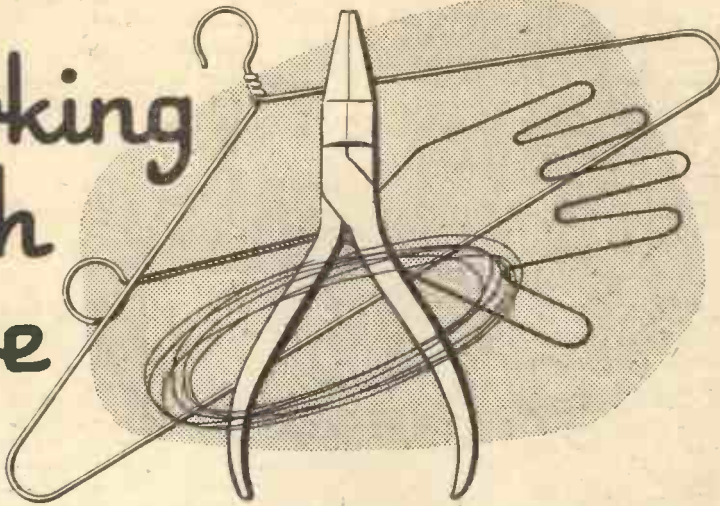

Fig. 10.—The solar cell, which will harness sun power to reset the memory unit.

Working With Wire



Details for Making Some Handy Home Items By Robin Shoan

SUITABLE wire can be bought at any ironmonger's by the pound, "gauge 14" brass or nickel covered being the best type for home items. Copper wire is too soft and lacks that slight "spring" which is a help to successful shaping.

The tools required for wire-work are a pair of square-nosed pliers, with a cutter incorporated, a small file and a block of wood having a spike in it, over which can be slipped cotton reels of various sizes. These latter have the lips trimmed off and are for use as formers for bending the wire round, the reels being of different sizes to give a range of curvatures. For quick work the block should be clamped to a table or held in a vice. Having something to work "against" or "round" is of the utmost value in most forms of wire fashioning. A glove to wear on the hand that will do the major part of the bending is an advantage.

The main question when making an item

Single length

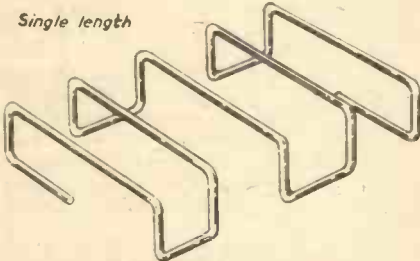

Fig. 1.—Cake stand.

Start here

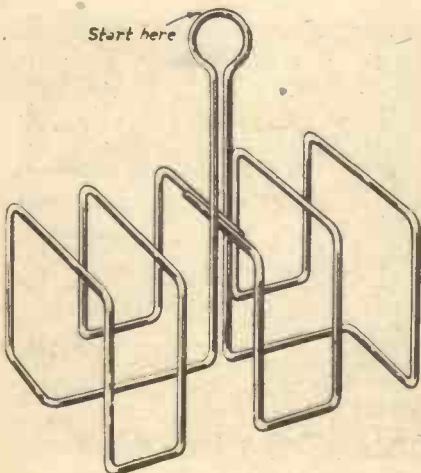

Fig. 2.—Toast rack.

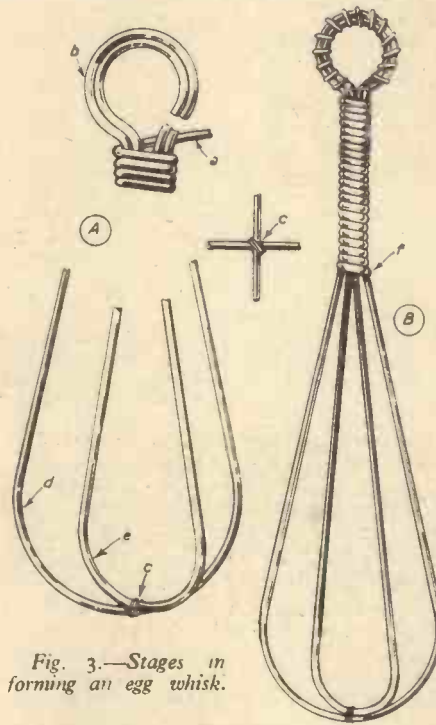

Fig. 3.—Stages in forming an egg whisk.

is that of how much wire it will take. Here is where a length of copper wire is handy to make a quick pattern, being easily shaped. When straightened out it is easy to measure the length needed. Points of bending can be measured off and indicated on the final material, so that they can be made with certainty.

A Cake Cooling Stand

For a very simple piece of work, first try the stand shown in Fig. 1. This is but one length of wire and can be made from any material you have handy, but brass wire will look well. In making this article, success is mainly a question of careful measuring. The stand can, with advantage, be shaped over a rectangle of wood which just fits inside and is later pulled out.

A Toast Rack

Fig. 2 shows a toast rack, which is a little more complicated. Nickel-covered wire looks well, but a brass stand can be very neat; either square or round section material can be used. A first pattern should be made here with some care in the copper wire. Work starts at the loop and the wire

follows down the upright, then out at right-angles along the base lengths and so on up to the squares. The track can be readily followed from the diagram. Finishing is effected by taking the two ends between the two strands of the upright.

As with the cake-cooling stand, the various corresponding lengths must be made the same and true right-angle bends formed, if the work is to be a success. It is all a question of careful measuring before working the final material.

An Egg Whisk

Fig. 3 shows a very useful kitchen item—an egg whisk. Two longish strips of wire are required (d) and (e), and a third length (a) of the same or smaller gauge for binding the shank and loop at the top—also a very thin piece is used to bind the two loops together where they cross.

First take the lengths (d) and (e) and bend them in the middle to two half circles of about 1½ in. dia., using a round piece of wood to get a perfect curve. Now collect the wires together and temporarily bind them at a point about 5 in. from the end. Continuing upwards, take two of the strands and curve them round to form the top loop (b), bringing them back on themselves till they meet the other two strands which must be cut off at just the right length. Bind now from the point where the strands were first brought together, up the entire length of the shank and round the loop, finishing at (f). At the other end the main loops are made to cross at right-angles, the intersection being bound tightly with the short piece of fine wire as (c). The completed whisk will appear as at (B). Nickel steel wire can be used with advantage for this item.

A Glove Drier

The glove-drying

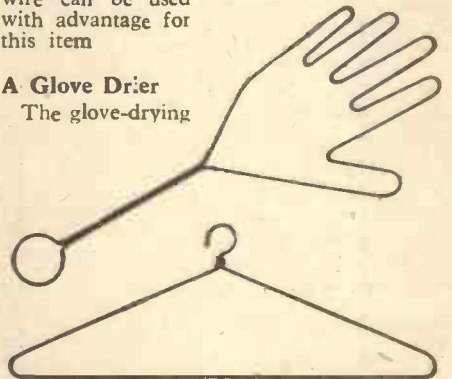
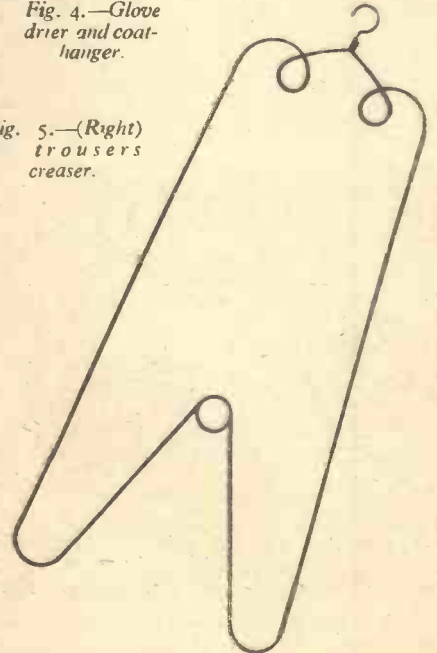

Fig. 4.—Glove drier and coat-hanger.

Fig. 5.—(Right) A trousers creaser.



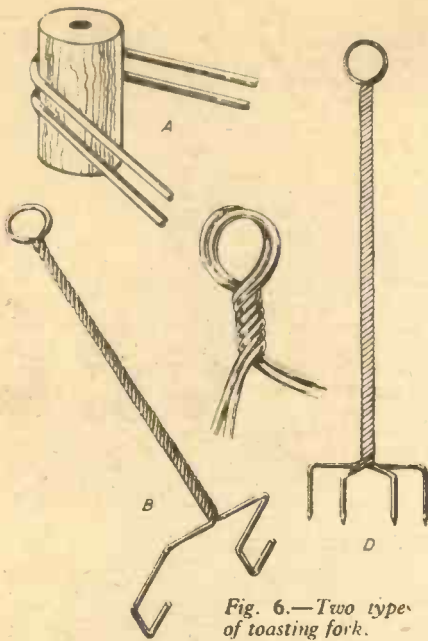

Fig. 6.—Two types of toasting fork.

frame shown in Fig. 4 is another very useful item. The part which goes inside the glove must be made of stiff wire but the binding can again be of fairly fine gauge. To obtain the correct shape lay an average-sized glove on a piece of paper and trace round it. Copy this shape in the soft wire again to get an idea of the length

required, and then fashion in the stiffer material, seeing to it that the start and finish is about a third of the way down the shank. With the finer wire now bind the whole shank either tightly or in a regular spiral which will cover the ends and make the article rigid.

A Coat-hanger

This, as shown in Fig. 4, is fashioned from a single length of stiff wire. Starting with lower strand, the wire is bent back on itself at a normal shoulder width, the corners being rounded. At the mid-points the two ends are turned upwards and twisted together to form the upright piece, the hook at the top completing the article.

A Trousers Creaser

Fig. 5 shows a frame for keeping the crease in trousers. Two are needed and they are inserted one in each leg, there being sufficient spring in the wire to press well into the creases and retaining their shape. About 12-gauge wire is used and the various loops, made to give extra springiness, are shaped round the reels. The frames are supplied with hooks on top so that the trousers, with frames inside, can be hung.

Toasting Forks

Two are shown in Fig. 6. One is the usual pronged type and the other a more novel type. Two strands of wire are needed for the conventional type, but one only for the novel kind. A loop is first made at the mid-point of the single or double wire round the spike in the board as (A). With this

firmly on the spike, twisting is continued for the desired length of fork. The strands are then divided, being taken out, down and up again for the novelty fork as (B), but finished with the orthodox prongs for the other. In the

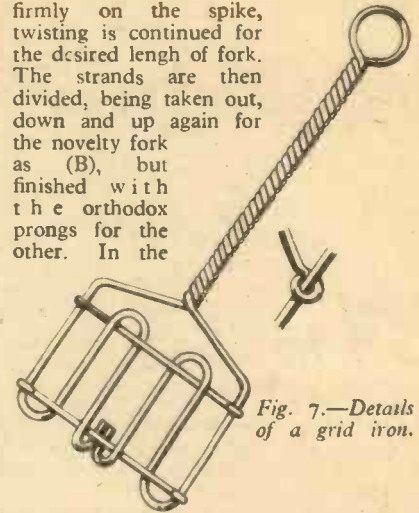

Fig. 7.—Details of a grid iron.

latter case file the ends of the prongs to a chisel edge to prevent the bread being broken. In the novel fork the bread is merely rested in the upturned ends.

A Grid Iron

Details of this are given in Fig. 7. The method of construction is the same as for the toasting fork, using the spike as shown at (A) in Fig. 6. One piece of wire is used and the two ends are finally held firmly by one of the two horizontal pieces which are added afterwards as shown.



Fuel-less Plane

SMALL amounts of atomic oxygen present about 60 miles above the earth's surface could be used to power a satellite or an unmanned plane. The plane would gather in uncombined oxygen atoms, which when brought together would provide enough energy to propel the plane through the thin drag-free atmosphere. Such a craft could be built in the near future and it is thought that future developments of the idea could be used to gather and store fuel for space ships. These would be fired through the earth's atmosphere by conventional means to the height of the fuel store, where they could re-fuel and continue their flight into further space.

Longer Days

BY comparing the time kept by the earth as it turns on its axis with that kept by an atomic clock, British and American scientists have discovered that the length of a day has been increasing by half a thousandth of a second a year since 1955. The atomic clock at the National Physical Laboratory uses the natural frequency of vibration of cesium atoms. Accuracy is possible to 1 part in 10 billion. In the U.S., photographic zenith tubes were used for observations to establish Universal Time.

Drilling for Oil Below the Sea

IN the Gulf of Mexico a drilling platform with 175ft. long legs is being used. It is towed to its destination and the portability of this type of off shore platform is emphasised by the fact that it is cheaper to move one 1,000 miles than to shift a land based drilling operation 15 miles.

Metals from the Sea

SCIENTISTS at Plymouth have found quantities of niobium and vanadium in the bodies of sea animals of the skate family and this means that they must have been absorbed from the sea. If methods can be found of extracting it, the sea could be a valuable source of these metals, which have recently become important in the hardening of high quality steels and for making aircraft steels corrosion and temperature resistant.

Liquids like Powders

A METHOD of treating liquids so that they resemble powders has been evolved in America. The liquid is broken up into droplets of microscopic size and then each droplet is coated with gelatine. The millions

of tiny capsules each only one millionth of an inch in diameter now closely resemble a powder. The liquid droplets are protected from air and from contamination and can be stored indefinitely.

Chemicals, perfumes, drugs or dyes can be stored by this method until they are ready for use, when they are released by crushing the capsules.

Another use which has been evolved is to coat paper with a "powder" containing dye and when this is used behind a top sheet of typing paper, the imprint of the key on the front sheet releases dyes on the papers behind and so makes a carbon copy without carbon paper.

The "powders" are also being used as a permanent memory unit in an electronic computer.



One of the "Snocat" tractors used on the transantarctic expedition and now being exhibited in Trafalgar Square.

Apparatus For Electro-Static Experiments

K. G. Vine Describes its Construction Using Modern Materials and the Tests Which Can be Carried Out With it (Concluded from the June issue.)

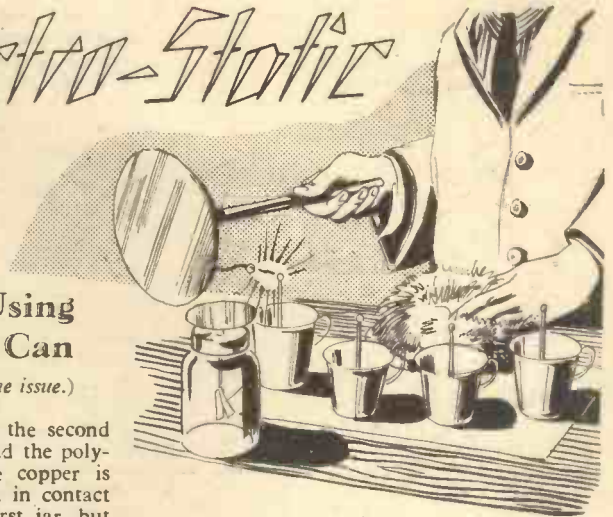

NOW place the plate on the table, press the metal disc on top of it, holding the disc by the insulated handle. Keeping it pressed down, touch it with a finger or earthed wire. Remove the finger or wire, then lift the metal disc by the handle. Hold it near the electroscope to make sure the metal disc is charged, then allow the metal solder blob to touch the blob of the Leyden jar. As the blobs get near, a small spark will jump. This process may then be repeated *ad lib.*; on a dry day it is not necessary to recharge the polythene plate more than once per half-hour. There is, of course, no need to check each time that the plate is charged with the electroscope.

After a number of charges have been transferred to the Leyden jar (say a score in the first instance) make a small discharging tool from some coaxial cable (Fig. 21). About 6in. of cable is stripped of the outer and metal cover, 2in. of the inner polythene is left in the centre for holding the tool in the fingers. If the wire is stranded run solder down it to give it strength and make solder blobs at each end. Bend it to a convenient radius.

If this tool is touched on to the outer cover of the jar and brought slowly towards the blob of the Leyden jar a fat spark will jump across. After a few seconds another smaller one can often be obtained. You may safely discharge the jar described with the fingers, the shock being harmless. Larger jars should be used in such a way with caution.

You may obtain a very high (and dangerous, so beware) voltage by wiring many of these jars in series (see Fig. 22). Each jar is warmed slightly in radiant heat to make sure it is dry and will hold a charge for an hour or so. It is then fully charged as described. One jar is placed on the table with the next jar standing on a polythene sheet or on two polythene rods (long playing records are probably suitable,

too). A wire is placed under the second jar between the silver paper and the polythene. This wire (thin bare copper is suitable) is then gently placed in contact with the solder blob of the first jar, but the act must be done using two polythene rods or pieces of polythene sheet in lieu of your fingers or pliers. Insulated pliers will not do.

Further jars may be added in the same way, each on a piece of polythene and wired to the previous jar. The jars should be arranged in a circle so that the first and last are near together. Using the discharging

Motor Car Static

On a hot summer's day after motoring through dusty atmosphere, or if the car is left where hot, dry sand from a dune will blow on to it, a charge may be detected in the metalwork. The author mounted his car on polythene blocks and ran the engine to gather information as to whether static was caused by the motor, the results obtained were negative.

Soundness of Insulators

If the electroscope is given a charge (it is best to use the negative one) the soundness of any insulator may be tested by touching the disc with the material. Dry wood will collapse the leaf at once and most glass will do so, too. Ebonite will do so slowly, but P.V.C. materials have hardly any effect. The soundness of the insulator of "sparking plugs" in a car may be judged, too. When new they are fairly good, but with age, even if cleaned thoroughly, they will discharge the electroscope at once.

Effectiveness of Tiny Picofarad Condensers

Small condensers may be held with one wire in the hand and the other touched on the charged electroscope. The leaves will drop a little as the condenser acquires a charge, but should then remain in that position with no further movement. If the leaves continue to subside the condenser has a faulty

dielectric.

High Voltage D.C. Supplies for Radio or T.V.

If the supply is earthed on one side simply bring a wire from the other side of the supply to the plate of the electroscope. The type A electroscope (Fig. 3) will show a deflection of a few degrees with 150 volts. 250 volts gives an easily seen movement of the leaf. 3,000 volts (from the author's oscilloscope supply) takes the leaf up to 90 deg., 2,000 volts to about 45 deg. These figures can only be approximate as the conditions vary for each and every electroscope.

On the small headphone-type instrument full deflection may be obtained with little over 1,000 volts. These instruments are useful for detecting voltages which connect to the supply via high value (megohm) resistors as other instruments give a false

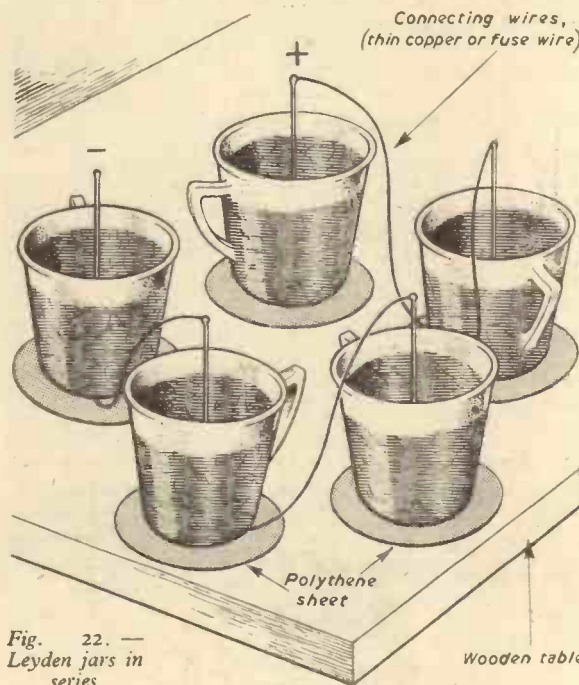

Fig. 22. — Leyden jars in series.

tool held between two fingers at the centre of the insulator bring the tool in contact with the foil of the first jar and near the solder blob of the last. A large, vigorous spark will be obtained. Larger size jars should only be used with extreme caution. A large voltage on its own is not harmful except to people with very weak hearts, but a large current (as obtained from Leyden jars made with polythene buckets) can be very unpleasant and harmful.

The following are a few suggested experiments.

Aerial Static

A well insulated wireless aerial (especially the T.V. type) will often pick up static electricity and if it is disconnected from the receiver and the electroscope brought near the end, a deflection will be obtained.

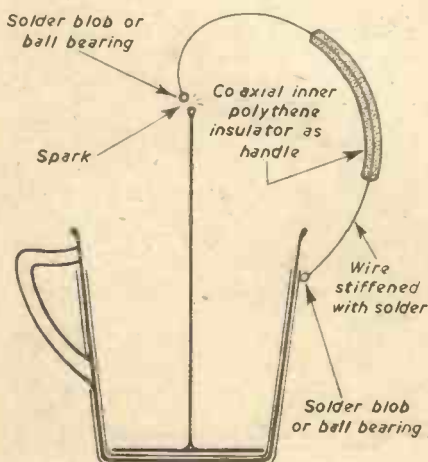

Fig. 21.—Discharging the Leyden jar.

and erroneous impression of a low voltage.

Where one side of the supply is not earthed this must be done, or, in the case of the headphone-type instrument, connected to the casing. Due care is necessary in all cases to safeguard against accidental shock.

Effectiveness of Patent Gramophone Record Cleaners

If a gramophone record is cleaned with an ordinary camel hair brush or piece of soft fur it gets a charge. This may be detected with the electrocope. If it is rubbed with a treated brush it should not do so if the brush does its job properly.

Magneto or H.T. Supply Test on I/C Engines and Model Planes, etc.

If the spark is allowed to jump on to the electrocope the leaf should go up to the 90 deg. mark as the voltage should be well over 3,000, usually being 10,000 volts. A running motor engine may be tested in this way, too, but the operation is somewhat tricky. Direct contact between the electrocope and the plug terminal is useless, the disc must be within a few thousandths of an inch of the plug terminal.

Leakage from H.T. cables is easily detected. Put the electrocope in contact

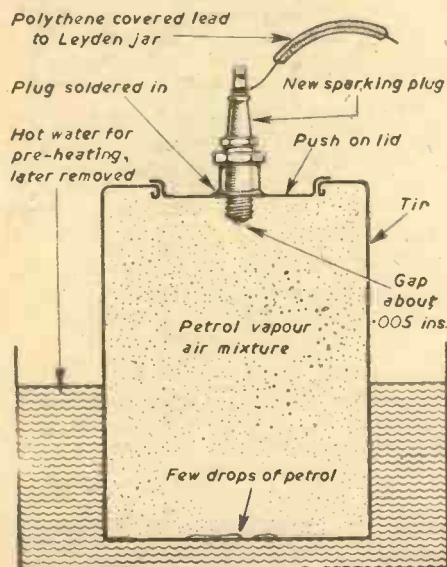

Fig. 23.—The explosion experiment.

with the metal part of the car, motor-cycle, etc. Connect a polythene-covered lead to the plate and run the end of the lead over the outside of the H.T. wires, distributor, etc.

Some Further Experiments

A gas burner with the gas turned low, especially if the air hole is closed, can be ignited with the spark from a Leyden jar. A few jars in series will do this very easily, but one is sufficient.

With care a small piece of cotton wool soaked in lighter fluid may be ignited in a similar way. Make sure none is on your hands when you do the experiment.

Methylated spirits, prewarmed by placing some in a bottle which has been kept in warm water for a few minutes, can also be used. Another way of using alcohol is to light the wool with a match, blow it out, and then it will easily be ignited with the spark.

A treacle tin or other similar container fitted with a large push-on type lid (no other type of lid will do, some could cause a dangerous explosion), has a sparking plug soldered into the lid (Fig. 24). It is possible with a detachable-type plug to fix it in with

the help of some packing washers. The plug must be a new one and must be perfectly clean inside and out. The points are set at about five thousandths of an inch by bending the outer electrode(s). The plug may be fixed in the tin or lid, the author fixed the plug in the final experiment in the lid as he found the plug lead stopped the lid being blown violently against the ceiling. The tin is warmed by placing the bottom half in hot water and a few drops of petrol are placed in it. The lid is pressed home. Three Leyden jars, carefully charged and wired in series, are then wired with outer foil of first to the tin and the inner foil of last by a well insulated polythene-covered wire to the plug. Hold the wire about a foot away from the plug and bring it gently to the terminal. A loud explosion will result which, with the tin suggested, is quite harmless. The optimum amount of petrol is quite important, a 1lb. tin taking about five drops.

The experiment works, not quite so violently, using ordinary coal gas. The amount required is small, too much makes a mixture which the spark will not ignite. See Fig. 23 for diagram of apparatus.

An electrocope which is holding its charge well may be used to detect radio-active substances and radiation. Messrs. Griffin and George supply a radio-active source of radium quite cheaply and it may be used in various experiments.

When the radium is brought up to the electrocope it will be seen to discharge much more rapidly, the more radio activity the quicker the discharge. If the radium is enclosed in various foils, etc., a rough measure of the effectiveness of the shield may be gained. The author tried using some luminous watches and found that some types caused the leaves to collapse over a period of some 20 minutes when placed a centimetre from the plate, the electrocope actually holding a charge on that day for over two hours. The radium

source mentioned will discharge the electrocope in a matter of three minutes or so.

Make the apparatus exactly to the specifications given, as small deviations in this type of apparatus (especially in insulators) may cause complete failure. Dampness must be stressed as the cause of electro-static experiment and a red radiant source of heat is ideal for drying apparatus prior to experiment. Note that a gas flame itself produces water and is not to be recommended.

Apparatus Required for Experiments

A few yards of co-axial cable with outer covers removed. Various insulating materials such as china, ebonite, glass, etc. Gas supply



Fig. 24.—Apparatus for the explosion experiment.

and burner (or other source of heat); petrol or benzene; methylated spirit or industrial alcohol; cotton wool; a treacle tin or other tin with push-on lid, and a new sparking plug. Other apparatus which may or may not be used includes: motor-cycle or car engine, model plane with electric ignition, sparking plug (old), luminous watches, etc., small radio condensers, T.V. aerial.

Radio-active source: (A89-900) 1 microgram of radium in protected container. Obtainable from Messrs Griffin and George, E.C.1.

PUZZLE CORNER

Squaring the Circle

THIS is a classical geometrical problem of antiquity, in which we are asked to draw a square which has the same area as a given circle. The text books tell us that the area of a circle can be expressed by the formula πr^2 , where r = the radius of the circle and π (the Greek letter pi) being either $3 \frac{1}{7}$ for general working purposes, or 3.1416 if you want to be more exact. The snag is we can never get an exact value for pi (which symbol, of course, represents the ratio between the diameter of the circle and its circumference). It is, as we say, transcendental. It has been worked out to over 700 decimal places and, presumably could be worked out by electronic computers to 7,000 places or 7,000,000 places, but we should not, as far as is known, work out the matter exactly even then. Such a number which cannot be expressed in mere figures is called a "surd." Therefore, as we do not know the exact area of the circle, we cannot construct our square. In actual practice we

can work out the problem to a very high degree of accuracy, but the ancient geometers and their modern counterparts are not directly concerned with practical applications.

Suppose the earth were a perfect sphere and we knew its exact diameter, we could calculate (taking pi to 100 decimal places) the size of an iron hoop to encircle it so that the difference produced by a change of temperature equal to the millionth of a millionth part of a degree would not exceed the error arising from the difference between the true ratio and this figure.

What Are the Weights?

ON the old-fashioned type of scales, using separate weights, it is possible to weigh any number of pounds of a substance from one to forty. Only four weights are used; can you say what they are?

The Answer

The weights are 1lb., 3lb., 9lb. and 27lb. Of course, sometimes a weight has to be put into the same scale pan as the substance being weighed. Thus 2lb. is obtained by using the 1lb. weight against the 3lb. weight. To weigh 20lb., the 27lb. and the 3lb. weights would be used against the 9lb. and the 1lb. It is an interesting puzzle to work out the remaining weights.



Fig. 1.—The completed table.

By A. E. SMITH

This Table is Modern in Appearance,
Light in Weight and Sturdy in Use

THE table shown in Fig. 1 consists of two end frames, each having two legs tenoned into a cross rail, screwed and glued to a top of $\frac{1}{2}$ in. plywood covered with Marleyfilm. The longitudinal rail prevents the top from bending.

The Legs

These are made from hardwood for strength and before commencing construction a full size drawing of one pair must be made from Fig. 2 so that measurements and angles may be taken from it. This drawing need not show all details; the outlines only will be sufficient. Fig. 3 shows the general construction of the underframing and Fig. 4 gives details of the joints used. The legs are tenoned into the rails so that they slope sideways, the slope towards the ends is obtained by planing the top of the rail after gluing, thus simplifying the mortising.

Cross Rails

Prepare the cross rails to 2 in. by $\frac{7}{8}$ in. and mark them off to 16 in. long. The legs are marked on the board side by side with alternate legs reversed and should be cut out 2 $\frac{1}{2}$ in. wide at one end tapering to 1 $\frac{1}{4}$ in. at the other. They are planed to $\frac{7}{8}$ in. thick and one edge is planed true. This is the outer edge from which all marking is done. Set a sliding bevel to the angle between the underside of the cross rail and the face of the legs and use this and a try-square to mark the position of the mortises and the shoulder lines of the tenons. Note that the lines across the face of the legs are square with the outer edge, only the lines across the edges are marked at an angle. Set a mortise gauge to a $\frac{3}{8}$ in. chisel and use this to gauge the mortises and tenons, working from the outer edges of rails and legs. Saw the tenons and chop out the mortises. Saw cuts for wedges are made

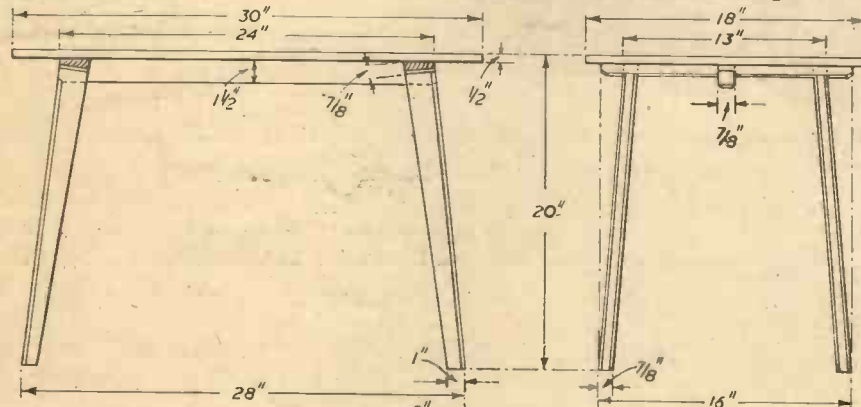

Fig. 2.—Side, end and plan elevations of the table.

about $\frac{3}{16}$ in. from the edges of the tenons and the mortises opened slightly to allow the tenon to expand when the wedges are driven in. Mark the bottoms of the legs to the correct angles with the sliding bevel,

saw off the waste and cut the $\frac{3}{16}$ in. bevels down the outer edges, also those on the end of the cross rails. Clean up the sides of the legs and the underside of the rails with smoothing plane and glasspaper, glue together and insert the wedges. A cardboard template is used to ensure that the legs are at the correct angle. When the glue has set, plane the inside of the legs to the correct slope, complete the cleaning up, and plane the top of the rails to give the outward slope, testing with the sliding bevel. Holes are bored as in Fig. 2 to take the screws that fix the rails to the top. The longitudinal rail is prepared to 1 $\frac{1}{2}$ in. \times $\frac{7}{8}$ in. and is notched into the underside of the cross rails as in Fig. 4. Note that the housing in the rails is parallel to their top surfaces. The whole of the underframing can now be polished and assembled with two 1 $\frac{1}{2}$ in. screws through the cross rails at each end.

The Top

The top is a piece of $\frac{1}{2}$ in. plywood, 30 in. \times 18 in., covered with Marleyfilm. The

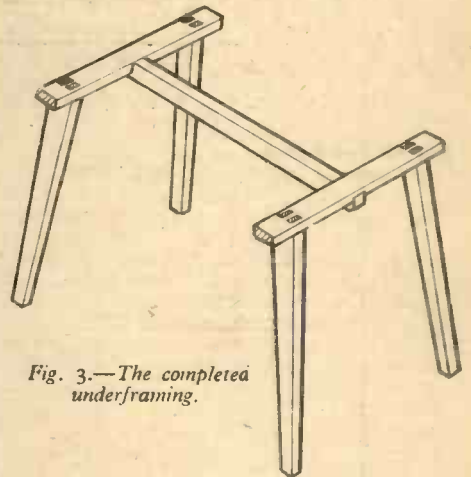
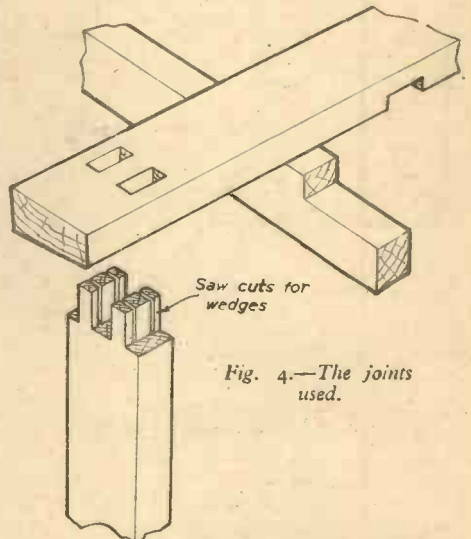

Fig. 3.—The completed underframing.



original was black with a yellow edging and was covered as follows:

Sand the plywood smooth and cover the top surface. The edges are then smoothed with a very fine-set plane and covered with strips of Marleyfilm just over $\frac{1}{2}$ in. wide. These are carefully trimmed with a chisel or sharp knife and finally smoothed with very fine glasspaper. If desired the Marleyfilm used for the top can be taken over the edges in the usual way but the use of a contrasting colour adds considerably to the appearance. The underframe is now screwed and glued in position and the table is finished.

An Illuminated Magnifier

Drawings and Instructions for Making a Device Which The Householder and Hobbyist Will Find Useful

By J. A. Logue

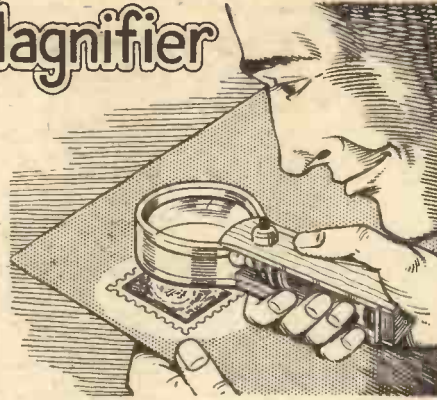

With the lens in position, this piece is fixed to the Perspex sides with No. 2 \times $\frac{3}{8}$ in.

An illuminated magnifier throws light on the subject to be magnified and is a useful gadget to have when examining stamps, maps, insects, woodwork for decay, metalwork for cracks or fractures, or in fact any minute object.

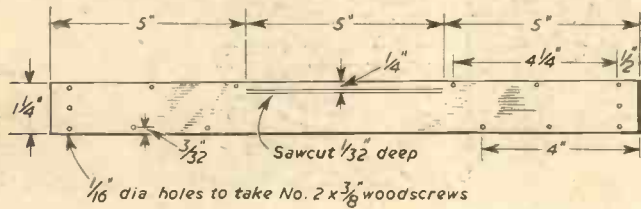

Fig. 1. — (Left) Cutting and drilling the Perspex.

Construction

A piece of coloured Perspex (cream, pink or white) 15 in. \times 1 1/4 in. \times 1/8 in. is prepared as shown in Fig. 1. The 15 in. dimension allows about 1/4 in. at each end for fitting and also some latitude when bending. The ends are trimmed to size after assembly. The edge of the lens fits into the sawcut—a small circular saw (drill attachment saw) is ideal for making this groove. 1/16 in. diameter holes are drilled to take No. 2 \times 3/8 in. wood screws and the holes are countersunk on the reverse side to the groove.

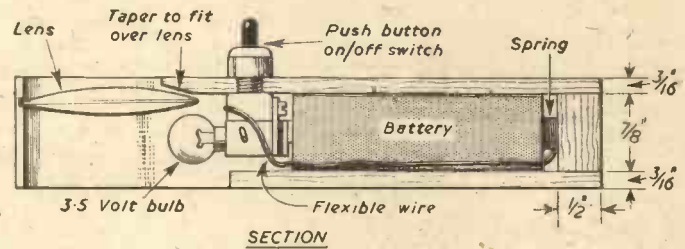

Fig. 3. — (Right) Section and plan views of the magnifier giving details of the switch and disposition of the other parts.

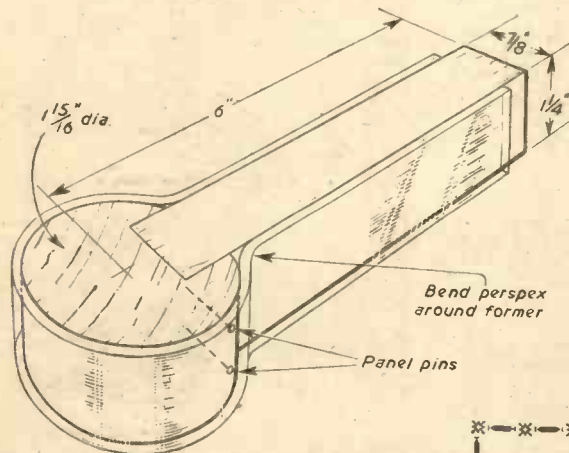

Fig. 2.—Bending the Perspex round the former.

Wooden Former

Fig. 2 shows the wooden former which is made for shaping the Perspex. A 1 5/16 in. diameter \times 1 1/4 in. piece of timber has a 3/8 in. \times 1 1/4 in. timber strip let into it, as shown, and held in place with panel pins. The strip of Perspex is heated in a domestic cooker oven for some minutes until pliable and then shaped around the former. Leather gloves should be worn when handling the warm Perspex to avoid burns. The Perspex is shown wrapped round the former in Fig. 2.

The Top

A piece of 3/16 in. thick mahogany is shaped as shown in the plan, Fig. 3, and is drilled to take the push button on/off switch.

wood screws; plated screws look best with the Perspex.

Lampholder and Switch

The lampholder is the type with two tags attached and this type can be mounted directly on the switch by enlarging the hole in the inner tag to take the switch grub-screw. The remaining tag will now be correctly positioned for contact with the brass battery cap and

the bulb will also be in its correct position, shielded as shown in the section Fig. 3.

The Bottom

A 4 1/2 in. \times 3/8 in. \times 3/16 in. strip of mahogany is now screwed into position along the bottom of the Perspex. An Ever Ready No. 8 battery or its equivalent will now fit snugly in the handle; the battery is in position in the section Fig. 3.

On a 3/4 in. \times 1/2 in. \times 1/2 in. block of timber a piece of compression spring about 1/2 in. long is fitted. Before fitting the block in place a flexible wire is connected between the switch and the spring to complete the electrical circuit. A washer and wood screw are used to clamp the end of the wire and also to fix the spring to the wooden block. The block fits into the end of the handle and it is unscrewed for fitting a fresh battery when needed.

The materials mentioned for the construction of this magnifier are not, of course, obligatory and with suitable modification, tinplate could be used for the sides. The dimensions could also be changed to accommodate an alternative lens which the constructor may have.

Materials Required

- 2 in. dia. magnifying lens.
- 15 in. \times 1 1/4 in. \times 1/8 in. coloured Perspex.
- 14—3/8 in. \times No. 2 plated wood screws.
- Push button on/off switch.
- Lampholder, bulb and battery.
- 1—5 in. \times 1 1/4 in. \times 3/16 in. mahogany strip.
- 1—4 1/2 in. \times 3/8 in. \times 3/16 in. mahogany strip.
- 1—3/4 in. \times 1/2 in. \times 1/2 in. mahogany block.
- Flexible wire, spring and screw
- Scraps of timber for former.

The National Do-It-Yourself Magazine

PRACTICAL HOUSEHOLDER

EDITED BY F. J. CAMM

July Issue Now on Sale

PRINCIPAL CONTENTS

- Plastic Relief Decoration; An Automatic Garden Sprinkler; Repairing Floorboards; A Sectional Garden Shed; Combined Refrigerator and Sink Unit; Laying a Lawn; Making Briquettes; Making Brick Incinerators; Replacing Window Panes; A Modern Three-piece Suite; A Lychgate; Apportionments on House Purchase; Dividing a Room; A Hinged Pelmet; Electrical Soil Warming; A Three-light Pendant; Garden Woodwork; A Bird Bath; Decorating Problems and Remedies; Automatic Draught Excluder; Adding a Wall and many other interesting articles.

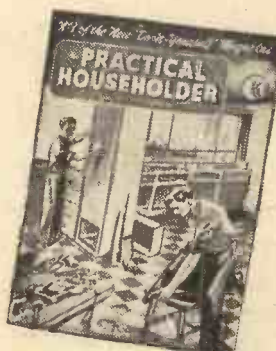

Repairing Tents

John Dee Tells You How to Correct Some Common Defects

ONE of the worst disasters that can befall is for a pole to break through the top. This can come about by the canvas rotting round the crown. It can also be caused by continually allowing the tent to become too taut during rain showers, which will eventually break stitches in the best of canvases; or the trouble may come about by a combination of both conditions.

Repairing the Crown

Repair is effected by renewing or refitting the existing crown "collar," which is quite within the scope of the practical man. A collar is a small circle of thick cord of a

flattening the ends and joining up with a few stitches.

Should the crown canvas be very weak then a patch must be sewn in. This is a piece of strong canvas (or lighter material for light-weight tents) cut as (B) for a bell tent, or to suit other shapes of tent. Join up the edges experimentally till the piece agrees with the existing slope and sew it in by tacking stitches round the edges, and at any other place where a few stitches would be useful. The new, or old, collar is now sewn under this as described.

Working with heavy canvas a sail-maker's "palm" is needed. This is a leather pad held in the hand by the thumb going through a hole, and it is for pushing the needle with its load through the material. For light-weight material a darning needle with strong thread will often do all that is necessary. To wax the twine or thread first is good practice.

Crown failure as suggested is often brought about by the tent frequently being allowed to get too taut during rain, a tautness which should be relieved by slackening the guys. Some campers make a habit of putting a flat stone under the pole which can be taken away when the rain starts, so slackening the guys all round in one action—and without having to go outside.

Eyelets breaking where the guys pass through the eaves is a common tent trouble. Here the repair is very similar to that at the crown but with everything on a smaller scale.

Guylines

A guyline at its upper end is secured to the canvas as shown in Fig. 2, by passing through a reinforced opening with a washer behind to spread the pressure. A knot behind the washer again finishes off the arrangement.

Reinforcement is generally given to the

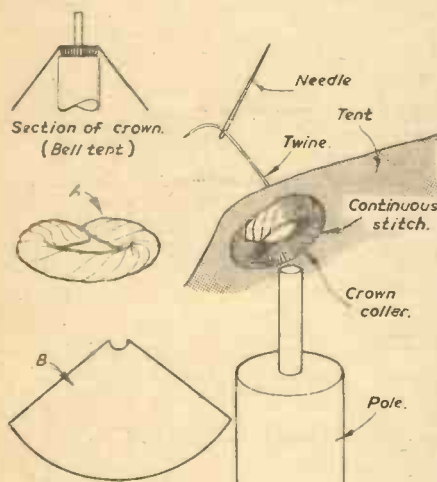

Fig. 1.—Repairing the crown.

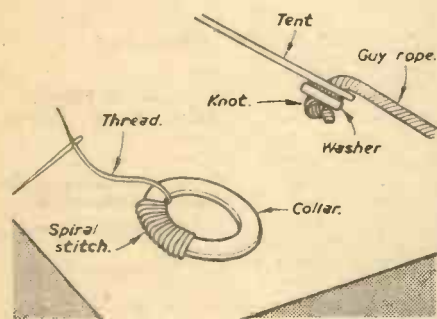

Fig. 2.—Repairing guyline eyelets.

less diameter than the pole which is sewn under the fabric at the location where the spike on top of the pole passes through—see Fig. 1. Thickness of the cord depends entirely on the size of the tent, bell tents having quite a heavy ring while in light-weight equipment the collar may be little more than string.

Should the collar be intact and the crown only torn, the fabric is drawn together, using a packing needle and twine, and the original circle of cord set back underneath and refastened by a continuous stitch spiralled over it by taking the needle a little further along the canvas every time it comes round.

A new collar may of course be needed, if so make it as shown at (A) in Fig. 1 by cutting the cord to the right length,

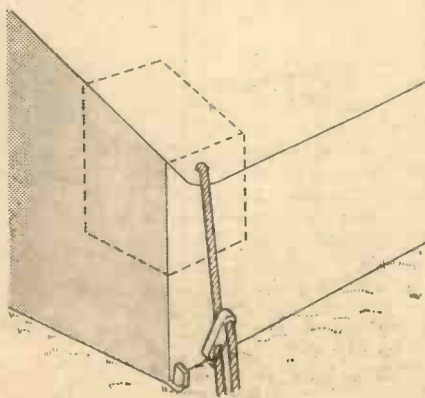

Fig. 3.—Sewing in a corner patch.



opening by a cord ring on the underside, but some very light-weight tents rely on simply a binding of the edges. In any case, when an eyelet has broken it should be reinforced by a new ring, which in lighter equipment can actually be a circle of fairly strong string. For heavier material thin cord is necessary.

Eyelet holes generally have become too

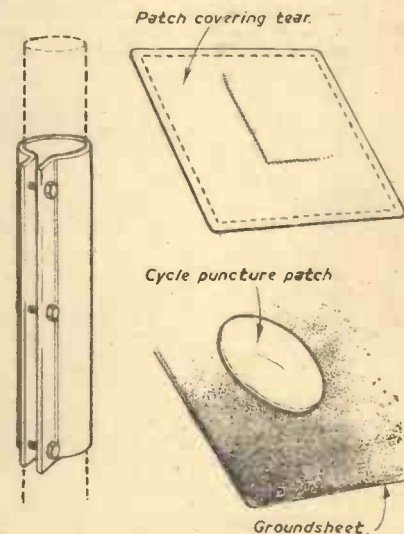

Fig. 4.—Pole repairs, patching a tear and repairing a groundsheet.

big, seldom having torn down to the edge seam. In repairing, the fringes of the hole are pulled together with fairly big stitches and the collar is sewn on as in Fig. 2 again (as with the crown) using a continuous spiral movement.

It should be remembered that broken eyelets are often caused by not slackening the guylines in rain, although they do tend to give way in the course of seasons by ordinary usage, as the whole weight and pull of the tent comes on them, especially in high winds.

Corner Patches

A rather more difficult point of failure that comes at times in the "patrol" and other rectangular tents, and which should

be dealt with at once, is in the corner (Fig. 3) where the end panel, wall and roof meet.

The corner guy should be slackened and the broken seams drawn together, always working from an unbroken stretch towards the damaged part. Working this way the various sections of canvas can be slowly drawn together in correct relation to one another. Starting in the middle of a break, correct aligning is difficult.

If the corner is very weak then a strengthener must be put in the angle. This is sewn in slowly, folding the material over in a pleat where necessary to get good fitting.

Square tears in both heavy-weight canvas and light fabric are dealt with by pulling the edges together and then covering with a rectangular patch stitched round the outside (Fig. 4).

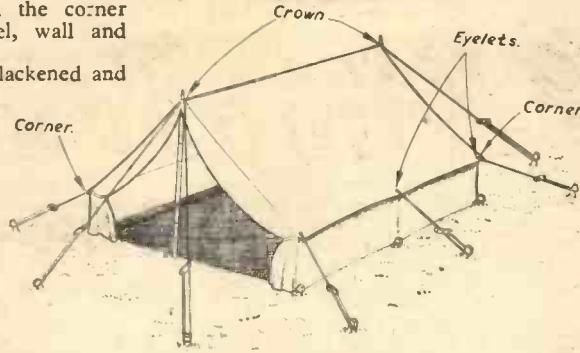

Fig. 5.—Parts of a tent which may require repairs.

Pole Repairs

Should a pole have cracked along an extended sloping line a good repair can be effected by making a simple binder as shown in Fig. 4. This is shaped from tinfoil, wrapped round the pole and lipped

as shown. Holes are punched in the lips and small bolts inserted.

The tinfoil must of course be so bent in the first wrap round that the lips are some little distance apart so that there is scope for the tightening effect of the bolts.

Groundsheets sometimes develop small holes. If not too large, such faults can be repaired with ordinary sticky cycle patching, this being put on the rubber side of the sheet with the usual solution as when mending a puncture (Fig. 4). Distinction must be made here between an accidental piercing of a groundsheet and one that is becoming badly perished. If the latter, scrap the sheet at once and get another.

Finally, with a view to effecting repairs, close examination should be made of all tapes, peg loops and brailing if the tent has this. Loops, etc., may seem small items, but a tent is a unified design and the giving away of one loop or tape may well impose an undue stress on some other part. The chief parts of a tent which may require attention are shown in Fig. 5.



A NOVEL HOME SAFE

By P R G.

Keep Your Valuables Safe from an Intruder

IT is always something of a problem to know where to deposit documents and small but fairly valuable items when going on a holiday or even when leaving the house empty for a short time. The "book safe" described here is one solution. To the average sneak thief, or even too curious a person, a book means nothing and passes unnoticed, this being the idea behind this form of hidden storage. There is no reason



Fig. 2.—The completed book safe.

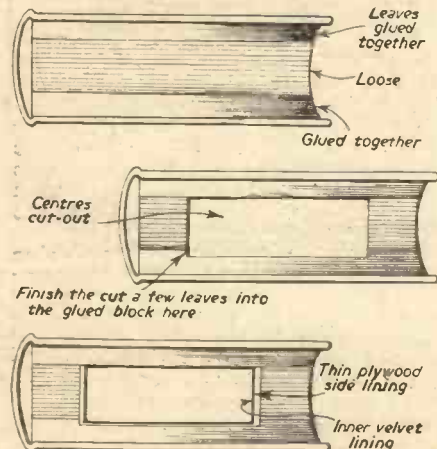

Fig. 1.—Three stages in making the safe.

though why the book safe should not be locked away with other books in, say, a cupboard for greater security.

Construction

Obtain a reasonably sized volume with a stiff back for which there is no further use. The volume should not in itself be too conspicuous or the purpose of the safe might well be defeated.

With a strong, but not too thick glue fasten together a fair number of the first and last pages (Fig. 1), putting the book

under pressure as they harden into a solid mass; the glue must be spread right over each page but not on the very edges as it is wished to preserve the appearance of untouched leaves on the outside.

After hardening, place on something firm and opening the top cover with its attendant leaves mark out a rectangle on the first of the loose pages, leaving at the very least a half-inch margin all round.

Pressing down very heavily with a steel edge, and using a keen blade, cut out the rectangle right through the loose leaves, stopping a few leaves into the solid leaves below. Remove the unwanted paper.

Lining the Cavity

This has the effect of joining all the leaves into one block—but from the inside. It is done by cutting two strips of oilcloth to lie along the upper and lower walls, and then two strips of thin plywood for the sides.

The oilcloth is liberally smeared with glue and put in position first and then the wood strips are similarly treated and set in place. If correctly cut they will jam between the lino strips, so giving greater firmness. When dry it will be found that a very strong framework results.

A final lining of velvet is now given to the whole of the inside. This is firmly glued in and cut from one piece, as shown.

Secret Lock

Lastly, a secret locking device is supplied. This is by gluing two blocks of cork in position as indicated, so that when the top cover closes they fit into the corners of the cavity. The blocks (a) can be cut from any large cork.

The wire pins (b) are then prepared, these being pushed through the loose leaves and oilcloth (top and bottom) and into the corks. a hand pressing down firmly on the closed book while this is being done. The heads are hidden in the loose leaves. The purpose of the pins is to prevent the back falling accidentally open when the safe is being handled as a book. It is not intended in any way to form a true lock, the basis of the idea being that the book will be left unnoticed and untouched.

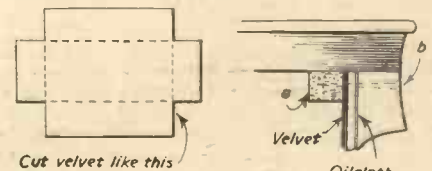
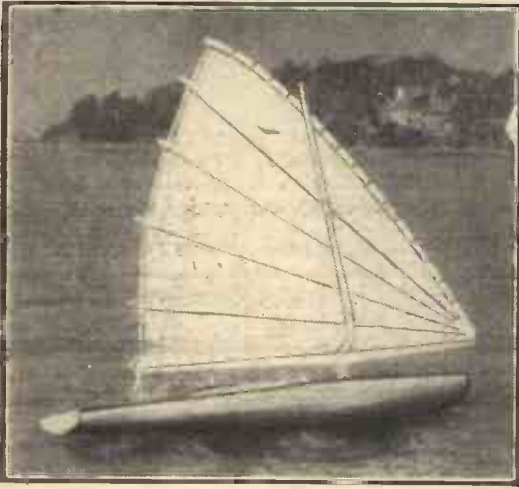

Fig. 3.—Cutting the liming and the lock

Making a Fibreglass Yacht

G. E. Bowden Concludes His Description of This Modern Method of Model Hull Building



The completed yacht sailing under an experimental rig.

FOR this job an equal weave both ways to give all round strength is required. Tyglas Y.227, obtainable from Messrs. Fothergill and Harvey, Ltd., Harvester House, Peter Street, Manchester, is suitable, although there are a number of manufacturers and a wide variety of woven cloths to choose from.

Having noted that the scrim lamination has just set brush on a fairly thick coat of resin main mix after catalysing, the accelerator having already been mixed in. Now lay on the glass cloth (Tyglas Y.227), and working outwards from the centre with the fingers and stippling with a resin brush, see that the resin works up through the

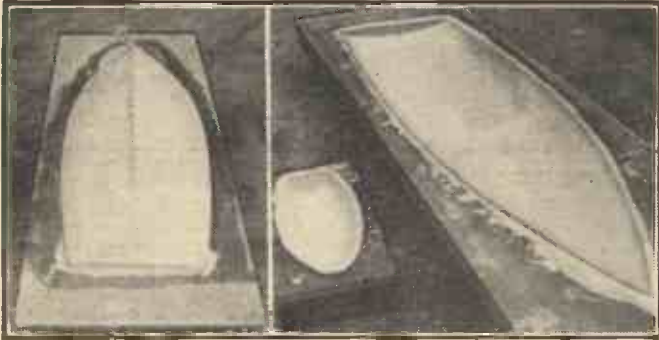

Fig. 9 (Left).—The female mould is now resined into its hardwood table surround, which keeps it rigid and of correct shape for the subsequent building of the boat hull inside.

Fig. 10 (Right).—The dark-coloured part in this photograph is where the blue-coloured P.V.A. release agent has started to be applied to the female mould. Note the dinghy mould on the left.

cloth and thoroughly wets out, with absolutely no air-pockets anywhere. Lay on the second lamination of glass cloth, whilst the first is still wet, after another coat of resin has been applied. Again work the resin well in with no air-pockets. Reinforce the transom, the bows, and where the load of the keel will be taken with pieces of extra cloth, well saturated. Stipple with short rapid strokes of the brush that do not pick up the cloth and admit air. I use a zinc wide paint brush of good make. Do not use too much resin mix for a good laminate is one with only just adequate resin and plenty of well wetted-out glass cloth. Fig. 8, which was included in last month's instalment, shows the cloth-covered mould of the 5ft. 6in. model already seen in Fig. 1. The drip edges clearly seen in the photograph, are later removed when the resin reaches the plastic stage and before it becomes dead hard. This is best done by a "surfile," which is undoubtedly the best instrument for all cleaning up work with fibre-glass, as

its openwork cutting surface does not clog like a file or rasp. A rasp or file is useful for local and final smoothing down work.

The glass laminate is now allowed to set hard during the night when it will be easily removed next day. It should be remembered that fibre-glass contracts as it hardens and, therefore, a boat made in a female mould is always easier to remove than the female mould from the male form. Should there be difficulty in removal slightly ease all round the gunwale and pour hot water between glass laminate and form to break up the suction.

The Hardwood Surround

After removal wash the P.V.A. release agent from form and female mould. The mould is now cemented with a resin putty mix into a hardwood surround or "table." This resin putty is made from a stiff mix of china clay, a little thixotropic resin, and a little glass mat cloth chopped up with scissors. It is catalysed and allowed to set hard (see Fig. 9).

The operator now has a permanent and indestructible female mould in which to

Fig. 12 (Right).—The first laminate of glass cloth is now wetted out with resin. Great care being taken to admit no air-pockets.

Fig. 13 (Right, below).—The second laminate of woven glass cloth is now wetted out, being worked into the first lamination (excluding glass scrim layer) whilst wet. A sample of the glass cloth Tyglas Y.227, can be seen on the right.

The Fibreglass Hull

The operation of hull building is very similar in principle to the building of the female mould but is done inside the mould instead of on top of a form.

Proceed as follows:

Polish the female mould with silicone wax polish and then paint it carefully with blue P.V.A. release agent and allow to dry (see Fig. 10). Make up the jel coat mix and the main mix as before, not forgetting to add anti-star resin to the jel coat mix. The amounts and proportions of mixes are the same as for making the female mould. Stir in the accelerator to give a fast set for the jel coat and a slower set for the laminates main mix. When ready to start work stir in catalyst to the jel coat mix, and immediately brush this as before but inside the female mould surface. As the jel coat sets brush on the first coat of main mix after catalysing. Approximately 1½lb. are required

Fig. 11 (Right).—The first layer of scrim to back up the "jel coat" is put into the female mould with a coat of resin.



build one or any number of boats. Deck or cabin tops can be made in the same way. This particular hull was fitted with a light three-ply deck.

During all fibre-glass operations the hands should be protected by rubbing in a barrier cream which protects the skin against resin and cleansing acetone. Use rubber gloves for small operations but to mould laminates well bare fingers are necessary to obtain an adequate sense of touch. A large dish of acetone should be kept beside the work into which brushes, scissors and tools can be put between laminating operations, etc., in order to prevent the resin hardening on them. Acetone dissolves uncured resin and is therefore used for cleaning before the resin hardens.

At the end of the day's work all tools and equipment, including the hands, should be thoroughly cleaned in fresh acetone and the stickiness washed off in hot water and detergent.

for this boat. Lay in the scrim lamination, working out all air, so that the scrim backs up the jel outside resin coat of the hull (Fig. 11). As the scrim lamination just sets give a second coat of resin main mix, and work in the first glass cloth (Tyglas Y.227) laminate. Whilst still wet, work in the second glass cloth laminate after another coat of resin (Figs. 12 and 13).

Reinforce transom corners, bow vee and where keel loads occur with strips of extra cloth, making sure this is well wetted out.

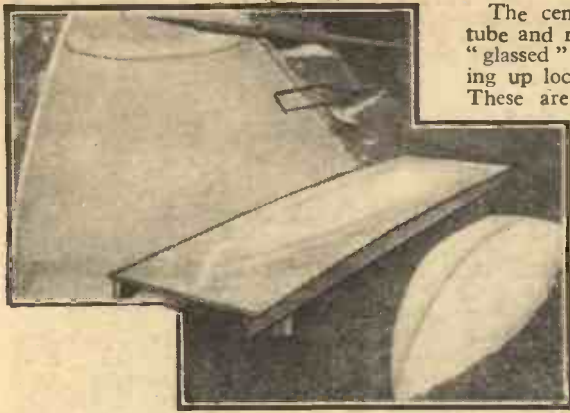

Fig. 14 (Top).—Clean the edges of the hull whilst the resin is hard, but slightly plastic, by “surfile” or rough rasp.

Fig. 16 (Right).—The three-ply “deckbeam” outline being cemented into position. Cramps are used until resin sets hard.

Give the whole hull inside a final careful stippling, adding a little resin where wanted, to give a fine finish inside the hull with no bare glass cloth showing. Remember not to put in too much resin, and that the best and strongest laminate is one with only just sufficient resin and plenty of glass.

Allow the edges to set to the plastic stage but firm, and then clean around the edge of the mould with the “surfile” (Fig. 14). Leave overnight to set hard, and on the following day remove the hull from the mould (Fig. 15).

Building in the Fittings

The hull shell now has its “deck beam” three-ply outline cemented into place by a resin putty mix with a little glass chopped up from mat or cloth to fill any gaps. The hull inside should be roughened up by sandpaper or rasp where the three-ply is to mate (see Fig 16).

The centreboard box, mast step, rubber tube and radio box hatch, are all fitted and “glassed” in where applicable, after roughing up locally where joints are to be made. These are shown in position in Fig. 17.

Fig. 15 (Left).—The finished hull is now removed from the female mould and the P.V.A. release agent, soluble in water, is washed off mould and hull.

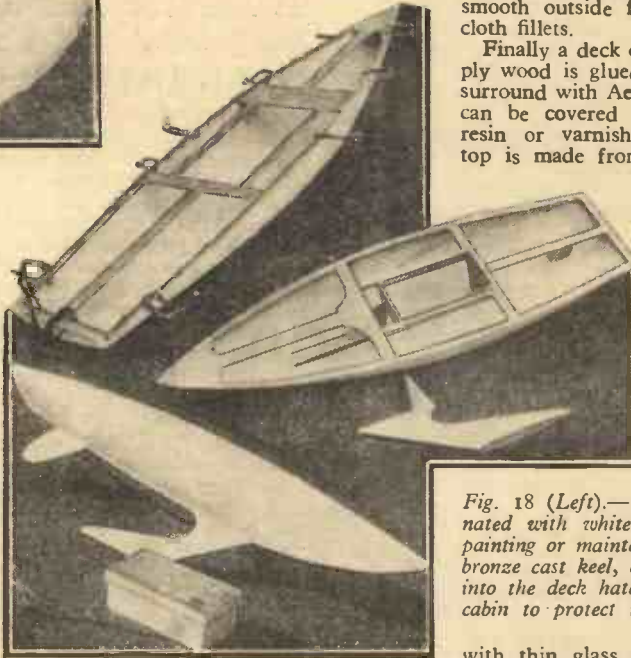

Fig. 17 (Left).—The “Centreboard” case, rudder tube, and radio hatch are placed into position and “glassed” up to the hull where applicable, using glass cloth strips and resin.

Fig. 18 (Left).—The completed hull, impregnated with white colouring now requires no painting or maintenance. Note the detachable bronze cast keel, and the radio box which fits into the deck hatch opening, with a fibreglass cabin to protect it from seawater spray.

An open weave glass cloth or scrim is used. Note the bronze cast keel, which is detachable for easy transport and for experimental change purposes, has a tang which fits into the “centreboard” box,

with thin glass cloth, which fits over the radio box to keep sea-water spray and waves from the radio box, which, in turn, has a Perspex top. Fig. 18 shows the finished hull with detachable keel of bronze in position, and the rudder fitted. The detachable radio box is seen below the hull.

A Camping Trailer
(Concluded from page 462)

also shows the method of fitting the tail-board.

The Lids

Two lids are now required each 7ft. 6in. X 1ft. 9in. The frames for these are halved together and made from some 2in. X 1in. deal, and subsequently covered with 3/16in. resin-bonded plywood.

These lids are secured with 9in. T-hinges. The knuckle of the hinges is level with the top edges of the sides. The longer part of the hinge is bent at right angles along the top of the lid (Fig. 13).

When the lids are raised they are held in place by a simple brace at each end secured by wing nuts and bolts, as shown in Fig. 14.

The Roof

The canvas roof of 8oz. duck material is supported over a framework made of electric conduit tubing. The three lengths of tubing are first flattened in the middle for a distance of about 1½in. and then bent down at an angle as shown in Fig. 15. The lower ends are also flattened and bent so that they can pass vertically down through some clips screwed to the inside of the lids.

A ridge pole also of conduit tubing is held in place along the flattened top of the

V-hoops with 3/16in. wing nuts and bolts. The canvas covering is made up from some 8oz. duck material. The part covering the V-roof is made from three strips

the canvas a 2in. wide strip of webbing is sewn on to counteract chafing the duck.

The ends are made as also shown in the diagram which shows the rear end only.

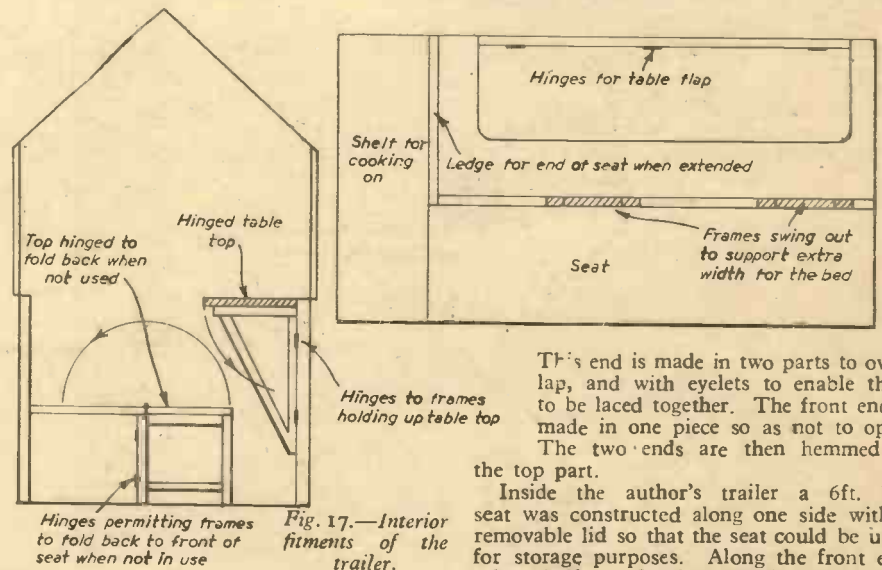

Fig. 17.—Interior fittings of the trailer.

7ft. long, sewn together to make an overall length of 7ft. 6in. as shown in Fig. 16. A wide hem is made along the two longer sides into which are fixed some eyelet holes. The cover is eventually lashed through these to cleats fixed along the bottom of the lids. Where the ridge pole comes in contact with

This end is made in two parts to overlap, and with eyelets to enable them to be laced together. The front end is made in one piece so as not to open. The two ends are then hemmed to the top part.

Inside the author's trailer a 6ft. box seat was constructed along one side with a removable lid so that the seat could be used for storage purposes. Along the front end a low shelf was fitted on which the cooking, etc., could be performed. Along the other long side a table flap was hinged which was useful for mealtimes, etc.

A further modification incorporated was a flap fixed to the front of the box seat which could be raised and held horizontal by hinged legs to form a bed (see Fig. 17).

A NEW BRITISH INTERCEPTOR

This Aircraft is Fitted with Both Rocket and Jet Engines



The new British S-R.177 interceptor.

THE S-R.177 is being constructed by two aircraft firms, Saunders Roe and de Havillands. It has been designed to keep pace with all the developments in weapons and operational requirements which can be reasonably anticipated. At any stage of its development it will be completely operational and capable of offering our island continuous protection.

The Two Engines

The chief distinguishing feature of this plane is its unique combination of both rocket and jet engines in the same fuselage. The turbojet engine, which is a de Havilland Gyron Junior is capable of developing a thrust of 10,000 pounds. The rocket engine is also made by de Havillands; it is a "Spectre" and uses the same fuel as the turbojet, i.e., kerosine.

The advantage of the two types of engine will become obvious when it is considered that a turbojet engine is extremely efficient at low altitudes, but the same engine at 60,000 ft. would deliver only 4 per cent. of its sea-level thrust. When considered in terms of thrust to engine weight ratio, the rocket engine at low altitudes is even more efficient than the turbojet and—more important—its thrust increases with altitude. It is in the thin atmosphere of 20 miles up where the air battles of the future will be fought. To be set against this advantage is

the rocket engine's very high consumption of fuel and oxidant.

The tremendous thrust of the rocket motor will be required only during combat and when a high speed bomber is being attacked at high altitude. Rocket fuel consumption will thus only need to be maintained for a few minutes. When the attack is over the interceptor will cut its rocket motor and cruise back to its base using the turbojet engine. When required, say, to climb and attack an enemy formation, both engines may be used at once, but when the warning is given far enough in advance the S-R.177 can cruise to the point of attack using only its turbojet.

Size and Versatility

It has been found that by combining a single large jet engine with a rocket engine, a smaller and lighter craft can be obtained than by using two large jet engines. The aircraft also has the advantage of greater versatility. Although its engine weight is less than with the pure jet aircraft, the S-R.177 will have a somewhat larger per-

centage of its take-off weight consisting of fuel. When this fuel is consumed, the landing weight will be considerably lower and thus the plane can land on short runways. With the vast reserves of power available, take-off presents no problem at all.

Its climbing capabilities are very high indeed, heights of 60,000 or 70,000 feet being attained in only a few minutes. Aerodynamic drag does not limit the machine's performance and it is capable of outperforming even the best turbojet aircraft at present known.

Wide Range of Duties

The S-R.177, with its versatility and large fuel capacity, is suitable for performing a wide range of duties—long range strike support, photo reconnaissance and ground attack duties as an all-kerosine aircraft operating on its jet engine alone.

Our artist's impression of the layout of the S-R.177 below will give some idea of the new plane. The turbojet is housed in line with and behind the air intake and the rocket motor immediately above it.

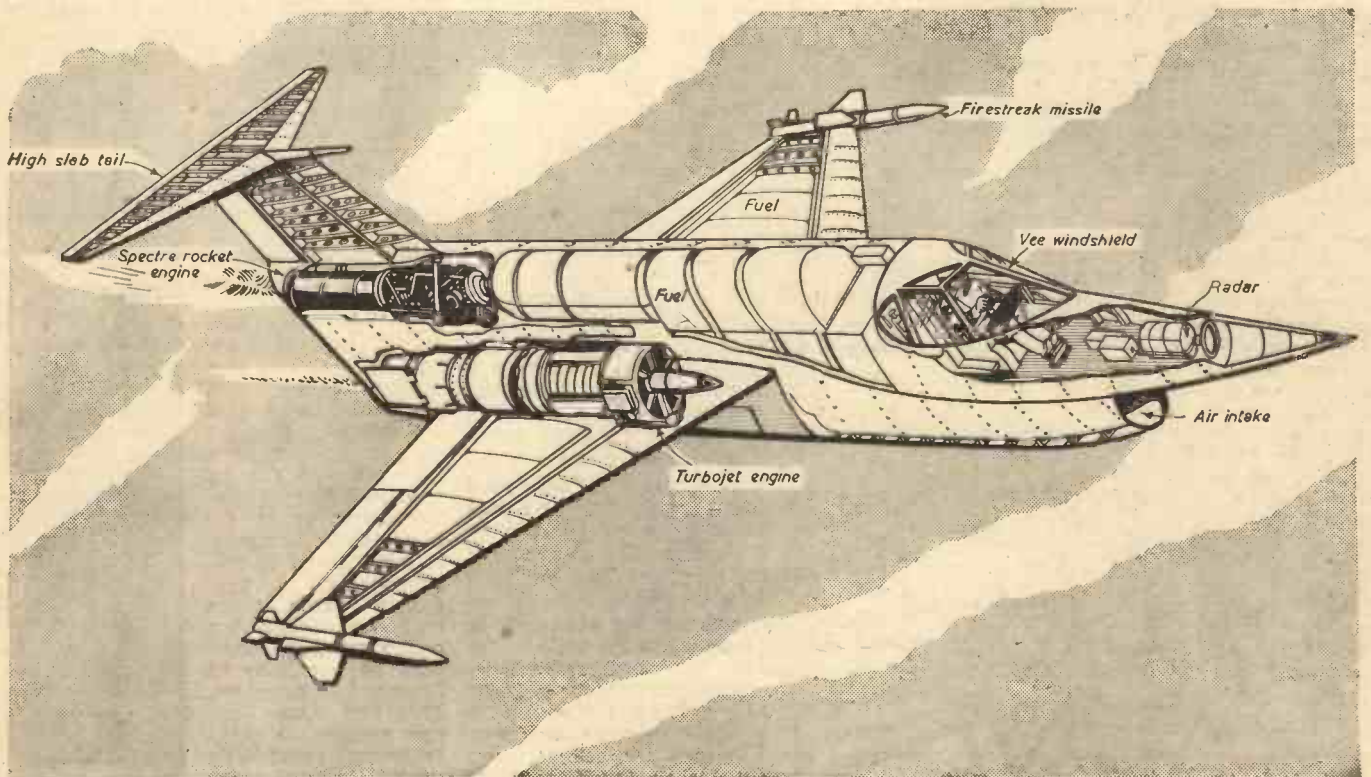

An artist's impression of the layout of the S-R.177.



NAME-PLATES are sold to the public at 3d., 6d. or 1s. each and, when the twenty are disposed of, the arrow is spun. When it comes to rest the bearer of the name-plate corresponding to the town which remains illuminated is invited to select any prize on the table. The prizes should cost about half or a little under half the total amount which will be collected on each spin.

Choose Your Own Design

The design is, of course, entirely elastic. The names can be those associated with any particular movement, they can be christian names, Walt Disney characters, Members of Parliament (for political functions), or even

plain numbers. Similarly, the dial can be designed to advertise the movement organising the fair, it can be symbolic of almost anything from an aeroplane to a Shakespearean comedy or drama. Names of towns and a railway engine were chosen for the model shown in Fig. 4 because they are of common appeal and it was intended to loan the spinner to other organisations when the association for which it was made was not using it.

Wheel Construction

A bicycle wheel is an ideal base on which to build up the mechanism of the spinner; the ball-bearings give it easy and continuous motion and the rim acts as a flywheel, regulating the speed and accumulating power. The size of the wheel is not critical, but a fairly long spindle is necessary—it is essential to have about 1½ in. clear of the cone at one end. Thoroughly clean and re-oil the bearings and test for truth. Remove the free-wheel or sprocket and, of course, the tyre and inner tube. Figs. 1 and 6 show that a shaped contact strip of insulating material (hardwood will do quite well) is fastened to the hub by being force-threaded on to it and strengthened by two 4B.A. bolts passing through the strip and between the angles formed by the spokes. (It is best to mark the positions for these bolts from the inside of the hub to ensure that they will engage in spaces where the spokes cross each other at an acute angle—this will prevent the possibility of back-lash.) But do not try to fit the strip at this stage as it is necessary, before cutting out the hole, to use the centre to mark off the exact distances for the two springs.

The Springs

The centre of the stud-contact spring (Fig. 6) is exactly 2 in. from the sprocket hole centre, and the foil-contact spring 2½ in. The first is a piece of very thin spring steel about 1½ in. long × ¼ in. wide. Fig. 3 explains the action of this spring and is an edge-on view. Presuming the spring is at "A" on the contact strip, it will be seen that it is unimpeded and therefore unbent but just making contact with stud No. 1. As the wheel is turned the spring advances towards "B"

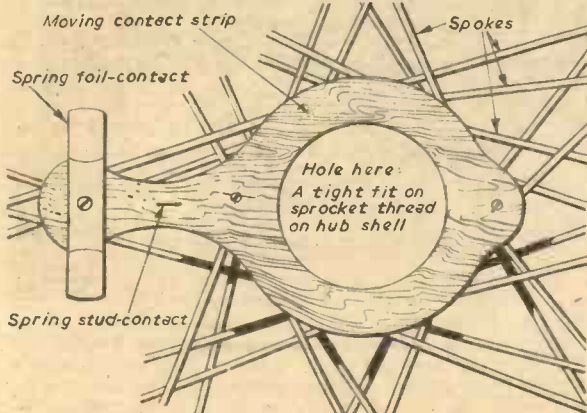

Fig. 1.—Facing view of moving contact strip and springs.

and its position at various stages during this movement is shown. As the fixed point moves along, the spring rides on top of the stud, bending as it does so. At point "B" it is just about to break contact with stud No. 1, and the moment it does so it straightens out and thus makes immediate contact with stud No. 2. This arrangement ensures that always one lamp, but only one lamp, is alight. With this mechanism there is no possibility of the arrow stopping between lights.

The second spring—the one which will make contact with the copper-foil circle—is, as Fig. 2 shows, a Terry tool clip opened out. This "opening out" is reasonably critical since the happy medium between assured contact and minimum friction must be attained. For the moment, however, open the spring so that its vertical height is ¾ in. and fasten it to the contact strip as shown in Figs. 1 and 6, first having sunk a very shallow groove in the strip into which the spring can settle down with no possibility of lateral movement. Note that when these two springs are fixed they must be electrically connected by inserting a small piece of copper foil (Fig. 6) at the back



Fig. 4.—The complete assembly.

Fig. 2.—Actions to tool.

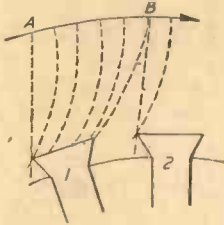

Fig. 3 (Left).—How the spring contact works.

and passing both bolts through it. The stud-contact spring will have to be bent at right-angles after it has passed through the strip. The slot through which it passes can best be made by a number of very fine drill holes and finished with a thin file. If there is too much play, wedge with a shaving or two of wood or fill with plastic wood or sealing wax, but be sure that the spring is fastened only by means of the bolt passing through it and the strip—you may have to replace it one day! The strip may now be placed on the wheel—springs outward—and fastened to the spokes by means of the two bolts.

The Contact Studs

Put the wheel aside for the present and work on the main strut and the circular base carrying the studs. The strut is 4ft. long,

a universal adhesive, but it is best to be on the safe side and pin it as well. $\frac{1}{4}$ in. fine brass pins should be used and placed very close to the outside and inside edges so that they do not foul the Terry spring. The top right of Fig. 5 shows an additional piece of copper foil soldered to the ring. Through this passes an ordinary wireless terminal with its head at the back of the plywood. This provides a means of connecting to the mains without interfering with the actual ring or the studs.

The twenty holes may now be enlarged to $\frac{3}{16}$ in. dia. and the plywood fastened to the main strut. This must be placed absolutely centrally, i.e., 2ft. from either end and in the middle of the board; use four screws as shown. It will now be found that several of the $\frac{3}{16}$ in. stud holes are blocked by the strut; drill these right through. The

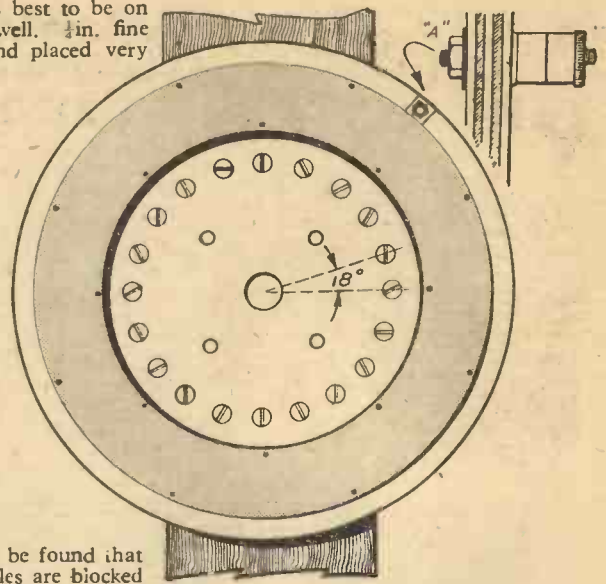

Fig. 5.—Face of contact side of the plywood dial carrying copper foil ring and stud contacts.

L★SPINNER★

Designed and Built
By Jameson Erroll

ould Be a Money Spinner at Your Local Fête, Garden Party or Carnival

3in. wide and 1in. thick. The base is of good quality $\frac{1}{4}$ in. ply and is a circle 7in. in diameter. From the centre of the ply describe an exact circle of 2in. radius. Use either an ink compass or steel dividers—a pencil line is too thick for the required degree of accuracy. Now place a protractor on the centre and mark spaces around half the circle exactly 18° apart—use compass point or steel scriber. With a steel ruler resting against each mark in turn and passing through the centre, mark off the remaining divisions on the other half of the circle. You should now have twenty marks on your circle each 18° from its neighbour; these will be the centres for the contact studs. The “studs” are $\frac{3}{16}$ in. countersunk-head Whitworth engineers’ bolts and it will be found that their heads measure exactly $\frac{5}{16}$ in. across. Fig. 5 is a face view. Before drilling the $\frac{3}{16}$ in. holes it is advisable to drill $\frac{1}{16}$ in. pilot holes.

The Copper Foil

This is a ring $\frac{1}{4}$ in. wide with an internal diameter of 5in. and an external diameter of 6 $\frac{1}{2}$ in. It is shown shaded in Fig. 5. It may be fastened to the plywood by means of

Whitworth bolts may now be fitted, and some of these will need to be 1in. long (when they pass through the ply only) and the others 1 $\frac{1}{4}$ in. long (when they pass through the ply and the strut). The heads should be kept $\frac{1}{4}$ in. above the surface of the ply and $\frac{1}{4}$ in. spacer washers, as used in old-time moving condenser construction, will ensure evenness. If care is taken, however, not to tighten the bolts too much, the countersunk heads will assist in correct alignment. Use steel washers between the back of the ply and strut and hexagon nuts. On the remaining length of these bolts the cable is later fitted and kept in place with another washer and nut.

The centre hole for the bicycle wheel spindle should now be drilled; this will probably be $\frac{1}{2}$ in. dia., but do not let it be so tight a fit that it has to be “threaded” on as you will have to remove it many times before the job is complete. If there is an insufficient length of spindle protruding from the back of the strut to ensure a really firm fitting, sink a hole in the back of the strut large enough to allow the nut to turn (see Fig. 6). You should now be able to check that both springs are working

correctly and will be able to make final adjustments to the tension of the Terry spring. Ensure that one or the other or both lugs of the spring make contact with the foil at all times, but guard against too much pressure. The wheel should run quite easily and come to a gradual stop. Given a fair spin to start with, it should make from 10

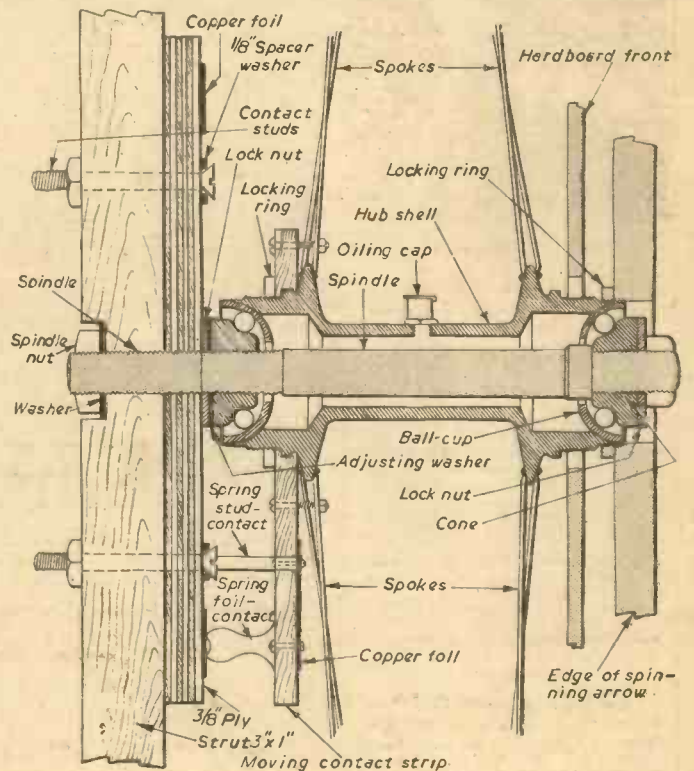

6.—Split section of working mechanism on 3in. x 1in. strut.



Completed spinner.

to 15 revolutions before stopping. Do not worry at this stage if it is to free from resistance that unbalanced weight tends to let it reverse slightly after it has stopped.

The Main Frame

This, as Fig. 9 shows, consists of a large, very shallow box. It is constructed of ex 5in. X 1in. deal and is 4ft. square. The front is of hardboard and is screwed to the edges of the frame with 3/4in. C/S No. 6 wood screws. Use round-head screws if preferred, but they are more difficult to drive. Before fixing, the front should be drilled to take the lampholders and have a central hole about 2 1/2in. dia. cut in it to clear the sprocket thread and locking ring on the front of the wheel. It is better to err on the large side than to cut too small a hole as this hardboard front must in no way impede the freedom of the wheel hub. In any case, the hole is afterwards hidden by a circular

what this distance really is provided it is constant. If carelessly marked, the arrow will not true up with the lighting and it will be found, for example, that the Derby light is on, but the arrow has stopped near the end of "Hull" or the beginning of "Hove." Although this is provided for by stipulating to the public that the place name which remains illuminated is the winner (not necessarily where the arrow is pointing) it is better to have no dis-

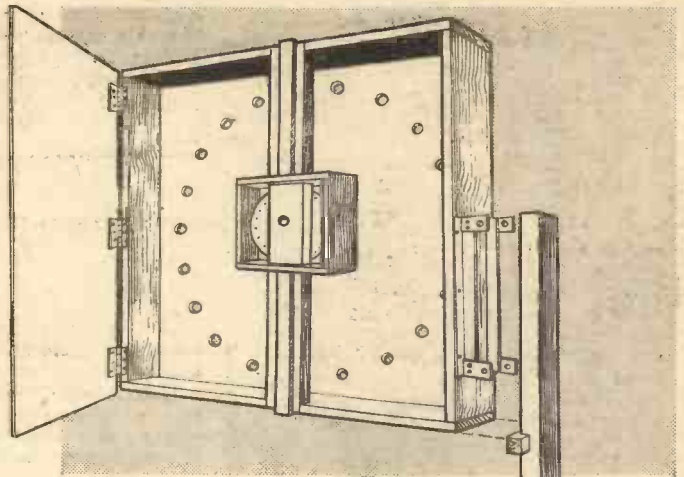

Fig. 9. — Back view of frame supporting hardboard front and strut to carry wheel and contact mechanism (w. wheel not shown).

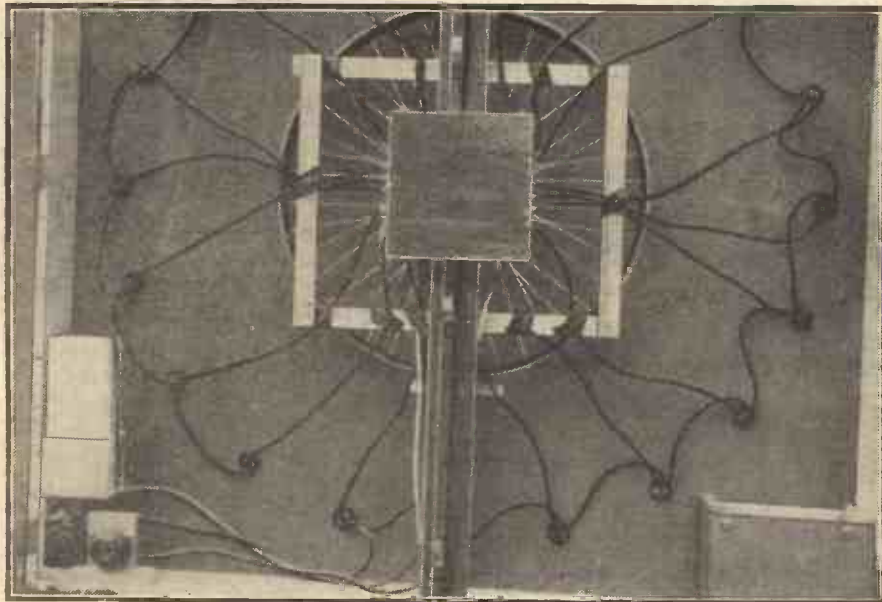

Fig. 8.—Interior view. On the left is a half box and strap holding the name plates. Bottom right is a box which holds the lamps when not in use. The centre box covers the live terminals of the 20 contact studs.

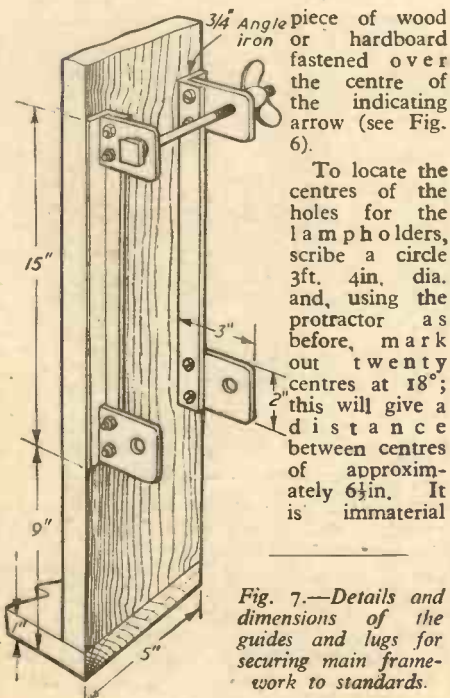

Fig. 7.—Details and dimensions of the guides and lugs for securing main frame-work to standards.

crepancies. The holes are drilled 1 1/4in. dia. and the shade rings are used to fasten the lampholders to the board.

Notches are cut centrally in the top and bottom edges of the frame to take the wheel strut so that it falls level. This may now be screwed on (minus the wheel, which will only get in the way and be liable to damage) and the little backless box fitted around the contacts. This should be deep enough to cover the bolt ends and should have a hinged hardboard cover as shown in photograph Fig. 8.

Down the centre of the strut are pinned

two hardboard strips 1in. wide. These carry four wooden turn-buttons for keeping the half-doors closed. They should be rounded slightly on their undersides.

The hardboard half-doors may now be cut and fitted. The box enclosing the contacts projects beyond the strut so gaps must be cut in the doors to enable them to close. Not less than three hinges should be used on each door; they can be screwed into the edges of the frame, but must be fixed to the hardboard with C/S bolts and nuts on the outside.

Guides and Lugs

These, as will be seen in Fig. 7, are made up of 3/4in. angle iron, mild steel lugs 3in. X 2in. X 1/4in., and 3/4in. bolts 3in. long supplied with fly nuts. Reference to Fig. 9 will show that the standards run between the insides of the angle iron and are kept in position by the bolts, the main frame resting on the cross blocks let into the standards. First drill the angle iron to take three or four No. 8 screws to fasten them to the main frame.

(To be Concluded)

PRACTICAL HOME MONEY MAKER

Edited By F. J. CAMM JULY ISSUE NOW ON SALE

Principal Contents

- High Class Canework ● Ready Selling Games ● Lockstitch Method of Rug Making
- Repairing Trunks and Carrying Bags ● Running a Mail Order Business ● Rubber Driven Models ● Cake Icing ● How to Sell Printing ● Clock Repairing ● Society Secretarial Services ● Forming a Private Company ● Making Working Sand Models
- Start a Stamp Business ● Autumn Sown Annuals ● Machine Knitting for Profit
- Clothes Repair and Valeting Service, and many other ideas for making money in your spare time.

About Binoculars

Some Points Which May Guide the Prospective Purchaser



ALTHOUGH there are several types of glasses made for special classes of work the optical systems of all fall under one of two heads: non-prismatic and prismatic.

In the first, usually spoken of as just "field glasses," rays from the subject pass straight through to the eye, but in the second the path is diverted by small triangular prisms of glass. The telescope gets its tremendous magnification by virtue of the great length from the eye-piece to the "objective" lens (the one at the far end). Being short, binoculars can never, therefore, be as powerful, but "prismatic" glasses can

8 × 30. The first number gives the magnification, thus 8 means that an object is seen through the glass eight times higher and eight times wider than it appears to the naked eye. The second figure, 30, gives in millimetres the diameter of the objective glass. It is a very important dimension, for on the size of this lens depends the brightness of the image and it gives some idea as to how useful the glasses will be in dull light.

The bigger the objective, the more light it collects, and certain binoculars known as "night glasses" have these end lenses very large indeed so that they give quite a good picture even when it is too dark to see the object with the unaided eye.

To compare the amount of light coming through two glasses, set them up a little distance away. A small circle will be seen, which will be bigger in the glass that passes the more light. In a well-designed glass the circle will be equal to the diameter of the

defined as giving 150 yards width at 1,000 yards range, see Fig. 3.

Focusing

High-grade prismatics have another advantage over plain "field glasses" in that they are made with a hinged bar in the centre which allows the two eye-pieces to be brought exactly before the pupils. This is really very important, for no two persons have the same between-eye distance and for perfect vision the eyes should look straight into the lens. If upon looking through a glass you see a shape as Fig. 4 you may know that the lenses are too far apart and

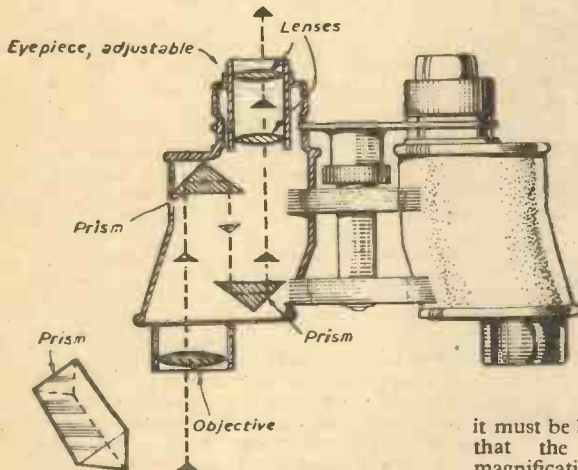
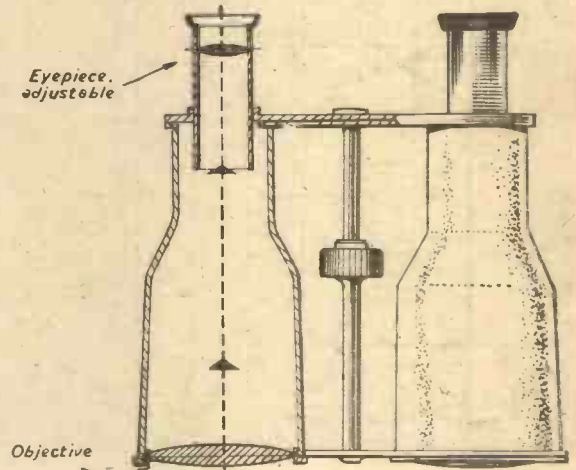

Fig. 1.—(Left) The principle of prismatic binoculars.

Fig. 2.—(Right) Details of non-prismatic binoculars.



give the greater magnification, as the prisms increase this all-important distance between eye-piece and objective.

The increased length is made possible, as shown in Fig. 1. The rays from the subject are collected by the "objective" and pass to the first prism. Here, by the simple laws of refraction they are bent to a right angle twice and pass on to the other prism. A reverse action takes place and the rays are bent back once more to the same direction they had when entering the objective. And so they reach the eye through the small lenses in the eye-piece.

With the other type of glass the rays travel straight from the entering lens to the eye-piece without any bending and, of course, by a shorter route. Hence there is less magnification. These glasses are shown in Fig. 2.

Magnification and Lens Diameter

Non-prismatic are generally vaguely advertised as "powerful," etc., but prismatic glasses are stamped with figures such as

objective divided by the magnification.

For general use a glass magnifying 8 times is considered ideal, but for specialist work they can be obtained up to × 25. When buying a glass

it must be borne in mind that the bigger the magnification the less of the picture you see at any one time. Thus it would be no good going to a race-meeting with binoculars so strong that, say, a jockey's cap filled the whole picture area. Very high-powered glasses, too, are more difficult to sight and to keep steady, for the slightest vibration causes a big movement of the image.

General Purpose Glasses

A good compromise is obtained with × 7 or × 8 binoculars. They cover a good field, give fine detail and are easily held. The "field" is the width of view a glass gives, and it is either described as a certain width at a certain range, or in terms of the angle the outer edges of the field make at the objective lens. Thus an 8.5 deg. glass can be

should be brought together till a perfect circle is seen.

Again, our two eyes never have quite the same strength, and to allow for this, good-

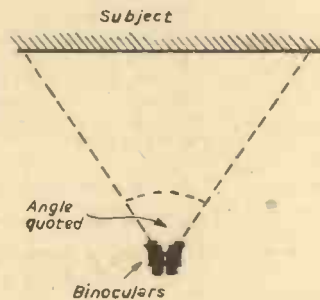

Fig. 3.—The binoculars' field.

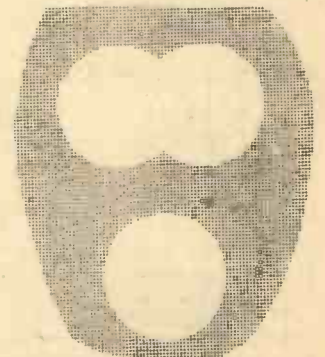

Fig. 4.—(Top) Glasses wrongly focused. (Below) The fault corrected.

quality binoculars have one eye-piece focusing independently of the other. This is very convenient and helps towards clear vision.

An interesting development of the prism principle is the "Monocular." This is, in effect, one half of a pair of binoculars and is used like a telescope; indeed, it is, in fact, a shortened telescope. Magnification of × 8, × 12, × 16 and up to × 25 can be obtained with it.

Changing the Speed of D.C. Motors

J. L. Watts Discusses the Various Aspects of this Problem

A FAIRLY common problem in connection with direct current (D.C.) motors is that of operating a motor at a different speed from that for which it was designed. It may be required to run the machine at one speed, or variable-speed operation may be required. It may be that a given motor must be suitably controlled or modified, or it may be desired to select a motor which can be modified for some

Thus, in general, a low-speed motor of given horse power is often a better proposition for modification than is a high-speed motor of the same horse power. If a high-speed motor is to be run at reduced speed it may be necessary to use a motor which, on its normal rated speed, has a greater horse power rating than is required on the lower speed. The relation between the full-load torque and the speed of motors will be discussed as the occasion arises.

In deciding upon the horse power required to drive a given load at a different speed, or at different speeds, it is necessary to consider the speed-torque characteristics of the load itself.

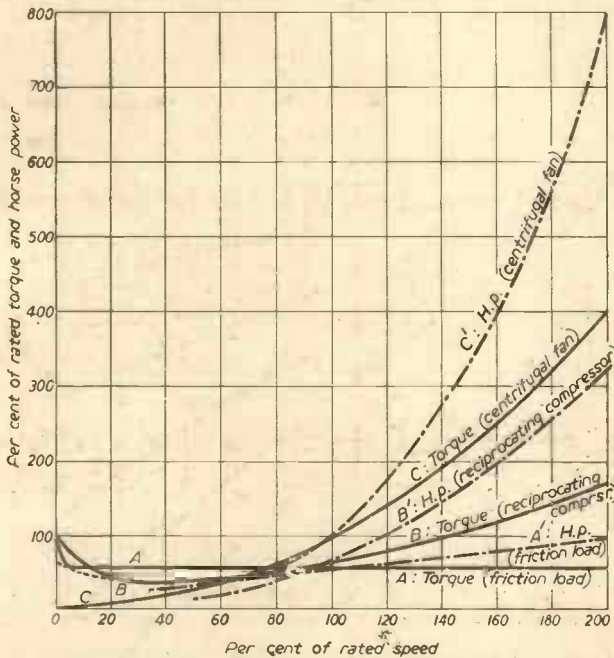

Fig. 1.—Torque and power requirements of various types of loads.

particular purpose. Fortunately D.C. motors can often be used on different speeds.

Power Requirements of Various Types of Loads

In all cases it is, however, necessary that the motor be large enough so that it can, without overheating, develop sufficient power to drive the load at whatever speed is required. Now the horse power developed by a motor is proportional to the product of its speed and torque, or turning moment. Thus a high-speed motor of given horse power has a lower, full-load torque than has a low-speed motor of the same horse power. The full-load torque of a motor is defined as the load torque which the motor can drive, without overheating, for the period of the motor rating.

The design of D.C. motors is such that, in general, a low-speed motor of given horse power has a larger physical size than that of a high-speed motor of the same horse power. This means that if a low-speed motor is modified to run at a higher speed it may be possible to increase its horse power; but if a high-speed motor is modified to run at a lower speed its horse power will be reduced.

Fig. 1 refers to various types of loads. Curve A shows the torque required to drive a simple rotating device in which the principal resistance to motion is friction, which may be somewhat higher at the instant of starting than after the drive has been started. Apart from the initial starting period, the horse power required to drive this type of load (proportional to torque \times speed) will be proportional to the speed. This has been represented by A' in Fig. 1 in the case of a load which requires half the motor horse power at the rated speed of the motor. It will be noted that if the speed of the drive is doubled the drive will then require the full rated horse power of the motor. This characteristic is similar to that of a lifted weight.

The curve B in Fig. 1 shows how the torque required to drive a reciprocating air compressor varies with the speed of the

compressor. It will be noted that if no pressure release valve is fitted the torque required to start the compressor will depend somewhat on the position of the piston in the cylinder at the instant of starting, as indicated by the dotted line at the start of curve B. The curve B' shows that the horse power required to drive such a compressor at double speed may be about four and a half times the power required to drive it at rated speed. On the other hand the torque required to drive a centrifugal fan is approximately proportional to speed² as indicated in curve C, the horse power required being approximately proportional to speed³, as in curve C'. Thus, if such a fan is to be driven at double its normal speed, about eight times the normal horse power may be required.

Series Motor with Armature Circuit Resistor

The simplest way of running a D.C. motor at a different speed is by connecting a resistor in the motor circuit and/or by altering the internal connections. Many small D.C. motors are series machines, having field coils F₁ and F₂ of comparatively thick-wire which are connected in series with the armature A. Often the field coils are connected on either side of the armature, as shown in the inset in Fig. 2, which also shows a speed control resistor R connected in series with the motor. The effect of such a resistor is to reduce the voltage applied to the armature so that, on a given armature current and load resistance torque, the motor runs at a reduced speed.

On a given load torque the motor speed is roughly proportional to the voltage applied to its armature. Thus to reduce the speed from N to N₁ r.p.m. the voltage applied to the motor may be reduced from the rated value V to V₁ volts. In this calculation internal volt drops in the motor have been ignored for simplicity. The volt drop required across the series resistor is, therefore $V - V_1$ volt, this being equal to $I_A \times R$, where I_A is the motor current (amps), and R the ohmic value of the series resistor. Thus R is roughly equal to $\frac{N - N_1}{N} \times \frac{V}{I_A} \dots (1)$.

It will be noted that the volt drop across a given resistor is proportional to the current I_A which flows through it. As will be seen from Fig. 2 the current I_A taken by a series motor is automatically governed by the motor torque which, under all stable running conditions, is just equal to the resistance torque of the load. Thus if the load torque and motor current are reduced on reduced speed, the volt drop across a series resistor will fall, causing the motor to run at a higher speed than would otherwise be the case. If the field magnets of a series motor are magnetically saturated the motor torque may be practically proportional to the motor current

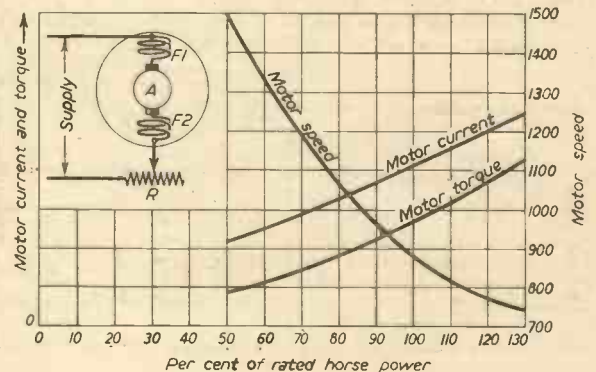

Fig. 2.—Characteristics of a series D.C. motor and method of speed reduction.

I_A; if the field magnets are unsaturated the motor torque of a series machine may be practically proportional to I_A². If, therefore, the load requires reduced torque, and thus reduced motor current I_A, to drive it at reduced speed, the value of series resistor required for a given speed reduction will

Read WIRE AND WIRE GAUGES 3/6 or 4/2 by post.

have to be increased, as will be understood from Formula (1).

Taking the extreme case where the load torque required is proportional to speed², as in curve C of Fig. 1, with an unsaturated series motor in which the torque is proportional to current², the actual motor current taken on changed speed will be practically proportional to the speed. Thus if I'_A is the motor current required to drive this load at the rated speed N , the current IA required to drive the load at the reduced speed N_1 , may be taken as equal to $\frac{N_1}{I'_A \times N}$. This

little example will illustrate that an increased value of series resistance is required if the required torque is less on reduced load.

When a series motor is used with a series resistor the torque developed by the motor is equal to the resistance torque of the load at all steady speeds, provided the series resistance is not so excessive as to stall the motor. However, the torque which the motor is capable of developing without overheating is approximately constant; thus the horse power which the motor can develop without overheating is approximately proportional to the motor speed.

Field Diverter Control of a Series Motor

It is sometimes required to raise the speed of a series motor. It is often possible to do so by connecting a diverter resistor in parallel with the field windings. If the field coils are connected on opposite sides of the armature, as in Fig. 3a, it is best first to reconnect them on one side only of the armature, as in Fig. 3b. It is essential that the relative direction of the current through the field coils be unchanged, thus the ends X and Y which were connected to the brushes in Fig. 3a must be connected together as in Fig. 3b. With a given voltage applied to the motor the speed will be almost inversely proportional to the strength of the field flux. When full load current flows through the motor armature the torque will be practically proportional to the field flux, with speed inversely proportional to the field flux.

With unsaturated field magnets the speed would be doubled if the field current were halved, as could be done by connecting in parallel with the field coils a resistor of ohmic value equal to that of the field windings. The resistance R_f of the field windings can be calculated by measuring the volt drop V_f across the ends of the series field windings whilst carrying a given field current, I_f . Then $R_f = \frac{V_f}{I_f}$. If the field magnets had a high degree of saturation a lower value of diverter resistance would be required for a given increase of speed. With the diverter method of speed control the

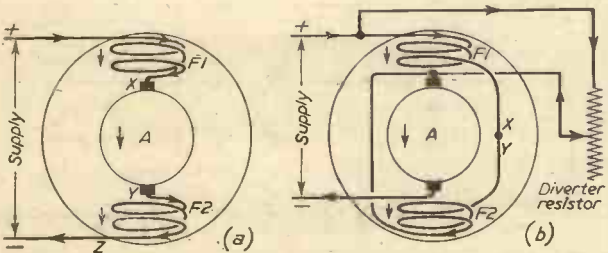

Fig. 3.—Use of a diverter resistor for raising the speed of a series D.C. motor.

torque which the motor can develop without overheating is practically inversely proportional to the speed, the permissible horse power loading being practically constant at all speeds. If this method of speed control is to be used with a load requiring a constant torque at all speeds the rated torque

of the motor at its rated speed must be more than the torque required at the maximum speed, in the ratio $\frac{\text{Maximum speed}}{\text{Rated speed}}$. If the torque required increases on increased speed a still higher torque ratio will be required.

Reconnection of Field Coils of a Series Motor

The speed of a series motor can also be raised by reconnecting the field coils into two parallel sets, in series with the armature, as in Fig. 4b. Care must be taken that the relative direction of the current through the field coils is unchanged. With unsaturated field magnets this system would double the speed of the motor on a given armature current but, in practice, the increase of speed is likely to be rather less than 100 per cent, due to saturation effect. The permissible load torque in either case will be roughly inversely proportional to the speed, with permissible horsepower loading practically unchanged.

Armature Circuit Control of a Shunt Motor

The field coils of a shunt motor are wound with relatively fine wire and are connected in parallel with the armature, as in the inset to Fig. 5, which also shows a resistor R in the armature circuit for speed control. This method can be used for reduction of motor speed. As in the case of a series motor the ohmic value of armature circuit resistor required to reduce the speed from N to N_1 r.p.m. on a supply of constant voltage V may be given by $R = \frac{N - N_1}{I_A} \times \frac{V}{I_A}$ ohms where I_A is the armature current required at the reduced speed. The armature current I_A taken by a shunt motor is approximately proportional to the torque, thus, if the torque is reduced at the lower speed, the reduced value of I_A will necessitate using an increased value of armature circuit resistance.

Take the extreme case where the torque required is proportional to speed², as in curve C of Fig. 1. If I'_A is the armature current required to drive the load at the rated speed N , the current I_A required to drive the load at the reduced

speed N_1 may be taken as equal to $I'_A \times \left(\frac{N_1}{N}\right)^2$. This indicates the considerable increase of armature circuit resistance required if the load torque falls on reduced speed. If the torque is proportional to speed², the series resistance required to halve the speed may be about four times that required with a constant-load torque.

With armature circuit resistance control of a shunt motor speed the permissible torque is practically independent of the speed, the permissible horse power being almost proportional to the speed. Thus this method of speed control is satisfactory provided the motor can develop sufficient torque to drive the load at the maximum speed required. Fig. 5 shows the reduction of speed with

torque is practically independent of the speed, the permissible horse power being almost proportional to the speed. Thus this method of speed control is satisfactory provided the motor can develop sufficient torque to drive the load at the maximum speed required. Fig. 5 shows the reduction of speed with

increasing values of armature circuit resistance from R_1 to R_5 . It will be noted that the use of such a series resistor allows the motor speed to vary considerably if the load torque varies. Also if a very high value of armature circuit resistance R_5 is used the motor may be unable to develop its rated full-load torque, even at standstill, due to the reduction of armature current.

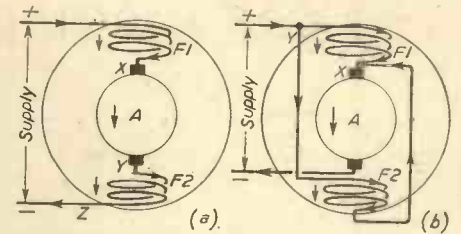

Fig. 4.—Re-connection of series field windings of a series motor for increased speed

Speed Control by Shunt Field Circuit Resistor

The speed of a shunt motor can be increased by connecting a resistor R in series with the shunt field windings alone, as in the inset to Fig. 6. The resistance R_f of the shunt field windings can be found by measuring the current I_f which flows through the shunt field windings when a

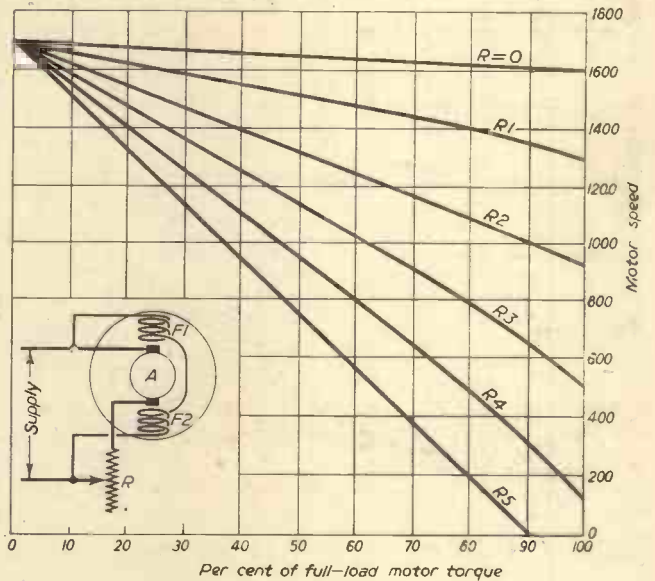

Fig. 5.—Effect of a series resistor in the armature circuit of a shunt motor.

voltage V is applied to the field windings. Then $R_f = \frac{V}{I_f}$. Due to saturation effect in

the field magnets the field circuit resistance required to double the motor speed will be rather more than that of the field windings themselves. Fig. 6 shows how the speed of a particular shunt motor varies with the field current. It will be noted in this case that if a series resistor of ohmic value equal to that of the field windings is connected in the field circuit to halve the field current the speed will be increased from 1,420 to 1,940 r.p.m., an increase of 37 per cent.

The permissible torque obtainable with field circuit control is practically inversely proportional to the speed, as may be seen from Fig. 6, the permissible horsepower being practically constant. With this system of control, therefore, the rated-full-load torque of the motor at rated speed must be greater than the torque required to drive the load at the maximum speed.

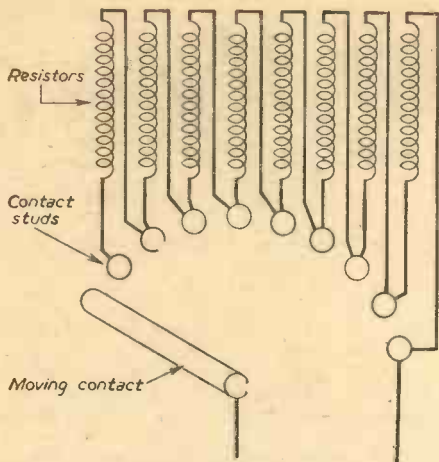

Fig. 7.—Arrangement of a variable resistor.

Construction of Resistors

Speed control resistors may be constructed by using resistance wire which is wound round into a spiral of about $\frac{1}{2}$ in. dia. and wrapped round, or secured to, a strip of asbestos board; or wound in a spiral of about $\frac{1}{2}$ in. dia. fitted into the grooves of a steatite electric fire former. If a precise or a variable speed is required, it is best to use a variable resistor. The wire may then be looped to contact studs on a tapping switch, as indicated in Fig. 7. The contact studs could consist of 2 B.A. brass cheese-headed screws on a panel of asbestos board. The resistors should be fitted in a well-ventilated metal case which is efficiently earthed. The moving contact may be operated by a $\frac{1}{2}$ in. dia. bakelite rod passing through the metal case to an insulated knob outside. The size of resistance wire must be large enough to carry the required current without overheating. Table I gives suitable sizes of Eureka resistance wire, together with the resistance per yard of the wire. These values enable the length of wire required to be readily calculated.

Speed Alteration by Rewinding

The speed of a motor can also be altered by rewinding the armature. Before so doing it is necessary to ascertain the number of turns per armature coil, the number of coils per slot, the size of wire used, and the lead between the armature coils and commutator segments. It is assumed that only two-pole motors are concerned, such motors having two parallel circuits through the armature. The number of armature coils may be equal to, or a multiple of, the number of armature slots. The number of coils, or coil sections, will be equal to the number of commutator segments.

In order to count the number of conductors per armature slot it is best to cut through all the conductors at the back of one slot and to count the number of wire ends. The number of turns per slot will then be equal to half the number of conductors in the slot. The number of turns per coil, or per coil section, will then be equal to the turns per slot \times number of armature slots divided by the number of commutator segments. If there are more

commutator segments than slots, as is quite usual, there may be more than one coil per slot; or each coil may have two or more sections with loops brought out to the commutator segments. The gauge of the armature conductors must then be accurately measured by means of a standard wire gauge or micrometer and identified as in columns 1 or 2 of Table I.

If the present number of armature conductors per slot is C and it is required to alter the motor speed from N to N_1 r.p.m. the new number of armature conductors per slot will require to be made equal to $C_1 = \frac{N}{N_1} \times C$. Thus for increased speed the

number of armature conductors must be reduced and vice versa. If the cross-sectional area of the present wire is A sq. in., the cross-sectional area A_1 of the new wire to be used should be approximately equal to $\frac{N_1}{N} \times A$ sq. in. In other words $C_1 \times A_1$ should be approximately equal to $C \times A$. Thus, if it is required to double the speed of a motor which has 160 conductors of 36 s.w.g. (0.0000454 sq. in.) per armature slot, the armature should be rewound with

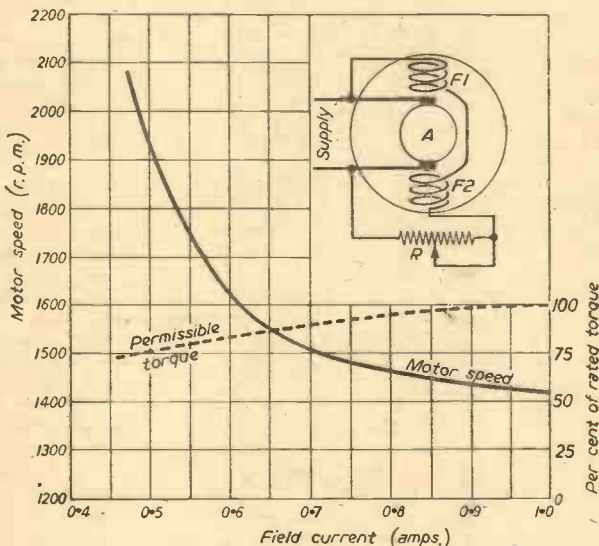

Fig. 6.—Effect of reducing the field current of a shunt motor.

80 conductors per slot of 32 s.w.g. (0.0000916 sq. in.). The existing coil span, and the lead between the armature coils and commutator segments, must be carefully copied. When rewinding the armature of a series motor each field coil should be similarly rewound. However, if the number of armature turns is halved to double the

CHANGING THE SPEED OF A D.C. MOTOR

Gauge of wire (s.w.g.)	Diam. of wire (inch)	Cross sectional area of wire (sq. inch)	Current (amps)	Resistance (ohms per yard)
13	0.092	0.006648	12.7	0.101
14	0.080	0.005027	9.5	0.134
15	0.072	0.004072	7.4	0.165
16	0.064	0.003217	6	0.209
17	0.056	0.002463	5.3	0.273
18	0.048	0.001810	4.3	0.372
19	0.040	0.001257	3.7	0.536
20	0.036	0.001018	3	0.661
21	0.032	0.000804	2.8	0.837
22	0.028	0.000616	2.2	1.093
23	0.024	0.000452	1.8	1.487
24	0.022	0.000380	1.5	1.77
25	0.020	0.000314	1.25	2.142
26	0.018	0.000254	1.05	2.645
27	0.0164	0.000211	0.9	3.186
28	0.0148	0.000172	0.76	3.914
29	0.0136	0.000145	0.68	4.634
30	0.0124	0.000121	0.59	5.575
31	0.0116	0.000106	0.52	6.37
32	0.0108	0.0000916	0.47	7.35
33	0.010	0.0000785	0.42	8.571
34	0.0092	0.0000665	0.37	10.128
35	0.0084	0.0000554	0.33	12.149
36	0.0076	0.0000454	0.28	14.840
37	0.0068	0.0000363	0.26	18.536

Table I.—Details of Eureka Resistance Wires.

motor speed the field coils could be reconnected in parallel, as in Fig. 4, without other alteration.

In order to change the speed of a shunt motor the armature may be similarly rewound, no alteration of the field windings being necessary.

When thus rewound the permissible full-load torque may be practically unchanged, the permissible horse power loading being practically proportional to the speed. It should be noted that the running speed of a series motor will still depend on the resistance torque of the load, the speed of a shunt motor being almost independent of the load. Care should be taken not to operate a motor at such a high speed that there is a risk of damage to the rotating windings and other parts due to the high centrifugal forces set up, these forces being proportional to speed. If the speed of a motor is very much reduced it may be advisable to reduce the load torque to avoid overheating due to reduced cooling. On changed speed there may be slight sparking at the brushes. If the brushes are adjustable it may be advisable to set them slightly backwards in the opposite direction to rotation otherwise brushes of higher resistance may be desirable. If a motor is rewound for increased speed and horse power it will, of course, take an increased current. This may not affect the commutation of a very small motor but, in the case of a big alteration to a larger motor, larger brushes may be advisable.



PRACTICAL MOTORIST & MOTOR CYCLIST

Edited by F. J. CAMM

July Issue Now On Sale

Principal Contents

- Beginner's Guide to the Motor Car
- Carburettor Maintenance
- Tests for the Ten Year Olds!
- Overhauling the Jaguar 1 1/2 Litre
- Overhauling the Pre-war Morris 10 cwt. Van
- Your Motor Cycle Explained
- and many other interesting articles
- Van Conversion
- Overhauling the Triumph Mayflower
- Diesel Conversions
- Overhauling the Post-war Standard Eight
- Your Insurance Simply Explained
- Garage Mechanic's Diary



Fig. 1.—The completed magnet.

A Powerful Lifting Magnet

The Magnet Described Will Carry a Current From an 8-volt Accumulator With No Other Resistance in Circuit and Will Easily Lift a Weight of 25lb.

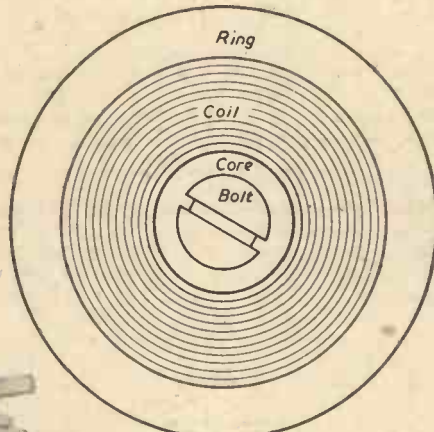

Fig. 3.—Plan view.

A LIFTING magnet is an electromagnet which is specially designed to support heavy weights by the application of a comparatively small electric current. The model described is capable of carrying a current from an 8-volt accumulator, with no other resistance in circuit, without undue heating up of the coil, and it is easily capable of supporting a load of 25lb. weight, or even more. The materials used are inexpensive, and the work involved is not beyond the skill of the young amateur constructor.

Fig. 1 shows the finished magnet, and Fig. 2 a vertical section. The dimensions given can, of course, be varied to suit individual requirements, and are merely intended

as a general guide. The main portions of the body of the magnet are shown separated in Fig. 6.

Magnet Construction

Obtain a piece of iron piping $1\frac{1}{2}$ in. internal diameter and about $\frac{1}{2}$ in. in thick-

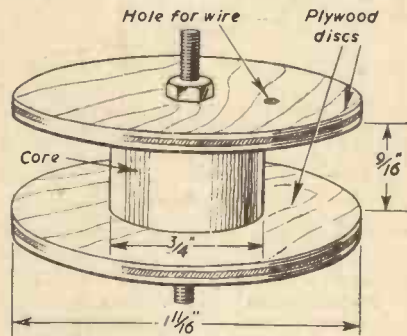

Fig. 4.—The coil former.

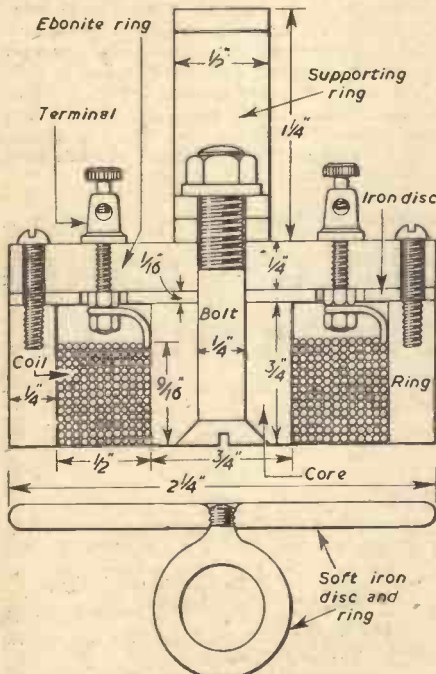

Fig. 2.—A sectional view.

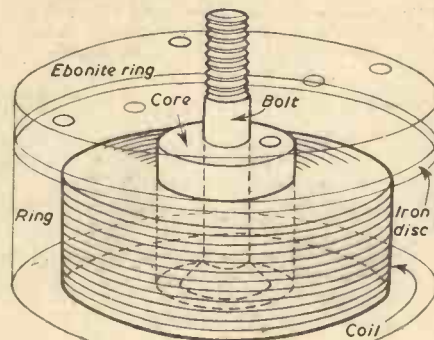

Fig. 5.—The ring, core, discs and bolt in position.

be referred to as the "ring" in all diagrams and description.

The "core" is made from a piece of $\frac{1}{2}$ in. soft iron rod, $\frac{3}{4}$ in. long, with the ends worked smooth and square. Through the centre, drill and countersink a hole to take a $\frac{1}{4}$ in. countersunk bolt (B.S.F. thread) fitted with a nut. This hole is, of course, drilled more easily on a lathe. A further disc of $\frac{1}{16}$ in. sheet iron of the same diameter as the outside of the ring is also drilled in the centre to allow the bolt to pass through it. The purpose of this disc is not only to add strength, but also to close the magnetic circuit. A similar disc of ebonite or other insulating material, $\frac{1}{4}$ in. thick, is also drilled in the centre to allow the bolt to pass through it easily. A supporting ring is made by turning a strip of $\frac{1}{16}$ in. sheet iron into a ring of about $1\frac{1}{2}$ in. dia. with the ends overlapping and drilled to take the bolt, as shown in Fig. 1.

It is advantageous to construct from a piece of $\frac{1}{2}$ in. soft sheet iron another disc of the same diameter as the iron and ebonite discs already mentioned, although this disc is not actually a portion of the magnet itself. Drill and tap it to take a stout eye. If the top of the hole is slightly countersunk and the eye screwed a little way through, riveted and then filed down level with the disc, there is no danger of the eye pulling through under strain.

Drill and tap the ring and the iron and ebonite discs all together so that later on they may be held together by four round-head 2 B.A. $\frac{3}{16}$ in. screws (see Figs. 2 and 6). Also drill together the discs, iron and ebonite, to allow the legs of two terminals to pass through the holes later.

(Concluded on page 486)

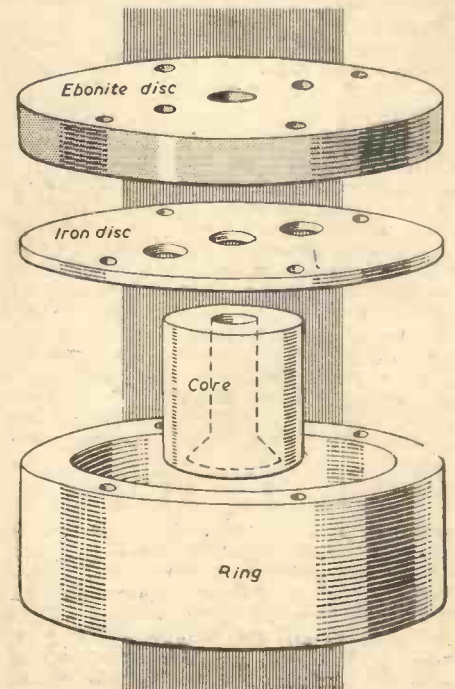

Fig. 6.—The main parts of the magnet.

ness. Cut off a short length, about $\frac{13}{16}$ in., and file and polish the ends until they are square, flat and smooth and the finished length is $\frac{3}{4}$ in. Of course, the appearance is improved if the outside surface of the piping is also finished off smoothly or even enamelled. This portion will afterwards

Making Rafts



By "Aqua"

Try One of These Craft On Your Holiday This Year!

THE easiest way to make a passenger-carrying craft is to follow the practice of the early, and not so early, tribesman and secure a log with sufficient

buoyancy to carry your weight and then supply it with an outrigger to prevent it rolling over.

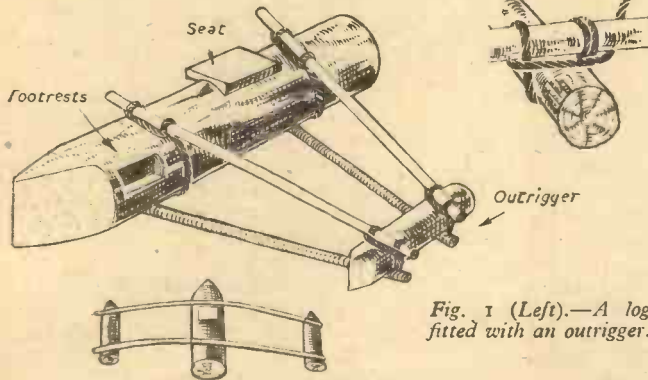

Fig. 1 (Left).—A log fitted with an outrigger.

Fig. 1 shows how this can be done by attaching a small log by means of four spars. The parts are secured together by cord lashings, the method of joining being shown in the inset. The cord is started by a clove-hitch. It is then taken under the lower spar and up and over the one at

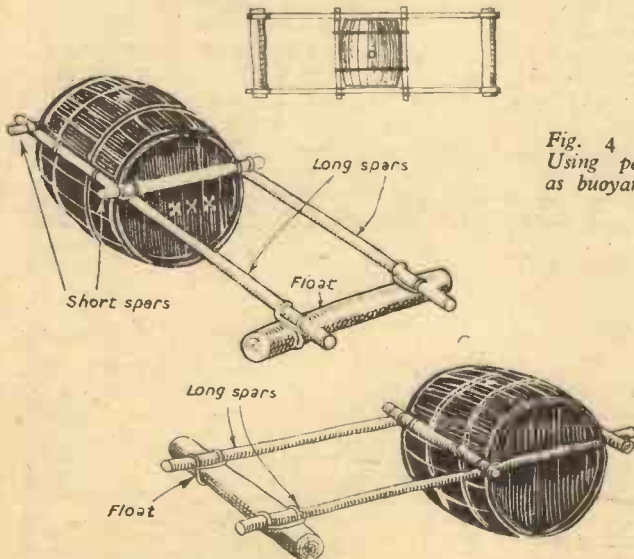

Fig. 2.—Using a barrel to make a raft.

right-angles. This is repeated several times and a finish off made by taking the cord horizontally between the two members, where it will automatically bind; but the lashing should be completed by pushing the end under an existing turn. This lashing is more or less standard for all this class of work. A

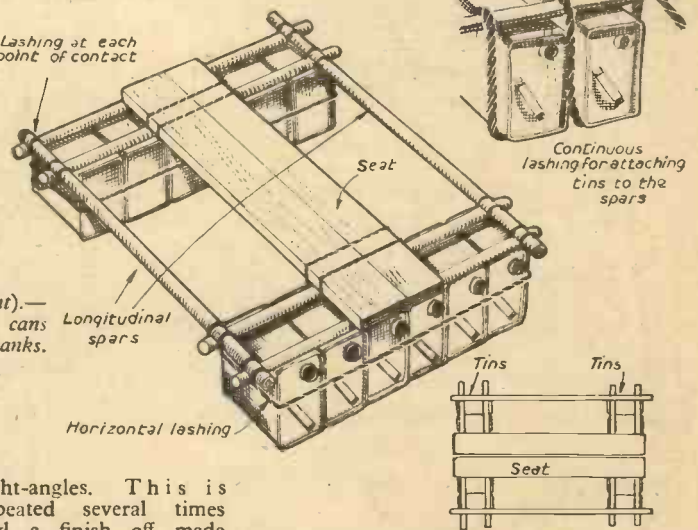

Fig. 4 (Right).—Using petrol cans as buoyancy tanks.

seat on top and foot rests can finally be added. Greater manoeuvrability is given by roughly pointing what will be the leading ends of the logs. Craft where transverse stability is given by outriggers fall into the catamaran category.

Using a Barrel

If a barrel can be procured this can be used in place of the log. The safe load a closed barrel will carry can be found by multiplying its capacity in gallons by nine, which gives the required figure in lbs. The outrigger can be done with the log in front

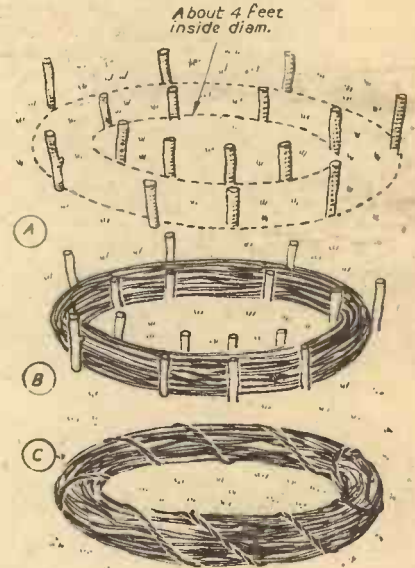

Fig. 3.—Three stages in making a covacle.

or at the side, as shown in Fig. 2. The log in front gives a more manageable craft, but not the same anti-rolling properties.

Two fairly long spars are needed in either case, two smaller cross-bars and a heavier piece of timber for the float. The two

main spars, cross-pieces and float are made into the frame as shown, which must sit on the barrel above its halfway line so that the upward thrust of its buoyancy does not tend to push it out, but rather makes things firmer. The barrel is held in position by two lashings, which go right round and take in the horizontal strips also.

As with the log, a more truly balanced craft is produced by laying the spars right

FREE - AN IMPORTANT BOOK

about YOUR CAREER · HOBBY...
...SPARE TIME WORK, etc....

...IN ANY OF THESE SUBJECTS:—

- | | |
|--------------------------------------|----------------------------------|
| Accountancy | Maintenance Eng. |
| Advertising | Mathematics |
| Aeronautical Eng. | M.C.A. Licences |
| A.R.B. Licences | Mechanical Eng. |
| Art (Fashion Illustrating, Humorous) | Metallurgy |
| Automobile Eng. | Motor Eng. |
| Banking | Painting & Decorating |
| Book-keeping | Photography |
| Building | P.M.G. Certs. |
| Business Management | Police |
| Carpentry | Production Eng. |
| Chemistry | Production Planning |
| City & Guilds Exams. | Radar |
| Civil Service | Radio |
| Commercial Subjects | Radio Amateurs (C. & G. Licence) |
| Commercial Art | Radio & Television Servicing |
| Computers | Refrigeration |
| Customs Officer | Sales Management |
| Draughtsmanship | Sanitary Eng. |
| Economics | Salesmanship |
| Electrical Eng. | Secretaryship |
| Electrical Installations | Servo Mechanisms |
| Electronics | Shorthand & Typing |
| Electronic Draughtsmanship | Short Story Writing |
| Eng. Drawing | Short Wave Radio |
| Export | Sound Recording |
| General Certificate of Education | Telecommunications |
| Heating & Ventilating Eng. | Television |
| 'Hi-Fi' Equipment | Time & Motion Study |
| High Speed Oil Engines | Transistors |
| Industrial Admin. | Tracing |
| Jig & Tool Design | Welding |
| Journalism | Workshop Practice |
| Languages | Works Management |
| Management | and many others |

Also courses for GENERAL CERTIFICATE OF EDUCATION, A.M.I.H. & V.E., A.M.S.E., A.M.Brit.I.R.E., A.M.I.Mech.E., A.M.I.E.D., A.M.I.M.I., A.F.R.Ae.S., A.M.I.P.E., A.M.I.I.A., A.C.C.A., A.C.I.S., A.C.C.S., A.C.W.A., City & Guilds Examinations, R.T.E.B. Servicing Certificates, R.S.A. Certificates, etc.



NEW PRACTICAL DO-IT-YOURSELF COURSES

YOU CAN MAKE AND SAVE MONEY IN:—

- RADIO & T/V BUILDING & SERVICING
- ELECTRICAL APPLIANCE REPAIR
- CHEMISTRY · PHOTOGRAPHY
- HI-FI EQUIPMENT, ETC.

All the above special courses include practical equipment as part of the training.

- Personal and Individual Tuition given by named tutors
- All equipment yours to keep
- Courses for Beginner or Advanced student

EMI INSTITUTES

E.M.I. Institutes
is associated with
"HIS MASTER'S VOICE",
COLUMBIA,
ETC.

POST TODAY

To:— E.M.I. INSTITUTES, Dept. 144K, LONDON, W.4.

Please send, without any obligation, your free Book to:—

NAME _____ AGE _____
(if under 21)

ADDRESS _____

Subject(s) of interest _____ With* } equipment
Without }

(We do not employ travellers or representatives)

*Delete as required

IC.118

JULY/58

The only Home Study College run by a World-wide industrial organisation

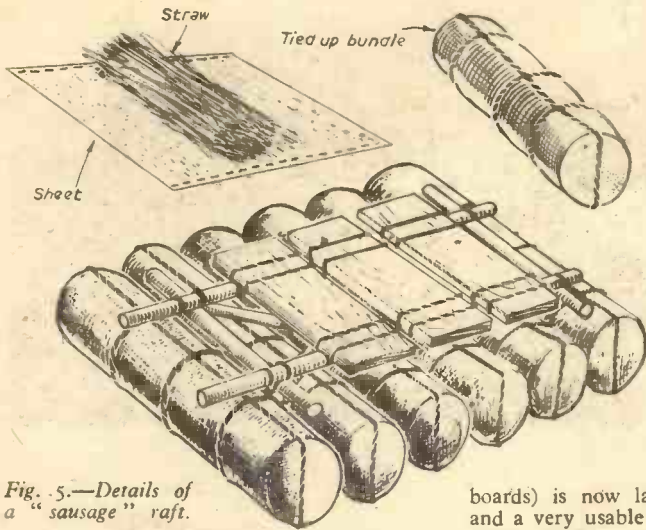

Fig. 5.—Details of a "sausage" raft.

across and having a float at each side, but one float gives the barrel—with careful navigating—all the anti-roll it needs.

A Coracle

This kind of craft can be made if a tarpaulin is available. First drive stakes into the ground as shown in Fig. 3, making a circle of approximately 4ft. inside diameter. Now work brushwood between the stakes till a thick wad has been obtained, and then bind together into a solid band by winding round pliable pieces or using cord. Lift the "fascine," as it is called, on to the tarpaulin and wrap the sides over, making good water-tight pleats. Lash firmly across the top and lay on some more brushwood for a floor and the raft is ready for use.

Using Petrol Cans

A dozen cans are required. These might be borrowed locally and returned after use. Two rows of six are made, with the tins narrow side up. Two spars are placed on

the top of the one row and two more on the other. The tins are now attached to the spars by a continuous lashing as shown in Fig. 4. Care must be taken to see that each row forms a solid block, and to ensure this a final lashing can be taken horizontally round everything, if this seems desirable. See to it that all the caps are screwed well down.

The two "floats" thus produced are now joined up by two longitudinal strips, lashing at all the points of contact with the transverse spars. A seat made of a board (or boards) is now lashed firmly in the centre and a very usable craft has been constructed upon which a person can ride out of the water.

The "Sausage" Raft

With six groundsheets an arrangement called the "sausage raft" can be made (Fig. 5). This, incidentally, has found favour in the eyes of the armed forces and it is stated that one 18ft. x 15ft. will carry 24 cwt.

The groundsheets are laid out and on each is placed a long truss of straw or soft brushwood. The ends and sides of the sheets are then taken over and the bundles so made lashed at intervals down their lengths. A simple frame is now made from four spars with, if possible, diagonals. A plank seat should go on top.

With a lashing similar to that used for the petrol tins the bundles, or "sausages," are lashed to the frame and all is ready for a launching. This raft is suitable for construction by Boy Scouts or similar organisations at summer camps.

The Log Raft

No article on improvised craft would be complete without some reference to the ordinary "log raft." This is the traditional raft of stories and is made by simply lashing together as many fairly straight pieces of wood as possible (Fig. 6). A raft like this might well be started and added to as the holiday near water continues. The logs are laid side by side and secured to two cross-members by the continuous and very elementary lashing shown. The weight-carrying capacity depends entirely on the number and size of the timbers used.

The ideal thing is to have logs perfectly straight and of equal diameter, but this is seldom feasible and quite a good raft can be put together with logs of various sizes.

Warning

As much fun can be had in shallow water as deep, so play safe and do not do anything

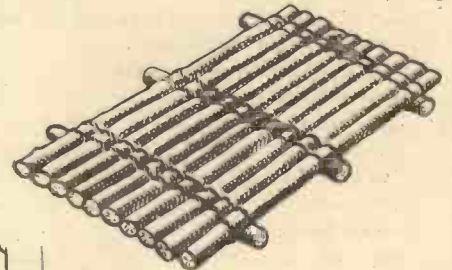

Fig. 6.—A completed log raft and details of a simple continuous lashing.

risky, even if you are a proficient swimmer. Rafts are good sport, but they are not streamlined boats and the best can become very unwieldy if caught in a current. To launch any raft built on the bank, have as many helpers as possible, lifting all round. Many lashings that will do their job well when the craft is uniformly supported by water may well become disturbed by unequal lifting or pulling about on land.

A Powerful Lifting Magnet

(Concluded from page 483)

The Coil

The next job is to wind the coil. This is carried out on a former (Fig. 4), which must first be constructed. The dimensions of the former are such that the finished coil will afterwards fit snugly into its proper

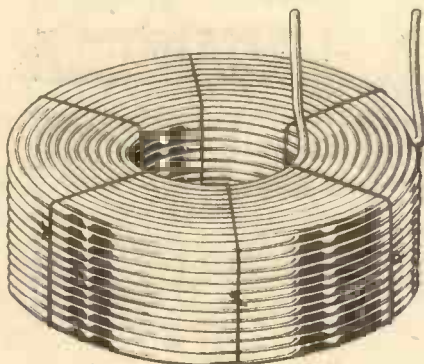

Fig. 7.—The completed coil.

position, as shown in Fig. 5, which is a transparent view of the ring, core, discs and bolt in position.

The centre of the former is a piece of 3/4 in. wood dowelling 9/16 in. long with the

ends truly squared. The discs are made of plywood and are 1 11/16 in. in dia. Drill a hole through the centre of the discs and dowelling and pass through them a piece of threaded brass rod so that the whole can be held firmly together by a nut at the top and another at the bottom. A hole to take one end of the wire should be drilled as shown at the edge of the dowelling. Wrap a piece of paper round the dowelling to facilitate the removal of the finished coil. The wire required is about 1 3/4 oz. of No. 28 D.C.C. copper.

To wind the coil, fix the former on a lathe or in a hand-drill clamped in a vice. Pass one end of the wire from the inside to the outside of the former through the hole at the edge of the dowelling. Secure it and begin to wind the rest of the wire on the former. Arrange between the paper and the first layer of wire several pieces of cotton thread to allow the coil to be tied up after completion, as shown in Fig. 7. After winding each layer of wire, apply with a brush a strong solution of shellac in methylated spirit, which, when it dries, will improve insulation and bind the coil together. When the former is completely filled, allow the coil to stand as long as possible so that the shellac solution may dry off thoroughly, then tie up the threads of cotton to secure the coil. Unscrew the nuts on the former, remove the discs and slip the coil off.

Assembling the Magnet

First pass the bolt through the core and

the iron and ebonite discs. Place the ring on the top of the bolt and secure the whole in position by the nut at the top of the bolt. The grip will be improved by a washer below the nut. Pass the terminals through the holes prepared for them in the discs, fasten the ends of the coil to them by small nuts and slip the coil over the core. Now fasten the ring in position by the screws. Set the coil back from the bottom face of the magnet about 1/100 in. and pour round it melted paraffin wax to improve the insulation and to maintain the coil in position. Remove the excess of wax, level it up, and the magnet is ready for use. Suspend the magnet by the ring on top. Connect the terminals of a 2-, 4-, 6- or 8-volt accumulator to the terminals of the magnet. Bring the soft sheet iron disc near it, when it will be strongly attracted. Hang weights on the eye which is screwed into it, when the lifting power of the magnet may be ascertained.

THE MODEL AEROPLANE HANDBOOK

An Important Work

By F. J. CAMM

312 Pages, 303 Illustrations, 12/6, by post 13/-
Construction and Principles of All Types

Published by

GEO. NEWNES LTD., TOWER HOUSE,
SOUTHAMPTON STREET, STRAND,
LONDON, W.C.2



DURIUM
Registered Trade Mark

**TIPPED
DRILLS**



for faster Masonry Drilling

You will get a great thrill when you find how fast you can drill a hole in the hardest brick with a Durium Drill. Used in a hand brace or suitable electric drill you can penetrate inches in seconds without disturbing noise, and what is more, you will get perfectly formed holes to make 100% efficient fixtures with Rawlplugs. You must try a standard Durium Drill for your next hole boring for Rawlplugs job. If you want to drill right through a wall for conduit or cable you can get a long series Durium Drill. Ask your local dealer for details or write to the Rawlplug Company Ltd., for a free fully illustrated sixteen page-booklet.

Sold in the bright orange and blue metal container clearly marked Rawlplug Durium.



Look for the name **DURIUM** on the drill shank, no other is a genuine **DURIUM** Drill.

PRICES:— No. 6, 9/6. No's 8, 10 & 12, 10/-. No's 14, 11/6; 16, 12/-; 18, 12/6; 20, 13/6; 22, 14/- each.

A FREE Re-sharpening voucher with every DURIUM DRILL



**IT'S FAR EASIER
WITH RAWLPLUGS!**

ESSENTIAL



PRODUCTS FOR THE HOME & WORKSHOP

**COMPLETE
RAWLPLUG
OUTFITS**

Rawlplugs provide a stronghold for every size of screw from No. 3 (1/4") to No. 30 (1 1/2"). For fixtures taking heavy loads like book racks, coat racks, kitchen cupboards, etc., use long Rawlplugs set deep into brickwork and use screws with the threaded part corresponding to the length of the Rawlplug. Follow the instructions given with every Rawlplug outfit and your fixtures will never let you down.

3/-

**POPULAR
TOOL 1/8**



A very cheap sturdy tool for making holes for No. 8 Rawlplugs. Turn the tool as you tap it with a light hammer. It is a very handy tool for the occasional light fixing job.

5/6

HANDY BOXES

When you have a set of Rawltools or Durium Drills you can buy the handy shilling boxes of Rawlplugs. Assorted sizes of Nos. 8, 10, 12 and 14 are packed for easy storage and selection

11/9



1/-

All Rawlplug Products can be obtained from Hardware Dealers, Ironmongers, Builders Merchants, and Stores everywhere.



PLASTIC WOOD

APPLIED LIKE PUTTY DRIES LIKE WOOD.—Can be cut, planed, polished and painted like wood. Will take nails and screws like wood. It does not blister, crack or decay. Rawlplug Plastic Wood is actually the best quality product of its kind on the market. Natural, Oak, Mahogany or Walnut. Large Tubes 1/-, Tins: 1/2 lb 2/3d., 1/2 lb 3/9d., 1 lb 6/6d.



DUROFIX

The indispensable adhesive for instant use on crockery, glass, wood, metal, celluloid and the thousand and one things handled by the hobbies enthusiast. Instant drying, insulating, waterproof and heatproof. Durofix is grand for repairs to electrical, sports and leather goods. Handy Tubes 9d., Large Tubes 1/3d., Commercial Size 5/-, 1/2 lb tins, 2/9d., 1 lb tins 10/6d.



DUROGLUE

UNDILUTED ANIMAL GLUE OF INCOMPARABLE STRENGTH. Ready for instant use for the many purposes for which an extra strong glue is needed. Wood, cloth, fabric, felt, leather and any greaseless surface can be stuck with Duroglue. Large Tubes 1/-, Tins: 1/2 lb 2/6d., 1 lb 4/9d.



TILE CEMENT

A LIQUID CEMENT possessing very strong adhesive qualities. For replacing tiles to walls, floors, fireplaces, hearths, curbs, etc., in kitchens, lavatories, bathrooms, halls, bedrooms, reception rooms, etc. Large Tubes 1/3d., 1/2 lb Tins 2/9d.

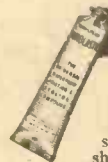

DUROLASTIC

ELASTIC SEALING COMPOUND Forms permanently elastic waterproof joints with great adhesive qualities to any dry surface. Resists vibration or shock and will not break away with expansion or contraction. Non-crumbling, non-staining, does not exude oil. Can be painted in a few hours. Ideal for boat builders.

Handy Tubes 10/6d.

Very large Tubes 1/9d.

WATSON'S SPECIAL OFFERS

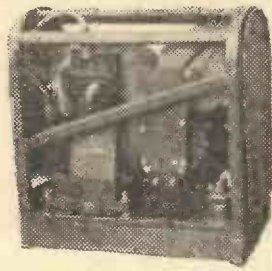

LIGHTWEIGHT CHARGING SETS. 12/18 v. 80 watt. Extremely neat and compact, powered by a 4-stroke engine and UNUSED. Easily carried. WEIGHT ONLY 46 lb. PRICE 212.10.0. Carr. 12/6.

HAND INSPECTION LAMPS. H.D. Safety Model with waterproof glass cover and protective guard complete with 10 yds. T.R.S. cable NEW, 27/6 each. Post 2/6.

BOLT OR WIRE CROPPERS will cut up to approx. 5/16in. MILD STEEL BOLTS, 10/6. Post 2/6.

PIPE CUTTERS, by "RECORD." Three-wheel type to cut any size pipe from 1/2in. to 2in. Gas, 35/- each. Post 3/-.

SLEDGE HAMMERS. 7 lb. Nosed with ash handle, 9/6. Carr. 2/6.

AIR FILTERS OR MOISTURE TRAPS. Approx. 6in. x 3 1/2in. diam. with inlet, outlet and moisture drain, 18/6. Post 2/6.

BRASS DRAIN TAPS. 1/2in. GAS THREAD NEW & BOXED, 2/6. Post 4d.

CANVAS TOOL ROLL. 17in. x 10in., provision for eight tools, also pocket and fastening tapes, 1/4 each. Post 4d. 14/- doz.

DINGHY MASTS. Telescopic aluminum extending from approx. 2ft. to nearly 9ft. Very light and strong. 9/6. Post 3/-.

BALL RACES taken from predictor, 5/16in. bore, 7/8in. diam. 1/2in. wide. Five for 14/-. Ten for 28/-. Post 1/4.

SMALL TRANSFORMERS. Input 230 or 110 v. A.C. Two separate outputs of 6 v.—35 watts. Extremely useful for powering electric bells, models, low voltage inspection lamps, etc. from mains supply. BRAND NEW. PRICE 17/-. Post 2/6.

ALSO AVAILABLE TRANSFORMERS with 200/250 A.C. input 12 volt 100 watts output. PRICE 30/-. Post 3/-.

Hundreds of other bargains available. Send 6d. stamp for MONSTER LIST.

EASTERN MOTORS
ALDEBURGH, SUFFOLK
Phone: 51

GAMAGES
RENOWNED SCREWCUTTING BACK GEARED
PRECISION LATHE

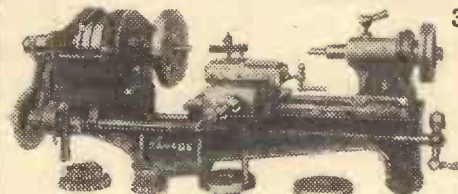

3 1/2 in. x 16 1/2 in. approx.
Today's Finest Value!
STILL ONLY £33
Or 9 Monthly Payments of 78/10
Part Carr. & Pkg., outside our run area, 12/6 Gt. Britain, plus 20/- for crate, returnable.

Brief details: Swing in gap of 3 1/2in. model, 8 1/2in. 10 change wheels. Equipment includes: Faceplate, Catchplate and Extra Backplate in rough screwed to fit mandrel nose. 16in. approx. between centres.

GAMAGES 1 in. MICROMETER

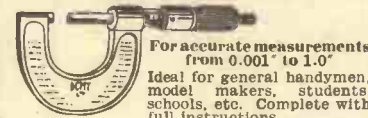

For accurate measurements from 0.001" to 1.0" Ideal for general handymen, model makers, students, schools, etc. Complete with full instructions.
Post & Pkg. 8d BARGAIN PRICE 10/-

2 in. MICROMETER 14/6, Post & Pkg. 10d.

Exceptionally Well Made STEEL TOOL BOXES

Removable inner tray, and hinged lids. Hasp for padlock fastening. Enamelled Dark Green.



Size 24 in. x 6 in. x 8 in. Two strong handles for carrying. Weight 17 1/2 lb.
BARGAIN PRICE 32/6
Carr. & Pkg 4/3 outside our extensive van area.
Gamages Tool and Motor Accessory List FREE.

GAMAGES, HOLBORN, LONDON, E.C.1. HOL 8484.

NEW CABLES & FITTINGS
TOUGH RUBBER CABLES

1/044 Twin	per yd.	25 yd.	50 yd.	100 yd.
1/044 3-core	8d.	12/6	22/6	43/6
3/029 Twin	9d.	17/3	31/3	61/6
3/029 T. & E.	8d.	15/9	28/6	55/6
7/029 T. & E.	9d.	18/3	33/9	66/-
7/029 Twin	1/1	25/9	48/3	95/-
7/029 T. & E.	1/1	31/3	58/6	115/-
7/044 Twin	1/11	46/-	88/-	174/-
Twin Lead 50 yds.	3/029 58/3	7/029 53/9		
WIR 50 yds.	3/029 11/6	7/029 12/3		
Earth Wire, 100 ft.	7/029 11/-	7/029 7/9		
PVC Transp. Flex.	50 yds., 10/-	Twin Twisted, 25 yds., 12/6	50 yds., 22/6	TRS
VIR, Lead Cables of all sizes.	HOLDERS C.G., 9/-	Batten, doz., 12/-	Roses, Brown, 9/-	
White, doz., 10/-	June Boxes, Sml., 11/-	Lge. doz., 13/-	Switches, 1-way, 18/-	
2-way, doz., 24/-	White Switches, 1-way, 24/-	2-way, doz., 30/-	Flush Switches, 1-way, 18/-	
2-way, doz., 24/-	Ceiling Cord, do., 1-way, 5/-	2-way, 6/-	2 amp, 2-pin Sw. plugs and Taps, ea., 3/-	
5 amp, 3-pin Sw. plugs and Taps, ea., 5/6	15 amp, 3-pin Sw. plugs and Taps, ea., 9/-	13 amp, 3-pin ditto, A.C. only, ea., 7/6	Wood Blocks, 3 x 1/2, 5/6	3 1/2 x 1, 7/6
3 x 3, 7/6	3 x 3 x 1, 7/-	5 1/2 x 3 1/2, 4/6	doz., 9/-	White, 3 x 1/2, 6/-
3 1/2 x 1, 7/-	4 x 1, 9/-	Cable Clips, Sml., 2/9	Med., grs., 3/3	10 amp, D.P. Insulated Sw. fuse 6/-
2 amp, 2-pin Ironclad 2-way 15 A. Splitr., 13/6	30 amp, Ironclad D.P. Switchfuse, 18/6	Metal 5-way Consumer Unit, 42/6	Sw. gear, Fusebds., Splitrs., all types, Lamp Bulbs, 15, 25, 40, 60 watt, 12; 75 watt, 15/-	100 watt, 17/-
150 watt, 24/-	200 watt, doz., 30/-	Carbon Bulbs, 230 v. 16 C.P., doz., 20/-	Immersion Heaters, 3 Kw., 50/-	Single Car Cable, 10 yds., 3/-
100 yds., 25/-	Conduit and Fittings, 1/2in. and 1/2in. Industrial Reflectors	Tubular Heaters, Fluorescent Fittings, Time Switches and all electrical equipment.	Full lists on request. Single items supplied. Satisfaction guaranteed. Terms: Cash with order; carriage paid if over 25/-; orders of £20 or over less 5 per cent. discount. Open daily, inc. Sat., 9 to 6; Thurs 9 to 1	Callers welcome

LONDON
WHOLESALE WAREHOUSE
165 (P.M.), QUEEN'S ROAD
PECKHAM, S.E.15
Tel.: NEW Cross 7143 or 0695

MAKE MONEY — making casts
with **VINAMOLD**
A grand spare-time occupation

WITHOUT any previous experience you can mass-produce any object from a chessman to a candlestick, statuette or model ship, in plaster, resin, concrete, etc. . . . with "VINAMOLD" the flexible mould that gives the BEST results. Easy to work, can be used over and over again. Needs NO special equipment, provides a profitable and enjoyable spare-time occupation with minimum outlay.

Write for full details and instructions. Also available: Illustrated booklet describing "VINAMOLD," methods of heating and melting, preparation of models and moulds, etc. Price 1/6 post free, from:—

VINATEX LTD. (Dept. P.M.3), CARSHALTON, SURREY

BRASS, COPPER, BRONZE, ALUMINIUM, LIGHT ALLOYS
Rod, Bar, Sheet, Tube, Strip, Wire
3,000 Standard Stock Sizes.
NO QUANTITY TOO SMALL.
List on application.

H. ROLLET & CO. LTD.
6, CHESHAM PLACE, LONDON, S.W.1
SLOane 3463
Also at LIVERPOOL LEEDS MANCHESTER BIRMINGHAM

BETTER CABINET MAKING

Eliminate the hard work in hand planing and give your work that professional look with the P.R.11 4 1/2 in. Bench Planer.

It Planes!
It Rebates!
It Bevels!

You can do a precision job on this sturdy machine, which will make your task so much easier, and bring greater pleasure to your Furniture making.

SEND FOR FULL DETAILS (TO DEPT. BP/43)

MYFORD BEESTON NOTTINGHAM

SOLID LEATHER BLACK ARMY DESPATCH RIDERS BOOTS ONLY 25/-
NEW Send 25/- only, plus 3/- post & handle on free 7 days' approval. Cash plus return postage instantly refunded if not worth £6.6.0. Take them to your boot dealer for independent valuation. Full chrome leather of finest quality calf length. Soles & heels are of finest HEAVY LEATHER, sewn, pegged and riveted. By best makers in country, every pair bearing maker's name which cannot be published. Unissued. Ideal M/Cyclists, Outdoor workers, Farmers, Riding, Fishing, etc. Ideal Jackboot. Sizes 5 to 13.

NEW! NEW! NEW!
ALL LEATHER ARMY BOOTS
Sizes 5 up to 14 inclusive. The greatest Ex-Ministry Army Boot offer ever made! New, super quality manufacture, and all leather materials. Made specifically for hard wear in all conditions to full Govt. specification, therefore there can be no harder wearing Boot, irrespective of price. A tremendous parcel enables us to offer at this special price of 18/6, post, etc., 2/6. Money back guarantee if not worth the price. Unissued. Lists, CLOTHING, FOOT-WEAR, WATCHES, RINGS, JEWELLERY, TENTS ETC. TERMS.

ONLY 18/6 PAIR

HEADQUARTER and GENERAL SUPPLIES LTD.
(DEPT. PMC 33), 196-200 COLDHARBOUR LANE, LOUGHBOROUGH JUNCTION, LONDON, S.E.5.
Open all Saturday. 1 p.m. Wednesday.



Letters to the Editor

The Editor Does Not Necessarily Agree with the Views of his Correspondents

Address your letters to The Editor, "Practical Mechanics," Geo. Newnes, Tower House, Southampton Street, London, W.C.2

Connecting Rod for Electric S.V. Engine

SIR,—I have made the electric slide valve engine described in your March, 1958, issue. The article is an excellent one, but I notice no details are given of the connecting rod. I devised my own, and perhaps other readers may be interested in the method I used:—

It is made in two halves, i.e., the connect-

ing rod shaft which is $5/32$ in. dia., and the big end bearing block made from $1/4$ in. brass. The brass is cut and filed to shape as shown on the plan. It is then drilled $5/32$ in. clearance for the crank. This should be a running fit. Another hole is drilled for the connecting rod shaft and this should be a push or forced fit. Two smaller holes are drilled to suit the bolts to be used on the big end bearing. The bearing block is next cut in half along the line on the plan. The small end is then filed to shape. One $1/16$ in. dia. clearance hole is drilled. The distance between centres is 3in. Note that all bearings must be running fits.—D. B. (Raynes Park).

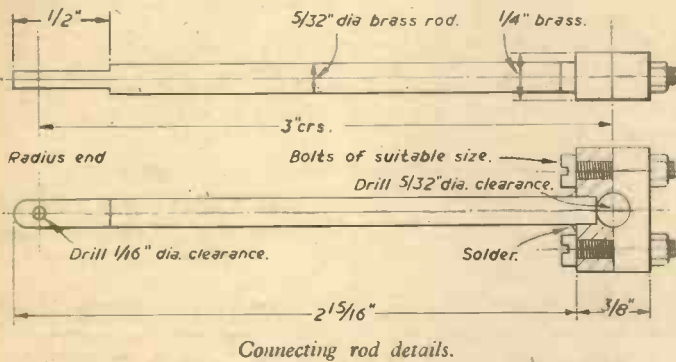

Moulding the Human Foot

SIR,—Re "Moulding Human Foot" (page 405, May, 1958, issue), your contributor's method in reply to G. Kendall (Watford) seems to me, a plaster caster for 50 years, rather long drawn out. I suggest the use of a waste mould to be the best way. A model tires quickly, so prepare beforehand two pieces of plaster, any shape, $3/4$ in. thick, but no wider than foot and heel, to be used as rests, and kept wet. Pare a little toilet soap and boil with water to make a paste. Obtain a 2ft. length of thin, strong twine or thread, a little ochre powder and solution of soft soap.

Prepare the 1in. deep fence next; this is best done with modelling clay, with foot on plaster rests, leaving a margin $3/4$ in. clear of foot. Soap the foot lightly with paste, then place centre of twine under heel, bringing both ends upwards over the ankle, soaping into position to height of leg required. Tint sufficient water with ochre and mix plaster for sole piece; pour into prepared fence, well covering rests, sink foot into plaster, keeping plaster as level as possible, but raise a little at arch. Now, before the plaster is really hard, hold a dinner knife vertically and revolve, making button-like depressions all round. This done, remove fence.

Clay wash or soap this joint right up to the foot. Quickly mix tinted plaster and cover the rest of foot, concentrating on getting at least $3/4$ in. of plaster over the twine and the heel. There is a right moment now, when plaster is starting to set, to pull downwards on both ends of the twine, thus obtaining three pieces of mould. While still wet, lather vigorously and wash in running water. When the water runs off,

the mould is ready for assembly. Wire the sole to top of the foot, but plaster the vertical joint. When set, wire this joint also.

Cast in white plaster. Before removing the wire chip or carve the mould from under and above the toes, the rest will fall away with a few light taps from a mallet.—G. WELLS (Kent).

Catamaran Modification

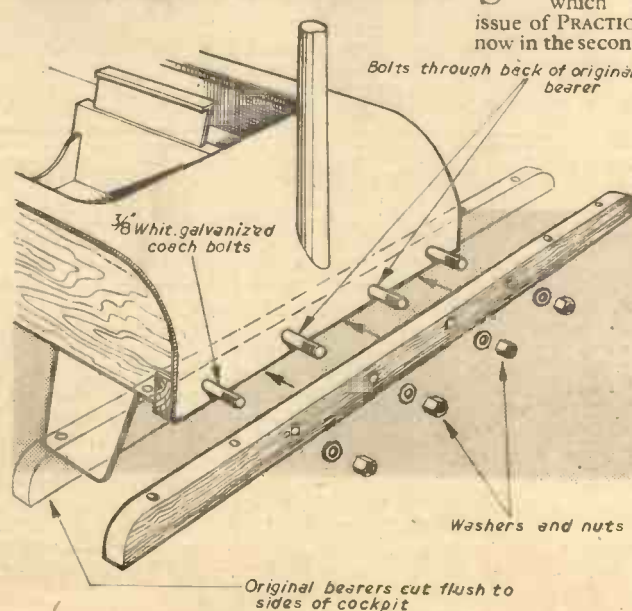

Details of the modified design.

Congratulations

SIR,—I have to-day re-read my February copy of PRACTICAL MECHANICS and would like to congratulate you—if I may—on your leading article headed "The Satellite Era." It can be no light task to keep in one's mind all the close practical details of mechanical engineering necessary for the many journals and books which you write or edit, and at the same time be able to move one's outlook to the more distant viewpoint.

If I may say so, your article shows that you are able to focus your viewpoint with remarkable success. This mental "focusing" from inches to many miles requires not only knowledge of the relevant facts, but a great deal of mental discipline.

Again, congratulations, for there is material for several chapters condensed into your article.—ANTONY AVENEL (Scarborough).

Green Fire-balls

SIR,—Radio-active decay is a natural process which cannot be accelerated in any way! So if strontium-90 is absorbed by any substance it would still take 30 years to decay to half its primary activity. I therefore disagree with Mr. H. E. Ford's view on green fire-balls as they would not be able to carry out the job for which they were designed. However, other points mentioned in Mr. Ford's letter in PRACTICAL MECHANICS, May, 1958, are definitely worth further thought, particularly if one believes in "Flying Saucers."—H. LECHNER (Worcs.).

Change of Address

SIR,—May I draw your attention to the fact that the Aethenius Society has changed its address to: The Aethenius Society, 15, Fulham High Street, Fulham, London, S.W.6.—H. E. FORD (Herts).

SIR,—While building the catamaran, which was described in a past issue of PRACTICAL MECHANICS, and which is now in the second PRACTICAL MECHANICS How-to-Make It Book, it occurred to me that it would be easier to carry the craft on top of a car if the 6ft. 8in. cockpit bearers could be modified so as not to protrude beyond the width of the car. Accordingly, the main 4in. X 2in. bearers were cut off flush with the cockpit sides and separate bearers made to bolt along their faces, as shown in the sketch.

This, of course, necessitated moving one main fixing frame in each of the two hulls. The hatches follow standard practice and are a fast fit and secured from loss by short lengths of chain.—R. W. B. (Kent).

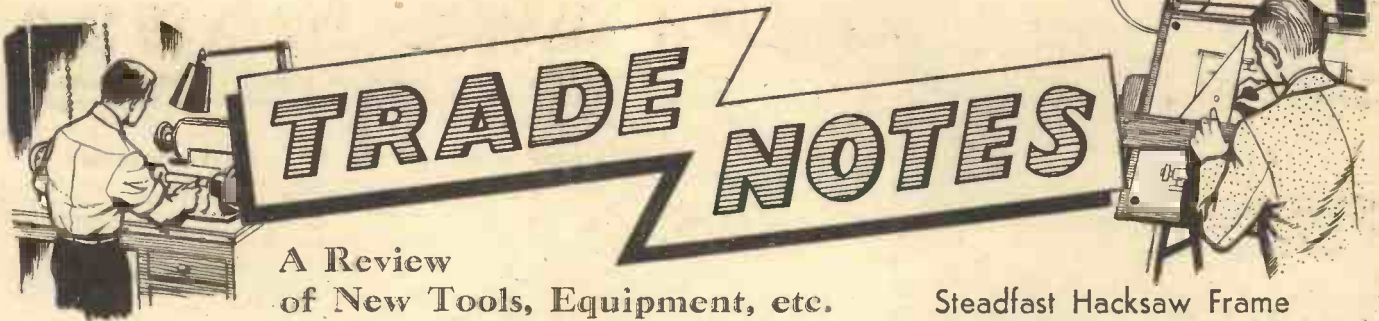

A Review
of New Tools, Equipment, etc.

WOLF GARDENING ATTACHMENTS

THE already extensive range of Wolf Home Power Equipment has now had a new item added to it—a verge trimming attachment. This is intended to be used with the cultivator and weeder attachment,

both pieces of equipment being shown in the photograph. The bronze alloy rotary cutting blade of the verge trimmer is self-sharpening and the spring loading allows a floating action to avoid damage from stones, etc. This attachment which the makers claim reduces the time taken for lawn edge trimming to only a fraction of that taken by hand, costs 58s. 6d.

The cultivator and weeder which can furrow, hoe, earth-up, work in fertilisers, etc., is run from either the Wolf Cub or Quartermaster power unit. The price is £5 19s. 6d. excluding power unit.

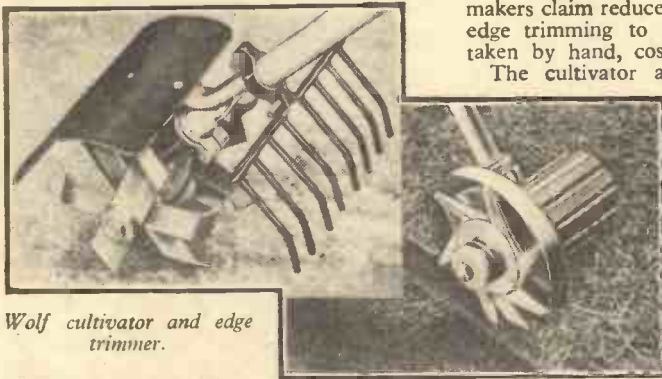

Wolf cultivator and edge trimmer.

Bench Crosscutting Machine

THE Dominion Machinery Co. Ltd., of Hipperholme, Halifax, are adding to their list of small machines a bench crosscutting machine. This takes up little space and can undertake all cutting work across the grain. The table is fixed so that an extension table can be built around it if required, but the top rail and the carriage on which the saw is mounted, rises and falls and is controlled by a hand wheel.



Bench crosscutting machine.

The machine will carry a wobble saw or grooving head and it is possible, therefore, to groove across the grain or to do stair strings or half tenons. The price is £70 complete.

THE HOME ELECTRICIAN

By F. J. CAMM

12/6 or 13/6 by post

from Geo. Newnes Ltd., Tower House,
Southampton Street, London, W.C.2



The Steadfast hacksaw frame.

Steadfast Hacksaw Frame

A NEW product is announced by J. Stead and Co., Ltd., of Manor Works, Cricket Inn Road, Sheffield. This is the Steadfast Hacksaw Frame in a plastic wallet, as shown. It incorporates an entirely new type of translucent amber plastic handle, which, it is claimed, gives a better grip and in conjunction with the adjustable oval tube frame forms a balanced tool of robust manufacture. The frame is sold complete with a 12in. X 24T Steadfast regular tungsten blade, the wallet also containing an additional 12in. X 18T blade, and a booklet describing the correct use of a hacksaw. The method of holding and tensioning the blades, as can be seen from the photograph, is unchanged from that of previous saws produced by this firm. Blade changing is effected merely by a few turns of a butterfly nut. The kit costs 19s. 6d., and is obtainable from ironmongers, tool merchants, garages, etc.

Flexible Drive "One Man Workshop"

THE power unit may be suspended or bench mounted. It does not have to be held in the hand, enabling the use of a more powerful electric motor. Two driving speeds are available, 1,500 r.p.m. and 9,600 r.p.m., and this fact, with the relatively high power of the electric motor, extends the range beyond that of home hobbies and minor repairs.

A single flexible drive, with a handpiece which can be adapted to be either of the collet or straight type, can be used with all the attachments provided. These include the "Kennedy" light hacksaw machine, which can cut 2in. square or 2½in. round steel bar; the well-proved "Burgess" light bandsaw, capable of sawing timber up to 3½in. thick and plastics, hardboard and light alloys in addition; a nibbling shear, a pneumatic drum sander, a drill chuck, sanding heads, burs and the whole host of small tools and accessories used for fettling, sanding, grinding, rasping and polishing of metals and softer materials.

It will appeal to the man working alone on small scale production, or in carrying out light repair work of all kinds. It will be valuable in many toolrooms, and very

suitable for educational and rehabilitation institutions.

Further information can be obtained from Flexible Drives (Gilmans) Limited, of 195, High Street, Smethwick, Staffs.



The flexible drive power unit.

READERS' SALES AND WANTS

The pre-paid charge for small advertisements is 6d. per word, with box number 1/6 extra (minimum order 6/-). Advertisements, together with remittance, should be sent to the Advertisement Director, PRACTICAL MECHANICS, Tower House, Southampton Street, London, W.C.2, for insertion in the next available issue.

TOOLS

COMPARE OUR PRICES! ELECTRIC DRILL ACCESSORIES AND HAND TOOLS

	Usual Price	Our Price
5" Sanding Pad & 12 Discs.		
Lambwood Bonim, 49/00	20	10/6
3" Grinding & Wire Wheels		
Calico Buff, Arbor	18/6	10/3
C/Saw Blades. Will fit		
Rip or C/C 5" Wolf, B. & D.	21/-	9/6
Teeth 1 1/2" Bridges	21/-	10/0
In Wallets & Round Shanks		
5 Wood Boring Bits 1 1/2"	15/-	9/6
6 Wood Centre Bits, 1-1"	19/6	10/9
5 Twist Drills 1 1/2"	18/6	12/9
1 1/2" 1/16" Drill		
7 Twist Drills 1 1/2"	16/-	11/9

HAND TOOLS

64" Block Plane. 14" Cutter	11/6	6/3
8" Adj. Spanner. Crescent Pat.	5/6	3/6
10" Adj. Wrench. Stillson Pat.	8/9	7/6

P. & P. L. - FREE BARGAIN LISTS FROM:
THE TOOL SERVICE CO. (DEPT. M),
39, ARLINGTON ROAD, SURREBITON,
SURREY.

POWER TOOLS.—We stock the lot. Cash or terms. H.D. Co. Ltd., 58, Commerce Rd., Wood Green, London, N.22.

SINGLE SPINDLE DRILL, motorised. £20. HarDall Limited, Wingate Road, Luton. (Tel.: 7380.)

"SOLO" SOLDERING TOOL 19/6
110 v. or 6 v. (Special adaptor for 200 240 v., 10/- extra). Automatic solder feed. Includes a 20ft. reel of ER50A Solder. It is a tool for electronic soldering or car wiring. Revolutionary in design and as perfect as an electric shaver. Instantly ready for use and cannot burn. In light metal case with full instructions for use. Post 2s.

DUKE & CO.
621/3, Romford Road, Manor Park, E.12
ILF. 6001/3

WRAGG 7in. Motorised Bench Shapers, adjustable stroke, automatic feed. £63; h.p. terms. Wragg Bros., Chapel Street, Leabrooks, Derbyshire.

WOODWORKING

WOODWORKING MACHINES, all cast-iron constructed. Complete Saw Benches, 7in., £45/15/-; 8in., £51/10/-; 10in., complete motorised, £30. Planers, 5in., £12; Bowl Turning Heads, £4; with 8in. Saw Tables, £7/10/-; Lathes, £7/10/-; Combination Lathes, £10/10/-; Motors, Pulleys, Belts, etc. 12 months' written and money refunded guarantee. 4d stamp for illustrated booklet. James Inns (Engineers), Marshall St. Nottingham.

SAWBENCHES, 8in. to 30in., from £9; Motorised, £13; Petrol Portable, £44. Planers, Bandsaws, Lathes, Saw Spindle and Planer Assemblies. Logging and Firewood Machines. Chain Saws Engines, Motors; deferred terms. Send 1/9 for handbook-catalogue and bargain offers. List free. Beverley Products, Sturton-le-Steeple 20, Notts

5IN. Tru-Plane, £18/15/-; 9in. Tru-Plane, £37; Mortise Attachments, £12/18/-; h.p. terms. Wragg Bros., Chapel Street Leabrooks, Derbyshire.

S.G.S. Woodworking Machinery.—Saw Bench Units: "Empire" (for saws to 12in.), £3/6/-; "Royal" (16in.), £5/3/-; "Empress" (20in.), £5/15/-; Motor, £13/6/-; £11/18/-; Min. Drill Chucks, 14/- extra. Planer Units, fitted with high-speed ball bearings: 4in., £4/15/-; 6in., £6/15/-; 8in., £8/10/-; Wood Turning Combination Lathes: 18in., 24in. or 30in., centres from £9/19/6. Obtainable from ironmongers, tool shops, etc., or write direct to: S.G.S. Engineers, Dept. 14, Old Cotessey, Norwich, Norfolk.

CHEMISTRY

PREPARE NOW FOR YOUR FUTURE
We specialise in supplying Laboratory Apparatus for the Student of Chemistry. Send today for free price list to:
VIKLAR (PM), 288, Station Road, Harrow, Middlesex.

SAW SALES AND SERVICE

SAW SERVICE BY POST.—Circular Saws set and sharpened, 5d. per in. diameter, tensioned, set and sharpened, 8d. per in.; recut, 1/3 per in.; minimum charge per saw, 3/-. (Prices include return postage.) 48-hour postal service; cash with order.

SAW SALES.—Special offer. Circular Saws made to your requirements, e.g., 5in., 12/6; 6in., 15/-; set bore and if rip or crosscut tooth; cash with order; postage paid. Dept. "C." J. A. Fowle, 18-22, Bell Street, London, N.W.1. (Established 1840.)

FOR SALE
AIR COMPRESSORS, single cylinder double action, 2 1/2 cu. ft. at up to 400lb. pressure, condition as new but slightly soiled, cost over £10, bargain at 35/- each. -N. Cooper, 10, Fowler Street, Nehells, Birmingham. 7.

You can repair that broken drill housing or lathe bed. You can join metal without costly welding equipment. There's a million and one jobs you can do with our "Fibreglass" Kits. Try one from the Firm who use "Fibreglass" every day...

AUTO PLASTICS (OLDHAM) LIMITED
Green St., Oldham, Lancs.
Car Body Repairers and General Fibreglass Moulders.

The Best "Fibreglass" Kits at the lowest prices. With full instructions price 10/- and 17/6, plus P. & P. 1/6.

"ASTRO TELESCOPE MAKING"
standard Ramsden push-in Eyepieces, 4in., 4in., 3in. focus, 35/-; S.A.E. List Achro. and non-Achro Object Glasses, Newtonian Mirrors, Eyepieces, etc. W. Burnet, Grand Suice, Boston, Lincs.

GOVERNMENT SURPLUS AND MANUFACTURERS CLEARANCE

BALL RACE.—3/8" x 1 1/8" bore, 1/2 x 3/16" bore, 3/4 x 1/4" bore, 1 1/8 ea. 7" x 3/8" bore, 21/- ea. 2 1/4" x 1" bore, 3/6 ea.

PNEUMATIC TYRED WHEELS & AXLES.—16" x 4". GIRLING brakes. £7.00 per pair.

MIN. MOTORS.—4 1/2 v. reversible totally enclosed, 5/ ea., 50/- doz.

BELT SAYS.—Magnifying 1 3/16" sq. mounted on adjustable framing filters, 5/ ea.

MORSE KEYS.—Small, 2/-; medium, 3/-; larger, 3/6. Buzzers, 3/- ea.

INERT CELLS.—New 1 1/2 v., 2/- ea. 18/- per doz.

BELLARS.—High speed, 1,000+1,000 ohm plate, cont. 7 1/8 ea. P.O. 3,000 type, 20,000 ohm coil, 4 pole c/o 20/- ea. 6,500 ohm coil, 3 make 2 break, 11/6 ea.

NIFE CELLS.—3 x 2 1/2 x 1" unused 5/- ea. 50/- per doz.

CLIP ASS.—P8 AM 4" jewelled bearings, ideal for boats, scouting, etc., unused, 25/- ea., used, 15/- ea.

NEWALL INDICATOR CLOCK GAUGES.—M-M new, 35/- ea.

BOLTS.—High tensile E.S.F. Cadmium plated, 1" to 4" long, 1/4", 5/16", 3/8" and 7/16" dia. assorted, 3/6 per lb., 2 lbs. 6/-.

RADIO VALVES.—6J6, 6CA, 6K7, 6J5, 6AD, 4/- ea. 12AT7, 12AU7, 12AX7, 7/- ea.

GEAR BOXES.—Radio 10-1, ball race mountings, 1 1/2" dia. spindle, 10/- ea.

CROMPTON PARKINSON.—24 v. 3/4 h.p. D.C. Motors, suitable factory trucks, invalid carriage, etc. £6.00 ea.

TECALEM.—Grease nipples, 4d. ea. 3/- doz. 20/- per 100.

METERS.—Moving coil, 2 1/2" diam, 50 microamp, £2.10. 100 microamp, £2.5.0. 100 milliamm, 12/6. 25 v., 2" diam., basic movement, 5 milliamm, 7/6 ea.

VIBRATORS.—Oak, 12 v. 4 pin, 5/- ea.

TORCH BULBS.—Ever Ready 2.5 v. and 3.5 v. 16/- per 100. 8/- per 50.

HEAD PHONES.—Moving iron, low impedance, 6/-; high, 9/-; balanced armature, low, 10/-; high, 15/-; moving coil, low only 10/- per pair.

TOGGLE SWITCHES.—Bakelite 6d.; metal 1/- ea.

TANNAY MICROPHONES.—With switch and lead, 7/6 ea.

I.T.A. AERIALS.—New and boxed, 3 element, 22/6; 5 element, £7.6. Co-ax cable, 6d. per yd. A.1. spaced, 3d. per yd.

DRILLS.—High speed. 9/16" No. 2 Morse tapered shank, 5/- ea.

MOTORS.—28 v. geared 2 1/2 x 1 5/8" dia. 12/6 ea. Less gears, 10/- ea.

HUGGETT'S LIMITED
2/4 PAWSONS ROAD, WEST CROYDON,
SURREY

FOR SALE (Continued)

U.S.A.A.F. Centrifugal Tachometers, range 500-3,500 r.p.m., graduated each 20 r.p.m., luminous markings, 3in. dial brand new, 19/6, post paid. 18in. Flexible Drives to suit, 5/6 Litco Flight Aids, Corner Hall, Hemel Hempstead, Herts. Box 1564.

3-SPINDLE DRILL, no motor. £12 10/-. H. Dall Limited, Wingate Road, Luton (Tel.: Luton 7380.)

"MAINS" from 12v Battery.—Brand new American Dynamo Unit in beautiful black crackle case; weighs about 38lb., but neat and compact; thousands of uses, no conversion required. In seconds makes marvellous, powerful 200-250 AC/DC electric motor, electric fan, dynamotor (gives 250 volts at about 100 watts from 12 volt car battery), runs mains radio, bulbs, etc. Makes ideal rotary transformer, battery charger, etc. Continuous duty, quiet running, doesn't overheat. Worth £25—only price 90/- with instructions, carriage paid; satisfaction guaranteed. Send remittance with order. Dept. C. Scientific Products, Manor Works, Cleveleys, Blackpool.

HOUSE SERVICE METERS, credit and prepayment; available from stock. Universal Electrical, 221, City Road, London, E.C.1.

SAWN TIMBER IS CHEAPER
Convert your saw bench spindle unit to a planing machine 1/2in. shaft, for only 39/6.

Our specially designed planing attachment is simply fitted in place of your saw blade, giving an excellent finish, 2in. width per pass. Terms Cash with Order. P. & P 2/- Mail order only. State shaft size

KELTON ENGINEERING PRODUCTS
48 CASTLE STREET, LIVERPOOL, 2

"PERSPEX" for all purposes clear or coloured dials, discs, engraving, Denny & Company Ltd., 115, Netherwood Road, W.14. (SHE 1426, 5152.)

CHEMICALS AND APPARATUS.—Free booklet of 100 Experiments with orders over 15/- Send 3d. stamp for catalogue and details of special offers. Scientific & Technical Supplies (Nottm.) Ltd., Dept. M. 9, Wellington Circus, Nottingham.

COMPRESSORS FOR SALE.—Twin Piston with tank 2 1/2 c.f.p.m., £4. Single Cyl., £2. All types Motors. S.A.E. for list. Wheelhouse, 13, Bell Road, Hounslow (HOU 3501.)

10Z., 2/3oz. and 1oz. hand-operated, 2 Bench-Type Thermoplastic Injection Moulding Machines for Hobbies and Industry. Dohm Ltd., 167, Victoria Street, London, S.W.1.

WATCHMAKERS

LEARN to be a Watch and Clock Repairer in your spare time and earn extra money at home. We can supply everything you need at unbeatable prices, including instructional books, Swiss watchmakers' tools, watches, watch and clock movements, lathes, cleaning machines, all spare parts for watches and clocks, etc. We also have a fine selection of musical box movements and kits. Send 9d. P.O. for bumper bargain catalogue. The Watchmakers Supply Company (Dept. P.M.), Carterton, Oxford.

WATCH PARTS

For all makes of watches, tools, instructional books, etc. Special Kits for beginners. Send 6d. for Super Bargain Catalogue. T. G. LADDER (Dept. B), Watchmakers Mail Order Service, Milestone Road, Carterton, Oxford.

WATCHES, any make, repaired with guarantee. Post confidently to: Young & Son, 133, London Road, Chippenham, Wilts.

WATCH REPAIR SERVICE, unrivalled for reliability and speed, coupled with reasonable charges. Part jobs welcomed. Material supplied. Hereford Watch Co., 13, Castle Street Hereford

PHOTOGRAPHY

PHOTO-ENLARGER Castings and Bellows for 35mm., 2 1/2in. x 2 1/2in., 2 1/2in. x 3 1/2in. 35/ per set: s.a.e. for details. V. J. Cottle, 84a, Chaplin Road, Easton, Bristol. 5.

BELLOWS. Camera, Enlarger, Process, Industrial Collapsible Machine Guards. Beers, 4, St. Cuthbert's Road, Derby (Tel.: 41263.)

SCOUT MK. 11 Ex. WD TELESCOPES, 25 x 50. Practically new, with case and sling, £7/15/- ea.; ditto, second-hand condition, £6/10/-. High-power Eyepieces per set: s.a.e. for details. V. J. Cottle, 84a, Chaplin Road, Easton, Bristol. 5.

Triple Power Conversion Kits for the above scopes, giving 35x and 40x terrestrial and 60 astro, 50/- extra. 6 Power Kits, giving 25x, 40x and 80x terr. and 60 and 120x astro, 25/- extra. If scope already purchased elsewhere send us the erector (centre lens system) from your scope when ordering triple or 6 power kits. Returned intact. Ex-Gov. Telescopes, terrestrial, all brass, in case 30x, 24in. x 2in., weight 7lbs., near new, £4/5/- ea. Telescope Sights, 13in. long, weight 20oz., 17/6. No. 42 Rifle Sight, 3x, 50/- near new. Tank Periscopes, boxed, unused, 7/6, post 2/-; Directors, with 4x optical sight, ideal for builders, etc., will lay out any angle with precision of theodolite, sound condition, 45/- ea., cost over £80; ditto, in near new condition, in leather case, £4/10/- ea.; ditto, minus case, £3/15/-; H. W. English, Rayleigh Rd., Hutton, Brentwood, Essex.

EXPOSURE METERS.—Build your own double-range incident light Exposure Meter with 50 x 37 mm. photocell, f/1.4 to 1/32. 1/1000th x 60 sec. film speed, 1/3 to 37" B.S. complete Countdown Kit, 50/-; s.a.e. details. G.R. Products, 22, Ranyemead Avenue, Bristol. 4

HOBBIES

ASTRONOMICAL TELESCOPES.—Grinding, Polishing Kit suitable up to 8in. mirror. Silicon Carbide; Grade 80, 1lb.; 180, 280, 320, 400, 600, 1lb.; Optical Rouge, 2oz.; Swedish Pitch, 1lb.; 25/- each, plus 2/6 postage. L. J. Mays & Co., 87, Mosley Street, Manchester. 2.

SEREN ASTRONOMICAL MIRRORS
12 Jeymer Drive (PM)
Greenford, Middx
EQUIPMENT FOR ASTRONOMERS
Mirrors, eyepieces, focusing mounts, spiders, etc. Do-it-yourself kits. S.A.E. for free details.

ILLUSTRATED CATALOGUE No. 13. Containing over 450 Items of Government Surplus and Model Radio Control Equipment, 2/- reduced on purchase of goods, 2/6 overseas. Send mail Arthur Salts Radio Control Ltd., Department P.M., 93, North Road Brighton.

HANDICRAFTS

MUSICAL BOX MOVEMENTS

14/9 post free.
More new kits available from 21/9 complete with movement. Please send 2d. stamp for new FREE illustrated brochure.
THE SWISSCROSS Co (Dept. V)
202, Tulse Hill, London, S.W.2

HOME BOAT BUILDING

BUILD YOUR OWN two-berth Cabin Cruiser. Kits supplied, also for Runabouts, Dinghies, Canoes, Water Skis. Illustrated brochure on request. Wyvern Boats (Wessex) Ltd., 10/F, North Street, Milborne Port, Sherborne, Dorset.

(Continued on next page)

(Continued from previous page)

ELECTRICAL

ALL TYPES OF ELECTRICAL GOODS at extremely competitive prices, e.g., 5 amp. Twin Cable, 48/- 100 yards; Lampholders, 7/- doz.; 5ft. Battens, 51/6; quality and immediate despatch guaranteed. Request list. Jaylow Supplies, 93, Fairholt Road, London, N.16. (Telephone: Stamford Hill 4384.)

CONVERT your ordinary Wash-boiler to electric. G.E.C. Circular Washboiler Elements, 200-250 volt, 2Kw., 9 1/2 in. diameter, one hole fixing, 22/6 each, plus 1/9 p. and p. London Warehouse, 165, Queens Road, Peckham, S.E.15.

EXTRACTION FANS, 6in., silent shaded pole, no interference. A.C. only, price 20/-, post 2/-; also New 1/20th h.p. Universal 230v. Geared Motors, 10-1 reduction, suitable for food mixers, price 22/6, post 2/-; 1/6th h.p. Motors, all types, £2/10/-. Wheelhouse, 13, Bell Road, Hounslow.

ENTER TRANSISTORS

You can build a simple Transistor Radio Receiver to work a loudspeaker. The only power required is a 4½ volt flash-lamp battery. Parts for Amplifiers for Crystal Set or One valve Set, 27/- and 54/-. Completely built Amplifier, 57/6, post free. Details and notes on transistors, 8d. in stamps to:

MORCO EXPERIMENTAL SUPPLIES

8-10, Granville Street, Sheffield, 2.

"STANFORD" ELECTRIC WELDER, 200/250 a.c., complete with heavy welding transformer, welding torch, earthing cable, goggles, carbons, case, instructions. Absolutely as new and perfect, £4; carriage paid. Will send c.o.d. McGrath, 584, North Drive, Cleveleys, near Blackpool.

FLUORESCENT LIGHTING FITTINGS for workshop and home. Complete range from 5ft. to 18ins. (also circular) at lowest prices anywhere. S.A.E. for illustrated leaflets and list of Control Gear Kits. Callers welcome. We are Fluorescent Lighting Specialists: E. Brill, Dept. C., 125A, Northcote Rd., London, S.W.11. (Battersea 8960.)

PLANNER, motorised, will machine over 24in. x 15in., £25. HarDall Limited, Wingate Road, Luton. (Tel.: Luton 7380.)

1/3 H.P. B.T.H. Motors and Switches for sale, 1,426 r.p.m. for 400-440 volts, 3 phase, 50 cycles. F. J. Edwards Limited, 359, Euston Road, London, N.W.1.

MODEL ELECTRIC MOTORS, amazingly powerful. "Mini Mo.", 9/6. "Maxi Mo.", 13/6, post free. 4 1/2 to 9v., 1 1/2 in. x 1 1/2 in. weight 14oz. Dept. (M). "Highland," Alkington Green, Middleton, Manchester. 3d. stamp full details.

BRAND NEW BROOK ELECTRIC MOTORS
Single Phase, 1 h.p. 1,500 r.p.m. £7.10.6
1 h.p. 1,500 r.p.m. £9.12.6
1 h.p. 3,000 r.p.m. £9.12.6
1 h.p. 1,500 r.p.m. £11. 0.0
1 h.p. 3,000 r.p.m. £11. 0.0

Fully guaranteed by makers, approval against cash. Carriage paid mainland. State voltage.

P. BLOOD & CO. ARCH STREET, RUGELEY, STAFFS.

FIBREGLASS

PLASTIC UNITS

Experimental Glass Fibre Unit, 14/9. Plastic Metal for Gear Casting, Plastic Dies, etc., 14/3. Porcelain-hard Cold Setting Finish for food preparation surfaces, baths, washing machines, etc., 16/9 pt. in white, cream, black, sky blue, red, clear and aluminium. S.A.E. for information list, price list, etc. **SILVER DEE PLASTICS** (Dept. 3), Hartington, Staveley, Chesterfield, Derbyshire.

MAGIC

HOUDINI'S 100 TRICKS, 8/- "Escapology" Secrets Revealed, 6/6. Professional "Telepathy" Presentation, 15/-. (Lists 6d.) Deville, 12, Carlton Avenue, Romley, Cheshire.

MISCELLANEOUS

AQUALUNG and Compressor Equipment. Ballraces and Miscellaneous Items. Lists 2d. Pryce, 157, Malden Road, Cheam.

"FORTUNES in FORMULAS", 900-page American book of formulae. American technical hobby and other books covering every interest. Stamp for lists. Herga Ltd. (Dept. F2), Hastings.

PERSONS WANTED TO MAKE UP HANDY BAGS AT HOME IN SPARE TIME.
SEND S.A.E. FOR DETAILS TO:—DEPT. N/M, BENTON SUPPLY, 9a, LIVERPOOL GARDENS, WORTHING

SUPER TONIC SUNLAMPS, listed £7/10/-, 80/-; s.a.e. brochure. Scientific Products, Dept. 1, Cleveleys, Lancs.

BUILD YOUR OWN Refrigerator. Everything to make Built-in or Cabinet Refrigerator. S.A.E. for Sealed Unit List and Schematic Diagram, or 1/- (refundable) for 32-page catalogue, including details of free 4 cu. ft. Cabinet Diagram offer. Hire purchase available. Wheelhouse, 13, Bell Road, Hounslow. (Phone: HOU 3501.)

BUILD YOUR OWN Refrigerator. New sealed units and access, etc. S.A.E. list. Deepfreeze, 24a, Cookon St., Blackpool.

PATENTS

Qualified service. Advice C. L. Browne, 114, Greenhayes Ave., Banstead, Surrey.

! A GOOD IDEA! CAN MAKE MONEY FOR YOU
LET US ASSIST YOU PROFESSIONALLY TO SELL YOUR INVENTION.
WRITE FOR FULL DETAILS. **PATENT, DEVELOPMENT & MARKETING CONSULTANTS**
16 Gore Court Rd., Sittingbourne, Kent.

EDUCATIONAL

LEARN IT AS YOU DO IT—we provide practical equipment combined with instruction in Radio, Television, Electricity, Mechanics, Chemistry, Photography, etc. Write for full details to E.M.I. Institutes, Dept. PM47, London, W.4.

$$X = \frac{-b \pm \sqrt{b^2 - 4ac}}{2a}$$

DON'T FUMBLE with Formula. Master Mathematics in 6 weeks the Understandable Way. 1st lesson and details free from **UNDERSTANDABLE MATHEMATICS** 11, Dryden Chambers, Oxford Street, London

FREE! Brochure giving details of Home Study Training in Radio, Television, and all branches of Electronics. Courses for - the hobby enthusiast or for those aiming at the A.M.Brit.I.R.E., City and Guilds, R.T.E.B., and other professional examinations. Train with the college operated by Britain's largest Electronics organisation. Moderate fees. Write to E.M.I. Institutes, Dept. PM28, London, W.4.

SITUATIONS VACANT

A.M.MECH.E., A.M.Brit.I.R.E., A. City and Guilds, etc., on "No Pass—No Fee" terms. Over 95% successes. For details of Exams and courses in all branches of Engineering, Building, etc., write for 144-page Handbook—Free. B.I.E.T. (Dept. 967B), 29, Wright's Lane, London, W.8.

ACCURATE HADHITTING



Webley AIR PISTOLS
AIR RIFLES • ACCESSORIES
Write for catalogue WEBLEY & SCOTT Ltd.
106 WEAMAN ST., BIRMINGHAM 4, ENGLAND

'POP' RIVETING
EASIER than Welding.
CHEAPER than Nuts & Bolts.
FASTER than any other method of joining.



Nose of 'POP' Riveter inserting 'POP' Rivet into a door panel.

Headed 'POP' Rivet gripping the sheets tightly.

'POP' RIVET ASSORTMENTS.
Box of 200 rivets, ... 11/-
Box of 1,000 rivets ... 33/4.

PLIER RIVETER—The handy tool for odd jobs and difficult corners, etc.: uses 5/32" & 1/8" dia. 'POP' rivets. £2.15.6

LAZY TONGS—The standard 'POP' riveting tool for motor body work, for 3/16", 5/32" & 1/8" dia. 'POP' rivets £4.11.0

MOTORISTS SELECTION

RIVETING SYSTEMS LTD. JORDAN ST., KNOTT MILL MANCHESTER 15

THE FAMOUS "DELSTAR" ARC WELDER



For rapid and efficient welding of metals up to ANY THICKNESS. High quality and robust construction. One man portable, operates from nearest mains power point. Indispensable for Workshop, Factory, Garage, etc. 3 current settings, snap action switch. 12 months Guarantee

MINOR 60 AMPS £34.13.0
MAJOR 100 AMPS £42.10.6

Immediate delivery. Carriage 7/-
Prices inclusive of all necessary fittings, face mask and supply of assorted gauge electrodes

HARRIS ENGINEERING CO.,
(Dept. P.M.24), 269 Kingsland Road
London, E.2. Phone: Shoreditch 5583

BOWMONK FIREPROOF GARAGES



From £31.10.0 with FREE delivery

STEEL FRAMED—EXTENSIBLE
LOWEST MONTHLY TERMS of any manufacturer including FREE "Peace-of-Mind" INSTALLMENTS INSURANCE.
Write NOW for — Free Colour Catalogue

BOWSER, MONKS & WHITEHOUSE LTD.
(Dept. ME12), Spring Gardens, DONCASTER

FREE CORRESPONDENCE COURSES IN STEAM

TWO COURSES: (1) A simplified Course for the practical man in need of basic information about steam and steam applications; (2) An Advanced Course for those with a background of technical training. There is no charge or obligation. Details on request to:

SPIRAX-SARCO LTD.
(TECHNICAL DEPT.) Cheltenham, Glos.

THE WORLD'S GREATEST BOOKSHOP

FOYLES
FOR BOOKS

LARGE DEPT FOR Technical Books
STOCK OF OVER THREE MILLION VOLUMES
QUICK POSTAL SERVICE
119-125 CHARING CROSS ROAD LONDON WC2
Gerrard 5660 (20 lines) • Open 9-6 (inc. Sat.)
2 mins. from Tottenham Court Rd. Str.

SERIES III NUCLEAVE PRESS

CROPS RIVETS PUNCHES

Ask your Tool Dealer or send for details to:—
Sole Manufacturers.
FITZNER LTD.
197-199, KINGS ROAD, KINGSTON-ON-THAMES



Your Queries Answered



A Tellurion

COULD you give me any practical advice on the making of a Tellurion? The model I should like to make is for practical demonstrations before geography students.—R. Evans (N. Wales).

A TELLURION is an instrument for illustrating the day and night effects on the earth. It may also demonstrate the seasons. Obviously the most simple way in which this can be done is either to obtain a globe, complete with continents and oceans, or to make one with a ball turned in hardwood. In either case it must be mounted on pivots in a half circular brass frame, the pivots making an angle of 23 deg. 27 min. with the vertical, so that it shall be capable of revolving at that angle. The best plan will be to buy a finished globe already mounted and on a stand. 10in. or 12in. diameter should suit your purpose.

In addition you will require a short standard lamp holder of about the same height as the globe. The lamp will require to be powerful so that it can be placed some distance away and perhaps screened to avoid glare in the eyes of the students. The lamp will represent the sun.

Waterproofing Concrete Garage Roof

I HAVE a pre-cast concrete garage which has developed several hair cracks. The roof consists of reinforced concrete panels with a black bituminous compound sealing the joints.

When it rains the water seeps through the hair cracks in the roof and makes the garage damp on the inside. How can I waterproof it?—F. C. Abbott (Sutton).

THERE are various bituminous compounds on the market which have been specially prepared for waterproofing concrete roofs. One such compound is

marketed by Messrs. Tretol of Tretol House, The Hyde, London, N.W.9. The fibrous compound is applied in two coats, coverage 8-10 sq. yards per gallon. We suggest you approach this firm, asking for their leaflet No. 32 on which full instructions are given.

Heating a Village Hall

I HAVE a problem concerning Space Heating for a local village hall. Being an electrician I have estimated that 57.25 kW. would be needed to heat the place electrically. The size of the hall is 60ft. X 35ft. X 12ft. rising to 18ft. which would be 31,500 cu. ft. I have allowed 1,500 watts per 1,000 cu. ft. of air space.

Could you please tell me.

1. Are the figures I have quoted correct?
2. How would this compare in cost of installation and running with any other form of heat?—M. Ackin (Lincoln).

IN order to make an exact estimate of the heating requirements of the hall it is necessary to take into account various factors, such as the changes of air required

we suggest that you obtain a copy of the "Mechanical World Electrical Year Book," price 3s. 6d. from Emmott & Co. Ltd., 31, King Street West, Manchester, 3. This book contains a few useful notes on electric space heating, including an example in which the various factors are taken into account.

If the heat losses from the hall with the doors closed, and at the required temperature, are 45kW., the average heat loss during the warming up period might be taken as 22.5 kW. In this case if 57.25 kW. of heating is used, the heat available for warming up would be 35.25 kW. If the heat absorbed by the air, walls, etc., at the required temperature could then be found, in kWh. the time required for warming up (in hours) could be estimated by dividing this figure by 35.25 in the case in question. However this calculation involves the weight and specific heat of the walls, etc., the construction of which is unknown. For buildings which are warmed daily it is advisable to allow 50 per cent. extra heater rating (over that necessary to make good the heat loss at the required temperature) if the hall is to be heated in one hour, or 20 per cent. extra if the hall is to be heated in three hours. For a building which is heated weekly 60 per cent. extra heater rating is advised if two hours can be allowed for pre-heating, or 50 per cent. extra if three hours can be allowed.

We are inclined to think that gas heaters would be less expensive than electric, but this depends on the local charges for electricity and gas for such heating.

3-phase Motors on Single-phase Mains

I HAVE been given several 1/2 h.p. and 1 h.p. 3-phase motors. Can I work these on single-phase mains? What are the ways of doing this without having to rewind the coils, etc?—J. W. Richards (St. Austell).

A THREE-PHASE motor can be run from single-phase mains if given a spin by hand before switching two of its three terminals on to the supply. However, even if the single-phase voltage is the same as the three-phase voltage for which the motors were designed, the possible horsepower output on single-phase will be no more than about half the rated value. If, as is usually the case, the single-phase voltage is much less than the three-phase voltage for which the motor was designed, the possible horsepower output on single-phase may be no more than about one quarter of the designed horsepower. In some cases a three-phase motor can be made self-starting on single-phase mains by connecting the third terminal of the motor to one pole of the supply through a suitable capacitor during starting only, but the starting torque is not likely to be very high, and the power developed during running is in no way increased. Up to 1/2 of the rated horsepower could probably be obtained if the stators were rewound for single-phase

QUERY SERVICE RULES

A stamped, addressed envelope, a sixpenny, crossed postal order, and the query coupon from the current issue which appears on the inside of back cover, must be enclosed with every letter containing a query. Every query and drawing which is sent must bear the name and address of the reader. Send your queries to the Editor PRACTICAL MECHANICS, Geo. Newnes Ltd., Tower House, Southampton Street Strand London, W.C.2.

per hour, and the construction of the buildings, size of windows, etc., which govern the heat loss. About 1,500 watts per 1,000 cubic feet is a good average figure for continuous heating, but if you wish to go into the matter in more detail

THE P.M. BLUE-PRINT SERVICE

- 12FT. ALL-WOOD CANOE. New Series No. 1. 4s.*
- 10-WATT MOTOR. New Series No. 2. 4s.*
- COMPRESSED-AIR MODEL-AERO ENGINE. New Series No. 3. 5s. 6d.*
- AIR RESERVOIR FOR COMPRESSED-AIR AERO ENGINE. New Series No. 3a. 1s. 6d.
- "SPORTS" PEDAL CAR. New Series No. 4. 5s. 6d.*
- F. J. CAMM'S FLASH STEAM PLANT. New Series. No. 5. 5s. 6d.*
- SYNCHRONOUS ELECTRIC CLOCK. New Series. No. 6. 5s. 6d.*
- ELECTRIC DOOR-CHIME. No. 7. 4s.*
- ASTRONOMICAL TELESCOPE. New Series Refractor. Object glass 3in. diam Magnification x 80. No. 8 (2 sheets), 7s. 6d.*
- CANVAS CANOE. New Series. No. 9. 4s.*
- DIASCOPE. New Series. No. 10. 4s.*
- EPISCOPE. New Series. No. 11. 4s.*
- PANTOGRAPH. New Series. No. 12. 2s.*

- COMPRESSED-AIR PAINT SPRAYING PLANT. New Series No. 13. 8s.*
- MASTER BATTERY CLOCK.* Blue-prints (2 sheets), 4s. Art board dial for above clock, 1s. 6d.
- OUTBOARD SPEEDBOAT 11s. per set of three sheets.
- LIGHTWEIGHT MODEL MONOPLANE Full-size blue-print, 4s.
- P.M. TRAILER CARAVAN Complete set, 11s.
- P.M. BATTERY SLAVE CLOCK, 2s. 6d. "PRACTICAL TELEVISION" RECEIVER (3 sheets), 11s.
- P.M. CABIN HIGHWING MONOPLANE. 1s. 6d.*
- P.M. TAPE RECORDER.* (2 sheets), 5s. 6d.

The above blue-prints are obtainable, post free, from Messrs. George Newnes, Ltd., Tower House, Southampton Street, Strand, W.C.2. An * denotes constructional details are available free with the blue-prints.

Making Polish

CAN you give me a formula for the preparation of a spray- or brush-on polish which could be applied to linoleum or tiled floors? I find the application of normal polish before using an electric polisher is almost as hard as polishing by hand.—C. H. Moore (Stroud).

GENERALLY speaking, it does not usually pay to attempt to make up one's own polish. We would urge you to take up the matter with the manufacturers of the electric polisher or with the makers of the linoleum. However, the following formula may prove of interest to you:

Linoleum Polish	
Carnauba wax	1lb.
Paraffin wax	1oz.
Yellow wax	7oz.
Turpentine	1 gal.
Tiles and Marble Polish	
Sodium silicate	1 part
Linseed oil	1 part
Precipitated chalk	1 part
Magnesium chloride	0.2 part
Water	10 parts
Gelatin	0.1 part

Tarnishing Silver

I WISH to tarnish silver and E.P.N.S. articles in the quickest possible manner. Can I do this in a closed container with acid fumes or can you suggest a more efficient way? The method must be quick and the equipment (if any) portable.—J. R. Yeates (Liverpool).

SULPHURETTED hydrogen is probably the quickest method of tarnishing silver. It has, as you know, an unpleasant smell of rotten eggs. But a small quantity evolved from the addition of dilute hydrochloric acid to ferrous sulphide should prove effective.

More conveniently you could carry a bottle of ammoniacal solution of hydrogen sulphide and dab the metal objects with a pad of cotton wool soaked in this solution.

Another alternative is to purchase a small tin of "Veet," which is a dipilatory. This should also tarnish silver and would be less messy than the first two methods.

Refractor Telescope

I AM anxious to build myself a telescope, and as I have an ex-govt. camera lens I wondered if it would be suitable for conversion. It is a 36in. f6.3 telephoto (dia. 6in.). If it is suitable, what eyepieces would it need?—B. J. Douglas (Northampton).

THE 36in. focus, f6.3 telephoto lens would be suitable for the telescope. The eyepieces used will depend on whether the image projected is required to be erect or inverted. If erect, for terrestrial observation, you will require four lenses and if inverted two. A terrestrial eyepiece is illustrated below. The two lenses F and EY, at the

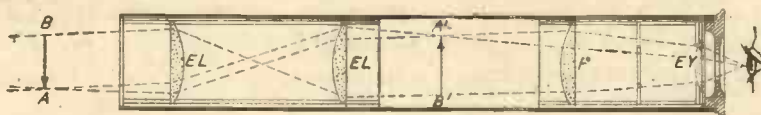

The terrestrial eyepiece.

eye end, will be all that are needed to make an astronomical eyepiece. The other two lenses can be separate and mounted in another tube which can be of such diameter as will slide into the main or first tube. You will thus have two eyepieces which are quickly convertible. Let the lens F and the two converting or erecting lenses be all three exactly alike, say 3/4in. diameter x 1in. focus. The eye lens EY can be 1/2in. or 3/4in. dia.

x 1/2in. or 3/4in. focus. They are to be all of Plano-convex form.

H. W. English, Rayleigh Road, Hutton, Brentwood, Essex, can supply ex-service eyepieces.

Radio-controlled Models

I HAVE followed your series on radio control and have built the necessary apparatus. I have, however, encountered difficulty with the multivibrator (January 1956). I am using a 12AU7 valve but whichever way I wire the circuit (i.e., changing the two halves of the valve over) it stubbornly refuses to function efficiently. A steady pulse is obtained which is not varied by the 50k pot. However, when the key switch is pushed to "Mark" the relay buzzes, indicating that there is not enough current to "hold" it. This relay has a resistance of 2KΩ and making the anode resistance up to 3K and 3.4K has no effect. I have also tried changing the capacitors from anode to grid over and this worsens the situation. Can you help?—M. Newbery (S.W.15).

PROBABLY your difficulty is due to parasitic oscillation in the 12AU7 valve. This effect was not encountered until after the article was written, but the performance of existing units has been improved by the simple expedient of including grid stopping resistors in the grid of each triode of the valve. A value of about 10,000Ω is suitable but not at all critical. The resistors should be soldered by the shortest possible wires directly to the grids of the valves (i.e. pins 2 and 7) and the other ends will then go to the respective junctions of the 56KΩ resistors and 1μF condensers.

The fact that the relay is buzzing when the key switch is pushed to "Mark" indicates that the multivibrator is still operating and has not been immobilised as required by cutting off one half of the valve. It is possible that the grid stoppers will clear the trouble but if not check the values of the 100KΩ and 270KΩ resistors which form the potential dividers to the cathode circuits. A voltage check at these points (with a high-resistance meter) should indicate a voltage of about a quarter of the H.T. line voltage when the key switch is pushed to "Mark" and "Space" alternately. The points should be at earth potential when a "Mark"/"Space" signal is being transmitted.

Dry Rot

WE live in a fairly old house. Below the wooden floor (about 18in. down) is the bare earth, which the builder left covered with a layer of shavings.

Quite recently this layer of shavings has become covered by a thick, yellow, furry fungus, which looks like a yellow carpet with a few orange or reddish brown blotches. It also has an unpleasant smell. The floor boards have been attacked from below and

are beginning to break in. I would like to know:

(a) If there is anything which could be sprayed on the fungus to kill it.

(b) If we scrape it up would there be danger from breathing in the tiny spores?—R. Williams (Oxford).

TO answer the second part there will be no danger to humans or animals in breathing the evil-smelling fungus.

From your description it would appear to be a severe attack of dry rot and to eradicate this the first thing to do is to carefully remove all timber which has been attacked and is unsound and in the open air burn it to a cinder. Scrape up all the shavings and remove them in a bucket and likewise burn. Take care when carrying the affected material that you do not drop one particle or get any stuck to your clothes. The spores can lie dormant for years and then without cause or reason commence to grow. Saturate the earth and all timber left in position and also any brickwork with "Rentokil." All the new timber to be put in position must also be treated. At regular intervals of, say, six weeks check that the attack has not broken out in another place.

Telescope Balance

I RECENTLY purchased a 4 1/2in. dia. telescope but find that it is out of balance on its stand, as the two thumbscrews which hold the barrel to the palm are set well forward, causing it to fall with the eyepiece downwards. Can I bore and tap new holes in the barrel for the setscrews? Have you any other suggestions?—J. Heron (Co. Down).

YES, to get your telescope perfectly balanced drill and tap fresh holes for the thumbscrews, although it must be borne in mind that this may not allow for any changes in the weights of various eyepieces

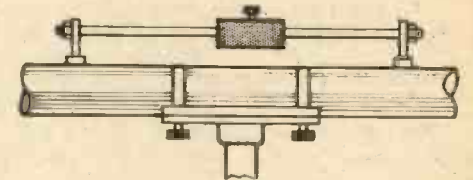

Movable balance weight.

or micrometers or other apparatus you may add at the eye end of the instrument. A better way would be to fit a movable balance weight to slide and clamp on a fixed bar. This is the usual way in which balance is achieved.

Another way would be to slot the holes either in the telescope barrel or in the palm. This is not so good because the screws go into solid plates or if they do not the slotted tube would be weak.

Preventing Resin Penetration

I AM constructing a linen cupboard, the framework of which is white pine and the slats for the shelves are the same material.

As the timber is inclined to be resinous in places, would you kindly advise me how I could treat it so that nothing will stain the linen?—M. A. Lawson (Scotland).

THERE are two methods by which you can make your cupboard resin proof. The first and most simple will be to cover the shelves with a good quality white paper, which may be stuck down with glue or preferably a good, strong paste, either all over or only at the edges, the latter preferably. The other will be to give each shelf a coat of shellac varnish (flake shellac dissolved in methylated spirit). Then on top of this put on a couple of coats of good quality flat white paint. The two methods could be combined: paste paper down first, pasting all over, then shellac this and finally paint it. No resin will come through this. Of course the sides and top of each compartment could be so treated if you think it necessary

EMI "HIS MASTER'S VOICE"

MARCONIPHONE · COLUMBIA

Announce NEW PRACTICAL WAY OF LEARNING AT HOME

NEW — completely up-to-date methods of giving instruction in a wide range of technical subjects specially designed and arranged for self-study at home under the skilled guidance of our teaching staff.

NEW — experimental outfits and lesson manuals are despatched on enrolment and remain the student's property. A tutor is allotted to each student for personal and individual tuition throughout the course.

Radio and television courses, with which specially prepared components are supplied, teach the basic electronic circuits (amplifiers, oscillators, detectors, etc.) and lead, by easy stages, to the complete design and servicing of modern Radio and T/V equipments.

If you are studying for an examination, wanting a new hobby or interest, commencing a career in industry or running your own full-time or part-time business, these practical courses are ideal and may be yours for moderate cost. Send off the coupon to-day for a free Brochure giving full details. There is no obligation whatsoever.

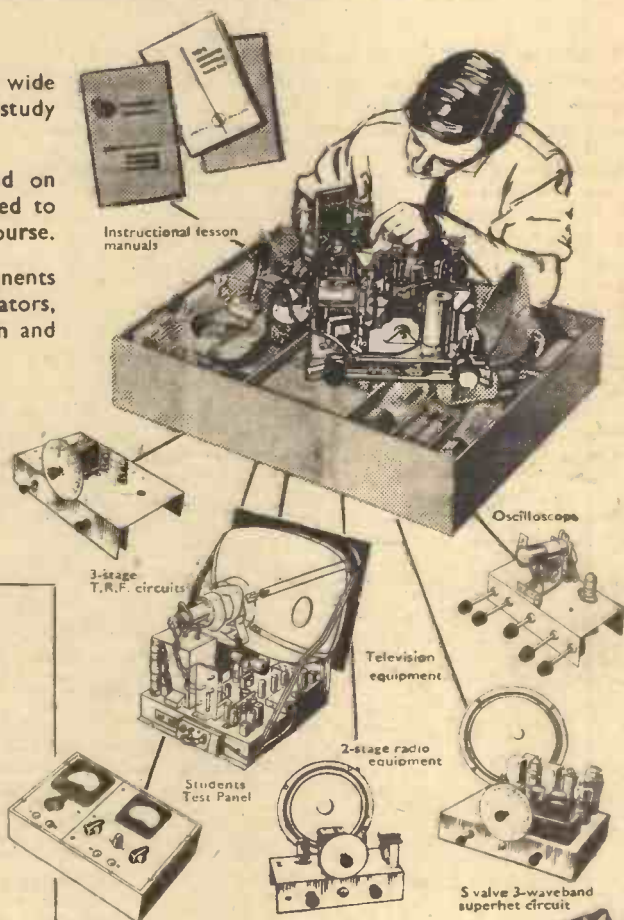

Courses with Equipment
RADIO · SHORT WAVE RADIO
TELEVISION · MECHANICS
CHEMISTRY · PHOTOGRAPHY
ELECTRICITY · CARPENTRY
ELECTRICAL WIRING
DRAUGHTSMANSHIP · ART, etc.

E.M.I. Factories
at Hayes,
England.

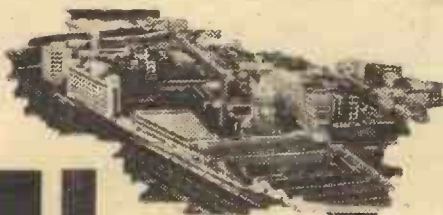

EMI INSTITUTES

Fill in for **FREE BROCHURE**

E.M.I. INSTITUTES, Dept. 144 x, London, W.4.

NAME _____ Age (if under 21)

ADDRESS _____

I am interested in the following subject(s) with/without equipments

(Jul/58) (We shall not worry you with personal visits)

FREE

BLOCK
CAPS
PLEASE

IC.107

The only Home Study College run by a World-wide industrial organisation

The 'MINORETTE' Motorised 230/250V. UNIVERSAL WOODWORKER

The 'Minorette' has an 18" lathe bed; 7" Tilting Circular Saw table complete with 7" Circular Saw blade; a combination table for use with slot mortiser; Sanding Disc, or as a panel support for repetition cutting; Slot Mortising chuck complete with a 1" bit, 6 1/2" sanding plate, 6" Grindstone and Arbor Belt and Pulleys. The 1/2 h.p. electric motor is double ended and is TV and Radio suppressed. Attachments can also be supplied for planing, grinding, grooving, comb jointing, flexible drives, etc. Illustrated leaflet free on request to Dept. PM5

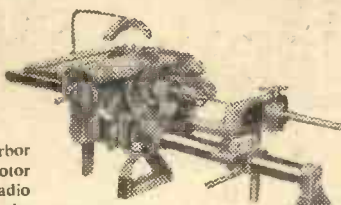

Supplied on 1st payment of **£4** Balance of 8 monthly payments of **£4.18.8.** Cash price **£39.17.6.**

PARRY AND SON (Tools) LTD.
329-333 OLD STREET, LONDON, E.C.1. Telephone *Sl10reditch* 9422/3/4

PARKERS SHEET METAL FOLDING MACHINE HEAVY VICE MODELS

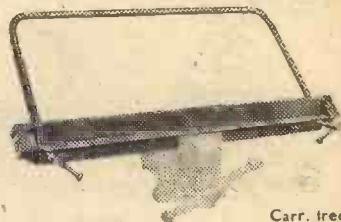

	Carr. free
No. 1. Capacity 18 gauge mild steel x 36in. wide	£7. 10. 0
No. 2. Capacity 18 gauge mild steel x 24in. wide	£5. 5. 0
No. 3. Capacity 16 gauge mild steel x 18in. wide	£5. 5. 0

End folding attachments for Radio Chassis, Tray and Box Making ... for 36in. model, 3/4 per foot. Other models, 2/-.
The two smaller models will form flanges. As supplied to Government Departments, Universities, Hospitals.

★ One year's guarantee. Money refunded if not satisfied. Send for details.

A. B. PARKER, Wheatcroft Works
Wellington St., BATLEY, Yorks. Tel.: 426

METALS AND ACCESSORIES

ALUMINIUM, BRASS, COPPER, STEEL, ETC.

Angle, Sheet, Tube, Foil, Strip, Channel, Rod, Bar, Wire, Moulding, Etc. Tin Plates, Silver Steel, Expanded Metal, Blanks, Rivets, Springs, Etc. Tools, Drills, Taps, Dies, Screws, Etc.

Formica, Perspex, Pegboard, Paxolin, Ebonite, Curtain Rail and Rod, Adhesives, Etc., and many other items for use in Home, Workshop, Etc.

LARGE or SMALL Quantities COMPARE our PRICES
MAIL ORDER SERVICE (2d. stamp for list) IMMEDIATE DESPATCH

CLAY BROS. & CO. (P.M. 11)

6a SPRINGBRIDGE ROAD, EALING, W.5

Phone: EALing 2215

2 MINS. EALING BROADWAY STATION, OPPOSITE BENTALLS

FOR THE ENTERPRISING "PRACTICAL MECHANIC"

We offer the following sets of machined castings: Power Hacksaw, Drilling Machines, Hand Shaper, Compound Milling Table and Machine Vice.

These sets are obtainable with all the heavy machining carried out by us and each set can be finished with the aid of a 3 1/2 in. lathe.

Hire purchase terms can be arranged.

Full details of all the above 1/- post free.

E. W. COWELL LTD
SYDNEY ROAD · WATFORD · HERTS

The Importance of Knowing How to Learn LANGUAGES

THE only satisfactory method of learning a foreign language is the direct method. In other words, you must learn French in French, German in German, Spanish in Spanish, and Italian in Italian. That is the Pelman system, and it is the only way. It naturally follows from this that the old-fashioned burden of memorising long lists of foreign words is entirely abolished when you learn a language by the direct way.

Another consequence is that it practically eliminates the difficulties and drudgeries of learning complicated grammatical rules and exceptions. It teaches you not only to read a foreign language, but to write, speak and understand it thoroughly and efficiently.

There are no classes to attend. You pick up the foreign language by correspondence in your spare time, in half the usual period.

Write for Free Book To-day

The Pelman method of learning languages is explained in four little books, one for each language:

**FRENCH SPANISH
GERMAN ITALIAN**

(Also Courses in Afrikaans and Urdu)

State which book you want and it will be sent to you with a specimen lesson, gratis and post free.

PELMAN LANGUAGES INSTITUTE,
130, Norfolk Mansions,
Wigmore Street, London, W.1.
WELbeck 1411

PELMAN (OVERSEAS) INSTITUTES:
Delhi, Melbourne, Durban, Paris, Amsterdam

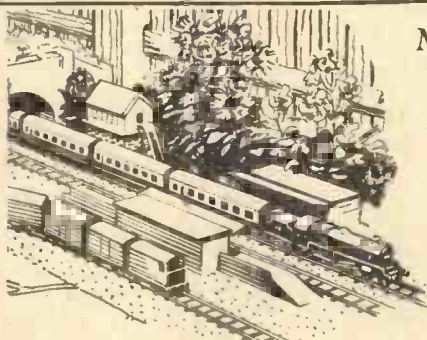

Make tracks for your Garden ...

And make them now with dry, sunny days ahead and the long light evenings of summer. What are your materials? Track parts, a few lengths of wood, a pound or so of mixed sand and cement and whatever else your ingenuity may suggest. So easy is it to begin this boundless, fascinating hobby. And what an attraction it will be, and how your friends will admire it! There's twice the interest in a garden that is served by a real live working railway.

For further details write to:—

BASSETT-LOWKE LTD.

21, Kingswell Street, Northampton

London: 112 High Holborn, W.C.1.

Manchester: 28, Corporation Street.

NOW a genuine Tungsten Carbide Tipped Masonry Drill for the householder



The only safe way to make a fixing in Masonry is to first drill a clean round hole. BLUE FLASH will do this with ease, its Diamond Hard tip will cut cleanly into brick, cement, stone or breeze, giving a perfect sized hole in which to fit a Plastic Maso Plug or ordinary wall plug.

ASK FOR

**BLUE
FLASH**

by MASON MASTER

COPPER BRAZED FOR USE IN ALL PORTABLE ELECTRIC OR HAND DRILLS Send for Leaflet P.M.

From your local Ironmongers and Tool Merchants.

No. 65/6 No. 85/6 No. 106/6 No. 126/6 No. 147/6

J. M. PERKINS & SMITH LTD., Braunston, Rugby.

THE PEOPLES ARC-WELDER

£15-12-0d

Complete with all accessories shown. Ready for plugging into 10 amp socket 230/250V A.C. mains. Infinitely variable control of welding current by hand wheel. Welds up to any thickness down to 22 sheet for the Motorist, Householder & Engineer. £15-12-0d less 10% OFF. CARRIAGE APPROX. 7/- AFTER DELIVERY. Uses Mg & Fe Standard Flux Coated Electrodes. One Duff's of each supplied with Welder. Extra Electrodes 7/- 100's 10/-

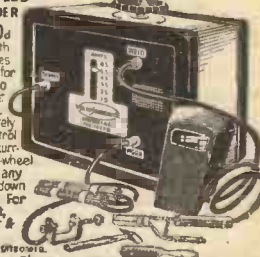

NEST OF DRAWERS



Overall size 7" wide x 5" deep x 11" high. 12 drawers, each measuring 3" wide x 4 1/2" deep x 1 1/2" high. Useful storage for the engineer, motorist and householder for nuts, bolts and small components. Green enamelled. £1. P. & P. 3/-

24v. HAND DRILLS

A.C./D.C. 24v., cons. 6 amps. Works on Car battery or Transformer, with 1" chuck and length of flex. Speed 900 r.p.m. Weight 7lbs. Ex-Civil Air Line. Unused. £5.4.0 each. P. & P. 3/-



24/12v. MOTORS, 1/3rd H.P.

D.C. only. Size 6" x 3 1/2". Spindle 1". Will drive boats, pumps and machinery. At 24v., 3,300 r.p.m., 18 amps., 1 1/3rd h.p. At 12v., 1,600 r.p.m., 10 amps., 1/3 h.p., 42/6.

HARMSWORTH, TOWNLEY & CO.
Jordan Street, Knott Mill, Manchester, 15

AUTOMATIC (TIME) SWITCHES

New and reconditioned 15 day clock-work and electric switches.

from 35/-

Send S.A.E. for illustrated details to:—

DONOHOO (TIMERS)
1 & 2 UPPER NORFOLK ST., NORTH SHIELDS, NORTHUMBERLAND



VOL. XXVI

JULY, 1958

No 432

All letters should be addressed to the Editor, "THE CYCLIST," George Newnes, Ltd., Tower House, Southampton Street, Strand, London, W.C.2

Phone: Temple Bar 4363
Telegrams: Newnes, Rand, London

WHAT I THINK By F. J. C.

THE MERIDEN PILGRIMAGE

THE Meriden Memorial Service this year attracted only about 1,000 cyclists, and the time has come to consider whether the excellent reasons which prompted this annual service have not now sufficiently lapsed into the limbo of the past to make the service unnecessary. As it stands, the service is giving undue prominence to the cyclists who fell in the 1914-18 war and ignores those who fell in the last war. Meriden is approximately the centre of England and it was considered therefore to be easily accessible to cyclists from every part of the country. Whilst it cannot be considered that a crowd of a thousand is small, nevertheless year by year the crowds have been declining in numbers.

TOO MUCH RACING ?

A READER takes me to task for my recent criticism of sporting cyclists whom I labelled as the "noisy minority." I said that they were small in numbers compared with the total number of cyclists and that too much attention was devoted in the press to racing results of events organised by comparatively small and nondescript clubs, that is to say, clubs with a membership of 20 or less.

The publication of the results of a club handicap held by such clubs can be of no possible interest whatever except to the 20 or so members of each of those clubs. Understandably, they like to see their names in print. Many of the events only attract an entry of 10 or less, and it is my view that it is a waste of space to publish such results—space which could be more profitably employed on other subjects. Such reports make dull reading, especially when set in small type. I suggest that in order to get into print, so to speak, the club should first of all distinguish itself in the field of sport, and that cannot be done in five minutes. Many of the clubs are of the "kerbstone wheeler" variety—mushroom clubs which start and flounder within a period of a few months.

Another point—touring articles should be the work of several men. Some of the touring articles, we fear, have been written from guide books, and not from personal experience. The technical side of the bicycle is almost entirely neglected. Cycling literature should be directed mainly at the large majority of cyclists, if it is to achieve wide circulation. Altogether too much prominence is being given to the sporting side. One might almost imagine that other forms of cycling do not exist. The sporting element has shown over a long period of years that it cannot and does not support periodicals. Cycling literature, as I have said, should be devoted to the multitude and space accorded to sport should bear a relationship to the whole, comparable to their numbers. Several clubs I know with large memberships take one copy of a periodical and pass it round.

I do not, therefore, withdraw anything from what I have written over a long period of years and I repeat that altogether too much attention is devoted to this noisy minority.

In view of the paucity of their support of

the cycling press, cycling clubs do not deserve a periodical at all. Their demands on publishers for free notepaper, advertisements in programmes, prizes and donations, are not only unreasonable but impertinent. Let us forget the 50,000 or so noisy ones and concentrate on the 10 million or so.

My correspondent also criticises my comments on the conduct of tourists at tea houses. He says he has never seen a bun fight at one of the recommended C.T.C. or N.C.U. houses, from which I must conclude that he has not been cycling for many years nor very far. For what other reason is it that hundreds of such houses have given up their official appointments and have notices outside stating "no cyclists"? The conduct of many of these cyclists is deplorable and a bad advertisement for the organisations to which they belong.

The organisations themselves do not sufficiently impress upon their local centres the importance of good conduct on the road and in their recommended establishments, and I have yet to learn of any member guilty of conduct prejudicial to the movement being expelled. It is unfortunately true that cyclists who join the associations are trained to become militant cyclists, always fighting for their rights and against imaginary grievances, manufactured for them by head office. Militant cyclists become offensive cyclists.

THE BUS STRIKE

THE public, confronted with the bus strike, rapidly adjusted itself to the stoppage of this form of public transport by using alternative vehicles. The sale of motorised bicycles and mopeds as well as bicycles rose sharply during the strike, still unsettled as we go to press. That accounts for the apparent calm amongst members of the public. There was no outcry by the public asking the Government to intervene in the dispute, and the public took the absence of buses calmly and prosaically. The strike has made people tend to be independent of public transport, with all the risks of stoppages due to strikes, official and unofficial. Many users of public service vehicles have deserted it forever and find that they are healthier for travelling under their own steam. The public has, indeed, become tired of the "stand and deliver" tactics, the methods of Dick Turpin presented in a new form.

AGREEMENT AT LAST!

THE three-man committee charged with the duty of finding a formula which would be equally agreeable to the three national bodies has produced a plan to which the three bodies now subscribe. A definition of categories has been agreed on and the various sides of the sport to be controlled by each has been agreed. A joint committee will act for all bodies; there will be no reclassification of riders and the N.C.U. retains its position as the representative of Great Britain in International Cycling Events. The agreement makes the best of a bad job; for the R.T.T.C. and the N.C.U. it has been a face-saving solution and for the B.L.R.C. a distinct victory. They have

forced the older bodies to recognise them, and whilst neither of them has submerged its identity to the B.L.R.C., there can be no doubt that the latter will from now on exercise a major influence on cycling sport.

PURCHASE TAX

THE President of the British Cycle and Motor Cycle Association has issued a statement on bicycles and purchase tax. He says that the cycle industry was amazed and dismayed by Mr. Maudling's reply in the House of Commons to the excellent case for a reduction in Purchase Tax on bicycles, as was sought in an amendment to the Finance Bill and which was sympathetically supported by so many Members of Parliament.

When Mr. Maudling stated that industries facing difficult times may have to adapt themselves to their changed conditions rather than expect help from the Government, it is difficult to believe that he was speaking of an industry which in 1951 produced over 4 million units and employed 26,000 people, but today is reduced to little more than half that production with the number of people employed suffering proportionately. The industry's concern is well known to the Government, for repeated representations on this subject have been made by the industry's association. What does Mr. Maudling expect the highly specialised cycle industry to do?

The cycle industry which has such a magnificent export record could, one would think, expect some sympathy and assistance from the Government to help it in its difficulty, more particularly when what is asked for is to help it to recover home market volume which is so much below pre-war figures. Such assistance would have put the industry in better shape to fight its grim battle in overseas markets.

This attitude of the British Government is in strong contrast to the advice given by President Eisenhower, who quite recently strongly recommended cycling to the American nation and exemplified the benefits to Great Britain that come from it.

For Mr. Maudling to say that purchase tax would only relieve the buyer by a matter of 10s. a week and to insinuate that it would make little difference is, in the view of the president, a misleading device and one denounced by the Government itself when used in commercial circles. The tax is the rate applicable on the cash sale and those who are experienced in the trade know that the present rate is a great deterrent to sales.

It is not a valid argument either to suggest that it would be inappropriate to apply the low rate of purchase tax to a bicycle as compared with what he describes as competitive transport. The bicycle cannot be compared with any other form of transport and therefore does not compete with it. Motor scooters, which Mr. Maudling instances, are in an entirely different category, being power driven and about ten times the price of the bicycle. It is unfortunate that Mr. Maudling should have selected for comparison a product supplied by foreign makers.

Detecting Wear

How to Find it in Time to Avoid Unnecessary Damage

ALL the moving parts on the bicycle will wear in time, but if deterioration is discovered early replacements can be made and further damage, caused by the worn part affecting other associated parts, may be avoided.

The Bearings

Perhaps the most important bearing on the cycle is the bottom bracket. This has to stand up to considerable strain and if not properly adjusted and oiled wear will soon be present. To test this bearing for wear, remove the chain, make sure that there is no side play and then spin the cranks. If the bottom bracket spindle binds in one position and is free in another it is almost certainly worn. When the bearing has been dismantled, inspect both the balls and cups for pitting. The cup will almost certainly have a polished track where the balls have run, but this is quite harmless unless the surface has been so badly worn as to be

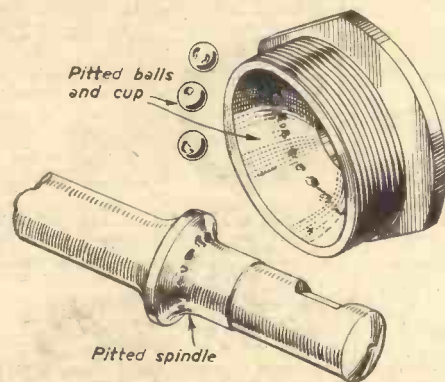

Fig. 1.—A pitted bottom bracket spindle and cup.

pitted. When the balls have been cleaned they should be smooth and shiny. If one or two are worn do not replace those only, but renew the whole set. Pitted cups should, of course, be replaced and the spindle also if the bearing surface is damaged (see Fig. 1).

The head bearing should be checked in the same way and wear will be indicated when it is found impossible to adjust the bearing satisfactorily; i.e., when bearing is tightened sufficiently to eliminate side play it is not free to rotate and when loosened so as to allow free rotation side play is present. Replacement of worn cups and balls will usually cure the trouble, but check also with cups which are a drive-fit in the head tube that they have not become "sloppy" and so require "packing" or replacement.

Wheel bearings and pedal bearings should be tested in exactly the same way as the bottom bracket for wear, and cones and balls replaced where necessary. Check also that the wheel and pedal spindles have not become bent.

Chainwheels and Chains

Wear on the chainwheel and driving sprocket is indicated by the shape of the teeth and a very old and worn sprocket will appear as shown at B in Fig. 2. This is known as "hooked" teeth, and replacement is called for. On the three- or five-pin

type of chain-wheel the pins or bolts sometimes become loose and the resulting movement between the ring and the spider causes wear to the threads. The cure is to replace the pins by slightly longer bolts which pass right through and can be secured by means of a nut.

The easiest method of testing a chain for wear is to fit it in position on the chainwheel and sprocket, pull the upper and lower strands towards one another until the chain is tight and then see if the chain will pull away from the front of the chainwheel. If it can be pulled clear of the teeth it is badly stretched and needs replacement. Check also for side play in the rollers by seeing if the chain will bend out of line sideways. Chain wear often does not need tests to be detected as it can make itself felt (or rather heard) by an irregular cracking sound when in use. If the cracking is regular a new chain may not be necessary—perhaps only the spring link needs renewal.

The Cotter Pins

A worn cotter pin will be felt in the pedalling action as soon as it occurs and reveals itself as a slight slip at the top of each rotation of the cranks. Whichever crank is loose, the slip is usually noticed in the left one, due to the fact that when the right-hand one is loose it is held firm by the chain wheel and the chain and instead the bottom bracket spindle (attached to the left-hand crank) slips inside the right-hand crank. A close visual inspection, however, will soon disclose the fault. Replacement is not always necessary. Sometimes a tap or two with a light hammer and a tightening of the nut will be all that is required, but if this treatment is of no avail remove the cotter (which will probably appear as in Fig. 3) and file and fit a new one.

Brakes

Here the chief site of wear is, of course, the brake blocks. Much can be done, how-

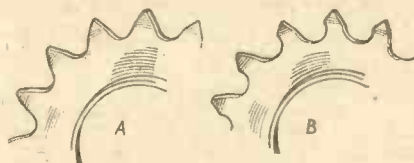

Fig. 2.—Worn sprocket teeth.

ever, to minimise this by correct fitting and using the correct type. Never let the blocks become as worn as the one in Fig. 3 or some distance from home you may find that the brake shoe is wearing on the rim. The main pivot of cable brakes is susceptible not so



much to actual wear but to bending. This is a point worth checking from time to time.

Brake cables, although frequent replacement should not be necessary, are prone to wear. Usually the cable rusts and frays near the nipple in the lever or perhaps where it is fitted to the actual brake mechanism. Replacement should be made immediately fraying is noticed. The pivot in the brake lever is another place to watch, particularly with the modern alloy levers.

Tyres

Tyres these days seldom succumb to plain, ordinary wear. Usually a particularly severe puncture, "blow out" or other accidental damage necessitates their replacement. Sometimes, however, wear can end the life of a tyre and the wear is almost always due to causes other than road wear. When you

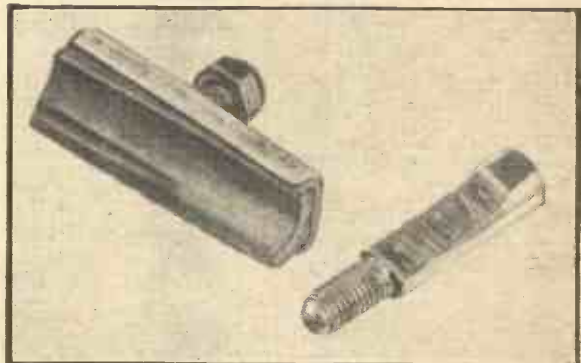

Fig. 3.—Badly worn brake block and cotter pin.

inspect your tyres look out for worn patches on the walls where the tyre could rub on the forks and look on the tread for any one spot which is badly worn due to frequent savage braking, resulting in a locked wheel and skidding. It is usually a rear tyre that suffers in this way, so remove it and fit it to the front wheel instead. When the former front tyre is in place on the rear wheel, remove the cause of the skidding.

Worn Threads

Due to frequent wheel changing, sprocket changing or perhaps to the fitting of the wrong type of nuts, screwthreads can become worn. This can sometimes be seen by the shiny state of the thread and perhaps by the looseness of the nuts or perhaps their excessive tightness in parts of the thread. A close inspection of a suspected thread will show it to be flattened on the top of each pitch, giving a smooth effect. It is wise to renew a component with such a worn thread before it strips completely.

Extra Special Carb. Grinding Wheels Offer. 6-7" dia. 1/4", 1/2", 3/4" thick. 12" or 3/4" hole. 10- the three. postage 2-. Value over 30-. 6 for £1. post paid. Ass. grits for tool and cutter grinding. also 5" dia. dish wheels. 1/2" hole. 4/9 each.

H.S. Reamers clearance. No. 1 M.T. shank. sizes 7/32", 3/8", 7/16" pair.

Fine Ground Thread Taps for instrument work. 1/4"-7/8" dia. 8 ass. 6-1. Actual value around £4.

H.S. Taper Pin Reamers. sizes 4, 5 and 7. 12- for 3.

1,000 H.S. Inserted Blade 'Expanding Reamers. 17/32", 19/32", 15- each: 21/32"-23/32", 16- each: 23/32"-25/32", 17/8 each: 25/32"-27/32", 15/8 each: 27/32"-31/32", 18/8 each: 15/16"-1 1/16", 20/- each: 1 1/16"-1 3/16", 27/6 each.

200 Cast Steel Circular Saws for wood. 4" dia. 7/8 each: 6" dia. 12- each: 8", 16/8 each: 10", 22/6 each: 12", 28/6 each. Please state size of hole required and if rip or cross cut teeth.

300 Lengths Precision Ground Silver Steel. 36" long. 5/16" dia. 4-9/16" dia. 10-: 5/8" dia. 12/6 per 3' length.

3,000 High Speed Routing Cutters. straight shank, two lip, as used for cutting slots in wood, sizes 3/8", clear 4- each.

10,000 H.S. Super-Quality Tool Bits. 1 1/4" square. 12" long. 15/16" dia. 5/8" square. 3" long. 20- doz. 3/8" square. 3" long. 25/- doz. 7/16" square. 3 1/2" long. 30- doz. Ground finish.

5,000 High Speed Slitting Saws and Slotting Cutters. 2 1/4" dia. 5/8" bore. 0.045", 0.051", 0.057", 0.058" thick. 3/9 each. 2 3/4" dia. 1" bore. 0.036", 0.048", 0.051", 0.056", 0.064", 0.072", 0.080" thick. 3/9 each. 3" dia. 1" bore. 3/64", 5/64" thick. 6/- each. 3 1/2" dia. 1" bore. 3/64", 5/64", 3/32", 11/64" thick. 7/8 each. 4" dia. 1" bore. 5/64", 7/64", 7/32" thick. 8/6 each. 5" dia. 1" bore. 5/64" thick. 12/6 each. 3/16" thick. 12/6.

500 Whitworth Screwing Tackle sets with bright polished steel die-stock, dies 2 1/4" dia. cutting 9/16", 5/8", 3/4", 7/8", 1" Whit. 50- per set. Also B.S.F. ditto. 50- per set. Only a third of real value.

1,000 High Speed Side and Face Cutters. 2 1/2" dia. 1" hole. 1 1/4", 3/8", 1 1/2" thick. 12- each. 1 1/2" dia. 1" hole. 1/2", 5/8" thick. 20- each. 3 1/2" dia. 1" hole. 3/8", 3/4" thick. 25- each. 4" dia. 1" hole. 7/8", 1" thick. 22 each. 5" dia. 1 1/4" hole. 1 1/2", 3/4" thick. 50- each.

2,000 Small H.S. Twist Drills. approx. 1 3/32", 3/32", 4- doz. Approx. 1/16"-1 1/8", 7/8 per doz. Approx. 9/32"-15/32", six for 10/-.

3,000 Circular Split Dies. 1" dia. cutting 1/4", 5/16", 3/8", 7/16", 1/2" Whit. B.S.F. also brass thread. 26 thread all sizes and American N.F. 12- per set of 5 sizes. 2 sets 22/6. 4 sets 42/6. Taps to suit. 12/6 per set. either taper or second or plug. 1" dia. stocks 6- each.

1,000 Hand Reamers. 5/16", 3/8" each. 5/8", 4/9 each.

7,000 Fraut & Whitney circular split dies. superior quality precision ground cutting edges. 13/16" dia. suitable for machine or hand use. Sizes 2, 4, 5, 8. B.A. 8/6 per set. 13/16" die stock. 3/8 each.

5,000 Ball Races. 1 1/8" bore. 3/8" o.d. 1 1/8" thick. 4- pair: 1 1/4" bore. 3/4" o.d. 7/32" thick. 4- pair: 8 mm. bore. 19 mm. o.d. 8 mm. thick. 4- pair: 9 mm. bore. 26 mm. o.d. 8 mm. thick. 4- pair: 3/8" bore. 7/8" o.d. 7/32" thick. 5- pair: 3/16" bore. 1 1/2" o.d. 5/32" thick. 4- pair.

2,000 Files 4-6" good assortment. 10- doz. also toolmakers' needle files. ass. 12/6 doz. 3" so. saw files. 10/6 doz. **Metal Marking Punches** sizes 3/32", 1/8" and 1/4". figures, 9/6 per set. letters 25- per set. any size. 1/2" figures. 15/- set.

2,000 Straight Shank End Mills. size 1 1/8", 5/32", 3/16", 7/32", 1/4", 5/16". list price 30/- set. 15/- set. also 3/8", 7/16", 1 1/2" ditto. 12/6 set.

500 H.S. 90° Counter-jinks. body 1 1/2" dia. Gift 6- each.

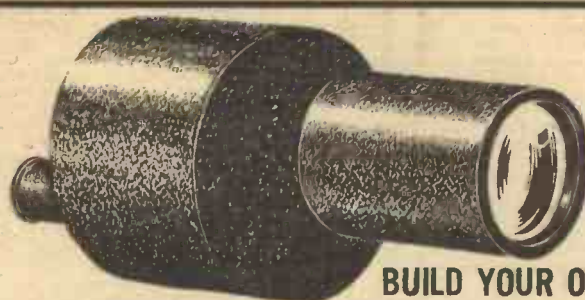

BUILD YOUR OWN

20x PRISMATIC TELESCOPE

WEIGHS ONLY 12oz.—EASILY CARRIED IN THE POCKET!

For the first time ever, you can now buy a kit from which you can make your own Prismatic Telescope. It is supplied with easy-to-follow instructions as described and approved by the "Model Engineer" and comes to you with optically ground prisms. This wonderfully designed optical system is fully corrected and will give excellent light transmission for day or night use. With its wide field of view, this high powered telescope also has a focusing eyepiece, it is only 6in. long and is ideal for sport, bird watching, spotting and astronomy.

79/6

Complete kit of Lenses & Prisms



SINE-BAR

This highly accurate instrument will measure any given angle, instantly, from 0° to 90° to 1 minute through its unique sine-bar mechanism which also incorporates the spirit level.

35/-

This is one of the finest Clinometers available today. Made of Gunmetal, it comes to you complete with leather case.

CLINOMETERS

GENERAL PURPOSE

These instruments are made for the high precision measurement of angles up to 90°. In gun metal with circular 2-way spirit level, length 7 1/2", height 2 1/2". Also ideal for setting milling and drilling tables and general workshop use. Manufactured to Government specification, they are offered at a fraction of the original price



27/6

UNITED TECHNICAL SUPPLIES LTD

DEPT. PM2, 3, HARROW ROAD, LONDON, W.2. Tel.: PAD 1133
Opposite Edgware Road Station. 5 mins. Marble Arch.

IMMERSSION HEATERS. 2 kW. or 3 kW., 11in. and 16in. £3.8.4. Thermostat for either of above heaters. £1.10.0.

THERMOSTATS. BW/1, 5 amps, 15/6. Post 6d. SN/40 1/2 amp., 5/6. Post, 4d. C. S. Convector Thermostat 15 amps, 25/- Post, 10d. Model MB for Immersion Heaters, 15 amp., £2. Post, 2/-. PF Room Thermostat 15 amps, £2 Post, 10d. M.L. Greenhouse Thermostat 10 amps, 35/- Post, 10d. P.J. Miniature Thermostat for Hotplates. 5 amps. 9/3. Post 6d.

FLEXIBLE ASBESTOS ELEMENT WIRE. 15 or 25 ohms/yd. 1/- per yard.

REPLACEMENT ELEMENTS Send 4d. stamp for lists.

TELEVISION SUPPRESSOR KIT, for appliances up to 1 amp., 3/6. Post Free.

BI-METAL. Hi-Flex 45 3/16in. x .010, 6d. per ft. Standard 6in. x 1/2in. x .036, 6d.

NEON ILLUMINATED INDICATOR SWITCH. 2 amps, 240 v. A.C., 10/6.

MAGNETS. Sintered Bar Magnets of great power and stability 1/2in. x 3/16in. x 1/16in., 9d. each. 8/- doz. Post 5d.

We also supply Silver Contact Screws and Rivets. Porcelain Interlocking Insulating Beads. Send 4d. stamp for list.

THE TECHNICAL SERVICES CO., Banstead, Surrey

Save on Repairs with **GLASS FIBRE** KITS FOR CARS, ETC. £5.10 £9.10 carriage paid

Reduced Prices Plus Post
More Materials
KIT I 12/6 2/-
KIT II 25/- 2/3
KIT III 30/- 2/6

These kits carry a comprehensive range of materials, with full instructions to suit all forms of car body repairs and model making. "Glass Reinforced Plastics" New Illustrated Booklet, 2/6 Post Free.

WESTPOLE MOTORS LTD.
69, BRAMLEY RD., LONDON, N.14. PAL 8331

CHEMISTRY APPARATUS
Send 3d. stamp for **COMPLETE PRICE LIST**

Booklets:
"Experiments" 1/2
"Formulas" 1/2
"Home Chemistry" new ed., 2/10 (Post Paid.)

BECK 60 HIGH STREET
Stoke Newington, London, N.16

BATTERY CHARGERS

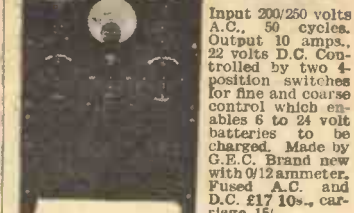

NIFF BATTERIES. Practically indestructible. 1.2 volts. 75 amps. Alkaline filled. Any voltage can be built up. Brand New. 25/- each, carriage 6/-.

VENT-AXIA FANS, EXTRACTION OR INTAKE. Brand new. Silent running. 200-250 volts A.C., 130/- 12 volt D.C., 90/- Post 3/-.

MEGGER Circuit Testing Ohmter. 2 scales 0/1000 Ohm and 100/200K Ohm. inf. with test probe. Brand New. £4.17.8. Post 3/-.

WEE MEGER 500 watts in leather case. Brand New. £12.10.0. Post 3/-.

HEATING ELEMENTS. Flat enclosed type 230 volts 500 watts. "Bray Chromalox." 10in. x 1 1/2in. 7/6. Post 1/6.

AVO TEST BRIDGES. 220, 240 v. A.C. Measures capacities from 5 pf to 50 mfd and resistances from 5 ohms to 50 megohms. Valve voltmeter range 0.1 to 15 volts and condenser leakage test. Brand New. Full working instructions supplied with instrument. £9.12.6. Post 3/-.

TEST SETS incorporating Wheatstone Bridge, Galvanometer. Brand new in case. 50/- Post 3/6.

CELL TESTING VOLTMETERS. 3-0-3. In leather case with prods. A first quality moving-coil meter. 25/- Post 3/6.

ELECTRIC MOTORS. 200/250 v. self-starting. 1 r.p.m. 35/- Post 1/8.

PORTABLE BLOWER. 200/250 v. A.C./D.C. 300 watts with switch and leads. 1 1/2in. outlet. 25/- Post 3/6.

RELAYS—HIGH SPEED. 1,700 + 1,700 ohms just the job for radio controlled models. 25/- each. Post 1/3.

BULKHEAD FITTING. 9in. diam. flat tripod type, suitable for lamps up to 100 watts, complete with pushbar switch lamp-holder. Ideal for farm buildings, garages, greenhouses, etc. Brand new. 17/6. Post 2/6.

TELEPHONES SOUND POWERED. No batteries required. Just connect with twin 8x for clear speech, can be used as a room-to-room telephone, extension speaker, baby alarm, etc. Crystal clear reception. Transmitter Receiver Units. 4/6 each. Twin Flex. 4 1/2in. vard. Post 1/4.

GEARED MOTOR for the model maker. small and very powerful. 4 r.p.m. at 12 v. D.C. or 8 r.p.m. at 24 v. D.C. 35/- post 2/6.

Works from 230 v. A.C. mains with transformer and rectifier. 12 v., 25/- or 24 v., 40/- extra.

TELEPHONE SETS. MODERN DESK TYPE. £8.17.6 per pair, complete.

WALL TYPE also available. 2 complete units 25. Batteries 5/6. Twin Wire 2d. per yd. W.T.O.H.R. 12 volt D.C. 1 1/2in. x 2 1/2in. approx. 3,000 r.p.m. with speed regulator in end cap. A precision job. 12/6 Post 1/8.

METERS GUARANTEED

F.S.D.	Size	Type	Price
50 Microamps	2 1/2in	MC/FR	70/-
100	2in	MC/FR	40/-
100	2in	MC/FR	50/-
250	3 1/2in	MC/FR	55/-
500	2in.	MC/FS	27/6
500	2 1/2in.	MC/FR	37/6
1 Milliamps	2in.	MC/FR	27/6
1	2in.	MC/FR	35/-
5	2in.	MC/FR	17/6
30	2 1/2in.	MC/FR	12/6
100	2 1/2in.	MC/FR	12/6
200	2 1/2in.	MC/FR	12/6
5 Ampere	2in.	MC/FS	27/6
15	2in.	MC/FR	10/6
25	2 1/2in.	M/FR D.C.	7/6
30-0-30	2in.	MC/FR	15/6
50-0-40	2in.	MC/FR	10/6
20 Volts	2in.	MC/FS	10/6
40	2in.	MC/FS	10/6
300 .. A.C. ..	2 1/2in.	M/FR	25/-
300	6in.	M/FR	150/-

CROSS POINTER

METER with 2 separate 100 microamp movements. Brand New. £2/6. Post 2/-.

HEADPHONES. High resistance 4,000 ohms. Type CHR. 13/6 pr. Post 1/6.

HEADPHONES. High resistance, very sensitive Balanced Armature. Type DHR. 17/6 pr. Post 1/6.

ROOM THERMOSTAT. Adjustable 45 to 75 deg. Fabr. 250 volts 10 amp. A.C. ideal for greenhouses, etc. 25/- Post 3/6.

INSPECTION LAMP. Fits on forehead, leaving hands free. battery case clips on belt. 7/6. Post 1/6. Takes E.R. Battery No. 1225. 2/8. Post 9d.

J. BURKE
192, Baslow Road, Totley, Sheffield.
Inspection Rear 38, Fitzwilliam St., Sheffield.

L. WILKINSON (CROYDON) LTD.
19, Lansdowne Road, Croydon

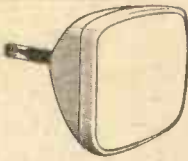

17" £7.10.0 RECT. T.V. TUBES 14" £5.10.0
12 months guarantee.

Six months full replacement, 6 months progressive. Made possible by the high quality of our tubes. Ins., Carr. 15/6. Convert your 9", 10", 12" tubes to 14", 15", 16" (round tubes). Our special offer for these sizes 45. Full instructions in our FREE CATALOGUE. 12" T.V. Tubes, £6. 3 months guarantee on round tubes. Ins., Carr. 15/6 on all tubes.

TERMS AVAILABLE

17" T.V. CHASSIS TUBE AND SPEAKER, £19.19.6

Latest improved circuits. Higher E.H.T. (brilliant picture) Improved sensitivity (for greater range). Chassis is easily fitted into any cabinet. 17" rectangular tube on adapted chassis. Less valves. 12 months guarantee on tube, 3 months guarantee on valves and chassis. With valves £25.19.6. Valve line-up 6SN7G, 6V6, EY51, 2-6D2's, EL38, EL41 and 7-6F1's. Turret tuner 50/- extra. State B.B.C. and I.T.A. channel required. Extra channels supplied at 7/6 each. Ins., Carr. (incl. tube), 25/-.

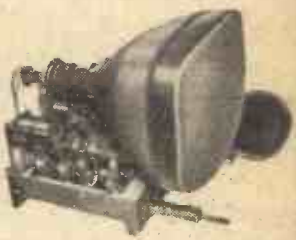

INSULATED TAPE, 1/6. Large roll in sealed metal container. BARGAIN 75ft. x 1/2" wide. It's a must at this price. Post 9d. N.B. Postage on 6 tins is only 2/-. Buy now and save money.

TELEPHONE SETS, 7/9. Ex-W.D. Wireless remote control Unit. E.Mk. II (ZAI194). New condition. Morse tapper, switched, jack plugs, etc. Less phone. Ins., Carr. 3/6.

COMPASS, 12/9. Ex A.M. Azimuth 0.2 A. No. 4 6" dia. Also Ex A.M. type P.A.A. 6 1/2" dia. Ideal for boats, cars, etc. Please state type required. Ins., Carr. 3/6.

SUPER CHASSIS, 99/6.

5 valve superhet chassis, including 8" P.M. speaker and valves. Four control knobs (tone, volume, tuning, w/change switch) Four w/band with position for gram. P.U. and extension speaker. A.C. Ins., Carr. 5/6.

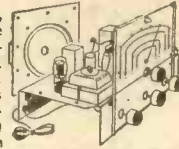

HOME RADIO, 79/6. 5 valve (octal) superhet. 3 waveband receiver. A.C./D.C. Universal mains can be adapted for gram. P.U. In wooden cabinet. 9 1/2" x 18 1/2" x 11 1/2". Ins. Carr. 7/6.

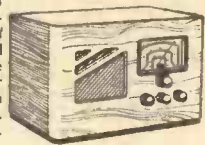

14" T.V. CHASSIS TUBE AND SPEAKER, £13.19.6
As above with 14" round tube. Less valves. 3 months guarantee. With valves, £19.19.6. Turret Tuner 50/- extra. Ins., Carr. 25/-.

T.V. CHASSIS, 25/6. Ideal only for spares. Although this chassis has a wealth of components, it is considered uneconomical to attempt rebuilding. This chassis is in 3 separate units. Power Pack. T/base and S/vison Strip. I.F.s 16-19.5 Mc/s. Drawings Free. Ins., Carr. 10/6.

IDEAL CHASSIS, 39/9.



Radio or Radiogram chassis. 5-valve 5/100. A.C. valve line-up 6K8, 6K7, 6Q7, 6V6, 5Z4. 3 waveband and gram, switched. Less valves. Chassis size: 19 1/2" x 9". 8" P.M. Speaker, 7/9 extra. Set of knobs 2/- extra. Complete set of valves, 45/9 extra. Ins., Carr. 5/6.

TRANSFORMERS

MAINS POWER TRANS. 9/9. 350-0-350 v. 250 mA. 6 v. heater at 5 A., 4 v. at 5 A., 4 v. centre tapped. Drop through type. Primary 200-250 v. (4 1/2" x 5" x 5"). Post, 3/9.

MAINS TRANS, 3/9. 350-0-350 v. 80 mA. 4 v., 4 v. heaters. 200-250 v. prim. Post, 2/-.

MAINS TRANS., 5/9. 280-0-280 mA., 6 v., 4 v. heaters. 200-250 v. prim. Post 2/3.

HEATER TRANS., 3/9. 1-2 Ratio auto trans. 2 v. at 1.4 amp. primary. 4 v. secondary. Post, 1/9.

O.P. TRANS., 1/3. Std. size. 2-5 ohms. Post, 1/- 20 for £1. Post 5/6.

EXTENSION SPEAKER, 29/9. Complete. Fitted with Bin. P.M. speaker "W.B." of "GOODMANS" of the highest quality. Standard matching to any receiver (2-5 ohms). Flex and switch included. Unrepeatable at this price. Money refunded if not completely satisfied. Ins., Carr. 3/6.



Bin. P.M. SPEAKER, 8/9. Ideal for kitchen and bedroom extension. P. & P. 2/6

RECTIFIERS, 2/9. 250 v. 100 mA. Full or half wave. Salvage guaranteed. Why hunt for those obsolete rectifier valves when you can cheaply replace with a modern selenium rectifier? P. & P. 1/3.

SOLO SOLDERING TOOL, 19/6. 110 v. or 6 v. (Special adaptor for 200/240 v., 10/- extra). Automatic solder feed. Includes a 20ft. reel of ERSIN 60/40 solder and spare parts. It is a tool for electronics soldering or car wiring. Revolutionary in design. Instantly ready for use and cannot burn. In light metal case with full instructions for use. Post, 2/9.

T.V. AERIALS, 25/6. For all I.T.A. channels For outdoor or loft. 3 elements. Famous manu facture. Sold at half the normal cost. P. & P. 2/6.

CLOCKWORK MECHANISM, 1/9. A perfectly engineered clockwork unit. Ex-W.D. (type ROF(B) 40SL). Can be modified for use as a darkroom timer. Clock or any mechanism requiring activation. FREE DRAWINGS. Post 1/4 for 5/- Post, 2/6.

OPEN ALL DAY SATURDAY.
DUKE & CO.

Closed Thursday 1 p.m. Send for Catalogue.
(Dept. 4) 621/3, ROMFORD ROAD, MANOR PARK, E.12. ILFORD 6001/3.
LIVERPOOL STREET TO MANOR PARK STATION, 10 MINUTES.

CAR AERIALS, 6/9. Whip antenna 50" long collapsing to 11". One hole fixing. P. & P. 1/-.

SPECIAL OFFER

G.E.C., B.T.H. & WESTINGHOUSE GERMANIUM CRYSTAL DIODES

1/- each Postage 3d.

Diagrams and three Crystal Set Circuits Free with each Diode.

A large purchase of these fully GUARANTEED diodes from the manufacturers enables us to make this attractive offer

COPPER INSTRUMENT WIRE ENAMELLED, TINNED, L.T.Z. COTTON AND SILK COVERED

B.A. SCREWS, NUTS, WASHERS. soldering tags, eyelets and rivets.

EBONITE AND BAKELITE PANELS, TUFNOL ROD, PAXOLIN TYPE COIL FORMERS AND TUBES ALL DIAMETERS.

Latest Radio Publications. SEND STAMP FOR LISTS

CRYSTAL SET

INCORPORATING THE SILICON CRYSTAL VALVE

Adjustable Iron Cored Coil

RECEPTION GUARANTEED Polished wood cabinet, 15/- post 1/3. A REAL CRYSTAL SET NOT A TOY

POST RADIO SUPPLIES 33 Bourne Gardens, London, E.4

THE JEFFERY TRANSFORMER CO.

(Winders to the late Galpins)

199, EDWARD ST., NEW CROSS, LONDON S.E.14 Tideway 4458

Leaflets sent gladly, on request

SUNDIAL new 8-inch motorised SAW BENCH DEPTH OF CUT 2 1/2 in.

For ripping, cross-cutting, mitring, tonguing & grooving & tenoning. Machined table top measures 14in. x 14in. Designed for clean and accurate sawing. Strong construction throughout in cast iron. Weight 93 lbs. Rise and fall spindle. Fence to full length of table. Vee Belt Motorised 1/2 h.p. T.V. and Radio suppressed motor. Press button starter switch fitted.

PARRY & SON (Tools) LTD.

329-333 OLD ST., LONDON, E.C.1. SHoreditch 9422, 9423, 9424.

IDEAL FOR WOOD, PLASTIC OR METALS £27



Supplied on 1st payment of £2.14.0, balance in 8 monthly payments of £3.6.10. Cash Price £27. Carriage and Packing 22/6.



A "FERROUS" ELECTRIC ARC WELDING SET will complete your workshop equipment. For joining and reinforcing, from approx. 1/16" up to any thickness. Mild Steel, Wrought or Malleable Iron. Type F.M.60 Heavy Duty complete with all equipment 190/240v. Single ph. 10/15 amp. (or domestic power supply) delivered free, ex stock. Cash (or C.O.D.) £23.10.0 H.P. Terms available.

illus. leaflet from manufacturers. FERROUS PRODUCTS (P.M.) LTD., Church Rd., Croydon, Surrey, CRO 8351/3

PLAY THE PIANO

REED ORGAN or ACCORDION in 3 months

New Home method. Definitely the easiest and quickest. Even if you have never played a note, you will be able to read music at a glance.

Write today without obligation for FREE LESSON state instrument



KLAVARSKRIBO (B.Z.6) 10a Highbury Place, London, N.5

GOVERNMENT

SURPLUS BARGAINS

TRIPPODS. Unused. 38" long. only 5lb. wt. Immensely strong. Carrying sling. Brass cap easily adapted to camera, etc., etc. Each 12/6. post 2/6.

LOW VOLTAGE MOTORS with REDUCTION GEAR, approx. 4/1 (24-45-90) 6-12 v. D.C. 1 amp. ea. 15/- post 1/9.

MOTOR ONLY as above (dimensions 3" x 2" x 2") ea. 7/6. post 1/6.

BATTERY CHARGING TRANSFORMERS, 11 v. & 17 v. A.C. (for 6 & 12 v. charging at 1 amp.) ea. 17/6. post 1/9.

RECTIFIERS to suit above, ea. 9/- post 8d.

(These transformers & rectifiers will run the above low voltage motors.)

TEST METERS. Moving Coil 0.15 v., 0/3 v., 0/60 m.Amps.; 0/5,000 ohms. In beautiful case 4" x 4" x 2 1/2" with selector terminals and switch. Wonderful Bargain. 15/- post 1/6.

POCKET VOLTMETERS. Moving Coil 0/15 v., 0/250 v., 15/- post 1/6.

MOTORS. 200/250 v. A.C./D.C. F.P.P. approx. 80 watts. High speed. 1" shaft. (Converted ex R.A.F. motor generator—power about equal to sewing machine motor.) Useful addition to workshop, ea. 30/- post 2/9.

Send 3d. stamps for list of other Motors, Transformers, Pumps, Lamps, Switches, etc., etc.

MILLIGANS

24, Harford Street, Liverpool, 3. Money Back Guarantee.

NU-CHROME

This New Invention Re-plates Metals, and gives hard chrome finish. Motor and cycle parts, household utensils, etc.

Do Your Own ELECTRO-PLATING

and Save £££. Complete Outfit 15/- post free. (Full money back guarantee.)

SEND TO-DAY to:

L. A. PRODUCTS, Dept. M.,

156, High St., Berkhamsted, Herts.

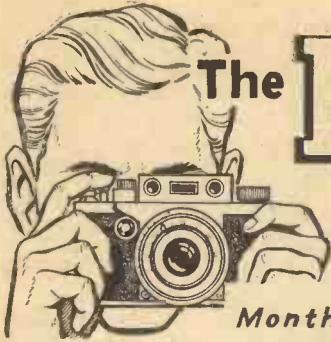

The Practical Photographer

No. 4. JULY, 1958

Monthly Supplement to "Practical Mechanics"



Before Building Your Enlarger

A Few Pointers Which Will Help Your Planning

FIRST, the enlarging lens should have the same focal length as the lens used in the camera and in the popular 120 size this would be 10cm. or just over 4in. The focal length must also be greater than the diagonal measurement of the negative. It is measured when the camera is focused at infinity, but as the camera is focused most often at distances less than infinity, when the lens will be farther away from the negative, it must be realised that the working focal length is greater than the figure marked on the lens. Actually, for the purpose of enlarging, the increase is about a quarter and the working focal length of a 4in. lens

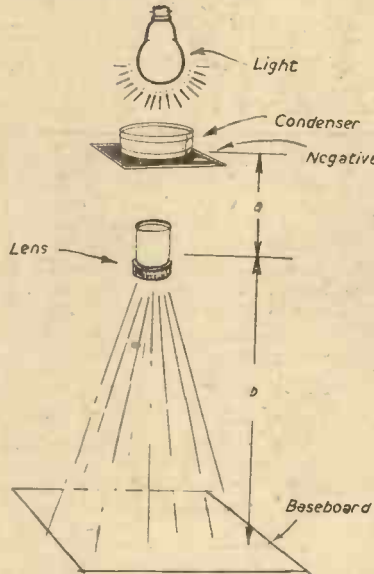

would be about 5in. This would be the dimension (a) in the sketch. Dimension (b) is obtained by multiplying the working focal length by the number of times enlargement required. For instance, a 4x enlargement would mean a lens to base-board distance of 4in. \times 5in. = 20in. These distances will be varied considerably according to the size of negative to be enlarged and the focal length of the lens used. Smaller negatives than those for which the lens is designed may be enlarged but not larger negatives. For instance, a 4in. focal length enlarging lens can be used to enlarge 127 or 35mm. negatives but not quarter plates. With the smaller sizes, of course, the lens carrier must be suitably masked.

The negative to lens and lens to base-board distances mentioned are only approximate.

The condenser used must also have a diameter greater than the diagonal measurement of the negative and the 120 size enlarger usually has 4 1/2 in. condenser lenses.

Distance between the lamp and the condenser is best found by experiment.

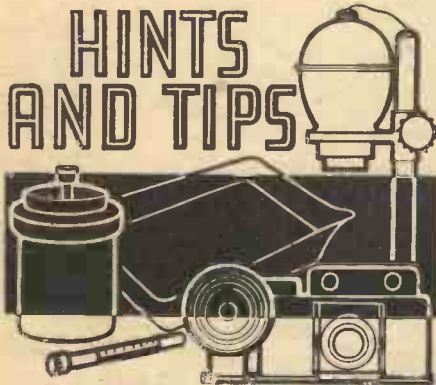

HINTS AND TIPS

A REFLEX ADVANTAGE

WHEN photographing children who are almost always self-conscious in front of the camera the twin-lens reflex is particularly useful. Turn sideways, keeping the camera in the direction of the subject, and carry on focusing. Then, while the child thinks your attention is elsewhere and has resumed a natural expression, press the shutter release.

By pointing the camera behind you under your arm it is still possible to focus perfectly and then take a photograph of someone who is standing behind you and completely unsuspecting.

BACK PORTRAITS

IF you have taken the portraits of your family and friends many times before and have grown somewhat tired at looking at them in your album, why not try something different? Photograph them from behind. You will be surprised at the amount

of character a good picture taken in this way will reveal. Take them without the subject knowing and, if possible, in some characteristic position, such as working at a desk, gardening, washing up or, perhaps, just leaning on the front gate. The subjects themselves will probably be interested, it's a view of themselves they never see!

A TRIPOD TIP

THE modern lightweight tripod, considering how very light and compact it is, is a fairly rigid structure, but when mounted on uneven ground, and particularly if the camera has a "sticky" shutter release, pictures showing traces of camera shake are apt to result. One very simple method of avoiding this is, of course, to use a cable release, but on the day this is forgotten "shake" can be avoided by using the delayed action device. An obvious tip? Maybe, but many photographers wouldn't think of it.

GET UP EARLY!



When you are holidaying at some picturesque town, either in this country or abroad, a drawback to picture making is that quaint old streets and buildings lose their charm for the photographer when it becomes necessary to include hundreds of fellow sightseers. The best way to avoid them is to take your pictures before they get up. The above photograph was taken in this way and the old town seen in its true character.



Photography Abroad

By A. E. BENSUSAN

How to Take Care of Your Equipment and How to Use It to the Best Advantage

THE selection of the various items of equipment needed for the holiday, and various other matters appertaining to holidays in general, have been dealt with in a previous article. The requirements for a holiday abroad are identical with, perhaps, added emphasis on the desirability for taking along all the film stock likely to be needed during the visit. Far better to bring back a small quantity of material unused than to need extra supplies and be unable to obtain the correct type of film in a small Continental village or town. In general terms, the prices of ordinary monochrome films vary very little from those ruling in Great Britain, but the supply situation is often rather unsatisfactory. In certain countries which import little foreign photographic material, and manufacture no reliable brands themselves, the prices of good quality films are out of all proportion to those asked here.

The possible exception to the rule for taking all the material necessary with you applies to colour film. In a number of Continental countries, well-known brands of colour film can be obtained at quite reasonable cost.

virtue of its corrosive nature, should always be kept from coming into contact with the camera and other equipment. If you do have to pack the photographic kit with your ordinary luggage, make sure that every item is well wrapped with clothing so as to afford the maximum protection against damage by shock.

as they really are if you wish to obtain a faithful record of the country. (Fig. 2).

Whatever you do, avoid giving offence to the local inhabitants. Where possible ask whether you may take photographs and, in most cases, instant agreement and much valuable help will be forthcoming. Keep an eye open for the back streets, off the usual tourists routes for these often have remarkable photographic possibilities. Here, too, it is possible to photograph buildings and other items as they really are, and without the doubtful false fronts and artificially aged features sometimes seen in the more frequently used thoroughfares (Fig. 3). Photograph everything which appeals to you and seems strange at first sight. Film is relatively inexpensive, and complete coverage is the only way to build up a truly comprehensive collection of pictures.



Fig. 2.—Look out for pictures of people in natural settings.



Fig. 1.—The station makes a good "record" photograph.

Arriving at your destination, the railway station itself brings a contact with a totally different world and, if you are planning to take a series of pictures illustrating your entire holiday, this must come quite early on the list (Fig. 1). Right away, enter the subject, date and photographic data in your record book so that you can check back at any time to ascertain whether you have taken that shot.

Be very careful to take a meter reading for every picture as, in the bright light and clean air of many Continental areas, exposures need to be rather short and guesswork could lead to drastic over-exposure.

Always Take the Camera

It is wise to carry your camera wherever you go while on holiday abroad. On a morning or evening stroll, a picture might be seen with the light perfect, and no fellow-tourists to spoil the view but, without the camera, it could be lost forever. This is particularly true where local customs are concerned; not the type of entertainment usually provided for the tourists but the normal and general activities of the people. Carrying a camera you might well be invited to take pictures of the local craft industries, but the opportunities for this sort of photography will generally be presented quite early in the day. Certainly before the average visitor is out and about. Catch the people

Processing

It is inadvisable to have the films processed locally. For one thing the quality of the developing services available outside the large cities is not all that it might be and, for another, any delay in delivering the finished work might mean leaving the negatives to be posted to your home address. Either way, the best course is to bring all exposed material home in your luggage, and attend to the processing yourself.



Fig. 3.—A quaint corner of a small Continental town.

The Customs

When taking photographic equipment abroad it is a wise policy to carry the receipts for the various items, particularly if they are of foreign origin. Rarely is one asked for these papers by a Customs official but, should this occur, any doubts will be alleviated right away. Check your equipment insurance policy well before leaving to see that all the items are correctly listed and valued, and that the policy is valid in the country or countries you are to visit and through which you pass. Temporary extension of the cover afforded by a policy for Great Britain only can be effected at a small cost to include most other countries.

Photographic gear is best carried on the person while travelling for, in this way, it is under constant supervision. It must, however, be adequately protected from salt water spray if the Channel crossing is to be made by steamer. Even a light breeze picks up considerable moisture which, by

A Table-Top Tripod

The Construction of This Unit is Described, Together With an Adjustable Head

By M. Katers



THE table tripod described is collapsible and, yet, when assembled is perfectly rigid. The measurements need not be strictly adhered to but can serve as a guide to any model similarly constructed. The adjustable head is indispensable wherever a tripod is used, either indoors or outside. The tripod was constructed entirely of mild steel and the head of brass. The materials can be obtained through any reputable ironmonger.

The Tripod Plate

This is the part to which the legs are attached. Fig. 1 shows the general dimensions. The only real point to watch here is the thickness. If the plate is too thin, then there is a centre pillar wobble which is photographically undesirable.

Legs and Centre Pillar

These are made of 5/16in. mild steel rod

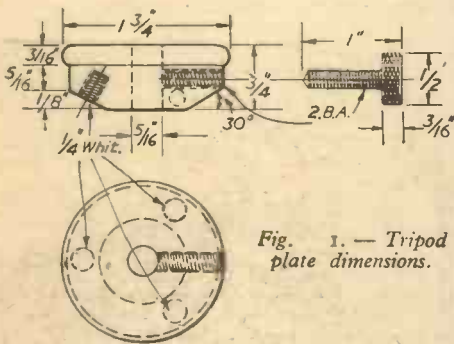

Fig. 1.— Tripod plate dimensions.

with a 1/4in. Whitworth thread at one end. This gives a shoulder to the legs when screwing them into the plate on assembling the tripod. The legs can be knurled if required but it is an unnecessary refinement.

The centre pillar should not be too long, or otherwise there will be camera sway which would be noticeable on exposures; a maximum of 12in. is suggested. The end of the pillar can either have a locknut or a camera screw adaptor. British cameras have a 1/4in. Whitworth bush and so the centre pillar can be screwed similarly and a locknut used. If, on the other hand, you have a continental camera then an adaptor is required as shown in Fig. 3. The Continental bush has a 3/8in. Whitworth thread

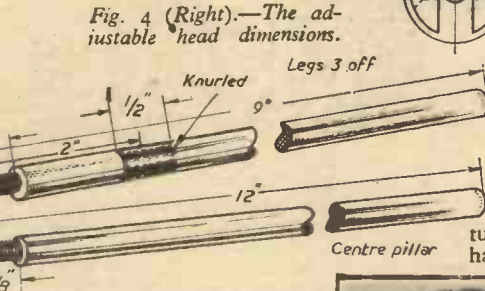

Fig. 2.—The legs and centre pillar.

Finish

Mild steel when heated in a clean flame to a cherry

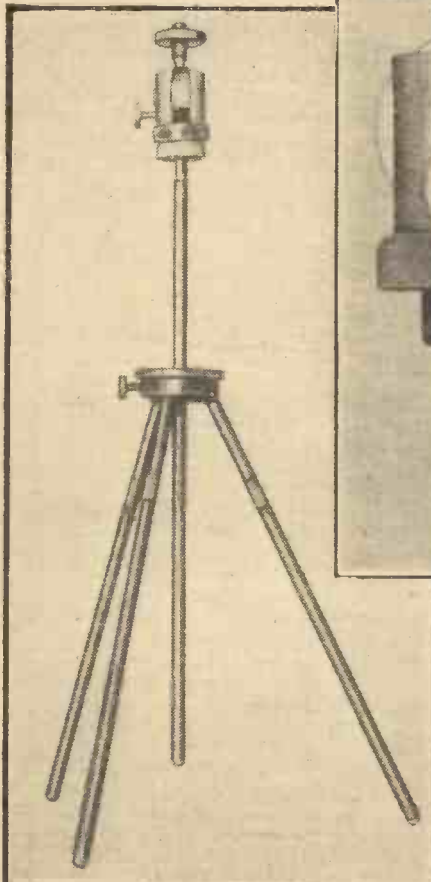
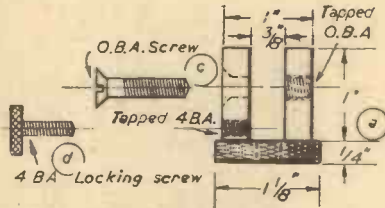

Fig. 3.—The completed tripod and adjustable head.



red will, when dropped into a tray of oil, give a blue-black finish. This gives a rustproof layer which is pleasing to the eye. The oil can be any car engine oil which is about to be discarded after use.

The Adjustable Head

The components are shown in Fig. 4. The photographs show how the parts are assembled. The barrel which is

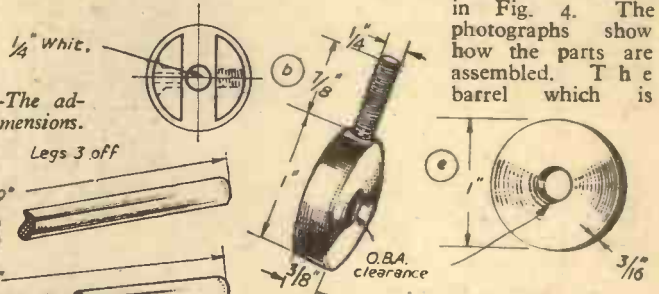

turned to the dimensions shown in Fig. 4a has the swivel (b) held in the slot. It is a

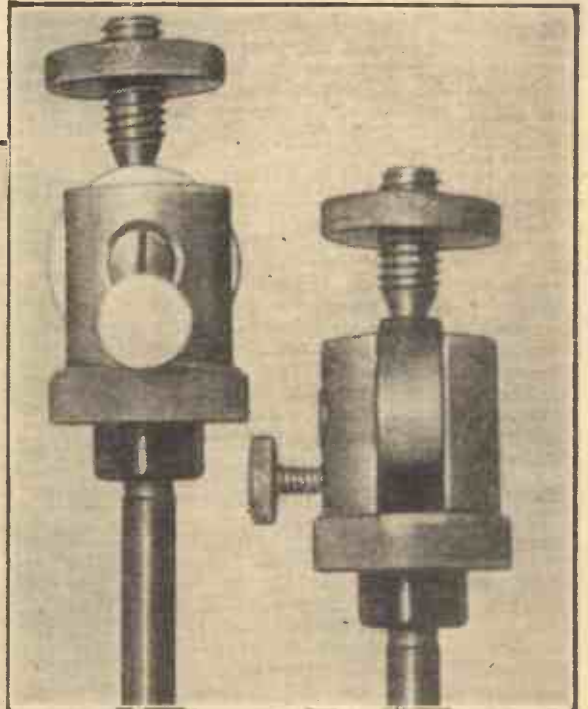

Fig. 5.—Two close-up views of the adjustable head.

neat smooth fit and rotates round the screw (c) which is countersunk into the barrel. The locking screw (d) holds the swivel in any desired position by jamming it against the barrel wall. The locking ring (e) locks the camera on to the head when ready for use.

If a continental camera is used, then the 1/4in. screwed Whitworth rod in the swivel (b) should be replaced by a 3/8in. screwed Whitworth rod.

When finished the brass was polished and lacquered.



Out of the ordinary with Infra-Red

E. Clements Explains the Technique
and Gives Some Examples

Focusing

Infra-red rays do not come to a focus in exactly the same plane as that formed by visible light and, in theory, therefore, focusing carried out by the latter will not provide accurate focusing for photography by infra-red. For the shorter focal length lenses, however, unless working at very close distances, the difference involved of approximately 1/50 of the focal length is insufficient to cause any appreciable inaccuracy. In fact, it would be difficult to make so minute a correction. For larger cameras and longer focal lengths the visual focusing usually employed may be carried out with the aid of a deep red filter which is the nearest one can get to the infra-red end of the spectrum.

Infra-red photography has not so far received very much attention from the pictorial photographer; but if one discards the normally accepted necessity to record all colours with absolute fidelity in monochrome and concentrate upon the purely visual effect of the picture, looking rather for strength and generally imposing results, there is in infra-red radiation the means of obtaining some very individual pictures. It is, of course, possible with a little experience to visualise the infra-red effect in a given scene so that one does not need to expose haphazardly in the hope of obtaining a striking result.

Although infra-red photography in the pictorial field has not as yet received very much attention a considerable amount of film has been used in the scientific and technical spheres.

Infra-red Flash

With the advent of flashbulbs coated to emit only infra-red rays, it has become pos-

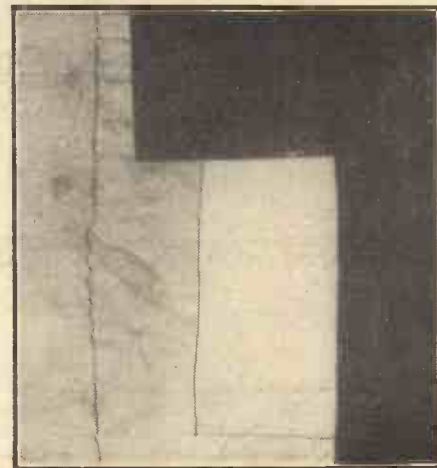

Fig. 1.—Several black materials photographed by infra-red.

ROLL films as normally supplied only record as far as the visible red, and in order to utilise the infra-red radiation have to be further treated with special dyes; 120 films so treated are now available.

Using Infra-red Film

An infra-red film, although handled in exactly the same manner as an ordinary one, must be used in conjunction with an infra-red filter. If gelatine, the filter may be placed between the lens components where it will be less liable to damage, but failing this, it may be accommodated either in front of or behind the lens. It is necessary, however, to ensure that the filter excludes all but the infra-red rays; if the filter is omitted, the image will be a normal panchromatic one. Exposures are a matter for practical experience; without the filter the film may be rated as a fast panchromatic, but with the filter, exposures in the region of 1/50 sec. at f8 are required in bright sunlight. It is not possible to give a definite speed to the film for infra-red exposure as no means are available to measure the infra-red content of the light. No ratio between visible and invisible light is possible in daylight; it should, nevertheless, be possible to establish such a ratio in artificial illumination.

Picture Characteristics

The photographs on the next page will convey a better impression of the characteristics of infra-red photography than the written word can hope to do. It will be seen that the main characteristic of such pictures is in the rendition of green foliage and grass which, as they reflect infra-red strongly, are rendered as practically white. Coniferous foliage, however, photographs somewhat darker than deciduous. A blue sky and, of course, water reflecting the blue, are rendered as completely black, although on a dull day a more normal sky will be obtained. The angle of camera to sun does affect the tone of the sky which reaches maximum depth as the camera is turned away from it. If the sky is clear, shadows will be quite black, as they are then illuminated by reflected sky light. As the drops of moisture in the air, which produce haze in a distant scene by scattering visible light, have far less effect on infra-red rays, these may be utilised to cut through the atmosphere and record details invisible to the eye.

sible to make instantaneous exposures in total darkness for as no light, apart from a very dull red glow, is seen the flash can be used in circumstances where a normal flash would be inadvisable. For instance, a very graphic series was recently made showing the reaction of a child audience to certain types of film. Many other uses for the infra-red flash will suggest themselves as the photographer explores this fascinating field, in fact on any occasion where the subject should not be aware of a flash or where a flash would not be permitted, the coated bulb could be used. It can, for example, be used in busy thoroughfares as a fill-in for night shots where contrasts are often difficult to handle; in these instances no filter should be used as it is necessary to record both infra-red light from the bulb together with the general illumination. A filter is unnecessary when exposing in total darkness.

Night shots with a close-up subject in the foreground and where it is necessary to obtain detail in background, need much the same consideration as synchro-sunlight pictures. The exposure required for the background should first be determined and this exposure used in conjunction with a bulb calculated to adequately illuminate the foreground at the given aperture. For instance a well illuminated background might require 1/25 sec. at f4.5 on HP3; bearing in mind that an infra-red bulb requires about two stops more than a clear bulb it is possible to choose from the wide variety of bulbs now available one which will give the desired balance. It is probably simpler, however, to standardise on one fairly strong bulb and cut the light by means of one or more diffusers.

Unsuitable for Portraits

Although infra-red is receiving ever greater attention from scientists and technologists it is not suitable for all subjects; a portrait taken by infra-red will show to-morrow's beard in male sitters, skin tones appear as a deathly white and eyes reproduce as black beads. Wrinkles are accentuated and a negroid skin reflecting infra-red almost as much as a white one will therefore be rendered quite light in tone.

In the specialised fields of criminology, plant pathology, textile investigation, etc., infra-red is invaluable. Fig. 1, for instance, illustrates the difference in rendering of several black dyes by infra-red; five pieces of black cloth which on panchromatic stock would all be reproduced as quite black have been photographed by infra-red with results varying from black to light grey. This result is a key to the uses of infra-red in textile investigation and other fields.

In camouflage detection, greens which are visually similar will probably show light and dark patches indicating that the object has been camouflaged and is not reflecting equally as would natural vegetation. The same principles are used in showing writing on a burnt document; the diseased section of a leaf against the healthy part, etc. It

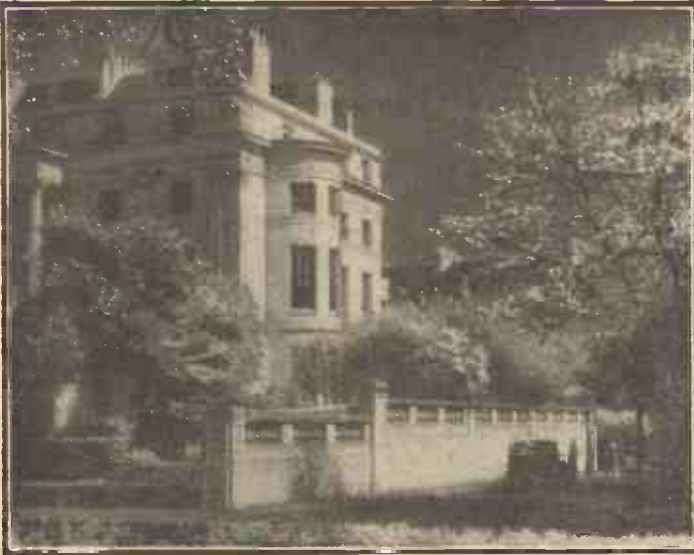

(Above) Nash architecture in Regents Park, London.

Exposure 1/12 sec. at f8. Note the contrast between buildings and sky.

(Below) Tulips, taken from a low viewpoint. Exposure 1/50 sec. at f8.



(Above) The Serpentine, Hyde Park. Exposure 1/50 sec. at f8. Note the darkened sky and water.



(Left) The lake. Exposure 1/50 sec. at f5.6. Note the almost white rendition of the foliage.



(Above) In the shadow of Eros. 1/50 sec. at f4.5, coated PF 25.

(Left) Counting the take. 1/25 sec. at f8, PF 25 coated bulb.

would be incorrect, however, to say that infra-red is always superior to panchromatic material in these fields; for most diseases which are visible the latter is often to be preferred. It is only when any penetration has to be made or a possible differentiation between visually equal tones has to be found that infra-red is superior.

Dish Developing a Film

MATERIALS REQUIRED, SAFELIGHT PRECAUTIONS AND STEP-BY-STEP INSTRUCTIONS

THE dish method of developing is used less to-day than in the past, most amateurs having decided that the modern developing tank makes the process both simpler and more convenient. However, for those who do not possess a tank, the method is described here.

35mm. films, owing to their length, are not suitable for dish development, but any of the "popular" sizes can be processed by this method.

Equipment Required

This is almost the same as for the tank method described in the April issue, except, of course, dishes will be required instead of the tank. Three will be required, one for developer, one for the fixer and the other for a stop bath solution (water). Some workers prefer to use bowls instead of dishes, which, as the film cannot scrape along the bottom, helps to prevent scratching.

The developer used can be one of the simple concentrated solution types which merely require dilution before use. Make sure when mixing the developer that the dilution instructions for *dish development* are followed and similarly that the correct developing times are noted. These, as will be seen, are shorter than for tank development owing to the stronger developer used. Fixer is mixed up the usual way.

ing will depend upon individual circumstances and preference, but in any case the dishes with their various solutions should be arranged in order, as shown in Fig. 1. A kitchen is shown here, as it is most probably the first choice of the beginner. It has the advantages of plenty of running hot and cold water and an adequate level working top, which the bathroom lacks. To prevent any accidents, spread newspapers over the table for the dishes to be placed on. Make certain that the windows are entirely blacked out—it would probably be better to work after dark.

Temperature

All the solutions should be used as near to the recommended temperature as possible. If the solutions are freshly mixed the correct temperatures may be obtained by the careful admixture of hot water in the dilution process. If stock solutions are used, the bottle containing them can be immersed in hot water or cold water, according to whether it is required to raise or lower the temperature. As the developer will be used first, it is a simple matter to ensure that this is at the right temperature, but it may be better to have the stop bath and fixing solution a few degrees warmer than required, so that when used they will have cooled to approximately the correct temperature.

Removing the Backing Paper

When the lamp has been switched off and the darkroom lamp switched on, start unrolling the backing paper from the film. When a short length of this has been unravelled the end of the film will appear. Attach one of the film clips to it and continue unrolling until the other end of the

film (attached to the backing paper with adhesive tape) comes into view. Tear this free and attach the other film clip. During this operation, handle the film by its edges only wherever possible.

If the film has a strong tendency to curl, it is a good idea to immerse it for a minute or two in a bowl of water which has previously been brought to the working temperature. The washing water which has been got ready for the final washing is clean and quite suitable for this. Many workers give this initial immersion whether the film has a tendency to curl or not.

Development

The actual development is done as shown in Fig. 2. The hands, holding the ends of the film, are raised and lowered alternately, keeping the fold of the film under the solution. The film should be run through the



Fig. 2.—Developing in progress.

solution from end to end, slowly, smoothly and regularly.

The negatives will appear faintly at first and then gradually becoming darker. They will probably look too dark before the correct developing period has elapsed, but make sure they stay in the developer for the correct time.

When the development time has elapsed, transfer the film, using the same see-saw action, to the stop bath and rinse for at least one minute. Finally, transfer to the fixer. As you continue the see-saw action, the film becomes patchy due to the partly dissolved emulsion. After several minutes of this, the light may be switched on and the rest of the fixing process carried out under it. Fixing must be continued for about five minutes after the emulsion has completely cleared. Finally, wash the film in running water for half an hour. You can use a washing-up bowl in the kitchen or the hand-basin in the bathroom for this, completely emptying the bowl or basin two or three times during the half hour. Clip the two ends of the film together while the washing is carried out.

Finally, hang the film up by one of the film clips in a dust-free room to dry. The other film clip can be hung on the other end as a weight to hold the film straight.

Cut Film and Plates

These are not so likely to be met with by the beginner, but if someone gives you a camera using this type of negative material the procedure adopted for development is approximately the same as for dish developing a film. Usually plates are dealt with one at a time. When placing the plate in the dish, make sure it is emulsion side upwards and, during the process, rock the dish. When development and fixing are completed the plates can be washed in a dish into which the tap is allowed to run gently. Finally, plates must be drained and dried on edge, while cut film can be attached by a corner to a line of some sort by means of film clips. If a number of plates is to be dealt with, it may be thought advisable to purchase special plate tanks and drying racks, which will greatly facilitate the process.



Fig. 1.—How the dishes are set out.

Two stainless steel film clips will be needed to hold the ends of the film; do not use either the bare fingers or ordinary paper clips.

The final item of equipment required is a darkroom safelight. If the film being processed is orthochromatic, i.e., not sensitive to red, a dark red or ruby safelight can be used. If the film is panchromatic, only a dark green safelight can be employed; it is important, too, to use only the bulb specified by the makers, even though this gives a very dim light. The safelight must be used with discretion and the film must not be exposed to its light for any length of time. If the simpler routine processes can be carried out in darkness, it is best to switch the lamp off for as long as possible.

The Darkroom

The room used to carry out the develop-

Freelance Photography

TAKE PHOTOGRAPHS FOR YOUR LOCAL PRESS AS A PAYING SIDELINE

By H. CULL

SOME local newspapers have their own photographers, but can often use prints taken at events which they are too

ing the subjects they are to photograph. I like to work differently, however, to obtain more natural results and, using a 35 mm. Retina exclusively, I take the action as it occurs. To this end I put a lot of forethought into estimating where the action will take place, then take up the best position, which I defend against all comers.



Fig. 1.—A local horse show picture.

busy to attend. Other papers rely entirely on amateur photographers, and the work can be very rewarding.

It is not a job for the rabid specialist in any particular field. You will have to be quick and sure of what you are doing, with half an eye open for the unrehearsed surprise. You will be asked to take a wide variety of subjects, from Lady So-and-So presenting a challenge cup, to action shots at football or athletics (see Fig. 5).

Anticipation

Whilst luck plays a large part in getting out-of-the-rut pictures, a lot can be done by intelligent anticipation. For example, in Fig. 3, the boys were ambling



Fig. 3.—An example of anticipation.

(Fig. 1), dog shows, rock 'n' roll contests (Fig. 6) and, of course, Lady So-and-So opening a bazaar, to mention only a few.

When there is no news, you can sometimes make your own by photographing such subjects as the steam-roller in Fig. 2. If the editor thinks it worth while he will send a reporter to interview the subject. In this case the driver had been driving steamrollers man and boy for 46 years.

On the whole, picture editors like to see numbers of potential newspaper buyers in their pictures, so the more you can get in the merrier. At times you will have difficulty in preventing too many from creeping in. Be firm, but remember *people* buy newspapers, inanimate objects do not, so that your picture of the log shaped like a sea-horse doesn't stand much chance of being accepted unless, of course, it has bitten someone!

Finally, if your pictures are very good, so that the newspaper reproduction is clear,



Fig. 4 (Top).—An example of intelligent posing.

Fig. 5.—A typical action shot.

do not expect to sell many prints privately. For some unaccountable reason people prefer to pay fourpence for a newspaper picture of themselves rather than half-a-crown for the superb picture you will, no doubt, make for them.



Fig. 2.—The photograph with a story.

round making no attempt to compete seriously in the walking race.

I saw what was happening and got round the track to take up a position where I thought the competitor would pass them. As he did so, they were making "curious" remarks, and shortly afterwards were disqualified.

When working alongside other Press men I have noticed that they concentrate on pos-



Fig. 6.—Local rock 'n' roll contest.

MANUAL of the MINIATURE CAMERA

21/- or 22/6 by post

INDOOR PHOTOGRAPHY

15/- or 16/1 by post

FROM GEORGE NEWNES LTD., TOWER HOUSE, SOUTHAMPTON STREET, LONDON, W.C.2

An Electro

JOHN HUCKLEBRIDGE GIVES FULL



Fig. 1.—The electronic flash unit and two reflectors.

THIS electronic flash outfit is the third in a series of flash outfits made by the author during the last few years. The previous models used 1,000-volt flash tubes and radio-type electrolytic condensers in series-parallel arrangements. Although these worked quite well, they were heavy, and because of their leakage current radio-type electrolytic condensers took too long to charge when using batteries. Also, due to the short duration of the flash, there was need for 50 per cent. extra development of the film. Finally, reflectors made from car headlamps tended to "beam" the light too much. The unit described here and shown completed in Fig. 1 was designed to overcome some of the above snags as cheaply as possible.

The Circuit

This provides for two lamps of 100 joules each using internal 4-volt accumulator with built-in charger or mains (A.C.) all housed in a box measuring 8in. X 5½in. X 6½in. The theoretical circuit is shown in Fig. 4 and in Fig. 8 a point-to-point wiring diagram is shown.

tors also prevent the full 200 joules lighting up one flash tube. When the lamps are plugged into the box (which should be done before switching on) there is a potential of 270 volts across the tube. This is not enough to start a discharge. Condensers C6 and C7 are charged to approximately 150 volts by the potential dividers R5 and R6. When the camera flash contacts or the open flash button S3 are closed, C6 is discharged through the primary of the trigger transformer TC causing a short pulse of several thousand volts to appear at the trigger electrode. This starts a discharge in the tube between the trigger electrode and the cathode, and then the 270 volts is high enough to keep the discharge going. Once the discharge has started the internal resistance of the tube is almost zero so the 100 joules stored in the main condensers are discharged in a few milli-seconds, giving a brief but bright flash.

The potentiometer R5 should be adjusted so that the neon stops flashing when the voltage across it reaches maximum (in about ten seconds when using one lamp).

C5 makes the neon flicker instead of just glowing on reaching working voltage. Discharging the main lamp automatically flashes the extension lamp so that no synchronising leads are required in the extension lamp. Switches S1A and S1B connect the

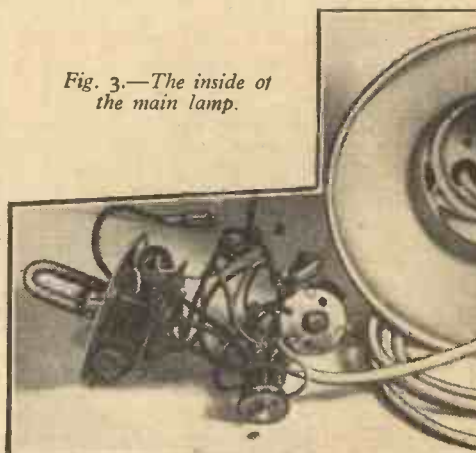

Fig. 3.—The inside of the main lamp.

battery either to the vibrator or the charger and S1C opens the secondary of the transformer circuit so that the main condensers are not being charged all the time the battery is being recharged. When the battery switch S2 is off this completes the mains primary side of the transformer and the flash may then be run off the mains or the battery charged. Do not forget to adjust the voltage adjuster as this is important with a small transformer.

S4 is the half-power switch. Closing S4

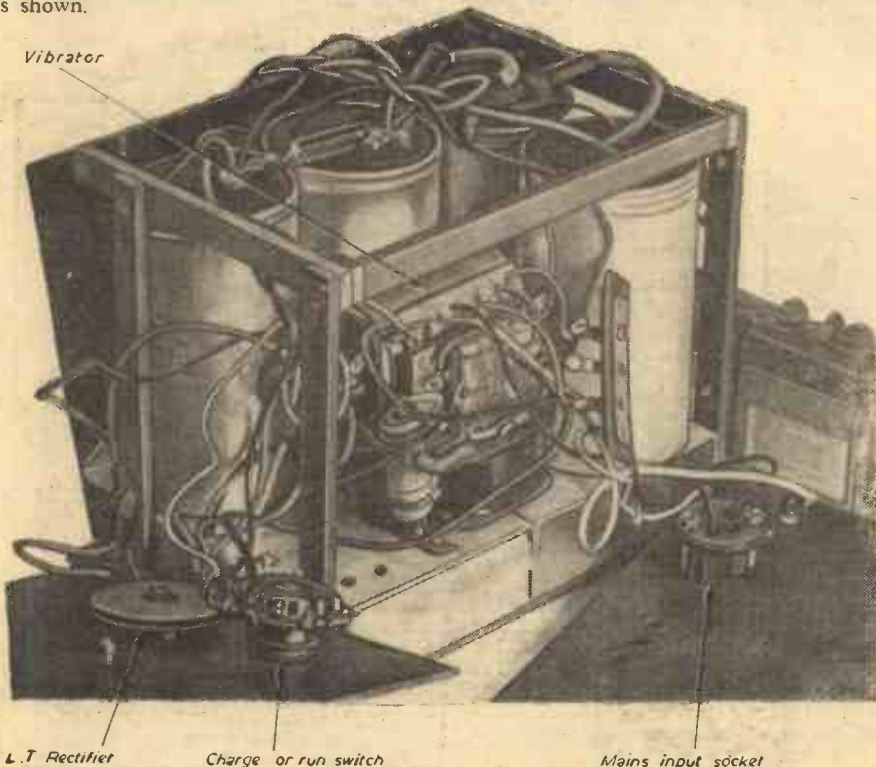

Fig. 2.—The unit with one end and one side removed.

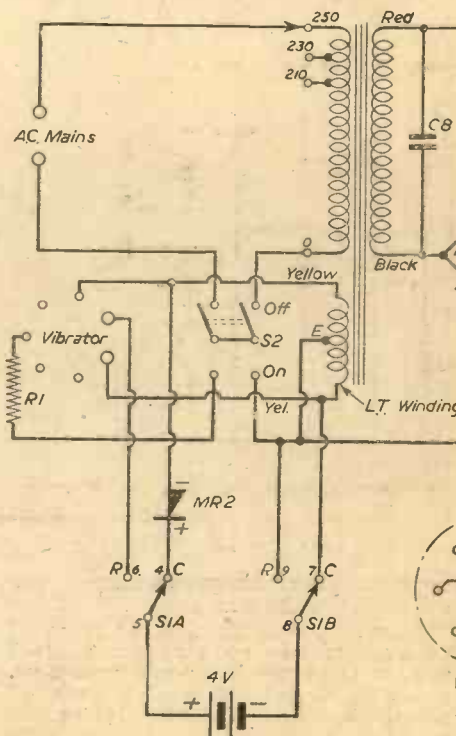

Fig. 4.—

mic Flash Outfit

CIRCUIT DETAILS AND NOTES ON CONSTRUCTION

shorts out R4, thus allowing the charge on C1 to combine with the charge on C2 and flow through the tube. Half-power is not required on the extension lamp, as if it is too bright it can be moved farther away from the subject.

ment panel are fixed to one side panel and two output sockets and S4 are on the top panel. A 1 1/2 in. plastic carrying strap completes the box. These details may be seen plainly in Figs. 2 and 6.

The Box

The box is made from an aluminium base, which is the battery container, and a skeleton of 1/2 x 3/16 in. Paxolin strip (see Figs. 2 and 6). These strips are held together by 6B.A. 3/8 in. c/s brass screws—the Paxolin takes a thread quite well. The side and top and bottom panels are of 1/8 in. black Perspex-like material. Each panel is held on

Reflectors

The two reflectors, which can be seen in Figs. 1, 3 and 5, are "surplus" from C. B. Miller & Co., 337, Brighton Road, South Croydon, Surrey, at 12s. 6d. each. They have

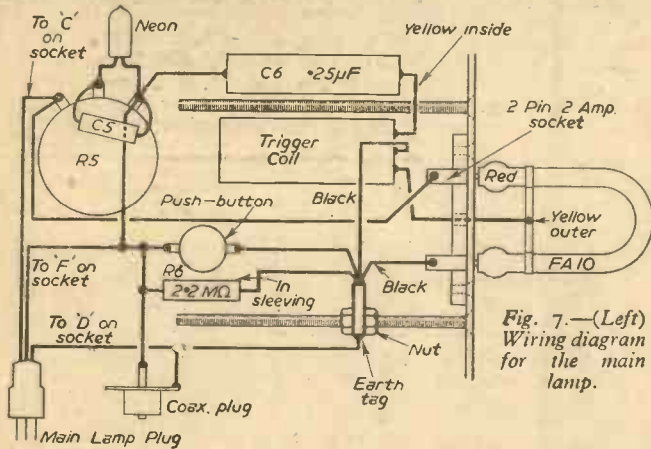
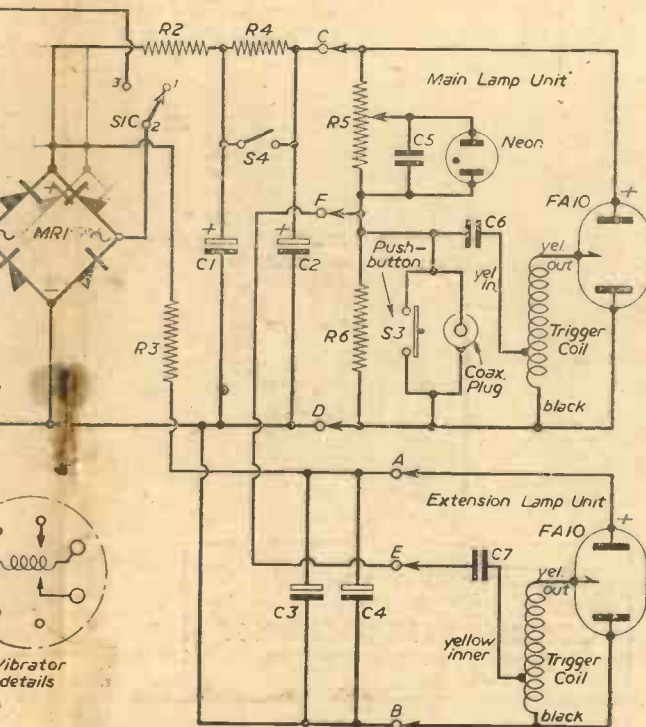

Fig. 7.—(Left) Wiring diagram for the main lamp.

only by four screws. The switch S1 and the L.T. rectifier are fixed to the end panel, S2, mains input socket and voltage adjust-



The theoretical circuit diagram.



Fig. 5.—Camera cradle and main and extension lamps.

Fig. 6.—(Right) A view with side and top removed showing some of the principal components and dimensions.

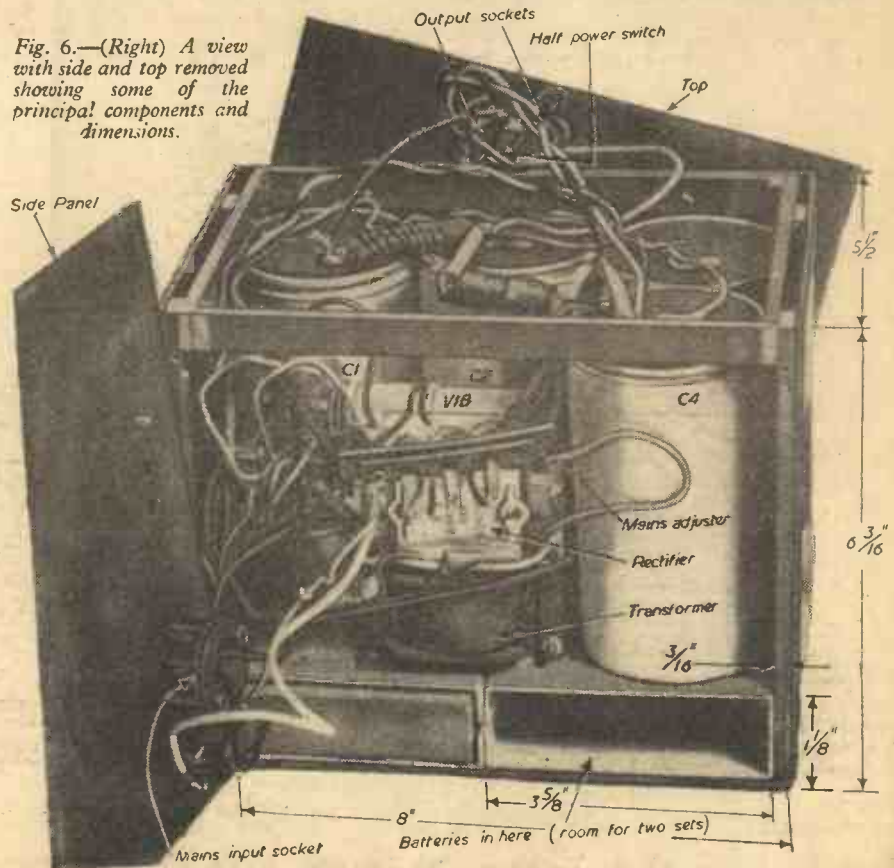

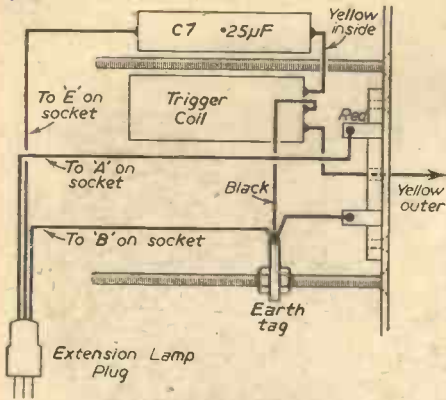

Fig. 9.—The extension lamp.

hole and joined to the metal strap between the flash tube legs. Two holes, 1½ in. apart, are made in this metal plate, and two 2½ in. 4 B.A. bolts are screwed through these holes for fixing in the reflector. The trigger coil and condensers C5 and C6 are strapped to the Paxolin disc supplied, and the disc is then pushed on the 4 B.A. bolts and held in place with a nut either side. The neon is pushed through a rubber grommet with its head just protruding, and the potentiometer is fixed to the inside. The wiring for the main lamp and the extension lamp is shown in Figs. 7 and 9. The power lead is

LIST OF COMPONENTS

- Mains battery transformer assembly (includes vibrator, vibrator socket, coil resistance R1, buffer capacitor C8 and Westalite rectifier-16RD 2-2-8-1, wired ready for mounting), £2.19.6, from General Electronics, 129, Portobello Road, London, W.11.
- 3 2-pin 2-amp sockets (1 for mains, 2 for flash tube holders).
- S2 battery toggle switch, double pole change-over.
- S1 A.B.C. 3-pole 2-way switch.
- S4 on/off single-pole toggle switch.
- M.R.2 L.T. charging rectifier, ½ amp.
- L.T. battery, 2 Exide Gel-Cel type PRA-3S.
- R1 (already in transformer assembly).
- R2, R3, 500 Ω 1 watt (charging resistors).
- R4 200 Ω wirewound.
- R5 2.2 MΩ ½ watt midget pot.
- R6 2.2 MΩ ½ watt.
- C1, C2, C3, C4, Daly photoflash capacitors 1,600 µF each 270 volts wkg. Type PFM 99/18 from Daly Condensers, Ltd., West Lodge Works, The Green, Ealing, London, W.5. 41/3 each.
- C5 .05 µF 200 volts wkg. midget type.
- C6, C7 .25 µF 250 volts wkg. midget type.
- C8 .05 µF (supplied in transformer assembly).

- TC 2 trigger coils 12/6 each (General Electronics or C. B. Miller).
- 2 reflectors 12/6 each (C. B. Miller & Co., 337, Brighton Road, South Croydon, Surrey).
- 1 neon, miniature pattern, 2/-. C. B. Miller.
- 2 miniature 3-pin plugs and sockets.
- 8 yards of 3-core P.V.C. connecting cable.
- 2 flash tubes Mazda type F.A.10, £2.10.0 each. (Tube is marked with red dot on the positive leg.)
- 1 mains voltage adjustment panel.
- 1 synchronising lead with suitable type plug on the end; the type of plug depends on the camera with which it is to be used.
- 4ft. zin. of ¼ in. × 3/16 in. Paxolin strip.
- Case comprising of 2 pieces 5½ in. × 8 in., 2 pieces 6½ in. × 8 in., 2 pieces 6½ in. × 5 5/16 in. of ¼ in. Perspex, Paxolin or other suitable material.
- Approx. 2ft. of 6 in. wide 3mm. aluminium sheet.
- Five dozen 6 B.A. ¼ in. long brass c/s headed screws.
- 4ft. of 1½ in. wide plastic strap.
- Red and black P.V.C. flex for wiring.
- Components not specially mentioned can be purchased from any radio dealer or from General Electronics.

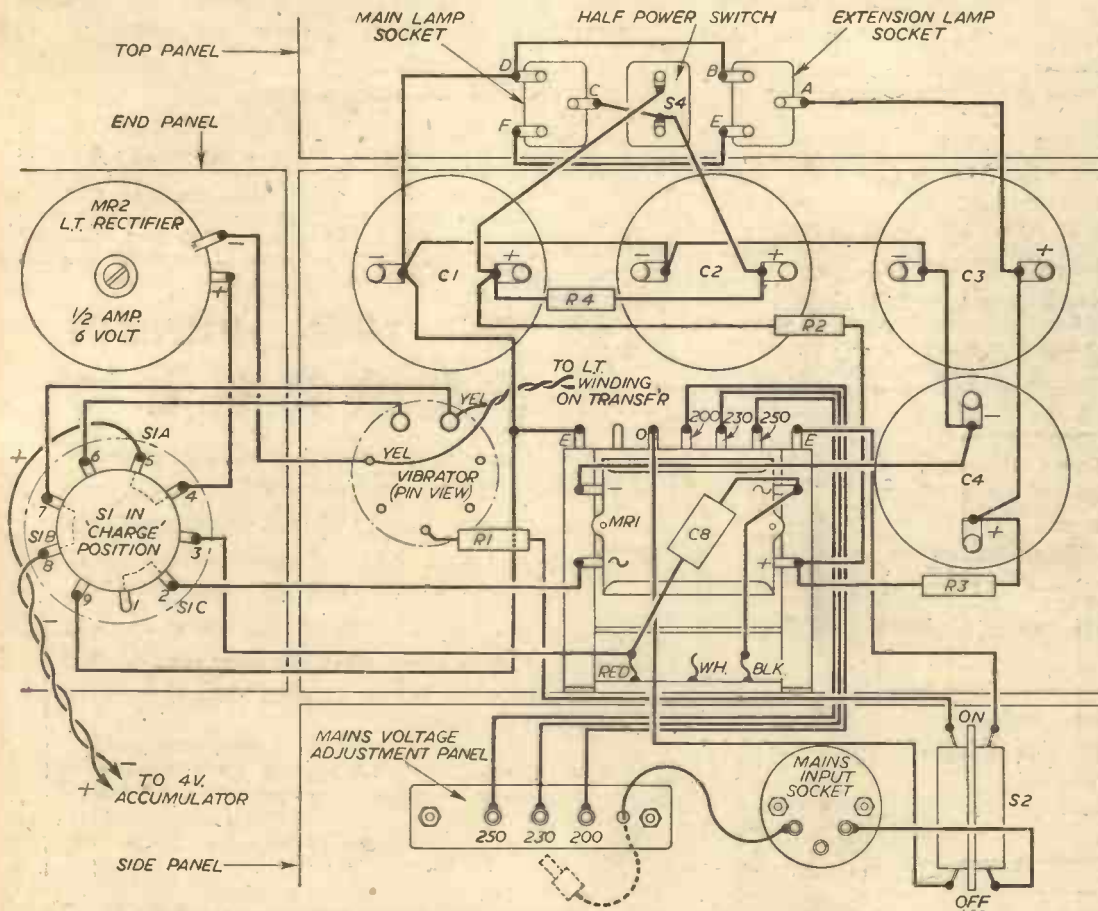

Fig. 8.—Wiring diagram of the power unit.

anchored on the inside and brought out through a grommet. The main lamp has 2 yards and the extension has 6 yards of three-core P.V.C. cable.

Warning

Do not make any alterations to the circuit without first making sure that the main condensers are discharged. This can be done

by flashing the tubes or shorting the condensers with a 500 Ω resistor. Do not short them with a screwdriver as this is detrimental to the condensers. Use only one hand and keep the other in your pocket.

To charge the batteries, take off the panel opposite the mains socket, pull out the batteries and stand them upright. Always take the batteries out before charging them.

In use, the main lamp is attached to the camera, and the extension screwed to the pan-and-tilt head of a tripod which is placed nearer and to one side of the subject. The author's arrangement is shown in Fig. 5. About three seconds after the neon lights the lamps are ready to flash. During waiting periods the box should only be switched on in short bursts—just long enough to keep the neon alight and so conserve the batteries. With two lamps, the flash number is not as critical as with only one lamp.

Exposure

For head and shoulder portraits—

- light subjects ... f22
- dark subjects ... f16
- Full lengths ... f11
- all others f8 or f5.6 depending on size.

This is using Verichrome Panchromatic film.

These exposures have been found by the author to give the best results, but it may be advisable for the individual user to establish his own standards by trial and error. Not every photographer will wish to use the same procedure and technique, but the outfit described is quite versatile.

AMATEUR PHOTOGRAPHY

15/-, 16/1 by post

COLOUR PHOTOGRAPHY FOR THE AMATEUR

21/-, 22/6 by post

GEORGE NEWNES, LTD., TOWER HOUSE, SOUTHAMPTON STREET, LONDON, W.C.2

**A QUALITY CAMERA AT
REMARKABLY LOW COST**

***Ferrania* TANIT**

The Ferrania TANIT camera is designed to halve the cost of film by taking 16 instead of 8 pictures on one roll.

The TANIT is of elegant and modern design, closely resembling an expensive miniature camera, at a remarkably low price. The body is pressure die-cast in aluminium alloy and the covering is grained morocco leather. The lens has an aperture of f/9, sufficient for normal lighting conditions. Will produce negatives capable of ample enlargement, and can be focussed from 5 ft. to infinity. The shutter, for instantaneous and time exposures, is synchronised for flash. To appreciate its remarkable qualities the TANIT has to be seen and handled, and we strongly recommend you to see one at your local photo shop.



16 PICTURES ON 127 FILM

Picture size: 3x4 cm. (16 pictures 1 1/4 in. x 1 5/8 in., on the standard 127 film). Camera size: 4 1/2 in. x 3 in. x 2 3/4 in. Weight: 9 ounces. Lens: Ferrania Primar f/9 with focussing scale. Shutter: Ferrania Silent B for instantaneous and bulb exposures, synchronised for flash. Viewfinder: double lens optical type. Tripod bush. Supplied complete with carrying strap, and 20-page instruction booklet.

Medium Yellow Filter, 6/6
Portrait Attachment, 6/6

£3. 2. 4
Every-ready Case 15/1



FROM ALL GOOD PHOTO SHOPS

NEVILLE BROWN & COMPANY LIMITED · LONDON W. 1.



**START PRINTING YOUR OWN
SNAPS AT HOME!**

Animals or architecture, landscapes or table-top pictures, the thing that really counts is the final print. To get the result that YOU want, exactly when you want it, you can't do better than to make your own prints at home. It's not expensive—Johnson Home Photography Kits range in price from as little as 13/6 upwards—and the instructions supplied make the whole process very easy to carry out.

Send s.o.e. for your free copy of the Outfits leaflet, Dept. 20, Johnsons of Hendon Ltd., 335, Hendon Way, London, N.W.4.

LONDON



N.W.4

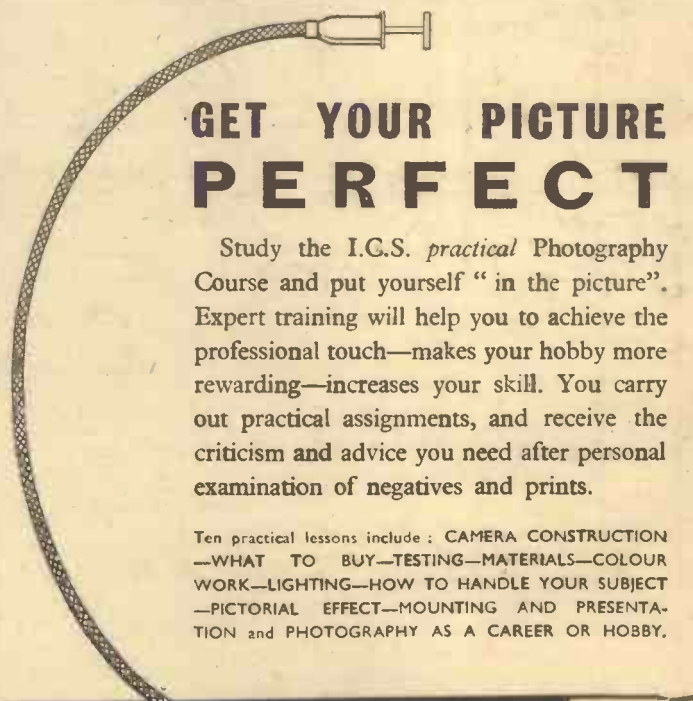

**GET YOUR PICTURE
PERFECT**

Study the I.C.S. *practical* Photography Course and put yourself "in the picture". Expert training will help you to achieve the professional touch—makes your hobby more rewarding—increases your skill. You carry out practical assignments, and receive the criticism and advice you need after personal examination of negatives and prints.

Ten practical lessons include: CAMERA CONSTRUCTION—WHAT TO BUY—TESTING—MATERIALS—COLOUR WORK—LIGHTING—HOW TO HANDLE YOUR SUBJECT—PICTORIAL EFFECT—MOUNTING AND PRESENTATION and PHOTOGRAPHY AS A CAREER OR HOBBY.

POST THIS COUPON TODAY

*for details of
Photography
Course*

INTERNATIONAL CORRESPONDENCE SCHOOLS
DEPT. 264A, INTERNATIONAL BUILDINGS, KINGSWAY, LONDON, WC2

NAME

ADDRESS 7.58

INTERNATIONAL CORRESPONDENCE SCHOOLS

Colour photography is not as expensive as you think. This lively, practical book shows how to get the thrill of colour in your photographs!

COLOUR PHOTOGRAPHY for the AMATEUR

by **M. LILLINGTON HALL, M.A. (Oxon.)**

This book is designed to help the amateur to add the magic of colour to his photography. It is written for the photographer who has some knowledge of monochrome work, but its easily-understood style should appeal even to the absolute beginner. The aim has been to produce a book which is clear, simple, and readable, but packed with just that information which the photographer needs.

It explains the fundamentals of colour photography, deals with the problems of exposure, contrast range and colour rendering, and gives practical advice on taking colour photographs indoors and outdoors, by daylight, artificial light and flashlight. Developing and printing colour film is not as difficult as is often supposed, and full information is given on this fascinating aspect of colour work.

A feature of the book is the large number of tables, many specially prepared by practical experiment. Another feature is that a special attempt has been made to give the very latest and most up-to-date information on colour films.

**An investment at only 21s. net.
FROM ALL BOOKSELLERS**

... or in case of difficulty simply complete the Order Form below.

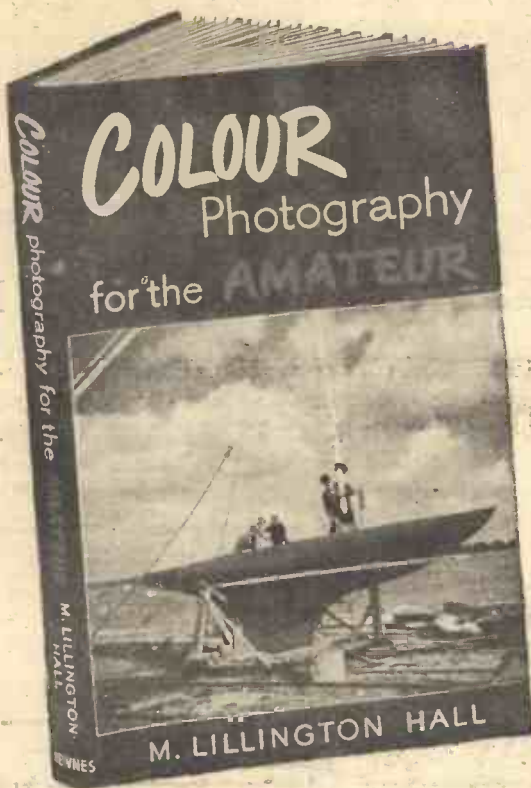

**With 34 tables
65 illustrations and
8 colour plates**

CONTENTS

Your Questions Answered—Light and Colour—
Choosing the Film—Exposure and Colour Rendering
—Colour and Composition—Colour Out of Doors—Colour Indoors—Flash
Indoors and Out—Processing Your Own Colour Films—Colour Prints—
Colour Derivations—Viewing your Transparencies—Index.

In its 2nd Edition within ONE YEAR!

The amateur photographer who begins to be interested in colour films at the present time is starting just at the right moment. The early experimental stage of hit-or-miss methods is over; every year the speed of colour films approaches more nearly to that of monochrome film, and the films and processes are continuously made more and more foolproof, so that even a beginner may expose his first colour film with confidence.

Take this year's holiday photographs in colour and impress yourself and your friends!

ORDER HERE

Please send me Cash on Delivery one copy of the 2nd Edition of
COLOUR PHOTOGRAPHY FOR THE AMATEUR (21s. net.)

Name

Address

NOTE.—Simply complete and post this C.O.D. order to **GEORGE NEWNES LTD., Tower House, Southampton Street, London, W.C.2.** Send no money now—just pay on delivery plus C.O.D. charges. (If you prefer, send a remittance for 22s. 3d.)

P.M.
July '58

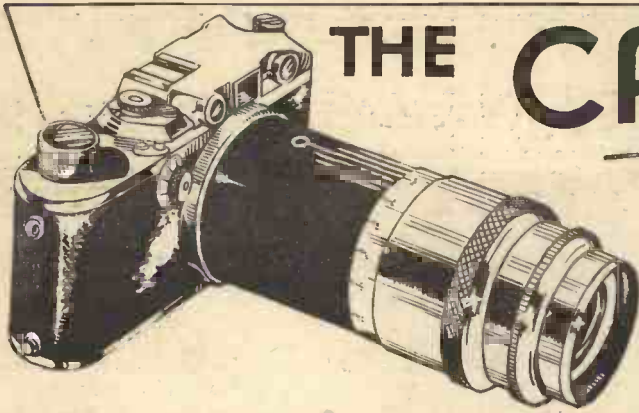

THE CAMERA LENS...

Part 2 of a Short Series Which Explains in Simple Language How the Camera Lens Works

By J. C. Lowden

(Continued from the June issue)

The Focal Length

THE focal length may be most simply defined as the precise distance behind a lens at which the rays of light reflected from an object "viewed" by the lens converge to form a clearly defined, inverted image.

This property is simply observed in the following manner. Take any simple lens—a small magnifying or burning glass is adequate. Hold it under any bright source of light. The sun is the ideal, but a pendant lamp will suffice (Fig. 6). Place a sheet of

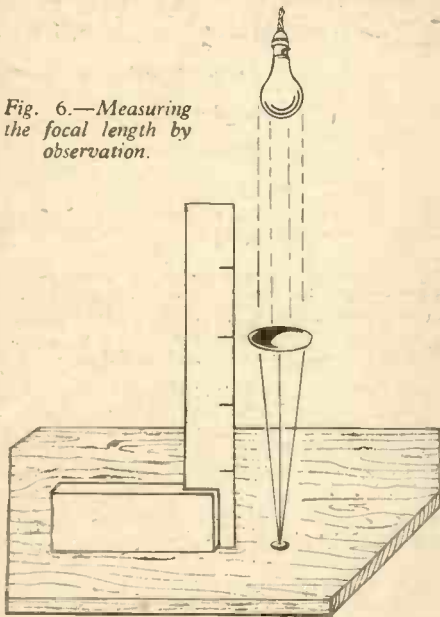

Fig. 6.—Measuring the focal length by observation.

paper on a flat surface under the lens. Raise or lower (focus) the lens until a clear image of the lamp or sun is resolved. (Beware of heat if you are using the sun.) Measure the distance between the centre of the disc and the paper. There, to the limit of accuracy of your measuring, is the focal length of the lens. The focal length of the lens can be manipulated within wide limits by the design. Once the lens is finished, however, it is a fixed quantity.

The focal length of a compound lens, i.e., one made up of more than one "element," can be determined by the focal lengths of the elements used. As a simple example, if two lenses of, say, 10in. focal length were mounted in a short cell the lens would be a simple "doublet" (Fig. 7) and the focal length of that doublet would be roughly half of the focal lengths of its elements, i.e., 5in.

(For the mathematically minded, the exact focal length of the doublet could be calculated by the use of the Gauss equation:

$$\text{Focal length of doublet} = \frac{F/L_1 \times F/L_2}{F/L_1 + F/L_2 - D}$$

D is the distance between the two elements and is a variable quantity.)

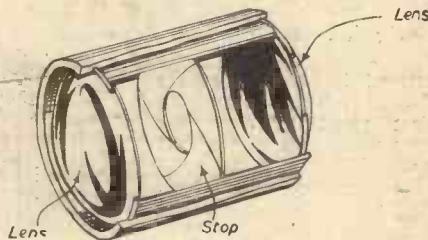

Fig. 7.—A simple doublet.

Since the good-quality photographic lens is made up of a multiplicity of glasses and sealed into a single unit it would be a formidable task to work out for oneself the focal length. The "direct observation" method would afford only an approximation, since the measurements of a compound lens must be taken from the nodal points, which would be difficult for the non-technician to locate.

Fortunately for the amateur, every good-quality lens has the focal length clearly engraved upon the lens mount. This is a fixed quantity, and (except for a special purpose, which comes under the heading of focusing) it cannot be controlled by the user.

Convertible lenses, in which the focal length could be varied by the removal or substitution of various components, were at one time essential items to a serious worker. Many of these excellent objectives are still giving yeoman service.

Among the many important considerations of the focal length of the lens is that it more or less determines the maximum size of the negative to be used. In a camera using a lens of "normal" (40-60 deg.) angle of acceptance the focal length of the lens fitted will be equal to, or somewhat larger than, the diagonal of the largest negative used in that camera.

TABLE OF FOCAL LENGTH/FILM SIZES

Negative	Focal length
35mm. (Leica size)	5cm. 2in.
2½ in. sq.	7.5-9cm. 3-3½ in.
2¼ × 3½ in.	10-11cm. 4-4½ in.
½ plate	13.5cm. 5½-6in.

This table is not complete, and individual cameras may vary slightly. The metric equivalents are approximate.

The F Number

The f number is the most important symbol in photography, for it denotes the working efficiency of the lens. The smaller the f number, the more efficient the lens—a fact which may puzzle the tyro until it is

realised that the number is really the denominator of a fraction.

The f No. is resolved in the following way:—

$$\text{Focal length} \\ \text{Diameter of lens}$$

Thus, a lens of 10in. focal length, with a diameter of 1in., would be rated at f/10, while a lens of the same focal length with a diameter of 2in. would be rated at f/5. Another term for the f ratio of a lens is the "aperture."

Lenses of long focal length are not made with such large apertures as lenses of shorter focal length. Referring to the previous example of a 10in. f/1 lens: to make this lens with a working aperture of f/2 (by no means unreasonable in modern usage) would require a disc of glass of a minimum diameter of 5in. This would introduce a great many difficulties, both in design and manufacture, and would increase the cost to an unreasonable degree. The same objections would be present, and probably intensified, if the designer set out to do the job with a multiplicity of compound lenses.

In a simple fixed-focus camera the aperture is fixed at the comparatively "slow" rating of f/11. This represents a lens of sufficient power to transmit the correct quan-

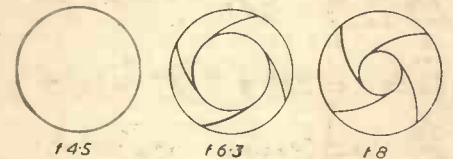

Fig. 8.—The iris diaphragm "stopping down."



Fig. 9.—Chromatic aberration. A—point of focus of blue rays. B—point of focus of yellow rays.

tity of light to give adequate exposure to normal "amateur" film under reasonable lighting conditions.

Variable "Stops"

Even quite unambitious cameras to-day, however, have lenses with maximum apertures of the order of f/4.5, and it will be clear that if sufficient light can be transmitted by an aperture of f/11, that passed by f/4.5 will be greatly excessive. The wide aperture, then, must be controlled by a "stop." In simple cameras this stop may be merely a blackened metal strip, pierced with holes. The strip is moved over the lens until the correct hole is selected.

In better equipment the aperture is controlled by the "Iris Diaphragm" (shown in

Fig. 8). This is a beautiful mechanism, consisting of a series of fine metal leaves. Each of these is pivoted at one end to a common "travel," and as this travel is moved the blades open or close. The degree of closure, within the limits of the travel, is unrestricted, save that it is not usual for complete closure to be made. The travel is usually actuated by a "setting ring" or lever.

The Setting Scale

For accurate exposure it is necessary to know precisely the size of the aperture, so the iris has a scale graduated in a series of closures. Each of these "steps" is so arranged that the larger aperture passes exactly twice as much light as that preceding it, e.g., $f/4$ passes twice as much light as $f/5.6$, while $f/5.6$ passes twice as much as $f/8$.

The British Standard Scale is as follows, the typical Continental Scale being given below it.

British: $f/2, f/2.8, f/4, f/5.6, f/8, f/16, f/22, f/32$.

Continental: $f/2.3, f/3.2, f/4.5, f/6.3, f/9, f/12.5, f/18, f/25, f/36$.

Yellow & blue rays

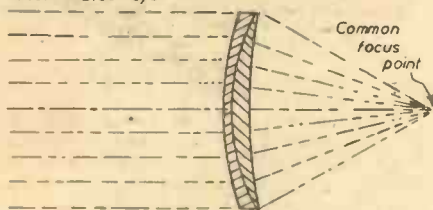

Fig. 10.—Achromatic lens.

Although these do not exactly correspond they may, for practical purposes, be regarded as equivalents.

A scale now obsolete, but still to be encountered in perfectly serviceable "vintage" models, is the Universal Scale (U.S.). In this scale the aperture $f/4$, then considered almost unapproachably "fast" was taken as unity. Thus:

$f/4, f/5.6, f/8, f/11, f/16, f/22$

U.S.: 1 2 4 8 16 32

Lenses are always specified by their maximum working apertures. In some lenses this maximum may not fit in the standard scale. As an example, the Skopar lens fitted to the writer's Vito has a maximum aperture of $f/3.5$. This is the widest aperture on the scale, which then follows on with the normal British scale. For practical purposes it is reckoned that the "extra" stop of $f/3.5$ is equivalent to doubling the value of the next stop.

When buying a camera, especially a moderately priced miniature, it is as well to be careful of a cheap lens with a huge aperture. Even with colour film exposures of the order of $f/2.8$ or so are rarely called for, and a well-designed lens of a maximum of $f/4.5$ or so may well be a better "buy" than one with a super-wide aperture but the resolving powers of which, even when closely stopped down, may be suspect. To design and build a really wide aperture lens which will give first-rate performance can never be cheap.

Referring to the original definition of a lens, the simplest form of lens to fulfil these basic conditions is a meniscus lens, in section a "crescent" or "meniscus." This lens, unfortunately, cannot be regarded as a serviceable camera objective. The first and really insuperable objection is as follows.

Chromatic Aberration

Anyone who has observed the effect of passing light through a prism is aware that

so-called "white" light is really a blend of light rays of differing colours, among which the blues and the yellows are the most important for photographic purposes. The simple meniscus bends the rays of light of different colours to different extents. Thus the yellow rays do not focus in the same plane as the blue rays, and it is not possible to reconcile these two planes of focus (see Fig. 9). This failing is known as "chromatic aberration." It is best

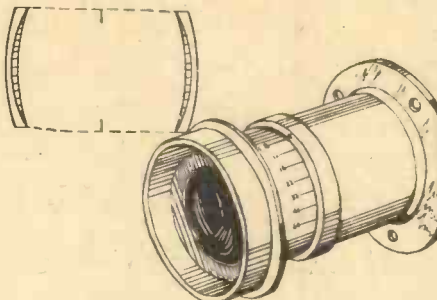

Fig. 11.—The rapid rectilinear lens.

observed by looking at the coloured fringes around an object viewed through the lenses fitted to cheap optical toys.

Meniscus lenses have been fitted to fixed-focus cameras of the toy quality, but their best use in photography is as supplementary lenses.

The Achromatic Lens

The problem of chromatic aberration was solved by Dollond, the English scientist, in the mid-Eighteenth century. By compounding two lenses of varying refractive indices and differing focal lengths he was able to produce a lens which focused the different coloured rays in the same plane (Fig. 10). This lens, not subject to chromatic aber-

ration, was termed achromatic. In its most efficient form the achromat is of meniscus section, and is usually termed a meniscus achromat. This type of lens, while eliminating the main boggy of chromatic aberration, is subject to other aberrations which preclude its use at apertures wider than $f/11$ or thereabouts. It is, however, perfectly adequate for simple fixed-focus cameras using a large negative which will not normally be subjected to the searching process of enlargement. It is, therefore, practically standard equipment on good quality box cameras.

The rapid progress of the other branches of photography greatly hastened the development of the lens. Various workers used different combinations of achromats, perhaps the best known of which was the famous Rapid Rectilinear (R.R.).

This was a combination of, basically, a pair of symmetrical achromatics with a stop in between, as shown in Fig. 11. This combination eliminated the worst aberration, linear distortion, to which the simple achromat was subject. Linear distortion implies an inability to render an accurate image of a straight line. While linear distortion was tolerable in portrait work, and

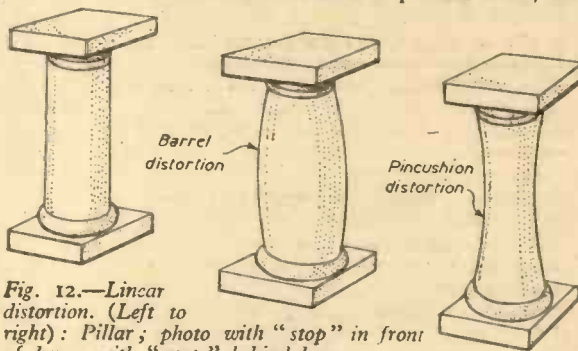

Fig. 12.—Linear distortion. (Left to right): Pillar; photo with "stop" in front of lens; with "stop" behind lens.

in landscape, to some extent, it was quite unacceptable in architectural photography (see Fig. 12). The R.R. remedied this grave defect, and it was termed "rapid" because it could be made at an aperture corresponding to $f/8$ —still a useful size.

Large negative cameras (film sizes 116-118) are still to be seen in use with R.R. lenses, and they give good service so long as the negatives are not over-enlarged.

While the rapid rectilinear and similar compound lenses represented a great advance in lens performance, they were still subject to a number of aberrations, and the two most obstinate of these were curvature of field and astigmatism. These two aberrations are closely allied.

Curvature of Field

The two glasses used together in compounding an achromat must be made to certain specifications if they are to focus blue and yellow rays together. They must also fulfil certain other conditions if the image to be focused is to be formed on an absolutely flat field. Unfortunately, these two factors are different, and irreconcilable, and the simple achromat is unable to bring the image to focus on a plane surface.

Curvature of field can best be observed in an enlarger, or projector, when one of the inexpensive achromat doublets is being used. At its widest aperture the lens "projects" an image which may well be perfectly defined in the centre, but which is blurred at the edges. If the lens is refocused so that the edges of the image are clear, then the centre is blurred. Fortunately, this defect can often be cured by "stopping down" the lens.

(To be concluded)

Camera Collections

Why Not Start One of Your Own?

MOST people have at some time or other in their lives been a collector. Schoolboys collect the most amazing variety of things, ranging from the more usual stamps and cigarette cards to things like matchbox tops, orange wrappers, cheese labels and door knockers; why not, now you are a photographer, collect photographs of one particular subject? Once the collection is in full swing, you may rediscover the enthusiasm of the true collector. Your collection may easily be allied to a subject in which you are already interested—the architect can make a collection of freak buildings, the motorist a collection of vintage cars, the horologist a collection of unique clocks, etc., etc. Those with no particular interest have the whole field of photo-collecting open to them, such things as windmills, sundials, signposts, gargoyles, bridges, wells, and one of the most popular subjects of all (although perhaps not for the reasons usually ascribed to the true collector) pub signs.

A photographer who collects pictures of one subject for any length of time, is bound to gain considerable knowledge of his subject and might possibly, in time, become an expert!

Replies to Readers' Letters



Roller Blind Shutter Repair

I HAVE a T. P. Reflex camera and the substance with which the inside of the roller blind shutter is coated has perished and cracked and is no longer light-proof, although the fabric and tapes are in good condition.

The cost of having new blinds fitted is prohibitive, bearing in mind the limited use to which the camera will be put.

Can you suggest a suitable substance with which the blinds may be coated to render them opaque? Or, alternatively, is the fitting of new blinds by the owner a practical proposition?—L. C. W. (Sheffield).

IF a limited number of pinholes exists, they may be filled with a sparing application of Bostik or rubber solution. If the blinds are in bad condition, new ones are really required. Thornton Pickard, Woodfield Road, Altrincham, would fit these. It is also possible that they would provide you with new blinds to fit yourself, if supplied with details of the camera.

Whether or not you could do this successfully depends upon your ability to note exactly how the shutter components operate, and upon replacing everything exactly as originally. It is necessary to mark the gears in the shutter mechanism, so that they may be replaced with the same teeth meshing, and if this is done, timing will be correct.

If you study the shutter drive before taking to pieces, this will become clear to you.

It does not seem very likely that the existing material could be made light-proof, if in bad condition.

Overcoming Parallax

THE camera I possess is a folding one; with the usual type of viewfinder fixed on the side and I am experiencing parallax when using the viewfinder on close-distance objects, e.g., portraits. Is there any way I can correct this?—W. Grant (Yorks).

THIS problem of parallax correction can, theoretically, only be overcome by having a viewfinder which is fully adjustable for every distance. In practice, however, it is generally sufficient to bear in mind that a little more space must be left at one side of the viewfinder when taking close-up photographs.

A hair, stuck to the finder at the required

place, is an improvement on memory and will still not affect the scope of the viewfinder for longer distance work.

If you take large numbers of close-up pictures, and the viewfinder is attached to the camera with two screws—as is often the case—it may be thought worth

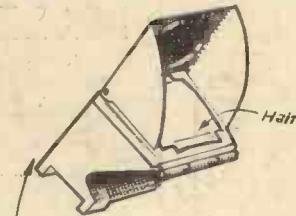

(Right).—The "Polly-Max" developing tank.

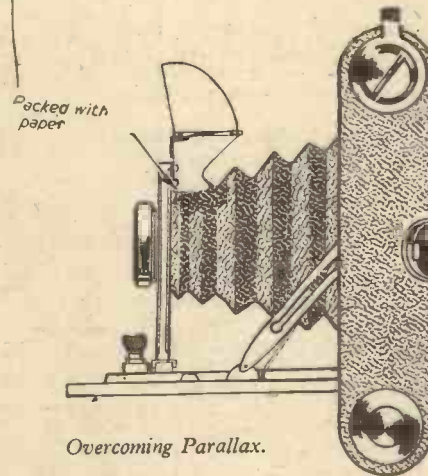

Overcoming Parallax.

while to pack up the base of the eyepiece side of the finder with thin card, until the area viewed coincides with the negative produced. In this event, you will still need to allow for correction but, this time, when the camera is used for longer distance work.

The amount to be allowed for correction in any of the schemes outlined above can only be found by experiment.

Improving the Negative

RE the article in the April issue, "Improving the Negative," under what light is intensification carried out when the negative is re-developed in a non-staining developer?—F. Sturgess (S.E.9).

WITH chromium, and certain other intensifying agents of a more specialised nature, it is necessary to remove the colour from the negative without destroying the image, before the actual intensification can take place. This is done in the manner stated in the article.

Now, in order to build up a more heavily coloured, or intensified negative, the film or plate is immersed in a non-staining developer, such as a standard M.Q. solution packaged by all the leading photographic manufacturers. This is done by ordinary lighting, and the process is far more rapid than the initial development given to the film. The process is complete when no further change occurs.

As you will see, if you try this method, a slight increase in negative density is obtained.

TRADE NOTE

THIS tank is made entirely of chemical resistant polystyrene and by a system of stops in the transparent flanges, not only can films of all the popular sizes be loaded, but a second film of the same size also.



"Second-exposure" of colour films without removal from the spiral; automatic "two-way" agitation; "Roto-Feed" easy loading; a "quick positive lock to the lid; clean filling and emptying (a full tank with lid on can be emptied in 20 seconds); a stirring rod in which a thermometer can be inserted; a practice loading film and very full instructions are other points worth noticing.

The retail price of the Polly-Max is 32s. 6d. Distribution to the trade is jointly by Johnsons of Hendon, Ltd., and Neville Brown and Co., Ltd.

YOUR OPINION

SIR,—I have been reading with interest your new "Practical Photographer" supplement and would like to express the hope that it will live up to its name and fill a long-felt want by supplying the amateur with real down-to-earth practical information.

Too much time is given these days, I feel, to the finer points of photography at the expense of the basic fundamentals, which, after all, occupy the minds of the majority of amateurs. Typical of this attitude is the emphasis laid on picture composition. I have seen a so-called expert criticise a photograph, which I would have been proud to have taken, for some reasons which can only have been based on personal preference and for others which were merely hair-splitting. I refuse to believe that trimming half an inch from the bottom of a half-plate print will turn it from a mediocre picture into a masterpiece! Even the generally accepted basic rules of composition—picture thirds, cone-shapes, diagonals, etc., have been frequently violated by the world's greatest painters; and yet in some schools of thought a photograph, unless it conforms rigidly to a set of rules, is termed bad composition. Personally I would rather take a badly composed picture of an attractive subject than a perfectly composed picture of an ugly one, but then perhaps that is another matter.—"REBEL" (Kent).

THE MASTRA V 35

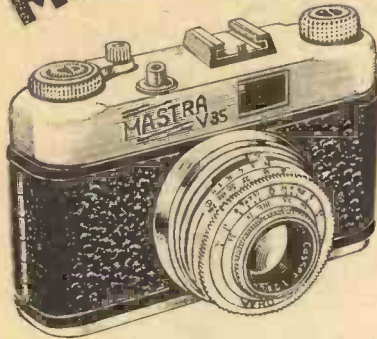

THE FIVE STAR CAMERA

With The Five Year Guarantee
And Only **£13-14-11**
EVER READY CASE £2-9-11

We are proud indeed to announce the new Mastra V35 camera which is specially produced for us to fantastic precision limits. To our own unique design, by expert German craftsmen. So confident are we of the Mastra's unequalled performance, reliable service and precise workmanship that we supply a five-year guarantee in writing with every camera.

The handsome, robust looking Mastra is of solid metal die-cast construction attractively finished in bright satin chrome and

hard-wearing leather with contemporary red and black lettering. The rigidly mounted $f/2.8$ Cassar coated lens of 45mm. focal length provides excellent definition for colour or monochrome film and is calibrated in feet with automatic depth of field scale. The Vero shutter featured on the Mastra is synchronised and has four speeds: $1/25$, $1/50$, $1/100$, $1/200$ and B, accommodating all lighting conditions. The aperture scale from $f/2.8$ to $f/16$ is conveniently situated on the top of the lens mount, easily seen from above, adjacent to the shutter speeds. The fully automatic leverwind system with one single movement transports the film from exposure to exposure, loads the shutter, sets the double exposure prevention mechanism and manipulates the film counter which at any time correctly indicates how many negatives remain unused. This leverwind with its many automatic functions makes the Mastra really simple to use and particularly suitable for the newcomer to photography who requires versatility with simplicity. Huge optical crystal clear viewfinder facilitating picture composition, true body release threaded for flexible cable, centrally situated tripod bush and spring loaded accessory shoe complete the specification of the new exclusive Mastra 35mm. camera. Send for our free two-colour leaflet.

NORTH STAFFS PHOTOGRAPHIC SERVICES
NEWCASTLE London Showroom:
36 WARDOUR STREET, W.1. STAFFS

YOU CAN DO IT!

You can bring your photography up to professional and exhibition standards by taking our Postal Course on Technique.

YOU CAN SELL YOUR PICTURES, cover your expenses and make a

PROFIT from photography. Learn how it can be done from our illustrated Prospectus, sent FREE.

MALLINSON'S School of Photography and Journalism

Dept. 41, 8/9, Petty Cury, Cambridge

A war surplus

ANGLE MEASURING CLINOMETER

Invaluable for setting angles for milling and shaping and for jigs, etc. Angles from 0-90 degrees can be read instantly to an accuracy of one minute of angle. This precision instrument is constructed of brass and weighs 2½ lbs.

Offered at fraction of cost **35/-**

WE WILL GLADLY SUBMIT ON 14 DAYS FREE TRIAL

CHARLES FRANK

67-73 SALTMARKET, GLASGOW C.I.

*Phone: BELL 2106/7

Established 1907

SEE EARTH SATELLITES



ASTRONOMICAL TELESCOPES 107/6 !!

COMPLETE SET, £8.15.0. Postages 15/- OR 25/- DEP. 10/- WEEKLY.

OUR NEW SUPER MODEL
See the Moon at Close Quarters, Examine the Immense Craters, Mountain Ranges, etc. Observe Saturn's Rings, Nebulae, Sputniks, etc.

Specification. 2 in. dia. Length 39 in. Mag 53 x Linear (equivalent 2809 X Area). Weight approx. 2 lb. 2 ozs.

Registered postage and packing including strong stowing cylinder, 12/-

Altazimuth Portable Clamp Stands. Extra 37/6, P.P. 2/6. Fixes anywhere. High Power Eyepieces 80 x, 30/- P.P. 2/-. (Equivalent 6400 X Area.)

Stamp for Full Particulars. Photographs 1/- set (returnable). Lists and Terms. Made to order.

HOLMES, WILSON & CO.
SCIENTIFIC INSTRUMENT MAKERS
(Dept. P.M.36), Martins Bank Chambers, 33, Bedford Street, North Shields, Northumberland.

IT'S KODAK FOR COLOUR!

KODACOLOR negative films 120/620, 10/10 each; processing charge, 6/6. KODACOLOR PRINTS, 3½in. x 5in., superb quality and value, 2/9 each.

KODACHROME 35 mm. 20-exp. cassettes, 23/-, inclusive of processing. EKTACHROME E.2 high-speed reversal transparency films, 35 mm., 14/6 each; 120/620, 19/6.

KODAK COLOUR PRINTS (from the above or any other type of colour trans.), 3½in. x 5in., 3/6 each; 5in. x 7in. (from 35 mm. only), 12/6 each.

EKTACHROME or ANSCOCROME processing, 35 mm. or roll-film, 9/-. FERRIANACOLOR processing, 7/6.

ILFORDCOLOR, AGFACOLOR, GEVACOLOR & ICICOLOR prints at standard rates. All colour films and equipment supplied. 1958 Catalogue now ready, free on request. C.W.O.

COLORCHROME
77 Cranleigh Rd., Southbourne, Bournemouth.

ELECTRONIC FLASH

Condensers, Pulse Coils, Resistors, etc., surplus to requirements but guaranteed new and unused. Send S.A.E. for full list and circuit diagram for 50-joule instrument.

Langham Photographic Insts., Ltd., 132, Stanley Park Rd., Carshalton, Surrey.

CAMERA BELLOWS

ALL TYPES SUPPLIED OR FITTED

SHUTTER BLIND MATERIAL • CAMERA COVER CLOTH • SEND STAMP FOR LIST
CLEMENT WAIN LIMITED, NEWCASTLE, STAFFS.

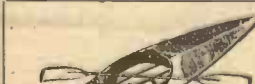

BUILD YOUR OWN CANOE

Printed illustrated instructions 1/6

TYNE FOLDING BOATS LTD.

206 Amyand Park Road, St. Margaret's, Twickenham, Middx.

SCREEN FABRIC MAKE YOUR OWN PROJECTION SCREEN

High Grade Fabric as used by Commercial Cine Screen Manufacturers. 48in. wide, any length cut at 18/- per yard.

Or— **CUT PIECES**

48in. x 36in. 18/- 48in. x 48in. 24/-
60in. x 48in. 30/- 72in. x 48in. 36/-
Send 3d. stamp for samples and instructions for making your own "Roll Up" Screen.
SPRING ROLLERS (Self Acting), 1½in. dia. Swedish Manufacture, complete with Brackets.
36in. 10/3; 42in. 10/9; 48in. 11/9; 54in. 13/3.

SAWYERS LTD.

ST. SEPULCHRE GATE DONCASTER

APPEAR IN YOUR OWN PHOTOGRAPHS

by fitting an Automatic Self-timer to your Camera—fits any make—attached to cable release—handsomely finished in nickel plate. In attractive plastic case. 24/2d. C.W.O.
Why not do it yourself and save pounds? Develop or print your own films with our kits. Prices from 13/6d. Free lists from **LORELL PHOTOGRAPHIC SERVICES** (Dept. FP2), 36 Todrell St., New Mills, Nr. Stockport, Ches.

HIGHSTONE UTILITIES

Ex-R.A.F. 2-valve (2 volt) Microphone Amplifiers, as used in "plane intercom." In self-contained metal case: can be used to make up a deaf aid outfit, intercommunication system, or with crystal set, complete with valves and Pifting instructions, 20/-, post 3/-. Useful wooden box with partitions to hold amplifier, 2/- extra. Amplifier, containing resistances, condensers, transformers, switches, etc., but less valves 10/-, post 3/-. Hand Microphones, with switch in handle and lead, 5/6. Tannoy, 7/-. Similar instruments, moving coil, 8/6. All post 1/6. Mask type with switch 3/6, post 6d. Throat Mikes, 5/-, post 7d. Mike Buttons (carbon), 2/-.
Moving coil, 3/6, post 4d.
Soldering Irons.—Our new streamlined iron is fitted with a pencil bit, 200/250 v. 50 watts, 11/6. Standard iron with adjustable bit, 200/250 v. 60 watts, 13/6. Heavy Duty Iron, 150 watts, 13/6, all post 1/-. These irons are guaranteed, and all parts are replaceable.
Meters.—20 amp. 2in., m/c, 8/6; 20 v. 2in., m/c, 8/6; 150 v. 2in., m/c, 10/-; 3.5 amp., 2in., T.C., 6/-; 4 amp., 2in., T.C., in case with switch, 9/8; 100 mA. 2in., m/c, 7/6, all post extra. Meter Movements. Units with 2-500 microamps, 9/-, post 1/6.
Bell Transformers.—These guaranteed transformers work from any A.C. mains giving 3, 5 or 8 volts output at 1 amp. operate bulb, buzzer or bell. Will supply light in bedroom or larder, etc., 9/-, post 1/-. Similar Transformer but output of 4, 8 or 12 volts, 13/6, post 1/6. BUZZERS for use with either the above or batteries, 4/3, post 5d.
G.P.O. Telephone Hand Com. Sets, 12/8, post 1/6. Telephone Hand Generator, 8/6, post 2/-.

S.B.C. Neon Indicator Lamps, for use on mains to show "live" side of switches, etc., 2/6, post 4d. Neon Indicator, complete with condenser, pencil type, with vest-pocket clip, 7/6, post 5d.
Crystal Sets. Our latest model is a real radio receiver, fitted with a permanent crystal detector. Have a set in your own room, 12/6, post 1/-. Spare Permanent Detectors, 2/- each. When ordered separately, 2/8; with clips and screws, 2/10, post 3d. Diodes, 2/6. 0005 Variable Condensers 2/6, post 8d. Headphones, brand new. S. G. Brown, G.E.C., etc. super-sensitive, 30/- a pair. Headphones in Good Order, 6/- Better Quality, 7/8 and 10/- Balanced Armature Type (very sensitive), 13/6. All post 1/6. New Single Earpieces, 3/6. Bal. armature type, 4/6 (two of these will make an intercom. set). Ex-R.A.F. earpiece, 2/6, post 6d. Money refunded if not completely satisfied.

HIGHSTONE UTILITIES

59, NEW WANSTEAD, LONDON, E.11.
New Illustrated List sent on request with 2d. stamp and S.A.E. Letters only.

The Bestfriend "ZEPHYR" (M) Motor and Accessories

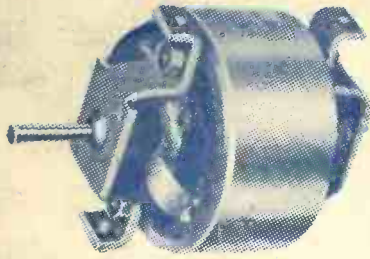

A silent, shaded pole motor, A.C. only, 200/250 volts, 2,600 R.P.M., 25 watts. $3\frac{1}{2}$ " x $2\frac{1}{2}$ ". Precision built and specially suitable where absolute silence is essential. Continuously rated and designed for use in construction of table and extractor fans, projector cooling units, fan heaters, cupboard airing devices, etc. An extremely high-class product,

designed by engineers with a quarter of a century of experience in motor construction. **37/6**
Post Free

An anti-vibration stand for above motor. Horizontal or vertical mounting. Supplied in breakdown form for home constructors. $8\frac{1}{2}$ " x $2\frac{1}{2}$ " x 2". Three point suspension. **7/6**
Steel, Cadmium plated. Post Free

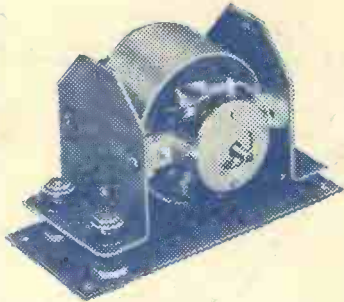

FANS

4 Bladed Metal 4" diam. 5/-
BAKELITE 3 Blades 8" diam
7/6 Post Free

The Bestfriend Electrical Co. Ltd.
BANSTEAD SURREY

Tel.: BURGH HEATH 1432

RIGHT!



for good braking

USE **Fibrax**
BRAKE BLOCKS

FOR SURE STOPPING

AND A LONG LIFE

FIBRAX BRAKE BLOCKS stand up to the toughest test—the split-second emergency. Yet they brake smoothly and firmly. Two types: SOFT RED for alloy rims, BLACK for steel rims.

Ask your dealer for "FIBRAX"

FIBRAX LTD., 110, ORMSIDE ST., OLD KENT RD., LONDON, S.E.15
New Cross 6785/6 P356A

Over 75 years
experience and world-wide
reputation for quality

THORNTON

DRAWING INSTRUMENTS
MINERVA SERIES PROFESSIONAL QUALITY
TECHSET SERIES STANDARD QUALITY
KINWEST SERIES SCHOOL QUALITY



JAYWESS SERIES
STUDENT QUALITY

Write for
illustrated leaflets
and address
of your
nearest stockist to:

A.G. THORNTON LTD.
P.O. BOX 3, WYTHENSHAW, MANCHESTER

MANUFACTURERS OF FIRST QUALITY DRAWING INSTRUMENTS
P.I.C. SLIDE RULES AND DRAWING EQUIPMENT



STOCKS and DIES

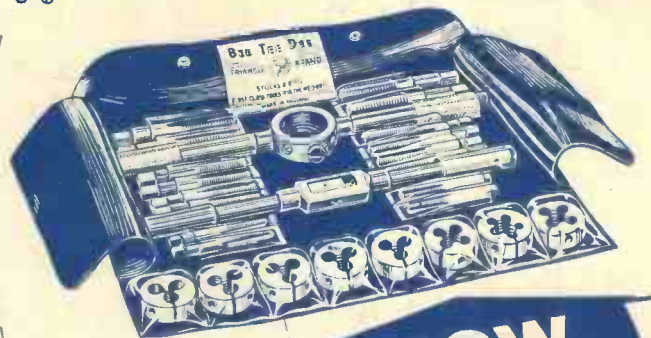

TRIANGLE
LEADS
AGAIN!

NOW
IN A DURABLE
PLASTIC
TOOL ROLL



- * NO COSTLY WOODEN CASES OR PACKING. All the value is in the tools!
- * THE FINEST QUALITY AMERICAN PATTERN TAP WRENCH IS PROVIDED. Not the Cheap Bar type.

- * ALL TOOLS 100% BRITISH AND FULLY WARRANTED
- * BRITISH CRAFTSMANSHIP SUPREME
- * AVAILABLE IN: B.S.W., B.S.F., Brass or Metric, N.F., N.C. and Unified threads.

The finest quality available at lowest prices
Obtainable from your usual tool specialists
THE BRITISH TAP & DIE CO. LTD.
TRIANGLE WORKS, EDMONTON, N.º.

Free Guide — SUCCESS IN ENGINEERING

One of the following Courses taken quietly at home in your spare time can be the means of securing substantial well-paid promotion in your present calling, or entry into a more congenial career with better prospects.

ENGINEERING, RADIO, AERO, ETC.

Aero. Draughtsmanship	Elec. Draughtsmanship
Jig & Tool Design	Machine " "
Press Tool & Die Design	Automobile " "
Sheet Metalwork	Structural " "
Automobile Repairs	R/F Concrete " "
Garage Management	Structural Engineering
Works M'gmt. & Admin.	Mathematics (all stages)
Practical Foremanship	Radio Technology
Ratefixing & Estimating	Telecommunications
Time & Motion Study	Wiring & Installation
Engineering Inspection	Television
Metallurgy	Radio Servicing
Refrigeration	Gen. Elec. Engineering
Welding (all branches)	Generators & Motors
Maintenance Engineering	Generation & Supply
Steam Engine Technology	Aircraft Mainten. Licences
I.C. Engine Technology	Aerodynamics
Diesel Engine Technology	Electrical Design
Ordnance Survey Dr'ship.	

BUILDING AND STRUCTURAL

L.I.O.B.	A.I.A.S.	A.R.S.H.	M.R.S.H.
A.M.I.P.H.E.	A.A.L.P.A.	A.F.S.	A.R.I.C.S.
Building Construction	Builders' Quantities	Carpentry & Joinery	Building Inspector
Costs & Accounts	Building Draughtsmanship	Heating and Ventilating	
Surveying & Levelling			
Clerk of Works			
Quantity Surveying			

GENERAL, LOCAL GOVERNMENT, ETC.

Gen. Cert. of Education	Common. Prelim. Exam.
Book-keeping (all stages)	A.C.I.S., A.C.C.S.
College of Preceptors	A.C.W.A. (Costing)
Woodwork Teacher	School Attendance Officer
Metalwork Teacher	Health Inspector
Housing Manager (A.I.Hsg.)	Civil Service Exams.

BECOME A DRAUGHTSMAN—LEARN AT HOME AND EARN BIG MONEY

Men and Youths urgently wanted for well paid positions as Draughtsmen, Inspectors, etc., in Aero, Jig and Tool, Press Tool, Electrical, Mechanical and other Branches of Engineering. Practical experience is unnecessary for those who are willing to learn—our Guaranteed "Home Study" courses will get you in. Those already engaged in the General Drawing Office should study some specialised Branch such as Jig and Tool or Press Tool Work and so considerably increase their scope and earning capacity.



★ OVER SEVENTY YEARS OF CONTINUOUS SUCCESS ★

NATIONAL INSTITUTE OF ENGINEERING

(In association with CHAMBERS COLLEGE—Founded 1885)
(Dept. 29)

148, HOLBORN, LONDON, E.C.1

SOUTH AFRICA: E.C.S.A., P.O. BOX NO. 8417, JOHANNESBURG
AUSTRALIA: P.O. BOX NO. 4570, MELBOURNE

FOUNDED 1885 - FOREMOST TODAY

132-PAGE BOOK FREE!
SEND FOR YOUR COPY

This remarkable **FREE GUIDE** explains:

- ★ Openings, prospects, salaries, etc., in Draughtsmanship and in all other branches of Engineering and Building.
- ★ How to obtain money-making technical qualifications through special **RAPID FULLY-GUARANTEED COURSES**.

MANY INTERESTING COURSES TO SELECT FROM!

A.M.I.Mech.E., A.M.I.M.I.,
A.M.Brit.I.R.E., A.M.I.P.E.,
A.M.I.C.E., A.M.I.Struct.E.,
A.M.I.Mun.E., M.R.S.H.,
A.M.I.E.D., A.F.R.Ae.S.,
London B.Sc., Degrees.

Fully guaranteed postal courses for all the above and many other examinations and careers. Fully described in the New Free Guide.



THE ACID TEST OF TUTORIAL EFFICIENCY SUCCESS—OR NO FEE

We definitely guarantee that if you fail to pass the examination for which you are preparing under our guidance, or if you are not satisfied in every way with our tutorial service—then your **Tuition Fee will be returned in full** and without question. This is surely the acid test of tutorial efficiency.

If you have ambition you must investigate the **Tutorial and Employment services** we offer. Founded in 1885, our success record is unapproachable.

ALL TEXTBOOKS ARE SUPPLIED FREE
PROMPT TUTORIAL SERVICE GUARANTEED
NO AGENTS OR TRAVELLERS EMPLOYED



Free Coupon

To: NATIONAL INSTITUTE OF ENGINEERING
(Dept. 29), 148-150, Holborn, London, E.C.1.

Please Forward your Free Guide to:

NAME

ADDRESS

My general interest is in: (1) ENGINEERING
(2) AERO (3) RADIO (4) BUILDING
(5) MUNICIPAL WORK

The subject of examination in which I am especially interested is

To be filled in where you already have a special preference.
(2d. stamp only required if unsealed envelope used.)



(Place a cross against the branches in which you are interested.)