

*Radio-Controlled Models-New Series*

NEWNES

1!

# PRACTICAL MECHANICS

EDITOR: F. J. CAMM  
AUGUST 1955



1855 — 1955

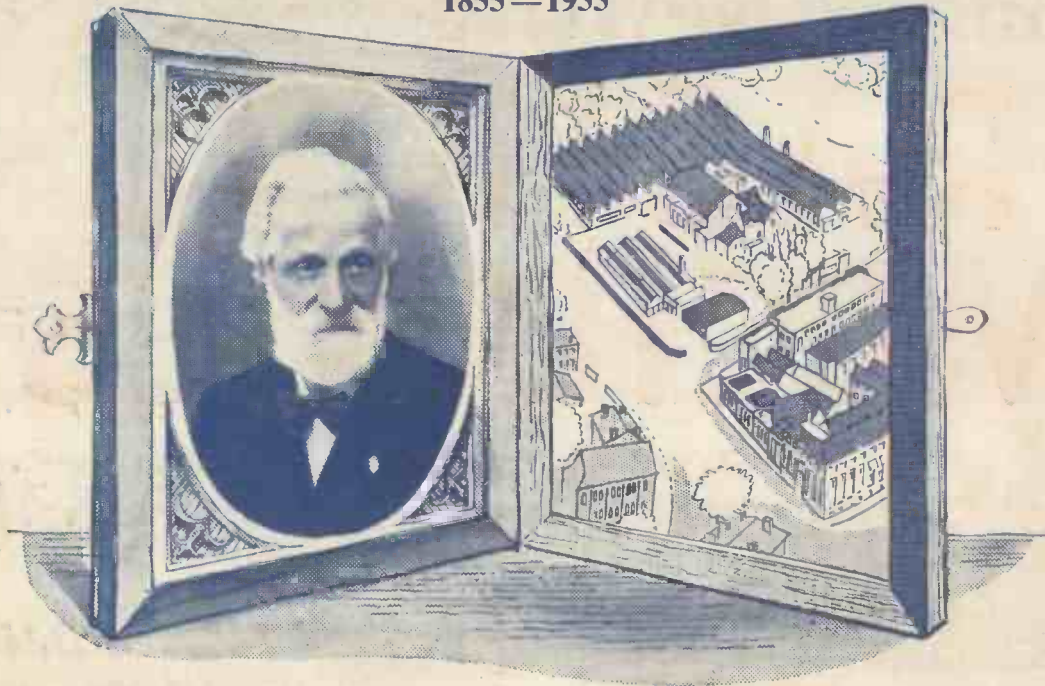

## Victorian ... WITH VISION

IT WAS 1855 . . . Balaclava, Sebastopol, the Alma, were making the headlines . . . the Great Exhibition was still fresh in men's memory . . . and a young Herbert Terry was hanging out his sign as "Maker of Presswork and Springs".

### SUPPLYING AN AWAKENING WORLD

He chose well his locale . . . in Redditch, where the green Worcestershire fields march with Shakespeare's county, near Birmingham, the growing manufacturing centre of Victorian England. The world of 1855 was very much an enterprising young man's oyster . . . the Industrial Revolution in full flood . . . overseas markets opening with every packet that sailed . . . new trades, new outlets for his wares.

### THE MAKING OF GOOD SPRINGS AND PRESSWORK

The planted acorn sprouted and grew apace. Through the succeeding decades, Herbert Terry, his sons and grandsons, tough and resilient as their products, expanded and developed their business of making good springs and presswork—and their ancillaries—designing new springs for each new industry as it developed. Their presswork, and its applications, kept pace with the spring side of the business.



### TRADE CYCLE

The 80's saw the beginning of the cycling boom, with Terrys really 'going to town' on its whirling wheels. A notable Terry contribution to cycling comfort was the invention by Mr. Victor Terry of the celebrated Spring Seat Saddle, which has never been surpassed. The graph of manufacture-cum-sales showed a steep rise, with Terrys inventing, adapting, exploring every possible application of their products to the new industry. This was to be repeated when, later, the automobile took to the road.

### THE LAMP OF 1001 ANGLES



Pausing, for a moment, from their task of supplying the staple trades, Terrys took time off to develop their now world-famous Anglepoise Lamp—whose flexible, yet 'stay put' action, based, as might be expected, on spring action and re-action, has made it a 'best seller'.

### PIONEER'S REWARD

Long before he passed to his rest, Herbert Terry saw the firm he founded becoming the greatest Springs and Presswork Specialists in the world—a position they have maintained due tribute to a Victorian with vision.

## TERRY'S of Redditch

HERBERT TERRY & SONS LIMITED · LONDON · BIRMINGHAM · MANCHESTER



# DORMER

CUTS COSTS FIVE WAYS!

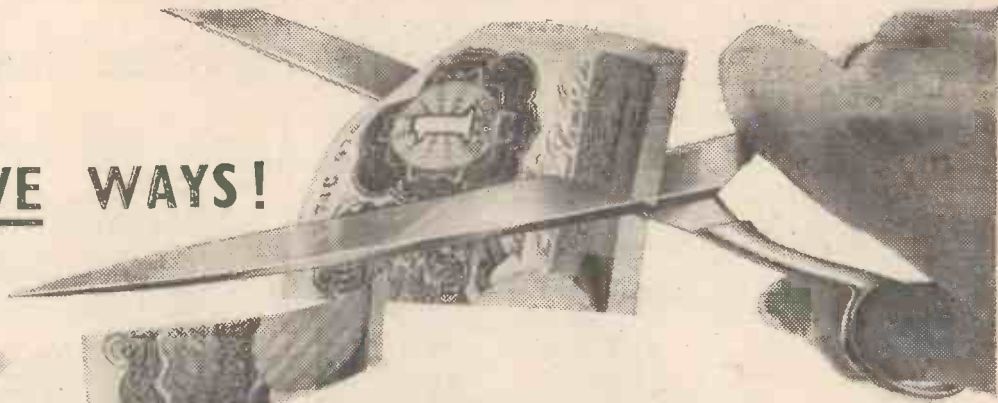

**THE SHEFFIELD TWIST DRILL AND STEEL COMPANY LIMITED**  
SHEFFIELD ENGLAND

DORMER TOOLS ARE OBTAINABLE FROM YOUR USUAL ENGINEERS' MERCHANTS

- LONGER LIFE
- FASTER SPEEDS
- MORE ACCURATE PERFORMANCE
- LESS TOOL-CHANGING
- LESS RE-GRINDING

## WORN OUT REFRIGERATORS

### GIVE YOURS A NEW LEASE OF LIFE

These silent running "Sealed Systems" will completely modernise that Pre-war Refrigerator. They are ready to install, no technical knowledge required. Fit it yourself, SILENT. EFFICIENT. CHEAP. 5 YEARS FREE REPLACEMENT WRITTEN GUARANTEE WITH EACH UNIT. NO MORE SERVICING EXPENSES.

9 MODELS AVAILABLE, RANGING IN SIZE FROM 3 cu. ft. to 9 cu. ft.  
Prices from £27/10/0 to £34/10/0.  
Free Delivery in British Isles.

Send stamped, addressed envelope for "SEALED SYSTEMS." Free Reduced Price Leaflet.  
Latest complete general catalogue with many 'Hits & Tips,' price 1/- post free. (Refunded on first order.)

**BRAID BROS.**  
for Home Refrigerator Construction  
50, Birchwood Ave., Hackbridge, Surrey  
Tel.: Wallington 9309.

Meet us at THE MODEL ENGINEER EXHIBITION Stand X&Y

We do not wish to be associated with Scrapped Second-hand Ice-cream Components.

## CLAMP YOUR WORK HYDRAULICALLY!

This folder shows how to SLASH ASSEMBLY TIMES



Simple • Inexpensive  
Instantaneous  
for

MILLING • DRILLING  
WELDING • GLUEING  
and every Clamping Problem

**POWER JACKS LIMITED**  
VALETTA RD. - ACTON - LONDON - W.3  
TEL: SHEPHERDS BUSH 3443 (41 lines) - GRAMS NEWSBORNERS, LALME LONDON

A **NEWTON** PRODUCT

# MORE POWER OPERATIONS

than any other  
Do-it-yourself Equipment

## Wolf Cub HOME CONSTRUCTOR EQUIPMENT

DRILLING



SANDING



PLANING

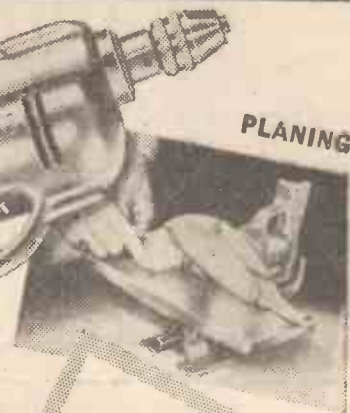

WOODTURNING

also  
BENCH SAWING  
PORTABLE POLISHING  
FRETSAWING  
GRINDING • BUFFING  
WIREBRUSHING, etc.

*Entirely New!*

### CUB BOOK of PROFITABLE PLEASURE

100 pages  
350 illustrations  
77 designs, etc.

Only 5/6

There's simply nothing like Wolf Cub equipment! Look at the amazing number of operations you can perform with it—and there are many others. How simple too! You can start with the Cub Electric Drill and build up a complete power workshop at easy pocket money stages. Remember, there are still more exciting attachments to come!

**FREE!** Write today for  
fully illustrated Brochure  
"Profitable Pleasure"

Ask your dealer for full scale  
**MAKIT** TRANSFER  
PATTERNS

Obtainable from all leading Tool Merchants

## WOLF ELECTRIC TOOLS LIMITED

Pioneer Works, Hanger Lane, London, W.5. Phone: Perivale 5631



An Improved version of the original "BEE."

## A new "BEE" out of the E.D. bonnet!

Designed, developed and manufactured in the E.D. Hive of Industry, where so many winners have been born and bred.

Another addition to our unique range of Diesels that are now famous for their successful performance in open competitions all over the world.

Simple to fit, easy to operate and proved beyond all doubt the best power units for all models.

"THE ENGINE WITH A STING"

Britain's most popular Diesel—over 300,000 sold.  
Gives an astonishing high efficiency and power for weight ratio.  
Bore .437 ins. Stroke .400 ins. R.P.M. 7,000 plus.  
Induction: Rotary disc., 180 deg.  
Height 2 1/2 ins. Length, 3 ins. Width, 1 1/2 ins. Weight, 3 ozs.

Price £2.15.0 incl. P. Tax

**E.D. again 1st.**

RIPMAX and AEROMODELLER TROPHIES  
Sunday, May 8th

These two Trophies were won jointly by Mr. O. E. Helmsley and Mr. Geo. Honnest-Redlich—both tying for first place in both competitions.

E.D. EQUIPMENT USED EXCLUSIVELY BY THE WINNERS

Write for new illustrated list, giving details of all E.D. Engines, Radio Control Units, Accessories, Spare Parts, etc.

**E.D. ELECTRONIC DEVELOPMENTS (SURREY) LTD**  
KINGSTON DEVELOPMENT ENGINEERS  
4411-2 18, VILLIERS ROAD, KINGSTON-ON-THAMES, SURREY, ENGLAND.

## PLASTICS

The only way to do production work of plastic articles is by INJECTION moulding. We can supply you with Machines and Moulds.

PLASTIC INJECTION



### PLASTIC INJECTION MACHINES

FROM £9.15.0 TO £52.10.0

← FOR THIS MACHINE

MOULDS from stock or made to your own requirements.

Write for full details to :

**THE SMALL POWER MACHINE CO., LTD.,**

4, Sunleigh Parade, Alperton, Wembley, Middx.

Telephone :  
Wembley 1383.



Keep lathes, drills and hand tools thoroughly lubricated, clean and rust-free with ESSO HANDY OIL. This specially blended, all-purpose oil, in a can with a long oiler spout, is always ready for instant use.

Use regularly for  
**BICYCLES  
 PERAMBULATORS  
 LAWN MOWERS  
 SEWING MACHINES  
 CAR FITTINGS  
 LOCKS, HINGES,  
 GUNS**

Every handy man needs

**Esso Handy Oil**

OILER TIN WITH SPOUT 1/3d  
 REFILL BOTTLE - - 1/-

STEMCO LTD., LONDON, N.W.1

**THIS**

**IS THE TOOL FOR YOU**

If your work requires good production on high tensile and alloy steels or general machinery, then a Stag Major 'Superweld' Tool is the job for you. You get a long-life cutting end of the finest super high-speed steel, a good solid end electrically fuse-butt-welded to a tough strong steel shank, ready heat-treated to give maximum cutting efficiency. Yet the cost is low, for you do not pay for a whole shank of high speed steel you will not be able to use.

Delivery from stock of standard shapes and sizes which meet all ordinary needs: send for a shape chart and further details of these useful tools.

**Stag Major  
 'SUPERWELD' Tools**

Write for details to:

**EDGAR ALLEN & CO. LIMITED  
 IMPERIAL STEEL WORKS · SHEFFIELD 9**

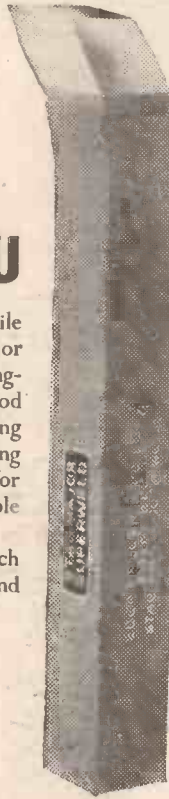

# I.C.S. TRAINED MEN are in Greater Demand than ever

—Maximum production depends on high technical skill, such as that acquired by the I.C.S. Students  
**TENS OF THOUSANDS MORE TRAINED MEN ARE URGENTLY NEEDED NOW —BUT THERE IS NO WORTH-WHILE PLACE FOR THE UNTRAINED**

*Ambitious men everywhere have succeeded through I.C.S. Home-Study Courses. So also can you.*

The man with an I.C.S. Training in any one of the subjects listed below knows it thoroughly, completely, practically. And he knows how to apply it in his everyday work.

- |                         |   |                                      |
|-------------------------|---|--------------------------------------|
| Accountancy             | Electric Power, Light-<br>ing, Transmission | Motor Vehicle Elec.                  |
| Air Conditioning        | Electronics                                 | Municipal Engineering                |
| Architecture            | Eng. Shop Practice                          | Plumbing                             |
| Architectural Drawing   | Fire Engineering                            | Production Engineering               |
| Boiler Engineering      | Foremanship                                 | Quantity Surveying                   |
| Book-keeping            | Fuel Technology                             | Radio Engineering                    |
| Building Construction   | Heating and Ventilation                     | Radio Service Eng.                   |
| Building Specifications | Hydraulic Engineering                       | Refrigeration                        |
| Business Training       | Illumination Eng.                           | Salesmanship                         |
| Business Management     | Industrial Management                       | Sanitary and Domestic<br>Engineering |
| Carpentry and Joinery   | Machine Designing                           | Sheet-Metal Work                     |
| Chemistry, I. & O.      | Machine-Tool Work                           | Short-Story Writing                  |
| Civil Engineering       | Maintenance Eng.                            | Steam-Engineering                    |
| Clerk of Works          | Marine Engineering                          | Structural Steelwork                 |
| Coal Mining             | Mechanical Drawing                          | Surveying                            |
| Concrete Engineering    | Mechanical Engineering                      | Television Technology                |
| Diesel Engines          | Mining Engineering                          | Welding, Gas and Elec.               |
| Draughtsmanship         | Motor Engineering                           | Woodwork Drawing                     |
| Drawing Office Practice | Motor Mechanics                             | Works Engineering                    |
| Electrical Engineering  |   |                                      |

Students intending to sit for examinations in Mech. Eng., Architecture, Quantities, Civil Eng., and others, should enrol NOW for preparatory Courses. Using a specially prepared Study Programme, the student studies in his spare time at his own pace and, with time for revision, sits with full confidence of success.

Courses are also available for General Certificate of Education and most other Technical, Professional, Commercial and Civil Service Exams.

(I.C.S. Examination Students are coached until successful)

Moderate fees include ALL books required.

If you need technical training, our advice concerning your work and your career is yours for the asking—without obligation. Let us send our special free booklet on the subject in which you are specially interested.

The successful man DOES to-day what the failure INTENDS doing to-morrow.

Write to us TO-DAY

Dept. 169B, I.C.S., 71, KINGSWAY, W.C.2.

CUT HERE

## INTERNATIONAL CORRESPONDENCE SCHOOLS

Dept. 169B, International Buildings, Kingsway, London, W.C.2.

REDUCED SUMMER TERMS: This coupon will save you money.

Please send me free booklet on.....

Name..... Age.....

(USE BLOCK LETTERS)

Address.....

Addresses for Overseas Readers

- Australia: 140, Elizabeth Street, Sydney.
- Egypt: 40, Sharia Abdel Kkalek Sarwat Pasha, Cairo.
- Eire: 3, North Earl Street, Dublin.
- India: Lakshmi Bldg., Sir Pheroza Mehta Rd., Fort, Bombay.
- New Zealand: 182, Wakefield Street, Wellington.
- N. Ireland: 26, Howard Street, Belfast.
- South Africa: Dept. L., 45, Shortmarket Street, Cape Town.

**NEW!**

**EXPERIMENTAL KITS  
in Radio, T.V. etc.**

**LEARN THE PRACTICAL WAY**

Specially prepared sets of radio parts (which you receive upon enrolment) with which we teach you, in your own home, the working of fundamental electronic circuits and bring you easily to the point when you can construct and service radio sets. Whether you are a student for an examination; starting a new hobby; intent upon a career in industry; or running your own business — these Practical Courses are intended for YOU — and may be yours at very moderate cost.

**EASY TERMS FROM 15/- A MONTH**

**POST THIS COUPON TODAY**

Please send me your FREE book on Practical Courses.  
To : E.M.I. INSTITUTES, Dept. No. 144X, Grove  
Park Road, London, W.4.

NAME \_\_\_\_\_

ADDRESS \_\_\_\_\_

SUBJECT(S) \_\_\_\_\_ IC.67  
AUG. \_\_\_\_\_

**BEGINNER'S RADIO OUTFITS** — A course in basic principles.

**ADVANCED RADIO OUTFITS** — Instruction and equipment from which you build a Radio Receiver.

**TELEVISION** — Instruction and equipment for building a Television Receiver.

Also for Mechanics, Electricity, Chemistry, Photography, Carpentry, Draughtsmanship, Commercial Art, Amateur S.W. Radio, Languages.

All lessons

and equipment

supplied immedi-

ately and becomes

your own property

**EXPERIMENTAL OUTFITS:**



**E.M.I. INSTITUTES** The only Postal College which is part of a world-wide Industrial Organisation

**THE REVOLUTIONARY FLOORING !!**

★ **Redimix**

the modern true  
**POLYVINYL PLASTIC FLOORING**

Builders all over the country are using  
"REDIMIX" for their new bungalows and  
houses because it is the most modern flooring  
material—it does not require specialists to  
lay it—and it is cheap in cost.

**FREE**

**AMAZING  
OFFER**

To introduce "REDIMIX", the new wonderful Polyvinyl Plastic Flooring, The Laymatt Flooring Company will present **FREE OF CHARGE ONE EXTRA TIN FOR EVERY TIN ORDERED**

"REDIMIX" POLYVINYL FLOORING is a plastic which comes to you in a tin—ready for laying. It is ideal for covering any kind of existing surface—concrete, quarry tiles, flagstones, compositions of all kinds, timber—in fact, any unsightly and uncomfortable dusty floors.

It is supplied in a very wide range of beautiful colourings, from plain to a multitude of marbled and veined colours.

Apply at once for your free order form and beautiful colour chart to:—

DESK P.M.7,  
The LAYMATT FLOORING COMPANY,  
36-40 Seabourne Rd., Bournemouth.



**'YOU LAY IT YOURSELF' !!**

**MAKE MONEY — making casts  
with VINAMOLD**

A grand spare-time occupation

WITHOUT any previous experience you can mass-produce any object, from a chessman to a candlestick, statuette or model ship, in plaster, resin, concrete, etc. with "VINAMOLD" the flexible mould that gives the BEST results. Easy to work, can be used over and over again. Needs NO special equipment, provides a profitable and enjoyable spare-time occupation with minimum outlay.

Write for full details and instructions. Also available: Illustrated booklet describing "VINAMOLD," methods of heating and melting, preparation of models and moulds, etc. Price 1/6 post free, from:—

VINATEX LTD. (Dept. P.M.3), CARSHALTON, SURREY



*Tipped with 100% TUNGSTEN CARBIDE*

*Accept no substitute for masonry drilling*

**MASON MASTER**  
ARE THE BEST YOU CAN BUY

AND TO BE ON THE SAFE SIDE USE  
**MASO-PLUGS** FOR FIXING

JOHN M. PERKINS & SMITH, LTD., BRAUNSTON, Nr. RUGBY  
Telephone: Braunston 238. Telegrams: Drills, Braunston, Rugby.

# THE AMAZING EMCO-UNIMAT

## Complete portable power workshop!

The Emco-Unimat, a miniature ball-bearing machine tool, is the perfect equipment for model makers and amateur craftsmen. The standard motorised lathe, as illustrated, can be used as a pillar drill, milling machine, grinding machine, or hand-drill—and no extras are needed—though much additional equipment is available for its more extended use. We emphasise the fact that the Emco-Unimat is a precision tool, capable of a variety of machine shop operations on a miniature scale.

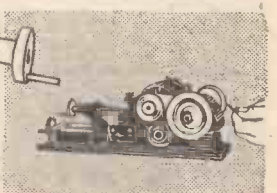
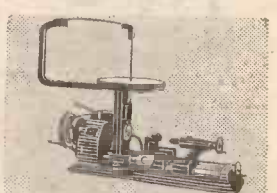
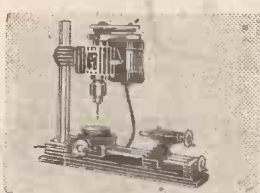
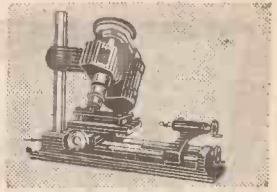
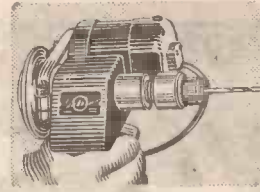
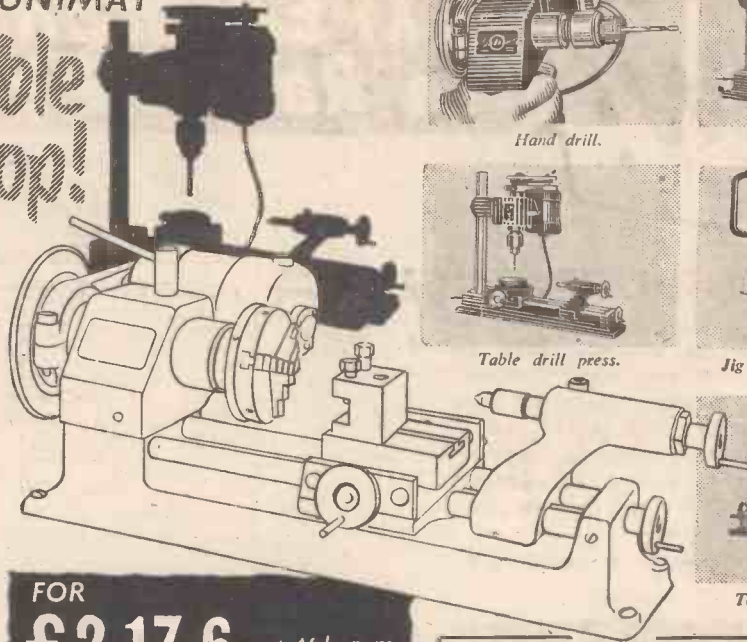

1. TURNING
2. DRILLING
3. MILLING
4. GRINDING
5. WOOD TURNING
6. POLISHING

precision tool, capable of a variety of machine shop operations on a miniature scale.



FOR  
**£2-17-6** and 46/- p.m.  
DEPOSIT for 12 months  
 CASH PRICE £27 17 6

SPECIFICATION	ADDITIONAL EQUIPMENT
Centre height 1½ in. Takes between centres 6½ in. Hollow Spindle admits ¼ in. Drill Chuck Cap ½ in. Chuck to drill table, max. 4½ in.	Jig saw, SC Lathe Chuck, circular saw, drilling vice, milling table, and clamps, Flexible shaft.

WRITE FOR FULL DETAILS TO SOLE CONCESSIONAIRES:

**J. & H. SMITH LTD.,** Dept. P.M.5, 16 Harrison Street, Leeds, 1.

London's most fascinating Exhibition

**THE MODEL ENGINEER EXHIBITION**

Jan 17-27 11am-5pm and the Exhibitions of Inventions

New Horticultural Hall Westminster.

GET THERE BY BUSES 10, 11, 24, 29, 39, 46, 70, 76, 134 to Army & Navy Stores. 2, 36, 57, 69, 169, 181, 185 to Rochester Row. 3, 59a, 77, 77a, 88, 159 to Horseferry Road. By UNDERGROUND to St. James's Park.

HUNDREDS OF EXAMPLES of Amateur Craftsmanship

Every kind of land, sea and air model—all incredibly detailed and accurate.—can be seen at this most fascinating Exhibition. Also demonstrations by experts of the SKILLS involved, RADIO CONTROL of ships on the water tank, PASSENGER CARRYING Live Steam Track and MUSIC from a miniature model organ. Adults 3/-. Children 1/6.

**New Horticultural Hall**

**AUGUST 17-27 11 am-9 pm daily**

**THE ULTRA LENS AIDS PRODUCTION**

This unequalled electric magnifier is of the most modern design and has proved its extreme and sustained usefulness to countless industrial firms engaged on minute examination of every conceivable object.

Whether you are manufacturing, buying or selling, there are occasions when you have to submit some objects to a very close scrutiny. At these times the ULTRA LENS becomes indispensable.

Triple lenses ensure distortion-free magnification and eliminate the necessity for adjustment of focus. The focus is always perfect.

The ULTRA LENS achieves a six-fold magnification in a brilliantly lit field which is shadowless.

Actual Size 6 3/4 x 1 5/8

BRITISH MADE

The ULTRA LENS is used extensively in collieries, foundries, electricity works, tool shops, forges, motor works, and practically every branch of the engineering trade. TELEVISION engineers need it to examine INTERLACING of picture.

Write today for full particulars and price list to

**THE ULTRA LENS COMPANY**

Tel.: TRAFALGAR 2055  
 17c, Oxendon Street, London, S.W.1.

**S. G. Brown**

**AUDIO AIDS**

Headphones with individual volume control. Ideal for use with church and cinema deaf aid installations or for individuals with Impaired hearing. They provide the essential clarity of reception when listening to Radio and TV.

Send for Brochure "P" of all types available. If desired, advice is given on selection of type most suited to individual needs.

S. G. Brown provide Headphones and associated equipment for all known purposes.

**S. G. Brown, Ltd.**

**SHAKESPEARE STREET, WATFORD, HERTS.**

Telephone: Watford 7241.



## TO YOUNG ENGINEERS WITH AMBITION

*A Career in the Merchant Navy*

Here is an attractive opportunity for young and ambitious engineers.

The British Tanker Company (the shipping organisation of The British Petroleum Company) operates one of the largest privately-owned tanker fleets in the world and offers young engineers every opportunity of reaching the highest ranks in the marine engineering profession.

If you are interested in ships an extremely well-paid career is open to you in this vital branch of Britain's Merchant Navy.

**To Qualify 1** (a) You should be nearing the completion of your apprenticeship as a fitter or fitter and turner and must have had some experience on heavy machinery or power plant maintenance, or (b) You should be nearing the completion of an apprenticeship in Mechanical or Heavy Electrical Engineering which has included a large proportion of practical workshop experience.

**2** You should have obtained your Ordinary National Certificate or be likely to obtain this before the completion of your apprenticeship, or alternatively have successfully pursued a part-time course of technical training in a college your application can still be considered.

If you are interested please write for further details to:  
Dept. PM 4.

# The British Tanker Co. Ltd

BRITANNIC HOUSE, FINSBURY CIRCUS, LONDON, E.C.2

## OMARO SLIDE RULES

MODEL L.I. Calculation of weights of steel sections

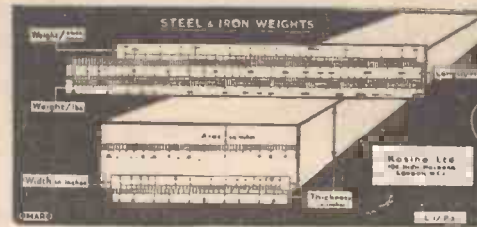

Multiple scales giving simultaneously

- Area of cross section.
- Weight per foot.
- Weight per length in feet (1-10,000 feet).
- Lengths per cwt.(s) and ton(s).

according to width and thickness.

These scales can also be used for any other section if weight/foot or area are known. See our model P.L. 6/3 post free.

MODEL M.I. Trigonometrical Functions

Natural values of Sine, Cosine, Tangent and Cotangent from 0° to 90° increasing by 10', 2.184 values.

Standard Qual. (glazed) 6/3 post free.

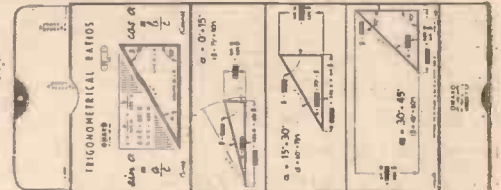

MODEL P.I. Steel and Iron Sections

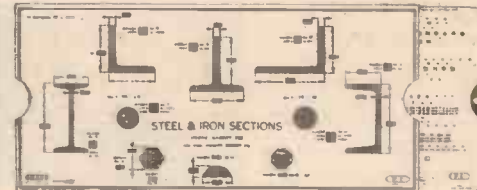

Principal dimensions and weights per foot or square foot of steel and iron sections, i.e., of Equal and Unequal Angles, T-Bars, Beams, Channels, Rounds, Squares, Hexagons, Octagons, Convex Feather Edges, Sheets and Flats, 2,989 Values, Dimensions, etc.

Standard Quality (glazed) 6/3 post free.

Special Quality (unglazed) 3/9 post free.

List of other Models on application.

Kosine Ltd., 104, High Holborn, London, W.C.1

Telephone: HOLborn 1301

MONEY BACK GUARANTEE **DUKE** John GRA 6677 CWO COD  
621 ROMFORD RD. LONDON, E.12.

### RADIO GRAM CHASSIS 29/6 Including Speaker

5 VALVE S/HET. 3 w/band. A.C. mains, complete but less valves and dial. All used, tested, and guaranteed. Carr. 4/6. Drawings 2/6 or free with order. Knobs 1/6 a set extra. Complete with valves 97/6.

**RADIO CHASSIS.** 7/9. A.C. or universal, s/het receivers, less valves & Dial, and electrolytics, otherwise believed to be in working order. Note:—Our Bin. M.E. Speaker fits some of these sets. We match on request with order. P. & P. 3/6.

**V.H.F. 1124 RECEIVER.** 17/6 with 6 valves, ex-W.D., new condition, 6 channel switching. Receives T.V. sound, police, fire and amateurs. 30.5 m/cs to 40 m/cs. I.F. 7 m/cs. Post 2/6. Drawings and Conversion data free with each set.

**SPEAKERS.** 10/9. Bin., 6 1/2 in., 5 in. and 3 1/2 in. Std., 3-5 ohms, or with O.P. transformer, 14/9. Reconditioned. Post 1/9.

**SPEAKERS.** 2/9. Bin. M. Energised. Field 1k, 2k and 5k ohms; or with O.P. trans., 4/9. Reconditioned. Post 1/9.

**V.H.F. 1125 SET.** 7/9. New and boxed, This little set is a V.H.F. receiver, requires modification to put it into service. Complete with valves. Post 2/3.

**R.F. 24 UNIT.** 12/6. New and packed, tuning 20-30 m/cs. Including 3 valves. Post 2/-.

**T.V. TUBES and T.V. CHASSIS.** We can now accept your further orders this month, after we have completed your overwhelming response to our previous ads. We are sorry for the past delay in despatch.

**O.P. TRANSFORMERS.** 1/9. Salvage, used, tested, guaranteed. Std. size. Post 9d. Sample will convince you.

**2 GANG CONDENSERS.** 1/9. Std. size. .0005 used, tested. Also 3 Gang at 2/9. Post 9d.

**I.F. TRANSFORMERS.** 2/6 pair. 465 k/cs. Post 6d.

**MAINS TRANSFORMER.** 5/9. 350-0-350, 12V+4V. Primary 100, 120, 200, 250. Make ideal auto trans. Post 2/-.

**MAINS TRANSFORMER.** 9/9. 350-0-350, 22 heater windings. 6V and 5V. Post 2/-.

**MAINS TRANSFORMER.** 3/9. 350-0-350, 4V + 4V, primary 200-250. Tested guaranteed. Post 2/-.

**TILLEY LANTERNS.** 37/6. Famous everywhere for excellent light and low paraffin consumption, no smell. List price 68/-, complete with new mantle and globe. Postage and packing 1/6.

**MOTORS.** 12/9. 240V. Scophony, ideal for small grinder, polisher, etc. P. & P. 1/3. 12-24 volt motors, with flexible shaft, 18ct. gold brushes, 7/6. Post 2/6.

2/d. stamp only for Complete Catalogue.

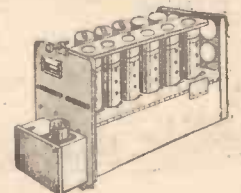



# LAY YOUR OWN FLOORS

Oak and Beech Flooring Blocks Free of Purchase Tax



Hardwood floors are not difficult to lay on concrete or wooden sub-floors. We supply kiln dried flooring blocks manufactured in Sweden from Prime quality Scandinavian Oak and Beech ready for laying with full instructions. At a modest cost you can transform concrete or softwood floors into beautiful polished Parquet floors that will last a lifetime, and add to the value of your property.

**Beech 16/6**  
Per Sq. Yard

**Oak 19/6**  
Per Sq. Yard

FULL DETAILS, SAMPLE AND LAYING INSTRUCTIONS ON APPLICATION

**THE SURREYBOARD COMPANY, LIMITED**

(Dept. PM.) · 72 HIGH STREET · CROYDON · SURREY

## THE "FLUXITE QUINS" AT WORK

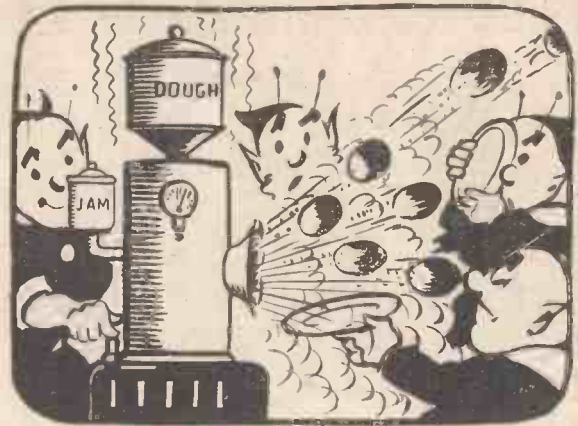

"Our doughnut dispenser is great Slick service. You don't have to wait It's the best gadget yet Made with FLUXITE, you bet If you're ready just hold up your plate."

# FLUXITE

**SOLDERING FLUID**

and its famous equal



**THE SOLDERING PASTE**

*Simplify all Soldering!*

The standard sizes of FLUXITE FLUID are :-

4 fluid ozs. 8 fluid ozs.

20 fluid ozs. ½ & 1 gallon cans.

**FLUXITE LTD BERMONDSEY ST. LONDON S.E.1**

TELEPHONE : HOP 2632

EXPORT ENQUIRIES INVITED

GM.12

### LAFCO

THE HANDYMAN'S FRIEND

### MAIL ORDER

At no extra cost (Postage & Packing costs borne by us.)

#### WOLF CUB ½ in. ELECTRIC DRILL



£5.19.6 CASH

or 14/8 deposit and 8 monthly payments of the same amount.

#### OTHER WOLF EQUIPMENT

Drill Stand Complete (64/6) or 7/11 and 8 x 7/11. Sanding and Polishing Kit (£7.0.6) or 17/2 and 8 x 17/2. Lathe Kit (inc. Tools, etc.) (£10.17.0) or 26/7 and 8 x 26/7. Saw Kit (£10.5.0) or 25/1 and 8 x 25/1. No. 3 DG & B Set (25/-) or 3/1 and 8 x 3/1. No. 5 Saw Set (£2.19.6) or 7/4 and 8 x 7/4. No. 8 Fretsaw Set (£3.15.0) or 9/2 and 8 x 9/2. Fretwork Kit (£10.19.6) or 26/10 and 8 x 26/10. Complete Outfit (exc. Fretsaw) (£16.17.6) or 41/3 and 8 x 41/3. No. 9 Bench Sander Set (38/6) or 4/8 and 8 x 4/8. No. 10 Bench Planer Set (69/6) or 8/6 and 8 x 8/6.

#### BLACK & DECKER

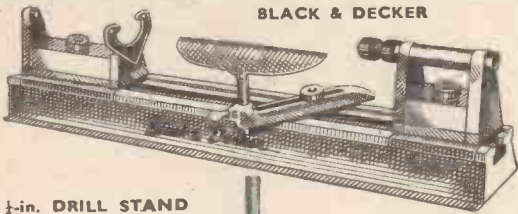

**HOOVER ELECTRIC MOTORS**  
(1 h.p.)  
1,420 r.p.m.  
£12 Cash or 20/4 deposit and 8 monthly payments of 29/4

#### ½ in. DRILL STAND

To take ½ in. Elec. Drill as shown. Yours for 7/11 and 8 x 7/11 (Cash £3.7.6)



B & D Craftman Lathe, 12/3 deposit and 8 monthly payments of 12/3 (£5.5.0 cash). Drill, 13/11 and 8 x 13/11 (£5.19.6). No. 44 Sander, 29/2 and 8 x 29/2 (£12.10.0). 5in. Sander Polisher Kit, 23/- and 8 x 23/- (£9.17.6). ½ in. Elec. Drill Kit, 27/11 and 8 x 27/11 (£11.17.6). ½ in. Portable Electric Drill, 28/11 and 8 x 28/11 (£12.7.6). Abrasive Kit, 3/4 and 8 x 3/4 (27/6). Disc Sanding Table Attachment, 3/11 and 8 x 3/11 (32/6). ½ in. Bench Stand, 12/11 and 8 x 12/11 (£5.10.0). 6in. H.D. Electric Saw, 40/3 and 8 x 40/3 (£17.5.0). 5in. Portable Saw Attachment, 7/7 and 8 x 7/7 (£3.5.0) and Lathe Saw Table, 6/5 and 8 x 6/5 (£2.15.0).

DESK 207

**"LAFCO"**

3, Corbatts Passage, Rotherhithe New Road, Bermondsey, S.E.16. Bermondsey 4341 Ext. 1.

# VALUABLE NEW HANDBOOK FREE TO AMBITIOUS ENGINEERS

Have you had your copy of "Engineering Opportunities"?

The new edition of "ENGINEERING OPPORTUNITIES" is now available—without charge—to all who are anxious for a worthwhile post in Engineering. Frank, informative and completely up to date, the new "ENGINEERING OPPORTUNITIES" should be in the hands of every person engaged in any branch of the Engineering industry, irrespective of age, experience or training.

**We definitely Guarantee  
"NO PASS—NO FEE"**

This remarkable book gives details of examinations and courses in every branch of Engineering, Building, etc., outlines the openings available and the essential requirements to quick promotion and describes the advantages of our Special Appointments Department.

## WHICH OF THESE IS YOUR PET SUBJECT?

**MECHANICAL ENGINEERING**  
Gen. Mech. Eng.—Maintenance — Draughtsmanship—Heavy Diesel—Die & Press Tool Work—Welding—Production Eng.—Jig & Tool Design—Sheet Metal Work—Works Management — Mining — Refrigeration—Metallurgy.

**ELECTRICAL ENGINEERING**  
Gen. Elec. Eng.—Elementary & Advanced Elec. Technology — Installations Draughtsmanship—Supply — Maintenance — Design — Electrical Traction — Mining Electrical Eng.—Power Station Equipment, etc.

**RADIO ENGINEERING**  
Gen. Radio Eng.—Radio Servicing, Maintenance & Repairs—Sound Film Projection — Telegraphy — Telephony — Television — C. & G. Telecommunications.

**AUTOMOBILE ENGINEERING**  
Gen. Automobile Eng.—Motor Maintenance & Repairs — High Speed Diesel—Garage Mngment.

**CIVIL ENGINEERING**  
Gen. Civil Eng.—Sanitary Eng.—Structural Eng.—Road Eng. — Reinforced Concrete—Geology.

**BUILDING**  
Gen. Building—Heating & Ventilation—Architectural Draughtsmanship — Surveying — Clerk of Works — Carpentry and Joinery — Quantities — Valuations

WE HAVE A WIDE RANGE OF AERONAUTICAL COURSES AND COURSES IN FORESTRY, TIMBER TECHNOLOGY, PLASTICS, G.P.O. ENG., TEXTILE TECHNOLOGY, ETC., ETC.

One of these qualifications would increase your earning power WHICH ONE?

A.M.I.Mech.E., A.M.I.C.E., A.M.I.P.E., B.Sc., A.M.Brit.I.R.E., A.F.R.Ae.S., A.M.I.M.I., L.I.O.B., A.R.I.B.A., A.M.I.H. & V.E., M.R.San.I., F.R.I.C.S., A.M.I.E.D., CITY & GUILDS, COMMON PRELIM., GEN. CERT. OF EDUCATION, ETC.

**THE BRITISH INSTITUTE OF ENGINEERING TECHNOLOGY**



410A, COLLEGE HOUSE,  
29-31, WRIGHT'S LANE,  
KENSINGTON, W.8.

Phone: WEStern 9861

### WHAT THIS BOOK TELLS YOU

- ★ HOW to get a better paid, more interesting job.
- ★ HOW to qualify for rapid promotion.
- ★ HOW to put some valuable letters after your name and become a "key-man" . . . quickly and easily.
- ★ HOW to benefit from our free Advisory and Appointments Depts.
- ★ WHERE today's real opportunities are . . . and HOW you can take advantage of the chances you are now missing.
- ★ HOW, irrespective of your age, education or experience, YOU can succeed in any branch of Engineering that appeals to you.

144 PAGES OF EXPERT CAREER-GUIDANCE

You are bound to benefit from reading "ENGINEERING OPPORTUNITIES," and if you are earning less than £15 a week you should send for your copy of this enlightening book now—FREE and without obligation.



Only 1d. stamp is needed if posted in an unsealed envelope.

## POST NOW!

TO: B.I.E.T. 410A, COLLEGE HOUSE, 29-31, WRIGHT'S LANE, KENSINGTON, W.8.

Please send me FREE and without obligation, a copy of "ENGINEERING OPPORTUNITIES." I am interested in (state subject, exam., or career).....

NAME .....

ADDRESS .....

WRITE IF YOU PREFER NOT TO CUT THIS PAGE

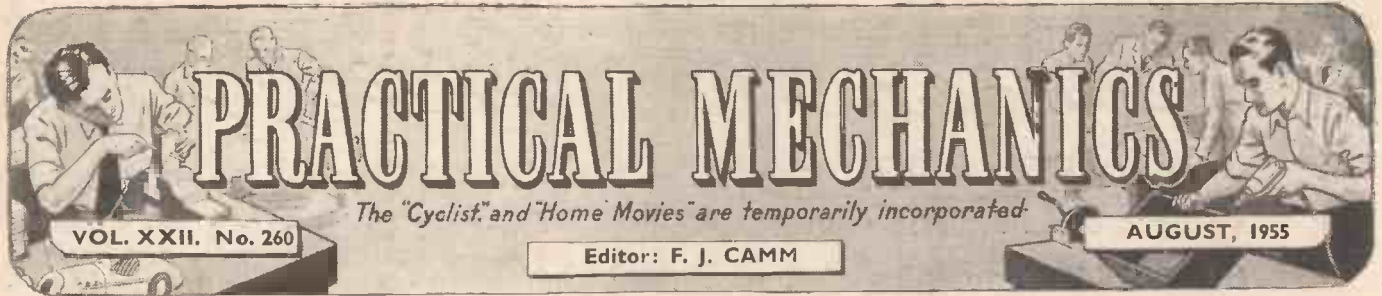

### The Age of the Automaton

THE remarkable scientific achievements of the past half-century have made the robot a reality. Machines capable of thought now control other machines in the modern automatic factory, and calculations made by human beings and therefore subject to the risk of human error are now performed by electronic brains, the most remarkable example of which was pioneered by the National Physical Laboratory. The science of electronics impinges on our daily life more and more as the months go by and fresh applications are developed. A large amount of manual labour has been taken away from manufacture by electronic and mechanical devices, resulting in increased and better quality production, lower costs, better working conditions and more leisure. At the recent British Instrument Industries' Exhibition the electronic brain, technically known as the electronic digital computer, now produced commercially as standard equipment, demonstrated how complicated mathematical problems could be completed in one hour against two years taken by conventional methods. The stroboscope shows how the movement of rapidly moving machines can be studied, vibration eliminated, and sporadic changes in speed corrected automatically. The rotor of a dynamo revolving at thousands of revolutions per minute can be studied like a still photograph, and a newspaper or periodical can be read whilst it is running through the printing presses at very high speed. A balancing machine will balance shafts and rotors automatically. A sound level meter detects sound so quiet that it would need an area as large as Great Britain to collect sound energy to light a 60-watt bulb, yet the same meter will measure the stentorian din from a jet engine. Alarms and signals can be automatically brought into action if the fire in the boilers should fail. Each new discovery introduces problems of new materials. For example, the handling of newly discovered chemicals and compounds as well as radioactive material has been responsible for a new type of glass. Some of the automatic machines will do the work of a whole team of engineers and will detect faults, report output, sound alarms at

## FAIR COMMENT

By

### The Editor

failure, reject imperfect products and produce far more accurate parts than is possible by ordinary methods. For those engaged in the measurement of electric current there is now a device which can be clipped to the outside of a live cable which will give the current passing through and the voltage and these readings can be obtained without interruption to the supply. They are equally effective with small current as with large.

It is pleasant to be able to recall that most of these developments have been pioneered by Englishmen.

These changes have brought about a revolution in public interest in things mechanical and scientific, which has resulted in a greatly improved standard of technical knowledge throughout the country. I have observed the gradual change in the public outlook during my lectures over the past 20 years. Recently I gave a lecture on "Scientific Signs of the Times," in Felixstowe during the Felixstowe Book Week. During question time the questions from the audience, composed of young and old of both sexes, ranged from screw-thread systems, atomic power in cars, the possibility of the steam car, space travel, life on Jupiter, flying saucers, our road policy, patents, hypnotism, atomic power and the weather, electronic brains, battery watches, boomerang missiles, to automobile design, to mention but a few

of the subjects with which I dealt in the space of an hour and a half. I was delighted on this occasion to make the acquaintance of so many readers local to the district.

The general nature of the queries we receive in this office also indicates the trend. Interest in the radio control of models continues to grow, and that is why this month we commence publication of a new series on that subject. Schoolboys now talk about atomic energy and electronics with facility and knowledge. It has been the function of this journal for over twenty-one years to keep our readers informed of all new inventions and developments, from all over the world.

We may expect even greater development within the next ten years.

### The First Guided Missile

THE invention of guided missiles has been claimed by almost every country, especially Russia, Italy and America. The fact is that the guided missile was British in its entirety, as is now admitted by America. It was invented by our contributor, Professor A. M. Low, as long ago as 1914, and it has now been accepted on loan by the Imperial War Museum. During the handing-over ceremony, at which Lord Brabazon of Tara spoke, Professor Low dealt with his initial experiments. At that time he was Honorary Assistant Professor of Physics at the Ordnance College, Woolwich. It was at that time that he demonstrated the principle of TV and the ideas of scanning, which had been first mooted by Nipkow in 1890. It is right that the pioneer work of Professor Low should be set on record and now that the Imperial War Museum has set the seal upon the date of invention of the first guided missile, perhaps we shall hear less from other countries anxious to dispute British scientific supremacy.

### Another "Practical"

NEXT month I shall have some interesting news to impart concerning a new member of the Practical Group of journals, upon which I have been engaged for the past nine months: It is a journal which will be eagerly read by every reader of this journal.—F. J. C.

#### SUBSCRIPTION RATES

including postage for one year

Inland	14s. per annum.
Abroad	14s. per annum.

Editorial and Advertisement Office: "Practical Mechanics," George Newnes, Ltd., Tower House, Southampton Street, Strand, W.C.2  
Phone: Temple Bar 4363

Telegrams: Newnes, Rand, London.

Copyright in all drawings, photographs and articles published in "Practical Mechanics" is specially reserved throughout the countries signatory to the Berne Convention and the U.S.A. Reproductions or imitations of any of these are therefore expressly forbidden.

# A Submarine Speech Line

Making a Useful Accessory

By E. T. FEARON

**T**REASURE-HUNTING under the sea and marine biological observation, both popular pursuits of members of the British Sub-aqua Club, are alike hindered by their submarine environment, which Captain Cousteau describes as "The Silent World." Accurate navigation will bring a surface vessel close to a wreck which is to be investigated (if the charted position of the wreck is equally accurate), but it is left to aqualung divers to finally pinpoint its position. One method used in the Mediterranean is to tow the diver on a submarine sled, called a "manta-glider," so



An aqualung diver wearing the American throat microphone.

for the Underwater Enthusiast

T.30-S, and is available from S. Kershaw, 31, Bromsgrove Street, Birmingham, 5, at 3s. post free (see Fig. 1).

There are two capsules containing carbon granules, and each capsule is contained in a plastic case whose wall is also the diaphragm.

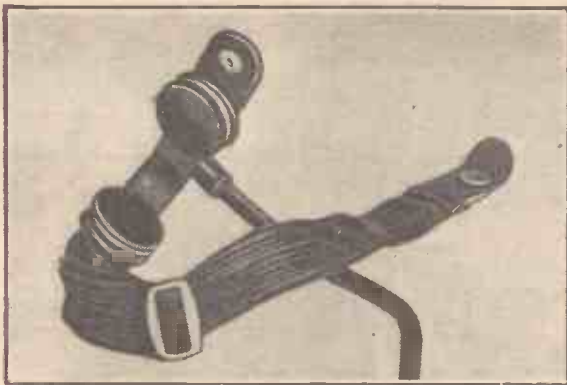

Fig. 1.—American T.30-S throat microphone.

type of microphone because the dive-mask covers only the eyes and nose, and the mouth has to grip the mouthpiece terminating the inlet and outlet tubes of the compressed-air set. For this reason experiments were made with various types of throat microphone which are available on the ex-W.D. surplus market. The most sensitive type tested was also, luckily, the most easily waterproofed. It is an American model, reference



Fig. 3.—The amplifier chassis and batteries removed from the phenol-fibre case.

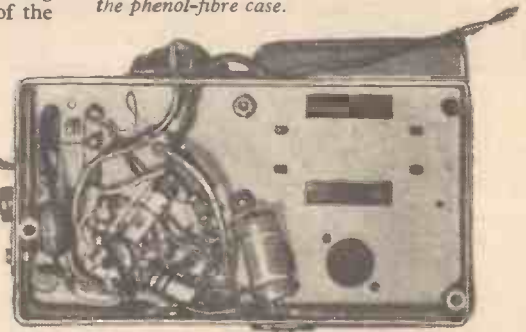

Fig. 4.—The chassis area measures only 5 7/8 in. x 3 3/4 in. but there is ample space underneath.

that he can make a search of the sea bed at close range. Failing this the diver may be towed, but more slowly this time, by a simple tow-rope. The purpose of either method is to complete the search as speedily as possible and with the minimum of effort by the diver so as to conserve his air supply.

It is clear that telephonic communication between the diver and the boat, even if only in the direction of diver-to-boat, would be of great value for this purpose, just as it would in the study of marine biology. For some reason the faculties do not appear to work well under considerable water pressure, and in any case a step-by-step account by the diver of a search on the seabed has far greater value to the marine biologist than a perhaps imperfectly memorised one.

### Carbon-capsule Throat Microphone

A recent broadcast of cave-diving activities from the well-known Wookey Hole in the Mendip Hills featured a commentary by a diver while actually under water. This was accomplished with the help of a tiny microphone inside the diver's mask, and was possible because he was using a closed-circuit oxygen set which had a mask covering both the nose and mouth.

Aqualung divers, however, cannot use this



Fig. 2.—The throat microphone, the cased two-valve amplifier and batteries, 60ft. of bell flex and the high impedance earphones.

A rubber moulding covers all of the plastic case except the diaphragm, and is gripped in place by a circular steel spring. For purposes of complete waterproof protection this spring must be removed and replaced by a loop of strong twine, held by a very tightly tied knot.

As the microphone carries practically no current and has a polarising voltage of only 1 1/2 volts, it may be connected to its valve amplifier through PVC insulated twin bell flex. After soldering two ends of the flex to the microphone plug points, the points may be waterproofed by the application of several coats of waterproof adhesive. In the model

illustrated in Fig. 2 there were 60ft. of this flex used, and it was quite adequate for the purpose in mind—which was a renewed search for the wreck of the ill-fated Santa Cruz, which is lying in not more than 40ft. of water in Cardigan Bay.

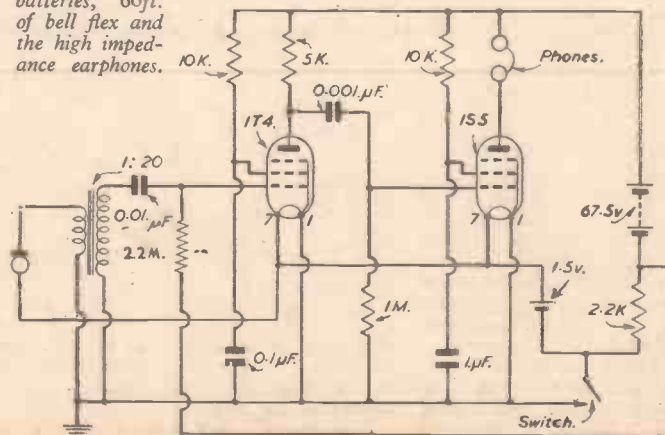

Fig. 5(Left).—Two-valve amplifier circuit. Tolerances are not critical and 1/2 watt resistors may be used throughout. Only one microphone is shown, but there are actually two in series.

**The Two-valve Amplifier**

This amplifier is only intended to reproduce speech frequencies, and the speech is already of indifferent quality when produced at the microphone, so it would be more true to say that the amplifier was designed to use whatever happened to be in the radio and TV scrapbox than to say it was designed to amplify a certain range of frequencies. In other words, the choice of components is not at all critical.

The chassis, which can be seen in Figs. 3 and 4, and the microphone input transformer of ratio approximately 20:1, were both obtained from an aircraft radio transceiver. The two valves are also obtainable from Government-surplus stores, and are both B7G-based 1.5-volt battery types. If an output valve such as the 1S4 had been available it would probably have been used instead of the 1S5, but the existing valve (used without its diode anode connected) serves very well.

Fig. 5 is the circuit diagram, and Fig. 6 shows the valve socket connections, viewed from beneath the chassis.

High-impedance earphones must be used, or else an output transformer will be needed to match the impedance of the 'phones to the output impedance of the valve. The ratio of this transformer would vary between 10:1 and 40:1, according to the impedance of the 'phones used; again the requirement is not critical.

The 1T4 valve has to have -10 volts grid-

bias applied to ensure that it gives distortionless amplification, and this bias has to be taken from the 67.5 volts of the H.T. battery. The total H.T. current taken by the two valves is 4.4 milliamps, so a 2,200-ohm resistor is required in the H.T.—lead to put the chassis potential 10 volts above that on the grid of the 1T4 valve.

**Power Supplies**

The miniature H.T. battery used is particularly suitable for this application, for it measures only 3½in. x 2½in. x 1¼in., but any small 67.5 volt battery will do.

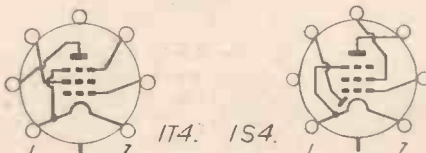

Fig. 6.—Valve base connections of the two valves viewed from underneath chassis.

As valves with low anode currents are used in the circuit, one H.T. battery will outlast several L.T. cells, even though the L.T. consumption also is low and gives twice the life that could be expected from the cell in a hand-torch. The valves have 1.5 volt filaments, so only one cell of the U2 or similar type is needed.

**The Case**

For the model illustrated, the case was made from synthetic resin-bonded fibre sheet, ¼in. thick for the ends, 5/16in. thick for the lid, and ¼in. thick for the sides and bottom. Two holes were cut in the lid for the tops of the valves to fit in, and it then became possible to see when the amplifier was switched on. In addition, this meant that the size of the case was reduced slightly, and the tops of the valves were firmly supported. Easy withdrawal of the complete chassis is ensured by a slot cut in one end of the case, above the on-off switch. All that is now required is removal of the lid, and two chassis-securing bolts in the bottom.

**Practice Makes Perfect**

Although the microphone capsules are placed so that they pick up the vibrations from the vocal chords, they still will not reproduce clearly consonants which are slurred because the rubber aqualung mouthpiece is held between the lips. Therefore, words containing the consonants B, F, M, P, V and W must be avoided, and practice will be required to ensure the clear enunciation of all other consonants.

No experiments have been made with two-way speech, but this should be possible with a second amplifier, connecting to a bone-conduction deaf-aid receiver worn by the diver.

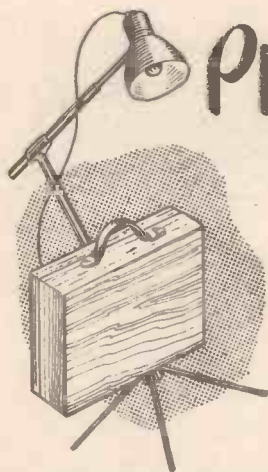

# Photographic lighting apparatus

## An Indoor Photographic Lighting Unit with Interchangeable Parts

By J. B. KNIGHT

making a box, I suggest the purchase of a leather and canvas sports bag; a few lengths of webbing sewn to the inside would secure the masts and legs, and the length of the bag would accommodate the full length of

**T**HIS outfit comprises three flood-lamps, two on vertical stands and one on a boom mounting. The bulbs used are No. 1 Photo Floods (No. 2 bulbs should not be used unless heavier electrical components are substituted). No. 1 Photo Flood bulbs have a rating of 275 watts and are "over-run" to give an 800 watt light, which results in a very short bulb life (about two hours). To help offset this and increase running economy, a switch to allow the lamps to "warm up" in series and to be used in parallel for making the exposures is included in the switchboard.

The equipment is portable, cheap and fairly easy to make, the components which will present the average enthusiast with any difficulty. I suggest a large garage might give an estimate for this work, failing a friend with a model-maker's lathe. Although precision work is not required, every effort should be made to achieve interchangeability in the following items: legs and bases, brackets and top spigots, reflectors and bulb-holders, to avoid annoyance when setting up the lamps for work. Labelling the parts is a poor substitute for being able to select pieces at random for assembly when in a hurry.

My lamps, with stands, leads and bulbs, all pack into a wooden box measuring 18in. x 12in. x 6in., the switch box being built into the inside of the lid. To avoid

the column for the boom lamp, which could be made in one piece instead of being jointed, as mine has had to be. The switchboard could then be made in the form of a self-contained unit, and carried in the bag.

The author's box is shown in Fig. 5a.

**List of Main Items Required**

Three aluminium telescopic tent poles at 5s. 9d. each (Messrs. Headquarters and General Supplies, Ltd.); 3 aluminium mugs at about 1s. 4d.; 3 aluminium basins at about 1s. 9d.; 3 bayonet plugs or 2-pin 5-amp. plugs; 3 lamp-holders (brass type); 3 batten lamp-holders or 2-pin 5-amp. sockets; 1 5-amp. tumbler switch; 1 double-pole, double-throw (D.P.D.T.) "M.E.M." 30-amp. cooker switch at 7s. 6d.; 1 3-pin 15-amp. plug.

**Miscellaneous Items**

Three No. 1 Photo Flood bulbs at 2s. 3d. each; twin flex; 1/8in. diameter mild steel

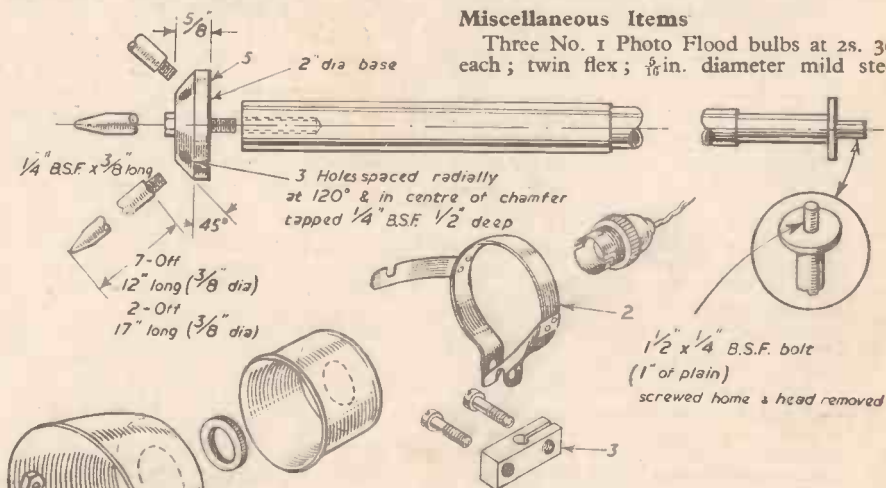

Figs. 1-5.—Details of construction.

bar for legs; mild steel water-pipe for boom column; bolts, wing-nuts, etc. (see text); 3½in. wide x 20 g. thick x 2ft. long pieces of aluminium alloy strip; 2in. diameter x 6in. long brass or dural.

**Reflectors and Lamp-holders**

There are three of these. Mark off 2½in. diameter hole in the bottom of basin, drill

circle of holes tight to the inside of scribe line, chisel out and clean up with a half-round file (Fig. 1). Cut strip of 20 g. (or thereabouts) aluminium sheet  $\frac{1}{4}$  in. wide and long enough to wrap round mug fairly tightly and leave



Fig. 5a.—How the equipment packs away.

ends  $\frac{1}{4}$  in. apart (Fig. 2). Two lengths of  $\frac{1}{4}$  in. wide strip are next riveted in position on first strip forming tongues (see Fig. 2), their length allowing them to project beyond the mouth of the mug and up the side of the basin by at least  $1\frac{1}{4}$  in. Make up bracket (Fig. 3) and assemble with  $\frac{1}{4}$  in. wide strip, which must grip the mug tightly when wing-nut is tightened. Drill  $\frac{3}{8}$  in. diameter holes in tongues and, holding mug to basin, spot through into basin. Drill basin and fit 2 B.A. roundhead screws with one nut on each outside basin and locknut inside, allowing thickness of tongue between screw head and outside nut (Fig. 4). Slot tongues on alternate edges. Basin and mug can now be assembled and disengaged with twisting motion. Drill and file  $1\frac{1}{4}$  in. diameter hole in centre of mug base and fit bulb-holder.

**Bases and Legs**

These, with one other item, comprise all the turning needed. Turn up seven 12 in. legs and two 17 in. legs and three bases to drawing (Fig. 5). The lathe can conveniently be used for marking off and drilling the three  $\frac{1}{4}$  in. B.S.F. tapped holes, as shown. Drill and tap  $\frac{1}{4}$  in. Whit. right through and insert and lock  $\frac{1}{4}$  in. Whit. bolt as shown (2 off). The third one should be drilled  $\frac{1}{4}$  in. diameter clearance right through.

**Telescopic Masts**

Prepare three of these. Each is supplied plugged at each end, the plug at the smaller end being flanged. It may be found necessary to drill, tap and fit grub screws (4 B.A.), to prevent plugs turning. These plugs must be drilled and tapped right through  $\frac{1}{4}$  in. B.S.F. at the top end (smaller diameter), and  $\frac{1}{4}$  in. Whit. at the bottom. A  $1\frac{1}{2}$  in. x  $\frac{1}{4}$  in. bolt with 1 in. of plain shank is screwed into the top plug and the head cut off. This is to take the lamp bracket.

**Boom Stand**

This requires only two main items extra to the vertical units, namely, a 24 in. x 1 in. diameter column and the clip to attach the telescopic mast. One end of the column is plugged with mild steel, this plug being the remaining item of turning. It is drilled and tapped  $\frac{1}{4}$  in. Whit., the upper end of the tube

being squeezed flat and drilled  $\frac{1}{4}$  in. clearance. The clip is made from 16 g. mild steel, hammered to shape over a bar slightly smaller in diameter than the mast, and drilled  $\frac{1}{4}$  in. clearance as shown. A  $\frac{1}{4}$  in. B.S.F. bolt and wing-nut secures the mast in the clip to the top of the column. A short length of chain is fastened to the head of a  $\frac{1}{4}$  in. Whit. bolt, which is screwed into the mast end. A hook formed by bending a 2 B.A. bolt and screwed into the column is engaged by the free end of the chain, holding the mast at the required elevation. Selecting different links allows the elevation angle to be varied.

**Electrical**

No great difficulty should be experienced in wiring up the switchboard if the diagram is carefully followed. The theoretical system, and the actual wiring layout are shown.

I advise the non-electrically minded in the interest of "safety first," to seek the advice

3 batten type lamp holders or 2 pin 5amp. sockets

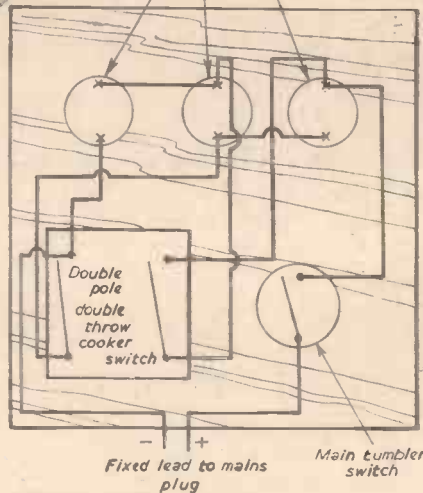

Fig. 6.—The wiring and theoretical circuits.

of a practical electrician, if there is any doubt about successfully carrying out this part of the job.

**Assembly of Vertical Lamps**

For use, the two vertical lamps will be assembled as shown in Fig. 7. Obviously six of the seven 12 in. legs will be employed together with two masts, two lamps complete and the two bases which have  $\frac{1}{4}$  in. Whit. bolts. In stripping down for transport it is only necessary to disengage the reflector

(basin) from the bulb-holder (mug, complete with strap and still attached to bracket), lift bulb-holder complete from top of mast (loosen wing-nut, not shown), and coil flex around mug, unscrew collapsed mast from base and unscrew legs.

**Assembly of Boom Lamp**

The assembly differs only slightly from the vertical lamps. The two 17 in. legs and 12 in.



Fig. 7.—The assembled lamps.

leg are screwed into the base piece, which has the  $\frac{1}{4}$  in. plain hole. When standing on its legs the base therefore is canted at a considerable angle. The mast is now secured to the top of the 1 in. diameter water-pipe by means of the M.S. clip and a  $\frac{1}{4}$  in. B.S.F. bolt and wing-nut, the bolt passing through the clip and the hole in the flattened end of the water-pipe. This assembly is now secured to the base by means of a loose  $\frac{1}{4}$  in. Whit. bolt such that the top of the mast overhangs between the two 17 in. legs. This position is essential, since the "overhang" of the boom would otherwise cause the unit to be unstable when fully extended. The reason for a plain hole and loose bolt in the base becomes obvious, since the angular position of the boom relative to the legs can be assumed every time. The hook and chain control the elevation.

In dismantling, the only extra stripping is to withdraw the screw securing the mast to the water-pipe, leaving the clip in position on the mast. The rest of the stripping is the same as for the vertical units since the screw and chain are left screwed into the bottom of the mast.

**THE PRACTICAL WIRELESS ENCYCLOPÆDIA**

By F. J. CAMM

The Entirely New 12th Edition of the Famous Standard Work

Considerably enlarged, amplified and entirely re-written and re-illustrated. Complete Television Section, with theoretical and constructional data.

All the facts, figures, and constructional data of Radio and Television—Definitions, Terms, Units—Principles, Circuits, etc. Over 300,000 copies sold!

Price 21/- or 22/- by post from:

GEORGE NEWNES LTD., Tower House, Southampton Street, Strand, W.C.2

# A BATTERY ALARM

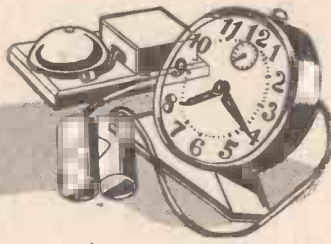

## A Gadget to Wake the Heavy Sleeper

By J. A. ROBERTS

**T**HIS simple device has proved invaluable in overcoming the inability of most types of domestic alarm clock to ring loud enough or long enough to waken a heavy sleeper.

Providing the clock is reliable, is properly wound and set, properly placed against the three guide-pins in the bottom of the case and the latter placed well out of reach of the sleeper so that he must get up and cross the room to stop it, fears of not waking up will be at an end. The bell will ring as loudly as is required, and continue to ring until switched off.

The device can be made for a few shillings, is adaptable to most types of domestic alarm clock, and in operation no more is required than is ordinarily done before retiring, i.e., take the clock out of the case, wind and set, and replace against the three guide-pins mentioned.

### Operation

When the alarm goes off the winding key turns, one-half kicking up a specially designed

three guide-pins being arranged as shown to provide right, left and rear stops. The spacing of these guide-pins will depend upon the dimensions of the foot with which the clock is fitted.

If a clock having two pin feet, with the back of the clock resting on the table, is to be used some other guide arrangement will have to be used, such as a pair of V-shaped blocks into which these two feet can be placed. I do not recommend this type of clock, as most of them lean back slightly, and trouble might be encountered in the engagement of the bell crank switch.

Both winding keys are indicated by the dotted lines Fig. 1; time wind on the left, alarm wind on the right, as is the usual commercial practice. It will be seen how, in

path of the alarm wind key the greater will be the degree of rise and fall; this is a matter for careful adjustment of the adjustable collar mentioned.

A drop-down front, vignetted to match the clock face, could be fitted to the cabinet to hide from view those parts of the bell, switch, battery, wiring and variable resistance not hidden by the clock. Whether or not this front is left down during the night will depend upon the volume of sound required to waken the sleeper. It has been found from experience that, until the battery becomes weak at least, the bell is quite loud enough with the front closed, and the simple action of pushing in the plunger is all that is left to do on waking.

Generally speaking, it is the length or duration of the alarm bell ringing which wakes the sleeper as much as the volume.

### Arrangement of Parts

Fig. 2 shows the general layout of the various components as seen with top of case removed, the elementary circuit being shown in Fig. 4. Fig. 3 shows how tough most of the length of the contact spring is in line

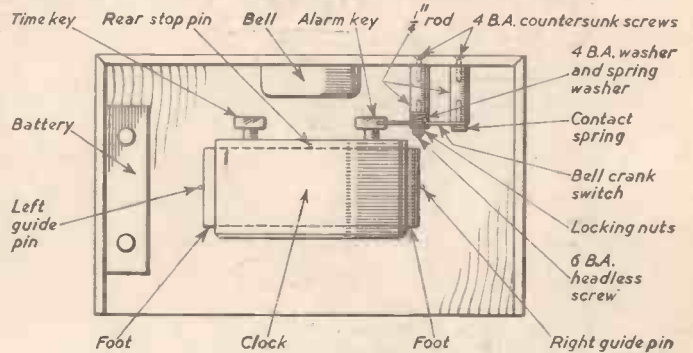
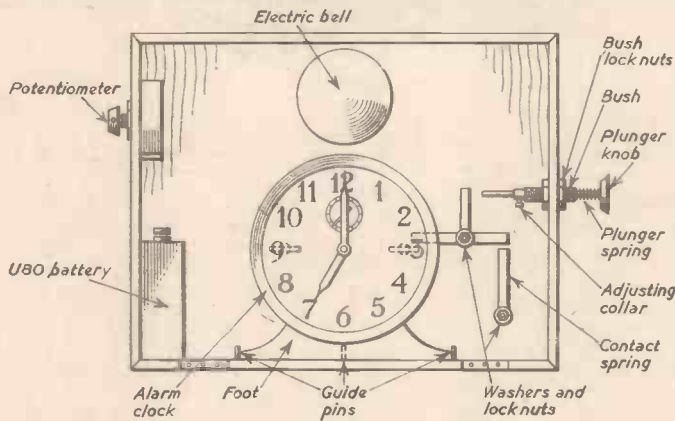

Fig. 1 (Left). — A front view showing the clock in place. Fig. 2 (Above). — A plan view showing the general layout.



switch which switches on an electric bell, the volume of which can be controlled by a variable resistance at the side of the case.

To switch off the bell a plunger at the opposite side of the case is pushed in, thus switching off the arm and resetting the same for the next time.

The clock is not itself interfered with in any way, and if normally used in another room it can be removed from the case for this purpose. If used only as a bedroom alarm it can be left permanently in the case, the simple operation of withdrawing, setting and replacing being performed only once per day.

The dimensions of alarm clocks vary with their type and make, and it is impossible to give more than a general idea of the arrangement. The actual positioning of the components is largely a matter of trial and error, though no great difficulty should be experienced if the top of the case, which carries no part of the assembly, is left off until the correct position of these has been found, and the device assembled and functioning correctly.

### Locating the Clock

A clock is shown in position in Fig. 1, the

Figs. 3 and 4 (Right). — A further view of the contact mechanism, and the circuit diagram.

descending smoothly into engagement with the spring contact, thus switching on the electric bell. It will stay there, with the bell ringing, until the plunger is pushed in, the bell thereby being disconnected and the bell crank switch reset.

The plunger works between limits provided by the knob at one end and the adjustable collar shown, sufficient amount of travel being provided in the switching-off action for the contact side of the bell crank switch to rise clear of the contact spring and the opposite side to fall sufficiently far to come into contact with the alarm wind key at the next operation.

It is clear that the greater the overlap by which the bell crank switch intrudes into the

with the falling end of the bell crank switch the first  $\frac{1}{16}$  in. is bent to allow the latter to pass to the straight section. Here it is held during the ringing period by the correct damping effect of the two locking nuts pressing the bell crank switch against the spring washer, combined with the binding effect of the contact spring; both factors need correct adjustment.

In some alarm clocks the two keys are hinged, and fall flat against the back of the clock after winding; if a clock of this type is to be used the alarm wind key must be replaced by one of the rigid type. This will usually be done by the local clock repairer for a few pence.

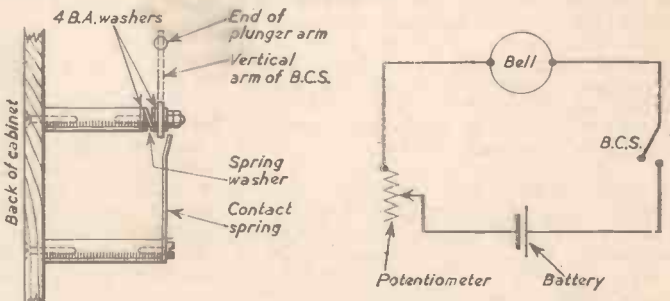

Usually the bell of the clock will have stopped ringing before the plunger is operated, and if not the user must wait until it has done so, otherwise, naturally the electric bell will be switched on again, but no difficulty should be experienced here as the tone of the two bells is usually quite distinct.

Care must also be taken that after winding the alarm wind key is not left in such a position that it will foul the left-hand arm of the bell crank switch as the clock is being placed in the case; this could inadvertently happen.

Both of these possible faults can be overcome by the simple expedient of not winding the alarm more than half-way and stopping winding when the key is in such a position that there is no danger of it fouling the switch; the fouling position can be easily found and avoided.

**Assembly**

If it is proposed to purchase a new electric bell the type having its coils enclosed within the dome is recommended, and this should be screwed to the back of the cabinet before the top is fixed. Position the clock centrally on the bottom of the case with at least  $\frac{1}{2}$  in. clear of the bell. Mark for the position of the rear stop pin, remove the clock and drive in this pin. Replace and re-align clock and mark positions of right and left guide pins.

These pins are firmly hammered in, a fraction of an inch play being allowed for easy removal and replacing of the clock. This is replaced, first turning the alarm wind key into a horizontal position. The length of the arm carrying the bell crank switch can then be determined and, as will be seen from Fig 2, it will be slightly less than the distance from the centre of the alarm wind key to the rear

of the cabinet, the difference being made up by the washer arrangement, the left-hand horizontal arm of the bell crank switch thus lying centrally in the path of the rising arm of the alarm wind key. The degree of overlap of these two arms determines the distance the bell crank switch travels in its throw;  $\frac{1}{2}$  in. should be ample.

The contact spring supporting arm is the same length as its companion. It is screwed to the back of the cabinet in such a position that the end of the contact spring it carries, which should be about  $1\frac{1}{2}$  in. long, is just clear of the contact end of the right-hand horizontal arm of the bell crank switch.

In alignment with the vertical arm of the latter is placed the plunger assembly, which consists of a bush, held by two nuts, into which a  $\frac{1}{2}$  in. rod slides. This bush can be made by drilling a 1 in. length of 0 B.A. headless screw  $\frac{1}{2}$  in. clearance. The plunger rod is threaded a short distance at one end and screwed into a small ebonite knob between which and the external end of the bush is a spring about  $\frac{1}{2}$  in. long, placed over the plunger arm as in Fig. 1. This whole assembly can often be obtained ready made in the

form of a single hole fixing push-pull switch at W.D. stores. The adjustable collar can be made from a  $\frac{1}{2}$  in. length of  $\frac{1}{2}$  in. rod, drilled  $\frac{1}{2}$  in. clearance and tapped for 6 B.A. setscrew. Upon the position of this on the plunger arm will depend the degree of throw of the plunger, which in turn is determined by the amount the bell crank switch travels when actuated by the alarm wind key, according to the length of the latter and the degree into the arc of which the former protrudes.

It might be advisable to fit a very small knob to the internal end of the plunger in order to provide full pressure to the vertical arm of the bell crank switch or, alternatively, a small striking plate could be soldered to the latter where the plunger strikes. The bell crank switch itself is a T-shaped plate, having three arms, each approx. 1 in. long cut from brass or steel plate  $\frac{1}{16}$  in. to  $\frac{1}{8}$  in. thick. The contact spring is a length of ordinary clock spring of such thickness that it will yield under pressure, yet be strong enough to hold the arm in position once it has moved. If the contact spring is strong enough the contacts will be self-cleaning and no trouble should occur through carbonisation.



# A mechanical potato peeler

A Labour-saving Device for the Kitchen

By W. J. STANNAGE

**T**HIS potato peeler was designed to be operated by hand, as not every district has a high enough water pressure to allow a water turbine to be used as a means of driving. The peeler rests on the draining board and an aluminium tray conveys the rasped-off peel into the sink.

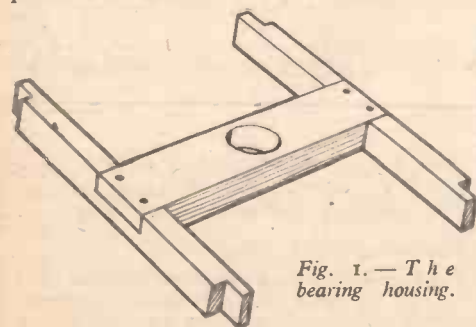

**Parts Required**

The bevel gears used were taken from a cheap breast drill, obtained from a world-famous store for a few shillings. The casing is made of wood, glued and screwed to four 1 in. square uprights. The thickness of the wood is not important, provided that the

finished casing or box is strong and firm. The inside measurements are 12 in. x 12 in., but the exact height cannot be given as this will depend on the diameter of the gears, etc. Another exact measurement that cannot be given is the position of the supports for the rotor bearing as this also depends on the components used.

The rotor is a piece of  $\frac{1}{2}$  in. thick timber, 10 in. diameter, and the cylinder is 12 in. O.D. x 9 in. high. This item is made from perforated zinc, and the joint soldered.

Check the bore of the small gear wheel and obtain a ball-bearing with a similar bore. It should be noted that as a threaded spindle is required on which to mount the rotor the spindle should be of a diameter suitable for threading with standard dies. Thus, if the bore of the wheel is not suitable it should be bored or reamed to a standard size. The author was fortunate enough to get a wheel with a  $\frac{1}{2}$  in. bore, so  $\frac{1}{2}$  in. diameter B.M.S. was used for the spindle, and a  $\frac{1}{2}$  in. bore bearing. The other dimensions of the bearing are unimportant.

**Construction**

Firstly, make up the bearing housing and supports as shown in Fig. 1. The housing is

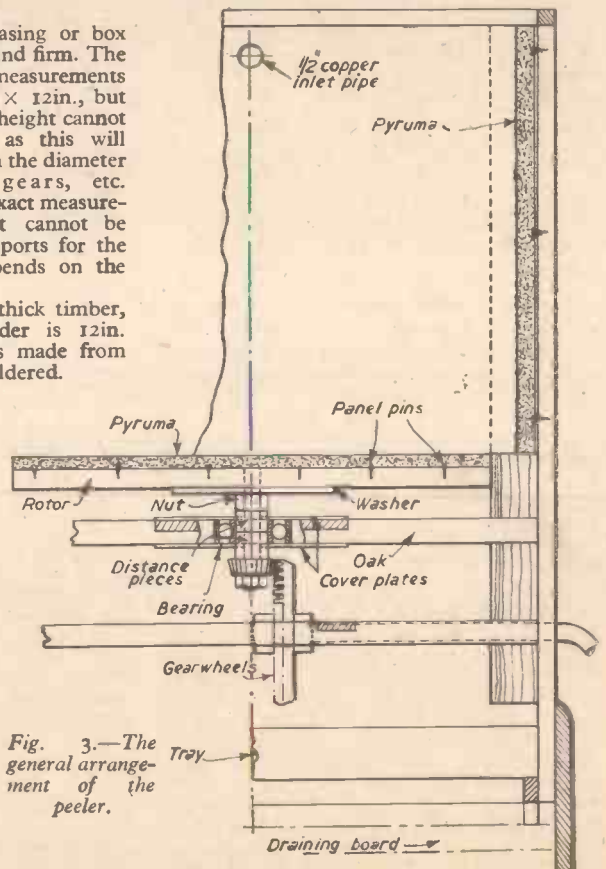



oak of similar thickness as the bearing and wide enough to allow the accommodating hole to be drilled. The joints are notched and screwed as shown in the drawing. Attach this assembly to the four uprights that form the corner pieces of the box. As the exact position cannot be determined it is as well to cut the uprights longer than will be required, and attach in a position that will leave surplus material that can be removed later. The joints are halved, glued and screwed.

Next fit the bearing in the housing and make the two cover plates shown in Fig. 2. These are bolted in position with four 3/16in. hexagonal-head screws. The centre hole is the same diameter as the inside race of the bearing. Now turn up two 1/4in.-long distance pieces, the bore of which is the same as the bearing and the O.D. slightly less than the centre holes in the cover plates. Cut a large washer, approximately 3in. diameter, from a piece of heavy-gauge sheet iron, and bore the centre hole the same diameter as the bearing. Bore a similar-sized hole in the centre of the rotor disc.

**The Spindle and Bearing Assembly**

To make the spindle, select a 6in. approx. length of B.M.S. and thread one end B.S.F. for a length of about 1 1/2in. Screw a nut down tightly to this end of the thread, place the large washer in position, then the rotor disc, next a standard washer and finally a nut. Screw the whole assembly up tight and cut off any surplus thread.

Now fit a distance piece and push the spindle down through the bearing. Fit the other distance piece, then the small gear wheel and mark the spindle for cutting, making

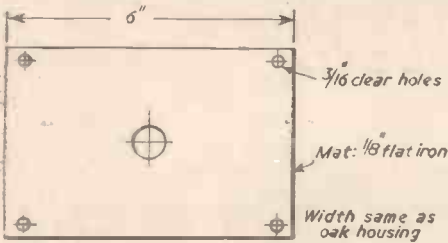

Fig. 2.—The cover plates.

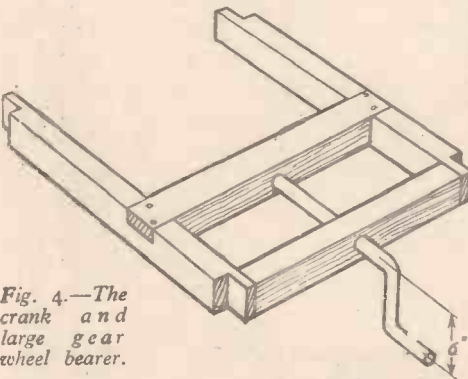

Fig. 4.—The crank and large gear wheel bearer.

allowance for a nut to be fitted. Remove the last-fitted components, cut the spindle where marked and thread the end. Reassemble and tighten up. See Fig. 3.

**The Crank Bearer**

With this complete assembly in position, make up the bearing assembly for the large gear wheel as shown in Fig. 4. Note that the front bearing is secured to the front of the box with screws and glue, but at this stage of the construction it is attached to the side supports with fine nails. The centre hole of the wheel is drilled out to a convenient size (3/4in. in the writer's case) and a crank bent from 1/4in. B.M.S. as shown in the drawing. The end was threaded B.S.F. and the wheel clamped between two nuts. The reader must work out

for himself the position of the bearing nearest the wheel as this will depend on the size of gears used. Also the position of the assembly where it is attached to the uprights. The two gears must mesh, and fitting is carried out with this in view.

The timber that forms the bearing for the crank is 1in. square oak. The writer found that this provides a good bearing surface and that no bushings were necessary; brass bushes may be fitted if desired.

At this stage the cylinder may be held in position and its height marked off on the four uprights. The bottom of the cylinder should be level with the top of the rotor. Cut off the surplus wood from the tops of the uprights. Next mark off and cut the lower sections of the uprights level with the bottom of the large gear wheel.

Now make from 18 s.w.g. aluminium the tray shown in Fig. 5. This item, which is a push-in fit, sits below the large wheel and is supported on two 1/4in. x 1/4in. runners, which

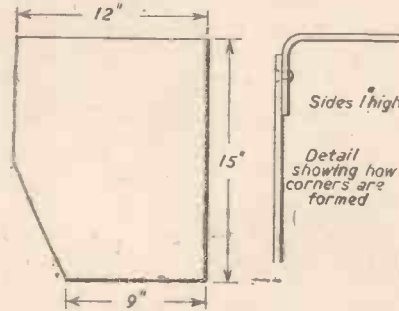

Fig. 5.—Details of the tray.

are fitted on a slope to direct the peel and water into the sink, as shown in Fig. 6.

**The Panels**

Having completed the runners and the tray, it is now possible to calculate the length of the back panel which should extend past the ends of the uprights far enough to allow the runners to be screwed on at the required angle. Add the width of a saw-cut to the calculations as the back panel must be fitted in two pieces. The top piece, which is the length of the cylinder (i.e., 9in.), is glued and screwed into place and the bottom part is only screwed. This allows it to be removed to permit a spanner to be fitted to the nut under the rotor—necessary for final assembly and future maintenance.

The side panel opposite the outlet is the same length as back, and can be cut and secured.

The front panel is similar, with a clearance hole drilled to take the crank. A piece of timber 3in. wide is screwed to the front in such a position as to allow 1 1/2in. to extend below the panel. This projects down over the front edge of the draining board and makes the peeler much easier to hold in position when in use. This can be seen in Fig. 3.

The other side panel (on the sink side) extends only to the top of the tray.

At this point it is as well to point out that if the draining board is at the right-hand side of the sink the slope of the tray and the angle of the outlet will be opposite that shown in the drawings.

A top can now be cut from 1/4in. plywood. The measurements are the same as the outside dimensions of the box and a 12in. diameter hole is cut in the centre. This top is glued and nailed in position.

In a central position at the top of the outlet-side panel drill a hole to accommodate a short length of copper pipe. Hold the cylinder in position and mark off the position of a corresponding hole. Remove the cylinder and cut out this hole. The pipe is shown in Fig. 7.

Remove the rotor by taking off the nut at the bottom of the gear wheel. A box spanner will be useful here, and the lower portion of the back panel should be removed to allow a set spanner to grip the nut under the rotor.

Secure the cylinder in position using 1/4in. No. 6 woodscrews. The top of the cylinder is level with the top of the box and the screws are placed at intervals around the top edge, also down the sides where contact is made with the box sides. Care should be taken that the holes for the copper pipe are in line.

Now cover the inside of the cylinder with a 1/4in. thick layer of "Pyruma" putty cement. The copper pipe should be pushed into position, the end being flush with the cement. Also cover the rotor with cement to a depth of 1/4in., first driving in panel pins at intervals to form a key. The surface of the "Pyruma" must be roughened and this can easily be done by dabbing it lightly with a wire brush. Leave aside to dry naturally.

**Assembly Details**

Fit the rotor, gear wheel, etc., in position and tighten the nuts well. Next, fit the driving crank and large wheel. Some form of handle is required for the crank but this can easily be devised by the reader. A brass washer is made to fit over the copper pipe and fixed to the side panel with small screw-nails. When in position it can be soldered to the pipe. A lid is required the same dimensions as the top. It is hinged to the back panel and fitted with a handle which also provides a good grip for holding the peeler when the crank is

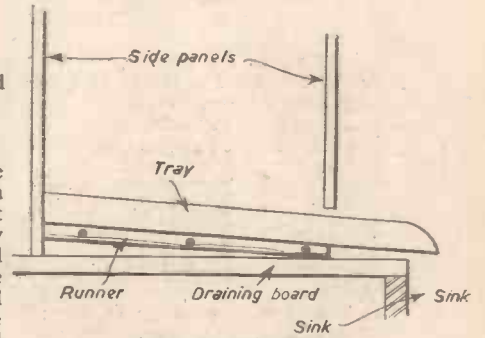

Fig. 6.—The runners.

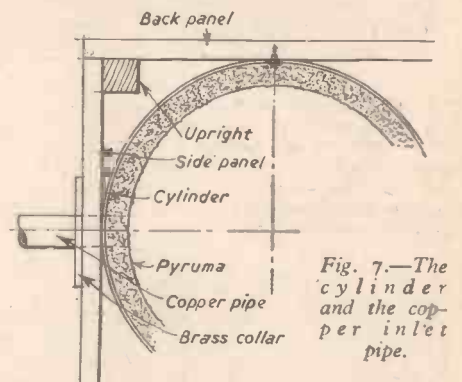

Fig. 7.—The cylinder and the copper inlet pipe.

being turned. As the woodwork is exposed to water it should be given several coats of best-quality paint of any desired colour.

**Operating the Device**

Place the peeler on the draining board with the outlet slightly overhanging the sink. Attach a short length of 1/4in. hose pipe to the copper pipe and the other end to the cold water tap. Place a few potatoes in the cylinder and close the lid. Turn on the tap and turn the crank. A fierce stream of water is unnecessary; just enough to wash out the peel.

Once a week, or thereabouts, the tray may be removed and the inside of the machine given a wash out.



## A Unit to Simulate the Acceleration and Deceleration of High-speed Aircraft for Experimental Purposes

THE development of the gas turbine has made possible the building of aircraft capable of flying at speeds considerably in excess of those attainable with piston-engined machines, and the problems of designing airframes which can withstand the stresses imposed by the violent acceleration and deceleration of such aircraft during manoeuvres have, to a large extent, already been solved. To assess the capacity of the human body to withstand these forces is, however, a problem of greater complexity, as tests under actual flight conditions may well cause a pilot to black out, with possibly fatal results.

The man-carrying centrifuge described here has recently been installed at the R.A.F. Institute of Aviation Medicine (I.A.M.) under contract with the Air Ministry. The design requirements were specified by the Air Ministry Works Directorate to meet the functional requirements of the Institute of Aviation Medicine and this division supervised the construction, installation and tests. These tests take place under accurately controlled conditions and the centrifuge is equipped with apparatus to facilitate medical research into the effects of the tests on the human body and with "teletalk" equipment which enables the subject to describe his reactions to an observer.

The contract for the centrifuge was placed with M. B. Wild and Co., Ltd., of Birmingham, who acted as main contractors, all the electrical plant and control gear being supplied by the General Electric Co., Ltd.

### Principles of Operation

The centrifuge (Fig. 1) consists basically of a horizontal arm rotating under a precisely controlled cycle of acceleration and deceleration which can be accurately repeated any number of times. The rotating arm is a fabricated tubular structure of high tensile steel and light alloy. Length 62ft. 6in. and cross-section approximately 9ft. 6in. square, excluding depth of king post bracing. It has a car suspended at each end and is mounted on a 12-ton flywheel attached to a vertical spindle driving motor installed in a central pit in the centrifuge chamber.

Some facts and figures are given below:

Weight of totally enclosed car.—Variable from 1,150 to 3,300lb.

Total weight of rotating mass.—42 tons.

Maximum peripheral speed at path of car.—115 m.p.h.

Time from rest to attain maximum peripheral speed.—9 seconds.

Fig. 1.—The man-carrying centrifuge.



Fig. 2.—A "subject" seated in one of the cars.

Minimum time for cycle (over maximum range).—18 seconds.

Tolerance over complete cycle (acceleration, constant speed and retardation referred to pre-determined requirements)= $\pm 2$  per cent.

Peak horsepower of motor during acceleration=2,200 horsepower.

### Theory of Operation

Though design problems of considerable complexity had to be solved before details of construction could be settled, the basic theory of the operation of the centrifuge can be stated in simple terms. The cars attached to the arm, when rotated at uniform speed by the driving motor, are subjected to an acceleration, in a direction towards the axis of rotation, of magnitude  $w^2/r$ , where  $w$  is the angular velocity and  $r$  the radius of the arm. Thus the magnitude of the acceleration is controlled by the speed of the motor and the effective radius of the arm; consequently, the rate of change of acceleration is governed by the rate of change of motor speed. Each car is mounted on trunnions, fore and aft, so that it can swing out to maintain the direction of the resultant acceleration on the subject unchanged as the centrifuge speeds up. Hydraulic dampers are provided to check any tendency of the cars to overswing or oscillate.

The speed of the motor is varied, in accordance with the programme required, by the electrical control gear.

On each side of centre, provision is made for the attachment of a car at distances roft., 15ft., 20ft., 25ft. and 30ft. from centre of rotation so that alternative radii can be selected. At the maximum motor speed of 54 rev./min. and the full radius of 30ft., the acceleration produced has a magnitude of approximately 30 times the normal acceleration of gravity.

### Operation Control

The centrifuge can be operated either automatically or manually by a "controller" seated at his desk in the control room, or by either of the two "subjects" in the cars. When the two "subjects" are jointly controlling the speed, the mechanism is so arranged that the speed automatically follows the lower setting, while in an emergency the arm can be brought to rest by the "controller," by the "subjects" or by "observers" seated at the centre of the arm on either side of the driving spindle. The observers travel round with the centrifuge and have a clear view of the "subjects" through the Perspex roofs of the cars. A "subject" is shown seated in a car in Fig. 2.

### Two Emergency Features

For normal braking the inherent regenerative characteristic of the Ward Leonard equipment is used, but in cases of emergency—i.e., interruption of power supply or failure of electrical equipment, such as to result in the absence of controlled regenerative facilities—then the arm is brought to rest under emergency friction braking.

In the event of an emergency arising due to a condition of excessive out-of-balance in the loading of the rotating arm, rollers are fitted to minimise the damage.

These rollers and the brake shoes are seen in Fig. 3.

### End Chambers

As an alternative to the arm assembly described above, the cars may be completely removed and each end of the arm converted into a chamber. The walls are lined with foamed rubber to act as crash barriers and prevent injury when a subject is in contact with the wall.

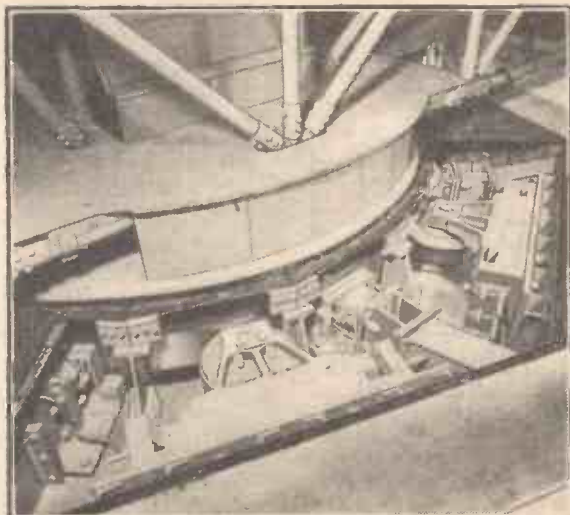
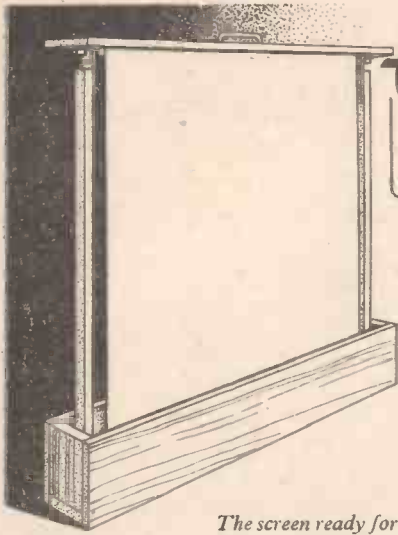

Fig. 3.—Centre section of the arm, showing rollers and brake shoes.

These chambers provide accommodation for investigation as to capacity of individuals to execute simple tasks when subject to low values of "g." They also enable tests to be carried out on accelerometers, strain gauges and similar mechanisms.

# A Portable PROJECTION SCREEN

A Simply-made, Easy-to-carry Accessory for the Projection Enthusiast By FERGUSON SPROTT



The screen ready for use.

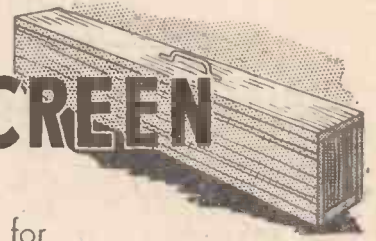

To enjoy the full brilliance of colour transparencies during projection it is essential to use an efficient screen which will reflect the maximum amount of light. This should be obvious; how often, though, does the amateur "make do" with a sheet of cloth or drawing-paper improvised for this purpose, unaware of the consequent loss of brilliance in what should be sparkling colour? A time comes, however, when a more suitable screen is considered desirable, possibly one which could be easily transported to the club or to a friend's house for an evening's show. The cost of such a screen is in most cases a deterrent.

With the above in mind, a suitable screen has been designed as illustrated. The construction is simple, requiring only a minimum of tools, and would provide pleasure in making and using, not to mention a considerable saving in cost.

The design centres around the application of a spring roller as used for window blinds; this is enclosed in a wooden carrying case, and can be speedily erected for use.

The details given are to suit a 3ft. by 3ft. screen. A square shaped screen is essential so as to include both the vertical and horizontal frames of transparencies. The size and shape, however, could easily be altered to suit personal requirements, as, for instance, a rectangular shape for cine work.

### The Carrying Case

This can be made from softwood, such as deal, Oregon pine or similar wood. Make the bottom and ends from 3/4 in. thick material, the lid from 1/2 in. material, and the sides from 1/2 in. plywood. The parts after planing to size can be nailed together, and the heads of the nails punched slightly below the surface to be filled with putty when painting. At this stage screw the 1/2 in. by 1/4 in. battens, marked A in Fig. 1, to the ends of the case. These are for fastening the plywood division marked C.

### The Roller

We shall next require a spring roller, 1 1/2 in. in diameter and 3ft. 1in. long. These are usually in standard lengths, one end of which can be cut to bring the roller to the required length.

The brackets normally used for blinds are unsuitable for our purpose, and it will be necessary to make two new ones from 1/2 in. by 1/2 in. steel strip; B in Fig. 2 gives particulars of these. One bracket has a clearance hole for the cylindrical pin at one end of the roller and the other end has a slot, as shown, which should be made a clearance fit for the spring-loaded tongue of the roller. This slot terminates in a rectangle in the centre of the bracket to prevent the roller coming undone when in use. After drilling and filing the brackets to shape they can be bent at right-angles to complete.

The brackets can now be screwed in position inside the case, spaced equidistant from each end, with the roller a good fit between them, so that it can easily be removed when required.

Just above the roller is a 1 1/2 in. by 1/2 in. plywood division, marked C, on which rest

the struts. This is screwed to the battens marked A, which are already screwed to the ends, see Fig. 1. In the centre a 1in. by 1/2 in. metal bracket, D, is added as additional support; when fitting this support to the side of the case it is best to use a couple of 3/8 in. countersunk screws through holes in the plywood sides into tapped holes in the bracket; this will be stronger than using wood screws through the bracket into the plywood. Leave the final screwing of this division until the screen is attached to the roller and finally placed in the case.

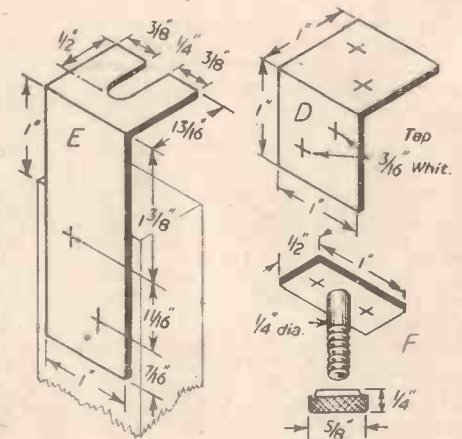

Drill holes marked + to suit woodscrews

Fig. 2.—Details and dimensions of the various metal brackets.

### The Struts

These can be 1 1/2 in. by 1/2 in. in section, the lower one is 3ft. 1in. long, the upper one 3ft. 1/2 in. long. To one end of each is fitted a 1 1/2 in. butt hinge. To the other end is screwed the slotted angle piece, E, allowing it to project 1in. beyond the end of the strut.

With the struts now ready, fit them in position in the case. Position the lower one first and screw the hinge to the end of the case. Similarly, screw in position the other strut and try both struts to make sure that they both swing up evenly and squarely into position.

### The Lid

Little work is required to this beyond fixing the two screws, F, which hold the struts. The plates of these should be sunk flush with the top, making a neat job. Finally fit a handle and snap fasteners, or hooks and eyes for carrying. The 1/2 in. by 1/2 in. strip shown inside the lid is for fastening the screen, which we can now consider.

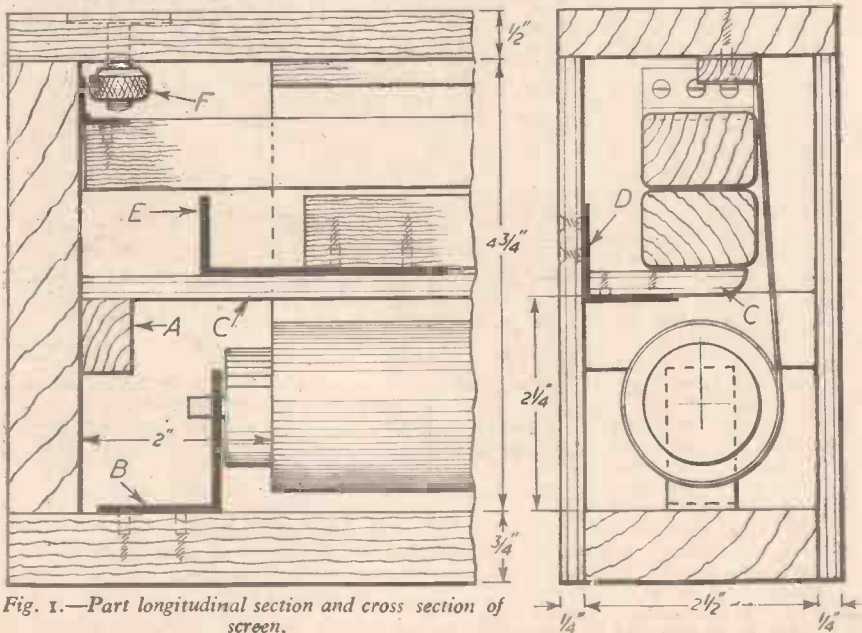

Fig. 1.—Part longitudinal section and cross section of screen.

**The Screen**

As mentioned earlier the quality of the screen is important. Suitable material for this purpose either beaded or plain can be purchased from retailers, and it is a matter of personal preference which you choose. However, a suitable screen can be made from a length of cotton or preferably linen. The screen should be damped slightly and ironed, so that all creases are removed, leaving quite flat. Next nail together a temporary wooden frame of such size that it can be stretched and fixed by drawing pins.

The screen is now ready for painting with a suitable white paint, which can be purchased from any photographic suppliers. Give two coats, allowing time for each coat to dry thoroughly. Finally a narrow black margin can be painted around the edge to complete.

With the roller removed from the case and the lid to hand, we now proceed to fasten the screen. First make sure the end of the screen is cut square, so that it will run squarely on the roller. Fold the end over about a 1/4 in. and tack evenly to the roller, spacing the tacks about 1 in. apart. Be sure to use tacks about 1/4 in. long for this purpose; longer tacks may interfere with the working of the roller. A

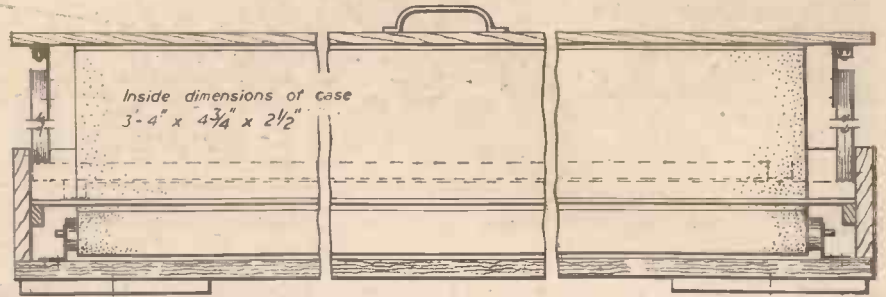

Fig. 3.—A section of the screen in the erect position. The struts are swung erect from the dotted position and are shown broken.

length of 1 in. wide surgical tape is stretched along the roller, half the width covering the tacks and half on the roller; this will protect the screen from the tack heads and give added strength.

The other end of the screen which has been squared is now fixed to the underside of the lid by placing the end of the screen under the hardwood strip and screwing to the lid with closely spaced screws. This completes the job and the roller can now be replaced in the case. The plywood division can now be fixed permanently in position.

**Completion**

It is a simple job to erect the screen; all that is required is to raise the lid, swing up the struts and tighten the screws under the angles, see heading sketch and Fig. 3.

The two feet, 9 in. by 3 in. by 1/2 in., attached firmly to the bottom of the case by a single screw, can be swung at right-angles to the case, thus giving additional support to the screen.

The finish is a matter of taste, but perhaps the most suitable is a dull or flat black paint used on the outside and inside; this has the advantage of not reflecting light.

# Making a Cold Frame

A Unit for Construction by the Handyman-gardener

By T. H. E. MARSH

IN a cold frame seeds may be set, plants grown and cuttings kept all winter, and no single piece of garden equipment has so universal a use. It is desirable, therefore, that a few pains be taken to make a good job of a substantial frame.

A convenient size is 3 ft. x 3 ft., approximately, or 3 ft. x 6 ft., approximately. In fact, 3 ft. wide by multiples of approximately 3 ft. long will be found to be almost ideal.

The frame itself may be made of brick, asbestos cement sheets, or tongued and grooved floor boarding. The light should be of wood and glass. Substitutes for glass are not so good and are inclined to produce weaker plants.

For a brick frame to the sizes shown in Fig. 1, you will require 39 bricks and six half-bricks, 56 lb. of sand and 14 lb. of cement to allow for 1/4 in. joints.

For an asbestos cement frame you will want a sheet 1/2 in. or preferably 3/4 in. thick, 3 ft. x 3 ft. 2 in. long. Cut this as shown in Fig. 2. If you use timber, then you must obtain six lengths of 1 in. floor boarding 6 in. wide x 3 ft. long. Also required for asbestos cement or wood are four corner pieces 1 1/4 in. square x 1 ft. 9 in. long.

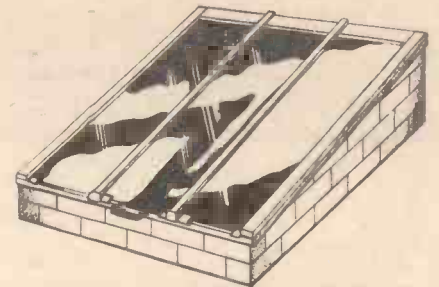

Fig. 1.—The completed cold frame.

For the timber light you require: one piece 2 1/2 in. wide x 1 1/2 in. thick x 3 ft. 4 in.; one piece 2 1/2 in. wide x 2 in. thick x 3 ft. 4 in.; two pieces 2 1/2 in. wide x 2 in. thick x 3 ft. 2 in.; two pieces 1 1/2 in. deep x 1 in. wide x 3 ft. 2 in.; six pieces 1/2 in. x 1/2 in. x 2 ft. 11 1/2 in. long; three pieces 1/2 in. x 1/2 in. x 10 in. long.

Make up the frame with halved joints well glued and fixed with five number 12 x 2 in. screws in each corner. The auxiliary framing members are half-jointed at both ends,

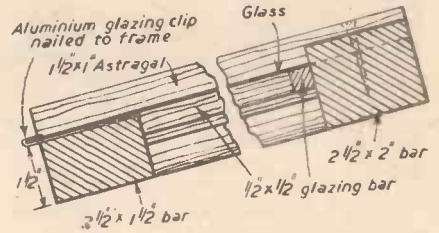

Fig. 4.—A section of the frame.

place and give the light at least two good coats of outdoor paint. A brass handle screwed in the middle of the bottom framing bar completes the cold frame.

FOR THE MODEL MAKER AND HANDYMAN

**THE MODEL AEROPLANE HANDBOOK**

Construction and Principles of all Types  
12/6 (13/- by post)

**MODEL BOAT BUILDING**

Constructional details of Model Sailing and Power Boats.  
5/- (5/6 by post)

**THE HOW-TO-MAKE-IT BOOK**

12/6 (13/- by post)

From George Newnes, Ltd., Tower House, Southampton Street, Strand, W.C.2.

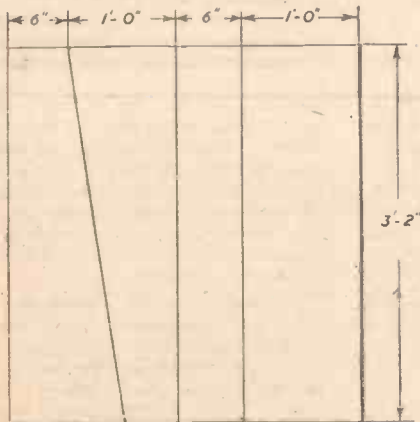

Fig. 2.—Method of cutting when using asbestos cement sheet.

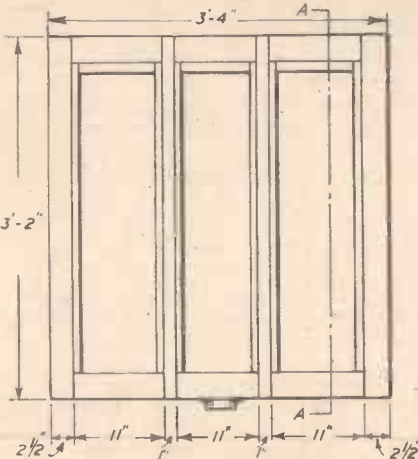

Fig. 3.—Top, dimensioned view of the wooden light.

let into grooves in the back member, and glued or screwed into place. The front ends merely fit into the front bar and are similarly fixed. The 1/2 in. square glazing bars are nailed in place and the whole frame receives a good coat of red lead oxide to preserve the wood.

Six aluminium cleats 3 in. x 1 in. wide as shown in Figs. 1 and 4, are required, cut from sheet aluminium 1/16 in. thick. These are nailed to the bottom framing bar and bent up over the glass. The glass size is 3 ft. x 10 1/2 in. x about 1/4 in. thick. Putty the glass to

# A Gauge 'O' Steam Locomotive

Constructional Details and Scale Drawings of a Loco to Run on the "O" Gauge Layout Given in Our May and June Issues

By E. W. TWINING

ONLY one engine is dealt with here, and it represents the British Railways latest passenger and mixed traffic class, the Pacific, or 4-6-2 type, which is numbered from 70,000 onwards and is known as "Class 7." The first of the batch was named "Britannia" and was turned out of Crewe works in 1951. It was designed and built under the direction of Mr. R. A. Riddles, who is a member of the Mechanical and Electrical Engineering Executive. Derby, Swindon, Brighton and Doncaster all had much to do with the design and construction as a whole.

These engines are almost as large as any engines running in this country, since they just about fill the smallest dimensions of our loading gauge. It was partly for that reason why I chose the type, because it enables us to get the biggest diameter boiler having a parallel tube and coupled with a wide firebox. At the same time the driving wheels are but 6ft. 2in. diameter and there are only two cylinders. In addition there is the fact that these engines represent the latest on our rails. Notwithstanding their size, the small driving wheels and 250lb.



The B.R. locomotive "Britannia." British Railways photograph

boiler pressure, they give a tractive effort at starting of only 32,160lb., which is much less than that of the Great Western "King" class whose tractive force is 40,300lb., the highest of any batch of engines in this country.

Turning to the drawings for our model :

Fig. 1 is a complete side elevation of the engine and tender, and Fig. 2 is made up of four end elevations—the front and back of the engine and the front and back of the tender. Fig. 3 is a longitudinal section through the engine and Fig. 4 a set of cross-sections ; the first is

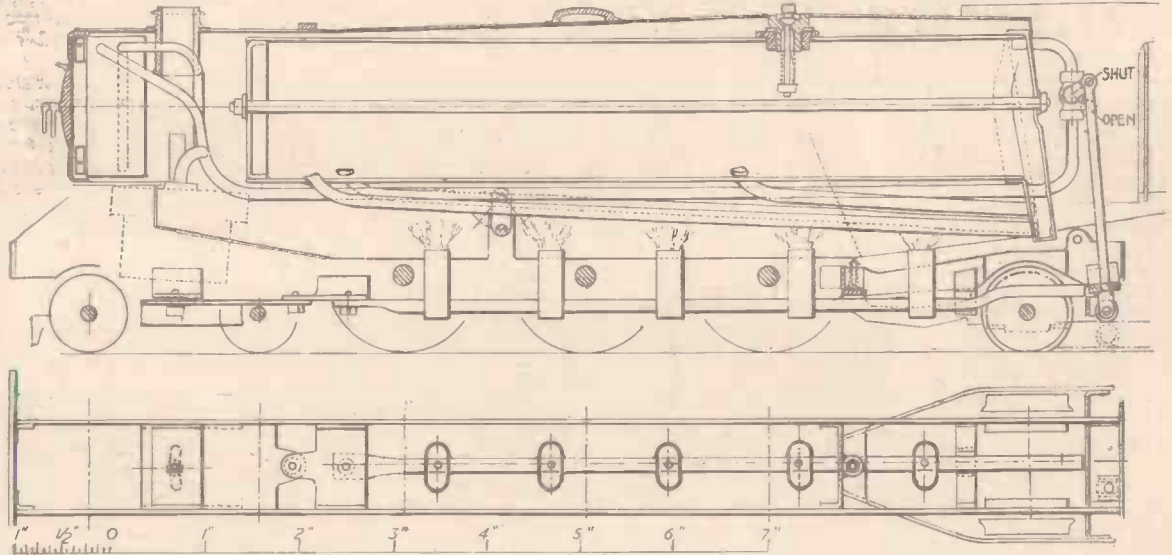

Fig. 3.—Sectional elevation, showing boiler, water tubes, spirit burners, regulator and lubricator, etc.

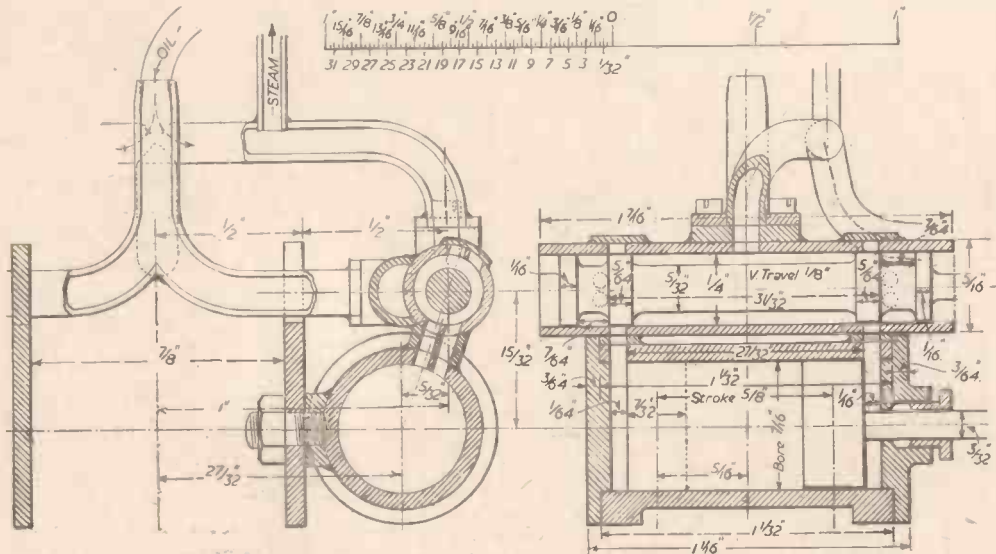

Fig. 5.—Sections through one of the cylinders, steam and exhaust pipe, etc. These will be described next month.

through the cylinders and smoke box, the second through the dome and driving axle, and the third through the part which is normally the fire box. These two drawings, Figs. 3 and 4, show the form and arrangement of the boiler and its water tubes. It will be noticed that in the third cross-section is drawn what appears to be six water tubes, but the one which is on the centre line and is close up to the boiler barrel is the steam pipe. This pipe, coming down from the regulator cock in the cab, passes along the whole length of the boiler through the flames and then it divides to the left and right and goes to the valve chests. Arranged thus, it will get plenty of superheat.

**The Displacement Lubricator**  
In the longitudinal section and the left-hand cross-section it will be seen that, occupying the front of the smoke box, I have drawn an oil box. This is a displacement lubricator and to it two pipes are taken, both of them 1/16 in. in diameter. One

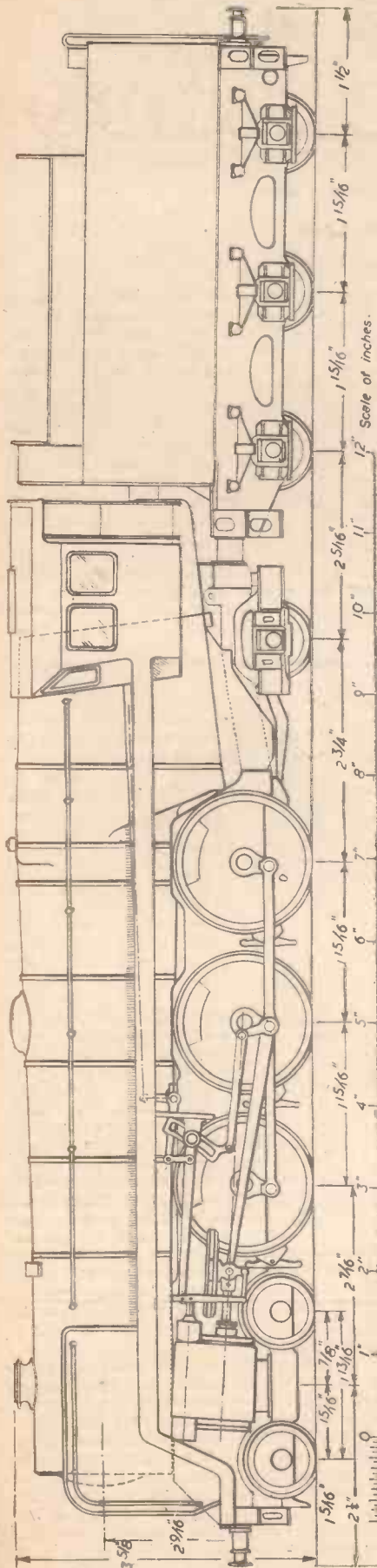

Fig. 1.—Elevation of British Railways passenger and mixed traffic Class 7 locomotive.

of these rises from a point to one side of the centre of the steam branch pipe and the other comes down at the centre exactly where the steam pipe branches to either side. Assuming the pipe coming from one side of the centre enters the lubricator and its end is carried down to the bottom, through the oil, steam will enter the pipe and as its temperature will be lowered by the oil some of that steam will be condensed and the resulting water will fall to the bottom of the box. This water will slowly accumulate and in doing so will lift the oil which will overflow, drop by drop, down the other pipe and will be carried right and left, along with the steam, to the valves and cylinders.

To recharge the lubricator I have provided two large-diameter cheese-head screws on the front of the box, one at the top and one at the bottom. To empty the water away

length of 8 1/2 in. or a little less when shaped at the back-end. The water tubes are to be fairly thin; they will be of copper and will have an outside diameter of 3/16 in. The steam pipe will be, or can be, a little smaller, say a diameter of 5/32 in., and also made of thin metal. None of the pipes should have their walls more than 1/32 in. thick.

**The Wheels**

The wheels should be rough turned and drilled, then the axles turned and shouldered for the wheels, which should make a driving fit on the axles, but before fitting them make and fit on those axles which have inside bearings—the axle boxes. These will be the six coupled wheels and the four bogie wheels. Be careful when driving the second wheel on each coupled axle to see that the cranks on one side make precisely 90 deg. with those on the other side, and that all three pairs of coupled wheels have all cranks in the same direction. Then, on a small lathe, mount each axle, one after the other, on centres and, taking very light cuts, finish the wheels dead true, particularly the treads and the flanges. At the same time turn the cranks and the inner faces of the hubs. Mark out the radius 5/16 in. for the crank pins and drill for these. Crank pins must first be turned and then be forced in, but the force required will depend upon whether they are to be riveted over on the inside or not. I prefer lightly to knock in and rivet over after all the valve gear is made and is working.

The frames are a simple matter, they are to be cut from steel plate 1/16 in. bare in thickness and all distance pieces can be either screwed or riveted. The

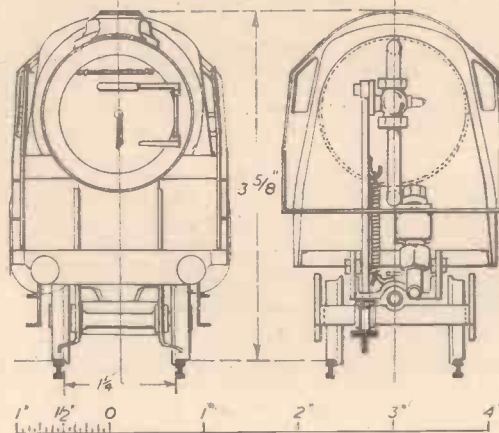

Fig. 2 (above and right).—Front and back elevations of engine and tender.

unscrew both openings, make sure that all water is out, replace the bottom screw and fill up to the top with lubricating oil. Make sure that screws are tightly screwed home. In order to get access to this lubricator the smoke box front and the dummy door is made a push-in fit so that it is gripped and held by friction with the smoke box tube.

**The Boiler**

It will be advisable to silver solder the whole of the boiler together and also to include the lubricator and all the pipe joints. Note that the extreme back of the fire box is wide and is made up of two plates between which water circulates. There is a longitudinal stay running through the barrel of the boiler. This will support the ends in line with the

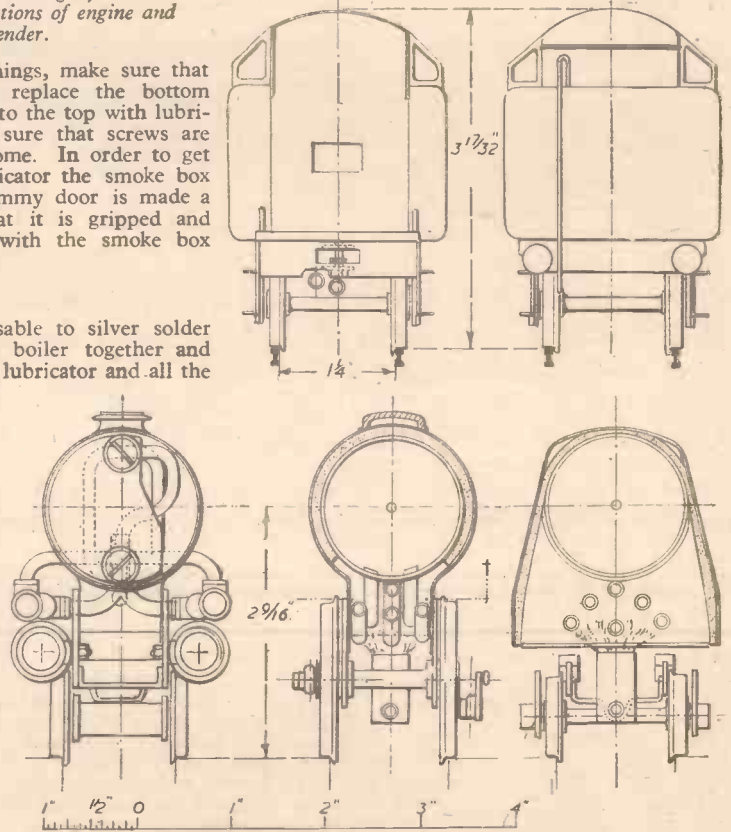

Fig. 4 (Right).—Cross sections through cylinders, through driving axle, and through fire box.

barrel, but the double fire box plates, being flat, will require three additional short stays, arranged nearly horizontally, one of them, the middle one, being placed just below the steam pipe. They should be riveted over and soldered. The boiler barrel is a piece of copper tubing 1 1/2 in. diameter by a maximum

engine is so small that axle boxes are arranged to slide directly in the horns; there are no axle box guides, horn plates or brackets. At the trailing axle, and also on the tender, the guides will each be made in one piece with its own axle box and will move up and down with the box.

(To be continued)

# Building a Home Workshop



## 4.—The Surface Plate

By "TUBAL CAINE"

(Continued from July issue)

ONE operation which the model engineer must repeatedly carry out on all types of models and gadgets is the marking out of various castings and pieces of material prior to machining them on the lathe, milling machine or shaping machine. Though the care imparted to this work is reflected in the quality and accuracy of a detail, surprisingly few home workshops have a really good marking out table.

A favourite method is the use of a thick sheet of plate glass; this, besides possessing a reasonably true surface, costs very little.

For marking out cast articles and those parts made from black bar material, this surface plate is useful and sufficiently accurate, but when close accuracy is desired some alternative idea is necessary. Occasionally one is fortunate enough to secure a fairly large and thick piece of cast iron—perhaps already machined, which will, if carefully scraped perfectly flat, make an ideal table on which to carry out this work.

However, cast-iron plates of this type seldom remain true for very long; even pieces which may have been standing for several months have a tendency gradually to distort, and this, of course, is just not good enough for an accessory which is, after all, the basis of all the work carried out. Most of these plates have a peculiar and annoying habit of merely warping on one corner and, if this is corrected, the same error creeps back a month or so later on the same corner. A flat cast-iron plate is not therefore a substitute for the sheet of glass, though for such operations as placing it across the bed of a lathe while a dial indicator is being applied to test the truth of a shaft, it has no equal.

Sheets of thick laminated plastic about 3/4 in. thick may also make a surface plate of reasonable accuracy, though the author has no experience of this material in that capacity. For, possibly, those readers engaged on the construction of ship models, where there is little risk of the soft surface of a plate becoming damaged, this idea may solve a long-felt want, but the continued use of a steel-based scribing block will scratch the smooth top facing and soon make it unfit for further use.

Slate is another material which I have not encountered in this work, but is one worth consideration. Personally, I would say that slate is most suitable for the builders of model ships and model aircraft, but for what I term engineering work, I do not believe it can equal cast iron.

From this rather brief analysis of the various materials available as a surface table, it is concluded that cast iron is the hardest wearing and the most accurate, and does, with reasonable attention to see that small particles of grit do not become embedded in the smooth

face, give long service before scraping is necessary.

### Cast Iron Surface Plates

For those readers who are engaged on the building of a small gauge model locomotive, the addition of a plate about 9 in. square is a most valuable asset to a workshop. These may be purchased—at a cost of several pounds—but the home-made article is just as effective, though it is agreed that the scraping process does become tedious, especially if the surface is badly warped during the machining stages.

Incidentally, these surface plates are obtainable from Messrs. Alfred Herbert, Ltd., of Coventry, the price being about £3. They are made in two grades—planed and unplaned for those who have the time and skill to scrape the surface. It is proposed to describe for readers who have never yet attempted this process some of the "secrets" which appear to surround this operation in another article; in the meantime let us consider the actual construction of this design because the pattern is not difficult to make.

Fig. 1 shows a plan and elevation of a surface plate 9 in. square. The dimensions

Next, the side walls underneath are just as easily made, and consist of narrow boards held together with thin nails or screws. There is no need to joint them in the usual manner with dovetails as this takes too long, and the addition of the four cross braces will prevent any movement. A relief about 1/4 in. deep is provided on each of these side members as the drawing indicates, and this leaves four right-angled feet at the corners. This idea is useful when the surface plate must stand on a rough wood bench, and it simplifies the question of adjustment when setting the plate perfectly level.

We turn now to the cross ribs and these are again narrow boards 1/4 in. thick. The easiest way to attach them is to nail first the two marked A and B, and these you will observe pass right across the plate from corner to corner. Space them 1 1/2 in. apart and bevel the ends to ensure they correspond with the outside walls. Next "fill in" the remaining two ribs with the pieces C, D, E, F, G and H. It greatly assists matters if the square framework is previously attached to the top board—then the cross braces have something on which to stand while nailing or gluing is carried out. The two short inner

members are not very easily nailed except through the top boards, and these will not hold them properly. So gluing is perhaps preferable for these items. They are cut to length to fit fairly tightly between the long braces, and the addition of two or three nails in each is a further precaution against movement. Remember we are only making one casting from this pattern, and because it remains in the sand but a few minutes, this method of attachment will prove satisfactory.

To revert for a moment to the jig patterns mentioned earlier, the patternmaker seldom spends much time providing nice fillets in each corner (in this case where the cross braces join the side walls) because this all takes time and with a little co-operation on the part of the moulder they are really unnecessary.

The usual practice in most patternshops is to leave this type of pattern unpainted, except for a black line in each corner where the fillet would normally appear. All corners are treated in this way—just a quick brush along each corner to leave a line about 1/4 in. wide is enough to tell the moulder that he is left to provide the mould with the essential corner radii. These do not take very long in the foundry and a gentle application of a moulding tool soon removes the sharp edge of sand, and a brush over again quickly smooths those corners not easily accessible. The process is performed almost as quickly as I can write this description, and it will save an hour or

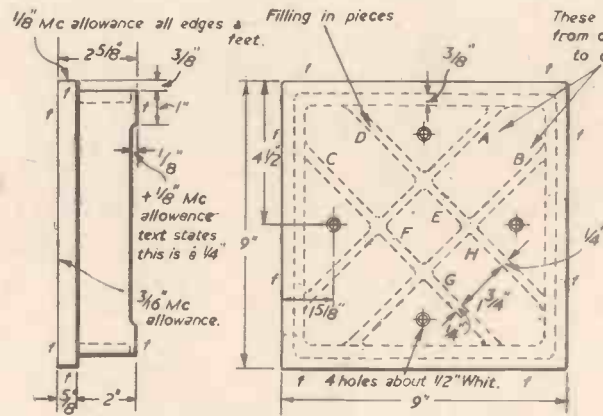

Fig. 1.—Plan and elevation of a 9 in. square surface plate.

shown are finished sizes, so both the machining and contraction allowances must be added to them.

### The Pattern

As probably only one casting will be produced from this pattern, we can adopt perhaps rather rough and ready methods in the making of this item. Patterns for jigs and fixtures where only a single casting is needed are made in the same way, so the reader is at least following full size practice in adopting these tactics.

The top is merely two or more boards made up to a width of 9 in., and though some may wish to join them together, if they are simply nailed in close proximity this is good enough—the pattern is only in the mould for a matter of minutes and a moulder will smooth away any slight projections that arise when he is finishing the cavities.

two of the patternmaker's time. The pattern is now ready for moulding and your local foundry will readily provide the necessary casting from it.

**Machining and Contraction Allowances**

These of course you must add to the pattern when constructing it. For cast iron the recommended addition to a pattern to overcome the shrinkage which takes place is  $\frac{1}{16}$  in. per foot, and I would suggest that you allow  $\frac{3}{16}$  in. on the top face and  $\frac{1}{8}$  in. on the four sides and feet. I have indicated on the drawing with the letter "f" where this machining allowance should appear—again a method which follows true engineering practice. The reason for the slight extra amount on the top face is to ensure the planing or shaping tool can really get beneath the scale and hard spots to the good metal before finishing commences, but to keep things consistent, you can if you wish allow  $\frac{3}{16}$  in. on all the faces and edges.

**Machining the Casting**

This is where a number of readers are going to meet with difficulties, if they attempt the work in their own workshop, because generally the machines available are not really suitable for this task. These readers would do better if they purchased a surface plate already planed from Messrs. Herbert Ltd.—one of their "B" type which is planed and guaranteed true to .001 in. and, if they

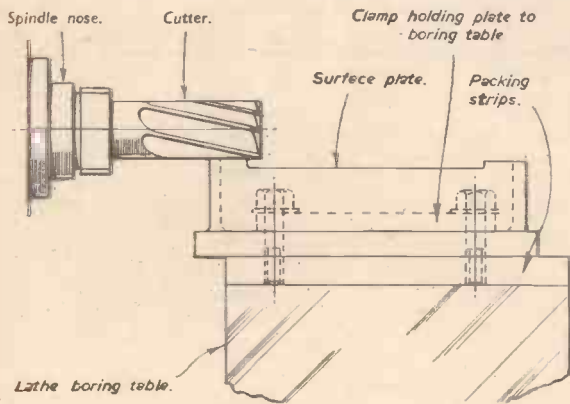

Fig. 2.—Arrangement for holding on the boring table of the lathe.

think it necessary, scrape the surface in the approved manner.

Not many readers have a shaping or small planing machine in their workshops, though probably quite a number have access to one of suitable capacity. Alternatively one can put the work out to the local small engineering shop with instruction to first rough machine it all over, and then to finish it after a period of natural weathering. All this costs money, however, and there will be many who will seriously consider tackling the process even though the available equipment is not built for the task.

The lathe is the answer to this problem and, with care, a machining of the broad top surface is feasible, provided some extra fittings are made. The easiest way to undertake this operation, the writer suggests, is first to make a large milling cutter of the inserted-tooth fly type, with about four tools held securely and protruding from the face of the tool head. This class of cutter is most useful for other similar large castings or even the machining of wood articles, so next month I will describe and illustrate an easily-made tool which takes only a few hours to produce.

To return to the setting up problem, the four feet are used as the locating medium. These are not very difficult to finish as the plate is simply clamped on the lathe boring

table and a cut passed over as shown in Fig. 2. Because of casting irregularities these feet are not perfectly level at that stage, and a certain amount of adjustment by filing is necessary, using another flat surface as a base to take a check. The previously mentioned thick sheet of glass is useful in this respect, and with the careful application of feelers the feet are soon made level.

Now we come to the machining of the large flat area on which the marking processes will be subsequently carried out. Clamping is awkward unless some special holes are provided, and, as these are often useful for temporarily holding a top-heavy article, I suggest you drill and tap four holes about  $\frac{1}{8}$  in. Whit. where shown in Fig. 1.

This surface plate is now ready to be set up on the table of the lathe and the arrangement for holding it is seen in Fig. 3. A rather large angle plate is the basis of this set coupled with two long strips about one inch square, and the usual type of plate clamp.

The provision of tapping holes in the top surface of the casting then permits the cutter to pass over without interference. Incidentally the one inch square strips provide additional height to the angle plate and they locate against the feet. This ensures a very wide spacing and therefore gives the maximum support to the casting—an essential feature in view of the large cutter used for this operation.

From 2 to 4 cuts across in various directions should clean up the face satisfactorily, and when this is completed the table is laid on this flat surface and the edges also cleaned in the appropriate manner.

Obviously this type of set will not necessarily produce an accurately machined casting, but it will remove the skin, and a scraping operation should make a perfectly level surface. Though I have described this work as being a single operation, I would strongly urge readers contemplating making this slab to first rough machine all the faces prior to a weathering stage. Both sets are of course identical so one description will suffice for the second operation.

It has become a recognised fact in the large engineering workshops that leaving castings out in the factory yard for a day or so does not allow sufficient time for the metal to settle, and much more attention is being given to artificial weathering. This is, however, a process which the amateur engineer cannot very well carry out, so I advise a fairly long period for the casting out in the open air, say a month, for it to settle.

**General Notes**

A power feed to the slide is an asset for work of this nature because it stops the cutter grabbing at the workpiece and so causing it to pull the casting from the table. A downward cut is also essential as the cutter thrust is taken on the lathe table and this reduces the chances of severe chatter occurring.

Few small centre lathes have such a long travel to the cross slide to permit the cutter to pass over without a further reset, but moving a casting along for another cut is often

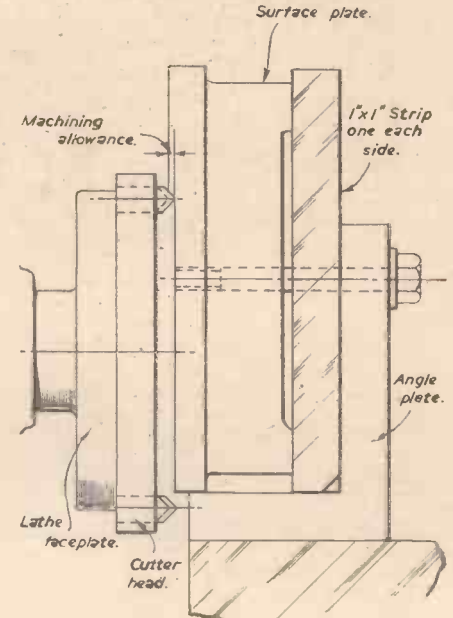

Fig. 3.—Arrangement for machining the large flat area.

practised in the workshops if an exceptionally large component is encountered. Thus the reader should follow full scale practice and perform the operation in the same way.

The machining of this casting is a little out of the run of ordinary home workshops, but such a milling stage is possible as I have proved to my satisfaction, using a Myford lathe, but obviously a very light "baby" machine is not the tool for such work. Nor would I advise a nervous reader to undertake a process which will prove a little frightening, especially if the cutter starts to chatter badly; but for those who do eventually finish the surface plate it will amply repay the time and trouble expended on it. For those having a large centre lathe, facing on the faceplate is of course possible, but this article is designed primarily for those not so fortunate and who must fall back on the methods outlined in order to complete the machining.

(To be continued)



**PRACTICAL MOTORIST AND MOTOR CYCLIST**

Edited by F. J. CAMM

August Issue now On Sale

**Principal Contents :**

- The Singer Engine ; Reconditioning Oil Pumps ; Aligning and Repairing the Chassis ; Overhauling the Gearbox ; Bottom Half Attention ; Fitting an Ammeter to the Morris Minor ; Adjusting Bendix Brakes ; Overhauling the Austin 8 Tourer ; Engine Gaskets and Washers ; Overhauling the Standard Vanguard Engine ; Buying a Second-hand Car ; Garage Mechanic's Diary ; Accessory Review ; Motor Cycle Overhaul ; our Experts Advise and many other valuable articles.



# A simplified ORRERY

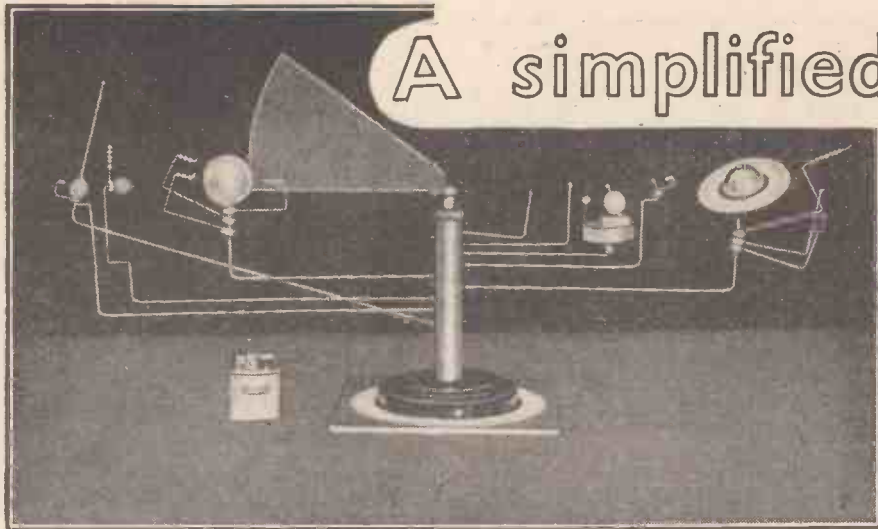

Fig. 11a.—The completed orrery. The cigarette lighter gives some idea of the size.

Constructional Details and a History of the Instrument

By FRANK W. COUSINS, A.M.I.E.E.,  
A.C.I.P.A., F.R.A.S.

(Concluded from the July issue)

true model, enables the Moon to be brought satisfactorily into the model. A Moon bead truly comparative with the  $\frac{1}{4}$ in. diameter Earth bead would be  $\frac{1}{32}$ in. Such a bead is too small to be of use. The enlarged Earth is made with a diameter of  $\frac{11}{16}$ in. and the enlarged Moon bead is  $\frac{3}{16}$ in. diameter. No data has been given for the Moon as yet as it is not a planet and must be considered when we turn to the planets' satellites. It is able to take pride of place over all other satellites, however, as it is the very beautiful satellite of our Earth.

In size the Moon is 2,160 miles in diameter ; mean distance from the Earth is 238,900 miles. Inclination of orbit to Ecliptic:  $5^{\circ} 8'$ . Period about primary: 27.321 days. Axial rotation as viewed from Earth: None.

THE beads are easy to provide for the Earth, Mercury, Venus, Mars and Pluto as these beads may be found on a cheap pearl necklace. The beads for Uranus and Neptune may come from a large-bead necklace, but the "beads" for Jupiter and Saturn—if beads they may be called—are best made from aluminium. Failing the use of a lathe, the bead for Saturn is almost exactly the size of the standard ping-pong ball. A child's ball

in its orbit about the Sun. For example, in Fig. 13 we show the orbit of Saturn. Notice the direction of its axis at position A and position B. Now, if we fix Saturn in the model as shown in Fig. 14A and move the orbit rod to the position shown in Fig. 14B (movement through  $180^{\circ}$ ), then the true movement of Saturn has not been demonstrated. We have to twist the wire holding Saturn in its orbit rod to give the position

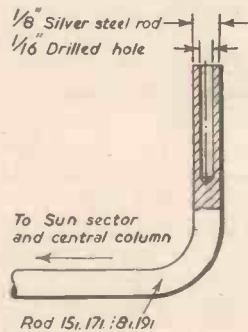

Fig. 12.—Orbit rod construction.

may, with some judicious selection, be suitable for Jupiter. A locknut 22 enables the entire orbit system to be locked in any position. The extremities of the silver steel rods, remote from the column 10 in the case of rods 12, 13, 16, and 20, are filed to a fine needle point to take the beads for Mercury, Venus, Jupiter and Pluto. The inclinations of these planets' axes to their orbits, except Jupiter, are not known with accuracy. This statement, for the sake of truth, should be qualified, for the author has, since making his model, seen that the famous astronomer Kuiper, working with the 82in. telescope at Yerkes, has found the axis of Venus to be tilted at 32 deg. to a normal through the plane of the orbit. This feature may readily be incorporated.

In the case of Jupiter its equator is tilted at  $3^{\circ}$  approximately to the plane of its orbit ; this very small tilt is ignored in the model and the planet is set squarely on the needle-piece at the end of the orbit wire or rod.

The orbit rods 15, 17, 18, and 19, are drilled at the ends to take a fine wire, as shown in Fig. 12. The fine wire carries the planet and is bent as shown to the angles in Fig. 11. It is important that the wires should be able to revolve easily in the drilled holes. The reason for this is obvious when one appreciates that the axes of the planets are substantially unchanged in direction as the planet moves

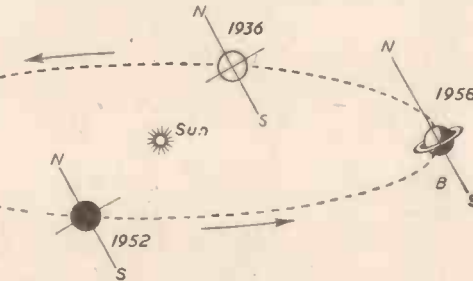

Fig. 13.—The orbit of Saturn.

shown in Fig. 14C. The correct motion can be demonstrated with a parallel linkage, as crudely shown in Fig. 14D. This is not easily incorporated in the model and a twist of the wire will enable the true conditions to be met for demonstration.

### Earth/Moon System

Referring again to Fig. 11, it will be seen that at 23 we have provided an enlarged Earth/Moon system. The Earth/Moon system is always of special interest and the enlargement, while divorced from the scale of the

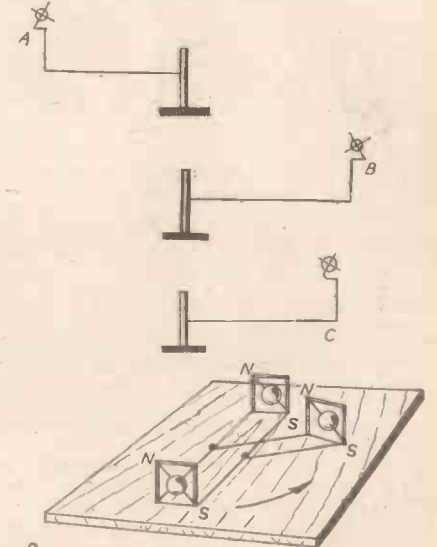

Fig. 14.—Details of the arrangement for the orbit of Saturn.

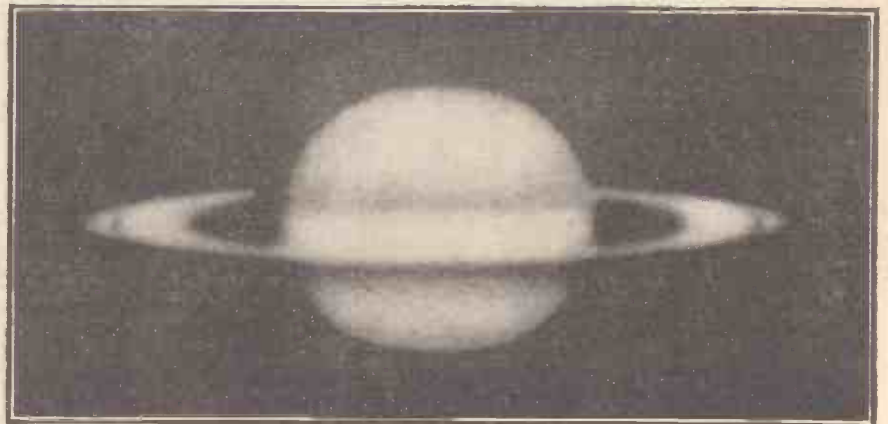

Fig. 17.—Saturn seen through the 200in. telescope at Palomar.

Axial rotation as viewed from a point outside Solar System: Same as period about primary.

The enlarged Earth and Moon in the model should be spaced apart about 20in. This is not readily accommodated and so once again true distances must be ignored in the model. We have, as seen in Fig. 11 at 23, provided a

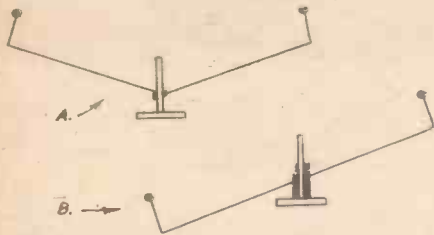

Fig. 15.—(a) The effect of an inclined washer. (b) The effect of the tripartite washer.

Moon carriage 24, free to revolve on a spindle 25 which is so set on to the orbit rod 14 of the Earth that the axis of the spindle 25 is 85° to the horizontal. This makes the floor of the Moon carriage 24 revolve in a plane tilted at 5° to the horizontal, which in the model is the plane of the Ecliptic. Hence, the Moon's orbit is correctly disposed with an error of only six minutes of arc. An Earth carriage 26 is free to revolve on the end of spindle 25; it, however, is drilled so that the carriage 26 is horizontal. The Earth wire 27, which is in fact the Earth's axis, is at the well-known angle of 23½ deg., so that the equator makes 23½ deg. with the plane of the orbit. A friction wheel 28 contacts the inner periphery of the wall 29 of the Moon carriage and an anti-clockwise rotation of the Moon carriage (viewed from above) will cause the Moon *per se* to move about the Earth and the Earth *per se* to rotate on its axis in an anti-clockwise direction. In fact, the Earth should make about 28 rotations for one complete revolution of the Moon about the Earth; this would not be easily arranged without gearing. The Moon's equator plane is inclined to the plane of the path in which she travels round the Earth by an angle of approximately 7°; this is clearly shown in Fig. 11.

**The Tripartite Washer**

The tripartite washer assemblies need just a final elucidation. The hole in the middle washer of the three has to be large enough on the central spindle to take up the extremes of tilt shown in Fig. 11 and the scrap view on the left. The dotted lines make the size of the inner hole clear, but this may be readily decided by making a drawing as shown. Small pegs are driven into the upper and lower components of the tripartite system so that the upper and lower components can be held stationary by the fingers while the central washer carrying the orbit rod is rotated.

The tripartite washer assembly is, to the author's mind, the one novel feature in this type of orrery. A simple inclined washer is *no use*, for one half-turn will produce the effect shown in Fig. 15a. This is not the way the planets, with highly-inclined orbits, move. The correct motion is shown in Fig. 15b, and this the tripartite washer assembly readily provides.

**The Satellites of the Superior Planets**

The superior planets are those farther from the Sun than the Earth. All except Pluto have numerous satellites. No orrery to the author's knowledge attempts to show the satellite systems. Admittedly, to show them in full working order would be no mean task. In the orrery under consideration it has been thought best to concentrate on two features only, (a) the number of satellites and (b) the inclination of the orbit. With the aid of a detailed drawing, presented in Fig. 16, the

mechanism of the satellites is not difficult to appreciate.

**Satellites of Mars**

It will be seen from Fig. 11 that Mars has a satellite washer M<sub>1</sub> to which is fixed a satellite wire M<sub>2</sub> on which two minute beads P<sub>1</sub> and D are fixed with glue. The bead P represents the satellite Phobos, and the bead D the satellite Deimos, the two famous moons of Mars. They revolve in the equatorial plane of the planet. Phobos has the greater speed, owing to its close proximity to Mars, making a revolution about the primary in 7 hours 39 minutes. Deimos makes a revolution in 30 hours 17 minutes. It is of interest to note that on Mars the moons would appear to go opposite ways in the Martian sky. Mars makes one rotation in 24 hours 37 minutes, and

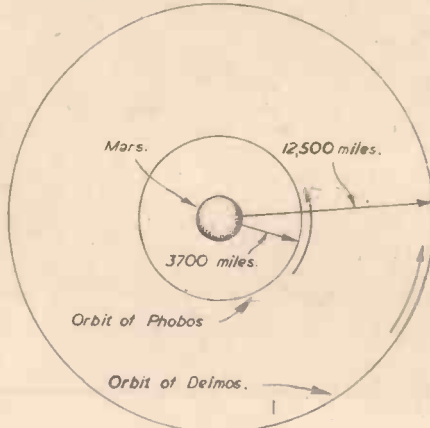

Fig. 16a.—The Satellites of Mars and their orbits.



Fig. 16b.—The Satellites of Jupiter.

Phobos, with its great speed, will enable an observer to see it rapidly pass across the sky substantially unaffected by the motion of the planet. Thus Deimos will rise and set moving from east to west and Phobos will rise and set moving from west to east even though they both have the same anti-clockwise direction of revolution about their primary.

The size of Phobos is reckoned to be about 7.5 miles in diameter and Deimos 6.2 miles in diameter. It is not possible to represent this on the model to scale and for all the satellites a *standard* small bead has been used.

In Fig. 16a, Phobos and Deimos are shown in their orbits at their respective distances from Mars.

A slight digression may be of interest to readers. Phobos and Deimos were discovered by Asaph Hall in 1877 using the great telescope of the observatory at Washington. In 1726 Jonathan Swift published his *Gulliver's Travels* and in his satirical treatment of the astronomers of Laputa he postulated two moons for Mars. Swift's "guess" was exceedingly close to the true facts and caused some hard thinking to be done in the early part of this century.

*Swift's Moons postulated:*

Two in number; Inner moon distant by 3 diameters of Mars, outer moon by 5 diameters; Inner moon revolves in 10 hours, outer moon in 21½ hours.

*Actual Moons:*

Two in number; Inner moon distant by 1½ diameters of Mars, outer moon by 3½

diameters; Inner moon revolves in 7½ hours, outer moon in 30½ hours.

**Satellites of Jupiter**

Jupiter has a complex system of Moons. Twelve are known and these are grouped in three orbit planes if we are permitted a little licence with the inclinations of the orbits. In Fig. 11, it will be seen that Jupiter is provided with three satellite washers, J<sub>1</sub>, J<sub>2</sub>, J<sub>3</sub>.

Five of the moons, Nos. V, I, II, III and IV move in the equatorial plane of the planet. Moon No. V is the nearest to the planet. Moons No. I, II, III and IV were discovered by Galileo and are named Io, Europa, Ganymede and Callisto.

The moons are shown to size in Fig. 16b. A table of data is provided in Fig. 16c. Moons No. VIII, IX and XI have their revolutions retrograde. These are marked on Fig. 11. Viewed from the Celestial North Pole (looking down on the model) these moons will revolve clockwise about Jupiter; all the other moons keep to the general motion of revolution—anti-clockwise.

**Satellites of Saturn**

This planet also has a complex satellite system. There are nine satellites grouped mainly in three orbit planes and in Fig. 11 one can see the three satellite washers S<sub>1</sub>, S<sub>2</sub>, S<sub>3</sub>. Satellites I, II, III, IV, V, VI and VII are in the equatorial plane of the planet.

Satellite IX revolves about the planet in a retrograde manner. That is clockwise viewed from above in the model. All the others move anti-clockwise.

The sizes of the main satellites are shown in Fig. 16d and a table of data appears at Fig. 16c.

Saturn's rings are an extension of its satellite system. These are shown at S<sub>4</sub> in Fig. 11. They may be made from a piece of thin card marked with indian ink and glued to the globe of Saturn. The construction is

Name	Distance from Jupiter in Astronomical units*	Period	Inclination of orbit
V.	... .0012	11 h. 57 m.	3°
I. Io	... .0028	1 d. 18 h. 27 m.	3° 7'
II. Europa	... .0048	3 d. 13 h. 13 m.	3° 6'
III. Ganymede	... .0071	7 d. 3 h. 42 m.	3° 27'
IV. Callisto	... .0125	16 d. 16 h. 32 m.	2° 43'
VI.	... .0765	250 d.	28° 45'
X.	... .0773	260 d.	28° 24'
VII.	... .0785	260 d.	27° 58'
XII.	... .140	unknown	unknown
XI.	... .150	692 d.	163° 37'
VIII.	... .157	739 d.	148° 4'
IX.	... .158	745 d.	156°

Fig. 16c.—Data for Jupiter's moons.

\* Astronomical unit, 92,900,000 miles. Distance of Earth from Sun.

based on the sizes given below, taken from the Handbook of the British Astronomical Association for 1953, page 59:

Diameter	Miles	Ratio
Ring A. outer*	169,300	1.0000
inner	149,000	0.8801
Ring B. outer	145,500	0.8599
inner	112,600	0.6650
Ring C. inner	92,900	0.5486

\* The diameter of Ring A outer in the model is 2 21/32 in.

It is thought that the rings are composed of myriads of small satellites, possibly ice crystals, each revolving in a specific orbit. The rings were discovered by Galileo in 1610. In 1675 Cassini noticed that the rings are really two concentric rings with an open space between them, and in 1850 Professor Bond discovered the innermost dark ring.

Saturn's equatorial diameter is about 75,000 miles and the inner ring begins with a diameter of 93,000 miles approximately. Thus a clear space of 9,000 miles lies between the planet and the ring system.

In 1886 Kirkwood pointed out that the almost complete absence of ring particles from Cassini's division was probably due to the revolution period of particles at that distance from Saturn being approximately one-half, one-third and one-quarter the periods of Saturn's satellites Mimas, Enceladus and Tethys respectively, so that the oft-repeated perturbations of these satellites would soon force any particles into different orbits. For full details see A. F. O'D. Alexander's paper "Saturn's Rings—Minor Divisions and Kirkwood's Gaps," *Journal of British Astronomical Association*, vol. 64, No. 1, pp. 26-29.

The rings are very thin, being less than fifty miles in thickness.

A magnificent photograph of Saturn taken with the world's greatest telescope at Palomar appears in Fig. 17. The Cassini division is quite distinct, as also is the dark space of 9,000 miles mentioned above.

**Satellites of Uranus**

Uranus has five satellites, all moving in orbits which are in the plane of the planet's equator.

The five satellites are clearly seen in Fig. 11 on a wire supported by a satellite-washer U<sub>1</sub>.

The four outer satellites have retrograde motion about the primary.

The size of satellites I, II, III and IV is shown in Fig. 16f. The size of satellite No. V, Miranda, is not known.

Note the very strange tilt of the axis of

Name	Distance from Uranus in Astronomical units*	Period	Inclination of orbit
V. Miranda ...	.0008	Unknown	—
I. Ariel ...	.0012	2 d. 12 h. 29 m.	98°
II. Umbriel ...	.0017	4 d. 3 h. 27 m.	98°
III. Titania ...	.0029	8 d. 16 h. 56 m.	98°
IV. Oberon ...	.0039	13 d. 11 h. 7 m.	98°

Fig. 16h.—Data for Uranus' satellites.

\* Astronomical unit, 92,900,000 miles. Distance of Earth from Sun.

Uranus. Its rotation on its axis is in keeping with all other planets of the solar system but when viewed from the Earth the motion, would appear to be opposite to what it actually is. The model does enable one to understand this phenomenon, which is made more clear from Fig. 16g. Data for the satellites are given in the table at Fig. 16h.

**Neptune's Satellites**

There are two of these, Triton and Nereid. These are shown in Fig. 11 on a satellite-wire supported by a washer N<sub>1</sub>. Triton is about



Fig. 16d.—The satellites of Saturn.

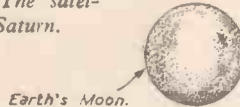

Name	Distance from Saturn in Astronomical units*	Period	Inclination of orbit
I. Mimas ...	.00124	22 h. 37 m.	26° 45'
II. Enceladus ...	.00159	1 d. 8 h. 53 m.	26° 45'
III. Tethys ...	.00196	1 d. 21 h. 18 m.	26° 45'
IV. Dione ...	.00252	2 d. 17 h. 41 m.	26° 45'
V. Rhea ...	.00352	4 d. 12 h. 25 m.	26° 42'
VI. Titan ...	.00816	15 d. 22 h. 41 m.	26° 7'
VII. Hyperion ...	.00989	21 d. 6 h. 38 m.	26°
VIII. Iapetus ...	.0238	79 d. 7 h. 56 m.	16° 18'
IX. Phoebe ...	.0866	550 d.	174° 7'

Fig. 16e.—Data for Saturn's moons.

\* Astronomical unit, 92,900,000 miles. Distance of Earth from Sun.



Fig. 16f.—The satellites of Uranus.

one and a half times the size of our own Moon, making a revolution about Neptune in 5 days 21 hours. Very little is known of the recently discovered satellite Nereid.

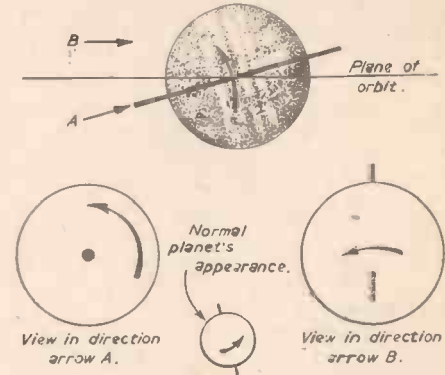

Fig. 16g.—The rotation of the planet Uranus.

**Distances of Planets From the Sun**

Finally some idea of the distances of the planets from the Sun must be given. In the opening paragraphs it was explained that the distances were too vast to be utilised.

The Earth, at 92,900,000 miles from the Sun, would have to be 121ft. from the central column. Using 121ft. as the Astronomical Unit for the model and calling the Earth's distance from the Sun unity, the distances of the other planets are as follows:

Mercury ...	0.38
Venus ...	0.72
Earth ...	1
Mars ...	1.52
Jupiter ...	5.2
Saturn ...	9.5
Uranus ...	19.1
Neptune ...	30.05
Pluto ...	39.5

The model is a worth-while construction for the amateur. In building it one gets a real working knowledge of the solar system. The finished model is ideal for demonstration at lectures and children find it a great help in clarifying many of their problems in elementary astronomy.

Ideas dealing with the academic uses to which the model may be put will be presented in a further article.

# Water-activated Batteries

ONE of the most interesting developments in storage battery engineering is the recent utilisation by Chloride Batteries, Ltd., Clifton Junction, Swinton, Manchester, of a novel electro-chemical principle in the design of cell units for "one shot" and emergency applications.

The original problem was to find an alternative to the water-operated calcium flare once used with life-saving apparatus at sea. Now banned completely by international regulations, these flares were often dangerous, as petroleum or fuel oil might well be floating on the water.

The solution was provided by a special water-activated battery which now illuminates small electric lamps on life-jackets, floats and rafts to aid rescue workers when a ship or aircraft is lost at sea after dark.

A typical example from the new range of water-activated cells consists of special dry charged plates of cuprous chloride, which remain completely inert whilst protected from moisture by sealing tape or some similar means. In an emergency, the tape is ripped off and as soon as the plates come into contact with either salt or fresh water the battery is energised. Once begun, the discharge then continues until the capacity is exhausted.



Examples of water-activated batteries.

A battery of this type has outstanding advantages for "one shot" emergency applications. It can be used for high discharge rates for relatively short periods, or for low-rate work over longer periods, and has in either case an outstandingly high performance for its weight and volume. Protected from moisture, it remains completely inert under widely varying temperatures and humidities for an unlimited period. Dependent upon the application, the unit may be designed to function whilst totally immersed in water for the duration of its discharge—as in the case of flares or life-jacket lights—or after an initial wetting when sufficient water is absorbed to

enable the required performance to be obtained.

A number of water-activated batteries of different sizes and capacities has been developed, most of them employing cuprous chloride and magnesium electrodes. The smallest of these—working on a slightly different principle with lead peroxide and magnesium electrodes—is designed to replace the candles once carried by meteorological balloons. Weighing less than half an ounce complete with bulb, it is simply dipped in water and attached to the balloon after which the light will burn for at least 45 minutes.

Two intermediate sizes in the cuprous chloride-magnesium category have been produced for Mae Wests and other air/sea rescue equipment. Sewn into the life-jacket, the battery illuminates a 1.5 volt bulb consuming 0.24 watt mounted on the shoulder. The smaller of the two, weighing only 2½ ounces in its experimental container, will burn for 12 hours and the larger, weighing 4 ounces, for 24 hours.

The fourth and largest of the water-activated batteries in the commercial range, intended for life-saving rafts and floats, will illuminate a 2.5 volt, 2 watt bulb for at least 24 hours, whilst another version has been specially designed for a lifebuoy light manufactured by Venner Electronics, Ltd.

Larger units with a capacity of up to 200 Ah have also been developed.

**R**ADIO control has occupied the thoughts of modellers for many years now, but since the war, when many men had gained radio experience and good, compact equipment became available on the surplus market, the range of interest has widened considerably. Although in the past radio control has been presented as a complex and specialised art, we maintain that good and reliable control can be achieved with very simple equipment and without a lot of specialised knowledge. In addition, the surplus market enables the careful buyer to fit up his model at very reasonable cost. It is hoped, therefore, in these articles to describe straightforward and well-tried systems and to guide the reader round some of the pitfalls into which the beginner can fall.

To-day we are not content with systems which produce erratic control and just enable the model to turn right instead of left, but we must have means of making the model behave as nearly as possible like its full-size counterpart. This calls for a system which will allow the operator to execute turns of just the right rate at the exact time and place required, and in the more complex schemes to have good control of the model's speed.

This series of articles will deal mainly with the control of model boats, but this material

Fig. 1.—Mr. Aldridge operating a radio-controlled boat.



# RADIO CONTROL

can apply with very little alteration to land vehicles, which offer a very interesting but so far poorly patronised field. The control of aircraft is, of course, well advanced and whilst it is true that some basic principles are common to all types of radio

control the aircraft field has tended to become rather specialised due to weight limitations, together with the rather different type of control required.

One of the first articles on radio control was published in 1910 and dealt with the control of a model boat, which shows

(Bottom).—Mr. E. C. Kennedy's model of an Admiral's Barge, 36in. long, propelled by 3.5 cc. diesel and with a Kitchin rudder.

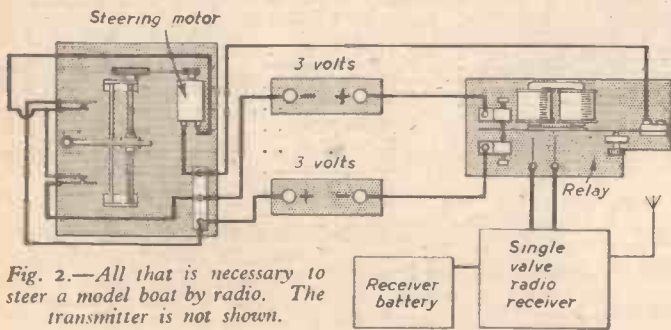

Fig. 2.—All that is necessary to steer a model boat by radio. The transmitter is not shown.

(Above).—Mr. H. Blott's model tanker "Lucrecia," electrically propelled, fitted with single valve super-regenerative receiver and equipped with steering control only. A good example of work by a beginner.

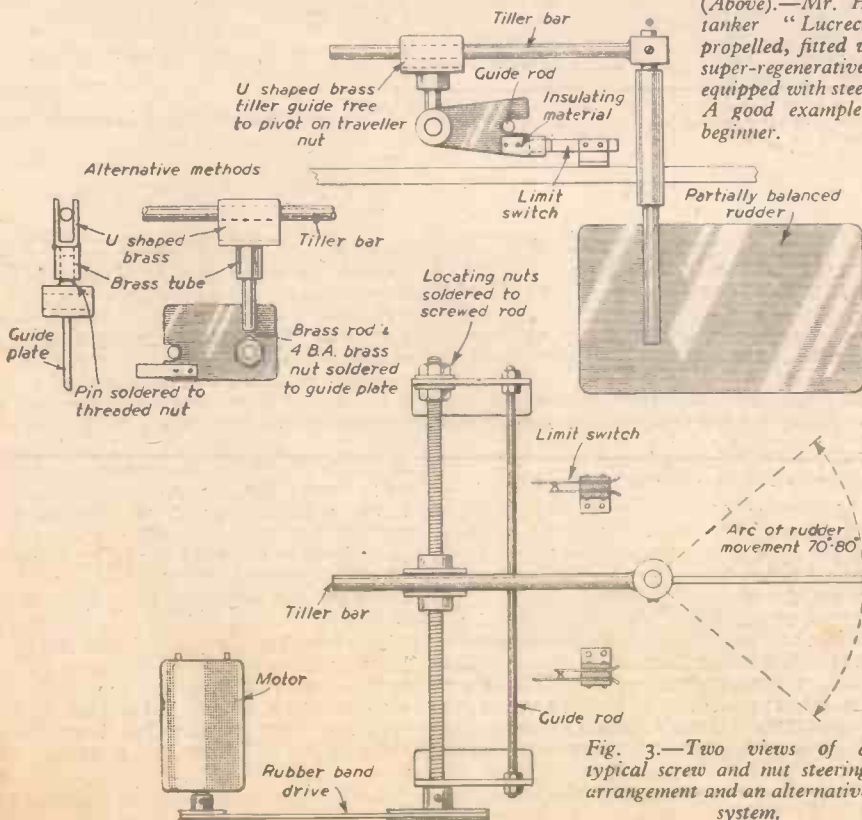

Fig. 3.—Two views of a typical screw and nut steering arrangement and an alternative system.

(Top right).—Mr. D. W. Aldridge's "Little Bee" 36in. long electrically propelled model cabin cruiser. Radio receiver is a six-valve superhet. (This receiver enables the boat to be operated when there are other vessels operating at the same time due to its high selectivity.) Steering is proportional, i.e., "steering wheel" type of control at control box. Engine speed can be increased or decreased (or reversed) at will. All mark/space operation.

that there is nothing new about the hobby. Progress before the war, however, was slow, since most of the radio components, relays and the like were large and heavy and by modern standards not very efficient. After the war it was obvious that this position had changed radically. Plenty of gear was now available and the number of enthusiasts was much larger.

### The Sequence Control System

Most of the schemes employed until then were based on the sequence system of control. In this system a rotary switch with, say, four positions is fitted in the model and arranged so that with the switch in each position a particular function is carried out. The radio gear is so arranged that a short burst of energy from the transmitter having been picked up by the receiver moves the



(Left to Right).—

# CONTROLLED MODELS

## NEW SERIES

### 1.—Introduction and Simple Steering Control Gear

By MEMBERS OF THE I.R.C.M.S.

switch from position 1 to position 2, and two or three pulses in rapid succession (about four per second) will move the switch two or three positions. The switch may be arranged so that position 1 gives rudder port, position 2 rudder central. It will be seen that by giving the appropriate number of pulses of energy from the transmitter the rudder can be turned to port or starboard or can be returned to centre.

The snag with this system is that if the operator wishes to turn to starboard it may be that the rotary switch is in such a position that it will have to pass through the "rudder port" position. This will mean that whilst the rudder may be turned to port only for a very short time the boat will deviate slightly in the wrong direction. A much more serious snag, however, is the delay which takes place between the operator wishing to start a turn and the control mechanism putting this into effect due to the switch having to pass through one or two other positions. This makes it very difficult to steer an accurate course between

buoys and almost impossible to hold a reasonably straight course with a cross wind. The sequence method of steering control is,

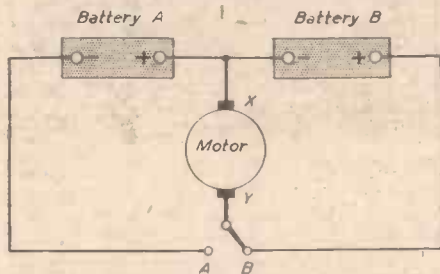

Fig. 4.—Circuit for reversing motor, using two batteries.

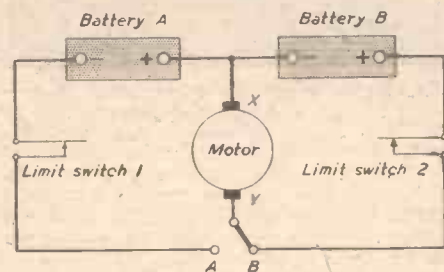

Fig. 5.—Reversing circuit with limit switches incorporated.

therefore, falling into disfavour and is being replaced by systems which enable the operator to simulate full-size practice more accurately. Sequence control is, however, still holding its own as a means of controlling the smaller types of aircraft, due to the fact that the weight of the mechanisms can be kept very low. Some very ingenious schemes have been evolved which overcome some of the snags of the system and it looks as though it will be a long time before this method is ousted from the small plane field. Sequence is still used most effectively in boats as a means of controlling other functions after steering has been catered for by better methods.

#### Requirements for Effective Control

Before embarking on the construction of any radio-controlled model it will be as well to summarise the requirements of any system which will give effective control of the model. Most of the points applying to boats also apply

to land models. The basic needs are:—

1. Instantaneous steering control in either direction must be available at all times.

In controlling a boat the operator's hands will continually be on the rudder control, and there is normally no question of being able to set a course, then leaving it for a while. This is due chiefly to the effect of crosswinds and also to the fact that it is almost impossible to straighten up out of a turn at exactly the right moment. As a result continuous steering corrections have to be made and it is these which the sequence system cannot competently handle. The half-second or so delay with the sequence system can make all the difference

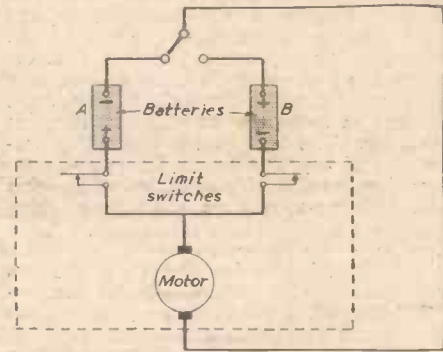

Fig. 6.—Alternative method of wiring. (Only three wires connect to steering gear.)

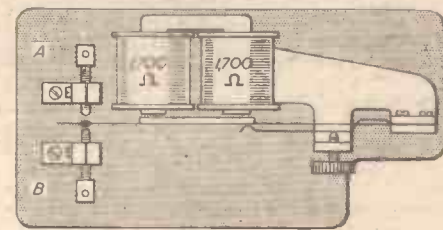

Fig. 7.—The Siemens high-speed relay.

between a boat which can execute a clean course and one which behaves erratically.

2. Maximum reliability is required from every component used.

This may seem fairly obvious, but through these articles we hope to point out the not so obvious places where reliability must be carefully watched. Sound design of all mechanisms, careful construction and patient testing to eliminate snags will be amply repaid by having a model which operates as you want it to at all times.

3. Do not expect components to do more work than they were designed for.

The Government surplus market has been and still is a very fruitful source of components for the radio man. Small valves, compact relays and good small motors are available at very reasonable cost, along with various types of small accumulators, etc. Whilst it is important to keep expenditure down, it is folly to overdo this. For example, it is a good rule never to use resistors or condensers and the like stripped from ex W.D. equipment. The new components are not very expensive and untold trouble can be caused and hours wasted due to faulty components in the radio gear. Surplus gear should be bought carefully and there are plenty of good clean components, sometimes unused, available.

4. Limited radius of control is quite adequate.

It is a common fallacy to think that long-range control is required and that a large and powerful transmitter will, therefore, be needed. It is a fact that for the control of a normal size of model boat, say, up to 6ft. in length, the maximum range at which the boat can be operated is set by the ability of the operator

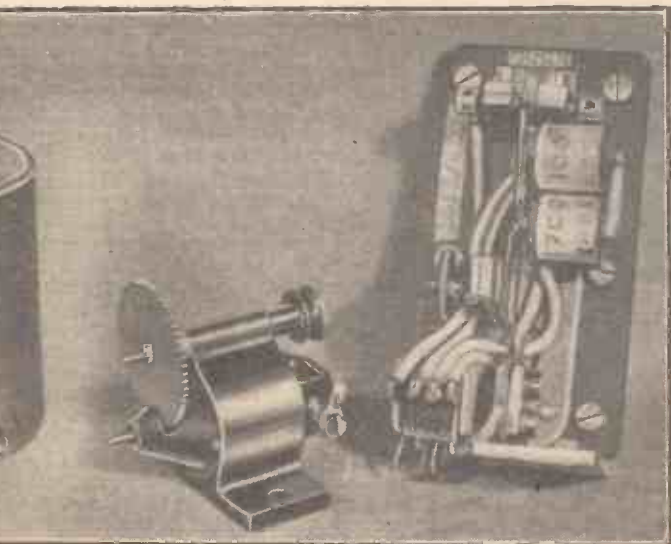

Government surplus P.M. type of motor: "Mighty Midget" and Siemens high-speed relay.

to see the model from the control point. On water which is perfectly calm visibility can be quite good, but with the normal amount of surface ripple, together with glare from the sun, the operator will have difficulty in seeing whether his boat is coming towards him or turning away at a range of 80 to 100 yds. The best distance will be found to be about 50 to 60 yds.

Fig. 1 gives a good idea of the size and general layout of a typical boat, together with the portable transmitter, which is quite compact, employing a telescopic aerial for easy stowing and transportation. This equipment was made by Mr. D. W. Aldridge, who is seen carrying out inshore manoeuvres. The transmitter carries only the on/off switch, and all the boat controls are brought to the small control or "beep" box which Mr. Aldridge is holding (see cover also). This is a very sound scheme, which allows the operator some freedom of movement to stop and start his boat, etc. The boat here is electrically propelled and is 36in. long. Its performance nowadays is well nigh perfect, but we feel that Mr. Aldridge must have had some teething troubles which led him to name it "Little Bee."

It is intended to describe the mechanism and operation of a well-trying rudder mechanism first of all. Later in the series the control of this will be shown, after which details of the receiver and how this does its job will be given. The place occupied by the transmitter will follow and at the same time various auxiliary equipments will be described. In this article rudder control only will be aimed at, but the control of speed, etc., will be dealt with in later articles. Beginners would be well advised to try steering control first and it will subsequently be shown how the further controls can be added to the simple system without having to remake a lot of the original equipment. This approach allows the modeller to gain valuable experience on simple gear before going on to the more elaborate systems.

### Simple Steering Control Gear

Figs. 2 and 3 illustrate a type of mechanism suitable for steering a model boat. It will be seen that it is simply a screwed rod driven by a small electric motor. A nut travels on the screwed rod and is arranged by a simple mechanical linkage to operate the tiller bar of the rudder. For land vehicles a similar system

about 35-40 degrees either side of centre, otherwise too much braking action takes place. Another point is that due to the fact that screwed rod drives sometimes tend to stick for no apparent reason provision should be made where possible for the electric driving motor to drive through a simple form of mechanism often used for propeller shafts on models, i.e., a cranked pin engaging



An alternative type of steering mechanism.—  
Mr. H. Blott's winch-type control.

with an arm. This permits the drive motor considerable angular freedom and, therefore, the build up of kinetic energy before engaging the drive. The use of elastic bands as belt drives also gives a certain amount of freedom to the motor in this respect.

### The Steering Motor

So far as the electric steering motor is concerned there are on the market a number of small motors suitable for the job. Size is, of course, governed by the size of the model and, therefore, by the mechanical output needed to operate the rudder. For boats up

(this is because of the need for reversing) which is reliable and which will always start upon application of the current.

Whilst on the subject of electric motor mechanical output it should perhaps be pointed out that the work necessary to turn a rudder, particularly when using small diesel engines for the main drive, can be considerably reduced by the use of a partially balanced rudder. In this type a portion of the rudder blade area is arranged to be in front of the rudder post. The wash from the propeller therefore bears on it and assists in turning the portion astern of the post.

### Limit Switches

These are very simple affairs which perform the very necessary function of preventing the motor from trying to drive the rudder beyond the limit of its travel. In the case of the screwed-rod type of drive this would cause the model to go round in circles. The switches employed are simply pairs of thin strips of springy brass arranged so as normally to be in contact with each other. When the travelling nut reaches nearly the limit of its travel it should be arranged so as to push the end of one of the pieces of brass and so drive them apart, thereby breaking the circuit and stopping the movement. The circuit is wired so that the motion can be reversed, however, and the switch resets itself when the nut travels in the opposite direction.

Brass shim strip can be used for the switches, but better results are obtained using pairs of contacts stripped from old Post Office equipment. Do not make the switch contacts too stiff in the mechanical sense; otherwise the drive may jam. Make sure that the striker which opens the limit switches is of an insulating material otherwise short circuits may be experienced.

### Reversing Arrangements

To operate the rudder, it will be obvious that the electric motor must be capable of rotating in either direction to give port or starboard control. The simplest way of doing this is by the use of two batteries so connected in the circuit that each will drive the motor in alternative directions.

Fig. 4 illustrates how they can be connected using two batteries A and B connected in series (i.e., the negative of one connected to the positive of the other). If the moving arm of the switch is moved to position A the motor will be energised by battery A and terminal X will become positive, while terminal Y is negative. If the moving arm is positioned at B, however, battery B is used and terminal X then becomes negative and Y positive. Depending upon which side the switch arm rests, therefore, the motor runs clockwise or anti-clockwise. This is, of course, conditional upon a permanent-magnet type of motor being used, as motors with energised field coils require special treatment and are generally unsuitable for this type of work.

It will be seen that the circuit consists of two halves, so the limit switches can be wired one in each half as shown in Fig. 5. The mechanism should be arranged so that the nut travels towards the limit switch which is in the half of the circuit in operation at the time. When the limit switch is opened it therefore cuts off current and stops the motor. As soon as the control switch is moved to the other side the current then flows in the opposite direction through the motor and it commences to run back again, therefore resetting the opened limit switch.

This simple circuit is the basis of a lot of radio-control circuits. A variation which simply juggles with the position of the components in the circuit but simplifies the wiring in the model is shown in Fig. 6. This operates in exactly the same manner as before, but it will be seen that only three wires now

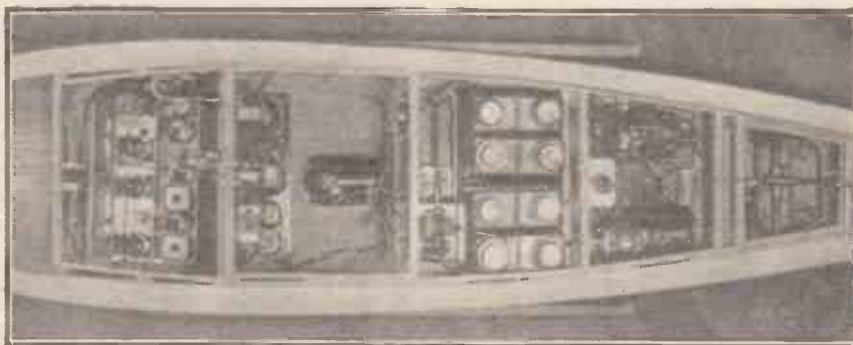

Interior of "Little Bee." Contents of compartments reading from left to right.—(A) Six-valve superhet receiver; (B) radio receiver batteries and main driving motor; (C) engine speed controller and main driving batteries; (D) pulse decoding unit ("Intergear"); (E) steering mechanism.

could be employed to operate the steering mechanism.

Readers will appreciate that this is but one of a number of systems which can be employed, alternatives being worm and gear types or simple gear trains. The essential is to operate the rudder from full port to full starboard in a time of approximately 4 seconds. This time has been found from experience to give the most satisfactory handling of the model. The rudder should be made to operate only

to about 3ft. 6in. long, however, satisfactory results are obtainable from the "Mighty Midget" motor, which is particularly attractive because of its geared drive and light weight. For larger models some of the small D.C. permanent magnet motors currently available as ex W.D. supplies could no doubt be employed, but we have not so far tried them in this application. In essentials, however, what should be aimed at is a small light permanent-magnet type of motor

feed to the motor and limit switches, which are grouped at the stern of the model, whereas using the original circuit six wires were needed.

**Batteries**

When using "Mighty Midget" motors we would recommend that only 3 volts are applied from each battery in the pair. This gives a much longer life to the small commutator and the leaf brushes. A pair of twin-cell cycle-lamp batteries will give reasonably good service, but when they can be obtained we would recommend the use of a pair of Nife type of alkaline accumulators, type No. 5J1961, which give a terminal voltage of 2.5 each (rising to 3 volts when freshly charged). Four to six of these batteries give excellent results when used for powering the main driving motor of the boat. We understand they can be obtained from A. T. Sallis, 93, North Road, Brighton. It is most desirable that batteries for controlling rudder and other mechanisms should be kept separate from the main driving batteries when using electric propulsion, as, due to the heavy current demands made by the driving motor, the battery voltage falls steadily. This would affect the steering after a short time, causing a slower response to the control.

It would appear that according to the position of the switch in Fig. 5 the model would either circle to port or starboard (the switch must be either to one side or the other, and cannot stop in the middle). What

is required is a neutral control which holds the rudder stationary. This is actually achieved by a delightfully simple expedient. The switch is made to move from side to side at a regular steady rate of about four or five times per second with the result that the steering motor rotates no more than a few turns before it is reversed and rotates the same number back again. In practice it is found that, due to inevitable backlash in the gearing, the rudder does not follow this movement, and it is held still at any intermediate position between its extremes of travel. Thus we are able to steer to port by holding the switch to one side, to starboard by holding it to the other, and to maintain any intermediate position by switching steadily between the two.

**Using a Relay**

When the apparatus is transferred to the model it is, of course, no longer possible to use a switch as such to effect the control, and this is where we change it for a magnetically operated switch—a relay.

Relays are made in many varied forms, but for this particular application a sensitive high resistance type (about 3,000 to 5,000 ohms) should be chosen. The radio controlled model trade make special relays, but very good results are obtainable from Siemens high-speed types (3,400 ohms), which can be obtained on the surplus market.

As will be seen from Fig. 7, the relay is

simply a switch having the moving arm fitted with a soft iron polepiece. This is attracted to the magnet assembly when current is passed through the coils and connection is then made between contact A and the moving arm. When the current through the coils is removed or reduced below a critical value spring pressure, which can be varied in a Siemens relay, causes the arm to fall back and rest on contact B. It is the job of the receiver in the model to cause the current in the coil of the relay to change and therefore operate the steering gear. In simple receivers the relay energising coil is connected in the output circuit. When no signal is being received the current in this coil may be 3 or 4 mA, and this will drop to about 1 mA. on receipt of a signal from the transmitter. Therefore, when the relay shown in Fig. 7 is substituted for the switch in Fig. 5 it will be seen that, if the transmitter is radiating, the moving arm will contact B and battery B will drive the rudder motor in one direction. When the transmitter is cut off the moving arm will pull in and contact A, when battery A will reverse the direction of the rudder motor.

To hold the rudder stationary marks and spaces of equal length are required so that the rudder motor will oscillate an equal amount in each direction; in other words, 50 per cent. of the time will be on mark and 50 per cent. on space. This type of signal is known as a 50/50 Mark/Space transmission.

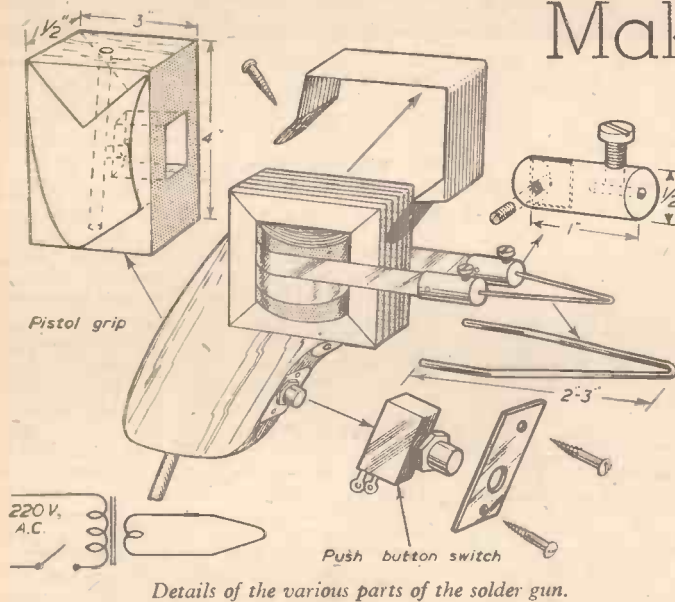

**A** SOLDER gun which takes only seven seconds to heat can easily be constructed from a discarded power transformer which has a good primary winding.

The transformer is stripped down and all the windings removed except the 220-volt primary. A piece of empire cloth is wrapped over the core and the low voltage, high current secondary is then put on. This consists of a piece of 1/16 in. copper strip about 1/2 in. wide, wound on one-and-a-half times round the primary. The ends are left protruding about 2 1/2 in. to 3 in.

The core may now be taped up and impregnated with wax or varnish. The laminations are replaced and the transformer is ready to be mounted on the handle.

A pistol-grip handle can be cut from a 1 1/2 in. by 3 in. by 1/4 in. block of wood, to the shape shown in the diagram. A hole is drilled through the block to take the power cord and an opening cut out for the switch.

A small push-button switch or a micro-

switch of the S.P.S.T. type can be used.

The switch is fitted on a plate, as shown, and this is screwed on the handle after the wiring has been done, as shown on the schematic diagram.

The transformer is held in place by a bracket made of 1/8 in. brass and bent to suit the size of transformer used.

A 1/4 in. hole is drilled about a 1/4 in. from the ends of the copper strip.

Two 1 in. bushes to take the tip are made of 1/4 in. diameter brass. A 1/4 in. hole is drilled

halfway through the bush and the opposite

# Making a Solder Gun

By W. G. CRAWFORD

switch of the S.P.S.T. type can be used. The switch is fitted on a plate, as shown, and this is screwed on the handle after the wiring has been done, as shown on the schematic diagram.

The transformer is held in place by a bracket made of 1/8 in. brass and bent to suit the size of transformer used.

A 1/4 in. hole is drilled about a 1/4 in. from the ends of the copper strip.

Two 1 in. bushes to take the tip are made of 1/4 in. diameter brass. A 1/4 in. hole is drilled

end is slotted to fit over the secondary winding. A 1/4 in. hole is drilled across the slotted end. A 6 B.A. by 1/4 in. screw and nut holds the bush on to the winding. The other end is drilled and tapped to take a 4 B.A. grub screw, which holds the tip.

The tip is made from a piece of 16 S.W.G. tinned copper wire, bent in the shape of a "V." Slightly heavier wire could be used, but a thicker tip would be slower in heating and the transformer might become hot.

Some dimensions are left out from the drawing as these will depend on the transformer available.

This is a very handy soldering tool once one gets used to using it. It can reach into places where an ordinary soldering iron could not. The tip may be bent around to any angle to suit the user.

A solder gun constructed as above has been in use over the past three years and, except for renewal of the tip, has never given any trouble at all.

## BOOKS Received

**How To Read Workshop Drawings.**  
By W. Longland. 63 pages. Price 3s. 6d.  
Published by Percival Marshall and Co., Ltd.

**THIS** slim volume, with its self-explanatory title should contain much of interest and value both for the professional and amateur workman. The amateur with a constructional hobby and the professional faced with a job which must be interpreted from drawings will appreciate being told how to read the information contained in a blueprint. A section on electrical symbols is included and there are some excellent line illustrations.

**Ships in Bottles.** By J. P. Lauder and R. H. Biggs. 74 pages. Price 3s. 6d.  
Published by Percival Marshall and Co., Ltd.

**EVERYONE** must, at some time or another, wonder how it is done and this little book sets out to give the explanation. In its pages are included full details of model construction and how these are persuaded into their bottles.

**Micrometers, Slide Gauges and Calipers.**  
By A. W. Marshall and G. Gentry. 78 pages. Price 3s. Published by Percival Marshall and Co., Ltd.

**WRITTEN** in simple language, this booklet sets out to instruct the practical worker in understanding and intelligent use of these measuring instruments. This is a fully up-to-date, revised edition and is adequately illustrated.

# The Transport Helicopter



Condensed from a Lecture Given by Dr. Igor I. Sikorsky to the Ins. of Mechanical Engineers

Fig. 2.—The Sikorsky S-55. These helicopters rendered valuable service on the Korean front and were used by the Air Rescue Service in their 1952 transatlantic flight.

156,005 m.p.h. reached by pilot Warrant Officer Billy Western in August of 1954. The official world's helicopter altitude record of 24,500ft. was established at Bridgeport on 17th October, 1954, by this same pilot. Both these records were achieved by the American S-59 Army helicopter powered by a 400 h.p. Artouste Turbomeca turbine (Fig. 4).

The longest helicopter non-stop flight, 1,234 miles, was completed by test pilot Elton J. Smith, piloting a 47-D1 Bell helicopter, powered by a 200 h.p. Franklin engine, which flew from Ft. Worth, Texas, to Niagara Falls, New York, on 17th September, 1952.

The heaviest useful load carried was well in excess of 10,000lb., lifted by the American S-56 Marine assault helicopter powered by two Pratt and Whitney R-2,800 engines. This flight took place in January, 1955.

One of the most significant long-distance flights was the crossing of the Atlantic by two helicopters of the Air Rescue Service in the summer of 1952. The helicopters used were two American S-55s powered by Pratt and Whitney 600 h.p. Wasp engines. This flight was conducted under frequently adverse weather conditions, and demonstrated the ability of the helicopter to be ferried to virtually any point on the globe, provided refuelling arrangements would be available at intervals of, say, 1,000 miles or so.

## Helicopter Activities

Sikorsky helicopters are in regular operation with several leading airway companies. They have been used with success for many

THE transport helicopter is not merely another type of aircraft or even another vehicle of transportation. In several important respects it is the most universal vehicle ever created and used by man.

As a rule every ground vehicle, from the pack animal to the railroad and automobile, is in need of a trail or road from the point of departure to the point of arrival. This is also true with respect to ships which require a waterway sufficiently deep and free of ice along their entire route. The aeroplane is free to fly anywhere, but its departure and arrival necessitate the availability of a hard-surfaced airport with a long runway or a deck of an aircraft carrier.

In contrast with this, the helicopter requires neither a prepared space for departure and arrival nor a road to follow. It is free from both.

Practically every vehicle used by man is limited with respect to the load it carries, not only as regards weight, but also with respect to the size or bulk of the object to be transported. Such is the case with the railroad, truck or aeroplane. Indirectly, this is equally true with respect to the steamship because, as a rule, any object or cargo must be delivered to and from the ship. Such limitation does not exist where the helicopter is concerned. Here only the weight limitation must be observed, but not the length or bulk of the objects to be carried. This feature is of tremendous importance and has already been extensively applied by military as well as by commercial operators of helicopters.

The third unique feature of the helicopter is its ability to pick up virtually any of its cargo and deliver it exactly at the destination point. It can, if necessary, complete both the pick-up and the delivery without alighting.

## History

The idea of the helicopter is very old, and probably antedates that of the aeroplane or even the balloon. Over 400 years ago Leonardo da Vinci made sketches of a man-carrying helicopter.

In France, around 1784, Launoy and Bienvenu made a flying model of a helicopter. In England, around the middle of the nineteenth century, the famous student of flying Sir George Cayley (1773-1857) made a model of a power-driven man-carrying helicopter.

During the latter half of the nineteenth century several other projects were made and interesting flying models demonstrated and in 1907 Louis Breguet was apparently the first man to take off in a helicopter. Between the 1914-18 and 1939-45 wars, the autogyro was created by Juan de la Cierva in Spain and several helicopters were produced in different countries with gradually increasing degrees of success until, around 1937, Dr. Heinrich Focke produced what was probably the first practical helicopter. It was capable of rising

to an altitude of several thousand feet, flying from town to town, making auto-rotative landings, and demonstrating full control in flight.

In 1939 in Stratford, Connecticut, the American VS-300 (Fig. 1) made its first flights. This was the world's first successful single-main-rotor helicopter and led, in 1943, to the R4, which, at Bridgeport, Connecticut, became history's first production helicopter.

During the 1939-45 war these helicopters were used for the first time in actual operation for liaison and rescue missions. Later, several commercial airlines inaugurated services with somewhat larger helicopters of similar general design.

It may be considered that the helicopter reached its maturity during the Korean conflict (Figs. 2 and 3). Korea has been rightly called "the proving ground of the helicopter." Helicopters delivered replacements, food, medical supplies and ammunition to the battle lines. They laid communication wires. It is recorded that Army engineers flew a bridge into position one piece at a time so that troops could move up into new territory. On another occasion they flew 34,000lb. of supplies to infantrymen who were temporarily isolated.



Fig. 1.—Sikorsky VS-300, with 3 control rotors. In 1941, this aircraft, piloted by the designer established the official world helicopter endurance record of 1hr. 32½mins.

It became the chief means of travel for battle commanders and enabled them to visit, inspect and supervise even the front-line positions to an extent never before possible.

Perhaps the proudest record is written in the roster of men who are living because the helicopter was on hand to save their lives or to deliver them to first-aid stations for medical treatment.

## Facts and Figures

The official world record for speed is

special projects by private operators, such as prospecting and assisting in the installation of high-tension electric lines over inaccessible high mountains in British Columbia. In the course of this operation thousands of men and hundreds of tons of supplies were transported. Some of the cargoes carried included materials for the erection of a village of 21 houses to house the personnel working on the project. One operation included the hauling of equipment to inaccessible mountain areas in Norway, where micro-wave stations were being built. One of the pieces,



## Where will it turn up next?

The Flamemaster torch turns up in the most unlikely places and among a surprising number of trades. Our books show that glass blowers, laboratory technicians, jewellers, dental mechanics and all kinds of metal workers were among the first to welcome this new precision heating tool, and that recently we've had orders from model engineers, electrical engineers, lead-burners and garage mechanics.

Why do they all find the Flamemaster so handy?

Because: Installation is extremely simple.

Flame control is easy and reliable.

Waste is eliminated by our trigger grip economiser.

Leaks are impossible.

## FLAMEMASTER MARK II

If you'd like to deal with your heating problem in the up-to-date way, write for full details to:—

**STONE-CHANCE LIMITED**, DEPT. F20, LIGHTHOUSE WORKS, SMETHWICK 40, BIRMINGHAM.  
TELEPHONE: BROADWELL 2651. LONDON OFFICE: 28 ST. JAMES'S SQUARE, S.W.1. TEL: WHITEHALL 6002.

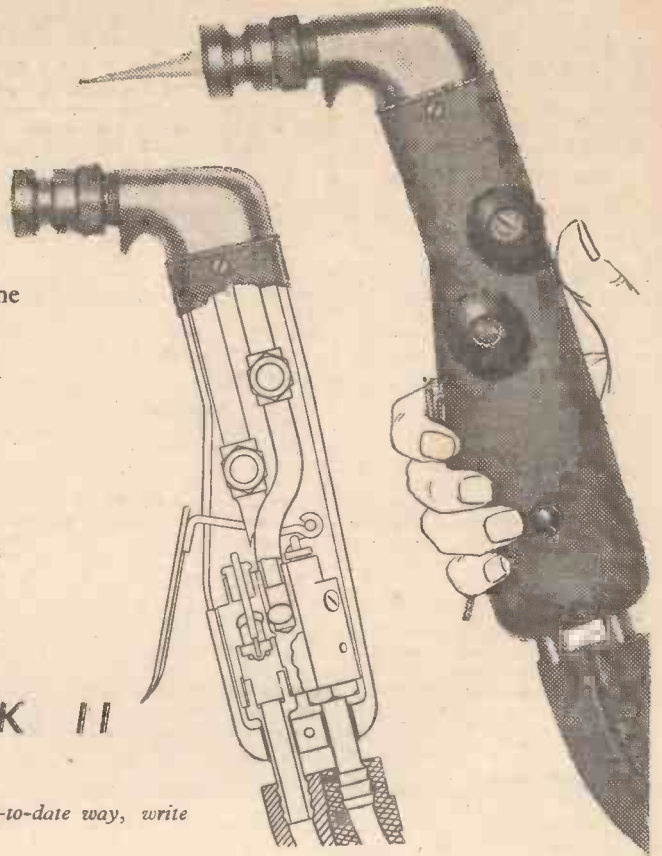



### POPULAR RANGE OF PERMANENT MAGNETS

*wide range of types and sizes always in stock*

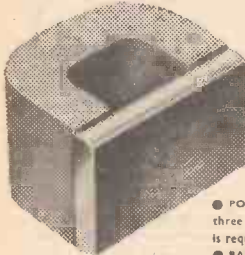

**POWER MAGNET**

- **POWER MAGNETS** . . . Alcomax magnets in three sizes. Use where extra performance is required.
- **BAR MAGNETS** . . . . . in pairs. For general purposes. 2" and 3" sizes available.
- **POCKET MAGNETS** . . . Useful to every engineer for hundreds of uses in workshop or home.
- **MINOR MAGNETS** . . . . . Ideal for the model engineer. Compact yet powerful.
- **POT MAGNETS** . . . . . in three sizes. Powerful Alcomax assemblies for holding and lifting. Mild steel pot can be machined.
- **BUTTON MAGNETS** . . . For magnetic indicators, doorcatches and as magnetic collectors. In three sizes.

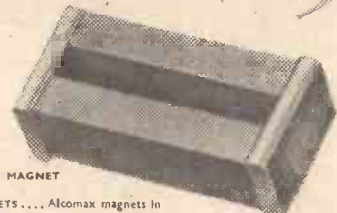

**BAR MAGNET**



**POT MAGNET**



**MINOR MAGNET**



**POCKET MAGNET**



**BUTTON MAGNET**

Made by James Neill & Company (Sheffield) Limited and obtainable from your usual tool distributor

EM37



## STARTING POINT FOR YOUR RAILWAY

There's realism in a solid metal P.W. track built from Bassett-Lowke sets. All parts being made to withstand years of wear and weather, the tracks are equally suitable for indoor and outdoor use. For clockwork and steam systems out-of-doors, or electric indoors, choose Set "A." For out-of-doors electric operation or extensive indoor use, Set "B."

### TRACK PART SETS for making 18ft. of realistic Gauge "O" Permanent Way.

Set "A" (with steel rail) ..	40/-
Set "B" (with brass rail) ..	50/-
Set A/E for electric traction ..	51/-
Set B/E for electric traction ..	61/-

**Each Set Comprises:**

- 12 36in. lengths rail.
- 12 fishplates.
- 216 chairs.
- 108 sleepers.
- 500 spikes.
- 500 panel pins.
- 12 battens.
- Track Gauge.
- Chair fixing jig.
- Purch.

Illustrated instruction book, "Laying Permanent Way."



**MODEL RAILWAYS GAUGE 'O' & GAUGE 'OO'**

**BASSETT-LOWKE LTD.**  
NORTHAMPTON.  
LONDON, MANCHESTER.

This 100-page fully illustrated book is packed with interest for model railway enthusiasts. The most comprehensive Bassett-Lowke book ever issued! Send 2/- to Department MR.12.

## BASSETT-LOWKE LTD

Head Office and Works:

### NORTHAMPTON

<b>LONDON:</b> 112, High Holborn, W.C.1.	<b>MANCHESTER:</b> 28, Corporation Street.
---	---

# MODEL IT FIRST ...

with

## 'Plasticine'

Regd.

IF YOU WANT to see the mechanical snags in anything you are making, try modelling it in "Plasticine" first. You'll save time and trouble by unforeseen factors. "Plasticine" was used in an experiment on making the three coupling links for railway carriages from one block of steel. Besides experimental models it can be very useful for holding screws in position, picking up nuts dropped in inaccessible places, or securing wires during testing. There are dozens of ways in which "Plasticine" can be useful to you—get some to-day and see how it can help you. It is available in sixteen colours.

**HARBUTT'S PLASTICINE LTD.**

Bathampton, Bath, Somerset

# GAMAGES

## NEW ALL-PURPOSE MACHINE

### SAWBENCH—LATHE—DRILL PRESS

The finest multi-purpose machine of its type, based on a popular American design, with all the features of expensive machines. A WORKSHOP IN ITSELF! Driven by 1in. capacity electric drill, supplied to fit "Wolf Cub," "Bridges" and "Black and Decker." Strong alloy castings with Black crackle finish.

**SAWBENCH.** 5in. Sheffield made Rip Saw blade with arbor for fitting into drill chuck. Supported on oil-impregnated bearing ball. Size 8in. by 7in. with rise and fall tilting action, Sawguard, Sliding fence, etc.

**LATHE.** 4in. faceplate, fixing and revolving wood centres with screw type tailstock (drill chuck is removed to fix faceplate on to drive).

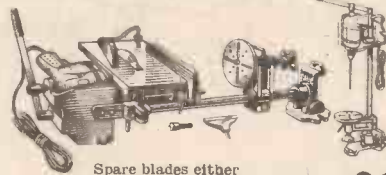

**DRILL PRESS.** The end bed bar is hinged to allow the machine to stand on end and convert into a useful Drill press. Overall length 29in. Overall height 9in. Polished Steel Bed Bar 1in. dia.

Spare blades either Rip or Fine tooth for cross-cutting 12/6 each extra.

**BARGAIN PRICE £8.17.6** Or 43/- deposit & 9 monthly Payments of **16/3**

Carr. & Pkg. 7/6 outside 50 miles radius of Holborn in Eng. & Wales.

### Two useful tools for the handyman ...

#### THREAD RESTORERS

This is the most practical tool that can be used for restoring threads when a die cannot do the job. Serves the following popular threads: W 12, 11, 12, 13, 14, 16, 18, 20, 24, threads per inch.



Post & Pkg. 9d.

9/6

#### SPOTLIGHT SCREWDRIVERS

Fitted with small light with self-contained battery. Most useful for jobs in dark and awkward places. Overall length 8in.



7/6 Post & Pkg. 4d. outside our van area.

GAMAGES TOOL AND MOTOR CAR ACCESSORY LIST FREE.

Car Park Opposite the Store.

Open Thursday till 7 p.m.

**GAMAGES, HOLBORN, LONDON, E.C.1. HOL. 8484**

## NEW CABLES & FITTINGS

### TOUGH RUBBER CABLES

1/044 Twin	per yd. 25 yd.	50 yd. 100 yd.
1/044 3-core	10/d. 21/-	40/- 78/6
3/029 Twin	10/d. 19/3	37/- 72/-
3/029 T. & E.	11/d. 23/3	45/- 87/6
7/029 Twin	13/d. 31/6	61/- 120/-
7/029 T. & E.	17/d. 39/3	76/6 150/6
7/044 Twin	2/5	59/6 117/- 232/-
Twin Lead	50 yds. 3/029 66/3, 7/029 108/6,	
VIR	50 yds. 3/029 16/3, 7/029 27/6, Earth Wire	
	100 ft. 7/029 11/6, 7/029 7/-, Twin PVC Transp.	
	Flex 50 yds. 10/-, Twin Maroon 25 yds. 12/6,	
	50 yds. 22/6, TRS, VIR Lead Cables of all	
	sizes. Holders, C.G. 9/-, Batten doz. 12/-,	
	Ros. Brown 8/-, White doz. 10/-, Jng. Boxes Sm. 11/-, Lge. doz. 13/-, Switches	
	1-way 18/-, 2-way doz. 24/-, Mutac Silent	
	Switches 1-way 18/-, 2-way doz. 24/-, Ceiling	
	Cord, do. 1-way 5/-, 2-way 6/-, 2 amp. 2-pin	
	Swplugs & Tops, ea. 3/-, 5 amp. 3-pin	
	Swplugs & Tops, ea. 5/6, 15 amp. 3-pin	
	Swplugs & Tops, ea. 9/-, 15 amp. 3-pin ditto	
	A.C. only, ea. 6/-, Wood Blocks 3 x 1/4 4/6,	
	3 x 1/2 6/-, 3 x 3/4 8/-, 5 x 3/4 10/-, doz. 7/6,	
	White, 3 x 1/2 6/-, 3 x 3/4 7/-, 4 x 1/2 9/-, Cable	
	Clips Sml. 2/9, Med. grs. 3/3, 10 amp. D.P.	
	Insulated Swfuse 6/6, 21 amp. Ironclad 2-	
	way 15 A. Spltr. 13/6, 30 amp. Ironclad D.P.	
	Switchfuse 19/6, 60A. Metal 8-way Con-	
	sumer Unit 45/-, Sw. gear, Fusebox, Spltrs.,	
	all types, Cooler Control with 13A. Socket,	
	27/6, Lamp Bulbs 15, 25, 40, 60 watt, 12/-,	
	75 watt 15/-, 100 watt 17/-, 150 watt 24/-, 200	
	doz. 30/-, Carbon Bulbs 230 v. 16 CP	
	doz. 20/-, Immersion Heaters, 1 kW 37/6,	
	A.C. Motors, 1 h.p. 220/240 v. 60/-, 1 h.p. 230/	
	220 v. 110/-, 1 h.p. do. 135/-, Coppered Aerial	
	Rods, doz. 1/-, Single Car Cable 10 yd. 3/-,	
	100 yds. 25/-, Conduit & Fittings, 1in. & 1 1/2in.	
	Industrial Reflectors, Tubular Heaters,	
	Fluorescent Fittings, Time Switches,	
	Meters, Electric Motors and all electrical	
	equipment. Full lists on request. Single	
	items supplied. Satisfaction guaranteed.	
	Terms: Cash with order; carriage paid if	
	over £4; orders of £20 or over less 5 per	
	cent. discount.	

## LONDON WHOLESALE WAREHOUSE

165 (PM), QUEENS ROAD, PECKHAM, S.E.15

Tel.: New Cross 7143 or 0890.

### EXTRACTS FROM OUR NEW CATALOGUE

**IDENTIFICATION TELESCOPES.** Can be used simultaneously by two observers. Tremendous clarity with powers of 12X and 30X and Object Glass dia. of 60mm. Cost £185. Perfect condition £15, carriage paid.  
**EX-R.A.F. BINOCULAR HOLDERS.** Eliminates Binocular shake. Invaluable to users of high-powered Binoculars. 21/-, post free.  
**TERRY ANGLEPOISE TYPE LAMPS.** s.b.c. holder and pygmy reflector 31/6, post extra 1/6. Larger reflector with b.c. holder 5/9.  
**9 x 50 U.S.A. ELBOW TELESCOPES.** 57/6 each plus 2/6 postage.  
**RIFLE SIGHTS.** For .22 and .303. Four types available. Prices £2/15/-; £3/10/-; £4/5/-; £5/15/-.  
**GRID LIQUID COMPASSES.** 4in. and 6in. Dials. 30/- each.  
**PRISM BINOCULARS:**  
 Brand new BX with case at £6/19/6 and £8/17/6. Bausch & Lomb Pattern Canadian Naval Type at £11/15/-. Ross 7 x 50 ex-Govt. Perfect at £20. New 10 x 50 Coated. Centre Focusing. Leather case. At £25.  
**SEXTANTS:**  
 Heznanith Endless Tangent Screw at £12/10/-. (Huge selection from 50/- to £19/10/-.) New Light Weight 20X TELESCOPES. £4/17/6 each.  
**EX-ADMIRALTY BAROGRAPHS.** Perfect condition, at £15 each.  
 All these items and many others are fully described in our new catalogue which is free on request. All purchases covered by our guarantee of "satisfaction or refund of payment."

**CHARLES FRANK,**

67-73, SALTMARKET, GLASGOW, C.I.

Established 1907.

Phone: Bell 2106/7.

### WESTPOLE MOTORS Ltd.

WESTPOLE AVENUE, COCKFOSTERS, BARNET, HERTS. Barnet 3615

# ★ GLASS FIBRE ★

FABRICS, MATS, RESINS, ETC.

KIT No. I 15/- Make your own GLASS FIBRE Models. These  
 „ No. II 25/- KITS carry a comprehensive range of materials,  
 „ No. III 30/- with full instructions to suit all forms of  
 Postage 1/6 Model making.

### PLEASURE AND PROFIT

#### SILK SCREEN PRINTER with ALL SUPPLIES & FREE COURSE!

**PRINTS IN SIX COLOURS** This is the great new printing and colouring process for amateurs or professionals alike and all hobbyists. Its versatility is enormous. It will print a few copies, or hundreds, to a professional standard, in solid colours, or intricate designs, on cloth, paper, wood, glass, metal, etc. Print greeting cards, toys, models, drawings, paintings in full colour, photographs, type-script. Fluorescent colours, suede flock and novelty finishes, transfer papers for printing your own transfers also available. Can also be used as first-rate duplicator with any typewriter. Nowhere else is such a large and comprehensive outfit offered for so little money. As supplied to H.M. Government, Educational Authorities, Printers and private users throughout the world. Thousands testify to the quality and amazing value. Do not miss this opportunity.

—ON PAPER, WOOD, CLOTH, PLASTICS, etc.  
**AMERICAN PUBLISHERS SERVICE**  
 (Graphic Arts Div.), DOCKING ROAD, SEDGFORD, NORFOLK

### This IS the BARGAIN OF THE YEAR

COMPARE THE VALUE SEE WHAT YOU GET! Large 16in. x 12in. PRINTING FRAME. Stout Laminated WOODEN BASE. Patented ADJUSTABLE HINGES (for printing on material up to 1in. thick). Fine Quality SQUEEGEE SIX CONTAINERS COLOURS — Red, Blue, Yellow, Green, Black, White. STENCIL FILM (design traced and applied with hot iron). STENCIL CUTTERS and HOLDER. Register Guides, Masking Tape, etc. etc. And FREE 10/- COURSE giving step by step procedure for every application of process, including PHOTO STENCILS, DAY GLO. FLOCK finishes, etc. for 47/6 post paid REFUND GUARANTEED IF NOT APPROVED WITHIN 7 DAYS.

### Frank's Special Bargains

**TERRY LAMPS.** Ex-Govt. Spring-friction. Anglepoise type. Pygmy reflector, s.b.c. holder, wall/bench fitting. Unused and perfect at under half-cost. Price 31/6 Post 1/6. Extra available (not Terry). Larger reflector and holder for standard bulbs. 5/9. Cast iron table bases, 8/6.



**GRID LIQUID COMPASS.** 4in. and 6in. dial. Ideal boat or car. Cost appr. £20. Perfect. 30/- post free

9 x 50 U.S. ARMY PRISMATIC ELBOW TELESCOPES. Internal filters. Weight 5 1/2 lbs. Cost £88 Perfect. 57/6 Post 2/6.



**EX-A.M. ROSS REFLECTOR SIGHTS.** Comprises optical system of four lenses, L. a. n. p. housing with rheostat. Perfect. 12/6 post free.

**ADMIRALTY TELESCOPES.** Single Draw. Closed 18in. Mag. 16/18X. Cost appr. £10. Good condition. 59/6, post free.



"SATISFACTION OR REFUND ON ALL GOODS."

**CHARLES FRANK**  
 67-73 SALTMARKET · GLASGOW

a generator and its base plate, was delivered to the site by an S-55 in approximately 18 minutes. Later it was learnt that when the helicopters had already left Norway and one of these generators had to be replaced it required five men and three horses and took 10 days to haul the replacement generator to the site.

Very interesting also was the successful operation in Northern Labrador where helicopters were used for prospecting and carrying personnel, all necessary equipment, food, fuel, instruments and machinery for drilling, etc.

Another example is the use of the helicopter for controlling malaria and other diseases in the Belgian Congo, where the mortality rate was decreased to less than 1 per cent. of what it had been.

In peacetime emergencies, helicopters have proved just as valuable and important as they did in war. During the recent floods in the Netherlands several hundred lives were saved by the use of helicopters. Numerous others were saved under various emergencies in Alaska, in Newfoundland, as well as in many parts of the United States and other countries.

In July, 1954, ten S-55 models were used in the stricken flood areas of Austria and Bavaria.

Among all the multitude of successful missions accomplished by the helicopter the most impressive are still those connected with rescue operations.

#### Types of Helicopter

The foregoing mostly describes the single-rotor helicopter. This is because the author is much more familiar with the single-rotor helicopter, which he considers to represent the most promising configuration and because most of the successful practical applications of the helicopter in war and in peace have, so far, been achieved with them.

It is possible to foresee, in the immediate future, the development of two distinct lines of design. The first would correspond and be similar to the airliner or transport aeroplane. The second would be a freight and cargo carrier, and would be a craft in its own class with virtually no parallel in any other aircraft or even in any other vehicle of travel.



Fig. 3.—S-55, being employed to transport an aircraft fuselage.

The passenger transport would be essentially the further development of the modern helicopter as currently used. It means an aircraft with a body-fuselage and interior arrangements essentially similar to those used in corresponding military transports or airliners. Such aircraft would usually be equipped with soundproofing, comfortable and attractive interior arrangements and seating, proper heating and ventilation, etc. The helicopter may gradually become somewhat different from the airliner. For instance, in the helicopter it would be desirable



Fig. 4.—Sikorsky S-59. The first turbine-powered helicopter—built for the U.S. army.

to use larger entrance doors, or more of them, in order to expedite the loading and unloading of the aircraft in the case of short-range flights. Furthermore, it would be desirable to use larger windows because the view from a helicopter cabin is completely unobstructed and the helicopter generally flies at lower altitude and, in the majority of cases, offers much more interesting scenery than that which could be viewed from the aeroplane.

The freight type whose appearance may confidently be expected in the near future would be a special freight-cargo helicopter, specifically designed to lift any type of object or load, including large and bulky ones, and to carry them on the outside, suspended below the body of the aircraft.

In the crane helicopter it is possible to use any conventional helicopter-lifting rotors and methods of control, power plant, transmissions, etc. The main difference would be in the body, location of the pilot's cabin, landing gear, and powerful special lifting-crane devices that would allow for picking up an object, if necessary with the helicopter hovering over the ground. The cargo helicopter may virtually have no fuselage-body as we know it and may simply represent a flying frame or possibly have a needle-like fuselage of small cross-section adequate to accommodate the transmission and other accessories, and either a hoist or other arrangement that could be used to suspend and, if necessary, to lift the loads.

The pilot's cabin could be suspended below a narrow tubular fuselage substantially behind the centre of gravity of the aircraft. Such location would somewhat obstruct upward vision from the pilot's cabin, but vision forward would be satisfactory while vision downward would be excellent.

The main advantage of such arrangement would be that the pilot would have excellent vision of the object which he is to lift, of the whole procedure of attaching and lifting and, finally, would have excellent opportunity to direct the aircraft in a way that would permit bringing and lowering the object precisely where it may be needed. This would permit, for instance, carrying and lowering a transportable house directly upon its foundation, delivering high-tension towers in a vertical position and placing them accurately on their bases. It would, in fact, combine the countless number of problems of transportation

with the problems of actually lowering objects or materials, erecting machinery or sections of a bridge, etc., directly where they are intended to be and solve both in one operation.

Some very useful work of this description has already been carried out by helicopters with relatively modest power and lifting capacity. The possibilities for using a cargo aircraft with adequate lifting power and a properly located pilot's cabin are almost unlimited.

#### Possible Future Development

The pure helicopter is an aircraft in which all lift and forward components are derived exclusively from the action of one or several lifting rotors. There are reasons to maintain that the operating speed of such aircraft will never be much in excess of 200 m.p.h., although several methods are being studied to increase it.

A speed somewhat higher than the velocity of the pure helicopter could be obtained by the use of the compound helicopter or "gyrodyne." By this term is meant an aircraft which, besides the lifting rotor, has small auxiliary wings and probably propellers or jets. As the aircraft accelerates the wings will carry part of the load and, with the main rotor being unloaded, it would be possible to postpone or prevent stalling of the retreating blades and consequently exceed the speed range of the pure helicopter by perhaps 50-75 m.p.h. or even more.

The wings and propulsive members of the compound helicopter would be useless during hovering. Consequently, conditions being identical, the compound helicopter should, as a rule, be expected to have less payload than the pure helicopter of comparable size and power. This fact, together with its greater simplicity and smaller maintenance cost, would result in the pure helicopter remaining a useful and popular type of aircraft that would be extensively utilised for a great variety of short-range missions. Nevertheless, for intermediate ranges, the compound helicopter, with its higher speed, may offer sufficient advantages to justify its use.

The convertible type would offer a considerable increase in speed. As the name signifies, it means an aircraft which can take off vertically and hover as an ordinary helicopter and then become converted into an aeroplane and travel at a considerable speed, perhaps several hundred miles per hour. For landing the ship could be reconverted into a helicopter and hover and land in the usual manner. Such an aircraft is undoubtedly possible and a large number of different and frequently very ingenious projects have been made. I believe, however, that such aircraft would always remain considerably more expensive and less efficient than either the pure helicopter or the pure aeroplane of equal lifting capacity. Therefore, I can

force only a limited utilisation of the convertible type.

A very promising aircraft of similar potential performance is the vertical take-off aeroplane. I do not believe that it could even approach the hovering characteristics of a true helicopter with all the great safety and service significance of this machine. However, the V.T.O. should be capable of rising into the air vertically and landing with no run. Once in the air it would proceed as an aeroplane which, in fact, it never ceases to be. The military value of such aircraft may be substantial and it seems that a good beginning has already been made in the production of such planes.

In respect to size, I believe there is no limitation in sight, and it would be possible to produce giant helicopters as soon as they would be needed.

### Configuration

While it is possible to foresee a great variety of configurations using different numbers and arrangements of lifting rotors, and different methods of applying power, yet there are reasons to believe that a single-rotor aircraft would remain the most important type. For machines of up to 100 tons or so the use of engines and a transmission carrying power to the rotor shaft, or directly to the rotor hub, seems to be the most practical. At present a metal-gear transmission is used in the vast majority of practical helicopters. It is possible that hydraulic or pneumatic transmissions will be used in the future if made more efficient.

Concerning maintenance, life expectancy and reliability of helicopter transmissions, they are all quite reasonable even at the present time and may well be expected, in the near future, to be in line with the characteristics of the best modern aeronautical engines or turbines. It is believed, therefore, that piston engines or turbines, combined with the metal-gear transmission, would represent the power unit for the majority of helicopters for an indefinitely long period of time to come.

In certain cases, particularly for still larger machines, it may be advantageous to eliminate the transmission and apply the force directly at the tips of the blades in the form of jets, that is, mounting the complete turbo-jet units on the tips of the lifting rotor blades.

While the construction of such aircraft would involve the serious engineering problem of producing a turbo-jet capable of withstanding considerable centrifugal and gyroscopic forces, it would also involve the problem of carrying heavy loads on the tips of the blades. In spite of the serious and novel problems which would be encountered, an aircraft of this type would certainly be possible and such arrangement may become particularly interesting in a helicopter of a gross weight much in excess of 100 tons.

In respect to other characteristics, I believe it may be expected that in future helicopters, particularly in the large ones, we will use heavier disk-loadings and lighter power-loadings and it may be advantageous to use a greater number of blades of a moderate chord. There are reasons to believe that this would increase the smoothness and decrease the control loads of the aircraft.

Aircraft engines will continue to be the principal power plant on helicopters, as at present, but there will be increased use of the turbine because the helicopter will profit even more from its characteristics than would the aeroplane.

### The Use of Nuclear Power for Helicopters

There is no doubt that nuclear power could be used to drive the helicopter as soon as a suitable power plant became available.

The major problem in this case would still be to protect and insulate the occupants

from the powerful radiation that would be created by the nuclear reactor. It is probable that on a sufficiently large machine a reactor could be situated far in the very bow of a fuselage of the aircraft and be properly insulated, while the crew could be located far behind, in the rear end of the craft. This, or similar solutions, however, may involve certain difficulties. It is probable that during operation the entire aircraft, including transmission and rotor blades, would become powerfully radioactive and the blades, in turn, would spread radioactivity to all parts of the aircraft, consequently making the method of protecting the crew extremely difficult, if not impossible.

### Isolating the Reactor

Another method would be to separate completely the reactor, together with turbines, into one unit that could be carried by the helicopter, suspended on a length of cable about 200ft. long or, if necessary, even more. By insulating either this unit or the crew compartment, or both, it would perhaps be possible to protect the occupants of the aircraft. However, in this case, transmission of power would present a serious problem.

The final arrangement, which, so far, appears to be the best, would be the reverse one. Let us suppose that the reactor, with all its accessories and the turbines directly geared to the rotor, are located in the cabin of the aircraft. However, no members of the crew occupy places in or even near the aircraft. They are all in a separate cabin which is suspended under the helicopter on a cable a couple of hundred feet long. Controls will be transmitted from this suspended cabin into the helicopter by way of electricity or by other means. The aircraft would then be operated as follows:

At the onset the helicopter is located on

the ground 200ft. or more from the cabin. From the cabin the pilot controls the helicopter, takes it off, pilots it into vertical position above the cabin and, continuing slowly to climb, finally lifts the cabin and proceeds on his flight, with the cabin remaining suspended far below the helicopter. During landing the procedure is reversed. It is believed that, in such circumstances, shielding of the cabin could be accomplished within a reasonable expenditure of weight and the nuclear-powered helicopter would become feasible.

It is very probable that, in line with further developments of nuclear physics, other ways of using nuclear energy in helicopters would be proposed. In fact, a conventional arrangement may become possible if lighter and more efficient methods of protective insulation are developed.

The greatest obstacle, which will probably prevent the use of atomic energy in helicopters for some time to come, is the fact that there may not be sufficient advantages in doing so. While very fast, nuclear-powered, possibly supersonic, aeroplanes with virtually unlimited flying range would be tremendously valuable, yet practically all the missions of the helicopter are for short range, except in the case of ferrying of the aircraft, for which refuelling can usually be arranged without much difficulty. Consequently, it does not seem that the use of a delicate and very expensive source of power would be justified.

This modest newcomer into the field of aviation, in no way nearly as spectacular as the previous one, nevertheless may have at least as great, if not greater, an impact on future human history. There is no doubt that the helicopter will prove a modest, faithful and tremendously useful servant of mankind, capable of performing a countless number of services, either scheduled, non-scheduled or emergency, in peace and war.

## Multi-coin Mechanism for Turnstiles

WHAT is claimed to be the simplest multi-coin mechanism yet developed for turnstiles has been patented by Sir W. H. Bailey & Co. Ltd. (Albion Works, Patricroft, Lancs). It has only two moving parts, so that trouble-free operation is ensured and maintenance is reduced to the simplest routine.

forward and allowing the coin to fall through a slot in the bedplate. The device immediately returns to the locked position, under the action of the spring, when pressure on the plunger is released.

The bedplate of the mechanism is a heavy manganese-bronze casting with substantial hardened steel lock lever and coin guide. The coin insert or guide can be adjusted to take coins of any size.

The patented feature for selecting or rejecting a coin before its arrival at the operating mechanism is also simple. From the coin slot in the top-plate of the

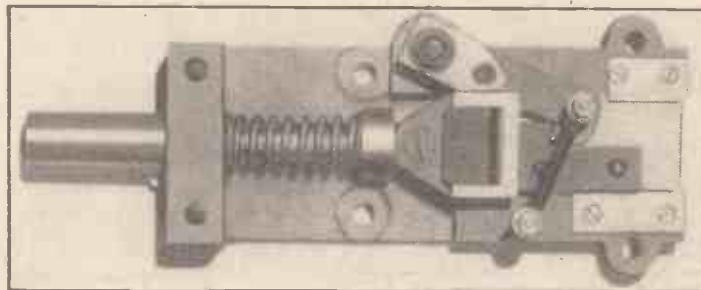

The new multi-coin mechanism.

turnstile a coin of the correct diameter is passed to the operating mechanism, but one of a lesser diameter is returned through a rejection chute.

The principles of the mechanism can be seen in the photograph. A spring-loaded plunger—operated by the movement of the turnstile arms—is normally in the locked position but is freed by the insertion of a coin of the appropriate size. The correct coin falls into the slot in the centre of the mechanism and acts as a key when the plunger is pushed forward. The coin is forced against a projection on the locking lever which lifts it out of the locked position, so permitting the plunger to travel

It is claimed that the new mechanism offers the user the advantages of speedier and easier operation—in former types of coin-operated mechanisms the coin had to be cleared and the lock actuated by manual means. With the new mechanism this is completely automatic, so that the passage of traffic is speeded up and running costs are reduced.

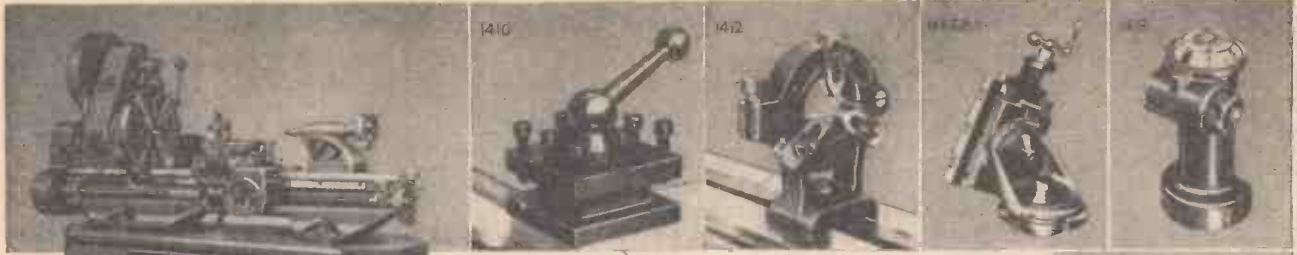

ML7. 3 1/2" x 20"  
CENTRE LATHE

*The finest Value  
in the World.*

**MYFORD  
LATHES**

**MADE ON MODERN PRECISION PLANT, THEY ARE THE  
STANDARD BY WHICH SMALL LATHES ARE JUDGED**

The many thousands in use by Industrial Engineers, coupled with the most comprehensive range of Equipment available for any Lathe, is the finest guarantee of satisfaction you can have.



You can be proud to own a Lathe that is acclaimed throughout the World. Designed with all the features required by the most exacting Model Engineer, Myford Lathes are produced to stand up to continued use in the Engineering Industry.

**YOU MUST NOT FAIL TO SEE**

THE ML7 AND SUPER 7—3 1/2" LATHES (METAL WORKING)  
ML8 MULTI-PURPOSE WOODWORKER AND P.R.11 PLANER (WOOD)

**IN ACTION**

AT THE "MODEL ENGINEER" EXHIBITION, NEW HORTICULTURAL HALL,  
WESTMINSTER, LONDON, S.W.1—17th-27th AUGUST, 1955

**ON STAND (Nos. 5, 9 and 12)**

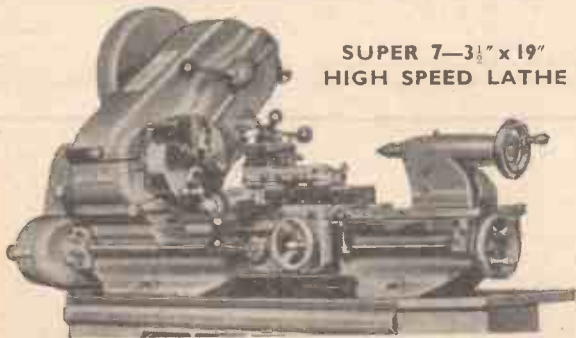

SUPER 7—3 1/2" x 19"  
HIGH SPEED LATHE

The Super 7 accommodates 10" in Gap—7" over Bed and 4 1/8" over Boring Table. Full length 19" between Centres. Advanced Spindle Design—Cone Bearing at Front and Twin Angular Contact Bearings at Rear—14 Spindle Speeds from 25-2150 r.p.m. Clutch Control. Long Boring Table to carry Rear Tool Post, Friction Setting Index Dials. Ejector Type Tailstock, etc.

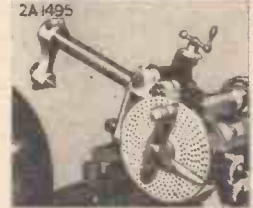

TELEPHONE:  
BEESTON 25-4222  
(3 lines)

**MYFORD ENGINEERING COMPANY LTD**  
BEESTON NOTTINGHAM ENGLAND

TELEGRAMS:  
MYFORD BEESTON  
NOTTINGHAM

**ELECTRIC PAINT SPRAYER**

**For 4/- deposit**



Cash 75/-. Or 4/- deposit and 6 monthly payments of 13/6.

Paint easily, evenly, twice as fast with the Burgess Electric Sprayer. Sprays paint, varnish, etc. Complete with sturdy glass container, flex, nozzle for ceiling spraying and extra nozzle discs for different liquids. A.C. mains only—state your actual voltage. Fully Guaranteed. Leaflet free.

**"BARONET" ELECTRIC PAINT STRIPPER**

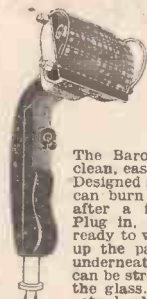

**39/6 cash** without switch  
**42/6 cash** with switch

The Baronet Paint Stripper is clean, easy, safe and economical. Designed so that even a beginner can burn off old paint expertly after a few minutes' practice. Plug in, switch on, and you're ready to work. Quickly blisters up the paint for scraper to go underneath. Window frames, etc. can be stripped without cracking the glass. AC/DC—State your actual voltage.

**YOURS for 14 days FREE PHILISHAVE**

World's Largest Sale

Try the wonderful Philishave Electric Dry Shaver FREE for 14 days. Send only 5/- deposit (returnable if not satisfied). Two shaving heads with two 6-bladed cutters have unique rotary action which genuinely shaves—doesn't just snip at the hairs. Result—better, quicker shave. Operates 110/250 volts A.C./D.C. £7.9.3 cash less your deposit. Or 5/- deposit can be first payment, followed by 8 monthly payments of £1. 12 months' guarantee.

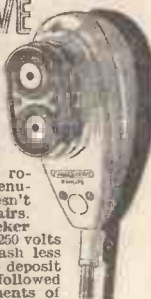

**DRILL FASTER** with a **Black & Decker ELECTRIC DRILL** 12/-

The Black & Decker U-1 1/4 in. DEPOSIT Portable Electric Drill saves hours on home and workshop jobs. Drills wood, steel, brick, etc. Also drives sanding discs, polisher pads, etc. Fully suppressed. £5.19.6 or 12/- deposit and 6 monthly payments of £1. Also 1/2 in. Drill, U-20, £12.7.6 or 25/- deposit and 8 monthly payments of £1.11.0. A.C./D.C. motor. Voltages 110 to 250. State your actual voltage. Also 5 in. Saw attachment, only £3.5.0 or 5/- down and 6 monthly payments of 11/-.

Illustrated brochure of this and other Shavers Free on request.

SEND FOR COMPLETE TOOL LIST

**BARGAIN DISTRIBUTORS (DEPT. 16), 5 SILVER STREET, LUTON**

**VERSATILE!**



Make-spray painting a pleasure and obtain that professional finish by using a B.E.N. Model IM Spray Gun.

The Model IM is a pressure feed internal atomising spray gun designed to handle a wide variety of finishing materials such as oil paints, cellulose and synthetics, distempers, plastic emulsion paints and all kinds of insecticides and fungicides.

Requires only 2 cu. ft. of air per minute and can be used with even the smallest compressor.

Send for Publication CB.109 giving full details.

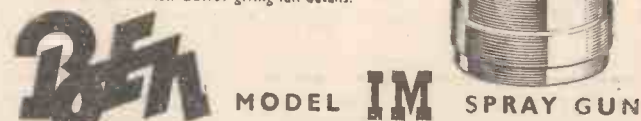

B.E.N. PATENTS LTD. (Division of Broom & Wade Ltd.) P.O. Box No. 10, Dept. X, HIGH WYCOMBE, BUCKS C.P. 166

**DO YOU COUNT IN LIFE?**

How To Achieve Your Secret Ambition



THE secret ambition of thousands of men and women is to live a life that counts for something. They may not give

any vocal expression to this ambition but it is there all the time beneath their daily hours.

They are not content to live always in a rut, to be one unit in a multitude, to exist for ever undistinguished and unknown, to be always ignored not merely by strangers but by neighbours, relatives and business colleagues. They want to develop Personality and to do work that is worth while.

This is where Pelmanism helps. Pelmanism develops Personality. It develops Individuality.

Remember—Everything you do is preceded by your attitude of mind.

**HOW TO LEARN LANGUAGES**  
The Pelman Languages Institute teaches French, German, Spanish and Italian, without translation. Write for particulars and specimen lesson of the language that interests you, which will be sent gratis and post free.

Reduced fees for H.M. Forces.

Pelman Languages Institute, 130, Norfolk Mansions, Wigmore St., London, W.1.

It strengthens the weak Will. It banishes Diffidence and Shyness and gives Self-confidence. The feeling of inferiority which haunts so many people disappears after a course of Pelmanism. By increasing the efficiency of your mind Pelmanism gives you a well-founded belief in yourself and your powers; it develops Courage, Resolution, Initiative, Self-respect: it inspires you to new effort and thus enables you to get out of the rut into the high road to success.

Reduced fees for Her Majesty's Forces. (Apply for Services Enrolment Form.)

Further, by increasing your Efficiency it increases also your Income-earning Power.

Send for Free Book

The Pelman Course is simple and interesting and takes up very little time; you can enrol on the most convenient terms. The Course is fully described in a book entitled *The Science of Success*, which will be sent to you, gratis and post free, on application to:

**PELMAN INSTITUTE**  
130, Norfolk Mansions,  
Wigmore Street, London, W.1.

WELbeck 1411/2  
Established over 50 years.

PELMAN (OVERSEAS) INSTITUTES. DELHI. 10 Allipore Road. MELBOURNE: 396 Flinders Lane. DURBAN: Natal Bank Chambers (P.O. Box 1488). PARIS: 176 Boulevard Haussmann. AMSTERDAM: Prinsengracht 1021.

**MIDLAND INSTRUMENT CO. OFFER:—**

**MOTORS**, 200/250 v. A.C./D.C., taking .1 amp., fitted reduction gearbox, providing 3 drives of approx. 60, 12 and 1 1/2 r.p.m., also fitted 2 sets cam-operated contacts and governor, new, unused, 30/-, post and packing 2/6. **AMMETERS**, 0-14 amps. D.C. flush panel mounting, requires 1 1/4 in. dia. hole, latest design, ideal for battery chargers, etc., brand new, 7/8, post 4d. **TELEKULAR SPECTACLE BINOCULARS**, attractive plastic frame, separate eyepiece focusing, wide folding sides, ideal for sports, theatre, TV, etc., now widely advertised at over twice our price, brand new, 7/6, post 6d. **ROSS ACHROMAT LENSES**, un-mounted, all 40 mm. (1 1/2 in. plus) dia., 5 different types, f. 1.7, f. 2, f. 2.3, f. 2.7, f. 3, focal lengths are approx. 2 1/2 in., 3 in., 3 1/2 in., 4 in. and 4 1/2 in. respectively, new, unused and perfect, ideal for projectors, enlargers, epidiascopes, telescopes, etc., 10/- each, post 6d., 50/- the 5, post paid. **POWER SUPPLY UNITS** No. 5, complete except for the 6v. accumulator, brand new in sealed cartons, 40/-, carriage 5/-, Scot. 47/6. N.I. 10/- Contains the following items sold separately: **HAND GENERATORS** (above) generates 6 v. 5 amp. at 100 r.p.m., has enclosed gearbox, fitted detachable folding handle, with out-out and base mounting generator holder, sound possibilities as wind charger, also operates as motor, with powerful reduction drive, brand new, 25/-, post 2/3. **VIBRATOR UNITS** (above) 6 v. input, provides all L.T. and H.T. supplies for the 18 and 33 sets, complete with vibrator, plugs and leads, size 9 in. x 6 1/2 in. x 3 1/2 in., brand new, 20/-, post 2/3. Spare Mallory Type 650 non-synch vibrators, brand new, 5/-, post 6d. **SELVSYN TRANSMITTERS** (Magslips), 3In. type, pure synchro x-y-1-2-3, suitable as master or slave, 50 v. 50-cycle single phase A.C. operated. When two or more of these are wired up, the rotation by hand (or other means) of one will result in a 100 per cent. follow in the other(s), both clockwise or anti-clockwise, supplied brand new with test report, in tropicalised sealed cartons, value £8 each, our price 25/-, post 2/-; 2 for 50/-, post paid with wiring diagram. **TELEPHONE SETS**, consists of 2 combined receivers and microphones, connected by 20ft. twin flexible, provides perfect 2-way communication (up to 1 mile with extra flex), self-energised, no battery required, complete, ready for use, new, boxed, 12/6, post 1/-. **"K" TYPE CYLINDER LOCKS**, deadlocking and thiefproof, has 7 concentric tumblers instead of the usual 5 in line, interchangeable with ordinary cylinder locks for right- or left-hand doors, complete with 2 keys and all fittings, instruction booklet, list price 18/9, our price, new, boxed, 5/-, post 1/1; 2 for 10/-, post paid. **HIGH-LOW IMMERSION HEATERS**, 230/250 v. 2,000 watts, removable link for 3-heat control, plated copper stem 18 in. long from fixing screw, removable brass top termination cover with insulated cable bush, new, unused and guaranteed, 45/-, post paid. **U.S. DINGHY TRANSMITTERS**, complete self-contained hand powered, turning the handle by anyone (quite untrained) provides the power for the 2 v. transmitter and automatically sends out s. o. s. signals on the International Distress Band of 600 metres, sea range 2500/500 miles, complete with aerial usually suspended by kite or hydrogen balloon (not provided), all contained in a waterproof aluminium case, size 10 in. x 9 in. x 8 in., weight 17 lbs., operating instructions on side, new, unused, 45/-, carriage paid. **RATCHET SPANNERS**, 10 in. lever, reversible to screw or unscrew, 1 in. Whit. socket, superior make, value 25/-, our price, brand new, boxed, 4/8, post 1/-. Also hundreds of other interesting items. Send 3d. with s.a.e. for current lists.

**MIDLAND INSTRUMENT CO.,**

MOORPOOL CIRCLE, BIRMINGHAM, 17.

Tel. HAR. 1331



**Radio Active Electricity**

SIR,—Your reader's query in the May issue of PRACTICAL MECHANICS, concerning "Atomic Electricity," and the replies in the June issue, have prompted me to write.

Quite evidently the first letter with its "atomic strainer" is a grand piece of humour.

The second letter is more to the point, but what must be clearly understood is that an electric current is only a movement of electrons in a conductor, and only this.

Whatever methods may arise in the future for tapping direct from the "pile," e.g., by ionisation, electric current will always be the same. Fear of "atomic current" is hardly understandable; or perhaps I have yet to witness sulphuric acid pouring out of the negative terminal of an accumulator.—JOHN M. WOOD (Manchester, 13).

SIR,—After your publication of a letter expressing some apprehension regarding possible dangers in the home from "radio-active electricity," I confidently awaited letters from readers anxious to allay such fears.

However, of the two such letters which you have published in the June issue, one of them has completely missed the point (or the letter is a joke).

To avoid further confusion, I consider it to be worth emphasising that the electricity to be produced by the nuclear stations now in construction, is *not* a new electricity, but is, in fact, produced in conventional turbine-driven generators similar to the ones used in the modern large power stations.

The energy generated by the controlled fission process in the pile appears in the form of heat, is transferred from the pile coolant to a steam cycle and the steam used to rotate the generator shaft in the normal way.

The electricity itself is "born," not in the pile, but in the rotating rotor windings of the generator, and is as "old-fashioned" as any in production to-day.—J. L. PHILLIPS, B.Sc., A.R.I.C. (Cumberland).

SIR,—Regarding the various letters on "radio-active electricity," I am at a loss to understand the very technical sounding letter of Messrs. A. King and P. Hawkins (June issue). Electricity cannot possibly be radio-active, as radio-activity is the decay of the atom nucleus, whereas, as every school-boy knows, electricity is the movement of electrons.

In an atomic power station the pile is simply used in place of coal, etc., to provide heat for producing steam to power the turbines.—L. DOHERTY (Malta, G.C.).

**Calendar Clock Mechanism**

SIR,—Re Mr. Hartley's query in the June issue, "Horological Hints and Helps," by F. W. Britten, published by the "Technical Press, Ltd.," 5, Ave Maria Lane, Ludgate Hill, E.C.4, contains a chapter devoted to calendar work.

It gives a very good description of a perpetual calendar, with lettered diagram showing, of course, how the correction is made for Leap Year.—L. T. BERRY (Dovercourt).

# Letters to the Editor

**The Editor Does not Necessarily Agree with the Views of his Correspondents**

SIR,—The complete action for calendar work, including Leap Year correction, can be done with only three additional wheels or discs to a standard clock movement. The discs are moved by suitably located pegs and two of them are engraved—1 to 31, and Jan. to Dec. I cannot remember the precise arrangement, but it is clearly described in detail in "Clocks, Watches, and Bells," by, I think, that famous horologist Edmund Beckett (afterwards Lord Grimthorpe).

A perfect specimen of this action can be seen in the Point of Ayr Lighthouse, Isle of Man. This clock was made in Edinburgh about 100 years ago and I believe it is still in use and perfectly reliable.—S. ORME (Stockport).

**The P.M. Folding Outboard Motor Boat**

SIR,—Whilst on holiday last summer at Pentewan Sands, in Cornwall, I became very interested in a small boat, which, being an old P.M. reader, I recognised as the P.M. Folding Outboard Motor Boat, less outboard motor. I got into conversation with the owner and later was taken for a trip in it. He informed me that the boat had been partly constructed at home and completed on the beach; it was used by him for fishing. I found the boat light and responsive and, owing to its very shallow draught,



The P.M. Motor Boat photographed by Mr. R. W. T. Bradley.

it required the minimum amount of effort in rowing.—R. W. T. BRADLEY (Balham).

**The Railway of the Future**

SIR,—Mr. Zalewski seems to be a little late with this idea. Something very similar was proposed to provide a 100 m.p.h. service between Glasgow and Edinburgh, many years ago. A start was actually made on it, but it fell through for lack of capital. A small section of the actual line and coaches can be seen to this day at Milngavie, Glasgow. I think the only variation from Mr. Zalewski's proposition is that the Milngavie coaches are on wheels arranged at various angles to prevent derailment.—S. ORME (Stockport).

SIR,—Mr. Zalewski certainly has an idea worthy of intensive experiment in his railway system operating on sliding bearings.

Model engineers should note the possibilities, as the scale model is often the prototype nowadays.

I suggest electricity as the power source, with an "electro-magnetic rail" superseding the present "live rail." The vehicle would carry only the armature or rotor of the motor. The field coils would be distributed between the running rails and could be mounted on a third rail in the form of studs. Some switching method would have to be devised to replace the commutator, and give the necessary intermittent power to the stationary "field." Electrical engineers will no doubt spot many snags here, but perhaps the momentum of the vehicle could be used in some way. The driver would require only a brake and probably a clutch on the armature. The clutch would give all necessary speed control both for starting and stopping. Additional braking power could be obtained by utilising the magnetic-power of the field coils. Perhaps the rotor could even be driven by a small diesel-engine not in itself powerful enough to drive a normal wheeled vehicle.—RICHARD A. HEPPELL (Birmingham, 32).

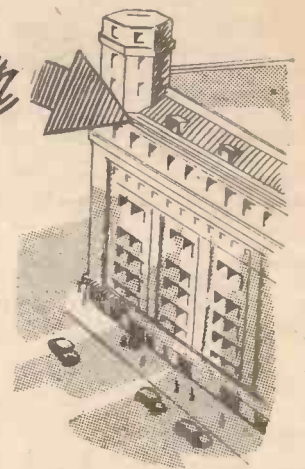

SIR,—Re "The Railway of the Future," I wonder how many people today remember the model of the "Magnetic Railway" that was demonstrated in London way back in 1912-13? I think the inventor was an American. Its speed was unbelievable; when the power was full on it simply vanished and appeared at the other end of the hall. Its acceleration was amazing.

The inventor (who demonstrated it) said there was practically no limit to its speed, 300 to 500 m.p.h. being well within its scope.

It was all done by magnetism. There were no motors at all. Down the centre of the track there were magnets that exerted a repulsive effect. This lifted the coach off the lines and the coach was suspended in the air. All along the track were arches through which the coach travelled. These arches were electro-magnets which attracted the coach. As soon as the coach has passed into the arch the current was switched off that arch to the next. There was a kind of guide rail which kept the coach from going off the track. The only resistance to the cigar-shaped coach was the air. I believe the magnetic lift (if one can call it that) was 28lb. per horsepower.

I think the inventor hoped the Post Office

would take it up and there was talk that a track of 18 miles was to be constructed.

In those days such a speed was unthinkable for passengers, and that, I fancy, was the reason it was not taken up. Incidentally, the deceleration was as unbelievable as all the rest. I remember a gentleman putting a bowler hat over the buffers at the end, and in spite of the tremendous speed the coach just gently touched the hat without any damage at all.—C. V. THOMPSON (W.14).

**Connector for Balloon Inflation**

**SIR**,—The article on inflating balloons in the May issue has prompted me to send you a drawing of an inflator which I have made and which has been entirely satisfactory in operation. Unlike the one in your article, it may be used in any position. As with yours, the pump used is fitted with double

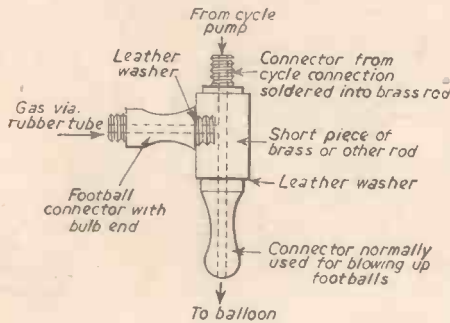

Mr. C. J. Locke's balloon inflator.

cup washers. The football connector is threaded to fit a hole tapped in the brass rod. The sketch will supply all further particulars. C. J. LOCKE (Plymouth).

**Stripping and Bleaching Mahogany**

**SIR**,—Regarding your reader's query and answer given for stripping and bleaching a mahogany fireplace surround in the June issue of PRACTICAL MECHANICS, I am inclined to think that your reader may make little progress.

Chloride of lime, being an alkaline base, will tend to darken the wood in quite a vigorous manner, and your recommended method of stripping down can be quite tedious.

Proprietary bleaches employing usually a first solution of alkaline base either dilute caustic potash or ammonia and second solution of high strength hydrogen peroxide are to be preferred, but even these must be applied on bare wood with no trace of stain or filler, etc., existing.

Though alkaline solutions are used in the first instance with proprietary bleaches, their marked tendency to darken hardwoods is a necessary evil in order to cause the reaction with the hydrogen peroxide, the stained matter being washed out after reaction has taken place.

Writing from experience, I should advise stripping off all polish with one of the ether or chloroform based proprietary strippers, a good going over with turps and wire-wool to remove traces of filler, stain, etc., finishing with methylated spirit and wire-wool to clean up the surface. Finally, at least two applications of proprietary bleach are required.

When bleaching old woodwork it has always been pointed out to me as a "must" that all traces of stain, polish, filler, etc., must be removed. Proprietary bleaches can be quite active, remembering that it is advisable to wear rubber gloves when undertaking this process.—J. N. WOOD (Manchester, 13).

**Encouraging Originality**

**SIR**,—With reference to Mr. Wace's recent letter (June, 1955) I do not think a limited company could run effectively, but I am sure that a society of inventors can fill a much needed position as liaison between the

inventor and industry. If such a society existed it could pass on unbiased opinion on its members' inventions, see that it was fully protected, iron out production and marketing difficulties and then present it to an appropriate manufacturing concern covered by a fair contract, between the inventor and the manufacturers.

With this assistance the inventor could gain a position relative to the other individual constructive professions (i.e., art and writing). Further, manufacturers would be made to realise that the inventor is not a necessary evil that torments him with his silly gadgets, but an important member of society on whose shoulders rests the future of industry. Admitted most large concerns run huge research establishments that attempt to keep the company abreast of the world, but a basic new line of thought usually comes from outside the company.

I have not considered very deeply the £ s. d. side of such a society, but I am sure that the fees could be kept moderate.—L. W. TEW-CRAGG (Enfield).

**A Car Ashtray**

**SIR**,—Some of your readers may be interested in the car ashtray which I have made and found most effective.

As shown on the sketch the ashtray is made of short lengths of light gauge copper tubing sweated together into a block 2in. high, with the four centre tubes 1/4in. shorter. The base is of thin copper sweated to the block. The

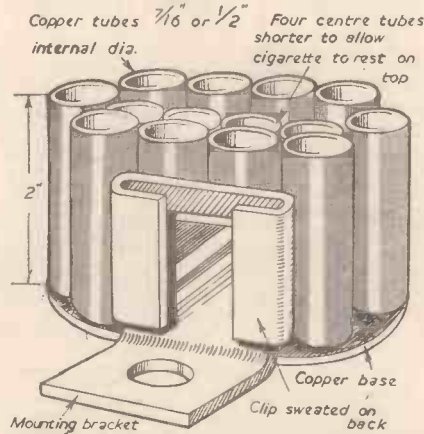

Mr. R. S. Wallace's car ashtray.

internal diameter of the tubes is 7/16in., but I think 1/4in. would do equally well. A mounting clip as shown is soldered on the back of the block and slips over a mounting bracket.

In use, cigarettes dropped lighted end down into any tube are extinguished almost instantly without having to be stubbed. To empty the ashtray it is necessary only to slip it off the clip, invert it and give it a shake.—R. S. WALLACE (Nottingham).

**Feathering Arrows**

**SIR**,—L. F. Moss, of New Zealand, wishes to know how to fix the feathers on to the arrows he is making ("Information Sought," June issue). I would suggest a jig consisting of a baseboard on which is mounted a pair of V blocks and a hinged arm with a spring clip screwed to the end, see sketch.

Also shown is an equilateral triangle, drilled centrally and having a light spring of brass to hold it on the arrow shaft. All parts can be made of odd scraps of wood.

To operate, turn back the hinged arm, grip the feather in the clip so that only a little over 1/16in. protrudes along its length. Now push the triangle over the arrow shaft to be feathered and lay the shaft in the V blocks with the "nick" against the stop of the left-hand V block. Turn the arrow until a point of the triangle rests against the baseboard.

Swing the hinged arm forward so that the feather rests against the shaft and makes contact all along its length. When this is satisfactory, swing the arm back again, apply balsa cement fairly liberally along the feather, and again swing the arm and feather forward on to the shaft, and leave it until the cement has dried, say, half an hour.

Then continue with the second, and then third feathers.

To trim the feathers, L. F. Moss may care to adapt an American gadget, though I hesitate to suggest it.

It is to fix an electric bowl fire element on a baseboard, pull out part of the heater

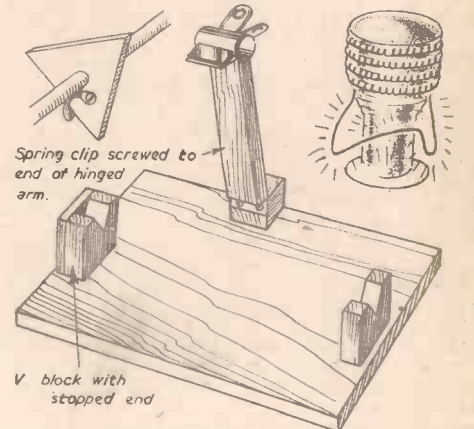

Jig and trimming device for feathering arrows.

wire and bend it to the shape of the trimmed feather. When the arrow is rotated in the V blocks the red-hot wire burns the feathers to shape. (see sketch). Personally, I should think this would be a most uncomfortable procedure, and none too safe at that. But having fixed and trimmed the feathers the V blocks can be used again, this time to apply the coloured bands of enamel on the shafts. Just hold the paint brush still and rotate the arrows. Finally, apply a coat of varnish.—J. R. DORRITT (New Zealand).

**A Synchronous Electric Clock Correction**

**SIR**,—I should like to point out an error in the caption of Fig. 5 on page 396 of the June issue of PRACTICAL MECHANICS. The title "Drive to hour hand," and the reference on the top wheel, "Hour hand wheel," should read "Drive to minute hand" and "Minute hand wheel," respectively; the hour hand, which being, of course, driven through the normal 12:1 reduction gear, as stated in the article.—C. C. LEIGHTON (Surrey).

**Compensated Pendulum—Correction**

**SIR**,—Re the letter in the July issue on the subject of the compensated pendulum bob, the material for the tube should be Invar, not brass as stated in my article. I regret the error and my thanks are due to Mr. Craig for pointing out same.—J. A. ROBERTS (W.2).

**Non-drying Adhesive**

**SIR**,—Re PRACTICAL MECHANICS, June, 1955, page 414, in answer to F. Fitton (Lancs), there is an adhesive on the market under the name "Copydex" suitable for his requirements.—T. V. ROE (Derby).

**THE MODEL AEROPLANE HANDBOOK**  
By F. J. CAMM  
312 Pages, 303 Illustrations, 12/6, by post 13/-  
Construction and Principles of All Types  
Published by  
**GEO. NEWNES LTD., TOWER HOUSE**  
SOUTHAMPTON STREET, STRAND  
LONDON, W.C.2







# Trade Notes

## New Lathe Accessories

**C**URRENTLY being introduced to the metalworking industry is a new Swiss-made lathe accessory designed to eliminate the driving plate and lathe dog. It makes it possible to machine the entire length of the workpiece without re-chucking, speeding up the operation considerably and eliminating possible inaccuracy due to the re-setting of the tool in the second operation. Accidents from whirling lathe dogs are also prevented.

The work is set up between the live tailstock centre and the "Rotor" automatic driving centre. The latter incorporates a spring-loaded centre and driving disc. By pressing the workpiece against the driving disc, the spring-loaded centre is automatically locked and operates as a fixed centre, assuring concentric running under high operating pressure. The self-aligning driving disc, with serrations on its face, adjusts itself automatically to the end of the workpiece, in case it has not been faced

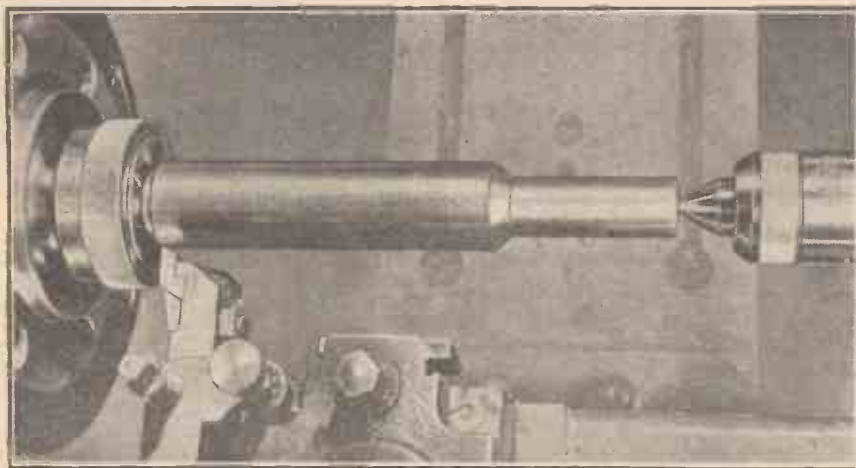

The "Rotor" automatic driving centre in use.

square. Variations in depth of centre holes are compensated for by the springloaded centre. Discs are furnished with each "Rotor" centre to handle a wide range of diameters. Standard shanks have Nos. 2-5 Morse taper.

Another product of the same company—Rotor Construction d'Appariels Scherler & Co., Zurich, Switzerland—is the "Rotor" rotating lathe centre, designed to run true within .0001in. The rotating centre is guided by its entire cone shaft and is provided with two adjustable roller bearings, the axial thrust being taken by a ball thrust bearing. The centre is sealed against entry of coolant and foreign matter.

The range includes heavy duty "Super" centres to deal with very high speeds and heavy loads and reinforced "Stabil" centres for extra heavy axial thrust.

Descriptive literature and more data are available from the distributors for Great Britain and the Commonwealth, Insley Industrial Supply Co., Ltd., 21/22, Poland Street, London, W.1.

## Model Ship Plans, Machinery and Fittings

**F**ROM Messrs. Bassett-Lowke, Ltd., we have received a copy of a new leaflet which should be of interest to all model ship makers. Listed therein are some 15 sets of plans of craft varying from cabin cruisers to whale-catchers, steam plant, electric motors and accumulators, propellers and shafts, and

all the multitudinous deck fittings etc., used in this hobby.

## Johnson Print-A-Snap Pack

**E**VERYONE starts practical photography at home by trying their hand at making contact prints, and here, in the most economical and convenient pack, are the materials required.

In a strong wallet, which can be used to hold the finished prints, is developer, fixer, a simple cardboard printing frame and a packet of the new Johnson Contact Paper. Full instructions are supplied.

Packs with either 24 sheets of paper  $2\frac{1}{2} \times 2\frac{1}{2}$ in. or 16 sheets  $2\frac{1}{2} \times 3\frac{1}{2}$ in. are available, each with the appropriate printing frame. The retail price is 3s.

For the beginner or for the man who occasionally wishes to make some extra prints, the Johnson Print-A-Snap Pack is a most economical proposition.

Both these screwdrivers are available in sizes 3in., 4in., 6in., 8in. and 10in. They are precision made for the engineer and of extremely robust construction, beautifully finished and well balanced.

## Cago Universal "Swivelsaw"

**T**HIS saw has two unique features. First, the blades are interchangeable for cutting metal or wood, and second, the handle is completely universal, permitting the blade to approach the work at any angle. This should make it very useful for those "awkward to reach" places so frequently encountered. The saw is of robust construction and will be useful to engineers, garages, metalworkers and woodworkers as well as to the handyman. The retail price is 15s. for the

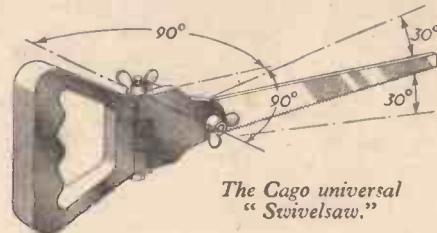

The Cago universal "Swivelsaw."

saw without the blades. These are 2s. 3d. each for the No. 1 tungsten steel metal-cutting blade and 2s. each for the No. 2 carbon steel wood-cutting blade. Details of the saw's versatility may be seen from the diagram. The saw will be available through retail ironmongers, but any enquiry should be addressed to the makers, Cago (Sales), Ltd., Vernon House, 510A, Coventry Road, Birmingham, 10.

## Easy-flo Paint

**F**ROM Johnson, Matthey and Co., Ltd., the precious metal specialists, comes news that their Easy-flo silver brazing alloy is now available in a new form. In certain brazing applications, the nature of the assembly is such that a paste preparation is more convenient than brazing material in one of the more familiar solid forms. Easy-flo paint, consisting of a mixture of finely divided Easy-flo metal powder and flux in a liquid medium, has been produced to meet such requirements. It will satisfactorily braze a wide range of materials and can be used with any of the various methods of heating in general use. Full details of Easy-flo paint are given in Data Sheet 2129, available free on request from Johnson, Matthey and Co., Ltd., 73-83, Hatton Garden, London, E.C.1.

Each ship or aircraft is manoeuvred by a speed and helm unit, the resulting movement being thrown on to a big screen at one end of the hall. The movement is shown by a spot of light projected from a position above a control desk.

To this desk flows all information as the "battle" develops. At any time the controller can stop this to point out mistakes or settle cases of doubt. The confidential book describing this installation is in English, French, Italian, Turkish and Greek.

## Vickers Valiant Trials

**A** VICKERS VALIANT four-engined jet bomber is to be sent to Australia for bomb ballistic trials at the Woomera range. The trials are of a routine nature.

## Atom Ship

**P**RESIDENT EISENHOWER asked Congress for \$12,650,000 (£4,518,000) to start construction of the world's first atomic-powered merchant ship.

## Highest TV Tower

**T**HE highest television tower in Europe has been built at Bolzano, 7,873ft. up in the Italian Alps.

## Stanley Screwdrivers

**F**ROM the very well-known firm of tool-makers, Stanley Works (G.B.), Ltd., Rutland Road, Sheffield, 3, we have received samples of their Nos. 25 and 45 screwdrivers.



## Electronic Tactical Teacher

**A**N electronic Action Speed Tactical Teacher enabling sea battles employing the latest ideas and weapons to be "fought" in the lecture room, is being completed at the Royal Naval Tactical School at Woolwich.

It allows competing teams to stage realistic synthetic exercises at action speed. One example is "fighting" a convoy to its destination against submarine, air and surface attack.

Opposing teams direct movements from separate sound-proof cubicles, which represent the operations rooms of ships and the cockpits of aircraft.

Up to 14 teams can take part in the exercise, each having its own cubicle. Five of these cubicles are fitted so that they can be either surface ships or submarines with torpedo firing gear.

# Your Queries Answered



## RULES

A stamped, addressed envelope, a sixpenny, crossed postal order, and the query coupon from the current issue, which appears on the inside of back cover, must be enclosed with every letter containing a query. Every query and drawing which is sent must bear the name and address of the reader. Send your queries to the Editor, PRACTICAL MECHANICS, Geo. Newnes, Ltd., Tower House, Southampton Street, Strand, London, W.C.2.

## Substance for Opalised Lamps

**C**OULD you please let me know the substance which is now used for "opalising" electric lamps? I wish to process the lower tips of photoflood lamps for enlarging purposes.—E. L. Payne (Bournemouth).

**O**PAL bulbs are often double-textured, the outside of the bulb consisting of a very thin layer of opal which is superimposed upon an inner bulb of clear glass. Other opal bulbs, however, are white sprayed with a colloidal solution of clay and sodium silicate on to the exterior surface. This coating is subsequently dried and fixed with ammonium chloride.

Possible suppliers of materials are:—Harrington Bros., Ltd., 4, Oliver's Yard, 53a, City Rd., Finsbury, London, E.C.1; Griffin and Tatlock, Ltd., Kemble St., Kingsway, London, W.C.2.

## Sealing Leaded Windows

**I** SHOULD be very pleased if you could suggest a method of sealing old leaded windows to prevent wind and rain creeping through. The leads are old and rather thin and would not stand any rough treatment.—E. C. Garrett (Northampton).

**S**INCE it appears unlikely, due to thin conditions, that you could beat these lead strips satisfactorily, it is probable that the application of thin putty squeezed in with a knife could be used. It will adhere satisfactorily to the lead and glass.

An alternative is to use black bostic sealing compound (used for adhering rubber to glass, metal, glass to metal, etc.). This latter method has the advantage of never getting "hard" like putty and, therefore, should never work or flake out. It is messy to use, but is soluble in petrol and, therefore, easily cleaned off. It is quite impervious to weather, hot, cold or wet.

## Continuous Spray Painting

**I** AM proposing to spray red oxide paint under pressure for considerable periods (four to eight hours daily) inside a building.

Could you please give me information as to possible effect on health. Also, the type of extraction plant I should need for safety?—T. H. Goodman (Kettering).

**W**HERE interior spray finishing is carried on continuously, a spray booth, equipped with an exhaust system, is necessary. Alternatively, the spray room must be exhausted by a fan or fans capable of giving at least 30 and preferably 60 air changes per hour. The former is advised, of sufficient capacity to accommodate the largest pieces normally handled, with about 20 per cent. clearance over its greatest dimension. If possible the booth should be located against an outside wall or beneath a low roof, so that a long fume-discharge duct is not necessary.

The exhaust fan, fitted at the back of the booth, should produce an inward velocity of 80-100ft. per min. over the open area of the booth. This discharge duct should be slightly larger in diameter than the fan, and as straight and short as possible; to reduce resistance to the flow of air to a minimum. Furthermore, it is necessary to fit weather cowls to the discharge stack; allowing sufficient space between the top of the stack and underside of the cowl to permit the exhaust air to escape freely.

## Windcharger Queries

**I** HAVE a small house remote from the electricity grid on Dartmoor, and wish to install some form of electric light

without too much expense. Could I have your opinion on the following points?

(1) I have a Chorehouse D.C./A.C. 250-watt generator which I propose to use to run a television set, Hoover and electric iron. The house has two large basement rooms with an old copper and chimney. Would it be best to have the exhaust outside or up the chimney? I want to make the unit as quiet as possible, and thought of making a felt-lined box!

(2) For general lighting on 12 volts I estimate three 6-amp., eight 3-amp. and four ½-amp. lights and an electric pump to keep the roof tank filled from the well. I take it that a 24-volt installation would economise in amps. Could I get a 24-volt windcharger which would keep a 200 amp. battery well charged? Also, as the

Readers are asked to note that we have discontinued our electrical query service. Replies that appear in these pages from time to time are old ones and are published as being of general interest. Will readers requiring information on other subjects please be as brief as possible with their enquiries.

house is about 1,000ft. above sea-level, there is always a breeze, but the charge would not be very constant.—S. A. Gorsend (Oxford).

**T**HE exhaust pipe from the engine should be outside the house, and we would strongly advise that the generating set also should be placed in an outhouse of some sort. If it were enclosed in a small enclosure adequate to reduce the noise to an appreciable degree, the set would probably overheat considerably. By using a 24-volt installation instead of, say, a 12-volt installation, smaller cables can be used for the same power loss in the cables.

We rather doubt whether a small commercial windcharger would be large enough to keep the 200 amp.-hour battery well charged if the battery is used to supply the loads mentioned. Quite a large wind-power plant would probably be required, depending on the available winds. You could use any type of accumulator, although alkaline batteries are best charged at a fairly high rate. It appears to us that a better proposition might be to install a petrol- or paraffin-engined plant to drive a dynamo of fairly high rating, which will operate at more than 24 volts. You might be able to obtain a suitable second-hand plant through the advertisement columns of a trade paper such as the *Electrical Times* or the *Electrical Review*.

## Dual Voltage Motor

**I** RECENTLY obtained an electric motor rated at 1.5 h.p. It is a synchronous, repulsion start, single phase, 1,460 r.p.m., with two sets of windings—connected either in parallel for 240 volts at 9 amps., or series for 480 volts at 4.5 amps.

I have no "starter" and have just switched on with the motor connected to a 15-amp. circuit. It starts, but there is a slight smell of burning carbon; should I use a starter? If so, could I buy an ex-Service variable resistance or could I make one?

I wish to use it to drive the biggest circular saw possible—to saw logs

(Continued on page 508)

## THE P.M. BLUE-PRINT SERVICE

12FT. ALL-WOOD CANOE. New Series. No. 1, 3s. 6d.\*

10-WATT MOTOR. New Series. No. 2, 3s. 6d.\*

COMPRESSED-AIR MODEL AERO ENGINE. New Series. No. 3, 5s.\*

AIR RESERVOIR FOR COMPRESSED-AIR AERO ENGINE. New Series. No. 3a, 1s.

"SPORTS" PEDAL CAR. New Series. No. 4, 5s.\*

F. J. CAMM'S FLASH STEAM PLANT. New Series. No. 5, 5s.\*

SYNCHRONOUS ELECTRIC CLOCK. New Series. No. 6, 5s.\*

ELECTRIC DOOR-CHIME. No. 7, 3s. 6d.\*

ASTRONOMICAL TELESCOPE. New Series. Refractor. Object glass 3in. diam. Magnification X80. No. 8 (2 sheets), 7s.\*

CANVAS CANOE. New Series. No. 9, 3s. 6d.\*

DIASCOPE. New Series. No. 10, 3s. 6d.\*

EPISCOPE. New Series. No. 11, 3s. 6d.\*

PANTOGRAPH. New Series. No. 12, 1s. 6d.\*

COMPRESSED-AIR PAINT SPRAYING PLANT. New Series. No. 13, 7s. 6d.\*

MASTER BATTERY CLOCK.\*

Blue-prints (2 sheets), 3s. 6d.

Art board dial for above clock, 1s.

OUTBOARD SPEEDBOAT.

10s. 6d. per set of three sheets.

LIGHTWEIGHT MODEL MONOPLANE.

Full-size blue-print, 3s. 6d.

P.M. TRAILER CARAVAN.

Complete set, 10s. 6d.\*

P.M. BATTERY SLAVE CLOCK, 2s.

"PRACTICAL TELEVISION" RECEIVER

(3 sheets), 10s. 6d.

P.M. CABIN HIGHWING MONOPLANE.

1s.\*

P.M. TAPE RECORDER

(2 sheets), 5s.

The above blue-prints are obtainable, post free, from Messrs. George Newnes, Ltd., Tower House, Southampton Street, Strand, W.C.2.

An \* denotes constructional details are available free with the blue-prints.

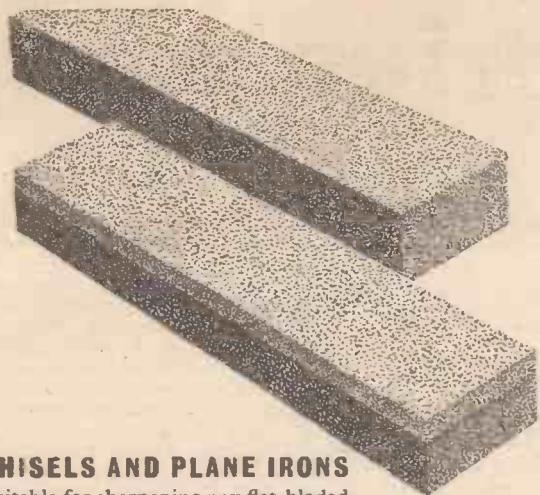

**1. FOR CHISELS AND PLANE IRONS**

Flat stones suitable for sharpening any flat-bladed tool, and for outside-bevelled gouges. In coarse or fine grits of silicon carbide or ALOXITE (aluminium oxide). Combination (coarse and fine) stones also available.

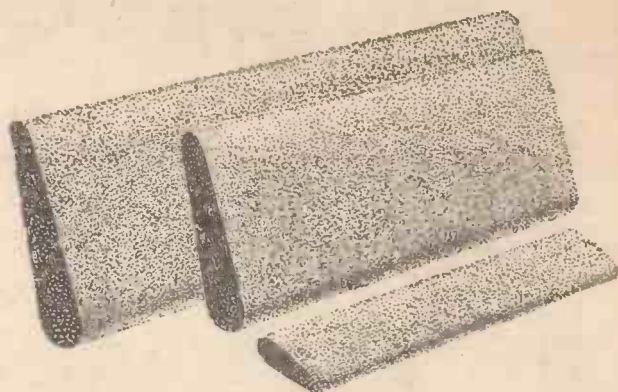

**2. FOR GOUGES WITH INSIDE BEVEL**

Slipstones of various sizes, in silicon carbide or ALOXITE (aluminium oxide), for all tools that need sharpening on an inside curve.

# Sharpening Stones by CARBORUNDUM

**3. FOR SHARPENING GIMLETS**

Bore a hole with gimlet in hard wood. Fill hole with silicon carbide grain by CARBORUNDUM (120 to 180 grit). Work gimlet in hole with a little oil. Then repeat in a second hole, without oil.

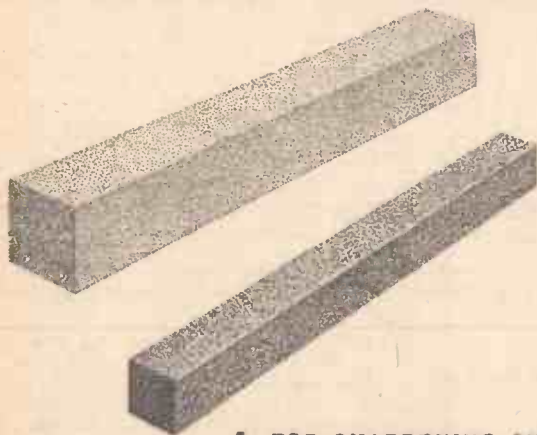

**4. FOR SHARPENING AUGER BITS**

Small stones like these are ideal for sharpening auger bits and other small tools. Auger bits should be sharpened so that the bevel is on the upper side of the cutting blades.

**5. FOR SMALL OR INACCESSIBLE SHARPENING JOBS**

CARBORUNDUM make a complete range of small sticks of different section and different grit sizes, for every kind of small sharpening job.



**SOLD BY TOOLSHOPS AND GOOD  
HARDWARE STORES EVERYWHERE  
THERE'S A PRODUCT BY  
CARBORUNDUM  
FOR EVERY SHARPENING JOB**



Write for pamphlet, 'The Art of Sharpening', to Dept. H, The Carborundum Company Limited. Responsible organizations may borrow an entertaining 16 mm. sound film, in colour, called 'Here's How', on the same subject, from the same address.

THE CARBORUNDUM COMPANY LIMITED, TRAFFORD PARK, MANCHESTER 17

principally—and also to drive a lathe. I should welcome suggestions.

I understand a three-phase motor is more powerful than a single phase; could I connect this motor for three phase?—W. S. Norway (Taunton).

IN a dual-voltage motor it is usual to connect the two sets of windings in series for use on the maximum voltage and in parallel for use on half that voltage. It is quite practicable to start up a motor of this size and type by switching it direct on line. As you may be aware, however, the starting current and torque will largely depend on the brush position which is apt to be rather critical. It is possible that the brush burning could be eliminated by polishing the commutator with carborundum cloth.

If you wish to reduce the starting current you could use a starting resistance which will also reduce the starting torque developed. For use on a 240-volt supply such a resistance could consist of approximately 10 ohms value, for which purpose about 20 yards of 16 s.w.g. nickel-chrome resistance wire would be suitable. The wire could be wound into a spiral and connected to the contact studs of a starter.

The motor could be used to drive a circular saw of 12 to 15 in. in diameter or a centre lathe up to about 7 in. centre height. Considerable alterations would be required to use the motor on three-phase and we would not advise you to convert the motor for such use.

#### Bandsaw Details

I AM endeavouring to build a small bandsaw suitable for boat-building requirements. I've not yet decided on the actual size, but I had in mind something with band pulleys not less than 15 in. diameter and not more than 18 in.

I should be pleased if you would tell me, for each of the above sizes, what the correct revs. per min. should be to give the right cutting speeds for oak and similar timbers? Also, what horsepower motor would be necessary to drive the saw? That is taking an average thickness of timber, say, 3 in., and perhaps an occasional thickness of 6 in.

Thirdly, what is the maximum distance between the centres of the band pulleys such a machine can be efficiently run, without too much whipping and twisting of the bands?—F. G. Marlow (Bucks).

THE whole question of the size of the machine and particularly the diameter of the wheels or band pulleys depends upon what bandsaws are available and what is the minimum diameter around which they are capable of bending and running. The joints in the saw are brazed and it is obvious that a joint will not stand up for long if it is subjected to bending around too small a diameter.

It is recommended that you go to a firm of saw makers or suppliers of woodworking machine tools, find out what saws are available and ask their advice regarding wheel diameter.

It must be borne in mind that the smaller the diameter the greater the limits which would be set to the size of the work which could be swung around on the saw table.

With regard to power, a motor of not less than three-quarter horsepower would be required and this for a comparatively light saw and not very heavy or fast cutting. Your saw suppliers will advise you as to best speed in feet per minute from which you can calculate the revolution speed of the band wheels.

#### Filling a Barometer Tube

I HAVE a 33 in. old type barometer which has no mercury in it. I have made a few attempts to put mercury into the tube, but cannot get rid of the

air bubbles. Can you tell me how to fill it and at the same time eliminate these air bubbles?—T. J. Quilter (Co. Kerry).

PROCURE a small glass funnel with stem narrow enough to enable you to stretch a rubber tube over the spout. This rubber tube should also be small enough to fit as loosely as possible into the barometer tube. Slope the tube slightly from the horizontal so that closed end "A" is lower than "B."

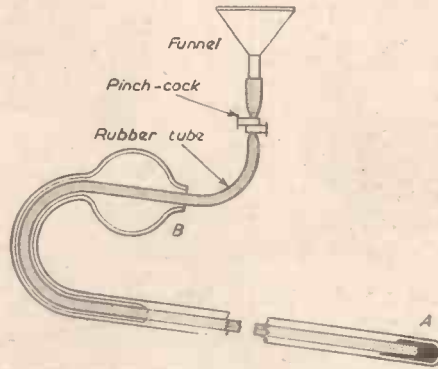

The apparatus and method used for filling barometer tube

Then pass the free end of the rubber tube into end "B" and force it gradually down to end "A." Attach a "pinch-cock" to rubber tube just below where it is attached to spout of funnel (see sketch). Pour mercury into funnel and then open the "pinch-cock" very gradually and allow only a trickle of mercury to run from funnel down the tube into bottom (sealed) end of mercury glass tube. Withdraw the rubber tube gradually as mercury runs in. If this manipulation is carried out carefully you will be able to fill your tube free of air bubbles. The glass tube should be warmed over a gas-stove to a temperature slightly higher than the room temperature. If the room is at 60 deg. F., then warm up to round about 100 deg. F., i.e., slightly above body temperature.

#### Anodizing Plant

I AM interested in making a small anodizing plant for various-sized plates of aluminium from 2 in. square up to 12 in. x 10 in. I would have to do the larger sizes perhaps 12 at a time and the small ones approximately 70 to 80 at a time.

Please tell me what equipment would I require, apart from the vats?

Could you also advise me as to the simplest acid to use: sulphuric, chromic or oxalic?

My trouble is I do quite a bit of work in aluminium plates and have been asked if I can complete the work by anodizing the plates; would it be an economic proposition to undertake the work from a 1d. per sq. in.? Could you recommend a reliable up-to-date handbook on the subject?—J. H. Simpson (Bournemouth).

FOR use with a sulphuric acid solution we would suggest that you use a D.C. current density of about 2 amps per square decimetre and a D.C. voltage up to about 15 volts. Thus, you would need about 200 amps output to carry out the work at the proposed rate.

It would be simpler to use a solution of pure oxalic acid (12oz. per gallon) because A.C. could then be used from a transformer and no rectifier would be required. The transformer could have a maximum output of 25 volts with tapplings for lower voltages down to about 12 volts. Furthermore you could probably carry out work at the proposed rate with approximately 100 amps. With this

method, in addition to the tank, you would require the tapped transformer, ammeter, busbars and connecting cables, with a fumes fan.

The work should be polished prior to anodizing however, degreased with carbon tetrachloride, washed in soapy water and rinsed before anodizing; after anodizing the work should be boiled in clean water, rinsed and dried. Consequently, a number of receptacles will be required together with a good deal of floor space. It may be necessary to agitate the solution by means of compressed air from a small rotary motor-driven pump, whilst a pump may be required for filtering the solution. We regret that we are unable to advise you of an economic price for the work; this will obviously depend to a large degree on the amount of work to be done.

Useful small books are: "Electro-plating and Anodizing," by E. Molloy (George Newnes, Ltd.); "Electro-plating," by C. Warburton (Percival Marshall and Co., Ltd.).

## Information Sought

Readers are invited to supply the required information to answer the following queries:

Mr. R. J. Finn (Kent) enquires: "Can you supply details for the construction of a colour temperature meter for use in colour photography?"

"Handiman" (Glasgow) asks: "Is it possible to use a ¼ in. Wolf Cub electric drill (running light 2,400 r.p.m., full load 1,330 r.p.m., 210 watts) for use in beating eggs and cake mixtures? I do not know suitable revs. and power for these purposes. I had thought of connecting a Kenwood whisk to the drill through some gearing if necessary."

From P. Garland comes the following: "Could you inform me how a form of electricity known as 'The Electric Breeze' is generated? I have been informed that it is made by high-frequency current, but that tells me nothing of the constructive details nor the electrical arrangements."

From Mr. M. A. Lewis (Essex) we have received the following: "I have made two 'One-string Fiddles,' as described in your December issue of 1953.

"I am wondering if you can advise on how to make the bows to go with them."

Mr. S. M. Algar (Catford) writes: "Can you supply a design for a four-wheel trolley suitable for boys of eight to 12 years? Having acquired a heavy-duty set of pram wheels and axles, I wish to make a sturdy, lasting trolley with a simple steering gear and hand or foot brake. The type I have in mind is that which appears each year in the Soap Box Derby. I have facilities for woodwork, metalwork, gas and electric welding."

W. H. Vernon asks: "Could you supply me with details of the construction of a permanent type of water softener, one with a capacity of about 500 gallons before regeneration?"

Mr. C. H. Ellis writes: "I wish to sound-proof a small box-room. I pick up cars, whistling kettles and the usual domestic harmony on my tape recorder and wish to eliminate this."

BE PREPARED FOR I.T.A.

COMMERCIAL T.V. STARTS VERY SOON

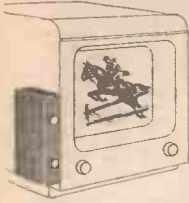

I.T.A.—Fixes to the side or back of your T.V. and will give you the new commercial station by the flick of a switch. You do nothing to your set, simply plug in mains and aerial leads. Suitable for any T.V.—full instructions given. Price £6/10/- or 30/- deposit and six payments of £1. Order to-day to ensure being in time for the opening of the new station.

BUILD YOUR OWN CONVERTER

The Elpreq Band III Converter has given very satisfactory results from the experimental Beulah Hill station. It uses 3 valves, is not at all difficult to make and can be lined up with a simple 25/- signal generator (instruction details 2/6d.). Price for all the components, including constructional data is £3/10/-—data available separately price 2/6.

GREAT SUMMER SALE

UNBREAKABLE GLASS PANELS

1/- Post 1/-

Size 10 1/2 x 9 1/2 in.—parcel of five panels 5/- Post Free.



FISHING ROD FROM DINGHY MAST

Tubular aluminium, not separate sections, extends like telescope from 15 ins. to 9 ft. 3/6 each.

BAKELITE CABINET

10/-

Carr. 3/6 Two tone with built-in handle. Note.—All have slight imperfections but these are hardly noticeable and will not affect the soundness of the set.



CONSTRUCTOR'S PARCEL

12/6

Post 1/-

Five valve superhet chassis—size 15 x 5 x 2 in. with three waveband glass scale, pulley, driving head, etc.

Also TABLE CABINET

Veneered and polished—takes the above chassis. 39/6. Post 2/6.

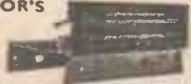

ALTIMETER

(Imperfect).

3/6

Post 1/-

These contain aneroid barometer movement.

CONSTRUCTOR'S PARCEL

14/6

Post 2/6

Bakelite cabinet, complete with dial, metal chassis and back, and plans of T.R.F.



THREE-SPEED GRAM MOTOR

230-240 A.C. mains operated, complete with turntable—plays 33, 45 and 78 r.p.m. records.



59/6

Post 3/6

INSTRUMENT CASE

2/6

Post 9d.

Veneered and polished—undrilled.



CARBON RESISTORS

50 assorted 1/2 and 1 watt resistors. Ranging between 10 ohms and 10 meg. ohms. (Our Selection.) Price 5/- pkt. 50 at 1 watt. 7/6.



12" TELE-CABINET

17/6

Carr. 3/6.

Veneered and Polished—Perfect. New and unused.



ELECTRONIC PRECISION EQUIPMENT, LTD.

Post orders should be addressed to Dept. 1, 123 Terminus Road, Eastbourne.

Personal shoppers, however, can call at:

- 42-46, Windmill Hill, 152-3, Fleet Street, 29, Stroud Green Road, 249, High Rd., Kilburn. Ruislip, Middx. E.C.4. Finsbury Park, N.4. Phone: MAIDA VALE 4921

NEW- for you!

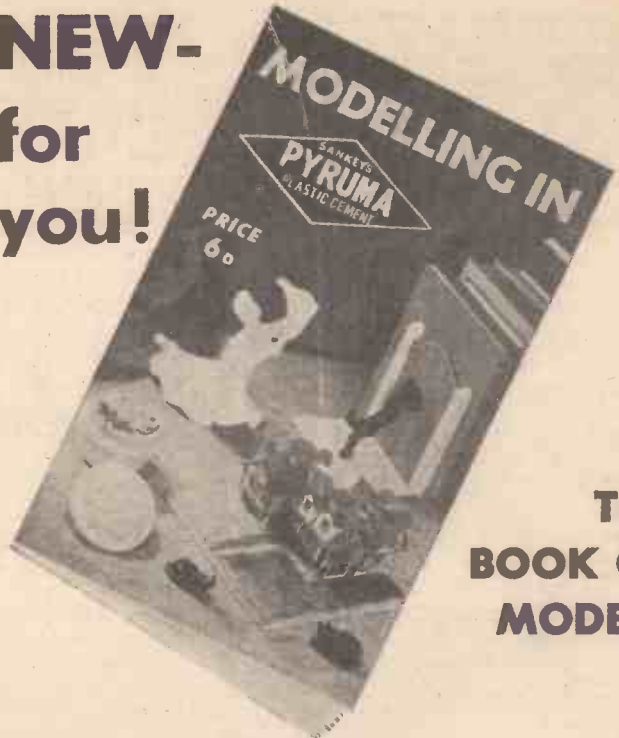

This BOOK OF MODELS

MODELS of every kind from one plastic ready-to-use material—PYRUMA! This book with new methods—new ideas—shows you how to acquire simple skill in making many types of permanent models listed below. And pages in full colour show how your models of animals, buildings, figures, etc., can be painted in natural tints.

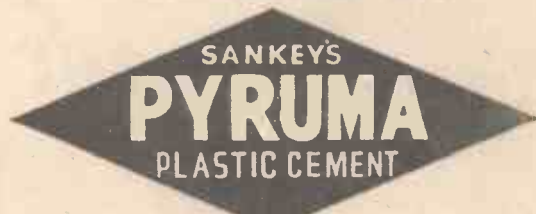

Pyruma is supplied, plastic and ready for immediate use, in air-tight tins, obtainable from your local Ironmonger, Hobbies shop or Art material dealer, from 1s. 6d. upwards. Finished Pyruma Models can be baked or air dried to stone hardness ready for colouring after simple treatment. Send 6d. in stamps with the coupon below for the book which shows how to make

MODEL RAILWAY STATIONS, SIGNAL CABINS, FARM COTTAGES, SHIPS, FIGURES, ANIMALS, ASH-TRAYS, BOOK-ENDS, MODEL FURNITURE, PLAQUES, RELIEF MAPS, ETC.

COUPON

TO: J.H. SANKEY & SON, LTD. DEPT. P.M., ILFORD, ESSEX. Est. 1857.

Enclosed 6d. in stamps for PYRUMA MODELLING INSTRUCTION BOOK addressed to:

NAME (Block Letters) .....

ADDRESS .....

INTER-COM OUTFIT 8/6

2-way communication of speech and music over long distances—sound powered—no valves, no batteries. Contains two ex-Air Force transmitter-receiver units, 100ft. wire and how to connect and make cases for walkie-talkie telephone, microphone, extn. loudspeaker, baby alarm, etc.

VIBRO ELECTRIC Metal Engraving Pen

Operates from 4 or 8 volt accumulator or A.C. Transformer. Engraves Brass, Copper, Silver, Nickel, Aluminium, etc.

10/-



SALE BLO-LITE 2/6 post 6d.

Super-heat flame, PERFECT for Light Brazing, Soldering, Tinning, Sweating etc. Fits into ordinary Gas Tubing. Full instructions.

5-BLADE SAW KIT

A compact unit of saws. One for every job. SPRING STEEL Tempered and Hardened. Wood Saw, Pruning Saw, Tenon Saw, Key Hole, Metal Saw.

9/- BARGAIN. Post 1/-.

5/- deposit, 8 mthly. 5/-

A.C./D.C. PAINT STRIPPER

(no paraffin). Old paint goes like magic. Cost 1d. per hour. One year guarantee.

4/-

Deposit and 8 mthly. New self-contained Model—Electric Paint SPRAYER. Free Jet for ceiling, Jar, Flex, Plug and Filter. Guar.

Cash 75/-



John Bull (P.M.B) 246 HIGH ST., HARLESDEN, N.W.10







VOL. XXIII

AUGUST, 1955

No. 399

All letters should be addressed to the Editor, "THE CYCLIST," George Newnes, Ltd., Tower House, Southampton Street, Strand, London, W.C.2

Phone: Temple Bar 4363  
Telegrams: Newnes, Rand, London

WHAT I THINK

By F. J. C.

# The American Bicycle Industry

ONE of the best customers for British bicycles is the United States of America. The manufacturers there are very concerned about British competition and they are endeavouring to obtain protection by means of an absolute quota or by an increase in the tariff against all imported bicycles. The Bicycle Tariff Commission have recommended to President Eisenhower that such tariff should be granted, but he is by no means satisfied that this is desirable, and he has called for further evidence, before he reaches a decision.

The American Bicycle Manufacturers' Fourth Report in support of the tariff is careless with the truth and makes some surprising and quite untenable claims. The report emphasises rising U.S.A. imports, but omits to state that total sales have risen also, and the American manufacturers' own production figures during the first quarter this year are substantially up on the equivalent period last year.

The reason why American bicycles do not sell to the same extent as the British bicycle is that manufacturers have continued to produce balloon tyre bicycles without acknowledging the change in the character of demand. That is to say, the preference of the Americans for the lightweight English-type bicycle. If they had produced a real competitor to the British bicycle, they would have had no cause to complain. The report says that imports have not added anything new to their markets except low prices, and that all types and models have always been produced in the U.S.A. As the British manufacturers state, this claim is strangely at variance with the generally accepted facts—clearly recognised by the President. The English lightweight bicycle itself was something new to the American market, and has created tremendous interest and a great new demand. Quite apart from style and type, however, British manufacturers have introduced to the U.S. many design factors never offered by the American industry; perhaps the outstanding example is the multispeed gear, invented and pioneered in this country.

In a letter sent by the British Cycle and Motor Cycle Manufacturers to 7,000 U.S. cycle dealers, the following comments are made: "Did you know that American bicycle makers complained of injury as long ago as 1938, when imports were only two per cent. of the market? Did you also know that in 1946 they appealed for an increased tariff, without which they faced (they said) 'inevitable ruin'? No such increase was granted, of course, yet in the following year (1947) the Industry achieved its all-time record year; Did you appreciate, too, when they appealed to the Commission once again last year (1954) prophesying their impending doom, that they had just completed one of the most successful years in their history (1953)?"

"You must know the answer to this much better than we, but at the public hearing the American manufacturers continually argued

that there is no fundamental difference between bikes; 'a bike is a bike' they kept repeating and all that concerns the consumer is price. Do you believe this? Listen to President Eisenhower writing to the Tariff Commission's chairman: "... in the face of this growing American demand for lightweight bicycles, further facts should be developed as to why domestic manufacturers have continued to produce predominantly balloon tyre bicycles, as to the steps they are taking to adjust their operations to this change in the character of demand."

### Cycle Tracks

ACCORDING to the monthly Bulletin of the British Road Federation there is much confused thinking on the subject of cycle tracks.

They are a subject on which no definite principle has been evolved and it is high time that a real constructive investigation should take place, as a result of which large scale experiments could be carried out.

The objections, so far as the present situation is concerned, are real and must be taken into consideration.

These objections are mainly as follows:

- (i) Cycle tracks break off at all road junctions, which are major accident points.
- (ii) The rider is impeded by crossing pedestrians, prams and tradesmen delivering goods.
- (iii) The right hand turn becomes more difficult and dangerous.
- (iv) Strong objection is taken by cyclists to any compulsion as to their use.

There are two positions where the construction of cycle tracks should prove beneficial:

- (i) Fronting, or preferably backing, lines of factories.
- (ii) Alongside heavily trafficked roads where speed is allowed.

It may well be that the best position is at a part of the carriageway with notices at intervals "Motorists, keep off cycle track," or separated by post and rail fencing. The surface could be coloured and a broken white line between the carriageway and the cycle track is probably required. This should at least stop cyclists from dodging in and out of traffic.

### Speed Limits

IN the third Rees Jeffrys triennial lecture given by Major R. A. B. Smith, it was stated that in 1830 the London-Birmingham run was accomplished by coach at an average speed of over 14 miles an hour. Coaching was, however, killed by railways and by 1850 it was dead except for the purpose of carrying mails: the railways at that time averaged 30 miles an hour. Steam appeared on the roads, but was so successful that the railway and canal interests forced a Bill through Parliament in 1861 limiting the speed to 10 miles an hour, and later in 1864 the Man and Red Flag Act was passed limiting the speed to four miles an hour. This act was not repealed until 1896.

It would appear that we are adopting much the same methods today. The railways are to be vastly improved, the tracks are to be modernised to fit the traffic, goods trains are to travel at from 30 to even 60 miles an hour. Whereas on the roads we are to be controlled by 30 mile speed limits, the roads are to remain for the most part as they were when vehicles could hardly move faster than 10 miles an hour. Dangerous road junctions and bends are to remain such for many years except for the gesture on the part of the Chancellor of the Exchequer which will allow a modicum of improvement over the next five years—or will it become ten?

Quite apart from the increase in the Highways Rate, motor taxation totalled £212,000,000 at the time of the 1951 election. In 1954/5 motor taxation brought in almost double that sum, £405,000,000. In 1951 £80½ million were spent on the roads, and in 1954/5 only £90 million. These figures demonstrate that the money has been obtained for making new roads, but by the usual trick of political fraud and chicanery it has been used for the relief of general taxation. The roads daily become more congested and the Government's solution is to arm the police with power to prosecute road-users for offences they cannot help committing. There are only 8,250 miles of trunk roads in Great Britain out of a total mileage of 186,000, and on these roads more than 200,000 people are killed or injured every year, largely due to the inadequacy of the roads.



Hardraw Force  
Yorks.  
The famous falls of the Foss  
Beck is lovely Westleydale.



# A Cycle Rucksack Frame

A Simply-made Frame for Carrying an Ordinary Frame Rucksack on the Back of a Cycle By D. GREEN

**T**HIS simply made gadget fulfils the need of those hikers who may at some time wish to do a little cycle camping without going to the extra expense of buying pannier bags and frame. It makes possible the use of the hiker's frame rucksack for both cycle camping and hiking. The prototype cost three shillings to produce, but three subsequent models, made up with offcut metal and parts salvaged from the local rubbish tip, cost 6d. each—the cost of the retaining washers! The original model has travelled some 300 miles, supporting a full camping kit, including food, and has proved itself to be better than panniers in the following of its features:

- (a) Low cost of construction.
- (b) Greater load carrying capacity.
- (c) Ease of storage. (The frame packs flat.)
- (d) Even with the rucksack in position the rear light remains clearly visible from behind.

**Disadvantages**

- (a) All the weight is not within the wheel-base—though this defect may easily be countered if the rucksack is packed with bulky but light objects at the bottom.

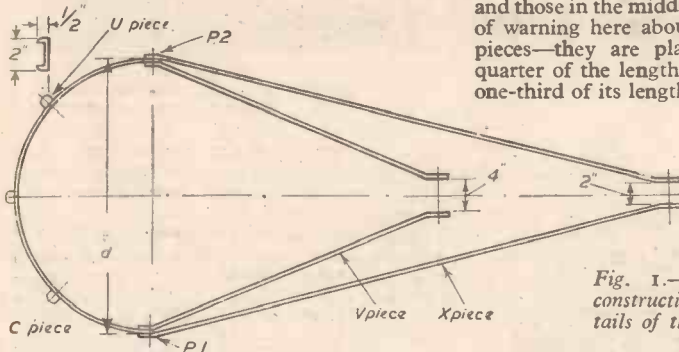

Fig. 1.—General constructional details of the frame.

- (b) Owing to the width of the average rucksack (16in.) the frame cannot be made as slim as panniers, and therefore some of the weight is not carried as near to the central gravity line of the cycle as is to be desired.

For the construction  $\frac{3}{16}$ in. by  $\frac{1}{4}$ in. mild steel bar is used; about 9ft. is required in the case of the ex-commando rucksack, and a little less for most Bergans.

Size of rucksack Distance 'D' of Fig.1	C	X	V	Offset on V	Offset on X
12in.	21in.	24in.	14in.	4in.	5in.
14in.	26in.	25in.	12in.	5in.	6in.
15in.	27 $\frac{1}{2}$ in.	26in.	12in.	5 $\frac{1}{2}$ in.	6 $\frac{1}{2}$ in.
16in.	29in.	26in.	12in.	6in.	7in.
17in.	31in.	28in.	12in.	6 $\frac{1}{2}$ in.	7 $\frac{1}{2}$ in.
18in.	32in.	28in.	12in.	7in.	8in.
20in.	35in.	30in.	10in.	8in.	9in.

**Cutting**

This strip should be cut up into: One length C (Fig. 1), which is determined by measuring the frame size (distance across the body harness), and referring to the table below; two lengths X refer again to the tables; two lengths V, the lengths of which may be determined as before; three  $\frac{1}{4}$ in. lengths for the U pieces which hold the body harness in position.

The corners and rough-sawn edges should now be rounded off on a grindstone or with a file.

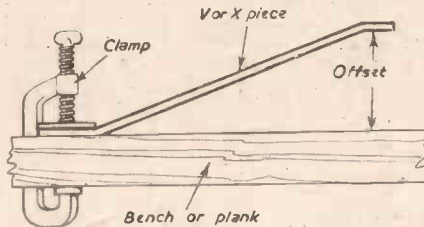

Fig. 2.—Measuring the offset.

**Drilling**

The drills needed are: A  $\frac{13}{32}$ in. or  $\frac{7}{16}$ in. for the holes in the two V pieces which are to fit over the back axle of the cycle; a  $\frac{5}{16}$ in. drill for the holes in the two X pieces which are to fit on the saddle lug; a  $\frac{1}{4}$ in. drill for the holes at the other ends of the X and V pieces, those at the ends and those around the circumference of the C piece and those in the middle of the U pieces. A note of warning here about the position of the U pieces—they are placed at intervals of a quarter of the length of the C piece, and not one-third of its length.

All the holes should be drilled  $\frac{1}{16}$ in. from the ends of the components, and allowance has been made for this in the tables.

**Bending**

First take the C piece and bend it into an even half-circle, taking care that it does not kink where the holes have been drilled. The bending may be done fairly easily by hand, but if any difficulty is experienced it may be bent round a tree or other suitable object; it should not, however, be bent in a vice, as the metal then bends in small "kinks" and these give the finished rucksack frame an ungainly appearance.

Using a vice, bend the ends of the two V pieces with the  $\frac{1}{4}$ in. holes slightly inwards  $\frac{1}{16}$ in. from the end of the component. Now see table for the offset to which each V piece must be bent. They should be bent in the opposite direction to the first bend,  $\frac{1}{16}$ in. from the end with the  $\frac{3}{16}$ in. holes. To test the offset, clamp the component to the bench as shown in Fig. 2 and measure the distance from the

bench to the slight bend (which should now run parallel to the bench). A similar procedure is now adopted to bend the two X pieces. First the end with the  $\frac{1}{4}$ in. holes must be bent very slightly inwards  $\frac{1}{16}$ in. from the end of the component. Next see tables for the offset and bend the components to this measurement. Test the offset as before.

Only the U pieces now remain to be bent. First mark the metal fairly deeply with a hacksaw (so that it bends more easily)  $\frac{1}{16}$ in. from each end. Then bend it in a vice, taking care that it does not "kink" at the holes.

**Painting**

All the parts must now be thoroughly cleaned with emery cloth and given two thin coats of paint of the same colour as the cycle to which the frame is to be fixed. Hang the parts (by means of a cord through the holes) in a dust free place to dry.

**Assembly**

Two  $\frac{3}{16}$ in. by  $\frac{3}{16}$ in. Whit. bolts, three  $\frac{1}{4}$ in. by  $\frac{3}{16}$ in. countersunk bolts, and one 2in. by  $\frac{1}{2}$ in. B.S.F. bolt (all made of steel) and complete with nuts are required. Four  $\frac{1}{4}$ in. retaining washers similar to the type sold under the trade name "Keeptite" will also be required. The combined cost of nuts, bolts and washers is about 1s. 3d.

The frame can now be assembled. First lay all the components in positions as in Fig. 1. Place the two  $\frac{1}{2}$ in. x  $\frac{3}{16}$ in. Whit. bolts (P1 and P2 in Fig. 1) complete with retaining washers (one at each end of the bolt) in position and screw the nuts on lightly. Next place the U pieces in position and screw them into place at 90 degrees to the C piece, as in Fig. 1.

All that now remains to be done is to bolt the frame on to the cycle by means of the 2in. by  $\frac{1}{2}$ in. bolt and the wheel nuts, tighten up the nuts on P1 and P2, and to fasten on the loaded rucksack. After fairly extensive trials it was found that the best method of fastening the rucksack to the frame is by means of webbing



The frame completed and fitted to a cycle.

straps (spares from the rucksack), and a strong piece of cord or strap through the eye provided for hanging the rucksack.

**EVERY CYCLIST'S POCKET BOOK**  
3rd EDITION by F. J. Camm

**NEW**  
**OUR 1955 SUPA-HANDBOOK**  
**"THE HOME CONSTRUCTOR"**  
**20**  
**CIRCUITS**  
**76**  
**PAGES**  
**FOR 2/6 ONLY**  
 incorporating these star attractions

- \***20 CIRCUITS.**—Superhets. P.R.F. Sets, Amplifiers, Feeder Units, Test Equipment, etc.
- \***SUPERHETS.**—Full constructional details, supra-simplified layout and point-to-point wiring diagrams for building superhets.
- \***COIL PACK.**—Full constructional details for building a superhet coil pack.
- \***CAR RADIO.**—Full constructional details.
- \***BATTERY CHARGER.** complete details for building a **CHEAP CHARGER.**
- \***RADIO GEN.**—Pages of information. Resistance Colour Code, Formulae, and "know-how".
- \***RADIO CONTROL.**—General information and list.
- \***RADIOGRAM.**—Constructors' list.
- \***CATALOGUE.**—Profusely illustrated catalogue and price list of components, receivers, books, Wolf Cub, Black and Decker, Xacto, Tools, etc.

**YOU CAN'T GET BETTER VALUE! IT'S TOPS!**

\*"The most helpful book in the Trade."

**SEND 2/6 FOR YOUR COPY TODAY!**

And, of course, our variable iron-dust cored **COILS** offer outstanding value at 3/- ea. 10-30, 16-50, 30-75, 75-200, 190-550, 800-2,000 metres. Aerial, H.F. or Osc.

**SUPACOILS (Dept. M.8)**  
 21, Markhouse Road, London, E.17  
 Phone KEYstone 6896.

BUY DIRECT FROM ACTUAL MANUFACTURERS  
 AT  
**HALF PRICE** EMULSION **PLASTIMUL** PAINT

"PLASTIMUL" EMULSION PAINT is easy to use—absolutely odourless and dries quickly

**FREE Offer!!!**

**2 FOR 1**

To introduce the world's latest and finest Plastic Paint to you, we will for a short period present—

**ABSOLUTELY FREE—ONE tin with EVERY tin ordered.**

For instance :—If you order one pint you get two pints—if you order two pints you get four pints and if you ordered fifty gallons you would receive one hundred gallons. All carriage paid home !!!

**YOU WILL RECEIVE DOUBLE THE QUANTITY THAT YOU PAY FOR**

There is going to be a lot of painting done this year. **NOW** is your chance—Stock up while the going's good—This offer cannot remain open indefinitely.



Write off at once now for your **FREE PRIVILEGE ORDER FORM**, beautiful brochure and colour chart

Write to Desk P.M.P. 7 :

Plastics Division  
**THE LAYMATT FLOORING COMPANY**  
 36-40, Seabourne Road,  
 Bournemouth, Hants



**THIS MONTH'S OFFER**

**DYNAMOS.**—D.C. shunt wound, 14/32 volt 9 amp., speed 2,500 r.p.m., 95/-, crg. 5/-, 12 volts 29 amps., shunt 3,000 r.p.m., 75/-, crg. 3/6. 12 volts 50 amps., shunt 750/950 r.p.m., £20. 12 volts 50 amps., shunt 3,000 r.p.m., 27/10/-, 50/68 volts 10 amps., shunt 1,000 r.p.m., £12/10/-, crg. 10/-.

**MOTORS.**—A.C. Brand New, 230 volts, 50 cycle S.P. Capacitor start, ball-bearings, drip proof, speed 1,440 r.p.m., 1/2 h.p., £7/5/-, or 1/2 h.p., £6/17/6, crg. extra. 1/2 h.p. 230 volt A.C. Motors, Brand New, 1,440 r.p.m., 95/-, crg. extra. 4 h.p. 230 volt 50 cy. S.P. B.K.B. Motor, 1,440 r.p.m. New, surplus, £25, crg. extra. **BATTERY CHARGERS.**—Lesdix NITN-DAY Battery Charger, double wound transformer, metal rectifier and ballast resistance in vent. metal case, fitted ammeter, 230 volts 50 cycles input, 12 volts 4 amps., D.C. output, 85/-, 6 volts 2 amps. D.C. output, 70/-, crg. 3/6 extra.

**TUNGAR BATTERY CHARGER** for small garage charging. Brand new, complete with Tungar valve. 110 volts A.C. 50 cy. input, 75 volts 6 amps. D.C. output, £16/10/-, 230 volts A.C. input, 75 volts 6 amps. D.C. output, £18/10/-. In vent. metal case with meter and control switch, will charge 1-12 six-volt batteries at one time.

**THE LESDIX CRYSTAL SET.**—In neat black or brown bakelite case, the coil is litz wound tapped for long or short aerial, var. condenser, crystal diode needing no adjustment, sockets for aerial, earth and headphones. All aerial tested and supplied complete with double headphones fitted headband and cord, 30/-, post 2/6.

**G.P.O. MAGNETIC COUNTERS** to 9999, surplus stock, in good condition, 5/-, post 1/6.

**TELEPHONE CONSTRUCTORS PARTS.**—G.P.O. wall type telephones, in polished wood cases, 8in. x 6in. x 3in., fitted microphone, magneto bell, switch-hook and contacts, transformer, condenser and connection strip. Hand magneto generator and G.P.O. receiver also supplied with wiring diagram, 50/- pair, crg. 5/-.

**ELECTRADIX RADIOS**

Dept. H.  
 214, Queenstown Road, London, S.W.8  
 Telephone : MACaulay 21159

**FLYING SAUCER REVIEW**

—for sane reports and investigations of the greatest enigma of our times

Published 6 times a year

Subscription £1 1s. 0d., which includes the use of a research service

Write to:

**Flying Saucer Review,**  
 1, Doughty Street,  
 London W.C.1

**RECOMMENDED TOOLS on THE BEST TERMS . . .**

	Cash Price	Deposit	Monthly payments		
			12 mths.	18 mths.	24 mths.
MYFORD M.L.7 BENCH LATHE ...	£51.17.6	£7.17.6	79/7	55/3	42/11
MYFORD SUPER 7 BENCH LATHE ...	£78.10.0	£13. 2.3	118/3	82/1	63/9
FOBCO STAR 0-1/2" BENCH DRILL WITH JACOBS CHUCK ...	£37. 4.3	£6. 4.3	56/8	38/11	30/2
FOBCO STAR PEDESTAL DRILL WITH JACOBS CHUCK ...	£42. 7.1	£7. 2.1	63/9	44/3	34/5
MYFORD P.R.11 PLANER WITH ROLLER EXT. ARMS ...	£22.10.0	£4.10.0	33/-	—	—
MYFORD M.L.8 WOODWORKING LATHE WITH R/T ATTACHMENT ...	£25. 0.0	£5. 0.0	36/8	—	—
SELECTA 6" BENCH GRINDER ...	£17. 5.0	£3. 5.0	25/8	—	—
WOLF CUB 1/2" DRILL ...	£5.19.6	29/6	8/3	—	—
WOLF CUB OUTFIT sets 1-7 ...	£16.17.6	84/6	23/2	—	—
BLACK & DECKER 1/2" DRILL ...	£5.19.6	29/6	8/3	—	—
BLACK & DECKER 5" SANDER POLISHER ...	£8. 7.6	40/-	11/8	—	—
BRIDGES 1/2" TOOL POWER DRILL ...	£7.10.0	35/-	10/6	—	—
BRIDGES COMPLETE HOME WORKSHOP ...	£23.12.0	72/-	36/8	—	—

Illustrated literature gladly sent. All goods despatched fully insured against loss or damage in transit. A 1/- stamp will bring you a copy of our comprehensive illustrated catalogue of blueprints, castings and materials for many "L.B.S.C." designed small steam loco's, workshop equipment, etc.

**A. J. REEVES & CO.**

416, MOSELEY ROAD, BIRMINGHAM, 12  
 Grams: "Reevesco, Birmingham." Phone: CALthorpe 2554.

"THE CHOICE OF EXPERIENCE"

# Black & Decker

## ELECTRIC UTILITY TOOLS ON EASY TERMS



1001 jobs can be tackled with these high quality tools. Every item interference suppressed and guaranteed. Build up your home workshop. Write for free full catalogue and easy terms schedule.

	Cash Price	Deposit	8 Mthly. of
1in. Drill	£5.19.6	12.0	14.10
1in. Drill Stand	£3.14.3	8.0	9.3
1in. Drill Kit	£12.9.6	£1.5.0	£1.11.2
5in. Sander Polisher			
Drill	£9.10.0	£1.0.0	£1.3.7
Craftsman's Lathe	£5.15.6	12.0	14.4
Lathe Saw Table	£3.0.8	6.8	7.6
5in. Port. Saw Att.	£3.11.6	7.0	9.0
1in. Drill	£13.12.6	£1.7.6	£1.14.0
1in. Drill Stand	£8.1.0	13.0	15.0
6in. H.D. Saw	£19.0.0	£2.0.0	£2.7.3
No. 44 Orb Sander	£13.15.0	£1.7.6	£1.14.4

When ordering please send Cash Price or Deposit and state Mains Voltage. All items post free.

### THE "I & G" UNIVERSAL SAW

Fits any electric hand drill. Will Jig saw, Cross cut, Rip saw, Hack saw, etc. Complete with attachments and two extra saw blades. Send for leaflet.



Cash Price **49/6** Post Free  
 OR EASY TERMS **6/-** deposit & 8 monthly payments of 6/-

### LATERAL SANDER-POLISHER

Vibratory principle at approx. 12,000 strokes per min. 200/240v. A.C. only. Ideal for sanding wood: polishing cars, etc. Send for leaflet.



Cash Price **75/-** or **5/-** deposit & 8 monthly payments of 10/-

### BURGESS PAINT SPRAYER



With new nozzle att. for overhead spraying. Easy to handle as brush, twice as fast. Just plug in and spray. For paints, insecticides, varnish, lacquer, light oils, etc. Fully guar. A.C. mains only, state voltage. Send for leaflet.

POST FREE

Cash Price **75/-** or 4/- dep. & 8 mthly. payments of 10/-

### THE HORVELL ELECTRIC PAINT STRIPPER

CASH PRICE **30/-** P.&P. 1/-  
 Extra Cable 1/- yard. Spare Element, 5/6.  
 No Blowlamp needed. The easy way to remove paint from all types of wood. The "Horvell" stripper removes it quickly by heat and pressure leaving a perfectly smooth surface. Send for leaflet. State exact voltage.

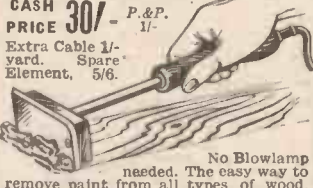

SPRAYER & STRIPPER TOGETHER **7/-** DEP. & 8 MONTHLY OF 14/-

KINGSWOOD SUPPLIES (Dept. P.M.12)

2, 3 & 4, Sile Place, London, W.2. Telephone PAD 8189

# STOP!!

Pull up in time by fitting



## Fibrax BRAKE BLOCKS

You brake gently, but firmly with FIBRAX brakes. The great thing is they are SURE in emergency. And they spell S-A-F-E-T-Y on the steepest gradients. For Steel rims, Fibrax Black Blocks; for alloy rims, Soft Red Blocks.

**FOR SAFETY'S SAKE - FIT A SET NOW**

FIBRAX LIMITED  
 2, Tudor Street, London, E.C.4

# HALFORDS The shop for CYCLISTS



### TOURING BAGS



Halford Renshaw Bags, from 4/8. Size 11in. x 9in. x 6in. as illustrated with one end pocket, 13/9. Larger models with two pockets, 18/-. Brooks-Midland-Baycliff-Cykewear bags always in stock.

**TYRES** Halfords stock tyres for every cycling purpose. Halford Renshaw, 10/7. "Speed", 9/9. Full range of Dunlop Tyres in stock.

### CYCLE STANDS

"Shuresta" Kickup ... 8/9  
 "Shuresta" Twinleg ... 15/6  
 Floor Stands from ... 7/7

### HANDLEBAR BENDS



All Rounder or Light Tourist Model. Chromium Plated ... 6/6 pair

### FEEDING BOTTLES



"Coloral" 3-pint single, 2/11.  
 "Coloral" 1-pint single, 4/6.  
 Carriers from 2/-

### REAR CARRIERS



Stay fitting with spring clip size 16in. x 5 3/4in. Black, as illustrated ... 7/6  
 As above. Raleigh Green ... 8/-

### HANDLEBAR GRIPS

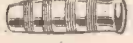

Popular 4in. rubber 3/4in. diameter, black ... 10d. pair.  
 Others from ... 1/6 pair.

### CYCOMETERS



Lucas Cyclometer, mileage recorder 24", 26", 27", or 28" wheel ... 7/6

### SPEEDOMETERS

Smith's Speed and Mileage Recorder combined. For 26" wheel fitting.



Right- or left-hand drive available ... 38/6  
 De-luxe model ... 49/6

### BELLS & HORNS



2 1/2in. Dome N.P. Bell, 1/8.  
 Genuine Lucas "Challis" pattern as illustrated from 4/-.  
 Bulb Horns from 1/11.

### BRAKES

British made Caliper Front Brakes ... 8/6  
 British made Caliper Rear Brakes ... 8/11  
 Monitor, Phillips and Webbs available.



### HUBS

Sturmy-Archer 3-speed wide ratio (AW) ... 40/9  
 4-speed wide ratio (FW) ... 45/-  
 Full range of Sturmy-Archer Gears, Brakes and Dynos available, either loose hubs or built into wheels.



### WATERPROOF CLOTHING P.V.C.

Colours: Black or Gold. All welded seams.  
 Capes, 42in. zipp opening, 28/11.  
 42in. Button opening, 27/9.  
 36in. Button opening, 26/6.  
 Leggings, button opening, 28in., 30in., 32in., 18/11 pair.  
 Sou'westers, small, medium and large, 6/6.



Branches throughout England, Scotland and Wales.

# HALFORD CYCLE CO LTD

HEAD OFFICE: 45 CARPENTER ROAD, EDGBASTON, BIRMINGHAM 15

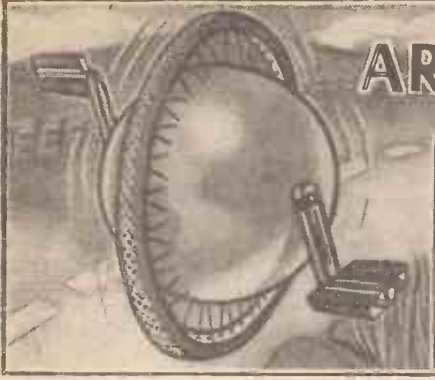

# AROUND THE WHEELWORLD

By ICARUS

Ltd. The nine-day event covered 1,066 miles of some of the most difficult roads of Britain. The stages included Manchester to Scarborough, Scarborough to Whitley Bay, Whitley Bay to Musselburgh, Edinburgh to Glasgow, Glasgow to Carlisle, Carlisle to Keswick, Keswick to Morecambe, Morecambe to Colwyn Bay, Colwyn Bay to Wolverhampton, and Wolverhampton to Chiswick, finishing at the Polytechnic Stadium.

I hope this event survives as an annual red letter day in the cyclist's sporting calendar.

### NCU-RTTC Suspension of BLRC Riders

THE following letter has been sent by the National Secretary of the BLRC to the NCU and RTTC on the instruction of the National Chairman:

"I have been instructed to write and say that we understand that the NCU and RTTC have recently taken certain action against a

the unsatisfactory position, which incidentally is becoming serious. The present situation is due solely to the bilateral action of the NCU and RTTC in firstly withdrawing from the Joint Agreement of 1953 and from repudiating the agreement reached on January 2nd, 1955.

"If you now feel, as we do, that something must be done, in the interests of the sport, to reach agreement I am ready to arrange a meeting to this end."

### The Speed Limit

THE comments on the speed limit in last month's issue remind me that the 20th anniversary of the introduction of the speed limit of 30 miles per hour in built-up areas occurred on March 18th this year. The Pedestrians' Association says that it was largely responsible for this measure and says that although the limit was in operation only nine and a half months in 1935 there was a reduction of 231 or 23.1 per cent. in the number of deaths in the Metropolitan Police Area, as well as a substantial reduction in the number of injured. The President of the Association says that after 20 years the standard of observance of the limit may not be so high as in 1935, but the figures underline the importance of the enforcement of the law that in the last 20 years must have saved thousands of lives and tens of thousands of injuries. The Ministry of Transport, however, does not altogether subscribe to these views and there is no real evidence to prove that speed in the last twenty years has been responsible for the increase in accidents. The Minister of Transport is at present examining proposals for introducing differential speed limits on main traffic routes in the London area. Some roads may be down to 15 miles an hour and some up to 45 miles an hour. The police are in favour of this idea. Mr. R. Graham Page, M.B., in an article some time ago in the *Liverpool Post* is in favour of the speed limit being retained. He says, "I need no statistics to tell me that road accidents occur because a motor car is travelling at such a speed that it cannot stop."

### Terry's Centenary

THE famous firm of Herbert Terry and Sons, Ltd., which makes springs of every type for every industry, this year celebrates its centenary. The firm was founded by Mr. Herbert Terry, who started in a small way with wire parts for the fishing tackle trade, growing up with the expanding engineering, cycle and motor industries.

In 1902 Mr. Terry relinquished control of the firm, and his three sons, Mr. Charles Terry, Mr. A. Victor Terry and Mr. Alfred E. Terry, took control. Mr. Charles was chairman for 41 years, and concerned himself with the financial side, Mr. Victor was the inventor and Mr. Alfred was generally interested in sales.

All these three directors have now passed on, and the firm is under the control of Mr. Norman V. Terry, chairman, son of Mr. Victor, Mr. H. Philip Terry son of Mr. Charles, and Mr. David E. Terry, son of the late Mr. C. Douglas Terry and grandson of Mr. Alfred.

To celebrate the centenary, in addition to the profit sharing bonus, the workers are being awarded £1 for each year's service with the firm, and this will mean a share out of about £25,000.

### An Underwater Unicycle

ACCORDING to *Aluminium News*, the Aero-Jet General Corp. of Azusa, California, U.S.A., is producing something like an underwater unicycle called an Aquaped. Made of aluminium extrusions, castings and sheet, the 19lb. underwater vehicle propels the user at three times the speed possible with fins.

The swimmer is held in place by suspenders on a bicycle-like seat, and propels the Aquaped by pedalling. The pedals are geared to two counter-rotating propellers mounted on concentric shafts. Manoeuvring is simple and a slight positive buoyancy in the vehicle allows the swimmer to surface or submerge at will.

More timid bathers may find the hazards of submerged and mechanised swimmers a greater problem than the traditional starfish, shells, crabs and broken bottles.

### The Oats

THE Amateur Circuit of Britain for the Quaker Oats Trophy attracted a large field of competitors in 16 national and regional teams, and included the leading amateur racing cyclists. It is probably the toughest amateur cycle stage race of the year, and is organised by the British League of Racing Cyclists and sponsored by Quaker Oats,



Mr. F. J. Camm lecturing at the Felixstowe County Modern School, during the Felixstowe Book Week. On the platform is Mr. C. Clark Ramsay, Publicity Manager of George Newnes Book Dept. and Mr. G. F. H. Girling, F.R.G.S., M.I.S.T., the headmaster. The subject of Mr. Camm's lecture was "Scientific Signs of the Times"

number of BLRC members who have competed in an event run under the rules of the BLRC.

"We shall be glad if you will advise us—through me—at the earliest possible moment on what grounds this action was taken. As both the RTTC and NCU permit their members to compete in BLRC events, it follows that there must be tacit recognition of the rules of the BLRC by both bodies.

"As these rules conform with those laid down by the UCI it is difficult to understand how the action of declaring certain BLRC members as 'non-amateurs' can possibly be justified. The BLRC, on its part, places no embargo on any of its members belonging to or competing in events run under the rules of either the NCU or RTTC and makes no attempt to interfere in any way with the rules of these two bodies and we consider that the bilateral action taken is entirely out of order.

"The BLRC is always ready and willing to meet both the NCU and RTTC for the purposes of reaching an agreement and ending



The Monnow Bridge, Monmouth, with its defensive tower dating from 1272.

# Wayside Thoughts

By F. J. URRY, M.B.E.

MAY was a turbulent month in its youth and middle age, though it did manage to draw a scarf of sunshine round its shoulders in its last week, suggesting that summer was only just round the corner. I went about in gloves during my riding hours most of the month, and I do not remember when that protection lasted so long into the year and was so comforting. Cold Mays are not uncommon, though usually we do get a sunny break to make us dream of lovely faraway places and memories of yesteryear.

There was a Tuesday in the month when winter in full blast definitely and defiantly returned; the gale roared and flung the blossom violently to the ground; the rain ran on for 14 hours with periods of sleet and snow, and the driven cold was bone-aching. That, however, is all past now until after the leaves turn and the harvest is gathered, so we can look forward to days along the road patterned with sunshine. In these long evenings, I rest under some ancient oak, and dreaming, wonder how many changes and chances that marvel of the woods has seen occur;

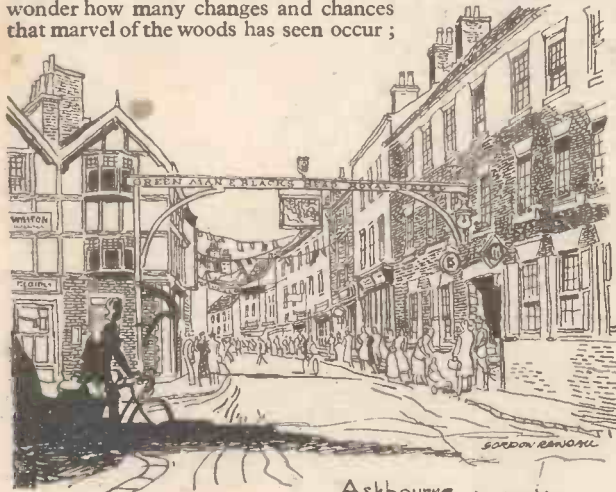

Ashbourne, Derbyshire.

how many times he has groaned through the storms and rustled his garments—as he does now—in the quiet breath of an English summer. I love to make these short excursions on long summer evenings, for the taste of tobacco is always better in the balmy air with the shifting foliage shadows printing a pattern at your feet. The use of a bicycle in summer is the active equipment of contemplation, and that gift of changing thoughts and words with an old friend across the buzz of insects is one of the rich experiences of life that never palls.

## A Brilliant Journey

ON the second of those stormy Saturdays in May I went to keep a business appointment at Abergavenny which enabled me to have lunch with an old friend in his cottage high up on the slope of the Black Mountains. It was a day of rain, sleet and sun, and a wind like a whetted knife, which made you wince when it struck home.

Twenty years ago I would have made a long week-end of the journey and enjoyed every minute of the time, now I started at 10 o'clock and was home again just before eight, and some of the miles were made slowly, for it was that rare kind of day when the visions were magnified between the bustling storms. We went the "curly" way from Worcester to Hereford and the blown

blossom snowed on us when we stopped to empty a thermos flask of coffee just beyond the Wyese City. After this a black cloud emptied its contents with a vicious bout of hail, and then the sun made everything sparkle including the white top of Skirrig Mountain and the hills beyond. But the sun—when it did shine—was powerful and the peppering of hail quickly disappeared. Our duty call over, we turned up the Honddu Valley, and in a wind-sheltered seat it was almost like summer, with a sparkling river and the comely slope of the hills green with the verdure of spring nearly up to their rock-naked edges.

We passed Llanthony Abbey on the easy grades, after which the road narrowed and became rocky, for the tarred surface ceased for a few miles, though that old rough way between Lord Hereford's Knob and Hay Bluff is being rejuvenated for the sake of the modern travellers. After lunch we found the evidence on the moor summit—steam-roller and tar and cooker and a hut of tools. I don't know whether to be glad or sorry, for the last time I went that way was on a bicycle and I glissaded into Cusop Vale near Hay over a grass-grown track mudded and rutty with winter storms. When you rise the summit after climbing that green little pass, what a transformation, particularly lovely on this day of swinging storms, for the green panorama ran in beauty along the Wye Valley from Three Cocks to

consider how much hard work and organisation is undertaken by men and women with that sense of loyalty to club or institution which drives them on to great effort and sometimes brilliant results. But when everything goes right—except the weather—few folk give the disappointed ones a thought. But thank heaven, there are still some generous people left in this selfish world, for otherwise, amateur sport run cleanly would be in danger of dying out. Yes, the weather can be an ally or an enemy and when it is the latter with a blasted temperature that makes the racing man don a sleeved jersey under his gay sporting raiment, it is a foe indeed.

## The Next Day

THE very next day there came a streak of sunshine and a light breeze moving slowly enough for the sun to warm it. I went out into the lanes and for half an hour sat in the shelter of a wood and watched the scene pass before me, gay young things chattering and singing as if in praise of this better day, a day when the month appeared to be trying to regain its English reputation.

Later I passed on my way to call and cheer a relative lately bereaved and, of course, we talked of the old days and wondered if we could recapture a little of their nostalgic benison now we are both beyond the allotted span. And the upshot of that conversation resulted in a temporary assignation for a journey in September, but how it will be performed—if ever—and where, was left until later.

Old-cyclists are never satisfied, never quite content, always a trifle restless, due to the cycling fever still left in their veins. I remember when the late F. T. Bidlake was feeling the years, how he would, when staying with me, persuade my people to take him farther and farther over once familiar ground, as if a fever drove on his desire. And how my old friend—for he was that in very truth—did



Udimore  
Sussex.  
The little 13<sup>th</sup> cent. church.

the Epints, and beyond them the Brecon Beacons and the Carmarthen Vans with here and there a sudden diamond flash of the river as the sun caught a loop in its light. The long journey was alone worth that five miles quiet parade of the elevated way, and I was thankful my physical decline made no impact on my mental appreciation of so glorious a scene.

## Regret for the Workers

A WEEK later I was the witness at a sports meeting, and the racing was excellent and often exciting. But wind and rain and particularly a freezing temperature kept the crowd at their fireside and really I do not blame them, for winter, on that day, certainly "lingered in the lap of May." I do not know what the monetary loss will be; no doubt that can be repaired by the generosity of interested parties; but I do know how disappointed the honorary workers feel, because I have borne that depression myself in the days gone by. I think people seldom

hate picnics, and how we did like them. I often pass hotels now that were once country pubs, and regaled the fine old man; and always the picture returns to me of F. T. B. balancing a hot plate on a bony knee trying to carve a lamb chop. Yes, he never did acquire the simple habit of a picnic meal.

## PRACTICAL MECHANICS HANDBOOK

7th Edition

By F. J. Camm.

12/6d. or by post 13/-.

Over 75 years  
experience and worldwide  
reputation for quality

# THORNTON

**DRAWING INSTRUMENTS**  
MINERVA SERIES PROFESSIONAL QUALITY  
JAYWESS SERIES STUDENT QUALITY  
KINWEST SERIES SCHOOL QUALITY



Write for  
illustrated leaflets  
and address  
of your  
nearest stockist to:

**A.G. THORNTON LTD.**  
P.O. BOX 3, WYTHENSHAW, MANCHESTER

MANUFACTURERS OF FIRST QUALITY DRAWING INSTRUMENTS  
P.L.C. SLIDE RULES AND DRAWING EQUIPMENT

# "Baker's" Regd

## SOLDERING FLUID



**QUICK · CLEAN · CERTAIN · ECONOMICAL**

PRODUCT OF SIR Wm. BURNETT & CO. (Chemicals) LTD.  
GREAT WEST ROAD · ISLEWORTH · MIDDLESEX · ENGLAND

## PRINT YOUR OWN SNAPSHOTS

with this super

### 3/- PHOTOGRAPHY KIT!

Think of it! Now you can make your own prints of holiday snapshots with this Johnson Print-A-Snap Pack. It's wonderful fun and so easy too. Each pack has everything you need for making perfect pictures from your negatives!

There are two sizes. One has 16 sheets of  $3\frac{1}{2} \times 2\frac{1}{2}$  in. contact paper—that's for the camera that takes 8 pictures on each roll of 120 film. But if your camera takes 12 pictures to a roll, ask for the pack with 24 sheets.  $2\frac{1}{2} \times 2\frac{1}{2}$  in. Get the Johnson Print-A-Snap Pack today and show the family what you can do!

Only 3/- a pack



1 pkt. developer.  
1 pkt. fixing powder.  
1 pkt. of the new Johnson Contact paper, a cardboard printing frame and a sturdy wallet for keeping your prints in after you've made them together with full instructions

Ask any Photo Dealer for

## THE JOHNSON PRINT-A-SNAP PACK

**Send Now** for New Brochure detailing all points and interesting features; answered questions you would ask, showing machines in use and articles such as toys, patterns and turnery made on these machines. Ask also for details of fittings to the "Coronet" range and other makes. Is long hole drilling a problem to you? Send now for details of BORING ATTACHMENT and long drills, to suit any lathes

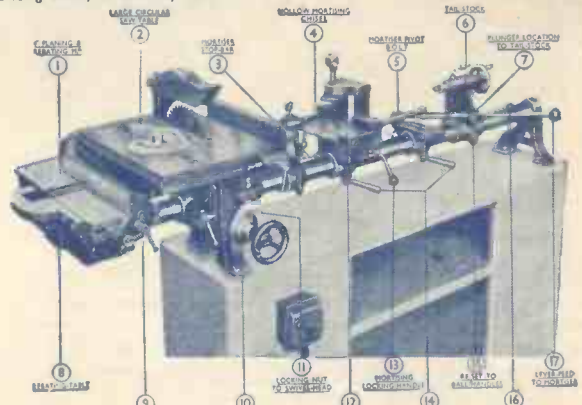

FITTINGS AND ACCESSORIES FOR ALL LATHES:

- CUP CENTRE No. 1 Morse Taper Shank.
- 4 Prong DRIVING CENTRE (Positive Drive for large or small work).
- GRINDING WHEEL ARBOR No. 1 Morse Taper—suit any machine with No. 1 Morse Taper.
- REVOLVING CENTRE.
- 5" WOBBLE SAW—Ploughs  $\frac{3}{16}$ " to  $\frac{1}{8}$ ". Index for quick setting and fine adjustment.
- TURNING TOOLS, set of six 18" overall, beautifully handled.
- WOODSCREW CHUCK to suit any machine No. 1 or 2 Morse.
- 3 Jaw CHUCK and Self Centering 4 Jaw Independent Chuck.
- COMPOUND SLIDEREST—for wood and metal turning.
- ELECTRIC MOTORS, Brook  $\frac{1}{2}$  and  $\frac{1}{4}$  h.p.
- GRINDING WHEELS, SLIPSTONES, etc.

Write: Dept. P.M., enclosing stamp, for Catalogues showing photographs and price, etc.

**CORONET TOOL CO.** 8, MANSFIELD ROAD, DERBY  
Also at CITY ROAD MILLS, DERBY.

"Practical Mechanics" Advice Bureau. **COUPON**  
This coupon is available until August 31st, 1955, and must be attached to all letters containing queries, together with 6d. Postal Order. A stamped, addressed envelope must also be enclosed.  
Practical Mechanics. August, 1955.

# Free Guide — SUCCESS IN ENGINEERING

**132-PAGE BOOK FREE!**  
**SEND FOR YOUR COPY**

One of the following Courses taken quietly at home in your spare time can be the means of securing substantial well-paid promotion in your present calling, or entry into a more congenial career with better prospects.

## ENGINEERING, RADIO, AERO, ETC.

Aero. Draughtsmanship	Elec. Draughtsmanship
Jig & Tool Design	Machine " "
Press Tool & Die Design	Automobile " "
Sheet Metalwork	Structural " "
Automobile Repairs	R/F Concrete " "
Garage Management	Structural Engineering
Works M'gmt. & Admin	Mathematics (all stages)
Practical Foremanship	Radio Technology
Ratefixing & Estimating	Telecommunications
Time & Motion Study	Wiring & Installation
Engineering Inspection	Television
Metallurgy	Radio Servicing
Refrigeration	Gen. Elec. Engineering
Welding (all branches)	Generators & Motors
Maintenance Engineering	Generation & Supply
Steam Engine Technology	Aircraft Mainten. Licences
I.C. Engine Technology	Aerodynamics
Diesel Engine Technology	Electrical Design
Ordnance Survey Dr'ship.	

## BUILDING AND STRUCTURAL

L.I.O.B.	A.I.A.S.	A.R.San.I.	M.R.San.I.
A.M.I.San.E.	A.A.L.P.A.	L.A.B.S.S.	A.R.I.C.S.
Building Construction	Builders' Quantities	Carpentry & Joinery	Building Inspector
Costs & Accounts	Building Draughtsmanship	Heating and Ventilating	
Surveying & Levelling			
Clerk of Works			
Quantity Surveying			

## GENERAL, LOCAL GOVERNMENT, ETC

Gen. Cert. of Education	Common. Prelim. Exam.
Book-keeping (all stages)	A.C.I.S., A.C.C.S.
College of Preceptors	A.C.W.A. (Costing)
Woodwork Teacher	School Attendance Officer
Metalwork Teacher	Sanitary Inspector
Housing Manager (A.I.Hsg.)	Civil Service Exams.

## BECOME A DRAUGHTSMAN—LEARN AT HOME AND EARN BIG MONEY

Men and Youths urgently wanted for well paid positions as Draughtsmen, Inspectors, etc., in Aero, Jig and Tool, Press Tool, Electrical, Mechanical and other Branches of Engineering. Practical experience is unnecessary for those who are willing to learn—our Guaranteed "Home Study" courses will get you in. Those already engaged in the General Drawing Office should study some specialised Branch such as Jig and Tool or Press Tool Work and so considerably increase their scope and earning capacity.



★ OVER SIXTY YEARS OF CONTINUOUS SUCCESS ★

**NATIONAL INSTITUTE OF ENGINEERING**

(Dept. 29)

**148, HOLBORN, LONDON, E.C.1**

SOUTH AFRICA: E.C.S.A., P.O. BOX NO. 8417, JOHANNESBURG

This remarkable **FREE GUIDE** explains :

- ★ Openings, prospects, salaries, etc., in Draughtsmanship and in all other branches of Engineering and Building.
- ★ How to obtain money-making technical qualifications through special **RAPID FULLY-GUARANTEED COURSES**.

## MANY INTERESTING COURSES TO SELECT FROM!

A.M.I.Mech.E., A.M.I.M.I.,  
A.M.Brit.I.R.E., A.M.I.P.E.,  
A.M.I.C.E., A.M.I.Struct.E.,  
A.M.I.Mun.E., M.R.San.I.,  
A.M.I.E.D., A.F.R.Ae.S.,  
London B.Sc., Degrees.

Fully guaranteed postal courses for all the above and many other examinations and careers. Fully described in the New Free Guide



## THE ACID TEST OF TUTORIAL EFFICIENCY SUCCESS—OR NO FEE

We definitely guarantee that if you fail to pass the examination for which you are preparing under our guidance, or if you are not satisfied in every way with our tutorial service—then your Tuition Fee will be returned in full and without question. This is surely the acid test of tutorial efficiency.

If you have ambition you must investigate the Tutorial and Employment services we offer. Founded in 1885, our success record is unapproachable.

**ALL TEXTBOOKS ARE SUPPLIED FREE  
PROMPT TUTORIAL SERVICE GUARANTEED  
NO AGENTS OR TRAVELLERS EMPLOYED**

## Free Coupon

To : NATIONAL INSTITUTE OF ENGINEERING  
(Dept. 29), 148-150, Holborn, London, E.C.1.

Please Forward your Free Guide to

NAME .....

ADDRESS .....

My general interest is in : (1) ENGINEERING  
(2) AERO (3) RADIO (4) BUILDING  
(5) MUNICIPAL WORK

SEND OFF  
THIS COUPON  
NOW AND BE  
ALL SET FOR  
**SUCCESS**

(Place a cross against the branches in which you are interested.)

The subject of examination in which I am especially interested is

To be filled in where you already have a special preference.  
(1½d. stamp only required if unsealed envelope used.)

**FOUNDED 1885 - FOREMOST TODAY**