

A SENSITIVE HYGROSCOPE

NEWNES

1/4

# PRACTICAL MECHANICS

EDITOR: F. J. CAMM

JULY 1951

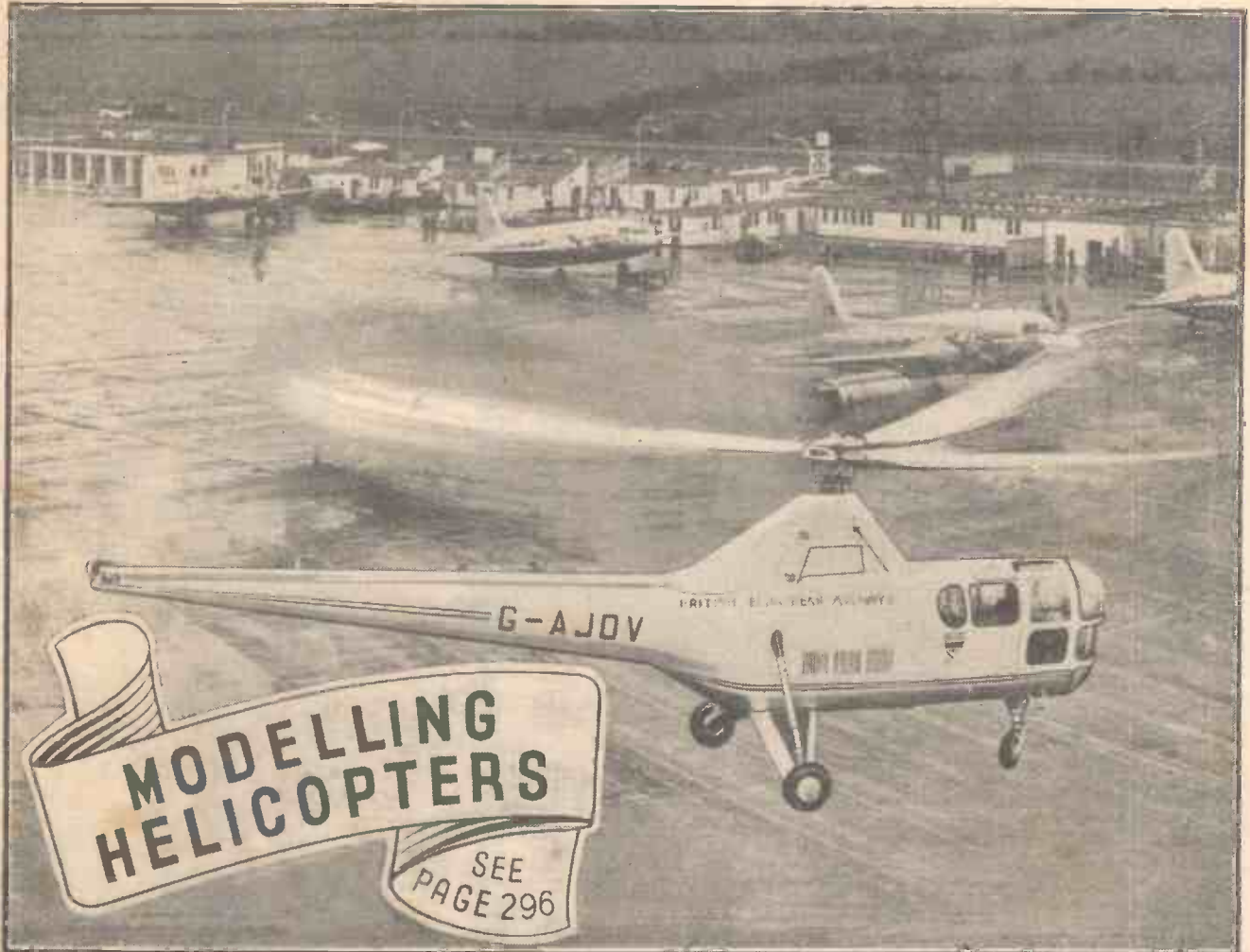

## PRINCIPAL CONTENTS

A SMALL TABLE CHURN  
DECORATING MATERIALS  
STUDIES IN ELECTRICITY

EXPERIMENTAL PILE AT HARWELL  
BUILDING ALUMINIUM BOATS  
AUTOMATIC TELEPHONES

WORLD OF MODELS  
QUERIES AND ENQUIRIES  
A CYCLIST'S HORSEPOWER

When I want a *CLIP* I turn to

# TERRY'S

*(the Spring people)*

I go to TERRY'S for all kinds of CLIPS—steel, bronze, stainless, etc. When I want a clip made to specification, Terry's Research Department is a big help in the matter of design (Terry's with 96 years' experience should know a thing or two !)



*and 3 Special Clips*

Nos. 80 and 81 come from 1/4" to 2" from stock. No. 300, an exceptionally good drawing board clip, costs 5/- a doz. (inc. p.t.) from stock.



No. 81



No. 300



No. 80

Want to know all about springs?  
Here is the most comprehensive text - book on springs in existence.

Post free 10/6



Sole Makers : HERBERT TERRY & SONS, LTD., REDDITCH • London • Birmingham • Manchester

## Tool Bargains!!

Now is the time to buy your tools; those offered below are of the best quality, fully guaranteed, free of purchase tax, and available for immediate delivery.

Best quality double pinion hand drills,  $\frac{1}{2}$  in. capacity, 17/-; sets of cramp heads, 8/6 set; 6in. jaw woodwork vices, steel screw, 13/6; 6in. combination wood and metalwork vice, 12/6; Record "Imp" engineers' table vice, 2 $\frac{1}{2}$  in. jaws, 21/-; Record sash cramps, 24in. 18/6; 30in. 19/-; 36in. 19/6; 48in. 20/6. Record adjustable smooth planes, No. 04, 30/6; 04 $\frac{1}{2}$ , 35/6; iron jack planes 05, 37/6; 05 $\frac{1}{2}$ , 42/-. Sets of 6 carpenter chisels,  $\frac{1}{2}$  in. to 1 in., 16/6 set; carpenters' expanding bits, a complete set of bits in one,  $\frac{1}{2}$  in. to 1 $\frac{1}{2}$  in., 12/6;  $\frac{3}{4}$  in. to 3 in., 17/9;  $\frac{1}{2}$  in. Black and Decker utility electric drills, £5/10/-; engineers' vices, 3in. 25/6; 3 $\frac{1}{2}$  in. 35/-; 4in., 45/-; 4 $\frac{1}{2}$  in. 53/-; carpenters' bow saws, 8in. 11/6; 10in. 12/3; 12in. 13/6;  $\frac{1}{2}$  in. capacity two-speed breast drills, 29/-; saw sharpening vices 18/6; 8in. best quality black handled cutting out shears, 11/6 pair; 7in. quick grip woodworkers' vices, 44/-; push screwdrivers, 12/6; plow planes with 3 irons, 22/-; adjustable plow planes with 8 best quality irons,  $\frac{1}{2}$  in. to  $\frac{3}{4}$  in., 36/3; best quality handsaws, 22in. 13/3; 24in. 13/9; 26in. 14/3; steel back tenon saws, 10in. 10/6; 12in. 12/9; adjustable rebate and fillister-planes, 26/3; 10in. super quality ratchet braces, 16/6;  $\frac{1}{2}$  pint paraffin blowlamps, 22/6; 1 pint glue-pots, 8/6; 1lb. adze eye claw hammer, 8/9; handy tools (axe, hammer, nailpuller), 10/6; electricians' toolbags, 14in. 15/9; 16in. 16/9.

Carriage paid on orders to the value of 50/-. For under that amount send 2/- for postage; any excess will be refunded.

Illustrated list of tools, electric tools, wood and metalwork machines free on request.

**PARRY & SON (TOOLS), LTD.,**

329-333, OLD ST., LONDON, E.C.1.

Telephone: Clerkenwell 3918-3859

## TRACK FOR GARDEN RAILWAYS

7 $\frac{1}{4}$ " to 10 $\frac{1}{4}$ " Gauge

Model railway enthusiasts will be glad to know that Bassett-Lowke can now supply a full range of track materials for garden railways. 7 $\frac{1}{4}$  in. to 10 $\frac{1}{4}$  in. gauge available for immediate delivery.

RAIL in 14ft. lengths punched at each end for fishplate bolts—2 $\frac{1}{2}$  lbs. per foot run.  $\frac{1}{2}$  in. tread, 1 17/32 in. high, 1 $\frac{1}{2}$  in. wide on foot, 22/6 per 14ft. length. P.T., 5/- (Minimum quantity 4 lengths.)

FISHPLATES for above, comprising 2 mild steel plates punched with 4 holes with 4 fishplate bolts at 1/3 complete. P.T. 3/6.

HOLDING DOWN DOG SPIKES for fixing rail to wood sleepers (as illustrated). 10/- per 100.

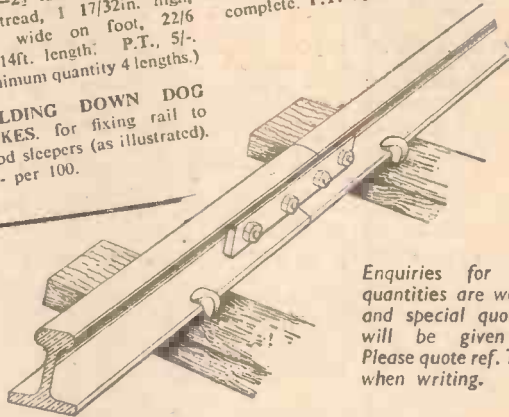

Enquiries for larger quantities are welcome and special quotations will be given free. Please quote ref. TM/12 when writing.

**BASSETT - LOWKE LTD**

Head Office and Works:  
**NORTHAMPTON**

London: 112, High Holborn, W.C.1. Manchester: 28 Corporation Street

ALL AMATEUR PHOTOGRAPHERS SHOULD TRY THIS WONDERFUL NEW DEVELOPER

# Unitol

A CONCENTRATED LIQUID FINE GRAIN DEVELOPER



A one - solution, fine grain developer with excellent keeping qualities and always instantly ready for use. Dilute one ounce with just the right amount of water to fill YOUR tank, develop the film and pour the solution away. No trouble, no waste. Gives maximum speed consistent with fine grain and yields negatives of superlative enlarging quality. No filtering or dissolving necessary. A standardized technique gets you the same superb results every time.

225 c.c. (8oz.) size ..... 3/6  
570 c.c. (20oz.) size ..... 6/6

Get the UNITOL CALCULATOR with your first bottle of Unitol. It gives the right developing time for any film in any tank at all dilutions. It only costs 4d. and your dealer will be able to supply.

**JOHNSONS OF HENDON LTD.**  
LONDON, N.W.4. ESTABLISHED 1743



**JOHNSON J-20 TANK**

For developing size-20 roll films in daylight. Takes 10 $\frac{1}{2}$ -oz. of solution. Easy-to-load, sturdy one-piece spiral. Pouring lip for splash-free emptying. Triple light-trapped lid. Complete with new Two-Way Agitation movement and a Calculator Disc.

PRICE 25/-

## HAND BENCH DRILLING MACHINES

WITH ADJUSTABLE AUTOMATIC FEED AND 0- $\frac{1}{2}$  in. CHUCK.

Height  
20in.

Column dia.  
1in.

Weight  
17 lbs.  
(7.7 kg.)

Chuck to base  
Min. .0  
Max. 9in.

Depth of feed  
2 $\frac{1}{2}$  in.

0- $\frac{1}{2}$  in. 3 jaw self-centring chuck.



These machine tools are of heavy and accurate construction. The precision ground spindle is fitted with an automatic and adjustable feed control, and ball thrust. Castings are of finest grey iron. All machines are guaranteed.

PRICE **45/-** carriage 2/6.

We take this opportunity of thanking the many customers who have been kind enough to write expressing their appreciation of the quality and value of these machines.

From the manufacturers:

**ELLIOTT MACHINE CO.** QUEENS ROAD, TWICKENHAM

# I.C.S. TRAINED MEN are in Greater Demand than Ever—Maximum production depends on high technical skill, such as that acquired by I.C.S. Students

**TENS OF THOUSANDS MORE TRAINED  
MEN ARE URGENTLY NEEDED NOW  
—BUT THERE IS NO WORTH-WHILE  
PLACE FOR THE UNTRAINED**

*Ambitious men everywhere have succeeded through  
I.C.S. Home-Study Courses. So also can you.*

The man with an I.C.S. Training in any one of the subjects listed below knows it thoroughly, completely, practically. And he knows how to apply it in his everyday work.

- |                         |                         |                        |
|-------------------------|-------------------------|------------------------|
| Accountancy             | Draughtsmanship         | Motor Engineering      |
| Advertising             | Drawing Office Practice | Motor Mechanic         |
| Air and Vacuum          | Electrical Engineering  | Motor Vehicle Elec.    |
| Brakes                  | Electric Power, Light-  | Municipal Eng.         |
| Air-Conditioning        | ing, Transmission       | Plastic                |
| Arable Farming          | Traction                | Plumbing               |
| Architecture            | Eng. Shop Practice      | Quantity Surveying     |
| Architectural Drawing   | Fire Engineering        | Radio Engineering      |
| Auditing                | Foremanship             | Radio Service Eng.     |
| Boiler Engineering      | Free-Lance Journalism   | Refrigeration          |
| Book-keeping            | Fuel Technology         | Sales Management       |
| Building Construction   | Heating and Ventilation | Salesmanship           |
| Building Specifications | Horticulture            | Sanitary and Domestic  |
| Business Training       | Hydraulic Engineering   | Engineering            |
| Business Management     | Illumination Eng.       | Sheet-Metal Work       |
| Carpentry and Joinery   | Industrial Management   | Short-Story Writing    |
| Chemical Engineering    | Lettering               | Steam Engineering      |
| Chemistry, I. & O.      | Machine Designing       | Structural Steelwork   |
| Civil Engineering       | Machine-Tool Work       | Surveying              |
| Clerk of Works          | Marine Engineers        | Telegraph Engineering  |
| Coal Mining             | Mechanical Drawing      | Television Technology  |
| Commercial Art          | Mechanical Engineering  | Welding, Gas and Elec. |
| Concrete Engineering    | Mine Surveying          | Woodworking Drawing    |
| Diesel Engines          | Mining Engineering      | Works Engineering      |

Students intending to sit for 1952 examinations in Architecture, Quantities, Civil Eng., Mech. Eng., and others, should enrol NOW for preparatory Courses.

Using a specially-prepared Study Programme, the student will complete his Course, with time for revision, before the examination date, when he will sit with full confidence of success.

Courses are also available for most other Technical, Professional, Commercial, and Civil Service Exams.

(I.C.S. Examination Students are coached until successful.)

**GENEROUS DISCOUNT GRANTED TO ALL MEMBERS OF H.M. FORCES.**

If you need technical training, our advice on any matter concerning your work and your career is yours for the asking—free and without obligation. Let us send you our special free booklet on the subject in which you are specially interested. **DON'T DELAY. Make ACTION your watchword.**

The successful man **DOES** to-day what the failure **INTENDS** doing to-morrow. Write to us **TO-DAY**.

Use this Coupon

**INTERNATIONAL CORRESPONDENCE SCHOOLS LTD.**

Dept. 95, International Buildings, Kingsway, London, W.C.2.

Please send me the free booklet describing your Courses in

Name: (USE BLOCK LETTERS) Age:

Address:

Addresses for Overseas Readers:

- Australia: 140, Elizabeth Street, Sydney.
- Egypt: 40, Sharia Abdel Khalek Sarwat Pasha, Cairo.
- Eire: 13, Anglesea Street, Dublin, C.4.
- India: Lakshmi Bldgs., Sir Pherozsha Mehta Rd., Fort, Bombay.
- New Zealand: 182, Wakefield Street, Wellington.
- N. Ireland: 26, Howard Street, Belfast.
- South Africa: 45, Shortmarket Street, Cape Town.



## FRANK'S of GLASGOW

### SELECTED MISCELLANEOUS ITEMS

#### PRISMATIC BINOCULARS

Best British makes, including Kershaw, Ross, etc. 6 x 30. Eye-piece focusing. Complete with Web Case. Guaranteed condition. Post 2/- extra ... .. £7 5 0

#### U.S. Government STAR IDENTIFIERS

Consists of Star Base and seven Templates. Can be used to spot or identify stars. Complete with instructions and leatherette wallet. Postage 9d. extra ... .. 4 6

#### PRISMATIC ELBOW TELESCOPES

Power 7 x. Weight 6 lb. Image erect. Definition is crisp and free from distortion. Post free ... .. 27 6

#### HAND SIGNALLING LAMPS

Diameter of reflector 5in. Bulb pre-focus 12 volt, 36 watt. This lamp gives a brilliant beam and is suitable for use as spotlight, inspection lamp, etc. Cover glass available in green, amber or clear. Post 1/- extra ... .. 15 0

#### POCKET FOCUSING MICROSCOPES

A precision instrument constructed in our own workshops. The optical system consists of 8 lenses (4 achromatic doublets). Definition is crisp and free from colour and distortion. Magnification 20 x. Post free... .. 27 6

#### ASSORTED LENSES & PRISMS

Parcel of 10 assorted lenses and prisms. The lot. Post free ... .. 10 0

SATISFACTION ON ALL PURCHASES OR REFUND OF PAYMENT

*Charles Frank*

67-73 SALTMARKET, GLASGOW, C.I.

PHONE: BELL 2106

INSTRUMENT MAKERS AND DEALERS SINCE 1907

## READY TO WORK RADIOS

### Battery Personnel Chassis

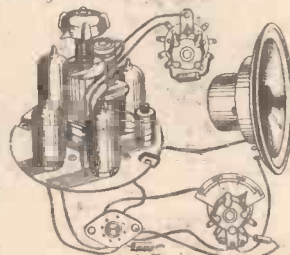

wave-bands, 59/6. Ditto but medium wave only, 49/6. Add 2/6 to cover postage and insurance.

This 4-valve all-dry battery-operated receiver is of such small dimensions that it will fit into a cabinet only about 6in. x 4in. x 3in. and still leave ample room for batteries. The chassis is all wired and complete with speaker, volume control, wave-change switch, etc., etc., and only first grade components have been used. Prices are: Chassis complete with valves (three type 1T4 and one type 3V4)—ready to operate on long and medium wave-bands, 99/6. Ditto but medium wave only, 89/6. Chassis without valves, long and medium

### All Mains Chassis

This is the equivalent of a 4-valve receiver for it uses three valves and a metal rectifier. It is all wired up ready to work off A.C. mains, complete with modern valves, ganged tuning, high precision dust cored coil, first grade condensers and resistors, all on metal chassis. Tunes long and medium wave-bands. Large clear dial.

#### Receivers

Home services; Light programme; Luxembourg, etc. Chassis size approx. 9in. x 4in. x 5in. Complete with valves, but less speaker, 59/6. Suitable speaker with matching transformer, 16/6—nothing else needed.

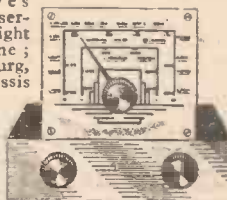

### Cabinets for Above

Here is an illustration of the type of cabinet you could make for this set. We have none to supply at the moment, but expect some and will give purchasers of the chassis first refusal of them if and when they arrive.

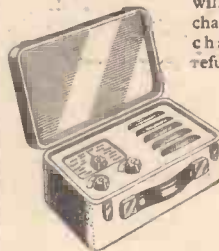

**E. P. E. LTD.** (1) Electron House, Windmill Hill, Ruislip Manor, Middlesex

**QUALITY REPRODUCTION**



Where High Sensitivity is desired it is definitely obtainable when you choose and use S. G. BROWN Type "F" (Featherweight) Headphones.

D.C. Resistance 4,000 ohms.

Impedance 14,000 ohms at 1,000 c.p.s. Weight 9 ozs.

"F"



High quality Reproduction is one of the outstanding characteristics of S. G. BROWN Type "K" Moving Coil Headphones. Excellent for DX work, laboratory purposes, monitoring, etc.

D.C. Resistance 47 ohms. Impedance 52 ohms at 1,000 c.p.s.

"K"

SEND FOR BROCHURE "P.M." IT GIVES DETAILS OF ALL TYPES OF S. G. BROWN HEADPHONES.

**S.G. Brown, Ltd.**

SHAKESPEARE STREET, WATFORD, HERTS.

Telephone: Watford 7241

(2)

*The* **Leytool**  
**HAND DRILL**



The "Leytool" Hand Drill Brace is a noteworthy improvement on all previous hand drills. Well balanced, with a comfortable grip that fits snugly into the hand, it is compact in size and is positively a pleasure to use. Solid one-piece die-cast body. All gears accurately cut and totally enclosed. Specially hardened chuck spindle and jaws. Self-lubricating bearings. Takes drills up to 1/4-inch diameter. Standard of manufacture equal to a high-grade precision tool for accuracy. **27/6**

If any difficulty in obtaining locally, send your order direct, or write for fully descriptive booklet.

Patent No. 587049

**OTHER LEYTOOLS**



2-Speed Combination Breast Drill  
Ratchet Spanners (Mechanic's Set)  
Universally Jointed Socket Spanners  
4-bladed Pocket Screwdriver

**LEYTOOLS are QUALITY TOOLS**

All Leytools are entirely original and patented designs. Write for free illustrated booklet.

**LEYTONSTONE JIG & TOOL CO., LTD.**, High Road, Leyton, London, E.13  
Telephone: LEYtonstone 5022-3-4

**TRIX**  
**x-acto**  
**HOBBY KNIVES & TOOLS**

**MORE skill at your fingertips!**



**No. 86 TOOL CHEST** *Almost a workshop in itself. A complete assortment of tools in handsome, fitted wooden chest.* **84/-**

**No. 5 KNIFE** for heavy duty. With one No. 19 blade **6/6**  
**No. 2 KNIFE** for normal cutting. With one No. 22 blade **3/6**  
**No. 1 KNIFE** for delicate work. With one No. 11 blade **3/-**

Try the perfect balance of X-acto knives, test the scalpel-keen sharpness of X-acto interchangeable blades and you'll soon be convinced that X-acto makes creative hands even more skilful. Call at your dealers and see the complete range of knives, blades, tools and attractive kits or write for illustrated folder.

\* X-acto blades are available separately in packets. 5 short blades, straight 2/6, five short blades, curved 3/9 and 2 long blades 2/-

**TRIX LTD., 11, OLD BURLINGTON STREET, LONDON, W.1.**

# ENGINEERS

## ★ FREE BROCHURES ★ NEW COURSES

Technical training is vital to your success. Our Home Study Courses have now been very widely extended in range. Write or 'phone for FREE BROCHURES detailing our courses of TECHNICAL TRAINING IN ALL BRANCHES OF ENGINEERING covering the syllabuses of the various professional examinations, City and Guilds, etc. Moderate terms. Facilities for easy payment.

"The only postal college which is part of a great industry"

Write to Dept. 144 :

## E.M.I. INSTITUTES

10, PEMBROKE SQUARE, NOTTING HILL GATE, LONDON, W.2. TELEPHONE: BAYSWATER 5131/2

Associated with  
"H.M.V."  
MARCONIPHONE  
COLUMBIA  
ETC.

I.12a.

## SENSATIONAL TAPE RECORDING INVENTION BY QUALTAPE ENGINEERS

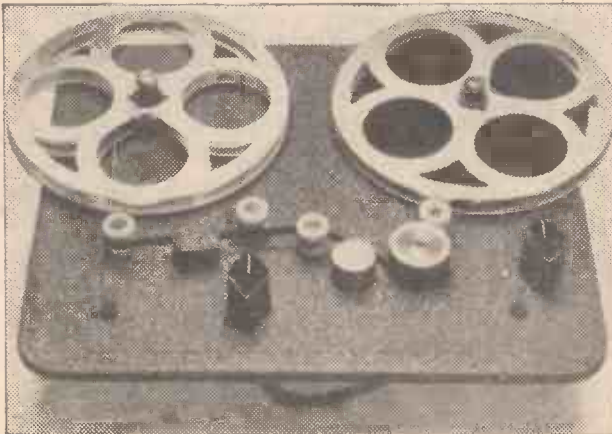

Your Radio or Radio Gramophone can now be used in conjunction with the Qualtape Deck and Pre-amplifier. Radio and Records faithfully and perfectly recorded, without use of Microphone and whilst listening. Reproduction is guaranteed equal to your radio. Microphone jack is provided for other purposes. Wow is non-existent. Post Card brings illustrated brochure and details of all Qualtape manufactures. Demonstrations by appointment.

Address : **DEPT. P.A.**  
**ELECTRONIC SERVICE**  
**(Hallamshire) LTD.**  
BUTTON LANE - SHEFFIELD  
Telephone : Sheffield 21690

## Build your own AMPLIFIER

The M.O.S. "EASY-to-BUILD" Kit makes it child's play.  
Type A1  
Even if you know nothing of radio YOU CAN BUILD this wonderful amplifier. Can be used with a microphone for HOME BROADCASTING, or you can play your records through it. Kit complete down to nuts and bolts and solder. DEFINITELY NOTHING ELSE TO BUY. Instruction manual contains easy step-by-step instructions. YOU CANNOT GO WRONG. Have endless fun giving your own "radio" programmes. Send at once for Complete Kit with Instruction Manual. **£4.12.6**

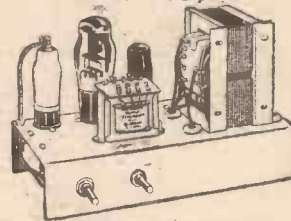

Instruction Manual only, 3/6 Post free

For A.C. Mains only, 200-250 v.

## AMPLIFIER Type A2 for AC/DC 200-250v.

Employs same fundamental circuit as the A1. Gives first-class reproduction. Kit complete in every detail. Complete kit with instructions **65/-**  
Instruction manual only, 3/-  
Tone control kit, 5/-

## RADIO TUNING UNIT

Type RF1. Complete Medium Wave Tuning Unit for use with the A1 or other A.C. amplifier. A "straight" T.R.F. circuit is employed using two high gain pentodes. Reproduction is excellent. High sensitivity means it may be used in areas of moderate signal strength. Complete kit with instructions **52/6**  
Instruction manual only, 2/-  
Note:—Increase in Purchase Tax compels us to make new prices effective immediately.

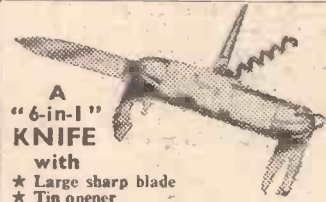

## A "6-in-1" KNIFE

with  
★ Large sharp blade  
★ Tin opener  
★ Bottle Opener  
★ Screwdriver  
★ Corkscrew  
★ Awl (spike)  
★ Safety Ring.  
A really useful knife of high-grade steel with "Pearleen" handle. Dozens of uses. A grand gift for anyone. **7/6**  
Only Plus 6d. Postage

## "IVALEK" de luxe CRYSTAL SET

A radio set in the palm of your hand! A beautifully made receiver, that looks good and IS GOOD. The receiver is constructed on an aluminium chassis and the circuit used, although simple, is highly efficient. All that is required is an aerial and earth, and a pair of high-resistance headphones for good, trouble-free reception. **17/6**  
At pre-Budget Price  
Post and Packing 9d.

## M.O.S. MAIL ORDER SUPPLY

The Radio Centre  
(Dept. PM7),  
33, Tottenham Court Road,  
London, W.1.

## SPORTS GLASSES

Small binoculars in pastel plastic with superficial magnification X5. Extra lightweight **14/6**  
Plus 9d. post, packing.

## Experimenters! Build the MATCHBOX RADIO SET

With the aid of our full instructions you can build a complete radio set in a matchbox, using parts purchased from your radio dealer.

Tuning arrangements include a medium wave inductor with station selector switch, and a long-wave coil for the B.B.C. Light Programme on 1,500 metres.

Demodulation is achieved by the use of a non-linear impedance unit of a new type, giving loud, clear reception.

This receiver works off a short indoor aerial in many districts, and being powered entirely by the incoming signal, requires no batteries.

Full step-by-step instructions, working drawings, and theoretical wiring diagram.

Price 3/- Post Free.

JOHN O'BEIRNE (P), 137, Cotham Brow, Bristol, 6.  
MAIL ORDER ONLY.

## Plastics LTD (MANCHESTER)

11 Whitworth Street, Manchester, 1. Tel: Cen. 0272-1725.

BRITAIN'S LEADING STOCKISTS OF:

- "PERSEPEX" (Acrylic) sheet, rod and tube.
- "CRINOTHENE."
- B.X. ACRYLIC ROD.
- P.V.C. SHEETING (Admiralty Specification).
- "CASEIN" Rod, Sheet and Tube.
- CELLULOSE ACETATE Film and Sheet.

Official Stockists for:  
IMPERIAL CHEMICAL INDUSTRIES LTD., ERINOID LTD.,  
B.X. PLASTICS LTD., UTILEX LTD.  
Catering especially for Industry, The Hobbyist and the Model Maker.  
Contractors to the Admiralty, most Government Departments, Schools, Institutions, etc.

Trade and Technical enquiries solicited.  
Fabrication, Engraving, Moulding, Cutting to Size, Shape, Contour a speciality.



**THORNTON'S  
DRAWING  
INSTRUMENTS**

We are the largest manufacturers of high-grade Drawing Instruments and Slide Rules in the British Empire, and have gained a reputation throughout the world for superb quality and accuracy. Insist on using only Thornton's for complete satisfaction. Our illustrated Catalogue, which includes particulars of all drawing instruments, sent on request.

**PIC  
SLIDE  
RULES**

**A. G. THORNTON LTD**  
*Drawing Instrument Specialists*  
WYTHENS H A W E, M A N C H E S T E R  
Tel: WYThenshawe 2277 (4 lines)

See the latest advances in  
**MODEL  
ENGINEERING**

- \* FINE COMPETITION MODELS OF ALL TYPES.
- \* LATEST TOOLS AND WORKSHOP EQUIPMENT.
- \* GRAPHIC WORKING MODEL OF THE SINKING OF THE 'EGYPT'—a triumph of the Model-makers' craft.
- \* EXPERT DEMONSTRATIONS of Brazing, Soldering and Woodwork.

Don't miss this finest opportunity of meeting fellow-enthusiasts and discussing problems and techniques.

**MODEL ENGINEER EXHIBITION**  
HORTICULTURAL HALL,  
WESTMINSTER, LONDON  
August 22nd to September 1st  
Admission 2/9d.; under 14, 1/6d.

**ML7 Lathe Improvement**

Every new ML7 is now fitted with nipples to replace the ball-type oilers, and an oil-gun is supplied with each machine. This gives extra-efficient pressure-lubrication to Britain's finest 3½ in. lathe. Because of the world-wide demand, your Tool Merchant cannot give speedy ML7 delivery. Remember, though, that quality is high, cost is low and that Myford Lathes are Well Worth Waiting For.

**MYFORD**  
THE CRAFTSMAN'S CHOICE

**"CHAMPION"  
MODEL 2 DRILLING MACHINE**

**SPECIFICATION**

Spindle Travel	2in.	Overall size of Base	7 x 10in.
Depth of Gap	4½in.	Height of Column	18½in.
Diameter of Table	5½in.	Nett weight	28 lbs.
Diameter of Column	1½in.	Standard Equipment	½in. Drill Chuck
Size of Baseplate (working surface)	6½ x 7in.		

Price **£13 · 15 · 0** Carriage Paid.  
Matching Motor Pulley ½in. or ¾in. bore 11/- each.

**A. J. REEVES & CO.**  
416, MOSELEY RD., BIRMINGHAM, 12.  
Grams: "Reevesco Birmingham"  
Phone: CALthorpe 2554

**"THE CHOICE OF EXPERIENCE"**

Most sizes available from stock!

**Bridges MICRO-DRILLS**

**STRAIGHT FLUTE DRILLS.** A well-designed drill particularly recommended for drilling brass. Range of sizes: .35 mm. (.0138") to 3.0 mm. (.1181")

<p><b>PIVOT DRILLS</b></p> <p>Widely used by watch and clock making trades for drilling very small holes. Range of sizes: .05 mm. (.002") to .5 mm. (.0197")</p>	<p><b>FLAT DRILLS</b></p> <p>Similar to pivot drills but made in larger sizes. Range of sizes: .25 mm. (.0098") to 3.0 mm. (.1181")</p>
<p><b>STANDARD SPIRAL FLUTE DRILLS</b></p> <p>A general purpose drill of improved flute design for easy ejection of swarf. Range of sizes: .1 mm. (.0039") to 3.0 mm. (.1181")</p>	<p><b>SINGLE SPIRAL FLUTE DRILLS</b></p> <p>For drilling small holes to extremely fine limits. Range of sizes: .1 mm. (.0039") to 3.0 mm. (.1181")</p>

**WRITE FOR STOCK LIST**  
**S. N. BRIDGES & CO. LTD.**  
Bridges Place, Parsons Green Lane, London, S.W.6.

# FREE!

to every ambitious engineer this valuable 176-page handbook!

# B

Better days lie ahead if you add "ENGINEERING OPPORTUNITIES" to your bookshelf. If you want to put yourself in line for quick promotion, higher pay and all that goes with it, as well as the sort of job you've always wanted, this enlightening guide to success—176 pages of vital, right up-to-date information—is your blue-print for a brighter future.

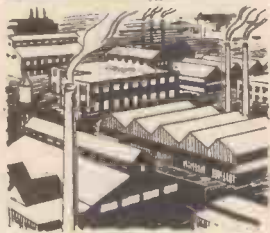

# I

In this book you will find out how to take advantage of to-day's opportunities; how you can rise to a position that ensures success, prosperity and security—the sort of job which, in Peace or War, Prosperity or Slump, makes you a "key" man on whom the craftsman or fighting-man is equally dependent.

# E

"ENGINEERING OPPORTUNITIES," besides showing how you can be helped to become a trained technician in your spare time, describes our unique Advisory and Employment Depts. Read about them and also about the superb range of Home Study Courses you can choose from... learn something of the methods that have already brought success to men in all branches of engineering throughout the world.



# T

Thousands of B.I.E.T. Students—ordinary people with no special advantages except a real desire to succeed—have, under our guidance passed *A.M.I.Mech.E.*, *A.M.I.C.E.*, *CITY & GUILDS* and other major examinations. Because of our outstanding successes, you, too, can be confident of your success, under the guidance of B.I.E.T.

WRITE IF YOU PREFER NOT TO CUT PAGE

**POST THIS COUPON TODAY!**

Please send me a FREE copy of the latest 176-page edition of "ENGINEERING OPPORTUNITIES"

IT IS UNDERSTOOD THAT NO REPRESENTATIVE WILL CALL ON ME

NAME .....

ADDRESS .....

.....

I am interested in.....  
(State subject, exam, or type of appointment that appeals to you.)

**B. I. E. T. 410A SHAKESPEARE HOUSE,  
17-19, STRATFORD PLACE, LONDON, W.1.**

Which  
of  
these  
is  
your  
Pet  
Subject?



**Mechanical Engineering**

A.M.I.Mech.E.—CITY & GUILDS—General Mechanical Eng.—Maintenance Eng.—Diesel Eng.—Sheet Metal Work—Welding—Metallurgy—Machine Drawing & Design—Refrigeration, etc.

**Electrical Engineering**

CITY & GUILDS—General Electrical Eng.—Installations—Illuminating Eng.—Electrical Science—Electricity Supply—Meters & Measuring Instruments—Mains Eng., etc.

**Radio & Television**

A.M.Brit.I.R.E.—SERVICING CERTIFICATE—C. & G. Telecommunications—General Radio Eng.—Radio Servicing—Television Servicing—Sound Film Projection—Electronic Eng., etc.

**Production Engineering**

A.M.I.P.E.—Works Management—Foremanship—Staff Supervision—Planning Eng.—Costing, etc.

**Automobile Engineering**

A.M.I.M.I.—CITY & GUILDS—General Automobile Eng.—Automobile Repairs—High Speed Diesels—Garage Management, etc.

**Building & Civil Engineering**

A.M.I.C.E.—F.R.I.C.S.—L.I.O.B.—General Building—Architectural Drawing—Sanitary Eng.—General Civil Eng.—Surveying—Specifications & Quantities—Heating & Ventilating—Painting & Decorating—Plumbing—Carpentry & Joinery—Timber Technology, etc.

PLASTICS—DRAUGHTSMANSHIP—AERONAUTICAL ENG.—FORESTRY

**SOME LETTERS AFTER YOUR NAME?**

A.M.I.Mech.E. A.M.I.C.E. F.R.I.C.S. A.M.S.E.  
A.M.I.Struct.E. L.I.O.B. A.M.Brit.I.R.E.  
A.F.R.Ae.S. A.M.I.P.E. A.M.I.M.I.

HUNDREDS OF OTHER COURSES

(Tell us what interests you)

**WE DEFINITELY GUARANTEE  
"NO PASS-NO FEE"**

We have printed "ENGINEERING OPPORTUNITIES" more than a hundred times and distributed over a million copies, to ambitious men. Whatever your age, education or experience, if you are earning less than £12 a week, you really cannot afford to miss reading it. Send for your own copy to-day—FREE and without obligation.

**BRITISH INSTITUTE OF  
ENGINEERING TECHNOLOGY**

**THE B.I.E.T. IS THE LEADING INSTITUTE OF ITS KIND IN THE WORLD**



# PRACTICAL MECHANICS

EDITOR  
F. J. CAMM

JULY, 1951  
VOL. XVIII. No. 211

Owing to the paper shortage "The Cyclist," "Practical Motorist," and "Home Movies" are temporarily incorporated.

FAIR COMMENT

By The Editor

## The Work of the N.P.L.

I HAVE often commented on the important work carried out by the National Physical Laboratory at Teddington. It is a modest body in that it does not sing its own praises, and shuns publicity. The general public is largely unaware of the valuable contributions it has made to the world of science and invention, and to industry generally. It was founded in the year 1900, and until 1918, when it became part of the newly-formed Department of Scientific and Industrial Research, it was controlled by the Royal Society. It is the second of the great national standardising laboratories, the Physikalisch Technische Reichsanstalt in Berlin having been founded in 1887 whilst the National Bureau in Washington was founded in 1901.

The N.P.L. is responsible for maintaining the national standards of mass and length, and the electrical and photometric standards. In addition to a considerable programme of fundamental research work the laboratory makes accurate determination of physical constants, carries out investigations of special problems on behalf of government departments, research associations, technical institutions, and industrial firms, and undertakes tests on instruments and materials.

The laboratory also provides an advisory service which is available free of charge to all inquirers with appropriate problems, and visits to the laboratory by appointment to discuss such difficulties are welcome.

The present testing policy of the laboratory is to encourage industry to undertake as far as possible its own testing during production, and to confine work at the N.P.L. to the testing and certification of laboratory or working standards, and to assistance in the development of prototype apparatus. To assist industry to maintain its own testing standards the laboratory calibrates reference standards and also on application advises on control and sample testing of products within its scope.

It was with more than ordinary interest that I recently visited the N.P.L. to inspect its exhibition and demonstration of scientific work and apparatus. This exhibition gave visual indication of

its great work. For example, an examination of the model of the Severn Suspension Bridge showed how the original constructional problems were overcome. In the past suspension bridges have been damaged or destroyed by oscillations due to wind.

In 1946, when the Severn Suspension Bridge was projected, a special investigation was begun at the laboratory on behalf of the Ministry of Transport to guide the designers on the aerodynamic side. The search for a stable and economic bridge design has depended mainly on two types of tests in wind-tunnels. The simpler method uses rigid "sectional" models, representing a sample length of the bridge suspended by platform only. These models are supported by springs in the tunnel airstream with freedom to oscillate in various simple ways, and from a study of their behaviour the most suitable bridge forms can be isolated. However, as such models cannot actually bend and twist, and can only be tested conveniently in winds normal to the span, confirmatory experiments by more elaborate method are also necessary. For this purpose a "full" flexible model copy of a complete suspension bridge is required, and its dimensions, masses and stiffnesses must be scaled in such a way that the oscillations of the full-scale bridge are truly reproduced.

Another exhibit showed the creep of metals. The study of the creep of metals at room and higher temperatures has been carried out in the engineering division for over 30

years, and has been of continuous assistance in the development of steam power plant, for ever higher temperatures as time proceeded, and in the choice of light alloys for reciprocating aircraft engines. It has also provided the information on high temperature materials which was needed for the development of the gas turbine engine.

The estuary of the River Wyre dries out at low water on spring tides except for a narrow channel. Surveys of both the channel and the sides have been carried out at intervals since 1944, and it has been established that the low water channel fluctuates in position from one side of the estuary to the other in some seven years. This fluctuation is extremely inconvenient to shipping using the estuary, as the boats entering or leaving on a high tide follow the course of the channel. Experiments are being carried out on a model to find the best means of stabilising the low water channel.

It is constructed by a pneumatic type of tide generator situated at the seaward end. Any variation of range and shape of tide can be reproduced.

For locating thunderstorms, the Meteorological Office uses a number of direction finders at widely separated stations; bearings are taken on the atmospherics originating in the storm. Results of satisfactory accuracy are obtained, but the method has the disadvantage that observing staff must be maintained at remote out-stations and telephone communication must be provided between them. Consideration is being given to possible methods of storm location from a single station, by taking a bearing and having some method for determining the distance of the storm.

A possible method of distance measurement is to study the waveform of the atmospheric. One type of waveform consists of an impulse which has been propagated along the ground, followed by a series of impulses, caused by the same lightning flash, but propagated by successive reflections between the earth and the ionosphere. By measuring the time intervals between a number of these echoes it is possible to derive the distance of the storm.—F. J. C.

### SUBSCRIPTION RATES

including postage for one year

Inland - - - -	14s. per annum.
Abroad - - - -	14s. per annum.
Canada - - - -	13s. per annum.

Editorial and Advertisement Office: "Practical Mechanics," George Newnes, Ltd., Tower House, Southampton Street, Strand, W.C.2  
Phone: Temple Bar 4363

Telegrams: Newnes, Rand, London.

Registered at the G.P.O. for transmission by Canadian Magazine Post.

Copyright in all drawings, photographs and articles published in "Practical Mechanics" is specially reserved throughout the countries signatory to the Berne Convention and the U.S.A. Reproductions or imitations of any of these are therefore expressly forbidden.

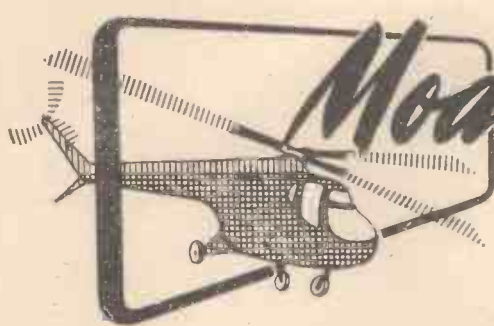

# Modelling Helicopters

With Notes on the Various Motors for Supplying the Power

By E. W. TWINING

**A**S I understand it, aero modellers are likely to welcome something which is new in their hobby: a line which opens up a fresh field for experimenting and research. Such a field is provided by the helicopter.

I have used the word "research" deliberately, for, although most makers of model-aeroplanes are content to buy a parcel of materials for building, accompanied by a drawing from which to work, there are others who both design and make their own drawings for their machines. It is to this class of model-maker that I trust this article will appeal. In it I give no really definite instructions for constructing models on any of the lines which

I shall follow it up. There is no motor; the power is supplied by the energy stored up in the weights at the rotor blade tips, by the ripping off of a cord wound around a bobbin attached to the rotor shaft. The machine, if we can call it by such a dignified title, is drawn in side elevation, end elevation and plan in Fig. 1, whilst in Fig. 2 is a detailed or exploded view of the rotor shaft A, bearings C and G, bobbin E, bobbin driving plate F, thrust washers D, and the rotor hub driving plates BB. These last, together with F, are soldered to the wire shaft. The body of the model is carved from balsa wood, with hardwood to take the bearings. The rotor

form of a hook to engage the rubber in the usual way. In the lower rotor-hub two quarter-inch dowel sticks are glued; these constitute the frame of the machine. At their lower ends the sticks are shouldered down to form spigots for fitting into sockets, i.e., simple holes drilled through a piece of  $\frac{1}{8}$  in. plywood. Through this plywood a double-ended wire hook is fixed by soldering in little plates of tin. The rubber skein is placed over the upper and lower hooks.

To wind the rubber a drill brace is used having a hook held in the chuck. With this engaging with the lowest one on the model the plywood is pulled off the dowel-stick spigots, the rubber wound and then the plywood replaced. Thus it will be seen that when the rotors are released the frame, and with it the lower rotor, will revolve in one direction, whilst the upper rotor will be rotated oppositely. I have figured in the drawing some suitable measurements for the rotors but the length of the frame will depend upon the amount of rubber to be put on. It must be borne in mind of course that the longer the rubber the greater will be the weight, and if made too long its weight will be in excess of the total lift of the rotors. The static torque of a fully wound rubber motor of a given number of strands is, within limits, the same whether it be long or short, and excessive length only has the effect of adding weight. This is a fact that is too often forgotten.

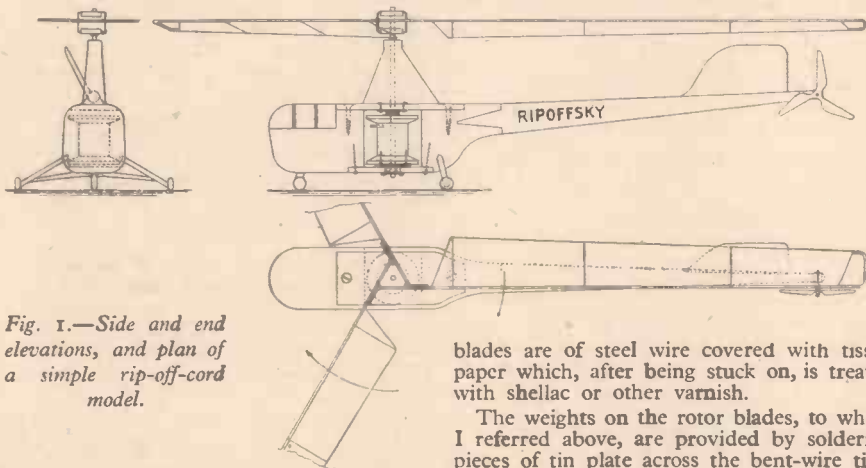

Fig. 1.—Side and end elevations, and plan of a simple rip-off-cord model.

I shall illustrate, nor is there any guarantee that such models will produce helical flight, although the simple machines should do so. It has been my purpose to suggest only the lines on which investigation and experiment should proceed.

I would point, at the outset, to the fact that whatever form the ultimately successful model assumes it can bear no resemblance to the present-day full-size helicopters: the Bristol "171" or the Westland-Sikorsky "S.51," unless the engines can be radio controlled, and that would be difficult.

The reason why existing large machines cannot be copied in miniature is that the rotor blades have an enormous aspect ratio; that is to say they are very long and narrow and, although a model made to the same proportions may rise, climb, and go on climbing, when the engine stops there would be no parachute or autogyro effect from the rotor blades, with the consequence that the model would inevitably fall and be smashed to pieces on striking the ground. In order to provide for safe descent the blades must be of low aspect ratio and have the proportions of normal aeroplane wings—which is what they virtually are and will be treated here as such.

### A Simple Model

The first design, in spite of what I have said about scale models, and in spite of its simplicity, bears a greater resemblance to a full-size prototype than anything with which

blades are of steel wire covered with tissue paper which, after being stuck on, is treated with shellac or other varnish.

The weights on the rotor blades, to which I referred above, are provided by soldering pieces of tin plate across the bent-wire tips, the recesses so formed being filled either with bits of sheet lead or built up with solder. A hook is shown in the bobbin E, Fig. 2, for the ripping cord. The name, having a somewhat Russian sound, written on the model in Fig. 1, is of course a pun on the mechanical action of the cord.

At the extreme end of the tail is shown in Fig. 1 a fin made from thin balsa sheet; this is set over at an angle so that the downwash from the rotor blades shall tend to correct the rotation of the fuselage. The little torque-reaction rotor at the tail does nothing; it is there merely for appearance and to give realism.

### Rubber Driven

I suppose it is practically unavoidable that in referring to all possible forms, or sources, of power applicable to the driving of aircraft models the twisted rubber skein must be included and suggested in connection with types other than aeroplanes. That being so I give a design here for something which can be looked upon only as an aerodynamical experiment, since it consists of nothing more than two contra-rotative pairs of lifting blades, a mere skeleton frame and a rubber motor. This is shown complete in one drawing, Fig. 3, where it will be seen that there are two rotors, one above the other, and running in opposite directions on the same axial line. The shaft for the upper rotor passes through, and has a bearing in, the hub of the lower rotor, below which the shaft is bent to the

### Calculations

In designing aircraft models it is very useful to make calculations before building, in the same way as it is necessary in connection with full size machines. For the benefit of those who are not very familiar with the relationship between areas of lifting surfaces, speeds and weights I think I may very well give some simple formulæ which are used and which I have myself employed in the preparation of the design and suggestions contained in this article. The fundamental equation is:

$$L = Kl \times A \times f \times V^2 = \text{weight in pounds.}$$

Where L is the total weight of the aircraft.

Kl is the lift co-efficient of the wing section used in lbs./units.

A the area of the wings, or lifting surfaces, in square feet.

V the velocity through the air, and f a multiplying or correcting factor which, if the calculation is to be made in miles per hour, is .0051, and if in feet per second is .00238.

The value of Kl varies not only with the contours of the wing section but with the angle of incidence as well and,

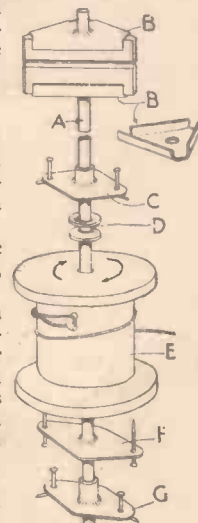

Fig. 2.—The "rip-off" rotor shaft.

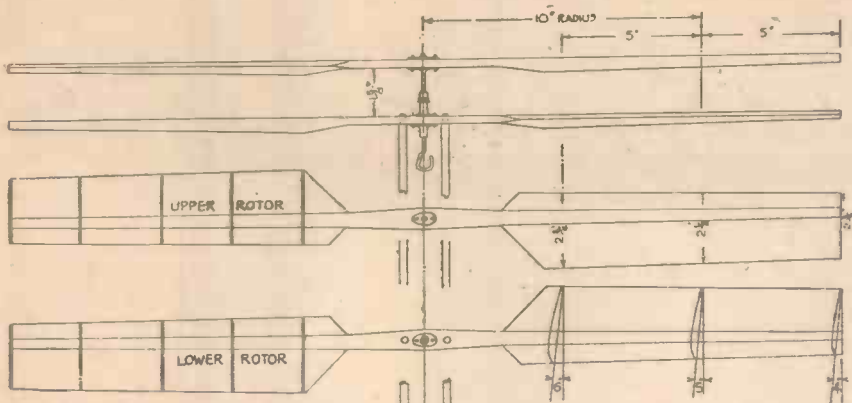

Fig. 3.—Rotor details for a rubber-driven model.

which is 96 sq. in. and  $\frac{96}{4} = 24$  sq. in. for each blade of the rotors. If the span or effective length of the blade is 10in., then  $\frac{24}{10} = 2.4$ in. for the mean chord.

For convenience I have made this, as figured in the drawing, 2½in. and, since the blade is slightly tapered, the chord at the tip will be 2⅝in. and at the inner end of the 10in., 2⅜in.

**Jetex Propulsion**

The next model is designed without any calculations, for the simple reason that I have no data on which to base them; for instance, the rotor velocity is a factor the value of which is quite

unknown.

The model introduces an attempt at jet propulsion, a source of power which, so far as I am aware, has never been tried on a miniature helicopter. The motor—there is to be one on each of three blades—is the "Jetex 100." This little power unit has a weight of 10 drams (⅝ ounce) and yields a thrust of one ounce. The manufacturers state that one such motor will fly an ordinary light aeroplane model of from 18in. to 30in. span. If we take the smaller of these dimensions and assume a mean chord of 3in., we have 54in. of wing area, but the proposed helicopter which I have drawn in Fig. 4 has no fuselage or tail unit and the only aerodynamic drag results from the wings or rotor blades, so I have shown these each with a minimum area of 45.5 sq. in., but it will be noted that I have, to the dimensioned length of the blades, added the words "or over."

In the drawing I have shown what appears to be two jets; only one is intended for each

blade, but I am not quite sure which position would be best for it, A or B. In a certain experimental man-lifting machine, built in America, two pulse-jet motors were fitted at the wing tips, one on each rotor blade, but in our Jetex motored model I am inclined to favour the mid-blade position A, for I rather think we should get a higher revolution speed. However, this can be a matter for experiment. The units must be detachable from the rotors for charging with fuel blocks and fuses.

In order to give the model stability the rotor shaft should be prolonged downward, but it should not be longer than is necessary. Such a shaft can be of straight dowel wood of 3/16in. or ¼in. diameter. Then I think it might be worth trying, on the first flight or two, having a fine thread on the end of the stabilising rod. Such a thread could have lead shot clipped to it at intervals of 2ft. or 3ft. so that as the machine rises the weighted thread would hang and the length of thread taken up would be an amount sufficient to balance the lift. The model would then never be out of the control of the operator. When it is seen how the model behaves, the use of thread could be discontinued. To fasten the shot to the thread, each shot is partly split with a chisel or knife, the thread inserted in the cut and the split closed up again with hammer or pliers.

**Engine-driven Helicopters**

In designing model helicopters powered by internal combustion engines, problems are met with which do not arise in any other kind of aircraft, nor yet, as regards at least one of them, in the case of full-size vertical lift machines. One of these problems, to which I have already referred, is the necessity for making rotor blades which will have a parachute effect when the engine stops and so prevent the machine from crashing. Of course, in the case of the full-size helicopter, the blades have, in spite of their great length and small width, a large supporting area; moreover, although the machine with a disabled or cut-out engine is bound to descend, the pilot can put it into such an attitude that the rotors continue to revolve and act in the same way as did those non-driven blades of the Cierva autogyro. In the case of a model, however, when the engine cuts out, owing to fuel exhaustion, long narrow blades without any pilot control would be of little use to sustain it.

Another problem in an engine-powered model lies in the enormous difference between the revolution speed of the engine and that of the rotors, which difference necessitates the introduction of gearing. In a model plane the propeller can usually take all the revolutions which the engine can give, and can be directly mounted on, or coupled to, the crank-shaft, but not so in the helicopter.

(To be continued.)

throughout my calculations for this article I have assumed the modest figure of .300, the mean angle being five degrees.

Obviously, the order of the factors in the equation can be changed and if some of the values are known then the formula would be written differently. Thus, if everything is known except the velocity we should write:

$$V = \frac{W(\text{lbs.})}{\sqrt{KI f A}}$$

Or if the area is the factor which is required to be found the equation would read:

$$A = \frac{W}{KI f V^2}$$

It is this last which I have used in every case because velocity was arrived at either by calculation or known revolution speeds and the weight (W) was found by adding together the carefully estimated weights of the individual parts comprising the machine in question. For f I have used the feet-per-second factor since, for models and especially for helicopters it is more direct and simple than miles-per-hour, for, of course, the velocity of the rotor blades is the result of the revolution speed per minute.

Returning to the matter of the rubber-driven helicopter, I have assumed a point for maximum efficiency in the radius of the rotor blade at 10in. from the centre, and treated the outer 10in., that is to say, 5in. on each side of that radius, as effective lifting surface; further I have estimated the revolution speed to be five per second.

Now 10in. radius or 20in. diameter  $\times 3.1416$  gives a circumference of 5.25ft. and this  $\times$  five revolutions per second = 26.25ft. per sec., and this figure squared = 689. I have carefully estimated the weight of the model to be 5¼ ounces, which we can call .33 lbs.

Substituting actual figures for the symbols in the formula we have:

$$\text{Area} = \frac{.33\text{lb.}}{.300 \times .00238 \times 689} = .67 \text{ sq. feet.}$$

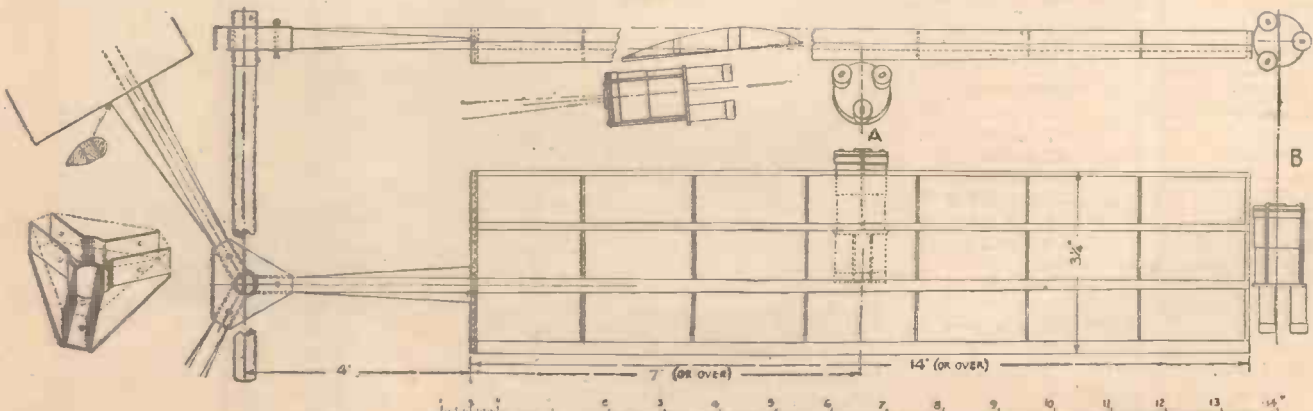
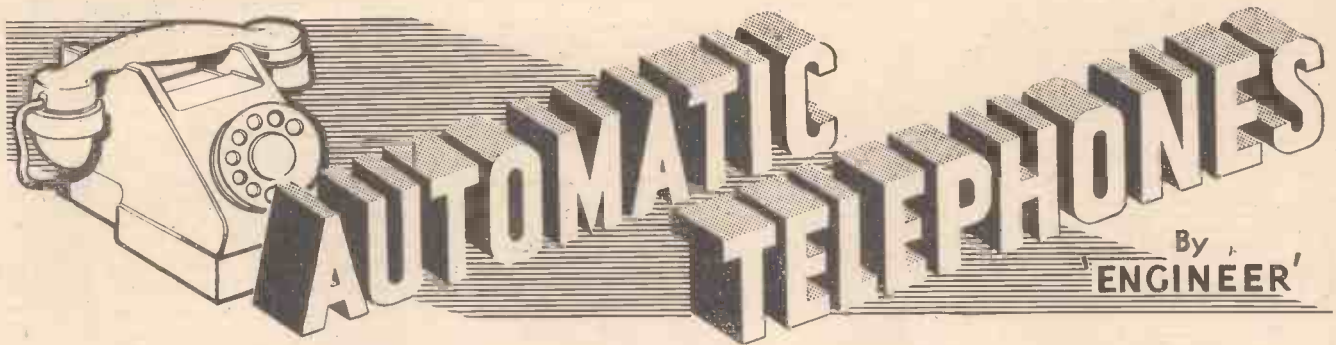

Fig. 4.—Miniature jet propulsion of rotors.



# AUTOMATIC TELEPHONES

By ENGINEER

## The Operation of the Modern Automatic Telephone Exchange Simply Explained

(Concluded from page 261, June issue)

ON dialling the digit five the subscriber puts his finger into the appropriate hole and pulls the disc of the dial round to the finger stop and lets it go, the spring taking the disc back to normal. Nothing happens to the interrupter springs until the dial starts to return to normal having been released by the subscriber's finger, but while the dial is returning to normal the interrupter springs open and close a number of times corresponding to the digit dialled, in this case five times. The speed of the dial is such that the breaks occur at the rate of ten per second, and the ratio of break to make is roughly two to one. On the other hand the line is open about .066 seconds at each break. At the selector the impulsing relay becomes de-energised momentarily at each break caused by the dial springs so that when the digit five is dialled the impulsing relay will fall back five times. Each time it falls back it sends an impulse to the magnet of the selector. At the end of the first train of impulses there is a slight pause during which time the subscriber is moving the dial round for the second digit. This pause is of necessity sufficiently long to indicate to the selector that the first train is finished and to enable it to prepare for the reception of the second train of impulses. This pause is very important and is known as the inter-train or inter-digital pause. If you look at your dial you will notice that there appears to be an unnecessarily long gap between the first finger hole and the finger stop. One reason for this is to ensure that there will be an inter-digital pause of at least half a second, no matter how quickly the subscriber dials.

### The Selector

We will now consider what the selector looks like.

There are two main types of selector, the final selector and the group selector. As in the case of the line finder, the final selector has arms wiping over terminals to which the outlets are wired. The terminals are arranged in ten rows of ten and, unlike the line finder, the wipers when at rest are not touching any terminal at all. The first train of impulses takes the wipers up to the beginning of the fifth row, still not yet in contact with any terminal. They are waiting as it were, on the threshold of the fifth row until the second digit (two) is dialled. The wipers then move in step-by-step to the second contact on the fifth row having wiped over the first contact *en route*. The wipers are now resting on the terminals on line No. 52. In the manual case, if the operator when plugging in to line 52 had carried the plug upwards to the beginning of the fifth row of jacks, then carried it horizontally along the fifth row until she reached the second jack and then plugged in, the analogy would be almost complete.

It will be seen, therefore, that the final selector receives two digits, that is, two trains of impulses, and as a result its wipers are

set on to one of a hundred possible positions. The group selector which has not so far come into our description is very similar in appearance to a final selector, but is arranged to accept one train of impulses only which raises the wipers to the required level and then automatically searches for an idle outlet in that level.

Returning to the establishment of the automatic call, we have got to where wipers on the final selector had reached the terminals of the wanted line. Immediately after the last digit is received a test is made to see whether the wanted subscriber's line is free or engaged in exactly the same way as the

operator applied the click test before plugging in; in both the automatic and manual cases the difference between a free and engaged subscriber is denoted by characteristic potential. If the line is free ringing current is automatically connected to it and is automatically stopped or tripped when the wanted party replies. If the line turns out to be engaged, in the manual case the operator will tell the calling party that the line is engaged. In the automatic case the selector tells the calling party also, using what is known as the busy tone, which is a tone of 400 cycles per second interrupted  $\frac{3}{4}$ -second on,  $\frac{3}{4}$ -second off.

### Lines Between Two Exchanges

Let us now imagine a second exchange of

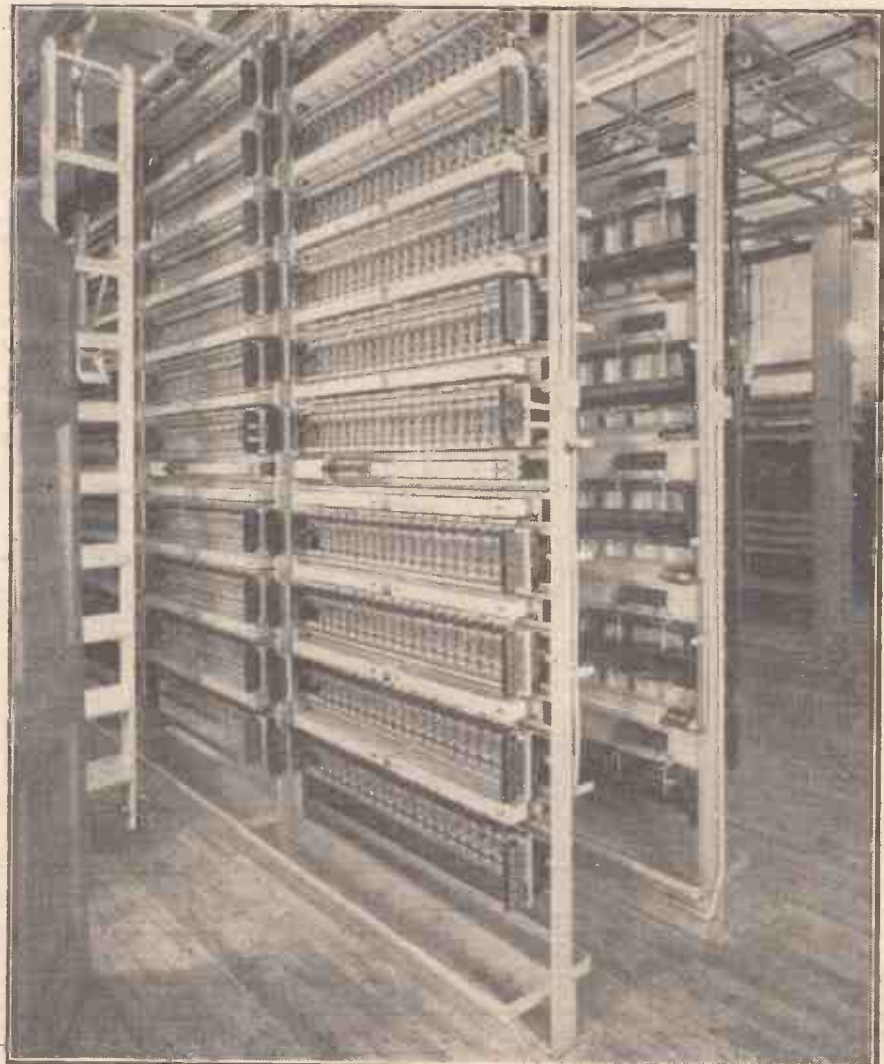

Line switch rack in a modern automatic telephone exchange.

similar type a few miles away, and that the two sets of subscribers want to be able to talk to each other. The first thing to do is to provide some lines between the two exchanges, tie lines or junctions as they are called. The number of these lines depends upon the number of inter-exchange calls that are expected to take place during the busiest hour and are calculated by the mathematicians in the same way as the selectors. In the manual case we will assume that these junctions are terminated on jacks at each end. The subscriber on exchange X wanting a subscriber on exchange Y will lift his receiver in the ordinary way and will ask the operator for a line to the Y exchange. The operator selects a free junction to the Y exchange and plugs into it, thus extending the call to the Y operator who completes the call as before.

In the automatic equivalent the subscriber will dial a special digit, such as seven, followed by the two digits of the subscriber's number on the Y exchange.

In these circumstances the selector behaves rather differently from the one previously described. In response to the first digit, that is seven in this case, it steps up to the beginning of the seventh level, on which the junctions to the Y exchange are terminated, but instead of stepping in, in that level in response to the next digit dialled, it steps in automatically moving from contact to contact until it finds a junction which is not in use. It then stops this rotary movement and cuts through to the idle junction which it has just found. The selector which receives

one digit from the dial and steps up to the corresponding level and then searches for an idle outlet in that level is known as a group selector as distinct from the final selector which has already been described. The other end of the junction to the Y exchange is connected to a final selector, which is ready and waiting to receive the last two digits which the subscriber on the X exchange is about to dial. The time taken by the group selector to find an idle junction in the wanted level is very short in that it hunts at a speed of perhaps 30 steps a second, so that even if it has to search as far as the tenth contact before it finds an idle junction the time taken will be less than half a second. If it did not go at this speed the subscriber might start dialling the next digit before the line had been extended to the final selector which would result, of course, in a lost call.

**Three-digit System**

Having introduced the Y exchange it will be necessary, or desirable, to use a three-digit system throughout for both local calls and calls to the Y exchange. This means that a subscriber originating a call becomes connected to a group selector instead of a final selector. I have deliberately laboured this point because we are approaching the point where we depart from the analogy of the manual system. In a manual exchange of ten thousand lines, which is the maximum size of a four-digit exchange, the operator can reach all ten thousand jacks, so that all she has to do to establish any local call is to insert the calling plug into the wanted jack. In the automatic case it would not be economical to use such a large switch. To get over this the automatic exchange is first of all divided into ten thousand-line blocks, and then each thousand-line block is divided into ten hundred-line blocks. The subscriber dialling say 8765 would seize a first selector circuit from which he would receive dial tone and dial into it the first digit, that is, eight. This will step the first selector up to the eighth level and cause it to search for an idle junction to the eighth thousand-line block, where the junction will terminate on a selector in this block which is known as a second selector. This selector will receive the second digit, that is seven, and in response will step up to the seventh level and search for an idle outlet in the seventh hundred-line block. This junction will terminate on a final selector which will receive the last two digits, that is, five and four. In response to the digit five, it will step up to the threshold of the fifth level, and in response to the digit four it will step into the fourth contact in that level which contact will be connected to the subscriber's number, 8765. The number of junctions between each block is calculated from the number of simultaneous calls which are likely to take place between the blocks of subscribers concerned which will, therefore, give you the number of selectors required at each stage. In an evenly balanced exchange of ten thousand lines the mathematicians might decide that a thousand first selectors are required and perhaps a hundred second

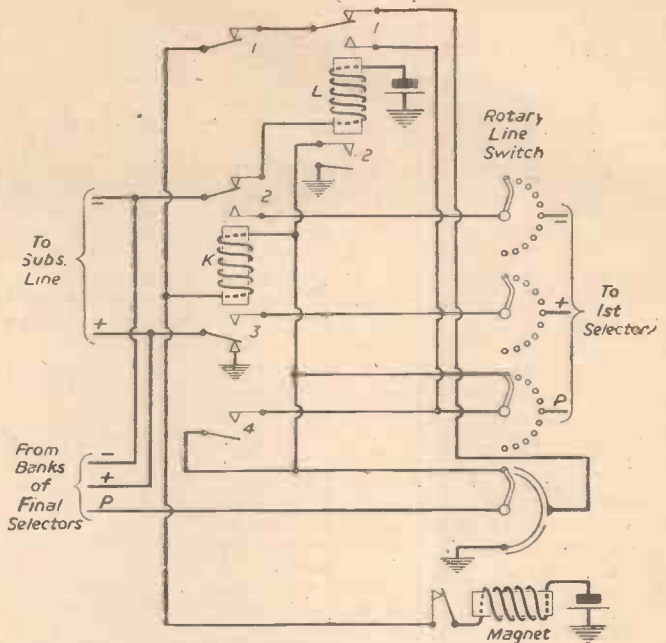

Fig. 3.—A typical subscriber's line circuit.

selectors for each block of a thousand lines, and perhaps ten final selectors for each block of a hundred lines, adding up to about 3,000 selectors altogether, each having a hundred outlets. If you had a ten-thousand-line selector, probably only a third or quarter would be required, but each switch would be enormous if it had access to all ten thousand lines. The operator, on the other hand, can reach all ten thousand lines just as easily as she can a hundred, so that it is not necessary in a manual case to divide the exchange into conveniently sized blocks.

**Two-hundred-line Blocks**

It should be stated here that in the larger automatic exchanges it is usual to divide the exchange up in 200-line blocks instead of 100-line blocks described above. The reason for this is because it is more economical to do so. A 200-line final selector is not very much larger than a hundred-line selector and the mathematicians will tell you that if the incoming calls arriving at a hundred-line block require, say, ten final selectors to handle them, double the traffic to the 200-line block would require perhaps only fifteen 200-point final selectors, so that on this basis twenty 100-point final selectors are doing substantially the same work as fifteen 200-line selectors, and if the cost of a 200-line final selector is less than half as much again as that of a hundred-line final selector, then it is more economical to use 200-line blocks.

In the foregoing description we have considered group selectors with ten levels and ten outlets per level, making a hundred outlets altogether. In modern exchange practice it is usual to employ 200-outlet group selectors which are made up of ten levels of twenty contacts per level. The reason for this is to enable the group selector to hunt over larger groups. Supposing for example you are dialling 8765, the digit eight goes into a first selector which steps up to the eighth level and searches for an idle outlet to the eighth thousand-line block. There may be some hundreds of circuits to choose from. With a hundred-point group selector you have access to only ten of these circuits, and if that particular ten are all busy you cannot get any further with your call. With a 200-point selector you have access to twenty, so that the chances of finding all twenty busy are very much smaller than

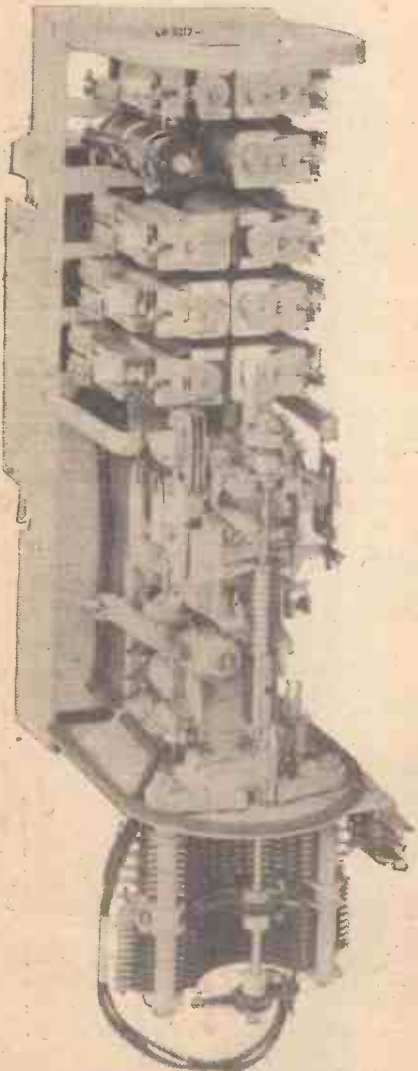

A typical final selector unit.

finding ten busy. In other words, you have a more efficient switching system. The mathematicians will tell you that if you are searching in groups of ten you will want so many circuits to carry the traffic, but if you are searching in groups of twenty you will want considerably fewer to carry the same traffic, so that while you are using slightly more expensive first selectors, in that they are 200 instead of 100 outlets, you are saving in the total number of second selectors that you have got to provide. It is, therefore, a question of weighing up the economics for a given set of traffic conditions.

### Circuit Arrangements

The subscriber originating a call lifts his receiver, thereby making a direct-current loop. This causes relay L in the subscriber's line circuit to operate (Fig. 3). (Circuit:—Battery, winding of relay L, K<sub>2</sub>, subscriber's loop, K<sub>3</sub> to earth.) L operates causing the rotary line switch to drive off its home position. (Circuit:—Battery, magnet winding of the rotary line switch, self-interrupted contacts, K<sub>1</sub>, L<sub>1</sub>, P wiper, home contact, L<sub>2</sub> to earth.) The switch thus moves on to the first outlet to the first selectors. If this outlet

is already busy there will be earth potential on the P contact, in which case the switch will drive on to the second outlet. (Circuit:—Battery, magnet winding of the rotary line switch, self-interrupted contacts, K<sub>1</sub>, L<sub>1</sub>, P wiper to the P contact and thence to the characteristic earth potential.) And so on until the switch reaches an outlet with no earth potential, where it will remain. With no earth potential to short-circuit it, relay K will now operate. (Circuit:—Battery, magnet winding of the rotary line switch, winding of the K relay, L<sub>2</sub> to earth.) The resistance of the winding of the K relay is sufficiently high to prevent the magnet operating, so that the switch will not take a further step. The K relay will extend the subscriber loop via the —Ve and +Ve wipers of the rotary line switch to the free first selector which has just been found, and almost immediately afterwards the first selector will put an earth potential on the P wire to prevent anyone else butting in. The K relay will lock itself to this earth, so that it will remain operated throughout the conversation. (Circuit:—Battery, winding of the rotary line switch magnet, self-interrupters, winding of relay K, K<sub>4</sub>, P wiper to this earth in the first

selector.) At K<sub>1</sub>, relay K on operating will break any possible driving circuit for the rotary line switch. At K<sub>3</sub>, earth potential is removed from the positive line and at K<sub>2</sub> the circuit for relay L is broken, causing that relay to release. At the end of the conversation, the earth potential disappears from the P wire, causing relay K to release.

### The Home Position

The rotary line switch then steps round to its home position. (Circuit:—Battery, magnet winding, interrupters, K<sub>1</sub>, L<sub>1</sub>, "off-normal" bank of the rotary line switch, wiper, to earth.) When the wipers reach the home position this homing circuit is broken at the "off-normal" bank. From the moment the subscriber lifts his receiver until the rotary line switch is back to normal after the conversation is over, the "P" lead to the final selector bank has an earth potential connected either by L<sub>2</sub> or by the off-normal bank of the rotary line switch. This earth potential causes the line to give the "engaged" signal to any final selector testing it.

Note.—In the first part of this article which appears on page 260 of the June issue, the reference to Fig. 2 in the centre column should read Fig. 1b.

# A Small Table Churn

## Constructional Details of a Useful Domestic Appliance

By S. BIRBECK

**T**HIS table churn is the result of a holiday spent on a farm near Penzance, in Cornwall. One day I was given the task of helping to make a small amount of butter, just for the farmhouse, and as the quantity was insufficient to be churned in the big churn, the method adopted was to

Feeling very pleased with the success of my buttermaking I decided to make a small table churn, and on returning home I set to work and built the churn as illustrated in Fig. 1.

### Constructional Details

The glass jar I bought from a sweet shop for 2s. 3d. The side plates are flame-cut, from  $\frac{3}{4}$  in. mild steel plate and filed up. Four distance bars of  $\frac{3}{8}$  in. diameter M.S. rod drilled and tapped 2 B.A. fix the side plates in their correct position. The band around the jar is made in two pieces, and is bent from  $\frac{3}{8}$  in. x 2 in. M.S. plate, and to form this I cut out from a piece of 1 in. thick oak a cross section profile of the jar. I then formed the band in two halves, but leaving it a good  $\frac{1}{8}$  in. larger all round on the inside than the outside of the jar. This was to accommodate some leather packing which I intended to introduce between the jar and the steel strap. At the ends of the half straps, pieces of  $\frac{3}{8}$  in. x  $\frac{1}{2}$  in. x  $\frac{3}{8}$  in. M.S. angle are riveted and drilled to take 4 B.A. nuts and bolts. The trunnions are made from  $\frac{3}{8}$  in. diameter silver steel rod and are forced into the mild steel flanges, which can be seen in the illustration, Fig. 2, and which are riveted to the half straps around the jar.

Some thin sheet leather strips  $2\frac{1}{2}$  in. wide were cut and fitted between the straps and the jar so that when the two half straps were tightly bolted the whole assembly gripped the jar securely. At the final assembly Bostik cement was used on the jar, leather and inside face of the steel straps. When the straps were finally tightened up the surplus leather strip was trimmed off with a sharp knife.

As will be seen, the bearings can be opened by pulling out the pin and lifting up the centre tongue which is in fact the top half of the bearing. This is hinged between the two plates bolted to the top of the main side plate and which extend above it. This method enables the jar to be quickly lifted out for washing, etc.

### Fixing the Handle

The handle is adapted from an old gramophone handle, and is fitted by means of a cotter pin in much the same manner as a bicycle pedal crank. A flat was filed on the trunnion to coincide with a tapered flat on the  $\frac{3}{8}$  in. diameter cotter pin. Handles are frequently not given sufficient thought when being designed, and have a nasty habit of working loose. It is hoped that the method used will prove lasting.

To give a finish to the job, a coat of flat red paint followed by red enamel was applied, and a thin sheet rubber washer cut to fit inside the screw cap of the jar. In use, the jar is slowly revolved so that the cream cascades from one end of the jar to the other.



Fig. 1.—The completed churn.

put the cream in a bowl and stir it with a wooden spoon.

This made my arm ache after quite a few minutes, and I began to wonder if there was not a better way of doing the job. After some more stirring and some thinking, I asked the farmer's wife if she had a large glass jar. She found an empty sweet jar with a screw-top lid and we poured the cream into this, and I sat and gently splashed it from end to end of the jar. After about five minutes the cream turned, and out came a large lump of butter.

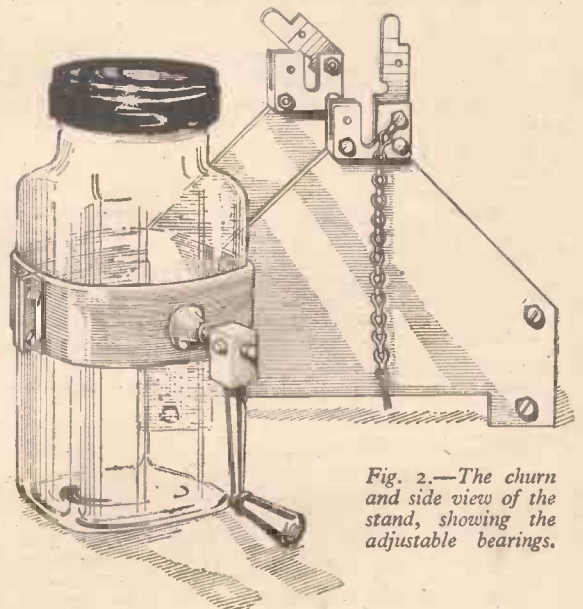

Fig. 2.—The churn and side view of the stand, showing the adjustable bearings.

# The Experimental Pile at Harwell

This Article Describes the Essential Features of the Graphite Low Energy Experimental Pile (Gleep) at Harwell, and Gives an Account of the Experimental Work

**T**HE Gleep is a slow neutron reactor using graphite as a moderator and natural uranium and uranium dioxide as fissile material.

It was constructed to meet two main requirements:

- (a) To run at as high a power as possible without elaborate cooling arrangements. This high power was needed so that radio-active isotopes could be produced in Gleep until such time as the larger Harwell pile (BEPO) became divergent.
- (b) To compare slow neutron absorption

blocks stacked in such a manner as to resemble a parquet floor. The graphite blocks are of two standard types, each measuring 7½ in. by 7½ in. by 29 in. Various non-standard and half blocks are incorporated, but leading dimensions of all blocks are based upon the fundamental "pitch" unit of 7½ in. The edges of some blocks are chamfered, and grooves are cut in other blocks, so that a lattice of diamond-shaped holes of 1.85 in. side runs through the pile from A face to C face.

The reacting core is loaded with uranium metal up to a radius of 1.75 m., the outer

thickness around the sides and is 4 ft. thick on the top of the pile.

On the B face of the pile there is a hole in the shield which is filled by graphite blocks to form a square-section thermal column of 5 ft. side and 7 ft. long. There is a large access hole on the top of the pile so that an additional thermal column can be stacked on the top of the pile if it is required.

There is an elementary ventilation system for the pile capable of delivering 5,000 c.f.m. of air. This is provided to remove active argon from the pile and to provide some cooling of the uranium cartridges. The air is forced by the baffle on A face to flow over the uranium cartridges and is extracted by a suction fan on the top of the pile. When the air system is on, it is arranged that the pressure inside the pile is always less than atmospheric; this ensures that there is no leak of radio-active air into the building. The air is ejected through a short stack on the roof of the building (the top of the stack is 60 ft. above ground level), and when the air has diffused to ground level outside the building its activity is below the tolerance level.

By using the air-cooling system the pile can be run at a power of 100 kW.

## Control Rods

The Gleep has an excess effective reproduction constant of  $2 \times 10^{-3}$ , when all absorbers are removed from the pile. This excess  $k$  is controlled by four cadmium rods which move together as shown in Fig. 1. These four rods are known as the coarse control; the single rod shown in Fig. 1 is used as a fine control. All the control rods can be moved up and down by electric motors which are situated on the outside of the pile and operated from the pile control room.

In addition there are two sets (each consisting of three rods) of emergency shut-down rods. These cadmium rods are held right out of the pile when it is operating, by magnetic clutches. If the pile power rises above a pre-set level a trip circuit cuts off the current to the magnetic clutches and the emergency rods fall into the pile under gravity. On the end of a shut-down rod shaft is a disc keyed to the shaft and positioned to rotate between the poles of four electromagnets to form an electric brake. As the rods approach the "fully in" position the magnets of the brake are energised and the rod motion is retarded to a gentle halt.

To indicate the position of the control rods in the pile, two transmitter magslips, driven through gearing so that one rotates 50 times as fast as the other, are mounted near the drive motors. These transmitters are electrically connected to receivers in the control room, so that direct readings of the positions of the rods are given on two dials. By this means the position of the rods can be read with an accuracy of  $\pm 1$  mm.

## Power Level

The power level of the pile is measured by six ionisation chambers of 5 litres volume, containing boron trifluoride gas at a pressure of 20.7 cm.Hg. Three of these chambers are used for pile control and the other three are used to operate the emergency shut-down mechanism. All the chambers have pre-amplifiers attached to them, the main amplifiers being in the pile control room. Initially, as the pile power is raised from

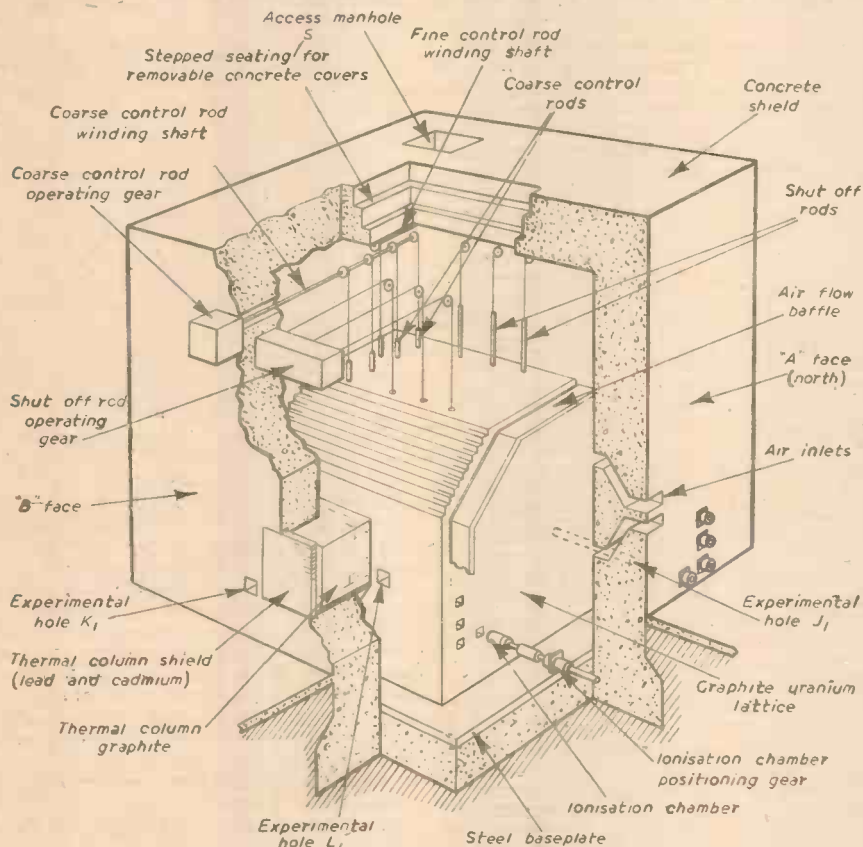

Fig. 1.—Showing the general arrangement of Gleep.

cross-sections of the elements by the pile modulation method.

As a later development it was found that Gleep could be used to provide an accurately known and reproducible thermal neutron flux in the range  $10^6$  to  $10^8$  n/cm<sup>2</sup>/sec. This flux can now be used to determine activation cross-sections.

## The Pile

The pile is built in the form of a right octagonal prism of graphite lying on one of its sides. The reacting core is cylindrical (length 5.24 m., radius 2.86 m.) with the uranium rods lying horizontally in the form of a line lattice of pitch 7½ in.; the reflector forms the remainder of the octagon, the lower corners of which are filled in with graphite introduced for constructional reasons only. Fig. 1 shows the general arrangement of Gleep.

The total quantity of graphite in the pile is 505 long tons. The graphite is stacked in 40 layers, each layer being built with graphite

region being loaded with uranium dioxide.

The uranium metal is in the form of cylindrical bars 12 in. long by 0.9 in. diameter, and is sprayed with aluminium of 0.003 in. thickness to prevent the escape of recoil fission products.

The uranium dioxide is pressed, in order to increase its density, into pellets 1.6 in. in diameter and 2 in. long. These pellets are wrapped in paper containers and inserted in batches of six into aluminium cans of 0.01 in. thickness. This makes a uranium dioxide cartridge 12 in. long by 1.62 in. diameter, weighing 2.6 kg.

The Gleep contains 12 tons of uranium metal and 21 tons of uranium dioxide.

## The Graphite Structure

There is a 3 ft. air space between the sides of the graphite structure and the inside of the biological shield. This allows access to the inside of the pile if the necessity arises for the removal of any of the uranium cartridges. The concrete biological shield is of 5 ft.

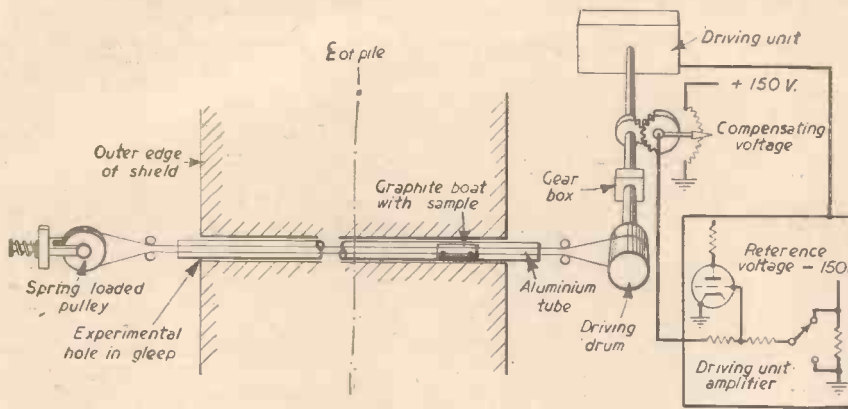

Fig. 2.—Schematic diagram of the electro-mechanical equipment.

zero, the resistor in series with a chamber is changed, so that the chamber measures all powers up to 1 kW. without any change of position. (The resistor can be changed by operating a wafer switch outside the pile.)

Above 1 kW. the chamber is wound out of the pile successively to two pre-set positions, in which the neutron fluxes are factors of 10 and 100 times lower than the flux at the original position.

In this way, with only three positions for each chamber, six decades of pile power can be measured. It will be seen from Fig. 1 that there are eight ionisation chamber holes in the pile. The two additional holes are used for experimental work; one of them is used permanently for work with the Gleep oscillator.

**Resistance Thermometers**

Rough temperature measurements are made at four points in the pile by means of resistance thermometers. Two of these thermometers are strapped on to uranium cartridges near the centre of the pile, one is embedded in a uranium dioxide cartridge, and the remaining one is embedded in a graphite cylinder which has been lowered down one of the vertical experimental holes. The temperatures are recorded continuously in the control room, and it is arranged that if the temperature of the uranium metal cartridges exceeds 60 deg. C. the pile is automatically shut down.

Gleep has only seven experimental holes, so details of all of them are given below:

- (a) Hole J<sub>1</sub>, running from face A to face C through the centre of the pile, 3in. diameter. Since this hole is along the axis of the pile, and therefore parallel to the uranium holes, it is used for pile oscillator work.
- (b) Hole J, running from face B to face D through the centre of the pile and thermal column, 3in. diameter.
- (c) Hole K, to one side of the thermal column, running from face B to face D, 5in. x 4in. The maximum slow neutron flux in this hole at 100 kW. is  $3.0 \times 10^{10}$  n/cm<sup>2</sup>/sec, and this hole was used for the manufacture of radio-isotopes when Gleep first began operating.
- (d) Hole L<sub>1</sub>, to one side of the thermal column, running from face B to face D, 8in. x 8in. This hole can be used for testing the effect on the reproduction constant of the pile of inserting large quantities of material.
- (e) Hole W, running from top to bottom of the pile through the centre, 3in. diameter.
- (f) Holes X and Y, running from top to bottom either side of hole W, 4½in. diameter.

Although, in the foregoing list, holes J<sub>1</sub>, J and W are all stated to pass through the centre of the pile, they are, in fact, offset from each other by half of a lattice pitch.

**Temperature and Pressure Coefficients of Gleep**

Soon after Gleep started operating the pile control rods were calibrated so that the

amount of k they took up when in a given position in the pile was known. This was done by first of all balancing the pile with the control rods so that it was running steadily at low power, then withdrawing the control rods a measured amount, at the same time observing the rate of rise of pile power. From a knowledge of the number of delayed neutron emitters, the half lives of these emitters and the rate of rise of pile power, it is possible to calculate the change which has been made in the effective reproduction constant (2).

Also shortly after the pile started operating, a run was made at 100 kW. without the air-cooling system on. As the temperature of the pile rose, the control rods had to be withdrawn in order to keep the power at 100 kW. From the calibration of the control rods and the measured temperature rise the temperature coefficient of the pile was deduced.

The temperature coefficient depends on the temperature distribution in the pile, but for a pile running without any cooling the temperature is, of course, highest at the centre and falls off towards the edges in much the same way as the thermal neutron flux does.

For such a temperature distribution, and for the same change in the graphite temperature as in the uranium temperature at the centre of the pile, the temperature coefficient was found to be:

Change in effective reproduction constant is:  $-2.9 \times 10^{-5}/^{\circ}\text{C}$ .

It should be noted that the pile has a negative temperature coefficient, and that this prevents the pile from rising to a very high temperature if, for example, the control system were to fail. In fact, since the excess k of Gleep is only  $2 \times 10^{-3}$ , a temperature coefficient of  $2.9 \times 10^{-5}/^{\circ}\text{C}$ . means that the Gleep could only rise 70°C. in temperature before all the excess k disappeared.

The pressure coefficient of the pile was measured in the following way. The pile was run steadily at low power for about half an hour, and then the control rods were set in position. Next, with all the holes in the pile shield closed as well as possible, the extractor fan was switched on. This put

the pile under 3.5 cm. of water suction (the mean value as recorded by a manometer on either side of the pile), and the rise in pile power was observed for 15 minutes.

From the rate of rise of pile power the pressure coefficient was calculated, and the answer obtained was:

Change in effective reproduction constant is:  $-6.5 \times 10^{-6}/\text{mb}$ .

This coefficient is also negative, since an increase in atmospheric pressure increases the amount of nitrogen in the pile and reduces its reactivity.

**High Power Running of the Pile**

In order to check that no dangerous amount of activity was escaping from the stack at high power running, a 20 atmosphere Argon chamber was installed in the top of the stack to measure the gamma activity of the effluent from the pile. During the initial runs at high power it was noticed that not only did this chamber give a higher current than would be expected from the Argon 41 activity, but also that this activity built up with time when working at a constant power level. This suggested that fission product activity was escaping from the uranium in the pile, and the following experiments confirmed this.

An aluminium tube was placed through the J hole of the pile. Arrangements were made to flow air through this tube and then over a Geiger-Müller counter. With the pile running at constant power, a given flow of air was passed through the system and the background counting rate due to the Argon 41 was determined. A small foil of bare uranium of known area was then put into the centre of the tube and the counting rate due to the fission products carried off from the foil obtained. This bare foil was then replaced, first by samples of the aluminium-sprayed uranium rod, and secondly by a uranium dioxide cartridge. The results of this comparison of bare uranium with the two types of cartridge used in the pile showed that whereas the aluminium spraying was 99.5 per cent. efficient, the uranium dioxide cartridges were leaking gaseous fission products into the air-stream at a very high rate.

In view of these results the channels of the pile containing the uranium dioxide cartridges were blocked off from the air-stream. Since they form the outside ring of the pile where the neutron flux (and therefore the heat output) is low compared with the central channels, this did not, in fact, make the oxide cartridges rise appreciably in temperature when running at 100 kW.

The discharge of fission products with the associated build-up of activity on the stack monitor was reduced by a factor of 10.

**Experimental Work Done on Gleep**

Most of the experiments described here were done with the Gleep oscillator, and so an account of this oscillator is given first.

The oscillator takes small samples rapidly from the edge of the pile to the centre of hole J<sub>1</sub>. These samples are moved in and out

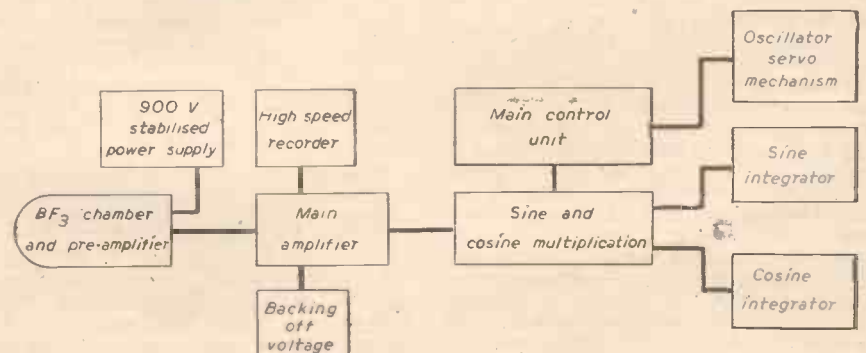

Fig. 3.—Schematic diagram of the electrical equipment.



of the pile with periodic motion, and this induces a periodic modulation in the power level of the pile. This periodic modulation in the power level is measured by a boron trifluoride ionisation chamber, is amplified, and the resulting signal integrated. The integrated signal is a measure of the change in *k* produced by a sample.

The samples are housed in a graphite container and can be driven from the outside of the pile shield to the centre of the pile by means of an electro-mechanical system (Fig. 2). The samples are moved between these two positions in a regular manner so as to produce a periodic modulation of the pile power (the samples remain in each position for 30 seconds and take three seconds to move from one position to the other).

**Block Diagram**

Figure 3 is a block diagram of the electrical apparatus used in the measurements. The main control unit governs the motion of a sample in the pile. The current from the boron trifluoride ionisation chamber consists of two parts:

- (a) A steady current, which produces a voltage across the resistor in series with the chamber. This voltage is balanced by a "backing-off" voltage, which is a measure of the mean chamber current.
- (b) A periodically varying current due to the periodic modulation of the pile by a sample. The voltage that this produces across the resistor is amplified by the D.C. amplifier. The voltage output from the amplifier is multiplied separately by sine and cosine

factors of the same periodicity as the motion of the sample (this is done by having sliders moving with simple harmonic motion across resistor cards connected to the output of the amplifier), and is then fed into two velodyne integrators and integrated for one complete period.

The integrated answers are thus proportional to the two fundamental components in the Fourier analysis of the pile modulation. If we consider only the first harmonic components in the pile modulation, it may be shown that the percentage modulation (the actual depth of modulation divided by the mean power level) produced by a sample is proportional to the change in *k* it would produce if placed at the centre of the pile (49). Thus the integrated answers are a measure of change in *k*.

# Copying Cradle for a Leica Camera

A Handy Unit for Miniature Camera Users

By R. C. WALKER

**E**XTENSION tubes for use with Leica Elmar lenses for reproduction of very small photographs, line drawings, etc., are now easily obtainable, but the possessor of such useful accessories is left in doubt as to the best way to support the camera when copying. Since the depth of focus under such conditions is very small, some precision in mounting is essential. It is not difficult for the amateur who is handy with simple tools to construct a mounting cradle which will prove extremely useful.

Faced with the job of making a number of copies of small line drawings, the writer made up the device described below at the cost of a few shillings.

**Constructional Details**

First of all it is necessary to make the frame which is to support the camera horizontally. This was constructed from a sheet of 1/16in. or 3/32in. aluminium which had previously formed the baseboard of some experimental radio equipment. The fact that this sheet already had a number of small holes drilled in it where they were not wanted was merely incidental! This plate must be perfectly flat, otherwise it is useless. For this reason, wood, even if well seasoned, is useless unless inconveniently thick.

The centre portion of this metal sheet is cut out to the shape and size indicated in Fig. 1 by drilling holes at the corners of the marked outline and joining the holes by hacksaw cuts. The ragged edges of the hole are then filed down smooth.

At each corner of the plate a 3/8in. or 1/2in. diameter hole is drilled in the positions shown. These holes serve to allow the camera support to be moved in vertical guides, as shown in Fig. 2.

In order to fix the camera in position, four pieces of hardwood of 1/2in. or 3/8in. square section, cut to the lengths shown, are prepared and covered on two sides with strips of velvet cut to shape and glued in position. Those wooden strips are fixed to the base-plate by marking their outline on the latter with a pencil and then drilling and countersinking holes from the opposite side to receive No. 3 3/8in. wood screws. If the holes are drilled slightly too large there will be sufficient play to enable the final screwing down to be done with the camera in position so as to secure a comfortable push fit.

**Base**

The remaining half of the cradle can now be constructed as follows. A base,

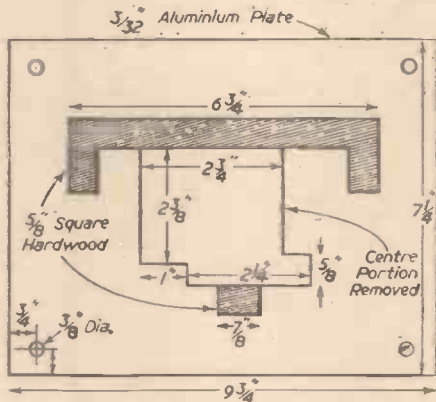

Fig. 1. Plan of camera carrier

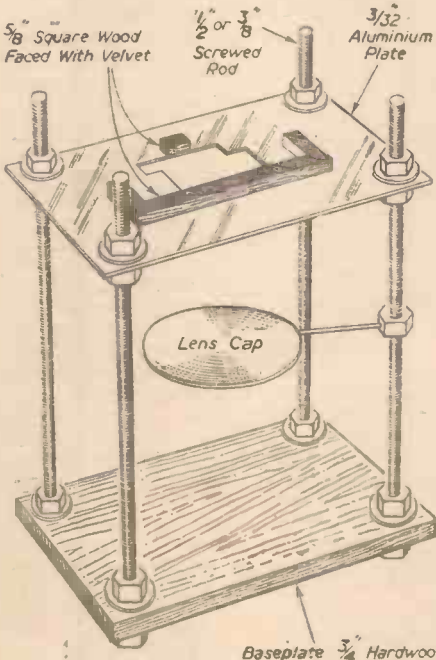

Fig. 2. Perspective view of the finished cradle

similar to the camera support must be made, and this can also be of metal, or well-seasoned hardwood not less than 3/4in. thick.

This base should be slightly larger than the camera carrier and should be drilled at the corners in exactly the same positions. Assuming that the size of the holes chosen is 1/2in., it is now necessary to secure four 12in. lengths of screwed 1/4in. rod each with four hexagonal nuts and two washers. At each corner of the base one screwed rod is inserted and made spanner tight between the two nuts and washers. The screwed rods must not protrude through the bottom nuts since these form the supporting feet and must be identical in order to stand level.

If now the work has been carefully done the holes in the camera carrier will coincide exactly with the spacing of the uprights, and the camera carrier can be supported at each corner by one of the remaining nuts.

**Calibrating**

To calibrate the device the baseboard should be placed on a level surface and tested with a spirit level in two directions at right angles to each other. With the 3:1 extension tube on the camera the lens mount should be 200 mm. from the object plane. Run the nuts up the vertical pillars until this is approximately correct, then finally test each distance with callipers and screw the remaining nut down finger tight to clamp the upper side of the camera carrier and hold it in position.

By giving the supporting nuts a fraction of a turn the height of the camera carrier can be adjusted with considerable precision. When the final position is attained a simple distance gauge can be made from a straight piece of 1/4in. rod so that the position of the carrier can at any future time be set up quickly without the use of callipers.

The same procedure can be carried out with the three other extension tubes supplied for the Leica camera, and three corresponding gauges made for use with them.

**Lens Cap**

Since all copying requires time exposures, a convenient lens cap can be made from a matt black metal disc with a supporting arm screwed into a nut on one of the upright pillars, as shown in Fig. 2. This enables it to be swung out of position quite easily when required.

# MAKING DECORATING MATERIALS

## Cutting Costs by Making Your Own Paints and Distempers

By J. F. STIRLING

**H**OUSEHOLD decorating at any season of the year is a serious business nowadays, if only on account of the high costs of the materials used. There is, of course, no doubting the excellence of the majority of the products retailed by the local decorator's shop. Yet, for many a small job of home decorating, it is often possible to make up one's own preparations and, with them, turn out a result which is in every way as satisfactory as that obtained by the use of the recognised proprietary products.

It is mostly a case of grasping the basic principles underlying decorative materials, for, after all, there is nothing mysterious in paints, distempers, pigments, and all the rest. You merely experiment in a small way, and having satisfied yourself of the quality of your product you make it up on a larger scale for your own immediate purpose.

### Nature of Paint

Let us consider, in the first place, the nature of paint. There are many types of paint, but it is the oil paints with which we shall deal in the present instance. A paint is merely a mixture of pigment and "vehicle," the latter being the oil or oil-resin solution in which the pigment is bound. The vehicle contains "driers" also. These are materials (usually dissolved in white spirit) which promote the absorption of oxygen by the paint oils, with the formation of a resinous material which binds the pigment particles together and thus keeps them in position when the paint is brushed or sprayed on to a surface. In the case of cellulose paints, a solution of cellulose usually constitutes the "vehicle" in which the pigments are ground. Such paints do not contain driers since they dry not by a skin-forming oxidation but merely by a simple evaporation of the vehicle solvents.

A paint pigment must, naturally, be very finely ground and free of grit. Obviously, it should be reasonably stable to light. Often the pigment is very considerably "extended" or diluted with a white and inert material, such as China clay, barytes, silica flour, or even common whiting. The greater the proportion of extender in the pigment the smaller the manufacturing costs of the paint, but the less, also, the colour "body" of the paint.

The basis of all good oil paint is linseed

oil, or one of its substitutes, which must, incidentally, be a "drying" oil, i.e., an oil which will abstract oxygen from the air and so set up film-formation. Turpentine substitute, otherwise white spirit, is *not* a drying oil. Its role is merely that of a diluent of the drying oil, thus being useful in keeping down costs.

If we brush a thin film of raw linseed oil on to a clean surface the oil film will remain tacky for weeks, assuming that it is not absorbed into the surface. If, however, we mix a little "drier" with the linseed oil, the resulting film will dry overnight, or in a matter of days, according to the amount of "drier" mixed with the oil.

Most paints contain from 60 to 80 per cent. of solid constituent. This means the pigment plus the extender. The remainder of the paint consists of the vehicle, i.e., the drying oil and its diluent (or "thinner"); the dissolved resins (if any), and, of course, the very necessary "drier."

### "Flat" Oil Paint

With this knowledge in mind we may now



An old-fashioned metal pestle and mortar makes an excellent appliance for the small-scale hand-grinding of mineral paint pigments.

essay to make up a small batch of paint for ourselves and afterwards try it out on a home decorating job. Let us try first an undercoat paint which will dry with a flat surface. Here is the general formula:

Pigment ...	70 per cent	(by weight).
Drying oil... 15	"	"
Thinner ... 15	"	"

In the above formula the pigment used may contain up to 50 per cent. of its bulk of extender (barytes, whiting, China clay, etc.), whilst the drying oil is usually raw linseed oil, although other drying oils, such as tung oil, may be used. The thinner is nearly always white spirit which, for economy, may contain up to 25 per cent. of its bulk of paraffin.

The subject of paint driers is a complicated and highly technical one. The paint drier should be mixed with, or dissolved in, the drying oil, and it should constitute some 2-3 per cent. of the weight of the drying oil. The more drier you put in the quicker the paint dries. Do not forget, however, that the drier has a sort of continuing action even after the paint film is quite hard, and, therefore, the use of too much drier will

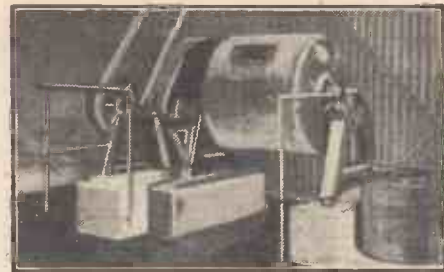

The orthodox paint mill. It is a rotating cylinder or drum, containing a number of steel balls. The pigment and paint "vehicle" are charged into the drum and the latter is rotated for two or three days, during which time the steel balls continuously grind the pigment into the vehicle.

result in a paint which will, in time, become astonishingly brittle and which will chip away very readily.

Solutions of drying materials can be purchased ready made at most decorators' shops. Their compositions vary a good deal, because there are many different materials which will act as driers. From the amateur's viewpoint the most convenient driers are those of the naphthenate class, either lead naphthenate or cobalt naphthenate. An excellent drier for all classes of oil paint is a simple mixture of 95 parts (by weight) of cobalt naphthenate and 5 parts of lead naphthenate. This mixture causes the paint layer to dry at a uniform rate throughout. It does not result in a hard paint skin being formed with still-soft paint underneath, as many of the driers do. The above mixture should be dissolved in the linseed oil of the paint *before* the thinner is added to it.

Incidentally, if you cannot get the naphthenate driers locally, you will obtain them from any good firm of laboratory suppliers, or, perhaps, direct from the manufacturers, Messrs. Thos. Tyrer & Co., Ltd., Stratford, London, E.15.

In making a batch of paint to the above formula, dissolve the 2 or 3 per cent. of mixed driers in the linseed oil. The oil will have to be warmed for this purpose. Then, when the oil has cooled down, stir in the thinner—white spirit or white spirit-paraffin mixture.

### Grinding Essential

The pigment (plus extender, if used) must be quite dry. It is best to put it in a warm oven for a few days beforehand. The pigment must be as fine as flour, also. Do not tumble the whole of the pigment in the liquid medium. It is better to add a little of the oil to the pigment so as to form a paste and then, gradually, to thin this paste out by adding more and more oil. Mere stirring is not sufficient in this paint-mixing business. The oil and pigment must be ground *together*. If you can command the services of the orthodox pestle and mortar, so much the better. If not, use something heavy in order to force the pigment particles into intimate contact with the oil. On the commercial scale, the pigment and oils are ground together for days. Hence, ordinarily speaking, the longer you grind the paint mixture the better the paint. Having made the batch of paint, brush a little of it out on to an unabsorbent surface to test its drying time. If it dries too slowly, add a little more of the drier. Bear in mind that rapid drying is not necessarily the sign of a good paint. Normally, a drying time of about 24-36 hours is quick enough for most purposes, and a paint which takes this time to dry will not become unduly brittle in the course of time.



One cannot use a mechanical paint mill for small-scale paint-making. In this case the pigment should be made into a paste with a little of the oil or "vehicle" as shown here. The paste is then gradually "reduced" by further additions of oil.

The drying time, however, is dependent on the proportion of driers in the paint.

**Full Gloss Paints**

The following is the formula for a full gloss paint. It is made up on precisely the same principle as the previous flat paint. Note that its pigment content is less (which means that the proportion of extender in the



*A thick film of softened and disintegrated paint being scraped away after treatment with a paint remover.*

pigment will have to be rather less) and that its drying oil content is more than double that of the former flat paint. It is the high drying oil content which imparts the gloss to the paint.

Pigment .....	60 per cent. (by wt.)
Drying oil .....	34 " "
Thinner .....	6 " "

Here, the thinner has been cut down to a minimum, being just sufficient to make the paint flow easily under a brush. You can, if you wish, increase the proportion of thinner (white spirit) but it is likely to be at the expense of the gloss. A little oil varnish mixed with the oil heightens the gloss, but this admixture is by no means necessary to get a good paint.

Priming paints for woodwork are simple to make. They consist of raw linseed oil mixed with one-third of its bulk (or even more) of white spirit or paraffin thinner and worked up to ordinary paint consistency with a mixture of equal parts of white lead, red lead and silica flour or whiting, the latter acting as an "extender." The red lead increases the hardness of the film, and, for outside work, its use is more or less essential. For indoor work the red lead can be dispensed with and the proportion of extender increased.

In a priming paint for use on metalwork, pigment consisting of 80 per cent. of red lead and 20 per cent. extender is often used. Zinc dust, micaceous iron oxide, and even ground slate are often used for the pigments of grey priming paints.

Bituminous paints and "varnishes" are simple enough to make. Most of them are merely solutions of blended bitumens in solvent naphtha. An excellent blend contains about 70 per cent. (by weight) of a hard, glossy bitumen (such as natural "gilsonite") with a softer grade of bitumen. The two bitumens are gently melted together and then thinned out carefully with the naphtha until a black liquid of paint consistency is obtained. By stirring into this mixture a quantity of red iron oxide, the brick-red coloured bituminous paint is obtained. Such paints, of course, are useless for household interiors, but they are of very decided value as protective paints for sheds, gutters, etc., if only for their high water resistance.

**Cellulose Enamels**

Cellulose paints comprise a highly technical subject for the amateur to tackle. They are, also, apt to be expensive. The simplest type of cellulose paint or enamel is made by working a pigment (and extender, if desired) into

a viscous medium made by dissolving scrap celluloid in a mixture of amyl acetate and acetone (equal parts) and by adding a few drops of castor oil in order to "plasticise" the paint and to prevent it from becoming too brittle.

A better type of vehicle or medium for a cellulose paint has the following formula:

Scrap celluloid .....	15 parts (by wt.)
Ethyl acetate .....	17 " "
Amyl acetate .....	25 " "
Naphtha (water-white) .....	60 " "
Benzene .....	40 " "
Boiled linseed oil ...	8 " "
Methylated spirit ...	26 " "
Castor oil .....	3 " "

Pigment is ground into this medium to make a cellulose paint which adheres well to clean metal work.

Often the home decorator may desire to paint over a somewhat porous surface. This is a somewhat wasteful operation because much of the paint oil is absorbed into the surface, and, therefore, the surface should first of all be dressed with a sealing liquid, which is merely a diluted flat paint. A typical sealing liquid is the following:

Pigment (and extender) .....	50 per cent. (by wt.)
Boiled linseed oil .....	30 " "
White spirit thinner .....	20 " "

After this has dried out, the porous surface can be painted directly with an ordinary gloss paint.

Another item which can readily be manufactured at home is the common paint stopping which is used for filling up holes and cracks in woodwork and other surfaces prior



*Fine sieving of the ground and dry pigment is a necessity in colour-making in order to eliminate gritty particles.*

to painting. This is merely a mixture of putty and white lead paste in about equal proportions. If sufficient red lead is worked into the mixture to colour it pink, the material dries harder.

Putty, incidentally, is composed of 82 per cent. of whiting ground into 18 per cent. of raw linseed oil, both proportions by weight. The whiting must be quite dry before being used for this purpose.

**Colour Washes**

Coming now to water paints, the simplest of this class is ordinary whitewash, made by stirring up whiting in water. This gives a soft white colour which is generally not improved by stirring a little blue into it, since the blue often imparts a greyish tone to the white surface. Other pigments, however, can be stirred into the mixture to produce the usual "colour-washes," a little yellow ochre (not overdone in amount) being very effective in producing a "cream-wash." For indoor work on ceilings it is better to use a solution of size, say 5 parts of size in 95 parts of water, as a binder in place of plain water.

Limewash, strictly speaking, is a mixture of quicklime and tallow, about 12lb. of

tallow being mixed with every 1 cwt. of quicklime. Water is added to this mixture, and the heat generated by the slaking of the quicklime melts the tallow so that the latter mixes with the lime. Boiling water is then added to form a thin cream. The tallow and the lime interact, forming calcium stearate which acts as a binder and which is also water-resisting. For outdoor work this "limewash" is better than any other of its type.

**Making Distempers**

Household distempers are not easy to make. They are of two types, the lime-casein paint, and the more common "oil-bound water paint." The latter is nothing more or less than pigments dispersed in an emulsion of a drying oil in water.

Dissolve about 10 parts of glue or gelatine in 90 parts of water. To this liquid add a few drops of carbolic acid to prevent it from going mouldy. Then warm it and dissolve about 5 parts of shredded soap in every 95 parts of the liquid. Stirring the soap-gelatine liquid, drop into it (drop by drop) 10 parts of raw linseed oil. Then grind into this liquid sufficient whiting to form a creamy, brushable medium. Here is your "oil-bound distemper." You have broken up the linseed oil into minute globules in the soap-gelatine solution and, subsequently, you have coated the tiny particles of pigment with this mixture. The result is that when you brush the paint on to a surface the water evaporates, leaving behind the glue or gelatine, and the thin film of linseed oil which is thus deposited on the surface oxidises, so that the pigment particles are lightly bound with the resinous product of the oil oxidation plus the gelatine or glue. The medium, therefore, amply holds the pigment particles so that they do not easily brush off. Such paint, too, when dried out on a surface is "washable," but should not be scrubbed.

In this connection, a note on the so-called "petrifying liquids" which are sold in shops may be of interest. This title is an absurd misnomer. The liquids are not petrifying in any sense whatever. They are merely sealing liquids. Most of them are just diluted forms of the oil emulsion which is used for the making of the paint or distemper. Thus, if you dilute, say, one-third with water the oil-emulsion prepared as above, you obtain a "petrifying" liquid. This, when brushed over the wall surface, prior to distemping, not only seals the pores of the wall but also provides an additional "key" for the paint to attach itself to. The liquid improves the adherence and the durability of the paint, but it is definitely not in any sense a petrifier.

**Pigment Preparation**

The distemper prepared on the above lines will be white. Coloured pigments are all made on a basis of whiting, the colouring-agent being mixed in small proportion with the whiting. On the small scale, this admixture requires some care. Suppose, for

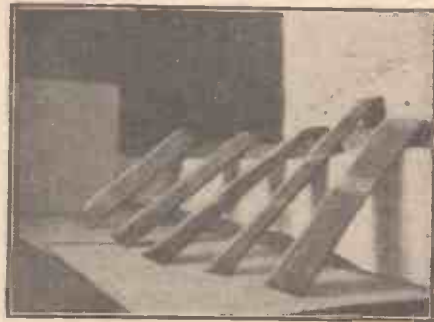

*Paint test-strips awaiting routine inspection in a commercial paint laboratory.*

instance, you are making pigment for the ever-popular cream distemper. This pigment is merely whiting plus a little yellow ochre, say, 2 per cent. of the latter. It would be a very difficult job, without adequate machinery, to get an even result by trying to stir 2 per cent. of yellow ochre into 98 per cent. of whiting. The best way is to take one-half of the whiting and to grind it with the full total of yellow ochre, a little at a time. You will then have one-half of the whiting pigmented. Subsequently the pigmented half and the unpigmented half of the whiting are ground together to produce a mass of whiting which is uniformly pigmented throughout.

This matter of pigmentation is most important, for which reason it is always advisable to make up the whole of the distemper required in one operation after carrying out experimental trials.

The alternative type of distemper is based on lime and casein. A typical formula is given below:—

Pigment and extender	80	per cent.	(by wt.)
Casein powder	10	"	"
Slaked lime	6	"	"
Borax	4	"	"

This is a very good distemper, its main disadvantage being the rather high cost of the casein. It is made up dry, and is then made ready for use by grinding it with water to a thin paste, which is brushed on to the wall. In practice, the paste is made up with

hot water, and the mixture is allowed to stand for about an hour before use in order to let the traces of air mixed with the powder escape. If this is not done, "pinholes" may appear on the wall.

After the distempered surface has dried off, carbon dioxide is slowly abstracted from the air and a chemical reaction sets in, whereby the casein becomes quite insoluble.

#### Paint-removers

The subject of paints is nowadays very closely allied to that of paint-removers, of which there are now many brands on the market. Solutions of caustic soda very rapidly soften paint and thus facilitate its ready removal, but the objection to these powerful alkalis is that they attack woodwork and many varieties of metalwork.

The modern "solvent" paint removers are much better in operation. They consist of mixed solvents containing a little dissolved wax. When brushed on to a paint surface the solvents would normally evaporate rapidly. However, a wax skin forms on the surface of the applied layer of paint remover. This retards the evaporation of the solvent, so that the latter is given time to attack the paint layer below it and thus soften it. The result is that after a minute or two the whole coat of paint becomes softened throughout so that it is able to be scraped away with a blunt-edged tool.

A typical formula for a modern paint remover is:

Benzol	5	parts (by vol.)
Ethyl acetate	3	" "
Acetone	2	" "
Paraffin wax	1/2	part "

The ethyl acetate can be dispensed with and the proportion of acetone increased, but, in this instance, the liquid will be more volatile. Any kind of wax can be used in place of paraffin wax. The wax should be melted and then slowly stirred into the mixed solvents. Remember that the solvents are highly inflammable.

Finally, a note on a good paint brush cleaner, a preparation which is, at times, in great demand. Here is an excellent formula for such a medium:

A.	Petrol, paraffin or white spirit	2	parts (by vol.)
	Oleic acid	1	part "

B.	Strong ammonia	1/4	" "
	Methylated spirit	1/4	" "

Mix A and B separately. Then stir B into A (not vice versa) until a smooth cream results. The mixed liquids can be kept for any length of time in well-corked or stoppered bottles.

This preparation will conquer the most refractory and obstinate paint-hardened brush without harming its bristles. Merely stand the brush for 24 hours in the mixed liquid. Then wash it out thoroughly with hot water and soap.

## New Diesel Locomotive for British Railways



Perspective view of the completed locomotive.

which are directly driven by auxiliary engines. These latter engines are A.E.C. 6-cylinder marine type A210D units 120 mm. bore and 140 mm. stroke, employing Ricardo Comet III combustion chambers. These engines operate over the speed range of 1,300 to 1,800 r.p.m.

The transmission system is entirely mechanical, and involves the use of differential gears as the means of grouping together the output of a number of propelling engines. Each engine drives the input side of a Vulcan Sinclair fluid coupling through Bibby spring couplings on the ends of the crankshafts. To further extend the speed range a special type of gearbox is incorporated.

The final drive to the driving wheels of the locomotive is by a form of Pennsylvania drive in which tubular quill shafts surround the two centre axles, the ends of the

**A** NEW diesel-mechanical locomotive for main line traction has recently been built at the L.M.R. Works at Derby. Numbered 10100, the new locomotive has been jointly developed by Mr. H. G. Ivatt, M.I.Mech.E., chief mechanical engineer of the London Midland Region, and Fell Developments Ltd. The locomotive has eight-coupled driving wheels, and a four-wheeled bogie at each end.

Four main propelling engines are employed, each of 500 nominal h.p. and two auxiliary engines driving the blowers, etc., each developing 150 h.p. The main engines, which are arranged in pairs at the ends of the locomotive, are vee-type 12-cylinder R.P.H. series made by Davey Paxman and Co., Ltd., Colchester. They are of 7in. bore and 7 1/2 in. stroke, and operate over a speed range of 500 to 1,500 r.p.m.

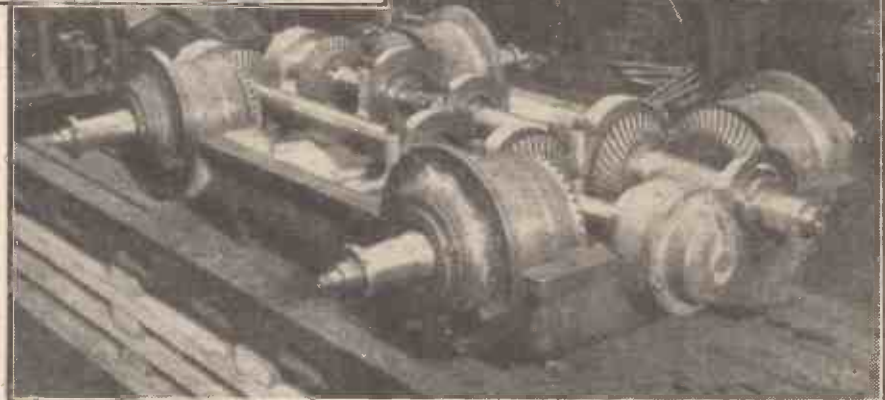

Gearbox top casting, with spiral bevel gear wheels and three clutches assembled.

#### Supercharged Engines

The main engines are supercharged by two Holmes Connersville Roots type blowers,

quill shafts carrying spiders, the arms of which are provided with rubber pads making contact with the spokes of the driving wheels.

# Studies in Electricity and Magnetism

Current Directions : Electric Distribution Mains : Electromagnetic Quantities

**K**IRCHOFF'S Laws are useful in solving circuit problems of a type which do not yield readily to straightforward methods. And the only way to learn Kirchoff's Laws is by using them—or studying plenty of examples. I am not going to give much space to the statements of the Laws. They are adequately covered in almost every textbook, while it will be more to the point in this series to discuss one or two typical applications.

But certain rules and conventions must receive preliminary attention.

### Signs of Currents

First, "signs" must be given a wider meaning than when thinking, for example, of an electric current as having a conventional + to - direction (or - to + in terms of electrons).

Kirchoff's first Law says that at any "point," or "junction," in a circuit, the algebraic sum of the currents is zero.

In other words: if Fig. 1 represents a junction P of several wires, as much current flows away, as towards P. Here,  $i_1$  and  $i_2$  flow



Fig. 1.—Why must the "algebraic sum of currents meeting at a junction" P, always be zero?

towards, and  $i_3$  and  $i_4$  away from P, so therefore:—

$$(i_1 + i_2) = (i_3 + i_4)$$

and algebraically:—

$$i_1 + i_2 - i_3 - i_4 = 0.$$

But we are quite at liberty to reverse both sets of signs. If we decide to give currents flowing towards a junction a + sign, those flowing away must be prefixed with - signs. Alternatively, we might decide upon the opposite convention, making  $i_1$  and  $i_2$  negative and  $i_3$  and  $i_4$  positive.

Rules of algebra merely demand that one set of signs shall be negative, or that the algebraic sum shall be zero. Thus if we adopt reversed conventions:—

$$i_1 - i_2 + i_3 + i_4 = 0.$$

or,

$$(i_3 + i_4) = (i_1 + i_2)$$

i.e., we are still stating that as much current flows away as towards point P.

So much for junctions. In a given circuit problem, we may also suppose any arbitrary current directions; we may denote them by  $x, y, z$  (or  $i_1, i_2, i_3$ , etc.), and, for convenience, give them all positive signs.

Then, as long as we keep to our conventions throughout as regards junctions, and the signs of potential-differences or E.M.F., our signs will come out right in the final answers. Thus,  $x$  may work out to a negative answer, signifying that the true direction is opposite to the arbitrary one assumed at the start.

We will illustrate these points by considering a fairly simple problem.

### A Battery Problem

In Fig. 2(a), is shown a battery consisting of two groups of 6v. each. We note, however,

By H. REES, A.M.I.E.E.

the two groups are coupled in opposition: the "—" terminals are joined together, and the "+" terminals connected through two resistances of 1 ohm and 2 ohms, respectively. A third resistance  $R=3$  ohms is joined between the junction of the batteries and the junction of the two external resistances.

It is required to find the currents supplied by the batteries, the currents in the resistances, and the potential difference across R.

With the network as drawn in Fig. 2(a), this may appear a somewhat tricky problem, one of those which has a "diagonal" resistance, like a Wheatstone Bridge—the sort of thing it is impossible to tackle without Kirchoff's equations.

We may simplify the circuit somewhat as in Fig. 2(b). At least, this does give us a layout that seems more amenable to electrical common sense, although it may still not be very clear how easy the problem is until we redraw as in Fig. 3.

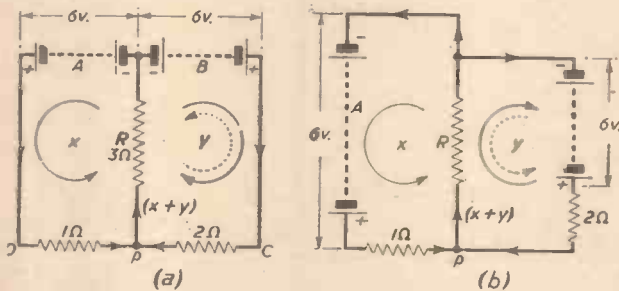

Fig. 2.—Can you "simplify" these circuits to find the currents in the resistances without the help of Kirchoff's Laws? (See Fig. 3.)

This should be a much more familiar circuit. We have two 6v. batteries joined in parallel, with a resistance of 1 ohm in series with one, and 2 ohms in series with the other. Finally, an external load resistance of 3 ohms is connected to the parallel combination.

If we were dealing with primary cells, we might regard the 1 ohm and 2 ohms as internal resistances; we may do likewise with accumulators, even though the resistance figures are much larger than what we would generally find in secondary batteries. Let us call them "internal resistances" of batteries A and B.

### A Simple Solution

Then, without any Kirchoff equations:—

E.M.F. of Battery = 6v.

Internal resistance of battery = 1 ohm in parallel with 2 ohms = 2/3 ohm.

Total circuit resistance = Internal Resistance + External Resistance = 3 2/3 ohms.

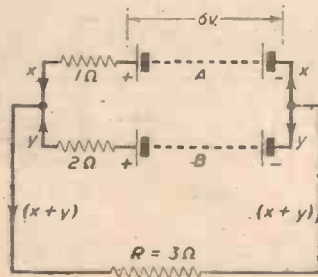

Fig. 3 (Left).—A fairly straightforward circuit to deal with.

Fig. 4.—The battery A, Figs. 2 and 3, may be replaced by a dynamo, with a battery B and load resistance R connected. Use Kirchoff's Laws to find  $x, y$  and  $(x+y)$ , as before, for various values of the generator E.M.F.

Total current supplied =  $6v. \div 3 \frac{2}{3} = 6 \times \frac{3}{11} = 1.636A.$

Next, to find the current supplied by each battery, we may make use of the laws of inverse proportion—remembering that a current will divide between two resistances in parallel in inverse proportion to the resistances—the battery of lower internal resistance will supply the most current.

As long as the E.M.F.s are exactly equal, "sharing of loads" between two (or more) batteries in parallel is simply a case of current-division through their respective parallel resistances. Thus, in our example:—

Current supplied by battery A =  $2/3$  of  $1.636A. = 1.09A.$

Current supplied by battery B =  $1/3$  of  $1.636A. = 0.545A.$

The p.d. across R is the "terminal voltage" of the battery when supplying the above current =  $R \times$  Total Current =  $3 \times 1.636 = 4.908$  volts = 4.91v. approximately.

We can glean a little information regarding load-division from these figures. The current supplied by each battery must be such as to give the same terminal voltage: 4.91v. from each battery.

Thus, battery A supplies 1.09A., giving a drop in 1 ohm of 1.09v., or a terminal p.d. of  $6v. - 1.09v. = 4.91v.$  Battery B supplies half the current, through twice the internal resistance of A, so having an internal drop of  $0.545 \times 2 = 1.09v.$  and a terminal p.d. of 4.91v. as for A.

We will next work the same problem by Kirchoff's Laws.

### Solving by Equations

In Figs. 2 and 3 we have denoted current directions by the circular arrows, denoting by  $x$  the current supplied by A, and the current from B by  $y$ .

Looking at the terminal signs, it is easy to see that  $x$  and  $y$  must have the directions indicated—this should not be regarded as a general rule if E.M.F.s are unequal, but we shall presently show how any directions taken at random will give the correct answers.

At junction p, therefore, we have  $x$  and  $y$  directed towards p, so that each may be considered of positive sign, and the current in R is then  $(x+y)$ .

The rest is a matter of writing voltage equations. The E.M.F. of A. (6v.) is the same as the sum of the volts dropped in 1 ohm in series with 3 ohms, or:—

$$x + 3(x+y) = 6v. \quad \dots \dots \text{Eq. (1)}$$

$$\therefore 4x + 3y = 6 \quad \dots \dots \text{Eq. (1)}$$

$$\text{Similarly for battery B:—}$$

$$2y + 3(x+y) = 6v. \quad \dots \dots \text{Eq. (2)}$$

$$3x + 5y = 6 \quad \dots \dots \text{Eq. (2)}$$

Solving these two simultaneous equations for  $x$  and  $y$ , gives:—

$$x = 12/11 = 1.09A.$$

$$y = 6/11 = 0.545A.$$

$$\text{Total current in } R = (x+y) = 18/11 = 1.635A.$$

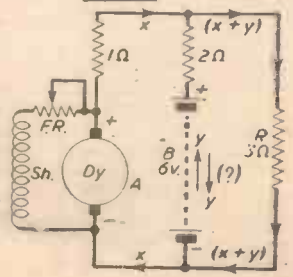

It will be seen that equations are formed on the principle that the E.M.F. of a "source" is totally lost in resistances. In some cases we may have a closed mesh of resistances in which there is no source of E.M.F., when our voltage expressions must be equated to zero. Also, if we do choose random current directions—some of them "wrong" relative to battery terminal signs (or to the signs of p.d.s across certain resistances), negative signs must be put in the right places in our voltage equations.

Our answers will come out correct if we are perfectly clear on these voltage conventions. Many conventions are possible, and since this is probably the main difficulty in applying Kirchoff's rules, we will once again rework our example with one current shown the wrong way round.

**Choosing "Wrong" Current Directions**

Suppose, in Fig. 2, we had indicated the current  $x$  flowing normally from + to - of A, but that  $y$  had been given a wrong direction, from - to + of B, as shown by the dotted circular arrow.

Observe that  $y$  will now be a current flowing against the E.M.F. of battery B, i.e., with B connected as in Fig. 2. We shall have to denote this somewhat nonsensical fact by correct signs in our voltage equations. Otherwise, of course, our answers will be sheer nonsense!

As suggested, many conventions are possible, and we must be quite sure the one we use is correct. Thus, the current in R is now  $(x-y)$ , and we could write our equations:—

$$x + 3(x - y) = 6v. \quad \text{(Eq. 1)}$$

$$4x - 3y = 6 \quad \text{(Eq. 1)}$$

and, for battery B:

$$2y - 3(x - y) = -6v. \quad \text{(Eq. 2)}$$

$$-3x + 5y = -6 \quad \text{(Eq. 2)}$$

Solving this pair of equations gives:  $x = 1.09A.$ , but,  $y = -0.545A.$  The answer for  $y$  comes out negative, merely signifying that the true current direction (for B) is opposite to the wrong one which we deliberately assumed at the start. Thus our answers mean exactly the same as before: B supplies 0.545A. in the direction of the full-line arrow.

**Another Meaning**

There is a little explaining to do as regards these signs: for example, whether "voltages" or potential differences are of the same or opposite sign to the E.M.F. in a circuit.

We have touched upon such questions before, and perhaps it will be interesting to discuss sign conventions in full as we proceed with this series. But just now let us apply still another method that should be understandable.

In reversing the arrow for  $y$ , Fig. 2, what is really being signified?

Obviously that battery B has been reversed. Actually, battery B has not been reversed in any way—it remains exactly the same as it is shown in Figs. 2 and 3. Still, a current  $y$  flows (by hypothesis) in the direction of the dotted arrow?

If you think about it, this is the same as saying that a current flows right round the circuit formed by ADpCB:  $x$  amperes from Battery A, but  $y$  amperes return via battery B, because  $(x-y)$  amperes go along the path provided by R.

This would be possible if B was reversed so as to form, with A, a battery giving 12v.

It is not possible with the batteries connected as shown, since the total E.M.F. around the mesh ADpCB = 6v. - 6v. = 0. Therefore, if—for argument's sake—we have  $y$  in the direction of the dotted arrow, we must write:—

$$P.D. \text{ across } 1 \text{ ohm} + P.D. \text{ across } 2 \text{ ohms} = \text{total E.M.F.} = 0,$$

$$x + 2y = 0 \dots \dots \dots \text{our (Eq. 2)}$$

$$\text{Eq. 1 is, as before: } x + 3(x - y) = 6v.$$

$$\text{or, } 4x - 3y = 6 \dots \dots \dots \text{(Eq. 1)}$$

$$\text{Solving this pair gives } x = 1.09A., y = -0.545A., \text{ exactly as before: } y = 0.545A. \text{ in the positive direction of the E.M.F. of B (full-line arrow).}$$

This second solution also exemplifies an interesting case where a voltage expression has to be equated to zero.

**Dynamo-battery Load Conditions**

Our example may seem rather remote from actual circuits, but it is really a most important case.

We have taken a fairly simple problem where the battery E.M.F.s were exactly equal and the load current divided to give equal terminal voltages—note carefully the distinction in these terms.

What if the E.M.F.'s are unequal? Or, under some condition, the terminal voltage

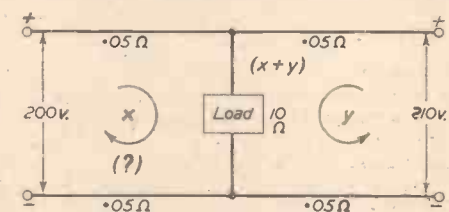

Fig. 5.—A D.C. supply main is fed from both ends, with voltages as shown. A single load of 10 ohms is shown connected. Are the given current directions correct? Use Kirchoff's Laws to find the magnitude and sign of the currents. (Resistances of cables are as shown.)

of one battery equals the E.M.F. of the other? What happens afterwards?

Instead of battery A, we may substitute a shunt dynamo coupled to B and to the external load R, Fig. 4. If the E.M.F.s were equal, the current conditions will be as in our problem. The dynamo supplies  $x$ -amperes (to R); the battery supplies  $y$ -amperes; hence the total current in R is  $(x+y)$  amperes.

Next, starting with 6v., let us increase the dynamo E.M.F., say in steps of 2v., up to 12v. What will happen? With R connected, when will the battery start taking a charging current, which is the same as asking whether or when  $y$  will have a negative sign?

At first, when dynamo E.M.F. = battery E.M.F. = 6v., each will supply a proportion of the total load current inversely as their internal resistances (neglecting shunt excitation, etc.). As the generator volts are increased, the dynamo will supply an increasing current to the external circuit.

In fact, even at nearly constant voltage (of the battery) the current in R will increase.

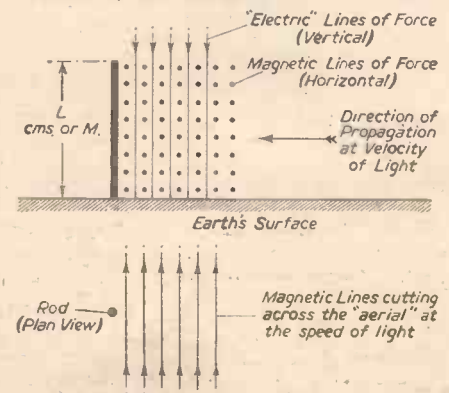

Fig. 6.—How a simple vertical rod (or aerial) is "cut" by the magnetic field of a travelling "wireless wave," which is at right-angles to an electric field of force.

But meanwhile the proportion of current supplied by the battery will be decreasing, until at a certain point it simply "floats"—neither supplying or taking current.

After that point,  $y$  will reverse: begin taking on negative values, signifying a charging current.

This will be the behaviour when R is switched on. Of course, with only the battery itself, the dynamo will supply charging current immediately its E.M.F. is slightly in excess of 6v.—a current which will increase rapidly with increase in the (generator) E.M.F.

**Electric Distribution Mains**

You can have an interesting time analysing the conditions by applying Kirchoff's Laws as before.

The equations we used will do. Using the same resistance values, suppose the dynamo (=battery "A") gives 8v., with the E.M.F. of B fixed at 6v. Adopting straight conventions, find  $x$ ,  $y$  and  $(x+y)$ .

Next, increase the dynamo E.M.F. to 10v., then 12v. Write and solve the equations for these two cases. You should find that the battery will "float" at an E.M.F. of 8v., and afterwards start taking a charging current. In other words,  $y$  will first become 0, then change sign.

I will give the solutions later. Of course, the dynamo is supposed to be a plain shunt type, without self-regulation as in cars, and we also neglect causes of voltage-loss other than internal resistance, e.g., armature reactions (see my articles on "Dynamo and Motor Problems").

Our circuit principles are also of great importance for the solution of problems on distribution networks.

To take a fairly easy example: a D.C. main supplying a street of houses is fed at both ends, as in Fig. 5—it is supposed that independent supplies exist at both ends, but that the load conditions are such as to give 200v. at one end and 210v. at the other. The resistances of the connecting cables and load are as indicated.

What are the current values  $x$ ,  $y$  and  $(x+y)$ ? What is the voltage existing across the load? Is  $y$  of "positive" sign, as given, or should it be "negative"? What will a negative sign denote? How much power in kW. is supplied from each end?

This is a somewhat simpler problem than the generator/battery on-load. You should have no difficulty in writing and solving the equations if you keep Figs. 2 and 3 in mind. If desired, regard the supplies at each end derived from "batteries" whose internal resistances are those of the connecting cables.

**More About Electromagnetic Quantities**

I have already touched upon some useful calculations in electromagnetism, such as the "BLv. Formula" for estimating induced E.M.F.s in moving conductors.

I believe I mentioned that these mathematics applied generally to things other than wires moving in magnetic fields.

Thus the BLv formula has something to say regarding the high-frequency E.M.F.s induced in a conductor forming an "aerial" in your back garden or around the picture rail in a room. The simplest case is that of a vertical rod of length L cms., "cut" by the horizontal magnetic field from a distant transmitter, Fig. 6.

"Electromagnetic Waves" are not easy to visualise. Something—a "disturbance" in the form of a "wave"—travels through space with the speed of light (186,000 miles per sec. =  $3 \times 10^8$  metres per sec.).

We can look upon this wave from two standpoints—both of which really come to the same thing. The "waves" consist of vertical electric lines of force (an electrostatic field), sweeping past at the velocity of light.

(To be continued)

# "Moulds" and Their Uses

## A Triumph of British Chemistry

By Professor A. M. LOW

**M**ODERN warfare, fortunately for mankind, is not wholly destructive. In war-time, thanks to the urgent need for munitions and the unlimited sums of money available, scientific research is speeded up and in consequence many discoveries, delayed in peace-time for lack of the necessary funds, are given every chance of quick development.

New and more deadly weapons have been devised whereby man may destroy his fellow men, but at the same time new and more deadly weapons have been found to combat disease and to save thousands of lives. Indeed, given the opportunity, there seems no limit to the ingenuity of the human brain.

In almost every branch of medical science new drugs and new techniques have been found. To-day, a wounded soldier has three-and-a-half times as many chances of recovery as his counterpart in the first World War. The work carried out by British scientists in recent medical research stands second to none, and should benefit the whole world.

### Penicillin

Perhaps the most spectacular discovery made by British researchers that immediately springs to mind is that of penicillin, one of the many mould substances which are now being used in the service of man.

Certain of these materials are technically known as antibiotics. That is to say, they are organisms capable of inhibiting the growth of others. The mould *Penicillium notatum* wafted in through the window of an Oxford laboratory in 1929 and was observed by Professor Alexander Fleming. It is now giving us penicillin, a drug, by far the most potent germicide yet discovered, and is effecting cures at a speed which a few years ago would have seemed almost miraculous.

To many the word "mould" implies something decayed, something that is unhealthy. Spores of moulds are found everywhere in the air and, in fact, they do turn dead into living matter. From the air comes the green mould found on stale bread, the greyish patches that settle on improperly bottled jam, and the mould that causes dry rot in the wood of our homes.

An example of the utilisation of moulds by man for his own ends is the case of Stilton and Gorgonzola cheese, where they are injected to produce the delicate green veining characteristic of these delicacies. These moulds are of the *Penicillium* species.

Thousands of moulds have been isolated and identified in British laboratories, but only a fraction of them have as yet been utilised. As scientific knowledge has advanced, however, moulds have been put to work more and more to assist required chemical changes, giving either new products or helping existing types to be made from new sources.

### Citromyces

Moulds are extremely individualistic and there is considerable variation in the way they grow and the chemical changes they produce during the process of feeding.

For example, in the case of *Citromyces*, on one diet it produces citric acid, but on another it produces oxalic acid. In the past, the only source of citric acid was the juice of lemons, procurable only from Sicily and Italy, but the accidental discovery that a certain mould yielded citric acid when fed

on sugar made the manufacture of this acid in large quantities a commercial possibility. Although it was some years before large-scale production was economically practicable, research went on and at length it was possible to regulate the life of the mould so that it produced citric acid instead of oxalic acid, or other more poisonous substances.

Moulds need certain specific conditions if they are to live and thrive. There must be correct temperature, humidity and oxygen. They are extremely prolific, but their work is done on the surface of the solutions owing to their need for oxygen, and one of the



Penicillin fermenters of 5,000 gallons capacity, as used in the Glaxo Laboratories.

great difficulties has been to find a method whereby oxygen can be applied to the whole mass of a solution.

By the use of air under pressure this problem seems to have been solved and, in future, we may see factories where the workers are mould cells working a 24-hour day turning raw material into chemicals or food. Already in Britain bacteria are employed making useful gas from waste material and supply cheap lighting and heat to large cities.

We can see for ourselves how moulds and bacteria work in gardens and fields by breaking down organic material by the process of decay. They cause a series of chemical changes until the material is finally absorbed again by plants through the soil.

By the proper use of these moulds it should be possible to make use of this refuse much more quickly. There is no reason why huge piles of waste vegetable matter should not be employed at gas works and the inflammable gas they produce used for cook-

ing and heating, or even for bottling under pressure to drive our motor-cars.

### Sugar from Sawdust

There are other organisms which digest wood for certain insects. Already we can turn sawdust into sugar, and there is little doubt that we shall one day be able to turn the thousands of tons of sawdust from our lumber mills into a concentrated food for livestock. Just picture these mountains of sawdust and then think of this cheap raw material put to good use by the work of moulds.

Yeasts are substances closely allied to moulds and have long been used to bring about chemical reactions, such as breaking down the sugar into alcohol in beer.

Recently greater use has been made of yeasts in industrial chemistry. One of the latest yeast products is a yeast that lives on sugar cane and can be processed to give a rich protein food containing many of the essential vitamins or mineral salts lacking in some normal diets. In the West Indies Britain has set up factories for production of this yeast to supplement native diets lacking the necessary proteins.

Normally, vegetables are eaten by cattle and sheep and then turned into protein, which is taken in by human beings when they eat the animals. The waste involved by this process may be saved by this yeast, factory-produced. The further advantages of this short-circuiting method are likely to be very great in these post-war years.

Patulin, helvoic acid, penicidin and vivillin are examples of other antibiotics developed by British scientists and the names of Fleming, who located penicillin, and Florey, who applied it to medicine, will be written for ever in the history of medical research.

Moulds are amazing substances. In the future we may be able to destroy harmful bacteria by the use of moulds that devour them wholesale, or by others that literally eat the harmful organisms out of house and home and so starve them to death.

The time will come when moulds will be watched and guarded with the greatest possible care. In the future rare and expensive chemicals may be manufactured cheaply with the help of moulds to carry out their synthesis.

With freedom for research Britain is prepared to carry on in peacetime with the great work she advanced during the war years: no less than the health and happiness of mankind.

# Building Aluminium Boats—5

With Notes on Design

By G. F. WALLACE, A.F.R.Ae.S.

(Concluded from page 266, June issue)

**I**N this concluding article plans and descriptions are given of small boats specially designed for amateur construction in aluminium. This article must be read in conjunction with the first and second articles of the series, as each boat is given a general arrangement drawing, a development drawing of bottom and sides, a table of frame dimensions and a list of the material required to build the hull. This information should be sufficient to enable the boats to be built without difficulty.

## 11ft. Punt

This is the simplest boat of all, as it has no curves in plan or elevation, requires no formed chine angle, and no faying angles on the frame gussets. The frame angle is also used for the chines. Owing to its simplicity, no separate development drawing or table of frames sizes is necessary, and all information required is shown on the plan and elevation drawings in the June issue. If required, rowlocks can be fitted, as previously described. The materials required are as follows:

**Sheet.**—A.W.6, four sheets 6ft. x 3ft. x 18 S.W.G.

**Angle.**—A.W.7, 120ft. 1 1/8 in. x 1/2 in. (Booths No. S1607 or similar.)

**Rivets.**—2lb. 5/32 in. diameter x 1/2 in. long.

## 12ft. 6in. and 16ft. 6in. Canoes

Although more difficult than the punt, these canoes are fairly simple to build. The 16ft. 6in. canoe is intended as a two-seater, and is the same as the 12ft. 6in. canoe with the two centre bays extended 4ft. extra in length. The design is such that the development of the sides are rectangles and very simple to lay out. There are no watertight bulkheads or inspection hatches in the deck, so separate arrangements have to be made for buoyancy, if required. There are two methods of forming the gunwale shown. In method A the deck has to be laid progressively in short lengths, otherwise it is impossible to get at the rivets. In method B the deck can be laid in long lengths and the gunwale also acts as a rubbing strake. The small skeg is unusual in canoes but considerably improves the control of the canoe in high winds. The frame dimensions are shown in table 1.

Radius of sides, 16ft. 11in. Flare angle, 20°.

### Materials Required:

**12ft. 6in. Canoe:**  
**Sheet.**—A.W.6, two sheets 2ft. x 6ft. x 20 S.W.G.; five sheets 1ft. x 6ft. x 20 S.W.G.; two sheets 2ft. x 6ft. x 22 S.W.G.

**Soft Aluminium.**—One sheet 3ft. x 6ft. x 18 S.W.G.

**Angle.**—A.W.7, 90ft. 1 in. x 1/2 in. (Booths No. S1152 or similar.)

If method B gunwale is used 114ft. will be required.

**Rivets.**—2lb. 5/32 in. diameter x 1/2 in. long;

**Soft Aluminium.**—Three sheets 3ft. x 6ft. x 18 S.W.G.

**Rivets.**—2lb. 5/32 in. diameter x 1/2 in. long; 1lb. 5/32 in. diameter x 3/8 in. long.

**Angle.**—A.W.7, 120ft. 1 in. x 1/2 in. (Booths section No. S1152.)

If method B gunwale is used 150ft. angle will be required.

## 9ft. Sampan

This type of craft is often known as a praam, but a praam is a round bilge boat, and it is considered that sampan is a more accurate description. It is intended as a

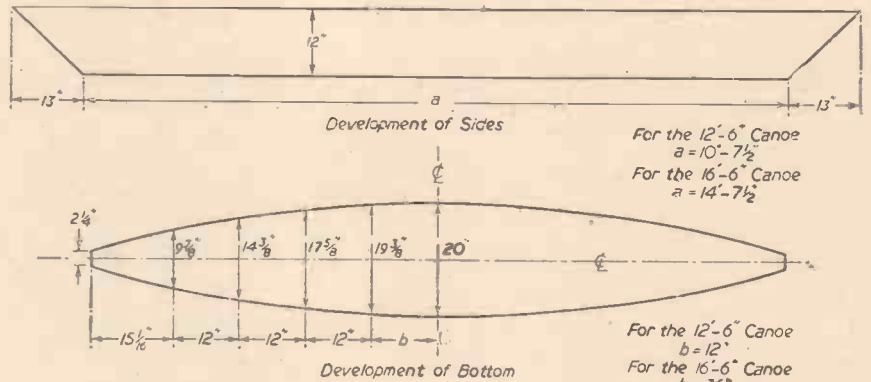

Development plans for 12ft. 6in. and 16ft. 6in. Canoes.

1lb. 5/32 in. diameter x 3/8 in. long.

The 22 S.W.G. sheet is for the deck, but some 20 S.W.G. sheet will have to be used between stations five and six.

rowing and sailing boat, although an impressive performance under sail cannot be expected for a boat of this size. It has two watertight bulkheads, forming air tanks at

Frame No.	Height	Half width bottom	Half width top	Height above datum	Side angle	Bottom angle
1 & 9	11 1/2 in.	4 13/16 in.	9 in.	1 1/2 in.	14°	4°
2 & 8	11 1/2 in.	7 9/16 in.	11 1/2 in.	1 in.	10°	3 1/2°
3 & 7	11 1/2 in.	8 13/16 in.	12 1/2 in.	7/16 in.	7°	2 1/2°
4 & 6	11 1/2 in.	9 11/16 in.	13 13/16 in.	8/32 in.	3°	1°
5	11 1/2 in.	10 in.	14 1/16 in.	—	—	—

Table 1.—Frame dimensions.

16ft. 6in. Canoe:

**Sheet.**—A.W.6, three sheets 2ft. x 6ft. x 20 S.W.G.; seven sheets 1ft. x 6ft. x 20 S.W.G.; three sheets 2ft. x 6ft. x 22 S.W.G.

each end, and should be virtually unsinkable, provided the joints between deck and hull are carefully made and are watertight. The forward skeg is an unusual feature on a boat

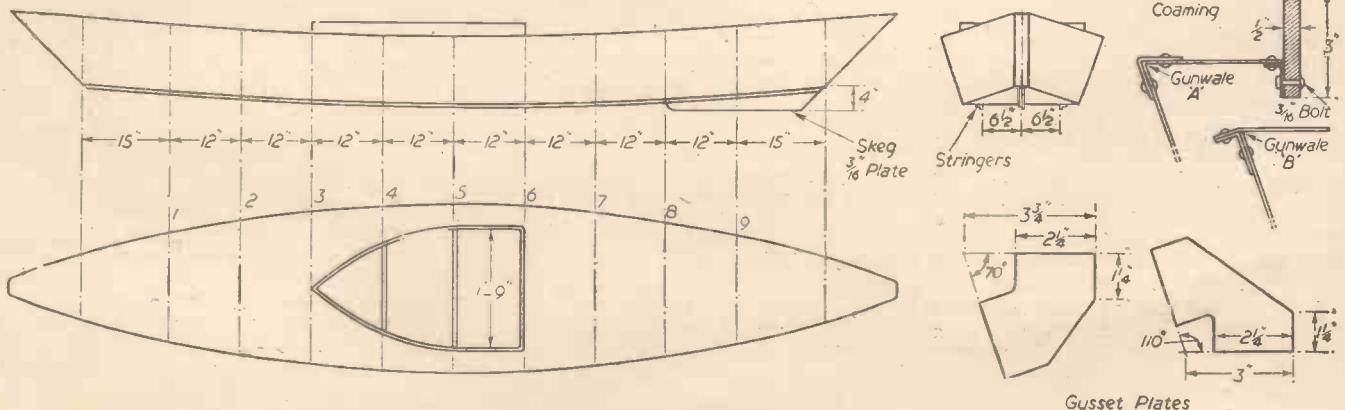

Side elevation, plan and end view of a 12ft. 6in. Canoe, and details of coaming and gusset plates.



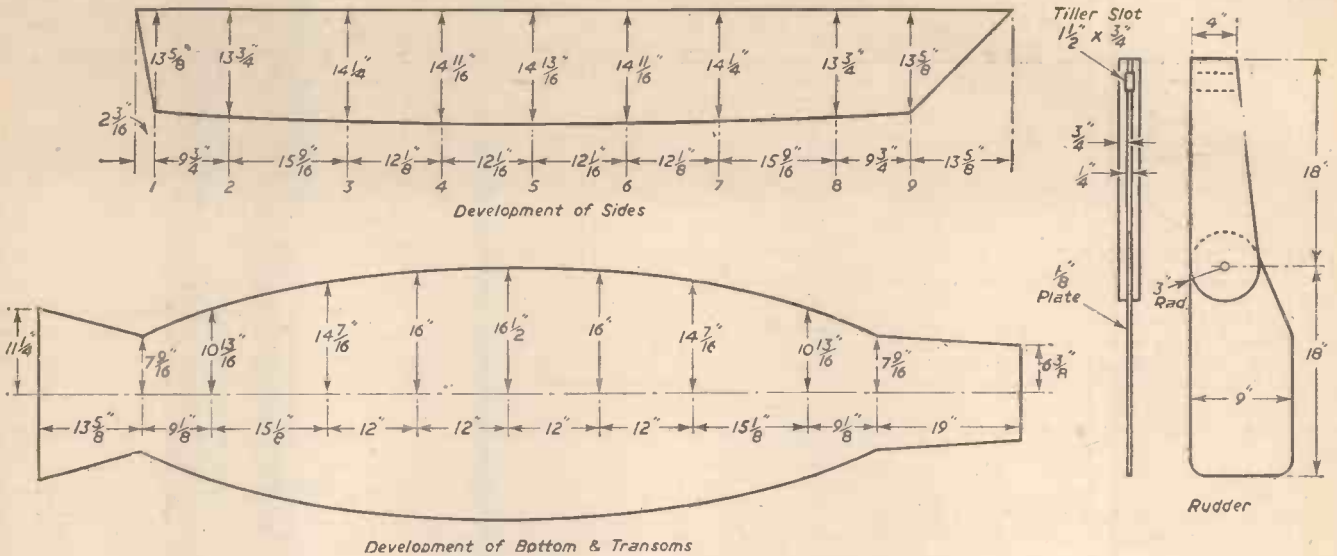

Development plans for a 9ft. Sampan, and details of rudder.

of this type, but it greatly improves the control of the boat. Although not shown on the drawing, an outboard bracket could be fitted and an  $\frac{1}{2}$ -h.p. engine would be sufficient to propel the boat. The boat is double ended and the gunwale is a straight line in development, making it a fairly simple boat to build. The angle of flare is  $20^\circ$  and the radius of the sides is 9ft. 7in. The frame dimensions are given in Table 2.

**Soft Aluminium.**—One sheet 6ft.  $\times$  3ft.  $\times$  16 S.W.G.  
**Angle.**—A.W.7, 100ft.  $\frac{3}{16}$  in.  $\times$  1  $\frac{1}{8}$  in.  $\times$  12 S.W.G. (Booths No. S1607).  
**Rivets.**—2lb.  $\frac{5}{32}$  in. (soft aluminium) diameter  $\times$   $\frac{1}{4}$  in. long; 1lb.  $\frac{5}{32}$  in. diameter  $\times$   $\frac{3}{8}$  in. long.

**12ft Skiff**

This is intended as a general purposes

radius of sides for the front half of the boat is 10ft. 10in. and for the rear half of the boat 26ft. 0in. The plan and elevation drawings of this boat were given in the March issue. In case there is any difficulty in setting out a 26ft. 0in. radius, the ordinates for this radius are as follows :

x	y
1ft. 0in.	2 $\frac{1}{2}$ in.
2ft. 0in.	4 $\frac{1}{2}$ in.
3ft. 0in.	5 $\frac{1}{2}$ in.
4ft. 0in.	6 $\frac{3}{8}$ in.
5ft. 6in.	7 in.

The frame dimensions are given in Table 3.

Frame No.	Height	Half width bottom	Half width top	Height above datum	Side angle	Bottom angle
1	2 $\frac{13}{16}$ in.	7 $\frac{9}{16}$ in.	12 $\frac{1}{2}$ in.	4 $\frac{1}{2}$ in.	24°	8°
2 & 8	12 $\frac{13}{16}$ in.	10 $\frac{13}{16}$ in.	15 $\frac{1}{2}$ in.	3 $\frac{1}{2}$ in.	20°	8°
3 & 7	13 $\frac{1}{2}$ in.	14 $\frac{7}{16}$ in.	19 $\frac{9}{16}$ in.	1 $\frac{9}{32}$ in.	12°	6°
4 & 6	13 $\frac{1}{2}$ in.	16 in.	20 $\frac{13}{16}$ in.	$\frac{1}{2}$ in.	6°	3°
5	14 in.	16 $\frac{1}{2}$ in.	21 $\frac{1}{2}$ in.	—	—	—

Table 2.—Frame dimensions for a 9ft. Sampan.

The gusset plates for the frames are the same as shown for the 12ft. sailing dinghy.

**Materials Required :**

**Sheet.**—A.W.6, five sheets 6ft.  $\times$  3ft.  $\times$  18 S.W.G.

rowing and outboard boat. It is straightforward to build, although more difficult than the previous boats. There are buoyancy tanks at each end fitted with hatches. This boat has a high load-carrying capacity for its length. The angle of flare is  $20^\circ$ . The

**Materials Required :**

**Sheet.**—A.W.6, five sheets 6ft.  $\times$  3ft.  $\times$  18 S.W.G.

**Soft Aluminium.**—One sheet, 6ft.  $\times$  3ft.  $\times$  16 S.W.G.

**Angle.**—A.W.7, 140ft.  $\frac{3}{16}$  in.  $\times$  1  $\frac{1}{8}$  in.  $\times$  12 S.W.G. (Booths No. S1607.)

**Rivets.**—1lb.  $\frac{5}{32}$  in. (soft aluminium) diameter  $\times$   $\frac{1}{4}$  in. long; 1lb.  $\frac{5}{32}$  in. diameter  $\times$   $\frac{3}{8}$  in. long.

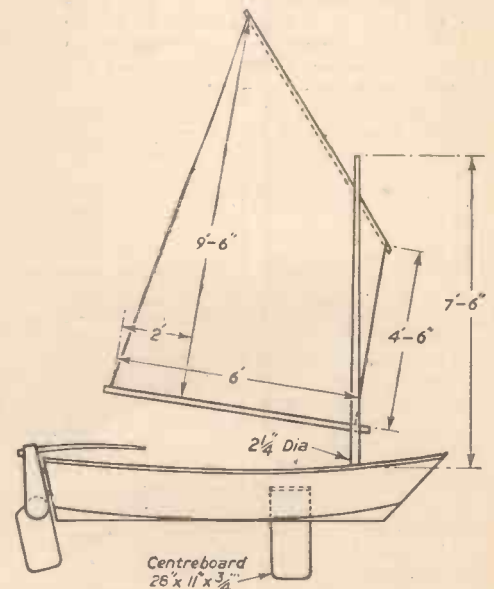
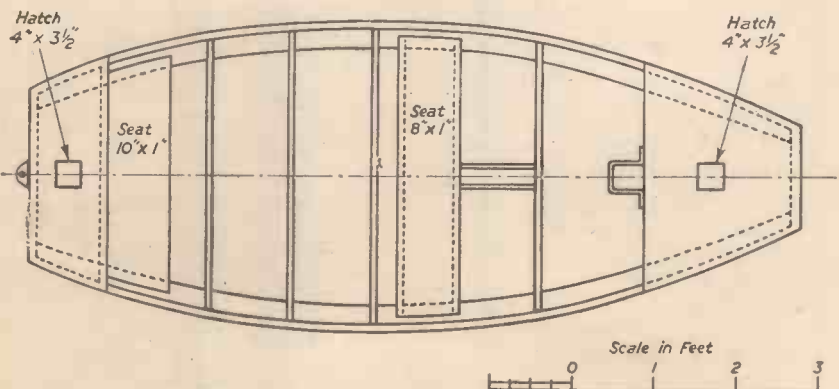
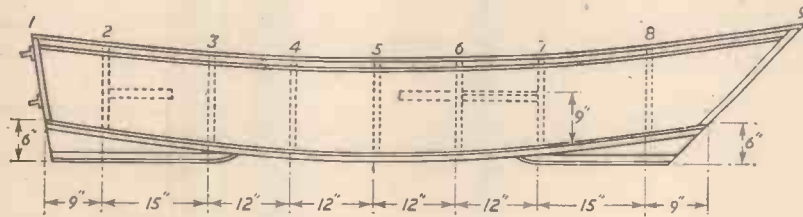

Side elevation and plan of a 9ft. aluminium Sampan, and a profile of the completed boat.

Frame No.	Height	Half width bottom	Half width top	Height above datum	Side angle	Bottom angle
1	—	—	—	5in.	11°	—
2	13 <sup>9</sup> / <sub>16</sub> in.	14 <sup>1</sup> / <sub>2</sub> in.	18 <sup>1</sup> / <sub>2</sub> in.	3 <sup>1</sup> / <sub>2</sub> in.	10°	5°
3	14 <sup>1</sup> / <sub>2</sub> in.	16 <sup>1</sup> / <sub>2</sub> in.	20 <sup>1</sup> / <sub>2</sub> in.	2 <sup>1</sup> / <sub>2</sub> in.	7°	5°
4	15 <sup>1</sup> / <sub>16</sub> in.	17 <sup>9</sup> / <sub>16</sub> in.	23in.	1 <sup>1</sup> / <sub>2</sub> in.	5 <sup>1</sup> / <sub>2</sub> °	5°
5	15 <sup>15</sup> / <sub>16</sub> in.	17 <sup>15</sup> / <sub>16</sub> in.	23 <sup>1</sup> / <sub>2</sub> in.	1 <sup>1</sup> / <sub>16</sub> in.	1°	2°
6	16in.	17 <sup>1</sup> / <sub>2</sub> in.	23 <sup>11</sup> / <sub>16</sub> in.	—	3°	—
7	15 <sup>1</sup> / <sub>2</sub> in.	16 <sup>1</sup> / <sub>2</sub> in.	22 <sup>1</sup> / <sub>2</sub> in.	1 <sup>15</sup> / <sub>16</sub> in.	9°	5°
8	15 <sup>1</sup> / <sub>2</sub> in.	13 <sup>11</sup> / <sub>16</sub> in.	19 <sup>1</sup> / <sub>2</sub> in.	2 <sup>1</sup> / <sub>16</sub> in.	16°	5°
9	15 <sup>15</sup> / <sub>16</sub> in.	8 <sup>1</sup> / <sub>2</sub> in.	14 <sup>1</sup> / <sub>2</sub> in.	3 <sup>1</sup> / <sub>2</sub> in.	22 <sup>1</sup> / <sub>2</sub> °	5°

Table 3.—Frame dimensions for a 12ft. Skiff.

**12ft. Sailing Dinghy**

This boat is the type known as a "knock-about" or "utility" dinghy. It is not intended for racing, the sail plan being designed for safety and ease of handling rather than speed. It is easy to row and can be fitted with an outboard bracket; a 1<sup>1</sup>/<sub>2</sub> h.p. engine is sufficient to propel the boat. The gusset plates shown on the drawings for this boat (April issue), are also used on the 9ft. Sampan and the 12ft. Skiff.

The angle of flare is 15°.

The bow radius is 9ft. 0in. and the after radius is 30ft. 0in.

The frame dimensions are tabulated in table 4.

**Materials Required:**

**Sheet.**—A.W.6, three sheets 8ft. x 4ft. x 18 S.W.G.; one sheet 8ft. x 4ft. x 20 S.W.G.

**Soft Aluminium.**—One sheet 6ft. x 3ft. x 16 S.W.G.

**Angle.**—A.W.7, 120ft. 1<sup>1</sup>/<sub>2</sub>in. x 1<sup>1</sup>/<sub>2</sub>in. x 12 S.W.G. (Booths No. S1607.)

**Rivets.**—2lb. <sup>5</sup>/<sub>32</sub>in. diameter (soft aluminium) x <sup>1</sup>/<sub>2</sub>in. long; 1lb. <sup>5</sup>/<sub>32</sub>in. diameter x <sup>1</sup>/<sub>2</sub>in. long.

It will be noticed that all the above designs are flat-bottomed boats; the reason for this is that owing to the prejudice against flat-

bottomed boats in this country very few designs are published. Several excellent designs of hard chine Vee-bottomed boats have been published, however, most of them racing boats. Although most of them have been designed for wooden construction in the

Frame No.	Height	Half width bottom	Half width top	Height above datum	Side angle	Bottom angle
1	11 <sup>1</sup> / <sub>16</sub> in.	17 <sup>11</sup> / <sub>16</sub> in.	20 <sup>1</sup> / <sub>2</sub> in.	6in.	8°	7°
2	12 <sup>1</sup> / <sub>2</sub> in.	19 <sup>5</sup> / <sub>16</sub> in.	22 <sup>1</sup> / <sub>2</sub> in.	3 <sup>15</sup> / <sub>16</sub> in.	7°	7°
3	13 <sup>7</sup> / <sub>16</sub> in.	20 <sup>11</sup> / <sub>16</sub> in.	24 <sup>1</sup> / <sub>2</sub> in.	2 <sup>9</sup> / <sub>16</sub> in.	7°	6°
4	14 <sup>1</sup> / <sub>2</sub> in.	21 <sup>9</sup> / <sub>16</sub> in.	25 <sup>7</sup> / <sub>16</sub> in.	1 <sup>1</sup> / <sub>2</sub> in.	2°	4°
5	15in.	22in.	26 <sup>1</sup> / <sub>16</sub> in.	—	—	—
6	14 <sup>15</sup> / <sub>16</sub> in.	21 <sup>13</sup> / <sub>16</sub> in.	25 <sup>1</sup> / <sub>2</sub> in.	1 <sup>1</sup> / <sub>16</sub> in.	4°	—
7	14 <sup>13</sup> / <sub>16</sub> in.	19 <sup>13</sup> / <sub>16</sub> in.	23 <sup>1</sup> / <sub>2</sub> in.	1 <sup>1</sup> / <sub>2</sub> in.	12°	2°
8	14 <sup>1</sup> / <sub>2</sub> in.	15 <sup>1</sup> / <sub>2</sub> in.	19 <sup>1</sup> / <sub>2</sub> in.	1 <sup>1</sup> / <sub>2</sub> in.	20°	4°
9	14 <sup>1</sup> / <sub>2</sub> in.	8 <sup>1</sup> / <sub>2</sub> in.	12 <sup>1</sup> / <sub>2</sub> in.	2 <sup>1</sup> / <sub>2</sub> in.	28 <sup>1</sup> / <sub>2</sub> °	8°

Table 4.—Frame dimensions for a 12 ft. Sailing Dinghy.

first place, the designs can be easily adapted to aluminium construction. The following is a short description of some of these designs, intended for amateur construction.

**"Yachting World" "Cadet"**

This is a 10ft. Vee-bottomed racing dinghy; designed for plywood construction it could

be fairly easily adapted for aluminium construction, but an aluminium boat could not be raced in the "Cadet" Class races.

**British Moth**

This is an 11ft. high performance racing boat and has been designed for manufacture in both plywood and aluminium, although the system of building in aluminium is not the one advocated in the present series of articles.

**"Yachts and Yachting" 15-footer**

This is a utility boat, designed for both wood and aluminium construction. It is a bigger boat than the others described and would be more difficult to build. It is a strong and roomy boat and ideal for family excursions.

Owing to fluctuations in prices, it is always

difficult to say anything very definite about the cost of boats. However, for what it is worth, the following is the total cost, in 1949, for two of the boats described. This includes all gear, such as oars, sails, etc.

9ft. Sampan	..	..	..	£26
12ft. Sailing Dinghy	..	..	..	£32

# Welded Bridges of the Future

THE James F. Lincoln Arc Welding Foundation of America has announced awards of \$10,750 in its 1950 Welded Bridges of the Future programme for the design of an all welded 250ft. highway bridge. Thirteen engineers and bridge designers have achieved international engineering recognition in the programme in competition with some of the foremost bridge designers in the world. The competition attracted designers from sixteen different countries, in many of which the building of welded bridges has been a necessity for over twenty years in order to conserve steel.

The first award of \$5,000 (£1,786) was given to James H. Jennison, 39, Pasadena, California, head of the Development Engineering Division, U.S. Naval Ordnance Test Station. Second award of \$2,500 (£893) went to Ernst Amstutz, of Zurich, Switzerland. The third award, \$1,250 (£449) was given to Professor Thomas C. Kavanagh, 38, Professor of Civil Engineering, Pennsylvania State College, Pennsylvania, who in the 1949 bridge competition took first award.

Among the ten recipients of honourable mention awards, each receiving \$200 (£72), were two competitors from the British Isles.

This competition was sponsored by the Lincoln Foundation to promote the building of better bridges for less money and with less steel. The rules of the competition were formulated to stimulate designers' ingenuity and originality in developing new design ideas, new shapes for structural steel members and new fabricating and erecting methods.

Dr. E. E. Dreese, chairman of the board of

trustees of the foundation, states: "Bridges built to-day use more steel and are more expensive than is necessary because designs are based on old fabricating methods which do not utilise the strength of steel as completely as do designs based on welding. The welded bridges designed for this competition, it is estimated, could be built to-day with

20 to 30 per cent. less steel than would be required for equivalent riveted bridges."

Professor Kavanagh, third award winner, in acknowledging the influence of European welded bridges in his design, said: "The importance of this successful experience in welded bridge construction in Europe cannot be emphasised too strongly to American engineers, whose technical literature simply has not succeeded in getting across to its readers this truly remarkable story of achievement in welding."



The design, by James H. Jennison, of Pasadena, which took first award.

# A Sensitive Hygroscope

A Simple but Efficient Instrument for Detecting Humidity in the Atmosphere

By J. DIMOND

**A** HYGROSCOPE, or damp detector, is sometimes very useful in a house for registering the humidity of the atmosphere, especially in a workshop, where there are steel tools liable to rust.

The instrument described was made after many experiments in design and in testing various substances which would be sensitive to changes in humidity. The accompanying illustrations show the general lay-out.

A complete revolution of the pointer is registered when the instrument is moved from a living-room which is normally dry, to an upstairs room in which the atmosphere is more humid. It would be a very simple matter to arrange electrical contacts on the dial and pointer so that when the humidity has reached a certain point, the electrical circuit is closed and a bell rings.

The material which actuates the instrument, consists of a strip of cellophane  $\frac{1}{2}$  in. wide, and the actual strip used was obtained from cellulose self-adhesive tape with the sticky substance removed with turps substitute.

The sensitivity of the instrument can be varied either by altering the length of the

Wood Block  $\frac{3}{8}$ " Thick, Screwed To Backboard  
Cut Away To Take Gears

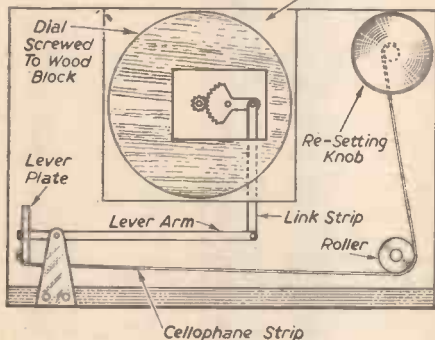

Fig. 1.—Front elevation (with dial removed) and side elevation of the completed hygroscope.

cellophane strip, a longer strip being more sensitive than a short one. The alteration in length is obtained by fitting the re-setting spindle bush either in the top right corner of the back-board, or in the bottom right corner, the bushes for the re-setting spindle and for the roller being made the same diameter to make them easily interchangeable. The sensitivity can also be varied by altering the length of the small lever plate which is secured to the left-hand end of the lever arm, the lever plate being drilled with three holes for this purpose. The cellophane strip is secured to the lever plate by a 6 B.A. screw.

## Constructional Details

The lever arm is made from  $\frac{3}{16}$  in. diameter drawn brass rod  $4\frac{3}{4}$  in. long overall, and the pivot, which is made from  $\frac{5}{64}$  in. diameter silver steel, is turned down to  $\frac{1}{16}$  in. diameter at each end and is fitted  $\frac{1}{2}$  in. from the left-hand end of the lever arm.

The link strip connecting the lever arm to the quadrant arm is made from 26 gauge hard phosphor bronze strip, and the end of the lever arm and of the quadrant arm are slotted to accommodate the link strip and drilled to take 22 gauge phosphor-bronze pins which form the pivots.

The quadrant and pinion were obtained

from an ex-government gear-box, the quadrant (cut from a brass gear-wheel rim diameter) has 16 teeth, and the pinion which

boss is a  $\frac{1}{2}$  in. diameter rivet drilled to suit the spindle of the pinion. (Fig. 2.)

The re-setting spindle is made from  $\frac{1}{2}$  in. diameter brass rod and is slotted to take the cellophane strip. The spindle is screwed at the back end and fitted with a spring

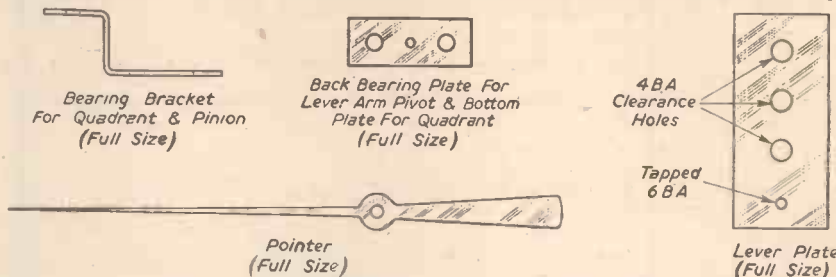

Fig. 2.—Details of bearing bracket, lever plate and pointer.

gears into it is  $\frac{3}{16}$  in. diameter and has 11 teeth.

The spindles of the quadrant and pinion are turned down at each end to  $\frac{1}{16}$  in. diameter.

The brackets and plates forming the bearings for the pivots of quadrant, pinion and lever arm are made from 22 gauge hard phosphor bronze strip.

## Dial and Pointer

The dial is made from ivory, and is  $\frac{1}{2}$  in. in diameter marked in divisions, and a stop is fitted to prevent more than a complete revolution of the pointer; stop-pins are also fitted to the back-board to prevent the quadrant from coming out of gear with the pinion.

The pointer is made from 26 gauge hard bronze strip, and is balanced; the central

washer for easy turning. The re-setting arrangement was found useful as it enabled the pointer to be set at mid position and variations in humidity registered easier.

The roller shown at the bottom right corner is made of ebonite  $\frac{1}{2}$  in. diameter, and revolves on a brass axle screwed into a plugged bush of the same size as the bush for the re-setting spindle.

All parts must, of course, work very freely, especially the quadrant and pinion.

## Operation

If the instrument is placed in an upstairs room and the pointer set as far as it will go clockwise, the pointer will fall to minimum or thereabouts when any steam is emanating from the downstairs kitchen, through washing clothes, cooking, etc.

When the atmosphere is humid, the cellophane strip softens and the weight of the lever arm stretches the cellophane and allows the arm to drop, thus causing the pointer to rotate anti-clockwise. When the atmosphere gets drier the cellophane strip contracts, thus raising the lever arm and causing the pointer to rotate clockwise.

## In a Belfast Shipyard

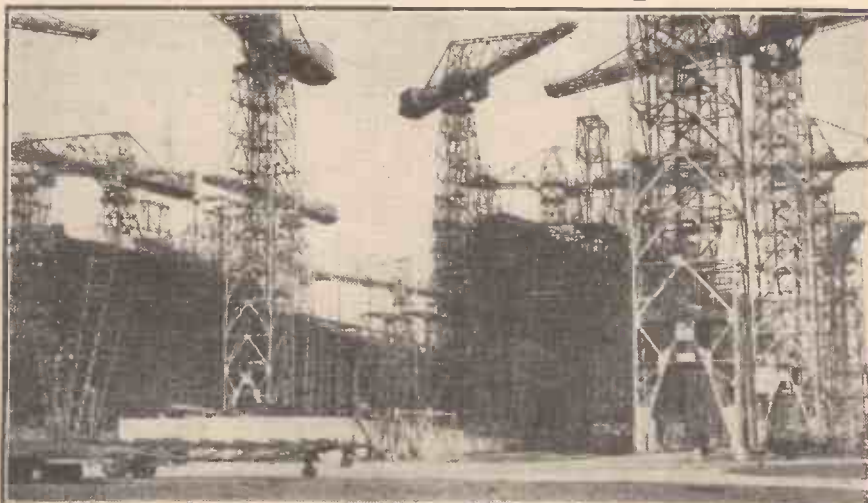

A remarkable array of giant cranes and scaffolding at the Musgrave yard of Harland and Wolff at Belfast.



# The World of Models

Ship Models at the Festival of Britain : The Basle Toy Exhibition

THE Festival of Britain being a focus of interest this year, both at home and abroad, it is good to know that models are featured in many of the exhibits in London and elsewhere. Some remarkable examples of model work are to be seen in the Shipping Section of the South Bank Exhibition in London, a large part of the modelmaking having been entrusted to Messrs. Bassett-Lowke, Ltd., the well known model engineering firm.

Largest of these models is a longitudinal section of a cargo vessel, 50ft. in length and one-sixth actual size. Open at both ends, this model will show the construction of the ship as well as stowage of cargo and other details. Another model, 15ft. long, represents a floating dock, complete with working model cranes on either side and, in the dock, a model of the Union Castle ship m.s. *Stirling Castle*.

Most impressive are three 20ft. models of the stern sections of three vessels: one a

## By "MOTILUS"

that of the new *Orcades* of the Orient Line. This model is cut off at a section through the tourist entrance. It shows the very fine

staircase running through three decks and the entrance to the tourist smoke room and lounge can be seen. On one of the decks are shown two of the tourist four-berth cabins, completely furnished. The section

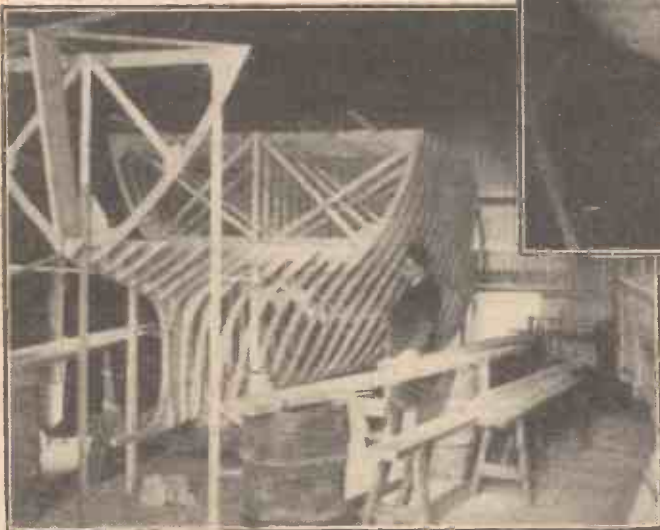

Fig. 1 (above).—Photograph taken during construction of the model of the stern portion of a tanker, for the Marine Section of the Festival of Britain South Bank Exhibition. Scale: 1½ in. to 1ft.

Fig. 3 (right).—Photograph of the two nautical models built by Mr. G. Porteous of Glasgow. In the foreground is the paddle steamer (¼ in. to 1ft.) and behind is "The Golden Hind" galleon (¼ in. to 1ft.).

liner, one a tanker (Fig. 1), and the other a whaling factory ship. Owing to their size, these models have had to be made in two sections, joining at the waterline, which makes construction, as well as transport, considerably easier. All three models are to the same scale, 1½ in. to 1ft., or one-eighth actual size, each weighing about 2 tons.

The stern of the liner shown (Fig 2) is

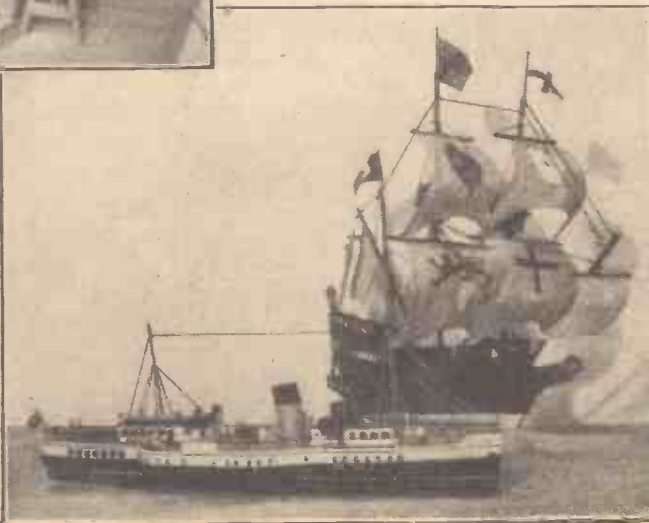

Fig. 2.—This photograph shows the model of the stern portion of the new Orient liner, "Orcades," during plating process on the hull. Scale, 1½ in. to 1ft. (one eighth actual size).

also includes a view of the propeller shafts disappearing down the shaft tunnels.

The whaler model shows part of the factory deck and the boilers and machinery used for converting the raw blubber into oil.

Messrs. Wm. Harvie & Co., of Birmingham, makers of ships' navigation lights, have a large collection of water-line ship models,

all to a scale of 1/32 in. to 1ft. Messrs. Harvie & Co. are lending a selection of 50 of these models for display in the Shipping Section at the Festival. They represent a large variety of British ships engaged in trade and passenger services all over the world. Among them are models of the following interesting vessels:—

The famous tea clipper, *Cutty Sark* (1869); the *Campania* (1893), *Mauretania* (1907) and *Queen Elizabeth* (1940), all of the Cunard fleet; *Virginian* (1904) of the Allan Line and the first turbine passenger vessel on the North Atlantic

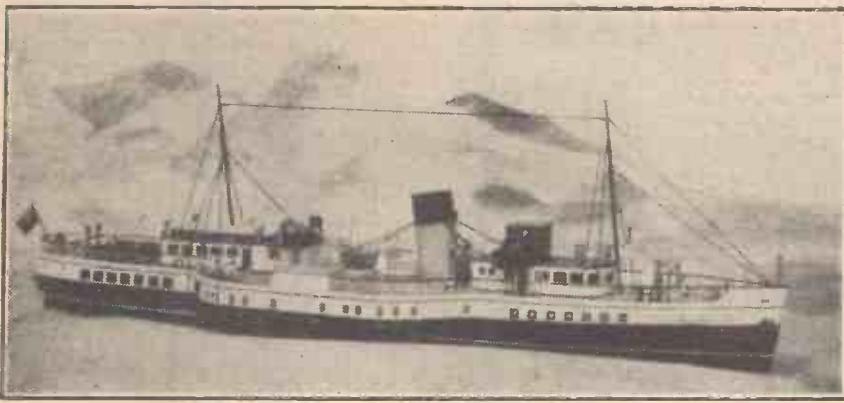

Fig. 4.—The model paddle steamer, "Marchioness of Lorne," built by Mr. G. Porteous, is shown here against a scenic background. Scale:  $\frac{1}{4}$  in. to 1ft.

service; *Gripsholm* (1925), Swedish America Line and first passenger motor ship in the North Atlantic; *Dominion Monarch* (1939), flagship of the Shaw Savill & Albion Line; *Andes* (1939), finest ship in the Royal Mail fleet; *St. Essylt* (1948) of the South American Saint Line, outstanding for her streamlined appearance; *Lymington* (1938), unpretentious British Railways car ferry plying between the Isle of Wight and the mainland; *Arnhem* (1947), British Railways, Eastern Region, cross-Channel boat for the for the Continent. Some outstanding post-war ships are also included, among them the *Port Brisbane* (1949), a Port Line refrigerator vessel; *Wanstead* (1950), Watts & Watts, specially noted for good accommodation for her crew; and the unusual *Pathfinder* (1950) of the Pan-ore Steamship Co., a United States vessel for carrying bauxite. All the ships represented were built in British shipyards.

**Model of the "Golden Hind"**

I was most interested to receive a letter from a reader in Glasgow, Mr. G. Porteous, who is a keen modelmaker. Mr. Porteous sent me photographs and details of two ship models he has built.

One of the models is of the *Golden Hind* galleon (Fig. 3) made to a scale of  $\frac{1}{4}$  in. to 1ft. (1/48th actual size), from "Modelcraft" plans. For this Mr. Porteous used various odd pieces of wood and made the sails from an old shirt, starched. All his painting and carving were done by hand, and it took two years of spare-time work to complete the model.

The other prototype chosen by Mr. Porteous was of our own times, the paddle steamer *Marchioness of Lorne*. For this he was

able to obtain plans from the L.M.S. Railway Company, for whom this vessel was built in 1935. The model (Fig. 4) which also took

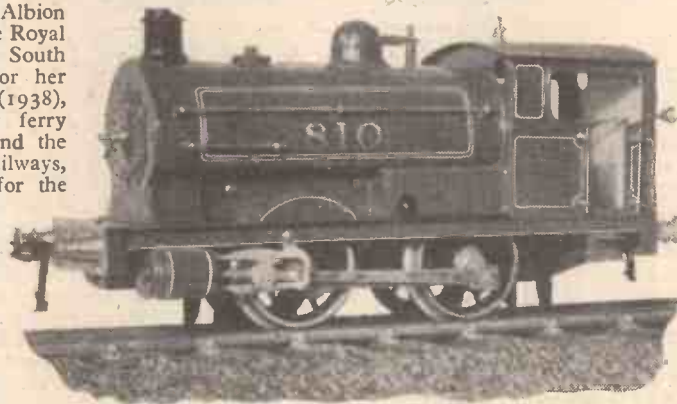

Fig. 6.—Gauge 0 "Peckett" tank locomotive of about 1906, produced for clockwork or electric propulsion.

two years to make, during spare-time hours, is to a scale of  $\frac{1}{4}$  in. to 1ft. (1/96th actual size) and the only items purchased ready-made were the handrail stanchions and electric motor for propulsion.

The hull of the paddle steamer model is

of balsa wood on plywood frames, with hardwood for bow and stern. The decks are cedarwood, the bridge and deck houses being made from card and celluloid faced with wood spills. The model is complete with all outside fittings such as lifeboats, lifebelts, seats, gangways, fans, windlass, capstans, telegraphs, bell, lamps, etc. The majority of the small fittings were made from plastic knitting needles and the masts were made from metal knitting needles. Wood spills were used to make seats, stairs and gangways. Inside, Mr. Porteous has included the first-class lounge aft, with stairway leading to the deck.

Propulsion is by means of a pen torch battery through a type 240 electrotor, geared down 50 to 1 on to the paddle shaft, gears being obtained from an old alarm clock.

The excellent results can be seen from the illustrations of the models which are a credit to the ingenuity of the builder in the materials he used, and his application of them.

A short while ago the inhabitants of Basle, Swiss commercial city, wished to raise funds for the building of a new sanatorium in the Alps and so they organised a series of charity gatherings. Among them was a most interesting exhibition of toys, under the direction of Dr. F. Zschokke, Assistant Curator of the famous Basle Museum. Dr. Zschokke aimed to extend the period of his exhibition from the age of Adam up to 1918, but in practice he did not manage to get quite so far back as Adam, but he admitted some post-1918 exhibits.

In the realm of playthings there are hardly anything you could think of that was not shown at this exhibition. Toys and models from many European countries were displayed; there were dolls, tin soldiers, marionettes, musical boxes and musical clocks, magic lanterns, dolls houses, toy theatre, and, of course, a great many models including motor cars, ships and railways.

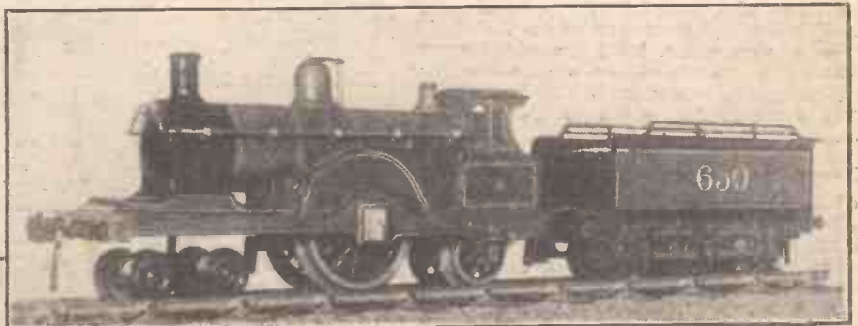

Fig. 7.—Gauge 0 Midland Railway locomotive model and tender of about 1912. Made for clockwork or electric drive.

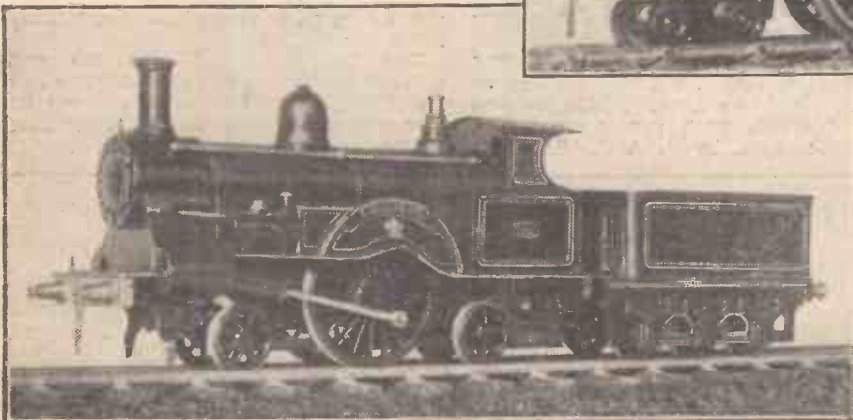

Fig. 5.—"Lady of the Lake": a gauge 1 steam locomotive and one of the first to be made commercially which bore a close resemblance to a prototype. Date about 1902.

Among the models a very interesting collection came from England, loaned by a well known firm of model engineers. At Dr. Zschokke's suggestion they sent to Basle a selection of working model steam locomotives and rolling stock, such as their company produced between 1900 and 1918. As contrasts, they also sent a pre-1900 toy locomotive and a popular model locomotive of the present-day, a *Flying Scotsman*.

The first of the realistic models was a gauge 1 *Lady of the Lake* locomotive (Fig. 5). This was the first satisfactory

(Continued on page 316)



**Perpetual Motion**

**S**IR,—With reference to your Editorial Comment in the May issue of PRACTICAL MECHANICS, it may interest you to know that I still have the PRACTICAL MECHANICS of November, 1934, in which your article "Is Perpetual Motion Possible?" appeared. While I agree with several of your remarks, I think the approach to this subject by the experts is wrong.

During the war I attended a scientific discussion, and on the subject of perpetual motion the lecturer maintained that the rotation of the world is not perpetual as one day it will stop.

Would it not be better to put a period to this and say, if a mechanism will go till it wears out, or a breakage requires repairing, then that is perpetual motion? If so, a clock that is driven by atmospheric changes is perpetual. We take advantage of nature in many ways, so why not do the same in seeking perpetual motion? I saw a fish wheel many years ago that had been turning round for I don't know how many years without stopping, and, but for wearing out, it is probably turning now.

If it were officially stated that anything that would go for a year without any outside power, or stored power such as a spring or falling weight, is perpetual motion, it would give inventors something to go on.—C. THOMPSON (London, W.).

**S**IR,—I read with interest your article on Perpetual Motion, especially the section dealing with the unbalanced wheel. I would like to suggest the following extension to this idea:

Each individual spoke of an unbalanced wheel such as you mention should be wound with insulated wire, and the polished steel ball should be a permanent magnet.

When the machine is set in motion current would be generated by electro-magnetic induction, and this current could be made to give extra motive power to the wheel.—D. L. BINNS (Bradley).

**Preparing Hydrogen Gas**

**S**IR,—I am afraid J. R. Smith, whose letter appeared in the May issue of PRACTICAL MECHANICS, is under a misapprehension when he says that the reaction  $CuO + H_2 = Cu + H_2O$  is not reversible.

It is reversible, and whenever I require hydrogen, which is quite frequently, I mostly use this method as it is cheap. The copper must, however, be red-hot, otherwise the steam will not combine with it. I must also point out that the copper steam pipes are not made red-hot by the passage of steam down them, therefore the copper is not attacked by the steam.—J. R. GIBSON (Peterborough).

**House Telephones**

**S**IR,—I read the article by R. V. Hardy on House Telephones, in the May issue, with interest.

I have recently used a simple telephone circuit as shown in the diagram, and it is giving a perfect performance over a distance of 200ft. between living room and greenhouse. The most obvious advantage over Mr. Hardy's

**FROM READERS**

circuit is that only a pair of wires are required.

The handsets I use are of G.P.O. specification and only slightly different from those in common use.

$S_1$  and  $S_2$  is a morse tapper with knob removed. When the 'phone is hanging on the morse keys the audio circuit is open and

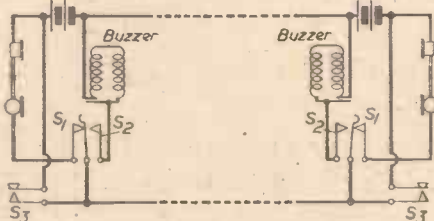

A simple circuit for house telephones.

the buzzer circuit closed.  $S_3$  is a push button and when closed operates the buzzers. When the 'phone is lifted a spring in the key forces the arm up, opening the buzzer circuit and closing the audio circuit.

**Club Reports**

**Aylesbury and District Model Engineers**

**T**HE April meeting, held as usual at Hampden Buildings, Temple Square, on April 18th, was this time devoted to a talk by Mr. G. Dow, Public Relations Officer of the London Midland Region. His talk, "Modelling the Midland Railway," was very interesting, being fully illustrated with photographs. After a very comprehensive historical survey he discussed his o gauge layout. A most enjoyable time was had by all those present.—E. H. SMITH, hon. sec., Mulberry Tree Cottage, Devonshire Avenue, Amersham, Bucks.

**Harrow and Wembley Society of Model Engineers**

**T**HE Harrow and Wembley Society's new track at L.M.R. Athletics Club sports ground, Headstone Lane, Wealdstone, was officially opened at 3 p.m. on Saturday, May 26th, 1951, by R. A. Riddles, Esq.,

I am at present experimenting to find a circuit for a three-station type by connecting a third 'phone in parallel with the other two, but the quality of speech has decreased and I hope to find a remedy soon.

I used a circuit like Mr. Hardy's years ago but I soon discarded it because of the impracticable amount of wire required.—N. BEVERIDGE (Motherwell).

**Rowlocks or Crutches?**

**S**IR,—I have been reading with interest the articles in PRACTICAL MECHANICS on Building Aluminium Boats, by G. F. Wallace.

But may I venture to point out that he has confused a rowlock with a crutch. A rowlock is a space cut in the washstrake of a double-banked boat, e.g., a cutter, whereas a crutch is a separate metal fitting, affixed in socket plates fitted inside the gunwale, as shown in the May issue of PRACTICAL MECHANICS—R. N. HOWE (Bulwick).

**S**IR,—In reply to Mr. R. N. Howe's letter, he is, of course, correct as far as the Royal Navy is concerned, the definition of rowlocks and crutches being laid down in the Admiralty's "Manual of Seamanship" and the "Seaman's Pocket Book." In civilian life true rowlocks have not been used for the last 50 years or so, and among longshoremen, fishermen and yachtsmen "crutches" are known universally as "rowlocks," possibly because they are less likely to be confused with boom crutches. As opposed to the Admiralty, the War Office handbooks on assault boats, pontoons, etc., use the nomenclature "rowlocks." The use of "rowlocks" in my articles, therefore, arises not from my confusion, but to conform with civilian usage, as it was anticipated that the average reader would be a civilian amateur mechanic rather than a Naval Rating.—G. F. WALLACE (Christchurch).

C.B.E., of the Railway Executives, and President of the Institution of Locomotive Engineers.—C. E. SALMON, hon. secretary, 11, Brook Drive, Harrow.

**WORLD OF MODELS**

(Continued from page 315)

attempt to produce an inexpensive model locomotive, working by steam, which also bore a close resemblance to an actual full-size locomotive. This was a semi-scale model of a popular express engine on the London & North-Western Railway from the year 1900.

A more advanced model (Fig. 6) was the "Peckett" tank locomotive, produced about 1906, and a good replica of a shunting tank locomotive then used in British shunting yards. It was operated by clockwork mechanism, or by an electrically-driven locomotive. Another model, of a later period (Fig. 7), was an old Midland Railway locomotive and tender.

The Basle Toy Exhibition was well attended and proved a great success, so that Dr. Zschokke was pleased to be able to pass over quite a substantial sum to the funds for the Alpine sanatorium.

**THE MODEL AEROPLANE HANDBOOK**

An Important New Work: 312 Pages, 303 Illustrations, 12/6, by post 13/-

By F. J. CAMM

A Short History of Model Aeronautics; Principles of Design; Airscrews; Wings; Undercarriages; Folding Airscrews—Retractable Undercarriages; Fuselages; The Elastic Motor; Gearing and Special Mechanisms; Making Model Wheels; Geared Winding Devices; Model Aeroplane Stability; Downthrust; Model Petrol Engines; Adjusting Model Petrol Engines; Compressed Air Engines; How to Form and Run a Model Aero Club; F.A.I. and S.M.A.E. Rules; S.M.A.E. Com-

petition Cups; A Lightweight Duration Model; A Wakefield Model; A Farman Type Model Monoplane; A Composite Model; Ornithopters—or Wing-flapping Models; A low-wing Petrol Monoplane; A Duration Glider; Winch-launching-Model Gliders; A streamlined Wakefield Model; A Model Antoviro; A Super Duration Biplane; Flying Model Aeroplanes; A Flash Steam Plant; Model Diesel Engines; Weights of Wood; Piano Wire Sizes, Areas and Weights; Schedule of British Records.

GEO. NEWNES LTD., TOWER HOUSE, SOUTHAMPTON ST., STRAND, LONDON, W.C.2

# POWER for the ambitious craftsman!

**17'6**

**HORIZONTAL STAND**  
for grinding and tool sharpening, buffing and polishing



A fully powered 1/4 inch Electric Drill for only **£6-10**

**59'6**

**1/4 INCH BENCH STAND**  
Here's the way to convert your 'HANDY UTILITY' Drill into a sturdy drill-press. You'll find plenty of jobs that demand a Bench Stand.



NOT just a drill but almost an electric workshop on its own—that's 'HANDY UTILITY,' the versatile power tool for faster, smoother, deeper drilling in steel, cast iron, brass . . . for easier drilling in wood, perspex, ceramics . . . for grinding, buffing and polishing metal parts . . . for cleaning off rust and old paint! Drilling capacity in steel 1/4 in.—in hardwood at least 1/2 in.

The mate of all work

**ELECTRIC**  
**HANDY-UTILITY**  
**TOOLS**

A PRODUCT OF BLACK & DECKER LTD.

**1/4 INCH DRILL KIT**  
Drill, 13 h/s Bits, Horiz. Stand, Grinding Wheel, Wire Wheel Brush, Buff, Arbor, Metal Carrying Case.

**£11-15**

**ACCESSORY KIT**  
Grinding Wheel, Wire Wheel Brush, Buff, Arbor, etc.

**19'6**



OBTAINABLE FROM YOUR LOCAL TOOL SHOP, IRONMONGER OR STORE

# Trade Notes

## The Golmet Auto-liner

**GOLMET LIMITED**, of Virginia Park, Caerphilly, Glam, have produced a new draughting apparatus called the "Golmet Auto-liner," the purpose of which is to draw accurately spaced parallel lines. It can be utilised for cross-hatching, ruling, graphical work, etc.

The apparatus consists of an aluminium cast body on which runs a stainless steel bar holding a Perspex ruler. By means of a

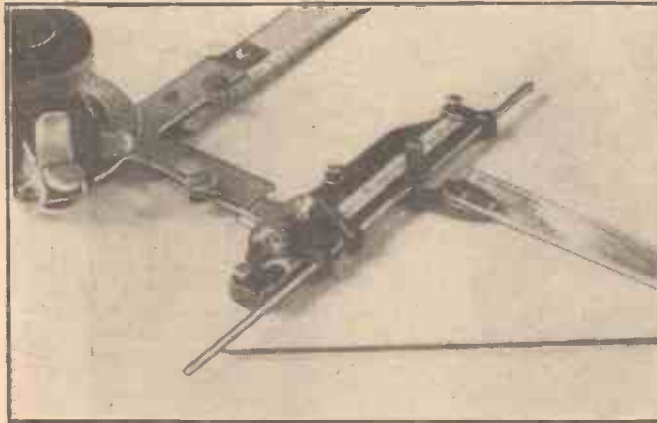

The Golmet Auto-liner

small lever this bar can be moved in a downward direction. This distance of movement is controlled by a screw, and the spacing can be adjusted from 0- $\frac{1}{4}$  in. The main body also carries a small scale, and a pointer fixed indirectly to the ruler shows the distance through which the ruler moves. Three pinned screws hold the "auto-liner" securely on the drawing-board in any position. The instrument may be attached to any standard draughting machine by means of a small bracket, thus becoming an integral cross-hatching attachment.

The body of the "auto-liner" is available in grey or black crackle finish, and all the screws are chromium plated. The instru-

ment is now in production, and the retail price is £2 5s.

## Myford Lathes

**DUE** to an increasing demand, Myford Engineering Co., Ltd., Beeston, Nottingham, are working to full capacity on the production of their ML7 3 $\frac{1}{2}$  in. x 20 in. metal-working lathe, ML8 4 in. x 30 in. wood-working lathe, and MG9 precision cylindrical grinding machine. The firm's lathes have

been selected by the Council of Industrial Design for exhibition at the Festival of Britain, and they will also be shown at the first European Machine Tools Exhibition at Paris in September. Recent additions to the plant include B.S.A. bar and chucking automatics, B.S.A.-Landis universal grinding machines, Drummond maxicut gear shapers, etc. Latest improvements in the production of the ML 7 lathe is the fitment of nipples to all lubrication points

previously fitted with ball-type oilers, thus enabling pressure lubrication. An oil-gun has been added to the standard equipment of every lathe.

Myford lathes are available in Canada through the company's branch sales office at 1, West Avenue South, Hamilton, Ontario, in the charge of Mr. S. Jackson. They are distributed on the eastern seaboard, Nova Scotia, New Brunswick and Prince Edward Island by the old-established firm of E. S. Stephenson and Co., Ltd., Saint John, N.B., and are also available from the many branches of T. Easton and Co., Ltd., Vancouver, B.C.

made chiefly from wood and cardboard, using the dining-room table as a workbench. There are chapters on every phase of designing, building and finishing which will cover the requirements of all those wishing to build a satisfying model of their favourite sports or racing car. The book is profusely illustrated with half-tones and line drawings.

Other books received from Percival Marshall and Co., are:

**Electric Control of Clockwork Railways.**

By Ernest F. Carter. Price 3s. net.

**How to Build That Garage Workshop.**

By T. E. Dutton. Price 5s. net.

**Belt Drives in the Small Workshop.**

By "Duplex." Price 3s. 6d. net.

## "Model Engineer" Exhibition

**THIS** year's "Model Engineer" Exhibition is to be held at the New Royal Horticultural Hall, Westminster, from August 22nd to September 1st.

One of the chief attractions will be radio-controlled marine models, for they will be able to show their paces on the 30ft. x 40ft. water tank which will form the central feature. There will also be a first-class model railway layout.

Eager to take full advantage of the Festival

## A Review of the Latest Appliances, Tools and Accessories

### The "Staffa" Senior Former Head

**THIS** accessory has been designed and is marketed by Chamberlain Industries, Ltd., Staffa Road, Leyton, London, E.10, for users of their popular two-stage hydraulic tube-bending machine. Its purpose is to extend the range of this model to deal with 2 $\frac{1}{2}$  in. and 3 in. normal bore steam and gas tubes of all classes. Thus, by the provision of the accessory, the two-stage machine may be employed for steam and gas tubes of  $\frac{1}{2}$  in.,  $\frac{3}{4}$  in., 1 in., 1 $\frac{1}{4}$  in., 1 $\frac{1}{2}$  in., 2 in., 2 $\frac{1}{2}$  in. and 3 in. tubes.

The senior former head is manufactured from mild steel, accurately fabricated, and is supplied complete with end formers, end former pins, 2 $\frac{1}{2}$  in. and 3 in. centre formers, 2 x 6 in. and 1 x 9 in. extension rams (the last-named items for increasing the angle of bend from 90 deg. to 160 deg.).

To fit the senior former head it is only necessary to unscrew the existing wing head,

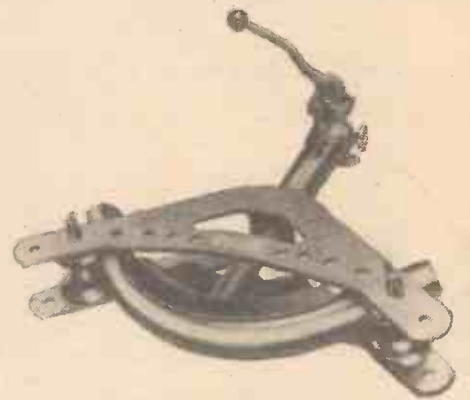

The "Staffa" senior former head tube-bending machine attachment.

replacing it with the larger unit. The end formers may be used as rollers in order to "wheel" this attachment to and from the work.

of Britain to show overseas visitors the best work of British model makers, the organisers hope that entries in the engineering model section will make the competitions keener, and the exhibition more attractive than ever before.

Displays by loan exhibits will include a life-like reproduction of the unusual movements of the s.s. *Egypt* when she sank on fire, demonstrations of a radio-controlled launch, a radio-controlled destroyer, a radio-controlled tank which fires small calibre shells from its guns and, it is hoped, a radio-controlled airship.

Championship cups will be awarded for the best locomotive, steam or motor ship, sailing ship, general engineering model, and aircraft model. Silver and bronze medals will be awarded for high-quality work, and diplomas will be given in recognition of unusual merit.

Club team championship cups will be offered for the best team of three engineering models and the best team of three aircraft models.

Entry forms and rules can be obtained from The Manager, "The Model Engineer," Exhibition Offices, 23, Great Queen Street, London, W.C.2. They must be completed and returned by July 16th.

## Books Reviewed

**The Amateur's Microscope.** By R. F. E. Miller. Published by Percival Marshall & Co., Ltd. 136 pages. Price 7s. 6d.

**THIS** book is intended for those who have recently acquired a microscope, or who contemplate doing so, and need some assistance in understanding how to use the instrument to the best advantage. The first part of the book deals with the early history of the microscope, and a detailed description of the modern instrument in its various forms. Next, there are chapters on simple optics, and the various accessories commonly used with the microscope. In the second half of the book such subjects as illumination, focusing, recording observations and photomicrography are explained. The concluding chapters deal with making your own apparatus, and the preparation of specimens and, finally, there is an appendix covering the electron microscope. The book is well illustrated in line and half-tone.

**Racing Cars in Miniature.** By Rex Hays. Published by Percival Marshall and Co., Ltd. 92 pages. Price 7s. 6d. net.

**I**n this book the author explains how first-class models of racing cars can be



# Flamemaster Plus



The Flamemaster Torch, already versatile by any standards, now has an alternative to the Flexiflame Unit, a new standard jet . . . **The Maxiflame Unit.**

Burns butane or coal gas with compressed air. Gives a wide range of flame sizes at air pressure from 5 to 25 PSI. There are also two new attachments:—

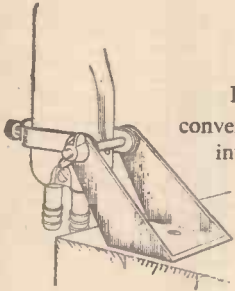

**Bench Clamp**  
converting the Flamemaster into a bench burner.

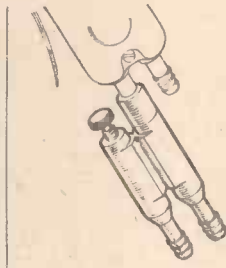

**Oxygen/Air Mixer**  
for use with Flexiflame Unit to give hot glass-working flame.

The Flamemaster is suitable for: hard and soft glassworking, soldering, brazing, lead-burning, working of precious metals, etc.

The Flamemaster and some accessories are now reduced in price.

Send for illustrated folder to:—

CHANCE BROTHERS LIMITED (Dept. F20), Lighthouse Works, Smethwick 40, Birmingham (West Bromwich 1051). London Office: 28 St. James's Square, S.W.1 (Whitehall 6002)

*Chance*  
PRODUCT

Britool 0-9 B.A. Box Spanner Tool sets. Chrome Alloy Steel, in steel boxes, 26/-.

Moving Coil Microphones with Pressel Switch, 6/6. Matched Transformer, 5/-.

Small 24 v. D.C. Multi-gear Motor with reversible clutch, 11/6.

Meters, M.C., 2in. 0-300 v., 10/-; 0-1 mA., 13/6.

Multimeter Kit. 2½in. Meter. Reads volts D.C. 3-30-150-300-600 mA. 60 and ohms 5,000 with 1½ v. Battery—in black ebonite case 6in. x 4½in. x 1½in., 17/6.

250-watt Double Wound Transformers. 230/115 v. Made by G.E.C. With Steel Shroud. New. £27/6 each.

200/240 v. A.C./D.C. Motors, 1½ H.P., 5½in. spindle each end, 5½ x 3½in. 32/- each or fitted with 2½in. Grindstone, 36/6.

6 v. Vibrator Packs in black metal cases, 7½in. x 3½in. x 5½in., 200 v., 40 mA., 18/6.

14/36 P.V.C. Flex, 26/- 100 yds.

Powerful Small Blower Motors, 24 v. and 12 v. A.C./D.C., 14/-.

Army Carbon Microphone with switch, 4/6. Trans. to match, 3/6.

Transformers. Input 200/240 v. Sec. tapped 3-4-5-6-8-9-10-12-15-18-20-24-30 volts at 2 amps., 21/- 12 months Guarantee.

VCR138/ECR35 3½in. Scope Tubes. New and Boxed, 21/6.

All Carriage Paid. Money Back Guarantee from:

**THE RADIO & ELECTRICAL MART,**  
253B, Portobello Road, London, W.11  
Park 6026.

Largest stocks,  
best selections  
and Bargains in Ex-Services Radio and Electronic Equipment

## CLYDESDALE

### HAND COMPASSES

**MAGNETIC MARCHING COMPASS MK1** is a compact pocket size unit enclosed in a small bakelite case 2½in. x 2½in. x 9/10in. deep when folded. Objects can be sighted by means of V sight and aperture embodied in the compass. Instructions enclosed with each unit.

CLYDESDALE'S PRICE ONLY **21/-** POST PAID

**HAND COMPASS TYPE 06-A.** Ex.-R.A.F. hand compass fitted with a sighting prism enabling a viewed object to be sighted and the bearing read simultaneously. The cardinal disc, marked in degrees 0-360, can be illuminated for use at night, the handle of the compass being vertically a 2-cell flask light, the illumination penetrating through the bottom of the compass proper.

Compass diam. 4½in, length 9in. Complete with transit case 10½in. x 5½in. x 5½in.

CLYDESDALE'S PRICE ONLY **£3/15/0** CARRIAGE PAID

### SPERRY COMPUTER, TYPE BB, REF. 10992 "M"

The Sperry Computer employs over 100 various precision gear wheels, helicals, rollers spirals, levels, ratchets, worm drives, skew gears and variable pitch worm gears. Precision pitch stabilising gyro unit.

Servo syphon system unit with four concertino type reservoirs, small bore servo tubes, and servo switch. Two 24-volt D.C. 1.5 A. motors with pulley shaft each end and reversing clutch mechanism. Selsyn 24-volt repeater motor (9/2292). Slow motion dials, counters, aneroids, capsules, shafts, springs, metal and flexible tubing, plus over 800 springs, washers, nuts and bolts, etc.

The complete unit is enclosed in a metal box with removable side covers: 19in. x 14½in. x 3½in. finish in black crackle and suspended in a tubular metal cradle frame by four heavy duty anti-vibration mountings. Weight 96 lb.

CLYDESDALE'S PRICE ONLY **69/6** Each CARRIAGE PAID

### MISCELLANEOUS

Desacator Pumps (in original transit case)	..	..	..	..	£5 10 0
Packard Coolant Pumps ..	..	..	..	..	£2 9 6
24-volt Motor Driven Prop Feathering Pump	..	..	..	..	£2 0 0

**CLYDESDALE** SUPPLY CO. LTD. • 2 BRIDGE STREET GLASGOW - C.5

Phone: SOUTH 2706/9. Please Print Name and Address.

Send now for new illustrated lists.

### Accumulators

Exide 10 volt, 5 amperes/hour, head acid glass-cased accumulators, 6½in. by 2½in. by 4½in. Five 2-volt cells in series can be tapped for lower voltage. Useful for experiment's, alarm circuits, models, etc. Brand new and unused, 7/6 each. Postage and packing, 1/-.

### Relays

**NAF 1118-2.** Struthers-Dunn, 160 ohm coil, S.P., normally open; exceptionally heavy silvered contacts; mounted on flat bakelite panel; adjustable armature; dim. 4in. by 3in. by 1½in. Price 4/-.

**RPX 576.** Struthers-Dunn; 2 coils of 18 ohms each; 2 S.P. contacts normally open; consisting of 2 relays mounted on bakelite panel; contacts rated 50 amps. each; dim. 4in. by 3½in. by 1½in. Price 6/-.

**10F/1252.** Type 10; 160 ohm coil, normally open, and S.P. action; easily modified to double-pole; exceptionally heavy silvered contacts; adjustable armature; dim. 3in. by 2½in. by 1½in. Price 5/6.

**5C/1968.** 65 ohm coil; S.P. normally open; housed in bakelite case with removable lid; heavy contacts; screw terminals; dim. 4in. by 1½in. by 1½in. Price 5/6.

**10F/151.** 2 coils, 1 being double wound; 2 10hm coil and 1.5+11 ohm coil; all contacts normally open; 2 ohm coil energised six contacts made to one side 1.5+11 ohm coil energised six contacts made to other side. All separate poles, heavy contacts; contacts adjustable by screw and locking nut; mounted in bakelite frame; dim. 7½in. by 3½in. Price 8/6.

### Capillary Thermometers

Calibrated —36+55 degrees Centigrade; 2½in. diameter indicator; dashboard mounting; capillary length 16ft. Made by Cambridge Instrument Company. An excellent instrument for car, refrigerator, boat, and laboratory, etc. A rsalbu. Boxed unused, 9/6 each. Postage and packing, 1/-.

• Send S.A.E. for our Super Detailed List

**WILFLO PRODUCTS**  
216-222, GORBALS STREET  
GLASGOW, C.5

# TAKE UP PELMANISM

And Bring Out Your Latent Talents

YOU must have often asked yourself why you don't get what you want out of life. The answer is that your mind is a battle-ground where confidence and inferiority complex strive for control. When confidence has the upper hand things go well for you. In business, in social life, in affairs of the heart, your confidence brings success.

Then why are you not always confident? Over 750,000 men and women have proved that confidence can be increased by Pelmanism and that inferiority complex can be conquered for ever.

Is your enemy here? Amongst the hindrances and troubles swept away for ever by Pelmanism are—  
 Worry Procrastination  
 Indecision Mind-Wandering  
 Frustration Lack of Confidence  
 Forgetfulness Unnecessary Fears

When you have cleared your mind of its difficulties and weaknesses, Pelmanism will tune your mind, sharpen and strengthen it and develop many of these stirring qualities—

- Initiative
- Ambition
- Originality
- Personality
- Concentration
- Self-Confidence
- Earning Power
- Reliable Memory

All qualities of the utmost value in every walk of life.

Reduced fees for serving and ex-Service members of His Majesty's Forces (Apply for Services Enrolment Form)

Practical Psychology applied to your own needs

Pelmanism is an education not from outside, but from within you. It makes all other education fruitful because it shows you how to use it. Unlike any other form of training, Pelmanism helps you to use all your power, your knowledge and your strength of mind and character, while others can use only a fraction of the dormant ability that they were born with.

The Pelman Course is fully described in a book entitled "The Science of Success" which will be sent to you, gratis and post free, on application to:—

**PELMAN INSTITUTE,**  
 (Established over 50 years)  
 130, Norfolk Mansions,  
 Wigmore Street, London, W.1.  
 Callers welcomed.

POST THIS COUPON TO-DAY

To the Pelman Institute,  
 130, Norfolk Mansions, Wigmore  
 St., London, W.1.

Please send me, gratis and post free,  
 "The Science of Success"

Name .....  
 Address .....

PELMAN (OVERSEAS) INSTITUTES. PARIS: 176 Boulevard Haussmann. AMSTERDAM: Prinsengracht 1021. MELBOURNE: 396 Flinders Lane. JOHANNESBURG: P.O. Box 4123. DURBAN: Natal Bank Chambers (P.O. Box 1489). DELHI: 10 Alipore Road.

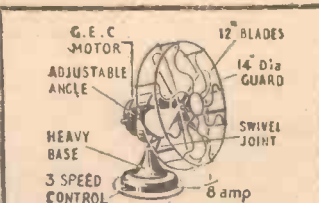

### TABLE FAN BY G.E.C.

Brand new, A.C. 200-250v, weight 18lb., 3-speed control lever. Will last a lifetime. Worth over £10. **85/-**

### TANK-COMMANDER'S PERISCOPE

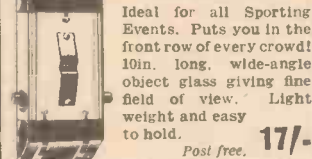

Ideal for all Sporting Events. Puts you in the front row of every crowd! 10in. long, wide-angle object glass giving fine field of view. Light weight and easy to hold. **17/-** Post free.

### PULLIN MOTOR

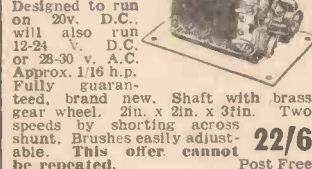

Designed to run on 20v. D.C., will also run 12-24 v. D.C. or 28-30 v. A.C. Approx. 1/16 h.p. Fully guaranteed, brand new. Shaft with brass gear wheel. 2in. x 2in. x 3/16in. Two speeds by shorting across shunt. Brushes easily adjustable. This offer cannot be repeated. **22/6** Post Free

### PHOTOGRAPHIC CHEMICALS

HYP0 (Anhydrous), 10lb. in 2lb. tins, post free. 21/-; FIXER, Acid Chrome, to make 2l. gals., post free, 13/6; SODIUM CARBONATE, 7lb. tin, post free, 11/-; PYRO-METOL DEVELOPER, optional stain, 5 x 5 qt. size, post free, 11/-.

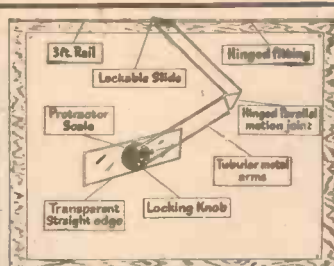

### DRAWING ARM

Originally RAF plotter, but ideal for all draughtsman's purposes. Includes long metal rail for mounting at edge of board, elbowed parallel arm, etc. Will cover larger than Imperial size. Tubular metal throughout, and does same work as drawing machine eight times the price. **22/6** Postage and packing 1/6.

### DI-POLE AERIAL

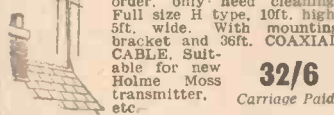

Ex-Govt. Television or Short-wave Aerials. Good working order, only need cleaning. Full size H type, 10ft. high, 5ft. wide. With mounting bracket and 36ft. COAXIAL CABLE, Suitable for new Holme Moss transmitter, etc. **32/6** Carriage Paid.

### HAND GENERATOR

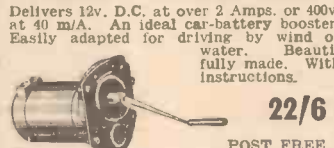

Delivers 12v. D.C. at over 2 Amps. or 400v. at 40 mA. An ideal car-battery booster. Easily adapted for driving by wind or water. Beautifully made. With instructions. **22/6** POST FREE

### AERO-SPARES CO.

(Dept. 10), 71, HIGH HOLBORN, LONDON, W.C.1. Phone: AMB. 2871/2.

# GALPINS

ELECTRICAL STORES,  
 408, HIGH ST., LEWISHAM,  
 LONDON, S.E.13

Tel.: Lee Green 0309. Near Lewisham Hospital  
**TERMS: CASH WITH ORDER.**  
 NO. C.O.D. All goods sent on 7 days' approval against cash.

EARLY CLOSING DAY THURSDAY

**B.S.I. FIRST GRADE SWITCHBOARD VOLT METERS.** 6in. scale, moving coil, 0-200 volts, 30/-; 0-75 volts, 30/-; A.C. ditto, 0-300 volts, 47/6.

**EX-RADAR MAINS TRANSFORMERS.** 230 volts 50 cycles input, 4 kV, or 5 kV. OUTPUT with 3 L.T.s. 6.3 v. 2 a., 2 v. 2 a., 4 v. 2 a. These transformers are in oil, new, boxed. £313/- each, carriage 7/6.

**MAINS VARIABLE RESISTANCES.** 14 ohms to carry 1 to 4 amps, 12/6 each; 0.4 ohms to carry 25 amps, 10/-; 1,500 ohms to carry 0.45 amps.

**VOLTAGE CHANGER TRANSFORMERS (New).** 500 watts tapped 0, 110, 200, 230 volts, can be used either way, 65/- each, carriage 3/6.

**ELECTRIC LIGHT CHECK METERS,** quarterly type, for sub-letting garages, apartments, etc., all fully guaranteed electrically for 200/250 volts, A.C. mains, 50 cys., 1 ph., 5 amp. load, 17/6 each; 10 amp. load, 20/- each; 20 amp. load, 25/- each; 50 amp. load, 37/6 each; carriage, 2/- extra on each; special discount of 10 per cent. on quantities of one dozen or more.

**POWER TRANSFORMER AUTO WOUND** voltage changer tapped 0, 110, 150, 180 and 230 volts at 1,600 watts, £55/- each, carriage 3/6; another tapped 0, 110, 200, 230 volts at 350 watts at 48/6 each, carriage 2/-.

**DOUBLE WOUND 3,000-WATT VOLTAGE CHANGER TRANSFORMERS.** 130 to 250 volts or vice versa, weight 100 lb., £10 each, carriage 10/-.

**MAINS BOOSTER TRANSFORMERS.** 1,500 watts tapped 0, 6, 10, 19, 175, 200, 225, 240 and 250 volts, good condition, electrically guaranteed, £415/- each, carriage 5/-.

**SWITCHBOARD METERS.** 4in. scale, 0 to 14 amp. D.C., 17/6 each; 0 to 30 amps. A.C./D.C., 22/6; 0 to 14 amps. A.C./D.C., 22/6 each. All fully guaranteed.

**MAINS TRANSFORMERS (New).** All 200/250 volt primaries in steps of 10 volts. Output 350/0/350 volts, 300 mA., 6.3 v. 8 a., 6.3 v. 8 a., 4 v. 4 a., 5 v. 4 a., 62/6 each; 500/0/500 volts 300 mA., 6.3 v. 8 a., 6.3 v. 8 a., 5 v. 4 a., 62/6 each; 500/0/500 volts, 4 v. 4 a., 300 mA., 6.3 v. 8 a., 6.3 v. 8 a., 6.3 v. 4 a., 5 v. 4 a., 3 v. 4 a., 67/6 each; 350/0/350 volts, 250 mA., 6.3 v. 8 a., 4 v. 8 a., 4 v. 4 a., 6.3 v. 3 a., 6.3 v. 3 a., 6.3 v. 3 a., 39/6 each, carriage 3/6.

**MAINS TRANSFORMERS (New),** all with 200/250 volt primaries in steps of 10 volts; output 350/0/350 volts, 180 mA., 6.3 v. 8 a., 5 v. 3 a., 37/6 each; 350/0/350 volts, 180 mA., 6.3 v. 4 a., 5 v. 3 a., 4 v. 4 a., 37/6 each; 500/0/500 volts, 150 mA., 6.3 v. 5 a., 4 v. 4 a., 5 v. 3 a., 42/6 each; 425/0/425 volts, 160 mA., 6.3 v. 3 a., 6.3 v. 3 a., 5.3 a., 39/6 each, carriage extra 1/6.

**MAINS TRANSFORMERS.** 230 volts 50 cys., 1 ph. input, tapped output, 0, 6, 12, 18 volts at 4 amps., at 17/6 each, post 1/6; another 230 volt input, 700/0/700 volt, 70 mA., 12 v. 1 a., 4 v. 2 1/2 a., 27/6 each, post 1/6.

**METERS, EX-W.D. SURPLUS (New),** 2in. scale, moving coil 0 to 20 volts, 6/- each, post 9d.; another 0 to 10 volts, 7/7 each, post 9d.; another 0 to 10 amp., 12/6 each, post 9d.

**DUCCOIN VARIABLE TARIFF ELECTRIC LIGHT Id./Is. SLOT METERS,** all fully guaranteed 200/250 volt A.C. mains 5 amp. load, 42/6 each, carriage 2/6.

**SMALL SIZE CREDIT-TYPE ELECTRIC METERS,** 200/250 volt A.C. mains, overall size 4 1/2 in. x 3 1/2 in. x 3 1/2 in., weight 4 lb., 10 amp. load, 25/-, post 1/-; 20 amp. load, 30/-, post 1/-; 25 amp. load, 35/-, post 1/-, fully guaranteed electrically.

**ROTARY CONVERTERS, EX-NAVAL,** well-known makers, 100 volts D.C. input 230 volts 50 cys. 1 phase at 250 watt output, capable of 100 per cent. overload, weight 100 lb., condition as new, £101/0/- each, carr. paid.

**EX-R.A.F. MICROPHONE TESTERS.** These contain a 2 1/2 in. scale 0 to 450 microamp. meter shunted to 1 mAmp., calibrated 0 to 10 volts, moving coil, complete with 1 mA. rectifier, "mike transformer," etc., all contained in polished wood box, as new, 17/6 each.

# Sensitised Materials for and PHOTO COPYING BLUE PRINTS

As actual manufacturers of all types of sensitised photo materials, Haldens are in a unique position as print room suppliers. Materials for Blue Prints, Dyeline Prints, Gas Developed Prints, Sepia Prints, "Ferazo" Blue Prints, Ferro Gallic Prints, etc. The brand names "Dyalyn," "Neut-ralyn," "Vaporax," "Cyano," "Ferazo" are your guarantee of complete satisfaction.



Illustrated is the "Ferazo" Developing Machine. Write for fully descriptive leaflet.



J. HALDEN & CO., LTD., 8, ALBERT SQUARE, MANCHESTER 2. Branches at London, Newcastle-on-Tyne, Birmingham, Glasgow, Leeds and Bristol.

# QUERIES and ENQUIRIES

A stamped, addressed envelope, three penny stamps, and the query coupon from the current issue, which appears on page 72 (THE CYCLIST), must be enclosed with every letter containing a query. Every query and drawing which is sent must bear the name and address of the reader. Send your queries to the Editor, PRACTICAL MECHANICS, Geo. Newnes, Ltd., Tower House, Southampton Street, Strand, London, W.C.2.

## Water Softener Details

COULD you let me have constructional details for making a water softener? I have machine-shop facilities consisting of bench, lathe, drill and miller. Would it be safe to drink the water from such a water softener?—J. H. Light (Abersychan, Mon.).

MODERN domestic water-softeners operate on the chemical "base-exchange" system. The water is trickled through a column of a zeolite material, which abstracts the hardness-forming elements from the water, leaving it of almost zero hardness. Eventually, the "active material" loses its power. It is then "regenerated" merely by trickling a solution of common salt through it, when it becomes as good as new again. This cycle of operations can be repeated over and over again.

For the softening column you can use a clean earthenware pipe about 2ft. long and 4in. diameter. This is suitably capped at the lower end so that the softened water may be led off to a tap. The softening column has, at its lower part, a layer of small, sharp grit or spar, and also a similar layer at its upper end. Between these layers is the "active material," which you can obtain from The Permutit Co., Ltd., Gunnersbury Avenue, London, W.4. All you have to do is to trickle the hard water through the softening column, and then to collect it by suitable means from the lower end of the column. You will also be able to obtain active material and a booklet on softening from Sofnol, Ltd., Greenwich, London, S.E.

The active material costs about 6s. 6d. per lb. Water softened by a zeolite softener is quite drinkable.

Our suggestion is that you obtain some active material and that you try out a softener "in the rough." With your facilities you will soon be able to devise and construct a better-made article. Do not have iron attachments or fittings in contact with the softened water, since these readily rust. If, however, it is essential that such fittings are used, give them several coats of a bakelite varnish. Stainless steel, although it is very expensive, is an excellent material for the metal parts of a softener. So, also, is monel metal.

## Dyeing Teasels

I WISH to dye some dry teasels for decoration with different colours. Could you suggest some inexpensive dyes for this purpose?—R. B. Askew (Oxtd).

DISSOLVE 2 parts of sodium sulphate (Glauber's salt) and 6 parts of dye in 92 parts of water. The dye and sodium sulphate should be weighed in grams, the water measured in ccs. Place the dye solution thus made in a non-metallic vessel, which stands in a pan of water. Immerse the teasels in the solution. Then gradually heat the water in the pan until it reaches nearly boiling-point. This should take about 30 mins. Maintain the water at this temperature for another 30 mins. Then allow the water to cool slowly. After this remove the teasels from the dye bath and rinse them in cold water. They will now be dyed a fairly full shade. If you want still fuller shades, stand the teasels, before dyeing, in a solution containing 3 parts of tannic acid in 97 parts of water for about 2 hours. Then rinse them briefly, and dye them as usual.

Any aniline dye of the basic class will suit your purpose. Suggested dyes are: Magenta, neutral red, safranin (orange), chrysoidine (yellow), phosphine (orange), auramine (yellow), methyl green, methyl violet, malachite green, brilliant green, Victoria blue, night blue, methylene blue, Meldola's blue, Bismarck brown, nigrosine (black), diazine black, rhodamine (blue-red), primrose, crystal violet, fast scarlet.

These dyes cost about 2s. per oz. at laboratory supply dealers, such as Messrs. Vicosins Ltd., 148, Pinner Road, Harrow, Middlesex, or Messrs. W. and J. George and Becker, Ltd., 17-29, Hatton Wall, London, E.C.1.

It is possible that some of the ordinary household dyes may be of use, particularly if the teasels are pre-treated in the tannin solution, but this cannot be guaranteed.

## French Polish Reviver

WHAT is the correct mixture for a furniture polish reviver, using the following: Vinegar, linseed oil, methylated spirit, turpentine, and butter of antimony? It is intended for reviving

the lustre of french polish.—C. H. Downs (Johannesburg, S. Africa).

THE french polish reviver to which you refer is compounded of a mixture of equal parts of vinegar, raw linseed oil and methylated spirit, to which a very little (less than 1 per cent.) of "butter of antimony" (antimony chloride) has been added as a grease-killer. The mixture is well shaken up before use. It is applied with a wadding or a very soft cloth, after which the surface is well polished up with a soft rag. Note that turpentine is not required.

The following formula is a much simpler and less expensive one, and, for french-polished surfaces, is equally as efficient:

Paraffin oil	1 part (by vol.)
Water	4 " "
Fine, sieved whiting	Sufficient to impart milkiness when the liquid is shaken up.

The above mixture is well shaken up, applied with a soft cloth in the ordinary way, and the surface is finally polished with a soft cloth until it is quite dry.

## Moulding Material for Puppet Heads

I HAVE recently seen stage decorations and also puppet heads made from a kind of rubber. They seemed to have been made by casting and heating in metal moulds, and were in different degrees of hardness. Can you tell me what this

Readers are asked to note that we have discontinued our electrical query service. Replies that appear in these pages from time to time are old ones and are published as being of general interest. Will readers requiring information on other subjects please be as brief as possible with their enquiries.

material is likely to be, and where it can be obtained?—H. Simpson (Welwyn Garden City).

THE rubber compositions to which you refer are mainly mixtures of rubber with synthetic resins. They vary enormously in composition, but below we give a typical formula:

Rubber powder	.. 35 parts (by weight)
Dark coumarone resin	.. 35 " "
Heavy mineral oil	.. 10-40 " "
Ester gum	.. 20-40 " "

Such material is not produced for retailing, and we doubt whether you will be able to obtain it at all. The material is difficult to make on a small scale. We

## THE P.M. BLUEPRINT SERVICE

12FT. ALL-WOOD CANOE \*New Series, No. 1 3s. 6d.

10-WATT MOTOR. New Series. \* No. 2, 3s. 6d.  
COMPRESSED-AIR MODEL AERO ENGINE \*  
New Series. No. 3, 5s.

AIR RESERVOIR FOR COMPRESSED-AIR  
AERO ENGINE. New Series. No. 3a, 1s.  
"SPORTS" PEDAL CAR.\*New Series, No. 4, 5s.

F. J. CAMM'S FLASH STEAM PLANT.\* New  
Series. No. 5, 5s.

SYNCHRONOUS ELECTRIC CLOCK. New  
Series. No. 6, 5s.\*

ELECTRIC DOOR-CHIME. No. 7, 3s. 6d.  
ASTRONOMICAL TELESCOPE. New Series.  
No. 8 (2 sheets), 7s.\*

CANVAS CANOE. New Series. No. 9, 3s. 6d.  
DIASCOPE. New Series. No. 10, 3s. 6d.

EPISCOPE. New Series. No. 11, 3s. 6d.\*

PANTOGRAPH. New Series. No. 12, 1s. 6d.\*

COMPRESSED-AIR PAINT SPRAYING  
PLANT. New Series. No. 13, 7s. 6d.\*

£20 CAR\*  
(Designed by F. J. CAMM)

10s. 6d. per set of four sheets  
MASTER BATTERY CLOCK  
Blueprints (2 sheets), 3s. 6d.

Art board dial for above clock, 1s.

OUTBOARD SPEEDBOAT  
10s. 6d. per set of three sheets.

SUPER-DURATION BIPLANE  
Full-size blueprint, 2s.

THE 1-c.c. TWO-STROKE PETROL ENGINE  
Complete set, 7s. 6d.

STREAMLINED WAKEFIELD  
MONOPLANE — 3s. 6d.

LIGHTWEIGHT MODEL MONOPLANE  
Full-size blueprint, 3s. 6d.

P.M. TRAILER CARAVAN  
Complete set, 10s. 6d.

P.M. BATTERY SLAVE CLOCK\*—2s.

The above blueprints are obtainable, post free,  
from Messrs. George Newnes, Ltd., Tower House,  
Southampton Street, Strand, W.C.2.

An \* denotes constructional details are available, free,  
with the blueprints.

suggest you might be able to use some bakelite mixture which would give similar results. To this end, you should apply to the Technical Department of Bakelite, Ltd., 18, Grosvenor Gardens, London, S.W.1.

## Checking a 6in. Centre Lathe

WHAT is the best way of checking a 6in. centre lathe for accuracy of bed and headstock, etc.? What faults should I expect to find in a fairly old lathe (about 15 years), and how could I rectify these?—D. B. Dawson (Parkstone).

YOU will find that wear in a lathe takes place in three major positions, and we suggest you investigate these because they are important.

First, the saddle, which is used mostly close up to the chuck, will prove difficult to move when traversed toward the end of the bed. This proves that a fair degree of wear has occurred at the headstock end and the packing gibs have been adjusted to take up this discrepancy.

Next, the face of the tailstock which contacts the bed will eventually wear, causing the rear centre to be lower than the headstock member. This is ascertained by the use of a dial indicator and a fairly long parallel mandrel mounted between centres.

Finally, the headstock bearings may be worn, which will necessitate replacing them if roller races are used, but coned bearings may be adjusted if they are in fairly good condition.

Rectification of the bed and tailstock will prove a lengthy job if scraping is resorted to, particularly if the parts are in bad condition.

We suggest you obtain the services of a millwright or skilled turner, who will examine the machine and advise on the best course to adopt.

You may find that it will be preferable to plane the bed, and this work is best delegated to a firm with the necessary equipment.

If you adopt the scraping procedure, then you will require a good sized surface plate and parallel strips to ensure first-class surface results.

## Fixing Rubber "Tiles"

I INTEND to fix rubber "tiles" to my bathroom floor, and shall be glad if you will tell me where I can obtain the tiles. As the floor is somewhat uneven, which is the best way to level it—the orthodox way and then cement the tiles to the wood, or is it required that some other material is first affixed?—C. Wilkinson (Blackburn).

YOU may have difficulty in obtaining rubber "tiles," since these are ordinarily supplied only to flooring companies and are not extensively in use.

However, you should make inquiries of Messrs. Reddaway & Co., Ltd., Pendleton, Salford, 6, Lancs.; The Greengate Rubber Co., Ltd., Salford, Lancs.; North British Rubber Co., Ltd., Edinburgh; Leyland & Birmingham Rubber Co., Ltd., Chorley, Lancs.; India Rubber, Gutta Percha & Telegraph Works Co., Ltd., Silvertown, London, E.16.

If you are unable to procure the "tiles" which you require, a good substitute may be obtained by cutting up rubber sheeting of at least 1/4in. thickness.

The uneven floor should be concreted to an even level, and the rubber tiles laid on this, using a bituminous adhesive. A thick bituminous paint will do for the purpose, but it is better to use one of the special rubber-bitumen adhesives prepared by the rubber-tile manufacturers or recommended by them.

You cannot cement rubber "tiles" to wood. The rubber tiles must be cemented by an adhesive containing an organic solvent, such as a rubber solution or a solution of bitumen in naphtha.

## Insulating Tape

WOULD you kindly give me the formula for making insulating tape?—C. E. Mason (Ashford).

FROM a local asphaltting firm, obtain a small quantity of medium-soft bitumen. Dissolve this in an equal bulk of hot naphtha so as to obtain a thick, pasty, black substance. Work into this an equal bulk of thick rubber solution (obtained from a tube). Spread this medium by means of a blunt edge rapidly over one side only of a strong fabric tape. Stretch the tape out for a day or more in order to allow the naphtha and other solvents in the mixture to evaporate. Then dust over the material a very fine powder, such as Fuller's earth or talc, in order to prevent the fabric surfaces adhering when they are rolled up.

## Antique Finish on Oak

I AM making a set of nesting coffee tables in oak, and I want to give them a finish so that they look antique—in colour, not dented or marked in any way. Could you please supply me with a formula so that I can mix a suitable stain?

I believe that before applying a stain of any form to wood it is necessary to use a grain filler. Is this correct, and what is the filler?—R. Bayliss (Birmingham).

IF, as you say, your coffee tables are of oak, you will best get the dark, antique appearance of old oak by staining them lightly with a solution of Brilliant Green in methylated spirit, followed by staining with any brown dye in methylated spirit. The green stain should be applied first, and only lightly, so as just to tint the woodwork green. If the green stain is too strong, the woodwork will become almost black when the brown stain is applied and the surface finally polished. No filling treatment is required for the woodwork before the stains are applied.

Alternatively, you can use the dye, "Antique Brown,

and then give one coat only to the woodwork. You should be able to obtain this dye, and the others before mentioned, either from Messrs. Philip Harris & Co., Ltd., Birmingham, or from Messrs. W. & J. George & Becker, Ltd., 157, Great Charles Street, Birmingham, 3. The cost of the dye is about 2s. per oz. You should not require more than 1oz. of each for your work.

The stained woodwork should be sandpapered lightly and then polished. We recommend a very light coating of shellac varnish, followed by a wax polish. This will give a dull sheen, and not the high glaze of a modern furniture varnish.

**Polishing "Perspex" Windscreen**

Will you please advise me on the following—I have a small car fitted with a "Perspex" windscreen. This screen splits up the rays of approaching lights at night in rather an alarming manner. I have been given to understand that polishing will alleviate this trouble, and I would appreciate full details on the correct method.—A. Smith (Canterbury).

Assuming that your windscreen is surface finished in a reasonable manner, that is to say, it admits of clear, undistorted visibility in daytime, no amount of super-polishing will give it better visual characteristics at night-time. The whole trouble is caused by certain unevenness in the windscreen surface. This cannot be polished away. If you wish to try, use fine Tripoli powder wetted with water. We believe that I.C.I., Ltd., London, S.W.1, supplies preparations for the polishing of "Perspex," but these only deal with fine polishing, and would be useless for your requirement.

It is possible that your windscreen has warped in some way, and that its surface has taken on itself the form of a wave. Plastic screens do, at times, behave in this manner, particularly after prolonged exposure to the hot sun. There is no remedy for the trouble.

**Cement for Washbasin Flange**

Could you please suggest a suitable cement (heat and waterproof) for sealing a leak in a white glazed washbasin at the point where the outlet pipe flange is affixed inside the basin?—G. Marchbank (Oswestry).

To seal the washbasin flange properly, the entire waste-pipe assembly should be removed, cleaned up and then replaced with the aid of a suitable washer and a little red-lead paste. However, the following material will make a good cement for your purpose, and this will last a long time, provided that it is not subjected to mechanical damage.

This cement is made by mixing together equal parts of putty and white-lead paste. After you have made a perfect blend of the two, work in a little red lead—just sufficient to colour the material pink. This is the material which forms the cement. When freshly prepared, it is plastic, but it slowly hardens and becomes dead hard in time. When surface-hard, it should be given a coating of a good white paint so as to match-up its appearance with that of the washbasin enamel.

**Maintaining Humidity for Mushroom Growing**

Can you inform me how to maintain a high humidity (70 to 80 per cent.) in a small building devoted to mushroom growing, and what type of plant I should require?—W. H. Saul (Newcastle-on-Tyne).

You should readily be able to obtain a relative humidity of 80 per cent. for mushroom growing, because this degree of humidity is very common in cellars of old houses. We note, however, that you do not describe the type of building in which you propose to culture the mushrooms. All you need to do, however, is to spray water on the walls, floor or ceiling every day, or, at least, every other day. If you cannot arrange this, keep water continually in shallow vessels disposed about the building.

Working on a more ambitious scale, you would need merely a sprinkler attachment to a water pipe, tap or hose-pipe, the water to which could be turned on for a short time every day. Much of the detail, however, depends on the nature and design of the building.

**Light-generating Bulbs**

Have you any information concerning bulbs which, when shaken, emit a weak light? I have seen one or two references to these in American journals.—E. D. (Swindon).

The bulbs to which you refer contain mercury and they are, of course, evacuated. When shaken violently they give off a faint fluorescent glow which can be seen in a darkened room. It is a well-known laboratory experiment, but it has no practical application, as the light given off is very minute. It is possible that you may be able to obtain such bulbs from Griffin and Tatlock, Kemble Street, Kingsway, London, W.C.2.

**Bakelite Paint for Sunny Positions**

May I have your suggestion for a preventative for the following trouble?

The front door of my house receives the full glare of summer sunshine (facing S.S.E.). It is not possible to fix a veranda to shelter the door, and a canvas curtain is used daily, but whether the door is painted or varnished, at the end of each summer it is badly blistered.—W. G. Clarke (Ryde, I. of W.).

The orthodox oil paints containing plenty of oil are not suitable for hot, sunny positions. For this type of use it is better to employ paints based on synthetic resins which contain a minimum of oil. Paints based on bakelite are quite good for this purpose, and you will be able to obtain particulars of them by directing an inquiry to the Technical Department of Bakelite, Ltd., 18, Grosvenor Gardens, London, S.W.1.

If, as you say, the existing paint is badly blistered, it would be advisable for you to remove the whole of the paint by burning off with a blow lamp. After sandpapering, the wood should be given a thin coat of a grey priming paint and, over this, a thin coat of the bakelite paint—should be applied.

By this means you will get a great improvement, but we must point out that no paint is 100 per cent. heat-proof, and that for the maximum utility of the paint you will have to devise some form of screening from the hot summer-time rays of the sun.

The method above recommended has, also, the sanction of the Paint Research Association Committee.

**Water-heating System**

Will you please inform me if a hot-water system on the lines shown in the sketch would be efficient? The source of heat is the exhaust from an internal combustion engine, and

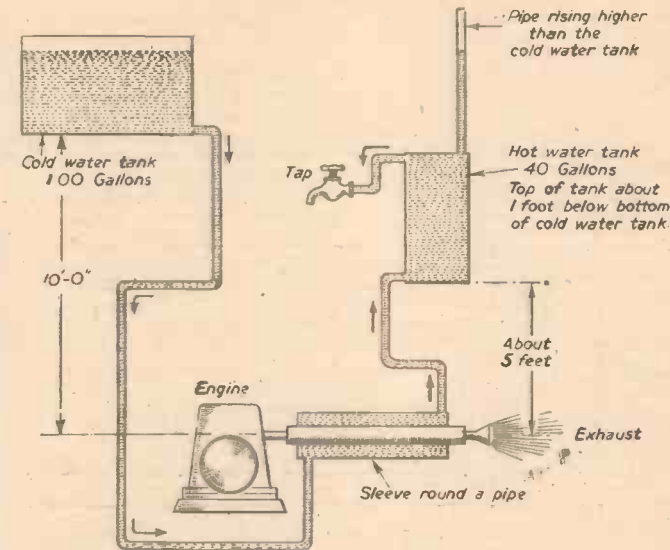

Diagram of proposed water-heating system utilising the exhaust from an I.C. engine.

the water supply is from a tank collecting rain water. It will be installed in a rural district. There is about 10ft. head of water between the cold water tank and engine exhaust.

Should the outlet from the hot water tank be at the top?—E. H. Price (London, E.C.).

The water-heating system which you outline in your sketch will operate, but we hardly think that it will be very efficient, unless, of course, the engine exhaust is continually available.

The cold water inlet pipe to the heating sleeve must be below, and the outlet pipe above, as shown in the sketch, otherwise, the entering water will not obtain its full quota of heat. It is better for the hot water outlet from the hot water tank to be taken at an upper level rather than from a lower level, but this matter is not an essential, and the arrangement will work no matter from what position the hot water may be taken from the hot water tank.

If, as you say, the cold water tank collects rainwater, a filtering gauze should be placed across the outlet pipe from this tank in order to prevent dirt and debris getting into the heating system, and possibly causing blockages. The utilisation of soft water (such as rainwater) for heating purposes is very good, because it will not give rise to furring and deposits within the system.

If possible, the hot water pipe between the heater and the hot water tank should be well lagged with asbestos sheeting. The same applies to the hot water tank itself. By this means you will not only conserve heat, but you will increase the heating efficiency of the system.

**Copper-plating Non-metallic Articles**

I wish to copper-plate a number of articles made of wood, leather and bakelite, but find difficulty in making the surface conductive. I have been using the following method: First fasten a wire to the article, dip in hot paraffin wax, withdraw, allow to cool, rub with graphite and plate in the usual copper sulphate and sulphuric acid bath. This method, however, is slow, troublesome and does not work very well. I have used an American paint made for this purpose called "Spray Bronze," which is sprayed on the article, and dries in a few minutes. But this

cannot be got in Ireland. Kindly let me know if any firm in England can supply something similar, or would it be possible to make it myself?—A. Ross (Tralee, Ireland).

Fine plumbago can be used quite successfully for dusting on as a conducting coating for plating non-metallic articles. It can be obtained from any laboratory suppliers, as, for example, Messrs. Vicsons, Ltd., 148, Pinner Road, Harrow, Middlesex. For many years it was employed for this purpose in the manufacture of the early gramophone records.

Various bronze powders can be obtained from Messrs. Johnson & Bloy, Ltd., Metana House, Hind Court, Fleet Street, London, E.C.4. These are worked into a dilute methylated spirit varnish and then sprayed on to the surface. In this way you will imitate the American product which you name.

In our opinion the best method is to use the Colloidal Graphite preparation supplied by Messrs. E. G. Acheson, Ltd., 9, Gayfere Street, London, S.W.1. This liquid can be sprayed or brushed on to the non-metallic surface. After drying it is baked on to the surface at a temperature of approximately 130 deg. C. for 15 minutes. This improves the conductivity of the applied coating. We suggest you write to the above firm for their "Information Sheet" No. C/01/a on "Conducting Coatings for Electro-deposition."

We note that you are using the acid copper sulphate bath. This is not the best of copper-plating baths for fine work, since it tends to give coarse deposits. The usual cyanide bath is much better and gives finer results. It is essentially a solution of copper cyanide in potassium cyanide solution. It is, of course, excessively poisonous, but is much used commercially. Provided that you can supply satisfactory references, you would be able to obtain cyanide copper-plating salts ready made from Messrs. R. Cruickshank, Ltd., Camden Street, Birmingham, or from Hoklykem, Ltd., Hockley Hill, Birmingham.

**Cementing Wood and "Perspex" to Glass**

I recently fitted an open bookcase with sliding plate-glass fronts and to move them to and fro I stuck thin pieces of wood to the glass with glue. These pieces of wood have now come off.

Can you suggest any other more suitable material to use—say "Perspex"—and the correct method of sticking it to the glass?—L. R. Smithson (Potters Bar).

It is never advisable to attempt to handle a sheet of glass by means of an object which is cemented to it, for the reason that if undue force is applied the cemented object will either come away from the glass or the glass will crack or actually fracture owing to its characteristic inability to withstand severe strain.

Wood is quite suitable for attaching to glass provided that it is given a fairly large, flat area of contact. The face of the wood should be smoothed, but not polished. It should be smeared over with a small amount of cellulose cement (of the "Durofix" type, which is sold in tubes). The contact area of the glass should be similarly treated. Both surfaces should then be allowed to dry. They should then be coated with a layer of cement again and pressed into firm contact. If possible, the wooden surface should be slid on to the glass surface in order to get rid of air bubbles and to exclude voids. The wood should be held under light pressure overnight.

Aqueous cements are not suitable for relatively heavy objects, because when the cement or glue dries its film tends to spring away from the glass. However, for cementing very light objects to glass, a solution of 10 parts of gelatine and 90 parts of water is excellent.

"Perspex" cannot be attached to glass by means of any aqueous cement or even with the aid of a cellulose cement on the above lines. This is because the cement will not wet the Perspex surface. For cementing Perspex you must use a solution of Perspex itself in trichlorethylene. This gives a thickish, rubbery, clear solution which spreads evenly over the Perspex surface and adequately wets it.

Another type of cement which is said to give excellent results—although we have had no experience of it—is made by dissolving gum arabic in a little water until a solution of treacle-like consistency is obtained. This is mixed to the form of a sticky white paste by working powdered calomel (mercurous chloride) into it. It is then used at once. The cement hardens within a few hours, but should be left for a day at least before any strain is placed on it.

**PRACTICAL WIRELESS**  
1/- Every Month

**DUKE & CO.**  
(New Deliveries)

**PANNIER BAGS.** 7/8. Rubberised canvas. 14 x 10 1/2 in. Require only fixing clips. Post 1/6.  
**METAL RECTIFIERS.** 360v. 150 m/a., half wave. 7 1/2 x 1 1/2 in. dia., 7/6 each.  
**FUSE CARRIERS.** 15 amp. complete MEM. Kentark minors. 1/6 each.  
**BESIDE RADIO KIT.** In bakelite cabinet. 4 valve T.R.F. Universal or A.C., for only 24/15/6. Or ivory cabinet. 6/- extra. Assembled. 35/- extra. New and improved circuits. THE ONLY set now available at this price. (Cabinet approx. 12 x 6 x 6 in.) Post and packing 2/6.

**MICRO SWITCH.** SP/ST. 3/6. Also Mercury switches. 3/6.  
**BULGIN ROTARY SWITCH.** Single type. 1/6 each.

**EX-MILITARY BOAT.** 13ft. NEW. All accessories. Inflatable. 6 gns.  
**GERMAN INVASION BOAT.** 50/- 20 to 30ft. x 6 to 8ft. wide, inflatable. Carr. extra.

**HEAD LAMPS.** Ex L.P.T.B. Std. : single bolt fitting. 7/6 plus 1/6 post.  
**MIDGET CHOKES.** 10 henry. 50 mill. 300 ohms. 1/6 each, or 4 for 5/-.

**H.T. BATTERIES.** 90 volts minimum guaranteed, and 3 volts L.T. Std. : British All-dry connections. 5/6 plus 1/6 post.

**AUTOGUARD.** Perfect anti-theft device for ALL vehicles, incl. motor cycles, easily adapted to home burglar alarm. With instructions. 7/6.

**RELAYS.** Type 10K/22. 1,000 ohms, break one, make three. 12/6 each.  
**BRASS HINGES (Small).** non-magnetic. 1/6 pair.

**NI-CHROME WIRE.** 50 yd. spool<sup>s</sup> of .014 wire for only 2/- . Or 25 yds. .022, same price. A fraction of to-day's price. Post extra.

**AERIALS.** Tough spring steel copper plated, 3 sections total length 12ft., 8/6 plus 1/6 carr.

Money back guaranteed. Cash with order please. Or C.O.D.  
Please allow sufficient for Post and Packing. Stamps ONLY for lists.

219, Ilford Lane, Ilford, Essex  
ILFord 0295



MASON MASTER 'S' DRILL      GLAZEMASTER GLASS DRILL

Slip a "MASON MASTER" into a wheel-brace and turn. No matter if it is brick, tile, concrete or marble the carbide tip penetrates easily and quickly and gives a clean round hole.  
Sizes from 5/32 in. to 3/4 in. The "GLAZEMASTER" bores holes in glass of any thickness without fear of splintering or breakage. You just let the drill do the work. Type B as illustrated for craftsmen. Type A for the handyman. Send for illustrated Book-let 'L.'

JOHN M. PERKINS & SMITH LTD.  
Braunston, Near Rugby.  
Phone : Braunston 238.

OBTAINABLE FROM ALL GOOD TOOL STOCKISTS

**CHEMICAL APPARATUS AND CHEMICALS CATALOGUES**

Send 7 1/2 d. Post Free

**VICSONS LTD.** Contractors to Education Authorities and many of the large Industrial laboratories

148, PINNER ROAD, HARROW, MIDDLESEX

FOR ALL LABORATORY APPARATUS

Book : "Magnetic Recording" 25/-, post 9d.



**BUILD THIS RADIO!**

NOW YOU can not only build radios a completely new and easy way, but can actually save a lot of money! Our range of aluminium chassis are completely prefabricated for ALL components. These—and our unique Construction Sheets and ALIGNED AND SEALED Tuning Units—enable ANYONE, whether novice or expert, to build a variety of domestic receivers, feeder units and quality amplifiers with the sure knowledge that failure is impossible!

Full details of this 5 valve Superhet, and many other sets (including circuits and parts) in the NEW EDITION of our famous "HOME CONSTRUCTOR'S HANDBOOK," which has been acclaimed the world over. From the vast quantities sold, also from letters in our files, there is no doubt this book satisfies EVERYBODY interested in radio. If by chance you haven't had a copy you really are missing to-day's best value! Send to us NOW for the latest issue, price 2/-. (Worth very many times this purely introductory price.)

**RODING LABORATORIES (OF ILFORD)**  
MAIL ONLY to:—Dept. PMJ,  
694, LEA BRIDGE ROAD, E.10

**HOLIDAY RELAXATIONS!**

**ELECTRIC MOTORS,** a special buy: 1/4 h.p., 230 v. A.C., 6in. long by 4in. in diameter, with 5/16in. shaft, 45s. each plus 5s. carriage.

**STILL IN STOCK,** the popular small motors suitable for sewing machines, supplied complete with fitted belt and on/off switch, 21/6 inc. post.

For chilly nights treat yourself to an electric blanket, price £16, complete, or we can supply the necessary infra-red unit for attaching to your own blanket, at only 22/6 plus 9d. post. Unit is 6 yds. long by 3 1/2 in. dia., and comes complete with on/off switch and 2-pin mains plug; during the summer when the Ideal boiler isn't working the unit can be used to warm the airing cupboard. For 220-50 v. A.C. or D.C.

**FOR SUMMER PAINTING,** buy a Goblin spray-gun; will fit to almost any make of vacuum cleaner and can be used for redistempering walls, painting or varnishing doors, cellulosing furniture, or with soapy water for shampooing carpets, washing down paintwork, etc., 13/6 plus 9d. post.

**CONVERT YOUR RADIOGRAM** into a Magnetic Recorder; easily done, no permanent parts to disfigure the gram. Complete kit including spool of tape for £5/19/6. Details and circuits 1/-. Other Recording accessories: EMI-tape 25/- . G.E.C. tape 30/- per 1/2 hour reel, spare reels, 4/6. 45KC bias oscillator coils, 5/6. Constructional Data on Magnetic Recording, 5/-.

**TAPE RECORDER DECKS** with fast forward and reverse speeds, supplied with reel of tape; nicely finished article £14/10/-. Delivery approx. 3 weeks.

**PARK RADIO OF MANOR PARK, 676/8, Romford Road, E.12.**

Price £8 5s. 0d. Carr. Extra.

**The 'Adept' Bench Hand Shaper**  
Length of stroke of ram, 9 1/2 in.  
No. 2B. H. Shaper, 6 1/2 in. stroke  
Price £15 0s. 0d. Ask your dealer. Manufactured by

Price 25-0-0d. Postage and Packing, 2s. 6d. (U.K.) Chuck. Reversible Jaws; 35/- of Accessories is available.

**The SUPER 'ADEPT' LATHE**  
1 1/2 in. centres, 6in. between centres.  
The "Adept" 2 1/2 in. 4-Jaw Independent A Good Range

**F. W. PORTASS, 8 SELLERS STREET, SHEFFIELD.**

**PRACTICAL MECHANICS** (full Apprenticeship or Pupillage) may secure status of Professional Membership by using this COUPON.—To the Secretary, INSTITUTE OF EXECUTIVE ENGINEERS AND OFFICERS, EXECUTIVE CHAMBERS, 241, BRISTOL ROAD, BIRMINGHAM, 5. I AM INTERESTED IN MEMBERSHIP: PLEASE SEND ME AT ONCE PARTICULARS AND APPLICATION FORM:

NAME IN FULL (Block Letters).....

ADDRESS (Home).....  
(Block Letters)  
Present position..... Industry.....

Date.....1951 Age..... Signature.....

**Interesting Bargains**

**MICROPHONES.** Table type in adjustable table stand and on heavy base with on-off switch, sound power type, need no battery, new and boxed, 8/6, post 1/6. Fine Granule double button hand mike mounted in bakelite case and on handle with switch, 6/6, post 9d. The Famous G.P.O. Mike Button. The lin. brass body forms the fine granular chamber, diaphragm is of fine mica, needs only battery and transformer. Button, 3/6; Transformer, 2/6, post 9d.

**HEATER ELEMENTS.** 24 volt 75 watt, flat copper plate with insulated connector fitted one end, 4in. x 2in. x 3/4 in., suitable for soil-heating, etc., 1/6, post 3d. Special prices for quantity orders.

**MOTOR BLOWERS.** 24 volt D.C. for valve cooling, etc., high speed, comprises enclosed motor fitted blower with 1 1/2 in. x 3/4 in. outlet, 2/1/-, post 2/-.

**MOTOR PUMPS** for table decoration, battery model, bakelite body fitted motor, battery holder for two U2 cells covered chrome dome with jet and spray attachments. A filter is fitted in the base which is mounted on rubber feet for submersion in water in table bowl, 5/1/- . A.C. model as above for use with transformer from 230 volts, A.C. supply, 5/7/6.

**CRYSTAL SETS.** The Lesdix Festival Model, wound coil, var. tuning cond., ever-set diode detector, phone transformer with socket, all fitted in black bakelite case 6in. x 4 1/2 in. x 1 1/2 in., supplied with headphones specially sensitive to crystal reception, fitted cord and plug, all aerial tested, 30/-, post 1/6. Crystal Set only with terminals for own headphones, 2/1/-, post 1/-.

**SLOW-MOTION DRIVES** for radio, 2/-.

**METERS.** A.C./D.C. Voltmeters, 2 1/2 in. flush; 0-15 volts, 1/7/6. D.C. M.C. Voltmeter, 2in. flush, 0-20 volts, 8/6. Ammeters, D.C. M.C., 50-0-50 amps., 8/6. A.C. Switchboard Ammeters, 1 1/2 in. G.E.C., 0-40 amp., 35/-; 0-60 volts, 35/-.

**FREQUENCY METERS,** 5in. Crompton, 230 volts, 40/60 cy., £7/10/-; 7in. Ironclad Switchboard, 40/60 cy., 230 volts, £10.

**CHECK METERS.** A.C., 50 cy., 200/220 volts, 100 amps., 35/-; 50 amps., 30/-; 20 amps., 25/-; 5 amps., 1/7/6. Surplus stocks by leading makers.

Please include postage for mail orders.

**ELECTRADIX RADIOS**  
214, Queenstown Road, London, S.W.8  
Telephone : MA Caulay 2159

**Announcing**

**"LINESIDE" KITS**

"00" Gauge

**for Railway Modellers**

These kits are ideal for the man who would like to find out just where the fascination lies in scenic railway modelling for they enable him to make a start on a simple but satisfying job at small expense. They contain printed card and wood parts, printed celluloid windows, detailed authentic plans, brick and tile building papers. The first off are

**LARGE SIGNAL CABIN..... 3/8**  
**WATER TOWERS (2 types in 1 kit) 2/9**  
**COUNTRY STATION..... 5/6**  
**PLATFORMS..... 3/8**

Postage: Single kit 6d., two or more 10d.

★ **The full MODEL CRAFT LIST for 1951** gives details of more than 600 plans, planbooks, kits and accessories covering every aspect of the model-maker's art, ships, aircraft, road vehicles, houses, etc. It costs 1/- post free and includes a 1/- refund voucher for use in buying Modelcraft goods.

**Modelcraft Ltd**  
77(L), Grosvenor Rd., London, S.W.1

*If you want  
Reliability*

ask for

**DUNLOP**



1H311



**ACCESSORIES WITH A GREAT NAME**

**WILCO ELECTRONICS**

204, Lower Addiscombe Rd., Croydon.

**AIRCRAFT CLOCKS** with splendid 8-day jewelled movement, flange type, made to stringent Govt. specification. Brand new guaranteed. Ideal for car, study, bedroom, etc., will withstand vibration and shocks. Special offer, 65/- each, post free.

**RECTIFIER UNIT.** Will give a D.C. output from A.C. mains. Ideal for model work, charging accumulators, etc. Will keep your car battery fully charged and insure good starting. Can be left on all night. Input, 200 volts A.C.; Output, 4 amp. 6 or 12 volts D.C.; in neat case with meter, fuses, control switch. £8/6/0. Pkg. & carr., 4/-.

**BATTERY CHARGERS "WESTALITE."** Input 100/250 v. A.C. Output 12 v. 16 amps., variable metered output, fused, worth £34. Our price while they last, £15. Carr. & Pkg., 15/-.

**POWER UNITS.** Comprising standard mains transformer. 350-0-350 volts 80 MVA., 6.3 volt 1 a., 6.3 volt 3 a., 5 volt 2 a., L.F. choke, 8-8 Mfd. condensers, 5Z4G valve, etc., contained in steel case 9in. x 8in. x 8in. Sufficient room to build in small amplifier. Brand new £2 10/0, carr. and pkg., 2/6.

**"ELF" CIRCUIT BREAKER.** 220 volts 1-2 amps. size 3 inches round. 10/6. Post 1/-.

**KLAXON GEARED MOTORS** No. IK55B3-W7. Torque lbs. in. 15. R.p.m. 175. Motor r.p.m. 1,400 at 230 v. A.C. Split phase induction type, £10 each.

**KLAXON CAPACITOR INDUCTION MOTORS** with dia. fan, 140 h.p. 220/240 v. A.C., 2,700 r.p.m. No. EM5CB2 with condenser, 55/- each.

**24 VOLT D.C. MOTORS** with double ended shaft 2in. x 3in., 10/6, postage 1/-.

**THERMOSTAT SWITCH.**—Bimetal type in sealed glass tube, 2in. x 1in. 30 deg. Cent. Ideal for Aquariums, Wax and Oil Baths, Gluepots, etc. Will control 1 amp. at 240 v. 5/- each.

**VOLTMETERS.**—0-300 A.C. Moving Iron 2in. Flush, 17/6; 3in. Flush or Surface, 22/6.

**MASTS, TELESCOPIC,** extending to 12ft. in 7 sections, 15/6, post 1/-.

**THERMOSTAT.** Satchwell 112in. stem 0-250 volts A.C./D.C., 10 to 90 deg. Cent., 35/-.

**P.M. SPEAKERS.**—6in. Rola in case with transformer and volume control, 40/- Post 1/6.

**PRECISION TOOLS FOR PRACTICAL MECHANICS DELIVERY FROM STOCK**



**JAGROSE 3" LATHE**

Surfacing, Screw-cutting, Set-over Tailstock, Hollow Mandrel, Complete with set of Screw-cutting Gears.

**£28-10-0**

E.P. Terms £7-10-0 deposit, 7 monthly payments of 69/-.

**SPECIAL LONDON AGENTS FOR THE FAMOUS**

**PORTRASS LATHES.**

3in. Dreadnought II Model £49-10-0

3 1/2 Heavy Duty Model £65-0-0

4 1/2in. Dreadnought Model £72-10-0

or on Easy Payment Terms.

TRADE ENQUIRIES INVITED

Send for particulars P.M.I.

**JAMES GROSE LTD.,**

379-381, EUSTON ROAD, LONDON, N.W.1. EUS 5231

**TRANSFORMERS**

M.T.1.—250-0-250 v. 80 m/a; 0-4 v. 5 a.; 6.3 v. 3.5 a.; 0-4-5 v. 2 a.

M.T.2.—Same as M.T.1. but 350-0-350 v.

M.T.3.—28 v.; 2 a.; tapped every 3 volts. All primaries tapped for 200 to 250 v.

M.T.4. Auto 0-10-125-200-230-250v. 100 watts.

Examine what you buy.

From component dealers or write to us if unobtainable.

The correct price for these transformers is 21/- each.



**THE DOUGLAS COIL CO.,**  
BRINKLOW, RUGBY.

**TELEVISION DIPOLE INSULATORS**

High grade ex-Government Polyethylene Insulators with Brass Stubs, need two pieces of 1/2 in. i/d Tubing only to form a highly efficient Dipole or "H" Aerial, for all areas. Our Special Price 5/- each, post etc. 1/6.

**TELEVISION MASTS**

Still a few 2in. o/d Steel Masts in 5ft. 6in. sections. Wonderful Value. 11ft. (2 sections), 12/6 each, carr. 2/6. 22ft. (4 sections), 22/6 each, carr. 3/6. Now is the time to alter and obtain full efficiency from your aerial system. Obtainable only from the Midland Television Specialists.

**WALTON'S WIRELESS STORES**

48, STAFFORD STREET, WOLVERHAMPTON

**AMATEUR LENS WORKERS**

*All Supplies*

**Lists on Request**

We have for sale, surplus to our requirements, two automatic lens smoothing and polishing machines. Motorised 230/1/50. Complete on stands.

Price £50 each. Carriage extra.

**MASON & GANTLETT LIMITED**

Menisor Optical Works  
HALL ROAD, NORWICH

Meters. 10v., 21in. Rectifier (a.c.) in wooden carrying case, 14/6; 15v., 21in. m/c., 9/6; 150v., 2in. m/c., 10/-; 3,500v., 3in. m/c., 20/-; 6,000v., 3in. m/c., 57/6; 15,000v., 2in. m/c. double reading, 8/-; 3.5 amp 2in. D.C., 5/-; 4 amp., 2in. T.C. in case with switch, 7/6. Units containing 2-500 microamps, 5/-, post 8d. All meters post extra.

**Bell Transformers.** These guaranteed transformers work from any A.C. Mains, giving 3, 5 or 8 volts output at 1 amp., operate bulb, buzzer or bell. Will supply light in bedroom or ladder, etc. PRICES 8/-, post 8d. BELLS for use with either the above or batteries, 6/-, post 6d. BUZZERS 3/-, or Heavy Duty 4/6, post 5d.

**Ex-R.A.F. 2-valve (2-volt) Microphone Amplifiers,** as used in "plane inter-com." in self-contained metal case; can be used to make up a dead air outfit, intercommunication system, or with crystal set, complete with valves, 20/-, post 1/6. Useful wooden box with partitions to hold amplifier, 2/- extra. Ditto, less valves, 10/-.

One valve amplifier, complete with valve, 9/6, post 1/-.

**Hand Microphones,** with switch in handle, and lead, 4/-. Similar instrument, moving coil, 7/6, post 6d.

**Mike Transformers (carbon), 2/-.** Moving Coil, 4/6; Buttons, 5/-. All post 4d. each. Sparking Plug Neon Testers, with vest-pocket clip, 3/3, or with gauge, 3/6, post 3d. S.B.C. Neon Indicator Lamps, for use on mains to show "live" side of switches, etc., 3/6, post 4d. Soldering Irons.—Our new, streamlined iron is fitted with a curved pencil bit, 200/250v., 50 watts, 10/-.

Standard Iron with adjustable bit 200/250v., 60 watts, 11/-.

Heavy Duty Iron 150 watts, 14/6, all post 6d. Crystal Sets. Our latest Model is a real radio receiver, fitted with a permanent crystal detector. Have a set in your own room.

10/6, post 6d. De Luxe Receiver in polished oak cabinet, 18/6, post 1/-.

**HIGHSTONE UTILITIES**

58, NEW WANSTEAD, LONDON, E.11. New illustrated List sent on request with ld. stamp and S.A.E. Letters only.

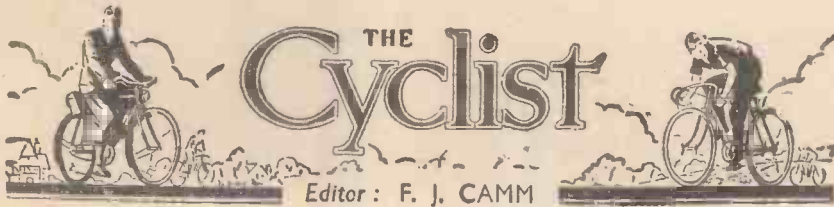

VOL. XIX

JULY, 1951

No. 350

All letters should be addressed to the Editor, "THE CYCLIST," George Newnes, Ltd., Tower House, Southampton Street, Strand, London, W.C.2.

Phone: Temple Bar 4363

Telegrams: Newnes, Rand, London

## Comments of the Month

### Latest C.T.C. Antic. Invitation by C.T.C. to Motorists' Organisations Declined.

FOR rather more than fifty years the C.T.C. has been a factory for the concoction of spiteful and venomous phrases against other road users, and particularly motorists. Members of the C.T.C. have described motorists as "murderers," "licensed libertines," and refer to the "callous and immoral attitude of motorists" with little regard for the meanings of the words they use.

Not so long ago we had to rebuke a prominent member of the C.T.C. for his careless use of expletives; indeed, it has been our public duty to criticise C.T.C. officials on a number of occasions because of their ill-conceived road policy. We have at the same time never failed to give them credit for the great work they did for cyclists in the early days of their existence, when saner counsels prevailed. Fortunately, much of the good work has been rendered nugatory because of the splenetic attitude they have adopted towards other road users—in the past, even towards pedestrians.

It is with great surprise, therefore, that we learn that the C.T.C. during May, with a naïveté which would put Alice in Wonderland in the shade, invited motoring organisations and the Pedestrians' Association to a meeting with the object of ascertaining the root cause of accidents and eliminating the "slanging match" which they say has been going on between the various bodies!! The impertinence of the suggestion, in view of past C.T.C. policy, we will pass by, since the A.A. and the R.A.C. have declined it in dignified terms which convey their real feelings on the matter.

We learned, as a result of a telephone conversation with the Pedestrians' Association, which has at least one member of the C.T.C. on its committee, that it has agreed to such a meeting. Presumably the meeting will not now take place. No useful purpose would have been served in any case, since there is a sufficient number of organisations working to that end, but which the C.T.C. has severely criticised from time to time. There is Rospa, from which the C.T.C. recently withdrew because "propaganda by the Royal Society had encouraged leniency by spreading the idea that victims of accidents are themselves to blame" (a statement which is demonstrably and patently untrue), the Roadfarers' Club, whose membership is drawn from all sections of road users, the Order of the Road, and various Government committees.

It might be thought that the C.T.C. should have remained a member of Rospa if it genuinely wished to bring about a better spirit between motorists, cyclists and pedestrians. It is worthy of comment here that the decision to withdraw from Rospa was by the narrow margin of one vote!

According to a contemporary, R. C. Shaw, the present secretary of the C.T.C. said: *Everybody knows that the chief factor, though it is not the only factor, of course, is the behaviour of road*

By F. J. C.

*users themselves, and that is a matter which the road-users' organisations are best fitted to influence. If we all got together—the motorists, the pedestrians and the cyclists—in the right spirit, we could raise the standard of roadmanship all round. The reckless or incompetent cyclist is a disgrace to the cycling community, just as the dangerous driver is a disgrace to the motoring community, but if a cycling organisation criticises the driver or tries to influence his behaviour in any way, the attempt is suspected and resented. It fails. Similarly, if a reckless cyclist is 'attacked' by a motoring critic, even though the criticism may be justified, the result is seldom helpful. I am sure that if the road-users' organisations did agree to tackle this problem in the way I have in mind—each determined to enhance the reputation of its own class and to discuss the problem as a whole with the others—then we could get somewhere."*

Now we are entitled to examine this statement very carefully indeed and to ask some pertinent questions. Is it sincere? Is the C.T.C.'s sudden change of policy an attempt to make virtue out of necessity, because of internal criticisms of its attitude towards other road users? Is it filled with contrition for its former attitude? Has its recent attitude towards motorised bicycles anything to do with this change of policy? Is it the leopard with its unchanging spots endeavouring to take upon itself the integument of a chameleon? What rifts have taken place in the C.T.C. lute? Is there an official change of policy, and have those who voted against withdrawal from Rospa impressed their will on the narrow majority which brought it about? Will the C.T.C. rejoin Rospa?

How does R. C. Shaw align this new policy with his previous (but quite erroneous) statement that: *"It is . . . the law of the land that the protection of cyclists cannot be combined with an interest in the welfare of motorists."*

These are but a few of the questions which readily occur. How can a body which has been hostile all these years carry out the new policy without admitting to its members that hitherto it has been wrong?

For many years there have been members of the C.T.C. who have criticised its anti-motoring policy.

It is true that the C.T.C. represents but a very small minority of the total number of cyclists—rather less than one-in-two-hundred. The motoring organisations *in toto* have a membership of one-in-three; but for their bitter policy, the C.T.C. membership could have been comparable.

In any case the words quoted come ill from the secretary of the C.T.C. whose views on motorists are well known. Of course, the

paid secretary of any association must carry out the policy laid down. His statements do not necessarily reflect his own personal views, and so we are entitled to conclude that statements which go out under his name represent the official views of the C.T.C.—the boneless wonder of the cycling world.

In the absence of any official communication from the C.T.C. and the Pedestrians' Association, we telephoned the three bodies concerned. The A.A. stated that existing organisations were adequate to deal with the problem, and that their policy was not to criticise other road users; this was the policy also of the R.A.C. They had declined the invitation to attend the suggested meeting.

The Pedestrians' Association informed us that they had agreed to such a meeting.

The Royal Society for the Prevention of Accidents, in expressing regret that the C.T.C. broke away, and the hope that they will eventually rejoin, stated that the Ministry of Transport looked on the Society as the avenue through which all road interests can and should get together. It has always been their policy to promote a better spirit of co-operation between motorists, cyclists and pedestrians in tackling the problem of road accidents.

It is worthy of comment that the advertisement manager of a motoring journal, published by a firm which also publishes a cycling journal, some years ago issued, for the facetious delectation of his friends, a tableau in colour representing an imaginary Lord Mayor's Show. The caption to the cyclists' part of the tableau showed a number of cyclists on a typical chariot "with escort of the captious company of cycle grousers." That was in 1936!

Every sensible person is in favour of co-operation between road users. No one section is entitled to say that the other is mainly to blame. All sections are to blame, and we refuse to accept the C.T.C. policy that motorists are the chief offenders merely because they own dangerous machines. There are as many accidents caused by cyclists as motorists, and far more caused by pedestrians than is generally supposed. There is no compulsory insurance for cyclists and pedestrians. Quite often the cyclist and the pedestrian escape scatheless.

The fact that they often suffer the penalty of their own carelessness does not absolve motorists from exercising the greatest care, nor cyclists and pedestrians from exercising similar caution. Self-preservation is the first law of nature.

If a solution to the problem can be found by sincere co-operation so much the better. Failing that co-operation it will be found in other ways, maybe by legislation. Perhaps the C.T.C. sees the red light and now realises that its past carping and hectoring policy is forcing the Government to think along those lines.

# A CYCLIST'S HORSEPOWER

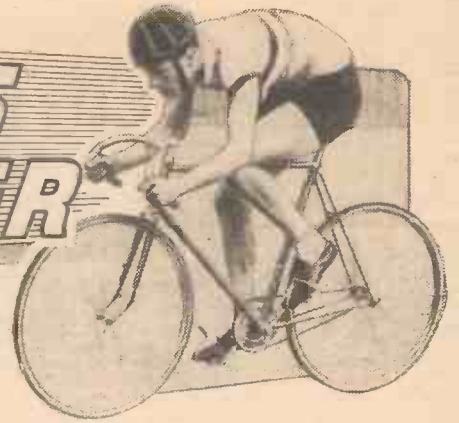

The Effects of Weight, Hills and Winds

By "CYCLE DESIGNER"

**T**HERE is no really reliable data on the resistance of a cyclist, but it is possible to form a shrewd estimate from motor-car tests. It is at the tyres that most of the road resistance is set up; friction of the transmission is relatively small, for even in a car, beyond the engine, practically all the bearings run on balls or rollers. With a car on a good road surface this road resistance may be put at about 40lb. a ton. Allowing, then, for the difference between a free and independent track and two tracks tied together as it were, resistance at the tyres of a cycle might reasonably be put at less than half that of a car. Add to this the slightly less proportionate resistances in the transmission and the greater proportion of live to dead weight in a cycle, and we shall not be far out if we put its road resistance at about 18lb. a ton.

Supposing, then, that a cyclist and his machine together weighed 200lb. and presented 5½ sq. ft. to air resistance, at 11 miles an hour on the level his rolling resistance would come to 1.61lb., air resistance to 1.87lb., and he would be giving out .102 horsepower—just over one-tenth.

Up a gradient of 1 in 30 at eight miles an hour he would have to develop .057 h.p. in propelling his machine, but up the hill would also have to raise it and his own weight at the rate of 23.47ft. a minute, which would take another .142 h.p.—total .199 or just short of one-fifth of one horsepower.

At five miles an hour up a rise of 1 in 10 he would have to raise himself at the rate of 44ft. a minute, and this would absorb .267 h.p., while the mere work of pushing the machine along at five miles an hour would only take .027, making .294 h.p. in all, or just less than two-sevenths of one horsepower.

### Resistance at 20 m.p.h.

At 20 miles an hour air resistance would be relatively high (6.49lb.), and at that speed would account for .346 out of the .432 h.p. necessary.

These figures will give a fair general idea of the power the rider gives out on the level or uphill. Free-wheeling downhill, however, he would, of course, be travelling without exerting any power directly, and only so indirectly if he was coasting at less than his average speed and consequently had to pedal the harder elsewhere to make up time. But free-wheeling faster than his average speed the opposite would be the case, and the run downhill would "make up time" for him, enabling him to go at easier speeds farther on and yet maintain

his average. It would then simply mean that the work he had put in by raising himself and his machine up the hill was being given out again downhill faster than was required for his average speed. He would be getting some of his own back, and faster than he paid it out.

### Comparative Figures

For convenience of reference and comparison the foregoing figures for cycle and car are given here in tabular form :

CYCLE SPEEDS AND GRADIENTS		
20 m.p.h., level	.. .. .	.432 h.p.
11 m.p.h., level	.. .. .	.102 h.p.
8 m.p.h., up 1 in 30	.. .. .	.199 h.p.
5 m.p.h., up 1 in 10	.. .. .	.294 h.p.

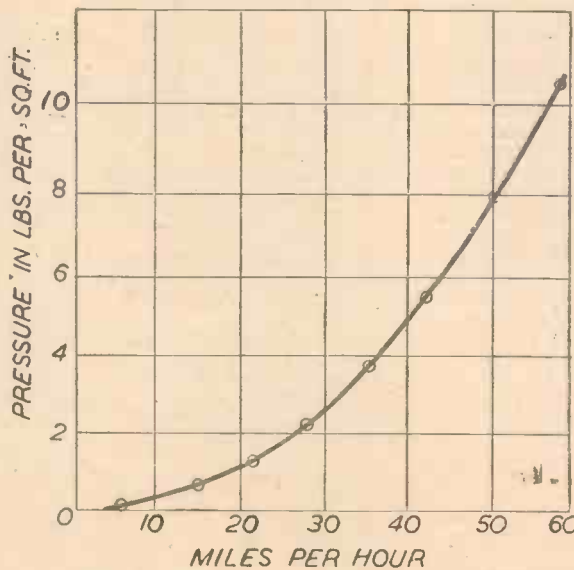

Chart plotted from actual wind resistance tests.

CAR SPEEDS AND GRADIENTS		
59 m.p.h., level	.. .. .	39.33 h.p.
35 m.p.h., level	.. .. .	30.45 h.p.
27 m.p.h., up 1 in 30	.. .. .	11.43 h.p.
20 m.p.h., up 1 in 10	.. .. .	15.34 h.p.

### Comparative Efficiencies

But the comparisons possible between a living engine and a metallic man-made one are strictly limited, especially in efficiency. A car engine will do so much work for so much fuel, and there the matter ends, simple and clear-cut. With the human machine, however, it is not possible to calculate in watertight compartments, as it were, like this; we cannot say where the effect of one

day's or one meal's fuel begins or ends. Thus the nearest comparable conditions are when both "machines" are similarly doing their utmost over extended periods. Let us investigate the "all out" conditions then, in each case.

### A Man's Fuel

Of course, his fuel will vary according to his individual constitution and requirements, but as a rough average it is generally reckoned that the daily food of a man doing light or moderate work should contain about 10,000 to 11,500 B.Th.U.; for moderately hard work, 11,750 to 13,000; hard work, 13,500 to 16,500; and very hard work up to 22,000 heat units. The university boat race crew average about 16,000, lumbermen 22,000 to 23,000.

Supposing the cyclist is out for a 12-hour record, he would certainly need a special dietary fully equivalent to that of the lumberman. Suppose we gave him 24,000 heat units for the day's work. That, if converted without loss into work, would mean 18,540,000 ft.-lbs. But the work that he will do, in actually propelling his machine at a steady 20 miles an hour for the 12 hours, would be only 10,264,320 ft.-lbs., which is 55.37 per cent. of the total work value of the fuel. And quite enough, too. In other words, the rider's efficiency is 55.37 per cent. as against only 23 per cent. for the car engine, which at least will give you some idea of how far man's achievements are still behind Nature.

### Weight, Hills and Wind

We have already dealt with the power exerted by a cyclist under a few typical conditions and of how he compares with a car engine in this matter, but some rider may want to know how variable external factors, such as weight, hills and wind, may affect him.

To get at this information calculations must be made more analytically, and as a basis we should know the powers required on the level in still air. In giving these, however, we can at the same time see how weight affects the question. We may begin then with the horsepowers required at various speeds on the level by riders of three typical weights, weighing with their machines 150, 190 and 230 lb. respectively. Allowing, in each case, 35lb. for the machine, this would give us a light-weight at 11st. 11lb. and a heavy-weight scaling 13st. 13lb. Assuming a rolling resistance of 18lb. to the ton and an area of 5 sq. ft. presented to air resistance, then we get the following results.



H.P. at various speeds on level

Miles per hour	8	10	12	16	20	25	30
Weight	h.p.	h.p.	h.p.	h.p.	h.p.	h.p.	h.p.
Light	.048	.070	.109	.220	.410	.777	1.293
Middle	.055	.078	.119	.234	.428	.798	1.319
Heavy	.062	.086	.129	.248	.444	.820	1.345

Compare these figures with those for the middle-weight on the level and you will see that it will cost him nearly the same effort to ride up 1 in 10 at 4 miles an hour as on the level at 16; up 1 in 20 at 4 m.p.h. practically as much as on the level at 12.

Wind Resistances

Now for the winds. Roughly speaking, in theory the pressure of air varies as the square of its speed: double the speed and quadruple the pressure, treble the speed and pressure increases ninefold, and so on. In practice, however, pressures do not appear to follow rigidly this rate of increase, but rise more or less as indicated by the chart on page 66 which has been compiled from a series of actual tests (each marked with a cross). Here the height of the graph line above any speed along the base gives the pressure for that speed.

However, more information can be given in a few figures than in a whole book of words, so here are the figures based on the pressures in the chart. To those who have studied weather it may be explained that in this table the Beaufort scale has been adopted, the wind velocities being as near as possible the middle ones in their respective classes. Also a weight of 190lb. has been assumed for rider and machine combined, and the total area offered to wind resistance has been put at 5 sq. ft.

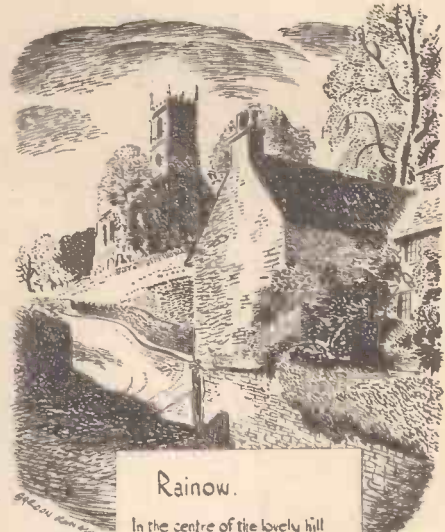

Rainow.  
In the centre of the lovely hill country of Cheshire and on the edge of Macclesfield Forest.

That will give some idea of the terrific effort required for unpaced sprinting, though, of course, for the highest speeds a lighter machine than 35lb. would be used. Still, supposing the machine only weighed 20lb. and the difference of 15lb. was added to the rider's weight, the middle-weight would only scale 12st. 2lb.—not unreasonably heavy.

It is presumed air resistance area is the same in all cases, but middle- and light-weights might quite possibly offer a rather smaller area, and in that event their figures would be slightly less at the lower speeds; more markedly so at the higher, for, as will be seen later, air resistance increases as the square of the speed. This being so, on purpose to avoid complicating the issue, if you cast your eye down the columns you will see the effect of weight, pure and simple. It does not amount to much, but being a constant quantity it naturally represents a far larger proportion of the effort at the lower speeds, where the totals are comparatively small: at 8 miles an hour it means a difference of over 25 per cent. as between light- and heavy-weight.

The Effect of Hills

Hills, of course, generally entail far more extra effort. In hill climbing the power you exert is made up of the work for overcoming the resistances just sufficiently to roll along the level at a given speed and the work required in the time to raise the weight of yourself and machine to the height entailed by the hill. In the latter, for a given effort, the speed is inversely proportional to the steepness of the gradient: halve the gradient and you could double your speed without more effort—this, of course, entirely apart from the work requisite to overcome rolling and air resistances. How the whole thing pans out in still air for a middle-weight weighing, with bicycle, 190lb. is shown in the table below.

H.P. Uphill at Various Speeds

Gradient	1 in 8	1 in 10	1 in 12	1 in 16	1 in 20	1 in 30
Speed m.p.h.						
3						
Road and air	.013	.013	.013	.013	.013	.013
Hill	.190	.152	.127	.095	.076	.051
Total	.203	.165	.140	.108	.089	.064
4						
Road and air	.019	.019	.019	.019	.019	.019
Hill	.253	.203	.169	.127	.101	.068
Total	.272	.222	.188	.146	.120	.087
5						
Road and air	.026	.026	.026	.026	.026	.026
Hill	.317	.254	.211	.159	.127	.085
Total	.343	.280	.237	.185	.153	.111
6						
Road and air	.034	.034	.034	.034	.034	.034
Hill	.380	.304	.253	.190	.152	.101
Total	.414	.338	.287	.224	.186	.135
7						
Road and air	.044	.044	.044	.044	.044	.044
Hill	.444	.355	.296	.222	.177	.118
Total	.488	.399	.340	.266	.221	.162
8						
Road and air	.055	.055	.055	.055	.055	.055
Hill	.507	.405	.338	.254	.202	.135
Total	.562	.460	.393	.309	.257	.190
9						
Road and air	.067	.067	.067	.067	.067	.067
Hill	.570	.456	.380	.285	.228	.152
Total	.637	.523	.447	.352	.295	.219
10						
Road and air	.082	.082	.082	.082	.082	.082
Hill	.634	.507	.423	.317	.253	.169
Total	.716	.589	.505	.399	.355	.251
11						
Road and air	.100	.100	.100	.100	.100	.100
Hill	.696	.557	.463	.348	.278	.186
Total	.796	.657	.563	.448	.378	.286
12						
Road and air	.119	.119	.119	.119	.119	.119
Hill	.760	.608	.507	.380	.304	.203
Total	.879	.727	.626	.499	.423	.322

Wind Miles an Hour	H.P. Against Winds				
	Calm	Light Breeze	Moderate Wind	Strong Wind	Gale
0					
7					
18					
30					
46					
Speeds m.p.h.	h.p.	h.p.	h.p.	h.p.	h.p.
8	.055	.099	.251	.491	.985
10	.078	.155	.355	.687	1.310
12	.119	.218	.484	.913	
16	.234	.406	.797	1.452	
20	.428	.673	1.255		
25	.798	1.125			

In these figures the projected area of rider and machine has been taken without allowing anything for the modified streamline effect of the more or less rounded parts, like arms, legs, cycle tubes and tyres, so the actual wind resistances might be rather less than those shown. Yet, even if quite a considerable allowance was made for this, the figures suffice to give a fairly approximate idea of wind resistances and to show their relative effects at various velocities.

Following Winds

Incidentally, it might be thought at first sight that a following wind would help one just as much as a head wind of the same velocity would hinder, but, of course, this is not so. Take the case of a man riding at 8 m.p.h. against a dead head wind of 30 m.p.h. Now the cyclist will be travelling through the air at 8 m.p.h., but the air, additionally, will be going past him at 30 m.p.h. with a total effect of 38 m.p.h., the pressure of which will be around 44lb. per sq. ft. A following wind will be going past stationary objects at 30 m.p.h., just as when it was ahead, but the rider will be moving in the same direction at 8 m.p.h., so relatively to him the wind will only be travelling at 22 m.p.h., and exercising on him a net pressure of only about 145lb. to the sq. ft.—an obvious enough point, but even clever people are apt to overlook the obvious, sometimes more so than ordinary mortals.

It will probably surprise a good few

readers to see figures running to over one horsepower, yet some men can deliver work at such a rate, though naturally they cannot keep it up for any prolonged period. Along a good-surfaced, give-and-take road, allowing for uphill and downhill, and following as well as head winds, the ordinary man probably only develops somewhere around one-tenth of a horse-power. Even that in most occupations would be quite hard work, but in cycling a man is mainly using the strongest limbs of his body, and those best fitted to heavy mechanical work.

2nd Edition

A Cyclist's "Bible"

EVERY CYCLIST'S POCKET BOOK

By F. J. CAMM

400 Pages, 120 Illustrations, Fully Indexed.

84 Pages of Indexed Road Routes of England and Scotland.

Chief Contents:

Bicycle Measurements; The "Gear" of a Bicycle; Frames; Standard Frame Angles; Handlebars; Saddles; Brakes; Pedals; Chains; Chain Wheels and Sprockets; The Variable Gear Hub; Deraillleur Gears; Tyres; Rims; Clothes and Equipment; Tandems; Lamps; Cyclometers; Adjusting Bearings; Reenamelling a Bicycle; Overhauling the Bicycle; Wheel Building; Calculating Spoke Lengths; Summary of Cycling Law; Touring; Touring by Numbers; Map Reading; Road Routes Simplified; Cycle Camping; Touring Abroad; Interesting Cycling Facts; National Clubs and Associations; Railway and Cloakroom Charges; Calculating Speed from Pedal Strokes; Tables of Gradients; Constants for Reckoning Speed; Table Showing Speeds per Hour; Gear Table for Single-Speed Machine; British Standard Cycle Threads; Cycle Thread for Spokes and Nipples; Lighting-up Variations; Road Records and Routes; Records and Standards; Women's Road Records; Principal Road Routes of Great Britain; Road Statistics; Bicycles in Use Throughout the World; Index.

Price 7/6 net, or 7/9 by post, from George Newnes, Ltd., Tower House, Southampton Street, Strand, W.C.2.

# Around the Wheelworld

By ICARUS

## Frank Urry Resigns from C.T.C.

IT was with great surprise that I learned that Frank Urry has resigned from the C.T.C. after practically a lifetime's membership. He resigned on April 21st, when he handed in his badge and everything else relating to the C.T.C. He has done great service as a councillor, on various committees, and has been one of the mainstays of the C.T.C. ever since he joined it.

Although I do not know the circumstances which led up to his resignation, I know that he would not have taken this drastic step had he not been in profound disagreement over something or the other.

There has been disagreement within the C.T.C. ranks for many years, and more recently opinions have been divided over matters of finance, withdrawal from Rospa, and other matters. The C.T.C. can ill-afford to lose men of the calibre of Frank Urry, and in my view his resignation may have serious repercussions.

At the moment of going to press, Frank is enjoying a cycle tour in Ireland, so I am unable to check up the facts with him.

## Lander and the League

I LEARN from an official of the B.L.R.C. that Lander will not be granted an independent licence because of his infringement of Rule 25 (a). Lander was the 1950 Brighton to Glasgow race winner.

Rule 25 (a) reads: "That any member who takes out a professional racing licence with any cycling organisation antagonistic to the League may, upon application, be reinstated in the League, but such members shall not be allowed to apply for any category racing licence, neither shall any racing licence be granted to such riders. The application of this rule shall not be subject to appeal."

It is by no means certain that Lander did take out an N.C.U. licence, although we must presume that had he done so the N.C.U. would be regarded as an antagonistic body, especially in view of its recent efforts behind the scenes (note: behind the scenes!) in connection with the London-Holyhead event which was successfully run in spite of this. It is true that he applied to the N.C.U. for a professional racing licence, but owing to the time which would elapse before the application was considered, he decided not to go further.

Then an illness followed which caused him to postpone his return to the B.L.R.C. It was in connection with League events that Lander made his name, both as an amateur and as a trained rider.

## The Festival

THE Festival of Cycling held at the Dunlop Sports Field, Erdington, Birmingham, was its anticipated success. It seems to me that such an event should be an annual affair, and it should be staged outside the authority of the closed corporations. Even in connection with the Festival, I understand that there was preliminary bickering, hectoring, and jockeying for position in its early stages. Let us run some events in England to make cycling really attractive to the vast ten million or so, and not merely consider organised cycling which concerns itself with racing.

The comparatively small memberships of the associations indicates that their programme and their policy does not appeal to cyclists generally. The Festival did.

## Rear Warnings Again

LORD LUCAS was instructed by the Minister of Transport recently to meet a deputation from the National Committee on Cycling for an exchange of views on cyclists' rear warnings. Surely nothing further can be said on the subject. The Minister must be well aware of the point of view of cyclists on this topic. He has plenty of evidence in his own department in the form of memoranda, correspondence, and reports.

I have often expressed the view that I see no need for rear lights on any vehicles, least of all on motor cars, although in their case as they have to illuminate the rear number no further hardship is imposed on them in also having to show a red light, since one lamp serves both purposes.

If the rear-lamp argument is carried to its logical conclusion the most vulnerable traffic on the road is pedestrians, and therefore pedestrians should carry reflectors, rear lamps and white patches when they walk in the road.

I can imagine Mr. T. C. Foley of the Pedestrians' Association raising his arms in holy horror at the suggestion. At the same time I am bound to confess that I have not heard any opposition to the fitting of rear lights from those outside the cycling organisations. I think the opposition is largely a fomented one—a few pugnacious people of pugnacious temperament endeavouring to impose their will.

## Bicycle Show

NO less than 150 firms will exhibit at the Bicycle Show at Earls Court which this year takes place from November 10th to 17th inclusive. This is rather late in the year because the cycling season proper has closed. None the less, I am prepared to guarantee that the attendances will not be less because the foggy month of November has been selected. There is something fascinating about the Cycle Show which is lacking from most others.

## Accidents in Ireland

ACCORDING to the Ministry of Commerce, road accident statistics in Northern Ireland during March show that

no fewer than 30 accidents were attributable to pedal cyclists, three of whom were killed and forty-seven injured during the month.

The following ingenuous advice is given at the end of the statistics: "Pedal cyclist in particular are urged to take extra care, especially when entering major roads. They should keep their machines in good order, should normally ride in single file, and never more than two abreast, and should keep to the inner side of the carriageway or their proper traffic lane. They should give undivided attention to the proper control of their machines." No less than 68 accidents were mainly attributable to pedestrians and 63 to drivers of motor vehicles. This proves what I have contended for many years: That accidents are due to carelessness on the part of all users, and therefore blame attaches to all of them.

## London-Holyhead

THE Marquis of Donegall started the B.L.R.C. London-Holyhead which took place on June 9th, starting from Marble Arch at 5 p.m. There were not any incidents as was forecast by antagonists of the League: I was glad to see that Jimmy Kain was chief judge. Timekeepers were F. J. Camm and H. Genders. I hope to give a fuller report next month. It attracted a great amount of national Press publicity, rather more in fact than the Festival of Cycling.

## Record Bicycle Exports

DURING April British bicycle exports created a new record, 261,774 for £1,969,739, as against the previous record, in January of this year, of 236,519 for £1,702,792. The largest purchasers were Malaya (33,096), India (22,409), British West Africa (20,494), Pakistan (13,937) and Mexico (12,738).

Exports of motor-cycles during April rose to 9,860 (4,169 more than for the same month last year), bringing in £958,965. Most of these went to Australia (1,840), U.S.A. (1,351) and Canada (838).

The total value of cycles and motor-cycles exported during the first four months of the year was £9,305,127, compared with £7,229,415 for the corresponding period last year.



Spring Sunshine  
The lane to the old Church  
of SEND, near Woking  
Surrey

**IMPORTANT NOTICE to**  
**Owners of MOTORISED BICYCLES!**  
 You've got the **EXTRA MOTIVE POWER**  
**NOW** you need the **EXTRA BRAKING POWER**  
 of  
**"Cantilevers"** (REGD.)  
**MOST POWERFUL and SMOOTH ACTING**  
**CYCLE BRAKES in the WORLD**

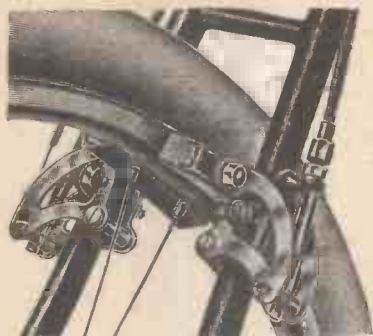

CANTILEVERS have been given special tests on bicycles fitted with many of the leading Motor Units, and as a result they are being strongly recommended for their complete **EFFICIENCY** and **RELIABILITY**. Your life depends upon your brakes, and the addition of a motor unit to your bicycle makes it vital that you are equipped with the best brakes obtainable. CANTILEVERS will give you complete **CONFIDENCE** in ANY EMERGENCY. Fixed rigidly on the forks or stays, they are always positive in action, smooth and powerful, grip well in the wet, and give long service. Special models available for use on Westwood rims. Fitted with our Locking Lever, they make the ideal **SAFEGUARD** against petty thieving. Twelve month guarantee with all new brakes.

**SAFETY FIRST! Second Thoughts are Too Late!**  
 THE RESILION CO. LTD. 200, LIVERPOOL ROAD, LONDON, N.I.

*Cycling is grand fun....*  
**IT'S TIME YOU HAD A**  
  
**BSA**

CYCLING really is grand when you ride a B.S.A. with B.S.A. 3-speed hub with Snap Control for quick, positive change of gear.



**COUPON:** To B.S.A. Cycles Ltd.,  
 12, Armoury Rd., Birmingham, 11

Please send me at once the B.S.A. Cycle catalogue

NAME.....  
 ADDRESS.....

*Keep  
 your eye  
 on  
 Halfords*



... and be sure of the finest selection of spares, accessories and equipment, including a full range of "Halford" "Raleigh" and "Robin Hood" Cycles—there's a Halford's branch in every large town.



**THE HALFORD  
 CYCLE COMPANY LIMITED**  
 HEAD OFFICE  
 239, CORPORATION STREET, BIRMINGHAM, 4

222 BRANCHES IN ENGLAND, SCOTLAND AND WALES

# Cycling Safety Campaign

*- the greatest invention since the pneumatic tyre*

## PALCO SHOCK ABSORBERS

- Lessen wobble over bumps
- Reduce skidding on any surface
- Assure safety when cornering
- Increase braking efficiency
- Lengthen life of tyres
- Comfort. Safety. Economy.

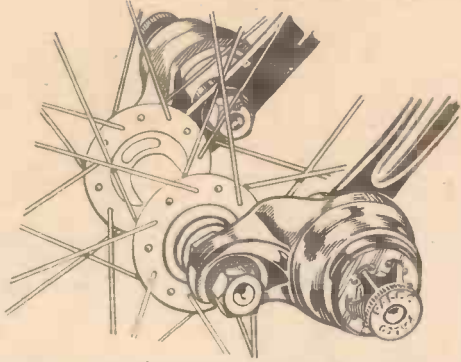

All these and many other advantages are gained by fitting PALCO Shock Absorbers. Join the many thousands of Palco Safety Campaigners.

FOR STANDARD CYCLES De-Luxe type with adjuster 25/-  
 FOR MOTORISED CYCLES & TANDEMS De-Luxe type with adjuster 30/-  
 Easily fitted. Adjustable to rider's weight. Approved by leading Cycle Clubs.

PALCO CYCLE PRODUCTS LTD (Dept. PM),  
 221, KNIGHTSBRIDGE, LONDON, SW7. Telephone: KNF. 1611 (2 lines) 240-10A.



### THE "FLUXITE QUINS" AT WORK

"Thank FLUXITE our cleaner's like new, just see how it goes now," cried OO.  
 "All the bits left about, have gone clean up the spout!"  
 Cried Polly, "And my feathers, too!"

For all SOLDERING work—you need FLUXITE—the paste flux—with which even dirty metals are soldered and "tinned." For the jointing of lead—without solder; and the "running" of white metal bearings—without "tinning" the bearing. It is suitable for ALL METALS—excepting ALUMINIUM—and can be used with safety on ELECTRICAL and other sensitive apparatus.

**With Fluxite joints can be "wiped" successfully that are impossible by any other method**

Used for over 40 years in Government works and by leading engineers and manufacturers. Of all Ironmongers—in tins, from 1/- upwards.

● TO CYCLISTS! For stronger wheels that will remain round and true, here's a time-tested tip. Tie the spokes where they cross with fine wire AND SOLDER. It's simple—with FLUXITE—but IMPORTANT.



THE "FLUXITE" GUN puts "FLUXITE" where you want it by a simple pressure.  
 Price 2/6 or filled 3/6.

ALL MECHANICS WILL HAVE  
**FLUXITE**  
 IT SIMPLIFIES ALL SOLDERING

Write for Book on the ART OF "SOFT" SOLDERING and for Leaflets on CASE-HARDENING STEEL and TEMPERING TOOLS with FLUXITE. Also on "WIPED JOINTS." Price 1d. Each.

FLUXITE LTD., Dept. P.M., Bermondsey Street, S.E.1

## CHOOSE YOUR DYNAMO LIGHTING

—WITH THE SAME CARE YOU CHOSE YOUR CYCLE

No cycle is complete without efficient Dynamo Lighting. Make absolutely sure you get the best by choosing Miller. For, with Miller you buy much more than a set—you also get years of unflinching service—in terms of thoroughly reliable Cycle Dynamo Lighting at all speeds.

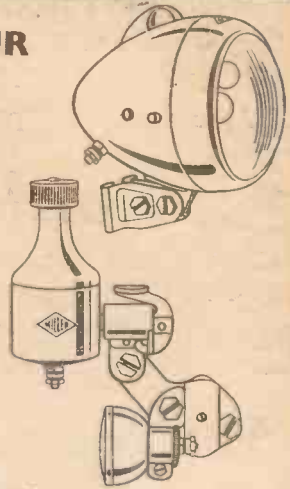

H. MILLER & CO., LTD., BIRMINGHAM.

## Let's STOP here!



Hirnant Pass, N. Montgomeryshire, near Lake Vyrnwy, 3 miles S.E. Blaenau, 1641 feet above sea level. Delightful example of North Wales scenery.

You can stop anywhere with FIBRAX

FIBRAX—does its job in practical fashion—gently yet so firmly! Made in two types for all brakes: soft red for alloy rims, black for steel rims. Both act well and last long.

FROM ALL GOOD DEALERS

# Fibrax

## BRAKE BLOCKS

FIBRAX LIMITED, 2 TUDOR STREET, LONDON, E.C.4



Lymm, Cheshire.

A fine example of a market cross standing on steps cut into the solid rock. The old stocks stand on a lower step.

## Wayside Thoughts

By F. J. URRY

but the "Frog," keen to try a new mac, was all for the road, and as the five miles to Corwen were easy ones I thought I would try him out. I need not have worried, for at Corwen he swallowed a cold fizzy drink, tucked a handkerchief round his neck to mop up the rain running off his thatch, and away we went along the valley road. Never had I seen the Dee invading so much land, or the comely hills, ridged with snow, so bitterly blasted with storm rain. Gallant old ewes stood over their lambs and the cattle turned their tails to the wind. No one wanted the road that morn-

grey little town, but on this day it was positively gloomy, the only relief being the icy monument of Cader astride the horizon. That was a fine sight in the sun with the ridges clear and shining in glory. The "Frog," boylike, was sorry to part with the railway, so when we came to Penmaenpool persuaded me to cross the river and stay for lunch to give him a chance to interview the signalman and the drivers of a couple of trains that stayed to drop passengers. The tide was full and running out as we went down the estuary of the Mawddach, probably the loveliest ride in all Wales, and for those eight miles the sun was with us.

### Stinging Inclemency

NO sooner had we passed to the sea than the cold, grey clouds swept inland and made a parade of Barmouth front most uninviting. We were glad to get back to the partial shelter of the highway walls and creep on through the deepening greyness before the clouds were charged with damp. In a way I was surprised at the slender traffic, and yet I suppose the weather was really enough to daunt any but the hardy

outdoor folk. Here and there a car stood forlornly by the roadside like a tired toad, neglected if not forgotten, and one presumed the erstwhile occupants were by the fireside—and I did not blame them. Just beyond Dyffryn a guest house stood on a high rock displaying a welcome sign, and the rain was beginning to sweep whiningly into our laps. We enquired, and we were invited to take tea by the makings of a good fire. Then the storm really struck, rattled the windows and cast its dreary mantle over the land. Could the good folk accommodate us for the night? They could and did so very comfortably. Although our progress was slow between the storms, we were very happy and comfortable.

### Wayside Luck

THE following day looked fine in its early hours, but it was cold and brittle, and my hope of enjoying a smoke on the top of the rise before Harlech, to again absorb that lovely trinity of vision, the sea, the hills and the winding valleys, was frozen out. The lad, as lads will, went prowling round the castle while I drank tea and enjoyed the limited view from the window of the shelter. We slipped to the level and came to that romantic gorge entrance of the Maentwrog Valley, a spot I have associated with Fennimore Cooper's stories since the days of my youth. It was a charming ride to Maentwrog with a flood tide sparkling, but no sooner had we crossed the bridge and taken the rougher road to Rhyd over the big climb than the sunshine forsook us, and by the time we were over the ridge it was raining hard. Everything more than a couple of hundred yards away was wiped out—the hills, the river and flat lands, usually so full of colour, running down to Tremadoc. Lunch seemed to offer the chance for a slow-up in the torrent, and the little inn at Tanlan entertained us splendidly. But there was no let-up; it just teemed down daggers of water that hurt when they hit. The road through the hills by Nant-y-Mar, giving the finest near view of Snowdon I know, was out of the question. Aberglaslyn was magnificent, but we were the only sight-seers; we climbed to Beddgelert, invaded an old friend's house on the slopes of Aran, and that was the end of the day's riding.

ing, and Llandrillo might have been a deserted village except for the blown plumes of smoke. Yet we were gay enough plugging through the dreary atmosphere, and it struck me then what other game could I play and enjoy in such conditions. We passed three hikers wet to the skin but sounding cheerful withal, and one farm worker so covered with sacks that he looked like a perambulating grain load. Just before Llandrillo sleet mixed itself with the rain, and it stung as it was driven into our faces. We ran the machines into shelter and dived into the fire-cheerful house. Could they get us lunch? They could in half an hour, so we slipped out of our macs, warmed ourselves and watched the blizzard. It was more than an hour after lunch when the rain eased up a bit that we took the back road to Bala, riding through dozens of little rills that had outgrown their conduits.

### Cutting It Short

BALA was dead in the storm. The cold rain was rodded and hard, the prospect bleak, and seventeen lonely miles to Dolgelly. True, it was only 4.30, and the "Frog" wanted to go on, and I didn't. I know the road, and had had enough of the weather for one day; so it was the "Blue Lion," tea and a fire, dinner and comfort. Not much of a day, but good enough for its temper. When we breakfasted next morning, it rained with a moan in the wind, but an hour later the watery sun threw a shadow down the street. We borrowed an oil can from the garage—it was needed—and then caught the blast of the north-wester across the flooded lake and off the snowy slopes of the Aran which looked charmingly alpine in the sun. But only for a minute. The grey clouds dusted them into nothingness as we took the early slopes of the low pass over the Arenigs, up which my young relative led me most of the way, only dropping behind to see the tiny train wangle its way to the summit. Then we felt the slope in our favour and rattled down to meet the coming storm sweeping up the valley like grey doom. It hit us just by the big milk depot and I made for that obvious shelter; the "Frog" saw a tea invitation in the cottage opposite and soon we were imbibing before a jolly fire. For half an hour the rain persisted and then as suddenly gave way to the cold brittle sunshine with all the warmth blown out of it by the bitter wind. Dolgelly always is a

### The Good Companion

WE carried through a little pilgrimage a few weeks ago, my grandson and I, into weather that was desperate. Our roads were made lonely as a result of it, and I've never known the weather to be so dismally chill at that time of the year, with such rain and extreme cold; but fortunately I had the right companion, a lad who took everything with a smile, wanted to butt into the weather even when dusk was descending, and had to be restrained from too much adventure. That is a nice thought—the possibility of a descendant carrying into his manhood the constant love of cycling despite all the modern attractions of rushing round the country without seeing it. When we started out in the late afternoon of a coldly blustering day, ten miles of hard windy going made me joyfully aware I had the right companion. We stepped out of the station at Gobowen to see the white ridges of the Berwyns under snow, dusted ever and anon by the gloomy grey clouds of evening. The journey to Llangollen was uneventful as far as riding was concerned except for the powerful head wind, and it was only when the Vale came into full vision with the fanged ruins of Dinas Bran as the romantic exclamation, that the "Frog" started to ask questions who built it and why, and who were the Princes of Central Wales? Previously I had taken him along the canal and over the aqueduct spanning the Ceiriog Valley, a very good introduction to Wales, and on the way emptying my mind of such knowledge of Thomas Telford—the Scottish Border lad, who from tending sheep became the greatest road and canal engineer of his time—until the lad posed me unanswerable questions on the whys and wherefores, indicating a growing mind avid for general knowledge. And so we climbed the long slopes to Glyndyrdwy in the grim, grey evening, and because the "Berwyn Arms" was full of disappointed fishermen—I had stayed there on my first tour sixty years ago—we tripped back to the village and found good fare and great comfort at Mrs. Edwards's house near the station.

### Back to January

I WAS told it rained all that night with determination, and, looking at the tawny, raging Dee, believed the postman's tale. We had breakfast with the fishermen and, ready to start, I was for waiting an hour to give the weather an opportunity to improve,

PRACTICAL ENGINEERING

6d. Every Friday

# CYCLORAMA

By  
H. W. ELEY



Devizes, Wilts. Looking across the Square to the 16th century coaching inn—the Bear. The most famous landlord was Thomas Lawrence, whose youngest son became the well known artist and eventually the President of the Royal Academy.

## Scottish Lament

EVER since I have been writing these notes I have had the pleasure of receiving quite a batch of letters from cyclist readers, and many a warm friendship has been forged through this correspondence. I exchange letters with riders as far apart as Devon and Lincolnshire, and I treasure postcards from tourists in Lakeland and the Shakespeare country. But now . . . comes a lament from over the Border, and a cycling Scot takes me to task because, so he avers, I have never written a paragraph about the glories of Scotland; never enthused about Caledonian hills and glens; never paid tribute to the beauties of Loch Awe or the bonny banks of Clyde! Well, I deserve the censure, and plead my ignorance of much of Scotland. I have toured there, but it was in the long ago, and my memories are dim, though I recall with joy the glories of Stirling and the enchantment of the Trossachs. I must make a vow . . . and take my bike over the Border, and then pay due homage to Scotland and Scottish loveliness. So . . . Duncan Alastair MacPherson (that's not the real name of my sorrowing scribe!)—look out for atonement in full measure.

## An Essex "Worthy"

I MET him in a small village not so many miles from Chelmsford, and I chatted to him over a pot of ale in a genuine village inn. A little, gnarled, wizened man, with a complexion the colour of walnut, and a

grand head of grizzled grey hair. He had worked, as man and boy, on one farm for over sixty years, and—in the true tradition of so many of our old agricultural labourers—had commenced at the humble task of scaring crows from the crops. In his teens he had been a wagoner's lad, and driven glossy-coated Suffolk Punch horses down the Essex lanes; had started to milk at the age of eleven; had done hedging and ditching, sowing and reaping, stack-building, looked after poultry and geese, and at times acted as shepherd of a flock of Suffolk sheep. All his long life he had worked . . . and worked . . . and worked. Never seen a film, never been to a dance (not even a "village top"); never visited a dentist; has had eleven children . . . and at eighty, this son of the English soil was happy and contented, hale and hearty, and "owed no man a halfpenny." A bit of the oak of old England . . . and how glad I was to stand him a pint or two of ale, and fill his blackened clay pipe, and wish him well. . . .

## Cycle-proud

HOW I love to see a cyclist proud of his machine . . . as proud when it is a veteran as he was on the day he bought it, new and gleaming, from the local cycle shop. Far too many riders lose this sense of "pride in the bike" and it is a pity, for regular cleaning and oiling, regular use of spanners and inflators, make such a world of difference to the pleasures of riding. And saddles need care, too . . . those sagging springs make for discomfort, and I can never understand the mentality of riders who will set out on a longish tour with uncomfortable saddles. It pays to be a bit "cranky" about cycle-care . . . and there is a man in my village whose machine, though ancient, is a joy to behold. Personally, I set apart a given day for my "cleaning up" and find that it pays.

## The Disappearing Tricycle

IT is seldom nowadays that one sees a tricycle being ridden on our roads. Time was when it was not at all uncommon to see an elderly gentleman mounted on a "trike." I wonder how many are produced to-day? The number may well be greater than I think, and it would be interesting to know. I seem to remember that in my boyhood days there used to be quite large

"rallies" of tricycle riders, and not all were old bearded gentlemen!

## Havens of Retirement

WHEN a man has retired from active business he somewhat naturally likes to meet others who have also "discarded the harness"—to compare notes on how leisure is being spent, to ascertain what hobbies are being cultivated, to exchange views on the best "retirement spots" . . . and in the latter connection I recently had an interesting chat with two retired men from a big industrial organisation. One had chosen sunny Devon as the place to spend the evening of his days . . . and he did not regret his choice! The other, a Lancastrian by birth, had gone back to his native heath, and was happy in the magical area around Pendle Hill. Well, many factors govern the choice of where to live "on pension" and, personally, I have no regrets that I chose to come to grey Derbyshire, where the wide moors are near, and the fertile valleys, and the little towns hard by The Peak. Derbyshire is a county of many faces, many lovely, and if it is not so warm and genial as the counties of the south, it has a fascination all its own. In retirement one thing is vital . . . a man must have a hobby, or he will "rust out." A bike, a garden, some chickens, maybe a bit of fishing . . . and the "evening time" can be full and happy.

## Edwardian Flashback

I CAME across a book the other day which took me right back to the spacious days of King Edward the Seventh . . . a faded volume containing many pictures of the Royal Family in the halcyon days which ended with the death of King Edward in May, 1910. One picture intrigued me greatly . . . a picture of His Majesty "with his Beeston-Humber bicycle." Apparently, King Edward was quite an enthusiastic cyclist, and, indeed, the present King has been photographed (in Windsor Great Park, I believe) out cycling with his daughters when they were small children. Yes! cycling has the Royal Seal upon it . . . and it is truly a royal pastime. But a "Beeston-Humber" . . . that name was a real "flashback" to bygone days! Maybe I shall next see a picture of a celebrity riding his "Swift"—the famous bike from Chylesmore Works. . . .

## Summer Dreaming

JULY!—and it is good to saunter through the lanes and sniff the sweet scent of hay, and find shade 'neath the big leafy elms, and see the choked riot of wild flowers in the ditches, and look up at the little clouds scudding across the blue sky, and lean over a gate and watch the sleek cows in the lush meadows. High summer brings its own delights, and, if sometimes the days are sultry and almost too hot . . . there is always the cool tap-room of the village inn, where one may sit and sip ale, and smoke a contemplative pipe, and listen to the gossip of countrymen who talk the immemorial language of the land. Make the most of July, for, come August, the greenery fades, and the heralds of autumn whisper in the trees. Just now the garden borders are flaming with colour and the bees drone sleepily in the flowers of the tall hollyhocks. Lazy days . . . and it's good to have a place in the sun. . . .

"Practical Mechanics" Advice Bureau  
This coupon is available until July 31st, 1951, and must be attached to all letters containing queries, together with 3 penny stamps. A stamped, addressed envelope must also be enclosed.  
Practical Mechanics. July, 1951.

COUPON

Published about the 30th of each month by GEORGE NEWNES, LIMITED, Tower House, Southampton Street, Strand, London, W.C.2. and Printed in England by W. Speaight & Sons, Ltd., Exmouth Street, London, W.10. Sole Agents for Australia and New Zealand—Gordon & Gotch (A/asia), Ltd. Sole Agents for South Africa—Central News Agency, Ltd. Subscription Rate (including postage): For one year, Inland and Abroad 14s. (Canada 13s.). Registered at the G.P.O. for transmission by Canadian Magazine Post.

**NOW AVAILABLE  
GERMANIUM  
CRYSTAL DIODES**

LATEST, SMALLEST,  
SUPREME CRYSTAL DETECTOR  
Midget Size, 5/16in. x 3/16in.  
Wire Ends for Easy Fixing.  
4/6 each, postage 2/4d.  
Wiring instructions for a cheap, simple,  
but high quality Crystal Set included.  
Technical Details and Selected Types  
available.  
**SILICON CRYSTAL VALVE**  
3/6 each, postage 2/4d.  
Fixing Brackets 3d. Extra.

**COPPER INSTRUMENT WIRE**  
ENAMELLED, TINNED, LITZ.  
COTTON AND SILK COVERED.  
Most gauges available.

B.A. SCREWS, NUTS, WASHERS,  
soldering tags, eyelets and rivets.  
EBONITE AND BAKELITE PANELS,  
TUFNOL ROD, PAXOLIN TYPE COIL  
FORMERS AND TUBES.  
ALL DIAMETERS.

Latest Radio Publications.  
SEND STAMP FOR LISTS.  
**CRYSTAL SET**  
INCORPORATING THE SILICON  
CRYSTAL VALVE  
Adjustable Iron Cored Coil.  
**RECEPTION GUARANTEED**  
Polished wood cabinet, 15/-, post 9d.  
A REAL CRYSTAL SET NOT A TOY.  
**POST RADIO SUPPLIES**  
33 Bourne Gardens, London, E.4

**MATRIC.**

WHY needlessly handicap yourself  
and watch other people winning  
success and security? Whatever your  
age, you can now prepare for the all  
important Matriculation Examination  
at home on "NO PASS—NO FEE"  
terms. Write now for our valuable  
"GUIDE TO MATRICULATION"  
which explains the new regulations,  
etc., and the easiest and quickest  
way to matriculate—FREE and  
without obligation.  
**BRITISH TUTORIAL INSTITUTE**  
(Dept. 160), 356, Oxford Street,  
LONDON, W.1.

**"NO PASS—NO FEE"**

**BOOKS:**  
"Working Model Railways" ... 3/-  
"Electric Model Railways" ... 3/-  
"Make Your Own G.O. Motor" ... 3/6  
"Miniature Traffic Working" ... 3/6  
"Model Railways Encyclopaedia" ... 15/-

**RAILWAY PARTS:**  
Scale Petrol Pumps ... 00 0  
Water Cranes ... 2/0 4/6  
EX-R.A.F. 16 S.W. Boxes ... 5/6 5/6  
20 v. Bulbs for Hornby ... 1/2d

**MODEL BOATS:**  
Jetcraft, Power Boats. 10in. long.  
Usually 8/6. Now 3/6.  
Postage extra. "00" or "0" Parts List 3d.  
**TYLDESLEY & HOLBROOK (M.F.T.A.)**  
109, DEANSGATE, MANCHESTER, 3.

**SAW & GRINDING ASSEMBLIES**  
Spindles for Circular Saws, grinding and  
drilling from 4/6. Circular Saw Tables  
with adjustable guide for 6in. saws,  
19.9; for 8in., 25/-. Bearings, flanges  
and pulleys all sizes. Vee and round  
belting, countershafts, F.H.P. motors.  
Shafting Collars from 1in., 1/-. Plum-  
mer Blocks from 3/6.  
Send 8d. for illustrated Catalogue.  
**BEVERLEY PRODUCTS,**  
23, Oakwood Avenue, Leeds, 8

**1 H.P. 220/250v. Single Phase Electric  
Motors**  
Special offer B.T.H. reconditioned  
motors, 1,450 r.p.m. A.C. suitable  
domestic supply. Made for silencing  
mounting, no feet supplied. Price  
£3/19/6 carriage 5/6d. Many other  
bargains. Send S.A.E. for List.  
L. C. Northall, 16, Holly Rd., Quinton,  
B'ham, 32. Phone: WOO 3186.  
Retail Branch, 416, High Street,  
Smethwick.

20 Geneva Pocket Watch Movements all  
from Gold and Silver cases, take 20/- the 20.  
10 English Lever Movements, 30/- the 10.  
10 Swiss Lever Jewelled Pocket Move-  
ments, 30/- the 10. Ten assorted Wrist-  
let Watches, very useful for material, £3/10/-  
the 20. **MERKELS, Jewellers, Pilgrim  
Street, Newcastle-on-Tyne.**

**NO MAN CAN KNOW TOO  
MUCH OF HIS PRODUCT**

The Ultra Lens is a revealing eye of six actual  
diametrical magnifications, which brings  
out points of strength or weakness, and  
enables the most minute measure-  
ments to be gauged accurately.  
Whether you are engaged  
in manufacturing, buy-  
ing or selling, it  
is an ally of  
real value.  
No instru-  
ment you can  
buy will more  
quickly justify  
and pay for itself.  
Full particulars  
on request.

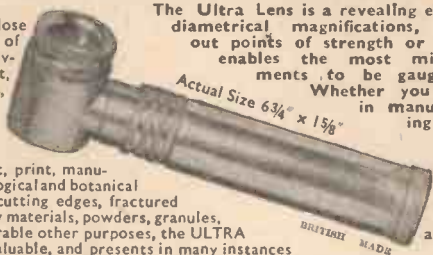

For the close  
scrutiny of  
every conceiv-  
able object,  
metals, tools,  
fabrics,  
fibres,  
minerals,  
precious  
stones, paint, print, manu-  
scripts, biological and botanical  
specimens, cutting edges, fractured  
surfaces, raw materials, powders, granules,  
and innumerable other purposes, the ULTRA  
LENS is invaluable, and presents in many instances  
hitherto unsuspected data which can be used to advantage.  
PRICE £4 15s. 0d., complete in case with spare bulb, battery and transparent  
measuring scale. ADAPTOR, A.C. Mains, 27/-; Transformer, if required, 6/6.

**THE ULTRA LENS COMPANY,**  
75, Finsbury Court, Finsbury Pavement, London, E.C.2.

**"KARLENITE"  
PLASTIC MARBLE**

The entirely new Artificial Stone for casting Bookends; Ashtrays; Wall-vases;  
Statuettes, etc. "Karlenite" sets granite-hard with a scintillating crystalline  
structure which very closely resembles marble or alabaster. It is enormously  
strong; highly resistant to heat and impervious to water. Literally any type of  
natural "veining" can be simulated in any colour and a range of pigments is  
available for this purpose.

**MAKE YOUR OWN  
FLEXIBLE MOULDS**  
in "PLASTIMOULD" SYNTHETIC RUBBER

Prepared in liquid form for making permanent elastic moulds. Ideal for repetition-  
casting Plaques, Bookends, etc., in plaster, cement or "Karlenite." It will faithfully  
reproduce even the most minute details of ornamentation and surface texture.  
"Plastimould" is incredibly simple to use and moulds can be taken from any  
type of pattern, including wood, metal, plaster, stone, glass, ivory, etc.

Send 1s. for full details of this easy, fascinating and profitable hobby. Money  
refunded to bona fide enquirers.

**KARLENA ART STONE CO. LTD.**  
(Dept. PM5), 55, Deansgate Arcade, Deansgate, MANCHESTER, 3

**Jubilee**  
PATENTED  
WORM  
DRIVE  
CLIP

Absolutely leakproof  
joints on Air, Water,  
and Oil lines are  
swiftly and easily made  
by using "Jubilee" Worm  
Drive Clips. They stand  
up to any pressure.

★ Write for details  
and prices

RP/12 THE FINEST  
CLIP IN THE  
WORLD.

**L. ROBINSON & CO., (GILLINGHAM) LTD.**  
Gillingham Kent

**RATCHET & REVOLUTION  
COUNTERS**

Ask for  
Leaflet No. 18/6  
Speed up to  
6,000 r.p.m.  
**B. & F. CARTER  
& Co., Ltd., Bolton**  
Members of B.E.S.T.E.C. Organisation.

**Mains Transformers  
UPRIGHT — DROP  
THROUGH AS  
ILLUSTRATED.**  
Two Types Only.  
Guaranteed.  
No. 1: 250-0-250v., 80  
mA., 0-4-6.3v., 5 amp.  
0-4-5v., 2 amp. No. 2:  
Same, but 350v. Both  
15/-, post 1/- for 1 to 3.  
**HILLFIELDS RADIO,**  
8, Burnham Road,  
Whitby, Coventry

**HARGO GeoMetric  
RANGEFINDERS**  
Scaled Feet and Metres  
Measures 3" x 3 1/2" x 1 1/2". Brand  
New in Maker's Wrappings.  
Post 3d. extra.  
**10/6**  
R. Godfrey, 108 Horseferry Rd., S W 1

**CHEMISTRY APPARATUS**  
Send Stamp for  
COMPLETE PRICE LIST

Booklets:  
"Experiments" 7d.  
"Formulas" 10d.  
"Home Chemistry" 2/3  
Post Paid.

(Scientific Dept. A)  
**BECK 60 HIGH STREET,**  
Stoke Newington, London, N.16

**IMPETUS Precision PLANERS**  
Circular safety type cutter-head High  
quality tempered steel knives. Tables  
mounted on machined inclined ways.  
Ground table-surfaces. Fences  
adjustable to 45 deg.  
4 in. MODEL £9.0.0  
Motorised, £17.10.0. 6 in. MODEL  
£27.10.0. Motorised £44.0.0. Send for  
Catalogues of other "Impetus" Products.  
**JOHN P. M. S. STEEL, Dept. 80,**  
BINGLEY, YORKS.  
Phone: BINGLEY 3551 (4 lines)

**ADANA PRINTING MACHINES**  
Print in the odd hours with an  
Adana—still the most absorbing  
of crafts. No. 1 H/S  
Machine £4.10.0  
No. 2 H/S Machine  
£9.15.0. Will  
quickly pay for itself.  
Send for illustrated  
folder to Dept. P.M. 45  
**ADANA (Printing Machines) Ltd., Twicken-  
ham, or call 8, Gray's Inn Rd., London, W.G.1.**

**WEBLEY AIR PISTOLS**  
Marvellously  
accurate for  
target prac-  
tice.  
No licence required to  
purchase for use on  
enclosed premises.  
Senior. Mark I  
Junior. Webley Air Rifle  
Write for List. **WEBLEY & SCOTT, LTD.,**  
106, Weaman Street, Birmingham, Eng.

**JOHN FARMER**  
(Incorporating the Mail Order Dept.  
of the Midland Instrument Co.)  
For Government Surplus Stock, etc.

**ALTIMETERS,** these contain a high  
grade aneroid movement, they are  
marked in 1,000ft. divs. (lin. mercury)  
they are suitable as ordinary weather  
barometers, fraction of original cost.  
new, boxed, 7/6, post 8d. "K" TYPE  
**DEAD LOCKING CYLINDER  
LATCHES,** cylinder has 7 tumbler sets,  
and have many features which give  
increased security compared with  
ordinary cylinder locks, with which  
they are interchangeable, brand new,  
boxed, complete with 2 keys and all  
fittings, booklet giving directions for  
fitting, usual price, 18/8, our price  
7/6 post paid, 3 for 20/-, post paid.  
**SINGLE HEADPHONES,** high re-  
sistance, fitted lyd. twin cord, new,  
unused, 2/6, post 4d. **AMMETERS,**  
hot wire, 0-9 amps., A.C./D.C., 3in.  
diam., new, boxed, 10/-, post 6d.  
**ANTENNA RODS** (whip aeri-  
als), consists of three 4ft. heavily copper  
plated steel tubular sections that  
screw into each other, total length  
12ft., base 1/2in. diam., tapers to 1/4in.,  
weight 11 oz., ideal for aeri-als, etc., or  
makes a superb fishing rod, matt green  
finish, new, packed in cardboard tubes,  
7/6, carriage 1/-, 3 for 20/-, carriage 1/6.  
**SCOPHONY SWITCH MOTORS,**  
3-phase A.C. motors, fitted right angle  
gearing that actuates 2 sets of cam-  
operated contacts, ball-bearing fan  
cooled, size 5in. 4 1/2in. x 3 1/2in. new,  
boxed, 5/-, post 10d. **VEEDER  
COUNTERS,** 0-0999, plated case en-  
closed, direct side shaft 1in. diam.  
operated, 5/-, post 3d. **T.R.S. CABLE,**  
250 v. insulation, single 1/4in., mostly  
C.M.A. stock 100 yd. coils, 35/-, post  
1/6, other sizes up to 7,052 in stock.  
**RUBBER COVERED** and braided  
maroon flexible cable, 4-core, 17/00/6,  
100 yd. coils, 50/-, carriage 2/6. **SMALL  
BLOWER MOTORS,** 24 v. A.C./D.C.,  
1 amp. size overall, length 4 1/2in., motor  
2 1/2in. diam., blower casting 3in. diam.,  
new, unused, 10/-, post 10d. **ANTI-  
VIBRATION MOUNTINGS REF.**  
10A/17621, 10 lbs., 16 coiled spring type  
base 2 1/2in. square, height 1 1/2in., anodised  
steel, new, boxed, set of 4 mountings,  
2/6, post 6d., 6/- doz., post 10d. **CRYSTAL  
SET COILS,** dual range, med. and  
long wave, complete with circuit, 3/-,  
post 3d. Send S.A.E. for new May and  
June Lists, together with supplement.  
Order from: **JOHN FARMER (Dept.  
A2), 194, HARBORNE PARK ROAD,  
BIRMINGHAM, 17**  
Tel.: HARBORNE 1355.

**"SPARKS"  
DATA SHEETS**

Recognised as the Safest, the Simplest  
and the finest Radio Constructional  
Sheets. All my Designs are FULLY  
GUARANTEED.  
**THE POCKET PAK.** The finest little self-  
contained Pocket Portable one-valve ob-  
tainable. Med. waves. Good 'phone sigs.  
Most widely used and always praised ... 3/-  
**THE CRUISER.** A three-valve T.R.F.  
High-gain Set. Specially designed for use  
where only a short aerial can be used. Ideal  
for Caravans, Camping, Yachts, etc. M.L.  
waves. All-dry Batteries ... 3/4  
**THE "UNIVERSAL FOUR."** A 3-valve  
plus Rect A.C./D.C. M/L wave T.R.F. Circuit  
giving 4 watts output. Widely used ... 3/-  
**THE "CUR."** A 2-valve plus Rect. Power  
and Quality on the "local" stations.  
A.C./D.C. operation. M/L waves ... 3/-  
**THE CORVETTE.** A compact all-wave  
Superhet. Good results anywhere with  
"hook-up" aerial, or a good E-type with  
self-contained aerial. Chassis size 5 1/2 x 4 1/2  
x 2 1/2. All-dry Batteries ... 3/-  
The above are only a few of my designs.  
SEND STAMP FOR COMPLETE LIST.  
COMPONENTS SUPPLIED.

**L. ORMOND SPARKS (M)**  
48A, HIGH ST., SWANAGE, DORSET

**JUNEERO**  
Patent Multi-  
Purpose Tool

it punches,  
bends, shears  
and threads.  
Specially designed  
for Model Making,  
Metal Working and Home Repairs.  
With "Xakto"  
slide gauge 27/6. **20/-**  
**J. BULL (PM7)** Post 2/-.  
246, High St., Harlesden, N.W.10

# Free Guide - "Success in Engineering"

One of the following Courses taken at home in your spare time can definitely be the means of securing substantial promotion in your present calling, or entry into a more congenial career with better prospects.

## ENGINEERING, AERO, ETC.

Plastic — Radio — Aero Engines — Aircraft Design — Welding — Aerodynamics — Electrical Engineering — Television — Electric Wiring — Diesel Engineering — Generation and Supply — Works Management — Metallurgy — Refrigeration — Planning. Estimating. Rate-fixing — Time and Motion Study — Aero Inspection — Automobile Engineering — Sheet-metal Work — Engineering Draughtsmanship — Aero Draughtsmanship — Jig and Tool Draughtsmanship — Press Tool and Die Draughtsmanship — Structural or R/F Concrete Draughtsmanship — Sanitary Engineering.

## GENERAL

Gen. Cert. of Educ. — College of Preceptors — A.C.C.S. — A.C.I.S. — Aircraft Apprentice.

## MUNICIPAL SERVICE

School Attendance Officer — Handicraft Teacher — Registrar — Housing Manager — Sanitary Inspector — Weights and Measures Inspector — Inst. of Mun. Engineers — A.R.I.C.S. — L.A.B.S.S.

## "PRACTICAL ENGINEERING" said—

We recommend all readers interested in improving their position to apply for a copy of this valuable book. "Success in Engineering" is not a pamphlet. It is a 132-page book, containing valuable and vital information on all branches of engineering. . . . There are many engaged in engineering who owe their success to The National Institute of Engineering.

## The FREE GUIDE explains :

- Openings, prospects, salaries, etc., in Draughtsmanship, Inspection, and opportunities in all other branches of Engineering and Building.
- How to obtain money-making technical qualifications through special RAPID FULLY-GUARANTEED COURSES.

Write now for your copy of this remarkable publication.

A.M.I.Mech.E., A.M.I.M.I.,  
A.M.Brit.I.R.E., A.M.I.P.E.,  
A.M.I.C.E., A.M.I.Struct.E.,  
A.M.I.Mun.E., M.R.San.I.,  
A.M.I.E.D., A.F.R.Ae.S.,  
London B.Sc., Degrees.

Fully guaranteed postal courses for all the above and many other examinations. Fully described in the Free Guide.



## THE BUILDING BOOM— SECURE YOUR SHARE!

The Free Guide also gives particulars of our extensive range of modern Building and Structural Courses, Building Draughtsmanship, etc. The great post-war Building programme offers unlimited prospects to technically trained men.

## BECOME A DRAUGHTSMAN— QUALIFY AT HOME AND EARN BIG MONEY

Men and Youths urgently wanted for well paid positions as Draughtsmen, Inspectors, etc., in Aero, Jig and Tool, Press Tool, Electrical, Mechanical and other Branches of Engineering. Practical experience is unnecessary for those who are willing to learn—our Guaranteed "Home Study" courses will get you in. Those already engaged in the General Drawing Office should study some specialised Branch such as Jig and Tool or Press Tool Work and so considerably increase their scope and earning capacity.



## THE ACID TEST OF TUTORIAL EFFICIENCY SUCCESS—OR NO FEE

We definitely guarantee that if you fail to pass the examination for which you are preparing under our guidance, or if you are not satisfied in every way with our tutorial service—then your Tuition Fee will be returned in full and without question. This is surely the acid test of tutorial efficiency.

If you have ambition you must investigate the Tutorial and Employment services we are able to offer. Founded in 1885, our success record is unapproachable.

Why not fill in and post the attached Coupon NOW for further details and Free Authoritative Guide to openings in Engineering and Building? This book contains a mine of valuable and exclusive information and may well prove to be the turning point in your career.

## PROMPT TUTORIAL SERVICE GUARANTEED

## FREE COUPON

To NATIONAL INSTITUTE OF ENGINEERING  
(Dept. 29), 148, Holborn, London, E.C.1.

Please Forward your Free Guide to

NAME.....  
ADDRESS.....

My general interest is in : (1) ENGINEERING (Place a cross against the branches in which you are interested.)  
(2) AERO (3) RADIO (4) BUILDING  
(5) MUNICIPAL WORK

The subject or examination in which I am especially interested is

To be filled in where you already have a special preference.  
(Id. stamp only required if unsealed envelope used.)

NATIONAL INSTITUTE OF ENGINEERING

(Dept. 29)

148, HOLBORN, LONDON, E.C.1

OVER SIXTY YEARS OF  
CONTINUOUS SUCCESS

SOUTH AFRICA: E.C.S.A. P.O. BOX 8417 JOHANNESBURG.

FOUNDED 1885—FOREMOST TODAY—OVER 100,000 SUCCESSSES