

A HAND VACUUM CLEANER

NEWNES

1/4

# PRACTICAL MECHANICS

EDITOR: F. J. CAMM

FEBRUARY 1951



## PRINCIPAL CONTENTS

A Reflecting Telescope  
Decorative Electric Lighting  
Model Engineering Practice

Direct Current Motors  
Shellac in Modern Times  
Wood Turning

World of Models  
Letters from Readers  
Cyclist Section

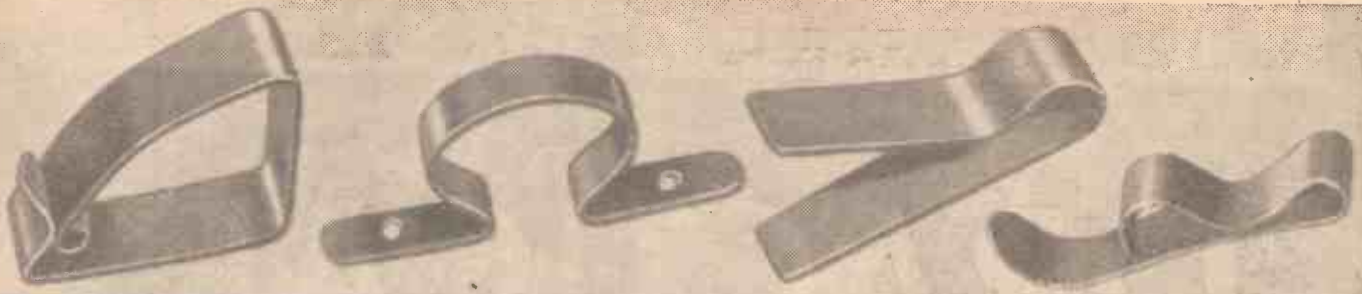

**THAT CLIP YOU NEED**



**IS MADE BY**

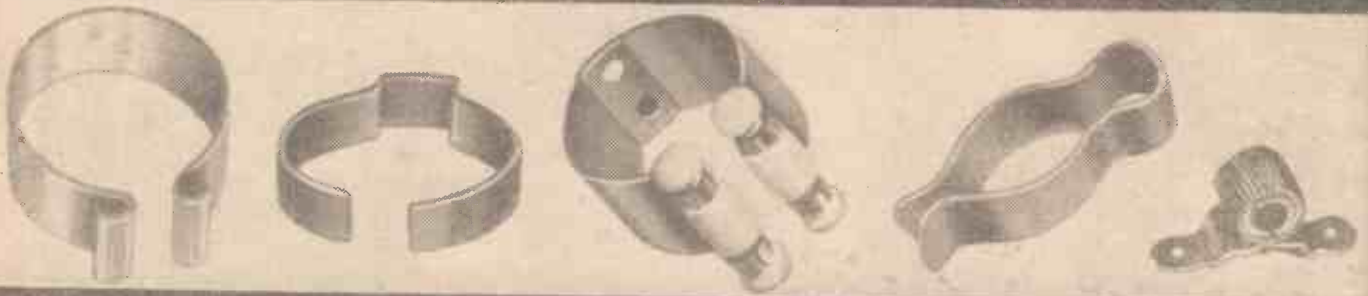

**TERRY'S** *(the Spring people)*

*and 3 Special Clips*

Two very popular types, 80 and 81. In a range of sizes from  $\frac{1}{2}$ " to 2" from stock. No. 300 is a very popular drawing board clip with a host of additional uses. 5/- a doz. (incl. P.T.) from stock.



Clips in every shape, size and form . . . steel clips, bronze clips, stainless clips, little clips, big clips, clips made exactly as you want them. If you desire it we can design any kind of clip to your own exact specification. (We've been designing clips for 95 years!)

Sole Makers:  
**HERBERT TERRY & SONS LTD.,**  
 London - REDDITCH - Manchester  
 Birmingham

← WANT TO KNOW ALL ABOUT SPRINGS? HERE IS THE MANUAL — 10/6 POST FREE.



# TYZACK'S 'ZYTO' MACHINERY FOR WOOD AND METALWORK

THE "ZYTO" 3½in. SCREWCUTTING AND TURNING LATHE

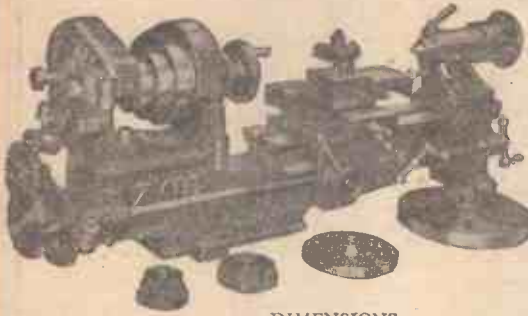

Back geared, with tumbler reverse, hollow mandrel and tailstock, fully compound slide rest rack feed set over tailstock. 12½in. between centres. **£25/10/0** Extended payments arranged with pleasure—please ask for details.

### DIMENSIONS

Height of centres ..	3½ins.	Headstock mandrel admits ..	¼ins.
Distance between centres ..	12½ins.	Tailstock barrel admits ..	¼ins.
Height from gap ..	4½ins.	Headstock pulley, 3 speeds ½in. flat belt	
Height from saddle ..	2ins.	Faceplate—diameter ..	6ins.
Guide screw ..	8 T.P.I.	Overall length of lathe ..	30ins.

FULLY ILLUSTRATED LEAFLET FREE AND POST FREE ON REQUEST

## MOTORISED LATHE COMPLETE ON STAND

£45/10/0

The "ZYTO" Ten Saw Table Ball-bearing Spindle. 18in. x 14in. table takes 10in. saws, right and left hand mitre slide cutting table with rise and fall motion, long rip fence, guards in accordance with Home Office rules.



Price **£18/13/9**

FULLY ILLUSTRATED LEAFLET FREE AND POST FREE ON REQUEST.

PLEASE SEND US YOUR ENQUIRIES FOR ALL WOOD AND METALWORK MACHINERY

**S. TYZACK & SON LTD.** 341-345 OLD STREET, LONDON, E.C.1

Telephones: CLerkenwell 8301 (ten lines)

# Gauge 'O' BASSETT-LOWKE 'PERMAG' MOTOR BOGIE UNIT

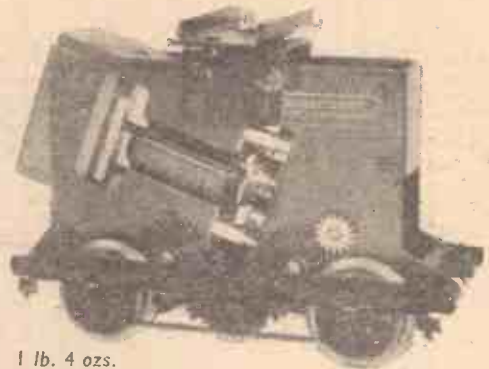

Weight: 1 lb. 4 ozs.  
12v. D.C. .6 to 1.5 amps.

Designed for use in all forms of Motor Coach Trains. Fitted with the same Motor Unit as in the famous Bassett-Lowke Electric Mechanisms. Sturdily built and of sound constitution.

Wheel Base, 2½in.

Length Overall, 4½in.

Adjusting Plate can be raised by ½in.

Wheel Diameter, ½in.

Height from rail to fixing plate at lowest position, 2½in.

Price on application.

Visitors to London or Manchester are cordially invited to our Showrooms where they can inspect all the latest Bassett-Lowke Models. Our Staff will be very pleased to discuss details of any of our Models. Send for New Gauge 'O' Model Railway Catalogue (GO/12). Price 1/-.

## BASSETT - LOWKE LTD.

NORTHAMPTON

LONDON: 112, High Holborn, W.C.1.

MANCHESTER: 28, Corporation St., 4.



# Sensitised Materials for PHOTO COPYING and BLUE PRINTS

As actual manufacturers of all types of sensitised photo materials, Haldens are in a unique position as print room suppliers. Materials for Blue Prints, Dyeline Prints, Gas Developed Prints, Sepia Prints, "Ferazo" Blue Prints, Ferro Gallic Prints, etc. The brand names "Dyalyn," "Neutralyn," "Vaporax," "Cyano," "Ferazo" are your guarantee of complete satisfaction.



Illustrated is the "Ferazo" Developing Machine. Write for fully descriptive leaflet.

# Haldens OF MANCHESTER

J. HALDEN & CO., LTD., 8, ALBERT SQUARE, MANCHESTER 2.  
Bra. c. at London, Newcastle-on-Tyne, Birmingham, Glasgow, Leeds and Bristol.

## A NOTE TO AMATEUR PHOTOGRAPHERS

Of course you can do this if you want to but—



—when you're tired get a **JOHNSON TANK**

THE old-fashioned method of developing roll films by splashing them up and down in a dish is out. The modern method, used by amateurs and professional workers, is in a Johnson Tank.

## JOHNSON J-20 TANK

PROVIDES a very economical way of developing your size-20 roll films. The film is transferred to the tank spiral in the dark. The lid is then locked on, by a quarter turn, and all the rest of the work—developing, fixing and

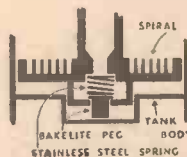

All the latest J-20 developing tanks are fitted with the new Two-way agitation movement which ensures even development.

washing is done in daylight inside the tank. Half an ounce of concentrated AZOL in 10½ ozs. of water will make the developing solution. 1 oz. of Acid Hypo in 10½ ozs. of water makes the fixing solution. There is a deep, built-in funnel for easy filling and a pouring lip.

Price 22/6

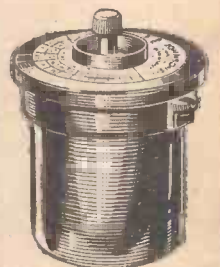

JOHNSONS of HENDON LTD.  
LONDON, N.W.4. ESTABLISHED 1743.

# ★ "A College backed by an Industry"



*E.M.I. Institutes have behind them the vast resources of Electric & Musical Industries Ltd. ('H.M.V.');*  
*Columbia; Marconiphone; etc.)*

## More qualified engineers urgently required everywhere

Because of our unique industrial backing our Home Study courses have a severely practical basis. The range has recently been considerably extended. We can therefore offer the most up-to-date instruction in many branches of engineering, including those covering the syllabuses of the examinations conducted by the various Professional Institutions.

*For Free Brochure giving details of Home Study and Daytime Attendance Courses at moderate fees apply to:*

## E.M.I. INSTITUTES Dept. 144

10 PEMBRIIDGE SQUARE, LONDON, W.2. Telephone: BAYswater 5131/2

## FRANK'S of GLASGOW

### SELECTED MISCELLANEOUS ITEMS

#### PRISMATIC ELBOW TELESCOPES

This is a beautifully-constructed instrument by Cooke, Troughton and Simms, used for aircraft observation. Magnification 7 x. Weight 6 lb. ... each 27 6

#### ASSORTED LENSES

Parcel of ten assorted Lenses. Includes one 3½ in. dia. convex Lens, focal length 3½ in. One convex meniscus Lens, 2½ in. dia., focal length 4½ in. 8 assorted small convex Lenses ... The lot 10 0

#### EX-W.D. PRISMATIC BINOCULARS, by Ross, Kershaw, etc. 6 x 30. Eyepiece focusing. These instruments have a wide field of view and brilliant definition. Every glass has been examined in our own workshops, and is guaranteed to be in sound optical and mechanical condition. Complete with web case and straps (Leather cases available if desired 7/6 extra) ... 7 5 0

**SPERRY BOMB-SIGHT COMPUTOR TYPE BB**  
Contains over 100 various precision gears, helicals, spirals, bevels, worms, etc. Three motors, dials, counters, aneroid capsules, etc. In metal case 10 in. x 17½ in. x 22½ in. As new, carriage paid ... 55 0

**POCKET FOCUSING MICROSCOPES**  
A precision instrument constructed in our own workshops. The optical system consists of 8 lenses (4 achromatic doublets). Definition is crisp and free from colour and distortion. Magnification 20 x ... 27 6

**MASTER CONTACTORS TYPE II—24 volt**  
A precision mechanical device driven by a twelve-hour clock which makes and breaks contact 120 times per minute. Spark suppressors are built in. Contained in rubber-lined oak box. Brand new ... 9 6

**SATISFACTION ON ALL PURCHASES OR REFUND OF PAYMENT**

*Charles Frank*

67-73 SALTMARKET, GLASGOW, C.I.  
PHONE: BELL 2106  
INSTRUMENT MAKERS AND DEALERS SINCE 1907

## The Leytool COMBINATION BREAST DRILL

### BRAND-NEW DESIGN AFFORDS THESE UNIQUE FEATURES

Can be used as a Hand or Breast Drill.  
Breast pad adjustable for length and can be revolved for use on knee, etc.  
2-speed easy-change totally enclosed gear box.  
Operating handle adjustable—3 positions.

The whole job is beautifully engineered and constructed—bearings are self-oiling phosphor bronze. Ball race takes drilling pressure. See it at your local toolshop or write for illustrated leaflet.



### OTHER LEYTOOLS



**PRECISION HAND DRILL**  
¼ in. dia. capacity.



**RATCHET SPANNERS**  
(150 Stock sizes.)



Universally Jointed **SOCKET SCREWDRIVERS**  
18 Stock sizes.



**4-BLADED POCKET SCREWDRIVER.**

All Leytools are entirely original and patented designs. Send for illustrated booklet.

**LEYTONSTONE JIG & TOOL CO., LTD.**  
Leytool Works, High Road, Leyton, London, E.10.  
Telephone: Leytonstone 5022-3



# RAWLPLUG PRODUCTS

**INDISPENSABLE  
IN THE WORKSHOP  
HANDY IN THE HOME**



## FIXING DEVICES AND TOOLS

The Rawlplug Popular Outfit costs only 2/6 complete. Larger sizes are obtainable.

Whatever your fixing problems, there's a Rawlplug Device that will solve it for you—easily and quickly. Rawlplugs make neat and absolutely firm fixings in any material from brick or tile to stone or slate, with a size for every screw from No. 3 up to 1/4 in. coach screws. Rawlplug Tools are easy to use and ensure a perfect hole without damage to surrounding surfaces. Other Rawlplug Devices include Rawlbolts for heavy duty fixings, Rawlanchors and Toggle Bolts for thin or hollow materials and Rawlclips for instant fixing of conduits and cables to girders—a device in fact for every need.

Rawlplug fixing devices and products can be obtained from Ironmongers, Hardware Dealers, Stores or Model Makers Suppliers.



### SCRAPER

A remarkably efficient and economical scraper, built to last a lifetime. Gives smooth finish without chatter or scratching. Easy-grip handle

made solid with blade carrier in seasoned hardwood, polished and varnished. Total length approx. 6in. Fitted renewable 2 1/2 in. Cadmium Plated Steel Blade, with cutting edge ground like a razor. 3/- each.

B389C



### DUROFIX

The indispensable adhesive for instant use on crockery, glass, wood, metal, celluloid and the hobbies enthusiast. Instant drying, insulating, waterproof and heatproof. Durofix is grand for repairs to electrical, sports and leather goods. Tubes 9d. and 1 3. Tins 2/9 and 7/6.



### DUROGLUE

UNDILUTED ANIMAL GLUE OF INCOMPARABLE STRENGTH

Ready for instant use for the many purposes for which an extra strong glue is needed. Wood, cloth, fabric, felt, leather and any greaseless surface can be stuck with Duroglue. Tubes 6d. and 1-. Tins 2 3 and 3 9.



### PLASTIC WOOD

APPLIED LIKE PUTTY, DRIES LIKE WOOD

Can be cut, planed, polished and painted like wood. Will take nails and screws like wood. It does not blister, crack or decay. Rawlplug Plastic Wood is actually the best quality product of its kind on the market. Tubes 10d. Tins 2/- and 5/-.



### TILE CEMENT

A LIQUID CEMENT OF TREMENDOUS STRENGTH

Remarkable for its great adhesive qualities, Rawlplug Tile Cement speedily fixes loose tiles to walls, floors, fireplaces, hearths, curbs, etc., in kitchens, lavatories, bathrooms, halls, bedrooms, reception rooms, etc. 2/3 per tin.

THE RAWLPLUG COMPANY LTD. LONDON. S.W.7.

## ELECTRICS BARGAINS



**ELECTRIC PANEL HEATERS** totally enclosed elements—heavy cast iron frame—Ideal for Stores—offices—garages. 750 watts, 23/6 plus 5/6 carr. ; 250 watts, e.g. 4 hours for 1 unit, 23/6 plus 5/6 carr. ; 500 watt (medium) model, 23/6 plus 5/6.

### MAINS/BATTERY MOTOR WITH GEARBOX

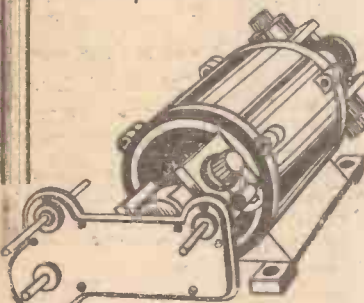

This is a very versatile motor as it will operate off any battery between 6 and 24 volts, or off A.C. or D.C. mains of any voltage. The motor runs at about 2,000 revs. depending, of course, upon the voltage and type of input. The gearbox reduces the speed to about 3 revs. per minute. Size is approx. 7 1/4 in. x 4 in. x 4 in. This is ideal for driving models, turntables, etc., or with gearbox removed it will operate a buffing wheel or similar device. 14/5 Plus carr. 1/6.



### METAL TRIPOD

Tremendously strong, but not at all heavy. 3ft. high and with brass male and female threaded top. Black japanned pressed steel, unused, but may need repainting. 3 6 each, plus 2/6 post and packing.

### HOUSE TELEPHONES WALL OR DESK MOUNTING



Suitable for intercommunication between Offices, Workshops, Stores, Garages, Bix houses, Kitchens, etc. Each station consists of normal size Bakelite handset as illustrated, and desk or wall mounting cabinet with built-in Selector switch, buzzer and push. All stations can communicate with one another independently. Each installation is absolutely complete and internally wired. All you do to install is to run the multi-core cable between stations.  
3 station installation complete with 50 yds. 5 core cable. £8/10 0. Ref. 318.  
4 station installation complete with 50 yds. 6 core cable. £9/10 0. Ref. 319.  
2 station installation complete with 25 yds. 4 core cable. £5/17 6. Ref. 320.

**PRECISION EQUIPMENT, (1) Electron House, WINDMILL HILL, RUISLIP MANOR, MIDDLESEX.**

## Tools and Machines for the Handyman



Fretsaws for wood, metal, plastic, etc.

Fretwood, Stripwood, Beading.



TOOLS SETS FROM 9/-

Designs and Kits for Models, Toys, etc.

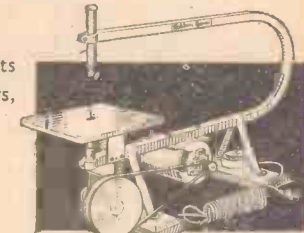

MOTOR MACHINES



Ask for Hobbies at any Ironmongers, Stores, etc., or Hobbies own Branches in London, Glasgow, Manchester, Birmingham, Sheffield, Leeds, Hull, Southampton and Bristol. Free illustrated leaflets from Hobbies, Ltd., Dept. 7, Dereham, Norfolk.



**HAVE YOU SEEN  
THE NEW**

# Wolf Cub

**MORE than an electric DRILL.**



**...THE POWER UNIT for all these Kits**

**WOLF CUB 1/4 in. HOME CONSTRUCTOR ELECTRIC DRILL**

Beautifully streamstyled and amazingly compact. Weighs only 3 lbs.—ample speed and reserve power for all general purposes. Plugs into any lighting or power socket.

**£4-19-6**

Thousands are finding hours of profitable pleasure from Wolf Cub Home Constructor Equipment. Here is the new electric power way to do all the fitting and repairing jobs at home—beautifying the home—making useful presents for friends—modelling and scores of other handicrafts. Look at the astoundingly low price of the Wolf Cub electric drill and remember that it is the power unit of all the Kits illustrated.

★ **LOW PRICE CONVERSION SETS**  
Convert Wolf Cub or any Kit to form complete Wolf Home Constructor Equipment at attractive low prices.

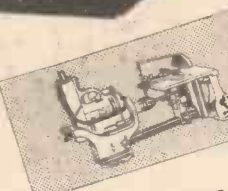

**WOLF CUB HOME CONSTRUCTOR SAW KIT**

PRICE **£8-18-6** COMPLETE

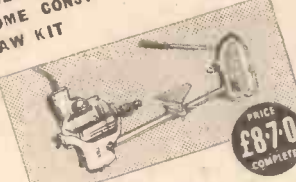

**WOLF CUB HOME CONSTRUCTOR LATHE KIT**

PRICE **£8-7-0** COMPLETE



**WOLF CUB HOME CONSTRUCTOR DRILLING, GRINDING & POLISHING KIT**

PRICE **£7-1-6** COMPLETE

Ask your tool supplier for full details or write direct to—

**WOLF ELECTRIC TOOLS, LTD., PIONEER WORKS, HANGER LANE, LONDON, W.5**  
BRANCHES: BIRMINGHAM, MANCHESTER, LEEDS, BRISTOL. TELEPHONE: PERIVALE 5631

## METAL DETECTION KIT



Price including working drawings **22/6**  
Carriage and packing 12/6.

**WINCHES OR HOISTS**  
Worm driven, reduction 187.5 to 1, drive by 1/2 in. sq. shaft, can be hand operated or motorised, fitted clutch and clutch release, quick no-load wind, triple stranded steel cable extends to 6ft., end of cable fitted massive shackle, suspension by steel bar 1/2 in. dia. at top of winch, size overall 8 1/2 in. x 6 in. x 5 1/2 in., weight 13lbs., suitable for loads up to 12 cwt. New. **£5** (Carr. Paid)

### 5/- SPECIAL METER OFFER 5/-

While they last!  
A Portable test instrument having the following ranges: 0-15v. D.C.; 0-60MA.; 0-5,000 ohms. Complete with shoulder carrying strap.  
Those who have already purchased the portable test instrument illustrated have a chance to purchase another instrument to provide spares in case of damage to the main meter. The meters offered are new but are defective in one way or another, but can be classed as "repairable." **5/-** post paid.

- ★ 2 1/2" diameter scale
- ★ Moving coil movement
- ★ A Multimeter easily assembled from these instruments
- ★ Made by Aron Instruments
- ★ Our usual price 15/-



Terms: Cash with Order  
**MAIL ORDER SUPPLY CO.**

The Radio Centre  
33, TOTTENHAM COURT ROAD, LONDON, W.1. Telephone: MUSEUM 6667

## PLASTIC MARBLE

New Artificial Stone for casting Bookends, Ashtrays, Wall Vases, etc. Sets granite-hard with a scintillating crystalline structure closely resembling Alabaster. Enormously strong, highly resistant to heat, and impervious to water. Any type of 'natural veining' can be simulated in any colour.

## FLEXIBLE MOULDS

Are easily prepared with 'Elastomould' Synthetic Rubber Solution. Sold in handy liquid form. Makes ideal moulds for casting Plaques, etc. Will faithfully duplicate the most minute details.

Send 1/- for full details of this easy, fascinating and profitable hobby. Money refunded to bona fide enquirers.

Dept. P.M.I., KARLENA ART STONE CO.  
55 Deansgate Arcade, Deansgate, Manchester, 3.

### THINGS TO MAKE AND DO

- STILL IN STOCK**, the popular small motors for sewing machines, complete with fitted driving belt and on/off switch. Only 21/6 including postage.
- TREAT YOURSELF** to an electric blanket, £9 10s. Or we can supply the infra-red warming unit which you can zig-zag and stitch into your own blanket. Unit is six yards long by 3 1/2 in. "thick" and comes complete with an on/off switch and 2-pin mains plug. For 200-250 v., 17/6, post 8d.
- RE-DISTEMPER YOUR WALLS** or cellulose your furniture with a Goblin Spray gun: will fit to practically any cylinder-type vacuum cleaner; three nipples are supplied for paint, distemper and cellulose. Gun can also be used with soapy water for shampooing carpets, washing down paintwork, etc. Price 11/3, inc. post. Spare jars, 3/-, inc. post.
- MAKE A GARDEN FOUNTAIN** in your pool: electric water pumps to lift water to a height of 15ft., deliver up to 250 gallons per hour. Work from 24 v., but are supplied with a transformer to reduce 230 v. mains to 24 v. The two, £3 8s., including carriage. Same pump can be used for drawing water from a well, emptying flooded cellars, emptying washing machines, etc.
- LOUDSPEAKING EQUIPMENT**—Self-amplifying microphones, complete with one loudspeaker, 50/-, plus 2/6 carriage. Spare speakers, 35/- each, inc. post.
- MAKE A TRICKLE CHARGER**, for 10/8, plus 10d. post., and keep your 6 v. car or motorbike battery up to instant action. Transformer 230 v. A.C. and rectifier with wiring diagram.
- ELECTRIC MOTORS**, all horse-powers, always in stock; send 1d. stamp for list.
- MAGNETIC RECORDING** accessories in stock: EMI-tape, 25/- reel, plus 10d. post; spare reels, 4/8 each; 45 Kc. oscillator coils, 5/6, plus 6d. post. Send 1d. stamp for full list of accessories.
- PARK RADIO OF MANOR PARK, 676/8 ROMFORD ROAD, LONDON, E.12**





**"KINWEST"  
DRAWING  
MATERIALS**

We are the largest manufacturers of high-grade Drawing Instruments and Slide-Rules in the British Empire, and our Kinwest Drawing Materials have gained a reputation throughout the world for superb quality and accuracy. Insist on using only Thornton's for complete satisfaction.

Our illustrated Catalogue, which includes particulars of Drawing Boards, Tee and Set Squares, Scales, Drawing Instruments, Curves, Protractors, etc., is sent Post Free on request.

**A. G. THORNTON LTD**  
*Drawing Instrument Specialists*  
 WYTHENSHAW, MANCHESTER  
 Tel: WYThenshawe 2277 (4 lines)

**CHEMICAL APPARATUS CATALOGUE**  
 POST 2/6 FREE

The Abridged Chemical List S.A.E.

**VICSONS LTD**  
 148 PINNER RD. HARROW, MIDDLESEX.  
 FOR ALL LABORATORY APPARATUS

Contractors to Education Authorities and many of the large industrial laboratories

NOW STOCKING  
**"SOUNDMIRROR"**  
 MAGNETIC TAPE RECORDER AND REPRODUCER

FOR RECORDING AND REPRODUCING ALL RECORDABLE SOUNDS

SEND FOR FULL DETAILS

For Your **MYFORD** LATHE

Send now for full details (Leaflet 101) of the Myford Patent Collet (Patent App. 20189)—a simple two-piece job for converting ML7 or "M" type lathes from centre to collet turning. The collet and ring avoid excessive overhang, give maximum possible accuracy and good grip. Chuck or backplate is not required thereby eliminating multiple errors.

MYFORD ENGINEERING CO. LTD., BEESTON, NOTTINGHAM

*One plastic material*



**MAKES MANY PERMANENT MODELS**

and utility objects, from simple instructions in illustrated Booklet—please read below.



**ONLY 4<sup>D</sup> IN STAMPS BRINGS BOOK**

... showing how such models as those above, and many others, can be made, without skill or special tools, from Sankey's PYRUMA Plastic Cement. Ready for immediate use in its plastic state, Pyruma sets or bakes to stone-hardness, and can be painted or enamelled in all colours according to instructions. Therefore realistic natural-colour models can be made from Pyruma, including

HOUSES, BUILDINGS FOR MODEL RAILWAYS, DOCKS AND AIRPORTS, SHIPS, MODEL FURNITURE, ANIMALS, FIGURES, RELIEF MAPS, Etc. as well as utility objects such as ASH TRAYS, BOOKENDS, MENU HOLDERS, PAPER WEIGHTS, ORNAMENTS and DECORATIVE OBJECTS.

Pyruma is inexpensive, and easily obtainable in tins from Ironmongers, Art Material Dealers and Hobbies Shops. Send 4d. in stamps to the address below for illustrated Instruction Book.



Dept. 4

**J.H. SANKEY & SON LTD**

ILFORD EST. 1857 ESSEX

# FREE!

to every ambitious engineer  
this valuable 176-page handbook!

# B

Better days lie ahead if you add "ENGINEERING OPPORTUNITIES" to your bookshelf. If you want to put yourself in line for quick promotion, higher pay and all that goes with it, as well as the sort of job you've always wanted, this enlightening guide to success—176 pages of vital, right up-to-date information—is your blue-print for a brighter future.

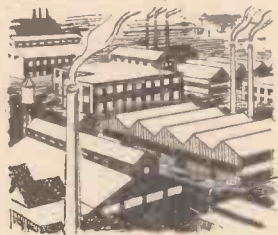

# I

In this book you will find out how to take advantage of to-day's opportunities; how you can rise to a position that ensures success, prosperity and security—the sort of job which, in Peace or War, Prosperity or Slump, makes you a "key" man on whom the craftsman or fighting-man is equally dependent.

# E

"ENGINEERING OPPORTUNITIES," besides showing how you can be helped to become a trained technician in your spare time, describes our unique Advisory and Employment Depts. Read about them and also about the superb range of Home Study Courses you can choose from... learn something of the methods that have already brought success to men in all branches of engineering throughout the world.



# T

Thousands of B.I.E.T. Students—ordinary people with no special advantages except a real desire to succeed—have, under our guidance passed A.M.I.Mech.E., A.M.I.C.E., CITY & GUILDS and other major examinations. Because of our outstanding successes, you, too, can be confident of your success, under the guidance of B.I.E.T.

WRITE IF YOU PREFER NOT TO CUT PAGE

## POST THIS COUPON TODAY!

Please send me a FREE copy of the latest 176-page edition of "ENGINEERING OPPORTUNITIES" IT IS UNDERSTOOD THAT NO REPRESENTATIVE WILL CALL ON ME  
NAME .....

ADDRESS .....

I am interested in.....  
(State subject, exam, or type of appointment that appeals to you.)

B.I.E.T. 410A SHAKESPEARE HOUSE,  
17-19, STRATFORD PLACE, LONDON, W.1.

Which  
of  
these  
is  
your  
Pet  
Subject?



### Mechanical Engineering

A.M.I.Mech.E.—CITY & GUILDS—General Mechanical Eng.—Maintenance Eng.—Diesel Eng.—Sheet Metal Work—Welding—Metallurgy—Machine Drawing & Design—Refrigeration, etc.

### Electrical Engineering

CITY & GUILDS—General Electrical Eng.—Installations—Illuminating Eng.—Electrical Science—Electricity Supply—Meters & Measuring Instruments—Mains Eng., etc.

### Radio & Television

A.M.Brit.I.R.E.—SERVICING CERTIFICATE—C. & G. Telecommunications—General Radio Eng.—Radio Servicing—Television Servicing—Sound Film Projection—Electronic Eng., etc.

### Production Engineering

A.M.I.P.E.—Works Management—Foremanship—Staff Supervision—Planning Eng.—Costing, etc.

### Automobile Engineering

A.M.I.M.I.—CITY & GUILDS—General Automobile Eng.—Automobile Repairs—High Speed Diesels—Garage Management, etc.

### Building & Civil Engineering

A.M.I.C.E.—F.R.I.C.S.—L.I.O.B.—General Building—Architectural Drawing—Sanitary Eng.—General Civil Eng.—Surveying—Specifications & Quantities—Heating & Ventilating—Painting & Decorating—Plumbing—Carpentry & Joinery—Timber Technology, etc.

PLASTICS—DRAUGHTSMANSHIP—AERONAUTICAL ENG.—FORESTRY

### SOME LETTERS AFTER YOUR NAME?

A.M.I.Mech.E. A.M.I.C.E. F.R.I.C.S. A.M.S.E.  
A.M.I.Struct.E. L.I.O.B. A.M.Brit.I.R.E.  
A.F.R.Ae.S. A.M.I.P.E. A.M.I.M.I.

HUNDREDS OF OTHER COURSES  
(Tell us what interests you)

## WE DEFINITELY GUARANTEE "NO PASS-NO FEE"

We have printed "ENGINEERING OPPORTUNITIES" more than a hundred times and distributed over a million copies to ambitious men. Whatever your age, education or experience, if you are earning less than £12 a week, you really cannot afford to miss reading it. Send for your own copy to-day—FREE and without obligation.

BRITISH INSTITUTE OF  
ENGINEERING TECHNOLOGY

THE B.I.E.T. IS THE LEADING INSTITUTE OF ITS KIND IN THE WORLD



# PRACTICAL MECHANICS

EDITOR  
F. J. CAMM

FEBRUARY, 1951  
VOL. XVIII. No. 206

Owing to the paper shortage "The Cyclist," "Practical Motorist," and "Home Movies" are temporarily incorporated.

## FAIR COMMENT

By The Editor

### OUR CHANGE IN PRICE

READERS will have noticed that, commencing with this issue, the price of this magazine has been increased to 1s. We greatly regret that the cost of production which has continued to rise for a long time past has compelled us reluctantly to make this increase. Paper alone to-day is costing four times its pre-war price.

If we are to maintain the high technical standard we have set and give our readers and the trade the service to which they are entitled, no other course is open to us.

The price increase will enable us to retain our high standard and to continue to provide for our readers material written by all the leading authorities in the various technical fields covered by this journal.

We are certain that our readers will endorse this policy.

### TELEVISION BY WIRE

ONE of the problems which have beset the B.B.C. Television Service is that of providing "canned" programmes. With blind broadcasts it is easy enough to record a programme on wire or wax so that it may be repeated as and when required. The filming of the television programmes is the only method at present in use and this is not altogether satisfactory. Now, a group of broadcast relay companies, which at present relay the B.B.C. and selected foreign broadcast programmes to about 3,000,000 British people, announce that they have developed practical systems of television rediffusion which they intend to install at home and abroad. Viewers will, by this system, be provided with interference-free television in addition to a choice of broadcast programmes brought to their home at a weekly charge, which will include the hire of the receiver, full maintenance, and replacements.

Experiments which have led to the perfection of the system have been conducted for the past 15 years. One of these, a communal television aerial system has been in operation in London flats and hotels since 1937, while another will supply simultaneous distribution of more than one television programme in addition to a choice of broadcast programmes.

This announcement should bring hope to the 8,000,000 people living either in geographical blackspot areas or in parts of the country not covered by the television development programme, which aims to cover 85 per cent. of the population by the end of 1954.

Television developments proceed apace. When the first issue of our companion journal *Practical Television* went to press in March, 1950, there were 285,000 owners of television receivers in this country. In the short space of 10 months that number has grown to between 500,000 and 600,000 and each week sees a steady rise. Correspondingly, the number of requests which I receive for constructional details of a television receiver continues to increase. Space, unfortunately, is too restricted in this journal to devote to this subject, but we have published at 3s. 6d. or by post 3s. 9d. a comprehensive booklet illustrated by diagrams and photographs, which describes the construction of a highly efficient console television receiver, produced in our own laboratories. It was exhibited at the Radio Show at Birmingham last year, and attracted most favourable comment.

### NOTE TO INTENDING CONTRIBUTORS

NO one is more qualified to write an article on a given subject than one who has practical acquaintance with it, or who has actually made the article being described. I receive a large number of letters from would-be contributors asking how they should set about the task, and I therefore give these general notes for their guidance.

Unless your handwriting is very clear manuscripts should be typewritten; but in any case they should be written on one side of the paper only with plenty of space between the lines to allow for editorial corrections and additions, or deletions. There should be a 1in. margin on each side of the paper. Illustrations, which must be referred to in the text, should be figure numbered and captioned. They

should be made on separate sheets of paper, with the title of the article and the name of the contributor on each. Articles should extend from 1,000 to 2,000 words according to the subject.

Sketches need only be in the rough, but where photographs are available, they should be included. Preference is given to articles which have actually been made. Include a list of components and the names and addresses of suppliers. It is annoying to a reader who wishes to make a particular article when the contributor does not mention where the parts can be obtained. I do not require articles which describe how to convert some piece of scrap into something else as such scrap may not be generally available. All of the materials used should be easily obtainable.

Most important of all, write your name and address in the top left-hand corner of the manuscript. Send photographs and drawings flat, and enclose a stamped, addressed envelope for return in case of rejection.

It is best in the first place to send a précis of the article to see if the idea is acceptable. Remember that a manuscript may be rejected not because of lack of merit, but because it collides with an article which has already been published, or is in hand for early publication.

The submission of a précis avoids the contributor preparing manuscripts which are unacceptable for these or other reasons. We pay for everything we use on a generous scale.

### "PRACTICAL ENGINEERING" DATA SHEETS

EVER since the conclusion of the series of Data Sheets issued by our companion weekly *Practical Engineering* were completed there has been a steady correspondence asking for more. It will be remembered that eight of these sheets were given away every week for 32 weeks making a total of 256 sheets altogether. Thus readers were presented with a valuable textbook. To satisfy the demand a new series has been prepared and will commence in *Practical Engineering* dated February 23rd. In these days of paper shortage and restricted supplies it is increasingly necessary to place a regular order with your newsagent for the delivery of *Practical Engineering* every Friday.

The new series will deal with almost every type of mechanism and mechanical movement.—F. J. C.

### SUBSCRIPTION RATES

including postage for one year

Inland	- - - -	14s. per annum.
Abroad	- - - -	14s. per annum.
Canada	- - - -	13s. per annum.

Editorial and Advertisement Office: "Practical Mechanics," George Newnes, Ltd.  
Tower House, Southampton Street, Strand, W.C.2  
Phone: Temple Bar 4363

Telegrams: Newnes, Rand, London  
Registered at the G.P.O. for transmission by Canadian Magazine Post.

Copyright in all drawings, photographs and articles published in "Practical Mechanics" is specially reserved throughout the countries signatory to the Berne Convention and the U.S.A. Reproductions or imitations of any of these are therefore expressly forbidden.

# A Reflecting Telescope

## Constructional Details of a 6in. Reflector with an Equatorial Mounting

By T. J. MULLIGAN

**A**MATEUR telescope making, which as a hobby had its beginnings in Britain, appears at last to be coming back into favour. Apart from the American books, edited by A. G. Ingaels, which are not readily obtainable here, there are only one or two books on the subject available for the amateur. The Americans took up telescope making where we left off and developed it with considerable enthusiasm; amateurs all over the States took to making their own telescopes, industriously grinding and polishing mirrors of all sizes and producing a large number of first-rate instruments.

As a hobby telescope making has everything to commend it. There is real satisfaction to be had from the production of an excellent permanent optical surface entirely by the labour of one's hands; and the construction of the mounting presents an irresistible challenge to the individual inventiveness and improvisation—readers will remember the mounting made by Mr. H. L. Pugh recently illustrated in PRACTICAL MECHANICS, in which he made ingenious use of two steering wheel assemblies. These improvisations are the real attraction of telescope making; many things can be called into service—pipe fittings, automobile parts, odd bits of machinery—even the humble "bike" can be transformed into a mounting. Home-made telescopes are rarely alike and there is endless scope for individual skill and inventiveness.

The methods by which a 6in. reflector could be made, together with instructions for completing the telescope tube were published in the March-April, 1948, issues. Some amateurs will have completed their mirrors and tubes and are still undecided about a method of mounting: apart from the difficulty of finding suitable materials it is not always easy to visualise a satisfactory method of assembling. This article presents an equatorial mounting which is about as simple as any mounting can be; it is not to be regarded as the last word in efficiency, but rather as an idea upon which to work, although for its weight this bicycle frame mounting is surprisingly stable. Its chief defect, which experienced telescope makers will notice at once, is the small diameter of the spindles and bearings in the two axes;

larger bearings make for stability. The mounting is, however, well worth making if no more suitable materials are available; it is neat in appearance, as can be seen from the accompanying illustrations, Figs. 1 and 2, and not too heavy to be carried from place to place. With the exception of one or two odds and ends all the component parts were obtained from a broken and discarded bicycle frame.

### Construction

Reduced to essentials, an equatorial mounting consists of two axes rigidly mounted at right angles to each other, one axis pointing to the pole of the heavens (or parallel with the earth's axis). Although not vitally necessary, some form of slow-motion drive should be

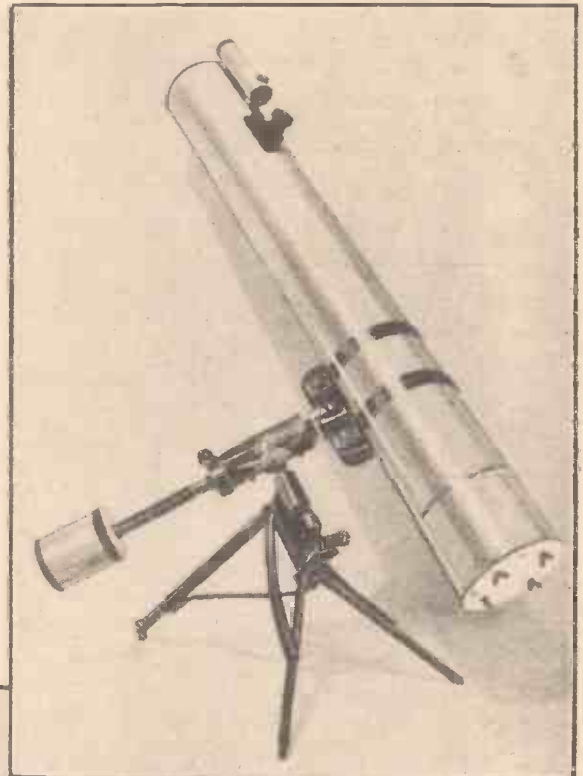

Fig. 1.—The finished telescope on its equatorial mounting.

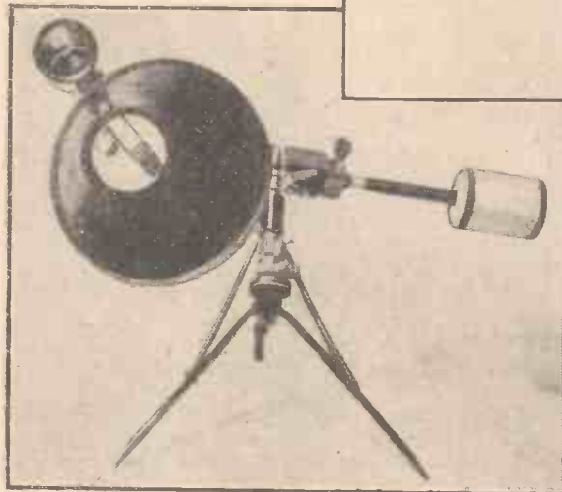

Fig. 2.—View looking down the telescope tube. This photograph was taken at a slight angle to show the reflection of the prism in the mirror.

an ordnance survey map of the district. Some measure of adjustment is provided by moving the seat pillar, which is a tight push fit in the long leg of the tripod. The other axis—the declination axis (Fig. 6)—fixed at right angles to the polar axis, permits the tube to be swept from pole to horizon in any direction. Once an object has been centred in the field of the eyepiece, its movement can be followed by rotating the tube around the polar axis only, and if the angle of the polar axis is correct, the star will remain in the centre of the field. An additional refinement, which can be added

later if desired, is a driving clock fixed to the polar axis, and this would rotate the telescope at the correct speed to keep the star in the centre of the field.

### Counterbalance Weight

The counterbalance weight is a tin into

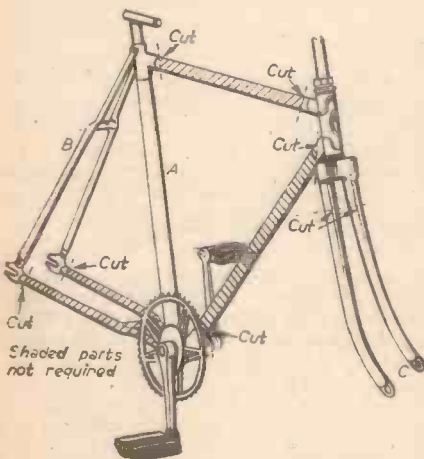

Fig. 3.—Showing the parts of a bicycle frame which are used for the telescope mounting.

fitted to each axis; the drives used in the telescope illustrated were dismantled from ex-Government gunsights and fitted by means of bushes.

Details of the construction of the mounting are shown in Figs. 3 and 4; the tubular construction of a bicycle frame makes for rigidity, and the two spindles and bearings are ready to hand in the fork and gear wheel assemblies. These are cut from the frame as indicated, and the cut edges filed smooth and flush with the tube. The spindles and ball bearings should, of course, be kept apart until the mounting has been cleaned up and made ready for final assembly.

Dimensions here are not important, but there is one essential—the polar axis (Fig. 5) must point directly to the celestial pole, the point in the heavens close to Polaris, the Pole Star, around which all the constellations appear to rotate. The spindle will then be parallel with the earth's axis. The angle will vary from place to place, and will be equal to the latitude at which the telescope is situated; this angle is shown on the edge of

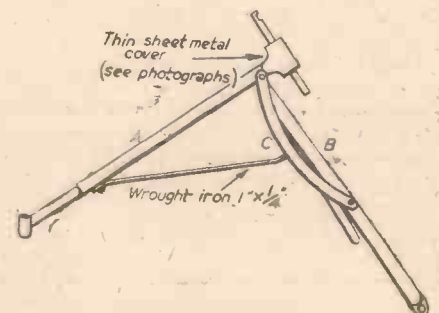

Fig. 4.—Details of the tripod and polar axis.





Fig. 5.—Close-up view of the polar axis, showing gunsight slow-motion drive.

which molten lead has been poured. The tin should first have a length of bicycle frame tube centred in it, around which the lead is poured, thus fixing it firmly. So the piece of tube should be chosen so that it is a tight fit on the fork spindle; details are shown in Fig. 7. The counterbalance weight can then be adjusted so that it exactly balances the telescope tube; this has the effect of locating the centre of gravity at a point centrally above the three legs of the mounting, and as close as possible to the polar axis. The telescope is thus made easy to "swing," and since the whole weight is shared equally between the three legs, the mounting is stable and there is no tendency to rock.

Smooth working is only possible when the telescope is perfectly balanced; and if worm drives of the type shown in Fig. 5 are used their action will be jerky if the balance is not good. The balance of the tube in relation to the declination axis is determined by the position of the two fixing bands along the length of the tube, and this should be near the cell end, otherwise it will not be possible to swing the tube into a vertical position. It will probably be necessary to fit an extra weight inside the cell to achieve this balance.

The height of the mounting has been kept low; this makes for considerable ease of observing, it being possible to use a chair in most positions of the tube.

**The Finder**

A finder is very necessary, as it is very difficult to find even a bright object in the night sky without a finder. A telescope of this magnification needs to be sighted like a gun.

Full details of the finder used are shown in Fig. 8; the two lenses and prism should

be easy enough to obtain. There is no necessity to be precise about diameters and focal lengths in this case, as the magnification of the finder does not matter; all that is necessary is that it should produce an image of the constellations which is recognisable. Cross hairs can be dispensed with at a pinch; it is easy enough in practice to centre an object in the field. In the finder shown the objective is a 50mm. binocular objective of 6in. focal length, and the prism also came originally from a pair of binoculars. The eyepiece is a simple plano-convex of zin. focal length—not the perfect eyepiece, but sufficiently good for the purpose; eye-relief is generous, and the image can be inspected with the eye a comfortable distance away.

**Screw Adjustment**

When fitted to the telescope tube the finder will require to be adjusted by means of slotted screw-holes and shims or washers so that its optical axis lies parallel with that of the telescope. This is best carried out in daylight by centring some easily recognisable landscape object such as a distant house, or a tree, in the field of the reflector, then adjusting the finder so that the same object is in the centre of the finder eyepiece field.

Make sure before carrying out this operation that the optical axis of the reflector is parallel with the axis of the telescope tube.

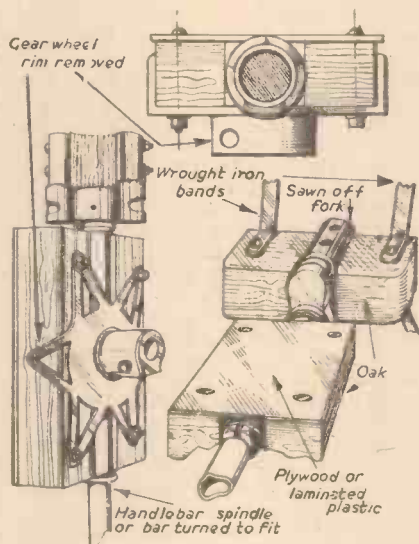

Fig. 6.—Details of declination axis.

To do this, first check the position of the Newtonian prism or flat mirror; this should be in the centre of the tube. Next, remove the eyepiece and observe by looking down into the prism the image of the 6in. reflector; if the optical axis is correctly aligned, the image of the prism will appear in the centre of the reflector.

**The Telescope Tube**

The tube is made from three pieces of 2ozin. tinplate with a removable cell for the

mirror. As mentioned in previous articles, the tube can be made from wood if desired; it can be built up from laths, and can be of square section instead of being tubular. The components can even be mounted upon a single plank. A metal tube is, in the writer's opinion, the best choice, because of its rigidity and better appearance; wood is always liable to warp and twist the axes out of alignment.

Dimensions are given in Fig. 9. It should be mentioned here that the focal length of the mirror used in this particular telescope is shorter than was mentioned in the previous articles on mirror making, where the focal length of the 6in. mirror was taken as being 60in. In the telescope illustrated in this article, the 6in. mirror has a focal length of 48in., the resulting shorter tube-length making the telescope more easily manageable.

**Eyepiece**

The adjustable eyepiece is, inevitably, another piece of ex-Government equipment; the original tin. eyepiece lenses were removed and the mounting bored to take standard eyepieces, the three-start screw adjustment being retained.

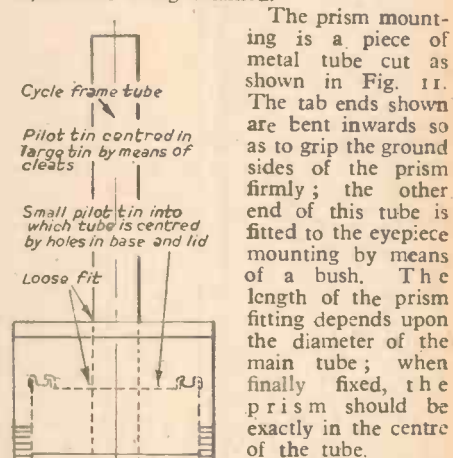

Fig. 7.—Counterbalance weight.

base should be an easy sliding fit in the cell.

The cell is a good fit on the main tube, and is secured by means of three rivets 120 deg. apart which engage in corresponding bayonet slots in the edge of the cell.

**Permanent Site**

There is an obvious advantage in having a permanent site for the telescope, and the best arrangement would be a concrete pier with bolts set into it to which the legs of the mounting could be screwed; the telescope could be then brought indoors when not in use.

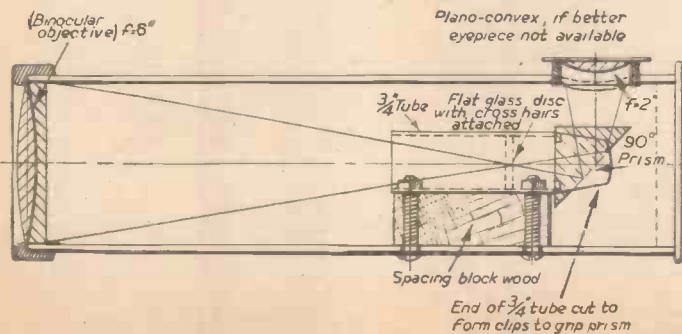
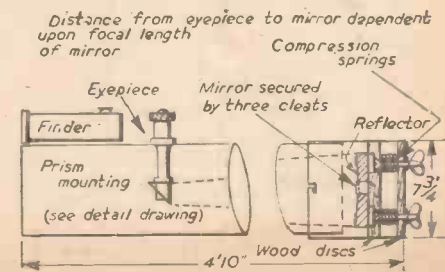

Fig. 8 (Left).—Section of the finder, showing positions of the prism and eyepiece.

Fig. 9 (Right).—Details of the telescope tube showing the mirror and compression springs.



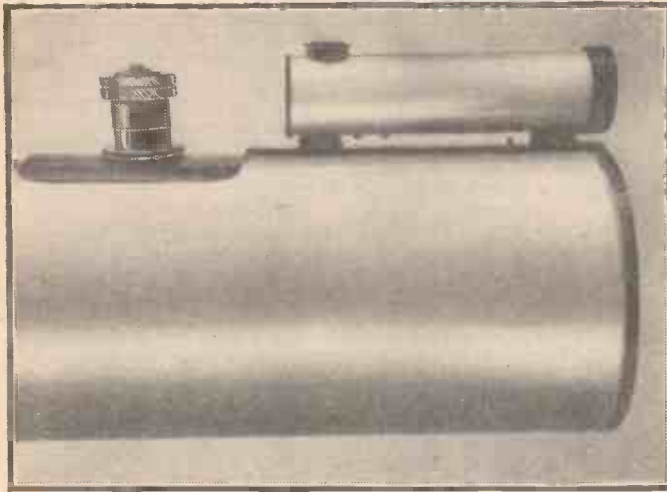

Fig. 10.—Open end of telescope tube, showing a convenient arrangement of finder and ex-Government eyepiece.

Finally, the design of this mounting need not be followed too slavishly; and if you can get the materials aim at much larger and heavier spindles and bearings. A visit to an automobile scrap yard might prove profitable; remember, the larger the bearings the more stable the telescope. Stability makes all the difference to full enjoyment of the instrument, especially when using high-power eyepieces, when the slightest vibration makes the star "dance."

There is a type of ex-Government light artillery gunsight on the market for which the slow-motion drives used in this mounting were taken; apart from the slow-motion drive this gunsight contains an excellent eyepiece, an erector prism, a "house" prism and a right-angle prism—all good quality, and invaluable to telescope makers.

### Results

A few words about the results to be expected from a telescope like the one described, which has a 6in. mirror and a focal length of 48in. (f/8). The image is inverted and not suitable for terrestrial use, although an erect image of landscape subjects can be obtained by looking down into the eyepiece with one's back to the view: pro-

viding the mirror is reasonably good, the image is very bright and clear, and will permit the use of high power eyepieces. The attitude necessary is not particularly comfortable, however, and soon causes a "crick" in the neck.

For astronomical work the telescope comes into its own. Due to the large diameter objective (large compared with the familiar type of draw telescope) much brighter images and increased resolution of heavenly bodies are possible; it will "split" many close double stars and produce clean, sharp planetary images—the bands and satellites of Jupiter, rings and satellites of Saturn, etc. Many more stars will be visible, although those which can normally be seen with the unaided eye will not be increased in size. A good reflector will show stars as minute discs (without any "rays"), but these discs are not true images—their circular form is due to diffraction. Even the nearest and brightest stars have excessively small apparent diameters, only a fraction of a second of arc; as near as we know to the familiar "no magnitude" geometrical point. A real circular image of a star could only be produced by a telescope with a very large aperture; it is expected that in good seeing

Bush to fit eyepiece



Tab's flattened and emerald smooth to grip prism

Fig. 11.—Detail of the prism mounting.

conditions the 200in. Mount Palomar giant instrument will reveal tiny disc images of some of the nearer and larger stars, but as far as 6in. reflectors are concerned stars are points incapable of magnification. The light grasp of this 6in. mirror is, however, so very much greater than the unaided eye that countless hitherto unseen stars become visible, and the bright stars become vastly brighter.

The moon, even with an eyepiece of moderate power, is a truly beautiful object, although when full is inclined to appear flat and featureless; the mountains, craters and ravines cast little or no shadow upon the moon's surface due to the illumination being almost exactly overhead. But in the phases between new and full moon all the features in the region of the shadow or terminator stand out vividly, starkly silhouetted against the long, intensely black shadows, and mountain ranges which appeared as insignificant white patches at full moon

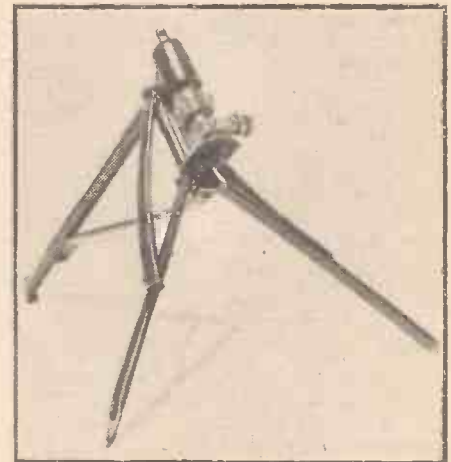

Fig. 12.—Another view of the tripod, showing how bicycle-fork pieces are used for strengthening.

stand out with startling clarity and in considerable detail. This telescope will be found to be worth the effort of construction even if it were to be used for no other purpose than the study of the moon.

## Items of Interest

### Johnsons' Photographic Competition Results

**M**ESSRS. JOHNSONS, of Hendon, have recently issued a list of prizewinners in their autumn competition, which closed on Oct. 31st, 1950. There were so many meritorious prints that the firm doubled the number of consolation prizes to 40. In each of the first three classes prizes of £10, £5, £2 and £1 were awarded. In Class 4 (Special Novices Section) two first prizes of £5, three second prizes of £2, five third prizes of £1, and eight fourth prizes of 10s. were awarded.

The next competition closes on April 30th, 1951, and leaflets giving the rules and prizes are obtainable free on application to Johnsons of Hendon, Ltd., Hendon Way, Hendon, London, N.W.4.

### Another Million Candles!

**I**N 1907 Chance Brothers placed a lighthouse at Colombo. Some time this year that lighthouse is to be replaced by one of the most up-to-date in design. When the old lighthouse, which stands in the centre of the town, is finally extinguished, beams of

light flashing in groups of three will wink from a new stone tower of handsome design on the seashore. The reflection of these million candles will be seen by every ship many miles beyond the horizon, before they approach the famous port.

The new lighthouse will be all-electrically operated, and will be one of the most powerful lights bordering the Indian Ocean. The electricity for this light will be drawn from the local mains supply, but Chance Brothers are ready for any power failures. They will install a diesel engine-driven alternator plant which automatically starts up if the mains electricity should so much as falter. This engine also stops automatically immediately the mains supply is restored!

The source of light, housed in a cage of prisms, is a mere 1½ kilowatt electric bulb. And if that should burn out, a second bulb automatically swings into focus!

The electric motor, which rotates the "optic" or cage of prisms to produce the flashing beams, is provided with a second standby in case of trouble in that direction.

### Flying Boat's 22,000 Miles Tour

**I**T has been announced that a Sealand flying boat, designed and built by Short Brothers and Harland, Belfast, has set out on one of the longest demonstration tours ever undertaken by a British aircraft manufacturer. The aircraft took off from Port of Spain, Trinidad, at the beginning of November, and the first section of the itinerary includes Venezuela, Colombia, British Guiana, French Guiana, Brazil, Uruguay, Argentina, Paraguay and Chile, where flights and demonstrations are being given to mining engineers, oilmen, cattle ranchers and business executives. After returning over the same route as far as Trinidad, the Sealand will head north, making for New York, via the West Indies, Haiti, Cuba and Miami. Then the aircraft will cross into Canada, ending its long journey at Toronto. It is calculated that altogether the tour, which will last until mid-April, will cover over 22,000 miles.

The Sealand is a 5-8 passenger twin engined amphibian, and is designed for areas where freight and passenger carriage is impracticable for normal aircraft. It can be landed and flown off from small lakes and rivers in hitherto inaccessible places where there are no aerodromes.



# A Hand Vacuum Cleaner

## Constructional Details of a Useful Domestic Appliance

By F. G. RAYER

THE vacuum cleaner shown in the accompanying illustrations is made from one of the ex-Service motor blowers which can be obtained from many stores, and is in a portable form which considerably simplifies construction. Though operated from a 24-volt supply, such blowers are obtainable suitable for voltages between 12 and 80, so that no difficulty will arise in operating them from a transformer, or with a suitable series-dropper arrangement, where mains are available.

The complete unit is held in the hand, the dust-bag being of moderate size. Brushes and other fittings can be slipped on the inlet tube for dusting chairs, curtains, and so on. The floor can be done by adding an extension tube, and the vacuum created is ample for removing grit, dust, etc., from carpets and floors. The total cost of the unit, including brushes and flex, will be less than twenty shillings.

### Motor and Blower

This is shown in Fig. 1, and the type obtained should be that with a fairly large blower fan in a circular metal casing. The screws holding the motor to the latter should be removed and the blower casing slipped off. The latter has a central hole and it is here that the inlet tube must be fixed, as illustrated.

Fig. 2 shows how the inlet tube is made. If a suitable length of large-diameter brass or copper tubing is to hand, this could be used. Otherwise take a piece of tinfoil 4 in. by 2½ in. and bend it carefully round a piece of wood or other circular object to obtain the tubular shape, afterwards soldering along the overlapping edge. The large washer illustrated is then cut from tin or other metal which can be soldered easily; it should be a push fit over the tube mentioned, and is soldered in position.

Four 6 B.A. bolts, heads countersunk on the inside, hold the inlet tube to the blower casing. These bolts pass through holes drilled in the casing and the washer mentioned, and should have spring washers under the nuts so that the vibration will not make these work loose.

The handle is made from strong but workable metal, cut as shown in Fig. 2 and curved to the shape depicted in Fig. 1. Sheet brass of 12 or 14 s.w.g. is suitable, or two thicknesses of thinner material can be used.

A 4 B.A. countersunk bolt secures the front of the handle to the blower casing.

The blower should then be replaced on the motor and the retaining bolts put in, after which the rear end of the handle is secured by a bolt at the end of the motor.

### Dusting Tools

Each of these is made with a tube which is a push fit over the inlet tube described. These tubes, which will require to be 1¼ in. inside if the dimensions given in Fig. 2 are followed, are made from tin curved and soldered as mentioned.

The brushes are of ordinary type, obtained from a hardware shop. The small circular one is 2 in. in diameter, and the long one about 2 in. by 6 in. The former is shown at "A" in Fig. 3, the latter at "B."

The small brush has a tin diameter hole drilled in its centre. A tinfoil washer with a 1¼ in. diameter central hole is soldered to the sloping end of the tube. Small wood-screws secure this washer to the top of the brush, thereby completing this part.

The large brush is made in a similar way, the cut-out in it being about 1 in. by 4½ in. The piece "C" is then bent up and soldered to a flat piece 1½ in. by 5 in. This flat piece has a central cut-out 1 in. by 4½ in. and is screwed to the top of the brush so that this opening is over that in the brush. To



The hand vacuum cleaner ready for use. (Note.—In this illustration an additional wooden finger grip is shown fitted to the handle.)

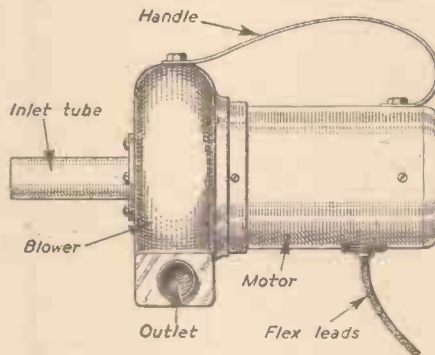
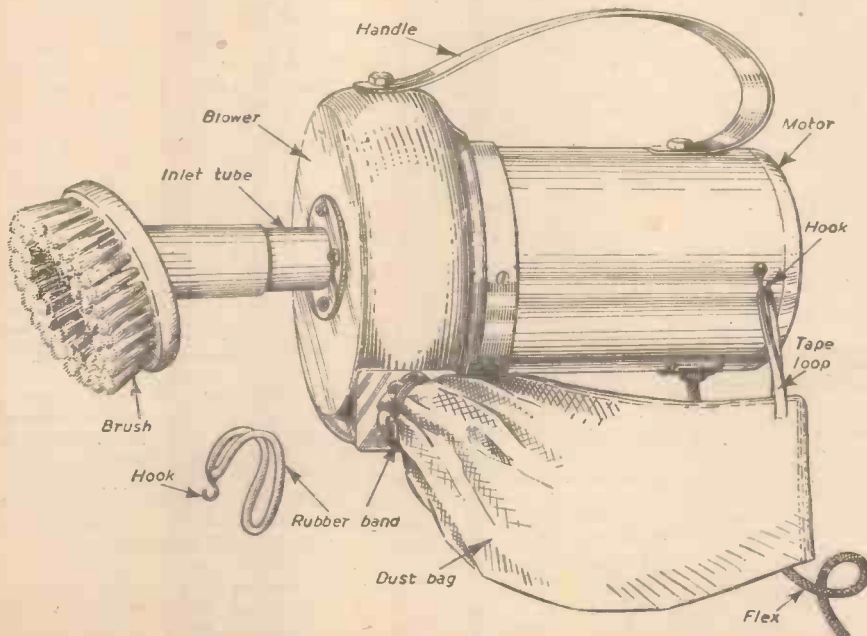

Fig. 1.—The completed unit minus the dust bag and brush.



The complete vacuum cleaner, indicating the disposition of the various parts.

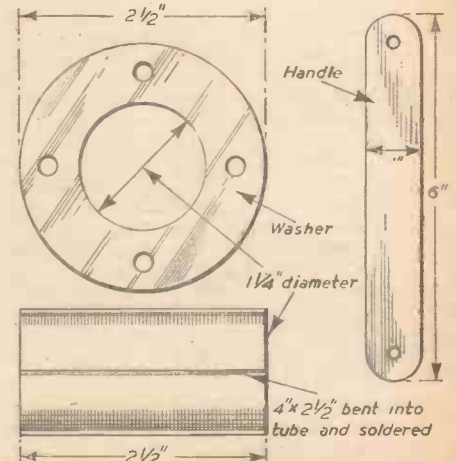

Fig. 2.—Details of handle and inlet tube.

facilitate the use of this wider brush on carpets and floors, the tube soldered to it should be about 18in. or more long. Do not fit either brush flat with the end of the tube, or it will be found the duster is awkward to use. An angle of about 45 degrees, as shown at "A" in Fig. 3, is most convenient.

**Electrical Circuits**

If the vacuum duster is to be run from a suitable voltage supply, it is merely necessary to take two flexible leads from motor to wall-plug. But with 230- to 250-volt mains some method of reducing the voltage is necessary as these blowers are not made for such supplies. Here, a series resistor may be used, and is equally suitable for both A.C. and D.C. mains; alternatively, with A.C. mains a transformer can be employed.

primary should, of course, be suitable for the mains available. If the transformer becomes very hot, this shows it is being overrun and is incapable of delivering sufficient current. If a transformer is being bought or wound and the exact consumption of the motor is not known, a transformer capable of delivering a fairly high current is recommended. There is no necessity that the maximum current the transformer can deliver be taken, and chances of overloading the component are thereby avoided.

The consumption of the blower also depends on its voltage. Optional connections on the motor already mentioned allowed use from a 12v. supply, current then being approximately 2 amps. The 80v. blowers consume far less; some advertisers state these are suitable for intermittent use on 230v. mains, but to avoid damage a series resistor would

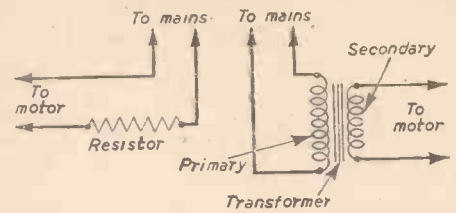

Fig. 4.—Circuits for mains operation.

resistor can easily be found by trying various lamps, etc., until the blower runs very briskly, yet does not become hot after a period of use.

The transformer, fire element, or lamp should be mounted in a small ventilated box which can be placed near the wall plug. Twin flex of sufficient length to enable the duster to reach any part of the room is taken from this box.

Where an earth socket is available, a third lead may be taken from this to the motor casing. With the series resistor arrangement this safeguard is particularly desirable, and the usual care as regards insulation should be taken, as with all mains apparatus, to avoid any possibility of shocks. If the wall plugs are not of the switched type, a switch can be added in the mains supply leads to the box mentioned, if desired.

**Dust-Bag**

This was made from a piece of material about 18in. by 12in., folded over and sewn to form a bag 12in. deep and 9in. wide. The open end is placed over the outlet of the blower and secured by a strong elastic band, doubled and with a small wire hook at the end. (This was found easy to remove and replace, only a few seconds being necessary to empty the bag.) The rear end of the bag is supported by a tape loop which is slipped over a small hook on the motor casing.

The material must allow a current of air to pass, but should be closely woven. If dust escapes, this will show the cloth is too coarse, but any kind of "proofed" material must not be used, or the flow of air will be too severely hindered.

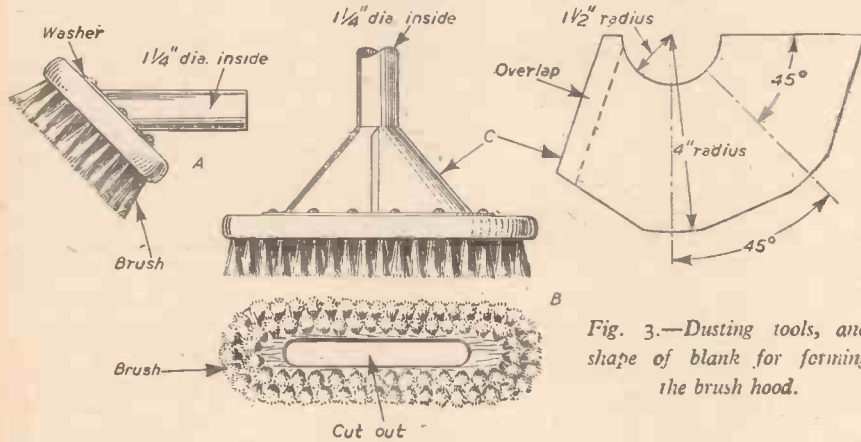

Fig. 3.—Dusting tools, and shape of blank for forming the brush hood.

The consumption of the motors varies, but was approximately 1 amp. in the case of that used by the writer. Quite a small mains transformer would therefore be suitable. (This *not* including midget transformers such as those used for electric bells.) The secondary should give a voltage approximately suitable for the motor—e.g., 24 volts, if the popular 24v. blower is used. The

probably be desirable.

The latter is also shown in Fig. 4, and can be used on any A.C. or D.C. mains with any motor. For 24v., 1amp. motors, a 250-watt lamp can be used. With motors taking more current, a small electric-fire element will answer the purpose. With motors taking under 1 amp, a lamp of smaller wattage is necessary. A suitable value of

# Mathematics as a Pastime

Slow Alongside Rapid Progress

By W. J. WESTON

**H**ORSE-COPERS were ever astute. You remember that story of the dealer proposing an alternative price when the buyer demurred to the first. "Give me a farthing," he said, "for the first nail in the horseshoes, two farthings for the second, four for the third, and so on to the twenty-fourth. You can have the horse for nothing." Calculation after acceptance might well have dismayed the buyer.

For here you have progression. On the one hand you have a slow rise in the index of the powers of 2: it is 1:2:2<sup>2</sup>:2<sup>3</sup>:2<sup>4</sup> and so on up to the 2<sup>23</sup>. The powers grow by equal additions, that is 0:1:2; and you have what is called, with no particular aptitude in the name, an arithmetical progression. On the other hand you have a rapid rise in the value of each term in the series: it is 1:2:4:8:16:... till at the 24th term you reach 8,388,608. The values grow by equal multiplication and you have what is called, again with no particular aptitude in the name, a geometrical progression.

Now there are aspects of this particular geometrical progression that must have startled you before you examined it fully. One is that each term of the series exceeds all that have gone before by 1: 4 is 1 more than

1+2; 8 is one more than 1+2+4 and so on. If the "bank" put no limit upon the number of times you may double your stake in the event of loss, and if you had adequate funds to finance a run of losses as long as is not beyond expectation, you can always win. The first time your luck turns you recoup all losses and have one over. It's slow but sure.

Look at the progression the other way round and you have this: the last term is more by 1 than 1/2 of the last but one, +1/2 of the last but two, and so on. That is, 1 is always greater than 1/2+1/4+1/8+1/16 however far you go. Cut a loaf into halves; cut one half into quarters: the 1/2+1/4 leaves a deficiency of 1/4. Then 1/2+1/4+1/8 leaves a deficiency of 1/8. Ever the deficiency diminishes but it never disappears.

A second aspect of the geometrical progression is that you have an easy way of reaching the sum of all the terms in the series. There is no need for the tedious adding of 1/2d.+1/4d.+1/8d.+1/16d., and so on. You have only to estimate the value of the succeeding term (in our particular instance the 25th, which

would be 2<sup>24</sup>) and deduct 1 from it. For here is our series:

$$1 + 2 + 2^2 + 2^3 + \dots + 2^{23} = 2^{24} - 1$$

And here is our series multiplied all the way along by the common factor, 2 that is:

$$2 + 2^2 + 2^3 + \dots + 2^{23} + 2^{24} = 2^{24} - 2$$

The second is twice the sum of the first. But, as you see, the only value in the second that is not in the first is 2<sup>24</sup>. And the only value in the first that is not in the second is 1. If then you take the first from the second, you get 2<sup>24</sup>-1. Now 2<sup>24</sup> is the formidable number of 16,777,216, which even in farthings amounts to £17,476 5s. 4d. So, returning to the buyer the odd farthing, the alternative price is £17,476 5s. 3 1/2d.

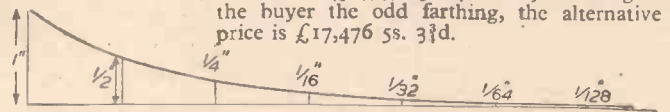

Diagram illustrating a peculiarity of geometrical progression.

You have most likely recognised this series as a particular instance of the general statement for the sum of any geometrical progression.

Thus:

$$S(\text{um}) = 1 + r + r^2 + \dots + r^{n-1} = \frac{1-r^n}{1-r}$$

[r being the common factor and n the number of terms in the progression]

The difference is (1-r<sup>n</sup>). For all the terms r<sup>1</sup> to r<sup>n-1</sup> are in both. S(1-r) is therefore 1-r<sup>n</sup>. Therefore S is  $\frac{1-r^n}{1-r}$  which is also  $\frac{r^n-1}{r-1}$



# Shellac in Modern Times

The Origin and Uses of this Age-old Material

By J. F. STIRLING

**S**HELLAC is a truly ubiquitous material, known the world over, and indispensable to the manufacturer, the engineer, scientific worker, the craftsman and the home hobbyist. A material which, in some at least of its properties, is, even in this era of synthetic resins, still unsurpassed for excellence, cheapness and durability, to say nothing of convenience of use.

Yet, in spite of the fact that shellac has been employed in the various arts for literally thousands of years, it is still one of the most "unscientific" materials handled in modern times. Apparently, chemical science, in its enthusiastic and usually triumphant unravellings of the inner mysteries of other natural products, has been content to side-track shellac, as it has many of the other natural resins. Being sticky, gummy masses, they are difficult stuffs to delve into and to investigate in the laboratory, particularly when you cannot create them yourself according to some preconceived plan, as they do in the synthetic resin industry. Nevertheless, research centres dealing with the chemistry of shellac have been set up in London, and also in India, the country of its origin, and there is little doubt that ultimately the shellac industry will place itself on as firm a scientific foundation as that on which its great and ever increasing competitor—the synthetic resin industry—has been reared.

Quite apart from its long and rather romantic history, which need not concern us here, shellac is a stuff which is worth looking into from a scientific point of view. In the first place, it is relatively cheap, and, although the annual production of the material, a matter of some 32,000 tons, is not enormous, there are no natural or commodity restrictions militating against its supply, as there seems to be nowadays in the case of so many other materials. Indeed, we have reliable authority for the statement that, if necessary, India could double its shellac production within about four years.

There is a decided advantage in utilising natural products. In the first place, they are the creations of natural agencies, which are usually unlimited. Again, they are usually of high quality, although, unlike synthetic products, the quality of the products tends annoyingly to vary from time to time and in very strange and unexpected ways; but, usually, if one can get Dame Nature to produce reliable materials she does the job extraordinarily well, although she apparently takes a keen delight in refusing to let you into the secret details of her operations.

## Insect Origin

In the case of shellac, Nature uses a minute insect for bringing this resin into being. Shellac is unique in being the only natural resin of insect origin. British India is its main centre of production, but smaller supplies come from Burma and Siam.

Lac, the natural resin which, in England, we know better under the brand name of "shellac," is the product of a small insect rejoicing in the scientific title of *coccus lacca*. It feeds on the banyan or religious tree of the Hindus and on several allied

(Right) A group of shellac fragments of the amber-coloured shellac of commerce, the best qualities of which are semi-transparent.



species of shrubs. The young insects are so tiny and they are produced in such myriads that, when they swarm up the trees the branches thereof appear to be covered with a red powder or dust. Many of the insects adhere to the feet of birds and so are carried from tree to tree, thus propagating the species.

Each insect is provided by Nature with an elongated beak terminating with a sharply-pointed lancet-like appendage with which it penetrates the young twigs of the growing tree and thereupon draws up a quantity of sap from the tree. If there are too many of the insects on any particular tree, the latter is exhausted of its sap. Hence it tends to wither. So that one of the problems of the shellac producer is to keep his insect producers within reasonable numerical limits, otherwise he loses them and, also, his trees.

After a time the lac insect begins to exude a sticky secretion through certain pores of its body. This is lac. The stuff is exuded in long, thin filaments which are coiled neatly and which quickly cover the entire body of the insect, effectively cementing it to the twig on which it has taken up its abode.

They are rather wonderful things these minute lac coils. They are approximately all of the same dimensions and contain the

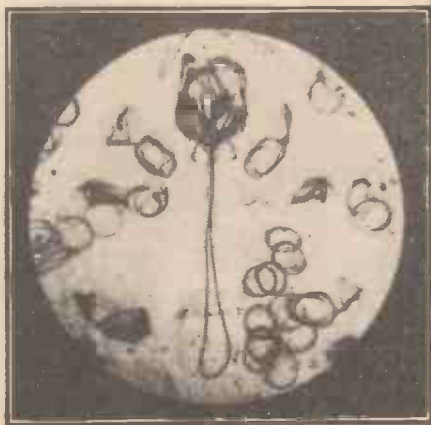

A lac insect exuding its characteristic filament of resin. (A photomicrograph x 100.)

same length of filament and an identical quantity of lac, which is, at this stage, a beautiful golden colour.

Then the insect, after growing a little, becomes inanimate. It becomes something akin to a minute cell or bag which is filled with a red dye, and in this condition it remains (under natural circumstances) until it lays its next season's eggs and afterwards dies.

The lac insects are sociable insects and they like living close together, so close together, in fact, that the entire twig on which they have fed and had their being

becomes encrusted with a mass of resin. Sometimes, during the gathering season, the twigs and branches of the trees are broken off, but more usually the lac incrustations are broken off by hammering with a wooden mallet.

Villagers often cultivate lac on trees in their own gardens and, under these circumstances, the gathering of the product offers no special difficulties. But when lac is cultivated in large areas its gathering is always a difficult matter and one which calls for some type of mechanisation to be applied to it.

## Processing the Lac

After gathering, the lac is taken to a central factory, in which the twigs are broken up into short lengths. The product is then known as *sticklac*. Much of it, in this condition, is hand-picked and graded. It is then ground up to coarse particle-size either by hand-mills or by machine-driven rollers. The product, after screening from dirt, is called *seed-lac*.

The seed-lac is subjected to a water treatment in large earthenware vessels, being covered by water therein and allowed to stand for 12 hours. It is then vigorously ground against the vessel sides by a native who stands *inside* the vessel and rubs the lac with his feet and, at the same time, against the sides of the vessel, using for this latter purpose a bamboo pole.

In this process a good deal of water-soluble dye comes away, and the residual lac, after removal from the vessel and being finally washed in clean water, is spread out on the floor to dry. It is then separated into large and small grains by some process of hand-screening (here again more mechanisation is necessary to increase the efficiency of the process), and the various grain sizes are afterwards blended to produce the required grades of shellac. It is at this stage, too, that much adulteration with inferior and darkly coloured lacs becomes possible.

## Shellac Appears

The blended seed-lac is put into long, closely woven cotton bags which are carefully run over a charcoal fire in a special firing-room, the fireplace resembling a Dutch oven. By means of a windlass arrangement the bag is slowly twisted so that the molten material is squeezed through the fabric on to the outer sides of the bag. It is then scraped off and spread over a porcelain cylinder about 2ft. 6in. long and 10in. diam., which is filled with warm water. Finally, it is removed from the cylinder by a skilled native, stretched to its utmost extent with his hands (and often with his feet!), so that the original mass of material





*Seed-lac.* A compressed mass of lac grains, previous to its refining into true shellac. This specimen is about 2ft. in length.

is extended to a thin sheet measuring about 5ft. by 4ft. This, after cooling, becomes hard and brittle. It is then broken up into small pieces, and the result is the *shell-lac*, with which we are all so familiar. The name, of course, alludes to the thinness of the individual fragments of resin, each appearing as if it constituted a piece of broken shell.

Such, in brief, is the main outline of shellac production as it is practised even at the present day. There is, of course, a lot of room for improvement in production details, and there is little doubt that these much-needed advancements will be forthcoming as time goes on and as Western ideas and methods creep slowly into the traditional East.

#### Chemical Mechanism

What the chemists and the scientific men are most interested in is the chemical mechanism, by means of which the almost microscopic lac insect sucks up the clear sap of the tree into its body and within a few days transforms it into the highly viscous and commercially utilisable resin which comes to us in the form of shellac. It is, however, a mechanism even the barest outlines of which are a closed book to us. We do not know how the lac insect effects this almost miraculous transformation any more than the insect knows itself. If we could imitate the process it is possible that we might do it better, although there may be many people who will cast doubt on that supposition.

The trouble is that we do not know much about the chemical composition of shellac (to call it by its better-known name). As far back as 1804 a London chemist named Charles Hatchett (an amateur, by the way) made a rough analysis of shellac, in which he showed that it contained about 90 per cent. of resin and 4 per cent. of wax, together with colouring matter and impurities. Hatchett's analysis remains pretty sound even to-day, and we know precious little more about the true nature of the resins and the wax than he did.

#### Laccaic Acid

The water-soluble dye, from which a wide range of brilliant colours can be obtained, seems to have been fairly well identified as *laccic acid*, or one of its salts, and the wax which accompanies the shellac appears to have a composition similar to that of beeswax, although it has a higher melting-point than the latter and is much harder.

However, the precise constitution of the shellac resin still eludes our understanding. Besides the water-soluble dye, which is washed out before the lac resin reaches the shellac stage, there is another dye in the material. This is an alkali-soluble dye which occurs in ordinary shellac to the extent

of from .1 to 1.5 per cent. It is to the presence of this dye that shellac owes its varying colours. You see this dye easily when you dissolve shellac in alkalis such as sodium carbonate solution, caustic soda, ammonia or even borax solutions, because the dye combines with the alkali with such readiness that the solution becomes purple-blue in shade.

The composition of this peculiar dye is unknown, and chemists and manufacturers have been more concerned about getting rid of it in order to produce a very light-coloured shellac. This is usually done by bleaching with chlorine gas, but this method of de-colourisation is not very satisfactory because the product is, in many ways, inferior to the unbleached shellac, particularly as regards its keeping qualities, its plasticity and its capacity for solution in alcohol. It is, indeed, a high price to pay for a lighter-coloured shellac. Nevertheless, the bleached material is much used, largely for incorporation in cellulose lacquers.

#### Solubility in Alcohol

The feature of ordinary shellac, which renders it of such universal use, is its ready solubility in alcohol; that is to say, in the various industrial and methylated spirits, thereby giving rise to the innumerable polishes and lacquers which are made from it. The exact quality of a shellac polish depends very much on the proportion of resin and wax which it contains, the smaller the amount of wax the more readily soluble the product.

Even in spirit solution, shellac will darken after a time, and the same applies when it is deposited in the form of a thin film on wood or metal. For most purposes, however, this



The neatly coiled filaments of lac resin as produced by lac insects. Although of microscopic dimensions, they coalesce readily, forming a large incrustation of lac around the insect and the twigs on which it lives. (Photomicrograph x 175.)

progressive darkening is quite immaterial, although the mechanism of its occurrence is not known.

There seem to be a large number of different compounds in the resin of shellac, but most of these appear to consist of esters or organic salts of an acidic substance to which the name dihydroxy-fiococerylic acid has been given. For the benefit of those interested readers, the supposed constitution of this important acid may be given in full. It is:  $\text{C}_7\text{H}_7\text{O}_7$ ,  $\text{CH}_2$ ,  $(\text{CH}_2\text{OH})$ ,  $(\text{CH}_2)_7$ ,  $\text{CH}_2\text{OH}$ ,  $\text{COOH}$

#### A Chemical Conjecture

Naturally combined with different alcohols, this acid gives the resinous mixture which forms the basis of lac, and which comes to us for a multitude of uses in the form of shellac. Such, at least, is modern chemical conjecture, which is based on sound reasoning. But nobody has ever synthesised dihydroxy-fiococerylic acid and from it built up a resinous mixture akin to natural shellac.

Shellac is particularly valuable as a varnish and a lacquer because it gives a smooth finish and takes a high polish. The film of shellac has a great power of adhesion to woodwork and metal in thin layers, and it is tough and hard. Moreover, it has good elasticity and excellent electrical resistance. A shellac film has a large degree of immunity to atmospheric changes, but although it can stand up against water it is not completely water-resistant, as it is generally supposed to be. A shellac film does not repel a layer of deposited moisture as do many other varnish films, and it is possible that a little of the water is absorbed—and retained—by the shellac, ultimately to its detriment.

Until now, shellac resin has been the great insulating stand-by of the electrical industries, the dielectric powers of shellac being very great. But increasing needs and continual demands for higher and higher dielectric powers have fostered research in the direction of resins of still greater insulating properties. Shellac, therefore, is being faced with growing competition in this particular direction.

As a constituent of gramophone records, a considerable proportion of the world's annual shellac supply enters our homes. Indeed, between them, the greatest bulk of shellac production is shared by the electrical and the gramophone industries, the arts, crafts, and the various paint, lacquer and decorative industries utilising only a smaller annual amount of the material.

#### Three Crops Annually

India gathers at least three separate crops of shellac each year—in the spring, summer and autumn; but of these the spring crop is the most important, constituting about 60 per cent. of the whole.

There is at Ranchi, in India, a very flourishing Indian Lac Research Institute, which was founded in 1925, and which has done much, not merely on the "theoretical" side of shellac, but particularly in endeavouring to bring into being up-to-date notions concerning its production, refining, grading and marketing.

America is, of course, the world's biggest consumer of shellac, and after that nation comes Britain and her Dominions.

It is strange that sustained attempts have not been made to culture the very valuable and hard-working shellac insect in districts other than India. That such measures would not meet with any economic success in view of India's established industry is not to be doubted at the present time. Nevertheless, just as the rubber industry thrived on transportation of the original rubber trees to more convenient climes, so also might the shellac industry prosper under a little change of environment, should such a measure be found possible.

Science up to the present time has hardly touched shellac. The material as it comes to us is still very much a commodity of the olden times, a product hoary with the antiquity of a few thousand years. Excellent as it is in many of its properties, able as it is to withstand the fierce competition, economic and technical, of the synthetic resins, it still leaves scope for scientific and technical development. And, when shellac's chemical composition is worked out with a little more precision and certainty, that development will assuredly come.



# Direct-current Motors—2

Their Characteristics and Performance

By J. L. WATTS

(Continued from page 96, January issue.)

WHEN the motor has reached a steady speed on the first starter stud against full load torque it will then be developing a back e.m.f. which is equal to one-third of the supply voltage. This follows because the current has now fallen to two-thirds of the original value without change of armature circuit resistance.  $I_a'' = \frac{V - e'}{R_x} = \frac{2}{3} \frac{V}{R_x}$

Thus  $e'$  is equal to  $\frac{V}{3}$ . The speed reached on the first stud under these conditions will be almost equal to one-third of the full speed. As soon as the motor has reached a steady speed, however, the starter should be moved to the next stud to cut the first section  $R_1$  of the resistance out of the armature circuit. The armature current will immediately rise to the value  $I_a''' = \frac{V - e'}{R_x - R_1}$ .  $R_1$  is chosen so that  $\frac{V - e'}{R_x - R_1}$  is equal to  $\frac{1.5(V - e')}{R_x}$ ; thus the armature current  $I_a'''$  immediately rises to the value  $1.5 I_a$  again, and the motor torque rises to 1.5 times the full load value. This causes further acceleration with falling current and torque until the motor speed again becomes steady at a higher value. The next section of resistance  $R_2$  is then cut out, and so on until the whole of the starter resistance  $R_1$  is cut out and the motor has accelerated to its full speed. The armature current will then be equal to  $\frac{V - e''}{R_a}$ , where  $e''$  is the back e.m.f. at full speed.

**Protective Devices**  
The back e.m.f. is proportional to the product of speed and magnetic field strength  $\phi$ . In a large motor the full load back e.m.f. is practically equal to the applied voltage  $V$ , as the armature resistance  $R_a$  is comparatively low. In Fig. 6 the moving contact arm is shown at A and the starting resistance at B. When the arm A makes contact with the first stud the armature is fed through B, whilst the shunt field coils are fed through the under voltage release coil C. As the starter arm is moved over the studs to accelerate the motor, part of the starting resistance is connected in the field circuit. This has little effect on the field current, however, because the starting resistance has a low value relative to the field coil resistance. When the arm A is fully over and the resistance B is cut out of the armature circuit, it is also cut out of the field circuit by the arm also making contact with the auxiliary stud D. In some starters the same effect is obtained by having a segmental field contact, or by contact between the arm A and the under voltage release magnet in the full-on position.

Should the supply fail, the coil C is de-energised and its magnetism fails; a spring then returns the arm A to the off position to prevent the motor restarting when the supply is resumed. The overload coil E carries the motor current. In the event of mechanical overload or electrical fault the current and magnetic effect of this coil increases. If the current exceeds a set value the armature G is attracted, closing the contacts F to short-circuit and de-energise C so that the starter returns to the off position.

**Determination of Starting Resistances**  
Fig. 7 shows a simple graphical method which may be employed to determine the values of the resistance steps necessary in the starter of a shunt motor to keep the

armature current within desired limits at starting. It is first necessary to calculate the total armature circuit resistance  $R_x$  required to limit the starting current to the required value, as mentioned above. The line OP is then drawn to scale to represent  $R_x$ . At the point P a vertical line PD is drawn to scale to represent the maximum armature current, DC being drawn parallel to OP. The line AB represents the minimum armature current, which will obviously depend on the load torque against which the motor has to start. OF is measured off proportional to the armature resistance  $R_a$  and a vertical drawn from F to cut AB at G. Through G a line is drawn from O to cut

at opposite polarity to the next field poles. Fig. 8 shows the connections of a double-pole two-way switch used for reversing the current in the shunt field coils S.F. The armature is shown at A and the interpole coils at I.P. For simplicity the protective coils have been omitted from the diagram of the starter.

A motor should not be reversed whilst running at speed, unless the machine is specially designed for such arduous duty. First, the momentum of the motor and its coupled load will cause the motor to continue to rotate, with falling speed, in the former direction of rotation for a short time after the reversing switch has been thrown over, before it comes to rest and then accelerates in the opposite direction. During this brief interval the field magnetism is reversed, which automatically reverses the back e.m.f. Thus the effective voltage which acts on the armature whilst slowing down is  $V + e$ , not  $V - e$ . The increased voltage across each armature coil introduces a risk of flash over at the commutator or breakdown of the insulation.

Secondly, the armature current may rise to a very high value as, during this interval,  $I_a$  will be equal to  $\frac{V + e}{R_a}$ . This will increase the rate of heating of the armature conductors and will cause them to exert a very high reversing torque by reaction between the armature currents and the magnetic field. This high armature torque acts in opposition to the torque created by the momentum of the armature and its coupled load, which places a considerable strain on the armature shaft.

Thirdly, the effect of reversing the connections to the field coils whilst carrying current is to reverse the magnetic flux which is created by and linked with the coil. Now when a considerable flux linked with a coil is changed there is a voltage induced in the coil, the value of which is proportional to the number of coil turns and the rate of change of flux. Thus if the field current is rapidly reversed a very high voltage may be induced in the coils which may break down the insulation, and will cause severe sparking which will damage the contacts of the reversing switch. Thus the reversing switch should be operated when the motor is at rest, and after the motor has been switched off to de-energise the field windings. Otherwise the motor must be of very robust construction and must have a discharge resistance or other path through which the induced energy of

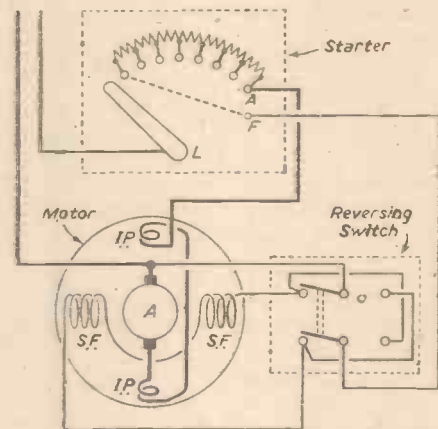

Fig. 8.—Connections of reversing switch for a shunt motor.

DC at H; a vertical dropped from H to cut OP gives the point K, such that KF is proportional to the last section of starter resistance  $R_n$ . From O a line drawn through L to M and a vertical from M gives the next resistance step  $R_{n-1}$  proportional to KN, and so on, completion of the figure giving the first resistance step  $R_1$ .

**Interpoles**  
Many motors, other than those of fractional horsepower sizes, are provided with interpoles, which are narrow poles fitted midway between the main field poles and wound with a few turns of comparatively thick wire which are connected in series with the armature. The purpose of the interpoles is to assist commutation and minimise sparking at the brushes, by counteracting the e.m.f.s of self and mutual induction in the armature coils as they are short-circuited by their commutator segments passing under the brushes. The magnetic polarity of an interpole on a motor should be opposite to that of the next main field pole forward in the direction of rotation. Interpoles enable the brushes of a motor to be kept in the neutral position, and are thus practically essential on a large reversing motor.

**Reversing the Shunt Motor**  
A shunt motor can be reversed by reversing either the field current or the armature current. Since the field current is comparatively low compared with the armature current it is more usual to reverse the field current. If the armature current is reversed instead it should be remembered that the polarity of the interpoles should also be reversed, i.e. the armature and the interpoles should be treated as one unit. This is necessary in order to maintain the interpoles

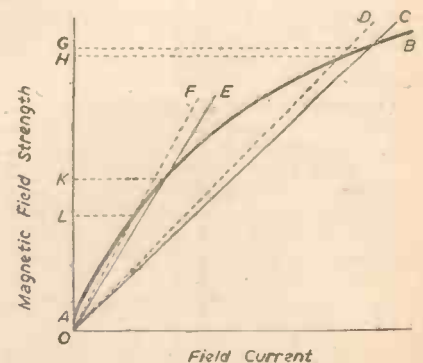

Fig. 9.—Magnetisation curve of a D.C. motor.



the field system can be dissipated when the field is reversed. In addition, a resistance is advisable in the armature circuit during reversal in order to limit the armature current.

There is another method which can be applied to reverse a shunt motor if the leads to the brushes are fairly long and flexible. This is by moving the whole set of brushes round through one complete pole pitch, which is equivalent to reversing the connections to fixed brushes. If this method is adopted with an interpole motor the connections to the interpoles should also be reversed; this being the only occasion when the connections between an armature and the interpoles should be disturbed for reversal.

**Speed Control by Armature Resistance**

As in the case of other D.C. motors, the speed of a shunt motor is proportional to  $\frac{e}{\phi}$  where  $e$  is the back e.m.f. generated in the armature and  $\phi$  is the field flux. In a large motor " $e$ " is practically equal to the voltage  $V$  applied to the armature. Thus the speed of a shunt motor may be changed by varying either the field current or the armature voltage.

Usually it is only practicable to reduce the speed by reduction of armature voltage, and not to increase the armature voltage, a simple method being to connect a series resistance in the armature circuit. If  $R_c$  is the value of the control resistance in ohms, the voltage applied to the armature will then be reduced from  $V$  to  $V - I_a R_c$ . Due to the fact that the armature current  $I_a$  varies with the load on the motor the product  $I_a R_c$ , which is the volt drop across the control resistance, will vary with the motor load. One of the disadvantages of this system of speed control is that it results in considerable variation of speed on a varying load, as indicated by the curve D in Fig. 5. In order to maintain a steady speed on a varying load the control resistance must be adjusted for each change of load.

Furthermore the method is uneconomical on account of the considerable losses of power ( $I_a^2 R_c$  watts) which must be dissipated as heat at the control resistance on reduced speed. On half-speed the electrical power which is thus wasted is practically equal to the power which is usefully employed in mechanical work. The method, however, is convenient for small motors; or for larger motors where a small reduction of speed only is required, or speed reduction is required for brief periods only.

Since the torque of a motor is proportional to  $I_a \phi$ , and the maximum current which the armature can carry without overheating depends very largely on the size of wire with which it is wound and is thus almost constant, the safe full load torque obtainable with a constant flux  $\phi$  and series armature resistance control is practically constant. This means that the safe full load horsepower, which is proportional to the product of torque and speed, is practically proportional to the speed. If a considerable reduction of speed is obtained, however, the ventilation of the motor may be adversely affected, so that the safe full load armature current and torque may have to be reduced somewhat. In this case the safe full load horsepower will be reduced to a greater degree than the speed.

**Speed Control by Field Regulation**

The speed of a shunt motor can be increased by connecting a resistance in the shunt field circuit to reduce the field current  $I_f$  and the field flux  $\phi$ . The amount of speed increase obtainable is limited by the centrifugal stresses set up in the armature, which are proportional to (speed)<sup>3</sup>, and by sparking which may occur at the commutator with a very weak field. This method of speed control is economical: the losses in the field control resistance are equal to  $I_f^2 R_d$ , where  $R_d$  is the

value of control resistance.  $I_f$  is comparatively small, however. The motor torque is proportional to  $I_a \phi$  and the speed to  $\frac{e}{\phi}$ ; thus

when  $\phi$  is reduced the speed is increased but the torque is reduced in inverse ratio. The safe full load horsepower obtainable with field control is thus practically constant, subject to a possible slight increase at high speed due to improved ventilation. A motor should always be started up with maximum field strength, otherwise the back e.m.f. during starting will be low and the consequent high value of armature current may melt the protective fuses. The curve C in Fig. 5 illustrates the effect of field control resistance.

The field flux  $\phi$  of a motor is not directly proportional to the value of the field current  $I_f$ , as shown by the curve AB in Fig. 9. Due to magnetic saturation of the field

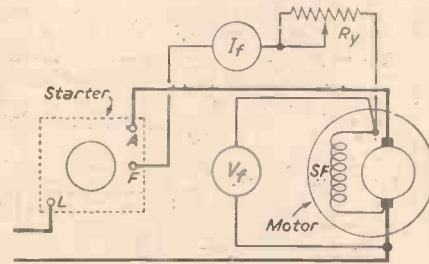

Fig. 10.—Determination of value of shunt field control resistance.

magnets the field flux  $\phi$  tends towards a certain limiting value. Thus it is not possible to calculate directly the value of field current required to provide a given speed-change.

We know that the speed  $N$  is equal to  $\frac{e}{\phi}$  and that  $e = V - I_a R_a$ . Thus  $\phi = \frac{V - I_a R_a}{N}$

from which the value of  $\phi$  required can be calculated if  $I_a$  and  $R_a$  are known. The value of field current  $I_f$  could then be found if the magnetisation curve of the motor were available. Since  $I_f = \frac{V}{R_f + R_d}$  where  $R_f$  is the resistance of the field windings,  $R_d$ , the value of field control resistance required, will be equal to  $\frac{V}{I_f} - R_f$  ohms. Usually, however, the simplest way of finding  $R_d$  is to use a temporary resistance  $R_y$ , as in Fig. 10, varying its value until the required speed is obtained. If the voltage  $V_f$  and the field current  $I_f$  are then measured,  $R_y$ , which is equal to  $R_d$ , will be  $\frac{V - V_f}{I_f}$ .

Fig 9 shows that the speed of a shunt motor may be rather unstable if the field is operated well below saturation point, as with field flux of value OK. The line OE represents the field current at a given voltage. If the voltage falls by 5 per cent. the field current will be represented by the line OF, and the field flux will fall to the value OL, with considerable reduction of torque, which causes an immediate increase of armature current and considerable rise of speed. This may be compared with the much reduced change of  $\phi$  due to 5 per cent. change of voltage at the values OG and OH.

**Effect of Changed Voltage**

If the voltage applied to a shunt motor as a whole is reduced the field current  $I_f$  will be reduced in a similar ratio; but the field magnetic flux will be reduced to a less degree, depending on the degree of magnetic saturation of the field magnets. This will tend to increase the speed, but to a less degree than the voltage change. The reduced voltage applied to the armature also will have the opposite effect, however, so that the speed of

the motor will actually fall somewhat, but not quite to the same extent as the voltage. The safe full load current will be practically unchanged, the safe full load torque will be reduced practically in proportion to the flux  $\phi$ , the speed reduced, and the safe full load horsepower reduced in proportion to the applied voltage  $V$ .

If the voltage applied to a shunt motor is increased the increased armature voltage will tend to raise the speed almost in the same ratio as the voltage. The field current will increase in a similar ratio, but the field flux will increase to a less degree, depending on the point on the magnetisation curve at which the motor was designed to run. The safe full load armature current will be practically unchanged, the full load torque increased in proportion to  $\phi$ , the speed increased, and the full load horsepower increased in proportion to the voltage.

However, little or no increase of field current  $I_f$  is advisable, otherwise the shunt field coils may become overheated and burn out. It is therefore advisable to connect a resistance in the shunt field circuit in order to limit  $I_f$  to its normal value if the voltage is increased. In this case the safe full load torque will be unchanged, whilst the speed and full load horsepower will be increased practically in proportion to the voltage.

The shunt field coils of a motor are usually connected in series with each other. Thus the motor could be used on half normal voltage by reconnecting the field coils into two parallel sets; each field coil would then carry its normal current and  $\phi$  would be unchanged. The safe full load armature current would then be practically unchanged, the full load torque unchanged, whilst the speed and full load horsepower would be practically proportional to the voltage.

**Modification of Shunt Motor for Different Voltages**

In order to rewind a motor for a different voltage two points should be kept in mind. For maximum efficiency the designed value of field flux  $\phi$  should be retained if possible. In order to achieve this the ampere turns on each field coil should be unchanged, i.e., by changing the turns in proportion to the voltage and the field current in inverse proportion to the voltage. This means that the coil resistance should be proportional to (voltage)<sup>2</sup>. This can be practically obtained by rewinding each field coil with turns proportional to the voltage; using wire having a cross-sectional area which is inversely proportional to the voltage, i.e., diameter of wire inversely proportional to the square root of the voltage. The motor speed is proportional to the back e.m.f. per turn of armature winding, and inversely proportional to  $\phi$ . Thus if  $\phi$  is unchanged, and the same speed is required on a different voltage, the e.m.f. per turn should be unchanged. In other words, the number of armature turns should be changed in proportion to the back e.m.f., i.e., practically in proportion to the applied voltage  $V$ . The size of wire will then need to be altered as in the case of the field coils.

(To be continued)

**Refresher Course in Mathematics**  
 By F. J. CAMM  
 8/6, by post 9/-  
**Gears & Gear Cutting**  
 6/-, by post 6/6  
 From GEORGE NEWNES, LTD.,  
 Tower House, Southampton St., Strand, W.C.2



16th Article of a New Series

# MODEL ENGINEERING PRACTICE

by J. J. Camm

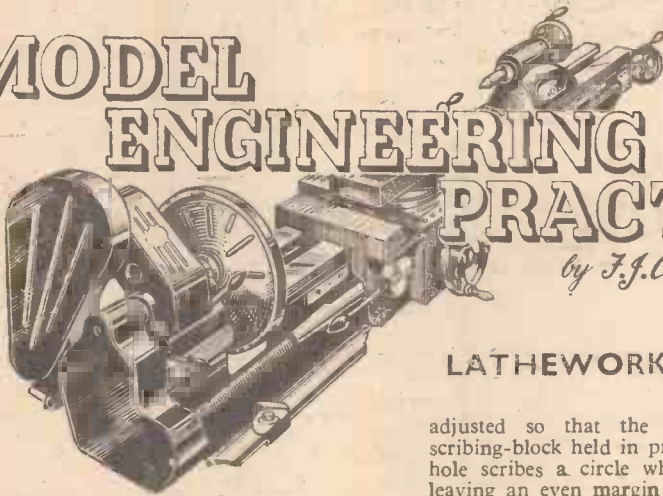

### Using the Face-plate

**B**EGINNERS in lathe work tend to ignore the varied uses of the face-plate, and often laboriously perform by hand, work which could be more conveniently and accurately effected by clamping it either to the face-plate or to an angle-plate attached to the face-plate. In this article, therefore, are shown a number of face-plate operations representative of the many uses of this useful piece of lathe equipment. The face-plate has a number of narrow slots of varying lengths cast in it, and the angle-plate base also has holes cast in it. It is thus possible to clamp the angle-plate to the face-plate in any desired position to accommodate castings or pieces of work having irregular contours. The face-plate is not only useful for certain boring operations, but also for certain facing operations—that is to say, the turning of flat surfaces, as distinct from truly cylindrical surfaces. It is a fact that there are many other irregular forms which can be turned in a lathe by means of simple settings.

### Setting Up

The important part of lathe work is always the setting-up process, and it is necessary,



Fig. 40.—Method of setting tail stock for taper turning.

having marked out the casting, to use various bench tools in conjunction with the surface of the lathe saddle or bed, or the surface of the face-plate itself, to ensure that the machining operation will not cut into metal that it is not desired to remove. The lathe-bed is parallel to the lathe-spindle, and the face-plate is at right angles to it. The steel square and the scribing-block can hence be used to good advantage in checking the position of the casting and the result of a preliminary cut. If a test after the first cut reveals that the first setting was faulty, or that the casting has moved, there is time to reset before taking the finishing cut.

A good example of face-plate work occurs in the case of a square block or a split crank-case casting, in which case the two halves would first be faced, then fastened together, and finally the mouth bored to receive the cylinder spigot. In the case of a casting of this nature which already has a rough cored hole, the position of the casting should be

### LATHEWORK (Continued)

adjusted so that the scribing-point of a scribing-block held in proximity to the cored hole scribes a circle which fairly covers it, leaving an even margin for boring. If it is necessary to chamfer the corners this may also be done by suitably setting the slide-rest and cutting tool. The illustrations in this article show other face-plate applications. One example, that of a right-angle elbow or pipe coupling, shown in Fig. 45, is a good example, for unless this is carefully mounted

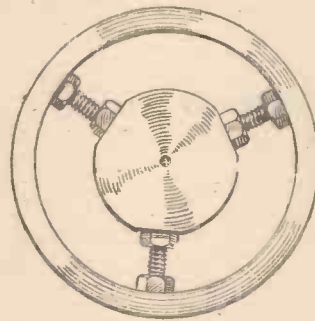

Fig. 37.—Method of mounting thin tubes between centres.

it is possible that the facing operation on the second surface will turn away the entire flange before it can be brought into right angles with the first. It is possible, also,

to undertake drilling with work mounted in this way. The drill should be mounted in the tailstock, the hole centres, of course, first being centre-punched in the casting and the position of the latter adjusted accordingly.

### Alternative Methods

Some readers may not possess face-plates, and whilst it is always advisable to purchase this useful accessory (an angle-plate is not an absolute necessity in every case) it is possible sometimes to adopt alternative methods. Two examples are shown in Figs. 46 and 47.

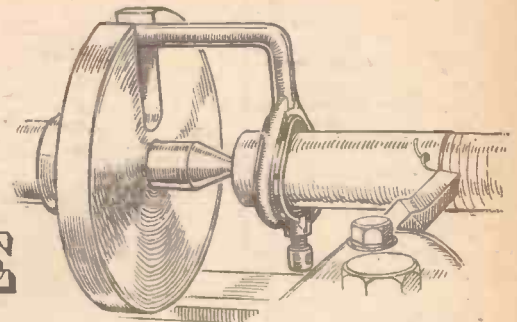

Fig. 39.—(Left) The catch-pin and bent-tail carrier.

### Second Operations

A lot of machining time can be saved by tackling a job the right way round. Even a plain-shouldered bush is produced quicker by having sufficient material standing out of the chuck completely to machine and part off, than by having a casting equal in length to the required bush, boring the hole, afterwards finishing the outside on a mandrel, between the centres.

### Holding Work on Pegs

A common form of holder for second operations is by means of a turned peg or plug. This can be employed for holding work having a cleanly machined hole of reasonable size in it, and about which the remaining portion of the turning must be true. A piece of round bar material, either

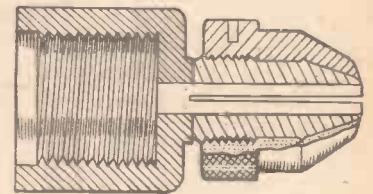

Fig. 38.—A split chuck adaptor for the lathe.

steel or brass, is firmly gripped in the chuck, leaving sufficient projection on which a plug is turned to suit the hole in the job. The diameter at the back must be made slightly larger than at the nose. All turning marks must be removed with a fine file and the surface of the pin polished.

Too much taper will cause the work to wobble, and when on the plug it must, in order to be properly driven without the likelihood of slipping under cut, be clear of the shoulder formed by the turning. Particular care should be taken when fitting to a peg a job having a blind hole in it, and a small flat must be filed along the peg to allow the air to escape from the hole. Holes that are too shallow to provide sufficient drive, such as a ball-race housing, may be held on to the peg with a nut and washer screwed over a stud turned on, or tapped into, the end of the peg.

### Use for a Pipe Centre

It is frequently necessary to bolt work on to the face-plate to do some further

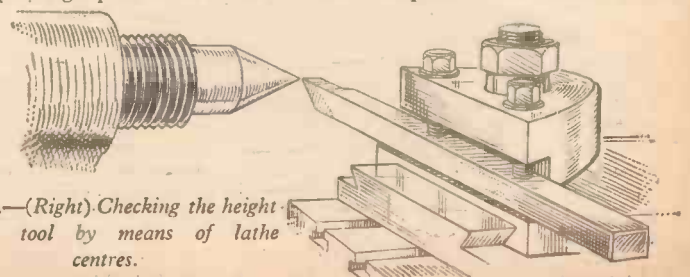

Fig. 41.—(Right) Checking the height of the tool by means of lathe centres.

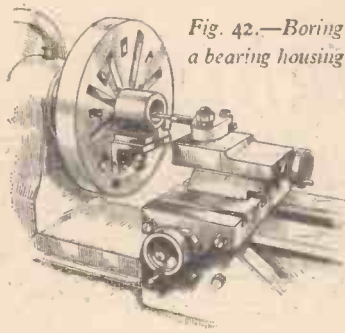

Fig. 42.—Boring a bearing housing

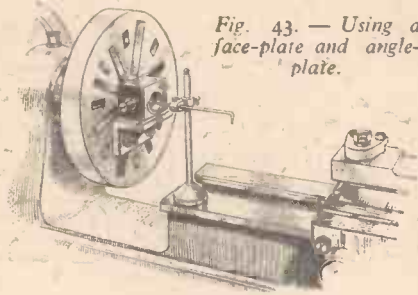

Fig. 43.—Using a face-plate and angle-plate.

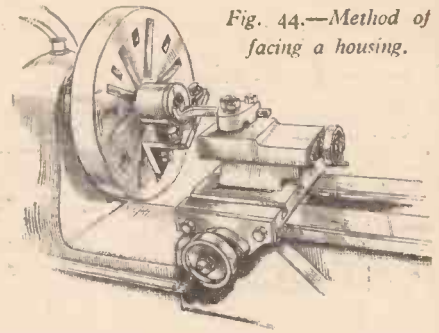

Fig. 44.—Method of facing a housing.

machining true with an existing machined hole. A lot can be done to place the work in such a position that it will, when bolted up, run almost true by using a pipe centre held in the tailstock and engaging with the edge of the hole, to hold the job on the face-plate while being bolted or clamped on to it. A pipe centre is of large diameter and is turned to an angle of 90 deg. inclusive.

**Mandrels**

As distinct from the pegs described, mandrels are used for holding second operation work between the centres. That shown in Fig. 48 is a solid mandrel. These are obtainable 1/4 in. diameter and upwards in standard sizes. The centres are in recesses

of the sleeve, allowing the sleeve to expand when pushed on to the mandrel. In use, the sleeve nearest in diameter to the hole in the job is selected, and the sleeve expanded until the work pushes on.

Another type of expanding mandrel is that shown in Fig. 50. This is made in a range of sizes, one being specially made to suit the needs of small shops. The body of the mandrel is screwed for most of its length. Three slots are cut from end to end, these being spaced at 120 deg. apart; the slots are parallel in their width, but the bottoms taper in relation to the axis. Into these slots strips are fitted, the tops of which are machined concentric with the centres. Projections on the ends of the strips fit into a recess in the screwed collar which pulls them

mandrel, which is screwed for the greater part of its length. A tapped hole in the other cone fits this thread closely, and flats (or a hexagon for a spanner) form the means of adjustment. It may be as well to mention that before being mounted on a mandrel of this description the ends of the tube should be faced.

**Mandrels to Fit Into Head**

Useful items that can be made as an addition to the equipment of the lathe are the mandrels shown in Figs. 51 and 52. They are made with a taper shank to fit into the nose of the lathe. The second one is split and is expanded by means of a taper-headed screw. Where the lathe has a hollow spindle and the design of the thrust arrangement will permit, the taper plug may be attached to a draw-bar passing through the spindle.

After turning the shank to suit the nose of the lathe, the remainder of the turning is done in position; the angle of the taper for expansion purposes should not be too steep. These mandrels can be made in a range of useful sizes, or one of, say, 3/8 in. diameter, made with split sleeves to take the larger sizes.

The one shown in Fig. 51 is for turning discs and wheels. A stud is turned on the front of the shank, having a plain portion slightly larger than the thread.

(To be continued)

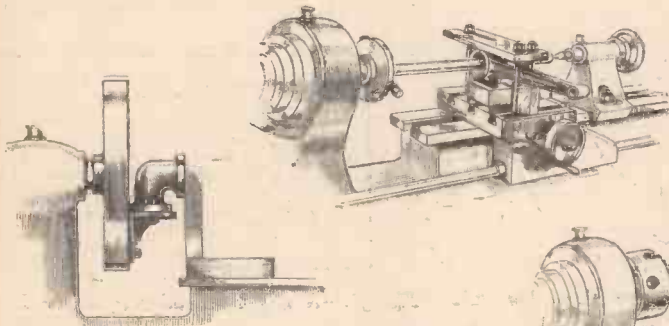

Fig. 45.—Testing a pipe elbow after mounting.

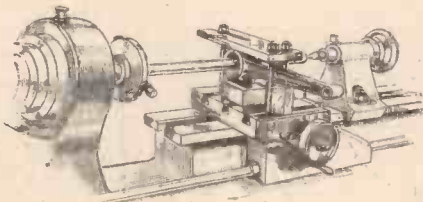

Fig. 46.—(Left) One method of boring a connecting rod.

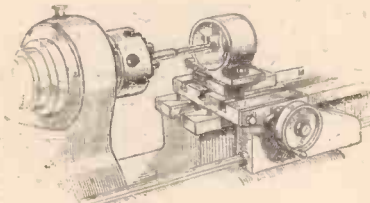

Fig. 47.—(Right) Boring with the work mounted on the rest.

so as to protect them from damage, and the mandrels are hardened and ground. The ground portion is slightly tapered, the largest end being usually that on which the size is marked.

A type of adjustable mandrel is seen in Fig. 49: the body of the mandrel is fairly steeply tapered. On to this fit a series of sleeves. These are bored out taper to suit the mandrel, and a row of equally spaced holes is drilled close to each end, the holes one end being staggered to come between those on the opposite end. Cuts are made with a saw into each hole from the far end

along the mandrel. The screwed portion is turned away on the front to permit small-diameter work to be held.

**Tube Mandrels**

Very thin tube is best held on a solid type of mandrel. A positive drive without fear of distortion can be obtained by warming the mandrel and lightly coating with beeswax. The tube is also warmed before it is put in position. An adjustable cone mandrel for heavier tube is shown in Fig. 53. The work is held between the faces of two cones; one cone is made integral with the body of the

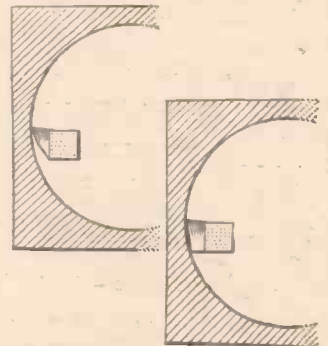

Fig. 54.—When using a boring bar see that the tool does not "double contact" with the bore. Grind a clearance, if necessary.

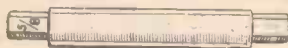

Fig. 48.—A solid mandrel.

Fig. 49.—An adjustable mandrel.



Fig. 50.—An expanding mandrel.

Fig. 51.—A mandrel for turning discs and wheels.



Fig. 52.—A split mandrel expanded by means of a taper screw.

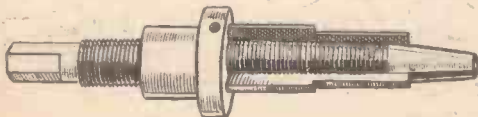
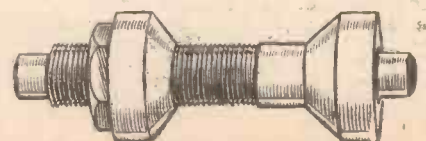

Fig. 53.—An adjustable mandrel for tubes.





# Decorative Electric Lighting

## How to Arrange Simple Circuits for Low-voltage Bulbs

By "HANDYMAN"

SMALL coloured bulbs may be bought to connect in series as shown in Fig. 1. These bulbs are frequently of the 25 volt type, and ten wired in series can be used with 200 to 250 volt mains, either A.C. or D.C. All the bulbs should consume approximately the same current, and the voltage of them, when added together, should at least equal the supply voltage. If this is remembered other types of bulbs may be employed.

With such a circuit, the failure of any one bulb will put the whole string of lights out. Individual requirements may differ, but about 2ft. of flex should be left between each bulb. The addition of a few extra bulbs will not much reduce brilliance, and will prolong the life of the bulbs.

### Large Bulb Circuit

When bulbs are wired in series there is no necessity that they should all be of the same voltage, and this fact enables torch bulbs to be used, as illustrated in Fig. 2. All the torch bulbs should consume approximately the same current (this can be assured by buying them all of the same type and size). If 3.5 volt bulbs are used, the consumption will normally be about .3 amp. The number of bulbs employed depends wholly on personal preference. (Ten or a dozen is a useful number.) The large lamp is then selected to be of such a wattage that about .3 amp passes. The easiest way to find a lamp suitable for the bulbs used is to try those which are to hand, or can be borrowed from lights in the house, beginning with one of small wattage. If the torch bulbs do not light with sufficient brilliance, substitute a lamp of higher wattage. For .3 amp bulbs, a 60-watt lamp will be

giving a fairly high current output can be used, the voltage of the torch bulbs being selected to suit the transformer secondary. The total current consumption of the bulbs can be found by adding together their consumption.

The primary should be suitable for the mains used, and it must not be overlooked that transformers cannot be used on D.C. mains. Fig. 3 also shows an easy way of fitting a switch, and this can be followed

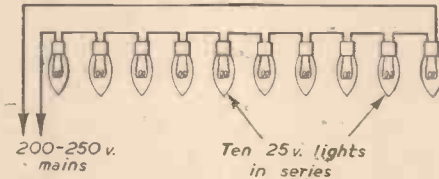

Fig. 1.—Arrangement of "fairy light" chains for A.C. or D.C.

with the other circuits, if required. If the mains supply point has a switch, this extra switch is not required.

With a 4- or 6-volt transformer, 6.3 volt

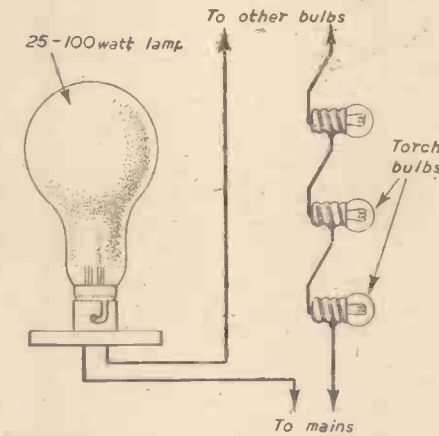

Fig. 2.—Series circuit employing a large bulb.

bulbs can be used. A transformer may be to hand. If so, two or more bulbs may be connected in series, if necessary, in order to make up a chain suitable for the secondary voltage.

In the circuit shown at "A" in Fig. 4, the 3.5 volt bulbs are wired in pairs, and may be operated from a 6-volt transformer. With a 12-volt transformer, 6.3 volt bulbs could be used. Alternatively, the 3.5 volt bulbs could be wired as shown at "B." Should the transformer deliver 25 volts,

"fairy lights" in parallel could be used, or 6.3 volt bulbs in fours, as at "B."

These circuits are also particularly useful for accumulator operation, if no mains are available, when a car accumulator can be brought into service. The current consumption will be very low.

If a transformer is to be bought especially for this purpose, a "heater transformer" giving 6.3 volts output will be easy to obtain, and can be used with 6.3 volt bulbs. If, however, it is particularly desired to use the fairy lights, a transformer with a higher voltage output will be necessary. Transformers with many different outputs can readily be obtained.

### Wiring Details

With the circuits in Figs. 1 and 2 proper care should be taken so that no bare contacts, connections or leads are left, because the mains are connected directly to the lamps. Proper bulb holders should be employed, with good-quality flex, and a proper plug used to take the supply voltage from the mains.

With the low-voltage circuits, no chance of shock exists (unless the transformer is faulty) and it is quite feasible to solder the bulbs directly to the flex. Twin flex can be used, both leads being bared at suitable intervals.

When bulbs are wired in parallel, the remaining bulbs will not be affected if one burns out. With bulbs in series, the

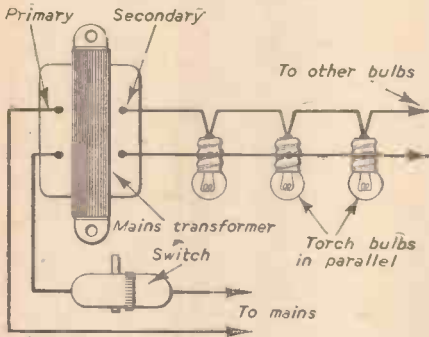

Fig. 3.—A low-voltage circuit using a transformer.

required; but other bulbs are equally suitable, if the lamp is selected as described.

The large lamp can frequently be put to good use—it might be placed at the foot of the tree in a coloured shade, hung in a large coloured lantern, or so on. Due to the voltage drop in the torch bulbs, it will not light at full brilliance.

### Low-voltage Circuits

These have much to recommend them, and are particularly necessary if any kind of automatic switching is employed, or where absolute safety is essential. The circuit is shown in Fig. 3.

Almost any mains transformer capable of

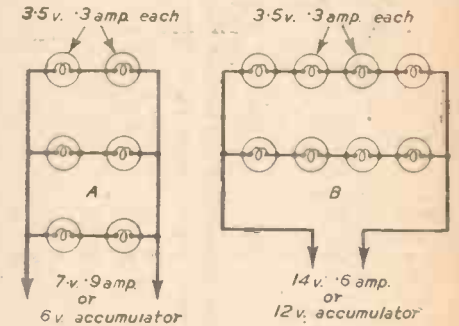

Fig. 4.—Series-parallel circuits.

use of screw holders will greatly facilitate replacing defective bulbs.

Finally, operation from dry batteries is only feasible on a limited scale. As economical running is essential from such batteries, .06 amp dial-light bulbs are most suitable, and eight or ten of these, wired as shown in Fig. 4 ("A"), will not provide an excessive load for a fairly large dry battery.

## NOW READY!

The Entirely New 12th Edition of the Famous Standard Work

## THE PRACTICAL WIRELESS ENCYCLOPEDIA

By F. J. CAMM

Considerably enlarged, amplified and entirely re-written and re-illustrated. Complete Television Section, with theoretical and constructional data.

All the facts, figures, and constructional data of Radio and Television—Definitions, Terms, Units—Principles, Circuits, etc. Over 300,000 copies sold!

Price 21/- or 21/10 by post from:

GEORGE NEWNES LTD., Tower House, Southampton Street, Strand, W.C.2



**Velocity of Escape**

SIR,—May I give an explanation of the problem raised by "Planetas" (Northampton) concerning the velocity of escape, and acceleration due to gravity at the planetary surfaces?

The velocity of escape is the minimum velocity which must be given to a projectile at the surface of the planet, such that the projectile will just escape from the gravitational attraction of the planet. Alternatively, it may be thought of as the velocity which a body would have on arriving at the planetary surface after having fallen from an infinite distance. According to Newton, the force acting on a mass *m*, distant *x* from a planet of radius *R* and mass *M* is:

$$F = GMm/x^2 \text{ where } G \text{ is the constant of gravitation.}$$

The equation of motion is then:

$$m \frac{d^2x}{dt^2} = -GMm/x^2$$

and since  $\frac{d^2x}{dt^2} = \frac{dv}{dt} = v \frac{dv}{dx}$  then:

$$\int v dv = -GM \int \frac{1}{x^2} dx$$

(*v* being the instantaneous velocity of the body)

$$\text{or } \frac{1}{2}v^2 = GM/x$$

the constant of integration being zero, since  $v=0$  when  $x=\infty$ .

At the planet's surface,  $x=R$ ; thus the escape velocity, *V*, is given by:

$$V = \sqrt{\frac{2GM}{R}} \dots \dots \dots (1)$$

Consider now a mass *m* near the planet's surface. It will, under free fall, have an acceleration *g*.

$$\therefore g = MG/R^2$$

and substituting this into (1), we have:

$$V = \sqrt{(2Rg)}$$

Thus it can be seen that the escape velocity depends on both the acceleration due to gravity at the surface and the radius of the planet.

By substituting for *M* in (1) in terms of the radius of the planet and its mean density  $\rho$ , we obtain

$$V = R \sqrt{\frac{8G\pi\rho}{3}}$$

If, then, all planets had the same density (which, incidentally, is not even approximately true), *V* would be directly proportional to the radius. When values of *M* and *R* are substituted into these equations, it is found that the figure quoted for the escape velocity of Mars should not be 1.5 mls./sec., but 3.13 mls./sec. Other values of *V* and *g* for the planets and the Moon I give below.

Planet	Velocity of escape (mils/sec)	Acceleration due to gravity (feet/sec <sup>2</sup> )
Mercury	2.26	9.0
Venus	6.39	28.5
Earth	6.95	32.2
Moon	1.45	5.1
Mars	3.13	12.3
Jupiter	37.6	87.2
Saturn	22.5	37.5
Uranus	13.5	31.1
Neptune	14.1	31.9
Pluto	3.3	16

I hope that your reader will find in this the answer to his problem.—D. SHREWSBURY (Stockport).

**FROM READERS**

SIR,—Your reader "Planetas" asks whether or not the velocity of escape of a plane is directly proportional to the value of *g*. It is not. The formula is

$$V.E = \sqrt{2gR}$$

where *R* is the radius of the planet.

There can be no doubt about this relation, nor any possibility of a "new approach." It is obtained by a simple integration. Details can be obtained from many physics text-books, or from A. C. Clarke's "Interplanetary Flight."—R. J. SCAMMELL, B.Sc. (Fellow of British Interplanetary Society).

**Astro-photographic Telescopes**

SIR,—I read with interest the article on astro-photographic reflector telescopes (P.M., Sept-Oct. issue), by E. W. Twining. As an amateur astronomer and telescope builder may I attempt to correct the impression given in the preamble of Mr. Twining's

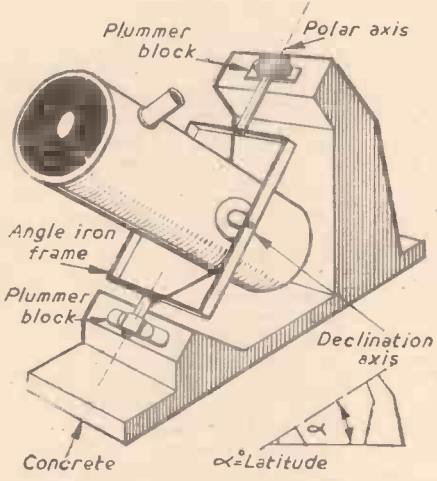

Cradle mounting as used for the Hooker telescope at Mt. Wilson.

article, viz., that the only way in which to satisfactorily see and record astronomical phenomena is the photographic plate.

No such sweeping generalisation can be permitted to pass without qualification, for the sake of your readers who may be drawn to the cultural and edifying hobby of amateur astronomy.

Photography *per se* is nothing to do with astronomy in that it is only an alternative means of observation. While I would be the first to agree that photography is a valuable tool in sidereal research, it needs to be carefully applied and necessitates expensive apparatus if the results are to be scientifically analysed. In *no way* does photography replace visual observation—the lifeblood of the amateur observer. To say, as does Mr. Twining, "telescope builders appear to have no object—beyond visual observation," is equivalent to placing the telescope on the list of obsolete instruments and to ignore the

great work before photography by those paragons of assiduous observation, Galileo, Galilei, Flamsteed, Bradley and Herschel, to mention but a few. Drawings at the telescope showing details of Jupiter, Mars, Saturn and the Moon are still highly prized when made by observers having trained eyes. This statement may be verified by scanning the Memoirs of the British Astronomical Association's Jupiter, Mars, and Lunar sections. The eye will pick up detail lost on the photographic plate due to the graininess of image. Photography for the amateur is subject to more serious limitations than visual work.

I note the elegant German type mounting of Mr. Twining's reflector, and the very ambitious drive—but it is not, to my mind, the kind of instrument open to that grand body of men, the impecunious amateurs. In telescope mountings the keynote is rigidity and the most satisfactory and simple one is the English type with a cradle, as used on the famous 100in. Hooker telescope at Mt. Wilson. I have employed this method (see accompanying sketch) after much deliberation and can recommend it to any of your readers hoping to build their own instrument on simple but effective lines.—F. W. COUSINS, A.M.I.E.E. (Greenford).

**Micro-projection**

SIR,—In the December issue of "P.M." you published a description of a micro-projector. I have used a micro-projector for very many years, but instead of using a lens for concentrating the light I use an ex-Army daylight signalling lamp. These lamps are fitted with glass parabolic reflectors, and by fitting a small bayonet cap lampholder in the correct position in the lamp housing, low-voltage class F projector lamps can be used, or ordinary motor-car lamps, but the low-voltage projector lamps are far superior, as they give an intense spot of light which is ideal for microscopic work. Using a screen at about 6ft. from the eyepiece of the microscope I get the following magnifications:

- 3in. objective and X6 eyepiece, 110 diameters.
- 1 1/2in. objective and X6 eyepiece, 190 diameters.
- 1in. objective and X6 eyepiece, 350 diameters.
- 3/4in. objective and X6 eyepiece, 450 diameters.
- 1/2in. objective and X6 eyepiece, 1,500 diameters.
- 1/4in. objective and X15 eyepiece, 5,000 diameters.

The disc of light on the screen at 6ft. from the eyepiece is about 3ft. in diameter and, except in the last stated instance, is well illuminated.

I use O.N. 19 glass for absorbing the heat generated by the lamp, and with this animalculæ in pond water can be shown on the screen and are not instantly killed by the heat. For projection on the table I use a glass right-angle prism with the eyepiece or an Amici prism without the eyepiece.

Diatoms show up very well indeed on the screen, and the use of the stage micrometer is very instructive in showing the size of these small creatures. Another very interesting example is that of cheese mites, which can be seen crawling about and are 2in. to 3in. long.—J. DIMOND (Bournemouth).

**Acid-resistant Surface**

SIR,—In the December issue of "P.M." I noted the query of G. H. Willis, of Hackney, about preserving the top of his laboratory bench, and as an alternative to the method given may I suggest the following formula.

The wood must be new or freshly planed.



**Solution 1**

Ferrous sulphate	..	..	20 g.m.
Copper sulphate	..	..	20 g.m.
Potassium permanganate	..	..	40 g.m.
Water sufficient to make	..	..	500 c.c.

Apply two coats of this solution with an interval of at least 12 hours between applications. When thoroughly dry, apply two coats of the following solution.

**Solution 2**

Aniline oil	..	..	60 c.c.
Hydrochloric acid	..	..	90 c.c.
Water sufficient to make	..	..	500 c.c.

When the treated surface is thoroughly dry, apply one coat of raw linseed oil with a cloth. When dry, wash with hot soapsuds. The excess of black comes off, leaving a good ebony finish.

The only disadvantage is the length of the process, but for home application this should not matter.—L. TEWY (Erdington).

**Long-playing Records**

**SIR**,—May I query your statement that no one has yet devised a pick-up or needle as satisfactory as those designed to play 78 r.p.m. records? Those of your readers who, like me, are purchasing and using P.U.s and L.P. records such as are now being produced in this country, can tell you an entirely different story. I can only surmise that you haven't yet heard, say, Petrouchka on microgroove, using, of course, a good P.U. amplifier and speaker combination. Whilst one swallow does not make a summer, it is a fact that some of the L.P. discs used in conjunction with some well-known pick-ups have reached a standard of reproduction surpassing that of the 78 r.p.m. Whilst combined units for playing L.P. and other records may not have realised the highest pinnacle, this does not mean that no one has yet devised a P.U. or needle which will give results to compare with those obtaining on 78 r.p.m. Perhaps you will look deeper into this matter and give us some information on the subject.—J. GOODFELLOW (Chaddesden).

**SIR**,—Seventy-eight or 33—which is it to be?

From your article in PRACTICAL MECHANICS dated December, 1950, it looks as though from your point of view we shall have to wait to see what America and E.M.I. decide before we shall be able to make any progress in this country.

If this attitude prevails there would have been no progress made in the gramophone industry. This is the first big change in gramophone records reproduction since the acoustic, when, with a lot of publicity, Gramophone Industries announced they had discovered a method of producing a record without any scratch. Hence the electric recording. But it did not eliminate scratch, not even with fibre needles, which had to be sharpened after each record.

Now, for the first time in gramophone history, we have a pick-up which will allow us to play almost indefinitely without having to bother changing or sharpening needles. In addition to this we have a record which will give us 25 minutes on a 12in. playing record, as against a standard 78 of four and a half minutes' playing time. Fortunately, there has been a company in this country who could see the possibilities of the long-playing record.

Decca, from my point of view, have done a wonderful job; they have produced a motor and pick-up for the small sum of £8 18s. and can convert their standard job to long-playing records. I have made the change and am quite happy about it.

To be able to hear a concerto without jumping up and down every four and a half minutes, apart from the banging and scraping of the automatic record changer, and without

scratch, is a jewel picked out in this modern age.—"BOLSON" (Padworth).

**Testing Spirit Levels**

**SIR**,—With regard to the answer to the query by W. A. Hindley (Reading) about testing spirit levels, the method suggested will not be found satisfactory, since there is no means of checking that the wood is floating "on an even keel." The level of the wood on the water can be upset by differences in density in the wood and differences in its moisture absorption, as well as by any displacement of the instrument from the centre of flotation of the wood. The usual method for testing spirit levels is as follows.

The bubble-tube should be adjustably mounted in its staff, which should be truly straight and parallel on top and bottom surfaces. First, set the bubble-tube approximately by eye. Then take a straight piece of wood or steel, about the same length as the instrument to be tested and wide enough for it to stand upon. Level up this straight-edge by means of the instrument, and hold in a vice. Then turn the instrument end for end and note the displacement of the bubble from the centre. Now, by means of the adjusting-screws, bring the bubble half-way back to the centre, and, without further touching the screws, level up the straight-edge again. Repeat the process until the bubble reads level whichever way the instrument is turned.

The "vertical" bubble can be adjusted in a similar manner, holding the straight-edge vertically in the vice.

It is presumed that the querist will buy his bubble-tubes, but otherwise they can easily be made by heating and bending glass tubes to a slight circular arc, filling with coloured spirit or water, and sealing off.—G. M. BOYD (West Wickham).

**SIR**,—With reference to the query "Testing Spirit Levels," in the December, 1950, issue, the answer given seems to me to be an inaccurate means of testing spirit levels. I may point out that the floating piece of wood, although, perhaps, quite rectilinear in shape, may be slightly heavier at one end than

the other (no timber is of uniform specific gravity throughout), and the heavier end would lie slightly deeper in the water than the other. Again, the level may not be exactly central on the piece of wood, with similar results.

We are constantly using levels at our works and they have to be highly accurate and sensitive, calling for frequent checking. A method we use, with very satisfactory results, is as follows:

The base of the level (which should be very slightly hollow lengthwise to avoid interference from grit, etc., on flat surfaces) is supported at each end by blocks of metal or hard wood (we use steel parallels) securely fixed to a rigid base. The exact position of the level is marked on the blocks and the position of the bubble is noted (say, this is  $\frac{1}{16}$  in. to the left of central). The level is then reversed end for end and placed exactly on the marks and the position of the bubble is again noted (say, this is  $\frac{1}{16}$  in. to the left). This will clearly indicate that both the level and the blocks are out of true, but before the level is interfered with the blocks should be packed up so that the bubble shows equal displacement from central in each position, i.e., to the left in one position and to the right upon reversal. The blocks will then be very nearly level and attention should then be given to the level by carefully planing off thin shavings from the underside at the appropriate end, taking care that the surface is slightly hollow as before mentioned. The whole process is then repeated, bringing the blocks still nearer level and the bubble more central.

Some three or four repetitions will be necessary, the ultimate object being to obtain an exactly central reading of the bubble in both positions.

The plumb level can be tested in much the same way using a length of steel shafting (or similar) set vertically, and the level placed first vertically on one side and then the other, diametrically opposite.—V. N. SPENCER (Bristol).

**Mathematical Problems**

Owing to a typing error in the letter from L. Gaudet (January issue, page 100), the last term in the sixth line of the second paragraph should read  $b^2$  instead of  $c^2$ .

## Club Reports

**Beaufoy Model Engineering Society**

THE Beaufoy Model Engineering Workshops reopened on Monday, January 8th, 1951, and once again these excellent workshops are available to modellers.

A qualified technical adviser is always present from Monday to Friday, 7-9 p.m., to advise members and especially to give advice to beginners.

The variety of machine tools for use should be a great advantage to those without facilities of their own, and the experienced modeller is sure to find them useful for his heavier work.

The annual fee is 6s., and we welcome all to the friendly atmosphere of our workshops. Interested readers are invited to pay us a visit one night and see at first hand the facilities we have to offer.

Hon. Secretary, S. T. Hunt, Beaufoy Institute, 39, Black Prince Road, S.E.11.

**Whitchurch and District Model Engineering Society**

AT the annual general meeting held on November 2nd, 1950, the new committee was elected and general ideas for the New Year discussed. The headquarters and workshop have now been removed to fresh quarters, and the amenities the Society can offer to its members are being steadily in-

creased. Plans for 1951 include the re-wiring and purchase of further equipment for the workshop, the laying of tracks for locomotives between gauge 00 and five-inch in the workshop, and a social evening in the Y.M.C.A. for members and wives. Membership of the Society is increasing, but further new members would be very welcome. If anyone is interested will they please contact the Hon. Secretary, W. D. Harris, 177, Whitchurch Road, Cardiff.

## Book Received

**It's Bound to Happen.** By Professor S. M. Low. Published by Burke Publishing Co., Ltd. 204 pages. Price 10s. 6d. net.

THIS is a remarkable book by an author who has a great gift for foreseeing future possibilities and presenting them simply but vividly in non-technical language. Here, within the covers of this book, is the astonishing but realistic picture of the life that everyone will probably be living during the next 100 years. In his forecast of the future Professor Low bases every prophecy on solid facts, widely known and accepted to-day. The fascination of this book lies in the fact that it concerns us all intimately, describing the problems of the atomic age, new electronically heated clothing and automatic dust collectors as well as the food of the future. The book is illustrated with several humorous drawings by Henry Hewitt.



# RADIO-CONTROLLED MODELS

Their Development, Construction and Operation

By C. E. BOWDEN, A.I.Mech.E.

**C**ERTAIN noteworthy developments in the world of models that work have occurred since the war, and these developments have heightened the interest of the mechanically-minded man and boy of to-day.

The diesel model engine created thousands of new modellers. The glow-plug motor, developed in America, is now giving a new impetus to fast models of boats, aeroplanes and cars, whilst the model jet-reaction engine has put up sensational speeds of control-line models, particularly in America and Switzerland. From time to time I have discussed these various forms of power units in PRACTICAL MECHANICS.

Working models are therefore well developed, but now comes the time when modellers want to control their flight path, and boat course, by remote control in a desired direction. Radio control is the obvious answer, provided the man in the street can obtain radio gear that is simple, reliable and reasonably cheap. Once one has controlled a model by radio an uncontrolled model becomes dull by comparison. Not only is cheap radio gear now commercially obtainable, but it is becoming increasingly reliable and easy to operate. A great deal of development has taken place during the past two years or so, during which time I have used all the well-known radio sets. The first were far from simple, and results were very varied, even for the man well versed in radio, but matters have improved enormously, until to-day it is possible for a non-technical man of ordinary mechanical ability to buy and operate a radio set by simply following the maker's directions. In fact, one well-known manufacturer told me that he preferred his products to fall into the hands of non-technical radio men, because the technical "experts"

*The author's large 10ft.-span model, powered by a 14 c.c. Forster petrol motor and controlled by a three-valve "modulated" receiver.*



so often caused trouble by fiddling with the works, trying to "improve" the set.

Already our present sets are being drastically reduced in size and weight due to the introduction of the new British mini-gas-filled Hivac valve. The Americans have had a similar valve for some years in their R.K.61, and as a result have become used to smaller receiving sets. The new valve has a short life if too great a current is used. It is therefore economical to use not more than 1.5 to 1.8 milliamps.

Quite a number of years ago America took seriously to model radio, which spread rapidly, although, strangely enough, the Americans still require a licence to operate, whereas we in this country of controls in excelsis can operate a model radio set without a licence, which we had to procure not long ago, provided we keep within a given wave-length. This fact has given model radio a great fillip over here of late.

It may be mentioned that Mr. Jeffries was flying radio-controlled model aeroplanes before the last war, and during the war developed a radio model for the Government, making frequent flights of over half an hour and more. Squadron Leader Peter Hunt was also developing early models of note, and Mr. Honnest Redlich, perhaps our leading practical radio man to-day, has developed the commercial E.D. radio sets and written an excellent book on the subject of radio for models. Dr. Good has been the outstandingly successful exponent at radio competitions in America for a number of years. All these "giants" of radio have flown most successfully by using rudder control alone, sometimes assisted by an engine control. There is a reason for this as we shall shortly see.

### British Commercial Set Reliability

Although our sets have got to the stage where it is not necessary to have much technical knowledge to operate them, this does not mean that model radio is quite as simple as switching on a B.B.C. radio programme. But we are not far from this happy state of affairs in some sets. There is often too much technical jargon written on the subject, which is, of course, interesting to the purely radio enthusiast, but is frequently confusing and often alarming to the far more numerous band of novices who merely want to fly their aeroplanes or operate their boats or yachts by radio. Simple non-technical explanation is required for the average man interested in controlling his model. It is a good plan, if circumstances permit, to find a combination in which a sound builder of models with practical experience of flying, teams up with a man with reasonable radio knowledge, but who has not the urge to rebuild the radio continually rather than see the model per-

form! On the other hand, the lone hand can get along nicely, as I do, by himself, with occasional chats to the radio "experts." It is frequently remarked by American radio leaders that the actual model design is more important than the radio, which has now become so reliable. I entirely agree with this view and have frequently noticed that the radio experts seldom do much practical flying or boating unless they have an experienced model man with them. It is by no means true that everyone has the knowledge and experience of trim to design and fly a suitable model for radio. I would

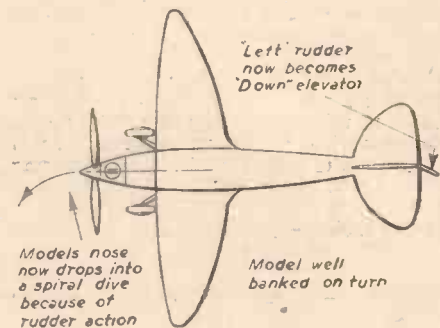

Fig. 2.—Height is lost when a model turns and increases its bank.

suggest that beginners without much model experience should buy a well-known kit from which to build the model and then fit it with the most suitable engine and radio to fit their pocket and the type of model, which is largely a matter of size. Most boats of sufficient buoyancy are suitable for radio.

### Some Misconceptions

So many people believe that because they have flown a free-flight model aircraft in well-trimmed circles that all they have to do is to fit radio and turn right or left on rudder, or climb or dive by elevator control. They forget, for instance, that a left-hand circle (which is the safest with the normal engine rotation, anti-clockwise) holds the nose down due to banking and propeller torque, which prevents a stall under power. If the same model is suddenly turned right by rudder control it will climb violently, and maybe stall, unless properly designed with regard to thrust-line position, and the correct amount of "downthrust" is given together with "offset" of thrust, to the engine mounting. Incidentally, it has recently been recognised that downthrust to a limited degree is a very vital factor in radio flight when making turns from left to right and vice versa. Many years ago I drew much fire from the "experts" because I advocated downthrust

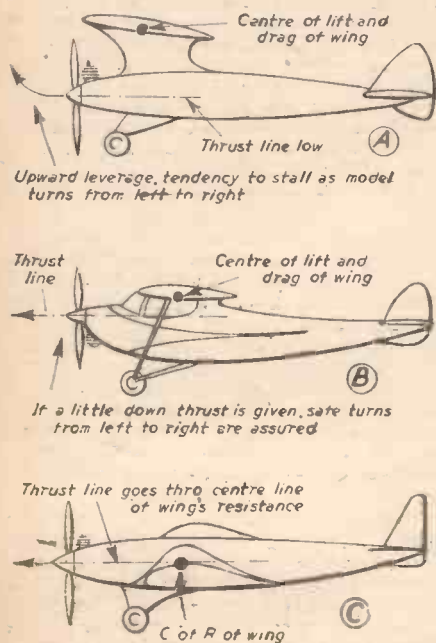

Fig. 1.—Design factors for a radio-controlled model-acroplane.



as a safety device. All the acknowledged experts of to-day admit the value of correct downthrust and offset of thrust to obtain straight flight so necessary for radio, for unless the flight can be got reasonably

Vultee Aircraft Corporation carried out preliminary tests on a 15-foot span model of their Navy flying boat patrol bomber, the X.P.4.Y-1. The model was fitted with full length slots to give similar lift in comparison with the full-size project. This was to allow for "scale effect" between airflow over small and large wings.

The motors were two twin-cylinder Ohlsson and Rice petrol engines with spark ignition. There were seven operations that had to be carried out in order to fully test the machine: Therefore seven frequencies were used with amplitude modulation for positioning, which permitted simultaneous and independent control of the throttles, flaps, aerolons, elevator, rudder and ignition. The radio gear for all this work weighed 15lb. in the model, whereas our modern "thyration" lightweight model sets giving rudder control now weigh approximately 7½oz. all up in the model. A couple of years ago this weight was nearer 2lb., if reliable batteries were used.



Fig. 4.—Colonel Taplin's special high-powered, clipped wing stunt model fitted with a 3-5 c.c. diesel and an E.D. "modulated" three-valve receiver.

straight, turns from one side to the other cannot be made by a reasonably sized rudder.

Some newcomers to the idea of radio flight believe that all that need be done is to connect up an elevator and the radio will make the model lose height or climb. Well,

**The Stable Model Set-up**

Let us assume that you have flown free-flight models—I will deal with boats later. You have probably flown pylon contest types, specially developed for duration competitions,

up, one of the secrets being to keep it in a turn which holds the nose sufficiently down to prevent a stall under power, when it is properly trimmed for gliding. The low thrust line would otherwise take control and loop the model. As a result this sort of model when trimmed properly will corkscrew upward like a scalded cat, provided the trim is not upset, but try to turn it by rudder the other way under power and wonderful and fearful things happen. This is definitely not the kind of aircraft for radio control unless the result desired is zooming and looping all over the sky. There are some who actually try to get this effect, and it is regretted that some of the radio competitions are now providing rules to encourage this end. The real and difficult art is to obtain realistic stable flight with turns, etc., under control, and not a mere series of buckings about the sky by going from one rudder to the other on an unstable model.

For your first radio model at least you require a machine that has just sufficient power to fly vigorously with a sound climb to gain height lost in each manoeuvre. This means a model with its thrust line high, or near the centre of the wing's lift and drag, as shown in Fig. 1. On the pylon model the wing is far above the thrust line, which gives a sharp pulling up leverage when the model flies straight. This causes stalling during the straight flight that must be sought on a radio model, so that the rudder can operate either way. The only safe way is to locate the thrust line near the centre of resistance of the wing as shown in Fig. 1 (B and C). Radio gear is too costly to risk in one inglorious matchwood crash of a poorly designed and trimmed model unsuited to the job.

We must trim our model to fly as straight as possible under power, and glide as straight as possible, so that the rudder has a chance to turn against engine torque, which tries to turn the model over in the opposite direction to that in which the engine is revolving. If the model turns in left circles under power, the radio rudder will get it into a violent left turn aided by engine torque, and possibly not have sufficient power to turn right against engine torque added to a possible cross-wind. This can be a distressing state of affairs, and one so often seen on model radio-controlled aircraft.

If we fit an outside rudder to make sure of a right-hand turn under the above adverse circumstances, as some people do, the model will immediately whip into a spiral dive on a left turn.

It is also necessary to get a model trimmed to glide straight with fin set straight, and no warps in wing or tail, or the model will not turn evenly on the glide by radio. It will land one wing low in a turn and probably

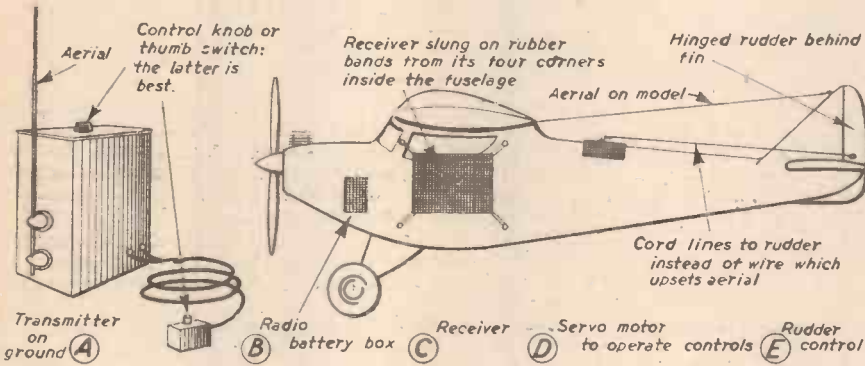

Fig. 5.—The normal radio set-up for controlling model aeroplanes and boats.

it may be done that way, but it requires very great experience, and the fact remains that almost every well-known practical exponent of radio flying uses the rudder to lose and gain height as well as to turn, except for a few who employ the American "rudivator" which provides a mixture of rudder and elevator by arresting a spinning vane at the rear of the model at varying positions. A down elevator will cause a dive and much increased speed, because it has to be full down, and at present is not proportional as required. It is not possible, with commercial sets, to ease the model gently out of the dive.

The same applies to up elevator which must come right back. The model, therefore, may get into violent fugoid flight, with controls that have to be all or nothing. Thus we find Dr. Good and our leaders of radio flight mostly using rudder alone. This is not to say that perhaps in the not very distant future we shall develop proportional control commercially. But it is not obtainable yet. In the meantime, I can assure the reader that he will be doing very nicely if he can fly with reasonable precision and stability with rudder alone, for it is surprising what a number of manoeuvres can be done with this control.

Certain American firms constructing full-size aircraft try out their new designs, by large radio-controlled models, before building the full-size prototype. For instance, the

in order to get a terrific zooming climb for altitude after a specified engine run of limited duration. The greater the height the greater is the chance of a long glide to win a duration competition. This sort of model is kept from stalling by a certain "trim" set-

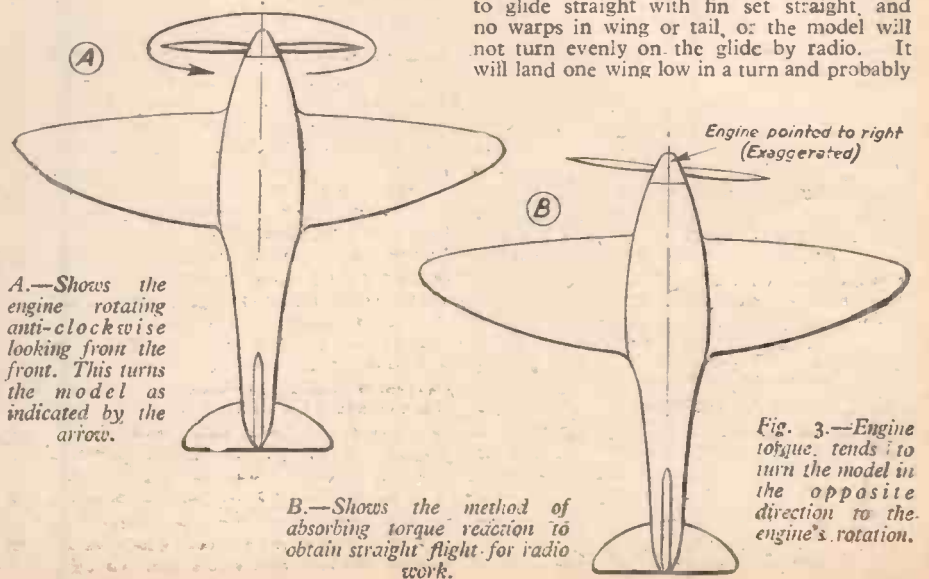

A.—Shows the engine rotating anti-clockwise looking from the front. This turns the model as indicated by the arrow.

B.—Shows the method of absorbing torque reaction to obtain straight flight for radio work.

Fig. 3.—Engine torque tends to turn the model in the opposite direction to the engine's rotation.



cartwheel crash. Now leave these straight flight settings. The subsequent climb and straight power flight are controlled by engine "downthrust" and "offset" of thrust, which need only be small if the model is designed properly, with the thrust line close to the wing's line of lift and drag, as already mentioned. All these settings will be ruined if the model is over-powered or has a propeller giving excessive drag or resistance through incorrect pitch or badly shaped blades.

Unless the model is right it is a waste of time to get the radio correct. That is why I have opened this article by discussing the model before the radio gear. I have observed, time after time, that modellers fit engines with far too great power for radio flight. I repeat that the power should be just sufficient to cause a reasonable climb to regain height lost by turning to a reasonable amount. I do not refer to a prolonged turn

starts to turn to the left from an even keel. Bank then develops, which automatically increases as the model turns until it eventually becomes over 45 deg. and the model is on its side in the air. (See Fig. 2.)

There is no pilot to reduce bank by opposite aileron. The rudder under these circumstances becomes a down elevator. The model's nose will obviously drop into a spiral dive if the turn is persisted in. This is how height is lost. By centralising controls a well-designed stable model will pull out of the downward spiral and straighten out its path, but it will have gained speed in the dive and this will cause a climbing zoom. This can be checked by giving a short burst of rudder either way, and then centralising as the nose comes down, and before new speed has been gained in a new spiral. If we want to turn flatly with little height lost, it is necessary to give rudder and take it off as the nose drops, centralise quickly, quickly

Engine gyroscopic action makes a right-handed turn more dangerous if persisted in for a long time. It is, therefore, best to lose height by spiral diving to the left, for the model will come out more easily this way. A sufficiently large rudder must be fitted to turn right against torque. The difficulty to turn right may be increased by a cross-wind to fight against, but too large a rudder causes rapid spiralling to the left. It is, therefore, a happy compromise which is required. A deep belly up forward in the fuselage tends to hold the nose up on turns. This will be observed on certain of my radio models in the illustrations. A leading American radio man has actually fitted lower fins to the forward end of his normal depth fuselages to obtain this effect.

It will now be realised that the operator has to allow for quite a number of factors introduced by torque and gyroscopic effect. Torque is the greater, but the situation changes on the glide when engine torque dies away. These forces will be increased, and so will instability, if the model is over-powered, and flying too fast, when any errors of trim will show up to disadvantage.

Although I have now given the main idea behind radio flying, there are many refinements which the modeller will find out from practice, but we may sum up by saying that a stable, slow-flying model, but one that has sufficient speed to fight forward against reasonable breezes, will give the newcomer the best results, and later, if stunt flying is desired, a clipped wing and fast over-powered model will provide all that is required.

It should be mentioned that an elevator can be interconnected to the rudder so that a limited up elevation takes place as the rudder is applied. This will hold the model

in a tight turn with nose up. It prevents losing height intentionally. I have obtained a similar effect by fitting a pendulum elevator control to a low-wing model. Many people do not like these aids because they cannot lose height by spiralling down when desired.

#### The Two Principles of Radio for Models

A short description of the two principles employed by commercially obtainable radio equipment will help the newcomer to model radio control to understand which is most suited to his particular type of model. This is largely a matter of the model's size and the depth of the owner's pocket. We have arrived at the stage where it is possible to buy a comparatively cheap set weighing as little as 7½ oz. all-up in the model. This, naturally, suits small models. A larger set will give foolproof operation for the larger model of greater wingspan. The all-up weight in the model will be just over 1lb.

For the purposes of a simple non-technical description to suit the beginner, I will call the two principles most in favour by manufacturers: (1). The "dipping" receiver principle (Fig. 6a). (2). The "rising current modulated" system (Fig. 4). These two different principles have a different type of transmitter. The "dipping" system is nowadays lighter and cheaper, but cannot as yet be made entirely "crashproof," because it is possible, under certain circumstances, to get a stuck-on rudder control, the dangers of which I have already enlarged upon, due to bad tuning, battery drop, or relay failure.

(To be continued)

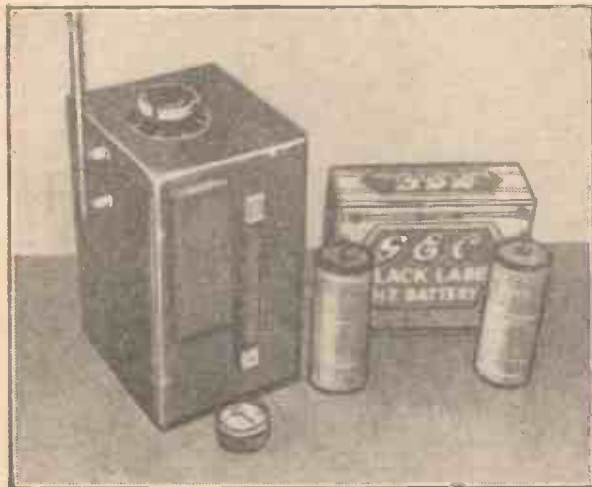

Fig. 6.—The transmitter case is used to form a firm base to support a long aerial made in detachable sections. The case also contains high tension and low tension batteries obtainable from any radio shop.



Fig. 6a.—The "dipping" radio set has two switches—one for the receiver and the other for the Servo motor. When the receiver is tuned the meter is withdrawn and a "shorting out" plug is placed in the panel. This plug is not necessary in the case of the "modulated" receiver. Note the hatch in the wing platform to give access to the radio equipment for any adjustments in the workroom.

to purposely lose height in a big way. Let us see how this is done.

#### How to Fly on Rudder Only

It must be appreciated that most commercial model radio sets only give controls in sequence. This means the operator has to go from left rudder to centralise, and, if elevator or other controls are used, he must go through these before he gets right rudder. This requires a good memory and very calm thinking in tight spots as the operator watches his model perform, perhaps at a distance under difficult visibility conditions. Hence, the reason for most leading flyers going all out for the simplicity of rudder control only, especially when it is realised that a great deal can be done with this one control, including losing height and stunts. Here one may decide to turn left and give left rudder. The rudder is then automatically centralised as the signal is taken off and one may want to turn left again, in which case it is necessary to give a quick right rudder, and then centralise, before getting left rudder again. Even this simple set-up can cause some delay and quick thinking when the model is a tiny object to the eye in the distance travelling away from the operator, with, perhaps, a cross-wind to fight against engine torque on a right turn. Assuming that we use rudder alone, at any rate at the beginning of our radio flying, how can we adequately control our model to lose height and regain height as desired?

When left rudder is given, the model

goes over to opposite rudder, quickly take it off, and return to a longer burst of left rudder, and so on. In this way we make our turn in a series of little turns and lose no height if skilful anticipation is indulged in. If we want to loop or do other exciting manoeuvres this can be done by holding on a turn and its subsequent spiral dive until great excess speed has been obtained, when a centralised or opposite rudder will cause the model to violently zoom upward and come over on to its back. If the model is purposely over-powered, quite complicated stunts can be done in this way.

This increasing turn and bank with rudder hard over until a steep spiral develops is precisely what happens when the radio fails and the relay sticks on in a "dipping" type of set. I will describe the type shortly. The reader should make a note of this point and remember the reasons, for it has a bearing on choice of set principle, and at first a crash due to a stuck-on relay and control may not be attributed to the radio. A perfectly stable model may be blamed for radio faults. It is possible to guard against this danger in one type of set, and it may be said here that the secret of no-damage flying is (a) that the rudder does actually come off when desired; (b) that the Servo motor is set up to automatically return to neutral as the signal is taken off. Thus, as we hold on the signal the rudder is held on, and as we stop the signal the rudder returns automatically to neutral.

The novice will note that propeller torque helps a left turn and vice versa. (See Fig. 3.)



# Sounds You Can't Hear

## Ultrasonics, Their Characteristics and Uses

By Prof. A. M. LOW

**A**N employee at a factory making jet-engined planes was recently reported to have "gone sick" as a result of the noises—the first case of what has been christened "supersonic sickness." Far above the highest sound that can be heard by the human ear, or even the ear of a dog or a bat, are vibrations of the same nature as those producing all sound. Although you cannot hear these "supersonic" vibrations they have an effect on living tissues. Just what is this effect, in the case of human beings, we do not yet fully understand. This case of reported sickness is likely to stimulate research.

The study of sound and ultrasonics was greatly stimulated by its use for submarine detection during World War I. The first submarine locators depended upon sounds generated by the submarine itself—the noise of its motors, or even, with highly sensitive hydrophones, of men moving about inside it. Acoustics were used to locate submarines when their motors were switched off and they were making no normal sound. One of the valuable properties of short wave vibrations is that they can be focused in a beam-like light. For submarine detection, the searching ship sends out an underwater "beam" of high-frequency sound. When this strikes a solid object it is reflected in a somewhat similar manner to light. Hydrophones detect the reflected sounds and, by directional finding, locate the reflecting surface—the submarine. Knowing the velocity of sound in salt water, the time taken for the sound to travel to the submarine and back gives its distance. Corrections have to be made for the temperature and salinity of the water, which affects the velocity of sound in it. In practice all these calculations are made automatically and the instruments show the distance and compass bearing of the reflecting surface.

### Automatic Sounding

After the war this principle was extensively used for automatic sounding of the depth under a ship. Supersonic sound signals travelling downwards are reflected from the sea-bed and the time taken for the double journey reveals the distance they have travelled—twice the depth of water under the ship. The advantages of the new type sounder now used on many kinds of ship are greater accuracy and the fact that continuous sounding can be taken. Even in skilled hands the "lead" used for so long to take soundings requires time. The "fathometer," or echo sounder, can write a continuous picture of the sea-bed. This is so accurate that a wreck lying on the sea-bed can be located as an unexpected "bump" in the readings. The *Laurentic*, among other wrecks, was located in this way—finding the ship by dragging might have taken many months. Another application of the principle is to discover the presence of shoals of fish. The fish reflect the vibrations and record their presence many fathoms below.

It was when scientists learned to generate sounds of much higher frequencies that really spectacular results were obtained. The normal range of sounds we hear run from 40 to 4,000 vibrations a second. The limit of human hearing is generally reckoned at 10,000. Certain animals can hear what for human beings are "ultra-sounds." A

whistle can be made, for instance, which is completely inaudible to the person blowing it because the sounds generated are beyond the range of his ear, but which will summon a dog whose ear is built to hear higher sounds.

### Over 1,000,000 Frequencies a Second

The supersonics to which I have been referring are generally in the range below 100,000 frequencies a second. They may be generated with the aid of a rapidly alternating magnetic field. The alternations produce tiny alterations in the length of a piece of metal in the field, and this in turn creates alternations in the pressure in the air. To generate higher frequencies, the scientists turned to quartz crystals. Small slabs of crystals are made to constrict and expand by electric charges. By this means supersonic frequencies of over 1,000,000 per second have been produced.

The first phenomenon noticed with these sounds was that the shape of the liquid in the bath containing the crystal changed. The supersonic vibrations raised the liquid up into a mound and anything placed in this mound absorbed the vibrations. For instance, when a little water is placed in it in a suitable container, the water appears to boil. If a glass rod is dipped into it, the rod appears to become hot. What actually happens is that the extremely rapid vibrations of the rod create friction with the skin which can produce a burn—the rod itself remains almost cool.

Through a fine glass rod and by other means the vibrations can be transmitted to living tissues, and it has been found that bacteria and other simple organisms are destroyed. They are literally shaken to pieces by vibration. Here we have on a minute scale the modern scientific counterpart of the walls of Jericho collapsing at the blast of trumpets, but in this case the walls are those of minute cells and the "blast" is that of a sound thousands of times "higher" than the note of a trumpet.

### "Death Rays"!

Experiments made by M. Langevin, a pioneer of ultrasonics, showed that fish might be killed by exposure to a sound beam in water for two or three minutes. In the years between the wars these experiments naturally gave rise to talk of "death rays." Could these vibrations be created in such a way that human beings in their path would be affected? The possibility was encouraged by reports that German workers in a high-frequency laboratory had been taken ill, and that it has been discovered that their red blood corpuscles had been destroyed, and by similar rumours.

But, in fact, a little sober consideration showed that hopes—or fears—of such a death ray was quite unfounded in the light of our present knowledge. One characteristic of ultrasonic vibrations is that they have a very short range. Whereas an audible sound might travel for some miles, sounds with shorter wave-lengths had a very short range—a matter of a few yards. They carried very much better in liquids—hence all the experiments were carried out in oil- or water-baths. But you could hardly expect your enemy to oblige by immersing himself

in an oil-bath or catching hold of a special conductor! There was the further point that for the destruction of cells some minutes were required, and, again, whatever might be done in the laboratory, you could not expect an enemy would wait while you focused your supersonic "death ray." The possibility of a "death sound ray" was, therefore, dismissed.

### "Homogenizing" Milk

But that did not prevent a number of interesting practical developments in the new science of supersonics. One of the effects of these vibrations is to mix "unmixable" liquids. When the waves cross the boundary between the two liquids they overcome the resistance between them and form an emulsion. In this way water and oil and water and mercury have been emulsified. A few years ago a patent was taken out in the U.S.A. to use supersonic vibrations to "homogenize" milk. The "curd" tension is reduced and, it is claimed, the milk is very much more digestible. Homogenization is also valuable in various processes of manufacturing milk. In this device the milk is passed through a small chamber, one wall of which is vibrated supersonically.

The sterilisation of milk by supersonic vibrations has been tried experimentally. L. A. Chambers and Newton Gaines, in the U.S.A., passed polluted milk through a vessel surrounded by nickel which carried the supersonic vibrations. It was found that all bacteria were destroyed and plans were made for constructing a commercial plant capable of "pasteurising" milk in this way at the rate of 1,500 gallons an hour. The advantage over heat-treatment is, of course, that there is no alteration in the chemical or nutritive value of the milk. There is the general difficulty in using high speed vibrations to destroy bacteria, however, that the smallest organisms are liable to escape owing to their relatively small dimensions. The higher the frequency, the smaller the cells affected.

Other effects of supersonic vibrations which have been noted are chemical. It has been found that crystallisations may be started by ultrasonic vibrations and certain chemical reactions may be accelerated. A notable instance was the production of an isocyanate from acid azide. The azide was dissolved in benzene and subjected to high-frequency sound. The atoms within the molecule were rearranged, although the exact process by which this was done is not understood.

More recently Dr. Pierre Grabar, of the Pasteur Institute, has been successful in breaking down the "benzene ring," the closed ring of six carbon atoms which is the fundamental building block in organic chemistry, the basis of everything living.

### Commercial Application

The commercial application of supersonics is in its infancy, and there may be interesting developments. Laundry work is one example of tests now being undertaken. At the moment there is again a certain amount of concern whether high-frequency sounds generated accidentally can affect human beings in laboratories. The possibility of their doing so "in the open" can, probably, be ruled out—if a jet plane passing overhead was generating high-frequency inaudible sounds it is doubtful whether they would have sufficient energy to reach the ground.



# Wood Turning—13

By FREDERICK JACE

THIS article deals with various examples of wood turning which combine a number of operations already dealt with. In Fig. 141, for example, is shown a vase which, with slight modification, could also be an eggcup or a pepper-box. Fig. 142 reveals the first operation, in other words, boring the central hole. A hardwood should be used, first turned between centres using

### A Sugar Bowl

The next example is the bowl shown in Fig. 149, which may be used for sugar, etc. This, of course, is in two parts, including the lid. It is chucked in the ordinary way, hollowed out and finished externally as with the vase. It must be much larger in external diameter, of course. Such work can conveniently be turned also on the screw chuck

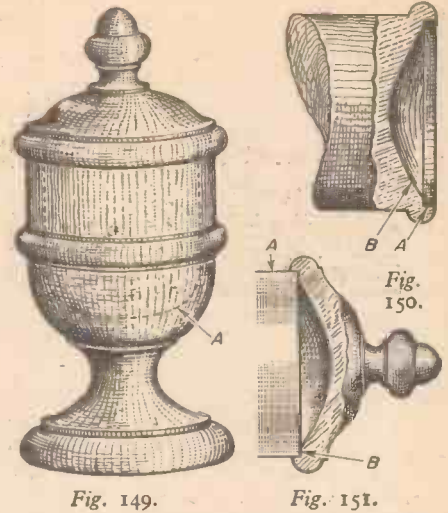
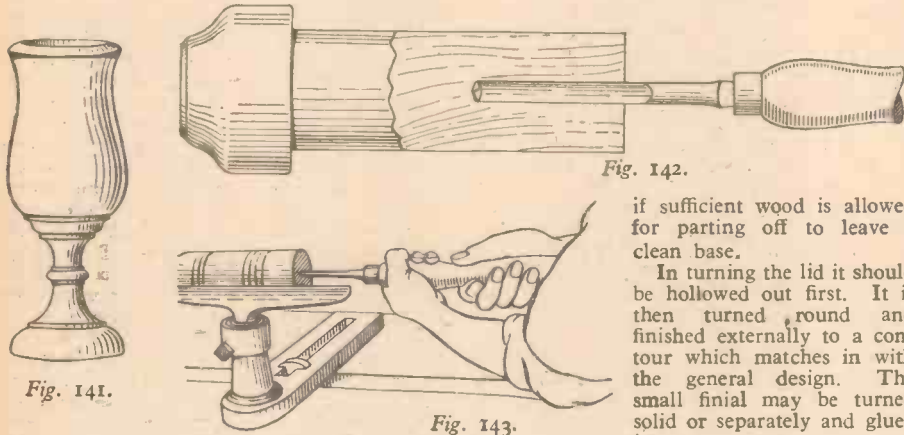

Fig. 149. Fig. 151. Figs. 149 to 151.—Turning lidded bowls.



Figs. 141 to 143.—Turning ornamental vases, etc.

the prong chuck and back centre, and rough turned on the outside. It should then be chucked in the cup chuck and hollowed out with the gouge.

Fig. 143 shows how the boring tool is held in the early stages of hollowing out, thus providing the starting hole for boring, whilst Fig. 144 shows how the hole is enlarged, the end view of the tool being shown in Fig. 145. Fig. 146 shows the hook tool in use in completing the hollowing-out process. These diagrams are self-explanatory and are really typical of the operations necessary for all work of this sort.

The finishing of the outside is clearly indicated in Fig. 147. The fancy of the operator can be allowed free play in the shaping, although if a number of cups or vases are required a template should be cut.

The foot and stem are the final parts to be shaped, and then the completed job is cut off with a parting tool, held as shown in Fig. 148.

if sufficient wood is allowed for parting off to leave a clean base.

In turning the lid it should be hollowed out first. It is then turned round and finished externally to a contour which matches in with the general design. The small finial may be turned solid or separately and glued in.

The recess for the snap needs to be turned to a nice push-fit over the body, although a better method is to turn a small spigot on it which fits inside the bowl portion.

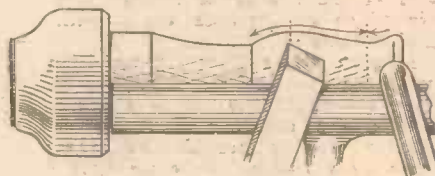

Fig. 147.

and the Black and Decker may be purchased quite cheaply and be converted into wood-turning lathes, polishers, grinders, etc., the reader has at hand really adaptable tools not only for wood turning but for a variety of other operations. The portable electric drill which is the basis of these machines can be mounted into a head forming the motorised headstock, whilst the castings provide for a round bar bed which carries the toolrest and the tailstock.

For those, however, who require an orthodox wood-turning lathe the Myford M.L.8

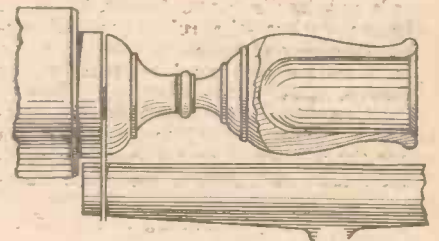

Fig. 148.

Figs. 147 and 148.—Finishing the outsides.

### Rolling Pins

Figs. 150 and 151 show the recess for the lid and the method of chucking it for finishing. Figs. 152 to 155 show rolling pins of the plain and serrated types, as well as a pestle. These are examples of plain cylindrical turning, and need no special reference, beyond saying that those which are grooved and serrated for decorative pastry work should be made of a hardwood such as oak or elm, and the grooves turned with a small beading tool before being cross-cut with a tenon saw. They should be about 3 1/2 in. in diameter, and the handles may be turned solid or separately. They should be about 18 in. in length.

Readers will find a ready market for articles of this sort, and it should be mentioned that now that portable electric tools such as the Wolf Cub

is recommended. This is a beautifully designed motorised lathe on a cabinet stand which houses all the tools and accessories. It was illustrated in the opening article of this series.

(To be continued)

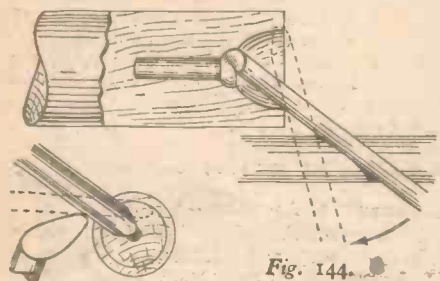

Fig. 144.



Fig. 145.



Fig. 146.

Figs. 144 to 146.—Hollowing out the vase.



Fig. 150.



Fig. 151.



Fig. 152.



Fig. 153.

Figs. 152 to 155.—Rolling pins and pestles.



# The WORLD of MODELS

Northampton Society's Exhibition : Swiss Modelmaker's Work : New Gauge 0 Model Locomotive

ALL model clubs who organise their own annual or bi-annual exhibitions hope each time that their display will be bigger and better than the last. The Northampton Society of Model Engineers held their third post-war exhibition in October last year, and it was throughout a testimony of the increasing strength of the Society, both in membership and in quality of work. A remarkably good balance was maintained between the various sections.

The Society were proud to include in their display a "Grasshopper" beam engine by Mr. H. J. Hawker, who was awarded a bronze medal for this excellent piece of model engineering at the 1950 London "Model Engineer" Exhibition. At the Northampton Exhibition, Mr. Hawker was able to add a first-class diploma to his credit.

Another first-class diploma and also one of the special cups were awarded to Mr. K.

By "MOTILUS"

L.N.E.R. 462 "Pacific" locomotive (see Fig. 1), constructed from "L.B.S.C.'s" notes on "Hielan' Lassie," a familiar theme well executed, and to a scale of  $\frac{3}{4}$  in. to 1 ft. Also a good model, for which Mr. J. S. Robertson won a special prize, was that of the "Brighton Belle" electric Pullman train for gauge O. Special feature of this model was the good painting and lettering.

Another well-made exhibit, which was awarded a first-class diploma, was a coal-fired model traction engine, built to a scale of 1 in. to 1 ft., by Mr. A. Wallace (Fig. 2).

Some outstanding exhibits were displayed in the shipping section. Dr. Stephen Rowland, himself a master mariner and well known for his lovely ship models, loaned his model of a full-rigged sailing ship, *Naworth Castle*. This ship, 1,900 tons,

will eventually be radio-controlled. This model has had an eventful history: it inadvertently hit a punt on the River Ouse at Bedford while undergoing trials and was sunk. Repeated attempts to locate it on the river bed failed and at last the services of a diver were enlisted, this time with success and the model was recovered and restored.

An interesting series of waterline model ships, to a scale of 1 in. to 100 ft., were exhibited by Mr. S. J. S. Hughes. These represent fifteen troopships, in all of which Mr. Hughes has served. The models, finished in the grey colour demanded by wartime exigencies, won a first prize.

A second prize went to Mr. F. E. Harratt for an unusual model of a N.F.S. firefloat, *Maid of the Mist*, as made and used (during the last war) on the River Nene by the Northampton Fire Service. It is always refreshing to see models of local interest in provincial exhibitions.

Among the loan models was an excellent working model cabin cruiser, about 4 ft. long and named *Diana*. The model is electrically driven and very good in detail and finish, items sometimes overlooked in working models.

There were not a great many aircraft models shown, but there was some good-quality work in this section. First prize winner was Mr. J. Haynes, who exhibited a "Chrislea Super Ace" 54 in. wing span model, with engine powered and built for future radio control.

## The "Tumble Inn"

A most fascinating and fanciful model, the "Tumble Inn" (Fig. 3), described by modelmaker Mr. K. H. Cullen as "a fantasy in the Walt Disney style," drew much admiration from visitors. This tavern model, to a scale of  $\frac{3}{4}$  in. to 1 ft., took Mr. Cullen eighteen months to build in his spare time, and won him a first-class diploma at the exhibi-

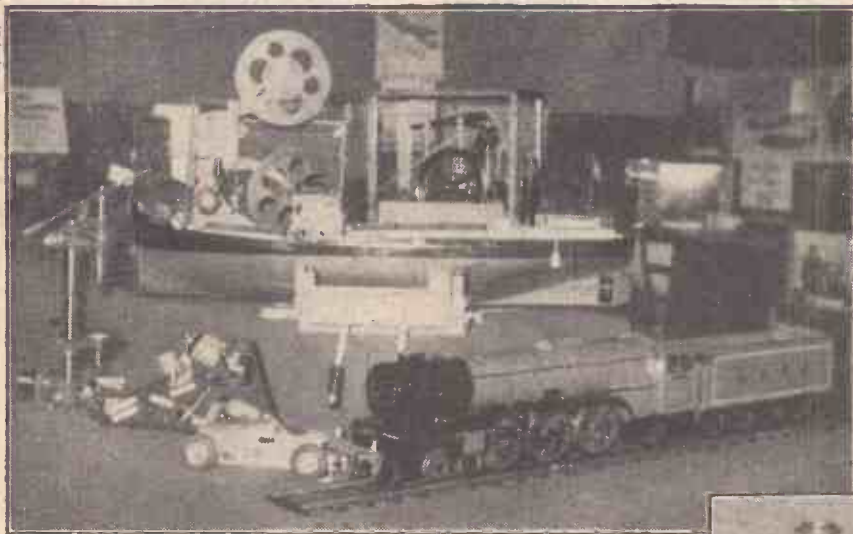

Fig. 1.—An arranged group of first-class diploma-winning models at the 1950 Exhibition of the Northampton Society of Model Engineers. In the foreground is the L.N.E.R. 462 "Pacific" locomotive,  $\frac{3}{4}$  in. gauge, by Mr. A. G. Bates. Mr. H. J. Hawker's beam engine can be seen in its glass case.

Harris for his lathe attachments, comprising running centre, backslide parting tool-holder, four-tool turret and fixed steady; all showed evidence of careful workmanship and were well finished. An unusual entry, a timing clock for controlling a photographic enlarger, won a first-class diploma for Mr. J. B. D. Willis.

A small working model railway added interest to the railway section, especially as the railway was American-style. Although the track base folded up into quite a manageable size, it was a fairly comprehensive layout.

First prize winner in the locomotive section was Mr. A. G. Bates, who entered a

was the last sailing ship to be built for Messrs. J. Chambers & Co.

First-class diploma for working model ships went to Mr. J. S. Penny for his working model of a steam coaster, *Helena*. The model is 4 ft. 6 in. long, has a Stuart BB engine and blow lamp fired, centre-flue boiler. It also has a working electric windlass and

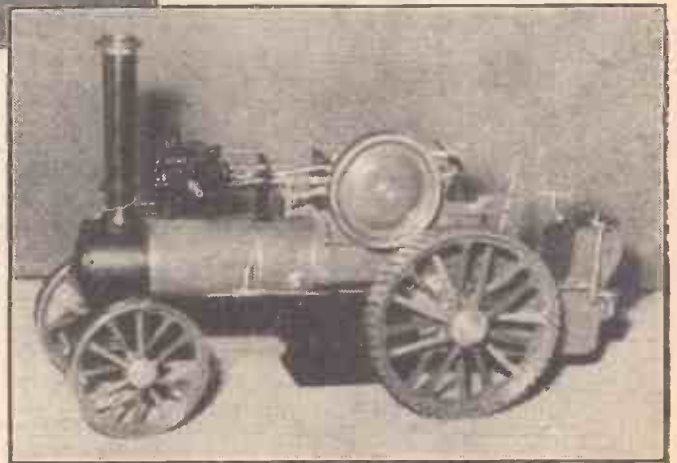

Fig. 2.—This coal-fired traction engine model, built by Mr. A. Wallace to a scale of 1 in. to 1 ft., was awarded a first-class diploma at the Exhibition of the Northampton Society of Model Engineers.





tion. The "Tumble Inn" stands 26in. high, on a base measuring 20in. by 24in. Built entirely of wood, the walls are plastered with "Alabastine" and painted in artist's oil colours with a flat natural finish to give a weathered effect. In the construction Mr. Cullen used panel pins, pin points, glue and two gross  $\frac{5}{16}$ in. brass screws.

#### Balsa Wood Tiles

The roof of the model is of plywood, the overlaid "tiles" being made from over 100ft. of 1in. wide balsa wood, carved and laid in overlapping strips. On one side is an outside stairway to the upper floor, a woodshed

Fig. 3 (Above).—An interesting and amusing model that proved a great attraction at the Northampton Society's Exhibition. This imaginative model, the "Tumble Inn," was built by Mr. K. H. Cullen of Northampton and is to a scale of  $\frac{1}{4}$ in. to 1ft. (Photo by Basil Moore, Northampton.)



Fig. 5.—An untouched photograph of the new Gauge O, 4-4-0 locomotive, with corresponding tinplate coaches. The locomotive is supplied with either clockwork or electric propulsion. The name selected for this new production is "Prince Charles."

with firewood, axe and chopping block and a crumpled stone wall. A small pigeon house is in the bonnet end of the roof at the back of the inn. The posts surrounding the model are carved from clothes pegs and the crazy paving is made of balsa wood slabs set in "Alabastine." Cobblestones near the side door are made from haricot beans set in plaster.

Mr. Cullen tells me that originally he intended this model to be a shelter, nesting-box and feeding-table for small birds, to be

set on a post in the garden; but now that he has finished the work he feels a more suitable situation for the "Tumble Inn" is under a glass case!

#### A Swiss Modelmaker's Work

A Swiss correspondent, Mr. Roger Vielle, of Vevey, has sent me some photographs and interesting details of a model steam locomotive that he has built recently for  $7\frac{1}{2}$ in. gauge (Fig. 4). Representing the French locomotive 231, the model took three years to build, as Mr. Vielle worked only in his spare time in the evenings. He made all the parts himself, and as he did not know whether any books were published in French or German on the subject of scale modelmaking, he built

without sample, plans or drawings of any kind.

#### 100-metre Track

Mr. Vielle has a 100-metre track layout and his complete train consists of locomotive, tender and three bogie wagons. The three wagons are no doubt usually filled with enthusiastic passengers when the train is operating, as can be seen from the illustration.

The locomotive model itself is 2 metres long and has a boiler capacity of 15 litres, with a superheater and waterfed by two pumps, one mechanical and one steam pump. Piston diameter is 31 mm., cylinder bore 0.60 cm. and pressure is 16 kgs.

#### New Gauge O Model Locomotive

For a long time there has been a demand for a simplified gauge O model of a popular British Railways passenger locomotive, at a reasonable price, and also for suitable coaches to run with it. With this in mind, Messrs. Bassett-Lowke, Ltd., have now produced a model locomotive, British made throughout, which should meet this need among gauge O model railway enthusiasts.



Fig. 4.—Mr. Vielle prepares his  $7\frac{1}{2}$ in. gauge French steam locomotive for a run.

This new model (Fig 5) is based on a 4-4-0 passenger type British Railways locomotive with a 6-wheeled tender. It is available for clockwork and for permanent magnet, 12-volt DC electric propulsion. It is offered in either blue or green livery, and the new British Railways passenger corridor coaches recently introduced by the same firm team up very well; at the same time, for those requiring a goods train, the locomotive can be used equally well with lithographed steel goods vehicles. With the tinplate rail and points now available, it is once more possible to obtain a gauge O scale model railway at a moderate cost.

## BOOKS FOR ENGINEERS

By F. J. CAMM

Screw Thread Tables, 5/-, by post 5/3.

Refresher Course in Mathematics, 8/6, by post, 9/-.

Gears and Gear Cutting, 6/-, by post 6/6.

Workshop Calculations, Tables and Formulae, 6/-, by post 6/6.

Dictionary of Metals and Alloys, 10/6, by post 11/-.

Wire and Wire Gauges (Vest Pocket Book), 3/6, by post 3/9.

Metric and Decimal Tables, 3/6, by post 3/9.

Screw Thread Manual, 6/-, by post 6/6.

From GEORGE NEWNES, LTD., TOWER HOUSE, SOUTHAMPTON STREET, STRAND, W.C.2.



**MAKE MORE** in  
*your own workshop!*

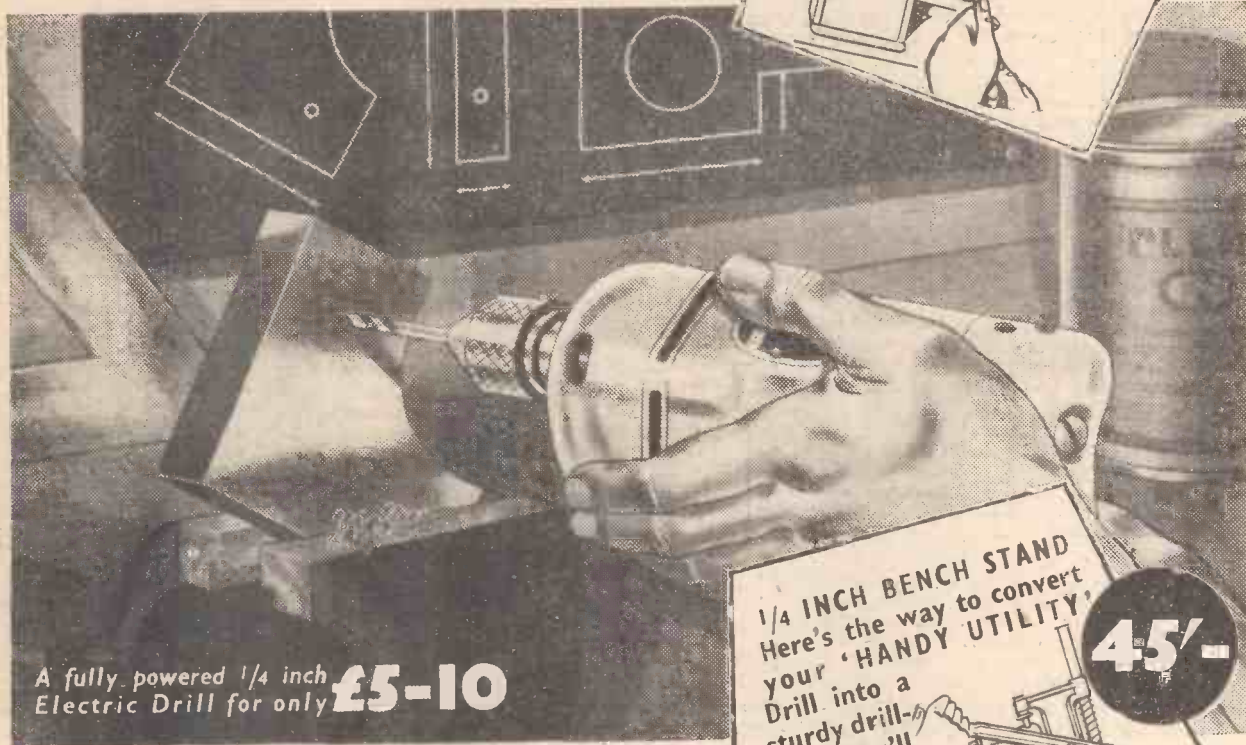

A fully powered 1/4 inch Electric Drill for only **£5-10**

**14/-**  
HORIZONTAL STAND  
for grinding and tool  
sharpening, buffing and  
polishing

**45/-**  
1/4 INCH BENCH STAND  
Here's the way to convert  
your 'HANDY UTILITY'  
Drill into a  
sturdy drill-  
press. You'll  
find plenty  
of jobs that  
demand a  
Bench Stand.

NOW ... put those ambitious ideas into practice! Invest in this powerful, low-priced 1/4" Portable Electric Drill! Make faster, neater, deeper holes in wood, steel, plastics ... grind and buff metals! 'HANDY UTILITY' and its accessories are like a workshop on their own. With the Wire Wheel Brush, will remove paint and rust around the home as well.

*The mate of all work*

**ELECTRIC  
HANDY-UTILITY  
TOOLS**

**10-17-6**  
1/4 INCH DRILL KIT  
Drill, 13 h/s Bits,  
Horiz. Stand, Grinding  
Wheel, Wire Wheel  
Brush, Buff, Arbor,  
Metal Carrying Case.

**17/6**  
ACCESSORY KIT  
Grinding Wheel, Wire  
Wheel Brush, Buff,  
Arbor. etc.



A PRODUCT OF BLACK & DECKER LTD.

OBTAINABLE FROM YOUR LOCAL TOOL SHOP, IRONMONGER OR STORE

# Trade Notes

## The Falcon Automatic Electrical Car Lighter

THE new Falcon lighter is designed to fit easily on the underside of the dashboard. Withdrawal of the small knob automatically lights the glass fibre wick of the torch. The housing for the lighter is moulded from non-inflammable Beetle plastic material, and it cleans with a damp cloth. The main body of the lighter, containing fuel tank and mechanism, simply slides in, and is firmly held in position by spring clips. A single refuelling lasts for months. Models for operation on either 6 volts or 12 volts are obtainable, price £2 2s., plus £1 1s.

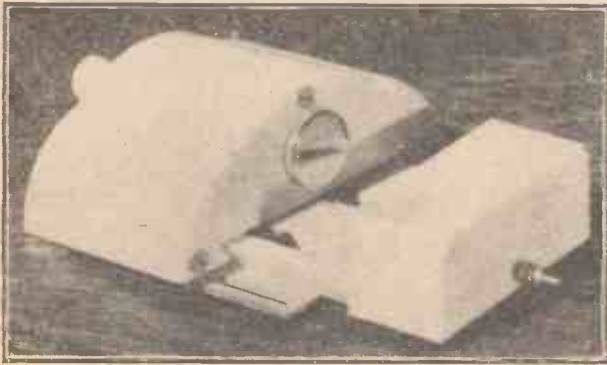

(Above) Rear view of the Falcon lighter (inverted), showing how the fuel tank slides into position. (Right) How the lighter operates by simply withdrawing the torch. One filling supplies the lighter for months.

purchase tax, from garages and accessory distributors, or direct from the makers, The Hillier Engineering Company, Ltd., Oldham Road, Rochdale, Lancs.

## Johnson's New "Unitol" Developer

UNITOL is an entirely new type of liquid fine grain developer. One ounce of the concentrated solution is diluted with water to make any required volume of developer up to 25 ounces. This is used once and then discarded. There is nothing to dissolve and nothing to filter. Only the required amount of solution for any size of tank need be prepared. Unitol produces negatives of such high quality and gradation that, even at considerable degrees of enlargement, little trace of grain is shown. Unitol sells at 3s. 6d. for an 8 oz. bottle. A handy rotating calculator, which shows at a glance the correct developing time for any dilution in any size of tank, can be obtained for 4d. from Johnsons of Hendon, Ltd., Hendon Way, Hendon, N.W.4.

## "Happy Snapshots"

OUTWARDLY, there is nothing to indicate that "Happy Snapshots," a new counter leaflet now being distributed to photographic dealers all over the country by Philips Electrical Ltd., the makers of "Photoflux" flashbulbs, is anything but a miniature snapshot album. Inside, however, there is much that is both interesting and instructive for the amateur photographer.

The effect of a miniature album is heightened by a series of delightful photographs on the first few pages. A page outlining the possibilities of flash photography,

leads into some useful hints on flash technique. Some helpful hints are also given on how to take effective flashlight photographs with ordinary cameras.

## "Pyrobit" Fume Extractor

IN many industrial operations, such as soldering, brazing, welding and heat treatments, fumes are given off which are liable to affect the health of the worker. This is especially the case when the fumes are generated in close proximity to the worker. The "Pyrobit" Fume Extractor solves this problem in an entirely new way by utilising the considerable heat emission of the electric

fumes from the work, and dispersing such fumes in diluted form above the level of the worker's head. Further particulars and prices can be obtained from The Acru Electric Tool Manufacturing Co., Ltd., 123, Hyde Road, Ardwick, Manchester, 12.

## Scale Model Ships

BASSETT-LOWKE, LTD., of St. Andrews Street, Northampton, have recently issued a new edition of their Model Ships Catalogue which, as usual, is attractively produced on art paper. In addition to many standard lines, some new items have been introduced, including a

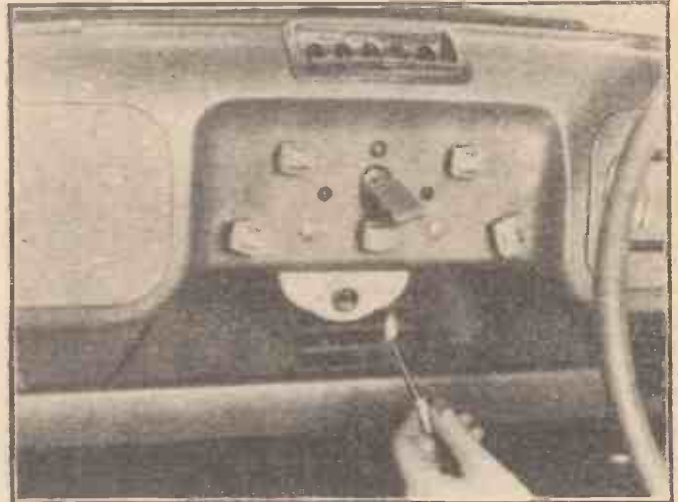

The "Pyrobit" Fume Extractor in use.

lamp which illuminates the work-bench. This new appliance is a combined ventilation and work-illuminating device, comprising an air duct and an electric lamp which provides the necessary light, and at the same time the required amount of heat to create a 'chimney' effect capable of withdrawing

clockwork boat motor, which should be of special interest to small-boat enthusiasts. The range of inexpensive ships fittings, such as steering wheels, bollards, ventilators, anchors, skylights, companion ways and port and starboard lights, has been extended. An old friend, the centre-flue launch boiler, has been reintroduced. The catalogue, which is priced at 1s., is obtainable from the above address.

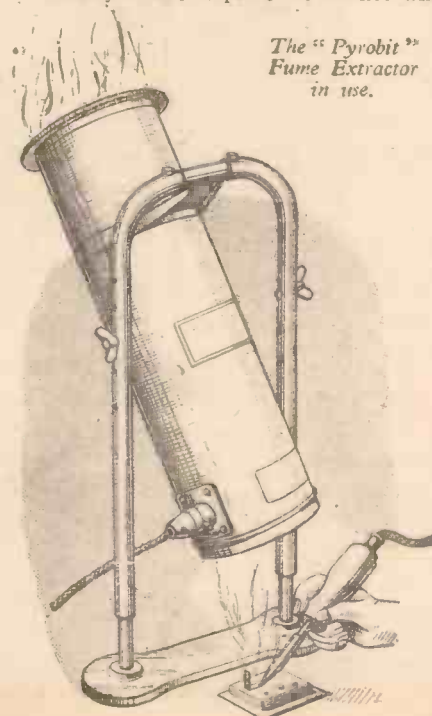

## JUST PUBLISHED

### A Cyclist's "Bible"

EVERY CYCLIST'S POCKET BOOK  
By F. J. CAMM

400 Pages, 120 Illustrations, Fully Indexed.  
84 Pages of Indexed Road Routes of England and Scotland:

#### Chief Contents:

Bicycle Measurements; The "Gear" of a Bicycle; Frames; Standard Frame Angles; Handlebars; Saddles; Brakes; Pedals; Chains; Chain Wheels and Sprockets; The Variable Gear Hub; Derailleur Gears; Tyres; Rims; Clothes and Equipment; Tandems; Lamps; Cyclometers; Adjusting Bearings; Re-enamelling a Bicycle; Overhauling the Bicycle; Wheel Building; Calculating Spoke Lengths; Summary of Cycling Law; Touring; Touring by Numbers; Map Reading; Road Routes Simplified; Cycle Camping; Touring Abroad; Interesting Cycling Facts; National Clubs and Associations; Railway and Cloakroom Charges; Calculating Speed from Pedal Strokes; Tables of Gradients; Constants for Reckoning Speed; Table Showing Speeds per Hour; Gear Table for Single-Speed Machine; British Standard Cycle Threads; Cycle Thread for Spokes and Nipples; Lighting-up Variations; Road Records and Routes; Records and Standards; Women's Road Records; Principal Road Routes of Great Britain; Road Statistics; Bicycles in Use Throughout the World; Index.

Price 7/6 net, or 7/9 by post, from George Newnes, Ltd., Tower House, Southampton Street, Strand, W.C.2.



**BUILD YOUR OWN RADIO!**



Are you a Beginner, Servicing man, Dealer, Experimenter or Hobbyist? Whatever your interest in radio you will find something for you in the NEW EDITION of our world-famous publication "THE HOME CONSTRUCTOR'S HANDBOOK." Here are some of the good things it contains:

- ELEVEN tested and guaranteed circuits with full descriptions and COMPLETE parts lists.
  - Feeder Units, Tuning Units and Superhets, (A.C./D.C. and Battery).
  - Quality Amplifiers.
  - Test Gear.
  - Coils (Used in "P.W." 9 valver!)
  - Servicing and Constructional Hints and Tips.
  - Resistance Colour Code, Charts, etc.
  - Useful Formulae.
  - And many other interesting items. The price is 1/6 ONLY (worth many times this purely introductory price). So SEND NOW for your copy. Vast numbers of beginners have built modern factory-designed superhets, using our Tuning Units. Failure is impossible, when using our UNIQUE easy-as-abc Construction Sheets.
- MODEL 30 TUNING UNIT.** 30 wave-band—consisting of iron-cored 30 coil pack, iron-cored I.F.T.'s, J.B. 2-gang Condenser, and 3-colour 8" x 6" dial. ALIGNED AND SEALED AS A UNIT in a standard 5 valve superhet. receiver. No further adjustments necessary whatsoever! 69/9 (inc.).
- MODEL 40 TUNING UNIT.** Similar to above but with R.F. stage 99/8 (inc.) or 120/3 (inc.), with spin-wheel J.B. SL8 Tuner. H.C. Handbook given FREE to all purchasers of either unit. Mail order ONLY DIRECT FROM

**RODING LABORATORIES**  
(MAIL ORDER DEPT. M.I.)  
70, LORD AVENUE, ILFORD, ESSEX.

**TRIX**  
**X-acto**  
**No. 86 TOOL CHEST**  
**The Desk-drawer Workshop**



**No. 86**  
**TOOL CHEST**  
**63/-**  
**COMPLETE**

If your craftwork and model-making demand accurate cutting and carving, then here's a kit of first-rate tools for the job.

It contains three perfectly balanced, interchangeable blade knives which can be loaded in five seconds from a selection of X-acto blades, gouges, routers and punches.

A spokeshave, block plane, balsa stripper, sanding block and steel rule complete this outstanding kit in a polished wooden cabinet—remarkable value for 63/-.

Get one and get more fun from your hobby.

Write for illustrated leaflet.

**TRIX LTD., 11 OLD BURLINGTON ST., LONDON, W.1**

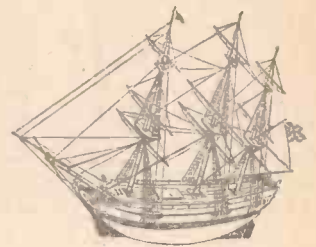

H.M.S. Bounty

**MODEL CRAFT**  
**1951 LIST**

**JUST OUT!**

Gives details of nearly 700 plans, planbooks, kits and accessories for model-makers, including

GALLEONS, CLIPPERS, RACING YACHTS, FOWER-BOATS, MERCHANT AND WARSHIPS, AIRCRAFT, RAILWAY AND ROADSIDE FEATURES, LORRIES, BUSES, TRAMS, CARS, DOLLS' HOUSES, etc.

**PRICE 1/-** and you get that back when you purchase Modelcraft goods by using the REFUND VOUCHER which is contained in every copy.



**MODEL CRAFT LTD.,**  
77(L), Grosvenor Rd., London, S.W.1.

**UNUSED Ex-W.D. BARGAIN**

FRACTIONAL H.P. EX-R.A.F.



**1/10 H.P. BRAND NEW ELECTRIC MOTOR.**  
Made by Ecovors.  
EACH ONLY **37/6**  
Carr. 2/6

Not to be confused with smaller, cheaper types. Size 1 1/2 in. x 5 1/2 in. x 5 1/2 in. Weight 18 lbs. Volts 200-250 : state A.C. or D.C. 2,000 r.p.m. Ideal for polishing, grinders, etc. Extending spindle 5 in. diam., 3 in. long. All-purpose extra. spindles to screw on 7/8 pair extra.

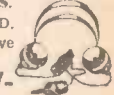
**EX-ARMY HEADPHONES.**  
BRAND NEW AND BOXED.  
Ideal for Crystal or Valve Sets, hospitals, etc. 

**POST FREE 5/6 TWO PAIRS 10/-**

**PRECIS. INSTS.** Bal. Arm. Units, Reed drive corrug. alum. Diaphragms, dbl. H/bands, 8ft. cords and plug. Worth about 42/- pair. Also makes telephone set by connecting earpieces to any length twin flex.

**ROTARY TRANSFORMERS T31.** Input 18 v. D.C. 12 amps. ; Output 220 v. 11 amps. ; and 7.2 v. 13 amps. Or converts to good Mains Motor for A.C. or D.C. 25/- incl.

**ELECTRIC BELLS.** Made by Western Electric, double gong with moulded case, loud tone direct from 230/250 volts A.C., 50 cycles. 15/- each, post 1/-.

**CAUSTIC SODA.** B.P. 98 per cent. (pure) flake, by leading makers, in 5lb. tins at only 15/- per tin incl.

**SCREENED LEADS.** 18ft. long, 1/4 in. diam. spade terminals each end. Technically perfect. 3/6 each, post 3d.

**LAMP BULBS**

Million lamps, 150 types, for Projectors, Searchlights, Floodlights, Signal, Mines, Car, Aircraft, Yacht, Ship, Workshop, House, Miscellaneous, etc. All unused in original wrappers at low cost. Id. S.A.E. for LISTS—1d. S.A.E. for RADIO/ELEC. LISTS.

**AUTO COLLECTIONS LTD.,**  
15, LAWRENCE STREET,  
NORTHAMPTON.

**WILCO ELECTRONICS**

204, Lower Addiscombe Rd., Croydon

**CLOCKWORK MECHANISM.**—Precision made movement with contacts making and breaking twice per second, can be used for switching on and off lamps, etc. Brand new in sound-proof cabinet with thermostat temperature control. Price 15/6, postage 1/6.

**WEE MEGGERS** in leather carrying case, brand new, 250 v. 20 megohms, 27/10/0 each.

**SHOWCASES.**—Hardwood with plate glass opening front, 3ft. 3in. x 2ft. 3in. x 5 1/2 in. Ideal for shops, factories, etc., 45/- carriage 10/-.

**GEARED CAPACITOR MOTOR.** 200/240 v. A.C. 30 watt, size 7 1/2 in. x 4 1/2 in., 1,500 r.p.m., with 300 r.p.m. on final shaft, standard foot mounting, brand new, reversible, with capacitor, 84/-, post 1/6.

**KLAXON GEARED MOTORS** No. IK55B3—W17. Torque lbs. ins. 15. R.p.m. 175. Motor r.p.m. 1,400 at 230 v. A.C. Split phase induction type, 210 each.

**KLAXON CAPACITOR INDUCTION MOTORS** with 4 in. fan, 230 v. 230 v. 240 v. A.C. 2,700 r.p.m. No. EM5CB2 with condenser, 55/- each.

**WESTINGHOUSE RECTIFIER UNIT.** Input 200/250 volts, A.C. Output 50 volts D.C. 0.75 amps., 25. 15 amps., 27.

**UNISELECTOR SWITCHES.** 25 way 8 bank, 8 wipers, 37.5 ohms, 27/6, post 1/-.

**BATTERY CHARGERS "WESTALITE."** Input 100/250 v. A.C. Output 12 v. 16 amps., variable metered output, fused, worth 234. Our price while they last 210 10 0, carr. 10/-.

**24 VOLT D.C. MOTORS** with double ended shaft 2 1/2 in. x 3 1/2 in., 10/6, postage 1/-.

**THERMOSTAT SWITCH.**—Bimetal type in sealed glass tube, 2 1/2 in. x 1 1/2 in. 30 deg. Cent. Ideal for Aquariums, 5/- each.

**VOLTMETERS.**—0-300 A.C. Moving Iron 2 1/2 in. Flush, 17/6 ; 3 1/2 in. Flush or Surface, 22/6 ; 0-250 A.C. Moving Coil Rectifier Type, 3 1/2 in. Flush, 30/-.

**MASTS, TELESCOPIC** extending to 12ft. in 7 sections, 15/6, post 1/-.

**THERMOSTAT.** Satchwell 1 1/2 in. stem 0/250 volts A.C./D.C., 10 to 90 deg. Cent. 2/6.

**BOMB RELEASE UNITS,** suitable for photographic exposure timers, 1 second intervals up to 8 seconds, 10/6 each ; up to 16 seconds, 15/6 each. Post and pkg., 1/6.

**SPEAKERS.**—P.M. 8 in. Goodman, in wall case, with transformer, 21/- Post & pks. 2/6.

**CYCLE LAMP BATTERIES TYPE 800.**—E.R. Make. Sealed Carton of 20 for 10/- Post Free.



**Super Bargains**

**DYNAMOS.** C.A.V. 12 volt D.C., 10 amps., 1,400 r.p.m. ideal Windchargers, 50/- . Heavy current Dynamos, 12 volts 50 amps., 3,000 r.p.m., £4.10. 6 volt 5 amp. hand generators geared to slow speed, easily adapted for windcharging, 25/- ea. Carriage on any Dynamo 5/- extra.

**HAND MAGNETO GENERATORS.** P.M. steel Magnet, wound armature driven by gearing in handle, output approx. 70 volts 25 m.a. A.C., 8/6, post 1/6; larger model 4-magnet type in hard wood case with external terminals, 10/- ea., post 2/- . G.P.O. Mag. Bell in polished wood case, Bin. x 6in. x 3 1/2in., fitted Condenser, Transformers, Switch-hook, connection strip, etc., 3/6, post 1/6. G.P.O. long Magnet bell receiver, 2/6, post 9d.

**CRYSTAL SETS.** The Lesdix Boudoir Model in neat black bakelite case fitted variable condenser, coil, diode detector and terminals, 17/5, post 1/6. With this special diode detector you have no Crystal worry; it is ever permanent.

**HEADPHONES,** new and sensitive to crystal reception, with headband and cord, 10/-, postage 9d. Single L.R. Headphone with headband and cord, 1/9, post 6d. Single L.R. 50 ohm phone unit with adjustable diaphragm, 1/6, post 6d.

**ELECTRO-MAGNETS, D.C.,** 6 volt, twin coil, weight 10 ozs.; lift 4 lbs., 5/-, post 6d.

**HORSESHOE MAGNETS.** Swift Levick S.L. S.36 circular horseshoe, 1 1/2in. dia., 3/4in. thick, 1in. polar gap drilled pole, weight 2 ozs., lift 3 lbs., 2/6. Large stock of horseshoe magnets in several sizes; send for Magnet leaflet.

**NIFE CELLS.** 12 volts 45 a.h., 9 cells per crate, new £8.10. These long-life batteries are ideal for caravan or small house lighting; larger sizes quoted for.

**TRANSFORMERS.** Foster double wound, 230 volts/50 volts 2 amps., 15/-, post 2/- . Transformers for your Electric Train, 230 volts/12 volts 3 amps., 32/-, 230 volts/20 volts 2 amps., 30/- . Bell Transformers, 230 volts/3-5-8 volts 1 amp., 10/-, in bakelite case.

**BRUSH UP YOUR MORSE** with an Electradix Morse Code set comprising beautifully made, precision Air Ministry Morse Key, Buzzer terminal block, single phone with head band and wiring diagram, 6/-, post 9d. Morse key on polished wood base with battery holder and space for Buzzer, 2/6, post 6d. Practice Buzzer, 2/- . High Note tiny Townsend Buzzer Tunable note, 5/-.

**WIRE.** Glass covered wire 21 gauge on reels, 14-20 lbs. each, 4/6 lb. Reels charged 1/3 extra and credited for if returned. Larger quantities at cheaper rates.

**FIELD WIRE,** new D.8 twin wire, £8.10 per half mile twin wire.

**HOUSE TELEPHONES.** Surplus G.P.O. wall phones comprising Mike in bakelite case mounted on Polished wood case Bin. x 6in. x 3 1/2in., magneto bell, condenser, transformer, switch-hook and contacts, long magnet bell receiver and hand magneto Generator, a Kit of parts with wiring diagram, 35/- per pair, carr. 5/- extra.

**DIMMER RESISTANCES,** 100 ohms 1/2 amp., totally enclosed panel type, 2/6 ea., open type 10 ohms 1 amp., 2/6, post 6d.

**THE DEM. CONTINUITY TESTER,** a self-contained portable circuit tester for all electrical Circuits; totally enclosed in polished wood case 6 1/2in. x 3 1/2in. x 2 1/2in., with carrying strap and contact switch, price with battery and single phone, 5/-, post 1/-.

**SWITCHES.** Dewar Key Switches, 7 pole C.O., new 3/6, post 6d. Yaxley 8-pole 1-way or 3-pole 3-way, 2/6 ea. Lucas 8-way Switchboxes, 3/-, post 1/-.

**DOWTY LIVE LINE HYDRAULIC PUMPS,** 25/- ea. Water Pumps, 12 volt, lift 2ft., throw 10ft., handle 100 g.p.h. £5.10. Stuart Turner Motor Pumps, 230 volts A.C., lift 3ft., throw 10ft., capacity 100 g.p.h. Rotary Suds Pump, only £4.10.

**WAVEMETER, Model 69.** New, in box Bin. x 8 1/2in. x Bin., fitted variable inductance with heavy knob and scale, trimmer condenser fixed condenser, on/off switch, valve holder and space for batteries (without microammeter), 12/6, plus 2/6 postage and packing.

**RELAYS.** G.P.O. bank of 20 100 ohm Relays enclosed in metal case, 10/-, post 2/- . G.P.O. Relays in circular metal cases, as new, operate on 61/2 volts 30 ohms, 2 S.P.C.O. contacts, 165 ohms, D.P.C.O. contacts 1,000 ohms, 2,000 ohms both 2-S.P.C.O. contacts. 2/6 each, or 25/- doz., post 6d. each relay.

**CATHODE RAY TUBES.** V.C.R. 97 new and crated, 35/-.

Please include postage for mail orders.

**ELECTRADIX RADIOS**

214, Queenstown Road, London, S.W.8  
Telephone: MACaulay 2159

**WRITE TO US FOR THE FOLLOWING MATERIALS**

- 'PERSPEX' ACRYLIC SHEET—cut to any size.
- 'CATALIN' CAST RESIN in a multitude of shapes.
- 'CATACOL' RESIN ADHESIVE
- 'CATACAST' CASTING RESIN } and accelerator
- 'VINAMOULD' FLEXIBLE MOULDING COMPOUND

... and every other requisite for the serious Craftworker. 1/6 procures our Illustrated Catalogue and 3d. our price list.



Dept. 3a, 13-17, Victoria Street, HUDDERSFIELD

**THERMOELECTRICS LTD.**

CHAPEL WORKS. HAMPTON-ON-THAMES.

Here is an opportunity for the amateur engineer to acquire a precision Bi-metal Thermostat, capable of controlling A.C. currents of 1 AMP. within the temperature range 50 degrees Fahrenheit to 200 degrees Fahrenheit.

**ROOM THERMOSTAT.** 40-80 deg. F., 60-100 deg. F., or 6-27 deg. C. 15 amps, 250 v. A.C. 1/10 amp. D.C. **PRICE 3/9 EACH**



**IMMERSION THERMOSTAT.** 90-100 deg. F., 13 amps, 250 v. A.C. **35/-**

**CONVECTOR THERMOSTAT.** 40-80 deg. F., 15 amps, 250 v. A.C. 1/10 amp. D.C. **23/6**

Controlled Heating for the Experimental Engineer.

**SPECIAL OFFER.** Asbestos Covered, Fully Flexible Heating Cord. 60 ohms per yard. Price: 1/- per yard.

**BARGAINS FROM BATLEY'S**

- Motorists' Inspection Lamps, with cable, bulbs, crocodile grip handle, 16/6.
- Barrage Balloon Fabric, waterproof, irregular-shaped sheets, approx. 10ft. x 11ft., 30/-; 14ft. x 14ft., 50/-; 14ft. x 18ft., 70/-.
- Plastic Asbestos Compound, for repairing leaking roofs, making moulds, hundreds of other uses, 14-lb. drum, 6/6; cwt., 42/-.
- Wire Lashings, galvanized, 42in. long, loop at each end, 6/- dozen, 48/- gross.
- Metal Springs, strong, 9in. x 1 1/2in., 2/6 each, 24/- dozen.
- Paint, cellulose, 5-gallon drums, stone and light green, 25/-.
- Paint Remover, 5-gallon drums, 50/-.
- Metal Boxes, insulated with 2in. thick cork, 24in. x 16in. x 12in. deep, O/M hinged lid, drop handles, 12/6.
- Lead Pencils, best quality, 25/- gross, sample dozen, 2/6.
- 14lb. assorted Cotter and Split Pins, 20/-.
- Model Engine and Boiler, stationary-type, £25.
- Metal Boxes, 6in. x 6in. x 6in., 2/6 each, 18/- dozen.
- Engine-driven Alternator, 1,200/2,400 cycles, 1,200 watts, excitation 24 volts, D.C., 45/-.

Orders of £5 upwards sent carriage paid.  
**BATLEY & CO., Gorseys Works, STOCKPORT**  
(Phone: STO 3880).

**DRILLS—HIGH SPEED**

New and best quality. Sets complete with Stand. Fractions—1/16th to 1/2in.

x 64ths	...	67/6
Letter A-Z	...	41/6
Number 1-60	...	63/-

Special bargain selections of assorted high speed drills, boxed—no stands

Set HS-A 12 drills app. 3/64 to 1in.	6/-
Set HS-B 12 drills app. 3/64 to 1in.	9/-
Set HS-C 30 drills app. 3/64 to 7/16	20/-

All above post free.

Terms: c.w.o. or c.o.d.

**BULLERS**  
Printing Office St., Doncaster.  
Est. 1916 Phone: 2345

**CRYSTAL SET AMPLIFIER.** Will work a loudspeaker at good strength from your crystal set without alteration. Price complete, 32/6. Suitable crystal set, if required, 14/6, post 9d.

**A.C. BATTERY CHARGER** parts for car accumulators, easily assembled parts with diagram for 6 or 12 volt cells, charging at 11 amps, 30/-, 3 amps, 42/6, 4 amps, 50/-. Postage 1/-.

**PHOTO-ELECTRIC CELLS.** For all sound films, high fidelity production, speech and music. Small tube size, 2in. x 1 1/2in. dia., 20/6. Midget tube, 1 1/2in. x 1 1/2in., 22/6.

**COMPLETE OPTICAL SYSTEM** for 35 or 16 mm, sound film, 42/-.

**ECONOMIC ELECTRIC CO.,**  
64, London Road, Twickenham

**PRACTICAL MECHANICS** (full Apprenticeship or Pupillage) may secure status of Professional Membership by using this COUPON.—To the Secretary, INSTITUTE OF EXECUTIVE ENGINEERS AND OFFICERS, EXECUTIVE CHAMBERS, 241, BRISTOL ROAD, BIRMINGHAM, 3.

**I AM INTERESTED IN MEMBERSHIP: PLEASE SEND ME AT ONCE PARTICULARS AND APPLICATION FORM:**

NAME IN FULL (Block Letters).....  
ADDRESS (Home).....  
(Block letters)  
Present position..... Age.....  
Date..... 1951. Signature.....

Britool Chrome Alloy Steel B.A. Sets 0.9 in steel boxes, 26/-.

Westinghouse 5 M.A. Bridge Meter Rectifiers, 7/6.

8in. Rola P.M. Speakers in Steel Black Crackle Cabinets, 9in. x 9in. x 9in., 31/6.

U.S. Air Force Throat Microphones, New and Boxed, 3/-.

New Brown's Moving Reed Headphones. Best in the World, 7/6.

Moving Coil Microphones. 3in. diameter, with Pressel Switch, 5/6. Matched Transformer, 5/6.

Small 24 v. D.C. Multi-gear Motor with reversible clutch, 11/6.

Powerful small Motors, 24 v. or 110 v. A.C./D.C. with geared spindle, 3 1/2in. x 2 1/2in. x 2 1/2in., 8/6. 24v. Trans. 13/6

Headphones with Breast Plate Microphones. Packed in wooden boxes. Operate with 4 1/2 v. Battery, 10/- a set.

Meters. M/c., 0-250 Milliamps, 2 1/2in., 10/- . 2in. 0-300 v. 10/-.

Miniature Motors, 24v. A.C./D.C., 2 1/2in. x 1 1/2in. x 1 1/2in., 8/6. Post paid, 24v. Trans. 13/6

250-watt Double Wound Transformers; 230/115 v. Made by G.E.C. With Steel Shroud. New. £27/6 each.

New Osram, Crompton, Mazda, etc., 12 v. Car Bulbs. Double contact 10 watt, 1/3.

Army Carbon Microphone with switch. New and Boxed, 4/6. Trans. to match 3/-.

Admiralty S.M. Dials, 100-l with vernier. White Ivorine dial 0-100. Worm driven. New and Boxed, 8/6. Transformers, 230/24v., 13/6.

All Carriage Paid. Money Back Guarantee from:

**THERADIO & ELECTRICAL MART,**  
253B, Portobello Road, London, W.11.  
Park 6026.

**DUKE & CO.**

**I.L.T. BATTERIES.** 5.6-150 volt guaranteed minimum; tapped 21.90-111, 1 L.T., All-Dry. All are tested before despatch. Allow 1/6 post.

**MOTOR BLOWERS.**—13rd b.p., easily rewound from 110 5/Phase to 230v. A.C. Or will work from transformer or resistance. Forge type blower 3 1/2in. diameter outlet. Motor is 2,850 to 3,450 r.p.m., 1in. spindle. To clear, 50/- Carriage extra.

**DUNLOPILLO.**—Supplies still available, 32 x 18 x 2in. flat. 12/6, plus post. VALVES from 2/6—6JGGT, SP41, E.A.50, EB34, 6H8, L.P.2. Valve SP73, 3/6. Valves at 5 p: 12A6, TH33, VP133, HL133DD, Pen.383. Valves at 6/6: 6V6, IR5, 6K7GT, 6Q7, and many more.

**EXTENSION SPEAKER.**—5in., in cabinet only, 14/6.

**CHOKES.** Midgets, made by Lee's, 10 Henry, 50 mill., 300 ohms, 4 for 5/- . Also 10 Henry, 80 mill., 250 ohms, 8/6: 10 Henry, 100 mill., 300 ohms, 9/6.

**METAL RECS.**—Very small, ideal for midgets, 250v., 60 m/amps, 6/6.

**1155 AND 1154 RECEIVER (A.C.)** (Transmitter not converted). £15 the two.

**CAR SPOTLIGHTS,** and Headlamps, ex-L.P.T.B., only 7/6 each.

**CABINETS** (Philco). A few extra again available, 17/6 each.

**SUPER-PRO-HAMMERLUND.**—22-valve, all-wave, super radio-receiver that has everything and can get anything on the air. Set includes speaker and power pack. Sacrifice £40.

**WALKIE-TALKIE.**—A few left only at 17/6. Only one valve (ATP) and switch (send-receive) short. FREE set of drawings supplied with each one.

**FREE OFFER** of phones with No. 18 Superhet receiver. Short-wave, complete, and working. Frequency range easily changed (I.F.465). To clear, 17/6. Instructions and drawings included.

**T.V. LENSES,** 50/-, or "Filter"-filled, 55/-; 8in., 9in. or 10in. only.

Money back guarantee if not satisfied. Cash with Order, please, and allow sufficient for postage or carriage.

Stamps ONLY for LISTS.  
**219, ILFORD LANE, ILFORD, ESSEX.**  
Phone: ILFord 0295.



**CAR COMPASS**

A neat spirit-filled compass for dashboard mounting. Incorporates built-in North-South and East-West compensators and is ideal for cars, boats or sailplanes. American-made for aircraft use. Easily mounted by means of the anti-vibration bracket fitted at back. Post free each **28/6**



**PSYCHROMETER**

A beautifully made, brand new, ex-R.A.F. meteorological instrument consisting of Wet and Dry Bulb Thermometers. Calibrated from -10 to +110 degrees F., and tubes are over 15 ins. in length. Made by leading British instrument makers, and in very solid frame with good water-tank and scientifically accurate screening to bulbs. **42/6** Carriage paid. Each

**MINIATURE BLOWER**

For valve cooling, super-charger and numerous other uses. Brand new American-made for 24-volt D.C. operation (rated at 27 volt, 1/135 h.p., 5,000 r.p.m., 0.74 amp.). Beautifully made. 3 1/2 in. long, 1 1/2 in. diameter. **12/6** post 9d.

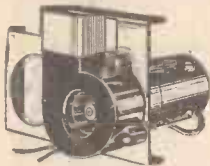

**MONSTER SPARES COLLECTION**



Biggest assortment of spare aircraft parts ever made available. Each parcel weighs approx. 25lbs. and is sent to you carriage paid. Contents guaranteed to include 4 fine aircraft instruments, such as Air Speed Indicator, R.P.M. Indicator, Rate of Climb Indicator, Turn and Bank Gyro Indicator, Electric Thermometers, etc. etc. plus a large number of miscellaneous parts of use to the Model Engineer. Large number of small gears, movements, syphon tubes and other mechanisms of use to the amateur mechanic experimenter, etc. We have sold over 1,400 of our smaller parcels and are offering this monster selection in response to the heavy demand from our customers. We estimate maker's price of this parcel to be over £80! Carriage paid in U.K. **25/-** ONLY

**ROSS X PRESS**

Wide-angle lens. 5in. f. 95 deg. wide angle, giving immense field of vision. Suitable for types of cameras. Complete with iris and flange mount; specially recommended for landscapes and panoramas. Postage 1/6. **£7.10.0**

As above but without maker's name actually engraved thereon. Postage 1/6 **£6.10.0**

**AERO SPARES Co.,**

(Dept. 85)  
70-71, HIGH HOLBORN,  
LONDON, W.C.1  
(Tel.: AMBassador 287112)

**A new solder FOR WORKSHOP AND HANDYMAN**

- CONTAINS 2 CORES OF FLUX
- NO EXTRA FLUX REQUIRED
- REPLACES STICK SOLDER, FLUID AND PASTE FLUXES
- IF DESIRED FLUX RESIDUE READILY WASHES OFF WITH WATER
- SO FAST THAT IT WILL EVEN SOLDER BLUED SPRING STEEL WITHOUT PRE-CLEANING



No. 10 KIT 2/- each



SIZE 8 CARTON 5/- each

Available in 5/- retail cartons (4 specifications) or 2/- Multicore Solder Kit contains 2 specifications Arax Multicore Solder and 2 specifications Ersin Multicore Solder for electrical wire to tag joints. Now obtainable from many stores. In case of difficulty 5/- cartons or 2/- Multicore Solder Kits sent post free on receipt of postal order or stamps.

MULTICORE SOLDERS LTD., MELLIER HOUSE, ALBEMARLE STREET, LONDON, W.1

**You Can Become a HANDICRAFTS INSTRUCTOR**

Men who enjoy making things in wood or metal can turn their hobby into a permanent and interesting Career! Short hours, long holidays, and security in a job you would really enjoy, can be yours if you become a Handicrafts Instructor. Let us send you details of the easiest and quickest way to get the necessary qualification.

We definitely Guarantee "NO PASS - NO FEE"

If you would like to know about our unique method of preparing you for one of these appointments, write today, and we will send you an informative 176-page Handbook—FREE and without obligation. Mark your letter "Handicrafts Instructor."

British Institute of Engineering Technology  
591, Shakespeare House,  
17/19, Stratford Pl., London, W 1 **BIET**

**TARGET BLOWPIPES**

The "Target" FINE FLAME Gas Blowpipe (self-blowing) is ideal for all those small and delicate soldering and brazing jobs essential to model making. Fine intense flame easily melts small copper rivets. Soldering and small brazing jobs done in no time. PRICE 2s. 8d. each. POST FREE.

The "Target" FIERCE FLAME Gas Blowpipe (self-blowing). For soldering and brazing LARGER jobs, gives a fierce roaring 4-inch flame. Guaranteed to melt in copper tube. PRICE with full instructions, 6s. 6d. each. POST FREE. Retailers Enquiries Welcomed. **TARGET MFG. CO.** Wollaston, Wellingborough (Dept. P.M.)



**Plastics LTD** (MANCHESTER)

11 Whitworth Street, Manchester, 1. Tel: Cen. 0272-1725.

BRITAIN'S LEADING STOCKISTS OF:  
"PERSPEX" (Acrylic) sheet, rod and tube,  
"CRINOTHENE,"  
B.X. ACRYLIC ROD,  
P.V.C. SHEETING (Admiralty Specification),  
"CASEIN" Rod, Sheet and Tube,  
CELLULOSE ACETATE Film and Sheet.

Official Stockists for:  
IMPERIAL CHEMICAL INDUSTRIES LTD., ERINOID LTD.,  
B.X. PLASTICS LTD., UTILEX LTD.  
Catering especially for Industry, The Hobbyist and the Model Maker.  
Contractors to the Admiralty, most Government Departments, Schools, Institutions, etc.  
Trade and Technical enquiries solicited.  
Fabrication, Engraving, Moulding, Cutting to Size, Shape, Contour a speciality

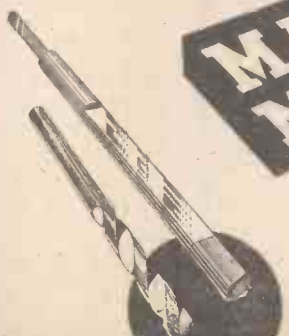

**TUNGSTEN CARBIDE DRILLS**

For clean round holes in brick, concrete, marble, glazed tiles and rock, etc. Sizes from 5/32in. to 2in. dia. Send for full details. YOU CAN GET MASON MASTER DRILLS FROM ALL GOOD TOOL STOCKISTS.

**JOHN M. PERKINS & SMITH LTD.**  
Braunston, Near Rugby  
Phone: Braunston 238

**THE TIP DOES THE TRICK**

**PORTASS**



**LATHES ARE SOUND IN THE HEAD**

Special offers to Mechanics Readers  
The Portass Latho & Machine Tool Co.,  
Buttermere Rd. Tel.: 51353. Sheffield 8.

**CHEMISTRY APPARATUS**  
Send Stamp for COMPLETE PRICE LIST



Booklets:  
"Experiments" 7d.  
"Formulas" 10d  
"Home Chemistry" 2/3  
Post Paid.

**BECK** (Scientific Dept. A)  
60 HIGH STREET,  
Stoke Newington, London, N.16



**Largest stocks, best selections**  
**CLYDESDALE**  
 and Bargains in Ex-Services Radio and Electronic Equipment

**Hand-Driven Generator**

H. 409. Hand-driven Generator 10K/13043 comprising of a 40 : 1 gearing unit driving a generator producing 6.3 v. .5 a. and 300 v. 50 ma complete with ratchet handle. -Diam. 7in. long. Used, but in good condition.

CLYDESDALE'S PRICE ONLY **13/6** POST PAID

H. 408. Hand-driven Generator by BENDIX, comprising of a 70 : 1 geared unit driving a generator producing 28 v. .175 a. and 300 v. at 40 ma. The generator is detachable, measuring 4½in. x 2½in. The unit is complete with ratchet handle. Used, but in good condition.

CLYDESDALE'S PRICE ONLY **13/6** POST PAID

**Magnetic Compass**

H. 406. Magnetic marching Compass MK 1 for day or night use, enclosed in a black Bakelite case 3in. x 2½in. x ½in., complete with instructions for use.

CLYDESDALE'S PRICE ONLY **21/-** each POST PAID

**Sperry Computer, Type BB. Ref. 10992 "M."**

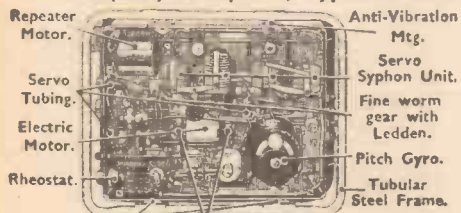

This unit represents a wealth of mechanical and electrical components. Consists of: Over 100 various precision gear wheels, helicals, rollers, spirals, levels, ratchets, worm drives, skew gears and variable pitch worm gear. Precision pitch stabilizing gyro unit. Servo syphon unit with four concertina type reservoirs, small bore servo tubes, servo switch.

Anti-Vibration Mtg. Reversible Friction Clutch. Two 24-volt D.C. 1.5 A. motors with pulleys shaft each end and reversing clutch mechanism. Selsyn 24 volt repeater motor (9/2282). Slow motion dials, counters, aneroid, capsules, shafts, springs, metal and flexible tubing, plus over 800 springs, washers, nuts and bolts, etc., etc.

The complete unit is enclosed in a metal box with removable side covers: 19 x 14½ x 3½ins. finished in black crackle and suspended in a tubular metal cradle frame by four heavy duty anti-vibration mountings. Weight 96 lbs.

This unit was designed for use with the American T1 Bombsight. CLYDESDALE'S PRICE ONLY **69/6** each CARRIAGE PAID

**CLYDESDALE SUPPLY CO. LTD.** • 2 BRIDGE STREET GLASGOW - C.5

Phone: SOUTH 270619.

Please Print Name and Address.

Send now for new illustrated lists.

**Midland Instrument Co.**

For Govt. Surplus Stock Etc.

**TELEPHONE SETS**, consists of 2 combined telephones and microphones, 25-ft. twin connecting flex, provides perfect 2-way communication, self-energised (sound power), no battery required, complete ready for use, new boxed, 7/6, post 7d. **MAINS TRANSFORMERS**, multiple L.T., input 200-220-240-v. 1-phase 50-cycles, output tappings giving 3-4-5-6-9-9-10-12-15-18-20-24-30 v. at 2-amps, new boxed, 20/-, post 1/3. **RECTIFIERS**, selenium full-wave, A.C. input 15-v., output D.C. 12-v. at 11-amp., suitable for use with above transformer, new unused, 7/6, post 7d. **CRYSTAL RECTIFIERS**, the ideal crystal set detector, CV102, new in lead capsules, 3/6, post 3d. **BLOWER MOTORS**, small type, 24-v. A.C./D.C., or 12-v. with less effect, new unused, 7/6, post 10d. **TELEPHONE HANDSETS**, modern G.P.O. pattern, fitted 4-ft. 4-way cord and plug, new boxed, 7/6, post 10d. **WINCHES**, geared, reduction 187.5 to 1, fitted triple stranded steel cable 21-ft. long with massive shackle at end, fitted clutch and clutch release, suspension by steel bar, drive by ½in. sq. shaft, can be hand operated or motorised, suitable for loads up to 12 cwt., new, unused, an exceptional offer, 30/-, post 1/6. **INERTIA SWITCHES**, make contact on impact, new boxed, 2/6, post 10d. **MOTOR GENERATORS, TYPE 34**, 3-commutator P.M. field, input 24-v., output 200-v. at 30-mA, and 6.3-v. at 2-amp., also suitable for 6 or 200-v. input, with corresponding voltage outputs, new unused, 5/-, post 1/6. **HEADPHONES**, balanced armature high resistance, for maximum sensitivity, ideal for crystal sets, new boxed, 7/6, post 10d.

Also relays, amplifiers, mains and L.T. motors, switches, counters, compasses, burglar alarms, accumulators, thermostats, compressors, selector switches, immersion heaters, microphones, batteries, fans, meters, cable, speakers, valves, lamps, and hundreds of other interesting Radio, Electronic and Mechanical Items; send s.a.c. for our current 20-page lists.

MOORPOOL CIRCLE, BIRMINGHAM 17.

Tel. HARBORNE 1308 or 2664

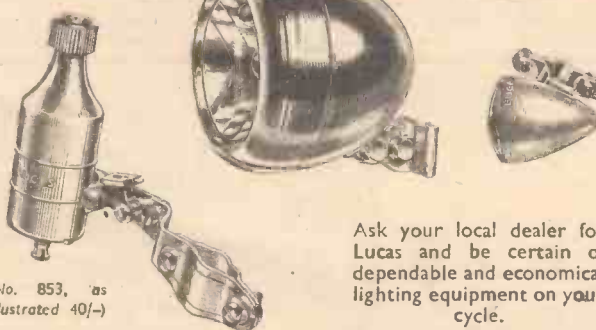
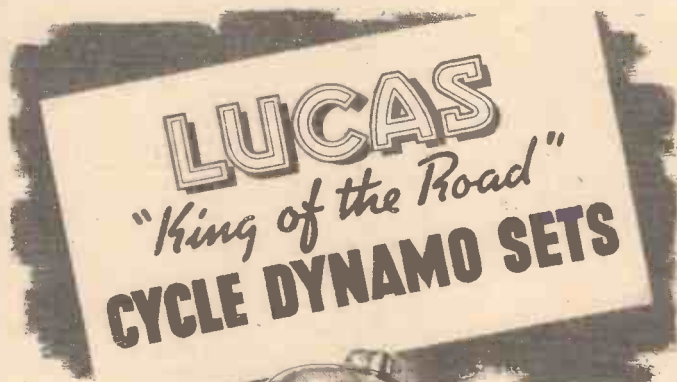

(No. 853, as illustrated 40/-)

Ask your local dealer for Lucas and be certain of dependable and economical lighting equipment on your cycle.

Sets, Prices : 27/6 to 40/-

*The finest Lighting Sets for Cycles*

JOSEPH LUCAS (CYCLE ACCESSORIES), LTD., BIRMINGHAM 6

**HIGH SENSITIVITY**



"F"

Because of their High Sensitivity the S. G. BROWN Type "F" (Featherweight) Headphones are a popular choice by all requiring efficient, long and dependable service.

D.C. Resistance 4,000 ohms; Impedance 14,000 ohms at 1,000 c.p.s. Sensitivity 8 Dbs below 1 microwatt per bar at 1,000 c.p.s. Weight 9 oz.

SEND FOR BROCHURE "P.M." IT GIVES DETAILS OF ALL TYPES OF S. G. BROWN HEADPHONES.



"K"

The S. G. BROWN Type "K" Moving Coil Headphones supply that High Quality Reproduction so essential for DX work, monitoring, laboratory purposes, etc.

D.C. Resistance 47 ohms. Impedance 52 ohms at 1,000 c.p.s. Sensitivity 1.2 x 10<sup>-12</sup> watts at 1 kc. = .0002 DYNE/CM<sup>2</sup>.

**S.G. Brown, Ltd.**

SHAKESPEARE STREET, WATFORD, HERTS.

Telephone: Watford 7241

**NOW AVAILABLE GERMANIUM CRYSTAL DIODES**

LATEST, SMALLEST, SUPREME CRYSTAL DETECTOR.

Midget Size, 5/16in. x 3/16in. Wire Ends for Easy Fixing. 4/6 each, postage 2½d.

Wiring instructions for a cheap, simple but high quality Crystal Set included. Technical Details and Selected Types available.

**COPPER INSTRUMENT WIRE ENAMELLED, TINNED, LITZ, COTTON AND SILK COVERED.**

Most gauges available.

B.A. SCREWS, NUTS, WASHERS, soldering tags, eyelets and rivets. EBONITE AND BAKELITE PANELS, TUFNOL ROD, PAXOLIN TYPE COIL FORMERS AND TUBES. ALL DIAMETERS.

Latest Radio Publications.

SEND STAMP FOR LISTS.

**CRYSTAL SET INCORPORATING THE SILICON CRYSTAL VALVE**

Adjustable-Iron Cored Coil.

**RECEPTION GUARANTEED**

Polished wood cabinet, 15/-, post 9d. A REAL CRYSTAL SET, NOT A TOY.

**POST RADIO SUPPLIES**  
 33 Bourne Gardens, London, E.4

**THOMPSON TRANSFORMERS**  
 Delivery of Transformers, 7-10 days. Delivery of Rectifiers, 4 weeks (if out of stock). Demand very great. Special Sizes (Transformers):  
 For Trains, 12v. 3 amp. ... 26/-  
 For Chargers, 18v. 3 amp. ... 26/-  
 For Ground Heating, 7v. 6 amp. ... 26/-  
 Postage and packing, 2/- extra.  
 2/d. stamp for List of other sizes.  
**T. W. THOMPSON & CO.,**  
 176, GREENWICH HIGH ROAD, GREENWICH S.E.10





# THE Cyclist



Editor: F. J. C. M.M.

VOL. XIX

FEBRUARY, 1951

No. 345

All letters should be addressed to the Editor, "THE CYCLIST," George Newnes, Ltd., Tower House, Southampton Street, Strand, London, W.C.2.

Phone: Temple Bar 4363

Telegrams: Newnes, Rand, London

## Comments of the Month

By F. J. C.

### Courtesy, Caution and Cant

ACCORDING to the Royal Society for the Prevention of Accidents, 1951 is to be a Road Courtesy year, the object being to reduce "the mounting toll of killed and injured on the roads."

Before we deal with the suggestion that courtesy on the roads can appreciably affect the problem, let us recall certain statistics.

In 1949 the total number of killed and injured in road accidents was 176,779, composed of 4,773 killed and 172,006 injured. The highest number of persons killed in any one year was 9,169 in 1941, which was a black-out year. This means that just over 13 people are killed and nearly 500 injured on the roads every day.

Lord Lucas, of the Ministry of Transport, has said that his Ministry "is at its wits' end to find a solution to the problem."

Now the Royal Society for the Prevention of Accidents is a strictly impartial body, and in its wisdom it feels that if all road users exercised a greater degree of courtesy there would be fewer accidents. This implies that they feel that lack of courtesy is the prime cause of accidents, because they have made it the main plank in their Road Safety campaign.

We entirely disagree with it. The majority of accidents are caused by carelessness and thoughtlessness, and these are quite unrelated to lack of courtesy. In any case, courtesy is not a thing which can be taught. A person is either naturally courteous or not, and in any case it would mean a finer definition than the loose generality which the society thinks constitutes courtesy.

If there is anything more abortive than casting pearls before swine it is casting artificial pearls before real swine. The road hog, the dangerous driver, the cyclist who is always fighting for his rights, the jay-walking pedestrian, all these are unlikely to be affected by some altruistic campaign to teach them the error of their ways. And, indeed, if courtesy is to be engendered amongst all road users it certainly needs to be encouraged amongst those bodies which profess to lead the various sections of road users. No one can suggest for a moment that there is accord and amity between the various cycling associations, nor between them and the motoring associations.

The Pedestrians Association ploughs its lonely furrow. In furtherance of its campaign the society urges that all should make and keep one resolution in 1951: "I will be courteous at all times on the road." The interpretation of what is courtesy is left apparently to the individual, and each person has his own idea of what constitutes courtesy.

We do not think that road users will become converted into modern versions of the little Lord Fauntleroy, and much as we wish the society well in its well-meaning efforts we do not think that they will have

much effect upon the problem, the root causes of which are well known. There are those who feel that the rigid enforcement of the law would reduce accidents, when the whole history of legislation proves the reverse. As legislation has become more onerous and punitive accident statistics have risen. Those two facts, which are unrelated in themselves, prove that inflicting heavier penalties and making more regulations do not strike at the root of the trouble. In any case a penalty is only inflicted after an event, and prevention is better than cure. The teaching of road safety in the schools on the principle that self-preservation is the first law of nature is likely to have more effect, although some years must elapse before the children of to-day become the road users of to-morrow. Road sense cannot be acquired from textbooks or teaching. It is an instinctive thing.

### Ministry of Transport

A large measure of the blame for accidents reposes on the doorstep of the Ministry of Transport, which has singularly failed to do what it is paid to do. Had the hundreds of millions of pounds paid into the Road Fund been used for the proper purpose instead of being misappropriated by a process of legerdemain, which in ordinary business would have amounted to fraud or misappropriation, the accidents statistics would have declined to negligible proportions. We are trying to make the traffic fit the roads instead of the roads fit to receive the traffic.

It is significant that the Ministry of Transport decided not to sponsor a National Safety Week in 1951, no doubt as a result of the nugatory results of its previous campaign, which was more of a caricature than a serious effort. The M.O.T. spent large sums of money on a poster campaign, only to find at the end that accidents had risen. Little wonder, therefore, that there is lack of confidence in this new effort.

Although Britain has lost her claim to having the most densely trafficked roads in the world (Belgium now leads with 17.7 vehicles to the mile), there are still 16.9 vehicles to the mile in Great Britain, which is equal to one for every one hundred yards of road.

We still say that if a large number of unnecessary traffic signals were removed and traffic generally speeded up (remember that most accidents occur in busy places where the speed is lowest but the traffic most dense) there would be a drop in the number of accidents in populous places. We have drawn the attention of the M.O.T. to this matter on a large number of occasions during the past 16 years.

### Roadfarers' Club Memorandum

The Roadfarers' Club prepared, as a result of a careful investigation, and at the request

of the Ministry of Transport, a carefully prepared memorandum on the design and layout of roads in built-up areas. This was approved by the Ministry because, after consideration, it stated that the recommendations would be adopted as and when possible. The memorandum was illustrated by specially taken photographs showing the causes of congestion and the dangers to which it gave rise.

The Roadfarers' Club is a body whose members are drawn from all sections of road users, and it cannot therefore be said that it exists to advance the cause of motorists.

Many prominent cyclists serve on its council.

We find it possible to agree with the society when it says that nine out of every 10 accidents are avoidable, because under existing road conditions they are primarily due to the road users' own fault and disregard of the Highway Code. Also when they say "we must be realists. Economic circumstances prevent us getting the roads we want, and the police are under-strength." In that last sentence is implied the cause and the suggested cure. So much of our propaganda deals with the effect instead of the cause. They want someone punished severely for an effect when the real people to be punished should be those who could have prevented it.

Road casualties to-day are about 8 per cent. below pre-war level, although there are a million more vehicles on the road than in pre-war, an increase since 1939 of 2½ million in the population. If penalties for road offences are to be insisted upon they should be made to apply to every form of road user, including pedestrians, since by their numbers they are the most careless of all, suffer most as the result of accidents, and yet whilst causing innumerable accidents, more often than not escape injury and are not even involved.

### Coloured Cats' Eyes

A READER has made the suggestion in a "Public Enquiry" broadcast in the North Region Service that cats' eyes down the middle of roads should be coloured amber near a pedestrian crossing, red-amber-green alternating for "Traffic Lights Ahead." This seems a sensible suggestion.

Another reader suggests that there should be a speed limit on all stretches of the main roads out of London, and that there should be more (!) traffic lights. Needless to say, this suggestion came from a member of the Pedestrians' Association, which is to take up with the Ministry of Transport the 42 per cent. increase in casualties on no-limit London roads in 1949, compared with 12 per cent. rise in 30 m.p.h. areas. It is also to ask for a public enquiry into safety on arterial roads now lined with houses, factories and schools.





Salisbury.

The lovely High Street Gate built with materials from the Norman Castle at Old Sarum.

# Paragons.

## Pedal Boat For Two

FROM two aircraft drop-tanks and a few odds and ends from the scrap heap, together with two sets of bicycle pedals, a keen fisherman living in Honolulu has built himself a two-seater boat. The drop-tanks act as pontoons and are connected together by sheet metal and two side-by-side sets of pedals are fitted, which drive a partly-submerged paddle wheel at the rear of the boat. In the floor of the boat is fitted a thick sheet of glass through which the fish are clearly visible. The boat has lever steering and if both occupants pull their weight it has a top speed of 5 knots.

## The Difference

A STRIKING difference was discovered, when cycles were inspected at Grimsby for roadworthiness, in connection with the local "errand boys' Derby," between the machines owned by the boys and those belonging to their employers. The employers' cycles had broken pedals, badly-worn tyres, broken and missing spokes, wheels out of true, and other defects, while those machines which belonged to the boys themselves were in good condition. The road safety officer commented that cycle repairers had told him that economy is the watchword where the maintenance of errand boys' cycles is concerned, and the employers seem to begrudge spending money on them. Of the 23 machines examined, only two were free from faults. Altogether there were 76 faults on the remaining 21 machines and there were only three with one fault each.

## Ingenious!

AMONGST the exhibits at the Grimsby Model Engineering Society's Exhibition was a bicycle converted into a light motor-cycle, the conversion having been carried out by Mr. Westfield, a cycle agent, of Lord Street, Grimsby. Mr. Westfield remodelled the cycle frame and built in one of the light-weight cycle engines designed to be attached over the rear wheel of a cycle. The machine is a well-balanced production.

## B.B.C. Visit to Cycle Factory

WHEN the B.B.C.'s Richard Dimbleby went to Barton-on-Humber to make recordings for his "Down Your Way" pro-

gramme, he paid a visit to the factory of the Elswick-Hopper Cycle Co., Ltd., and interviewed Miss May Handsley, who for the past 30 years has been press shop store-keeper at the factory.

## Congratulations!

MR. C. NICHOLSON, for many years in business as a cycle and motor agent at 152, Lord Street, Grimsby, and his wife celebrated their diamond wedding anniversary on November 29th.

## A Stayer

MRS. ADA LIZZIE MACRAE, who has just died at Deeping St. James, Lincs, at the age of 85, continued to cycle right up to the age of 81. Which probably explains her longevity.

## Grimsby Riders Want Colours

AT the November meeting of the Lincolnshire district council of the Road Time Trials Council, representatives of Grimsby Clarion Club suggested that next season riders in road races should be allowed to wear coloured vests instead of all black. The suggestion received considerable support from the district council, and should be strongly supported by members of the Road Time Trials Council, according to all appearances.

## Tring Cycle Agent's Death

FORMERLY of Stamford, Lincs, Mr. William Philip Fancourt, of 79, High Street, Tring, Herts, a cycle, radio and electrical engineer, in business for the past 16 years at Tring, has died at the age of 48. He started his career as an engineer and carried his skill with him when he commenced his own business.

## Encircling Gloom

THE bad state of Highfield Road, March, Cambs, and the fact that three lamps in the road only serve to make the gloom—and the mud—slightly more depressing, has moved a visitor to the town to write a verse; having seen the lights "the first in 20 years." The verse runs:—

"Lead kindly light amid the encircling gloom,

Lead thou me on.

The night is dark, the road is thick with mud,

Lead thou me on.

Hold on my feet—I dare not ask to see

The road made up—

The shock would finish me."

Whether it is the verse, or the voice of conscience, no one knows, but the Urban District Council is considering making up the road.

## Paget Company's Transfer

NOTED as the originators of the Paget cycle cape, Messrs. J. Cecil Paget, Ltd., have opened an office in Market Square, St. Neots, Hunts., and a warehouse and finishing room in Huntingdon Street. The firm will continue to have its factories in Manchester and Northampton. Mr. Paget, senior, who invented the cape some 50 years ago, is now 79 years old, but as keen a cyclist as ever he was, and last summer he made a 400-mile tour in eight days. He is a member of the Fellowship of Old Time Cyclists and a life member of the North Road Cycling Club. He joined this latter club 50 years ago, and was for many years its

captain. He is also a life member of the C.T.C., and in his time has set up a number of records. Mr. Paget's sons also have his love of cycling, and Mr. Cecil Paget is a founder-member of the St. Neots C.C. which was revived in 1937, and has held every office in the club, being now hon. vice-president. He is also a member of the North Road Club, and has done much for the sport and has also been responsible for the organisation of two British championship events. Mr. W. J. Paget, who is a director of the firm, with his brother, Cecil, and his father, was one of the members of the "Buckshee Wheelers" when he was serving with Middle East Command during the last war.

## Annual Nightmare

USERS of the road skirting the Humber in the neighbourhood of South Ferryby are again complaining that nothing has been done to improve the safety of the road, which is described as an absolute nightmare in the winter and in the dark. In many parts there is nothing between the road and the river except a few concrete posts. With ice or snow on the road, or a thick fog, only a miracle prevents road-users from leaving the road and ending in the river. If the authorities can do no more, they might put up notices advising that lifebelts should be worn and rubber dinghies carried by all users of this stretch of road.

## Watling Street Improvement

WORK has been started on the reconstruction of the dangerous hump-backed canal bridge known as Hands Bridge, in the parish of Watford, on the Watling Street, and to enable the work to be carried out, a stretch of road some nine miles long in the Daventry area was closed to traffic. There have been scores of accidents at Hands Bridge, which is only 17ft. 3in. wide between the parapets, with a mere 16ft. carriage-way. The new bridge will have a 22ft. carriage-way and will be 60ft. wide. Several hundred yards of the road will have to be remade, and at its deepest point the road will have to be raised 14ft., and it is estimated that it will be at least twelve months before the work is completed.

## Asking Too Much

IT was suggested that the reverse sides of I road signs coming under the jurisdiction of the East Suffolk Roads Committee should be painted green in order to blend with the surrounding countryside, but the suggestion has been rejected. The roadmen, who already have to cycle with pots of red, black and white paint on their machines to touch up the signs, said it was asking too much to expect them to carry a pot of green paint as well. Just imagine the rainbow effect if they fell off!

## The Dog Menace

THE County Constabulary report for Warwickshire covering October reveals that during the month more road accidents were caused by dogs in Nuneaton than in any other town in Warwickshire. Taking the county as a whole, there has been an increase of 29 in the number of deaths due to road accidents during the first ten months of 1950 as compared with the corresponding period last year.

## No Skids—They Hope!

A NEW type of concrete road has been laid down by German engineers near Hanover which, it is claimed, will be skid-proof even when there is more than 20 deg. of frost. The road will cost some 13 per cent. more than the ordinary concrete road surface, but if it comes up to expectations the extra cost will be worth-while.



# Around the Wheelworld

By ICARUS

## Dearer Tyres

THE recent increase by 10 per cent. in the price of bicycle tyres is due to an increase in the cost of rubber, cotton, and other raw materials, which I am told are now over four times the price as compared with prices ruling at the beginning of 1950. The increase represents only additional factory costs, and there is no increase in the retailer's profit. If you do not want to blame the Government, blame world conditions!

## Road and Traffic Problems

I SEE that the Joint Committee of the R.A.C., the A.A., and the Royal Scottish Automobile Club have made the following decisions:—

To impress upon the Ministry of Transport the urgent need for (a) the clarification of the rights and obligations of different road users at pedestrian crossings, and (b) the issue of revised regulations dealing comprehensively with the size, colour and type of traffic signs.

To express dissatisfaction with the Government's failure to carry out "a comprehensive and progressive programme of road development for the purpose of promoting traffic movement and reducing road accidents," and to emphasise that "such action is now an urgent and vital necessity in the national interest."

I think cyclists will support these two decisions.

## A Grim Inn

ABOUT 50 guests assembled in the Blue Room of the old Ostrich Inn, at Colnbrook, to witness the unveiling of a model of the bed which debouched the sleeping guests into the brewhouse vat beneath when they were asleep. The unveiling ceremony was performed by Lord Donegall, assisted by Lord Semphill, the flying pioneer.

The model is constructed from Honduras mahogany (not, of course, the Honduras mahogany of the original bed as might have been implied from Lord Donegall's remarks). It must have been many centuries since so many people assembled in that famous Blue Room where the murders were committed.

I possess a copy of the original edition of Deloney's "Thomas of Reading," which dealt with the last known murder there. It is said that over 60 murders were committed by means of this lethal four-poster, but they were not all committed in the 16th century.

When the bolt was drawn by Lord Donegall, the sleeping "body" slid neatly into the vat beneath and the 61st "murder" was committed.

recommended. When I am satisfied that supplies of brakes and bells are available to equip any bicycles still without them, I will consider making regulations on the subject."

The questioner then enquired: "Is the Right Hon. Gentleman aware that in a town like Cambridge, where the number of bicycles is very great, owing to the presence of the University, the problem of accidents is becoming more acute every day?"



The Marquis of Donegall chatting with Mr. F. J. Camm and Lord Semphill in the Ostrich Inn at Colnbrook. Note the four-poster on the mantelpiece. The model is the work of Mr. Camm.

## Compulsory Bells and Brakes?

THE Minister of Transport was recently asked in the House of Commons when he intended to issue regulations requiring all bicycles to be equipped with a bell and two efficient brakes. He replied: "I am informed that for some years manufacturers have been equipping bicycles with a brake or brakes as

The Minister of Transport added: "On the other hand, I would like to say that, from my experience of travelling through Cambridge, I think they have an excellent road safety committee which draws the attention of the public to this danger."

## Festival of Cycling

THE Dunlop Company are organising a Festival of Cycling, which will be run next Whitsun in the Midlands, Lancashire, the South of England, and Scotland.

World champions will compete first at Halesowen (Manor Abbey Sports Ground), on Whit-Saturday afternoon (May 12th), then at Fallowfield, Manchester, on Whit-Monday afternoon (May 14th); at Preston Park, Brighton, on the Wednesday evening (May 16th); and at Helenvale Recreation Ground, Glasgow, on the following Saturday afternoon (May 19th).

## Wembley Six Days

THE date of the Six Days Race at Wembley this year is May 27th to June 2nd. The last Six Days Race in England was in 1939. A special track is now in course of construction.

## Every Cyclist's Pocket Book

By F. J. Camm.

400 Pages. 84pp. Indexed Road Routes  
7/6 (by post, 7/10)

From George Newnes Ltd., Tower House,  
Southampton Street, Strand, W.C.2



A warrior with his two "cyclist" sons in the native reservation in Natal.





The last of an old  
Middlesex Inn.

### The Old Magpies at Sisson.

Dating from the 13<sup>th</sup> century this unique little thatched hostelry has been used by countless travellers. It is romantically associated with Dick Turpin and other noted highwaymen. It is now to be demolished to make room for further extensions to London Airport.

#### A Difficult Query

MANY of my old cycling friends with whom I raced and sported in the long ago often ask me how I account for the speed-up of the present generation of racing lads. It is a difficult question to answer, and each of us confronted by such a query can only give his own indications of the reason, or reasons. I do not think road surfaces have much to do with the matter, because in the inter-war periods our highways were never in a better condition, and many of them have yet to reach the standard of the 'thirties. Yet, year by year, since the ending of the war, times have become faster and faster, and at the moment there seems to be no limit to the improvement. Bicycles may have a little to do with the matter, and especially tyres and gears, but very little, certainly not enough to account for to-day's express cycling speeds; while food has, I imagine, declined in athletic values, though not nearly so much as some people would have us believe. So it comes to this, that improvement must reside in the individual and his training methods. Possibly, it is true that the racing man is just that; he is mainly the cycling athlete with little or no interest in the other many phases of the pastime. To me that seems a pity for I've found so much joy in cycling that I feel these young people in their worship of speed are breaking the pleasure of the game on the wheel of passing fame. That, however, does not answer the query propounded—it is merely an individual opinion. I have watched these speedy lads both in training and racing, and I believe it is the nervous energy expended on the game that is the main ingredient in the speedier performances. They live with and for racing, and always seem to forget riding in their struggles with the bicycle. No doubt they get fun out of their deeds, but the manner of doing them is a constant strain, and it can be seen in their faces, not only during and after the race, but at the start of it. Sometimes, indeed, I wonder if the thrill of improved performances is worth the strain and in most

cases the sacrifice of cycling as I understand that term. In the old days we enjoyed our racing—it was part of our young cycling—and if we were not champions that didn't matter overmuch so long as the spirit of club life flamed brightly. We were certainly a happy crowd when our Saturdays were devoted to the speed game; high tea in the flame of sunset light was a real festival, and the night ride home a genial institution. Those days have gone for ever, and I sometimes wonder if the modern ones with all their nervous tension are as good for the propagation of the sport and pastime—especially the latter. Nervous energy; I think that is the answer, and no doubt it is the reason why many of the modern boys having had their little day disappear, and cycling as a game to be played down the years means nothing to them.

#### Here's a Promise

THAT conclusion is a saddening thought to me because I'm quite sure the pleasure of cycling has been enhanced down the years, and some of it at least is the resulting memory of those early days and the good times given to us. The deeds for me are not now so hectic and exciting, but the quieter years are just as full of interest, and I still get a thrill when the chance of a holiday is in sight. And I'm sure I enjoy

## Wayside Thoughts

By F. J. URRY

my touring more as a result of my racing. You see, I know how to ride out the day without imposing weariness on the traveller, to slip into a wind without violent effort, and to make every journey one of observation, not only of beauty of land and sea and sky, but of the incidents of field and hedgerow, of village and town, of ruins where history resides and the lovely spiritual monuments whose interiors are harbours of peace. These things, in the company of a good companion, are not only joys in themselves but for all the years ahead, facts which make my cycling holidays so full of memories pleasant to contemplate. That is part of the intimacy of cycling, a delightful fragrance that no other form of travel seems to leave along the trail of the years. And I can promise every young and vigorous racing man these middle chapters of joy if he will allow his splendid athletic powers in the sport to slip into the way of genial journeying to bring to him the full essence of cycling.

#### Whither Away?

EASTER falls early this year, and there might even be snow on the ground or the sudden storm blotting out every prospect. Sounds cheerful I know, but I am confident the wheeling tribe will take the holiday in their stride and enjoy all of it—and a bit more if they could get it. I have known Easter when a club party started for Wales in a snowstorm, and in crossing the Kerrys literally fought their way up to the Anchor Inn, sliding down (literally) into Newtown through a couple of inches of snow. It did not deter us then, "this winter lingering," and it will not deter the lads and lasses of to-day. Actually, on the law of averages, we are due for a decent Easter, for it seems years since I shed most of my outer garments one early Easter I spent in the Isle of Wight, wondering if the sprites of summer had mistaken the month of the year. Being early I suppose most folk will flock south this first holiday of the year, which, to be a trifle ungracious, seems a very good reason why I should journey north, for I love

to get away from the over-populated places and feel the spirit of an explorer sending me over some of the lesser pass crossings. So it is highly probable Wales will be my happy roaming ground, trailing round Snowdonia by little-used roads to come down for sleep and food at the appropriate time into the kind valleys. I have numerous friends scattered around the Principality, so the question of accommodation will not arise; yet it might be that my family will say—indeed, they are at the moment saying—"It is time we went to Wight again, the island of your forefathers." Well, I could not greatly object, but I do not enjoy visiting relatives whom one knows so little about, and quite probably they find it hard to feel friendliness even though they simulate it. There are many other areas to visit, and even my own Midlands can give me joyous journeys; yet, somehow, when there are several days in a row, most of us want to get as far from the home circuit as possible. I suppose it is naturally the result of habits fostered in the days of long ago.

#### These Changed Times

WHAT joyous times we had in the old days planning a tour to match purses that did not bulge with golden coins. We could obtain good accommodation then for a couple of guineas a week, and many a wayside hostel welcomed your 4s. 6d. for bed and breakfast. The other side of the story is that £3 a week was a decent wage for a young man, and it was my weight of wealth until 1905, when I had been a consistent tourist for over a decade. I sometimes hear young people complain they cannot afford this, that and the other, and wonder how we managed to have such a good time on what was left to us after the needful home payments. Other times, other habits; but I still think the modern tourist has the better of things, taking his wanderings with a degree of sang-froid we could not afford, for it was necessary then to know our liability within half a crown before venturing. The thrill of mapping a tour never leaves the old rider, it returns to him with all the freshness of the first adventure when he gets out the maps and plans a route, and it brings a thousand pictures of the countryside and the intense memories of many incidents when first he passed that way. How much the people miss of the pleasures of anticipation and recollection who have never planned a tour, delved into books for information and gossiped for weeks of the days to come, and the days that have been. If you tour at Easter, start now and project your mind forward, for it is part of the rare—too rare—enjoyment of wandering to lose the pleasure in a whirl of carelessness. And be sure I shall be doing this very thing, wondering what changes have taken place along the road, and if "old Ben" still keeps that tavern sitting at the edge of the village pond where the noisy ducks awaken you too early in the morning. I know the young tourist has much to learn, and if he likes it he can go to school in a text-book, but I believe he will be happier—certainly in his recollections—if he plans for himself and takes the road as a pioneer without the restrictions of too much advice.

FOURTH EDITION.

## REFRESHER COURSE IN MATHEMATICS

By F. J. CAMM  
8/6, by post 9/-



**REG HARRIS**  
*keeps in front*  
**on DUNLOP**

Reg Harris, World's Professional Sprint Champion and "Sportsman of the year", rides to victory on the tyres that give him the greatest speed and reliability—DUNLOP.



Choose **DUNLOP** the Champion's Tyre

50H/352

*Cycling is grand fun....*

**IT'S TIME YOU HAD A**

**BSA**

CYCLING really is grand when you ride a B.S.A. with B.S.A. 3-speed hub with Snap Control for quick, positive change of gear.



**COUPON:** To B.S.A. Cycles Ltd., 12, Armoury Rd., Birmingham, 11

Please send me at once the B.S.A. Cycle catalogue

NAME.....  
 ADDRESS.....

**IMPORTANT NOTICE** to  
 Owners of **MOTORISED BICYCLES!**  
 You've got the **EXTRA MOTIVE POWER**  
**NOW** you need the **EXTRA BRAKING POWER**  
 of

**"Cantilevers"** (REGD.)

**MOST POWERFUL and SMOOTH ACTING  
 CYCLE BRAKES in the WORLD**

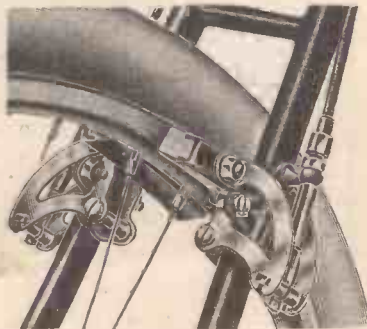

CANTILEVERS have been given special tests on bicycles fitted with many of the leading Motor Units, and as a result they are being strongly recommended for their complete **EFFICIENCY** and **RELIABILITY**. Your life depends upon your brakes, and the addition of a motor unit to your bicycle makes it vital that you are equipped with the best brakes obtainable. **CANTILEVERS** will give you complete **CONFIDENCE** in **ANY EMERGENCY**. Fixed rigidly on the forks or stays, they are always positive in action, smooth and powerful, grip well in the wet, and give long service. Special models available for use on Westwood rims. Fitted with our Locking Lever, they make the ideal **SAFEGUARD** against petty thieving. Twelve month guarantee with all new brakes.

**SAFETY FIRST! Second Thoughts are Too Late!**

THE RESILION CO. LTD., 200, LIVERPOOL ROAD, LONDON. N.1.



# I.C.S. TRAINED MEN are in Greater Demand than Ever

—Maximum production depends on high technical skill, such as that acquired by I.C.S. Students

**TENS OF THOUSANDS MORE TRAINED MEN ARE URGENTLY NEEDED NOW—BUT THERE IS NO WORTH-WHILE PLACE FOR THE UNTRAINED**

*Ambitious men everywhere have succeeded through I.C.S. Home-Study Courses. So also can you.*

The man with an I.C.S. Training in any one of the subjects listed below knows it thoroughly, completely, practically. And he knows how to apply it in his everyday work.

- |                         |                         |                        |
|-------------------------|-------------------------|------------------------|
| Accountancy             | Draughtsmanship         | Motor Engineering      |
| Advertising             | Drawing Office Practice | Motor Mechanic         |
| Air and Vacuum          | Electrical Engineering  | Motor Vehicle Elec.    |
| Brakes                  | Electric Power, Light-  | Municipal Eng.         |
| Air-Conditioning        | ing, Transmission       | Plastic                |
| Arable Farming          | Traction                | Plumbing               |
| Architecture            | Eng. Shop Practice      | Quantity Surveying     |
| Architectural Drawing   | Fire Engineering        | Radio Engineering      |
| Auditing                | Foremanship             | Radio Service Eng.     |
| Boiler Engineering      | Free-Lance Journalism   | Refrigeration          |
| Book-keeping            | Fuel Technology         | Sales Management       |
| Building Construction   | Heating and Ventilation | Salesmanship           |
| Building Specifications | Horticulture            | Sanitary and Domestic  |
| Business Training       | Hydraulic Engineering   | Engineering            |
| Business Management     | Illumination Eng.       | Sheet-Metal Work       |
| Carpentry and Joinery   | Industrial Management   | Short-Story Writing    |
| Chemical Engineering    | Lettering               | Steam Engineering      |
| Chemistry, I. & O.      | Machine Designing       | Structural Steelwork   |
| Civil Engineering       | Machine-Tool Work       | Surveying              |
| Clerk of Works          | Marine Engineers        | Telegraph Engineering  |
| Coal Mining             | Mechanical Drawing      | Television Technology  |
| Commercial Art          | Mechanical Engineering  | Welding, Gas and Elec. |
| Concrete Engineering    | Mine Surveying          | Woodworking Drawing    |
| Diesel Engines          | Mining Engineering      | Works Engineering      |

And most of the Technical, Professional, Commercial and Civil Service and Educational Examinations.

(I.C.S. students preparing for Examinations are coached till successful)

If you need technical training, our advice on any matter concerning your work and your career is yours for the asking—free and without obligation. Let us send you our special free booklet on the subject in which you are specially interested. **DON'T DELAY. Make ACTION your watchword.**

The successful man **DOES** to-day what the failure **INTENDS** doing to-morrow. Write to us **TO-DAY**

Use this Coupon

**INTERNATIONAL CORRESPONDENCE SCHOOLS LTD.**

Dept. 95, International Buildings, Kingsway, London, W.C.2.

Please send me the free booklet describing your Courses in

Name..... Age.....  
(USE BLOCK LETTERS)

Address.....

**Addresses for Overseas Readers**

- Australia : 140, Elizabeth Street, Sydney.
- Egypt : 40, Sharia Abdel Khalek Sarwat Pasha, Cairo.
- Ire : 13, Angelsea Street, Dublin, C.4.
- India : Lakshmi Bldgs., Sir Pheroosha Mehta Rd., Fort, Bombay.
- New Zealand : 182, Wakfield Street, Wellington.
- N. Ireland : 26, Howard Street, Belfast.
- South Africa : 45, Shortmarket Street, Cape Town.

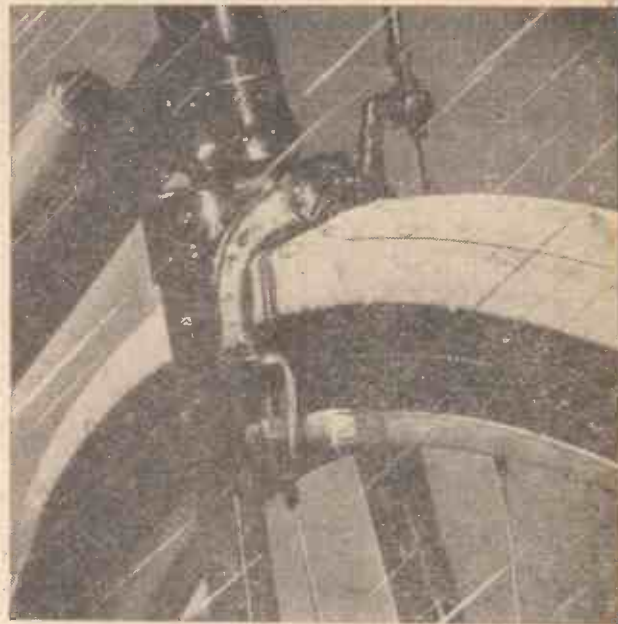

**A smooth,  
sure GRIP,  
wet or dry**

Ferodo All Weather Brake Blocks are made of a special friction material that is practically unaffected by weather and can be relied on to give you safe, positive control for long hills or emergency stops.

The price of standard sizes is now

**6 D.  
A PAIR**

**HUB BRAKES.** Ferodo Linings are supplied in boxed sets, complete with rivets, for all makes of hub brake. The size is exact, and the friction characteristics correct, for each type. Also available in roll form.

**FERODO**

**ALL WEATHER BRAKE BLOCKS  
AND LININGS FOR HUB BRAKES**

FERODO LIMITED, CHAPEL-EN-LE-FRITH. **REG'D TRADE MARK**  
A member of the Turner & Newall Organization **FERODO**



# CYCLORAMA

By  
H. W. ELEY



Buttermere  
Cumberland.

*In its lonely setting—the little village church standing by the Sail Beck.*

## The Lure of Staffordshire

MY residence in my retirement is actually in Derbyshire, but so near to the Staffordshire border that I find it an easy matter to cycle to some of the beauty spots of that little-known and little-appreciated county. How many there are who dismiss Staffordshire as ugly and uninteresting! And how woefully wrong they are in their judgment! True, the industrial towns of the Potteries and the Black Country are not beautiful . . . but in between there is a glorious belt of country well worth exploring. The whole valley of the Trent is good for cycling, and it is no bad plan to make the little cathedral city of Lichfield one's centre. Lichfield Cathedral is usually known as the "Lady of Cathedrals," on account of its delicate beauty and rare architecture. It is much smaller than many of our other cathedrals, but yields to none in beauty. From Lichfield, the cyclist can easily reach some of the best of the Staffordshire scenic spots . . . there is that lovely village of Hoar Cross, with its very ornate and lovely church, enriched and beautified by the Meynell family. There is Needwood Forest, now but a shadow of its former self, but still glorious, as it was in the days when it was an exclusive Royal hunting domain. There is Abbots Bromley, and its neighbour Kings Bromley . . . and at the former village, every September, there is the famous "Horned Dance," dating back to ancient pagan days, remote in its origin, and full of interest still.

If you care for inns and taverns, and good English ale, then in Staffordshire you can ride to "Beoropolis" . . . the ancient town of Burton-upon-Trent, and there imbibe some famous brew, following your rest at an inn with a stroll round the town, to look at the fine parish church of St. Modwen, and the crumbling fragment of the old monastery wall by the banks of the wide Trent. Yes, Staffordshire has charm and beauty indeed. . . .

## A Sprig of Shamrock

THE seventeenth of March is Saint Patrick's Day, and I know that on the morning of the seventeenth I shall receive a little sprig of moist green shamrock from an old friend in Dublin. It will revive good memories of days spent in the ancient city by the Liffey . . . days when the pomp and splendour of the Viceregal Lodge had not departed from the land; days when gay British uniforms added a touch of colour to the Dublin streets; and the sight of the green emblem will recall happy rides in County Wicklow, and the alluring Vale of Avoca, and all the grand country around Glendalough. There is a legend, of course, that the shamrock will only grow in Erin's Isle, but whether this is true I do not know; but it certainly belongs to Ireland, like colleens, and leprechauns, and "potheen." Some day, I must ride again in Wicklow. . . .

## Pump Stealing

I AM told that in some areas there is a bad epidemic of cycle pump stealing. What a shabby trick it is to take a pump! Offenders should be punished sharply. But the wise cyclist will take no risks, and remove his pump before he parks his machine . . . or, perhaps better still, lock it in some way to his mount, so that it cannot be removed.

## The Birthplace of the "Pickwick" Bicycle Club

THERE is no older cycling club than the "Pickwick"—and it was founded at the Downs Hotel, at Hackney, in the year 1870. It says much for the enthusiasm of the cycling community that the old club still flourishes, and that its members, true to the Dickensian tradition, adopt the names of characters from the immortal "Pickwick Papers." Looking back over the almost innumerable functions and dinners and banquets I attended in my business days, none brings a happier memory than the Pickwick Bicycle Club lunch or dinner. Good fellowship . . . all the venerable romance of Dickens . . . the yarns with "Old Timers" . . . the great bowl of steaming punch . . . what delights to muse upon, when, pipe alight and the fire glowing, I let myself slip back along the years, and try to recapture the joys of yesterday!

## Back to 1909

IT was an entry in an old diary, accidentally discovered when I was searching for some papers, which took my memory racing back to the good and peaceful days of the year 1909 . . . and the entry related to a cycle ride from Birmingham to Bewdley, from

which pleasant place I explored the Wyre Forest. I noted that my mount then was a "New Hudson," and that I had two punctures on my outward journey. The faded entry brought memories of the year . . . King Edward the Seventh on the throne; not a murmur about world wars; Lloyd George making fiery speeches, and arousing the ire of belted earls and noble dukes; "Minoru" winning the Derby for His Majesty . . . and aeroplanes—strange things, to be laughed at as the toys of "cranks." Ah well! we have travelled a long and hard road since then, but it is good to look back to that ride into Worcestershire; good to recall the green glades of Wyre, and the noble trees, and the inns of my route, and the enjoyable tea at "Jasmine Cottage." It is unwise to linger too long in the golden past . . . so I switch on my radio, and listen to the latest news from Korea.

## The Dunlop Calendar

FEW pieces of publicity matter can be better known, or more greatly appreciated, than the famous Dunlop Calendar—always reproduced superlatively, looking like a genuine oil-painting, and always depicting some notable scene or building. I like the 1951 subject . . . Cambridge, and it strikes me as a worthy successor to all the fore-runners in the long series. I recall that the very first calendar was issued in 1921, and I believe that every one of the original pictures has been painted by that versatile artist, C. E. Turner. The Dunlop Calendar is by way of being an institution, and one sees it in garages, in offices, on the walls of rooms in remote country inns, and—suitably framed—adorning the rooms of stately residences. The secret of its huge success? Just, I think, that the advertising matter is subdued and quite inconspicuous . . . and the company commissions a fine artist to do the job.

## Easter Parade

AN early Easter . . . and personally, I prefer the great festival to fall a little later . . . when April has kissed the countryside, and there is more chance of the chill winds having departed. Still . . . Easter is the immemorial festival of the road, and the time when good cyclists like to make their first long runs and tours. Before the magic holiday, it is wise to give the old bike a thorough overhaul, and a good clean and oiling . . . riding is so much easier and pleasant when the oil-can and the spanner have been in action!

## The Cyclist and His Hobbies

SO many hobbies and interests "go well" with cycling: if you are a "camera-fiend" you can enlarge your area of operations enormously if you ride a cycle. And it is the same with fishing . . . many a good stream is possible if you can sling your rods and creel over your back, and journey out by bike. And the entomologist . . . he can reach those commons where, in high summer, the Holly Blues, and the Painted Ladies, and the Peacocks abound. In fact, whatever one's hobby, the cycle is a wonderful adjunct to it, and enables wide areas to be covered without fatigue. In my own case, living in this grey but pleasant Derbyshire land, my cycle takes me to trout streams, well stocked, and giving good sport. And, if I feel in the mood for scenic grandeur, then I can ride out to Dovedale, and revel in "England's Switzerland"; leaving my machine at a cottage, I can explore the wild moorland where the grouse come; I can walk through grassy dales, bordered by towering peaks. Without a cycle . . . why, man is chained and confined!



# My Point of View

By "WAYFARER"



The famous HOOPS INN  
on the road to Clowelly  
N. Devon.

## Crowning Gift

IT may be that the crowning gift bestowed upon us by the little old bicycle is that it enables even blind people to enjoy many of the pleasures attaching to the open road. For instance, an East Anglian lady has recently indulged in a 450-mile cycle tour to Devon and back on the rear seat of a tandem. The fact that she is totally blind did not prevent her from enjoying many of the delights which accrue from cycling. While she would be denied the exquisite pageantry of the countryside and the splendour of the heavens, it is possible that she would be amply compensated by the fragrance of the flowers and field crops and by "the wind on the heath." It is a really great pastime that enables physically deficient people to participate in it. So hats off to the bicycle.

## Approximation

A BIRMINGHAM daily newspaper recently published the world-shaking announcement that four girl students from a training college in the Midlands had just returned from a cycling tour through France, which cost them "about £10 each." This news is doubtless very interesting, and we must be grateful for it at a time when there is such a shortage of newsprint, but how much more vital the information would have been—charitably presuming it possesses any news value at all (which I doubt, having regard to the fact that hundreds, if not thousands, of cyclists from this country annually spend their holidays on the Continent)—had the duration of the tour been mentioned. I hate to seem fussy, but the figures of cost in connection with any form of holiday are utterly meaningless unless one knows how long the holiday lasts.

## Those Cyclists!

I RUBBED my eyes on reading an article in the *Radio Times* which commenced thus: "Cyclists are responsible for a large percentage of road accidents. For example,

in Deptford this year, cyclists have been involved in a quarter of the total road accidents—and two out of three of these have been attributed to a careless rider." Just that—and I have no doubt that many people with anti-cycling minds are running round in circles and throwing their hats in the air, ejaculating: "I told you so!"

As soon as I had retrieved my breath after reading this impertinent and unfair statement, I addressed myself to our contemporary in the hope—a vain one, as it transpired—of securing equal publicity for a frank comment. Just over three weeks after my letter was despatched I received from the editor a communication which was supposed to be explanatory. It was also delightfully vague. The authority for the preposterous statement was, he "assumed," the Metropolitan Police, "who make a careful study and analysis of road accidents." I refrain from criticising the police because the assumption is so airy and indefinite, and I prefer to confine my attention to the *Radio Times*, which, so far as I am concerned, is "the prisoner at the bar." The editor assures me that his periodical is not "anti" anything and I accept his word for it. Having re-read the paragraph which was the subject of my criticism, he considers that the word "involved" would have been better than the word "responsible," and that admission causes me to wonder why what I had to say to his readers was denied publicity.

Anyhow, let us re-write the first sentence of the statement now under criticism: "Cyclists are involved in a large percentage of road accidents." Are they really? I wonder whether the editorial writer of this wild and damaging dictum is aware that cyclists far outnumber any other class of road-user. I hardly think he can be. Does he realise the millions of miles travelled by cyclists in bulk during the course of a year? Does he understand that the bicycle is the frailest vehicle on the road—and that the

cyclist receives a great deal less than justice at the hands of other road-users? On figures, is the cyclist involved in a larger percentage of trouble than should fall to his lot, bearing in mind the size of the cycling army? Let us look at the figures, as generously provided (with most engaging anonymity) by the *Radio Times*. In Deptford (why pick Deptford?) cyclists have been "involved" in a quarter of the total road accidents—"and two out of three of these have been attributed to a careless rider." Say, for the sake of argument, there were 300 road accidents in Deptford this year. Cyclists have been "involved" (that blessed word again!) in one-quarter of them, that is, in 75, and 50 of these 75 "have been attributed to a careless rider"—not the same one every time, of course! So now we come to the "large percentage of road accidents" in which cyclists are "involved"—and for which, according to the uncorrected printed word in our contemporary, cyclists are "responsible." If my arithmetic is correct, that "large percentage" is less than 17. Thus the position is that the biggest class of road-user is to blame (or has the blame gratuitously attributed to him) for a minor percentage of the troubles which disfigure our national life along the roads. I suggest to the editor of the *Radio Times* that he should now get busy on a revised version of "Much ado about nothing."

## Wail From the Past

THE habit of *The Birmingham Post* in reprinting, day by day, an extract from its pages of 50 years ago is occasionally of great interest to cyclists. An anonymous letter-writer to our contemporary on an August day half a century back had quite a lot to say about the sins of cyclists—or, as he preferred to put it, "the great plague of cyclists." A man of fairly active habits, who claimed to be able to take care of himself in a crowd, his unspoken prayer before leaving home every morning was: "Deliver me from cads on castors." On the day he wrote he said that his prayer had been answered—otherwise "I should have been seriously injured by a fellow who charged without warning and laughed loudly as he rode away." The letter concluded thus: "Has not the time arrived for legislation to step between the scorcher and the long-suffering public?" To-day, 50 years later, the requested legislation still tarries. The long-suffering public has become used to cyclists, and I hope that it is no longer true of us that we "charge without warning" and laugh as we ride away. There is every reason why we should ride carefully, if only because, in an encounter with even a pedestrian, we are liable to get the worst of things.

## WORKSHOP CALCULATIONS TABLES AND FORMULÆ

Ninth Edition

by F. J. CAMM

A handbook dealing with methods of calculation, solution to workshop problems, and the rules and formulæ necessary in various workshop processes. It contains all the information a mechanic normally requires.

From all booksellers, 6/- net,  
by post 6/6 from the publisher,

GEORGE NEWNES, LTD. (Book Dept.),  
Tower House, Southampton Street, W.C.2

"Practical Mechanics" Advice Bureau COUPON  
This coupon is available until February 28th, 1951, and must be attached to all letters containing queries, together with 3 penny stamps. A stamped, addressed envelope must also be enclosed.  
Practical Mechanics February, 1951

Published about the 30th of each month by GEORGE NEWNES, LIMITED, Tower House, Southampton Street, Strand, London, W.C.2, and Printed in England by W. Speaight & Sons, Ltd., Exmoor Street, London, W.10. Sole Agents for Australia and New Zealand—Gordon & Gotch (A/asia), Ltd. Sole Agents for South Africa—Central News Agency, Ltd. Subscription Rate (including postage): For one year, Inland and Abroad 14s. (Canada) 13s. Registered at the G.P.O. for transmission by Canadian Magazine Post.



### Jewel Bearing

Precision jewel bearing for instrument makers, repairers and model makers, etc., 1.20in. diameter, .047in. thick; metal housing complete with drilled jewel.  
Price 2/- each. Post and packing, 3d.

### Warning Units

12 volt Buzzer Units as fitted to aircraft landing gear circuits for indicating faulty operation. This unit gives a loud, high-pitched note, and could be used as a door buzzer, calling device, warning, alarm, etc. 3 1/2in. by 2 1/2in. complete with enclosed terminals, ready to operate. All brand new and unused; boxed. Price 9/6 each. Postage and packing 9d.

### Control Units

Complete units for incorporation in domestic electric wiring systems. This unit replaces the usual method whereby the fuses, main switch, etc., are installed as separate units. This is a complete outfit to provide all facilities in one unit and is made to very high standards as part of the equipment for prefabricated houses. The units measure 10in. by 10in. by 4in. approx., in cream enamel finish, and are all brand new and unused, slightly store soiled. Cable entries are provided together with 6 circuit fuses, 2 indicator lamps, main switch, cooker switch, kettle switch, light switch all ready wired. This can also be used in a workshop, bench, etc., to provide separate controls, fusing, etc., where required. Price 27/6 each, carriage paid.

### View Finders

2 1/2in. by 2in. by 1 1/2in. thick concave lens mounted in a metal frame fitted with mounting spindle and sighting arm; grid etched in flat side of lens; precision manufacture.  
Price 15/6. Postage and packing, 1/-.

### Pressure Gauges

Capillary type, 0-150 p.s.i. Fan type dashboard, mounting meter, complete with tubing and engine connection; tubing length averages 40ft. Boxed, new.  
Price 9/6 each. Postage and packing, 1/6.

### Send S.A.E. for our Super Detailed List

### WILFLO PRODUCTS

216-222, GORBALS STREET  
GLASGOW, C.5

## MATRIC.

WHY needlessly handicap yourself and watch other people winning success and security? Whatever your age, you can now prepare for the all important Matriculation Examination at home on "NO PASS—NO FEE" terms. Write now for our valuable "GUIDE TO MATRICULATION" which explains the new regulations, etc., and the easiest and quickest way to matriculate—FREE and without obligation.

BRITISH TUTORIAL INSTITUTE  
(Dept. 160), 356, Oxford Street,  
LONDON, W.1.

### "NO PASS—NO FEE"

## Jubilee

Patented  
WORM DRIVE  
CLIP



Absolutely leakproof joints on Air, Water, and Oil lines are swiftly and easily made by using "Jubilee" Worm Drive Clips. They stand up to any pressure.

Write for details R/12.

THE FINEST  
CLIP IN THE  
WORLD.

L. ROBINSON & CO. (GILLINGHAM) LTD.  
Gillingham, Kent.

### CIRCULAR SAW SPINDLES

Spindle only 4/6. Complete assemblies with bearings, flanges and pulley, 17/6. Universal spindle assemblies for sawing, drilling and grinding from 25". Drilling Head with 1in. capacity chuck, 15/-.

Beaverley Products  
28, Oakwood Avenue, Leeds, 8.

## NO MAN CAN KNOW TOO MUCH OF HIS PRODUCT

For the close scrutiny of every conceivable object, metals, tools, fabrics, minerals, precious stones, paint, print, manu-

The Ultra Lens is a revealing eye of six actual diametrical magnifications, which brings out points of strength or weakness, enables the most minute measurements to be gauged accurately.

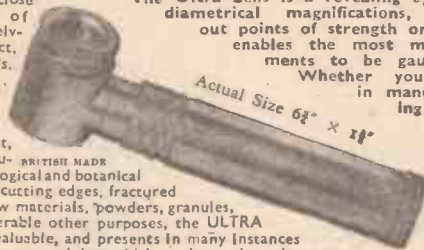

Actual Size 6 1/2" x 1 1/2"

Whether you are engaged in manufacturing, buying or selling, it is an ally of real value. No instrument you can buy will more quickly justify and pay for itself.

Full particulars on request.  
PRICE £4 15s. 0d., complete in case with spare bulb, battery and transparent measuring scale. ADAPTOR, A.C. Mains, 27/-; Transformer, if required, 6/5

THE ULTRA LENS COMPANY,  
75, Finsbury Court, Finsbury Pavement, London, E.C.2.

## MODEL ENGINEERS

### FOR THE TURNER:

Lathes from 1 1/2in. to 5in. Bench Millers. Drilling Machines. Hand Bench Shaping Machines.

### FOR THE WOODWORKER:

Wood Turning Lathes 3 1/2in.—5 1/2in. centre height. 4 1/2in., 7in. and 10 1/2in. Ball Bearing Planers at competitive prices. 6in. and 12in. Saw Benches, Sanders, Grinders, Jigsaws.

Perspex, Catalin and Acetate Sheets always in stock.

## NUTTALL'S (LATHES) LIMITED, MANSFIELD, NOTTS.

### SIMPLE!!! Make your own COMBINATION SAW BENCH with a UTILITY SPINDLE

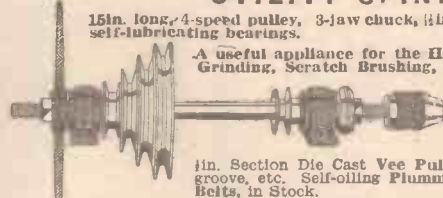

15in. long, 4-speed pulley, 3-jaw chuck, 1in. capacity. Spindle runs in self-lubricating bearings.

A useful appliance for the Handyman, for Circular Sawing, Grinding, Scratch Brushing, Polishing, Drilling, etc.

Cash with Order—30/-  
or complete with 8-in. Circular Saw. 48/6  
post 1/6.

1in. Section Die Cast Vee Pulleys, single, twin, triple, multi-groove, etc. Self-oiling Plummer Blocks and 1in. Section Vee Belts, in Stock.

STAMPED ADDRESSED ENVELOPE FOR LISTS.

J. SIMBLE & SONS, 76 Queens Rd., Watford, Herts. Phone: Watford 6052.

### POCKET RADIOS 48/- POST FREE

"SKYROMA" POCKET Short-wave Radios (or M.W.). Only 5 1/2in. x 3 1/2in. x 1 1/2in.: Works Anywhere! World-wide Reception! Should Last a Lifetime, but Miniature Valves, Spares, etc., Obtainable; Smallest in the World! Complete Kit Down to Last Screw, Simple Instructions, Case, etc. Send Cheque—Cash—C.O.D. (Deposits Accepted).  
MAYFAIR PRODUCTS (D10),  
15 Mount-Pleasant Road, Hastings, Sussex. Lists, 6d.

### BOOKS:

"Railway Modellers' Handbook" ... 2/6  
"Working Model Railways" ... 3/-  
"Make Your Own G.O. Motor" ... 3/6  
"Model Railway Encyclopaedia" ... 15/-

### RAILWAY PARTS:

Scale Bicycles ... 2/6 2/6  
Scale Bushes or Shrivs ... 4/6 4/6  
Plastic Station Staff ... 3/6 4/8  
Elastic Passengers ... 4/11 3/8  
Siding Passengers ... 4/11 7/4  
Scale Petrol Pumps ... 1/- 1/-  
Water Cranes ... 2/6 4/6  
Ex-R.A.F. 16 S.W. Boxes ... 5/6 1/2d.  
20-volt Lamps for Hornby  
Mighty Midget Geared Motor 3/4 volt 14/3  
Midget 5 Amp. Reverse Switch ... 2/6  
Postage extra. "00" or "0" Parts List 3d.

TYLDESLEY & HOLBROOK (M.E.T.A.),  
109, DEANSGATE, MANCHESTER, 3

Mains Transformers UPRIGHT—DROP THROUGH AS ILLUSTRATED.  
Two Types Only. Guaranteed.

No. 1: 250-0-250v., 80 mA., 0.4-6.3v., 5 amp. 0.4-8v., 2 amp. No. 2: Same, but 350v. Both 14/6, post 1/- for 1 to 3.  
HILLFIELDS RADIO,  
8, Burnham Road, Whitley, Coventry

### ADANA PRINTING MACHINES

Print in the odd hours with an Adana—still the most absorbing of crafts. No. 1 H/S Machine £4.10.0 No. 2 H/S Machine £9.15.0. Will 1 quickly pay for itself. Send for illustrated folder to Dept. P.M. 40  
ADANA (Printing Machines) Ltd., Twickenham, or call 8, Grays Inn Rd., London, W.C.1.

THE WATCH MATERIAL SHORTAGE. Twenty Geneva pocket watch movements, take 20/- the twenty. Ten English Lever movements, 30/- the ten. Ten wrist-let watch movements, 30/- the ten. All from gold and silver cases.—MERKEL'S JEWELLERS, PILGRIM STREET, NEWCASTLE.

## SPARKS' DATA SHEETS

Now recognised as the Safest, the Simplest and the Finest Radio Constructional Sheets obtainable. All my Designs being Fully Tested and Guaranteed, you are sure of COMPLETE SATISFACTION.

### GOOD LISTENING WITH ECONOMY

Four more of my TESTED and PROVED A.C./D.C. Designs:

THE "CHALLENGER" Portable. Radio in any room without Aerial or Earth. Fine tone and power, M/L waves. Very popular ... 3/-

THE "UNIVERSAL FOUR." A 3-valve plus Rect. M/L wave T.R.F. Circuit giving 4 watts output. Widely used and praised ... 3/-

THE "CUB." A 2-valve plus Rect. Power and Quality on the "local" station. An exceptional little set on M/L waves ... 3/-

THE "OLD FOLK'S TWO." plus Rect. Similar to the Cub but with 3 station selection by switch. Greatly appreciated ... 3/-

The above are only 4 of the 40 designs available.

SEND STAMP FOR COMPLETE LIST.

COMPONENTS SUPPLIED.

### L. ORMOND SPARKS (M)

48A, HIGH STREET,  
SWANAGE, DORSET.

## WALTON'S of WOLVERHAMPTON

Our New Year Bargain list is now ready. Have you received your copy? If not you must miss Bargains. This month we are specialising in units for stripping. Brief details below:

UNIT No. 1.—Transmitter Portion of a Four Station Push Button Installation, contains about 1/6 worth of parts, 6/6, plus 1/- postage.

UNIT No. 2.—Similar to above, about 30/- worth of parts, 7/6, plus 1/- postage.

UNIT No. 3.—TX Portion of No. 18 Walkie Talkie, 6/-, postage 9d.

UNIT No. 4.—U.S.A. Radar Unit with Dynamotor and about 50/- worth of other parts, 18/6, postage 1/6. Our lists shows many more at prices from 3/6.

### Walton's Wireless Stores

203, STAVELEY RD., Mail Orders.  
48, STAFFORD STREET, WOLVERHAMPTON. Callers Only.

### I Will Teach You to Play the Piano

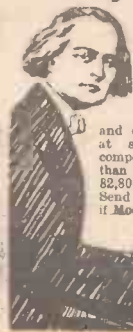

Without Drudgery, Fatigue or Failure. Even if you are of middle age and do not know a note, fun-clear, fascinating lessons, using ordinary musical notation, no freakish methods. BY POST, in your home, making failure impossible and enabling you to read and play at eight any standard musical composition. My class is seldom less than 2,000 pupils. I have taught over 82,800, and I CAN TEACH YOU. Send for free book and advice. Say if Moderate, Elementary, or Beginner.

Mr. H. BECKER,  
(Dept. 358)  
69, Fleet St.,  
London,  
E.64



# Free Guide - "Success in Engineering"

One of the following Courses taken at home in your spare time can definitely be the means of securing substantial promotion in your present calling, or entry into a more congenial career with better prospects.

## ENGINEERING, AERO, ETC.

Plastic—Radio—Aero Engines—Aircraft Design—Welding—Aerodynamics—Electrical Engineering—Television—Electric Wiring—Diesel Engineering—Generation and Supply—Works Management—Metallurgy—Refrigeration—Planning. Estimating. Rate-fixing—Time and Motion Study—Aero Inspection—Automobile Engineering—Sheet-metal Work—Engineering Draughtsmanship—Aero Draughtsmanship—Jig and Tool Draughtsmanship—Press Tool and Die Draughtsmanship—Structural or RIF Concrete Draughtsmanship—Sanitary Engineering.

## GENERAL

Matriculation—College of Preceptors—A.C.C.S.—A.C.I.S.—Aircraft Apprentice.

## MUNICIPAL SERVICE

School Attendance Officer—Handicraft Teacher—Registrar—Housing Manager—Sanitary Inspector—Weights and Measures Inspector—Inst. of Mun. Engineers—A.R.I.C.S.—L.A.B.S.S.

"PRACTICAL ENGINEERING" said—

We recommend all readers interested in improving their position to apply for a copy of this valuable book. "Success in Engineering" is not a pamphlet. It is a 132-page book, containing valuable and vital information on all branches of engineering. . . . There are many engaged in engineering who owe their success to The National Institute of Engineering.

The FREE GUIDE explains:

- Openings, prospects, salaries, etc., in Draughtsmanship, Inspection, and opportunities in all other branches of Engineering and Building.
- How to obtain money-making technical qualifications through special RAPID FULLY-GUARANTEED COURSES.

Write now for your copy of this remarkable publication.

A.M.I.E.E., A.M.I.Mech.E.,  
A.M.Brit.I.R.E., A.M.i.P.E.,  
A.M.I.C.E., A.M.I.Struct.E.,  
A.M.I.Mun.E. M.R.San.I.,  
A.M.I.E.D., A.F.R.Ae.S.,  
London B.Sc., Degrees.

Fully guaranteed postal courses for all the above and many other examinations. Fully described in the Free Guide.



## THE BUILDING BOOM— SECURE YOUR SHARE!

The Free Guide also gives particulars of our extensive range of modern Building and Structural Courses, Building Draughtsmanship, etc. The great post-war Building programme offers unlimited prospects to technically trained men.

## BECOME A DRAUGHTSMAN QUALIFY AT HOME AND EARN BIG MONEY

Men and Youths urgently wanted for well paid positions as Draughtsmen, Inspectors, etc., in Aero, Jig and Tool, Press Tool, Electrical, Mechanical and other Branches of Engineering. Practical experience is unnecessary for those who are willing to learn—our Guaranteed



"Home Study" courses will get you in. Those already engaged in the General Drawing Office should study some specialised Branch such as Jig and Tool or Press Tool Work and so considerably increase their scope and earning capacity.

## THE ACID TEST OF TUTORIAL EFFICIENCY SUCCESS—OR NO FEE

We definitely guarantee that if you fail to pass the examination for which you are preparing under our guidance, or if you are not satisfied in every way with our tutorial service—then your Tuition Fee will be returned in full and without question. This is surely the acid test of tutorial efficiency.

If you have ambition you must investigate the Tutorial and Employment services we are able to offer. Founded in 1885, our success record is unapproachable.

Why not fill in and post the attached Coupon NOW for further details and Free Authoritative Guide to openings in Engineering and Building? This book contains a mine of valuable and exclusive information and may well prove to be the turning point in your career.

PROMPT TUTORIAL SERVICE GUARANTEED

## FREE COUPON

To NATIONAL INSTITUTE OF ENGINEERING  
(Dept. 29), 148, Holborn, London, E.C.1.

Please Forward your Free Guide to

NAME.....

ADDRESS.....

My general interest is in: (1) ENGINEERING (Place a cross against the branches in which you are interested.)  
(2) AERO (3) RADIO (4) BUILDING  
(5) MUNICIPAL WORK

The subject or examination in which I am especially interested is

To be filled in where you already have a special preference:  
(rd. stamp only required if unsealed envelope used.)

NATIONAL INSTITUTE OF ENGINEERING

(Dept. 29)

148, HOLBORN, LONDON, E.C.1

OVER SIXTY YEARS OF  
CONTINUOUS SUCCESS

SOUTH AFRICA: E.C.S.A. P.O. BOX 8417 JOHANNESBURG.

FOUNDED 1885—FOREMOST TODAY—OVER 100,000 SUCCESSSES