

*Salin*

RADIO-CONTROLLED MODEL CRUISER

NEWNES

9<sup>D</sup>

# PRACTICAL MECHANICS

EDITOR : F. J. CAMM

MARCH 1950

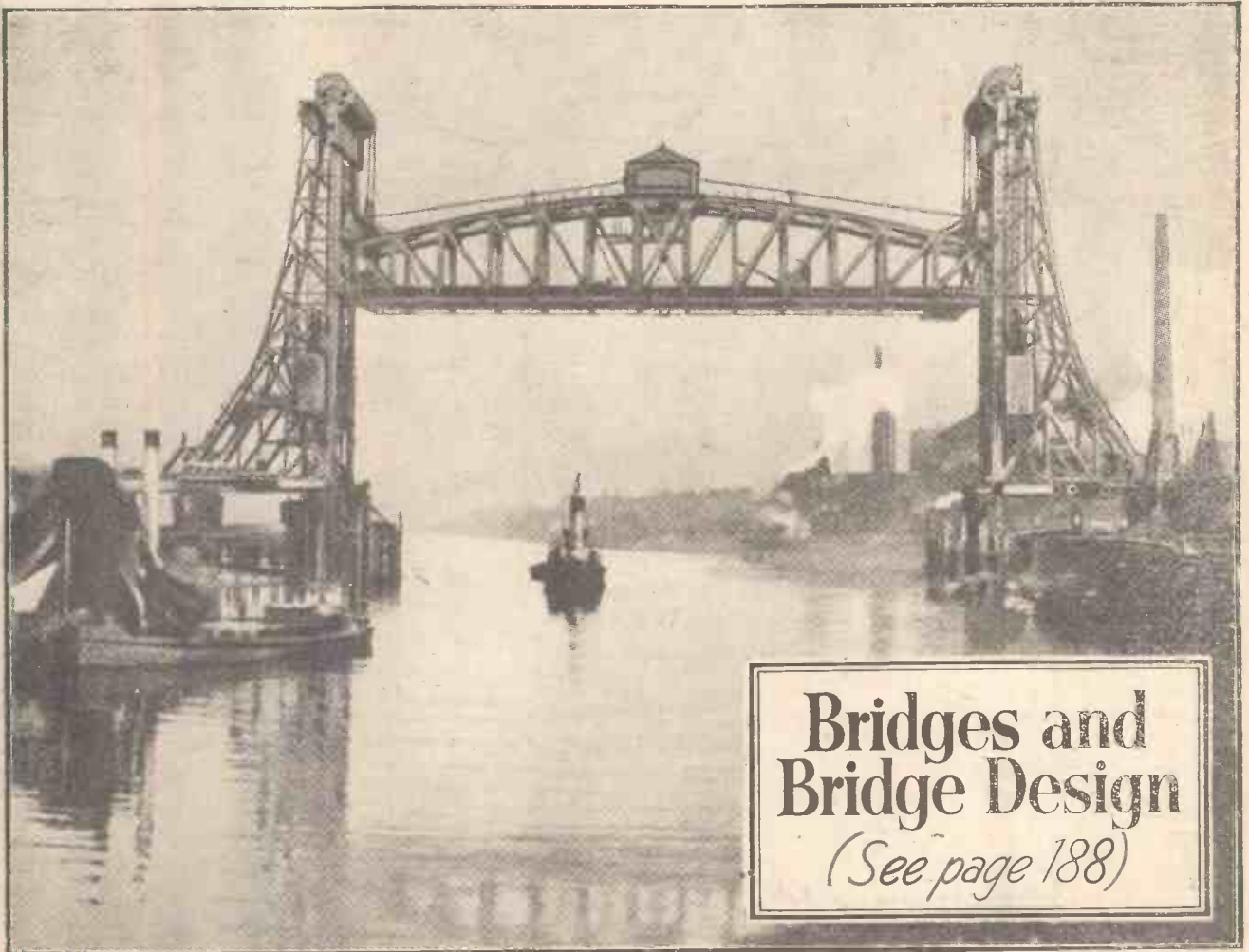

**Bridges and  
Bridge Design**  
*(See page 188)*

### PRINCIPAL CONTENTS

Model Aircraft of Loaded Elevator  
Type  
Timing Unit for Chimes  
Dynamo and Motor Problems

Wood Turning  
Close-ups Without Guesswork  
Elements of Mechanics

World of Models  
Letters from Readers  
Cyclist Section

**YOU NEED CLIPS**

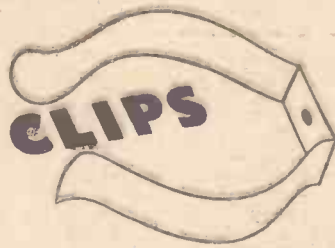

**TERRY'S MAKE CLIPS**

in every shape and size—steel clips, bronze clips, stainless clips, etc., etc.  
 Here we show a tiny selection from the enormous range we have produced.  
 Our Research Department can design any clip to your own specification.  
 (94 years of clip-making experience is at your disposal.)



No. 81

Two popular types. In a range of sizes to grip from 1" to 2". Delivery from Stock.



No. 80



No. 300

A drawing board clip. Plated finish, delivery from Stock. 4 1/2 doz. plus P.T.

The most comprehensive and informative text book on springs yet published. 10/6 post free.

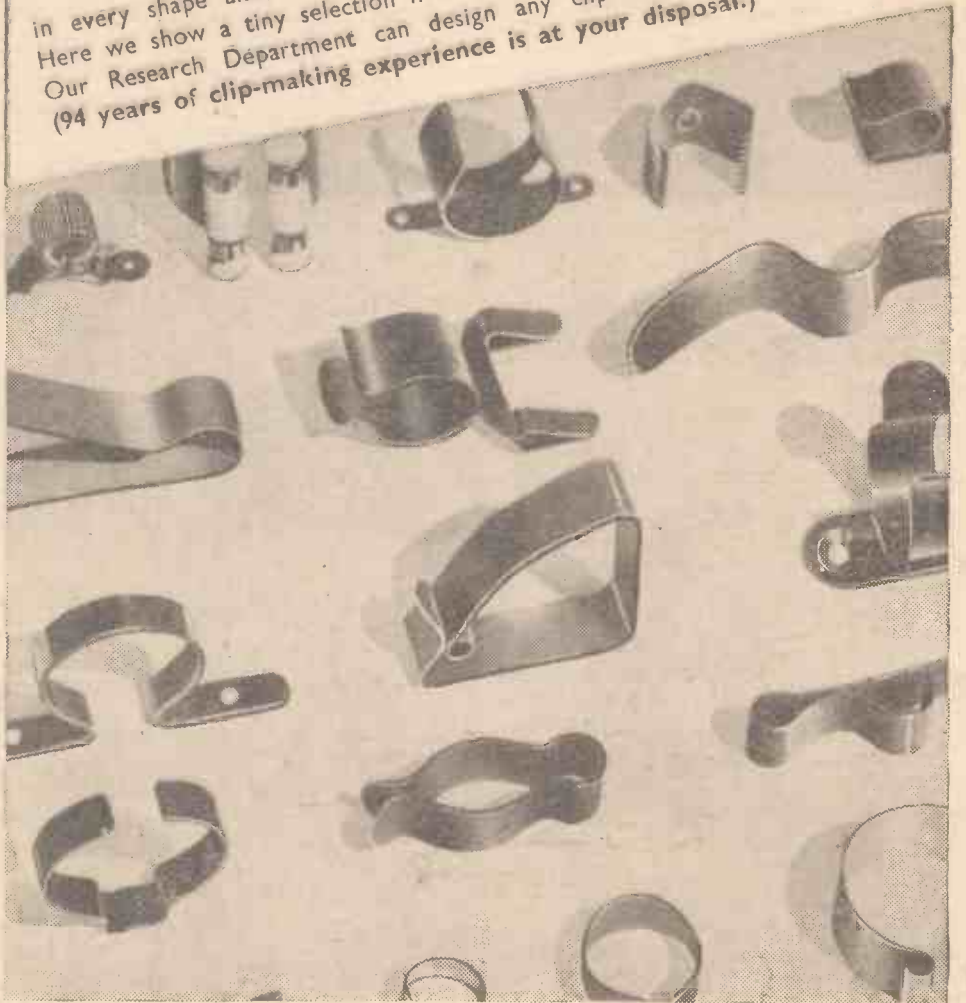

**TERRY**



Sole Makers :

HERBERT TERRY & SONS LTD. REDDITCH. London • Birmingham • Manchester



# THE 'ZYTO' 3<sup>3</sup>/<sub>8</sub> in. LATHE

BACK GEARED : SCREWCUTTING : SLIDING : SURFACING GAP BED : SET-OVER TAILSTOCK : COMPOUND SLIDE REST : ETC  
12<sup>1</sup>/<sub>2</sub> in. BETWEEN CENTRES BRITAIN'S FINEST LATHE VALUE

£6/10/0

FIRST PAYMENT AND TWELVE PAYMENTS OF 35/10

CASH PRICE £25/10/0

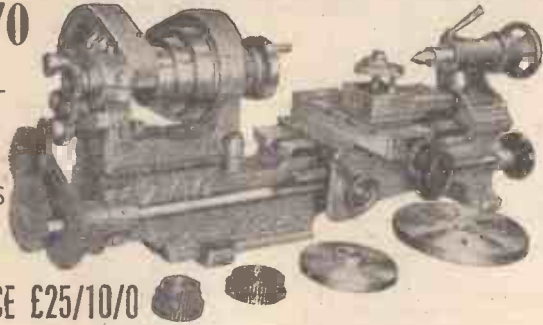

BRIEF SPECIFICATIONS:

HEIGHT OF CENTRES 3<sup>3</sup>/<sub>8</sub> in. DISTANCE BETWEEN CENTRES 12<sup>1</sup>/<sub>2</sub> in.  
HEADSTOCK MANDREL ADMITS 3/4 in. TAILSTOCK BARREL ADMITS 1/2 in.  
HEIGHT FROM SADDLE 2 in. HEIGHT FROM GAP 4<sup>1</sup>/<sub>2</sub> in.

## BOOK YOUR LATHE NOW

MOTORISED MODEL COMPLETE ON STAND  
FIRST PAYMENT £11 10 0 TWELVE PAYMENTS OF 62/4

Cash Price £45/10/0

ILLUSTRATED LEAFLET AND FULL DETAILS FREE ON REQUEST

## S. TYZACK & SON LTD.

WOODWORKING & METALWORKING TOOLS & MACHINERY MANUFACTURERS

341, 343 & 345, OLD STREET, LONDON, E.C.1.

Telephone: CLERKENWELL 8301 (10 lines) Telegrams: TYZGAR AVE. LONDON

# THORNTON'S Quality INSTRUMENTS & SLIDE RULES



# Accuracy

For over 70 years Thornton's Drawing Instruments have been used by the Engineers and Surveyors responsible for the world's most famous constructions. The more important your work the greater the necessity for Reliable and Accurate Drawing Instruments. Insist on using only Thornton's for complete satisfaction. Illustrated catalogue sent post free on request.

## A. G. THORNTON LTD

Drawing Instrument Specialists

WYTHENSHAW, MANCHESTER

Tel: WYThenshawe 2277 (4 lines)

NOW—

## NEW ACCESSORIES for your Gauge '0' MODEL RAILWAY



**PASSENGER COACHES.** First or Third-class corridor coaches and third-class composite brakes, finished in British Railways colours. A new design compensating bogie is fitted and the vehicles are supplied with corridor connections. These are the finest low-priced Gauge "0" passenger coach models introduced since the war, and will be an attractive feature of your railway system. Price each £2 4s., inc. P.T.

**GOODS ROLLING STOCK IN STEEL.** We have introduced three L.M.S. types, the brake van, a covered van and a standard open van. Fitted with correct type axle boxes, anti-friction metal wheels and standard couplings.

Prices: Open van—7/6, plus 1/3 purchase tax.  
Covered van—9/9, plus 1/11 purchase tax.  
Brake van—10/-, plus 2/2 purchase tax.

**SIGNALS.** Upper Quadrant Signals. All metal with balance weights for hand or lever operation.

Single Arm, Home or Distant—7/5, including purchase tax.

Double Arm, Home and Distant Arms—9/11, including purchase tax.

Double Arm Signal, Home or Distant—15/5, including purchase tax.

These are supplied with either right- or left-hand brackets.

**COLOUR LIGHT SIGNALS.** 2 Aspect (Home or Distant), 12/11, including purchase tax.

3 Aspect, 16/-, including purchase tax.

We also supply best quality hand-made signals in upper or lower quadrant pattern.

Single Arm, 14/4, including purchase tax.

Double Arm, 24/4, including purchase tax.

Double Arm Bracket, 24/4, including purchase tax.

Three-Arm Bracket, 25/-, including purchase tax.

Three-Arm Bracket, 34/4, including purchase tax.

Four-Arm Gantry, 56/3, including purchase tax.

**LOADING GAUGE.** No. 100210 of wood, with brass fittings, fixed on small cast-iron base. Price 5/-, plus 1/3 purchase tax.

Write for Gauge "0" MODEL RAILWAY CATALOGUE (GO/12), price 1/-, or call at our London and Manchester Branches for full details.

## BASSETT-LOWKE LTD.

### NORTHAMPTON

London: 112, High Holborn, W.C.1.  
Manchester: 28, Corporation Street.



## Of interest to all Amateur Photographers living in the country

You can save time, and money, by developing your own films in a JOHNSON J-20 DAYLIGHT DEVELOPING TANK. It's very simple. The film is transferred to the tank spiral—in the dark—the light trapped lid is locked on by a quarter turn, and everything else, developing, fixing and washing, is done inside the tank in full daylight. Half an ounce of concentrated AZOL in 10 oz. of water makes the developer. One ounce of ACID HYPO in 10 oz. of water makes the fixing solution. The film is washed while still in the tank. No trouble and no mess.

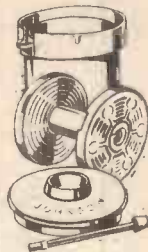

J-20 Tank for Roll Film size 20. Sold by photographic dealers. PRICE 21/-

SEE YOUR NEGATIVES WITHIN AN HOUR OF TAKING THE PICTURES

AZOL developer and the ACID HYPO can also be used to make prints on contact paper by candle or lamp light. You will need a printing frame and a couple of dishes. Nothing else. Your interest in photography will be doubled if you do your developing at home and you see your pictures quickly.

FOR THREE PENCE IN STAMPS WE WILL SEND YOU A 64-PAGE BOOK ON HOME PHOTOGRAPHY

(Mention Practical Mechanics)



Concentrated one-solution developer 2 1/2 oz. PRICE 3/-



Acid Hypo for fixing. 250 - grm. tin. PRICE 11/6

## JOHNSONS OF HENDON LTD., London, N.W. 4

Established 1743

# CYCLISTS!

Imported just for YOU!

## LONG BEAM (AMERICAN TYPE) FOCUSING TORCHES

(Empire made)

It is more than 10 years since a focusing torch such as this could be obtained AND at a price less than current non-focusing types. **SOLID BRASS NICKEL-PLATED** finish with adjustable ring focus head. Pull out loop in base, spare bulb container inside case.

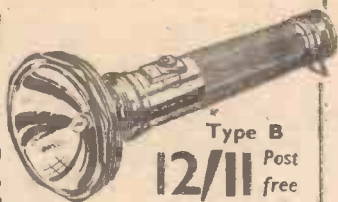

Type B  
**12/11** Post free

Complete with standard British batteries and bulb, ready for use, and fully guaranteed.

Throws a beam 400ft. long. Ideal for the cyclist, handyman, etc. Overall length 8in.

Diameter of head 3 1/2 in.  
Diameter of body 1-9/16 in.

### 20-1 REDUCTION GEARS

- A. Input shaft is 9/16in. in diameter flush to case, machined down to 3/16in. by 5/16in. deep, radiused at end to fit a Key Coupling.
- B. Output shaft 2 1/2 in. long. Diameter 9/16in. for a distance of 1/2 in. reducing to 1/2 in. diameter for a distance of 1/2 in. Remainder of the length is screwed approximately 1/2 in. Whit.
- C. Overall diameter of the Gear Casing 5 1/2 in. Fixing Base 6 1/2 in. x 3 1/2 in. suitable for drilling up to 1/2 in. diameter fixing holes.
- D. Input end is machined with register and drilled with six 1/2 in. holes. Input Shaft is at 90 deg. to the output. Suitable for up to 1 h.p. motors.

Price—BRAND NEW **£4.** Carriage Paid.

### M.O.S. NEWSLETTER

Send 1/- for specimen copy or 5/- for year's subscription.

## WAKE TO MUSIC!

### M.O.S. RADIO ALARM KIT

This simple Radio-Alarm Time Switch may be made in a few hours with the common or garden tools found in every workshop. Apart from the alarm clock and radio set which every household has, no other equipment is needed. **PRICE 12/6** POST FREE.

### SPEDA UNIVERSAL PUNCH

Designed and produced to fill a long felt want for a multiple cutting tool for light alloys. **PRICE 26/-** POST Delivery from stock. **FREE.**

## £10,000 was spent to give YOU PERFECT SOLDERING!

For a limited period we are offering the already famous **BURGOYNE INSTANT HEAT SOLDERING GUN** (advertised and sold by the makers at 79/6) for ONLY **52/6!!**

We are setting a standard for value which we will find hard to beat. This offer has been possible only by an ACCIDENT—a blocked export shipment that missed the last boat to South Africa!

### SAVE TIME ON SOLDERING

Just press the button, count seven, and solder, and the bit will remain at soldering heat until you release the pressure when it cools off instantly. No waiting to warm up or cool down—No element to burn out—No mica to crack or splinter—No risk of shock. For A.C. mains, 200-250 v. Low consumption. A tool on the design of which £10,000 was spent! No engineer can afford to be without one.

### BOSTIK CEMENT

Available in handy pocket-size tubes. Ideal for waterproof sealing. Price **1/-** per tube or six for 5/- (Add postage).

### COPPER SECTIONAL AERIAL

**RODS.** Each 12in. length—push into each other to build up any length required. **4/-** for **24** (Postage and packing 9d.)



### DE-LUXE

### CRYSTAL SET

Fits into the palm of your hand!

Complete in attractive cream or brown cabinet with tuning scale.

**15/-**

(Post 9d.)



Terms: Cash with order.

## MAIL ORDER SUPPLY CO.

THE RADIO CENTRE, 33 TOTTENHAM COURT ROAD, LONDON, W.1

Telephone: MU5eum 6667-8-9.

## HIGH FIDELITY REPRODUCTION

### S. G. BROWN, Type 'K'

Moving Coil Headphones supply that High Fidelity Reproduction demanded for DX work, monitoring and laboratory purposes, etc.

### OUTSTANDING CHARACTERISTICS

D.C. RESISTANCE 47 Ohms.

IMPEDANCE 52 Ohms at 1,000 c.p.s.

SENSITIVITY, 1.2 x 10<sup>-12</sup> watts at 1 kc. .0002 Dyne/cm<sup>2</sup>.

PRICE **£5.5.0** PER PAIR

Descriptive Literature on request.

Your local dealer can supply.



TYPE 'K'

★ For details of other S. G. Brown Headphones (prices from 30/- to 77/6) write for illustrated Brochure "P.M."

# S.G. Brown, Ltd.

Telephone: Watford 7241

SHAKESPEARE STREET, WATFORD, HERTS

## TAKE UP PELMANISM

And Develop Your Greatest Asset

DO you find life humdrum and boring? Do you think of your job as "the same old monotonous routine"? Why remain in a groove, only half alive, when you have the latent ability which could enable you to enjoy life to the full and to "hold down" an interesting, progressive job.

Half fees for serving and ex-Service members of His Majesty's Forces. (Apply for Services Enrolment Form.)

Are you making the most of your greatest asset—your mind? The Pelman Institute with its unrivalled half-a-century of experience will show you how to develop this invaluable asset to the fullest capacity. Pelmanism will lift you out of the rut and eliminate your feelings of Frustration and Inferiority. It will teach you how to dispel your Fears and to overcome such failings as Aimlessness and Depression.

The Course will give increased power and energy to your mind: will strengthen your Will-Power, and develop your Initiative. You will find that your outlook on life will change to one of cheerfulness and optimism, and with your increased Efficiency, will come Happiness, Success and Financial Betterment.

Pelmanists are not left to make the applications themselves. An experienced and sympathetic instructional staff shows them, in exact detail, how to apply the principles of Pelmanism to their own circumstances and aspirations.

The Pelman Course is fully described in a book entitled "The Science of Success," which will be sent you, gratis and post-free, on application to:—

### PELMAN INSTITUTE,

(Established over 50 years)  
130, Norfolk Mansions,  
Wigmore Street, London, W.1.  
Callers welcomed.

### HOW TO LEARN LANGUAGES

The Pelman Languages Institute teaches French, German, Spanish and Italian, without translation. Write for particulars and specimen lesson of the language that interests you, which will be sent gratis and post free.

Pelman Languages Institute,  
130, Norfolk Mansions, Wigmore St.,  
London, W.1.

POST THIS COUPON TO-DAY  
To the Pelman Institute,  
130, Norfolk Mansions, Wigmore  
Street, London, W.1.

"The Science of Success," please.

Name .....

Address .....



# RAWLPLUG PRODUCTS

**INDISPENSABLE  
IN THE WORKSHOP  
HANDY IN THE HOME**



## FIXING DEVICES AND TOOLS

The Rawlplug Popular Outfit costs only 2/6 complete. Larger sizes are obtainable.

Whatever your fixing problems there's a Rawlplug Device that will solve it for you—easily and quickly. Rawlplugs make neat and absolutely firm fixings in any material from brick or tile to stone or slate, with a size for every screw from No. 3 up to 1/2" coach screws. Rawlplug Tools are easy to use and ensure a perfect hole without damage to surrounding surfaces. Other Rawlplug Devices include Rawlbolts for heavy duty fixings, Rawlanchors and Toggle Bolts for thin or hollow materials and Rawlclips for instant fixing of conduits and cables to girders—a device in fact for every need.

Rawlplug fixing devices and products can be obtained from ironmongers, Hardware Dealers, Stores or Model Makers Suppliers.



## SCRAPER

B389C

A remarkably efficient and economical scraper, built to last a lifetime. Gives smooth finish without chatter or scratching. Easy-grip handle made solid with blade carrier in seasoned hardwood, polished and varnished. Total length approx. 6". Fitted renewable 2 1/2" Cadmium Plated Steel Blade, with cutting edge ground like a razor. 3/- each.



## DUROFIX

The indispensable adhesive for instant use on crockery, glass, wood, metal, celluloid and the thousand and one things handled by the hobbies enthusiast. Instant drying, insulating, water-proof and heatproof. Durofix is grand for repairs to electrical, sports and leather goods. Tubes 9d. and 1/3d. Tins 2/9d. and 7/6d.



## DUROGLUE

**UNDILUTED ANIMAL  
GLUE OF INCOMPARABLE  
STRENGTH**

Ready for instant use for the many purposes for which an extra-strong glue is needed. Wood, cloth, fabric, felt, leather and any greaseless surface can be stuck with Duroglue. Tubes 6d. and 1/-. Tins 2/3d. and 3/9d.



## PLASTIC WOOD

**APPLIED LIKE  
PUTTY,  
DRIES LIKE WOOD**

Can be cut, planed, polished and painted like wood. Will take nails and screws like wood. It does not blister, crack or decay. Rawlplug Plastic Wood is actually the best quality product of its kind on the market. Tubes 9d. Tins 2/- and 5/-.



## TILE CEMENT

**A LIQUID CEMENT  
OF TREMENDOUS  
STRENGTH**

Remarkable for its great adhesive qualities, Rawlplug Tile Cement speedily fixes loose tiles to walls, floors, fireplaces, hearths, curbs, etc., in kitchens, lavatories, bathrooms, halls, bedrooms, reception rooms, etc. 2/3d. per tin.

**THE RAWLPLUG COMPANY LTD. LONDON. S.W.7.**

# Baker's SOLDERING FLUID

ESTABLISHED 1834

**SIR Wm. BURNETT & CO. (CHEMICALS) LTD.  
GREAT WEST ROAD, ISLEWORTH, MIDDLESEX**

BELFAST · TORONTO · MELBOURNE  
JOHANNESBURG · WELLINGTON N.Z.

Smec's

## 1950 SMALL EQUIPMENT REVIEW

## NUMBER ONE

# POWER DRILLING MACHINES

It gives us great pleasure to introduce a new range of Power Drilling Machines at a very competitive price. This has been achieved by improved production methods with no sacrifice of quality.

Special features include:—

Fully precision ground spindle and quill assembly—precision ground driving sleeves—sensitive accurate feed—Graduated depth stop—adjustable cushioned spring return—positive locking devices throughout. Powered by 1/4 h.p. motor with flush mounted rotary switch.



### General Specifications:

	Floor Model	Bench Model
Column Height	60 in.	30 in.
Stroke	4 1/2 "	4 1/2 "
Distance (column to centre of drill)	7 1/2 "	7 1/2 "
Overall Height (with head in highest position)	68 1/2 "	38 1/2 "
Overall Width	15 "	15 "
Overall Depth (front to back)	22 1/2 "	22 1/2 "
Net Weight, complete with electrical equipment	162lb.	150lb.
Code No.	3453	3451
Price including Single Phase Motor and 1/2 in. Drill Chuck	£32 5s. 0d.	£30 5s. 0d.
Code No.	3454	3452
Price including Three Phase Motor, and 1/2 in. Drill Chuck	£30 10s. 0d.	£28 10s. 0d.
	Carriage Extra	

Special F.O.B. Quotations gladly AIR MAILED to Overseas Customers

PERSONAL HIRE PURCHASE QUOTATIONS ON REQUEST.

### Technical Specification:

Drilling capacity up to 1/2 in. Motor, 1/4 h.p.  
Motor spindle speed 1,440 r.p.m.  
Drill spindle speeds, 4,000/2,300/1,400/900/500 r.p.m.  
Base (overall), 17 in. x 13 1/2 in.  
Base work-table, 13 in. x 7 1/2 in.

These drilling machines will handle all metalwork such as drilling and tapping together with morticing, routing, drilling and sanding in woodwork. Special base provided for woodwork.

## T. GARNER & SON LTD.

HAND & MACHINE TOOL DIVISION,  
Phone 2968 P.B.E. Redbrook Wks., Gawber,  
Grimsby. Garner 2968, Barnsley. **BARNESLEY.**



# I.C.S. TRAINED MEN are in Greater Demand than Ever

—Maximum production depends on high technical skill, such as that acquired by I.C.S. Students

**TENS OF THOUSANDS MORE TRAINED MEN ARE URGENTLY NEEDED NOW—BUT THERE IS NO WORTH-WHILE PLACE FOR THE UNTRAINED**

*Ambitious men everywhere have succeeded through I.C.S. Home-Study Courses. So also can you.*

The man with an I.C.S. Training in any one of the subjects listed below knows it thoroughly, completely, practically. And he knows how to apply it in his everyday work.

- |                         |                         |                       |
|-------------------------|-------------------------|-----------------------|
| Accountancy             | Diesel Engines          | Mining Engineering    |
| Advertising             | Draughtsmanship         | Motor Engineering     |
| Aero Engineering        | Drawing Office Practice | Motor Mechanic        |
| Air and Vacuum          | Electrical Engineering  | Motor Vehicle Elec.   |
| Brakes                  | Electric Power, Light-  | Municipal Eng.        |
| Air-Conditioning        | ing, Transmission       | Plastics              |
| Architecture            | Traction                | Plumbing              |
| Architectural Drawing   | Eng. Shop Practice      | Quantity Surveying    |
| Auditing                | Fire Engineering        | Radio Engineering     |
| Boiler Engineering      | Foremanship             | Radio Service Eng.    |
| Book-keeping            | Free-Lance Journalism   | Refrigeration         |
| Building Construction   | Fuel Technology         | Sales Management      |
| Building Specifications | Heating and Ventilation | Salesmanship          |
| Business Training       | Hydraulic Engineering   | Sanitary and Domestic |
| Business Management     | Hydro-Electric          | Engineering           |
| Carpentry               | Illumination Eng.       | Sheet-Metal Work      |
| Chemical Engineering    | Industrial Management   | Short-Story Writing   |
| Chemistry, I. & O.      | Joinery                 | Steam Engineering     |
| Civil Engineering       | Lettering               | Structural Steelwork  |
| Clerk of Works          | Machine Designing       | Surveying             |
| Coal Mining             | Machine-Tool Work       | Telegraph Engineering |
| Colliery Examiner's     | Marine Engineers        | Television Technology |
| Colliery Overman's      | Mechanical Drawing      | Welding, Gas and Elec |
| Commercial Art          | Mechanical Engineering  | Woodworking Drawing   |
| Concrete Engineering    | Mine Surveying          | Works Engineering     |

And most of the Technical, Professional, Commercial and Civil Service Examinations; also U.C.T.A. Exam in Salesmanship.

(I.C.S. students preparing for Examinations are coached till successful)

If you need technical training, our advice on any matter concerning your work and your career is yours for the asking—free and without obligation. Let us send you our special free booklet on the subject in which you are specially interested, **DON'T DELAY. Make ACTION your watchword**

The successful man **DOES** to-day what the failure **INTENDS** doing to-morrow. Write to us **TO-DAY**

Use this Coupon

**INTERNATIONAL CORRESPONDENCE SCHOOLS LTD.**  
Dept. 95, International Buildings, Kingsway, London, W.C.2.

Please send me the free booklet describing your Courses in

Name..... Age.....  
(USE BLOCK LETTERS)

Address.....



- Addresses for Overseas Readers
- Australia: 140, Elizabeth Street, Sydney.
  - Egypt: 40, Sharia Abdel Khalek Sarwat Pasha, Cairo.
  - Eire: 13, Anglesea Street, Dublin, C.4.
  - India: Lakshmi Bldgs., Sir Pheroza Mehta Rd., Fort, Bombay.
  - New Zealand: 182, Wakefield Street, Wellington.
  - N. Ireland: 26, Howard Street, Belfast.
  - South Africa: 45 Shortmarket Street, Cape Town.

# A new solder FOR WORKSHOP AND HANDYMAN

- CONTAINS 2 CORES OF FLUX
- NO EXTRA FLUX REQUIRED
- REPLACES STICK SOLDER, FLUID AND PASTE FLUXES
- IF DESIRED FLUX RESIDUE READILY WASHES OFF WITH WATER
- SO FAST THAT IT WILL EVEN SOLDER BLUED SPRING STEEL WITHOUT PRE-CLEANING



No. 10 KIT 2/- each

SIZE 8  
CARTON  
5/- each



Available in 5/- retail cartons (4 specifications) or 2/- Multicore Solder Kit contains 2 specifications Arax Multicore Solder and 2 specifications Ersin Multicore

Solder for electrical wire to tag joints. Now obtainable from many stores. In case of difficulty 5/- cartons or 2/- Multicore Solder Kits sent post free on receipt of postal order or stamps.

MULTICORE SOLDERS LTD., MELLIER HOUSE, ALBEMARLE STREET, LONDON, W.1

## PLASTICS (MANCHESTER) LTD.

11 Whitworth Street, Manchester, 1. Tel: Gen. 0272-1725.

BUY YOUR SUPPLIES FROM THE LEADING PLASTIC STOCKISTS FOR THE MODEL MAKER AND HOBBYIST

As Official Stockists for IMPERIAL CHEMICAL INDUSTRIES LTD. IRINOID, LTD., and UTILEX, LTD.

### WE STOCK

- "PERSPEX" (Acrylic sheet). Clear and all colours sheet and rod. From 1/16in. thick upwards (Standard I.C.I. prices).
- "CRINOTHENE" (Brand of Polythene). This is a ductile embossed sheet about .015 thick in all colours. Sold by the yard, 34in. wide. Used for lampshades, bags, etc.
- "CASEIN" Sheet, Rod and Tubes, etc.
- CAST RESIN in a variety of shades and forms.
- P.V.C. SHEETING (Admiralty Specification) for Curtains, Aprons, Rainwear, Shower Curtains, etc.
- ACETATE FILM and SHEET. All colours, plain and embossed, for Lampshades, Fabricating, etc.
- Lacquers and Dyes for "Perspex" (Acrylic Resin). Cements, Polishes, Luminescent Powders, Transfers, Instructional Manuals, etc.
- Specialists in fabrication, injection moulding and engraving.
- FREE PRICE LISTS AND INFORMATION ON REQUEST.

# THE "Gala"

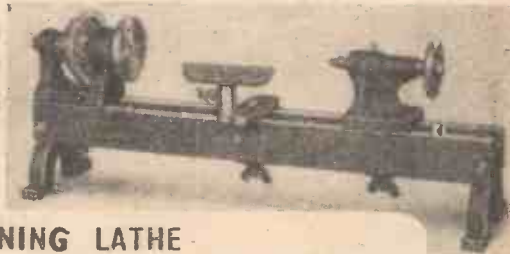

## WOOD TURNING LATHE

MODEL A.  
Work up to 18 inches  
£9.0.0

MODEL B.  
Work up to 28 inches.  
£9.10.0

Trade enquiries invited.

In two sizes: Model A—2ft. 6in. bed (18in. between centres). Model B—3ft. 4in. bed (28in. between centres). Suitable for turning hard woods, plastics, etc. Headstock: best quality grey cast iron with steel spindle; precision ground all over. Four-step cone pulley for 1in. Vee belt. Height to centre 3 1/2in. Tailstock: of grey cast iron with steel barrel, bored No. 1 Morse taper, carrying hardened steel centre. The Lathe is adaptable for treadle, countershaft or direct motor drive.

**SCOTTISH PRECISION ENGINEERING CO.**  
27 Cadogan Street, Glasgow, Scotland.



## TELEVISION WITHOUT TEARS

OUR Kit of Parts (complete down to the last nut and bolt) is proving doubly popular because (a) the price of £15 19s. 6d. is astonishingly low, and (b) the explicit nature of our instructions and point-to-point wiring diagrams ensures success for all. Its most convincing feature, however, is that the conversion of ex-Government units is NOT involved.

The Televisor is built from standard radio components and assembled on two chassis, one for the Vision Receiver, Sound Receiver and Time Base, the other for the Power Supplies. It operates from A.C. Mains 200-250 volts.

Price of the comprehensive point-to-point wiring diagrams and 17 pages of data is 5s., post free. May we urge you to send for these initially? If a Kit is subsequently purchased the 5s. will, of course, be credited. PLEASE SPECIFY LONDON OR SUTTON COLDFIELD WHEN ORDERING THIS DATA.

**COMPLETE KIT OF PARTS ONLY**  
**£16 19s. 6d.**  
Carriage and packing 10/-

### NOTE THESE ★ FEATURES

★ No knowledge of television technique essential. ★ All parts complete, brand new and of the finest quality. ★ All parts may be purchased separately. ★ Unique "after-sales" service for LONDON frequency Receivers. Testing and alignment of receivers after completion of assembly undertaken for a nominal sum.

Our Televisor is equal to many commercial models. Why not come along for a demonstration during viewing hours? You will be surprised and delighted at its simplicity of construction and outstanding performance.

### UNIQUE OFFERS!

Wireless Set No. 18. Battery superhet. Frequency coverage 6-9 Megacycles. Valve line-up: three ARPI2 and one AR8; and 465 Kc/s I.F. Transformers. In new condition but store soiled. ONLY 21/-, post free.

American I.F.F. Units. Supplied complete with 10 International Octal based valves and motor generator, which is easily converted to a motor running from either A.C. or D.C. 230 v. mains. Valve line-up: six of 6SH7, two 6H6 and two 7193; including reduction drive, carbon pile voltage regulator and chock-full of condensers, resistors and relays. In new condition, 27/6 each. A bargain for the Practical Mechanic.

"VIEWMASTER" envelope for BIRMINGHAM, just ready! Complete data Sheet. The "Viewmaster" uses a 9-inch or 12-inch tube.

### Best Buy at Britain's

**CHARLES BRITAIN (RADIO) LTD.**

(Dept. P.M.) Phone: TEMple Bar 0545

11, Upper Saint Martin's Lane, London, W.C.2

Shop Hours: 9-6 p.m. (9-1 p.m. Thursday) -

OPEN ALL DAY SATURDAY

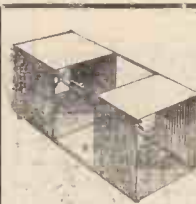

**BOX KITES**  
Ex-R.A.F. brand new. Light alloy collapsible frame. High quality canvas. (Post and packing 9d.) **10/6**  
or complete in handy metal container with special anti-twist cord. (Post & packing 9d.) **12/6**

**SOLDERING PASTE**  
"CHEMICO" brand ex-Air Ministry stock in 4 oz. and 8 oz. tins. (Carriage paid) **12/6**  
7 lb.

**PAN 16 mm. CINE FILM**



Special offer limited quantity only. Each container has 12 rolls of 25 ft. each. (Post & packing 9d.) Per tin, **15/6**

**TANK COMMANDER'S PERISCOPE**

Ideal for race meetings, etc., 10 in. long, large wide-angle object glass giving fine field of view. Light construction, easy to hold up. Good finish. A fine double prismatic optical instrument with binocular vision. **15/6**  
(Post 1s. 6d.)

**ANTI-VIBRATION MOUNTINGS**

Suitable for installation on light motors, radios, machinery of all types, etc. Rubber seat bonded metal. Each mounting takes a 10 lb. load in any position. Full flexibility. One dozen mount-ings (post 6d.) **16/-** Also 6 lb. pattern **12/-** 8 lb. pattern **15/-** per dozen

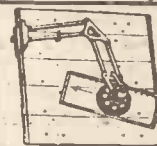

**CHARTBOARD**

Parallel arms, rule and protractor 17 in. sq. Makes a handy small drawing machine and is constructed to rigid A.M. standards. A hinged perspex cover for tracing, etc., is included. (Postage 1s. 3d.) **25/-**



**G.S.A.P. CAMERA**

Made by Bell & Howell (U.S.A.) takes standard 16 mm. cine cassette. Variable speed, incorporates Ansix 12 in. f. 3.5 lens assembly complete with filter and iris. A fine compact camera which can be used for normal 16 mm. Cine photography, little conversion necessary. Complete in small attache transit case. (Carriage 2s.) **£6/10/0**

**230 V MINIATURE MOTORS**

These motors will run from 200/250 V, 50 cycle A.C. mains. Made by Sangamo for electric meters and now surplus to meter manufacturers requirements. Dimensions of motor 1 1/2 in. diameter x 7/8 in. depth. Weight only a few oz. but rigidly constructed. Self starting, no shunt or resistance necessary in circuit. Motor supplied with 1 in. geared shaft and three small feet for fixing, or mounted on baseplate 2 1/2 in. sq. with long chain of reduction gearwheels. Brand new. **12/6** or with baseplate & **15/-** reduction gearing. Post Free. Motor only

**AERO-SPARES CO.**

LONDON, W.C.1.

(DEPT. 77), 71 HIGH HOLBORN,

Telephone: AMBassador 2871/2. (all depts.)

## CHEMICAL APPARATUS CATALOGUE

POST **2/6** FREE

The Abridged Chemical List, S.A.E.

**VICSONS LTD**  
148 PINNER RD., HARROW, MIDDLESEX.  
FOR ALL LABORATORY APPARATUS

Contractors to Education Authorities and many of the large industrial laboratories

**SCHOOL and RESEARCH LABORATORIES**

have you yet had our illustrated catalogue?

If not write for a copy to-day (free)

## MODERN DRAWING OFFICE Furniture

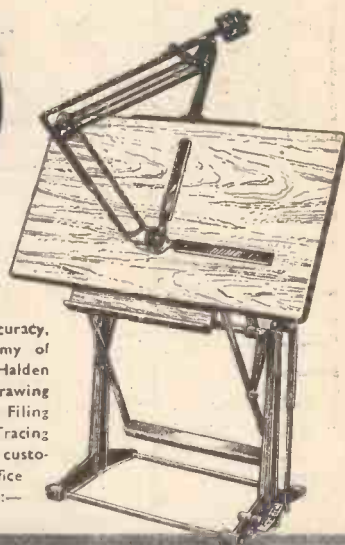

No finer range of Drawing Office Furniture is available than the Halden range. Every up-to-date refinement making for greater accuracy, greater ease in use, and economy of space has been introduced to the Halden designs. The range includes Drawing Tables, Cabinets, Drawing Boards, Filing Cabinets, Trestles and Glass Tracing Tables. Large size boards made to customer's own specification. For all office furniture and accessories consult:—



# Haldens OF MANCHESTER

J. HALDEN & CO., LTD., 8, ALBERT SQUARE, MANCHESTER, 2.

Branches at:— London, Newcastle-on-Tyne, Birmingham, Glasgow, Leeds and Bristol.

## MODEL RAILWAY CLUB EXHIBITION

EASTER WEEK, TUES. APRIL 11 to SAT. APRIL 15

The work of members of the Model Railway Club, over 3,000 models of locomotives, coaches, wagons, signals and working tracks. Free rides behind real steam engines.

**CENTRAL HALL, WESTMINSTER**

Tuesday, 2 p.m. to 9 p.m. Thereafter, 11 a.m. to 9 p.m.

ADMISSION - Adults 2/6, Children under 14, 1/-

Special terms for organised parties on application to R. C. Panton, 162a, Strand, London, W.C.2.

# FREE! TO AMBITIOUS ENGINEERS



**This enlarged and entirely new edition of the valuable Handbook "ENGINEERING OPPORTUNITIES"**

For 21 years this unique book has been a guiding light to Engineers all over the world. More than 1,000,000 copies have been distributed . . . there have been 104 editions. Still the demand continues! After months of research, we have been able to produce a better and even bigger "ENGINEERING OPPORTUNITIES" packed from cover to cover with vital, up-to-the-minute information that every engineer requires—information you must have if you want rapid promotion, higher pay, and one of the many worth-while appointments open to technically trained men.

**176 PAGES OF PRACTICAL GUIDANCE**

"ENGINEERING OPPORTUNITIES" explains the modern, quick way of preparing in your spare time for recognised engineering examinations, outlines hundreds of examination and non-examination courses in all branches of Engineering, describes the benefits of our Employment Dept., and enables you to visualise a secure, better paid and more important position for yourself.

**We definitely Guarantee "NO PASS—NO FEE"**

B.I.E.T. has helped thousands of ambitious men. We can and will help you. It will cost you no more than a stamp to inquire, and in any case "ENGINEERING OPPORTUNITIES" is well worth having. It will reveal many opportunities you are now missing and, if you are earning less than £10 a week, will be of special interest to you. Make sure of your FREE copy by posting the coupon now.

**----- POST THIS COUPON TODAY! -----**

*(Write if you prefer not to cut page)*

Please send me FREE and entirely without obligation a copy of the new and enlarged edition of "ENGINEERING OPPORTUNITIES."

NAME .....

ADDRESS .....

I am interested in .....

(State subject, exam., or type of appointment that appeals to you.)

**BRITISH INSTITUTE OF ENGINEERING TECHNOLOGY  
410A Shakespeare House, 17-19 Stratford Place, London, W.1**

**WHICH IS YOUR SUBJECT?**

**Mechanical Engineering**

A.M.I.Mech.E.—CITY & GUILDS—General Mechanical Eng.—Maintenance Eng.—Diesel Eng.—Sheet Metal Work—Welding—Metallurgy—Machine Drawing & Design—Refrigeration, etc.

**Electrical Engineering**

A.M.I.E.E.—CITY & GUILDS—General Electrical Eng.—Installations—Illuminating Eng.—Electrical Science—Electricity Supply—Meters & Measuring Instruments—Mains Eng., etc.

**Radio and Television**

A.M.Brit.I.R.E.—SERVICING CERTIFICATE—C. & G. Telecommunications—General Radio Eng.—Radio Servicing—Television Servicing—Sound Film Projection—Electronic Eng., etc.

**Production Engineering**

A.M.I.P.E.—Works Management—Foremanship—Staff Supervision—Planning Eng.—Costing, etc.

**Automobile Engineering**

A.M.I.M.I.—CITY & GUILDS—General Automobile Eng.—Automobile Repairs—High Speed Diesels—Garage Management, etc.

**Building & Civil Engineering**

A.M.I.C.E.—F.R.I.C.S.—L.I.O.B.—General Building—Architectural Drawing—Sanitary Eng.—General Civil Eng.—Surveying—Specifications & Quantities—Heating & Ventilating—Painting & Decorating—Plumbing—Carpentry & Joinery—Timber Technology, etc.

PLASTICS—DRAUGHTSMANSHIP—AERONAUTICAL ENG.—FORESTRY

**SOME LETTERS AFTER YOUR NAME**

A.M.I.Mech.E. A.M.I.E.E. A.M.I.C.E.  
F.R.I.C.S. A.M.I.Struct.E. L.I.O.B.  
A.M.Brit.I.R.E. A.F.R.Ae.S. A.M.I.P.E.

HUNDREDS OF OTHER COURSES

(Tell us what interests you)

# BIET

**THE B.I.E.T. IS THE LEADING INSTITUTE OF ITS KIND IN THE WORLD**



# PRACTICAL MECHANICS

EDITOR  
F. J. CAMM

MARCH 1950  
VOL. XVII. No. 197

Owing to the paper shortage "The Cyclist," "Practical Motorist," and "Home Movies" are temporarily incorporated.

## FAIR COMMENT

### SCIENCE AND TECHNOLOGY AT THE FESTIVAL OF BRITAIN

THE Festival of Britain will be held from May till September, 1951, and in it will be represented the various branches of science and technology from the British point of view. The main exhibition will be on the South Bank of the Thames, and the main theme of it is that British contributions to civilisation have been the result of two factors—the natural resources of the country and the spirit of enterprise and initiative of the British people. The scientific and technical exhibits will, therefore, be selected to show these developments from their inception. The exhibition will be in two parts, one upstream and the other downstream. The upstream part, "The Land," will indicate how the natural resources of the country have been developed. It will show wild life, agriculture and forestry, natural resources such as coal, iron, limestone and salt, power and production, the sea, the cliffs, transport and telecommunications.

The downstream portion will represent "The People," and it will show British character and tradition, homes and gardens, television, new schools, health, sport, and so on.

The South Bank Exhibition will show the Dome of Discovery, and this will illustrate the contributions which Britain has made in exploration and discovery, quite apart from the initiative it has shown in the physical fields of geography and mining. The exploration of the outer space, investigation of the structure of matter, biological and kindred discoveries will all here be represented. Civil engineering, for example, will be represented by working models of mining installations and bridges; in the transport section there will be exhibits showing docks, harbours, roads, railways, airfields, water supplies and drainage.

At Kelvin Hall, Glasgow, will be held the Exhibition of Industrial Power, the two main themes of which are the "Power of Coal" and the "Power of Water"; but the former will illustrate the development of British mining, iron and steel, machine tools, power units, from the steam engine to the present day, the generation and transmission of electric power, railways and shipbuilding.

The latter will demonstrate the North of Scotland Hydro Electric scheme, civil engineering work in docks and harbours and overseas irrigation schemes.

There will also be a section devoted to the power of the future—nuclear energy.

At the Science Exhibition at South Kensington the growth of knowledge of the nature and structure of matter will form the subject of a special display. The visitor to this exhibition will sequentially pass through a series of rooms in which ordinary objects are magnified successively until eventually a representation of the inner structure of the nucleus is displayed.

The latest results of current research work will be displayed in the final section, including the application of nuclear fission products to medicine, the study of cosmic rays from

### By THE EDITOR

outer space, the chemical synthesis of new dyes, drugs and plastics.

This exhibition, therefore, should help to destroy the belief held in some quarters that Great Britain is effete. It will show that this country has led the world and is a master among the apprentices. Too many of our speakers have been granted money by the Treasury to go abroad and denigrate this country.

In past years we have had some splendid national exhibitions, commencing with the remarkable exhibition nearly a hundred years ago held in Hyde Park and ending with the exhibitions at the White City organised by Imre Kirralffy. Those exhibitions gave an enormous fillip to English trade, and they have been perpetuated in a somewhat smaller form by the British Industries Fair and similar smaller specialised exhibitions. Some may feel that the Festival of Britain is merely duplicating the work of special exhibitions such as the Motor Show, the Cycle Show, Radiolympia, the Textile Exhibition, the Engineering and Marine Exhibition, etc., where those interested in particular subjects do not have to waste time on subjects in which they are either not interested or of which they know nothing. Indeed, it was as a result of the difficulties of making large exhibitions pay that they were discontinued in favour of the smaller specialised exhibitions. As the Festival of Britain is a Government-sponsored affair, the question of profit and loss does not arise, because whatever the loss it can be passed off on to the taxpayer.

The previous exhibition of this character was not a success, and in saying this we are not belittling the motives nor the vision of those who have promoted the Festival of Britain. We merely hope that their experience will not provide further confirmation of the belief held in industry that industries as such become lost amongst the welter of interest provided. For a particular industry to profit from an advertisement of this sort it expects business to flow, not only to spend a large sum of money to provide a sort of poppy show for the public.

There is, indeed, a growing belief that there are far too many exhibitions. Almost every week there is an exhibition of some

sort being held somewhere, and attendances at exhibitions since the war do not encourage the belief that the public is clamouring for more of them.

It is impossible to plan an exhibition on so vast a scale without splitting it up, as indeed has been done, into a number of smaller exhibitions. A visitor from overseas to this Festival will have to spend a considerable amount of time in travelling between the various venues.

### TELEVISION DEVELOPMENTS

DEVELOPMENTS in television recently demonstrated at Alexandra Palace proved that it is impossible to improve the technical quality of the television programmes. Apparatus was shown which would enable events such as the Olympic Games and the Boat Race to be televised—recorded on cinematograph film and broadcast in the evening programme. At the present time about six hours has been required for processing the sound and vision film, but this time will be reduced by recording the sound on magnetic tape and reproducing it in synchronism with the film carrying the vision programme.

The cameras employed do not incorporate the usual shutter mechanisms. The film is drawn through at a constant speed, while the image of the picture is maintained stationary relatively to it by a system of oscillating and rotating mirrors.

### T.V. AERIALS ON COUNCIL HOUSES

BEFORE banning or discouraging the use of outdoor television aerials on council houses a number of local authorities consulted a special panel of aerial experts formed by the Radio and Electronic Component Manufacturers Federation. The majority of other councils who discourage outdoor aerials without technical advice prove very amenable to reason and willing to be guided when approached by the panel.

This information was given on Friday, February 3rd by Mr. D. S. A. Gardner, lecturing on behalf of the R.E.C.M.F. to the London branch of the Institute of Housing at County Hall, London. He was explaining the various types of aerials on the market and their functions in regard to good television reception.

In his talk, Mr. Gardner emphasised that no hard and fast rule for aerials could be laid down. Every case must be judged on local conditions and the amount of electrical interference in the area. It was impossible to predict the minimum standard of aerial which would give satisfactory reception in any area. A case was on record of an indoor aerial giving very satisfactory results, while on the other side of the street an outdoor television aerial was absolutely necessary.

Mr. Gardner suggested that other councils and local authorities might follow the lead given recently by the L.C.C., who have indicated that they will consult the R.E.C.M.F. panel if difficulties are met.

### SUBSCRIPTION RATES

including postage for one year

Inland	- - -	10s. 6d. per annum.
Abroad	- - -	10s. 6d. per annum.
Canada	- - -	10s. per annum.

Editorial and Advertisement Office: "Practical Mechanics," George Newnes, Ltd., Tower House, Southampton Street, Strand, W.C.2  
Phone: Temple Bar 4363.

Telegrams: Newnes, Rand, London.  
Registered at the G.P.O. for transmission by Canadian Magazine Post.

Copyright in all drawings, photographs and articles published in "Practical Mechanics" is specially reserved throughout the countries signatory to the Berne Convention and the U.S.A. Reproductions or imitations of any of these are therefore expressly forbidden.

# Bridges and Bridge Design

The Evolution of Some of the World's Most Famous Bridges

By G. W. McARD, A.M.I.Mech.E.

**P**ROBABLY no single factor throughout the whole history of man has contributed more to the progress of civilisation than the building of bridges. Admittedly, roads are the main highways along which men have travelled, but roads would be too fragmentary if the bridge-builder's skill was unavailable, and the great railway systems throughout the world would quickly come to a standstill when their bridges are destroyed. Many have been the designs employed; and the materials chosen scarcely less numerous, as the following notes will show, and the few failures which



Fig. 6.—The Forth bridge—Sir Wm. Arrol & Co.

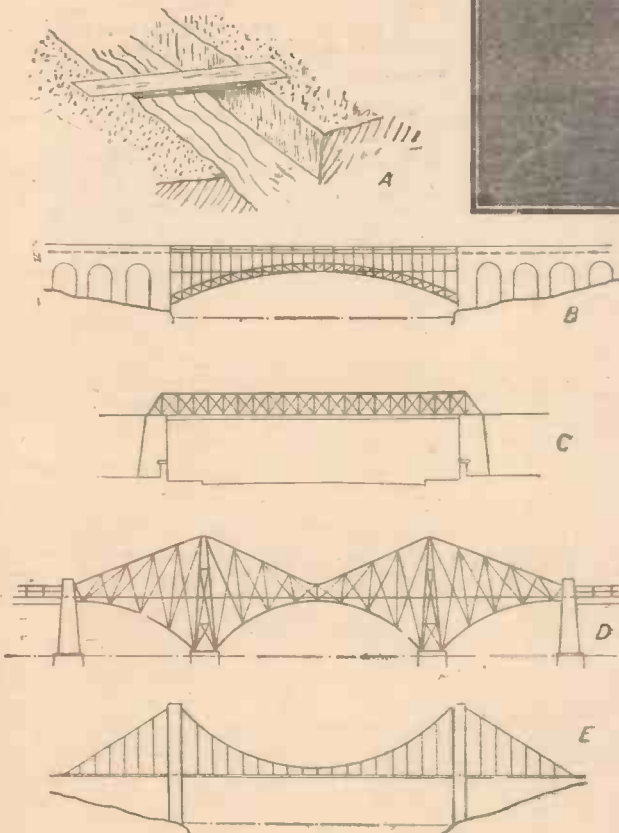

Fig. 1.—Typical forms of bridges.

have occurred serve as warning beacons for succeeding builders.

From the earliest times man has been faced with the problem of crossing the rivers and gullies in his path. A tree trunk or a slab of stone might serve for a local stream too wide to jump and too deep to ford, but for a river or wide ravine a more involved solution was necessary, especially if it was essential to transport his tribe and their belongings—perhaps his warriors and their weapons—to a remote destination. When a rope bridge was selected the same principle was used as is chosen to-day by the numerous rocket brigades round our coastline when a ship founders on rocks to which it is unsafe to send a lifeboat. The propellants alone differed, an arrow in olden times fulfilling the same purpose as the rocket achieves to-day in life-saving methods. The arrow conveyed the end of a thin cord to the opposite bank, and those

psychological, as provided would be quite ineffectual if the traveller stumbled.

Where the distance to be bridged was shorter and conditions more favourable, a timber structure would be provided. Long, straight tree trunks, stripped of all branches and other irregularities, would serve for the longitudinal girders and be secured at the terminal points. If necessary, these would be strengthened by lashing to posts driven into the bed of the

stream at the centre of the span, after which the transverse members, formed from the younger trees and saplings, would be laid closely together and fastened to the side members as the track developed.

who had already crossed to the other side could now haul in the stronger ropes. Several of these would be passed and secured to trees or other projections at the desired terminal, after which the slack was taken up and the ropes made fast at the starting point, a distance being allowed transversely between each set of ropes, sufficient to carry the desired track. The latter would be formed of short, straight lengths of trees cut from adjacent forests and securely lashed to the main longitudinals already suspended at equal levels.

### Materials Used

Materials used by bridge builders throughout the centuries provide, to some extent, a history of human progress, and include rope, timber, stone, concrete, cast iron, wrought iron, steel and, more recently, aluminium. The ropes of early days were formed by plaiting the long, thin roots of certain trees, these strands, each of which has considerable strength, affording a rope



Fig. 2.—Solid, or plate, girder bridge.

tenacity which would yield relatively high safety factors if judged by modern standards. Timber was extensively available and was, therefore, a natural material to use, though doubtless each length would be scanned for faults with an eye no less keen than that of a modern engineering inspector.

Stone and brick have been commonly used for thousands of years, the shaping of the stones being dependent on the provision of suitable metal cutting tools and the skill of the masons. The use of reinforced concrete on a large scale is a relatively modern process, though it is interesting to learn that concrete was actually a Roman discovery, and obtained by mixing burnt lime with a volcanic clay. In liquid form, mixed



Fig. 3.—Example of cantilever-cum-girder bridge construction.



with stone or granite chippings, it was poured into wooden moulds on very similar lines to those employed to-day, and the weather resistance of these early structures was extremely high.

**Iron and Steel Construction**

So far as metals are concerned, iron was naturally the forerunner, and although much early development took place in the production of wrought iron bar sections, the iron casting was the first process used successfully in metal bridge components and dated from the late eighteenth century. This was followed by wrought iron structures, the more malleable metal affording vastly increased scope to the designer and paving the way

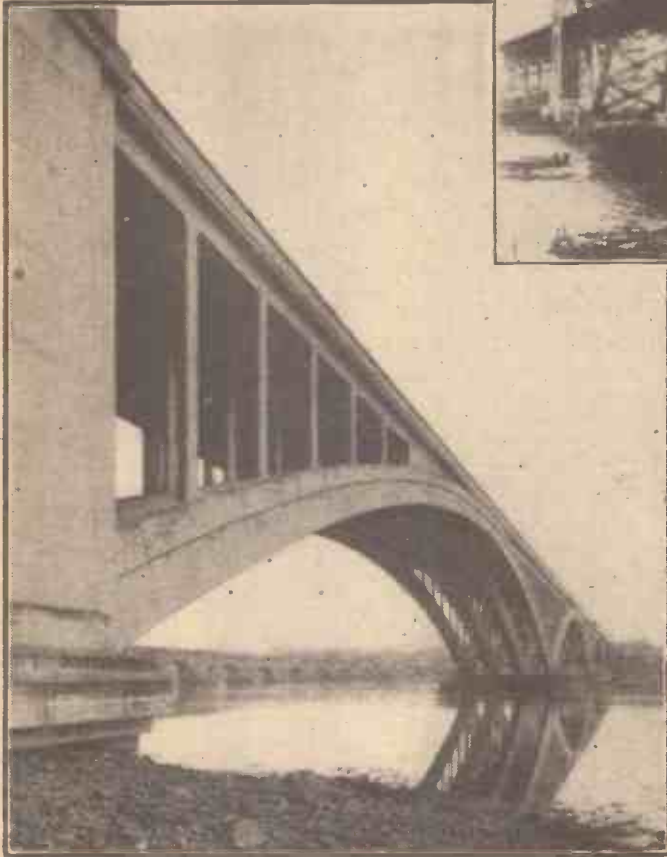

Fig. 4.—Royal Tweed bridge, Berwick—Holloway Bros., London.

for later edifices first in steel and, more recently, in aluminium alloys. The steel bridge of modern construction may take either of two forms, riveted or welded, the latter having achieved a considerable measure of success in the comparatively short time since its introduction.

In all bridges formed of iron or steel, deterioration risks have to be considered and provided against; even aluminium is not altogether immune, though these risks are greatly lessened by its use. All iron and steel bridges owned by leading authorities are inspected at regular and relatively frequent intervals, a thorough programme of cleaning and painting being carried out on a carefully planned schedule to safeguard against the inroads of rust and corrosion. Chromador steel is a special grade which has been introduced, having higher tensile strength than ordinary mild steel and a greater resistance to corrosion. Admittedly, all steel bridge structures are carefully inspected, but corrosion is an insidious foe and begins its deadly work wherever defects, however slight, occur in the paintwork. The advantage then lies with the steel best able to resist. The use of a higher stress value enables a bridge designer to save on his total



Fig. 5.—Sydney Harbour bridge—Dorman Long & Co.

steel requirements, and more than offsets the slightly higher rates per ton charged for the better grade material. Possibly rustless steel may prove the ideal among the heavier metals at some future date, but costs will have to be greatly reduced before this occurs.

**Roman Bridge Builders**

Without doubt, the greatest bridge builders of early times were the Romans, as they were also the finest road makers, and the two branches appear to have worked with the utmost harmony. When pressing home their attack on a race to be subjugated, wooden structures

served for the passage of their troops and munitions, but stone bridges replaced the wooden frames as colonisation proceeded. The detailed account given by Cæsar in his records of the famous bridge over the Rhine never fails to excite admiration even at this distance of time, and modern planners may find food for thought in the fact that the structure was completed in ten days from the time of "delivery" of the timber required, and the entire army transported to the western bank.

When thinking of the timber bridges built by the Romans, many will recall the famous epic in the Lays of Ancient Rome, describing the stand made by Horatius and his two mighty companions against the ranks of Tuscany, culminating in the defeat of the attackers when the bridge was hewn down. Later, stone constructions replaced these timber bridges, and several of the former remain to this day, though naturally subjected to considerable repairs in the interval. Other stone bridges built by this race are still in existence, one of which—the famous Pont du Gard—employed a triple arch construction somewhat on the lines used by the old cathedral builders in their naves, with

the main arches formed at the base carrying the clerestory above, itself surmounted by the triforium.

As the mathematical solution of the many problems which arise in bridge design is of relatively recent date, it must be obvious that the earlier structures depended largely on the good judgment of their builders, and the fact that so few disasters have occurred speaks volumes for the soundness of their design. For the transport of troops with their fighting equipment stresses, had these been available, would doubtless have been on the low side, but with the coming of heavier transport, including steam locomotives and heavy road motor units, rule of thumb methods were totally inadequate. Much investigation has taken place during the past century in determining the stresses sustained under every possible condition when engines of various designs and axle loadings are passing over, and every care is taken by those responsible for the maintenance in first-class order of all bridges on their systems.

**Pontoon Bridges**

For the passage of troops over wide rivers the pontoon bridge was used for hundreds of years, many notable examples being recorded in ancient, as well as later, history. These structures generally took the form of a wooden platform supported by cables which stretched from bank to bank, the cables being supported throughout their length by floats, whose size and number were determined by the load to be transported and the width of the river to be negotiated. The floats varied in type from inflated skins (or bottles) to sealed casks, and, later, to boats placed with their prows pointing against the flow of the river, the cables being firmly secured to each of the floats.

Perhaps the most famous of the earlier pontoon bridges was that used by Xerxes to transport his armies of two million men over the Dardanelles—then the Hellespont—to fight the forces of the new power of Greece. For these bridges two separate and parallel platforms were thrown from bank to bank, one of these being supported by 360 boats and the other by 314. With so many units the cables were obviously of no mean length, and were tightened against the pull of the stream by capstans mounted on the river bank.



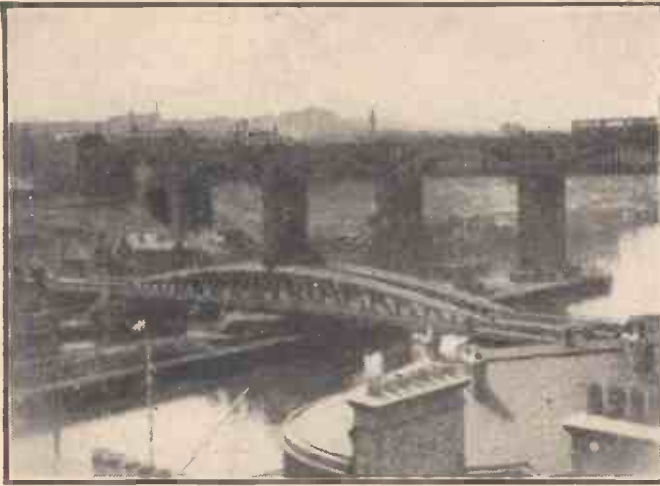

Fig. 7.—Tyne High Level and Swing bridges—  
Vickers-Armstrongs.

Tyne Bridge at Newcastle, the latter being modelled on the lines of the Sydney Harbour bridge, though much smaller in size.

Of bridges in which the "beam" form of construction is employed, possibly two of the best designs in England are the Britannia tubular bridge over the Tyne between Newcastle and Gateshead, both of which, curiously enough, owe their origin to the same engineer, Robert Stephenson, son of the famous locomotive builder. The Britannia bridge employs two parallel rectangular section steel tubes,

one each for the up and down lines, Chester to Holyhead. These are supported by two abutments and three towers, the central tower being known by the name of the bridge—Britannia. The two central spans each measure 460 feet, and the side spans 230 feet.

The Newcastle to Gateshead bridge, shown in the background in Fig. 7, is of totally different design, and combines overhead rail tracks with a suspended roadway in which a central passage for vehicular traffic is used, with side walks for pedestrians.

first-named was originally planned to be a suspension bridge, its designer, Sir Thomas Bouch, having actually secured permission from Parliament and commenced operations in December, 1879, when several spans failed in the ill-fated Tay bridge, of which he was the designer and constructor. This disaster brought to a regrettable end his career as a bridge builder, and when the Forth bridge was ultimately built it was of the cantilever type, with central beam sections over the main spans. The cantilever arms each measure 675 feet in length, and the suspended beam sections which link adjacent ends of the cantilevers measure 350 feet long each. The bridge is well shown in Fig. 6.

The Quebec bridge is of somewhat similar design, but differs in its profile, as indicated in Fig. 8, which compares the Forth and Quebec bridge outlines. It also differs in certain details—the main structure in the Canadian bridge sits on two rectangular piers, one beneath each of the huge cantilever sections, whereas the Forth bridge employs four circular piers for the support of each corresponding unit. Two major mishaps overshadowed the Quebec bridge before completion. In 1907, through the failure of a compression member, the entire structure, then nearing completion, collapsed and crashed into the St. Lawrence. Nine years later, as the centre suspended span of the new bridge was being raised from barges to its final height of 150 feet above water level for coupling to the cantilever extremities, defects in the lifting gear caused the span to slip and fall into the river. The two disasters involved the loss of nearly 100

### Progress in Design

Bridge design is an excellent illustration of the process of evolution in engineering structures. A plank or combination of these may serve for pedestrian traffic over a gully or stream of small dimensions, as at "A" in Fig. 1. But the plank deflects too greatly if the distance between supports, or the load, is increased appreciably, and one of several alternative designs may then be employed, viz., the arch "B," the beam "C," the cantilever "D" or the suspension "E."

The arch took hundreds of years to perfect, and depends for its grace on the curve selected, and for its strength on the ability of the abutments to resist the side pressure of the arch stones. The beam may be of solid construction, as in Fig. 2, or of lattice work, as in "C," Fig. 1. The cantilever principle is sometimes used alone, as in "D," Fig. 1, though more frequently it is employed in conjunction with the lattice beam, as in Fig. 3. The suspension bridge, however, never appears to be used in combination with any other, and stands as a striking testimony to the skill of the builder. In every case the stresses can be computed mathematically to-day with great accuracy and assurance where metals of known strength are used. With timber, however, the position is rather different owing to the uncertain character of the material, and the possibility of internal defects which cannot be determined.

### Modern Arch Bridge

The arch bridge may be constructed of stone, concrete or steel, the first two being smaller dimensionally in regard to the arch than when steel is used, and more arches will therefore be required. But if the arch is of steel, a very much larger span can be allowed, and an excellent example is the St. Louis bridge over the Mississippi, where the average length of each of the three spans is slightly over 500 feet. A fine modern arch bridge in reinforced concrete—the largest in this country—is shown in Fig. 4. The bridge is known as of the arch rib and open spandrel type, with a total length of 1,406ft., and has four spans measuring 167ft., 248ft., 285ft. and 361ft.

The steel overhead arch construction is well illustrated by the famous Sydney Harbour bridge shown in Fig. 5, with a total length of 2½ miles; the centre span measures 1,650ft., five approach spans being provided on each side. The total weight of steel used was 53,000 tons, and the bridge took over seven years to complete. Other examples of this type are the well-known Hell Gate Bridge, New York, and the new

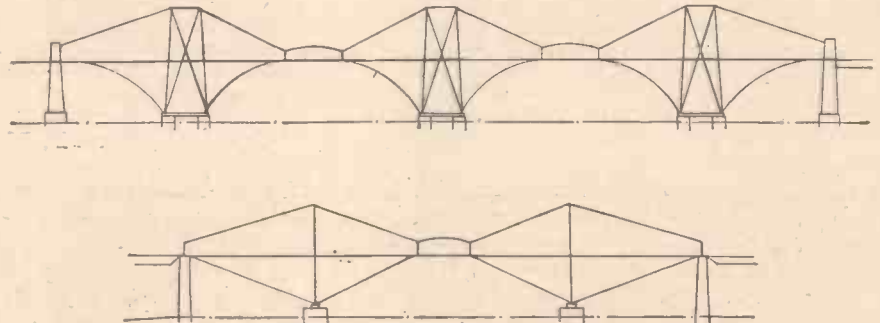

Fig. 8.—Relative profiles of Forth and Quebec bridges.

The total length of the structure is approximately 4,000 feet, the upper deck being carried on a cast iron ribbed arch, with the lower roadways slung from the arch on wrought-iron rods, and the thrust taken up by horizontal tie bars. The foundation for this bridge involved the use of piles, driven home for the first time by steam power.

### Cantilever Bridges

The cantilever bridge has a feature which, outstanding from all other attractions it possesses, renders it peculiarly ideal for railway service—extreme rigidity. Two famous structures in this class are the Forth Bridge and the Quebec bridge, with main spans of 1,700 feet and 1,800 feet respectively. The

lives, but the following year gave success to the builders, and saw the completion of what is a magnificent monument to the skill and indomitability of the bridge builder.

### Suspension Bridges

Numerous suspension bridges are in use in various parts of the world, possibly the best known in this country being the Menai Suspension bridge, completed in 1826 by Thomas Telford, one of the early school of famous British engineers, and part founder of the Institution of Civil Engineers. In this unit the main "cables" from which the roadway was suspended are virtually chains, and comprise a series of eyebar links.

(To be continued)

## THE MODEL AEROPLANE HANDBOOK

An Important New Work: 312 Pages, 303 Illustrations, 12/6, by post 13/-

By F. J. CAMM

A Short History of Model Aeronautics; Principles of Design; Airscrews; Wings; Undercarriages; Folding Airscrews—Retractable Undercarriages; Fuselages; The Elastic Motor; Gearing and Special Mechanisms; Making Model Wheels; Gear and Winding Devices; Model Aeroplane Stability; Downthrust; Model Petrol Engines; Adjusting Model Petrol Engines; Compressed Air Engines; How to Form and Run a Model Aero Club; F.A.I. and S.M.A.E. Rules; S.M.A.E. Com-

petition Cups; A Lightweight Duration Model; A Wakefield Model; A Farman Type Model Monoplane; A composite Model; Ornithopters—or Wing-flapping Models; A low-wing Petrol Monoplane; A Duration Glider; Winch-launching Model Gliders; A streamlined Wakefield Model; A Model Autoziro; A Super Duration Biplane; Flying Model Aeroplanes; A Flash Steam Plant; Model Diesel Engines; Weights of Wood; Piano Wire Sizes, Areas and Weights; Schedule of British Records.

GEO. NEWNES LTD., TOWER HOUSE, SOUTHAMPTON ST., STRAND, LONDON, W.C.2



# A Chime-timing Unit

Constructional Details of a Compact Unit for Controlling a Four-note Chime

By "HANDYMAN"

**T**HIS simply constructed unit can be made in two hours with a soldering iron and screwdriver. The components needed are as follow: one relay, approx. 200-300 ohms, with two-pole make; one relay, approx. 200-300 ohms, with one-pole make; one relay, approx. 200-300 ohms, with one make and one break; two condensers, approx. 800 mfd., 12 volts working.

The above items can all be purchased from advertisers in PRACTICAL MECHANICS for a few shillings. The fact that all solenoids are operated via relays permits fine-gauge wire to be used to the bell pushes, also enabling pushes to be quite a distance from the chimes. If the unit is connected to an existing two-note chime it will repeat with approx. one sec. between the second two notes. It would be ideal to use with two P.M. chimes, or a simple modification made to P.M. chimes, when the two solenoids could be mounted, one above the other, with tubes cut to required lengths.

### When the Front Door Push is Pressed

The first relay coil (Fig. 1) is energised, closing both pairs of contacts, one pair of contacts completing the circuit to the first solenoid, causing the first note to be struck. The other pair of contacts completes the circuit to No. 2 relay coil, and "A" condenser, causing the open contacts to close, which completes circuit to No. 3 relay coil and "B" condenser. The closed contacts

on No. 2 relay are now open, and relay No. 3 contacts are closed.

When the front-door push is released No. 1 relay is de-energised, breaking the circuit to No. 1 solenoid, causing the second note to be struck, also breaking the circuit to No. 2 relay coil, which does not release till the current in that section of the circuit drops below that required to maintain sufficient flux to hold relay in (approx. 1 sec.). When relay No. 2 releases 1 and 2, pair of contacts open, breaking the circuit to No. 3 relay coil, contacts 3 and 4 also close, and for approx. 1 sec. relay No. 3 contacts remain closed till current, as previously explained in relay No. 2, drops. The instant No. 2 relay opens, solenoid No. 2 is energised and the third note is struck. No. 2 solenoid is de-energised in approx. 1 sec., when contacts of No. 3 relay open and fourth note is struck.

### Construction Details

A 9-volt grid bias battery is quite suitable, but a longer delay between notes can be obtained by using 12 volts or, as in the case of my own instrument, a transformer and metal rectifier can be used.

To mount the components (see Fig. 2), obtain a piece of board for a base, cut three small strips from sheet metal and drill as shown to mount the relays. Condensers have their fixing tabs on them.

Hold the batteries in place with small brackets made from sheet metal, then screw

the three-pin socket and the two-pin sockets to the baseboard.

### Wiring Details (Switching Circuit)

No. 1 pin of the three-pin socket is taken to contact No. 2 of relay No. 3, also to No. 3 contact of relay No. 1. No. 1 and 2 pin of three-pin socket is taken to contact No. 1 of No. 1 relay. No. 3 and 4 pin of the three-pin socket is taken to No. 3 contact of No. 2 relay. Connect contact No. 4 of relay No. 2 to contact No. 1 of relay No. 3.

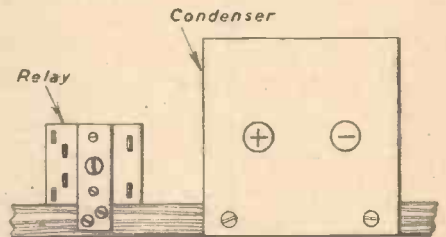

Fig. 2.—Method of mounting components.

### Timing Circuit

Battery positive to front-door push; battery positive to No. 4 contact of No. 1 relay; battery positive to No. 2 contact of No. 2 relay; battery positive to tradesman's door push; battery negative to negative coil pins of all relays; battery negative to negative pins of both condensers. Front-door push to positive coil connection of relay No. 1; tradesman's door push to positive coil connection of relay No. 3; No. 2 contact of relay No. 1 to positive coil of No. 2 relay and positive of "A" condenser; No. 1 contact of relay No. 2 to positive coil of No. 3 relay and positive of "B" condenser.

### External Connections

The chimes may still use their existing power supply. No. 1 lead from chimes which formerly went to door push is connected to No. 1 pin of three-pin socket, via a plug. Remaining lead from chimes is connected to pin marked 1 and 2 on the three-pin socket, completing the circuit to first pair of notes. Pin marked 3 and 4 of three-pin socket is now connected via the plug to the positive of second solenoid. The solenoid negatives are connected together.

To make a two-note chime repeat one has only to short pins marked 1 and 2, and 3 and 4, which will cause the chime to repeat once after door push has been released.

### Testing

Test unit by shorting pins 1 and 2 and 3 and 4 on the three-pin socket. Connect lamp battery in series with pin of three-pin socket and either pin 1 and 2 or pin 3 and 4 of three-pin socket. Now short circuit front-door push socket, which should cause the lamp to light. Release shorting strip and lamp should go out and relight in approximately one second, remaining alight for about one second. Now short out tradesman's socket, and lamp will light; remove shorting strip and lamp will go out in about one second.

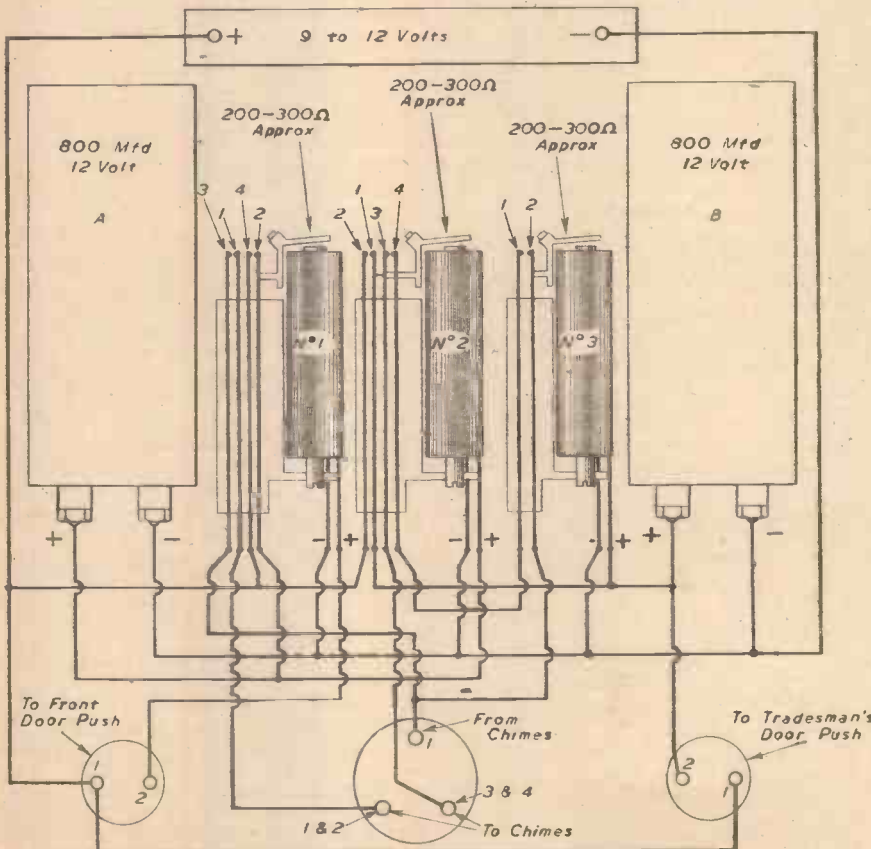

Fig. 1.—Circuit diagram of the timing unit.

# A Model Aircraft of Loaded-Elevator Type

## Constructional Details of a Novel Model Monoplane

By E. W. TWINING

**I**N a recent article contributed by me to this journal I referred to the model aeroplane of the loaded-elevator type, which at one time was known as the "Canard"; meaning a duck. I pointed out the advantages of this wing arrangement over machines of orthodox type with a leading main wing and propeller in front.

It then occurred to me to design a model which would have a sufficiently pleasing appearance of modernity to induce present-day aeromodellists to get away from the orthodox form and try out something more uncommon. I cannot say "more original" because the type, as a type, dates back to the early days of flying and I do not think that any machine with this wing arrangement has been built in either full size or model size for the last fifteen years.

To all intents and purposes the model is exactly the same in principle and construction as the one which was the first winner of the Wakefield Cup, the chief differences being that in the present design a fuselage is fitted around the main compression spar and the wing sections are improved and more efficient than were those of my early machines.

The side view and plan of the model, mentioned above, are reproduced in Fig. 1 and in Fig. 2 is shown a back elevation.

Whether this model will conform to the S.M.A.E. rules as regards fuselage length, cross sectional area and the areas, added together, of the supporting surface, I do not know, for frankly I do not understand the ruling on these points. The formula, as I have seen it, is not written as a mathematical one; in any case, the rubber motors are not wholly enclosed in the fuselage, although I have brought the prop. spindle bearings as closely together as possible, by overlapping the propeller discs, so as to cover as much of the motors as possible. However, I trust

that some readers will build it, just for the sake of watching how this type of aircraft behaves in the air, and in making a landing; to say nothing of taking off when a good runway surface is available.

### Main Spar

As will be seen from the general arrangement drawings, the machine has, through the longitudinal centre line of the fuselage, a main spar to which either directly, or

Unless a light wood known as bass is available, it would be best to use silver spruce for this main spar, planed down to rectangular cross section measuring  $\frac{1}{4}$  in. by  $\frac{5}{16}$  in. It can be lightened by piercing it with slots and, preferably, covering it with the thinnest of fine silk, glued or cellulose cemented on.

This covering will be best done after all attachments are made to it, such as, for instance, those shown in Fig. 3, where I have

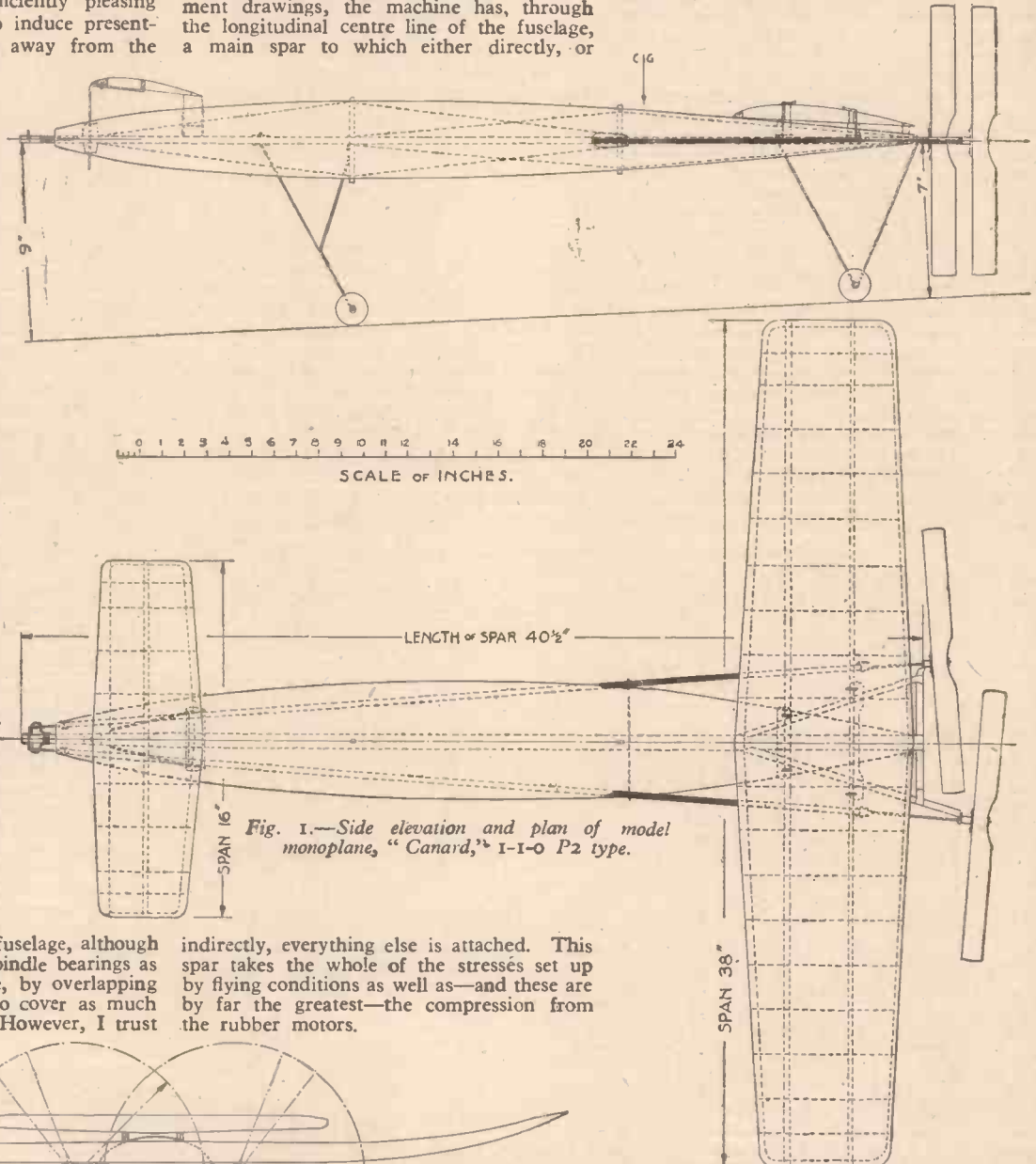

Fig. 1.—Side elevation and plan of model monoplane, "Canard," 1-1-0 P2 type.

Fig. 2.—Rear elevation of the "Canard" model monoplane.

indirectly, everything else is attached. This spar takes the whole of the stresses set up by flying conditions as well as—and these are by far the greatest—the compression from the rubber motors.

drawn the propeller-bearing crossbar with its struts. The main spar is notched to receive these struts, and aft of these notches the spar is reduced in width to  $\frac{1}{4}$  in., the slots being correspondingly narrower. Although the struts and propeller bar can be of spruce, I think straight grained birch would be preferable.



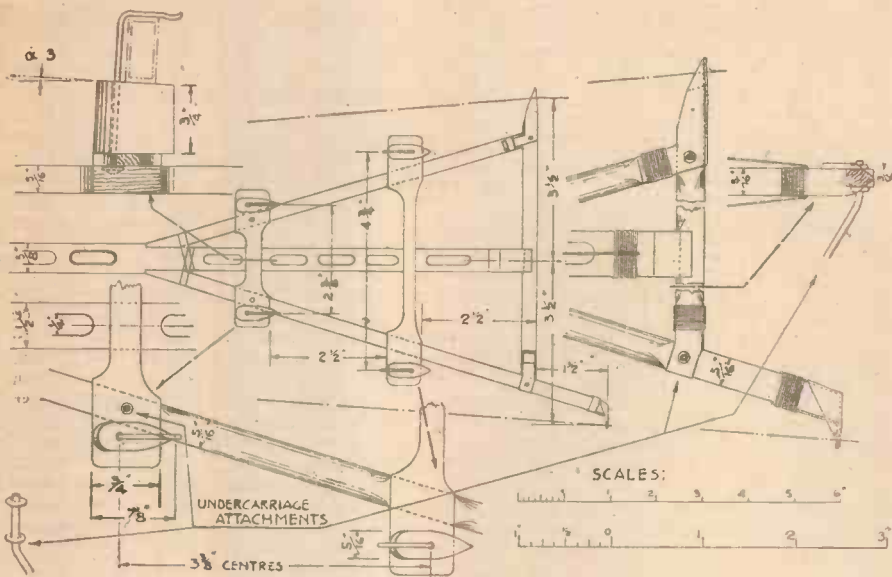

Fig. 3.—Details of propeller crossbar, main wing fastenings, etc.

Fig. 3 shows the blocks and crosspieces to receive the main plane, which plane, or wing, is detachable by means of the turnpins shown. The crosspieces should be of spruce, but the blocks can be of hard balsa wood with the grain vertical. Note that the top surfaces of all of the blocks make an angle of three degrees with the horizontal centre-line of the machine. This is the angle of incidence of the main plane.

The spar will need to be stiffened vertically, and this is best provided for by outriggers or kingposts to take bracing wires, as drawn in Fig. 4. The posts will have a thickness of 1/16 in. and be of birch. They are glued into the spar and are further made immovable

**Elevator**

The leading plane or "elevator" is at the forward end of the machine. The back support for this is shown in Fig. 5, and I think balsa wood may be used for the whole of it. Note that it consists of seven pieces. Observe, too, that the rake of the top surfaces of the side blocks is 6° with the horizontal, which means that, although the angle of the elevator is variable, it is anticipated that this plane will make a positive angle of 3° with the main wings. In this drawing, Fig. 5, the curious looking things in the cross-section are the rubber motors.

Fig. 6 shows the whole of the details of the front end of the main spar. Here is indicated the taper which, for about seven and a half inches, is given to it in plan. This taper will be from the before-mentioned 3/8 in. down to 1/4 in. at which point it receives the tinplate bearings for the front rubber hooks.

The drawing also shows the front support and adjustment for the elevator. This support which is made from piano wire of about 18 or 20 gauge should, when

fastened to the elevator, make a friction grip in two little hardwood blocks glued or cemented to the spar. This does not mean that the wire must be a tight fit in the hole but that, with the trailing edge of the elevator pressing down on the back support, the wire, where it passes through the spar, will thrust against the forward side of the hole in the top block and against the rear side of the hole in the bottom block. Thus we have, by the bending or flexing of the wire and a friction grip, a means whereby the exact angle of the elevator can be adjusted to give the correct amount of lift to the front of the machine and so obtain perfect longitudinal stability.

At the top right hand corner of Fig. 6 is shown the bent wire which crosses the main supporting and adjusting wire. This bent piece need not be of the same hard steel; a piece of tinned iron or brass wire will do and will be found much easier to bend to the sharp kinks indicated. It will be bound to the hard steel with fine tinned iron wire and soldered. For attachment to the middle

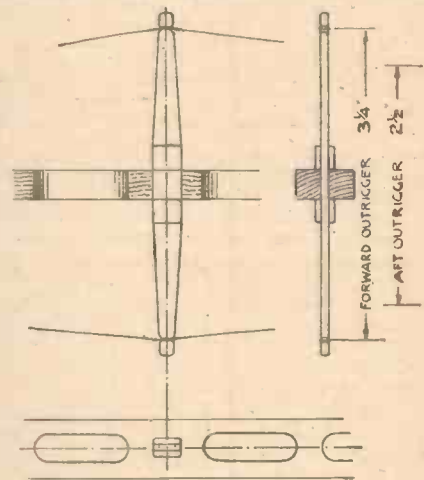

Fig. 4.—Spar outriggers.

spar of the elevator a little strip of tinplate is soldered to the end of the steel wire.

**Winder for Rubber Motors**

I now come to a very important item in connection with this model aircraft, namely, the possibility of winding both the rubber motors at the same time. They must be so wound for if one of them were fully wound before the other was started the spar would almost certainly collapse. Of course, it would be possible for two people with two drill

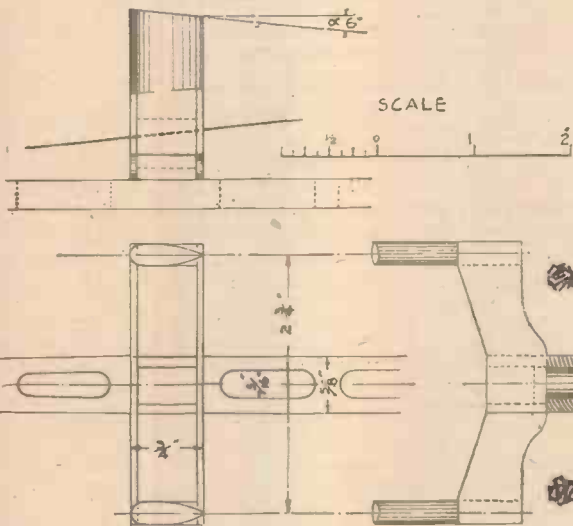
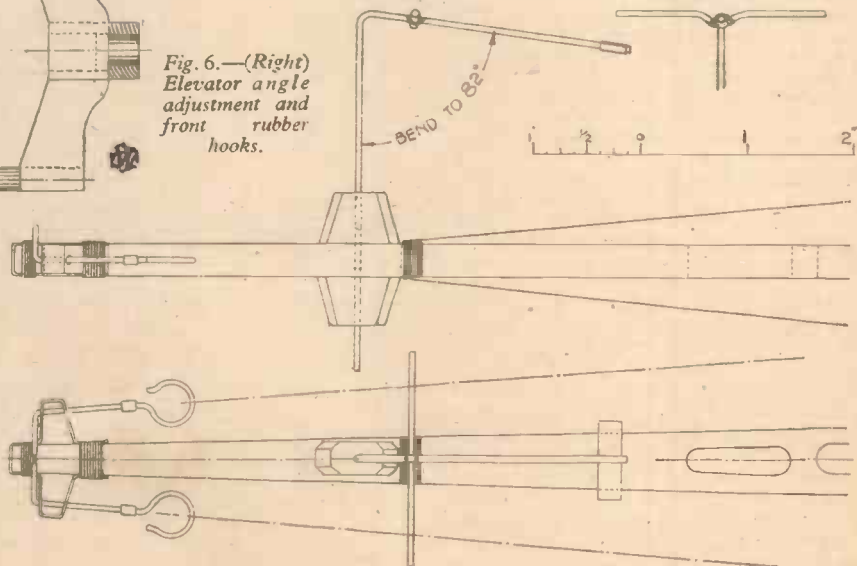

Fig. 5.—Elevator back supports.

by having little flat pieces of balsa glued above and below the spar. The wires are of steel; the finest music wire (banjo, I believe) obtainable. There is no need to terminate any wire on the spar; let the ends of each wire be at top and bottom of the post and where it passes through the spar bind the spar with a few turns of soft tinned iron wire, soldered. This, as shown in Fig. 3, close to the propeller crossbar, will prevent the steel wire from cutting into the end grain of the spruce spar. There is no need to put great tension on the bracing wires; just pull them as tight as possible, but be careful to see that the straight line of the spar is not distorted.

Fig. 6.—(Right) Elevator angle adjustment and front rubber hooks.



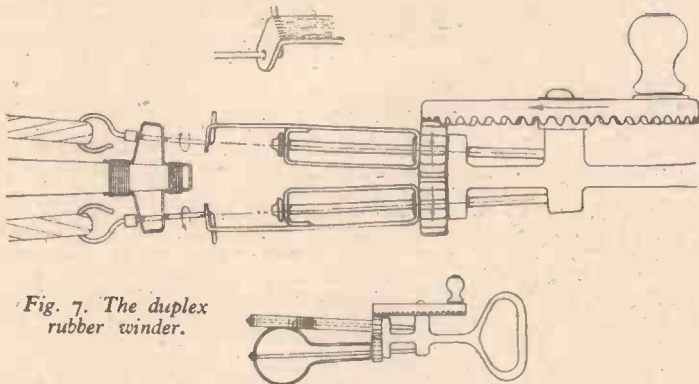

Fig. 7. The duplex rubber winder.

braces, both turning together and in time, to wind the propellers in the usual way, but it would be an awkward job and they would have to turn in opposite directions.

In the old days when we flew machines with twin screws we made a tool which we called a "double winder"—for the caption

I think the method of applying this tool to the machine will be obvious by referring to the drawings of the rubber-hooks, first in Fig. 6 and then in Fig. 7. To pass the two holes in the winder over the hook extensions the latter are turned upwards; the winder is then held in a vertical position over the

under Fig. 7 I have chosen a more dignified name. It was made from a geared egg-whisk which is shown in its original and unaltered state in the small sketch attached to Fig. 7. The larger drawing shows how it was adapted to its new purpose, from beating eggs to winding rubber motors, by cutting away certain portions, bending the remaining parts and soldering them.

extensions, passed downwards and turned to the horizontal when the holes come to the bend in the hooks. Whilst winding, an assistant must hold the propellers and crossbar and pull lightly. The winder also pulls and so keeps the hook extensions clear of the spar. When the rubbers are fully wound the tension is eased, the hooks will be drawn back and the winder disengaged. The hook extensions will then spring back and reassume the positions shown in Fig. 6.

In the event of the reader being unable to buy one of these egg-whisks, it will be a fairly simple matter to make one, using a piece of thick brassplate for the frame with brackets soldered on to take the spindles on which the two pinions revolve. These spindles are fixed and would be soldered into the brackets. The crown wheel and pinions might be bought from a firm of model suppliers or from a clockmaker. It would be as well to make the gear ratio an even number, such as four-to-one or five-to-one, in order to facilitate counting the turns on the rubbers. (To be concluded)

## The Law About Patents

### 4.—Employer and Employed

AFTER much close study, much patient and persistent trial, the inventor evolves a better method of achieving a useful result. We can hardly expect him to make his discovery into a part of the general knowledge if nothing induces him to do so; for the power to do what none other can is well worth preserving. In the past there were money awards or titles or decorations in exchange for the disclosure. The modern award—a monopoly restricted in time to exploit the invention—is more satisfying to the inventor and less costly to the State.

But to whom is the award due when, as happens often enough to cause a deal of contention, it is an employee that perfects the invention, and the invention is related to his employment? In some countries—the United States and Switzerland amongst them—express legislation decides the question. In the United States the patent belongs to the employer in either of these two events: the employee has sold to the employer a right to take out a patent for a device evolved as an incident of his work; or the scope of the service of the employee includes the search after new inventions. In Switzerland the law prohibits a bargain that would prevent an employee from having a reasonable reward for his invention. In this country the ownership, when dispute does arise, is determined by what the lawyers call "equity," which is a fancy name for what the ordinary man calls "fairness."

#### Right of Ownership

The rules that emerge from the several decisions are these. The employer alone may be entitled to the patent. He is when the basic idea is his and when his employee has contributed, in fulfilment of his service agreement, no more than the craftsman's technical skill in working out that basic idea. Such an invention is what the French courts call a "service invention." It arises from the fulfilment of the professional duty of the employee; it originates from the instructions of the employer, the employee being merely the skilled executant of the instructions. So the manager of the team may devise a novel way of scoring a goal. But he is slow to put his device into effect; he must leave that to his swift-moving, quick-thinking players.

The employer's right to the ownership of the patent under these conditions is wholly parallel to a newspaper's ownership of copyright in its reports. *The Times* reporter gives his more or less verbatim report of a political speech. The copyright in the speech as reported belongs to *The Times*. For it arose out of the employment for which *The Times* paid; and it is *The Times* that can obtain compensation when a copying takes place.

More often than not employer and employee have contributed to the discovery. There has been a real co-operation. In that

event the patent is joint property. In practice, indeed, it is hard to discriminate between these two types. For he will be a strange employee that does not co-operate in some degree, however slight, towards the perfecting of an invention. The new Patent Act recognises this, and provides a ready means of allocating how far the employer, how far the employee, has contributed; how far, therefore, each is entitled to a share in the profits from the successful exploitation of the patent. The allocation will call for an acute and piercing judgment; but at all events it is swift and cheap.

There can be no doubt, finally, that the employee alone may be solely entitled to the patent. Connected with his work it may be. But it has been evolved in his own time; it embodies his own idea; he alone has wrought it to perfection.

## Books Received

**Garden Railways.** By R. E. Tustin. Published by Percival Marshall & Co. Ltd., 110 pages. Price 10/6 net.

THIS interesting book is based on the author's own experience of model garden railways, and deals in a very entertaining manner with the choice of sites and general layout. There are chapters covering levelling, track foundations, viaducts, bridges, tunnels, stations and station buildings, track laying, signalling, motive power and construction of rolling stock. There are also some general notes and recommendations. The book, which is well illustrated by several clear line diagrams and half tones, should prove useful to anyone contemplating the construction of a model railway in a garden.

**Look, Listen and Touch.** By Prof. A. M. Low. Published by John Gifford Ltd., 426 pages. Price 9/6 net.

THIS is a book about queer things which often we never see and nearly always neglect. Professor Low is well known as an inventor and scientist, and for his books and lectures on popular science, and in this book of bedside stories he shows that science can be both life and amusement. The book has to be read to realise the fascination of the little things in everyday life. Insects, television, time, radio, atoms, magic, doctors, bombs, motor-cars, cinemas, sleep, hypnotism, travel, fashion, wool-gathering and birds, are only a few of the many subjects dealt with. No one need be bored by reading this interesting book.

**Scottish Highlands (Cycling Touring Guides—No. 3).** By Harold Brierclyffe. Published by English Universities Press for Temple Press, Ltd. 140 pages. Price 2s. 6d. net.

AN informative and well-written little book that will enable the cycling tourist to make the most of his visit. There are eight chapters covering such subjects as The Western Highlands, The Far North, Remoter Corners of the Highlands, The Islands of Scotland and Hill-climbing in the Highlands.

**The Novice's Workshop.** By Ian Bradley and Norman Hallows. Published by Percival Marshall and Co., Ltd. 112 pages. Price 3s. 6d. net.

ALTHOUGH this handbook is intended primarily for the beginner in model engineering the more experienced worker may find in its pages much of practical interest.

In order that progress, both in equipping the workshop and in the use of tools, may be made step by step, Part I of the book deals with hand tools, whilst in Part II the selection and practical use of the electrically-driven drilling machine, the grinding machine and the lathe are described. The book is profusely illustrated with clear-cut diagrams.

Other books received from Percival Marshall and Co. are:

"Model Railway Signals." By Ernest F. Carter. Price 3s. net.

"Model Railways for the Beginner." By Ernest F. Carter. Price 3s. net.

"Walschaert's Valve Gear." By Henry Greenly. Price 3s. net.



9th Article of a New Series

# MODEL ENGINEERING PRACTICE

by F. J. Camm

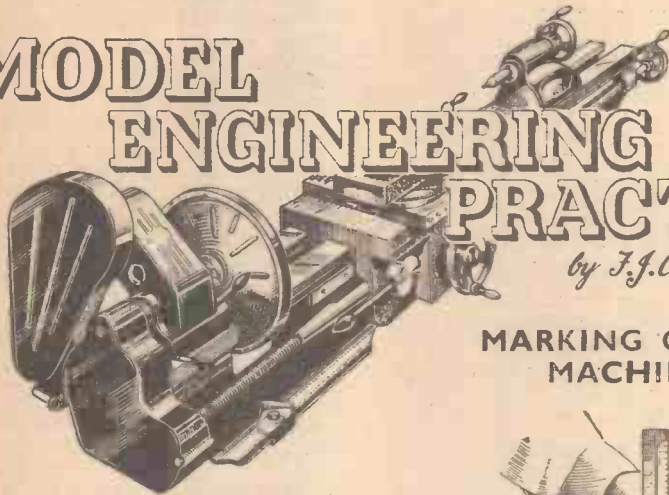

## MARKING OUT FOR MACHINING

A CERTAIN amount of marking out is required on most machining jobs, with the exception of, perhaps, purely cylindrical work that is finished when it comes from the lathe. Other items may require drilling, surfacing, slotting, or keyways in them before completing, and the positions of details in relation to previously machined surfaces are more often than not a matter of small importance.

The essential tools are a surface gauge or scribing block, a good stiff steel rule, small dividers, square, scriber and a centre punch. A small angle bracket is useful under certain conditions, when one or two clamps will also be required for use in conjunction with it. A simple form of scribing block consists of a reasonably heavy circular base, the underside of which is machined and recessed so that it will lay flat without rocking, and capable of sliding freely on a flat surface. This base supports a vertical spindle upon which slides a split boss carrying a scribing needle, the needle being locked by the action of tightening a knurled nut. The setting of the point of the scriber is dependent on trial and error or lightly tapping the scriber, when only held friction tight, in the desired up and down direction. A scribing block of the type shown in Fig. 84 is much more desirable for fine work. The spindle of this is connected to a rocker bar which has a screw adjustment at the rear end. After setting the point of the scriber approximately and locking it tight, it is corrected by tilting the bar to raise or lower the point by means of the knurled adjusting screw. It is necessary to have a flat surface on which to rest the work while marking off. Failing a proper machined surface plate, a square of plate glass makes an efficient substitute for light work.

### Coating for Marking Out

To make the marking easily visible, it is usual to coat the surface of the work to be carried out. Bright steel is coppered for this purpose by rubbing on with a piece of

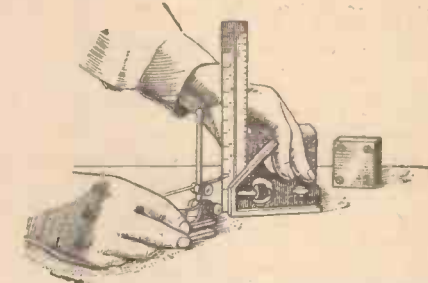

Fig. 84.—An efficient type of scribing block and universal square.

rag a solution made by dissolving copper sulphate crystals in water with the addition of a few drops of sulphuric acid. This is kept in a bottle for use as required. The

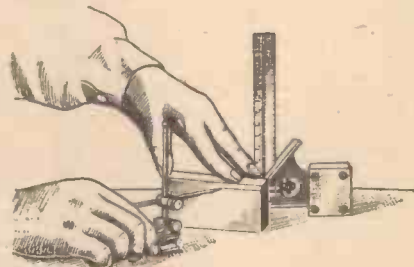

Fig. 85.—To produce a straight line, draw the needle along the surface of the work so that the point is trailing.

steel must be clean and free from oil, otherwise coppering will not result. Wipe the surface dry immediately, and if the marking out is to be retained on the work for several days, rub over with oil to fill the lines and prevent them from rusting. Cast or forged surfaces are prepared by chalking over.

### Marking Out

Supposing that it is necessary to mark lines on a machined face, one  $27/32$ in. away from a machined edge and another one  $29/32$ in. away from it, a rule is held vertically against the face of an angle bracket or square block, so that the end of the rule is touching the surface plate. The point of the scriber is then adjusted against the markings on the rule to the first dimension, and the job to be marked is laid down on the machined edge and a line made on the face of the work. Fig. 84 shows the method of setting the scriber. The second line, being  $29/32$ in. away from the first one, is  $1\frac{1}{2}$ in. away from the base, to which dimension the scriber is then set. Draw the needle along the surface of the work so that the point is trailing, as in Fig. 85. This will produce a straight line. If the needle is presented square to the work, a "jumping" action takes place, with the result that the line is wavy. Where the rule in a com-

ination square is used, a slightly different procedure may be adopted. After making the first marking, slide the rule upwards in the head of the square until a fair line is reached, when the scriber is raised the required distance. This is particularly useful when the dimensions are in odd sixty-fourths, and when it is apt to be confusing to count up from an odd fine marking.

### Use of the Vee Blocks

Vee blocks are essential for cylindrical work. For most work of this nature it is essential that the dimensions are worked from the centre line of the bar. To find the centre of a shaft by this method, lay it in the vee blocks and set the end of the scriber near enough central; make a short line on the end of the shaft or, in the case of a tube, at each edge; turn completely over, and make another mark parallel to the first, resetting the point of the scriber exactly between the lines. If the lines are fairly wide apart, a further trial is made; if not, the marking is continued along the bar as required and firmly continued on the end, if necessary, for further reference.

The casting being marked out in Fig. 86 is to be drilled through the boss at a definite distance up from the centre hole. This is done by mounting the job on a mandrel, the centre of which is found in the manner stated. The height of the centre is noted by placing the scriber point against the rule and the distance that the hole is to be above centre added to it.

### Using the Angle Brackets

Work that has a machined face or boss, but that requires marking out in a direction in which there is not a machined surface to rest it upon, has to be clamped to a false vertical surface for the purpose. The casting in Fig. 87 is such an instance, and which calls for the use of an angle bracket and clamp. Having been previously machined on the base, the casting is clamped with this face against the face of the bracket, one side of the casting being squared up with the surface plate. The centre of the slot in the rough casting is found by transferring the height of the edges to the rule and the dimensions worked from a point midway between.

### Rough Castings and Forgings

Rough castings and forgings that are to be marked out for facing or other machining, and on which there are no previously machined surfaces, are packed up so that the important points on the casting lay level with the plate. This can be checked by using the bent edge of the scriber as a gauge. When level, a line is scribed at the distance down to which the machining is to be carried.

Not infrequently it is necessary to mark off from the centre of a rough cored hole, to do which it becomes necessary to stop the hole up in a temporary manner to provide a centre for the dividers. This can be done by wedging a strip of hardwood across the mouth of the hole.

Holes that are to be bored on the face plate are set up to scribed circle.

(To be continued)

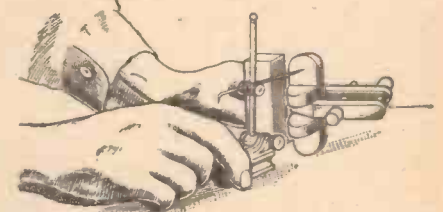

Fig. 87.—Work that requires marking out in a direction in which there is not a machined surface to rest it upon has to be clamped to a false vertical surface for the purpose.

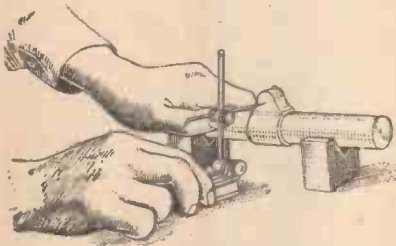

Fig. 86.—The casting being marked out above is to be drilled through the boss at a definite distance up from the centre hole.



# Dynamo and Motor Problems—6

Back E.M.F.; Parallel Running of Dynamos; Regenerative Effects; Resistance in Field Circuit

By H. REES, A.M.I.E.E.

SINCE we are drawing to a close of this series D.C. motor characteristics must engage a little more attention.

While every dynamo or motor is "a reversible machine," it by no means follows that every dynamo is suitable for use as a motor for a given job, whilst there is a large, widely used class of motors which would be useless as generators.

We touched upon this question before. A motor may be required for severe starting duties, designed electrically and mechanically to handle momentary currents five or ten times the normal full-load current—as when a small starter motor is suddenly switched across a battery. Design features may have to be such as to stand up to onerous industrial conditions, for example, windings constructed to withstand abnormal temperatures, etc.

Even if the same type of machine would do a generator which works in ideal surroundings would be ill adapted for such applications, though driving a load in a light machine-shop would be well within its capabilities.

A car engine can easily drive a small dynamo for maintaining the battery in condition. It would be disastrous to try to employ this same machine as a "self-starter." A separate motor must be provided for the job, or the dynamo must incorporate special motor windings.

Again, the type of motor employed for heavy starting duties or rapid acceleration of trains and trolley buses, while excellent for these purposes, would be no use whatever for driving a machine-shop where a reasonably constant speed is essential. In fact, it has a dangerous "racing" characteristic which rules it out for all applications where the mechanical load is liable to be removed off the shaft.

As a generator this type gives an output voltage which builds-up with the electrical load, and undergoes wide fluctuations as more lamps, heaters, etc., are switched on and off. With only a few lamps connected, the volts will be insufficient to make them glow; if too many are switched on the output voltage may blow the lot!

Evidently, no one in his senses would jump for a "bargain" in a series motor with the

idea of using it as a dynamo to supply a variable load or for battery-charging.

### General Principles

The electromagnetic principles of generators and motors have been outlined in my articles, "Studies In Electricity and Magnetism."

Briefly, the action in one depends upon conductors cutting magnetic lines of force; in the other—a motor—current-carrying conductors (supplied with current from an outside source) set up magnetic fields, which react upon the main field to cause rotation of the armature.

While these are entirely distinct principles, a matter of some slight difficulty to beginners is to realise that both apply to one and the same machine, whether working as a dynamo or a motor.

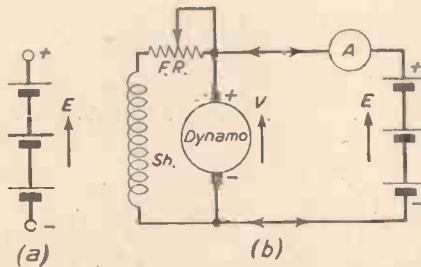

Fig. 2.—The e.m.f. of a battery (E) becomes a back e.m.f., acting against the generator volts (V), in (b). In the same way, the e.m.f. generated in a motor sets up the main opposition to the current taken from the mains supply.

True, a dynamo cannot be made to take power from a supply and thus do useful mechanical work as a motor, at the same time as it is supplying power as a dynamo. Neither of course can the e.m.f. generated by a motor be used to light lamps when the machine is taking power from a supply and exerting mechanical power.

But, as mentioned in our first article, the current supplied by a generator causes a "magnetic drag," which the engine has to overcome, a force opposite to that exerted by the engine, or a "motoring force" tending to revolve the armature the opposite way to that which it is being driven. Hence the "Motor Principle" applies.

It is by this principle we decide what the rotation would be if used as a motor. Instances have been considered. For a given field polarity, an armature current in the same direction as the current generated by the dynamo will run the armature in the opposite direction as a motor.

Or if a dynamo takes a reverse current through the armature, say from a battery supply, while retaining the normal field polarity it will "motor" in the same direction as it is driven as a dynamo.

These points are summarised once more in Fig. 1, it being assumed we are considering a shunt-wound machine.

### Back E.M.F. of Motor

Conversely, when an armature is "taking power" and so running as a motor the

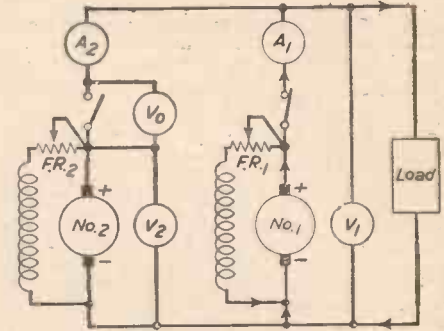

Fig. 3.—Bringing a second generator, No. 2, in parallel with another already supplying power on the busbars.  $V_1$  main busbar voltmeter;  $V_2$  machine v/m, which can usually be switched across either machine;  $V_0$  is a voltmeter which will indicate zero when the e.m.f. of No. 2 is exactly equal to the busbar volts.  $A_1$  and  $A_2$  are ammeters.

conductors cut lines of force exactly as in a dynamo.

In consequence, the laws of electromagnetic induction state that e.m.f. is generated. The motor is at the same time functioning as a generator—as a dynamo—though the "volts" generated are not very tangible.

This is a difficulty in understanding "back e.m.f."—it is never a tangible thing. The idea may be difficult because the facts themselves are so simple. If you put a 12 v. battery to charge, you have, to begin with, about 12 v. generated in the battery: an e.m.f. acting outwards to the + terminal, or away from the - terminal (Fig. 2a). Let us call this E volts.

You connect your battery to a dynamo or other source giving V volts (Fig. 2b). Therefore V is also an e.m.f. acting outwards to the + terminal of the dynamo. But the E volts from the battery do not go out of existence merely by making the connections! It is still "there," as a few facts will quickly show.

With an ammeter A in the circuit, if  $V = E$ , exactly, no amperes will flow either way. The ammeter indication remains at zero, because 12 v. from the dynamo is exactly counterbalanced by 12 v. back e.m.f. from the battery; if we raise the dynamo volts a little (a small fraction of volt) charging current will flow; but if V is adjusted to a value less than E the battery becomes a "supply source," passing a discharge current back via the dynamo—which can be very heavy, even with a small voltage-difference, because of the low resistance of the circuit.

The resultant or effective voltage acting on the circuit resistance is  $(V - E)$ ; which is "negative" if  $V < E$ ; or = 0 if  $V = E$  and is "positive" (denotes a forward charging current) if  $V > E$ . The current is:

$$I = \frac{\text{Effective Voltage}}{\text{Resistance}} = \frac{(V - E)}{R}$$

which, as stated, will be negative (a discharge current) if  $V < E$ .

This is an important equation for batteries and motors. It is simple Ohm's Law, except that the voltage is not V or E but their difference. It will tell us more if we write the symbols in various ways. Thus:

$$(V - E) = IR = \text{volts dropped in resistance.}$$

In other words: the current that will flow will be such as to cause the difference-voltage  $(V - E)$  to be wholly absorbed in resistance. If the resistance is very small the current can be appreciable, even though  $(V - E)$  is only itself a fraction of a volt. For instance: suppose  $(V - E) = 0.2$  v., but that  $R = 0.01$  of an ohm. The current =  $0.2 \div 0.01 = 20$  amperes.

Also:

$$V = E + IR = \text{Back e.m.f.} + \text{resistance drop.}$$

$$E = V - IR = \text{Supply volts} - \text{drop.}$$

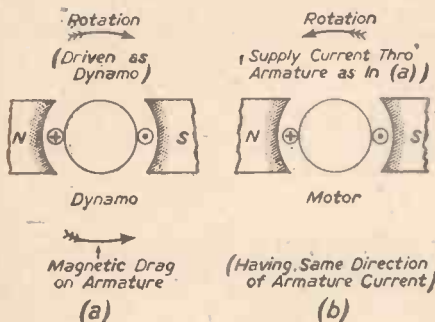

Fig. 1.—A summary of "rotation principles" applied to a motor (b) with current supplied through the armature in the same direction as the current generated in the dynamo (a).



Keep these expressions in mind when considering the low-resistance circuit of a motor armature. By doing so you will get a clear understanding why, *with a constant field*, the speed is nearly constant at all loads on the shaft, but will fluctuate much more if resistance is deliberately added.

We shall come to that in a moment. From our battery illustration you should be able to see why we cannot observe directly the volts generated by dynamo-action in a machine normally running as a motor. They are there all right, but are masked by the applied voltage  $V$ . It is  $V$  that drives current through the armature, overcoming both  $E$ , and the IR drop. If you connected a lamp across the terminals  $V$  would supply current through it as for every other load across the mains.

**Parallel-running**

The back e.m.f. cannot be made to supply power—no more than the e.m.f. of a battery when charging—unless we apply drive to run the machine above its normal motoring speed, i.e., cause  $E$  to become greater than  $V$ , when it would become a generator.

Consider two generators running in parallel (Fig. 3) to supply more current than one machine can carry.

Suppose No. 1 machine is already connected to the switchboard and supplying current. The load becomes too heavy, and we wish to switch No. 2 in parallel. First No. 2 is run up to speed, and its field rheostat carefully adjusted until voltmeter  $V_2$  reads exactly the same as the busbar voltage  $V_1$ —or, we might arrange a voltmeter  $V_0$ , connected as shown to read zero, this indicating there are two equal and opposite voltages across its terminals.

It will now be safe to close the switch or circuit-breaker of No. 2. Its e.m.f.  $E$  is exactly equal to the busbar volts  $V$ : we may regard  $E$  as a "back e.m.f.," exactly equal to an "applied voltage." Thus, No. 2 will neither take or supply current when the switch is closed.

The procedure afterwards is to make No. 2 "take load." Its voltage is slightly raised by means of  $FR_2$  until the ammeter  $A_2$  indicates load is taken off No. 1—at the same time the field resistance of No. 1 should be slightly lowered, the adjustments being repeated until each generator is taking the right proportion of the total amperes.

But suppose we had switched-in No. 2 prematurely, or when its e.m.f.  $E$  is slightly less than  $V$ . It would at once start taking a motoring current from No. 1, indicated by a reversed ammeter reading.  $E$  would be a back e.m.f. exactly as in every motor.

It is interesting to note, too, that No. 2 cannot supply current as long as its e.m.f. is only just equal to the terminal voltage of No. 1.

**Regenerative Effects**

There are also ways of observing the back e.m.f. of a motor—when it is slowing down after being switched off.

With a lamp  $L$  across the main terminals —on the motor side of the main switch (Fig. 4a), the light will go down gradually when  $S$  is opened. If the supply source were the only "voltage" the lamp should go out at once—supply current ceasing at the instant of opening the switch.

But as long as conductors cut lines of force a decreasing e.m.f.  $E$  is generated. In the absence of  $V$  this supplies current through the lamp. The same effect may be observed in starters held on by a "no-volt" electromagnet. If a motor is stopped by means of the main switch the starter handle continues to be held-on for a while, since the back e.m.f. supplies current through the coil and shunt field (refer to the diagrams of a manual type starter given in our first article). Fig. 4b

answers a question which was mentioned in one article—on "regenerative braking." When a starter or switch or controller is put to "off" a suitable value of resistance  $R$  is shunted across the armature. The back e.m.f. supplies current through it, in a direction "tending to stop" rotation and in fact bringing the armature quickly to rest.

If you have a small low-voltage motor try shunting a piece of wire across the armature terminals during the decelerating period (after the battery supply is taken off) and observe how quickly motion is arrested.

This type of electric brake has numerous applications on trains, cranes, etc.

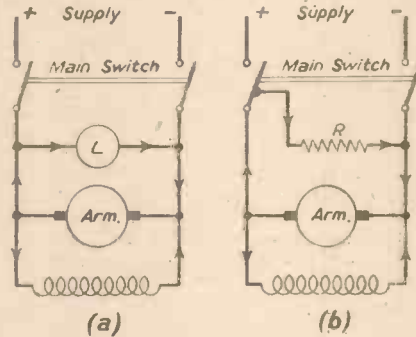

Fig. 4.—"Regenerative" effects in a motor after opening the main D.P. Switch: (a) a lamp  $L$  goes down gradually; (b) a low resistance  $R$  shunted across the armature will give a sharp braking effect—regenerative braking.

**The Shunt Motor**

If you are perfectly clear about back e.m.f. we may proceed to discuss types of motors.

For nearly constant-speed applications, not demanding large torques, the plain shunt-wound type is ideal. The constant-speed characteristic partly arises from the fact that the motor has a constant field, at all loads. In fact, this is the explanation, but armature resistance also determines how constant the speed will be.

The shunt is connected directly across the supply mains, thus takes a small current which is quite independent of the main current through the armature. During starting the shunt should be energised at full voltage by taking one end to the supply side of the starting resistance as in Fig. 5.

The current through the armature is

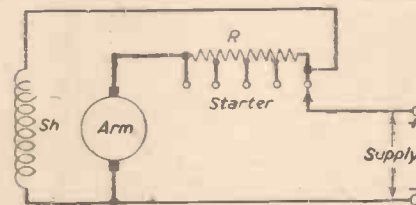

Fig. 5.—The shunt is connected directly across the mains voltage, independently of the armature and its starting resistance  $R$ . The constant speed behaviour of a shunt motor is largely due to the constant field flux thus obtained.

determined by the back e.m.f. and resistance as already explained, i.e.,  $I = (V - E) / R_a$ .

But at starting there is little or no back e.m.f. to keep the current within bounds, hence additional resistance  $R$  has to be inserted and gradually cut out as the armature accelerates—as the speed rises, back e.m.f. takes the place of resistance, reducing the effective voltage.

Very small fractional h.p. motors may, however, be switched directly across the supply without extra resistance. The resistance of the armature itself is generally sufficient to limit the peak starting current, whilst acceleration is rapid.

It is largely a question of time—the accel-

eration period. If there is "flywheel effect" to delay acceleration it may be desirable to use a resistance in cases where it might otherwise not be necessary. Also, when large motors are to be started off-load a resistance of much smaller current rating than usual will do—equivalent to a starter for a much smaller motor.

**Starting Current**

Consider a shunt motor whose armature resistance—including brushes, leads, etc.—is 0.1 ohm. Suppose it is designed for 50 v.

If we switched this directly across 50 v. without added resistance the starting current will rise to an instantaneous peak of  $50/0.1 = 500$  amperes, though the normal full-load current under running conditions may be less than 50 amperes.

If it was anything but "instantaneous," such a current could do a lot of damage in a short space of time. Think of it: 500 A, in a resistance of 0.1 ohm will generate heat at a rate equivalent to a power dissipation of 25 kilowatts! If there are many turns on the armature, pretty severe electromagnetic stresses will also be set up.

Fortunately, things are not quite as bad. The armature accelerates quickly—let us hope—"E" comes into existence, opposing the applied voltage, so reducing the effective volts acting on resistance and therefore the current.

Thus, giving  $E$  a series of values: 0, 10 v., 20 v., 30 v., 40 v. and, finally, 48 v., the current during starting will be as follows:

$V = 50 \text{ v. } R = 0.1 \text{ ohm.}$

E	Effective volts (V-E)	Armature current I <sub>A</sub>
0	50 v.	500 a.
10 v.	40 v.	400 a.
20 v.	30 v.	300 a.
30 v.	20 v.	200 a.
40 v.	10 v.	100 a.
48 v.	2 v.	20 a.

These are plotted as a graph (Fig. 6). The final steady value of current is 20 a., implying that the motor is taking  $50 \times 20 = 1,000$  watts (1 kW.) of power, thus having a mechanical load on the shaft around 1 b.h.p. If running "light" without any load, the back e.m.f. may rise further to, say, 49.5 v., when the no-load armature current would be 5 A. or less—depending on the size of motor.

Note from the table that the final effective voltage acting upon the resistance of the armature is only 2 volts! The supply is at 50 v., but 48 v. are exactly neutralised by the equal and opposite back e.m.f. of -48 v. Nevertheless, 2 v. across 0.1 ohm gives a current of 20 amperes.

**Why the Speed is Constant**

Now, the back e.m.f. is simply proportional to the speed. The motor, in our case, will run up to a speed at which it generates a back e.m.f. of 48 volts at full load; or, on no-load, the speed will rise a slight bit further, so as to generate 49.5 v.

You see: the final steady speed will be that which gives a back e.m.f. such that the "watts" taken from the supply are just sufficient to overcome all losses—including those in the load. That, of course, is true of every machine. A steady speed will be reached when (at the final speed): Energy Supplied = Energy Lost in various frictional and "work" losses.

To understand the constant-speed characteristic, consider the above figures again. When running light, the motor takes 5 A., generating 49.5 v. When mechanical load is put on the shaft the speed falls slightly, to cause the back e.m.f. to drop to 48 v.—when the armature takes 15 A. more to cope with the extra load.

At no-load the power is 250 watts—to



make up for armature windage, frictional, and iron losses; when load comes on, this increases to 1,000 watts, though the back e.m.f. has only changed from 49.5 v. to 48 v.—a drop of 1.5 v. in  $49.5 = 3/99$ , or roughly 3 per cent.

So the speed will drop 3 per cent. when load comes on. Thus, strictly, a shunt motor is not quite a constant speed machine. The speed must drop a little to enable the armature to take more power from the mains. If the normal speed when running light was 1,500 r.p.m. we would lose about 45 r.p.m. in order to drop the back e.m.f. from 49.5 v. to 48 v.

**Effect of Armature Resistance**

Why is a speed variation of only 3 per cent. sufficient to raise the current and power taken 400 per cent.?

The figures are almost self-explanatory. Because of the low resistance (0.1 ohm) the back e.m.f. (therefore the speed) need only fall by 1.5 v. to increase the current from 5 a. to 20 a.

As always, the current through a resistance depends on a "voltage"—here, an effective voltage: the difference of two nearly equal e.m.f. When a resistance is small, a small effective voltage will cause a large current to flow. Hence the motor adjusts its power requirements by a drop in speed proportional to the amount the back e.m.f. has to change.

But if a permanent resistance was added in series the speed drop will be much more. Suppose this is 0.9 ohm (for obtaining speed reduction), making, with the armature resistance, a total of 1 ohm.

Running light, the motor normally requires 250 watts input. Reckoning upon the same input current, the volts dropped in resistance will be  $5 \text{ a.} \times 1 = 5 \text{ volts}$ , and the back e.m.f. =  $(50 - 5) = 45 \text{ v.}$ —compared with 49.5 v. without added resistance.

The normal speed, running light, was 1,500 r.p.m. At a total armature circuit resistance of 1 ohm, this becomes,  $45/49.5 \times 1,500 = 0.91 \times 1,500 = 1,365 \text{ revs.}$ —a drop of about 9 per cent. on the normal no-load speed.

Next, consider the speed-change from no-load to full-load. On the basis of 20 a. input current, the total drop in resistance will be 20 volts, the back e.m.f. = 30 v., and the new speed,  $30/45 \times 100 = 66 \text{ per cent.}$  or  $0.66 \times 1,365 = 900 \text{ r.p.m.}$ , approximate fall of 34 per cent.

The 0.9 ohm will dissipate as heat a power of  $20^2 \times 0.9 = 360 \text{ watts}$ —equivalent to running six 60 watt lamps continuously. Thus it can be a costly business reducing the speed of motors by series resistances, and, as seen, we lose almost entirely an approach to a constant-speed characteristic.

Of course, it will not require the same power input to drive a load at 900 as at 1,500 r.p.m., but there is an extra loss in resistance. The power actually converted into mechanical b.h.p. at the shaft can be found in each case by multiplying Armature Current by Back e.m.f. In our example we assumed a constant power taken from the mains, 20 a. at 50 v. Then, adding resistance simply means that more of it will be wasted instead of being usefully converted.

**Resistance in Field Circuit**

This outline of shunt-motor behaviour would not be complete without some reference to the effect of adding resistance into the shunt field circuit.

Making the field weaker will increase the speed. We put a field rheostat in circuit with a dynamo for varying the voltage generated—at a speed which will be that of the driving-motor or engine.

In a motor this rheostat becomes a speed regulator. To raise the speed we insert more resistance, thus cutting down the field current and the flux. At the same time, it

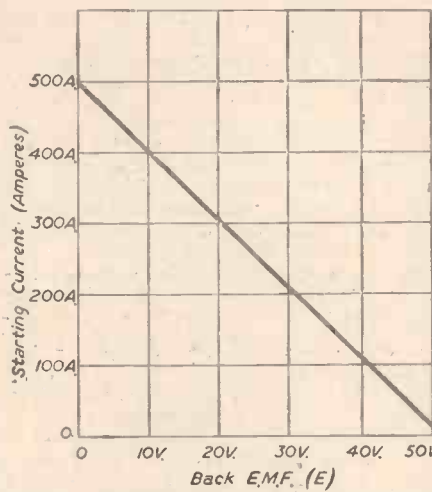

Fig. 6.—Values in the Table plotted to show the large current (500 A.) at the instant of starting. The current falls as shown with rise of speed, and back e.m.f., to about 20 a. at  $E=48 \text{ v.}$

will be observed that the motor takes more amperes from the supply—more power input has to be supplied to drive a load at a higher speed.

It is often puzzling to students why making the field weaker should increase the speed? Reasoning in terms of the magnetic forces exerted by the armature conductors, it may seem that the speed should fall. Note, however, that the armature current (hence the power taken) increases, and we may again explain matters in terms of back e.m.f.

Consider the motor on-load, taking 20 a. as before—but without added armature resistance. The back e.m.f. was 48 v. and the effective voltage overcoming armature resistance was 2 v.

We make the field weaker by inserting resistance. Immediately, the back e.m.f. becomes less than 48 v.—the armature conductors are cutting a weaker flux. Suppose it falls to 45 v. The effective difference-voltage acting on armature resistance is now  $50 \text{ v.} - 45 \text{ v.} = 5 \text{ v.}$  In consequence the current will tend to rise to  $5/0.1 = 50 \text{ a.}$ , which would represent a power of 2.5 kW.

from the supply, compared with 1 kW. at full field.

In fact, the tendency for the current to rise will, even with a weaker field, be such as to accelerate the armature. The current-increase will be out of all proportion to the reduction in field, hence exerting an accelerating torque.

So the armature speeds-up—from the increased power taken. It will speed-up to a point where the back e.m.f. is—not exactly 48 v. as before—but some lesser value, say, 47 v. The motor will then be taking 30 a., or 1.5 kW., representing a larger b.h.p. at the shaft.

A given "load" is being driven at higher speed. "Horse-power" is a rate of working, hence "r.p.m." determines h.p. output. Acceleration ceases when the power taken from the supply just equals the total losses (in the load and motor) at some value of increased speed.

**Limits of Speed Control**

While on no-load the speed can actually be raised until a motor "races" by sufficiently weakening the field; there are obvious limits to the amount of normal speed-control that may be applied.

There are obvious limitations—mechanical and electrical. A given diameter of armature and flywheel must not be run at a speed which gives rise to dangerous centrifugal forces. As seen, the armature current rises with speed. Overheating will be the ultimate result, and in all cases where appreciable speed-increase is required by using field-control the armature temperature should be watched—especially where the normal running temperature tends to be high.

Finally, if not fitted with interpoles, commutation troubles will appear. Interpole motors are thus suitable for a much wider range of speed-control than non-interpole types.

As regards "racing," just mentioned: most motors will start on no-load even when the shunt field circuit is broken. Residual flux will give enough starting torque. But disaster quickly results if a machine is allowed to accelerate under such conditions. The speed will simply go on increasing until something gives way. A word to the wise should be sufficient.

**The "Gyrodyne"**

By M. F. ALLWARD

THIS unusual name was given to the Fairey machine because it is not an autogiro, and it differs from the normal conception of a helicopter. In an autogiro, the rotor is not power driven, and the term helicopter has come to denote a rotating wing aircraft, the main rotor of which provides both the lifting and traction forces.

Prior to the Gyrodyne "single rotor" helicopters had a sideways facing tail rotor to

counter the torque of the main rotor, and a considerable proportion of the power available was used solely for this purpose. On the Gyrodyne, however, the asymmetrically positioned variable pitch propeller fulfils two purposes; it counters the torque of the main rotor and at the same time also provides most of the traction force pulling the machine horizontally through the air. As the machine nears its maximum speed, the main rotor absorbs a lower proportion of the available power and more power can be fed to the propeller to pull the machine along.

The relative efficiency of this arrangement is illustrated by the superior performance of the Gyrodyne. The cruising speed, as might be expected, is considerably higher than that of contemporary helicopters, and last year the Gyrodyne won the world speed record for rotating wing aircraft at 124.3 m.p.h.



Front view of the Fairey "Gyrodyne."



NEW SERIES

# Wood Turning—7

## Further Examples of Handled Tools

By FREDERICK JACE

THE illustrations this month give further examples of handled tools. The piece of wood intended for a handle should, of course, be cut from square section material, having the edges chamfered off to give it a rough circular section. The wood is then centred to receive the prong and tailstock centres, and it is a good plan then to bore the holes for the tang as there is less likelihood of the wood splitting.

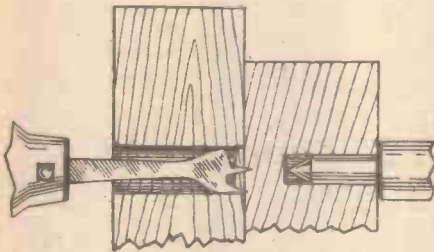

Fig. 55.—How to bore a hole in a mallet head.

The ferrules, as shown last month, can be slipped over the tailstock centre to act as a gauge.

When turning a mallet, the hole for the handle is drilled as shown in Fig. 55, after the head, of course, is turned. The boring bit it will be seen is chucked in the lathe and the block for the mallet is gradually fed up to the bit by means of the tailstock centre until the bit completely penetrates the block. The work is now reversed and bored through from the opposite side. It will be seen that a pressure block is interposed.

Plumbers mallets need to be made of a heavy wood, and lignum-vitæ should be used when it can be obtained. Alternatively, boxwood or ash should be used. Ash is usually employed for the handles. Fig. 58 indicates how such a mallet is chucked. It will be seen that they are turned to shape and the chucking pieces finally cut off with a chisel. The plumber's tompon is turned in a similar manner.

Mallets of fancy shape, such as a chairman's gavel, or a conjuror's mallet, may take the form shown in Fig. 60. They are nearly always made of boxwood, although some pleasing effects can be obtained by gluing together alternate layers or laminations of equal thicknesses of light and dark coloured woods such as mahogany or American white wood or satinwood. Make certain to use an odd number of laminations so that the outside layers are of similar colour. These mallets may be chucked either between centres or in the cup chuck. Such small mallets may be turned two at a time. (See Fig. 62.)

The maul used by stonemasons is usually made of beech with the grain running across it; it has an ash handle. (See Fig. 63.) They may be chucked on a wooden mandrel as shown in Fig. 64, the handle being spigoted as shown in Fig. 65. The sculptor's maul and its handle are shown in Figs. 66 and 67.



Fig. 62.—Two mallet heads may be turned in the same operation, as shown here.

### Variegated Woods

In connection with the use of variegated woods, the process lends itself to the production of inlaying where the design can be circular in motif. To achieve the best results, however, an eccentric chuck is necessary so that the work can be turned off centre. The circular grooves are turned with a 1/4th chisel, square ended of course, and the annular discs to be inlaid are separately turned from a piece of different coloured wood. Several colours of wood should be used in accord with the previously prepared design.

They are fixed in place with glue and should have a board placed over them with a heavy weight on top to ensure that they are firmly seated. The inlay should be turned slightly higher than necessary, and when the glue is set the work should be re-chucked and the excess turned off, taking a final skimming cut over the whole surface to clean away the excess glue.

Such chucks are available from the tool stores. If possible a geometric turning chuck of the Holtzappel type should be purchased, as this has a wide range of settings for turning ellipses, ovals, hexagons and other non-circular shapes. In fact, such a chuck is quite necessary



Fig. 56.—A special block which is used for boring cylindrical work.

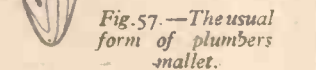

Fig. 57.—The usual form of plumbers mallet.

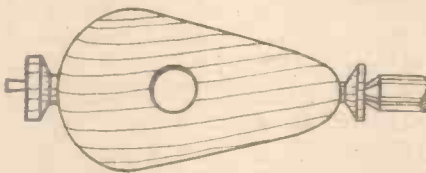

Fig. 58.—(Above) How the head of the mallet is chucked.

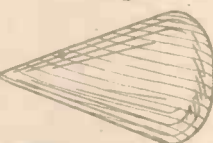

Fig. 59.—(Left) The tompon used by plumbers.

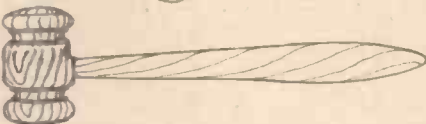

Fig. 60.—A mallet of fancy form for light work.



Fig. 61.—The handle to the fancy mallet.

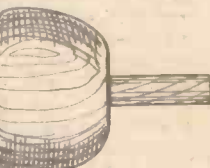

Fig. 63.—The maul used by stonemasons.



Fig. 65.—The handle for the maul.

if ornamental and decorative wood turning is to be undertaken. Some really pleasing effects can be obtained by inlaying metal into wood—a process known as damascening.

### Marketable Wooden Articles

Indeed, a ready market can be found for turned wooden articles which have those finishing touches which commercial products lack. There is a good sale for inlaid trays, salvers, candlesticks, powder boxes, pin trays and other bric-a-brac, provided that they are not just plain turned articles. It is the design of a turned wooden article which sells it, as well as the choice of the correct wood for the purpose. There are firms which specialise in the supply of small pieces of the fancy

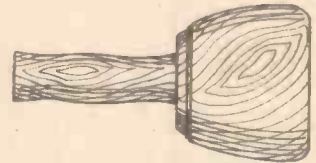

Fig. 66.—A sculptor's maul.



Fig. 67.—The handle for the sculptor's maul.

woods such as teak, Honduras mahogany, sycamore, boxwood, larch, lancewood, American whitewood, satinwood, and birdseye maple.

If cheapness and economy is a factor, some of the softer of these woods can be obtained as veneers, which may be glued over a wooden turning in one of the cheaper woods such as pine.

It is necessary, not only to master the art of turning, but also the equally skilled art of finishing, and it is worth while giving some time to practising french polishing, since most wooden articles are finished that way. Some articles may be finished with varnish after the grain has been filled with gold size and smoothly glass-papered.

Another method of finishing which is finding favour is spray-cellulose. There are several cheap spray-guns on the market which may be operated by the exhaust section of a vacuum-cleaner, and they may be used not only for applying paints of the cellulose variety but also for gold size, varnish and ordinary paint.

With cellulose a wood filler is necessary, and this is supplied by the makers of the cellulose paint. Thinners are required to reduce the cellulose to spraying consistency.

After the cellulose is dry the work may be polished in the lathe, using one of the cellulose polishers used for motor-cars.

If certain parts of the turned work need to be gilded, the wood should first be filled with a coat of gold size, which is allowed to dry. It is then glass-papered quite smooth, and a second thin coat of gold size is applied. When this has become tacky—that is to say, almost dry—the gold leaf which is supplied on tissue-paper is smeared over the surface and it will adhere. By a combination of these finishes some very pleasing effects can be obtained. The beadings, for example, can be picked out in gilt against black cellulose on the body of the work.

(To be continued)

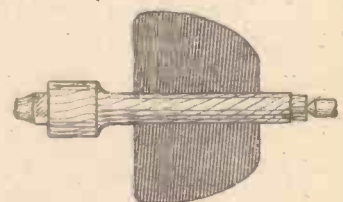

Fig. 64.—How to chuck the maul on a mandrel made of hardwood.

# Close-ups Without Guesswork

The Use of Supplementary Lenses and a Device for Correcting Parallax in Cameras

By C. S. WEDLOCK

THE following article is intended to indicate to the owner of a camera, not normally fitted with a focusing screen, how he can use supplementary lenses without wondering what is going to appear on his film. Usually, close-ups undertaken without the aid of a focusing screen give rise to a number of uncertainties in the operator's mind. He wonders if his subject is really in focus, and he knows that critical focusing depends upon the correct combination of (a) camera-object distance; (b) the setting of the ordinary focusing scale, and (c) the focal length of the supplementary lens. Additionally, the first of these variables (and to a lesser extent the other two as well) is also influenced by the size of the object being photographed. Another problem, that of parallax, usually causes further uncertainty.

It is not surprising then, that many an amateur who tries a table-top subject now and again, using supplementary lenses and relying entirely on published tables for focusing, is unsuccessful and loses confidence in his ability to tackle anything closer than the usual 3 feet or so.

Provided, however, that a certain amount of careful, but not difficult, preparatory work is undertaken, close-up work can be as exact and certain in its results as any other branch of photography—and little or no expense is involved.

## Temporary Focusing Screen

The first step is to fit the camera with a temporary focusing screen. This is not difficult and all that is needed is a piece of ground glass of sufficient size not merely to cover the framing aperture in the back of the camera, but to extend on to the rollers or guides over which the film passes. This is vitally important in order to ensure that the ground glass lies in the same plane as the film and remember that the ground side goes towards the lens! Holding it in place can usually be accomplished by one or two rubber bands hooked over convenient projections at the ends of the camera.

Next, with this screen in position, open the shutter, set the lens to full aperture and have a look at the inverted image on the screen. If the image is inclined to be lacking in brilliance or clarity, then try rubbing the merest trace of grease over the ground side of the screen; this invariably works wonders.

The next step is to deal with the focusing scale. Few cameras have a scale with a really generous number of markings, but these can be supplemented by actually setting up the camera with the focusing screen in place, focusing it at full aperture on to an object set at various distances, and mark-

ing off the focusing scale. A very easily focused object is a table lamp minus its decorative shade and with a bold black cross painted on the bulb. Also, it is often more convenient to cover the existing scale with a piece of paper stuck on with one of the cellulose adhesives, and marking this off with a finely-pointed H or 2H pencil.

These preliminaries over, set up the camera firmly, with its temporary focusing screen and supplementary lens in place; and set the lens to full aperture. Now set the camera, focusing to its minimum setting, and move the lamp used before until it is absolutely in focus. Note down on paper (a) the focusing scale setting and (b) the

may be too small to be able to exactly judge the limits of view. The alternative method to overcome this difficulty is to use two lamps marked with crosses, and shift them so that the centres of the crosses come at the edges of the field of view, finally measuring the actual distance between the cross centres. It is only necessary to measure the field of view horizontally, as the vertical field will always be the same ratio of it, depending upon the proportions of the camera's picture frame.

## Plotting a Graph

The last stage is to turn all the data collected into a more convenient form, i.e., plot them on a graph and for each lens we can plot two graphs on one piece of paper. First plot the camera-object distances along the horizontal axis of the graph against the field of view along the vertical axis, this will give a straight-line graph. Next plot the focusing scale settings along the horizontal axis against the same vertical axis as before, thus producing a curve.

Now, to use these graphs at some future occasion when it is impossible to unload the camera to put the focusing screen in: first measure the set-up to be photographed and obtain the size of the field of view, then read across from this point on the vertical axis of the graph to where it intercepts the two graphs: the interception on the straight-line graph will give the required camera distance, and that on the curved graph will give the setting of the focusing scale. In actual practice it is wise to take the camera a little farther away than the graph indicates in order to leave a little margin for trimming, etc.

The graphs just mentioned are, so to speak, only the framework. It is possible to plot not merely the camera-object distance, but the far and near limits of focus instead, thus getting two straight-line graphs instead of one, indicating the depth of focus available at full aperture. One might even repeat the whole performance at various apertures and thus obtain a whole family of graphs for each supplementary lens.

The diagram, Fig. 1, shows the graph used by the writer. In this case the camera is a 35 mm. model with supplementaries of 1, 2 and 3 diopters, which give a range in focusing from just under 11in. to just over 32in. The unaided camera lens will focus down to 30in. By plotting the graphs for all three lenses on one piece of graph paper it can instantly be seen which particular lens is to be used and, when the lenses overlap, where there is a choice of two lenses. For example, suppose the object to be photographed requires 12in. room from left to right. Finding 12in. on the vertical scale and reading across horizontally, it is seen that there are two alternatives—either to place the camera at 19½in. distant, set the focusing scale to 3½ft. and use the 1-diopter lens; or place the camera at 19in. distant, set the focusing to 11½ft. and use the 2-diopter lens.

## Correcting Parallax

Correction of parallax when the viewfinder lens is in line with the camera lens provides no great difficulty—the amount of separation can be measured and the camera moved accordingly, or one of the devices now upon the market can be used. But many cameras suffer from parallax in two direc-

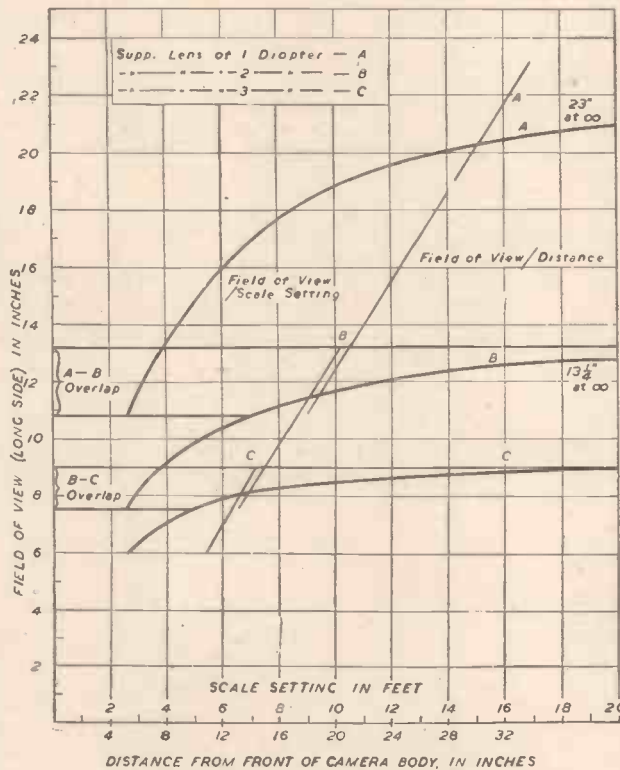

Fig. 1.—Graph indicating camera-object distances and field of view details.

distance of the bulb from some convenient point on the camera. Reset the focusing scale to the next mark and repeat the operation until all scale settings have been covered, making sure that the distances are measured from the same part of the camera each time.

It will be found with relatively low-power supplementaries that no exact distance for focusing can be determined—in other words there is an appreciable depth of focus. In this case, either take the mid-point in the depth, or note down both near and far distances of focus.

The next step is to measure the amount of subject included, at the various scale settings, and this can be done in one of two ways. One way is to set up a plainly graduated stick or rule at the various distances from the camera, and by inspection of the focusing screen, see how much of it is included in the field of view, noting down the data obtained. This will be easy at close distances, but at greater distances the image



tions, and in this particular case the finder lens is situated above and to the right of the camera lens when viewed from the front.

The first step is to measure as accurately as possible the distance between the centres of the finding and taking lenses, and then to determine the angle of the line between the centres and the base of the camera front; sighting along the edge of an adjustable protractor gives quite accurate results.

Next, build up a slotted block, as shown in Fig. 2, so that the angle of the slot is the same as that previously measured on

the camera. The block itself can conveniently be made in four pieces—front and rear plates enclosing the two separated halves of the centre. On the base is screwed an adaptor to enable the block to be screwed on to a tripod—the writer used the threaded disc from an old ball-and-socket head.

Before the block is finally closed, the camera cradle is put into the slot and then the block assembly completed. The cradle consists of a triangular construction as shown, the top side forming the actual platform for the camera and the sides of the cradle being so dimensioned that it can slide through the block by an amount at least equal to the lens's separation first measured. Securing the camera to the platform is a matter for individual choice, but a straightforward solution can be found in four brass strips (straightened curtain-runner supports from a chain-stores) screwed vertically on to the platform, as shown in Fig. 2. The opened camera sits neatly down in between them, Fig. 3, the front two supports coming in the angle formed by the lens

baseboard and the camera body and the rear supports against the camera back.

**Operation**

In use, the cradle is first lowered through the slot to its lowest position and the subject composed in the finder of the camera. Then the cradle is raised through the slot by an amount equal to the lens' separation and prevented from slipping back by a peg in a hole drilled in the cradle above the block. Thus the camera-taking lens now occupies the same position as the finder lens when the subject was being composed, and the exposure can be made in confidence that there will be no "cutting off" in the picture.

No dimensions have been given as these will naturally vary for different cameras, but it is important that the material used for construction be as light as possible, consistent with strength, so that there will not be an undue tendency to wobble when attached to the tripod and with the camera in position. The writer used Perspex throughout, with full success, but aluminium or one of its alloys could be used instead.

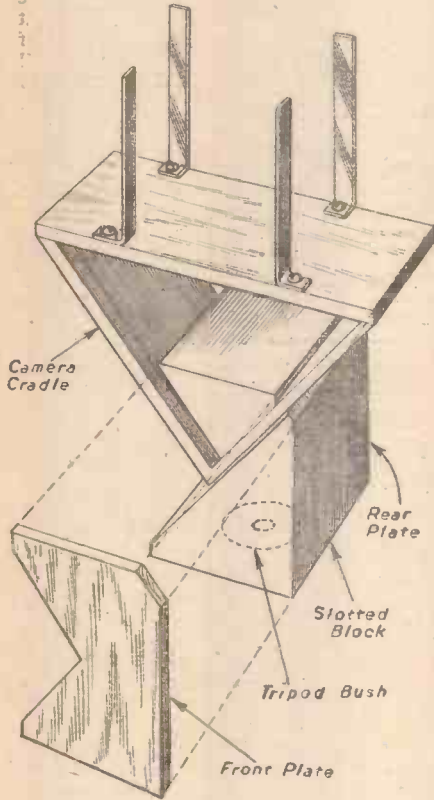
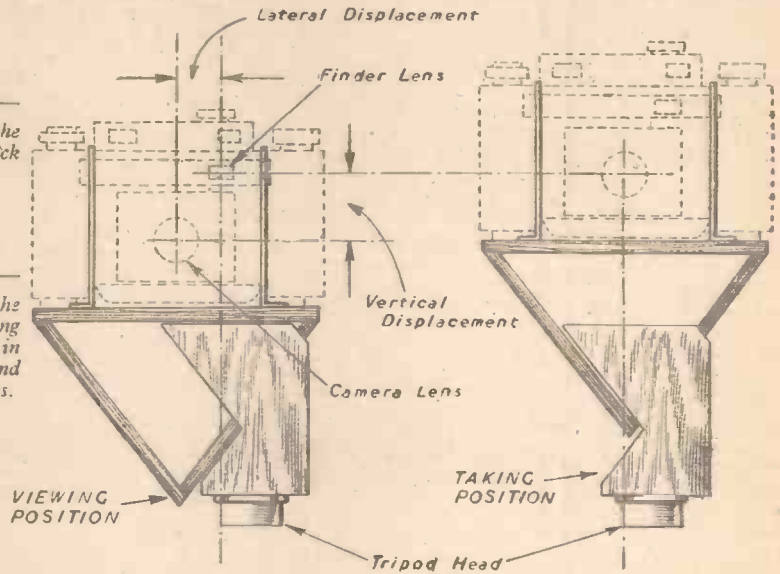

Fig. 2 (Left).—Details of the slotted block fitment.

Fig. 3 (Right).—Two views of the cradle showing the camera in the viewing and taking positions.



# Mathematics as a Pastime

## The "Tower of Hanoi"

By W. J. WESTON

**M**AKE the Tower of Hanoi with the accompanying sketch as your guide. You will get and give a deal of pleasure from play with the toy; you will get, too, practice that will make you realise how formidable the number 2 becomes when it comes into its powers.

The problem posed by the toy is to transfer the rings on to another peg where they will rest in the same order as at first. Two fetters on freedom are, however, imposed: you are to move only one ring at a time; you must not let a larger ring stand on a smaller. You see the idea? Before you can transfer the largest ring to its destined peg you must have heaped the others on a second peg. Try with two rings; cardboard discs moved to three points on the table will do for demonstration. The minimum number of moves needed is 3; you place the smaller ring on the second peg; you place the larger ring on its destined peg at the 2nd move; you surmount it with the smaller ring at the third move. With 3 rings the largest ring is transferred at the fourth move; with 4, at the eighth move; and so on. And the least number of moves is always a power of 2 less 1. That is,

- With 2 rings: 3 moves required  
( $2^2 - 1$ ): a series 1+2
- With 3 rings: 7 moves required:  
( $2^3 - 1$ ): a series 1+2+4
- With 4 rings: 15 moves required:  
( $2^4 - 1$ ): a series 1+2+4+8
- With n rings: ( $2^n - 1$ ):  
a series 1+2+ $2^{n-1}$

Demonstrate to your friend with 2 and 3 rings. He will very likely undertake—even though subject to a penalty for failure—to

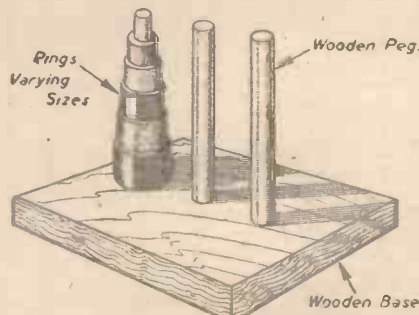

The "Tower of Hanoi" toy.

transfer the 5 in fewer moves than 31, in 30, say. He cannot; 31, that is  $2^5 - 1$ , is the minimum without allowing any for mistaken moves.

Perhaps you have heard of the tradition that, when the foundations of the world were fixed, the founder invoked this power of 2 to determine the duration. The patience of man, pitted against 2 in its strength, was to hasten the coming of a better-world. On a brass plate were three pegs a cubit high (about twenty inches, that is), and on one peg were placed 64 golden discs, the largest resting on the plate, the others ever diminishing in size rising above it. The discs are to be transferred to another peg under the rigid rules of one at a time and never a larger on a smaller. Day and night without cessation the hands of an attendant flicker across the pegs. When the transfer shall be accomplished and the sixty-four discs be again towering in due order of precedence on one peg, this present world will vanish as though it had never been. Like an unsubstantial pageant faded it will leave not a rack behind.

Sleep undisturbed; though: the testing of the prophecy is not yet. Make a calculation. The minimum number of moves is  $2^{64} - 1$ . the logarithm of 2 is .3010; the logarithm of  $2^{64}$  is, therefore, 19.2640. The anti-logarithm of .2640 is 1.832. Assuming a second for a move, the full number of seconds requisite is  $1,832 \times 10^{16}$ , less 1. And a rough calculation gives you a duration of something like 60 millions, not of years but of centuries.



# Radio-controlled

## Constructional Details of the Model H.M.S.

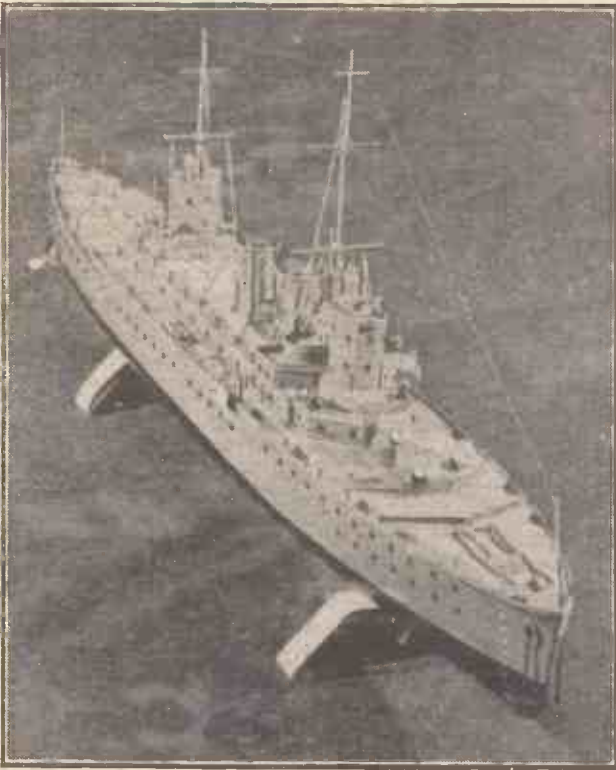

Three-quarter front view of the finished radio-controlled model cruiser.

THE hull of this model, which was designed and built by the writer, was carved from a solid piece of selected yellow pine, a wood which proved to be very easy to work.

The overall dimensions are: Length 5ft. in., beam 8½ in., depth (inside) 5½ in. The scale is ¼ in. to 1ft. (approx.)

The hull was hollowed out to leave a wall thickness of ¼ in. The forward part of the deck, i.e. from the bow to the second gun turret, is a fixture and is made from best quality 3/16 in. plywood; the quarter deck is also 3/16 in. plywood and is a fixture, with a concealed trap. This is to give access to the rudder control gear.

All decks are painted and lined black to represent planks.

### Superstructure

The superstructure is built on a separate plywood deck, 24 in. by 5½ in. by 1½ in. This acts as a lid, covering opening in main deck. This is easily removed, and is held in position by two clips disguised as searchlights. The greater part of the superstructure is made from aluminium and zinc.

Control tower, bridge, and aft control tower, also funnels, are made from sheet zinc, brass and aluminium.

Main and aft fire control top searchlights, torpedo director tower, capstans, bollards, fairleads, and 4.7 high-angle guns, are turned from hard brass, hand finished.

Both masts (one tripod) are of brass rod and tube, and are made telescopic to facilitate carrying in the boat case.

Brass rod was used for the 102 rail stanchions (3 rail) which were turned on a small lathe and finished by hand, steel wire being used for the rail. At four points small chains have been fitted in place of rail; these give access to gangways.

Gun turrets are made from hard wood with guns turned from brass rod. All guns are fitted with blast bags painted white. Guns are made to elevate, depress and train, and are fitted with brass spindles and bushes with the idea to turn by power at a later date.

The forward gun turret when turned operates a switch controlling power from 4½ volt dry battery energizing the main relay, which switches the propulsion motors on and off.

The purpose of this switch is to prevent the dry battery running down when the receiver is switched off. Up-to-date rudder control gear is not fitted. This will be effected by using a clockwork multiple-contact rotary switch. By this means it will be possible to give full differential left and right control using a small electric motor and worm reduction, gear, etc. Mechanism for this purpose is now being constructed, and will be ready for test in the near future.

The rudder is made from sheet brass, fitted with a 3/16 in. diameter shaft in brass bearings.

At present the rudder can be locked in any position by a capstan on deck.

### Propulsion Motors

Propulsion is by twin electric motors (6-volt) driving four propellers, these being three-bladed 2 in. diam. made from hard brass and hand finished; they weigh 2½ ozs. each. They rotate in opposite directions, this being done from a gear box attached to the motor body. All bearings, spindles, and gears are brass, the gears being hand cut.

It was feared at first, that the motor would be noisy, but this was not so in the water. Propeller shafts are 3/16 in. diam. steel, stern tubes are 5/16 in. brass, felt water-seals being provided at each end.

Tubes are held in position by shaft brackets on the outside of hull, and by brackets on the watertight bulkhead inside. Brass drivers are fitted to shafts, held in position by small split pins

Motor is held in position on a felt pad (to damp vibration) by two quick release bolts

Power for the motor is provided by an "Exide" 3 M.B.I 6-volt celluloid "free" acid accumulator. This type of battery proved very efficient, and able to stand up to comparatively heavy discharge currents for appreciable periods.

The drive to the propellers is via driving dogs attached to motor shafts, and these dogs engage slotted drivers on the propeller shafts. This method proved a little noisy, but very efficient

After final rubbing down, the hull received two coats of waterproof filling, followed by a rubbing down with wet carborundum paper

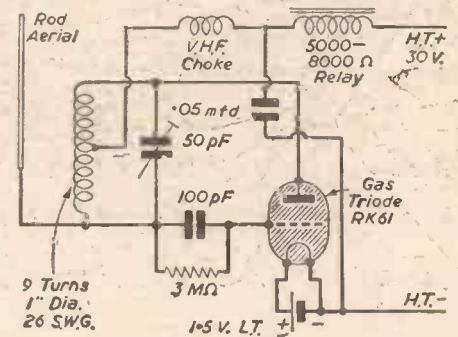

Circuit diagram of receiver.

(fine grade). Four coats of "Battleship Grey" paint were applied to water-line level, and from this point to within 3 in. of keel, the hull is finished black, remainder being finished red-oxide. Superstructure and deck fittings are painted grey and black.

Boat carries two whalers slung on davits amidships. Speed boat and shore boat are stowed on the superstructure, and can be lowered by means of a boat crane.

The inside of hull received two coats of waterproof filling and is finished black.

### Receiver Details

The radio control receiver is a single-

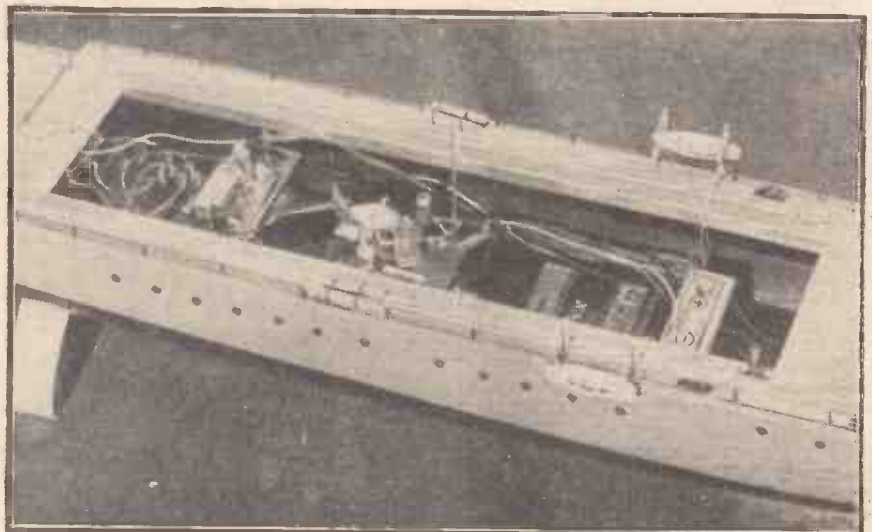

View amidships with part of deck removed showing the radio receiver, batteries, etc.



# Model Cruiser

"Barrie-Town"

By A. R. CASEBROOK

valver and was designed and built with the assistance of a friend in the writer's workshop.

Miniature components are used throughout, and the valve used is a small size 3-element gas triode (RK6r), this being most useful in applications requiring economy of space, weight and battery drain.

The coil on the receiver is wound with nine turns of 26 gauge tinned copper wire, and is about 1in. diam. and self-supporting.

The receiver is designed for use as a self-quenching super-regenerative detector which

operates a small relay on the receiver, and this in turn operates the main motor relay, which has heavy contacts to take the load off the motor battery. A small indicator lamp operates at the same time.

When a multiple contact rotary switch is used it is wired to receiver relay and besides operating the rudder control, gives stop and start positions.

The length of receiver aerial is 6ft. 6in., and this is fitted between masts and down to jack-staff on small insulators, wire from an old radio coil being used. Size of complete receiver is: panel 3½in. by 2½in. suspended by rubber bands against shock and engine vibration, on four brass rods 3in. high on a plywood base 6in. by 5in.; weight of the complete receiver and battery is 200zs.

The battery used is a "Drymax" 514 (layer type) 69 volt H.T. 1.5 L.T., size 4½in. by 3½in. by 1½in. On test it was surprising to note the length of time this type of battery would operate the receiver.

### Valve Operating Note

The valve must always be operated with sufficient series resistance in the anode circuit to limit the anode current to the maximum rated value.

The useful life of the valve depends upon the anode current and may be prolonged by operating the valve with as low an anode current as possible. The valve is approximately 1 9/16in. long, ½in. diam.

### Transmitter

The transmitter is a two-valve tuned anode, tuned grid circuit of simple design, using two low drain 1.4 volt battery pentodes (Mullard D.L. 35). When the transmitter is in operation an unmodulated R.F. signal is transmitted.

On switching to stand-by position the valve filaments are switched on.

The main H.T. positive lead is also switched, this being operated to transmit a signal.

An 8-section steel copper-coated rod aerial is used, mounted on insulated brackets on the side of the case.

The coils on the transmitter, which are 1in. diam., are wound with 26 gauge tinned copper wire. They are self-supporting and there are 8 turns on each.

Experiments were carried out using a ¼ W- di-pole aerial; this proved more satisfactory than a rod aerial, but was abandoned in favour of the rod type owing to transport difficulties.

Batteries used are 120 volt H.T. 1.5 volt L.T.

Complete transmitter is carried in a wooden aluminium-lined case with a hinged



Rear view of the completed model with part of superstructure removed.

door, size 17½in. by 9in. by 4½in., with a leather carrying handle on top.

### Trimming

The trimming of the transmitter proved difficult and very critical, and needed great care in adjustment. Two trimmers are provided: (1) range; (2) signal. It was found that when the transmitter was used by trees, bushes, etc., or damp ground, this affected the operation of the transmitter. With the receiver out of the boat, control of the relay was over 500 yds. with good conditions. When fitted in the boat full control was maintained up to 300 yds. I am of the opinion that a good and safe working distance is about 200 yds.

By way of experiment a transmitter was built with miniature components using two "Drymax" 514 batteries. This was housed in a carrying case 8in. by 6in. by 4in., complete with batteries. This proved very satisfactory, but was abandoned in favour of a larger transmitter using a long life H.T. battery. When easy transport must be considered the small type is ideal.

In the design and construction of the receiver and transmitter one rule has been adhered to, namely, *simplicity*, and in the course of many experiments this policy was found to be well worth while.

Bearing this point in mind, I venture to think that a boat built on the lines of H.M.S. *Barrie-Town* is the answer to the beginner contemplating the construction of a radio-controlled model boat.

The construction of the boat occupied 19 months of spare time work, this being carried out in the author's up-to-date model workshop, where every tool is available for model construction. Aerial rods, spare batteries, tools and test meter are carried in the boat case, and are held in position by spring clips.

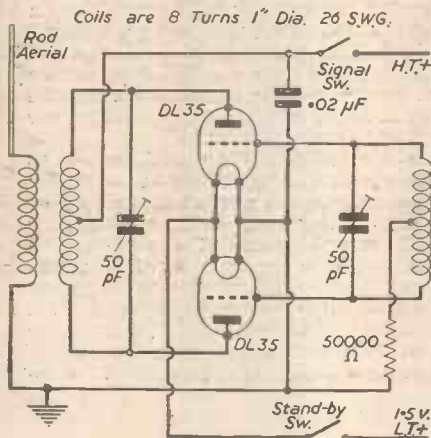

Circuit diagram of transmitter.

will operate a high resistance relay in the anode circuit upon reception of a radio signal.

The flexible terminal leads may be soldered directly to circuit components without the use of sockets. Standard subminiature sockets may be used by cutting leads.

On reception of a radio signal the receiver

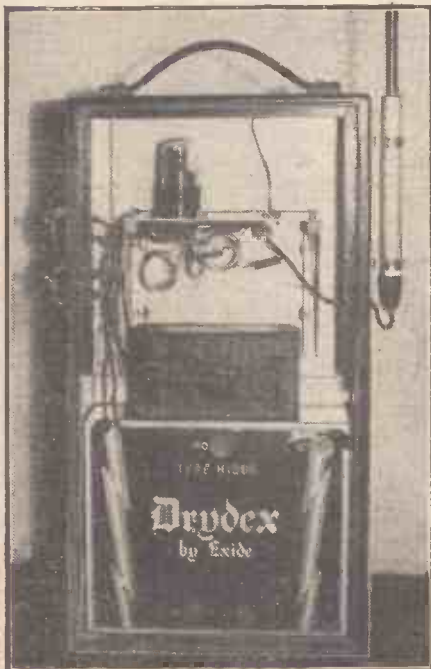

The portable transmitter in its carrying case.

# The Elements of Mechanics and Mechanisms—29

## Gear Tooth-forms (contd.)

(ALL RIGHTS RESERVED)

THE heat generated by friction can be sufficient to raise local temperature to the melting point of the metal. Partial welding then occurs and pieces are torn from one surface by adhesion to the other. Rapid destruction of the teeth may occur in this way.

Inadequate lubrication permits seizure in a minor degree by metallic contact at isolated points, the result being a gradual wearing away of the teeth, particularly on the areas outside the pitch circles.

If the gears and lubricant are correctly chosen for the work they have to do the tooth surfaces will withstand the load almost indefinitely without change after first "bedding-in." This is because the lubricant has sufficient film strength to prevent metallic contact from occurring and the materials of

For example, if at a particular instant one pair is at the stage of engagement shown in the upper diagram in Fig. 47, the other pair is at the stage shown in the lower diagram. There are thus three pairs of teeth in contact at that instant.

A little later there will be only one pair in contact in the first pair of gears and still a pair of teeth in contact in the second pair of gears. Further study of contact conditions will show that the number of pairs of teeth in engagement is always either two or three. The irregularity in action is less than in the case of a single pair of gears because the change from two to three is less severe than from one to two.

It will be seen also that the improvement due to staggering need not stop there, because

its dimensions may be answered by remembering that any section of a helical gear on a plane perpendicular to its centre line is the same as any other such section except for angular position. Furthermore, the amount of angular displacement between any two sections is proportional to the distance between the sections. If in passing from plane A to plane B the section of the gear turns through a complete revolution, the distance between A and B is the "lead." In other words, the lead is the distance in which a tooth spiral (or helix) would make a complete revolution if the gear were wide enough for the tooth to extend so far (see Fig. 48). Actually, few helical gears are so wide as this.

The object of using the helical gears is to reduce the irregularity of action caused by differences between stages of engagement of spur gears. Now a little reflection will show that if the trailing end of one tooth of a helical gear is in the same angular position as the leading end of the next following tooth in the gear, every stage in engagement of the tooth is covered at some point or other in the face-width, whatever the angular position of the gear as a whole. If one tooth just "overlaps" the next in this way, every stage of engagement is taking place at every instant. This gives the smoothest possible engagement of the gears and no further overlapping produces any improvement. The condition for overlap is that the face-width shall be equal to the lead divided by the number of teeth. Expressed in another way, the condition is that the face-width shall be equal to the transverse pitch multiplied by the co-tangent of the spiral angle.

In practice it sometimes happens that the face-width is made greater than this and there is some justification for the view that for the smoothest possible running it should be an exact multiple of the width required just to produce overlap. The advantage gained by insisting on this is, in most cases, extremely small.

### Spiral Angle

If the surface of the complete cylinder shown in Fig. 48 were cut along a straight line parallel to the axis and unrolled so as to lie flat, the result would be a rectangle as shown in Fig. 49. The length of one side is the circumference of the cylinder, and of the other, the lead of the helix or spiral. The unrolled (or "developed") spiral is a diagonal of the rectangle.

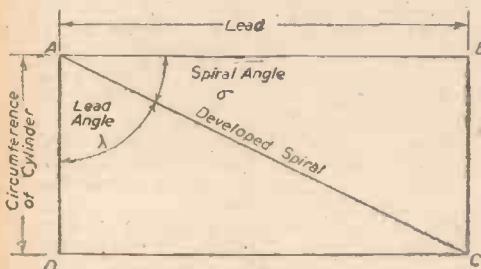

Fig. 49.—Development of spiral.

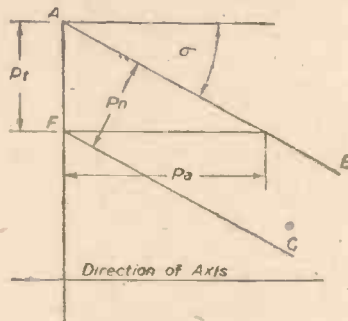

Fig. 50.—Development of tooth spirals.

the gear teeth are strong enough to resist the contact pressures transmitted through the oil without failure due to fatigue.

### Application of Load to Spur Gear Teeth

The tooth action of spur gears, even when accurately made, tend to show irregularity. The reason is that each tooth receives its load over the whole width of face at once as it first makes contact with its mating tooth. Similarly, the load is suddenly taken off when contact ceases.

To look at the matter in another way it may be noted that at some stages of engagement there are two pairs of teeth in contact and at other stages only one pair (see Fig. 47). The change from one condition to the other takes place instantaneously and the suddenness of the change produces an irregularity in action that may show itself as noise if the speed of the gears is high.

Assuming reasonable accuracy in the manufacture of the gears, irregularity of action resulting from the nature of contact between spur gears would not produce any serious stresses or other objectionable mechanical effects. It is the nuisance of noise that makes the matter serious.

### Spur Gears with Staggered Teeth

A way of reducing the irregularity of action inseparable from spur-gear contact is to use two pairs of similar gears of half the original face-width, mounted side by side on the same two shafts. The teeth of two adjacent similar gears are set, not in line, but "staggered" by half a pitch, with the result that the two pairs of gears are not at the same stage of engagement at the same time.

it would be possible (although expensive) to mount three or more pairs of similar gears with teeth staggered by an amount equal to the pitch divided by the number of gears and a further improvement in smoothness of action would result.

The theoretical ideal is the use of an infinite number of infinitely narrow gears with teeth staggered at equal spacing over one pitch. The helical gear is the practical embodiment of that ideal.

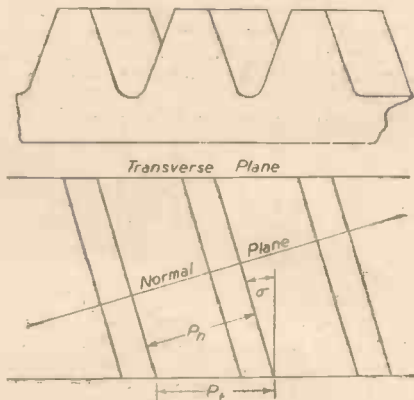

Fig. 51.—Dimensions of helical rack.

Although the twisted nature of the tooth of a helical gear suggests that its geometrical nature is much more complicated than that of the spur gear, most questions regarding

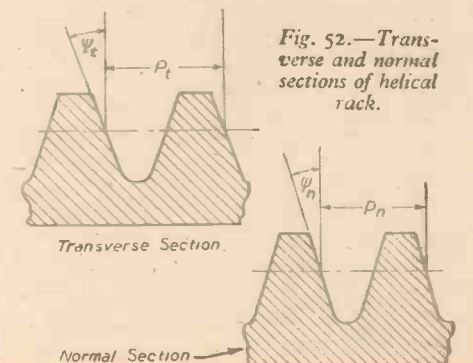

Fig. 52.—Transverse and normal sections of helical rack.



The angle between the helix and the line on the cylinder parallel to the axis is the "spiral angle" denoted by  $\sigma$ . (It is also called the "helix angle.") The angle between the helix and a line on the cylinder perpendicular to its axis is the "lead angle" denoted by  $\lambda$ . (It is sometimes called the "worm angle.") It will be noted that these two angles add up to 90 deg., i.e.,  $\sigma + \lambda = 90$  deg.

Now if the diameter of the cylinder is  $d$ , the circumference (AD in Fig. 49 is  $\pi d$ . Hence:—

$$\tan \delta = \frac{BC}{AB} = \frac{AD}{L} = \frac{\pi d}{L}$$

where  $L$  is the lead.

Consideration of this kind may be made to any cylinder between the tip-cylinder and the root-cylinder of the gear and, therefore  $d$  is not fixed to one value. Consequently, the value of the spiral angle depends on the diameter of the cylinder on which the spiral lies. A helical gear has, therefore, any number of spiral angles between certain limits.

An important point to note, however, is that the lead is the same whatever cylinder may be considered. If a spiral angle is mentioned without qualification it must be taken to refer to the pitch cylinder of generation.

**Pitches of Helical Gears**

Fig. 50 represents a portion of the developed pitch cylinder of a helical gear; it corresponds to the top left-hand corner of Fig. 49. The straight line AE represents the developed spiral of the intersection of one tooth with the pitch cylinder and FG that of the next tooth. The distance AF measured round the pitch circle in a plane perpendicular to the centre line of the gear is what would be called the "circular pitch" of a spur gear. Here, for purposes of distinction, it is called the "transverse circular pitch," or more usually "transverse pitch" of the helical gear. It is denoted by  $p_t$ .

The shortest distance between the tooth spirals is measured perpendicular to them. It is called the "normal pitch" and is denoted by  $p_n$ .

The distance between adjacent spirals measured parallel to the axis of the gear is called the "axial pitch," and is denoted by  $p_a$ .

The relations between the pitches are expressed by:—

$$\begin{aligned} p_t &= p_n \sec \sigma & p_a &= p_n \operatorname{cosec} \sigma \\ p_n &= p_t \cos \sigma & p_a &= p_t \cot \sigma \\ p_a &= p_a \sin \sigma & p_t &= p_a \tan \sigma \end{aligned}$$

**The Helical Rack**

An involute spur gear will mesh with a rack having straight-sided teeth. Sections of

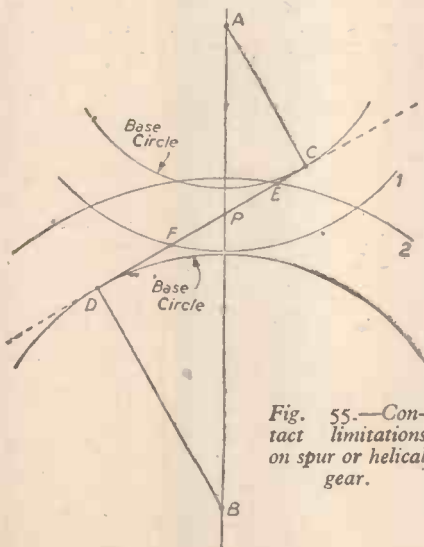

Fig. 55.—Contact limitations on spur or helical gear.

an involute helical gear on planes perpendicular to its axis are identical involute spur gears, angularly displaced, which would mesh with identical parallel racks laterally displaced. The collection of all such racks forms a "helical" or "spiral" rack (see Fig. 51).

The teeth of this rack do not run perpendicular to the end face shown in Fig. 51, but they are inclined to the perpendicular at an angle equal to the spiral angle of the gear at the pitch cylinder of engagement with the rack. The section of the rack on its end plane (perpendicular to the axis of the gear) is called the "transverse section." The section on a plane perpendicular to the teeth is called the "normal section."

The pitch of the rack on the normal section is its "normal pitch" ( $p_n$ ) and that on its end section is the transverse pitch ( $p_t$ ). As in the case of the gear itself

$$p_t = p_n \sec \sigma$$

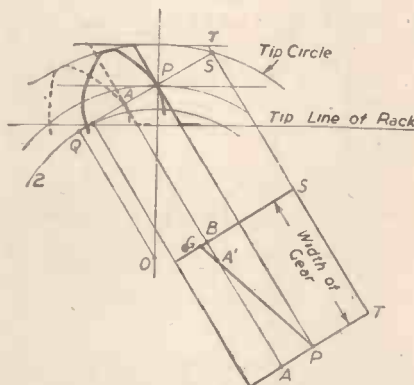

Fig. 53.—Contact lines on helical gear teeth.

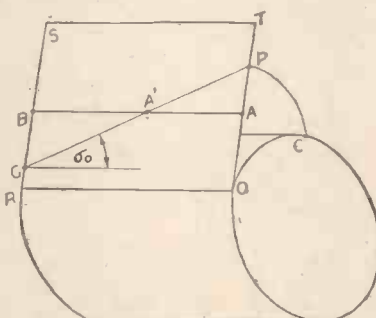

Fig. 54.—Plane of action of helical gear.

Fig. 52 shows the transverse section and the normal section of the rack, the teeth being straight-sided in each case. The tooth depth is the same in both cases, but the normal pitch and normal tooth thickness are less than the corresponding dimensions on the transverse section. Consequently the pressure angles differ, the normal pressure angle ( $\varphi_n$ ) being less than the transverse pressure angle  $\varphi_t$ . The relation between them is

$$\tan \varphi_t = \tan \varphi_n \sec \sigma$$

This relation also applies between the normal pressure angle, transverse pressure angle and spiral angle on any selected cylinder in the gear.

**Normal Section of Helical Gear Tooth**

The transverse section of a helical involute gear meshes with the straight-sided rack section of a helical rack. The normal section of such a rack also has straight-sided teeth, and it is therefore tempting to think of the normal section of a helical involute gear tooth as being of involute form. This is not the case, although it is true that the normal pressure angle at the pitch cylinder is equal to the normal pressure angle of the mating helical rack.

**Contact Between Involute Helical Gear and Rack**

Fig. 53 represents the end view of an involute helical gear meshing with a rack. The full lines show the tooth forms in the nearer end plane of the gear. The line PQ is the line of pressure (path of contact) and the circle 2 is the base circle. It is important to note that the path of contact and base circle in any other plane perpendicular to the axis of the gear appear identical in the view with those shown in the end plane.

Now, if consideration be given to any other plane perpendicular to the axis of the gear, the section of the rack tooth is a straight line (shown dotted) parallel to the original profile passing through P. As the line of pressure for the second plane is still the line PQ, the point of contact of rack profile and gear tooth profile in that plane is the point of intersection (A) of the dotted profile with PQ.

The straight lines similar to PQ in different planes perpendicular to the axis together form a tangent plane to the base cylinder, as shown in the perspective view Fig. 54. Thus the contact point which appears at A in the end view of the gear is actually at some point A' on the line AB parallel to the axis.

Thus all points of contact at every instant lie in the tangent plane QRST. At any one instant the points of contact also lie on the flank of the rack tooth in the position it occupies at that instant. Since the end view of a rack shows a straight profile, the flank itself is a plane. The intersection of this plane with the tangent plane is a straight line, and since the points of contact lie in both planes, they lie in a straight line.

If the tangent plane in Fig. 54 be considered as a flexible sheet, it can be wrapped on to the cylinder so that P moves down the involute profile to C. When this has been done the originally straight line PG is wrapped on to the base cylinder, and in that position it represents the points of origin of the involute profiles on all planes perpendicular to the axis. The angle it makes with a line parallel to the axis is then the base spiral angle ( $\sigma_0$ ) and this is, therefore, the angle between the straight line PG and QR.

As the gear rotates and the rack moves in step with it, the line of contact PG moves along the fixed tangent plane QRST. The line PG moves parallel to itself because in every position its inclination to QR is the base spiral angle. In every position it is the line of intersection of gear tooth profile and tangent plane.

**Contact Between Involute Helical Gears with Parallel Shafts**

If two involute helical gears are set with axes parallel, there is a plane tangent to both base cylinders (actually there are two, one corresponding to contact between each mating pair of sets of flanks). If the gears have equal base spiral angles (and the hands of helix are opposite) the tooth profiles intersect the tangent plane in parallel straight lines.

(To be continued)

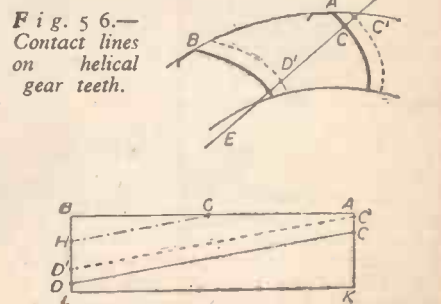

Fig. 56.—Contact lines on helical gear teeth.

# The WORLD of MODELS



R.S.A. Lectures : Bonn Model Railway Club : New Model Railway Equipment

**T**HIS month I am pleased to be able to present to readers an unusual model of an ancient ship: a model of H.M.S. *Cornwall*, an early nineteenth-century warship, built in 1815 at Bombay, where she was launched as H.M.S. *Wellesley*. The date of her change of name is not certain. The ship had features not usually found in other ships of the period, such as two ship's boats slung amidships over a well deck, the three other boats being slung aft. The *Cornwall* finished her career as a training ship on the Thames, and was unfortunately sunk and became a complete wreck during bombing in 1941.

Last year the Indian authorities wished to have a model of the *Cornwall* built from the original ship's timbers, which had been salvaged and were stored in Chatham Dockyard. Bassett-Lowke, Ltd., of Northampton, were entrusted by the High Commissioner for India, through the Admiralty, to obtain the necessary information for making such a model to a scale of 3/16in. to 1ft.

Thus, in due course, the model (Fig. 1) was constructed from selected teak, cut from the old ship's timbers, some of them measuring as much as 14in. square. Only a small quantity of suitable wood could be obtained from these baulks of timber, however, as to all appearances it would seem that naval ratings of those days passed their spare time by driving anything from a tintack to a 6in. spike into the woodwork of their ship! Masts for the model were made from part of the heel of the bowsprit, which was of pinewood

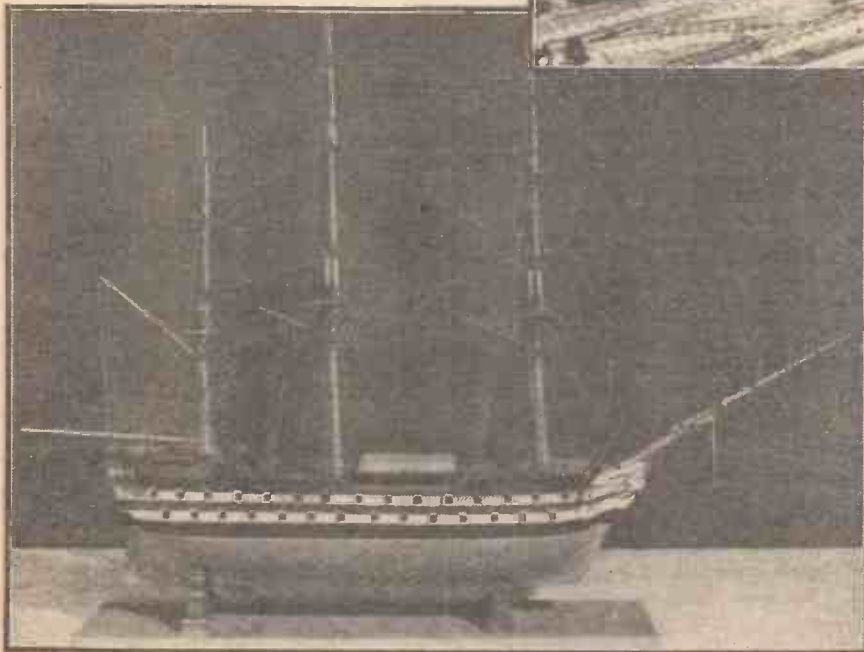

Fig. 1.—A broadside view of the special model made of H.M.S. "Cornwall," a ship built in India in 1815. The model was mainly built from the timbers of the original ship. Scale: 3/16in. to 1ft.

By "MOTILUS"

and 30in. in diameter. The model had a copper finish on the base of the hull, the woodwork being painted black and white above the waterline.

The *Cornwall* was rated as a 74-gun ship. This does not necessarily mean that only 74 guns were carried. The most accurate information available indicated that the establishment of 1770, which does not

appear to have been changed, specified 28 32-pounders, 28 18-pounders and 18 9-pounders. Quite often these ships substituted carronades for guns on the upper deck, in which case the carronades rated lower than guns so that the actual number of pieces would be more than 74. The model *Cornwall* was fitted out in this manner.

The principal measurements of the model are: overall length, 31½in.; beam, 8in.; from top of mainmast to keel, 39in.; and

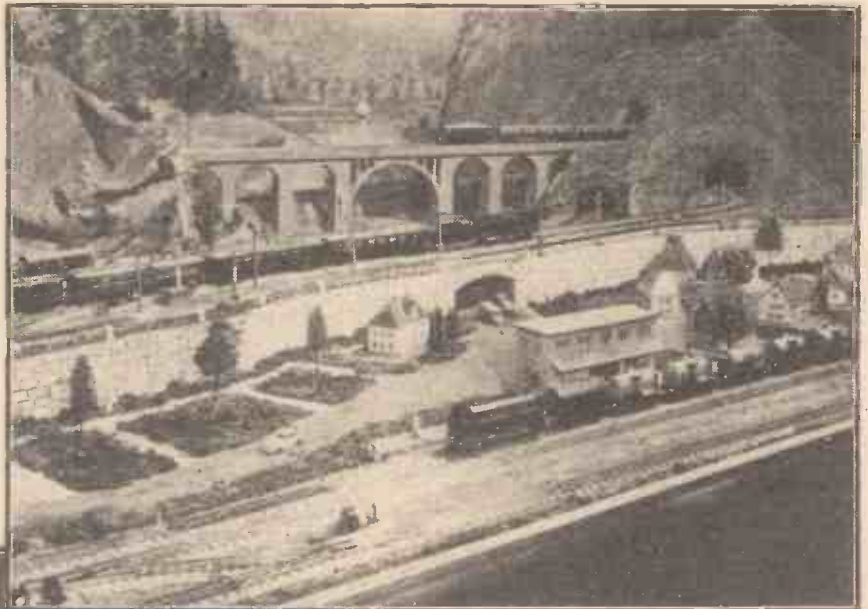

Fig. 2.—A portion of the 00 gauge Märklin model railway of the German club at Bonn. This shows the excellent distant scenery constructed by members of the club.

from figurehead to stern, 35in. The identity of the figurehead is unfortunately not known, so is open to speculation.

After a detailed inspection of this model by an Admiralty Overseer, it was carefully packed for shipment to India, the *Cornwall*'s country of origin.

## R.S.A. Lectures

The Royal Society of Arts holds annually two Juvenile Lectures for young relatives and friends of their members. These usually take place during the schools Christmas vacation and are known as the Dr. Mann Juvenile Lectures. In 1948/49 the lecture subjects were "Puppets" and "Model Railways." Last Christmas the first lecture was entitled "Ships from the Days of Noah," and was given by Lt.-Cmdr. G. B. P. Naish, Assistant Director of the National Maritime Museum at Greenwich. The lecture room was filled with enthusiastic boys and girls who were keen listeners.

Lt.-Cmdr. Naish illustrated his talk with lantern slides and also with a number of



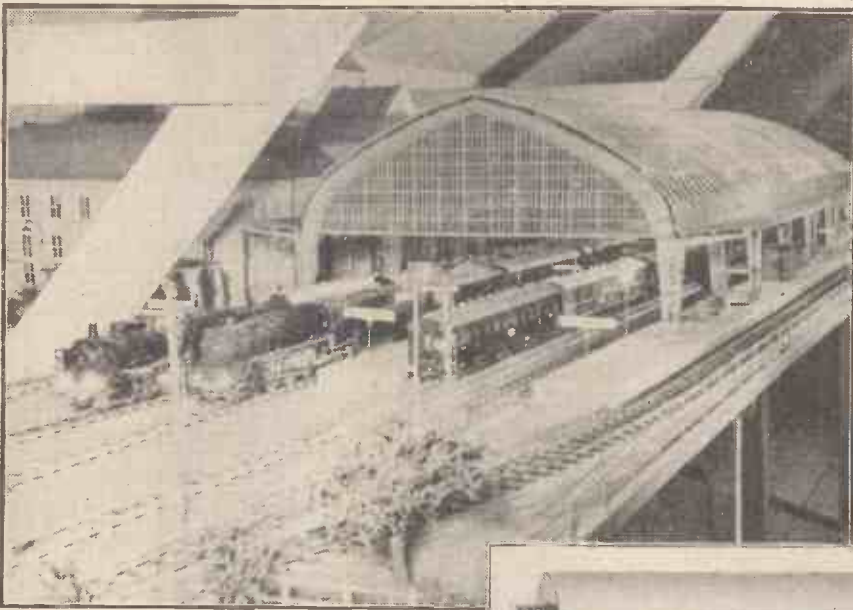

Fig. 3.—The central station on the gauge 1 model railway built over a period of 15 years by Mr. Wieland, of Frankfurt-on-Main, with the help of enthusiastic friends.

scale model ships, which he used for reference to form and detail. Among them was a chronological series of small waterline model ships, some 40 in number, and all to a scale of 1 in. to 100 ft. These models commenced with Noah's Ark and finished with the huge modern liner, R.M.S. *Queen Elizabeth*.

Two most effective models for the purpose of illustrating this talk were made of stiff paper, unpainted. They represented an Egyptian nobleman's Nile boat of about 1500 B.C. and a Greek bireme, or galley, a Mediterranean warship of about 500 B.C. Finished just in time for the occasion was a lovely model of Drake's *Golden Hind*, made by the lieutenant-commander's father: a fully detailed model this, which naturally had a great appeal for the young audience.

**Bonn Model Railway Club**

News of model-making in Germany continues to reach me fairly frequently. I am amazed at the progress made by model clubs and individual groups in that country, despite depression following the late war. From the city of Bonn, on the Rhine, I have news of the work of the model railway club there. They have a 00 gauge system, mostly using locomotives and rolling stock of the well-known German firm of Maerklin of Goppingen, but also with a few Trix productions. All the layout and scenic effects, which are excellent, have been built by members of the club. Fairly recently they have commenced on the more difficult task of building their own locomotives and rolling stock, with a layout for a completely new system. The illustration, Fig. 2, will give some idea of the realism of the original Maerklin layout to which they have added such a fine scenic background and surround, a triumph seldom attained successfully in a 00 gauge display.

**Gauge 1 Model Railway**

Emil, Frh. von Bronsfeld, who sent me the foregoing news, has also sent me some interesting particulars of a gauge 1 model railway that has been built up over a period of fifteen years by Mr. Wieland and his friends in Frankfurt-on-Main. Mr. Bronsfeld describes it as being "the best and finest comprehensive model railway layout he ever saw." Being in gauge 1 it must cover a large area and the stock includes representative locomotives of the German State Railways, as well as a

variety of different types of passenger and goods rolling stock. Mr. Wieland himself is a butcher and none of the friends who helped him with this railway are technicians or engineers. The majority of them are tradesmen such as butchers, barbers and merchants, with only amateur knowledge of

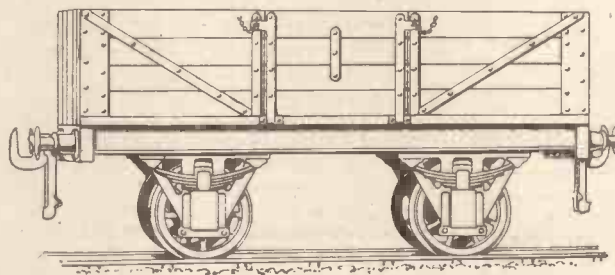

Fig. 5.—A line drawing of a new gauge 0, all-metal goods vehicle, the detail shown in the scale drawing being lithographed on the side of the vehicle.

engineering or mechanics. The only photograph available at present of this gauge 1 model railway is one showing the large, terminal station. (Fig. 3.)

In Frankfurt-on-Main 00 gauge enthusiasts can join the "Maerklin Model Railway

Friends," under the able guidance of Mr. Willi Hunold (Paul-Ehrlich-Strasse, 8), their president. This club welcomes correspondence from other 00 gauge fans in all countries. I hope, in a later issue, to be able to give more particulars of the activities of this club and some photographs of what appears to be an excellent 00 gauge layout.

**New Model Railway Equipment**

Among new model railway equipment recently introduced for gauge 0 are British Railways passenger coaches. Three types are available, 1st and 3rd class corridor coaches (Fig. 4), and a 3rd composite brake. They are finished in the new British Railways colours of lake and cream. An entirely new kind of compensated bogie is fitted to them all and they are complete with corridor connections. These are now the finest lower-priced scale gauge 0 passenger coaches introduced since the war. In the new colours they should make an attractive feature for any gauge 0 railway layout.

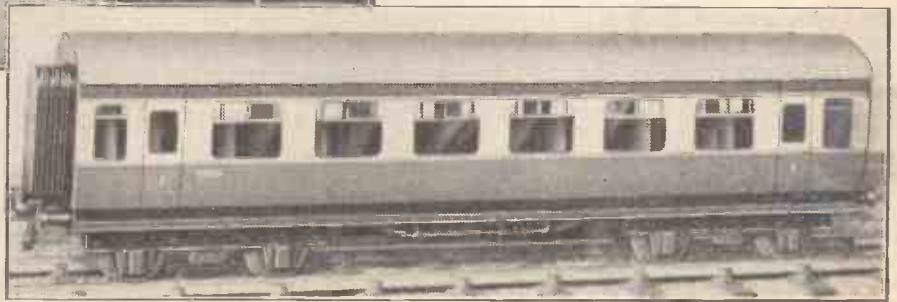

Fig. 4.—A photograph of one of the new gauge 0 British Railways passenger coaches—a 1st class corridor coach, fitted with compensated bogie and corridor connections.

In addition to passenger coaches, there is a new series of goods rolling stock, also for gauge 0, in lithographed steel tinsplate. They offer the best value in well-made, substantially constructed goods wagons. They represent three London Midland Region types: brake van, a covered van and a standard open

wagon (Fig. 5). They are all fitted with correct axle boxes, anti-friction metal wheels and standard couplings to prevent interlocking. They will certainly supply the present demand for attractive goods vehicles for gauge 0 model railway owners.

**Newnes' Engineer's Reference Book**

Edited by F. J. Camm

THE third edition of this important work is now ready. It contains nearly 300 pages of new matter in addition to complete revision. The new sections cover Fan Engineering; Centreless Grinding; Induction Heating; Plain Bearings; Belt Transmission; Investment Moulding; Lapping and Honing; Hobbing; Surface Finishing; Properties of Plastics; Air Compressors; Compressed Air Data; Corrosion Treatment; Mirror Finishing; Polishing and Buffing; Gas Welding; Weights; Additional Screw Thread Tables; Weights of Materials; Use of Rubber in Presses; Shaft-

ing; Pipe Flanges; Lighting of Buildings; Factors of Numbers up to 9999; Compound and Angular Indexing; Double Depths of Threads; Form Tool Grinding.

The book comprises over 1600 pages, fully cross-referenced, and hundreds of diagrams, tables and formulae of great value to mechanical, civil, structural, automobile, and aeronautical engineers, designers, draughtsmen, works managers, gauge and toolmakers, fitters and turners, foundryworkers, die-casters, milling, planing, grinding and shaping operatives, wire workers, gear-cutters, die-sinkers, heating and ventilating engineers, costing and production engineers, electroplaters, welders, time and motion study engineers.

It costs 45s., or 46s. by post.





### Long-distance Telephones

**SIR**,—With reference to a letter in the January issue by Mr. Williams on Long Distance Telephones, I agree with him on the point that the Marquis was very much misinformed on the subject.

Actually, the first successful demonstration of two-voice frequency signalling (2VF) took place at the British Post Office Research Station in 1932. The system was put into use in 1939, and since then has become the common system of trunk signalling in England and Ireland.

As far back as 1932 a 12-channel voice frequency telegraph system was put into operation between London and Dundee, and like the trunk system, it is also a very common system of communication.

In his article, the Marquis also made reference to the fact that the operator did not use a dial, but a ten-button key, and it would appear that the Marquis considered this something new. As a matter of interest, keysending, as it is called, was demonstrated at the Telephone Exhibition held at the Imperial Institute, South Kensington, in January, 1932. There is also an instrument available called the Autodial, which does away with dials and keys. All that is necessary is to move a pointer on the instrument to the name of the person you wish to dial and then press a lever and the required number is automatically dialled.

It is hoped that this will show that the British engineers are not as far behind the times as the Marquis would have one believe.—C. J. DONOGHUE (Tralee, Co. Kerry.)

### Screwdriver Theory

**SIR**,—Regarding the screwdriver theory I am in complete agreement with your correspondent (Mr. Dew) regarding the "crank-action" as indicated by him (December, 1949). Further, his statement, "as much effort is frequently used for this purpose (i.e. keeping the tip of the blade in the screw-slot) as for actual screwing" is also true; surely then the logical analogy is to assume that the screwdriver is effectively the shaft, and the wrist and forearm the crank-pin!—C. CHAFFEY (Bristol).

### Electric Gas Lighter

**SIR**,—In the September issue of PRACTICAL MECHANICS there is an article on an electrical gas lighter. It is rather a formidable arrangement using a spark coil, etc. During the war years I made a lighter on this principle, but of much simpler construction, and the following details may be of interest to other readers. The components required are: One output transformer of radio set (6s.), one ignition pencil (1s.). Strip the secondary winding (low ohms) and replace by one to give about 20 volts output when primary is on 220 volts A.C. Primary turns 3,000 approx. (*in situ*), new secondary winding 300 turns approx. (wind on). When the gauze end is brushed against the cooker jet a spark is made which ignites gas. The cooker burner must be in contact with the gas nozzle. One end of the 20 volt winding is earthed to cooker frame and the other is fed through a hollow former to a gauze brush. This former is of wood or fibre. The trans-

former is permanently across the 220 volts supply and consumes nothing, due to the poor power factor. When using to light the cooker the pulse is so rapid that the recording of the meter is negligible. I have had this lighter

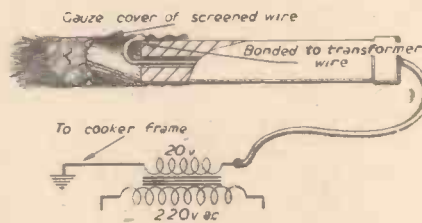

Electric gas-lighter details (P. V. Buckley)

in use since 1941, and it has cost nothing more than a new piece of gauze once a year.—P. V. BUCKLEY (Cork).

### Tandem Air Compressor

**SIR**,—I have read with great interest the letter from A. Webster, of New Malden, giving details of his compressor. Would it be at all possible for Mr. Webster to supply further details of this compressor, especially in regard to the air receiver, safety valves, and oil pump?—A. WASSALL (Birmingham).

**SIR**,—The points Mr. Wassall would like explained concerning my compressor unit are given below:—

1.—There is only one oil pump, connected to the base of both compressors, which also are joined together to allow the oil to remain level in each compressor.

2.—The air connections are clearly shown in the diagram in the December issue. The two compressors are joined together by a tee-piece which fixes on the side of the tank.

3.—The Perspex covers were fitted to observe the oil level, as without these it is hard to determine the oil level. Some kind of plate must be fitted or the oil will splash out with the suction, and compression of the piston. Perspex is as easy as any other material to work and also serves a double purpose. The compressors are not supplied with plates as they were originally screwed to the body of some other part of an aircraft.

4.—It requires  $\frac{1}{4}$  h.p. to drive this machine, and I do not think it can be done with less. I find my motor which is a Hoover  $\frac{1}{4}$  h.p. after a one hour run is warm—about 105 degrees. When the safety valve was screwed down and the pressure reaches about 50lb. it would not turn it.

5.—The pressure is raised to 30lb. and is controlled by the safety valve which can be adjusted to requirement. When in continual use on the spray it remains around 25-30lb.; if left, the safety valve or blow-off takes care of the rest.

I should like to point out this compressor only supplies 2 cu. feet a minute at 30lb. and

a spray gun over this capacity may not be so satisfactory. The B.E.N.S. model, as I pointed out before, works quite satisfactorily.—A. WEBSTER (New Malden).

### Contact Lenses

**SIR**,—With reference to the article on contact lenses, by C. Pallonza (Hull), I think he must be an exceptional person with regard to wearing contact lenses. From what I have read in various papers, the writers and wearers give a wearing period of three or four hours at a time, and during night-time they suffer from a form of corona which they say cannot be dispersed, except by removing the lenses from the eyes.

The short time of wearing was one main reason for not purchasing a pair myself some years ago, when they were 40 guineas per pair, and it meant several visits to London. What the prices are now I do not know, but I understand they are experimenting with plastic outer lenses with the focal lenses in the centre, which should reduce the cost. I have wondered why it is not possible to fix the lens centre to the lens of the human eye without the cap to affix under the eyelid. It would allow the rest of the eye to breathe, which I think is necessary.—P. WATKINS (Wolverhampton).

### Portable Air Compressor

**SIR**,—I have taken great interest in reading the article by C. W. Dean, on "A Portable Air Compressor," but I am sorry to state that the air compression factors given are not met with in practice. He pointed out laws according to Boyle,  $PV=C$ , but in practice it will be found that the compression of the air in the cylinder is polytropic, that is, compression is governed by a law of the type  $PV^n=C$  with the value of  $n$  intermediate between isothermal and adiabatic changes. It is apparent from diagrams that isothermal compression is the ideal to be aimed at; this, however, is not obtained in practice even with the best available methods of cooling. Calculation for a single stage is given by

$$\text{h.p.} = \frac{n}{n-1} P_1 V_1 \left\{ \left( \frac{P_2}{P_1} \right)^{\frac{n-1}{n}} - 1 \right\} / 33,000$$

Mr. Dean also mentioned "pushing air into the receiver against a mean effective pressure of 75lb. per square inch"; but the M.E.P. is neither a gauge nor an absolute pressure; it is the pressure calculated on engines that if acting on the piston throughout the whole stroke, will perform the same amount of work, i.e., it is a net pressure difference after all positive and negative work done has been totalled up. This 75lb. per square inch occurs only for a fraction of the stroke—in fact, it is a discharge pressure. Also when the speed of the compressor was increased and the h.p. found on his formula the error in calculations is still increased, because the faster you run a compressor, the faster you approach the adiabatic line, i.e.  $PV^n=C$ ; the value of  $n$  gets higher. Previous tests have shown that the lowest value of  $n$  reached with a great quantity of cool water supply and a slow running compressor is about 1.2.—L. SACCO (Malta).

**SIR**,—With reference to Mr. Sacco's letter, the reasoning and information he gives are very sound, and it would be very necessary to apply the formula given before attempting the design of an entirely new compressor plant, and which would normally be for more continuous running. I consulted my copy of Duncan's and used the same formula at first as Mr. Sacco gives. Theory and practice did not work in the design of this small plant which was chiefly to take advantage of the low-priced compressors, which are still normally obtainable from the Air Ministry surplus supply stores,



but it is also more difficult to obtain from the surplus stores.

The whole unit was an adaptation, and a compromise was necessary to get the motor to drive the compressor, and careful attention must be given to the heat rise above ambient temperature, noting that these compressors are air-cooled.

Mr. Sacco's long explanation of M.E.P. would not have been necessary but for an error, which I regret, occurring in the copying of my final notes. It should read: "against an effective pressure."

By the way the compressors are Heywood type and B.T.H. The Heywood, being larger, gives better results and needs  $\frac{1}{2}$  h.p. motor.—CHARLES W. DEAN (Leeds).

**Water-wheel Plant**

SIR, It is disturbing to find on page 142 of the January issue of PRACTICAL MECHANICS that it describes as "quite satisfactory" a querist's projected plan for a water-wheel plant.

A few seconds consideration will show the scheme to be unsound, unless a larger flow of water is available.

For the sake of simplicity, assume the overall efficiency of the plant to be 100 per cent. This means there will be no losses, and all of the potential energy of the water in the tank will be put to useful work.

Your querist wants to use a 12-volt, 10 amp. dynamo. It is reasonable to assume he wants his 120 watts.

Converting 120 watts into ft. lb./sec. then, the plant is required to have an output of

$$120 \times \frac{550\text{ft.}}{746} \text{ lb./sec.}$$

$$= 88.5 \text{ ft. lb./sec.}$$

As 100 per cent. overall efficiency is assumed,

the potential energy of the water in the tanks must change at the rate of 88.5 ft. lb./sec.

So far, so good.

Now the flow of water is restricted to 6 gallons per minute. This is 60lb. of water per minute or 1lb of water per second. The maximum head of water is 20ft. approx. Hence, the maximum work which water flowing from the tank at the rate of 6 gallons per minute can do is  $20 \times 1$  ft. lb./sec. This 20 ft. lb. per second is hardly one quarter of that required for 120 watts output at 100 per cent. efficiency.

Therefore, even were the overall efficiency 100 per cent., the plant would not work, unless the querist would be satisfied with just a few watts output.

As the plant is a small one, I think it would be an achievement to get even 50 per cent. overall efficiency in it. This would call for an input of 177 ft. lb./sec. of energy to get the 120 watts output.

Hence, assuming a head of 20ft. again, and for an input to the wheel of 177 ft. lb./sec., then  $\frac{177}{20}$  lb. of water would have to flow per second.

Converting this to gallons per minute, we find that  $\frac{177}{20} \times \frac{1}{10} \times 60$  gallons are required per minute, i.e., 53.1 gallons-minute, which is vastly different from the 6 gallons available.

It is true that if your querist only wanted to operate the plant in short bursts, he could empty the tank in a few minutes at a rate greater than 6 gallons per minute, then wait until it filled up again, and so on. Then he would get more power out of the system during its operating periods. I think, however, that this is an unlikely method of operation.

Presumably a cock of some sort will be necessary at the water-wheel to regulate the flow of water of the system, if such a system is put into use.

A point worth mentioning is that a turbine is likely to be twice as efficient from a hydraulic point of view as a water-wheel, if the latter has only flat blades on it sticking radially out.

The last paragraph of the reply to the query on the water wheel, recommending correspondence with specialist firms, is indeed quite sound.—H. V. HOOLEY (Bangor).

[The querist wanted to drive a small dynamo by water power and did not specify the required dynamo output.

If querist required a minimum of 120 watts dynamo output, Mr. Hooley's argument is reasonable, provided that a continuous minimum of 120-watt output is required. But he only assumes this detail, and in dealing with these queries one assumes as little as possible.

One cannot deal with these queries unless a querist gives all relevant details and all details were not supplied in this instance. In any case, the water-wheel-dynamo arrangement would work, although as pointed out, it would not give much output. Since we have not heard anything from the querist, we may presume that he has not found the answer quite as unsatisfactory as Mr. Hooley has done.

Again, he stresses the superiority of a small turbine. Has not this very point been stressed in the answer to the query?

So far as we saw it on paper, the querist's plan was satisfactory, and it was sound so long as only a restricted electrical output was desired.—Ed.]



# Club Notes

Club secretaries are sked to note that the latest date for receiving copy is the first of the month for the following month's issue.

**Kodak Society of Experimental Engineers and Craftsmen**

WE are pleased to announce that we are holding our next open exhibition on Saturday, April 1st, and Sunday, April 2nd. Further particulars can be had from: MR. G. G. CORDER, Hon. Exhibition Organiser, Kodak Hall, Wealdstone, Middlesex.

**Harrow and Wembley Society of Model Engineers**

PROGRAMME of events for March and April: Wednesday, March 1st, committee meeting; Wednesday, March 8th, jumble sale; Wednesday, March 15th, no meeting; Wednesday, March 22nd, marine night—talk on a marine subject; Wednesday, March 29th, no meeting; Saturday, April 1st, Kodak exhibition; Sunday, April 2nd, Kodak

exhibition. The marine section hold their section meeting every other Thursday at 6, Birchmead Avenue, Pinner, to which all interested club members are welcome—J. H. SUMMERS, Hon. Secretary.

**Bolton and District Society of Model Engineers**

AT the annual general meeting of the above society on January 10th, the following officers were elected: Mr. J. Clayton, chairman; Mr. C. E. Picken, vice-chairman; Mr. P. Smith, treasurer; Mr. N. Brooks, hon. secretary.

For the monthly meeting on March 14th, Mr. R. A. Crispin is to lecture on "Craftsmanship in Bygone Years." The club workshop is now nearing completion, and Thursday nights are working nights. For the

benefit of model-car fans the opening date at Leverhulme Park track will be Sunday, May 21st, when all enthusiasts will be assured of a hearty welcome. All model engineers in the district are cordially invited to attend any meeting.—Hon. Secretary, NORMAN BROOKS, 12, Cleveleys Avenue, Bolton, Lancs.

**Hobbies Exhibition at Cheltenham**

A HOBBIES exhibition, sponsored by the Cheltenham Corporation, with the assistance of local societies, was held at the Rotunda, Cheltenham, from December 21st to January 7th. There was a unique and varied display of interesting hobbies, handicraft work, and scale models.

In addition to the wireless stand, which was arranged by the Cheltenham Amateur Radio Society, there were many other varied exhibits which not only thrilled the young visitors but adults as well.

Among the societies taking part were: Cheltenham Art Club, Cheltenham Cage Bird Society, Cheltenham Philatelic Society, Cheltenham Model Aero Club, Cheltenham School of Art, The Roal Puppets, Cheltenham Society of Model Engineers, St. Mark's Community Association, Gloucestershire Beekeepers' Association, Workers Education Association (Cheltenham branch), and the Cheltenham Camera Club.

**Birmingham Cine Arts Society**

A NEW club with the above name has recently been formed in Birmingham. The aim of the organisers is to serve all interested in amateur cine work. There are two sections, one being for all interested in experimental apparatus and constructional work, and the other intended for those members interested in any type of sound recording. Further information can be obtained from F. A. INSHAW, 8, Corrie Craft, Sheldon, Birmingham 26.



# Trade Notes

## Mitre and Shaving Machine

A NEW addition to the "Mitor" range of tools for woodworkers is the Mitor No. 301 Mitre and Shaving Machine, which is designed for fine shaving, and will produce a perfect mitre from any timber up to 3in. square. It cuts at all angles from 45° to 90° in both directions, and a positive location is provided at both these angles. There are clamping screws for all angle settings. The twin cutters are made from Tungsten steel, manufactured by Samuel Osborn and

The new "Mitor" No. 301 Mitre and Shaving Machine.

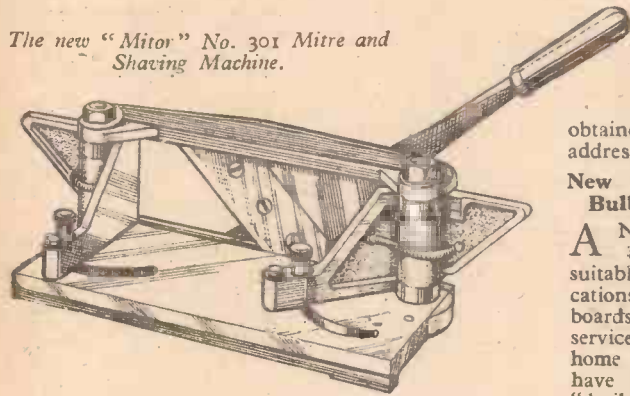

Co., Ltd., of Sheffield, and are supplied ground to a cutting edge ready for use. Easy operation of the machine is ensured by the double-gear action. Further information can be obtained from Mitor Limited, Vaughan Road, Harpenden, Herts.

## The Home Constructors' Handbook

RADING LABORATORIES, 70, Lord Avenue, Ilford, Essex, the large stockists of standard new radio equipment, have

just issued this very useful and informative handbook which is intended to assist the beginner, as well as the more advanced constructor, in building an efficient modern radio receiver. Circuit diagrams are given of a Model 30 feeder unit; Model 40 feeder unit; 5-valve A.C. set; 5-valve A.C./D.C. set; 6-valve A.C. set; 6-valve A.C./D.C. set; 5-watt amplifier and power pack; and a 10-watt quality amplifier. Particulars of various coil packs and matched tuning units, which the firm supply, are given together with servicing and construction hints. Also included is a price list of various components.

Copies of this 32-page handbook can be obtained for 1s., post free, from the address given.

## New 300-watt Weatherproof Bulb

A NEW 300-watt weatherproof incandescent reflector lamp suitable for outdoor lighting applications such as signs and billboards, general floodlighting of service stations and factory yards, home sports areas and gardens, have been added to the line of "built-in" reflector lamps manu-

factured by Sylvania Electric Products, Inc., of America.

## For Outdoor Use

Recommended especially for outdoor use, the new R-40 (designating a reflector bulb 5in. diameter) lamp is enclosed in a heat-resistant glass bulb which absorbs the thermal shocks caused by rain, snow, insects, oil and other elements more efficiently than standard reflector bulbs. According to

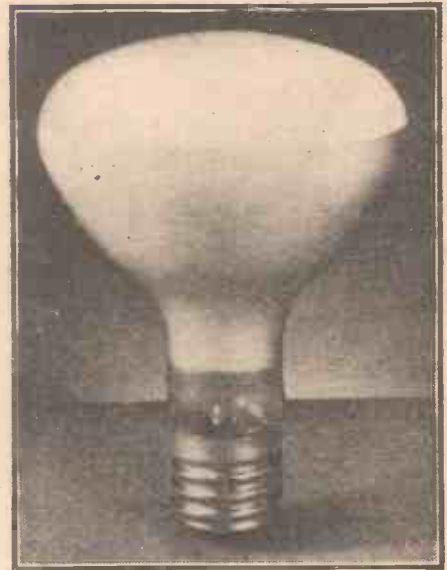

The 300-watt weatherproof reflector bulb.

Sylvania engineers, there is no restriction on the burning position of the lamp, which has a rated average life of 1,000 hours, although its resistance to thermal shock is said to be somewhat better when operated in a base-up position.

## Screw Base

Operating on 115, 120 and 125 volts, this Sylvania reflector floodlight has a mogul screw base. With a number of lampholders made specially for the mogul base reflector type lamp now available, the new Sylvania bulbs can be mounted either singly or in clusters, allowing a wide range of light output from one grouping to meet virtually every conceivable lighting requirement.

# Items of Interest

## New Pocket Book

WE have recently published from the offices of this journal a comprehensive vest pocket book entitled, "Newnes' Metric and Decimal Tables," which costs 3s. 6d. or 3s. 9d. by post.

The following are the contents: The Metric System Explained; Standard Measures of Capacity, Length and Weight; Centimetre-gramme-second System; Foot-pound System; Metric Horse-power; Rough Approximations to Metric Units; Metric Measures of Length, Weight, Area and Capacity; Conversion Factors; British and Metric Equivalents, etc.; Feet and Inches into Metres; Millimetres into Inches; Inches into Millimetres; Metres into Feet; Decimals of an Inch into Fractions and Millimetres; Areas and Volumes: British to Metric; Areas and Volumes: Metric to British; Pounds into Kilogrammes; Kilogrammes into Pounds; Decimals of a Ton into Cwt., Qr., Lb.; Conversion Tables; Metric Conversion of Fractions; Standard (Density) Height; Temperature Conversion Table; Values of Single Degrees; Conversion Diagram, Centigrade and Fahrenheit Temperature Scales; Comparison of Thermometers; Table for Converting Minutes into Decimals of a Degree; Inches and 32nds to Millimetres; Inches and 16ths to Millimetres; Lb. per Square Inch to Kilogrammes per Square Centimetre; Conversion Tables: Kilogrammes to Pounds; Cubic Centimetre Capacity of Engines;

Decimal Equivalents of Standard Drill Sizes; Watchmakers' Table of Equivalents and Measurement of Lengths; Miles per Hour to Kilometres per Hour; Speed Table in Feet per Second; Constants for Calculating Speeds; Speed Conversion Table; Stress Conversion Tables; International Standard Threads; Metric Screw Threads; French Standard Threads; International and French Standard Thread Gauges; German Metric Threads; Metric Thread (Trapezoidal); Tubing Formulae; Useful Load Equivalents; Wire Gauge Equivalents; and Decimal Coinage of the World; also index.

## The Bennett College 50 Years of Training by Post

THE Bennett College, Sheffield, the famous study-at-home organisation which has helped thousands of men and women to reach highly paid appointments in all fields of commerce, science and industry, recently celebrated its 50th anniversary.

Bennett College trained men are to be found holding important posts at home and abroad after studying under The Bennett College plan of personal tuition whereby the individual student receives training as thorough, and as detailed, as though the tutors were actually at his side.

The Bennett College has an enthusiastic, expert staff ever ready to help the ambitious man to get to the top of whatever profession he has chosen.

## New Norwegian Liner Oslofjord

THE maiden voyage of a new vessel is usually an event of note. The first transatlantic crossing of the 16,500-ton Norwegian American Line's *Oslofjord* is an international occasion of European co-operation at its best.

The *Oslofjord* has been built to continue the ferry service between Oslo and New York at a service speed of 20 knots. There is accommodation for 226 first-class and 350 tourist class passengers. The overall length is 577 ft.

This passenger liner takes the place of a previous vessel of the same name lost in the war.

Both the main propulsion and the auxiliary engines are diesels supplied by Machinefabrick Gebr. Storck & Co., of Hengelo, Holland, to whom the G.E.C. has supplied four 220v. D.C. generators of 2,100 kW. total capacity. These are 330 r.p.m. standard open-type drip-proof marine pattern for use in the 220v. earthed negative auxiliary system. Two of the generators are of 600 kW., and two are 450 kW. The outputs are remote controlled by thirty electrically operated circuit breakers of the well-known G.E.C. line contact type fitted with overload trips and time relays. These generators supply the ship's power requirements apart from propulsion.

**PRACTICAL ENGINEERING**  
4d. Every Friday



# GALPINS

ELECTRICAL STORES  
408, HIGH STREET, LEWISHAM,  
LONDON, S.E.13.

Telephone: Lee Green 0309. Near Lewisham Hospital.

TERMS: CASH WITH ORDER. N.O.C.O.D.

THURSDAY EARLY CLOSING

**METERS**, all ex-Govt., new boxed, all first-grade, moving coil, 2" scale, 0 to 20 V, 6/6 each; 0 to 40 V, 10/6 each; 0 to 10 A, 15/- each. 2 1/2" scale, 0 to 10 mA, 12/6 each; 350/0/350 mV, 12/6 each; another 3 reading type 0 to 50 and 150 V, 0 to 15 A, 17/6 each; another 0 to 4 A, THERMO coupled 2 1/2" scale, 10/- each; another calibrated 50 cycles, 0 to 20 V, 12/6 each.

**MAINS VARIABLE RESISTANCES**, slider type protected, 1,500 ohms carrying 0.45 A, 27/6 each; ditto, not protected, 14 ohms, 1 to 4 A, 15/- each; ditto, 0.4 ohms to carry 25 A, 12/6 each; ditto, 60 ohms to carry 1 1/2 A, 15/- each; ditto, 5.7 ohms to carry 8 1/2 A, 17/6 each.

**CHARGING SWITCHBOARDS**, 1,250 W, 36 V, d.c. Containing all 5 meters AIV and 5 variable resistances, slider type, also cut-outs and fuses, at 24 10s. each, carriage paid.

**MAINS TRANSFORMERS**, 200/250 V. Input in steps of 10 V, output 350/0/350 V, 300 mA, 4 V 8 A, 4 V 4 A, 6.3 V 6 A, 6.3 V tapped at 2 V 2 A (ELECTRONIC), 57/6 each; ditto, 425/0/425 V, 150 mA, 6.3 V 3 A, 6.3 V 3 A, 5 V 3 A (Williams Amplifier), 39/6 each.

**ELECTRIC LIGHT CHECK METERS**, useful for sub-letting, etc. All fully guaranteed electrically. All 200/250 V, 50 cycles, 1 phase, 2 1/2 A load, 15/-; 5 A, 18/6; 10 A, 21/-; 20 A, 25/-; 50 A, 35/- each; 100 A, 55/- each. (Please allow 2/- extra for carriage).

**PRE-PAYMENT II- SLOT METERS**, 200/250 V, 50 cycles, 1 phase. Electrically guaranteed, 2 1/2 A load, 27/6; 5 A load, 37/6 each.

**MAINS TRANSFORMERS**, 200/250 V. Input in steps of 10 V, output 500/350/0/350 500 V, 250 mA, 6.3 V, 6 A, 6.3 V tapped 2 V at 2 A, 5 V tapped at 4 V 4 A twice, 67/6 each; ditto, 450/0/450 V, 300 mA, 6.3 V, 8 A twice, 4 V 4 A, 5 V 4 A, 62/6 each.

**EX-R.A.F. ROTARY CONVERTERS**, 24 V, d.c. input 50 V, 50 cycle, 1 phase a.c. output, at 450 W. Condition as new, £3 15s. each, carriage 3/6. Mains Transformer, 230 V. Input 150/0/150 V, 150 mA, 6.3 V 8 A, 5 V 3 A, output (new, ex-Govt.), 15/- each.

**MAINS TRANSFORMERS**, 200/250 V. Input in steps of 10 V, output 500/0/500 V, 250 mA, 6.3 V 8 A, 6.3 V 8 A, 4 V 4 A, 5 V 4 A, 65/- each; ditto 350/0/350 V, 300 mA, 5 V 4 A, 6.3 V 8 A; 6.3 V 8 A, 4 V 4 A, 62/6 each.

**LARGE TYPE RECTIFIERS**. Output 50V 1 A, d.c. input 70/75 v.a.c. Half wave type, 8/6 each, post 1/6.

**EX-NAVAL CATHODE RAY INDICATOR POWER UNITS** (new). Sold for component parts only, consisting of approx. 150 resistances and condensers of various values. H.V. condensers, chokes, all mounted on solid brass chassis, weight 90 lb., to clear 25/- each.

**MAINS TRANSFORMERS**, 200/250 V. Input in steps of 10 V, output tapped 0, 6, 12, 18 and 24 V, at 10/12 A, 47/- each; ditto tapped 0, 6, 12 and 20 V at 4/5 A, 29/-; ditto tapped 0, 6, 12, 18, 24 V at 25/30 A, 68/6 each.

**EX-NAVAL TELEPHONE HANDSETS** BAKELITE PATTERN (self-energised), no battery required, complete with wall bracket (new), 15/- per pair, post 1/6.

**MAINS TRANSFORMERS**, all 200/250 V, 50 cycle, 1 phase input, output 700/0/700 V, 70 mA, 4 V 2 1/2 A, 12 V 1 A, 30/- each. Another 525/525 V, 150 mA, 6.3 V 5 A, 5 V 3 A, 37/- each. Another 2,350 V at 500 mA, 85/- each. Mains Smoothing Chokes, 10 Hy. 100 mA, 6/-; 150 mA, 8/6; 350 mA, 25/-; 5 Hy. 250 mA, 17/6.

**EX-R.A.F. MICROPHONE TESTERS** (new). These consist of a Ferranti 0 to 450 mA, 2 1/2" scale meter shunted to 1 mA incorporated Westinghouse rectifier, the whole encased in polished teak case, calibrated at present 0 to 10 V, 25/- each.

**MAINS TRANSFORMERS** 200/250 V. Input in steps of 10 V, output 350/0/350 V, 180 mA, 4 V 4 A, 5 V 3 A, 6.3 V 4 A, 37/6 each; another 500/0/500 V 150 mA, 4 V 4 A, 6.3 V 4 A, 5 V 3 A, 42/6 each; another 350/0/350 V 160 mA, 6.3 V 8 A, 5 V tapped 4 V 3 A, 39/6.

**PRE-PAYMENT II- SLOT ELECTRIC LIGHT CHECK METERS**, 200/250 V 50 Cys. 1 ph., guaranteed electrically, 10 A load, 42/6; 20 A load, 50/- each, carriage 2/6 each in quantities of 6 or more, 10 per cent. discount.

# CLYDESDALE

Bargains in Ex-Services Electronic Equipment

## INFRA-RED IMAGE CONVERTER CELL

Sniperscope. Snooperscope. The famous wartime "Cat's-eye" tube used in "Tabby" for night spying and observation.

Provides a Silver Caesium Oxide Screen for the conversion of Infra-red Rays to visible rays, using an Infra-red light source. Data provided.

Dimensions overall:—dia. 2 1/2 in. x 1 1/2 in. Screen dia. 1 1/2 in.

CLYDESDALE'S PRICE ONLY 12/6 each. POST PAID.

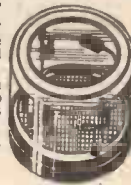

## Brand New in maker's cartons.

### A UNIVERSAL MOTOR

By simple external wiring. Full data supplied for 220-250 volts, A.C. or D.C. mains. New method gives better than 1/8 h.p.

Ideal for light bench work, when the fan is removed a 1 1/2 in. spindle is available for driving.

Motor Generator type 29. Size 1 1/2 x 5 1/2 x 5 1/2 ins. Input, 24 V, 15 A. Output, 1,200 V, 200 mA.

CLYDESDALE'S PRICE ONLY 25/- CARRIAGE PAID.

### HEAVY DUTY VARIABLE RESISTANCE

E. 170, 14 ohm 5 amps. wire wound on tubular ceramic former, 1 1/2 x 1 1/2 ins. dia. with cast metal fixing feet. Brass rod carriers, variable slider.

CLYDESDALE'S PRICE ONLY 12/6 each. POST PAID.

### In maker's carton. REMOTE CONTACTOR No. 4.

Relay (24 V.) with Ratchet drive mechanism, switch, etc., used for remote switching. Unit size: dia. 3 1/2 in.; flange dia. 4 1/2 in.; depth, 2 1/2 in.

CLYDESDALE'S 2/8 each. PRICE ONLY 27/6 per doz. POST PAID.

### Ex. ROYAL NAVY SOUND POWERED TELEPHONE



Requires NO batteries, and will give long service without attention. Complete with warning indicator lamp and generator, giving a high-pitched note which can be heard through any noise, where a number of telephones are used, the indicator lamp would indicate

which one is being called. Dim. —7 1/2 x 9 x 7 1/2 ins. for wall mounting. Designed for ships' use, but can be used in the home, office or factory.

CLYDESDALE'S PRICE ONLY 27/6 each.

### TINSEL FLEX

H.151. Jumper Lead Ass. (for WS-19). 60ft. of 5-core tinsel flex, fitted each end with a 5-way rubber plug—2A-2994. Price 7/6 each, post paid.

**NOW READY** New Illustrated List No. 6 (152 pages). Send 6d. to cover distribution cost. Please print name and address.

Brand New.

### 5 PUSH BUTTON UNIT CONTROLLER ELECTRIC, TYPE 1A. 10J/17

E.133. 5-digit push button switch, with 5 pilot bulb holders, 23 pos. 4 pole Key Switch, wired to 12-pin Jones type plus, in metal box, 5 1/2 x 4 x 1 1/2 ins. Wiring diagram supplied.

CLYDESDALE'S PRICE ONLY 3/11 each. 38/- per doz. POST PAID.

Order direct from: **CLYDESDALE SUPPLY CO. LTD.** 2, Bridge Street, Glasgow, C.5. Phone: SOUTH 2706/9  
Visit Our Branches in Scotland, England and Northern Ireland

## Make your own—DOMESTIC REFRIGERATOR

Full instructions and detailed Working Drawings for making a fully Automatic Compressor Operated Refrigerator of 6 to 8 cubic ft. capacity. Designed by specialists especially for the Home Constructor. If you wish to obtain a copy, send us your address together with S.A.E. for further particulars and post your letter to our registered London address:—**BCM/TECHNIPRINTS LONDON, W.C.1**

## YOU can become a first-class RADIO ENGINEER

We are specialists in Home-Study Courses in Radio Engineering, Servicing, Transmission, Television, Mathematics and Radio Calculations.

### T. & C. RADIO COLLEGE

Post coupon now for free booklet and learn how you can qualify for well-paid employment or profitable spare-time work.

To: R. Heath Bradley, T.C.R.C., 50, Harland Road, Southbourne, Bournemouth.

Name: \_\_\_\_\_  
Address: \_\_\_\_\_  
M 57

(Post coupon in unsealed envelope—1d. Postage.)

# HIGHSTONE UTILITIES

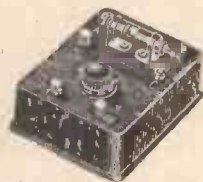

**Crystal Sets** Our latest Model is a real radio receiver, which is fitted with a permanent crystal detector. Why not have a set in your own room? 9/6, post 6d. De Luxe Receiver in polished oak cabinet, 18/6, post 1/-.

**Spare Permanent Detectors**, 2/- each. When ordered separately, 2/6. With clips and screws, 8/10, post 3d. Headphones, brand new, S. G. Brown, G.E.C., etc., 15/-, 25/-, and super sensitive, 30/- a pair, post 8d.

**New Headphones**, 10/- a pair. Balanced armature type (very sensitive), 12/6 a pair. Both post 8d. New Stereo Earpieces, 3/6. Bal. armature type, 4/6; ex-R.A.F. earpiece, 2/-, post 4d. Headphones, in good order, 4/6 and 5/6 (better quality, 7/6), all post 6d. Headphones with moving coil mikes, 25/-, post 1/6. Headphone Cords, 1/3 a pair, post 3d. Replacement Bands, 1/3, post 4d. Wire Bands, 6d. (All Headphones listed are suitable for use with our Crystal Sets.)



**Bell Transformers**. These, guaranteed transformers work from any A.C. Mains, giving 3, 5, or 8 volts output at 1 amp., operate bulb, buzzer or bell. Will supply light in bedroom or lavatory, etc.

PRICE 8/-, post 6d. BELLS for use with either the above or batteries, 6/-, post 6d.

**EX-R.A.F. 2-valve (2-volt) Microphone Amplifiers** as used in 'plane inter-com., in self-contained metal case; can be used to make up a deaf aid outfit, intercommunication system, or with crystal set; complete with valves, 20/-, post 1/6. Used in wooden box with partitions to hold amplifier, 2/- extra. Ditto, less valves, 10/-, one valve amplifier, complete with valve, 9/6, post 1/6.

**Hand Microphones**, with switch in handle and lead, 4/-, similar instrument, moving coil, 7/6, post 6d.

**Sparking Plug Neon Testers**, with vest-pocket clip, 3/3, and with gauge, 3/6, post 3d. S.B.C. Neon Indicator Lamps, for use on mains, showing "live" side of switches, etc., 3/6, post 4d.

**Soldering Irons**—Our new streamlined iron is supplied with

two interchangeable bits, one each straight and curved; 200/250 v. 50 watts, 9/-, post 6d. Standard iron with adjustable bit, 200/250 v., 60 watts, 9/6, post 6d. Heavy Duty Iron, 150 watts, 12/6, post 8d. All parts replaceable and fully guaranteed. Small Soldering Irons, for use on gas, 1/4, post 4d. Resin-cored solder for easy soldering, 6d. packets, or 1lb. reels, 6/-, postage extra.

**Microphones**.—Just the thing for impromptu concert singing, room communication, etc. Bakelite table model, 6/9; Suspension type, 8/6, post 6d. Mike Buttons (carbon), 2/-, Moving Coil, 4/6; Transformers, 5/-, post 4d. each.

**Rotary Transformers**, 12 v. D.C. input, in soundproof cabinet, for Car Radio, etc.; will also light two 230 v. 25 w. lamps in series, or as a motor, 22/6 each, carriage 2/6. 24 v. input; Output 1,230 v., 2 amp. in case with suppressors, etc., easily converted to run as a high voltage motor, 25/-, carr. 3/6. Also 12 v. input; Output, 6 v. 5 amp., 150 v. 10 mA, and 300 v. 20/240 mA., 22/6, carriage 3/6.

**Morse Keys**—Standard size keys wired to work Buzzer or Lamp, 3/-, post 6d. Slightly smaller keys, 2/6, post 4d. BUZZERS, 3/-, or heavy duty, 4/6, post 5d.

**Terminals**, brass, 2BA, mounted on strip, 6d. pair. Winder PBA, brass, 1/6 doz., post 4d. 0005 Airspaced Variable Condensers, 2/6, post 4d. 0003 twin coils with trimmers, 2/6, post 4d. 24-volt 15 mA. M.E.S. Bulbs for model railways, etc., 1/- each, 10/- doz., post 4d.

**Fuses**.—1 amp., 1 1/2 in., packet of 10, 2/6, post 3d. Also 150 mA, and 250 mA, same price. Bargain Parcels of really useful equipment, containing Switching Meters, condensers, Resistances, Phones, etc., 10/- or double assortment, 17/6; treble, 25/-, All carriage paid. This country only.

**Field Intercommunication Sets**, complete with ringing hand generator, bell, signal lamp, morse key, relay, in strong metal case with circuit diagram, 20/- each, carr. 2/6; 27/6 pair, carr. 3/6. Ex-G.P.O. Telephone Twin Bells, with box, 5/-, post 9d. Telephone hand generator, with handle, 7/6, post 1/6; Bell, 4/6, post 6d.

**Meters**. 10v. 2 1/2 in. Rectifier (a.c.) in wooden carrying case, 17/6; 15v., 2 1/2 in. m/c, 9/6; 150 v., 2 1/2 in. m/c, 10/-; 300v., 2 1/2 in. m/c, 13/6; 3,000 v., 3 1/2 in. m/c, 20/-; 6,000 v., 3 1/2 in. m/c, 27/6; 15,000 v., 2 1/2 in. m/c, double scale, 9/-; 100 mA., 2 1/2 in. m/c, 7/6; 3.5 amp. 2 1/2 in. T.C. 5/-; 4 amp., 2 1/2 in. T.C. in case with switch, 7/6; 20 amp., 2 1/2 in. m/c, 9/6. Meter Movements, 2 in. size with magnet and case (500 microamp.) 2/6. Units containing two Movements, 5/-, All meters post extra. Money refunded if not completely satisfied.

**HIGHSTONE UTILITIES**, 58, New Winstead, London, E.11. Letters only: New Illustrated List sent on request with 1d stamp and S.A.E.



### It Pays to Purchase ELECTRADIX BARGAINS

**METERS.**—D.C. moving coil voltmeters, Zn. panel type, 0-30 volts, 4/- . Ammeters, 50-0-50 amps, with shunt, 5/- . Ammeters, 0-20 or 0-25, 4/- each. Voltmeters, 2 1/2 in. flush panel, 100-0-100 volts, 6/- . Milli-ammeter, 0-1 ma, 10/- .

**TRANSFORMERS** for soil warming. Foster 100 watt size, 50 volts 2 amps output, 230 volts input, double wound, 15/- ; postage 2/- . B.T.H. 200/230/250 volts to 2 volts 20 amps and 75 volts 6 amps with 15 taps, 45/- ; carriage 5/- . Auto Transformers, 230/110 volts 85 watts, 25/- ; 150 watts, 35/- ; 1 k.W., £7/10/- . We can supply transformers for all purposes—send us your enquiries.

**RESISTANCES**, variable wire wound, laminated brushgear, 3 ohms 10 amps, 12/6 . 1.2 ohms 15 amps, 10/- . 6 ohms 6 amps, 15/- . 300 ohms 1/2 amp, 15/- . 290 ohms 1/2 amp, 15/- . Isential Geared Resistances for lab. work, 60 ohms 2 1/2 amps, 35/- . **DIMMING RESISTANCES**, 100 ohms 1/2 amp, 2/- . post 6d. Stage Dimmers, all sizes to 5,000 watts ; send for prices.

**RADIO SUPPRESSORS**. Choke and condenser type, in iron box, 2-way, 5/- ; 3-way, 7/6 .

**D.C. DYNAMOS**. 12 volt 10 amp. C.A.V. 1,400 r.p.m., 40/- . 24 volt 100 amp. 4,000/6,000 r.p.m., £5/10/- . 30 volt 5 amp. 1,500 r.p.m., 35/- . Carriage on any dynamo 5/- extra.

**DYNAMOS** for battery charging on boats, etc., for use ashore or afloat. 24 volts 30 amps 4 pole 1,000/1,200 r.p.m., shunt wound, fan cooled, £20 each. 24 volts 18 amps 1,000 r.p.m., shunt, fan cooled, £17. 24 volts 18 amps 1,200 r.p.m., encl. ven., shunt wound, £12/10/- . Carriage extra.

**MOTORS, A.C.** 50 cycle 230 volts 1/2 h.p. new 1,425 r.p.m., £5/10/- . 1/3rd h.p. 230 volts 50 cycles A.C. capacitor start 1,425 r.p.m., new £8/10/- . Reconditioned motors, G.E.C. 230 volts A.C. 1/2 h.p. 1,425 r.p.m., £4. 3-phase 50 cycle 1/2 h.p. 440 volts 1,425 r.p.m., £7.

**MOTORS, D.C.** 1/2 h.p., 110 volts 1,400 r.p.m. A.E.C., 30/- .

**IRONCLAD SWITCHGEAR**. We have a large stock of ironclad fuses and switch-fuses, new condition, by leading makers, 15-30-60 amps. Write for special leaflet, "P.M."

**LIQUID LEVEL INDICATORS** with ball float geared to watch dial panel gauge for 9in. rise and fall, 7/6. Level indicators with ball float, less meter, 3/6.

**PUMPS**. Rotary Suds Pumps, lift 8ft. head 35ft., capacity 60 g.p.h., with pulley, £4.

**MOTOR PUMPS**. Suds type, 2 h.p., 200 or 400 volts 3-phase 50 cy. 1,425 r.p.m. 10ft. head, 600 g.p.h., £8/10/- .

**MAGNETO BELLS**, in polished box, 8in. x 6in. x 3 1/2in., with condenser, connection strip, switch-hook and contacts, 5/- . G.P.O. Candlestick Mike with switch-hook and cords, 7/6. Postage 1/6.

**ELECTRO MAGNETS**. D.C., 6 volts, weight 10oz., lift 4lb. on 6 volts, 3/6. on 4 volts and 1 1/2 lb. on 2 volts, 5/- each, post 6d.

**MAGNETS**. Swift Levick S.L.S.36 Instrument type circular horseshoe, 1 1/2 in. dia., 1/2 in. thick, with 1/2 in. polar gap, drilled poles, weight 2oz., lift 3lb., 2/6 each ; six for 12/6.

**THE ALNI DISC MAGNET**, 1/2 in. dia., 1/2 in. thick, 3/16 in. centre hole, a powerful magnet in pot with keeper, 3/6. Permanent flat bar magnets, 2 1/2 in. x 1 1/2 in. x 1/2 in., 2/- pair.

**RECORDER PARTS**. Chart, drum and clips, 5/6. 9in. Traverse Shaft, 4in., threaded 120 to inch, with bearings, 12/6. Stylus with carriage rods and brackets, 7/6.

**THE DEM. CONTINUITY TESTER**, a self-contained circuit tester in wood box with battery and single 'phone, 7/6, post 1/- .

**MORSE KEY AND BUZZER** for practice. A.M. Key perfect balance, with insulated knob and high-note buzzer in metal case, 4/6, post free. Townsend high-note buzzer with plat. contacts, 5/- . G.P.O. twin coil test buzzer, 2/6.

**HEADPHONES**. Single L.R. 'phone with headband and cord, 2/- ; double headphone suitable for crystal set reception, with headband and cord, 5/- . postage 9d. Moving coil, single 'phone units, 45 ohms resistance, 1/2 in. coil, 5/- .

**THE FAMOUS CHORE HORSE** lighting plant for small house or bungalow, 300 watt, 12/15 volt, 20 amp., complete with switchboard and fuel tank. 1 h.p. single-cylinder four-stroke engine, air-cooled, in first-class condition, £17. All lighting plants and surplus Government stock reconditioned and in good condition. Prices Ex-Battersea stores. Write for full list. Please include postage for mail orders.

**ELECTRADIX RADIOS** 214, Queenstown Road, Battersea, London, S.W.8

Telephone : MACaulay 2159

### You Can Become a HANDICRAFTS INSTRUCTOR

EXPERIENCE NOT ESSENTIAL

Men who enjoy making things in wood or metal can turn their hobby into a well-paid, permanent and interesting Career! Short hours, long holidays, and security in a job you would really enjoy, can be yours if you become a Handicrafts Instructor. Let us send you details of the easiest and quickest way to get the necessary qualification.

We definitely guarantee "NO PASS — NO FEE"

If you would like to know about our unique method of preparing you for one of these excellent appointments, write today, and we will send you an informative 176-page Handbook—FREE and without obligation. Mark your letter "Handicrafts Instructor."

British Institute of Engineering Technology  
591, Shakespeare House,  
17/19, Stratford Pl., London, W.1 **BIET**

### CARAVAN CHASSIS

and chassis undergear 8 to 35 cwt. Lightweight Camping and Commercial Trailers. Towing Hitches. Jockey Wheels. Brake Operated Legs. Aluminium Sheets 6ft. x 3ft., 24, 22, 20, 18 and 16 g. ; 8ft. x 4ft., 22, 20 and 18 g. Comprehensive stocks of Beading, Angle, J Drain, T Door Plate and Strip. Veneered Oak panels. Insulation Board, Glass Wool, Sinks, Windows and Roof Ventilators. Stockists for Color Gas, Bottogas and Labolam Cushioning. Puffers Stoves and Gasan Chemical Closets. Send for our detailed illustrated list and visit our Showrooms. Open all day Saturday.

**WATFORD WHEEL & TRUCK WORKS**  
173-175, Queens Road, Watford, Herts.  
Phone : Watford 5730.

### QUICKER CLEANER CHEAPER

A Perfect Finish with all PAINTS DISTEMPERS, CELLULOSE ETC.

RETAIL **19/6** PRICE



S.A.E. FOR ILL. LEAFLET C.O.D. ON REQUEST

### FITS YOUR VACUUM CLEANER

WRITE : VAC ACCESSORIES  
28 HELENA ROAD, LONDON, W.5

### CHEMISTRY APPARATUS

Send Stamp for COMPLETE PRICE LIST



Booklets:  
"Experiments" 7d.  
"Formulas" 10d.  
"Home Chemistry" 2/3 Post Paid

(Scientific Dept. A)  
**BECK** 60 HIGH STREET,  
Stoke Newington, London, N.16

Price £7 10s. 0d. Carr. Extra.

The 'Adept' Bench Hand Shaper  
Length of stroke of ram, 2 1/2 ins.  
No. 2B.H. shaper, 6 1/2 in. stroke.  
Price, £13 13s. 0d.  
"Ask your dealer."  
Manufactured by:  
**ADEPT WORKS,**



### No. 19 TRANSMITTER-RECEIVER UNITS

Once again we have been fortunate to secure a limited number of these useful chassis. They were, in most cases, brand new and of Canadian manufacture, but to conform to regulations were partially dismantled by the Ministry before release, and are sold by us for the many components, which include: One 4-gang 0005 Tuning Condenser, 1 single 0005 Tuning Condenser, each fitted with slow-motion dials, 3 I.F. Transformers, approx. 15 Valveholders, several Pots, Xalzyie switches, ceramic Trimmers, and several dozen condensers, resistors, etc. Our Special Price is 12/6, carriage paid. We regret that when we last advertised these chassis the colossal demand exhausted all our stocks and we were forced to disappoint certain customers. If these customers will again apply, their orders will have preference.

**POWER UNIT** for the above works direct from a 12v. or 24v. Battery and is actually two units in one (a Rotary Transformer and a Vibrator Unit) output 265v. at 120 m.a. and 540v. at 25 m.a. Brand new, Canadian manufacture ; also contain Fuses, Indicator Lamp Changeover Switches, etc. A Few Only, at 49/6, carriage paid. We can also supply a spare Brand New valve type 024 and Rectifier unit, 10/- . Send S.A.E. for latest lists.

**WALTON'S WIRELESS STORES,**  
203, Staveley Road, Wolverhampton  
48, Stafford Street, Wolverhampton  
(Callers only)

**Jubilee**  
PATENTED WORM DRIVE CLIP



Absolutely leakproof joints on Air, Water, and Oil lines, are swiftly and easily made by using "Jubilee" Worm Drive Clips. They stand up to any pressure.

★ Write for "Jubilee" giving references RP/12. THE FINEST CLIP IN THE WORLD.

**L. ROBINSON & CO. (GILLINGHAM) LTD.**  
Gillingham Kent

**PRINTERS**  
WITH Pride IN THEIR WORK



### FORREST PRINTING WORKS

240 Holloway Rd., London, N.7  
Telephone - - NORTH 2004

### SAVE MONEY!

Make your own **ELECTRIC CIGARETTE LIGHTER** (Battery Operated), from easily followed Instructions and Diagrams.  
Price 3/6 Post Free.  
**THE SHOPS BUY THEM FROM YOU TOO!**  
**P. M. BARHAM,**  
Bridge Avenue, St. Sampsons, Guernsey, C.I.

### THE BURGESS vibro-tool

\* Writes on **STEEL, GLASS WOOD or PLASTICS.**

The Vibro-Tool enables you to write on Steel, Glass, Wood or Plastics as easily as writing with a pencil.

Operates off 220-250 volt, 50 cycle A.C. Supply. Just connect to any electric light socket or plug point.

Sole distributors for Scotland : H. A. Dawson-Bowman, 8110, Beech Avenue, Glasgow, S.1.

Complets with standard engraving point, 52/6  
De Luxe Kit, 97/6



**BURGESS PRODUCTS COMPANY, LTD.,**  
Vibro-Tool Dept.,  
Hinckley, Leicester

### ANTI-VIBRATION MOUNTINGS

Rubber Metal - bonded



A useful mounting that will be found invaluable in the installation of machines, equipment, instruments, electrical apparatus, motors, etc., and wherever complete elimination of vibration is essential.

Can be mounted to take an 8lb. load in any position. Gives flexibility in all directions.

Box of 10 Mountings  
**7/6 Post Free**  
(Dept. P.M.)

**WIRELESS INSTRUMENTS (LEDS) LTD**  
54-56, The Headrow, Leeds  
Tel: 22262

The **SUPER ADEPT LATHE**  
11 in. centres, 6 in. between centres.

The "Adept" 2 1/2 in. 4-Jaw Postage and Packing, 2/- . Independent Chuck. Reversible Jaws, 32-. A Good Range of Accessories is Available.

Price £4 10s. 0d.

**F. W. PORTASS,**  
SELLERS STREET, SHEFFIELD, 8





# QUERIES and ENQUIRIES

A stamped, addressed envelope, three penny stamps, and the query coupon from the current issue, which appears on page 48 (THE CYCLIST), must be enclosed with every letter containing a query. Every query and drawing which is sent must bear the name and address of the reader. Send your queries to the Editor, PRACTICAL MECHANICS, Geo. Newnes, Ltd., Tower House, Southampton Street, Strand, London, W.C.2.

## Cultures of Diatoms

**CAN** you please inform me if there is any method of making pure cultures of diatoms. If so, what is the method of procedure, and the medium, and how can the latter be made or obtained?

Also, can you please supply me with the address of a firm which supplies samples of diatomaceous earths, oozes, etc.—K. A. Reynolds (Winchester).  
**THE** great family of diatomaceae, which is a branch of the family of confervoid algae, although occurring in all fresh, brackish or salt water, is very difficult to cultivate under artificial or laboratory conditions. The best way to go about diatom cultivation is to build a shallow tank and to place a few aquatic plants in it, the plants being rooted in a thick layer of ordinary pond mud, which mud must have been previously boiled with water for 10 minutes in order to sterilise it. After the lapse of a few weeks, individual living diatoms may be sought out and selected from pond mud or from underneath stones and twigs in brackish waters, and these may then be "implanted" merely by laying them on the surface of the mud in the tank. With a little patience—and, also, some luck—the "seed" diatoms, once they have become acclimatised to their new conditions, will begin to grow and to multiply, mainly by division.

You will almost certainly not get absolutely pure strains of diatoms by this method, but if you take care to culture only one species of diatoms, say, the "chain" diatoms—*diatom vulgare*—which is to be found in the mud of all ponds, this particular species will be by far the most numerous in the tank. Individual specimens may then be transferred to another similar tank and, in this way, the diatoms may be made to grow in almost unadmixed colonies. But the task is a rather lengthy one and it calls for care and patience.

Diatomaceous earths may be obtained from any laboratory supplying firms, such as Messrs. A. M. MacCarthy, 37, Standford Road, Moseley, Birmingham, 13, or from Messrs. Vicsons, Ltd., 148, Pinner Road, Harrow, Middx.

You will, however, be more likely to get just the type of earth materials which you require if you will approach a good firm which specialises in microscopical supplies, such as Messrs. W. Watson and Sons, Ltd., High Barnet, Herts.

## Transparent Cement

**I** HAVE built a lean-to type of greenhouse and after making a good job of the construction find I have made a blunder in the way I have butt-ended the panes of glass together on the long side (or front) of the greenhouse. I find that water moving down tends to seep through the butt-ends of the panes.

Instead of taking out the panes, overlapping and reputting them I would like to know if there is some way of sealing these butt-ends which is not too expensive and does not shut out too much light, such as a transparent adhesive tape which would exclude rain from the inside and would remain weather resistant?—W. C. Palliser (Northampton).

**A** POLYVINYL acetate cement, which is quite transparent, seems to be the best remedy for your trouble, in connection with the greenhouse glazing. Dissolve about 25 parts of Gelva resin No. 7 in 75 parts of warm methylated spirits. This will give you a clear varnish. If not thick enough to stay put without running, dissolve more of the Gelva 7. If too thick to be forced down between the overlapping glass sheets by means of a thin spatula blade, add more of the methylated spirits.

This cement will dry out in a few hours to a transparent film which resists water, greases, petrol, lubricating oils. It has good adhesive properties.

Gelva resin No. 7 is obtainable, price about 3s. per lb., from Shawinigan, Ltd., Marlow House, Lloyd's Avenue, London, E.C.3.

The cement can be thickened to any extent by mixing the powdered Gelva resin with it.

After prolonged contact with water, the cement will swell a little and become milky in appearance, but it will dry again and become transparent.

## Copper-naphthenate : Sodium-benzoate

**I** HAVE heard that copper-naphthenate is an excellent wood preservative and also that sodium-benzoate will give protection to metal tools, but I have been unable to obtain these materials.

I would be glad to know where I can obtain the above materials, and how to use them.—W. A. Scott (Bexhill).

**COPPER-NAPHTHENATE** is an excellent wood preserver against fungus, moulds, mildews, rotting organisms and boring larvae. The copper-naphthenate is a soft, green material. It is soluble in naphtha or paraffin. Dissolve 10 parts of the naphthenate in 90 parts of either of these solvents (parts by weight). This makes the necessary solution in which the wood-work is immersed or which is brushed liberally on to the wood. The solution should be used hot, since it penetrates the wood better in that state. The naphthenate is insoluble in water. Hence, it is not bleached out of the wood by washing, moisture or rain. The wood is stained green by this treatment. If this stain is objected to, zinc-naphthenate, which is colourless, can be used in place of copper-naphthenate with equal effect and efficiency.

You will be able to obtain copper and zinc-naphthenates from Messrs. Thomas Tyrer and Co., Ltd., Stratford, London, E.15, the price being about 3s. 6d. per lb.

A weak solution of sodium-benzoate in water, say three parts of the benzoate in 97 of hot water, has been supposed to immunise certain tool steels from rusting, but, in our opinion, it is not effective. Sometimes it has been used in conjunction with greases, but in all such instances it is obvious that it is the grease which has effected the rust protection, not the sodium-benzoate. However, if you want to experiment with this material,

Readers are asked to note that we have discontinued our electrical query service. Replies that appear in these pages from time to time are old ones, and are published as being of general interest. Will readers requiring information on other subjects please be as brief as possible with their enquiries.

you can obtain it from either Messrs. Vicsons, Ltd., 148, Pinner Road, Harrow, Middx., or Messrs. W. and J. George and Becker, Ltd., 17-29, Hatton Wall, London, E.C.1. The price is approximately 7s. 6d. per lb. You should, incidentally, be able to obtain small quantities of sodium-benzoate from your local pharmacy.

## Painting on Glass

**CAN** you give me details of the process for painting on glass. I am making some small glass table-mats?

Is it possible to obtain circles or squares of glass ready cut?—N. Thompson (London, S.W.).  
**VARIOUS** mixtures of dyed waxes and resin may be used for glass painting, but the more satisfactory results are obtained by means of pigmented cellulose enamels. These can usually be obtained in paint shops and, also, in handicraft shops and from dealers in artists' materials.

You can make such paints for yourself by dissolving scrap celluloid in cellulose or, alternatively, in a mixture of approximately equal parts of amyl acetate and acetone, until a thick, varnish-like liquid is obtained. Into this, grind a quantity of the pigment and then press the resulting enamel through fine cloth into small, shallow jars which have well-fitting screw-top lids. Use an ordinary brush for the painting, and keep it under one of the above liquids when not in use.

We doubt whether you will be able to obtain ready-cut glass in small sizes at the present time. However, there's nothing like trying, and we would advise you to direct your inquiries to one or more of the following firms: Messrs. Pilkington Brothers, Ltd., St. Helens, Lancs. Messrs. Samuel Krinks & Sons, Ltd., Soho Pool Works, Hockley, Birmingham. Messrs. Josiah Lane & Sons, Ltd., Eve Hill Works, Park Road, Dudley.

Bear in mind, also, the fact that a good source of supply of small rectangular pieces of glass is usually any amateur or professional photographer who uses plates in preference to films for his work. Such glass is, of course, thin, but it may often be had almost for the asking.

## Dicyanine

**WOULD** you kindly supply the following information concerning dicyanine dye, and its properties when mixed with grain alcohol:

- (1) What are its properties?
- (2) To what radiations is it sensitive?
- (3) Who can supply it?
- (4) What is the approximate cost?

—W. McDonald (Belfast).  
**DICYANINE** is a blue dyestuff, soluble in spirit or in water. It is not "sensitive" to any special radiations. Its former use depended on the fact that photographic emulsions which are treated with a 1 in 5,000 solution of the dye acquire a very special sensitivity to deep-red light and, also, to the near infra-red rays. It was used for this purpose up to about 1930, at which time it was superseded by the much more efficient Neocyanine, a dyestuff belonging to the same "cyanin" class of dyes. Neocyanine is a much more efficient sensitiser to infra-red rays, and has now completely displaced dicyanine for use in this work.

Dicyanine used formerly to be made by one German firm only. It has now been manufactured in Britain and in America. Its price is in the region of £3 per gram, but it can be purchased in solution form at considerably lower prices.

It is supplied by Ilford, Ltd., Ilford, London, or by Kodak, Ltd., Kingsway, London, W.C.2. You could also obtain it through any local firm of laboratory suppliers or even through your neighbouring pharmacist.

## Scouring Powder

**CAN** you supply a formula for a fairly cheap powder for cleaning sinks, buckets, pans, etc.?—J. A. Beech (Prestwick).

**ANY** abrasive material saturated with soapy water containing a little soda will make an excellent household scouring powder. You can use fine brickdust for this purpose, or ground stone of any description. Even common whiting will do, although it is a very poor abrasive. Silica powder (obtainable from Messrs. A. M. MacCarthy, 37, Sandford Road, Moseley, Birmingham, 13) is a very powerful, fine abrasive and is a constituent of most metal polishes. Granite dust, Fuller's earth, ground Portland stone, sandstone, rottenstone (obtainable from the above source) are other abrasive powders.

A very good type of "universal" household powder has the following composition:

Dried powdered clay	.. 1 part (by volume).
Silica powder	.. .. 1 "
Soap powder	.. .. 2 "
Common soda	.. .. 1 "

If you want a white product, substitute china clay or fireclay for ordinary powdered clay.

The above materials are intimately mixed together in the dry state, the mixture then being kept in a dry place.

This formula is capable of much variation. For instance, if you desire the product to be less abrasive, use a small quantity of silica powder, or substitute some milder abrasive (such as brickdust) for it. If you want it to be less "strong" or alkaline, decrease or omit the soda. The soap proportion can be omitted or lessened if you think it unnecessary for your particular purpose.

Thus, the above preparation is cheap, simple, effective, and capable of variation to suit any ordinary scouring purpose.

## Cleaning Mercury Barometers

**I** HAVE to repair several mercury barometers. The chief problem seems to lay in the mercury tube, filling, etc. Can you give me detailed information on how to go about it?

I am advised to clean both tube and mercury in dilute acid—which acid?—A. R. Hitchcock (Bury St. Edmunds).

**THE** cleaning and adjustment of mercury barometers is not a very difficult matter. It calls for "knack" and practice which is very easily acquired, but not so

## THE P.M. BLUEPRINT SERVICE

- 12 FT. ALL-WOOD CANOE.\* New Series. No. 1. 3s. 6d.
- 10-WATT MOTOR. New Series.\* No. 2. 3s. 6d.
- COMPRESSED-AIR MODEL AERO ENGINE.\* New Series. No. 3. 5s.
- AIR RESERVOIR FOR COMPRESSED-AIR AERO ENGINE. New Series. No. 3a. 1s.
- "SPORTS" PEDAL CAR.\* New Series. No. 4. 5s.
- F. J. CAMM'S FLASH STEAM PLANT.\* New Series. No. 5. 5s.
- SYNCHRONOUS ELECTRIC CLOCK. New Series. No. 6. 5s.\*
- ELECTRIC DOOR-CHIME. No. 7. 3s. 6d.\*
- ASTRONOMICAL TELESCOPE. New Series. No. 8 (2 sheets). 7s.\*
- CANVAS CANOE. New Series. No. 9. 3s. 6d.\*
- DIASCOPE. New Series. No. 10. 3s. 6d.\*
- EPISCOPE. New Series. No. 11. 3s. 6d.\*
- PANTOGRAPH. New Series. No. 12. 1s. 6d.\*
- COMPRESSED-AIR PAINT SPRAYING PLANT. New Series No. 13. 7s. 6d.\*

- £20 CAR.\* (Designed by F. J. CAMM), 10s. 6d. per set of four sheets.
- MASTER BATTERY CLOCK.\* Blueprints (2 sheets), 3s. 6d. Art board dial for above clock, 1s.
- OUTBOARD SPEEDBOAT 10s. 6d. per set of three sheets.
- SUPER-DURATION BIPLANE.\* Full-size blueprint, 2s.
- The 1-c.c. TWO-STROKE PETROL ENGINE.\* Complete set, 7s. 6d.
- STREAMLINED WAKEFIELD MONOPLANE—3s. 6d.
- LIGHTWEIGHT MODEL MONOPLANE Full-size blueprint. 3s. 6d.
- P.M. TRAILER CARAVAN.\* Complete set, 10s. 6d.
- P.M. BATTERY SLAVE CLOCK\*—2s.

The above blueprints are obtainable, post free, from Messrs. George Newnes, Ltd., Tower House, Southampton Street, Strand, W.C.2.

An \* denotes constructional details are available, free, with the blueprint.



easily described in written words. If you happen to have a copy of PRACTICAL MECHANICS for March, 1937, you will find therein an illustrated article dealing with the filling of a mercury barometer.

Essentially, the details are these: The barometer tube is placed on a layer of warm sand or in a long bath of hot water. Thus heated, a portion of the air is expelled. The tube is upturned quickly, and a little mercury is poured into the lower cup. With the thumb placed over the top of the cup, the tube is inverted and some of the mercury is jerked round the bend into the tube. This jerking process constitutes the "knack." If the jerking is too violent the mercury may shoot around the bend and break the tube. If there is not sufficient jerk in the movement the mercury will not get round the bend.

The above sequence of operations must be continued until the tube is completely full of mercury when in its inverted condition. Then, when the tube is returned to its normal upright position the mercury will sink to its normal "atmospheric" level, giving a vertical column of about 30in. The space between the top of the tube and the mercury level therein will be an almost complete vacuum.

The inside of the tube must be scrupulously clean. It is best to swill it out with a caustic soda solution (1 part in 6 of water), using a flexible wire brush to work up and down the tube. After this, the caustic soda must be washed out of the tube and the latter filled with chromic acid solution (strength immaterial). Allow this to remain within the tube for one week. Next, rinse the tube out, first with clean water, then with distilled water. Finally, put the cleaned tube away in a warm place to dry out thoroughly. This will take some considerable time. The drying can be accelerated by filling the tube with rectified spirit (which absorbs the water) and then by emptying it again and then allowing the traces of spirit to evaporate from the tube interior. Rectified spirit, being subject to Excise duty, is expensive. Note, also, that caustic soda and particularly chromic acid are very corrosive.

In order to clean the mercury, place it in a chamois leather bag containing one or two pinholes at the bottom. Squeeze it through this bag into a glass vessel containing dilute nitric acid (1 part in 4 of water). The mercury should fall into the water as a gentle silvery "rain." Decant the acid from the mercury. Wash the mercury in clean water several times. Then repeat the whole process six or eight times. Finally, force the mercury through the chamois leather bag into clean water. Do this, also, six times. The mercury will now be clean and free from contamination. After the water has been poured away from it, the mercury should be dried by dabbing it with white blotting paper. It will now be ready for barometer filling. It is, of course, absolutely essential for the mercury to be perfectly dry before being charged into the barometer tube, otherwise you will get traces of water vapour at the top of the tube, and this will render the instrument hopelessly inaccurate.

The mercury must not be allowed to come into contact with any metal surface, otherwise it will pick up contaminations. All manipulations with it must be conducted in glass or porcelain vessels. The hands must, of course, be scrupulously clean and grease-free.

### Removing Moss from Tarmac Path

I HAVE patches of moss which is spreading rapidly on a tarmac path to my garage. Is there any means of destroying the moss and preventing complete spreading?—H. J. Albers (Leeds).

THE moss on your tarmac path would be best removed by hand scraping. Oils, creosotes and similar materials cannot be used for its eradication because they would combine with the oily binder of the tarmac path and render it permanently soft.

If you cannot undertake hand scraping, the path should be sprayed (in dry weather) bi-weekly with a strong solution of copper-sulphate made by dissolving 1 part of this material in 3 parts of water. The copper is toxic to most forms of plant life, and it kills the moss more or less rapidly. The greatest care should be taken that the material does not come into contact with the roots of plants which are growing on the sides of the path.

It is sometimes recommended to scatter powdered copper-sulphate on the path. This is a dangerous practice, however, because when the rain comes it may wash the material on to neighbouring plant beds. Also, grains of the material may be blown about by the winds and thereby do harm to any adjacent plant beds.

Do not use any sodas on the path. They adversely affect the binder of the tarmac. Copper-sulphate is the safest agent in all such cases, and it does its work pretty well. It is, also, inexpensive.

### Galvanising Iron

COULD you state the process at present employed in galvanising iron, as I wish to make some flower boxes of this material, and have been told that the acid used in the plating is bad for all forms of plant life.

If acid has to be used, could you give me a formula for a solvent to check the action of the acid?—A. W. Dare (Portsmouth).

THERE are two methods of galvanising (i.e., zinc-coating) iron or steel. The first is by dipping the metal into a bath of molten zinc. The second method is by electro-plating the zinc on the surface of the metal.

Before either of these treatments, the metal is surface-cleaned by means of sulphuric or hydrochloric acid. Usually, all traces of acid are removed in subsequent processes, but this is not always the case, so that occasionally the galvanised metal may be slightly acid.

However, such acid traces would be neutralised by

the soil, and plant-growth would not be affected in any way.

The real reason why many plants will not grow well in galvanised containers lies not in the acidity of the galvanised metal, but, rather, in the acidity of the soil itself or in the acid products which may be generated by plant growth. These slight acid traces attack the zinc of the galvanised metal. Thus the soil becomes contaminated by traces of soluble zinc compounds.

Now zinc compounds, when they are soluble, are all poisonous. If they do not poison the growth of beneficial moulds and bacteria in the soil. Soluble zinc compounds are also directly poisonous to plant life. Hence, because of this, a plant will not grow in a soil which contains a substantial amount of zinc compounds, and this is the reason why, often enough, a plant which has been placed in a galvanised (zinc-coated) container slowly languishes and dies. It has, in reality, been poisoned not by any residual acid in the zinc coating but rather by the soluble zinc compounds which have been created and absorbed into the soil, as stated above.

There is no treatment which you could apply to a galvanised metal to prevent this action, apart from heavily lacquering it with a cellulose lacquer, and even this would, in time, fail to protect the metal.

### Hot-water System

THE accompanying diagram shows the hot-water system in my house. Can you please advise me on the following points:

When the water in the rising main is frozen is it safe to light the fire which heats the boiler?

Can you please explain briefly why it is, or is not, safe.

Also, if hot water is run off, will the hot tank always remain full? In other words, am I right in

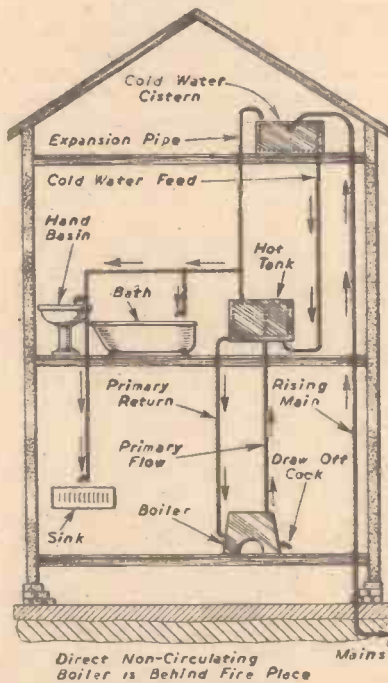

Diagram of a small domestic hot-water system (G. Lindley).

assuming that it is impossible to empty the hot tank, apart from drawing it off from the draw-off cock?—G. Lindley (Ash Vale).

WHEN the water in the rising main is frozen it is not safe to light the boiler fire. This is for the reason that as the hot water is gradually drawn off from the domestic taps, it is replaced automatically from the cold water cistern. If, therefore, the cold water cistern cannot be refilled, owing to the stoppage of the main water, the boiler supply of water must necessarily be cut off. This will give rise to an overheated boiler, leaking boiler unions and, possibly, ultimate cracking of the boiler, particularly if it is a cast-iron one.

If the hot water is drawn off, it will be replaced in the hot tank by cold water from the cold-water cistern, but, naturally, if the uprising cold main is stopped by freezing, the entire water supply of the system will be cut off.

### Anti-freeze Solution: Bleaching Piano Keys

(1) CAN you give me particulars of a safe anti-freeze for an 8 h.p. car?

(2) Also, what are the bleaching and polishing ingredients for: (1) Ivory piano keys; (2) celluloid keys and (3) plastic keys.—C. B. Clarke (Northampton).

(1) A GOOD anti-freeze consists of diethylene glycol added to water in the proportion of one part to three parts of water.

Another composition is—

Methyl alcohol 35 parts (by vol.).

Isopropyl alcohol 65 "

The anti-freeze is made by mixing equal quantities of the above mixed alcohols and water.

These anti-freezes do not contain mineral salts and they cannot affect any internal parts of the water circulatory system.

The material may be obtained (in gallon lots) from General Metallurgical and Chemical, Ltd., 120, Moor-gate, London, E.C.2.

(2) The bleaching of ivory pianoforte keys has been a subject of debate since the earliest days of the piano trade. It must be remembered that ivory, in its natural state, is not white, but creamy coloured, and even yellow. Consequently, ivory keys continually tend to revert to their natural shade. The factors which accelerate this reversion are dampness, darkness and the slightly acid secretion of the human skin. You may have noticed that ivory mouthpieces of wind instruments, such as recorders, go yellow in just the same way.

Strong solutions of citric acid, salts of lemon, hydrogen peroxide (with and without ammonia), oxalic acid and so forth have all been recommended as bleaching agents for yellowed ivory keys, and with varying degrees of success. It is possible to use a paste of bleaching powder (chloride of lime), which is smeared over the ivory key and then acidified with dilute acetic acid or hydrochloric acid (one part in four of water). This gives the maximum bleaching effect, but it must be most carefully done, care being taken not to wet the wood of the key, otherwise swelling (with consequent sticking) will take place.

A safer way, in our opinion, is to treat the ivory surface with a strong solution of Chloramine-T, which is manufactured by Boots Pure Drug Co., Ltd., of Nottingham, and which may be obtained at the local pharmacies of this organisation. Chloramine-T is much milder and safer in action than ordinary bleaching powder, but it takes much longer to act.

Celluloid keys should not turn yellow. If they do, the fault is in the material itself, and it is impossible to remedy it by means of bleaching. If bleaching action by any of the above agents is forced, in the case of a celluloid key, the celluloid material itself will be attacked and, in bad cases, may even disintegrate entirely. Much the same applies to keys of pigmented plastic material. But surely these latter do not yellow in normal use? The white pigment contained in the plastic material should prevent such action. A plastic key which has yellowed is a more or less hopeless proposition, and it points to a badly compounded plastic material.

We have known cases in which celluloid keys have been yellowed by cigarettes having been left alight in contact with the keys, the cigarettes having been placed in such a position by a careless player. In all such instances, you will find that the celluloid material has been actually scorched, rendering bleaching impossible. If the extent of scorching is not deep, the marks may be removed by abrasive and polishing treatment.

A good abrasive for dealing with keys in cases where it is desired to remove a slightly yellowed surface is—

Tallow	20 parts
Soap	30 "
Paraffin oil	18 "
White wax	8 "
Fine Tripoli powder	60 "
Water	20 "

Melt together the tallow and the white wax, and dissolve them in the hot paraffin oil. Dissolve the soap in the water. Mix the two solutions. Then add the mixed solutions to the Tripoli powder so as to make a stiff paste.

This paste is of both an abrasive and a polishing nature. It will give a good polish by rubbing. If you desire it to be more abrasive in character, replace some of the Tripoli powder by silica flour.

### Cleaning Inside of Kettle: "Sawing" Pottery

(1) I have soft-soldered part of a copper kettle and shall be glad if you can inform me as to the medium used to remove the tarnish, flux, etc., from the inside to leave some perfectly clean?

(2) What is the method employed to drilling holes and sawing or grinding pot-earthenware? Are there special tools for this purpose? I have tried drilling and sawing, but after a second or two both high-speed drills and also saws are blunted and rendered useless.—J. Bramhill (Rotherham).

(1) TO clean-up the inside of your copper kettle after soldering use some clean, wet sand and work it round inside the kettle by means of a rag tied to the end of a stick. This will effect a simple scouring action which will be quite effective. Afterwards, place a handful of washing soda in the kettle. Fill up with water and then boil it gently for five or 10 minutes. Finally, rinse the kettle out thoroughly with plenty of fresh water. The kettle will now be ready for normal use.

(2) Ceramic or pottery materials are nowadays cut by means of a "carborundum saw," which comprises a carborundum-tipped steel disc about 3in. diameter revolving at a high speed. Very often the sawing is done under water. Such material is drilled with carborundum-tipped drills and even with diamond-tipped drills. Ordinary steel drills, however, may be used quite satisfactorily (albeit slowly) if they are well lubricated with water or turpentine all the time. The drills should run at a fairly high speed without great pressure. The smaller the hole, the higher the speed of the drill.

Quite a number of pottery repairers work with steel drills and ordinary fine hacksaws, but they see always that the work is well lubricated.



**MIDLAND INSTRUMENT CO.**  
For Govt. Surplus Stock etc.

**"CHOBERT" RIVETERS TYPE "R."** An automatic hand-operated tool for repetition plating of tubular rivets, takes approx. 90 rivets in magazine, with 2 of each 3-size mandrels and other spares, instructional booklet, new unused in wood cases with leather carrying handle, size 2 3/4 in. x 6 in. x 5 1/2 in., worth £15, our price 37/8, post 1/4. Fully illustrated and descriptive booklet sent on receipt of 7/8, refunded in full when returned. **HOOVER INDUCTION MOTORS TYPE-SP-201**, shaded pole type, 200-250 v. A.C. mains, approx. 90-watts, speed 1,500 r.p.m., size 3 1/2 in. long, 2 1/4 in. dia. fitted 1 1/2 in. long, 1/4 in. dia. shaft, the ideal motor for 101 uses, brand new boxed, 20/-, post 8d. **PARMEKO TRANSFORMERS**, input-230v. 50-cycles, outputs, 4-6-8-10-12-14 and 18-volt, 1 amp, size 1 1/2 in. x 3 1/2 in., weight 4 1/2 lb., brand new boxed, worth 50/-, our price 15/-, post 1/4. **TELEPHONE CABLE D-8**, twin twisted tough rubber covered and braided yellow and black, 860ft. wound on wood drums, brand new, 25/-, carriage 5/-.

**FLEXIBLE DRIVES**, approx. 1/2 in. dia. spiral metal outer casing ideal for light power transmission and remote control, brand new stock, 4 different lengths, 3ft., 2/6, 6ft., 3/6, 8ft., 4/6, 12ft. 5/6, post 3d. extra. **ASTROGRAPHIS U.S. PATTERN**, designed for projecting star sheets, complete with 4 spare 24v. m.e.s. lamps, tools and instructions, in very smart and closed centrifugal fan blower, powerful air delivery or vacuum, new unused condition, bargain 15/-, post 1/4. **TELEPHONE SETS**, consists of 2 combined telephones and microphones, 25ft. twin connecting flex, provides perfect 2-way communication, self-energised, no battery required, complete ready for use, brand new boxed, 7/8, post 9d.

Also hundreds of other interesting Radio, Electronic and Mechanical items, send s.a.e. for current lists. Our C.O.D. service is cancelled for the time being.

**MOORPOOL CIRCLE, BIRMINGHAM, 17.**

Tel.: HARborne 1308 or 2664

**MYFORD WOODWORKING LATHE**



TYPE ML8

MANUFACTURERS OF QUALITY WOODWORKING AND METALWORKING LATHES.

SUPPLIED THROUGH LEADING TOOL MERCHANTS

**MYFORD ENGINEERING COMPANY LIMITED**  
BESTON NOTTINGHAM Phone: 54222 (3 lines)

08.101

**THE LATEST TYPE FIXED CRYSTAL DETECTOR THE CRYSTAL VALVE**

as used in radar receivers.

Overall size 1/2 in. x 1/2 in. AMAZING RESULTS

3/6 each, postage 2/3d. Protective Tube and Fixing Brackets, 3d. extra.

Wiring instructions for a cheap, simple but high quality Crystal Set included with each Detector.

**CRYSTAL SET INCORPORATING THE LATEST CRYSTAL VALVE**

Adjustable Iron Cored Coil RECEPTION GUARANTEED Polished wood cabinet, 15/- post 9d.

Send S.A.E. for lists of copper wires, screws, nuts, paxolin tubes, ebonite, tufnol rod and panels, etc.

**POST RADIO SUPPLIES**  
33 Bourne Gardens, London, E.4

**NORTHERN RADIO SERVICES** are now pleased to extend their unique service to television constructors. **VIEWMASTER** (London and Midland) full constructional manual and parts list, 5/3. **ELECTRONIC ENGINEERING TELEVISOR**, London, 5/3; Midland, 4/9. All parts available. **N.R.S. AMPLIFIERS** (4-watt, £5-10-0; 15-watt, 10 gns.) and **H-F1 TUNERS** (T.R.F., £5-10-0; Superhet, £8-10-0) still available (full Bargain Catalogue 2/6). **COLLARO RC49 MIXED AUTOCHANGER**, 11d. **RC500 9-Record Autochanger**, £10-15-0. **MARCONI AC100 10-Record** (not mixed) Autochanger with Hi-Fi pickup and transformer, 10 gns. **COLLARO AC504 MOTOR/PICKUP/AUTOSTOP UNITS**, £5-3-2. **AC47** centre-drive gram motor, var. speed with 12in. non-magnetic turntable, £5-18-4. Full range **WHARFEDALE SPEAKERS** in stock. **AMPLION ALL-PURPOSE TEST METER** (1,800 o.p.v.), £3-7-6. **FIFCO All-in-One RADIOMETER**, for Radio and Electrical testing, 25/-, **REMINGTON ELECTRIC SHAVERS** four and five head models. Home-built **SIGNAL TRACER**, enormous help in Radio repairs, earns its price in no time. Complete kit, 87/6, ready built, 5 gns. **GRAMPLAN MOVING COIL MICROPHONE**, 25/-; Folding Floor Stand (chrom.), 42/6. **ROTHERMEL D104 Crystal Mike**, 5 gns. Bgn. List 2/6. **TERMS: C.W.O. or C.O.D.**

**N.R.S., 16, Kings College Road, Swiss Cottage, London, N.W.3**  
Primrose 8314.

**FRACTIONAL H.P. EX-R.A.F.**  
1st H.P. BRAND NEW, ELECTRIC MOTORS made by Hoovers.

EACH ONLY 37/6 Carr. 2/6



Not to be confused with smaller cheaper types. Size 1 1/2 in. x 5 1/2 in. x 5 1/2 in. Weight 18lb. Volts 200/250 A.C. or D.C. 2,000 r.p.m. Ideal for Polishing, Grinders, etc. Existing Spindle 1/2 in. diam., 1 1/2 in. long. All-purpose Extn. Spindles to screw on, 7/6 pair extra.

**EX-ARMY HEADPHONES, BRAND NEW AND BOXED.**

Ideal for Crystal or Valve Sets, Hospitals, etc. Post Free 5/6 Pairs 10/- Per Pair. Precis. Insts.; Bal. Arm Units; Reed drive Corrug. Alum. Diaphragms; Dbie. H/Bands; 8ft. Cords and Plug. Worth about 42/-! Also makes Boys' Tel. Set by connecting earpieces to flex. Send 1d. S.A.E. for Radio/Elec. List.

**EX-GOVT. ELEC. LAMP BULBS**

Brand New, ex-R.N. and R.A.F. Ring makes, less than half price. Abbreviations: v.=volts; w.=watts; T.=tubular bulb; R.=round bulb; Os.=Osram; Maz.=Mazda; Sie.=Siemens; Ed.=Ediswan. Postage extra.  
Fitted Medium Prefocus Cap.—  
10v. 240w. R. Os.; 11v. 264w. R. Os.; 12v. 240w. R. Sie.; 20v. 240w. R. Sie.; 24v. 240w. R. Maz.; 24v. 250w. T. Maz.; 25v. 240w. R. Sie.; 22v. 250w. R. Maz.; 110v. 240w. R. Maz.; ALL AT 10/- each.  
12v. 100w. T. Sie.; 12v. 100w. R. Ed.; 30v. 100w. T. Maz.; 100v. 100w. T. Os.; 110v. 100w. T. Os.; 220v. 100w. T. Os.; ALL AT 7/6 each.  
Fitted Gollath Prefocus Cap: 22v. 350w. R. Maz. 12/6; 24v. 400w. T. Os. 10/-; 26v. 350w. R. Maz. 12/6; 110v. 1,000w. T. Ed., 15/-.  
Fitted Sperry Prefocus Cap: 42v. 2,500w. T. Sie. 20/-; 80v. 1,500w. T. Maz. 7/6; 105v. 500w. T. Sie., 15/-.  
**ALDIS** (Spec. Ftg.): 12v. or 24v. 36w. 2/6. Also 80v. 3,000w., or 10,000w. G.E.S. Os. £2 or £5; 230v. 3,000w. Hpost Maz. £2. Send 1d. S.A.E. for List of 150 other types, 2v. to 230v. for Boats, Cars, Mines, Workshop, etc.

**AUTO COLLECTIONS LTD.,**  
15, Lawrence Street, Northampton.

**THE WORLD'S GREATEST BOOKSHOP**



New and secondhand Books on every subject. Stock of 3 million volumes  
Large Dept. for Technical Books  
119-125 CHARING CROSS RD. LONDON, W.C.2  
Gerrard 5660 (16 lines)  
Open 9-6 (inc. Sats)

**HEXAGON KEY SPANNERS**

Complete + 6d. Post., Pkg.  
\* 9 HIGH GRADE STEEL KEYS \*  
\* SPECIAL ALLOY RACK \*  
(Lists now available)  
**MORTONS, 13, Camden Road, Walthamstow, London, E.17.**

**EXCLUSIVE HOME STUDY COURSES BY T.I.G.B.**

for A.M.I.Mech.E., A.M.I.E.E., A.M.I.Chem.E., City & Guilds, etc.  
The Technological Institute of Great Britain offers private and exclusive postal instruction for A.M.I.Mech.E., A.M.I.C.E., A.M.I.Chem.E., City and Guilds, etc. Those who are seriously interested in obtaining a recognised technical qualification or desire a Diploma Course in any branch of engineering should consult T.I.G.B.—The Professional Engineering Tutors.

**THE INSTITUTE'S PROSPECTUS**  
An outline of Study Schemes, method of enrolment and fees are contained in the Programme of Studies freely obtainable on application to the Registrar, T.I.G.B., 218, Temple Bar House, London, E.C.4. Please state subject of interest and training to date (if any) to assist in the suggestion of suitable studies. Every enrolment application is closely vetted before acceptance.

**The Technological Institute of Great Britain**  
218, Temple Bar House, London, E.C.4



**Plans for 1/2 in. to 1ft. scale model of an OLD TIME 12pdr. CANNON**

The model is approx. 4 1/2 in. long but will scale down for use on model galleons or enlarge for use on lawns as an ornament or as a yacht race starting gun. Details include methods of lashing to bulwarks, deck, etc., and equipment such as rammers, sponges, etc. Old time ship modellers will find these plans extremely helpful, whether they can include all the detail in their models or not.

PRICE: 2/6 Post Paid 2/9

**Modelcraft 1950 List 1/-**

The list gives details of over 600 items; plans, planbooks, kits, accessories, etc., and in addition historical notes and hints on doing the work by experts in many fields of modelmaking. No modeller should be without it. Post free or from your model shop.

**MODEL CRAFT LTD.**  
77(L), Grosvenor Rd., London, S.W.1

**"DUREX" AIDS ASSEMBLY AND REPAIR**

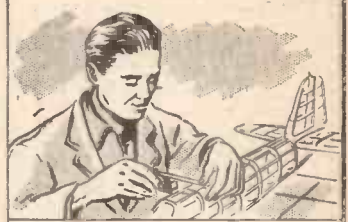

**"DUREX" HELPS IN THE DRAWING OFFICE — ALSO REPAIRS TORN & DAMAGED PLANS**



"DUREX" Tapes it easy! Holds tracings to the board! Mends torn plans invisibly! Aids the model builder in assembly or repair! Clean to handle, transparent as glass, and housed in its own self-dispenser!

Trade enquiries: Durex Abrasives Ltd., Birmingham, 8  
**"DUREX" Cellulose TAPE**



# Whatever you do . . .



Whether you're taking part or going merely to watch and shout encouragement, the Dunlop Sprite is your tyre. It's unbeatable for every type of fast road work—that's why it was awarded the C.T.C. Plaque in 1933—and it's just the tyre to take you safely through the winter.

## . . . rely on **DUNLOP**

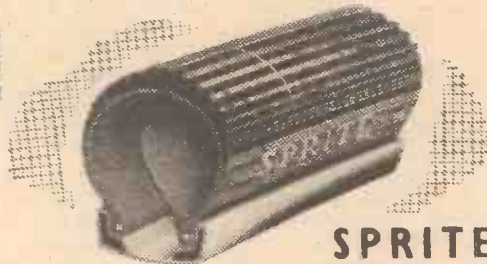

**SPRITE**

50H/305

### Feeling Chilly! Then make a **CONVECTION HEATER**

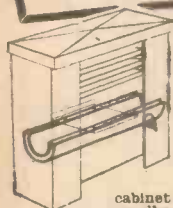

Ex. Admiralty HEATING UNITS fitted with 3-pin brass plug and socket. Copper-clad enclosed elements are used and these are again enclosed in sheet metal half cylindrical containers. Fit one of these

into a metal cabinet and you have an excellent convection heater.\*

In places where appearance is not important all you need extra is the wire, as the heaters work perfectly well as they are, without extra casing, the actual element being totally enclosed.

**PRICES:**

- 2 k. w. 220/230 v. 9/- each
- 500 w. 220/230 v. 9/- each
- 2 k. w. 110 v. 5/- each
- 500 w. 110 v. 5/- each

CARRIAGE 2/- EXTRA per Heater.

\* Sketches and details of suitable cabinet are supplied with each heater.

Two 110 v. types wired in series can be used on 220/230 v. mains without any difficulty arising.

### MOTORISTS!!!

Get away to an easy start whatever the weather by using a **PORTABLE CAR HEATER**

Made for the Services these portable heaters will save freeze-ups and prevent your car being ruined by a cracked cylinder block. Just place one of these heaters under the bonnet and plug into the mains. Absolutely safe, being flame-proof there is no fire risk, and no messy filling with fuel. All motorists should order right away whilst stocks last. 500 w. 220/230 v. Price, 17/6. Plus 2/6 carriage.

Write to Dept. K

**INSTRUMENT CO.**  
11, GUNNERSBURY LANE,  
ACTON, W.3.

Send 2jd. stamped, addressed envelope for our latest list.

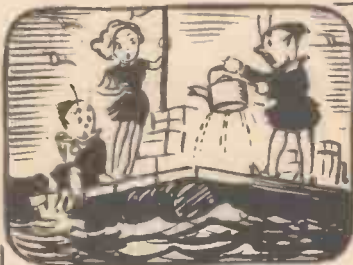

### THE "FLUXITE QUINS" AT WORK

"Being saved from the shipwreck's all right,  
But now we're in a worse plight.  
We've everything here  
From biscuits to beer,  
But no FLUXITE to solder this tight."

For all **SOLDERING** work—you need **FLUXITE**—the paste flux—with which even dirty metals are soldered and "tinned." For the jointing of lead—without solder; and the "running" of white metal bearings—without "tinning" the bearing. It is suitable for **ALL METALS**—excepting **ALUMINIUM**—and can be used with safety on **ELECTRICAL** and other sensitive apparatus.

**With Fluxite joints can be "wiped" successfully that are impossible by any other method**

Used for over 40 years in Government works and by leading engineers and manufacturers. Of all Ironmongers—in tins, 10d., 1/6 and 3/-.

● **TO CYCLISTS!** For stronger wheels that will remain round and true, here's a time-tested tip. Tie the spokes where they cross with fine wire **AND SOLDER**. It's simple—with **FLUXITE**—but **IMPORTANT**.



ALL MECHANICS WILL HAVE

# FLUXITE

IT SIMPLIFIES ALL SOLDERING

Write for Book on the **ART OF "SOFT" SOLDERING** and for Leaflets on **CASE-HARDENING STEEL** and **TEMPERING TOOLS** with **FLUXITE**. Also on **"WIPED JOINTS."** Price 1d. Each.

**FLUXITE LTD., Dept. P.M., Bermondsey Street, S.E.1**

**TELEPHONE SETS**, comprising 2 C.P.O. hand-phones, 2 bells, 2 pushes and 80ft. twin wire. Price 48/6, post free. Makes an excellent inter-office, works or domestic installation. Really professional instruments. Brand new, not rubbish. Single instrument, 11/6. **BATTERY CHARGERS** for A.C. mains. For charging 2-volt accumulators at 1 amp. Parts with diagram, 15/-. Complete, 21/6. Postage 10d. **FOR TRICKLE CHARGING CAR CELLS**, parts with diagram. Output 11 amps. for 6v. cells, 28/6 set. For 12v. cells, 28/6 set. Post 10d. **PHOTO-ELECTRIC CELLS**.—For all sound films, high fidelity production, speech and music. Small tube size, 2in. x 3in. dia., 26/6. Midset tube, 1in. x 1in., 22/6. **COMPLETE OPTICAL SYSTEM** for 35 or 16 mm. sound film, 2in. long, 1in. diam., projects 0.0005in. light. Price 22/6.

**ECONOMIC ELECTRIC CO.,**  
64, London Road, Twickenham.

## REFILL YOUR OWN BALL PEN

### VISCOID REFILL KIT

Post Free 3/8 inc. tax.

COMPLETE WITH TOOL AND ILLUSTRATED FILLING INSTRUCTIONS  
CONTAINS SUFFICIENT INK  
FOR 15 AVERAGE REFILLS

AVAILABLE IN BLUE AND RED

TRADE ENQUIRIES INVITED  
P-M VISCOID INKS,  
6, SHERLOCK MEWS,  
BAKER ST., LONDON, W.1

### ADANA PRINTING MACHINES

Print in the odd hours with an Adana—still the most absorbing of crafts. No. 1 H/S Machine 24/10.0. No. 2 H/S Machine 29.15.0. Will quickly pay for itself. Send for illustrated folder to Dept. P.M. 32 **ADANA (Printing Machines) LTD.,** 15-18 Church St., Twickenham, Middx.





VOL. XVIII

MARCH, 1950

No. 336

All letters should be addressed to the Editor, "THE CYCLIST," George Newnes, Ltd., Tower House, Southampton Street, Strand, London, W.C.2.

Phone: Temple Bar 4363

Telegrams: Newnce, Rand, London

## Comments of the Month

By F. J. C.

### Too Many Rules!

TIME trials in this country were formerly governed, if that word can be used, by the old Road Racing Council, which had about a dozen "recommendations" to control road sport.

These recommendations worked reasonably well. Every cyclist knew them and did his best to comply with them. It is true that a recommendation has not the same force as a rule or regulation but none the less breaches of the recommendations were rare. The Road Racing Council lacked authority and of course a recommendation is only a recommendation and failure to adopt it did not necessarily mean that a ride was invalidated. It was not a body which existed to homologate record times, and so before the war the Road Time Trials Council was formed to take over from the R.R.C. the complete control of road sport. Up to that period time trials were very much the Cinderella of cycling. The N.C.U. were opposed to them, having abandoned control of them and of road records in the 'nineties, and there was no really authoritative body which could place the sport on a sound footing.

This the R.T.T.C. undoubtedly set out to do, and had it confined its attention to converting the recommendations into enforceable rules that would have been as far as it need have gone. Instead it hatched up a lengthy and complicated list of rules, many of which are honoured more in the breach than in the observance; indeed, it is doubtful whether any time trial official knows the rules off by heart.

At each A.G.M. since its formation the agenda has been cluttered up with propositions for more rules and many more have been added to the original set. The attitude of the Council seems to be that cyclists are thoroughly untrustworthy, are all potential cheats, and that their every movement must be governed by a rule. This is not the atmosphere which permeated the old Road Racing Council. A group of people commandeered the sport and are acting as dictators to it, much as the N.C.U. tried to be but failed.

### Black Clothing!

At this year's Annual General Meeting there were no less than ninety-five items on the agenda. We might usefully remark here that a body which exists to make rules and enforce them should equally obey them. This meeting was undoubtedly *ultra vires* because the agenda was distributed much too late for proper instructions to be given to the club delegates. This was challenged and put to the vote, but the delegates voted in favour of continuing the meeting. Stripped of the claptrap that usually is part of the A.G.M., which many think is intended to provide them with an opportunity of hearing their own voices and impressing others with their importance, there was little on the agenda worthy of comment excepting the decision, which is keenly resented among the clubs,

that all cyclists partaking in time trials must wear black clothing, and the only relief allowed is an official panel not exceeding 4ins. by 3ins., which may be displayed on either arm with club colours or other flashes. It was not clear from the discussion why the R.T.T.C. wished to follow the stupid example of the R.R.A. in insisting on black clothing. The R.R.A. advice was that cyclists attempting an R.R.A. record must be "inconspicuously attired," the approved attire being black tights which proclaimed to all and sundry that the wearers were racing cyclists—the very thing which the dress was designed to avoid.

### National Committee

The proprietors of our sport, however, have made themselves most unpopular by this new decision. There were no less than nine items on the agenda dealing with clothing—as if it really matters. The real proposition, however, came from the National Committee, and it sought to make every visible part of the rider's costume black, including cap, shorts, tights, socks, jackets and jerseys, with the exception of the panel referred to above. This proposition was amended to include the words "all clothing" instead of specifying components of it. The matter was discussed with heat and vigour. One delegate stated that the council's attitude in accepting the committee's recommendation would shake the sport throughout the country. In this forecast he proved a good prophet, for there have been protests from a large number of clubs, letters have appeared in the Press, and many clubs have threatened open defiance of the rule. In our view it is an unenforceable rule, quite apart from the difficulty in which it places many cyclists who may not be able to afford to scrap their existing attire in order to comply with a capricious rule. The R.T.T.C., since passing the resolution, has, as a result of the opposition, shelved it on the face-saving excuse of clothing shortage! Deliberations of an international character are not conducted with greater vigour than an R.T.T.C. A.G.M. The delegates consider that they are deciding matters of far greater importance than the impact of atomic warfare on society, and the introduction of the hydrogen bomb to them sinks into insignificance when compared with the importance of deciding whether a cyclist should wear a black tie or green furbelows. Surely someone next year should suggest that the edges of cyclists' shorts should be trimmed with a neat lace in petit point, a decoration usually associated with a female's garment!

### Prior Publicity!

It was too much to hope that the question of publicity in relation to time trials would not be brought up for a fresh airing. As usual there were two points of view. Most of the delegates opposed prior publicity in any shape or form, although the North District Council had a proposition to scrap the

publicity regulation. It was heavily defeated. For at least another year, therefore, time trials will be conducted in the usual hole and corner fashion for a reason which no longer applies, namely, the attitude of the police in the 'nineties towards cyclists. They are far too busy watching parked cars to bother about cyclists. No one gave any valid reasons why there should not be prior publicity, and the chief spokesman for the National Committee's proposal did not disclose one. Amongst a quagmire of tangled verbiage we selected the phrases "unfortunate results" and "police interest." As the speaker must well know, a blaze of publicity has been directed towards massed start racing on the roads, but it has not had unfortunate results. As far as police interest is concerned, it is *non est*. Some merely pugnaciously wish to inflict their will on the rest of the community, their will being that the sport should be run as it was in their youth. The R.T.T.C. Council is quite out of touch with modern tendencies in cycling. The delegates themselves having been cradled in this atmosphere voted against sound propositions, such as that which suggested number cards for the competitors. The use of these would reduce to a minimum the noise made at checking points, since it would not be necessary for the competitor to shout his number to the checker. It would also assist checkers and timekeepers, for it is not unknown for a timekeeper to miss a number and it equally is not unknown for a competitor to forget his number or to shout the wrong one. It would also prove useful in helping to eliminate paced riding. The only arguments against it were cost (such cards would cost only a few pence a hundred) and the slight trouble it would give to the competitor in having to return the number, and the small amount of time required to fit it!

However, most of the delegates to this pompous body had their say and hoped, of course, that a roving photographer would take their pictures! The meeting came to an end with the feeling among the delegates that peace in the world was secured for at least another year. Considering the heat that was generated during some parts of the discussion we are happy to be able to record that none of the delegates whose motions had been defeated indulged in free fighting, nor was there a repetition of the cat-calling and shying of paper balls which took place when many of these self-same delegates met at the Albert Hall Cycling Concert some years ago.

### Paid Advocates

We repeat what we have said so many times before that the time is overdue for an entirely new cycling body representative of all cycling interests, controlled by one central council governing two committees—one for racing and one for touring. Efforts have been made to amalgamate the two existing organisations, but those efforts have failed chiefly because they are peopled by those whose minds are back in the days of the old Ordinary.



# Paragrams



The Chequers,  
Tonbridge.

Although much restored  
this fine medieval timbered  
inn makes an attractive picture  
in this old Kentish town.

## Sealed Beam For Cyclists

THE American General Electric Company has now developed a sealed-beam headlight, resembling the type of headlight used on cars, especially for the use of cyclists. The lamp can be attached either to the handlebars or to the front forks and it is claimed that it gives three times more light than the ordinary cycle lamp, without any of those annoying dark patches which seem to appear just where one needs light. If only we had a few more of those elusive dollars!

## Comfort!

IN all seriousness, a large department store in Canada is showing in its latest catalogue a fur cover for a bicycle saddle. It is guaranteed to provide just that little bit of extra comfort that is needed in winter and, what is more, the saddle cover also has a tail, which flaps in the wind as the cyclist rides along. They're not so mighty tough in the North as we thought, evidently!

## Getting The Wheels Turning

PROGRESS is being made with the organisation at March, Cambs, of the March Wheelers' Cycling Club. The first committee meeting has been held and the club president, captain and other officials have been elected, and tentative plans are under consideration for next season's activities.

## Woman Champion Married

MISS MARJORIE BROWN, of Hexthorpe, Yorks, for the past two years national women's 880 yards cycling champion, has been married at St. Jude's Church, Hexthorpe, to Mr. John Padley, of Doncaster. The bride has for some time been a member of Brodsworth R.C. and she left the church under an archway of cycle wheels, held aloft by some of her fellow club-members.

## Cheap Repair Cost Life

AT the inquest at Chesterfield on a 57-year-old cyclist, who was fatally injured after being thrown from his machine, it was disclosed that a length of piano wire was being used instead of a proper brake cable. The wire apparently snapped when the cyclist tried to brake and avoid hitting a pedestrian. The cyclist fell heavily,

sustaining a fractured skull and other injuries, and died some fifteen minutes after being admitted to hospital.

## Automatic Gear Change

A GERMAN factory is reported to be starting production of an automatic gear change device suitable for all types of vehicles. It is claimed that a modified model can also be used on bicycles.

## Devaluation?

WHEN a man appeared at Cambridge Borough Magistrates' Court charged with the theft of a bicycle, a cycle repair agent told the Bench that the man offered to sell him a cycle for £4, but he finally paid him £2 10s. The owner

of the stolen cycle said he valued it at £10. The accused was committed for trial at the next Cambridge Borough Quarter Sessions.

## Cycle Track for Scunthorpe

SCUNTHORPE Borough Council have accepted a tender for the building of a new footpath and cycle track on the Lincoln Gardens Estate. Before this Estate was developed there was a much-used footpath on the site, which still remains, and as a considerable number of cyclists regularly use this route, and there is much traffic, it is hoped by the Council that the new cycle track will help to prevent accidents.

## From Road to River

TEMPORARILY forsaking the open road for the open river, a team of anglers from Grimsby Cyclists' Club took part in the fishing match for the "Grimsby News" shield. Members of the team were G. Wilson, E. Barratt, F. Grimoldby and J. Betts, and they wielded their rods with such effect that they won the shield with an aggregate catch of 9lb. 9oz. 8dr.

## A 294,688-mile Ride

MR. STEPHEN LAXTON, of Rippingale, Lincs, who at 75 is the oldest sub-postmaster in the district, has just worked out the distance he has cycled with the mail in the Fens since he first started—and the total works out at 294,688 miles. He first started on his rounds when he was 19 years old, and he has never been involved in an accident. Even now he is still doing his 12 miles a day, quite unconcernedly, starting at 7.15 a.m., and it has to be a very bad winter with very deep snow to stop him getting through.

## Veteran Rider Passes

MR. HARRY MONUMENT, known locally as "Old Monny," of "The Orchard," North Somercotes, Grimsby, has died at the age of 87—and he was cycling almost up to the end. His first machine was one of the old penny-farthings, which he rode regularly until more "modern" machines came along, and on which he won many races. He was a real enthusiast, and even at an advanced age he never let such trifles as rain

and wind upset his plans if he had prepared for a run. At one time he was skipper of a Grimsby boat, so maybe that and cycling together toughened him!

## Two New Doncaster District Clubs

THERE are now 10 cycling clubs in Doncaster and district, following the recent formation of Doncaster Paragon C.C. and Hatfield Main Welfare C.C. Doncaster Paragon C.C. has no connection with the Doncaster Paragon Road Club, which had to be disbanded in 1941, except for the similarity of names, and the Hatfield Club has a membership from the Hatfield Main Colliery. Mr. K. Turner, of Abercorn Road, Intake, Doncaster, has been appointed secretary of the Paragon C.C., and the Hatfield club's secretary is Mr. W. Hodge, one-time rider with Doncaster Wheelers and Thorne Paragon.

## Keeping in Training

MR. WALTER WATSON, of High Street, Grantham, a prominent member of the Grantham Road Club and manager of a butcher's shop in Stamford, regularly cycles the 42 miles to and from his work each week-day, apart from a month or two at the worst part of the winter. This year, Mr. Watson, who is 36 years old, carried off all seven of his club's challenge trophies, as he did once before in 1939. He feels that his daily rides have much to do with keeping him fit for club events, in which he has been competing for the past 17 years.

## More Restful!

SPEEDWAY rider Roy Dukes, who has retired from the track after a number of spills and injuries, has cast aside the motorcycle in favour of the more peaceful life as landlord of the Blue Peter Inn, Padholme Road, Peterborough. He has also become a member of Peterborough Cycling Club, and often takes the road with his fellow-members on recreational runs. During his speedway riding he has sustained a broken back, a broken leg and other less serious injuries, and he finds a peaceful run with his club much less trying.

## Coroner and "Slow" Signs

AT the inquest at Huntingdon on a cyclist killed at Wyton crossroads in a collision with a car while riding with his 10-year-old grand-daughter, who escaped injury, the coroner made some adverse comments regarding the use by local authorities of "Slow" signs. According to the evidence, the two cyclists went straight out on to the cross-roads and the coroner said these signs were "a snare and a delusion." He said: "It all comes to this, that these signs are no use at all." He suggested there was some error of judgment on the part of the motorist, who ought to have made certain that the cyclists saw him, but he did feel that whatever signs were put up there would always be someone to take a risk.

## Progressing Backwards!

A CHICAGO firm has given a \$40,000 order, which both pleases and puzzles a Birmingham cycle manufacturing concern. The order is for 400 brand-new penny-farthing cycles, and no clue is given as to the reason for this strange order. No one at the Birmingham factory has ever built a penny-farthing cycle but an old original model has been obtained as a pattern, and this is being copied, with a few modifications, such as tubular frame and pneumatic tyres. When the consignment of cycles reaches Chicago the natives should have a little innocent excitement watching 400 "penny-farthing learners" trying to ride the machines.



# Around the Wheelworld

By ICARUS



**Bakehouse Close.**  
The sketch shows Huntly House dating from 1570 - once the home of the Marquises of Huntly. Further down the Close stands Acheson House another old building dating from 1633. These quaint Closes are a great feature of old Edinburgh.

they infer that you must not like it. You must like or not like something to their order. It is not surprising that the main proposition came from Yorkshire, whose delegates tried to secure the removal of the paragraph which dealt with massed start racing. This paragraph was "its existence is now a definite menace not only to time trials sport in its state of freedom from interference, but from all cycling club and party riding." But the chief protagonist for the abolition of massed start racing secured the opportunity for dragging the usual red herrings across the scent. But he did not advance one single argument supported by fact. His opposition was based on fear and he reflected in that respect the former views of the N.C.U. But the N.C.U. have been proved wrong. After over five years of massed start racing, none of their gloomy forebodings have come true and once again their judgment has been proved unsound. The boneless wonder of the cycling movement has therefore made one of its typical gyrations and is now really seeking to obtain control of massed start racing. At the moment of going to press I learn that representatives of the two bodies are in the bill and coo stage, having become transmogrified from the bull and cow stage. Adversity does indeed make strange bed partners. Of course, the N.C.U. is perfectly prepared now to support massed start racing provided that it could control it and absorb the founding body. Such an amalgamation or condominium is undesirable. The league has nothing to gain from such an arrangement. However, T. Anderson, of Yorkshire, when the matter was discussed, pointed out that the authorities were fully aware of the difference between club riding, time trials and massed start events, and another delegate said that he was disgusted to encounter "this deceitful method of denigration of cyclists by other cyclists." When it was put to the vote sixteen delegates favoured the deletion of the paragraph, whilst twenty-five decided to leave the report as published. The matter is certain to bob up again next year. In the meantime, a rather interesting situation arises. The N.C.U. is flirting with the idea of running massed start races on the roads and has implied this in a letter to the M.O.T., whilst the R.T.T.C., which has a working arrangement with the N.C.U., is opposed to it! What will happen next year at the A.G.M. if the N.C.U. finally come to some agreement with the League and run massed start racing? Will the R.T.T.C. still think it is a menace? And if so will it break its agreement with the N.C.U.?

### A Private Member's Bill

THE Wolverhampton Corporation is sponsoring a private member's bill for Parliament which, if it became law, would mean that cycle racing on the roads in the Wolverhampton district would be illegal. It may be that if this bill goes through other districts would follow suit; or the bill may be withdrawn on promise of legislation covering the whole of the country to save a spate of private members' bills.

### A Dangerous Policy

MR. A. TYSON is the secretary of the Manchester Centre of the N.C.U. Road Safety Committee. This committee issued prior to the election a manifesto to Parliamentary candidates which really staggered me when I read it. This manifesto seriously asked prospective candidates if they were returned to power to pledge their support for

proposed legislation under which a cyclist would be given an endorsed card prohibiting him from riding a bicycle if he were to be convicted of riding a bicycle under the influence of alcohol! This is indeed a dangerous policy, for it is suggesting to the authorities as plainly as can be that cyclists are in the habit of getting drunk and riding a bicycle. I should certainly like to see a drunken man riding a bicycle. A drunken man can scarcely stand and he certainly would not be capable of that instinctive effort which is necessary to keep one upright on a two-wheeler. There is no evidence whatever to suggest that cyclists are drunkards and by continuation of the idea, why should not a pedestrian have a similar card if he is convicted of drunkenness? A pedestrian drunkard often causes an accident in which he himself is not physically involved. As I have remarked, anything which moves along the road is a vehicle and if a man is walking he is just as much a vehicle as one who dons a pair of giant's boots in the form of a geared two-wheeler. If rear lights are necessary on bicycles they are necessary on pedestrians. If a cyclist is to carry a card because he rides a bicycle when drunk, a pedestrian should suffer the same fate. The present law is quite adequate to deal with offenders. In any case, how could the police prevent a man so convicted from riding a bicycle? Is he to stop every cyclist and ask to see his card? When cyclists who ought to know better place their heads in the lion's mouth in this fashion and put ideas into the minds of the Government which were not there before, they must not complain if new laws against them are made. It was the C.T.C. remember that first started the rear light controversy. A few decades ago it was insisting that all horse drawn vehicles should carry rear lights because one or two cyclists, evidently with feeble headlamps or bad eyesight, had ridden into the backs of slow moving farm carts in country districts. Such a law was made, and cyclists only have themselves to blame now that they are expected to carry rear lights. The policy of the C.T.C. seems to have been "Inflict rear lights and penalties on other people, but not on us."

### The Sounding of Horns

MR. G. RICHARDSON, of Handsworth, corrects my statement made last month regarding the sounding of horns. I said that horns of cars may not be sounded after 11 p.m. when, of course, the correct hour is 11.30 p.m. The exact period during which horns may not be sounded is 11.30 p.m. to 7 a.m.

### The B.B.A.R.

AT the recent A.G.M. of the R.T.T.C. the London West District Council had a proposition to determine how excess entries in B.B.A.R. events should be dealt with. The proposition stipulated that 75 per cent. of the field will be selected from the fastest riders and the remainder will be chosen on the basis of making complete teams. When put to the vote, the poll was even, so the chairman used his casting vote in favour of the motion. Personally, I should like to see this competition abolished since it interferes with the normal club racing programme. A rider is obviously not going to enter an event in which he is not able to return a time which would help him in his B.B.A.R. aspirations. The rules under which it is run are mathematically wrong, and as it is a paper contest it is not a real contest. Much better to have an event on the road to find the best all-rounder, the event to be subdivided into short, medium and long distance events. You cannot find a best all-rounder on paper.

### Massed Start Racing

OF course at the A.G.M. there were those who wished to attack massed start racing. Because those on the council have said, "we do not like massed start racing,"

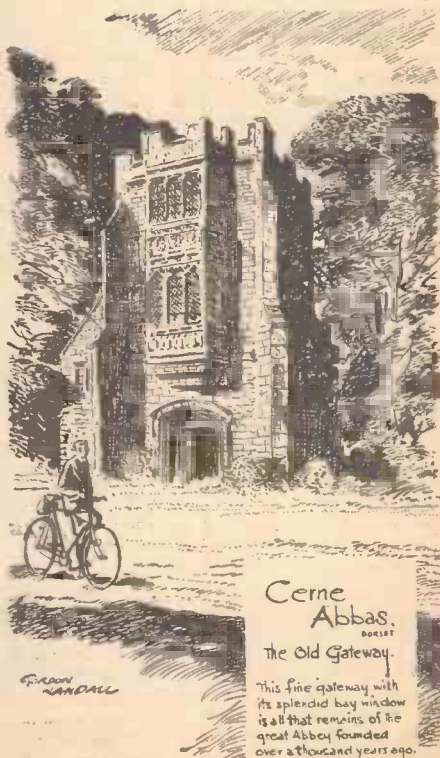

**Ceme Abbas.**  
Dorset  
The old Gateway.

This fine gateway with its splendid bay window is all that remains of the great Abbey founded over a thousand years ago.



# Wayside Thoughts

By F. J. URRY



A medieval corner  
of England.

In this lonely spot on Sedgemoor there is a small treasure house of ancient buildings. The sketch shows the charming little Priest's House, dating from the fourteenth century. Across the road is the old church and behind it the remains of the great abbey of Muchelney, founded by Athelstan as a thankoffering for his victory at Brunanburgh in 937. Only parts of the Abbot's House and cloister stand to-day, though work of uncovering further remains continues. Across the moor, a mile distant, rises the glorious tower of Huish Episcopi Church.

## Still Sound Practice

SOME riders appear to be getting a trifle querulous in their outlook on equipment. Recently, I have received numerous letters from the younger brigade criticising the cotter-pin anchorage of cranks to bracket axle, not because the fastening has failed but for the reason that it is considered old-fashioned and ugly. Yet it has served us admirably for many decades, and although various firms have tried other methods of locking the cranks—notably the late John Pugh for Rudge-Whitworth—none of the devices has withstood the test of time. To-day there are various foreign patents on crank fixing, and they are certainly neat in appearance, but, having no experience of them in performance, I am unable to express my opinion on the question of reliability, but what is the matter with the cotter-pin fixing? It has stood the test of time, it stands up to its job marvellously well even when thoroughly neglected, and, when properly fitted to marry with the axle key-way, will last as long as the metal holds together. Maybe it could be made neater for use on the high-class machine; maybe it will if we, the riders, are prepared to pay for the finer work; but I cannot see much wrong with cotter-pin fixing at present in use.

## The Wisdom of Fitness

AS a confirmed cyclist it is curious to me that so many people fail to understand the pastime and become very impatient with me when I try to explain my view of it. I am, in their view, cycling mad, and in mine, cycling wise, and between those differing opinions a wide gulf lies that needs bridging for the benefit, especially, of the growing oldsters. True, I have always been a cyclist because love of the countryside and of exercise was dominant in me, and pedalling provided me with the means of satisfying both natural desires.

But I submit I am not cycling mad in the sense my critics suggest, for up to the years when the competitive spirit burned in me I played many other games, and not altogether unsuccessfully, including cycle racing. I believe the great mistake is made by many sporting people (and racing cyclists are by no manner of means exempt from this criticism) that when the competitive urge dies down in them they sink into a kind of lethargy in the athletic sense and rust out instead of wearing out; and the older I grow the more convinced I am that this is true, for I see so many of my youthful friends suffering from the ills of the flesh which, peradventure, may have been circumvented by keeping the old body at work. It is so easy to ride, once you are reasonably fit, that the term work has little meaning to me in my cycling; but people will not believe this because they do not want to ride. There is the trouble for cycling to overcome, and there indeed is the trouble for the people to overcome. Actually it is "not the thing" to cycle, particularly if you can afford to motor—and sometimes if you cannot. Seems to me so many folk would rather suffer in health than ride a bicycle and keep fit and well. Strange, but unfortunately true; a curious trait in the modern human make-up.

## Curious Mentalities

IF I said to some of my friends "you are too purse-proud to ride a bicycle" they would be horrified at so outrageous a suggestion of snobbery. Yet it is true, for we are all snobs in some degree and on some subject. "Goodness," one man said to me recently, "my workpeople ride bicycles"; of course, and they wear shoes and coats and hats, and even have a little money in their pockets. It is all so very ridiculous when you consider that this means of travel is a way of health, and the certain avenue down which you will find beauty and the

great gift of silence. Personally, I never feel mean or little when I am aboard a bicycle; I feel on top of the world, free, individualistic and satisfied, a better specimen of humanity than I might have been had this best of all pastimes failed to interest me. No longer can I play the competitive games with the old verve, and thereby the fun of them largely evaporates; but I can ride my bicycle all day and gather that meed of athletic satisfaction that otherwise would be denied to me, and on the way automatically imbue my body with health and my mind with beauty. It is a great charm, but, alas, how few people believe it after the first glorious flush of youth has gone over them. Maybe the restlessness of life has had something to do with this wide and public attitude to cycling; maybe the general uplift in wages and salaries has encouraged certain types to imagine themselves little nabobs; or maybe the bicycle is so old and so common that the majority of modern people think—if they think of it at all—in terms of obsolescence. I only know the wisdom that has come to me by way of the bicycle, the wisdom of health and quiet joy, of easy movement and a lissom body, and in addition to these virtues, a youthful outlook which has made a fairly long spell of life happy and contented.

## Start it Right

I SOMETIMES wonder why the school curriculum ignores the pastime of cycling so completely. Certainly it tinkers with riding ability and upkeep of machines in a desultory manner and has sought to impose barriers suggestive of the dangers of riding, but as far as teaching cycling is concerned it is a dead letter. Perhaps there are not enough cycling teachers, perhaps educationalists have a similar outlook on cycling as the professional class of the ordinary public; it is just not done. I do not know the reasons for this neglect, but I do feel there are a thousand reasons why cycling should be taught in schools, and dozens why the use of a bicycle could add great value to many lessons. One has only to think of map-reading, contours, geography, not from a book but from hill-tops, botany, biology, and, perhaps more impressive than any, the inculcation of a real love of country into the minds of the younger generation. The bicycle is the visual cinema for this, the fact, not the picture, and intelligent instruction would be a new world of learning for many thousands of young folk. Difficult, you may say, amid the crowded towns, but why the towns? Half a day in the country under proper tutelage would mean a new interest in school life, and incidentally make more and better cyclists of thousands of scholars who would be encouraged to join the pastime. Nothing, I am convinced, could be better for their health and future well-being, and few things in my view would add greater interest to lessons. The idea could not be universal immediately, for the simple reason all schoolchildren are not cyclists, but then all schoolchildren used not to be uniformed, and the spread of that condition has grown, as would the cycling habit, once it was properly started and intelligently handled. What school will be the first to adopt a great and novel means of adding action to erudition, or are we so sunk in snobbery that a very simple and delightful value to education will never be given so excellent an opportunity to encourage health, good road sense, sound exercise, freedom and the right development of the individual?

## WIRE AND WIRE GAUGES

3/6, or 3/9 by post

From George Newnes Ltd., Tower House,  
Southampton Street, Strand, London, W.C.2



THE WORLD'S MOST PERFECT BRAKE

FIT  
OUR  
LOCK  
LEVERS  
AND



MAKE  
YOUR  
MACHINE  
THIEF-  
PROOF!

Whatever your Speed!  
Whatever the Gradient!  
Whatever the Conditions!  
"CANTILEVERS" (REGD.)

ensure  
MAXIMUM BRAKING EFFICIENCY

Fixed rigidly on the forks or stays, CANTILEVERS are always positive in action, smooth and powerful, grip well in the wet, and give long service. Available in Steel or LIGHT ALLOY with all WEARING PARTS reinforced in STEEL. Specially suitable for TANDEMS. Twelve-month Guarantee with all new Brakes.

Our special LOCK LEVER can be supplied with all Brakes, or separately for use with ANY existing Cable Brake. WHEN THE BRAKES ARE LOCKED ON, IT IS IMPOSSIBLE TO RIDE OR WHEEL THE BICYCLE AWAY.

NOTE: Brakes are supplied with ordinary or LOCK LEVERS in Straight or "C" Shape. Special length cables for frames over 21in. Alternative fittings for various shapes and sizes of forks and stays. Brake blocks for Steel or Alloy rims in three thicknesses for correct clearance. It is essential to obtain the alternatives best suited to your requirements. New and reconditioned Cables and all spare parts readily available. If in any difficulty write to us.

PRICES:	Cantilevers	...	...	...	...	...	...	22/6 to 37/6
	Cantilette	...	...	...	...	...	...	17/6 to 22/6
	Cycle Lock	...	...	...	...	...	...	17/6

Brakes supplied with Lock at an extra charge of 7/- only on Alloy Models, and 9/6 only on Steel Chrome Models.

THE RESILION CO., LTD., 200 LIVERPOOL ROAD, LONDON, N.1

CYCLISTS

fit only

Miller approved  
replacement bulbs

to your



DYNAMO

LIGHTING SET

for maximum life

H. MILLER & CO. LTD., ASTON BROOK ST., BIRMINGHAM 6

LOOK  
AROUND



Halfords



FOR EVERY  
ACCESSORY

THAT'S  
NECESSARY



★ OVER 220  
BRANCHES IN  
ENGLAND, SCOT-  
LAND & WALES

★ THERE  
IS A HALFORD  
BRANCH IN ALL  
LARGE TOWNS

THE HALFORD CYCLE CO LTD  
Head Office  
239, CORPORATION STREET  
BIRMINGHAM, 4 S.H.1



Someone's  
*mighty proud of his*  
**Hercules**

*THE FINEST BICYCLE BUILT TO-DAY*

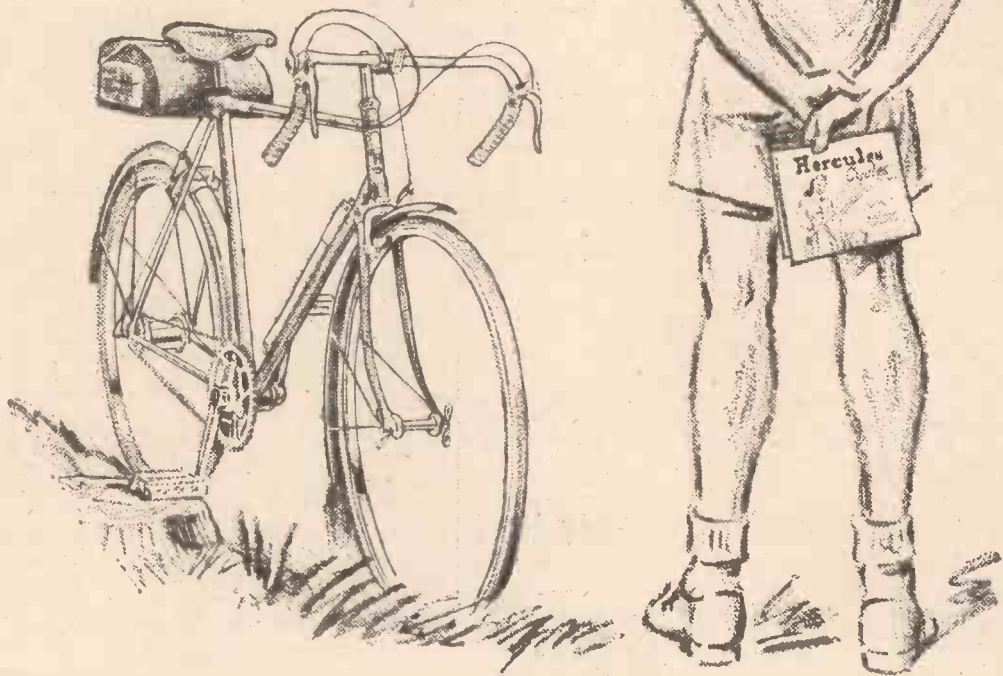

It's Bonderized to ensure rust-proofing! It's got "High Lustre" chromium plating and the finest finish ever known. It's the Finest Bicycle Built To-day. See your local Hercules Cycle Dealer.

The Hercules Cycle & Motor Co. Ltd., Aston, Birmingham





**Beddgelert.**

The well known little village set amidst some of the grandest scenery in Wales. It stands at the confluence of two mountain streams, the Colwyn and the Glaslyn.

**Census of Cyclists**

HOW many times have I heard discussions—some of them quite heated—about the number of cyclists there are in the world! My interest in this question was again aroused recently by an article published in *The Board of Trade Journal*, and written by the Director of the British Cycle and Motor-cycle Manufacturers' Union. The estimate given in this article, so far as the world is concerned, was about 60,000,000 cyclists. Although I personally regard this as merely a good guess, it may not be far out, and it certainly indicates the extent of the world market for bicycles—a market that has always been catered for, in the main, by Great Britain. Of course, we have had severe competition from time to time, and this article points out that, between the two world wars, competition from Japan was particularly fierce—at one time a complete Japanese machine was offered for 25s. However, Britain has reason for tremendous pride in her cycle industry, and if we turn our eyes to the export field we have cause for optimism, despite the difficulties caused when markets suddenly become closed to us, as the Indian market did in recent times. Two hundred thousand bicycles exported every month is "good going" and should bring a smile of satisfaction to the all-too-often melancholy face of Sir Stafford Cripps!

**Happy Clubmates**

I HAD just returned from a stroll through "my village," and whilst out in the good March air, I encountered a bunch of happy riders from some cycling club in the Nottingham-Leicester area. These smiling youths and girls were all mounted on gleaming modern machines; they were observing the rule of the road; some of them were singing snatches of song, and I paused to admire the little cavalcade passing through this somewhat remote village, where the advent of a bunch of cyclists is quite an occasion. It is a pity that the cottage which still exhibits a C.T.C. sign, and another indicating that teas are provided, no longer cater for the passing cyclist. I suppose rationing presents difficulties; anyway, where one used to be able to obtain a delectable tea, with plenty of butter and home-made jam, one is fortunate to-day if one can buy a bar of chocolate, or a packet of cigarettes.

**CYCLORAMA**

By  
**H. W. ELEY**

**Hills . . . and the Years!**

DERBYSHIRE, as everyone knows, is hilly country, and I find that my cycling in this good area, which is so near to Dove-dale and the glorious Manifold Valley, is apt to remind me that the years are passing, and that one cannot slip up hills, at the age of sixty, with that energy and élan which characterised the days of one's gay and care-free youth! However, a four-speed gear will work wonders, and I must not convey the impression that I am decrepit, or about to be a burden on the National Health Service, for I rejoice in much vigour. Life is full just now—the gay daffodils are waving in the orchard, and a chaffinch sings from the bough of an ancient apple tree.

**The Invention of the Bicycle**

ALL sorts of odd topics crop up when cyclists foregather, and the other week I heard quite an argument about the inven-

sure that it was invented by a German professor, and another had a hazy idea that it was invented by the same man who invented the spinning jenny. I could not bear to let such theories remain unchallenged, and I gave it, as a matter of established history, that one Kirkpatrick Macmillan, a Scottish blacksmith, should have the credit for the invention of one of the greatest boons ever conferred on the human race. Why, I fancy that we duly celebrated the centenary of the invention only a few years back.

**Derbyshire "Stonehenge"**

I HAD long known of Arborlow, to be found on the hills near Youlgreave and Monyash, but lately I have made better acquaintance with this ancient place. It certainly reminds me of Stonehenge, and Avebury, and I never gaze at the recumbent stones without awesome thoughts of the dim past, when quite possibly human sacrifices were made at this grim spot, where excavations have revealed bronze age remains. The main circle is some 812 feet in circumference, and there is a continuous earthwork connecting the circle with a sepulchral mound

known as Gib Hill. Here is my beloved Derbyshire in grim mood, a place of shadows, a place where the immemorial past touches to-day and from which one is glad to slip back to more homely, smiling countryside, where the sun glints through the trees, and some little tavern welcomes one with a creaking sign, proclaiming "The Cock and Sparrow," or "The White Hart," or "The Five Bells." A tankard of ale, and a smoke in some ancient taproom, are good antidotes to the grim mood of the past.

**Two Little Friends**

I KEEP them handy in my shed where I house my bike—that spanner and that little oilcan! What a world of difference their use can make! I need my bike to be easy running for the hills of this country where one is soon into the "stone-wall" districts, reminding one of Yorkshire. Spring and summer lie ahead and the old bike should have its quota of care and attention!

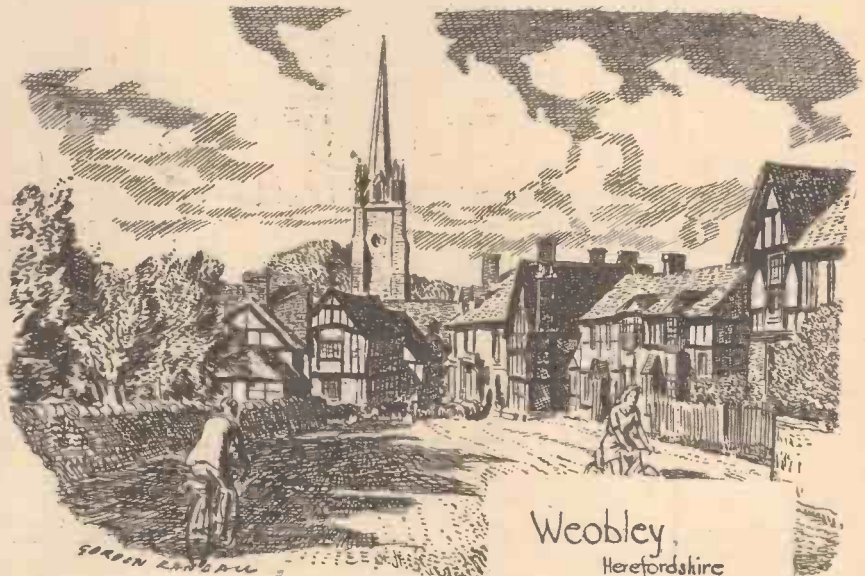

**Weobley,**  
Herefordshire

A village with many delightful half-timber houses, including the old Red Lion Inn. (centre).

tion of the bicycle; and strange were the stories told of how the bike came to be born. One young-fellow said that he was



# My Point of View

By "WAYFARER"



Llangollen—with its lovely 14th-century bridge over the Dee and its far-famed Vale.

## Selling the Pass

THE writer of a letter in a contemporary seems to me to give the show away. During a recent night ride he decided to use a cycle path. All went well "until I came across a lorry parked right across the path with no lights showing. I saw it only just in time and missed it by inches." Of course, the lorry had not the slightest right to be in that position, but surely the cyclist should have been keeping a more careful watch and have been proceeding at a pace to suit the power of his headlight. That is the kernel of our case against compulsory rear lights. I gather that the lorry was at right-angles across the cycle path. It is just problematical whether its lights (had it had them) could thus be seen by approaching cyclists. Suppose the lorry had been some form of unlightable obstruction. That, too, might have been seen "only just in time and missed by inches." Let us be reasonable in this matter of lighting, remembering that what is sauce for the goose is likewise sauce for the gander.

## Worth Noting

WHEN opening the last Cycle Show, the Parliamentary Secretary to the Ministry of Transport spoke of an industry in which Britain was "cock of the walk." There is no need to guess the name of that industry, whose exports during the first half of 1949 were worth more than £11,000,000. The "humble" push-bike used to-day (and then only at the risk of their lives) by deplorable errand-boys and by nobody else—symbol of a pastime which was killed by motoring years and years ago—its riders reviled as rank outsiders and undesirable, as a confounded nuisance to all other traffic, a danger and a menace to everybody, scorches

and hooligans—it is the bicycle, my friends, whose makers are proclaimed as "cock of the walk" and whose handiwork rakes in millions of pounds every year! Let the truth prevail!

## The Fitness of Things

I SEEM to recall that *The Times* review of the Cycle Show was labelled as being "From our Motoring Correspondent." Oh! the eternal fitness of things!

## Expected

THE Warwick County Police report on accidents in October last asserts that "20 per cent. of all accidents were caused by dogs straying on the roads." That result is quite what one would expect, having regard to the fact that so many reputed dog-

lovers allow their four-legged friends to stray and play at will on the traffic-laden suburban roads of to-day. When will people realise that conditions have been completely revolutionised within the last generation.

## Common Failing

OF a 76-year-old cyclist who was recently killed in a road accident, it was said at the inquest that he put out his arm and turned right at the same time, thus coming into collision with an overtaking motorist. This simultaneous action on the part of many cyclists—yes! many cyclists—causes one to be surprised that there are not far more accidents. It is a common failing with a certain type of rider, and I feel that it cannot be emphasised too frequently or too strongly that the giving of a signal does not confer on the signaller a right to carry out his intention immediately. He should make certain that he can safely turn from his course. Moreover, there should surely be a time-lag between the signalling process and the turning act. That seems to me to be elementary.

## Pictorial Evidence

WHEN on a visit to North Staffordshire recently I came across an interesting little poster addressed to cyclists. Warning us to see that our lamps are kept in good order, it depicted a night-riding cyclist approaching a large tree which had fallen across the road. The warning is a timely one, but I believe that it is hardly necessary in the case of the vast majority of that considerable contingent of wheel-folk who are keen on riding in the dark. The wise cyclist realises his vulnerability, and, as a general rule, matches his speed to the power of his headlamp. In the words of the

old tag, he knows that the price of safety is eternal vigilance. The other sort of cyclist—he (or she) who relies for forward lighting on something akin to a farthing dip—is a different proposition, who must be left to learn—painfully, if need be—in the hard school of experience.

## Mystery

TWO young cyclists (18 and 16 respectively), involved in a collision with a car, were the subject of a recent inquest in Hertfordshire. The driver of the car "elected not to give evidence." The jury "found that there was a certain amount of negligence by both parties." (If *certain*, it could presumably be specified—but it was not!) The coroner told the jury that "there was evidence that, although the cyclists were separated, they were on the correct side of the white line." The jury, in their wisdom, asked the coroner to make a strong recommendation to the "Cyclists' Union" (whatever that is) to "impress on its members that they should keep strictly to the rules of the road." There you have the whole story—as provided by the daily Press—in a small nutshell. How right was the cynic who said that speech was given to enable us to conceal our thoughts!

My only other comment is that there seems to be little justification for the jury's recommendation to the said "Cyclists' Union" that its members should keep strictly to the rules of the road. That recommendation is quite gratuitous, especially as we are not told what happened. Of course, it is an elementary duty of cyclists—and a matter of common sense—to obey the rules, and in all probability the members of that "Cyclists' Union" (a tiny minority of the cycling army) are just the very people to whom advice on the point is singularly unnecessary, it being generally admitted that club cyclists are the best behaved. One wonders, also, whether the motorist who "elected not to give evidence" was "keeping strictly to the rules of the road." A curious case, made so by inadequate and inefficient reporting. The alleged scarcity of newsprint will doubtless be blamed. If, however, the case was worth publicity, it was worth lucid publicity.

## Pea-soup

FOG is easily the most disconcerting item in the climatic programme from the traffic point of view. It slows up everything, and thus, in a way, reduces the exaggerated dangers of the road, but the thickened atmosphere distorts visibility, and it is at once disturbing and perplexing to find that the vehicle immediately in front of you is very much nearer than you think. Moreover, fog has a curious effect on the mind, so much so that, if you stray from the right path—finding yourself, perhaps, completely over on the wrong side of the road—it is difficult to regain your position or, indeed, to decide exactly where you are and what you should do. Then there are patches denser than others—and sudden breaks which tempt you to accelerate, only to find that you are back in the pea-soup a moment or two later. I dislike fog as heartily as do most people, but it holds no special terrors for me, and I know that, with careful behaviour, which includes a reasonable speed, a keen look-out, and general alertness, I shall be safe. At the same time, a long journey in fog, at a pace which does not enable you to keep warm, is the reverse of pleasant.

"Practical Mechanics" Advice Bureau **COUPON**

This coupon is available until March 31st, 1950, and must be attached to all letters containing queries, together with 3 penny stamps. A stamped, addressed envelope must also be enclosed.

Practical Mechanics

March, 1950

Published about the 30th of each month by GEORGE NEWNES, LIMITED, Tower House, Southampton Street, Strand, London, W.C.2, and Printed in England by W. Spaulight & Sons, Ltd., Exmoor Street, London, W.10. Sole Agents for Australia and New Zealand—Gordon & Gotch (A/S) Ltd. Sole Agents for South Africa—Central News Agency, Ltd. Subscription Rate (including postage): For one year, Inland and Abroad, 10s. 6d. (Canada 10s.). Registered at the G.P.O. for transmission by Canadian Magazine Post.

CONDITIONS OF SALE AND SUPPLY: This periodical is sold subject to the following conditions, namely, that it shall not, without the written consent of the publishers first given, be lent, re-sold, hired out or otherwise disposed of by way of Trade except at the full retail price of 9d., and that it shall not be lent, re-sold, hired out or otherwise disposed of in a mutilated condition or in any unauthorised cover by way of Trade, or affixed to or as part of any publication or advertising, literary or pictorial matter whatsoever.



# MATRIC.

WHY needlessly handicap yourself and watch other people winning success and security? Whatever your age, you can now prepare for the all important Matriculation Examination at home on "NO PASS—NO FEE" terms. Write now for our valuable "GUIDE TO MATRICULATION" which explains the easiest and quickest way to matriculate—FREE and without obligation.

**BRITISH TUTORIAL INSTITUTE**  
(Dept. 160), 356, Oxford Street,  
LONDON, W.1.

## "NO PASS—NO FEE"

### A GOOD PIANIST IS ALWAYS WELCOME



There is a way to become really FINE PIANIST and SIGHT READER. I will teach YOU quickly and enjoyably BY POST from ordinary music (no freakish methods) enabling you to read and play at sight any standard musical composition so that you shall give delight wherever you go. No practice drudgery, but simple interesting training a child could follow. A teacher by your side always, not for merely half an hour weekly. My class is seldom less than 2,000 pupils. I have taught over 30,750. I CAN TEACH YOU, even if you do not know a note. Send for free book and advice. Say Moderate, Elementary or Beginner.

Mr. H. Becker  
(Dept. 958),  
69, Fleet St.,  
London, E.C.4.

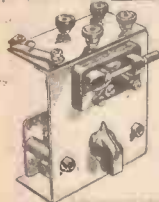

RADIO is interesting. With D3 Coil you can build this crystal set, or 1, 2, and 3 valve sets. The most comprehensive radio coil for simple circuits. With all blue-print and circuits, 5/-.

**HILLFIELDS RADIO.**  
Dept. M, 8, Burnham Rd., Whitley, Coventry.

## CYCLOP

**STOP-THIEF PUMP CLIPS**  
The Double-Roll locking action of these clips positively prevents snatching of cycle pumps—and falling off. Tested and approved by leading cycle journals. Try them. NICKEL 1/3, De Luxe CHROME 2/-.

Good cycle dealers or post free  
**KORVING, LTD. (P.M.)**  
12, Duke St., London, S.W.1.

**The "THAMES VALLEY" BATTERY CHARGER**  
2 - 6 - 12 VOLTS 1 AMP.  
with AMMETER  
for 200-250 volts 50 cycle mains  
for 42/6 post free  
Thames Valley Products (P)  
28 Camden Ave. Feltham, Middx.

**MODELMAKERS**  
4 h.p. Motors, 25.10.6d. Vee Pulleys, 1 1/2in., 2s. 6in. 7/6. 4-Groove Cone Pulleys, 5in., 9/6. Plummer Blocks 3/9. Shaping 3-speed Lathe Heads, 1in., 36/-. Modelmakers' Lathes and Spares, 1in. Hardboard 9d. sq. ft. Racecar and Aircraft Kits. Metal Cutting Saws, 1/3d.  
Send 6d. for fully illustrated Catalogue.  
**BEVERLY PRODUCTS,**  
28, Oakwood Avenue, Leeds, 8.

**SAILOR SAM'S SECRET**  
How to Make SHIPS IN BOTTLES  
Kits, 5/8 and 6/-  
**OLD TIME GALLEONS**  
Kits 6in. to 22in. From 8/- to 27/6  
Stocked by Model, Sports and ToyStores  
Please write for details  
**COOPER - CRAFT, LTD.**  
THE BRIDEWELL, NORWICH

**COPPER WIRE AND INSULATION MATERIALS,** etc. Most gauges in stock. Leathoid, Fibre, Mica, Varnish, etc. Also many other Radio, Electrical and Mechanical bargains at attractive prices. **ELECTRIC MOTORS FOR SALE ALL AT BARGAIN PRICES. REV. COUNTERS,** 3/6 each. Send S.A.E. for List.  
**L. C. Northall, 16, Holly Road, Quinton, Birmingham. 32.**  
Tel.: Woo 3166.

## NO MAN CAN KNOW TOO MUCH OF HIS PRODUCT

For the close scrutiny of every conceivable object, metals, tools, fabrics, fibres, minerals, precious stones, paint, print, manu-  
**BRITISH MADE**  
scripts, biological and botanical specimens, cutting edges, fractured surfaces, raw materials, powders, granules, and innumerable other purposes, the **ULTRA LENS** is invaluable, and presents in many instances hitherto unsuspected data which can be used to advantage.

The Ultra Lens is a revealing eye of six actual diametrical magnifications, which brings out points of strength or weakness, and enables the most minute measurements to be gauged accurately. Whether you are engaged in manufacturing, buying or selling, it is an ally of real value. No instrument you can buy will more quickly justify and pay for itself. Full particulars on request.

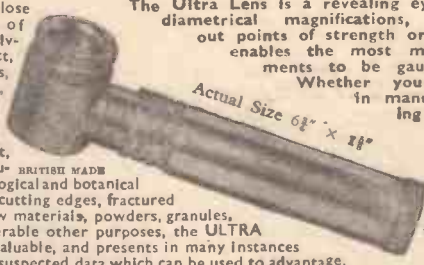

PRICE £4 15s. 0d., complete in case with spare bulb, battery and transparent measuring scale.

**THE ULTRA LENS COMPANY,**  
75, Finsbury Court, Finsbury Pavement, London, E.C.2.

## MODEL ENGINEERS

**FOR THE TURNER :**  
Lathes from 1 1/2in. to 5in. Bench Millers. Drilling Machines. Hand Bench Shaping Machines.

**FOR THE WOODWORKER :**  
Wood Turning Lathes 3 1/2in.—5 1/2in. centre height. 4 1/2in., 7in. and 10 1/2in. Ball Bearing Planers at competitive prices. 6in. and 12in. Saw Benches, Sanders, Grinders, Jigsaws.

Perspex, Catalin and Acetate Sheets always in stock.

**NUTTALL'S (LATHES) LIMITED,**  
MANSFIELD, NOTTS.

**CLEARANCE SALE**  
GUARANTEED BARGAINS  
2 volt 20 A.H. Accs. 6/11 each. Heavy Alnico Magnets, lift 50lb., 7/6 each. 20 Contact Stud Switches, 3/6 each. Bomb Timers, 9/6 each. Air Pumps, 1/9 1/6 each. Capillary Thermometers, 9/6 each. K24 Camera Magazines, 2/6 each, and a large selection of equipment of all types.  
S.A.E. for a copy of our Super Detailed List. Something for Everyone.  
**HAVE A GO WITH WILFLO. WRITE NOW.**  
**WILFLO PRODUCTS**  
222, Gorbals Street, Glasgow. C.5  
SOUTH 2385

**\*Multicraft CATALIN Material\***  
Rods, Cylinders, Sheets, Sections. The most versatile of all materials. Beautiful colours, easily worked. **Special Offer to Turners, assorted rods from 1in. up. 4lb. 25/-; 8lb. 48/-; Sample Box 10/-.** Assorted parcels 25/- & 50/- Stock List and Samples 6d.  
**Dept. PM, COULDEN & SMITH,**  
17, The Mead, West Wickham, Kent.

**THOMPSONS TRANSFORMERS**  
In steady demand for Home Cines, Trains, Motors, Chargers, Ground Heating, Clocks, etc.  
In any odd voltage to order -  
12 volts 2 amps., 26/-  
12 volts 5 amps., 32/-  
20 volts 2 amps., 26/-  
25 volts 6 amps., 42/-  
Made in many other sizes : List 2d. stamp  
**T. W. THOMPSON & Co., 176, Greenwiche High Road, Greenwich, S.E.10**

## P.E. EXPOSURE METER COMPONENTS

Selenium Light Cell . . . . . 6s. 6d.  
Microamp Meter Movement . . . . . 10s. 6d.  
Moulded Perspex Case . . . . . 9s. 0d.  
Ivory Conversion Dials . . . . . 5s. 6d.  
Assembly Instructions . . . . . 3s. 6d.

**G. R. PRODUCTS,**  
78, REPTON ROAD, BRISTOL. 4.

**REWINDS AND REPAIRS** to vacuum-cleaners, portable electric tools and all types of electric motors. Trade invited.—**Omega Electrical Rewinding Co., 318, High Road, Willlesden, London, N.W.10.**  
WILLesden 0769.

**BOOKS :**  
"Railway Modellers Handbook" . . . . . 2/6  
"British Passenger Locomotives" . . . . . 3/-  
"Freight & Mixed Traffic Locomotives" . . . . . 3/-  
"Planning and Layout" . . . . . 3/-  
"Garden Railways" . . . . . 10/6  
Sample L.M.S., G.W.R. or S.R. Postcards with List, 7d.

**USEFUL PARTS :**  
Green Grass Paper, 22in.x11in. . . . . 00 0  
Scale Station Figures . . . . . 4d. 7 1/2d.  
Wood Wagon Kits (usually 3/6) . . . . . 2/6  
20 v. Lamps for Hornby . . . . . 1/2d.  
Bakelite Wagons . . . . . 2/11 7/6  
Bakelite Vans . . . . . 3/6 8/6

**DOLLS' HOUSE PAPERS :**  
Brick, Tiles, Wallpaper, 1in. scale, per sheet . . . . . 5d.  
Postage extra. "00" or "0" Parts List, 3d. per post.

**TYLDESLEY & HOLBROOK (M.E.T.A.)**  
109, DEANSGATE, MANCHESTER, 3

**No. 1 PROGRESS BENCH DRILLING MACHINES**  
Speeds 340-2,580 r.p.m., 1/2 h.p. electric motor, 440 volts 3 phase 50 cycles or 220 volts single phase. Quickly adapted for Wood-Turning or as a Circular Saw. Swivel Table, Round Column, adjustable to drill from floor. List price 435/9/3, which includes the capacity chuck and guard. Carriage paid G.B.  
Large stock of Electric Motors from 1/2 h.p. to 100 h.p. Please let us quote you for your requirements in Tools and Machines.  
**JOHN DOCKER & Co. (Engrs.), Ltd.,**  
Clydesdale Works,  
32, Park Rd. North, W. 3. ACO9N 4841-2

**BOMB SIGHT SIGHTING HEADS**  
in steel case.  
Carr. paid 7/6 ea., to clear.  
**BROWN, 102, CLEVELAND ST., DONCASTER.**

**WEBLEY AIR PISTOLS**  
Marvelously accurate for target practice.  
No licence required to purchase.  
Senior Mark I Junior Webley Air Rifle  
Write for List. **WEBLEY & SCOTT LTD.,**  
106, Weaman Street, Birmingham, Eng.  
Plywood Off-Cuts, mixed, various thicknesses, 24in. x 15in. down, suitable toy models, cabinet making, handicrafts, £1 and 10/- parcels, carriage paid, Postal Order to.  
**Reeves, 33, Front Street, Monkseaton, Whitley Bay.**



## SPARKS' DATA SHEETS

Clear full-size Constructional Prints of Tested and Guaranteed Designs. Used by Discriminating Radio Constructors in the Five Continents.

### IMPORTANT ANNOUNCEMENT

Please Note  
**CHANGE OF ADDRESS**  
**SPARKS' DATA SHEETS ARE NOW OBTAINABLE ONLY FROM MY NEW ADDRESS :**

**L. ORMOND SPARKS (M)**  
48A, HIGH STREET,  
SWANAGE, DORSET.

OLD CLIENTS PLEASE NOTE.  
NEW CLIENTS PLEASE SEND STAMP FOR LIST.

THE SERVICE WILL BE THE SAME, SECOND TO NONE, AND ALL ORDERS AND INQUIRIES WILL RECEIVE MY PERSONAL ATTENTION.

**L. ORMOND SPARKS (M)**  
48A, HIGH STREET,  
SWANAGE, DORSET.

## No. 1 (Mark II) SUPPLY UNIT

Comprising One Generator—Input 12 volts, output 275 volts at 110 ma—500 volts at 50 ma. This makes a fine fractional H.P. Motor to run off 230 volts A.C. or D.C. Full instructions enclosed for 5 minute conversion. Also 4 H.F. Chokes—2 Cart-ridge Fuse Holders—Double Pole Switch—Pilot Lamp Holder—2 6-way Sockets—4 Condensers—1.30 mf. Electrolytic Condenser 450 volts. **Complete Unit in Chassis. Price 23/- Carriage Paid. Cash with Order.**  
**DEES** (Dept. P.M.) 59, Rolls Park Avenue, South Chingford, London E.4.

## Experimenters! Build the MATCHBOX RADIO SET.

With the aid of our full instructions you can build a complete radio set in a matchbox, using parts easily obtainable from your radio dealer. This is made possible by the use of the Crystal-Valve Radar Detector—a wartime discovery. Tunes the B.B.C. wavelengths, and works off a short indoor aerial in many districts. Powered entirely by the incoming signal, no batteries are required. Full step-by-step instructions, working drawings, and theoretical wiring diagram.

Price 2/9 Post Free.  
**JOHN O'BEIRNE (P.),**  
137, Cotham Brow, Bristol, 6.  
Post Orders Only.

## RATCHET & REVOLUTION COUNTERS

Ask for Leaflet No. 18/6  
Speed up to 6,000 r.p.m.  
**B. & F. CARTER & Co., Ltd., Bolton 5**  
Members of B.E.S.T.E.C. Organisation.





# Free Guide — "Success in Engineering"

One of the following Courses taken at home in your spare time can definitely be the means of securing substantial promotion in your present calling, or entry into a more congenial career with better prospects.

## ENGINEERING, AERO, ETC.

Plastic—Radio—Aero Engines—Aircraft Design—Welding—Aerodynamics—Electrical Engineering—Television—Electric Wiring—Diesel Engineering—Generation and Supply—Works Management—Metallurgy—Refrigeration—Planning. Estimating. Rate-fixing—Time and Motion Study—Aero Inspection—Automobile Engineering—Sheet-metal Work—Engineering Draughtsmanship—Aero Draughtsmanship—Jig and Tool Draughtsmanship—Press Tool and Die Draughtsmanship—Structural or R/F Concrete Draughtsmanship—Sanitary Engineering.

## GENERAL

Matriculation—College of Preceptors—A.C.C.S.—A.C.I.S.—Aircraft Apprentice.

## MUNICIPAL SERVICE

School Attendance Officer—Handicraft Teacher—Registrar—Housing Manager—Sanitary Inspector—Weights and Measures Inspector—Inst. of Mun. Engineers—A.R.I.C.S.—L.A.B.S.S.

"PRACTICAL ENGINEERING" said—

We recommend all readers interested in improving their position to apply for a copy of this valuable book. "Success in Engineering" is not a pamphlet. It is a 132-page book, containing valuable and vital information on all branches of engineering. . . . There are many engaged in engineering who owe their success to The National Institute of Engineering.

The FREE GUIDE explains:

- Openings, prospects, salaries, etc., in Draughtsmanship, Inspection, and opportunities in all other branches of Engineering and Building.
- How to obtain money-making technical qualifications through special RAPID FULLY-GUARANTEED COURSES.

Write now for your copy of this remarkable publication.

A.M.I.E.E., A.M.I.Mech.E.,  
A.M.Brit.I.R.E., A.M.I.P.E.,  
A.M.I.C.E., A.M.I.Struct.E.,  
A.M.I.Mun.E. M.R.San.I.,  
A.M.I.E.D., A.F.R.Ae.S.,  
London B.Sc., Degrees.

Fully guaranteed postal courses for all the above and many other examinations. Fully described in the Free Guide.

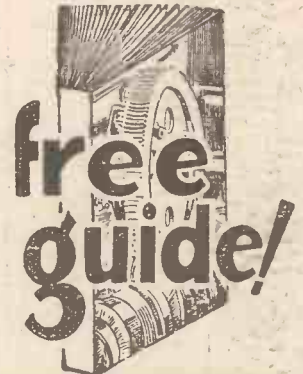

## THE BUILDING BOOM— SECURE YOUR SHARE!

The Free Guide also gives particulars of our extensive range of modern Building and Structural Courses, Building Draughtsmanship, etc. The great post-war Building programme offers unlimited prospects to technically trained men.

## BECOME A DRAUGHTSMAN— QUALIFY AT HOME AND EARN BIG MONEY

Men and Youths urgently wanted for well paid positions as Draughtsmen, Inspectors, etc., in Aero, Jig and Tool, Press Tool, Electrical, Mechanical and other Branches of Engineering. Practical experience is unnecessary for those who are willing to learn—our Guaranteed "Home Study" courses will get you in. Those already engaged in the General Drawing Office should study some specialised Branch such as Jig and Tool or Press Tool Work and so considerably increase their scope and earning capacity.

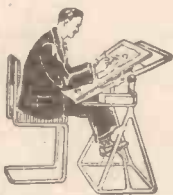

## THE ACID TEST OF TUTORIAL EFFICIENCY SUCCESS—OR NO FEE

We definitely guarantee that if you fail to pass the examination for which you are preparing under our guidance, or if you are not satisfied in every way with our tutorial service—then your Tuition Fee will be returned in full and without question. This is surely the acid test of tutorial efficiency.

If you have ambition you must investigate the Tutorial and Employment services we are able to offer. Founded in 1885, our success record is unapproachable.

Why not fill in and post the attached Coupon NOW for further details and Free Authoritative Guide to openings in Engineering and Building? This book contains a mine of valuable and exclusive information and may well prove to be the turning point in your career.

PROMPT TUTORIAL SERVICE GUARANTEED

## FREE COUPON

To NATIONAL INSTITUTE OF ENGINEERING  
(Dept. 29), 148, Holborn, London, E.C.1.

Please Forward your Free Guide to

NAME.....

ADDRESS.....

My general interest is in: (1) ENGINEERING (Place a cross against the branches in which you are interested.)  
(2) AERO (3) RADIO (4) BUILDING  
(5) MUNICIPAL WORK

The subject or examination in which I am especially interested is

To be filled in where you already have a special preference.  
(1d. stamp only required if unsealed envelope used.)

NATIONAL INSTITUTE OF ENGINEERING

(Dept. 29)

148, HOLBORN, LONDON, E.C.1

OVER SIXTY YEARS OF  
CONTINUOUS SUCCESS

SOUTH AFRICAN BRANCH: E.C.S.A. P.O. BOX 8417 JOHANNESBURG.

FOUNDED 1885—FOREMOST TODAY—OVER 100,000 SUCCESSES