

**THE "FLUXITE QUINS" AT WORK**

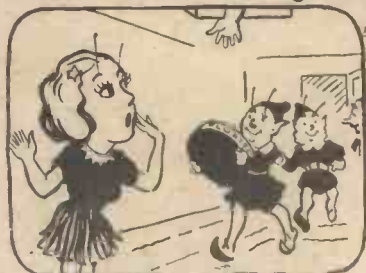

"Help! There's a man in the loft!"  
 Came a voice "All right, OO, don't be soft! I'm up here mending leaks  
 And this job'll take weeks  
 Pass the **FLUXITE**, stop howling" OI scoffed

See that **FLUXITE** is always by you—in the house—garage—workshop—wherever speedy soldering is needed. Used for 30 years in Government works and by leading engineers and manufacturers. Of ironmongers—in tins, 4d., 8d., 1/4 and 2/8. Ask to see the **FLUXITE SMALL SPACE SOLDERING SET**—complete but substantial—complete with full instructions, 8/7. Write for Free Book on the **ART OF "SOFT" SOLDERING** and ask for Leaflet on **CASE-HARDENING STEEL and TEMPERING TOOLS with FLUXITE.**

**TO CYCLISTS!** Your wheels will NOT keep round and true unless the spokes are tied with fine wire at the crossings and **SOLDERED**. This makes a much stronger wheel. It's simple—with **FLUXITE**—but **IMPORTANT!**

The **FLUXITE GUN** is always ready to put Fluxite on the soldering job instantly. A little pressure places the right quantity on the right spot and one charging lasts for ages. Price 1/6, or filled 2/6.

FLUXITE Ltd., Dept. P.M.,  
 Bermondsey Street, S.E.1

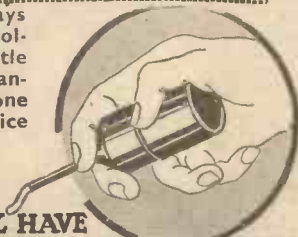

**ALL MECHANICS WILL HAVE**

**FLUXITE**

**IT SIMPLIFIES ALL SOLDERING**

*Team Work Wins!*



USE A *Johnsons*  
**TANK & CHEMICALS**

A lot depends on the Chemicals used for both your films and papers. You must have efficiency throughout.

Johnsons Azol or Fine Grain—for your films  
 Johnsons M.Q. or Amidol—for your prints,  
 and Johnsons Acid-Fixing for both—there's your team.

**Special Offer!**

For a 1/10 P.O. Johnsons will send you a trial set of Chemicals, including 1-oz. bottle of **AZOL**, to develop eight spools 2 1/4 in. by 3 1/2 in., 4-oz. tin **ACID-FIXING**, making 30-60 ozs. solution, one packet **M.Q. DEVELOPER**, enough for 36 gaslight prints. Address: Dept. 41.

JOHNSON & SONS Manufacturing Chemists LIMITED, HENDON, N.W.4.

**ENGINEERING  
 WORKSHOP PRACTICE**

Recent developments in engineering workshop practice have been so rapid that it has been found necessary to produce a new and revised edition. This new edition deals with the underlying principles, craftsmanship, machines, tools, measuring processes and machining methods of today, and it will prove indispensable to the engineer, draughtsman, mechanic, apprentice and engineering student. Its scope extends from simple hand tools and machines to the latest elaborate machines and methods employed for mass-production purposes.

**SOME OF THE SUBJECTS**

Files, Chisels, Scrapers, Shears, Punches, Burnishers, Hand Screw-cutting Tools, Spanners, Vices, Various Measuring methods. Verniers, Micrometers, Gauges, Optical Devices, Fluted and Twist Drills, Grinding Angles, Drilling Data, Small and Large Drilling Machines, Electric Drills, Practical Lathework in all its branches. Machining of Metals and Synthetic Materials. Tungsten-carbide and Diamond Tools. Lapping, Honing, Cleaning, Polishing and Rust-protection of various metals. Grinding Operations and Machines, Milling Operations, Cutters and Machines. Planing, Shaping, Slotting and Broaching Operations. Special Machines for Production Purposes. Plate and Bar Machines. Gears and Gear cutting Methods. Templates, Jigs and Fixtures. Overhauling and Adjusting Machines, Millwright Work. Welding, Brazing and Soldering Metals. Forging Work. Sheet Metal Work. Foundry Work. Patternmaking Practice. Press Work. Engineering Steel and other Metals; their Properties, Testing, Hardening, Tempering and Annealing, Engineers' Drawings. Workshop Calculations, Data, Hints and Recipes, British and Foreign Screw-thread Tables.

**THE ILLUSTRATIONS**

The book is lavishly illustrated so that the explanations are rendered very clear with examples taken up from actual works practice in many instances. There are 24 full-page plates and 1194 line and photographic illustrations in the text.

**ENGINEERING POCKET BOOK**

In order to make the work even more comprehensive we have brought out a pocket book, which is supplied free to all purchasers. It contains many useful tables of Screw Threads, Tapers, Angles, Drill Speeds and Sizes, etc.

**A FREE BOOKLET**

To the Caxton Publishing Co., Ltd.,  
 119 Clun House, Surrey Street,  
 London, W.C.2.

Please send me, free of charge, Illustrated Booklet describing "Engineering Workshop Practice."

Name.....  
 Send this form in unsealed envelope (1d. stamp), or a postcard.

Address.....

G:31.....

# ENGINEERS!

## WORK FOR THE WAR— PREPARE FOR THE PEACE

Never before has so much depended upon the skill of the Engineer. Never before has Engineering offered such marvellous opportunities to the trained man or woman.

Are you making the most of your possibilities? By proper training you can take over a job playing a much greater part in the national effort and, at the same time, you will be preparing yourself for a secure and well-paid post in a competitive peace-time labour market.

### WORK FOR THE WAR—PREPARE FOR THE PEACE !

“ENGINEERING OPPORTUNITIES” will show you the easiest, most rapid and most profitable way of studying those subjects which are essential to security and advancement. This well-known guide contains 208 pages of practical guidance and is unquestionably the finest and most complete handbook on successful Engineering careers ever compiled.

The handbook contains, among other intensely interesting matter, details of B.Sc. (Eng.), A.M.I.Mech.E., A.M.I.E.E., A.M.I.A.E., A.M.I.P.E., A.M.I.R.E., and other important Engineering Examinations; it outlines courses in all branches of Civil, Mechanical, Electrical, Automobile, Aeronautical, Radio and Production Engineering, Television, Draughtsmanship, Tracing, Government Employment, Building, etc., and explains the attractive advantages of our Employment Department.

### WE DEFINITELY GUARANTEE

## “NO PASS—NO FEE”



If you are earning less than £10 per week you cannot afford to miss reading “ENGINEERING OPPORTUNITIES.” In your own interests, we advise you to write (or forward the coupon) for your copy of this enlightening guide to well-paid posts—NOW. *There is no cost or obligation of any kind.*

## BRITISH INSTITUTE OF ENGINEERING TECHNOLOGY

Principal: Professor A. M. LOW.

410a, SHAKESPEARE HOUSE,  
17, 18 & 19, STRATFORD PLACE, LONDON, W.1

TEAR OFF HERE

### FREE COUPON

To B.I.E.T.  
410a, SHAKESPEARE HOUSE  
17, 18 & 19, STRATFORD PLACE  
LONDON, W.1.

Please forward, Free of cost or obligation of any kind, your 208-page Handbook, “ENGINEERING OPPORTUNITIES.”

Name .....

Address.....

.....

.....



## SUBSCRIPTION RATES

Inland - - - - - 11s. per annum.  
 Abroad - - - - - 10s. 6d. per annum.  
 Canada - - - - - 10s. per annum.

Editorial and Advertisement Office: "Practical  
 Mechanics," George Newnes, Ltd.  
 Tower House, Southampton Street, Strand, W.C.2

Phone: Temple Bar 4263

Telegrams: Newnes, Rand, London

Registered at the G.P.O. for transmission by  
 Canadian Magazine Post

Copyright in all drawings, photographs and  
 articles published in "Practical Mechanics"  
 is specially reserved throughout the  
 countries signatory to the Berne Convention  
 and the U.S.A. Reproductions or imitations  
 of any of these are therefore expressly  
 forbidden.

# PRACTICAL MECHANICS

Owing to the paper shortage "The Cyclist" and "Home Movies" are temporarily incorporated

Editor: F. J. CAMM

VOL. IX. OCTOBER, 1941 No. 97

## FAIR COMMENT

BY THE EDITOR

### Who Shall Manage?

DO not like the recommendations of the Select Committee on National Expenditure which in its latest report suggests that managements should take workmen more closely into their confidence, and in fact should be allowed to take a hand in the management. The report does not suggest that the members of the Committee are *au fait* with factory management, and, indeed, the report if acted upon would merely create petty rivalries and jealousies amongst workmen and slow up production. Let us investigate the matter closely.

#### The Workman and Management

AT present all firms employ departmental managers, works managers, toolroom foremen, machine shop foremen, charge hands, section leaders, chief draughtsmen, costing clerks, and so on. The management takes these chiefs into its confidence, and leaves them to control their various departments in accordance with their wishes. The Committee now suggests that almost every workman should be allowed to have a finger in the pie. Fortunately, this advice is not likely to be acted upon. What would happen? Every workman in the factory would be spending his time making suggestions regarding management instead of doing his job. He would be jealous of any of his mates whose opinion was sought. The workmen virtually have a hand in management under the present system. There are the charge hands, the foremen, and the managers, whom they can approach. There is a suggestion box into which workmen are encouraged to drop suggestions, for which they are paid. A workman is paid to do a job, and managements are paid to manage. We do not want in the workshops the old system of the colonel telling the adjutant, the adjutant telling the major, the major telling the captain, the captain telling the lieutenant, the lieutenant telling the sub-lieutenant, the sub-lieutenant telling the sergeant, the sergeant telling the corporal, and the corporal telling the private what to do. We want work, not a superabundance of red tape, with a few people doing the work and a multitude standing over them managing and telling them what to do.

#### Managements Must Be Careful

ANOTHER point. Managements cannot take workmen into their confidence. Suppose there is a delay so that workmen are kept idle for a day or so. Should the management call the workmen together and

explain that there has been a mistake in Government quarters causing change in design, or even the scrapping of design? Should the management tell the workmen that certain material has not arrived because it has been sunk? Would they not then be accused of preaching despondency? If careless talk costs lives, managements must be particularly careful. It would not encourage workmen in many cases if they were taken into the confidence of the management. I deplore the report of the Select Committee in presenting the innuendo that managements are incompetent, and that workmen should be left to manage the factory themselves.

In one respect we agree with the report when it says that those who make exceptional efforts on the industrial front under conditions of special difficulty should be rewarded by prizes and distinction, and publicity given to their achievements. A man who invents a new machine or a new device or produces an exceptional amount of work in a given time is equally entitled to distinction and reward as the soldier on the battlefield, or the pilot in an air combat, for without the efforts of the designers and the craftsmen, the soldier would be useless.

#### Too Many Committees

THERE are now so many Committees advising the Government that confusion is bound to arise. What is wanted is a more compact Ministry of Munitions, as in the last war. You do not require separate Ministries for Air, War, Army and Navy. It is impossible to co-ordinate their efforts and their requirements, and that is why there are so many complaints of muddle and delay. I am glad to see that Lord Beaverbrook is endeavouring to destroy the disease of Government Formania—the multiplicity of documents which must be filled in and signed before a simple job can be performed, or a small quantity of material can be supplied. He has asked firms to indicate which forms they consider are unnecessary. Nearly every firm nowadays spends a large proportion of its time filling up forms and supplying statistics which are never looked at and are quite useless. There needs to be considerable speeding up of Government machinery for that is the first requisite to increased output. You cannot increase output unless manufacturers can obtain speedy release of materials and quick decision on points arising out of the manufacture of that material. There are too many people

associated with statistics and too few doing the work upon which statistics are based. Some, indeed, of the Government Departments could be abolished with profit to the taxpayer, and to the war effort. Any obstructive machinery found to exist in Government circles should be ruthlessly destroyed.

#### National Air Raid Distress Fund

I AM asked to help the Lord Mayor of London's Appeal in connection with his National Air Raid Distress Fund. This I gladly do for I cannot think of any Fund more worthy of support than one which helps to alleviate the suffering and mitigate the loss suffered by those whose homes have been bombed. The Lord Mayor invites you, and I couple my appeal with his, to put a penny in a tin or a box as a thankoffering for every raid-free night. If, however, a blitz occurs, make it twopence, or even more. He appeals to every citizen to do this, and to send the collection of pennies quarterly to him at the Mansion House, London, E.C. At the Mansion House come gifts of money and of kind from the four corners of the earth, and it is there that the Lord Mayor receives and dispenses his Fund. I hope my readers will respond to this appeal.

#### New Books

WE have recently published at the price of 1/- or 1/2 by post from the offices of this journal, a valuable booklet entitled "Mastering Morse." It is designed to help those who aspire to enter one of the radio branches of the various Services. It deals with the various methods of mastering the Morse code, with the International Q Code, with abbreviations, and it also describes the construction of a two-valve short-wave receiver by means of which Morse transmission may be picked up further to aid the student in mastering the code.

Another new book recently published is "Wire and Wire Gauges," which costs 3/6, or 3/9 by post. This details every known wire standard of British, American and Continental origin, as well as containing sections on wire drawing, wire ropes, and wire splicing. It is produced in Vest Pocket Form, and is similar in style and price to our Radio Engineers' Vest Pocket Book.

We shall shortly publish in our Vest Pocket series, "Newnes' Engineers' Vest Pocket Book." This will cost 7/6, or by post 8/-, and will contain 608 pages of facts, formulae, data, memoranda.

# Hydraulic Aircraft

## How Various Controls on by Hydraulic



"Battle," Blackburn "Skua," and Armstrong Whitworth "Whitley."

### Hydraulic Operation of Undercarriages

For the hydraulic operation of undercarriages, flaps, bomb-hoists and doors, the source of power is, in most cases, an engine-driven pump, with an emergency hand-pump for use when the aircraft is on the ground, or when it is not

operating end of each service there is an hydraulic jack, and incorporated in the system is a selector valve whereby one or more of the services can be operated at will. An electrical warning device indicates the position of the undercarriage units, and a reserve pipe line in combination with a header tank provides alternative means of lowering. The illustration, Fig. 1, shows a typical example of a complete Lockheed installation for the operation of a retractable undercarriage, tail wheel, and flaps.

It will be noticed that the engine-driven pump is in the forward part of the machine, and is connected, by means of flexible hose, to the pipe lines running to various parts of the aircraft, and to the supply tank containing a special operating fluid. The pump is of the rotary annular displacement type. The driving shaft, which is integral with the rotor head, has three equally spaced radial slots engaging with pins which are

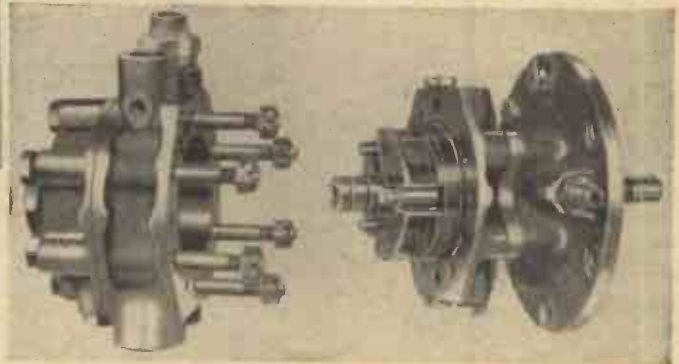

Fig. 7 (Above)  
The "Ensign" undercarriage.

Fig. 2 (Right)  
Engine-driven pump.

ONE of the most important developments in modern aircraft design is the application of hydraulic equipment for operating various parts of the machine, such as the retraction of undercarriages, wing flaps, pumps, etc.

Hydraulic operation has two outstanding advantages; firstly, large loads can be dealt with easily, and, secondly, a high velocity ratio can be obtained without complication. Other advantages are low maintenance and ease of installation.

A system of hydraulic control known as the "Lockheed" is fitted in a number of British warplanes including the Fairey

convenient or possible to use the engine-driven pump. In some cases, however, particularly on small machines or where one circuit only is required, it is possible to dispense with the engine-driven pump and use a hand pump alone. At the

attached to three segments which rotate in an annular groove (see Fig. 2). This groove is offset from the centre of the shaft, thus causing the segments to travel at differing circumferential speeds depending on the speed of the rotor and the effective radius which varies with the position of the driving pins relative to the offset between the rotor and the annular groove. Ports are cut into the annular groove on the opposite side of the segment from the driving pin, and are arranged so that while any two segments are moving away from each other, the gap between them is passing over an annular port, and that while they are moving together the gap is passing over a delivery port.

The pump is normally rated to operate between 650 and 900 lbs. per sq. in., but an

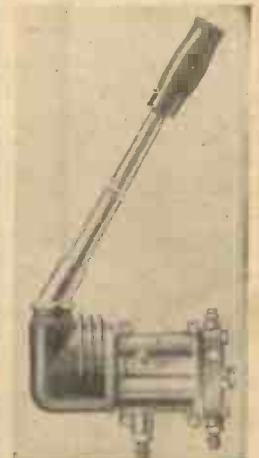

Fig. 3. Hand pump.

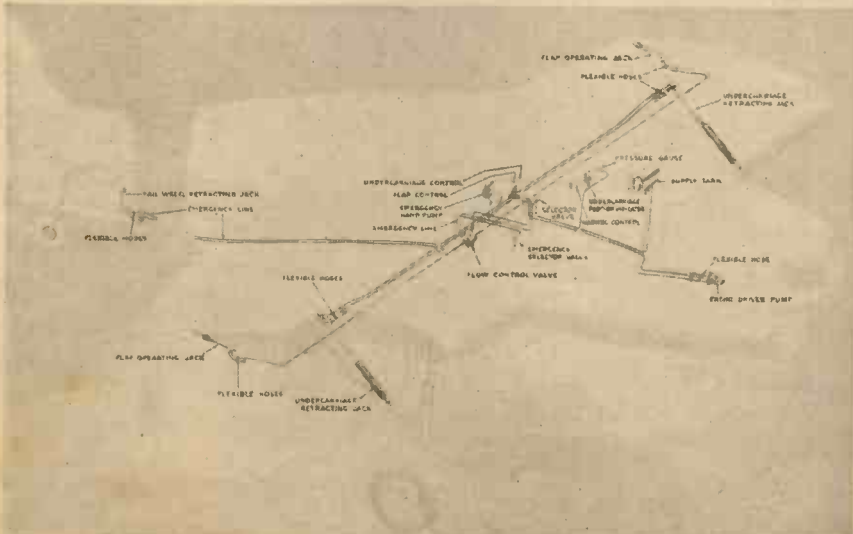

Fig. 1. Typical arrangement of Lockheed operation for undercarriage, flaps, and tail wheel.



# Controls

## Modern Aircraft are Operated Equipment

overload test up to 1,600 lbs. per sq. in. is carried out on every pump to allow for unusual conditions. Above this pressure a relief valve by-passes the delivery back to the supply tank.

### Hand Pump

In cases of emergency a hand pump, Fig. 3, is used, which also operates the services when the aircraft is on the ground, and it is not convenient to use the engine-driven pump. The hand pump is of the double-acting type, having a power stroke in both directions of handle movement, and a displacement of approximately .6 cu. ins. per double stroke. Pressures up to 1,600 lbs. per sq. in. can be generated without undue effort on the handle. The pump is mounted in the cockpit alongside the pilot's seat.

### Selector Valve

The unit which controls the hydraulic system is known as the selector valve, Fig. 4, and this is also mounted in the



Fig. 4. Selector valve.

cockpit within easy reach of the pilot. This control requires a minimum amount of concentration on the part of the pilot, and its action is as follows: When any lever is moved, it remains in the selected position until the operation which it represents is completed, after which the lever returns automatically to the neutral position. At any time, however, the operation may be stopped or reversed by moving the lever manually. The position of the selector valve is indicated in Fig. 1.

### Flow Control Valve

This unit (Fig. 5) is primarily a double-acting hydraulic lock automatically controlled, together with adjustable pressure relief valves. Its action is such that when pressure is applied on one side of the valve, the other side allows the free return from the non-pressure line. It can be used for the locking of over-centre mechanisms on undercarriages, for the locking of flaps in any position, and for other similar applications. The unit also has drain points and

gauge connections, so that pressure checks can be carried out without breaking the hydraulic circuit.

### Hydraulic Jacks

These jacks are specially designed for operating retractable undercarriages, wing flaps, retractable tail wheels, and bomb doors, etc. The jacks also act as struts. The illustration, Fig. 6, gives a good idea of the size of the Lockheed hydraulic jacks that have been specially developed for operating the retractable undercarriage of the Armstrong Whitworth Imperial Airways "Ensign" class of air liner. This is

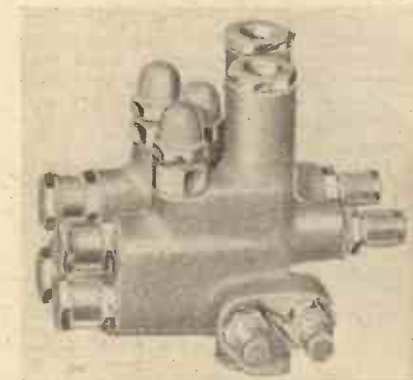

Fig. 5. Flow control valve.

the largest retractable undercarriage in the world, and in addition Lockheed hydraulic equipment also operates the undercarriage doors, and the flaps. Fig. 7 shows the hydraulic jacks in position on the "Ensign" machine. There are two undercarriage jacks per wheel, and each jack has an extended length of seven feet and can exert a maximum thrust of six tons; internal locks are provided for the undercarriage in the "down" position, each of these locks being able to withstand a load of ten tons.

The retractable undercarriage, and the undercarriage doors are interlocked so that the doors cannot shut until the undercarriage wheels are fully retracted, nor can the wheels begin to fall until the doors are fully open. The complete system, including the flaps, is operated by three pumps mounted on three out of the four engines, and is controlled by two levers in the cockpit.

### Emergency Selector Valve

In cases of emergency it may be necessary to quickly bring into operation the reserve lowering line to the undercarriage, and for this purpose an emergency selector valve is provided. This component is so designed that immediately on operation it opens



Fig. 6. A Lockheed hydraulic jack, specially designed for operating the retractable undercarriage of the Armstrong Whitworth Imperial Airways "Ensign" air liner.

a direct connection from the hand-pump to the reserve undercarriage pipeline, and at the same time couples up to the suction side of the hand-pump a reserve of fluid for which special provision is made in the header tank. The emergency selector valve is completely balanced hydraulically, and only a small operating effort is needed. Special automatic change-over valves are fitted to the undercarriage jacks where this reserve arrangement is in force.

### Wing Bolt Equipment

This equipment is designed to provide quick operation of the attachment bolts which secure the wings in the spread position on aircraft having folding wings. In the form in which the equipment is used in a number of Service aircraft, there are two self-contained systems, one for each wing.

A handpump of a type convenient for mounting in the leading edge of the wing section is connected to two wing bolts providing power operation of the bolts in both directions. One stroke of the handpump is sufficient to operate both pins fully. The handpump is positioned so that the handle and the selector knob for "in" and "out" provide a convenient two-handed operation for ground or deck personnel. An illustration of the handpump is given in Fig. 8. The wing bolt are additionally fitted with

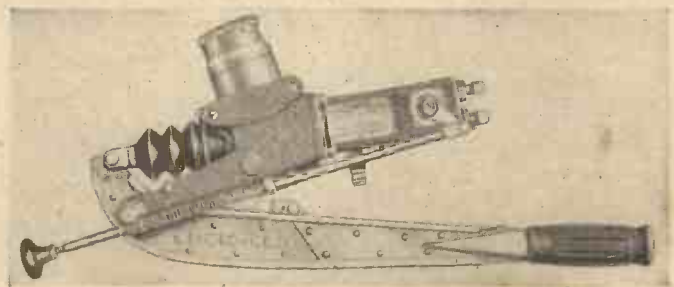

Fig. 8. Hand-Pump for Wing Bolt Equipment.

emergency mechanical operation for use in cases where the equipment may have been damaged on active service.

**Main and Auxiliary Services**

Services which it is preferable to operate hydraulically are divided into two categories: those in which a considerable quantity of work has to be carried out; and those which require only a small amount of work, but where hydraulic control is the most convenient method of

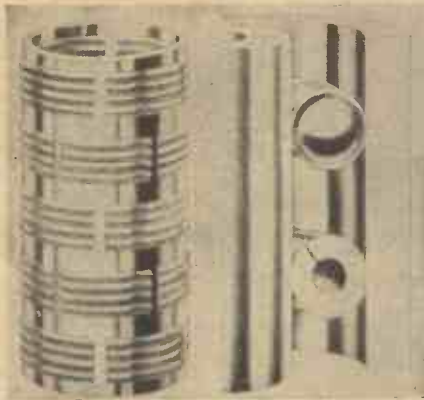

Fig. 11. Details of the axial roller bearing.

operation. In the diagram, Fig. 9, the main services are operated by an engine-driven pump (or a hand-pump if the engine pump is inoperative), and the subsidiary service via hydraulic accumulators normally charged by the engine pump, but

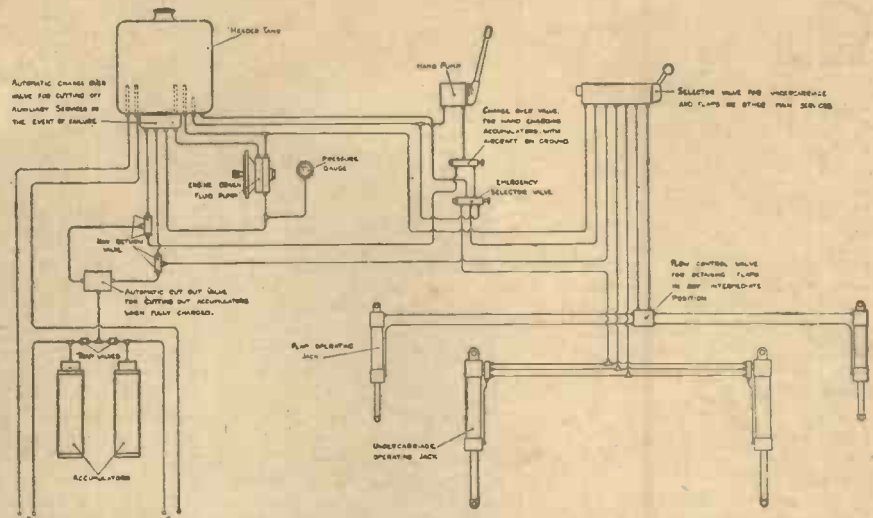

Fig. 9. Diagrammatic arrangement of complete hydraulic system for main and auxiliary services.

which can also be charged by the hand-pump when the aircraft is on the ground. Failure in any of the services which causes external leakage, no matter how small, operates an automatic change-over valve situated at the base of the header tank as soon as the leakage exceeds a predetermined amount, and thereby isolates the services operated by the accumulators from the services directly operated from the engine pump. This special feature provides a far greater degree of immunity from danger caused by gunfire.

certain parts of the pipelines are made from the same rubber composition as Lockheed glands, and provided that the correct fluid is used, they give indefinite service. The ultimate bursting pressure is in the region of 6,000-8,000 lbs. per sq. in.

**Shock Absorber Strut**

An extremely efficient strut, known as the "Lockheed" "Airdraulic" shock-absorber strut, is based on the principle of air cushioning combined with hydraulic damping. Each strut consists of two simple telescopic tubes of almost equal diameter, and has a very efficient energy absorption. The accompanying illustration, Fig. 10, shows a typical strut in its extended and compressed positions. In operation, the top chamber contains fluid, and the lower one contains compressed air, the floating piston serving to separate the fluid from the air. As the strut is compressed, the fluid in the chamber above the main piston is forced through the radial holes therein and thence through the central choke orifice in the flutter plate into the lower chamber above the floating piston, thereby forcing this piston to move downwards against the column of compressed air.

**Operating Fluid**

The special fluid for use with Lockheed hydraulic units has been developed after many years of experience and research work. Its setting point, being the temperature at which it changes from the liquid to the solid state, is lower than -40 degrees C. At the same time it has a high vaporising range so that there is no risk of vapour being given off which would affect the operation of the system. Between these two extremes the fluid has a very low rate of viscosity change, a point which is most important in keeping losses to a minimum. Another feature is that the fluid is totally inert to rubber, and the metals with which it comes in contact. The flexible hoses used for connecting

On the return stroke, the fluid returning from the lower fluid chamber to the upper chamber causes the flutter plate to seat against the radial holes in the main piston, leaving only the small central return choke orifice through which the fluid flows at a restricted speed into the upper chamber. The strut is constructed mainly of light gauge high tensile steel tubes and light alloy internal parts, thus reducing its weight to a minimum.

**Axial Roller Bearing**

Another important feature of the "Airdraulic" strut is the incorporation of the axial roller bearing, details of which are given in Fig. 11. One of the major problems associated with the design of cantilever undercarriages has been that of reducing friction between the telescopic members of the legs to prevent "sticking," harsh taxiing qualities, and the tendency of the aircraft to list to one side due to bad recovery of the shock absorbers. Hitherto, plain telescopic bearings have been generally employed owing to the difficulty in housing suitable frictionless bearings; the "Lockheed" axial roller bearing which is extremely simple and efficient, takes up no more room than a normal plain bush.

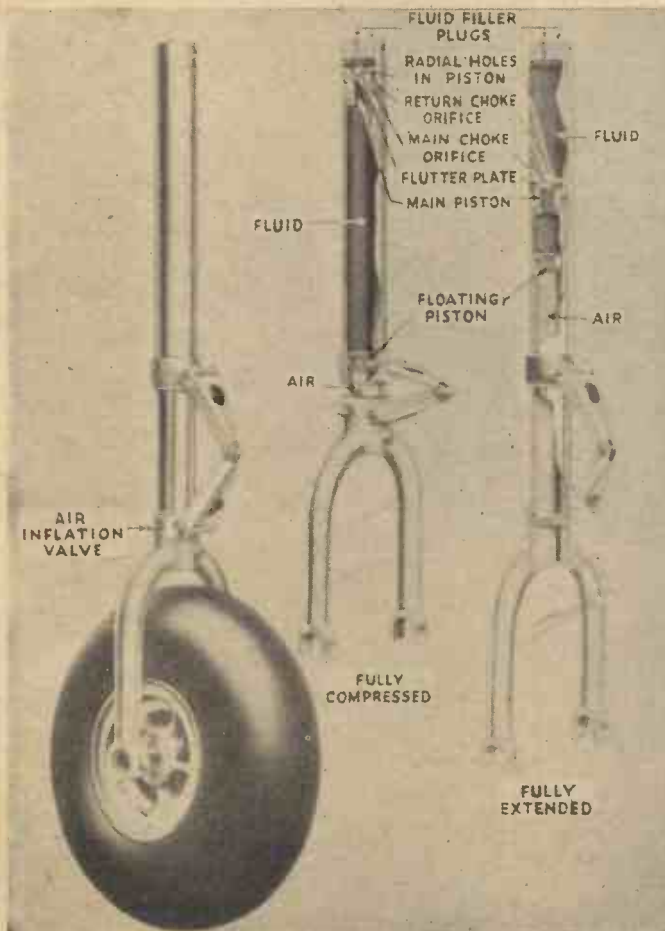

Figs. 10. (Left) A typical Lockheed full-cantilever "airdraulic" strut.





Figs. 1 and 2. (Left) A van with a box crate. (Right) A van fitted with a Walsh collapsible crate.

# Running Cars on Coal Gas

Some of the Problems Connected with the Simple Conversion of Petrol Vehicles to Operate on Low-Pressure Town Gas. By E. A. C. Chamberlain, Ph.D., D.I.C.

**W**HEN a simple conversion of a petrol vehicle is undertaken it is understood that minimum alterations will be made to the engine, and that either petrol or gas may be used at will. The primary consideration of such a conversion is that the cost of the alterations shall be as low as possible consistent with reasonable performance on the alternative fuel, and that the performance on petrol shall not be adversely affected by any of the alterations made. Secondly, it is important that any driver should be able to change from one fuel to another easily and rapidly.

These restrictions operate against optimum performance on gas, and possible improvements in engine performance have to be rejected in view of high cost of alteration or resulting difficulties when running on petrol. However, the last year has shown that the simple conversion can be most successful, and that the limitations imposed do not seriously affect the value of gas as an alternative fuel. The low-pressure system can, therefore, make a valuable contribution to the national economy of petrol.

### Power Output

The power development of a particular engine is entirely dependent on the properties of the fuel supplied to it, and will vary with different fuels. It has been found that town gas gives a smaller power output than petrol, and it has been thought advisable to review the theoretical considerations involved in order to check the experimental results obtained on the test bed. The chief considerations are:—

1. The net calorific value of the fuel/air mixture.
2. The specific volume change on combustion.
3. The specific heats of the products of combustion and the degree of dissociation at high temperatures.
4. The latent heat of evaporation of the fuel if liquid.
5. The specific gravity of the fuel/air mixture.
6. The radiation from the flame and hot products.

The two fuels between which comparison has been made are No. 3 petrol as specified in Technical Data on Fuel and town gas of the following analysis:—  
 $\text{CO}_2$ —2.5  $\text{O}_2$ —0.6,  $\text{C}_2\text{H}_6$ —2.6,  $\text{CO}$ —10.8,  
 $\text{CH}_4$ —21.1,  $\text{C}_2\text{H}_4$ —0.7,  $\text{H}_2$ —54.4,  $\text{N}_2$ —7.0.  
 500 B.Th.U. cub. ft. gross, 456 B.Th.U. net.

When running on gas the fuel/air ratio for optimum power is about 1 : 4.1 by volume, so that the fuel/air mixture entering the cylinder on each induction stroke con-

It is not possible to estimate singly the effect of these factors, since they are all interdependent, but it is possible to indicate their general significance.

The difference in calorific value of the fuel/air mixtures is 10.3 per cent., and this is the most important of the factors tending to reduce the power output on gas, but it must be considered in conjunction with factors 2 and 3. The specific volume change indicates an expansion of 5.2 per cent. on petrol and a contraction of 8.5 per cent.

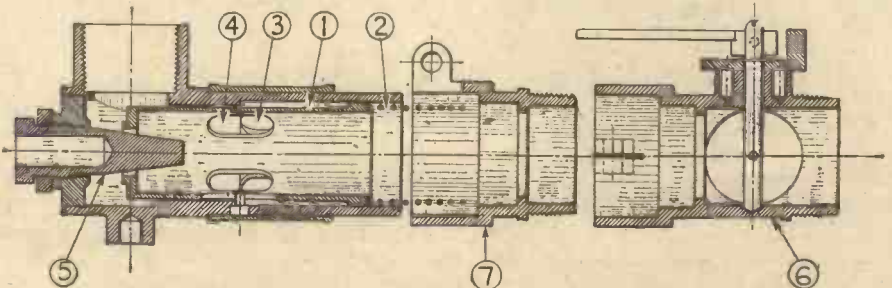

Fig. 3. G.L.C. Carburettor No. 2, showing petrol carburettor adaptor (7) and butterfly throttle (6).

sists of 80 per cent. air and 20 per cent. fuel. On petrol the fuel enters in the form of a heavy vapour occupying under 2 per cent. of the total volume inspired. There is, therefore, in effect a loss in volumetric efficiency when operating on gas.

The following figures are taken as a basis of comparison between the two fuels:—

with gas, so that the ratio of volumes after combustion is

$$V_{\text{gas}}/V_{\text{petrol}} = 0.861$$

This factor obviously reacts in favour of petrol, since it tends to give a bigger pressure development in the cylinder with a lower working temperature. However, the higher specific heat of the products of

	No. 3 Petrol	Town Gas
Calorific value of theoretical fuel/air mixture (air 60 per cent. RH., 60° F.)	95.0 B.Th.U./cub. ft.	85.2 B.Th.U./cub. ft.
Specific volume change on combustion, i.e., volume of products net at S.T.P. volume of mixture at S.T.P. . . .	1.062	0.915
Mean specific heat of products of combustion, 0-2200° C.	0.02385 B.Th.U. cub. ft.	0.0244 B.Th.U. cub. ft.
Latent heat of evaporation . . . . .	254 B.Th.U./lb.	—
Specific gravity of the fuel/air mixture	1.04	0.89



combustion of town gas tend to reduce the flame temperatures. The combined effect of these three factors may be considered as follows:—The theoretical flame temperature (ignoring dissociation) is—with petrol, 2080° C., 2353° A; gas, 2120° C, 2393° A.

The effect of this difference on the pressure development is of the order of 1.5 per cent. in favour of gas. Considered in conjunction with the V gas/V petrol ratio, 0.861, the ratio of pressures developed at constant volume under these ideal conditions will be:—

$$0.861 \times 1.015 = 0.875;$$

so that the pressure development on gas is less by 12.5 per cent.

It is interesting to note the effect of rich mixtures on the specific volume change which occurs with both gas and petrol. Taking, for example, town gas:—

	Theoretical mixture for complete combustion		
Air gas ratio .. .. .	4.3 : 1	4 : 1	3.5 : 1
Specific volume change .. .. .	0.915	0.956	0.974
Potential heat in flue products .. .. .	Nil	8.6%	22.4%

This increase is due to the larger number of molecules owing to the existence of some carbon monoxide and hydrogen in place of carbon dioxide and water vapour. The actual power developed will, of course, depend on the balance between the increase in the specific volume change and the decrease due to the loss of heat developed. The figures given indicate that the maximum power mixture will be about 4.1:1. Burstall, working on a single-cylinder engine, found that maximum power was obtained with a 20 per cent. rich coal gas air mixture (i.e., an air gas ratio of 3.82 : 1); but this result was obtained by adjusting ignition timing valve setting, etc., to give the optimum power and not under simple conversion conditions. We have found in experiments on a Commer 14/4 and an Austin 16/6 that the maximum power is obtained with the mixture giving an exhaust analysis of 10 per cent. CO<sub>2</sub> and 1.4 per cent. CO on gas of the composition previously given. This corresponds to an air gas ratio of 4.14 : 1, a result very close to that obtained theoretically.

The latent heat of evaporation of the fuel has a considerable effect on the volumetric efficiency of the engine, since with petrol the air fuel charge is cooled by about 28° C. If the temperature of the charge drawn into the cylinder is taken as 380° A, the result of this cooling effect is to increase the volumetric efficiency by about 7 per cent. On gas this intrinsic cooling effect is absent, and the working temperature of the cylinder will also be higher; so it may be anticipated that the warming of the entering charge by convection on the cylinder walls will be greater with gas than with petrol and that the temperature difference will be increased.

The differences in viscosity and specific gravity of the air fuel mixture will become important as far as these factors influence the discharge characteristics of the two mixtures through the valve gear. It is not possible to calculate for a general case the value of this effect, but the equivalent effect on any engine will be inversely proportional to the square roots of the densities of the two mixtures. Here the advantage lies with town gas, since

$$\sqrt{\text{petrol}/\text{gas}} = \sqrt{1.04/0.89} = 1.08.$$

**Cooling Losses from the Burning Charge**

It is necessary at this point to consider

what differences exist in the energy dissipation with gas and with petrol. Little data is available on the conduction from hot gases to the cylinder walls under the conditions of turbulence that exist in an engine cylinder. At low temperatures (100° C. to 500° C.) the rate of cooling is proportional to the temperature difference between the hot gases and the walls of the cylinder. The percentage loss by conduction will, therefore, vary as the surface volume ratio of the cylinder, and will therefore be lower as the diameter of the cylinder increases, an important factor when comparison is made between the large-bore gas engine and the relatively small-bore multi-cylinder high-speed petrol engine converted to gas. At elevated temperatures, however, the simple temperature difference relationship is not valid. According to David the rate of cooling increases rapidly at

higher temperatures, being proportional to the second power of the temperature difference at 1500° C. and to as much as the fifth power at 2400° C. It will be realised, therefore, that though the calculated flame temperatures of gas and petrol differ by only 40° C., the effect on the conduction losses may well be more significant.

The radiation losses may be considered as arising primarily from the carbon dioxide and water vapour contents of the explosion products (Sohack). As pointed out by Bone and Townend, it might be supposed that as gases under suitable conditions are capable of absorbing the radiations which they emit, they would therefore be opaque to such radiations; but it must be remembered that the molecules are relatively far apart, and hence a large percentage of the radiations escapes. Callendar arrived at the conclusion that the emission from a gas layer 5 cms. thick at 20 atmos. would be within half per cent. of that from an infinite depth.

It is possible, therefore, to calculate approximately the radiation for the two air fuel mixtures being considered. The simplified formula recently proposed for estimating these losses is:—

$$Q \text{ CO}_2 = 3.5 \sqrt[3]{PS(T/100)^3}$$

$$Q \text{ H}_2\text{O} = 35 \cdot P \cdot S^2 (T/100)^2$$

where Q = radiation in K cal/m<sup>2</sup> hr.

P = partial pressure in atmospheres.

S = depth of radiating layer in meters.

T = temperature ° A.

Radiation from other gases present can be ignored.

The exhaust gas analysis (wet), at theoretical fuel/air ratio for petrol and town gas is as follows:—

	Petrol.	Town gas.
CO <sub>2</sub> .. .. .	12.9	9.9
H <sub>2</sub> O .. .. .	13.3	20.4
N <sub>2</sub> .. .. .	73.8	69.7

The difference is appreciable, and in practice it will be still further emphasised by the CO and H<sub>2</sub> present in the products from petrol which will reduce the CO<sub>2</sub> and H<sub>2</sub>O percentages. As an example, the radiation from the two exhaust gases has been calculated for a pressure of 20 atmospheres at 2500° C. with a radiating layer 6 cms. deep.

Petrol	QCO <sub>2</sub> = 268,000	K cal/m <sup>2</sup> hr.
	QH <sub>2</sub> O = 533,000	" "
Gas	QCO <sub>2</sub> + QH <sub>2</sub> O = 801,000	" "
	QCO <sub>2</sub> = 245,600	" "
	QH <sub>2</sub> O = 753,000	" "
	QCO <sub>2</sub> + QH <sub>2</sub> O = 998,600	" "

Under these conditions—i.e., identical flame temperatures—there is with gas 23.6 per cent. more radiation from the products of combustion. It should be remembered that this computation ignores radiation from incandescent carbon particles in the flame



Fig. 4. Gas carburettor showing method of fixing to the S.U. petrol carburettor. The air flap is in the closed position for running on gas

**Loss of Potential Heat in Exhaust Gases**

The optimum power setting on a petrol engine requires a rich fuel/air mixture, and as a result an appreciable part of the exhaust loss is made up of potential energy of unburned gases. A typical analysis on petrol would be :

CO	10%	H <sub>2</sub>	2.8
O.	1%	CH	0.25
CO	5%	N <sub>2</sub>	80.95

This potential heat corresponds to about 17 per cent. of the gross calorific value of the fuel. The optimum power setting on gas is also on the rich side of the neutral mixture, but in a simple conversion it is found that enrichment beyond 105 per cent. of the correct mixture fails to increase the power developed. It follows that on petrol the waste heat includes up to 6.9 per cent. of the gross C.V. as latent heat plus 10 to 12 per cent. as potential heat, while on gas up to 10 per cent. is present as latent heat and the potential heat in unburned products is small. If two engines are running on petrol and town gas at equal thermal efficiencies the amount of sensible heat is, therefore, greater on gas than on petrol.

(To be concluded)



## THE MONTH IN THE WORLD OF

## Science and Invention

**Gas Driven Watch**

**A** WATCH which derives its power from the gas given off by liquified methane gas was recently exhibited at the Swiss Watch Fair. It is an automatic timepiece able to go for a number of years on this new power. The gas helps to keep the mechanism free from rust or penetration by dust, and also preserves the oil against oxydation.

**Secret Telephone Talks**

**M**ANY may have wondered how highly confidential Transatlantic telephone talks are kept secret, since at one time it was possible for amateur wireless listeners to tune in on the radio-telephone and overhear conversations. In order to defeat eavesdroppers, the Post Office engineers use an ingeniously devised apparatus called a "scrambler." By means of this, the current carrying the human voice is split up and mixed, and sent through the ether as a warbling jumble unlike any known tongue. At the receiving end the distorted words are "unscrambled" and smoothed out. In order to prevent any outsider decoding the jumble, the method of "scrambling" is frequently changed. Post Office engineers claim that conversation with overseas countries is even more private than that over ordinary land-lines.

**Motor Fuel from Maize**

**A**CCORDING to scientists of the Fuel Research Institute of Pretoria a single season's crop of maize would yield motor fuel equivalent to 30,000,000 gallons of petrol. An equivalent to many times that figure, they consider, could be obtained from the waste from forests and sawmills.

**Concrete Ships**

**A** FERRO-CONCRETE ship, the first large sea-going vessel to be built of this material in this country during the present war, is now afloat. The vessel is of some 2,000 tons deadweight and is a cargo motorship with propelling machinery consisting of a Doxford oil engine. As such ships can be built by men formerly employed in the building trade and civil engineering, a great saving of steel and of men skilled in ship construction is effected.

**Bullet-proof Armour**

**T**HE Australian Production Director, Mr. F. S. Daly, announced recently that a new process for producing bullet-proof armour for fighting vehicles had been discovered.

**New A.A. Predictor**

**I**T was recently revealed that a new A.A. predictor has been produced which is so accurate and sensitive that, according to one commanding officer, it "practically thinks for itself." The windows of the factory had to be kept closed in order to prevent dust getting on the delicate parts used in the assembly, which requires the same care and delicacy as is necessary in making an expensive watch.

**South Africa's Electric Furnace**

**W**HAT is believed to be one of the biggest and also one of the first electric furnaces to be built in South Africa, was recently installed at an engineering

works in Benoni. It is specially designed for carburising, and was built by Messrs. Rennert and Lenz, Ltd. The furnace took four months to complete, has a power consumption of 60 kilowatts, and a normal temperature of 900 degrees Centigrade.

**Brighton Engineer's Invention**

**M**R. R. C. MOORE, a Brighton electrical engineer, has invented a radio device for detecting people buried beneath the debris of demolished buildings. It consists of a simple electrical amplifying apparatus and a padded loud-speaker horn three feet in height. The horn when placed in the debris draws in every sound, such as deep breathing and slight taps. At a demonstration a volunteer crawled into a small hole under a large pile of debris, and a whispered conversation was clearly heard by a press representative. The chairman of Brighton A.R.P. Committee, Captain B. Dutton Briant, states that the device will not be patented, and any local authority wanting details or a test can apply to the A.R.P. controller at Brighton Town Hall.

**Inventions Wanted**

**A**MONG the inventions the military authorities in Washington would like are a wireless-operated aerial torpedo, a wireless-operated machine gun, an interceptor-ray for precision firing on distant enemy positions, shells that explode instantly after piercing the toughest armour, an air-cooled machine gun as light as a rifle, a flat air-cooled engine for streamline mounting in aeroplane wings, a recoil mechanism for mounting 75-millimetre cannon on Flying Fortresses, and oxygen helmets for invasion landing for infantry from submarines. It is pointed out by the experts that they do not expect a mystery weapon.

**New British Tank**

**T**HE latest type of British light cruiser tank to come off the assembly lines is named the Covenantor. It is a sister to the Crusader, and is slightly less weighty than the 16-ton Valentine. The new tank has a fine turn of speed, is very manoeuvrable, has excellent armour, and formidable firing power.



An A.T.S. girl at action station on a locator in an A.A. training camp somewhere in the west of England.

**American Tank's Aero-Engine**

**A** WRIGHT aero-engine similar to the type fitted to many aircraft, provides the power for the U.S. Army's M3 medium tank. The power of the engine is 400 h.p., rather less than most modern military aircraft engines, but is large for any ground vehicle, and is capable of moving this 28-ton tank at a maximum speed of 25 m.p.h. The Chrysler and the Baldwin Locomotive factories are producing it. It is 9 ft. high, 9 ft. wide, and 22 ft. long, and is fitted with disc clutches, and a synchromesh gearbox having five forward and one reverse gears. The Cletrac method of steering is employed, a feature of which is that power is always applied to each track, but the inner track can be slowed down to one-sixth of the speed of the outer. The tracks, consisting of 79 shoes, are covered with rubber on the contacting surfaces, and have rubber bushes on the connecting hinges so that no metal-to-metal contact occurs.

**New Aeroplane Tyres**

**T**HE Firestone Company of Canada have introduced a new rayon aeroplane tyre which is 14 lb. lighter than the tyres usually used on transport aircraft. It is claimed that it is much stronger, and that it has stood up to 38 per cent. more punishment during tests.



## Fog Dispersal

**H**OUGHTON AND RADFORD, of the Massachusetts Institute of Technology, have developed a method of dispersing fog by means of sulphur chloride solution. It is sprayed into the air, and being able to absorb moisture, removes the source of fog. It may not be generally understood by engineers that fog is due to droplets of moisture in a humid air condensing, and remaining air borne. Often fine dust particles act as foci, encouraging moisture to settle out as fog particles. The Houghton-Radford idea is to spray the sulphur chloride solution into the air, when the fog is deposited in the form of raindrops. They have found that by delivering 85 gallons per minute into the air they can cut a slice of 30 ft. high, 150 ft. wide and 1,500 ft. long in a fog, so enabling, it is presumed, an aircraft to land in weather where visibility is about nil.

## Explosive Rivets

**R**IVETS are again in the American news and this time they are explosive, which perhaps, is in keeping with the general trend of things. They are considered to have solved the "blind" fastening problem, in which the other side of the rivet is inaccessible. While the explosive rivet is by no means a new idea, that they have now been adopted in the aircraft industry in the States is due in a large measure to development work of the great organisation of E. I. du Pont de Nemours, of Delaware. The rivet is set on the blind side by means of a small charge of explosive, inserted in a hollow end to the shank. By careful control of the charge, which is solid, the shank can be held to an expansion of 0.02 in., the firing of the explosive being carried out by means of an electric iron, shaped like a soldering iron. It is claimed that a man can set 15-20 rivets per minute, and seeing that there may be 800 "blind" side riveting points in a fighter and up to 10,000 in a large bomber, the necessity for speed is clearly apparent. The expansion takes place in 1½ to 2½ secs. after the application of the silver-tipped iron, which, incidentally, weighs less than five pounds. The rivets are of aluminium alloy, in various sizes, and are anodised. No reference is made to the composition of the explosive in *Automotive Industries*, July 15th, 1941, in which journal the announcement of the patented rivet is made. But stuffing is required to hold in the explosive, and one may surmise that one of the secrets of the success of this idea lies in the machinery by which a charge of sufficient accuracy is loaded into the shank cavity. The heads of the rivets are die cast.

## Cosmic Rays Demonstration

**C**OSMIC rays demonstration in Cal-Tech's famous world's largest "Wilson Cloud Chamber" were recently given by Dr. Carl Anderson, Nobel Prize-winning discoverer of the positive electron power, and Leon Katz, teaching fellow, as a feature of the 25th annual meeting of the American Association for the Advancement of Science, Pacific Coast Division. Observers saw paths left by cosmic rays which entered a vapour-saturated, circular, glassed-in, two-foot chamber. In a highly charged magnetic field, the rays, which bombard everything on earth, from some unknown source, in stellar space, sped through the vaporised atmosphere at incredible speed. But behind them they left a trail in the form of "raindrops" condensed on particles resulting from the collision between the rays and atoms of the vapour. (See photograph.)

## Warm and Buoyant

**A** NEW kind of clothing has two reasons for its existence. Intended for those who travel by sea, firstly, it is claimed for it that it will keep out the cold. Secondly, its inventor has formed a device, which, in the event of the wearer being suddenly immersed in deep water, at once becomes a life-saving appliance.

The invention is a jacket, preferably sleeveless, provided with insets of Kapok both at the front and the back. The distinguishing feature of this garment is that the front of the jacket, at the lower part of the side seams, is not attached to the back. As a consequence, the front part can be turned up or rolled up to produce a double layer of Kapok on the wearer's chest. It is so arranged in order to support him face upwards in the water.

## Light on the Water

**H**ERE is yet another invention for the saving of those in peril on the sea. This time it is an improved battery-operated electric lamp fitted to rafts and life-jackets. It is of the kind in which the lamp is automatically lit when the water is entered. The device comprises a holder fitted with a lamp bulb, having a transparent cover. The electric circuit to the lamp bulb closes to illuminate the lamp when it touches the water. The automatic switching is effected by a movable contact member arranged to engage one of two fixed contacts in the lamp circuit. The movable contact member is operated by a float member. The two fixed contacts are normally bridged by a ball of mercury when the lamp is in a vertical position. Tilting or inverting of the lamp causes the mercury to roll from the bridging position, which breaks the electrical circuit.

The benefits of this invention are twofold. It will enable rescuers to locate the survivors of a shipwreck, and it is intended to prevent them from being run down by an oncoming vessel.

## Immunity from Petrol Fires

**R**.A.F. scientific experts recently investigated a liquid which it is claimed will render airmen immune from petrol fires. At a demonstration, a man applied the liquid to his face, hands, and clothing, taking care to run it into his hair also. Petrol was then poured over him and set alight. He merely brushed the flames away. When petrol was poured over his suit and set alight, the flames were shaken out.

## Translucent Bricks

**A**CCORDING to the American journal, *Science*, translucent hollow bricks that admit daylight and contain gases and electrodes to act as electric discharge lamps at night, have been produced by a well-known electrical manufacturing concern in

the United States, and patents have been assigned to the firm.

## Air-Raid Protection

**W**ITH the aid of ingenious machines, scientists have been making tests on the effects of blast and devising methods of safety in air raids. It has been found that the human body will stand up to blast from even a large bomb, much better than bricks and mortar. Strips of paper, and bracing devices on shop windows, have been proved to be useless. A spring hammer shattered glass which was not properly protected with varnish or net fabric. Other tests were carried out by dropping a steel ball, and exploding a balloon inflated with hydrogen and oxygen in a blast tunnel. All glass will break if the blast is sufficiently strong, but good anti-scatter

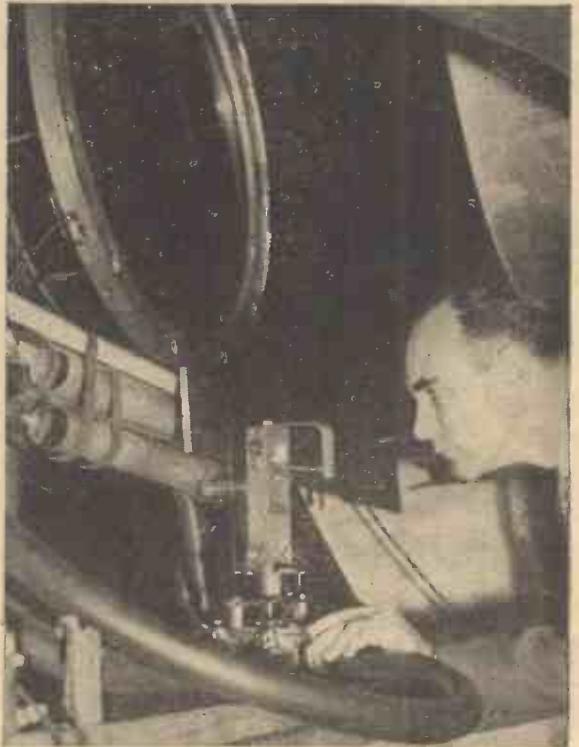

Dr. Carl Anderson operating the Wilson cloud chamber. (See paragraph.)

treatment will hold the pieces together, and small-mesh wire netting is also a good preventive. Civilian steel helmets are a good protection against shrapnel, as was shown when a half-inch bullet was fired, at a short distance, at a new helmet. It dented it, but the resilient lining would have prevented injury to the head.

## Radio Life-saving Device

**M**OST ships now carry a new type of radio transmitter which, though only of suitcase size, is powerful enough to be heard up to 200 miles. An S.O.S. can be sent out by an unskilled person by pressing a button. The worth of the set, which is water-tight and buoyant, has already been proved in the case of a lifeboat with seventeen men aboard who sent out an S.O.S. which was heard ninety miles away. They were saved within seven hours. Other new devices for life-saving at sea are electric light-buoys attached to ships' life-rafts for use at night, and an apparatus which flashes the S.O.S. signal in Morse continuously for 48 hours, and if used only at night will last a week.





An R.A.F. rescue launch at high speed. These launches, which are armed for defence, are constantly on the alert to pick up airmen who have come down in the sea.

# The World of Aviation

A Heavy Bomber, Sun Lamps for Airmen, and The Fastest Trainer

## 83-Tons Plane

A PLANE that could make eight trips, with 20 tons of bombs, from Britain to Berlin without refuelling, has been built in the United States. It is the Douglas B19, an 83-ton bomber that can remain in the air two days, or carry 180 passengers from New York to London, non-stop. As a troop carrier it has accommodation for 200 fully equipped soldiers. It is necessary to climb a 14-step ladder in order to get into the plane. Some idea of its great size and intricate construction can be gathered from the fact that five hundred engineers spent 700,000 hours making and installing the equipment. General construction occupied workers for 1,500,000 hours.

From the day the first blue-print was started to the first flight, the bomber has taken four years to build. In its construction 3,000,000 rivets and 12 miles of electrical wiring have been used. Its airscrews are 17 feet long and are the largest ever made. Landing wheels are 8 ft. high, and the wing-spread is 212 feet. The range is 8,000 miles, speed is in excess of 200 m.p.h., and fuel capacity is 11,000 gallons.

There are twelve gun stations, each of which has its own heating system. There are ten in the flight crew, and with gunners the total crew is 23. The wings are hollow so that the four engines can be serviced in flight. In addition to the four main engines there are two auxiliaries under the flight room to provide power for the hydraulic systems, radio, lighting, and for operating many other power-driven mechanisms.

## Aircraft that Reverses

IGOR SIKORSKY, a Russian aircraft designer in Connecticut, recently succeeded in building a plane that can climb

almost vertically, and fly both backwards and forwards. It is a strange looking machine, powered by a simple 90 h.p. motor, with a large rotor or airscrew mounted horizontally above the engine. Two smaller rotors are on the tail plane and another where the rudder would normally be. He made his test flight over an acre of ground, flying forward at about 50 m.p.h., and backward at 20 m.p.h. The plane remained stationary for just over an hour, and descended almost vertically. Two rotors are used as elevators and one as a rudder. By controlling the speed and pitch of these, Sikorsky was able to maintain complete control of all the operations.

## A Problem for "Spotters"

THE Potez 63-11 which is a twin-engine, low-wing monoplane designed for reconnaissance and bombing, will certainly prove rather a problem to aircraft spotters. It has a speed of 270 m.p.h. and is in use with the Free French, Vichy and German Air Force. It is powered by two 670 h.p. Hispano-Suiza engines.

## Sun-lamps for Night Fighters

NIGHT fighter pilots are deprived of their normal quota of sunshine and ultra-violet rays because, being on the "night-shift," they have to sleep during the daytime.

To counteract this, and to assist in maintaining at the highest level the physical fitness of these front line defenders of Britain, Lord Nuffield has offered to provide facilities for sun-ray treatment. This special treatment can, if desired, be taken while the night fighter pilots are wearing dark glasses to adapt their eyes for night vision.

Lord Nuffield's offer has been readily

accepted by Sir Archibald Sinclair, Secretary of State for Air, and each of the aerodromes at which night fighter pilots are stationed will shortly be equipped with the latest type of collective irradiation apparatus. The new type apparatus enables the treatment to be enjoyed by as many as twelve pilots simultaneously.

## Fastest Trainer Faster Still

PROBABLY the fastest trainer aircraft in the world when it was introduced into the R.A.F. flying schools shortly before the war, the Miles Master has now been given a lot of extra speed by being equipped with a more powerful engine. Known as the Master II, this stoutly built low wing monoplane now has a Bristol Mercury motor, a radial type used in such famous aircraft as the Gloster Gladiator fighters, and the early Bristol Blenheim bombers. The first Master had a R.R. Kestrel engine with a maximum output of about 700 h.p. derated for training purposes to around 600 h.p. A constant speed Rotol airscrew as fitted to the earlier type is continued in the Mark II.

Besides adding something like 30 m.p.h. to its maximum speed, the "extra horses" also improve the take-off considerably. This is a useful point, as it keeps the trainer technique abreast of similar developments in the performance of the service fighters to which pupil pilots next graduate. The use of an air-cooled motor has an advantage, especially useful at training schools where a high percentage of "serviceability" is demanded, and maximum speed is not a first consideration. Maintenance problems are somewhat simplified and accessibility is improved. Another modification in the new Master is an improved type of sliding hood, a development which adds to the safety features for the protection of the pilot.

# Controlling Gunfire

## Action Stations!

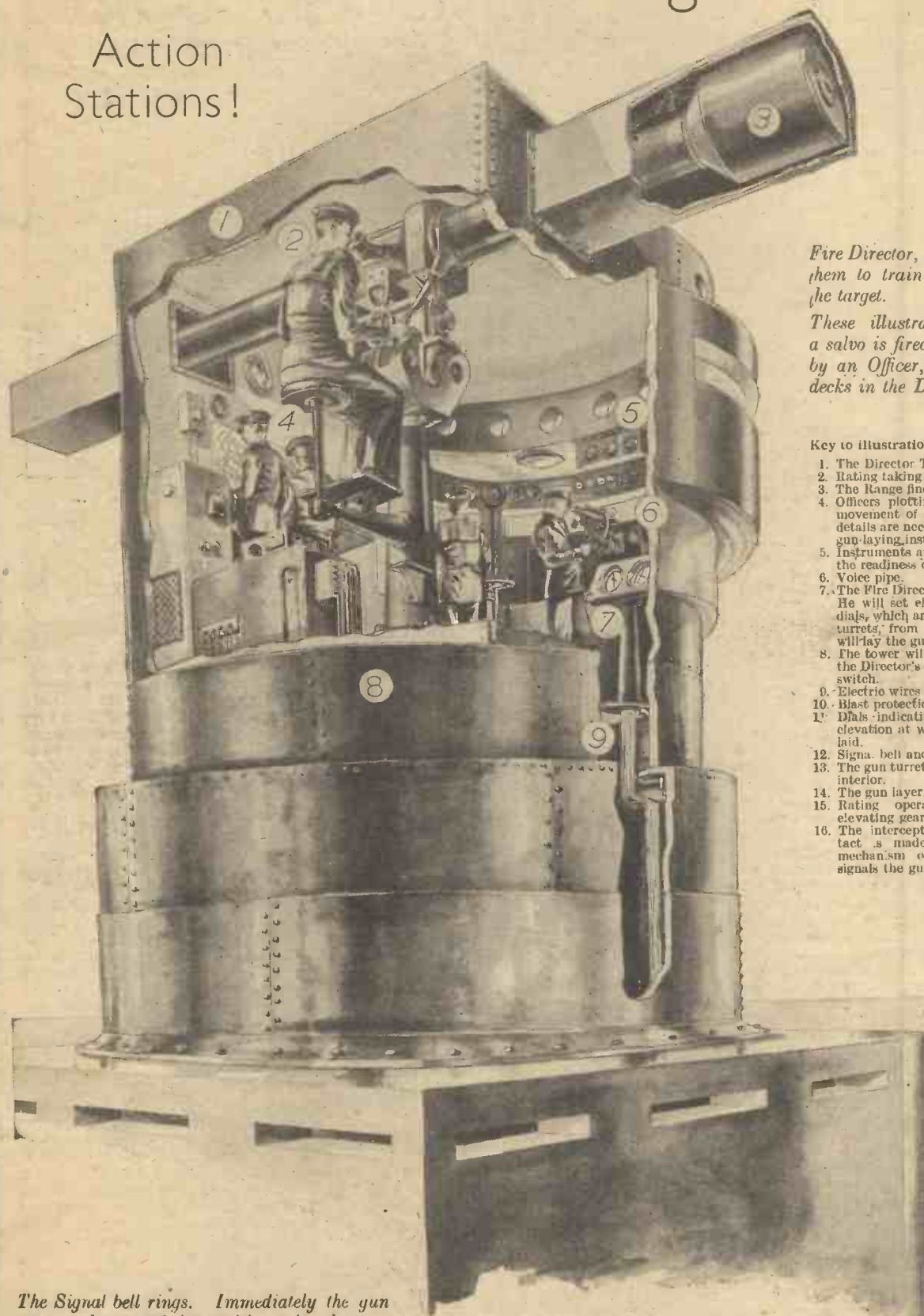

*Fire Director, which will enable them to train the guns on to the target.*

*These illustrations show how a salvo is fired from one button by an Officer, high above the decks in the Director Tower.*

### Key to illustrations.

1. The Director Tower.
2. Rating taking the Range.
3. The Range finder.
4. Officers plotting course, speed and movement of ship on chart. These details are necessary to work out the gun-laying instructions.
5. Instruments and signals which state the readiness of all guns to fire.
6. Voice pipe.
7. The Fire Director sighting the target. He will set elevation and direction dials, which are duplicated in all gun turrets, from which the gun almer will lay the gun.
8. The tower will rotate in response to the Director's operation of the power switch.
9. Electric wires leading to gun turrets.
10. Blast protection.
11. Dials indicating the direction and elevation at which the gun must be laid.
12. Signal bell and lamps.
13. The gun turret cut away to show the interior.
14. The gun layer.
15. Rating operating the hydraulic elevating gear.
16. The interceptor which, when contact is made with the electrical mechanism on the breech block, signals the guns' readiness to fire.

*The Signal bell rings. Immediately the gun crews take up their positions in the gun turrets, awaiting the instructions from the*



# on Board a Warship

17. The breech open to receive the shell.
18. The arm and mechanism which closes the breech (in Navy parlance, "shutting the oven door").
19. The hoist which carries the shell into the loading tray.
20. The loading tray.
21. The shell.
22. Rating inserting the firing tube which will detonate the cordite charge which in turn propels the shell.
23. The twin gun.

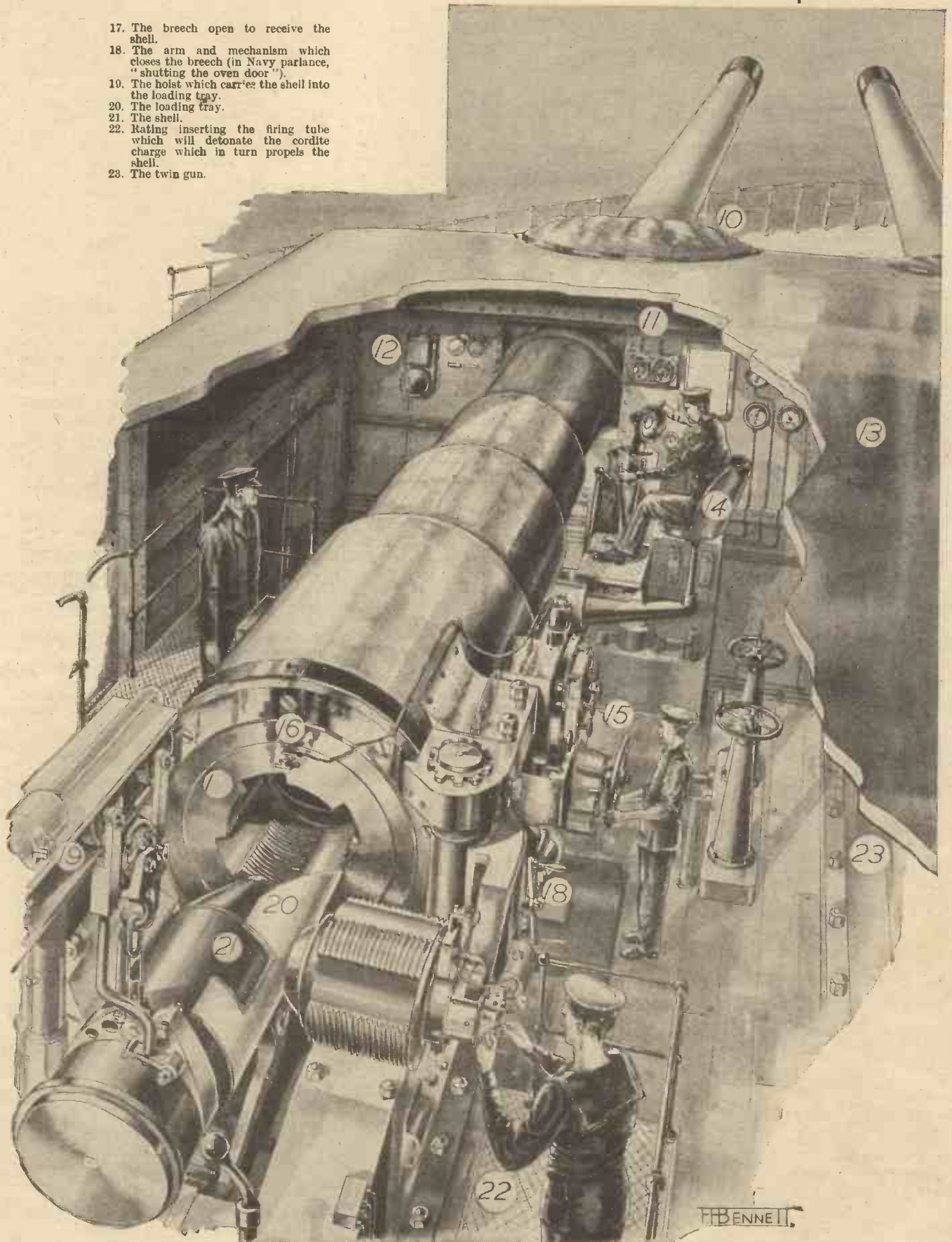

# Indexing a Dividing Plate

## Constructional Details of a Useful Lathe Fitment

WHEN using the lathe for milling work held in the chuck or between centres, and using a milling spindle carried in the tool post of the compound slide rest, it is necessary to have a dividing plate fixed to the lathe mandrel so that work can be located at accurate circumferential distances for milling on it such cuts as wheel tooth spaces, etc., where accuracy of pitch is automatically obtained. This is valuable and necessary in many munition jobs.

There is no difficulty in rigging the dividing plate up with a suitable stop, but there is great difficulty in dividing the plate itself unless the workshop is already provided with an accurate plate. The object of these notes is to describe a method by means of which the plate can be divided with sufficient accuracy for all mechanical jobs, including gear tooth cutting.

### The Dividing Head

As regards the dividing head shown fitted to the lathe mandrel in Fig. 2, this needs little technical description; the plate should be made as large in diameter as possible to just clear the ways of the lathe bed. It is made of  $\frac{1}{8}$  in. or  $\frac{3}{16}$  inch brass sheet or plate, with a central hole to exactly fit the parallel part of the lathe mandrel nose, and is held up by the chuck plate or the drive plate. It can also be held by the faceplate although seldom required to be used for faceplate work.

To locate it, a hole is drilled through the plate into the shoulder of the mandrel nose, as shown in the part sectioned in Fig. 2. A silver steel pin is fitted in the hole in the dividing plate and sweated in. Its projecting end enters the hole in the mandrel shoulder and locates the plate to the lathe mandrel. The close fit of this pin in the hole is important, there must not be the slightest shake or circular movement of the plate.

### Stop Pin

The stop-pin is at the end of a spring blade as shown, and it enters the holes in the plate and holds the plate, and therefore the lathe mandrel, in position for any one of the divisions the plate is arranged to supply. The bottom end of the spring blade is pivoted on an angle block screwed to the lathe bed so that it can move sideways to allow the stop-pin to register with any one of the rows of dividing holes on the dividing plate. The holes are bored parallel and the stop-pin is parallel with a very slight taper for  $\frac{1}{8}$  in. at the front to facilitate entering. The holes are reamed so that all are alike and the stop-pin is turned to exactly fit.

### Location of the Holes

Take a large sheet of tin plate, the larger the better. Cut a hole in the centre the same diameter as the hole in the plate that we are going to divide. Turn a bush of brass to exactly fit the hole, and with a flange at the back and bore it while held by the back flange so that the hole is truly concentric with the parallel part of the bush.

This bush is then sweated in the central hole in the big tin-plate sheet and projects out of the front of the plate. It is to act as a guide to a rotating arm as shown in Fig. 1.

This rotating arm is fitted to a parallel

plug which exactly fits the bore in the bush. It is cranked down so that when the plate we are to divide is fitted over the bush, and the rotating arm is fitted in the bush, the latter fits down flat on the dividing plate. Also it is again slightly cranked so that its outer and longer portion fits down flat on the tin plate sheet when the latter is laid down on an even smooth table or bench in which has been cut a recess to accommodate the flange of the bush.

The rotating arm is first used to describe circles on the tin plate. These may be  $\frac{1}{4}$  in. apart, and as many as there are circles of dimension on the dividing plate we are

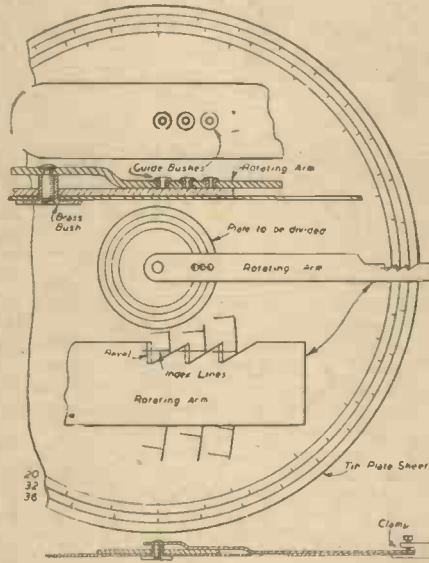

Fig. 1. Method of locating the holes.

making. These circles can be drawn by drilling holes in the rotating arm and fitting a sharp scriber to exactly fit the hole and drawing the circle by rotating the arm.

### Setting of Divisions.

On these circles we can set out with dividers the number of divisions we want on each row of holes in the dividing plate. This should be done very carefully and the circles intersected at each point by a thin scribed line.

On the rotating arm, at that part which fits flat on the dividing plate, drill holes one for each circle of dimensions we are going to use. These holes should be three-sixteenths of an inch in diameter and at distances away from each other at  $\frac{1}{8}$  in. intervals inwards from the edge of the plate so as to get the circles as large in diameter as possible. With a scriber in these holes exactly fitting them, and turned with its point dead

concentric with its outside wall, scribe circles on the dividing plate. These circles will determine the position of the holes.

Drill and finally reamer these holes to  $\frac{1}{8}$  in. and fit steel bushes, the outside diameter to fit the reamed holes, and the hole in the bush  $\frac{1}{8}$  in. diameter. These are to act as drill guides.

At that end of the rotating arm which lies on the large circles on the tin-plate sheet, file three bevels so that their thin edge can lie on the lines with the scribed lines we have made across the circles radial to the centre. This end of the rotating arm should be used to scribe a circle on the tin plate, which can then be cut to this circle. A small clamp is used, as shown, to clamp the rotating arm to the tin plate. It is applied directly at the end of the plate, and is fixed when the scribed line across the circle coincides with the bevel edge line on the rotating arm.

Then the drill bush, in the arm corresponding to that circle on the division plate, which corresponds to the large circle on the tin sheet from which we are taking our direction, is used to drill the plug holes in our dividing plate. The drill should exactly fit the bush.

### Minimising Error

In this way any error at the big circle is reduced by the difference in length away from the centre, as compared with the distance away from the centre of the circles on the dividing plate. If the scribing is done carefully with a very fine, sharp scriber and close to the edge of the rotating arm, and if the alignment is carefully made when clamping the arm for drilling, then any inaccuracy in the actual holes in the plate when finished will be negligible.

It will be seen that, the greater the diameter of the big circles as compared with the small ones we are dividing, the more any very slight inaccuracy in the dividing of the big circles will be reduced in the division of the actual plate.

The holes having thus been drilled, they can be opened out to suit the stop-pin on the stop spring, Fig. 2, by reaming. But it is best to have them very close to size of the holes in the guide bushes, and if a reamer is used, a stop sleeve must be clamped on it so that it goes down the same distance in all holes.

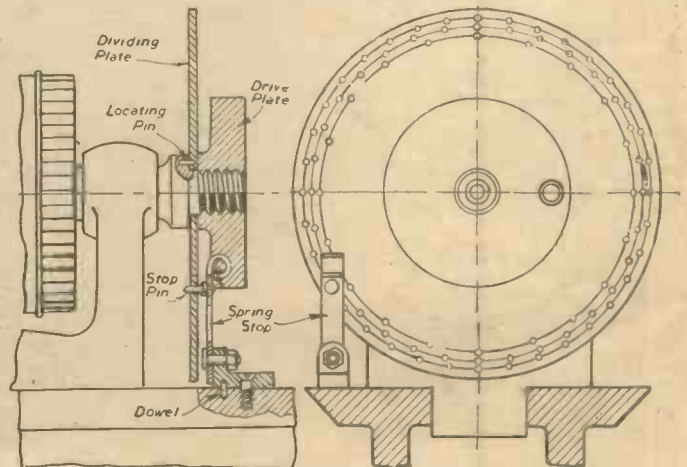

Fig. 2. The dividing plate fitted to a lathe mandrel. Note the position of the springs-top.



# Making a Success of Your Photography

By JOHN J. CURTIS, A.R.P.S.

## Making Bromide Prints



*Showing how nine test exposures can be obtained on one piece of paper.*

we speak of contrast we refer to the difference between the blacks and the whites, and the strongest contrast that it is possible to get is between a perfectly solid black and a pure white. If you try to imagine a picture built up of these two qualities only, you will realise that it is something on the lines of a sheet of printed typematter; it is without form and is lacking in what we may term light and shade; but as soon as we start introducing that light and shade we not only get form or shape by breaking down the blacks with dark greys or changing some of the whites into light greys, but the more of these greys we introduce, the longer our line or range of gradation becomes. If you examine a good landscape photograph you will see that it is broken up into at least three stages, the foreground, middle distance, and distance, and each of these is, to a large extent, represented and put into its right place, by reason of its depth of tones or gradations between black and white. If you inspect a portrait you will see that there is a moulding of the features brought about by light and shade, which again is this same idea of tones.

**T**HE last article of this series was devoted to the making of gaslight prints, and although I told you that most amateurs use this type of paper when they start printing, yet, as they progress, they seem to desire a medium which will give them something that is rather different, something similar to the prints which are to be seen in the windows of a professional's studio, or like those prints which are exhibited on the walls at the local camera club's exhibition. Consequently they make a change and try a packet of bromide paper for a batch of negatives which have the appearance of being rather more pictorial than some of the others.

When you were in the habit of having the prints made for you by the local chemist, they were mostly made on gaslight paper, and perhaps on a glossy surface; that was all right when the subjects were just ordinary snapshots taken as records of some happy occasion, or of a particularly interesting place you happened to be visiting, but as you began to learn a little more about your camera and its possibilities, you realised that it was possible to get rather better pictorial effects in the snapshots; you were actually taking more care in the selection of subject, and in the exposures, with the result that the negatives

were a decided improvement on the previous year's collection.

The main difference between gaslight and bromide papers is the speed, and some makes of bromide paper can be 1,000 times faster than gaslight paper, or, to put it another way, if a certain brand of gaslight paper required an exposure of one minute, the bromide would only want one-thousandth part of a minute. This extraordinary speed brings about the second difference in favour of bromide, it enables this paper to be used for making enlargements, which cannot be done satisfactorily on gaslight owing to the slow speed of the emulsion necessitating a long exposure, which in turn would tend to cause fogging. There is a third point which, while it is perhaps of greater interest to the advanced worker who makes his pictures by enlarging, is undoubtedly one which concerns those of us who make contact prints; it is generally agreed that with bromide a longer range of "gradation" is possible than with the gaslight variety, which is recognised as giving more "contrast."

### Half-Tones

We must follow this point farther to get to its actual meaning, and to see exactly how it expresses itself in the print. When

### Pictorial Work

Now you will realise what the more advanced amateurs mean when they talk about half-tones in their prints; most pictorialists when making their exhibition work aim at reproducing as many of the "half-tones" as existed in the original subject when the exposure was made, and so they are careful about the exposure, the developing of the film, the selection of the paper for printing, the exposure and the developing of the print.

Bromide paper will give, for most negatives, just that extra power to enable the amateur to get the best results, once he knows how to manipulate it. There are many grades and surfaces, also speeds of



*Showing under-exposure of a bromide print—No 1 end of the test strip.*



*Over exposure of a bromide print—No. 9 end of the test strip.*





Correct exposure A combination of the exposures given for test strips 4 and 8.

this type of paper, and each manufacturer has several varieties; amateurs, therefore, have a very wide selection from which to make a choice and, as they progress with the work, they will be able to very quickly decide which will suit a certain subject or type of negative, and on this point I would like to give a strong word of advice to those who really want to know more about this selection. Whenever you have the opportunity of visiting a photographic exhibition, study the effects gained by using a particular surface or grade of paper. Also notice how very few of the prints accepted for hanging are made on a glossy paper; usually the matt or semi-matt surfaces are used for this class of work, while the glossy comes into its own when the prints are for reproduction in the press.

#### Developing Bromide Prints

Now for a few remarks respecting the developer for getting the best out of our bromide prints, and as I always like to give in these notes the results of my own experiences, I shall have to talk to you about a developer which has not yet been mentioned; it is Amidol. There are certain developers which are only suitable for certain work, as, for instance, Pyro, which can only be used for negative making; there are others which can be used for both negative and print making, such as M-Q, or to give it the right chemical name, Metol-Hydroquinone; there is also a third group which can lay claim to being suitable for both, but much better for one than the other, and this is where Amidol must be included. This is better for the development of bromide paper than for any other work; most professionals and trade workers will prefer Amidol for their prints because of the very rich blacks and clean whites it yields, and also because there is not the tendency to stain, as with M-Q and, finally, it is quickly prepared, and there is always an advantage in using a freshly made solution.

#### Tubes and Tablets

The most convenient form for those who are only doing occasional work is the tubes of Amidol developer, which contain the whole of the chemicals required for making 10 ounces of developer, the cost being 5d. each. Another form of developer which has distinct advantage to those with limited accommodation is the Johnson Tablets, and with these a minimum amount of solution can be quickly prepared just at the time of using.

I have already mentioned about the speed of bromide paper and many of you will be rather puzzled how to regulate the manipulation of such high-speed material. In the last article, which concerned the printing of gaslight paper, I advised you to standardise your work as much as possible, and one of the hints was that you should always work with the printing frame 12 inches from the light. As bromide paper is so very much faster, the only practical method that can be adopted is to increase this distance, and it is very obvious that the actual time for exposure cannot be reduced if we want to have any control over it. For making contact prints on bromide paper, I recommend that the distance between frame and light be 4 feet, and for a normal negative and normal paper the approximate time of exposure with a 40-watt lamp will be 10 seconds; these figures will give you some data on which to make your first trials, and you will not be far out, but you must remember that there is a lot of variation in the speed of the various makes of paper, therefore, I again emphasise the necessity for test "strip" exposures

Test Strips

So important is this making of test "strips" that I have included some illustrations which will serve to demonstrate not only this and the article on gaslight papers, but also the future one on enlarging; and here I want to explain the series.

#### Test Strips

In the first illustration I have marked by means of lines each of the sections, and the

second and third are prints which I purposely made to show the result of gross under- and over-exposure, they had the times which I used for the strip numbers one and nine; they demonstrate the possible bad results arising from guessing or taking haphazard means of arriving at the time of exposure. The fourth is what I claim to be the correct, and is a combination, for the left-hand half of the print I allowed the time given to the fourth strip, but for the right-hand side I gave the time allowed for the strip number eight.

#### Combined Exposures

Some of you may ask, "How do you make this combined exposure?" It is done by means of shading with a piece of card the part of the negative which it is necessary to retard or to hold back from printing while the exposure is being made. In this particular negative the right-hand section (left-hand of the print) is "thin" and the time required for printing it is very short compared to the left-hand side of the negative, it is therefore necessary to hold it back for a bit while the left gets its full share. This little dodge will be dealt with more fully in the article on enlarging.

The fixing bath for bromide papers is exactly the same strength as the one used for gaslight papers, and you should allow the same length of time for the bath to do its job; but, again, I would warn you not to allow your print to remain exposed to the air after taking it from the developer; plunge it into the fixing immediately, and wait ten minutes before turning on the white light.

#### STANDARD WORKS

DICTIONARY OF METALS AND THEIR ALLOYS

Price 6s. (By Post 6s. 6d.)

WATCHES: ADJUSTMENT AND REPAIR

Price 6s. (By Post 6s. 6d.)

Obtainable from all bookseller, or by post from George Newnes Ltd. (Book Dept.), Tower House, Southampton Street, London, W.C.2



A negative of this type always makes a good enlargement. Note the gradations, or half tones, from whites to black, and the effect of distance and middle distance.



# MASTERS OF MECHANICS

## No. 69. Eli Whitney and the Invention of the Cotton-Gin.

CONSEQUENT upon the enormous increase in the demand for cotton goods which was the direct result of the English cotton machinery inventions of the 18th century, the American cotton planters of the last couple of decades of that century found themselves in a very unenviable position.

The southern American States, from which the world's raw cotton of the time principally came, possessed ample acres for an extension of the cotton crop, but, as the American growers pointed out and lamented, it was useless increasing your cotton acreage when you could only clean and prepare a very limited amount of the raw cotton in any given year.

Raw cotton occurs in the form of a "boll," which latter looks like a mass of snowy-white, fuzzy lint projecting from the bursted seed-pod of the cotton plant. The lint is really the protective hairs of the cotton seed, for the long white hairs are attached firmly to the dark brown seeds of the plant and it is only with considerable difficulty that they are torn away from the seed by hand.

So long as cotton was in only moderate demand, the slave-owning cotton-planters of the southern American States had a fairly comfortable and a prosperous time. They could afford to have their raw cotton crop de-seeded by hand labour, and, despite the fact that this work was enormously slow and relatively expensive, even although done by slaves, the cotton planters were, in general amply able to satisfy the world's demands for their "vegetable wool."

### The "Big Five"

The inventions of the "big five" of the English cotton industry—Kay, Hargreaves, Crompton, Arkwright and Cartwright—brought about repercussions which affected the American cotton planters severely. No longer were they able to control an easy industry, for suddenly they found themselves in the position of constituting a veritable bottle-neck of the new cotton industry. The English machines for cotton production were clamouring ceaselessly for the white, linty product of the American cotton farms, yet the planters were unable to supply the prepared cotton owing to the fact that they found it practically impossible to remove the seeds from the raw cotton at a speed and with an efficiency ample enough to satisfy the ever-increasing demands of the English cotton masters.

It was a deplorable situation, and the American cotton planters well realised that fact.

One evening, at about the time when the eighteenth century had entered upon its last decade, a number of wealthy and influential planters were assembled in a big plantation house on the Savannah River, in Georgia. Their discussion was a serious one, for it concerned the paramount necessity of devising some means of speeding up deliveries of prepared raw cotton to meet the insistent English demands.

The lady of the house, who acted as hostess to the assembled gathering showed herself greatly interested in the deliberations of the local worthies. Her contribution to the discussion was a suggestion that the

company might do worse than to take into its confidence a young friend of hers, whom she had staying in the house.

This individual was Eli Whitney, a man of clever intellect, who had taken a degree at the Yale University and who, in the same year, had come to Georgia as an assistant school teacher.



Eli Whitney

History records but little of the earlier career of this Whitney. He was born at Westborough, Massachusetts, on December 8th, 1765, and, although of humble origin, he found the means, by dint of hard and unsparing work, to impart a good education to himself, and thereby to raise himself into a better sphere of life.

At the time of the above-mentioned incident in the plantation house on the banks of the Savannah River, Eli Whitney would be but twenty-five or twenty-six years of age. So far as we can ascertain, he had had no mechanical training, and there were certainly no inventions, even immature ones, to his credit. Yet he had,



A model of Whitney's first cotton-gin

somehow or other, obtained the reputation of being "clever," of being ingenious, probably in view of the fact that since his arrival in the State of Georgia, he had interested himself with exceptional keenness in the methods of cotton growing and preparation which were practised locally.

Even for the amply confident Whitney, however, it was an unusual, and a somewhat overwhelming experience to be introduced on the spur of the moment to an assembly of expert cotton planters, and to be asked to invent a machine which would do away with hand labour in the removal of cotton hairs from their seeds.

### Whitney's Great Problem

Whitney, however, took the proposition as a compliment to his growing reputation—and, also, as a challenge to his innate ingenuity.

"It is a new problem, gentlemen," he observed. "I come from the North, where, as you know, we never see the snow of your cotton fields as it grows in the boll. But let me make a few experiments with your 'vegetable wool'; it may be that something will come of it."

On the evening of the next day, Whitney began to devote his mind seriously to this novel and economically vital problem. He began by pulling the cotton seeds from the "lint" by hand. Then he tried to effect the same severance by means of a razor, and by dint of various arrangements of moving knives. At last, he arrived at the fundamental conclusion that the only possible manner of de-seeding or "ginning" raw cotton would be by means of some mechanism which imitated the pulling motion of the human fingers.

Raw cotton, as it is gathered from the plants, is known as "seed cotton." Roughly speaking, it contains about twice as much seeds as "lint," which latter is the name technically applied to the cotton hairs themselves.

For example, it takes about 1,500 pounds of seed cotton to make up one 500-pound bale of "lint cotton," as the de-seeded or "ginned" cotton is termed. The seeds which are removed from the seed cotton do not, of course, represent wasted material. On the contrary, they are of value, and, usually, they are run into hydraulic presses and therein made to give up a considerable amount of a light-yellow, sweet, clear oil—cottonseed oil—which has many uses in the industrial world.

### The First Cotton Gin

Eli Whitney took about a year to devise his "gin" for the de-seeding of cotton. Incidentally, the word "gin" (which is merely a simple contraction of "engine") was, in the eighteenth century, applied widely to a variety of types of machinery. Nowadays, however, the word persists in common speech only by way of allusion to the de-seeding of cotton, and to the machine employed for that purpose.

Whitney started off in his quest for the de-seeding or ginning machine by obtaining permission to build a workshop in the cellar of the Georgian plantation house in which he was lodging. In this somewhat gloomy apartment he spent the whole of his spare time for a year, during which period, aided



by borrowed and bought tools, pieces of timber, odd scraps of metal and various other accessories, he slowly brought into being his now historic cotton gin, the machine which, by removing the one bottleneck from the world's cotton industry, was to make possible the production of cotton goods on as vast a scale as could be imagined.

Whitney's gin was simple enough in principle, so much so that it is remarkable that it had not been invented previously. In it, a large number of rows of small steel hooks or fingers were set in a cylinder turned by a hand crank (and, in subsequent models, by a small steam engine). A quantity of the seed cotton is placed into a hopper and brought into contact with the revolving teeth or "saws" on the cylinder, a suitable metal grating separating the seed cotton from the revolving cylinder. The teeth of the "saws" catch the cotton hairs, this effect being made more positive by means of a revolving brush which, in the original Whitney gin, rotated in a direction opposite to that of the cylinder. The cotton hairs are sheared off the seeds, for, although the latter may be pressed up against the grating, they are too large to pass through it.

#### Improved Models

In later and improved models, the cotton was blown out of the gin by means of a strong air blast into a conveyor which removed it to a "gin box" which supplied the material from which the cotton bales were built up.

Such was the general principle of Eli Whitney's cotton gin. It is a principle which, despite the competition of other types of gin, has persisted to the present day, all the modern "saw gins" being based upon Whitney's fundamental notions.

Whitney patented his gin in 1793. Its success, on the material side, was immediate and enormous. In ten years' time, cotton production in America increased from a couple of million to nearly fifty million pounds annually, thereby creating unprecedented wealth for many people.

Unfortunately, however, Whitney himself did not prosper as a result of his invention. On the contrary, he was rendered almost penniless in consequence of it. For the details of his cotton gin were so openly filched by rival and infringing factions that he had to spend the majority of his income, and most of his time in fighting patent-infringement actions in the Courts. It transpired that, subsequent to his taking out his basic patent, one or two unscrupulous cotton planters had got wind of his projected machine, and had actually been instrumental in causing his workshop to be broken into in order to gain the details of his mechanical invention. These individuals had subsequently set up cotton gins of their own, in virtue of which they were enabled to contest the legality of the Whitney patent.

#### Fourteen Years of Litigation

For fourteen long years Eli Whitney, almost a lone hand, fought for his patent rights against all comers in the American Courts. Eventually, his claim to the honour of the invention was established and legalised, but not before, as has already been mentioned, the inventor himself was reduced almost to a dire penury.

Strange to say, Whitney never allowed himself to become embittered as a result of this sad, yet common experience. He quickly realised that his prospects of making a competence out of his gin were now very meagre ones. As a result, he made a bold decision, broke away from his gin

and subsequently went in for the manufacture of guns, rifles and other firearms.

In this ordnance manufacture, Whitney rose to great success. He created many inventions in firearm manufacture. But for none of them would he apply for a patent.

"The experience I have had with patents in the case of the cotton-gin will last me through my life," was one of his assertions. Never again would he allow himself to be induced to seek legal protection for his inventions, either in the design of firearms or in the construction of the necessary intricate machinery for their making.

#### Whitneyville

Proceeding north, Whitney built a small factory for firearm manufacture at New Haven, Connecticut. This, after many successful years, in which it gradually increased in output and extent, formed the nucleus for the manufacturing industry of Whitneyville which grew out of it.

In 1817, after returning to the north, Whitney found time to marry. His home-life reflected his character and it was ideally happy. Into his expanding business at New Haven he took his brother as a partner, and with the latter he shared his success and his eventual fortune.

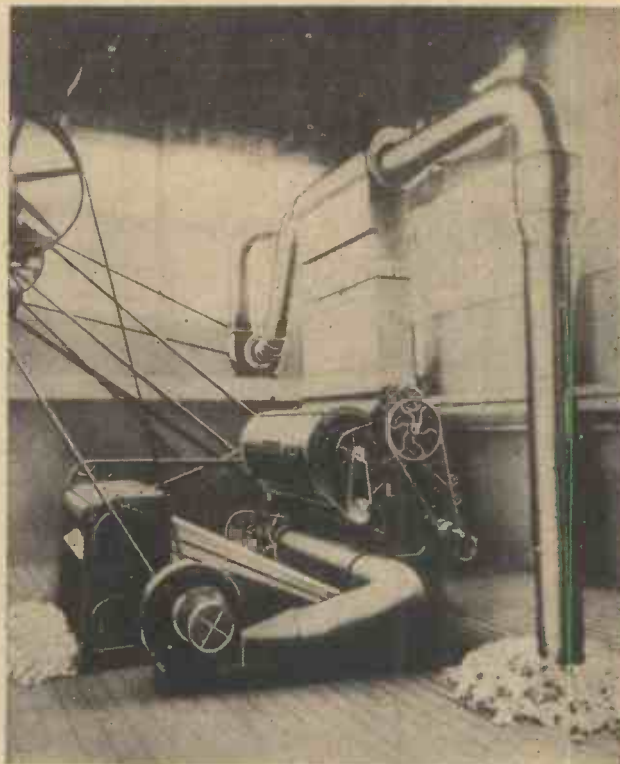

A modern high-speed cotton-gin, made by Messrs. Platt Bros., Oldham.

Whitney died on 8th January, 1825, whilst still in active control of his New Haven factory. His children carried on the business, but they had not the originality and the decided streak of mechanical genius of their father. Before long, the Whitney business had lost its traditions. It became merely one of the great American industries.

## Tin for Opacifying Glass

### Tin in Glass

**MODIFICATIONS** of colour and transparency and the production of certain finishes on glassware are obtained by using tin as a constituent.

One of the best opacifiers known to glass-makers is stannic acid. This is due to its dense whiteness and its low solubility in glass. For centuries it was the only opacifying agent available, and examples of tin oxide opals of Ancient Egyptian manufacture are preserved in the multi-coloured beads which were some of the earliest attempts at glass-making. Another example, believed to have been made in the first century of the Christian era, is the famous Portland Vase. It has a base of blue glass ornamented with opal glass human figures in bold relief on the surface. To obtain this effect the blue vase was first blown and then entirely encased in a thick layer of opal of nearly the same thermal expansion. After very carefully annealing the composite vase, and when cold, the opal glass was laboriously ground away until the blue glass was exposed and the detail of the figures perfected. The Venetians used opal glass threads for their intricate lace-work effects on goblets and vases.

Clear glass encased with a thin flash of tin-opal glass is used for making the modern opal glass shades for oil and gas lamps. The outcome of this was the popular

opal electric lighting pendants. The opacifying agents used in recent years, however, have been low-cost substitutes such as fluorides. When the more rapid erosion of the melting pots is taken into account, it is doubtful whether these substitutes are cheaper in the long run.

In the opal glass backing of tubing intended for thermometers, burettes, levels and gauge glass, tin oxide continues to be used almost exclusively, firstly, because of the great density obtainable which permits of a very thin "flash" of opal being used, secondly, tin opals are considerably tougher than the substitutes, and thirdly, the opalescence is more stable during melting and working.

Stannous chloride is used in the production of ruby glasses which derive their colour from the presence in them of colloidal gold or, more commonly, copper.

By exposing finished articles in a kiln to the vapour of stannic chloride, an iridescent rainbow-like effect is obtained on table and decorative glassware. A very slight etching of the surface is caused by this process.

Under the name of "putty powder," stannic oxide is used as an abrasive for polishing the rough surface of cuts produced by carborundum wheels in the manufacture of cut table-glass. It is suspended in water and fed on to the edge of a wooden polishing wheel shaped to the angle of the cut.



# Our Busy Inventors

## Revised Dominoes

WE are all familiar with those flat, oblong pieces made of ivory, bone or wood, dotted somewhat after the manner of dice. By the way, the word domino comes from *dominus*, Latin for lord. The name was originally applied to a clerical dress, and the game is said to have been so called from the black under-surface of the pieces.

An inventor now suggests that the design on dominoes can be improved. He contends that, in playing this game, not only is it necessary to be able readily to see and reckon by means of the "pips" the numerical value of the pieces, but also to count the number of dominoes already played. This, he maintains, is not easy for persons with imperfect or failing eyesight, or when the game is played in a poor light. Therefore, he has devised and submitted to the British Patent Office a domino which will obviate this disadvantage.

According to his invention, the values on dominoes are represented by distinctive coloured surfaces instead of by spots. Preferably the coloured surfaces bear numbers in order to assist players in memorising the colour, and the number with which it is associated. This also helps a count in the event of the game ending by reason of players being left with dominoes in hand.

The colour and number code adopted might conveniently be as follows:

0	represented by	Black
1	"	White
2	"	Purple
3	"	Yellow
4	"	Blue
5	"	Green
6	"	Red

It remains to be seen whether this revised domino will oust the traditional design.

## Turn Signs on Cars

FROM Australia comes a direction indicator for vehicles. The object of this invention is to show clearly when a driver is about to turn and whether he is going to the right or the left.

The well-known methods at present in use are the projection of the driver's forearm through the window and the provision of illuminated mechanical arms which are operated to show the intention of the driver.

The new device is a near relation of traffic lights. It includes a series of three lamps, one green and two red. These triple lamps are carried by a support mounted on the top of a car or lorry in such a position that they are slightly above the roof. They are arranged so as to display a red lamp on either side of a green one.

The lamps are connected to the vehicle battery through a two-way switch. When the driver is about to turn to the right, a red light shows on the right of the green, and when he intends to go to the left, a red light shines on the left of the green.

Upon the switch being returned to the neutral position, the lamps are extinguished.

## Beauty and the Black-out

TO equip beauty in the black-out, and in the air-raid shelter, there has been designed a vanity case which caters compactly for the facial toilet. Contained therein are a mirror, a drawer for face powder, accom-

## By "Dynamo"

modation for a lipstick, a battery and an electric light bulb. The light is automatically switched on when the case is opened.

The information on this page is specially supplied to "Practical Mechanics" by Messrs. Hughes & Young, Patent Agents, of 9 Warwick Court, High Holborn, London, W.C.1, who will be pleased to send free to readers mentioning this paper, a copy of their handbook "How to Patent an Invention."

## Key to the Keyhole

THE belated roisterer, and even the sedate citizen on dark nights accentuated by the black-out find the latch-key hole



A girl graduate of the North Western University, Catherine Ferguson, engaged in defence research work. She is here seen using an optical pyrometer for studying metals at high temperatures in the Electric Research Laboratory in Schenectady.

annoyingly elusive. More than one method has been devised with the object of guiding the key into the obscure aperture. Yet another is the subject of an accepted application to the British Patent Office.

It has hitherto been proposed to provide lock fittings with self-luminous material intended to locate the key-hole.

The purpose of the new invention is to furnish luminous attachments to indicate the position of the keyhole, and to enable the key easily to be inserted in the orifice.

The means of locating the keyhole on the guide attachments are by cutting away and forming, if desired, an L or V, a circle or part of a circle, or a combination of these shapes.

Further literally to enlighten the home-comer so that he may distinguish his house or garage, the inventor uses distinctive combinations of various colours. A yellow

luminous guide could indicate the front door of one's domicile, while the portal of one's neighbour might exhibit a verdant guide. Other varieties for specific places could be arranged. But one must not be colour blind nor ignorant of the code.

## Yet Another Shelter

WHEN Jules Verne wrote "Five Weeks in a Balloon," he put the aeronaut in a cage beneath a balloon with a second one within it *a la* the pneumatic tyre with its inner tube. This principle has been adopted in the contrivance of a newly-devised air-raid shelter. A bell-shaped cell is constructed of special sheet metal qualified to resist bullets and splinters. There is an outer shell and an inner one, and between the two is a space.

The inventor maintains that this type of shelter very considerably increases the protection against being pierced by machine gun, rifle and revolver bullets, and also splinters of a bursting bomb. He is of opinion that the effect of the inner shell in preventing further penetration by missiles which have already passed through the outer shell is, for some obscure reason, derived partly from the existence of the space between the two.

This shelter, which accommodates from one to four persons, is specially adapted for use on board ship as a means of shielding the navigating officer or a look-out on the bridge or deck of a vessel.

## Good Pull-up

THE use of magnets in sweeping for submarines and mines is not a new idea. But it is affirmed that even very powerful magnets tend to slip. In view of this possibility, there has been conceived seizing apparatus which reinforces a magnet with a suction disc. According to this contrivance, immediately the magnet is attracted to a ferrous surface, it pulls the suction disc into contact with it. And a very firm attachment results resisting a pull many times greater than if the magnet was employed alone.

## Foil That Foils

THE peril of splintering glass when an air-raid is in progress has moved an inventor to contrive a new way of applying thin self-adhesive to glass for protecting it and minimising the scattering of splinters as the result of the bursting of a bomb.

His apparatus consists of a frame on which a roll of foil is mounted. The frame carries a roller which presses against the roll and simultaneously presses the foil against the surface to which it is to be applied.

## Long Life For Clothes

IN these days of coupons, a method of making clothes durable is naturally welcome. I note an improved process for protecting textile material from rot, corrosion, etc. It is claimed that this process will render yarn, cloth or ready-made goods, for example, rot-proof by a simple method. The method consists in impregnating the fabric with a chemical solution, particulars of which are given in the complete specification which has recently been accepted by the British Patent Office.

It is a paradoxical fact that one way to make a garment last is to wear it. The moth-eaten dress is usually the one which hangs idly in the wardrobe.



# Variable-Pitch

## Developments which Led to Variable- and Contra- Pitch

gear on a motor car. The need for this change of pitch can be understood if one thinks of the different densities of the air at the different heights aircraft operate. Down below it is dense and heavy, and a fine pitch is desirable to slice through it at the most efficient driving

Taking three-bladed airscrews for example, it is known that when run at the correct tip speeds, airscrew diameters increase by approximately 6 in. for each 2,000 feet in full throttle height, and that this situation can only be remedied by widening the blades. Apart from any other consideration, therefore, there is a strong tendency to increase the number of blades used on the latest airscrews, irrespective of how such blades may be arranged.

The present tendency towards four-bladed airscrews arises in consequence of the above considerations, and the four-bladed airscrew is becoming an accepted design within certain ranges of powers and altitudes.

### Tip Speeds

In view of the fact that airscrew tip speeds are limited to about 94 degrees of the local speed of sound, for highest efficiency the spiral angle of advance is becoming very high, and at speeds and full throttle heights already contemplated, this angle will have reached a figure in the neighbourhood of 55 degrees or more. Any airscrew having all its blades moving in one

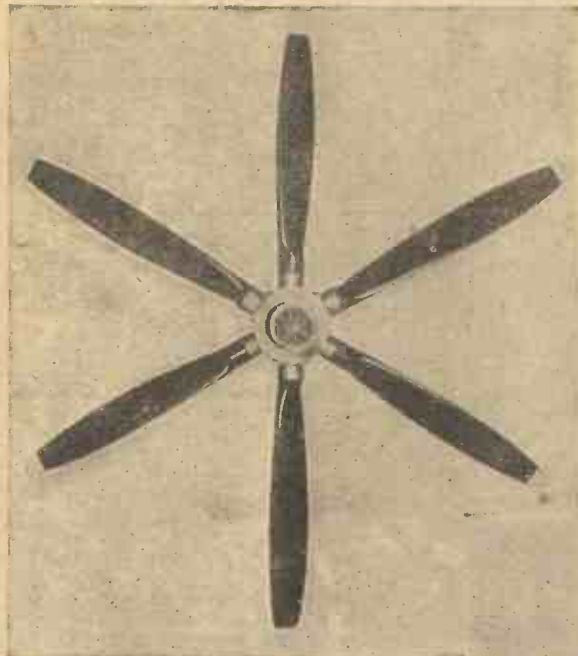

Illustration by courtesy of Rotol Airscrews Ltd.

Figs. 1 and 2. A front and side view of the Rotol "constant-speed" contra-rotating airscrew.

**P**ARALLEL with the progress in aircraft and their power plants advances have been going on continually in that vital link between the two—the airscrew. In fact, much of the advance achieved by modern aircraft has only been made possible through the more efficient airscrews with which they are fitted. To quote one example, the speed and all-round performance of the famous Hurricane and Spitfire fighters was stepped up considerably by changing over from fixed wooden airscrews to a more modern type with variable-pitch blades.

To those not initiated in the mysteries of aeronautics, the "fan" as it is familiarly termed by fliers, is just something which goes round and pulls the machine along. Recollections of the old-time wooden "prop," a rigid two-bladed affair, not unlike a ship's propeller, still linger. Those outside the world of flying may not realise that the modern airscrew is a highly complicated piece of machinery, with hundreds of component parts. In some cases it even embodies its own electric or hydraulic motor and an automatic governor for altering the pitch, or angle of the blades. Incidentally, airscrews are no longer "propellers," because they do not propel. They pull, being almost universally mounted in front of the engines.

### 2,000 h.p. Motors

Modern aircraft are now mounting motors of 2,000 or more horse-power in a single unit. That terrific power output has to be absorbed by those blades whirling round at 20 to 40 revs. a second and turned into forward motion with as little loss as possible. Clearance of the airscrew from the ground and the wing mounted guns limits the practicable size of the blades, and consequently there has been a tendency to employ more blades to each airscrew. First three, now four-bladed types have been evolved for modern high performance motors.

Aside from this change a great development has been made in the mastery of the technique of varying the pitch of the blades according to the work to be done. In a way this operation can be compared to changing

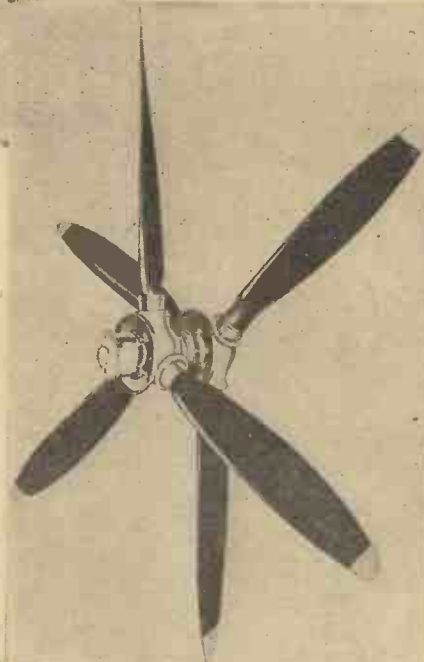

Illustration by courtesy of Rotol Airscrews Ltd.

angle. High up in the sub-stratosphere it is thin and tenuous and to get sufficient thrust a coarser pitch is needed.

First step in this direction was the evolution of the manually controlled V-P (variable-pitch) airscrew. The perfecting of metal alloys made this advance possible. First two-bladed, then three-bladed types were designed. Their higher efficiency was amply proved in the supreme test of war conditions. Next came the C.S. (Constant Speed) airscrew, in which the pitch can be varied throughout a whole range of angles, and can also be automatically controlled by a governor unit working off the engine.

### Greater Efficiency

Besides achieving greater efficiency in take-off, climb and level flight at all altitudes, the modern C.S. airscrew has the ability to "feather"; that is, glide easily through the air with a stopped engine; also to apply reverse thrust, an asset in taxiing big flying-boats in confined spaces on the water.

### Constant Speed Contra-rotating Airscrews

It is well known that increased engine ratings and greater throttle heights are making it very difficult to absorb the desired powers with airscrews of existing diameter.

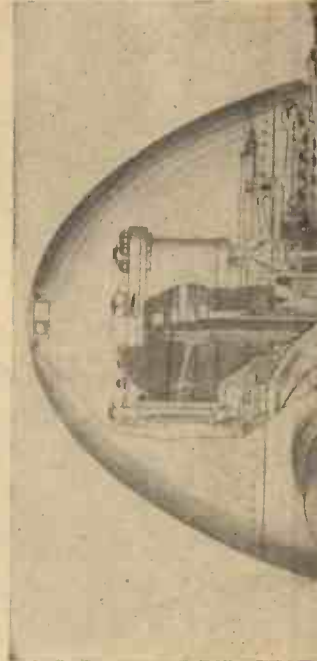

Fig. 3. The Rotol 35 degree pitch airscrew.

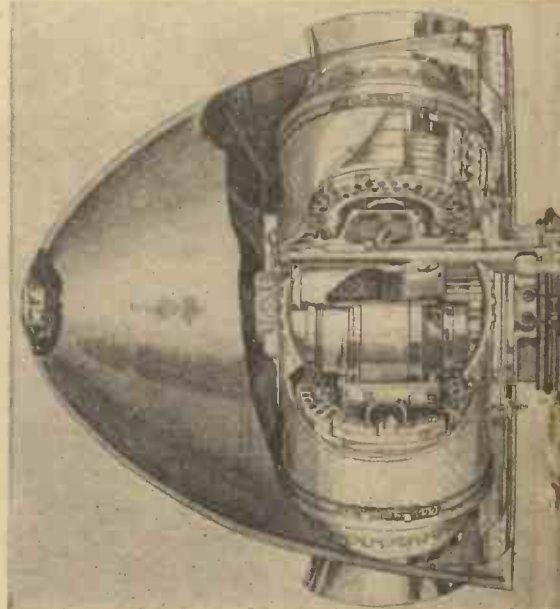

Fig. 4. The Rotol 20 degree range internal cylinder pitch airscrew.



# Airscrews

## The Technique of Each Airscrew

direction will have a large rotational component in the slipstream at such a high spiral angle of advance, resulting in an ever-increasing drop in efficiency as the situation develops.

All the above factors tend to favour the development of contra rotating screws because the design lends itself to the use of six or even eight blades of any given dia-

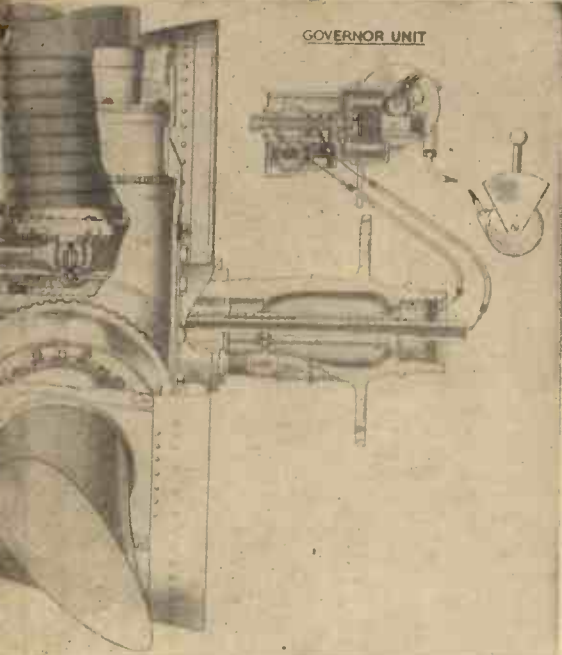

GOVERNOR UNIT

Illustration by courtesy of Roto! Airscrews Ltd. of a three range external cylinder "constant-speed" variable-pitch airscrew.

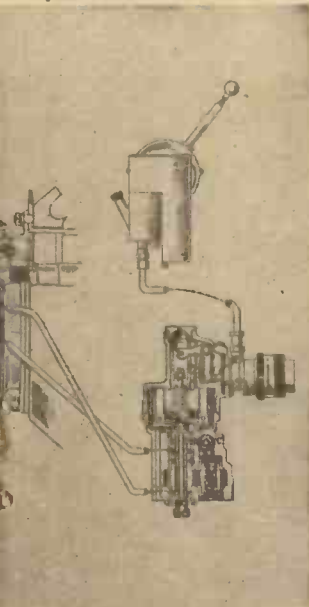

Illustration by courtesy of Roto! Airscrews Ltd. of a three range external cylinder "constant-speed" variable-pitch airscrew.

meter, whilst at the same time the straightening of the slipstream by the rear airscrew reduces the losses due to slipstream rotation, and should enable satisfactory efficiency figures to be recorded even at the higher spiral angles of advance. The use of six or eight blades, particularly in a contra-rotating design has the further advantage that under the conditions of great full throttle height mentioned above, the best airscrews for maximum speed will also be very close to the optimum airscrew for take-off and climb so that a satisfactory combination of desirable features should result.

### A Roto! Design

Thus, Roto! Airscrews, Ltd., have pro-

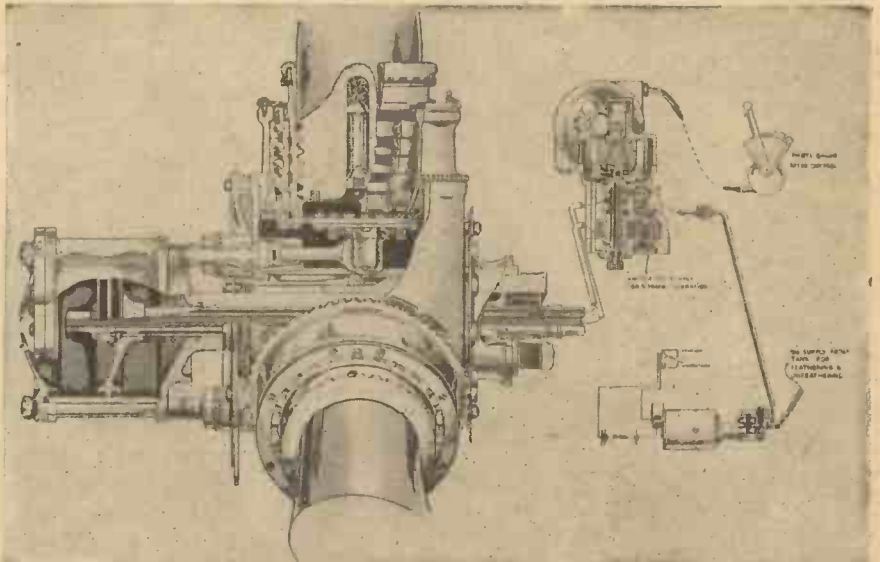

Fig. 5. The Roto! hydraulic feathering "constant-speed" variable-pitch airscrew.

duced a six-bladed "constant-speed" contra-rotating airscrew, the mechanism of which is extremely simple and in accordance with the soundly established hydraulic principles of operation. Although robust, the mechanism provides constant speeding characteristics identical with those obtained on airscrews of current normal type and similar facilities for feathering. So direct is the Roto! mechanism that it may fairly be said that any increase in complication of those contra-rotating airscrew is far more apparent than real, being in fact mainly on account of the extra number of blades employed.

In accordance with Roto! standard practice, the hubs are capable of taking either wood or metal blades of any type, complete with cushion mounted spinner and moving jet de-icing equipment. On aircraft requiring exceptional take-off thrusts, the Roto! wooden blades are expected to meet these conditions beyond any other type as they do on the ordinary three-bladed airscrews of the present day, whilst for ultra-speed conditions thin metal blades with specially designed aerofoil sections can be installed. The special features of this

type of airscrew are constant speeding, simple operation, high rate of pitch change; quick feathering and de-icing, also incidental points in favour of the contra-rotating design are:—

Elimination of swing at take-off.

Abolition of swing when the throttle is opened or closed suddenly in the air on single-engined aircraft.

Improved handling characteristics during aerobatics.

Virtual elimination of torque reaction on the aircraft during take-off and in flight.

Improvement in air-flow around the fuselage or engine nacelles of the aircraft so that it is possible for the aircraft designers to set the rudders and fins straight, with consequent reduction in drag of the aircraft.

Advantages indirectly arising from reduced airscrew diameter in special designs, including such features as undercarriage height and spacing of engines in multi-engined aircraft.

### Electrically-operated Airscrew

In Fig. 3 is shown the Roto! 35 degrees (Continued in centre column of page 32.)

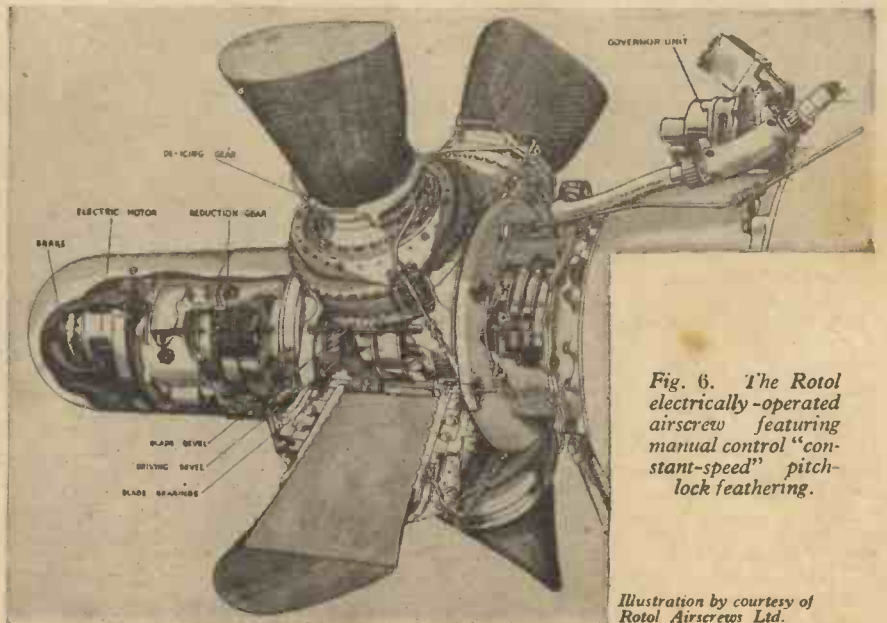

Fig. 6. The Roto! electrically-operated manual control pitch-lock feathering.

Illustration by courtesy of Roto! Airscrews Ltd.



# 108.92 M.P.H. on a Bicycle

A Record Ride by Alfred Le Tourneur in the United States

**A**LFRÉD LE TOURNEUR'S feat of riding a bicycle at the rate of 108.92 miles per hour was recently recorded in the United States. A wonderful performance for a rider to accomplish, but his effort could not have been made were it not for a very well-made bicycle.

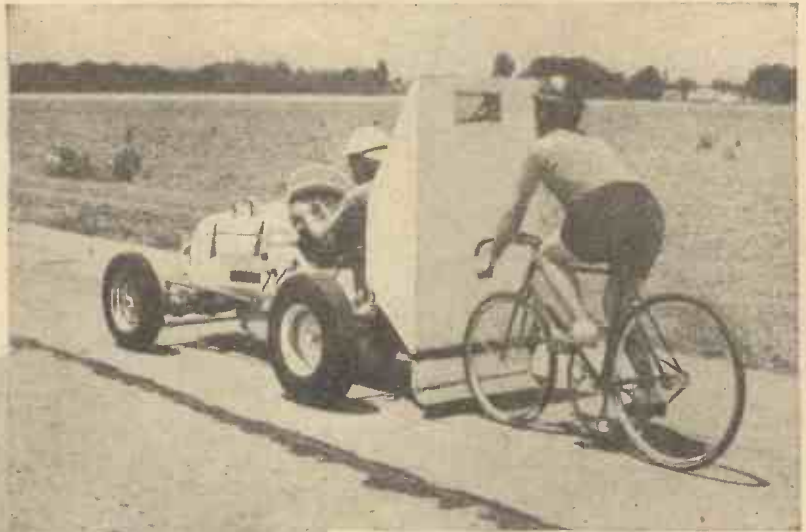

*They're Off! Le Tourneur and Houscholder start on their perilous ride against time on the concrete track.*

*(Below). We made it! The riders shake hands on the completion of their record-breaking run.*



Such a performance proves that expert design, fine materials, and high-class craftsmanship combined were necessary in this severe test, and it is interesting to know that it was an American made bicycle—an Arnold, Schwinn Paramount.

## Preliminary Tests

In the accompanying illustrations, Le Tourneur is seen wearing a crash helmet, and he is paced by Ronney Houscholder. A number of preliminary tests were run, and on the official test the driver of the pacing car was instructed to come as close over the 100 mile mark as possible. When the timers got together, the time was 97.85. After a few minutes interval, the second run was started and Houscholder was instructed to be wide open one mile before the starting post was reached, with the result that a speed of 108.92 m.p.h. was reached. The test was held on a concrete highway with a gradient of 2 in 100.

It required three miles to get up speed—four miles to stop after the record was made. The front and rear wheels turned 22½ times per second, which carried the rider a distance of 159 feet per second. W. Spencer, who managed the event, stated:—"I thought that if we could have a bicycle made that could withstand the terrific lacing of 100 miles per hour, that after we had made the one run (if we were successful in not breaking our necks) that this was all we could expect of the bicycle. but here is a



machine that has covered a total of 76 miles at speeds ranging from 75 m.p.h. to 109 m.p.h."

Riding at a speed of one mile in thirty-three seconds requires hours of practice, nerves of steel, perfect co-ordination between rider and driver, and a bicycle able to withstand the terrific pace. Le Tourneur had the nerve and also a Schwinn-built bicycle.

## Mile-a-Minute

Whilst on the subject of paced riding it is as well to remember that it was an Englishman who first achieved a paced ride of a mile-a-minute. It was A. E. Wills who, in 1908, became the first man ever to ride

60 miles in 60 minutes. Also we must not forget Leon Vanderstuyft, who accomplished the amazing performance of riding for one hour at an average speed of 76 m.p.h. The exact distance was 76 miles 503 yards in the hour from a standing start. This is the greatest distance covered in the hour to date, but not recognised as an official record by the U.C.I. (Union Cycliste International) as there were no restrictions as to the method of pacing, and the roller was close up.

Harry Grant, an Englishman, is the official holder of the world's paced hour record with a distance of 56 miles 928 yards. This record was put up at the Parc des Princes, Paris, in 1932.



# Join the Well-Paid Ranks of the TRAINED MEN

**THOUSANDS OF TRAINED WORKERS ARE URGENTLY NEEDED BY EMPLOYERS IN ALL PARTS OF THE COUNTRY. SKILLED MEN ARE BEING PAID EXCEPTIONALLY HIGH WAGES**

*Why not become one? You can. Many I.C.S. Students have done so since war began—by means of a few months' spare-time study*

The man who enrolls for an I.C.S. Course learns the subject he studies thoroughly, completely, practically. We are not content merely to teach principles: we show our students how to apply that training in their everyday work. We train them to be *successful*—and we offer you the benefit of our 50 years' matchless experience.



*If you need technical training, our advice on any matter concerning your work and your career is yours for the asking—free and without obligation. Let us send you a booklet dealing with the subject in which you are specially interested. It is packed with valuable information. DON'T DELAY. Make "ACTION" your watchword.*

**The successful man does today what the failure INTENDS to do tomorrow. Write to us TODAY**

**The I.C.S. Offer Special Courses of Training in the following Subjects:**

- |                           |                        |
|---------------------------|------------------------|
| Accountancy               | Highway Engineering    |
| Advertising               | Horticulturist         |
| Aeronautical Engineering  | Hydraulic Engineering  |
| Aero Engine Fitting       | Insurance              |
| Aero Fitting and Rigging  | Joinery                |
| Aeroplane Designing       | Journalism             |
| Agriculture               | Machine-Tool Work      |
| Air-Conditioning          | Marine Engineering     |
| Architecture              | Mechanical Engineering |
| Architectural Drawing     | Mine Electrician       |
| Boilermaking              | Mine Fireman           |
| Book-keeping              | Mine Surveying         |
| Building Construction     | Mining Engineering     |
| Building Contracting      | Motor Engineering      |
| Business Training         | Motor Mechanic         |
| Business Management       | Moulder                |
| Cabinet Making            | Patternmaking          |
| Carpentry                 | Quantity Surveying     |
| Chemical Engineering      | Radio Engineering      |
| Civil Engineering         | Radio Servicing        |
| Clerk of Works            | Refrigeration          |
| Colliery Overman          | Salesmanship           |
| Colliery Management       | Sanitary Engineering   |
| Commercial Art            | Secretarial Work       |
| Concrete Engineering      | Sheet-Metal Work       |
| Cost Accountancy          | Ship Draughtsman       |
| Dairy Farming             | Steam Fitter           |
| Diesel Engineering        | Structural Steelwork   |
| Display                   | Surveying              |
| Draughtsmanship           | Telegraph Engineering  |
| Electrical Engineering    | Telephone Engineering  |
| Engineer in Charge        | Television             |
| Engineering Shop Practice | Templating             |
| Fire Engineering          | Textile Designing      |
| Fitter                    | Textile Manufacturing  |
| Forgeman                  | Toolmaking             |
| Foundry Work              | Turner                 |
| Garage Management         | Welding                |
| Gas-Power Engineering     | Woodworking            |
| Ground Engineer           | Works Engineering      |
| Heating and Ventilating   | Works Management       |

**COUPON FOR FREE BOOKLET**  
(USE PENNY STAMP ON UNSEALED ENVELOPE)

## INTERNATIONAL CORRESPONDENCE SCHOOLS, LTD.

Dept. 95, International Buildings, Kingsway, London, W.C.2

Please tell me how I can become highly efficient in the subject I state below and send me, FREE of CHARGE or OBLIGATION, your Special Booklet.

SUBJECT (or EXAMINATION).....

NAME..... Age.....

ADDRESS.....





**S.TYZACK & SON LTD., INCORPORATING GEO. ADAMS "LONDON'S FINEST TOOL SHOPS"**



**"ZYTO"**  
Super Quality Sliding Tailstock Dieholder No. 1 M.T. shank long barrel, precision finish. For 13/16 in. O.D. dies. Price 8/9. For 1 in. O.D. dies, 11/3. With No. 2 M.T. shank, 13/9. **DELIVERY FROM STOCK.**

**BRITISH MADE ADJUSTABLE AUTOMATIC CENTRE PUNCH**

With finger control adjustment for fine to heavy indentations. Fitted with Pocket Clip and supplied with leather wallet case 6/6. **DELIVERY FROM STOCK**



**"ZYTO" Screwcutting Indicator.** A smaller edition of that which is fitted to larger lathes. Specially suitable for lathes by Drummond etc., with split or half nut on lead screw. 11/3. **DELIVERY FROM STOCK.**

**"ZYTO" New Pattern 4-way Turret Toolholder.** With spring stop swivel base. Superior quality and finish. Now made in malleable unbreakable 47/6. **DELIVERY FROM STOCK.**

Catalogue of Wood-working Tools and Machinery, fully illustrated, One Shilling, post free. Catalogue of Engineers' Tools, including Lathes and Geo. Adams' specialities, One Shilling, post free.

**S. TYZACK & SON LTD., 341-345 OLD ST., LONDON, E.C.1**

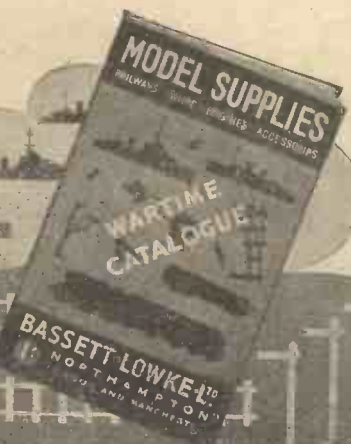

**SUPPLIES IN WARTIME**

are always difficult and even more so when they interfere with essential production. However, there are still certain articles in the model world we can supply, and to make these features available in easy form for reference we have taken from our Ships List and our Model Railways and Stationary Engines Catalogue (not our "0" gauge and "00" gauge lists) those lines we can still supply. This is our **WARTIME LIST** (as illustrated) which contains over 130 pages of our various model supplies listed at present-day prices. **SEND FOR WTC/12. Wartime List-Post free 1/-.**

A fine Tax-free Model in gauge "0" is our smart 0-6-0 Tank, available in S.R. and L.N.E.R. colours and fitted with first-class mechanism. Prices: Clockwork £2 2s. 0d. Electric d.c. 6-8 volts Junior Permag £2 10s. GR/12 is our catalogue devoted exclusively to gauge "0" railways. Price 6d. TT/12 is our booklet of the Twin Train Table Railway in gauge "00." Price 3d. post free.

**BASSETT-LOWKE LTD.**  
NORTHAMPTON, London: 112, High Holborn, W.C.1. Manchester: 28, Corporation Street.

**TECHNICALLY QUALIFIED ENGINEERS**

**Key Men of the War**

Qualify by home-study with The T.I.G.B. for Big Pay Technical Posts in Wartime Engineering—Aeronautical, Mechanical, Electrical, Chemical, Wireles, etc.

**How to Qualify:—**

Take a recognised Engineering Qualification such as A.M.I.Mech.E., A.M.I.E.E., A.F.R. Ae.S., A.M.I.Chem.E., etc., in which professional examinations T.I.G.B. Students have gained 25 **FIRST PLACES** and Hundreds of Passes

Write to-day for "The Engineer's Guide to Success," containing world's widest choice of engineering courses covering all Branches and qualifications.

**The Technological Institute of Great Britain**

218 Temple Bar House London - - E.C.4

**Free!**



This space will be used to advertise the **ADEPT' LATHES** and **SHAPERS** in the happier times coming, when we hope to be able to give more prompt deliveries. Meanwhile we would assure all our friends that we are making strenuous endeavours to give deliveries of the orders we have on hand and ask their kind indulgence.

When replying to Advertisers please mention "Practical Mechanics."

**ELECTRADIX**

**METERS.** Lesdix panel A.C. or D.C. 2 1/2 in. dia., in 1 amp., 3 amps., 5 amps. or 10 amps., 10/- **GALVOS,** vertical 7/6.

**A.C. OR DC Mains Magnets,** 2-poles wound, 110 volts or 220 volts. Lift 7 lbs. 4/6.

**ALTERNATOR.** Perm. Magnet Alternator. Hand drive, 80 volts, 25 m/a. Useful tester. 10/6

**SIGNAL GEAR.** Morse Keys. B1, 5/- Type M, 6/6. Type PF. 9/6. Type IV. 12/6. Fuller Govt. Key, 17/6.

**8-WAY Lucas-Rotax Switch boxes,** D.P. reverse and fuses, 3/6.

**BUZZERS.** Practice, 3/6. Brass cased, 4/6. Bakelite boxed, 5/6. D3 Govt. no contacts, 5/- Townsend shrill note wavemeter type, 10/-.

**DYNAMOS AND MOTORS. D.C.** 50/70 volts 3 amps., 1/16 h.p., 35/- 100/110 volts, 1 amp., ball bearing enclosed, 1/12 h.p., 25/- Ditto, 200/250 volts 1/2 amp., 17/6.

**MICRO MOTORS** 20 volts. A.C., 8/-

**NOTE NEW ADDRESS:**

Our New Works and Offices are near Queen's Road Station, Battersea, 31 Tram from Holborn or 137 Bus from Sloane Square Underground.

**ELECTRADIX RADIOS**  
19, BROUGHTON STREET,  
Queenstown Road, S.W.8

Telephone: **MACAULAY 2159.**

**BLUSHING FREE**

to all sufferers, particulars of a proved home treatment that quickly removes all embarrassment, and permanently cures blushing and flushing of the face and neck. Enclose stamp to pay postage to Mr. P. TEMPLE (Specialist), 51 Tenterden Drive, Hendon, London, N.W.4. (Cannot, at present, be supplied to Northern Ireland.) (Est. 40 years.)



**VARNENE gives a First Class finish**

You can be sure of a pleasing finish to your woodwork by using Varnene. This fine Oil Varnish Stain ensures a durable, hard-wearing gloss and is easy and economical to apply because it never becomes tacky while working.



Obtainable from Handicraft Stores, Ironmongers, Oilmen, Grocers and General Dealers.

**VARNENE THE FINER OIL VARNISH STAIN**

**CHISWICK PRODUCTS LTD., LONDON. W.4.**

in Dark Oak, Walnut, Mahogany, Light Oak and Ebony,



## A NEW SERIES

# The Story of Chemical Discovery

## No. 8. The Chemical Investigations of Michael Faraday.

**T**HE world has long acknowledged the renowned Michael Faraday as an electrical discoverer of towering genius, yet, singularly enough, it seldom accords to him his full share of credit as a pioneer chemical experimenter of far-reaching perception and originality.

In much the same way, however, as the science of electricity has been built up upon Faraday's original electrical researches, so, also, are many of the foundations of practical chemistry the outcome of the brilliant and amazingly accurate laboratory investigations of this prince of practical experimenters.

The facts of Faraday's life are well known and it is, therefore, unnecessary to repeat them in any detail here. The lad was born at Newington Butts, London, on September 22nd, 1791, his father being a journeyman blacksmith and a man of dissolute habits. After early years of extreme poverty, young Michael Faraday became an errand boy at a bookseller's shop in London. Subsequently, he was accepted as an apprentice, and during his apprenticeship he was taught the trade of bookbinding, an occupation which he seems to have hated pretty thoroughly.

A customer of the establishment in which young Faraday was employed noted that he was a lad of more than average acumen. Accordingly, he gave him a ticket to hear one of Sir Humphry Davy's science lectures at the Royal Institution. One thing led to another. Faraday attended a few more lectures and, at last, took the bold step of writing to Sir Humphry begging to be taken on as his assistant.

### At the Royal Institution

It would appear that Davy endeavoured to dissuade Faraday from embarking upon a scientific career. But Faraday was not to be put off from his quest for a scientific career. So the whole business ended up favourably for Faraday—and, incidentally, for posterity—by his becoming a personal assistant to Davy and, ultimately, in his succeeding that scientific worthy at the Royal Institution.

There were times when Faraday could have carved out for himself a lucrative career. In his earlier years, he undertook commercial analysis of materials. In 1830, he made about £1,000 as a result of this work, and in the following year his income was considerably more. But the claims of pure science became more and more insistent and impelling so that before long Faraday found himself faced with the choice of money-making or a career of pure scientific research.

Fortunately for the world at large, Faraday did not hesitate in his choice of pure research as a career. In the following year (1832), as a direct result of his voluntary selection of occupation, his income had descended from the £1,000 level to the meagre

sum of exactly £155 9s., and in subsequent years it was sometimes even less. But Faraday cared little, for although he had a wife, he possessed no family, and the material wants of both his wife and himself seemed to grow more and more negligible with the passing of the years.



Michael Faraday

Faraday's scientific life was a long cavalcade of successes, with seldom a total failure among them. There was something almost uncanny about his strange perception and marvellous intuition, for he seemed to have the power of pre-determining which experiments were likely to lead to success, and which of them would be of little use to him.

### Discovery of Ethylene

Faraday was the first to bring about the union of carbon and chlorine. He obtained the gas ethylene, by treating alcohol with

sulphuric acid. This, when treated with chlorine gas gave rise to various chlorides of carbon which Faraday, at the outset of his chemical career, investigated closely.

As early as 1825, Faraday, whilst working in the Royal Institution laboratory, made one of his greatest chemical discoveries, that of benzene, which liquid he termed "bicarburet of hydrogen." This nowadays ubiquitous liquid he discovered by distilling the evil-smelling oil obtained in the manufacture of an illuminating gas derived by strongly heating fats.

A whole department of chemistry, which includes almost innumerable dyes, drugs, photographic and other chemicals has been built up upon the chemistry of benzene, Faraday's "bicarburet of hydrogen." Yet Faraday himself took little credit for this chance discovery of his. To him it was merely one discovery among many.

About the same time, Faraday passed chlorine gas into ice-cold water. He found that the pungent-smelling gas entered into combination with the water, forming peculiar greenish-yellow watery crystals, which became known as *chlorine hydrate*.

### Liquefaction of Gases

Another almost chance discovery, but it led directly to a new field of chemistry, that of the liquefaction of gases.

Faraday introduced a few dry crystals of his chlorine hydrate into one limb of a hairpin-shaped strong glass tube. The opposing limb of the tube he sealed up by fusing the glass. Then he gently heated the limb of the tube containing the chlorine hydrate. Under the influence of the applied heat, chlorine gas was driven off from the hydrate. Its pressure increased in the tube until, suddenly, the gas actually began to condense to a yellow liquid in the free limb of the tube. Faraday had actually liquefied a gas by means of subjecting it to pressure.

On the first day of these experiments, Faraday, it would seem, failed to appreciate the true significance of his feat. On that morning a certain Dr. Paris came into the laboratory. and seeing Faraday working

with a glass tube in which some apparently oily drips had collected, railed him good-humouredly upon the uselessness of working with dirty apparatus. Faraday took the taunt more or less in silence, but when, afterwards, he started to open the bent tube by filing it across, the tube suddenly exploded and the contents, including the "oil," vanished.

The next day the fussy Dr. J. A. Paris received from Faraday the following laconic note:—

Dear Sir,—The "oil" you noticed yesterday turned out to be liquid chlorine. — Yours faithfully, Michael Faraday.

Following this experiment, Faraday endeavoured, by generating gases in bent tubes, to liquify them in a manner similar to his liquefaction of chlorine. With

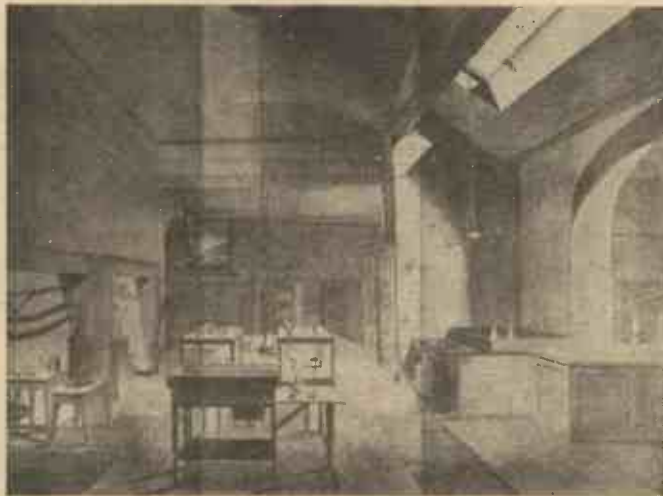

This illustration depicts the interior of Faraday's laboratory at the Royal Institution in which all his famous discoveries were made.



gases such as sulphur dioxide, carbon dioxide, hydrogen sulphide, nitrous oxide, ammonia, hydrogen chloride, hydrogen bromide, hydrogen iodide and cyanogen, he succeeded, although not before many startling dangerous explosions due to bursting tubes had taken place in the august Royal Institution laboratory.

Such experiments made Faraday reason thus: all the so-called "gases" which we know, such as air, nitrogen, carbon dioxide, chlorine, and so forth, are in reality the vapours of extremely low-boiling-point liquids. Hence, you can liquefy a gas either by cooling it down to its natural boiling-point or by subjecting it to a sufficient degree of compression.

This reasoning worked satisfactorily for many gases, but a number of common gases seemed to defy this generalisation. These were the so-called "permanent" gases, such as hydrogen, oxygen, nitric oxide, nitrogen, carbon monoxide, and methane ("marsh gas"), which could not be liquefied by any known degree of pressure. Faraday, in after years, rightly concluded that the term "permanent gas" was, in reality, a misnomer, and that, given a sufficient intensity of pressure and/or cold, any gas, "permanent" or otherwise, could be converted into a free-flowing liquid.

Upon Faraday's experiments on the liquefaction of gases have been based not only important chemical theories concerning the nature and characteristics of molecules but also a number of technical applications of the highest importance. Modern refrigeration, one of the achievements of our twentieth century civilisation, by the advantage which it takes of the laws of gaseous liquefaction and pressures, merely embodies an application of Faraday's experiments. So do the many systems of gas-purification, air-liquefaction, oxygen-production, and the hundred and one other industrial processes which depend for their success upon the liquefaction of gases.

#### Experiments in Electrolysis

Another vital chemical work of Faraday's was his discovery of the *electro-chemical equivalent* of the elements. Upon this investigation, the practical science of electroplating and industrial electro-deposition is based.

Faraday, in his experiments on the electrolysis of chemical solutions, began, as he always did, by studying fundamentals. He passed electric currents through solutions of simple chemical salts, such as copper

sulphate and zinc sulphate. He found that the same quantity of current would, in equal lengths of time, liberate *equivalent* quantities of the elements from their compounds. In other words, the amount of work done by a current is directly proportional to the quantity of electricity which passes through the chemical solution or "electrolyte." Such is Faraday's first Law of Electrolysis.

Since the matter may be somewhat involved to the reader, we must explain it at greater length. Suppose a current passes for a given time through a solution of copper sulphate and that, in so doing, it liberates 63 grains of copper. The same

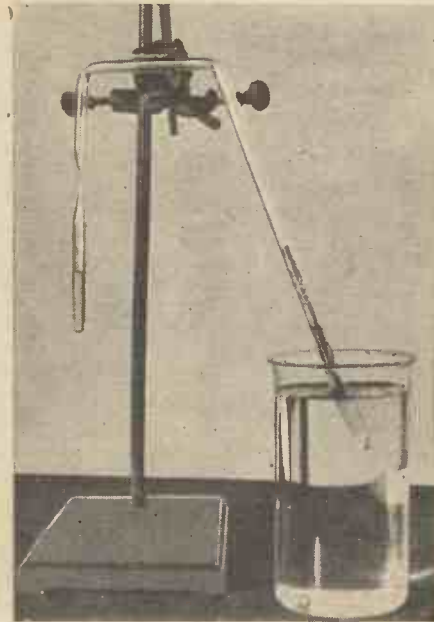

*Illustrating Faraday's original method of small-scale gas liquefaction. In this instance liquid sulphur dioxide ( $SO_2$ ) is seen in the left-hand limb of the sealed glass tube, having been generated by the action of concentrated sulphuric acid on metallic copper contained in the right-hand limb of the tube. The latter is immersed in a vessel of hot water to speed up the evolution of the gas.*

current passing for the same length of time through a solution of zinc sulphate would liberate 65 grains of metallic zinc, 63 and

65 being the respective atomic weights of copper and zinc. The same amount of current passing for the same time through a chemical solution will always liberate the metallic element of the solution in the same proportion or ratio, this latter constituting the electro-chemical equivalent of that particular element.

Faraday often expressed his opinion that chemical energy or affinity and electricity are one and the same thing. In other words, that it is electrical attraction between, for example, the atoms of chlorine and the atoms of hydrogen which causes these two gases to combine together with the formation of a definite compound—hydrogen chloride or hydrochloric acid, HCl. Faraday proved that definite quantities of electricity are always associated with atoms of matter, this statement of his paving the way to the later elaborate theories of the electrical constitution of matter and the nature of electricity itself.

Experimenters from all parts of the world flocked to London to see the great Faraday in his later and more mature years.

Faraday's habits were methodical and regular—monotonous, many of us might nowadays call them. He carried out his laboratory experiments between definite hours of the day, dined at a definite time took his relaxation at a definite hour, and, in general, ruled himself with a rod of inexorable, yet gentle, discipline.

#### Popular Lectures

Faraday found time to write several books and, also, to give periodical lectures on "Popular" science. His fame as an exponent of popular science became so extensive that even the austere Prince Consort took his English Queen, Victoria, to hear Faraday and to be astounded by his many spectacular experiments.

In many respects, Faraday was the man who first really popularised science in the Victorian age. Being utterly without "side," he was ever approachable at all times, even by the poorest. He never forgot his own humble beginnings and, in consequence, his was a hand which was always extended to guide other aspirants to the paths of pure and applied science.

In 1861, Faraday, on account of failing faculties, resigned part of his duties at the Royal Institution. He slowly became more and more enfeebled. Ultimately, on 25th August, 1867, he passed away, to the sincere regret of every thinking member of the nation.

## New Niagara Bridge

THE new Rainbow Bridge across the river and gorge at Niagara Falls will be completed by the autumn. Many difficult engineering problems have been solved in its construction. At the point where the new bridge crosses, the gorge is about 200 feet deep and 1,000 feet wide. The great steel arch of the bridge has a span of 950 feet and rises from its supporting abutments on the American and Canadian sides of the river to the level of the top of the gorge. It is said to be the longest hingeless arch in the world.

At this point the river flows at from 25 to 30 miles an hour, has a volume of about 6,000,000,000 pounds of water a minute, and is more than 175 feet deep. The erection of any kind of supporting piers or substructure in the stream was considered impossible or economically impractical. The piers and the approach spans rest on solid rock which forms the sides of the

Niagara gorge, so that they do not have contact with the river, and are high above any possible water or ice pack level.

#### Steel Girder Construction

Two steel box girder ribs spaced 56 feet apart form the main arch span, which is of the hingeless ribbed type. Each arch section is made up of 24 girders 12 feet high weighing from 49 to 75 tons. In both ribs of the arch there are about 3,500 tons of steel, while the superstructure and decking account for a further 2,000 tons. In order to resist forces produced by wind pressure or live loads, the two ribs are braced together with steel members for rigidity. Steel spandrel columns, resting on the arch ribs, carry the steel floor girders and concrete deck of the roadway above.

A novel method was used by the engineers when setting the big arch in

position. On top of each of the Canadian and American abutments, steel towers 130 feet high, more than 30 storeys above the river level, were built. An 85-ton derrick lowered the sections of the arch into the gorge, where they were received by a 40-ton stiff-leg derrick which travelled the arch, setting each section in place. When all sections were in place, a keystone of steel, about 11 inches wide, was used to join the 475-foot sections extending from each shore. A permanent keystone carefully machined to fit to one-one-hundredth of an inch replaced this later. When this piece was set, the arch became self-supporting on its abutments, and the temporary cable supports and tower could then be removed. The joint between the steel arch and abutment is made by a 60-ton grillage and skew-back bolted to the abutment at each terminal with 32 anchor bolts set in concrete.



# Broadcast Reception on Tap

A Description of Three Systems for Distributing Broadcast Programmes to All Parts of a House

ONE of the disadvantages of a remote controlled broadcast receiver is that the programme being reproduced in, for example, the living-room of a house, is not always clearly audible in, say, an upstairs bedroom from which the receiver is being controlled. An arrangement in which the programme can be distributed to all parts of a house and intercepted at any desired point is clearly very desirable, and the present article describes systems of this kind, developed by the Radio Corporation of America.

In one system, oscillations are generated by a local oscillator and modulated by a portion of the audio energy available at the output transformer of the receiver. The modulated oscillations are then impressed upon the power supply line and picked up at any remote point by simply plugging into an available power supply line outlet. The modulated oscillations may be transmitted also as electro-magnetic waves and picked up at a remote point by a suitable pick-up device.

### Alternative Systems

In another system in which a superheterodyne receiver is employed, the use of an auxiliary oscillator may be avoided since with that type of receiver a portion of the intermediate frequency energy may be transmitted or distributed as desired. In a third system a portion of the intermediate frequency energy of a superheterodyne receiver is combined with locally generated oscillations, its frequency changed to a more convenient value and then impressed upon the power line or otherwise transmitted.

To receive the signals from any one of the aforesaid modifications, a suitable detecting arrangement is provided, and possibly an amplifying device which acts to bring the signal energy up to the desired level. In a modification of the receiver, the signals are first impressed upon an amplifier and the output fed to a detector and then the resulting audio frequency is amplified in an audio frequency amplifier, and the output

Fig. 1. Circuit diagram of a receiver in combination with a remote-control unit.

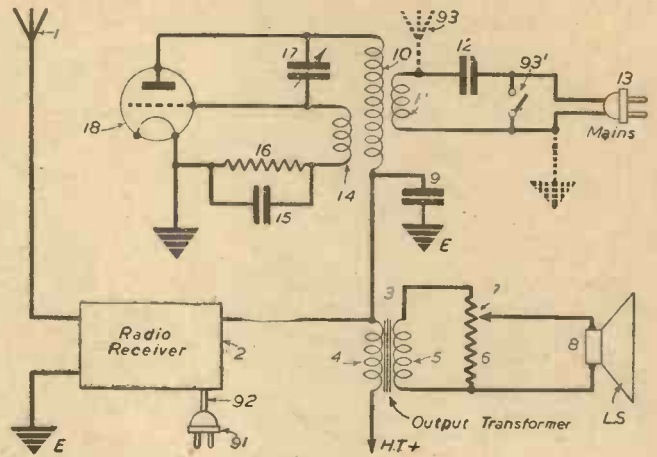

fed to a loudspeaker. A receiving unit in combination with a remote control unit makes it possible for one to go from one room to another and not only control the remote radio receiver located, let us say, in the living-room or the cellar, but also to receive the programme in such a way as to provide real enjoyment.

Figure 1 shows the aerial 1 and earth connection E of a radio receiver 2, to the output transformer 3 of which is connected a loudspeaker 8, and the audio frequency output is used to modulate the output of a local oscillator. The output transformer 3 is provided with a primary winding 4, and a secondary winding 5, and across the latter is provided a volume control resistor 6, having a variable tap 7. The loudspeaker 8 is connected between the variable tap 7 and one end of the resistor 6 to permit adjustment of the volume at the receiver. The receiver 2 may be connected to a suitable power supply line by a cable 92 and a plug 91.

The plug 91 and cable 92 not only supply the radio receiver with power for energising the valves and other elements, but also picks up from the power line the control signals sent out from a remote point which determine the operation of the receiver.

The local oscillator includes a valve 18 having a grid coil 14 and a plate coil 10 coupled together, and the usual grid leak 16 and condenser 15 are provided. For tuning the oscillator, a variable condenser 17 is connected between the plate and grid of the valve 18 and is thereby effectively shunted across the plate coil 10. In order that the audio frequency output may modulate the

oscillator 18 the coil 10 is connected to a point of the primary 4 of output transformer 3, thus providing a circuit for applying plate potential to the valve 18. The connection between the plate coil 10 and the primary 4 is by-passed to earth by a suitable condenser 9.

The modulated oscillations are preferably impressed upon the power line by inserting the plug 13 into a suitable power line socket, it being noted that the plug 13 is coupled to the plate coil through the winding 11 and the condenser 12. The size of the condenser 12 should be such as to prevent current from the power supply line from being impressed across the winding 10, and yet it should permit the modulated energy to pass freely through it and on to the power line. For this purpose it has been found that a condenser of the order of .01 microfarad is suitable. If it is desired to transmit the signals over the air, this may be accomplished by providing suitable means, such as an aerial 93 (shown in dotted lines), and in such a case plug 13 is not inserted into the power line, but is short circuited by a switch 93.

### Superhet Receiver

Referring now to the superheterodyne type of receiver shown in Figure 2, the aerial 1 is coupled to a radio frequency amplifier 19, the output of which feeds into a first detector arrangement shown at 20, to which a local oscillator 21 is connected. The tuned output circuit of the I.F. amplifier 22 includes a condenser 23 in shunt with the primary 24 of an intermediate frequency transformer, the secondary 25 of which forms with tuning condenser 26 the input circuit of a second detector 29, the output of which is fed through an audio-frequency amplifier 30 to a loudspeaker 8.

A portion of the intermediate frequency energy is fed to the power line through the coupling coil 27 and series condenser 28, the purpose of which is similar to that of the condenser 12 in Figure 1. The arrangement of Figure 2 avoids the use of the auxiliary oscillator necessary in the system shown in Figure 1.

In some instances, as when it is desired to avoid excessive interference, it may be desirable not to impress the intermediate frequency upon the power line but to change its frequency to some other value which is less likely to interfere with other receivers. An arrangement for changing

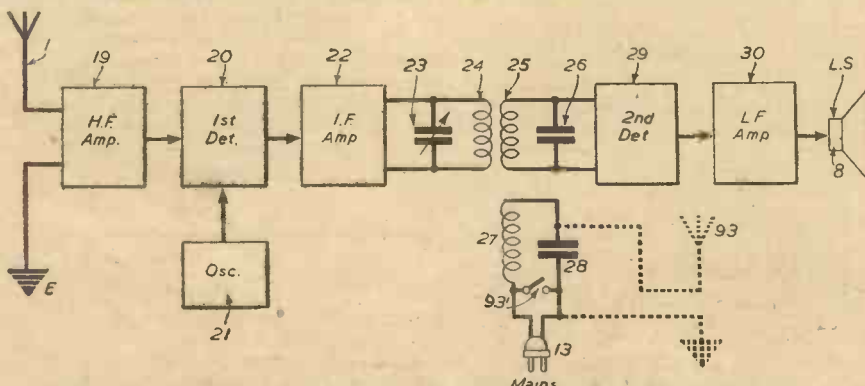

Fig. 2. Showing the stages of a superhet receiver, together with the plug-in unit.



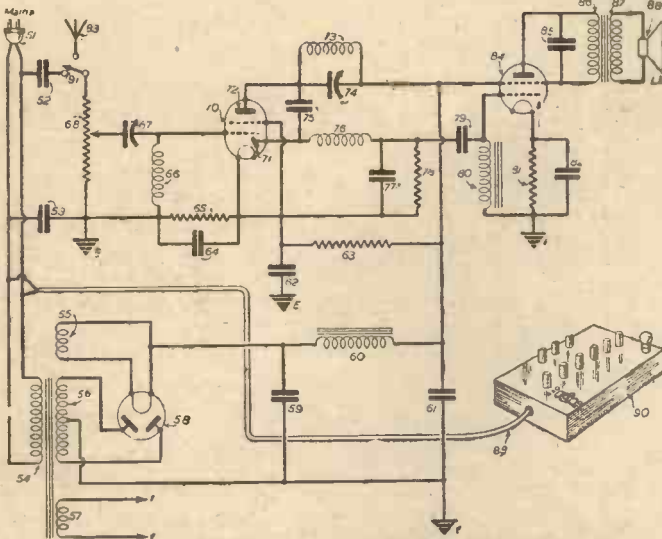

Fig. 3. Circuit diagram of a receiver which may be used for receiving transmissions from either of the systems shown in Figs. 1, 2 and 4.

the frequency of a portion of the intermediate frequency energy is illustrated in Figure 4, the initial stages of which are similar to those of Figure 2. Part of the output of amplifier 22 is fed to the frequency changer 34 and part of it is fed to the second detector 29.

Coupling between the amplifier 22 and the valve 34 is provided by a condenser 32 connected to the third grid of the valve 34 by a conductor 31 having an earthed shield 33. The second grid of valve 34 is connected to H.T.+ through the coil 39 and resistor 40 in series, it being noted that the connection between the coil 39 and resistor 40 is by-passed to earth through a by-pass condenser 41. The first grid of the valve 34 is connected to the cathode thereof through a condenser 36, and a tuned circuit comprising coil 38, which is coupled to the coil 39 and shunted by a condenser 37. The cathode is earthed through resistor 42, and a leak resistance 35 is provided between the first grid and cathode.

The second grid acts as the plate of a triode, the grid of which is constituted by the first grid of the valve. The coupling between 38 and 39 produces oscillations of a frequency which is determined by the tuned circuit made up of the coil 38 and condenser 37. These oscillations are combined with the intermediate frequency oscillations impressed upon the third grid of valve 34 from which combination there is produced the desired frequency to which the circuit comprising coil 47 and condenser 46 is tuned. The new frequency may be impressed upon the power line through coupling of the coils 47 and 49 and plug 13, or, again, it may be fed to aerial 93 if it is desired to transmit the new frequency over the air.

**Receiver Details**

A representative receiver which may be used for receiving the energy transmitted by any one of the systems shown in Figures 1, 2 and 4, is illustrated in Figure 3. In such a receiver the plug 51 is inserted into a suitable power supply line socket and the programme signals impressed upon the power line are fed through condensers 52 and 53, and impressed across the resistor 68, and thus

first grid, an auxiliary grid, a main anode 72, and a diode anode 71. The tuned circuit 66, 67, is connected between the first grid and the cathode. A grid leak resistor 65 shunted by a condenser 64 is in the connection between the tuned circuit 66, 67, and the cathode of valve 7. The signals impressed upon the first grid of the valve 7 from the tuned circuits 66, 67, which appear in amplified form on the main plate 72, are fed to the diode anode 71 through a coupling condenser 75. The diode anode 71 is connected to the cathode of valve 70 through coil 76 and resistor 78 in series, the latter being shunted by a condenser 77. From the connection of the diode 71 with respect to the signals which are fed from the tuned circuit 66, 67, to the first grid of the valve 70 are rectified in the diode portion of the valve 70, and the audio-frequency signals representing the programme appear in the output of the diode circuit.

**Audio-Frequency Amplification**

It is usually necessary to amplify the audio frequency, and for this purpose there is provided an amplifier valve 84, the first

exclude the power supply current. For this purpose it has been found that condensers of .01 microfarad are suitable. Resistor 68 is provided with a slider through which a resonant circuit which includes condenser 67 and coil 66 is connected across any desired portion of the resistor 68. This resonant circuit is tuned by means of the variable condenser 67 to the frequency of the energy which is impressed upon the power line by any one of the systems shown in Figures 1, 2 and 3. To amplify the energy there is provided a valve 70 having a cathode, a

grid of which is connected to a point of the diode circuit intermediate the coil 76 and resistor 78 through a coupling condenser 79, and thus the audio frequency energy is impressed upon the first grid of the valve 83. The condenser 79 is preferably of small capacity so that the mains cycle component which may be present, due to the connection of the system across the power line, may be eliminated from the first grid of valve 84. This grid is also connected to earth through a choke coil 80. The grid circuit of valve 84 is completed by connection of the cathode thereof to earth through the bias resistor 81, which is by-passed by condenser 82.

The right-hand side of the filter choke 60 can be considered as the positive terminal of the power supply means, and the earthed point to which the centrepoint of secondary 56 is connected may be considered as the return circuit. The anode of the valve 84 is connected to the positive terminal of the power supply system, that is, to the right-hand side of filter choke 60 through the primary 86 of an output transformer, across the secondary 87 of which is connected the loudspeaker 88. The primary 86 of the output transformer is shunted by a condenser 85. In order to provide a suitable positive potential for the auxiliary grid of the valve 84, there is provided a connection between said auxiliary grid and the right-hand end of the choke coil 60. It should also be noted that the auxiliary grid of the valve 70 is also connected to the right-hand end of the filter choke 60 through a resistor 63, the grid end of which is connected to earth through a by-pass condenser 62.

Associated with the receiving unit there is provided a remote control device 90, which may be connected to the power line by a suitable cable 89, as shown.

**Portable Unit**

Figure 5 shows a portable controlling and receiving unit contained in a cabinet B provided with a handle H. LS represents the loudspeaker, S is the "on and off" switch, PL the pilot light, PB the push-buttons for controlling the receiver, P the plug for plugging the unit into a power supply line outlet, and C the connecting cord. It is obvious when considering Figure 5 that a person going from room to room in a house or apartment may plug into the power supply line and control the receiver, and at the same time receive the signals which are received by the remote receiver through the loudspeaker LS.

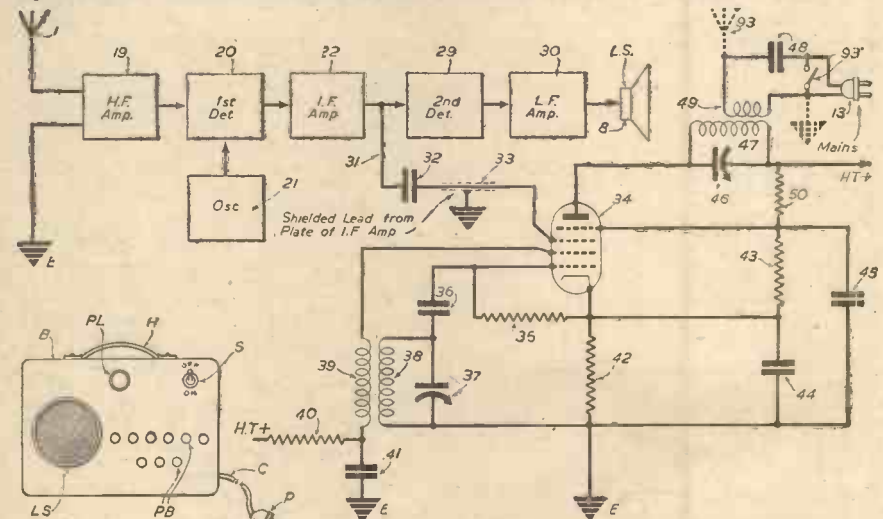

Fig. 5. A portable controlling and receiving unit.

Fig. 4. Schematic diagram of a superhet receiver in combination with the remote-control unit, showing arrangement for changing the I.F.



Cut out the  
Black-out Blues!  
with a Fret-saw!

# HOBBIES 1942 HANDBOOK for The Handyman

Suggestions and details for all kinds of things to make in wood—Models, Galleons, Planes, Guns, Doll's Houses, etc. Over 250 particulars. Large gift plan (30 ins. by 20 ins.) for a model Tank. Also coloured Alphabet Jigsaw Picture. Complete editorial chapters on various pastimes and full catalogue section for the craftsman.



104 PAGES  
GIFT DESIGN  
AND JIGSAW

Ask at any newsagent,  
bookstall, or Hobbies  
Branch. Or sent post  
free for 8d. from  
Hobbies Ltd. (Dept. 70)  
Dereham, Norfolk.

6<sup>D</sup>

## MORSE CODE MADE EASY



BUZZERS. Single coil model 2/6.  
HEAVY double coil 3/8.



### MICROPHONES

Just the thing for impromptu concerts, room to room communication, etc. Bakelite table model 5/-.  
Suspension type 6/6 as illustrated. Easy-to-follow instructions included.

**BELL TRANSFORMERS**  
These step-down transformers work from any A.C. Mains giving 3, 5 or 8 volts output at 1 Amp., operate bulb, buzzer or bell. Also provide an A.R.P. light in bed-room, shelter, etc.  
**PRICE 5/6.**

**LEARN AND PRACTISE MORSE** on a regulation size Tapping Key. Our heavy brass model is mounted on a wooden base, has an adjustable gap and nickel contacts. Key is wired to work buzzer or flash lamp by using a 41 volt battery or the transformer illustrated. **BRASS KEY 8/8, CHROMIUM PLATED 7/6.** W.O. Model, with heavy brass bar, and the addition of a front bracket. Polished Brass only 9/6. The above keys are supplied to the Services for Morse instruction. Junior Key, mounted on a bakelite base together with a buzzer, 4/6. Should you require a complete outfit, our D.X. 2 Set, consists of a heavy brass key mounted on a large polished board together with a heavy duty double coil buzzer, flash lamp bulb holder, and two switches to bring either into circuit. Terminals are also provided for distant sending and receiving. Very fine job 17/8.

**CRYSTAL SETS.** Our latest model is a **REAL RADIO RECEIVER** and is fitted with a **PERMANENT CRYSTAL DETECTOR.** 7/6. **HEADPHONES,** for use with Crystal Sets and if necessary Tapping Keys or Microphones, 10/6. 12/6. or recommended 'phones 7/6 and 8/6 per pair.



ASK FOR OUR NEW LIST B.P. OF USEFUL ELECTRICAL ACCESSORIES  
Money refunded if not completely satisfied. Please include postage, any excess will be refunded.  
**HIGHSTONE UTILITIES 58 NEW WANSTEAD, LONDON, E.11**

## E. GRAY & SON, Ltd.

offer the following items from stock.

4-jaw Chucks, "Crown" 4in. Lightweight, 24/6. Heavy-weight 4in., 60/-, 10in. 114/-.  
"Burnerd" 3½in., 31/3, 4in., 32/6, 6in., 73/9.  
Backplate Castings, 3½in. 1/6 4½in. 2/8, 5in. 3/6, 6½in. 4/3, 7½in. 7/6.  
Drill Stands, 1-60 or 1¼-½, 2/6.  
Angle Plates, 3x2x2, 3/3; 3x2½x2, 3/9; 4x2x2, 4/3; 4½x3½x3 6/4; 7x4x4, 15/3.  
Drill Chucks, key type with No. 1 M/T Shank, ½in., 31/-.  
Tool-post Grinder, Electric, with wheel and internal attachment, 107/8.  
Faceplate Clamps, 2in. 5d., 2½in. 4d., 3in. 5d., 4½in. 9d.  
Carborundum Wheels, from 1in.x½in. at 1/6 to 6in.x1in. at 10/6.  
Drill Sockets, No. 1 to 2 M.T., 2/4.  
**3, CLERKENWELL ROAD, LONDON, E.C.1.**  
Est. 1822. Clerkenwell 1174



Thank goodness for  
the **radio/wireless**  
mechanics at base



For hours before the raid the Radio/Wireless Mechanics at the base were checking and testing the radio gear—putting the last ounce of performance in the wonderful R.A.F. transmitters. Men are urgently wanted for this highly important and intensely interesting job. If you've a sound elementary education the R.A.F. will train you from the start. (Age 18-34—older men accepted if they know something about radio.) **ALSO NEEDED URGENTLY**—men to train as Flight Mechanics (age 18-42), Armourers (age 18-42), Electricians (age 18-42).

Go to-day to the R.A.F. section of the nearest Combined Recruiting Centre (address from any Employment Exchange) or post the coupon.

Train with the

# RAF

for these vital  
ground duties

To Air Ministry Information Bureau,  
Kingsway, London, W.C.2

Please send me latest details of

- Radio/Wireless Mechanics
- Flight Mechanics
- Armourers  Electricians

X against the one in which you are interested.

NAME.....

ADDRESS.....



# THE WORLD OF MODELS—

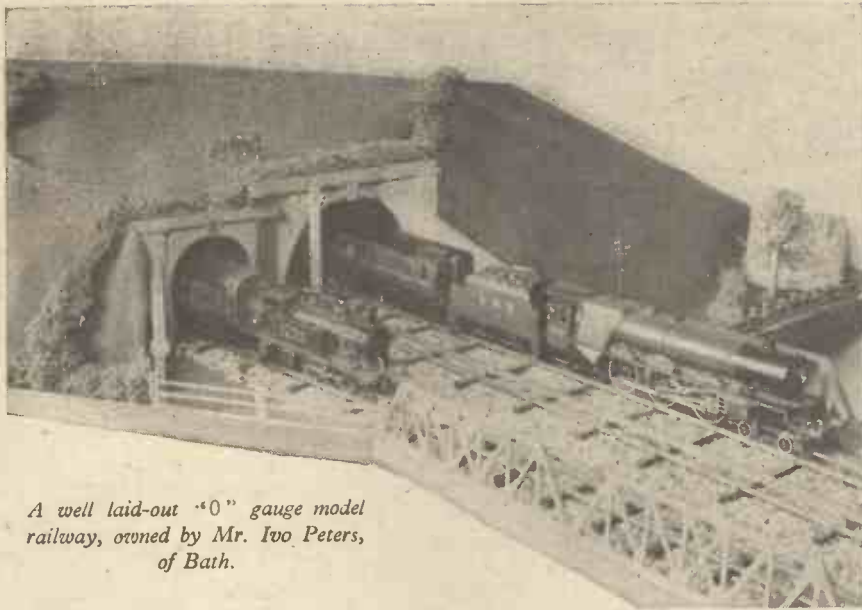

A well laid-out "0" gauge model railway, owned by Mr. Ivo Peters, of Bath.

## An "0" Gauge Model Railway

VISITORS to Bath have no doubt admired the famous Royal Crescent, which contains probably some of the finest architecture that England produced in the eighteenth century.

In one of the houses near the centre lives Mr. Ivo Peters, the owner of an excellent gauge "0" model railway. He has devoted a special room in his home to this and in addition to excellent planning has expended more time than is usual on the scenery and has produced many picturesque effects on the line.

The track is laid in small scale permanent way with centre rail traction and works on 20 volts. In the electrical equipment of the railway, he has been assisted by an electrical engineering friend, Mr. Alfred Young, of Keynsham, and the whole scheme is very efficiently arranged.

The locomotives and rolling stock are mostly Bassett-Lowke and Hornby, and he also has introduced in one section of the railway a small gauge "00" layout which blends very well into the scheme.

Our picture shows an L.M.S. Passenger train being hauled by a Bassett-Lowke "Princess Elizabeth," and an L.M.S. Suburban train hauled by an 0-4-4 Tank locomotive.

## Model Railway Standards at last

Readers of *Practical Mechanics* who have for many years deplored the varying measurements adopted among model railway makers, both professional and amateur, will welcome the announcement that the Model Railway Standards Committee, which was formed on the initiative of the Right Honourable J. T. C. Moore-Brabazon, M.C., M.P., Minister of Aircraft Production, and a keen model railway enthusiast, have made their first announcement

that the commercial standards for gauge "0" railways have been agreed upon.

These, with the exception of a few small details, are the standards adopted by Bassett-Lowke Ltd. for the past four to five years. These slight alterations are included in a new blue print just published by Bassett-Lowke Ltd. at 2/6 post free. The accompanying diagrams give the dimensions on the metric system, as well as in inches. This standard is for ordinary commercial models, where fine "true-to-scale" limits are not required.

Notes about several interest-developments in the model

Standard for Gauge "0" "true-scale" models for exhibition purposes (7 mm. to 1 ft.)

- Dimensions are as follows:—
- Track gauge—32 millimetres.
- Back to back distance of wheels—29 millimetres.
- Flange thickness—1 millimetre.
- Flange depth for locomotives and sprung rolling stock—1.25 millimetres.
- Flange depth for unsprung stock—1.5 millimetres.
- Width of wheel (total)—3.5 millimetres.
- Flangeways for straight track—2 millimetres maximum.
- Flangeways for curved track—2.5 millimetres maximum.
- Width of rail-head—1.5 millimetres.
- Height of rail—3.5 millimetres.

Sleepers to be 7 millimetres by 63 millimetres, spaced 18 millimetres apart on running lines generally, and 24 millimetres apart on sidings. On double tracks the "6 ft. way" is to be taken as 80 millimetres measured from centre to centre of tracks.

Collector-rails to be made of 1 by 2 millimetres "00" gauge rail spaced 5 millimetres, face to face, from running rail.

Height of collectors to be 2.5 millimetres above the running rails.

The committee are now busily engaged on the standards for gauge "00," which present a much more complicated problem. There are already two standards used in America, 16½ millimetres gauge, and 19 millimetres gauge, besides other variations.

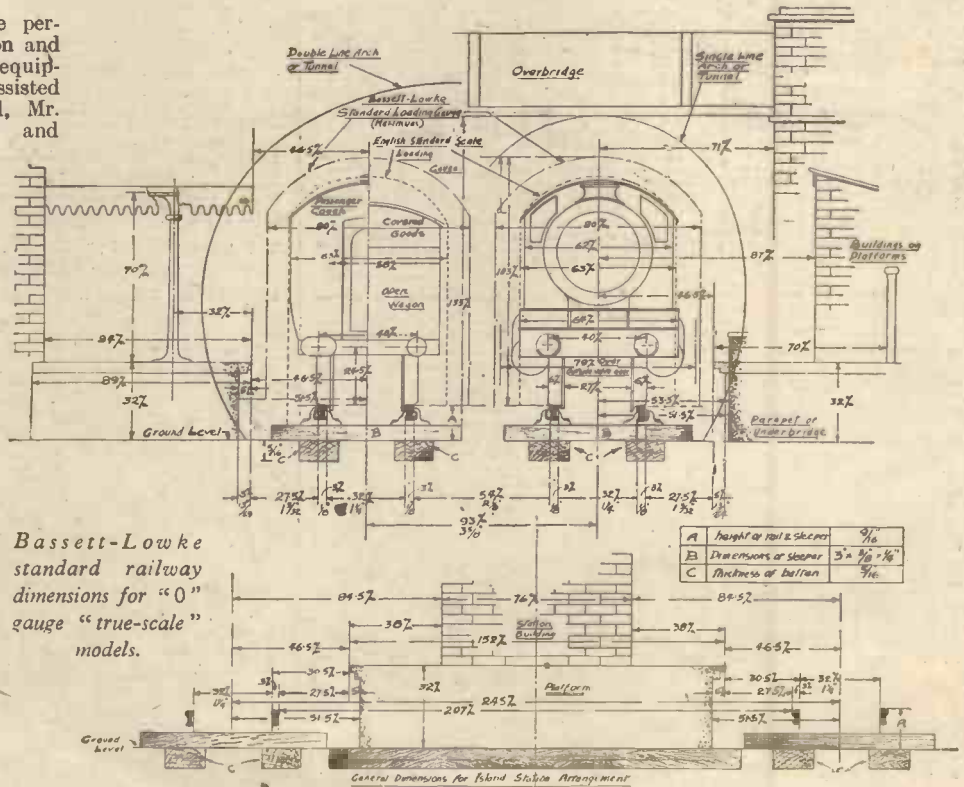

Bassett-Lowke standard railway dimensions for "0" gauge "true-scale" models.



# By "Motilus"

ing railways, and the latest railway world of Standards

I am sure everyone wishes the committee success in their difficult and arduous task, but one which is essential if model railway production is to be set on a proper basis.

The committee is officially named the British Railway Modelling Standards Bureau, and the Chairman is Mr. J. N. Maskelyne (editor of the *Model Railway News*).

### Another "0" Gauge Railway

The other day I had the pleasure of calling to see an old friend—Cecil J. Allen, the well-known railway writer, who now lives at Hatch End, Middlesex. In the garden of his new home there he has ample space for his splendid gauge "0" railway, and during the long summer evenings, when his work has permitted, he has been finding relaxation in relaying his track and has made good progress with an entirely remodelled layout. This new scheme includes in all about 500 feet of track and here is a picture taken on my visit, when I found him busy on the triangle. I hope when the railway is complete and in running order, to give readers further details of what, I am sure, will be a most railway-like model line.

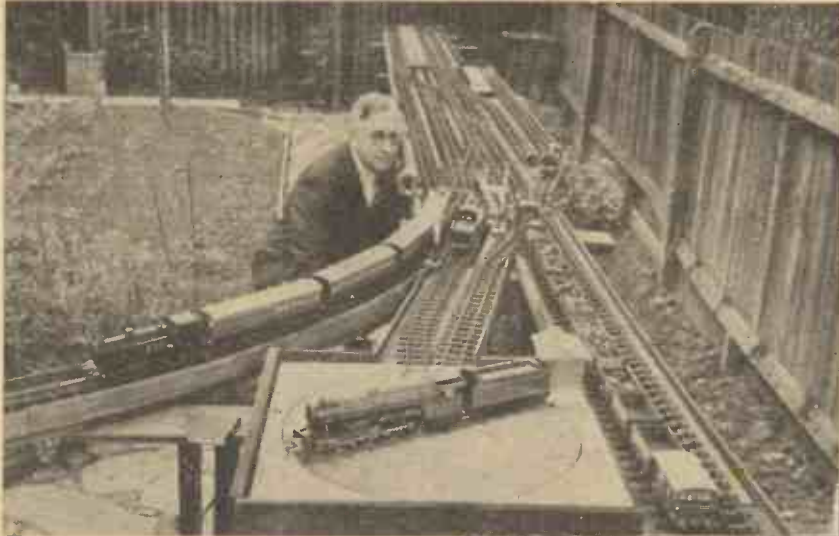

Mr. Cecil J. Allen, and his "0" gauge model garden railway.

### "Model" Expenditure

Models have many uses, and Councillor W. J. Bassett-Lowke, managing director of Bassett-Lowke, Ltd., introduces models into his municipal activities. Here we see him presenting to the Rotary Club of Northampton in "model" form the Income and Expenditure of the town of Northampton. The left-hand column represents in scale the income from Rates, Government Grants, and the Trading Services of the Municipality, such as Transport, Water, Public Markets, etc., and the centre large column the expenditure to the same scale, which must balance, and includes Education, Housing, Highways, etc. Then as a contrast the first thin column to the same scale represents the amount paid in Rent

These are, of course, peace-time figures, and would differ considerably to-day with the amounts being spent on A.R.P. and the Defence Services, but they present a very interesting comparison in model form.

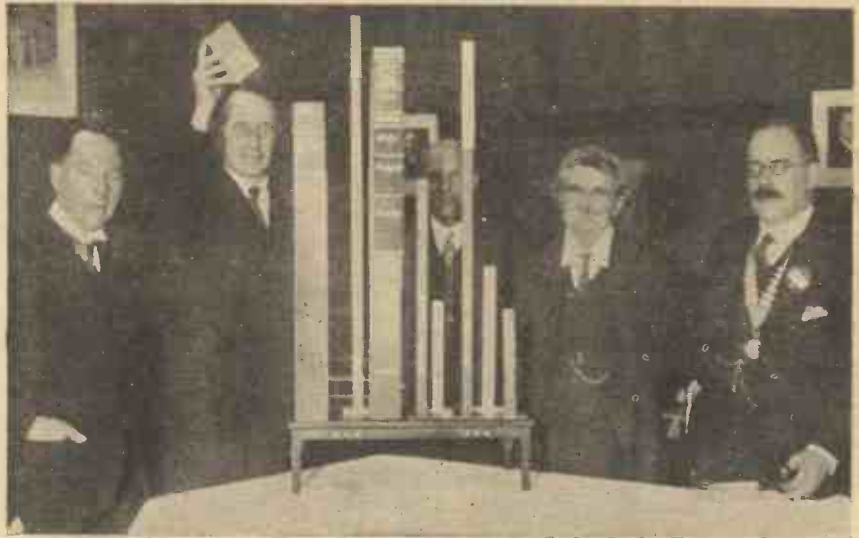

"Models" of Income and Expenditure displayed at the Rotary Club in Northampton. by Councillor W. J. Bassett-Lowke.

in Northampton. The other five represent as follows: (1) the amount spent in drink, (2) on smoking, (3) in wages and materials by the Corporation, (4) the amount paid by the rate-payers, and (5) the last, the amount spent in entertainment and amusements.

### Realistic Model Railway Smash

Readers will no doubt recall a reference to Mr. C. B. Smith's railway at Lincoln in *Practical Mechanics* for February 1941. Now I see he has been staging a model railway smash, and he sends me this photograph.

An "Enterprise" is the "damaged" locomotive, and the Super Enterprise can be seen to the rear on the right of the picture and the King George V in the right foreground.

The breakdown crane and truck have arrived on the scene (by the way, these are Mr. Smith's own make), and it would appear that the line will soon be normal again.

Mr. Smith reports that the track is in first-class condition, and traffic is increasing as spare time permits. He is also a keen 9.5 mm. cine fan, and has taken some very good shots of his line under working conditions. It is amazing the number of model railway owners who are also either 9.5 or 16 mm. users. Certainly, a combination of two fascinating and absorbing hobbies which the war has curtailed through lack of supplies, but the interest and enthusiasm of its devotees is in no way damped. They still "GO TO IT"!

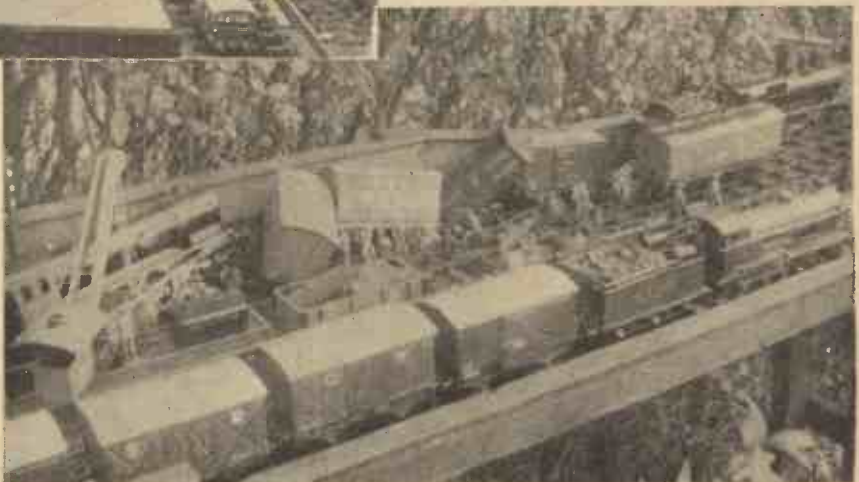

A realistic model railway smash, complete with model break-down crane and railwaymen.





## QUERIES and ENQUIRIES

A stamped addressed envelope, three penny stamps, and the query coupon from the current issue, which appears on this page, must be enclosed with every letter containing a query. Every query and drawing which is sent must bear the name and address of the reader. Send your queries to the Editor, PRACTICAL MECHANICS, Geo. Newnes, Ltd., Tower House, Southampton Street, Strand, London, W.C.2.

### Solenoid Winding

WOULD you please inform me what alteration in the wiring is necessary to convert a 12 volt solenoid for a 6 volt circuit. I have a 12 volt Lucas headlamp with dipping device which is wound with 6 coils (left hand) of 22 S.W.G. on the primary circuit, and 6 coils (right hand) of 32 S.W.G. on the secondary circuit. How many coils and what gauge of wire will I require for re-winding to suit a 6 volt circuit?—S. C. Ross (Downend).

THE power exerted by a solenoid is proportional to its "ampere-turns," and when changing from one voltage to another, the resistance of the windings must be so altered that current multiplied by turns remains unchanged. A winding that originally suited a 12-volt circuit would, for instance, require twice the current at half the original voltage, and therefore one-fourth of the original resistance in ohms. Winding revisions such as these can be quickly settled by reference to wire tables such as that published in "Dynamo Design & Construction" (Avery). After gauging the original winding, a new gauge can be selected with one-fourth of its resistance, weight for weight, as shown in the columns headed "Resistance in ohms per lb."

### Silver Phosphate

I CANNOT see why the precipitate formed by the addition of silver nitrate solution to ammonium phosphate solution should give a clear solution with dilute potassium hydroxide. Does the solution lie in the fact that a complete ammine with silver is formed, or should one assume that the "ammonium phosphate" is a mixture of the di-sodium and di-hydrogen salts, and the solubility product of these is not exceeded in the presence of potassium hydroxide?—K. S. Tetlow (Mytholmroyd).

WHEN ammonium phosphate solution is added to a solution of silver nitrate, it gives a light-yellow (NOT a white) precipitate of silver phosphate. This silver phosphate, although insoluble in water, dissolves in solutions of ammonia, potassium hydroxide and sodium hydroxide. No complex compound with silver is formed, the effect being one of simple solution.

Thus, if you add a solution of ammonium phosphate to a solution of silver nitrate, and dissolve the yellowish precipitate of silver phosphate by adding a little dilute potassium hydroxide, you will obtain a perfectly clear, water-white solution. If to this solution you add cautiously a few drops of dilute nitric acid, the silver phosphate will be re-precipitated owing to the neutralisation of the potassium hydroxide by the nitric acid. If, however, too great an amount of nitric acid is added, the re-precipitated silver phosphate will again dissolve, since it is also soluble in free nitric acid.

### Photo-Cells

I SHALL be grateful for any information you can give me regarding the type of photo cell which generates a small quantity of electricity. I do not refer to the photo-electric vacuum tube, in which light merely controls the flow of electricity from a battery, but to the barrier-layer photo cell, in which light actually produces electric power. If you know of any book which deals with this effect, will you please include it in your answer?—H. Hanlock (West Drayton).

THE type of photo cell to which you refer comprises a light-sensitive cathode suitably positioned within a highly-evacuated glass tube or bulb. In close proximity to the cathode is a suitably-designed anode. The cathode usually presents a specially sensitised surface which strongly emits electrons upon exposure to light. These negatively-charged electrons proceed to the anode or positive electrode of the cell and, by so doing, set up a current.

### Variable Pitch Airscrews

(Continued from page 21)

range external cylinder "constant-speed" variable pitch airscrew. It consists of three or four blades operated by an externally-mounted cylinder giving greater range. It is suitable for single-engined aircraft, and blade travel is limited to 35 degrees. In Fig. 4 is shown the Rotol 20 degree range internal cylinder "constant-speed" variable-pitch airscrew. It has three blades, wood or metal, operated by a hydraulic cylinder enclosed within the hub, and is suitable for trainer and other installations requiring only moderate range of blade travel. The Rotol hydraulic feathering "constant-speed" variable-pitch propeller is shown in Fig. 5. This has three or four wood or metal blades, identical with a 35-degree airscrew, with the 35-degree limit stop removed, thus enabling the blades to reach a feathered attitude in order to prevent the wind-milling of a damaged engine. Finally, we come to Fig. 6, which shows the Rotol electrically-operated airscrew, featuring manual control "constant-speed" pitch-lock feathering. Three or four wood or metal blades are operated by an electric motor situated at the front of the hub through medium of high ratio reduction gear. It has operational characteristics similar to a hydraulic feathering airscrew. Its advantages include feathering, potential ability to reverse blades for manoeuvring flying boats, and positive locking of blades in any desired pitch and constant speeding.

The actual amount of current created by the cathode of the cell is relatively small. For instance, a cathode comprising a thin film of caesium on silver gives a current of 24 microamps. per lumen of light energy, whilst a film of rubidium on silver generates a 5 microamp. current per lumen of light. These photo-sensitive films are among the highest obtainable.

A cathode of sensitised sodium gives on 0.6 microamps. per lumen of light, whilst a cadmium surface produces less than 0.1 microamp. per light lumen. Photo cells of the type you mention are known as the "self-generating" cells. They are made by the General Electric Co., Ltd., Wembley, from whom you may be able to obtain particulars. We doubt, however, whether you will be able to purchase one of these cells from the makers nowadays. However, you might be able to obtain such a cell from Electradix Radios, Ltd., 19 Broughton Street, Battersea, S.W.11.

### Waterproofing a Concrete Shelter

EARLY in 1939 I had a concrete dug-out constructed of 12 in. reinforced concrete. It is completely below ground in clay soil. The shelter failed to be waterproof and in 1940 I had the interior and floor chipped and two half-inch renderings of Celocrete treated cement plastered to a depth of one inch. This had the desired effect, and throughout last winter the shelter was perfectly dry. Recently, however, moisture has appeared on the floor and walls one foot up, and whilst it is impracticable to detect a definite leak, the conditions are becoming worse. Can you inform me if concrete tends to become porous with age, and if you know of any application which can be made internally or otherwise which will overcome my difficulty?—F. W. Horsnell (Chelmsford).

MOISTURE has always a great tendency to rise upwards through concrete, and we are of the opinion that it would be throwing money away for you to endeavour to treat the concrete of your shelter with any preparation, for the reason that any such treatment would be only palliative.

A permanent cure for your trouble can be effected by having your shelter asphalted. This can be done by your nearest building and asphaltting contractor. You should instruct him to lay two separate half-inch coats of hard flooring asphalt mastic and to make a coving in this material around the bottom sides of the shelter interior. This treatment, which is a radical one, and which should not cost much, will defy any damp and moisture, except moisture due to internal condensation within the shelter. It may be that your contractor may not be able to obtain supplies of asphalt mastic for this private purpose. If not, he can obtain a substitute made from pitch, but, if possible, you should stipulate genuine asphalt mastic, this being the most serviceable, enduring, and reliable. If asphaltting is out of the question for you, you might try laying on the shelter floor two layers of thin roofing felt and concreting half inch over these. This treatment should stop the trouble of ascending moisture to a large extent.

### OUR ADVICE BUREAU COUPON

This coupon is available until Oct. 31st, 1941, and must be attached to all letters containing queries, together with 3 penny stamps. A stamped addressed envelope must also be enclosed.

PRACTICAL MECHANICS, Oct., 1941.





All letters should be addressed to the Editor, "THE CYCLIST," George Newnes Ltd., Tower House, Southampton Street, Strand, London, W.C.2.

Phone: Temple Bar 4363

Telegrams: Newnes, Rand, London

VOL. X

OCTOBER, 1941

No. 236

*Comments of the Month*

By F. J. C.

## More About Bicycle Transmission

WE published an article last month by Mr. C. A. Smith dealing with defects in bicycle transmission as we now know it, and containing suggestions for improvements. We have pointed out on more than one occasion that chains are practically faultless and that most transmission troubles are due to eccentric chain wheels and sprockets, soft material, and incorrect tooth form.

The obvious solution as our contributor points out is to use chain wheels and sprockets cut to the tooth form laid down by the British Standards Institution, for this form after considerable investigation by the Institution (and after consultation with bicycle manufacturers and designers) was agreed to be the best. It coincides with the Renolds tooth form. It is inconceivable that chain manufacturers would recommend a tooth form which did not enable their chains to uphold their reputation. They know that the chain is likely to be blamed if it breaks, when the fault is elsewhere.

### Friction

We know that there are diverse views on tooth form. It is said that the friction of cycle transmission is so small that any improvement would merely effect a fractional saving of something which is in itself but a fraction. In other words, it is suggested that only about 2 per cent. of the leg power applied is lost in friction. With this we profoundly disagree. Even with a new bicycle much more than that is dissipated in friction, but when the machine has been running for 500 or 600 miles and wear has taken place, the friction is even greater.

Anything which would prevent initial friction from increasing is of benefit, and the best method of preventing friction is to prevent wear. The best method of preventing wear is to use generated teeth, and a hardened blank, using a tooth form which enables the roller snugly to fit the dedendum of the tooth.

A temporary advantage can be gained by using a tooth form which gives the roller virtually three-point contact—at the bottom of the tooth space, and at the two points of contact of the roller with the

pitch line of the teeth. Within 500 miles, however, as the load is being taken through point contact the chain wheel would soon wear, and when the chain teeth wear the chain wheel and sprocket are out of pitch. The sequel is that clicking and cracking noises develop, the chain tends to ride up on the teeth to find its correct pitch position, and it also derails itself.

### Complete Chain Transmission Sets

Perhaps our chain makers after the war will supply chain and chain wheel sets complete. We do know that all manufacturers of these important parts of a bicycle are very closely considering the matter now that it has been aired in these columns. The Renold and Coventry Chain Co., Ltd., write in connection with Mr. C. A. Smith's article: "We have read the article entitled 'Better Bicycle Transmission,' published in your last issue, and we are in full agreement with it. Mr. Hans Renold has read the article with very full understanding and appreciation of your interest in the matter. We propose to despatch reprints of the article to all our Agents throughout the world. We are most interested in this question of providing the best transmission for bicycles, and greatly appreciate your efforts in maintaining the public interest." We have some other interesting correspondence on this matter, which we propose to print next month, together with further comments from Mr. C. A. Smith.

We think that a gear case is a great help, for it prevents the dust combining with the oil on the chain to form a most effective grinding compound which soon ruins soft chain wheels, as well as the chain.

On this question of friction there is another point worthy of consideration. Theoretically only four teeth are required on the chain wheel. These would be disposed at right angles to one another and, of course, on the points where the intersecting diameters would strike the circumference of the chain wheel. Such a small number of teeth, however, would soon wear out. If the gear was cut with intermittent teeth, that is to say, a pair of teeth, a space equivalent to three teeth,

another pair of teeth, and so on, considerable transmission friction would be eliminated. This idea is partly developed in the block centre chain which virtually has alternate teeth.

Custom dies hard. There are racing men who consider that improved transmission would not make the slightest difference. Unfortunately, very few racing cyclists are engineers, and are unwilling to try what they consider to be some new-fangled idea. The ideas, however, outlined in this journal on improved bicycle transmission are not new fangled. They are as old as machine tool design, and have been known as long as we have had gears. It is indeed a matter concerning which the users of bicycles ought not to be left to express an opinion at all. Correct transmission should be fitted to every machine when it is sent from the Works. There now seems reasonable hope that when manufacturers are able to give their attention once again to bicycle design, they will redesign their transmission on the lines we have suggested.

### The B.S.I. Tooth Form

To repeat what was said last month, it is mechanically wrong to run almost perfect chains on imperfect chain wheels and sprockets. We believe that it will be in the best interests of chain makers themselves to insist within the framework of the Cycle Industry itself that bicycles using their chains should use correct gears. The matter has been considered by the Cycle Improvements Committee of the Manufacturers' Union. The conclusion reached has not been made public. We do know, however, that their representatives who sat on the B.S.I. Committee agreed with the specification which the B.S.I. published for the guidance of chain wheel manufacturers.

The B.S.I. is an organisation supported by every industry. It is an independent body which spends months and sometimes years investigating various problems associated with manufacturer and user. When their recommendations are published, manufacturers should adopt them. The B.S.I. standardises what is right, and rejects what is wrong.





Cyclist members of the West Sussex Civil Defence Messenger Service receiving instructions from Miss D. M. Johnson, the Bicycle Messenger Supervisor.

### Cyclists' Messenger Service

TO maintain contacts in outlying districts in the event of a breakdown in the telephone or telegraph service there has been organised in West Sussex, a Civil Defence Messenger Service of relays of cyclists. Started by the West Sussex Women's Voluntary Service it is the first area to start such a scheme, and cyclists of both sexes are available in all villages to carry messages. See illustration on this page.

### Cycling R.A.F. Pilots

A GROWING number of R.A.F. personnel, many noted fighting pilots included, daily ride cycles. Pilots declare that the silent passage is soothing.

### Club Secretaries in Forces

POPULAR racing secretary of the Lawrence C.C., Les. Jones, is now in the Royal Artillery. Another well-known road-time secretary in the Forces is L. Lovvott, Coronation C.C.

### Well Known Rider in R.N.

PERCY SCHOLES, West Penrine Road Club, and well-known in north-eastern road circles, is a sub-lieutenant in the Royal Navy.

### A.P.C. Cycling Section

C. A. EASTER, former secretary of the Belle Vue C.C., now serving with the Army Pay Corps, has been asked by his Commanding Officer to form a cycling section of his unit for providing exercise and recreation on Saturday afternoons.

### Club Members "Missing"

BARRAS Road Club have been most unfortunate in the loss of serving members. Jack Tunnah, R.A.F., has been reported "missing." Similarly reported are Colin Campbell and Ken Noble.

### Mentioned in Dispatches

TOMMY MARK, Barras Road Club has been mentioned in dispatches for splendid conduct in the field. He brought a motor convoy safely over mountain paths after senior officers had been lost.

### Midland Riders With Forces

FORTY-SIX members of the Midland Cycling and Athletic Club, mostly racing riders, are serving with the Forces. Two are prisoners of war.

### In R.A.F. Hereford C.C.

R. C. MILLER, formerly of the Barnet C.C., is now one of the leading riders in the R.A.F. Hereford C.C.

### Injured Rider's Recovery

FRED MURRAY, who suffered serious injuries in an air raid, has successfully recovered to compete on the track. He has performed creditably.

### Scots' Timekeeper's Holiday

GEORGE R. HERD, of Edinburgh, one of Scotland's best known timekeepers, spent a three-weeks holiday on his tour touching London.

# Paragrams

## Jack Reed Ordered East

A FOUNDER member of his club, Jack Reed, Gosport C.C., who combined also the duties of treasurer, time-keeper, runs captain, and chairman, has been ordered to the East on special Government work.

## Cyclist Dispatch Riders

POLICE Superintendent Gilbody, of Biggleswade, Bedfordshire, attended an event promoted by the Bedfordshire Road Club, and at tea which followed, spoke of the advantage of having cyclist dispatch rider in A.R.P. and Home Guard duties.

## Veteran's 9,515 Miles

A FOUNDER-MEMBER and vice-president of the Swindon Wheelers, Mr. A. Edington, was recently presented with a certificate to commemorate a recorded mileage of 9,515 miles in his 70th year.

## Noted Clubman on Leave

ERIC POVEY, noted member of the North Road and Marlborough A.C., spent some time with his clubs when home on leave after serving aboard a battleship for some months.

## Sheffield Club's New Members

RUTLAND C.C. (Sheffield) report the enrolment of fifteen new members in a month.

## Tandem Rider's Marriage

CRACK tandemist of the Glade C.C., Jimmy Newman has married Miss Ada Edell, a member of the same club.

## Clubman's Prize!

A MEMBER of the Coronation C.C., Albert Lefever, now with the R.A.F., competed in a local five-mile cycle race and lapped the field. First prize was a cigarette case with lighter attached. Lefever is a non-smoker!

## Secretary for 30th Year

FOR the 30th year, Mr. W. Lacey, Hyde Road, Ladywood, Birmingham, is secretary of the Birmingham Crescent Wheelers.

## Cheshire Clubman Joins R.N.

SMITH PARKER, Cheshire Road Club, and R.E.A. record holder, has joined the Navy.

## New Young Riders

ALTHOUGH some thirty members of the Bedfordshire Road Club have joined the Forces, some twenty-two very keen new young riders have joined this premier Bedfordshire organisation. Many have met with success in time trials.

## N.C.U. Members' Wedding

TWO members of the N.C.U. staff, Brian McGrath and Miss Iris Scott, have married.

## Sergeant Clague

WE are happy to be able to announce that L/Sergt. J. Curven Clague, who was reported as "missing" after the evacuation of Crete, has subsequently been mentioned on the German wireless as being a prisoner of war.

## Rochdale Clubman Killed

WILFRED PROCTOR, formerly a keen rider with the National Clarion C.C., Rochdale Section, has been killed in a motor cycle accident.

## Trackman as A.F.S. Commandant

THE former North of Scotland track star, W. Mackenzie, of Elgin, is now A.F.S. Commandant in his home town.

## Scots Controlling Body Objects

THE Scottish Amateur C.A. recently refused a request by the Central Scotland Wheelers to hold a "25" on the same date as the West of Scotland Clarion "100."

Some months ago, the West of Scotland T.T.A. and the Mid-Scotland T.T.A. agreed to allow only one open event each Sunday in their areas, and to ensure a fair entry for all promoters.

Because of this agreement, the request from the Central Scotland Wheelers was declined.

## Protests from Sutherland

SUTHERLAND, most remote of Scottish counties, has protested against a Ministry of Transport proposal to cut road grants by £2,000 to £9,395. The County Surveyor stated that it would be impossible to maintain the roads with a reduced grant.

## Australia Has Hostels

YOUTH hostels have reached Australia. Some have been established in Victoria, mainly on the Yarra River, which has its mouth at Melbourne. Hostels are about 14 miles apart, and all are within 100 miles of the city, some of them in the Kinglake National Park.

## Unusual Tricycle

AN Elgin, Morayshire, cycle agent, Thomas Hay, has an unusual 70-year-old tricycle in his possession. This has a 48-in. rear wheel, which is driven by cranks and levers—not chains—from moorings on the front axle. Steering is of a dual type, through levers and a track rod, to the front wheels.

## No Lights—Serious Thing

"WE regard it as a serious thing in present conditions to ride a bicycle without lights," the chairman of Baldock (Hertfordshire) Benevolent Society told a cyclist brought before him. A fine of £1 was imposed for riding without front or rear lights.

## Preservation of Eskdale

IT was announced at the annual meeting of the National Trust in London that it has been found possible to proceed with a scheme for the preservation of Eskdale, one of the loveliest of Lakeland valleys.

## Club Champion Joins R.A.F.

J. MCKISSOCK, former champion of the Ayr Road Club, recently joined up—in the R.A.F.

## Cycle Stealing from Swimming Pools

CYCLE stealing from swimming pools has been on the increase lately, and some places, such as Letchworth (Hertfordshire) have had to deal strongly with offenders.

## George Medal for Liverpool Cyclist

JAMES ARMSTRONG, a 16-year-old cyclist messenger of Bootle, Lancashire has won the George Medal. He carried food to men posted near unexploded bombs, and although blown from his bicycle by blast, he carried on.

## Place for Cyclists in Tyne Tunnel Scheme

PROVISION for cyclists is to be made in the Tyne Tunnel to be constructed between Jarrow and Hebburn at the end of the war. Plans for the tunnel have been approved by the Northumberland County Council. Cyclists and pedestrians will use a special part of the tunnel 15 feet wide, while the total road width for other traffic will be 21 feet.

## "Autumn Tints" Meet

THE famous "Autumn Tints" group of North country wheelmen and women and veterans all, recently met near Preston. Amongst those present was Tom Hughes, of Wigan, who was celebrating his 78th birthday.

## Son for Fast Clubgirl

SPEEDY Ella Barratt, now Mrs. Jack Kerr, of the White Heather C.C., now has a son. Before the war she was one of the fastest time trialists in the Edinburgh area.



"Most miles

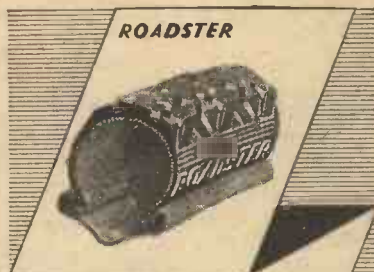

The deep rugged tread of the Firestone Roadster gives greater safety and mileage. Underneath are cords of the finest quality, giving extra strength and flexibility. Sizes 28 x 1½, 26 x 1½, 26 x 1¾. TUBE 2/7. COVER 7/2

per shilling"



The Firestone Sports tyre is designed for speed with extra safety. Its light weight is achieved by extra fine quality—ensuring flexibility and liveliness and great strength. Sizes 28 x 1½, 26 x 1½, red or black. TUBE 2/4. COVER 6/1

is what you

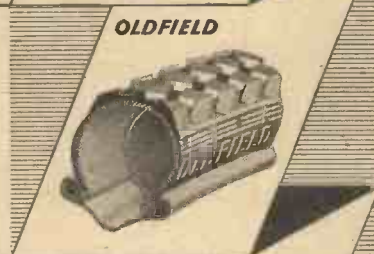

This deep rugged tyre is renowned for its substantial saving in first cost, yet giving wonderful mileage and safety. Sizes 28 x 1½, 26 x 1½, 26 x 1¾, 26 x 1½. TUBE 1/10. COVER 4/5

get when



High quality at a wonderfully low price, only made possible by the experience and skill of Firestone Tyre engineers. Sizes 28 x 1½, 26 x 1½, black only. 26 x 1¾, 26 x 1½, red or black. TUBE 1/7. COVER 3/6

you fit...

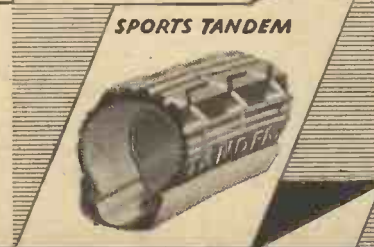

With a deep tread of Sports tyre design and cord fabric impregnated with extra rubber, the Firestone 26 x 1¾ Tandem tyre has extra strength and liveliness, perfectly balanced. TUBE 2/7. COVER 6/1

(Purchase Tax additional)

# Firestone

MADE IN ENGLAND

## CYCLE TYRES

FIRESTONE TYRE & RUBBER CO LTD • GREAT WEST ROAD • BRENTFORD • MIDDY





(Left) C. A. (Bath Road) Smith with a pacing machine, part of Mr. Southon's collection. (Right) Mr. Southon and Mr. Smith with an early velocipede, from Mr. Southon's Museum.

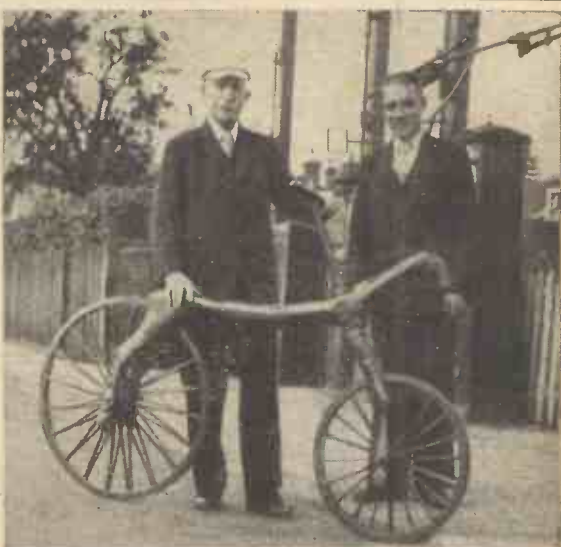

## AROUND THE WHEELWORLD By Icarus

### Museum of Old Cycles

ONE of the most complete exhibitions of old cycles exists in the village of Shalford, outside Guildford. It is owned by a local cycle agent, Mr. Southon, who has enthusiastically collected the machines over a long period of years. They are in splendid condition, and include an early bone-shaker, a pacing machine, geared Faciles, Ordinaries of all types, tricycles, the early forms of gear, and even unicycles. Each machine is correctly labelled, and the whole Museum is free from the anachronisms sometimes associated with museum pieces.

Mr. Southon has carefully cleaned and restored the machines, although he was told to leave them in their original rusty condition! I paid a visit to this Exhibition in the company of C. A. (Bath Road) Smith, who had inspected the Exhibition many times before and thought that I would be interested in it. I spent a most interesting couple of hours and I have no doubt that Mr. Southon will be glad to show readers of this journal his collection if they write to make an appointment. Mr. Southon is, himself, a keen cyclist and a skilled mechanic of no mean order. He owns some of the very earliest motor cars which he has driven in the R.A.C. Emancipation Day Run to Brighton, and has won many awards. Some of his early machines he loans out to charitable Fetes. You see Mr. Southon with C. A. Smith in one of the pictures. The other photograph is of a pacing machine.

### Old Clubs

CLUBS which are 50 or more years old are deserving of the veneration of the present generation, for they helped to lay the foundations of the industry, sport and pastime. It is important, however, that they should continue to exist as cycling clubs, and thus show their continued belief in cycling. Some of them unfortunately in the passage of the years have developed into social clubs, and as such cease to exist as cycling clubs proper. To have been first merely proves antiquity. To have remained first shows that vigour and virility have remained. Thus, some of the younger clubs which have become first are entitled to greater consideration than those which merely live on a reputation created by their forebears, and which has gone before. Each new generation of members of a club should carry on the heritage handed down to them. We must not, therefore, be

unduly impressed because some old member of an old club expresses an opinion on modern cycling. His opinion has ceased to carry the weight of up-to-dateness.

### The Cyclist Club

THE editorial in last month's issue suggesting that the time is ripe for the formation of a non-sporting organisation with the headquarters in London where cyclists could meet for lunch, discussions, committee meetings, and lectures, is a good one. I was browsing through my library of cycling books (I believe it is the most complete in the country), and I came across the rules of "The Cyclist Club" which was formed in the 1890's, with their headquarters at Queen Anne's Gate, London, S.W. I see that the Vice-Presidents included Capt. Eustace Balfour, Baden Powell, Lord Sherbrooke, R. Todd, Major Knox Holmes, and Dr. W. B. Richardson. The Committee included such famous names as H. T. Arnott, C. A. (Bath Road) Smith, E. B. Stroud, A. Thompson (all of the Bath Road Club), J. Dring (the famous Secretary of the Stanley B.C., which staged the first Stanley Show), George Lacy Hillier (recently deceased and member of the Brixton Ramblers), H. G. Kelly (of the North Road Club), F. P. Low (of the Anerley), Steven Leach (of the Ripley Road Club), W. McCandlish (of the Speedwell C.C.), C. W. Nairn (of the Ripley Road Club), H. J. Swindley (of the Ripley Road Club), and J. S. Whatton (of the London B.C.).

The list of Members includes such noteworthy names as H. E. Abrahams, A. H. and J. H. Adams, J. H., P. H. and J. W. Ball, E. Baggallay, B. H. Benjafield, F. T. Bidlake, A. L. and F. Bower, E. Dangerfield, Admiral East, T. W. Evans, W. G. Gates (afterwards the famous pilot), H. C. Grant, R. J. Mecredy, G. Norris, F. J. Osmond, P. L. Renouf (inventor of almost every form of frame design), A. W. Rumney, E. R. Shipton, nearly all of the famous Smiths, C. P. Sisley, and F. P. Wood.

Rule 1 of the Constitution says:—"The Club shall consist of gentlemen who are or have been cyclists, or who are actively interested in the sport of cycling." The Club was registered under the name of "The Cyclists' Club House Ltd." The entrance fee was a guinea, and the annual subscription of Town Members was two guineas, countrymen one guinea, and foreign members half-a-guinea.

### Welsh Highland Railway—Walking Route

AT the Annual General Meeting of the Liverpool and District Ramblers' Federation held last March it was unanimously resolved to urge that the derelict Welsh Highland Railway Track (recently removed for the purpose of converting it into munitions of war) be given to the nation as a walking route. The Welsh Highland Railway Company was incorporated on the 30th of March, 1922, for the purpose of developing the Slate Quarries and Mines of Snowdonia and affording to visitors a means of enjoying the scenic attractions of the district. Sums of money were subscribed by private individuals, and public authorities including the Ministry of Transport and the Caernarvonshire County Council. Although the capital was £120,000, the railway never paid a dividend. The service was abandoned in 1937, and the track has been lying unused since that date. The line commences at Dinas near Caernarvon, and runs for 25 miles through the valleys and foothills of Snowdonia. It terminates at Portmadoc. The proposal to convert the track into a walking route arises from the fact that a special way for pedestrians between the towns named does not at present exist. The Liverpool and District Ramblers Federation is anxious to learn the views of other interested organisations. Letters should be addressed to Andrew Blair, Dol-y-Wern, Wavertree Nook Road, Garden Suburb, Liverpool 15.

### Ross Wins

I AM glad that L. J. Ross of the East Liverpool Wheelers succeeded in winning his appeal against the decision of the National Committee of the Road Time Trials Council which declared him to be "no longer an amateur." The Appeals Committee in agreeing to his reinstatement, ordered that he be suspended from participation as a competitor in any event until August 1st, 1942. In these difficult times, any attempt by the R.T.T.C. to adopt an autocratic attitude will bring the Council to ruin. Moreover, any member of the R.T.T.C. Committee who indulges either in speech or written word in wild charges which cannot later be substantiated, is merely loosening the tendrils which connect it to the sport. The old Road Racing Council failed in its efforts to control the sport and the R.T.T.C. was formed to take its place.

Any attempt at dictatorship will cause a similar collapse of the R.T.T.C. Feeling seems to be particularly strong in the Midlands.

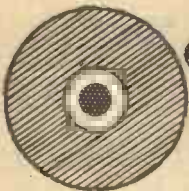

Maybe they're difficult to get -  
**Very** difficult  
but they're  
to wear out!

**N**  **ORTH**  
**BRITISH**  
**CYCLE**  
**TYRES**

MADE BY THE NORTH BRITISH RUBBER COMPANY, LIMITED

*inventors of the first detachable pneumatic tyre*



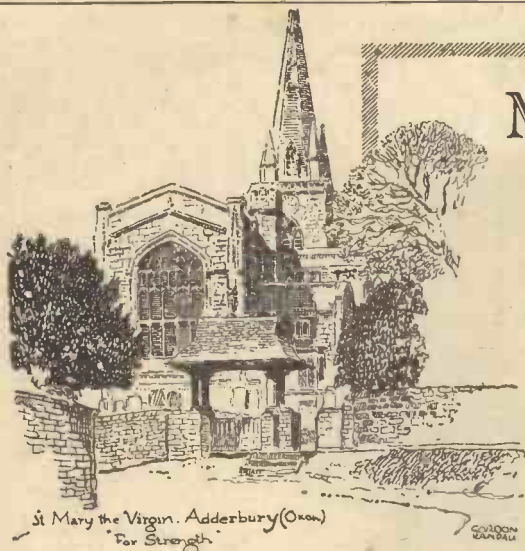

# My Point of View

BY "WAYFARER"

sin"; for, having drawn the tube from its air and located the puncture, I was horrified to discover that my solution container was as empty as a fisherman's creel (and bait-box) at the end of a bad day. In the circumstances, what was to be done? I gathered the tyre together again, gave the boys a bob to get a repair outfit when they came to a village—yes! it was hush-money if you like!—and faded out of sight as quickly as possible

## Along the Road

IN the course of widespread travel on the roads of a variety of counties, I have been gratified to find how little deterioration is evident in road surfaces. I suppose that, on balance, there is more traffic about than in pre-war days. For, while private motoring is severely restricted, an enormous increase must have taken place in the number of service vehicles of all sorts, including tanks. Yet, so far as one can tell, and taking things as a whole, our roads are as good as ever. In the last war, military traffic pounded the highways into "doll-rags," and one presumes that our present-day immunity is due to the fact that roads have been made for and fitted to the type of vehicle falling to their lot—practically all of it air-cushioned. Looking to the experience of the last two years, there seems no reason why the roads of this country should "go to pieces," and we must hope that, when the war ends, we shall find surfaces still in satisfactory condition.

On one of my recent journeys I met a long-drawn-out convoy of which it seemed to take hours—literally hours—to dispose. Tribute must be paid to the considerate manner in which the great trail of vehicles

was proceeding. They were driven at a very reasonable speed, well to the left of the road, and there was no bunching. Thus other traffic, proceeding on its "lawful occasions," was not inconvenienced to any appreciable extent. One other point might be mentioned in this connection: the indispensable bicycle was very much in evidence, for here and there, throughout the convoy, an Army bicycle could be seen hanging on the front or rear of a motor vehicle.

## Food Problems

CATERING difficulties are being tackled by different people in varying ways. Some caterers have "thrown in their hand"; others threaten to do so, asserting that there is nothing in the business except worry; others, again, are making the best of the difficulties inseparable from war-time conditions. And there is a fourth class—which takes a bit of finding. Recently, at lunch-time, I returned to one of my old haunts—a most popular house of call with cyclists—and was able to obtain for lunch (in the course of a day's ride which topped 80 miles) two rounds of bread and butter, a little cake and jam, and a pot of tea. The caterer said that she "daren't" let me have any eggs. Two or three hours later I called at another popular house for early tea, only to find that there was nothing doing. Ultimately, I had a late tea—was I hungry, d'ye think?—and there was not the slightest difficulty over eggs, or anything else. I had plenty of bread and butter (and when I say "butter," I mean it), and honey, and home-made cake which took me back to pre-war days. Breakfast was on the same generous scale, and the charges were uninflated. On another day, at a Cotswold farm, I was placed in the happy position of operating on the largest piece of roast beef seen for months, which I carved for four people besides myself. That was accompanied by cider and followed by four sorts of sweet, with cheese and a pot of tea to wind up the "show." Again, a moderate charge! Later, I called for tea at a third farm where I can always rely on obtaining a jolly good tea of bread and butter, with jam or honey, and home-made cake—and probably with cream in my tea. The farm did not fail me. I do not profess to understand the catering regulations, and I don't intend to try—so long, at least, as I can get all these nice meals!

## Don't Do It!

THE folly, practised by a certain type of cyclist, of travelling at speed closely behind a large motor vehicle was demonstrated to me the other evening when the tail-board fell off a hurrying lorry. The cyclist, who was almost underneath it, was sufficiently quick-witted to make a violent swerve, and somehow escaped hitting the obstruction—and sustaining (in all probability) a serious injury. The danger of speeding along in the wake of a unit doing, say, "30's" is self-evident. It is one of those things that should be avoided . . . in the interests of one's health!

THE world has been told—rather belatedly, owing to the war—that August Bank Holiday was one of the wettest on record. So *that's* why, at the end of an 85-mile cycling jaunt, it was necessary for me to dry my cape and shoes!

## "Satan Correcting Sin"

THESE days of practically no tyre "troubles"—I have just had my first puncture of the year—possess their drawbacks: you almost forget how to detach the tyre, and put it back in position again, and the tendency is for the rubber solution to go off on its own, leaving you stranded when you need the sticky stuff. Recently, I encountered three lads, one of whom had a very flat tyre. Had I a repair outfit? In my best "heavy father" fashion I replied in the affirmative, and, there being no hurry, I parked my bicycle and magnanimously took in hand the job of doing the necessary repair. Fortunately for me—and through some happy accident—I restrained myself from preaching a little sermon on the folly of cyclists going out without proper equipment. That, indeed, would have been a clear case of "Satan correcting

# What the Clubmen are Doing

## Topp Wins Aberdeen "50"

THE only Aberdeen "50" of 1941, promoted by the North-East of Scotland T.T.A., was won by J. Topp, Aberdeen Wheelers, with 2-14-45, nearly two minutes ahead of the next man, P. Taylor, Sprite Road Club.

## Barnsley Club's Team Race Wins

IN fifteen consecutive week-ends, Barnsley Road Club scored a similar number of team race wins. During the corresponding period members secured no fewer than 73 prizes in open events; forty-five of which were team race rewards; six were fastest time prizes; sixteen minor awards and six handicap prizes.

## Medway Club's Tandem Record

S. L. HUTCHINS and D. Marvel broke the Medway S. Wheelers' Gillingham-Shearnes' tandem record in 1 hr. 10 mins. 18 secs., which bettered the previous best by nine minutes. C. Tryell broke the club single record for the same course with a time of 1 hr. 25 mins. 36 secs.

## Club Record Beaten

A. MALNICK, Norlon Road Club, has beaten his club's Barnet-Ickleford-Barnet record, covering the hilly forty-nine miles in 2 hrs. 26 mins. 13 secs.

## Bath Veteran's "25"

AT the age of 40, A. Maggs, Avon Road Club, won the Bath Veterans "25" on a hilly course. His time was 1 hr. 12 mins. 40 secs. The combined ages of sixteen riders in this event was over 100 years. The youngest rider was age 40!

## Club Sec. as Pilot Officer

W. J. LOVEJOY, former secretary of the Cavendish C.C., has qualified as a pilot officer.

## Norwood Clubman's "Wings"

SGT. PILOT KENT is the first member of the Norwood Paragon to get his "wings."

## Clubmen in Iceland

HAROLD NASH, Poly. C.C., is serving with the British Forces in Iceland. He is in the same section as two members of the Priory Wheelers.

## Swindon Clubman's Death

SWINDON Wheelers are mourning the loss of one of their most popular members, Sub-Lieut. Ken. Trueman, R.N.V.R. He died of wounds received on active service. He was an ideal captain, and a fast rider up to fifty miles.

## Scots Team "25" Record Broken

RIDING in the Lancia C.C. "25" over a West of Scotland course, Glasgow Wheelers recently beat their own Scots team "25" record of 3 hrs. 9 mins. 59 secs., which was set up last year.

The new time, which is subject to confirmation by the Scottish Amateur C.A., is 3.9.24, and was set up by J. Brinkins, A. Hendry, and H. R. Herd.

## Edinburgh Club's Position

THE White Heather C.C., in pre-war days Edinburgh's most active mixed club, has lost all but one of its male members to the Forces. The girl members are trying to keep the club in existence until the boys come home.

## Fastest Scots "25"

THE fastest Scots "25" up to the end of July was the Mid-Scotland T.T.A. event, which attracted riders from Glasgow, Aberdeen, Edinburgh, Fife, and Ayrshire, as well as Mid-Scotland. The winner was J. Armour, Auchterderran Wheelers, who clocked 1-1-51, the fastest Scots time of 1941.

The following week-end, on August 3rd, however, Armour improved to 1-1-18 in the Hamilton C.C. "25," club, course, and Scots 1941 record.

## Killed in the Near East

ROBERT GREIG, formerly a keen member of the Bon-Accord C.C., an Aberdeen club, has been reported killed in the Near East fighting. Greig was a notable figure in the north-east of Scotland in pre-war days, as he was 6 ft. 2 ins. in height.

## Hannab Scots "50" Star

GLASGOW Wheelers James Brinkins and Alex. Hendry have led the way in most of the Clydeside "opens" this season, but George Hannah, West of Scotland Clarion, has beaten them twice in "50's." The last occasion was in the Douglas "50" over Renfrewshire roads, when he clocked 2 hrs. 10 mins. 23 secs.

## Brinkins's Best "100"

JAMES BRINKINS, one of the Glasgow Wheelers, has done many fine rides in his career of ten years as a time trialist, but his West of Scotland T.T.A. open "100" win with 4 hrs. 40 mins. 41 secs. was one of his most notable successes. On a hard day, over a very hard course, Brinkins rode his fastest "100."

He did not go unchallenged, however, for young J. G. Robertson, Glasgow Nightingale, was surprise second man, only 26 seconds behind Brinkins.

## Fast Time in Aberdeen "25"

FASTEST North of Scotland times of 1941 were clocked in the Aberdeen Wheelers open "25," held over Deeside roads. J. Topp, of the promoting club, won the event with 1 hr. 4 mins. 21 secs., but George Turner, Central Scotland Wheelers, started one minute late after travelling 140 miles to the event, and clocked 1-4-55.

But for his late start, Turner would have won the event.

## "Bill" Hudson in Navy

"BILL" HUDSON, of Heywood, Lancashire, a former official of the Cyclists' Touring Club, Rochdale Section, and the West Pennine Road Club, has joined the Navy as a radio mechanic.

## Clydeside Clubman Lost

"BERTIE" CRAIG, of the Glasgow United C.C. and the West of Scotland T.T.A., has been lost while returning in an R.A.F. bomber from a raid on enemy territory.

He volunteered early in the war, and has another cyclist brother, "Freddy" Craig, in the R.A.F.



# WAYSIDE THOUGHTS

By F. J. URRY



## Bicycles and War

WE are hard driven in this country to meet the growing demand for bicycles, and, indeed, they cannot be met now, while the future is certain to see the position worsen. Yet we are probably better off in the matter of supplies than most of the manufacturing countries, including U.S.A., for I have a long letter in front of me from a prominent American manufacturer asking for details of the lines followed by the British trade in obtaining a quota of raw material for the purpose of keeping a short supply of bicycles for the service of the travelling public, and particularly for our war workers. In U.S.A. the supply problem has grown so acute that the cycle trade there is in grave danger of disappearing owing entirely to the call for weapons and munitions for us, and for the American re-armament. This is a most unfortunate position for the U.S.A. maker and trader, for during the last few years both sections of the industry have collaborated in a propaganda effort which is beginning to show signs of a returning interest in cycling by Americans, as a method of adult enjoyment, and to cut off supplies now would be a loss of effort at a time when world circumstances give a complete justification of the value of the bicycle as an instrument of travel. Hitherto the bicycle in America has been regarded as a toy in the main; but with restricted petrol supplies, higher cost of cars and living, the bicycle is proving to Americans a vehicle capable of filling a travel gap, as it has done in this country. This shortage of supplies in U.S.A. explains the many enquiries our British makers have recently received, and since the ukase still holds that 75 per cent. of the material released for the manufacture of British bicycles must be used for export business, it is more than likely our products will find a ready market among our American friends.

## A Rest and Recreation

IT was at the end of July that I was granted a week's holiday, and had the good luck to find accommodation at a little farmhouse-inn among the comely hills of Radnorshire, a border county through which most of us pass rapidly on our way to the sea, and do not linger for the purpose of seeing the beauty. Yet Radnor is really one of the remote spots, the kind of place country lovers dream about, but like many simple things in life, neglected for the more ostentatious grandeur of the Principality farther north. I rode the 86 miles from home on a very hot day, and once more discovered that a good morning's trek, a lazy afternoon, and a lively evening jaunt makes up a day of easy and enjoyable riding. It is a mistake, particularly on a hot day, to push for mileage in the afternoon, for in such conditions you invite a sense of weariness instead of the satisfaction of quiet pleasure amid unfamiliar scenes. After that full day, the heat moderated, and my journeys were never more than 40 miles from my centre, but over roads shown as thin lines on the map, linking up tiny villages cupped among these rounded hills. Every day I climbed to over 1,200 ft. along these mountain roads, crossed lovely moors with panoramic views that would be famous for their beauty if the way to these tops were paved and nicely graded; and drifted, with brakes hard on, to wonderful upland valleys tucked in the folds of the hills, that seemed a paradise to the town dweller in these halecyon summer days. Fortune has favoured me in the matter of weather, for the scuds of rain passed over, to leave the hills jewelled and varnished in sunshine, and the long visions as clear as a painted scene on a gigantic back screen. Yes, I carried my lunch and bought my tea where I could; and it is a pleasure to record that never once was I refused the hospitality of these remote farms. It was a perfect little holiday, full of quiet exploration and gentle peace.

## The Ultra-critical

SOME people tell me such a holiday would not suit them, and I can well believe it, for many folk have been brought up on the excitements of noise and glare, and without the band-stand and the pierrots would look upon themselves as outcasts in a lonely laud. Some of my wheeling comrades are apt to sneer at this type just because they happen to love the country; but have you ever considered how crowded would be the lovely hills if all our tastes in holidays ran in one direction? Sometimes this intolerance among my friends and the people I meet along the road, walkers included, annoys me, because it only sets up antagonisms that have no purpose, and does not add one cubit to your own enthusiasms. Because I love the country and adore the beauty to be found in these Islands is no just reason for the criticism of folk who fail to find

a poem in a line of hills sweeping to a valley where the silver streak of a river shines and glistens under the summer skies. Yet I shall go on quietly advocating the spell that cycle roaming has woven in golden threads through my life, and the golden friends I have made during that advocacy, without, I hope, denying the joy other folk find in their leisure time recreations. If I believe there are thousands still in the prime of life, and professing a sincere love of the countryside, who have yet to discover what the possession and the easy use of a bicycle may mean to them, possibly I may win one or two more advocates to my way of happiness; and that will content me more than all the railing that some people mistake for enthusiasm.

## As We Grow Older

I CAME back from that short holiday possessing a fresher feeling for work and more contentment than ever with cycling as a recreation, which makes no demands on other men, and what demands it makes on its advocate are for the benefit of his health and satisfaction. But I re-discovered a thing which may be worth retelling for the use of all tourists, and perhaps especially for such that have reached an age when recovery of lost tissue is not so swiftly undertaken as in the days of youth! On occasion, the weather was hot, and as it happened I made my two longest trips on days that were sweltering. One of these days was the outward journey of 86 miles, just over 40 of which I rode before lunch, and then the wind increased and faced me in a steady stream. I frankly admit I was not quite comfortable after my re-start, and instead of struggling with the mileage, I gave it best after an hour, found a shady bank, filled a pipe, and amused myself with a few chapters of a favourite book. Soon after four o'clock, I rode four miles to tea, and an hour later faced the long rises to Radnor Forest as bright and happy as a lark. Most old tourists know that afternoon feeling on a longish ride, and I'm afraid most of us will not sufficiently recognise and combat it to make cycling as easy as it should, and can be. We are still the slaves of schedule, and one grows fairly old at the game before one shakes free of its shackles. This afternoon slackness is not peculiar to any age or type, it makes itself felt in the racing man as well as the lazy tourist, but the latter has no business to allow it to make an afternoon weary of no better purpose than to arrive somewhere at the mentally pre-arranged hour. That, indeed, is to destroy the real freedom of cycling, an unwise act to which most of us are prone without any rhyme or reason. Maybe I have broken down this bad habit of "pushing on" at long last; though I expect there will be lapses on occasion for no better reason than to follow the foibles of a restless companion. But this little warning is worth heeding if the days of your cycling would be filled with the visions of beauty, the splendour of bird-song, the scent of the countryside, and the quietly abiding joy of happy memories.

# Notes of a Highwayman

By Leonard Ellis

## Cycling Without Signposts

CYCLING to-day is undertaken under conditions that know no parallel. Even during the last war, restrictions were not so complete, catering was not so difficult, accommodation was not so limited, and, above all, we did have our signposts. We did not realise in those days how much we depended upon signposts. Many of us were inclined to ignore them contemptuously. We were fully aware of our skill at map-reading, and when the next signpost came just where we expected it, inevitably we conceded that the signpost was right. It was just where we thought it ought to be. It never occurred to us to look at things the other way. Supposing the signpost was not there, should we have taken that road with exactly the same amount of confidence? In the light of modern experience, I doubt it. I flatter myself that I can read a map as well as many others, but I frankly confess that now, finding myself in lanes with which I am not completely familiar, I can, and do, get myself hopelessly lost. The map is all very well, but even the great Bartholomew admits that no map is ever absolutely accurate; after years of intensive correction and revision, a new sheet is printed, and before the ink is dry new features appear in the landscape. A little narrow lane is widened to cope with traffic proceeding to a new aerodrome; in a score of ways road-building during war-time has been revolutionised. When we encounter this unexpected wide road we are puzzled and bewildered; we try to make it fit the map and in time we are gloriously lost.

## The Fun of Getting Lost

YES, gloriously, for have you ever noticed that after cycling over the same lanes year after year they tend to become commonplace? The ability to get lost is a novel and exciting experience. We are tempted,

sometimes forced, to blunder into little tracks, the existence of which we never imagined. These lead us to unexpected little scenes that put a new complexion on an old face. There is a real thrill in getting lost, particularly when you are aware that you are bounded by a square or triangle of main roads, and that you must sooner or later cross one of them however much you flounder. This semi-blind blundering is particularly helpful to the photographer. He knows, or thinks he



Off the beaten track—somewhere in Bedfordshire.

knows, all the likely spots for pictures and just which time of day suits them best. To stumble across something fresh is a real capture. Particularly along canal towpaths is there an exceptional field for pictures. Quaint little locks, sequestered backwaters, artificial weirs, and curious survivals in the form of swing bridges.

## Along Boundary Lane

I KNOW a little lane not many miles from my home, the sort of lane that no sane cyclist would dream of following unless he went out definitely and deliberately for a "mud plug." We call it "Boundary Lane," simply because it runs along the county boundary for several miles—or does the county boundary run along it—I don't know. No one else calls it anything, simply because few people know it exists. It is missed by many cyclists because it is a "white road" on the map, and its very existence is obscured by the band of colour that shows a county boundary. I suppose at one time it was really important. I expect that it started somewhere and even went somewhere else. To-day I have my doubts. I frequently stumble across the lane while trying to lose myself, and never fail to get some enjoyment from its stony, muddy, narrow little track. In the summer the bramble trailers make an almost impenetrable tangle, specially designed for winding round and round the pedals. In the hottest weather there is always a silny deposit on the stones of the bed—I hesitate to say surface. But I have found more than one uncommon wild flower growing there in profusion. I have chased squirrels along the fence and I have dumped my bicycle and stalked and found the cuckoo "cucking" as though he thought there was no one within miles of him.

It's an ill wind that blows nobody good, and I for one am thankful, for a time at least, that our routes are not ready-made reach-me-downs; that we are compelled to find our own way and sometimes to lose it.



For all emergencies  
in all weathers —



you can trust

# FERODO

'All-Weather'

## BRAKE BLOCKS

SMOOTH RUNNING • NOISELESS • LONG LASTING

REGD. TRADE MARK

FERODO LIMITED • CHAPEL - EN - LE - FRITH

**THE FINEST CYCLE DYNAMO HEAD BULBS PROCURABLE**

THIS SPECIAL form of the MOUNTING of the FILAMENT known as "CATCH BACK" SECURES EFFECTIVE LIGHT from the WHOLE FILAMENT, as against the minute hot-spot of Light, at the focal point only, of other Filaments.

THIS SPECIAL SHAPE OF TUBA secures 30% GREATER VOLUME WITHIN the BAL-LOON, so greatly INCREASING the LIFE that VACUUM instead of Gas can be used.

THIS WIDER STRETCH of the longer FILAMENT secures LIGHT IMMEDIATELY IN FRONT, stretching FAR AHEAD, and ILLUMINATING BOTH SIDES of the road.

THIS STRONGER FILAMENT for Vacuum enables Lower Amperage, with Higher Voltage—EVEN MORE THAN 13 VOLTS FROM 6V 3W DYNAMOS—securing much HIGHER BRILLIANCY of LIGHT. This output of over 13 Volts has been certified by the N.P.L.

THIS THIRD SUPPORT secures EXTRA RESISTANCE against ROAD JARS and any other SHOCKS

THIS LOWER AMPERAGE Filament used secures INSTANTANEOUS LIGHT, even at WALKING SPEED, which containing Infra-Red Rays, PENETRATES THE FOG.



Regd. Des. 828997.

**BAYONET CAPPED BULBS (i.e. push-in) For LUCAS, MILLER, etc.**

Description	Ref. No.	Frosted or Clear	Price
For use with Lucas 6V 3W or Miller 6V 3.24W	LSC	Clear	1/-
	LSF	Frosted	1/1½
For use with Lucas 1.8W Dynamos	L9C	Clear	1/-
	L9F	Frosted	1/1½
For use with Miller 6V 3W Dynamos	MSC	Clear	1/-
	MSF	Frosted	1/1½
For use with V.E.C. or Miller 6V 6W	M9C	Clear	1/-
	M9F	Frosted	1/1½



**M.E.S. CAPPED (i.e. screw-in) For BEMO-STARLITE, LUCIFER, etc.**

For use with 6V .3A (1.8W) Dynamos	852	Clear	7½d.
	851	Frosted	9d.
Specially for Bemo or Starlite	862	Clear	7½d.
	861	Frosted	9d.
For use with 6V .5A (3W) and Philidyne Dynamos	872	Clear	7½d.
	871	Frosted	9d.
Specially for Lucas 6V 3W or Miller 6V 3.24W when M.E.S. needed	874	Clear	7½d.
	873	Frosted	9d.



Apart from Bemo only, always use Tre Vita 6V .04A Tail, with Tre Vita Tuba Head Bulbs. Price 7½d. each.

The Purchase Tax upon 7½d. to 9½d. is 2d.; upon 10d. to 1/- is 2½d.; upon 1/0½ to 1/2 is 3d.; upon 1/2½ to 1/4½ is 3½d. Send for Special Leaflet. Send for Price List. Individual Bulbs Supplied. No Charge for Postage.

VITALITY BULBS LTD., NEVILLE PLACE, LONDON, N.22.

**RIGID and RELIABLE**



LIKE

**"CANTILEVERS"**

(Regd.)

12s. each, Front or Rear 1 in nickel or enamel finish.

THE ROLLS-ROYCE of CYCLE BRAKES.

Chromium plated 14s.

For TANDEMS 13s. Front or Rear, in chrome 15s.

THEY HALL-MARK YOUR BICYCLE

ILLUSTRATED CATALOGUE ON REQUEST

**THE RESILION & LTD.**  
200, LIVERPOOL ROAD, LONDON, N.1.