

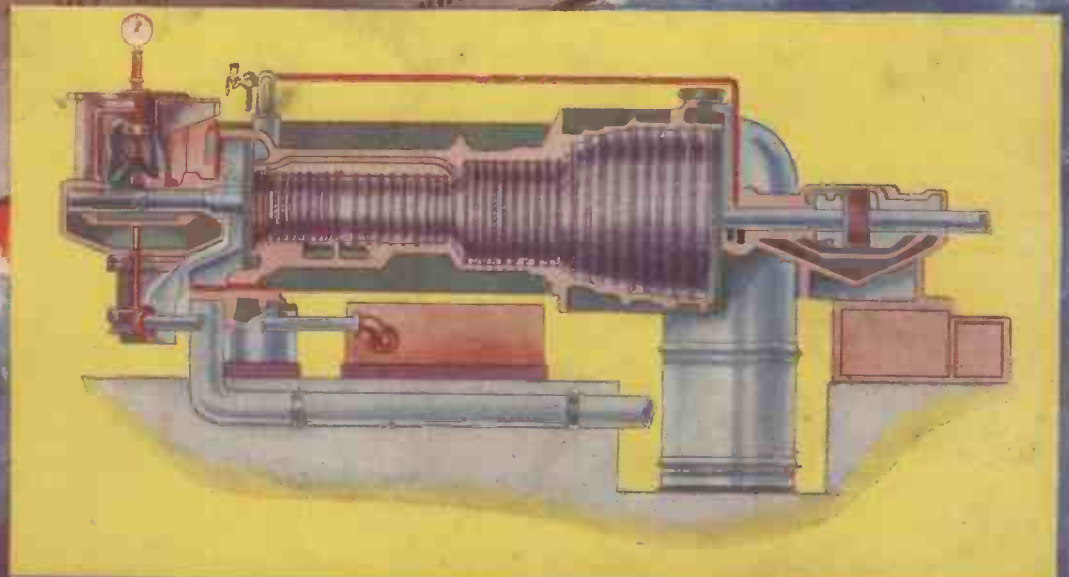
THE STEAM TURBINE—How it works!

NEWNES

# PRACTICAL MECHANICS

APRIL 1939

6<sup>d</sup>



# YOU HAVE BEEN WARNED BY RADIO

Professor Hilton on November 19th, 1936 from the B.B.C. broadcast a warning. The warning was to the effect that while there are many really good and reliable Colleges teaching by correspondence, there are many others which are colleges by name only. He said some so-called colleges rented a couple of rooms in a large building in a well-known street. Some made great promises which they did not intend to fulfil. Some claimed successes they could not prove. In some cases the names of prominent men were quoted who were in no way connected with the working of the College.

## NOW BE ADVISED BY ME

The big name of a College is no proof of its national standing. The Bennett College has been established over 30 years and our entire building is devoted to Bennett College work. No other business of any kind is either on or attached to The Bennett College. We have seating accommodation for over 10,000. We have a permanent staff of over 190 people on the College premises. Our Professional Staff have all passed their examinations, and our tutors are all experts in their own specialised work. We do not send out any homework to be corrected by tired, spare-time tutors. All students' homework is corrected on the College premises the same day that it arrives, and is returned by evening post. This College is Technical, Scientific, General and Commercial, thus enabling us to cater for all requirements; this is important to Cost and Works Accountants, and all who have to deal with rate fixing, machinery allowances, and it is also of great importance in many of the Civil Service Examinations. This is an entirely British College. Most of our textbooks are written on the College premises by our own professional staff, especially for tutorial purposes. Our tutors specialise in teaching students for the examinations they themselves have already passed.

## THERE IS NO OTHER COLLEGE IN THIS KINGDOM THAT CAN CLAIM ALL THE ABOVE ADVANTAGES

It is not necessary for students to attend the College; we can send exactly the same tuition to you by post for a reasonable fee, payable monthly.

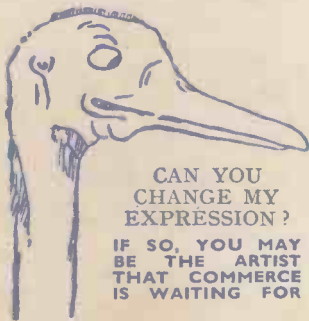
Anyone who reads the journals knows that there are many things advertised that one can study, and any kind of study is good. It is training for the brain, but the best thing to study, surely, is a course specially prepared to teach your own vocation, or prepare you for the examination which you have in view. Knowing that you are master of your job gives you self-confidence and personality, but a Diploma from a College is absolute proof of your efficiency. We have agencies in all English-speaking corners of the world. The nature of our business makes us keep in touch with employment requirements in all parts of the world, therefore we specialise in preparing students for the good positions which we know exist, and for all the worthwhile examinations. We are prepared to produce, on demand, over 10,000 unsolicited testimonials from successful students, or in default we will hand over £100 to charity.

## THE ABOVE VAST ORGANISATION CAN HAVE BEEN CREATED ONLY BY THE SUCCESS OF OUR STUDENTS

There is a tide in the affairs of man which, if taken at the flood, leads on to fortune and success. There are three things which come not back, the sped arrow, the spoken word, and the lost opportunity.

This is your opportunity. If it is your desire to make progress and establish yourself in a good career, write to us for free particulars on any subject which interests you, or if your career is not decided, write and tell us of your likes and dislikes, and we will give you practical advice as to the possibilities of a vocation and how to succeed in it. You will be under no obligation whatever. It is our pleasure to help. We never take students for courses unless we feel satisfied they are suitable.

Do not forget that success is not the prerogative of the brilliant. Our experience of over 30 years proves that *the will to succeed* achieves more than outstanding brilliancy.



CAN YOU CHANGE MY EXPRESSION?

IF SO, YOU MAY BE THE ARTIST THAT COMMERCE IS WAITING FOR

Just try it for yourself, trace or draw the outline and then put in the features.

There are hundreds of openings in connection with Humorous Papers, Advertisement Drawing, Posters, Calendars, Catalogues, Textile Designs, Book Illustrations, etc.

60 per cent. of Commercial Art Work is done by "Free Lance Artists" who do their work at home and sell it to the highest bidders. Many Commercial Artists draw "retaining fees" from various sources, others prefer to work full-time employment or partnership arrangement. We teach you not only how to draw what is wanted, but how to make buyers want what you draw. Many of our students who originally took up Commercial Art as a hobby have since turned it into a full-time paying profession with studio and staff of assistant artists; there is no limit to the possibilities. Let us send full particulars for a FREE TRIAL and details of our course for your inspection. You will be under no obligation whatever.

*Jim Duck*

ART DEPT. 76.



## LET ME BE YOUR FATHER

Let me tell you how to make a success of your career.

If your future is undecided or appears unsatisfactory, let us talk it over together. I want to help, and it will cost you nothing to get my help, and you will be under no obligation whatever.

## DO ANY OF THESE SUBJECTS INTEREST YOU?

- |   |  |
|---|--|
| Accountancy Examinations                              | Mathematics  |
| Advertising and Sales Management                      | Matriculation                                      |
| A.M.I. Fire E. Exam.                                  | Metalurgy  |
| Applied Mechanics                                     | Mining, all subjects                               |
| Army Certificates                                     | Mining, Electrical Engineering                     |
| Auctioneers and Estate Agents                         | Motor Engineering                                  |
| Aviation Engineering                                  | Motor Trade  |
| Banking   | Municipal and County Engineers                     |
| Bollers   | Naval Architecture                                 |
| Book-keeping, Accountancy and Modern Business Methods | Pattern Making                                     |
| B.Sc. (Eng.)  | Police, Special Course                             |
| B.Sc. (Estate Management)                             | Preceptors, College of Pumps and Pumping Machinery |
| Building, Architecture and Clerk of Works             | Radio Service Engineering                          |
| Cambridge Senior School Certificate                   | Road Making and Maintenance                        |
| Civil Engineering                                     | Salesmanship, I.S.M.A.                             |
| Civil Service   | Sanitation   |
| All Commercial Subjects                               | Secretarial Exams.                                 |
| Commercial Art  | Sheet Metal Work                                   |
| Concrete and Structural Engineering                   | Shipbuilding                                       |
| Draughtsmanship, All branches                         | Shorthand (Pitman's)                               |
| Engineering, All branches, subjects and examinations  | Structural Engineering                             |
| General Education                                     | Surveying  |
| G.P.O. Eng. Dept.                                     | Teachers of Handicrafts                            |
| Heating and Ventilating                               | Telephony and Telegraphy                           |
| Industrial Chemistry                                  | Transport Inst., Exams.                            |
| Insurance   | Weights and Measures Inspector                     |
|   | Welding  |
|   | Wireless Telegraphy and Telephony                  |
|   | Works Managers                                     |

If you do not see your own requirements above, write to us on any subject. Full particulars free.

A STAFF OF 197 are in daily attendance at this College at your service.

## YOUNG MEN

Young men physically fit and whose careers are not definitely fixed should join the Police Force. We have special Courses for Entrance and Promotion. 1/- per week brings success. Full Particulars Free. Address: POLICE DEPT. 76.

## ENGINEERS

now is your chance to dig yourselves into a Key Position and make your future solid. It needs technical Training; we can give you that by post. Full particulars free. Dept. 76.



THE MOST SUCCESSFUL AND MOST PROGRESSIVE COLLEGE IN THE WORLD.

## HOW TO STUDY

In your spare time when it suits YOU. You fix your own time, you do not GO to your studies—the postman brings THEM TO YOU. There is nothing that a classroom teacher can show on a blackboard that we cannot show on a white paper. The lesson on a blackboard will be cleaned off, but our lessons are PERMANENT. A class-room teacher cannot give you a private word of encouragement, but a Correspondence Tutor can do so whenever your work deserves it. On the other hand, he can, where necessary, point out your mistakes PRIVATELY.

DEPT. 76, THE BENNETT COLLEGE LTD., SHEFFIELD



# If it's a RAWLPLUG PRODUCT it's the BEST OF ITS KIND



## RAWLPLUG DUROFIX

Durofix resists heat and water, and is ready for instant use without first warming as is necessary with most cements. It is colourless, and joins made with Durofix are almost invisible. There are hundreds of uses for Durofix in every home. Sold in tubes at 6d. and 1/- each.



## RAWLPLUG PLASTIC WOOD

Rawlplug Plastic Wood is a pliable material which can be moulded and fashioned into any shape desired. Hardens when dry and becomes exactly like real wood, when it can be cut, stained, planed or painted. Waterproof and weatherproof. Tubes at 6d. and 1/- and in tins from 9d. upwards.

## RAWLPLUGS

It's so easy to make neat permanent fixtures with Rawlplugs—without damage to walls or decorations. Every Rawlplug Outfit contains full equipment for fixing any ordinary article to any material. A Rawlplug Outfit is indispensable to every householder who takes a pride in his home. Complete outfits, 1/6, 3/6 or 5/6.



## RAWLPLUG TILE DRILLS

The Rawlplug Tile-Drill is a twist drill of very high quality. It can be used for drilling holes in tiles, brick and soft stone, and can be re-sharpened very easily. Very quiet and outstandingly efficient in use. Prices from 9d. to 1/9 each. Sizes from 1/8" to 3/8".



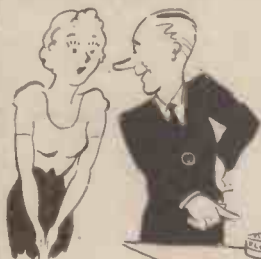
## "JUNIOR" ELECTRIC DRILL

A practical electric hand drill for the handyman's workshop. Sturdy, light and dependable, it ensures accurate drilling. Drills wood or metal. Takes up to 1/4" drills. Can also be used for sandpapering, buffing, burnishing, etc. All voltages. Price 3/6 each.

## RAWLPLUG BLOW LAMPS

The Rawlplug Spirit Blow Lamp is an efficient lamp for all soldering work. Can be used for heating and tinning the soldering iron and for "sweating" joints. A very useful lamp for all general heating purposes. Price 1/3 each.

8227 The Rawlplug Co., Ltd., Rawlplug House, Cromwell Road, London, S.W.7



"Aladdin," said Handyman Lynne,  
"In a lamp kept his servant, a  
Djinn;  
Still, I think that you would  
Agree mine's just as good;  
It's called FLUXITE—its house is  
this tin!"

See that FLUXITE is always by you—in the house—garage—workshop—wherever speedy soldering is needed. Used for 30 years in government works and by leading engineers and manufacturers.

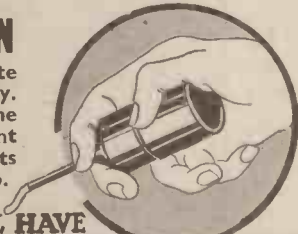
At Ironmongers—in tins, 4d., 8d., 1/4 and 2/8. Ask to see the FLUXITE SMALL-SPACE SOLDERING SET—compact but substantial—complete with full instructions, 7/6.

Write for Free Book on the ART OF "SOFT" SOLDERING and ask for Leaflet on CASE-HARDENING STEEL and TEMPERING TOOLS with FLUXITE.

TO CYCLISTS! Your wheels will NOT keep round and true unless the spokes are tied with fine wire at the crossings and SOLDERED. This makes a much stronger wheel. It's simple—with FLUXITE—but IMPORTANT.

## THE FLUXITE GUN

is always ready to put Fluxite on the soldering job instantly. A little pressure places the right quantity on the right spot and one charging lasts for ages. Priced 1/6, or filled 2/6.



ALL MECHANICS WILL HAVE

# FLUXITE

IT SIMPLIFIES ALL SOLDERING

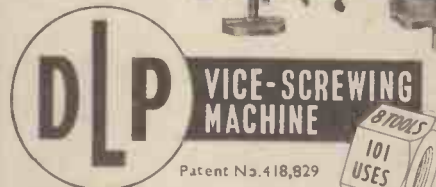
FLUXITE Ltd., Dept. P.M., Dragon Works, Bermondsey St., S.E.1

## There's Room on your Bench for

- ★ 3 1/2" Parallel Vice.
- ★ 1/4" to 2" Pipe Vice.
- ★ Tube, Rod and Strip Bender.
- ★ Screwing Machine (up to 3/4" Whit., 1/2" Gas or 1" Conduit.)
- ★ Cable, Rod and Pin Cutter.
- ★ Cable Stripper.
- ★ Flat and Conical Anvils.
- ★ Punching Machine.

The D.L.P. Vice-Screwing Machine combines the functions of all the above, and gives results at least as good as the separate tools. Space required is only 12" x 18".

PRICE  
£5.17.6



Patent No. 418,829

May be obtained through your local Tool Merchant

Sole Distributors for the British Isles:—

BUCK & HICKMAN LTD., 2, Whitechapel Road, E.1.  
Overseas Enquiries to DeLaPre Components Ltd., Northampton.

# AMBITIOUS ENGINEERS

## THIS IMPORTANT HANDBOOK ON SUCCESSFUL ENGINEERING CAREERS

# FREE ON REQUEST



After months of intensive effort and research, we are pleased to announce that the New edition of our Handbook, "ENGINEERING OPPORTUNITIES," is now out of the publishers' hands and ready for *free distribution*. Containing 268 pages of practical guidance, this book is, beyond argument, the finest and most complete handbook on Successful Engineering Careers ever compiled. It is a book that should be on the bookshelf of every person interested in engineering, whatever his age, position or experience.

The Handbook contains, among other intensely interesting matter, details of B.Sc., A.M.I.C.E., A.M.I.Mech.E., A.M.I.E.E., A.M.I.A.E., A.M.I.W.T., A.M.I.R.E., CIVIL SERVICE, and other important Engineering Examinations: outlines courses in all branches of CIVIL, MECHANICAL, ELECTRICAL, AUTOMOBILE, RADIO, TELEVISION and AERONAUTICAL ENGINEERING, BUILDING, GOVERNMENT EMPLOYMENT, etc., and explains the unique advantages of our Employment Department.

### WE DEFINITELY GUARANTEE "NO PASS-NO FEE"



If you are earning less than £10 per week you cannot *afford* to miss reading "ENGINEERING OPPORTUNITIES." In your own interests, we advise you to write (or forward the coupon) for your copy of this enlightening guide to well-paid posts—NOW. *There is no cost or obligation of any kind.*

**BRITISH INSTITUTE OF  
ENGINEERING TECHNOLOGY**  
410a, SHAKESPEARE HOUSE,  
17, 18 & 19, STRATFORD PLACE, LONDON, W.1

----- TEAR OFF HERE -----  
**FREE COUPON**

BRITISH INSTITUTE OF  
ENGINEERING TECHNOLOGY,  
410a, Shakespeare House,  
17-19, Stratford Place, W.1.

Please forward, **Free of cost or obligation of any kind**, your 268-page Handbook, "ENGINEERING OPPORTUNITIES"

NAME .....

ADDRESS.....

.....

.....



## SUBSCRIPTION RATES

Inland and Abroad 7s. 6d. per annum  
Canada - - 7s. per annum

Editorial and Advertisement Offices: "Practical  
Mechanics," George Newnes Ltd.  
Tower House, Southampton Street, Strand, W.C.2.

Phone: Temple Bar 4363.

Telegrams: Newnes, Rand, London.

Registered at the G.P.O. for transmission by  
Canadian Magazine Post.

Copyright in all drawings, photographs, and  
articles published in "Practical Mechanics"  
is specifically reserved throughout the  
countries signatory to the Berne Convention  
and the U.S.A. Reproductions or imitations  
of any of these are therefore expressly  
forbidden.

# PRACTICAL MECHANICS

Editor : F. J. CAMM

VOL. VI. APRIL, 1939. No. 67.

## FAIR COMMENT

### A Letter from the Editor

ONE of the pleasant aspects of this journal is the cordial relationship which exists between the readers, the contributors, and the Editor. My extremely large mail daily bears tribute to the almost family feeling existing between us, and to the esteem in which this journal is held. We, of course, encourage correspondence from our readers, and reciprocate the kindly thoughts so many of them express. Occasionally, however, we receive a letter of the other sort, and where the criticisms are well founded or based on a sincere desire to help in the interests of other readers, most careful attention is given to the suggestions made.

#### Criticism Welcomed

IN isolated cases we receive a letter from a reader who does not choose the happiest of phrases. This is such a rare occurrence that it is all the more noticeable, and usually such a letter goes into the wastepaper basket. The other day, however, we received a letter from K. B., of Birmingham, relative to last month's leader, in which I recommended those who wished to qualify for good positions in engineering, and kindred trades, to go in for a practical training. As a result of this, K. B. wrote that he thought it was in bad taste for this leader to appear opposite an advertisement for a correspondence course. K. B. of Birmingham is apparently under the impression that editorial opinions are flavoured by the advertiser. Such a point of view is, of course, distinctly quaint, and it becomes the more ludicrous when you remember that a correspondence course is intended as a valuable and reliable means of acquiring knowledge in your spare time—knowledge which in the ordinary course is only obtainable through the usual colleges. I do not think that there is one correspondence college which disagrees with the views expressed in my

leader that those who wish to qualify for the big jobs cannot short-circuit practical training. The gravamen of my article was that a practical training is necessary. I have advised on many other occasions that this should be augmented by technical study, and correspondence courses. Apparently, however, K. B. is under the impression that you need not bother with practical training, but only have to undertake a correspondence course in order to become a really experienced and qualified person.

#### Editorial Policy

YOU will remember that I had to deal with this correspondent and his inability to understand what was or was not a master clock, and also with his statements which savour of the individual who visited the Zoo but did not believe the hyena, that the slave clocks to be used in connection with our master clocks could only keep time with themselves but not with the master clock. There have been many hundreds of these clocks built in the last few months, and we have received numerous letters from readers who state that the system is working perfectly and keeping perfect time. In a later article, on this subject which appeared on page 259 of our issue dated February, 1939, we explained this matter in detail to indicate where K. B. had misunderstood the matter. He now thinks that I have committed "a grievous blunder of choosing a page immediately facing a full-page advertisement offering purely technical tuition by post for an editorial urgently advising its readers to take a course of practical training in preference to technical instruction." Here, again, K. B. cannot have read the article with care, for in no part of that article did I suggest that a reader should choose practical instruction in preference to technical. The grammar in the above quotation is K. B.'s.

#### Practice and Theory Co-related

HOWEVER, we are always prepared to meet criticism, and in fact, encourage it, but the phraseology used by K. B. of Birmingham is not of the happiest.

#### Never Too Late!

BEARING on this matter is another letter I have received from a reader, and it serves to illustrate my point. This reader says: "I am now 26 years of age, and I left school when I was 16. I obtained a job almost immediately with one of our leading companies at a fair salary. At the age of 26, I now perceive that I have no further prospects of improving my position, nor of increasing my salary. I have been told, in fact, that if I want more money, I must look out for another job. I have a fair knowledge of mathematics, and have matriculated. I am keenly interested in engineering, and should be glad of your advice, if you do not think that I am too old to start again."

I have advised this reader to apply for a job in an engineering works, either as an engineering student, or an engineering apprentice, and to take a correspondence course in engineering. I am certain that he will make good, for from the tenor of his letter he appreciates that the practical training must augment technical training, and in fact, are co-related.

#### Advice

OUR views on careers are regularly sought by parents and schoolmasters, and many hundreds of readers have made good in their chosen profession by following our advice.

We are always glad to give it, for in these difficult times a timely hint as to the best course to pursue can avoid wasted years in blind-alley occupations.

## "Frozen" Petrol

MR. A. JORDANOFF, a Bulgarian war pilot, has proposed the use of "frozen" petrol for aircraft to reduce the risk of fire. During a demonstration of the fuel in America, the fuel was so cold that it took a blow-lamp 14 seconds to ignite it.

Mr. Jordanoff's process consists of an alcohol and dry-ice cooling system which reduces the petrol to 150 degrees Fahrenheit below zero. The petrol is non-inflammable at this temperature but is still liquid enough to flow out of the tank into a heating apparatus which makes it suitable for engine consumption.

## World's Most Luxurious Train

THE Linke-Hoffman works at Breslau, have just completed for the King of Greece what is claimed to be the most

# THE MONTH IN SCIENCE AND

In this way it is hoped to focus on the television camera mosaic a picture which can be scanned and reproduced subsequently on a receiver screen.

This is, of course, an up-to-date extension of the nocto-vision experiments undertaken by Baird in 1928 on a low-definition standard.

## A Transparent Book

DR. T. J. JONAS, a dentist of Chicago, has invented a transparent book. The pages consist of thin sheets of cellulose

Wales) police force, brought to fruition recently a two-year-old ambition of her trainer, Constable Denholm of the Bourke Street Police Barracks.

With a miniature receiving set strapped to her back, Zoe performed numerous tricks at the direction of Denholm, who was secreted at a microphone 50 yards away. She walked up and down ladders, turned a tap on and off, put on her own collar and took it off again, fired a revolver, and filled a billycan from a tub of water.

## An Automatic Navigator

WHAT is known as an automatic navigator for aircraft has been built by Mr. J. A. McGillivray, radio superintendent at Air Service Training, Ltd., Hamble.

By means of this robot it will be possible for a pilot to know where he is within a radius of two miles, whether he can see land or not. His position is shown by two pointers which intersect on a map or chart fitted inside the plane. Briefly, the apparatus consists of two automatic direction-finders which operate continuously and simultaneously.

## Most Powerful Lighthouse

A LIGHTHOUSE capable of throwing a 29-mile beam was recently put into operation on the island of Ushant, off the Brittany coast. It is said to be the most powerful lighthouse in the world.

## New Electric Iron

A SYDENHAM firm are now manufacturing a new type of electric iron which will be welcomed by housewives. It is cordless and functions automatically on being put on a stand beside the worker.

## Water Speed Record

A NEW Blue Bird speedboat is now under construction in which Sir Malcolm Campbell will defend his water speed record of 130.9 m.p.h. later in the year. No decision has yet been reached where the attempt will be made and the boat is being built in secret.

A boat is being built in Italy in which Count Rossi will attempt in the summer to beat Sir Malcolm's record. If he is successful Sir Malcolm will endeavour to recapture the record. Otherwise he will try to improve on his present record.

## New Design of Postage Stamp

THE Postmaster General announces that stamps of two new values, 7d. and 8d., are being included in the King George VI series of postage stamps, and are now on sale.

The stamps, like the ½d. to 6d. stamps of



Dr. Jonas demonstrating to dental nursing students how to use the transparent school book.

luxurious train in the world. The coach in which the King will travel is a "traveling throne-room," whilst special devices are fitted to the bed which eliminate vibration. Wireless and telephone are also provided and the temperature in the train can be always kept at the same level by means of electricity.

## A Powerful Locomotive

A LOCOMOTIVE has been constructed at the railway works in Valenciennes which is claimed to be the most powerful in the world. It weighs 160 tons when loaded with fuel and water.

It will operate on the African coast line and will be fueled by wood instead of coal, as wood is plentiful along the coast.

## Television and Fog

IT is not always possible to have ideal weather conditions when televising an outdoor scene. It has now been proposed to "flood" fog-obscured objects with a searchlight beam from which all light rays have been filtered except the infra-red.

material, each page carrying a coloured picture building up an idea in step-by-step sequence. As the pages are turned, the pictures superimpose themselves upon each other to form a composite whole. Dr. Jonas invented the book idea as a form of visual education, and hopes to have public schools adopt the idea for an easier means of teaching school subjects.

The basic idea was conceived by its inventor when he was a student in Vienna some years ago. Unfamiliar with the language, he made sketches of surgical operations during lectures, adding drawings step by step. The pages of his notebook being thin, he found he could see the sketch on the preceding page without turning back, and the thought of an entire operation procedure developed in step-by-step picture sequence with transparent pictures occurred to him. He now uses it in his dental school.

## Radio For a Dog

ZOE, a wonder Alsatian police dog attached to the Sydney (New South



# THE WORLD OF INVENTION

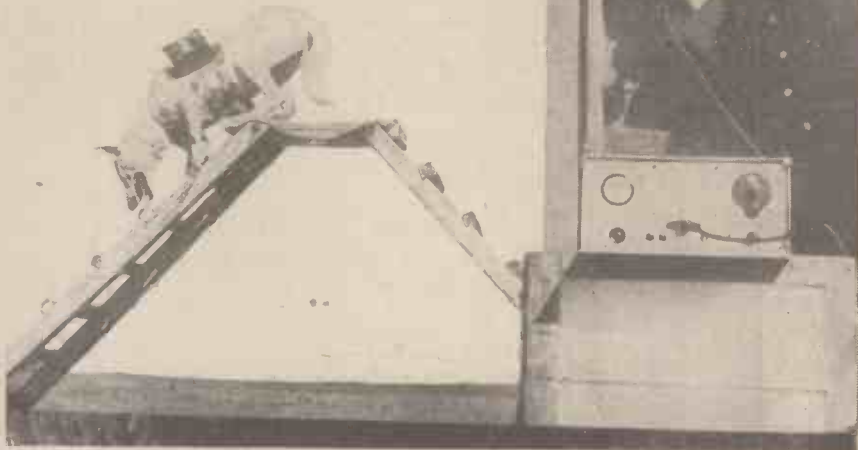
the new series already issued, are printed in photogravure, but the design is different. The design, which is the work of Mr. Edmund Dulac, consists of the head of His Majesty set in the centre of the stamp against a dark background of hexagonal shape. A hexagonal frame of lighter shade surrounds this background, and includes, as part of its decoration, a crown placed directly above the head, the value of the stamp in words beneath the head, and the words "Postage-Revenue" at the sides. In the corners of the stamp the four heraldic emblems, the Rose, the Thistle, the Daffodil and the Shamrock complete the design. The colour of the 7d. stamp is yellow-green and that of the 8d. violet-red.

## A Radio Buoy

**A**N ordinary buoy, containing a miniature radio transmitter designed to guide the transit of shipping regardless of weather, has been placed in the main ship channel of Boston Harbour by the lighthouse service. The radio equipment powered by batteries, is placed in a watertight container and sealed in the buoy. A small aerial extends from the buoy, radiating code signals on frequencies assigned to this lighthouse service. The value of the device depends on its ability to operate continuously. If successful it will be installed in other harbours.

## 550 Miles Per Hour

**T**HE Supermarine Spitfire planes, one of the fastest fighter aircraft on issue to any air force in the world, are being turned out in large numbers at Eastleigh. The machines have a top speed of 350 m.p.h.



Constable Denholm gives instructions to Zoe by means of the wireless set strapped to the dog's back.

During diving tests these planes attained speeds of between 520 and 550 m.p.h. Air experts have expressed the opinion that the limit diving speed of an aeroplane is about 500 m.p.h. A "shock wave" develops at that speed and prevents further acceleration.

## World's Longest Bridge

**T**HE Bronx Whitestone Bridge, which extends for 135 ft. along Long Island South, is the sixth bridge connecting Long Island with New York. It cost £4,500,000 to build, and is the longest bridge of its type in the world.

## "Absolute Zero"

**A**T the Kamerlingh Onnes Laboratories for Low Temperatures Research at Leiden, Holland is to be found the coldest spot in the world. It is contained in a thermos flask in which a temperature only a fraction above absolute zero was attained (representing some 490 degrees of frost) by exposing liquid helium to a magnetic field. Absolute zero, that is lack of any amount of warmth whatever, is, in terms of temperature 273.12 degrees Celsius below Centigrade or about 491 degrees of frost. They are not far from it at Leiden, the lowest temperature obtained so far is 273.076 Centigrade which means that only 44/1000th degrees are in between Absolute Zero and the present result.

Professor Keesen, a famous Dutch scientist, was the first man ever to produce a temperature as low as 272.41 C. under zero. The man who has given the world the lowest temperature ever obtained is Professor W. J. de Haas. He has produced a temperature that was merely a fraction above Absolute Zero—this being brought about by exposing liquid helium to the magnetic field of a giant magnet. See p. 350.

## A "Flying Box Car"

**A** NEW aeroplane designed by a U.S. aircraft designer may revolutionise modern warfare. The plane is constructed similarly to the huge box-like lorries used in transport business.

The tail of the plane swings open, and all types of bulky freight, or even small tanks can be loaded or unloaded with ease. The plane is a high-wing monoplane with twin motors, and is fitted with the newly developed tricycle landing gear, which enables the plane to remain in a level position on the ground.

## Research Helps Safety On the Roads

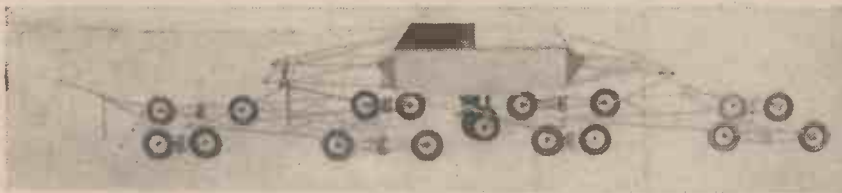
**T**HE Ministry of Transport has made road research one of its foremost cares



A view of Spitfires being assembled in one of the shops at Eastleigh. In the foreground are Merlin II engines waiting to be installed.



Road Machine No. 3 is the name given to this machine whose business it is to destroy experimental road surfaces.



This weird vehicle is used for measuring surface irregularity. The arrangement of the wheels is to reduce the possibility of errors.

skidding, apart from carelessness of drivers and the general public, must be considered the main reason of road accidents, and to put an end to it a staff of scientists is busily engaged examining and compiling knowledge on the surfaces of roads.

By far the largest section of work, however, is dealing with bituminous materials of road construction. The main problem involved was the fact that the testing of such materials in practice on the highways took long periods of time, amounting generally to years. The scientist overcame this difficulty by the construction of a number of road machines. Some 500 yards of main road near the laboratory were made available on which a series of 40 different road carpets which had shown defects in practice was designed and laid on a concrete foundation. The road machines are now used to test the different carpets which are examined after each test with scientific precision.

As British roads are well trafficked, the road engineer is concerned with conditions demanding a very high degree of surface perfection. It is hoped that Science will help to satisfy this demand and thus make the roads safe for their users.

## New Refrigeration Equipment

DELCO have designed and built an especial direct current motor to operate the refrigeration equipment on the Coronation Scot, shipped by L.M.S. for exhibition at the New York World's Fair.

The motor is  $\frac{1}{2}$ -h.p. and is totally enclosed. The windings are designed to take care of the wide variation in voltages encountered in railway work.

The train's refrigeration equipment consists of three two-door cabinets supplied by Frigidaire, two measuring 2 ft. 4 in. wide

and one measuring 4 ft. wide, used for storing wines and general foodstuffs.

The evaporators are of the direct expansion type known as the Frigidaire FSC-15TF and are fitted with three ice-making trays giving 6 lbs. of ice in cube form per freezing. In conjunction with these three evaporators Frigidaire supplied one of their latest type Flowing Cold Compressors, Model F2-50, Freon Fully Automatic Air-Cooled Compressor. The Delco motor and compressor are fixed beneath the floor of the

restaurant-car, and are slung from the framework on special iron girders.

While the train is running, the electric supply is taken from direct driven generators and when the train is stationary the supply is then automatically switched off to a battery which is charged while the train is running.

The refrigerant is Freon-12, standard for all Frigidaire equipment, and is non-toxic, non-odorous and non-flammable in use.

## New Power Station

A £2,500,000 super electric power station is to be erected at Strongford, Stoke-on-Trent. It will be part of the national grid scheme.

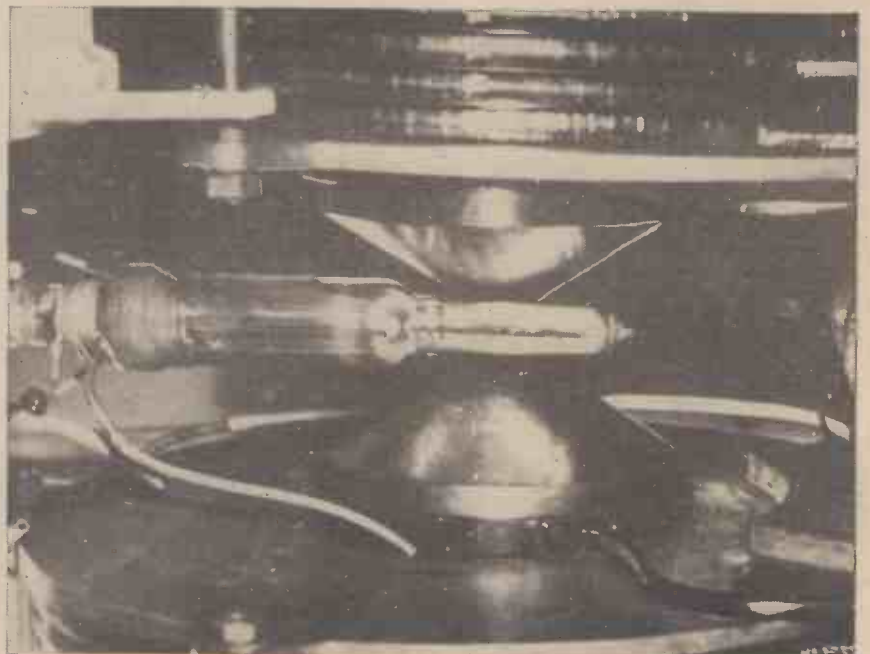
## Explosion-proof Airship

THE American Mechanical Engineering Co. have submitted plans to the United States Navy for the construction of an all-metal airship that will be proof against lightning, fire and explosions. The airship will be capable of a speed of 100 miles per hour and would be filled with helium, a non-inflammable gas. It will be unusual in design, and be shaped like a raindrop. A rotary many-bladed fan in the nose and propellers underneath would propel the airship.

## Jump-start Autogiro

M.R. R. A. C. BRIE recently demonstrated the jump-start autogiro flying machine, type C.40, at the Army Staff College, Camberley. No forward run is needed for the machine when taking off, and it lands almost vertically. The Navy have already placed an order for this machine, and it is possible that the Army will also adopt it.

It is a two-seater machine, and appears to be of greater utility than any helicopter that has so far been produced.



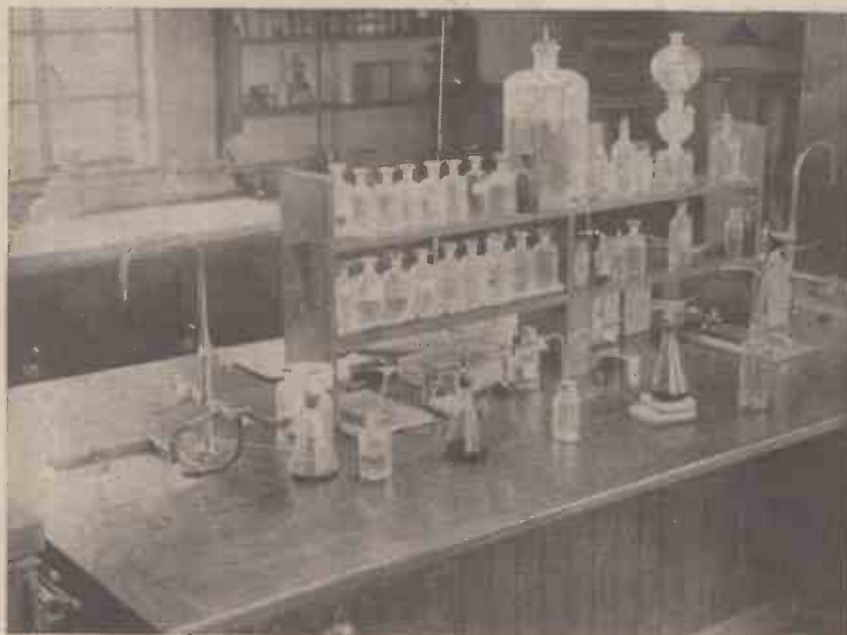
A vacuum flask in which a temperature only a fraction above absolute zero was attained (representing some 490 degrees of frost) by exposing liquid helium to a magnetic field. See para. on page 349.



A NEW SERIES

# CHEMISTRY FOR AMATEURS

## No. 1. The Home Laboratory and its Equipment



An orthodox laboratory bench, the design of which the amateur should endeavour to copy as far as possible.

**C**HEMISTRY, that most absorbing of practical sciences, is one which, to a large extent, may be followed under even the crudest of laboratory conditions.

There is, indeed, no reason why the amateur adherent of this essential science should forgo practical experimentation merely because he has not access to a conventionally designed and furnished laboratory. Given the necessary interest in the subject, and, of course, a small amount of financial aid, a chemical work-bench may be fitted up almost anywhere.

Experimenters denied such a convenience indoors have not infrequently fitted up workbenches for experiments in corners of outhouses, sheds, and other similar structures, whilst not a few hardy enthusiasts have even gone so far as to conduct the whole of their experiments out of doors!

There are few adherents of practical chemistry, however, who will not be able to fix upon some convenient room, shed or outhouse in which to conduct their experiments, and it is for such enthusiasts that this series of articles is being written.

### "Fume Cupboard"

Naturally, the home experimenter must take every care not to let the practice of his hobby cause annoyance or distress to other folk. The amateur chemist has no excuse for preparing evil-smelling gases, as, for instance, sulphuretted hydrogen, in any indoor apartment. In the absence of the orthodox laboratory "fume cupboard," such preparations must invariably be made out of doors, or, at least, in an outhouse where the unavoidable "stink" can affect no one other than the enthusiastic experimenter himself.

Similarly, no domestic utensils should be used for the purpose of chemical experimentation. Many of the chemicals which the experimenter will handle, although they

may not be included in the front rank of poisons, are nevertheless harmful even in traces. Hence risks of their getting into food should never be taken.

The precise design of the home laboratory will primarily be governed by the available accommodation. The amateur who is able to devote an entire room to his hobby, and who is able to command gas, water and electricity, supplies is, indeed, experimenting *de luxe*. More numerous, however, are the individuals who can merely afford a single bench in a

corner of a room, cellar, or outhouse for their experimenting. Yet, despite the apparent crudity of this arrangement, much excellent chemical work can be done on a solitary bench of this description, and, after all, the experimenter in such conditions can always look forward to the time when he is able to extend his accommodation and equipment, or find fresh surroundings for the latter.

For the majority of chemical experiments, a plain wooden table or bench cannot be improved upon. The table or bench surface should be quite smooth and it should be regularly waxed in order to render it water-repellent and reasonably chemical-proof. For such a waxing purpose a few candle ends dissolved in linseed oil, turpentine or white spirit form a cheap and effective preparation.

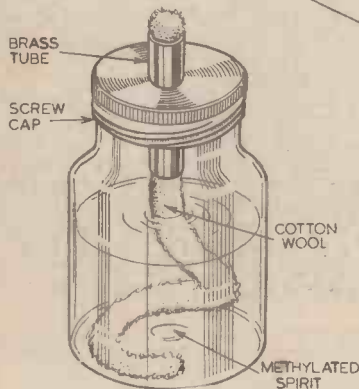
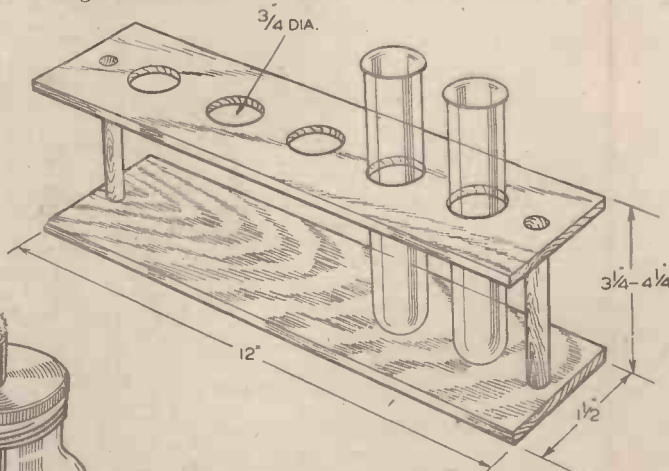
### The Bench

If a choice of position for the bench or table is possible, let it be one in which there is plenty of available light, such as under a window. Here there is not only ample light, but the window (and the window-sill) itself can be made to function quite effectively as a fume cupboard for "stink" experiments, the necessary apparatus being set out on the outer window-sill and the window closed during the course of the evil-smelling experiment.

Chemical bottles, containers, etc., should not usually be stored on the workbench itself. It is far better to have the various bottles on conveniently situated shelves, for in these circumstances there will be no danger of the bottles being knocked over or their contents contaminated with drippings from broken test tubes and other vessels.

"Stock" chemicals which are not in

(Right) Showing a simple form of test-tube rack made from two strips of plywood separated by upright strips (Below) An old screw-cap bottle converted into a handy spirit lamp.



frequent use are best kept in a cupboard. Every chemical and every bottle containing any substance or material should be clearly labelled. Poisons, such as ammonia, mineral acids and other substances, are legally required to be sold in ribbed bottles so that they can be distinguished from innocuous substances, even in the dark. On no account, therefore, should this procedure be departed from in the amateur's

laboratory, otherwise serious consequences may result.

One or two table or bench drawers are a great convenience in the home laboratory, for in these may be placed stirring rods, clips, wire, matches, corks, stoppers and the hundred and one odds and ends which will gradually accumulate in the laboratory. In the absence, therefore, of such drawers, some form of storage boxes will be necessary.

#### Heating

Some method of heating is absolutely essential in the home laboratory. If the experimenter is fortunate enough to be able to command a gas supply, he will then require one or two small bunsen burners and, perhaps, a diminutive gas ring. Other experimenters, devoid of gas supply, will find that a spirit lamp burning ordinary methylated spirits will make a good substitute for the more orthodox bunsen burner. Quite an effective spirit lamp can be made by selecting a wide-necked bottle having a screw-down metal cap and by fitting a short length of brass tubing through the metal cap. Through the brass tubing is threaded some cotton wool reaching down into methylated spirit contained in the bottle.

If a water tap and sink are absent from the laboratory, a large jug can be used for the water supply and a suitable basin for the "sink." A bucket will be necessary in which to throw away waste fluids (except acids, which must be disposed of down an outside drain) and a wooden waste box should also be provided.

The actual equipment of the home laboratory will depend upon the actual size and arrangement of the laboratory and the financial resources of the individual experimenter.

#### Fitting the Laboratory

It is possible to expend a small fortune in fitting-up a laboratory, and, on the other hand, it is possible to provide "workable" equipment for simple experiments in a home laboratory at a cost of under ten shillings. The amateur experimenter, as a general rule, should obtain his apparatus and chemicals as he requires them. It is, indeed, possible to improvise quite a good deal of laboratory equipment. Test-tube stands, for instance, may be made very cheaply by drilling holes in a strip of plywood and fitting two horizontal supports. Likewise, expensive bottles (apart from the necessary ribbed "poison" bottles) need not be acquired for laboratory stock purposes. Flasks, glass funnels, beakers, test-tubes and evaporating basins, however, are necessary, and these should be purchased from any reputable firm of laboratory and chemical suppliers.

The amateur, if he is not known to the chemical-supplying firm, may nowadays have some difficulty in obtaining a number of chemicals. Within very recent years the laws governing the sale of many types of chemicals have undergone drastic revision with the result that the purchaser of chemicals must be able to convince the supplier that he requires his supplies for *bona fide* purposes.

In beginning the practical study of chemistry, no matter whether it is undertaken for serious purposes or merely as an interesting and instructive hobby, it is necessary for us to have a clear idea of what is meant by the term "chemical compound," and of how such a substance differs from a mere mixture of materials.

#### A Simple Experiment

To grasp this essential difference, let us perform the following simple experiment: Mix together two parts of flowers of sulphur

and one part of coarse iron filings. A grey-green mixture will result, and if it is examined under a magnifying glass, particles of sulphur will be seen existing side by side with the individual iron filings. What is more, if we take a magnet, and stroke it through and through the sulphur-iron filings mixture we shall find it easily possible to remove all the iron filings from the mixture, leaving the sulphur behind.

Obviously, therefore, this greyish-green substance is very definitely a mixture of sulphur and iron filings which may readily be separated into its two ingredients.

Suppose, now, that we half-fill a glass test tube with this iron filings-sulphur mixture and heat it strongly in the flame of a bunsen burner or spirit lamp. The sulphur will quickly melt, but before long, the contents of the tube will suddenly glow at a red heat, this glow spreading throughout the mixture.

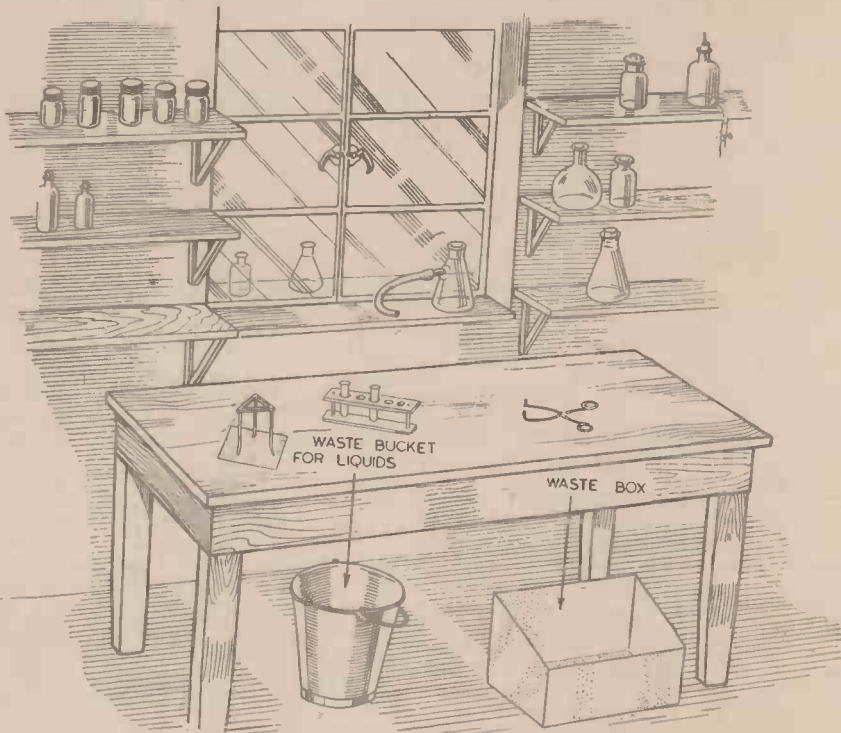
On cooling, the test-tube will have to be broken in order to extract its contents.

separate identity and cannot ordinarily be recovered from the compound.

Here, in this sulphur-iron combination we have a good example of chemical action, that mysterious process of atomic linking by means of which all the hundreds of thousands of known chemicals are brought into existence. Chemical action consists of the linking up of atom with atom. Sometimes, as, for example, in the experiment which we have just made, this atomic linking takes place with such fierce energy that the reacting or combining substances are heated to redness, and, even, to whiteness.

A piece of magnesium ribbon burning in air is another good example of chemical action, the magnesium atoms chemically combining with the oxygen atoms in the air to form a white, powdery substance, magnesium oxide, which is the "ash" of the burnt magnesium ribbon.

This "ash," or magnesium oxide, contains one part of oxygen and one part of



Showing a simple type of chemical bench fitted up under a window.

Such contents will be found to be very different from the simple mixture of sulphur and iron filings which originally went into the test-tube. In appearance a greyish coke-like mass, the tube's contents will be found to contain no free particles of sulphur and none either of iron. This coke-like material is actually a *compound* of iron and sulphur, and it is termed *iron sulphide*.

#### Chemical Action

Under the action of heat, the atoms of sulphur and the atoms of iron have combined with each other to form this new material, iron sulphide, from which, by ordinary methods, neither the iron nor the sulphur may be recovered.

We now have a working idea of the nature of a mixture and of a chemical compound. The ingredients of a mixture can be separated and they do not lose their separate identity. When, however, substances, under the influence of heat or through other agencies, form compounds, the components of the compound lose their

magnesium. Yet we cannot distinguish the magnesium and the oxygen as such in the magnesium oxide, for they are so linked up as to lose their separate identity. Magnesium oxide, therefore, is a compound of magnesium and oxygen, not a mere mixture of the two.

#### Sodium

Sodium is a metal which is so soft that it can be cut through like cheese with a knife. Immediately the bright cut surface of a lump of sodium is exposed to air, it turns white, becoming covered with a layer of sodium oxide.

Here we see a well-defined chemical action going on at ordinary temperatures and without requiring any external aid such as heating.

It is on account of its intense avidity for oxygen that metallic sodium is always kept under oil, for if it were exposed to air, it would very rapidly combine with the atmospheric oxygen, forming sodium oxide and with the consequent disappearance of

(Continued on page 379)



# TOOLMAKING AND TOOL DESIGN—5.

The Principles and Methods of Making Press Tools, Jigs, Gauges and Fixtures

By W. H. DELLER

**T**HE workpiece shown in Fig. 24 is drilled in the base and through one side. The side hole is counter-bored after drilling while the work is still in the jig. Actually the example can represent a casting or drop forging and the only machining performed on the part prior to drilling is that on the bottom surface. This consists of milling the base and the slot extending from end to end of the part. In such a case as this it would be correct to presume that the base would be machined to a dimension taken from the top of the boss and therefore as the hole in the boss would need to be approximately central the part would be positioned endwise in the jig by means of a clamp engaging it.

**A Jig for Handling the Part**

A suggested method of handling the part illustrated in Fig. 24 is shown at Fig. 25. As will be seen the "built up" method of construction is employed. The side plates are of cast iron machined on both sides and are slightly relieved in the centre bottom to leave feet at the ends. At the top (as drawn) the plates are cut away in a similar manner but to a greater extent to permit easy access to the clamping screw in the swinging clamp member. The bottom member is of steel and has a machined tongue to register the slot in the base of the work-piece. It is intended that the tongue should clear the bottom of the slot by a slight amount. Therefore the sides of the tongue should be undercut at their junction with the base in order to provide swarf clearance. This part carries the bushes for the blind holes shown dotted in Fig. 24 and should be subsequently hardened and finished by surface grinding. Needless to say, in any event, the surfaces which abut on to the side plates require to be parallel.

The side plates are attached to the base member by means of studs passing clear through the side plates and base member. Hardened jig feet in the form of blind nuts screwed on to the end of the studs secure the parts together. Additional security is provided by dowelling the parts on both sides.

At the top the jig side plates are separated by means of shouldered studs as illustrated in Fig. 26. These studs are accurately machined over the shoulders to a dimension equal to that of the width of the base member. At their outer ends these studs are provided with feet similar to those at the bottom.

**Swinging Clamp Member**

The swinging clamp member shown in a raised position in Fig. 25 is illustrated in Fig. 26. This may be machined from steel or made from a casting. In width this part requires to be slightly less than that of the base member in order that it will work freely between the side plates. The hole in

the boss should be large enough to pass the largest diameter of the shouldered stud freely but without unnecessary slackness.

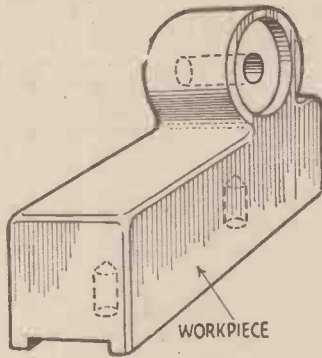


Fig. 24.—A workpiece drilled in the base and through one side.

The vee block portion should be large enough to position the bossed portion of the work. A slot at the front end receives a swinging clamping screw. A slot at the back end of the clamp clears a pin fixed into the stud, as in Fig. 26, and its purpose is



Fig. 27.—A stop pin fixed in the stud.

to prevent the clamping member from falling completely over when raised beyond the vertical. The pin is therefore positioned suitably to accomplish this object. The boss on the swinging stud is treated in the same manner as indicated in the illustration of the jig.

By reference to Fig. 28 the action of the clamping member is made clear. A stop pin in the base member roughly determines the position of the part in an endwise direction before the clamp comes into operation. The pin, however, should be so placed that the vee block will tend to draw the part away from it otherwise the boss may not be centralised. After the clamp is tightened down on to the boss the pressure-screw is tightened to hold the back end of

the casting down on its seating. This screw is provided with a swivelling pad to avoid marking the surface of the job. The side plates are bored to received the bushes. Should the fittings require to be "hardened" both holes should be fitted with liners to house the "slip-bushes" otherwise one side only requires bushing and a clearance hole provided in the opposite side plate to clear the counter-boring cutter.

In order that the jig shall lie properly on the feet, one set of feet need to be surface ground, after securing, from one side plate and the opposite set of feet ground while the jig is resting on the finished set. The top set of feet should also be surface finished after the jig is assembled.

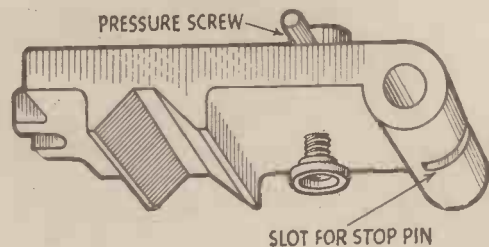
**Alternative Clamping Arrangement**

The device illustrated in Fig. 29 may be substituted for the swinging stud. It consists of a pair of short links separated by a tubular distance piece. A simple cam has pins machined on either side to suit the smaller holes in the links. Where this method is adopted two short distance pieces will be required to centralise the links on the stud. The slot at the front of the clamping plate will be replaced by a simple tongue. A short bar handle forms the means of operating the cam and is so positioned that when the clamp is secured it does not project above the jig feet.

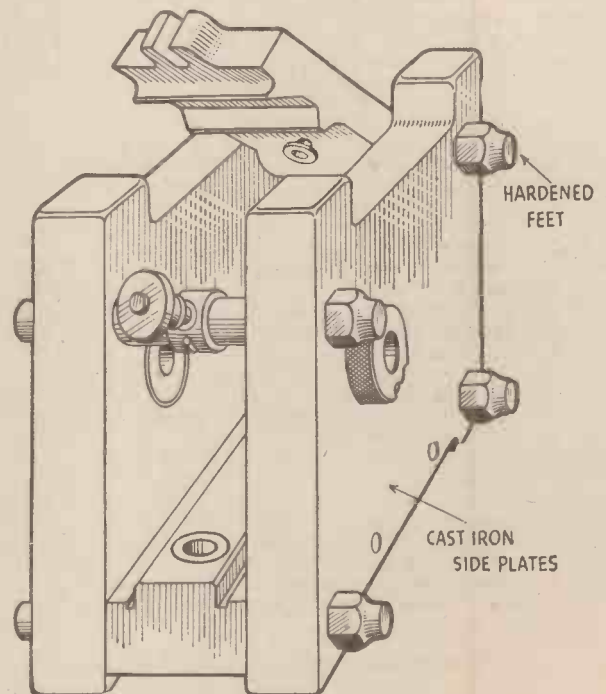
Attention must be drawn to the fact that although the free end of the swinging clamp has no definite abutment against which to rest, it is not intended to take care of a wide range in variation of depth from the boss to the base of the work. Therefore even if a wider tolerance is permissible this dimension should be kept within 1/32 in.

**Surface Condition of Work**

Where the surface condition of the work

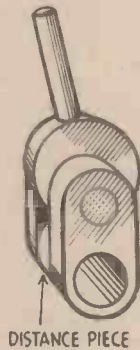


Figs. 25 and 26.—(Right) Details of the jig with the swinging clamp-member in a raised position. This clamp is shown in detail on the left.



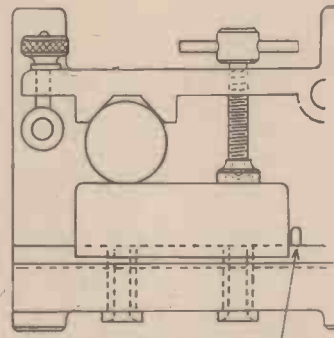
about the boss is rough or uneven it may be desirable to reduce the width of the vee block considerably in order to secure an average bearing. Should the boss be "barrel" shaped as would be the case if the part were drop-forged or hot-pressed the vee block will require clearing away in the centre to allow the vees so formed to bear on either side of the boss.

Reverting to the original arrangement, where objection is taken to the method suggested for locking the clamping member, another arrangement may be substituted which dispenses with the necessity of tightening two screws. It consists of a spring-loaded vee block which is mounted on the plate in lieu of the fixed block. This will then allow the plate to shut against a latch such as that previously described. Where this course is adopted the position of the pressure screw is rearranged to distribute the load as evenly as possible between the holes in the base of the work.



#### Range of Application

While the range of application of this particular example, as described, is not as great as that of the jig for cylindrical



STOP PIN DETERMINES APPROXIMATE POSITION

Figs. 28 and 29.—(Above) Showing the action of the clamping member and (left) This device may be substituted for the swinging stud.

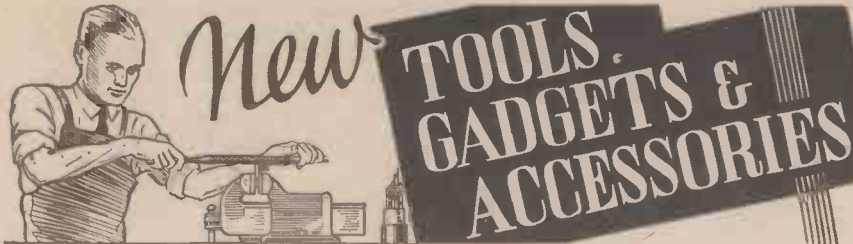
work previously given, the reader will recognise its suitability, with certain

modifications, for a particular type of work.

Thus, for work needing a bottom location from a machined surface and approximate end location for the centralisation of a boss, the only departure from the arrangement shown might be in the shape of the locating surface on the bottom member. An article having a double boss, that is, one like that illustrated in Fig. 24 at each end of the work, could be taken care of by a male vee block bearing between the inner flanks of the bosses and backed up by a pressure screw. For work where end location depends upon a previously machined face, a spring-loaded wedge attached to the hinged member can be utilised to press the surface of the work against a suitable end locating pad in the jig.

The provision of suitably disposed projecting pads on the inner surfaces of the jig would permit the accommodation of work machined on the base and sides.

In passing mention must be made of the fact that with the omission of the swinging clamp arrangement and the provision of larger diameter shouldered studs, drilled and tapped to pass pressure screws, the basis of a further design is provided for a great variety of work.



### Saws That Will Last

THE metal and wood cutting saws generally used by cabinet-makers and locksmiths have undergone many improvements in line with modern developments in technical processes. Nowadays, for instance, best quality saw blades are made of tungsten alloys and can cut the hardest materials.

Another design has now entered the market, a saw with teeth of different sizes, making the initial stages of the work easier, preventing slipping and breaking of the teeth, which very often occurs with hard material. Another innovation is in the form of circular saws with exchangeable teeth of hard metal, recommended more particularly for cutting abrasive material, and also stone, artificial resin, grey cast iron, porcelain, etc.

### Guillotine Cutting

IN the majority of cases the circular shears have been used generally up to the present for cutting rolls of paper in a lengthwise direction, but just lately the guillotine has been adopted for cutting substances such as paper of all thicknesses, films, foils, ribbons, etc. A specialist firm have produced a very simple and effective means of guillotine cutting which make use of glass-hard steel bushes to take the counter-thrust of the cut, the number of these bushes being optional and their width anything that may be required. The shaft holding the knife is not driven and the individual knife rollers which are carried by spring-loaded holders can be set very easily, the spring pressure being adjustable to suit whatever kind of material has to be cut. The knives can also be easily detached for sharpening without any need to remove the shaft from its bearings. A particular advantage of this new design is that the knife rollers ensure

clean and accurate cuts on account of the novel type of fixing used for them, and the glass-hard thrust surfaces may also be used for years without any fear of ridges forming in them. At ordinary cutting speeds the knife will cut approximately 500 miles of cigarette paper or 250 miles of toilet paper, or even as much as 622 miles of typewriter ribbon before having to be re-sharpened. The outstanding feature of this type of machine is the ease and rapidity with which the width of cut can be altered and the

through the process. At the same time the "Perawin" is passed through special filters which remove all dirt, dust and soluble matter it has taken up, so that after it has been purified in this way it is ready for use over again for the next lot of articles. The mechanical material is on very well-thought-out lines and comprises the cleaning drum, two speed driving motor, and the heating and filtering arrangements, all in a compact form which takes up but little space.

### Ring Cutters in Two Parts

SHARPENING the knives on rollers and heavy roll-cutting machines has always been a very awkward operation which takes up a great deal of time—either the entire shaft has to be taken away from the machine so as to lift up the knives, or else they have to be sharpened as an overtime job when the machine is not working. A ring cutter has now been produced which,

### Some of the Interesting Gadgets which were Exhibited for the First Time at the recent Leipzig Fair

knife changed for sharpening without having to remove the shaft.

### Chemical Cleaning

CHEMICAL cleaning—the removal of spots, grease, gum, tar, etc.—is a science in itself, on which a big branch of industry has grown up, and development is to be found in this line also, both of a chemical, as well as a mechanical nature.

A new cleaner now on the market is "Perawin," a non-poisonous and non-explosive chemical which is absolutely harmless to fabrics or other materials. Cleaning machines are made with drums capable of taking from 26 lbs. to 330 lbs. weight of articles to be cleaned, the cleaning being done by washing them in warmed "Perawin" which dissolves all grease and cleans them. The chemical is removed from the drum afterwards by centrifugal force, and it is only very seldom that an article calls for any further work, so thorough is the cleaning process, in spite of the way the articles are protected when going

as distinct from the usual circular or plate knife, can be changed in a few minutes at any time without having to lift out the shaft. This ring cutter is made in two parts, but operates without any gap and with great accuracy nevertheless, owing to the special type of connector fitted. Where the nature of the material to be cut (e.g. paper) is such as to require the knives to be sprung, a leaf or thrust spring can be fitted in the back of the cutter ring without any further alteration. The method of fixing the ring cutters to the shafts is instantaneous and does away with bolts altogether. The two knives are semi-circular and may be ground on a circular knife-grinding machine or else on any ordinary lathe of the kind found in any workshop. The predominant advantage of this ring cutter is the great saving of time in changing the knives, as well as the very much longer life of the knives in comparison with ordinary ones of the plate and circular types; the rings are, moreover, made from high-grade special alloy steel which has wonderful cutting properties.



# Colour Photographs On Paper

By G. L. Wakefield, A.R.P.S.

Building up Photographs in Colour by the simple Superimposition of Three-Coloured Images in Blue-green, Magenta and Yellow.

**M**OST keen photographers have tried their hand at colour photography with one of the transparency processes such as Dufaycolor or Kodachrome, but very few attempt to make paper prints in natural colour. These are not so difficult to make as is generally supposed, and the amateur who is accustomed to methodical working will have no trouble in producing good results at low cost. In addition to the attractiveness of the colour print, there is no more fascinating occupation than that of building up a picture of myriad hues and tints by the simple superimposition of three coloured images in blue-green, magenta, and yellow.

There are several methods by which a colour print can be made, but they all demand a set of colour separation negatives as a basis, so these will be discussed first. The subject is photographed three times through three filters, blue-violet, green, and

Fig. 1.—A Rolleiflex camera fitted with a home-made sliding filter holder, and gelatine filters.



film can be quickly changed between exposures. A rigid tripod will be required so that the camera can be kept perfectly still while the picture is being taken. This will ensure that all three negatives will be exactly the same size, for any variation will cause lack of register in the final print. The tricolour filters, blue-violet, green, and red can be bought for a few shillings in the form of gelatine film. A set should be obtained large enough to cover the front of the camera lens. Fig. 1 shows a camera fitted with a simple sliding filter holder that enables the filters to be changed between exposures without danger of jolting the camera. Fig. 5 shows how the holder is constructed using thin card and glue. The filters are mounted between thin cards as shown, and in doing this, care must be taken not to mark the filters in any way, otherwise the definition of the negatives may be impaired. The completed holder should be painted with Indian ink to make it a matt black.

Panchromatic roll-film must be used for

colour work, and while any good make is suitable, Ilford Hyper-sensitive roll-film is recommended because with this, the exposures through the three filters are approximately equal.

### Film Factors

Packed with all roll-films will be found a leaflet giving the multiplying factors for different filters, and the factors for the tri-colour filters are grouped together. The factors for the film mentioned above are :—

Blue-violet	6
Green	5
Red	5

For practical purposes the factors for this film can be called 6 for all three filters. This means that we can give equal exposures to the three negatives, thus avoiding the



Fig. 2.—Print from a red filter negative. Prints in blue

red. During the three exposures the subject must remain stationary, so it can be seen that we are limited to scenes in which no movement occurs, but in spite of this there are a host of good pictures for the colour photographer. Any landscape can be tackled on a still day, and architecture offers great scope. Indoors still-life of all kinds can be photographed either by daylight or artificial light.

### Camera Used

Any type of camera is suitable, but one taking roll-film is most convenient as the



Fig. 3.—A print from a blue-violet negative. Prints in yellow.



Fig. 4.—A print from a green filter negative. Prints in red.

(Continued from page 355)

necessity for altering the shutter setting, and enabling us to expose the three records very rapidly.

Assuming that a suitable subject has been selected, the camera is set up on the tripod, the legs of which should be firmly wedged in the ground if possible. Focusing should be carried out in the usual way, and the filter holder and filters placed on the camera lens with the red filter in position. It is advisable always to expose colour negatives in the same order, i.e. red, green, and blue-violet, as this prevents any chance of mistakes being made in exposing, and also simplifies the identification of the negatives after development. With some subjects, there is surprisingly little difference between the three negatives, but so long as they are always exposed in the same order, the negatives can be identified with their respective filters before the film is cut up.

#### Exposure

The exposure necessary with the film in use, but without any filter, should be found by means of a reliable exposure meter. This figure must be multiplied by six to find the actual exposure necessary with each of the three filters. Thus, assuming that the exposure without a filter is  $\frac{1}{25}$ th of a second,  $\frac{1}{4}$  of a second will be needed with the filters. The three exposures should be given as quickly as possible, one after the other winding on the film and changing the filter between each. If the subject is a landscape with trees that tend to be blown about by a light breeze, the exposures should be made between gusts. It is pretty certain that the branches come to rest in the same position when the wind drops.

If a film is being used where the filter

factors are not equal, the exposure without a filter is multiplied by the factor for each colour. Assuming that the factors are:—

Blue-violet	7
Green	9
Red	11

Then, the actual exposures given must be:—

Blue-violet	$\frac{1}{25}$ " x 7 = $\frac{7}{25}$ " approx.
Green	$\frac{1}{25}$ " x 9 = $\frac{9}{25}$ " "
Red	$\frac{1}{25}$ " x 11 = $\frac{11}{25}$ " "

It will be seen that in such a case we are confronted by some awkward fractions which

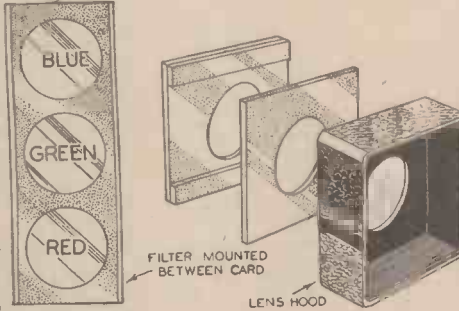


Fig. 5.—Showing the construction of a simple sliding filter holder. A lens hood of card is a useful addition.

cannot be given by the automatic shutter speeds. The difficulty can be overcome only by using a smaller stop so that the exposure without a filter is something like  $\frac{1}{4}$  a second. There is no objection to this except that with long exposures there is a greater danger of slight movement in the subject.

#### Developing

The completely exposed film can be developed either in a tank or a dish using

any of the usual developers or the following:

Metol	20 grains
Hydrokinone	60 grains
Sodium Sulphite (cryst)	1½ ounces
Sodium Carbonate (cryst)	1½ ounces
Potassium Bromide	16 grains
Water up to	20 ounces

The above stock solution is diluted with an equal quantity of water for dish development, and to simplify the job of deciding when development is complete, the film should be desensitised first. This is done by running it for two minutes through a 1:5,000 solution of Pinacryptol Green, and then transferring to the developer without intermediate washing. After this treatment a bright orange safelight can be used for watching the progress of development, instead of having to work in darkness as normally one must do with panchromatic emulsions. Negatives for colour work should be kept soft in contrast, and over development avoided at all costs. The soft type of negative recognised as suitable for enlarging on to a normal bromide paper should be aimed at.

An ordinary acid-fixing bath should be used, and washing should be thorough. Before hanging to dry, the film should be hardened in a 5 per cent. solution of formaldehyde for ten minutes. No further washing is necessary after this, and the film can be hung up to dry in a place as free from dust as possible. The hardening will prevent the dry film from absorbing moisture from the air and expanding, perhaps unevenly.

The negatives are now ready to be printed, but before cutting the film into separate exposures, the colour of the filter used for each should be marked clearly by scratching with a sharp point in the margin.

"Kent's Mechanical Engineers' Handbook." Vol. II. Power. By Robert Thurston Kent, M.E. London. Chapman and Hall, Ltd. 1,254 pages. Price 25s. net.

THIS volume, which is one of a series of five, is the eleventh edition of this well-known work, and covers very exhaustively the various sources of power used in modern engineering. The book is divided into seventeen sections, the subjects dealt with including Air, Water, Heat, Combustion and Fuels, Steam, The Steam Engine, The Steam Turbine, Condensing and Cooling Equipment, Refrigeration and Ice Making, Heating, Ventilating and Air Conditioning, Internal Combustion Engines, Gas Producers, Transportation, Electric Power, and Power Test Codes. The last section is confined to Mathematical Tables. Some of the more important sections are sub-divided under various headings, for example, the contents of Section 3—Heat, are classified under the following headings:—Measurement of Heat, Heat Transmission, Evaporators and Evaporation, Dryers and Drying, Heat Insulation, and Thermodynamics. The book should prove indispensable to engineers and draughtsmen.

"Design and Shop Practice." Vol. III. Eleventh Edition. Kents' Mechanical Engineers' Handbook. By Robert Thurston Kent. London. Chapman and Hall, Ltd. Price 25s. net.

LIKE its companion volume, Power, this work is divided into sections, twenty-eight in all, covering the very wide field of design and shop practice, as applied to present day engineering. During the past ten years the development of many new materials of engineering, and the improvements in tools and machinery, have made a good deal of the data in the earlier editions obsolete, and the book, therefore, has been practically re-written, to bring it thoroughly up-to-date.



The subject matter covers such subjects as General Properties of materials, Non-Ferrous Metals and Alloys, Strength of Materials, Mechanism and Mechanics, Bearings and Lubricants, Structures and Buildings, Foundry Practice and Woodworking. In addition to numerous line drawings, a very full index is included.

"Practical Mechanics Handbook." By F. J. Camm. 400 pages; 379 illustrations. Price 6s. Published by George Newnes, Ltd.

THIS is an extremely valuable book, packed with facts, figures, tables and formulae for the mechanic, fitter, turner,

draughtsman, engineer and designer. It deals with Mensuration; Powers and Roots of Useful Factors; Trigonometrical Functions; Metric System; Imperial Weights and Measures; Mechanical Drawing; Principles of Mechanical Drawing; Blueprints; Reading and Using the Micrometer and Vernier; Drills and Drilling; Special Cutters; Reamers; Other Cutters; Small Taps, Dies, etc.; Files and Filing; Marking Out for Machining; Lathe Tools and Tool Angles; Turning Between Centres; Boring; Screw Cutting; Lathe Equipment; Lathe Centres; Lathe Tool-Bits; Grinding Operations; Grinding in the Lathe; The Dividing Head; Gears; Soft Soldering; Silver Soldering and Brazing; Soldering Aluminium; Making Spot Welders; Riveting; Polishing and Finishing Metal; Hardening and Tempering; Case Hardening; Chemical Colouring of Metals; Electro-plating; Chemical Plating; Spray Method of Coating Surfaces with Metal; Rust-proofing Iron and Steel Bolts; Nuts and Screws; Pattern Making for Castings; Casting

Small Parts; Sheet Metal-work; Repousse Work; Sharpening and Setting Woodworking Tools; Wood Finishers; Woodwork Joints; Silvering Glass; Battery Charging; How to Obtain a Patent; Workshop Receipts; Glues, Cements and Adhesives; Repairing Gear Teeth; Temperature Recording Paints; Tables. The book is well indexed.



The "Practical Mechanics Handbook" showing one of the many well-illustrated chapters.



# THE STORY OF THE THERMOMETER

## The Eventful History of a Universal Instrument



James Prescott Joule.

Of all the measuring instruments of science, none, perhaps, has attained such a universal degree of common usage in everyday life as the thermometer. Yet the thermometer, even in its crudest form, is hardly more than three centuries old. A few of the ancients, it is true, as, for instance, the celebrated Hero of Alexandria, seem to have devised instruments which effected crude thermometric measurements, but, for all practical intents and purposes, the fact of heat being an accurately measurable entity does not seem to have dawned upon mankind until the time of Galileo at the beginning of the seventeenth century.

### First Known Thermometer

Although there is a little doubt about the matter of the thermometer's origin, it is to the famous Italian physicist and astronomer, Galileo, that the invention of the first working thermometer is nowadays ascribed. Whether Galileo's idea was an entirely original one, we have no means of knowing. Certain, however, is it that this famous scientific worker produced the first known thermometer or heat-measurer. In its earliest form, Galileo's instrument consisted of a long narrow tube with a bulb at the end which dipped below the level of a quantity of water contained in a glass vessel. On heating the glass bulb, the air therein expanded and pushed the water in its stem downwards.

In his later instruments, Galileo dispensed with the separate vessel of water and employed simply a tube having a bulb at one end and an open reservoir at the other. This instrument, Galileo filled with oil or wine. In principle, of course, it was precisely the same as his previous instrument, the upper glass bulb being heated and the expanding air within it pushing the liquid down along the vertical tube.

As a matter of fact, Galileo's instruments were not thermometers pure and simple. They were barometers, as well, for the liquid-level in the vertical tube was affected by the external pressure of the atmosphere, although Galileo does not seem to have realised this.

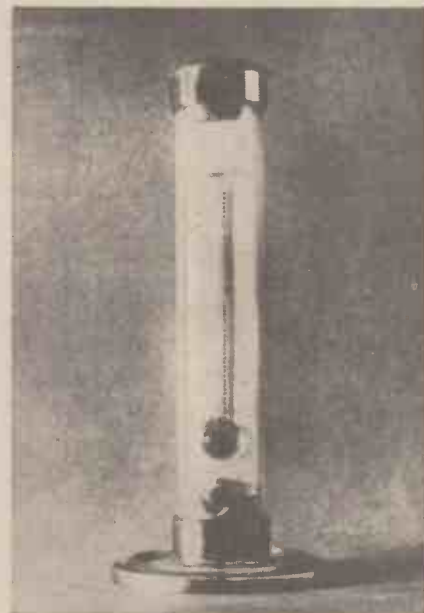
Galileo's instruments were made about the year 1601-2. After this date we have to skip a period of some fifty years until, about 1657 we find that some now unknown and possibly very humble genius employed by the Scientific Academy at Florence has hit upon the idea of making heat measure-

ments by means of the expansion of a liquid sealed with a tube.

### The Modern Thermometer

Here we have the first germ of our modern thermometer and the prototype of all our present-day liquid-expansion instruments.

About the previously mentioned year, the Florence Academy was turning out on a semi-commercial scale crude thermometers consisting of a narrow glass tube having a bulb blown at one end of it. The bulb was filled with wine, alcohol or oil, and its tube was sealed off at the end. Under the



One of the world's earliest thermometers. An Italian-made instrument constructed in 1660 now in the possession of the Cavendish Laboratory, Cambridge.

influence of temperature variations, the column of liquid in the tube expanded or contracted. No one, however, appears to have thought of attaching a scale to these early thermometers. Individual owners, it would seem, noted the height of the liquid column on hot summer days and made a mark on the tube accordingly. Another mark was made at the liquid level on a cold winter's day. Physicians who used these crude instruments would mark the stems at places corresponding to the bodily temperature of their patients in various stages of fevers, but there was no standard thermometric scale by means of which accurate readings could be made.

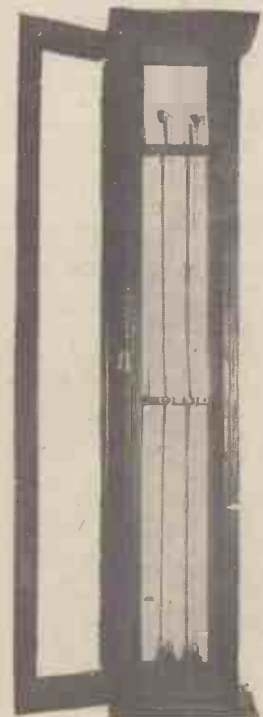


It is to the famous Italian, Galileo, that the invention of the first working thermometer is nowadays ascribed.

It was our own Sir Isaac Newton who, in 1701, first introduced the practice of calibrating thermometers; that is to say of marking their stems at the freezing and boiling points of water. Apart from this, however, Newton did little to popularise the use of the thermometer. His thermometric "scale" was clumsy, inadequate and hopelessly impracticable.

### Mercury Thermometer

The introduction of the mercury thermometer was the next step in the evolution of the instrument. Roemer, the Danish



These are the two most sensitive thermometers in the world. They are housed in Manchester and were used by scientist Joule in making determinations of the mechanical equivalent of heat.

astronomer who first determined the speed of light, constructed the first mercury-filled thermometer in the year 1709, although Halley, the English Astronomer-Royal, is said to have originally suggested the notion. Roemer's thermometers, however, were crudely made and they attained very little popularity.

Undoubtedly the first individual to construct really serviceable thermometers was Gabriel Daniel Fahrenheit, of Amsterdam. Fahrenheit is worthy of the title of "Father of the Thermometer," for it was he who raised the thermometer from the status of a mere trifling toy to that of an accurate, reliable and exceedingly useful instrument. Realising that mercury was the best of all liquids for thermometer use on account of its low freezing and high boiling points, its regularity of expansion and its non-clinging properties, Fahrenheit set himself to produce first-class instruments of this type. He took up thermometer manufacture in 1714. At a single stroke, he improved upon thermometer construction enormously by making the bulbs of the instruments cylindrical in shape instead of spherical, thereby enabling the mercury in the bulb to gain or lose heat more rapidly than was possible with a spherical bulb.

#### Fahrenheit

Fahrenheit, too, was the first man to provide a scale for his thermometers. He inserted the bulbs of his instruments in a mixture of ice and salt of definite proportions and he marked 0 (Zero) at the level to which the mercury columns sank under these conditions.

He next took the temperature of the human body, and marked his thermometer 96 degrees to correspond with this. Then he found that instruments so marked showed a temperature of 32 degrees when immersed in melting ice and 212 degrees when placed in boiling water. Thus it is that we obtained our present-day Fahrenheit scale on which 32 and 212 degrees represent the freezing and boiling points of water respectively.

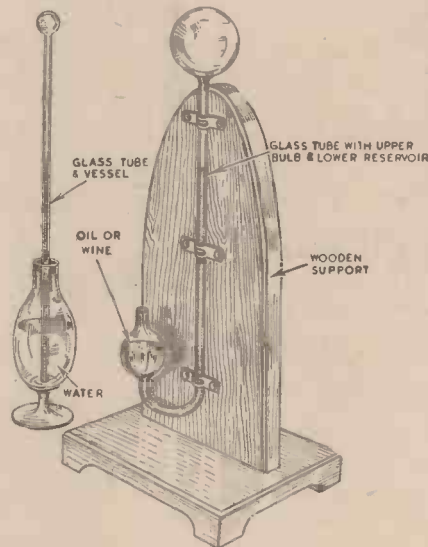
#### In Recent Years

It is interesting to note that of recent years many attempts have been made to replace mercury as a thermometer metal with the metal, gallium, which melts at about 28 degrees Centigrade and which has a higher boiling point than mercury. Gallium, like mercury, expands very regularly, and a gallium-filled thermometer would be excellent for accurate high-temperature estimations. Unfortunately, however, Gallium "wets" glass, that is to

The world's first "mechanical" thermometer. An original Breguet "dial" thermometer made in 1880.



say, it tends to cling to the inner sides of the thermometer tube and does not form the clear convex surface which is so characteristic of the ordinary mercury column. On this account alone, gallium-filled thermometers are inadmissible although, no doubt, some non-clinging gallium alloy may ultimately be used in place of the pure metal.



Two types of air-thermometer made by Galileo.

Although the Fahrenheit scale is used in everyday life in this country and in America, the Centigrade scale, introduced by Celsius in the latter part of the eighteenth century, is a much better one and is employed by scientific workers the world

over. On the Centigrade thermometric scale the freezing point of water is taken as 0 (Zero) degrees, the boiling point of that liquid being 100 degrees.

One seldom comes across the Reaumur scale nowadays, but at one time it was common. Reaumur, shortly after the time of Fahrenheit, marked the freezing point of water on the thermometer as 0 (Zero) and the boiling point as 80 degrees. Other "freak" scales there were also, but they attained but little use.

Fahrenheit's belief in the superiority of the mercury-filled thermometer was amply justified, for, towards the end of the eighteenth century, practically every thermometer which was manufactured conformed to this specification. It is true, of course, that thermometers filled with coloured spirit are still made on the mass scale at the present day. Such instruments, whilst being amply serviceable for everyday household use, cannot possibly compete in accuracy with the mercury-filled instruments, but they can be produced at a considerably less cost.

Of the many specialised types of thermometers which have been devised and manufactured since the pioneering days of Fahrenheit it is impossible to make mention. Electrical thermometers, which depend for their action upon the increasing resistance of a special electrical element, with increase in temperature, have been much to the fore in recent years for high-temperature measurements, as have, also, those thermometric instruments which estimate high temperatures by measuring the heat radiations with the aid of a thermo-couple. Despite, however, all these modern devices, the simple mercury thermometer constructed on lines initiated by old Gabriel Fahrenheit, still remains unequalled for absolute reliability and extreme accuracy.

#### "Mechanical" Instruments

The modern tendency in household thermometers has been in the direction of "mechanical" or "dial" instruments in which the temperature readings are indicated by a pointer moving across a dial. Such instruments work upon the principle of the expansion of a curved strip composed of two dissimilar metals. Actually, the first of these mechanical thermometers was made as far back as 1800 by a Paris watchmaker, Abraham Breguet by name. Breguet's first dial thermometer comprised a sensitive arrangement of gold, silver and platinum strips, in virtue of the expansion of which a pointer was caused to revolve around a circular scale. Breguet's thermometers had some measure of popularity, but, due to the materials of their construction, they were exceedingly expensive articles. They were also unreliable and were easily thrown out of adjustment. Consequently, the mercury-filled thermometer experienced very little competition from Breguet's ingenious device, as, indeed, for all scientific purposes, it has done from any similar and subsequent "mechanical" device.

## THREE FINE BOOKS

### THE MODEL AIRCRAFT BOOK

3/6, by post 4/-

### POWER-DRIVEN MODEL AIRCRAFT

1/-, by post 1/2

### MODEL AEROPLANES AND AIRSHIPS

1/-, by post 1/2

The above books are obtainable from Messrs. G. Newnes, Ltd., Tower House, Southampton Street, Strand, W.C.2

The actual thermometer used by John Dalton, first modern discoverer of the Atomic Theory of Matter.





# A Sub-Stratosphere 'Plane



Pilots operating the great 18-ton sub-stratosphere aeroplane will gaze upon many innovations which are considerably in advance of present-day equipment.

IMPORTANT indications of what the high-altitude-operating transport 'planes of the future will offer in safety and comfort are contained in the first detailed description of the giant, multi-motored, sub-stratosphere-flying, 30-passenger Curtiss-Wright "CW-20" luxury liner now nearing completion in the St. Louis (Missouri, U.S.A.) airplane factory of the Curtiss-Wright Corporation, made public by C. W. France, vice-president and general manager of that organisation. The new 'plane dwarfs all present-day bi-motored transports.

Most revolutionary of its innovations, many of which are considerably in advance of present-day equipment, is an amazing "tell-tale" device which automatically checks the functioning of 47 details of the "CW 20" operation for the pilots and, supplementing the so-called Sperry "automatic pilot," is virtually a "fourth pilot." It marks one of the aircraft manufacturing industry's principal contributions to date in simplifying the air line pilot's work and hence adding to safety.

### Danger Signals

This device is similar to the indicating signal systems used by the railroads and the electrical power industry to warn of

danger or improper operation, and is essentially a panel of lights situated on the

**Details of a Revolutionary "Tell-tale" Signal System which Automatically Checks the Instruments for Pilots; A Five-second Retracting Landing Gear which Absorbs 900-ft. Verticle Descent; Non-icing Ailerons; Fifteen-foot Electric Propellers—Largest Ever Operated Commercially**

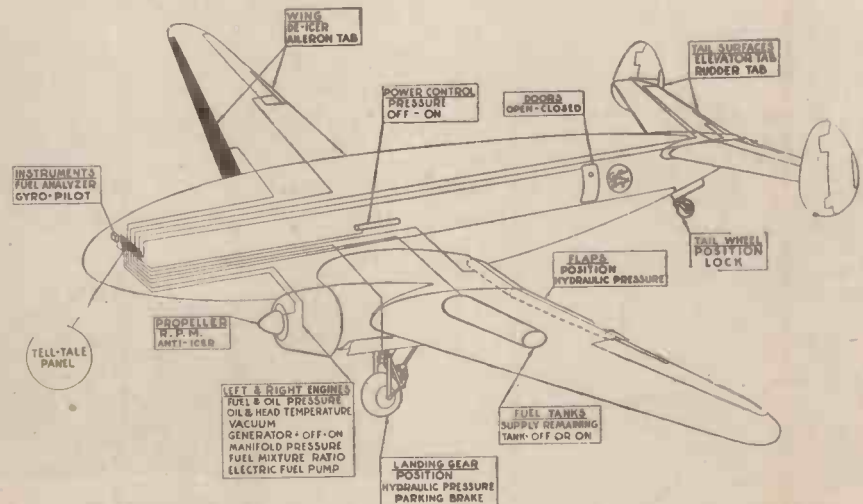
instrument panel in full view of both pilots, and electrically connected to the various vital operating parts of the 'plane in such a way as to report constantly on their functioning. It indicates everything, from engine temperature to whether the stewardess shut the passenger-cabin door.

If the pilot wishes to land, he simply presses one of the 10 pre-selector switches marked "land." Lights immediately show on the "tell-tale" panel to indicate what adjustments are necessary. As the landing gear is lowered, that light goes out, and as the landing flaps, ailerons, and elevators are operated, their corresponding lights flash out. The pilot cuts his engines, handles any other details indicated until the panel is dark, then lands.

The "tell-tale" panel checks every operation, providing for taxiing, take-off, cruising and landing, and further enables the pilots to quickly check on either of their two 1,600-h.p. Wright Cyclone engines simply by pressing switches for the "right engine" or "left engine." Lights immediately appear on the panel to indicate any improper operating condition.

### Complicated Operations

To further eliminate for the pilots those complicated operations which the Civil Aeronautics Authority finds often causes "pilot fatigue" and resultant errors in operation, Curtiss-Wright engineers have developed facilities for the new low-mid wing, all-metal "CW-20" which reduces



This diagrammatic drawing illustrates some of the vital operating parts upon which the newly designed "tell-tale" system constantly maintains an automatic check for the pilots. Any malfunctioning of the luxury liner's vital parts is thus immediately indicated for readjustment.



An artist's conception of the Curtiss-Wright Model 20 Transport in flight. This 'plane, powered with two 1,600 h.p. Wright double-row Cyclones, has a top speed of 237 m.p.h.

the number of pilots' controls 37 per cent. below those required on modern air liners; provided large, hubless, spokeless wheels, assuring full vision of all instruments; centrally placed essential instruments in duplicate to prevent strain on pilots; installed single-movement control levers for operating flaps and landing gear; duplicated radio systems to assure continued communication, and developed radio microphones which retract into ceiling wells and cannot interfere with operation of the controls. The spacious cockpit will accommodate a third member of the crew.

Landing gear retracts in from five to six seconds, can be lowered in three seconds, cannot retract while the 'plane's weight rests upon it, and will absorb vertical decent at the rate of 900 ft. per minute, the result of gear with an 18-in. shock-absorber travel developed by Curtiss-Wright engineers, the same who designed aviation's first retractable landing gear for a commercial 'plane and the world's first sleeper 'plane. The tail wheel also is retractable.

Three years of extensive research and flight testing by the engineers who designed the famous Curtiss 'planes operated in every branch of America's air forces, have produced a monoplane type of wing which provides complete stability and control of the "CW-20" at speeds even below the stalling point, and led to the development of a slotted type of wing flap, which enables the 237-miles-per-hour, 18-ton liner to land at a minimum speed of 66 miles per hour.

#### The Icing Hazard

The icing hazard, an old obstacle to airline operations, also has been thoroughly provided for. Special tests in a refrigerated wind-tunnel have resulted in the development of a special airfoil section and hinge arrangement for the ailerons, which assures ice-free operation of these controls and, together with a non-icing carburetter, pneumatic de-icers on the wing and tail, and liquid de-icers for the propellers and the pilots' wind shields, enables the new "CW-20" to operate under the most severe flight conditions.

Conforming with the air transport industry's conclusion that the greatest income-producing transport is one which is equipped with a minimum number of large power

plants, the new "CW-20" is powered with two 1,600-h.p. Wright double-row Cyclones, which have the highest power rating ever accorded an American-built engine. Each is installed with dynamic suspension to absorb vibration and equipped with a 15-ft. Curtiss electric "full-feathering" propeller, the largest used by any present-day commercial 'planes. Two 500-gallon petrol tanks are located in the wing, outboard of either engine, a very important safety feature.

Declaring that the new 30-passenger luxury liner was designed to meet the air transport industry's demand for larger equipment possessing the combination of large load capacity, luxurious accommodations, economical operation, maximum

safety, and high operating speed, Mr. France pointed out that it also is available in types sleeping 20 passengers or seating 38 passengers. Its nacelle and centre section, he revealed, are designed to accommodate engines with ratings up to 2,000 h.p., while its ground and fuselage clearance is sufficient to permit the use of larger diameter propellers to accommodate such horsepower.

While the pilots enter through a special hatch in the cockpit floor, passengers board the new transport through a door which opens from the top of the fuselage, pass the stewardess' large food galley, then gaze upon a roomy, indirectly lighted, air-conditioned cabin which provides head room for persons over 6 ft. tall, and is equipped with 30 luxuriously upholstered, reclining chairs. Unlike present-day operating air liners, the "CW-20" offers separate wash-rooms and toilets for men and women, all fully equipped even to an outlet provided in the men's room for an electric razor.

Conversation may be carried on in a normal manner, Curtiss-Wright engineers having soundproofed the cabin to reduce the noise level to about sixty decibels, approximately ten decibels lower than that of any other air liner now in operation.

Marking still another radical departure in accepted transport design, engineers have solved the cargo space problem by providing beneath the cabin floor four roomy compartments with a total capacity of over six hundred cubic feet, which give easy access and reduce load-balancing complications. Three accommodate baggage, express and mail, while the fourth is for storing accessories.

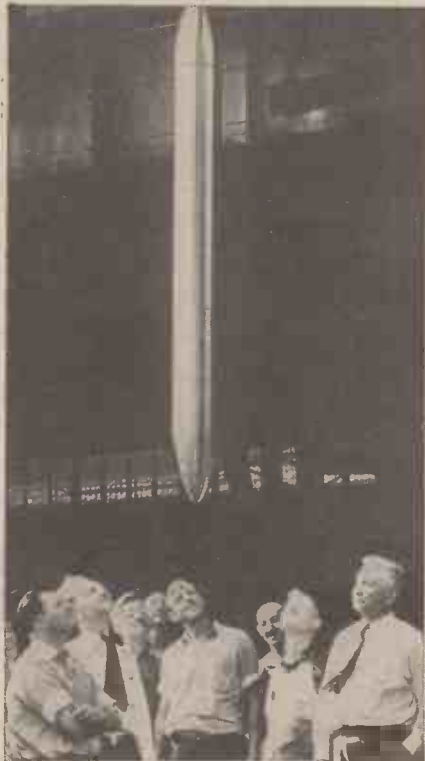
The heating system differs from those employed in the past by operating completely independent of the engines and providing the passenger cabin and lounge, vestibule, galley, pilots' cockpit, and even the cargo compartments (the latter to prevent goods from freezing in transit) with temperature of 70 degrees F. when the outside temperature is as low as 40 degrees F.



To simplify the pilot's operation of the 'plane engineers have developed the above pictured "telltale" device which automatically checks the functioning of all instruments and vital parts of the 'plane, and, supplementing the so-called Sperry "automatic pilot," is virtually a "fourth pilot." Experts say it decreases "pilot fatigue" and hence increases air line safety.



# 5,000 Years Hence



The 7½-ft. Time Capsule constructed of cupaloy, the result of five years' research to make copper as hard as steel.

FIVE thousand years from now historians of the future will receive an 800-pound metal letter, a cupaloy *Time Capsule* containing information about us and our times. It will be deposited fifty feet below the surface of the New York World's Fair grounds by the Westinghouse Electric and Manufacturing Company and officials of the Fair.

And if future historians do find the *Capsule*, major credit will go to a Canadian geophysicist, Sherwin Kelly, head of Geophysical Explorations, Ltd., of Toronto, upon whom the Westinghouse Electric and Manufacturing Company called to provide information for discovering the *Capsule* by electro-magnetic prospecting.

Mr. Kelly's message to the future is to be published in a specially prepared *Book of Record of the Time Capsule*, which will be preserved in libraries, museums, and other repositories throughout the world. The book is printed on special rag paper, with specially compounded permanent inks, and well bound. It is expected that some copies will survive for 5,000 years, and will guide future historians back to the spot where the metal *Capsule* waits. In addition to exact latitude and longitude, given accurately enough to locate a spot less than an inch in diameter on the earth's surface, instructions are given for building and using geophysical prospecting instruments to locate the *Time Capsule*.

### The Message

The message to the future, signed by Mr. Kelly, is as follows:

"Though in all probability methods more sensitive than any we have to-day will be employed in the future to seek for metallic

bodies beneath the earth, it is possible, too, that this will become a lost art. It is therefore suggested that the *Time Capsule* may be discovered by detecting the secondary electro-magnetic field induced in it by a strong primary electrical field created at the surface of the ground.

"Construct a loop some ten feet in diameter, composed of several turns of well-insulated wire, fashioned in such a manner that it can be moved systematically over the area within which the *Capsule* is believed to lie. While the loop stands, vertically, pass through it an alternating current of 1,000 to 5,000 cycles, using a power source of approximately 200 watts. The primary electro-magnetic field thus set up around the loop will intersect any metallic material in the vicinity such as the *Capsule*, and induce in it a secondary current. This current will produce a secondary electro-magnetic field such as will distort the primary field of the "energising" loop. This distortion, properly interpreted, will indicate the location of the *Time Capsule*.

## How Radio will help Future Scientists to locate a buried "Time Capsule" containing the Records of our Generation

### A Second Coil

"To investigate this phenomenon, construct a second, smaller coil, approximately a foot in diameter, made up of a large number of turns of insulated wire. To the coil should be connected an amplifier which in turn is connected to some type of current indicator, such as a galvanometer or telephone receiver. Some means should be provided for accurately measuring the 'strike' or direction of the coil in the horizontal plane, as well as its 'dip' or deviation from the vertical position. On level ground, where there is nothing to distort the primary field, the current generated in the small, or 'pick-up,' coil will be at a minimum (that is, produce the least deflection of the galvanometer needle or the least sound in the telephone receiver) when its plane is perpendicular to that of the large coil. Conversely, the maximum current will be observed when the two coils are in the same plane. It is well to take both observations as a check-up before beginning the search for the *Capsule*. If the instrument is working properly, the positions of minimum and maximum current in the pick-up coil should be at right

angles to each other.

"In exploring for the *Capsule*, observations may be made with the pick-up coil in two ways.

"*First*: Take measurements in the plane of the energising loop, moving farther and farther away from it in short stages of 5 or 10 ft. Do not work too close to the energising loop. If during this survey the pick-up coil passes over buried metallic material it will be noted that the positions of the coil do not correspond to those described for an undistorted field. The divergence from the normal dip will be at a maximum over the hidden body, whereas the deviation from the normal strike will increase as the metallic substance is approached, reverse to a maximum in the opposite direction as the spot is passed over, and then decrease as the coil moves farther away.

### Within a Few Feet

"*Second*: Take readings along lines at right angles to the measurements suggested

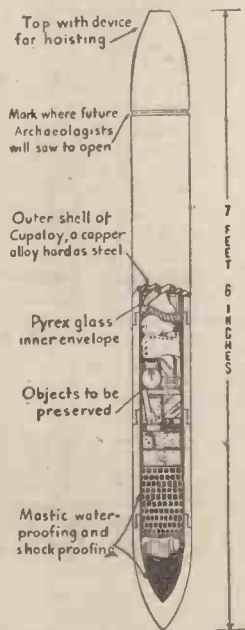
in the first method above. These readings should be taken approximately 5 to 10 ft. apart, extending 50 to 100 ft. each side of the plane of the energising coil. The lines of observation should cross the first line every 5 ft. Observe the position of maximum current in the pick-up coil. In an undisturbed field the coil should stand vertically. As the metallic body is approached the position of maximum current in the pick-up will stand at an angle from the vertical, and its plane will point roughly to the buried metallic mass. When it passes over the *Capsule*, the plane of maximum current of the pick-up coil will again become vertical. As the coil passes beyond, it will reverse, and point in the opposite direction. The strike will undergo a maximum deviation from its normal position as the *Capsule* is passed.

"By a combination of these two methods it should be possible to locate the position of the *Time Capsule* within a few feet.

### What the Capsule Contains

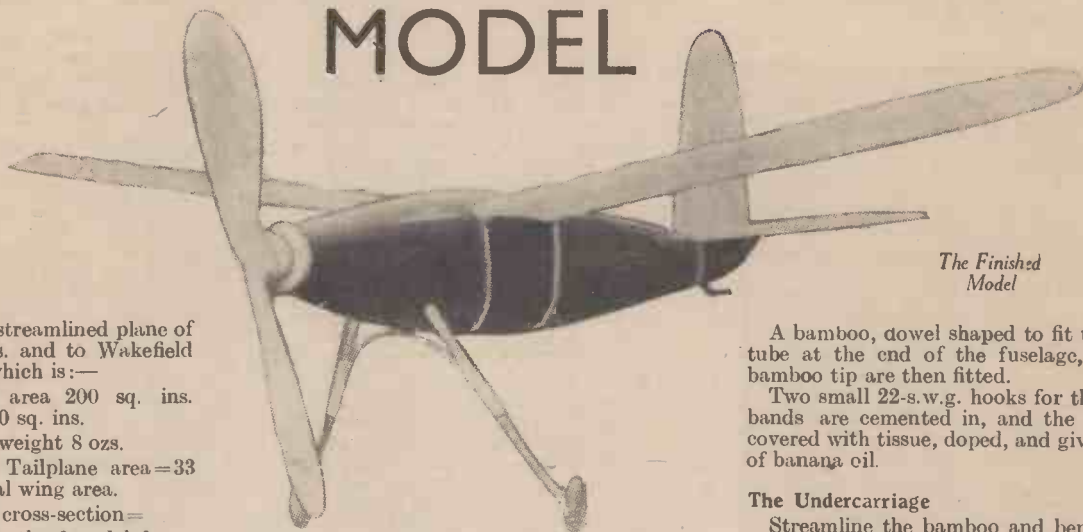
The 5,000-year Westinghouse *Time Capsule* will contain books reproduced in micro-film, statements of this age's scientific engineering, industrial, social, religious and philosophic achievements. It will also contain specially preserved small articles that moderns wear or use; motion picture film illustrating how we look, act and talk; photographs of famous people and things of our time, and messages from great men of to-day for the future.

Westinghouse engineers and metallurgists have designed the *Time Capsule* for permanence. It is torpedo-shaped, 7½ ft. long and 8 ins. in diameter. The outer shell is made of cupaloy, a new temperable alloy of copper which has the strength of steel and high resistance to corrosion. The inner crypt is lined with a Pyrex glass envelope set in waterproof plastic. This crypt will contain film and articles, preserved in an inert gas (nitrogen).—*Radio News*



How the *Time Capsule* is made up and loaded.

# A STREAMLINED WAKEFIELD MODEL



The Finished Model

**T**HIS is a streamlined plane of 206 sq. ins. and to Wakefield formula, which is:—

1. Mainplane area 200 sq. ins. plus or minus 10 sq. ins.
2. Minimum weight 8 ozs.
3. Maximum Tailplane area = 33 per-cent. of total wing area.
4. Maximum cross-section =  $\frac{\text{overall length of model}^2}{100}$

First, carefully draw the plans full size.

## Fuselage

The fuselage is streamlined and is built of 24  $\frac{1}{16}$ -sq.-in. balsa stringers cemented on to formers, cut from  $\frac{1}{16}$ -in. sheet.

Carefully cut all the formers, and sand to make sure that there are no rough edges to harm the rubber motor.

Cement the top and bottom stringers in position first, and then add the other stringers, checking the fuselage for trueness. Cement  $\frac{1}{16}$ -in. strip balsa between the two stringers for the undercarriage tubes, and below the wing mounting, as shown. The stringers above the wing mounting are now cut away, and a piece of  $\frac{1}{16}$ -in. sheet balsa about  $\frac{1}{2}$  in. wide is cemented on the top of each side of the fuselage.

Then cut the stringers above the tailplane away and reinforce with  $\frac{1}{16}$ -in. sheet balsa as shown. Also cement two cross-grained pieces of  $\frac{1}{16}$ -in. sheet balsa for the  $\frac{1}{2}$ -in. bamboo peg used for holding the rubber motor in position.

Plank the nose of the fuselage between formers Nos. 1 and 2, with  $\frac{1}{16}$ -in. sheet.

The 18-s.w.g. brass tubes for the undercarriage are now cemented in place and a paper tube, about  $\frac{1}{2}$ -in. diameter hole, is cemented at the end of the fuselage. Cover with two layers of tissue, the grain of the first going round the fuselage and the grain of the second going lengthways along the fuselage. Dope, and when dry apply two coats of banana oil.

## The Wing

The wing span is 47 ins., with a constant chord of 5 ins., giving a total area of 206 sq. ins. The dihedral is  $3\frac{1}{2}$  ins., and the sweep back 1 in.

It is constructed in two halves, with a leading edge of  $\frac{1}{4}$  sq. in. set in diamond, and mainspar of  $\frac{1}{2}$  in. by  $\frac{3}{8}$  in., and a trailing edge  $\frac{1}{2}$  in. by  $\frac{3}{8}$  in. shaped to the airfoil section.

The ribs, which are spaced at 2-in. intervals, are cut from  $\frac{1}{16}$ -in. sheet, and the section used is R.A.F. 32.

Crack the leading and trailing edges for the dihedral and sweep back, but cut the mainspar to shape. Cement well, and reinforce the mainspar with thin plywood.

Bend the tips from bamboo, and cement

in position. Make two paper tubes, about  $1\frac{1}{2}$  ins. long and  $\frac{1}{2}$ -in. diameter hole, and shape two bamboo dowels to fit. Cement one dowel and one tube into each half as shown.

Cement the bamboo pegs used for wing fixing, and reinforce the wing at A and B.

Cover with strong white tissue, dope, and apply two coats of banana oil.

A piece of  $\frac{3}{16}$ -in. balsa is cemented just behind the leading edge to give the wing the necessary incidence.

The hatch which fits over the wing can now be made from two layers of  $\frac{3}{32}$ -in.

## This Model is Extremely Stable and Capable of Good Flying Performance

sheet balsa, shaped and cemented together. A shaped former is cemented at each end, and the hatch should fit tightly between formers Nos. 5 and 8.

## The Tailplane

The tailplane has a span of 17 ins. and tapers from 4 ins. to  $3\frac{1}{2}$  ins., giving an area of 66 sq. ins.

The leading edge is  $\frac{1}{2}$ -sq.-in. balsa set in diamond, the mainspar is  $\frac{1}{2}$  in. by  $\frac{1}{4}$  in., and the trailing edge is  $\frac{1}{2}$  in. by  $\frac{1}{4}$  in. shaped to the airfoil section. The ribs are cut from  $\frac{1}{16}$ -in. sheet balsa, and are spaced 2 ins. apart. The section used is Clark "Y."

Bend two tips from bamboo and cement in position. Two small hooks are bent from 22 s.w.g., and are cemented and bound to the leading edge.

Cover with tissue, dope, and when dry apply one coat of banana oil.

## The Rudder

The rudder is 8 ins. high, with a width of  $3\frac{1}{2}$  ins. at the tip and  $5\frac{1}{2}$  ins. at the base.

Shape a piece of  $\frac{1}{16}$ -in. sheet balsa to fit on top of the tailplane, for the base of the rudder, and cut the ribs which are streamlined in section from  $\frac{3}{32}$ -in. sheet balsa.

Cement the leading edge and front spar (which are both  $\frac{1}{2}$  sq. in.) to the base, and then fit the ribs to them at  $1\frac{1}{2}$ -in. intervals.

The rear spar ( $\frac{1}{2}$ -in. by  $\frac{3}{16}$ -in. balsa) and the shaped trailing edge ( $\frac{1}{2}$  in. by  $\frac{1}{2}$  in.) are then cemented in position.

A bamboo, dowel shaped to fit the paper tube at the end of the fuselage, and the bamboo tip are then fitted.

Two small 22-s.w.g. hooks for the rubber bands are cemented in, and the rudder is covered with tissue, doped, and given a coat of banana oil.

## The Undercarriage

Streamline the bamboo and bend all the wire fittings from 18 s.w.g.

Bind and cement these fittings and fit a cross piece of light bamboo, to give the required width of track.

The wheels are made of three laminations of  $\frac{1}{16}$ -in. sheet balsa, sanded to a streamlined shape, and bushed with 18-s.w.g. tubing.

## The Propeller

Lay out the block as shown in the drawing, and test for balance.

Carve carefully and when completed make sure that it balances perfectly.

Cover with tissue and apply one coat of thick banana oil. Test again for balance, and fit 16-s.w.g. bush. Be careful not to carve the blades too thin near the spinner.

The freewheel is self-explanatory. The noseblock is built up of  $\frac{1}{2}$ -in. sheet balsa, and is fitted with a 16-s.w.g. bush, and a ball-race is fitted between the propeller and noseblock.

The trimming weight (about  $\frac{1}{2}$  oz.) can be made of lead, which can easily be beaten into a streamlined shape which fits the fuselage.

This weight runs on thread, which is tensioned by a rubber band at the rear of the fuselage.

Be sure that this weight does not slide too easily on the thread, and does not sway about when the model is flying.

The model flies best on 18 strands  $\frac{3}{16}$ -in. flat rubber about 48 ins. long, "White" rubber tensioned, and well lubricated. The model is trimmed by moving the weight backwards and forwards along the fuselage.

The wing and tailplane are fixed by rubber bands passing round the fuselage. The rudder is fixed by the peg fitting into the paper tube at the rear of the fuselage, and a rubber band being passed round the fuselage from the hook on the leading edge.

The model is very stable and flies well, the best results being obtained when flying in wide circles against the torque.

	Weights	
Fuselage	...	2½ ozs.
Wings	...	1½ ozs.
Undercarriage	...	½ oz.
Tailplane and Rudder	...	½ oz.
Propeller	...	1 oz.
Rubber	...	2½ ozs.
		<u>8½ ozs.</u>





# HEAT TREATMENT OF TOOL STEELS



× 450 12% Cr. and 2% C steel correctly hardened and tempered.

THE above title covers a large amount of a very important branch of the science of metallurgy, and to deal with it in detail, it would be necessary to write a very lengthy treatise. Although the subject matter of this article is not new, it is thought that whilst there is a vast amount of available literature, such literature is too technical for the "small" user who is concerned with his products, and consequently does not want to have to make a detailed study of his tools.

## .90% Carbon Steel

One of the most widely used—and abused—tool steels is the ordinary .90% carbon quality. The heat treatment of this steel should present very little difficulty. Care must be taken in heating to, and at, the quenching temperature (760° C.-780° C.) and that the attainment of temperature has not been too rapid, or that soaking at this temperature has not been maintained for too long or too short a time. Further, the actual quenching must not be "slipshod." The reader might be inclined to say, "How can heat treatment be easy when there are so many difficulties?" but when much time and money have been spent in preparing a tool, is not the consideration of these difficulties of major importance?

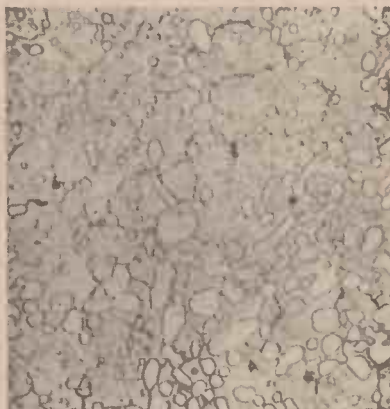
With regard to the first difficulty. The tool must not be placed in a furnace which is already at the required temperature. This may sound obvious, but it is a process adopted nevertheless, with the result that the tools often crack owing to uneven expansion. This danger may be minimised by first warming the tool in front or on top of the furnace, and then placing it in the furnace, which should be at a temperature of about 500° C. The temperature should then be raised slowly, allowing at least as much time to attain quenching temperature as will be allowed at that temperature for soaking. Even longer may be required by very large masses.

## Quenching

The second difficulty—soaking—is sometimes perplexing to the hardener, especially if the tool is of an intricate shape and has varying thicknesses of metal. In such cases, slow and uniform heating are essential to prevent warping and spalling of corners, etc. When the quenching temperature is reached, a good rule is to allow  $\frac{1}{2}$  hour to  $\frac{3}{4}$  hour per 1 in. of thickness for soaking, taking into account the thickest parts.

Finally, there is the consideration of

With Special Reference to Highly Alloyed Types  
By L. Price



× 450 12% Cr. steel overheated in hardening—not tempered.

quenching. Most failures occur at this stage, but it is not always fair to blame the actual quenching. The difficulties dealt with above are perhaps the major causes, especially that of insufficient soaking, which, it will be readily appreciated, leaves the steel in a very unsatisfactory condition. The hypoeutectoid solution of cementite does not begin until the required temperature (760° C.-780° C.) is reached and then requires a minimum time. Hence, if this time is not allowed, it will be seen that the result is incomplete change of pearlite to austenite throughout the mass instead of the completely formed solid solution, austenite. The phenomenon of hardening is accompanied by a volume change (in the transformation of the austenite to hard martensite) and hence the seriousness of insufficient soaking will be seen, for not only will it result in "soft-spots," but there will also be a tendency to cracking. Where possible in quenching, the thicker portions should be the first to enter the water, thus making the rate of cooling as uniform as possible. This precaution is necessary in order to reduce the danger of cracking. With some tools it might be advisable to quench on a falling temperature, i.e. allowing the temperature of the surface of the tool to fall slightly, though still above the critical temperature before quenching. In this way the quenching speed of the whole of the tool is made more uniform. Quenching in this manner tends to eliminate the tempering effect which the hot interior has on the already cold and hard exterior, and consequently produces uniform hardness.

## Normalising Treatment

So much for the actual hardening of this steel. It might be advisable at this stage, however, to mention that successful hardening is greatly enhanced if, with all steels, a normalising treatment is given prior to hardening, in order to release machining stresses which are a frequent cause of distortion. Holes, such as bolt holes, should be plugged with clay, or asbestos wool, and if possible sharp angles should be avoided in the design. Intense stresses are set-up



× 450 12% Cr. 2% C steel overheated in hardening—tempered.

at sharp corners, and these may be sufficient to crack the tool either in quenching or immediately after quenching. Stresses are unavoidable, and a wise plan is to remove the tool from the quenching medium when it is hand warm and temper at 100° C. for a short time to relieve these stresses. Dies and punches may not be required in the "glassy" hard condition, and so it will be necessary to increase the temperature or period of tempering. With this steel, however, it is rarely found necessary to exceed 250° C.

## Cold-Heading Die Steel

This steel, which is used quite extensively in cold-heading operations, differs very little from the one dealt with above. It has a carbon content of .90/1.0% and a vanadium content of .20/.30%. The effect of the vanadium is to give increased hardenability, grain refinement and resistance to shock. It also raises the hardening temperature to about 810° C. The same precautions as mentioned above in .90% carbon quality steels should be taken with this type.

## Oil-Hardening Die Steels

The chances of breaking of tools are considerably lessened when oil-hardening steels are used, since the quench is not so drastic. For a typical example an oil-hardening non-shrinking die steel will be taken. It has an analysis as follows:—

Carbon	0.90/1.10%
Chromium	0.50/0.60%
Vanadium	0.25%
Manganese	1.2/1.5%

The dimensional changes in hardening are very small, hence the property of non-shrinking or non-distortion. The hardening temperature generally adopted is 760° C.-780° C., although the steel may be hardened from 800° C. without any grave consequences. This may lead to a slight coarsening of the grain, however, which should be avoided wherever possible. The "golden rule" is, therefore, "use the lowest permissible temperature in all heat treatment." The same procedure and precautions in heating and method of quenching as with the .90% carbon steel are advisable, although the allowance of a little longer time for soaking may be beneficial. Water quenching must never be adopted. With regard to the tempering, this is, of course, decided by the purpose for which the tool is to be used, but it is carried out in much the same way as with a carbon steel.

(To be continued)



# BUILDING A HARD COURT FOR QUOIT TENNIS

By G. Long, F.R.G.S.

Quoit Tennis is an Excellent Substitute for Ordinary Tennis and a Hard Court can be Built in the Average Suburban Garden at Little Cost.

**"KEEP FIT"** is the slogan of the hour, and it is certain that good health is the most precious thing anyone can possess. Regular outdoor exercise is the keystone of fitness, but it is not easy for the town dweller to obtain this in its more attractive forms. The gardens of the well-to-do are now fitted with hard tennis courts, but these cost too much for many of us, and require more space than can be found in the average suburban back garden.

Quoit tennis is an excellent substitute, as a hard court can be made at very small cost. It will go in a very small garden, and the construction of it will provide interesting work during several week-ends. The game is very similar to lawn tennis, but a rubber ring is used instead of a racquet and ball. It is a very fast game and includes a lot of bending and stretching, which is just the thing to prevent middle-age spread, and to safeguard a youthful figure.

The size of quoit tennis courts is not fixed. The commercial firms who build them make a doubles court 50 ft. by 25 ft., the



(Left) The completed court.

outside lines being 40 ft. by 18 ft. Many of us, however, have learned the game at sea, and the size of court used on most liners is 24 ft. by 14 ft. outside lines, with, of course, a surround and runback beyond this.

When constructing my own court I used 24 ft. by 14 ft. outside lines with five feet of runback at each end, and three feet at

each side, making the size of the whole court 34 ft. by 20 ft.

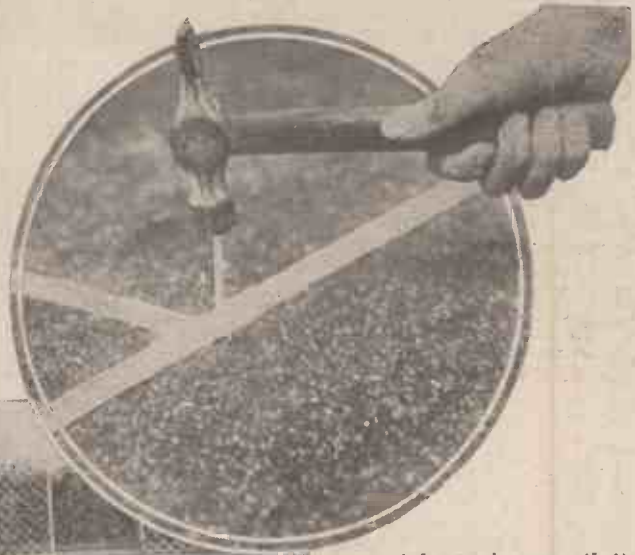
**Levelling the Ground**

The plot of ground is first levelled, and then a low concrete wall is constructed all round to contain the material. The thickness of the foundations depends on the nature of the subsoil, where it is firm and dry the containing wall should be 6 in. above ground level, which, with 6 in. of foundations, makes a total height of 1 ft. My own court is made on a patch of swampy ground, flooded in winter, and so the containing wall is 2 ft. 6 in. high to allow for ample drainage. The wall is made of concrete, the mixing being 1 cwt. of cement, 2 cwt. fine gravel and 1½ cwt. broken up clinker. This is thoroughly mixed, and turned over twice when dry, and twice when wet. Enough water is added to make it *wet but not runny*. Previously the footings for the wall are cut out, making a trench 6 in. deep and 6 in. wide, and 1 in. planks are fixed at each side to hold the concrete. The wet mixture is shovelled in and well rammed down. As my own wall was high, I inserted two strands of barbed wire which ran the whole way round, and were twisted together at the ends; thus binding the whole together. Drainage holes were made at intervals by inserting tapered pieces of wood, which can be knocked out when the concrete has set. If it is intended to make a surround of netting, the posts must be inserted while the concrete is wet.

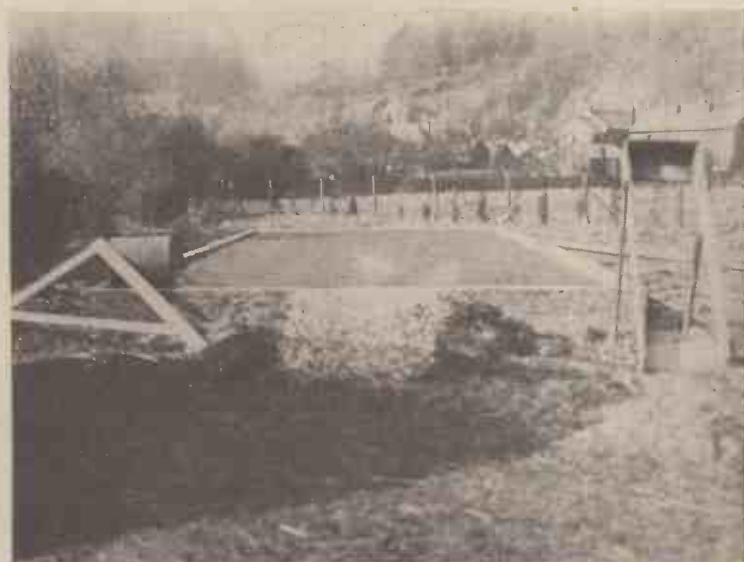
**Laying the Court**

I used a number of short pipes which were let into the concrete, and these served as slots to hold the uprights, which were thus removable for alterations or repairs, but they can be bedded in the concrete if desired. The retaining walls of wood should be left for ten days to allow the concrete to set well, and if the weather is frosty the top of the concrete should be covered with old sacking or frost will ruin the set.

When the wood frames have been taken



(Above) Laying the tape. (Left) The completed court.



The partly finished court showing the sifter and set square used.

down, we next lay the court itself. I used boiler clinkers, but domestic ashes will do quite well. These were sifted through a sieve. For an ordinary court, on dry ground, coarse ashes or clinker should be laid to a depth of  $3\frac{1}{2}$  in., raked smooth and rolled down, and 1 in. of fine ashes are placed above this and well rolled. The rolling is much more effective if done after heavy rain. We next come to the final surface dressing, which can be obtained from the various firms who build hard courts. I used En Tout Cas red dressing, which was placed on the ashes to a depth of  $\frac{1}{4}$  in., well watered and rolled, the cost is 59s. 6d. a ton, and a small amount of their fine dressing (7s. a sack) is scattered over the first layer, well watered and rolled, but better results can be obtained by heavy rain than any amount of watering.

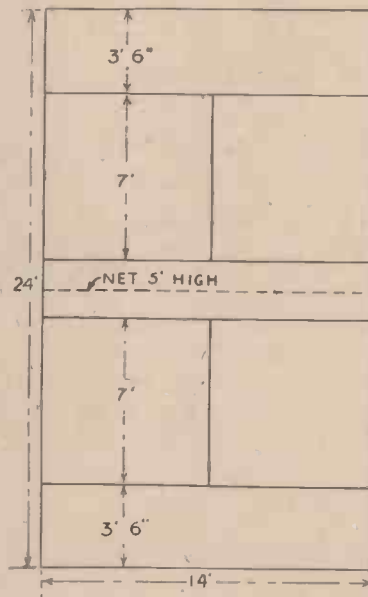
The fixing of the lines is quite simple. They can be bought from sports dealers at about 3d. per foot in long strips of lead, drilled with holes and painted white. They are simply nailed down.

A wire-netting surround is not necessary, but it is a great convenience. Mine is 9 ft. high, made of 3-in. interlink wire netting, supported by old gas pipes which are stayed by wire stays.

I then obtained a number of old pipes, and even if you do not get them for nothing, it should be possible to get them at scrap metal price. The pipes were dropped into the slots and were stayed by stout wire guys.

The net can be bought from any sports dealer. It is held in position by strings tied to the uprights. The top is 5 ft. above the court. The court is likely to be a little

loose at first, as it takes time, watering and rolling, to make hard courts really firm, but they allow play in all kinds of weather, and even after heavy rain.



Method of marking out the court.

They must be rolled before play, and after play the surface is smoothed with a soft broom, and rolled down. Care must be taken to keep the lead tapes free of grit or

the roller will drive it in and soon wear them out.

Padder, or ball tennis with wooden racquets, is played on a similar but larger court, 51 ft. by 18 ft. The wooden bats make it possible to get quite a fast game of tennis on this small court.

The construction of a full-size lawn tennis court is carried out in exactly the same way, but of course is much larger, and it is more difficult to get the surface level.

To assist drainage I arranged for a fall of  $1/200$  from one end to the other, and even in the wettest weather the surface has always kept free from flooding.

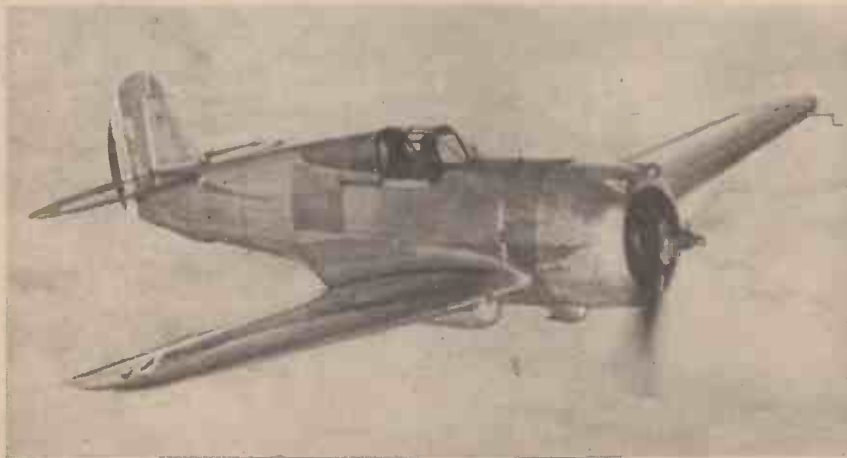
When heavy rain has fallen give the court a good rolling. A sack tied on the roller prevents the loose surface being picked up.

In very wet weather there is a tendency for moss and weeds to grow on the court. The best treatment is to water it with a solution of caustic soda, or weed killer. This should be applied *after* heavy rain but not during rain. Take 8 lbs. of soda to 15 galls. of water. Remember the soda will injure skin, so keep it off your hands or clothes.

If a hard court as described is well looked after it is possible to play in all weathers, even shortly after heavy rain, but *not* when the surface is thawing after severe frost. When the frost has gone, the nails must be pressed down and the court well rolled.

If the surface becomes too soft and mushy, spread on a light layer of the coarse surfacing material. If it is too loose and gritty dust on some of the fine surfacing material. These dressings are most effective after heavy rain, and should be well rolled in.

## Pilot Reaches Speed of 575 M.P.H.



An all-metal, single-seat type, this pursuit plane is similar to the Curtiss P-36A, the standard Pursuit plane of the U.S. Army Air Corps, and like it carries as standard equipment, a Curtiss electric propeller which held the speed of the engine to normal operation during the 575 miles per hour dive which started at an altitude of 22,000 feet (6,700 m.)

**A** CURTISS Hawk 75A Pursuit plane, one of a large number now being constructed for the French Air Force by the Curtiss Aeroplane Division of the Curtiss-Wright Corporation in its Buffalo, N.Y. factory, recently exceeded all known speed records for terminal velocity dives by free-diving over 575 miles per hour (925 Km./H.), in acceptance tests. It was the fastest speed at which any man-propelled machine has ever travelled.

While National Aeronautic Association officials declared that no Federation Aeronautique Internationale records even

approach this speed, experts supervising the flight test pointed out that the plane probably exceeded a speed of 600 miles per hour since it dived so fast the marker on the Recording Air Speed Indicator exceeded the range of the instrument and actually moved off the graph-paper roll.

Flown by the Curtiss organisation's chief test pilot, H. Lloyd Child, one of America's outstanding flight engineers, the new Curtiss Hawk began its dive at an altitude of 22,000 feet (6,700 m.) and reached its great speed during a free dive of 9,000 feet (2,700 m.). Pilot Child, declared that "he

### A 'Plane Dives To Attain It!

felt no ill effects and did not realise" that he had set a new speed record.

The terrific speed was recorded on instruments installed by the French Government's representatives who witnessed the flight. A photographic record from the French-Recording Air Speed Indicator, which charted the terminal velocity dive, presented a series of wavy lines representing the plane's climb to 22,000 feet, and featured two sharp upright lines. One, tracing the dive, extended completely off the margin of the graph while the other represented the decreasing speed following the pull-out.

In his report to Curtiss officials, Pilot Child revealed that at no time during the dive did the engine speed exceed 2,550 revolutions per minute. Its normal rated speed in level flight. Engineers attributed this to the unlimited blade pitch range of the plane's Curtiss electric propeller which prevented the engine from exceeding its normal rated r.p.m. and thus avoided any unusual strain on it during the dive.

Previously, one of the limiting factors in the speed at which an airplane could dive was the engine's r.p.m.'s, as overspeeding results in serious damage to the engine. With propellers of limited pitch range, the engine often exceeds allowable limits before the airplane reaches maximum speed in a dive, with the result that unlimited dives often have been restricted by propeller design rather than the strength of the airplane structure.



I'M A HANDY MAN IN A WORKSHOP

says  
*Pioneer Pete*

This little fellow represents the latest in Lighting Sets. His home is Britannia House, where a large range of the most compact, sturdy and dependable jobs yet seen is awaiting to light your workshop, to drive your lathe, or run your model railway.

We have a set of just the right capacity at just the right price for your problem. May we send you a catalogue?



**PRICES  
FROM  
£11**

**PIONEER**  
*Generating Sets*

"BLUE DIAMOND" (9 Models) A.C. and D.C. 175/350 watts. Volts 6, 12, 32, 110 D.C. Combination 110 and 230 A.C. and D.C. Sets.

"CHAMPION" (15 Models) D.C. 100/250 watts. Volts 6, 12, 32 and 110 D.C.

**THE BRITISH MOTOR BOAT MANUFACTURING CO., LTD.**  
Britannia House (Dept. P.M.2), Ampton Street (nr. King's Cross), London, W.C.1.  
Phone: Terminus 6361 (5 lines)



"00" PRINCESS ROYAL CLASS LOCOMOTIVE, LMS.

We specialise in High-Class Locomotives of any Gauge. Let us quote you for your next Requirements.

	Gauge 0	Gauge 00
L.M.S. Streamline Pacific ...	£23-£33	£13-£18
" Non- " " ...	£20-£30	£12-£17
" Stanier 5xP... ...	£18-£28	£11-£16
" Royal Scot ... ...	£18-£28	£11-£16
G.W. King ... ...	£19-£30	£10-£15
" Castle, etc. ... ...	£18-£28	£10-£15
L.N.E.R. Streamline Pacific	£23-£33	£13-£18
" Non- " " ...	£20-£30	£12-£17
" Sandringham ... ...	£18-£28	£10-£15
" GN Atlantic ... ...	£14-£20	£9-£13

The above are approximate prices according to amount of detail, and are for electric or clockwork movements.

**MULTI-MODELS LTD.** 10-11 NEW BURLINGTON ST.  
REGENT ST. LONDON W.1.  
TELEPHONE REGENT 5676

**THE  
MODEL  
RAILWAY  
EXHIBITION**



Locomotives, Coaches, Wagons, etc.  
Working Models, Antiques, etc.  
Free Rides Free Cinema Display

**CENTRAL HALL  
WESTMINSTER**

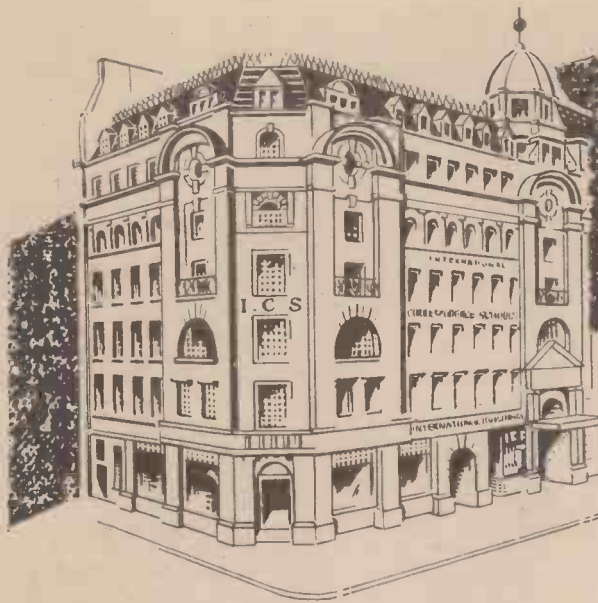
**APRIL 11th — APRIL 15th**  
**TUESDAY: 2 p.m. to 10 p.m.**  
**Other Days: 11 a.m. to 10 p.m.**

**ADMISSION**

**Adults 1/3** **Children 6d.**  
(Incl. tax) (under 12)

Rest Lounge, Restaurant and Refreshments in the Exhibition.

SPECIAL RATES FOR PARTIES:—  
Apply Hon. Sec.: 85 Wood Vale, London, N.10



*Your Work - AND Your Pay*

This is  
**INTERNATIONAL BUILDINGS**  
**KINGSWAY, LONDON**

Head Offices of the

**INTERNATIONAL**  
**CORRESPONDENCE SCHOOLS**

It is the centre from which radiates technical, commercial, and professional instruction that has been of great benefit to tens of thousands of ambitious people.

The I.C.S. is the greatest as well as the largest institution in the Empire devoted to spare-time training. Its prestige is unequalled. Several State Departments have entered into working arrangements with the I.C.S. for the training of men.

More than 1,500 I.C.S. text-books, prepared at International Buildings, are marvels of clearness, accuracy, and practical helpfulness.

There are 80 Instructors at Kingsway, many of them Associates, Members, or Fellows of their respective technical or professional bodies. All are specialists, and expert in giving the student individual attention throughout his Course of Study.

Among the 400 I.C.S. Courses there is one that can qualify YOU for Promotion and better Pay.

The size of your salary is more or less in accordance with the measure of what you know and therefore can do. The more you know, the greater your pay.

Success—progress won by merit—depends on trained ability. Unless you have studied IN YOUR SPARE TIME, you have little chance of promotion, for knowledge that comes through everyday work is not enough.

You must know the principles underlying your work and be familiar with the many processes closely related to that work. *The one and only means of obtaining such knowledge is specialized study.*

No man need be without that extra efficiency which adds so much to his income, security, and happiness. He can acquire it on easy terms, by the simple I.C.S. method of teaching by post.

If you are in the early stages of your career and have not yet had a specialized training, you should start to get one without delay. Or perhaps you feel that your knowledge is a little out of date and ought to be modernized. In either case

**The International Correspondence Schools can help you.**

*Our expert advice on any matter concerning your work and your career is yours for the asking—free and without obligation. Let us send you a booklet dealing with the subject in which you are especially interested. It is packed with valuable information.*

The I.C.S. offer instruction in the subjects given below.

Write for Special Booklet to-day or use the Coupon.

**COUPON FOR FREE BOOKLET**

**INTERNATIONAL CORRESPONDENCE SCHOOLS, LTD. (Dept. 95), International Buildings, Kingsway, London, W.C.2**

Please send me your booklet containing full particulars of the Course of Correspondence Training before which I have marked X. I assume no obligation.

- |   |  |  |   |
|---|--|--|---|
| <input type="checkbox"/> Accountancy              | <input type="checkbox"/> Diesel Engineering        | <input type="checkbox"/> Lettering                       | <input type="checkbox"/> Scientific Management      |
| <input type="checkbox"/> Advertising              | <input type="checkbox"/> Draughtsmanship           | <input type="checkbox"/> Mechanical Drawing              | <input type="checkbox"/> Short-Story Writing        |
| <input type="checkbox"/> Aeronautical Engineering | <input type="checkbox"/> Electrical Engineering    | <input type="checkbox"/> Mechanical Engineering          | <input type="checkbox"/> Steam Engineering          |
| <input type="checkbox"/> Air Conditioning         | <input type="checkbox"/> Engineering Shop Practice | <input type="checkbox"/> Mining Engineering              | <input type="checkbox"/> Surveying                  |
| <input type="checkbox"/> Architecture             | <input type="checkbox"/> Fire Engineering          | <input type="checkbox"/> Motor Engineering               | <input type="checkbox"/> Telephone and Telegraph En |
| <input type="checkbox"/> Boiler Engineering       | <input type="checkbox"/> Garage Management         | <input type="checkbox"/> Pattern-making                  | <input type="checkbox"/> Textiles                   |
| <input type="checkbox"/> Book-keeping             | <input type="checkbox"/> Gas-Power Engineering     | <input type="checkbox"/> Plumbing                        | <input type="checkbox"/> Welding, Gas and Electric  |
| <input type="checkbox"/> Building                 | <input type="checkbox"/> Heating and Ventilation   | <input type="checkbox"/> Radio Engineering and Servicing | <input type="checkbox"/> Wireless Engineering       |
| <input type="checkbox"/> Chemical Engineering     | <input type="checkbox"/> Hydro Electric            | <input type="checkbox"/> Salesmanship                    | <input type="checkbox"/> Woodworking                |
| <input type="checkbox"/> Civil Engineering        | <input type="checkbox"/> Journalism                | <input type="checkbox"/> Sanitary Engineering            | <input type="checkbox"/> Works Management           |

**EXAMINATIONS**

Technical, Professional, Matriculation, and Civil Service. State the one you wish to pass.....

NOTE.—If your subject is not on the above list, write it here.....

NAME..... AGE.....

ADDRESS.....





# NEW INVENTIONS

## Combined Gun and Camera

THE United States Patent Office has granted a Patent for a combined gun and camera. This firearm and motion picture photographic apparatus includes a trigger on the gun to which is pivoted a supplementary trigger. When this supplementary trigger is pressed, the photographic apparatus is actuated to cause pictures to be taken. Further pressing of the supplementary trigger will discharge the firearm.

I have no information as to the object of this twin-shooting weapon, which is decidedly problematical. It might be useful for photographing an enraged wild beast and shooting him before he has time to resent the insult.

## Snares for Snails

IF it were possible for a dumb creature to bring an action for libel or slander against schoolmasters and philosophers who, to point a moral, so often vilify it, the snail would have an excellent chance of recovering heavy damages. The alleged dilatoriness of this familiar member of the mollusc family is proverbial. Yet, considering that it



Here's something to interest housewives who have juggled with hot eggs when trying to take them out of the saucepan. This latest egg-timer, which is scaled from one to five minutes is fitted to a wire container into which the eggs are placed before being boiled. By lifting the egg-timer the water drains off and the eggs are brought out of the saucepan dry.

carries its streamlined domicile—a kind of portable air-raid shelter—its pace really entitles it to a prize for velocity.

But, although one may admire the snail's architectural skill, this creeping thing must be regarded as a foe in our gardens. To prevent its depredations, a Frenchman has concocted a special substance for which he has applied for a patent in this country. The compound is a mixture of husks of cereals and of solidified and undissolved alcohol. This product attracts and poisons the snail and the slug. It may be deposited in small cups around the crops to be protected, and remains effective for several days. Of use all the year round, it is not injurious to vegetation.

The following information is specially supplied to "Practical Mechanics," by Messrs. Hughes & Young (Est. 1829), Patent Agents, of 9 Warwick Court, High Holborn, London, W.C.1, who will be pleased to send readers, mentioning this paper, free of charge, a copy of their handbook, "How to Patent an Invention."

### INVENTIONS OF 1938

The number of applications by inventors for British patents during 1938 shows a definite advance compared with recent years.

The expansion in aircraft production has resulted in a large number of devices relating to aeroplanes. Amongst these are several for counteracting spinning and for mounting batteries of guns in wings and protection from ice formation, which is a frequent cause of accidental firing upon landing.

The extended use of electricity for factory and domestic work continues to inspire inventors to supply a great number of new electrically-operated devices.

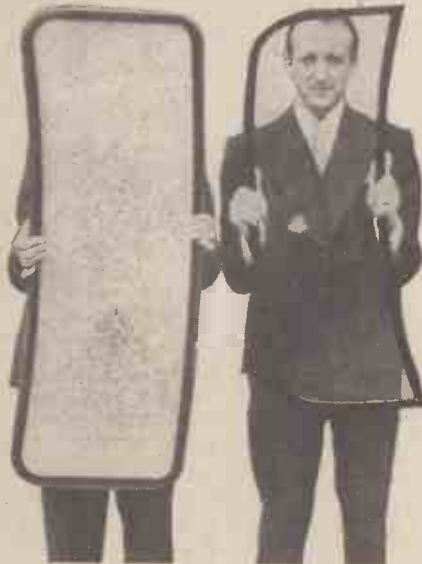
Also inventions relating to converting vehicles for gas protection purposes.

A safety pocket operated some distance from the pocket by means of a zip fastener has been patented.

Also a portable lethal chamber, the size of a Gladstone bag, specially designed for animal welfare work.

A scoring board for darts with a magnetically adjusted indicator makes a great appeal to dart players.

A ladies combined lipstick and mirror which necessitates the use of only one hand, should have a big sale.



After a number of accidents recently, following the windscreens and windows of motor-cars being struck by missiles, interesting experiments have been made at an Acton (London) glass factory. Various types of glass were catapulted and fired at—the after-effects being carefully noted. It was proved that laminated glass did not splinter, crack or become opaque, as was observed with one type of safety type glass shown on the left.



He keeps nothing under his hat—everything is on the outside. Fitted with mirrors, it is known as the periscope hat, designed for use at race meetings, in crowds, etc., and was on show at the British Industries Fair at the White City.

I presume that, in France, the succulent edible snail, so dear to the palates of the fellow-countrymen of the inventor, will be exempted from the destroying agent.

## Double-Bedded Spectacle Case

THE optician has performed a miracle in the shape of eyeglasses which are imperceptibly bi-focal. But some folks still use two pairs of spectacles—one for long distance and the other for reading. Now, to provide against the inconvenience of carrying two separate cases, there has been devised a simple, durable and inexpensive construction which will comfortably and safely house two pairs of spectacles. The dimensions of the case do not greatly exceed those of that which accommodates only one pair of spectacles. Dual compartments protect against friction and means is provided for maintaining bows in position.

## Mechanical Educator

A SWISS has applied in this country for a patent for an educational appliance for teaching arithmetic. He points out that, hitherto, the initial lessons in mental arithmetic are given by the teacher by verbally setting a task or writing it on a blackboard. The former method has the drawback that it may prove a strain upon the teacher's vocal organs. And the latter system necessitates the back of the schoolmaster being turned, which may be prejudicial to discipline. Referring to various calculating apparatuses which have been tried, he mentions that these have the disadvantage of displaying a large number of figures, which, when arranged in tabular form, the task imposed loses its clearness, and the attention of the scholars is diverted from the problem itself.

The new educational appliance takes into consideration the fact that the interest of children is naturally held by things which

are movable. An interchangeable band provided with numbers is moved past a window opening. In the neighbourhood of this, members are furnished to take small interchangeable tablets, each of which nearest to the window has an operating sign, while the most remote carries a number. And the whole is arranged in such a manner that the number at any time visible in the window, the operating sign and the number in the vicinity of the window represent the task. Thus the interest of the pupils is kept from flagging and they are attractively taught at least one of the three "R's."

### Make-Up for Cricket Bats

THE longevity and effectiveness of a cricket bat depend largely upon its resilience. It seems that it has been the practice to treat the blade of a cricket bat as carefully as a lady makes up her face. When new, prior to use, it is freely oiled and "faced," in order to harden the surface of the blade, to render it pliant and to prevent splitting. The treatment has to be repeated at frequent intervals during the life of the bat. Even with this treatment, the blade has a "cussed" tendency to split or chip at the edges, becoming also gradually heavier.

One of the objects of an invention for which a patent has been applied is to provide a process for impregnating the blade with rubber, the use of which will dispense with the necessity for the oiling and "facing" operations. It will also furnish a permanent binder for the cell structure of the blade, enabling it to withstand the shock of impact, and thus increasing its durability.

### Rubber Kettle Holder

THE old-world cloth kettle holder which was peddled in the days of Queen Victoria is still often a subterfuge for alms. But it now has a powerful rival in the shape of an adjustable holder, for which a patent has recently been applied.

Many domestic articles are provided with metal handles, e.g. kettles, cooking pans, flat irons, etc. But, owing to their shape, they are not comfortable to handle for a long period; or, being composed of metal, they convey heat too readily and are liable to make handling inconvenient and painful.

To obviate these disadvantages, the inventress—in this instance appropriately a lady—has devised a moulded strip of resilient, insulating medium adapted to lie along the outer side of a handle and having inwardly turned flanges lengthwise. These flanges are so moulded that their free edges press firmly against the moulded strip between the corners at the junction of the flap parts and the remainder of the strip.

The handle may be made of vulcanized rubber with plain or beaded edges. And, if desired, an advertisement may be incorporated therewith.

### Anti-Germ Screen

PORTABLE screens in hospitals are not a novelty. One example is covered with non-transparent material, so that the patient is invisible from the external point of view. Screens of glass in wood and metal frames have also been in use. But they are inconveniently heavy, and cannot with ease be adapted to varying conditions.

One of the latest things in this category is a screen for enabling a bed to be partially or totally enclosed. The object being to prevent the spread of infection. This screen consists of a portable frame, on which is stretched flexible, waterproof, washable material provided with transparent, flexible and non-inflammable windows.

### Rainbow Rubber

MOTHER-OF-PEARL—sometimes called nacre—which is the lining of oyster and other shells is undoubtedly a thing of beauty. An inventor has thought out a way of causing articles made of hard rubber to produce the same iridescent effect. This phenomenon is explained to be caused by the surface breaking up the light rays, assuming that the light is white light. But it is stated that, up to the present time, this mother-of-pearl appearance has not been produced on the surface of hard



A new method of receiving electric treatment demonstrated in Berlin. The current goes around the wires of the cage while the patient sits inside. This method is claimed to have more healing qualities than Ultra-violet rays. A small instrument is worn around the neck, the light in which goes out immediately the circuit is broken.

rubber. The foregoing inventor has manufactured an article comprising a moulded, coloured hard rubber compound containing arsenic sulphide, the surface of which presents distinguishable areas which reflect light with different degrees of intensity, depending upon the angle from which the article is viewed.

It will now be possible to manufacture small articles for toilet, household and similar purposes, which will not only be useful but will claim kinship with the rainbow.

### Training Machine for Ski-ing

IN the same way that a child can, on dry land, learn the actions necessary in swimming, so there has recently been devised apparatus adapted to facilitate the art of ski-ing. The appliance comprises a flywheel on an axis symmetrically arranged between two parallel axes each carrying one pair of bicycle-like pedal cranks. The two cranks on each side of the flywheel being connected form a foot platform. And these cranks are so arranged that they drive the flywheel.

To render more efficacious the preparatory training for ski-ing, the mode of fixing of the feet upon the blades allows the mobility of the heel relative to the platform.

An apprenticeship on this contrivance will qualify the tourist for a brilliant display upon the scintillating snows of St. Moritz.

### Automatic Car Light Switch

THERE has appeared an improved device relating to systems for automatically switching on and off vehicle lights particularly those used for parking purposes. In systems of the latter kind, when the vehicle is standing on a public road, it is necessary to obtain the automatic illumination at nightfall, and the switching off when daylight reappears. On the contrary, when the car is in a garage, the lights should not be switched on in darkness. In this way, unnecessary consumption of electric current is avoided.

In connection with a photo-sensitive apparatus for switching lights on and off, the device referred to has made its advent. It is characterised by the fact that the current of the lights is controlled by a circuit breaker. This includes a pendulum adapted to be applied either against a permanent magnet so as to close the circuit, or against an electro-magnet for keeping the circuit open. The latter magnet is energised when the photo-sensitive apparatus is in darkness. Thus the illumination will be adjusted according to the nature of the circumstances.

### New Valve for Compressors

THE valves of large compressors call for special features which are not easy to realise, and if they are not forthcoming, the deficiency is plainly noticeable in the life of these parts of the machine. For instance, the continual shocks to which plate valves are subjected lessen the wearing resistance of the material to a considerable extent, and so a well-known firm in Western Germany have introduced a new type of valve. One feature of these valves is a novel arrangement of the springs as well as of the entire valve slot guides which reduces the mechanical stresses on the material considerably; another is the employment of a special alloy steel in their construction which results chiefly in the valve plates being very much more durable than ordinary material. This durability, in turn, enhanced by the special machining the material undergoes, the valve plates, for example, being milled, and not stamped out, thus avoiding even the very tiniest hairline cracks. Their design, their construction and the material of which they are made all result in the life of these valves being several times as much as those produced in the ordinary way.

## PRACTICAL LEATHERWORK AND OTHER ALLIED CRAFTS

By Fred Jace

This handbook not only deals exhaustively with leatherworking, but other crafts such as Appliqué, Gesso, Raffia, Batik, stencilling and rugmaking. It contains 96 pages and 179 photographs and diagrams.

From all Booksellers, 1s. or by post 1s. 2d. from the publishers, George Newnes, Ltd., (Book Dept.), Tower House, Southampton Street, Strand, W.C.2.





# The PARSONS STEAM TURBINE

*How it Works!*

A Brief History of Sir Charles Parsons, who Devised the Principle of Compounding, which was a Characteristic Feature of his Pioneer Turbine of 1884, and is now Universally Employed

**I**N an ordinary reciprocating engine the work is done by the pressure of the steam against a moving piston. In a turbine there is no element corresponding to the piston, but the mass of the steam itself is set in motion by its own elasticity. Since the density of steam is small, the velocity attained is consequently high, and the problem of the designer is to use the momentum of the rapidly moving steam for the production of work. This may be done in several ways. Jets of steam may be caused to exert an impulse on moving blades, or advantage may be taken of the reaction of jets of steam on the moving orifices from which they emerge, or a combination of both principles may be employed.

The simplest type of impulse turbine is that invented by Dr. Gustav de Laval. This consists of a single bladed wheel acted on by one or more jets of steam, as shown in Fig. 4. To abstract the greatest possible amount of work from the steam in this way, the blades would have to travel at almost half the speed of the steam. With ordinary boiler pressures the steam

would issue from the nozzles at something like 4,000 feet per second, and considerations of centrifugal force prohibit a blade speed even approaching half this velocity. The efficiency of a single impulse wheel cannot, therefore, be high, and turbines of this design are, in fact, only built for comparatively small powers when efficiency is not of primary importance.

### Pioneer Turbine

To reduce the steam velocity to a figure appropriate to practical blade speeds, Sir Charles Parsons devised the principle of compounding, which was a characteristic feature of his pioneer turbine of 1884, and is now universally employed. In a compound turbine, the total fall in pressure of the steam from the boiler pressure to the condenser vacuum is made to take place by a series of steps or stages. By employing a sufficient number of stages, the velocity acquired in each stage may be kept as low as desired, and the blading may therefore be made to work under conditions of maximum efficiency.

All commercial turbines are compounded in this way. A compound impulse turbine consists of a number of bladed wheels fixed to a shaft, each wheel running in a separate compartment of the casing, as shown in Fig. 2. The steam enters the first compartment through a set of nozzles, and has its acquired velocity abstracted by the wheel in that compartment. It then passes through another set of nozzles into the second compartment, where its freshly acquired velocity is again abstracted, and so on along the whole turbine. The number of compartments or stages may be anything from about a dozen to forty or more, depending on the steam conditions, the speed of rotation and the efficiency desired.

As an alternative to the impulse principle, in which steam from fixed nozzles acts on moving blades, it would be possible to construct a turbine to develop power from the reactive force of a moving jet. This was the principle employed in the classical Aeropile of Hero of Alexandria, and it is also characteristic of the Barkers Mill, or reaction water turbine. A few steam tur-

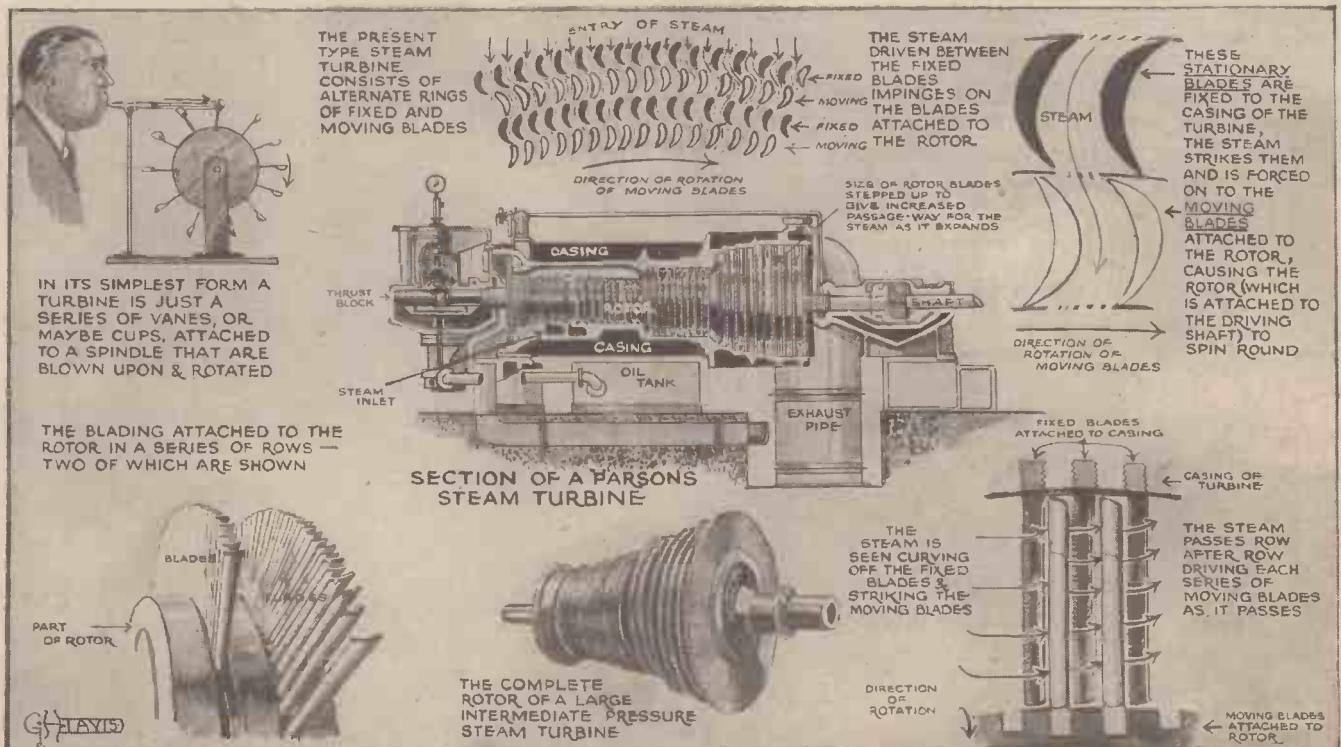
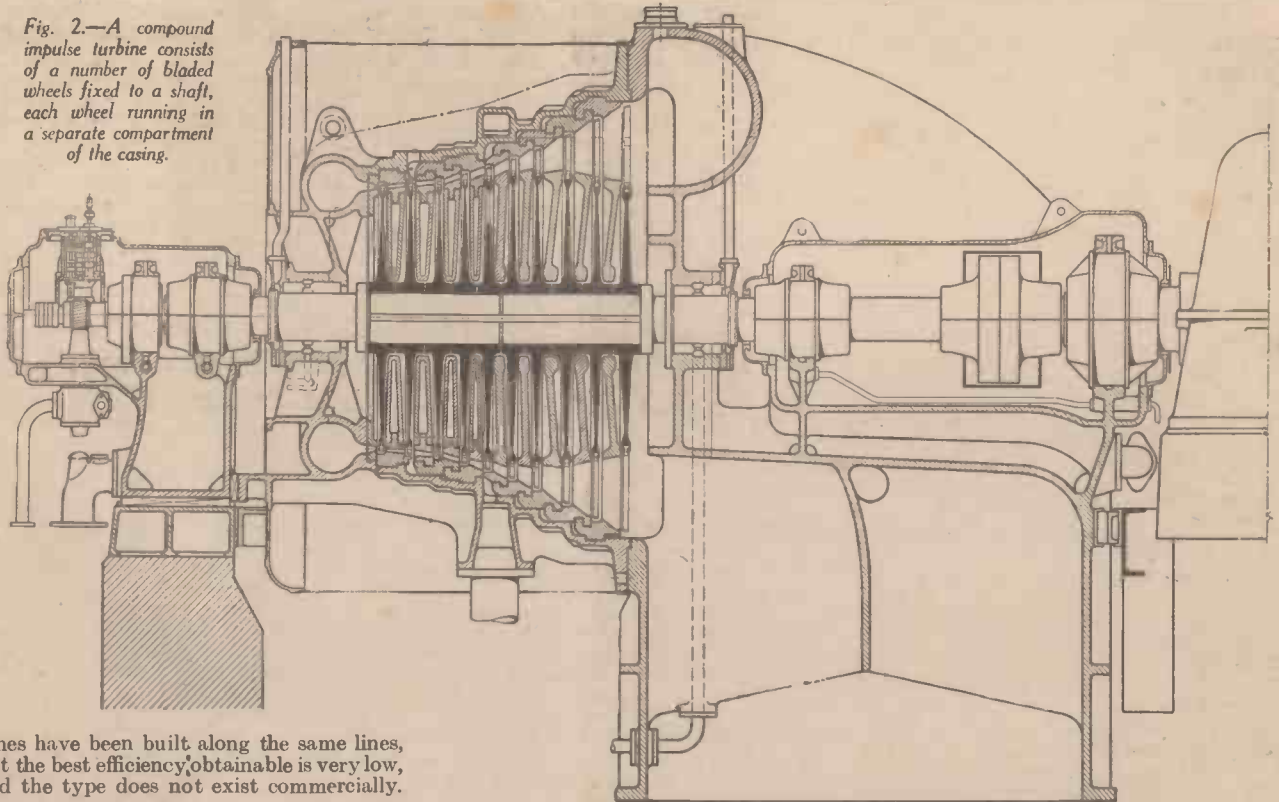


Fig. 1.—This series of pictorial diagrams shows how the steam turbine works. The motion imparted to the propeller shaft is never jerky but always even and speedy

Fig. 2.—A compound impulse turbine consists of a number of bladed wheels fixed to a shaft, each wheel running in a separate compartment of the casing.



bines have been built along the same lines, but the best efficiency obtainable is very low, and the type does not exist commercially.

**Moving Blades**

The name of reaction turbine is now always applied to machines in which the moving blades are propelled partly by the impulse of steam issuing from fixed jets, and partly by the reaction of the steam expanding in the moving blades themselves. A reaction turbine may therefore be defined as one in which the steam always undergoes a drop in pressure during its passage through the moving blades, whereas in the impulse type the whole fall of pressure takes place in the nozzles, and the steam leaves the moving blades at the same pressure as that at which it entered them. In the Parsons turbine the fixed steam jets are produced by stationary blades which act as nozzles, and as an equal pressure drop takes place in both fixed and moving blades, these are identical in form, as shown in Fig. 7. This similarity of form and function permits of a construction of great simplicity. The turbine rotor, instead of being composed of a number of independent wheels, has a plain cylindrical or conical surface, while the casing is a simple cylinder without compartments or internal diaphragms. One consequence of this is that

a very large number of pressure stages can be accommodated in a reasonable length, so that the steam velocities are small, the stresses in the blades are low, and the action of the blading is very efficient.

**A Modern Turbine**

A modern Parsons turbine with a capacity of 30,000 k.w. at 3,000 r.p.m. is shown in section in Fig. 6. The machine in question is designed to work with steam at a pressure of 650 lbs. per sq. in., super-heated to 850 deg. Fahr., and to exhaust into a condenser with a vacuum of 28.75 inches at the maximum load of the machine. The turbine consists of two cylinders in tandem. The steam enters the h.p. cylinder through the belt shown at A and expands to approximately atmospheric pressure in passing through the blading of this cylinder. It is then taken by a pair of overhead pipes to the l.p. cylinder, in which the expansion is continued down to the condenser vacuum. The l.p. cylinder is of the double flow type, the steam entering at the centre of its length and flowing to an exhaust branch at each end. This arrangement not only balances the end-pressure due to the action

of the steam, but also permits the large volume of steam to be dealt with by blading of half the length that would otherwise be required.

The h.p. cylinder is a casting of molybdenum steel, on account of the superior qualities of this alloy as regards resistance to the effects of steam at high temperatures and pressures. It is as nearly as possible of uniform thickness and rigidity, and as a further precaution against distortion by temperature stresses, the heavy flanges along the horizontal joint are sawn through at the boltholes in order that the cylinder shall not be subject to any constraint by the relatively cooler flanges. The rotor is a hollow forging, integral with the shaft at one end and closed at the other by a forging which is extended to form the second bearing. It carries fifty-one rows of moving blades, and as there are, of course, an equal number of rows of fixed blades, the steam has to undergo no fewer than 102



Fig. 3.—Groups of segmented blading ready for insertion into a Parsons turbine.

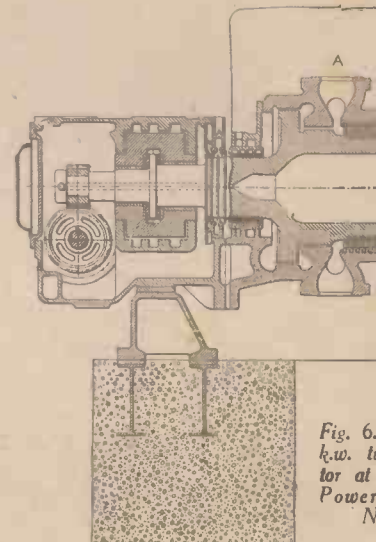


Fig. 6. 30,000 k.w. turbine rotor at Power N



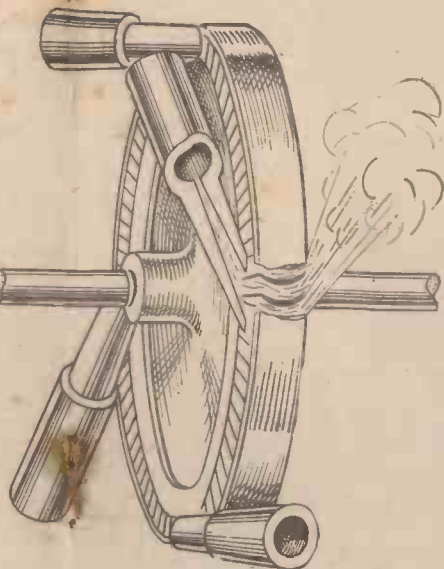
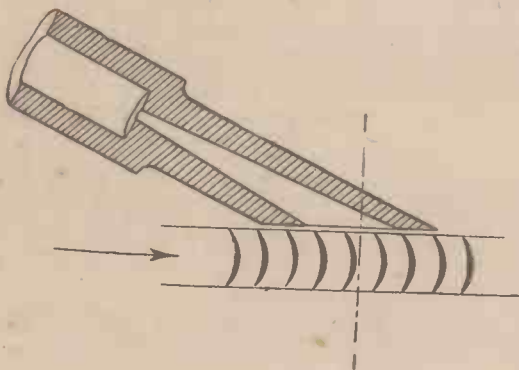


Fig. 4.—Left (and below) is shown the principle of the De Laval steam turbine.



Fig. 5.—(Right) Nowadays our fastest ships are fitted with turbines. Here we show the lower portion of a turbine casing as installed in one of our big liners.



“end-tightened” type. Both fixed and moving blades are provided with sharp-edged overhanging shrouds which are almost in contact with the foundations of the next blade row. This type of blading secures a high economy of steam and at the same time permits of ample clearance over the blade tips, so that the blading cannot be damaged by contact due to vibration of the turbine or distortion of the casing. Such blading is invariably employed for the high-pressure portion of Parsons turbines, where the density of the steam is sufficient to make the control of leakage important, and where distortion effects are most likely to be encountered. The clearances over the blade tips may be a quarter of an inch or more, while the axial clearance on which the leakage depends may be safely kept down to 0.01 of an inch. As these axial clearances are controllable by an adjustable thrust bearing, they can be maintained indefinitely.

In the remainder of the h.p. cylinder, and throughout the l.p. cylinder, where, owing to the increased volume of the steam, a little leakage is of less importance, radial clearance blades are used. The “end-

tightened” blading and most of the radial clearance blading is of the segmental type, shown in Fig. 7, in which the blades and their distance pieces are welded and brazed into groups before being fitted in the turbine. Each group consists of from eight to twelve blades, and constitutes a short arc of the whole circle of blading. The longer blades, towards the exhaust ends of the l.p. cylinder, are rolled integrally with their roots which act as spacing pieces. The tips of the radial clearance blades are thinned to knife-edges which would be harmlessly rubbed away in the event of accidental contact while running. The blading material throughout the turbine is of stainless iron which is not subject to corrosion. To prevent erosion from water particles in the steam, the blades at the exhaust ends of the l.p. rotor are fitted with shields of tungsten steel.

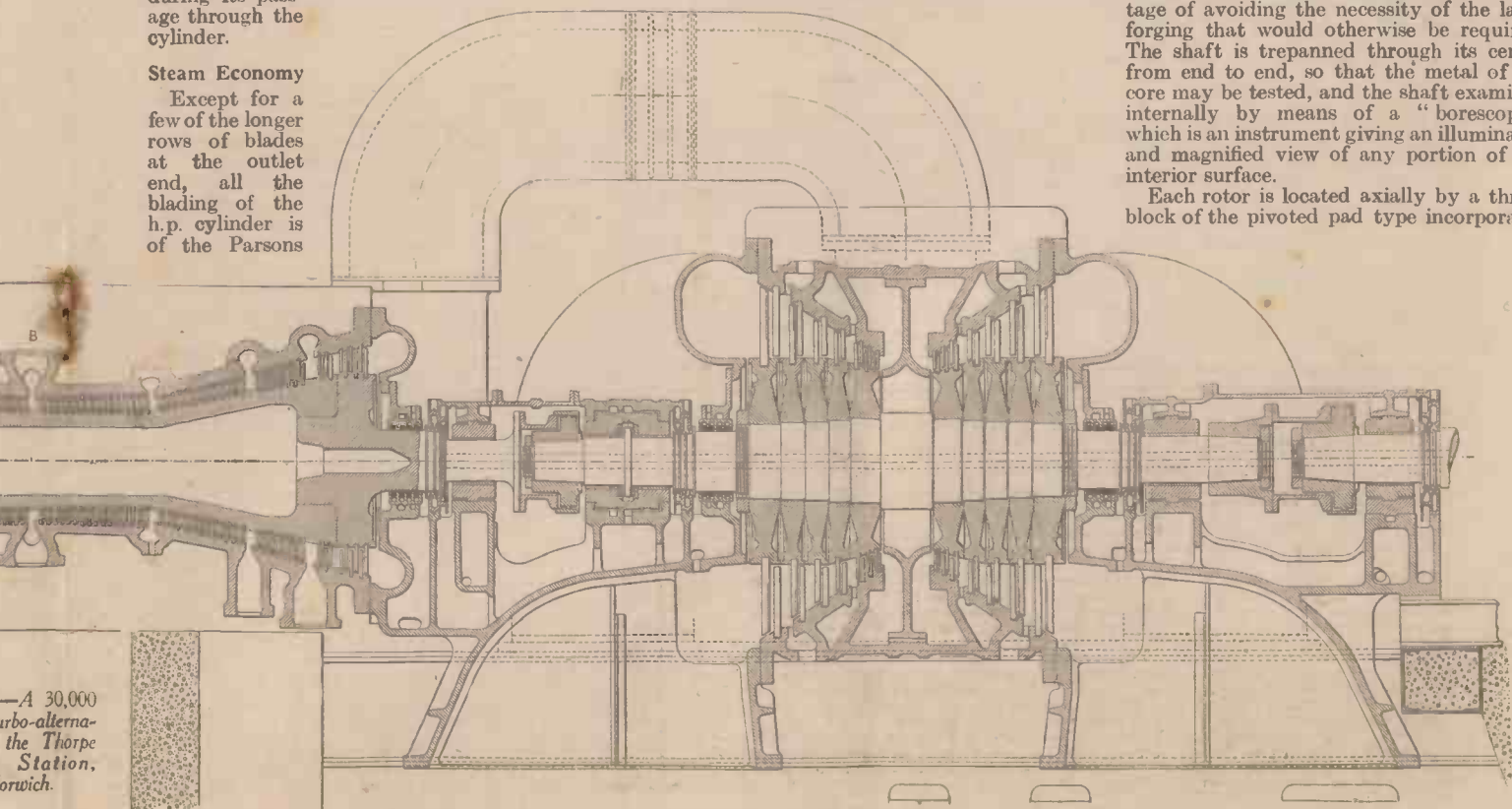
The l.p. cylinder of the turbine is of cast iron, as it is not subjected to great changes in temperature or pressure. The rotor is built up of thick discs shrunk on to the shaft. The discs are close together so that their circumferences form what are virtually two continuous cylindrical surfaces, this method of construction having the advantage of avoiding the necessity of the large forging that would otherwise be required. The shaft is trepanned through its centre from end to end, so that the metal of the core may be tested, and the shaft examined internally by means of a “borescope,” which is an instrument giving an illuminated and magnified view of any portion of the interior surface.

Each rotor is located axially by a thrust block of the pivoted pad type incorporated

successive partial expansions during its passage through the cylinder.

**Steam Economy**

Except for a few of the longer rows of blades at the outlet end, all the blading of the h.p. cylinder is of the Parsons



—A 30,000 turbo-alternator at the Thorpe Station, Norwich.

in one of the bearings, and steam tightness is secured by carbon-packed glands. The two rotors are united by a flexible claw-tooth coupling, and a similar coupling connects the l.p. rotor to the shaft of the alternator. The governor and oil pump are driven by a worm-gear housed in the pedestal of the h.p. bearing. The governor is of the centrifugal type and acts by controlling the oil pressure in a pilot circuit, allowing more or less oil to escape according to the speed of the turbine. The supply of oil to the bearings, and for the operation of the steam valves is, of course, unaffected by the action of the governor. Any failure of the oil-pressure will bring about the immediate closing of both the main stop-valve and the two governor valves, thus entirely shutting off steam from the turbine. The oil-pressure can be released by the operator at any time if he wishes to shut the turbine down suddenly, and it will also

be released by the action of an emergency governor in case of the turbine speed attaining a predetermined value. When the turbine has been stopped in this way, the main stop-valve cannot be reopened until the proper oil pressure has been restored by the auxiliary oil pump.

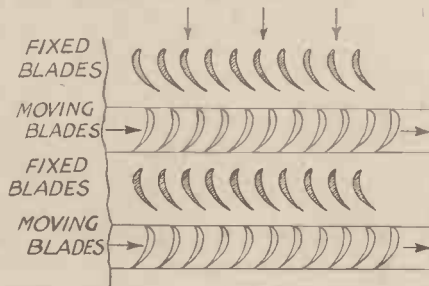


Fig. 7.—Plan of the blade arrangement.

There are two governor valves, one of which controls the admission of steam to the belt A until the most economical load of the turbine is reached. After this point, the second valve opens automatically and allows live steam to enter the belt B, thus short-circuiting the first section of blading and enabling the turbine to carry the extra load. The next belt seen round the h.p. cylinder is provided for balancing purposes, being connected by a steam pipe to the front side of the larger of the two dummy pistons to balance the end-thrust of the steam on the conical portion of the h.p. blading. The two remaining belts are for the extraction of partially expanded steam from the turbine for feed-heating. Altogether four tapplings of steam are taken for this purpose, the condensate being thus raised successively to a total temperature of 310 deg. Fahr. before passing to the boilers.

## AROUND THE TRADE

### Novelties Now On The Market

#### The Anglepoise Lamp

**P**oor lighting in the home or office causes one's work to suffer through eyestrain and fatigue. This can be overcome, however, by using the Anglepoise lamp, which can be adjusted to any position and throws a powerful beam on to the work only, and not into the worker's eyes. It is sold in various types. There is the clamp bracket type which can be clamped into any desired position at a moment's notice, the bracket type for fitting to a wall, etc., or, if desired, it can be obtained on a stand. The lamp is a workmanlike job and has a solid metal base, chromium plated arms and tireless springs for perfect balance. It is sold in various colours—red, green, orange, black, blue, cream and all gold—which is the standard finish. With chromium-plated arms, base and shade it costs £3 8s. 6d., with gold arms, base and shade, £2 18s. 6d.; with chromium plated arms and enamelled base and shade, £2 18s. 6d.; and dull black arms and enamelled base and shade, £2 10s.

#### Pocket Humatagraph

**W**EATHER changes are largely due to the moisture in the air. Perhaps you have a thermometer to tell you how hot or cold it is, but your health and comfort is affected more by humidity than by the temperature. The small pocket hygrometer shown on this page will give you what you want. It is known as the Humatagraph, and is so sensitive that if it is held between the palms of the hands for two minutes it will be affected by the moisture of the hands and go over several points. The calibration is neatly uniform and easily legible. A

folded arm or whirler is provided which enables the operator to secure the rapid movement of air over the sensitive absorbent fibre in the instrument and thus determine the humidity of the air in a few minutes. Two minutes' rapid whirling will give a very accurate reading. The nickel-plated whirler



The Pocket-model Humatagraph.

is 17½ ins. long when open, and 7½ ins. when folded. It has an especially designed catch which holds the Humatagraph securely. It takes only a few seconds to secure the instrument in place. Without case it costs 12s. 6d., with case 14s. 6d., and the whirler costs 5s. 6d.

#### Photography as a Hobby

**P**HOTOGRAPHY is growing in popularity every year as a fascinating and thrilling hobby. Modern apparatus is so ingenious and cleverly designed that with

a few weeks' experience, an ordinary intelligent amateur can take pictures almost as good as those which he sees every day in the daily press and the numerous illustrated journals.

Although picture-making is easier to-day, acquiring good apparatus is, perhaps, becoming more difficult because the modern miniature camera is rather an expensive item and will cost anything from 9 or 10 guineas up to £60. It is, however, possible to obtain such apparatus by deferred payments, which can be spread over periods up to two years.

City Sale & Exchange (1929), Ltd., 59 Cheapside, are pioneers of this method of acquiring first-class apparatus without any financial strain.

Readers interested in really good photographic apparatus should write to this firm and get fuller particulars.

## BOOKS RECEIVED

"Commonsense and A.R.P." By Major-General C. H. Foulkes, C.B., D.S.C.

**O**NE of the pressing needs of the moment is the adequate defence of the public against air raids. Many schemes have been proposed by the Government, but this book has been specially written for the house-owner and small trader, and explains how to provide shelters by making use of the materials at immediate disposal, instead of expending large sums of money on concrete, sandbags, etc. Other subjects dealt with include Air Raid Risks, High Explosives Ideal Shelters, Fire Precautions, First Aid, Decontamination, and Communications. The price of the book is 1s. (by post 1s. 2d.) from C. Arthur Pearson, Ltd. (Book Dept.), Tower House, Southampton Street, London, W.C.2.

"Everyman's Astronomy." By Mary Proctor, F.R.A.S. Published by The Scientific Book Club. 246 pages. 2s. 6d. net.

**T**HIS book, which is written in non-technical language, contains a fascinating collection of astronomical facts which should make interesting reading for the intelligent layman. As is well known, the author has made a life-long study of astronomy, and the subject is dealt with in a very entertaining and lucid manner. Celestial Photography; The Future of the Moon; The Great Meteor Crater of Arizona; and How Meteors are Trapped by a Camera are among the subjects dealt with in some of the seventeen chapters of the book, an important feature of which is the remarkable collection of photographic illustrations.

The Handiest Book Yet Published for Draughtsmen, Fitters, Turners, Mechanics, Pattern-Makers, Erectors, Foundrymen, Millwrights and Technical Students

### WORKSHOP CALCULATIONS, TABLES AND FORMULÆ

By F. J. CAMM

(Editor of Practical Mechanics)

3/6, or 3/10 by post from Geo. Newnes, Ltd., Tower House, Southampton Street, Strand, London, W.C.2.

Its Comprehensive and Fully Illustrated Contents include:—The Micrometer and Vernier; Mensuration; Trigonometrical Formulæ; Extracting Square Root; Extracting Cube Root; Continued Fractions; Arithmetical Progression; Geometrical Progression; Harmonical Progression; English Weights and Measures; Horse Power; Force, Energy, and Power; Heat, Time, and Velocity; Electrical Units; Comparison of Thermometers; Pulleys; Parallelogram Forces; Pendulum; Levers; Centrifugal Force; Moments of Inertia; Metric Systems; Screw Cutting; Tool Grinding Angles; Lubricants for Cutting; Spur Gearing; Tapers and Angles; Bevel Gears; Worm and Worm Wheels; Spiral or Screw Gearing; Pulley Calculations; The Dividing Head; Differential Indexing; The Slide Rule; H.P. Required to Drive Shop Tools; Table of Cutting Speeds; Proportion of Keys and Cotter; Standard Screw Threads; Drill Sizes; Circle Spacing Table; Tapers and Angles; Melting Points of Metals; Weights of Materials; Twist Drills for Wood Screws; Wood Screw Proportions; Weights of Woods; Powers and Roots of Numbers; Wire and Sheet-Metal Gauges; Natural Sines, Cosines and Tangents; Logarithms and Antilogarithms.



# DECORATIVE HOUSE LIGHTING

*It is Sometimes Desirable to Change Existing Lighting Schemes by Introducing a New Type of Lamp or General Lighting. This Article tells You How this may be Accomplished*

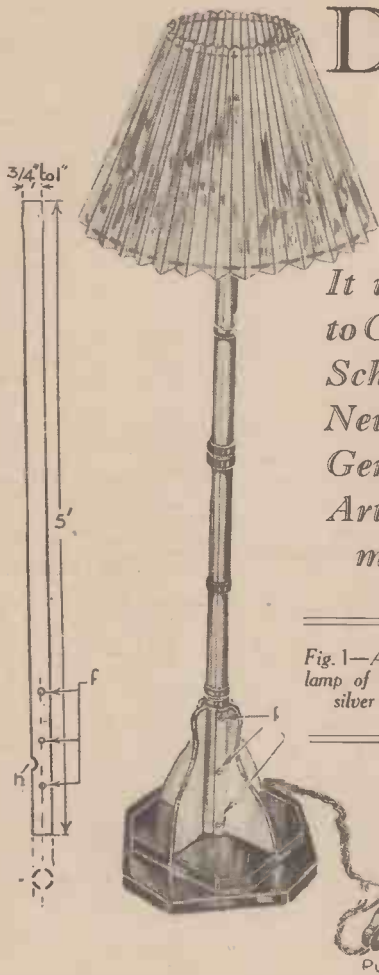


Fig. 1—A Standard lamp of black and silver design.

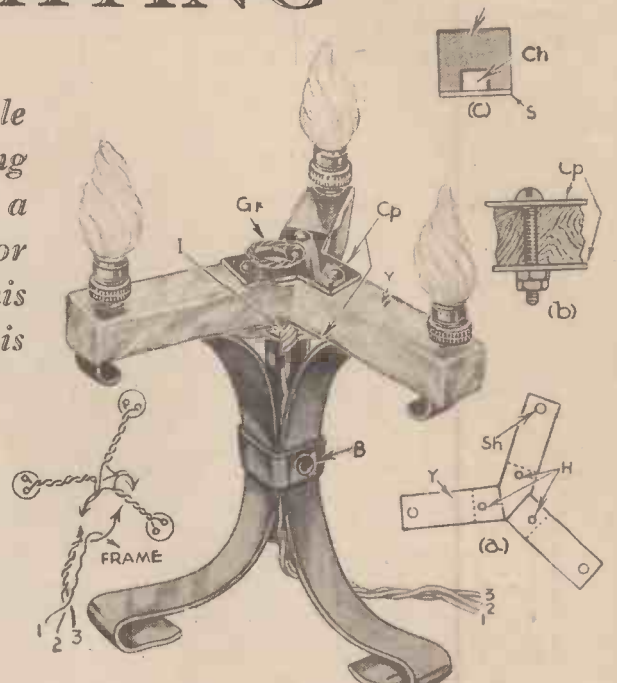


Fig. 2.—A modern version of the old or drop type candle lamp.

MANY pleasant effects may be obtained in a room by carrying out improvements on the existing lighting arrangements. In some instances it may only be necessary to alter the positions of lamps, obtaining quite a different aspect and colour contrast, whilst at times it is refreshing to completely change the scheme by introducing a new type of lamp or general lighting.

A new 2 or 5 amp electric light point will provide a suitable fitting for wall light or serviceable little table lamp, and although the centre drop type of lighting predominates in most homes, it is quite possible to get over the annoying concentrated glare effect by the introduction of other lamps, reducing the power (wattage) of the centre and balancing up with these other lamps.

Wall lights offer a particularly good approach to even distribution, but it is desirable to have light wall-paper unless very distinct contrast is required, but, failing the use of wall lights, separate lamps can be positioned to give very nearly the same artistic effect. Standard lamps are of two types, the reflecting ceiling type and the more conventional shaded pattern about which we propose to deal.

Apart from the question of clear illumination with even distribution, the secondary consideration is style, and invariably simplicity rules.

### Standard Lamp Design

The standard lamp shown in Fig. 1 is a black and silver design, and it will be noticed that the softening effect to the otherwise hard appearance, is accomplished by fitting at equidistant points down the

tube, black rings, these serving to relieve or break the monotony of the silver. The shade illustrated is included in this pictorial so that the "contour" question can be exemplified, and although details are not given of this particular style, the data on the construction of another type of adaptable drop or standard shade, given later, will show the methods to adopt should it be desired to make one up.

The base of this standard comprises five separate pieces of wood arranged in accordance with the diagram, Fig. 3, whilst by this method, the four fancy supports are better secured without the unsightly appearance of too many screw heads, these supports serving to strengthen the assembly.

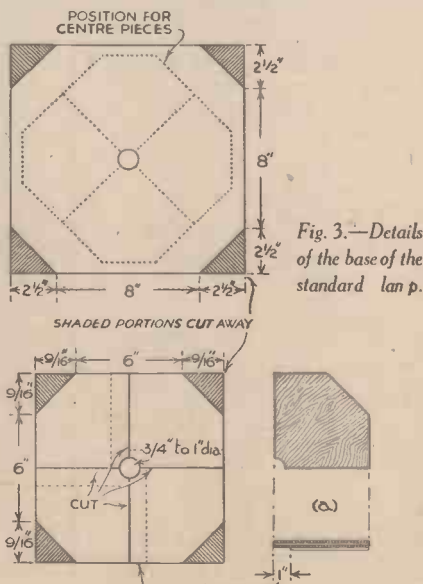


Fig. 3.—Details of the base of the standard lamp.

The supporting plates shown in Fig. 5 are made from two sheets of 18 S.W.G. aluminium.

The design should be first of all drawn out on a piece of paper squared to the size of the uncut aluminium plates, then with a scribing tool the curve can be pricked through on to the aluminium, using the same drawing for both plates. Next a line should be scribed from corner to corner as depicted, and the plate should then be cut along this line.

### Bending the Plates

The resultant triangular sections can now be cut off with a pad saw, the remainder of the curve in each piece being filed down with a half-round file. To bend each plate to obtain the fixing flanges, the bending lines, represented dotted in the diagram, should be scribed, and a light scoring made along these, bending between two pieces of wood let in to the jaws of the vice.

The drillings should be carried out before bending.

Allowance should be made as indicated by "X" for the sinking of each design plate before scribing the fixing hole positions in the tube flange.

With regard to the base blocks, it will be seen that 7-ply wood is used for the base proper, 5-ply being used for the quarter blocks.

The standard chromium-plated brass tube is to be fitted into the large base, and a hole should therefore be drilled right through this block, but as this base is not provided with feet (although they can be fitted if desired), the flex lead from the socket will have to be taken through a 5/8 in. diameter hole, drilled into the tube near the base.

Now a final word on the decorative rings and assembling, the rest of the detailing being self-explanatory from the diagrams. The sleeves are to be held in position by

grub screws, but as the exact position for these rings is optional, drillings have not been included for the grub screws in the brass tube. Dowel wood or thick ebonite tubing cut to the approximate proportions shown serve admirably, and in the case of wood, it should be possible to obtain a really good finish with glossy paint or enamel. After fitting the sleeves, the light socket assembly should be wired and screwed to the tube as shown in Fig. 7.

**Switch Socket Mount**

The switch socket mount "R" is fashioned from a piece of 18 S.W.G. aluminium, being drilled for 4BA clearance at "P" in each flange "F." A  $\frac{5}{8}$  in. hole should be made centrally at "T" for the fixture of the switch socket, this allowing the threaded portion "E" to be passed through and secured by the flex clamp sleeve as shown.

Short 4BA round-headed screws clamp the switch socket mount to the tube by the two 4BA tapped holes "O" after wiring up.

The base assembly can next be attempted, fitting each design plate 1 in. flange into each recess with short countersunk wood screws. When the tube is fitted, the quarter blocks Fig. 3 (a) automatically centre themselves, but it will be necessary to adjust the relationship of the base

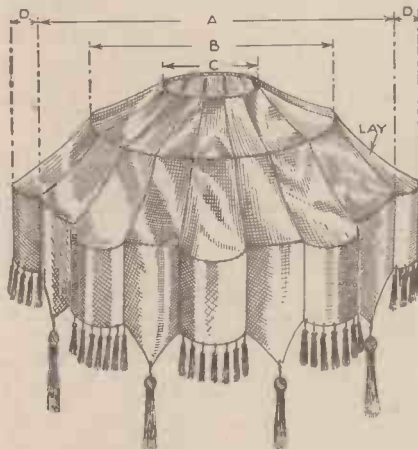


Fig. 4.—A design for a large shade.

corners, thus a trial assembly will be advisable at this point to mark off the hole positions in the base block, for fixing the quarter blocks by well countersunk screws let up through this base.

Three 4BA Csk. hd. (nickel finished) screws are used for fixing each plate and the base can then be completed by painting with two under coats and two coats of black Japan enamel, and finally a piece of baize should be neatly glued to the bottom.

The wiring is quite simple, the only point which requires emphasizing being the inclusion of a third wire in the lead for earthing the metal-work of the lamp.

**A Suitable Shade**

The suggestion given in Figs. 4 and 8 for a shade, is based on the modern tendency for reasonably shallow and proportionately deep frame, and is particularly suitable for the chromium and black standard just described, since it rather accentuates the slender stem without in any way giving that overbalanced appearance.

To commence, it will be found useful to make rough comparisons first of all with cut-out newspaper discs, these representing the wire rings, and the contours can be decided upon at this stage.

Ascertaining the depth for each ring is, of course, quite simply a trial by error

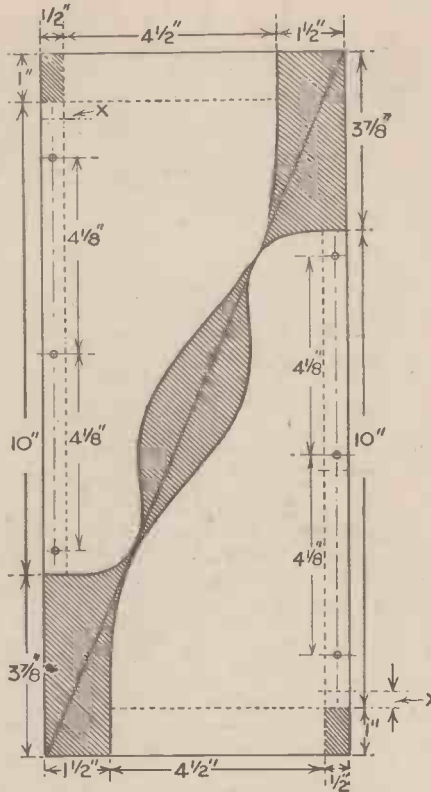


Fig. 5.—How the supporting plates for the base of the lamp standard are made.

process, but the point which often causes difficulty is the allowances to be made for the "lay" of the covering material afterwards. For a large shade of the style shown in Fig. 4, suitable measurements can be given as follows:—

Diameter "A" equals 18 in. to 20 in.; diameter "B" equals 10 in. to 12 in.; diameter "C" equals 3 1/2 in. to 5 in.

Depths "E," "F," and "G" being approximately 2 1/2 in., 2 1/2 in. and 3 1/2 in., respectively.

The circumference for each of the rings should then be marked out in pencil on a piece of wood.

Stout nails driven into the wood just inside the scribed circumferences provide an accurate foundation for moulding the wire into the rings. The type of wire used is galvanized and of about 10 or 12 gauge, the amount required being determined by summing up the individual lengths whilst leaving sufficient for any errors; usually this wire is purchaseable in pre-arranged

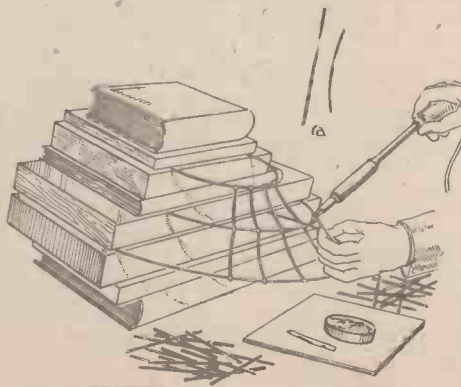


Fig. 6.—The framework for the shade.

coils, and is quite reasonable in price. Allowance should be made for "take-up" in the curved joining wires when cutting these pieces "W.WI," and this is illustrated by the inset (a) in Fig. 6.

Fig. 6 shows how, after moulding the rings—not forgetting that two lower rings of identical size are required—the framework can be soldered. If silk covering is preferred to parchment or buckram, then the wiring will have to be bound with tape so that the silk can be sewn on with strong silk thread. With parchment or buckram, binding in this manner is not essential, the pieces being hoe punched then simply over-stitched onto the wire frame. Decorative effect can be obtained either by the use of a silk fringe or silk tassels as shown.

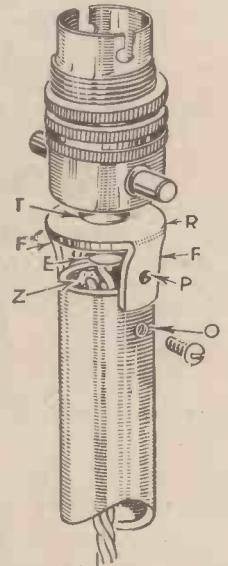


Fig. 7.—The light socket assembly for the standard lamp.

**A Wall Light**

A neat wall light is shown in Figs. 9 and 10.

For preference the lighting power should be kept below 60 watts for average conditions of use, and the overall measurements should allow the light bulb to be centred well away from the glass and back plate "G," so as to obtain even distribution and prevent effects of overheating.

The flex lead also should be kept well away from the bulb, and although for

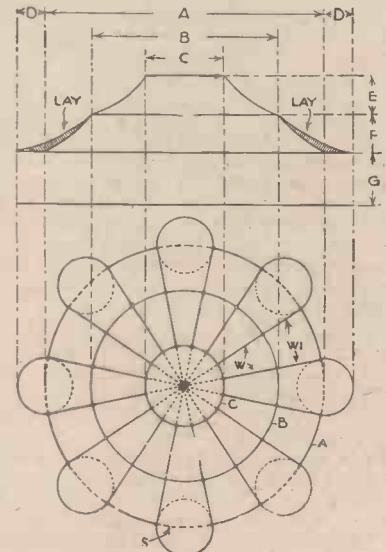


Fig. 8.—How the shade design is plotted out.

clarity this is shown as a lead-covered lead in the illustration, it is desirable when possible to pass a flex lead through the bottom of the frame via a rubber grummet.

The frame design is made up from brass angle strips "B," these being held in the desired form by a clamping plate "E" of 16 gauge aluminium or brass and 4BA



# THE MODERN MOTOR ENGINEER

In view of the many recent developments that have taken place in Motor Engineering, it has been considered necessary to bring out an entirely new and revised edition of "The Modern Motor Engineer" to meet the demands of the garage manager and mechanic for a practical up-to-date book of instruction on all phases of their work.

## BREAKDOWNS ON THE ROAD

A feature of special value is the section dealing with breakdowns on the road. Repairs are treated in great detail, and instruction is given in welding, brazing, sheet metal work, machinery and grinding. There is also a section on chassis frame straightening and repairs.

## THE SCOPE OF THE WORK

Among the many subjects which are dealt with in detail are: Garage Lay-out and Equipment—Dismantling, Tuning and Repairs of Engines—Clutches, Gear Boxes, Transmission, Springing and Brakes—Modern Ignition Systems—Armature Winding and Repairs—Carburettors—Tyre Troubles—High-speed Oil Engines—How to Cost Garage Jobs—Legal Requirements—etc., etc.

## ELECTRICAL DIAGRAMS

A volume entitled "Electrical Diagrams" is given free to all purchasers of this work. This volume, handsomely bound, contains about 70 electrical wiring diagrams, and electrical data of the most popular English and American Cars and commercial vehicles. Its value to motor engineers cannot be overstressed.

## THE ILLUSTRATIONS

The work is fully illustrated with 32 full-page plates and over 1,600 illustrations in the text, all of which have been chosen for their practical value.

## THE MOTOR ENGINEERS' CHART

Supplied free with this new edition is a specially prepared chart, which shows, by means of diagrams and tables, all the information regarding measurements, etc., which the engineer or mechanic is likely to require in his day-to-day work.

## A FREE BOOKLET

To the Caxton Publishing Co., Ltd.,  
119, Clun House, Surrey Street,  
London, W.C.2.

Please send me, free of charge, Booklet, describing "The Modern Motor Engineer."

Name.....  
Send this form in unsealed envelope  
(½d. stamp).

Address.....

O.19 .....

# MODERN ELECTRIC WIRING

The New and Revised Edition of "Modern Electric Wiring" is a practical guide to the wiring of Private Dwellings, Business Premises, Factories, and Public Buildings, for Lighting, Heating and Power, with chapters on Wireless Practice, Electric Motors, Talking Picture Equipment, and Neon Illumination.

The author has had a wide and varied experience in the practice of wiring, and is therefore able to describe in detail how every phase of the work should be carried out.

## THE SCOPE OF THE WORK

General Principles of Electrical Conductivity—Materials—Wire Gauges—Insulators, Insulation, and Resistances—Systems of Wiring—Safety Fuses—Illumination, Heaters, Cookers, Small Motors, Appliances—Wiring Layouts—Lighting, Heating, and Cooking—Temporary Wiring—Measuring Instruments, Meters, and Mains—Bells and Signals—Domestic Telephones—Testing—Wiring for Wireless Installations—Power Amplifiers, Public Speech and Talking Picture Equipment—The Workshop—Electric Motors and Generators—Principle of Neon Illumination—Specifications, etc.

## THE WORKSHOP

To the ambitious wireman, anxious to commence business, the chapter on the workshop will be full of interest because, apart from equipment and routine (with specimens of time and material sheets), the business side is also discussed and useful hints given as to carrying out work, stock-taking, calculating profits, etc.

## THE ILLUSTRATIONS

"Modern Electric Wiring" contains over 270 illustrations, the majority of which are wiring diagrams, specially designed to demonstrate practical working, and many of them suitable for use in actual practice.

## AN OPINION

Mr. G. B. BENNETT, Tudor Road, Leicester, writes: "I am delighted with 'Modern Electric Wiring.' It treats a big subject in a manner remarkably easy to understand. It is the best book on Electric Wiring I have seen."

## A FREE BOOKLET

To the Caxton Publishing Co., Ltd.,  
119, Clun House, Surrey Street,  
London, W.C.2.

Please send me, free of charge, Illustrated Booklet describing "Modern Electric Wiring."

Name.....  
Send this form in unsealed envelope  
(½d. stamp).

Address.....

S.19 .....

# ENGINEERING WORKSHOP PRACTICE

This up-to-date book provides a complete practical course of instruction in every important branch of engineering workshop methods, materials, and equipment. It deals with the underlying principles, craftsmanship, machines, tools, measuring processes and machining methods of to-day, and it will prove indispensable to engineer, draughtsman, mechanic, apprentice, and engineering student. Its scope extends from simple hand tools to the latest elaborate machines employed for mass-production purposes.

## DATA AND RECIPES

Apart from the mass of practical instructional and descriptive information given, there is a wealth of data, formulae, workshop recipes, hints and tips which render this book a valuable reference work.

## SOME OF THE SUBJECTS

Hand Tools, Measuring Methods, Verniers, Micrometers, Gauges, Optical Devices, Fluted and Twist Drills, Grinding Angles, Drilling Data, Drilling Machines, Electric Drills, Lathework, Machining of Metals and Synthetic Materials, Tungsten-carbide and Diamond Tools, Lapping, Honing, Cleaning, Polishing and Rust-protection of various metals. Grinding Operations and Machines, Milling Operations, Cutters and Machines, Planing, Shaping, Slotting and Broaching. Plate and Bar Machines. Gears and Gear Cutting Methods, Templates, Jigs and Fixtures. Overhauling and Adjusting Machines, Millwright Work, Welding, Brazing and Soldering Metals, Forging Work. Sheet Metal Work. Foundry Work. Patternmaking. Press Work. Engineering Steel and other Metals; their properties, Testing, Hardening, Tempering and Annealing. Engineers' Drawings. Workshop Calculations, Data, Hints and Recipes.

## THE ILLUSTRATIONS

The book is lavishly illustrated so that the explanations are rendered very clear with examples taken from actual works practice in many instances. There are 24 full-page plates and 877 illustrations in the text.

## ENGINEERING CHART

In order to make the work even more comprehensive, a chart, which can either be carried in the pocket, or hung upon the workshop wall, is supplied free to all purchasers. It contains many useful Tables of Screw Threads, Tapers, Angles, Drill Speeds and Sizes, etc.

## A FREE BOOKLET

To the Caxton Publishing Co., Ltd.,  
119, Clun House, Surrey Street,  
London, W.C.2.

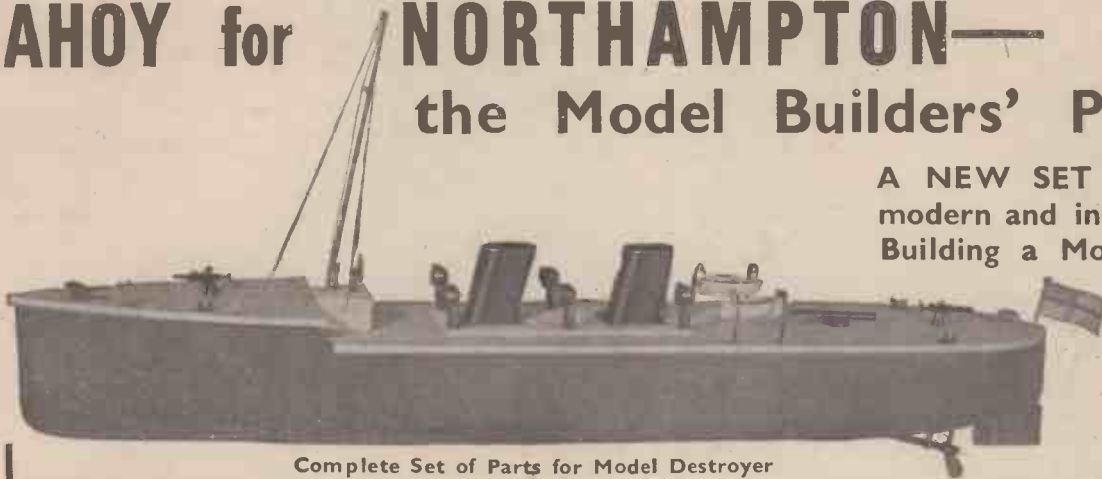
Please send me, free of charge, Illustrated Booklet describing "Engineering Workshop Practice."

Name.....  
Send this form in unsealed envelope  
(½d. stamp).

Address.....

G. 19 .....

# AHOY for NORTHAMPTON— the Model Builders' Paradise!



Complete Set of Parts for Model Destroyer

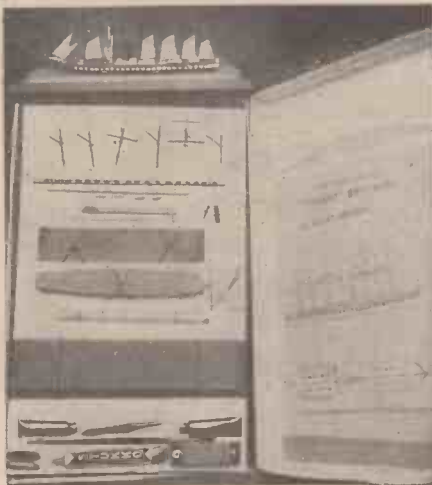
**A NEW SET OF PARTS—  
modern and inexpensive for  
Building a Model Destroyer**

Comprising: Finished Hull with Bridge and Decking; Electric Power Unit No. 1461/U fitted, also Propeller Shaft, Stern Tube and Rudder Post; Dry Battery and 26 Fittings. Price complete **45/-**

## REDUCTIONS in our NEW SHIPS LIST S.12

include our working scale model liners of the *Queen Mary* and *Normandie* (in electric drive), which now cost £15 15s.; also our waterline parts of the *Britannia*, the *Great Britain* (as illustrated), which now cost 11/6d. each complete, and the *Great Eastern*, 14/6d. New waterline models in our scale model series include new R.M.S. *Mauretania*, and M.V. *Dominion Monarch* (100ft. to 1 inch).

Send for NEW S.12. Price 6d.



## SEND FOR OUR LIST OF BARGAINS

of:—Locomotives, Coaches, Wagons, Signals, Mechanisms clockwork and electric; parts for building up points, wagons, etc.; bogies, track, tinplate, brass permanent way (popular type), etc.; scale model ships, motor boats, yachts; boilers, steam turbines; parts, etc.

Ask for:—BL. 12, free and post free. If in LONDON during Easter visit our Bargain Stand at the MODEL RAILWAY CLUB EXHIBITION, Central Hall Westminster, Tuesday the 11th to Saturday the 15th, inclusive.

## THE HULLS—

It is difficult for the amateur boat builder to make himself a suitable hull, yet he wants one on which he knows he can rely. Our experience satisfies us that the hand-carved hull is the best in the long run, and our new range of hulls this season are the finest produced at the money.

**Type 1.C Destroyer Hull.** In lengths 24, 30 and 39 in., 11/6, 14/- and 22/6 respectively. **Type 2C. Racing Motor Boat Hull.** In lengths 18, 22, 25 and 30 in., 5/6, 6/6, 7/6 and 10/6 respectively. **Type 3 Liner Hull** Length 30 in. Price 24/-

For details of other Hulls available see our new Ships List, S.12.



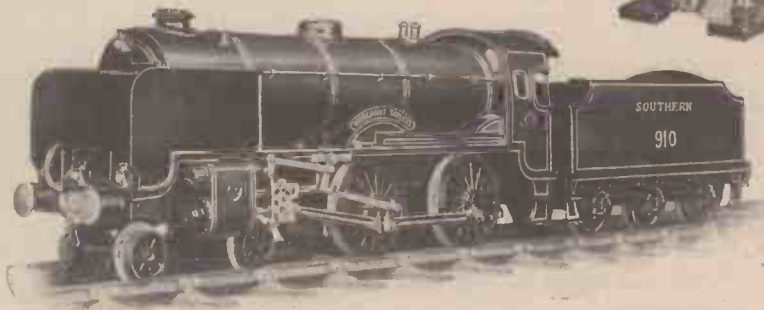
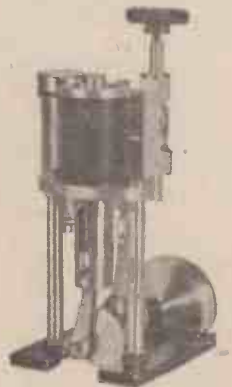
The hull needs ballast and a Brass Keel can be fitted for 5/-.

## AND THE ENGINE

There is always a demand among model boat builders for a reliable, efficient and well-constructed engine and our new "ECLIPSE" engine fulfils all these conditions. It is a practical design, fully tested out, and is suitable for boats up to 3 feet long, where a good turn of speed is required.

Suitable boilers for this engine are the *Twin Drum Minor* and our "*Streamlinia*" type.

A Few Technical Details:—  
Engine, made throughout of hard brass castings and non-rusting material, fitted with displacement lubricator.  
Cylinder— $\frac{1}{2}$  in. stroke x  $\frac{7}{16}$  in. bore. Packed piston.  
Screw down stop valve on steam chest with union for  $\frac{5}{32}$  in. pipe.  
Height to top of cylinder  $3\frac{1}{2}$  in. Base  $2 \times 1\frac{1}{2}$  in. Price 18/6.



## A BARGAIN!

S.R. Locomotive in clockwork—nine models only going at knockout prices

OUR CATALOGUES. GR12. Our latest and most fascinating book on "Gauge O Model Railways." Price 3d. TT12. Booklet of the Twin Train Table Railway in gauge "OO." Price 2d. A12. Railway List of all gauges. Price 6d. S12. Model Ships and Ship Fittings. Price 6d. B12. (In two Sections) B1. Engines, Fittings, Boilers, 3d. B2. Materials, Castings, Parts, 3d.

# BASSETT-LOWKE LTD., NORTHAMPTON

LONDON: 112, High Holborn, W.C.1 MANCHESTER: 28, Corporation Street



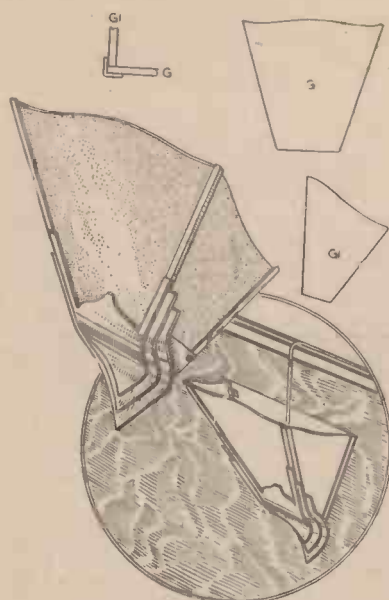


Fig. 9.—An attractive wall light.

esk. hd. screws, "F," let through clearance holes in each strip at the base, and screwed into tapped holes provided in these strips.

The design plates "D" are also fashioned from aluminium, but of 18 S.W.G. fitting one over the other in step fashion, 4BA esk. hd. screws clamping these plates to the angle strip mounting plate "E." The lamp socket is screwed into a brass mounting bracket "A" secured by screws and reinforced by soldering to the back tin plate "G." This back plate should be soldered down each side of the rear angle strips.

The glass retaining pieces "C" (two only of which are required) are of tin and soldered to the back plate as shown. These glass plates should be drawn to the required size on a piece of paper for the glazier, whilst the choice of moulding design can be made from the usually wide selection. The method of inter-locking the plates when fitting, is shown in the inset Fig. 9. There is just one other important point concerning the wiring, should lead-covered cable be used, then it will be necessary to earth the lead sheathing and the frame of the lamp.

**A Hall Lamp**

For a simple design of low-power hall lamp or nursery night-light Fig. 11 falls in

with the essential requirements, and it's very attractiveness depends on its simplicity. The assembly illustrated can be modified to suite individual taste but as a guide the following constructional features are given.

With the curved effect, "E," it will be found simpler if two sections of identical pattern are cut from either aluminium or brass, but brass is preferable so that the edges can finally be soldered. A straight edge can be obtained simply, and is possibly the better way, by cutting the whole design from a single sheet of metal and bending to the given shape. "B" is a small brass socket mounting cap which can be soldered to the side plates, "A," after assembly.

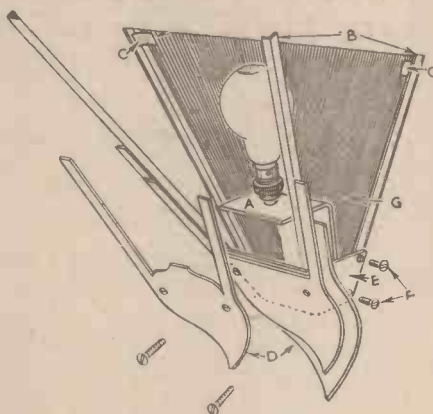


Fig. 10.—Method of constructing the wall light.

To make the job sturdy the metal work should be mounted on a piece of three-ply wood cut to the contour of the back flanges; this is clearly shown by "C."

The front elevation in the inset (a) gives a good idea of the proportions and it can be said that the simpler the shade design, the better, whilst if it is not desired to go to the expense of chromium plating or spraying, the whole of the metalwork can be sandpapered down and either left as a matt finish or coated with shellac.

The modern version of the old table or drop-type candle lamp is shown in Fig. 2. This style fits in very well with the more modest brown and cream or orange schemes, the light from the candle lamps providing a pleasantly soft aspect with clear illumination.

The arms "Y," can be cut from length of oak and by beating with a smooth round headed hammer, the "oldish" look is provided. These arms are clamped in the particular model illustrated, by using a small gate ring "Gr," cut to the shape shown, long black bolts clamping the arms together between the clamping plates "Cp."

**Scroll Supports**

The scroll supports were obtained by cutting and bending some soft steel strip, and it was not found necessary to resort to heat when making the curves. The centre clamping is effected by a short piece of this same steel strip, hammered round and fixed by a bolt "B" and nut.

For fitting the sockets and recessing the wiring, the "Y" arms required channelling as indicated in the inset (c) by "Ch," and it will be seen that the scroll strips "S" keep the wire from sagging.

The other inset (b) shows how the "Y" arms are cut and the clamping plate bolt holes, "H," the end holes "Sh" being for the socket fitments.

When fixing the feeder wires to the sockets, it is essential that each connection be thoroughly insulated from its neighbour, and, as illustrated at "I," this should be carried out by first of all binding each connection individually, finally rebinding all three sets of leads or feeders together. The lead numbered (1) in the wiring inset is the earth wire return and should be connected by soldering or clamping under the "B" bolt head of the scroll feet assembly, shown as "Frame."

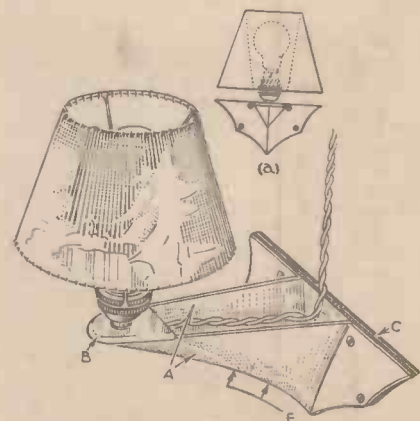


Fig. 11.—A design for a low-power hall light.

**CHEMISTRY FOR AMATEURS**

(Continued from page 352)

the metallic sodium.

Suppose we cut a small fragment from a lump of metallic sodium and fling it into a basin of cold water, what happens? Immediately the sodium touches the water, it melts, assumes the shape of a small spherical globule and swims rapidly around the water with a persistent hissing noise, eventually disappearing completely with a miniature flash of flame.

In this spectacular instance the sodium is combining with some of the water atoms, forming a substance called sodium hydroxide and liberating hydrogen gas. The latter escapes into the air, but the sodium hydroxide (better known as "caustic soda") dissolves in the water, imparting to it a characteristic slimy feel.

Here again, in this experiment, we have

witnessed a chemical action, whereby a metal has combined with the oxygen and a portion of the hydrogen contained in water, and has set the remaining hydrogen free.

**Chemical Elements**

Finally, in our introductory article of this series, we come to the consideration of what is meant by the chemical "elements." These are, as the term itself implies, elementary bodies which cannot, by chemical means, be further simplified.

The iron sulphide which we made in the previous experiment is obviously not an element, for we saw that it contains both iron and sulphur. Neither, too, is magnesium oxide an element, since that compound contains magnesium and oxygen.

However, the oxygen, magnesium, iron and sulphur contained in the above compounds cannot by any known chemical means be resolved or split up into simpler substances. Iron is iron through and through. Sulphur contains nothing else but sulphur. Magnesium is simply magnesium and nothing else.

**Hundred Elements**

For this reason, iron, magnesium, sulphur and oxygen are called "elements," since they are elementary materials and cannot be split up into anything simpler.

There are nearly a hundred of these "elements," each totally distinct from the other, each containing nothing but itself. These elements are the "bricks" of the chemist, the materials from which, by dint of various combinations, he makes up all his wonderful compounds. They are Nature's own bricks, too, for all material things are made up of one, two or more elements.

# CONJURING WITH DICE BLOCKS AND CUBES



Fig. 2.—A shell die with hinged top and the tube shaped cover. The shell, which the audience take to be a solid cube is vanished by covering it with the tube and pushing the hand through, which opens the top of the shell back against the inside of the tube.

PROBABLY the first thing a conjurer thinks of doing with an article that is to be the subject of a trick is making it disappear and finding it somewhere else. I shall therefore begin this aspect of the subject with some of the ways of preparing blocks and dice for this effect.

Fig. 1 shows a solid cube fitted with a shell which exactly resembles it. The shell is made of thin metal or wood or, in small sizes, of stiff card. One side is missing, enabling it to fit over the solid cube and the inside of the shell is painted dead black.

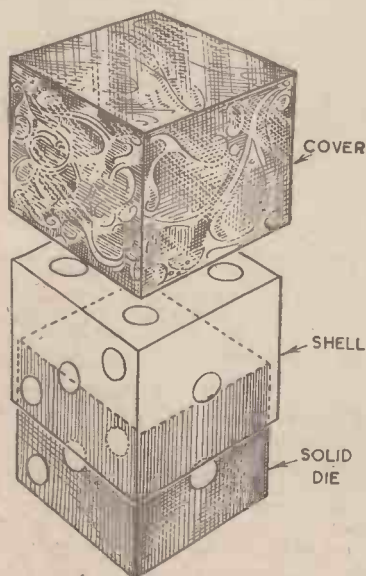


Fig. 1.—A solid cube fitted with a shell which exactly resembles it.

With it is used a cover which is virtually another shell fitting snugly over the first, but whereas the shell proper is decorated to resemble the solid cube, the cover is either plain or covered with some fancy

*By Norman Hunter*  
(The Well-known Conjurer of "Maskelyne's Mysteries" Fame).  
Further Articles on the Secrets of Conjuring will appear Regularly and Exclusively in this Journal

ornament. The inside of this also is dead black.

### Method of Operation

The performer begins by having the shell inside the cover, where it appears to be part of the cover itself. The solid cube is thrown up and caught, rapped, and if desired given for examination. The cover is then dropped over to show that its purpose is to hide the cube. The cover is immediately removed but the shell is left behind on the solid cube, and the cover may then be examined. Cube and shell are then placed in a hat while a tray is

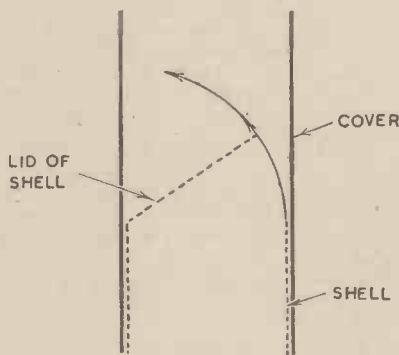


Fig. 3.—The hinged top of the shell being swung back against the inside of the shell.

shown. The cube is then taken from the hat and placed on the tray. Actually only the shell is removed, the solid cube remaining in the hat unknown to the audience. The cover is placed over the shell, a pass is made, cover and shell are picked up together and the wand rattled inside to prove that the cube has vanished. The solid cube is then tipped out of the hat, falling with a convincing thud on the floor.

There are many variations and improvements to this simple method. One is shown in Fig. 2. Here the shell has a hinged top and the cover is twice the height of the cube. Exactly the same procedure is gone through as before but this time when the shell is vanished the performer may thrust his hand through shell and cover, the hinged top of the shell being swung back against the inside of the cover as shown in Fig. 3.



Fig. 5.—A colour changing die. The white shell is three sides and is finger palmed off under cover of stroking the die.

### Another Effect

With this apparatus another and totally different effect can also be performed. A plain black cube is used but the shell is spotted with white spots like a regular die. At the outset the shell is in the cover with its lid open and the audience may be allowed to look right through the apparently empty chimney. The solid cube is shown and the cover placed over it, the hinged top of the shell being prevented from falling either by a little catch at the top of the cover or by working the trick on a tray very slightly tilted towards the hinged side of the shell. A number of white paper discs are now dropped into the chimney and, of course, fall upon the solid cube. The hinged top of the shell is now allowed to fall down and the cover is lifted, exposing apparently the same block now equipped with the white paper discs in the right places to make it a proper die.

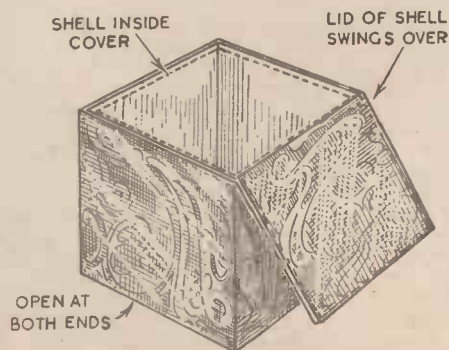


Fig. 4.—A simple method of vanishing the shell.



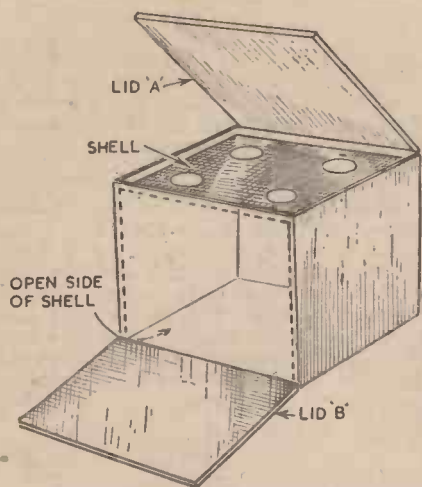


Fig. 6.—The shell, fitted with a sixth side which is hinged and opens with the lid of the box so that no reversing has to be done.

Another variation of the shell and cover idea consists in having the cover open at both ends but the same height as the cube. The top of the shell is hinged with tape, sufficient play being allowed for it to fold right round outside the cover. The inside of the lid is decorated to match the outside of the cover. The vanish of the shell by this method is shown clearly in Fig. 4.

**Modifying the Shell**

Fig. 5 shows a modification of the shell, used with a very small die. In this case the shell has three sides only and is of a different colour from the solid die. The effect this time is a change of colour. Shell and die are held so that only the three sides of the shell can be seen, the hands being otherwise obviously empty. By

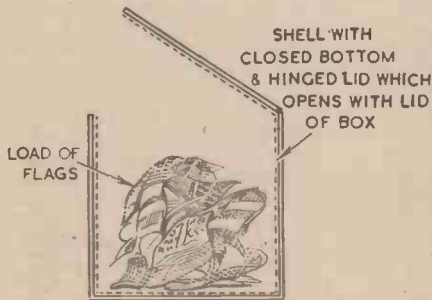


Fig. 7.—Changing the apparently solid cube into a number of flags.

stroking the die with the free hand, the shell is nipped off in the curl of the fingers and the die shown to have changed colour. The shell is disposed of behind some object on the table in the act of picking up the wand to rap the die and prove it solid.

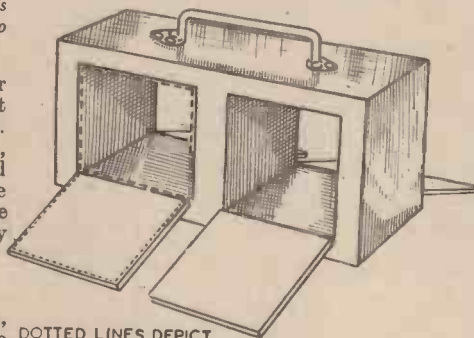
Coming back to the five-sided shell we find another use for it by employing a box instead of the usual cover. The box is just large enough to take the shell and it has a lid at either end, though the audience are not allowed to see that there is more than one lid. The supposed solid die, really the shell, having been placed into the box, the latter is closed, secretly turned over and opened at the other end, when the open side of the shell is exposed and the shell appears as the inside of the box.

**Vanishing Orange**

Sometimes this apparatus is used to cause a die and an orange to change places. In this case, the shell is not at any time

placed over the die but is, at the start of the trick, inside the box. An orange is dropped into the box which is closed, reversed and opened and the shell die with the orange inside is tipped out. The solid die meantime has been changed for a duplicate orange in some other piece of apparatus. Another use for the box and shell is to change the apparently solid cube into a number of flags. In this form of the trick the die shell is usually supplied with a sixth side which is hinged and opens with the lid of the box so that no reversing has to be done. Figs. 6 and 7 will make clear the details of these methods.

A very popular trick with a box and a die is that known as the sliding die box. In this effect the die is placed in a box having two compartments with a door front and back of each. The performer says that he will make the die vanish and proceeds to show that the box is empty by opening first one door and then another. The



DOTTED LINES DEPICT SHELL LID OPENED WITH DOOR

Fig. 8.—The box with the shell die in one compartment.

audience, however, hear the die sliding from one compartment of the box to the other and think they have guessed the secret. They ask for all four doors to be opened. At first the performer pretends not to understand and the excitement is worked up until finally all four doors are opened together and the die has vanished.

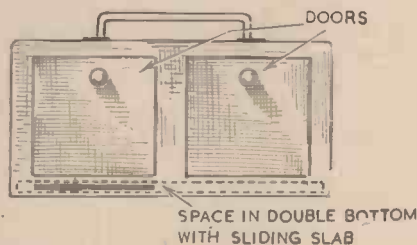


Fig. 9.—A slit of wood sliding between the two thicknesses of the double bottom.

**Box and Shell**

This box is little more than an adaptation of the ordinary box and shell except that it has doors front and back instead of a lid at the top. Fig 8 shows the box with the shell die in one compartment. The die can be vanished at any moment by simply opening the lid of the shell with the door, care being taken that the lid is at the back. The sliding sound which the audience take to be the die moving from one compartment to the other is caused by a slab of wood sliding between the two thicknesses of the double bottom as shown in Fig. 9.

Fig. 10 illustrates a trick in which no shells are used at all. In effect, three blocks are shown and a box of the same size marked "Lift," also a tall cover decorated like a house. The lift is marked

by having some borrowed article placed in it, which is shown from time to time during the trick to prove that no substitution of the lift takes place. The lift is dropped into the tube and the other three blocks go in on top. When the cover is removed the lift has risen one floor. Again the blocks are dropped in and the lift rises another floor and so on until it is at the top. All the apparatus can be examined.

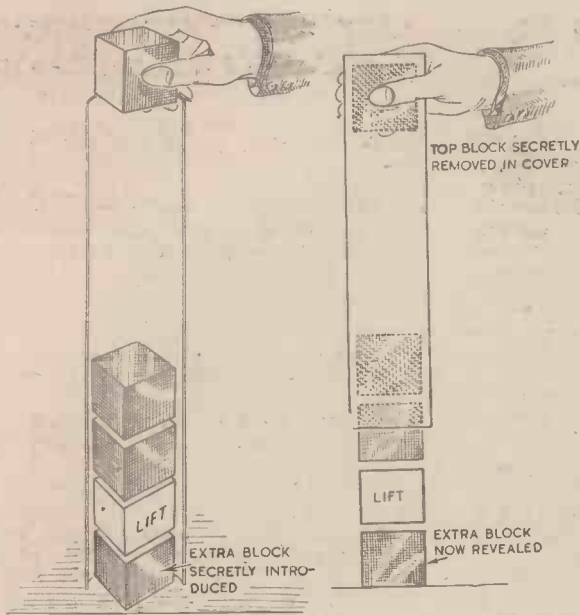
As the illustration shows, the secret depends upon the use, in a special way, of an extra block exactly like the other three. This at the beginning is on a wooden tray behind the others. The chimney is either of cardboard so that a block can be retained in it by pressure from the outside or, if of wood, a small hole is bored in the right position so that when the cover is dropped over the stack, the top block can be lifted secretly inside the cover.

**The Effect**

The conjurer begins by showing the cover empty. He then puts it down over the hidden block and takes away those in front. The borrowed article having been put into the lift box, this is dropped into the cover from the top. The sound of it striking the block already inside being similar to the sound the audience would expect to hear if it struck the tray, everything appears to be quite fair. The three visible blocks then go in on top of the lift. As the lift is already one block up, the apparent rise is simply a matter of taking off the top block when the cover is lifted (see Figs. 11 and 12). This is then allowed to slide gently to the bottom of the cover, which is put on the tray and the blocks again dropped in. This time a block goes in first, then the lift and finally the other two blocks. Apparently the lift is in the position at which the last stage of the trick left it, that is to say one from the bottom. Lifting the cover and with it the top block, however, reveals, of course, that the lift is now two blocks up. The final move is a repetition of the others. The extra block is got rid of into a bag behind the table or into some other convenient receptacle and everything may be freely shown. If the cover has not been prepared with a hole for lifting the block, all the articles can, of course, be examined. I have performed this trick a number of times at Maskelyne's and got a great deal

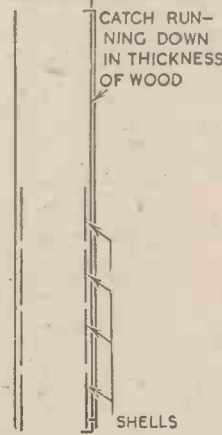


Fig. 10.—A lift effect. The lift is made to rise floor by floor by the use, unknown to the audience, of an extra block, shown in the photograph just inside the tube.



Figs. 11 to 13.—As the lift is already one block up the apparent rise is simply a matter of taking off the top block when the cover is lifted.

(Below) The tall cover has a device for gripping or releasing the shells.



of fun out of it by persuading the audience to sing out "Up she goes" when the lift is supposed to rise.

**Stack of Blocks**

Another trick with a stack of blocks consists of having the blocks numbered from 1 to 4 and making them re-arrange their order to correspond with a similarly numbered set of cards. This is managed by having a shell to each block. The shells are open top and bottom and have numbers on them exactly like the blocks. The tall cover has a device for gripping or releasing the shells so that the blocks with shells on them may be revealed when it is lifted or the shells may be removed and the blocks alone exposed. (See Fig. 13.)

The performance of the trick resolves itself into arranging the blocks with the figures in a certain order and fitting the shells over them in a different order. By removing the shells the numbered blocks appear to change places. The blocks are then re-arranged and the cover put on, being removed to leave the shells in place once more. A further change is thus effected by exposing now the backs of the shells which are numbered differently from the fronts. The backs of the blocks being also numbered differently from the fronts, it will be seen that it requires only a careful planning of the movements and perhaps a note to aid the memory to enable the conjurer to keep rearranging the set of numbered cards and make the blocks always re-arrange themselves to correspond

**Letters on Blocks**

The same trick is also performed with letters on the blocks, the letters in this case forming words when rearranged. The usual letters employed are T, S, R and A. With these various words such as ARTS and TARS can be formed and the climax is reached when the performer invites the blocks to say what they think of his performance, or of the audience. The resulting formation of letters is RATS, which needless to say puts an end to the trick.

Now for a totally different form of blocks trick which has recently found favour. The block, a large one of about five or six inches across, has a hole running through from side to side. With it is used a frame about two inches wide also furnished with a hole at each side. The block is placed

in the frame and a length of ribbon is threaded through both by means of a long bodkin. The conjurer pulls the ribbon backwards and forwards through block and

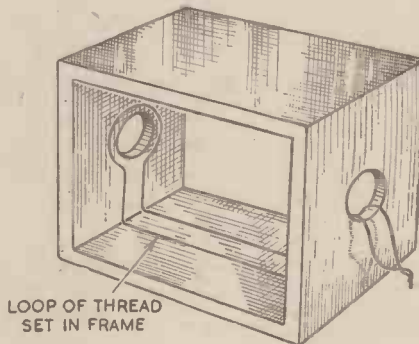


Fig. 14.—A loop of black thread is fixed round one of the holes in the frame on the inside with wax.

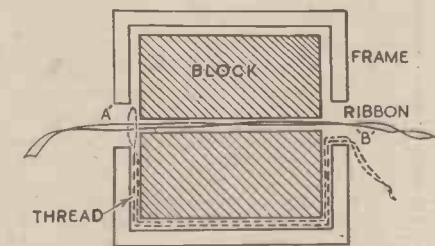


Fig. 15.—The ribbon is now, in front of the audience threaded through the frame and block as shown

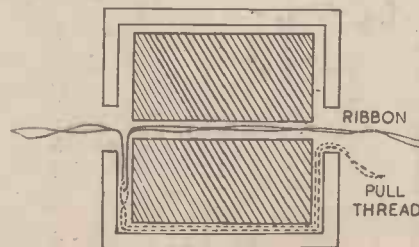
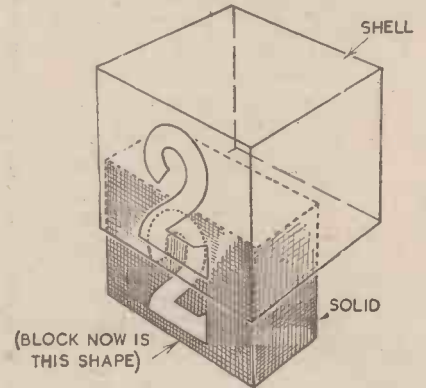


Fig. 16.—The loop draws the ribbon down between the block and the frame and out through the hole in the side.

frame to prove that all is as it appears, then the ends of the ribbon are given to two people to hold. While the ends are so held the magician quietly removes the block from the frame and the audience see that it comes away free of the ribbon, yet all the apparatus can be examined.

**How it is Done**

There is no trick about ribbon, block or frame, but the frame is lined with black velvet for ease in working. Prior to showing the trick a loop of black thread is fixed round one of the holes in the frame, on the inside, with wax. The loop is then laid along the inside of the frame and out through the opposite hole as shown in Fig. 14. The projecting end of the loop is



usually knotted so that it can be found and gripped easily.

The ribbon is now, in front of the audience, threaded through frame and block as shown in Fig. 15. The position of the thread is shown by the dotted line. The ribbon is pulled backwards and forwards a few times. Finally after it has been pulled through side A, where the loop of thread encircles the hole in the frame, until only a foot or so hangs out at the other side, the conjurer grips, not the ribbon at side B but the knotted end of the thread loop. This he pulls vigorously. The loop draws the ribbon down between block and frame and out at the hole in side B (Fig. 16). To the audience the ribbon seems simply to have been pulled farther through the block and frame but actually it is now clear of the block and running round the frame. The thread loop is dropped to the floor unnoticed.

The trick is now done and the conjurer is in a position to lift the block free of frame and ribbon, when of course the apparatus may be given for examination, as no trace of the method used remains.

**THE P.M. LIST OF BLUEPRINTS**

- F. J. CAMM'S PETROL-DRIVEN MODEL MONOPLANE 7s. 6d. per set of four sheets, full-size.
- The "PRACTICAL MECHANICS" £20 CAR (Designed by F. J. CAMM.) 10s. 6d. per set of four sheets.
- "PRACTICAL MECHANICS" MASTER BATTERY CLOCK Blueprint 1s.
- The "PRACTICAL MECHANIC" OUTBOARD SPEEDBOAT 7s. 6d. per set of three sheets.
- A MODEL AUTOGYRO Full-size blueprint, 1s.
- SUPER-DURATION BIPLANE Full-size blueprint, 1s.
- The P.M. "PETREL" MODEL MONOPLANE Complete set, 5s.
- The 1-c.c. TWO-STROKE PETROL ENGINE Complete set, 5s.
- STREAMLINED WAKEFIELD MONOPLANE—2s.

The above blueprints are obtainable post free from Messrs. G. Newnes Ltd., Tower House, Strand, WC2



# SKYBIRDS

FIRST AND BEST SOLID NON-FLYING 1/72nd scale model Aircraft Construction with every accessory to make the complete Hobby.

THE WORLD'S FASTEST FIGHTERS

- "Hurricane," price 2/6
- "Spitfire," price 2/6
- "Gladiator," price 3/-
- "Skua," price 4/6

NOW READY—

**THE MILES "MASTER"**  
Britain's fastest trainer, price 2/6  
**SPECIAL SHADOW SHADING**  
Paint Outfit, price 1/6

Build a SKYBIRD MODEL and become a member of the SKYBIRD LEAGUE.

The new Skybird Album contains the history of the Skybird League, the Monthly News Bulletin and Price List, all fully illustrated, post free, 1/3.

**SKYBIRDS**  
**LATEST SUCCESS!**  
**THE NEW No. 2 FLYING MODEL**  
BETTER VALUE THAN EVER



The "SPEEDY" Low-Wing Monoplane span 32 ins. Shaped Ribs! FINISHED Airscrew. Cantilever Undercarriage. Complete KIT. Price 6/6  
Send 1d. postage for new Illustrated Price List.

**"SKYBIRDS"** (Desk P.M.)  
3, Aldermanbury Avenue, London, E.C.2



Easily made from our castings 12/6 per set. Complete Engines ready to run from £3 15s.

**J. HALLAM & SON**  
Upton, Poole, Dorset

MINIATURE PETROL ENGINES for Aeroplanes and Speed Boats. 1 to 15 cc. Send 3d. for particulars

## MAKE MORE MONEY

£3 to £6 weekly can be earned at home in a wonderful business of your own. No matter where you live you can commence to make money in your spare or whole time. No risk, canvassing or experience required. A wonderful opportunity for anyone wishing to add pounds to their income. Particulars, stamp.

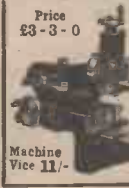
**BALLARD, York House, 12 Hambrook Road, LONDON, S.E.25.**



## HOW TO OBTAIN A PERFECT LOOKING NOSE

My latest improved Model 25 corrects all ill-shaped noses quickly, painlessly, permanently and comfortably at home. It is the only nose-shaping appliance of precise adjustment, a safe and guaranteed device that will actually give you a perfect looking nose. Write for free booklet, testimonials and Money-Back Guarantee terms.

(M. TRILETY, SPECIALIST D.273.)  
45, HATTON GARDEN, LONDON, E.C.3



**The 'ADEPT' Bench Hand Shaper**  
Length of stroke of ram, 3 1/2 ins.; Length of cross travel of slide, 3 ins.; Size of Table, 4 1/2 ins. x 4 ins.; Rise and fall of Table, 3 ins.; Vertical feed of tool slide, 3 1/2 ins.; Maximum distance between tool and table, 3 ins.; Weight, 18 lbs. Also the 'Adept' No. 2B.H. Shaper, 6 1/2-in. stroke. Price £6-9-6.  
Manufactured by F. W. PORTASS, SELLERS STREET, SHEFFIELD.

# 3 1/2 MYFORD 3 1/2

BEST VALUE—INEXPENSIVE



SUPPLIED TO NUMEROUS LARGE WORKS AND INSTRUCTIONAL CENTRES, ETC.  
Bench - Treadle - Motorised Lathes & Accessories  
Send P.C. for free illustrated list (your tool merchants' address would be appreciated)  
**MYFORD ENG. Co., Ltd., Beeston, Nottm.**

## Indispensable to the Modern Handyman

# The Home Mechanic ENCYCLOPEDIA

By F. J. CAMM

Sections on Aircraft, Television, Models, Astronomy, Electricity, Photography, Chemistry, Woodwork, Motor Cars, Wireless and Home Cinema. Over 600 illustrations.

3/6 net. From all Booksellers, or direct by post 4/- from the Publishers.

**GEORGE NEWNES LTD. (Book Dept.),**  
Tower House, Southampton Street, London, W.C.2.

# BECK'S CHEMISTRY

FOR YOUR HOME LABORATORY

SPECIAL 2/6 OFFER

(Carriage paid)

OF USEFUL APPARATUS  
BEEHIVE SHELF GAS JAR  
and PLATE DELIVERY TUBE.

Many other sets at prices from 2, 6 to 105/-.

Write for FREE CATALOGUE.

"EXPERIMENTS IN CHEMISTRY," 6d. P.O.

**BECK** (Scientific Dept. A), 60, High St., Stoke Newington, London, N.16.

# BE A MAN!

STRENGTHEN YOUR VITAL FORCES

Are you a victim of Inferiority Complex, Self-Consciousness, Unreasonable Fears, Bad Concentration and Memory, Timidity, Lack of Self-Control, Weak Will, Bad Habits, Thinness, Flabbiness, Nervous Disorganisation, etc.

To trace the cause, write for my free book—  
**"DO YOU DESIRE HEALTH?"**

Sent POST FREE in plain envelope.

Also write to me fully in confidence for a FREE and considered opinion of your case.

Over 30 years' experience in the drugless Treatment of Nervous disorders and ill-health arising from weakening and health-destroying habits and a lack of usually self-will.

All replies and books sent in plain sealed envelopes.

**I. W. STANDWELL, Curative Physical Culture Consultant**  
Dept. P.M., 329, High Holborn, London, W.C.1

# ENGINEERS

The size of your pay packet depends almost entirely on your knowledge, and the ability to apply that knowledge. The successful engineer can easily earn £500 and upwards per annum. Will you let us show you how?

We offer you the means of qualifying for entry and advancement in the engineering industry in the simplest and most efficient manner, viz., by home-study—undertaken in your spare time.

Our 120-page Engineering Guide (1939 edition) describes numerous Examination and Diploma Courses in Engineering, including:—

### ENGINEERING

- Inst. of Electrical Engineers, A.M.I.E.E.
- Inst. of Wireless Technology, A.M.I.W.T.
- Inst. of Civil Engineers, A.M.I.C.E.
- Inst. of Structural Engineers, A.M.I.Struct.E.
- Inst. of Builders, L.I.O.B.
- Inst. of Sanitary Engineers, A.M.I.S.E.
- Royal Sanitary Institute, M.R.S.I.
- Inst. of Mechanical Engineers, A.M.I.Mech.E.
- Inst. of Automobile Engineers, A.M.I.A.E.
- Royal Aeronautical Society, A.F.R.Ae.S.
- London B.Sc. Degrees
- Wireless—Telegraphy—Telephony
- Electrical Engineering

### Television—Electric Wiring

- Talking Picture Work
- Works Management
- Building Construction
- Sanitary Engineering
- Sheet Metal Work
- Refrigeration
- Motor Engineering
- Engineering Draughtsmanship
- Electrical Draughtsmanship
- Jig and Tool Draughtsmanship
- Die and Press Tool Draughtsmanship
- Aeronautical Draughtsmanship
- Structural Draughtsmanship
- Building Draughtsmanship
- Clerk of Works
- Building Inspection

### Registrar—Relieving Officer

- Sanitary Inspector
- Weights and Measures Inspector
- M. & Cy. Engineers

### GENERAL

- Matriculation—Bookkeeping
- College of Preceptors
- Chartered Institute of Secretaries
- Massage—Institute of Hygiene

### CIVIL SERVICE

- Clerical (age 16-17)
- Executive (age 18-19)
- Tax Inspector (age 21-24)
- Patent Office (age 20-25)
- G.P.O. Engineering (age 18-23)
- Typist (age 16-25)
- Customs (age 19-21)
- Board of Trade (age 20-25)
- Police College (age 20-26)
- Police Force (under 27)

### MUNICIPAL SERVICE

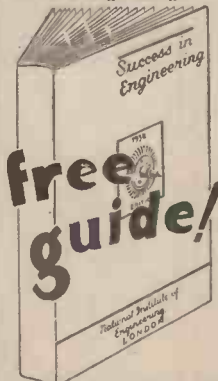
- School Attendance Officer
- Handicraft Teacher

If you do not see your requirements above just explain what they are. We are able to advise on all branches of Engineering, Civil Service, Municipal Work, etc.

## THE ACID TEST OF TUTORIAL EFFICIENCY: Success—or No Fee

We definitely guarantee that if you fail to pass the examination for which you are preparing under our guidance or if you are not satisfied in every way with our tutorial service—then your tuition fee will be returned in full and without question. This is surely the acid test of tutorial efficiency.

If you have ambition you must investigate the service we are able to offer. Founded in 1885, our Success Record is unapproachable.



free guide!

Why not fill in and post the attached coupon for a free copy of this indispensable guide? It will be sent post free and without any obligation on your part.

**COUPON**  
**NATIONAL INSTITUTE OF ENGINEERING**  
(Dept. 29) STAPLE INN BUILDINGS, W.C.1.  
Please forward your 1939 Engineering Guide to:—

NAME.....  
ADDRESS.....  
Exam. or subject in which interested.....  
(d. stamp only required if unsealed.)

**NATIONAL INSTITUTE OF ENGINEERING (DEPT. 29),**  
Staple Inn Buildings, High Holborn, London, W.C.1

(South Africa Branch: E.C.S.A. P.O. Box 8417 Johannesburg)  
(Founded 1885) Over 80,000 Successes

**"Endeavour" Yachts**



These new Yachts are the latest thing for fast racing work. All of the hulls are hand made in best yellow pine. The two largest Yachts are fitted with Braine type automatic steering. Painted Pale Blue. Cabin Skylight extra.

Prices :

- 17 in. Yacht with automatic rudder .. 12/-
  - 21 in. Yacht with automatic rudder .. 18/6
  - 27 in. Yacht with Braine type steering 39/6
  - 36 in. Yacht with Braine type steering 75/-
- Carriage extra.

Send for Bond's 208-page 1939 Catalogue, Price 6d. It illustrates and lists all the requirements of the Model Maker and includes all Tools and Materials.

**BOND'S O' EUSTON ROAD LTD.**  
357, Euston Road, London, N.W.1

Telephone : EUSton 5441-2.

Est. 1887.

**Megow  
Balsa Flying Kits**



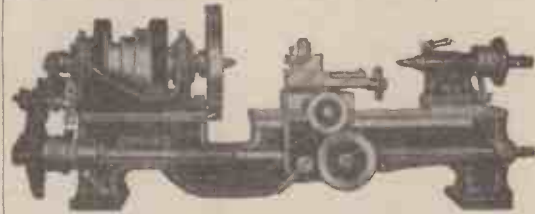
Kits for 12 In. wing span Flying Models of the AERONCA, BOEING P12E, CURTISS PURSUIT, HELL DIVER, LOCKHEED VEGA, MONOCOUCPE, PUSS MOTH, STINSON RELIANT, TAYLOR CUB, VULTEE VIA, WACO, CURTIS FALCON, SPAD, SOP-WITH CAMEL, NIEUPORT, GULF HAWK, HORNET MOTH, MILES MAGISTER.

Price 9d. Postage 3d.

Kits for 24 in. wing span Flying Models of the STINSON RELIANT, WACO CUSTOM, MONOCOUCPE, CONSOLIDATED P/30, FAIRCHILD, HAWKER FIGHTER, CURTISS HAWK, RICHMAN and MERRILL'S VULTEE. Price 2/-.

Postage 4d.

FOR ACCURATE WORK AND PERFECT FINISH  
**A "MILNES" LATHE is Essential**



7 in. diameter Centre Lathe

**SELF-CONTAINED ELECTRIC OR COUNTERSHAFT DRIVE**  
Robust construction in every detail with easy means of adjustment ensure a lifetime's efficient service from "MILNES" MACHINES

Send for full lists to: **HENRY MILNES, LIMITED, INGLEBY LATHE WORKS, BRADFORD, YORKSHIRE. ENGLAND.**

PRO PAT

**MAKE IT WITH UNIT 'X'**  
in Wood or Metal



Turns, Drills, Moulds & Grooves, Surface Grinds, Sands, Jigsaws, Rivets, Circular Saws, Polishes, Mills, Punches, Spins, Dovetails, Grinds Tools.

**95%**

COMPLETE or 15/- cash and nine payments of 10/-

Equipment includes: Circular Saw, Grinding Stone, Buff, Jigsaw and Blades, Sanding Drum, One Tilting Table, 1/2 in. Chuck, Punch, Tool Post and Cutting Tool, Spanner, Oil-Can.

THESE IS NO LIMIT TO THE NUMBER OF OPERATIONS POSSIBLE ON THIS MARVELLOUS MACHINE. ACCURATE WORK TO FINE LIMITS. IN WOOD OR METAL.

**TRIANGLE PRODUCTS LTD., BLAKE STREET, MANCHESTER, 15**

**"SOLDO"**  
THE SELF-HEATING  
SOLDERING IRON

Can be used  
anytime and  
anywhere ...

**SIMPLE AND SAFE**

With the "SOLDO" IRON you are not dependent on Gas or Electric heating; just place a Mox tablet in the special container in the iron and ignite with fusee supplied.  
**READY FOR USE IN 30 SECONDS.**  
Descriptive Leaflet "P," Free on Request.

**SOLDO CO., LTD., 5, SICILIAN AVENUE, LONDON, W.C.1.**



PRICE of complete outfit. "Soldo" Iron, 10 Mox tablets, box of fusees. Post Free. **10/-**

FREE with each order. A sample of "Soldo" Tinning Compound.

NOTE.—The "Soldo" Iron can also be heated by gas, if desired.

**FOR ALL  
MODEL RAILWAY SUPPLIES**

From Super Detail Engines  
to a packet of pins

TRY

**GRESHAM MODEL RAILWAYS,**  
79 GRESHAM STREET, E.C.2 LTD.

Send for free price lists and second-hand bargains list

**VALUE KITS!**



**Build this detail perfect model  
Westland "LYSANDER"**

Scale 1/4" = 1 ft., 25" wing span. You can easily build one just as fine from our super kit. This model is a perfect flying job, too, and takes off ground. Send P.O. to-day!

Kit Price only 10/6d., post free U.K.  
Send 4d. stamp for illustrated Catalogue.

**NORTHERN MODEL AIRCRAFT Co., 25 Lower Mosley St., MANCHESTER, 2**

**FLYING SCALE TYPES**

	Post Paid
Hawker Hurricane Span 12"	2/3
Heston Phoenix " 12"	1/9
Gloster Gladiator " 21"	3/-
Hawk Pursuit " 20"	3/-
Caudron Renault Racer	3/-

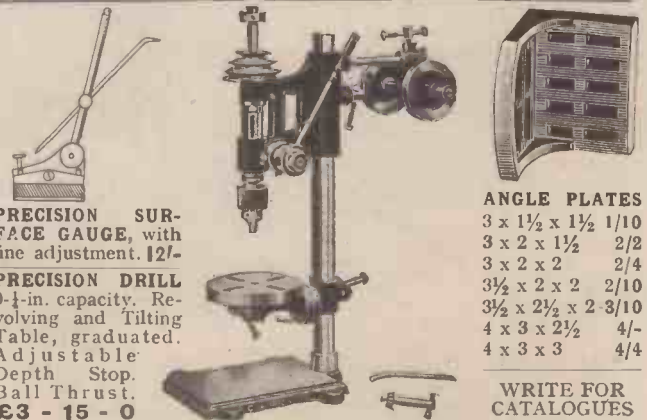
"Aeromodel" Series in stock, also Frog "Penguin" Kits.

**DURATION TYPES**

	Post Paid
Condor "Curlew" Span 20"	5/3
Condor "Clipper" " 30"	8/6

**"NORMAC" Super Thrust PROPELLERS**

We hold the finest range in the country. Once used—always preferred.



**PRECISION SURFACE GAUGE**, with fine adjustment. 12/-

**PRECISION DRILL** 0-1/4-in. capacity. Revolving and Tilting Table, graduated. Adjustable Depth Stop. Ball Thrust. **£3 - 15 - 0**

**ANGLE PLATES**

3 x 1 1/2 x 1 1/2	1/10
3 x 2 x 1 1/2	2/2
3 x 2 x 2	2/4
3 1/2 x 2 x 2	2/10
3 1/2 x 2 1/2 x 2	3/10
4 x 3 x 2 1/2	4/-
4 x 3 x 3	4/4

WRITE FOR CATALOGUES

**E. GRAY & SON LTD.,** 18-20 CLERKENWELL RD., LONDON, E.C.1



# MODEL AERO TOPICS

## Affiliated Clubs

OVER 110 clubs are now affiliated to the S.M.A.E. This encompasses a membership of several thousand, and it is hoped that by the end of this year all of the important clubs will become affiliated.

## Current News from the World of Model Aviation



The "Privateer" petrol-driven model made from a Model Shop kit. The kit with all ribs cut out costs £3 15s. 6d. The engine which is a Syncro Special costs £3 7s. 6d. complete with airscrew.

## The Wakefield Fund

THE Wakefield Fund at present stands at something under £100. All clubs are therefore asked to organise socials and other functions, and to donate the profits towards this fund. Several hundreds of pounds will be necessary to send the team abroad, and we have excellent prospects of bringing the cup back.

## Records Passed

THE S.M.A.E. have passed the following records: Indoor fuselage, Mr. L. A. Woodthorpe, 2 mins. 30 secs., and R.O.G. Mr. R. W. M. MacKenzie, 3 mins. 35 secs

## New Competition

MESSRS. CATON, LTD., have offered the S.M.A.E. a trophy to be put up for annual competition. The first prize in connection with it will be 5 guineas, second 3 guineas, and third, 1 guinea. The competition is for the best flight of the year made either in, or out of, S.M.A.E. competitions.

The only stipulations are that the flights must be timed by S.M.A.E. timekeepers, and the competition is open for rubber-driven models only, and such must conform to the S.M.A.E. fuselage formula. The competition will be open any time during the 1939 Competition Season. The trophy itself will take the form of a barometer with shields on the base upon which to engrave the names of the various winners.

## Vice-President of the S.M.A.E.

MR. J. T. C. MOORE-BRABAZON, who has been associated with aircraft from the start in this country, has accepted the Vice-presidency of the S.M.A.E.

## S.M.A.E. Headquarters

IT is likely that the S.M.A.E. will be provided with office accommodation at the new headquarters of the Royal Aeronautical Society.

## New S.M.A.E. Officials

THE following are the S.M.A.E. officials for 1939: President, Dr. A. P. Thurston; Vice-Presidents, Duke of Richmond

Aero Club, Captain Pritchard, Secretary of the Aeronautical Society, and Colonel Moore-Brabazon be invited to become vice-presidents. The Chairman is Mr. A. F. Houlberg, and vice-Chairman Mr. L. J. Hawkins; Hon. sec. Mr. E. H. Cosh, who has been elected a fellow of the S.M.A.E. and given an honorarium of £20. The Hon. treasurer is Mr. L. J. Hawkins; Competition secretary, Mr. J. P. Smith; Technical secretary, Mr. R. M. Bullock, and Press secretary, Mr. York.

## New Method of Construction

AN ingenious method of constructing model aeroplanes has been evolved by the Authentic Model Co., of 44, Leigh Street, Warrington. A tube is used, this running the entire length of the fuselage. The various bulkheads are threaded on to this thus ensuring perfect alignment. It is claimed that this method is lighter and stronger than the usual system. The tube also acts as a motor guard and protects the model from damage which would otherwise be caused by a breakage of the rubber motor. The range of models offered by this company includes the Miles Kestrel Trainer, and the Percival Mew Gull, both to a scale of  $\frac{1}{4}$ -in. to the foot. This range will be increased shortly. The kits include all the necessary materials and blueprints. The Kestrel kit costs 5s. and the Mew Gull 3s. 6d.

## New Lines From Bonds O' Euston Road

BONDS O' EUSTON ROAD, LTD., list in their very complete Model & Experimental Engineering Handbook, the 1939 edition of which costs 6d., a number of new model aircraft lines. This company not only stock all the necessary parts for making all types of model aeroplanes, and has one of the completest stocks of model engines and parts in London, but it also supplies scale model kits. A new range in the latter are the Aeromodel Kits which include the Hawker Fury, the Miles Magister, the Foster Wicko, the Hawker Hind, the Tiger Moth, and the Leopard Moth. These range in span from 14 $\frac{1}{2}$  ins. to 18 $\frac{1}{2}$  ins. and the prices vary from 3s. to 6s. A cheaper line of kits of non-flying models are available at 9d. each, and include the Aeronca, China Clipper, the Curtiss Condor, the Hawker Fighter, etc., etc. Petrol engine enthusiasts will be interested in the Ohlsson and Syncro Ace engines shown in the catalogue, and the kits of parts for petrol-driven models. Another item for the power-engine enthusiast is the stainless steel stranded wire. A further new line



Mr. L. Wilson of South Africa has made this model from instructions given in our May, 1934, issue.

and Gordon, Major C. E. Bowden, C. R. Fairey, A. S. Houlberg, B. K. Johnson, Percival Marshall, and Geoffrey Smith.

At the A.G.M., at which these appointments were made, it was proposed that Commander Perrin, Secretary of the Royal



The "Privateer Junior" also supplied by the Model Shop. It has a 4 ft. 6 in. wing span and is powered by a Trojan engine.

is the H.O. propeller in satin walnut, and light bass wood, in diameters ranging from 8 ins. to 14 ins. There is also a compressed air engine plant. A copy of this catalogue should be in every modeller's hands.

#### Flying Scale Model of the Hawker Hurricane

ONE of the illustrations shows the realistic lines of the model Hawker Hurricane marketed by Aeromodels, Ltd., of 48, Lark Lane, Liverpool, 17. This has a wing span of 22 ins., and the very complete kit costs 5s., by post 5s. 6d. Their new lines include the Fairey Battle (27 in. wing span), and the Westland Lysander (25 in. wing span). The kit of the former costs 5s. 6d. and the latter 5s. The well-illustrated catalogue gives details of a number of other kits, including one for the Aero Lark duration model, the kit for which costs 5s. It is of 24 in. span and weighs 1½ ozs. The firm supplies balsa, elastic, tissue, piano wire, airscrews, etc.

#### New Frog Model

LINES BROS., LTD., are introducing the Frog Vickers Wellesley which is supplied in the winder box at 3s. 6d. and the flying construction kit of the Spitfire at 2s., and a similar kit for the Vickers Wellesley at 2s. 6d. They are also marketing the New Penguin non-flying scale models of the Hawker Hurricane, the Monospar Ambulance, the Westland Lysander, Blenheim Bomber, the Blackburn Skua, and Vickers Wellington.

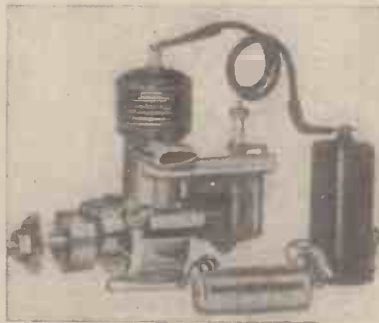
#### Hamley's New Lines

HAMLEY BROS. stock not only kits of parts and complete models, but all of the necessary materials and accessories including petrol engines. Their model aircraft department is in charge of a practical aeromodeller. Two new lines which I notice are the Gulfstream Glider, and the 32 in. wing span Lysander. The Gulfstream Glider is of 60 in. wing span, 36 in. long, weighs between 6 and 7 ozs. and the complete kit costs 17s. 6d. This includes all bulkheads ready cut out and slotted, all wing ribs, and numerous other ready-made parts. Also cement, dope, covering, strip wood, and blueprints. The glider complies with the S.M.A.E. rules for the King Peter Cup, and other contests. The model has an excellent performance, and it is of Messrs. Hamley's design. The construction is entirely of balsa, and is built on the Monospar system. The Lysander is complete in almost every detail including cabin arrangements, ailerons, elevators, and engine. When finished with a camouflaged dope a perfect



The "Standard Buccaneer" supplied by Model Aircraft Supplies. It is of 5½ ft. wing span.

replica of the prototype results. The bulkheads are cut to shape and slotted to take the springers. The model has a duration of 30 secs. It weighs 4 ozs. and the kit costs 15s. 6d. I notice that they are marketing the Monarch Petrol Model. This is well designed, the engine being totally enclosed. It somewhat resembles the Miles Hawk. The motor used is the Gwin aero 7 c.c. with outside exhaust, and



The Ohlsson "23" engine weighs only 4½ oz. (bare engine), and is obtainable from Bonds O' Euston Road.

the engine cowl is detachable. The kit includes wheels, timer, blueprints, dope, covering, bulkheads, and many of the parts are finished and ready for use. The machine is of 84 in. wing span, weighs 4 lbs. and the kit costs 5 guineas.

#### Model Aircraft Supplies

MODEL AIRCRAFT SUPPLIES, LTD., of 171, New Kent Road, London, S.E.1, have a most complete range of petrol

engines and kits, the smallest model being the Buccaneer "48." This model, as its name implies, has a wing span of 48 ins. and is driven by the Ohlsson "23." The price of the kit including dopes and cements, with full-size drawings and printed parts, is £1 ls. 0d., carriage paid. The Standard Buccaneer with a wing span of 5½ ft., chord 10 in., when in flying trim, weighs approximately 3½ lbs. The price with dope and cement is 32s., carriage paid. The Berkeley Super Buccaneer has a wing span of 7½ ft., chord 14 ins., and a total weight of approximately 5½ lbs., complete with dope and cement. 42s., carriage paid.



This model of the "Hawker Hurricane" which has a 22 in. wing span is obtainable from Aeromodels, Ltd. The kit costs 5s.

Both these latter two models are powered with the Brown Junior engine. The price of this engine is £3 2s. 6d., while the Ohlsson "23" is £4 2s. 6d. All three models are similar in appearance and have the same lines as the model illustrated.

#### Studierte Aircraft Models

STUDIETTE HANDCRAFT, Kemp Street, Birmingham, 5, have added to their range of ship models a series of model aircraft kits including the Miles Magister, the Luton Major, the Hawker Fury, the Puss Moth, the Tutor Mark 1, the Super Marine Spitfire. These kits of flying scale models cost from 2s. 6d. to 6s. 6d., and they are complete with all the parts and drawings.

#### Northern Model Aircraft

NORTHERN MODEL AIRCRAFT CO., of 25, Lower Mosley Street, Manchester, 2, are specialists in the designing of duration type models. The latest additions to their range include the Condor "Curlew" and "Clipper," both of which are notable for clean aerodynamic design and simple type of construction.

The Condor "Curlew" is a parasol type monoplane of 20 ins. wing span of balsa and tissue construction, rubber driven, and capable of an average flight round

(Continued on page 399)



The Condor Clipper supplied by the Northern Model Aircraft Co. This plane is capable of flights of over 6 minutes duration.



PRACTICAL MECHANICS WIRELESS SUPPLEMENT

# AUTOMATIC TUNING

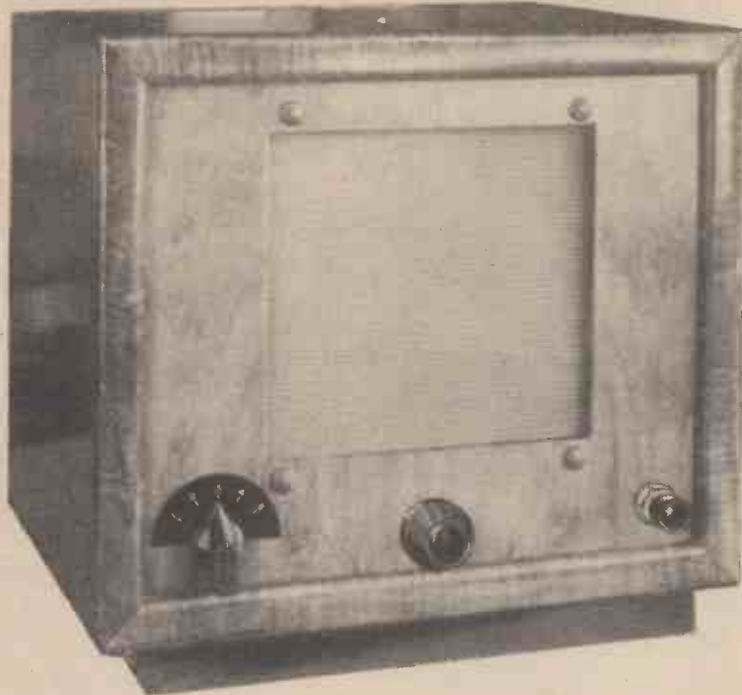


Fig. 1.—A simple automatic receiver in which station selection is carried out by means of a rotary switch.

## Suggestions For Converting Existing Receivers For The Automatic Selection Of A Few Stations

to be operated, or where the risk of interaction is to be avoided without modifying the wiring, the multi-contact rotary type of switch should be employed, and this will actually enable a neat automatic receiver to be built up on the lines of that illustrated in Fig. 1. This is a five-station set of the superhet type, with a volume control as the only additional panel device. The set is switched on and off by the right-hand control and the appropriate station selected by

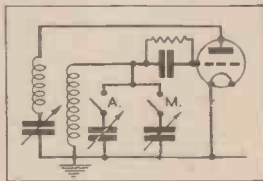
THIS season's commercial receivers will feature mainly the push-button or dial method of tuning, and will consequently appeal to the non-technical members of the family. The idea is not new, as we have already explained, but the housewife who is at home all day will undoubtedly find that a receiver in which the operation of a switch or a button selects a station, without the problem of finding the right spot on the dial, is not only a time-saver, but also an advantage. Many housewives fail to use the standard domestic receiver as often as they would prefer, simply because they are rather confused by the number of controls, or are uncertain just how to set the tuning indicator. Fortunately, it is a simple matter to modify the majority of existing receivers so that the advantages of automatic tuning may be incorporated, and although it is obviously impossible in a single article to explain how every individual receiver may be modified, the following instructions will serve to indicate the lines of procedure, and from them it should be possible to make the adjustments to most standard receivers.

### Buttons or Switches

The manufacturers are now able to supply complete push-button units which may be built into a receiver. The constructor can, however, make use of switches for station selection, and whilst these will operate in just the same manner, they have the disadvantage that when a change of station is needed the switch in use will have to be returned to its original position before the new switch is operated. This is the only drawback to the use of standard toggle switches. It is not a difficult matter to follow this point, however, as should a new switch be operated without the former one being set back, the station will not be received and a glance will show that more than one switch is in the "on" position

For a simple receiver the ordinary on-off or two-point switch may be used, and naturally with such a receiver only two or three stations will be heard. With a more ambitious receiver, where about half a dozen stations or more can be tuned in, more than one tuning circuit will be in use, and thus multi-point switches will have to be used. Bulgin four-point toggle switches, type S.88, will enable four circuits to be switched, but care will have to be taken to avoid interaction where an H.F. and detector stage are controlled on one switch

Where three or more circuits are



COIL ← → GRID

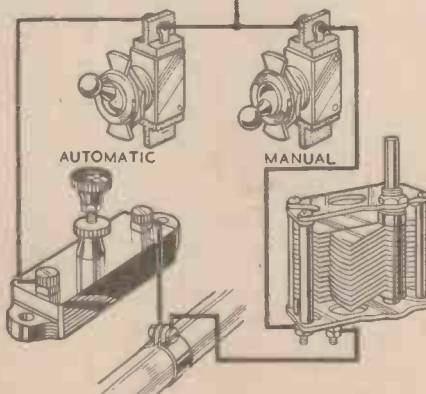


Fig. 3.—For tuning more than one circuit, combination switches of this type may be employed.

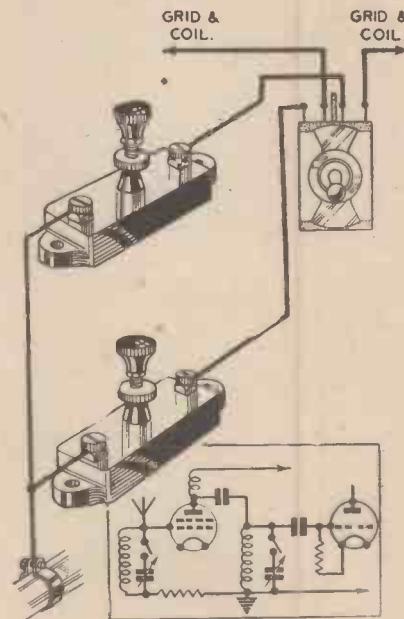


Fig. 2.—A simple scheme in which ordinary on-off switches are employed. Only two are shown, but any number may be used.

a ganged rotary switch of the Bulgin S.154 type.

### Circuit Arrangements

To make the use of these switches perfectly clear, we show in Fig. 3 the method of use, and in each case it should be noted that a switch or a contact for "manual" control may be provided, so that the normal tuning condenser may be retained for normal operation. In Fig. 3, two ordinary on/off switches are shown, the one marked "M" being used for manual operation or, in other words, switching in the ordinary variable condenser. This is a simple detector circuit and the reaction control would be brought out as a panel control merely to increase the strength of a weak station should it be required. The second switch brings into circuit an ordinary pre-set condenser with a maximum capacity of .0005 mfd. or .0003 mfd., and this should be adjusted to one of the stations it is required to hear. The lock-nut attached to the adjusting screw of the pre-set should be

tightened when the station is accurately tuned, so that it will not move and upset the adjustment. A similar pre-set and associated switch should be provided for each station which can be obtained, and all the switches may be placed in a neat row on a small bakelite or ebonite panel inset into the cabinet on the lines shown in the cover illustration this week. If desired, to simplify matters the manual control switch may be placed apart so that it will not be overlooked when it is desired to change from manual to automatic.

**Switching Several Circuits**

In Fig. 2 a two-circuit device is indicated, and the Bulgin S.88 switch is shown here. Although the two pre-sets for each station are here shown in a line, they may, of course, be placed anywhere on the chassis, preferably close to the coils which they tune, and the leads run by the most direct route to each condenser. Some shielding may be found necessary, but where possible it should be avoided, as it will raise the capacity and, in some cases, may prevent the condenser from tuning low enough to obtain the required station. A similar scheme to this may be employed in a simple superhet, which will require two or

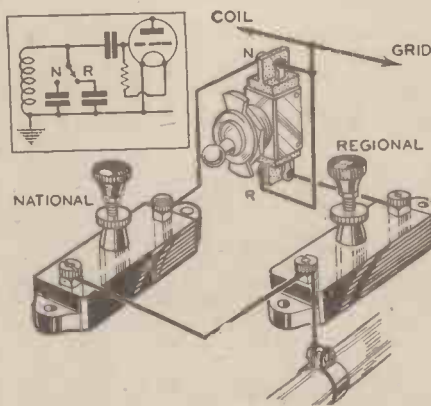


Fig. 4.—A change-over switch to bring in the required pre-set.

of connection, and is illustrated in Fig. 6. For this, ordinary single-circuit jacks are needed, and these cost slightly less than the ordinary toggle switches. Used in conjunction with them is an ordinary jack plug, and this should be provided with a short-circuiting wire, and the jacks should, of course, be arranged in a row fairly close

to be attached in place of the shorting wire and these may be anchored inside the receiver at a shorting strip of metal.

At least one of the ideas mentioned should be found applicable to the various types of receiver now being used by our readers.

In view of the fact that the pre-set may work out of adjustment due to vibration or atmospheric conditions, a good plan is to mount all of the condensers on a strip in such a position that the adjusting screw may be easily accessible through holes in the cabinet or panel. Then an ordinary screwdriver may be used, as desired, for readjusting those which require it. Furthermore, although a reaction condenser may be brought out to a panel control, this may be avoided by fitting further pre-sets in the reaction circuits and adjusting these for each station, switching them by using double-pole or ganged switches. This idea does not, however, work very well with ordinary battery receivers owing to the variation required as the H.T. battery becomes discharged.

When using twisted feeders they should not be tuned, as standing waves on the feeder will produce excessive losses. If it is desired to tune the feeder, then the two

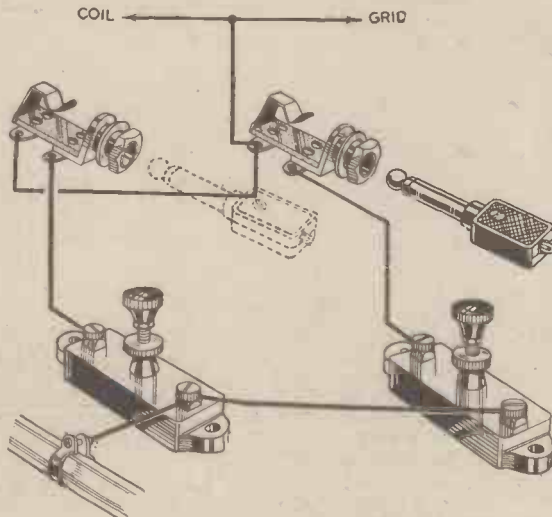


Fig. 6.—Using jacks and a plug instead of switches. This scheme may be used to prevent unauthorised use of the set.

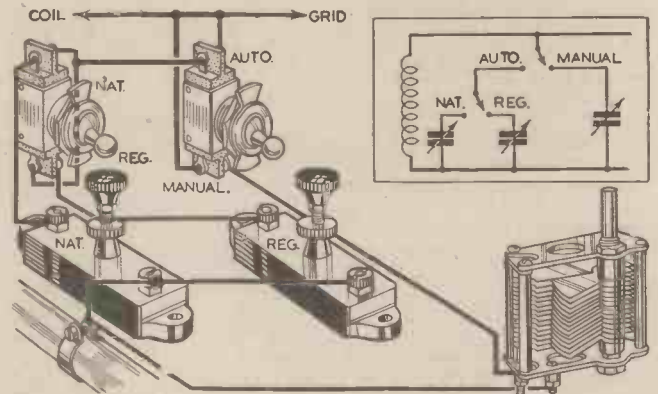


Fig. 5.—A change-over switch to bring in auto or manual tuning.

together, as in the case of the switches. One contact on each jack should be joined to a condenser and the frames of each

wires should be kept parallel throughout their length. If, however, the feeder has to turn the corner of a house or make an angle for any reason, or if it has to run close to a large earthed body, then the twisted arrangement should be employed.

jack connected to earth. For manual control a separate jack may be provided and wired as shown in Fig. 7. The jack may be left in any plug, according to the station being received, and if it is desired to safeguard it against loss, two short lengths of flex may

three tuned circuits, but in this case the oscillation tuning condenser must be carefully placed, as it must not be capable of interaction with the remaining circuits

**Change-over Switch**

It may be thought desirable in some districts merely to provide two stations for normal use, say the National and Regional. In this case the matter is simplified and a simple single switch of the change-over type may be employed. In Fig. 4 is seen how such a switch should be wired for a simple circuit of the type indicated in Fig. 3, one pre-set being connected to each pole of the switch. In this case, of course, manual control is not available unless a separate on/off switch is used to bring into action the change-over switch, and this could be effected by a separate switch as shown in Fig. 5.

**Plug and Socket**

There is a further scheme which will avoid the necessity for returning a switch when a change is desired and which will ensure that all difficulties are removed. This consists of the plug-and-socket method

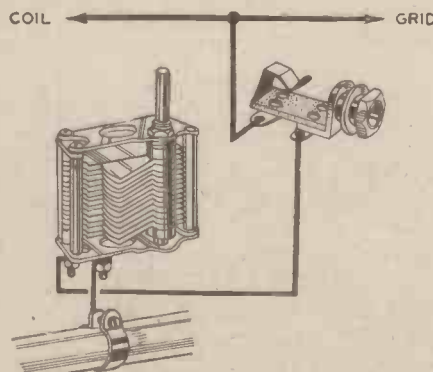


Fig. 7.—A separate jack enables manual tuning to be used.

## PRACTICAL WIRELESS SERVICE MANUAL

By F. J. CAMM

A Complete, Practical and Up-to-date Work on the Testing of all Types of Wireless Receivers. It contains 288 Pages and Over 220 Photographs, Diagrams and Plans.

From all Booksellers 5s. net or by post 5s. 6d., direct from the Publishers, George Newnes, Ltd. (Book Dept.), Tower House, Southampton Street, London, W.C.2.



AROUND THE TRADE—

# In The Model Railway World



A realistic "00" gauge layout recently constructed for a customer by Multi-Models, Ltd.

### Model Railway Exhibition

AS last year, this year's exhibition will be at Central Hall, Westminster, and will be from April 11th to April 15th. The same extensive space has been booked and visitors will be able to examine the exhibits in comfort. The exhibits not shown working, passenger-carrying track (free rides for all) and trade stands will be staged on the ground floor, and the many working track layouts and the cinema will be found in the basement, together with the lounge and refreshments.

There will be a greater number of working track layouts than last year, and many additional phases of railway operation will be demonstrated. Many of the exhibits are produced by members of The Model Railway Club Ltd.

Models of signal cabins, buildings, locking frames and signals will be exhibited, and hardly any object in connection with the operation of our railways will fail to be represented by one or more models.

The cinema (entrance free) will show a selection of films dealing with models and real railway subjects, and for the interest of the ladies and non-technical visitors, there will be films of general and comic interest.

### Model Railway Accessories

THE sketches on this page show a number of model railway accessories marketed by Bond's o' Euston Road. An interesting gadget is the nail presser (2s., postage 3d.), which enables you to lay track twice as fast, and you will not hit your fingers or the chair by mistake. Another advantage is that it is silent in operation. All you have to do is to place the nail in the chair hole or in the nail presser and simply

press. A new all-metal nail presser (2s. 6d. postage 3d.) for Gauge "00" has just been produced in addition to the one previously mentioned which is not suitable for "00" gauge. Also shown in the sketches are some manganese bronze stamped main horns (4d. each), and tender springs and



A super-detail model constructed by Gresham Model Railways, Ltd.

horns (6d. each). These hot manganese bronze stampings are extremely clean and true and a touch of the file is only needed to fit the axle boxes, no other fitting or machining being required. As well as an extensive range of model railway accessories this firm also market scale castings for various types of locomotives.

### Multi-Models

READERS interested in the popular "00" gauge should pay a visit to the extensive showrooms of Multi-Models Ltd., 10-11 New Burlington Street, Regent Street, London, W.1.

This firm stock a large range in this gauge and recently they had a £400 order to supply a complete railway system in miniature to one of their customers. As well as a large amount of rolling stock no fewer than 23 locomotives were included in the layout.

### All Metal Scale "00" Coaches

HAMBLINGS have now introduced a new range of all metal "00" coaches that are to correct 4 m/m scale, and have many interesting and new features that are introduced to "00" gauge for the first time.

The coaches are all metal throughout, and have machine cut windows; these are correctly glazed with the top ventilating sections as can be seen on the photo produced herewith. The greatest innovation is the introduction of correct scale spring buffers that really do depress most realistically; this overcomes to a large extent the usual difficulty of buffer locking when used on sharp curves, as a result in the past it has been necessary to increase the amount of gap between coaches to prevent the buffers coming together on curves. On straight track a very much out of scale distance between coaches gave a bad appearance.

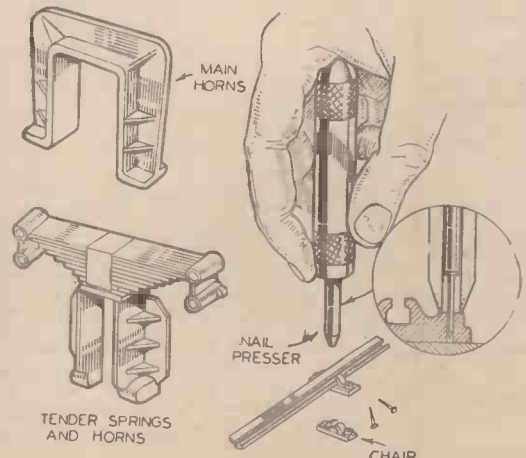
The next interesting feature is the spring

bogies; these are correctly equalised, and allow for realistic riding of the coach, the bogies being constructed with free running bearings running in brass side frames. The coaches are fitted with correct scale vents on the roof, flexible corridor connections, couplings, and are hand painted and lined

(Continued on page 399)

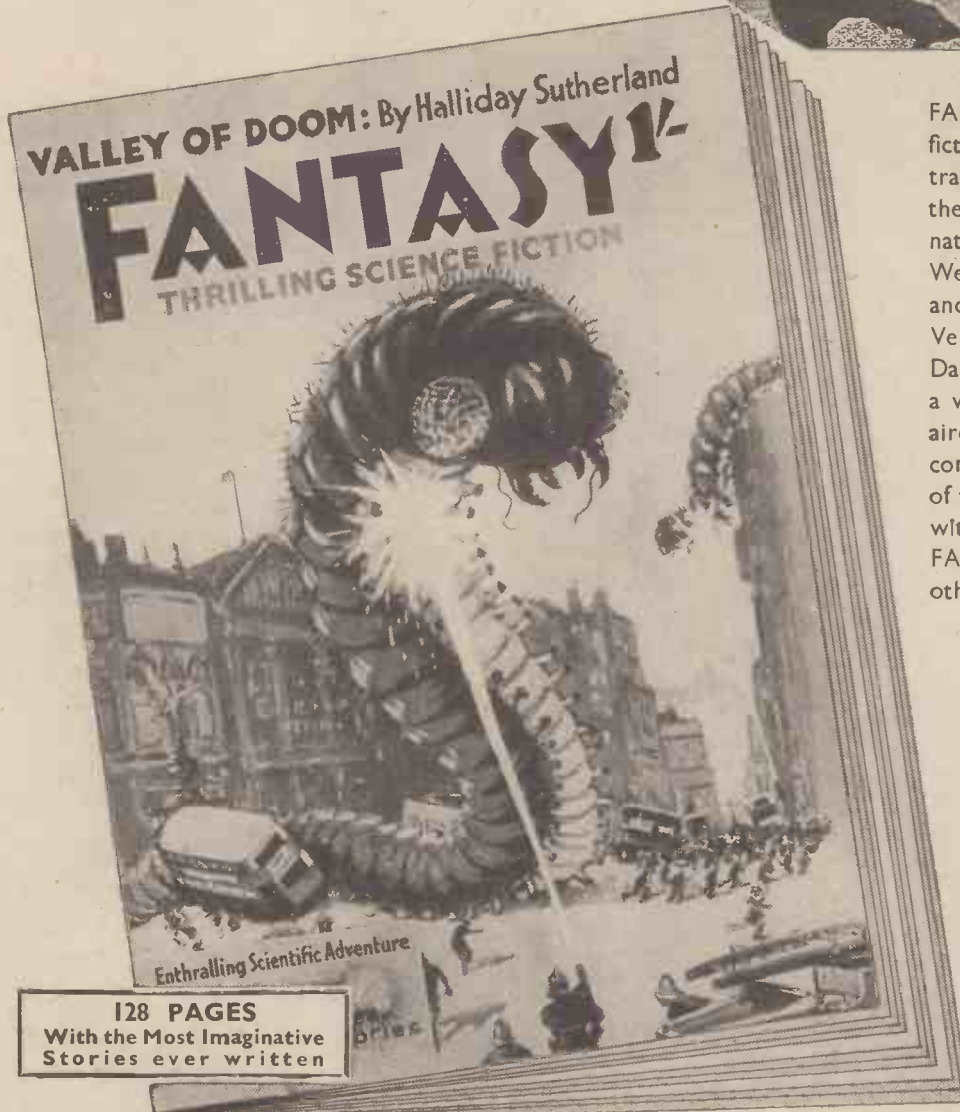
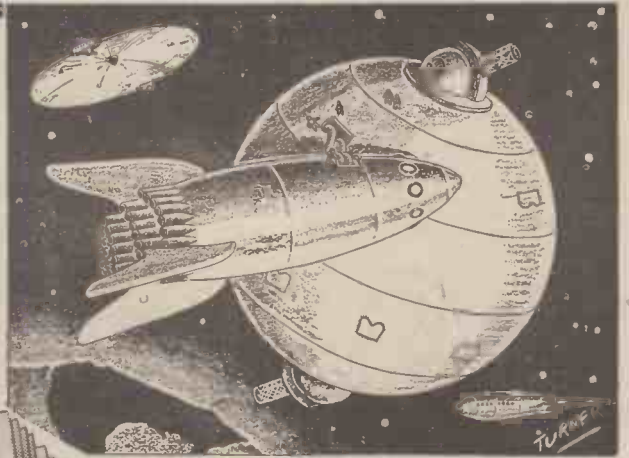


One of the all-metal scale "00" gauge coaches made by Hamblings.



Some of the accessories marketed by Bond's o' Euston Road.

# The Magazine Of SCIENCE FICTION



**128 PAGES**  
With the Most Imaginative  
Stories ever written

FANTASY is a magazine of popular fiction in the H. G. Wells-Jules Verne tradition—a magazine to stimulate the imagination in that most fascinating of all fields, the future. What Wells foresaw—the moving stairway and television—has come to pass. Verne's "Round the World in Eighty Days" has been reduced to less than a week. FANTASY'S stories of the aircraft of to-morrow, of wars to come, and of scientific achievements of the future . . . these, too, are all within the bounds of possibility. FANTASY will entertain you as no other story magazine.

You must read these Long  
Complete Stories

**WINGED TERROR**  
**THE TROJAN BEAM**  
**CLIMATICA**  
**VALLEY OF DOOM**  
**VAMPIRE OF THE VOID**  
**PEOPLE OF THE DEEP**  
**THE DISCOVERY OF NIL**

Special Science Feature  
**TERMINAL IN SPACE**

# FANTASY 1/-

Of all Newsagents and Bookstalls, or by post 1/2 from The Publisher,  
George Newnes, Ltd., Tower House, Southampton Street, Strand, London, W.C.2.



# MASTERS OF MECHANICS

## No. 43. The Eventful Career of Sir William Fairbairn, Mechanical Engineer and Factory Owner



*A train leaving the famous tubular bridge at Conway, North Wales—*

**O**F all the mechanical and civil engineers who graced England in the spacious times of the last century, William Fairbairn was one of the most famed, yet, at the same time, the least spectacular. For Fairbairn, although he possessed inventive gifts which he used to the full, contented himself more with the task of improving the work of others, rather than with that of originating entirely new notions. And because he had the energy and initiative to carry out his self-appointed tasks scientifically, sincerely and efficiently, he rose to a pinnacle of fame which, in his boyhood days, he must hardly have dared to dream of.

William Fairbairn was born at Kelso on February 19th, 1789, the son of hard-working, thrifty and honest Scotch parents. His mother, indeed, was a woman of great beauty who traced her descent from a noble Scotch clan. Her industry, it would seem, was amazing, for not only would she go out and till a portion of the family land, but she would also spin wool for the use of her numerous family and weave it up into articles of clothing, sheets and bedding.

From his mother William Fairbairn learnt his first lessons of industry and perseverance and, as he himself remarked, he owed to her the habits of sustained effort and forcefulness of purpose which so characterised him in his adult years.

### Bad Times

Some years after Fairbairn was born, the family fell upon bad days, which resulted eventually in it having to remove farther north into Ross-shire in which county Fairbairn senior, aided by his brother, leased a farm for the purpose of sheep rearing. On this somewhat inhospitable farmstead, William Fairbairn lived his early days. To some extent, he was allowed to grow up a wild youngster, without any systematic instruction whatever. But, curiously enough, this semi-isolation seemed to serve him a good purpose, for he occupied his ample spare-time by constructing all sorts of mechanical toys with the aid of a small knife, a hammer and various odds and ends of wood and nails which he found lying about.

Afterwards, he was sent away for a time



*—and the suspension bridge over the Menai Straits, these are two of the best-known bridges built by Fairbairn.*

to live with an uncle who was a school-master and under whose strict and spartan tuition he learnt the rudiments of arithmetic, bookkeeping and land surveying.

Owing, however, to the dire necessity of earning some pittance in order to contribute to the family's funds, Fairbairn, in August, 1803, was dispatched to Kelso, his birth-place, and there given work as a stonemason's boy. He remained at Kelso for only a few weeks, however, a rather serious accident which he met with in the mason's yard compelling him to give up his newly-found work.

Back, therefore, young William returned to his father's farm up in Ross-shire and things, indeed, began to look black for the Fairbairn family. But, as usual, it was only the darkness before the dawn, for, before long, Fairbairn senior obtained a position as Steward of a farm belonging to the owners of the Percy Main Colliery, near North Shields. William, then fourteen years of age, was given work at the colliery and, in the following year—1804—he found himself bound as apprentice to a Mr. John

Robinson, the millwright and engineer of the colliery.

### His First Job

Young Fairbairn took up his new duties enthusiastically and almost passionately.

For years William Fairbairn worked away industriously in the colliery millwright's shop. Then, after his lengthy period of

apprenticeship had terminated, he found himself appointed to the charge of the main pumps and the steam engine of the Percy Main Colliery. This, indeed, was a job after his own heart, one for which he had longed throughout the often tedious and irksome days of his apprenticeship.

The job was no easy one. Often, on cold winter days, he had to suspend himself from a rope for hours at a time whilst he examined and repaired the pumping machinery. But, against this was the fact that the position allowed him increased scope for reading and for private study, and, also, if one may intrude a romantic note in an article of this nature, to meet with a pleasant young country girl, Dorothy Mar, by name, who afterwards became his wife.

At this period, also, he came in contact with the subsequently renowned George Stephenson, who was then in charge of a Colliery engine and equipment about two miles away. A close friendship developed between Fairbairn and Stephenson and it grew into one which lasted throughout their lives.

### Fairbairn Comes to London

Whether it was the impossibility of marrying and settling down with Dorothy Mar which unsettled him there is no means of telling. Nevertheless, the fact remains that, soon after he met her, Fairbairn became more and more dissatisfied with his job at the Percy Main Colliery, North Shields, a dissatisfaction which grew so much that eventually it drove him out of the town and resulted in his embarking at North Shields on a coal boat bound for the Port of London.

On December 15th (or thereabouts) 1811, Fairbairn arrived in the east end of London accompanied by a fellow workman named Hogg. Between them they possessed the sum of six pounds, their total and combined savings, and they put up for the night at a lodging house near the dockside.

Six pounds—even in the year 1811—did not last long between two hungry men seeking work in London. Before many weeks had elapsed, the two wanderers found themselves down to their last shilling or two and with still no work in sight. Hogg reproached Fairbairn bitterly for ever having persuaded him to leave the North Shields colliery, but Fairbairn managed to remain cheerful and to rouse the flagging spirits of his companion.

### Work At Last

Eventually the two did get work in London. It was at a ropery which had been newly built at Shadwell, and here Fairbairn, at least, seems to have made some progress, for he fell in with a Mr. Hall, an East-End clergyman, with whom he invented and actually constructed a machine for digging potatoes. Fairbairn and Hall spent £20 on their invention, which eventually turned out to be a failure. Then, owing to some mishap at the ropery, Fairbairn lost his employment and once again found himself practically destitute. He tried to make a living for himself by setting up as an itinerant engineer and a repairer of machinery, but, apart from making a few pounds profit on a sausage machine which he constructed for a Tottenham Court Road butcher, this enterprise came to nought.

Driven out of London by poverty, Fairbairn walked around the south of England, picking up odd jobs here and there. Subsequently he obtained a post as a mechanic in a Dublin iron foundry, and finally he settled in Manchester, the city which was to witness his astonishing success.

Fairbairn had obtained an engineering position in Manchester, and, on the strength of it, Miss Dorothy Mar quickly became Mrs. William Fairbairn. The struggle, however, was not yet over. A new bridge had been projected over the river Irwell, which divides the cities of Manchester and Salford. The design for the bridge was made a subject for public competition, and Fairbairn, enthusiastic as ever, entered his own design for the bridge. It so happened, however, that his employer, a Mr. Hewes, had also sent in a design for the consideration of the authorities. As a result, Fairbairn's position in the employ of Hewes was rendered so uncomfortable that, within a week, he gave in his notice and voluntarily left his hard-won situation.

### His Own Business

Although Fairbairn's design for the Manchester-Salford bridge did not win any special mention, the incident of his giving in his notice to his employer, Hewes, served as the turning point to the whole of his career. Thereafter, Fairbairn decided that he would work in no man's employ and that,

by hook or by crook, he would start in business for himself in the neighbourhood of Manchester, then almost the largest engineering centre in the country.

Fitting up a tiny workshop, Fairbairn forthwith began to look around for profitable work to perform in it. His first "order" comprised the construction of an iron shed or "conservatory" which he made for a Mr. Hulme, of Clayton, near Manchester. Then he found a partner, a Mr. James Lillie, who, with him, founded, in 1817, the firm of Fairbairn and Lillie, Manufacturing Engineers.

But it was not all plain sailing yet. Fairbairn and Lillie could only afford to employ a single workman, and, to make matters worse, they had practically no machinery or equipment for their newly-established business. One prospective customer, indeed, before placing a valued order with Fairbairn, insisted in inspecting the latter's "premises" in order to satisfy himself that the two partners were competent to undertake his work. Fairbairn, managed to assure the over-inquiring customer of his ability to carry out his order, and, by working from five o'clock in the morning until nine at night for several weeks on end, the "firm" managed to complete its first big commission within the appointed time.

### Rapid Progress

That order provided the nucleus around which the firm of Fairbairn and Lillie subsequently grew. Within five years the firm had acquired stock and machinery amounting to £5,000 in market value and they were able to take over more reasonable premises in which to carry on business. Six years later the firm found itself with a cash balance of £30,000, whereupon Mr. Lillie withdrew from the business, leaving Fairbairn sole proprietor of the works.

The departure of Lillie from the firm appears to have spurred Fairbairn to further efforts. The opening of the Manchester and Liverpool railway greatly alarmed the English canal proprietors, who found themselves flung out of business by the railroad interests. Almost in despair, they approached Fairbairn at his Manchester factory, the result being that he designed and constructed a small iron steam vessel for canal use, which craft he christened the *Lord Dundas*.

Further demands were made upon Fairbairn in the sphere of steamer construction and, to cope with these, he took over a factory on the Thames near London. For thirteen years this factory was continued, during which time Fairbairn designed and constructed no fewer than a hundred steam-driven vessels, among which were some for the Admiralty and for the East India Company.

Railways naturally occupied a good deal of Fairbairn's attention. He took out patents for improved forms of rail construction, locomotive-making and boiler construction. These several "departments" of his now huge business he reserved for his Manchester works.

### A Riveting Machine

In connection with the construction of his boilers, Fairbairn invented a riveting machine, which, by the aid of two men and a boy, fixed as many rivets in an hour as could formerly be done by three men and a boy in a working day of twelve hours.

In later life, Fairbairn entered into civil engineering, combining the mechanical side of engineering with the purely structural aspects of constructional science. Indeed, in this connection, Fairbairn has been called one of our first Civil Engineers.

Over a period of years, he studied the many problems of bridge-building, and finally, in 1846, he took out a patent for the building of "tubular" bridges, a type of bridge-construction which he afterwards made peculiarly his own.

Between the years 1846 and 1851, Fairbairn had built more than a hundred tubular bridges in Europe, of which the Suspension Bridge over the Menai Straits and the famous tubular bridge at Conway, North Wales are the best-known examples.

Fresh from his triumphs at bridge-building, Fairbairn turned to armaments and to the construction of armament factories. Here further successes awaited him. He built, also, great textile works, particularly for the woollen trade, not only in this country, but also in Russia and in other parts of Europe.

Distinctions showered themselves upon him. One of the original founders of the British Association, he was elected a Fellow of the Royal Society in 1850, whilst, subsequently, the Universities of Edinburgh and Cambridge conferred their highest degrees upon him.

### Public Funeral

Foreign Governments, too, vied with one another in honouring Fairbairn, but the crowning honour of his lifetime came when Queen Victoria conferred upon him, in 1869, the great distinction of the English baronetcy.

But, somehow or other, the success which came so abundantly to Fairbairn did not spoil him. To the end he preferred to call himself "plain William Fairbairn, of Manchester." To the end, also, he remained singularly approachable by all who needed his advice, and particularly by those who were in any way connected with engineering science.

And when, eventually, William Fairbairn died on August 18th, 1874 at the advanced age of eighty-five years, he was given a public funeral at which thousands of people attended. For Fairbairn, even during his lifetime, had universally been acknowledged a mechanical and civil engineer of universal reputation, and, as a contemporary journal, in its Obituary notice of him, put it, "His footprints are to be found in every path which the engineer can tread, and the sands of Time can never efface them."

## THE HOME MECHANIC ENCYCLOPEDIA

By F. J. CAMM

(Editor of "Practical and Amateur Wireless" etc.)

An up-to-date and comprehensive guide to the Mechanical, Scientific and Technical Interests of the day—with expert articles on Aircraft, Television, Models, Astronomy, Electricity, Photography, Chemistry, Woodwork, Motor Cars, Wireless, Home Cinema, with over 600 illustrations.

Only 3/6 Net

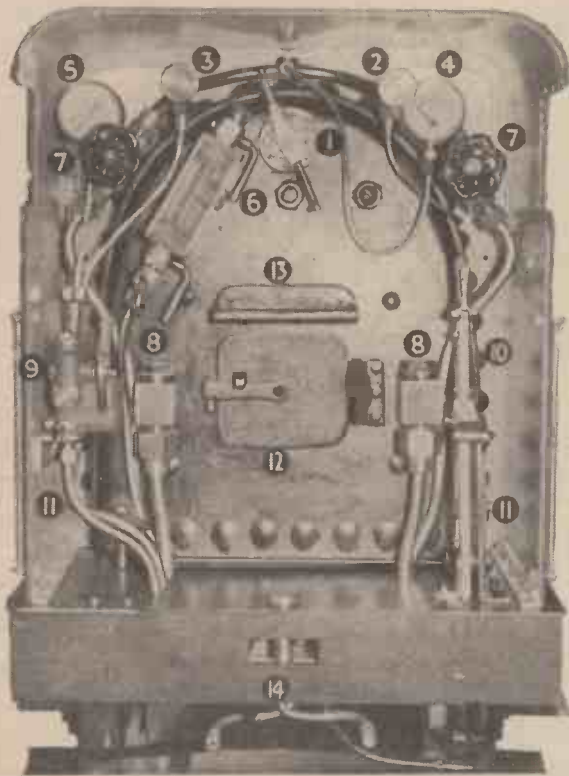
4/- post free from the Publishers—Book Dept., George Newnes, Ltd., Tower House, Southampton Street, Strand, London, W.C.2

NEWNES : LONDON



# "MOTILUS" PEEPS INTO THE MODEL WORLD

**"Motilus"—Our Model Fan—Has Been Very Busy with his Camera Again, and Among his Incursions into the Model World was a lightning visit to the Toy Section of the British Industries Fair**



Inside the driving cab of a model locomotive. (1) The regulator—main driving control of the loco. (2) Blower for drawing the fire up. (3) Steam feed to the ejector. (4) Steam pressure gauge, showing the correct pressure of the boiler. (5) Vacuum gauge, which shows if the brakes are working correctly. (6) Water gauge, which shows the level of water in the boiler. (7) Injectors for feeding the boiler. (8) Check-

a new 2-inch scale 4-4-2 Atlantic locomotive (which has since been shipped to India) and the fittings looked so smart and complete that I took out my camera and here is the result. The various fittings are numbered and described for your perusal, and I also learnt of the intricacies of raising steam in an engine like this.

The boiler is filled three parts with water, and an extension chimney, which attaches to the ordinary engine chimney, is fitted. This is for the auxiliary blower (either a foot bellows or electric fan). The fire is laid off fine wood, adding thicker wood until the steam pressure is 15 to 20 lbs. Now the ordinary steam blower (2) can be brought into action and the auxiliary blower dis-

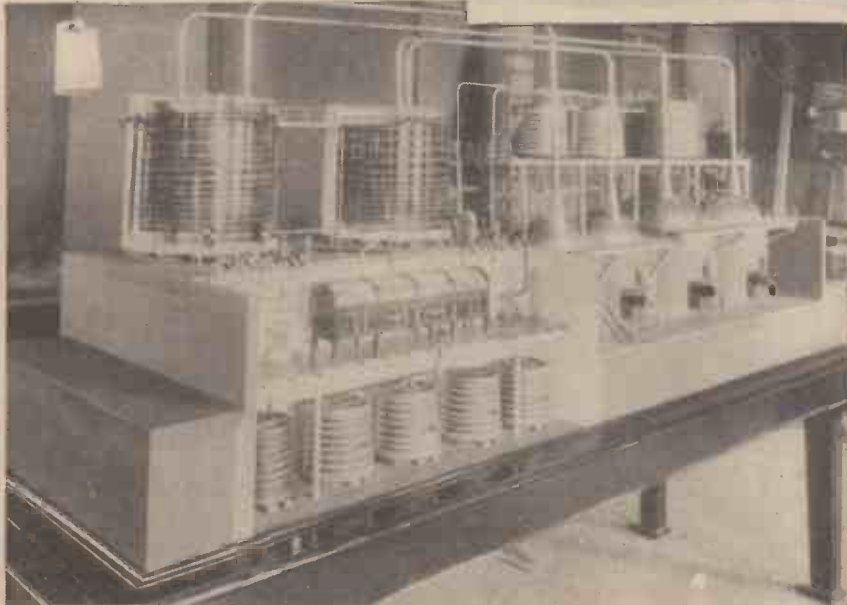
values for injectors delivering water to boiler. (9) Vacuum ejector, which operates the brake. (10) Reversing lever. (11) Partially hidden blow-out cocks for cleaning out boiler. (12) Fire box door. (13) Flame guard. (14) Water-supply pipes to injectors.

### Inside the Driving Cab

It has long been a cliché among model makers to write of the thrill of being "your own engine driver." Last September I went inside the cab of the "Duchess of Gloucester" and listened to a short account of how this huge streamliner is handled. Naturally enough, she was beyond my capacity in engine driving, but the other day I was looking into the cab of



A three-master clipper ship inside a bottle.



A model of a whisky still.

pensed with. Coal is added to the fire until the pressure is brought up to 100 lbs., which is the pressure at which the pop valves are set to blow off.

### Ready for a Run

Now the locomotive is ready for the run. The driver opens the regulator very steadily. If he jerks, the automatic release cocks on the cylinders cannot get rid of the surplus water quickly enough, and a shower will emerge from the chimney. Nevertheless off she goes, and the driver can adjust the regulator to gain the speed he requires. When mounting a gradient the locomotive will need more steam so he opens her out; while downhill, speed is kept up by her own momentum. Also if the locomotive has been correctly stoked she will make steam instead of losing it, but never run with the fire-box door open.

It depends on the length of the run, how he will use the injectors (7), but if it is of any length and the boiler requires feeding, the water is always turned on first. Before you open the injector the water must be overflowing from the overflow pipe. Then simply open the steam valve sharp and the



Some of the latest Penguin series of model aircraft.

water will immediately be picked up to feed the boiler.

Some engines are fitted with steam brakes and some with vacuum brakes, but in either case the brakes operate by a lever on the left (9), and the reversing lever (10) pushes forward for the forward gear and backward for the reverse gear.

#### Model Ships

There is a revival this year of the novelty model ship encased in a bottle. The three-masted clipper ship shown on other page was made for Messrs. Bassett Lowke by an old seafaring man who lives on the coast, and keeps sea still in his life as he models gallant ships of the last century, when sail was still supreme. I examined one of these novelties closely and the ship is exceedingly well made, with all sails set, and mounted on a blue, foam-topped sea. An unusual setting for a Haig's dimple bottle!

#### Model of Whisky Still

Alcohol is not often combined with model-making, but this week I saw another instance of this—a model of an Irish Pot Still Distillery which was being renovated for the New York World's Fair. This model was first made for the Wembley Exhibition of 1925, and also went to the Glasgow Empire Exhibition last year. Mr. Twining, who made the model, told me some interesting facts about the distilling. Irish pot still whisky is produced in two parts—brewing and distilling. In the first brewing process, ground malt, barley, wheat, and oats are mixed with hot water in mash tuns and the resulting saccharine solution of wort is drained off, the grains cooled and run into fermenting vessels, where yeast is mixed with it, causing a fermentation which takes three days to complete. In the distilling process the alcohol solution or wash is pumped from the fermenting vessels into a wash charger through the red pump. This charge of wash is run in equal parts into each wash still. The furnaces are then lighted and after two hours the wash begins to boil. The alcohol vapour is cooled and condensed by cold water circulating outside the coils, and passes through the spirit safe to the vats below. This first distillate is called low wines, and is collected into the low wines receivers. The wash left in the stills is free from alcohol and is sold to dairymen who buy the spent grains from the brewing process for cattle feeding.

The low wines are now pumped into the No. 2 feints charges and are run into the feints still, where a second distillation takes place. Approximately one half is distilled off and collected in the feints receiver, the

residue being valueless and discharged to the sewer. The feints are now pumped to the No. 1 feints charger and run into the spirit stills for re-distillation, and the product of this—approximately 60%—is spirit or new whisky, and is pumped to the spirit stores and racked into sherry casks, which are placed into bonded warehouses to mature for 7, 10, 12, or 15 years.

Several parts of this model work, though it produces no spirit! The furnaces flicker, and water runs from the taps in the spirit safe.

#### At the B.I.F.

And now for the British Industries Fair. The Toy Section seemed as well populated as ever, and I already saw in evidence models of the *Queen Elizabeth*—though these were mostly scenic. Messrs. Meccano had a gauge "0" and gauge "00" layout, and Messrs. Lines had a particularly fine display of aeroplanes. The photograph above shows some of the latest Penguin series—some of which are not yet in production. There is the Vickers Wellington—one of Britain's heaviest long-range bombers, the Westland Lysander, army 'plane used for reconnaissance and co-operation work (has guns in wheel spats), the Bristol Blenheim, Vickers supermarine Spitfire (sister 'plane to Hurricane and fastest single-seater fighter in the world), the Hawker Hurricane which has eight guns to converge on a spot in front of

'plane. Both these 'planes have retractable undercarriages. The three front models are the Blackburn Skua, latest type of bombing 'plane, with folding wing for hangarage space, and used on aircraft carriers, the Vickers Wellesley, and the Monospar Ambulance. There was also on show a sectional model of an Empire Flying Boat, showing control room, pilot's seat, instruments, etc., also radio set and workings. Directly below this is a compartment in which is stored marine gear for mooring. Then comes the mail compartment, and aft of this is the toilet saloon with wash basins, towels, etc. Aft of this is the first passenger saloon, and two others, also with furniture exactly to scale, and then the luggage compartment. All the windows are transparent, and the excellent detail is done by injection moulding.

#### Model Railway

The Trix gauge "00" train layout certainly was a stand to catch the eye, and when you examined the detail of the 16 ft. x 14 ft. layout, which could run four trains simultaneously, I think you would come to the conclusion more than ever that Twin Trains are a remarkable discovery. Among their new features for 1939 are three new locomotives—a double ender Tank Locomotive with 2-4-2 wheel arrangement, 4-4-0 Midland Compound and similar L.N.E.R. models, and 4-4-0 S.R. Locomotive. Also I notice they are to have "Many-ways" Shops for adding to stations, with various interesting contents, electrically lighted, while in coaches they will have scale-model Pullman saloons and S.R. coaches. The auto-control of the Trix Twin Railway will give a novel new control with the level-crossing gates, which are an innovation for next season. Trix, Ltd., have also issued a little service department bulletin which gives useful hints on maintaining locomotives, track and points in apple-pie order, including many necessary do's and don'ts.

#### Dolls Furniture

Another stand which caught my eye was that for "Pit-a-Pat" Dolls House Furniture, which is some of the best furniture in miniature I have seen. There were very complete sets on show for bedroom, dining-room, lounge, nursery, kitchen, bathroom, and scullery, besides such up-to-date articles as a radiogram, television set, garden couch hammock and nursery piano, which have only just been introduced.



"Pit-a-Pat" dolls house furniture.





## Play in 3 months —by amazing new way

If you have never played a note—or if you learnt, but never got far—you will be able to read music at a glance and your own playing will surprise you. All the old difficulties have been “smashed” by the new scientific, amazingly simple **Klavarskribo** method replacing the cumbersome, difficult old method. Klavarskribo students play more music, better and with less effort after 3 months than after 3 years by the old method. This may sound exaggerated to you; but just read these extracts from recent testimonials—“Marvellous—a delight—wonderful—a revelation,” etc. Students simply do not know how to find words strong enough to give expression to their praise for the method that brings them so much enjoyment. As easy and successful for children as for adults

## FREE LESSON

for

### Piano, Reed-Organ or Accordion

Give us your address so that we may send you without obligation a free lesson (after which you play simple melodies) of the famous correspondence course for Piano, Reed-Organ, or Accordion, containing full information about this amazing, **INEXPENSIVE**, simple method and our postal lessons, and a large number of testimonials from progressive musicians and other people of all ranks.

Think of the great joy of being able to play really well. A few months will be sufficient to bring within your reach music you didn't dream you could ever learn to play. You will be the envy and admiration of your friends, who will think a miracle has happened.

*Klavarskribo*

KLAVARSKRIBO INSTITUTE, 1 (BZ) ST. PAUL'S CHURCHYARD, LONDON, E.C.4

## SCALE “OO” RAILWAYS

When visiting the

### MODEL RAILWAY CLUB EXHIBITION, Central Hall, Westminster,

Inspect our range of new all-metal scale coaches. Cut-out glazed windows, sprung free running bogies, floor removable, flexible corridor connections. Hand painted and lined to prototype. Price **17/6**

Send for leaflet PM39 for full description. EACH.

Fully illustrated 60-page catalogue post free 6d.

### THE ORIGINAL SCALE “OO” PIONEERS **HAMBLING'S**

10, CECIL COURT, CHARING CROSS ROAD, W.C.2. Tel. 4704.

## GET FIRST-CLASS MOVIES AND SNAPSHOTS FOR JUST A FEW PENCE A DAY!



We give you two years to pay—it's a chance to have the best whilst you're about it. Get in touch with us now and start enjoying perfect movie and snapshot making with a camera that (with care) will give you a lifetime's happy service.

### ROLLEICORD No. 1A

A versatile model at a popular price. It takes 12 pictures on 3½ by 2½ in. roll film for 1/-. and shows the picture full size and right way up on the ground-glass focussing screen with full provision for parallax compensation. Automatic film wind makes overlapping of exposures impossible. With f/4.5 Zeiss Triotar lens and Compur shutter speeded to 1/300th sec., T. and B. £12 10 0  
24 Monthly Payments of.....11/3

### CINE-KODAK “8”

As easy to use as an ordinary snapshot camera. Easy daylight loading. Halves running costs. Takes 25 ft. of 16-m.m. film, half of which is exposed at a time. With f/3.5 lens.

Cash price.....£10 0 0  
24 Monthly Payments of.....9/-

Good allowance on your used apparatus in part exchange—Literature and advice free!

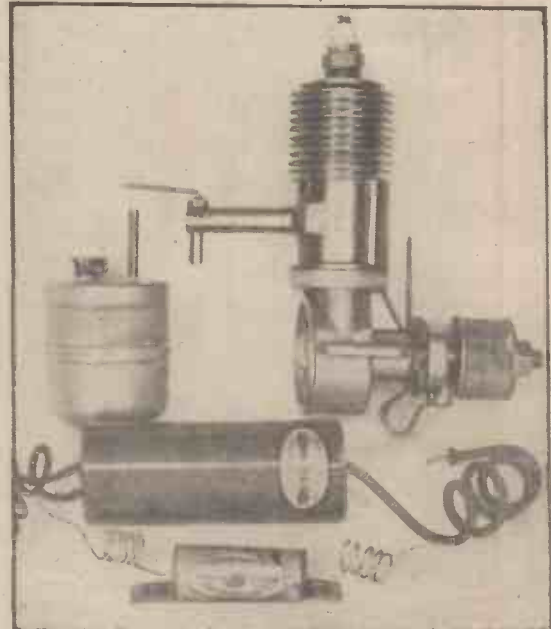
## CITY SALE & EXCHANGE

(1929 LTD.)

59/60, CHEAPSIDE, LONDON, E.C.2

Phone: CITY 1124 5-6

## POWER FLYING



### M.A.S. PRESENT **BROWN JUNR. 'D'**

Aluminium piston and rings. Motor weight, bare, 6½ ozs. 1/5 h.p. Height 4¼ in. Length 5¼ in. R.P.M. range 1,200 to 10,000.

It pays in the long run to get a Brown Junior Motor. Guaranteed performance. Special fuel filter to prevent stalling on steep climb. Two-piece fuel tank is easy to clean. Foolproof wiring. Special coil and spark plug give top performance. Price £3/2/6. Postage 6d.

MODEL AIRCRAFT SUPPLIES, LTD.,  
171, NEW KENT RD., LONDON, S.E.1.



## QUERIES and ENQUIRIES

A stamped addressed envelope, three penny stamps, and the query coupon from the current issue, which appears on page 400, must be enclosed with every letter containing a query. Every query and drawing which is sent must bear the name and address of the sender. Send your queries to the Editor, PRACTICAL MECHANICS, Geo. Newnes, Ltd., Tower House, Southampton Street, Strand, London, W.C.2.

### PAINTING A CYCLE FRAME

"WOULD silver amalgam, similar to that used by jewellers, be suitable for painting a bicycle frame if covered with a coat of cellulose afterwards?" L. M. (Yorks).

ORDINARY jeweller's "silver amalgam" would be totally unsuitable material for treating bicycle frames with since, even when protected with varnish, it would not be durable in outside weathers. It would also, of course, be costly material to obtain and, even supposing it to be durable mechanically, it would quickly tarnish under all normal conditions. In general, amalgam surfacings on metals are useless in those cases in which the metal articles have to withstand severe wearing conditions.

### HYDRAULIC RAMS

"WHAT is the formula for finding the output of a hydraulic ram?" N. C. (Cornwall).

YOU do not appear to have stated your query very clearly. There is, however, no simple formula for obtaining the output of a hydraulic ram from the sparse data which you supply. Perhaps, however, the following information may solve your problem.

If the piston of a hydraulic ram is, say, half an inch in diameter and the water-cylinder of the ram 1 foot in diameter, then the pressure of the water on the base of the water-cylinder will be to the pressure on the piston as a square foot to a quarter of a square inch, that is to say, as 144 square inches to a quarter of a square inch, or 576:1. Thus if the pressure of a ton be imparted to the piston of such a hydraulic ram, the cylinder-plate will be moved upwards with a pressure of 576 tons.

### PURIFYING A SWIMMING POOL

"HOW can I purify a swimming pool 25 ft. by 12 ft. by 6 ft? I have been told that copper sulphate can be used. If so, how much and how often?" A. S. (Liverpool).

UNFORTUNATELY, you do not mention the type of impurity it is most desired to remove from your swimming pool water. If you are troubled with green algae and slimy, filamentous growths in the water, copper sulphate will prove an excellent eradicator, about a dessertspoonful of the copper sulphate being dissolved in a pond of the dimensions you mention. This treatment need not be renewed for six months or more, unless, of course, the water is completely changed within that period.

Other impurities are best rendered innocuous by dissolving two dessertspoonful of fresh chloride of lime in the water at intervals of, say, two or three months. The chlorine liberated by the chloride of lime, will completely sterilise the water. Suspended impurities, leaves, mud, etc., cannot be removed by chemical means, but must be removed by some sort of screening or filtration.

### A WATER SOFTENER

"IN an issue of a few months ago you published an article on the water softener. As I am contemplating making a water softener could you supply me with a method for making a quantity of artificial zeolites?" W. C. (Ilford).

ARTIFICIAL zeolites and other water-softening "exchange" bases cannot be made at home, since high temperatures are required in their production. They may, however, be purchased fairly cheaply from chemical supply firms, such as British Drughouses, Ltd., Graham Street, City Road, London, N.1. "Permutit" is a well-known product of this description.

### WOOL WINDER

"DO you think that the enclosed idea for a self-adjusting wool-winder would be fit matter for patenting? The simplicity of the design makes me think that it could be manufactured quite cheaply." A. C. (Norfolk).

AN adjustable holder for receiving skeins of wool whilst being wound into a ball is not novel. There has been such a device on the market for at least the last 20 years. You are advised to make inquiries from shops dealing in wool work materials.

The specific method of construction may be novel, but as it will not be possible at this date to obtain any wide protection on the device, it is not thought that it will have any chance of being made a commercial success.

### CRICKET SCORE BOARD

"I HAVE designed a cricket score board, suitable for ordinary club cricket, on the principle of a perpetual calendar, i.e., the numbers being painted on canvas strips and operated by means of rollers.

I enclose herewith sketches showing front and side views; the rollers shown in the latter are for operating the digits. Other rollers are, of course, incorporated to work the tens and hundreds. I have made a rough working model which I will send to you for inspection if you so desire." L. C. (Sussex).

THE improved cricket score board is not thought to be broadly novel, and you are advised to make a search amongst prior patent specifications dealing with the subject. Even should a search not disclose the actual construction employed, it is doubtful if any patent of any commercial value could be obtained for the invention.

In order to support a patent, subject matter or invention, as well as novelty and utility, are required, and it is doubtful if the subject matter in view of analogous arrangements is sufficient to support a valid patent; in any case, it is not thought to have any commercial possibilities, and therefore not worth the expense of patenting.

### MERCURIC CHLORIDE

"(1) HOW can one test the strength of mercuric chloride in an amalgamating solution of ammonium, mercuric, and zinc chlorides?

"The strength falls in use, which is, to amalgamate the surface of steel plates before dipping in molten lead-tin alloy.

"(2) How to test for the gluconic acid content of a pickling bath. I have tests for sulphuric, and hydrochloric acids, as well as for the iron saturation.

N.B.—The gluconic acid may be made by the oxidation of sugars, probably dextrose or levulose, or both.

"(3) Is there a conveniently applied test to determine whether the surface of steel is de-scaled enough to take molten metal? Appearance is very deceptive.

"(4) Do you know of any book or journal dealing with such matters as indicated?" T. R. (London, N.W.).

(1) TAKE a known volume of the amalgamating solution, acidify it by adding a small amount of hydrochloric acid and then heat the solution to near boiling point. Add, now, to the solution, drop by drop a strong solution of stannous chloride. This will precipitate the mercury in the solution in the form of a black deposit. When no further precipitation takes place, cease adding the stannous chloride solution. Filter off the precipitated mercury and weigh it. This will give you the quantity of mercury in your original amalgamating solution.

(2) Gluconic acid,  $\text{CH}_2 \cdot (\text{OH}) \cdot (\text{CH} \cdot \text{OH})_4 \cdot \text{COOH}$ , is not easy to estimate in the pickling bath you mention, and there is no simple quantitative test for it. Perhaps the best way for you to estimate the gluconic acid present would be to add a strong solution of phenylhydrazine to the bath drop by drop, the bath being gently warmed. This will precipitate the gluconic acid in the form of gluconic phenylhydrazone, a crystalline substance melting at 200 degrees C. The amount of this precipitated will give you a good idea of the gluconic acid content of the bath.

(3) There is no test for the thoroughness of de-scaling of metal surfaces. Metal workers usually judge the extent of de-scaling by the physical appearance of the metal surface, a test which, admittedly, is not always easy to apply. In this instance, however, practical experience of de-scaling processes counts a good deal.

(4) There are no published books dealing solely with de-scaling and allied topics. You might, however, find the following works useful and they may probably be available in the Manchester Technical Library:

T. G. Bamford & H. Harris: The Metallurgist's Manual.

C. Schnabel: Handbook of Metallurgy (2 vols.).

S. Field & A. D. Weill: Electro-plating.

W. E. Hughes: Modern Electroplating.

J. N. Friend: Corrosion of Iron and Steel.

E. S. Hedges: Protective Films on Metals.

You will also find several periodicals dealing with metal trades available in the Manchester Reference Library.

### MAKING TOLUENE

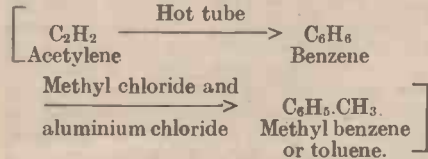
"HOW can I make toluene from acetylene? Please give the chemical symbol for acetylene.

"Can the impure hydrogen, which is liberated from electrolysed sea-water, be used along with carbon to form acetylene?" J. P. (Glasgow).

FROM a purely practical standpoint, you will not have much success in attempting to make toluene from acetylene, and we would not advise you to waste time in such



a useless endeavour. However, for your information, we may say that when acetylene (chemical formula:  $C_2H_2$ ) is passed through a red-hot metal tube, a portion of it is converted into benzene. Now, when benzene is treated with methyl chloride in the presence of anhydrous aluminium chloride (Friedel-Craft's reaction) a portion of it is converted into toluene. We may thus summarise the above sequence of reactions:



Yes, the impure hydrogen formed by the electrolysis of sea water might be used in the preparation of acetylene, but, as mentioned previously, chemical reactions such as these are (on the small scale, at any rate) of theoretical interest and not of practical use.

**CELLULOSE THINNERS**

"(1) **WHAT** is the formula for cellulose thinners?"

"(2) What is a good formula for removing a previously treated surface, whether cellulose or enamel?"

"(3) What is the formula for a surface priming and stopping compound for use before cellulose spraying?" S. W. (Glasgow).

(1) **BY** "cellulose thinners" we presume you mean liquids for thinning down cellulose paints and enamels. The nature of these thinners is governed entirely by the solvents used in the preparation of the cellulose paints or enamels. Hence it is not possible for us to give you the composition of a suitable thinner unless we know the composition of the cellulose enamel with which it is to be incorporated. A liquid, however, composed of 2 parts ethyl acetate, 1 part acetone, 1 part amyl (or butyl) acetate and 2 parts toluene makes an effective thinner for general use. The toluene may be omitted if desired, but it makes the thinner "go farther" and so cheapens its production cost.

(2) You can make a good paint and enamel-remover by dissolving some wax in benzole and by adding an equal volume of acetone to the liquid. Paint the liquid on to the surface, allow it to remain for one minute and then scrape off the softened paint with a blunt knife.

(3) Here again, the formula you desire depends entirely upon the type of wood which is being treated. Ordinary glue-size solution will suffice in many instances, but the finest woods are generally rubbed over lightly with a solution of celluloid in acetone and amyl acetate. For all ordinary purposes, however, we should recommend ordinary sizing for the purpose of surface priming before cellulose spraying on wood.

**AN EXPANDING BRAKE**

"**WHAT** is the best method of marketing the improved expanding brake I have designed and what is its commercial value, if any? I have already taken out a provisional specification." C. T. H. (Stockport.)

**YOU** are advised to either insert an advertisement in one of the Trade Papers offering the invention for sale or on royalty, or to write a short letter to motor car manufacturers, asking if they are interested in an invention relating to expanding brakes, the latter course being probably the preferable one.

No particulars of the invention need be given in the first letter, but it will be as well

to point out briefly the advantages claimed for the invention, and to follow this up with a short description and sketches, or model, if possible, on receipt of a favourable reply.

**A UNION FOR TUBING**

"**I** ENCLOSE herewith a rough sketch of a union for light gauge tube.

"The idea is to obtain a swivel joint of full bore and one that is easily uncoupled with finger pressure.

"At present it differs from orthodox unions in that it has a spring which brings the two ground seats together.

"I should be glad to have your opinion as to whether you think it a fit subject for a provisional patent." R. P. (Stoke-on-Trent).

**THE** improved union for light gauge tubes, if novel, which is believed to be the case, forms fit subject matter for protection by letters patent.

You are advised to file an application for patent with a provisional specification which will give you protection (not a "provisional patent," as there is no such thing) for about 12 months at the least expense.

If a complete patent is desired, a complete specification must be filed within 12 or 13 months from date of application.

**SELF-CONTAINED TOOTH BRUSH**

"**I** HAVE devised a tooth brush which is self-contained and would like your opinion as to whether it is practical and worth patenting." R. P. (Wilts.).

**THE** improved construction of tooth brush is novel and forms fit subject matter for protection by letters patent. It is thought, however, that the broad idea of utilising the handle as a reservoir for soap in shaving brushes is not novel, and you are advised to make a search amongst prior patent specifications relating to reservoir brushes. There may be some difficulty in working out the idea on a commercial basis, as it is thought that the construction would be too expensive to allow of it being produced at such a selling price as to have any extensive sale, and a further difficulty would be encountered in getting users to take the trouble to refill the handle when empty.

In view of the above opinion it is questionable whether it is worth the cost of patenting.

**MECHANISM FOR CINÉ PROJECTOR**

"**I** ENCLOSE a drawing of a mechanism for supplying the intermittent motion to the film in a ciné projector (either home-made or professional). I think it is new and worth patenting." E. S. (Honor Oak Park, S.E.23).

**THE** improved mechanism for obtaining the intermittent motion in cinema projectors is thought to be novel and therefore forms fit subject matter for protection by patent.

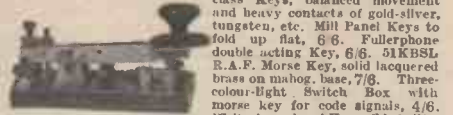
If in practical application there are no difficulties it should have commercial possibilities. It is thought that if the spring is sufficiently strong to obtain a quick movement, there may be some jarring on suddenly stopping the gate, but a model of the mechanism should prove the correctness, or otherwise of this contention.

It would be advisable to file an application for patent with a provisional specification, so as to obtain protection as soon as possible at the least expense. By such means you will obtain protection for about 12 months, during which time it should be possible to ascertain if the invention is likely to be of commercial value.

**ELECTRADIX**

Everyone should learn Morse

**SIGNAL TRANSMITTING KEYS.** We offer several types of first-class Keys, balanced movement and heavy contacts of gold-silver, tungsten, etc. Mill Panel Keys to fold up flat, 6/6. Fullrange double acting Key, 6/6. 51KBSL R.A.F. Morse Key, solid lacquered brass on mahog. base, 7/8. Three-colour-light Switch Box with morse key for code signals, 4/6. Walter's enclosed Key, all bakelite, Marconi, 12/6.



10/6. Super Transmitting Radio Key, 51KE, 21/- Ship Keys

**BUZZERS.** Buzzers for Signals, Wave-meters or Testin. High Note Model T, smallest Buzzer possible, very sensitive. Platinum contacts. List, 10/-, Sale, 6/-. High Note "D.M." Buzzer in case, 3/6. Service Buzzer No. 24, 12/8. Dill Double Circuit Twin Buzzers, 10/-, 20 volt G.P.O. Buzzers, 3/6. Small Buzzer, 1/6. Larger models, 2/6 and 3/-.

**G.P.O. £2 MORSE SOUNDER BUZZERS.** On Mahogany base, 7/6. Telegraph Vertical Needle Signal Galv., 4/-.

**BELLS.** G.P.O. type trembler Circular Desk Bell, with movement in gong, 1/6. Wall Bells, trembler, 3/-. Ditto, large size, 7/6. Large metal 12-volt single stroke Bells, 10/-.

**MAINS BELLS.** 50 volt all brass, 41-in. gong, single stroke, 12/6. A.R.P. 230-volt Ironclad Trembler Alarm Bells, with 10-in. gong, outdoor type, listed 80/-, Sale 37/6. Single Bell Wire, 1 1/2 yard, Twin Bell Wire, 3/- 100 yards. Hooters, 6 and 12 volts, 4/6. Bell Transformers for A.C. 100 volt, 2/6. 230 volt, 5/6 and 15/-.

**BELL-PUSHES.** Small Wall, 4d.; Medium, 6d. Heavy Brass, 1/- Pear Pendant, 8d. Volt meter flush panel tlny Push, 8d. Midget Erindol Push, 4d. Tuckers Push "off," normally closed, for m/a readings, etc., 6d.

We have just taken delivery of nearly a thousand surplus small Motors in almost new condition. 1/100th h.p. to 1/8th h.p. are offered at bargain prices. All voltages.

**MOTOR BARGAINS,** in midget h.p. Motors for A.C. or D.C., 200/250 volts, 1/110th h.p. D.O.T. type totally enclosed, K.B. Cover, 2,000 revs., at a price never before offered, 7/6 only. Next larger G.M. No. 2 type, high speed, 1/60th h.p., 4000 revs., 9/6. Larger still 1/48th h.p. Model G.E. No. 1, 12/6. All as new and first rate for model-driving or light duty.

**EMERGENCY 12-VOLT LIGHTING SETS.** "V" Dynamo sets for use with 12-volt battery, 12/16 volts, 10 amps. Enclosed type ball bearing, Vee pulley. Special complete Switchboard for same with ammeter, max. min. auto cut-out and In. Main Switch and Fuses. The set, 65/- Generator only, 35/-. C.Z. Meter, 7/8. 30 AMP. & k.w. Model T.B. Generator, 12/16 volts, 45/-, or with 30-30 amp. meter and D.P. fuses, 52/6.

**WIND DYNAMOS.** Start generating at 300 revs. up to 2,000 revs., 8/10 amps., ball-bearing, enclosed type, 35/-.

**LUCAS AERO,** 9/12 volts, 250 watts D.C. with enclosed Automatic Cut-out. Used on aircraft for L.T. supply to lighting, heating and wireless. Cost £15. Sale 25/-.

**H.T. DUAL,** cost £12. 600 volts, 100 m.a. and L.T. 6 volts, 5 amps. Sale, 20/-.

**L.T. DYNAMOS.** Mackle Plating, 12 volts 40 amps., 25. Crypto 20 volts 8 amps., ball bearings, 55/-. Ditto Crompton 30 volts 15 amps., £3 10/-. Crompton 80 volts 20 amps., £7 10/-. 100 volts 25 amps., £9 10/-. 100 volts 30 amps., £12.

**TO MODEL MAKERS.** Parcels of brass rods, 2 ft. long, 1/4 in., 3/16 in., 5/32 in. and 1/8 in., 2 lbs., post free, 2/6. 4 lbs., parcel post free, 4/6. Fine Turning Metal for brass bearings, etc., solid drawn, 1 1/4 in. dia., 1/8 in. bore, 1 ft. long, 4 lbs., 4/8.

**VIBRATOR BATTERY SUPERSEDER,** with metal rectifier, for H.T. from your 2-volt battery. Three output volt tappings. A boon to those who are not on the mains. Reduced from £3 15/- to Sale Price 37/6.

**MICROPHONES.** New models, high efficiency, low prices. The famous W.E. Button type Microphone, 1/- No. 11 hand or s/nf Mike, solid bakelite body, 5/- Super midget table stand bakelite Mike with transformer in base semi-transparent, worth a guinea, 10/- only. The well-known W.W. 11 table Mike with square bakelite case, fitted switch and transformer, and detachable bronze table stand, 12/6.

**HOME RADIO AND CAR CHARGERS.** The A.C. NITNDAY will keep your battery fit without attention. Model N/A6, 100/250 volts A.C. and D.C. 6/8 volts & amp., 15/- Model N/B6, 100/250 volts to D.C. 6/8 volts 1 amp., 25/- Model N/C8, 100/250 volts to D.C. 6/8 volts 2 amps., 35/- Model N/D12, 100/250 volts to 12 volts 1 amp., 32/- Ditto, 12 volts 2 amps. with 6-volt tap, 55/- 5 amps. 24/10/-.

**HAND COMBINATION MICROTELEPHONE.** Transmitter and Receiver. For use on any bell circuit, 7/6. **POCKET HEAD PHONES,** W.D. all leather headband, strap and cord, 2/6 pair. L.R. type with aluminium headbands, 2/9. Brown's lightweight, 4,000 ohms, 4/6. House, Office and Field Telephones, wall and table, 10/- and 15/-.

**FEIGH HOME RECORDING.** Geared Tone Arm and Cutter sets complete for radiogram, 37/6. Blank 6-in. discs, 3/3 per dozen.

**DIAL TUNING.** 10-point Finger Switch Dials, as illus., used on G.P.O. Automatic Telephones. These have spring drive, governor, clutch and contacts inside. Price 2/6.

**PARCELS** of experimental odd coils, magnets, wire chokes, switches, terminals, etc., post free, 10 lbs., 7/-; 7 lbs., 5/-.

**METERS.** 1,000 Switchboard, Service and panel Meters in stock, lowest prices, all ranges. 50 micro-amm. 40/- Weston Table 0-30, 15/6. Charging Pole Testers, 2/6. 0-20 volts, 5/-; 0-30 volts, 5/-; 0-100 volts, 5/6; 0-200 volts, 6/- All A.C. or D.C. Repairs to all types.

Send for "Radio Electrical" Scientific Illus. List "P.M." Free.

**ELECTRADIX RADIOS**

218, UPPER THAMES STREET, LONDON, E.C.4

Telephone: Central 4611

# FREE SERVICE FOR READERS

**R**EADERS requiring information concerning goods or services advertised in PRACTICAL MECHANICS should give names of Advertisers from whom particulars are desired. Any number of names may be included and we will obtain for you catalogues, lists, and any other information you may be wanting. **THERE IS NO CHARGE FOR THIS SERVICE.**

Readers desiring particulars from a number of Advertisers will, by this method, save time and postage. If any Advertiser stipulates that stamps or postal orders are necessary before samples or catalogues are sent, please enclose the necessary amount with your instructions. You are cordially invited to make full use of this Service.

**ADVERT. SERVICE DEPT.,**  
 PRACTICAL MECHANICS,  
 TOWER HOUSE, SOUTHAMPTON  
 STREET, STRAND, W.C.2

*Please obtain and send to me particulars from the Advertisers in your April issue whose names I give on list attached.*

Advertiser	Page No.	Information Required
------------	----------	----------------------

*Attach sheet of paper, with particulars, and your name and address (written in **BLOCK** letters), with date, to this announcement.*

## PERFUMERY PREPARATIONS

- (1) "WHAT is the name and approximate cost of the 95 per cent. alcohol used in perfumery preparations?"
- (2) "Could methylated spirits be used in place of this alcohol?"
- (3) "Is petrolatum (white or yellow) an alternative name for vaseline and petroleum jelly?"
- (4) "Are the following oils similar: white oil, liquid vaseline and liquid paraffin?"
- (5) "Could either benzaldehyde or nitrobenzene (oil of myrbane) be successfully substituted for almond oil, and, if so, which is preferable?"
- (6) "Can you give me the name of a firm or firms who sell small quantities (about 1 oz.) of essential oils, such as neroli, rose, lavender, ylang-ylang, etc.,

- (1) THE alcohol you refer to is known as "ethyl alcohol, pure, 90 per cent." (not 95 per cent.). Its price, retail, is about 19s. per lb., duty paid, and for high-class perfumery preparations its use is really essential. Such alcohol can be obtained from Messrs. Harrington Brothers, Ltd., Oliver's Yard, City Road, London, E.C.1, or from Messrs. A. Boake, Roberts and Co., Ltd., Stratford, London, E.15.
- (2) Ordinary methylated spirit can NOT be used in place of the purer alcohol for toilet preparations, etc. It is possible, however, to arrange with your local Excise Officer and a firm of suppliers for you to obtain a purer grade of alcohol in bulk at cheaper rates. Either of the above firms would advise you on the necessary procedure.

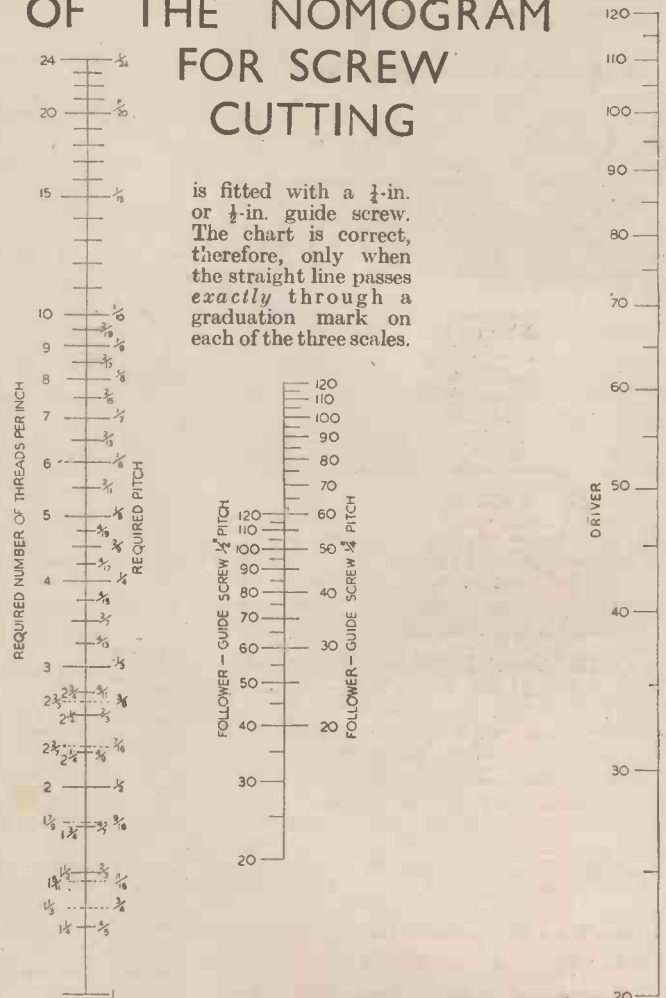
Alternatively, you might experiment with the use of iso-propyl alcohol, an alcohol similar to ethyl alcohol, but, not being dutiable, retailing at about 2s. 6d. per lb. For very many purposes, this alcohol is a good substitute for pure ethyl alcohol, and, like the latter, can be diluted with water.

- (3) Vaseline is a trade name. Petroleum jelly and petrolatum are identical with it.
- (4) Liquid paraffin (medicinal) is a highly purified form of higher-paraffin distillate, "liquid vaseline," being a similar preparation but of thicker consistency and containing hydrocarbon liquids of higher boiling point. "White spirit" is a purified form of mineral paraffin, of higher boiling point than ordinary paraffin oil. All these substances, however, have a common origin—the crude petroleum of the oil wells.
- (5) The answer to this question is in the affirmative, provided that the benzaldehyde or nitrobenzene are used for perfumery purposes only. If, however, the almond oil is being used as an emollient, it cannot be substituted by the above two compounds.
- Benzaldehyde is the odiferous constituent of oil of bitter almonds, in which it is present to the extent of about 99 per cent. It has a much superior odour to nitrobenzene, which, in truth, has a crude and nasty almond-like smell and is only used in the cheapest (and often worthless) preparations.
- (6) You can obtain small supplies of various essential oils from Messrs. Goodwin, Tidswell & Co., Ltd., Carnarvon Street, Cheetham, Manchester.

## THE USE OF THE NOMOGRAM FOR SCREW CUTTING

*A slip appeared in the chart accompanying the above article which appeared on page 294 of our March, 1939 issue. Through an oversight the chart was shown incorrectly spaced and we now show the correct chart, which should be used in conjunction with the article.*


This Nomogram gives the required combination of change wheels to cut from one to twenty-four threads per inch on lathes having guide screws of 1/4-in. or 1/2-in. pitch. In accordance with the principle of the Nomogram, a straight line drawn across the three scales joins three related points, but, in using this chart, it must be remembered that the portions of the scales lying between the graduations have no meaning. This is because, in the first place, change wheels go up in multiples of five teeth, and in the second place, portions of the "threads per inch" scale, lying between the graduations, represent threads which cannot be cut with a simple train of wheels when the lathe



is fitted with a 1/4-in. or 1/2-in. guide screw. The chart is correct, therefore, only when the straight line passes exactly through a graduation mark on each of the three scales.



**Free!**



**200 Courses**


## ENGINEER'S Guide to Success

This Great Guide shows how to study at home with The T.I.G.B. for a well-paid post. Contains the widest choice of engineering courses in the world—over 200—including MECHANICAL, CIVIL, ELECTRICAL, AUTOMOBILE, AERONAUTICAL, RADIO, TELEVISION, CHEMICAL, etc.—alone gives the Regulations for Qualifications such as A.M.I.Mech.E., A.M.Inst.C.E., A.M.I.E.E., C. & G., G.P.O., etc.—contains remarkable tributes from Engineering Institutions and eminent technical men to the successful tuition methods of The T.I.G.B.—and details latest successes of T.I.G.B. students in all fields. Training until successful guaranteed for the one fee. Write for Free copy TO-DAY.

**THE TECHNOLOGICAL INSTITUTE OF GREAT BRITAIN,**  
 218 Temple Bar House, London, E.C.4  
 Founded 1917. 20,000 Successes.

## An Absorbing Hobby

BUILDING A STUART MODEL IS AN ENGROSSING PASTIME, AND THE RESULT A CONTINUOUS PLEASURE



**We Illustrate:**  
**STUART NO. 10.**  
 High Speed Steam Engine.  
 Bore  $\frac{3}{4}$ ".  
 Stroke  $\frac{3}{4}$ ".

Each set is quite complete—drawings and instructions are included.

If you have a lathe—		
The rough castings	- -	8/6
If not—		
Fully machined set	- -	18/6
Ditto, with all holes drilled and tapped	- - -	25/-

This and many other Stuart engines are fully described in the 72-page CATALOGUE No. 3, 6d. post free.

**STUART TURNER LTD.**  
**HENLEY - ON - THAMES**

**Around the Trade—**  
**IN THE MODEL RAILWAY WORLD**  
*(Continued from page 389)*

to prototype. Another ingenious feature is that the complete floor and chassis of the coach is detachable quite easily, thereby enabling "detail" enthusiasts to model the internal furnishing of the coach.

We really can say that these coaches are good value for the money, the price being only 17s. 6d., and we should recommend all interested, to call and see these at Hamblings showrooms, 10 Cecil Court, Charing Cross Road, London, W.C.2.

**Complete Model Railways**  
**GRESHAM MODEL RAILWAYS LTD.**  
 Have one of the very few shops in the world that sell nothing but model railways. They make up, however, for this specialisation by the variety and attractiveness of the goods they stock. It is possible for the customer to buy a complete second-hand model railway here at a very modest figure, or should he so desire he can have made a super detail model such as we picture, the cost of which will, of course, vary with the amount of detail. This particular engine is an exact copy of one built for a Brazilian coffee estate by Messrs. Hudswell Clarke, Ltd., of Leeds, and is from drawings supplied by them.

Another feature of Gresham Model Railways, Ltd., is the issue of a monthly used models list, which is sent free to anyone interested. The address is:—Gresham Model Railways, Ltd., 79 Gresham Street, E.C.2.

**MODEL AERO TOPICS**  
*Continued from page 386*

60 seconds. The kit is absolutely complete with printed ribs and several finished parts including a "Normac" Super Thrust ready-carved propeller and retails at 5s. An ideal beginner's model.

The Condor "Clipper" has a wing span of 30 ins. and is a high wing monoplane of similar construction to the "Curlew." This model was introduced only nine months ago, but it is claimed that in so short a time it has won many open club contests and the National Biplane Contest, an additional standard type wing being fitted for this purpose and the machine created a new British record for that class with a flight of 135.73 seconds. Over sixteen customers have recorded flights longer than six minutes duration with Standard Condor "Clippers." This kit also contains a finished "Normac" Super Thrust Propeller, a very complete range of which are illustrated in the new profusely illustrated Catalogue and Handbook, a copy of which will be sent on receipt of 4d. stamp. The kit of the "Clipper" retails at 8s. 6d.

**Model Aircraft Stores**  
**THIS** company, of 127b, Hankinson Road, Bournemouth, who supply the well-known Comet and Spitfire model aircraft engines, issue a most complete catalogue of everything necessary for model making. They list blueprints of popular flying models, gears, wood, piano wire, tubing, dope, banana oil, adhesives, technical books, compressed air engines, airscrews, construction kits, etc., etc.

## BE A RADIO EXPERT

**Earn £30 to £60 month**



**THIS POWERFUL ALL-WAVE RADIO SET**  
*Free!* with your **TRAINING**  
 10 Big Kits of Radio Parts and instructions to build this 8-tube Receiver.

### I Train You at Home In Spare Time for a Good Radio Position

I prepare you for a Radio service business of your own, requiring no capital... or for a big paying position in Broadcasting, Loud Speaker Systems, Service Work in stores, Talking Pictures, Short Wave Radio, Radio Operators, Radio Retailing and Distributing, Television, etc. Special Money-Making Lessons show you how to make money AT ONCE by doing spare time Radio Service Work in your neighborhood while learning. Diploma and Degree upon graduation.

**FREE BOOK**  
 Your OPPORTUNITIES IN RADIO

The distance between us makes no difference, as my internationally known method of training keeps you constantly in Lessons. Post coupon today for my FREE 42-page illustrated book.

**Post Coupon TODAY!**

C. H. MANSFIELD, Pres.  
 Department 3035  
 Hollywood Radio & Television Institute  
 810 W. 6th St., Los Angeles, Calif., U.S.A.

Send me free book, "Your Opportunities in Radio," telling how you can prepare me for a good position in Radio.

Name: \_\_\_\_\_  
 Address: \_\_\_\_\_

Letter Postage to U. S. 14d. Post Card 10.

---

## CHARGE IT AT HOME



with a "SILEX" Battery Charger. Cheap to run. Prices: 2 v.,  $\frac{1}{2}$  amp., 8/6; 1 amp., 12/6; 2 amps., 18/6; 6 v., 1 amp., 15/- Special Car Battery Models: 6 v., 2 amps., 25/-; 12 v., 30/- Commercial Charger for 1-14, 2-v. cells, 0-3 ammeter, Low, Medium and High tappings, 50/- Larger Models quoted for. H.T. Accumulator Charger, 150 v., 250 M/A, complete, 35/- Combined H.T. Eliminator and 1-amp. Charger, 21/- All above for 200-250 v. A.C., with metal rectifiers, robust mains Transformers, strong steel cases. To Use JUST PLUG-IN, FIT SPADES, SWITCH ON. That's ALL! Send 3d. for Real PHOTO and 7 Days' FREE TRIAL TERMS. Transformers and Rectifiers supplied for any purpose.

**BRIGHTON RADIO SERVICE**  
 34 Middle Street, Brighton

# BUY, EXCHANGE OR SELL

## TOOLS

1" Round Dies, Screwing  $\frac{1}{8}$ ";  $\frac{3}{16}$ ";  $\frac{1}{4}$ ";  $\frac{5}{16}$ "; Whit., B.S.F.; or Brass 26 Threads; or American Fine. S.A.E. for Yankee Cars, Set of Five Dies 2/9; Four Sets 10/-; Best Quality 1" Die-Stocks, all Steel unbreakable with Hardened adjusting Screws, 1/9 each.—Below.

4,000 Taps, same sizes and threads as Dies, 2/9 set, four sets 10/-.—Below.

3 Tons Files, assorted parcels for General shop use, 3 doz. 8" to 12", 10/-; 2 doz. 12" to 16", 10/- Car. for. Paid with £2 order.—Below.

Bright Mild Steel, round, approx. 50 ft. assorted  $\frac{1}{8}$ " to  $\frac{1}{2}$ " diam., 5/8; ditto 50 ft. Squares, Flats, Small Hexagon, 8/6.—Below.

Superfine Files, 6", for Gauge making or fine tool work, 4/- doz.—Below.

Vee Blocks and Clamps, Starret pattern, accurate, first-class finish, 2/6 each; 4/6 pair.—Below.

Fine Emery Wheels,  $\frac{1}{8}$ " to  $\frac{3}{8}$ " thick,  $\frac{1}{2}$ " hole;  $2\frac{1}{2}$ " to 4" diam., extremely useful for Grinding Drills, Small Tools. Special selection, 2/6 per doz.—Below.

Genuine Carborundum Wheels, 0" diam., 1" wide; 1" hole; suitable general tool use, 6/- each. Ditto  $1\frac{1}{2}$ " wide, 8/-;  $1\frac{1}{2}$ ", 10/-; ditto 14" diam.,  $1\frac{1}{2}$ " and  $1\frac{3}{4}$ " wide, 5" hole, 12/- each. Smaller wheels, 4" diam.,  $\frac{1}{2}$ " wide,  $\frac{1}{2}$ " hole, 1/9;  $3\frac{1}{2}$ " ditto, 1/6; 3" ditto, 1/3; also Rough Wheels 8" diam.,  $1\frac{1}{2}$ " wide, 1" hole, 3/9 each; 7", 2/6; 6", 2/- each.—Below.

250 Gross Genuine Tungsten Hack-Saw Blades, 8", 0", 10", 12", 14" to 32" teeth;  $\frac{1}{8}$ " wide; a few gross 12",  $\frac{5}{16}$ " wide. These are very slightly stock soiled but guaranteed serviceable, 8/6 gross. Three gross lots, 22/6. Power Blades, 12" by 1", 2/6; 14", 3/6 doz., subject to order.—Below.

600 Large Gas Thread Taps, Taper, 2nds, Plugs,  $1\frac{1}{2}$ " 2/6;  $1\frac{1}{4}$ ", 3/-;  $1\frac{1}{2}$ ", 3/6; 2", 4/-; 2 $\frac{1}{2}$ ", 4/6; 2 $\frac{3}{4}$ ", 5/- each.—Below.

1,000 Taps in Electric Conduit and Brass 26 threads. 8", 1/-; 2", 1/3; 3", 1/6; 1", 1/9 each.—Below.

Morse Taper Sleeves, best quality, ground finish, 1-2, 1/6; 2-3, 1/10; 3-4, 2/6.—Below.

Mild Steel Blanks, any thickness to 1", sawn from bar to your exact requirements,  $1\frac{1}{2}$ " diam., 6d.;  $1\frac{1}{4}$ ", 8d.;  $1\frac{1}{2}$ ", 10d.; 2", 1/-; 2 $\frac{1}{2}$ ", 1/6; 3", 2/-; 3 $\frac{1}{2}$ ", 2/3; 4", 2/6; also  $1\frac{1}{2}$ " thick, plus 10%; 2" thick plus 15%.—Below.

Special Clearance guaranteed quality Small Taps and Dies,  $\frac{1}{8}$ " Circular Split Dies, British and American make only. Usual price 10d. to 1/3 each. Sizes:  $\frac{1}{8}$ "; 5/32";  $\frac{3}{16}$ "; 7/32";  $\frac{1}{4}$ "; 9/32";  $\frac{5}{16}$ ". Whitworth, B.S.F. also Model Engineer 40 Threads in all above sizes; also 0, 1, 2, 3, 4, 6 B.A. Clear 6d. each, 5/6 doz.—Below.

Small Taps in all above sizes. Taper; Second or Plugs,  $\frac{1}{8}$ " to  $\frac{1}{2}$ " Whit., B.S.F. Also 0 to 6 B.A. 4d. each; 3/- doz.; 9/32" and  $\frac{1}{8}$ " 6d. each. Please note we have no stock of M.E. 40 Thread Taps.—Below.

Die-Stocks for above Dies, steel throughout, hardened adjusting screws, 9d. each; Tap Wrenches, 0 to  $\frac{1}{2}$ " Adjustable, all steel, 9d. each.

Three tons ground bright Tool Steel Pieces,  $\frac{1}{2}$ " to  $1\frac{1}{2}$ " diam., various lengths up to 6", easily hardened in water or oil. Guaranteed the very best quality material actually costing from 1/9 to 3/- per lb. A stock is essential for making Cutters, End Mills, Pin Drills, Punches, High Speed Shafts, etc., etc. 5 lbs. assorted, 3/-; 14 lbs., 7/-; also larger sizes,  $\frac{1}{2}$ " to  $1\frac{1}{2}$ ", 10 lbs., 4/-; 28 lbs., 10/-. Also larger sizes  $1\frac{1}{2}$ " to 3" diam., in blanks and short pieces, not bright, 28 lbs., 6/6; 1 cwt. assorted,  $\frac{1}{2}$ " to 3", 30/-;  $\frac{1}{2}$  cwt., 15/6;  $\frac{1}{4}$  cwt., 9/- We guarantee you a good assortment for general use.—Below.

700 Cutting Off Grinding Wheels, approx. 7 $\frac{1}{2}$ " diam.  $1\frac{1}{2}$ " thick,  $\frac{1}{8}$ " hole, 2/8 each; ditto, approx. 6" diam. 1/9 each.—Below.

Hexagon Die-Nuts, invaluable to all repair shops. Genuine clearance prices: Whit., B.S.F., S.A.E., U.S.S.; also brass 26 thread, sizes  $\frac{1}{8}$ ",  $\frac{3}{16}$ ",  $\frac{1}{4}$ ",  $\frac{5}{16}$ ",  $\frac{3}{8}$ ". Usual price, 7/6 set; outstanding value, 2/9 set. Also  $\frac{1}{8}$ ",  $\frac{3}{16}$ ",  $\frac{1}{4}$ ", in same threads, 4/- set of four. Any four sets  $\frac{1}{2}$ " to 1", 24/-, for thirty-six die-nuts.—Below.

700 Large Split Dies, best quality. Dies  $1\frac{1}{2}$ " diam.,  $\frac{1}{2}$ " thick, cutting  $\frac{1}{8}$ ",  $\frac{3}{16}$ ",  $\frac{1}{4}$ ",  $\frac{5}{16}$ ",  $\frac{3}{8}$ ". Whit. and B.S.F. Gas,  $\frac{1}{2}$ " by 24 threads, 1/3 each. Also  $1\frac{1}{2}$ " diam. Dies,  $\frac{1}{2}$ " Whit. only, 2/- each. Also 2" diam. Dies,  $\frac{1}{2}$ ",  $\frac{3}{8}$ ",  $\frac{1}{4}$ " Whit.,  $\frac{1}{2}$ " B.S.F.,  $\frac{1}{2}$ " Gas, 1/4 by 26,  $\frac{1}{2}$ " by 20,  $\frac{3}{4}$ " by 30 threads, 2/9 each, Worth double. Also  $2\frac{1}{2}$ " diam. Dies,  $\frac{1}{2}$ ",  $\frac{3}{8}$ ",  $\frac{1}{4}$ " Whit.,  $\frac{1}{2}$ ",  $\frac{3}{8}$ " B.S.F.,  $\frac{1}{2}$ ",  $\frac{1}{2}$ " Electric Conduit,  $\frac{1}{2}$ ",  $\frac{3}{8}$ " Gas, 3/6 each.

J. BURKE, 30 TRIPPET LANE, SHEFFIELD, 1

## TOOLS—Continued

1,200 Best Quality Taps, Tapers, 2nds, Plugs.  $\frac{1}{8}$ ", 9d.;  $\frac{3}{16}$ ", 1/-;  $\frac{1}{4}$ ", 1/3;  $\frac{5}{16}$ ", 1/6, Whit., B.S.F. Also in gas thread,  $\frac{1}{8}$ ", 6d.;  $\frac{3}{16}$ ", 9d.;  $\frac{1}{4}$ ", 10d.;  $\frac{5}{16}$ ";  $\frac{3}{8}$ ", 1/3;  $\frac{1}{2}$ ", 1/6;  $\frac{3}{4}$ ", 1/9; 1", 2/-.—Below.

12 Only Ball-bearing Double-ended Grinding Heads, to take  $\frac{1}{8}$ " bore wheels. Practically new, 15/- each. Six only Stands for same, fitted with rise and fall slide independent each side. Make very good tool and cutter grinders or surface or special grinders. Stands 10/- each, if purchased with grinder.

2/9 any lot. Eight lots £1.—Below.

$\frac{3}{8}$ " Toolholder with four H.S. Tools.

$\frac{3}{8}$ " Adj. Boring Tool with H.S. Tool.

$\frac{1}{2}$ " Drill Chuck, taper or straight shank

$\frac{1}{8}$ " to  $\frac{1}{2}$ " Silver Steel, 13 pieces.

$\frac{1}{2}$ " to 1" Silver Steel, 4 lb., 2" to 4" long.

500 Ass. Brass and Steel Screws, etc.

100 Steel Hex. Bolts and Nuts,  $\frac{1}{2}$ " to  $\frac{1}{2}$ ".

16 H.S. Drills, 1/32" to 5/32".

12 Drills,  $\frac{1}{8}$ " to  $\frac{1}{2}$ " Carbon.

Set 1" Dies,  $\frac{1}{8}$ ",  $\frac{3}{16}$ ",  $\frac{1}{4}$ ",  $\frac{5}{16}$ ",  $\frac{3}{8}$ ", Whit.

Ditto, B.S.F. 26 threads or S.A.E.

Set  $\frac{1}{2}$ " to  $\frac{1}{2}$ " Taps, same as Dies. T.S. or P.

Slitting Saws, five 1/32" to  $\frac{1}{4}$ " thick, 1" hole.

Two dozen Fine and Odd Thread Taps to  $\frac{1}{2}$ ".

Three dozen Tungsten Hack-saws to 12".

18 Grinding Wheels,  $\frac{1}{2}$ " to 1" diam.

Three H.S. Tap Fluting Cutters,  $1\frac{1}{2}$ " diam.

One dozen Ass. Files, 4" to 12".

Six Files, 12" to 16". Note postage terms.

Dozen Toolmaker's Needle Files, indispensable.

Best Carborundum Wheel, 7" by  $\frac{1}{2}$ " by  $\frac{1}{2}$ " hole.

200 Springs to approx. 6" long.

Small Taps, 7, 8, 9, 10, 12, B.A.,  $\frac{1}{8}$ ", 3/32" Whit. 6d. each, 5/9 dozen. No dies in these sizes.

High-Speed End Mills,  $\frac{1}{8}$ ", 2/9; Straight Shank,  $\frac{3}{8}$ " carbon ditto, 1/9.

£1 Orders Carriage Paid, except abroad. Money refunded if not satisfied with any of the above bargains.

J. BURKE, 30 TRIPPET LANE, SHEFFIELD, 1

GRAYSON'S Glass-boring Outfits and Tube Cutters avoid risk.—Below.

DRILLS, Taps, Dies, Files, Chisels and Punches. Best quality at keenest prices.—Grayson & Company, 300 Campo Lane, Sheffield.



**OUTSTANDING EARS CORRECTED**  
The Universal Ear Shaping ORO. Treatment, produces amazing, immediate and permanent results. CONSPICUOUS EARS assume their normal position within a few minutes. No mechanical contrivance. Oro is ideal in that each application is INVISIBLE, comfortable and harmless. Praised by Doctors. Hundreds of satisfied users. Write for free booklet and testimonials.  
M. TRILETTI (R 146),  
45, Hatton Garden, London, E.C.1.

## OUR ADVICE BUREAU COUPON

This coupon is available until April 29, 1939, and must be attached to all letters containing queries, together with 3 penny stamps. A stamped addressed envelope must also be enclosed.  
PRACTICAL MECHANICS, APRIL, 1939.

## TOOLS—Continued

BRAND NEW POWER TOOLS of quality. 10 in. Bandsaws, 54/-. Jigsaws, 22/6. Wood Planing Machines, 80/-. Bench Drills, 11/-. Circular Saws, from 25/-. 3 in. S.C. Toolroom Lathes, from £4 10s. New 1 in. Chromium Plated Micrometers, 12/6. Electric Drills, 32/6. Grinders, Spray Plants, Guns, Air Compressors, etc.—John P. Steel, Clyde St. Mills, Bingley.

Complete Ball-bearing Saw Benches from £4 18s. 6d. Easy terms. Lists Free.—Hartop, Engineers, Bedford.

MYFORD LATHE SPECIALISTS. Cash or no deposit terms from 10/- monthly. Immediate deliveries anywhere.—Nuttalls, 20 Albert Street, Mansfield.

## CANOE

BOAT AND CANOE. Kits from 27/6. All types completed craft. List stamp. Trade.—Metacraft (P), Christchurch, Hants.

## CINEMATOGRAPHY

ART CINE FILMS. Exclusive 9.5 and 16-mm. Free Films to Cine Camera or Projector buyers. All makes. State wants.—P. M. Dane, 64 Stanley Street, Liverpool 1.

CINEMATOGRAPH FILMS. Standard Size from 6d. 100 feet. Machines, Accessories. Sample Films 1/- and 2/6 post free. Catalogues free.—"Filmeries," 57 Lancaster Road, Leytonstone, E.11.

WANTED FOR PROMPT CASH, Miniature Cameras, Enlargers and Accessories, Cine Cameras, Projectors and Films, Microscopes, Telescopes, and Binoculars; small Lathes and Precision Tools.—Frank, 67 Saltmarket, Glasgow.

## CLOCK MOVEMENTS

CLOCK MOVEMENTS of every description ready for cases. Lists post free.—Needham, 25 Stratton Road, Manchester, 16.

## ELECTRICAL

A.C., D.C. MOTORS, Grinders, Fans, Drills, Chargers. 1039 interesting lines. List free. Esaco Electrical Services, 18pm, Brixton Road, S.W.9.

SUPER A.C. MOTORS. Brand New, 1/10 h.p., 30/-;  $\frac{1}{8}$  h.p., 38/6;  $\frac{1}{4}$  h.p., 38/6;  $\frac{1}{2}$  h.p., 55/-; larger sizes. Electric Tools, Machines, Pumps, Compressors, etc.—ohn P. Steel, Clyde Street Mills, Bingley.

A.C./D.C. MOTORS,  $\frac{1}{8}$  h.p., 4,000 r., 11/-; 1/12th h.p., 8,000 r., 10/-. Blowers, etc., all 200-250 v. Stamp particulars.—Brookes, Banners Street, Cradley, Staffs.

SMALL ELECTRIC MOTORS, tools, workshop gear, list.—Scott, 149 Albert Road, Middlesbrough.

## MUSICAL INSTRUMENTS

BAND GUIDE. Hints on the Bugle, Drum, Flute, Staff Parade formation, etc. Free, post paid.—Potter's (Manufacturers), West Street, London, W.C.2.

## MODEL MAKING

MONEY MAKING MODELS for us spare time. Particulars, samples, 6d.—H. Elliott, 17 John Bright Street, Birmingham, 1.

## MISCELLANEOUS

HEADPHONES, CRYSTALS, CRYSTAL SETS, microphones, model aeroplanes; tricks, jokes, etc. Lists with diagrams, FREE, or send 3d. for 40-page ILLUSTRATED CATALOGUE.—POST RADIO, 2 COPENHAGEN STREET, London, N.1.

TELESCOPES, MICROSCOPES, Scientific Instruments, etc. Send for lists. Sale or Exchange.—C. V. Bolton, F.S.M.C., 49a, Leigh Road, Leigh, Lancs.

"PHOTO-ENGRAVING."—A practical Handbook with complete set of materials for engraving printing blocks, 4/6.—Industries, 2 Waldegrave Park, Twickenham.

TELESCOPES! Reflecting and refracting. Eye pieces, silvering, refiguring, repairs. Equatorial stands. Everything supplied.—Irving's, 258 Kingston Road, Teddington.



# BUY, EXCHANGE OR SELL

Advertisements are accepted for these columns at 3d. per word (minimum 12 words at 3s.—advertisements of less than 12 words are charged at the minimum rate of 3s.) subject to a discount of 2½% for 6 consecutive monthly insertions or 5% for 12 consecutive monthly insertions. **TERMS:**—Cash with order. Cheques, Postal Orders, etc., should be made payable to George Newnes, Ltd. *The Proprietors reserve the right to refuse or withdraw advertisements at their discretion.* All advertisements must be received on or before the 5th of the month preceding date of publication and should be addressed to the Advertisement Manager, "Practical Mechanics," George Newnes Ltd., Tower House, Southampton Street, Strand, W.C.2.

## PATENTS

**REGINALD W. BARKER & CO.** (Established 1886), 56 Ludgate Hill, London, E.C.4.—Patent and Trade Mark Booklets Gratis.

## PATENTS AND INVENTIONS

**AMERICA.** Sell your patents through "INVENTION," leading U.S.A. monthly. Specimen copy 2/3 annually 25/- from British Agents, INTERNATIONAL ENGINEERING CONCESSIONAIRES, LTD., 3 Duke Street, St. James's, S.W.1.

**WE SUCCESSFULLY SELL** inventions, patented and unpatented. Write for proof, and tell us what you have for sale.—Chartered Institute of American Inventors, Dept. 10-C, Washington, D.C., U.S.A.

## PHOTOGRAPHY

**PHOTOGRAPHIC MATERIALS.** Plates, Films, Mounts, Chemicals, etc. Interesting, money-saving lists and samples free.—"Klumber's," 105 Queens Road, Brighton.

**"PANTOGRAPHS"** make large accurate drawings from small photographs, etc., easily. 1/-.—Cooke, 33, Hawthorn Road, Levenshulme, Manchester.

£500 worth, good, cheap Photo Materials, Films, Plates, Cards, Papers, Chemicals, Catalogue and 4 Samples free.—Hackett's Works, July Road, Liverpool 6.

**DON'T TAKE RISKS.** Good developers mean good results. Our reliable stock developers keep twelve months after mixing. Satisfaction certain to amateurs and professionals. Best developers ever put on the market. Make two pints strong developer. 6d. each, 6 for 2/3, 12 for 4/-. Post free.—Hackett's Works, July Road, Liverpool 6.

## HEIGHT COMMANDS!

so why not be taller



Short people can gain height and health with the aid of a box of Challoner's famous formula.

**H.T.N. TABLETS** and easy system; well tried and safe. No strenuous exercises or old-fashioned appliances. If one box is insufficient we guarantee to supply a further box FREE.

G. Y. (Watford) writes: "I have never had confidence in any system till I tried yours, now I've gained in height, weight and fitness." Act now! Full particulars 1/4d. Sample 7/4d. Book on height improvement 3d., sent under plain sealed cover.

stamps or P.O. only. Sent under plain sealed cover. **THE CHALLONER CO.** (late Bond Street), Dept. V.83 Laboratory & Works, Hyde Heath, Amersham, Bucks

## JUBILEE

## WORM DRIVE HOSE CLIPS

The long-life clip with the ever-tight grip.

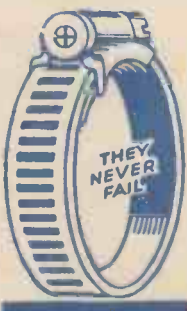
The Best Known

For Radiator Joints, Air, Oil, and Water Hose Joints.

We guarantee a Tight Joint.

Stocked by all Garages and Accessory Dealers.

**L. ROBINSON & CO.**  
25 London Chambers,  
GILLINGHAM, KENT.



## SITUATIONS VACANT

**G.P.O. ENGINEERING DEPT.** (no experience required). Commencing £3/13/0 per week. Age 18-23. Excellent prospects. Free details of Entrance Exam. from B.I.E.T. (Dept. 579), 17-19 Stratford Place, London, W.1.

**DRAUGHTSMEN.** Numerous vacancies available in Electrical, Mechanical, Aeronautical and other Branches of Engineering, Building, G.P.O., etc., for men age 17-40. Exp. unnecessary if willing to learn. Details of openings, salaries, prospects, etc., FREE from N.I.E. (Dept. 372), Staple Inn Buildings, W.C.1.

## MODELS

**EVERYTHING FOR** electrical rewinds and repairs. Screws, nuts, and washers for model engineers. Lists free.—Lumen Electric Co., Litherland, Liverpool, 21.

**FOR TRIX TWIN RAILWAYS.** Some special 4-4-OT types, including a G.W.R. and Coaches. Particulars 1½d.—Georges', 11, Friars Street, Ipswich.

**STEEL TUBING,** Seamless, ¼ in. to 5½ in., 1/32nd in. to 3/8th in. thick. Please say lengths you cut to. Hack Saw blades, 2/- doz.—Cotes, Church Walk, Brentford, Middlesex.

## ENGINEERING

**MINIATURE BALL RACES** from 1½ mm. o/d. Send 2d. stamp for particulars of 1930 REDUCED PRICES. Sample, 1s. 6d. post free. Dept. P, MINIATURE BEARINGS, LTD., 3 Duke Street, St. James's, S.W.1.

## ENGRAVING EQUIPMENT

**ELECTRIC ENGRAVING EQUIPMENT SPECIALISTS.** Send for details of equipment for engraving nameplates, tools, dog collars, etc.—RUNBAKEN ELECTRICAL PRODUCTS, MANCHESTER 3.

## METAL WORK

**MAKE METAL TOYS.** Easy, profitable with "Success" Moulds. List Free. Complete trial mould, 1s. 6d.—Lee's, 1 Birkin Avenue, Nottingham.

You NEED this "IMPETUS" MOTOR TOOL an Electric High Speed hand grinder, file, router, etc., that SAVES TIME, EFFORT & EXPENSE. Faster, easier and more accurate. Nothing on the market to touch it at 68/- nett. Send for detailed specification NOW and be up to the minute. Super model, £5 5.  
**JOHN P. S. STEEL**  
Clyde Street Mills, Bingley.



## NERVOUSNESS

Every nerve sufferer should send for my interesting book which describes a simple, inexpensive home treatment for Self-consciousness, Blushing, Depression, Worry, Insomnia, Weak Nerves, Morbid Fears, and similar nervous disorders. This wonderful book will be sent in a plain sealed envelope to any sufferer without charge or obligation. Write NOW and learn how to conquer your nervousness before it conquers you!

**HENRY J. RIVERS** (Dept.) 116 HIGH HOLBORN, LONDON, W.C.1

## HAVE YOU A RED NOSE?

Send a stamp to pay postage, and you will learn how to rid yourself of such a terrible affliction free of charge.

Address in confidence—  
**P TEMPLE, Specialist**  
"Commerce House," 72 Oxford Street, W.1  
(Est. 38 years.)

## MICROSCOPY

**"THE MICROSCOPE AND ENTOMOLOGICAL MONTHLY."** The premier journal for all students of nature. 1s. from newsgagents, or 1s. 1d. from Microscope, 20/21 Took's Court, London, E.C.4.

**MICROSCOPIC OBJECTS**—unmounted, prepared. Assorted packet, 2/- Leng, "Elhanan," Brierley Road, Bournemouth.

**MICROSCOPES—INCLINABLE STAND AND MIRROR,** 7/9. Case of ten specimens, 1/-—Beeby, P.M.A., 77, Orde Avenue, Wellington-on-Tyne.

**MICROSCOPES,** telescopes, glasses, new and second-hand lenses, etc.—Mackett & Company, Manufacturing Opticians, 51 Millers Road, Brighton.

## MONEY-MAKING OPPORTUNITIES

**SALES REPRESENTATIVE** wanted, spare time; 35s. weekly easily made.—Richfords, Ltd., 8a, Snow Hill, London.

## WOODWORK

**CABINET HARDWOODS,** Oak, Mahogany, Ash, Whitewood, Plywoods. Lowest Prices. Send Cutting Lists.—Wilfred Parr & Co., March Works, Lancaster Road, Leytonstone, E.11.

## WATCHMAKING

**WATCH & CLOCK REPAIRERS.** Send 3d. for complete list of material and tools. Blakiston & Co., Ainsdale, Southport.

## WIRELESS

Crystal Set Kits, complete, 3/11, post free. Bargain 3-valve sets, perfect, 19/6. W. J. Buckle, 63, Avenue Approach, Bury St. Edmunds.

*It's easier to solder with*

"Baker's" Solderine. For all electrical work and wherever paste flux is preferred. Popular sizes include: 2oz. tins, 6d.; 4oz. tins, 8d. Also supplied in bulk. Obtainable from all wholesalers.

**"Baker's" SOLDERINE PASTE**

Sir Wm. BURNETT & Co. (Incorporated) Ltd.  
Great West Rd., Isleworth Middx.  
Tel. 2400-2401-2402

## INVENTORS

### VALUABLE GUIDE

General Advice Free. POST FREE 6d.  
**CHATWIN & CO.** Est. 1880  
Regd. Patent, Design and Trade Mark Agents for all countries.  
253 (D) Gray's Inn Road, London, W.C.1.

## WEBLEY AIR PISTOLS

Marvellously accurate for target practice.

No licence required to purchase or use at home.

Senior 45/., Mark 1 32/6

Junior 21/., Webley Air Rifle 95/-

Write for List. WEBLEY & SCOTT LTD., 106 WEAMAN STREET, BIRMINGHAM.







# GAMAGES

Send for copies of  
Gamages' Tool  
Bargain Leaflets  
for Metalworkers  
and Woodworkers

## The GAMAGE 3in. BACK GEARED, SCREW CUTTING, SLIDING, MILLING and SURFACING LATHE with COMPOUND SLIDE REST

GUARANTEED TRUE to .001 in.



Send for fully  
Descriptive  
Lathe  
Leaflet

Headstock and Bed are of ample proportions; with large-diameter mandrel in long adjustable bearings. Quick Traverse Handle for Saddle Return. Saddle has machine-cut slots. All gears are machine-cut. Dimensions: Swing in gap, 8 in.; Swing over saddle 3 1/2 in.; Mandrel nose 1 in. Whitworth; Mandrel and tailstock barrel bored 1 in. clear; Centres standard No. 1 Morse taper; Cross-slide traverse, 3 1/2 in.; Top-side traverse, 3 in.; Lead-screw, 1/2 in. diameter by 8 T.P.1; Cone pulley, 3 1/2 in., 2 1/2 in. by 1/2 in. width; Back-gear ratio, 6 to 1; Approximate weight 60 lb. With compound Slide Rest and Back Gear, 20 in. between Centres, including 6 in. Face Plate, 2 1/2 in. Driver Plate, Machined Chuck Plate, 10 Change Wheels and Double Clasp Nut.

Cash Price

**£6 7 1 6**

OR DELIVERED ON FIRST OF 12 MONTHLY PAYMENTS OF **11 6**

Also with single clasp nut, <sup>Cash Price</sup> £5/19/6, or 12 Monthly Payments of 10/9.

Carriage Outside Our Extensive Delivery Area, England or Wales, 3/6.

Suitable for Very Fine Work



### 1 5/8" PLAIN, GAP BED LATHE with Compound Slide Rest

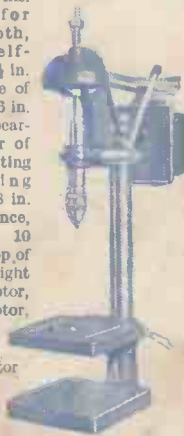
Constructed on orthodox lines. Overall length, 12 1/2 in. Length of bed, 8 in. Maximum distance between centres, 6 1/2 in. Height of centres from gap, 2 in. The nose of the solid mandrel is 1/2 in. x 20 threads. Bearings adjustable for wear. Compound slide rest has vee slides with gib and adjusting screws. Tailstock is of the sliding barrel type, and is held in position by a set screw. Driver plate, 1 1/2 in. dia. Weight, 8 lb. Carriage 1/8 England or Wales. Foot Motor, 18/6. Carrier 1/3. Set of Six Tools, 3/-; Belt, 2/-.

**21 6**

## ELECTRIC DRILLING MACHINES

BENCH TYPE. Three speeds, sensitive feed; depth of feed, 3 in.; spindle graduated in 16ths.

Stop collar for regulating depth, three jaw, self-centring chuck, 1/2 in. capacity. Centre of chuck to pillar, 6 in. Oilite bronze bearings; diameter of pillar, 1 1/2 in. Fitting and swivelling table, 8 in. by 8 in. Maximum distance, chuck to table, 10 in. Height to top of frame, 30 in. Weight with 1/2 h.p. motor, 67 lb. Without motor, 45 lb.



Cash Price with motor

**£8.7.6**

OR DELIVERED ON FIRST OF TWELVE MONTHLY PAYMENTS OF **15 3**

Without motor, Cash Price £5/12/6, or 12 Monthly Payments of 10/3. Also Floor type: Maximum distance, chuck to table, 33 in. Height to top of frame, 56 in. Weight with 1/2 h.p. motor, 80 lb. Without motor, 59 lb. Cash Price with motor, £9/5/0, or Delivered on First of 12 Monthly Payments of 16/9. Without Motor, Cash Price £6/10/0, or 12 Monthly Payments of 11/6.



## PARALLEL VICE

at a Substantial Reduction

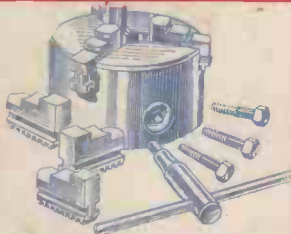
With instantaneous grip. Best cast iron, and fitted with hardened steel detachable jaws. Mild steel screw and handle. One size only: width of jaws, 3 1/2 in.; depth, 4 in.; maximum opening, 4 in. Weight, 32 lb.

Original list price, 29/6.

Carriage 1/6, England or Wales.

**21 6**

## Three-Jaw Self-Centring LATHE CHUCKS



A high-grade special iron of extra resistance to tensile and bending stresses is used for the manufacture of the bodies of these chucks. The jaws, scroll, pinions, and screws are made from finest case-hardened steel. Diameter, 3 1/2 in. Diameter of recess, 2.48 in. Bore, 3/8 in. Weight, 3 3/4 lb. With two sets of jaws.

**32/-**

## 1/4 h.p. SPLIT-PHASE INDUCTION MOTOR Protected Type with Sleeve Bearings



These motors may be connected to the mains through an ordinary single-pole tumbler switch. A serviceable, heavily constructed motor which will give years of trouble-free service. 2,850 r.p.m. Guaranteed for 12 months.

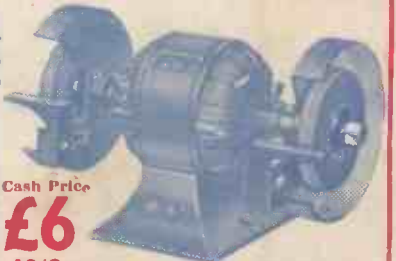
Original list price, 67/6

For 200/220 or 230/250 volts, 50 cycles A.C., single phase, Carriage, England or Wales, 1/6 extra.

**55 4**

## ELECTRIC DOUBLE GRINDERS

Operated by self-contained 1/2 h.p. motor for 222/240 volts A.C. 50 cycles. Single-phase 3,000 r.p.m. 2.7 amps., k.w. 0.25. Diameter of grinding wheels 6 in., 1/2 in. thick. Overall measurements: 18 in. long, 9 1/2 in. wide, 10 1/2 in. high. Weight 60 lb. With 9 ft. cab tyre flex.



Cash Price

**£6**

Or Delivered on First of 12 Monthly Payments of **10 9**

Carriage 2/-, England or Wales.

GAMAGES, HOLBORN, LONDON, E.C.1

Telephone: HOLborn 8484.

City Branch, 107 Cheapside, E.C.2.

Published about the 30th of each month by GEORGE NEWNES, LIMITED, Tower House, Southampton Street, Strand, London, W.C.2, and Printed in England by THE SUN ENGRAVING CO., LTD., London and Watford. Sole Agents for Australia and New Zealand—Gordon & Gotch, Ltd. Sole Agents for South Africa—Central News Agency, Ltd. Subscription Rates: Inland and Abroad, 7s. 6d. per annum Canada, 7s. per annum. Registered at the G.P.O. for transmission by Canadian Magazine Post.