

FLOATING HANGARS AND AERODROMES

NEWNES

# PRACTICAL MECHANICS

JANUARY

6<sup>d</sup>

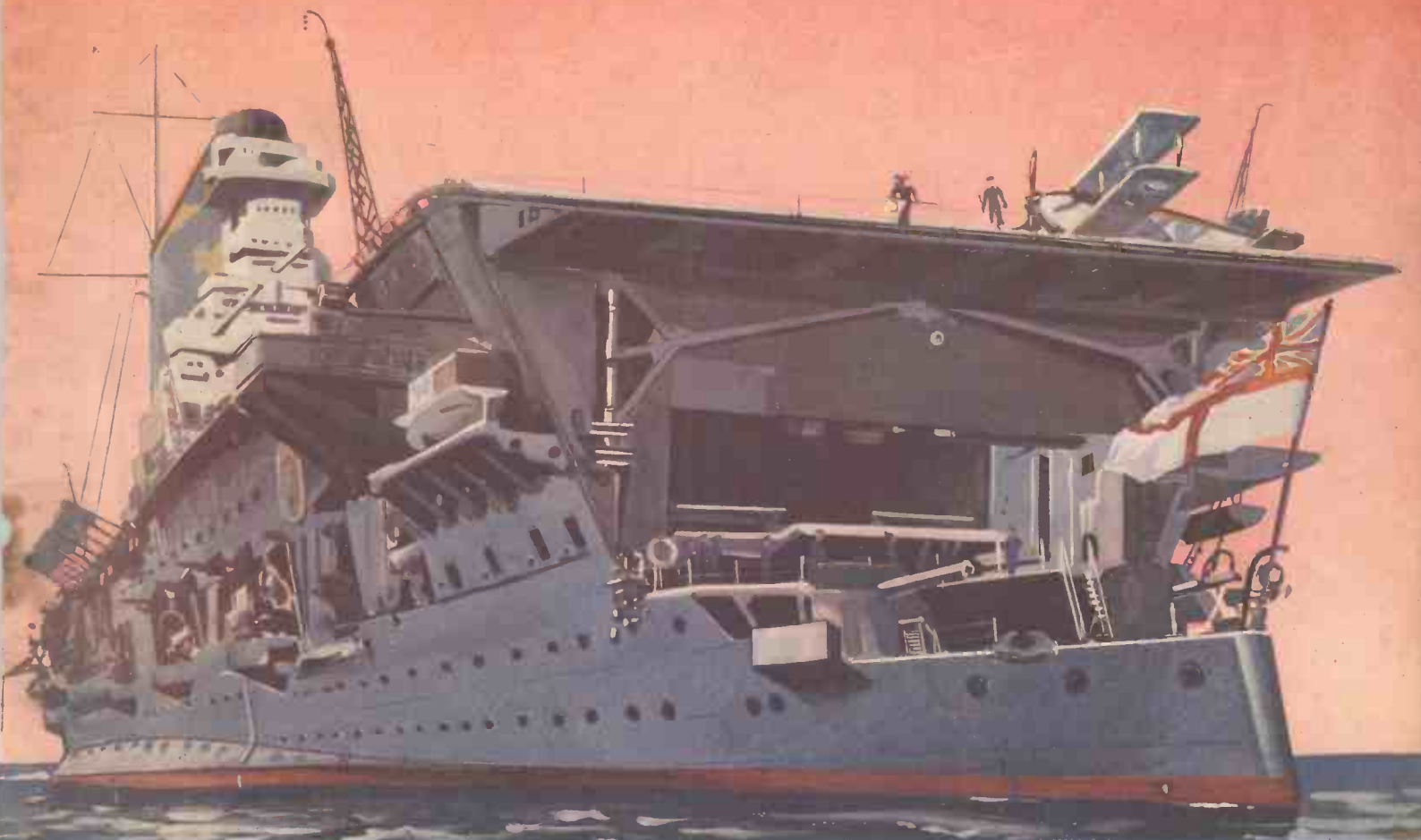

MODERN SHIP DESIGN • A 15 c.c. PETROL-ENGINEED HYDROPLANE • THE DIESEL ENGINE EXPLAINED • LATERAL CONTROL ON LIGHT AEROPLANES • MODEL AEROPLANES • RAILWAYS • MODERN TRAIN FERRIES • WIRELESS • LATEST NOVELTIES • TOOLS ETC.ETC.

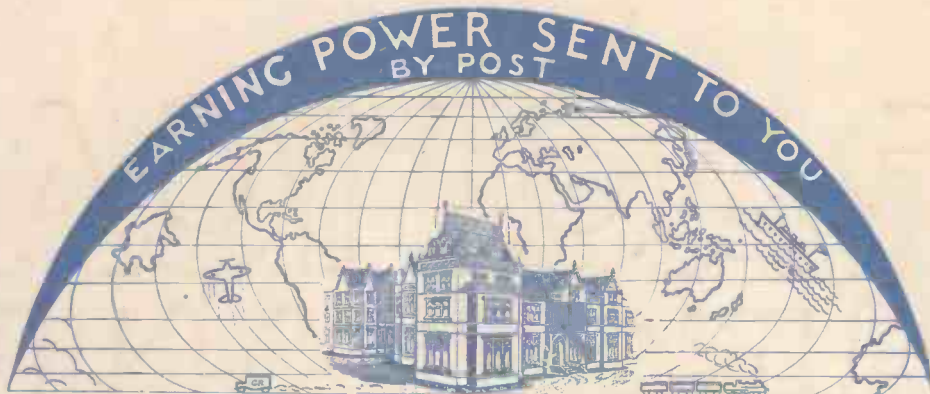

LET ME BE YOUR FATHER

35 YEARS' PRACTICAL EXPERIENCE

*J. Bennett*



LET ME BE YOUR BIG BROTHER

15 YEARS HELPING HIM

*J. Bennett*

IT IS THE PERSONAL TOUCH WHICH COUNTS IN POSTAL TUITION

*Let us tell YOU how to make a success of the life before you - by using your spare evenings wisely and pleasantly*

THE MOST SUCCESSFUL AND MOST PROGRESSIVE CORRESPONDENCE COLLEGE IN THE WORLD

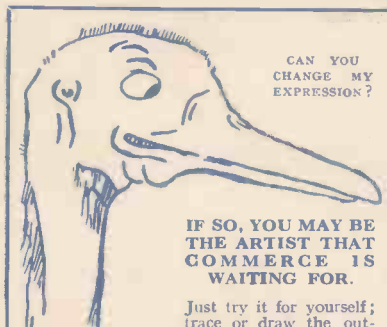

CAN YOU CHANGE MY EXPRESSION?

IF SO, YOU MAY BE THE ARTIST THAT COMMERCE IS WAITING FOR.

Just try it for yourself; trace or draw the outline and then put in the features.

*Jim Duck*

There are hundreds of openings in connection with Humorous Papers, Advertisement Drawing, Posters, Calendars, Catalogues, Textile Designs, Book Illustrations, etc. 60% of Commercial Art Work is done by "Free Lance Artists" who do their work at home and sell it to the highest bidders. Many Commercial Artists draw "retaining fees" from various sources, others prefer to work full-time employment or partnership arrangement. We teach you not only how to draw what is wanted but how to make buyers want what you draw. Many of our students who originally took up Commercial Art as a hobby have since turned it into a full-time paying profession with studio and staff of assistant artists; there is no limit to the possibilities. Let us send full particulars for a FREE TRIAL and details of our course for your inspection. You will be under no obligation whatever.

YOU CAN HAVE A COLLEGE TRAINING IN ALMOST ANY CAREER FOR A FEW SHILLINGS MONTHLY

Accountancy Examinations  
Advertising and Sales Management  
A.M.I. Fire E. Exam.  
Applied Mechanics  
Army Certificates  
Auctioneers & Estate Agents  
Aviation Engineering  
Banking  
Boilers  
Book-keeping Accountancy and Modern Business Methods  
B.Sc. (Eng.)  
B.Sc. (Estate Management)  
Building, Architecture and Clerk of Works  
Cambridge Senior School Certificate  
Civil Engineering  
Civil Service  
All Commercial Subjects  
Commercial Art  
Concrete and Structural Engineering  
Draughtsmanship, all branches  
Engineering, all branches, subjects and exams.  
General Education  
G.P.O. Eng. Dept.  
Heating and Ventilating  
Industrial Chemistry  
Insurance Mathematics

Matriculation Metallurgy  
Mining, all subjects  
Mining, Electrical Engineering  
Motor Engineering  
Motor Trade  
Municipal and County Engineers  
Naval Architecture  
Pattern Making  
Police, Special Course  
Preceptors, College of Pumps and Pumping Machinery  
Radio Service Engineering  
Radio Communication  
Road Making and Maintenance  
Salesmanship Sanitation  
Secretarial Exams.  
Shorthand (Pitman's)  
Structural Engineering  
Surveying  
Teachers of Handicrafts  
Telephony and Telegraphy  
Transport Inst. Exams.  
Weights and Measures Inspector  
Welding  
Wireless Telegraphy and Telephony  
Works Managers

If you do not see your own requirements above, write to us on any subject.

Also ask for our New Book (Free of Charge)  
**THE HUMAN MACHINE**  
Secrets of Success

**SIGNS of the TIMES**

The Budget has restored  
**POLICE OPPORTUNITIES**

The Air Force is to be increased  
**AVIATION must DEVELOP**

Pay Cuts have been restored  
**CIVIL SERVICE**

Suitable to both sexes. Ages 15½ to 24.  
**G.P.O. ENG. DEPT.**

CUSTOMS AND EXCISE; INSP. OF TAXES, ETC. NO EXPERIENCE REQUIRED. OPEN EXAMS.

**MATRICULATION**

There are many ways of commencing a career, but Matriculation is the jumping-off board for all the best ones.

We prepare candidates for all  
**INSTITUTE EXAMS.**

TECHNICAL, ACCOUNTANCY, SECRETARIAL, INSURANCE, ETC.  
**Engineers & Draughtsmen**

All Branches — Employers are advertising for them.  
TELEPHONY, RADIO and MOTOR ENGINEERING are expanding rapidly. There are lots of vacancies. Our postal courses will make you eligible. Advice on all careers Free.

THE MAN DOES NOT GO FAR WHERE ACTION LAGS BEHIND DECISION

**YOUNG MEN**

Young men physically fit and whose careers are not definitely fixed should join the Police Force. We have special Courses for Entrance and Promotion. 1/- per week brings success. Full Particulars Free.

Address:  
**POLICE DEPT. 76.**



DEPT. 76, THE BENNETT COLLEGE, SHEFFIELD.

EVERY DEPARTMENT IS A COMPLETE COLLEGE.

EVERY STUDENT IS A CLASS TO HIMSELF.



# Practical Mechanics

VOL. III. No. 28  
JANUARY  
1936

Edited by F. J. CAMM

SUBSCRIPTION RATES :  
Inland and Abroad, 7s. 6d. per annum  
Canada - - 7s. per annum

Editorial and Advertisement Offices : "Practical Mechanics," George Newnes Ltd., 8-11 Southampton Street, Strand, W.C.2. Registered at the G.P.O. for transmission by Canadian Magazine Post.

## A New Aid to Science

**PROFESSOR W. D. HARKENS**, of the University of Chicago, has invented an ingenious electron-gun instrument. The device simplifies the problem of obtaining pictures of the molecular surface structure by means of a photograph produced by electron beams.

## A Portable X-ray Machine

**CONSIDERED** as the most important achievement in diagnosing bone fractures, a new high-speed portable shock-proof X-ray unit has been perfected. Its advantage is that patients need not be disturbed if they are in pain as the portable X-ray machine can be brought to the bedside. Through a fluoroscope, the doctor may view every portion of the patient's body for possible fractures.

## Fresh Milk and Butter

**THEODOR HOFUIS**, of Duisburg, Germany, has constructed a tank called the "Hofuis-tank." By means of a certain oxygen pressure inside the tank, it is possible to keep milk and butter, placed inside, fresh for at least two months.

## An Oil-burning Mail Plane

**GERMANY'S** newest trans-Atlantic mail plane burns heavy oil. It is equipped with two Diesel engines of the "Juno 5" type. The machine, which weighs 9.2 tons, has a cruising radius of 2,800 miles and can carry 3 cwt. of mail. It can be launched by a catapult from a ship.

## 200 m.p.h. Air Liner

**THE** fastest British air liner ever seen aloft recently made its first test flight. For an hour it raced round Hanworth Aerodrome. Her top speed, with ten passengers and two pilots, is known to be more than 200 m.p.h. Economical cruising speed is expected to be at least 190 m.p.h.

## A New "Death Ray"

**ACCLAIM** to have invented a heat ray by means of which aircraft could be destroyed in a flash, is made by Mr. L. G. Anderson, of Melbourne. He states that he has been advised by the United States Navy Department that his invention has lived up to its claims.

## The "Queen Mary's" Maiden Voyage

**WE** learn that the *Queen Mary* is scheduled to make her maiden voyage

## Notes, News, and Views

to New York from Southampton and Cherbourg on May 27th, 1936.

### Into the Stratosphere

**IN** a recent ascent, it is stated that the U.S. stratosphere balloon, Explorer II, reached a record height of 74,000 ft., or about 14 miles.

### 70,000 Degrees of Heat

**SOME** remarkable illustrations of the heat of the stars, and the tremendous amount of energy radiated by them, were given by Sir James Jeans in a lecture at the Royal Institution. The sun, he said, is relatively cool at 6,000 degrees centigrade. Yet from each square inch of its surface it radiates away about 50 h.p. The area of the surface of the sun that would be covered by a locomotive would give enough energy to run all the railways in England. Sirius has a temperature of from 10,000 to 11,000 degrees, but the hottest stars of all are 70,000 degrees.

### The "Graf Zeppelin"

**THE Graf Zeppelin** recently completed its 500th journey on its flight from Pernambuco (Brazil) to Bathurst (Gambia). Earlier Zepps have made as many flights, but these have averaged about sixty miles each, whereas the average of the *Graf Zeppelin's* flights has been nearly 2,000 miles, and it has flown over 900,000 miles in all.

### Television in France

**A NEW** television studio in the Ministry of Post's building in Paris, was recently inaugurated by Monsieur Mandel, French Minister of Posts. Groups of up to six persons are scanned entirely by mechanical means. One-hundred-and-eighty-line definition, and 25 frames per second are employed.

### Record for Light Planes

**MR. E. W. STITT**, an American, will, as soon as weather conditions permit, take off in his "Mosquito Aeroplane," in an attempt to break the world's non-stop flying record for light aircraft. The present record of approximately 1,809 miles was set up by two airmen in 1931.

## Bicycles of the Future

**AN** ultra-modern bicycle has recently been produced in America. It has a siren, speedometer, built-in lights, light switches, and

the tools are concealed in the saddle.

### A Giant Funnel

**THE** funnel for the new motor vessel *Athlone Castle*, now on the slips of the Queen's Island Shipyard, Belfast, had to be built on the dock as there was no shed with a door large enough through which to take the funnel after its completion.

### The Light of the Sky at Night

**IT** is stated that Professor Kaplan, of America, has been carrying out experiments proving that between the stars the sky is not dead black. He has, it is reported, discovered more about the light of the sky at night than any other man, but his chief achievement has been to reproduce this light in the laboratory. To make this weird, dim light, Kaplan pumps a little nitrogen into a glass container and passes on an electric current through the tube.

### World's Fastest Fighting Plane

**A NEW** single-seater Hawker monoplane was recently tested out at Brooklands. The machine proved itself the fastest fighter in the world, although its speed was not stated.

### A Binding Case Reminder

**WE** again draw readers attention to the fact that the Index to Volume II of PRACTICAL MECHANICS is now available at 7d. by post from the publisher, George Newnes, Ltd., 8-11 Southampton Street, Strand, London, W.C.2. Binding cases, complete with title page and index, cost 3s. 6d. by post from the same address. Those readers desiring a copy should apply at once as there are only a few copies left. A bound volume of PRACTICAL MECHANICS is a Golden Treasury of knowledge—a storehouse of the most reliable facts and information on every branch of modern scientific progress, endeavour and invention. A bound volume will enable you to refresh your memory on some favoured topic as well as have it to hand in your workshop as a guide to workshop methods and processes.

# FLOATING HANGARS and AERODROMES

An unusual aerial view of the "Saratoga" with nearly one hundred combat planes drawn up on its deck.

In many respects, the organisation and equipment of a Squadron of the Fleet Air Arm involves vastly more serious and complicated problems than in the case of a similar squadron operating from a land base. For not only is the provision of a floating aerodrome an obvious necessity, but the navigational problems involved in piloting an aircraft from an aircraft carrier require the most meticulous calculation. Visibility at sea very often extends over a range of many miles, but it also often falls to only a few hundred yards almost without warning, and it is then no easy matter for a pilot to find his way home to the carrier after a long reconnaissance flight, unless he has kept a very accurate record of his navigation during the flight.

Short flights, however, do not present the same difficulties, and it was very early in the World War of 1914-18 that aircraft demonstrated their value as a means of guiding the conduct of a major naval operation. Although they were used almost solely for reconnaissance duties and not in an offensive capacity, their services were found to be invaluable. They suffered from serious limitations, however, in that if a "land" plane was used, their useful range was greatly restricted, while if a seaplane was used, it was incapable of alighting with safety on anything but the calmest sea. Even to-day, a seaplane is incapable of withstanding a swell which

Although Aircraft Carriers have not yet Taken Part in a Major Naval Engagement, it is Obvious that such a Vessel is a Formidable Foe, as will be Gathered from this Interesting Article

to even a small vessel represents a most moderate sea.

## Aircraft in Naval Operations

Long before the construction of the first aircraft carrier was considered, the Admiralty had appreciated the value of aircraft in a naval operation, and in the early months of 1914, just before the War, they had purchased a tramp steamer which was then in course of construction and had modified its design for use as an "Aircraft Tender." The vessel, which was named *Ark Royal*, had a displacement of less than 7,000 tons and was far too small to permit of the construction of a deck for landing. Actually, a small flying-off deck was provided on the forward part of the ship and two cranes were installed for hoisting seaplanes on board. The *Ark Royal* was an invaluable vessel during the early years of the War, but the impossibility of effecting a landing, or of even taking a seaplane on board in rough weather, was a serious limitation.

Three more small vessels were taken over

by the Admiralty for service as aircraft tenders before the construction of the first real carrier. One was the *Campania*, a passenger liner which was completed in 1916, and this vessel was particularly interesting in that a flying-off deck was provided which was equipped with special wheeled trollies on which a seaplane could be mounted. These trollies enabled a normal seaplane to take off from the deck like an ordinary aeroplane, a feature which considerably increased the value of the vessel. The other two tenders were the *Riviera* and the *Engadine*, the latter being the only aircraft tender present at the Battle of Jutland.

## The First Aircraft Carrier

The first vessel to be constructed in the form of an aircraft carrier as we know them to-day, was the *Argus*, a vessel of nearly 15,000 tons which was originally designed as a passenger and cargo boat for Italian owners. Her construction had been commenced early in 1914 at Beardmore's yard, but on the declaration of war, all work on the ship was stopped and it was not until 1916 that the hull was purchased by the Admiralty and the design converted to a carrier. A complete flying deck was fitted which extended to practically the full length of the ship, and a large hangar was



H.M.S. "Furious" is capable of a speed of 31 knots, and her clear deck expanse of 700 feet in length and 80 feet wide makes landing a comparatively simple matter.

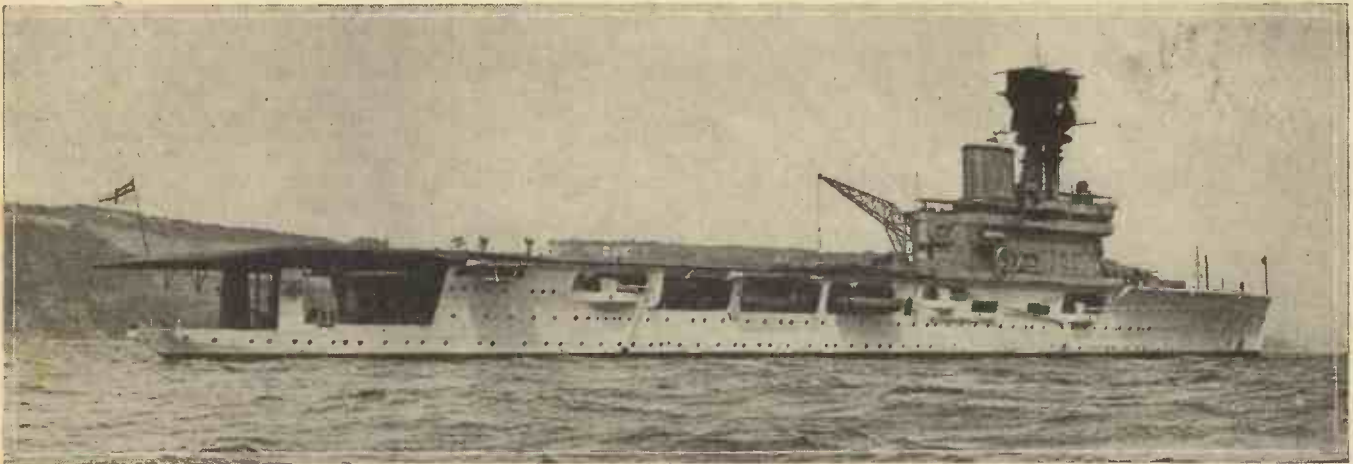

H.M.S. "Hermes" was the first vessel to be designed and constructed especially as an aircraft carrier.

constructed beneath the flying deck. A further revolutionary change was effected in the total abolition of funnels, and enormous horizontal flues were constructed to carry the boiler gases beneath the flying deck to discharge at the stern. The hangar was 350 ft. in length and nearly 70 ft. wide, and it could accommodate twenty aircraft of both land and sea types. Fully equipped workshops were installed capable of carrying out major overhauls and, so far as accommodation and equipment was concerned, the *Argus* was a complete floating aerodrome. Two electric lifts were provided for raising aircraft from the hangar to the flight deck, and the flight deck itself was equipped with wind-breaking palisades which could be simultaneously raised along the sides of the deck to give shelter to a machine on the deck.

With so many revolutionary features in her design, it would not have been surprising if the ship had not proved a success. In actual fact, however, the *Argus* was a most serviceable vessel; she was the first really successful aircraft carrier ever built, although the fact that she was not completed until September 1918, rendered her of no service during the War.

#### An Expensive Experiment

The demands of the Admiralty were not satisfied by the building of the *Argus*, and

in 1917 it was decided to modify the design of a cruiser, the construction of which was being completed at Armstrong's yard. The vessel, which had been named the *Furious*, was destined to prove an expensive experiment. As originally constructed, she carried two 18-in. guns and was intended for service as a light cruiser. The first modification to her appearance was the removal of the front gun turret and the fitting of a flying-off deck with a hangar for seaplanes beneath. The next alteration was the removal of the rear gun turret and the building of a flying-on deck over the aft end of the vessel. This deck was not a success, however, on account of the air disturbance during landing due to the funnel gases and eddy currents. Once again the ship was reconstructed and she was finally completed in 1925; her funnels had been removed and a clear deck fitted, and her present appearance is very similar to that of the *Argus*, which largely served as the model upon which her final design was based. In spite of her chequered career, H.M.S. *Furious* has since proved a serviceable ship; she is capable of a speed of 31 knots and her clear deck expanse of 700 ft. in length and 80 ft. wide, makes landing a comparatively simple matter.

#### The Aircraft Carrier "Hermes"

So far, all the carriers constructed had

been converted from designs originally produced for ships of quite different purposes, but about the same time as the *Furious* was appropriated for service as a carrier, the designs for the *Hermes* were drawn up. The *Hermes* was the first vessel to be designed and constructed specially as an aircraft carrier. She is a comparatively small ship, having a displacement of barely 11,000 tons, but she has the reputation of being a splendid sea boat with little tendency to roll in rough weather.

Her design includes one feature of fundamental importance. Unlike the *Argus* and the *Furious*, which were equipped with an unobstructed flying deck covering almost the entire vessel, the *Hermes* was built with a conventional funnel and control turret, but instead of being placed on the centre line of the vessel they were built on an island on the extreme starboard side at the widest part of the deck. In this position they offer little obstruction to the landing or taking off of aircraft, and although their presence inevitably causes some disturbance of the air to a landing aircraft, yet many pilots prefer their presence because they render the judgment of the height of a machine above the deck a much easier matter than is the case with the clear decks of the *Argus* and the *Furious*. It is a curious fact that judgment of height is



H.M.S. "Eagle" is a heavy boat, having a displacement of 25,000 tons, but although it is such a large vessel it can only accommodate 20 aircraft.



H.M.S. "Courageous," flagship of the aircraft carriers, photographed from the air with some of her machines arranged on deck. She carries a total of approximately 50 aircraft of three distinct types—fighters, torpedo bombers, and reconnaissance. These are raised and lowered into the hangars under the flight deck by lifts, both of which are down in this photograph, and the wells can be seen.

extremely difficult unless there is some elevated object upon which to form one's estimate, and it is therefore probable that all future carriers will be of the *Island* type.

#### The "Eagle"

A few months after the *Hermes* was laid down, the Admiralty decided to appropriate and adapt yet another hull which had been lying half-completed on the slips since the outbreak of war. This vessel was the *Almirante Cochrane*, which had been designed as a dreadnought for the Chilean Government. The hull was purchased late in 1917 and the design modified to that of an aircraft carrier of the *Island* type, similar to the *Hermes*. The vessel, which was renamed the *Eagle*, took no part in the Great War, as her trials only commenced in the spring of 1920, and she was not finally completed until 1923.

She is a heavy boat for a carrier, having a displacement of nearly 25,000 tons and her normal complement of twenty aircraft is on the small side for so large a vessel.

#### The "Courageous" and the "Glorious"

The British Navy only possesses two other aircraft carriers, the *Courageous* and the *Glorious*. Both of these vessels were commenced early in 1915 as part of the Emergency War Programme. Both of them were built as ordinary cruisers in the short time of twenty months and they are to-day capable of a speed of 31 knots. They are modern vessels in every sense, equipped to burn oil fuel in the eighteen boilers with which each is provided. The turbines, which are of the geared Parsons type, develop over 90,000 horse-power.

For the first few years of their lives, both of these ships served in their original capacity as cruisers, but by 1924, the necessity for providing further accommodation for squadrons of the Fleet Air Arm caused the Admiralty to decide on their conversion to aircraft carriers. In their modified state, they are both carriers of the *Island* type with a single streamlined funnel and the control turret situated on the extreme starboard beam, and they normally carry a complement of four complete aircraft squadrons.

Whether aircraft-carriers will continue to be of the *Island* type or will revert to the totally clear decks of the *Argus* and the *Furious* is a much-debated question. The Japanese favour the clear-deck type, all their carriers with one exception having unobstructed decks, but the United States show a clear preference for the *Island* type, and it is probably this design which will eventually prove the more popular.

#### Largest Aircraft Carriers in the World

The largest aircraft carriers in the world are the *Lexington* and the *Saratoga*, both of which belong to the United States Navy. They have a displacement of 33,000 tons, and each can accommodate a total of 90 aircraft. Not only is their machinery the most powerful ever fitted to a warship, but it operates electrically throughout. The flight deck is nearly 900 ft. long and between 85 ft. and 90 ft. wide, and a catapult is fitted to the bow of each ship which is capable of launching the heaviest aircraft. These ships cost over £9,000,000 each and they represent the climax of American practice in the design of aircraft carriers.

Although no aircraft carrier has yet taken part in a major naval engagement, it is obvious that such a vessel is a formidable foe, and it can be said with certainty that the fleet aircraft will be the deciding factor in future engagements.



An impressive photograph of nearly 100 planes, quartered on the aircraft carrier "Saratoga."

# Recording Sound on Paper

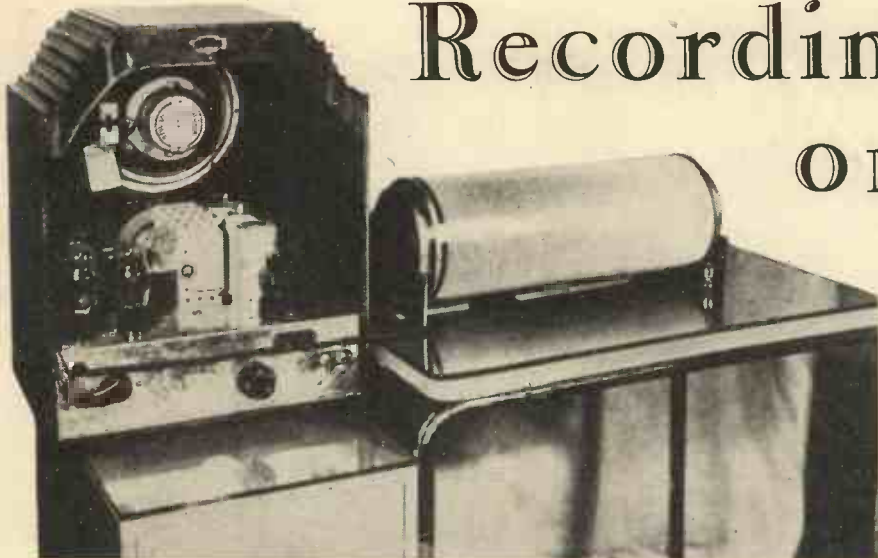

*The apparatus used for reproducing the sounds on a printed newspaper.*

**A** NEW process of recording sound on paper was recently demonstrated in London by M. Georges Rubissow, the European representative of the *Companie Funadora Fotoliptofono, S.A.*, of Buenos Aires. The principal inventor of the system is an engineer, Fernando Crudo, who has specialised in different radio and sound reproduction experiments since 1923, and who completed his researches in 1932.

The new invention, or rather the quite new industry which is created by this invention, consists of the printing of the ordinary paper or newspaper in the form of a square sheet of normal size. The printing is made in the ordinary way with ordinary printing ink, and the help of the ordinary cliché, with only one difference, that instead of characters phonograms are used which reproduce all sounds, as voice, several voices, music, choirs, etc., in the most perfect condition.

The cliché is very easily obtained by the well-known microphone combined with amplifier and oscillograph, which register different sounds, voices, and music, etc., on the negative, from which the cliché then is made. The cliché, one or several, is given to the printer, newspaper printer, or book printer, who prints from it the sound pages, or the speaking paper. One hour after the voice or the music has been registered, you can get thousands and thousands of printed sheets which may be distributed like newspapers or like speaking books, etc., as the ordinary paper is distributed at present.

## Reproducing Sounds

For reproducing the sounds from this printed paper you need only place it in the *Fotoliptofono* apparatus where, with the help of a photo-electric cell, and ordinary radio apparatus, you obtain the perfect reproduction of the voice, music, sound, etc., which quality is quite as good as gramophone records and even better than the talking film. The sound-paper record, during the reproduction, is not touched at all, because it is only a beam of light which strikes the phonogram of these printed sound records, and that is why the sound record is practically indestructible. The light beam replaces the needles of a gramophone. There are absolutely no noises, such as the whirring of the motor with the gramophone.

## The History of the Fotoliptofono

Many leading electrical sound industries throughout the world have been occupied for years in trying to produce this speaking paper. They used long pieces of paper, about one quarter of a mile long, on which one or more phonograms had been put in a photographic way, but it was practically impossible to use such long rolls of paper strips, and even more impossible to print them, so they were not commercialised.

The sound record of *Fotoliptofono*, which may be printed at the rate of 50,000 an hour, condensed in one sheet of about 17 in. x 20 in., contains about one quarter of a mile of phonograms, so one sheet replaces about one quarter of a mile of paper rolls, which were used by the previous inventors. What a big difference, in the case of *Fotoliptofono*, to print one ordinary sheet, where other inventors found they must have one quarter of a mile long strips of paper, which, of course, is practically impossible to print. And even if it could be done, it would be of practically no interest,

because you could not easily handle rolls a quarter of a mile long.

## Quality of Sound

The quality of the printed record of *Fotoliptofono* is extremely high. As you know, the radio and the talking film have obtained wonderful results, and applied to *Fotoliptofono*, these results have greatly improved the process of sound reproduction. The ordinary gramophone generally uses 3,500 to 4,000 frequencies per second. A very good cinema now gives about 5,000 to 6,000 frequencies per second. The lowest frequencies that the gramophone can take are about 200. The *Fotoliptofono* can easily offer with ordinary print, about 7,000 frequencies per second, but if they are put on the market, 5,000 frequencies, and even then the quality will be much higher than that of an ordinary gramophone record. The lower frequencies in *Fotoliptofono* may easily begin at 16 frequencies per second, instead of hundreds as with a gramophone.

Many people possess a good radio, and, for a few pounds, it will be possible to buy the *Fotoliptofono* apparatus which must be connected to the radio, in order to operate the printed pages.

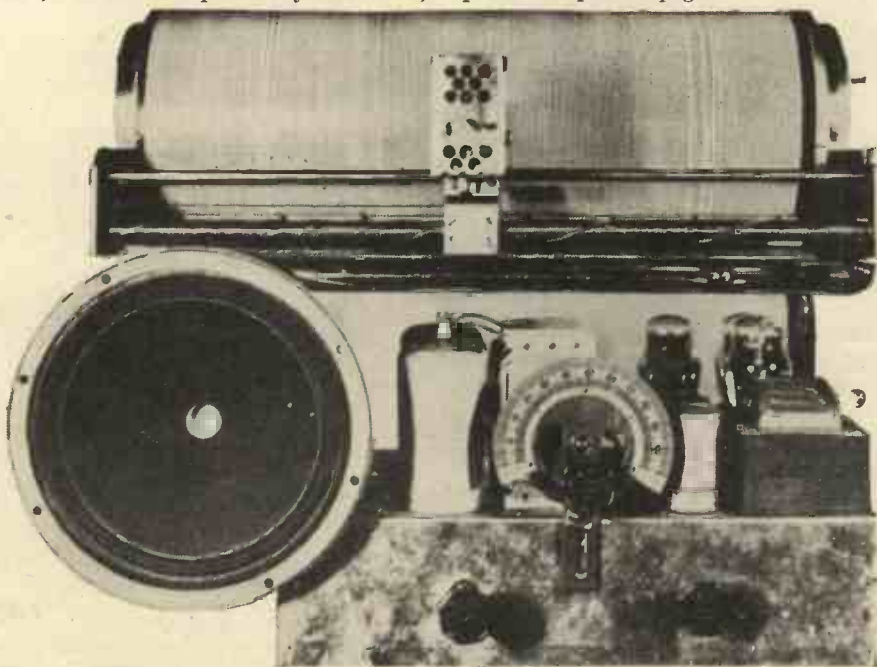

*Further details of the apparatus used in the new process described on this page.*



This impressive-looking saloon was built experimentally to test out the possibilities of the Diesel engine or high-speed purposes.

## The Diesel Engine Explained

ASK any ordinarily well-informed man-in-the-street how a Diesel engine works and, if he is at all interested in such things he will probably say, "A Diesel engine? Yes, of course—they compress air in the cylinder, which heats it up, and then squirt in crude oil which is fired by the high temperature." Roughly speaking, he is quite right, although his description is only partly true. There is far more in the Diesel principle than that, and because this type of engine, especially in the smaller high-speed sizes, is rapidly becoming more and more popular for road transport service as well as for industrial and marine drives, a rather more intimate account of the happenings in a Diesel cylinder will prove interesting.

In the first place, we ought to disillusion ourselves about "crude oil." Crude oil is the name given to the products of the oil wells before refinement, and is far too valuable and too costly to be employed in its native state for use in Diesel or other engines, because it contains the valuable light oils and essences which are distilled off in the refinery. Moreover, crude oil is almost as thick as tar, and not at all suitable for immediate use in an engine of any sort.

### Diesel Fuels

Actually, Diesel fuels, of which there are many grades, are quite highly refined products, distilled from the crude after the petrol and the kerosene and other constituents have been recovered. Also, while it is true that the larger, low-speed Diesels can be, and frequently are, operated, on comparatively low-grade fuels, good efficiency and trouble-free running of high-speed Diesels calls for a carefully selected fuel, of which more will be said later.

Returning, however, to the action in a Diesel cylinder, our man-in-the-street is quite right when he says that compression of air in the cylinder raises the temperature. It is not always recognised, however, that the compression reaches the neighbourhood of 500 lb. per square inch—over 30 atmospheres—and that the heat of compression raises its temperature to about 500° centigrade, at which temperature iron reaches a dull red heat.

Then, the statement that the fuel is squirted into the cylinder does not create quite the right impression. In order that the charge of fuel shall come into intimate contact with the air, it must be injected into the combustion space as a very fine

### For Mechanically-minded Readers, the Following Explanation of what Really Happens in a Diesel Cylinder will make Interesting Reading

spray, and to do this it is usually forced through one or more fine orifices at a pressure which may amount to 3,000 lb. per square inch. The fuel is injected just before the completion of the compression

moving spray of fuel—droplets averaging less than a thousandth of an inch in diameter so that, for example, a charge consisting of one two-hundredth of a cubic inch of fuel is ultimately divided into about 50,000,000 droplets. These become still more intimately mixed with the air and, moreover, as their speed diminishes, their temperature rises, thus further assisting in rapid combustion.

The rapidity with which this action takes place may be gauged from the statement that from the commencement of injection to the start of ignition, as little time as one six-hundredth of a second may elapse. It will thus be clear that very careful design of the injection system and combustion space, accurate timing, and also the use of

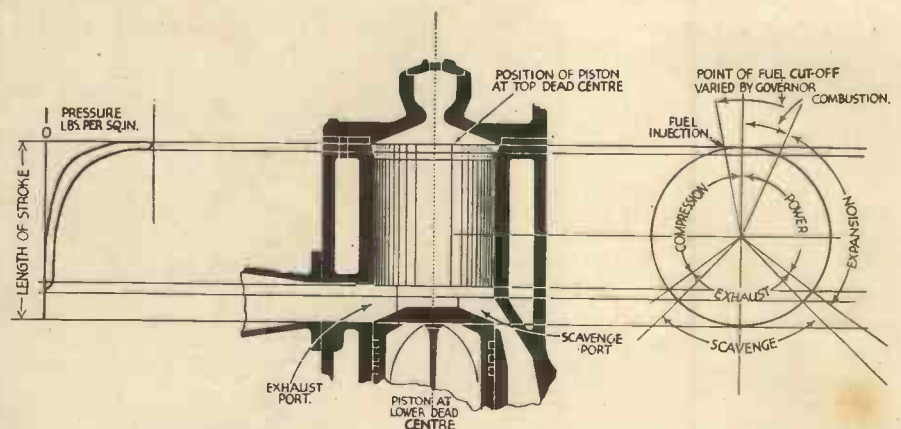

A diagram showing the sequence of operations in an atomic Diesel engine.

stroke, and for maximum engine efficiency, complete burning of the fuel must be achieved very early in the expansion stroke. To ensure this, complete and intimate mixing of the air and fuel are essential, and in addition to the atomising action of the nozzles, ingenious designs of combustion chamber are used to give the air a swirling motion.

### The Fuel Spray

This turbulence of the air is not simply to cause a complete mixing of air and fuel, but to assist in a very important mechanical action. The actual speed of the fuel spray on injection may be anything up to 300 miles per hour, so that relatively, the charge of air is stagnant. As a result, tiny particles are torn off the swiftly

a suitable fuel are essential for perfect operation.

### "Diesel Knock"

For example, if undue turbulence is achieved, or if too much fuel has entered the cylinder when combustion starts, the sudden rise of pressure on ignition will be so great that the so-called "Diesel knock," resulting in violent and even destructive vibration, will be set up. On the other hand, if the fuel is of a type which takes a long time for complete combustion, there will be uncontrolled burning, increased shock on bearings, and troubles such as damaged internal parts, in addition to which it will be difficult to start the engine from cold—a matter of great importance, particularly with road vehicles.



# DIE-CASTING

By W. H. Deller

It is only within Recent Times that Die-castings have Come into Use Extensively, but the Process Dates Back nearly 100 Years

IMPROVED technique, and the fact that alloys having a low melting point and remarkable physical properties coupled with stability, is leading to the increased use of die-castings. In many instances they are even being used to supplant parts fabricated from pressings with great success, as not only is assembly time reduced or completely cut out, but a much cleaner and neater product possessing great strength is the result. It is hard to find a branch, at all events in the lighter types of engineering, in which die-castings are not or could not be employed with success. This is borne out by the fact that to quote even a few instances, such castings are now used in large numbers in the automobile, motor-cycle, electrical, small mechanical, gramophone and wireless, clock, instrument making, typewriter and calculating machine, and toy industries.

Although die-castings have only come into use to any great extent generally within recent times, the origin of the process dates back a considerable number of years. As a matter of fact, it is close on one hundred years since printers' type was first cast by machine on practically the same lines that are in use for general die-casting at the present moment. Doubtless at that time, the need for such a revision of methods was partly brought about by the natural desire for increased production, but in all probability the change was necessitated by the difficulty or impossibility of making sound and clear-cut small type by ordinary gravity-casting methods.

### Sand-castings

Die-casting is essentially a process suited to the production of certain types of castings in quantities. In ordinary foundry practice, a pattern is used to form a cavity in sand into which the molten metal is poured, an individual mould being prepared for each casting required. On account of technical difficulties, it is improbable that this method will ever be superseded for metals have a high melting point. Sand-castings, except for very rough work, must be finished, at all events as far as important dimensions are concerned, by machining, and the preparation of unmachined surfaces to a condition suitable to receive a deposit which afterwards has to be polished, is a costly business. By the adoption of the die-casting process, finishing operations are almost entirely eliminated, but whereas

for sand-casting the preparation of a suitable pattern is in most cases an expensive item, the provision of a suitable die is a considerable one and therefore cannot be considered as a paying proposition unless the cost can be spread over a large number of castings. In comparing the cost of the castings, it has to be remembered that a die-casting represents a finished machined part except perhaps for, say, a tapping operation, so that where intricate machining operations have to be carried out on a part, the high cost of the work so involved

generally were confined to lightly stressed or purely ornamental parts that could be made from lead or tin-base alloys. This was on account of structural changes taking place in the then used zinc-base metals with ageing, resulting in serious changes in the formation of the castings or in disintegration. Comparatively recent developments have led to the introduction of zinc-base alloys in which these serious defects have been overcome and further, the mechanical and physical properties are such, that castings made from them can satisfactorily replace those formerly made of iron or brass for certain purposes. These facts have probably had much to do with the popularisation of the process.

### Die-casting Machines

Machines for the purpose of die-casting follow more or less the same lines as regards the method used for filling the dies. A section of this portion of the machine is seen in Fig. 1. It will be seen that this consists of a gas-heated metal pot, arranged within which, in such a manner that it is almost completely submerged in molten metal, is a cylinder having a bottom outlet terminating in a "gooseneck." The cylinder is fitted with a piston or plunger, and when this is at the top of its stroke a port is uncovered through which the molten metal flows into the cylinder and gooseneck. The means vary on different machines for bringing the dies up to the nozzle, but when the dies are in position the plunger is depressed, either by a hand lever or air pressure, to force the molten metal into the die cavity. As the dies are comparatively cool the solidification of the metal therein is almost instantaneous, so that the plunger can be raised again at once when the surplus metal in the nozzle drops back into the gooseneck. The die is then withdrawn from the nozzle, opened, and the casting ejected. With modern hand-operated or semi-automatic machines, the labour involved in performing the

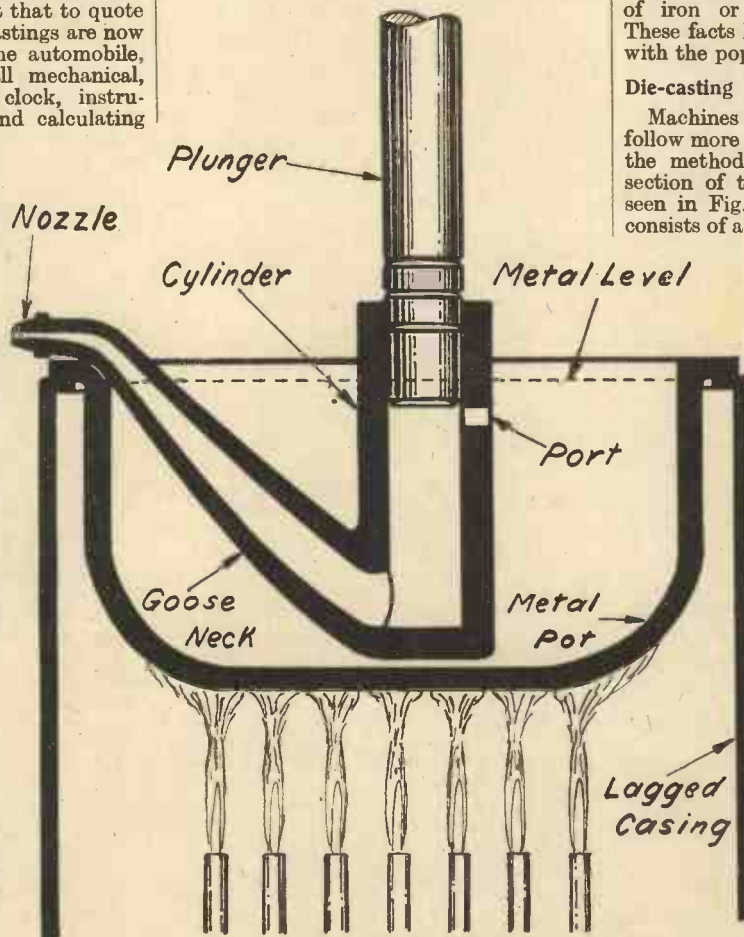

Fig. 1.—A cross section of the machine used for filling the dies.

might make a die more than worth while on a relatively small quantity.

Although within the space of a single article little more than a brief outline of the method can be given, sufficient can be said to convey to the reader the general principles of what is a really interesting process.

Whilst aluminium and certain types of bronze can be die-cast, by far the greater proportion of die-castings are made in zinc-base alloy. This metal casts well and with a good finish. Earlier die-castings

sequence of operations has been reduced to a minimum, and the rate at which castings are produced must be seen to be believed.

As may be imagined, the most interesting part of die-casting lies in the dies themselves, for seldom are two jobs alike and from a die-makers' point of view, each has to be dealt with in strict accordance with its peculiarities.

### Die Design

A die for producing a part full of cored

holes, such as a carburetter body, must of necessity be a complicated piece of work, as, for holes that are other than at right angles to the parting line, core-drawing mechanism has to be incorporated. It is thought, however, that the principle on which the dies are made and operated will be best explained by taking simpler forms of castings as an example. The casting shown at the bottom left-hand of Fig. 2

is firmly attached to this half and some means of pushing the casting off is required. It will be noticed that there are three holes, arranged triangular fashion, drilled through the face of the movable die. Two smaller holes are also in the die adjacent to the small core-pins, but these do not show so clearly in the photograph. The purpose of these holes is to receive the pins set in the ejector plate seen on the left-hand side



Fig. 2.—Some typical die-castings of handles, etc.

presents no difficulties as far as die-making is concerned, it being a really ideal job for die-casting methods. Perhaps it would be as well to explain that the dies are made in halves so that the casting can be removed, and it is known as the parting line where the faces of the half dies meet.

The die in which this particular part is made, is shown separated at the right-hand side of Fig. 3. When together, the halves are kept in alignment by the locating pins protruding from the fixed half of the die. In this half is sunk an impression of the top portion of the casting. The raised part on the opposite half corresponds in reverse to the inside of the casting as seen in the top left-hand corner of Fig. 2, the blind holes in the boss centres being formed by slightly tapered pins fixed in the die. On the left-hand side of the dies is seen the runner which matches up with the nozzle of the machine and through which the metal is admitted to the die cavity. Leading from the impression in the fixed die and seen at the right-hand side, is another shallow channel a few thousandths of an inch in depth. This is a vent through which the air in the cavity of the die is forced out by the incoming metal. The vent or vents must be so arranged that no air can be trapped in the die, as, if this happens, the cavity will not completely fill.

#### Removing the Finished Casting

The layout of the die must be carried out in such a manner that the casting comes away on the movable half when the dies are opened. Usually on account of shrinkage, or to the presence of cores, the casting

of the fixed die. This device functions as follows: when the dies are opened the travel of the movable die is continued until the plate reaches a stop which pushes it forward. The small pins do the actual work of ejecting. The purpose of the larger pins is merely to return the small pins to a

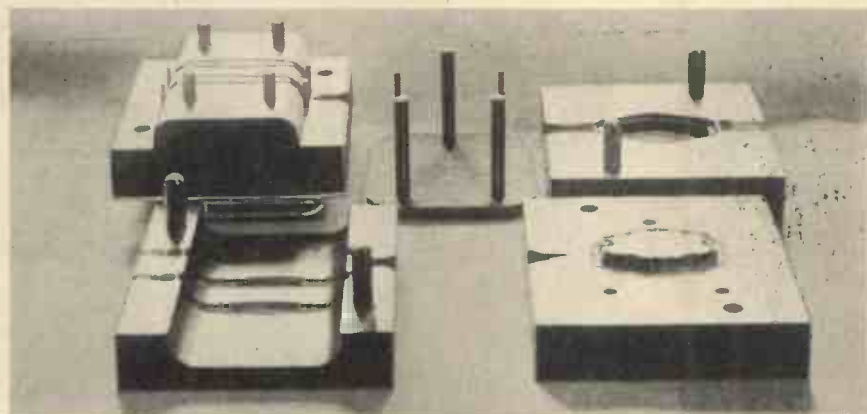

Fig. 3.—The dies for producing the castings shown in Fig. 2.

position flush with the surface of the die when ready for casting.

As previously mentioned, this die presents no real difficulties on account of the parting line of the casting being absolutely straight. It may be remarked that for the castings to be made with an absence of fin or "flash" at the parting line, the opposing faces of the die must fit perfectly and, therefore, flat surfaces are most easily produced with accuracy. The port-like openings in

the sides of the castings call for careful work in the making of the die. These are provided by making the projecting portion on the face of the movable die to fit perfectly, the sides of the opposite cavity in such a manner, of course, as not to prevent the die faces from bedding, the sides of the plug, as it were, being milled away in places to leave the bars between. When ejected from the die the castings appear as those shown in the top left-hand of Fig. 2, that is, with the runner included. The runner channel or gate in the die is cut fairly deep up to within about  $\frac{1}{4}$  in. of the cavity where the depth is reduced to approximately  $\frac{1}{8}$  in. Thus, the unwanted metal is joined to the casting by a very thin section only and is, therefore, easily broken off.

Although still a simple proposition as a die-casting, the one shown in the bottom right-hand corner of Fig. 2 presents more difficulties when the dies are considered. This will be apparent when the contour of the parting line of the dies at the left-hand side of Fig 3 is examined. These dies are made to cast two pieces at a time, the cavities being gated together. The ejector plate and pins are in the position that they occupy in the moving half of the die after a casting has been ejected. This view clearly shows how the plate is returned by the four large pins as the dies are closed.

While it may be said that the examples chosen are not strictly accurate jobs, the products from the dies are absolutely uniform as regards dimensions. The surface finish of the casting depends upon

the manner in which the die cavities are made free from scratches, and afterwards polished, plus the matter of keeping the molten metal at the correct temperature.

In conclusion it is hoped that sufficient has been mentioned to enable the reader to visualise that to make complicated parts, or fine parts, such as gear wheels to almost any reasonable degree of accuracy by this method is merely a matter of making correct shrinkage allowances and die designing.

#### WEARITE TEST INSTRUMENTS

THE service engineer will be interested in the latest range of test instruments from the Wearite range. In the illustration at the foot of this page are shown the valve-testing unit, the oscillator unit, the multimeter, and the meter unit. As may be seen, the instruments are made to match up, and they are extremely portable, and may be used individually or as a group to form a complete radio test outfit.

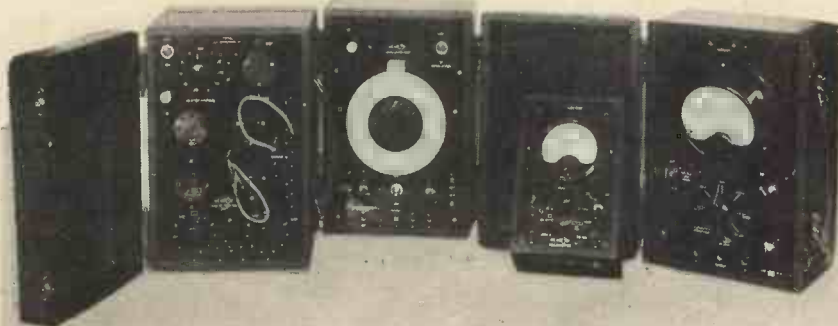



This aerial view shows left, the S.S. "Normandie," of the French line, the new Blue Ribbon ship of the seas, in the Hudson River, after her record-breaking maiden voyage, and right, the S.S. "Europa" of the German line, a former speed queen of the Atlantic, is berthed almost adjoining her.

**I**N the hey-day of sailing ships, design was a matter of tradition and experience. Shipbuilders built by eye alone. Some remarkably perfect hull forms came from the building yards of those days. The clippers of the Clyde attained speeds which have never since been exceeded under sail.

With the coming of steam, speed was not the only criterion. Owners began to consider economy in coal. The number of tons of coal burned for every ton of cargo carried, is the standard by which the modern cargo boat is judged. At high speeds, good design alone permits the saving of bunkerage space and horse-power which brings the running of the ship within economical figures.

#### Ship Tanks

Actually to-day, we still learn by experiment and experience. In the old days experience was picked up from the performance of each fresh ship which went off the building stocks. To-day, that method is too slow. The acquisition of experience has been accelerated by experimenting with ship models in ship-testing tanks.

There are several such tanks in use. There is one at the National Physical Laboratory at Teddington. Thornycrofts, of speed-boat fame, possess another. They are tanks about a hundred yards long by twenty yards wide. Along the sides are rail tracks on which run a bridge spanning the tank. The bridge travels at exactly controlled speeds up and down the tank. The models are towed from it by a dynamometer attachment which measures the force

The "Queen Mary" Crashing Through the Sea at Thirty Knots will meet Resistances Which are a good Deal Higher than those Overcome by an Aeroplane Flying at Four Hundred Miles an Hour. In These Days of High Speeds in the Air we are Apt to Lose Sight of the Perfection of Hull Form which Permits of High Speeds on the Sea

needed to urge the model through the water.

#### Model Ships Cast in Paraffin Wax

The models are cast in paraffin wax, scraped exactly to form, and finally polished. They are ballasted down with lead so that they sit properly in the water. Sometimes the models are made in sections, bow, midships, and stern sections. By fitting different bow sections, shall we say, to the same midships and stern sections, the effect of bow form can be studied. Similarly, the other sections can be experimented with separately. A fact which has emerged from this type of experiment is that the shape of the midships section is unimportant provided that both bow and stern lines ease into it smoothly. From

this springs the square sectional midships shape of most modern cargo ships. It is a shape which is easy to build and gives a great cargo-carrying capacity for the least hull surface. A wartime discovery was that the addition of a large underwater, anti-torpedo bilge to ships over their vital midships section, did not diminish their speed.

#### Skin Friction

By far the largest factor in ship resistance is the drag of the water on the hull. This is skin frictional resistance. It accounts for nearly 85 per cent. of the resistance in all but the highest speed ships. Accordingly, in low-speed ships they build for the biggest capacity for the least hull surface, and arrive at the bluff-bowed, short-sterned cargo boat exaggerated in form in the shape of the canal-boat sectioned oil-tanker.

#### Wave Resistance

For higher speeds, the resistance due to the waves created by a ship becomes important. The wash raised by a ship represents energy which has originally come from the ship's engines. Great savings in horse-power are effected by choosing those lines which give least wave formation. A ship moving through the water gives rise to no less than four systems of waves, two systems from the bows and two from the stern. The bows cause a hump of pressure as they part the water. The outer edge of this hump travels outward at an angle and causes what we call the wash of the ship. The inner edge

follows the ship and causes a series of wave crests along its sides. Where the ship begins to narrow again towards the stern and the water in streamline flow begins to close in again, another pressure system starts which causes a wave hollow that rises to a crest under the stern. The stern system of waves can be killed if the ship is designed correctly. The wave-length of both bow and stern waves depends on the speed of the ship. By choosing a suitable speed for a given overall length of ship, the crests of the bow waves may be made to occur on the top of the troughs of the stern wave. In this condition the wake of the ship is practically smooth and the only disturbance is the rolling divergent wave from the bows. The opposite case is seen when a boat is forced above the most suitable speed for its length. The bow and stern waves reinforce one another and a wave accumulates under the stern which has every appearance of dragging back on the boat, as in fact, it does.

Naval architects from model experiments have got this business of wave-making tied down to an exact mathematical expression. From the length and breadth of a ship it is possible to state the most economical maximum speed of which she will be capable. Or if a given speed is stipulated then the minimum overall length of the ship is practically fixed by the stipulation. It is thus not mere chance that the fastest liners are the biggest. Ship-owners building for

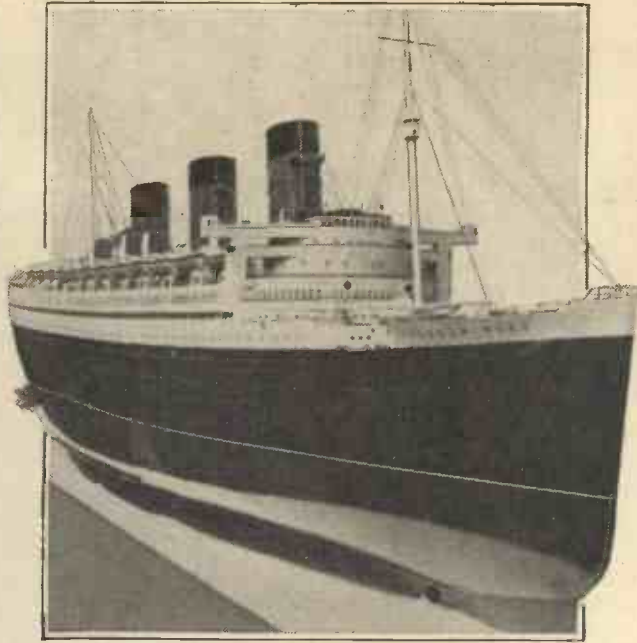

What the "Queen Mary" will look like when she makes her maiden voyage next May.

speed must allow the designers to give them length. Even then they have to resort to special devices such as long hollow bow sections and cruiser sterns to keep the

is thrown back so that it coincides with the first hollow of the stern wave. In most ships it is the second bow crest that is thrown in this position.

wave-making characteristics of the hull form reasonable at high speeds.

#### Cross-channel Steamers

An extreme form of hull dictated by wave-making considerations is instanced by cross-channel steamers. Limits of harbour accommodation and manoeuvrability do not permit these vessels to exceed about 300 feet in overall length. A 300-foot ship has a most economical speed of about sixteen knots. Cross-channel steamers, however, do about twenty-two knots. Such high speed for their length has only been attained by building them with extremely long bows, which extend well past their midship sections. In this way the first crest of the bow wave

## A NEW LAMP BRIGHTER THAN THE SUN

**A** NEW type of mercury-vapour lamp considerably smaller even than the smallest domestic lamp bulb, yet brighter than the sun, has just been perfected in the Philips Research Laboratories.

It is claimed that this lamp will completely revolutionise all industries dependent in any way upon super-brilliant illumination. It will abolish the revolving shutter of the cinema projector, and already one single lamp is being used to floodlight a large aerodrome.

This simpler form of lamp has a light intensity of one-quarter that of the sun—nearly twice that of the cumbersome carbon arc, and two-hundred times that of the ordinary electric lamp, which alone can compare with it for size.

#### Enormous Pressures

The secret of the brightness of the lamp seems to be the enormous pressures which constructional improvements have made possible. It works at a pressure of no less than 150 atmospheres, while lamps have been working at twice this pressure, with a brilliancy twice as intense.

The magnitude of this advance in the technique of the mercury lamp may be gauged by comparison of the following figures. Before the constructional discoveries which led to the present lamp, a mercury lamp of 9 Kw., with a luminous flux of 500,000 lumens (about 40,000 candlepower), could not be made smaller than about three feet in length, and about three inches in diameter. One of the new lamps of the same power is no larger than the stump of an ordinary lead pencil—an inch long, and a quarter of an inch thick.

#### Water-cooling

The discoveries which made this enormous reduction in size possible were, summarily, the use of water-cooling (the lamp works at a temperature of from four to eight thousand

*Although the Lamp is no Bigger Than the Stump of an Ordinary Lead Pencil it has a Luminous Flux of 500,000 Lumens (About 40,000 Candlepower)*

degrees Cent.) and the perfection of a method of applying this; the quartz instead of glass to withstand these terrific temperatures, and the tremendous pressures referred to above, and finally the discovery of a method of sealing thick tungsten wires

into the quartz tubes. The electrodes are of mercury, with specially prepared tungsten wire points.

Floodlighting, searchlights, spotlighting, photography, are among the more obvious uses for this amazing little lamp; it is also claimed that it will be particularly useful for medical purposes, since its light is whiter than any mercury lamp yet invented. Unlike the ordinary mercury lamp, it shows a continuous spectrum, including almost the full quota of red—a band usually absent from mercury light.

Experiments are now continuing with an even smaller lamp which will be at least one-eighth brighter than the sun.

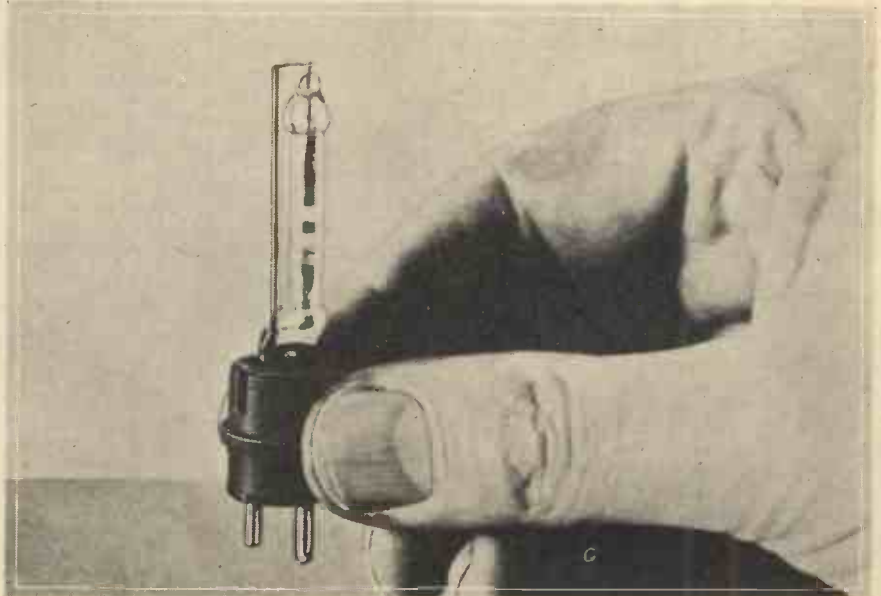

The size of the lamp may be gathered by comparison with the hand shown holding it.



# Lathe Work for AMATEURS

**A** DEVICE that will be found extremely useful for lathe work is a tool-holder which will take tool steel of small calibre, such as  $\frac{1}{4}$ -in. round cast steel. Such a tool-holder helps the amateur over the difficulty of forging tools out of bar-cast steel. It allows him to make a tool for a special job with the aid of a blow-lamp and with no forging: for the tool steel can be easily filed in the vice to the cutting shape required, and two or three tool-holders will

overhang of the cutter, which is quite small, will be available for facing or side cutting. The cutters should be made in various shapes of cutting edge to suit the job in hand. The slight downward or backward inclination of the holes will give the top rake of the tool.

If the holes are filed a  $\frac{1}{4}$  in. square after drilling, square tool steel may be used for the cutters. If round steel is used, the top surface of the cutter can be filed down to give width as shown in Fig. 4.

### Square and Round Cutters

An advantage of the square hole is that it gives more stock in the cutter with which to

the screw are first drilled. For the cutter hole, run the drill in the three-jaw chuck in the lathe, and feed the stock of the cutter-holder up by a centre hole in the other end in which the point of the back poppet head centre will rest. The blank is held from rotating by a shifting spanner on the square of the stock, and resting against the lathe bed to prevent rotation of the stock.

The hole for the pinching screw *A*, will be drilled right through, tapped to size for the  $\frac{1}{8}$ -in. screw, and then cleared for half its length to clearance size, i.e.  $\frac{1}{16}$  in., the other half is then tapped. The slot *B*, is then sawn down the stock into a  $\frac{1}{8}$ -in. hole *C*, which has previously been drilled across the

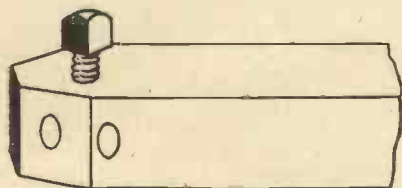

Fig. 1.—A simple form of holder for right- or left-hand side tool work.

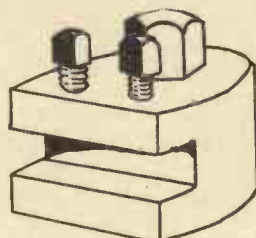

Fig. 2.—Details of the tool-post.

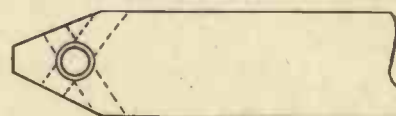

Fig. 3.—The dotted lines show the position of the holes for the small tool bits.

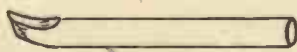
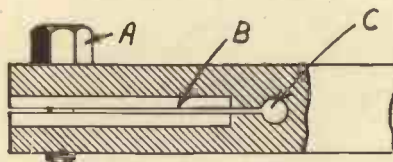

Fig. 4.—A cutter made from round steel.



Figs. 5 to 7 (Left).—A side and front view of an inside boring tool-holder and (above) inside boring can be accomplished with a cutter of the shape shown when fitted in the holder.

provide him with the means of applying them to any turning job.

There are many patented holders on the market, which are extremely useful tools, but if the cost of these is a consideration, it may be avoided by making the holder oneself. The job is quite simple, whilst personal preference in the matter, and ability to suit the tool to the type of tool-post fitted to the compound rest, will be another point in favour of making it.

### A Simple Holder

In Fig. 1, is shown a simple form of holder for right- or left-hand side tool work. It consists of a mild or cast steel bar of a size suitable for the tool-post (if of the open-side type as Fig. 2), and is sawn across at the ends so that two side faces form equal angles with the side of the tool.

From these side faces, and slightly sloping downwards back from the face, holes a  $\frac{1}{4}$  in. in diameter, shown in dotted lines in the plan view Fig. 3, are drilled to take the small tool bits which are made of  $\frac{1}{4}$ -in. cast tool-steel rod. At the point of intersection of the holes, and above them, a hole (tapping size for a  $\frac{1}{8}$ -in. Whitworth set-screw with square head) is drilled.

This set-screw will hold the round cutter from whichever side it is inserted, and the

form the shape of the cutting edge, but an advantage of the round cutter is that it can be tilted round to get an appropriate bottom rake. In the case of the square cutter, however, it will have to be ground sideways to obtain the rake for different jobs.

For inside boring a good tool can be made as shown in Fig. 5. Here we have a straight hole  $\frac{1}{4}$  in. or  $\frac{3}{8}$  in. in diameter, drilled right down the tool from one end but to one side of the stock, so as to leave room for a pinch screw. This is shown in the end view Fig. 6. The hole for the cutter and the hole for

stock. With this holder, inside boring can be done with a cutter of the shape shown at Fig. 7. The end will have to be set round when red hot, filed to shape, and then hardened and tempered.

### Cutter of Large Diameter

The cutter should be made of large diameter, as, if the inside turning is of any depth, the tool will be too springy. It will be found that a  $\frac{1}{4}$ -in. diameter will be suitable for most work, but for small model work, and work in non-ferrous metal, the cutter may be as small as  $\frac{3}{8}$ -in. diameter. These dimensions will depend on the size of the work generally undertaken. It is advisable, when using any of these tool holders, to keep the cutter edge in as near to the tool-holder stock as can be conveniently managed. This is, of course, dependent on the shape of the job in hand, and the ease of getting close up to the surface to be turned.

A split holder is better than one in which the cutter lies in a hole and is pinched by a set-screw, because a very much increased surface of the cutter comes in contact with the holder, and the heat generated in cutting is more readily and fully radiated away from the cutter to the mass of metal in the holder or stock.

## LATHE WORK FOR AMATEURS

By F. J. CAMM

96 Pages

1/- or 1/2 by post from Geo. Newnes Ltd., 8/11 Southampton Street, Strand, W.C.2.

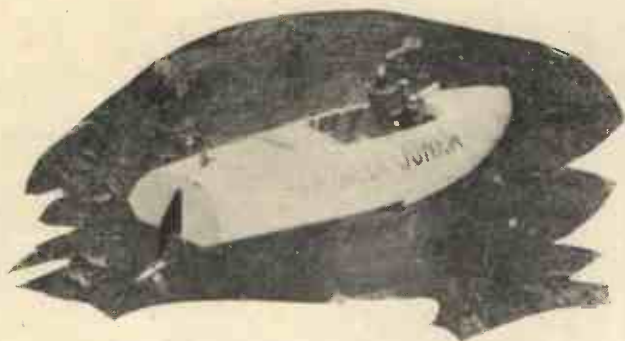

Fig. 1.—Showing the finished model hydroplane.

**T**HE construction of the hydroplane "Jildi Junior" was undertaken as a matter of interest to see if the application of a few petrol-model aeroplane principles, both of design and construction, would help to forward the cause of the 15-c.c. type speedboat.

It was noticeable that the 15-c.c. class of boat was, as a general rule, rather slow, and usually had difficulty in even keeping the line taut on a circular course. It had also been fairly obvious for some time that the 30-c.c. boat had become so fast that shortly a limit to its popularity for the majority of constructors might possibly take place. Obviously then, there was an opening for the development of the 15-c.c. class boat provided its speed capabilities could be raised.

How then should the problem be tackled? The 15-c.c. two-stroke "Atom Minor" engine which had proved its worth in flying petrol model aeroplanes seemed to be a suitable power unit to start off with, and the writer was thoroughly conversant with its moods and peculiarities.

From various tests that had been made with engines of different powers on my small outboard full-sized speedboat, I was satisfied that where limited power is available, weight of the hull is all important. I have heard well-known model speedboat men argue that weight is not important, and in fact that it is necessary in order to obtain a stable and even-running boat.

#### Undue Weight

I feel that experience with full-sized speed

hulls fitted with various powered engines and different numbers of passengers, soon makes one realise that this is a mistaken view, and that where an undue weight is required to keep a hull stable, there is something wrong in the design of the hull. Either the thrust line, weight distribution, planing angles, or planing surfaces are incorrect.

"Oiga Alba," Mr. Rankine's famous 30-c.c. boat has a very light hull. This craft is capable of over 40 m.p.h. I considered that if the weight could be reduced by incorporating aircraft methods of construction, the somewhat limited power then available from 15 c.c. could be made to yield more speed. Alty this weight reduction to a form of hull as streamlined as possible, and there is the possibility of doing something that will advance the speed of the 15-c.c. class of boat.

This last matter of streamlining is by no means all important, but it must help, however much the die-hards will try to point out that at the speeds at which the boats travel, wind resistance has no effect.

Finally, I

# A 15-c.c. PETROL-

By Captain

A Feature of the Construction of the  
the Present Record Holder in Class C  
structed on the Lines

I do not wish to claim that my boat is even a good one, I feel sure that it can be considerably improved, but I feel that its form of construction may be of interest to speedboat fans and may possibly form food for thought in the 15-c.c. class even if the reader discards the majority of the ideas that went to form the design.

I should mention that having built the hull which I am now about to describe, I found that I had even then constructed it far too robustly, and I hope a considerable amount of weight will be saved on my next hull of the series.

Perhaps also an explanation of the boat's name is necessary, as I have heard several people, whilst looking at the hull at regattas, suggest that the Hindustani name of the boat was rather a boastful one.

I think this is due to a mis-interpretation on their part of the word *jildi*. Actually it is an exhortation to "go quickly." I felt when naming it that there was no harm

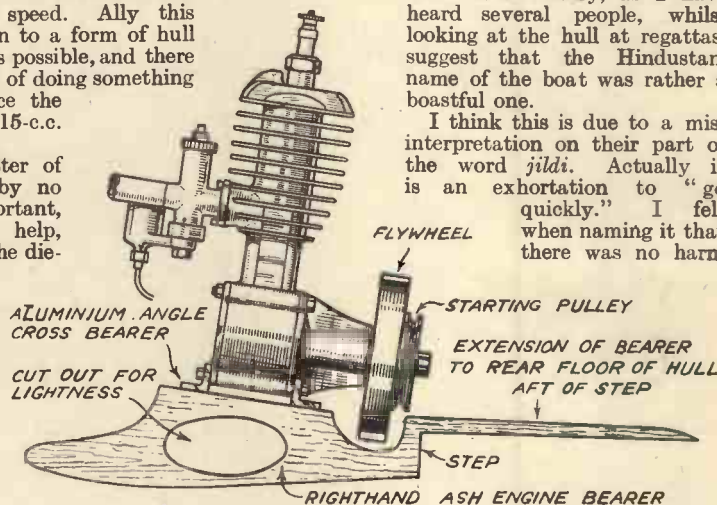

Fig. 3.—Details of the engine bearer and method of mounting the engine.

considered that the planing surfaces should offer as little resistance as possible by skin friction, but at the same time should be of ample surface so that the hull could skid over the water without any suggestion of digging in.

Nearly 25 m.p.h.

These then were the underlying ideas when I settled down to design "Jildi Junior." The result was encouraging, for the record was immediately put up by a considerable increase in m.p.h. The actual speed clocked for the 300 yds. being 24.78 m.p.h. There is no doubt that with more care and thought on future hulls, this speed will be greatly increased in the 15-c.c. class.

in telling it to get a move on. I should not like to tempt fate by giving the boat a name that included speed as an accomplished fact!

At the time of building "Jildi Junior" I happened to be living in Scotland, and my friend Mr. Rankine, of model speedboat fame, was interested in my project. He kindly consented to fit the engine with a miniature of one of his extraordinary simple and efficient carburetters. I consider these carburetters are splendid instruments for racing, as there is no uncertain tap twiddling and making of mixtures, just when the over-excited competitor is launching his aeroplane or his boat for some attempt for a cup or a record.

Anyway, up went the speed of my "Atom Minor" engines, and in particular the one to be fitted to "Jildi Junior." A little judicious opening of ports also assisted. As the reader is probably familiar with the "Atom Minor" engine I will only give a short description. The engine has been fully described in PRACTICAL MECHANICS. It is a two stroke, constructed chiefly of a light alloy and with a cast-iron cylinder liner. The cubic capacity is 14.2

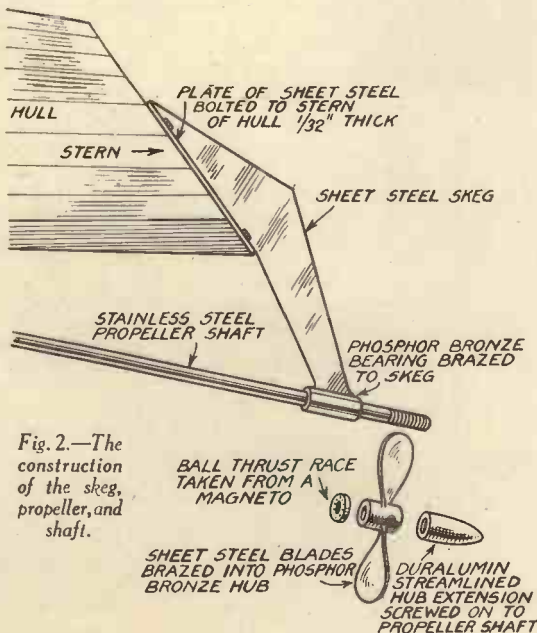

Fig. 2.—The construction of the skag, propeller, and shaft.

# ENGINED HYDROPLANE

## C. E. BOWDEN

### Hydroplane "Jildi Junior," which is for 15-c.c. Boats, is that it is Con- of a Model Aeroplane

c.c. and the weight with flywheel as fitted for "Jildi Junior" 1 lb. 14 oz. A Bosch green band sparking plug is fitted. The ignition is by non-trembler coil weighing 8 oz., the dry battery weighing 15 oz., and the condenser 2 oz. The "Atom Minor" engine used was one of the latest productions of A. E. Jones, Ltd.

This engine was put on Mr. Latta's well-known small brake and put under load. It was found that with the added r.p.m. gained by the special carburetter, and the increased port areas, that misfiring set in at the higher speeds. The ignition contact-breaker spring had to be substituted for a much stronger one, and a slight modification made to the gear. (The production aero engine is not designed for this big increase of speed.)

#### The Transmission and Propeller

The propeller shaft is a simple stainless steel shaft with no universal joint at the propeller end. The propeller is attached direct to the shaft and there is a plain phosphor-bronze bearing carried by the skeg. A small magneto ball-race is used as a thrust race to take the thrust of the propeller. This is fitted hard up against the rear end of the plain streamlined phosphor-bronze bearing (see Fig. 2).

It is a very debatable point whether a universal joint should be used in the propeller shaft at the propeller end and so reduce the angle of the thrust line with the planing surfaces.

Many consider this is essential. I do not propose to enter into an argument on the subject, more than to state that I came to the conclusion in the case of this boat, that I wished to obtain a certain amount of down thrust on the front plane, and I wished to keep the frictional losses on transmission as low as possible in view of the small engine capacity.

In view of the above, it was decided to eliminate a universal joint at the propeller end. The advisability of fitting a universal joint or not is bound up in the planing angles of the hull. Very fine planing angles and great speed probably do require a universal joint to reduce the thrust-line angle.

#### Details of the Skeg

The skeg has a triangular plate made of sheet steel  $\frac{3}{8}$  in. thick. This is bolted to the stern bulkhead. To this plate a sheet-steel skeg is brazed which is composed of  $\frac{1}{8}$ -in. thick material. At the bottom end

of the skeg a phosphor-bronze bearing, with its forward end streamlined, is brazed. A stainless steel propeller shaft of  $\frac{3}{8}$ -in. diameter passes through this bearing, and at the rear end of the bearing a small ball-thrust race is located to take the forward thrust of the propeller. This ball race is an old magneto race. The propeller hub, which is made of phosphor bronze, is next threaded on to the shaft and kept in position by a grub screw, which is located on the shaft by an indentation in the latter. On the extreme end of the shaft a duralumin streamlined extension is screwed on to a right-hand thread as the propeller revolves anti-clockwise, looking from the stern of the hull.

The propeller has two blades of high aspect ratio, and is 3 in. in diameter with a 9-in. pitch. The two blades are constructed of sheet steel twisted to give the correct pitch, and with very sharp leading and trailing edges. These two blades are brazed into saw-cuts in the phosphor-bronze hub.

There is a small knuckle-joint to take the drive from an extension of the engine main shaft. A steadying bearing of duralumin is located in the last former of the cockpit near its base, whilst the stern tube is merely constructed by making a hole in the floor of the hull where the propeller shaft goes through from the engine to the skeg bearing. The shaft is then placed in position, and inside the hull, around the shaft and hole, plastic wood is pressed. The shaft is then rotated a few times to ensure that it is free and the plastic wood allowed to dry. The result is an excellent stern tube with very little labour. Although suitable for a high-speed hull this would not do for a displacement hull where a constant pressure of water is doing its best to find an entrance into the hull via the stern tube.

#### The Engine Bearers and Mounting

The two engine bearers are made from ash  $\frac{3}{8}$  in. wide. (See Fig. 3.)

The bearers form an important part of the hull's backbone. Upon the top of the bearers there are two pieces of L-shaped "angle iron" of aluminium. The ends of these aluminium bearers are placed across the longitudinal ash bearers and kept in position by coarse-pitch wood screws. The upright sides of the L-shaped aluminium

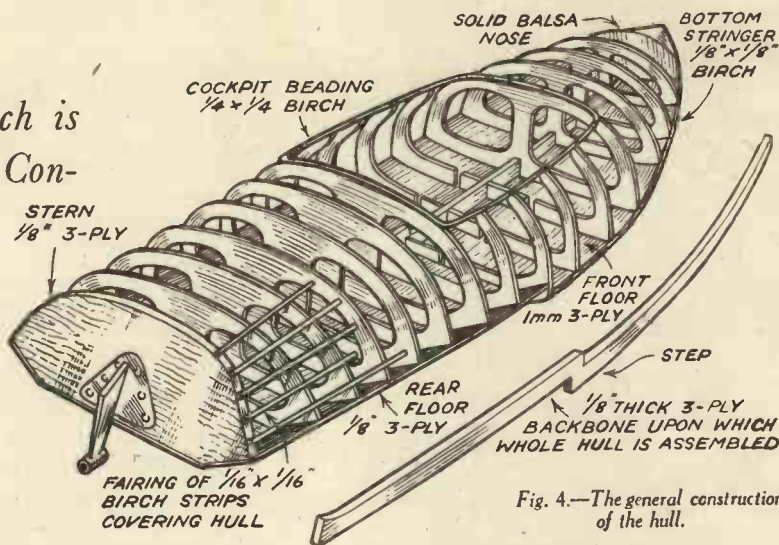

Fig. 4.—The general construction of the hull.

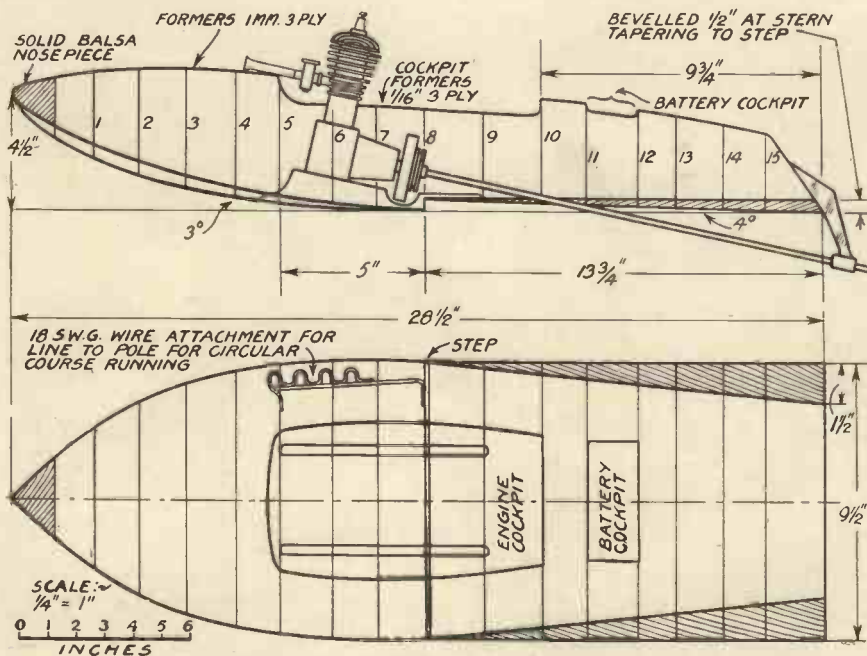

Fig. 5.—A side and plan view of the hydroplane.

bearers are drilled to receive the two bottom longitudinal crankcase bolts of the engine. Reference to Fig. 3 should make clear this method of attachment.

### The Construction of the Hull

As it was anticipated that it might not be all smooth sailing with an experimental hull, the construction was on the robust side. A central backbone of  $\frac{1}{4}$ -in. three-ply, and the two ash engine bearers already mentioned, formed the foundation.

Reference to both Figs. 4 and 5 should be made during this description, and if the reader is considering building a replica, he should first of all produce a full-sized drawing from Fig. 5, whilst Fig. 4 will give a general idea of the construction.

It will be observed that a number of closely spaced transverse formers of carefully fretted out 1-mm. thick plywood are attached to the main frame mentioned above. These formers are stuck into their correctly spaced positions with cellulose glue. This glue can be obtained at any ironmonger's and is waterproof.

Whilst the glue is setting hard, the formers are kept upright by placing wooden blocks on either side of each former. When all formers are set hard in position, a shaped nosepiece is carved from solid balsa wood and stuck in position. The stern former, of course, is not fretted out for lightness, and where the open cockpit is situated, the formers are of  $\frac{1}{8}$ -in. three-ply, as they are not supported by the top arches as in the case of all the other formers. Along the bottom outside corners of the formers, nicks are cut and  $\frac{1}{2}$ -in.  $\times$   $\frac{1}{2}$ -in. square lengths of birch are first steamed to the necessary bends and then stuck to the formers. In this way the foundation of the "hard chine" is formed. Whilst the glue is drying, where each former contacts with the lengths of birch, a piece of cotton is tied to keep the two in position.

These are removed later. It should be mentioned here that all the woodwork described is model aircraft material and can be obtained from any good model aircraft stores.

The ignition coil is tied down to the floor, aft of the step and immediately in front of the stern former by wire straps, and stuck down with glue. All necessary ignition wiring is carried out at this time as well, and led along the floor to the main cockpit.

### Birch Stringers for the Hull

Next, the entire hull has  $\frac{1}{16}$ -in.  $\times$   $\frac{1}{16}$ -in. square lengths of birch stuck on to the formers in the form of "stringing" as in aircraft practice. The birch stringers are placed approximately  $\frac{1}{2}$  in. apart and, whilst the glue is drying, are kept in position by some lengths of model aeroplane elastic wrapped around the hull. When the whole is dry this elastic is removed, and some flat strip balsa wood,  $\frac{1}{8}$  in. thick and  $1\frac{1}{2}$  in. wide, is stuck along the sides of the hull at the bottom edges to form a firm chine.

One tip with regard to the perhaps, unfamiliar method of "stringing." Each length of  $\frac{1}{16}$ -in.  $\times$   $\frac{1}{16}$ -in. birch should be placed on the outside edges of the formers. It is a mistake to cut nicks in the formers to take the stringers. The formers will then show up when the hull is covered with silk and so spoil the clean unbroken longitudinal line. Where the stringers touch the formers, a small blob of glue is placed.

After stringing, the bottom floor of the hull is stuck into place with plenty of glue. The floor forward of the step is composed of 1-mm. thick three-ply, and is difficult to stick down owing to its slight vee formation. But by wrapping the entire hull with elastic, and inserting suitable-sized wedges between the elastic and the plywood bottom where the concave vee is, the three-ply will be forced to the bottoms of the formers in its correct vee shape. In order to take the line from the pole in circular course racing, 18 S.W.G. spring steel wire is formed into a series of eyes, and this adjustable attachment has its ends of wire bound and glued to formers Nos. 5 and 8. (See Fig. 5.)

A second cockpit is left for the 4-volt rectangular dry battery between Nos. 11 and 12 formers;  $\frac{1}{4}$ -in. thick balsa slats are used to construct the sides for this cockpit, so that the battery fits snugly. The top is left open and the battery is covered with oiled silk wrapped round it to prevent damage by water. An oiled silk tobacco pouch is excellent for the purpose.

Now the whole hull is carefully sandpapered around the chine area to clean up the balsa slats, and any uneven spots are filled with plastic wood and afterwards sandpapered off. A knock-off ignition switch is also fitted just aft of the battery cockpit. This fitted with a bamboo arm

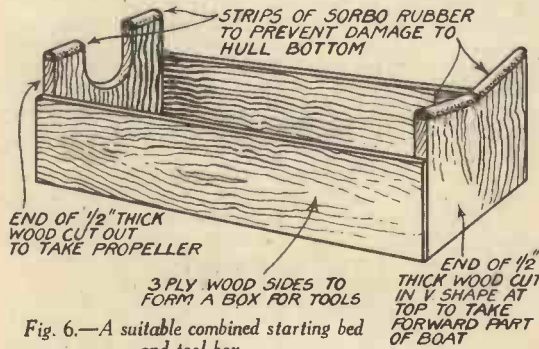

Fig. 6.—A suitable combined starting bed and tool box.

extending upwards 6 in., so that the boat can be stopped by hand whilst travelling around the circular course. The whole hull is then varnished with a coat of clear cellulose. This gives a waterproof finish inside.

### Covering with Silk and Finishing

The final operation is the covering of the whole hull with damp silk, doping, and painting.

A large pot of photo paste is obtained and some paste liberally smeared over the outside of the bottom floor to the step. A suitable piece of thin model aero jap silk is then stuck down on to the floor. This is then sprayed with water from a scent spray. It is then worked and carefully stretched with the fingers until no wrinkles can be found anywhere. The sides are then trimmed off by scissors and stuck over the edges.

When dry this silk covering will contract absolutely taut. Now proceed in a similar manner with the rear floor aft of the step. After the silk is dry cover the whole turtle-shaped top with one large piece of silk, having smeared photo paste along the edges of the chine, nosepiece, and stern. Spray with water and stretch the silk as before, trim off, and finish. When dry and contracted, if the silk has been well put on it will be without a wrinkle. The advantage of using photo paste is that if any part is not satisfactory, it can be wetted again and unstuck and the offending wrinkles worked out.

When dry, the whole is doped with full-strength aeroplane clear dope. This can be obtained from any aerodrome or from the makers direct.

"Jildi Junior" was doped with celloan dope. It is essential to use full-strength dope and not model dope. This gives the necessary stiffness to the hull to prevent distortion by engine torque and vibration.

The hull when dry will now be very strong and light, and can be given two coats of whatever coloured paint the constructor fancies. "Jildi Junior" is painted white with the name in red lettering. The whole boat weighed, with engine, coil, battery and petrol, etc., on its record breaking run, 6 lb. 4 oz.

### The Petrol Tank

The tank is a small cylindrical affair of brass,  $2\frac{1}{2}$  in. long and  $1\frac{1}{2}$  in. diameter. It is kept in position to the rear cockpit former by an aluminium strap. It is airtight and a rubber tube is led to a football bladder housed in the bows. Having filled up with petrol the filler cap is screwed on and the operator blows up the bladder to a pound or two's pressure by mouth, squeezing the bladder's extension rubber tube between his forefinger and thumb. He then places this tube on to the air inlet tube of the tank. The carburettor will now be pressure fed, and the system is far lighter and more simple than the usually more complicated method of valve and bicycle pump, etc.

### Operational Tips

A piece of blind cord is used to start up, the operator passing one end under the groove behind the flywheel. (See Fig. 3.)

By grasping both ends, whilst a friend gingerly holds the hull down on the starting-up bed, the operator can rapidly turn the engine over compression through pulling on one end of the cord and releasing the other as it nears the flywheel. A few pulls over compression with the carburettor inlet partially choked and then a final pull with ignition switched on, should start the engine. A few seconds throttled down to warm up and the boat is attached to the line, the throttle fully opened, and, at the same moment as the engine screams into activity with its 8,000 r.p.m., the hull is placed on to the water and given a slight push to take up the line evenly, and away goes the craft. The tank holds sufficient fuel for five to six laps on full throttle. A suitable starting bed and combined tool box is shown in Fig. 6.

MODEL BOAT BUILDING

The "ABC" of this most fascinating hobby - practical and comprehensive.

With 131 Illustrations

From all Booksellers

Only 1/- net

Newnes HOME MECHANIC Series



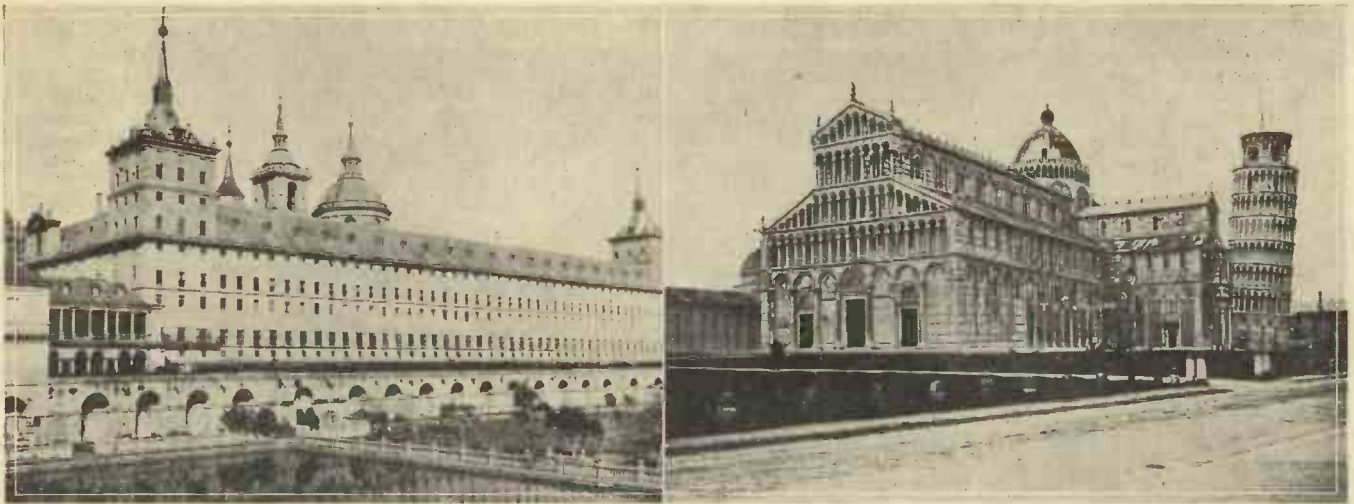

(Left) El Escorial, Spain, the world's greatest architectural white elephant. This view of part of one façade of the Escorial, gives a fair impression of its harsh, ugly prison-like style, and (right) the leaning tower of Pisa.

# Some Crazy Buildings

VERY many living creatures are accomplished builders, but *man alone can originate*. The comb of the bee, the web of the spider, the city of the ants, the dam of the beaver, and the nests of birds, beasts, and fishes are all built to a pattern, and never alter. Two newly mated young birds are said to build a nest as exquisitely beautiful and perfect as that

“The Evolution of the Home.” His creative powers, which enable him to *originate*, have sometimes produced freak or fantastic results. Crazy buildings are of many kinds and types. Some are so futile and useless that they are dubbed “Follies” by common consent. Meanwhile, we will consider some other crazy buildings, and among such the “leaning towers” certainly deserve mention. There are many such throughout the world, but the leaning tower of Pisa is by far the most beautiful and striking. It was built in 1174, is 179 ft. high, and *leans* 14 ft. Two questions are usually asked about this—and all other—leaning towers. Why does it lean, and why does it NOT fall?

Bologna. The Torre Asinelli (built 1109) is no less than 318 ft. high, or nearly as lofty as the Dome of St. Paul's, London. It is 4 ft. out of the perpendicular, and so leans very much less than the Torre Garisenda, which is less than half its height, and overhangs 7 ft. England has a number of leaning towers, and one of these is said to lean *at exactly the same angle as the tower of Pisa*. This is the handsome square tower of Temple Church, Bristol, which leans 5 ft., and makes a very striking effect. The Spire of Salisbury Cathedral also leans 4 ft., but it is so lofty (404 ft.) that the overhang is not very noticeable. It was caused by a later architect adding the spire, which had not been planned originally, and therefore the foundations were not strong enough for it. Architects sometimes had their own private joke, and there is an interesting example of this in Sir Christopher Wren's

By G. Long, F.R.G.S.

Crazy Buildings are of Many Kinds and Types. Some had their Origin in a Crazy Brain, or were Caused by a Subsidence of the Foundations, whilst others have been Deliberately Designed by Architects to Prove a Technical Point

### Why it does not Fall

The reason it does not fall is that—according to a well-known principle of dynamics—a vertical line drawn from the centre of gravity of the tower falls *within* the base. No building falls so long as this principle is adhered to, but directly it moves far enough for this vertical to fall outside the base, the tower comes down. Some have supposed that certain leaning towers have been deliberately designed by architects who desired novelty, and understood the principles necessary to ensure safety; but I think in most cases the “lean” was caused by a subsidence of the foundations. There are two more remarkable leaning towers in Italy, both in the ancient city of



The two leaning towers of Bologna, Italy.

of their parents, who may have enjoyed several seasons of house-building, but though these humbler creatures need serve no apprenticeship to learn their craft, yet they can never excel the work of their fellows.

Man, however, is a creature of brain, and not of instinct, so he must devote long years of toil to acquire skill and knowledge, but having done so there seems no limit to his possibilities, as we showed in our article on



The leaning tower of Bristol, Temple Church.

town hall at Windsor. The lower part forms a kind of market hall, and Wren planned it without supporting pillars. The Mayor, however, objected that it would be unsafe without a double row of pillars, so the architect added them. He made them all 2 in. short, so that they did not, and still do not, support the floor above, which, however, still stands after three centuries!

#### The Crooked House

In mining and salt-producing districts leaning buildings are very common. The Cheshire salt district is full of toppling and lop-sided houses, especially in Middlewich and Northwich. But the gem of all Britain is the "Crooked House" at Himley in Staffordshire, which I acclaim as England's craziest building. A century ago it was a village public-house, known as the "Glynne Arms," and remarkable for nothing save the solid work of the builders, which was demonstrated some ten years after it was finished when the ground sank

ing would stand on them, but inside the crooked house they appear to slope steeply. The most remarkable of these items is the long table in the back room, which has not been "corrected" sufficiently. It seems to *slope up*, but actually runs down, so that if a billiard ball is rolled down the slope it stops half-way, then turns back and rolls off at the upper end! The grandfather clocks also have to be set at a curious angle to the walls, because if they were parallel to the "uprights" of the building they would be so much out of the vertical that the pendulum could not swing. When the house first tilted, every clock stopped!

This remarkable "crazy building" has become quite celebrated in the Midlands, and thousands visit it every year.

#### Jezeel's Tower

Some crazy buildings had their origin in a crazy brain. The most remarkable of such structures in all Britain is probably Jezeel's Tower, which stands at the top of

There is a crazy building in Hampshire, which also had a religious origin, though of a much less sensational kind. It is known as the Farringdon Folly, and during the thirty years it was building it attracted much attention. The rector of the village, Mr. Massey, was a wealthy but eccentric individual, who conceived the idea of erecting a freak structure. Nobody knew what it was, or what it would become. He acted as his own architect, and kept two men working on it daily for thirty years; very expensive materials were used, many of the moulded bricks are said to have cost 20s. each, and the total expenditure was over £20,000. I visited it when under construction, and it was like a builder's nightmare. There were passages which led nowhere, and inner rooms complete in every way but having neither door nor window. The exterior was bizarre in the extreme, having two lofty but unsymmetrical towers placed near the middle for no apparent purpose, and a paucity of outside windows and doors. The rector never divulged its real purpose, and the secret died with him. Since then it has been taken in hand by a more practical mind, and has been completed. It is now a village hall, and school, but I am informed that the interior still contains queer passages leading to nowhere, and rooms which cannot be used. Old inhabitants still style it "The Folly."



(Below) The Crooked House, Himley, and (left) a room inside the Crooked House, showing the mysterious table. A billiards ball placed on the sloping surface of the table appears to run up-hill, and falls off at the top end.



under one end, and tilted the whole structure like a doll's house with a brick under one end. The amazing thing was that the house was quite undamaged. Not a ceiling cracked, not a wall bulged, not a floor gave way. It was as sound as a bell; but quite uninhabitable, all the same, until something was done about it. All the floors had to be raised at one end to permit furniture to stand in its place, and the shelves had to be slanted so that they were actually horizontal, although they naturally appear to be leaning.

Even to-day the structure is astonishing, but it is less "crooked" now than formerly, because about twenty years ago there was another movement of the earth, and it recovered about two feet of its lean. If we examine the house from outside it looks exactly like a sinking ship which is going down by the head. The inside effects are still more striking. All doors and windows slope steeply, and only the hanging lamps are really vertical; benches, shelves, and tables have to be made *horizontal*, or noth-

Chatham Hill in Kent. It is a gigantic, ugly, square, unfinished building, looking as if it were intended for an hotel, but its origin was much more romantic. Jezeel was a religious fanatic, who obtained a great following among the more ignorant local people. He claimed that the "coming of the Lord was at hand," but that all those who put their faith in the prophet Jezeel would rise to Heaven with him on the Day of Judgment, and meanwhile he (Jezeel) was immortal. The sect raised a considerable sum of money to build a temple on the hill-top which would serve as a place of worship until *Der Tag*, and then they were to assemble on its flat roof, and thence ascend to Heaven. Unfortunately Jezeel died before the building was finished, and this somewhat blighted the prospects of his movement, although, when I visited the place shortly before the outbreak of war, there were still a number of "Jezeelites" in the locality. I do not know if the tower still stands, it would certainly take some pulling down.

#### World's Record White Elephant

I fancy the world's record white elephant must be the famous Escorial near Madrid in Spain, which had its origin in the fevered brain of the fanatical King Philip, whose beard our gallant sea-rovers so well and truly singed. A great critic has called it "the grandest and gloomiest failure of modern times," and in the records of buildings it is the most monumental waste in history. It was intended to be a Royal Palace, and also to house a community of monks, but the site selected was a bare and barren hillside, as bleak as Dartmoor, so the people for whom it was intended simply would not stay there. The Royal Family refused to live in their palace, and only a handful of monks used the monastery. The ground-plan was Philip's own idea, and characteristically futile. It was a grid-iron, having the Palace as the Handle, and the Monastery as the Grid, in memory of the martyrdom of St. Lawrence. And over this vast surface is spread a maze

(continued on page 266)

# Masters of Mechanics

## In This Sixth Article of the Series we Deal with the Discovery of Atmospheric Pressure

**W**E live at the bottom of an ocean of air which is some two hundred miles deep. Air is a material substance. Consequently it possesses weight, and it is obvious that it must exert a pressure upon our bodies. As a matter of fact, the air surrounding us presses upon every square inch of our bodies with a weight equal to approximately fifteen pounds. A full-grown man, therefore, supports a total weight of air equivalent to several tons on the surface of his body.

Such facts are plain and straightforward ones, and they are well known to everybody possessing the least knowledge of science and mechanics. Time was, however, when the fact that air possesses weight was not realised. The reason for this is to be found in the fact that the air presses equally on all portions of our bodies. If, for instance, we stretch out a hand, the upward pressure of the air on the under surface of our hand is 15 lb. per square inch, and the downward pressure of the air on the upper surface of our hand is exactly the same, as is, also, the air pressure at the sides of our hand. Consequently, it was not until men found some method of removing the greater part of the air from a certain area that the resulting inequality of air pressure began to show itself and the pressure of the air became demonstrable beyond the slightest doubt.

### Creating the Vacuum

The story of the discovery of atmospheric pressure and of the means of creating the vacuum, that marvellous condition of emptiness which has made wireless and television possible in their present form, and which bids fair to enable us to wield still greater powers, goes back to the time of Galileo, the famous Italian mechanic, astronomer and physicist. "Nature abhors a vacuum," the early natural philosophers had cried, and later generations of scientific men had implicitly believed in this dictum. Even the great Galileo found no reason to question the assertion.

In 1641, the Grand Duke of Tuscany caused a new well to be sunk for the purpose of raising water to supply the fountains in his grounds. The new well was a deep one, and although the Grand Duke had had the best pumps installed, he found that they would not work. Galileo was brought to inspect the pumps, but he was unable to say why they would not work. Indeed, he sent to the Grand Duke the remarkable statement that although Nature abhorred a vacuum and would, therefore, allow water to be pumped by suction, yet she did not abhor a vacuum greater than that equivalent to 32 ft. of water! Galileo had found that water could be made to rise 32 ft. in a pipe by means of pumping or sucking, but that under no circumstances would it rise farther by these means.

### Evangelista Torricelli

About this period, a student of Galileo's, Evangelista Torricelli by name, began to be

struck by the fact that there was no satisfactory explanation of the fact that water would not rise by suction to a height greater than 32 ft. So much thought did the young Torricelli give to this undoubted fact that in 1643, hardly a year after Galileo's death, he announced to the world the fact that water rises by suction in a pipe not in consequence of the hypothetical abhorrence by Nature of a vacuum, but simply in virtue of atmospheric pressure. Torricelli had found by experiment that

water would rise by suction to a height of 32 ft. in a tube, and that under no circumstances would it rise higher. Torricelli had previously conceived the idea that the column of water in the tube was sustained by the pressure of the atmosphere on the water outside the tube. If such is the case, he argued, then the pressure of air against a liquid heavier than water should only be able to sustain a shorter column of that liquid.

In his experiments, Torricelli employed mercury or quicksilver, a liquid which is thirteen times heavier than water. He found that a column of this liquid would rise to a height of 30 in. or thereabouts and no more. He showed that the height of his mercury column varied slightly from day to day, thus proving that the atmospheric pressure underwent daily alterations.

### The Barometer

Thus came into being one of the world's fundamental measuring instruments, the barometer, or weight-measurer. Torricelli at one stroke exploded the ridiculous idea concerning Nature's abhorrence of a vacuum, and gave to scientific men and, indeed, to civilisation in general, an instrument which has been of inestimable value ever since. Torricelli's discovery was made in 1643, a date which we have already noted. Four years later, in 1647, Torricelli died. The Torricellian experiments, however, were taken up by other men. Of these latter experimenters, one in particular, Blaise Pascal, a Frenchman, deserves our attention, for he conclusively proved the correctness of Torricelli's assertions.

### Pascal's Letter

The following is a letter written by M. Pascal to his brother-in-law:

"I have thought of an experiment which, if it can be executed with accuracy, will alone be sufficient to elucidate this subject. It is to repeat the Torricellian experiment several times in the same day, with the same tube and the same mercury; sometimes at the foot, sometimes at the summit of a mountain 500 or 600 fathoms in height. By this means we shall ascertain whether the mercury in the tube will be at the same or at a different height at each of these stations. You perceive, without doubt, that this experiment is decisive; for, if the column of mercury be lower at the top of the hill than at the base, as I think it will be, it clearly shows that the pressure of the air is the sole cause of the suspension of the mercury in the tube, and not the horror of a vacuum; as it is evident there is a longer column of air at the bottom of a hill than at the top; but it would be absurd to suppose that Nature abhors a vacuum more at the base than at the summit of a hill. For, if the suspension of the mercury in the tube is owing to the pressure of the air, it is plain it must be equal to a column of air whose diameter is

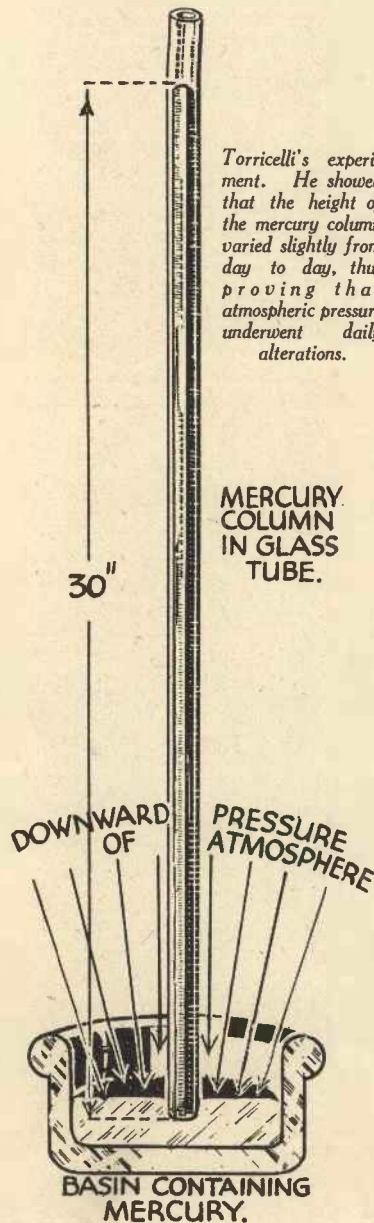

*Torricelli's experiment. He showed that the height of the mercury column varied slightly from day to day, thus proving that atmospheric pressure underwent daily alterations.*

the same as that of the mercurial column and whose height is equal to that of the atmosphere from the surface of the mercury in the basin. Now, the base remaining the same, it is evident that the pressure will be in proportion to the height of the column and that the higher the column of air, the longer will be the column of mercury that will be sustained."

Pascal applied the above test on September 19th, 1648, on a mountain in central France named 'Puy de Dome.' As he climbed to the summit of the mountain carrying the barometer with him, he found that the height of the mercury column progressively decreased, until at the summit of the mountain the mercury column was three inches less in height than it was at the base of the mountain. The experiment was repeated subsequently again and again, but ever with the same result. Thus were Torricelli's assertions concerning the nature of atmospheric pressure finally confirmed.

#### The Invention of the Air Pump

Torricelli's investigations in the subject of atmospheric pressure were followed by many important physical and mechanical results. Probably the most important of these was the invention of the air pump which was made in 1650 by Otto von Guericke, the now celebrated and somewhat romantic burgomaster of Magdeburg, in Prussia. Otto von Guericke was the first one in history to show by direct experiment that air possesses weight and, also, to demonstrate the exceedingly great pressures which can be set up by such an invisible medium.

Von Guericke, early in his career, realised the fact that air can, in many respects, be treated like water. He devised means of packing it into vessels and, also, of emptying vessels of it. Guericke's first notion was to fill a strong wooden barrel with water and

then completely to close the barrel, leaving merely a delivery tube through which the contents of the barrel could be drawn out by means of a suction pump. By this means, von Guericke thought that he would leave a completely empty space in the barrel. When, however, he found that air passed through the pores of the woodwork and between the joints he enclosed the barrel in a larger one and filled the space between the two barrels with water. Air still entered the barrel after the contained water had been drawn out, and it became evident that a mere barrel would never suffice for the purpose of creating a vacuum within.

#### An Interesting Experiment

Von Guericke next made a large hollow metallic globe. This had a delivery tube connected to a pump. The globe was not filled with water. The air was merely pumped out of it by means of the hand pump. At first, the pump was easy to operate. Quickly, however, the resistance of the pump rose with each stroke, until at last it was as much as the strength of two men could do to operate the pump. Suddenly, when this stage of exhaustion of the metal globe had been reached, the device suddenly collapsed with a loud noise. It had crumpled up just as if it had been squeezed in the hand of a giant, thereby demonstrating the power of atmospheric pressure.

The ingenious burgomaster next made a stronger hollow globe. This time, however, the globe was made in two separate portions or hemispheres which, under normal conditions, could readily be drawn apart. When, however, the globe was exhausted or even partially exhausted of air, it was found utterly impossible to separate the two halves. In one of Guericke's famous experiments, a platform was slung from the lower half of the exhausted globe, and on the

platform were placed heavy weights. Despite this, however, the bottom hemisphere of the globe refused to be drawn away from the upper one, the two halves being kept together by the external pressure of the atmosphere.

#### "Experiment of the Magdeburg Hemispheres"

Guricke's most famous experiment was one which he caused to be performed before the Emperor, Ferdinand the Third, at Ratisbon, in 1654. The experiment, which demonstrated in a spectacular manner the effects of atmospheric pressure, later came to be known as the "Experiment of the Magdeburg Hemispheres." Two separate metallic hemispheres when joined together formed a metal globe. This was exhausted of air by means of von Guericke's air-pump and an endeavour was made to pull the two halves of the globe apart by means of a team of powerful horses harnessed to the opposite halves of the globe. The attempt failed and thus demonstrated to all present the enormous force with which the pressure of the atmosphere kept the two hemispheres of the metal globe together when the air had been removed from within.

In the hands of English mechanicians, such as Robert Boyle and Robert Hooke, the air-pump became an instrument of scientific precision. Its use made possible many experiments which, previously, had been impossible. The creation of a vacuum or, to be more precise, of a partial vacuum within an enclosed vessel has, perhaps, given more practical benefits to the world than any other single principle. To Otto von Guericke, therefore, the worthy burgomaster of Magdeburg, must go the credit of not merely devising a single mechanical instrument but of formulating a principle which has been of inestimable service through the history of mechanical, electrical, and other scientific invention.

**A**N exhibition portraying the organisation and operation of the air service over Empire air routes was opened by the Secretary of State for Air on Thursday, December 5th, at the Science Museum, South Kensington, S.W.7, and will be on view to the public until January 31st.

The exhibition, which is organised and staged by Imperial Airways, Ltd., is popular in character, both in scope and

## THE EMPIRE'S AIRWAY EXHIBITION

treatment, and illustrates the development of air communications within the Empire by means of models, charts, maps, and

photographs. It includes models of every type of air-liner which has been owned by the Company since its inception, and sectional models of the new air-liners which are now under construction.

A part of the exhibition is devoted to the design of air ports and includes a large model of a modern combined land and air port, and dioramas of three famous Empire airports. There is also working models showing the part which wireless plays in the control of aircraft when flying in fog or above cloud; the visitor, by pressing a button, is able to hear the voice of the captain calling for his position and the replies from wireless stations on the ground.

#### Interesting Models

There are sections devoted to the building of a flying-boat and a land machine, and to aero engines. Operable models of a wind tunnel and a tank enable the visitor to gain some idea of the part which these instruments play in the design of air-liners.

The exhibition should prove of considerable educational interest at the present time, and serves to show the remarkable developments which have taken place in air transport during recent years; by way of comparison, the earlier historical development in aviation can be seen in the usual gallery of the National Aeronautical Collections in the Museum.



One of the models on view at the exhibition. It shows a new Short "pickaback" dual flying-boat for the Atlantic route, now under construction at Short Bros., Rochester. We hope to publish an article on this unusual form of aircraft in the next issue.

# LET PELMANISM MAKE 1936 YOUR YEAR

**W**HEN 1936 ends, you would like to look back on it as the best year you have ever passed.

You would like to feel that something stupendous had happened to you in 1936, that made your Success in Life sure.

You would like to enjoy life; to really enjoy it this means not only pleasures that come with extra money, but zest of living that comes with awakened mind, with quickened mental powers.

You would like your affairs to prosper, and your income to increase.

You would like to cease worrying, and to become confident in yourself and in your future.

All these good things, and many more, are possible for you.

If you really wish to realise them, Pelmanise!

## Change Your Disappointments Into Victories!

Pelmanism shows you how to so use your natural, and too often unsuspected, talents that you yourself can change your disappointments into victories, and attain the prosperity and the enjoyment of life that are the sure results of the Pelmanised mind.

You have within yourself a great store of abilities, of which you probably use only an infinitesimal part.

Pelmanism will reveal to you these hidden abilities, and possibilities, and will show you how to use them for your everlasting benefit.

## The Success of Pelmanism and of Pelmanists

Pelmanism is a twentieth century mind-training system based on sound principles of modern psychology.

Pelmanism has stood the test of nearly half a century of Success.

Pelmanists now number more than half a million—men and women in every walk of life.

Pelmanists themselves tell of their Success in life. Every day quantities of letters flow into the Pelman Institute telling of the benefits Pelmanists owe to Pelmanism.

## The Results of Right Thinking

Success results from an orderly mind, an obedient mind. Great people, famous people are lifted above the rank

and file by the power of their minds. They know how to think, and thinking right, they act right. They don't fumble, they don't bungle, they don't waste time and effort. Their minds are so controlled that they function with the accuracy and ease of a well-oiled machine.

People whose minds are trained the Pelman way have time and money for the diversions and amusements that both rest and stimulate the active civilised man and woman of to-day. Pelmanists don't just grind.

Once your mind is Pelmanised, and your life reorganised, you will be surprised and delighted to see how much more pleasure you get out of every single day.

## All Work and No Play

Once you set your mind to functioning the Pelman way, you will not only be more prosperous, but you will have more time. Your life will never be all work and no play after you have become a Pelmanist.

There are a number of indications that a mind does not function well. For example: lack of concentration—mind wandering, a faulty memory, timidity, self-consciousness, pessimism, quick temper, a feeling of frustration.

Pelmanism soon eradicates these faults, and substitutes in their places the qualities that win: ability to concentrate, reliable memory, courage, self-confidence, cheerfulness, even temper, punctuality.

## A Real Acquaintance with Yourself

No matter what school you may have attended, no matter what the extent of your knowledge, you can still acquire something of inestimable value through Pelmanism, because Pelmanism is the surest means towards the establishment of a real acquaintance with yourself. Pelmanism points the road that leads to your success.

The Course is given by correspondence only. Each Pelmanist selects his or her own time for the study of Pelmanism, consequently each Pelmanist is free to take as much or as little time as he or she desires for the completion of the Course. The Instructors at the Pelman Institute stand, in their relation to Pelmanists, as friends, and Pelmanists are invited to write freely to the Instructors concerning any problem that may arise. If you sincerely desire that 1936 be for you a great improvement over 1935, do not put off your decision to become a Pelmanist. Fill in the coupon at the bottom of this page, and mail it to-day. Take the first step now.

## Pelmanism Brings Out Your Possibilities

That Pelmanism sharpens the perceptions, cultivates the mind and develops those qualities that make for Success, there can be no doubt. Read what a Bank Cashier just wrote us:

"Pelmanism has had the greatest influence in my life. I have now an object in life, and know I am on the right way to realise it. Depression, moodiness, indecision are all removed—the result—Happiness—and what can that lead to? My whole outlook is changed, not just for the better, but for the best."

If Pelmanism can do so much for other people, what can it do for you? We have published recently a book called "The Science of Success" that tells just what Pelmanism is, just what Pelmanism does, and gives the experiences of Pelmanists, related by themselves. Fill in the coupon at the bottom of this page, mail it to-day, and by return of post you will receive a copy of "The Science of Success," free of charge, post paid. Read this book carefully. You will see what men and women in every walk of life say of Pelmanism. You will see

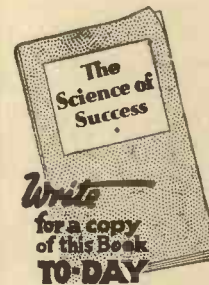

that no matter how discouraged, how tired one may be, Pelmanism restores confidence in life, develops self-reliance, and sets one's footsteps definitely on the path towards Success. Or, if you find it convenient to do so, call at

the Pelman Institute, Pelman House, Bloomsbury Street, London, W.C.1, and have a talk with the Director of Instruction. The interview entails no obligation.

Send for a free copy of "The Science of Success" and read more of what men and women say of the successes and benefits they have derived from a Correspondence Course of Pelmanism.

TO THE PELMAN INSTITUTE,  
130 Pelman House,  
Bloomsbury Street, London, W.C.1.

Please send me a free copy of "The Science of Success," containing full particulars of the Pelman Course.

NAME .....

ADDRESS .....

Occupation .....

All correspondence is confidential

PELMAN (OVERSEAS) INSTITUTES:  
PARIS, 80 Boulevard Haussmann. NEW YORK,  
271 North Avenue, New Rochelle. MELBOURNE, 396  
Flinders Lane. JOHANNESBURG, P.O. Box 4928.  
DURHAM, Natal Bank Chambers (P.O. Box 1489).  
DELHI, 10 Alipore Road. CALCUTTA, 102 Cive  
Street. AMSTERDAM, Damrak 68.

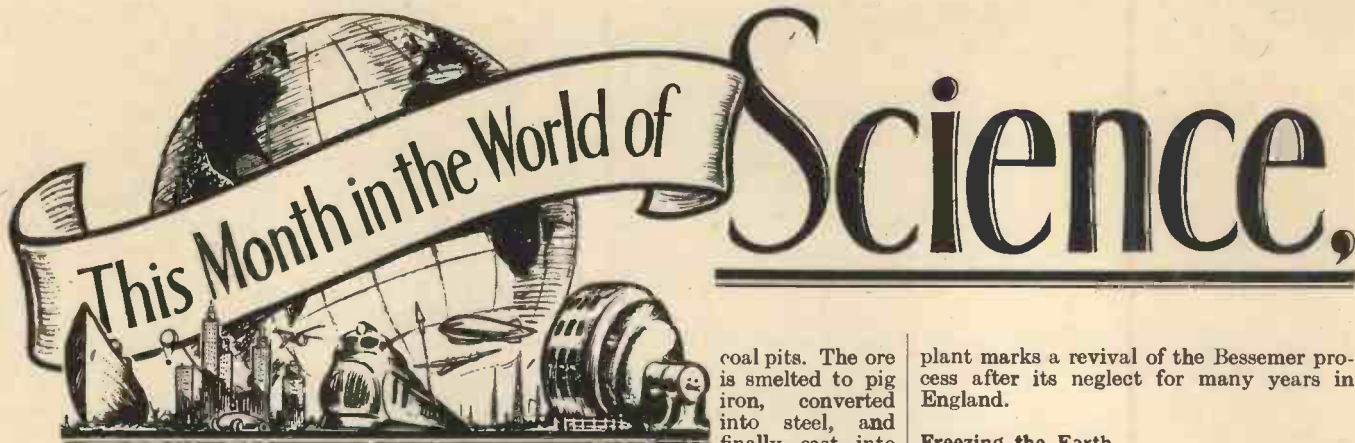

# This Month in the World of Science,

## Spinning Iron Pipes

**M**ANY thousands of miles of cast-iron pipes are made annually for laying gas and water mains. The old method of manufacture was by pouring the metal into a sand mould set in a vertical pit. Modern needs find this method too slow, and a process has been devised for spinning the pipes from the molten metal by centrifugal force. A hollow water-cooled cylinder acts as the mould. It is set rotating at a high speed and advanced up to a pouring ladle containing cast iron at 1400 degrees C. From the ladle a trough extends to the back of the mould. The white-hot metal flows down the trough, falls off on the

into sheets all in the one works. Perfect continuity of process is preserved. Handling is reduced to a minimum. The most modern methods of by-product recovery and fuel economy are practised.

A battery of 16 coke ovens making metallurgical coke for an installation of three blast furnaces, is fired by the blast-furnace gas. Otherwise, this gas would largely go to waste. The coking of the coal supplies by-product coal gas, sulphate of ammonia, road tar, and motor benzole. The coal gas is sufficient in quantity to supply the whole of the fuel requirements of steel reheating furnaces and of a first-class modern boiler house. The steam from the latter supplies

plant marks a revival of the Bessemer process after its neglect for many years in England.

## Freezing the Earth

**L**ARGE-SCALE refrigeration was the unusual device employed by engineers faced with the problem of sinking a deep shaft through swampy ground. A million gallons of water per hour were required to feed the condensers of the new Tir John Power Station at Swansea. The chosen source of supply was a dock over a mile away. An overhead pipe line of adequate size was impracticable. A tunnel was therefore decided on. But the intervening ground was too boggy to bear tunnelling unless they went down to solid rock. At the power station end the rock was level with the surface, but at the dock end it was 173 ft. down through mud, sand, and wet gravel strata. Where shafts are sunk through ground of this nature, it is usual to employ caissons and compressed air to keep back water. Here the excavation was too deep for this method, so they resorted to freezing the ground solid for nearly 200 ft. down.

Holes were drilled round the site of the proposed shaft, and flow and return pipes were inserted. A refrigerating plant was brought on to the site and coupled up to circulate brine chilled to 40 degrees below zero. Progress was slow and steady. After three and a half weeks freezing, trial bore holes showed that the site was surrounded by a wall of ice extending down to solid rock. Excavation was started with the refrigerating plant still at work. For 90 ft. down excavation was easy, but lower they found that they had overdone the job. The whole of the ground had become ice-bound, and was so solid that they had to blast their way through it.

## Plywood Barrel Machine

**A**N ingenious machine has been invented in Germany for making barrels on the plywood principle. The machine, fed with sheets of beechwood, veneer and glue, shapes, forms, and sticks the body of the barrel in one operation. The ingenuity of the invention lies in the arrangement whereby three plies of wood are stuck together with a non-overlapping joint. Ends for the tops and bottoms of the barrels are separately made on another machine, and are then rammed home in the body of the barrel. The barrels are so strong that they can be dropped from a height of 6 ft., when full of water, without bursting. Special glues are used when liquids are to be handled. Light, strong barrels of this kind will find ready commercial use, as they save considerably on freightage charges when compared with the steel drums in use at the present moment for handling such materials as tar, asphalt, flours, powders, and solid chemicals. As they are cheap in manufacture they can be

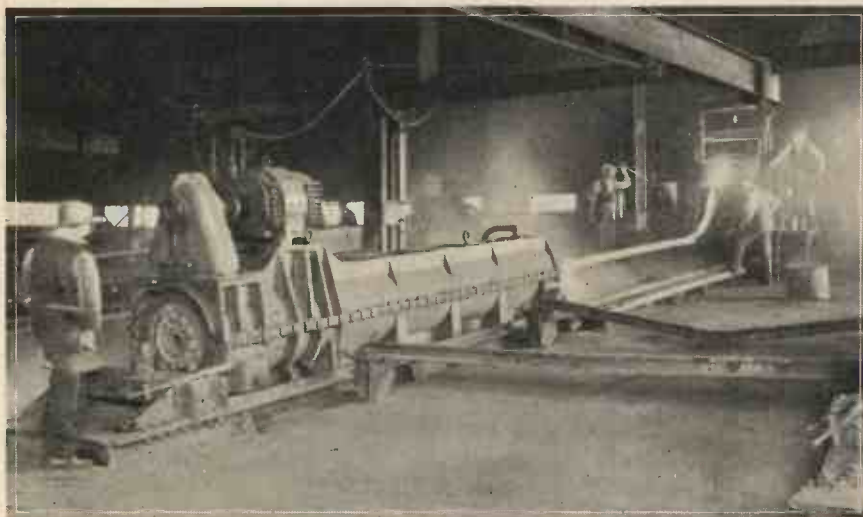

Centrifugally casting Stanton-Delavand spun iron pipes.

wall of the whirring mould, and is flung out radially in a dense even layer which almost instantly sets. The mould is caused to travel slowly away from the pouring ladle, so that it is gradually lined with metal throughout its whole length, until the complete pipe is cast. The rotation of the mould is then stopped. It is opened and the pipe is withdrawn to be sent to annealing furnaces. Before going to stock, the pipes are subjected to a hydraulic test. But failures are few because the process gives a dense casting unusually free from flaws.

## New British Steel Works

**C**ORBY, one of the most modern steel works is said to be an outstanding example of the perfect engineering layout. It is a self-contained works—mining its own iron ore and owning its own

sufficient power to run the whole plant.

From the blast furnaces the pig iron is run direct to batch mixing pots where it is kept hot by gas firing. At intervals it is run to one or other of the Bessemer converters. In these converters, which resemble large cupolas pivoted on trunnions, a blast of high-pressure air burns out the impurities from the pig iron and changes it into steel. The process is exceedingly rapid and needs a high degree of experienced control to get successful results. The steel is cast into ingots and taken straight to soaking pits, where it is kept hot ready for working and rolling.

The steel made at Corby is a mild steel which finds extensive use in the tin-plate industry and in the making of solid-drawn mild-steel tubes. Before tariff restrictions were placed on foreign steels, these needs were largely met from abroad. The new

# Invention & Progress

scrapped at the receiving end, and so save the charges for returning empties.

## Oil Centrifuges

**F**EATURED at recent engineering exhibitions have been centrifugal separators designed for marine use. Their purpose is the separation of oil from bilge water when the fuel tanks are being pumped out. They are similar in construction and principle to the common type of dairy cream separator. The mixture of oil and water, whirled at high speed, separates the water which is thrown outward, and oil which remains as a central core. Suitably arranged spouts guide each to its proper outflow. Shipowners find that the installation pays for itself many times over in the value of oil recovered. It is probable that an international regulation will require separators to be fitted to all oil-burning ships.

Oil centrifuges find application too for purifying diesel oils from traces of dirt and grit. This operation is highly necessary as the injection nozzles of diesel engines are extremely susceptible to blockage by solid matter present in the oil.

## A New Jointing Material

**A** NEW jointing material for aluminium has recently been produced, that should mark a great advance upon the construction of cycles, motor-cars, aeroplanes, etc. The discovery consists of a medium called "Alunise" (formerly named "Alusol") whereby it is now possible to join aluminium, hiduminium, duralumin, and other similar alloys, with a strength equal to that of the original material.

## Bicycles Built with a Spanner

**B**ICYCLES which can be taken to pieces, new parts substituted, and rebuilt in a few minutes are now being put on the market by New Hudson, Ltd., Icknield Street, Birmingham. Instead of constructing the frame of tubing, channel section steel not unlike miniature girders, is used. They are in five separate parts held together by steel bolts and a simple waterproof bracket.

## A High-wing Seaplane

**I**T will soon be possible to travel by air to Mandalay, in Upper Burma, by air. A new type of high-wing seaplane is undergoing trials at Rochester. Driven by four engines, each developing only 90 h.p., it is the smallest four-engined air-liner so far constructed.

## Rhodesia's New Bridge

**T**HE third longest single-span bridge in the world has just been completed in the wilds of Southern Rhodesia. Its single arch rises 280 ft. above the Sabi river and is 1,080 ft. long. This span is exceeded only by those of the Sydney Harbour Bridge and the Bayonne Bridge, south of New York.

## Noiseless Tube Railway

**L**ONDON Transport engineers think they have solved the problem of the noiseless Tube Railway. Owing to the fact that the temperature of the air in the Underground never varies by more than 10 degrees, it has been possible to lay a new type of "soft" steel rail welded in one continuous piece. Sleepers carrying the new track are laid in a special concrete bed which, besides absorbing vibration and noise, allow for possible variations due to heat.

## A Battleship Built in Sections

**I**T is stated that France's new 35,000-ton battleship, which is now under construction, will be 794 ft. long and will draw 26½ ft. of water. Work was commenced on 654 ft. of the battleship on Oct. 22nd last in the Salon dock at Brest. When the 654 ft. section has been floated the remainder will be joined to it. The reason for this is that the Salon docks are too small for the construction of the whole length of the vessel at once. The ship is expected to be completed by the end of 1938.

## An Automatic Typewriter

**T**O watch the Auto-typist shown on this page, deftly writing personalised letters at the rate of 125 words a minute, spacing and tabulating the lines with fascinating sureness, is an experience that will intrigue even those who are familiar with precision machinery. Yet the Auto-typist is so simple that any intelligent junior office worker can be taught, in less than an hour, to operate it. The pneumatic principal employed is identical with that incorporated in over one million player-

pianos. The machine operates on A.C. or D.C. from any electric-light socket, and costs no more to run than an electric fan. At the normal speed of 125 words per minute, and including time necessary for the insertion of stationery, typing of date, name, address, salutations, and an occasional record change, an Auto-typist will produce from 100 to 250 letters a day, according to length.

### SEVEN FEATURES OF THE AUTO-TYPIST

1. The Auto-typist is pneumatically operated—fast, silent, trouble free.
2. Nearly every make and model of typewriter can be used on the Auto-typist, including noiseless models.
3. Auto-typist records are rolled on spools, making them easy to file away, easy to handle, and easy to insert in the machine.
4. Records can be changed on the Auto-typist in five seconds. It is not necessary to "line them up." This is done automatically and means an important saving of time.
5. There is no large metal box under the Auto-typist to catch the record. It is constantly kept neatly rolled on a spool, an important feature in protecting it from tearing as well as a great convenience.
6. Auto-typist records are not wound forward by gears, likely to stretch and tear the paper. For that reason Auto-typist records will outlast those used on machines that operate electro-mechanically.
7. With a Selector Auto-typist you can automatically skip or automatically select any desired portion of the record.



The Auto-typist shown herewith can be set to stop automatically for the insertion manually of special references or data. Then, at a touch on the button shown, the pneumatic mechanism starts again, to stop later if necessary, a line or a paragraph further on, or to complete the letter to the last full stop.

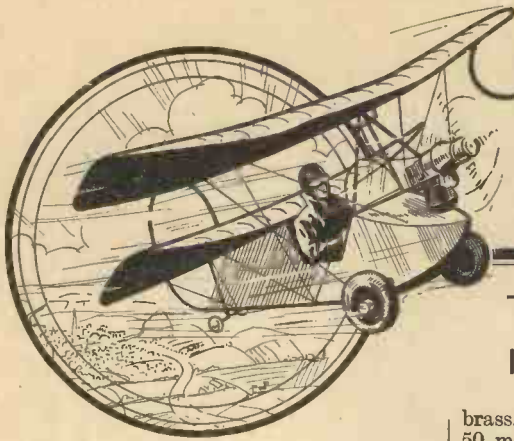

# How to Build the "FLYING FLEA"

This Month we Deal with its Engine Accessories, the Instrument Board, and Give Instructions for Flying

**Y**OU must not use the decompressor of two-stroke engines to stop the engine until it is throttled back. If you use it at open throttle, you may burn the valve of the decompressor, which will cause a leakage of power.

To stop the throttled engine, always use the decompressor to avoid back-fires as the airscrew stops.

The length and diameter of the exhaust pipe, i.e. its volume, is important to ensure the emptying of the cylinders, their cooling, and full power. The pipe shown in Fig. 40 is given as a guide, but your engine maker will advise you on this point. You can fly just as well without exhaust pipes, but it will be found advisable to fit one.

## The Fuel Filter

The use of a fuel filter is absolutely indispensable in the carburettor delivery line, and should be fixed to one of the arms of the motor support. However clean your spirit may be, you will always find a little dirt in the filter, and often water. You cannot prevent it, and you might have a stoppage at any time whilst in flight. There are plenty of good filters on the market; get a car model and not a motor-cycle filter, as the latter is too small.

## The Petrol Tank

As with the prototype, the tank is placed in front of the spar. It holds 12 litres, i.e. two 5-litre cans of fuel and a good measure of oil (1½ hours' flying). Sheet brass, although a little more expensive than tinned sheet, should be used for the tank as this will last for a considerable time.

Cut a sheet of 4 mm. thick brass as shown in Fig 35 (shown last month) just wide enough to go between the central ribs of the wing and about 800 mm. long. At each end hammer the edge for a width of 5 mm. over a piece of metal of .6 mm. to make a joint. Join together and insert a single rivet of copper at each end; then hammer flat.

After marking off with chalk the position of the bends, pass a plank, supported on the backs of two chairs, through the hollow drum thus formed, and bend it according to the template, and cut out in 3 mm. plywood.

This template, which follows the profile of the wing, except that it can project a bit on the curve of the upper surface, should be able to be forced gently into the bent drum.

While pressing on the plank, cut out with a carpenter's compass a disc of suitable diameter for a brass screw stopper (as from an oil can or other container). You had better try this job out first on a piece of

brass. Next cut out the lower hole about 50 mm. diameter.

Over this latter hole, rivet a 1-mm. brass plate drilled with two holes, ready to take two valve stems from a motor cycle tyre; see that the holes are drilled so that their washers are not up against the edges of the large opening. After riveting solder carefully.

## The Fuel Gauge

Now rivet and solder the small piece of rolled metal which will carry the aluminium rod, and also the float of cork measuring 40 mm. by 40 mm. A piece of .3 mm. steel wire unravelled from a spare piece of cable and straightened out, should be fixed to the aluminium rod vertically above the front hole. Passing through the valve body (you will have dispensed with the rest of the valve) the rod enters a 8 mm. glass tube (such as that which is in soda water syphon) closed at one end, and fixed at the other to the valve by a ring of treated rubber. At the end of the steel wire is a small black bead. This forms a gauge which will always tell you how much fuel you have left.

Jam your template of plywood into the tank, and, letting the edge rest on a metal block, flare out the edge with light taps of the hammer for a depth of 5 mm. When this has been done on both edges, place the tank flat on one edge on a piece of brass. Push down your template to the bottom to

ensure that the shape is maintained, and mark off along the flared edge, one side of the tank. When you cut this out with the shears, leave a spare edge of 5 mm. all round beyond the flare of the tank edge. Turn up the edge of the flat plate by hand with flat-nose pliers and bend it over the edge of the tank. Then turn it over again, hammering all along the joint. Hold up this work along the nose by a bar of metal shaped as shown in Fig. 35 (shown last month) held firmly in a vice and pressed up from the inside. After the first side has been done, put the float and its wire in place (but not the valves) and fit the second face. You will have to cut a 40-mm. hole in the first side through which to insert your metal bar for hammering over the second side.

## Soldering

All along the turn-up, spread a little soldering paste or killed spirits, and solder with a hot iron. This is quite easy on an edge already jointed. Also solder the stopper seating and a disc of metal to close the opening in the first side. Rinse with hot water, and test for leaks with a litre of spirit. The finished tank should weigh 1 kilo. 500 mm. If you are anxious to make long flights, make another tank which will balance the first on the other side of the spar. It can hold 22 litres, so that you can have sufficient fuel for a 4 hours' flight.

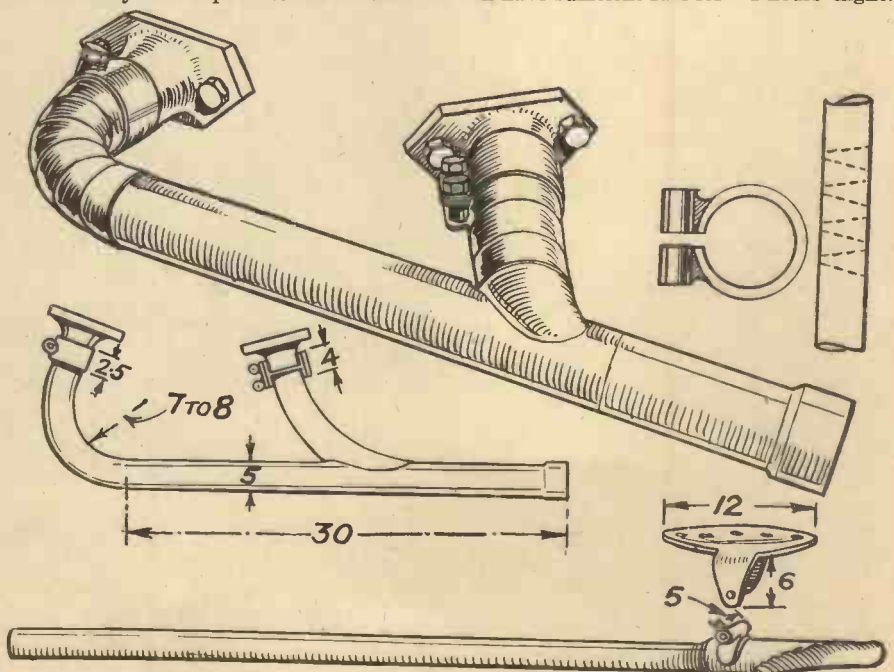

Fig. 40.—Details of the exhaust pipe. The pipe shown is given as a guide to the constructor, and the maker of the particular engine employed should be consulted



**The Piping**

The valves from the tyre tubes of which you will have cut off the head, will be furnished under their feet with a washer of fibre, passed with the aid of a piece of wire through the filling opening and screwed up tight by a nut. The valves and the wire receive a glass tube, and the others a petrol cock; these are joined by a tube of hardened rubber (insoluble in petrol), threaded on to each of them. A little alcohol varnish (insoluble in petrol) makes the fixing permanent. Remember that benzol may, in time, affect the rubber. If you are careful to bring the ends of all tubes flush together, you need not fear the obstruction of the pipes by the swelling of the rubber, and the arrangement will last for several months. The elasticity will prevent breakage. Soldered and screwed joints should not be used.

The two cocks are joined by a collector tube in brazed red copper (you can get T pieces ready-made in the shops). A hardened rubber piece joins the collector tube to the filter, before the carburetter. The length and flexibility of the tube permits the wing to pivot freely. Look over this hardened rubber tube often, and line it with a coiled spring (the guide tube of a Bowden assembly) to prevent its swelling. Drill a 2-mm. hole in each filter cap to let the air in as the fuel is used. The piping is so arranged that a single drop of fuel leaving the tank, will arrive under gravity, at the filter.

**The Oil System**

An oil can of 2 litres (tins as sold by oil vendors) can be fixed behind the spar next to the tank (see Fig. 37). Change its filter to the side. The weight is 300 grammes. Place a dropper under the oil tap (two corks in a large glass tube) to control the flow of oil (3 drops a second: five hours' supply). Use large pipes of 6 to 8 mm. interior diameter and beware of freezing in winter. Do not try to regulate the flow by the tap otherwise you may starve the pump. The weight of the tanks does not affect in any way the movement of the wing: it would not matter if they weighed 100 kilos. The control movements in flight are, in practice, of small amplitude and the inertia of the wing is of very small effect.

A shock absorber rubber of 12 mm. diameter and 250 mm. long, holds the wing in front and controls the incidence; it is hardly extended when the rear edge of the wing is raised to the full extent. It is fixed to a metal fitting of 1 mm. material fixed to the leading edge by three wood screws. At the lower end it is fixed to the foot of the front tube of the cabane.

The shock absorber prevents the wing from falling whilst the plane is at rest, but is not of any use in flight. Many people, on seeing the "Flea," will fix their attention on the central pivot of the wing, thinking that your life hangs on a 6 mm. bolt which fixes the unseen tubular axis. They forget that the wing is mainly supported by the bracing wires.

**The Instrument Board**

The dashboard instruments are delicate and fragile, but they are also heavy. It is desirable, therefore, to group them on the same support—the dashboard—and to give the whole assembly a certain independence from the machine. In this way, the vibrations of the engine are much reduced when they arrive at the instruments, and are only just enough to cancel out the inertia of their indicators without making

the needles vibrate. The dashboard proper (Fig. 41) is a 6 mm. panel pierced with the necessary openings. In the middle is the revolution counter, on the right is the watch, on the left is the air-speed indicator and the barometer is placed next to it, as shown.

This panel is nailed to a piece of hard wood making an angle with the piece marked A (Fig. 41) which is of 1.5 mm. plywood cut in a semi-circle, and edged with a cane (cane for clearing sinks) on which is nailed the rounded vertical piece in 1.5 mm. material thus making a sort of box. An arc in thin 6 mm. aluminium or duralium tube, or a 10-mm. cane, reinforces a plate of

celluloid of very transparent quality. The dashboard is secured to the boxwork by small screws, and to the arc by small collars of aluminium, held by an eyelet or a rivet. The whole assembly is placed on three pads of soft rubber (sponge rubber) leaving a gap of 10 to 15 mm. from the top of the cockpit. Three springs of 1 mm. steel, only lightly loaded, hold it more or less in position between the two rear legs of the cabane. The altimeter, the most sensitive instrument of the lot, will be simply an ordinary barometer. You can fix on the glass, a disc of paper showing the heights corresponding to the pressures marked on the

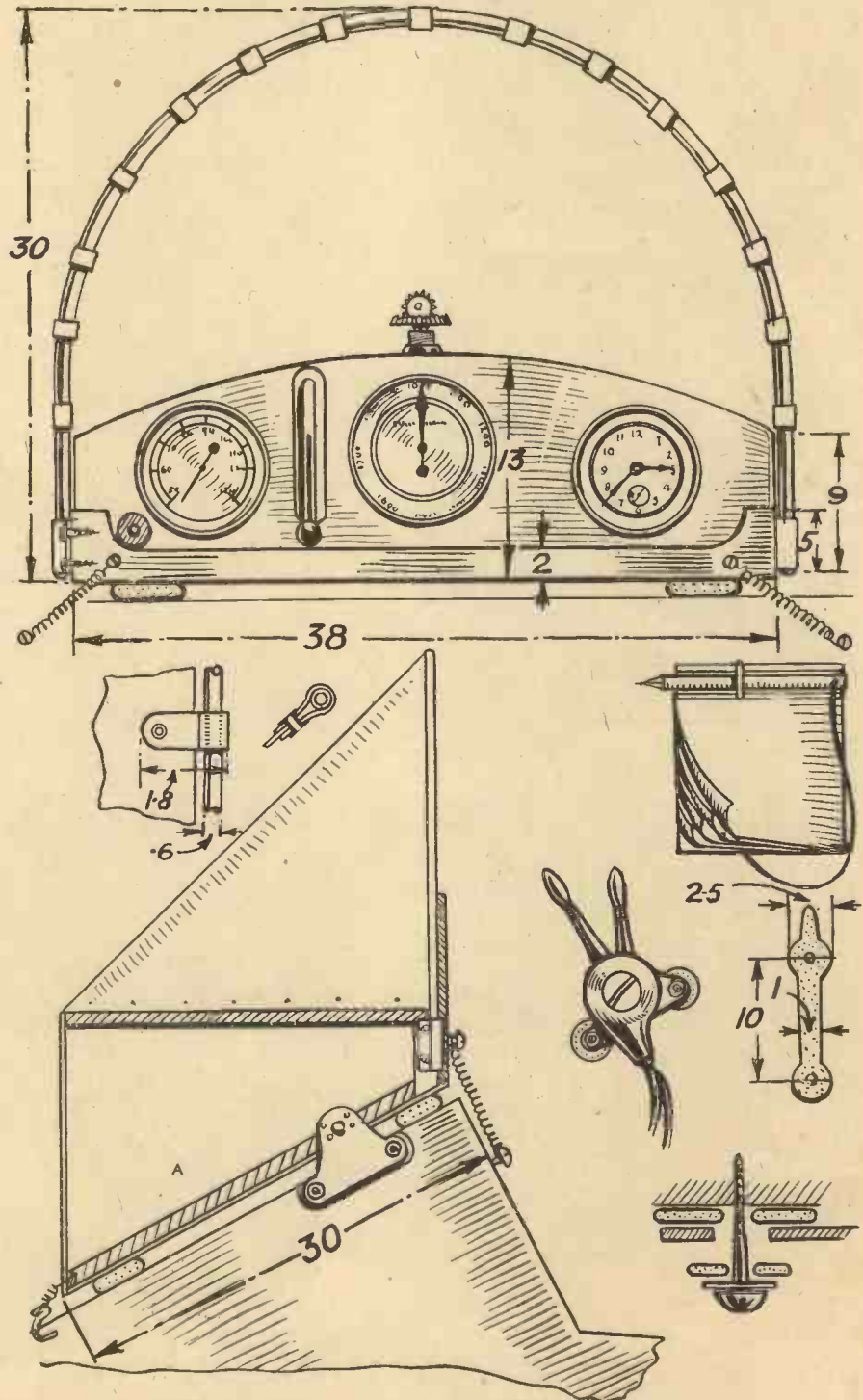

Fig. 41.—Showing the instrument board and position of the various instruments.

scale. A table of barometer readings is given below.

**BAROMETER READINGS**  
(Average—Corrected)

29.92 in. = 760 mm. =	0 ft.
28.86 in. = 733 mm. =	1,000 ft.
27.82 in. = 706 mm. =	2,000 ft.
26.81 in. = 681 mm. =	3,000 ft.
25.84 in. = 656 mm. =	4,000 ft.
24.89 in. = 632 mm. =	5,000 ft.

#### Using the Table

Before leaving the ground, set the barometer so that zero is opposite the barometer needle. Let us imagine that at this moment the pressure indicated by the needle is 76 on the original pressure scale. When in flight, at a given moment, the needle will have moved say to the mark 70, which means that you are flying at 2,000 ft. A good place for the barometer is to hang it by three springs from the arc above the dashboard. At your right hand on the panel, fix a few leaves of paper under a little aluminium strip with a rubber ring, through which you can pass a pencil fastened with a string. Before you take off you can write on it notes of use for your flight, things to think about when in the air, etc. During the flight, while flying with the left hand, you can make notes such as time of climb, etc.

#### The Compass

This is held in front of the pilot and ahead of the revolution counter at 40 mm. from the instrument board, by two arms made of 4 mm. rod of duralium or brass, bolted to

the bar. A thin red line, the "lubber's" line, is painted on the glass right along the centre line of the machine.

The metal work, more or less magnetic, which comes near the compass may make the needle defect in the following manner:

N.	N.E.	E.	S.E.	S.	S.W.	W.	N.W.
9°	55°	104°	149°	194°	234°	287°	325°

Thus, when the "lubber's" line is pointed at 234° on the card you know that the machine is pointing towards the S.W.; if you want to retrace your steps, turn until the figure 55° comes under the "lubber's" line, and you know that you are then pointing N.E.

These corrections were made by placing the machine with the engine running on a compass platform marked out to the exact points of the compass. This can be done by anybody with strings and pickers, or can be obtained at any aerodrome.

#### The Mapholder

An aluminium box measuring 140 mm. by 190 mm. fixed to the left of the panel, carries two tubes of 10 mm. aluminium. Wind on them a strip of map of 180 mm. width, under a celluloid cover. Right across the celluloid is a black line perpendicular to the line of the roller, and this has a small 1 mm. brass wire fixed under a washer. The wire is between the map and the celluloid, whilst the washer is above it. The unrolling of the map and the movement of the needle, enables one to mark the point over which one is flying.

#### The Throttle Controls

The throttle controls, with two handles belonging to a motor-cycle, are fixed out-

side on the left side of the cockpit (Fig. 41) with a strip of steel fixed by two wood screws, or rubber will be useful perhaps, to hold the throttle levers so that they will not close themselves under vibration.

#### Speed Indicator

The head of the speed indicator is made of brass and soldered according to the dimensions given in Fig. 37 (shown last month) and will be fixed at the end of a tube under the wing, to the metal fitting which holds the bracing wire. A small V made out of 2 mm. material, screwed on to the leading edge and bound on to the rod, will hold it steady. A 3 mm. or 4 mm. aluminium or copper tube will run along the leading edge to which it will be fixed with small fastenings, and will join the pressure head to the manometer (indicator). This latter is made from a glass tube which is inserted into a few centimetres of water diluted with alcohol, half and half, and coloured with a drop of red ink. The whole assembly is carried in a test-tube, fitted with a cork as shown in Fig. 32 (shown last month).

On the outside of the tube, graduations spaced at 10 mm. apart, will be painted in black except above the level of the liquid. This manometer functions very well when one is flying smoothly without turning near the ground or up aloft in calm air, but being very sensitive it shows up all gusts of wind. It shows a speed of 10 as well as 120 kilometres an hour. When one is swerving, being pivoted or turning, the accelerations rather spoil its indications. It would be better, therefore, to have a genuine airspeed indicator which is made like a barometer, and is independent of acceleration, centrifugal force, etc.

## Charting the Ocean Bed

ONE of the most important responsibilities of the U.S. Coast and Geodetic survey, is the maintenance of accurate nautical charts, discovering new information for the use of merchant and navy ships, and correcting ocean depth data.

Two of the instruments which are used in the current researches are the fathometer and the hydrophone. The fathometer, which determines depths, measures the time required for sound to travel to the bottom of the sea, and return to the survey ship as an echo. These tests are made at the rate of four per second, whilst the ship proceeds back and forth over the area at her regular speed. The positions of these depths are fixed by radio acoustic, ranging from two or more previously determined positions. These positions may be either shore stations or station ships, or a combination of both.

#### The Sound Receiver

The hydrophone, or sound receiver, picks up sound waves in the water, changes them into a radio signal and returns them to the surveying ship. When a bomb, thrown overboard and exploding in the depths, sends its vibrations in all directions, the hydrophone notes the time elapsed between the explosion and the return of the radio signal, measuring the time to one-hundredth of a second. Knowing the velocity of sound in sea water, the distance between the survey ship and each of the respective station ships or land stations can be calculated accurately, even when separated by as much as 100 miles. The photograph shows the captain and wireless operator of a survey ship working at the hydrophone.

They are shown testing the hydrophone preparatory to lowering it into the ocean in establishing a hydrophone station. The hydrophone is placed about a mile off shore and is connected to a wireless hut ashore, by

means of submarine cable. The mechanism inside the hydrophone receives sound waves which, in turn, are automatically transmitted to the surveying ship through the medium of the wireless hut.



Showing the wireless operator and captain of a survey ship operating the hydrophone.

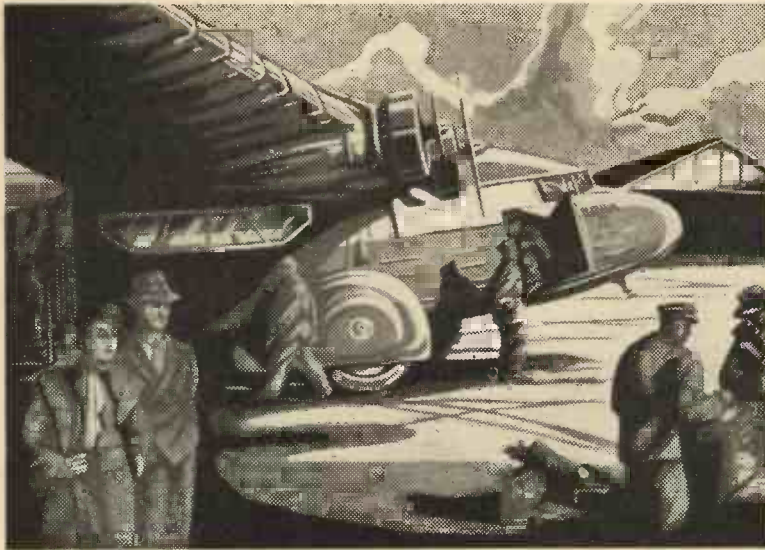

# “POPULAR FLYING”

6<sup>D.</sup>

THE NATIONAL AVIATION  
MAGAZINE FOR ALL  
WHO ARE INTERESTED  
IN THIS NEWEST MODE  
OF TRAVEL

Special contents of the January “Popular FLYING” include:

**HOW TO BUILD A FLYING SCALE MODEL**  
Sopwith “Camel.”

**RECORD BREAKING DOWN AFRICA**  
By D. Llewelyn—who, last month, with Mrs. Wyndham, broke the Cape-London Record.

**REUNION MEMORIES**  
By Mr. A. A. Nicod, 60 Squadron, R.F.C.

**FLYING OVER ABYSSINIA**  
By a war correspondent on the Italian Front.

**RECOLLECTIONS AND REFLECTIONS**  
By A. J. Insall, Curator of Photographic Records Imperial War Museum.

**THE HUN IN THE CHIMNEY**  
A true war story.

**STRIKING PICTURES OF THE BYRD ANTARCTIC EXPEDITION**

**REVIEW OF AIR POST STAMPS**

**REMARKABLE TOPICAL AND HISTORICAL PICTURES**

**LATEST AIR NEWS FROM ALL COUNTRIES**

**COMPLETE SHORT STORY, etc.**

Get “Popular FLYING” to-day—now on sale at all Newsagents and Bookstalls.

C. Arthur Pearson, Ltd.

## GRAFTON ELECTRIC Co.

One large section of our Latest List deals entirely with Measuring Instruments, Volt Meters, Ammeters, etc.

Single Range Instruments, Volts, or Amps from 4/6 to 77/6, Moving Coil and Moving Iron Milliamperes from 5/9

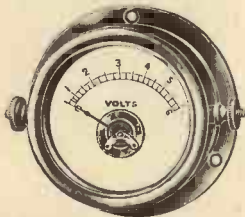

Multi Range Meters  
Pocket Type 6/120  
v., 32 M/A. 8/-  
Testing Sets Volts—Amps—M/Amps  
From £2 0s. 0d.  
to £12 12s. 0d.

SEND NOW for our 1935/36 Catalogue, 3d. post free. Acknowledged by Experimenters, Model Makers and Educational Authorities as the most complete reference. DEPT. P.

54 Grafton St., Tottenham Court Rd., LONDON, W.1

## “DUPLEX TAILSTOCK” 3 1/4-in. B.G.S.C. LATHE

POINTS OF SUPERIORITY.

Weight (bench model) 85 lbs. Concentric adjusted bronze bearings. Ground mandrel and tailstock barrel. Multi-purpose tailstock. Compare with any other make, and judge for yourself. List stamp please.

**WARD & POLLARD,**

Engineers, Orchard Works, Plumstead High St., London, S.E.18

**KEENEST PRICE**  
for all Materials, Manufactured Parts and complete FLYING FLEAS. DUNSTABLE SAILPLANE CO., Luton Aerodrome, Barton, Beds.

## FREE FLYING FACILITIES

It is proposed that a club be formed with branches where sufficient support is forthcoming, of which the membership fee will be little more than that charged by any other club, and this will entitle members to FREE FLYING and FREE BUILDING INSTRUCTION OF

## FLYING FLEA AIRCRAFT

Send stamped and addressed envelope for particulars to—

**E. G. PERMAN & CO.**

24-26 BROWNLOW MEWS,  
GRAY'S INN ROAD, LONDON, W.C.1

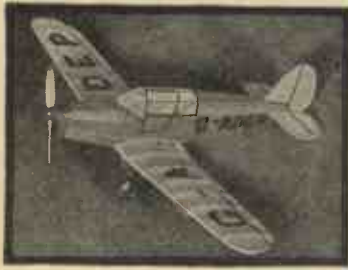

**PERCIVAL GULL 3/6**

Flying scale model. Wingspan 18 in. Length 12½ in. The plan for building it is clear and straightforward, and being a monoplane is quite easy to make. The kit includes all printed and strip balsa needed, shaped balsa flying prop, hardwood wheels, balsa for scale prop, quick-drying cement, bottle of blue dope for touch-up and all else needed. Extra full instructions. Complete kit, carriage paid, for 3/6.



**HAWKER FURY 6/6**

Wingspan 19½ in. Length 17 in. Exact ¼ scale. The Fuselage is built on Comet's Auto-line-up method. All control services are movable. It is a good strong flier. The kit contains all balsa needed, double size tube of quick-drying cement, carved balsa flying prop, sheet of silver tissue, bottle of aluminium dope for touch-up and all else needed. Complete kit, carriage paid, for 6/6.

**FLYING SCALE MODELS for the real Fascination of building— Fun of flying**

You have to try these kits yourself before you can realise the gripping fascination of building them up. How each part almost goes together itself on top of the full-sized plan—the joy of using a cement which is firm in 30 seconds. And when finished you have a model which will really do things and go places!

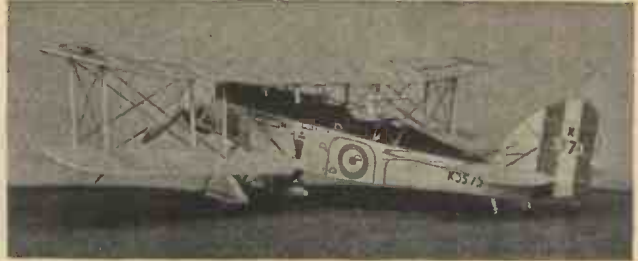

**WESTLAND WALLACE 3/6**

Flying scale model. Wingspan 18 in. Length 13 in. The plan is full of real scale details, oil cooling radiator, wing slots, navigation lights, elevator and rudder control wires, all rigging shown, auxiliary tail skid, and many more details. In fact the detail you would expect to find in a really expensive kit. Full instructions and material for movable machine gun or Scarff ring for rear cockpit. Cowl is built up from balsa, you do not have to carve it out. Comet's famous Auto-line-up method of fuselage construction. A special feature is that the kit includes SILVER TISSUE. The kit is very complete and includes all printed and strip balsa needed, shaped balsa flying prop, hardwood scale wheels, quick-drying cement, printed insignia, etc. Boys over 15 should find it fairly easy. Complete kit, carriage paid, for 3/6.

Send your Postal Order for these kits NOW. Get started on the finest hobby going. Your money back if you are not satisfied. You MUST state your nearest RAILWAY STATION, as the kits are sent by passenger train (carriage extra abroad). Send two 1d. stamps for 16-page catalogue showing over 30 models. Also has four pages of the most helpful instructions for building flying models.

**P. M. SWEETEN LTD.**  
Bank Hey Street, BLACKPOOL

**FLYING SCALE MODELS**

YOU can easily build scale model Planes that really fly from our Kits—no special skill or tools required. Kits absolutely complete with full-sized plans and instructions, Balsa, Cement, Dope, Tissue, etc.

We are sole Agents for the most famous American Kits and Accessories—  
SCIENTIFIC HI-FLYER KITS. CONSTRUCT-A-PLANE INC. KITS.  
LAWRENCE W. BROWN KITS (The makers of real planes).  
GENUINE "PAULOWNIA" PROPS, and IMP "TORNADO" MOTORS  
(as described in December issue of this Magazine).

Over 60 different Kits in stock of all popular Models, such as  
Fokker D7—Dr—Triplane—Nieuport—Goshawk—Mr. Mulligan, etc.  
16" span 1/9d. 20" span 3/3d. 25" span 6/6d.  
All post free. All complete.

Learn all about this fine new hobby. A 1½d. stamp brings our 1936 ten-page Illustrated Catalogue of all Kits and Accessories. Remember—we deal only in Model Plane Kits and Accessories.

**MODEL SUPPLY STORES**  
(Dept. P), 46 Derby Road, PRESTWICH, Lancs.

**MORE VALUE!** ALL 'LINDBERG' KITS are FULL VALUE FOR MONEY

This famous war-time fighter is a really SUPER DETAILED JOB. Shock absorbing landing gear, working controls from cockpit. Machine guns on SCARFF RING. A VERY COMPLETE KIT.



CARR. 6/6 PAID

BRISTOL FIGHTER F-2B

Illustrated Catalogue of Scale-Model Kits and Supplies, 1½d. post free.

Span 19½", Length 13½", Weight 1½ ozs. Coloured red and yellow with black and red details, struts and scale prop., natural wood colour, varnished.

**NORTHERN MODEL AIRCRAFT Co.**  
37a FOUNTAIN STREET, MANCHESTER 2.

**MICROSCOPES FOR ALL**

SPECIAL OFFER OF 1,700 BRAND NEW STUDENTS' PORTABLE MICROSCOPES, as illustrated.

Each model has inclinable body, swing mirror, stage clips, and is nicely finished in Black Crystalline Enamel and bright Nickel Plating. SHARP DEFINITION IS OBTAINABLE and GOOD WORK CAN BE DONE

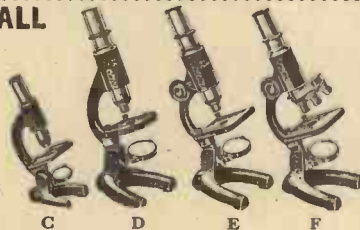

- Model C. Height 5½ in., sliding focus, magnification 25x linear Price 5/-
- Model D. Height 7 in., sliding focus, circular stage magnification 50x linear... Price 9/6
- Model E. Height 7 in., rack and pinion focusing, magnification 50x linear, square stage ... Price 12/6
- Model F. Height 7 in., rack and pinion focusing, triple nose-piece. 3 lenses, magnifications 25x, 50x, 100x, in wood case, with set of Dissecting Instruments. ... Price 30/-

IMMEDIATE DELIVERY FROM STOCK. Post Free in Great Britain.  
**BROADHURST, CLARKSON & CO.** 63 FARRINGTON ROAD, LONDON, E.C.1.

**"COMET" RIGHT ON TOP!**

The "COMET" Petrol Engine Model 1935 Awards:—

- FIRST PRIZE: B.M.A.S. Power Competition at Cranborne.
- SECOND PRIZE: S.M.A.E. Sir John Shelley Competition at Fairey's Aerodrome.
- FIRST PRIZE: B.M.A.S. "Hallum" Competition at Cranborne. Mr. Brooks' Petrol Engine Model flew from Cranborne to the Isle of Wight, 35 miles as the crow flies!

Build one of these Models this winter, powered with the 18 c.c. COMET ENGINE

**THE MODEL AIRCRAFT STORES**

133 RICHMOND PARK ROAD, BOURNEMOUTH

Please send 2d. stamps for price lists.



Two views of a model of a Westland Wallace aeroplane, a kit of parts for which is supplied by F. P. Sweeten Ltd., 38 Bank Hey Street, Blackpool, for 3s. 6d. A feature of this kit is that the cowling is built up from rings of  $\frac{1}{8}$ -in. sheet balsa.

## MODEL AERO TOPICS

By F. J. CANN

**M**ANY readers have written to me for further details of the AC:CO Engine which I described in last month's issue, particularly regarding dry ice. This is obtainable from Imperial Chemical Industries Ltd., Imperial Chemical House, Millbank, S.W.1, and consists of small blocks sometimes referred to as frozen snow. It is used by ice-cream vendors to maintain a low temperature round the ice-cream container. Dry ice is frozen carbon dioxide gas, and its temperature is 110 degrees below zero.



Two of the model aeroplanes made from kits of parts supplied by the Northern Model Aircraft Co. (Dept. C), 37a Fountain Street, Manchester. They also stock a fine range of model aeroplane accessories.



### Another Miniature Petrol Engine

**F**ROM America comes details of a miniature engine known as the Baby Cyclone. It employs a rotary valve system of carburation. It is of one-sixth horse power, two-stroke,  $\frac{3}{8}$ -in. bore,  $\frac{11}{16}$ -in. stroke, and has variable speeds of from 500 to 4,000 revolutions per minute, with a  $13\frac{1}{2}$ -in. propeller. The manufacturers claim that it will idle down until it just ticks over, the control being by needle valve. The petrol tank weighs  $1\frac{1}{4}$  oz., and an exhaust manifold is included. Ignition is by means of a specially light coil weighing only 2 oz. The cylinder and piston are of special alloy iron, ground and lapped together, the cylinder head is of duralumin, and the crankshaft is of nickel steel, drilled for lightness. The remainder

of the construction consists of die castings. The engine is  $3\frac{1}{2}$  in. deep,  $1\frac{1}{2}$  in. wide (without exhaust manifold), and  $4\frac{1}{2}$  in. high, its weight complete with two standard flash-lamp cells being only 15 oz. The price in America is 15 dollars 75 cents, and I suppose there would be an ad valorem duty of 33 $\frac{1}{2}$  per cent. on this.

### The AC:CO Gas Engine

**I**NTERESTED readers may care to know that the gas engines which I have referred to in the opening paragraph above are now available in this country from The Model Supply Stores, 46 Derby Road, Prestwich, Lancs. The prices which I gave last month were, of course, the English equivalent to the American price. The actual prices in this country are 27s. 6d. and 42s. for the 2-cylinder model and 4-cylinder models respectively. The increase in price is due to Customs duties.

### Astonishing Petrol Model Aeroplane Trip

**O**N July 21st of this year petrol model enthusiasts of the Bournemouth Model Aircraft Society set out from Bournemouth for Cranborne, twenty miles north of Bournemouth on the borders of Wiltshire and Dorsetshire. The object of the journey was to observe an attempt on the British record for petrol engine model aeroplanes by Mr. A. E. Brooks of Leicester.

The model was the "Sky Rocket," designed by him-

a little over ten minutes. An attempt was then made to follow the model by car, but this proved useless.

Some days later, however, Mr. G. F. Baster, of the Bournemouth Club, received news from Mr. Stride, a model engineer of East Cowes, that the model had been found, and was in the custody of the Receiver of Wrecks, Custom House, Cowes, Isle of Wight. The "Sky Rocket" had been rescued from the sea by the crew of a coasting steamer, fifty yards off the South Buoy, Cowes, on the morning after it had been launched from Cranborne.

After salvage negotiations had been concluded with the authorities, the model was returned to its owner at Leicester with the kind assistance of Mr. Stride. The model was somewhat the worse for wear, though the fuselage and undercarriage were undamaged. The distance covered was thirty-five miles "as the crow flies," but a longer distance was actually covered.

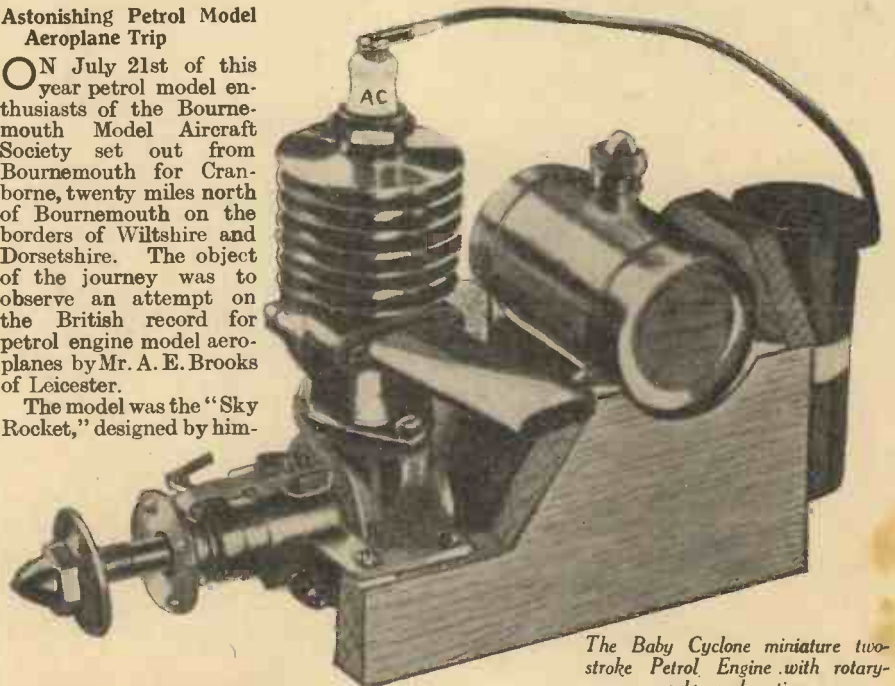

The Baby Cyclone miniature two-stroke Petrol Engine with rotary-valve carburation.

self, and fitted with an 18 c.c. "Comet" engine. The Society of Model Aeronautical Engineers' approved timekeepers strained their eyes to keep the model in sight, but they could not follow its progress more than

The sting of the report comes in its tail, however, as, though the model made such a performance, no record can be claimed as the flight was not observed in its entirety.

# A Petrol-Driven

By Capt. C.

(Continued from Page 188)



Fig. 6.—The petrol-driven model biplane in flight.

**F**IRST of all a full-sized drawing should be made up from the outline drawing in Fig. 3 of the fuselage (given last month) taking great care to locate thrust line and angles of incidence of main planes, etc., correctly. This also applies, of course, to the wings and tail plane. It is best to keep each component on a separate sheet of paper.

Over the drawing, a sheet of greaseproof paper should be placed. The whole is then kept down to the drawing-board by a few drawing-pins. The greaseproof paper will prevent the glue, to be used shortly, from sticking the fuselage to the drawing or board.

Now take four suitable length longerons of  $\frac{1}{8}$  in.  $\times$   $\frac{1}{8}$  in. square birch, place two along the upper line and two along the lower and place tacks on either side to keep them in position. Steam them carefully by holding the board over the spout of a steaming kettle, moving the board along so that each portion of the longerons is thoroughly soaked and heated. The spout of the kettle should be very close to the portion being heated.

Leave the longerons pinned down to the

stick each end into position whilst the longerons are pinned out flat on the board.

When the underneath fuselage side is completed, place little pieces of greaseproof paper between the bottom longerons and the top two where the uprights have been stuck to the underneath longerons. This will prevent the two sides of the fuselage sticking to each other when the top uprights are placed and glued in position.

Having glued the top uprights in position you now have the two sides of the fuselage complete. Leave for twenty-four hours to set hard and then the tacks can be taken away and the two sides of the fuselage can be handled up.

Now comes a rather ticklish operation, and one that must be carried out carefully and accurately, if the fuselage is to be true. Lay the two sides on the board, but upright, and carefully fit No. 1 former.

This No. 1 former has to be first cut out to shape from  $\frac{1}{8}$  in. thick three-ply wood.

It is circular and cut to the size of the

back of the engine mounting. The outside diameter is  $3\frac{1}{2}$  in. A rectangle is cut out in the centre into which is fitted the detachable engine mounting. This No. 1 former should have nicks cut in four places on its circumference, and the forward ends of the longerons bound and glued into the nicks. Great care should be taken to give a down-thrust angle for the engine of 8 degrees to the thrust line drawn straight down the fuselage and through the leading and trailing edge of the tailplane. Careful reference to Fig. 3 should be made here. In other words, the circular No. 1 former is tilted with the top further for-



Fig. 8.—A further view of the model in flight.

REAR COVER PLATE OF  
DURALUMIN THREADED  
INTO CONE MOUNTING.

SQUARE CUT IN NO 1 FORMER  
TO RECEIVE RAISED SQUARE  
ON REAR COVER PLATE OF  
CONE

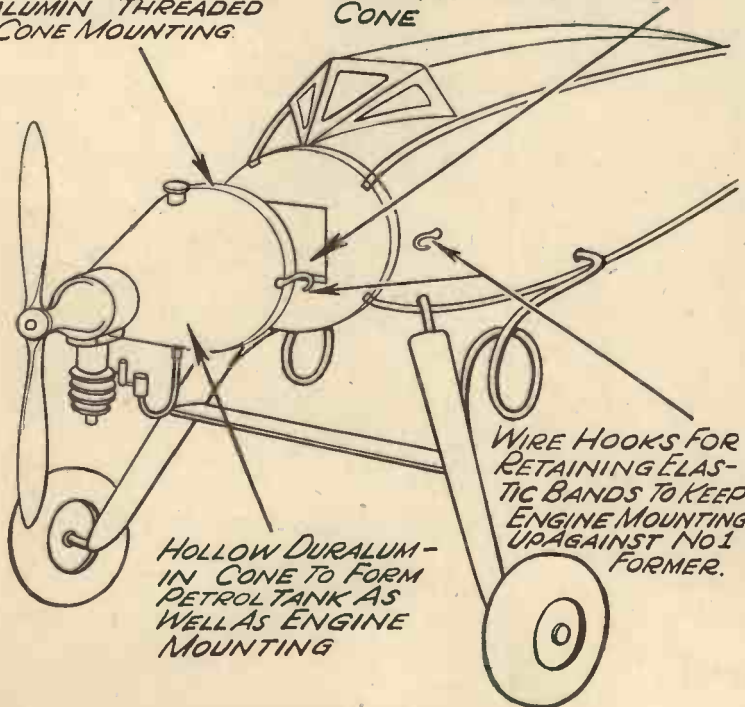

HOLLOW DURALUMIN  
CONE TO FORM  
PETROL TANK AS  
WELL AS ENGINE  
MOUNTING

WIRE HOOKS FOR  
RETAINING ELAS-  
TIC BANDS TO KEEP  
ENGINE MOUNTING  
UP AGAINST NO 1  
FORMER.

ward. Also be very careful that this No. 1 former is "square" with the centre line down the top of the fuselage.

If it is not, the model will turn too rapidly during flight and may get into a spin.

## Fuselage Construction

This part of the construction of the fuselage cannot be hurried, and having stuck and bound in No. 1 former, the next former, No. 2, can be stuck in and bound at its corners to the longerons. The whole should be then left to dry hard. Nos. 2, 3, 4, and 5 formers are all made of  $\frac{1}{8}$  in. three-ply wood in the form of rectangles, the measurements being taken from the full-sized drawing.

The centres of these formers should be fretted out for lightness, leaving rims of about  $\frac{1}{8}$  in. The distances between formers vary from each other (see Fig. 3).

The uprights already stuck in position will strengthen these  $\frac{1}{8}$ -in. three-ply formers, and should lie alongside the formers. Cross pieces of  $\frac{1}{8}$  in.  $\times$   $\frac{1}{8}$  in. birch are now glued in to strengthen the tops and bottoms of the three-ply formers.

The forward part of the fuselage is made very strong, as it has to take engine loads as well as compression loads where the wings are retained in position by elastic, as described later, and also undercarriage

Fig. 7.—The detachable engine mounting, which is of the cone type, shown detached.

# Model Biplane

E. Bowden

of Last Month's Issue)



Fig. 9.—The plane during a flight across country.

strains have to be allowed for.

When Nos. 1 and 2 formers are dry and firmly stuck, Nos. 3, 4, and 5 three-ply formers are inserted in the same manner, bound at the corners, and glued. Cross-pieces are also inserted to strengthen top and bottom.

After these formers are dry, the remaining cross-pieces of  $\frac{1}{4} \times \frac{1}{4}$  in. birch should be carefully cut to length, and the last former, No. 10, inserted first. This last former and No. 8 are also made of three-ply fretted out.

Having placed the last former, No. 10, in position, place No. 8 former in position. This former is where the leading edge of the tailplane will rest upon the fuselage. Finally stick in the remaining cross-pieces that you have already cut to the correct length, as shown in the drawing.

fore also be taken off and a rear float fitted if the owner later desires to experiment with the model as a seaplane.

The tail wheel is merely a simple but light three-ply disc with brass tube bush on a wire axle. Two forward and two rear wire struts are carried from this axle up to the brass tubes on the fuselage. These wire struts are turned inwards to form prongs to insert into the fuselage brass tubes.

The whole is kept in position with elastic bands to keep the prongs hard into the brass tubes.

### The Cabin

Next a small cabin must be erected on

top of the fuselage at the forward end (see Fig. 7). This cabin acts as the platform for the top main plane. The angle at which the top of this cabin forms to the thrust line must be carefully adhered to in order to ensure that the main plane takes up the correct angle of incidence when placed on top.

The cabin is constructed by gluing two uprights of balsa across the top of the fuselage, one at the front end just behind No. 2 former, and the other at the rear, 9 in. from the front upright.

A platform of  $\frac{1}{4}$  in. thick balsa slat is placed and glued on top of these uprights, and again care should be taken to check up that this platform is at the correct angle, as shown in Fig. 3, to the thrust line. Now insert uprights of balsa slat  $\frac{1}{4}$  in. thick every 3 in. between the platform and the top longerons. These will act as supports to the platform and should be glued into place. Finally the cabin sides and a V-shaped front of 1 mm. three-ply wood with windows of thin celluloid are stuck around the cabin and held in position by elastic wound round the fuselage until dry.

Next the front end of the fuselage, from No. 1 former to  $15\frac{1}{2}$  in. back, should be covered with sheets of 1 mm. three-ply wood. If it can be obtained, 0.8 mm. three-ply is even better and lighter, and is the material used by the writer.

This three-ply wood is stuck all along its edges and at uprights to the fuselage. The whole is kept in place until dry by wrapping old model aeroplane elastic around the fuselage.

When eventually covered with silk and doped, this forward end of the fuselage

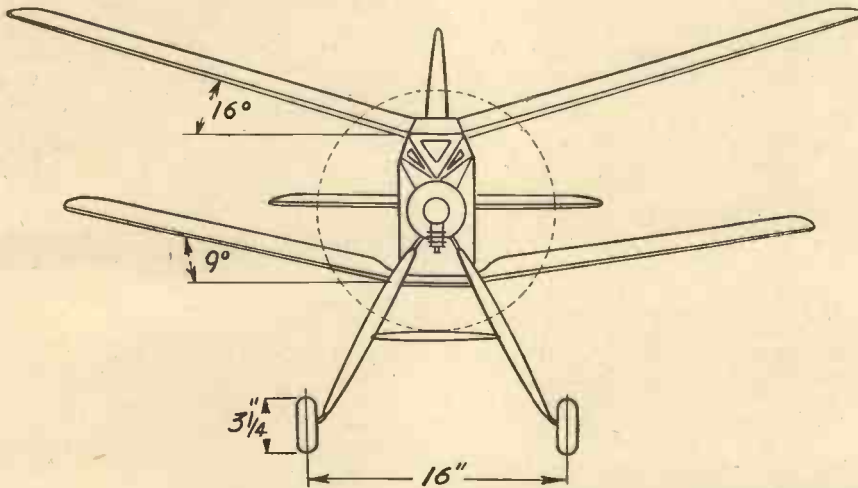

Fig. 10.—A front view of the biplane.

### The Fuselage Fittings

The first fitting to be tackled is the stern-piece. This is constructed of a small block of balsa wood and is merely a streamlined end shaped with a knife. It is then stuck on with glue to the last three-ply former, No. 10, already mentioned. The undercarriage, to be described later, requires two brass tubes to be bound across the fuselage bottom at Nos. 2 and 3 formers. These tubes are of  $\frac{1}{4}$  in. internal diameter to receive the wire prongs of the detachable undercarriage legs. After binding the two tubes along the bottoms of Nos. 2 and 3 formers with thread, they should be smeared well with glue to cement them firmly in position as they will have some severe shocks to deal with.

Before leaving undercarriage details the constructor should bind two smaller brass tubes across the fuselage at formers No. 8 and No. 9. These tubes accommodate the wire prongs of the detachable tail-wheel mounting in the same way as the main undercarriage. The tail wheel can there-

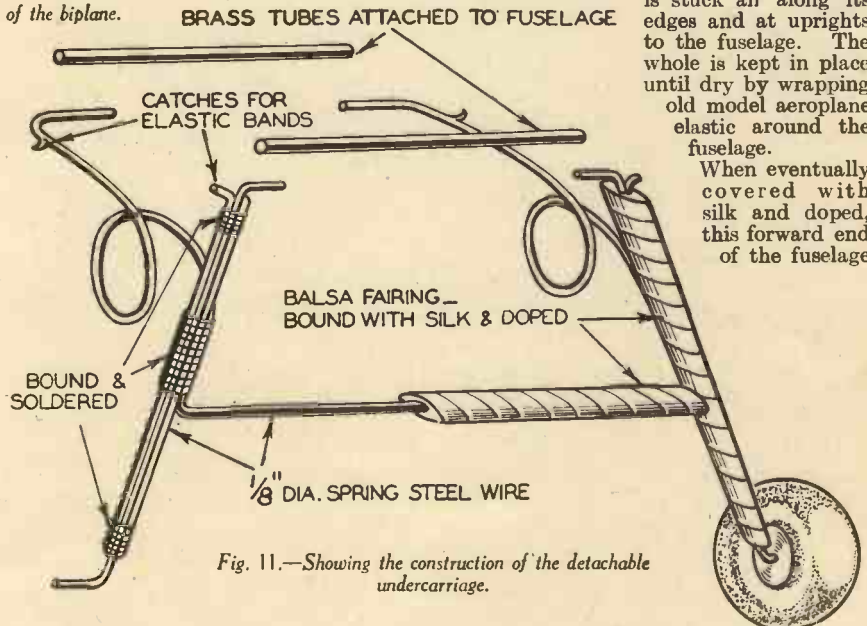

Fig. 11.—Showing the construction of the detachable undercarriage.

will be found to be very strong and resist all normal blows and the compression strains of the elastic retaining bands for the wings.

### The Engine

The light "Brown Junior" coil and condenser are now kept to the floor of the fuselage inside by wire retaining straps, and are positioned immediately in rear of No. 2 former. Wires are led out to the engine with plenty of slack to allow the engine to be knocked off or taken off its detachable mounts. It is unnecessary to give wiring details for the ignition as the Brown Junior comes to its purchaser ready wired up on its temporary base.

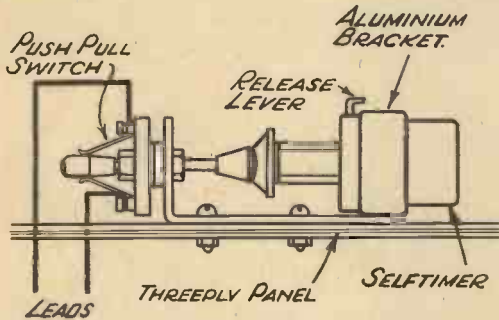

Fig. 12.—The automatic timing mechanism to regulate the duration of flight.

Wires must be carried back to No. 6 former where the automatic timing device to control the length of flight is fitted to a three-ply panel on the top of the fuselage. On this panel are also two sockets for the detachable plugs to start up the model from an accumulator on the ground.

This timing device will be described shortly, but of course will have to be constructed first in order to fit to the fuselage before covering with silk. Two leads to the small flash-lamp battery, that is used for actual flying, are brought out of the fuselage floor just behind No. 2 former. Snap clips are attached to the end of these leads, which can then be fastened to the flash-lamp battery terminals.

### The Battery

In this model the flash-lamp battery is kept on the outside of the fuselage by means of rubber bands. This is done in order to keep the fuselage free from the weight of constructing doors and a compartment inside. Furthermore, the battery can be slightly slid along the fuselage for final weight distribution and trim. On the writer's model this battery is found to be located immediately between the Nos. 1 and 2 formers. The whole fuselage should now be covered with damp jap silk.

Photographic paste is put along all edges, and the sides are covered first. Thus assume that we cover the left side first. A strip of silk the correct size is cut. The photographic paste is then applied to the edges. The silk roughly put on. It is then sprayed with water from a scent spray. The silk is then worked and stretched moderately tight in all directions with the fingers until there are no wrinkles anywhere. It is allowed to dry, when it will shrink up absolutely taut like a drum.

The opposite side is then covered. Finally the top and bottom are covered in this manner in their turn. The advantage of using photographic paste as an adhesive is that if a mistake is made the poorly-covered section can be unstuck by rewetting the silk with water, and the covering can be reworked into shape and the wrinkles eliminated.

Now give the whole fuselage a coat of aeroplane clear dope to keep the model taut. Allow it to thoroughly dry, and then apply two coats of coloured dope. One coat will sometimes suffice. My model is doped white all over, and white requires two coats to make a good-looking job. The fewer the coats the lighter the job. Dope and paint weigh quite a lot.

### The Automatic Timing Mechanism to Control Duration of Flight

This little piece of mechanism is most essential, and is quite easy to make.

It is composed of a "Kodak self-timer" and a push-pull electrical switch of the small variety.

The "Kodak self-timer" weighs approximately 1½ oz. only, and operates on the air-leak principle. It can be set to operate after any length of time from a few seconds to about four minutes. It is not dead accurate, but an approximate setting can be obtained sufficiently accurate to control the model and ensure that it does not fly out of the flying ground. It has the advantage of light weight and of having a powerful action, so that it can operate the pull-and-push ignition switch. Fig. 12 should be

examined for constructional details, and there should be no difficulty in making up the control mechanism from this drawing. The timer costs approximately 6s. from any chemist, and the switch 6d. from any cheap stores. The two are mounted on a piece of three-ply wood by the aluminium bracket shown in the diagram. The rectangle of three-ply wood with timer is then glued in position on the top of the fuselage between formers Nos. 6 and 7 before covering the fuselage with silk. The two insulated wires led from the timing mechanism are carried into the fuselage, one lead being taken from the coil to the timer, where the current is made or broken according to setting, the other lead being taken forward through the fuselage to the positive flash-lamp battery terminal.

The timing mechanism is situated at the rear end of the fuselage because it will be found that after starting the engine and running it up on the ground battery, the operator will have to move to the rear of his model before releasing it. The timer is then in a convenient position, so that the small lever on top can be depressed just before releasing the model for its flight. This lever releases the timing mechanism so that it operates after the given time as already set on the timer by screwing up or unscrewing the milled head.

This action of screwing up or unscrewing the milled head controls the speed of the air leak operating the "dashpot."

This explanation may sound lengthy, but it will be seen, on obtaining one of these automatic timers, that their operation is extraordinarily simple.

### How the Mechanism Works

Into the three-ply panel containing the timer there are also two electric sockets fitted. Plugs are placed into these sockets, and from the plugs leads are taken to an accumulator on the ground. The wiring is therefore arranged so that when the two plugs, positive and negative, are placed in their sockets the engine is on contact, and can be started up and warmed up, using the large battery on the ground.

Just before flight the Kodak self-timer switch is placed on contact, thus cutting-in the small 4½-volt pocket flash-lamp battery, which weighs 4 oz.

The two accumulator plugs are removed and the model is released for its flight after pressing the self-timer release lever. The very limited capacity of the flash-lamp battery is conserved in this way.

### The Undercarriage

On this model the undercarriage has been made detachable so that the model will pack up into a small space for transport purposes, and also so that seaplane floats can be fitted if the owner wishes to experiment in this direction.

The undercarriage is quite a simple affair and is made up from spring steel wire and balsa wood. It is practically indestructible and does not require any lathe work. A vice and soldering iron and a knife are all that are required.

Furthermore, it is designed to move in a backward direction first and then an upward direction when absorbing the landing shock of the model. A moment's reflection will make it clear that a petrol model glides into the ground at a flat angle and is not stalled on to the ground in a three-point landing as in the case of the full-sized machine.

The movement of the undercarriage in the model must therefore be backward first and then upward. If this sequence is not carried out, either the legs of the undercarriage will break or the bottom longerons of the fuselage will collapse.

### The Wheel Axle

If the reader will glance at Fig. 11 he will see the construction of the undercarriage. He will observe that there are two main legs of ¼-in. diameter spring steel wire bent inwards at the tops to form prongs to place into the forward brass tubes already located on the fuselage. The bottom ends of the legs are bent outwards to form stub axles for the wheels.

To these two main legs, two strengthening lengths of ¼-in. diameter steel wire are bound with florists' wire and soldered.

The top ends of these strengthening pieces are bent outwards to form retaining hooks, to prevent the elastic bands, used to keep the two legs tight against the fuselage, from slipping off.

About one-third of the distance from the top of the two legs a cross-bar is carried between the legs. This bar is also made of the same spring steel wire. It is turned up at each end for 1 in. These turned-up ends are bound to the legs with florists' wire and soldered. From this point the two rear spring legs are also attached by binding and soldering. These rear spring legs are made of the same spring steel wire and are in the form of two large circular springs. Their rear ends are turned inwards for 1½ in. to form prongs to insert into the rear brass tube fitted to the fuselage. Two small wire hooks are bound and soldered on to prevent the elastic retaining band from slipping off.

(To be continued.)

## A NEW HANDBOOK !

POWER-DRIVEN MODEL AIRCRAFT  
1/-, or 1/2 by post from George Newnes  
Ltd., 8-11 Southampton Street, Strand,  
W.C.2.



# Modern Train Ferries

A Train Ferry Enables Trains to be Run on to a Boat by Means of Railway Lines which Continue on Board, and the trains are Run Off the Same Way at the Other End, thus Dispensing with a Bridge

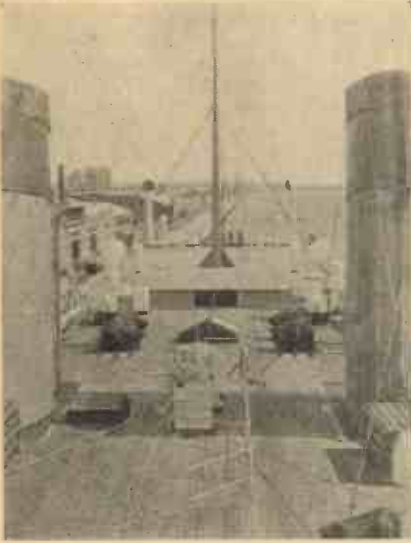

(From Left to Right). A view from the upper deck, showing the car park. The Swedish train ferry leaving Copenhagen Harbour for Malmö. A deck view, showing new patent davits which enable the boats to be launched even when there is a serious list on the ship.

**T**HE oldest method of crossing a deep waterway is by a ferry. Before bridges were built, it was usual to cross shallow rivers by means of a ford, and sometimes the bottom of the crossing was paved to enable wheeled traffic to pass through without bogging. When the water was too deep for fording, the ferry was the only alternative, and we know some of these were in use in Roman times. Thus, if we consult a map of the Roman roads, we shall find that Ermine Street came to a dead end (after passing Lincoln), on the banks of the Humber, and since no man would build a road merely to a river-bank, we may assume that a ferry was established to continue the journey.

The oldest ferry in Britain which is still working, is the famous Pilgrim's Ferry, on the River Wey, below Guildford. It has been running before recorded history, as we know from a law-suit fought about its rights in the fourteenth century.

Although modern mechanical progress has largely superseded the ferry by a bridge, there yet remain places where the crossing is too long for a bridge, or where the cost would be excessive.

## The Famous Free Ferry

Motorists on the West Coast of Scotland know how many ferries are still running over inlets of the sea and lochs, and all Londoners are familiar with the famous Free Ferry between North and South Woolwich, and the longer Tilbury-Gravesend crossing. These large steam-driven ferries can carry a considerable number of motor-cars as well as hundreds of people. They are fitted with hinged flaps by which vehicles can drive ashore. Before we reach the train ferry, these steam "floating bridges" are the biggest ferries. The usual method of propulsion is by means of two long chains, which are stretched from bank to bank, and are picked up by a cog-wheel arrangement on the ferry, and paid out again behind, so that the floating bridge hauls itself across by means of the chains. The advantage of this arrangement is that the huge unwieldy flat-bottomed boat cannot be deflected by

currents or tides, and is certain to arrive exactly at its landing-place. This, of course, is of the utmost importance, because

### INTERESTING BREVITIES

The oldest ferry in Britain which is still working is the famous Pilgrim's Ferry on the River Wey.

The first train ferry in this country was run over a hundred years ago

The Americans constructed their first train ferry in the late seventies

The Danes inaugurated their first train ferry in 1880

it is only here that a landing is possible. Floating-bridge services are usually run in pairs, with a third ship in reserve against breakdowns. There are good examples on

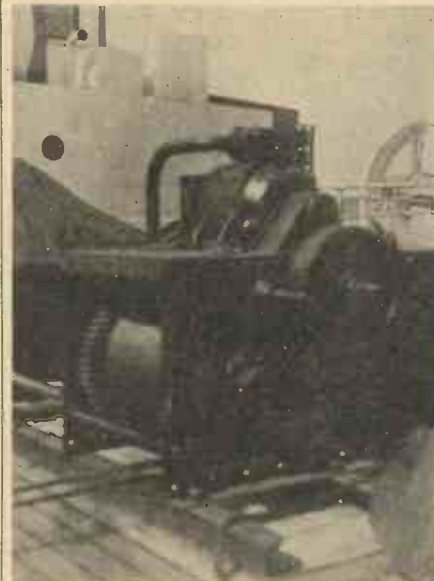

One of the electric deck winches.

the Thames; and at Portsmouth, Southampton, Plymouth, Cowes (I.W.), and four at Liverpool. There are also steam-ferry boats in many places which carry motor-cars, of which perhaps the best known to tourists is the Portsmouth-Isle-of-Wight car-ferry service.

The idea of the train ferry is merely an extension of the floating bridge carrying vehicles, and the first for trains was run in this country nearly a hundred years ago.

## The First Train ferry

When the railway age began, and the steel highway extended northwards through Scotland, the engineers soon came up against two great natural barriers, the Firth of Forth and the Firth of Tay. Further progress was impossible unless the water could be crossed, and the only alternative was a wide detour westwards. The first train-ferry was put in service between Granton and Burntisland in 1849. It was called the *Leviathan*, but its tonnage of 417 was small indeed in comparison with the later ferries. The general design, however, was much the same as we use to-day, the trains were run on to the boat by means of railway lines which continue on board, and were run off the same way at the other end. Needless to say the engines did not cross. This ferry was found very useful, and was followed soon after by a similar contrivance for crossing the Firth of Tay at Dundee. These ferries worked well for some years, as it was not till 1891 that the mighty Forth Bridge was opened for traffic, and the train-ferry was scrapped.

The Americans constructed their first train ferry in the late seventies, by which the Philadelphia and Reading Railway carried its traffic across New York Bay, and in 1880 the Danes inaugurated their first train ferry from Nyborg to Korsor over the Great Belt, a distance of 14 miles. This service—though greatly improved—is still running, and the crossing now takes about 1½ hours. There is no country in Europe so suitable for train ferries as the little kingdom of Denmark, which consists of a peninsula and a string of islands spread across the



Trucks on board the Harwich-Zeebrugge train ferry.

entrance to the Baltic, and so forming the natural highway from Europe to Southern Scandinavia. Nearly all the main through rail services are maintained by means of train ferries. Thus the run from Copenhagen (the capital) to Hamburg and the mainland of Europe, first crosses the Great Belt, 14½ miles to the island of Fyen, and then the Little Belt, a distance of 3 miles, to Fredericia in Jutland.

#### European Train ferries

There are two train ferries over the Baltic to Sweden, one runs from Copenhagen to Malmö (about 6 to 7 miles), and from Helsingor to Helsingborg over the narrowest part of the Sound, which is here about two miles wide. The main traffic however from Sweden to Europe is by train ferry over the Baltic from Tralleborg (Sweden) to Sassnitz in Germany, which are the largest and most up-to-date European train ferries yet running. The crossing takes four hours.

It is a strange fact, that although the train ferry was first installed in Great Britain, it was not used to connect our island with the Continent until comparatively recent years, although until a Channel Tunnel can be constructed, the train ferry is the only method of arranging direct through railway services from London to various parts of Europe.

The Great War, which stimulated mechanical ingenuity in so many ways, also gave us our first cross-channel train ferry.

The work of supplying our armies with men, munitions, and supplies imposed a great strain upon our resources, and this at a time when every hour saved was of the utmost importance.

To load and unload a truck, place its contents on a ship, land them, and again load and unload a truck involves much labour; and if the truck itself could be run on the ship *six operations* would be reduced to two. Accordingly three train-ferry steamers were placed in commission, and ran regularly between Richborough (Kent) and France. When the war ended the vessels were taken over by "Great Eastern Train Ferries Ltd." and a regular service between Harwich and Zeebrugge was in-

stalled, and worked by the L. & N.E.R. Co. Three steamers are employed, length 363 ft., beam 60 ft. and engines of 3,000 h.p. Four lines of railway track are mounted on the deck, and there is room for 54 loaded trucks. This service is mainly used for goods traffic, and has been found especially useful for the conveyance of perishable articles, or heavy and awkward machinery involving risk of damage in transhipment. Thus a thousand tons of electrical equipment was run direct from Newcastle to Ymuiden (Holland), 1,100 tons from Manchester to Budapest, 700 tons from Newcastle to Copenhagen. Among these loads were giant machines weighing 63 and 58 tons respectively. The whole equipment of a factory travelled from Roubaix (France) to Lancashire, and fourteen trucks brought the Schneider Trophy team from Italy to the Solent. It is also useful for fresh fruit, and oranges are

now loaded loose in a truck in Spain, and travel direct to the factory siding in England. This service, as mentioned, is mainly useful for goods, but important developments are in preparation for through passenger travel from London to all parts of Europe by the Short Sea Route. These boats are expected to commence running in 1936, and it will then be possible to go to bed in England, and wake up on the other side of the Channel, en route for Berlin, Rome, Istanbul, etc.

#### The Southern Railway

Three vessels have been specially built for the service by the Southern Railway in the Neptune Shipyard on the Tyne. They are each named after a famous Thames Ferry, the *Twickenham Ferry*, *Hampton*, and *Shepperton* respectively. Coaling is a simple matter as the trucks are run direct on board, and tipped into the hold. Each vessel will carry forty goods trucks, or twelve sleeping coaches, which stand on four lines of metals. There is accommodation for 500 passengers, and a special garage for motor-cars on the upper decks will hold 25 cars, which are driven on board up an incline.

Very great technical difficulties had to be overcome, owing to the great tidal differences in the Straits of Dover. The daily rise and fall varies between 10 and 20 ft., so that an inclined slip from the ship to the shore was out of the question—the gradient would be too steep for a heavy train. The alternative was a lock which the vessel could enter, and by which the level could be maintained at any state of the tide. The lock at Dover is nearing completion, and as the ships are already built, the service will soon commence.

The ferry-steamers are each 360 ft. long, with a speed of 16½ knots. The engines are coal fired, with automatic stokers.

Although these ferries will certainly be the most up-to-date in the world, the largest train ferry still remains in America. It is the *Contra Costa*, was built in 1914, with a tonnage of 4,500, and is working in California.

Train ferries will certainly speed up the crossing to France, and abolish the troublesome business of disembarkation with its long delays. It seems likely that such services will be so successful that the Channel Tunnel will no longer be demanded.



The L.N.E.R. Harwich-Zeebrugge train ferry.

# Lateral Control on Light Aeroplanes

By S. J. GARRATT

## A Method of Lateral Control Without the Complications of Ailerons, which Helps in the Development of the Light Aeroplane Movement

THE future of aviation as a popular pastime is undoubtedly wrapped up with the question of simplification—both in design and construction—of the aeroplane; but whether the simplification should be carried to the extent of dispensing with lateral control entirely, as is done on the "Flying Flea," is open to argument.

There seems to be little room for doubt that the "Flying Flea" is destined to do a great deal towards bringing flying within the reach of the man of moderate means, because the cost of outlay and upkeep is reduced to a fraction of the amount previously necessary. It is now possible to fly as cheaply as to run a car.

The main reason for this great reduction in cost is the simplification brought about by the revolutionary design of the controls. In the ordinary system of aeroplane construction, the angle of incidence of the wings has to be very carefully adjusted by skilled "riggers" to a fraction of a degree, and the wings are fixed in that position. But this delicate adjustment is quite unnecessary in the case of the "Flea" because the angle of incidence of the main wing is directly controlled by the pilot through the medium of the joy stick. With this novel arrangement, elevators on the tail are unnecessary and, therefore, the construction is very much simplified, the tail taking the form of a single fixed wing. A shorter fuselage can be used which further simplifies construction with consequent reduced cost. The rudder arrangement, however, remains normal, except that it is controlled by the stick instead of by the usual rudder bar.

### Dispensing with Ailerons

Another great step toward simplification is achieved in the "Flea" by dispensing with ailerons, thus leaving the main wing in one piece devoid of any moving parts, the adjustment of the angle of incidence being effected by means of a simple hinge fixing and controlled by wire cables.

It is interesting to consider the effect of this simplification from a theoretical point of view. The fore and aft control (obtained by altering the angle of incidence of the main wing, the tail remaining fixed) appears to be a very sound scheme and seems to be open to no objection whatever, in fact, it has probably all the advantages claimed by M. Mignet, the inventor.

The omission of the ailerons, although a praiseworthy step from the point of view of cost, is not so sound technically, for there is no control at all laterally. Although the

dihedral angle ultimately provides a form of lateral stability, it is only a secondary effect due to sideslip. Banking for a turn, for instance, can only occur after a sideslip, in fact it is correct to say the aeroplane sideslips into a bank. This is not necessarily dangerous, and probably one would get used to shift arrangement,

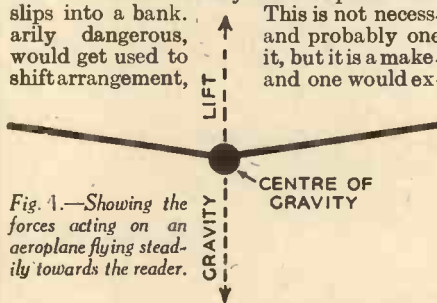
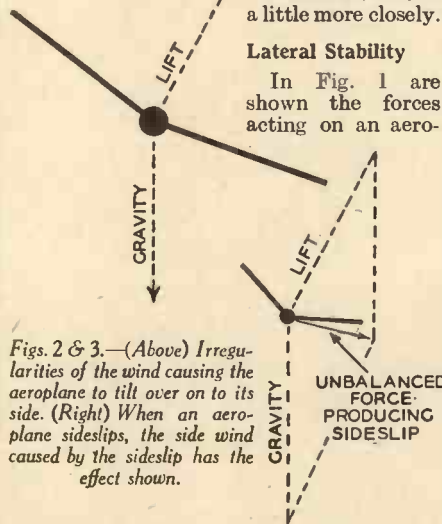

Fig. 1.—Showing the forces acting on an aeroplane flying steadily towards the reader.

pect the "Flea" to wallow about a good deal in flight.

To understand the reason why sideslip plays a part in the question of lateral stability, we must look into the matter a little more closely.



Figs. 2 & 3.—(Above) Irregularities of the wind causing the aeroplane to tilt over on to its side. (Right) When an aeroplane sideslips, the side wind caused by the sideslip has the effect shown.

plane flying steadily towards the reader. The lift on the wings and the force of gravity are both equal and both act through the centre of gravity, so there is no moment or twisting force to cause the

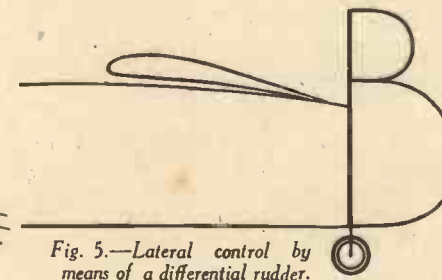

Fig. 5.—Lateral control by means of a differential rudder.

machine to tilt laterally about the line of flight. Now, in gusty weather, the irregularities of the wind will soon cause the aeroplane to tilt over to one side as shown in Fig. 2. The lift force remains in exactly the same relation to the aeroplane, as in Fig. 1, and tilts over with the aeroplane. The force of gravity still acts vertically, however, and both lift and gravity still act through the centre of gravity, so no matter how far over the wings may be tilted, there is as yet no restoring couple—or twisting force—to bring it back to an even keel. On completing a parallelogram of forces as shown in Fig. 3, it will be seen that there is an unbalanced resultant force acting sideways through the centre of gravity which tends to move the whole aeroplane sideways towards the depressed wing; but there is still no tendency for the aeroplane to resume an even keel. When the aeroplane sideslips under the influence of this unbalanced force, other forces are brought into play, for owing to the dihedral angle of the wings, the side wind caused by the sideslip has the effect shown in Fig. 4. It will be seen that the side wind is able to get underneath the lower wing, so tending to lift it up, and at the same time it blows over the raised wing, tending to push it down, so producing a couple which tilts the aeroplane back to the horizontal.

This is, of course, exactly what is required, but the objection is that the aeroplane must sideslip first and in the act of sideslipping, it will "yaw," or in other words, begin to turn. Rudder must be applied to correct the yaw, and this further increases sideslip.

### Making a Turn

Practically the same sequence of events takes place when the pilot wishes to make a turn. On moving the rudder over, the aeroplane attempts to make a flat turn (i.e. to turn without banking), and owing to the absence of bank, an outward sideslip occurs, the aeroplane then banking as a combined result of the sideslip and dihedral angle. As in the previous case it sideslips first and banks afterwards. On a normal aeroplane the wings would be banked by the pilot, through the medium of the ailerons, at the same time that the rudder was just over, thus avoiding any tendency to sideslip.

The provision of ailerons would undeniably spoil the attractive simplicity of the "Flying Flea" and besides adding complications in the mechanical sense, would probably become the legitimate prey of inspectors, who would have to certify them as airworthy at intervals, with resultant expense and delay.

In the hope of assisting the development of the light aeroplane movement, the author and the editor of PRACTICAL MECHANICS have evolved a method of lateral control without the complication of ailerons, in fact the controls retain the simplicity of those on the "Flea." This lateral control system takes the form of a differential rudder as shown in Fig. 5. The rudder becomes two rudders, a small one above a large one, both on the same rudder post and both connected to the same rudder control in the pilot's cockpit, but the wires to the top rudder are crossed so that the

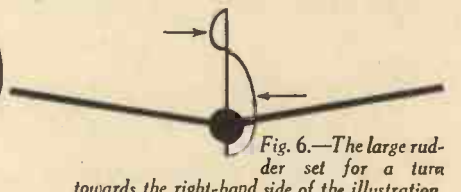

Fig. 6.—The large rudder set for a turn towards the right-hand side of the illustration.

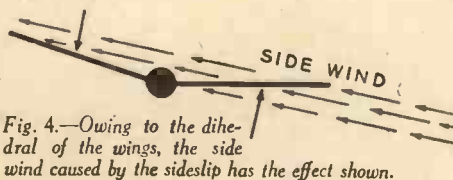

Fig. 4.—Owing to the dihedral of the wings, the side wind caused by the sideslip has the effect shown.

two rudders act in opposition. The rudder effect is then the difference between the two rudders and they, being mounted in different planes, will tend to twist the aeroplane about its longitudinal axis so as to cause it to bank automatically when making a turn.

**The Differential Rudder**

Fig. 6 shows a diagram comparable with Fig. 1, but with the differential rudder added. The lift and gravity forces remain as before. In Fig. 6 the large rudder is set for a turn towards the right-hand side of the illustration, and the forces acting on the two rudders will then tilt the aeroplane so

as to raise the outer wing, thus bringing the aeroplane to a banked attitude without waiting for sideslip. In the case shown in Fig. 2, where the level attitude is upset by exterior circumstances, a touch of rudder will correct the incipient yaw and bring up the dropped wing.

In making a turn, the rudder deflection would be reduced progressively as the aeroplane banks until, at the correct angle of bank, the turn will continue even though the rudder may have been brought back to mid position. This is quite a normal state of affairs, for it is always necessary to take off rudder and bank after the turn has

fairly started. This would also be necessary on the "Flying Flea," because when the aeroplane is banked, the rudder has a tendency to force the nose down; on a normal aeroplane a steep bank actually necessitates the use of opposite rudder to keep the nose from dropping, but steep banks are quite unnecessary on light aeroplanes to be used for straightforward flying, as distinct from "stunting."

It will be seen that the differential rudder adds nothing appreciable in the way of complications, but it should prove a useful contribution to the furtherance of simplicity in flying.

# The Home Telephone

ON page 135 of last month's issue we gave constructional details of a simple home telephone. A disadvantage of the telephone described was that the speaker also operated his own receiver, and as a result, listened to his own voice. With a twin line this could only be eliminated by a method of switching, and this is shown in the illustration on this page.

This method of wiring also has the ad-

## An Alternative Wiring Plan for the Telephone Described in Last Month's Issue

and receivers, it will be noted that the batteries are in opposition, thus virtually

dimensions can be given owing to the variation in material such as phones and cigar boxes, but this omission should not hinder in any way. It must also be understood that an earpiece used as a microphone leaves much to be desired as far as sensitivity is concerned, and the substitution of cheap microphones would doubtless prove beneficial, but if economy is the prior consideration the earpiece will prove a reasonable substitute.

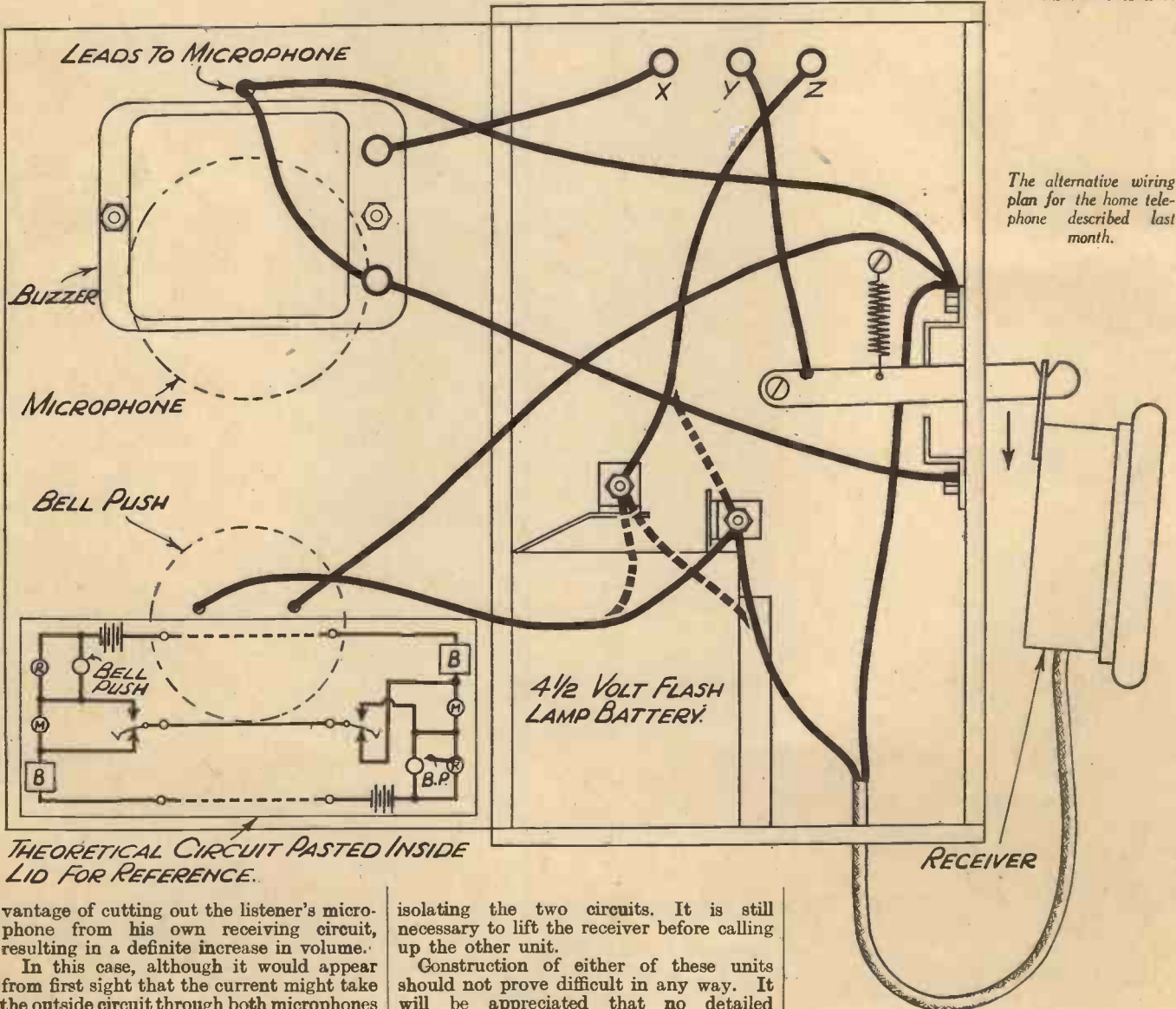

The alternative wiring plan for the home telephone described last month.

vantage of cutting out the listener's microphone from his own receiving circuit, resulting in a definite increase in volume.

In this case, although it would appear from first sight that the current might take the outside circuit through both microphones

isolating the two circuits. It is still necessary to lift the receiver before calling up the other unit.

Construction of either of these units should not prove difficult in any way. It will be appreciated that no detailed

# Woodworking for Beginners

(Continued from page 194 of last month's issue)

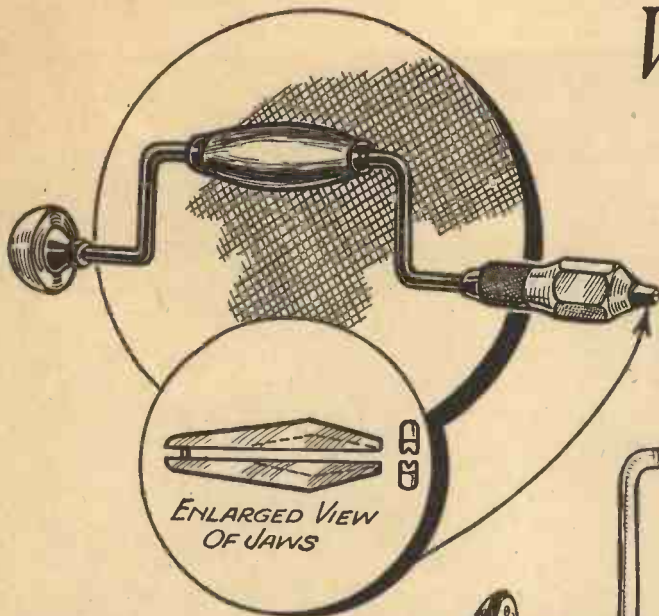

Figs. 9 and 10.—(Left) An ordinary brace and (inset) the shape of the jaws. (Below) A ratchet brace.

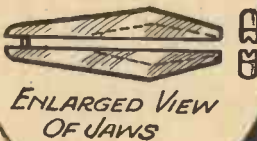

**Chisels.**—Tools coming within the general classification of "sharp edge tools." They are of several types, the main of which are as follow :

**Bevelled-edge Chisels.**—Made with blades from  $\frac{1}{4}$  in. to  $1\frac{1}{2}$  in. wide and used chiefly for accurate or delicate work. They should not be used for such purposes as mortising, since they are not very strong.

**Firmer Chisels.**—Similar to bevelled-edge ones, but stronger, having a blade of rectangular section. Are suitable for nearly every purpose.

**Mortise Chisels.**—Made principally in sizes from  $\frac{1}{4}$  in. to  $\frac{1}{2}$  in. They are much stronger than the two former types and have a blade of from  $\frac{3}{8}$  in. to  $\frac{1}{2}$  in. thick, according to size. The handle, instead of being fixed on a tang projecting from the blade, fits into a socket formed in the latter. (See Fig. 11.)

**Countersink Bits.**—See under Bits.

**Countersinking.**—Countersunk holes are required chiefly when using wood screws, their purpose being to allow the head to lie flush with the surface of the wood. Countersinking is done by means of one of the bits described under Bits, and illustrated in Fig. 6 (shown last month).

**Cramp.**—A device used for holding framework, etc., whilst the glued joints are

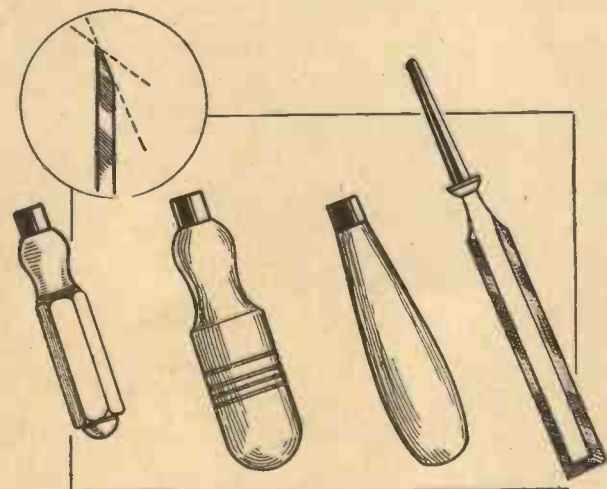

Fig. 11.—Different types of chisel handles. Grinding and sharpening angles for a chisel are shown inset. On the right is a bevelled-edge chisel with the handle removed.

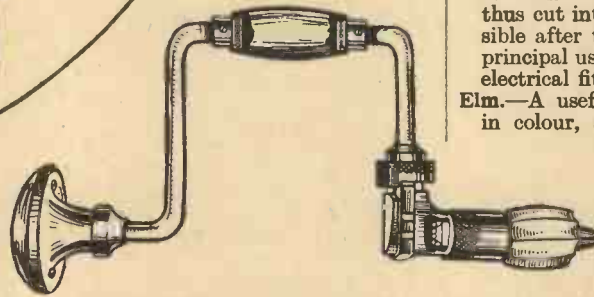

Fig. 12.—A joiner's cramp.

setting. Also for pressing floorboards close together when they are being laid. (See Fig. 12.) "G" cramps so-called because of their shape, are used for holding boards on the bench top whilst planing or otherwise working on them.

**Cross-cut Saws.**—See Saws.

**Cup Shake.**—A defect occurring in timber. (See under Shakes.)

**Dovetails.**—Joints used for fastening together corners of drawers or other wide pieces of wood. There are different types, viz. Common dovetails. Lap dovetail—a neater joint in which the cuts in the timber show on the surface only. This is the kind generally used for the joints at the front of drawers. Secret dovetail—a joint which combines dovetailing and mitreing. When completed it looks like a plain mitre, but is

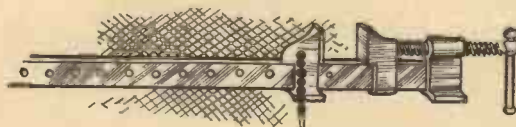

Fig. 13.—An Archimedian drill.

much stronger. This joint is very difficult to make and is not used extensively in practice; it is a recognised test of the joiner's skill.

**Dovetail Saws.**—See Saws.

**Drills.**—The Archimedian drill is the type most often used in woodwork, its purpose being to make small holes for nails. The drill points used in it are of the diamond-ended type as shown in an accompanying sketch. They can be bought cheaply, but are not difficult to make in a form suitable for light woodwork. The method is to flatten the end of a nail by striking it with a hammer, and then to file down the

end to make an angle of about 90 degrees. The cutting edges should be so filed that they have a "leading angle" of some 65 degrees.

**Ebony.**—A wood which is remarkable for its great density and almost black colour. It sinks in water and is extremely difficult to work. It is very liable to split and is thus cut into small sizes as early as possible after the tree has been felled. Its principal use is for cabinet work, parts of electrical fittings and tool handles.

**Elm.**—A useful hardwood, reddish brown in colour, and has an open and often twisted grain. There are four species growing in this country, but the small-leaved type is most common. Elm is very durable when kept either dry or under water, but will not stand alterna-

tions without rotting. It is most easily worked when quite fresh, and for this reason it is usual to store the timber under water. The wood is used for planks or piles in wet foundations, naves of wheels, pulley blocks, wooden springs, or for any purpose where sudden shocks have to be withstood.

**Exeter Hammer.**—A hammer with a cross pane, the underside of which is parallel to the upper surface. The portion of the head through which the eye passes is rectangular in section. (See Hammers.)

**Files.**—Obtainable in various patterns and sold according to the type, length, and cut. The main types are :

Flat—rectangular in section and in elevation. Hand-rectangular in section but with curved edges tapering toward the tip. Triangular (or saw)—triangular in section, mainly used for sharpening saws. Half round—with one flat and one curved surface. Round (or rat-tail)—circular in section.

The "cut" of files is determined by the number of teeth to the inch. For example, the bastard has about 16 teeth to the inch, the second cut 32 teeth, the smooth 60, and the dead smooth up to 100 teeth per inch.

Wood files are very liable to become quickly clogged when used on



Fig. 13.—An Archimedian drill.

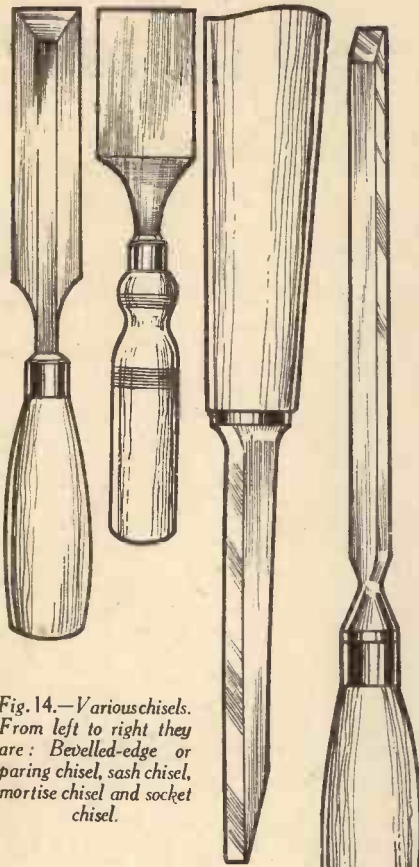

Fig. 14.—Various chisels. From left to right they are: Bevelled-edge or paring chisel, sash chisel, mortise chisel and socket chisel.

resinous wood and should therefore be frequently cleaned by means of a wire scratch brush. The process is simplified if the tool is first dipped into warm water. An alternative method of cleaning is to scrape the filings out of the teeth with a strip of zinc sheet; this removes the wood without damaging the edges of the teth.

**Fir.**—Otherwise known as spruce. It is grown largely in the British Isles and is productive of a useful soft wood generally referred to as white deal or spruce. A peculiar characteristic of the wood is that it contains a large number of small knots. These are hard and black, and in some samples are "dead" and loose so that they easily fall out. This wood is very durable and because of its whiteness is frequently used for tops of kitchen tables and for common joiner's work, such as for floorboards, packing cases, etc. The young trees can be made to grow very straight, and in that form are often used for scaffold poles and ladders.

**Firmer Chisel.**—See Chisels.

**Firmer Gouge.**—Also called outside-ground gouge, due to the fact that it is sharpened on the outside of the curve. (See Gouges.)

**French Glue.**—See Glue.

**French Nails.**—The ordinary kind of nails which are circular in section. They are often called wire nails and are obtainable in all lengths from about  $\frac{3}{4}$  in. upwards. (See Nails.)

**Gall Nuts.**—More commonly known as oak apples, are defects which occur in oak and are caused by the attacks of the gall-fly.

**Glass Paper.**—Otherwise called sand-paper. Can be obtained in a wide variety of grades from No. 3 (very coarse) by  $\frac{1}{2}$ 's to No.  $\frac{1}{2}$  and then to No. 0 and No. 00, the latter of which is very fine. Glass-paper

should wherever possible be used in a glass-papery block or on a cork block, called a "rubber." It is important to remember that a plane should never be used on work that has previously been glass papered, since particles of glass adhere to the surface and will blunt the plane iron very quickly.

**Glue.**—Can be obtained in two kinds: Scotch glue, which is very strong and dark brown in colour; French glue, which is clear and semi-transparent and rich amber in colour. French glue makes a closer joint, but is not so strong. There are other proprietary glues having an acetate base and which can be melted at very low temperatures. These latter are

being more widely used than the older fashioned kinds due to the greater ease with which they can be prepared for use. They are also claimed to be stronger than the other kinds, although they are appreciably more expensive.

Scotch and French glue is sold in hard cakes by the pound. Before use it must be broken up into small pieces, soaked overnight in water, and then boiled in a glue kettle. Sufficient water must be added during the boiling process to keep it quite fluid, and when ready for use it should be of such a consistency that it will run freely from the brush.

Fig. 15.—Firmer and paring gouges. At the bottom right the various curves of the edges are shown.

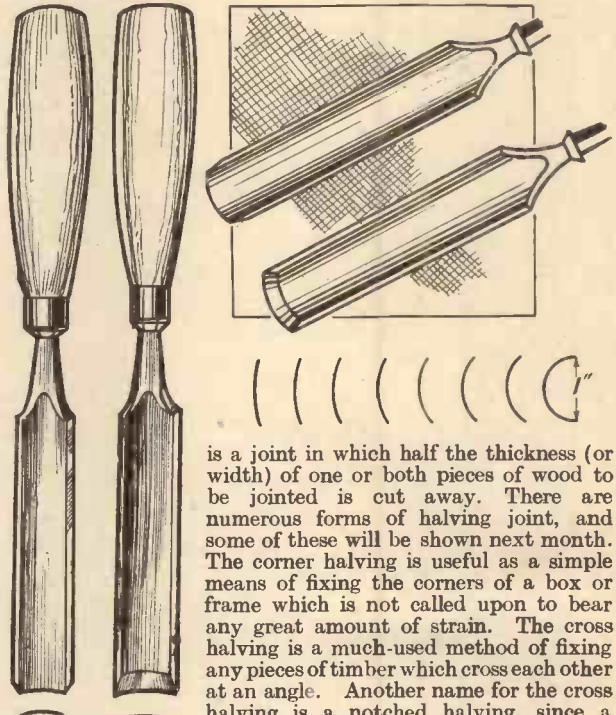

Care should always be taken that dust is excluded from glue, since this will seriously impair its efficiency. If a scum forms on the surface whilst boiling, this should be skimmed off.

**Gouges.**—These may briefly be described as chisels which are curved in the direction of their length. There are two main types of gouges, paring and firmer, and these are described under their respective names. (See Fig. 15.)

**Grain.**—An understanding of the grain in wood is very useful in all woodworking operations. In very few cases does the grain run parallel to the surface, and therefore if the wood is planed in one direction (with the grain) a smooth finish is obtained, whilst if it is planed in the opposite direction (against the grain) the surface tears away and becomes uneven and rough. This is particularly

true with hard woods, and it is thus always wise to examine them before commencing to work. Not only must the grain be watched when planing, but also when performing any other cutting operation, such as chiselling.

**Grounding Punch.**—Also called a matting punch. Is used for matting the surface of wood for simple decorative purposes. A suitable punch can be made from a square or round mild steel rod about  $\frac{1}{4}$  in. square or diameter and filing five or six grooves in each direction across one end.

**Gullet.**—The name given to the angle formed between the teeth of a saw.

**Half Rip Saw.**—See Saws.

**Halving Joint.**—As the name implies, this

is a joint in which half the thickness (or width) of one or both pieces of wood to be jointed is cut away. There are numerous forms of halving joint, and some of these will be shown next month. The corner halving is useful as a simple means of fixing the corners of a box or frame which is not called upon to bear any great amount of strain. The cross halving is a much-used method of fixing any pieces of timber which cross each other at an angle. Another name for the cross halving is a notched halving, since a notch is formed in each piece of wood.

**Hammers.**—Of various types, such as, for example: Cross pane (joiners'), straight pane (mechanics'), American (with claw end), Exeter (see under this heading), ball pane (mechanics'). Hammers are sold according to the type of head and to its weight, e.g. 8 oz. cross pane, 4 oz. Exeter. (See Fig. 16.)

**Heart Shake.**—A serious defect in timber. (See under Shakes.)

**Jack Plane.**—The kind of plane used for removing the rough initial surface from wood. It may be obtained in various lengths from about 10 in. to 14 in., having either a straight stock or a sunk handle. To set a plane it should be held in the left hand so that the operator can see straight down the sole; the sharp edge of the iron should then be seen as a black line. (To be continued.)

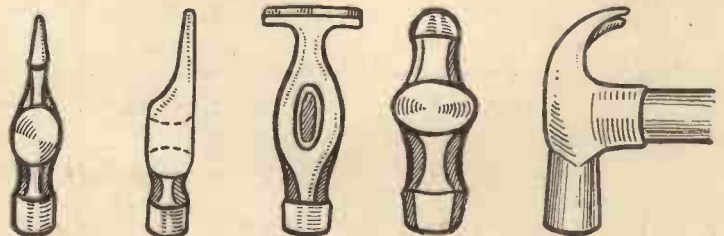
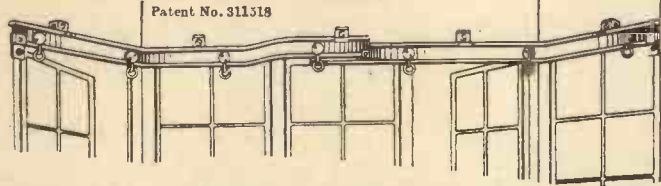

Fig. 16.—(From left to right)—A cross-pane hammer, an Exeter hammer, a thin pane hammer (for setting plate irons), a ball pane hammer, and an American claw hammer.

# A Screwdriver - a gimblet



and the **Beacon** 456 is ready to hang your curtains



perfectly. Any handyman can erect. Fits all shapes of windows—square bays, round and oval.

Most fittings **SOLID CHUNKS OF BRASS** and whole system is a thoroughly sound job. Stands hardest wear—woodwork would have to give way first.

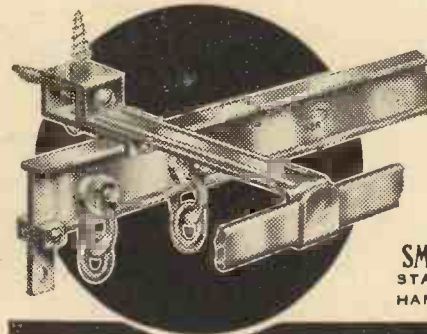

**IN FOUR QUALITIES.**  
 Strong (Brass) ... 1/- ft.  
 Light (Brass) ... 9d. ft.  
 Steel (Rustproofed) ... 9d. ft.

White (Aluminium Alloy) ... 9d. ft.  
 Complete with all fittings.

From all ironmongers. If any difficulty write for nearest stockist's name. Beware imitations.

Any length cut to order

**SMITH AND DAVIS, LIMITED**  
 STAMPED BRASSFOUNDERS  
 HAMPTON ST. BIRMINGHAM



## MOVIES ON EASY TERMS

"City Sale" offers you the chance of enjoying the finest of all home entertainments and hobbies, for the outlay of a few shillings down.

### PATHESCOPE "ACE"

Not a toy but a really splendid 9.5-mm. movie projector. Suitable for any voltage. Takes 30-ft. and 60-ft. spools of film. **37/6** It will give you hours of joy. Only

### PATHESCOPE 200B

With 200-watt lighting. Picture 10 ft. wide easily obtainable. Flickerless projection. Works off 110 volts. With lamp, plug, flex, adapter, and one empty **£15:0:0** 300-ft. super reel.  
 Nine monthly payments of 35/-.

### FILMS from our LIBRARY

All the latest comedies, dramas, interest and cartoon films at the lowest rates of hire. Send for catalogue.

### AGFA MOVECTOR DOMESTINO

Takes 400-ft. reels of 16-mm. film. Built-in resistance. 100-watt lamp. **£17:0:0** 50-mm. lens.  
 Nine monthly payments of 35/8.

### GENEROUS EXCHANGES LISTS POST FREE

**CITY SALE & EXCHANGE**  
 (1929) LTD.  
 59 & 60 CHEAPSIDE, LONDON, E.C.2

## ECONOMIC ELECTRIC CO. TWICKENHAM, LONDON, S.W.

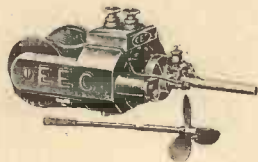

**THE NEW "MIDGET" MOTOR**  
 The smallest and most powerful motor on the market.  
 Size: 3 1/2 in. long, 1 1/2 in. wide, 2 1/2 in. high.  
 Weight 7 1/2 oz. Low centre makes it ideal for boat or loco. **4 VOLTS.**  
**PRICE: 5/6, post 4d.**  
 British Made by E.E.O.



**G.P.O. TAPPERS**  
 Substantial keys for practice use. An instrument, not a toy.  
 6/6 post free. Buzzers, 2/-, Sounders, 9/6.



**MICROPHONES**  
 For the Xmas Party great fun can be obtained by connecting one of these mikes to your receiver.  
 Price 8/6.  
 Button type 1/- p.p. Complete Broadcaster, 20/- p.p.

Our 70-page list contains a variety of small Mains Motors—for example, our 1/50 h.p. Ball Bearing Motor. Price 28/6, post 9d. Also over 500 other models for all purposes. Send for a copy now, 2d. post free.



## BALDNESS BARS PROMOTION

### A MODERN MIRACLE

MEDICAL Science has at last discovered a simple method whereby the dormant hair follicles can be restored to **VIGOROUS LIFE**, enabling them to produce new and naturally coloured hair.

One delighted Client of 89 1/2 who was bald for over 30 years reported that the "C.L.L." treatment produced a **FINE GROWTH OF NEW HAIR**. The ages of other equally grateful Clients range from 22 to 81. **MEDICALLY RECOMMENDED. £1,000 for denial.**

Write to-day for a copy of our Illustrated Book entitled "**HOW TO ACQUIRE PERFECT HAIR GROWTH.**" Post free privately from:—

**THE LABORATORIES (Dept. 56),**  
 37 New Bond Street, London, W.1.

The **ONLY** cure in the world for Baldness endorsed by the Press and the **MEDICAL PROFESSION.**

## HOME MOVIES

### SPECIAL OFFER

The "Ace" All-electric Projector for 9.5-mm. Mickey Mouse Films, complete, post free, **37/6**  
 9.5-mm. Mickey Mouse Films, 3/9 & 6/6 each.

We also offer a wide range of re-conditioned Home Cine Equipment and Films, and invite your enquiry for our complete free lists.

### Post Free Mail Order Service by return

No matter what your Movie requirements are, we can give prompt service and delivery of all new makes.

Complete 9.5-mm. and 16-mm. Film Libraries.

Specialists in { **MECCANO, HORNBY TRAINS and FROG AEROPLANES. PHOTOGRAPHIC.**

**EASIEST OF EASY PAYMENTS. PART EXCHANGES**

## THE AMATEUR CINE SERVICE LTD.

P.M. Dept., 52 WIDMORE ROAD, **BROMLEY, Kent.** Close Wednesdays 1 p.m.  
 Hours 9 a.m. to 8 p.m.

# "HARMONA"

The latest

# AMPLION

## Permanent Magnet MOVING COIL SPEAKER

Specified  
for the  
"PINNACLE"



The Moving Coil Unit of the "HARMONA" is of entirely new design, it employs the very latest development in Permanent Magnet Construction—the New Type Nickel Aluminium Alloy Magnet.

The resultant improvement in sensitivity and life-like reproduction is an outstanding achievement.

PRICE

**25/-**

*Fitted with Universal Transformer to match all Types of Output Values.*

## AMPLION RESISTANCES

are also specified by Mr. F. J. Camm.

A defective resistance can completely ruin the enjoyment of radio—and frequently does. Moreover, it is often difficult to trace the fault, as none but the most expensive testing equipment can definitely locate it.

### Amplion 1 Watt Wire-Wound Resistances

They are colour coded, compact and sturdy, and all values are *wire-wound*, this method of construction giving the most reliable form of resistance.

Send for descriptive Folders "P.M." of all Amplion Products.



PRICE **1/-** EACH  
ALL VALUES

## AMPLION (1932), LTD.

82-84 ROSOMAN STREET, LONDON, E.C.1

# EASY WIRING

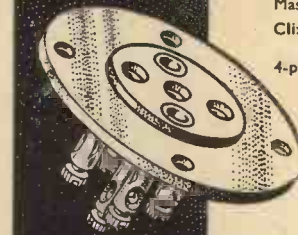
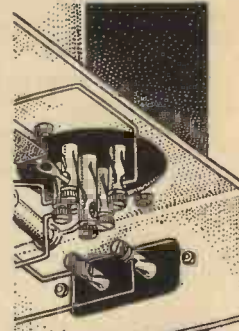

# CLIX

LECTRO LINX LIMITED,  
79a ROCHESTER ROW, LONDON, S.W.1

All Clix components, in addition to giving Perfect Contact, are easy to wire; for instance, in Clix Chassis Mounting Valveholders the centre socket of the 5-pin and two sockets of the 7-pin type are made longer than the others; this reduces the possibility of short-circuits and adds to the ease of wiring.

Clix "Master" Wander Plugs and Spade Terminals are simply and efficiently wired, and the special wire-to-wire wiring device makes for certain and lasting contact.

All Clix components illustrated are specified for

### "THE PINNACLE"

Spade Terminals for L.T.

Large - 2d. Small - 1½d.

Master Plugs for H.T. or G.B. 1½d.

Clix Standard Chassis Mounting Valveholders.

4-pin 8d. 5-pin 9d. 7-pin 1/-

Terminal trips.

A.I., A.2.E., 7d.

LS. 6d.

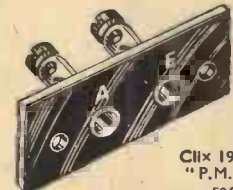

Clix 1936 Folders "P.M." Free on request.



# High-Fidelity Reproduction

In our opinion Mr. F. J. Camm has chosen a most excellent combination of Hivac valves for "THE PINNACLE." Readers will, we believe, be interested in the information now given concerning the 4-pin type Hivac variable-mu H.F. Pentode valve—one of the three types selected.

This Hivac VP215 (4-pin) is without doubt the most perfectly shielded valve of its type on the market. As will be seen from the illustration, the valve is built up in such a way that the split anodes are entirely enclosed in two Faraday Boxes, thus producing the best shielding system possible.

It is essential to shield the anode from the rest of the electrode system in order to obtain the minimum anode control-grid capacity so necessary when efficient high-frequency amplification is desired.

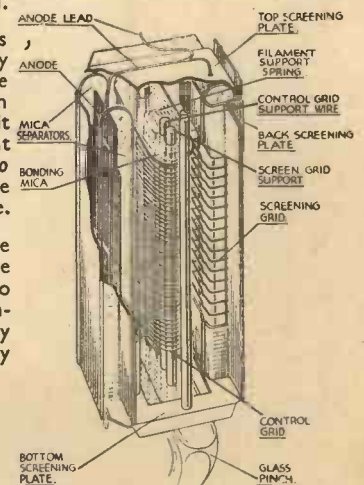

## HIVAC

THE SCIENTIFIC  
VALVE

British Made

HIVAC VP215 (4-pin)  
Illustration shows construction of the two Faraday Boxes.  
VP215, 10/6. H210, 3/9. Y220, 10/6.

High Vacuum Valve Co. Ltd., 113-117 Farringdon Road, London, E.C.1



ALL RADIO  
QUESTIONS  
ANSWERED  
FREE

# The PRACTICAL MECHANICS

Every Question  
must be accom-  
panied by the  
Coupon on  
page III of Cover

## Wireless Experimenter

**T**HE "Pinnacle" can truly be described as one of the very best battery receivers that has been described in PRACTICAL MECHANICS. Regular readers know what this means, and that it would be difficult to give greater praise to any set. There is, therefore, no necessity to emphasise the extreme efficiency of the receiver, or even to say that it is probably more effective than any simple three-valve battery set that could be made at a reasonable price. Another point of great interest is that the set has been designed on strictly economical lines; every unnecessary component has rigorously been omitted, and nothing except real essentials has been retained. This does not mean that those valuable refinements which are so popular on present-day sets have been omitted, for the set has every feature which is generally

### THE "PINNACLE"

An Efficient Three-valve Battery Receiver Designed on Strictly Economical Lines

are thus secured without the attendant disadvantages.

#### Variable Selectivity

It has been said that the sharpness of tuning is ample, and this statement might be amplified by stating that the London stations, when only about ten miles away, occupy no more than one degree of the tuning scale, even when the aerial is connected to the least selective tapping on the first coil. Moreover, either of these transmissions can be eliminated merely by rotating the knob of the trimmer condenser through a small angle; this is true proof of the correct matching of the two coils and their associated circuits. Reaction is provided, but this is required only when distant stations are being received, or when extreme selectivity is called for, such as, for instance, when the set is being used within two or three miles of the local station. Both coils, and also the tuning condenser, are

adequately screened so that there is no danger of "break-through" occurring.

It will be evident from the illustrations on this page that the set is entirely self-contained, the batteries and loud-speaker being all accommodated neatly within the popular type of horizontal cabinet specified.

#### The "Pinnacle" is Easy to Build

The whole of the constructional work is of the simplest possible nature, and can safely be undertaken by the beginner, even if he has never before attempted home construction. The chassis, which is of the metallised-wood type, is supplied in ready-made form by Messrs. Peto-Scott, and it is

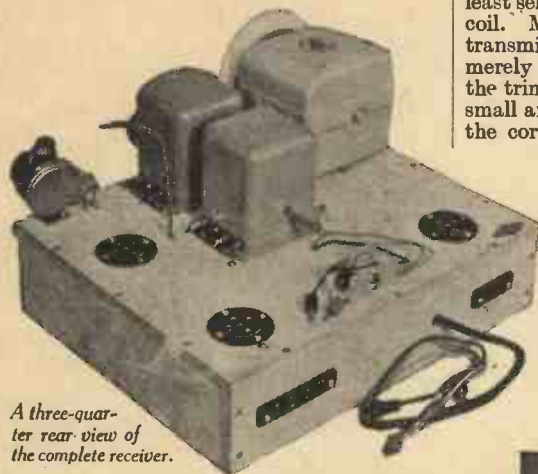

A three-quarter rear view of the complete receiver.

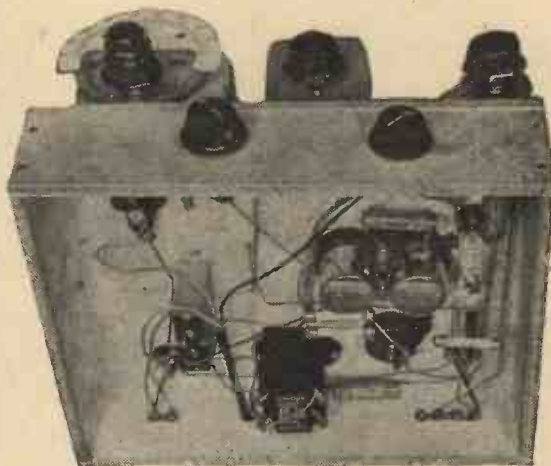

Another view of the "Pinnacle" which will help you in assembly.

wanted by the average listener. For example, there is a remarkably smooth-working volume control which operates on the first (variable-mu pentode) valve, whilst iron-cored tuning coils are used in both tuned circuits. The "Pinnacle" is selective enough for all requirements, but in addition there is ample provision for modifying the actual degree of selectivity to suit any particular set of conditions.

#### A Handsome Design

The special cabinet chosen is of very handsome design, and can be bought either as a plain table consolette, or with a set of legs so that the receiver may form a complete piece of furniture and may be stood on the floor. The controls are few in number, but nothing has been omitted which might make for better reception, or which might in any way simplify the operation. There are two tuned circuits, both of which may be controlled by means of a single knob, although an accessible trimmer is provided, and this takes the form of a second tuning knob concentric with the first. By this means the very distant stations which would never be received in the normal way can be brought in with ease; all the advantages of separate tuning condensers



The finished receiver in its cabinet and mounted on the neat pedestal.

a perfectly simple matter to mount the necessary components. The positions of all the parts can readily be determined by making reference to the wiring plans and also to the photographs. Most of the components are attached by means of  $\frac{3}{8}$ -in. and  $\frac{1}{2}$ -in. wood screws, but the two-gang tuning condenser is fitted by means of the three bolts which are supplied with it. A word of warning is called for in connection with this component, especially since two of the bolts are used on the underside of the chassis for taking earth-return connections. Because of this the bolts must necessarily be screwed up tight, and in doing this there is some danger of the tubular "legs" on top of the chassis breaking through the metallised surface, so that they do not make proper electrical contact with it. This eventuality can be avoided in one of two ways: one is to place washers between the feet and the chassis surface, and the other is to avoid tightening the bolts unduly.

The twin screened high-frequency choke is mounted by means of a  $\frac{3}{8}$ -in. bolt, the latter passing through the metal lug which is joined to the screening cases. By adopting this form of mounting the screen is properly earth-connected to the chassis by means of the bolt head.

**Constructional Pointers**

Terminal socket strips are used for making connection to the aerial and earth leads, and also to the loud-speaker, and these are mounted by means of wood screws after making two series of  $\frac{3}{8}$ -in. holes through which the metal sockets may pass.

The reaction condenser and on-off switch, it will be noted, are mounted on the three-ply front strip of the chassis, the latter having two  $\frac{1}{8}$ -in. holes for the purpose. The rest of the assembly is perfectly straightforward and calls for no comment.

**Straightforward Wiring**

Little explanation is called for in respect of the wiring, since this can readily be followed by referring to the large-scale wiring plans provided. Most of the connections are made by means of insulated connecting wire, and only a few of them require to be soldered. Those which are soldered are the connections to the volume control potentiometer and to the 1-mfd. fixed condenser. As can be seen from the various illustrations, the fixed resistances and tubular fixed condensers are attached to the various components by means of their own connecting wires, and these components have been placed in such positions that the wires do not need to be extended or even cut off short.

**Battery Connections**

There are three flexible leads, these being for the grid-bias battery connections, and they are passed through a hole made through the baseboard of the chassis near to the G.B. battery clip. The only other flexible leads are those which comprise the battery-cord assembly, and these are attached to the terminals by forming loops in their ends which fit over the terminal shanks.

After the wiring has been completed, and before the set is fitted into its cabinet, it is advisable to give it a preliminary trial and to set the trimmer on the rear half of the gang condenser.

**Setting the Trimmer**

There are very few preliminary adjustments to be made, chiefly because of the

*The Above and Underneath-chassis Wiring Plans of the "Pinnacle."*

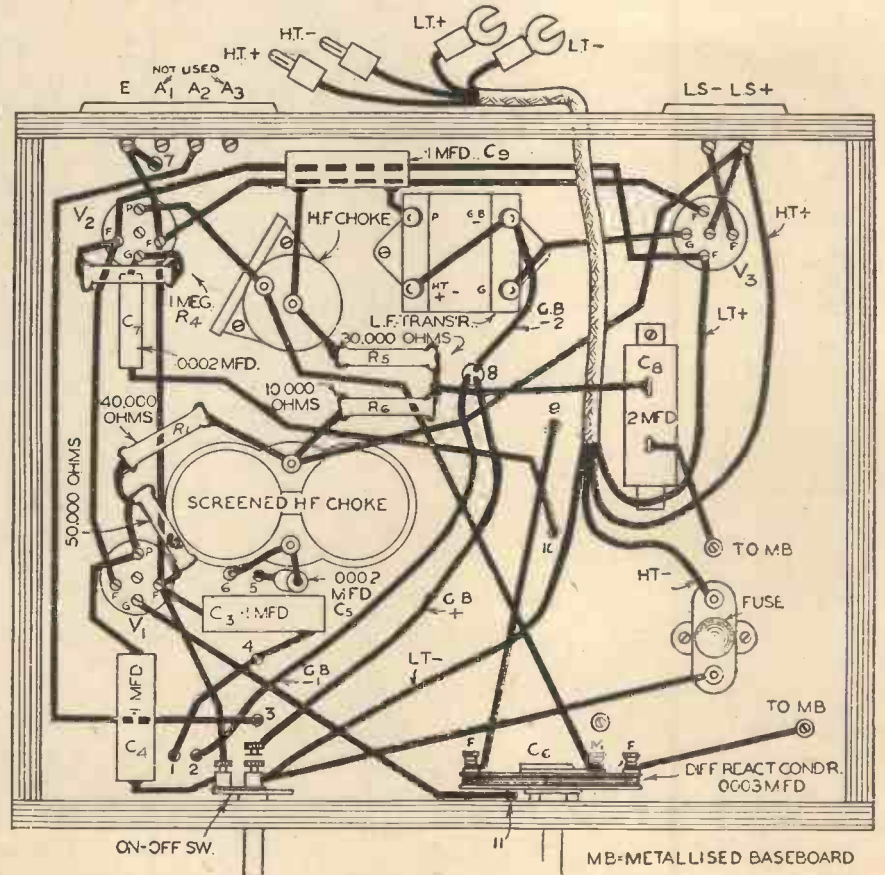
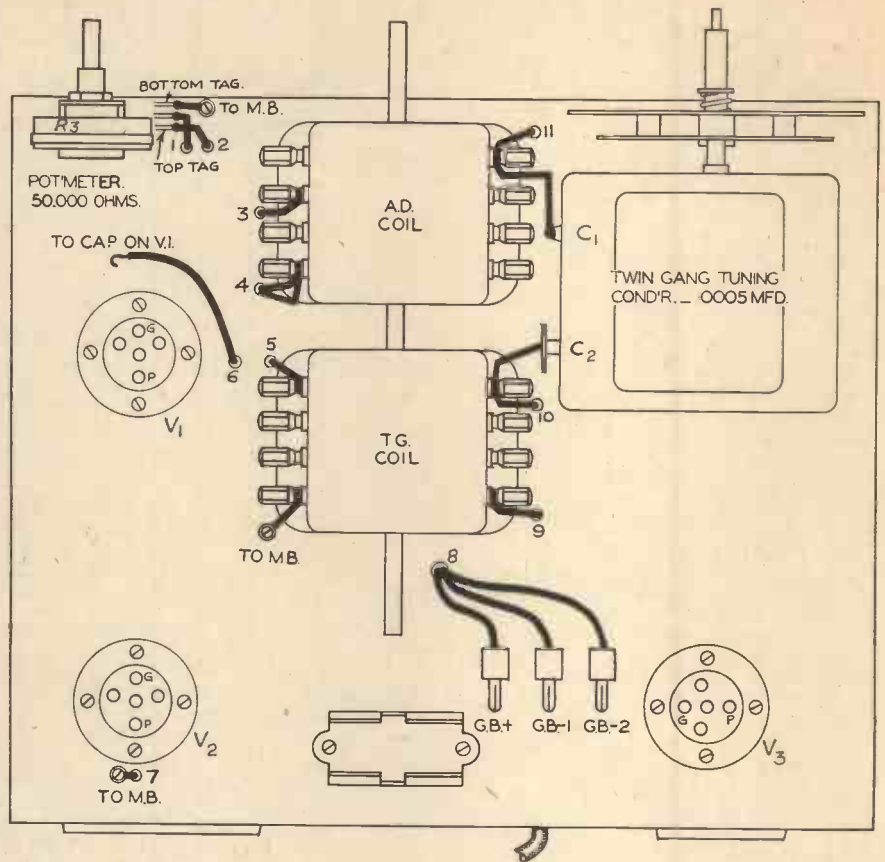

**LIST OF COMPONENTS FOR THE "PINNACLE"**

- Two Dual-range Coils, A. D. and T.G. (Wearite).
- One Two-gang Condenser "Unitune" (Jackson Bros.).
- One .0003-mfd. Differential Reaction Condenser (Peto-Scott).
- One 50,000-ohm Potentiometer (Ferranti).
- Five 1 watt Resistances: 10,000 ohms, 30,000 ohms, 40,000 ohms, 50,000 ohms, 1 megohm (Amplion).
- Three 1-mfd. Fixed Tubular Condensers (Amplion).
- One 1-mfd. Fixed Condenser (T.M.C.).
- Two .0002-mfd. Tubular Fixed Condensers (T.M.C.).
- One 3-point On-off Switch (Snap Switches).
- One 5:1 Niclet L.F. Transformer (Varley).
- Three Valveholders: two 4-pin, one 5-pin (Clix).
- One L.M.S. Screened H.F. Choke (Graham Farish).
- One Snap H.F. Choke (Graham Farish).
- Five Wander Plugs: G.B.-1, G.B.-2, G.B.+ , H.T.-, H.T.+ (Clix).
- Two Spade terminals: L.T.-, L.T.+ (Clix).
- One 100-mA. Fuse, Type F.5 (Bulgin).
- Two Component Brackets (B.R.G.).
- One Metaplex Chassis 12 x 10 x 3 in. (Peto-Scott).
- One Cabinet (Peto-Scott).
- Two Terminal Sockets: E, A1, A2, and L.S.- L.S.+ (Clix).
- One G.B. Battery Clip (Belling-Lee).
- One Speaker (Amplion).
- Three Valves, VP215, H210, Y220 (Hivac).
- One Accumulator Type D.M.G., 2 volt battery (Bixide).
- One H.T. Battery, 120 volts, Super Life (Drydex).
- One G.B. Battery 9 volts H.1001 (Drydex).

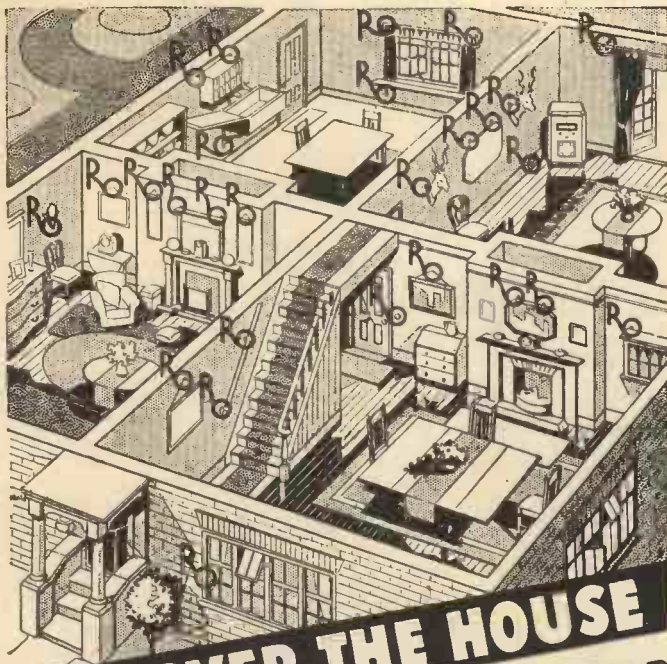

**ALL OVER THE HOUSE**  
**THERE ARE DOZENS OF USES FOR**

**T**HERE are hundreds of fixing jobs in every home, which can be made quicker, neater and more securely with Rawlplugs than by any other method. There is a Rawlplug suitable for every size of job—from the small No. 3 for lightweight fixtures to the No. 30, which will withstand a direct strain of 4 tons.

Remember—millions of Rawlplugs are used annually by the War Office, G.P.O., Municipal Authorities and by Builders and Electricians everywhere. Rawlplug Outfits, which are sold at 1/6, 3/6 and 5/6 by all Ironmongers and stores, contain complete equipment for all ordinary household fixtures.

Fully illustrated literature free on request to:

**THE RAWLPLUG CO., LTD.**  
 Rawlplug House, CROMWELL ROAD,  
 LONDON, S.W.7.



B.196

**A Really Portable ALL MAINS Set !**

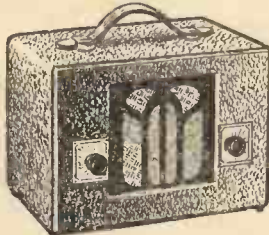

A.C. and D.C. 110-250 Volt.  
 5 Valves—Moving Coil—No Earth required—Self-contained Aerial—Long and Short Wave.

The latest thing from America, fine tone and excellent range. Attractively covered in washable Fabrikoid Leather in several colours, or in Polished Walnut Cabinet.

MEASURES 10" x 7" x 6"  
**SPECIAL PRICE £3.15**

Sent on 5 days' approval against cash. Satisfaction guaranteed or money refunded in full (less carriage charges).

Also **ELECTRIC SOLDERING IRONS**, any voltage AC/DC, 40 watt consumption, only 1/9. Better quality complete with wire stand 2/6. Send at once.

**DOUGLAS HOLT**  
 Estd. (1919) Ltd.

(Car and Radio Accessories)  
 9 Little Turnstile, Holborn, W.C.1.



**PIFCO TEST INSTRUMENTS**  
**ENSURE 100% EFFICIENCY FROM RADIO**

Buy to-day one 42/- Pifco Rotameter-de-Luxe (Moving-coil) or one 29/6 Rotameter (Moving-iron) and you will receive a complete set of 3 Pifco Valve Adaptors costing 15/- in velvet-lined case for 7/6. A Rotameter and set of Valve Adaptors will form a complete test set for your radio.



**PIFCO VALVE ADAPTORS**

**PIFCO ROTAMETER-DE-LUXE**

Each adaptor has a 5-pin base with top sockets for "plug-in" testing of 5, 7 or 9-pin valves under working conditions without alteration to set wiring. Four nickel-plated terminals complete with strapping lugs are fitted, to connect meter in either grid or anode circuit of valve.

(9 Ranges including valve test.) Every conceivable test, also valves, can be made with this amazing instrument (400 volts—500 ohms per volt). Black bakelite finish; complete with leads. In handsome velvet-lined case. Price 42/-.



Ask your dealer to-day to show you Rotameter and Adaptors, or write for Pifco Testmeter Folder, post free, from **PIFCO, LTD., SHUDEHILL, MANCHESTER**, or 150 Charing Cross Road, London, W.C.2.

**PIFCO ROTAMETERS and RADIOMETERS**  
**PIFCO ON THE SPOT WILL TRACE YOUR TROUBLES LIKE A SHOT**

**LOOK INTO WIRELESS TELEVISION THE FUTURE**



Television is the coming boom in wireless—it will bring even greater prosperity to the industry and create many more opportunities for a career. Men who foresaw the broadcasting boom made good—be trained and prepared for this television boom which must follow as surely as night follows day.

At the **WIRELESS COLLEGE** students receive training in all the latest developments in all branches of the Wireless profession. Marine, Aircraft, Manufacturing, Designing, Experimenting, Sales and Service, etc. College on sea front. Write for free prospectus.

**STUDENTS ACCEPTED AS BOARDERS. TRAINING FEE CAN BE PAID AFTER APPOINTMENT SECURED**

The **WIRELESS COLLEGE** COLWYN BAY N. WALES

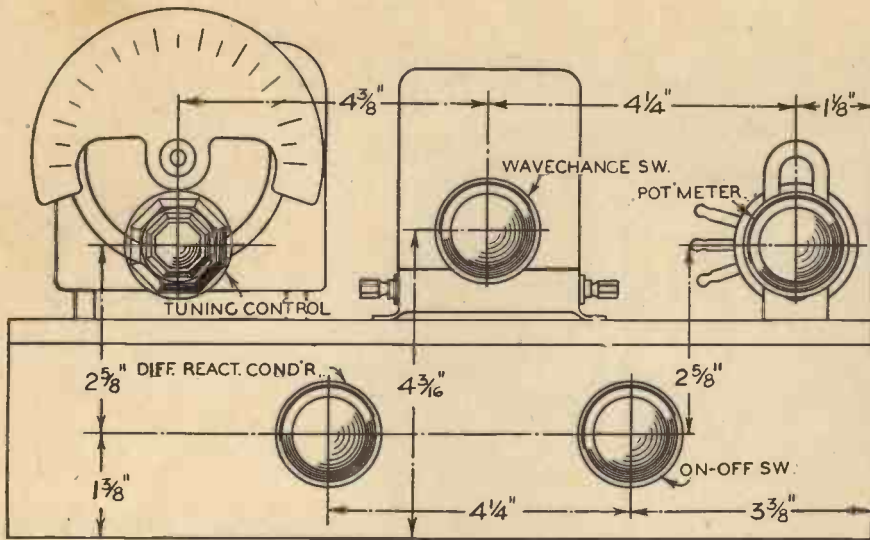

Use the dimensions shown here when drilling the cabinet front.

(clockwise rotation) position. Turn the wave-change switch to the left or right respectively, according to whether medium- or long-wave reception is required. Then switch on and tune to the desired station by rotating the larger knob on the gang condenser. When signals are heard, the smaller (trimmer) knob can be adjusted until maximum volume is obtained. A reduction in volume can then be secured by movement of the right-hand knob.

It will have been observed in studying the circuit diagram that both tuners are fitted with primary windings having two tappings by means of which different degrees of selectivity can be obtained. When testing out the original "Pinnacle" receivers, however, it was found that ample selectivity for all purposes could be obtained by connecting the aerial to the first tapping—that is, to terminal 2—on the type A.D. coil, and by connecting the H.F. coupling condenser direct to the end of the primary winding (terminal 1) on the T.G. coil. Should it ever be found that additional selectivity is required—for instance, when the set is being used "under the aerial" of a powerful transmitter—the aerial lead may conveniently be transferred to terminal 3. Alternatively, leads can be taken from terminals 1, 2, and 3 to the sockets marked A1, A2, and A3 respectively on the chassis terminal strip. Additionally, the lead from the tubular condenser, which is shown as being connected to terminal L on the T.G. coil, can be transferred to terminal 2 or 3.

fact that the tuning condenser is provided with an external trimmer, but it is best to set the star wheel of the other trimmer to about its midway (half-in) position. When this has been carried out it should be found that the external trimmer is somewhere near its midway setting when any station is tuned in. If this state does not obtain, a further slight alteration can, with advantage, be made to the star wheel.

plug, this being inserted into the socket marked A2.

For the benefit of beginners, it might be preferable to explain briefly the battery connections. Dealing first with the battery-cord assembly, the two spade terminals should be joined to the corresponding (red and black, or positive and negative) terminals on the accumulator respectively. The high-tension negative wander plug should be inserted in the negative socket of the H.T. battery, whilst the positive plug should be given a voltage of 100 to 120, according to the exact battery employed. In any case, the higher voltage is to be preferred on the score of optimum performance.

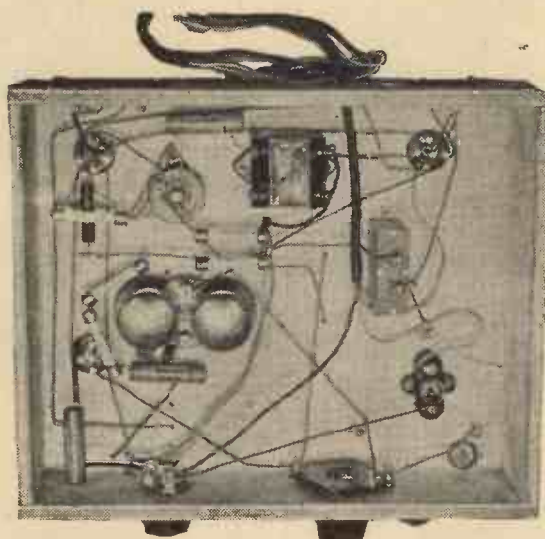

This under-chassis view of the "Pinnacle" shows the wiring and will assist you in connecting up.

**Grid Bias Voltages**

The grid-bias battery fits into the clip provided on top of the chassis, and the G.B. + plug should be inserted into the + socket, whilst the G.B. - 2 plug is inserted into the 9-volt socket. The best position for the G.B. - 1 wander plug depends upon the actual voltage of the H.T. battery, but assuming this to be of the voltage recommended, the plug should be placed in the 4½- or 6-volt socket; if the battery is only of about 100 volts, however, this plug should be given from 3 to 4½ volts. No matter which battery is used, it will be worth while to try different positions for the plug, choosing the highest one at which good quality of reproduction is secured. It is important to note that no alteration should be made to the G.B. voltages while the set is switched on; switch off every time an adjustment is to be made.

It is scarcely necessary to point out that the two plugs provided with the L.S. terminal sockets should be connected to the two "outside" terminals on the loud-speaker through a short length of twin flex. The earth lead should be attached to the plug marked E, whilst the aerial down-lead must be connected to the second

When all these connections have been made set the reaction condenser to zero and turn the volume control to the full-on

sired, be put out of action, it enables, when in use, the operator to completely control the movement of his locos.

**RUNNING MODELS FROM THE MAINS**

A FINE range of power units is now obtainable from Shenphone Electrical Products, 226, High Road, Leyton, E.10. The units are specially designed for the operation of model electric railways, etc., and supply smooth continuous outputs for this work. Rectification is obtained by using a graphite anode-tungsten rectifier, which, being of the static type, has no moving parts to wear or require attention. Also, a longer life is assured with this type of rectifier, a definite guarantee of 2,500 hours being given. Many of their units include a reversing speed controller. Although this can, if de-

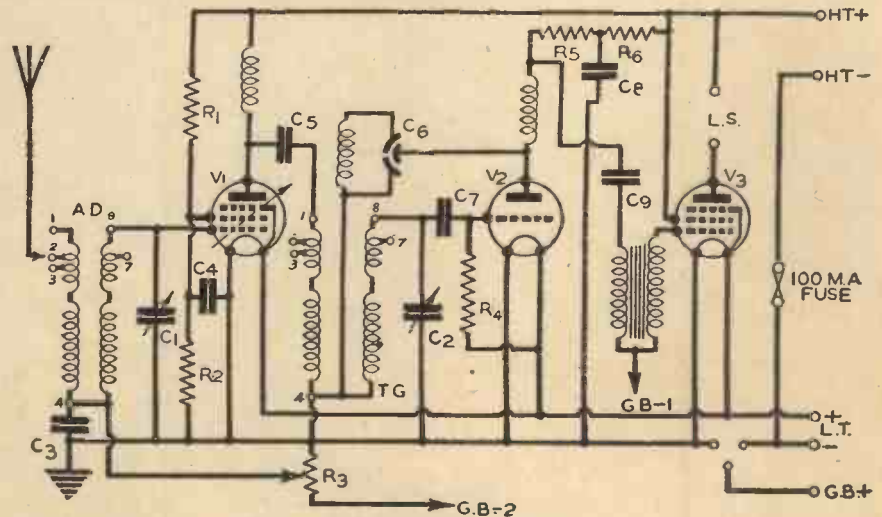

The circuit diagram of the "Pinnacle."

# WEARITE

## STANDARD TESTING INSTRUMENTS



### THE WEARITE METER UNIT.

A precision instrument conforming to 1st grade B.E.S.A. Specification with ranges (most of which are direct reading) as below. The Meter is a Moving Coil Instrument 3 1/2" diameter. A special output arrangement incorporates a series condenser for Output Meter requirements.

D.C. VOLTS	A.C. VOLTS	CURRENT
0-10	0-10	0-25 mA
0-50	0-50	0-10 mA
0-500	0-500	0-100 mA
(1,000 ohms per volt)	(1,000 ohms per volt)	
0-20	0-20	RESISTANCE
0-100	0-100	0-1,000 ohms
0-1,000	0-1,000	0-100,000 ohms
(500 ohms per volt)	(500 ohms per volt)	0-1 megohm
CAPACITY	INDUCTANCE	
05 mfd. to 4 mfd.	5 to 120 Henries	

**Price £6.17.6**

Other Instruments Include:—

VALVE TESTING UNIT .. .. .	44 17 6
OSCILLATOR UNIT .. .. .	26 15 0
FREQUENCY METER .. .. .	44 15 0
MULTIMETER .. .. .	34 5 0

**COUPON** To WRIGHT & WEAIRE, LTD.,  
740 High Road, Tottenham, London, N.17

Please send me literature giving full details of your test instruments, etc., also your latest catalogue of components and circuits, etc.

Name.....  
Address.....  
P.M. 1/36.

### The "PINNACLE"

uses these Wearite

### NUCLEON IRON-CORED COILS

ONE A.D. (Aerial) COIL  
ONE T.G. (H.F.) COIL

**Price each 12/6**

8213

For the  
**'PINNACLE'**  
these

**Exide**

AND

**Drydex**

**BATTERIES**  
are specified

FOR L.T.—Exide DMG, 2 volt;  
42 ampere hours **11/-**

FOR H.T.—Drydex Super-Life  
120 volts **10/6**

FOR G.B.—Drydex H1001,  
9 volts **10d.**

Obtainable from Exide Service Stations and all reputable dealers. Exide Service Stations give service on every make of battery.

Exide Batteries, Exide Works, Clifton Junction, near Manchester. Branches at London, Manchester, Birmingham, Bristol, Glasgow, Dublin and Belfast.

## ELECTRADIX

FINE TURNING METAL for brass-bearing bushes, etc. Solid drawn, 1 1/4 in. diam., 1 1/4 in. bore, 4 lb. per ft., sale 2/8; ditto, 2-in. diam., 1 1/2 in. bore, 3 1/2 lb. per ft., sale 2/6. Emery Cloth, Grinding Discs, coarse, 6 1/2-in. diam., 2/- doz. Larger, 9-in. diam., 4/- doz.

TWO 8 1/2-IN. DIAL CHART RECORDERS, for Draught or L.P. to 12-in. water, 37/6 each.  
CLOCK-IN Staffsine Employees Time Recorder, 70/-.  
ANEMOMETER. 6-dial type reading 1-1,000,000 e. air metres by Stanley, in pocket case, 50/-.

MIRROBS. 3 1/4 in. diam. Halo or Television, 1/8. Parabolic Concave, 10 in., 20/-; 20 in., 25/-; 24 in., 30/-.

Neon Lamps, 2/6 and 3/- each, with holder. Miniature Neons, 2/6.

LIGHT AND RAY CELLS—Selenium Raycraft, 21/-; Kingston, 15/-; Raycraft outfit with relay and amplifier, 45/-.

Photo-Cells, for sound on Film, Television and Ray Work, B.T.F., 15/-; R.C.A., 25/-; G.E.C., 25/- to 70/-.

Beck Angle Prisms, mounted in carrier, 5/6. Micrometer adjusters for lens, 1/-.

Eyepieces with Prism and lenses for photo-cell inspection, 12/6. New Ever-Ready Service Inspector's Handlamps with Battery Holder, 7/6.

THERMOMETERS. Panel, 2 1/2-in. clock dial, 5 ft. of tube, for distant indicating, reading 0 to 100° C., 7/6 and 10/6. Straight 0 to 100° F., 3 in., 6 in., and 12 in. for 1/4. Pocket, 5 in., Clinical, 9d. R.A.F. Air Speed Aero Indicators, 10/6.

RADIO RECEIVERS. Complete and ready for use, no battery or valves wanted with a crystal set, 7/6.

DYNAMOS. Bargains.

FOR CHARGING OR LIGHTING. 240-watt Enclosed Dynamo, 12/20 v., 12 amps, Ball Bearings, Vee Pulley, Type O, 25/-.

Marine type Switchboard with Ammeter, maximum and minimum Auto Cutout Main Switch and Fuses, Field Regulator, 25/- or 47/6 the pair.

DOUBLE CURRENT GENERATORS, D.C., 600 volts, 100 m.a., and 6 volts 3 amps, 40/-.

BINOCULARS AND TELESCOPES. Prisms, 55/-; Field, 40/-; Precision, 15/-; Navy Telescopes, 24-in. Gun Type, 17/6. Hand Range Telescopes, 25/-.

Stick Periscopes, 3 1/2 in. by 1 1/2 in. Mirror and Cover, Swivel back, 6d.

COMMUTATORS. An opportunity for amateurs. Engine built, 24 copper segments, mica insul. Worth 7/6. Sale, 2/6.

HEATERS. Immersion heaters, 110 volts, 2/6; 220 volts, 3/6; hot plates, 110 volts, 600 watts, 3/6; 660 watts, 5/-; 3-heats, 220 volts, Toasters, 7/6; 17/6; wax heaters, 100-250 volts, 15/-; bowl fires, 220 volts, bronze finish, 7/6; 1 kw. bar fire, 3/6; 1 kw., 220 volts, 17/6; Electric Soldering Irons, from 5/6.

**ELECTRADIX RADIOS**  
218 UPPER THAMES STREET, E.C.4.  
Telephone: Central 4611.

An old-fashioned Plumber of Poole Went back (true to type) for a tool. Thought madam, "All right, We've got some FLUXITE. I'll do it myself—he's a fool!"

See that FLUXITE is always by you—in the house—garage—workshop—wherever speedy soldering is needed. Used for 30 years in government works and by leading engineers and manufacturers. Of Ironmongers—in tins, 4d., 8d., 1/4 and 2/8. Ask to see the FLUXITE SMALL-SPACE SOLDERING SET—compact but substantial—complete with full instructions, 7/6.

Write for Free Book on the ART OF "SOFT" SOLDERING and ask for Leaflet on CASE-HARDENING STEEL and TEMPERING TOOLS with FLUXITE.

TO CYCLISTS: Your wheels will NOT keep round and true unless the spokes are tied with fine wire at the crossings AND SOLDERED. This makes a much stronger wheel. It's simple—with FLUXITE—but IMPORTANT.

## THE FLUXITE GUN

is always ready to put Fluxite on the soldering job instantly. A little pressure places the right quantity on the right spot and one charging lasts for ages. Price 1/6.

**ALL MECHANICS WILL HAVE**

# FLUXITE

**IT SIMPLIFIES ALL SOLDERING**

FLUXITE Ltd., Dept. P.M., Dragon Works, Barmondsey St., S.E.1

# "LILLIPUTIAN POWER."



Scale Model L.M.S. COMPOUND No. 1108.

An improved model of one of our most popular locomotives, whose prototype is noted for efficient and economic working over all parts of the L.M.S. system. These engines have a shapely and characteristic outline, and our re-built model embodies all these features. Length overall, 15 inches. Gauge "o."

Prices: Clockwork, 32/6; Electric, d.c., 8 volts, 39/6, a.c., 20 volts, 44/6.

THAT IS the name of our new Free Train Folder, No. 12, with all our popular lines—new and well known—depicted therein.

Send for your copy at once. By return of post the postman will bring this splendid two-colour pamphlet—bright blue and black—to your door.

On January 1st our new season's Catalogue, New A.12, comes out, describing railway models—and their accessories—from gauge "o" to 15-inch gauge. A.12, price 6d. post free.



Scale Model L.M.S. 4-6-4 Tank Locomotive No. 2536.

For many years we have been asked for a model super-detail scale model Tank Locomotive at a popular price, and after consideration have decided upon the new L.M.S. Tank designed by Mr. W. A. Stanier. Length overall, 13 inches. Gauge "o."

Prices: Clockwork, and Electric, d.c., 8 volts, £7 12s. 6d., a.c., 20 volts, with distant directional control, including controller, £8 17s. 6d.

The most popular gauge "o" scale locomotives we have ever made. "ROYAL SCOT" and "FLYING SCOTSMAN," 78/6 and 4 gns. respectively.

**SHIPS.** Does your interest lie in: Motor Boats, Yachts, Scale Model Ships, Waterline Models, Sets of Ship Parts, Drawings? If so, you will want S.12, 6d. post free.

## ENGINES.

Are you interested in: Engines, Boilers, Castings & Fittings, etc.? If so, write for B.12. Model Engine Catalogue, 6d. post free.



**BASSETT-LOWKE LTD., NORTHAMPTON,**  
 London: 112 High Holborn, W.C.1. Manchester: 28 Corporation St.

## ★ MERCO ★

Readers interested in "Model Railways in Miniature" MUST be interested in MERCO Products, which have made such modelling possible. Send 1½d. stamp for full lists and MERCO building paper samples to:

**MINIATURE EXHIBITION RAILWAYS CO.**  
 64 Watson Street, Dundee, Angus.

NOTE: Readers in the London area should make a personal visit to HAMBINGS, 26 Charing Cross Road, W.C.2. Entrance opposite Charing Cross Road P.O.

## "00" Gauge Miniature Railways

We supply sets of parts for home construction as follows:—

- Set of parts for Open Wagon, any railway . . . 2/3
- Set of parts for Closed Van, 20-ton type . . . 2/6
- Set of parts for Scale Loco, comprising 6-volt Electric mechanism ready for running, complete Body, Buffers, Boiler Fittings, etc. . . . 30/6

Send for lists and samples, 3d.

**HAMBINGS, 26 Charing Cross Road, W.C.2**

## BROOM'S INTERNATIONAL COURSE

No Course in the history of Physical Culture has ever achieved such remarkable results.

Over 20,000 testimonials have been certified by Accountant's Certificate. 700 Doctors and 27 Police Forces use this Course.

The Course consists of six Monthly Lessons. New apparatus is sent, including a new type of Spring Grip Dumbbells, New Leg Exerciser, Neck Exerciser, Roller Fore-Arm and Grip Outfit, and an All-steel Chest Expander, and the lessons are the last word in Physical Culture.

A New Book, packed with photos, giving the opinion of Experts on Modern Physical Culture methods, and it is FREE to every reader of this journal. It is the most instructional work on health and strength yet published, because it shows the quickest and surest route to success.

The full Course of six Monthly Lessons and Apparatus is 36s., or 1s. weekly, with a special MONEY BACK GUARANTEE.

SEND A POSTCARD FOR THIS BOOK: IT'S THE FIRST STEP TO BECOMING A MASTER MAN.

**H. BROOM, 553 HOLDERNESS RD., HULL**  
 The World's Premier Physical Culture Expert by Results



Bradley's

## ROSS for HEIGHT!



**CLIENTS GAIN 2 to 6 inches.**

- A. J., age 20 - gains 5 ins. in 5½ weeks.
- Miss L. F., 30 - " 2 " in 5 weeks.
- Miss C. A., 40 - " 1½ " in 6 weeks.
- L. K., age 20 - " 6½ " (5'8" to 6'2").

Increased my own height to 6 ft. 3½ ins.

Thousands of Testimonials from all over the world. Ross System Never Fails.

Full particulars 6d. stamp. Write now:—

**MALCOLM ROSS** Height Specialist, Scarborough, Eng. ←

No Appliances.  
 No Drugs.  
 No Dieting.

## FOYLES BOOKSELLERS TO THE WORLD

New and second-hand books on all technical subjects. Catalogues free on mentioning interests.

119-125 Charing Cross Rd., London, W.C.2. Telephone: Gerrard 5660 (12 lines)

# MODEL RAILWAY LAYOUTS



Fig. 1.—A view of the New Elmo Station on the West Midland Railway showing goods being backed up a 1 in 90 gradient.

**B**EFORE the subjects of baseboards and track-making are discussed, a few typical layout plans will prove interesting. Three designs are given, each one suited to a different kind of room, but first of all a few general principles which govern the matter of layout design must be given.

A common mistake is to allow no provision of track for the storage of wagons and coaches. Many an enthusiast has got hold of a thoroughly good plan to work upon and has completed the structure, only to find that he is limited to three coaches and about a dozen wagons owing to the fact that there is nowhere to leave them standing. Another important matter is that of providing plenty of headway clearance where more than one level of road is provided for. Bridges and tunnel entrances should not, except in special instances, be raised unduly for the clearance of rolling stock, but the greatest care must be taken to allow enough space to prevent any fouling. If it is simply the matter of a bridge headway, the standard loading gauge should be adhered to; but if it is a matter of leaving enough room for access to trains in case of derailment, there will be need for fully 3 in. or even slightly more. Where there is any covered trackway, it is a decided advantage if the whole of the upper covering of the tunnel can be made to lift off bodily. On no

.....By Edward Beal.....  
**Some Suggested model  
 00-Gauge Layout Plans  
 for a Small, Medium,  
 and Large Room.**

account should any point or crossing be placed within a tunnel or covered runway, and, wherever it is possible to do so, points should not be arranged at places difficult of access.

### Gradients

Avoid anything steeper than 1 in 40, and make your incline even more gradual than that if you can. It is often possible to shorten the length required for an incline, by running one track downwards and the other upwards, thereby reducing the distance, if necessary, by one half. There should be no curves sharper than 24-in. radius, 4-ft. diameter, measured to the outer rail, and, where it is at all possible, grade crossings should be entirely avoided. That is, where one line must directly cross another, the one should be carried over the other by means of a bridge.

The layout, Fig. 2, embodies the following interesting features. Two stations of the terminal type; up and down roads throughout; a continuous run so that trains may be operated as long as desired between the two stations; a single-line branch to a coal-mine; a large model dock basin complete with entrance lock, cargo crane, and three factories (F). These latter are arranged wholly on the background sheet, and may be built up of flat cardboard and brick-paper, using Mercro window sash papers. An absolute novelty incorporated is that of the gravity hump marshalling yard which we will discuss later. There is also a large locomotive depot to accommodate about a dozen engines. The whole of this system is included, without overcrowding, in a room 16 ft. by 12 ft., having an entrance on the north side. There are two levels in the layout, most of the formation on the east side being high-level (with rail-level 2½ in. above that of the low-level rail), the opposite west side being low, and the approach to the high-level occupying the north and south. The levels of the various tracks are clearly shown by the arrows.

### A Dock Basin

The dock basin is formed by simply removing certain of the boards which form

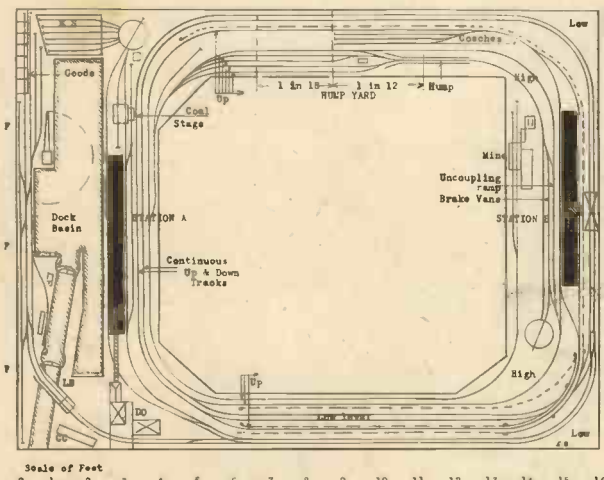

Fig. 2.—A plan of an 00-gauge layout for a room measuring 16 ft. x 12 ft.

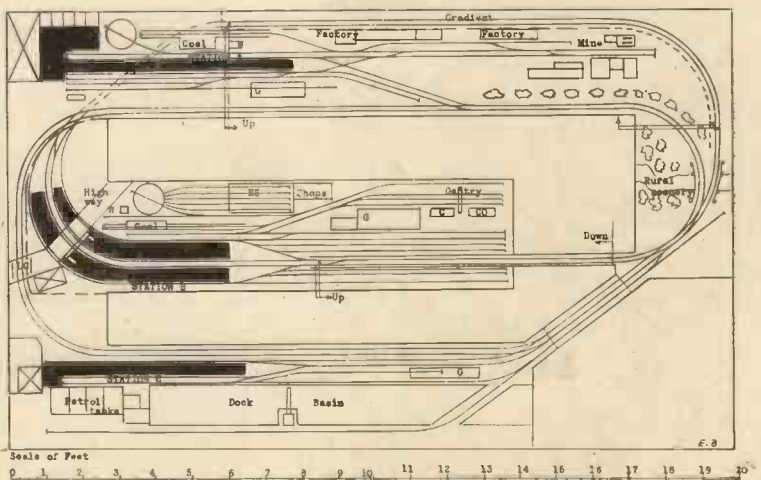

Fig. 3.—A layout plan for a room 20 ft. x 12 ft.

the base, and refitting these underneath the baseboard proper. The entrance lock, with the shapes for the dummy gates, will require to be specially cut out, the narrow jetty arm being laid in. To simulate water, the best material is heavy sheet glass, in one piece if possible, though the lock will require a separate piece. Between the boards and the glass should be laid thin cardboard or thick brown paper, suitably painted a dark, muddy brown, and sprinkled near the corners with some heather leaves or dyed sawdust.

Trains leave station *A*, running downward by the left-hand track, taking one of the tracks nearest the south wall, and joining the continuous track near the bridge. They pass under the building of station *B* and round the north side, down the continuous way on the east and then along the track marked "low level" between the two inclines on the south. They continue to take this circle as long as desired, then branch off up the left incline to the south and to station *B*. The other track, of course, is for the reverse run. Continuing from station *B*, the trains take the single inclined track above the coach sidings, and follow it right round the room to the pithead near station *B*.

#### The Hump Marshalling Yard

The hump marshalling yard will require elucidation. In planning this feature, which is the most instructive and fascinating of all railway models, it is desirable to branch the yard out of a high-level road and to run it by its normal down-grade out by a low-level. Fortunately, this is often possible, since these sorting yards are nearly always located in actual practice away from existing stations, and sometimes link up otherwise divided routes. We will assume that a goods train, with a main line engine at its head, arrives for marshalling on the track marked "ramp" at station *B*. This ramp is the well-known Lanal Uncoupling Ramp, and the engine is uncoupled on passing over it. It then runs on ahead, leaving its train, and taking the loco road just above the hump, coming down to the section which is parallel with the tracks on the west side. There it waits until required. Meanwhile, a shunting engine which has been waiting near or on the turntable at station *B*, gets behind the abandoned goods train and begins slowly to push. The points are set for the hump itself, which consists of a considerably raised length of track having a quite sudden fall on the off-side, and fitted with another ramp. As

the wagons pass over this hump they are automatically uncoupled, one at a time, and each runs quickly down the 1 in 12 gradient, taking the siding which is set for it, continuing to run more slowly down the 1 in 18, and coming to a pause before reaching the grid. The whole train is split up and arranged in this manner, each siding in the yard taking wagons for a certain district

that the doorway entrance is provided with a hinge flap in the baseboard for ingress; the hump yard has been so arranged that on this flap those tracks occur which do not require an outside conductor rail, though the main lines will require conductors.

#### A Layout for a Large Room

In Fig. 2 is shown a somewhat more

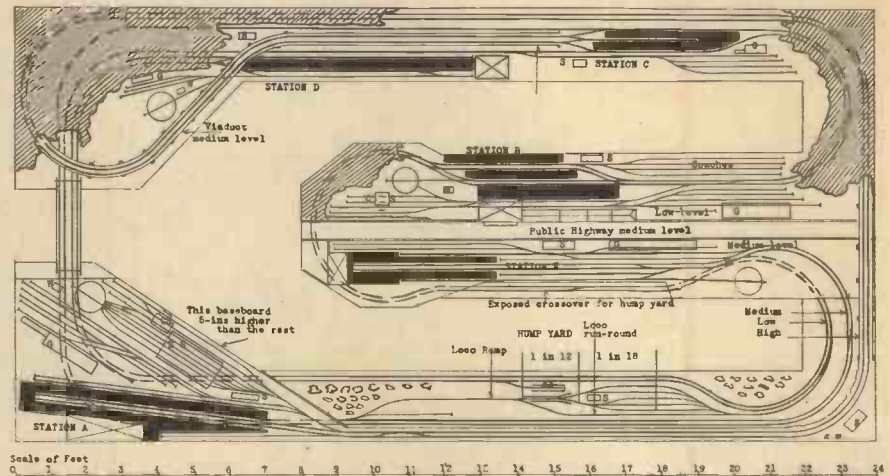

Fig. 4.—A layout plan for a room measuring 24 ft. × 12 ft.

or factory. The main line engine which has been waiting at the foot then gathers up the train again by backing in and out of the sidings and proceeds on its journey with its train correctly sorted. The hump itself is arranged to stand out well above the yard formation level, and the track upon it must be laid with some care and precision, all irregularities being avoided, yet the fall in gradient being definite and adequate. Much will depend upon the type of wheel bearings employed. The new "pin-point" bearings would require a slope less than half as steep as the common bearings. The builder should experiment with a batten before definitely settling upon the percentage to be adopted. The track marked "brake vans" serves the purpose indicated; several vans are stored at this point, so that if needs be the train can be broken up into more than one unit, the brake vans being, of course, sent down the hump last.

Reference letters will make clear the various buildings and other features. *F* means factory, *ES* engine shed, *G* goods shed, *LB* lifting bridge, *CC* conservancy cottages, *DO* dock offices. It will be noted

ambitious scheme for a large room, 20 ft. by 12 ft.—an unused garage being the ideal site. This plan, designed by the writer, has been in use in the south of England for some years, and appears to give every satisfaction to its enthusiastic owner. Here again there are two levels, with three stations and a dock. A large space near the corner is given over to the entrance, and there is a lift-bridge at this point. Starting from station *A*, the track being double all the way, trains take the double junction to the main line and follow the down-gradient over the bridge. Here station *B* is reached, where the main headquarters of the system are located. Tracks then pass beneath station *A* to the up-gradient on the north side, the trains running through rural scenery over the lift bridge and around the continuous run—a desirable feature for a small room—and thence finally to station *C* by the dock. There are a number of industries—two factories, a coal-mine, and a petroleum store. The locomotive depot at station *B* is very extensive. There is no turntable at station *C*, but one might readily be arranged near the tankery. In all in-

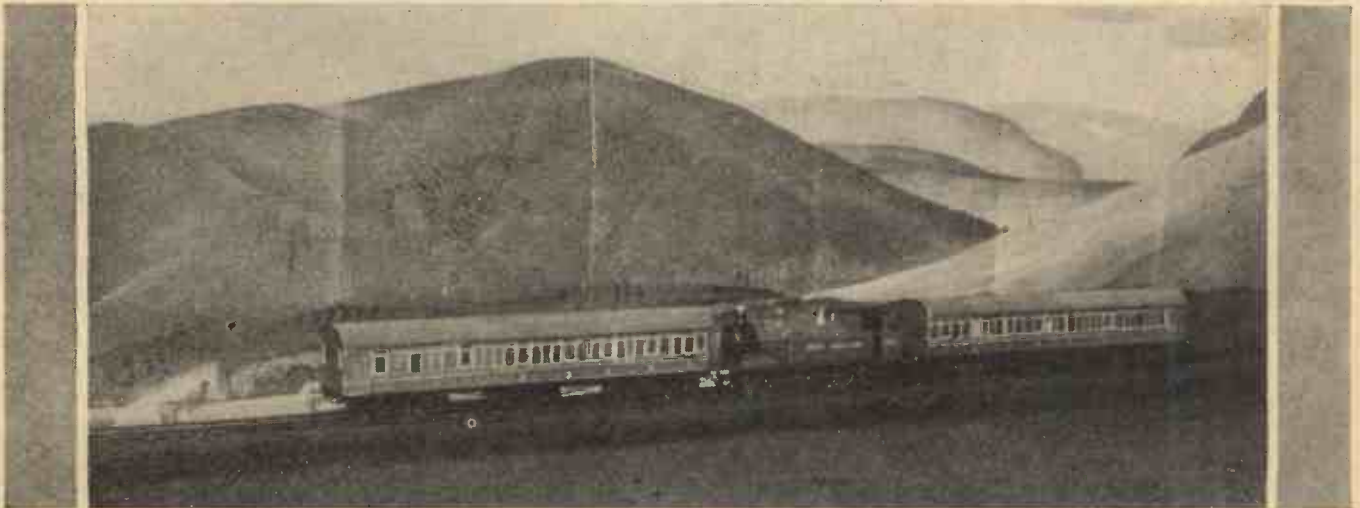

Fig. 5.—An 00-gauge auto steam train.



stances, crossovers for the escapement of engines arriving on trains at platforms, have been excluded from these plans, since the needs of these can be entirely eliminated by simply arranging a dead-alive section of conductor near the inner ends of such tracks. Arrived engines can thus be switched out and departure engines run on the other end of the trains, the arrival engine

The room is 24 ft. by 12 ft., and one purpose in including it is to show what rarely is shown—the beautiful amount of detail and the elaborate arrangement of roads which can be arranged within a fair-sized space in 00-Gauge. Nevertheless, the space is not really extraordinary; many an O-Gauge or large system occupies a much larger site to far less advantage. It is one of the common

tunnel loop in the north-west. Here they pass over the lengthy viaduct and run into the junction *C*. Here there is a double-track connection to station *E*, which we will discuss later. Continuing from station *C* the next halt is through the tunnel at the large station *B*. Then through another tunnel and underneath station *E*, around the room, to the north side, where *D* is at length reached. In the reverse direction, trains travel by way of the lift bridge near the doorway, under *A* and *E* to *B* and junction *C*. Here the downgrade may be taken instead of the road to the railhead *A*, and the route is by way of the lift bridge, along the south side, and up to the central, medium level station *E*.

**Three Levels**

On this layout there are three levels, but all gradients are extremely lenient, space being ample. The hump yard has an excellent situation between the medium and the low-level lines on the south side. Its arrangement is exactly as before. The island baseboard in the centre is divided by a medium (2½ in.) level public highway alongside of which are the station buildings for *B*, complete with baggage depot and three shops. There is no direct relation between this highway and station *E*, though the former serves to isolate the one side of the baseboard distinctly from the other. Note the exposed crossover for the hump yard. This enables goods trains after having been marshalled to pass from the up to the down track. There are generous locomotive facilities throughout; the main depot is at *A* where there is a mechanical coaling stage of the modern type, the running shed having approaches both by a grid and the turnable. There is a similar coaling stage at *B*, and here there are ample coach storing sidings. Here also there is a turntable, as will be found at the terminals *E* and *D*. The flying junction on the north side is of the opposite type to that in Fig. 1. There is a small engine shed at the hump yard, where the yard engine is kept. Note that the crossover for station *E* is situated on the east side of the layout, on the short straight section within the low-level loop.

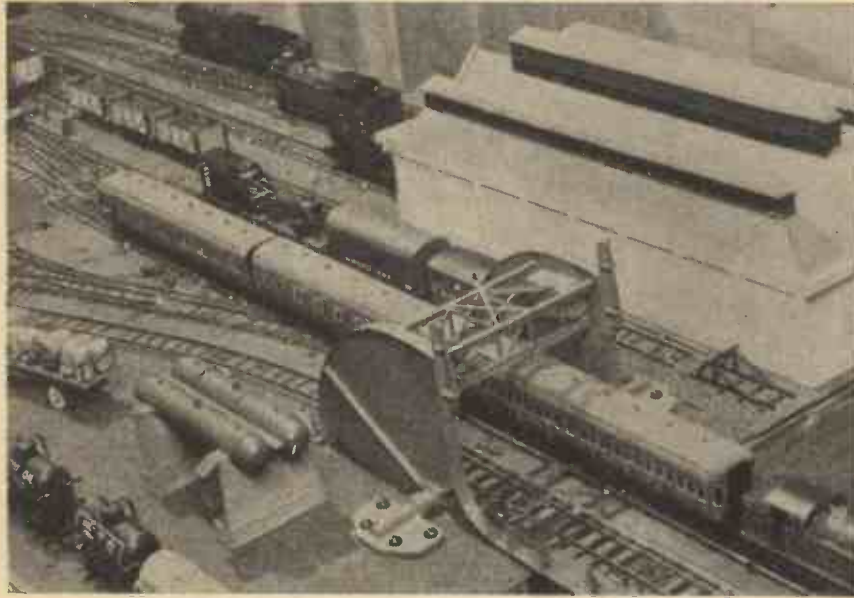

Fig. 6.—The bascule end of a new lift bridge on the West Midland Railway.

leaving after the train is out. An uncoupling ramp will, of course, also be required for uncoupling the arrived engine. Main line engines of considerable hauling power will be needed for this layout, as unfortunately there is a minimum gradient over the bridge to station *B*. The incline on the north side is not so severe.

**A Further Design**

The plan in Fig. 4 will be found a most interesting arrangement, though the space it requires is a little beyond the reach of many.

errors to assume that because there is a good-sized room at one's disposal, one will go in for a large gauge. For this reason, 00-Gauge never gets a fair trial, being nearly always confined to very restricted spaces. To lay this system would cost about one third the money involved in laying down a very limited O-Gauge system, notwithstanding the amount of track there appears to be.

The railhead is station *A*, and the route is not difficult to follow. Passenger trains first circle the room and take the concealed

## Operating a Sun-Ray Lamp

**M**ANY readers have shown a considerable amount of interest in the sun-ray lamp described in our last issue, and have asked for further details regarding the best method of operating it. The lamp can best be fed from a 200- to 250-volt supply of A.C. and should be connected *only* to a power point rated to supply not less than 10 amp. The reason for this is that the current is high when the arc is first "struck" by touching together the points of the carbons.

Additionally, it is necessary to connect a fixed resistance in series with the lamp to

The Particulars Given Below Are Especially Applicable to the Lamp Described on page 185 last month

prevent too great a current surge when the arc is first "struck." Such a resistance can be made very simply by using ½ lb. of 20-gauge Eureka resistance wire; this has a resistance of slightly under 28 ohms. The resistance of the carbons is about 2 ohms, so that the total resistance of the circuit is approximately 30 ohms. This

means that the maximum current which can flow when the lamp is first started is slightly over or under 8 amps.

A suitable form of construction for the resistance is shown below, where it will be seen that the wire is first made into a long spiral—about ¼ in. in diameter—after which it is wound round a strip of asbestos sheet, to which a pair of terminals is fitted. The simplest method of forming the spiral is to wind the resistance wire round a piece of iron rod; this should be about ⅜ in. diameter, because the turns will spring out slightly, due to the springy nature of the wire.

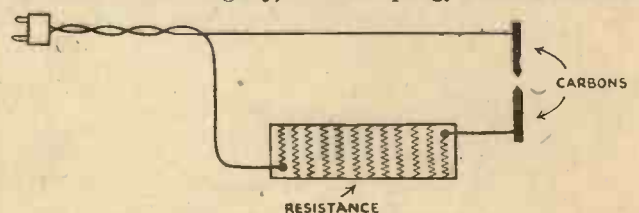
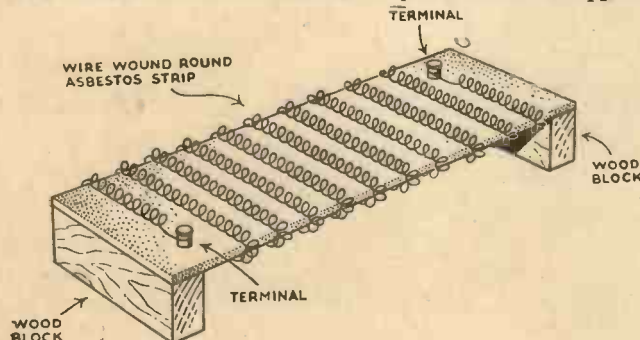

These two illustrations show the simple form of construction adopted for the series resistance, and also show how it is wired in series with the supply and the carbons. Provided that the correct length, gauge, and kind of wire is used it is not necessary that the exact form of construction shown should rigidly be adhered to.



**Newnes  
HOME  
MECHANIC  
BOOKS**

**ILLUSTRATED**

Your interest is bound to be here

- THE HOME WOODWORKER
- MODEL BOAT BUILDING
- THE HANDYMAN'S ENQUIRE WITHIN
- TOY MAKING FOR AMATEURS
- 25 SIMPLE WORKING MODELS
- MOTOR CAR UPKEEP AND OVERHAUL
- ACCUMULATORS—CAR AND WIRELESS
- MODEL AEROPLANES AND AIRSHIPS
- POWER DRIVEN MODEL AIRCRAFT
- SIMPLE ELECTRICAL APPARATUS
- LATHE WORK FOR AMATEURS

**Only  
1/- net**

From all Booksellers

**NEWNES**



# An Electric Spinning Game

There are several Ways of Playing this Simple Game, thus adding Excitement and Variety

A WIRE CONNECTS T<sub>1</sub> TO CENTRE BRACKET

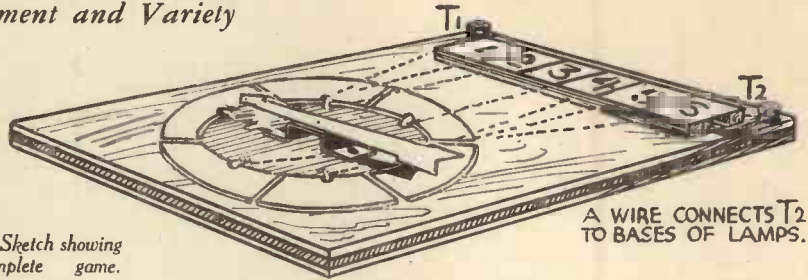

Fig. 1.—Sketch showing the complete game.

**T**HIS game, which works from a pocket battery, costs little more than a shilling, and will provide endless amusement during the winter months.

For a baseboard use a sheet of three-ply wood about 10 in. by 6 in., although you may make the model any size to suit yourself. Draw a circle of about 2½ in. radius on your baseboard, and another of 1½ in. from the same centre. Divide these circles into six parts by marking off the radius round the edge of each circle and cut out six pieces of tin to the shape shown in Fig. 1. These must be nailed or screwed to the base so as to leave a small gap between each piece. When cutting tin, it is always a good plan to make a paper pattern first. The pattern in this case is made by drawing the circles and dividing them as explained above. It will improve the appearance of the model if you make sure that the edges

them in position. These can be bought for a few pence, but if you prefer to make them yourself, fix to the base a strip of tin about 5 in. by ½ in. Then cut six pieces of tin 1½ in. by ¾ in. and bend as shown in Fig. 4. Make a hole into which your lamp will fit tightly. This may be done by punching a hole with a nail and enlarging it. Now screw the six brackets in position so that the bottom contact of each lamp will rest on the strip of tin. Make sure that each bracket is separated from the next by a small gap.

**Connecting the Parts**

Solder, or fix by screws, a wire to each piece of tin in the circle, and to the centre bracket. The wires are shown by broken lines in Fig. 1, whilst Fig. 4 makes it quite

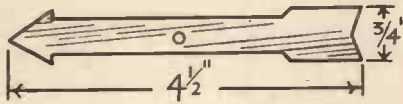

Figs. 2 to 4.—Details of the arrow, axle bracket, and lampholder connections.

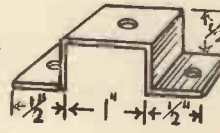

WIRE TO T<sub>2</sub>

of any pieces of tin that you may use are perfectly straight and smooth. If you do not possess a file, rub the tin on a stone to get a smooth edge. It is well worth your while to take a little trouble in order to make a model which will look neat and well finished.

**The Arrow**

The arrow is made from tin or sheet brass. An old pair of scissors will cut tin, but you may need special shears for sheet brass unless it is very thin. Make the arrow according to the size of your circle; 4½ in. by ¾ in. is a suitable size. Cut it to the shape shown in Fig. 2 and punch a hole in the centre.

The axle consists of a nail knocked through the baseboard from below. In order to make the arrow turn freely and to make a good contact, cut a piece of tin 3 in. by ¾ in. and bend it into a bracket as shown in Fig. 3. Punch a hole in the centre, slip it over the axle and nail or screw it to the board.

**Illuminated Score Board**

First obtain six small lampholders to take an ordinary 3.5-volt pocket bulb and screw

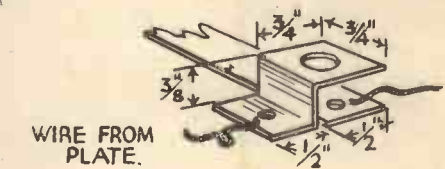

WIRE FROM PLATE.

clear how the wires must be connected to the lampholders. Each wire from the circle goes to a lampholder, and the wire from the centre bracket must be connected to the battery. Another wire goes from the tin strip under the lamps to the battery. If you have bought your lampholders, connect the bottom screw of each one to a piece of wire, which must go to the battery. This wire takes the place of the tin strip in the home-made lampholders.

Connect the wires from the tin plates to the lampholders, by passing them through holes and carrying them underneath the board so that they are out of sight. Remember that in all electrical models, the contacts must be tight and clean if you want good results.

**A Sliding Contact**

You can make a sliding contact between the arrow head and the circle by means of a short piece of copper flex. The arrow may be weighted by clipping a piece of tin round it. This will keep the wire in contact with the tin plates as the arrow turns.

Now make a box by nailing a suitable piece of wood on each side of the row of lamps and put a cardboard partition between each lamp. For the top of the box, glue a piece of tissue paper firmly in place and paint suitable numbers over each lamp.

# Money Making IDEAS

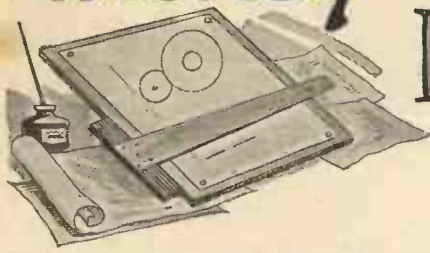

## AN ILLUMINATED DOG COLLAR

"**WOULD** an illuminated dog-collar be a fit subject for a patent, and do you think it would have any market value? "I have designed some for my own dogs, using different coloured lights to distinguish between them, and wondered if the idea was worth patenting." (E. P., Hants.)

**THE** broad idea of illuminating a dog collar is not patentable, but it may be possible to obtain a Patent for a specific method of carrying out such an idea. As no particulars are given of the method employed, it is not possible to advise further as to patentability of the proposed construction. The commercial value of such an invention will depend not only upon the cost at which the article can be sold, but also and principally upon the way it is marketed.

## AN ELECTRIC GAS-LIGHTER

"**MY** idea relates to an electric gas-lighter which ignites the gas by a spark, produced by pressure on a lever. "The spark is produced by electromagnets which are worked horizontally along the inside of the handle by means of the lever—one pull on the lever making one spark. "I should like to know if the idea is a novel one, and if I could get a patent on same." (H. C., Forest Gate.)

**THE** improved electric gas-lighter, if novel, would form fit subject for Patent. One of the earliest electric gas-lighters, some fifty years ago, employed a small influence machine in the handle which was operated by gearing set in motion by pressing a stud. The case of the handle was of ebonite, which was rubbed to generate an initial charge and the spark was produced at the end of a tube, forming an extension of the handle, as in a Wimshurst Influence Machine. A more recent invention, some twenty years ago, for use as a hand-lamp, comprised a small magneto within a casing, similar to a pocket-battery lamp, the magneto was operated by a rack mechanism set in motion on operating a pivoted handle against the action of a spring. It may be possible to obtain a Patent for a specific construction of lighter, but as no constructional particulars are given of the invention, no further useful advice can be given.

## AN AUTOMATIC GEAR-BOX

"**HAVE** just devised an idea for an automatic gear-box for a car. It is friction-driven, and the gear ratio is controlled by a governor. "When on a hill too steep to be taken in top gear, a small lever is moved, which acts against the governor, thus causing a lower ratio to be selected." (F. S., Sussex.)

Advice by our Patent Expert.

**THE** proposed automatic gear-box for motor road vehicles is not broadly novel. One of the earliest change speed gears employed a pair of coned drums, with either a belt or a movable disc between them.

The invention at present is extremely crude, and the object sought to be obtained has already been much more efficiently obtained by means of the "Hayes" friction-gear fitted to certain types of cars.

## AN IMPROVED CIGARETTE PACKET

"**I** SHOULD be grateful for your criticism of my improved design of cigarette packet, details of which are enclosed, and should be glad of information on the following points: (1) Do you consider the design suitable for the requirements of mass production and fit subject matter for protection by patent? (2) If so, would you advise me how to obtain a patent with a provisional specification. (3) What do you consider would be the commercial value of the idea?" (W. A., Kent.)

**THE** proposed cigarette packing is ingenious and in reply to the specific questions:

- (1) The packing is fit subject matter for protection by letters patent. As to the cost of mass production, this is not a matter on which an opinion can be usefully given. There does not seem to be any great difficulty in production, but it would possibly be more expensive than the more usual packings. Further information as to cost should be obtained from manufacturers making this class of goods.
- (2) The least expensive way of protecting the invention would be by filing an application for patent with a provisional specification which will give protection for twelve months, during which time it should be possible to ascertain the value of the invention.
- (3) Provided the production costs are not greatly in excess of present packings and the idea is novel it should have a distinct commercial value, since cigarette manufacturers are always anxious to obtain a selling advantage over their competitors.

## A DIRECT-CURRENT GENERATOR

"**I** PROPOSE constructing a homopolar or acyclic generator with the whole of the magnetic ironwork laminated, and to supply the field coil with a suitable speech current, superimposed upon a steady direct current. By running the generator up to a suitable speed by means of a prime-mover, I maintain that the armature current collected by the two brushes will be a steady D.C. current, with the speech current, similar to that in the field coil, superimposed upon it, but enormously magnified. The D.C. component could be suitably eliminated, and the remaining speech current passed into the primary of a transformer to be stepped up or down to the voltage required. "This, therefore, would be a means of amplifying a speech current without the use

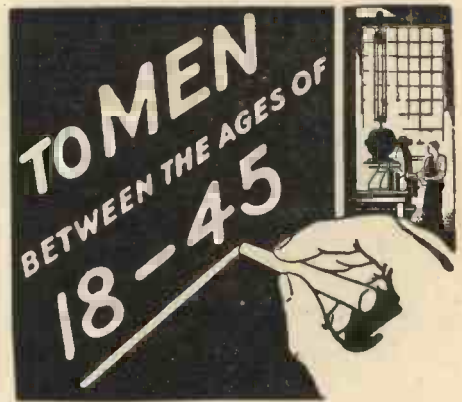

Things are happening to-day which vitally affect you!

If you are about 18, perhaps you are getting settled in your chosen work and already feeling the strain of competition for a better position. If you are in the 40's, your family responsibilities are near the peak, the necessity for money is tense—and younger men are challenging your job. And men of the ages between 18 and 45 face similar problems, in one form or another.

The most valuable employment security to-day is the security a man creates for himself—in himself! Through training, he is able to adapt himself to new conditions, to utilise experience without being handicapped by habit! He masters jobs and makes new jobs. He meets emergencies—and is not overwhelmed by them. And this is an age of emergencies.

For 44 years the International Correspondence Schools have helped thoughtful and ambitious men to acquire the training they need. To-day, with this need more urgent than ever, this world-famous institution offers greater opportunities than ever. Why not permit us to show you the way to greater security and larger earnings? Our expert advice is free. Write to-day.

.. COUPON FOR FREE BOOKLET ..  
INTERNATIONAL CORRESPONDENCE SCHOOLS, LTD.,  
Dept. 95, International Buildings, Kingsway, London, W.C.2.

Please send me your booklet containing full particulars of the Course of Correspondence Training before which I have marked X. I assume no obligation.

- |   |  |
|---|--|
| <input type="checkbox"/> Accountancy              | <input type="checkbox"/> Marine Engineering            |
| <input type="checkbox"/> Advertising              | <input type="checkbox"/> Mechanical Engineering        |
| <input type="checkbox"/> Aeronautical Engineering | <input type="checkbox"/> Mining Engineering            |
| <input type="checkbox"/> Architecture             | <input type="checkbox"/> Motor Engineering             |
| <input type="checkbox"/> Bookkeeping              | <input type="checkbox"/> Plumbing                      |
| <input type="checkbox"/> Building                 | <input type="checkbox"/> Radio                         |
| <input type="checkbox"/> Chemical Engineering     | <input type="checkbox"/> Railway Equipment and Running |
| <input type="checkbox"/> Civil Engineering        | <input type="checkbox"/> Salesmanship                  |
| <input type="checkbox"/> Draughtsmanship          | <input type="checkbox"/> Steam Engineering             |
| <input type="checkbox"/> Electrical Engineering   | <input type="checkbox"/> Textiles                      |
| <input type="checkbox"/> Engineering Design       | <input type="checkbox"/> Woodworking                   |
- Examinations, state which!.....

The I.C.S. teach wherever the post reaches and have a wide variety of courses of Study. If, therefore, your subject is not in the above list, write it here.

Name ..... Age .....

Address .....

**University  
Correspondence College**

Founder: WM. BRIGGS, LL.D., D.C.L., M.A., B.Sc.  
Principal: CECIL BRIGGS, M.A., M.C.

Students are prepared for

**MATRICULATION  
Intermediate and Degree**

Examinations of London University

The many special advantages offered by U.C.C. include the free loan of books to Matriculation and Special University Entrance Exam. Students. Fees are low and payment by instalments may be arranged without extra charge.

U.C.C. Successes at some London University Examinations during the ten years 1925-1934:

MATRIC. (Ordinary)	INTER.	B.A. & B.Sc.
4,377	2,383	2,333

**FREE GUIDES**

to London Matriculation (including the Special Entrance Exam. open to those over 23), Inter. Arts or Science, B.A. or B.Sc., may be had, post free, from the Registrar, 62 Burlington House, Cambridge

of thermionic valves and its associated complicated circuits.

"The initial speech current from a microphone, gramo or radio would then be amplified, by a preliminary valve amplifier, the output of which would be utilised as the field excitation for the proposed machine. The value of the above device to radio relay concerns, public address amplifier people, and as repeater apparatus for the General Post Office would be enormous.

"I wish to impress upon you the fact that the machine is not the usual commutator type of direct-current generator but the obsolete one-pole machine which was used many years ago as a plating and welding current generator, the output of which is an absolutely ripple-less direct current and yet does not make use of a commutator. Should you consider the above practical I should be obliged if you will give me the necessary advice on patenting same." (J. G., Carmarthen.)

THE proposed direct-current generator modified for the object in view, is thought to be novel and forms fit subject matter for protection by Patent.

It would probably be best to have a search made for novelty unless the inventor is fully cognizant with the subject matter of the invention. The invention appears to have great possibilities, and if the result of experiments prove the correctness of the theory, it should be a valuable commercial proposition.

**CRAZY BUILDINGS**

(Continued from page 232)

of corridors, halls, rooms, and passages, 120 miles of them, to say nothing of 1,200 doors and 2,673 windows. The cost was sixteen and a half million pesetas, perhaps equal to six and a half millions sterling today, but we could forgive it all if only it were beautiful. But, alas, it is as ugly as Dartmoor prison, which it closely resembles—I have seen both from outside. It is the world's most striking example of how little mere money and power can accomplish when brains and taste are lacking.

**The Empire State Building**

America has some modern white elephants, but—unlike El Escorial—they will be useful presently, and should pay handsomely when "Old Man Depression" has passed away. These are the biggest and latest skyscrapers, which—owing to the crisis—stand almost empty. The loftiest of all is the famous Empire State Building, now facetiously called the "Empty State Building," 1,250 ft. high, with 102 stories. It is so high that the top often pierces the clouds and stands in almost perpetual sunshine. It cost about ten and a half million pounds in our money, has 6,400 windows, and can provide room for 25,000 office workers, to say nothing of their business callers.

**A NEW HANDBOOK!**

Power-Driven Model Aircraft.

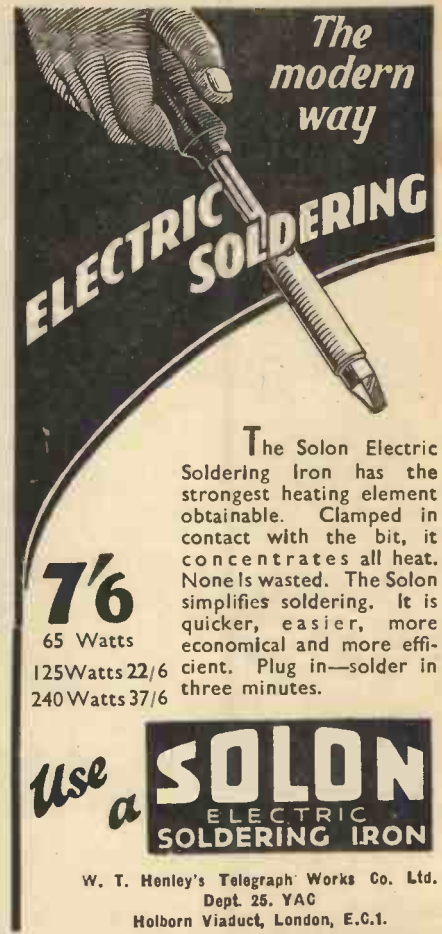

The Solon Electric Soldering Iron has the strongest heating element obtainable. Clamped in contact with the bit, it concentrates all heat. None is wasted. The Solon simplifies soldering. It is quicker, easier, more economical and more efficient. Plug in—solder in three minutes.

**7'6**  
65 Watts  
125Watts 22/6  
240 Watts 37/6

Use a **SOLOON** ELECTRIC SOLDERING IRON

W. T. Henley's Telegraph Works Co. Ltd.  
Dept. 25. YAG  
Holborn Viaduct, London, E.C.1.

**RUN YOUR MODELS FROM THE MAINS!!**

To obtain the utmost satisfaction with miniature Locos. or similar working models, it is essential that the source of supply is constant. The Heayberd TRAIN TRANSFORMER has been designed to give constant power with low running costs. A variable control is incorporated, enabling the model to be stopped, started, or speed increased or decreased. THESE MODEL TRANSFORMERS CAN BE HANDLED WITH PERFECT SAFETY.

**Model T101. Price 27/6**  
Output: Maximum 22 volts 3 amps.



Send Now for Free descriptive lists, of Heayberd Train Transformers, Rectifier Units, etc.

**F.C. HEAYBERD & CO.** 10 FINSBURY ST., LONDON E.C.2.

PLEASE SEND NOW FOR  
**THE STUART CATALOGUE NO. 3**  
6d. POST FREE

describing in 72 profusely illustrated pages the full range of Stuart products—STEAM ENGINES and BOILERS, PUMPS, PETROL ENGINES, FITTINGS, SCREWS, DRILLS, MATERIALS, ETC.



The "METEOR"

A high-speed engine complete with lubricator and stop valve

Only 18/6. Boxed 1/6 extra.

A most attractive present. Other engines from 5/-

**STUART TURNER LTD., HENLEY-ON-THAMES**

# The LATEST Novelties

The address of the makers of any device described below will be sent on application to the Editor, PRACTICAL MECHANICS 8-11, Southampton St., Strand, W.C. 2. Quote number at end of paragraph.

### A Picture Projector

KNOWN as the "K.W." Episkop the device shown on this page will be found suitable for projecting small photographs, cigarette cards, post cards, and views of small objects, etc., not larger than 3½ in. x 3½ in. Based on the principle of reflected light projection instead of the old-fashioned translucent method of the magic lantern, this projector can enlarge objects up to 15-18 times their original size. It can also project leaves, postage stamps, etc., in their original colours. The "K.W." Episkop is well ventilated and the sides are asbestos lined. Focusing is accomplished by means of a rack and pinion, and a silver-surfaced mirror projects the picture the right way up. The projector is arranged

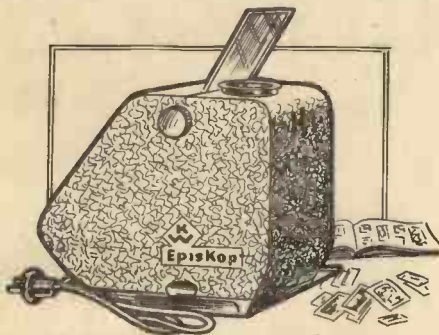

The "K.W." Episkop, which projects small objects such as leaves, cigarette cards, stamps, etc., in their original colours.

to take two pictures at once, so that whilst one is being shown, the one that has been shown may be removed and the next one inserted, thus avoiding delay. The pictures are held flat and kept in place by metal masks. Clear glass lamps of 100 watts (¼-watt type) are recommended for use in the projector. It weighs about 4½ lb. and measures 7½ in. x 4 in. x 9½ in. The price of the projector, including cable with switch and plug, picture carrier, and two metal masks is £5 15s. [162.]

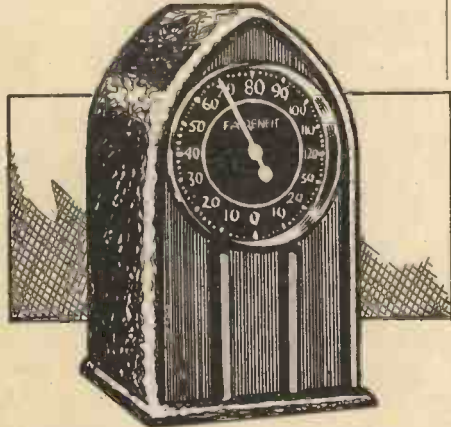

A neat and attractive thermometer which is similar in appearance to a clock.

### A Neat "Thermoclock"

THE thermometer shown herewith, which is not unlike a clock in appearance, is attractively designed in bakelite, and is practically indestructible. It can be used either as a room or bath thermometer. It sells at the very moderate price of 7s. 6d. [163.]

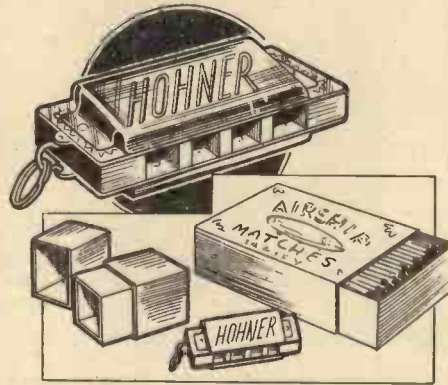

A midget mouthorgan, the size of which can be gathered by comparison with the matchbox shown.

### A Midget Mouthorgan

AGLANCE at the inset sketch will show the relation in size between a standard matchbox and this amazing little instrument. Although of such midget dimensions (it measures 1½ in. x ½ in. x ⅞ in.) it is possible to play a full octave, and the volume is quite surprising. Costing 1s. post free, it is supplied in a box but the ring shown in the sketch allows the instrument to be attached to the watch-chain. [164.]

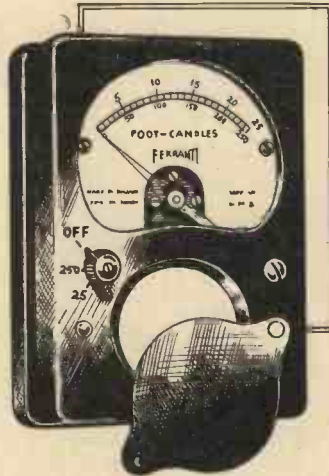

An ingenious light tester.

### An Ingenious Light Tester

THIS extremely useful instrument measures the intensity of light without the necessity for auxiliary apparatus of any kind. It consists of a sensitive moving-coil indicator, calibrated in conjunction

## THE GLUE THAT GRIPS Use STE-FIX

A PURE VEGETABLE GLUE ODOURLESS COLOURLESS

For Joinery, Fretwork, Leather, Model-making, Repairing Pottery, Glass-ware, etc., and for all purposes where a really powerful adhesive is required.

In Tubes 2d., 6d. and 9d.

Made by the Proprietors of STEPHENS' INKS, 57 Aldersgate Street, E.C.1.

ALWAYS READY FOR USE

## HEIGHT DOES COUNT



### Achieve It Easily

Short people can be made taller with the aid of a box of Challoner's Famous Formula—

### H.T.N. TABLETS

and easy system: well tried harmless and safe. No strenuous exercises or old-fashioned appliances. If one box is insufficient, we guarantee to supply a further box FREE of all charge. E.H. (Sutton) writes: "Results beyond expectations and I am as pleased as Punch." Act NOW! Send 1½d. stamp for full particulars in sealed envelope. Sample 7½d. Book on height improvement 3d. P.O. or stamps only. Colonial Return Air Mail 1/- extra.

THE CHALLONER CO (late of Bond St.) Department H34, Laboratory and Works: HYDE HEATH, AMERSHAM, BUCKS.

**GENUINE AND ONLY SUPER CHROMATIC MOUTH ORGAN**

CASH PRICE 10/6 POST FREE SPECIAL TUTOR  
SMALLER MODEL 6/6 POST FREE 1/- EXTRA

**LARRY ADLER**  
The world's greatest Harmonica Player.

This superb HOHNER INSTRUMENT can be played in ANY KEY (all 12 Keys) including all Sharps and Flats, exactly as your own Piano.

The world's BEST PIANO ACCORDIANS SUPPLIED. CASH OR EASY TERMS. SEND for ILLUSTRATED CATALOGUE TO:—  
**MODERN MUSIC STUDIO**  
High Holborn House (P.M.),  
52 High Holborn, London, W.G.1



**Can YOU Play the**

**Piano?** If you are a music lover, why have you not acquired this enjoyable accomplishment and great social asset? Doubtless because the prospect of practice! practice! practice! has dismayed and discouraged you. I AM ENROLLING 50-100 ADULT PUPILS EVERY WEEK. HAVE TAUGHT 2,800 THESE LAST 12 MONTHS, OVER 43,000 DURING 31 YEARS by post, by simple methods without mechanical practice, and I CAN TEACH YOU. I grade lessons to suit each pupil at start. Ordinary musical notation only used, no freakish methods, enabling you to read and play at sight any standard musical composition. Send P.C. for FREE book "Mind, Muscle and Keyboard," and form for FREE advice. Say Beginner, Elementary, Moderate or Advanced.

**Mr. H. BECKER,**  
(Dept. 258),  
69 Fleet Street,  
London, E.C.4.



**"Baker's" SOLDERING FLUXES**

Sold in 6d. and 1/- tins at all Cycle Accessory Dealers, Tool Shops, Ironmongers, etc.

Write for your free copy "Joining of Metals" to

**SIR W. M. BURNETT & CO. (CHEMICALS) LTD.**  
GREAT WEST ROAD, ISLEWORTH MIDDLESEX  
TELEPHONE: HOUNSLOW 0476

**USE WILCO MOTORS**

**THIS ONE**  
4-6 Volts

**12/6**  
Post Free

**Sturdily Built. Economical to run.**  
Made in several sizes for working off Batteries, Accumulators, or direct off the Electric Mains. Supplied with gearing as illustrated or just with 2 pulleys on shaft.

Other models and types from 3/- to 42/-.

**THE "WILCO" LOW VOLTAGE TRANSFORMER** with speed control, reduces 200/250 vt. A.C. to 2-8 volts. Capacity 3 amperes. Will drive small motors perfectly; also lights bulbs for models, etc. Price **15/6**  
Send for 40-page Electrical Catalogue "P.M." of other Models suitable for SPEED BOATS, etc., 3d., Post Free.

**L. WILKINSON, 8 City Road, London, E.C.**

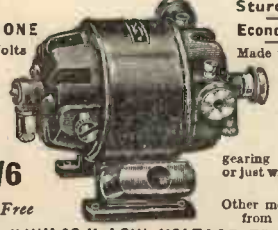

**Make More Money**

£3 to £6 weekly can be earned at home in a wonderful business of your own. No matter where you live you can commence to make money in your spare or whole time. No risk, canvassing or experience required. A wonderful opportunity for anyone wishing to add pounds to their income. Particulars, stamp.

**BALLARD, 71 Graces Rd., London, S.E.5**

with a photo-electric cell. The two are fitted in a polished black moulded case of handy size for carrying in the pocket. A small three-way switch at the front selects the range and, in addition, provides an "off" position. The cell is of the photo-voltaic type, which gives a potential between its plates when light falls on the front sensitised plate. The instrument has two ranges, enabling good reading to be taken of any light intensity from 1 to 250 foot-candles, and since direct values are given on the scales the instrument may be used by even an unskilled person. It costs £5 15s. 0d. [165.]

**A Glareless Lamp**  
**E**SPECIALLY designed to abolish glare, the glass bulb of this lamp is of novel formation. In the first place the bulb is



An electric light bulb specially designed to abolish glare.

moulded and not blown, as is the standard type of bulb, and thus greater strength is obtained. The moulding is carried out in such a way that the bulb is studded with tiny crystal-like incrustations, each of which is shaped to give perfect refraction of light, and it is claimed that these not only diffuse but also magnify the light from within the lamp. They may be obtained in sizes varying from 15 to 300 watts. [166.]

**The Silent "Bell."**  
**K**KNOWN as the "Sordoviso," the device illustrated hereunder will interest either those who are deaf or those who dislike noise. The device is connected with the electric bell system of the house and the electric lighting system, so that the bell push operates the lights. A switch

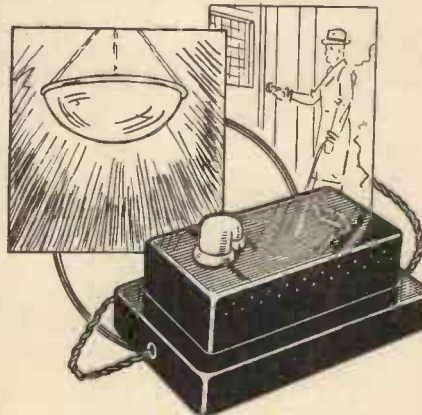

A novel type of "bell."

enables the device to be set for either day or night operation; that is, when the bell-push is pressed during the day the lights will automatically come on for a moment and at night they will flicker in an unmistakable way. Priced at 4 guineas, it is fully guaranteed and may be installed in a few minutes. [167.]

**Are Your EYES Weak**

If so, let us send you FREE our interesting book on "EYES" that gives complete advice upon how to strengthen and preserve the most WONDERFUL ORGAN OF THE HUMAN BODY. It shows how you can cure most defects without spectacles, drugs, or operations. All these admitted failures are superseded by the "Neu-Vita" System that successfully helps nature to strengthen the eyes and restore the vision. A safe mode of self-massage that gently stimulates the eyes by restoring the vital blood circulation—that is all your weak eyes need. For refractive errors—as Near-Sight, Far-Sight, Astigmatism, Squint, etc., due to eyeball distortion—the eye is moulded painlessly yet surely to normal shape. Five minutes' easy, self-home treatment wonderfully strengthens the eyes, counteracts eye-strain, cures headaches, corrects most eye troubles, and enables glasses to be discarded for good. Have faith in nature. Animals don't need spectacles; neither need humans.

**SEE NATURALLY**  
**Throw Away Your Eyeglasses.**

To spread eye knowledge the book (published price 1s.) is distributed freely at cost. Secure your FREE COPY now by sending 3d. (abroad, 6 foreign) stamps. Send no money or postcards. Simply enclose stamps, with full name and address to:

**NEU-VITA (Dept. J.F.28)**  
163-252 Central Buildings, London Bridge,  
London, S.E.1, England.



**THE "GRAYSON" LATHE**

**Price £4-5-0**

3-inch Centres, Back-Gear, Screw-Cutting Quick Traverse Action on Slide Rest. Delivered Free 50 miles radius of London. Leaflet P.E.1 free on request.

**E. GRAY & SON LTD.**  
(Established 1822)  
18 & 20 CLERKENWELL ROAD, LONDON, E.C.1

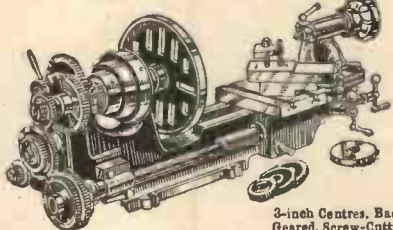

**BLUSHING FREE**

to all sufferers, particulars of a proved home treatment that quickly removes all embarrassment, and permanently cures blushing and flushing of the face and neck. Enclose stamp to pay postage to Mr. M. Temple (Specialist), "Palace House," 128 Shaftesbury Avenue (2nd Floor), London, W.1. (Est. 30 years.)

**DEFERRED TERMS ARRANGED**

**"IDEAL-LATHES"** 3 in. S.C. LATHES from £4.  
4 1/2 in. S.C.B.G. from £7/18/6. LISTS, Stamp please.  
J. WILLIMOTT & SON, Neville's Factory, Chilwell, Notts.

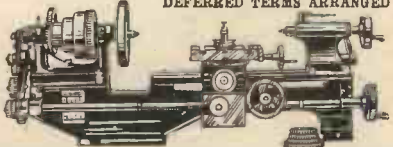

**WHEN REPLYING TO ADVERTISERS PLEASE BE SURE TO MENTION "PRACTICAL MECHANICS."**



A Review of the Latest Devices for the Amateur Mechanic. The address of the Makers of the Items mentioned can be had on application to the Editor. Please quote the number at the end of the paragraph.

**A Flashlight Screwdriver**

THE advantages of a flashlight screwdriver are immediately apparent, and its applications so numerous that it should have a place in every tool kit. It puts a definite spot of light on to the screw being driven, yet permits the operator to use both hands effectively on his work. The bit is securely anchored in the handle, which is specially designed for a firm grip. The insulated handle is made of the best quality

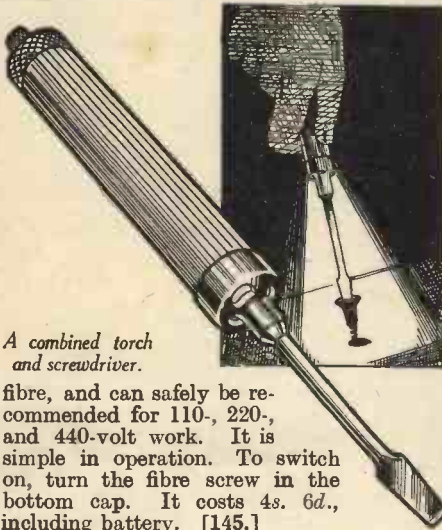

A combined torch and screwdriver.

fibre, and can safely be recommended for 110-, 220-, and 440-volt work. It is simple in operation. To switch on, turn the fibre screw in the bottom cap. It costs 4s. 6d., including battery. [145.]

**A Practical Saw**

THE difficulty experienced when cutting large surfaces of corrugated iron, asbestos, ebonite, etc., with an ordinary hack-saw will be appreciated by those who have attempted the task. The saw, illustrated on this page, has been specially designed for this job. The motion of operation, as will be seen from the inset sketch, is parallel to the work and this makes it possible to handle large surfaces. Two sizes are available. The 12-in. model, with 3 1/2 in. depth of cut, is sold at 8s. 3d., whilst the 16-in. model, with 7 1/2 in. depth of cut, costs 13s. 3d. Extra blades are obtainable at 4s. 3d. per doz. for the smaller and 11s. 2d. per doz. for the larger model. All the prices quoted are post free. [146.]

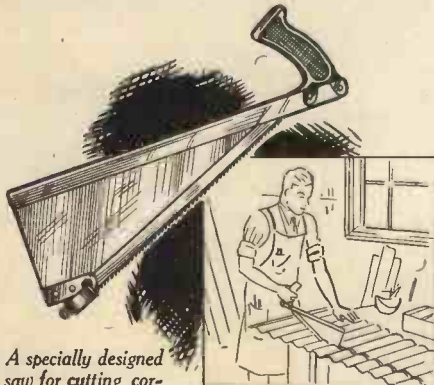

A specially designed saw for cutting corrugated iron, asbestos, etc.

**A One-hole Punch**

USEFUL for a variety of purposes in most offices this one-hole perforator should also "earn its keep" in the workshop, where it will be found very handy for punching holes in metal foil. Of exceptionally sturdy construction it is designed to punch holes through twenty-five sheets of paper and the solid steel plunger makes a hole



A one-hole punch that will be found suitable for a number of jobs.

3/8 in. in diameter. Two other models for 1/4 in. and 5/16 in. holes are available. The price is 3s. 6d. each, and the carriage is paid. [147.]

**Handy Pocket Torches**

A SMALL pocket torch is always a handy thing to carry about. The "Snaplite" is very compact, being flat and measuring only 3 in. high and about 1 1/2 in. wide. There is no external switch, the light being switched on by the "snap" lid which also forms the reflector for the light. It may be carried in the pocket, tool-box, anywhere, and will always be ready for use. A choice of six colourful designs is available. The price is 1s. 6d., and replacement batteries cost 6d. each.

Another interesting little device which incorporates the "Snaplite" is the "Kee Lite." This is a small fancy-leather case for carrying keys. The illumination provided by the torch enables one to select the right key on dark nights. Its size is such that it takes up very little room in the pocket or handbag. It is made in two grades at 3s. 6d. and 4s. 6d. in a variety of colours. [148.]

**A Midget Electric Grinder**

STURDILY constructed, the little electric grinder illustrated is easily clamped to the work bench and should prove a popular

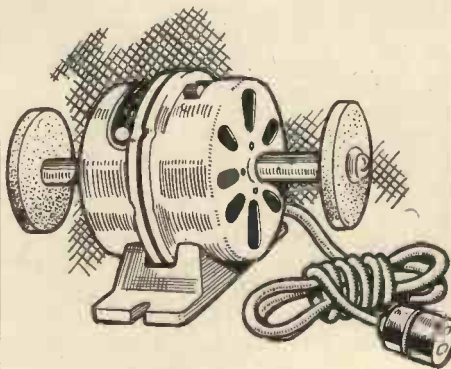

A midget electric grinder.

accessory to the practical mechanic's workshop. Operating from A.C. mains it is supplied with 2 yds. of stout rubber-covered cable. The two detachable grindstones (coarse and fine) are 2 in. in diameter and the switch, neatly mounted on the motor casing is a noteworthy feature. The price is 14s. 6d. carriage paid. [149.]

**Engineers' Guide**

Bright Prospects and Big Pay Opportunities for the trained man

Write to-day for this great Guide which contains world's widest choice of home-study engineering courses, and shows how to obtain a recognised Qualification such as A.M.I.Mech.E., A.M.I.E.E., A.F.R.Ae.S., etc. Mention branch, post or qualification that interests you, to THE TECHNOLOGICAL INSTITUTE OF GREAT BRITAIN, 123 Temple Bar House, London, E.C.4. (Founded 1917, 18,000 Successes.)



To Success



**MAN, READ THIS.**

You, too, can be a manly man—I guarantee to give you 10-25 lbs. more muscle, 2-6 ins. across your chest, 1-3 ins. on each arm, a splendid virile body, doubled strength, robust health, 12-28 lbs. increased weight—in 30 days or your money back.

World's record results from my 4-in-1 Course, the one complete all-round MAN-MAKING course which builds strength of Body, Brain, Nerve and Will. J. G. gains 40 1/2 ins. all-round muscle, 5 1/2 ins. on chest, 12 lbs. weight. W. H. increases 30 ins., 19 lbs. weight. J. B. gains 31 ins., health, strength, vitality. Testimony seen by Editors—thousands more. No apparatus. Pupil S. Davey (London) Recommended by "Health and Efficiency." For men aged 16-60. Complete 4-in-1 System costs not guineas, but only 5-. New intensive Course "How to Overcome Weakness and Build Virility" FREE if you enrol at once. LIONEL STEBBING, STEBBING INSTITUTE, Dept. G.P., 28 Dean Road, London, N.W.2.

**The DOSSSETT Studio**

SPECIALISTS IN TECHNICAL ILLUSTRATIONS



Write or 'phone us at HIGH HOLBORN HOUSE, HIGH HOLBORN, W.C.1. Tel. 8638.

**JUBILEE WORM DRIVE HOSE CLIPS**



The long-life clip with the ever-tight grip

The Best Known For Radiator Joints, Air, Oil, and Water Hose Joints.

Large sizes stop squeaking brakes.

Stocked by all Garages and Accessory Dealers

L. ROBINSON & CO., 25 London Chambers, GILLINGHAM, KENT.



**CASTING MOULDS**

Make your own lead soldiers, animals, Indians, etc.

Illustrated Catalogue free. J. Toymoulds, 18 Kenyon St., Birmingham

For Everyman



# NUFIX

TONIC DRESSING for the HAIR

13 & 19



Fixes without hardness or deposit. No gum. Does not soil Headwear or Linen. Contains emulsified vegetable oil. Prevents dryness. Eliminates Dandruff, and keeps the hair and scalp in perfect condition. Most economical in use. Trial Size 6d. From Chemists, Hair-dressers, etc. Manufacturers: Walden & Co. (Nufix), Ltd., London, N.W.9.

There are  
101 uses for  
HARBUTT'S  
**Plasticine**  
in the work-shop

Plasticine, in 16 colours, 1s. per lb.

Write for illustrated price lists to :—  
Harbutt's Plasticine Ltd., 241 Bathampton,  
Bath.

## Learn-To-Earn

### MONEY-IN-SPARE-TIME

Melton Fancy Leather Work offers a splendid opportunity for ALL to earn money making useful saleable articles at home on the Unit System. *Tuition Free.* Choice of several lines, weekly payments made on production sent to our works.

Write for Illustrated Booklet.

Dept. 521, The Melton Manufacturing Co.,  
265 Melton Road, LEICESTER.



The 'ADEPT' LATHE  
14 in. centres, 6 in. between centres. With compound slide-rest, £1, or with hand-rest only, 12/6. Screw Tall Stock 5/- extra. Post 1/-.

THE SUPER ADEPT, 30/-.

F. W. PORTASS, 83a Sellers Street, SHEFFIELD.

## PRACTICAL MECHANICS



# Replies to Queries and Enquiries

If a postal reply is desired, a stamped addressed envelope must be enclosed. Every query and drawing which is sent must bear the name and address of the sender and be accompanied by the coupon appearing on page 111 of cover. Send your queries to the Editor, PRACTICAL MECHANICS, Geo. Newnes Ltd., 8-11 Southampton Street, Strand, London, W.C.2.

### THERMO-COUPLES

"(1) IN connection with your reply to my earlier letter with regard to thermo-couples. I wonder whether you could let me know the voltage rise per couple per degree centigrade for the copper-constantan and the brass thermalloy couples.

"By very rough experiment, I found the figure for copper and iron to be 1/45,000 volt per degree centigrade. Is this correct?

"(2) Would you mind telling me the melting-point of constantan and thermalloy, as I cannot find them in tables.

"(3) Can the above metals be obtained in the form of insulated wire? I expect not, but it would be far simpler than fixing on loose sleeving.

"(4) Is it correct that soft solder melts at 188° C. and bismuth 272° C.?" (K. B., Winchmore Hill, N.21.)

(1) THE voltage rise per degree centigrade of a copper-constantan thermo-couple is of the order of approximately 13,500 microvolts (.013500 volt) and for the brass-thermalloy couple about 11,000 microvolts (.01100 volt), the latter figure being subject to considerable variation in accordance with the composition of the brass used. Your figure of 1/45,000 volt per degree Centigrade for the copper-iron couple is somewhat high.

(2) Constantan melts at approximately 1,200° C., thermalloy melting slightly above this temperature. Such thermo-couples, however, should not be used for temperatures above 500° C., since they oxidise or change in composition at higher temperatures. For temperatures above 500° C. thermo-couples of the platinum-iridium type are the most successful, although they give a third less current per degree rise in temperature than does a good copper-constantan couple.

(3) We doubt whether thermalloy can be obtained in the form of insulated wire, but we think that it is possible to obtain constantan in such form. Enquire at any large electrical wholesalers or wire companies.

(4) The melting-point of bismuth is 269° C., Ordinary soft solder melts at approximately 180° C., its exact melting-point being governed by the relative proportions of tin and lead present in the solder.

### THE THEORY OF BROWNIAN MOTION

"(1) COULD you explain the Browning Theory? I believe it says that if you pour milk and then tea into a cup, the milk and tea will mix much better, than if you pour tea and then milk into a cup. I am not sure that I have got the name right, but I think the principle is correct. I believe it is something to do with the molecules of the liquid.

"(2) Is it true that if you pour boiling milk and boiling coffee into a cup, they will curdle?

"(3) I have made an arc lamp from the inside of a battery. I took the carbon rods out, and connected them up to the mains, with a heating filament in the circuit in series as a resistance. I find, however, that the carbon rods have to be continually pushed nearer, as they are eaten away. Could you tell me the cause of this, and how it can be rectified? Should I use special carbon rods?

"(4) Could you explain how to make a simple apparatus for controlling a boat by wireless, having for preference an induction coil in the sending station?

"(5) What would be the best liquid fuel for a small rocket, and how could I purchase it, and what would be its cost?" (F. J., Surrey).

(1) YOU probably refer to the Theory of Brownian Motion, so-called after Robert Brown, a botanist, who first drew attention to the phenomena. If a very fine suspension of solid particles is made in water or in any other liquid and is examined under a high-powered microscope, the individual particles of solid matter suspended in the liquid will be seen to be in a state of continual motion and vibration. Similarly, if a cloud of tobacco smoke is passed into a glass cell and examined under the microscope, the individual smoke grains will be seen to be in a state of continual movement. Many theories have been suggested to account for these and similar phenomena, but the theory now universally accepted is that the solid particles suspended in a liquid or in a gas (air) are maintained in a state of haphazard movement owing to the motions of the actual molecules of the liquid or gas. They are, as it were, tossed about here and there by the moving molecules.

The Theory of Brownian Motion is allied to the Kinetic Theory of matter which postulates that all matter is in a state of perpetual motion and vibration. If two liquids are mixed, the particles or molecules of each liquid intermingle with those of the other liquid. It is easier for this intermingling of molecules to take place between some liquids than between others, but we think that in the example of the mixture of tea and milk which you refer to the easier admixture (if any) of tea infusion added to milk is due not to molecular influences but to the physical nature of the particles of milk-substance coagulated by the tea tannins.

(2) If boiling milk and boiling coffee infusion are mixed, true curdling of the milk will not take place. The mixed liquids, however, will form a surface skin due to the coagulation of the milk albumins by the heat and by the coffee tannins.

(3) When an electric arc is struck between two carbon rods, the ends of the rods invariably wear away, one forming a depression or crater and the other a point.



**PATENTS,  
TRADE MARKS  
AND DESIGNS**

**FREE!  
ADVICE, HANDBOOK  
AND CONSULTATIONS**

**KINGS PATENT AGENCY LTD.**

B. T. King, O.J.M.E., Patent Agent G.B., U.S.A. & Can.  
146a Queen Victoria Street, LONDON, E.C.4  
50 Years' References. TELEGRAMS: GHOLOGO, LONDON.  
PHONE: CRY 6191.

**PRACTICAL HINTS ON  
PATENTS**

Sent free on application.

**THE IMPERIAL PATENT SERVICE**  
First Avenue House, High Holborn, W.C.1.

Preliminary Consultation Free.

**PATENTS, DESIGNS  
AND TRADE MARKS**

A VALUABLE GUIDE ON INTERNATIONAL  
PROTECTION OF INVENTIONS.

100 Pages - Post Free, 6d.

**The TECHNICAL ADVERTISING AGENCY**  
253 (D) Gray's Inn Road, London, W.C.1

**WEBLEY AIR PISTOLS**

Marvellously  
accurate for  
target practice.

No license required to purchase.

Senior 45/-, Mark 1 30/-,  
Junior 20/-, Webley Air Rifle 80/-  
Write for List. WEBLEY & SCOTT LTD.,  
101 WEAMAN STREET, BIRMINGHAM, ENG.

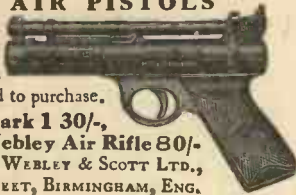

**DID YOU READ LAST MONTH'S  
MODEL RAILWAY ARTICLE ?**

HO SCALE MODEL OO  
3.5 m/m. RAILWAYS 4 m/m.

All the best models, parts and fittings, for Perfect  
Scale Model Miniature Railways are made and sold by  
**STEWART-REIDPATH LTD.**  
D11 Herne, Herne Bay, Kent.

Illustrated Catalogue - - - - 7d., post free.

**DON'T BE BULLIED**



Learn to tear no man. The  
BEST self-defence ever in-  
vented, namely, **JUITSU**.  
Easy to learn. Send 2 penny  
stamps for **SPLendid ILLU-  
STRATED LESSONS**. Photo  
ARTICLE, Testimonials and  
particulars, or P.O. 1/- for  
FIRST PART of my course.  
You will be more than  
delighted.  
Dept. F., Blenheim House, Bed-  
font Lane, Feltham, Middlesex.

**MAKE MONEY PICTURE FRAMING**



Picture Framing, Tray-making,  
Craft Work, etc. Wonderful  
Wholesale Bargains in Mould-  
ings, Beadings, Frets, Plys, Jaco-  
bean Legs, Table Tops, Corner and  
Tray Mouldings, Fine Art Pictures,  
New Chromium Beadings.  
Fully Illustrated Guide post free.  
**WATKINS PROVIDER**  
EXCHANGE WORKS, NEWPORT, MON.

**BE TALL**

Your Height increased  
in 14 days or money  
back. The amazing  
Stebbing System soon  
brings 3-4 inches

increase and new energy. The first, original and  
the one **GENUINE GUARANTEED** height increase  
System. Recommended by **Health an Efficiency**. Com-  
plete Course, 5/-, or 6/- kit free privately

**STEBBING SYSTEM**, Dept. M.F., 28 Dean Rd, London, N.W.1

This effect is due to the volatilisation of the carbon by the intense heat produced. Also, some of the carbon is actually burned away to carbon dioxide gas. There is no means of avoiding the wearing away of the carbon electrodes. Professionally made arc lamps contain devices whereby the carbon electrodes are continually kept at the same distance apart, one carbon being fed forward as it wears. Such devices may be hand-operated or controlled by electro-magnetic means or by mechanical arrangements. The commonest carbon rod adjustment is, of course, by means of a hand-operated screw, as used in optical lantern arc lamps.

(4) There is no simple apparatus for controlling a boat by means of wireless. It is, of course, quite possible to accomplish such a feat, but the apparatus required is complicated and it is obviously impossible for us to describe here the working details for the construction of such radio apparatus.

(5) You cannot use a liquid fuel in a small home-made rocket. Some experimental rockets, designed and constructed on a fairly large scale have used liquid fuels consisting of petrol and liquid oxygen. Such fuels, however, require very special precautions and it is quite impossible for any ordinary amateur constructor to make use of them.

**REPLIES in BRIEF**

**D. O. B. (Saltburn).**—The formula required for determining the exact number of turns of wire per volt is an involved one and depends upon the user having knowledge of the structure of the particular type of iron employed, the length of the magnetic circuit, the weight of metal, and so on. For this reason, we consider that it would not be of any value to give you the complete formula and suggest that you adhere to the "rule of thumb" method outlined in the article to which you refer, i.e. with core 1 in. cross-section use eight turns per volt at 50 cycles.

Stalloy stampings are obtainable from the Lumen Electric Co., 19 Scarisbrick Avenue, Litherland, Seaforth, Lancs.

**F. H. (Sheringham).**—It is impossible to tell you how to attach the plywood without details of the construction. Why not adopt the methods used in connection with the "Flying Flea?"

**E. W. J. (Northfleet).**—The discs are probably obtainable from C. Baker Ltd., 244, High Holborn, W.C.1.

**F. McV. (Manchester).**—We cannot trace any publishers of blue prints or books giving the information you require.

**F. E. P. (Birmingham).**—Without knowing the make of headphones, it is impossible to advise you. It is extremely probable that the letter "P" is merely a type number.

**H. F. (Dublin).**—Details of how to build the "Flying Flea" have appeared in our issues dated October, November, and December. Back issues will be sent to you for 7d. each, post free. You can easily convert the dimensions by remembering that there are 2.54 centimetres to an inch and 25.4 millimetres to an inch.

**H. C. O. (Watford).**—Plans of the "Petrol from Coal" model are not available.

**B. J. (Welwyn).**—The converted motorcycle engine will be unsuitable for the "Flying Flea." We do not recommend you to use an engine below 15 h.p. Unfortunately, we cannot undertake to modify the design to suit individual materials and equipment.

**'WELCOM'  
Model Aircraft**

Obtainable from Stores, Toy  
Dealers, Stationers, etc., or  
in case of difficulty from the  
sole manufacturers :

**Williams, Ellis & Co., Ltd.**  
82 Farringdon Street, E.C.4

Makers of the famous "Flying Flea" Model.

LISTS ON APPLICATION



**INEXPENSIVE  
CHEMISTRY  
EQUIPMENT**

APPARATUS & CHEMICALS  
FOR STUDENTS' LABORATORIES.

**SPECIAL PARCEL OF APPARATUS.**  
1 Flask, flat bottom 150 c.c., 1 Beaker, spouted 100 c.c., 3 Test  
Tubes 4 in. x 1/2 in., 1 Thistle Funnel 20 cm., 3 ft.  
Glass Tubing, 1 Rubber Cork 2 holes, 4 inches Rubber  
Connection Tubing, 1 Glass Stirring Rod. **2/6** Post  
Free

IF THIS SELECTION OF APPARATUS IS NOT WHAT YOU  
REQUIRE, WRITE FOR OUR NEW CATALOGUE CONTAINING  
FULL DETAILS OF OTHER SETS FROM 2/6 TO 105/-.

**BECK** (Scientific Dept. A.), 60 HIGH STREET,  
STOKE NEWINGTON, LONDON, N.16  
Write for New Catalogue—FREE.

**WHAT THE EYE  
CANNOT SEE 4/9**

**The Microscope Reveals!**

A most fascinating hobby and an education. Complete set comprises Powerful triple-lensed all-metal Table Microscope giving tremendous magnification, with adjustable focus and reflecting mirror, stage holder, spare slides, mounts and covers, for making own specimens, special tinted collecting jar, setting rod, tweezers and glass dip rod and powerful hand magnifying glass. Fitted box included, also full instructions for using this scientific instrument. Limited number only. Send NOW! **Wm. PENN** (Dept. M.4), 623 Holloway Road, London, N.19

**CHEESE!**  
**A BEES KNEE!**  
**POND WATER!**

**HAVE YOU A RED NOSE ?**

Send a stamp to pay postage, and you will learn how to rid yourself of such a terrible affliction free of charge.

Address in confidence—  
**P. TEMPLE, Specialist**  
"Palace House," 128 Shaftesbury Avenue, W.1  
(Est. 30 years.)

**RIFANCO RADIO-ANEX-A-GRAMS AND GRAMOPHONES**

YOU CAN turn a wireless set into a **RADIO-GRAM**. 1936, 40-page catalogue 2d., of complete machines, kits, electric and spring motors. Pick-ups, sound-boxes, tone-arms, horns, cabinets, hinges, lid-stays, springs, gears, repairs, needles. Piano-accordions, violins, mandolines, banjos, strings. Low prices. Trade supplied. List Free. (Also radio goods). Est. 32 years. D.285. **THE REGENT FITTINGS Co.**, 120 Old Street, London, E.C.1.



# BUY, EXCHANGE OR SELL

Advertisements are accepted for these columns at 2d. per word (minimum 12 words at 2s.—advertisements of less than 12 words are charged at the minimum rate of 2s.), subject to a discount of 2½% for 6 consecutive monthly insertions or 5% for 12 consecutive monthly insertions. **TERMS:**—Cash with order. Cheques, Postal Orders, etc., should be made payable to George Newnes Ltd. *The Proprietors reserve the right to refuse or withdraw advertisements at their discretion.* All advertisements must be received on or before the 5th of the month preceding date of publication and should be addressed to the Advertisement Manager, "Practical Mechanics," George Newnes Ltd., 8-11 Southampton Street, Strand, W.C.2.

## AIR COMPRESSORS

**BUILD "GUST-O-WIND" COMPRESSORS.** Castings or finished parts. Single or Multiple Cylinders.—Gusto Model Co., Whitefield, Lancs.

## BUSINESS OPPORTUNITIES

**MAKE MONEY** from Drained Motor Oil, **FULL INSTRUCTIONS** 1/-, **LIQUID LIGHT** Pocket Lamp, no matches, no heat. Costs only few pence to make. **COMPLETE INSTRUCTIONS** 1/-, **MAKE and SELL "ELECTRIC LINIMENT"** A £10/10/- **FORMULA** for 2/6. Thousands of formulas from shilling upwards. (Lists and literature 4d. stamps.) **"TECHNOCRAFT,"** 41 Longford Place, Manchester.

## CAMERAS

**FOLDING KODAK**, Cook Lens, 12/6; Vest Pocket Special 15/6; Postcard "Westminster," 25/6.—Hobbs, 20 Mansebrae, Glasgow, S.4.

## CINEMATOGRAPHY

**ARTISTIC CINE FILMS.** Exclusive productions now available in 9.5 mm. and 16 mm. List Free. Projectors from 27/6. Pocket Cinema 25/-.—P.M. Dane, 64 Stanley Street, Liverpool, 1.

**CINEMA TOGRAPH FILMS.**—Standard size from 6d. 100 feet. Machines, Accessories. Sample Films, 1/- and 2/6 post free. Catalogues free.—"Filmeries," 57 Lancaster Road, Leytonstone, E.11.

**CINEMA FILM (35 mm.).** 100 ft., 1/-; 200 ft., 1/9.—Hobbs, 20 Mansebrae, Glasgow, S.4.

**MOVIES AT HOME.** How to make your own Cinema Projector. Particulars free. Moviescope, Pear Tree Green, Dodinghurst, Essex.

**"FILMCRAFT."**—Here is a fascinating series of authoritative textbooks for everyone interested in the Cinema as the newest of the arts. The **Filmcraft** series, each 3s. 6d. net, includes volumes by Pudovkin, Adrien Brunel, G. E. Kendall, D. Charles Otley, Percy W. Harris. From all Booksellers and Newsagents.—George Newnes Ltd., 8-11 Southampton Street, Strand, London, W.C.2.

## ELECTRICAL

**ELECTRIC MOTORS, DRILLS, GRINDERS,** A.C.—D.C., all voltages, from 18/-. Lists free. Repair specialists.—EASCO, Electrical Service, 18 Brixton Road, S.W.9.

**INSTRUMENT MAKING,** Acoustic and Electrical, etc. Inventors' Models, Experimental Work, Machining, Gear Cutting, Turning, Screw Cutting, Milling, etc. Send requirements for quotation.—Gaydon & Co., Scientific Engineers, 42a Sydenham Road, Croydon.

**ELECTRIC MOTORS,** second-hand, guaranteed, all sizes, low prices.—Geeco Ltd., 47 Pitt Street, Glasgow, C.2.

**SURPLUS ELECTRICAL** and Engineering Materials, low prices.—The London Electric Firm, Croydon.

**ELECTRIC SOLDERING-IRONS** fit any light socket, two, as new, 2/- each.—Tayler, 9 Grove Rd., Balham, London.

**ELECTRIC LIGHTING,** 5/- a point: progressive wiring diagrams and instructions, 6d., materials, wholesale prices; lists free.—P. Symax & Co., 263 Lichfield Road, Birmingham, 6.

## ENGINEERING

**AN ENGINEERS' LIBRARY** for 8/6 post free. Fowler's Pocket Books 1936: Mechanics' and Machinists' 2/3, Mechanical Engineers' 3/3, Electrical Engineers' 3/3. Now ready.—Scientific Publishing Co., 53 New Bailey Street, Salford.

## ENGINES

**ENGINES.** Build Butler's ½-h.p. practical Model Petrol Engine. Set of Castings, 9/9. Interesting Catalogues 3d. **TAPS.** Your own stocks, dies, taps, ½ in., ⅜ in., ¼ in. and 3 taps, 12/-.—Write Profit-Sharing Works, Littleover, Derby.

## LITERATURE

**CALVERTS MECHANICS YEAR BOOK 1936.** Over 190 Pages. Illustrated Workshop Hints and Calculations. 8d. post free.—Endors & Co., 5 Bridge Street, Manchester.

## MAGIC

**WORLD'S GREATEST BOX MYSTERY** (Professional), £8. Consider exchange for Modern Duplicator, Typewriter.—Particulars "DEVILLE," 41 Longford Place, Manchester.

**PERPLEXITIES AND TANTALISERS.**—"The Strand Problems Book" is the finest collection of puzzles of all kinds ever assembled, mathematical, geographical, literary—acrostics and codes, by W. T. Williams (Tantalus) and G. H. Savage. Only 2s. 6d. net, from all Booksellers.—George Newnes, Ltd., 8-11 Southampton Street, Strand, London, W.C.2.

## METAL WORK

**MAKE METAL TOYS.** Mould List Free. Special trial offer—Complete metal mould, making lion, with simple instructions 1/6 (post extra abroad).—LEES, Bentinck Road, Nottingham.

## MISCELLANEOUS

**"DIE-CASTING IN LEAD"** tells how to make lead Soldiers, Cowboys, Animals, etc., with complete catalogue of sizes. 1/2.—Industries (below).

**"HOME TOYMAKING,"** just published, with 180 illustrations of practical amusing toys. 1/2.—Industries (below).

**DOLLS' HOUSE BRICKPAPER.** Roof, flooring, bedroom, kitchen and fancy papers. Six assorted sheets, 1/6; 12 sheets, 2/6.—Industries, 13 Gordon Avenue, Twickenham.

**STOP SMOKING.**—Send 2/6 for complete treatment; immediate results guaranteed.—"Peacock," 752D Bury Road, Bolton.

## MODELS

**INVENTORS' and ENGINEERS' Drawings, Models, Patterns.**—Bland, 105a Crawford Street, London, W.1.

**STEEL TUBING,** Seamless, ¼ in. to 4½ in., ½ in. to ¾ in. thick. Please say lengths you cut to. Cotes, Church Walk, Brentford, Middx.

**PERFECT SECOND-HAND MODEL BARGAINS.** Catalogue 4½d.—Model Exchange, 11 Friars Street, Ipswich.

**AN INVALUABLE Handbook.** **ACCUMULATORS.** Up to date, practical, dealing with every type of accumulator, methods of charging them at home, care and maintenance. This little book also explains how to erect a charging station. This is one of Newnes' Home Mechanic Books. Ask your Newsagent to show you other Titles in this Helpful Series. Obtainable at all Booksellers, 1s. each.—George Newnes, Ltd., 8-11 Southampton Street, Strand, London, W.C.2.

**ARE YOU HANDY** With Your Hands?—If you like making and mending things you ought to know about the "Home Mechanic" Series of 1s. Handbooks. They cover a wide field, from model and toy-making to motor-car upkeep and radio construction. Each is complete in itself and fully illustrated. Price 1s. each from all Booksellers and Newsagents (from whom a list of subjects can also be obtained).—George Newnes Ltd., 8-11 Southampton Street, Strand, London, W.C.2.

**"WORKING MODELS and How to Make Them."** Edited by F. J. Camm, 3s. 6d.—This book will appeal to all who are handy with tools. Contains complete instructions for the making of every kind of working model. Each model has been actually constructed in accordance with the details given and subjected to stringent tests. The instructions and diagrams are so clear that even the most elaborate model can be built without fear of failure. Obtainable at all Booksellers and Newsagents.—George Newnes, Ltd., 8-11 Southampton Street, Strand, London, W.C.2.

## MONEY-MAKING

**MONEY-MAKING OPPORTUNITIES** constantly occurring; highly recommended: particulars free; send postage.—Messrs. Green, 17 Church Lane, Hull.

**YOU WILL BE DELIGHTED** with our money-saving Catalogue. Endless variety. Postcard now.—Green's, 323 Albert Street, Lytham.

## MONEY-MAKING BOOKS

**SECRETS OF WEALTH** for the ambitious. Send for catalogue giving information on money-making ideas, mail order schemes, hypnotism, sports, etc. Send stamp to B. C. Aston (G), Halfway House, Bentley, Walsall, Staffs.

## MUSICAL INSTRUMENTS

**PIANO-ACCORDEON,** organ-like tone, fully guaranteed for only 20/- deposit. Write for list and 3-day **FREE TRIAL OFFER.**—Hessy's, 18/20 Manchester Street, Liverpool.

# BUY, EXCHANGE OR SELL FREE SERVICE FOR READERS

## PATENTS

**REGINALD W. BARKER & CO.** (Established 1886), 56 Ludgate Hill, London, E.C.4. Patent and Trade Mark Booklets Gratis.

## PHOTOGRAPHY

**£500** worth good, cheap Photo Material, Films, Plates, Cards, Papers, Chemicals, Catalogue and 4 Samples Free.—Hackett's Works, July Road, Liverpool 6.

**POSTCARDS FROM ANY PHOTO.** Time to finish, four days. 25 1/9; 50 3/-; 100 5/-; 500 17/-; 1,000 30/-. Enlargements 1/- Samples and List Free.—Hackett's Works, July Road, Liverpool 6.

**DON'T TAKE RISKS.** Good developers mean good results. Our reliable stock developers keep twelve months after mixing. Satisfaction certain to amateurs and professionals. Best developer ever put on the market. Makes two pints strong developer. 6d. each. 6 for 2/3, 12 for 4/-. Post free.—Hackett's Works, July Road, Liverpool 6.

**4 DELIGHTFUL, ARTISTIC STEREOSCOPIC SLIDES, 1/-.** Lists free.—Smith, 31 Henley Street, Oxford.

## SITUATIONS VACANT

**PERSONS WANTED** (either sex); homework, addressing envelopes, circulars, etc.: material supplied free. Write only—Somerville & Co., 49 Bow Lane, London, E.C.4.

**START A MAIL ORDER BUSINESS** in your own home. Commence small. Grow big. Success certain. Get "PRACTICAL MAIL-ORDER SELLING," 10,000 word handbook, with Traders' "DIRECTORY" English and Foreign wholesalers and manufacturers. (More practical information than many £3/3/- correspondence courses.) BOTH sent for 4/- post paid.—"TECHNOCRAFT" (see other advertisements).

**START your own business** in spare time. Details—Macfarlane & Co., 26 Hamilton Road, Rutherglen, Scotland.

## OFFER TO ENGINEERS

Our new Engineering Guide explains clearly how all the best jobs are secured. It shows how to obtain such money-making qualifications as A.M.I.C.E., A.M.I.E.E., A.M.I.Mech.E., A.M.I.W.T., A.F.R.A.S., etc. How to secure permanent and progressive posts in the Government and Municipal Service; and describes numerous "Better-pay" courses in Civil, Electrical, Wireless, Auto and Aero, etc., Engineering. Write to-day for FREE copy of this authoritative publication and details of our remarkable Guarantee of Success. National Institute of Engineering, Staple Inn Buildings, High Holborn, W.C.1.

## STAMPS

**FREE!!** Twenty Unused Colonials, "Neurope," 14d. Fifty for 9d.—G. H. Barnett, Limington, Somerset.

**STAMP COLLECTORS** send two shillings for complete Set St. Vincent Jubilee Stamps on Registered Envelope. Issue limited. Act immediately—Ormond Forde, Kingstown, St. Vincent, B.W.I.

**NINE DIFFERENT SILVER JUBILEE STAMPS** 2d. Request approvals, Sanders, 90 Newlands, Southampton.

## TOOLS

**GRAYSON'S** steel mouse threads flex through conduits. 5/- post free.—Below.

**GLASS-BORING** Outfits avoid risk.—Grayson & Company, 300 Campo Lane, Sheffield.

**UNDER COST!** 150 sets Highest Grade Lathe Tools.—Greenwood, Arnsden Road, Southport.

**THE IDEAL JUNIOR 3" LATHE.** SCBG Comp Rest. Quick return to Saddle. Full divided Nut to apron. Illustrated List.—Williamott, Neville's Factory, Chilwell, Notts.

**The "MYFORD" 3" LATHE.** The modern tool for Amateur and Engineer. Used by Technical Schools, Instrument Makers, Garages and Production Works. Moderate Price. Illustrated List from—The Myford Engineering Co., Neville Works, Beeston, Notts.

**ELECTRIC DRILLS** used reconditioned guaranteed, 18/9, electric grindstone 14/9 with new stone and motor over 1/2-h.p. used guaranteed. Above available all voltages A.C./D.C. Larger motors on application at greatly reduced prices.—Ansel Cine Co., 7 Highbury Terrace Mews, N.5.

## TURNED PARTS

**SMALL TURNED SCREWS, NUTS AND WASHERS.**—Assorted gross B.A., brass 2/-, steel 2/6. Whitworth, brass, 3/-, steel, 2/6. List and samples, 2d. Trade supplied.—J. H. Bennett, Station Road, Willesden Junction, N.W.10.

**SPECIAL OFFER.** 1/2 Gross Turned Screws with Nuts and Washers, Assorted BA sizes; 1/9 post free. A genuine bargain.—MICROCO, 26/31 Eyre St. Hill, E.C.1.

## WIRELESS

**A DICTIONARY OF WIRELESS TERMS,** by Ralph Stranger. A Wireless Work of Reference that should be on the bookshelf of every keen amateur. Compiled by a master of lucidity, it gives the meanings of all Technical terms in general use. Price 2s. 6d. from all Booksellers and Newsagents.—George Newnes, Ltd., 8-11 Southampton Street, Strand, London, W.C.2.

**FOR THE RADIO ENTHUSIAST.**—"The Wireless Constructor's Encyclopedia," by F. J. Camm (Editor of "Practical and Amateur Wireless"), third edition. Compiled by one of the most accomplished designers and writers on the practical side of Wireless, it covers the whole field. A veritable Treasury of Wireless Knowledge. Price 5s., from all Booksellers and Newsagents.—George Newnes, Ltd., 8-11 Southampton Street, Strand, London, W.C.2.

**FIFTY TESTED WIRELESS CIRCUITS,** by F. J. Camm, 2s. 6d.—This handbook contains every modern circuit, complete with instructions for assembling, component values, and notes on operation. Obtainable at all Booksellers and Newsagents.—George Newnes, Ltd., 8-11 Southampton Street, Strand, London, W.C.2.

**"THE MATHEMATICS OF WIRELESS,"** by Ralph Stranger.—This book is essential to the amateur who wants to gain a further knowledge of the subject without loss of time—or temper! Fully illustrated, 256 pages. Price 5s., from all Booksellers and Newsagents.—George Newnes, Ltd., 8-11 Southampton Street, Strand, London, W.C.2.

## WOODWORK

**CABINET HARDWOODS,** Oak, Mahogany, Ash, White-wood, Ply Woods, etc. Lowest Prices. Send Cutting lists. Planing free. Speciality prime Jap Oak, all thicknesses.—Wilfred Parr & Co., March Works, Lancaster Road, Leytonstone, E.11.

**READERS** requiring information concerning goods or services advertised in **PRACTICAL MECHANICS** should give names of Advertisers from whom particulars are desired. Any number of names may be included and we will obtain for you catalogues, lists, and any other information you may be wanting. **THERE IS NO CHARGE FOR THIS SERVICE.**

Readers desiring particulars from a number of Advertisers will, by this method, save time and postage. Half-penny stamp only is required if your envelope is left unsealed. If any Advertiser stipulates that stamps or postal orders are necessary before samples or catalogues are sent, please enclose the necessary amount with your instructions. You are cordially invited to make full use of this Service.

Post this to  
**ADVERT. SERVICE DEPT.,**  
PRACTICAL MECHANICS,  
8-11 SOUTHAMPTON STREET,  
STRAND, W.C.2

Please obtain and send to me particulars from the Advertisers in your January issue whose names I give on list attached.

Advertiser	Page No.	Information Required
------------	----------	----------------------

Attach sheet of paper, with particulars, and your name and address (written in **BLOCK** letters), with date, to this announcement.

## FREE ADVICE BUREAU COUPON

This coupon is available until January 31st, 1936, and must be attached to all letters containing queries.

PRACTICAL MECHANICS, JANUARY, 1936

**FREE!**



**FREE!**

# Engineers!

## THIS IMPORTANT HANDBOOK IS YOURS FOR THE ASKING!

**D**URING the past nine years we have distributed our unique Guide, entitled "ENGINEERING OPPORTUNITIES," to tens of thousands of ambitious engineers of all types and ages. This Handbook is something more than a Prospectus; it is a 268-page Guide to successful Engineering Careers.

Whatever your age or experience, whether you be an experienced engineer or a youngster contemplating an engineering career, "ENGINEERING OPPORTUNITIES" has much to tell you.

Apart from commonplace careers in the various branches of Engineering, the Guide reveals possibilities which are not widely known. For instance, do you realise that it is possible for a young man between 17 and 23 years of age, without practical experience, to obtain a permanent post in a Government Department at a commencing salary of over £4 per week?

This is but one of the unusual possibilities which are fully explained in "ENGINEERING OPPORTUNITIES." The Handbook also outlines over 100 Modern Home-Study Courses, including the following:—

- |  |   |  |   |
|--|---|--|---|
| <p><b>CIVIL ENGINEERING GROUP</b><br/>Specifications<br/>Road Engineering<br/>Hydraulics<br/>Municipal Engineering<br/>General Civil Engineering</p>                   | <p><b>STRUCTURAL ENGINEERING GROUP</b><br/>Structural Design<br/>Structural Engineering<br/>Reinforced Concrete<br/>Sanitary Engineering<br/>Geology</p>        | <p><b>MECHANICAL ENGINEERING GROUP</b><br/>Works Management<br/>Press Tool Work<br/>Maintenance Engineering<br/>Metallurgy<br/>Sheet Metal Work<br/>Welding<br/>Diesel Engines<br/>Refrigeration</p> | <p><b>HEAT ENGINEERING GROUP</b><br/>Heat Engines<br/>Workshop Practice<br/>Fitting and Erecting<br/>Inspection<br/>Ironfounding<br/>Pattern Making<br/>Draughtsmanship</p> |
| <p><b>SURVEYING GROUP</b><br/>Valuations<br/>Heating and Ventilating<br/>Clerk of Works</p>  | <p><b>SURVEYING AND LEVELLING GROUP</b><br/>Surveying and Levelling<br/>Building Construction</p>   | <p><b>GENERAL WIRELESS GROUP</b><br/>General Wireless<br/>Advanced Wireless<br/>Television</p>   | <p><b>WIRELESS GROUP</b><br/>Talking-picture Engineering<br/>Radio Servicing<br/>Receiver Design</p>  |
| <p><b>COMMERCIAL ENGINEERING GROUP</b><br/>Salesmanship<br/>Advertising<br/>Languages</p>  | <p><b>COMMERCIAL ENGINEERING GROUP</b><br/>Commercial Engineering<br/>Cost Accounts<br/>Works Management</p>  | <p><b>AUTOMOBILE ENGINEERING GROUP</b><br/>Garage Management<br/>Electrical Equipment</p>  | <p><b>AUTOMOBILE ENGINEERING GROUP</b><br/>Claims Assessing<br/>High-speed Diesels</p>  |
| <p><b>ELECTRICAL ENGINEERING GROUP</b><br/>Traction<br/>Electricity Supply<br/>Electrical Meters<br/>Electrical Design<br/>Installation<br/>Electrical Engineering</p> | <p><b>ELECTRICAL ENGINEERING GROUP</b><br/>Mains Engineering<br/>Telegraphy<br/>Telephony<br/>Alternating Currents<br/>Neon Lighting<br/>Power House Design</p> | <p><b>AERIAL NAVIGATION GROUP</b><br/>Aerial Navigation<br/>Aeroplane Design</p>   | <p><b>AERO. ENGINEERING GROUP</b><br/>Aero. Engines<br/>Aeronautical Engineering</p>  |

We specialise in preparing for all salary-increasing Examinations. One of these Examinations (all of which are fully described in "ENGINEERING OPPORTUNITIES") would multiply your earning power! **WHICH ONE?**

- |  |   |   |   |   |   |
|--|---|---|---|---|---|
| <p>A.M.I.C.E.<br/>A.M.I.Struct.E.<br/>Sanitary Inspectors<br/>A.M.I.H. &amp; V.E.<br/>A.M.I.Mech.E.<br/>A.M.I.P.E.</p> | <p>A.M.I.W.T.<br/>A.M.I.R.E.<br/>A.Rad.A.<br/>A.M.I.M.T.<br/>A.F.R.Ae.S.<br/>B.Sc. Degree</p> | <p>G.P.O. Suptd. of Traffic<br/>G.P.O. Prob. Inspectors<br/>Patent Office Examiner<br/>Handicrafts Instructor<br/>Inspector of Factories<br/>Aircraft Apprentices</p> | <p>Inst. Mun. &amp; Cy. E.<br/>M.R.San.I.<br/>F.S.I.<br/>A.R.I.B.A.<br/>L.I.O.B.<br/>F.A.I.</p> | <p>A.M.I. Fire E.<br/>A.M.I.E.E.<br/>A.M.I.A.E.<br/>A.M.I.Ae.E.<br/>City &amp; Guilds</p> | <p>London Matriculation<br/>Air Navigator's Certificate<br/>Pilot's "B" Licence<br/>Ground Engineer's Certificate</p> |
|--|---|---|---|---|---|

## WE DEFINITELY GUARANTEE "NO PASS—NO FEE"

If you have any desire for something more than a "bread-and-butter" job, you cannot afford to carry on any longer without reading "ENGINEERING OPPORTUNITIES," which explains clearly and definitely where your opportunities lie and the easiest way in which you may prepare for them. We have a special Employment Department which operates exclusively for our Members.

Write for your copy of "ENGINEERING OPPORTUNITIES" to-day. The book is FREE and post free, and will be sent to you without any obligation whatsoever. A postcard will bring the Handbook by return of post.

# The BRITISH INSTITUTE OF ENGINEERING TECHNOLOGY

Recently removed to greatly enlarged premises at:

410 SHAKESPEARE HOUSE, 17, 18, 19 STRATFORD PLACE, LONDON, W.1

OVERSEAS ENQUIRIES SHOULD BE ADDRESSED TO:

P.O. Box 3597S Sydney. P.O. Box 1025 Bombay. P.O. Box 4701 Johannesburg. 219 Bay Street, Toronto.