

PRACTICAL

JUNE 1987 · £1.25

ELECTRONICS

SCIENCE & TECHNOLOGY

SYNTHESISED
AF GENERATOR

INFRA-RED
HEADPHONES

MODERN TV
RECEIVERS

POLYWHATSIT
EFFECTS CONTROL

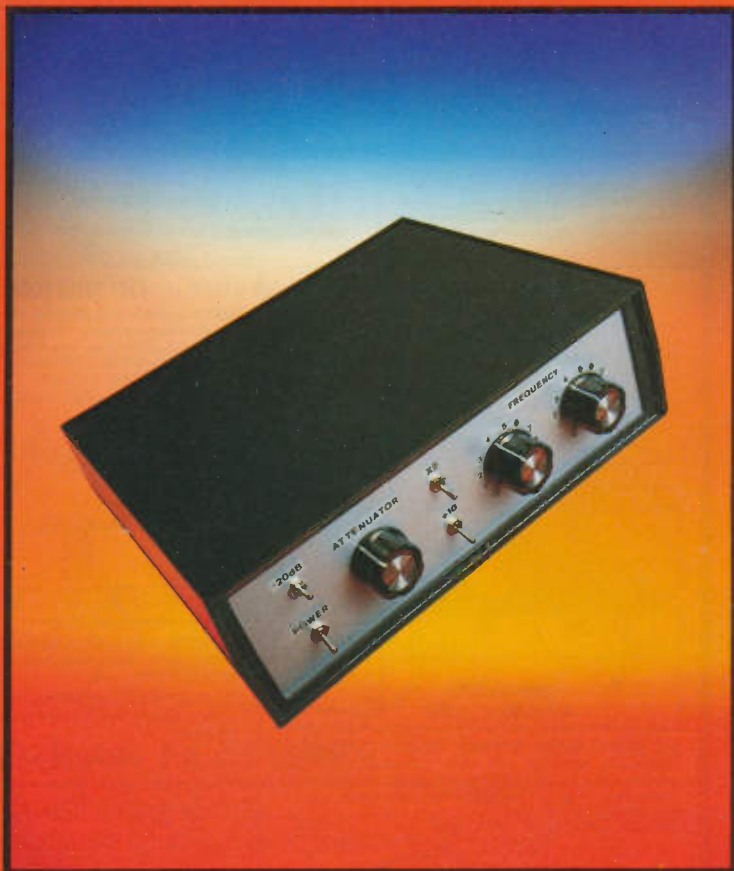

DESIGN — FREQUENCY
SYNTHESISERS THEORY AND PRACTICE

COMPUTING — ZX SPECTRUM
TWO CIRCUITS FOR EXTRA PORTS

TECHNOLOGY — SATELLITE
TV SCRAMBLING PROSPECTS

EXPERIMENTAL ELECTRONICS
EXCITING DESIGN IDEAS & PRACTICAL APPLICATIONS

PLUS:

- ★ SPACEWATCH
- ★ INDUSTRY NEWS
- ★ LOGIC PUZZLE
- ★ MARKET PLACE
- ★ PROJECTS GUIDE
- ★ PRINTING PE

THE SCIENCE MAGAZINE FOR SERIOUS ELECTRONICS AND COMPUTER ENTHUSIASTS

Full kits include pcb's, hardware, cases (unless stated otherwise), JC sockets, wire, nuts & bolts.
Article reprints extra 70p each.

AS FEATURED IN THIS ISSUE

BBC/D.C. MOTOR DRIVER.
FULL KIT WITH CASE, CB, AND SOFTWARE TAPE £24.49

THIS MONTH'S KITS - S.A.E. OR PHONE FOR PRICES

PASSIVE INFRA-RED DETECTOR July 86 £38.46
ECHO/REVERB UNIT July 86 £41.95
THERMOCOUPLE INTERFACE FOR DVM Jun 86 £15.98

ULTRASONIC TAPE MEASURE Mar 87 less case £26.21
VIDEO FADER Jan 87 £13.28
VIDEO ENHANCER Dec 86 £29.80
NOTCHER EFFECTS UNIT May 86 £31.46
TTL LOGIC CHECKER May 86 £20.95
SOUND ACTIVATED SWITCH Apr 86 £41.55
SCRATCH & RUMBLE FILTER (Stereo) Apr 86 £18.89
PHOTOGRAPHIC TRIGGER UNIT Apr 86 £35.68
TEMPERATURE/ANALOGUE INTERFACE Apr 86 £43.87
SPECTRUM HARDWARE RESTART (uncased) Mar 86 £28.49
AMSTRAD I/O Mar 86 £24.18
FIBROPTIC AUDIO LINK Mar 86 £27.65
FIBROPTIC CABLE 80p/metre
LOGIC PROBE Feb 86 £14.15
COMPUTER MOVEMENT DETECTOR Feb 86 £17.43
SPECTRUM SPEECH SYNTH & 8-BIT I/O PORT Jan 86 29.58
HIGH PERFORMANCE STEPPING MOTOR DRIVER Dec 85 £22.98

EXTRAS: Transformer £5.98; Case £2.95; BBC lead & plug £1.98; Motor-ID35 £14.50; MD200 £16.80.
CDMMDDRE USER PDRT EXPANDER Nov 85 £11.98
TOUCH CONTROL PSU Oct 85 £31.22
MODULATED SYNDROM Oct 85 £29.24
RS232 TD CENTRONICS CONVERTER Sept 85 £49.44
CAR BOOT ALARM Sept 85 £12.89
COMPUTER ENVELOPE SHAPER Aug 85 24.39
VOLT/METER MEMORY ADAPTOR July 85 £11.99
STYLUS KEYBOARD FOR COM 64 Jun 85 £10.50
SYNTHESIZER INTERFACE FOR CDM 64 Jun 85 £17.26
AMSTRAD SYNTHESIZER INTERFACE May 85 £27.90
CYLINDER THERMOSTAT May 85 £23.95
BBC POWER CONTROL INTERFACE Apr 85 £22.98
GUITAR ACTIVE TONE CONTROL less case Sept 83 £14.36
PROGRAM CONDITIONER June 83 £22.40
AUTO TEST SET May 83 £41.54
WIPEL DELAY Apr 83 less relay £9.89
BATTERY TESTER Apr 83 £15.90

DIGITAL CAPACITANCE METER

A superb instrument with a five digit 0.5 inch LED display giving direct readout of pF, nF and uF from 1pF to 1,000 uF.
Exceptionally easy to use. A crystal timebase eliminates setting up procedures.
Ideal for schools, labs, and industry as well as electronics enthusiasts from beginner to experts.
Complete kit - including PCB, case, all components and hardware, £39.57. Reprints of article 70p.

EDUCATIONAL SETS



ADVENTURES WITH ELECTRONICS

An easy to follow book suitable for all ages. Ideal for beginners. No soldering, uses an S/Dec Breadboard. Gives clear instructions with lots of pictures. 16 projects - including three radios, siren metronome, organ, inter-com, timer, etc. Helps you learn about electronic components and how circuits work. Component pack includes an S-Dec breadboard and all the components for the projects.
Adventures with Electronics £3.58.
Component pack £20.98 less battery.

HIGH PERFORMANCE STEPPING MOTOR DRIVER

As featured in December issue
Kit including PCB, I.C. & All Parts £22.98
Transformer 30V 18VA £5.98 extra
Case (houses PCB only) £2.95 extra
Lead & Connector for BBC Computer £1.98
Motors - ID35 £14.50 - MD200 £16.80
TEA1012 also available separately £6.88. Data £1.99

STEPPING MOTORS



48 STEPS
ID35 £14.50

200 STEPS
MD200 £16.80

BBC STEPPER MOTOR INTERFACE KIT £13.99 PCB, driver IC, components, connectors and leads included. Demonstration software, listings, circuit diagram, pcb layout and construction details given. Requires unregulated 12Vdc power supply.
INTERFACE KIT (ref PE) 13.99
OPTIONAL POWER SUPPLY PARTS £4.67

DRIVES ID35 AND MD200

PE HOBBYbus

Kit including double sided p.c.b. excluding DIN sockets £49.98.
DIN 41612 a+c sockets £2.20 each or 10 for £18.

DC MOTOR SETS

MOTOR - GEARBOX ASSEMBLIES 1.5V-4.5V
Miniature precision made. Complete with quality electric motors. Variable reductions ratios. Long 3mm dia output shafts.
Small unit - type MGS (3-2200rpm) £3.49
Large unit - type MGL (2-1150rpm) £3.98

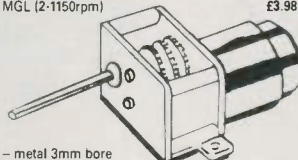

PULLEY WHEELS - metal 3mm bore
10mm dia £1.75
20mm dia £1.84
30mm £1.99
METAL COLLAR WITH screw - 3mm bore 24p
FLEXIBLE SPRINT COUPLING 3mm L31mm 68p
FLEXIBLE METAL COUPLING 3mm £2.98
DC MOTOR 1.5V-4.5V RPM 4,400-8,700
Shaft dia 2mm L10mm. Body 29x38mm
DC MOTOR TYPE - Dc28 £1.98
FLEXIBLE STEEL SPRING DRIVING BELT 47p
12" long. Joins to itself or 2 more can be joined where long lengths are needed.

MINI MODEL MOTORS 1.5-3V

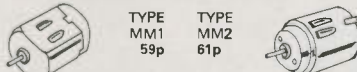

TYPE MM1 59p
TYPE MM2 61p

BBC HEART RATE

BBC Heart Rate Monitor - Ready Built £35.99

Practise relaxation or monitor fitness with this plug-in heart rate monitor. Connects directly to the BBC computer. Programs give continuous heart rate displays, bar charts, graphs etc. Supplied with sensor, software & instructions - ready to plug in and use.

DRY BATTERY CHARGER

AS FEATURED IN P.E.

We have produced a full kit of parts to build the Dry Battery Charger featured in the August issue of P.E.

This is a designer approved full kit of parts complete with Case, PCB, and a set of four special top quality Battery Holders.

The metal case lid swings open so that the batteries are fully enclosed during charging for complete safety. Any number of batteries (up to 4) can be charged at a time. The kit is supplied in 3 versions for AA cells, C cells, or D cells. These differ only in the type of battery holders and charging resistors supplied.

Conversion kits are available to change between types.

DIY BATTERY CHARGER KITS

AA cells - £24.12
C cells - £25.27
D cells - £26.57

VERKON DC-DC CONVERTERS

These compact efficient voltage converters allow one or two NICAD or ALKALINE cells to be used as the power source for circuits requiring 6, 9, 12, 14 or 20 volts. The economy and reliability gains that come from this arrangement are excellent - just compare the cost of a single NICAD cell with that of a NICAD PP3. This is only part of the story - we have a full leaflet which shows how to calculate the savings which can be made. Just send a stamped addressed envelope for more information, performance curves etc.

VERKON DC-DC CONVERTERS

V6 6 volts from 1 Nicd or Alk-Mn -£7.28
V9a 9 volts from 1 Nicd -£7.28
V12 12v from 1 Alk-Mn -£7.28
Vt12 14v from 2 x Nicd -£8.63
Vt18 20v from 2 x Nicd -£8.63

CATALOGUE

Brief details of each kit, book contents, and illustrations and descriptions of four range of tools and components are all included. Robotics and Computing section included.
Our advert shows just a selection of our products. Up to date price list enclosed. Official orders welcome. Catalogue & Price List - Send £1 in stamps etc or add £1 to your order. Price list only 9x4 SAE.
Catalogue free to schools/colleges requested on official letterhead.

SHOP NOW OPEN - CALLERS WELCOME

MAGENTA ELECTRONICS LTD.,
PE 15 HUNTER STREET,
BURTON-ON-TRENT,
STAFFS DE14 2ST.
0283 65435 Mon-Fri 9-5.
Shop Hours 9-5 Mon-Fri.
ADD £1.00 POST TO ALL ORDERS.
PRICES INCLUDE VAT.
SAE ALL ENQUIRIES.
OFFICIAL ORDER WELCOME.

Access/Barclaycard (Visa) by phone or post.
24 hr Answerphone for credit card orders.

OVERSEAS: Payment must be sterling.
IRISH REPUBLIC and BFPO: UK PRICES.
EUROPE: UK PRICES plus 10%.
ELSEWHERE: write for quote.



KAYCOMP MICROPROCESSOR TRAINER AND SINGLE BOARD COMPUTER

A new single board training and evaluation system for the 16-bit 68000 Series Microprocessor. A standard working system in kit form costs just £110.00 including VAT. Programs are developed and written with the aid of an on-board monitor program. The system is programmed and run via an RS232 link from either a standard terminal or a BBC Computer programmed to act as a terminal (we supply the necessary software). Optional extras include a line by line assembler, a peripheral I/O port and timer, and a G64 bus interface. Full sets of technical literature, programming information and manufacturers' data sheets are available to accompany the system.

AVAILABLE FROM STOCK NOW
PHONE OR WRITE FOR FULL DETAILS REF PE10

68000

68705 MICROCONTROLLER TRAINER

A stand-alone unit with hexadecimal keyboard and 9-digit seven-segment display. Uses a control oriented 68705 microprocessor with a comprehensive monitor system. A bank of 8 LEDs and switches allows I/O control programs to be run before connecting to 'real' external circuits. An A/D-D/A board is also available along with full support literature. An excellent introduction to machine code programming right down to 'bit' level. Used in many educational establishments. A complete system costs under £50.
All in stock - Phone or write for details PE10

68000 'Kaycomp' system with monitor program, 8MHz system clock, 2k x 16 RAM, and RS232 duart interface (in kit form need +5, +12, -12V supplies) £110.00
68230 P.I.T. add-on £11.97
G64 bus interface add-on £5.49
8k x 16 RAM upgrade £9.24
Assembler + disassembler program £24.46
Power Supply £11.99

CATALOGUE CASEBOOK



Last month we received details of the following catalogues and literature:

Cricklewood Electronics. Catalogue of electronic components and accessories vital to the home constructor. The cat's whisker cat - see their cover photo! **Cricklewood Electronics Ltd.**, 40 Cricklewood Broadway, London NW2 3ET. 01-450 0995.

Electromail. Over 700 pages of 'easy-to-buy' electronic and electrical products in their **March-June 1987 Catalogue**. A huge source of quality products. **Electromail**, PO Box 33, Corby, Northants NN17 9EL. 0536-204555.

Ericsson. New brochure illustrating connector ranges for micro, mini and mainframe users. **Ericsson Information Systems Ltd.**, 72 Northolt Road, Harrow, Middlesex HA2 0HE. 01-422 3442.

Gould Electronics. Publication announcement of new short form colour illustrated catalogue of oscilloscopes and allied systems. **Gould Electronics Ltd.**, Roebuck Road, Hainault, Ilford, Essex IG6 3UE. 01-500 1000.

Hitachi. Two free application design guides, 110 and 50 pages respectively, for systems designers using multiport video RAMs and Pseudo-Static RAMs. **Hitachi Electronic Components (UK) Ltd.**, 21 Upton Road, Watford, Herts WD1 7TP. 0923-46488.

Rapid Terminals. The 'Extra' colour illustrated magazine and catalogue of computers and associated products. **Rapid Terminals**, Rapid House, Denmark Street, High Wycombe, Bucks HP11 2BR. 0494-450111.

Siemens Components. Much more a magazine than a catalogue. Very informative with well written and illustrated articles and essays. **Siemens Ltd.**, Windmill Road, Sunbury-on-Thames, Middlesex TW16 7HS. 0932-785691.

Thermaloy Inc. Comprehensive 94 page catalogue of heat sinks, insulating and semiconductor accessories. A wealth of data. **MCP Electronics Ltd.**, Alperton, Wembley, Middlesex. 01-902 1191.

WHAT'S NEW



Easy as XYZ

Leewood Developments' range of three-axis positioning tables now has the benefit of an improved control interface which can be directly linked to a number of CAD packages coming into use. The interface commands are very similar to plotter commands, so that many CAD plotter/driver outputs can be adapted to drive the machine directly. Communication with the controller is via RS232, which allows most computers to be used as a host machine to send the ASCII command strings.

Linear Interpolation is standard on the X and Y axis which, combined with arc/circle vectors generated from the host computer's software, enables accurate cutting of curves to a resolution of down to one motor step. Applications so far include p.c.b. drilling, engraving and milling/drilling of light metal components.

The controller is available separately for users who want to connect their own stepper motor driven machines.

Contact: **Leewood Developments Ltd.**, Leewood Works, Upton, Hungtindon, Cambs PE17 5YQ. Tel. 0480 890860.

types, 50V Class 1 in ranges in the 0.5pf to 4700pf band, and 25V or 50V Class 2 in ranges in the 220pf to 0.33uf band. These can be combined to provide R/C networks for automatic insertion on surface mount p.c.b.s.

Toko Inc. are introducing large chip inductors for reflow or dip soldering. These include a low profile adjustable version with a range of 30 to 300MHz, inductance from 0.01 to 1.2μH, and bias oscillator type coils in the 10 to 100kHz bandwidth, inductances from 50μH to 7.5MH. Toko are also bringing in surface mounted communications and video filters, and TTL compatible delay lines with buffered inputs and outputs, giving delay times from 20ns to 30ns. Toko, through Cirkit, will supply components to customers own requirements.

These are featured in Cirkit's industrial catalogue, run by Cirkit Distribution. Cirkit Holdings supplies the well known catalogue for non-industrial customers.

Cirkit's electronic construction kits are being used at the Dhahran Technical Training Institute in the Middle East as part of their two year practical training course. The kits cover subjects from robotics to transmission lines. Cirkit established an educational division in 1986 to supply schools and colleges in the UK and overseas, and as part of a corporate emphasis on supporting practical education in electronics, instituted the Young Electronics Designer Award Scheme (YEDA).

Enquiries to either Cirkit Distribution or Cirkit Holdings can be addressed, as appropriate, to **Park Lane, Broxbourne, Herts EN10 7NQ. Tel. in either case (0992) 444111.**

Cirkit gets award

Cirkit Distribution are now supplying, as sole UK distributors, two ranges of surface mounting components from two manufacturers with whom they have long been associated.

Alps Electric Co. have introduced fixed chip resistors in power ratings from 0.1W to 1W with three-layer, erosion free electrodes, and multilayer ceramic chip capacitors of two

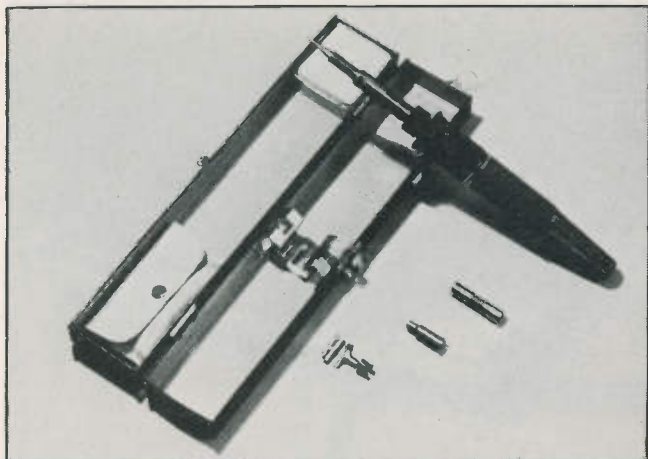

Hot point

Master Heat Tools are the suppliers of the Ultratorch 3 flameless heat tool, soldering iron and butane torch in one compact unit. Ultratorch 3 generates temperatures of over 1260 degrees C as a butane torch, up to 700 degrees C as a heat tool and up to 500 degrees C as a soldering iron. The complete kit comes with a solder tip, heat tool tip, heat shrink attachment, torch attachment and metal carrying case. The unit runs on butane lighter fuel, making it easily portable and inexpensive to run. Various extra trips are also available.

Contact: Master Heat Tools, Unit M, Portway Industrial Estate, Andover, Hants SP10 3LU. Tel. 0264 51347.

Fane would build

Fane Acoustics, makers of some of the UK's most highly regarded loudspeakers, have after three years and 50,000 copies been forced by rising prices to raise the price of their acclaimed handbook Loudspeaker Enclosure Design and Construction. The price is now £3.50, and the handbook can be ordered from Fane Acoustics Ltd., 286 Bradford Road, Batley, W. Yorks WF17 5PW. Tel. 0924 476431.



Sinclair scores again

Sir Clive Sinclair is back in the personal computer arena again - with a Z80-based, all-black, chocolate-box sized machine with a memory reliant on special cartridges and a limited number of output ports.

Despite a few Sinclair style trademarks, the new Z88 is different enough to make people sit up and take notice. Judging by its specification, it is a small and serious machine, offering, at a home micro price, the benefits of portability, on-board business style software, and up to 3 Mbytes of memory via eeprom expansion cartridges.

The computer was launched at the Birmingham 'Which Computer' show at the National Exhibition Centre, 17-20 February. Over the counter sales are not planned until the second half of 1987, but the Z88 will probably be a familiar sight in the press. The machine itself is 11½in by 8¼in by 7½in (293 by 209 by 23mm), weighs less than two pounds and is powered by four AA sized batteries, giving around 20 hours of computing or a year of standby, with full battery backup for the RAM. The built in screen incorporates a dark blue on grey l.c.d. 8 line by 80 column display dubbed 'supertwist' and there are three cartridge ports for memory expansion, and an RS232 serial printer port.

What about memory? The machine has a basic RAM of 32K, with 15K user RAM, but this is expandable via the three cartridge ports and 32K, 128K and 1M solid state RAM cartridges up to 3 Mbytes of memory. Alternatively, the ports can be occupied by a similar configuration of removeable eeprom cartridges. Cartridges are more compact and more resilient than disc or tape storage, and provide very fast access to their contents.

The screen area is divided into four windows: the working area, the menu options, machine status report, including battery

status, and a new feature, a screen map showing the complete layout of the current page, which is updated as work proceeds.

Built-in software, which is intended to make the Z88 entirely self contained, includes a spreadsheet, database selection, word processing, diary, calendar, real time clock and alarm. The computer's operating system, which is Cambridge Computers' own specially developed 'C-DOS' allows the user to switch tasks instantaneously, for example, between word processing and the diary, without extra saving and reloading. An almost unlimited number of separate tasks can be open at the same time - a great time saver. The operating system supports data exchange facilities to the IBM PC and compatibles.

The programming language and assembler used is the widely known BBC Basic, and there is a Z80 expansion bus for future expansion options.

The computer itself is being sold by mail order from Cambridge at an introductory price of £229.95 (£199.95 ex VAT), plus £7.50 post and packing. Cambridge Computers Ltd., FREEPOST, Cambridge CB4 1BR. Tel. 0223 312216.

Super cheap signals

Flight Electronics are opening up a 'vast new range' of test and measurement equipment by agreement with manufacturers GW Instrumentation of Taiwan. The equipment is expected to be around 20 per cent cheaper than branded units from other sources. Flight will be marketing the equipment directly in the UK and Eire.

The range includes oscilloscopes, function generators, multimeters, power supplies, other types of meter, frequency counter, audio/r.f. generators and accessories. Twenty six different bench power supplies from 18W to 200W cater for most applications in electronics and education. Seven oscilloscope types give capabilities up to 40MHz dual beam delayed sweep, and seven function generators offer facilities from very basic to a double function model with a 0.1Hz to 14MHz range.

GW Instrumentation exports mainly to the USA and Japan. A full description of the range is included in Flight's catalogue now available from Suzanne Kittow, Flight Electronics, Ascupart Street, Southampton SO1 1LU. Tel. 0703 227721.

COUNTDOWN

If you are organising any electronic, computing, electrical, scientific or radio event, big or small, drop us a line. We shall be glad to include it here. Send details to **COUNTDOWN**, Practical Electronics, 16 Garway Road, London W2 4NH.

PLEASE NOTE: Some events listed here may be trade only, or restricted to certain categories of visitor. Also, please check dates, times and other relevant details with the organisers before setting out as we cannot guarantee information accuracy.

May-June. Series of software training courses by Ericsson Information Systems Ltd. Birmingham. 01-422 3442.

May 12-15. Automan. National Exhibition Centre, Birmingham. 01-891 5051.

May 13-14. Laboratory Cambridge. Cambridge. 0799-26699.

May 13-15. EDS '87. Las Vegas, Nevada, USA. 0101-313-648-1440.

May 26. Developments in Instrumentation and Computation in Acoustics (IOA). Society of Chemical Industry, 14-15 Belgrave Square, London. 031-225 2143.

May 30-Jun 2. Summer Consumer Electronics Show '87. Chicago, Illinois, USA. 0101-202-547-8700.

Jun 2-3. Intel exhibition and conference. Wembley. 0793-696000.

Jun 2-5. British Manufacturing Technology Week (incorporating CIM). 01-891 3426.

Jun 16-18. Scottish Electronics Technology Show. Scottish Exhibition Centre. Glasgow. 01-891 5051.

Jun 16-18. OEM Scotland. Scottish Exhibition Centre, Glasgow. 01-891 5051.

June 17-18. Electronic Printing. Royal Lancaster Hotel, London. 0799-26699.

June 30. DEC Village '87 exhibition and seminars - Communications and Networking. Novotel Hotel, Hammersmith, London. 0494-26271.

CHIP COUNT!

This month's list of new component details received.

82385 - 32 bit cache memory controller (IT).
 80386 - 32 bit high speed CPU, coprocessor (IT).
 80387 - high performance 32 bit numerics coprocessor (IT).
 CHAS 68000 - 16 bit microprocessor trainer (LJ).
 CARL 68000 - 16 bit microprocessor trainer (LJ).
 IMS M212 - disc processor transputer periferal (RP).
 Long-Life Hyper-Red LEDs announcement (ML).
 PC 2000 - Programmable Controller Trainer (LJ).
 TP1900 - 175MHz video display driver IC (MC).
 TPV657. 860MHz Class A, 6 watt wide band transistor (MP).
 MAX232 - dual RS232 interface for 5V operation (VS).

Mitsubishi announce development of two very high speed one megabit EPROMs, and development of a 4-megabit DRAM. (They only quote a Japan telephone no - Tokyo 218 2171).

Manufacturers, and contact telephone numbers for further details. (HT) Hitachi, 0923-46488. (IT) Intel, 0793-696204. (LJ) LJ Electronics, 0603-748001. (MC) MCP Electronics, 01-902-6146. (ML) Mullard, 01-580-6633. (RP) Rapid Silicon, 0494-442266. (VS) Vero Speed, 0703 644555.

Watford Gap Closed

WE are delighted to learn that despite earlier understandings to the contrary, Watford Electronics have no intention of retiring from the sale of electronic components (PE Mar 87). Many hobbyists will breathe a sigh of relief at this affirmation of a continuing commitment to supplying full ranges of individual components.

For over a decade, Watford have been a major source of supply for many constructors, though of recent years they have also diversified to additional ranges, such as computer - related equipment. Their retreat from the sale of essential basic parts would have created a significant gap within the list of major suppliers catering for the redeveloping hobbyist electronics boom.

Watford Electronics are at 250 High Street, Watford, Herts, WD1 2AN. Tel: 0923-37774.

Pocket Pyrometer

THE Oryx pocket sized Pyrometer ODP1, for specific use with soldering irons, ensures use with soldering irons, ensures use against poor quality soldering. Users can be certain that tip temperatures are at a safe level for the product being soldered.

A non-flammable insulated lead feeds a thermocouple probe, which is detachable. By placing the iron tip in the thermocouple loop, temperatures between 200°C to 450°C will be displayed.

Weight is only 300gms and it is 5½ x 3" in size, using a 9 Volt battery to give 200 hours of life. Simple and effective, with obvious cost savings. The unit incorporates a low battery indicator.

Contact: Oryx, Greenwood Electronics, 28 Portman Road, READING RG3 1NE, Tel: 0734 595843



Vari-Speed Turntable

B.K. Electronics have introduced a variable speed turntable chassis to complement their growing range of audio equipment, and claim an unsurpassable price/performance standard. The prime objective of this turntable is to fulfill the requirement for a realistically priced product. The electro-mechanical design features incorporated into the turntable, B.K. Electronics say, satisfy the exacting demands for quality sound from the disco, leisure and studio environments. The Vari-Speed can also be applied to domestic hi-fidelity systems.

The many features include: electronic speed control, 33½ and 45 rpm with separate variable pitch control; high torque DC motor with electronic

servo drive; quick start; rigid steel chassis; full size 12" machined die-cast platter with strobed rim; belt driven; five point suspension; optically illuminated neon strobe prism; heavy duty transit screws; precision balanced 'S' shaped tone arm; universal head shell with standard ½" cartridge fixings; precision callibrated counter balance; anti-skate device; viscose damped cue lever; complete with integral mains power supply; power requirement 220-240V, 50-60Hz. Size: 390mm x 305mm. Weight: 3.25Kg. Supplied complete with paper mounting cut out template. Price: £49.99 + £3.00 P&P, including VAT.

Contact: B.K. Electronics, Unit 5, Comet Way, Southend-on-Sea, Essex SS2 6TR. Tel: (0702) 527572.



Mini Mains Adaptors

Clairtronic announce a new range of low voltage AC & DC Power Adaptors for use in a wide range of electronic, industrial and commercial applications for wall socket plug-in power units.

The range comprises AC only versions up to 500 mA, DC un-regulated to 500 mA and DC regulated to 1 Amp. Output voltages range from 5V to 12V fixed, with universal variable units offering a choice of five or six standard DC levels.

All adaptors employ the latest safety features including internal

thermal fuse and sleeved live pins.

A new feature of the range is the optional output connector which may be selected from one of five terminations generally used with mains adaptors. The choice includes two jack plugs, two co-axial plugs and the well known 4-way spider. Any one of these connector assemblies may be plugged in to the 15 mm cable integral to each Adaptor.

Contact: Clairtronic Ltd., Churchfield Road, Chalfont St Peter, Bucks SL9 9EP. Tel: (0753) 887227.

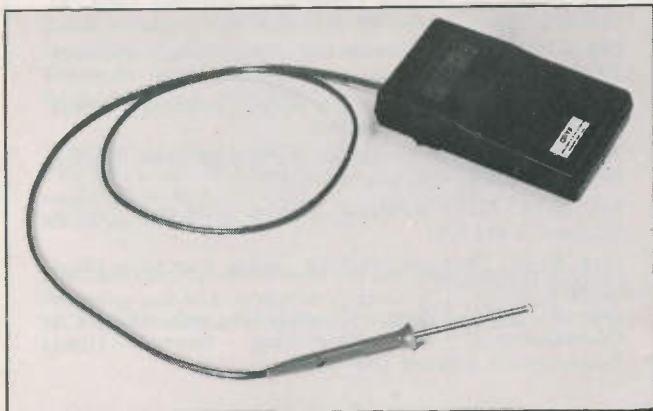

Tel: 0243 607108



TRANSISTORS

	Pence
BC107	15
BC107A	15
BC107B	15
BC108	15
BC108A	18
BC108B	15
BC108C	15
BC109	18
BC109B	18
BC109C	18
BC182	12
BC182B	12
BC183	12
BC183B	12
BC184	12
BC212	12
BC212B	12
BC213	12
BC213B	12
BC214	12
BC327	16
BC337	16
BC548	12
BCY70	22
BCY71	22
BD131	60
BD132	60
BD135	34
BD136	35
BF258	60
BFX85	40
BFX88	40
BFY50	37
BFY51	37
BFY52	39
TIP31	42
TIP31A	48
TIP31B	56
TIP31C	54
TIP32A	42
TIP32C	42
TIP33A	100
TIP41A	63
TIP42A	55
TIP3055	76
TIP2955	76
ZTX300	17
ZTX500	17
2N3053	60
2N3054	160
2N3707	12
2N3703	12
2N3705	12
2N3771	140
2N3904	£15
2N3906	£15

DIODES

	Pence
IN4001	5
IN4002	5
IN4003	6
IN4004	6
IN4448	6

TRIACS

	Pence
3 Amp 400V	75
8 Amp 400V	90

OPTO ISOLATORS

TIL111	
Transistor o/p	110
TIL113	
Darlington o/p	120
3021	
Triac driver	150

LEDs

T1 3/4 5mm	
Red	18
Yellow	18
Green	18
Super bright	
T1 3/4 5mm	
Red	35

ZENER DIODES

BZY88C 500m W	
4V7	10
10V	10
12V	10
BZX55C 500m W	
24V	10
BZX85C 1.3 Watt	
4V7	20
10V	20
12V	20
24V	20

VOLTAGE REGULATORS

LM317T	
+ 1.2V to 37V	150
LM341P	
+ 5V	60
LM7905	
- 5V	70

BRIDGE RECTIFIERS

W004 1.5A	50
6005 6A	90

CAPACITORS

	Pence
ELECTROLYTIC	
47uF 25V	10
100uF 25V	12
470uF 25V	28
1000uF 25V	36
TANTALUM BEAD	
.1uF 35V	10
.22uF 35V	10
.47uF 35V	10
1uF 35V	10
2.2uF 35V	15
4.7uF 35V	20
CERAMIC DISC	
220pF 500V	16
470pF 500V	6
1000pF 100V	6
2200pF 100V	6
4700pF 100V	6

RESISTORS

Metal Film 5% 1/3 Watt			
100R	680R	1K	1K2
2K2	4K7	5K6	6K8
10K	12K	15K	22K
27K	33K	39K	47K
56K	68K	82K	100K
120K	150K	180K	220K
270K	330K	390K	470K
560K	680K	820K	1M

2p

SKELETON PRESETS

	Pence
Horizontal	19
Vertical	19

LINEAR ICs

	Pence		
741	18	NE5534	80
555	30	ZN414	90
556	65	ZN416	160
LM301	28	LM308	70
NE5532	120	TL081	50

B.T. APPROVED TELEPHONES

B.T. Statesman with last number redial

Stone	£31.26
Brown	£31.26
Maroon	£31.26
Grey	£31.26

B.T. Viscount with last number redial

Beige	£26.04
Ice Grey	£26.04
Red	£26.04
White	£26.04

B.T. cordless Freeway 700ft range Security coded, last number redial with base paging

Ivory **£85.00**

Carriage on telephones and telephone accessories **£1.50**
Add 15% VAT to total allow ten days for delivery.

SUPER ALPHA GUARANTEE

All components brand new and by top manufacturers to full specification.

ORDERING: Cash, Postal-Order, Access or Visa, orders despatched same day by first class post. Add 50p p&p to order then add 15% VAT. Telephone orders welcome with Access or Visa, orders accepted by answer service outside office hours. Overseas orders add **£2.00** no VAT. Prices subject to alteration.

THE LEADING EDGE

NO MORE 'FREE' TV

Investors in expensive satellite TV receivers face more expense, or a glum time, when debs starts sending scrambled signals.



BY BARRY FOX

I don't like to be the bringer of bad tidings, and say I told you so, but anyone who has paid up to £2,000 for a backyard satellite dish system is soon in for a nasty shock.

By the end of this year the premium broadcast signals which they have been receiving will almost certainly be scrambled. Dish owners will then have to pay several hundred pounds for the extra electronics needed to de-scramble the signals plus an annual copyright licence fee which is stiffer than the BBC licence – or make do with watching programmes which are supported by heavy advertising.

For many months now, the firms broadcasting premium programmes by satellite for cable stations have been talking about scrambling their signals to prevent home dish owners watching their programmes free. Some, but by no means all, of the firms which sell satellite dish systems for home reception have been saving their skins by publishing small print warnings about this. But the print is usually very small. And most of the firms selling home dishes have just swept the issue under the carpet and issued no warnings at all.

I spoke recently with Andy Birchall, Chief Executive of the Premiere movie channel. "We have to scramble", says Birchall, "to protect the interests of the film companies who supply us".

Premiere buys rights on a feature film, and beams it up to the Intelsat satellite for cable stations to receive and distribute to their subscribers. Fees are fed back from the subscribers, to the cable station, to Premiere, and thus to the film company. Obviously, if people are watching at home on a domestic dish, they are getting something for nothing.

A year or so ago an agency service, called Galaxy, tried to collect copyright fees on a voluntary basis from home dish owners. The plan failed. Now anyone owning a dish has to volunteer the money, £75 a year, to Premiere. Only 200 people in Britain pay up. Out of how many? No-one knows.

The Department of Trade and Industry, which sells £10 satellite dish licences, has around 2000 dish owners

on record. Clearly there are more dishes than that, plus several thousand on the Continent owned by English speaking expatriates. "We will know exactly how many there are by the number of phone calls we get the morning after we start scrambling", says Birchall.

The DTI licence form clearly warns would-be viewers that they must "obtain all relevant consents and authorisations", relating to copyright. So there will be no sympathy from the government for dish owners who find their programmes have disappeared overnight.

Decoders will initially be in short supply. Cable stations will get them first. Then honest, voluntary fee-payers. The several thousand dishonest viewers will be offered amnesty and the chance to buy a decoder when stocks are available.

Decoder price will depend on the scrambling technology used. Premiere has been agonizing over the choice between two options. The first is what Birchall describes as "cheap and nasty". It is a modification of the conventional PAL tv signal. The synchronization pulses are doctored so that the pictures break up on screen unless a decoder is used. The snag is that the system can be easily defeated by an electronics engineer. Premiere know that soon after scrambling starts there will be a grey market in unauthorised decoders.

The more elegant solution is to use the completely new MAC tv standard developed by the IBA and adopted throughout Europe for future direct broadcasting from satellite. The MAC signal needs a MAC decoder for normal reception and the MAC signal can be additionally encrypted so that it can only be received by a MAC decoder with extra de-encryption circuitry. Inevitably all this costs much more than simple PAL signal doctored. The raw price of the MAC decoder chips will be at least £30. And they are not yet available. A decoder with de-encryption circuit will cost several hundred pounds.

Premiere may start using a PAL scrambler and then switch to MAC. So the dish owner will first need to buy one de-scrambling system, then another, in

addition to paying the annual copyright fee. For cable stations, the hardware costs will be insignificant. But for someone with a home dish they will be prohibitive.

One satellite service is already scrambled. Rupert Murdoch's Sky Channel is aimed at cable stations and reaches over 8 million homes in 18 countries across Europe. Sky has no interest in reaching a few thousand more by direct reception via backyard dishes. But Sky's rival, Super Channel, does not scramble and has no intention of doing so. "The more the merrier", say joint managing directors Richard Hooper (ex BT's Prestel viewdata) and Charles Levison (ex WEA Records). Super Channel is funded by all the ITV companies, except TV-AM and Thames. TV-AM was struggling to survive when, in January 1986, the ITV companies had to decide whether or not to buy shares in Super Channel. Thames decided to buy shares in the Luxembourg private company Astra, which hopes to launch its own satellite this year or next.

Although there are 60 cable stations in Britain theoretically capable of receiving Super Channel (or Sky) on satellite dishes for distribution to their subscribers, and although their cables 'pass' one million homes, less than 0.2 million of these homes have paid for connection to a cable service. Only around half these, i.e. 100,000, are served by a cable station which has equipped itself to handle the new Super Channel. By comparison over 2.5 million households in the Netherlands and 1.5 million in West Germany are able to receive Super Channel. In the Netherlands, over 3 million homes can now get Sky by cable.

Super Channel – like Sky – has no illusions about the so-called 'boom' in home satellite dish systems. "There are probably only around 10,000 home dishes throughout the whole of Europe", says Richard Hooper. "The direct satellite reception market is still peanuts. And we don't expect it to become significant before 1995."

PE

PE SCIENCE AND TECHNOLOGY

VOLUME 24 No. 6
JUNE 1987

ISSN 0032 - 6372

Editor:

John Becker

Sub-Editor:

Helen Armstrong

Personal Assistant:

Karen Poole

Advertisement Sales:

Ian Forbes, Alun Thomas,

Mike Thorburn

Advertisement Production:

Alfred Tonge

Publisher:

Angelo Zgorelec

PE Services

Practical Electronics offers a wide range of services to readers including: p.c.b.s, books, subscriptions, back numbers, and software listings. However, due to increased administration costs we can no longer provide photocopies of articles over five years old.

Readers' Enquiries

All editorial correspondence should be addressed to the editor and any letters requiring a reply should be accompanied by a stamped addressed envelope. Please address editorial correspondence to: Practical Electronics, 16 Garway Rd., London W2 4NH. Tel. 01-221 5422

We regret that lengthy technical enquiries cannot be answered over the phone.

Advertisements

All correspondence relating to advertisements, including classified ads, should be addressed to: The advertisement department, Practical Electronics.

PE EDITORIAL TEL. 01-221 5422

ADVERTISEMENT DEPT.

TEL. 01-434 0689

WRITING FOR PE

READERS frequently ask how they can write for PE, and what I look for when assessing the suitability of articles. In simple terms, I am looking for texts and circuits that are good examples of current or emerging technology; potentially useful or interesting to a wide readership; educationally informative; displaying a significantly different approach to a common subject; of a nature not previously published; explanations of a topical subject; showing practical computer control functions; illustrating the relationship of electronics to other disciplines or technologies, e.g. in industry, medicine, food production, conservation, energy harnessing, space, communications, information storage, entertainment, consumer applications, and so on.

Submitted texts should be typewritten or computer printed, (using a new ribbon!), with double line spacing, good margins, and in upper and lower case. Length depends on the subject, but as a guide, a full column of PE holds about 500 words, or two typed A4 pages.

Throughout an article, you should pay close attention to its logical progression, to spelling, and to grammar. Your approach should be positive, interesting and informative, avoiding repetition and long complex sentences, though don't be too terse. Try to communicate enthusiasm, but whilst a light hearted attitude may assist some articles, be wary of too much humour. Insert sub-headings where applicable, and include a good variety of relevant drawings (and photographs if possible).

For constructional articles, the opening paragraph should preferably be a brief statement of the objectives of the project. Next should come any relevant technical or general interest background information, followed by a detailed description of the circuitry, construction, testing and use.

Drawings should be neat and conform to our normal style for component representations, with part numbers and values entered clearly. If you are fortunate enough to have a CAD system, please use it! Working prototypes should be sent, and preferably with control legends already neatly lettered. We also need the original PCB track master (either lifesize or twice lifesize), a component positioning chart, circuit and wiring diagrams, a basic-function block diagram, and a full parts list arranged in our conventional order and style. Look at back issues of PE for such examples; total conformity is not vital, but consistency can make the Editor's job easier! However, it is pertinent to mention that some styles are under review, since abbreviations, like *l.e.d.*, *EPROM*, *BASIC*, etc., have become absorbed into the language as words in their own right.

If you have a worthwhile project or article to offer, please send it to me - I shall be delighted to give it careful consideration, and hopefully publish it for the benefit of all readers.

THE EDITOR

OUR JULY 1987 ISSUE WILL BE ON SALE FRIDAY, JUNE 5th 1987 (see page 2)

© Intrapress 1987. Copyright in all drawings, photographs and articles published in PRACTICAL ELECTRONICS is fully protected, and reproduction or imitations in whole or part are expressly forbidden. All reasonable precautions are taken by PRACTICAL ELECTRONICS to ensure that the advice and data given to readers is reliable. We cannot, however, guarantee it, and we cannot accept legal responsibility for it. Prices quoted are those current as we go to press.

74 SERIES		74273 2.00		74LS273 1.25		4076 0.65	
7400 0.30	74276 1.40	74LS276 1.40	74LS279 0.70	4077 0.25			
7401 0.30	74278 1.70	74LS280 1.90	74LS283 0.80	4078 0.25			
7402 0.30	74279 0.90	74LS284 0.80	74LS290 0.80	4081 0.25			
7403 0.30	74283 1.05	74LS292 0.80	74LS294 1.00	4082 0.25			
7404 0.30	74284 3.20	74LS296 1.00	74LS298 1.00	4083 0.60			
7405 0.30	74293 0.90	74LS295 1.40	74LS299 2.20	4086 0.75			
7406 0.40	74298 1.80	74LS299 1.40	74LS301 3.00	4089 1.20			
7407 0.40	74301 2.00	74LS298 1.00	74LS302 3.00	4093 0.35			
7408 0.30	74365A 0.80	74LS299 2.20	74LS303 3.00	4094 0.90			
7409 0.30	74366A 0.80	74LS301 3.00	74LS304 2.00	4095 0.95			
7410 0.30	74367A 0.80	74LS302 3.00	74LS305 2.00	4096 0.90			
7411 0.30	74376 1.60	74LS323 3.00	74LS324 2.00	4097 2.70			
7412 0.30	74390 1.10	74LS324 2.00	74LS325 1.20	4098 0.75			
7413 0.50	74393 1.20	74LS348 2.00	74LS352 1.20	4099 0.99			
7414 0.70	74490 1.40	74LS352 1.20	74LS353 1.20	4501 0.36			
7416 0.36		74LS353 1.20	74LS356 0.50	4502 0.55			
7417 0.40		74LS356 2.10	74LS363 1.80	4503 0.36			
7420 0.30		74LS363 1.80	74LS365 0.50	4504 0.95			
7421 0.60		74LS365 0.50	74LS366 0.50	4505 3.60			
7422 0.36		74LS366 0.50	74LS367 0.50	4506 0.90			
7423 0.36		74LS367 0.50	74LS368 1.30	4507 0.35			
7425 0.40		74LS373 0.70	74LS375 0.70	4508 1.20			
7426 0.40		74LS375 0.70	74LS377 1.30	4509 0.36			
7427 0.32		74LS377 1.30	74LS379 0.90	4511 0.55			
7428 0.43		74LS381 4.50	74LS385 3.25	4512 0.55			
7430 0.30		74LS385 3.25	74LS390 6.00	4513 1.50			
7432 0.36		74LS390 6.00	74LS393 1.80	4514 1.10			
7433 0.30		74LS393 1.80	74LS394 1.50	4515 1.10			
7434 0.30		74LS394 1.50	74LS396 2.25	4516 0.55			
7436 0.40		74LS400 2.00	74LS402 2.00	4517 2.20			
7439 0.40		74LS402 2.00	74LS404 1.50	4518 0.48			
7440 0.90		74LS404 1.50	74LS405 1.00	4519 0.32			
7441 0.90		74LS405 1.00	74LS406 1.00	4520 0.60			
7442A 1.00		74LS406 1.00	74LS407 1.20	4521 1.15			
7443A 1.00		74LS407 1.20	74LS408 1.20	4522 0.80			
7444 1.10		74LS408 1.20	74LS409 1.20	4523 0.70			
7445 0.70		74LS409 1.20	74LS410 1.20	4524 0.80			
7446A 1.00		74LS410 1.20	74LS411 1.20	4525 0.85			
7447A 1.00		74LS411 1.20	74LS412 1.20	4526 1.00			
7448 1.00		74LS412 1.20	74LS413 1.20	4527 0.80			
7450 0.36		74LS413 1.20	74LS414 1.20	4528 0.85			
7451 0.35		74LS414 1.20	74LS415 1.20	4529 1.00			
7453 0.38		74LS415 1.20	74LS416 1.20	4531 0.75			
7454 0.38		74LS416 1.20	74LS417 1.20	4532 0.65			
7456 0.55		74LS417 1.20	74LS418 1.20	4533 3.80			
7457 0.50		74LS418 1.20	74LS419 1.20	4534 2.50			
7472 0.45		74LS419 1.20	74LS420 1.20	4535 0.75			
7473 0.45		74LS420 1.20	74LS421 1.20	4536 2.50			
7474 0.50		74LS421 1.20	74LS422 1.20	4537 0.75			
7475 0.60		74LS422 1.20	74LS423 1.20	4538 1.00			
7476 0.45		74LS423 1.20	74LS424 1.20	4539 0.75			
7477 0.45		74LS424 1.20	74LS425 1.20	4540 1.10			
7478 0.45		74LS425 1.20	74LS426 1.20	4541 0.90			
7479 0.45		74LS426 1.20	74LS427 1.20	4542 0.70			
7480 0.55		74LS427 1.20	74LS428 1.20	4543 0.70			
7481 1.80		74LS428 1.20	74LS429 1.20	4544 0.90			
7483A 1.05		74LS429 1.20	74LS430 1.20	4545 0.40			
7484A 1.25		74LS430 1.20	74LS431 1.20	4546 1.40			
7485 1.10		74LS431 1.20	74LS432 1.20	4547 0.50			
7486 0.42		74LS432 1.20	74LS433 1.20	4548 0.48			
7489 2.10		74LS433 1.20	74LS434 1.20	4549 0.60			
7490A 0.50		74LS434 1.20	74LS435 1.20	4550 0.60			
7491 0.70		74LS435 1.20	74LS436 1.20	4551 2.40			
7492A 0.70		74LS436 1.20	74LS437 1.20	4552 0.50			
7493A 0.55		74LS437 1.20	74LS438 1.20	4553 0.36			
7494 0.80		74LS438 1.20	74LS439 1.20	4554 0.50			
7495 1.60		74LS439 1.20	74LS440 1.20	4555 0.90			
7497 2.90		74LS440 1.20	74LS441 1.20	4556 1.40			
74100 1.90		74LS441 1.20	74LS442 1.20	4557 2.40			
74107 0.50		74LS442 1.20	74LS443 1.20	4558 2.40			
74109 0.75		74LS443 1.20	74LS444 1.20	4559 1.70			
74110 0.75		74LS444 1.20	74LS445 1.20	4560 1.40			
74111 0.55		74LS445 1.20	74LS446 1.20	4561 1.40			
74116 1.70		74LS446 1.20	74LS447 1.20	4562 1.40			
74118 1.70		74LS447 1.20	74LS448 1.20	4563 0.50			
74119 1.70		74LS448 1.20	74LS449 1.20	4564 1.70			
74120 1.00		74LS449 1.20	74LS450 1.20	4565 2.40			
74121 0.55		74LS450 1.20	74LS451 1.20	4566 1.70			
74122 0.70		74LS451 1.20	74LS452 1.20	4567 1.70			
74123 0.80		74LS452 1.20	74LS453 1.20	4568 2.40			
74125 0.65		74LS453 1.20	74LS454 1.20	4569 1.70			
74126 0.55		74LS454 1.20	74LS455 1.20	4570 0.45			
74128 0.55		74LS455 1.20	74LS456 1.20	4571 2.40			
74132 0.75		74LS456 1.20	74LS457 1.20	4572 0.45			
74136 0.70		74LS457 1.20	74LS458 1.20	4573 0.48			
74141 0.90		74LS458 1.20	74LS459 1.20	4574 1.50			
74142 2.50		74LS459 1.20	74LS460 1.20	4575 2.40			
74143 2.70		74LS460 1.20	74LS461 1.20	4576 1.50			
74145 1.00		74LS461 1.20	74LS462 1.20	4577 1.50			
74147 1.70		74LS462 1.20	74LS463 1.20	4578 1.50			
74148 1.40		74LS463 1.20	74LS464 1.20	4579 1.50			
74150 1.75		74LS464 1.20	74LS465 1.20	4580 2.00			
74151A 0.70		74LS465 1.20	74LS466 1.20	4581 3.00			
74152 0.80		74LS466 1.20	74LS467 1.20	4582 3.00			
74154 1.40		74LS467 1.20	74LS468 1.20	4583 0.90			
74155 0.80		74LS468 1.20	74LS469 1.20	4584 0.48			
74156 0.90		74LS469 1.20	74LS470 1.20	4585 0.60			
74157 0.80		74LS470 1.20	74LS471 1.20	4586 0.60			
74159 2.25		74LS471 1.20	74LS472 1.20	4587 1.50			
74160 1.10		74LS472 1.20	74LS473 1.20	4588 1.50			
74161 0.80		74LS473 1.20	74LS474 1.20	4589 2.00			
74162 1.10		74LS474 1.20	74LS475 1.20	4590 2.00			
74163 1.10		74LS475 1.20	74LS476 1.20	4591 0.80			
74164 1.20		74LS476 1.20	74LS477 1.20	4592 1.20			
74165 1.10		74LS477 1.20	74LS478 1.20	4593 1.00			
74166 1.40		74LS478 1.20	74LS479 1.20	4594 1.50			
74167 4.00		74LS479 1.20	74LS480 1.20	4595 1.50			
74170 2.00		74LS480 1.20	74LS481 1.20	4596 1.00			
74172 4.20		74LS481 1.20	74LS482 1.20	4597 0.55			
74173 1.40		74LS482 1.20	74LS483 1.20	4598 0.60			
74174 1.10		74LS483 1.20	74LS484 1.20	4599 0.60			
74175 1.05		74LS484 1.20	74LS485 1.20	4600 1.25			
74176 1.00		74LS485 1.20	74LS486 1.20	4601 2.25			
74178 1.50		74LS486 1.20	74LS487 1.20	4602 1.40			
74179 1.50		74LS487 1.20	74LS488 1.20	4603 1.20			
74180 1.00		74LS488 1.20	74LS489 1.20	4604 0.55			
74181 3.40		74LS489 1.20	74LS490 1.20	4605 0.35			
74182 1.40		74LS490 1.20	74LS491 1.20	4606 0.35			
74184 1.80		74LS491 1.20	74LS492 1.20	4607 0.85			
74185A 1.80		74LS492 1.20	74LS493 1.20	4608 0.25			
74190 1.30		74LS493 1.20	74LS494 1.20	4609 0.24			
74191 1.30		74LS494 1.20	74LS495 1.20	4610 0.24			
74192 1.10		74LS495 1.20	74LS496 1.20	4611 0.24			
74193 1.15		74LS496 1.20	74LS497 1.20	4612 0.24			
74194 1.10		74LS497 1.20	74LS498 1.20	4613 0.24			
74195 0.80		74LS498 1.20	74LS499 1.20	4614 0.24			
74196 1.30		74LS499 1.20	74LS500 1.20	4615 0.24			
74197 1.10		74LS500 1.20	74LS501 1.20	4616 0.24			
74198 2.20		74LS501 1.20	74LS502 1.20	4617 0.24			
74199 2.20		74LS502 1.20	74LS503 1.20	4618 0.24			
74221 1.00		74LS503 1.20	74LS504 1.20	4619 0.24			
74251 1.00		74LS504 1.20	74LS505 1.20	4620 0.24			
74259 1.50		74LS505 1.20	74LS506 1.20	4621 0.24			
74265 0.80		74LS506 1.20	74LS507 1.20	4622 0.24			

Special offer to PE readers only - 10% off on all TTLs and CMOS

74ALS SERIES

74ALS00 0.45

74ALS02 0.45

74ALS04 0.50

74ALS08 0.50

74ALS10 0.50

74ALS12 0.45

74ALS16 0.50

74ALS20 0.45

74ALS24 0.45

74ALS30 0.50

74ALS32 0.45

74ALS36 1.50

74ALS40 0.45

74ALS48 1.50

74ALS64 2.50

74ALS80 2.50

74ALS128 2.50

74ALS256 2.50

74ALS512 2.50

74ALS1024 2.50

4000 SERIES

4001 0.20

4001 0.25

4002 0.24

4002 0.24

4006 0.70

4007 0.25

4008 0.60

4009 0.45

4010 0.60

4011 0.24

4012 0.25

4013 0.36

4014 0.60

4015 0.10

4016 0.36

4017 0.55

4018 0.60

4019 0.60

4020 0.60

4021 0.60

4022 0.60

4023 0.30

4024 0.40

4025 0.24

4026 0.50

4027 0.40

4028 0.60

4029 0.75

4030 0.35

4031 1.25

4032 1.80

4033 1.25

4034 2.50

4035 0.50

4036 2.50

4037 1.10

4038 1.00

4040 0.60

4041 0.55

4042 0.50

4043 0.60

4044 0.60

4045 0.60

4046 0.60

4047 0.60

4048

SYNTHESISED AF GENERATOR

THE AF SIG-GEN GOES DIGITAL

BY THE PROF

Frequency synthesised audio signals have a major advantage: switch-controlled, crystal derived signals are extremely accurate, and do not present the calibration problems associated with analogue sig-gens.

I do not know how many audio frequency signal generator designs have been published in the past, but there have certainly been a great many of them. I do not know what percentage of these have been based on the standard Wien bridge oscillator with thermistor stabilisation, but I would expect the percentage to be very high. The traditional Wien bridge oscillator designs certainly provide a very high level of performance, with distortion levels usually well under 1%, and in some cases at around 0.1% or less. This is more than adequate for frequency response and general testing (such as voltage gain measurements), and the better designs are suitable for distortion testing on high quality audio equipment.

There is actually another common form of audio signal generator these days, in the form of function generators which are often based on a version of the 8038 integrated circuit. These have a triangular oscillator which is fed to a trigger circuit to provide a squarewave signal, and to a non-linear amplifier which rounds off the peaks of the waveforms to give a reasonably accurate sine wave. By reasonably accurate I mean a signal with what is usually about 1% to 4% of total harmonic distortion. This is not particularly impressive, but is still perfectly satisfactory for frequency response measurements and many other forms of audio testing.

This audio signal generator design uses a different approach, and one which I have not encountered before (although I would not be so foolhardy as to claim it was a new way of tackling the problem). It is based on frequency synthesiser techniques, plus an interesting oscillator which could be described as an l.c.o. (logic controlled oscillator). It converts the logic pulses from the frequency synthesiser circuit into a reasonable sine wave signal at either a fiftieth or a hundredth of the input frequency. The output signal is a digital sine wave which, if carefully examined using an oscilloscope, shows the characteristic stepped nature of a

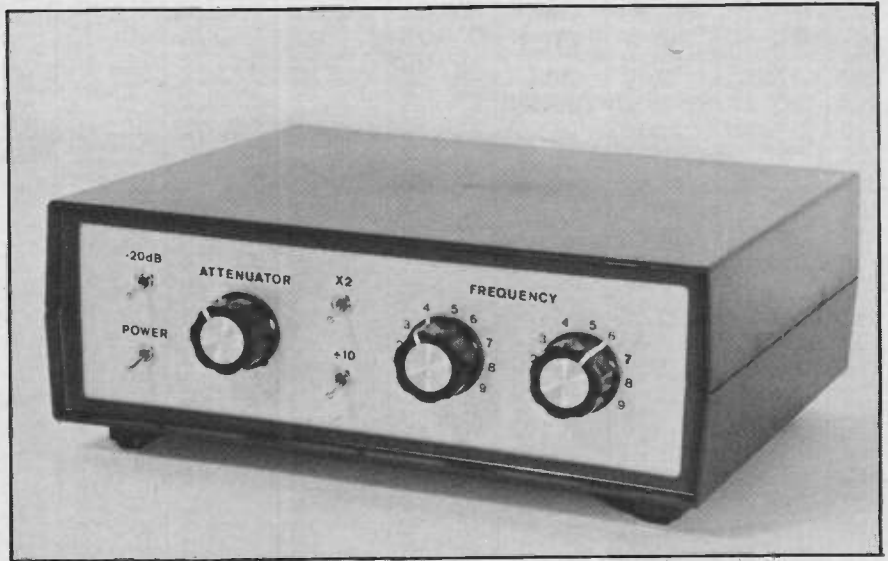

digitized signal. This limits the quality of the signal, but the distortion level is comparable to that of a simple function generator type sine wave source, and it is perfectly adequate for most types of audio testing.

The digital approach to audio signal generation might seem like an interesting but impractical way of doing things, but there is one very real advantage to this method which makes it very worthwhile, particularly for a home constructor design. Producing a conventional Wien or function generator type audio signal generator is not difficult, but fitting the frequency control with an accurate dial quite definitely is. Apart from the difficulty in producing a neat and accurate dial, some means of determining the correct calibration points is needed. Without access to a suitable frequency meter this can be difficult or even impossible. It is not necessary to be able to set the output frequency with a high degree of precision for all types of testing, but one of the most common tests is frequency response checking. This obviously requires the dial to be accurately calibrated over the full audio frequency range if meaningful results are to be obtained.

With the frequency synthesiser approach the output frequency is controlled by switches, and excellent accuracy is assured as all the frequencies

are derived from a crystal oscillator. In fact the output frequencies should be accurate to within a small fraction of one percent. With this design two 10-way rotary switches are used to select frequencies from 100Hz to 10kHz in 100Hz increments. This gives coverage of considerably less than the full audio frequency range, but this is rectified by the inclusion of two additional switches. One of these can be set to double the output frequency, so that the coverage is from 200Hz to 20kHz in 200Hz steps, and the 20kHz upper limit of the audio range is encompassed. The other switch can be used to divide the output frequency by ten, so that the coverage is from 10Hz to 1kHz in 10Hz increments (or 20Hz to 2kHz in 20Hz steps if the x2 switch is used as well). With a frequency synthesiser it is not possible to obtain any desired output frequency, but the range of frequencies available in this case should be more than adequate for normal frequency response measuring purposes, including such things as testing high Q bandpass and notch filters. The accuracy with which the output frequency can be set is actually likely to be better than that which can be achieved with many conventional designs where the dial accuracy and resolution are quite limited.

The output from the unit is about 6 volts peak to peak, and is virtually constant over the full frequency range.

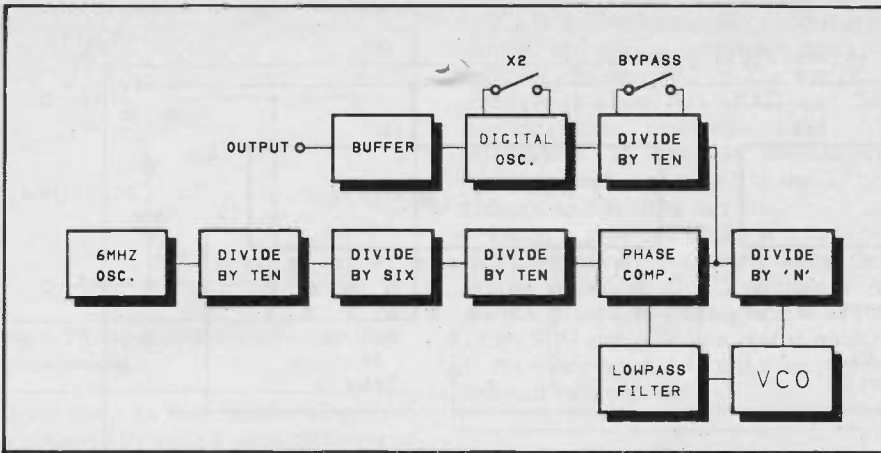

Fig.1. The Digital AF Generator Block diagram

There is a 20dB attenuation switch plus a continuously variable output attenuator. The use of low power CMOS circuitry enables the unit to be powered from an internal 9 volt battery.

SYSTEM OPERATION

The block diagram for the Synthesised Audio Generator appears in Fig.1. the subject of frequency synthesis is covered in some detail in an accompanying article in this month's issue, and so we will only consider the operation of this design fairly briefly. Those who require more information on the subject of frequency synthesis should refer to the other article.

Audio frequency synthesis can be rather difficult in that it is necessary to have a low reference frequency in order to give adequate resolution. With a reference frequency of perhaps only about 10 Hertz the phase locked loop would need to have a fairly slow response time in order to give reliable locking, and this could result in the unit taking several seconds or more in order to respond to changes in the selected frequency. In this case the problem is avoided completely by the use of an oscillator which requires a clock signal at fifty or one hundred times the required output frequency. This means that the frequency synthesiser part of the unit is working at relatively high frequencies, and consequently a high reference frequency and fast response time are used.

The reference frequency is derived from a 6MHz crystal oscillator via a three stage divider chain which has division rates of ten, six, and ten again. This gives a 10kHz reference frequency to the phase locked loop. The latter is comprised of the phase comparator, voltage controlled oscillator (v.c.o.) and lowpass filter. The divide by 'N' circuit between the v.c.o. and the phase comparator results in the v.c.o. being locked onto the reference frequency, or some multiple of it, depending on the division rate used. In this case the divide by 'N' circuit can be set for division rates in the range 1 to 100, giving a range of output frequencies from 10kHz to 1MHz. This is fed to a divide by ten circuit which can be bypassed, but which gives a modified output frequency range of 1kHz to 100kHz when it is switched into circuit.

The digital oscillator normally operates with an output frequency that is one hundredth of the clock frequency, and this gives an output frequency range of 100Hz to 10kHz in 100Hz increments, or 10Hz to 1kHz in 10Hz increments if the optional divide by ten circuit is switched in. This gives coverage of most of the audio frequency range, but leaves a gap from 10kHz to 20kHz. To overcome this, the digital oscillator can

be switched to the mode where its output frequency is at one fiftieth of the clock frequency. This doubles the output frequency, and extends the maximum available output frequency to upto the 20kHz upper limit of the audio range. The unit should only be operated in this mode when really necessary, since the quality of the output signal is lower in the 'x2' mode of the digital oscillator.

A buffer amplifier at the output of the unit provides a low output impedance, and the variable and switched attenuators are included here.

CIRCUIT OPERATION

The clock, divider, and phase locked loop circuits are shown in Fig.2. The clock oscillator is a simple single transistor type based on TR1, and its output directly drives IC4 which is a 4017BE one of ten decoder. In this case it operates as a straightforward divide by ten circuit with only the 'carry out' output being utilized. IC5 and IC6 are the divide by six and second divide by ten stages, and these are both 4018BE divide by 'N' devices wired in the appropriate modes.

IC7 is the phase locked loop, and this is a 4046BE low power CMOS type. Although it might seem as though practically any phase locked loop device will operate in this circuit with its relatively low maximum v.c.o. frequency, the requirements are more awkward than it might at first appear. CMOS compatibility and a low power consumption are a decided asset, but what makes the 4046BE suitable where most other types would fail is its ability to operate over a very wide v.c.o. frequency range. The v.c.o. must operate over a 100 to 1 frequency range, whereas most phase locked loop designs will only operate over a 10 to 1 range, or in some cases a range of less than 2 to 1. The 4046BE actually has two phase comparators; one where the free running v.c.o. goes to the centre frequency in the normal way, and one where it drops to zero frequency. It is this second phase comparator which is used in this circuit,

IC4 = 4017BE
IC5, 6, 8 = 4018BE
IC7 = 4046BE
TR1 = BC547

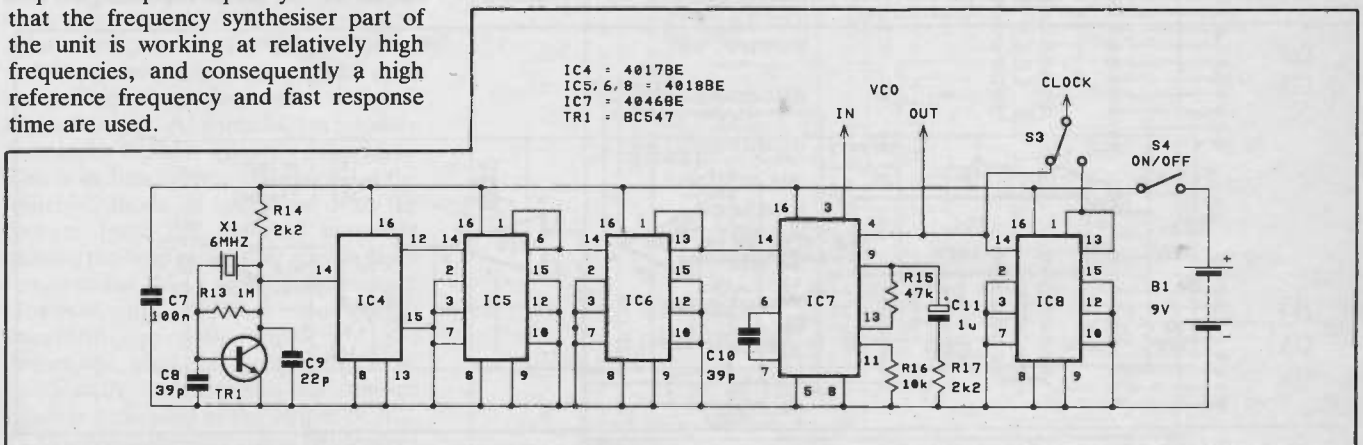

Fig.2. The clock, divider, and P.L.L. circuit

AF GENERATOR

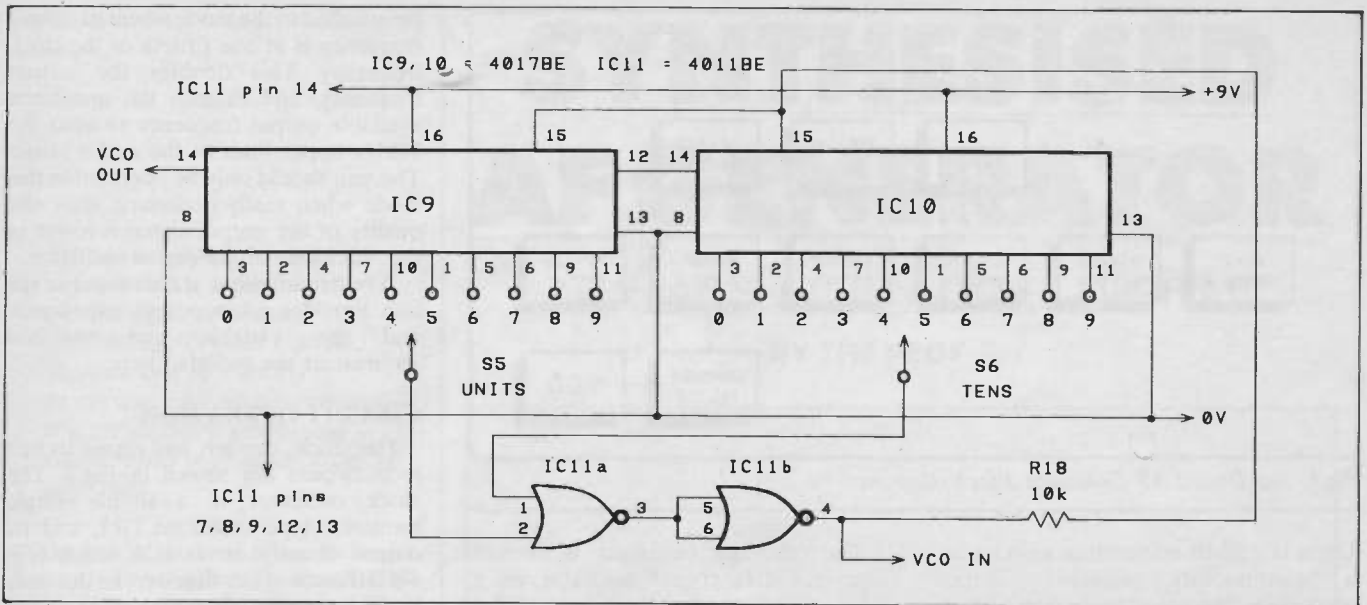

Fig.3. The divide by 'N' circuit diagram

and it is largely this unusual mode of operation which enables such a wide tracking range to be achieved. The ability of the v.c.o. to be adjusted over an enormous operating range via the control voltage is another factor which contributes to the wide tracking range.

IC10 and R16 are the timing components for the v.c.o., while R15 and C11 form the lowpass filter. The ultra-high input resistance at the v.c.o. input of IC7 helps to simplify design of the lowpass filter. R17 slightly reduces the efficiency of the filter, but it has the beneficial effect of reducing overshoot and gives a faster lock-on when the output frequency is changed.

IC8 is the divide by ten circuit driven from the v.c.o. output and this is another 4018BE. S34 is used to switch it in or out of circuit, as desired.

The divide by 'N' circuit appears in Fig.3, and this is built around two 4017BE one of ten decoders (IC9 and IC10). These are wired in series so as to give a divide by 100 action, but the 'carry out' output from the second stage (IC10) is ignored. Instead, two gates of IC11 are wired to give a simple 2 input AND

action, and these are used to reset IC9 and IC10 when the appropriate two outputs go high. For those who are unfamiliar with one of ten decoders it should perhaps be explained that they have ten outputs numbered from '0' to '9', and these each go high, in sequence, for one clock cycle. If, for example, S6 is set to '3' and S5 is set to '5', 35 input cycles will be needed before the counter is taken to the point where both these two outputs go high. When this happens the output of IC11b goes high and resets both devices back to zero. After a further 35 input cycles the '3' and '5' outputs go high again, the two counters are reset to zero once more, and so on, with a divide by 35 action being obtained. By setting S5 and S6 at the appropriate settings it is possible to obtain any division rate within the range of the circuit. The output signal is taken from the output of IC11b and is a series of narrow pulses. In fact the pulses might be too narrow for the phased locked loop to lock onto them properly, and in order to avoid this R18 is included between IC11b and the reset inputs. This has the effect of slightly delaying the reset action

so that the output pulses are lengthened somewhat, although they are still well under a microsecond in duration.

OSCILLATOR

Fig.4 shows the circuit diagram for the digital oscillator, buffer, and attenuator stages of the unit.

The oscillator is based on an MF10CN switched capacitor filter device (IC1). The MF10CN actually contains two second order filters, but in this circuit only one section of the device is used. A switched capacitor filter is similar to an ordinary C-R type, but the resistor is replaced with a low value capacitor and an electronic switch, as in Fig.5. Here Ca and the switch replace the resistor, while Cb is the normal filter capacitor.

With a normal C-R filter the resistor limits the rate at which current can charge and discharge the capacitor, and this gives the lowpass filtering. The effect is much the same with a switched capacitor type, but the rate of charge/discharge is limited by the ability of Ca to transfer current from the input to the output, or vice versa, depending on the

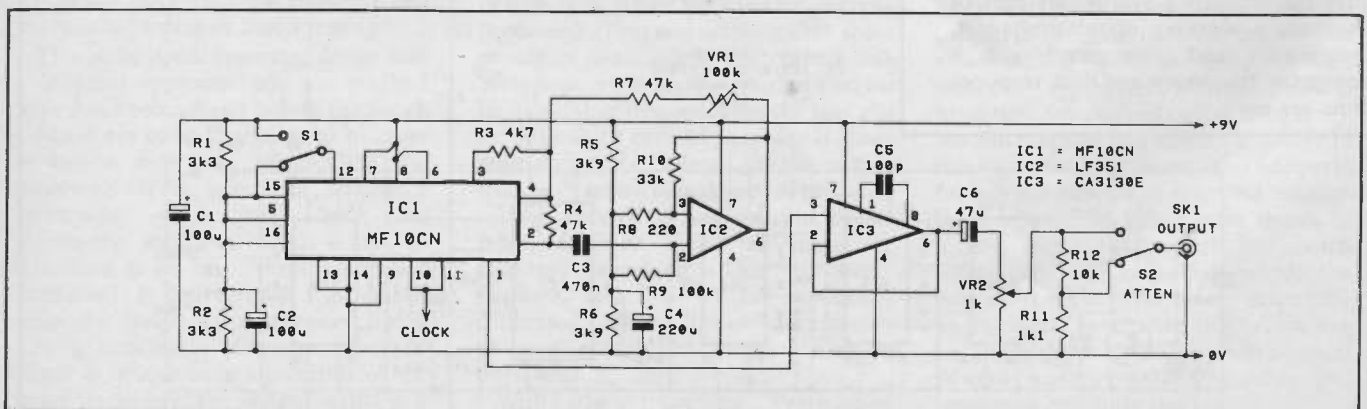

Fig.4. The circuit of the digital oscillator and output stages

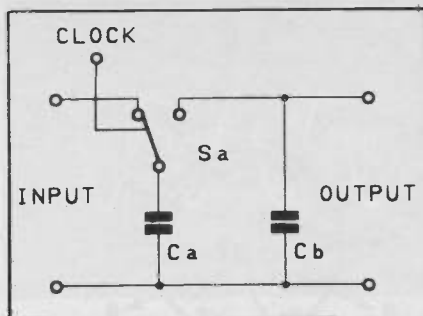

Fig. 5. The basic switched capacitor filter arrangement

signal polarity. This transfer of current is achieved by using a clock oscillator to continuously switch Sa from one setting to the other. How rapidly or otherwise the transfer is to be achieved depends on the value of Ca and on the clock frequency. It is this second factor that is of importance, since it gives a cutoff frequency that is a subdivision of the clock frequency, and with the MF10CN the operating frequency of the filter can be nominally either one hundredth or one fiftieth of the clock frequency.

The circuit of Fig. 4 operates by having the filter configured as a high Q bandpass type which is made to 'ring' continuously due to feedback provided by IC2. VR1 is adjusted for a feedback level which gives a strong but unclipped sinewave output. This configuration seems to give a consistent output level over the full frequency range covered, and there is no need for any stabilisation of the feedback level. S1 switches IC1 between the 50:1 and 100:1 modes, and these are obtained by taking pin 12 to the positive and mid supply rails respectively. This circuit only has a single supply rail, and so R1, R2, and C2 are used to generate a mid-supply level for biasing purposes.

It has to be pointed out that there is not a perfect 50:1 and 100:1 relationship between the clock and output frequencies, and the overall accuracy of the unit does not quite equal that of the frequency synthesiser section. The error could be as much as 1.5%, but is typically only 0.2%. In either case the unit gives more precise output frequencies than most conventional signal generators, and is certainly accurate enough for even quite demanding frequency response measurements. As explained previously, the output signal is a digitized sinewave. This is an inevitable consequence of the switching mode of operation, with the charges from the switched capacitor causing the output signal to alter in rapid jumps rather than varying continuously. However, the steps in the output waveform are quite small and the distortion level is sufficiently low. Incidentally, a reasonable squarewave signal is generated at the output of IC2, and a second sinewave signal (90 degrees phase shifted from the original) is generated at pin 2 of IC1.

IC3 is the buffer amplifier and it is a simple operational amplifier voltage follower circuit. VR2 is the variable attenuator while R11, R12, and S2 provide the switched 20dB of attenuation. If 40dB of attenuation would be preferred then R11 should be reduced to 100 ohms in value.

Power is provided by a 9 volt battery, and the total current consumption of the unit is approximately 25 milliamps. A fairly high capacity battery such as a PP9 or six HP7 size cells in a plastic holder is therefore needed in order to power the unit economically.

CONSTRUCTION

With the exceptions of the controls, battery, and output socket, all the components fit onto a single printed circuit board, together with a substantial number of link wires. Details of the printed circuit board are provided in Fig. 6.

There is nothing particularly unusual about construction of the board, but bear in mind that the integrated circuits are all MOS types apart from IC2, and that the appropriate handling precautions should therefore be taken

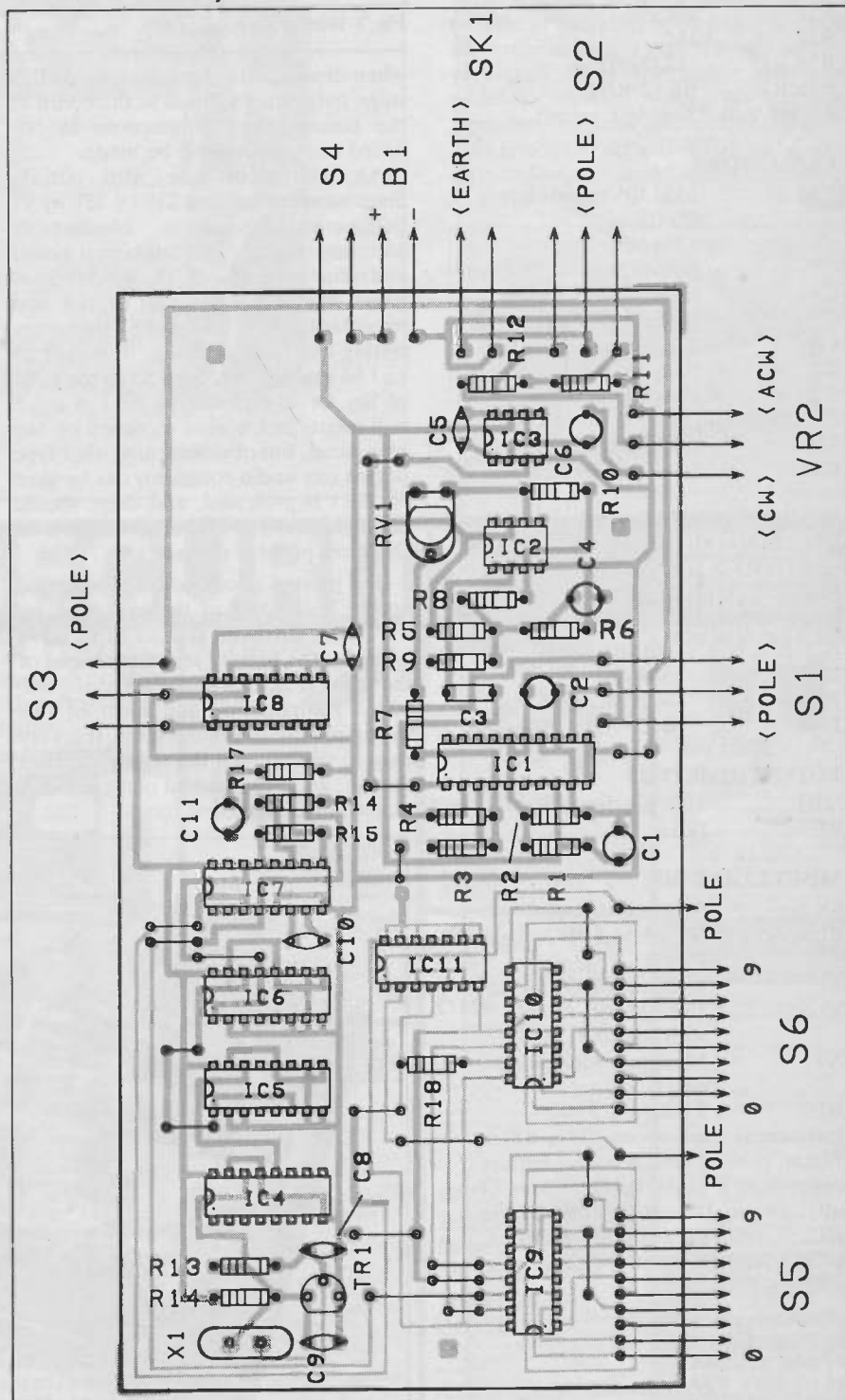

Fig. 6. Details of the printed circuit board

SYNTHESISED AF GENERATOR

COMPONENTS . . .

RESISTORS

R1,R2	3k3 (2 off)
R3	4k7
R4,R7,R15	47k (3 off)
R5,R6	3k9 (2 off)
R8	220
R9	100k
R10	33k
R11	1k1 1%
R12	10k 1%
R13	1M
R14,R17	2k2 (2 off)
R16,R18	10k (2 off)
All 1/4 watt 5% unless noted)	

CAPACITORS

C1,C2	100 μ 10Vradial elect (2 off)
C3	470n miniature polyester
C4	220 μ 10Vradial elect
C5	100p ceramic plate
C6	47 μ 10Vradial elect
C7	100n ceramic
C8,C10	39p ceramic plate (2 off)
C9	22p ceramic plate
C11	1 μ 63Vradial elect

SEMICONDUCTORS

IC1	MF10CN
IC2	LF351
IC3	CA3130E
IC4,IC9,IC10	4017BE (3 off)
IC5,IC6,IC8	4018BE (3 off)
IC7	4046BE
IC11	4011BE
TR1	BC547

POTENTIOMETERS

VR1	100k min hor preset
VR2	1k lin

MISCELLANEOUS

SK1	3.5mm jack socket
S1,S2,S3	Miniature SPDTtoggle (3 off)
S4	Miniature SPSTtoggle
S5,S6	12 way 1 pole rotary with end stop (2 off)
X1	Miniature wire ended 6MHz crystal
B1	9 volt (e.g. PP9)
Instrument case about 231 x 181 x 77mm, printed circuit board, battery connector, 8 pin DIL IC holder (2 off), 14 pin DIL IC holder, 16 pin DIL IC holder (7 off), 20 pin DIL IC holder, control knob (3 off), wire, solder, etc.	

PCB AVAILABLE FROM
PE PCB SERVICE.

KIT OF PARTS

AVAILABLE FROM MAGENTA

- See advert

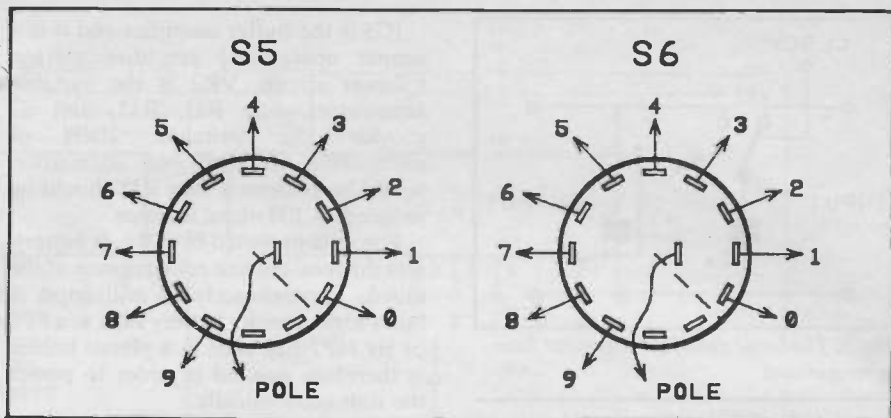

Fig.7. Wiring to S5 and S6

when dealing with these devices. At this stage only pins are fitted to the board at the points where connections to off-board components will be made.

An instrument case with outside dimensions of around 231 by 181 by 77 millimetres will comfortably accommodate the printed circuit board and other components. The precise front panel layout of the unit is not too important, but to make frequency setting easy it is advisable to mount S5 and S6 side by side, with S5 to the right of S6. On the prototype SK1 is a 3.5 millimetre jack socket mounted on the rear panel, but obviously any other type of two way audio connector can be used for SK1 if preferred, and there should be no difficulty in finding space for it on the front panel if necessary.

The printed circuit board is mounted on the base panel of the case, well towards the left hand side so as to leave room for the battery at the other end of the case. It is then wired up to the off-board components, and most of this wiring is quite straightforward. It is very easy to slip up with the rotary switches though, and Fig.7 should make it easier to get things right first time.

ADJUSTMENT

Before switching the unit on, set the attenuator controls for a reasonably high output signal level, and connect the output to an oscilloscope with the controls adjusted to realistic settings for the output signal that the generator should produce. Set VR1 at about half maximum resistance. Once switched on the unit should almost immediately burst into life and produce an output signal. If it does not, switch off and recheck all the wiring. If all is well, VR1 is adjusted for the lowest resistance setting (anti-clockwise adjustment gives reduced resistance) that gives an unclipped output signal at any setting of the frequency controls. Trying out the latter at various settings should soon reveal whether or not the frequency synthesiser is functioning properly. The unit should respond almost instantaneously to changes in the frequency controls. Although a setting of 10kHz might seem to be impossible, setting both S5 and S6 at '0' seems to give an output at this frequency rather than blocking operation of the unit, as one might have expected.

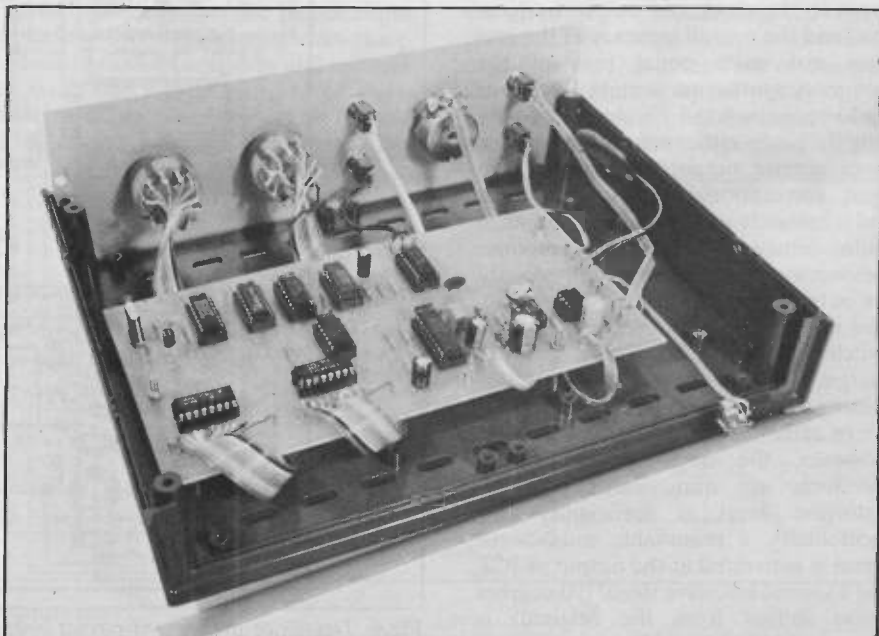

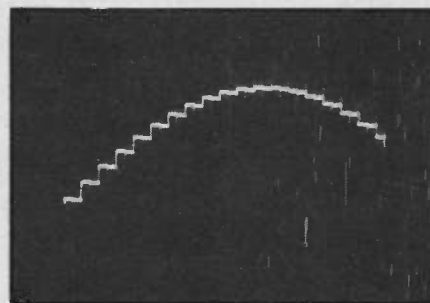
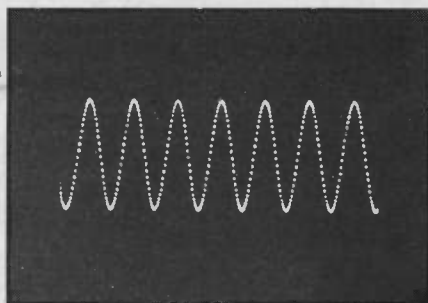
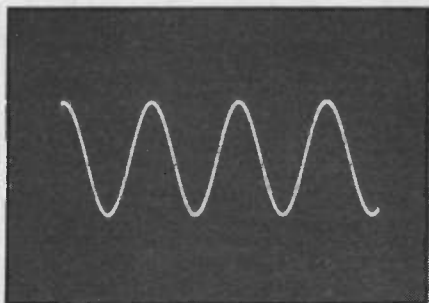

Typical waveform oscillograms

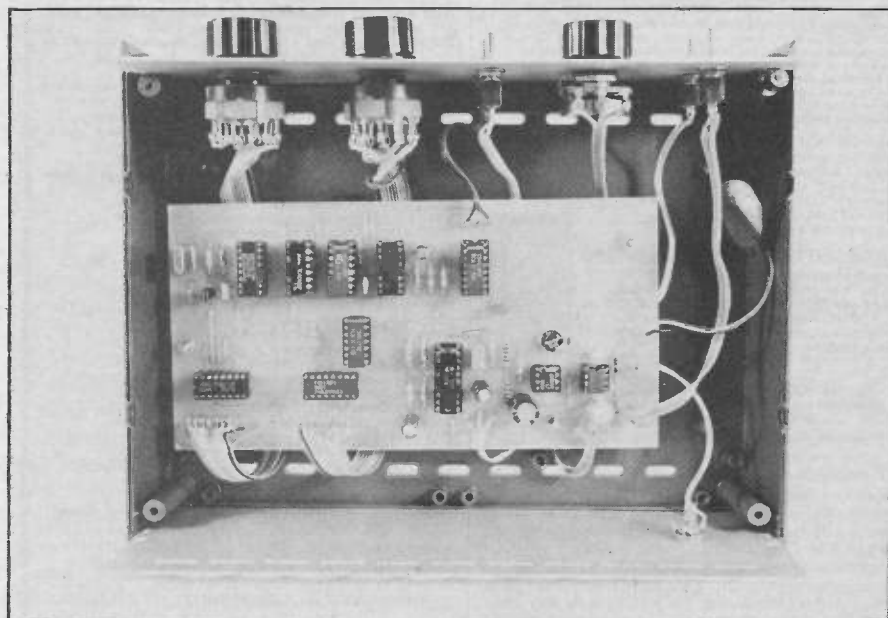

Even if you do not usually go to the trouble of marking front panel legends on projects, in this case the unit will be very difficult to use unless the four switches that control the output frequency are fully and clearly labelled. This is not too difficult to do using rub-on transfers, and is well worth the effort.

PE



INSTALL YOUR OWN SYSTEM AND SAVE

SECURITY

MODULES ACCESSORIES KITS

NEW

"PASSIVE INFRA-RED INTRUDER DETECTOR RP33"



- 12 metre detection range.
- Size only 80 x 60 x 40mm.
- 24 Detection zones.
- Wide 85° coverage.
- Switchable LED indicator.

This advanced new intrusion detector operates by detecting the body heat of an intruder moving within the detection field. The use of a dual element pyroelectric sensor means that changes in ambient temperatures are ignored, thus providing a stable and reliable performance. Easily installed in a room or hallway, the unit will provide effective detection of any intrusion. Operating from a 12V supply and consuming only 15mA, it is ideal for use with the CA 1382, CA 1250 or any equivalent high quality control unit. Supplied with full instructions, its performance compares with detectors costing more than twice the price.

£23.95 + V.A.T.

CA 1382 An advanced control unit with automatic loop testing.



- Fully automatic siren re-set.
- Audible entry/exit warning.
- Alarm Sounded memory.
- 2 separate loop inputs + 24hr circuits.
- Built-in electronic siren.
- Easily installed, full instructions supplied.

This latest control panel provides effective and reliable control for all types of security installations. Its advanced circuitry checks the loop circuits every time it is switched on, preventing incorrect operation. Using a simple 'on/off' key switch, it is easily operated by all members of the family. In addition it provides 24 hr. personal attack protection. Housed in a steel case, it is supplied with full operating instructions.

Only £44.95 + V.A.T.
Available in kit form with fully-built electronics £39.95 + V.A.T.

Digital Ultrasonic Detector US 5063 only £13.95



+ V.A.T.

- 3 levels of discrimination against false alarms
- Crystal control for greater stability
- Adjustable range up to 25ft
- Built-in delays
- 12V operation

This advanced module uses digital signal processing to provide the highest level of sensitivity whilst discriminating against potential false alarm conditions.

Individual Enclosure SC 5063 only £2.95 + V.A.T.

Suitable metal enclosure for housing the ultrasonic module type US 5063. Supplied with the necessary mounting pillars and screws etc.

Control Unit CA 1250 Price £19.95

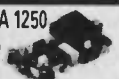

+ V.A.T.

This tried and tested control unit represents the finest value for money in control systems, providing the following features

- Built-in electronic siren drives 2 loud speakers
- Provides exit and entrance delays together with fixed alarm time
- Battery back-up with trickle charge facility
- Operates with magnetic switches, pressure pads, ultrasonic or I.R. units
- Anti-tamper and panic facility
- Stabilised output voltage
- 2 operating modes full alarm anti-tamper and panic facility
- Screw connections for ease of installation
- Separate relay contacts for external loads
- Test loop facility

500W Quartz Halogen Floodlight FL 500



only £14.95 + V.A.T.

Whilst intended for security lighting applications, this unit is suitable for lighting patios, pathways and gardens etc. Supplied complete with 500W lamp, priced only £14.95 - VAT Protective grill, £1.95 - VAT

Lighting Controller DP 3570 only £13.95 + V.A.T.



This versatile module provides timed-switching of loads up to 3A for pre-set times between 10 secs and 5 mins. The timed period being triggered by the opening or closing of an external loop or switch. The built-in 12V 250mA power supply is available for operating external sensors. Priced only £13.95 - VAT Suitable plastic enclosure £2.85 - VAT

HW 1250 - Enclosure & fixings for CA 1250 only £9.50 + V.A.T.



This attractive case is designed to house the control unit CA 1250, together with the appropriate LED indicators and key switch. Supplied with the necessary mounting pillars and punched front panel, the unit is given a professional appearance by an adhesive silk screened label. Size 200 x 180 x 70mm.

Infra-red System IR 1470



only £25.61 + V.A.T.

Consisting of separate transmitter and receiver both of which are housed in attractive moulded cases, the system provides an invisible modulated beam over distances of up to 50ft operating a relay when the beam is broken. Intended for use in security systems, but also ideal for photographic and measurement applications. Size 80 x 50 x 35mm

SAMPLE OF OUR WIDE RANGE OF ACCESSORIES

- AL 243 — Automatic Light Switch Switches 3A at 240V — £4.30
- VS 39 — Vibration Contact — £2.30
- IS 128 — Miniature 12V Siren provides 100db output — £6.95
- SL 157 — Siren Module — £2.95
- HS 588 — 5W Horn Speaker for use with control unit, siren module, etc. — £6.25

The above prices are plus V.A.T.

Complete systems from only

£39.95 + VAT

For full information of systems and accessories, send or call for details

RISCOMP LIMITED

Dept 7/6,
51 Poppy Road,
Princes Risborough,
BUCKS HP17 9DB.
Tel: (084 44) 6326.



Order by 'phone or mail or call at our showroom and see

UNITS ON DEMONSTRATION

Monday to Friday 9.00 — 5.00 p.m.
Saturday 9.00 — 1.00 p.m.

Please add 15% VAT and 75p P&P to all UK orders
Export no VAT — postage at cost



£1 BAKERS DOZEN PACKS

Price per pack is £1.00.* Order 12 you may choose another free. Items marked (sh) are not new but guaranteed ok.

1. 5 - 13 amp ring main junction boxes
2. 5 - 13 amp ring main splices
4. 5 - surface mounting switches 5A 250V
5. 3 - electrical switches, white flush mounting
6. 4 - in flex line switches with neons
9. 2 - mains transformers with 6V 1A secondaries
10. 2 - mains transformers with 12V 1/2 A secondaries
11. 1 - extension speaker cabinet for 6 1/2" speaker
12. 1 - glass reed switches
13. 2 - ultrasonic transmitter receivers with circuit
19. 2 - light dependent resistors
25. 4 - wafer switches - 6p 2 way, 4p 3 way, 2p 6 way, 2p 5 way, 1p 12 way small one hold fixing and good length 1/2 spindle your choice
28. 1 - 6 digit counter mains voltage
30. 2 - Nicad battery chargers
31. 1 - key switch with key
33. 2 - aerosol cans of ICI Dry Lubricant
34. 96 - 1 metre lengths colour-coded connecting wire
39. 1 - long and medium wave tuner kit
41. 8 - rocker switch-10 amp mains SPST
45. 1 - 24 hour time switch mains operated (s.h.)
49. 10 - neon valves - make good night lights
50. 2 - 12V DC or 24V AC, 3 CD relays
51. 1 - 12V 2 CD miniature relay very sensitive
52. 1 - 12V 4 CD miniature relay
54. 10 - rows of 32 gold plated IC sockets (total 320 sockets)
55. 1 - locking mechanism with 2 keys
56. 1 - miniature uniselect with circuit for electric jigsaw puzzle
60. 5 - ferrite rods 4" x 5/16" diameter aerials
61. 4 - ferrite slab aerials with L & M wave coils
63. 1 - Mullard thyristor trigger module
66. 1 - magnetic brake - stops rotation instantly
67. 1 - low pressure 3 level switch can be mouth operated
69. 2 - 25 watt pots 8 ohm
70. 2 - 25 watt pots 1000 ohm
71. 4 - wire wound pots - 18, 33, 50 and 100 ohm your choice
77. 1 - time reminder adjustable 1-60 mins clockwork
85. 1 - mains shaded pole motor 3" stack - 1/2 shaft
89. 1 - mains motor with gear box 1 rev per 24 hours
91. 2 - mains motors with gear box 16 rpm
96. 1 - thermostat for fridge
98. 1 - motorised stud switch (s.h.)
101. 1 - 2 1/2 hours delay switch
103. 1 - mains power supply unit - 6V DC
104. 1 - mains power supply unit - 4 1/2 V DC
107. 1 - 5" speaker size radio cabinet with handle
112. 1 - heating pad 200 watts mains
114. 1 - 1W amplifier Mullard 1172
115. 1 - wall mounting thermostat 24V
118. 1 - teak effect extension 5" speaker cabinet
120. 2 - p.c. boards with 2 amp full wave and 17 other recs
121. 4 - push push switches for table lamps etc.
122. 10 - mtrs twin screened flex white p.v.c. outer
124. 25 - clear plastic lenses 1 1/2 diameter
127. 4 - pilot bulb lamp metal clip on type
128. 10 - very fine drills for pcb's etc.
129. 4 - extra thin screw drivers for instruments
132. 2 - plastic boxes with windows, ideal for interrupted beam switch
134. 10 - model aircraft motor - require no on/off switch, just spin to start
137. 1 - 6 1/2" 4 ohm 10 watt speaker
142. 10 - 4 BA spanners 1 end open, other end closed
145. 2 - 4 reed relay kits 3V coil normally open or c/o if magnets added
146. 20 - pilot bulbs 6.5V 3A Philips
154. 1 - 12V drip proof relay - ideal for car jobs
155. 3 - varicap push button tuners with knobs
169. 4 - short wave air spaced trimmers 2-30f
172. 10 - 12V 6W bulbs Philips m.e.s.
178. 3 - oblong amber indicators with lilliputs 12V
180. 6 - round amber indicators with neons 240V
181. 100 - p.v.c. grommets 3/8 hole size
182. 1 - short wave tuning condenser 50 pf with 1/2" spindle
188. 1 - plastic box sloping metal front, 16 x 95mm average depth 45mm
193. 6 - 5 amp 3 pin flush sockets brown
195. 5 - B.C. lampholders brown bakelite threaded entry
196. 1 - m flex sintermat for electric blanket soldering iron etc.
197. 2 - thermostats: spindle setting - adjustable range for ovens etc.
199. 1 - mains operated solenoid with plunger 1" travel
200. 1 - 10 digit switch pad for telephones etc.
201. 8 - computer keyboard switches with knobs, pcb or vero mounting
206. 20 - mtrs 80 ohm, standard type co-ax off white
211. 1 - electric clock mains driven, always right time - not cased
216. 1 - stereo pre-amp Mullard EP9001
232. 2 - 12V solenoids, small with plunger
236. 1 - matts transformer 9V 1 amp secondary C core construction
241. 1 - car door speaker (very flat) 6 1/2" 15 ohm made for Radiomobile
242. 2 - speakers 6" x 4" 4 ohm 5 watt made for Radiomobile
243. 2 - speakers 6" x 4" 16 ohm 5 watt made for Radiomobile
244. 1 - mains motor with gear-box very small, toothed output 1 rpm
245. 4 - standard size pots, 1/2 meg with dp switch
249. 1 - 13A switched socket on double plate with fused spur
266. 2 - mains transformers 9V 1/2 A secondary
267. 1 - mains transformers 15V 1A secondary p.c.b. mounting
291. 1 - ten turns 3 watt pot 1/2 spindle 100 ohm
296. 3 - car lighter socket plugs
300. 1 - mains solenoid with plunger compact type
301. 10 - ceramic magnets Mullard 1" x 3/8 x 5/16
303. 12 pole 3 way ceramic wave charge switch
305. 1 - tubular dynamic microphone with desk rest
308. 1 - T.V. turret tuner (black & white T.V.)
310. 2 - oven thermostats
313. 5 - sub miniature micro switches
314. 1 - 12" 8 watt m fluorescent tube white
316. 1 - round pin kettle plug with moulded on lead
411. 1 - 1 1/2A magnetic trip saves repairing fuses
453. 2 - 2 1/4" 60ohm miniature speaker or microphone
454. 2 - 2 1/4" 8ohm miniature speaker or microphone
457. 2 - small plastic cases, could hold desk mic, small extension speaker etc.
463. 1 - mains relay 2 c/o 8A contacts with plastic dust cover
464. 2 - tubes Holts plastic filter/sticker
465. 3 - 5A 3 pin rubber/nylon plug tops
466. 4 - common cathode, 7 segment displays 5"
473. 1 - 5" speaker with built in tweeter, 4ohm, Radio mobile



VENNER TIME SWITCH

Mains operated with 20 amp switch, one on and one off per 24 hrs. repeats daily automatically correcting for the lengthening or shortening day. An expensive time switch but you can have it for only £2.95 without case, metal case - £2.95, adaptor kit to convert this into a normal 24hr. time switch but with the added advantage of up to 12 on/off per 24hrs. This makes an ideal controller for the immersion heater. Price of adaptor kit is £2.30.

Ex-Electricity Board. Guaranteed 12 months.

SOUND TO LIGHT UNIT



Complete kit of parts of a three channel sound to light unit controlling over 2000 watts of lighting. Use this at home if you wish but it is plenty rugged enough for disco work. The unit is housed in an attractive two tone metal case and has controls for each channel, and a master on/off. The audio input and output are by 1/2" sockets and three panel mounting fuse holders provide thyristor protection. A four pin plug and socket facilitate ease of connecting lamps. Special price is £14.95 in kit form.

12 VOLT MOTOR BY SMITHS

Made for use in cars, etc. these are very powerful and easily reversible. Size 3 1/2" long by 3" dia. They have a good length of 1/2" spindle - 1/10 hp £3.45 1/8 hp £5.75 1/6 hp £7.50

25A ELECTRICAL PROGRAMMER

Learn in your sleep. Have radio playing and kettle boiling as you wake - switch on lights to ward off intruders - have a warm house to come home to. You can do all these and more. By a famous maker with 25 amp on/off switch. A beautiful unit at £2.50

THIS MONTH'S SNIP

3" floppy disk drive unit plug in and with all electronics. Japanese made, brand new. We supply data showing how this can be used with the BBC, Commodore, Amstrad and other popular computers. Special snip price £29.50.

12V Battery Operated Siren (or you can work this off a 2V transformer). Makes a shocking noise, will frighten away any intruder. Japanese made one 50p each, 2 for £1, ref BD106. American, storage soiled but unused and guaranteed perfect, only 20p each, 5 for £1, ref BD221.

Wonderful Breakdown Value - Hand Held Stereo Unit Contains two beautiful miniature moving coil loud speakers. These could also be used as microphones, also contains many other useful parts including mini stereo amp, transistors, condensers, rocker switches etc. Use to this as a personal amplifier simply add a stethoest only £1, ref BD29.

Spit Motor Powerful mains operated induction motor with gearbox attached. Shaft has square hole which gives very easy coupling and quick release if required. Shaft speed 5rpm. Price £5, ref 5P54.

Geared Motor. Very powerful. Has 2 inch stack. Fitted gearbox gives final speed of 60 r.p.m. Should be suitable with more gearing to operate garage door etc. Mains operated. £4.00 + £1 postage. Ref: 4P15

Nicek Cadmium Rechargeable Battery. D size. High 4 amp power capacity. £2 each. Ref: 23141

20V - 0 - 20V 1A Mains Transformer Upright mounting. Primary thermal cutout to interrupt the supply if transformer overheats. Price £2, ref 2P138.

4 Books for £1. Book 1 describes the Mullard Unilux amplifier and gives details of a suitable cabinet. Book 2 describes several useful pieces of test equipment which could be quite easily constructed. Book 3 is electronic projects. Book 4 describes short wave receivers which can be easily constructed and is intended for mainly beginners. Our ref BD400.

Transformer in Waterproof Metal Case 24V 5A output. Ideal for garden lighting or to operate pond pump etc. Case has cable glands for mains in and low voltage output leads. Price £5 plus £1 post, ref 5P88.

Mains Relay With transparent plastic cover. Could be pcb or clip mounted, has single 8-10A c/o contact. Rear bargain 2 for £1, ref BD486.

Panel Meters Engraved vu, approximately 1 1/4" square. Luminate these from behind and you will have a really super looking panel. Rear bargain 2 for £1, ref BD366.

POWERFUL IONISER.

Generates approx. 10 times more IONS than the ETI and similar circuits. Will refresh your home, office, shop, work room etc. Makes you feel better and work harder - a complete mains operated kit, case included. £9.50 + £2 P&P.

TELEPHONE BITS

Master socket (has surge arrester - ringing condenser etc) and takes B.T. plug	£3.95
Extension socket	£2.95
Dual adaptors (2 from one socket)	£3.95
Cord terminating with B.T. plug 3 metres	£2.95
Kit for converting old entry terminal box to new B.T. master socket, complete with 4 core cable, cable clips and 2 BT extension sockets	£11.50
100 mtrs 4 core telephone cable	£8.50

J & N BULL ELECTRICAL

Dept PE, 250 PORTLAND ROAD, HOVE, BRIGHTON, SUSSEX BN3 5OT

MAIL ORDER TERMS: Cash, P.O. or cheque with order. Orders under £20 add £1 service charge. Monthly account orders accepted from schools and public companies. Access & B/card orders accepted. Brighton 0273 734648 or 203500.

£2 POUNDERS*

- 2P2 - Wall mounting thermostat, high precision with mercury switch and thermometer
- 2P3 - Variable and reversible 8-12v psu for model control
- 2P4 - 24 volt psu with separate channels for stereo
- 2P6 - 100W mains to 115V auto-transformer with voltage tappings
- 2P8 - Mains motor with gear box and variable speed selector. Series wound so suitable for further speed control.
- 2P9 - Time and set switch. Boxed, glass fronted and with knobs. Controls up to 15 amps. Ideal to program electric heaters
- 2P10 - 12 volt 5 amp mains transformer
- 2P12 - Disk or Tape precision motor - has balanced rotor and is reversible 230v mains operated 1500 rpm
- 2P14 - Mug Stop kit - when thrown emits piercing squeawk
- 2P15 - Interrupted Beam kit for burglar alarms, counters, etc.
- 2P17 - 2 rev pr minute mains driven motor, ideal to operate mirror ball
- 2P18 - Liquid/gas shut off valve mains solenoid operated
- 2P19 - Disco switch-motor drives 8 or more 10 amp change over micro switches supplied ready for mains operation
- 2P20 - 20 metres extension lead, 2 core - ideal most Black and Decker garden tools etc.
- 2P21 - 10 watt amplifier, Mullard module reference 1173
- 2P22 - Motor driven switch 20 secs on or off after push
- 2P26 - Counter resettable mains operated 3 digit
- 2P27 - Goodmans Speaker 8 inch round 8ohm 12 watt
- 2P28 - Drill Pump - always useful couples to any make portable drill
- 2P31 - 4 metres 98 way interconnecting wire easy to strip
- 2P32 - Hot Wire amp meter - 4 1/2 round surface mounting 0-10A - old but working and definitely a bit history
- 2P34 - Solenoid Air Valve mains operated
- 2P38 - 200 R.P.M. Geared Mains Motor 1" stack quite powerful, definitely large enough to drive a rotating aerial or a tumbler for polishing stones etc.
- 2P43 - Small type blower or extractor fan, motor inst so very compact, 230V
- 2P46 - Our famous drill control kit complete and with prepared case.
- 2P49 - Fire Alarm break glass switch in heavy cast case
- 2P51 - Stereo amplifier, 3w per channel
- 2P55 - Mains motor, extra powerful has 1 1/2" stack and good length of spindle
- 2P62 - 1 pair Goodmans 15 ohm speakers for Unilux
- 2P64 - 1 five bladed fan 6 1/2" with mains motor
- 2P66 - 1 2kw tangential heater 115v easily convertible for 230V
- 2P67 - 1 12v-0-12v 2 amp mains transformer
- 2P68 - 1 15v-0-15v 2 amp mains transformer
- 2P69 - 250v 80 ma & 80 v 5A mains transformer + 50p post
- 2P70 - 1 E.M.I. tape motor two speed and reversible
- 2P72 - 1 115v Muffin fan 4" x 4" approx. (s.h.)
- 2P82 - 9v-0-9v 2 amp mains transformer
- 2P84 - Modem board with press keys for telephone redialler
- 2P85 - 20v-0-20v 1/2 A Mains transformer
- 2P88 - Sengamo 24 hr time switch 20 amp (s.h.)
- 2P89 - 120 min. time switch with knob
- 2P90 - 90 min. time switch with edgewise engraved controller
- 2P94 - Telephone handset for EE home telephone circuit
- 2P97 - Mains transformer 24V 2A upright mounting
- 2P98 - 20m 4 core telephone cable, white outer
- 2P99 - 500 hardened pin type staples for telephone cable
- 2P101 - 15V mains transformer 4A upright mounting
- 2P105 - capillary type thermostat for air temperature with c/o switch
- 2P107 - membrane keyboard, telephone type
- 2P108 - mains motor with gear box giving 110rpm
- 2P109 - 5" wide black adhesive pvc tape 33m, add £1 post if not collecting
- 2P1231 - 25A rotary switch, surface mounting, cover engraved, high, medium, low, off
- 2P1281 - 5A noise filter mains for computer or amplifier
- 2P1341 - 9V 500mA psu, plugs into 13A socket
- 2P1381 - mains transformer 20V-0-20V 1A

OVER 400 GIFTS YOU CAN CHOOSE FROM



There is a total of over 400 packs in our Baker's dozen range and you become entitled to a free gift with each dozen pounds you spend on these packs. A classified list of these packs and our latest "News Letter" will be enclosed with your goods, and you will automatically receive our next news letters.

£5 POUNDERS*

- 5P1. 12 volt submersible pump complete with a tap and switch, an ideal caravan unit.
- 5P2. Sound to light kit complete in case suitable for up to 750 watts
- 5P6. 12V alarm bell with heavy 6" gong, suitable for outside if protected from direct rain fall. Ex GPO but in perfect order.
- 5P12. Equipment cooling fan - mini snail type mains operated.
- 5P13. Ping pong ball blower - or for any job that requires a powerful stream of air - ex computer. Collect or add £2 post.
- 5P15 - Uniselect 4 pole, 25 way 50 volt coil
- 5P18 - motor driven water pump as fitted to many washing machines
- 5P20 - 2 kits, matchbox size, surveillance transmitter and FM receiver
- 5P23 - miniature (appr. 2 1/2" wide) tangential blow heater, 1-2kw
- 5P24 - 1/2 hp motor, ex computer, 230V, mains operation 1450rpm. If not collect add £3 post
- 5P25 - special effects lighting switch. Up to 8 channels of lamps can be on or off for varying time periods
- 5P27 - cartridge player 12V, has high quality stereo amplifier
- 5P28 - gear pump, mains motor driven with inlet and outlet pipe connectors
- 5P34 - 24V 5A toroidal mains transformer
- 5P35 - modern board from telephone auto dialler, complete with keypad and all ICs
- 5P37 - 24 hour time switch, 2 on/off's and clockwork reserve, ex Elec. Board loading up to 50A. Add £1 post
- 5P41 - 5" extractor fan, very quiet runner (s.h.), grnt 12 mths.
- 5P45 - pack of 6 cooler clock switches
- 5P48 - telephone extension bell in black case, ex-GPO
- 5P52 - mains transformer 26V 10A upright mounting, add £2 post
- 5P54 - mains motor with gear box, final speed 5rpm
- 5P58 - Amstrad stereo tuner FM and LM and S. AM
- 5P60 - DC Muffin type fan 18 to 27v, only 3W
- 5P61 - drill pump mounted on frame, coupled to mains motor
- 5P62 - 2 1/2 kw tangential blow heater, add £1.50 post if not collecting
- 5P72 1 - turntable, base size appr. 17 1/2 x 9 1/2, suitable for VDU or similar
- 5P81 1 - stepping motor, 48 steps 75', 10-14V, bi-directional
- 5P86 1 - 200W mains transformer with 2 100 1A secondaries
- 5P88 1 - 24V 5A mains transformer in waterproof case

LIGHT CHASER KIT motor driven switch bank with connection diagram, used in connection with 4 sets of xmas lights makes a very eye catching display for home, shop or disco, only £5 ref 5P56.

FREQUENCY SYNTHESISERS

USUALLY ASSOCIATED WITH RADIO
FREQUENCY SYNTHESIS PLAYS
MANY OTHER ROLES

BY R.A. PENFOLD

FREQUENCY synthesisers are probably most closely associated with the world of radio, and in particular with scanning receivers and fancy looking communications equipment with high price tags. However, they are not limited to communications purposes, and find application in electronic music, test gear, and probably many other spheres of electronics as well. These synthesisers fall into two broad categories; the type which provides a series of output frequencies that are well and unevenly spaced out, and the kind which has a large number of closely and evenly spaced output frequencies covering what is often a relatively narrow frequency band. With this second type there are often several ranges so that a wide range of frequencies is covered overall, with a massive number of output frequencies available in total.

The first type of frequency synthesiser is a relatively simple type, and it generally takes the place of a series of oscillators, or a single oscillator having several switched frequency selective feedback networks. The second type acts as a replacement for a standard variable frequency oscillator (v.f.o.).

ADVANTAGES

So why bother to use frequency synthesis in place of traditional circuit techniques? Taking the more simple type of synthesiser first, a common application would be as a calibration oscillator where (say) outputs are required at 10MHz, 1MHz, 100kHz, and 10kHz. One way of achieving the desired result would be to have a crystal oscillator having four switched crystals of the appropriate operating frequencies. This would be a relatively expensive way of doing things though, especially where low output frequencies are involved and very expensive crystals would be required. Using frequency synthesis techniques, all that is needed is a single oscillator at the highest frequency required, with the synthesiser circuit then generating the lower frequencies that are required.

In electronic music applications frequency synthesis techniques can be used to produce a full range of musical notes and over a range of many octaves if required. This system has been used as the basis of many electronic organs and other instruments for some years

Frequency synthesisers are one alternative method of producing signals at a desired set of frequencies, whether for test purposes or for use in a musical instrument. They have advantages and disadvantages which must be taken into account when designing circuits. Here we look at some of them.

now, and although the circuitry involved may not be particularly simple, it is probably less involved than the alternative of having a separate oscillator to generate each note. Another point in its favour is that tuning requires the adjustment of just a single master oscillator, rather than individually adjusting each note. This makes initial setting up much faster and easier, as well as any periodic retuning that may be required. As any drift of one note will be matched by a drift of equal amount by all the others, the relative pitch is always correct, a factor which will often render any lack of pitch accuracy of comparatively minor importance. By using a crystal control in the master oscillator it is possible to obtain a very high degree of pitch accuracy without the need for any initial adjustment or retuning at all.

Variable frequency oscillators are used in the tuning systems of radio receivers, in AF and RF signal generators, etc., and in many ways they are very efficient. They are certainly quite simple by modern standards, even types with frills such as temperature compensation and highly stable supplies. Their main shortcomings are a lack of frequency stability, and problems with precisely setting the required frequency. There are methods of improving stability, but it takes a lot of effort and setting up to produce a design that is still substantially inferior to an average crystal oscillator in this respect. Accurate frequency setting can be achieved, but it again requires a lot of careful setting up initially, plus periodic checking and recalibration. It also usually involves an expensive precision drive mechanism and dial. Of course, a highly sophisticated drive and readout system is largely academic if the frequency stability of the oscillator is inadequate to justify the resolution of the drive and dial, and there have been pieces of equipment which fall into this trap.

With frequency synthesis techniques the output signal has a frequency stability that is equal to that of the master oscillator, which in practice is



The YAESU FRG-8800. Its synthesiser and up-converter technique give continuous tuning from 150 kHz to 30MHz (plus keyboard tuning and automatic scanning).

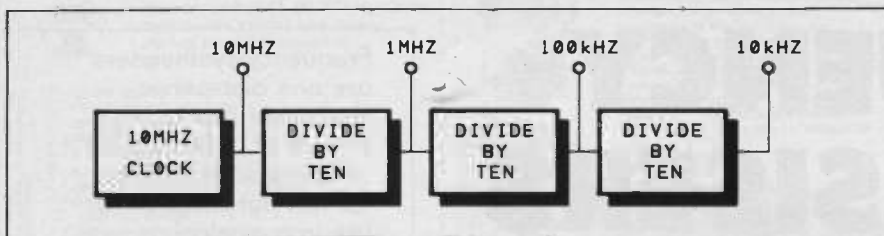

Fig.1. Block diagram for a simple frequency synthesiser

almost invariably a crystal type. This gives an output with very low levels of frequency drift, and the digital techniques ensure that the output frequency can be set very precisely without the need for complex setting up and frequent recalibration.

DRAWBACKS

Although frequency synthesisers have a lot in their favour, they have not completely ousted traditional frequency generator circuits, and are not without some drawbacks. With the simpler type the main problem is that it is not always possible to generate the set of frequencies that are required. They are produced from the master oscillator by a simple frequency division technique, and the required frequencies can only be produced precisely if they are all dividends of a practical master oscillator frequency. Otherwise a different form of frequency generator has to be used, or compromises over the accuracy of some of the output frequencies have to be accepted. Apart from this limitation this type of synthesiser represents a relatively inexpensive way of obtaining a range of accurate output frequencies, and is almost certain to be the most cost effective solution in the instances where it is applicable.

The main drawback of the second type of frequency synthesiser is that it is still very much more costly than a variable frequency oscillator. Special integrated circuits for this type of synthesiser are available, and these can help to ease the cost as well making the task of designing what is a fairly complex system very much easier. Synthesisers of this type are still far from cheap though, and custom chips are not available for every conceivable application for a circuit of this type. Possibly things will eventually progress to the point where a frequency synthesiser can be used as easily as a simple v.f.o., but this seems some way off at present.

Another drawback of these circuits is that they have limited resolution. With an ordinary v.f.o. there is, theoretically at any rate, infinite resolution, and any desired frequency can be set with absolute precision. In practice the mechanical side of the system will place some limitations on the resolution, but it would normally still be extremely high. With a frequency synthesiser it is possible to obtain very high resolution, but the

greater the resolution the more complex the system becomes, and the more difficult it becomes to control and display output frequencies.

The importance of good resolution depends very much on the precise application. In the case of something like an ordinary broadcast receiver or a citizens band radio it might seem that very high resolution would be needed in order to permit accurate tuning of stations. In practice this is not the case as a system of channels is adopted, with stations therefore being spaced at regular intervals down the band (10kHz channel spacing in the case of the U.K. 27MHz FM citizens band for example). The resolution of the system then only needs to be equal to the channel spacing, provided of course, that the system is designed to produce the right output frequencies with good accuracy.

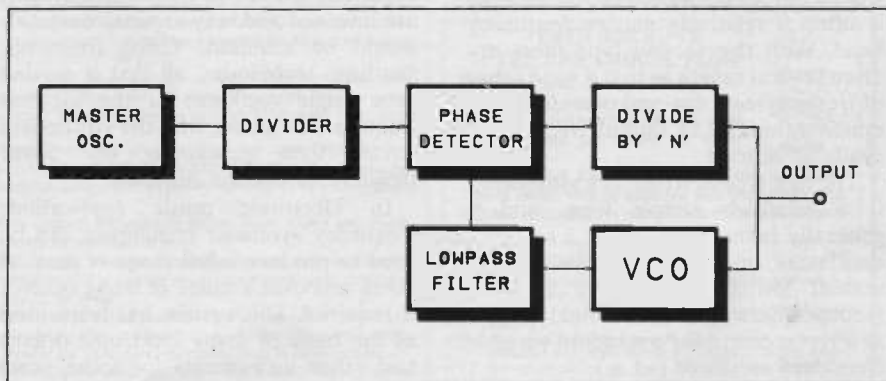

Fig.2. The standard frequency synthesiser arrangement

Not all applications require nice convenient output frequencies which are well suited to this form of frequency hopping. With something like a general coverage short wave receiver it might be necessary to tune to any frequency within the 1.6 to 30MHz frequency range. In particular, single sideband (SSB) signals are especially difficult, as the tuning needs to be within about 50 Hertz of the correct frequency if a reasonably intelligible audio output signal is to be obtained, and the tuning should preferably be within about 10 to 20 Hertz of the correct frequency. This is a tall order, with around one million output frequencies being needed in order to cover the full frequency range with good resolution. It is not impossible though, and a few hundred pounds will buy you a receiver that can do it.

frequencies are concerned. Frequencies can only be produced if they can be obtained by dividing the initial frequency by an integer. Also, the available frequencies are not evenly spread out, but are instead widely spaced near the beginning of the chain, with the spacing becoming less and less further down the chain. This suits some applications, including calibration oscillators and musical instruments, but it is totally useless in many others.

The system shown in the block diagram of Fig.2. is a much more versatile one, and it is the general type that is utilized in radio and similar applications. It is based on a phase locked loop (p.l.l.), and a conventional p.l.l. is formed by the phase detector, lowpass filter, and voltage controlled oscillator stages. The function of a phase

CONFIGURATIONS

The simplest type of frequency synthesiser is the divider type, as outlined in the example configuration of Fig.1. This is a popular set up for crystal calibration oscillators, and it simply consists of a 10MHz oscillator plus a chain of three divide by ten counter circuits to provide additional output frequencies of 1MHz, 100kHz, and 10kHz. This arrangement can be extended if necessary, and it does not need to take the form of a simple series of divider circuits. Branches can be added to permit awkward frequencies to be produced without rendering lower frequencies further down the chain impossible. In an electronic music application a special divider circuit (appropriately called a "top octave generator") is used to produce a full range of semitones at the highest octave that is required, and then each of these tones is fed to a chain of divide by two flip/flops which generate the notes for the lower octaves. This requires dozens of divider stages, but integrated circuits designed specifically for this application make this system much more practical than it would otherwise be.

This arrangement is unsuitable for many applications as it is rather restrictive as far as the available output

locked loop is to lock the voltage controlled oscillator onto the same frequency as, and in phase with, an input signal. It is achieved by comparing the two signals using a phase detector, and smoothing the output pulses from this circuit with a lowpass filter to generate a d.c. control voltage for the voltage controlled oscillator. Things are arranged so that if the oscillator is too high in frequency or ahead in phase, the output voltage from the lowpass filter is reduced. If it is low in frequency or lagging in phase, the output voltage from the lowpass filter increases. By a simple negative feedback action this keeps the voltage controlled oscillator quite accurately on the same frequency and in phase with the input signal, provided the latter stays within the tracking range of the circuit.

In this case the input to the phase locked loop is a reference frequency, and this would normally be at a fairly low frequency, as it must be equal to the required resolution of the circuit (assuming that the final output signal is not obtained via any divider circuits, as is sometimes the case). This reference signal is often generated by a crystal controlled master oscillator followed by some divider stages to give the required final frequency. This is not essential though, and depending on the application, it could be generated directly by a crystal oscillator, or even using a simple L-C or C-R oscillator. If the potential accuracy and stability of the system is to be properly realised though, a crystal oscillator is required.

If we ignore the divide by 'N' stage for a moment, the output frequency will simply be equal to the reference frequency. If we now take into account the divider circuit, and assume that it is a straightforward divide by two stage, the phase locked loop will still try to track the input signal, but it is the output from the divider circuit and not the voltage controlled oscillator that it tries to match to the input signal. In other words, to provide lock, the oscillator must be at twice the input frequency. With 'N' equal to three the oscillator goes to three times the reference frequency, with 'N' at four times the oscillator is locked at four times the reference frequency, and so on. The output of the voltage controlled oscillator can therefore be set to any multiple of the reference frequency simply by setting 'N' to the appropriate figure.

In practice things are not quite this simple as the phase locked loop will not have an infinite locking range, and there will be strict limits on the maximum and minimum frequencies that can be attained. If a very wide output frequency range is needed it is consequently necessary to have the voltage controlled oscillator cover this range in two or more bands. This can be achieved with the aid

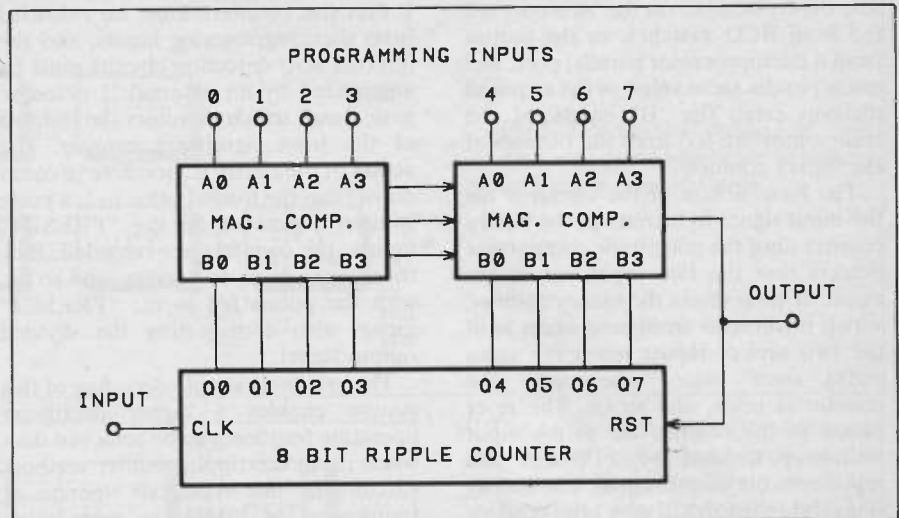

Fig.3. A divide by 'N' system based on a binary ripple counter

of solid state switching though, and to the user it might appear as though the frequencies are covered in a single range. This is certainly the case with some modern communications receivers which tune through the long, medium, and full short wave bands continuously, with perhaps the slightest of glitches as the boundary from one range to another is crossed.

With superheterodyne receivers the frequency covered by the v.f.o. is not the same as the frequency coverage of the receiver, as there is the intermediate frequency offset to consider. A popular technique with modern receivers is so called "up conversion", where the first I.F. is at a high frequency of around 45MHz or more. In order to achieve this, the oscillator must tune over a range of around 45MHz to 75MHz to give a difference frequency at the 45MHz i.f. and cover a 0 to 30MHz range. Although this is a frequency range of 30MHz, at these high frequencies it represents a span of under one octave, and it can be covered in a single range using a frequency synthesiser or a conventional v.f.o.

'N' DIVIDER

Where a modest number of output frequencies are required, it is possible to have a fairly simple divide by 'N' circuit with the division rate controlled by a switch or switches. Where a vast range of output frequencies are involved the divider is normally controlled by a microprocessor or some other fairly sophisticated digital control circuit. A microprocessor can control the divider (and hence the output frequency) under software control, or under manual control via a numeric keypad or a conventional rotary tuning type control. This type of tuning control is only a conventional type superficially, and the knob actually operates either an electro-magnetic pulse generator or an optical type. Actually two sets of pulses are generated, and the phasing of these

indicates to the control circuit which way the knob is being rotated. It then increases or decreases the division rate accordingly.

DIVIDERS

Although the system shown in Fig.2. looks very simple, in practice there are a few problems which have to be overcome. One of the simpler ones is that the output from the voltage controlled oscillator in a normal phase locked loop is either a squarewave or a triangular signal, but most frequency synthesiser applications require a reasonably pure sinewave. In radio frequency applications the oscillator is usually a fairly conventional L-C sinewave type with variable capacitance diodes to provide voltage control, and a trigger circuit to give a squared output to drive the phase comparator (which is often a form of exclusive OR gate). In an audio application, probably the most common approach is to use a tracking filter to convert a square or triangular waveform to a reasonable sinewave signal.

A more serious problem is that of providing a divide by 'N' action. There are standard TTL and CMOS logic chips which provide a programmable divider action, and these can be used in conjunction with mechanical switching, or under electronic control via electronic switches. A more common approach though, is to use an arrangement of the type shown in Fig.3, which is based on a magnitude comparator and a binary divider. In fact two 4-bit magnitude comparators in series are used in the set up of Fig.3, and it is generally less expensive to use a chain of 7485 (or similar) 4-bit types than to have a design based on (say) 8-bit magnitude comparators.

Magnitude comparators are perhaps not the best known of logic building blocks, but they are extremely useful devices that are quite simple in principle.

DESIGN FEATURE

The binary number on the 'A' inputs are fed from BCD switches, or the output from a microprocessor parallel port, and are set to the same value as the required division rate. The 'B' inputs of the comparator are fed from the outputs of the binary counter.

The basic action of the circuit is for the input signal to increment the binary counter until the magnitude comparator detects that the two input values are equal. It then resets the binary counter, which increments from zero again until the two sets of inputs reach the same states once more, whereupon the counter is reset, and so on. The reset pulses to the counter are at the input frequency divided by 'N', and this represents the output signal. The output signal is in the form of very brief positive pulses which may not suit the subsequent circuit. This can be overcome by using some form of pulse stretcher, such as a monostable multivibrator or a divide by two flip/flop. The latter is probably the best solution, although the system must then be designed to take into account the fact that it provides a divide by two action and halves all the output frequencies.

1 that the counters must be reloaded from the programming inputs, and the internal zero detection circuits must be augmented by an external '1 detector' gate circuit which monitors the outputs of the least significant counter. The action of the circuit is therefore to count down from the loaded value to 1, a pulse is then generated on the "PRESET" inputs, the counters are reloaded, they then count down to 1 again, and so on, with the pulses fed to the "PRESET" inputs also constituting the divided output signal.

The relatively simple decoding of this system enables a higher maximum operating frequency to be achieved than when using the ripple counter method. Circuits of this type can operate at frequencies of 20MHz or more using fairly fast logic devices, and LSI synthesiser chips using CMOS technology can achieve similar speeds with the aid of look ahead decoding. Of course, the output frequency of the synthesiser can be much greater than the maximum clock frequency of the divider circuit, since in most cases it is feasible to use a prescaler ahead of the divide by 'N' circuit.

tuning drive that suffered a severe case of "backlash", and would render accurate tuning virtually impossible. The response time can be increased by raising the cut-off frequency of the lowpass filter in the phase locked loop, but with a low reference frequency this would give an excessive ripple content on the control voltage to the v.c.o. In order to obtain an acceptably low level of noise on the output it is essential to have a well designed v.c.o. fed with a well smoothed control voltage.

With a low frequency synthesiser there is no real difficulty in overcoming this problem, and the system shown in Fig.5 almost certainly represents the easiest solution. This is basically just the same as the frequency synthesiser outlined in Fig.2 and discussed previously, but it has a divider circuit added at the output. With the example figures a 2kHz reference frequency is used, giving output frequencies from the v.c.o. at 2kHz, 4kHz, 6kHz, etc. However, the divide by one hundred action at the output reduces these frequencies to 20Hz, 40Hz, 60Hz, etc. Thus a resolution of 20Hz is achieved, but the phase locked loop can have a fast response time as it is operating at the relatively high frequency of 2kHz.

This system is less practical where output frequencies of many megahertz are required, since the v.c.o. and (more importantly) the divide by 'N' circuit, have to operate at frequencies which could well be a few hundred megahertz or more. This is actually quite feasible provided a prescaler is added ahead to the divide by 'N' circuit so that it is dealing with comparatively low frequencies. This is tolerable only if a fairly restricted output frequency range is acceptable.

Rather than use a prescaler to reduce the input frequency to the divide by 'N' circuit, in some designs the heterodyne principle is utilized. This requires only a simple addition to the standard synthesiser configuration, as shown in Fig.6. The output from the v.c.o. is mixed with the output from a high frequency oscillator, but here we are talking in terms of the type of mixer used in radio receivers, rather than a simple summing mode mixer as used in audio circuits. This type of mixer is really a form of modulator, and is essentially the same as the "ring" modulators that are used in electronic music. It therefore generates sum and difference output frequencies. If the output from the v.c.o. was at 100MHz for example, and an input to the divide by 'N' circuit at 20MHz was required, the high frequency oscillator could be set at 80MHz ($100\text{MHz} - 80\text{MHz} = 20\text{MHz}$) or 120MHz ($120\text{MHz} - 100\text{MHz} = 20\text{MHz}$). In either case the difference frequency is the required 20MHz output frequency. A bandpass or lowpass filter removes the sum signal.

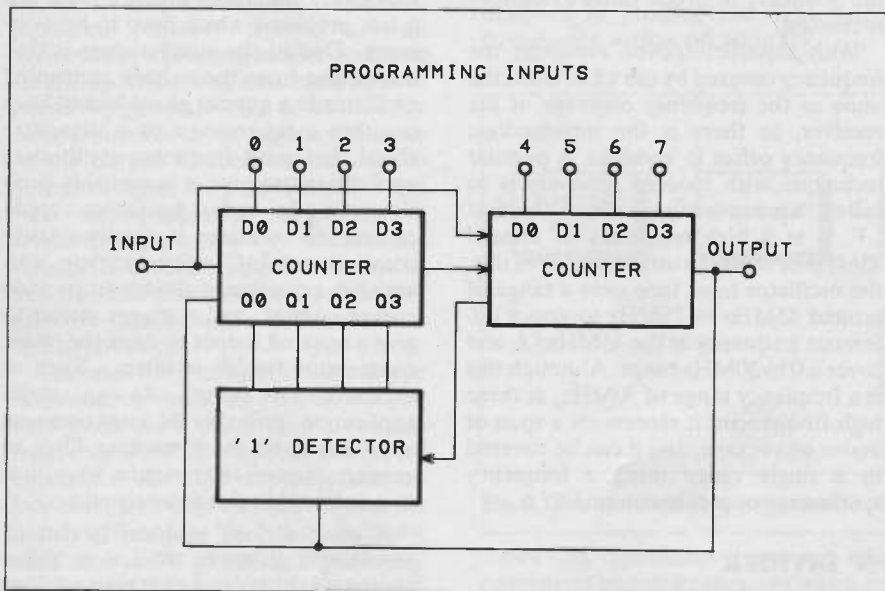

Fig.4. A divider by 'N' arrangement based on synchronous down counters

An alternative form of frequency divider, and one which is preferable for high frequency applications, is one that is based on a synchronous down counter. This set up is shown (in what is admittedly a rather over simplified form) in Fig.4. The required division rate is set up in binary fashion on the data inputs of the counters, which in this case consist of two 4-bit types cascaded to provide an 8-bit counter. The number is loaded into the counters which then count down until the value of 1 is reached. The counters have internal zero detection circuits which are used when cascading them, but in this case it is at a count of

QUICK RESPONSES

There is a problem with many frequency synthesisers in that they require good resolution, with perhaps 20 Hertz increments in the output frequency, but they must also respond reasonably quickly to changes on the programming inputs. With a radio receiver, for example, it would be no good having a manual tuning control where tuning down the band resulted in the set responding slowly and catching up after a few seconds, or even after around half a second. This would be like using a conventional receiver with a

DESIGN FEATURE

prescaling there are two output frequencies that will give the correct input frequency to the phase comparator. In this case the wide operating frequency is likely to result in both of these being within range of the v.c.o. In order to prevent the circuit from locking on to the wrong output frequency, the control voltage from the coarse tune synthesiser is buffered and fed to the main v.c.o. This takes the main v.c.o. to roughly the right frequency, with the phase locked loop then being used to keep it precisely locked.

CONCLUSION

Although they are still not really commonplace electronic circuits, frequency synthesisers have gradually become more widespread over the past few years, and are now to be found in many types of radio equipment, and in one form or another they can be found in many other types of electronic equipment. With LSI integrated circuits becoming less expensive, special synthesiser chips will probably make this type of circuit a practical proposition in an ever increasing range of applications, and result in their introduction into low cost equipment. Perhaps the biggest obstacle to their use, particularly in radio applications, is the large amount of radio frequency interference (r.f.i.) that is generated by the synthesiser



circuits themselves, and also by any digital control circuit that is used. Microprocessor controllers are particularly good at generating r.f.i. Heavy screening of the relevant circuitry is acceptable for something like a communications receiver, but is less than ideal for a pocket radio. No doubt a solution to the r.f.i. problem will be found in due course. **PE.**

NOW YOU'VE READ THE THEORY, PUT IT INTO PRACTISE BY BUILDING THE SYNTHESISING AF GENERATOR ON PAGE 12.

BI-PAK BARGAINS

Pak No	Qty Description	Price	Pak No	Qty Description	Price	Pak No	Qty Description	Price
RESISTORS			VP246			VP226		
VP1	300 Assorted Resistors, mixed values and types	£1.00	1	25 watt High Quality Low Cost Soldering Iron 240v AC Long life Element	£3.50	20	DIN Chassis Smts, metal 2-pin 180°/240°/360° mixed	£2.50
VP2	300 Carbon Resistors 1/2-watt, pre-formed, mixed	£1.00	1	15 watt "Lightweight" High Quality Low Cost Soldering Iron 240v AC	£3.50	18	DIN In-line Smts, plastic 2-pin 180°/240°/360° mixed	£2.50
VP3	200 1/2-watt Min. Carbon Resistors, mixed values	£1.00	1	High Suction Desoldering Pump, teflon nozzle. Auto Eject. Heavy duty return spring	£4.00	10	CIS Computer Cassette Tape, leadless	£3.00
VP4	200 1/4-watt Resistors, mixed values and types	£1.00	1	High Quality Soldering Iron Stand. Cast iron base. Tip cleaning spray	£4.00	10	Cassette Tape, 2 x 30 min, low noise	£5.00
VP5	50 Wirewound Resistors, mixed watt values	£1.00	1	Long Finger Grip, soldering aid. Heavy metal base. Serrated jaws with re-wettable action, ideal for holding small components. Fully adjustable	£3.00	10	Cassette Tape, 2 x 45 min, low noise	£8.00
VP1121	1 Sub Resistance Box, 36 values 50ohms-1kohms	£4.75	1	Multi-tester. Pocket size. 19 ranges. 10000 ohms/VDC - 4000 ohms/VAC. Fuse and diode protection. Mirrored scale. Leads with 2mm plugs. Batt. & instructions Inc.	£8.50	1	Cassette Head Cleaner/Tape, non abrasive, in case	£1.00
VP140	50 Precision Resistors, 1% tolerance	£1.00	1	Digital Multi-tester. 290 digits. Side switches for single-hand operation. High quality construction tough ABS body. Fully guaranteed. Overload protection. Input imp. 10Mohms. 19 ranges incl. 10uA/C plus diode & transistor test. Accuracy 0.8%. Complete with leads. Batt. and manual. Size 145 x 70 x 31 mm.	£25.00	1	Cassette Head Cleaner/Demagnetizer, in case	£2.00
VP181	100 1 and 2 watt Resistors, assorted values	£1.00	1	250 grams Etchant Granules (Fantic chloride) makes 1/2 pint	£1.00	1	Revolving Cassette Rack, holds 32, smoke perspex	£2.50
CAPACITORS			1	PCB Mini Drill. Operating voltage 5-14V DC - 1mm twist drill and collet for 8 to 12mm drills and tommy bar inc.	£5.00	1	Demagnetizer Curved Probe, 240v AC	£3.00
VP5	200 Assorted Capacitors, all types	£1.00	1	10000 Ohm/VDC - 4000 Ohm/VAC. Fuse and diode protection. Mirrored scale. Leads with 2mm plugs. Batt. & instructions Inc.	£18.50	1	YMS Video Head Cleaner Cassette. Wet type	£4.00
VP6	200 Ceramic Capacitors, Min. mixed values	£1.00	1	1 Pack of 3 Twist Drills, 11.5, 2mm for PCB Mini Drill	£1.00	1	Betamax Video Head Cleaner Cassette. Wet type	£4.00
VP8	100 Mixed Ceramic Disc 68pF-050pF	£1.00	1	Etching Pen. Etch resistant. Spares tip. Blue	£1.00	1	Universal Ni-Cad Battery Charger. AA-HP11-HP2-PP3	£8.00
VP9	100 Assorted Polyester/Polyethylene Capacitors	£1.00	1	PCB Mini Drill. Operating voltage 5-14V DC - 1mm twist drill and collet for 8 to 12mm drills and tommy bar inc.	£5.00	1	AA Ni-Cad Batteries. 1.25v 500 mA CR MA	£4.00
VP10	60 C280 Capacitors. Metal foil, mixed values	£1.00	1	Multi-tester. Pocket size. 19 ranges. 10000 ohms/VDC - 4000 ohms/VAC. Fuse and diode protection. Mirrored scale. Leads with 2mm plugs. Batt. & instructions Inc.	£18.50	1	2 C-HP11 Ni-Cad Batteries. Rechargeable	£2.50
VP11	50 Electrolytics, all sorts	£1.00	1	Digital Multi-tester. 290 digits. Side switches for single-hand operation. High quality construction tough ABS body. Fully guaranteed. Overload protection. Input imp. 10Mohms. 19 ranges incl. 10uA/C plus diode & transistor test. Accuracy 0.8%. Complete with leads. Batt. and manual. Size 145 x 70 x 31 mm.	£25.00	1	2 D-HP2 Ni-Cad Batteries. Rechargeable	£4.00
VP12	40 Electrolytics, 47mF-150mF, mixed volts	£1.00	1	250 grams Etchant Granules (Fantic chloride) makes 1/2 pint	£1.00	1	2 ORP12 Light Dependent Resistor	£1.50
VP13	30 Electrolytics, 150mF-100mF, mixed volts	£1.00	1	1 PCB Mini Drill. Operating voltage 5-14V DC - 1mm twist drill and collet for 8 to 12mm drills and tommy bar inc.	£5.00	1	4 Tricolour LEDs, 5mm Dia. 5mA 2v R.G.V.	£1.00
VP15	25 0.1/250v Min. Layer Metal Caps	£1.00	1	1 Pack of 3 Twist Drills, 11.5, 2mm for PCB Mini Drill	£1.00	1	3 Tri-colour LEDs, Rectangular 5mm R.G.V.	£1.00
VP146	25 Solid Tantalum Caps, mixed values	£1.00	1	Etching Pen. Etch resistant. Spares tip. Blue	£1.00	1	1 High Power Piezo Electric Siren. Emits Earpenetrating warbling sound. Ideal alarms. White plastic body with mounting bracket. Power 12v DC 150mA. Output 100dB (A) at 1m typ. Freq. 2.5KHz. Size 57 x 42 x 37mm	£6.00
VP180	25 Tantalum Bead Caps, assorted values	£1.00	1	Multi-tester. Pocket size. 19 ranges. 10000 ohms/VDC - 4000 ohms/VAC. Fuse and diode protection. Mirrored scale. Leads with 2mm plugs. Batt. & instructions Inc.	£18.50	1	1 Automatic Lighting Switch. Photo electric, weather proof. Switches lights or equipment "ON" at dusk "OFF" at dawn. Leads up to 3A at 240v AC. Size 50 x 45mm	£5.00
VP182	4 1000uF 50v Electrolytics	£1.00	1	Digital Multi-tester. 290 digits. Side switches for single-hand operation. High quality construction tough ABS body. Fully guaranteed. Overload protection. Input imp. 10Mohms. 19 ranges incl. 10uA/C plus diode & transistor test. Accuracy 0.8%. Complete with leads. Batt. and manual. Size 145 x 70 x 31 mm.	£25.00	1		
VP192	30 Min. Electrolytics, mixed values, 47mF-1000mF 816v	£1.00	1	250 grams Etchant Granules (Fantic chloride) makes 1/2 pint	£1.00			
VP193	6 Sub Min. Electrolytics, 2 x 1000-2200-3300mF 1016v	£1.00	1	1 PCB Mini Drill. Operating voltage 5-14V DC - 1mm twist drill and collet for 8 to 12mm drills and tommy bar inc.	£5.00			
VP74 SERES SALE "ROCK BOTTOM" PRICES			VP254			VP245		
VP223	50 Ass't TTL IC's "ALL GATES" new & coded our mix 7400-7453	£6.00	1	1 Pack of 3 Twist Drills, 11.5, 2mm for PCB Mini Drill	£1.00	1	1 6 x 4" Elliptical 8 ohms 4W RMS Freq. Res. 135-10000Hz General purpose Speaker. Gauss 7000	£2.50
VP224	100 Ass't TTL IC's "ALL GATES" new & coded our mix 7400-7453	£10.00	1	Etching Pen. Etch resistant. Spares tip. Blue	£1.00	1	1 7 x 5" Elliptical 8 ohms 4W RMS Freq. Res. 90-10000 Hz Speaker. Centre HF cone. Gauss 7500	£3.00
VP7413	4 7413 Dual NAND Schmitt Trigger 4 Input	£1.00	1	PCB Mini Drill. Operating voltage 5-14V DC - 1mm twist drill and collet for 8 to 12mm drills and tommy bar inc.	£5.00	1	1 8 x 5" Elliptical 8 ohms 8W RMS Speaker. Freq. Res. 45-16000 Hz. Gauss 7500	£4.50
VP7440	4 7440 Dual 4-Input Positive-Nand Buffer	£1.00	1	Multi-tester. Pocket size. 19 ranges. 10000 ohms/VDC - 4000 ohms/VAC. Fuse and diode protection. Mirrored scale. Leads with 2mm plugs. Batt. & instructions Inc.	£18.50	1	1 9 x 6" Elliptical 8 ohms 15W RMS Wide range speaker. Freq. Res. 60-10000 Hz. Gauss 10000. Centre HF cone	£4.50
VP7470	4 7470 Anti-gated Positived-edge-triggered Flip-Flop with preset	£1.00	1	1 Pack of 3 Twist Drills, 11.5, 2mm for PCB Mini Drill	£1.00	1	1 12" Round 8 ohms 12W RMS Freq. Res. 190-10K Hz. General purpose speaker. 100 x 100 x 35mm	£1.00
VP7480	4 7480 Gated Full Adder	£1.00	1	Etching Pen. Etch resistant. Spares tip. Blue	£1.00	1	1 5" Round 8 ohms 3W RMS Freq. Res. 90-9500 Hz. Car/General purpose Speaker. Gauss 7500. 133 x 42 mm	£3.00
VP7481	4 7481 16-Bit Random Access memories	£1.00	1	PCB Mini Drill. Operating voltage 5-14V DC - 1mm twist drill and collet for 8 to 12mm drills and tommy bar inc.	£5.00	1	1 5 1/2" Round 8 ohms 15W RMS Wide range speaker. Freq. Res. 50-15000 Hz. Air suspension. Centre HF Cone	£7.00
VP7490	4 7490 Decade Counter	£1.00	1	Multi-tester. Pocket size. 19 ranges. 10000 ohms/VDC - 4000 ohms/VAC. Fuse and diode protection. Mirrored scale. Leads with 2mm plugs. Batt. & instructions Inc.	£18.50	1	1 6" Round 8 ohms 5W RMS Freq. Res. 70-20000 Hz. General purpose Speaker. Gauss 5000	£2.50
VP7491	4 7491 9-Bit Shift Register	£1.00	1	1 Pack of 3 Twist Drills, 11.5, 2mm for PCB Mini Drill	£1.00	1	1 8" Round 8 ohms 10W RMS Freq. Res. 45-16000 Hz. Wide Range Speaker. Centre HF cone	£4.00
VP7492	4 7492 Divided by 12 Counter	£1.00	1	Etching Pen. Etch resistant. Spares tip. Blue	£1.00			
VP7493	4 7493 4-Bit Binary Counter	£1.00	1	PCB Mini Drill. Operating voltage 5-14V DC - 1mm twist drill and collet for 8 to 12mm drills and tommy bar inc.	£5.00			
VP7494	4 7494 4-Bit Shift Register	£1.00	1	Multi-tester. Pocket size. 19 ranges. 10000 ohms/VDC - 4000 ohms/VAC. Fuse and diode protection. Mirrored scale. Leads with 2mm plugs. Batt. & instructions Inc.	£18.50			
VP7495	4 7495 4-Bit Shift Register	£1.00	1	Digital Multi-tester. 290 digits. Side switches for single-hand operation. High quality construction tough ABS body. Fully guaranteed. Overload protection. Input imp. 10Mohms. 19 ranges incl. 10uA/C plus diode & transistor test. Accuracy 0.8%. Complete with leads. Batt. and manual. Size 145 x 70 x 31 mm.	£25.00			
VP74111	4 74111 Dual JK Master Slave Flip-flop	£1.00	1	250 grams Etchant Granules (Fantic chloride) makes 1/2 pint	£1.00			
VP74141	4 74141 BCD - Decimal Decoder/Driver	£1.00	1	1 PCB Mini Drill. Operating voltage 5-14V DC - 1mm twist drill and collet for 8 to 12mm drills and tommy bar inc.	£5.00			
VP74151	4 74151 1 of 8 Data Selectors/Multiplexers	£1.00	1	Multi-tester. Pocket size. 19 ranges. 10000 ohms/VDC - 4000 ohms/VAC. Fuse and diode protection. Mirrored scale. Leads with 2mm plugs. Batt. & instructions Inc.	£18.50			
VP74153	4 74153 Dual 4 line to 1 line Data Selectors/Multiplexers	£1.00	1	Digital Multi-tester. 290 digits. Side switches for single-hand operation. High quality construction tough ABS body. Fully guaranteed. Overload protection. Input imp. 10Mohms. 19 ranges incl. 10uA/C plus diode & transistor test. Accuracy 0.8%. Complete with leads. Batt. and manual. Size 145 x 70 x 31 mm.	£25.00			
VP74164	4 74164 8-Bit Parallel Output Serial Shift Registers	£1.00	1	250 grams Etchant Granules (Fantic chloride) makes 1/2 pint	£1.00			
MISCELLANEOUS			VP225			VP225A		
VP225	20 DIN Chassis Smts, metal 2-pin 180°/240°/360° mixed	£2.50	1	6 Tab Boards 38 way Paxaline	£1.00	1	20 DIN Chassis Smts, metal 2-pin 180°/240°/360° mixed	£2.50

BI-PAK

Send your orders to Dept. PE, BI-PAK, PO Box 6, WARE, HERTS
 TERMS CASH WITH ORDER. SAME DAY DESPATCH ACCESS
 BARCLAYCARD ALSO ACCEPTED
 TEL: 0763-48851. GPO 388 7006.
 ADD 15% VAT AND £1.50 PER ORDER POSTAGE AND PACKING

Use your credit card Ring us on 0763 48851 NOW and get your order even faster. Goods normally sent 2nd Class Mail.
 Remember you must add VAT at 15% to your order. Total Postage add £1.50 per Total order.

For KITS & COMPONENTS -
Choose the easy way - with
Send 50p* & SAE for CATALOGUE
 *refundable with first order



HIGH SECURITY LOCK KIT POWER STROBE KIT

Designed for use with our lock mechanism (701 150) this kit will operate from a 9V to 15V supply drawing a standby current of only 50uA. There are over 5000 possible 4-digit combinations and the sequence can be easily changed. To make things even more difficult for an unauthorised user an alarm can be sounded after 3 to 9 incorrect entries - selectable by means of a link. The alarm can sound for a few seconds to over 3 minutes during which time the keyboard is disabled preventing further entries. A latched or momentary output is available making the unit ideal for door locks, burglar alarms, car immobilisers, etc. A membrane keyboard or pushbutton switches may be used and a beep sounds when a key is depressed. Kit includes high quality PCB, all components, connectors, high power piezo buzzer and full assembly and user instructions.

XK121 LOCK KIT £15.95
350118 Set of keyboard Switches . £4.00
KB12S 12-Way Membrane Keyboard £9.98
701 150 Electric Lock Mechanism . £16.50

Designed to produce a high intensity light pulse at a variable frequency of 1 to 15Hz, this kit also includes circuitry to trigger the light from an external voltage source (eg. a loudspeaker) via an opto isolator. Instructions are also supplied on modifying the unit for manual triggering, as a slave flash in photographic applications or as a warning beacon in security applications. The kit includes a high quality pcb, components, connectors, 5Ws strobe tube and full assembly instructions. Supply: 240V ac. Size: 75x50x45.

XK124 Stroboscope Kit £12.50



8 WAY SEQUENCER KIT

The DL8000K is an 8-way sequencer kit with built in opto-isolated sound to light input which comes complete with a pre-programmed EPROM containing EIGHTY - YES 80! different sequences including standard flashing and chase routines. The KIT includes full instructions and all components (even the PCB connectors) and requires only a box and a control knob to complete. Other features include manual sequence speed adjustment, zero voltage switching, LED mimic lamps and sound to light LED and a 300W output per channel.

And the best thing about it is the price:
ONLY £28.50



DISCO LIGHTING KITS

DL1000K This value-for-money 4-way chaser features by-directional sequence and dimming. 1kW per channel. . £17.50
DLZ1000K - A lower cost uni-directional version of the above. Zero switching to reduce interference. £9.85
DLA/1 Optional opto input allowing audio 'beat'/light response 70p
DL3000K -3-channel sound to light kit features zero voltage switching, automatic level control and built-in microphone. 1kW per channel. £14.25

DVM/ULTRA SENSITIVE THERMOMETER KIT

Based on the ICL 7126 and a 3 1/2 digit liquid crystal display, this kit will form the basis of a digital multimeter (only a few additional resistors and switches are required - details supplied), or a sensitive digital thermometer (-50°C to +150°C) reading 0.1°. The kit has a sensitivity of 200mV for a full-scale reading, automatic polarity and overload indication. Typical battery life of 2 years (PP3). £17.00



ELECTRONIC GUARD DOG KIT

One of the best deterrents to a burglar is a guard dog and this new kit provides the barking without the bite! The kit when assembled can be connected to a doorbell, pressure mat or any other intruder detector and will produce a random series of threatening barks making the would-be intruder think you have a guide dog and try his luck elsewhere. The kit is supplied complete with high quality PCB, mains transformer, all components and instructions. The kit even includes a horn speaker which is essential to produce the loud sound required. The "dog" can be adjusted to produce barks ranging from a Terrier to an Alsatian and contains circuitry to produce a random series of barks giving a more realistic effect. Don't delay, fit one before you go on holiday and let our dog help you guard your home.

XK125 Complete kit of parts £21.95

VERSATILE REMOTE CONTROL KIT

This kit includes all components (+ transformer) to make a sensitive IR receiver with 16 logic outputs (0-15V) which with suitable interface circuitry (relays, triacs, etc - details supplied) can be used to switch up to 16 items of equipment on or off remotely. The outputs may be latched (to the last received code) or momentary (on during transmission) by specifying the decoder IC and a 15V stabilised supply is available to power external circuits.

Supply: 240V AC or 15-24V DC at 10mA. Size (excluding transformer) 9 x 4 x 2 cms. The companion transmitter is the MK18 which operates from a 9V PP3 battery and gives a range of up to 60ft. Two keyboards are available MK9 (4-way) and MK10 (16-way), depending on the number of outputs to be used.

MK12 IR Receiver (incl. transformer) £14.85
MK18 Transmitter £7.50
MK9 4-Way Keyboard £2.00
MK10 16-Way Keyboard £5.95
601 133 Box for Transmitter £2.60

TR ELECTRONICS
13 BOSTON RD.
LONDON W7 3SJ
Tel: 01 567 8910
ORDERING INFORMATION:
ALL PRICES EXCLUDE VAT

SEND 9" x 6" SAE & 50p FOR CATALOGUE OR CALL AT SHOP Mon-Fri 9-5 pm Saturday 10-4 pm



FREE P&P on orders over £20 (UK only), otherwise add 75p + VAT. Overseas P&P: Europe £2.75. Elsewhere £6.50. Send cheque/PO/ Barclaycard/Access No. with order. Giro No. 529314002. LOCAL AUTHORITY AND EXPORT ORDERS WELCOME GOODS BY RETURN SUBJECT TO AVAILABILITY

ELECTRONICS CAD

IBM PC (and compatibles), R.M. NIMBUS, BBC MODEL B, B+ and MASTER, AMSTRAD CPC and SPECTRUM 48K.

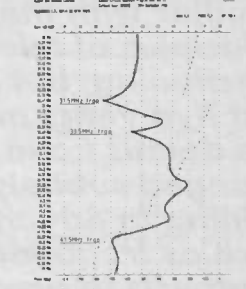
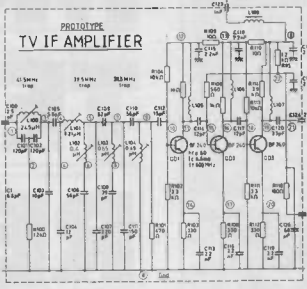

ANALYSER I and II compute the A.C. FREQUENCY RESPONSE of linear (analogue) circuits. GAIN and PHASE, INPUT IMPEDANCE, OUTPUT IMPEDANCE and GROUP DELAY (except Spectrum version) are calculated over any frequency range required. The programs are in use regularly for frequencies between 0.1Hz and 1.2GHz. The effect on performance of MODIFICATIONS to both circuit and component values can be speedily evaluated.

Circuits containing any combination of RESISTORS, CAPACITORS, INDUCTORS, TRANSFORMERS, BIPOLAR AND FIELD EFFECT TRANSISTORS and OPERATIONAL AMPLIFIERS can be simulated - up to 60 nodes and 180 components (IBM version).

Ideal for the analysis of ACTIVE and PASSIVE FILTER CIRCUITS, AUDIO AMPLIFIERS, LOUDSPEAKER CROSS-OVER NETWORKS, WIDE-BAND AMPLIFIERS, TUNED R.F. AMPLIFIERS, AERIAL MATCHING NETWORKS, TV I.F. and CHROMA FILTER CIRCUITS, LINEAR INTEGRATED CIRCUITS, etc.

STABILITY CRITERIA AND OSCILLATOR CIRCUITS can be evaluated by "breaking the loop". Tabular output on Analyser I. Full graphical output, increased circuit size and active component library facilities on Analyser II.

Check out your new designs in minutes rather than days.

ANALYSER can greatly reduce or even eliminate the need to breadboard new designs. Full AFTER SALES SERVICE with TELEPHONE QUERY HOT LINE and FREE update service. Used by INDUSTRIAL, GOVERNMENT and UNIVERSITY R & D DEPARTMENTS worldwide. IDEAL FOR TRAINING COURSES, VERY EASY TO USE. Prices from £20-£195.

For further details and example computations or for details on our Draughting program, please write or phone:
NUMBER ONE SYSTEMS LTD,
Ref PE Crown Street, St Ives, Huntingdon, Cambs. PE17 4EB.
Tel: (0480) 61778

MICROPROCESSOR CONTROL CARDS

- 6502 Based Card (Pictured) £55.20
 - ★ 2K SRAM
 - ★ 4K EPROM (supports 8K EPROM)
 - ★ 16 lines of I/O with handshake
- Z80 Based Card £80.00
 - ★ NMOS Processor
 - ★ 2K SRAM
 - ★ 4K EPROM (supports 8K EPROM)
 - ★ 2 8-bit ports with handshake
- PSU +/- 5V 1A £44.00
- ★ Detailed Application Notes £12.00

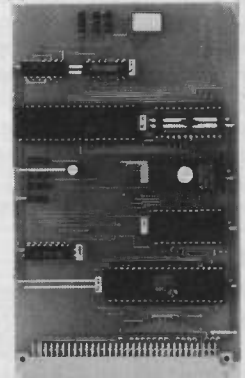

IBM COMPATIBLE SYSTEMS

- Standard 4.77 Mhz Motherboard 170.43
 - ★ 8080 and optional 8087 co-processor
 - 8 expansion slots. - 0K RAM installed - expandable to 640K.
 - ★ Keyboard 83-key typewriter layout £92.69
 - ★ 1/2 HT Tandon Drive D/S D/O £123.90
 - ★ FFD Controller £54.60
 - ★ Monochrome Adaptor £77.60
- Turbo 4.77/8 Mhz Motherboards £199.41
 - ★ 8088-2 and optional 8087 co-processor. - Dynamic speed reduction during disk operation for maximum throughput.

COMPLETE KIT OFFER PRICE
 8 Mhz version £525.00
 4.77 Mhz version £500.00
 All prices inc. VAT; C&P (UK) £2.50 per item. Allow up to 28 days delivery.



ELECTRONICS

JMJ ELECTRONICS,
14 BLENHEIM CLOSE, SHEPRETH, NR. ROYSTON,
HERTS SG8 6PT. TEL: ROYSTON (0763) 62184.

Nearly everyone is familiar with the principles of television functioning, but in the last five years many of the details have changed subtly, bringing in advances such as frequency synthesis in place of manual tuning and SAW filters in place of LC filters.

MODERN TELEVISION RECEIVERS

TELEVISION HAS BECOME MORE EFFICIENT BEHIND THE SCENES

BY MIKE SANDERS

IT IS a tribute to modern technology that television receivers have not increased much in cost over the last ten years. In fact, if inflation is taken into account, the price has probably decreased in real terms.

The widespread use of integrated circuits has led to more sophisticated signal processing. This has probably not achieved or improved the picture quality, only clever ways of doing the same thing. Sophisticated methods of automatic correction have delayed defects due to component ageing. In particular, frequency synthesis for signal tuning (as for video recorders) has largely replaced manual tuning.

We shall take a brief look at developments over the past five years or so in all aspects of receiver circuitry. A television receiver may be thought of as consisting of three parts: the power supplies, the horizontal and vertical scanning, and signal processing.

POWER SUPPLIES

Power supplies required in a colour television receiver range from as low as 5V for driving ICs to as high as 25kV for the final anode. Thyristor controlled power supplies have been used since the first generation of solid state receivers, and have continued in use to this day, with some modifications.

Although the first thyristors operated on a half wave mains rectified output, the use of a thyristor after a full wave rectifier is preferred by the UK Electricity Board. This reduces the amount of d.c. and harmonics fed back into the mains. It is also easier to smooth a 100Hz ripple than to smooth 50Hz. However, one of the main disadvantages of a full wave bridge rectifier without an isolating transformer is that the chassis is live, regardless of which way the mains is connected.

The thyristor switch has two main drawbacks: it is not isolated from the mains and it has a 50Hz ripple. Filtering this ripple leads to an expensive choke as well as heat dissipation.

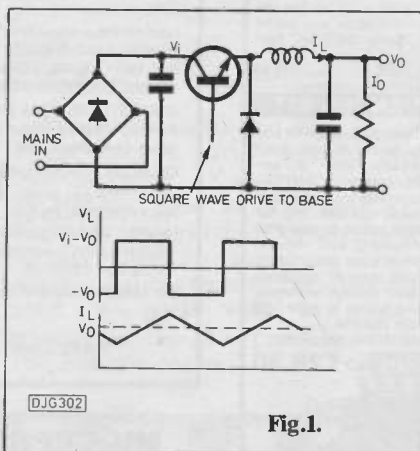

Instead, if we switch the control circuitry at a much higher frequency, we can reduce both problems. Such circuits are called switched mode power supplies (SMPS).

There are two main types of SMPS, the series on forward converter with the choke in series with the load and the parallel or flyback converter where the choke is in parallel with the load. Fig. 1 shows the series converter and the voltage and current waveforms across the choke. Fig. 2 shows the parallel converter.

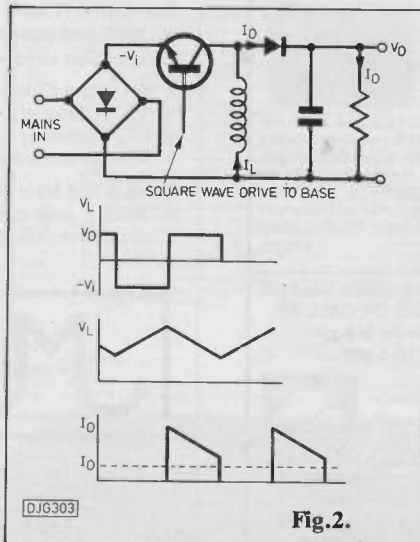

These circuits operate at line frequency or a multiple of line frequency. The input is rectified mains (i.e. virtually d.c.) and the output is d.c. so the circuits are d.c. to d.c. converters. In both instances the square wave drive is applied to the base of the control transistor.

The advantage of synchronising the power supply with the line timebase is that the SMPS wave can now drive the line output transistor. Also, beat frequency interference is prevented from entering the power supply.

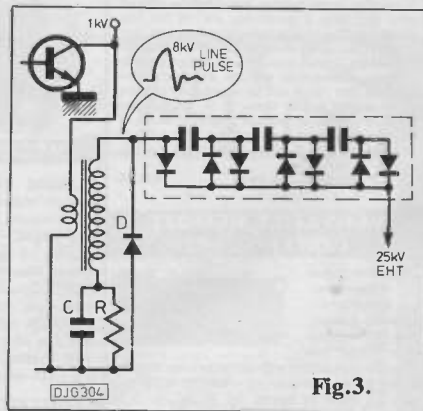

EHT GENERATION

There are two main methods of generating the extra high tension voltage (eht): a transformer with several secondary windings with diodes to charge the interlayer capacitance, or a transformer with an 8kV overwind to drive a tripler and produce the required 25kV.

A voltage less than 25kV would produce a poor colour picture, while voltages higher than 25kV would lead to flashovers, insulation breakdown and X-ray radiation.

The straight forward method of rectifying a sine wave is avoided since the rectifiers would require a peak inverse voltage of twice the desired voltage. Instead, the above methods rectify low duration pulses and the peak inverse voltage of the diodes need be no higher than the desired voltage.

Fig.4.

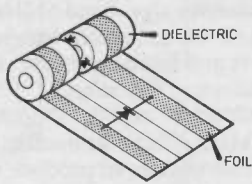

DJG 305

Fig. 3 shows how a tripler is employed in an eht circuit and Fig. 4 shows the construction of a tripler. Formerly a tripler was made up of discrete diodes and capacitors but the present technology rolls the diodes between the layers of tin foil for the capacitors. This package is not only reliable but can be produced again and again with the same parameters. In Fig. 3, the components, C and D, damp any overshoot of the line pulse.

SCANNING

The scanning requirements have not changed. However, scanning systems have become simpler with the development of self convergent coils. The energy requirement has also been reduced. For instance, the Mullard 30AX tube consumes 1.8W for vertical deflection compared to 2.9W for the 20AX tube.

The power for horizontal deflection has also been reduced from 5.6mJ to 4.7mJ. Not significant, one might say in terms of energy saving, but quite significant in helping to reduce the temperature of the receiver, since television sets dissipate a lot of heat.

The basic circuit for line deflection is shown in Fig. 5. This circuit may also be used to provide power to the field timebase, and timing for blanking and gating.

The usual 'S' correction and pincushion correction needs to be provided. The first is supplied by capacitor C in Fig. 5, and pincushion distortion can be corrected by modulation of the line scan amplitude. But the flyback waveform must not be modulated or the pulses and other derived supplies would also be modulated at field rate.

Diode modulators do the job well by modulating the current through the line deflecting system and since the line transformer voltage is kept constant, the

above mentioned nasties are avoided.

Two types of diode modulator are in use, the high and low voltage types. The diodes in the low voltage type operate at scan voltages. In the high voltage version, one of the diodes is an energy recovery device.

Fig.5.

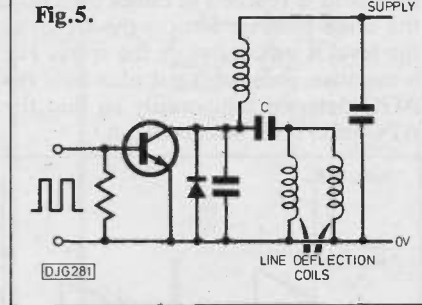

DJG 281

THE TUNER

There are two main demands on a tuner: selectivity and dynamic range. Selectivity means receiving the required signal and rejecting everything else. Dynamic range is related to the amplitude of the signal, i.e. the receiver must be able to receive weak signals without being overloaded by strong signals. Clearly some form of gain control is required.

The evolution of the tuner is interesting. The earliest ones employed a ganged rotary capacitor with fixed inductors. Then came the mechanical push button selectors. The present method is to use varicap diodes which are electrically controlled.

In addition, some television receivers employ frequency synthesisers, as do video recorders. Channel frequencies are stored in a read only memory until called up and associated with the

required transmitting station. Other frequency synthesisers employ an incremental tuning which hunts through the UHF band, stopping when a signal is detected to give the customer the opportunity to accept or reject it.

The 3dB points of a tuner are about 10MHz to 20MHz and the earliest varicap diodes were controlled by altering the emitter current of the RF transistor. Later, a grounded base RF transistor was used with a pin diode to control the input gain. Present tuners use a tetrode MOSFET, Fig. 6. D2, D3 and D5 are the varicap diodes and L10, L11 and L14 the tuned inductors. TR1 is the tetrode MOSFET operating at 10mA drain current. D4 is the mixer diode and a socket supplies an oscillator sample for frequency synthesis.

IF FILTERS

Television broadcasting stations employ vestigial sideband transmission, i.e. both sidebands up to 1MHz, and upper sideband only, above 1MHz.

The IF vision carrier is at 39.5MHz, sound carrier at 33.5MHz and colour sub-carrier at 35.1MHz. The vision carrier of the adjacent channel is at 31.5MHz, and the sound carrier of the other adjacent channel is at 41.5MHz. Therefore suitable traps need to be inserted as in Fig. 7.

Fig. 8 shows an acceptable IF response, and a sound shelf is employed so that the sound carrier does not change in amplitude if the IF drifts slightly.

The earliest circuits used a cascade of tuned stages which required delicate tuning. Then came integrated circuits which provide lumped gain, and computer aided design provided lumped filters. However, the introduction of

Fig.6. Circuit of Mullard U341 LO Tuner

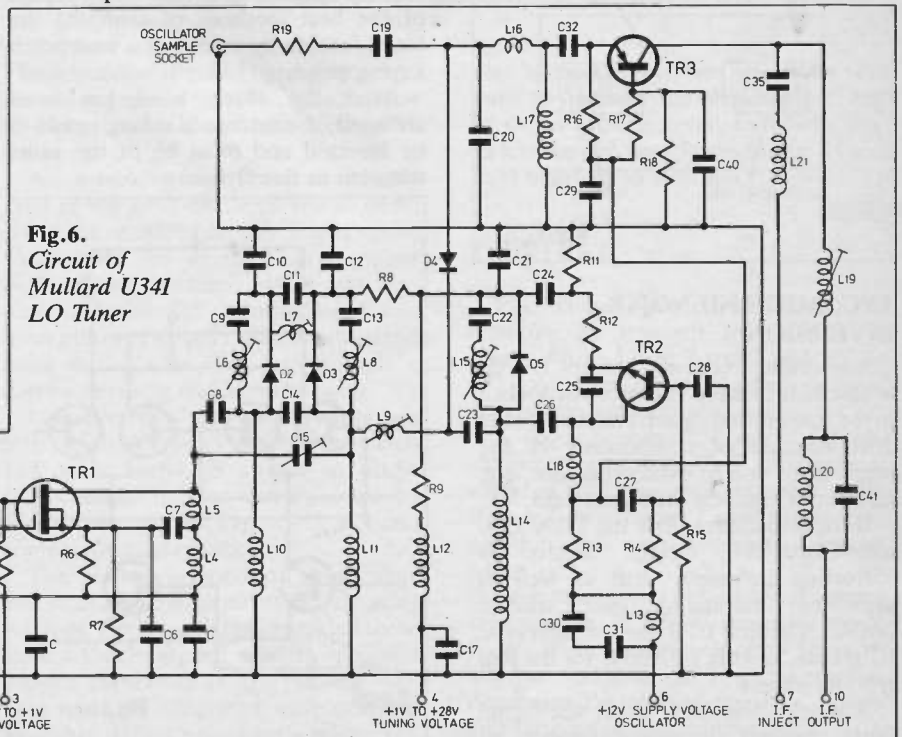

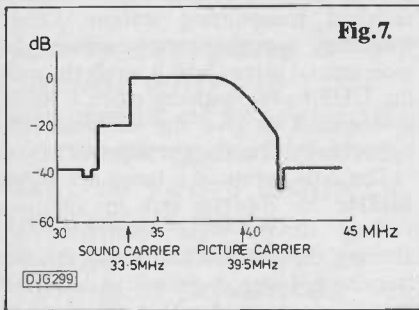

Teletext means that there is an even stricter requirement for a linear phase response and designers have turned to surface acoustic wave (SAW) filters.

SAW filters introduce a loss of about 10dB higher than conventional LC filters so an amplifier is required before the filter or the signal to noise ratio may be degraded. SAW technology is good up to 1GHz and employs a piezo-electric material as a substrate, Fig. 9. On this are mounted the transmitter and receiver which are in the shape of interleaved combs. The signal propagates through the lithium niobate crystal and the required response is obtained by suitable design of the crystal as well as combs.

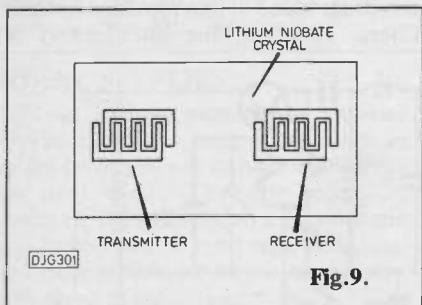
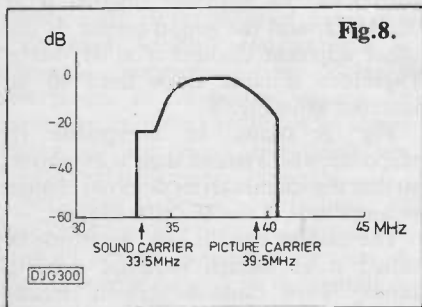

AFC, AGC AND NOISE INVERSION

Automatic frequency control (AFC) is essential to keep the receiver locked to the transmitted signal. The tuning may drift because of components in the receiver, or due to external causes, e.g. an aircraft crossing the signal path.

IF demodulators, like the TDA 3540 and TDA 3541, include circuits for correcting frequency drift as well as providing automatic gain control (AGC). The first IC is used for npn type RF stages, and the TDA 3541 for the pnp type RF stages.

Although the AGC holds the signal fairly constant, it cannot respond to

noise spikes. Such spikes would interfere with synchronisation in the black (negative) direction of the signal, or drive the tube hard, causing white spots in the peak white (positive) direction, Fig. 10.

The IF demodulator chip therefore includes a noise inverter. As soon as the threshold is reached in either direction, the noise inverter returns the signal to the level it was at before the spike. For a negative going spike it also kills the AGC detector temporarily so that the AFC level does not go to pot.

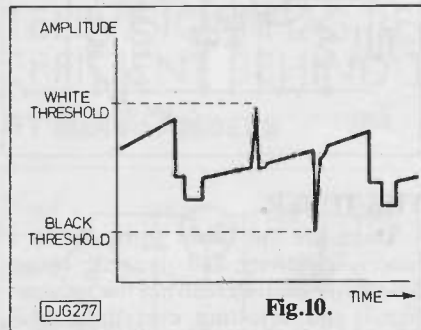

LUMINANCE

Processing of the luminance signal involves delay, brightness and contrast control, retrace blanking and black level clamping. The delay line is a wire, wound on a capacitive material. This is a low pass filter terminated in its characteristic impedance using resistors of 1Kohm to 2Kohm. This delay line produces a 6dB voltage loss.

In order to use a remote control for altering the brightness and contrast, the usual potentiometer on the set is of little use. Instead a variable gain stage is required with d.c. control.

The problem with varying the gain is that the black level is then altered. One of the best methods of clamping the black level is by means of a backporch keying pulse.

After the black level has been clamped, the retrace blanking needs to be inserted and must be of the same duration as line flyback.

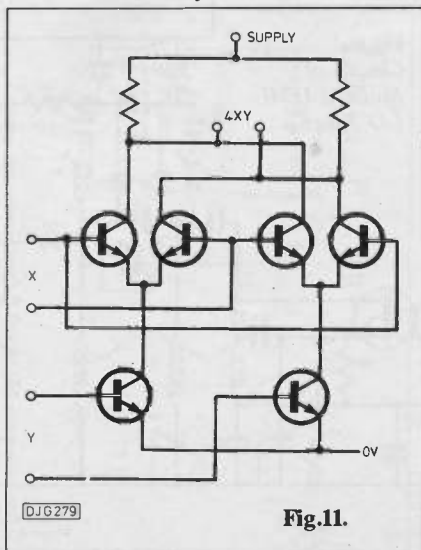

COLOUR DECODING

From the IF demodulated output, the luminance signal and 6MHz intercarrier sound are extracted, leaving the colour burst and luminance subcarrier which is quadrature modulated.

Modern decoders incorporate an 8.8MHz subcarrier oscillator and divide by two circuits to produce two 4.4MHz reference signals at 90°.

The four quadrant multiplier, Fig. 11, is the basic circuit which is used a lot in modern technology, for both colour demodulation as well as phase detection. Applying signals of x and y to the input results in 4xy at the output, and is linear if x and y are less than ± 0.5 . The circuit operates on both the amplitude as well as the phase of the inputs.

A PAL delay line is made of a glass sheet with piezo electric transducers along the edges. These transducers act as transmitter and receiver and the acoustic waves are delayed $64\mu s$. The delay line introduces a 9dB loss and has a 1MHz bandwidth at the subcarrier frequency. In order to produce the required delay, the sheet of glass must have precise dimensions and is ground under electric control to an accuracy of one wavelength of subcarrier.

RGB drive involves setting the black levels and where the drive is connected to the cathode of each gun, black level is set by adjusting the voltage on the first anode of each gun.

The modern technique is to use a dynamic method instead of the above manual method. The advantages of the dynamic method is that it compensates for the ageing of amplifiers and tubes.

In the dynamic method, three lines close to the end of field blanking are measured and stored. This is done for each colour close to cut off. The stored samples are then used for stabilising the d.c. level of each gun. TDA 3562A is one i.c. which incorporates black current stabilisation with colour decoding, and a complete circuit is shown in Fig. 12.

SYNCHRONISATION

Synchronisation is achieved by separating the sync pulses from the composite video waveform. From this, timing waveforms are obtained to drive a phase lock loop.

Although phase lock loops work well for line synchronisation, phase lock loops for field sync cause a delay in pull-in time after a channel change.

The simplest sync separator is a transistor with two time constants in the input, Fig. 13. A short time constant is required to avoid hum on the video content and a long time constant is required to avoid distortion of the field sync.

The modern method of achieving sync separation is obtained in i.c. form as TDA2571, TDA2576A and TDA2578. These have the advantage of not being

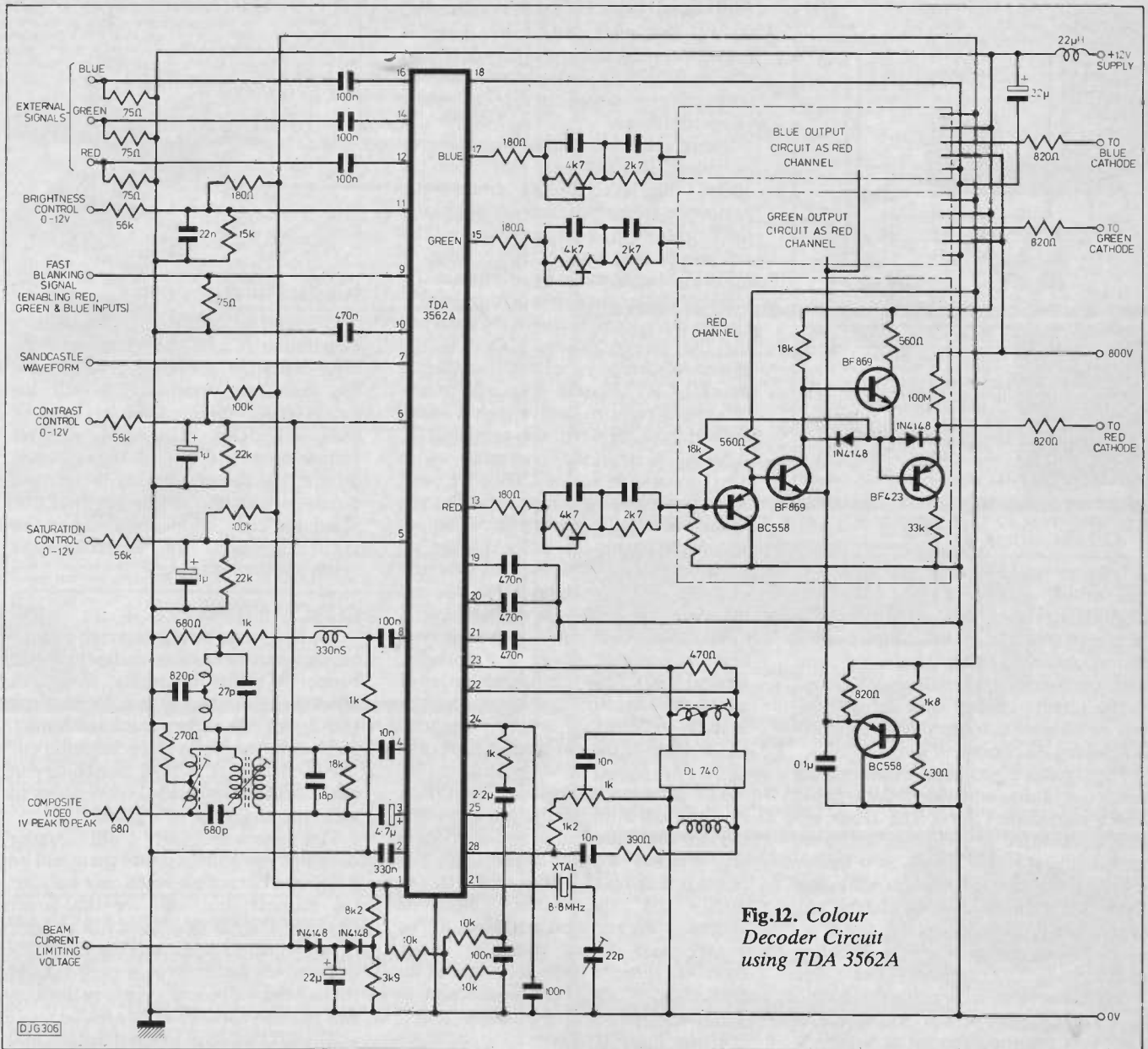

Fig.12. Colour Decoder Circuit using TDA 3562A

influenced by the video content as is the simple sync separator. These integrated circuits sense the video level and the sync peak, and slice in between. The result is a clean waveform without any video.

Phase lock loops have become quite sophisticated. For instance some have two operating speeds, fast and slow. Fast, say, for video recorder operation, and slow for other signals once initial lock has been obtained.

In addition, some receivers employ two phase lock loops. One to generate

a back porch clamp and burst gating, the second to provide fine tuning on the first by using a phase comparator to stabilise the raster.

An astable multivibrator is usually used as the field oscillator and must be set to the centre of its catching range to compensate for ageing. Large pulses permit good synchronisation but also pick up noise. On the other hand, low level pulses are better able to withstand noise during scan, but provide only a narrow catching and holding range.

In a video playback mode sync pulses may be out by $\pm 20\mu\text{s}$ due to tape stretch and it is useful to switch to direct synchronisation. This can be done by means of a +12V flag when a video recorder is in playback.

The timing information from sync pulses is also required in the decoder sections. Early receivers generated these from a timebase, but modern receivers provide these from a single pin on a chip. Two types of integrated waveform are available, called a sandcastle waveform.

Fig. 14 shows a two tier sandcastle with burst keying and line blanking, and Fig. 15 shows a three tiered waveform. Fig. 15 has the two waveforms of Fig. 14 and field blanking in addition.

TELETEXT

Teletext uses the silent periods of field blanking to transmit information in binary form. Lines 7 to 32 and 320 to 335 are available, but only some of these are used at present.

A page contains 24 rows with 40 characters per row. Each character is encoded in 7bits, plus one parity bit. Binary 0 is within $\pm 2\%$ of black level and binary 1 is 66% ($\pm 6\%$) of peak white.

Each row carries quite a lot of control information: 16 bits for the data clock; 8 for frame coding; 16 bits for row address and control. The control bits determine the colours, spacings, height and flashing of characters etc.

Fig.13.

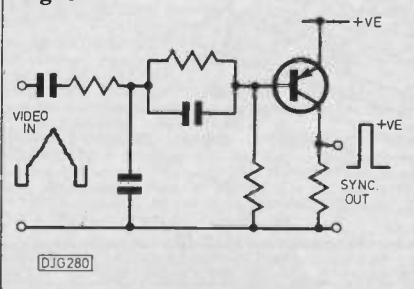

DJG280

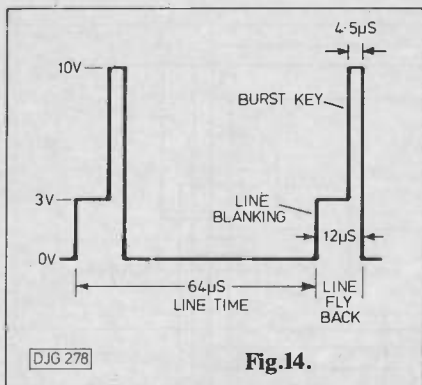

Fig.14.

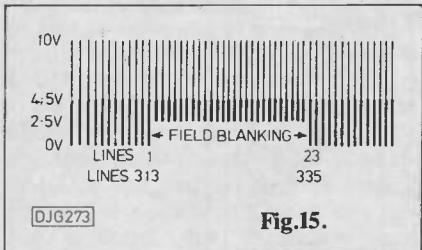

Fig.15.

Teletext transmission requires low quadrature distortion in the IF demodulator and constant group delay in the IF stages, otherwise intersymbol distortion would result. Hence the need for more precise devices like SAW filters.

The remote control uses either infrared or ultrasonic transmitters, typically employing 32 command keys.

The remote control (transmitter) sends out 12bits consisting of data (5bits) and a start code (7bits). The 12bits are also transmitted in complimented code and if this is not received as a mirror image of the first, the receiver will reject the command. This helps defeat any spurious interference.

Another method of defeating continuous interference, like line frequencies, is to use a mark space ratio of 66.6:16.6, i.e. a zero bit occupies 16.6% of the time compared to 66.6% for a 1bit.

FLAT SCREENS

The cathode ray tube is one of the last bastions of the valve era and although engineers would dearly like to replace it

with some kind of matrix addressed directly by semiconductors, there is nothing at present to beat the speed and efficiency of the cathode ray tube in addressing a large number of pixels (screen cells).

There are a number of limitations to providing large screen (say 75cm × 100cm) displays. Flicker around the perimeter appears to increase unless the field rate is also increased. The resolution also suffers since what is normally displayed on a conventional TV set is now enlarged by about four times.

Two main technologies have emerged for flat screen displays. One is the plasma discharge panel and the other is the flat CRT. Plasma discharge panels of around eight to twelve inches width are widely used on portable computers.

MOS integrated circuits with breakdown voltages of 250V have been used to address the screen cells. The gas plasma consists of a mixture of Helium and Xenon with the latter making up 0.5% to 2% of the volume. The structure of a typical cell is shown in Fig. 16, and the main limitation is low brightness.

The flat CRT is based on the electron beam waveguide where low voltages, around 100V, can propagate up to 1 metre at 99% efficiency. There could be as many as 500 electron guns positioned at the base of the 4in thick screen, Fig. 17.

The glass has to be about 6mm thick to withstand atmospheric pressures of 8 tons on each side and in addition, there are internal support structures. The beam is sent up the guide and -60V to -180V on the extract electrode addresses the required cell, Fig. 18. The beam guide forms a ladder mesh, therefore three of these are required for each of the colours and three modulators are also required.

Using these techniques brightnesses of 350cd/m² have been obtained for flat CRTs, compared to 700cd/m² for normal CRTs, and only 35cd/m² for plasma devices. The sizes of screen were approximately the same, about 22 × 25cm.

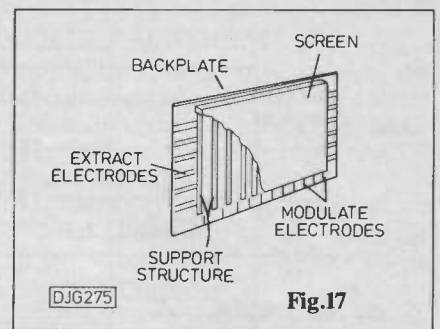

Fig.17

WORK OF THE CCIR

The International Radio Consultative Committee (CCIR) has been studying high definition television (HDTV) for the past four years. HDTV will use nearly twice the number of lines of today's systems. This will improve picture quality to that of 35mm film as used in the cinema. In addition, it will do away with the numerous analogue standards PAL, NTSC, SECAM and so avoid the need for interconversion between these standards.

CONCLUSIONS

We have seen how integrated circuits have provided gimmicks under the broad banner of signal processing: storage of black levels to compensate for electron gun ageing, frequency synthesis tuning, sandcastle waveform and generation etc. We have also seen how technology in other fields has provided SAW filters to meet the challenge of Teletext.

Flat screens are still under development and no doubt there will be a demand for such screens, not only for the flatness, but also for the larger pictures. Digital television will provide better signal to noise ratios and HDTV will provide better resolution. No doubt that all this will come to pass in the next five to ten years, so what next?

The ear perceives in a serial mode and is quite satisfied with stereophonic sound. But the eye perceives in a parallel mode and it may take three dimensional pictures to satisfy the eye. However, holography is another topic and still a thing of the future. PI

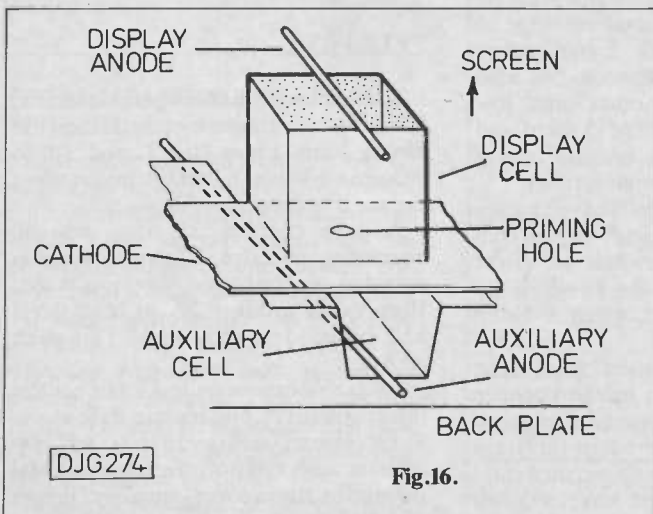

Fig.16.

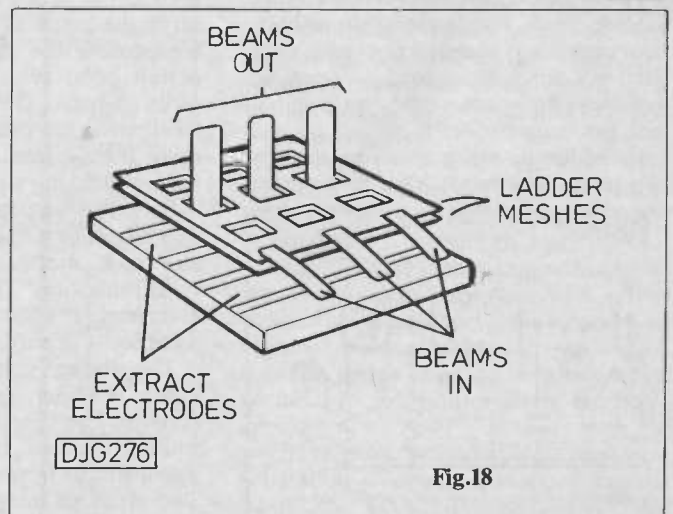
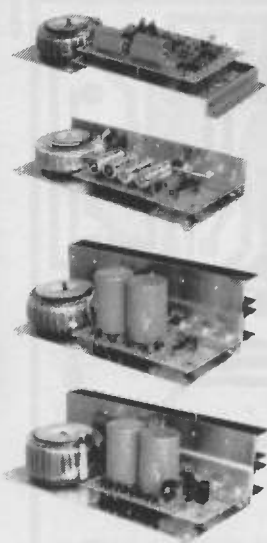

Fig.18

OMP POWER AMPLIFIER MODULES

* PRICES INCLUDE V.A.T. * PROMPT DELIVERIES * FRIENDLY SERVICE * LARGE S.A.E. 28p STAMP FOR CURRENT LIST

OMP POWER AMPLIFIER MODULES Now enjoy a world-wide reputation for quality, reliability and performance at a realistic price. Four models available to suit the needs of the professional and hobby market i.e. Industry, Leisure, Instrumental and Hi-Fi, etc. When comparing prices, NOTE all models include Toroidal power supply, Integral heat sink, Glass fibre P.C.B. and Drive circuits to power compatible Vu meter. Open and short circuit proof. **Supplied ready built and tested.**



OMP100 Mk II Bi-Polar Output power 110 watts R.M.S. into 4 ohms, Frequency Response 1Hz - 30KHz -3dB, T.H.D. 0.01%, S.N.R. -118dB, Sens for Max output 500mV at 10K, Size 355 x 115 x 65mm. **PRICE £33.99 + £3.00 P&P.**

OMP/MF100 Mos-Fet Output power 110 watts R.M.S. into 4 ohms, Frequency Response 1Hz - 100KHz -3dB, Damping Factor 80, Slew Rate 45V/uS, T.H.D. Typical 0.002%, Input Sensitivity 500mV, S.N.R. -125dB, Size 300 x 123 x 60mm. **PRICE £39.99 + £3.00 P&P.**

OMP/MF200 Mos-Fet Output power 200 watts R.M.S. into 4 ohms, Frequency Response 1Hz - 100KHz -3dB, Damping Factor 250, Slew Rate 50V/uS, T.H.D. Typical 0.001%, Input Sensitivity 500mV, S.N.R. -130dB, Size 300 x 150 x 100mm. **PRICE £62.99 + £3.50 P&P.**

OMP/MF300 Mos-Fet Output power 300 watts R.M.S. into 4 ohms, Frequency Response 1Hz - 100KHz -3dB, Damping Factor 350, Slew Rate 60V/uS, T.H.D. Typical 0.0008%, Input Sensitivity 500mV, S.N.R. -130dB, Size 330 x 147 x 102mm. **PRICE £79.99 + £4.50 P&P.**

NOTE: Mos Fets are supplied as standard (100KHz bandwidth & Input Sensitivity 500mV). If required, P.A. version (50KHz bandwidth & Input Sensitivity 775mV) Order - Standard or P.A.

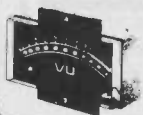

VU METER Compatible with our four amplifiers detailed above. A very accurate visual display employing 11 L.F.D. diodes (7 green, 4 d) plus an additional on/off indicator. Sophisticated logic control circuits for very fast rise and decay times. Tough moulded plastic case, with tinted acrylic front. Size 84 x 27 x 45mm. **PRICE £8.50 + 50p P&P.**

LOUDSPEAKERS 5" to 15" up to 400 WATTS R.M.S. Cabinet Fixing in stock. Huge selection of **McKenzie Loudspeakers** available including Cabinet Plans. Large S.A.E. (28p) for free details.



POWER RANGE
 B" 50 WATT R.M.S. Hi-Fi/Disco
 20 oz magnet, 1 1/2" ally voice coil. Ground ally fixing escutcheon. Res. Freq 40Hz. Freq Resp. to 6KHz. Sens. 92dB. PRICE £10.99 available with black grille £11.99 P&P £1.50 ea.
 12" 100 WATT R.M.S. Hi-Fi/Disco
 50 oz magnet, 2" ally voice coil. Ground ally fixing escutcheon. Die-cast chassis. White cone. Res. Freq. 25Hz. Freq. Resp. to 4KHz. Sens. 95dB. PRICE £28.60 + £3.00 P&P ea.

McKENZIE
 12" B5 WATT R.M.S. C1285GP Lead Guitar/Keyboard/Disco.
 2" ally voice coil. Ally centre dome. Res. Freq. 45Hz. Freq. Resp. to 6-5KHz. Sens. 98dB. PRICE £29.99 + £3.00 P&P ea.
 12" B5 WATT R.M.S. C1285TC P.A./Disco 2" ally voice coil. Twin cone. Res. Freq. 45Hz. Freq. Resp. to 14KHz. PRICE £31.49 + £3.00 P&P ea.
 15" 150 WATT R.M.S. C15 Bass Guitar/Disco.
 3" ally voice coil. Die-cast chassis. Res. Freq. 40Hz. Freq. Resp. to 4KHz. PRICE £57.87 + £4.00 P&P ea.
 10" 60 WATT R.M.S. 1060GP Gen. Purpose/Lead Guitar/Keyboard/Mid. P.A.
 2" voice coil. Res. Freq. 75Hz. Freq. Resp. to 7-5KHz. Sens. 99dB. PRICE £19.99 + £2.00 P&P.
 10" 200 WATT R.M.S. C10200GP Guitar/Keyboard/Disco.
 2" voice coil. Res. Freq. 45Hz. Freq. Resp. to 7KHz. Sens. 101dB. PRICE £44.76 + £3.00 P&P.
 15" 200 WATT R.M.S. C15200 High Power Bass.
 Res. Freq. 40Hz. Freq. Resp. to 5KHz. Sens. 101dB. PRICE £62.41 + £4.00 P&P.
 15" 400 WATT R.M.S. C15400 High Power Bass.
 Res. Freq. 40Hz. Freq. Resp. to 4KHz. Sens. 102dB. PRICE £89.52 + £4.00 P&P.

WEM
 5" 70 WATT R.M.S. Multiple Array Disco etc.
 1" voice coil. Res. Freq. 52Hz. Freq. Resp. to 5KHz. Sens. 89dB. PRICE £22.00 + £1.50 P&P ea.
 B" 150 WATT R.M.S. Multiple Array Disco etc.
 1" voice coil. Res. Freq. 48Hz. Freq. Resp. to 10KHz. Sens. 92dB. PRICE £32.00 + £1.50 P&P ea.
 10" 300 WATT R.M.S. Disco/Sound re-enforcement etc.
 1 1/2" voice coil. Res. Freq. 35Hz. Freq. Resp. to 4KHz. Sens. 92dB. PRICE £36.00 + £2.00 P&P ea.
 12" 300 WATT R.M.S. Disco/Sound re-enforcement etc.
 1 1/2" voice coil. Res. Freq. 35Hz. Freq. Resp. to 4KHz. Sens. 94dB. PRICE £47.00 + £3.00 P&P ea.

SOUNDLAB (Full Range Twin Cone)
 5" 60 WATT R.M.S. Hi-Fi/Multiple Array Disco etc.
 1" voice coil. Res. Freq. 63Hz. Freq. Resp. to 20KHz. Sens. 86dB. PRICE £9.99 + £1.00 P&P ea.
 6 1/2" 60 WATT R.M.S. Hi-Fi/Multiple Array Disco etc.
 1" voice coil. Res. Freq. 56Hz. Freq. Resp. to 20KHz. Sens. 89dB. PRICE £10.99 + £1.50 P&P ea.
 B" 60 WATT R.M.S. Hi-Fi/Multiple Array Disco etc.
 1 1/4" voice coil. Res. Freq. 38Hz. Freq. Resp. to 20KHz. Sens. 89dB. PRICE £12.99 + £1.50 P&P ea.
 10" 60 WATT R.M.S. Hi-Fi/Disco etc.
 1 1/4" voice coil. Res. Freq. 35Hz. Freq. Resp. to 15KHz. Sens. 89dB. PRICE £16.49 + £2.00 P&P

PANTEC HOBBY KITS. Proven designs including glass fibre printed circuit board and high quality components complete with instructions.

FM MICROTRANSMITTER (BUG) 90/105MHz with very sensitive microphone. Range 100/300 metres. 57 x 46 x 14mm (9 volt) Price: £8.62 + 75p P&P.
3 WATT FM TRANSMITTER 3 WATT B5/115MHz varicap controlled professional performance. Range up to 3 miles 35 x 84 x 12mm (12 volt) Price: £14.49 + 75p P&P.
SINGLE CHANNEL RADIO CONTROLLED TRANSMITTER/RECEIVER 27MHz. Range up to 500 metres. Double coded modulation. Receiver output operates relay with 2amp/240 volt contacts. Ideal for many applications. Receiver 90 x 70 x 22mm (9/12 volt). Price: £17.82 Transmitter 80 x 50 x 15mm (9/12 volt). Price: £11.29 P&P + 75p each. S.A.E. for complete list.



3 watt FM Transmitter

BURGLAR ALARM

Better to be 'Alarmed' than terrified. **Thunder's famous 'Minder' Burglar Alarm System.** Superior microwave principle. Supplied as three units, complete with interconnection cable. **FULLY GUARANTEED.**

Control Unit - Houses microwave radar unit, range up to 15 metres adjustable by sensitivity control. Three position, key operated fascia switch - off - test - armed 30 second exit and entry delay.
Indoor alarm - Electronic swept freq siren 104dB output.
Outdoor Alarm - Electronic swept freq siren 98dB output. Housed in a tamper-proof heavy duty metal case.

Both the control unit and outdoor alarm contain rechargeable batteries which provide full protection during mains failure. Power requirement 200/260 Volt AC 50/60Hz. Expandable with door sensors, panic buttons etc. Complete with instructions.

SAVE £138.00 Usual Price £228.85
BKE's PRICE £89.99 + £4.00 P&P
 Why buy a collection of self-assembly boards!

IDEAL for Workshops, Factories, Offices, Home, etc. Supplied ready built.



OMP LINNET LOUDSPEAKERS

The very best in quality and value. Made specially to suit today's need for compactness with high sound output levels. Finished in hard wearing black vinyl with protective corners, grille and carry handle. All models 8 ohms. Full range 45Hz - 20KHz. Size 20" x 15" x 12". Watts R.M.S. per cabinet. Sensitivity 1W 1mtr. dB

OMP 12-100 Watts 100dB. Price £149.99 per pair.
OMP 12-200 Watts 102dB. Price £199.99 per pair. Delivery: Securicor £8.00 per pair



OMP 19" STEREO RACK AMPS



Professional 19" cased Mos-Fet stereo amps. Used the World over in clubs, pubs, discos etc. With twin Vu meters, twin toroidal power supplies, XLR connections. MF600 Fan cooled. **Three models (Ratings R.M.S. into 4ohms). Input Sensitivity 775mV**

MF200 (100 + 100)W. £169.00
MF400 (200 + 200)W. £228.85
MF600 (300 + 300)W. £322.00 Securicor Delivery **£10.00**

BSR P295 ELECTRONIC TURNTABLE

* Electronic speed control 45 & 33 1/3 r.p.m. * Plus Minus variable pitch control * Bell driven * Aluminium platter with strobed rim * Cue lever * Anti-skate (bias device) * Adjustable counter balance * Manual arm * Standard 1/2" cartridge fixings * Supplied complete with cut out template * D.C. Operation 9-14V D.C. 65mA
 Price £36.99 - £3.00 P&P



ADC Q4 mag. cartridge for above. Price £4.99 ea. P&P 50p

PIEZO ELECTRIC TWEETERS MOTOROLA

Join the Piezo revolution. The low dynamic mass (no voice coil) of a Piezo tweeter produces an improved transient response with a lower distortion level than ordinary dynamic tweeters. As a crossover is not required these units can be added to existing speaker systems of up to 100 watts (more if 2 put in series) **FREE EXPLANATORY LEAFLETS SUPPLIED WITH EACH TWEETER.**

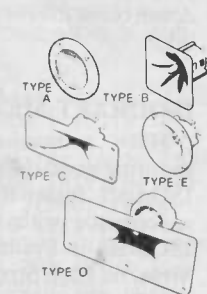

TYPE 'A' (KSN2036A) 3" round with protective wire mesh. Ideal for bookshelf and medium sized Hi-Fi speakers. Price £4.90 each + 40p P&P
TYPE 'B' (KSN1005A) 3 1/2" super horn. For general purpose speakers, disco and P.A. systems etc. Price £5.99 each + 40p P&P
TYPE 'C' (KSN6016A) 2" x 5" wide dispersion horn. For quality Hi-Fi systems and quality discos etc. Price £6.99 each + 40p P&P
TYPE 'D' (KSN1025A) 2" x 6" wide dispersion horn. Upper frequency response retained extending down to mid range (2KHz). Suitable for high quality Hi-Fi systems and quality discos. Price £9.99 each + 40p P&P
TYPE 'E' (KSN1038A) 3 3/4" horn tweeter with attractive silver finish trim. Suitable for Hi-Fi monitor systems etc. Price £5.99 each + 40p P&P
LEVEL CONTROL Combines on a recessed mounting plate, level control and cabinet input jack socket. 85 x 85 mm. Price £3.99 + 40p P&P

STEREO DISCO MIXER

STEREO DISCO MIXER with 2 x 5 band L & R graphic equalisers and twin 10 segment LED Vu Meters. Many outstanding features. 5 Inputs with individual faders providing a useful combination of the following - 3 Turntables (Mag), 3 Mics, 4 Line plus Mic with talk over switch. Headphone Monitor. Pan Pot L & R. Master Output controls. Output 775mV. Size 360 x 280 x 90mm. Price £134.99 - £3.00 P&P

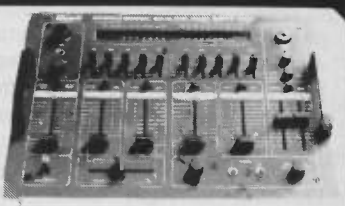

B. K. ELECTRONICS Dept PE

UNIT 5, COMET WAY, SOUTHEND-ON-SEA, ESSEX. SS2 6TR TEL: 0702-527572

POSTAL CHARGES PER ORDER £1.00 minimum. OFFICIAL ORDERS WELCOME. SCHOOLS, COLLEGES, GOVERNMENT BODIES, ETC. PRICES INCLUSIVE OF V.A.T. SALES COUNTER VISA/ACCESS/C.O.D. ACCEPTED.



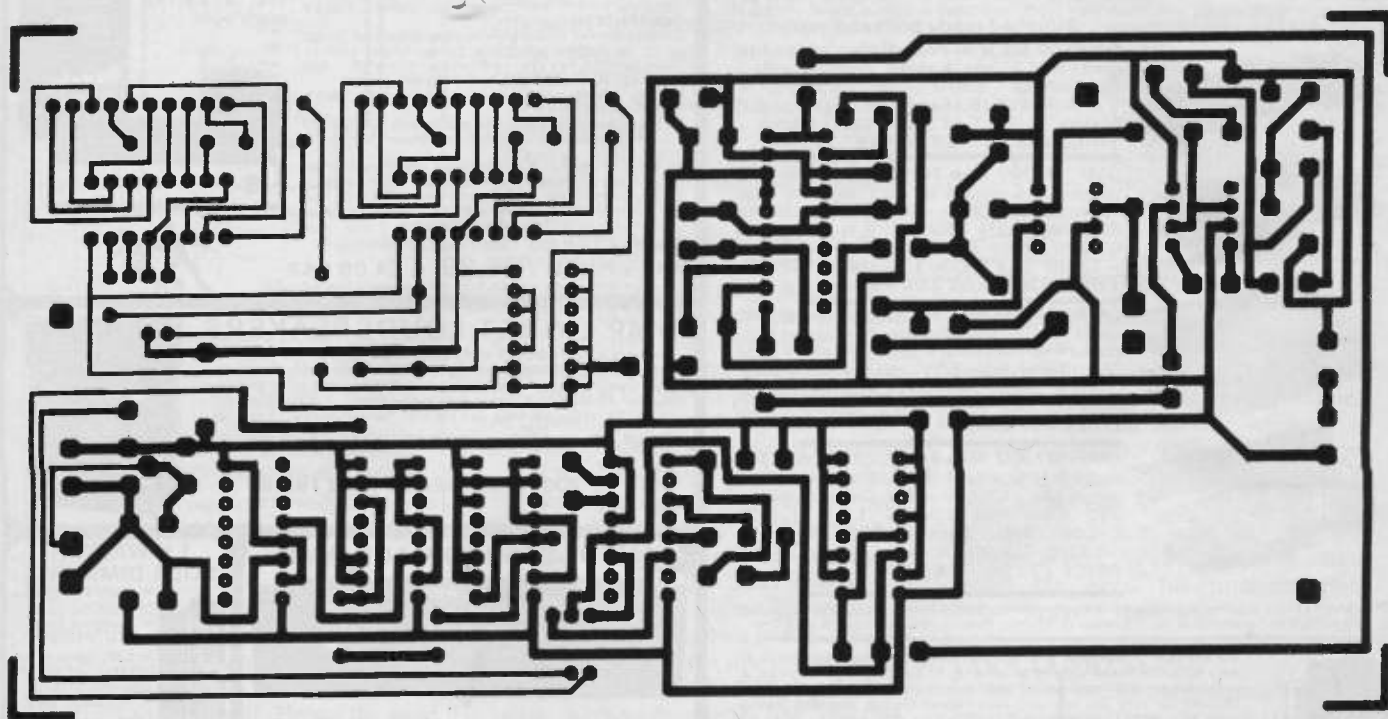

PE PCB 146. Synthesising AF Generator Board, available through the PE PCB Service.

HOW TO USE THESE TRACKS

FIRST MAKE TRANSPARENT COPY

(We regret that we cannot supply transparent copies of PCB track layouts.)

STUDIO COPY METHOD

Ask local photographic studio to produce high contrast 1 to 1 positive transparency.

HOME PHOTOGRAPHY METHOD

Using even, bright illumination, photograph track onto fine grain black and white negative film. Develop film for high contrast. Photographically enlarge image up to lifesize, and print onto high contrast lithographic cut film, such as Agfa Copyline HDU 3P Type 2. Develop in Agfa Litex G90T litho developer, or similar.

PHOTOCOPY METHOD

Ask local photocopy shop to make a good contrast copy onto acetate film.

(Some copiers are better than others – shop around.) Then touch up tracks with dense black ink, or photographic opaque ink.

ISODRAFT METHOD

Have a normal photocopy made, ensuring good dense black image. Spray ISOdraft Transparentiser onto copy in accordance with supplied instructions. ISOdraft is available from Cannon & Wrin, 68 High Street, Chislehurst, Kent. Tel: 01-476 0935.

PAINSTAKING METHODS

Draw image by hand onto clear film or drafting film using dense black ink. Draw direct onto copper surface of PCB fibreglass, using etch-resist inking pen. Use etch resist PCB tracks and pads, taping direct to copper surface, or onto drafting film.

NEXT PRINT ONTO PCB

Place positive transparency onto photosensitised copper clad fibre glass,

cover with glass to ensure full contact. Expose to Ultraviolet light for several minutes (experiment to find correct time – depends on UV intensity).

Develop PCB in Sodium Hydroxide (available from chemists) until clean track image is seen, wash in warm running water. Etch in hot Ferric Chloride, frequently withdrawing PCB to allow exposure to air. Wash PCB in running water, dry, and drill holes, normally using a 1mm drill bit.

(PCB materials and chemicals are available from several sources – study advertisements.)

*** CAUTION – ENSURE THAT UV LIGHT DOES NOT SHINE INTO YOUR EYES. PROTECT HANDS WITH RUBBER GLOVES WHEN USING CHEMICALS.**

ALTERNATIVE METHOD

Buy your PCB ready made through the PE PCB SERVICE, most are usually available – see page 60.



BINARY CHOP - PUZZLE NO 3

TEST YOUR POWERS OF LOGICAL DEDUCTION AND WIN 12 MONTH'S SUBSCRIPTION TO PE!

Send your answer to this puzzle to:

Binary Chop No. 3,
Practical Electronics,
16, Garway Road,
London W2 4NH

to reach us before 1st June 1987.

12 month's subscription to Practical Electronics will be awarded for the first three correct answers opened. The Editor's decision is final.

Answer in the August 1987 issue.

Look out for another mental challenge next month!

BINARY CHOP - PUZZLE NO 3

DECODE THIS 231 CHARACTER MESSAGE

THE SERIAL BINARY DATA CONVERTER OMITTED ALL LEADING ZEROS!
LETTERS A TO Z = ASCII 1 TO 26. NUMBERS 0 TO 9 = ASCII 48 TO 57.
COMMA = ASCII 44, FULL-STOP = ASCII 46, NO OTHER CODES ARE USED.

```
10111100110100100010000101011101011010110010111001011001100111010011
01111111101010010001011001010010001011101101101001000111110011011111
00101000010101110101101011001011100011100001000011001001101100111101
00110010100111010010111010100100010111101101001111010011100110011010
10111001100100111010011111000010011101100101110001010010010111101001
01001000101111110101101001111110101100111001110011110111110010111001
01101001010010110010100111011101101001111011100110011001101100110010
11001010111010010011111111010111111100101011111101011010010100100
01011001111101011011001011110100101001001001100001100101110010110
10010100101100101111111011010011110110100100111111101001101110100
11010010111100111000010010111101101100110011110111101001100111000
11001010011001110011010011001111111110111011001001111010011010010011
11001100110011011101000110110101110101011110101111001111001101001000101001
0001011110101110001010011111110101101110
```

THIS SHORT BINARY-CREATING PROGRAM MAY HELP.

```
10 FOR A=1 TO 57:A$="":FOR B=0 TO 5:D=A AND (2^B)
20 A$=STR$(ABS(D>0))+A$:NEXTB:PRINT VAL(A$):NEXTA:PRINT
```

ANSWER TO BINARY CHOP - PUZZLE NO 1

THE METHOD. NO CHARACTER WILL HAVE MORE THAN 6 BINARY DIGITS. THERE ARE 6 POSSIBLE LENGTHS, FROM 1 TO 6 DIGITS. NONE WILL START WITH 0. DECIMALISE EACH OF THE 6 WHERE VALID. TRANSLATE TO CHARACTERS AND SELECT 1. DELETE CODE FOR THIS FROM FRONT OF LIST. TAKE NEXT 6 AND REPEAT. IF CHOOSING CORRECTLY, A MESSAGE WILL APPEAR.

```
10100 1000 101 1101 101 10100 1000 1111 100 101110 1110 1111 11 1000
1 10010 1 11 10100 101 10010 10111 1001 1100 1100 1000 1 10110 101
1101 1111 10010 101 10100 1000 1 1110 110110 10 1001 1110 1 10010
11001 100 1001 111 1001 10100 10011 101110 10100 1000 101 10010 101
1 10010 101 110110 10000 1111 10011 10011 1001 10 1100 101 1100 101
1110 111 10100 1000 10011 101100 110 10010 1111 1101 110001 10100
1111 110110 100 1001 111 1001 10100 10011 101110 1110 1111 1110 101
10111 1001 1100 1100 10011 10100 1 10010 10100 10111 1001 10100 1000
110000 101110 100 101 11 1001 1101 1 1100 1001 10011 101 101 1 11
1000 1111 110 10100 1000 101 110110 10111 1000 101 10010 101 10110
1 1100 1001 100 101110 10100 10010 1 1110 10011 1100 1 10100 101
10100 1111 11 1000 1 10010 1 11 10100 101 10010 10011 1 1110 100
10011 101 1100 101 11 10100 110001 101110 100 101 1100 101 10100
101 11 1111 100 101 110 1111 10010 10100 1000 1001 10011 110 10010
1111 1101 110 10010 1111 1110 10100 1111 110 1100 1001 10011 10100
101110 10100 1 1011 101 1110 101 11000 10100 110110 1 1110 100 10010
101 10000 101 1 10100 101110 1001 110 11 1000 1111 1111 10011 1001
1110 111 11 1111 10010 10010 101 11 10100 1100 11001 101100 1 1101
101 10011 10011 1 111 101 10111 1001 1100 1100 1 10000 10000 101
1 10010 101110
```

THE WINNERS!

I am delighted at the incredible response to my brain teasing puzzle in Binary Chop No 1!

You've all obviously enjoyed trying to solve it, and most of you arrived at the correct answer. I suspect that some of you also must have spent a few interesting hours programming computers to come up with the answer, even though a computer is not needed to solve the problem. I would be most interested to see a listing of any programs that have been used to chop out the answers. Indeed, I will offer 12 month's subscription to PE for the best three program listings I receive by the closing date for puzzle number three.

The first three correct answers opened for puzzle number one were sent in by -

- Mr C. Gunn of Burnley, Lancs.
- James Robertson of Hayling Island, Hants.
- Michael Tuplin of Newbury, Berks.

These three readers will each receive twelve issues of PE, commencing with the July 1987 issue. Well done to all of you! Ed.

PE PROVIDES THE ANSWERS TO MANY PRACTICAL PROBLEMS
MAKE SURE OF YOUR COPY - PLACE A REGULAR ORDER!

DIGITAL POLY-WHATSIT!

BY JOHN BECKER

AN UNUSUAL EFFECTS UNIT

Following last month's ADA converter, the Polywhatsit is a dedicated controller which can produce conventional sound effects such as delay, echo and reverb, and also very unconventional ones, employing pitch shifting and reversal.

IN THE preceding article in May 1987, a general purpose audio analogue to digital to analogue converter (ADA) was described. This is suitable for use with a computer or a dedicated control unit for producing audio sound effects from sources such as musical instruments, high output microphones, and recordings.

The project to be described here shows an example of the type of dedicated controller that can be used with the ADA unit to produce the less conventional sound effects of pitch changing upwards and downwards with a range of over 3 octaves, and reverse tracking in which speech and musical phrases are played backwards. It also produces the more conventional effects such as echo, reverb and double tracking, with a time delay variable from 55ms to 440ms. Additionally, the conventional and unconventional functions can be combined to create effects that are grossly different to those normally published for audio units.

A-D-A AND CONTROLLER

In the ADA article it is shown that an audio signal can be repeatedly sampled, converted to a digital representation, sent out to a memory unit for processing, returned and converted back to analogue. Additionally, facilities for feed back and feed forward are included so that the type of effect that can be produced may be further varied by these controls in relation to the modification carried out at the memory control unit.

Basically the controller described here takes the digital signal from the ADA unit, stores it in a memory area of up to 8K bytes, and after a suitable delay returns it to the ADA. The way that the data is stored and retrieved is subject to several different parameters that determine the rate and direction in which the signal is read back. The block diagram in Fig. 1 shows the main functions.

DATA STORAGE

In Fig.2. the 8K byte memory chip, IC14, is used to store the data sent from the ADA. It has 65536 memory storage areas (64K), which are available in 8192 (8K) blocks of 8 bits (1 byte). Any byte



can be accessed at any time depending upon a 13 bit address code sent to the memory. For normal writing of incoming data to IC14, on receipt of the DAV high level from IC2 of the ADA, the 12 bit ripple counter IC13 sends its address data to IC14 via the gates IC10 to IC12. The 13th address bit is derived from the flip flop IC16b which is triggered by each 12th pulse from IC13, and passed through the gate IC18.

With DAV high IC14 has its internal data output control inhibited by the high level on pin 22, and can accept the presence of the incoming data byte from

ADA IC2. Approximately 4.5 microseconds later, a negative going pulse from ADA IC6 lasting for about 1 microsecond, triggers the memory to store (write) the incoming data byte at the relevantly addressed block. When the pulse ends, the memory goes into read mode, but with its outputs still inhibited. Shortly after the pulse has ended the DAV level falls to zero and the write address counter is stepped forward one place by the negative going edge. With DAV low the memory has its outputs enabled and the data stored at this new address becomes available to be read

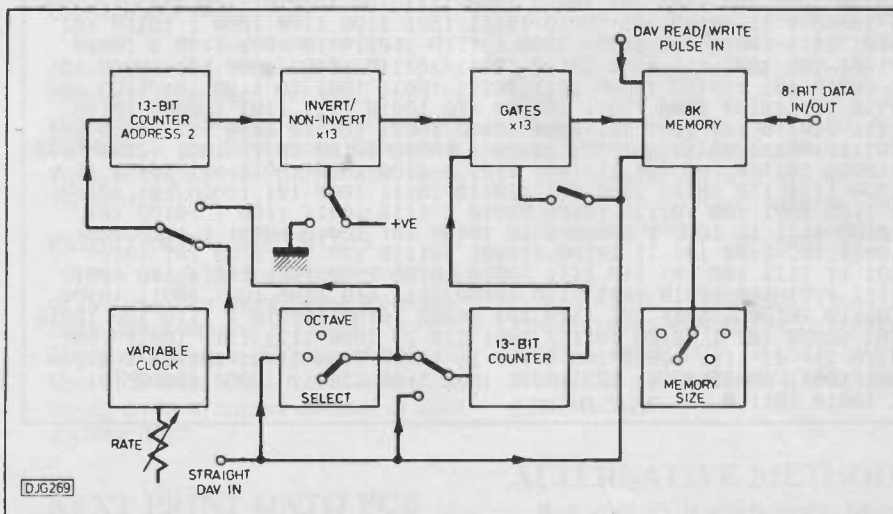

Fig.1. Digital Poly-whatsit! Block diagram

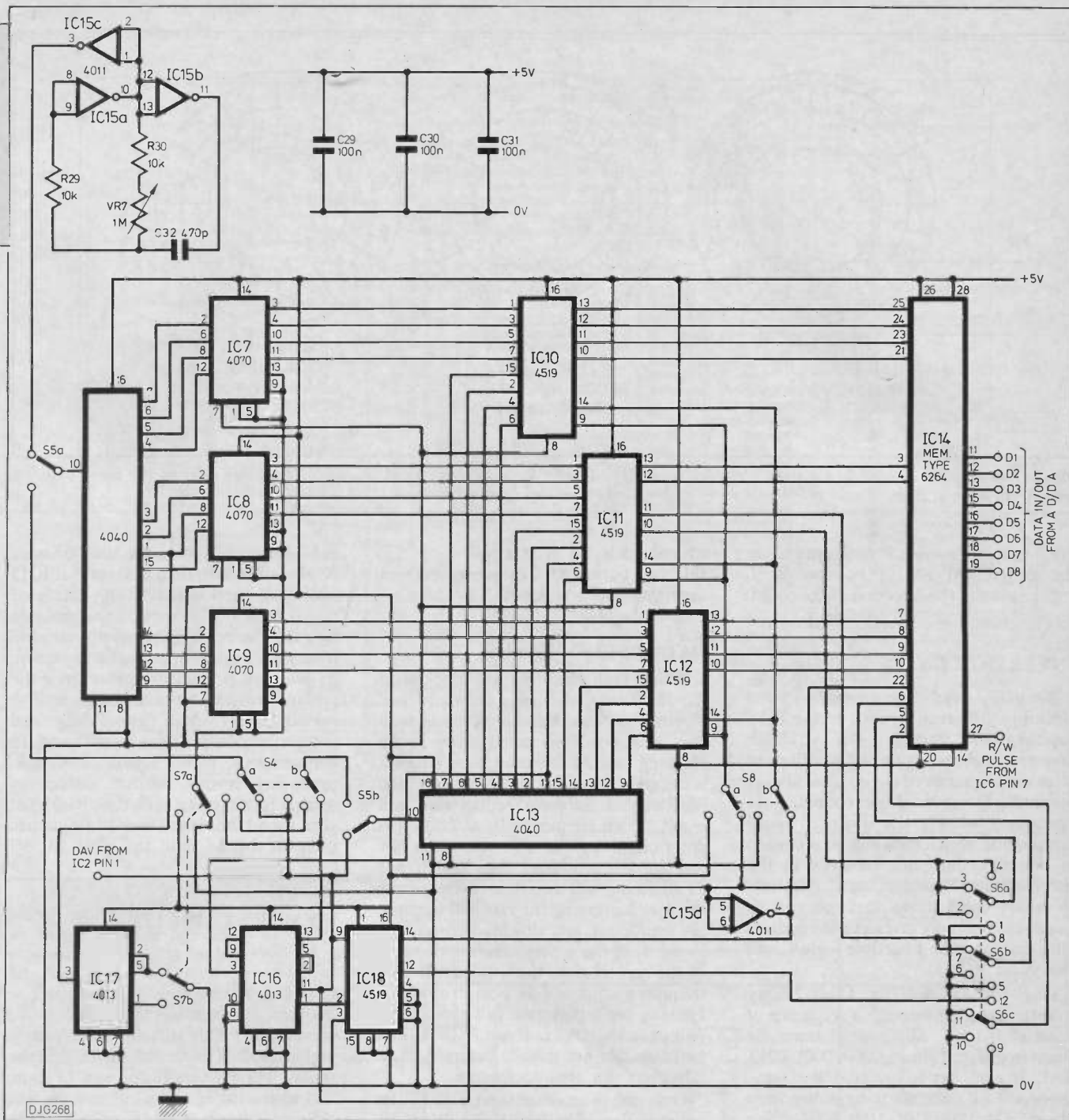

Fig.2. Circuit diagram of Digital Poly-whatsit controller

back by the ADA. Since this byte was recorded many cycles earlier, it is thus delayed in respect to its original storing, and is hence an echo signal. The echo delay depends upon the size of the memory, and the rate at which each byte is recorded.

READ BACK ADDRESS

The read back address can either be from IC13, as set by S8 controlling the gates IC10 to IC12 and IC18, or from the separately controlled address counter IC19 together with IC17, the latter being a flip flop triggered by the 12th bit to produce the 13th. This counter is normally clocking the address through at a different rate to IC13, depending

on whether the trigger comes via S4 or from the oscillator around IC15a-c. Whatever the trigger source, the 12 bits of IC19 go through the gates IC7 to IC9 and to the gates IC10 to IC12. The 13th bit goes direct to IC18 via S7b.

ADDRESSING GATES

The gates IC10-IC12 and IC18 are controlled by the voltage levels on their pins 9 and 14. These need to be of opposite polarity to each other for the gates to function as OR selectors. The selection is controlled by the DAV output from the ADA applied to pins 9, with an inversion performed by IC15a to control pins 14. When DAV is high, the gates are open only to IC13 and IC16b.

With DAV low, they are open only to the address lines from IC7 to IC9 and IC17. Switch S8 can remove this DAV control from the gates and replace it with fixed voltage levels so that the address is only derived from IC13 and IC16b. In this way the record and replay rates and displacement will be synchronised.

It will be of interest to digital enthusiasts that the address number arriving from the gates does not access the memory blocks of the same number. For example, the address counter sequence of 1 to 10 will actually access memory blocks 1, 512, 513, 64, 65, 576, 577, 1024, 1025, 1536 in that order. This is due to the address lines servicing the memory in an irregular order and does

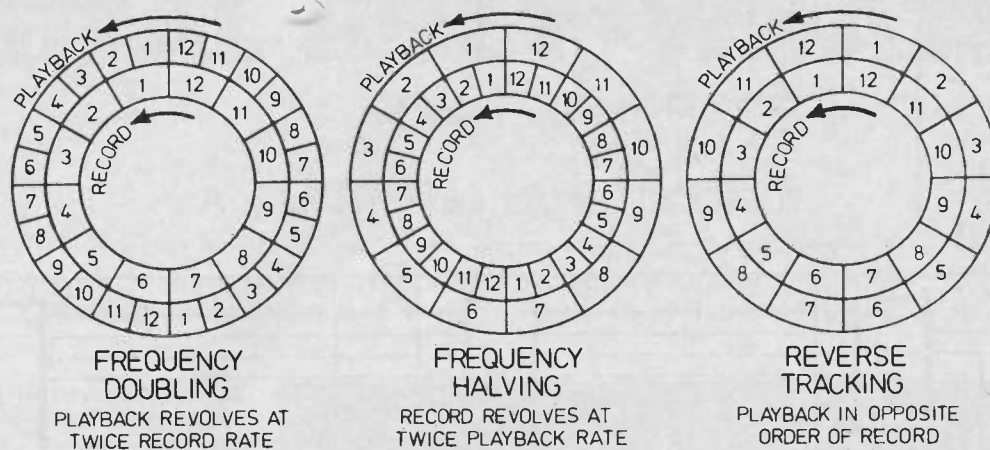

DJG272

Fig.3. Example of 12 byte block loop recorded and played back for different effects. Identical numbers refer to the same byte, whichever loop it is in.

not alter the correct functioning since the order will always be consistent, irrespective of the direction of the count, as binary analysis will confirm.

INVERSION GATES

Normally the two counters are clocking upwards from 0 to 8191, resetting and starting over. Although they are probably counting at different rates the sequence of the count is always forwards. However if one counter goes upwards while the other goes downwards, signal data can be recorded in one direction, but replayed in the reverse order. Examination of a decimal to binary chart shows that this can be achieved by simply inverting the address bits, making logic 1 become logic 0, and vice versa.

Take for example, a 4 bit binary counter clocking through a sequence of decimal 0 to 3. This would normally count in order of binary 0000, 0001, 0010, 0011. If each bit is inverted the same sequence of decimal 0 to 3 becomes binary 1111, 1110, 1101, 1100. Converting these inverted binary numbers back to decimal it will be seen that the sequence has now become decimal 15, 14, 13, 12. The full sequence of decimal 0 to 15 when inverted would thus become decimal 15 to 0. The same holds true even for 10 bit binary numbers. Consequently if the output of one counter is inverted in respect to the other, data will be recorded forwards, but replayed backwards. If the amount of data available from the memory is sufficiently large, speech for example will sound as though it is being spoken backwards.

The polarity of the first 12 bits is determined at the Exclusive OR gates IC7 to IC9. With S7a in the grounded position the gates pass the data through uninverted. In the positive position, the data is automatically inverted. Polarity

of the 13th bit is controlled by S7b selecting between the inverting and non-inverting outputs of IC17.

DATA REPLAY RATES

When both counters are clocked at the same rate, the rates of record and playback will be the same, even though they may be displaced in time. If the clocking rate of the read back counter is different from the write counter, then obviously a different replay rate will result. Since frequency by definition is determined by the rate at which the waveform is produced, then any change to the rate will result in a frequency change. Increasing the rate will increase the frequency, and slowing the rate will lower it. If the replay rate is twice that of the record rate, then there will be a frequency shift of one octave upwards. Halving the replay rate will produce an output one octave lower. Units that perform this are usually referred to as 'Octavers' for obvious reasons.

Octaving is accomplished here by the switched insertion by S4 of a divide by two counter IC16a. The DAV input goes to IC16a where the output rate is half that of the input. With S4 in position one, the divided rate clocks the write address counter and the DAV rate clocks the read counter. Playback thus occurs at twice the rate of record. In position two, both counters are clocked at the same rate by the DAV, so record and playback rates are the same. In position three, the record address counter is clocked by DAV, but the read counter is clocked by the divided rate, so replay is at half the rate of record.

VARIABLE FREQUENCY SHIFT

Variable frequency changes upwards and downwards are available by the inclusion of the oscillator IC15a-c which

can be switched in to the read counter IC19 via S5a. S5b then ensures that IC13 is only clocked by DAV. The oscillator rate is basically set by C32 and variable by VR7. The replay rate is fully variable from a little lower than one octave down, to over two octaves upwards. Since the replay rates can be reversed as well as varied, some quite astonishing and indescribable effects can be obtained. In conjunction with signal feedback, producing reverb, further interesting sounds result, since each time the signal goes round the reverb loop its frequency is again shifted until the filter cut off level intercedes.

MEMORY CAPACITY

By now you are probably puzzled as to how live data can continually be recorded at one rate and replayed at another. Surely something must be lost somewhere? This is quite true, with a higher rate of replay than record, the replay will eventually run out of data, and with a lower rate a big time lag will develop. However this is solved by the fact that the data is recorded in a loop. As soon as an address counter reaches the maximum, at the next change it will revert to zero and go through the cycle again. Consequently for a faster replay, once there is no data to read at the end of a cycle, so the earlier data is reread as the read loop goes round again. With a slower replay rate there is a jump ahead in the data reading as the write loop catches up and overtakes, and some information is ignored. With careful selection of the length of the loop, that is, with the size of memory, so the effect of repeating or losing data can be minimised. (Fig.3.)

The effective memory size attributable to IC14 depends upon the upper address limit. Normally with all 13 address lines in operation, all 8K of memory can be

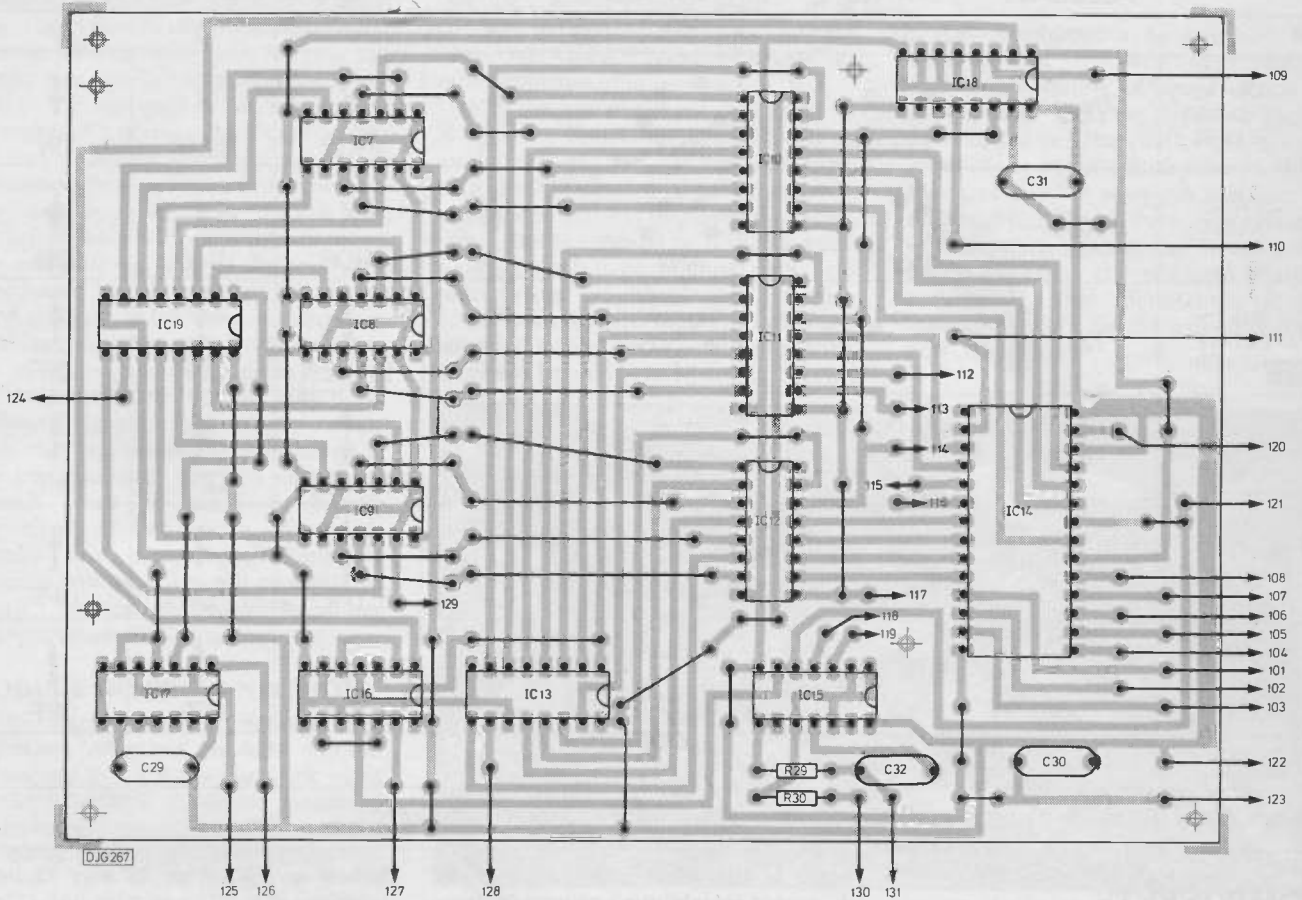

Fig.4. PCB details

P.C.B. PINS 101 TO 108 GO TO P.C.B.
PINS 1 TO 8 RESPECTIVELY

P.C.B. PIN 120 GOES TO
P.C.B. PIN 10

(P.C.B. PIN No's LESS
THAN 100 ARE ON
AUDIO P.C.B. 251A).

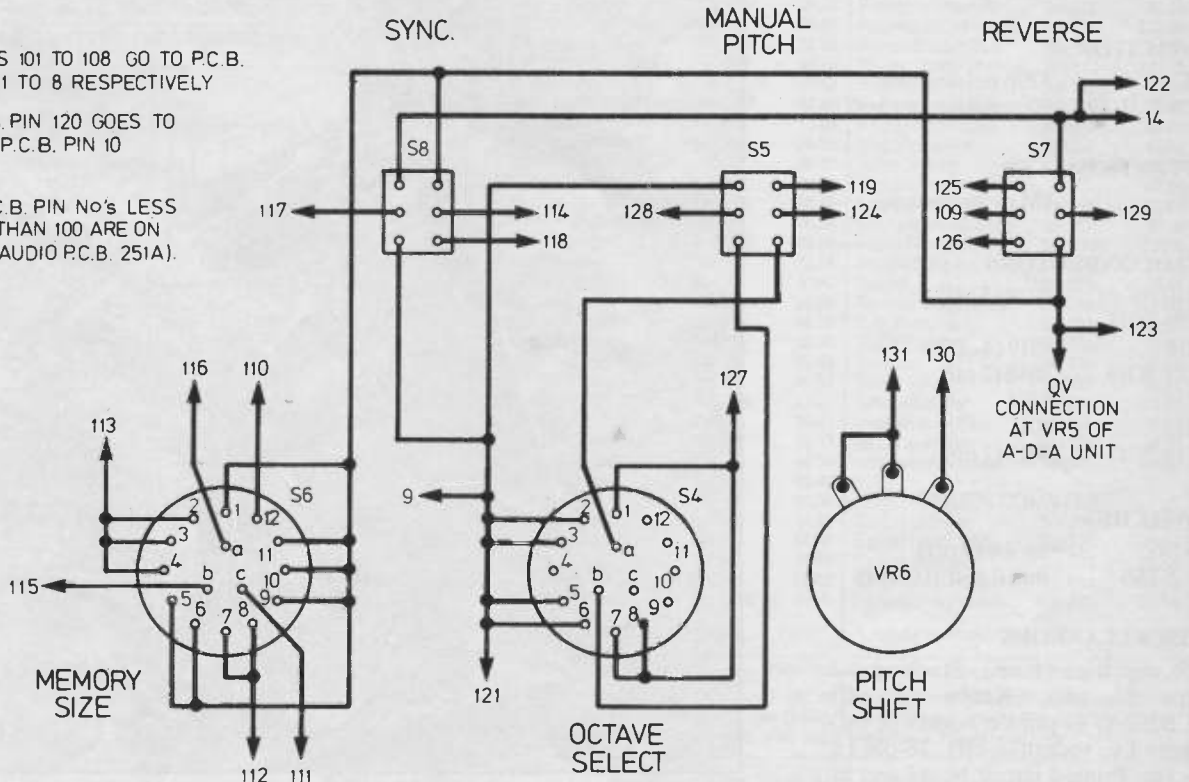

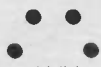

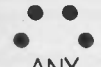

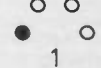

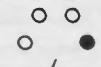
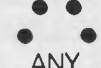

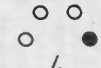

Fig.5. N.B. Wiring to be used in conjunction with chart for PCB 251A (ADA PCB published last month).

DIGITAL POLY-WHATSIT

	FEEDBACK	OCTAVE	MEMORY SIZE	ORIG.	REVERSE	PITCH MANUAL	SYNC.
	VR5	S4	S6	S3	S7	S5	S8
NORMAL ECHO AND REVERB	YES	 1 or 2	 ANY	↓ ON	X INOP	X INOP	↓ ON
NORMAL DOUBLE TRACK	NO	 1 or 2	 ANY	↓ ON	X INOP	X INOP	↓ ON
FIXED OCTAVE HIGHER	NO	 3	 1	↑ OFF	↕ EITHER	↑ OFF	↑ OFF
FIXED OCTAVE LOWER	NO	 1	 4	↑ OFF	↕ EITHER	↑ OFF	↑ OFF
VARIABLE FREQUENCY	NO	X INOP	 ANY	↑ OFF	↕ EITHER	↓ ON	↑ OFF
NORMAL REVERSE TRACK	NO	 2	 4	↑ OFF	↓ ON	↑ OFF	↑ OFF

DJ6270

Fig. 6. Control modes. Any combination of controls may be selected to produce other effects.

COMPONENTS . . .

RESISTORS

R29,R30 10K (2 off)
Both resistors 1/4w 5% carbon film

CAPACITORS

C32 470p polystyrene
C29-C31 100n polyester (3 off)

POTENTIOMETER

VR6 1M mono rotary

SEMICONDUCTORS

IC7-IC9 4070 (3 off)
IC10-IC12, IC18 4519 (4 off)
IC13,IC19 4040 (2 off)
IC14 6264
IC15 4011
IC16,IC17 4013 (2 off)

SWITCHES

S4,S6 3p-4w (2 off)
S5,S7,S8 min d.p.d.t. (3 off)

MISCELLANEOUS

Pcb clip tops (4 off), Stacking pcb clips (4 off), Knobs (3 off), PCB252A, 14-pin i.c. socket (6 off), 16-pin i.c. socket (6 off), 28-pin i.c. socket. Printed circuit board and kit of parts available from Phonosonics - see advert.

used. If the number is progressively decreased by inhibiting counter address lines, then fewer memory areas can be used. S6 can select which upper address lines are inhibited. If counter line 13 is inhibited, the usable memory size is

halved to 4K. With 13 and 12 both inhibited it is 2K, and with line 11 out as well it becomes 1K. So, by selection of the memory size, the loop replay rate can be altered, the jump ahead displacement changed, and the delay

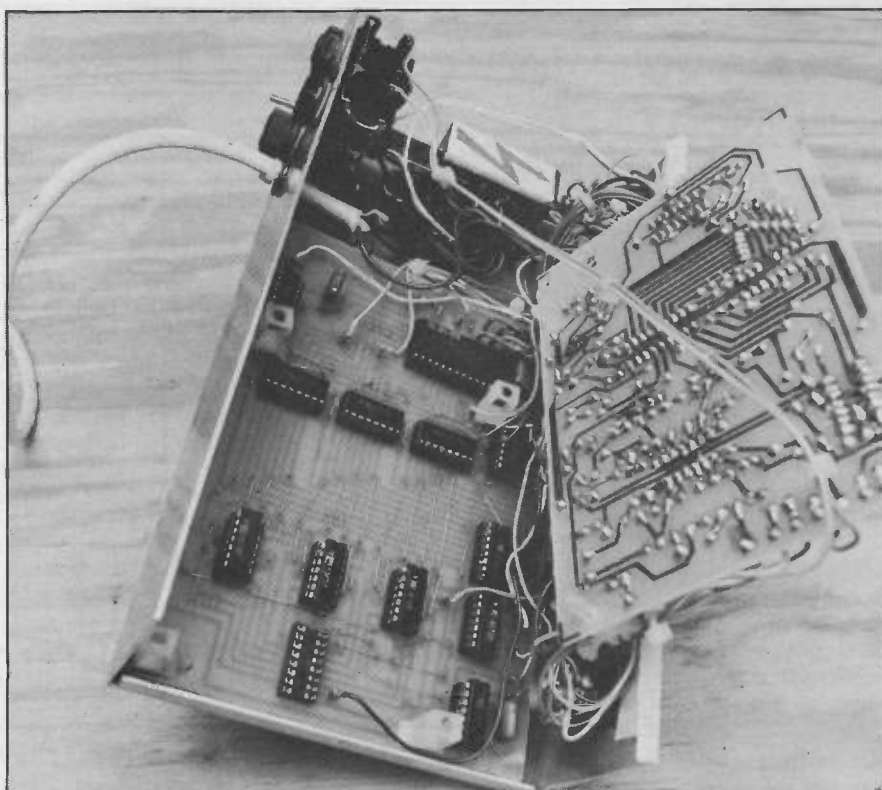

Interior of complete ADA Digital Poly-whatsit. The control board is at the bottom. The turned back board is the track side of the Audio ADA converter.

between record and read amended. These variations have a significant effect upon the nature of the sound produced.

It is inherent that with varying the replay rate of a live loop, that the result will not be the same as varying the rate of replay of a prerecorded signal on disc or tape where the information is in one continuous length. With a live record and playback system as is used in this unit, naturally there will be a join between the end and the start of the recording loop, and another join for the replay loop end and start. Unless the waveform frequency and the loop length and rate are synchronised, the sample bytes to either side of the loop join may be at different levels, and on a single frequency the waveform may hiccup at the join. On more complex waveforms though, such as speech or rapidly varying music frequencies, the join is usually less perceptible, though a tremolo type of effect will probably be heard, particularly with frequency changes upwards.

MODULE INTERCONNECTIONS

The interconnections between this digital controller and the ADA unit are shown in Fig.5. All the short link wires on the ADA PCB should be connected as shown in that article, and the optional computer control connections ignored. The unit here draws about 60mA and

takes its 5v supply voltage from the ADA stabilised power supply. Setting up is confined to the two presets VR2 and VR3 of the ADA as discussed previously, no other adjustment is needed.

With the box as shown, measuring 23 x 13 x 6.3cm, the digital board is mounted to the far rear left hand side, with the ADA board mounted above it using the selectively displaced mounting holes. The box should be drilled for the rotary controls to be mounted with their centres 3cm up, 3.5cm apart, starting 2.5cm from the left. Toggle switches are mounted in line between the pots with centres 4.6cm up.

USE

Any combination of switches and controls can be used to create a remarkable variety of sound effects in conjunction with the type of sound original fed in. The chart Fig.6. shows some of the major effects settings. With the large number of switch and control settings available, an even wider variety of fascinating effects can be actually produced. These effects are so unusual and varied, that there really is no descriptive name for the unit other than Poly-Whatsit!

PE



PRACTICAL

KIT CATALOGUE

PHONOSONICS

FASCINATING ELECTRONIC PROJECTS

MUSIC MODULES

DIGITAL INTERFACES

GEIGER COUNTERS

MANY MORE FINE DESIGNS

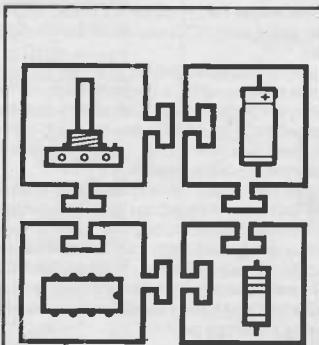

KITS THAT FIT

- ★ BE KIT CREATIVE
- ★ RAISE YOUR SKILLS
- ★ LEARN BY BUILDING
- ★ ENJOY BY USING

THROUGH ELECTRONICS UNDERSTAND ESSENTIAL TECHNOLOGY



POPULAR PROJECTS FROM A LEADING AUTHOR

A-D-A Interface*	Set 251	61.00	Mixer Simple 4 Chan	Set 256	19.99
Bass Boost	Set 138B	13.62	Mock Stereo	Set 213	24.37
Blow Box	Set 214	29.33	Morse Decoder*	Set 269	22.16
Chip Test 16-Pin*	Set 258S	32.50	Noise Gate	Set 227	26.61
Chip Test 24-Pin*	Set 258F	39.30	Phaser - Enhanced	Set 226	42.36
Chorus Flanger Dual	Set 235	59.99	Polywhatsit! FX	Set 252	122.69
Compander	Set 238	22.99	Reverb Simple Dual	Set 203	36.54
Cybervox Voice FX	Set 228	44.76	Reverb Simple Mono	Set 232	27.35
Digital Delay & MCS	Set 234RK	198.50	Rhythm Gen*	Set 185	34.64
Disco Light Control	Set 245F	62.50	Rhythm Generator	Set 240	59.99
Echo-Reverb Stereo	Set 218	57.66	Ring Mod (Simple)	Set 179	23.90
Envelope Shaper	Set 174	25.20	Ring Modulator	Set 231	45.58
Equaliser 3-Chan	Set 217	25.33	Roger 2-Gong	Set 126	16.63
Fader (Voice Op)	Set 167	22.22	Signal Generator	Set 233	46.96
Flanger (Mono)	Set 153	28.45	Sirens Drum Trig	Set 199	23.75
Frequency Changer	Set 172	45.56	Sirens Wheeby Jeeby	Set 151	21.16
Fuzz (Smooth)	Set 209F	19.58	Storm Wind & Rain	Set 250W	29.50
Guitar Modulo	Set 196	23.56	Storms Simple	Set 154	23.60
Guitar to Synth	Set 173	41.41	Sustain	Set 222	25.31
Hand Clapper	Set 197	26.69	Thunder & Lightning	Set 250T	29.50
Linkafex Chorus	Set 204	42.96	Tom-Tom Synth	Set 190	19.37
Linkafex Delay	Set 206	42.09	Treble Boost	Set 138T	13.62
Linkafex Equaliser	Set 216	25.43	Tremolo	Set 136	15.62
Linkafex Flange	Set 207	34.92	Tuner - Micro*	Set 257	55.32
Linkafex Fuzz	Set 209L	23.24	Tuner - Simple*	Set 259	22.50
Linkafex Modulo	Set 211	25.41	Vodalek Voice FX	Set 155	18.31
Linkafex Overdrive	Set 215	25.13	Voice Op Switch	Set 123	20.41
Linkafex Phaser	Set 205	34.38	Wah Auto & Manual	Set 140	24.36
Linkafex Sustain	Set 223	26.47			
Metronome	Set 143	21.35			
Mic Pre-Amp	Set 144	14.93			
Micro-Scope*	Set 247	44.50			
Micro-Trace*	Set 261	19.50			
Mini-Sampler	Set 246	75.00			
Mixer 4-Ch Stereo	Set 229S	82.15			

* Computer controlled (BBC, C64, PET)

GEIGER COUNTERS

Geiger (Audio)†	Set 274	65.00
Geiger (Audio) EE	Set 265	49.50
Geiger (Meter)†	Set 272	75.50
Geiger (Meter) PE	Set 264	59.50
Geigermite (Pocket)	Set 271	39.50

† Ready-built Geigers

Send A4 SAE for detailed catalogue, and with all enquiries (overseas send £1.00 or 5 I.R.C.'s).

Add 15% VAT. Add P&P - Sets over £50 add £2.50. Others add £1.50. Overseas P&P in catalogue. Text photocopies - Geiger & DDL Texts £1.50 each, others 50p, plus 50p post or large SAE. Insurance 50p per £50. Mail order, CWO, CHQ, PO, Access, Visa.

PHONOSONICS, DEPT PE76, 8 FINUCANE DRIVE,
ORPINGTON, KENT, BR5 4ED, Tel. 0689 37821.

HART

LINSLEY-HOOD SYNCHRODYNE AM RECEIVER

Very high quality kit for this recent design featured in 'Wireless World'. Advanced construction system, approved by the Author, uses 3 double sided PCBs in a stacked layout for total stability, ease of construction and minimal wiring. This module will form the AM section of an ultra high quality AM/FM switched bandwidth tuner to match our 300 series amplifiers. Power supply and tuning gang will be included with the FM section. K450 JLH Synchrondyne Kit Special Price. **£59.95**

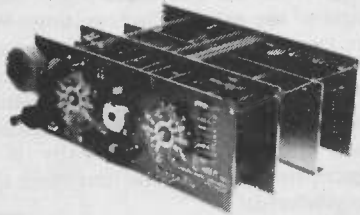

VFL600 VERTICAL FRONT LOADING CASSETTE MECHANISM

This latest addition to our range fulfils the need for a reasonably priced front loading cassette mechanism. This unit comes complete with stereo R/P and erase heads having standard mountings so that they may be exchanged for others in our range of heads if required. The mechanism also has a 3 digit counter, chrome operating keys, mechanical auto stop and a removable decorative cassette door with central window and key functions marked below. Cassette door carrier has a hydraulically damped 'soft eject' feature. Motor is internally governed and only needs a 12v DC supply with an average current of 80mA. Overall size 160mm wide including counter, 100mm high and 85mm deep including motor and keys. A robust and thoroughly useful deck for many purposes. **£24.30**

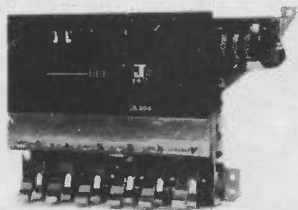

CAR RADIO FM IF AND STEREO DECODER

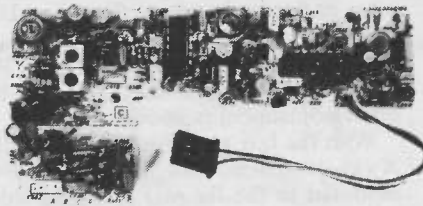

Miniature PCB with 10.7MHz ceramic filters, 2-transformer ratio detector, AX010 noise suppression IC and TCA4500A advanced stereo decoder IC. Only needs front end to make FM tuner or car radio. Complete with circuit. Incredible value at Only **£1.99**

LINSLEY HOOD 300 SERIES AMPLIFIER KITS

Ultra high quality, Moster output, Hi Fi amplifier kits by this famous designer. Two models of identical appearance are available, one giving 35 watts per channel output, the other 45. Careful design has made these amplifiers capable of superb sound quality. The delicacy and transparency of the tone quality enables them to outperform, on a side by side comparison, the majority of commercial amplifiers available today. Building is very easy as almost all components are fitted on easily removed printed circuit boards. Subsequent setting up needs only a simple multimeter to obtain the full specified performance. Both kits come with very comprehensive building instructions. **£30.79**
K300 35 35 Watt Complete Kit **£102.36**
K300 45 45 Watt Complete Kit
Reprints of Original Articles **£1.05 no Vat.**

LINSLEY-HOOD CASSETTE RECORDER CIRCUITS

Complete record and replay circuits for very high quality low noise stereo cassette recorder. Circuits are optimised for our HS16 Super Quality Sendust Alloy Head. Switched bias and equalisation to cater for chrome and ferric tapes. Very easy to assemble on plug-in PCBs. Complete with full instructions. Complete Stereo Record/Play Kit **£33.70**
VU Meters to suit **£2.30 each**
Reprints of original Articles **75p. no vat.**

STUART TAPE RECORDER CIRCUITS

Complete stereo record, replay and bias system for reel-to-reel recorders. These circuits will give studio quality with a good tape deck. Separate sections for record and replay give optimum performance and allow a third head monitoring system to be used where the deck has this fitted. Standard 250mV input and output levels. Full details are in our lists. **£1.30 no vat.**
Reprint of Original Articles

HIGH QUALITY REPLACEMENT CASSETTE HEADS



Do your tapes lack treble? A worn head could be the problem. Fitting one of our replacement heads could restore performance better than new! Standard mountings make fitting easy and our TC1 Test Cassette helps you set the azimuth spot-on. We are the actual importers which means you get the benefit of lower prices for prime parts. Compare us with other suppliers and see! The following is a list of our most popular heads, all are suitable for use on Dolby machines and are ex-stock.

- HC20 Permalloy Stereo Head. This is the standard head fitted as original equipment on most decks **£7.66**
- HS16 Sendust Alloy Super Head. The best head we can find. Longer life than Permalloy, higher output than Ferrite, fantastic frequency response **£14.86**
- HQ551-4 Track Head for auto-reverse or quadrophonic use. Full specification record and playback head **£14.60**
- SM166 Standard Mounting 2/2 Erase head. Compatible with above or HQ551 4 Track head **£5.90**
- HQ551-4 Track head **£2.25**
- H524 Standard Erase Head. Semi double gap, high efficiency **£7.35**
- H561 Metal Tape Erase Head. Full double gap **£7.35**
- HX100 Special Offer Stereo R/P Heads **£2.49**
- HRP373 Sendust Alloy Stereo Combination Head **£38.60**
- HRP373 Technical specification **15p**
- HS9510 2/4 Stereo OC Erase Head **£6.70**
- HQ751E 4/4 Erase compatible with HQ551 **£39.70**

HART TRIPLE-PURPOSE TEST CASSETTE TC1

One inexpensive test cassette enables you to set up VU level, head azimuth and tape speed. Invaluable when fitting new heads. Only **£4.66** plus VAT and 50p postage.

Tape Head De-magnetiser. Handy size mains operated unit prevents build up of residual head magnetisation causing noise on playback **£4.54**
Curved Pole Type for inaccessible head **£4.85**

send for your free copy of our LISTS. Overseas please send 2 IRCs to cover surface Post or 5 IRCs for Airmail. Please add part cost of post, packing and insurance as follows:

INLAND	Orders up to £10	50p	OVERSEAS
	Orders £10 to £49	£1	Please send sufficient to cover Surface or Air Post as required.
	Orders over £50	£1.50	

Personal callers are always very welcome but please note that we are closed all day Saturday

24 Hour Sales Line
(0691) 652894

PLEASE ADD VAT TO ALL PRICES

HART
HART ELECTRONICS KITS LTD.
5 PLYMOUTH HILL
OSWESTRY, SHROPSHIRE
SY10 9AF

PINEAPPLE SOFTWARE

Programs for the BBC models 'B' with disc drive with FREE updating service on all software

DIAGRAM

Still the only drawing program available for the BBC micro which gives you the ability to draw really large diagrams and scroll them smoothly around the screen stopping to edit them at any time if required. Pineapple's unique method of storing the diagram information on disc means that the size of diagrams is limited only by the free space on disc, and not the amount of computer memory you have available. (A blank 80 track disc will allow up to 39 mode 0 screens of diagram). The superb print routines supplied with the program enable large areas of the diagram to be printed in a single print run in a number of different sizes and rotated through 90 deg. if required. Full use can also be made of printers which have a wider than normal carriage available. The program is fully compatible with the Marconi Tracker ball described below.

PLEASE STATE 40 or 80 TRACK DISC & WHETHER STANDARD BBC or MASTER VERSION IS REQUIRED

PRICE £25.00 + VAT

DIAGRAM UTILITIES

A suite of six utility programs which add additional features to the 'Diagram' drawing program. The utilities include the saving and loading of areas of diagram to and from disc. The ability to display the whole of your large diagram on the screen at one time (in either 4*4 or 8*8 screen format). The addition of borders and screen indents to diagrams, and the ability to shift a whole diagram in any direction.

PRICE £10.00 + VAT

MARCONI TRACKER BALL

This high quality device comes with its own Icon Artmaster drawing program and utilities to enable it to be used in place of keyboard keys, joysticks, or with your own programs.

PRICE £60.00 + VAT p&p £1.75

PRICE INCLUDING 'DIAGRAM' SOFTWARE £79.00 + VAT p&p £1.75

TRACKER BALL for MASTER series

The Pointer ROM is supplied instead of the Icon Artmaster disc and enables the Tracker ball to work directly with the MASTER series computers. (e.g. to use with TIMPAINT etc.). Prices are the same as for the standard tracker ball.

POINTER

The Pointer Rom is available separately for people already owning tracker balls, and comes with instructions for use with the MASTER computer.

PRICE £12.50 + VAT



PCB

This new release from Pineapple is a printed circuit board draughting aid which is aimed at producing complex double sided PCB's very rapidly using a standard BBC micro and any FX compatible dot-matrix printer.

The program is supplied on EPROM and will run with any 32k BBC micro (including Master series). Also supplied is a disc containing a sample PCB layout to demonstrate the programs features.

By using an EPROM for the program code the maximum amount of RAM is available for storing component location and ASCII identification files etc. (Up to 500 components and 500 ASCII component descriptions may be stored for a given layout). These is no limit to the number of tracks for a given PCB, although the maximum size of board is restricted to 8" x 5.6".

Using a mode 1 screen, tracks on the top side of the board are shown in red, while those on the underside are blue. Each side of the board may be shown individually or superimposed. A component placement screen allows component outlines to be drawn for silk screen purposes and component numbers entered on this screen may be displayed during track routing to aid identification of roundels.

The print routines allow separate printouts of each side of the PCB in a very accurate expanded definition 1:1 or 2:1 scale, enabling direct contact printing to be used on resist covered copper clad board.

This program has too many superb features to describe adequately here, so please write or phone for more information and sample printouts.

PRICE £85.00 + VAT

CONVERTER LEADS

Converter leads to enable the Trackerball to run mouse software and the mouse to run trackerball software (inc. DIAGRAM). Please state which way round when ordering.

PRICE £8.00 + VAT

MICROSPICE

A new addition to our range of engineering software. Microspice is a very powerful DC and AC analogue circuit simulator package for any model BBC computer.

As well as all the usual facilities available with this type of program, non-linear effects, small signal, noise measurements and sweeps may be performed. Component values may be swept, allowing component tolerances to be investigated as well as thermal performance etc. Comprehensive transistor modelling is incorporated using a 20 parameter Ebers Moll description. The program is supplied on disc with a very comprehensive 49 page manual. Please write or phone for more information

PRICE £99.00 + VAT P&P FREE

ALL ORDERS SENT BY RETURN OF POST

39 Brownlea Gardens, Seven Kings, Ilford, Essex IG3 9NL. Tel: 01-599 1476

INFRA-RED TRANSCIEVERS

BY THE PROF

INFRA-RED GOES TO THE HEAD

IN a previous article in this series the subject of inductive loop transmission was considered, and the alternative of so-called 'cordless' infra-red headphones was mentioned. In this article we will take a detailed look at this interesting subject. Like inductive loop systems, the idea is to drive a pair of headphones without any direct connection from the signal source to the headphones. However, inductive loop systems are generally used where very high quality is not needed, whereas infra-red systems are aimed more towards hi-fi use. The quality that can be attained with even quite simple infra-red systems is higher than might be thought, and the main problem that has to be overcome with equipment of this type is obtaining a usable operating range, rather than obtaining low noise and distortion levels.

Another difficulty which has to be overcome is that of making the receiver unit small and light enough to be a practical proposition. There is little point in freeing oneself from a cumbersome connecting lead and replacing it with a heavy receiver unit which makes the headphones uncomfortable to wear. With this type of equipment it is normal for the receiver to be built onto the headphones, and it is usually placed on top of the headband where the infra-red detector will not be obscured from the transmitter by the user's head.

With most modern headphones this approach is bordering on the impossible since the headphones are of such light construction and have a type of headband which makes fixing the receiver in place very difficult. What is probably a more practical approach in most cases is to have the receiver unit connected to the headphones via a short lead, with the receiver then being positioned (say) on the arm of a chair. It is up to the constructor to choose whichever method best suits the individual circumstances, but in both cases the receiver needs to be as small and light as possible.

HEAD START

Cordless infra-red headphones invariably seem to be based on a frequency modulation (f.m.) system. The principle advantage of an f.m. system in this case is that it renders any non-linearity through the photocells irrelevant, and this is important as quite high levels of distortion could otherwise be introduced by these components. Of course, use of an f.m. system does not automatically give a high quality output, and in order to take advantage of this method it is essential that the modulator and demodulator both have good linearity. The block diagram of Fig.1 shows the arrangement used in my initial system.

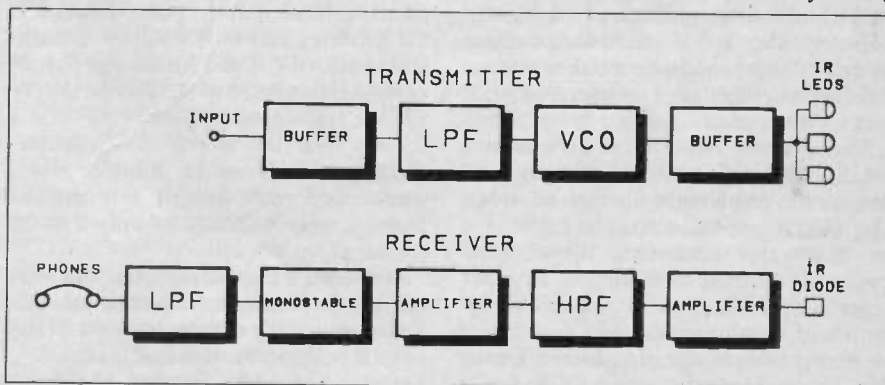

Fig.1. Block diagram of cordless infra-red headphone system

Starting with the transmitter side of things, a buffer stage and lowpass filter are used at the input. The buffer stage provides the unit with a reasonably high input impedance and provides a low output impedance that can drive the lowpass filter properly. The purpose of the lowpass filter is to remove input signals at frequencies close to the carrier frequency, which could otherwise cause unwanted heterodyne whistles and other noises on the final audio output signal. These frequencies are outside the audio range, but there is still a danger that the signal source will provide signals within the relevant frequency range. This could be caused by stray pick up of signals in the connecting cable, or due to

Cordless headphones can employ frequency modulated infra-red signals to transmit and receive near hi-fi quality audio. Ingenious deployment of photo diodes and l.e.d.s modifies the range and reception area of the signals.

distortion on the output signal. Some signal sources, particularly compact disc players and stereo f.m. tuners, tend to have a certain amount of output in the ultrasonic range.

The audio signal is fed to a voltage controlled oscillator (v.c.o.), and this has an output frequency which varies in sympathy with the applied control voltage. A type with good linearity is needed in this application, but these days there are several integrated circuits that enable a high quality v.c.o. to be produced without the need for undue complexity or expense.

A high current buffer stage is needed at the output because the infra-red l.e.d. must be driven at a fairly high current in order to obtain a reasonably strong

output signal. In fact a single l.e.d., even when driven at a current of one hundred milliamps or more, is unlikely to give usable results in practice. Ideally a bank of eight or more l.e.d.s are needed. Unfortunately, doubling the number of l.e.d.s in the bank does not double the range of the system. The infra-red signal spreads both vertically and horizontally, so that a doubling of range gives coverage over four times the area, but with only one quarter of the signal intensity. Using four times as many l.e.d.s in the bank therefore gives only a doubling of range. The practical consequence of this is that as the number of l.e.d.s in the bank is increased, the effect of each additional l.e.d. becomes

less. Thus, with eight l.e.d.s in the bank, to double the range of the unit a further twenty four would be needed, giving a total of thirty two.

The number of l.e.d.s used therefore has to be something of a compromise. About eight to ten l.e.d.s gives a useful increase in performance when compared to a single device and does not vastly increase the cost of the system. Further improving the performance by a worthwhile amount would require the use of what would probably be an impractical number of l.e.d.s, and would vastly increase costs.

A ploy which can be used to boost the performance of the system is to drive the l.e.d.s at a very high current, but to use a very short pulse width. For instance, with a 1:4 mark space ratio and a drive current of 250 milliamps the average l.e.d. current would be 50 milliamps. This gives strong pulses of infra-red but keeps the average l.e.d. current within an acceptable limit. In practice, this system is not quite as good as it would first appear. Using short pulses reduces the strength of the fundamental frequency and boosts the harmonics. The receiver therefore needs a wider bandwidth in order to prevent it from rounding off the pulses and reducing their peak amplitude. This wider bandwidth gives a higher noise level which tends to counteract the stronger transmitted signal. Nevertheless, the use of this pulsing technique seems to give some overall advantage, and it only requires the addition of a simple pulse shaping circuit of some kind between the v.c.o. and the buffer amplifier. This refinement has been included in the final version of the transmitter circuit.

The receiver uses a large area infra-red diode to detect the pulses from the transmitter. Although devices of this type offer a good compromise between sensitivity and bandwidth, the output level will normally be very low, at well under a millivolt peak to peak. A high degree of amplification must therefore be used to boost the signal to a level that can properly drive an f.m. demodulator. Highpass filtering is used in this part of the circuit in order to give a lower noise level, and lowpass filtering could also be used. However, as explained previously, with a narrow pulsed signal from the transmitter the receiver needs to have a wide bandwidth in order to give good results. There certainly seems to be no advantage in using additional components to give a faster roll-off than the natural high frequency roll-off of the amplifier, and no lowpass filtering has been included in the final design.

There are various types of demodulator that can be used in a low frequency f.m. application, including phased locked loop and quadrature detectors. What is probably the simplest

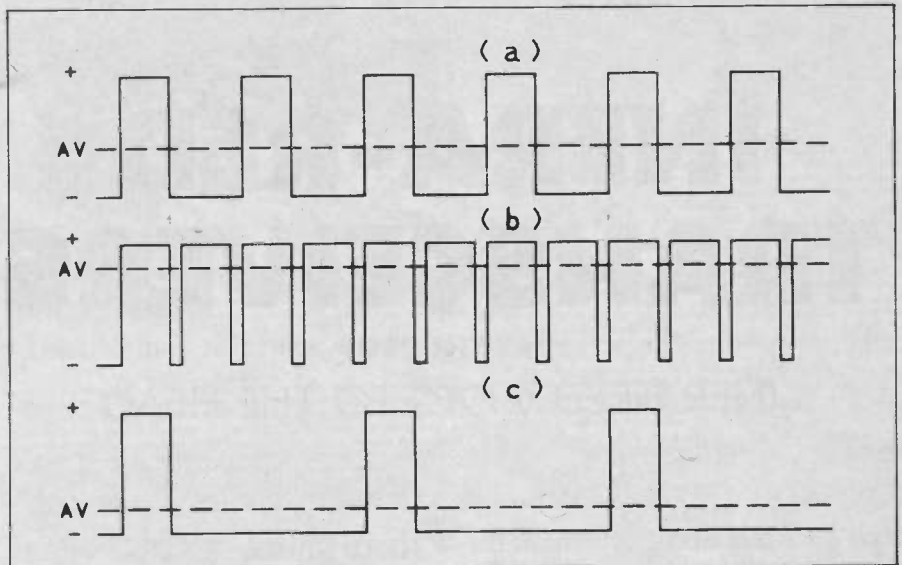

Fig.2. Monostable output waveforms

type, but one which offers excellent linearity, is an ordinary non-retriggerable monostable multivibrator plus a lowpass filter. This may seem like an unlikely form of demodulator, but it works no less well because of that. The waveforms of Fig.2 help to explain the way in which a monostable multivibrator can provide frequency to voltage conversion.

Taking Fig.2(a) first; this waveform has a 2:3 mark-space ratio, and the average output voltage is therefore 40% of the supply voltage. In Fig.2(b) the input frequency has been doubled and there are twice as many pulses in a given period of time, but the pulse duration is the same as before. This gives a mark-space ratio of 4:1, and the average output voltage is increased to 80% of the supply voltage. The input frequency in Fig.2(c) is only half that of our first example, and this spreads out the pulses to give a mark-space ratio of just 1:4, and an average output voltage of only 20% of the supply voltage.

It should be apparent from this that changes in the input frequency produce a corresponding change in the average output voltage. Furthermore, there is a linear relationship between the input frequency and the average output voltage. Apart from their simplicity, the excellent linearity over a wide input frequency range is the main attraction of this type of demodulator. Of course, the pulsed output waveform does not constitute a demodulated audio signal, but the lowpass filter has the effect of smoothing the pulses to give a proper audio output signal. In fact the pulses would probably give a quite acceptable audio output signal if fed direct to the headphones, as they would not respond to these high frequency pulses properly, and would provide a sort of mechanical lowpass filter which would integrate the pulses. In practice it is probably best to play safe and include reasonably effective lowpass filtering at the output of the

unit. Apart from anything else, this ensures that only an insignificant level of radio frequency interference is radiated from the headphones and the output lead.

TRANSMITTER CIRCUIT

The full circuit diagram of the transmitter unit appears in Fig.3. The input signal is fed to an operational amplifier voltage follower circuit based on IC1a, and this gives the unit an input impedance of about 50k. From here the signal is fed to the lowpass filter, and this is an active third order (18dB per octave) type which has IC1b as the buffer amplifier. The cutoff frequency is at approximately 20kHz, and consequently this filter does not prevent the unit from achieving the full audio bandwidth.

IC2 is a CMOS 4046BE micro-power phase locked loop, but in this circuit only its voltage controlled oscillator stage is used, and the other sections (such as the phase comparators) are ignored. The v.c.o. of the 4046BE is well suited to operation in low frequency f.m. systems as it has a wide frequency range with excellent linearity. The carrier frequency under quiescent conditions is about 70kHz, and is controlled by timing components R7 and C8.

IC3 is a 4001BE CMOS quad 2 input NOR gate, but here only two sections of the device are required and the other two simply have their inputs tied to earth to prevent spurious operations. The other two gates operate in a conventional CMOS monostable mode, and the output pulse duration can be adjusted by means of VR1. The l.e.d.s are driven via a VMOS power f.e.t. (TR1) which is suitably rapid in operation and can provide output currents of up to 2 amps. The infra-red l.e.d.s are driven in series connected pairs, with an individual current limiting resistor for each pair. In Fig.3 only two pairs of l.e.d.s are shown, but it is up to

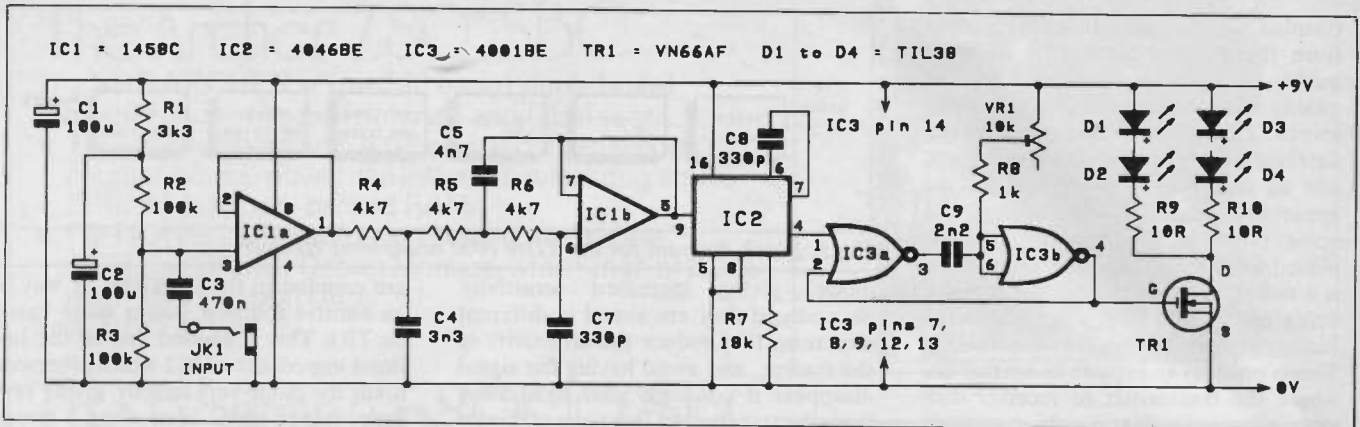

Fig.3. The complete transmitter circuit diagram

you as to how many are fitted to the unit. I used eight, and found that TR1 was capable of driving these satisfactorily. However, this is about the largest number that can be driven from a single VN66AF device, and if a greater number are to be driven, then one or more additional driver transistors will be needed. The monostable is well able to drive two or three VMOS transistors, and could in fact drive a dozen or more of these devices which have the high input impedances associated with field effect devices.

RECEIVER CIRCUIT

The circuit diagram of the receiver appears in Fig.4. D1 is the detector diode, and it is operated in the usual reverse bias mode. The pulses of infra-red cause D1's leakage level to increase, giving a sort of insensitive photo-resistor action. The TIL100 is a type which has a built-in infra-red filter. This helps to avoid problems with interference from the ambient light, and about the only likely source of infra-red interference is tungsten mains lighting. This is unlikely to give any 'hum' problems as the 100HZ signal is well below the signal frequency range and is severely attenuated by the highpass filtering. Also, a frequency modulation system has good immunity to sources of interference such as this.

A three stage amplifier is used, and this has three identical high gain common emitter stages with capacitive coupling. The coupling capacitors have

purposely been given quite low values so that they effectively form a three stage passive highpass filter in conjunction with the input impedances of the three amplifiers. The total voltage gain of the amplifiers is extremely high at well over 100dB, and the bandwidth is quite wide. This leaves the circuit open to problems with instability, although the fact that the input and output of the amplifier are out of phase helps to ease matters slightly. However, it is still necessary to take reasonable care with the component layout, especially if the circuit board is made as small as possible and the amplifier components are rather crammed together.

The monostable is a CMOS type that is essentially the same as the type used in the transmitter circuit. The lowpass filter is also basically the same as the one used in the transmitter, and again has a cutoff frequency of about 20kHz. The system thus achieves the full audio bandwidth, and is capable of high quality results in this respect.

IC2 is capable of driving most types of headphone satisfactorily. With most types series connection of the phones will give best results, but with high impedance (and possibly some medium impedance) types parallel connection must be used in order to give reasonable volume. With low impedance types it will probably be better if a resistor of about 47 ohms in value is connected in series with the output. This gives a certain amount of attenuation and gives a more

satisfactory load impedance for IC2. The unit will also drive a crystal earphone satisfactorily, but it is unsuitable for operation with low impedance magnetic types, or headphones that are designed to be driven direct from loudspeaker outputs.

IN USE

Before applying power to the transmitter, set VR1 at minimum resistance. Use a multimeter to monitor the supply current and adjust VR1 to bring the current up to 50 milliamps per pair of l.e.d.s (e.g. 200 milliamps with a bank of eight l.e.d.s). Note that if you use more than four l.e.d.s TR1 will need to be fitted with a small heatsink. The current consumption of the transmitter is obviously quite high which makes battery operation impractical unless a fairly high capacity NiCad rechargeable battery is used. A mains power supply would be a more practical proposition, and it must provide a reasonably well smoothed and stabilised 9 volt output. The unit can be driven from the headphone output of virtually any television set, hi-fi system, or whatever, and an input level of about 1 volt RMS is required. Some signal sources may not be able to supply a signal at quite this level, but will still probably provide enough output to give good results. However, if necessary the input stage could be revamped slightly so as to give a certain amount of voltage gain.

With a signal at a suitable level

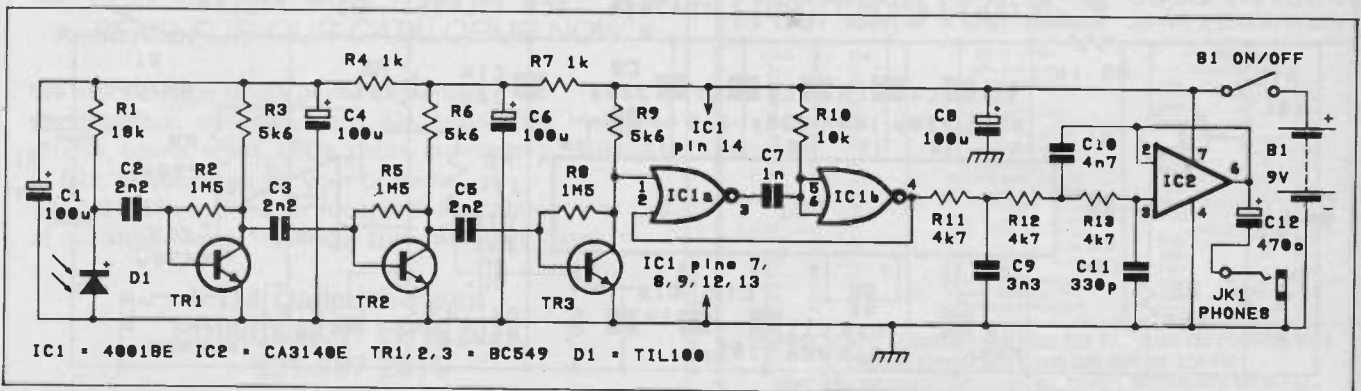

Fig.4. The cordless headphone receiver circuit

INFRA-RED TRANSCEIVERS

coupled to the transmitter, the output from the receiver should be of good quality with no obvious reduction in quality when compared with the signal source. This assumes that the infra-red detector diode is receiving a good signal, and an inadequate signal level will be apparent from a relatively poor signal to noise ratio. If the detector diode is placed too close to the transmitter there is a risk of the amplifier in the receiver being overloaded with a very distorted audio output being produced as a result. This is unlikely to happen in normal use where the transmitter to receiver distance is never likely to be short enough, but it can be avoided anyway simply by adding a 1N4148 silicon diode from the base of TR3 to the negative supply rail (the cathode connecting to TR3's base).

In use it is too little signal rather than too much which is likely to be the problem. I found that the system worked well at about 2 metres, but was starting to show signs of significant background noise at 3 metres, and all but ceased to work at 4 metres. This is quite usable in some circumstances, but would obviously be inadequate if the system was needed for operation in a large room with a fairly long distance between the transmitter and receiver.

IMPROVED RANGE

There is probably little scope for improving the range by making modifications to the transmitter, other than by adding more i.e.d.s. As already pointed out, it takes a lot of i.e.d.s and extra power to give a large improvement in range, but if only a marginal increase in performance is required this is an approach which would probably be worthwhile. Optical systems can give improved range, but these tend to make the system highly directional, which renders them useless in this application.

The receiver offers more scope for improvement, and one very simple way of obtaining improved performance is to add one or more photo-diodes in parallel with the existing one. This can improve performance in two ways. Firstly, if the diodes are all aimed in the same direction they will simply act as one large

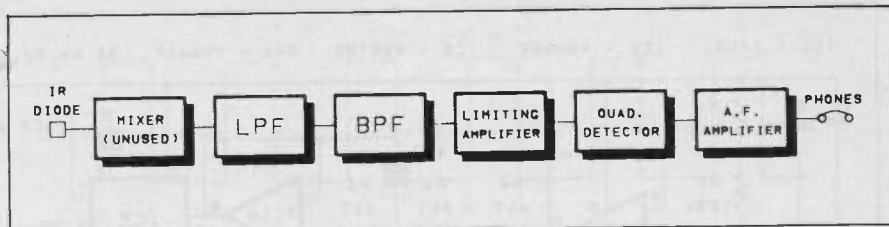

Fig.5. Block diagram for the TDA 7000 headphone receiver

diode, giving increased sensitivity. Secondly, if they are aimed in different directions they reduce the directivity of the system, and avoid having the signal disappear if you turn your head away from the transmitter. Two pairs of diodes facing in opposite directions seems to offer very good performance.

There is plenty of room for experiment with different types of receiver circuit. I tried one based on the TDA7000 f.m. radio integrated circuit, which is an unusual device that operates with an intermediate frequency of only about 70kHz and uses C-R intermediate stage filtering. There is insufficient space available here for a full description of this device, but when used in this application it provides the stages shown in the block diagram of Fig.5 (apart from the audio output stage which is provided by a separate device).

The mixer is unused in this case, but it is included in the signal chain as the only route into the i.f. stages is through this stage. The i.f. stages consist of a lowpass filter, a bandpass filter, and then a high gain limiting amplifier. The demodulator is a quadrature type, but it does not require a tuning inductor. In fact the only discrete component it uses is a capacitor which forms part of the phase shift network. The audio output level from the detector is quite low, and the audio amplifier has to furnish about 26dB of gain in order to give sufficient output to drive a pair of headphones.

The full circuit diagram of the TDA7000 version of the cordless headphone receiver appears in Fig.6. Most of the circuit consists of the TDA7000 itself and the numerous filter, phase shift, and decoupling capacitors that are needed in order to make it operate properly. The photo-diode (or diodes)

are coupled to the TDA7000 by way of an emitter follower buffer stage based on TR1. This is needed due to the low input impedance of IC1 which otherwise loads the diode very heavily, giving very little output signal even when a strong infra-red signal is received. At the output side IC2 acts as the audio amplifier and this is a simple inverting mode circuit.

The original transmitter circuit seems to operate well with this receiver circuit. About the only worthwhile modification to the transmitter is to replace R7 with a 10k fixed resistor and a 22k potentiometer in series, so that the output frequency can be optimised.

In use this receiver seems to provide better range and is less likely to cut-off if the photo-diode is not aimed in the general direction of the receiver. In terms of audio quality it does not quite seem to match the original circuit, and it is perhaps better suited to use where very high quality is not needed.

FURTHER DEVELOPMENT

Using these circuits with about eight i.e.d.s at the transmitter and several diodes at the receiver it is certainly possible to produce a practical cordless headphone system. I prefer the receiver with the monostable detector, as although this gives somewhat less range, it is still adequate in this respect for most purposes, and it has a noticeably higher audio output quality. A useful improvement would be a squelch circuit to cut off the audio output if the received signal should drop to an inadequate level.

The most obvious shortcoming of the system is that it is only monophonic. However stereo simulation just happens to be the topic covered in the next 'Experimental Electronics' article.

PE

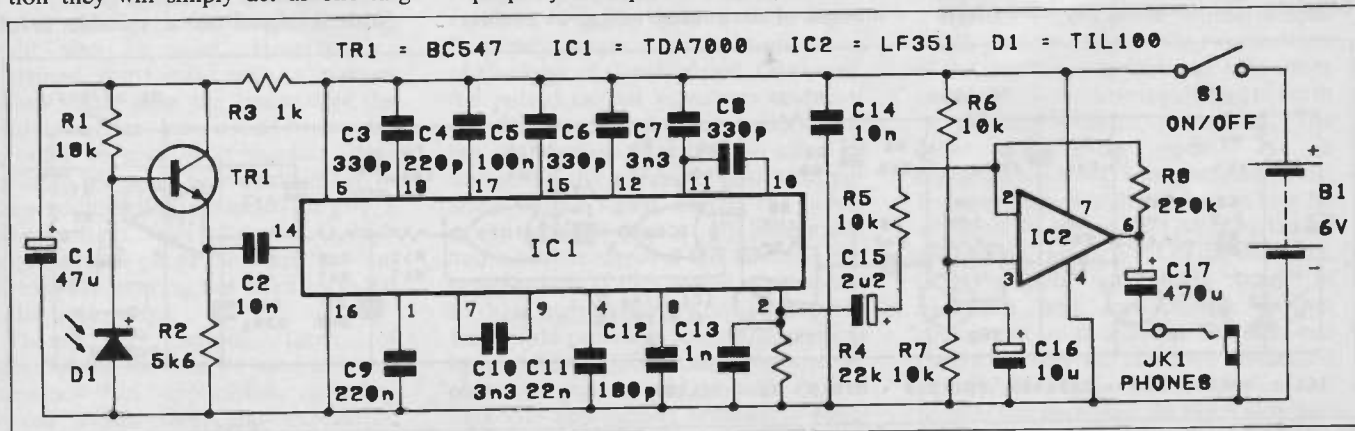
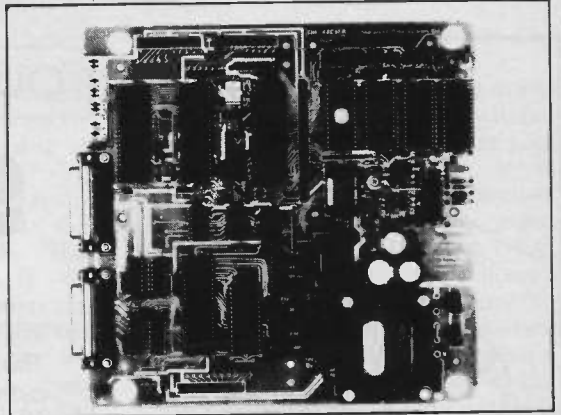

Fig.6. Circuit diagram for the TDA 7000 receiver

The Archer Z80 SBC

The **SDS ARCHER** – The Z80 based single board computer chosen by professionals and OEM users.

- ★ Top quality board with 4 parallel and 2 serial ports, counter-timers, power-fail interrupt, watchdog timer, EPROM & battery backed RAM.
 - ★ **OPTIONS:** on board power supply, smart case, ROMable BASIC, Debug Monitor, wide range of I/O & memory extension cards.
- from £185 + VAT.



The Bowman 68000 SBC

The **SDS BOWMAN** – The 68000 based single board computer for advanced high speed applications.

- ★ Extended double Eurocard with 2 parallel & 2 serial ports, battery backed CMOS RAM, EPROM, 2 counter-timers, watchdog timer, powerfail interrupt, & an optional zero wait state half megabyte D-RAM.
 - ★ Extended width versions with on board power supply and case.
- from £295 + VAT.



Sherwood Data Systems Ltd

Sherwood House, The Avenue, Farnham Common, Slough SL2 3JX, Tel. 02814-5067

THREE INTO ONE WILL GO – WITH THE CROTECH 3132

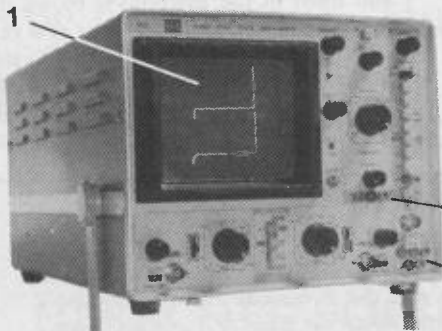

- SCOPE:**
DC – 20MHz Bandwidth
2mV/div Sensitivity
40ns – 0.2s/div Sweep
14 Trigger Functions
Including active TV trigger on line & frame.
- Triple Output DC Source**
+5V (1A); –ve grounded
±12V (200mA) Common Floating

- Active Component Comparator**
(for checking Transistors, diodes and I.C.'s etc)
Test Voltage: 8.6Vrms (28mA)

All for the price of a scope at
£285*

*(Excluding Delivery and VAT)
Correct at time of going to press

Crotech Instruments Limited

2 Stephenson Road, St. Ives, Huntingdon, Cambs. PE17 4WJ
Telephone: (0480) 301818



Also available from Audio Electronics & Henry's

OMNI ELECTRONICS

★ SEND FOR OUR CATALOGUE NOW ★

We stock a wide range of components: transformers, switches, pots, ICs, capacitors, resistors, diodes, boxes, triacs, LEDs, cable, connectors, PCBs – in fact, all you need for your projects.

Send 2 x 18p stamps for a copy of the catalogue or call at our shop Mon – Fri 9am – 6pm, Sat 9am – 5pm.

174 Dalkeith Road
EDINBURGH EH16 5DX
031-667 2611

Microkit Ltd

0536 744664
24 HR 7 DAYS/WEEK

CMOS	74LS	74HC
00	20	25
02	20	25
04	20	25
08	20	25
10	20	25
14	20	29
20	20	29
32	20	35
74	20	39
85	20	49
		47
		49
		49
138	40	49
139	40	49
157	40	55
158	40	55
163	55	55
166	60	60
175	55	55
193	60	75

SAVE OVER
40% ON OUR
EX EQUIPMENT
MEMORIES
AND EPROMS
1000's of delighted
customers
GUARANTEED UV
ERASED AND TESTED
4116 16K x 8 £0.75
EPROMS
2716 2K x 8 £1.50
2732 4K x 8 £1.20
2764 8K x 8 £1.50
27128 16K x 8 £1.75
All taken from working
boards. Try some. You
will SAVE POUNDS!!!!

MEMORIES		
DRAM 5V NMOS		
4164	64K x 1	£0.88
41256	256K x 1	£2.39
4416	16K x 1	£2.80
41464	64K x 1	£2.40
SRAM 5V NMOS		
2114LP	1K x 4	£1.50
2128LP	2K x 8	£2.50
SRAM 5V CMOS		
6116LP	2K x 8	£1.30
6264LP	8K x 8	£2.40
62256LP	32K x 8	£14.50
EPROM 5V NMOS		
2716	2K x 8	£2.70
2732	4K x 8	£2.65
2764	8K x 8	£2.45
27128A	16K x 8	£2.70
27256	32K x 8	£3.75
27512	512K x 8	£8.20

ADD VAT AT 15%. ORDERS UNDER £25 P&P £1. OVER £25 POSTAGE FREE.
ORDERS DISPATCHED SAME DAY BEFORE 3.30 PM.
DEPT (P6), 18A COLDERMEADOW AV., CORBY, NORTHANTS NN18 9AJ.



OUR REGULAR LOOK AT ASTRONOMY

SPACEWATCH

BY DR PATRICK MOORE, OBE

The supernova in the Large Magellanic Cloud is the biggest astronomical event directly observed since 1604 – but we won't see it in the Northern Hemisphere.

THE great new William Herschel telescope, at La Palma in the Canary Islands, is now near completion, and work has already started with the James Clark Maxwell telescope on Mauna Kea in Hawaii, which operates in the microwave region of the electromagnetic spectrum. Other new telescopes are on the way – though we must, sadly, record that there is still no news of a rescue operation for the mothballed 100-inch Hooker reflector on Mount Wilson, which was so long the most powerful telescope in the world, and which was responsible for fundamental advances. Also, it seems definite that our own Royal Greenwich Observatory is to lose its headquarters at Herstmonceux Castle, and will be transferred to Cambridge, where it will inevitably play a comparatively minor role.

An interesting theory has been proposed to explain why Sirius, the brightest star in the sky, was classed as red in ancient times by many astronomers, including Ptolemy of Alexandria. Sirius is certainly not red today – it is a white Main Sequence star

of spectral type A – and it is not the kind of star which would be expected to change over a short period of a few thousands of years. It has, however, a dim White Dwarf companion. Before reaching the White Dwarf stage, a star must become a Red Giant; and it has been suggested before now that Sirius B used to be a Red Giant in Ptolemy's time.

In America, F. Bruhweiler, Y. Kondo and E. Sion have now suggested that Sirius B went through a 'temporary red giant' phase, when the outer atmosphere of the star expanded and cooled because of a short-lived outburst. This would certainly explain the ancient redness of Sirius, but it looks as though a combination of a temporary red giant and the present Sirius would produce a star of outstanding brilliance – of which there is no mention in the old records. On the whole the theory seems unlikely, and it is more probable that we are dealing with a mistake in either observation or interpretation. Still, it is decidedly interesting.

THE SUPERNOVA IN THE LARGE CLOUD OF MAGELLAN

The first part of 1987 has been dominated by the news of a supernova in the Large Magellanic Cloud. It was discovered in February, and attained naked-eye visibility. It is therefore the brightest supernova seen since Kepler's Star of 1604.

Supernovæ are the greatest outbursts known to us. They are of two types. In the first of these we have to consider a binary system, one member of which is a White Dwarf. The White Dwarf pulls material away from its larger but less dense companion, finally becoming unstable and literally blowing itself to pieces in a cataclysmic outburst. With a Type II supernova, a very massive star 'runs out of fuel' and collapses; there is an implosion, followed by a shock-wave, and most of the material is blown off, leaving a remnant in the form of a very small, super-dense neutron star. Preliminary investigations showed that the Cloud supernova was of Type II. Moreover, instruments at the Mont

The Sky This Month

MAY 1987 is not a particularly good month from the point of view of the planetary observer. Venus, Jupiter and Saturn are all morning objects, but none is ideally placed even though all are bright – Venus and Jupiter particularly so. Saturn, with a magnitude of 0.1, remains in the constellation of Ophiuchus, which is not officially a member of the Zodiac but does cross the Zodiacal region between Scorpius and Sagittarius.

Mars remains on view during the early evening, moving from Taurus into Gemini, but it will be almost lost in the twilight before the end of May, and its magnitude is only 1.7 – not a great deal brighter than the Pole Star. Mercury passes through superior conjunction on May 7, but may just be glimpsed low in the west after sunset during the last days of the month.

The Moon is full on the 13th, and new on the 27th. There are no eclipses this month, and the only important meteor shower is that of the Eta Aquarids, which reaches its peak on May 5. This shower is associated with Halley's Comet, but there is no reason to expect any spectacular display this year – and Halley's Comet has now passed beyond the ken of all but giant instruments, not to return for more than seventy years.

We have lost Orion and the other brilliant winter stars, though Procyon and the Twins can still be seen for a while after sunset. The Great Bear or Plough is nearly overhead, and Leo, the Lion, is prominent in the high south; look for the curved Sickle, with the first-magnitude star Regulus. Follow round the Bear's 'tail', and you will come first to the brilliant orange Arcturus and then to Spica, in Virgo. Arcturus, with a magnitude of -0.04 , is actually the brightest star in the northern hemisphere of the sky; its only superiors – Sirius, Canopus, and Alpha Centauri – are all south of the celestial equator, and the latter two are never visible from Britain. Next in order come Vega, Capella and Rigel, all of which are fractionally below zero magnitude.

The low south of the sky is occupied by the vast, sprawling and frankly dull Hydra, the Watersnake, and in the south-east are some more large but dim groups: Hercules, Ophiuchus and Serpens. However, well before dawn the red supergiant Antares, in the Scorpion, has risen in the south-east. It is unfortunate that Scorpius is always inconveniently low down as seen from Britain; at its best, as seen from southern countries, it rivals Orion in splendour.

Blanc neutrino observatory recorded a 'neutrino burst' which seems to have indicated the collapse of the star's iron core.

Fortunately the pre-supernova star can be identified; it was a B-type blue supergiant, around 25 times as massive as the Sun and therefore a stellar heavyweight. Its magnitude was around 13, and the identification seems certain, so that for the first time we have definite information about the pre-outburst stage. To be visible with the naked eye over such a distance, the peak luminosity must have been tremendous: perhaps 15,000,000 times that of the Sun. The

distance of the Large Cloud, and hence of the supernova, is usually given as about 180,000 light-years, though astronomers at the Royal Greenwich Observatory prefer the lower value of about 155,000 light-years.

It is unfortunate that once again northern observers are deprived of the chance to make observations. The declination of the supernova is -69 degrees, so that to see it at all adequately one must go south of latitude 15 degrees north – even Hawaii will not do, and we must depend upon results from observatories in Australia, South Africa, New Zealand and South America; the

original discovery was made at the Las Campanas observatory in Chile.

At the time when I write these words (March 4, 1987) it is still too early to say how the supernova will behave, or how bright it will become; but it is undoubtedly one of the most important astronomical events for many years. Astrophysics have been more than anxious to study a relatively nearby supernova with modern-type equipment. They would dearly like one in our own Galaxy; but if this is impossible, then an outburst in the Large Cloud of Magellan is the next best thing! **PE**

Astronomy Now

Number. 1

April-June 1987

In the first issue:

PULSARS AS CLOCKS
by the Astronomer Royal,
Sir Francis Graham-Smith

**THE BIZARRE WORLD
OF MIRANDA**

by Dr. Garry E. Hunt

**FIRST STEPS IN
ASTROPHOTOGRAPHY**
by H.J.P. Arnold

**THE WILLIAM
HERSCHEL SOCIETY**
by A.V. Sims

**THE SCHMIDT-
NEWTONIAN**
by Barry Pemberton

plus a host of regular
features, including:

The Night Sky this Quarter
Reviews of Books and
Instruments
Society News
Letters and Comments
Latest Astronomical News
from Around the World
Observers' Page

NOW ON SALE at all good newsagents Price £1.25

PE BAZAAR

Can anyone advise where I can obtain 0.0005 – 10KWV capacitors. I have tried without success. A. Slade, High Hopes, Letton Close, Blandford, Dorset DT11 7SS.

Modular Technology Minimodem with cables. Reasonable offers. Tel: 061 723 5037.

Enthusiast Retiring. 10kg Parcel, 500 brand new components plus other goodies. £14.75 post free (5 only). K. Bailey, 40 Seymour Close, Selly Park, Birmingham B29 7JD.

Wanted: Any information on MAEL 4000 computer and Log Abax LX180 printer. Justin House, Church View, Atherington, Umberleigh, N. Devon EX37 9HY. Tel: 0271 79073 before 5 pm.
Avometer D.V.M. Never used £55.
P. Evans, 46 Station Road, Weston-Super-Mare, Avon. Tel: 7934 31931.

Power supply, Eagle RP230N 0-309v, twin meters, variable current limiting, VGC !65.00. Phone: 01-654 1882.

Wireless world, Vol. 29 July to Dec. 1931. Bound, good condition for years. Offers (0865) 779855.

Points Arising

Switch Mode PSU Design (April 87). Pages 28,29. The diagrams for Figs. 5 and 7 should be transposed, Pages 35,37, Fig.2 and 7 should be transposed.

PRINTING PE

RUN AT 220 METRES PER MINUTE, COOKED AT 160°C

BY JOHN BECKER

Electronics and computerisation has infiltrated the print industry in a multitude of ways. Practical Electronics is one of the many beneficiaries – your editor has been along to see what PE's printers are up to, and found a warm welcome.

At the end of February I drove out to Andover to watch McCorquodales print the April edition of PE, and for personal interest, to see how electronics is being used in modern printing.

Each month, about ten days or so prior to a new PE issue appearing on bookstalls, the fully edited text and illustrational material is compiled by our typesetters and photographic masters produced, each holding eight pages of PE, four across and two down. There can be up to four masters for each block of eight pages, one each for yellow, blue, red and black, produced by laser scanning the original through special colour filters. Known as separation masters, they are transparent and hold a positive monochrome image of the original, in the form of minute dots varying in size according to image density. Ingeniously, the dots are at different angles, depending on the colour to be printed. When combined at the printing stages, they recreate the original full colour image. Text areas are faithfully reproduced as hard images without dots.

PLATE MAKING

From these masters, the printers make a metal printing plate, in a fashion similar to one method of making PCBs. The plates are basically anodised aluminium sheets that have been coated with a photosensitive emulsion. The transparency is placed into contact with the sensitised surface, and enclosed in a vacuum press to ensure total contact across the entire surface area. It is then exposed to ultraviolet light for a few minutes, with electronic sensors measuring mains voltage, UV colour temperature and intensity, and controlling the exposure time so that a consistent overall exposure value is always achieved, irrespective of any fluctuation in conditions.

The plates are next fed through a chemical solution, which in effect develops and washes away the emulsion that has received direct exposure from the UV light, revealing the bare anodised aluminium surface. The dot image areas though, retain the emulsion, and it is to this surface that the printing ink will eventually be transferred. The processed image is then heat hardened in an oven electronically regulated at 270°C. The



toughened image is strong enough to allow over 500,000 prints to be made from one plate.

Once the plates have been made, they are analysed by electronic densitometers that assess the image densities across the entire area. On the plate sizes used for PE, 24 separate evenly spaced areas are measured, and the levels sensed are digitised and stored in a computer data bank. This information will ultimately be used to control the amount of ink applied through 24 nozzles equivalently spaced on the press. Finally, the plate is shaped at the ends, and secured to the printing rollers by means of precision cut registration holes and pins.

THE PRESSES

McCorquodales have three printing presses on line, each in operation 24 hours a day for five days a week. All are recently installed, and between them



print over forty different magazines, ranging from PE, Office At Home and Astronomy Now, to Amateur Gardening and Tit-Bits. The three machines have their own individual computers, keyboard terminals, and control consoles.

Each of the presses is in fact six different printing machines coupled in series, any number of which can be brought into operation simultaneously, depending on the job, and between them can handle up to three reels of paper. Each of the machines prints simultaneously onto both sides of the paper, or web as it is known, so handling the equivalent of 16 pages of PE at the same time. The first three in the series are just for black ink, and the next three are for the red, blue and yellow inks.

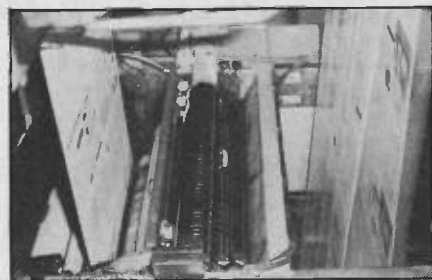

Water is sprayed onto the printing plates as they rotate. Because the aluminium is anodised, and so slightly porous, the water soaks into the pores preventing ink from being attracted. The greasy emulsion covered areas though, repel the water but readily attract ink as the plate passes the automatic dispensers. As the plate continues to rotate, the acquired ink is transferred to a synchronously rotating rubber roller, and then to the surface of the paper web as it passes.

When seeing the April PE going through, it was the three black ink units in operation first of all, between them printing 48 of the inner pages. When the required number of copies had been printed, the first two machines were disengaged. Following a period of cleaning down, fresh plates were then attached to the third black ink printer, and to the three colour printers. After this, the equipment was run again, printing the outer sixteen pages.

The printing speed is quite impressive, handling about 220 metres per minute on each machine, the equivalent of around 350 copies per minute. The total amount of paper used for editions of PE though, far exceeds the length of a single reel of paper. These measure 10,000 metres each, weigh over 750 kilos, and several are needed. Consequently, as one reel runs out, another must immediately take its place without interrupting the printing process. The changeovers are rapid, but interesting to watch.

Each huge paper dispensing stand holds two reels, either of which can be used. The paper is taken from one reel through a multiple series of pulley rollers that automatically control paper tension. Normally the rollers are close to full separation, but as the current paper reel nears its end, electronic sensors come into play, and at the relevant moment, the rollers close their spacing, letting the leading end of the paper continue at full speed, but enabling the trailing end to slow, and allowing the new reel to secure itself to the trailing end. Immediately following acquisition of the new reel, the rollers increase their separation again, bringing the reel up to correct rotational speed.

EXPERT SUPERVISION

All the machines have automatic control of their inking densities and precision alignment, though all operations are additionally under constant manual supervision. The computer sets the initial system control parameters, then the several operators use their expertise and experience to carry out the fine tuning, with the computer then maintaining control under any new parameters set manually.



Throughout the entire operation, copies are randomly extracted from the delivery end of the press, and examined in considerable detail, frequently with a magnifying glass, and various adjustments made to ensure the optimum print quality. To assist the detailed study, the extracted copies are placed on an examination easel underneath a bank of lights arranged like an audio parametric equaliser display. Horizontally there are 32 lights, though only 24 were in use as dictated by the sheet size, and 11 vertically, relating to percentage ink densities from nil to 100%. These lights correspond to the areas previously analysed



by the densitometer, and stored by the computer. Manual push buttons can increase or decrease the inking density factors, and the lights show a bar graph profile of the factors for each area. Any change made is immediately acted upon by the computer, which also stores the new data, so that should a repeat run be needed, the stored parameters can be recalled, and identical print qualities achieved.



REGISTERED APPROVAL

In addition to the inking levels, the registration accuracy of the separate images from each printing plate is under constant observation. Again the computer maintains very close control of positional parameters, using light sensors to detect specific registration marks on the plates. The operators though can modify the alignment by making panel controlled adjustments to the roller positions. These can be moved in three directions, horizontally across the page, lengthways for advancing or retarding the registration, or diagonally to compensate for any slight rotational misalignment of the plate.

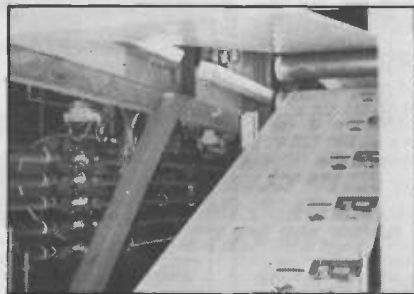

Opto-electronic devices are also much in evidence sensing for paper tears or breakage, and in the unusual event of these occurring, initiate the smooth shut down of all rollers simultaneously, preventing paper jams and spillage. I once saw the latter happen in an old paper mill – the scene of high speed spillage

was most dramatic, and it took an hour or more to sort out the mess!

During the printing process, as well as using computer aided inking and alignment control, an additional computer program is also running and displaying data on a VDU screen at the main control console. Numerous data factors can be called up, including the amount of paper required, the amount used, and the amount remaining on each reel. The printing rate is also displayed, together with the number of good copies so far printed, the reject level obtained during precision setting up, the time taken so far, the time scheduled, the remaining time available, and the percentage of the time budgeted. Access to the data files for other printing jobs, past or future, or pertaining to other printing lines, can also be called up.

Between them, the installation of the three complete printing lines cost around seven million pounds, and with a schedule involving over 40 titles, all of which have to be on newsagent's counters by specific dates, it is vital that all factors have to be under constant surveillance, ensuring that printing charges are both competitive and profitable.

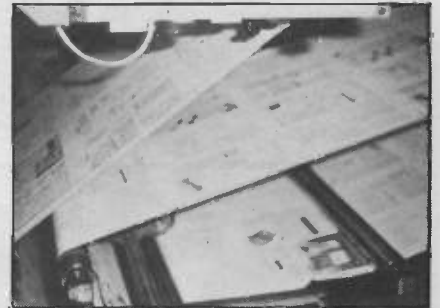

HOT OFF THE PRESS

Each of the three levels of paper leave the relevant printing machine and are routed, one above the other, into a vast gas fired drying oven. Thermal sensors and servo controls maintain the oven at 160°C, at which temperature the ink solvents evaporate and are burnt off. From the oven, the web passes over a bank of chrome cylinders internally cooled by flowing water. Thermostatically held at 15°C, the rollers shock-chill the paper web to set the ink pigment, and also restore the paper to a manageable temperature at which it can be folded without cracking through brittleness. With rate and tension still electronically controlled, the printed paper speeds out with the ink fully dry.

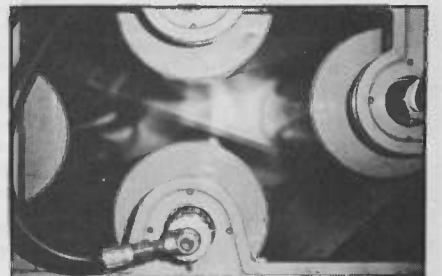

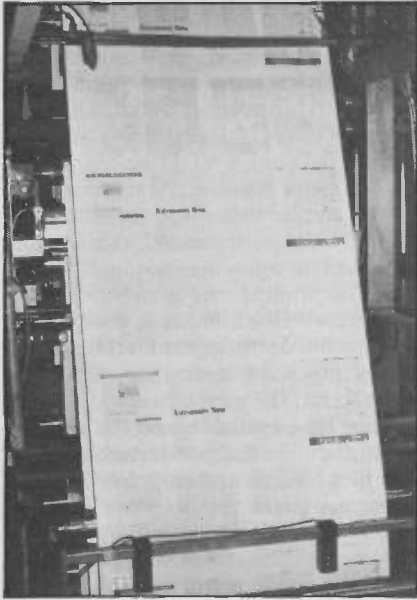

Now a clever series of rollers at 45 degrees to each other can take one length of paper and change its vertical position in respect to the others. This enables paper from the colour printers to be placed in a different makeup position, according to publishing requirements.

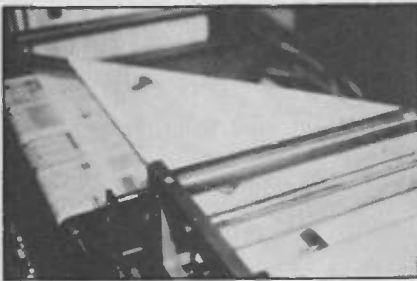

Following this, all three paper levels are brought together and routed into the first section of the folding machine. Here the impression is that of seeing the paper disappear down a vast funnel, but in fact this is an illusion and it is actually routed across and down another series of angled

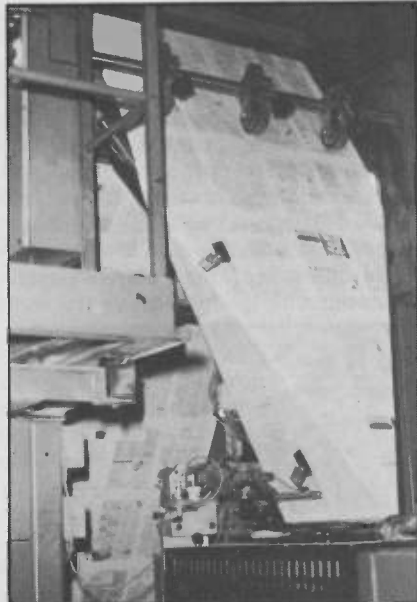

rollers. These cause a lengthways fold down the centre of the triple thickness, bringing the two sides together to now give a six sheet thickness. Immediately after this, two more folds are made, and a rotational guillotine slices the paper into magazine sized sections. With three reels of paper in use, this results in a 48 page section coming off the machine, along a conveyor, past the quality control supervisors, and to an automatic stacking machine.

At this point, the sides of the folded sections remain uncut, so the supervisors, taking frequent samples, can unfold them for examination alongside the bar graph profile and control displays, and make any necessary adjustments.



COMPLETION

The stacked sections go through to an enormous room in which the remaining stages are carried out. Electronic control is less evident here, and the equipment appears to be extremely fast conveyerised lines in which the various folded sections are combined and stitched with wire staples. Simultaneously, additional automatic equipment can enclose extra sections, such as promotional inserts etc. Following the stitchers, automatic machines guillotine-trim and stack the completed magazines into bundles of 50, turning the stack through 180 degrees every tenth copy, to keep the thickness even.



From there, bundles are wrapped in heavy duty polythene and strapped by more automatic equipment. The magazines are then ready for distribution to the trade and retail outlets by the specified day, on time for all eager readers to obtain their copies of the latest PE.

Throughout the full process, I was particularly impressed by several aspects. Firstly, that McCorquodales place strong emphasis on making visitors feel most welcome. Then, that a similar emphasis is placed upon minimising noise levels, and providing clean, spacious, and efficiently run premises, for the benefit of staff and customers. Thirdly, that electronics in many forms, both analogue and digital, from opto-sensors to complex computer controlled operations, is much in evidence. And finally, that everyone there takes great pride in ensuring that the magazine copy you receive is of the highest quality, for clarity of text, accuracy of colour rendition, and registration of four separate images.

We at PE work hard to offer you quality in projects and articles, and it is good to see at first hand that others in the production chain take as much care and interest in their work as we do. You really receive excellent value for the cover price of your favourite magazine.

PE

DON'T MISS A VITAL COPY!

Ever been in the middle of a project only to find the next issue sold out? An annual subscription to **PRACTICAL ELECTRONICS** solves the problem.

Wherever you live you'll receive a copy regularly each month. It's the quick, practical way to solve delivery problems.

SUBSCRIPTION RATES

U.K. (VAT INCL.) £15.00
Overseas £18.00

COMPLETE AND POST THIS ORDER FORM TODAY!

PRACTICAL

ELECTRONICS

SUBSCRIPTION ORDER FORM

Annual Subscription Rates
U.K. £15.00
Overseas £18.00
Students, Deduct £1 and quote Student Number

POST COPIES TO

NAME

ADDRESS

POST CODE

Complete this form and post it, with payment to: **Practical Electronics** Subscription Dept. Competition House, Farrdon Rd., Market Harborough, LE16 9NR.

I enclose my cheque/PO payable to Intrapress for

£..... Please Note: Subscriptions cannot be ordered by phone

Signature

SAXON MOSFET AMPLIFIERS

UNBEATABLE PRICES!!!



SLAVE MODEL

AP 100 100W RMS £69
AP 200 200W RMS £89

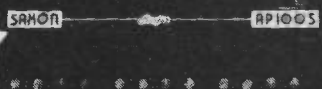

2 INPUT GENERAL PURPOSE MODEL

AP 100S £79
AP 200S £99

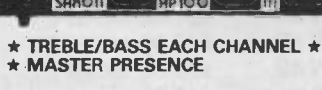

P.A. MODEL

★ 6 INPUTS
★ 3 CHANNELS
★ ECHO IN/OUT

AP 100M £99
AP 200M £119

★ TREBLE/BASS EACH CHANNEL ★ INDIVIDUAL VOLUMES
★ MASTER PRESENCE

Write or phone for a **FREE BROCHURE** on these incredible amplifiers

P.E. HYPERCHASER £84.95



4 CHANNEL PSEUDO INTELLIGENT LIGHT UNIT £209

★ 8 Channel Twin Preset Mixer ★ Strobe Outputs
★ 4 Independent Channels ★ 4/8 Channel Sequences
★ 8 Programmes ★ Manual Flash Buttons
★ Individual Dimming ★ Sound To Light

Not just a light unit but a sophisticated & comprehensive effects unit. A full kit of parts including P.C.B., Facia, Case, etc. Reprint of article on request.



P.E. STAR DESK £209

★ 8 + 4 CHANNEL LIGHT MIXING DESK
★ 8 Channel Twin Preset Mixer ★ Strobe Outputs
★ 4 Independent Channels ★ 4/8 Channel Sequences
★ 8 Programmes ★ Manual Flash Buttons
★ 1KW Output/Channel (can be boosted to 2KW/Ch)
★ Timed Crossfade ★ Soft/Hard Sequence

A truly magnificent unit ideal for clubs, groups, drama, etc. A full kit of parts inc. PCB, Facia, Case, etc. Reprint of article on request.

Access CROYDON DISCO CENTRE

327 Whitehorse Road, Croydon, Surrey CR0 2HS
(01) 884 8007 9am-5pm. Mon-Sat. (Closed Wed.)

Post & Packing £4 per item. Please allow 14 days for delivery



CMOS	4089	80p	74LS55	17p	74LS267	42p	280HCTC 600p	LINEAR IC'S	LM301	26p	
4000	13p	4094	48p	74LS74	22p	74LS259	58p	AN-214P	200p	LM311	35p
4001	13p	4095	58p	74LS75	28p	74LS280	38p	280AS10100p	180p	LM324	35p
4002	13p	4098	50p	74LS76	28p	74LS286	28p	280ADART 680p	140p	LM348	40p
4006	36p	4099	45p	74LS78	28p	74LS273	52p	AN-7110	160p	LM380	80p
4007	13p	4501	70p	74LS83	43p	74LS280	140p	AN-7114	160p	LM381	150p
4008	38p	4502	38p	74LS86	30p	74LS280	140p	AN-7120	180p	LM382	130p
4009	20p	4503	32p	74LS86	30p	74LS280	140p	AV3-1270	880p	LM387	100p
4010	21p	4504	55p	74LS90	32p	74LS293	30p	AV3-1350	300p	LM709 DIL	30p
4011	13p	4506	60p	74LS91	75p	74LS365	37p	AV3-8910	360p	LM723	40p
4012	13p	4509	60p	74LS92	38p	74LS368	37p	AV3-8912	180p	LM741 DIL	18p
4013	19p	4507	33p	74LS93	38p	74LS367	35p	AV5-3600	570p	LM741 MET	45p
4014	35p	4508	70p	74LS95	47p	74LS368	38p	CA270	40p	LM747	58p
4015	34p	4510	37p	74LS96	60p	74LS374	55p	CA3048	80p	LM748	35p
4016	18p	4512	42p	74LS107	32p	74LS374	55p	CA3060	180p	LM748	35p
4017	31p	4513	80p	74LS109	34p	74LS374	55p	CA3080E	70p	M-51513L	180p
4018	28p	4514	75p	74LS112	30p	74LS399	80p	CA3086	65p	M-51515BL	270p
4019	20p	4515	75p	74LS113	32p	74LS670	72p	CA3093E	150p	M-51516	280p
4020	35p	4516	75p	74LS114	35p			CA3090AQ	300p	M-51517L	280p
4021	38p	4517	120p	74LS122	40p			CA3130E	45p	MR3710	160p
4022	13p	4518	38p	74LS123	42p			CA3130S	100p	MS7350	280p
4023	13p	4519	38p	74LS123	42p			CA3140E	38p	MS7356	280p
4024	25p	4520	30p	74LS124	85p	2114	200p	CA3189E	250p	MC1327	70p
4025	13p	4521	30p	74LS126	38p	27256	400p	CA3240E	90p	NE555	20p
4026	60p	4522	50p	74LS132	40p	2718	200p	HA-1159W	110p	NE556	45p
4027	18p	4526	40p	74LS133	34p	2732	280p	HA-1191	180p	MS5580	118p
4028	25p	4528	40p	74LS136	35p	2764	240p	HA-1308W	170p	SAS570	110p
4029	35p	4529	40p	74LS138	35p	27128	250p	HA-1319	250p	SN76003N	140p
4030	17p	4529	75p	74LS138	35p	27128	250p	HA-1338	170p	SN76110N	70p
4031	90p	4532	52p	74LS145	83p	1118	75p	HA-1342	170p	SN7815	50p
4032	59p	4551	80p	74LS147	120p	1184	110p	HA-1368WR	180p	TA-7120	55p
4033	80p	4553	190p	74LS148	90p	8118	160p	HA-1388	180p	TA-7120	55p
4034	80p	4555	28p	74LS151	32p	8284-15	250p	HA-1397	140p	TA-7146P	400p
4035	48p	4556	28p	74LS153	40p	8502	300p	HA-1397	230p	TA-7193P	400p
4036	180p	4557	190p	74LS154	90p	8902	220p	HA-1397	260p	TA-7200	200p
4037	75p	4583	60p	74LS155	41p	8909	600p	HA-1398	240p	TA-7201	200p
4038	48p	4584	30p	74LS156	47p	8821	140p	LA-120	85p	TA-7203	180p
4039	190p	4585	42p	74LS157	30p	8840	310p	LA-1252	120p	TA-7204	110p
4040	36p			74LS158	33p	8850	110p	LA-1365	140p	TA-7205	80p
4041	38p			74LS158	33p	8850	110p	LA-1365	140p	TA-7205	80p
4042	30p			74LS158	33p	8850	110p	LA-1365	140p	TA-7205	80p
4043	39p	74LS00	15p	74LS162	48p	8085A	320p	LA-1368	140p	TA-7205	80p
4044	39p	74LS01	15p	74LS163	48p	8155	390p	LA-1377	120p	TA-7137P	45p
4045	72p	74LS02	15p	74LS164	43p	8156	360p	LA-14032	140p	TBA120S	45p
4046	45p	74LS03	15p	74LS165	43p	8224	270p	LA-4050	130p	TBA395	60p
4047	45p	74LS04	15p	74LS166	74p	8226	270p	LA-4051	180p	TBA396	60p
4048	27p	74LS05	15p	74LS168	92p	8228	270p	LA-4100	30p	TBA500	100p
4049	18p	74LS05	15p	74LS168	92p	8228	270p	LA-4101	100p	TBA530	100p
4050	20p	74LS08	15p	74LS169	65p	8243	250p	LA-4102SK	140p	TBA540	100p
4051	38p	74LS09	15p	74LS170	80p	8250	850p	LA-4201	85p	TBA810S	90p
4052	37p	74LS11	15p	74LS174	39p	8251	300p	LA-4112	250p	TBA820	75p
4053	37p	74LS12	15p	74LS175	42p	8253	340p	LA-4125	210p	TBA850	100p
4054	59p	74LS15	15p	74LS185	52p	8257A	370p	LA-4220	140p	TBA950	100p
4055	52p	74LS13	22p	74LS191	52p	8256A	1200p	LA-4422	130p	TBA990	100p
4056	52p	74LS14	30p	74LS192	50p	8257A	370p	LA-4430	170p	TCAR80	40p
4060	40p	74LS20	15p	74LS193	51p	8259	370p	LA-4481	170p	TCAR80	40p
4063	52p	74LS21	15p	74LS194	53p	8271	4400p	LA-4482	180p	TCAR90	100p
4066	20p	74LS22	15p	74LS195	52p	8272	1300p	LA-5112	120p	TD1170	100p
4067	130p	74LS22	15p	74LS196	62p	8272	1300p				
4068	13p	74LS26	38p	74LS197	52p	8279	650p				
4069	13p	74LS27	15p	74LS221	58p	8282	400p				
4070	13p	74LS28	15p	74LS240	55p	8283	400p				
4071	13p	74LS30	15p	74LS241	59p	8284	600p				
4072	13p	74LS32	17p	74LS242	56p	8284	1000p				
4073	13p	74LS33	17p	74LS243	60p	8284	1000p				
4075	13p	74LS37	18p	74LS244	60p	SP258AL2600p	74175				
4076	48p	74LS38	17p	74LS245	50p	Z80ACPU180p	74178				
4077	13p	74LS40	16p	74LS247	60p	Z80BCPU500p	74180				
4078	13p	74LS42	16p	74LS248	50p	Z80BCPU500p	74182				
4081	13p	74LS47	56p	74LS249	92p	Z80ADMA 650p	74192				
4082	13p	74LS48	56p	74LS251	30p	Z80AP10250p	74198				
4085	40p	74LS51	16p	74LS253	50p	Z80BP10 800p	74197				
4086	32p	74LS54	16p	74LS256	60p	Z80ACTC260p	74393				

CRICKLEWOOD ELECTRONICS LTD



FREE!
catalogue

It's no secret...

...that there is a real difference at Cricklewood Electronics

That's why you should never be without the **FREE CRICKLEWOOD ELECTRONICS COMPONENTS CATALOGUE**, for sheer variety, competitive prices and service from the U.K.'s number one 100% component shop. No gimmicks, no gadgets or computers, just components, millions of them, all easily available by mail order, calling or credit card telephone orders. Just pick up the phone (or a pen) to get your **FREE** copy now (no SAE required). You have nothing to lose.

CRICKLEWOOD ELECTRONICS LIMITED
40 Cricklewood Broadway, London NW2 3ET
Tel: 01-450 0995/01-452 0161
Telex: 91 4977





CCTV CAMERAS FROM ONLY £69.50 EACH PLUS CARRIAGE & VAT



Crofton Electronics are now able to offer C.C.T.V. cameras from as little as £69.50 + VAT & carriage. These cameras have been refurbished to a high standard. The output is 1volt p-p. and will work with most video equipment. These cameras are powered from 240volt mains, and have a vidicon rack giving a focusing range from an inch or two to infinity. A standard 16mm lens is also supplied. The sensitivity is in the order of 10 lux which allows their use in the domestic environment. Pictures can be produced with only 2.5 lux but with a worse signal to noise ratio. Low light versions are available having sensitivities of 0.1 lux (half moonlight) at £350 + VAT and carriage. Many other lenses are available from stock. A Mounting bush is standard. Many other cameras are available from stock both reconditioned and new, i.e. brand new mini 12volt camera at only £80 plus VAT and carriage, lens extra. Many other items of CCTV equipment such as monitors (both new and refurbished) switchers, panning units, housings, time and date generators are available from stock. We also supply camera and monitor tubes, as well as scanning yokes for a wide range of equipment.

SPECIAL SPECIAL SPECIAL SPECIAL

Currently on offer is a professional drive board and tube to make a superb 12" professional green panelled tube monitor at £23.50 inclusive. Would normally cost well over £200 +. Buy 10 off and they will only cost you £180.00 inclusive. Be sure to ask us to quote for any of your camera/monitor requirements - we will never be beaten on price.

HURRY HURRY HURRY

(Not many left. First come first served.)

Brand New Time Date generators at a fraction of their original price. Only £132 inclusive. Normal price £477. These generators are mains driven and accept normal composite video in. They produce video out with time/date/day/month/year added to the signal in normal or reverse video. Adjustable positioning anywhere on the screen. Switchable character size also provided. A REAL MUST FOR SECURITY APPLICATIONS WHEN RECORDING.

We also have a host of used items such as cooling fans power supplies at give away prices, so why not ask for a list?

Send a 40p SAE for our complete range of catalogues.
MOST MAJOR CREDIT CARDS ACCEPTED.

CROFTON ELECTRONICS
"KINGSHILL", NEXTEND, LYONSHALL, HEREFORDSHIRE HR5 3HZ. 05448 557

OSCILLOSCOPES

TELEQUIPMENT D75. Dual Trace 50MHz. Delay Sweep. With Manual **£325**
 COSSOR CDU150. Dual Trace 35MHz. Solid State. Portable 8 x 10 cm display with manual **£200**
 TELEQUIPMENT D61. Dual Trace 10MHz. With Manual **£150**
 TELEQUIPMENT D43. Dual Trace 15MHz. With Manual **£100**
 SOLARTRON CD1400. Dual Trace 15MHz. With Manual **£100**
 TELEQUIPMENT S54A. Single Trace 10MHz. Solid State. With Manual **£110**

OSCILLOSCOPE BARGAIN. Solartron CD1400. Dual beam 15MHz. Supplied with Manual **ONLY £85 each**

B + K Precision CRT Restorer/Analyser Model 467. Supplied with 2 bases and Manual (P&P £7) **only £125 each**
 LABGEAR Colour Bar Generator KG1. 8 Test patterns (P&P £3) **only £40 each**

ISOLATING TRANSFORMER 240V In - 240V Out. 240V Out - 500VA £15 P&P £5; 100VA £6 P&P £2; 24V Out - 500VA £6 P&P £5; 200VA £4 P&P £4.

AVO TRANSISTER TESTER TT169. Handheld GO/NOGO for In-situ Testing. Complete with Batteries, leads & instructions (P&P £3) **now only £12**

DISK DRIVE PSU. 240V 1N; 5V 1.6A & 12V 1.5A out. Size: W125mm. H75mm. D180mm. Cased Un-used. (P&P £2) **only £10**
 QWERTY KEYBOARD. Cased. ASCII Coded + Un-coded Keypad & Function Keys. Requires +/- 12V. With Info. Un-used. (P&P £4) **£25**
 QWERTY KEYBOARD (as in LYNX MICRO). Push to make. Cased (P&P £2) **only £5**
 DISK DRIVE 5¼" full height. 80 track double sided. Double density. With Manual. Used (P&P £5) **£45 each**
 SWITCHED MODE PSU +/-12V 0.25A; 5V 1.5A; 24V 1.4A **£30 each P&P £3**

COMMUNICATION RECEIVERS

RACAL RA17L. 500KHz-30MHz. With Manual **only £150 each**
 EDDYSTONE 730/4. 480KHz-30MHz. With Manual **only £110 each**

MULTIMETERS

AVO 9 Mk4 (identical to Avo8 Mk4 but scaled differently). Complete with Batteries & Leads. **£55**
 AVO 8 Mk2. Complete with Batteries & Leads. **£45**
 Above items in GOOD WORKING ORDER - appearance not A1 hence the price.
 AVO TEST SET No 1 (Military version of AVO 8) Complete with Batteries, Leads & Carrying Case **£65**
 AVO Model 7X. Complete with Batteries, Leads & Carrying Case **£40**
 AVO type TEST LEADS Red & Black with 2 Croc Clips & 2 Prods (P&P £2) **£5**
 ANALOGUE POCKET MULTIMETERS. PHILIPS/TAYLOR/AVO etc. Complete with Batteries & Leads **from £10**

STEPPING MOTORS

TYPE 1. 200 Steps per rev. 4 Phase (5 wire). 12/24V. Torque 25oz inch/will run on 5V with reduced torque) **£15 each**
 TYPE 2. 6/12 Steps per rev. 3 Phase. 12/24V (will work on 5V) **£2 each**
 5 off **£7.50**
 TYPE 3. NORTH AMERICAN PHILIPS. 24 Steps per rev. 4 wire 5V 3.3Amps 0-250 rpm 0-200 PPs **£6 each**
 TYPE 4. 200 Steps per rev. 120V (3 wire) Torque 25 oz inch **£4 each**
 TYPE 7. WARNER 24 Steps per rev. 3 Phase (6 wire). 28V. Holding Torque 45 oz inch **£5 each**

NEW EQUIPMENT

HAMEG OSCILLOSCOPE 605. Dual Trace 60MHz. Delay Sweep. Component Tester **£583**
 HAMEG OSCILLOSCOPE 203.6. Dual Trace 20MHz. Component Tester with 2 probes **£314**
 All Other Models Available

BLACK STAR FREQUENCY COUNTERS (P&P £4)
 Meteor 100-100MHz **£99**
 Meteor 600-600MHz **£126**
 Meteor 1000-1GHz **£175**
 BLACK STAR JUPITOR 500 FUNCTION GENERATOR. Sine/Square/Triangle. 0.1Hz 500KHz (P&P £4) **£110**

HUNG CHANG DMM 7030 3½ digit. Hand held 28 ranges including 10 Amp AC/OC 0.1%. Complete with Battery & Leads. (P&P £4) **£39.50**
 AS ABOVE. DMM6010. 0.25%. **£33.50**

OSCILLOSCOPES PROBES. Switched x 1; x 10 (P&P £2) **£11**

Used equipment - with 30 days guarantee. Manuals supplied if possible.
 This is a VERY SMALL SAMPLE OF STOCK. SAE or Telephone for Lists. Please check availability before ordering. CARRIAGE all units £16. VAT to be added to Total of Goods & Carriage.
 Callers welcome 9 a.m. to 5.30 p.m. Mon-Fri (until 8 p.m. Thurs)

STEWART OF READING

110 WYKEHAM ROAD, READING, BERKS RG6 1PL
 Telephone: 0734 68041

Amplifier Modules

The most sophisticated and highly protected modules available today.

MODULE	POWER/LOAD	PRICE
CE608	60W 8Ω	£21.00 Bi-Polar
CE1004	100W 4Ω	£24.50 Bi-Polar
CE1008	100W 8Ω	£27.50 Bi-Polar
CE1704	170W 4Ω	£35.00 Bi-Polar
CE1708	170W 8Ω	£35.00 Bi-Polar
CE3004	300W 4Ω	£49.00 Bi-Polar
FE908	120W 8Ω	£31.00 MOSFET
FE1704	220W 4Ω	£52.00 MOSFET
FET 3	450W 4Ω	£74.50 MOSFET
CPR 2	Stereo Preamp	£47.95
REG 2	+/-12v Supply	£16.00

Prices include P+P, VAT. All modules are guaranteed for 2 years. For more information on these modules and our other products please write (s.a.e.) or phone.

CRIMSON ELEKTRIK STOKE Agents:—
BRADLEY—MARSHALL
 382-386 EDGEWARE RD.
 LONDON.

PHOENIX WORKS
 500 KING ST.
 LONGTON
 STAKE—ON—TRENT
 STAFFS

WILMSLOW AUDIO
 35-39 CHURCH ST.
 WILMSLOW
 CHESHIRE.

TEL.(0782) 330520

AUDIOKITS Precision Components

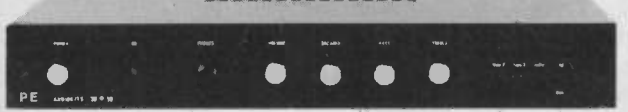

The new PE 30 + 30 integrated Amplifier (featured Practical Electronics Feb-April 87)

The PE 30 + 30 integrated amplifier is the first to benefit from Graham Nalty's research into Temperature Generated Distortion in transistors. As a result it exhibits a smoothness and musicality normally only expected from expensive valve amplifiers. Advanced power supply electronics and the use of Holco precision resistors in critical positions reaffirm its ability to give greater musical pleasure from your records, CDs and tapes. Yet you can buy the complete kit from AUDIOKITS for under £160 to build it yourself.

Complete Kits
 PE 30 + 30 standard 30W **£154.50**
 PE 30 + 30 standard with Extra Output Transistors for 40W **£162.50**
 PE 30 + 30 Audiophile improved version 40W Output **£350**

All parts for PE 30 + 30 are available separately.

Semi Conductors	Resistors	Hardware
MC7818CT 70p	100R, 2K2, 4K7 Bulk Foil £4.50	IN4148 4p
BC184C 12p	68K, 220K Bulk Foil £9	IN4002 5p
BC214C 12p	1R, 1W, Holco H2 £1.15	IN5401 15p
BC547C 12p	10R, Holco H8 70p	25A 200V Bridge £2.75
2SB737 75p	15R Holco H8 55p	35A 200V Bridge
2S0786 75p	22R1-442K Holco H8 35p	Motorola BYW62 £7
B0243C 80p	681R 1W Holco H2 40p	
BD244C 80p	15R-470K ¼W Metal Film 4p	Push Button Switch
MJ11015 £6	1R-470K ½W Metal Film 7p	Silver Plated
MJ11016 £5.50		2 pole c/o 80p
2N4401 25p		4 pole c/o £1.20
2N4403 25p		Button (Black) 25p
MPSA06 25p		Gold Plated Phono
MPSA56 25p		Chassis socket £2
OP2767 £8.25		TO3 Silicone
MAT02FH £8		Insulators 20p
		TO-220 Silicone
		Insulators 15p

For details please send: 9" x 4" SAE to
 AUDIOKITS, 6 MILL CLOSE, BORROWASH,
 DERBY DE7 3GU. TEL: 0332-674929.

NEW! from Cirkitt

SUMMER 1987 ELECTRONIC CONSTRUCTORS CATALOGUE



6 MULTIMETERS TO BE WON

PRICE ONLY £1.20

- Many new lines
- Extended range of test equipment
- £11 worth of discount vouchers
- 6 Multimeters to be won in easy to enter competition.
- Available at your local newsagent or direct from address below.

Cirkitt

(0992) 444111

Cirkitt Distribution Ltd Park Lane, Broxbourne, Herts EN10 7NQ
 Telephone: (0992) 444111 Telex: 22478

ZX SPECTRUM I/O PORT

BY P.B. SMALL

One output-only port, and one for true I/O,
on one piece of strip board.

THIS piece of hardware will add two ports to the Spectrum, mapped as 191 for OUTPUT only, and port 255 which can be used for both INPUT and OUTPUT operations.

IC2 acts as a decoder for seven of the lower address lines. When address lines 0 to 5 and 7 are high and the IORQ line is low, then the output from IC2 will be low. Dependant upon the state of address line 6, either IC4 or IC5 will be selected. If address line 6 is low (ie. OUT 191,n) IC4 is selected, whereupon the data on the data bus is latched onto the output, the latching signal being provided by the inversion of IC4's select line connected to IC6. If address line 6 is

high (ie. IN 255 or OUT 255,n) IC5 is enabled, and if a read operation is taking place then the RD line is consequently low and data is read from the 'outside world'. When this line is high then data is sent to the buffer IC5. However, if you do use this port for output, it should be noted that the data is not latched as with port A.

Construction of this project was effected by the author on a piece of VQ strip board about 80 x 80mm. When constructing the board it is important to note that ceramic disc capacitors C1 to C4 should be placed close to the i.c.s as per the circuit diagram.

MICROFORUM

This is the page where you can share your computer circuit ideas with other readers. If you have a circuit suitable for use with any home microcomputer, send it to us for possible inclusion in this section of PE.

Submissions should be typewritten, and be accompanied by a neat drawing of the circuit diagram.

Please send your ideas to:
Practical Electronics
16 Garway Road
London W2 4NH.

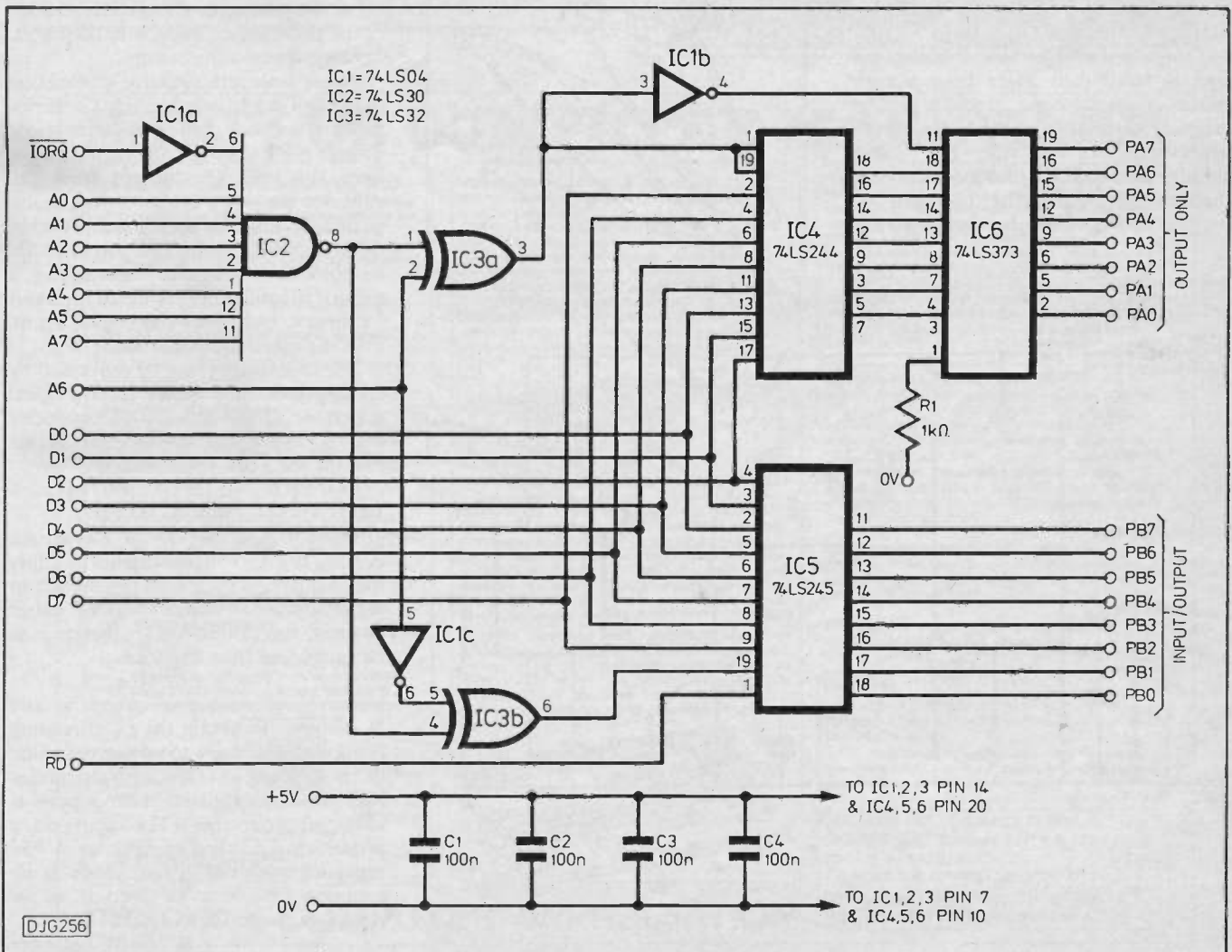

If you have any bright ideas that you think might interest other readers, why not send them, neatly drawn and type written, for possible inclusion in this section?

Self Powered Logic Monitor

THIS is a logic i.c. clip monitor that displays the true/false state of each pin of an i.c. by means of l.e.d.s.

The circuit is self-powered, in that it works out automatically which are the voltage and ground pins, and then draws its power from them. The circuit offers a high impedance to the pins being monitored, and therefore does not affect the circuit being examined. If small l.e.d.s. are used, it is possible to construct the circuit on top of an i.c. clip. Alternatively it can be constructed in a separate box, using ribbon cable for external connections.

This is a useful trouble shooting aid that is more convenient than a logic probe or oscilloscope, since it can be clipped on to an i.c. allowing observation of all the pin states simultaneously. It is suitable for use with the i.c.s. having from 16 to 40 pins.

J.C. Hegter, South Africa.

"INGENUITY UNLIMITED"

TWO PRACTICAL INVENTIONS
BY ENTHUSIASTIC READERS

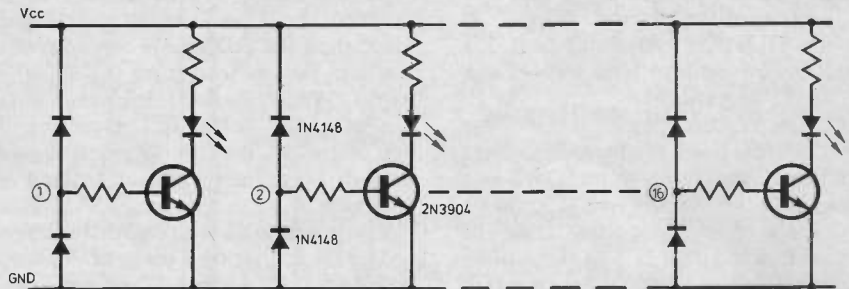

THIS CIRCUIT IS DUPLICATED FOR EACH PIN, WITH Vcc AND GND BEING COMMON TO ALL PINS.

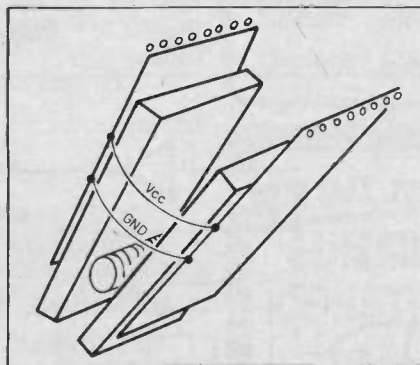

Tachometer

A tachometer is a useful aid when setting up a car engine, and the circuit shown has three ranges: 0-1000 r.p.m. for setting the idling speed; 0-3000 r.p.m. mid-range speeds; 0-10,000 r.p.m. for high speed adjustments.

Pulses from the negative connection of the coil are inverted by Tr1. The series resistor, zener diode and capacitor protect the transistor from high voltages from the coil. The output from Tr1 collector triggers a 555 monostable, the period of which is set by a switchable capacitor and resistor. The output of the monostable is a square wave having a mean d.c. level proportional to the input frequency, and hence the engine r.p.m. This is measured by the meter.

The tachometer may be calibrated by feeding in a square wave from a signal generator at the following frequencies and adjusting the appropriate preset resistor for a full scale reading:

- 1000 r.p.m. - 33.3 Hz.
- 3000 r.p.m. - 100 Hz.
- 10000 r.p.m. - 333 Hz.

These figures are for a four-stroke engine. For a six-stroke engine, multiply the frequencies by 1.5, and by 2.0 for an eight-cylinder engine. For other engines, the calibration frequency may be calculated from the formula:

$$F = N \times r / 120,$$

where N = number of cylinders, and R = r.p.m. To obtain the exact reading it may be necessary to adjust the value of the resistor in series with the preset resistor. A stabilised +8v supply is obtained from the +12v input via a protection diode and 8v regulator. A +5v regulator with a 3v zener diode in its common lead may be used if an 8v regulator cannot be obtained.

K. Wevill, Leicester

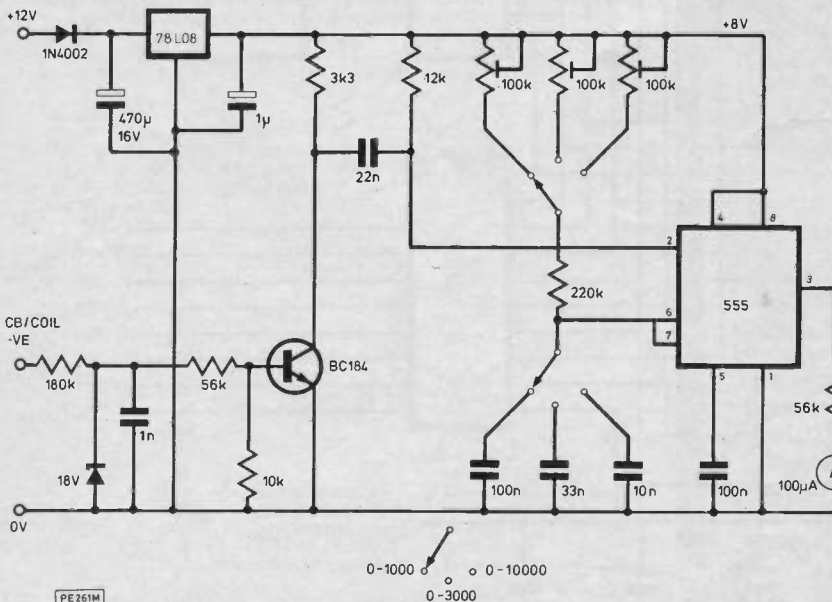

Books from Prentice-Hall

Microprocessor System Servicing

J. D. FERGUSON, L. MACARI AND P. WILLIAMS
Assuming a general knowledge of electronics, including digital techniques, this book presents the engineer or technician with a range of techniques for the location and solution of microprocessor (8- and 16-bit) faults.

1987 288 pages 13-581132-5 £14.95 paper

The Single Chip Microcomputer

S. J. CAHILL
Based on the 6802 and 6805 family of chips, this book provides an accessible overview of the principles and operation of single chip microcomputers

Optical Sensing Techniques and Signal Processing

TUDOR JENKINS
Designed for final year undergraduate or postgraduate students in departments of electronics and physics, this book will also be of use and interest to professionals required to set up experimental systems using optical sensors.

1987 256 pages 13-638107-3 £29.95 cloth

Engineering Foundations of Robotics

FRANCIS N-NAGY AND ANDRAS SIEGLER
Dealing with the design and control fundamentals of robot manipulators, this is a practical introduction to the engineering and mathematical principles of robot motion and positioning.

1986 320 pages 13-278797-0 £14.95 paper

RS-232 Simplified:

Everything You Need to Know About Connecting, Interfacing and Troubleshooting Peripheral Devices

BYRON W. PUTMAN
The sub-title says most of what you can say about this book in a short space!

1987 264 pages 13-783499-3 £17.35 paper

Prentice-Hall publishes a wide range of electronics and computer science books for engineers and students. For more information, please write to Jean Walmsley.

Prentice-Hall
SIMON & SCHUSTER INTERNATIONAL GROUP
66 Wood Lane End, Hemel Hempstead,
Hertfordshire, HP24 9RG, England

UNIVERSAL NICAD CHARGER

Charges any combination of AA, PP3, C & D cells, up to 4 cells simultaneously.

CDE PRICE £5.95 each

TECHNICAL NICAD CHARGER

Charges any combination of AAA, AA, PP3, C & D cells, up to 23 cells from 1.2V to 12V simultaneously. Test meter facility, use charging socket to charge various special batteries, connecting clipper or universal type plug.

CDE PRICE £24.00 each

NICADS

AA size	—	£1.10 each	500 mAhr
		(90p each when ordered with any charger)	
'C' cell	—	£2.50 each	1.2 Ahr
'D' cell	—	£2.80 each	1.2 Ahr
PP3	—	£6.90 each	100 mAhr

MINI-DRILL KIT WITH PRECISION TOOLS BY MAXICRAFT

Drill with selection of buffer heads, abrasive discs, polishers & drill bits, chucks & collets. 42W, 1800 rpm, 9-16V, 1.5A. For model makers, engravers and electronics enthusiasts.

CDE PRICE £19.50

TUNGSTEN CARBIDE DRILL BITS

1mm, ideal for glass fibre PCB's (1/8 shanks).

CDE PRICE £1.20 each or £5.50 for 5

PCB KIT

Includes 4 pieces copper clad, 2 etch resist pens, 4 sheets transfers, plastic tray, tweezers, circuit etchant and instructions.

CDE PRICE — complete kit £6.25

PCB BOOK

How to design and make your own PCB's.

CDE PRICE £1.95

ALL GOODS SUPPLIED BY CDE ARE FULLY GUARANTEED AGAINST DEFECT — FULL REFUND IF NOT SATISFIED.

PLEASE ADD £.100 PER ORDER FOR POST AND PACKING.

CROYDON DISCOUNT ELECTRONICS (CDE)
40 LOWER ADDISCOMBE ROAD, CROYDON,
SURREY CR0 6AA TEL: 01-688 2950
SHOP HOURS: Mon-Sat 10-5.30 (closed Weds.)

SURPLUS COMPUTER HARDWARE

ITT SCRIBE IN WORD PROCESSING SYSTEM.

Professional system originally selling at around £6000 without printer. Now offered with software included & a variety of different options available. This system is available from us ALL BRAND NEW at the cost of current budget systems, but with office-quality performance & features.

SOFTWARE INCLUDED:

- *DATABASE — allows information storage & retrieval by user-selectable criteria.
- *EDITING — including easy reformatting, global search & replace, save & move, cursor control etc.
- *AUTOMATIC LETTERWRITING — with merge, glossary file for much used phrases etc.
- *MATHS FUNCTIONS — screen maths allows addition of rows, columns & complete tables.
- *PROGRAMMABLE COMMANDS — allows format changes, accessing record block files, prompts etc.
- *HELP FILES — quicker to use than the comprehensive manual supplied.
- *BASIC COMPILER.

HARDWARE INCLUDED:

- *SCREEN/WORKSTATION — dual processor (16 bit TI 9995 & Z80H) with 128K memory, 12" green screen 25 x 80 character display with slow scrolling, QUME printer interface.
- *KEYBOARD — low-profile keyboard additionally has 43 clearly marked dedicated function keys.
- *DISC DRIVES — dual SHUGART 5 1/4" DSDS drives each 430K capacity formatted. **£296.00**

OPTIONS:

- *10mbyte MiniScribe WINCHESTER disc drive (£195).
- *NEC Model 3500 35cps daisy wheel printer (£295).
- *NEC Model 7700 55cps daisy wheel printer (£395).
- *128K additional memory with spelling check software (£40).
- *Communications hardware & software (£95).
- **COLOUR LEAFLET AVAILABLE**

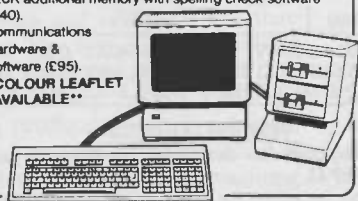

HITACHI Model 3068/SX 3" disc drives.

With SHUGART compatible interface (34 way edge connector) and suitable for BBC with DFS.
AMSTRAD 664/6128, TATUNG EINSTEIN & many others. Will usually replace 5 1/4" drives directly, 250K (double density unformatted) per side reversible; 40 track; standard power connector for 12V & 5V; overall power consumption typically 3.7W. Supplied **BRAND NEW** with connector pin-out details etc. but uncased without PSU. **Data cables** are available for AMSTRAD & BBC (£7.50) and an **installation pack** including data & power cables with instructions is available for the TATUNG EINSTEIN (£12.00)



MATMOS PC. Available without disc drives only. 64KB Z80A based keyboard sized machine with RGB, composite video outputs & UHF modulator. Serial, parallel, cassette & peripheral bus interfaces are provided, together with a ROM port. MICROSOFT BASIC is in ROM. Office quality machine originally sold at £350 by its big-name manufacturer. **BRAND NEW**

*Over 1500 already sold by us **£49.00**

MATMOS TERMINAL (Ver.2). MATMOS PC as above but with additional plug-in terminal emulation ROM. Features include *SET UP MENU *RS232 with handshake* all BAUD RATES to 9600* access to MICROSOFT BASIC which is still available to the user. **Cursor addressing and character attributes** are VT-52 compatible. (ROM is available separately at £20). **£69.00**

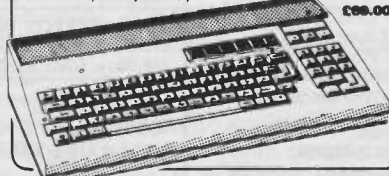

TOSHIBA Model T300 system (semi-compatible with IBM PC). With 6mHz 8088 processor, 256KB RAM, single half-height 5 1/4" floppy disc drive (640KB), high resolution green display, serial & parallel interfaces. Included are **MS-DOS Ver 2, MICROSOFT T-BASIC**, good manuals & comprehensive diagnostic disc. Available options include a colour monitor and memory extension. **BRAND NEW**

AS ABOVE but with dual floppy disc drives. **£380.00**

TOSHIBA Model Y100 CP/M system. With 64KB RAM, dual 500K 5 1/4" floppy disc drives, serial & parallel interfaces & **MICROSOFT BASIC** in ROM. **BRAND NEW**, **£198.00**

DEC PDP 11/73 system. With 500KB RAM, twin **AMPEX 20MB WINCHESTER** disc drives, single **TANDON 8"** floppy disc drive (DILOG controllers), DLV-11 serial interface & DZV-11 4 line asynch. multiplexor. All DEC system, except for disc drives/controllers, in DEC cabinet. **£4600.00**

DEC PDP 11/23 system. With 256KB RAM, single **FUJITSU 20MB WINCHESTER** disc drive, single **TANDON 8"** floppy disc drive, DLV-11J, & **XENIX** operating system with all original manuals. **£1800.00**

CANON Model A-1300 twin 5 1/4" disc drives. Cased **BRAND NEW** half height drives. DSDS, 80 track, 640 KB per drive, SHUGART compatible interface. Without PSU, per pair **£39.00**

FUJITSU 5 1/4" WINCHESTER disc drives. 5MB capacity with ST506 interface. **BRAND NEW** **£75.00**

Please note:
*VAT & CARRIAGE must be added to all items. Carriage is £3.00 + VAT for 3" disc drives, and £10.00 + VAT for most other items.
*SAE please, for further details of any item and complete stock list with details of many other items including test equipment, terminals, plotters etc. etc.

MATMOS Ltd., 1 Church Street, Cuckfield, W. Sussex RH17 5JZ. (0444) 414484/454377
COMPUTER APPRECIATION, 111 Northgate, Canterbury, Kent CT1 1BH. (0227) 470512. TELEX 966134 COMPAP

matmos & COMPUTER APPRECIATION

DIGITAL METERS

BTC5010EC... 10Mohm impedance DCV.0.2-1KV ACV.0.2-750v DC/AC amps 200uA-10 Amps Ohms.200R-20M Buzzer Test Transistor test (hfe and hoe) Temperature Range (-20C to 1370C) Capacitance Range (2000pF-20uF) All for only £60.00

BTC 105... 10Mohm impedance DCV.2V-1000v mA 2mA-2A ACV.200v-750v Ohms.2K-2M With leads/batt Ex. Value... £24.00

DM6013 Capacitance Meter 0-200-pF... 0-2000uF With leads etc Our price... £58.00

ABS PLASTIC BOXES

T3 71x46x22mm... 70p
MB1 75x56x35mm... 90p
MB2 95x71x35mm... 110p
MB3 115x95x37mm... 125p
MB350 145x95x55mm 176p
MB4 207x122x77mm 350p
MB6 213x142x57mm 300p

OTHER BOXES

VEROBOX... 4"x2"x1 1/2" £1.50
RS INSTR.CASE... 4 1/4"x2 1/4"x2" £1.15
DIE CAST BOX 5"x2"x1" £1.40
Many other boxes in stock

CONNECTORS

BNC Quikfit plug 75R... £1.00 Most types of BNC Flange skt 75R... £0.35 RF connectors BNC F-F coupler 50R... £1.00 are in stock.

D-range Multiway

D25 Male... £1.25
D25 Female... £1.60
D25 Shells... £0.90

BNC-BNC 75R Video Leads, 2 metre... £2.50
BNC-PL259 75R Video Leads, 2 metre... £2.50
PL259-PL259 Video Leads, 75R, 2m... £2.50
SCART-7 Pin DIN Lead, 2 metre... £2.50

XLR connectors

Line Male... £1.50
Line Female... £1.70
Chass Male... £1.30
Chass Fem... £1.90

LEMO Subminiature Professional connectors.

Swiss manufacture. Gold plated. 3 and 4 pin versions. Plugs... £4.00 Sockets... £3.00

professional DINs

5 Pin 180 deg Plug 50p
5 Pin 180 deg skt. 50p
2 Pin plug... 50p
3 Pin Latching pl. 90p
5 Pin 180 Latch. pl 90p
3 Pin Latching skt 55p
5 Pin 180 Latch. skt 60p
5 Pin 240 ringlok pl70p
4 Pin ringlok plug 70p

EDGE CONNECTORS IEC Leads

20 way.0.1.DS... £1.90 Unscreened
35 way.0.1.DS... £2.50 3 core lead, 1.5m
60 way.0.1.DS... £4.00 £0.80
78 way.0.1.SS... £3.50 Screened 3 core lead,
16 way.0.15.DS... £1.40 2.5 metres
36 way.0.156.DS... £2.50 £1.00

IDC Headers (Berg, T&B, 3M) Ribbon Cable (prices per foot)

Type Skt Plg R/A 10 way grey... 15 p 20 way r/bow... 40 p
20 way 85p 80p 80p 16 way grey... 20 p 34 way grey... 50 p
26 way 105p 95p 100p 20 way grey... 30 p 34 way r/bow... 70 p
34 way 125p 105p 120p Other varieties available xstock

INDUSTRIAL TIMERS

A range of brand new & boxed high reliability electromechanical timers manufactured by IZUMI DENKI. 240 volt operation and 5 amp contact sets are standard on all models.

RTMSP2N - octal base, 2 contact sets, start on power-up, power off reset. Types: 0-6 sec, 0-210 sec, 0-28 hr.
RTMUM2N - 72mm square panel mount. Screw terminals. Specs as above. Types: 0-35 sec, 0-70s, 0-210s, 0-7m, 0-35m, 0-210m
RTMYH2N - 72mm x 48mm panel mount. Screw terminals. Specs as above. Types: 0-210s, 0-35m, 0-210m.
RTMSP3B - octal base, 2 contact sets, separate clutch & motor connections. Power off reset. Types: 0-12s, 0-35s, 0-210s, 0-28h.
RTMSPIC - octal base, 2 contact sets, active reset capability. Types: 0-70s, 0-12m, 0-210s, 0-28h.
RTASP2N - similar to RTMSP2N but using pneumatic precision solenoid mechanism. Types: 0-5 sec.

All models have power on and time out indicators. Data sheets are available giving applications of these highly adaptable and cost effective units. List price - £35.00 +, our price... £10.00 ea

TRANSFORMERS

20-0-20v. 1.2VA... £1.90 20volt. 6VA... £0.90
12-0-12v. 12VA... £2.25 9volt. 50VA... £5.00
12-0-12v.2.8VA Mini PCB mounting. Encapsulated... £1.50
17-0-17v.15VA ILP toroidal. Epoxy potted type... £7.50
12-0-12v.120VA... £6.00 0-15-0-15v.100VA... £9.00
Heavy Duty Amplifier Grade Transformers.
35-0-35v.150VA... £10.00 35-0-35v.300VA... £15.00

CAPACITORS

Computer Grade Commercial Grade
470/250 Mullard... 50p 4700/16 Axial Mullard... 25p
100/350 tne... 50p 4700/63 Can Pricond... 110p
22000/63 Gould 85C... £4.00 10000/16 Rad. Nichicon... 30p

WE BUY SURPLUS STOCKS OFF ALL COMPONENTS FOR CASH

Fuselodge Ltd.



267 ACTON LANE,
CHISWICK, LONDON W4 5DD
Telephone: 01-994 6275

Terms of business
Cheque/PO with order. Mail order. phone for details of p&p charges for your order. Callers Welcome. Shop Hours 9.00am to 5.30pm 6 days a week.

PLEASE ADD 15% VAT TO ALL PRICES

SEMICONDUCTOR OFFERS

Motorola K1135A Baud Rate Generators.

1/6 pin DIL metal can package. Capable of supplying 16 different synchronous or a/sync stable reference frequencies for serial interface devices (modems, UARTS, keyboards etc). Baud rates of 50 to 19,200 can be generated from this versatile device. AVAILABLE AT A FRACTION OF LIST PRICE... £2.00 ea

Hewlett Packard HP5082-7730 Displays

0.3" Comm. Anode. Dual DP. Red... 10p

OTHER SPECIAL OFFERS

PAPST FANS

220/230V AC, 50/60Hz, 120 mm. Brand new & boxed... £7.00 each + VAT

UM1286 Modulators

High quality UHF modulators for interface of computers to TV sets. UM1286 is suitable for color or monochrome and incorporates a sound intercarrier facility Pretuned to Channel 36 and operates on 5V dc.OUR PRICE £4.00 ea

IBM Floppies

40 Trk. DS DD, in boxes of 10... £13.00/box

STC Attenuators

STC 74618GPA Precision Attenuators. 1 MHz bandwidth. Range 0-100dB in 0.1dB steps... £20.00

ELMA Instrument Cases

Supplied in kit form, these easy to assemble units are ideally suited for both the hobbyist or OEM user. Cases are finished in an attractive Pacific Blue, and are designed for either modular components or Eurocards. Size 12 1/2" x 5 1/2" x 9 1/2". Limited stocks available at only... £10.00

SLIDE POTENTIOMETERS

Metal body construction. By Alps and Tsubame
10K Lin. 60mm travel. 80mm f/c Mono... 60p
10K Lin. 45mm travel. 65mm f/c Mono. Centre notch... 60p
100K Lin. 45mm travel. 65mm f/c. Stereo. Centre notch... £1.00
Coloured tops for above sliders. Black, Green, Yell, White, Red... 10p each

KEYBOARD

Tatung VT4100 Professional Keyboard. Enclosed in white plastic case with feet and flexible connecting lead. Serial data output via standard 6way USA phone plug. Separate numeric keypad and 12 function keys. Supplied with full data sheet... Only £10.00

SWITCHMODE PSUS multi-rail type.

TOP QUALITY

Brand new triple output switchers + 5V at 6.0 Amps + 12V at 4.75 Amps - 12V at 0.5 Amps

Semi-enclosed construction with switched IEC mains input. Output on 0.156 Molex connector. Suitable for multi-disk users Supplied with data

Offer price £20.00

POWER SUPPLIES

Top quality second user units available ex-stock. All supplies tested to spec prior to sale.

SWITCHED MODE

GOULD MG 5-20...5 volt 20 amp... £20.00
GOULD MG 5-40...5 volt 40 amp... £35.00
GOULD MG 5-60...5 volt 60 amp... £45.00
MICROVHEC MVE 100F.. 5Ve8A, + 12Ve, -12Ve2A, + 12Ve1A... £25.00

SWITCHED MODE HIGH CURRENT

Advance 5volt 80 amp... £42.00
Farnell F2348, 5volt 100amp... £48.00
Powertech GNS-120-05A 5volt 120amp... £50.00

LINEAR

COUTANT GPES00/12 12 volt (nom) 5 amp. Very smooth... £25.00
ITT PM15005... 5volt 1.5 amp... £10.00
RS 5volt 1 amp encap... £10.00
MULLARD Unilex psu's... to clear... £25.00

MOTORS

PORTESCAP 01.28

Swiss engineered high precision DC motors 3-24V, with 3.056:1 reduction gearbox and tachogenerator. 3mm shaft... £10.00

STEPPERS

SANYO 103-606-2 2 Phase 4 pole 6Vdc. 3A. 1/4" shaft. Each... £10.00
SHINKOH 20PMA055 1 phase 3 pole 28V dc. 1.3A 1/4" shaft... £10.00

RELAYS

Continental Cradle Relays
2PCO-6,12,24 volt coils... £1.50
4PCO-6,12,24 volt coils... £2.00
Marvid.B15E 24ov,3PCO,5A,11-Pin... £3.00
AMF KUPI4D55 12volt,3PCO,10A... £3.00
PED 59srs 240v,4PCO,5A... £3.50
Izumi RH1V2 6V.SPCCO.10A.pcb... £1.50
Izumi RC1V3 12V.SPCCO.3A.pcb... £1.00
Izumi RD2V2 12V.2PCO.1A.pcb... £1.20
DIL Reed relays in stock.5v,12v,24v Form A,B,C,2A etc. Prices on request. Glass Beeds, 2",1 1/2",& 1" 50 p
Large quantities or relays in stock from DIL reeds to high current multi pole types and SSRs.

N.E.C. DIRECT BROADCAST SYSTEM LOCAL OSC MODULE TYPE MCS808 10GHz (ECS EUROPE) BRAND NEW, LIST PRICE £43, OUR PRICE £15.00 + VAT, & P&P £1.00 SUPPLIED WITH FULL DATA & SPEC SHEETS

VERY SPECIAL OFFER

68000 SERIES C.P.U. 8 Meg clock. Au - ceramic mul. spec 64 pin DIL package. Brand new boxed at £10 + VAT, P&P £1.

Please note: This advertisement represents a fraction of our current stockholding. It would be impossible to list our vast range of electronic components and equipment. As a headline component distributor we have a comprehensive stock of semiconductors (diodes, transistors, logic, memory, LSI parts and linears), caps, resistors, pots, switches (toggle, rocker, slide, rotary etc), opco components, ferrites, plugs... sockets... hoses... cable... lamps...

PRICES SUBJECT TO CHANGE WITHOUT NOTICE



REPORT BY
TOM IVALL

INDUSTRY NOTEBOOK

People's lives and industrial production

Cutting manpower is essential to maintain the cost efficiency of the electronics industries – or is it just an excuse for not taking a hard look at our technical efficiency?

As I write this, 550 people in Thorn EMI Electronics Ltd, mainly at Hayes and Feltham, are preparing themselves to be made redundant. A company spokesman recently said: "We are having to make people redundant to remain competitive in business."

This, then, is a further way in which the electronics industry affects our lives – through the livelihoods of those who work in it. I am not singling out Thorn EMI Electronics for special attention: redundancies are common enough these days. Nor am I forgetting that while existing jobs are being abolished in one firm, new jobs are being created in another. The real point is that this industry, like others, has the power to give and take away livelihoods. And, furthermore, it is starting to take its own medicine. Having developed techniques and systems to improve manufacturing efficiency or services in other industries, the electronics industry is now – somewhat belatedly in the UK – learning to apply them to itself.

As the Thorn EMI man said, the overall necessity for a company is to remain competitive. If you fail to do this, other firms, either in the UK or abroad, will eat into your market share – and this applies to both domestic and export markets. To remain competitive, and so survive in business, you have to offer goods or services on the market which are attractive or at least acceptable to that market, at prices which are no higher than those of your competitors and if possible below them. This means that the goods or services must be produced at the lowest possible cost consistent with the level of quality expected by the market.

One way of doing this is to cut production costs by reducing the input of labour required. Then for a given output in sales to the market the money input in wages and salaries is less than it was before. This is the principle behind what the government and others are currently describing as the country's increase in productivity. It is achieved either by the straightforward method of looking for situations of over-manning and correcting these by enforced redundancies, or by the more complicated strategy of re-equipping the

factory with new machines or systems that inherently require less labour than before. Obviously both methods can be used together.

In general, productivity is a measure of production efficiency – of a country, an industry, a factory, a process, a system or a machine. Being a measure of efficiency, it is expressed as an input/output ratio. For countries and industries the input is usually reckoned in units of labour and the output in units of product value, or money. For a particular manufacturing activity the product value should strictly be the added value imparted by the production process. This excludes the value of any materials or components used in the process which have already been manufactured elsewhere.

Thus in Britain overall productivity figures are commonly given in the form of pounds sterling per man/woman-hour. With factories or plants the output is more likely to be expressed in units of product quantity, giving a more meaningful productivity value such as so many electronic subassemblies per man/woman-shift.

But labour isn't everything. Productivity can also be measured in terms of capital-input/product-output – showing the efficiency of utilisation of capital investment – or in terms of materials-input/product-output – indicating the efficiency of materials utilisation. Nonetheless labour productivity is the most commonly used measure. First of all labour is needed in all industries. Secondly, it can be easily measured as an input. And thirdly, because the worker is also a consumer, labour productivity may be significant as an indicator of consumption and material standards of living.

Modern automation based on electronics is one of the technological advances that can be used to raise the productivity of a factory, a process or a machine. It increases the proportion of output relative to input. This may mean raising the output, if the demand is there, for a given available input. Alternatively, it may mean decreasing the input when a particular level of output must be maintained – say when the market can't be expanded. In

countries where labour is relatively costly, automation tends to be equated with the reduction of man/woman-hours required for input. But in countries where labour is cheap, greater weight is given to the efficient utilisation of the other two main factors of production – capital investment and raw materials.

So automation can increase the proportion of output to input in several ways. With respect to capital, it can give better utilisation of the available capacity of the plant and machinery. Then it can reduce the requirement for materials and cut down wastage in processing. Finally, with respect to labour, automation can give a straightforward reduction in the number of workers required – or perhaps the proportion of skilled, highly-paid workers needed.

In electronics manufacturing there are three main areas where new methods are beginning to be used to improve productivity. The first is the control of last-minute engineering changes made to subassemblies long after the development phase has finished. One well-known electronics company records an average of one such engineering change on each printed-circuit board every six weeks. These changes are bad because they raise costs by increasing lead times, making more work-in-progress and producing a larger inventory. The second problem being tackled is the reduction of unit costs. The third is cutting down the lead times.

Improved manufacturing techniques introduced by the electronics industry have included automatic component insertion machines, construction using surface mounted devices and, more comprehensively, computer integrated manufacturing. The strange thing is that the investment in such new equipment and techniques is usually justified by pointing to savings in the cost of labour input. Yet in the UK electronics industry the cost of direct labour probably averages only 5% or less of unit cost. It might be better all round for the country if the manufacturers worried less about getting rid of workers and concerned themselves more – like the Japanese – with improving the organisation and efficiency of their production. **PE**

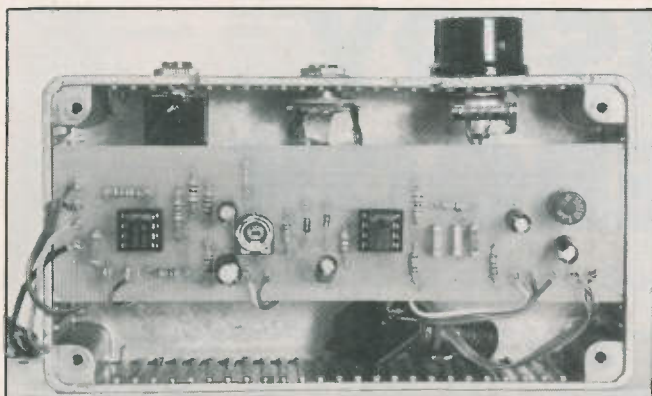

NICE AND EASY DOES IT

BUILDING the projects published in PE is a lot easier than some of you perhaps might think. Especially when you use one of our professionally made printed circuit boards.

It's almost like painting by numbers. All the PCBs are fully drilled, and basically all you need to do is slot in the components and carefully solder them to the PCB track pads. Their places are shown in the drawings published with the project.

IDENTITIES

Component identities are usually clearly marked on them. Even if they are colour coded, like some resistors and capacitors, their values are easily worked out from component colour code charts. From time to time we publish these charts, but if you don't already have one, send a 9in x 4in stamped and self-addressed envelope to the Editorial office asking for one.

TOOLS

For many projects you only need a few simple tools – Soldering iron between 15W and 25W, with a bevelled tip. Damp sponge for keeping the tip clean. Good multicore solder of 18swg or 22swg grade. Fine nose pliers for wire shaping. Adjustable spanner or heavy pliers for tightening nuts. Miniature screwdriver for adjusting preset controls. Small wire cutters for trimming component leads. Drill and selection of bits for drilling holes in boxes. Strong magnifying glass for checking joins in close up. It's also preferable to have a multimeter for setting and checking voltages. There are some very good low cost ones available through many of our advertisers, but get one that is rated at a minimum of 20,000 ohms per volt. Many projects do not require you to have a meter, but if you are serious about electronics, you really should have one.

ASSEMBLING THE PCB

Authors will sometimes offer their own advice on the order of assembly, but as a general guide, it is usually easier to assemble parts in order of size. Start though with the integrated circuit sockets. Please use them where possible, they make life much easier than if you solder the ICs themselves – with sockets you can just lift out an IC if you want.

Then insert and solder in order of resistors, diodes, presets, small capacitors, other capacitors, and finally transistors. Clip off the excess component leads after you have soldered them. Now use a magnifying glass, ideally one that you can hold to your eye, and take a good look at the joins, checking that they are satisfactorily soldered, and that no solder has spread between the PCB tracks and other joins. Be really thorough with visual checking since errors like this are the most likely reason for a circuit not working first time.

SOLDERING

Bring the tip of the iron into contact with the component lead and the PCB solder pad, then bring the end of the solder into contact with all three. Feeding it in as it melts. Once sufficient solder has melted to fully surround the pad and the lead, remove the solder, and then the iron. Now allow the joint to cool before touching it, otherwise the solder may set unsatisfactorily. If it does move, just reheat the joint once more.

WIRING

Connecting the PCB to the various panel controls is the final assembly stage. Do this just as methodically, following the published wiring diagram. You can connect the wires to the PCB in one of three ways. The best is to insert terminal pins into the connecting holes on the PCB, and then solder wires direct to them. Or, pass the end of the wire through the PCB hole, soldering it on the other side. Alternatively, the wire can be carefully soldered direct to the PCB tracking. In all cases first strip the plastic covering off the wire, twist the strands together, and apply solder to them to keep them secure.

TESTING

Now you are ready to test and use the project as described by the author. Components can occasionally fail, but these days it is extremely uncommon, and if you have followed the instructions, been careful with your joins, and bought the parts from a good supplier, you will have the enormous satisfaction of having built an interesting and working unit. It really can be easy if you do it with care.

THE SOCIETY OF ELECTROSCIENCE



An association which is widely recognised and respected, which endorses the status of its members, protects and promotes their interests, assists their careers and encourages their ethical standards is the foundation of every profession.

The Society of Electroscience is the specialist association for men and women who are professionally engaged in research, development, design, manufacture, commissioning, control and test of electrical, electronic and micro-electronic projects and equipment.

Efficiently run in conjunction with the Institution of Analysts & Programmers, the Society of Electroscience has a lower rate of subscription than any comparable professional body in Europe or North America. Additionally, no charge is to be made for the examination of a request for election where the Council concludes that a candidate has not reached the required standards of theory and practice.

Known and respected throughout the English speaking areas of the Free World, the two non-profit making organisations have members - December 1986 - in sixty-one independent states and countries. Applications from other scientists, engineers and technicians who are making or intend to be making, careers which significantly incorporate a branch of electroscience will be welcomed for consideration by the Council.

A guide to the gradings and requirements of membership and an application form is available free of charge upon request to the Applications Officer either by letter or, in normal office hours, by telephone.

01-894 4411

THE SOCIETY OF ELECTROSCIENCE
GIBSON HOUSE, FOURTH CROSS ROAD, TWICKENHAM
MIDDLESEX, TW2 5EL, ENGLAND

P.C. BOARDS

Printed circuit boards for certain PE constructional projects are available from the PE PCB Service, see list. They are fully drilled and roller tinned. All prices include VAT and postage and packing. Add £2 per board for overseas airmail. Remittances should be sent to: **PE PCB Service, Practical Electronics, 16 Garway Road, London W2 4NH.** Cheques should be crossed and made payable to **Intrapress.**

Please note that when ordering it is important to give project title, order code and the quantity. Please print name and address in Block Capitals. Do not send any other correspondence with your order.

Readers are advised to check with prices appearing in the current issue before ordering.

NOTE: Please allow 28 days for delivery. We can only supply boards listed here. You may send a photocopy of the Order Form.

TELEPHONE ORDERS (OPEN 24 HOURS)

You can now order your printed circuit boards by telephone, quoting your Access credit number. The number to ring is: 0268 289923. In stock items will be despatched within 24 hours of receipt of order. If you ring out of office hours please state your order, credit card number and address clearly, as the order is recorded on an answering machine.

Power Control Interface		503-01	£5.31
Disc Drive PSU		504-02	£7.79
Modular Audio Power System	APRIL '85		
Pt-3: Test Signal Source		504-09	£4.73
Power Supply		504-10	£4.70
Amstrad Synthesizer Interface		505-01	£4.77
Rugby Clock Pt-2		504-03	£30.84
"	MAY '85	504-05	£5.93
"		504-06	£11.70
"		504-07	£6.30
"		504-08	£12.60
CBM64 Music Keyboard			
Keyboard	JUNE '85	506-02	£5.19
Main PCB		506-03	£3.90
MTX 8 Channel A to D		507-01	£4.37
Voltmeter Memory Adapter	JULY '85	506-01	£3.90
Envelope Shaper	AUG '85	508-01	£4.11
Car Boot Alarm		509-01	£3.90
RS232To Centronics Converter	SEPT '85	509-03	£5.70
Touch Control PSU		001	£4.90
Exp. with Robots (double-sided)	OCT '85	004	£21.30
Modulated Syndrum		005	£4.90
CBM User Port Expander		006	£4.38
Model Railway/Track Control		010	£6.35
*Bytebox: ROM Board (double-sided)		002	£15.89
ZIFSocket		003	£3.90
RAM Board	NOV '85	007	£5.70
Battery Backed RAM		008	£4.13
EPR0M Board		009	£3.90
*Special Price - Complete set of 5 boards		00A	£29.25
	DEC '85		
Model Railway Rec Board - A		016	£4.33
Track Control Rec Board - B		017	£5.60
		018	£4.38
Test Load		019	£3.03
Exp. with Robots		022	£4.10
Spectrum Speech Synth & 8-Bit I/O Port (double sided)	JAN '86	023	£7.74

Dear PE, Please supply the following PCBs:

Board description	Code	Qty	Price
Name & Address:			

Burglar Alarm			
Main Board		020	£5.73
Bell Driver	FEB '86	021	£3.90
Logic Probe		024	£4.73
Computer Movement Detector		509-02	£3.90
Clock Timer		027	£7.58
Fibre Optic Audio Link			
Transmitter	MAR '86	025	£3.90
Receiver		026	£3.90
Set of two boards		00B	£6.90
Hardware Restart (double-sided)		508-02	£8.35
Temperature/Analogue Interface		101	£3.90
Sound Activated Switch		102	£6.17
Photographic Trigger Unit (set of 2)	APRIL '86	00C	£7.89
IEEE1000 PSU		105	£5.28
Scratch and Rumble Filter		106	£5.13
Notcher Effects Unit		107	£5.99
Logic Checker	MAY '86	108	£4.59
D. F. BeaconTimer		109	£6.18
STEBus backplane		110	£14.97
GuitarTracker		111	£6.98
Thermocouple Interface	JUNE '86	112	£3.90
PE Hobby Board		113	£29.00
BBC Light-pen		114	£3.90
Passive IR Detector		115	£3.90
200MHz counter			
Main board	JULY '86	116	£19.14
Display board		117	£14.35
Set of two boards		00D	£30.88
Fibre Optic Data Link			
Set of two boards	SEPT '86	00E	£10.14
PEHBD/A-A/D		120	£7.25
Drum Synthesizer		121	£7.67
Time Delay - Mains (Set of 2)	OCT '86	122	£7.92
Mains Dimmer		123	£3.90
Remote Joystick - Set of two boards	NOV '86	124	£10.86
Baby Alarm - Set of two boards		125	£10.71
Video Enhancer	DEC '86	126	£8.76
Video Fader	JAN '87	127	£4.50
Scrambler		128	£8.06
PE Promenader (double side) main board		129	£30.68
" Power supply		130	£9.53
PE Promenader Playback Unit		133	£14.52
PE Promenader Extension Prom	FEB '87	131	£9.05
PE Hi-Stab		132	£8.79
PE 30 Plus 30		134	£29.50
4 Channel Enhancer		135	£4.60
Light Pen	MAR '87	136	£4.10
Bell Repeater		137	£3.90
Ultrasonic Measure		138	£9.50
PEVigilante		139	£5.90
SMPSU Stepper		140	£3.90
" Booster	APR '87	141	£3.90
" Inverter		142	£3.90
Inductive Loop Transmitter		143	£3.90
" " Receiver		144	£3.90
Bright Fuzz	MAY '87	145	£3.90
Synthesising AFGenerator	JUN '87	146	£10.20

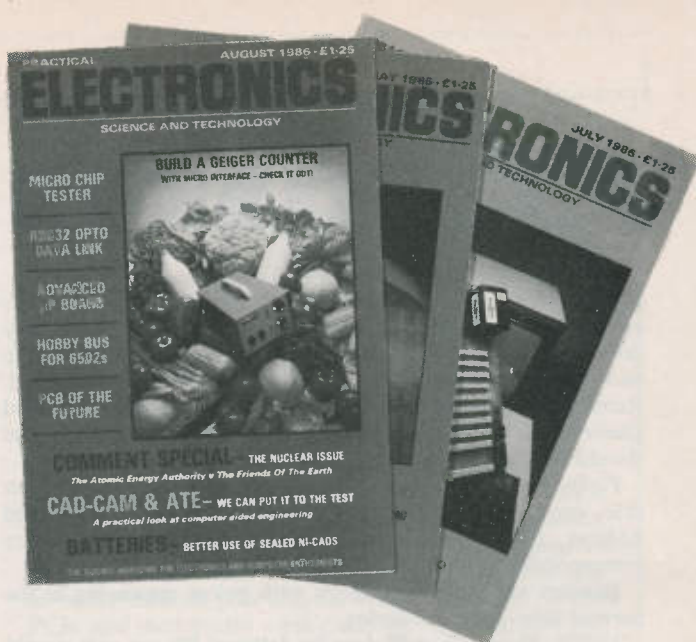

BACK ISSUES

Back issues are available from our editorial office at only £1.50 inc. p&p. should a back issue be out of stock we may be able to photocopy selected articles up to three years old at £1.00 each inc. p&p.

REMEMBER SUBSCRIBING TO PE AVOIDS FUTURE DISAPPOINTMENT.

PE BAZAAR

A free readers' advertising service

Please publish the following small ad. FREE in the next available issue. I am not a dealer in electronics or associated equipment. I have read the rules.

Signature Date

Please read the RULES then write your advertisement here - one word to each box. Add your name, address and/or phone no.

COUPON VALID FOR POSTING WITHIN ONE MONTH OF COVER DATE, (One month later for overseas readers.)

SEND TO: PRACTICAL ELECTRONICS,
16 GARWAY ROAD, LONDON,
W2 4NH.

YOU MAY SEND A PHOTOCOPY OF THIS FORM

RULES Maximum of 16 words plus address and/or phone no. Private advertisers only (trade or business ads. can be placed in our classified columns). Items related to electronics only. No computer software. PE cannot accept responsibility for the accuracy of ads. or for any transaction arising between readers as a result of a free ad. We reserve the right to refuse advertisements. Each ad. must be posted within one month of cover date. Ads will not appear (or be returned) if these rules are broken.

Name & Address:			

Wanted: 6502 M/C Progs. Also Oric Atmos Rom listing utility progs and Disc Drive, P/Plot etc. M.J. Last, 7 Peacock Rise, Ixworth, Bury St. Edmunds, Suffolk, IP31 2JA (0359 30858)

Wanted: Circuit diagrams for Lynx-128K and Hitachi MD0921 monitor. Lynx printer. Lynx Centronics interface. Will pay. Mr. J. Skrbec, Podcerkev 30, 61386 Stari trg/Loz, Yugoslavia.

Sale: Z80A CPU, Z80A CTC, TMS9929, 4116, 8 off, 2708 Eprom, new £19.00 lot. 061-865 5809. W. Ireland, 113 Bradfield Road, Urmston, Manchester, M31 1PF.

Rogers stereo Amps plus matching Sony FM/AM tuner, both valve units, first class condition £10 each. 01-661 1728, Fas Acker, 17 Crystal Palace Road, SE22

Wanted: Information on remote control I.C. LE1903 SAA3006P, will pay. Aidan Mitchell, 78 Castlemore Avenue, Belfast, BT6 9RG.

Following Norman Publications. Paid colour receiver: Q&A. CTV with particular reference to PAL. CTV picture faults. 12 Charterhouse Drive, Aintree, Liverpool, L10 8JZ.

Spectrum +, discs, printer, interface, mother board, cables, documentation, would split. May be viewed working. Offers? R.T. Lovelock, 14 Knightley Road, Exeter, Tel (0392) 75896.

Wanted: Circuit for Safgan scope model DT410. Please tel. Troon (0292) 314190. Sandy Hewat, 30 Fullarton Drive, Troon, Ayrshire, Scotland.

Collectors: Almost complete runs ETI 77-79, PE 78-84, plus a few. Want Elektor 59, WW 1583 & 1596. K. Wood, 46 Farmwood Close, Newport, Gwent. Tel 277037.

Retirement clearance: Giant 10kg parcel electronics (over 5,000 components - many new), Electrical, TV. £19 post free. K. Bailey, 40 Seymour Close, Selly Park, Birmingham, B29 7JD.

Wanted: ZX-81 FORTH ROM with manual. Pekka Lampila, Hintsank 5F50, 33560 Tampere, Finland.

Wanted: Constructional data and circuit diagrams for Antenna noise bridge and Antenna tuner (photo copies). M.O.A. Chari, Ladersattaravagen 97, 175 70 Jarfalla, Sweden.

Components: new assorted worth £10. £2.50 per bag inclusive post packing. Mr. D.J. Brown, 2 Glentworth Avenue, Whitmore Park, Coventry, West Midlands, CV6 2HW. Kersley 3195.

BBC 'B' Computer, 1.20.5 boxed, speech synth, advanced guide, tapesm 70+ magazines, dust cover, £200 o.n.o. P. Cassidy, 51 Limekiln Row, Castlefields, Runcorn, Cheshire WA7 2LT. Tel: 09285 66611 (office hours).

Radio Shack 12" Mono Monitor £40, Naspen Word Processor in 2 ROMS £15. A. Harris, 36 Banks Road, Biggleswade, Beds SG18 0DY.

Crofton C.C.T.V. Camera £80. Texas speech Synth £33. UK101 Sound Generator with two I/O ports £12. R.W. Hearn, 10 Speedwell Close, Pakefield, Lowestoft, Suffolk NR33 7DU. Tel: 0502 66026.

Seiksha GP-100A. 80-column and graphics dot-matrix printer. £65 o.n.o. A. Lee. Tel: 01-866 4579.

PE Mags 1969 to 1987. 5 missing. Offers to B.S. Hewson, 35 Knox Road, London E7. Tel: 01-555 3796.

FULL-TIME TRAINING COURSES

2 YEAR

**B-TEC National Diploma (OND)
ELECTRONICS &
COMMUNICATIONS ENGINEERING**
(Television & Computing)

15 MONTHS

**B-TEC National Certificate (ONC)
ELECTRONIC EQUIPMENT SERVICING**
(Television & Video)

15 MONTHS

**B-TEC National Certificate (ONC)
COMPUTING TECHNOLOGY**

9 MONTHS

**B-TEC Higher National Certificate (HNC)
COMPUTING TECHNOLOGY
& ROBOTICS**

HIGH PERCENTAGE OF COLLEGE BASED
PRACTICAL WORK

SHORT COURSES WITH PREVIOUS
KNOWLEDGE

NO EXTRA CHARGES FOR OVERSEAS
STUDENTS

COURSE COMMENCES
21st SEPTEMBER 1987

**LONDON ELECTRONICS
COLLEGE**

Dept: AA, 20 Penywern Road,
London SW5 9SU. Tel: 01-373 8721

SURPLUS/REDUNDANT ELECTRONIC COMPONENTS WANTED

I/Cs - Tuners - Transistors - Valves - Diodes
etc. any quantity considered - immediate
payment.

ADM ELECTRONIC SUPPLIES
Tel: 0827 873311

Free Membership to a new national electronics club. For details and a free pack of components worth over £10 send only £1 p&p to Dept PE Woodside, Dowsett Lane, Ramsden Heath, Billericay, Essex CM11.

d.c.electronics

THE Source For All Your Component Requirements.

ALL components are professional grade, brand new with manufacturers marking and guarantee.

SPECIAL BARGAINS - ONLY £1 EACH

- 200 0.25W resistors, mixed values (max 5 your choice)
- 50 0.4W resistors, mixed values (max 5 your choice)
- 40 1N4148 computer diodes
- 30 1N4001 1A power diodes
- 15 BC182L NPN transistors
- 15 BC212L PNP transistors
- 30 Ceramic plate caps - you specify value
- 10 Electrolytic caps 47-470uF - you specify value

Only our catalogue can tell the full story - send SAE (9x6) for your FREE copy now.

Dept. P, 34 The Platters,
Rainham, Kent, ME8 0DJ.

Mail order only, cash, PO or cheque with order.
50p P&P. Prices incl VAT.

Carbon Film Resistors 1/4W E24 series 0.51R to 10MΩ - 1p
100 off per value - 75p 1000 off in even hundreds per value - £7
Metal Film 1/4W 10R0 to 1MΩ 5% E12 series - 2p 1% E24 series - 3p
8C107/8/9 - 12p 8C547/8/9 - 8p 8C182L 184L - 10p
BFY50/51/52 - 20p 2N3055 - 50p TIP31A, 32A - 25p TIP41, 42 - 40p

Tantalum head subminiature electrolytics (Mids/Volts)
0.1/35, 0.2/25, 0.4/35, 3/316, 4/716 - 14p 4/7/35 - 15p
2/2/35, 4/7/25, 10/5 - 15p 4/7/35, 6/8/16 - 16p 10/16, 22/6 - 20p
22/16 - 30p 33/10 - 30p 47/10 - 35p 100/6 - 40p

Aluminium Electrolytics (Mids/Volts)
1/50, 2/2/50, 4/7/25, 4/7/50, 10/16, 10/25, 10/50 - 5p 22/16, 22/25 - 6p
22/50, 47/16, 47/25, 47/50 - 6p 100/16, 100/25 - 7p 100/50 - 12p
100/100 - 14p 220/16 - 18p 220/25, 220/50 - 10p 470/16, 470/25 - 11p
1000/25 - 18p 1000/35, 220/25 - 22p 4700/25 - 70p

Miniature Polyester Capacitors 250V Wkg. Vertical Mounting
.01, .015, .022, .033, .047, .068 - 4p 0.1 - 5p 0.15, .22 - 6p 0.47 - 8p

Mylar Capacitors 100V Wkg. Vertical Mounting E12 Series
1000p to 8200p - 3p .01 to .068 - 4p 0.1 - 5p 0.15, 0.22 - 6p

Subminiature Ceramic Plate 100V Wkg. E12 Series Vertical Mounting
2% 1P8 to 47P - 3p 56P to 330P - 4p 10% 390P to 4700P - 4p
Ceramic plate/disc E6 Series 50V 22P to .047 - 2p

Polystyrene Capacitors 63V Wkg. E12 Series Axial Mounting
10P to 820P - 3p 1000P to 10,000 - 4p 12,000P - 5p
1N4148 - 2p 1N4002 - 4p 1N5404 - 4p W01 bridge - 25p
0A91 - 6p AA143 - 8p W005 - 20p 1N4006 - 6p
Zener diodes E24 series 3V3 to 33V 400mW - 8p 1 watt - 12p
L.E.D's Red, Green & Yellow 3mm & 5mm - 10p 8mm - 35p
20mm fuse 0.1A to 5A quick blow - 5p Anti Surge - 8p
High Speed drills 0.8mm, 1.0mm, 1.3mm, 1.5mm, 2mm - 30p
Expo Reliant drilling machines 12V d.c. with improved 3-jaw chuck 6.50
Nicas AA - 80p HP11 - £2 PP3 - £4.20 Universal Charges - £6.50
Glass reed switches single pole make contacts - 8p Magnets - 12p
VAT inclusive. Return postage 20p (free over £5). Lists free.

THE C.R. SUPPLY CO.,
127 Chesterfield Road,
Sheffield S8 0RN. Tel. 557771.

TURN YOUR SURPLUS

ICS transistors etc into cash, immediate settlement. WE also welcome the opportunity to quote for complete factory clearance.

Contact **COLES-HARDING & Co,**
103 South Brink, Wisbech, Cambs.
ESTABLISHED 15 YEARS
Tel: 0945 584188



- Velleman Electronic Kits
- Test Equipment & Tools
- Instrument Cases

(Mon-Sat. 9.30-5.30 Closed Thurs)

13A Station Rd, Cullercoats, North Shields,
Tyne & Wear NE30 4PQ. Tel. 091 251 4363

PCB CHEMICALS

Ferric Chloride Etchant (Crystals)
1kg £4.00 5kg £18.00

Photo-sensitive board Developer
1 litre £2.00 5 litre £6.00

Photo-sensitive board Stripper
1 litre £3.00 5 litre £8.00

All prices include VAT & Carriage
Eagle Electronic Systems Ltd,
Boot Street, Earby, Colne, Lancs.
Tel: 0282 842763

MANUFACTURERS OF METAL CASES
Front panels professionally silk screen printed to your own design.

Send details of your requirements for a quotation.

PAYNE ELECTROPRINT LTD
Marcus Road, Dunkswell,
Honiton, Devon EX14 0RA.

DELUXE WALKIE TALKIES 49MHz, long range. £24.99/pair (normally £31.49). Satisfaction or refund. Send £3 now, pay balance upon receipt. 48hrs delivery. Xenon (Dept PE9), 24 Wharnclyffe Street, Barnsley, Yorkshire.

adam hall supplies Ltd.

The largest selection of flight case fittings and loudspeaker cabinet components in Europe.

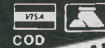

**HARDWARE
SOUND EQUIPMENT**

Stockists & Distributors of



A complete range of professional crossovers & filters.

Unit G, The Cordwainers, Temple Farm Industrial Est., Sutton Rd, Southend-on-Sea, Essex Tel: (0702) 613922

CUSTOMISED FRONT PANELS

Self adhesive labels to your own design in plastic or aluminium. Wide range of colours. DIY kit available.

FOTOBORD

Single Sided & Double Sided in a wide range of sizes. SAE for full price list.

MINIATURE CORDLESS SOLDERING IRON

New product - operates from butane, gas.

ELECTRONIC ALARM SYSTEMS

143 Farnham Road, Handsworth, Birmingham B21 8EF.
Tel. 021-523 6747. Private & professional enquiries welcome

THE SCIENTIFIC WIRE COMPANY
811 Forest Road, London E17. Telephone 01-531 1568

ENAMELLED COPPER WIRE				
SWG	1lb	8 oz	4 oz	2 oz
8 to 34	3.63	2.09	1.10	0.88
35 to 39	3.82	2.31	1.27	0.93
40 to 43	6.00	3.20	2.25	1.61
44 to 47	8.67	5.80	3.49	2.75
48	15.96	9.58	6.38	3.69
SILVER PLATED COPPER WIRE				
14 to 30	10.10	5.20	2.93	1.97
TINNED COPPER WIRE				
14 to 30	3.97	2.41	1.39	0.94
Fluxcore				
Solder	5.90	3.25	1.82	0.94

Post Free. Please add V.A.T. at 15%. Orders under £3.00 add 50p SAE for list of copper and resistance wire. Dealer enquiries welcome.

COPE ELECTRONICS LTD

Oak Street Trading Estate, Oak Street,
Quarry Bank, Brierley Hill West Midlands DY5 2JQ

MANUFACTURERS STOCK CLEARANCE!
THOUSANDS OF BRAND NEW COMPONENTS AT ROCK BOTTOM PRICES!

Op-Amps, Regulators, TTL, CMOS, LED'S, Displays, Transistors, Capacitors, Resistors, Switches, etc.etc...

All brand new and guaranteed.
No minimum order charge.

DON'T MISS THIS GREAT OPPORTUNITY.
SEND SAE FOR DETAILS OR RING
(0384) 74540.

SERVICES

SERVICE SHEETS from £2.50/1sae ctv/mus-c/combis £3.50/1sae. Sae Newnes & TV Technic Books in stock. Thousands Service & Repair Manuals. SAE Free Review/pricelists. TIS (PE), 76 Church St., Larkhall (0698 883334), Lanarkshire.

HEATHKIT U.K. SPARES AND SERVICE CENTRE. Cedar Electronics, Unit 12, Station Drive, Bredon, Tewkesbury, Glos. Tel. (0684) 73127.

MISCELLANEOUS

100 Various 74LS chips for £15. Ex-machine (not soldered). Also Z80 family available. Phone (0734) 64271.

CLEARING LABORATORY, scopes, generators, P.S.U.'s, bridges, analysers, meters, recorders etc. Tel. 0403-76236.

FIRE. Hundreds of deaths are caused by fire each year. Protect yourself and your family with this easy to fit pre-built Fire Alarm kit. We supply Control unit, 4 Sensors and Wire for only £68 inclusive of VAT etc. Extra sensors £6. Cheques/P.O./Cash to: Rainbow Computer and Electronics Products, Dept PE1, 98 Nelson Road, Ipswich IP4 4DU.

Berwick (ELECTRONICS) LTD.

60 Woodgrange Road,
London E7 0QH.
Telephone: 01-519 2438

		PRICE INC. VAT			PRICE INC. VAT
BE1	5 ass. rocker switches push fit	2.00	KRT100	Multi tester 8 ranges	5.75
BE2	5 ass. micro switches	2.00	5TW	5 pcs. min. cutter/pliers set	7.40
BE3	12 ass. slide switches	2.00	5T41	5 pcs. min. s/driver set metal handle	1.17
BE4	25 ass. din/coax chassis skts.	2.00	MC642	6 pcs. min. s/driver set plastic handle	0.77
BE5	16 ass. heat sinks	2.00	AD12	12V min. p.c.b. power drill .8-1.2mm	5.32
BE6	5 ass. volume controls	2.00	S1815	240V 15w solder iron	2.87
BE7	100 ass. electrolytic caps axial	2.00	S1340	240V 25w solder iron	2.81
BE8	100 ass. electrolytic caps radial	2.00	SIS110	Solder iron stand c/w sponge	2.26
BE9	60 ass. feet box/cabinet	2.00	ST503A	Helping hands (soldering assisted)	1.99
BE10	25 ass. control knobs	2.00	KTD80	Pick up tool (small component use)	1.79
BE11	100 ass. resistors	1.00	H28	Small craft knife (snap off blade)	0.40
BMB1	ABS box 77x56x37mm c/w lid*	1.20	H80	Large craft knife (snap off blade)	0.81
BMB2	ABS box 95x71x35mm c/w lid*	1.30	MV311	Mini vice (suction base) metal/plastic	1.00
BMB3	ABS box 115x95x37mm c/w lid*	1.55	MD316	Mini hand drill brass/plastic	1.15
BMB4	ABS box 207x122x77mm c/w lid*	4.05	JC7510	4 pcs. s/steel tweezer set	3.70
BMB5	ABS box 145x95x55mm c/w lid*	2.15	NRAA	Nicad rechargeable battery (AA size)	1.02
BMB6	ABS box 222x152x60mm c/w lid* * Black or white	2.90	C	Nicad rechargeable battery (C size)	1.99
BAB7	Aluminium box 2 3/4"x5 1/4"x1 1/2" C/W lid	1.10	D	Nicad rechargeable battery (D size)	2.10
BAB8	Aluminium box 4"x4"x1 1/2" C/W lid	1.35	PP3B	Nicad rechargeable battery (PP3 size)	5.79
BAB9	Aluminium box 4"x2 3/4"x1 1/2" C/W lid	1.10	398	Nicad univ. charger for above bats.	6.50
BAB10	Aluminium box 4"x5 1/4"x1 1/2" C/W lid	1.45	88LUX	13A power supply 3-12V DC unregulated	2.67
			REG12	13A power supply 6-12V DC regulated	5.32

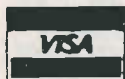

ACCESS/VISA CARD ORDER
£10.00 MINIMUM VALUE



POSTAGE & PACKING
PLEASE ADD
FOR ONE ITEM 0.60p
FOR TWO OR MORE £1.00

PERSONAL CALLERS
WELCOME
SHOP HOURS
MON-SAT 9am-6pm

MAKE YOUR INTERESTS PAY!

More than 8 million students throughout the world have found it worth their while! An ICS home-study course can help you get a better job, make more money and have more fun out of life! ICS has over 30 years experience in home-study courses and is the largest correspondence school in the world. You learn at your own pace, when and where you want under the guidance of expert 'personal' tutors. Find out how we can help YOU. Post or phone today for your FREE information pack on the course of your choice (tick one box only).

Electronics <input type="checkbox"/>	Radio, Audio and TV Servicing <input type="checkbox"/>
Basic Electronic Engineering (City & Guilds) <input type="checkbox"/>	Radio Amateur Licence Exam (City & Guilds) <input type="checkbox"/>
Electrical Engineering <input type="checkbox"/>	Car Mechanics <input type="checkbox"/>
Electrical Contracting/Installation <input type="checkbox"/>	Computer Programming <input type="checkbox"/>
GCE over 40 'O' and 'A' level subjects <input type="checkbox"/>	

ICS

Name _____ P. Code _____
Address _____
International Correspondence Schools, Dept EDS 67, 312/314 High St.,
Sutton, Surrey SM1 1PR. Tel: 01-643 9568 or 041-221 2926 (24 hrs.)

PLEASE MENTION
PRACTICAL
ELECTRONICS
WHEN REPLYING
TO ADVERTISING

INDEX TO ADVERTISERS

A.D.M. Electronic Supplies	61	Hall Supplies, Adam	61
Audiokits	52	Hart Electronic Kits	40
Berwick Electronics	24	I.C.S.	62
BiPak Components	24	J.M.J. Electronics	25
B.K. Electronics	31	London Electronics College	61
Bull, J.	18	Magenta Electronics	IFC
Cirkut	52	Maplin Electronics	OBC
Coles Harding	61	Microkit Ltd	45
Computer Appreciation	55	No One Systems	25
Cricklewood Electronics	51	Omni	45
Crimson Electronics	52	Phonosonics	39
Crofton Electronics	51	Pineapple Software	40
Crotech Instruments	45	Prentice Hall	55
Croydon Disco	51	Riscomp	17
Croydon Discount Electronics	55	Scientific Wire Co.	61
C.R. Supply Co.	61	Sherwood Data Systems	45
D.C. Electronics	61	Society of Electroscience	58
Dispay Electronics	IBC	Stewart of Reading	52
E.S.R. Electrical Components	61	Super Alpha	7
Electronic Alarm Services	61	Technomatic	10,11
Fuselodge	56	T.K. Electronics	25
Grandata	51		

COMPUTER WAREHOUSE

1000's OF BARGAINS FOR CALLERS

THE "ALLADINS' CAVE OF COMPUTER AND ELECTRONIC EQUIPMENT"

HOT LINE DATA BASE

DISTEL

The ORIGINAL FREE OF CHARGE dial up data base. Buy, browse or place YOUR OWN AD for goods or services to sell. 1000's of stock items, spares and one off bargains. Updated daily. ON LINE NOW. CCITT, 8 bit word, no parity. For 300 baud modems call 01-679 1888 For 1200-75 baud modems call 01-679 6183

FREE

Your monitor from its computer!! For only £29.95 it becomes a SUPERB HIGH QUALITY * COLOUR * TV SET

The fabulous TELEBOX, an INVALUABLE MUST for the owner of ANY video monitor with a composite input, colour or monochrome. Made by a major UK Co. as a TOP QUALITY, stand alone UHF tuner and costing OVER £75 to manufacture, this opportunity to give your monitor a DUAL FUNCTION must not be missed! The TELEBOX consists of a compact, stylish two tone charcoal moulded case, containing ALL electronics tuner, power supply etc to simply plug in and convert your previously dedicated computer monitor into a HIGH QUALITY COLOUR TV SET, giving a real benefit to ALL the family! Don't worry if your monitor doesn't have sound - THE TELEBOX even has an integral 4 watt audio amplifier for driving an external speaker. PLUS an auxiliary output for superb quality television sound via your headphones or HI FI system etc. Other features include: Compact dimensions of only 15.75" w x 7.5" d x 3.5" h, latest technology, BRITISH manufacture, fully tuneable 7 channel push button tuner, Auto AGC circuit, SAW filter, LED status indicator, fully isolated 240v AC power supply for total safety, Mains ON-OFF switch etc. Many other uses.

LIMITED QUANTITY - DON'T MISS THIS OFFER!!!

ONLY £29.95 OR £24.95 if purchased with ANY of our video monitors. Supplied BRAND NEW with full instructions and 2 YEAR warranty. Post and packing £3.50 *When used with colour crt.

COLOUR & MONOCHROME MONITOR SPECIALS

*SYSTEM ALPHA 14" COLOUR MULTI INPUT MONITOR. Made by the famous REDIFFUSION Co. for their own professional computer system this monitor has all the features to suit your immediate and future requirements. Two video inputs. RGB and PAL. Composite Video, allow direct connection to BBC/ITM, and most other makes of micro computers or VCR's including our very own TELEBOX. An internal speaker and audio amp may be connected to computer or VCR for superior sound quality. Many other features: PIL tube, Matching BBC case colour, Major controls on front panel. Separate Contrast and Brightness - even in RGB mode. Separate Colour and audio controls for Composite Video input, BNC plug for composite input, 15 way 'D' plug for RGB input, modular construction etc.

This Must Be ONE OF THE YEAR'S BEST BUYS. PC USER Supplied BRAND NEW and BOXED, complete with DATA and 90 day guarantee. ONLY £159.00, as above OR IBM PC Version £185.00 15 Day 'D' sct £1.00, BNC sct 75p BBC interface cable £5.50

DECCA 80 16" COLOUR monitor. RGB input. Little or hardly used manufacturer's surplus enables us to offer this special converted DECCA RGB Colour Video TV Monitor at a super low price of only £99.00, a price for a colour monitor as yet unheard of! Our own interface, safety modification and special 16" high definition PIL tube, coupled with the DECCA 80 series TV chassis give 80 column definition and quality found only on monitors costing 3 TIMES OUR PRICE. The quality for the price has to be seen to be believed! Supplied complete and ready to plug direct to a BBC MICRO computer or any other system with a TTL RGB output. Other features are: internal speaker, modular construction, auto degaussing circuit, attractive TEAK CASE, compact dimensions only 52cm W x 34 H x 24 D, 90 day guarantee. Although used, units are supplied in EXCELLENT condition. ONLY £99.00 + Carriage.

DECCA 80, 18" COLOUR monitor. Composite video input. Same as above model but fitted with Composite Video input and audio amp for COMPUTER, VCR or AUDIO VISUAL use. ONLY £99.00 + Carr.

REDIFFUSION MARK 3, 20" COLOUR monitor. Fitted with standard 75 ohm composite video input and sound amp. This large screen colour display is ideal for SCHOOLS, SHOPDS, DISCO'S, CLUBS and other AUDIO VISUAL applications. Supplied in AS NEW or little used condition ONLY £145.00 + Carr.

BUDGET RANGE EX EQUIPMENT MONOCHROME video monitors. All units are fully cased and set for 240v standard working with composite video inputs. Units are pre tested and set up to 80 column use. Even when MINOR screen burn's exist - normal data displays are unaffected. 30 day guarantee.

12" KGM 320-1 B/W bandwidth input, will display up to 132 x 25 lines. £32.95
12" GREEN SCREEN version of KGM 320-1. Only £39.95
9" KGM 324 GREEN SCREEN fully cased very compact unit. Only £49.00

Carriage and insurance on all monitors £10.00

DC POWER SUPPLY SPECIALS

GOULD OF 443 enclosed, compact switch mode supply with DC regulated outputs of +5v @ 5.5a, +12v @ 0.5a, -12v @ 0.1a and -23v @ 0.02a. Dim 18 x 11 x 6 cm. 110 or 240v input. BRAND NEW only £16.95
GOULD G6-40A 5v 40 amp switch mode supply NEW £130.00
AC-DC Linear PSU for DISK drive and SYSTEM applications. Constructed on a rugged ALLOY chassis to continuously supply fully regulated DC outputs of +5v @ 3 amps, -5v @ 0.6 amps and +24v @ 1.5 amps. Short circuit and overvoltage protected. 100 or 240v AC input. Dim 28 x 12.5 x 7 cm NEW £49.94
Carriage on all PSU's £3.00

KEYBOARDS

Manufacturer's BRAND NEW surplus

DEC LA34 Un-coded keyboard with 67 quality gold plated switches on X-Y matrix - ideal micro conversions etc £24.95
AMKEY MPNK-114 Superb word processor chassis keyboard on single PCB with 116 keys. Many features such as On board Micro, Single 5v rail, full ASCII coded character set with 31 function keys, numeric keypad, cursor pad and 9600 baud SERIAL TTL ASCII OUTPUT! Less than half price
Only £69.00 with data. Carriage on Keyboards £3.50



Double sided 40/80 track disk drives (1 Mb per drive), PSU, 4K of memory mapped screen RAM, disk controller, RS232, CENTRONICS and system expansion ports, and if that's not enough a ready to plug into STANDARD 8" DRIVE port for up to FOUR 8" disk drives, either in double density or IBM format. The ultra slim 92 key, detachable keyboard features 32 user definable keys, numeric keypad and text editing keys, even its own integral microprocessor which allows the main Z80A to devote ALL its time to USER programs, eliminating "lost character" problems found on other machines. The attractive, detachable 12" monitor combines a green, anti-glare etched screen, with full swivel and tilt movement for maximum user comfort. Supplied BRAND NEW with CPM 2.2, user manuals and full 90 day guarantee. Full data sheet and info on request

PC2000 System with CPM Etc. COST OVER £1400

NOW only £399

DON'T MISS THE CPM Deal OF the CENTURY The FABULOUS CPM TATUNG PC2000 Professional Business System

A cancelled export order and months of negotiation enables us to offer this professional PC, CPM system, recently on sale at OVER £1400, at a SCOOOP price just over the cost of the two internal disk drives!! Or less than the price of a dumb terminal!!

Not a toy, the BIG BROTHER of the EINSTEIN computer, the DUAL PROCESSOR PC2000 comprises a modern stylish three piece system with ALL the necessities for the SMALL BUSINESS, INDUSTRIAL, EDUCATIONAL or HOBBYIST USER. Used with the THOUSANDS of proven, tested and available CPM software packages such as WORDSTAR, FAST, DBASE2 etc, the PC2000 specification, at our prices, CANNOT BE BEATEN!!

The central processor plinth contains the 64K, Z80A processor, DUAL TEAC 55F 5 1/4" PC2000 Business System with CPM and 'Ready to Run' FAST Sales and Purchase ledger, supports up to 9000 Accounts, VAT etc. COST OVER £1700

NOW only £499 Carriage & Insurance £12.00

PC2000 Wordprocessor System with CPM and TEC FP25 daisywheel printer

NOW only £799

MODEMS

Join the communications revolution with our super range of DATA MODEMS, prices and specifications to suit all applications and budgets..... BRAND NEW State of the art products. DACOM DSL2123 Multi standard 300-300, 1200-75 Auto answer etc £288.00
DACOM DSL2123AQ Auto dial, smart modem with multi standard AUTO SPEED detect, and data buffer with flow control etc. £365.00
DACOM DSL2123GT The CREAM of the intelligent modems, auto dial, auto call, index, buffer etc etc. £498.00
Steebeck SB1212 V22 1200 baud FULL DUPLEX, sync or async, optional auto dial. £465.00
TRANSDATA 307A Acoustic coupler 300 baud full duplex, originate only, RS232C interface. £49.00

Ex BRITISH TELECOM full spec, CCITT, ruggedised, bargain offers. Sold TESTED with data. Will work on any MICRO or system with RS232C interface. MODEM 13A 300 baud unit, only 2" high fits under phone. CALL mode only £45.00
MODEM 20-1, 75-1200 baud. Compact unit for use as subscriber end to PRESTEL, TELECOM GOLD, MICRONET etc. £39.95 + pp £5.50
MODEM 20-2 1200-75 baud. Same as 20-1 but for computer end. £65.00 + pp £6.50
DATE 2412. Made by SE, Labs for BT this two part unit is for synchronous data links at 1200 or 2400 baud using 2780/3780 protocol etc. Many features include 2 or 4 wire working, self test, auto answer etc. COST OVER £800. Our price ONLY £199 + pp £8.00
DATEL 4800, RACAL MPS4800 baud modem, EX BT good working order, ONLY £295.00 + pp £8.00

SPECIAL OFFER

MODEM TG2393. Ex BT, up to 1200 baud full duplex 4 wire or half duplex over 2 wire line. ONLY £85.00 PER PAIR + pp £10.00

For more information contact our Sales Office.

MATRIX PRINTERS

SPECIAL BULK PURCHASE of these compact, high speed matrix printers. Built in Japan for the Hazeltine Corporation this unit features quality construction giving 100cps bidirectional, full pin addressable graphics, 6 type fonts, up to 9.5 single sheet or tractor paper handling, RS232C and CENTRONICS parallel interface. Many other features. BRAND NEW and BOXED. COST £420. Our price ONLY £199.00

RECHARGEABLE BATTERIES

Dry Fit MAINTENANCE FREE by Sonnenschein & Yuasa
A300 07191315 12v 3Ah NEW £13.95
A300 07191312 6v 3Ah NEW £9.95
A300 07191202 6-0-6v 1.8Ah TESTED Ex Equip £5.99

VDU TERMINALS

Standard VDU data entry terminals at give away prices!!

QUME QVT108. Current product, state of the art terminal with detachable keyboard, 12" Green screen, 2 page RAM, TVI 925 Hazeltine, ADMSA emulations, software setup, 25 x 80, Clock, Swivel and tilt base, Printer port. Function keys etc. BRAND NEW and BOXED AT ALMOST HALF PRICE ONLY £425.00
AJ510 - EX RENTAL, Z80 controlled, 15" green screen 24 x 80 display, graphics, cursor addressing, printer port etc. Very good condition TESTED complete with manual only £225.00
ADDS 520 - Dumb terminal, used, 12" b/w screen RS232C interface and printer port. TESTED. ONLY £125.00. Carriage on terminals £10.00
100's of other terminals in stock. CALL for more details.

SURPLUS SPECIALS ON PRESTEL - VIEWDATA - TELEX

PLESSE VUTEL, ultra compact unit, slightly larger than a telephone features a STANDARD DTMF TELEPHONE (tone dial) with 5" CRT monitor and integral modem etc. for direct connection to PRESTEL VIEWDATA etc. Designed to sell to the EXECUTIVE at over £600!! Our price BRAND NEW AND BOXED at only £99.00

DECCAFAX VP1 complete Professional PRESTEL system in slimline desk top unit containing Modem, Numeric keypad, CPU, PSU etc. Connects direct to standard RS232C monitor. Many other features include: Printer output, Full keyboard input, Cassette port etc. BRAND NEW with DATA. A FRACTION OF COST only £55.00

ALPHATANTER. Very compact unit with integral FULL ALPHA NUMERIC keyboard. Just add a domestic TV receiver and you have a superb PRESTEL system and via PRESTEL the cheapest TELEX service to be found!! Many features: CENTRONICS Printer output, Memory dialling etc. Supplied complete with data and DIY mod for RGB or Composite video outputs. AS NEW only £125.00

EX-STOCK INTEGRATED CIRCUITS

4164 200 ns D RAMS 9 for £11 4116 ns £1.50 2112 £10.00 2114 £2.50 2102 £2.00 6116 £2.50 EPROMS 2716 £4.50 2732 £3.00 2764 £4.95 27128 £5.50 6801 £2.50 6821 £1.68A09 £8 68B09 £10 8085A £5.50 8086 £15 8088 £8 NEC765 £8 WD2793 £28 8202A £22 8251 £7 8748 £15 Z80A DART £6.50 Z80A CPU £2.00. Thousands of IC's EX STOCK send SAE for list.

DISK DRIVES

Japanese 5 1/4" half height, 80 track double sided disk drives by TEAC, CANON, TOSHIBA etc. Sold as NEW with 90 day guarantee ONLY £85.00
TEC FB-503 Double sided 5 1/4" TRK NEW £75.00
SUGART SA400 SS FH 35 TRK £55.00
SIEMENS FDD100 SS FH 40 TRK £65.00

carriage on 5 1/4" drives £5.50
Brand New metal 5 1/4" DISK CASES with internal PSU.
DSKC1 for 2 HH or 1 FH drive £29.95 + pp £4.00
DSKC 2 for 1 HH drive £22.95 + pp £3.50
DKSC 3 As DSK1 LESS PSU £12.95 + pp £2.50
DKSC 4 As DSK2 LESS PSU £10.95 + pp £2.00
8" IBM format TESTED EX EQUIPMENT.
SHUGART 800/801 SS £175.00 + pp £8.50
SHUGART 851 DS £250.00 + pp £8.50
TWIN SHUGART 851 2 2 Mb total capacity in smart case complete with PSU etc. £395.00
MITSUBISHI M2894-63 8" DS 1 Mb equiv. to SHUGART S880R. BRAND NEW at £275.00 + pp £8.50
DYSAN 8" Alignment disk £29.00 + pp £1.00
Various disk drive PSU's Ex Stock SEE PSU section.

HARD DISK DRIVES
DRE/DIABLO Series 30 2.5 Mb front load £525.00
Exchangeable version £295.00. ME3029 PSU £95.00
DIABLO 44/DRE4000A, B 5+5 Mb from £750.00
CDC HAWK 5+5 Mb £795.00. CDC 9782 80 Mb PROMQ 81c £2500.00

PERTEC D3422 5+5 Mb £495.00
RODIME 5 1/4" Winchester ex-stock from £150 CALL Clearance Items - Sold as seen - No guarantee.
ICL 2314 Brand New 14" Mb Removable pack hard disk drive, cost over £2000 with data ONLY £99.00
BASF 6172 8" 23Mb Winchester £199.00

Unless stated all drives are refurbished with 90 day guarantee. Many other drives and spares in stock - call sales office for details.

All prices quoted are for U.K. Mainland, paid cash with order in Pounds Sterling PLUS VAT. Minimum order value £2.00. Minimum Credit Card order £10.00. Minimum BONA FIDE account orders from Government Depts., Schools, Universities and established companies £20.00. Where post and packing not indicated please ADD £1.00 + VAT. Warehouse open Mon-Fri 9.30-5.30. Sat 10.30-5.30. We reserve the right to change prices and specifications without notice. Trade, Bulk and Export

32 Biggin Way, Upper Norwood, London SE19 3XF
Telephone 01-679 4414 Telex 894502 Data 01-679 1888



IN METERS ... WE'RE MILES AHEAD

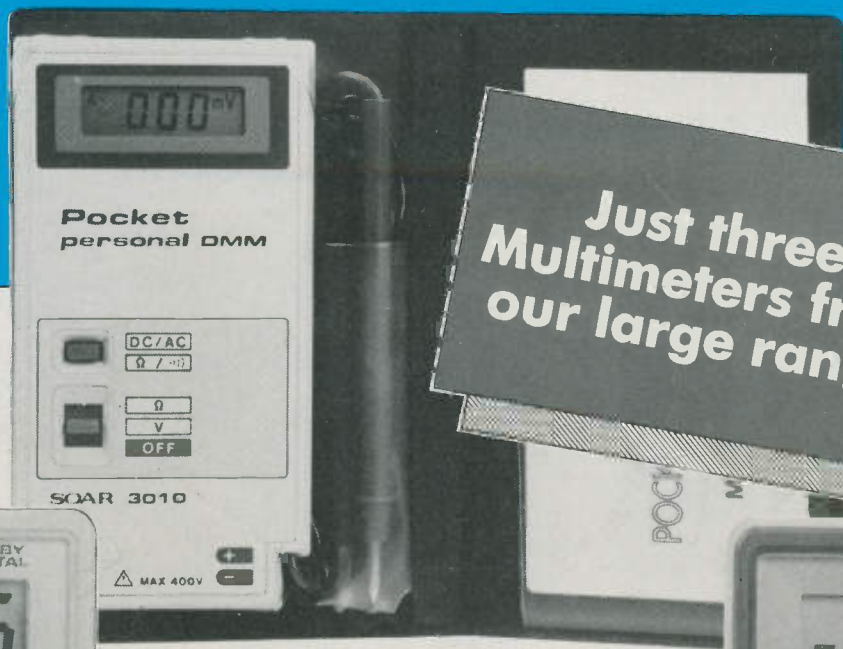

Just three
Multimeters from
our large range

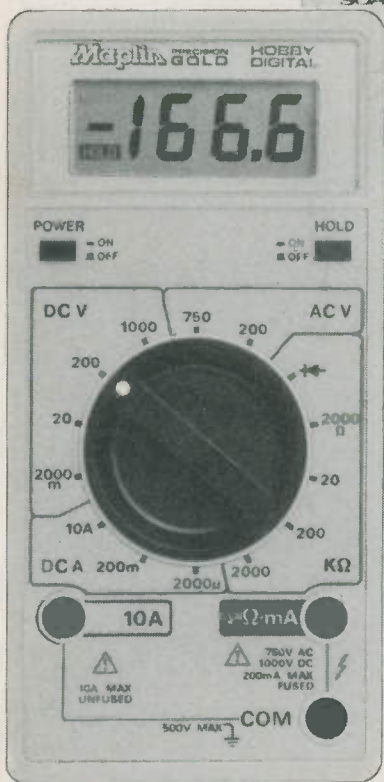

▲ **Pocket Digital Multimeter**
A calculator size autoranging DMM which reads 1mV-400V DC, 1mV-400V AC, 0.1Ω-2MΩ and has a continuity buzzer. Overall size only 120 x 75 x 15mm. Order Code YN78K **Price £24.95**

▲ **Hobby Digital Multimeter**
A very high quality multimeter at a very low price! 14 selectable ranges covering AC and DC volts, DC current and resistance. Also has a diode junction test range. Order Code YM63T **Price £28.95**

▶ **Auto Ranging Digital Multimeter with Transistor Tester**
A 6 position rotary switch selects off, volts, ohms/continuity, 20MΩ, 200mA/h_{FE} or 10A. Features include display hold, NPN and PNP transistor tester, autorange override and low battery indication. Order Code YM64U **Price £45.95**



All prices include VAT. Please add 50p towards postage. Prices firm until 15th August 1987. Subject to availability.

Maplin ELECTRONIC SUPPLIES LTD.

Mail Order: P.O. Box 3, Rayleigh, Essex SS6 8LR. Tel: Southend (0702) Sales: 554161, Enquiries: 552911; Trade sales: 554171, Trade enquiries: 552961.

Shops
Birmingham: Lynton Square, Perry Barr. Telephone: 021 356 7292.
London: 159-161 King Street, Hammersmith W6. Telephone: 01 748 0926.
Manchester: 8 Oxford Road. Telephone: 061 236 0281.
Southampton: 46-48 Bevois Valley Road. Telephone: 0703 225831.
Southend-on-Sea: 282-284 London Road, Westcliff-on-Sea, Essex. Tel: 0702 554000.
All shops except Manchester closed all day Monday.



Pick up a copy of our 1987 catalogue from any branch of W.H. Smith for just £1.50. Or to receive your copy by post just send £1.50 + 40p p & p to Mail Order address. If you live outside the U.K. please send £2.50 or 11 International Reply Coupons.