

PRACTICAL

NOVEMBER 1985 · £1.10

# ELECTRONICS

ROBOTICS · MICROS · ELECTRONICS · INTERFACING

**New  
Size**

**WE'RE**



**21 TODAY!**

**8  
EXTRA  
PAGES**

**Review...  
21 YEARS of ELECTRONICS**  
**DISCO LIGHTS CONTROL**  
**commodore  
USER PORT EXPANDER**

**Thanks to our READERS!**



# Industrial Soldering Equipment-for the discerning amateur

SEND FOR NEW CONCISE LEAFLETS

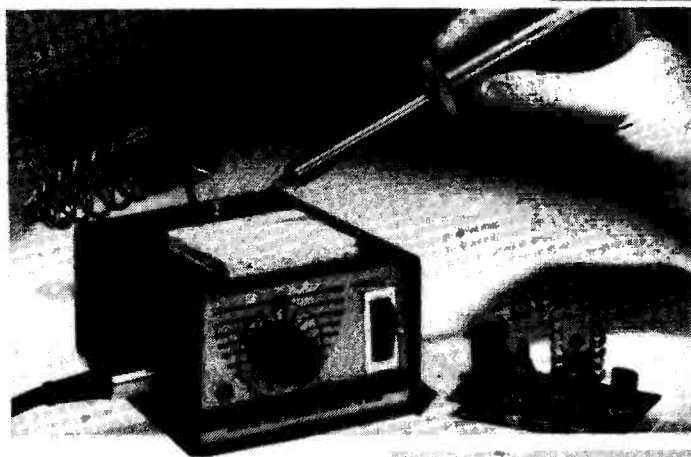

## 101 ELECTRONIC CONTROLLED SOLDERING STATION

for precision soldering  
with accuracy suitable  
for use on MOS, FET etc  
240V input - 24V on tool.  
Temperature range  
120-420°C  
Many extra features

## 'K' SERIES SOLDERING TOOLS FOR ALL APPLICATIONS

- K1000 micro soldering
- K2000 general electronic soldering
- K3000 heavy duty soldering

● Small selection of  
**AD-IRON® LONG LIFE  
SOLDERING TIPS**  
suitable for all Adcola  
soldering irons.

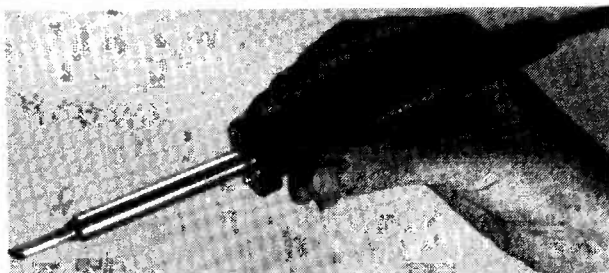

## ADCOLA ACCESSORIES include: SIDE CUTTERS



## SNIPE NOSE PLIERS

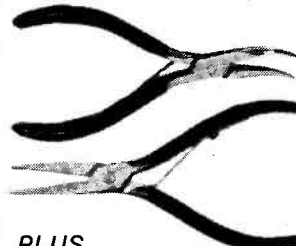

- PLUS
- Desoldering Braid
  - Desoldering Guns
  - Tip cleaners
  - Soldering aids
  - Lamps, Lenses etc

# ADCOLA

(Regd Trade Mark)

**ELECTRONIC PRODUCTION EQUIPMENT**

For a no obligation demonstration, please contact:  
ADCOLA PRODUCTS LIMITED Gauden Road London SW4 6LH  
Telephone Sales (01) 622 0291 Telex 21851 Adcola G

## CONSTRUCTIONAL PROJECTS

<b>MODEL RAILWAY TRACK CONTROL</b> by J. Milne Power Crazy? Control up to 144 points via a single pair of wires	10
<b>BYTEBOX</b> by Ray Stuart Part Two: System construction and installation—optional extras	26
<b>EXPERIMENTING WITH ROBOTS</b> by Mike Abbott Part Three: Squint	42
<b>DISCO LIGHTS CONTROLLER</b> by John M. H. Becker Versatile effects unit with optional facilities, including computer control and chaser sequencer	45
<b>COMMODORE USER PORT EXPANDER</b> by R. A. Penfold Enables many add-ons to be interfaced with CBM64 or VIC-20	50

## GENERAL FEATURES

<b>ROBOTICS REVIEW</b> by Nigel Clark A regular look at robotics and cybernetics	18
<b>INTRODUCTION TO MICROPROCESSOR SYSTEMS</b> by Michael Tooley BA and David Whitfield MA MSc CEng MIEE Part Two: Practical aspects of a micro system	20
<b>21 YEARS OF ELECTRONICS</b> by Fred Bennett Part One: Our 21st Birthday issue traces our progress—the first fourteen years	32
<b>SPACEWATCH</b> by Dr Patrick Moore OBE	40
<b>BBC MICRO FORUM</b> by D. Whitfield MA MSc CEng MIEE The Analogue Port Light Pen Input is expiscated	55

## NEWS & COMMENT

<b>EDITORIAL</b>	<b>7 LEADING EDGE</b>	<b>16 NEXT MONTH</b>	<b>57</b>
<b>NEWS &amp; MARKET PLACE</b>	<b>8 BAZAAR</b>	<b>41 P.C.B. SERVICE</b>	<b>58</b>
	<b>8 READOUT</b>	<b>52 SUBSCRIPTION SERVICE</b>	<b>58</b>

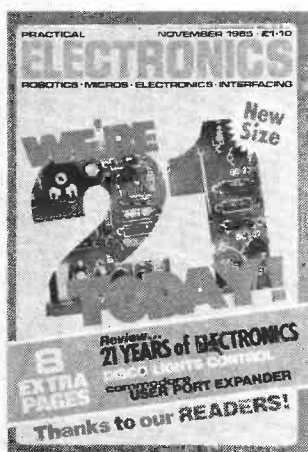

### FRONT COVER

A celebration of Twenty One Years of Practical Electronics (see special feature on page 32). Thanks to all our readers.

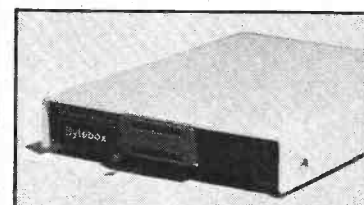
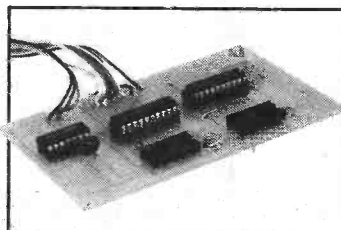
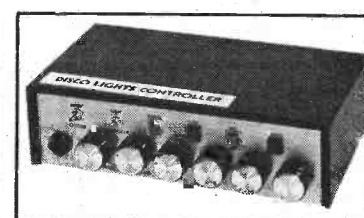
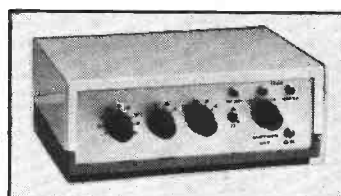

**OUR DECEMBER ISSUE WILL BE ON SALE FRIDAY, NOVEMBER 1st, 1985 (see page 57)**

© IPC Magazines Limited 1985. Copyright in all drawings, photographs and articles published in PRACTICAL ELECTRONICS is fully protected, and reproduction or imitations in whole or part are expressly forbidden. All reasonable precautions are taken by PRACTICAL ELECTRONICS to ensure that the advice and data given to readers are reliable. We cannot, however, guarantee it, and we cannot accept legal responsibility for it. Prices quoted are those current as we go to press.





## OMP POWER AMPLIFIER MODULES

Now enjoy a world-wide reputation for quality, reliability and performance at a realistic price. Four models available to suit the needs of the professional and hobby market. i.e. Industry, Leisure, Instrumental and Hi-Fi, etc. When comparing prices, NOTE all models include Toroidal power supply, Integral heat sink, Glass fibre P.C.B., and Drive circuits to power compatible Vu meter. Open and short circuit proof. **Supplied ready built and tested.**

- OMP 100 Mk II Amp. Module.** 110w R.M.S. 4ohms I/P Sens. 500mV ~ 10K. Size 360 x 115 x 72mm. Price: £32.99 + £2.50 P&P.
- OMP/MF100 Mos-Fet.** Very high spec. 110w R.M.S. both 4 & 8ohms I/P Sens. 500mV ~ 10K. Size 300 x 123 x 60mm. Price: £39.99 + £2.50 P&P.
- OMP/MF200 Mos-Fet.** Very high spec. 200w R.M.S. 4ohms I/P Sens. 500mV ~ 10K. Size 300 x 150 x 100mm. Price: £62.99 + £3.50 P&P.
- OMP/MF300 Mos-Fet.** Very high spec. 300w R.M.S. 4ohms I/P Sens. 500mV ~ 10K. Size 330 x 147 x 102mm. Price: £79.99 + £4.50 P&P.

Full specifications available on request.

NOTE: Mos Fets are supplied as standard (100KHz bandwidth & Input Sensitivity 500mV) If required, P.A. version (50KHz bandwidth & Input Sensitivity 775mV). Order — Standard or P.A.

**LARGE (28p) S.A.E. FOR CURRENT LIST**



MF100

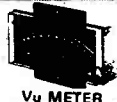

Vu METER

## PIEZO ELECTRIC TWEETERS — MOTOROLA

Join the Piezo revolution. The low dynamic mass (no voice coil) of a Piezo tweeter produces an improved transient response with a lower distortion level than ordinary dynamic tweeters. As a crossover is not required these units can be added to existing speaker systems of up to 100 watts (more if 2 pin in series). **FREE EXPLANATORY LEAFLETS SUPPLIED WITH EACH TWEETER.**

- TYPE 'A' (KSN2036A)** 3" round with protective wire mesh, ideal for bookshelf and medium sized Hi-Fi speakers. Price £4.90 each + 40p P&P.
- TYPE 'B' (KSN1005A)** 3 1/2" super horn. For general purpose speakers, disco and P.A. systems etc. Price £5.99 each + 40p P&P.
- TYPE 'C' (KSN6016A)** 2" x 5" wide dispersion horn. For quality Hi-Fi systems and quality discos etc. Price £6.99 each + 40p P&P.
- TYPE 'D' (KSN1025A)** 2" x 6" wide dispersion horn. Upper frequency response retained extending down to mid range (2KHz). Suitable for high quality Hi-Fi systems and quality discos. Price £9.99 each + 40p P&P.
- TYPE 'E' (KSN1038A)** 3 1/2" horn tweeter with attractive silver finish trim. Suitable for Hi-Fi monitor systems etc. Price £5.99 each + 40p P&P.

**LEVEL CONTROL** Combines on a recessed mounting plate, level control and cabinet input jack socket. 85 x 85 mm. Price £3.99 + 40p P&P.

Loudspeakers 5" to 18" Up to 300W R.M.S. S.A.E. for full lists. McKenzie speakers at advantageous prices. All speakers listed 8 ohm imp.

## LOUDSPEAKERS



Cabinet fixing in stock. S.A.E. for details.

- POWER RANGE**
- 8" 50 WATT R.M.S. Hi-Fi/Disco. 50 oz magnet. 1 1/2" ally voice coil. Ground ally fixing escutcheon. Res. Freq. 40Hz. Freq. Resp. to 6KHz. Sens. 92dB. PRICE £10.99 Available with black grille £11.99 P&P £1.50 ea.
  - 12" 100 WATT R.M.S. Hi-Fi/Disco. 50 oz magnet. 2" ally voice coil. Ground ally fixing escutcheon. Die-cast chassis. White cone. Res. Freq. 25Hz. Freq. Resp. to 4KHz. Sens. 95dB. PRICE £28.60 + £3.00 P&P ea.
  - 15" 100 WATT R.M.S. Hi-Fi/Disco. 50 oz magnet. 2" ally voice coil. Ground ally fixing escutcheon. Die-cast chassis. White cone. Res. Freq. 20Hz. Freq. Resp. to 2.5KHz. Sens. 97dB. PRICE £37.49 + £3.00 P&P ea.
- SOUNDLAB (Full Range Twin Cone)**
- 5" 60 WATT R.M.S. Hi-Fi/Multiple Array Disco etc. 1" voice coil. Res. Freq. 63Hz. Freq. Resp. to 20KHz. Sens. 86dB. PRICE £9.99 + £1.00 P&P ea.
  - 6 1/2" 60 WATT R.M.S. Hi-Fi/Multiple Array Disco etc. 1" voice coil. Res. Freq. 56Hz. Freq. Resp. to 20KHz. Sens. 89dB. PRICE £10.99 + £1.50 P&P ea.
  - 8" 60 WATT R.M.S. Hi-Fi/Multiple Array Disco etc. 1 1/2" voice coil. Res. Freq. 38Hz. Freq. Resp. to 20KHz. Sens. 89dB. PRICE £12.99 + £1.50 P&P ea.
- MCKENZIE**
- 12" 85 WATT R.M.S. C1285GP Lead guitar/keyboard/Disco. 2" ally voice coil. Ally centre dome. Res. Freq. 45Hz. Freq. Resp. to 6.5KHz. Sens. 98dB. PRICE £24.99 + £3.00 P&P ea.
  - 12" 85 WATT R.M.S. C1285TC P.A./Disco 2" ally voice coil. Twin cone. Res. Freq. 45Hz. Freq. Resp. to 14KHz. PRICE £24.99 + £3.00 P&P ea.
  - 15" 150 WATT R.M.S. C15 Bass Guitar/Disco. 3" ally voice coil. Die-cast chassis. Res. Freq. 40Hz. Freq. Resp. to 4KHz. PRICE £49.99 + £4.00 P&P ea.

## 19" STEREO RACK AMPS



Professional 19" cased Mos-Fet stereo amps with twin Vu meters, twin toroidal power supplies, XLR connections, MF600 Fan cooled. Three models (Ratings R.M.S. into 4ohms).

MF200 (100 + 100W) £169.00  
MF400 (200 + 200W) £228.85  
MF600 (300 + 300W) £274.85

Securicor Delivery £10.00

## STEREO DISCO MIXER

STEREO DISCO MIXER with 2 x 5 band L & R graphic equalisers and twin 10 segment LED Vu Meters. Many outstanding features. 5 Inputs with individual faders providing a useful combination of the following — 3 Turntables (Mag), 3 Mics, 4 Line plus Mic with talk over switch, Headphone Monitor, Pan Pot, L & R, Master Output controls. Output 775mV. Size 360 x 280 x 90mm. Price £134.99 — £3.00 P&P

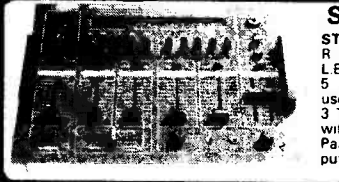

## HOBBY KITS. Proven designs including glass fibre printed circuit board and high quality components complete with instructions.

- FM MICROTRANSMITTER (BUG)** 90/105MHz with very sensitive microphone. Range 100/300 metres. 57 x 46 x 14mm (9 volt). Price: £8.62 + 75p P&P.
- 3 WATT FM TRANSMITTER** 3 WATT 85/115MHz varicap controlled professional performance. Range up to 3 miles 35 x 84 x 12mm (12 volt). Price: £14.49 + 75p P&P.

3 watt FM Transmitter

POSTAL CHARGES PER ORDER £1.00 minimum.

★ SAE for current lists. ★ Official orders welcome

★ All prices include VAT. ★ Sales Counter. ★



**B. K. ELECTRONICS**

UNIT 5, COMET WAY, SOUTHBEND ON SE4  
ESSEX SS2 6TR. TEL. 0742 527572



### SIREN KIT

Produces a loud swept frequency tone from a 9-15V supply. Enable input for easy connection to alarm circuits. Includes 5in horn speaker £7.90. Mini siren (with small speaker & box) £4.30

### BELL BOX

Brightly coloured and a deterrent by itself 950 130 £10.00

### PRESSURE MATS

23 x 7ins £1.70  
29 x 16ins £2.60

### XENON BEACON

12V. 170mA Orange weatherproof 950 133 £10.50

### TRIACS

### ALARM CONTROL UNIT

4 input circuits, 2 instant 2 delayed. Adjustable entry exist and alarm times. Built & tested. Full instructions supplied. Size 180 x 130 x 30mm 12 dc supply 950 160 £26.00

### VERO

BT Phone connectors starter pack £9.50

### FREE 28 page catalogue. Send 9x6 SAE NOW!

Telephone orders — Access & Barclaycard RING 01-567 8910 (24hrs)

### TOOLS

Side cutters £2.10 See Cat for full range.

### PANTEC KITS

BATTERIES NiCADs eg AA 90p & Chargers

### VELLEMAN KITS

### WINDOW TAPE

50m £2.50 Terminators 36p/pr

### CONTACTS

for doors & windows. Magnet & Reed Flush 950 140 £1.05 Surface 950 142 75p

### BOXES

Plastic diecast aluminium

### MULTIMETERS

Analogue from £6.50 Digital from £26.55

### DIGITAL LOCK KIT

operates from 5 to 18Vdc supply and gives 5040 combinations. 10 way keyboard supplied. 750mA output. Ideal for disabling car ignition or for door lock when used with 701 150 lock mechanism £11.50 701 150 £14.95

### CMOS

4001 16p 4017 39p

### HIGH SECURITY IR TRANSMITTER/RECEIVER

Operating from 9-15Vdc, both units have 8 switches and will operate only if these have been set to the same code. Receiver provides latched or momentary output. Ideal for car locks, garage door openers, burglar alarm switches etc. XK119 £21.75

### LEDs

from 9p

## ELECTRONICS

13 BOSTON RD LONDON W7 3SJ

Tel. Orders: 01-567 8910 Enquiries: 01-579 9794

Shop Hours: Mon-Fri. 9am-5pm Sat. 10am-4pm.

### ORDERING INFORMATION: ALL PRICES EXCLUDE VAT

FREE P&P on orders over £20 (UK only), otherwise add 75p + VAT. Overseas P&P: Europe £2.75. Elsewhere £6.50. Send cheque/PO/Barclaycard/Access No. with order. Giro No. 529314002.

LOCAL AUTHORITY AND EXPORT ORDERS WELCOME

GOODS BY RETURN SUBJECT TO AVAILABILITY

## TRANSFORMERS

**STOCK**      **PRICE**

VA	Price	P&P	Sec V	A	Pri	P&P
100	5.11	1.70	0.5	1	3.26	.96
200	9.96	1.89	1.38	3-0-3V	2	3.26
300	11.80	2.10	1.46	0x2	3.62	1.30
400	15.47	2.36	1.89	0-0-9	1	2.72
500	15.92	2.77	1.76	0x2	2.53	.96
600	24.94	2.94	1.84	0-0-2	5x2	3.53
750	24.94	2.94	1.84	0-0-2	1A x 2	4.48
800	36.00	3.10	2.33	15x2	2A x 2	2.53
1000	36.00	4.20	2.58	12-0-12	.05	3.21
2000	66.30	6.46	2.78	20x2	3x2	3.56
3000	124.12	O/A	3.08	20-12	9	4.34
4000	200.70	O/A	4.88	15-20x2	1A x 2	5.08
			4.95	15-27x2	5A x 2	5.07
				15-27x2	1A x 2	7.06
				0-CT-15V	5	2.06
				0-CT-15V	4A	7.28

**WINDING SERVICES**  
3VA-15KVA or 3-phase  
Plus Toroids  
Stock items by return  
PLEASE ADD 15% VAT TO ALL ITEMS AFTER P&P.

**120W or 12-0-12V**  
2x12V Secs. Pri. 240V

VA	Price	P&P
80	5.08	1.49
150	7.36	1.69
250	8.96	1.80
350	12.43	2.10
500	13.96	2.44
1000	24.93	2.96
1500	28.58	3.46
2000	44.34	4.20
3000	75.22	5.26
5000	113.11	O/A
7500	175.51	O/A
10000	287.89	O/A

**AVOS & MEGGERS**  
8 MK6 (latest) £152.50  
DA211 LCD £88.00  
2000 LCD £72.80  
Megger crank £125.00  
Megger Batt. £83.70  
Full Range Available

**METAL OXIDE 14W 5% RESISTORS £1/100 + VAT**  
12, 33, 47, 390, 430, 510, 560, 1K, 1K1, 1K3, 1K6, 1K8, 2K, 3K, 3K9, 15K, 16K, 24K, 27K, 39K, 56K, 82K, 100K, 110K, 120K, 130K, 150K, 200K, 220K, 270K, 300K. p.p.g 20p

**WIRELESS WORLD**  
Modem Project 600 Ω line isolator + mains transformers  
£6.90 inc VAT

**EDUCATIONAL METERS**  
Finger screw front terminals 0-10A, or 0-30V DC 78x98mm  
£3.98 + 50p P&P

**CASED AUTOS**  
24V Cable I/P  
115V USA Sigs O/P

VA	Price	P&P
20	7.57	1.59
80	8.91	1.70
150	12.78	1.91
250	16.47	2.70
500	25.28	2.80
1000	35.43	3.97
2000	63.40	4.76
3000	91.14	6.00

**BRIDGE RECTIFIERS**  
1A 400V .32  
2A 200V .45  
35A 100V 2.50  
12SA 500V 3.40

**MINIATURES (SCREENS)**

Sec V	A	Pri	P&P
0.5	1	3.26	.96
1	2	3.26	.96
2	4	3.62	1.30
3	6	2.72	.96
4	8	2.53	.96
5	10	3.53	1.30
6	12	4.48	.96
8	15	2.53	.96
10	20	3.21	.96
15	25	3.56	1.30
20	30	4.34	1.70
30	40	5.08	1.70
40	50	5.07	1.70
50	60	7.06	1.74
60	75	2.06	.96
75	100	7.28	1.40

**BARRIE ELECTRONICS LTD**  
Unit 211, Stratford Workshops  
Burford Road, London E15 2SP  
Tel. 01-555 0228 (3 lines)

# Crofton

## THE VIDEO SPECIALISTS

If you need a monochrome or colour monitor, digitiser, T.V. camera, or door entry system Crofton must be your first choice - here are a few reasons why!

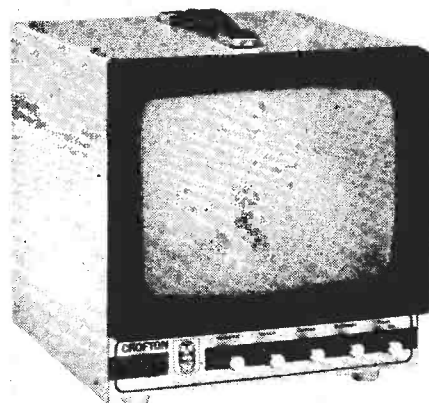

### THE CROFTON PM101

This 9 inch metal cased, monochrome monitor is incredible value at **ONLY £82.80**

### THE NOVEX 1414

This superb metal cased 14 inch RGB/COMPOSITE COLOUR MONITOR is unbelievable value at **ONLY £185.15**

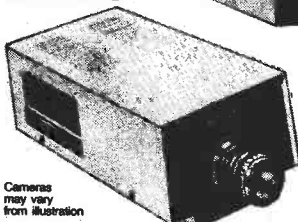
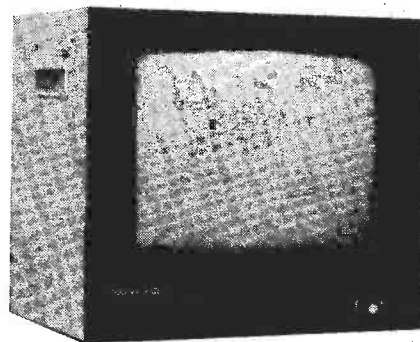

### CCTV CAMERAS

Though not new these cameras have been completely refurbished to a high standard in our own workshops and come complete with a standard lens, ready to work

**ONLY £78.20**

Short mains lead version requiring case respray available from £66.70  
Weatherproof housings, motorised pan & tilts etc. available at extra cost.

### THE CROFTON SPECIAL CCTV OFFER

The Crofton special CCTV package and the door entry system described by P.E. in the September 1985 issue are available at the following prices  
SPECIAL CCTV PACKAGE £183.00  
DOOR ENTRY SYSTEM £103.45  
NOTE: We can also offer a multiscan system enabling the outputs from 4 cameras to be displayed simultaneously or individually on a single screen.

ELECTRONIC KEY FOB - Quickly locate mislaid keys. Fob emits a shrill tone in response to your whistle! **ONLY £7.95 INC.**

ALL THE ABOVE INCLUDE VAT, CARRIAGE & INSURANCE AND AT THESE PRICES OUR STOCKS CANNOT LAST LONG.

**DON'T DELAY - PHONE YOUR ORDER TODAY!**  
MOST MAJOR CREDIT CARDS ACCEPTED

Delivery within 28 days.

Be sure to request our free catalogue describing our range of T.V. cameras, fixed and zoom lenses, sequential switchers, special and general monitors (colour and b/w including the PHILIPS 7502, PHILIPS 7522 and PHILIPS 2007 plus the full IKEGAMI range), video digitisers, light pens, eprom erasers etc.

**CROFTON ELECTRONICS** ☎ 01-891 1923

35 GROSVENOR ROAD, TWICKENHAM, MIDDLESEX TW1 4AD

## Master Electronics - Microprocessors

### ... Now! The Practical Way!

- **Electronics - Microprocessors** - Computer Technology is the career and hobby of the future. We can train you at home in a simple, practical and interesting way.
- **Recognise and handle all current electronic components and 'chips'.**
- **Carry out full programme of experimental work on electronic computer circuits including modern digital technology.**
- **Build an oscilloscope and master circuit diagram.**
- **Testing and servicing radio - T.V. - hi-fi and all types of electronic/computer/industrial equipment.**

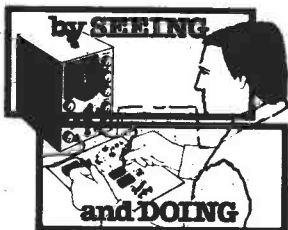

**New Job? New Career? New Hobby?**

SEND THIS COUPON NOW.

#### FREE! COLOUR BROCHURE

Please send your brochure without any obligation to

OR TELEPHONE US 082 67 6114  
OR TELEX 22758 (24 HR SERVICE)



NAME \_\_\_\_\_ I am interested in

ADDRESS \_\_\_\_\_  ELECTRONICS

MICROPROCESSORS

RADIO AMATEUR LICENCE

CITY & GUILDS EXAMS

Other Subjects \_\_\_\_\_

British National Radio & Electronics School P.O. Box 7, Tipton, West Midlands, B83 7JH

Full kits include pcb's, hardware, cases (unless stated otherwise), IC sockets, wire, nuts & bolts. Article reprints extra 70p each.

RS232 TO CENTRONICS CONVERTER Sept 85 £24.95  
 CAR BOOT ALARM Sept 85 £11.72  
 COMPUTER ENVELOPE SHAPER Aug 85 £22.19  
 VOLTMETER MEMORY ADAPTOR July 85 £10.98  
 STYLUS KEYBOARD FOR COM 64 Jun 85 £9.95  
 SYNTHESISER INTERFACE FOR COM 64 Jun 85 £16.99  
 AMSTRAD SYNTHESISER INTERFACE May 85 £26.38

CYLINDER THERMOSTAT May 85 £21.77  
 BBC POWER CONTROL INTERFACE Apr 85 £29.99  
 GUITAR ACTIVE TONE CONTROL less case Sept 83 £11.97  
 PROGRAM CONDITIONER June 83 £18.67  
 AUTO TEST SET May 83 £24.62  
 WIPER DELAY Apr 83 less relay £8.24  
 BATTERY TESTER Apr 83 £13.26

## THIS MONTH'S KITS

SAE or 'phone for prices

## LOGIC TUTOR

A specifically designed test bed for the practical side of the 8 part educational series 'Introduction to Digital Electronics' Practical Electronics Oct 83 — May 84. Full kit includes screen printed pcb, power supply, connector strips and turned pin sockets (less case).

**£34.98**

REPRINTS EXTRA 70p EACH

## EDUCATIONAL SETS FUN WITH ELECTRONICS

Enjoyable introduction to electronics. Full of very clear full colour pictures and easy to follow text. Ideal for all beginners — children and adults. Only basic tools needed. 64 full colour pages cover all aspects — soldering — fault finding — components (identification and how they work). Also full details of how to build 6 projects — burglar alarm, radio, games, etc. Requires soldering — 4 components SUPPLIED ALLOW ALL PROJECTS TO BE BUILT AND KEPT. Supplied less batteries & cases. **FUN WITH ELECTRONICS, COMPONENT PACK £16.99** BOOK EXTRA £1.75. Book available separately.



## ADVENTURES WITH ELECTRONICS

An easy to follow book suitable for all ages. Ideal for beginners. No soldering, uses an S-Dec Breadboard. Gives clear instructions with lots of pictures. 16 projects — including three radios, siren, metronome, organ, intercom, timer, etc. Helps you learn about electronic components and how circuits work. Component pack includes an S-Dec breadboard and all the components for the projects. **Adventures with Electronics £3.58.** Component pack £20.98 less battery.

## COMPUTER ACCESSORIES

**BBC TRACKBALL CONTROLLER.** 2" ball. 2 fire buttons. Analogue input port connector. Includes simple software listing for freethand drawing. Simply incorporate into your programs. £17.99. **BBC Digital Joystick.** 2 fire buttons. D plug connects to analogue input. £9.58.

## TOOLS

Antex X5 soldering iron 25W 240V £7.25, 12V £7.45, 24V £7.85, 110/15V £7.35.  
 Antex Model C soldering iron 240V £8.98  
 Heat sink tweezers 45p  
 Solder handy size 5 £1.39  
 Solder carton £2.50  
 Solder reel size 10 £4.87  
 Low cost pliers £1.98  
 Bent nose pliers £1.89

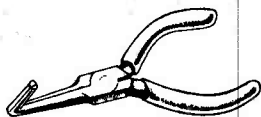

Mini drill 12V (MD1) £8.38  
 Multimeter Type 1 10000opv £6.98  
 Multimeter Type 2 20,000opv £17.98  
 Multimeter Type 3 30,000opv (taut baud) £27.98  
 Multimeter Type 4 10M digital £39.98  
 Desolder pump £5.48  
 Signal injector £2.98  
 Circuit tester 78p  
 Helping Hands jig & magnet £7.98  
 Miniature vice (plastic) £1.85

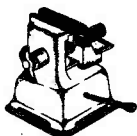

## BOOKS

A Practical Introduction to Microprocessors. Penfold £2.10  
 Basic Electronics. Holder & Stoughton £8.98  
 Beginners Guide to Building Electronic Projects. Penfold £2.25  
 BBC Micro. Osborne First Guide to £2.26  
 DIY Robotics & Sensors Billingsley, BBC £7.95  
 Commodore 64 £7.99  
 Elementary Electronics. Sladdin £5.98  
 Experiments with Your Computer (Science) £2.43  
 Science How to Design & Make Your Own PCBs. BP121 £2.15  
 How to Get Your Electronics Projects Working. BP110 £2.15  
 How to Make Computer Controlled Robots. Potter £3.20  
 How to Make Computer Model Controllers. Potter £3.19  
 Inside the Chip. Osborne £2.19  
 Interfacing to Microprocessors & Microcomputers £6.50  
 Machine Code for Beginners. Osborne £2.45  
 Making Music on the BBC Computer. Waugh £6.45  
 Micro Interfacing Circuits Book 1 £2.45  
 Microprocessors for Hobbyists. Coles £4.98  
 Practical Computer Experiments. Parr £1.95  
 Practical Things to do With a Microcomputer. Osborne £2.19  
 Programming for Education on the BBC Computer. Scriven/Hall £6.45  
 Questions & Answers — Electronics. Hickman £3.45  
 Understanding the Micro. Osborne £1.85  
 Osborne Introduction to Electronics £2.45

## BBC HEART RATE

BBC Heart Rate Monitor— Ready Built £35.99

Practise relaxation or monitor fitness with this plug in heart rate monitor. Connects directly to the BBC computer. Programs give continuous heart rate displays, bar charts, graphs etc. Supplied with sensor, software & instructions—ready to plug in and use.

## STEPPER MOTOR

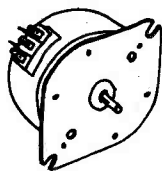

**BBC TO IC35 STEPPER MOTOR INTERFACE KIT £13.99**  
 PCB, driver IC, components, connectors and leads included. Demonstration software, listings, circuit diagram, pcb layout and construction details given. Requires unregulated 12Vdc power supply.  
**INTERFACE KIT (ref PE) £13.99.**  
**OPTIONAL POWER SUPPLY PARTS £4.67.**  
**ID35 STEPPER MOTOR 48 Steps. 12V £14.50.**



## DC MOTOR SETS

**MOTOR — GEARBOX ASSEMBLIES 1.5V-4.5V.** Miniature precision made. Complete with quality electric motors. Variable reduction ratios. Long 3mm dia output shafts.  
 Small unit — type MGS (3-2200rpm) £3.49  
 Large unit — type MGL (2-1150rpm) £3.98

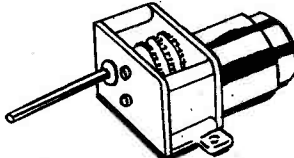

**PULLEY WHEELS — metal 3mm bore**  
 10mm dia 85p  
 20mm dia 98p  
 30mm £1.21  
**METAL COLLAR with screw — 3mm bore** 24p  
**FLEXIBLE SPRING COUPLING 3mm. L31mm** 68p  
**FLEXIBLE METAL COUPLING 3mm** £2.98  
**FISCHERTECHNIK DC MOTOR SETS**  
**SMALL TYPE 187** £9.85  
**LARGE TYPE 185** £9.90  
**DC MOTOR 1.5V-4.5V RPM 4,400-8,700**  
 Shaft dia 2mm L 10mm. Body 29x38mm  
**DC MOTOR TYPE — DC28** £1.98  
**FLEXIBLE STEEL SPRING DRIVING BELT** 47p  
 12" long. Joins to itself or 2 or more can be joined where long lengths are needed.

## BBC — DC MOTOR CONTROLLER

**FISCHERTECHNIK MOTOR CONTROL SYSTEM FOR THE BBC COMPUTER (BUILT) £46.55 (PE)**  
 A high precision DC motor driver and BBC B computer interface system. Supplied complete with applications software cassette.  
 Ready to run control system supplied complete with mains lead, ribbon cable and user port connector, and terminal posts and plugs for the motor connector. Also included are the software cassette of 3 programs and instructions. The software is easily transferable to disc.  
 Recommended motor is the Fischertechnik type 185 as used in the u-12 motor and gear set.  
 Motor (185) available separately £9.90.

## fischertechnik

We offer a range of the superb Fischertechnik sets. These cover robotics, electronics, electromechanics, motors and gears, and basic construction. Robotics kit build 11 different working models including a robot arm, graphics board, sorting system etc. Note that not all the models can be built at the same time. Simple to assemble. Easily combined with all other Fischertechnik kits. Top quality. Includes 2 motor's, an electromagnet, lamps, potentiometers, switches etc.  
**ROBOTICS Kit (554) PE £84.99**  
**Construction/base kit (ut1) £37.50**  
**Motors and Gears (ut2) £42.70**  
*Use ut2 to motorise ut1*  
**Electromechanics (ut3) £73.20**  
**Electronics (ut4) £93.90**

## BBC — ROBOTICS INTERFACE

A READY TO USE INTERFACE for the BBC computer and the Fischertechnik Computing and Robotics Kit (554). Allows the BBC computer to operate all 11 of the standard models which can be built from the Fischertechnik Robotics kit.  
 The interface features forward — reverse and on/off control of three DC motors; on/off control output for driving an electromagnet or similar device; and ten switch inputs for reading microswitches or other binary inputs.  
 Supplied complete with connectors and leads the interface requires a power source of 9-12 volts at 1A.  
 Detailed programming information is supplied with the interface. A separate software cassette with a comprehensive set of programs is also available.  
**FISCHERTECHNIK ROBOTICS — BBC COMPUTER INTERFACE (BUILT) (PE) £59.80**  
**ADDITIONAL SOFTWARE CASSETTE (OPTIONAL) £11.98**

## CATALOGUE

Brief details of each kit, book contents, and illustrations and descriptions of our range of tools and components are all included.  
 Robotics and Computing section included.  
 Our advert shows just a selection of our products.  
 Up to date price list enclosed. Official orders welcome.  
**Catalogue & Price List — Send £1 in stamps etc or add £1 to your order.**  
 Price list only 9x4 SAE.  
**Catalogue free to schools/colleges requested on official letterhead.**

## HOW TO ORDER

**MAGENTA ELECTRONICS LTD.**  
 PE1, 135 HUNTER ST.,  
 BURTON-ON-TRENT  
 STAFFS, DE14 2ST.  
**MAIL ORDER ONLY.**  
 0283 65435, Mon-Fri 9-5.  
 ADD 60p P&P TO ALL ORDERS.  
 PRICES INCLUDE VAT.  
 SAE ALL ENQUIRIES.  
 OFFICIAL ORDERS WELCOME.

## OUR PRICES INCLUDE VAT

Access/Barclaycard (Visa) by phone or post.  
 24 hr Answerphone for credit card orders

OVERSEAS: Payment must be sterling.  
 IRISH REPUBLIC and BFPO: UK PRICES.  
 EUROPE: UK PRICES plus 10%.  
 ELSEWHERE: write for quote.





## THANKS

WELCOME to our 21st anniversary issue. Yes, it seems amazing that this "new technology" has had its own dedicated hobbyist magazine for a full 21 years now. May I thank all our loyal readers for making this possible and refer you to page 32 for a little nostalgia.

While thinking about the history of PE I would like to pay tribute to Fred Bennett. Fred was the editor of PE from the first issue, was responsible for the creation of *Everyday Electronics* in 1971 and edited EE and PE until PE moved to Poole in 1978. Fred has just retired, spending his last months as a consultant editor on the magazines, during which time he researched and wrote the *21 Years of Electronics* feature for us, among other things.

PE owes its excellent reputation and strength over the years to Fred. I also owe him personal thanks for employing me in 1968, promoting and encouraging me over the years. The hobby and PE would have been the poorer without him. Thanks Fred. We wish you a long and happy retirement.

## ACTION!

My leader entitled *Twenty Years of Stagnation* in the July issue referred to the lack of change in electronics taught in our schools. The leader stirred up a number of letters on the subject, mainly from those in the teaching profession. The correspondence has attracted

a response from the Department of Education—though at the time of writing this amounts to a 'phone call saying they will write in time!

However, more importantly, it has resulted in contact with the Microelectronics Education Programme—a programme funded by the Education Departments of England, Wales and Northern Ireland and administered by the Council of Educational Technology for the United Kingdom.

## MEP

Exciting things *are* happening and in the January and February issues we expect to be able to publish a feature written by Mike Page and Graham Bevis of MEP. The feature will provide an insight into what has been done, what teaching material and products have been developed and made available and how the Programme has been planned to educate children in electronics. If, like us, you are worried about the situation, make sure you read this article.

Thank goodness a few brilliant and far-sighted people have been able to develop an excellent scheme—even if their funds will be cut off before they can complete their task—but more of that also in the feature.

Once again there is some interesting correspondence on another facet of this subject—see page 52.

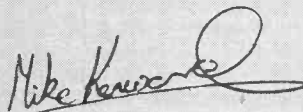

Editor Mike Kenward

Secretary Pauline Mitchell

Editorial Tel: Poole (0202) 671191

Advertisement Manager  
David Tilleard 01-261 6676

Secretary  
Christine Pocknell 01-261 6676

Ad. Make-up/Copy  
Brian Lamb 01-261 6601

Classified Ads.  
Mandy Morton 01-261 5846

Queries and letters concerning advertisements to:  
Practical Electronics Advertisements,  
King's Reach Tower,  
Stamford Street, London SE1 9LS  
Telex: 915748 MAGDIV-G

## Letters and Queries

We are unable to offer any advice on the use or purchase of commercial equipment or the incorporation or modification of designs published in PE. All letters requiring a reply should be accompanied by a stamped addressed envelope, or addressed envelope and international reply coupons, and each letter should relate to **one published project only. We are unable to answer letters relating to articles more than five years old.**

Components are usually available from advertisers; where we anticipate difficulties a source will be suggested.

## Old Projects

We advise readers to check that all parts are still available before commencing any project in a back-dated issue, as we cannot guarantee the indefinite availability of components used. **We are unable to answer letters relating to articles more than five years old.**

Technical and editorial queries and letters to:  
Practical Electronics Editorial,  
Westover House,  
West Quay Road, Poole,  
Dorset BH15 1JG

## SUBSCRIPTIONS

Copies of Practical Electronics are available by post, inland for £13, overseas for £15 per 12 issues, from: Practical Electronics, Subscriptions Department, IPC Magazines Ltd., Room 2816, King's Reach Tower, Stamford Street, London SE1 9LS. Cheques, postal orders and international money orders should be made payable to IPC Magazines Limited. Payment for subscriptions can also be made using a credit card.

Phone:  
**Editorial Poole (0202) 671191**

**We regret that lengthy technical enquiries cannot be answered over the telephone.**

## BACK NUMBERS and BINDERS . . .



Copies of most of our recent issues are available from: Post Sales Department (Practical Electronics), IPC Magazines Ltd., Lavington House, 25 Lavington Street, London SE1 0PF, at £1 each including Inland/Overseas p&p. When ordering please state title, month and/or issue required.

Binders for PE are available from the same address as back numbers at £5.50 each to UK or overseas addresses, including postage, packing and VAT.



Prices correct at time of going to press.

## AMSTRAD ADVANCE

Alan Sugar's 'good value for money' products have earned him quite a reputation in the consumer electronics world. His latest launch will, he says, "Blow the lid off the personal computer and word processing market." It's the Amstrad PCW8256 word processor/personal computer. This 256K RAM CP/M+ computer comes complete with built-in disc drive, keyboard, monitor, correspondence quality printer and word processing software, and has the facility for a second built-in disc drive. The price — £399 (+VAT).

An 82-key keyboard is provided with several function keys dedicated to the word processing software provided with the system. The keyboard is controlled by its own custom microprocessor enabling a simple cord connection to the main computer/display unit.

The word processing software supplied has been specifically written to provide all the features and facilities expected on a professional stand-alone word processing system—but using logical and carefully devised procedures that will be readily understood by even the novice computer user.

The word processing software allows for the creation of documents up to the maximum available disc capacity, and will permit simultaneous printing and editing. Features such as pagination, automatic paragraph alignment and re-alignment are provided, together with a powerful collection of editing features for cut/paste, etc. The large area screen includes a series of pull-down menus accessed by simple function key selection controlling all main edit controls and text format commands.

High Resolution Green Monitor, featuring 90 columns, and 32 lines of text, is standard, providing over 40 per cent more information area than available on standard 80 x 24 screen displays.

An integral "flip over" 3" disc including Amstrad established CP/M standards, is used, offering 180K of formatted storage space per side. A second drive may be fitted optionally.

A Z80A microprocessor with 265K bytes of RAM is provided as standard. Approximately 112K of this memory is organised for use as RAM-disc to enhance the speed of operation of the many CP/M programs using overlay techniques. Instead of accessing the disc drive to locate



program information not stored in the main memory, this technique uses much faster semiconductor RAM Disc and thus maintains complete compatibility with the vast range of existing CP/M software.

Separate custom microprocessors are used to control the printer and the keyboard.

The integral printer mechanism provides correspondence quality operation at approximately 20 cps, or draft quality text at 90 cps (Elite pitch typestyle). Features such as pitch, italics, boldface, underline, super and sub script are provided by the built-in software.

A tractor feed is supplied for continuous stationery, although single sheet operation is available with an automatic paper alignment system.

The first High Street supplier will be Dixons, who should have their first stock of machines on the shelf this week.

## ZX Supertape

For those who experience great frustration in the slow loading speed of cassette data to the Spectrum computer—relief is at hand.

The Sprint MKII data recorder from Challenge Research loads any ZX Spectrum micro, four times faster than a conventional cassette machine. The manufacturers claim that 99% of pre-recorded commercial software can be loaded without being copied onto different tape or re-saved in an alternative format. Unsuitable programs are those with non-standard tape formats, such as 'Hyperload' etc. Programs can be saved at quadruple speed as well as loaded at that rate.

The only connection required is to the Spectrum's expansion port via the ribbon cable (see photo). An expansion port on the back of the Sprint allows other peripherals to be used. No external power supply is required as the Spectrum itself provides the power for the unit. A full data sheet for the Sprint MKII can be obtained from the address below, price £69.95 inc. VAT and p&p.

A further product of interest from the same company is an azimuth alignment system for the Commodore 64. It consists of a pre-programmed cassette with a 'perfect' head alignment signal. A small screwdriver is required in addition to the kit, which with instructions costs £4.95 inc. VAT and p&p. Details from: Challenge Research Ltd., 218 High Street, Potters Bar, Herts. EN6 5BJ (0707 44063).

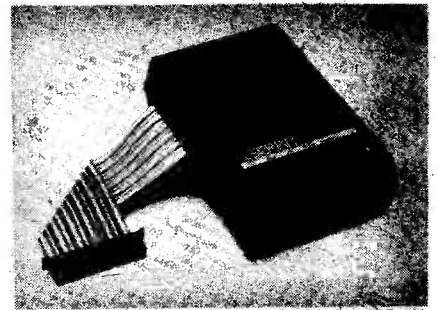

## SIR CLIVE ON BRIGHT SIDE

Now that Sir Clive Sinclair has lost the support of publisher Robert Maxwell and his proposed £12 million cash injection, Sinclair Research has had a further re-shuffle. Bill Jeffrey becomes chief executive, and Sir Clive himself will be Technical Consultant. Meanwhile C5 production has come to a complete standstill. The vehicle's builders Hoover

are still attempting to extract Sinclair from an estimated debt of £15 million.

On the bright side, Sir Clive claims that his share of the UK computer market has now climbed to around 40 per cent. Also the recent conclusion of a £10 million contract with Dixons, the High Street retailers, will further strengthen his position.

## Autosaver

With garage labour costs swinging either side of £10 per hour, an ability to diagnose electrical faults in cars is a boon to any car owner.

A 16-page brochure is available from Fluke Multimeters which gives a detailed system-by-system approach to car electric troubleshooting. Charging, starting, ignition and cooling systems are covered, as are procedures for locating current drains, shorts and bad earths in the wiring. The booklet features drawings and easy to read text, it is essentially for use with Fluke multimeters. Obtainable from Fluke (GB) Ltd., Colonial Way, Watford, Herts. WD2 4TT (0923 40511).

# MARKET PLACE

## QUART IN A PINT POT

Readers who power equipment with batteries such as PP3, PP9 etc., will be very well aware of the cost of these products.

In an effort to take advantage of the large price differential between batteries and single cells, J. Biles Engineering have recently introduced the Verkon V12, a high-efficiency dc-dc converter which lifts the voltage from a single 1.5V dry cell to provide a nominal 12V d.c. output at 50mA.

The cost-effectiveness of the system works like this; an alkaline-type PP3 has a typical 4.5 watt-hour capacity and costs about £1.79, whereas an alkaline "D" cell has a 15 watt-hour capacity but costs only 89p—the single cell has three times the capacity and costs half as much. At a conversion efficiency of over 75%, it is not difficult to see that the cost of the converter

could be recouped in a very short time, and further battery costs minimised.

Also available is the V9-a, a dc-dc converter which gives a nominal 9V d.c. output at 80mA from a single NiCad "D" cell.

The Verkon V12 and V9-a converters cost £5.70 (inc VAT and p&p). From, J. Biles Engineering, 120 Castle Lane, Solihull, West Midlands, B92 8RN. (05432 22382).

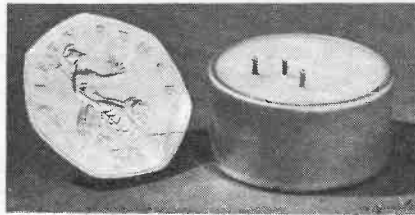

## A LEVEL OF UNDERSTANDING

Just because a problem has long since been solved does not mean that it cannot be improved upon. The new Ford Granada Scorpio owes its new fuel level indicator design to BICC-CITEL Ltd.



The company has designed and manufactured the thick-film fuel tank sender resistive element which indicates not only the amount of petrol in the tank but also enables the miles per gallon ratio to be calculated by the in-car computer.

The element consists of a thin ceramic tile on which the resistive track is screen printed using a specially devised cermet ink, capable of withstanding both the corrosive environment of blended petroleum and the constant track wear caused by the wiper.

To achieve maximum longevity of track life without losing the conformity of low contact resistance needed, the company's (patented) solution was to make the wiper run on a separate track made of conductive ink. This track is actually constructed from a series of parallel conductor bars which link into the resistive track. The wiper remains in constant contact with a number of these bars, so reducing the contact resistance to a low and consistent value. BICC-CITEL Ltd. (0793 487301).

## Briefly...

A company in the USA are marketing a VCR that will record TV programmes without the commercials. It is reckoned to be accurate "at least nine times out of ten". A commercial is fast recorded and recognised on a 'multiples of 30 seconds' basis. The machine then auto-rewinds and records the next part of the programme over what would have been the offending ad. Unfortunately the time taken to do this means that up to 14 seconds of the next piece of wanted material can be lost.

Ernie Higgins, a 59-year-old British Telecom engineer, has invented a device that will save BT around £10 million a year in maintenance costs. The "Mole", a device for pinpointing faults in underground cables, received first prize in a 'New Ideas' competition. The massive potential saving is based on an estimate that the device's accuracy will bring about a reduction in the number of holes which have to be dug for each fault from five to two. For his efforts Ernie was rewarded with a cheque for £2,000 and a silver plated salver.

Massive liquid crystal display screens have been developed by Matsushita for demonstration at the Tsukuba Expo '85. Three sizes are available, the largest measuring 3.2 metres tall by 4.3 metres wide. They are the second generation of slit-diffusion screens, developed in 1983.

## POINTS ARISING . . .

RUGBY CLOCK  
April/May '85

The following points have been brought to our attention regarding this project. These points are in addition to those already published in Points Arising, July issue.

The circuit diagram of the receiver should be altered as follows: IC2 pin 9 should be connected to IC2 pins 11 and 12.

These links have also been omitted from the p.c.b.

## Countdown . . .

Please check dates before setting out, as we cannot guarantee the accuracy of the information presented below. Note: some exhibitions may be trade only. If you are organising any electrical/electronics, radio or scientific event, big or small, we shall be glad to include it here. Address details to Brian Butler.

Technology Engineering Fair Oct. 8-11. NEC Birmingham. T1  
DEC User Show Oct. 15-17. Barbican Centre. Q2  
Computer Graphics Oct. 16-18. Wembley Conf. Centre. O  
Commodore Horizons Show Oct. 26/27. Tech. West Centre. F2  
Cellular Communications Int. Nov. 5-7. Wembley Conf. Centre. O  
Electronic Publishing Nov. 5-7. Wembley Conf. Centre. O

Compec Nov. 12-15. Olympia K2  
Electron & BBC User Nov 14-17. New Horticultural Hall, London L  
Computers In The City Nov. 19-21. Barbican Cntr. O  
Scottish Home Computer/Electronics Show Nov. 22-24. Anderston Centre, Glasgow W2

F2 Computer Marketplace (Exhibitions) Ltd. ☎ 01-930 1612  
K2 Reed Exhibitions, Surrey Ho., 1 Throwley Way, Sutton, Surrey.  
L Database ☎ 061-429 8157  
O Online ☎ 01-868 4466  
Q2 EMAP International Exhibitions ☎ 01-837 3699  
T1 Cahners ☎ 0483 38085  
W2 Trade Exhibitions Scotland ☎ 041-248 2895

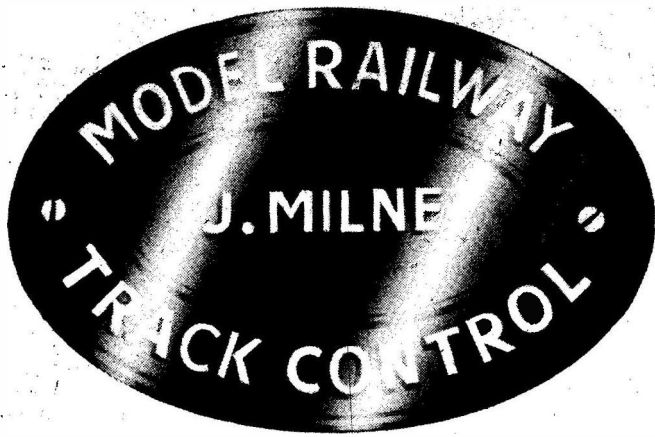

## PART ONE

FOR most model railway enthusiasts, the major part of their time and energy is taken in running, building, or improving their layout. This energy is usually concentrated on the system above the baseboard; and any work beneath, particularly the wiring, is a necessary evil. It is convenient to build a layout of any size on a series of interconnected baseboards, with the result that the track control wires have to cross several boards, back to the control point. This requires a connector at every board junction, so the layout can be moved. While the layout is being built, the wiring can be made neat and tidy, but once alterations and modifications start, the under board wiring can quickly become a mess.

The system described in this article reduces the track control wiring to a minimum, with particular emphasis on the operation of solenoid point motors. This is achieved by replacing the many wires from each point motor, back to the control position, with a single pair of wires, or lines. The lines carry a power supply, and control signals, from a control unit to a number of receiver units situated close to the point motors, as shown in Fig. 1. Two related systems are described: Type A is capable of operating up to 36 point motors, and Type B up to 144. In both of these, the receivers may be connected to the lines in any position, so allowing alterations and additions to be made relatively easily.

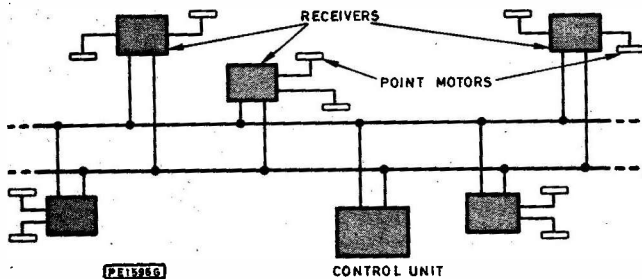

Fig. 1. Schematic diagram of the system

### CONTROL SIGNAL SYSTEM

The control unit supplies a d.c. voltage to the lines, which is interrupted by a pulse position modulated (ppm) signal. This type of signal coding is widely used in the remote control equipment for TVs etc, and is resistant to interference and misinterpretation. The signal consists of a series of six pulses, and the time interval between each is interpreted at the receiver as a five bit binary word. This can most easily be illustrated if the time intervals are considered in terms of cycles of the receiver decoding oscillator. Referring to Fig. 2, the first 20 cycles after a pulse is received are ignored, to prevent interference from pulse reflections. Another pulse received between 20 and 32 cycles is interpreted as "1", between 32 and 60 as "0", and between 60 and 120 as a word space "S". Two consecutive identical five bit words, correctly spaced, must be received before a word is recognised as a legitimate signal.

A five bit word allows up to 32 different signals, but by altering the rate of data transmission so that it is rejected by all the receivers except those adjusted to the particular data rate, the number of signals can be increased. In this system, a factor of two is used between adjacent data rates. The correctly set receiver will

see signal pulses for '1', '0' and 'S', at 26.6, 40 and 80 cycles, but when a signal at twice the data rate is received the pulse will be timed at 13, 20 and 40 cycles. Similarly a signal at half the set data rate will be timed at 53, 80 and 160 cycles, and would be rejected. The receiver decoding oscillator can be adjusted to run between 15Hz and 150kHz, giving a possible maximum of 14 data rates. However, the longest word 00000, requires a period of 560 cycles to be recognised, which is the equivalent of 3.7ms at the highest data rate, but 30s at the lowest, which is impractically long. The highest nine data rates are used, giving a maximum delay of about 1s before a word is recognised. This results in a total of 288 control signals, which can be used for 144 motors.

### SOLENOID POINT MOTORS

This type of motor is constructed with twin coils, and a soft iron armature, which connects to the point mechanism. The force on the armature, when a coil is energised, is in the direction to reduce the length of the magnetic circuit air path, and is roughly proportional to the square of the coil current, and inversely to the

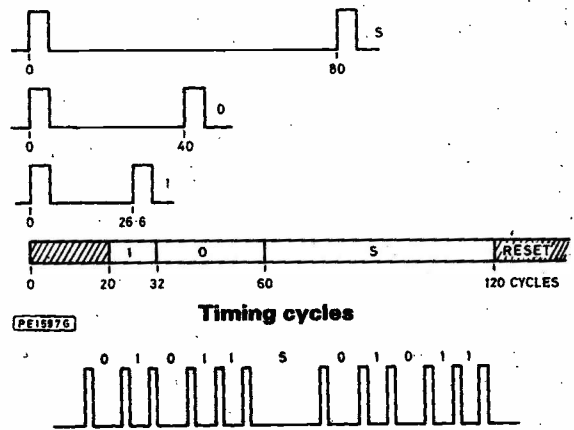
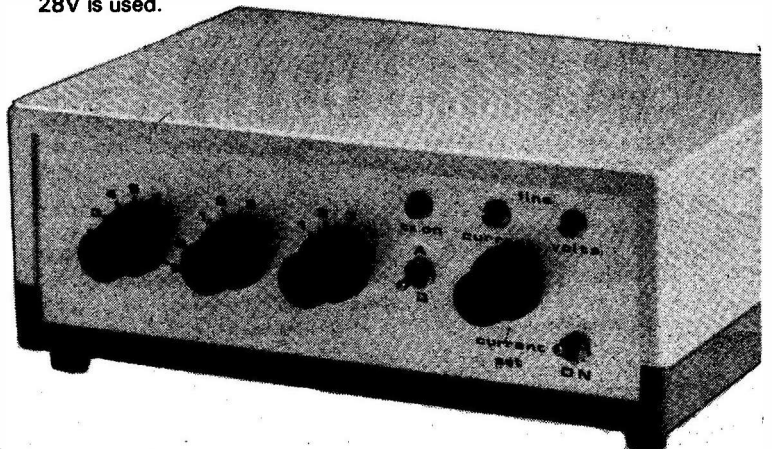
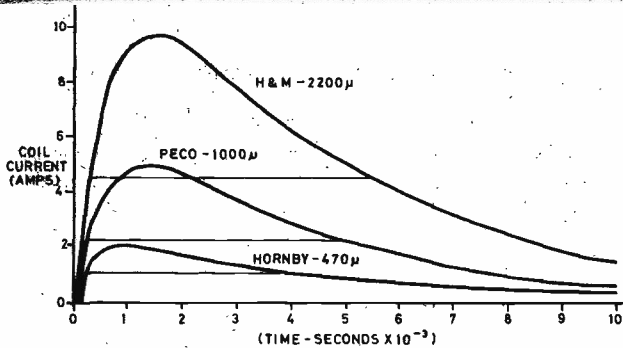

Fig. 2. "5 bit" word formation

square of the length of the magnetic air path. When mechanical stiction is also considered, the minimum coil current to complete an operation must be high initially, to cause the armature to start moving, but can fall progressively as the armature moves. This current demand can be provided by discharging a capacitor through the circuit, which has several advantages. By incorporating a suitable capacitor in each receiver, the high motor operating current will flow only in the short connecting wires, and the line wiring from the control unit has only to carry a lower recharging current. The motor coils have only a short time rating, and are easily burned out, but a capacitor discharge system prevents this occurring. The minimum operating current for the motor can be found using a constant voltage d.c. source, and the peak current supplied by a capacitor must exceed this current, to ensure that the motor armature starts to move. From a series of experiments, using a range of voltages and capacitor values, it was found that reliable operation could be ensured if the peak current was about twice this minimum, and the capacitor was large enough to supply an excess current for a period of 4 to 5ms, with the armature restrained. The peak current is basically voltage dependent, and as the motors are normally operated at about 12V, a line voltage of 28V is used.





**Fig. 3. Motor characteristics**

Table 1 gives typical values found from a small batch of three makes of 00 gauge point motors. The operating currents are for point mechanisms in fair condition, but not brand new. The "H and M" motor was difficult to assess, as it is a universal type, and the work required of it will vary. The uncoupled motor will operate at under 2A, but when connected to a point through a tortuous linkage, it required over 6A to move. The 4.5A quoted is for equipment in fair condition, and a reasonable linkage system. Two values are shown for coil inductance; the lower is where the armature is in the ready to operate position, and the higher after the armature has operated, and the difference reflects the change in length of the magnetic circuit air path.

Motor Type	Typical Values			Operating Current
	Coil Resistance	Coil Inductance (1)	Coil Inductance (2)	
Hornby	11.4Ω	3.5mH	8.0mH	1.0A
Peco	4.0Ω	2.3mH	4.9mH	2.2A
"H and M" SM3	1.8Ω	1.3mH	7.8mH	4.5A

**Table 1. Motor operating current**

It was mentioned earlier that there are two versions of this system, and when the A Type receivers are used, only a limited number of code words are acceptable, while the B Type can use all 32. The A Type word switch connections are shown in Fig. 6, and the words produced are listed in Table 2. The equivalent for the B Type is shown in Fig. 7 and Table 3. Each point is given an identification number of two digits for the A Type and three for the B. The first digit for both types gives the position of the data rate switch, S2. The A Type second digit gives the position of the word switch, S3, and the point motor can then be operated in either direction using switch S4. In a similar way for the B Type system, the second and third digits give the positions of switches S3 and S4, and the point is operated using S5.

Referring again to Fig. 4, an l.e.d. D3 indicates when IC2 is active, and a word is being generated. Transistor TR3 is normally held off when IC2 is inactive, but is switched on by the word pulses when a signal is generated, and in turn causes both TR4 and TR5 to switch on. The collector of TR4 is connected by R12 to IC3 vol-

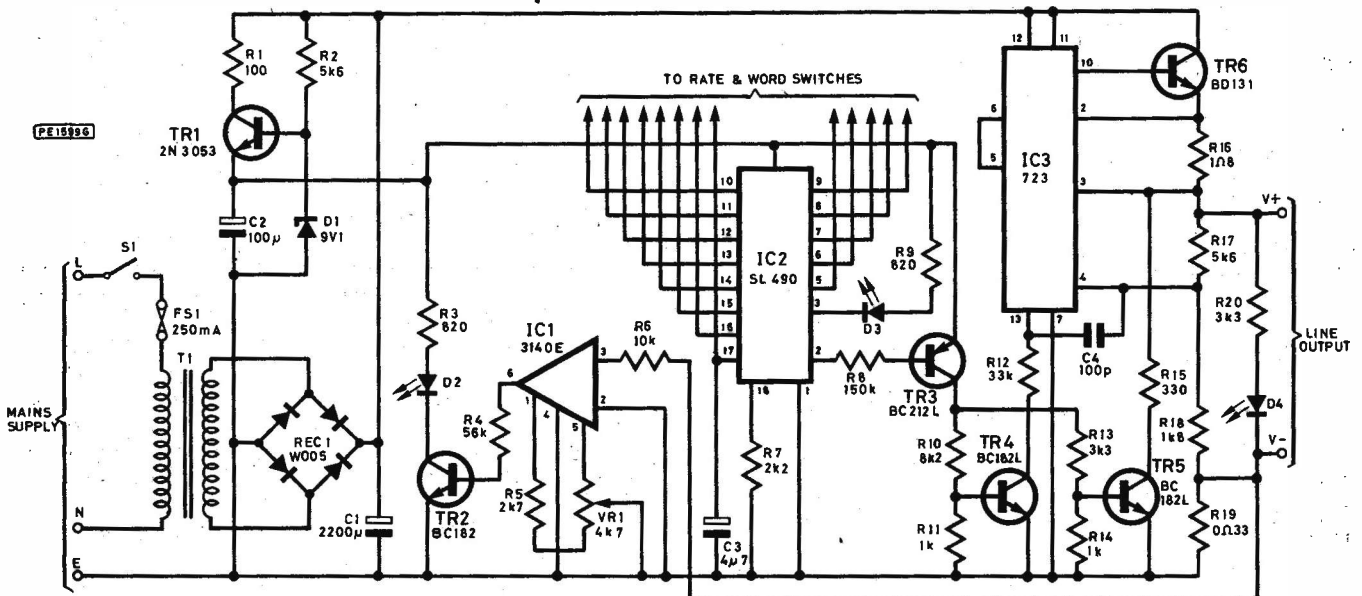

**Fig. 4. Circuit diagram of the control board**

Fig. 3 shows the calculated curves of current against time for the three motors, when connected to capacitors of suitable value. The curves are only valid up to the moment the armature starts to move, and the peak current shown only occurs if armature movement is prevented.

## THE CONTROL UNIT

The circuit diagram for the basic control unit is shown in Fig. 4. It is fundamentally a stabilised power supply unit, using a 723 voltage regulator, IC3, and a current boost transistor, TR6. The values of R17 and R18 were selected to give a nominal 28V line voltage, and R16 limits the short circuit current to around 300mA.

The control signals are generated by IC2, an SL490, which for the usual remote control applications has a fixed data rate, and word selection using an 8 by 4 switch key pad. The data rate is varied by changing the time constant of the components connected to the timing oscillator on the i.c. A convenient parameter to use when deriving the time constant components for both the signal generator and the receivers, is the time interval between pulses for a '0' to be transmitted ( $t_0$ ). For the SL490,  $t_0 = 1.4 CR$  secs, where R is between 15k and 60k. Fig. 5 shows the data rate switch and components, which give a value of  $t_0$  of 280μs, at the highest rate, and 71.4ms at the lowest.

tage error amplifier output, reducing the drive voltage to its output stage, causing TR6 to switch off. The rate of fall of line voltage is dependent on the stray capacitance of the line wiring, so TR5 provides an additional load on the output to the line connections, to improve the signal waveform at high data rates.

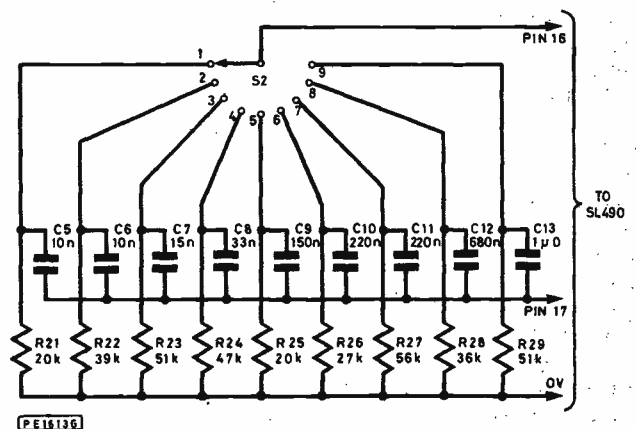

**Fig. 5. "Data Rate" switch connections**

The inputs to IC2 are connected each side of R19, so monitor the current in the external circuit. Potentiometer VR1 is adjusted so that TR2, and the l.e.d. D2, are just switched off, under stable conditions, with all the receivers connected. After a point motor has operated, the increase in line current while the receiver storage capacitor is recharging, will cause D2 to be illuminated, so giving some small measure of feedback that the required operation has occurred. TR1, together with R1, R2 and D1, provide a simple 8V regulated supply for the i.c.s.

## RECEIVERS

The circuit diagrams for the receivers are shown in Fig. 8 for Type A, and Fig. 9 for Type B. There are many similarities in the two types, so the common features are described first. Diode D1 protects the circuit against accidental reversal of the line connections, and diode D2 isolates the receiver from the line circuit when a control signal is being transmitted. Transistor TR1 inverts the negatively modulated line signal and changes the d.c. level to that required by IC1. IC1 decoding oscillator frequency is set by the time constant of the components connected to pin 2, such that  $t_0 = 6CR$  secs, where  $C = C2$ , and  $R = R6 + VR1$ .

TR2, D3, R4 and R5 are connected as a voltage regulator, to supply 15V for the i.c.s. Because the motor operating currents are relatively high, thyristors are used for switching. The continuous current rating of a thyristor is limited by maximum allowable junction temperature. Where the load current is not continuous, the rated current may be exceeded by a factor dependent on the thermal inertia of the junction. The overcurrent limit for a device is

Switch 3 & 4 Positions	Pins Connected	Word Generated	Receiver IC1 Output Pin No.
1A	15-5	00001	ML926 5 6 7 8
1B	14-5	00010	
2A	6-1	00100	
2B	7-1	01000	
3A	15-9	10001	ML927 5 6 7 8
3B	14-9	10010	
4A	10-1	10100	
4B	11-1	11000	

Table 2. Switch "Data Words", Type A

Switch 3,4&5 Positions	Pins Connected	Word Generated	Receiver IC1 Output	Receiver IC2 Input	IC2 O/P Pin D
11A	5-13	00011	1100	1010	— 2
11B	6-13	00111	1000	1000	— 3
12A	5-14	00010	1101	1011	— 15
12B	6-14	00110	1001	1001	— 14
13A	5-15	00001	1110	1110	— 7
13B	6-15	00101	1010	1100	— 1
14A	5-1	00000	1111	1111	— 4
14B	6-1	00100	1011	1101	— 6
21A	7-13	01011	0100	0010	2 —
21B	8-13	01111	0000	0000	3 —
22A	7-14	01010	0101	0011	15 —
22B	8-14	01110	0001	0001	14 —
23A	7-15	01001	0110	0110	7 —
23B	8-15	01101	0010	0100	1 —
24A	7-1	01000	0111	0111	4 —
24B	8-1	01100	0011	0101	6 —
31A	9-13	10011	1100	1010	— 2
31B	10-13	10111	1000	1000	— 3
32A	9-14	10010	1101	1011	— 15
32B	10-14	10110	1001	1001	— 14
33A	9-15	10001	1110	1110	— 7
33B	10-15	10101	1010	1101	— 1
34A	9-1	10000	1111	1111	— 4
34B	10-1	10100	1011	1101	— 6
41A	11-13	11011	0100	0010	2 —
41B	12-13	11111	0000	0000	3 —
42A	11-14	11010	0101	0011	15 —
42B	12-14	11110	0001	0001	14 —
43A	11-15	11001	0110	0110	7 —
43B	12-15	11101	0010	0100	1 —
44A	11-1	11000	0111	0111	4 —
44B	12-1	11100	0011	0101	6 —

Table 3. Switch "Data Words", Type B

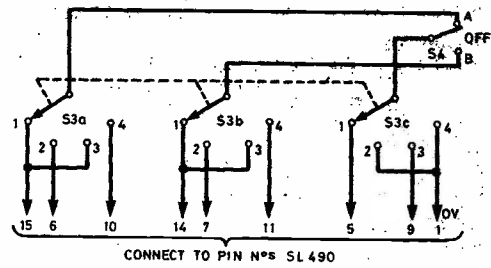

SWITCH S3: 3 POLE: 4 WAY  
SWITCH S4: 1 POLE: 2 WAY WITH CENTRE OFF

PE18169

Fig. 6. A Type switch connections

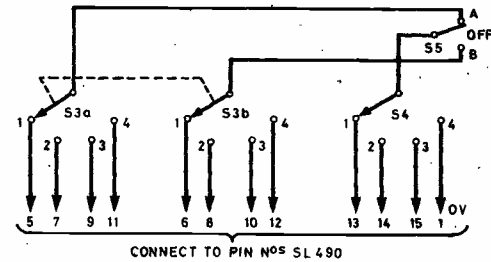

SWITCH S3: 2 POLE: 4 WAY  
SWITCH S4: 1 POLE: 4 WAY  
SWITCH S5: 1 POLE: 2 WAY WITH CENTRE OFF

PE18168

Fig. 7. B Type switch connections

its peak forward surge rating, where it will become damaged if repeatedly used at this current, even if allowed to cool between operations. Because the thyristors used in this system will only be operated intermittently, it is economic to use them to carry a peak current which exceeds the continuous rating, but not to produce a significant increase in the probability of failure. If the maximum current is limited to 50% of the surge rating, junction heating is then about 25% of that which may cause damage, and its useful life in this system is not reduced. For the two types of thyristor used, the 2N5060 series has a current rating of 0.8A, and a surge rating of 6.0A, and for the C106 family, 4.0A and 20A.

To build a complete system, a large number of thyristors are required, so it is worthwhile shopping around, keeping in mind that devices with a low voltage rating are usually cheaper. For use with the Hornby motor, thyristors with at least a 50V rating should be used. This is the result of mutual inductance between the coils, which causes a positive voltage spike to appear at the anode of the "off" thyristor at the moment of switching, and can cause it also to switch on. It is advisable not to use: 2N5060, C106Q1 or C106Q2, C106Y1 or C106Y2.

When the Peco motor is used, the choice of thyristor is a balance of economics and reliability. Any of the cheaper 2N5060 series will operate the motor, but the probability of failure becomes significant at 1000 operations. Of the C106 family, only the C106Q1 and C106Q2 cannot be used.

Any of the C106 family, except again C106Q1 and 2, are suitable when the "H and M" motor is used.

One problem with the use of thyristors in d.c. circuits is to ensure they always switch off. This will only occur when the load current falls to below its holding value, typically 1mA, or less. The method used is to delay the recharging of the storage capacitor C4, after an operation, for a period long enough to ensure that the load current has fallen to a low value. As C4 discharges, the fall in voltage causes both TR3 and TR4 to be switched off. After about 1 second, C3 is recharged by R10, allowing TR4 and so TR3 to switch on again. TR3 is connected as a constant current source, limiting C4 recharging current to about 25mA, which is set by the value of R8, giving a recharging time of around 1 second for each 1000µF.

## TYPE A RECEIVER

IC1 in these receivers is either the ML926 or the ML927. The 926 responds to code words 00000 to 01111, and the 927 to 10000 to 11111. These i.c.s have momentary outputs, that is, the output voltages are high only when a recognised code word is being received. The four outputs are linked by resistors and

capacitors to the gates of the thyristors to operate two motors. The acceptable code words for this receiver are limited to those which will trigger only one thyristor at a time.

### TYPE B RECEIVER

IC1 in this receiver is either a ML928 or a ML929. The 928 responds to code words 00000 to 01111, and the 929 to 10000 to 11111. These i.c.s have outputs that are latched at the last recognised code word, which allows all 16 combinations of the 4 bit code to be used. IC2 is a 4028 BCD to decimal decoder, connected to respond to a group of 8 of the 16, the 0 to 7 decimal outputs being connected. To enable the binary equivalent of 8 to 15 decimal also to be used, IC1 "D" bit is inverted by TR5, to produce "D̄". Either D or D̄ is selected by the position of a link on the board. Where a group of more than four points are close, an extension board can be used, allowing up to eight motors to be operated from one receiver. The circuit diagram for the extension board is shown in Fig. 10.

Another difference in the characteristics of the ML928 and ML929 is that their output logic is negative. Also, to improve the receiver board layout, "B" and "C" bits are reversed between IC1 and IC2. To help reduce the confusion, columns 4 to 6 in Table 3 list the code words expected at each stage, and appropriate energised pin number for IC2 output.

The output connections from IC2 and IC3 to the thyristor gates include a simple low pass filter. It was found that the 4028 can decode faster than IC1 can change its outputs, so briefly energising the wrong output, and some samples of the 2N5060 series thyristor were triggered by this short pulse. The filter delays the voltage rise at the thyristor gate, so that transients have no effect.

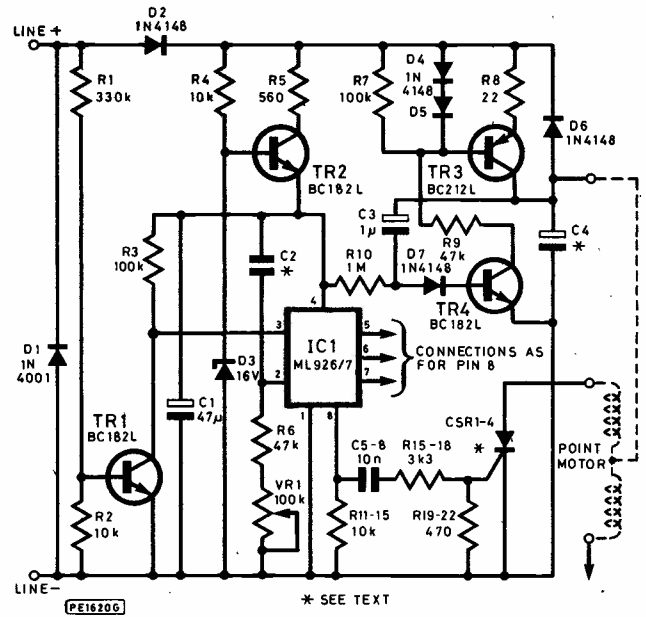

Fig. 8. A Type receiver board circuit diagram

using a current limited d.c. power supply, connect it to the 24V a.c. board edge connections, either way round, and switch on. Increase the voltage gradually until 34V is measured at C1, when the supply current should be around 5mA. Check the voltage at

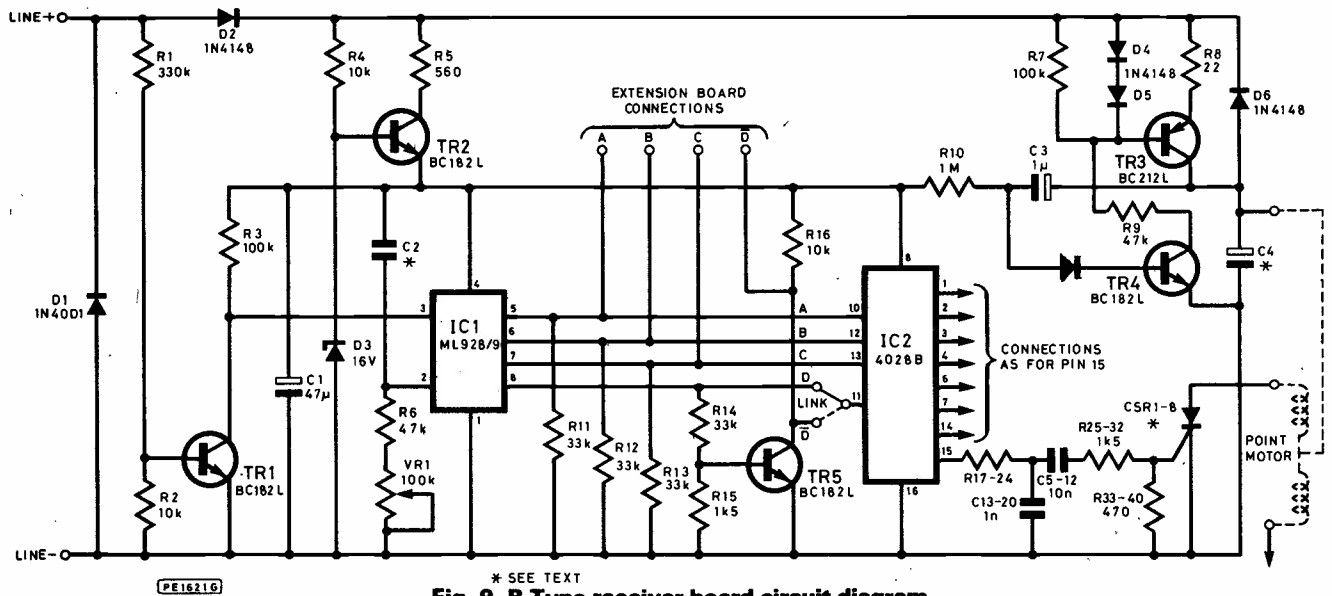

Fig. 9. B Type receiver board circuit diagram

### CONTROL UNIT CONSTRUCTION AND TESTING

The circuit board and the component layout are shown in Fig. 11. When all the components are fitted, and before inserting the i.c.s into their sockets, some initial checks can be made. Preferably

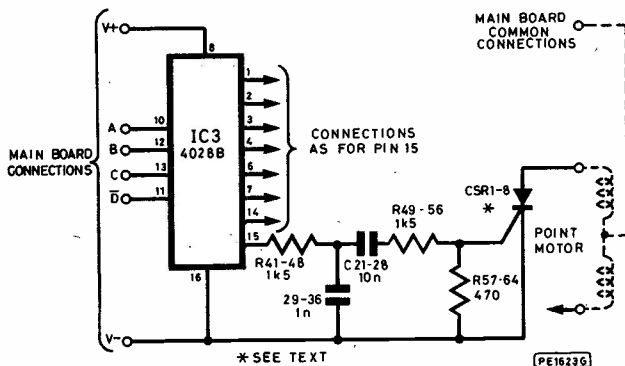
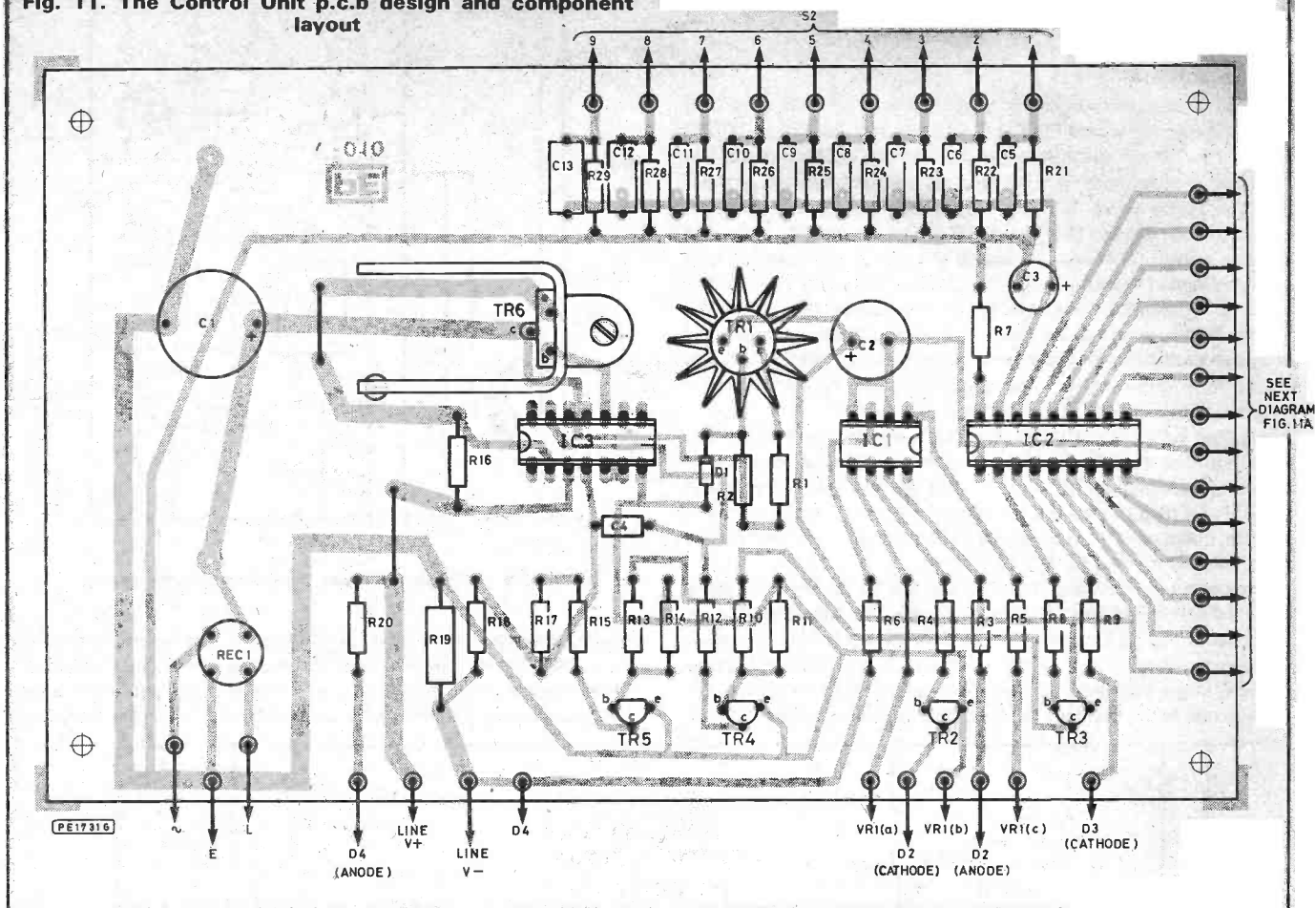

Fig. 10. Extension board circuit diagram

C2, which should be near 8V. Switch off the power supply, and plug in IC3. When switching on again, the supply current should have increased to about 10mA. Check that the voltage between line V+ and V- is  $28V \pm 1V$ ; if not, check the values of R17 and R18. Switch off again, and plug in IC1. When switched on again, there should be a small increase in the supply current, up to about 10-5mA. To positively test the operation of this i.c. without first connecting RV1 is difficult, but check the output voltage at pin 6. If it is low, touch across the line V+ and V- connections with a 1k resistor, to simulate a load current, when the output voltage should become high. If it is already high, short the connection from pin 5 to 0V, when it should change state.

Switch off, yet again, and this time temporarily connect a piece of wire between the edge terminals marked S2.1 and S2 (common). Similarly, connect a flexible piece of wire to the edge terminal marked 1(0V). Plug in IC2 and switch on, and there should be only a negligible increase in the supply current (30µA). Touch the free end of the flexible wire to the edge terminals for any of pins 5 to 12, when the supply current should immediately increase to about 24mA for the period of contact. Avoid contact with the end terminal, as it may result in damage to TR1. Check the voltage at the line terminals, and when using a moving coil voltmeter, it

Fig. 11. The Control Unit p.c.b design and component layout



should show a drop of between 2V and 3V when a signal is present.

If an oscilloscope is available, the signal waveform at the line terminals can be seen, and should be reasonably square, with a minimum voltage at each pulse not exceeding 15V. It is also useful to check TR4 and TR5 collectors, to ensure these fall to zero volts at each signal pulse.

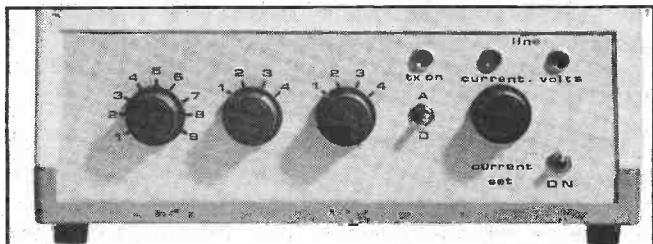

Photos illustrating the internal and external details of the Control Unit

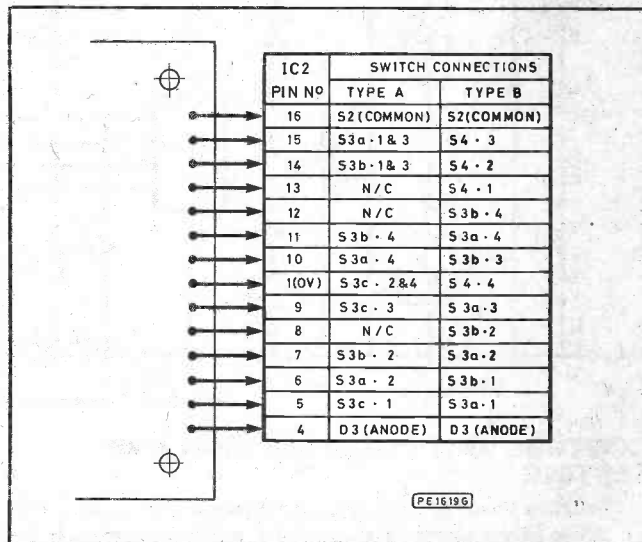
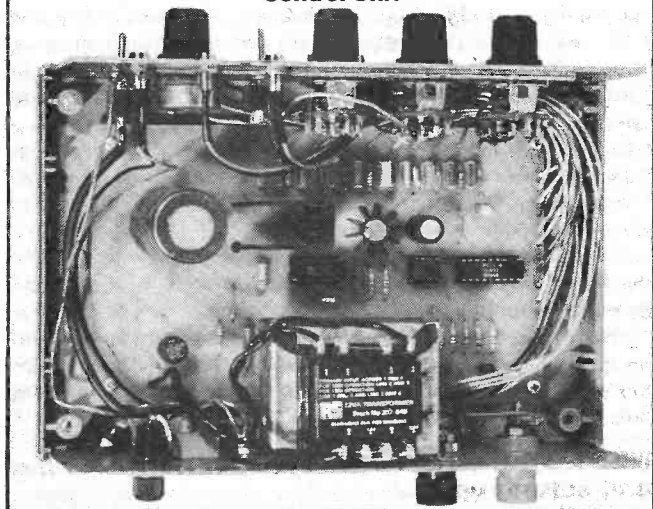

Fig. 11A. Switch connections to the Control Unit

It should now be possible to wire up the board in a suitable box with some confidence that it will work. This operation will be made easier if a selection of different coloured wires can be obtained, and soldered to the board initially, making a note of where each wire is connected. The board was designed to screw directly to the base of a type B Verobox, but its use will depend on the physical size of the transformer to be used. The transformer, line terminals and fuse holder are mounted on the rear panel, and the switches, VR1 and the l.e.d.s on the front. A separate strip of aluminium was used at the rear of the front panel, to accept the switch and pot anti-rotation pegs, to save drilling unsightly holes in the front panel. When connecting VR1, looking at the rear of the front panel, (a) is the anti-clockwise track end connection, (b) the wiper, and (c) the clockwise track end. Both front and rear panels should be connected to supply earth.



# COMPONENTS . . .

## CONTROL UNIT

### Resistors

R1	100
R2,R17	5k6 (2 off)
R3,R9	820 (2 off)
R4,R27	56k (2 off)
R5	2k7
R6	10k
R7	2k2
R8	150k
R10	8k2
R11,R14	1k (2 off)
R12	33k
R13,R20	3k3 (2 off)
R15	330
R16	1Ω8
R18	1k8
R19	0Ω33 1W
R21,R25	20k (2 off)
R22	39k
R23,R29	51k (2 off)
R24	47k
R26	27k
R28	36k
All resistors	1/4W 5% carbon film except R19
VR1	4k7 lin.

### Capacitors

C1	2200μ 40V elect.
C2	100μ 15V elect.
C3	4μ7 10V elect.
C4	100p polystyrene
C5,C6	10n polyester (2 off)
C7	15n polyester
C8	33n polyester
C9	150n polyester
C10,C11	220n polyester (3 off)
C12	680n polyester
C13	1μ polyester
(C5-C13)	±5%

### Semiconductors

D1	9V1 zener, 400mW
D2,D3	miniature l.e.d. (3 off)
D4	
REC1	50V, 1A. W005
TR1,	2N3053
TR2,TR4,	BC182L (3 off)
TR5	
TR3	BC212L
TR6	BD131
IC1	CA3140
IC2	SL490
IC3	723

### Switches

#### TYPE A

S1	Miniature toggle, S.P.S.T. 250V a.c.
S2	Rotary. 1 pole, 9 way
S3	Rotary. 3 pole, 4 way
S4	Miniature toggle, S.P.D.T. with centre off, or two miniature push-button, push to make

#### TYPE B

S1	Miniature toggle, S.P.S.T. 250V a.c.
S2	Rotary. 1 pole, 9 way
S3	Rotary. 2 pole, 4 way
S4	Rotary. 1 pole, 4 way
S5	Miniature toggle, S.P.D.T. with centre off

### Miscellaneous

Transformer. 240V prim. 24V sec. 12VA; fuse holder and 250mA fuse; heatsinks, TO126, TO5; insulated terminals (2 off); d.i.l. sockets: 18 pin, 14 pin, 8 pin. Plastic box to suit. Knobs, wire, etc. P.c.b PE PCB SERVICE-010

## RECEIVER BOARD (TYPE A)

### Resistors

R1	330k
R2,R4,	10k (6 off)
R11,	
R12,	
R13,R14	
R3,R7	100k (2 off)
R5	560
R6,R9	47k (2 off)
R8	22
R10	1M
R15 to	3k3 (4 off)
R18	
R19 to	470 (4 off)
R22	
VR1	100k preset, miniature horizontal

### Semiconductors

D1	1N4001
D2,	1N4148 (5 off)
D4-D7	
D3	16V zener 400mW
CSR1	2N5060 or C106 (4 off)
to CSR4	(*see text)
TR1	BC182L (3 off)
TR2,TR4	
TR3	BC212L
IC1	ML926 or ML927

### Capacitors

C1	47μ 25V elect.
C2*	See below
C3	1μ 35V tant.
C4*	See below
C5-C8	10n polyester

### C2 AND C4 OPTIONS (TYPE A AND B)

#### POINTS TYPE C4\*

Hornby	470μ 40V elect.
Peco	1000μ 40V elect.
"H and M"	2200μ 40V elect.

#### DATA RATE C2\*

1	270p polystyrene
2	560p polystyrene
3	1n5 polyester
4	3n3 polyester
5	6n8 polyester
6	15n polyester
7	33n polyester
8	68n polyester
9	150n polyester

### Miscellaneous

Wire; p.c.b. PE PCB SERVICE -013, d.i.l. socket; etc.

## RECEIVER BOARD (TYPE B)

### Resistors

R1	330k
R2,R4,	10k
R16	
R3,R7	100k
R5	560
R6,R9	47k
R8	22
R10	1M
R11-R14	33k
R15	1k5
R17-R32	1k5
R33-R40	470
All resistors	1/4W 5% carbon
VR1	100k preset, miniature horizontal

### Semiconductors

D1	1N4001
D2	1N4148
D4-D7	
D3	16V zener 400mW
CSR1-CSR4	2N5060 or C106
TR1,TR2,	BC182L
TR4,TR5	
TR3	BC212L
IC1	ML928 or ML929

### Capacitors

C1	47μ 25V elect.
C2*	See below
C3	1μ 35V Tant. bead
C4*	See below
C5-C12	10n polyester
C13-C20	1n ceramic

### Miscellaneous

P.c.b. PE PCB SERVICE -014 d.i.l. sockets; wire; etc.

## EXTENSION BOARD

### Resistors

R41-	1k5
R56	
R57-	470
R64	

### Capacitors

C21-C28	10n polyester
C29-C36	1n ceramic

### Semiconductors

IC3	4028B
CSR9-CSR16	2N5060

### Miscellaneous

P.c.b. PE PCB SERVICE -015.

When the wiring is complete, mount the board and panels upside down, in the bottom half of the box, so exposing the copper side of the board for voltage measurements. Check the board is clear of the panel mountings, and switch on. Check the voltage at C1 is about 34V, C2 at 8V, and the line terminals at 28V, as previously, also that D4 is illuminated. Rotate VR1 to ensure that D2 can be switched on and off, and leave in the position where it is just off. Select several rate and word switch positions, and check D3 is on only when S4 on type A, or S5 on type B, is operated. If D3 stays on, there is an open circuit on the rate selection switch.

A 100 ohms 5W resistor could be used to fully load the unit, but a resistor of a lower power rating may be used if it is only connected for short periods, while the checks are made. Check that the line voltage drop is less than 1V, and that D2 is on, but can be switched off by turning VR1.

Using an oscilloscope, the line signals at each word switch position can be compared with those given in Tables 2 or 3. With these checks complete, the circuit can be correctly fitted into its box, when it will be ready for use.

**NEXT MONTH: Final construction, testing and setting up.**

# THE LEADING EDGE

## CABLE—THE STORY SO FAR

The fortunes of cable and satellite are inextricably linked. Thorn-EMI, who are currently spending nearly £300 a house to cable parts of Swindon, believe that cable and satellite complement each other. This was originally the Government's way of thinking.

In theory, homes without dish aerials get their satellite programmes down a cable. The local cable station erects a communal dish aerial, collects the satellite programmes and routes them round town.

In practice this adds up to a wasteful and expensive system. A cable station can install a large dish and so pick up usable signals from a low power satellite transmitter. The whole point of a high power satellite is that, although expensive, it can serve small, domestic dishes.

The broadcasters are currently in a cleft stick. If they want to get a satellite service going before 1989 they must immediately sign hard contracts with United Satellites, the consortium of British Aerospace, British Telecom and GEC Marconi which the Government says is to build the DBS bird for Britain; but this now seems very unlikely.

Unisat says it will take three and a half years from sign-on to switch-on. It will also take that long to get suitable receivers in shops. Earlier this year the so-called Group of twenty-one (broadcasters and private companies like Thorn-EMI and Granada) were worried about signing. But they were equally worried about what will happen if they delay. There can then be no chance of a service until the next decade, by which time new receiver technology, especially low noise front ends, may have made high power transmissions unnecessary. Also, by then, enough of the country might be cabled to make the whole idea of DBS unnecessary. The state of play changes almost daily. In June the Group of 21 said no to Unisat, and abandoned plans for DBS. But in August the Government was again trying to create a DBS Service and may now re-think its ruling that the British satellite must come from the Unisat consortium. So what are the chances of Britain being cabled?

## LOOKING BACK

Actually Britain was being cabled as early as 1925. Many parts of the country were then without mains power and had to rely on re-chargeable wet acid accumulators to drive their radio sets.

Several enterprising companies offered radio signals at voltage level high enough to power a loudspeaker. The signals were distributed at 500V, by 2 kilowatt amplifiers, and stepped down to a safe 55V for the home. By the end of World War II nearly one in ten British radio licence

holders were wired into a system.

Interest soon grew in the idea of providing subscribers with TV signals in the same way. By 1950 the Home Office had licensed three companies, EMI, Rediffusion and British Relay, to distribute 405-line TV signals on the wires already installed for cable radio. The technical problems were daunting. Even for old-fashioned 405-line black and white pictures, a TV signal needs a much wider bandwidth than a radio signal. The cable engineers triumphed over adversity by taking the broadcast signal, in the v.h.f. band, and dropping it in frequency to the h.f. band.

Rediffusion cabled at 8.9MHz. Repeaters every 1500 metres piped the signals into homes, and blocks of flats, at 30V. A separate twisted pair of copper wires was used for each TV channel.

The problems became even more daunting when the BBC broadcasters started transmitting 625-line pictures in colour on the u.h.f. band. Despite the wider bandwidth it is possible to distribute cable TV signals in this way. The penalty is the need for repeaters at closer intervals and careful equalisation to boost the high frequencies and so compensate for their greater tendency to roll off.

## DIFFERING VIEWS

There are now 1.2 million homes in Britain, around 6 per cent of the total number, which receive their TV signals by cable. Of these 70 per cent are served by primitive twisted wire pairs. The other 30 per cent get their signals by more modern copper coax. This offers much wider bandwidth so in some areas of Britain, for instance Milton Keynes, the local cable TV station also pipes in out-of-area ITV channels. In MK there is also a closed circuit film channel for anyone willing to pay the subscription of nearly £10 a month.

Few people would pretend that cable is currently anything but a dying business. The number of subscribers peaked at 2.5 million in 1975 and remained level until 1980. It has been falling off since then to the current 1.2 million.

In America the situation is very different. By 1984 four out of ten US homes subscribed to cable and 60 per cent of these pay extra for premium channel entertainment. There are 6,000 cable stations across the country, most using relatively old-fashioned coax technology and offering 12 channels. But some modern systems offer 108 channels on a pair of coax cables.

British entrepreneurs have looked enviously across the Atlantic. But they have forgotten two important facts. In America the skyscraper cities, and vast areas to be covered, often make off-air TV reception difficult or impossible. Also the quality of

American TV programmes is appalling. All but the public service channels break up their entertainment fodder with repeated, banal, advertisements. So in America the promise of clearer pictures, better programmes and fewer interruptions has proved irresistible.

## GOVERNMENT REPORTS

In June 1981 Prime Minister Thatcher appointed a panel to advise her and the Government on information technology (IT). In March 1982 this Information Technology Advisory Panel published its first report on cable.

ITAP recommended that Britain should be cabled in time for the new DBS service which was then due to start in 1986. They also recommended that star switching be used, with junction boxes at the end of each street to distribute signals for around 100 subscribers. This technology lets viewers send back control data for interaction.

Most existing systems around the world are conventional tree and branch. A main trunk line splits into smaller branches which serve each home. So everyone gets every signal unless it is blocked by scrambling.

There is also much less chance of two-way interaction on tree and branch technology. The snag is that installing a two-way switched star system is more expensive than a simple one-way tree and branch.

The Home Secretary appointed Lord Hunt to produce the now famous report on cable. But Hunt was not concerned with technology, only programming.

Throughout 1982 the British Government, led by Kenneth Baker, Information Technology Minister, kept reminding people how valuable it would be to have a wired Britain, with a wide bandwidth, interactive system. "*Broad band cable means much more than an increase in the number of TV channels*" said Baker.

He talked of home banking, home shopping, burglar alarms, fire alarms, and message transmission. Behind it all the Government liked the idea of a wired society hooked into computers. It is much easier to keep tabs on people when they are voluntarily wired into a data bank!

In December 1982 Kenneth Baker announced that the licence period granted to firms interested in cabling Britain would depend on the technology used. They would get a 12 year licence for tree and branch and 20 years for switched star. But a fortnight later the then Home Secretary William Whitelaw contradicted Baker and said all franchises would start at 12 years.

The Department of Industry set up a working group under Dr. Tony Eden to produce drafts for technical standards. In November 1982 Sir Anthony Part published his report on DBS and reminded

Britain that "DBS needs cable for reception and cable needs DBS for choice of programming".

In April 1983 the Home Office published a White Paper on cable and promised that 12 pilot systems would be licensed, each covering 100,000 homes. In an effort to get things moving, the Home Office said that British Telecom and their private sector rival Mercury, could offer telephone services down cable links.

In July 1983 the Department of Trade and Industry invited applications for the 12 cable TV franchises. The Government emphasised that anyone applying for a franchise must promise to carry all the satellite programmes transmitted by DBS.

By September 1983 the Home Office had received 37 applications. In November they announced there had been only eleven successes, with 26 failures and one prize not awarded.

### UNDERGROUND TAX

The lucky franchise winners were told that they had to lay their cables underground, in ducts. The idea of a duct is that it makes it easier to replace the cable with more modern technology in years to come.

In practice the duct often collapses through the weight of earth, so the ground has to be dug up again anyway. In Holland they do not bother to lay in ducts any more.

The Inland Revenue soon got in on the act by arguing that ducting did not qualify for capital allowance tax relief. Then the 1984 Budget started to phase out all capital tax relief. Although the Inland Revenue relented on ducting, the firms laying cable are getting progressively less tax relief on what they invest.

Earlier this year Thorn-EMI in Swindon, the only one of the eleven franchises yet to start sending signals down newly laid cables, reckoned it cost £275 per house, even in a thickly populated area. Only one in ten homes is signing on when offered the chance. Predictably other franchise holders got cold feet and put their plans on ice.

Windsor for instance signed a deal with Mercury to provide secondary telephone services, but has not yet actually laid any cable. Rediffusion sold its cable TV interests to Robert Maxwell and Pergamon. Vision Hire withdrew.

Towards the end of last year, the Government created a cable authority to look after the wiring of Britain. In January the CA wrote to 40 companies asking them whether they would be interested in taking a franchise. Compare that with the situation just a year before, when 37 firms were asking for 12 franchises and the Government was not sufficiently impressed with their credentials to award all 12 on offer.

The industry and press run hot and cold over cable, on what seems like alternate days. First it is a dead duck and then there is a light at the end of the tunnel. Behind it all is a giant £ sign. Digging up the country is a primitive 19th century technology, which is expensive and inconveniences everyone.

There are short cuts, for instance by using existing underground ducts. The streets of London are riddled with ducts,

many of them old and unused. But this is not always the case in other cities, new towns or rural villages.

If Britain is to be wired, then someone somewhere has to foot the bill. And however enthusiastic the Prime Minister and Kenneth Baker may have been about wiring Britain, they are not prepared to pay a penny towards having the job done. Kenneth Baker is a lucky man. He left the IT Minister's chair just as the chickens started to come home to roost.

The prospects for cable have not been helped by the Government's decision, in May, to allow private homes, hotels and blocks of flats to erect their own large dish aerials and receive the programmes which are transmitted from low power satellites for cable stations to distribute. Previously such reception was illegal under the Wireless Telegraphy Acts.

### PHONE-IN

One of the few market research companies that takes market research into new technology seriously, CIT Research, believes that the only way to get Britain cabled is to stop worrying too much about high technology systems. Go for simple tree and branch, and if necessary sling the cables from poles and the eaves of houses, says CIT. This is already happening in Aberdeen where BT is involved and has existing telephone wire poles.

On the face of things, all this means that if Britain is wired, it will be with a low technology one way system suitable only

for transmitting passive entertainment. But not necessarily. The industry consistently ignores one obvious compromise.

Most homes already have a cable link; it's called the telephone. This can carry low rate data signals in two directions, as already used for electronic mail and view-data. A one-way, cheap cable link could be used in conjunction with a telephone link for interaction.

The subscriber would have a simple modem hooked to the telephone. Data instructions keyed into the modem and sent down the narrow bandwidth telephone link to the cable station would control the despatch of wide band video and teletext signals into the home for display on an addressable receiver.

Already Oracle, ITV's teletext service, is experimenting with the idea of closed circuit teletext broadcasts. Credit card companies will broadcast lists of stolen card numbers, and supermarkets will transmit the day's prices. These transmissions will be picked up on dedicated, address-coded receivers made available to subscribers. Such a system could surely be used for narrow cast cable.

The PM's ITAP team has been looking again at cable for Britain. It will be interesting to see how bluntly they manage to tell her, in the politest possible terms of course, that she has so far made an awful mess of wiring up Britain.

**BARRY FOX**

# An Unbeatable Combination...

From next month EE readers will be joined by readers of Electronics Monthly which is being merged with this magazine. The new EVERYDAY ELECTRONICS and ELECTRONICS MONTHLY will be stronger than EE with many more readers.

## NEXT MONTH IN EVERYDAY ELECTRONICS and ELECTRONICS MONTHLY

### THREE HALLOWEEN PROJECTS How to Frighten Grandad with a 555 Timer

### SMALL TOOL BUYERS GUIDE

Electronics hobbyists must have small tools. This buyers' guide will show you where to get just the types you need.

### LCR BRIDGE - The Second TEACH IN '86 PROJECT

Another project which complements the Teach-in '86 notes and a useful test instrument in its own right. Enables resistance, inductance and capacitance measurements with the minimum of effort.

## DON'T MISS OUT

There will be extra demand for copies so please place an order with your newsagent NOW! Fill in the coupon and hand it to your newsagent.

NOVEMBER 1985 ISSUE ON SALE FRIDAY, OCTOBER 18

Please order me a copy of  
EVERYDAY ELECTRONICS and  
ELECTRONICS MONTHLY each  
month.  
(IPC Magazines Limited)

Name \_\_\_\_\_  
Address \_\_\_\_\_

# Robotics Review *Nigel Clark*

It is now possible to obtain a computer-driven buggy for less than £70. **Pilot One** has launched its Computer Buggy Driver for about £40 to work with the £25 **Lego Buggy** for the hobby market.

The driver includes an interface/control unit for the BBC B, two optical sensors, software and explanatory manual. A major sales push has not yet been started but Stephen Partridge, production manager, said that it had attracted a great deal of attention when launched at the Acorn User show in July.

## .. designed to withstand the rigours of the classroom ..

The control unit has relay outputs to independently control the direction of two motors. A switch circuit is connected for controlling the lights, horns or an electromagnet.

There are three sensor lines, two being taken up with the optical sensors for the motors. The makers suggest that the other could be used for a bump sensor or white line follower, both of which can be obtained from Pilot One.

The software allows control direct from the keyboard or for the pre-planning of a route on screen which can then be filed and carried out. A full set of Basic procedures is provided to allow users to build up their own routines.

Although sold to go with the Buggy, the unit can be used for any two or three motor models. The software has the option to allow the configuration of the screen display to use names and motions for each motor defined by the user.

The Lego Buggy was developed for the schools *Microelectronics Programme* where it has already been well received. For schools Pilot sells the Buggy with drive and sensor leads to be used with its major digital interface unit, designed, the makers say, to withstand the rigours of the classroom. The interface can also be used to control a model car, crane and Lego railway set.

The buggy, which is supplied in kit form has two motors driving two wheels by worm drives, is also sold by the educational suppliers **Griffin and George** which has developed its own interface.

Partridge said that before the end of the year it was planned to release three new software packages for use with the equipment.

The **Memoco Electron**, not to be confused with the Movit Memocon Crawler, has gone on general release. The makers introduced it last year to gauge the reaction, which was very good throughout the world, and the arm is now on sale in 17 countries.

It is a programmable version of the **Tomy** Armatron with interfaces supplied for the C64, BBC B and Spectrum. With the Armatron costing only about £25 a few enthusiasts have published do-it-yourself conversions, but it is not a job for the fainthearted and this version eliminates the complexity of the work for only £130.

The Memoco can be controlled by the keyboard or joystick with individual motors for each of five axes and gripper, the Armatron has only one, with movement monitored by feedback circuits.

## .. national award for innovation and development ..

**Penman's** Robot Plotter has come second in a national award for innovation and development. The plotter, which operates in the same way as a turtle, was beaten for the top award in the *Prince of Wales Award for Industrial Innovations and Production 1985* by a Thyroid Testing Kit. The award is given not only for technical excellence but also for how it is developed and marketed.

Although designed as a plotter it has quickly become accepted as a teaching aid in the same way as a turtle. Costing about £250 it has software packages for the BBC B, the RML machines, Apple II, Apricot, Macintosh and IBM PC.

The Penman is a three colour plotter which operates on A3 paper. It can be used as a turtle or mouse and with any micro with a RS323 interface. Since the Penman was launched last year it has sold in its thousands and development has continued.

The Troll two-armed robot from **L. W. Staines** is taking longer to develop than anticipated. It had been hoped to have it ready for the *Acorn User Show* but the company is saying it cannot give a date yet. It is 95 per cent complete but a shortage of time with the Ogres doing so well has meant that the other five per cent is not getting the attention needed—we will keep you posted.

## .. no self respecting robot would be seen without its work cell ..

**L. J. Electronics** has been working on enhancements for its Atlas arm. Its software has been improved to allow for more edit facilities but the more noticeable development has been the provision of a work cell.

No self respecting robot can now be seen without its work cell and L. J. has produced a pick and place and sorting system. It includes four hardware modules and a control system known as TINA 6502.

The hardware consists of a parts dispenser which can provide a variety of parts, a motor-driven calliper unit, a weighing unit and an indexing table. The table has four parts bins, on a rotating base driven by a stepper motor, into which the parts after selection are placed by the Atlas.

A special software package is supplied which provides direct control over all the elements of the cell and the arm with the help of a screen representation.

One of the few Japanese companies to produce small robots is **Mitsubishi** with the RM101 being the bottom of its range—a five axis machine for about £1200. It uses stepper motors, can be controlled via a Centronics interface and can lift 500 grammes.

It is being sold in Britain as part of an educational package by **E & L Instruments** of Wrexham, control being provided by the company's Fox micro.

Mitsubishi also supplies a larger more robust version the RM201 at a cost of £6,000.



The Pilot One Buggy Controller linked to a BBC micro and a Lego model kit



Penman Product's Penplot which came second in the 1985 Prince of Wales Industrial Innovations and Production Awards



The Mitsubishi RM101 Movemaster being marketed by E & L Instruments



# THE START OF SOMETHING NEW

If you are leaving College and planning a career in modern communications or if your present job lacks interest and challenge... why not join us in GCHQ? We are recruiting

## RADIO OFFICERS

who after initial training will become members of an organisation that is in the forefront of communications technology. Government Communications Headquarters can offer you a satisfying and rewarding career in the wide field of communications. Training involves a 32 week course (38 weeks if you come straight from Nautical College) which will fit you for appointment to RADIO OFFICER.

Not only will you find the work as an R O extremely interesting but there are also good prospects for promotion, opportunities for overseas travel and a good salary. Add to this the security of working for an important Government Department and you could really have the start of something new.

The basic requirement for the job is two years' radio operating experience or hold a PMG, MPT or MRGC or be about to obtain a MRGC.

Registered disabled people are welcome to apply.

Salaries start at £4,762 at age 19 to £5,755 at age 25 and over during training and then £6,399 at 19 to £8,510 at 25 and over as a Radio Officer. Increments then follow annually to £11,741 inclusive of shift and weekend working allowances.

For full details and application form 'phone 0242 32912/3 or write to:



Recruitment Office, Government Communications Headquarters, Oakley, Priors Road, Cheltenham, Gloucestershire, GL52 5AJ.

## Introducing...



Featured in **WIRELESS WORLD** November issue

System from **£765.00**

**NAIAD**  
(ni-'ad water nymph)

## DESK TOP MICRO HYDRAULIC ROBOT

Available as kit or ready built. ■ 6 Axis, 500 gm capacity, 500 mm reach, 8 bit control system. ■ Self contained system controlled by BBC, Apple 11E, C64 computers. ■ Supplied with extensive software. ■ Many FMS (Flexible Manufacturing System) work cell additions also available.



Please phone for brochure: 0264 50093  
West Portway Industrial Estate, Andover SP10 3PE.  
A private and independent company giving prompt, personal service.

### ROBOTS for EDUCATION TRAINING and INDUSTRY



**MENTOR**  
System from £495

featured in Practical Electronics Sept. issue



**NEPTUNE**  
System from £2195

Hydraulic using water!

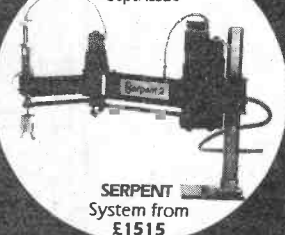

**SERPENT**  
System from £1515

**MENTOR** DC servo desktop robot; 8 bit control system; 300gm capacity; 420 reach.

**NEPTUNE I/II** 6/7 axes 8/12 bit control system 2.5kg capacity. 1120mm reach.

**SERPENT I/II** 5 axes 12 bit control system 2 kg capacity 400/650mm reach.

Robots programmed from keyboard or hand-held simulator (model robot).

Robots may also be taught by 'lead by the nose' method.

Extensive software is supplied free with each robot.

Leads available for connection to BBC, ZX Spectrum, Apple IIe, Commodore 64 and VIC 20.

Most other micros are also easily usable with these robots.

Robots available as kits or ready built.

FMS (Flexible Manufacturing System) work cell additions also available.

Please phone for brochure: 0264 50093.  
West Portway Industrial Estate, Andover SP10 3PE.  
A private and independent company giving prompt, personal service.



## PCB KIT £5.95

4 pieces copper clad, circuit etchant, 2 pens, 5 different sheets transfers, plastic tray & instructions.

Book 'How to Design & Make Your Own PCB's' £1.95

### AA NICAD CHARGER KIT

12-0-12 Transformer on PCB with diodes ex-used equip. series resistor, battery clips & holder mains lead & purpose designed plastic housing box & full instructions. £3.50

### MICRO SWITCHES

Selection of Micro Switches. 7 different types, with levers, buttons or rollers. 7 for £4. Further supplies of individual types, please select & describe £1 ea or 5 for £3.

### MINI-DRILL KIT & SPEED CONTROLLER

High Torque motor, 12V to 18V, 40W reversible 1000 rpm 5 pole rotor, carbon brushes 50x28mm dia. Chuck & set of Collets. 3 HSS Bits 1mm 0.8mm & 0.6mm. Speed controller kit & transformer + 3m of flex. Instructions. £11.95

OR ITEMS MAY be purchased separately: Speed Control £4.50; Transformer £2.90; Motor £2.90; Chuck & 3 precision collets £2; HSS Drill bits with shanks 1mm - 5 bits £1.50; 0.8 or 0.6mm - 5 bits £2.50 (bits not recomm. for glass fibre).

### TUNGSTEN CARBIDE BITS

1mm. Ideal for glass fibre PCBs. £1.20 ea or 5 for £5, or 10 in holder £8.75.

### DC MOTORS

TINY virtually inertia-less motor, i.e. no iron in rotor. 1.5-3V 15mm dia x 30mm + shaft 6x1.6mm. With governor - can be bypassed £1.50. NOMINAL 12V motor works down to 1V ex-unused equip. VCR transport mech. 33mm dia. 30mm o/a + shaft 12x2mm a bargain at 75p ea or 3 for £1.75. MINI TOY motors 1-3V 19x18x9mm 50p ea or 5 for £2.

### UNIVERSAL NICAD CHARGER

With battery test facility and LED indicators. For PP3, AA, C & D cells. £5.99

### BUTTON BATTERIES

1.5V for watches, calculators, cameras, lighters, etc. 4 types any mix £1.50. AG13 11.58x5.4mm AG10 11.58x3mm, AG12 11.58x4.2mm, AG3 7.87x3.6mm or any 8 for £2.50.

Goods sent by return post - please add 80p p&p to total order  
Shop open daily 10-5.30 (closed Wednesdays)

**CROYDON DISCOUNT ELECTRONICS**

40 Lower Addiscombe Road, Croydon CR0 6AA. Tel. 01-688 2950



£15

STEREO CASSETTE PLAYER M-G7

### NICAD RECHARGEABLE CELLS

AA/HP7 500mA Hr. Pack of 4 £1.50 or 4 pks for only £5. (Ex-equip. tested & guaranteed.)



### DIGITAL LCD MULTIMETER

RELIABLE, STABLE & ACCURATE  
RUGGED & EASY TO HANDLE

£29.95

- 3 1/2 DIGIT DISPLAY
- 13 RANGE

- Full Auto Polarity
- Overrange Indication
- Test Leads
- Spare Fuse
- Instructions Manual

■ DC-100V ■ DCmA-200 ■ ACV-500V ■ 1Q-2MΩ

# Introduction to MICRO SYSTEMS

MICHAEL TOOLEY BA    DAVID WHITFIELD MA MSc CEng MIEE    PART 2

LAST MONTH we looked at the general architecture of a microprocessor system, and saw the type of building blocks to be expected in a typical system. It is now time to get to grips with some of the more practical aspects of a micro system; after all, you cannot solder a generalised concept into a circuit board. To bring the subject down to specifics, therefore, we will start by looking at the 6800 CPU in some detail.

As we mentioned last month, the early articles in this series are using the 6800 micro family to illustrate the discussions. The straightforward organisation of the 6800 allows the basic principles to be grasped without (we hope!) becoming lost in the detail. Then we can move on from this base to some of the more sophisticated devices later in the series. Before we look at the 6800 CPU, however, there is one further basic concept which was not discussed last month which we shall be meeting time and again, and which is worthy of a more detailed examination at this stage.

## BUS CONNECTIONS

The concept of a "bus" is one in such widespread use in the field of micros that it is all too easily overlooked. However, it is important to be clear about what is meant by a bus, and how it should work if a micro system is to operate correctly. In this respect, a bus is rather akin to a power supply; it is taken very much for granted when working, but can be the source of untold problems when it is not.

In principle, a bus is little more than a set of connections which allows more than one device to transfer sets of related signals around the system. In practice, however, there is a little more to a bus than simply a way of providing parallel conductors between devices.

Looking back to last month's overall diagram of a 6800-based micro system, we saw for example that there were a number of devices all connected to the address bus. When the CPU outputs an address onto this bus, one (and, if the system is working properly, only one) of these devices will respond. Data is then transferred between the device addressed and the CPU. During this time, however, only the device addressed (out of all the devices connected to the data bus) must actually be driving the lines which make up the data bus. If more than one device does so, there will be conflict on the bus, and data corruption will almost inevitably result.

What is required, therefore, is that all of the devices which are capable of writing to the data bus are effectively disconnected from the bus, except the one actually putting data onto the bus. This is not quite the whole story, however, because the devices which are "disconnected" (i.e. not writing to the bus) may still need to be able to read data from the bus; they may after all be the device to whom the data on the bus is being sent.

Thus, for example, if the CPU is wanting to read data from the PIA, only the PIA's outputs on the data bus should be active, but the CPU still needs to be able to read from the bus.

The normal method of achieving the situation described (i.e. all devices able to read from the bus through the same connections that are used when in control of and writing to the bus) depends on the use of *tri-state* bus drivers. A device with a tri-state output is one which allows the resistance of the output circuit to go to a high impedance state (several M $\Omega$ ) when the device is not selected. This high impedance state means that the device is no longer effectively connected to the bus lines, and its output will follow whatever else is on the bus. Thus, the output of a tri-state device will be either at logic 0 or logic 1 (when the device is enabled), or in the high impedance state (when disabled).

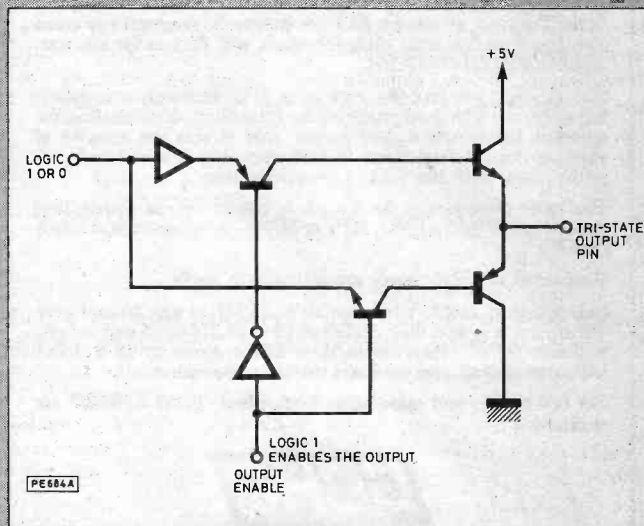

Fig. 2.1. Tri-state driver output stage

One way in which a tri-state output can be achieved is illustrated in Fig. 2.1, and shows the output enable control typical of such devices. With this enable line activated, the output behaves as an ordinary TTL gate, with either an active totem-pole pull-up for logic 1, or a current-sinking pull-down for logic 0. In the third state, when the enable control line is disabled, the internal circuitry is essentially disconnected from the output, and hence from the bus, which is then free to assume any value it likes.

The use of tri-state gates avoids the need for every element on the bus to be connected to the input of a data selector. On an 8-bit bus with eight elements attached, this would require a minimum of eight 8-way selectors, and would still not give us a bidirectional capability. Using tri-state drivers on the bus, however, all of the

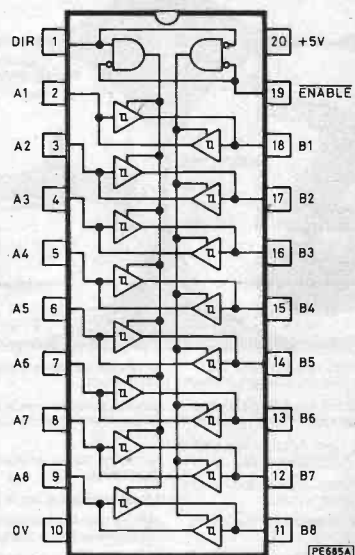

Fig. 2.2. Internal details of an octal bus transceiver chip

outputs remain physically connected directly together all of the time. The price to be paid for not having the data selectors is the marginally higher price of tri-state drivers when compared to standard types. Overall, however, a substantial saving and simplification usually results from using tri-state devices to drive the bus. All we then have to do to give us the basic framework for a bus is to make sure that only one such device is active on the bus at a time.

To complete the picture for a bidirectional bus, it is also necessary to add the capability for a device on the bus to receive data as well as to send it. This is usually achieved by combining a buffer gate in the same package as the tri-state driver. This allows the logic levels on the bus to be sensed as well as driven, without each device having to have two sets of connections to the bus; one for read and one for write. This has the advantage of keeping both the wiring and the load capacitance on the bus to a minimum. The result is that the receiver section of a *bus transceiver* can always be active, while the transmitter section is only in the active state (i.e. not high impedance) when the device is actually driving the bus.

The schematic for a typical octal bus transceiver is shown in Fig. 2.2. This provides, in a single 20-pin package, an 8-bit bus buffer with 3-state outputs. The device allows transmission from the "A" pins to the "B" pins, or vice versa, depending on the logic level at the direction control input. In the majority of devices used in modern micro systems, such bus transceivers are an integral part of the devices themselves. Memory devices, for example, usually include data bus transceivers, and only a single pin is then used for each data line for both reading and writing.

This is illustrated in Fig. 2.3, which shows the internal schematic for a 2114 static RAM device. The direction control for transceivers in such devices is derived from the R/W (or "Write Enable", WE) input. Discrete transceivers, on the other hand, are usually found at I/O points, e.g. in the 1MHz extension bus in the BBC Micro.

## 6800 CPU

The pin connections for the 6800 CPU are shown in Fig. 2.4, but as it stands this diagram tells us very little without some further interpretation. In this respect it is a useful first step to consider the pin connections in groups, and to relate these to the data, address and control buses introduced last month. Fig. 2.5 shows the processor's inputs and outputs grouped into four functional categories.

The signals on the control bus mentioned last month have been further divided into I/O Control Signals and Supervisory Signals. Just before we start on these categories, however, it is worth establishing how the chip gets its power. The supply for the 6800 is obtained from a single +5V rail; pins 1 and 21 (Vss) are connected to 0V, and pin 8 (Vcc) is connected to +5V.

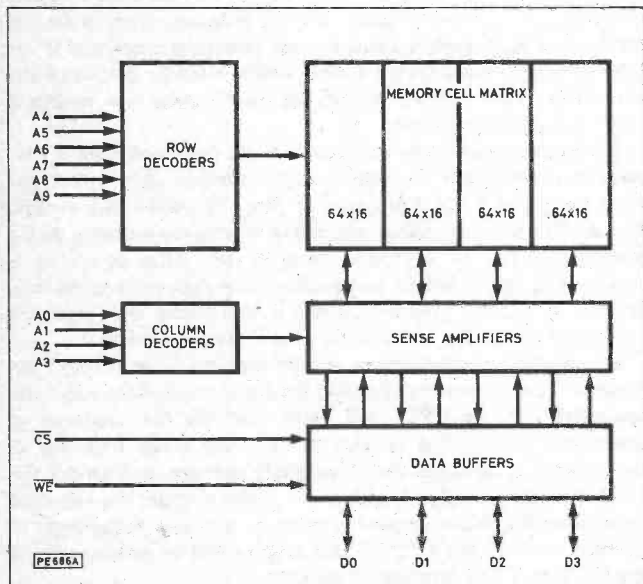

Fig. 2.3. Block diagram showing the internal organisation of a static memory device—this is a 2114 chip

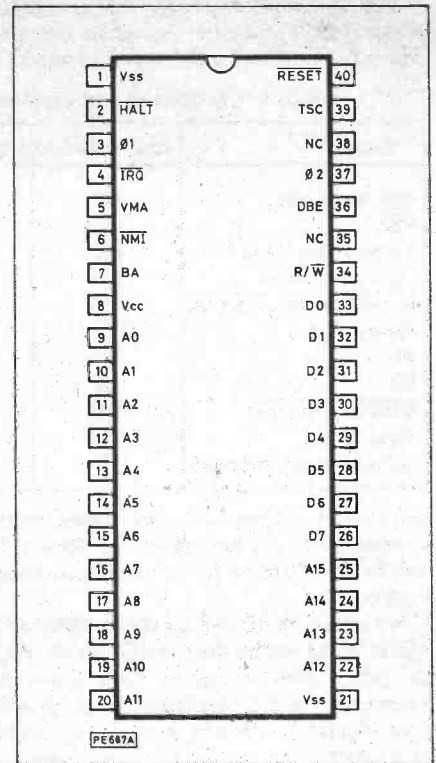

Fig. 2.4. The 6800 microprocessor. It is a 40-pin chip, as are most 8-bit micros. The address bus accounts for 16 pins, and the data bus for 8. The rest are for control lines, and power connections

## ADDRESS BUS & DATA BUS

The 16-bit address bus connections A0 (LSB) to A11 appear on pins 9 to 20, and connections A12 to A15 (MSB) on pins 22 to 25. These outputs are buffered out of the chip by tri-state bus drivers, each capable of driving up to one standard TTL load and 90 picofarads. The bidirectional data bus connections D0 (LSB) to D7 (MSB) appear on pins 33 down to 26, respectively. The data bus is capable of driving up to 130pF and one standard TTL load.

This typically allows the CPU to drive between 7 and 10 other 6800 family devices without further buffering, which is particularly convenient for small systems since it keeps the component count to a minimum.

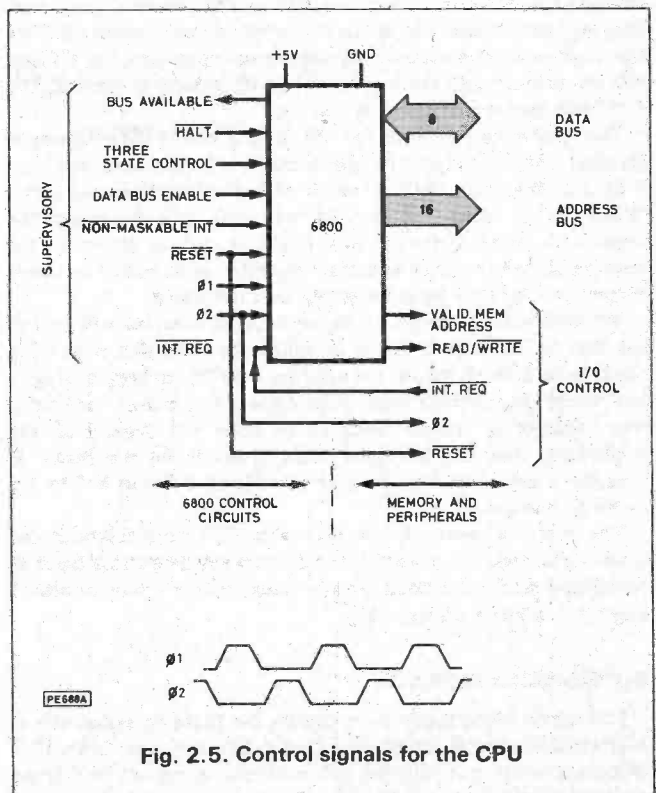

Fig. 2.5. Control signals for the CPU

## I/O CONTROL BUS

The I/O Control Bus in Fig. 2.5 is a rather mixed group of signals whose overall purpose is to regulate the operation of the system of which the 6800 forms the central element. The signals in both the

Table 1: I/O Control and Supervisory signals

Signal	Abbreviation	I/O Control	Supervisory
Bus Available	BA		*
Halt	Halt		*
Three-State Control	TSC		*
Data Bus Enable	DBE		*
Non-Maskable Interrupt	NMI	*	
Reset	Reset	*	*
$\phi_1$	$\phi_1$	*	*
$\phi_2$	$\phi_2$	*	*
Interrupt Request	IRQ	*	
Read/Write	R/W	*	
Valid Memory Address	VMA	*	

I/O control and the supervisory buses, together with their normal abbreviations, are summarised in Table 1. Some of the signals, it will be noted, appear in both groups, although usually for different reasons.

We start with the two signals on which all timing and synchronisation in the system depend, the clocks. The CPU operates from a two-phase non-overlapping clock whose two signals,  $\phi_1$  and  $\phi_2$  (shown in Fig. 2.5), are connected to pins 3 and 37, respectively. One of these clock phases,  $\phi_2$ , is used as part of the I/O control bus. It is applied to the enable/chip select inputs of the other devices to ensure that they are only enabled when the address bus and the VMA signal are stable. Other features of the clock signals are considered later under the supervisory signal heading.

The VMA signal (Valid Memory Address) from pin 5 indicates to all devices on the bus that the CPU is performing a read or write on the bus during a particular cycle. Data transfer is therefore disabled while VMA is at a logic low, since in this state the CPU is not performing a read or write. The R/W signal from pin 34 identifies whether the operation is a read (logic high) or a write (logic low). The convention here is that a read operation is one which transfers data to the CPU, whereas a write operation is one which transfers data from the CPU.

The Reset signal is the one used to reset and start the CPU from a powered down condition. It is connected to pin 40, but is also routed to all other devices on the bus so that, where appropriate, they may also be reset and hence start up in a known condition. This line must be held at a logic 1 during normal operation, but if taken low for at least eight clock cycles while the system is running, the CPU will restart as if just powered up.

The remaining signal on the I/O control bus is  $\overline{\text{IRQ}}$  (Interrupt Request). This is an input (on pin 4) which is pulled down to a logic 0 by any device on the bus which wishes to interrupt the CPU. When  $\overline{\text{IRQ}}$  is taken low, the CPU will wait until the end of the instruction which it is currently executing, before acting on the request. However, the programmer may choose to ignore interrupt requests at any time by masking out user interrupts.

We shall be coming back to interrupts again later, but suffice it to say that an interrupt is a way of telling the CPU that something needs to be done. It avoids the need for the CPU to keep having to look to see if something needs to be done (i.e. it avoids "polling"). The "something" which needs to be done will depend on the application, but the interrupt could typically be the result of pressing a key, requiring the key identity to be read before the operator releases it.

The interrupt approach thus allows the CPU to be carrying out other useful tasks while waiting for the next key depression (such as updating a readout), safe in the knowledge that it will be informed when the operator presses a key.

## SUPERVISORY SIGNALS

Moving on to the supervisory signals, the first new signal here is NMI (Non-Maskable Interrupt) on pin 6. This is similar to the  $\overline{\text{IRQ}}$  described above, but with the difference that it cannot be masked out by the programmer. It therefore tends to be used for interrupts

which cannot wait for a response; in the BBC Micro, for example, an NMI is used in the floppy disc interface.

The  $\phi_2$  input signal on pin 3 is simply the second phase of the two-phase system clock. During the period that  $\phi_1$  is high, the memory address for the next instruction is placed on the address bus, and in the following period (when  $\phi_2$  is high), the data bus is activated.

The DBE (Data Bus Enable) control input on pin 36 is used to enable the tri-state data bus drivers when set high, and is normally driven by the  $\phi_2$  signal. The signal is externally generated (rather than being internally connected to  $\phi_2$ ) so that it is possible for a device in the system other than the CPU to be given control of the bus. When held low, DBE causes the bus drivers to assume the high impedance output state, thereby allowing another device to assume control and put data onto the bus.

The Tri-State Control (TSC) input performs a similar function for the address bus as that performed for the data bus by DBE. When taken high (note: the opposite sense to that of DBE), the address bus and the R/W line are put into the high impedance state. Thus, the address bus is freed for use by other devices when TSC is high.

The final supervisory input to the CPU is the Halt signal on pin 2. Under normal conditions, this input is held inactive at a logic 1, and the CPU is allowed to fetch and execute instructions in accordance with its program. When the input is taken low, the CPU completes the execution of the current instruction and halts. This is also indicated by a change from low to high on the BA output (see below), and a change from high to low of the VMA output. Whenever the CPU is halted, the address bus, the data bus and the R/W line will all appear as high impedance connections on the bus lines. This has the effect of removing the CPU from the system bus. The only action which continues while the CPU is halted is the latching of interrupts on the NMI and  $\overline{\text{IRQ}}$  inputs, thereby keeping them ready to be serviced immediately after the Halt line returns to the logic high state.

The Bus Available (BA) supervisory output on pin 7 is normally inactive in the low state. It is taken high by the CPU on the activation of the Halt line, or by the execution of a "Wait" instruction. In either case, the CPU stops executing the program at the end of the current instruction, and sets the BA signal high. This indicates that all of the 3-state buffers are in the high impedance state. This condition will persist until either the Halt line is taken high again, or an interrupt occurs, depending on the original cause of the condition. The BA signal may therefore be used to notify external hardware that the CPU is off the bus.

## PROGRAMMING THE 6800

Now that we have looked at how the 6800 appears to the outside world, it is time to turn our attention inwards and look at the workings of the CPU from the programmer's viewpoint. With any micro system, the intelligence in the system can reasonably be said to reside in the control program. It is the program which causes the elements of the system to behave in the desired manner, and if you have ever been faced with a system which is totally devoid of any control program, you will readily appreciate quite how useless it really is without software!

This state should not be confused with the switch-on state of a typical microcomputer or home computer before its program has been loaded in RAM from tape or disc. The difference is that, because its operating system is stored in permanent memory, such a system responds to keyboard input straight after power-up is complete. A "bare" system on the other hand does not even do this, because it has no program to tell it that there is a keyboard connected to the bus, never mind what it should do with it.

The control program (more usually referred to as simply "the program", or "Operating System") is a set of instructions which are meaningful to the CPU, and which identify the sequence of operations which must be carried out. Any given sequence of instructions is designed for a particular purpose, and guides the CPU through the operations it must perform under the expected conditions. We therefore need to move on and look at the types of operations which the CPU (in this case we will be looking only at the 6800) may be instructed to perform.

The "art" of programming is then to use the available instructions in the most efficient manner to effect the desired results. Readers should note that this is not the subject of this series, since it



is felt that programming is a skill which most readily comes with practical experience. Instead, we aim to introduce the techniques involved, believing that real problems are then the best spur to applying them in earnest.

## THE 6800 INSTRUCTION SET

The 6800 CPU operates in the main on 8-bit numbers which are fetched from the memory via the data bus. Any given byte fetched from memory can represent either data or an instruction to be executed. The significance of a particular byte is determined only by where it is encountered in the program. As we have said before, this does mean that the CPU will quite happily attempt to execute data values as instructions, since it is unable to tell them apart. The results may be unexpected, but they will be explainable; this is not usually much comfort when this type of error does occur.

The 6800 has 72 unique instructions, but it recognises 197 of the possible 256 values which can be held in a single byte. This increased number results from the fact that many of the instructions have more than one addressing mode, each with its own instruction value. These addressing modes refer to the manner in which the program causes the CPU to obtain its data. They take account of the fact that the programmer needs a method of addressing both the CPU's internal registers and the external memory locations (which may be "real" memory or registers in peripheral devices on the buses).

The 197 different instructions provided by the 6800 fall into the following four major categories:

- (a) accumulator and memory
- (b) index register and stack
- (c) jump and branch
- (d) condition code register

From this, it is clear that we will need to look at the CPU's registers in a little more detail to make much sense of the instruction set.

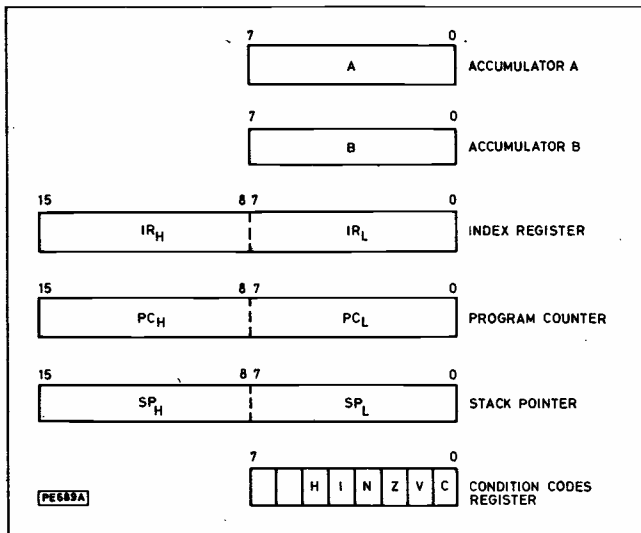

Fig. 2.6. Programming model of the CPU registers

## CPU REGISTERS

A programming model for the CPU is one of the standard methods of looking at a micro to gain an idea of its architecture. The model for the 6800 is shown in Fig. 2.6, and in fact is the same for the 6802. The 6802 is a software-compatible hardware variation on the 6800 which contains a number of additional "convenience" facilities, such as a small amount of internal RAM (128 bytes) and an on-board clock circuit.

There are six slight differences overall between the two devices, but the two devices are software compatible. The functions of the CPU registers shown in the figure are described in the following paragraphs. Most micros have similar registers, although the quantity of any given type, and the bit-lengths do tend to vary from type to type.

**Accumulators:** There are two 8-bit registers (A and B) which can be used for the storage or manipulation of data within the CPU. These two registers can be specified as the source and/or destination

of data in many operations. In some micros, which have only a single accumulator, there are even instructions which assume that it is to be used for the operation.

**Program Counter:** The program counter (PC) always contains the address of the next instruction byte to be fetched from memory. It is a 16-bit register which is automatically updated after each instruction fetch. When a jump operation is performed, the program counter is forced to a new value to cause the first instruction at the new program branch point to be fetched. The programmer need not be concerned directly with this register since it is automatically maintained by the CPU.

**Index Register:** The 16-bit index register (IR) holds memory addresses for use with certain types of instruction addressing modes. The contents of this register can be loaded, stored or manipulated by the programmer.

**Condition Codes Register:** This register (CCR) is really a collection of single-bit flags, gathered together in one place. The organisation of the register is shown in detail in Fig. 2.7. The two most significant bits are permanently set to logic 1, but are otherwise unused. Bit 4 is set by the programmer to indicate whether the CPU is to recognise user interrupts at the present time. Instructions are provided especially for clearing and setting the interrupt enable ("I") flag. The interrupts are ignored (masked) while the "I" flag is set to a logic 1.

The remaining bits hold the flag states which result from the last instruction which affected them. The flags indicate the result of arithmetic and logic operations (e.g. overflow, zero result). The state of the flags can be used to determine which sequence of instructions is executed next by using instructions whose result depends on the state of a particular flag, e.g. test to see if the result of an operation is zero, and continue the program at different points depending on the result.

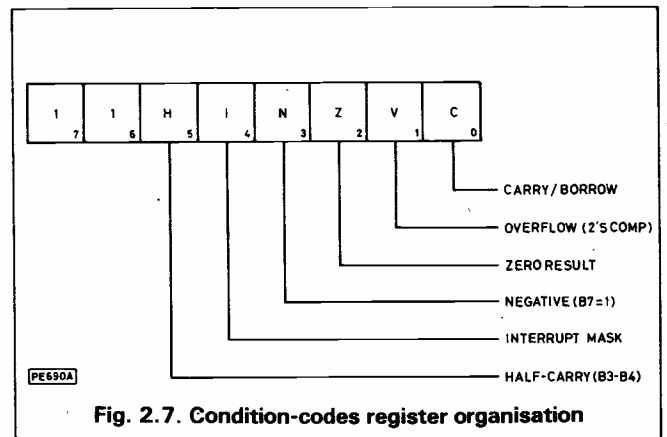

Fig. 2.7. Condition-codes register organisation

**Stack Pointer:** The stack pointer (SP) is a 16-bit register that holds a memory address. The address points to the next free location in a RAM area which the programmer allocates to the stack. The stack is used for saving the contents of all the CPU registers (including the PC) at a particular instant. Whenever a stack save operation is performed (e.g. automatically when an interrupt occurs), each register byte is saved in the location pointed to by the SP, and the value of SP is then decremented by 1.

The order in which the registers are saved (pushed) is shown in Fig. 2.8, where the state of the stack is shown after two stack saves. The stack is unloaded (contents of the registers restored to be the same as the values in RAM), in the reverse order to the order of the save. The value of SP is then incremented by 1 after each stack unload (pop) operation. Complete push and pop sequences occur automatically in some situations, but instructions are also provided to allow the programmer to manipulate the stack and the stack pointer. If the workings of the stack appear confusing, do not despair, as we will be coming back to it again later.

## ADDRESSING MODES

As we have said, the 6800 has 72 different types of instruction, with a total of 197 different variations on these basic types. It is usual practice to refer to each of the 72 types of instruction by means of a mnemonic. Typically, a 6800 mnemonic is three or four characters (e.g. LDAA is used for the instruction to load a value into

accumulator A), followed where necessary by addressing information to tell the CPU where to get/save the data from/to.

The mnemonics themselves are not actually understood by the CPU at all, but instead are provided for the convenience of programmers. When the program has been written, the mnemonics must be replaced by the appropriate instruction byte values in memory before they can be understood by the CPU. Software development (or programming) is usually now done by writing the instructions in terms of these mnemonics, and then using a special program (an assembler) to convert from the man-readable form (sometimes called source code) to the CPU-readable form (called object code).

The 6800 supports six different addressing modes, although not all modes are supported for each type of instruction. The modes are:

- (a) inherent
- (b) immediate
- (c) direct
- (d) extended
- (e) relative
- (f) indexed

The way in which an instruction type distinguishes between the addressing modes depends on the assembler used. However, it is usually clear from the form of the address (sometimes from the instruction itself) which mode is being used. Different micros have different numbers of addressing modes, but those in the 6800 are the basic ones which will usually be found in any micro, although the names do tend to change between manufacturers.

Each of the modes is described below, with examples. The addresses in the examples give actual memory addresses where appropriate, but many assemblers will allow the programmer to assign names to memory locations, and use these instead. Using actual addresses, however, avoids the difficulty of having to identify the possible differences between assemblers. To avoid any doubt, the object code bytes corresponding to the examples are also given in brackets.

### Inherent

Some instructions do not require any additional address information since the data required is already in the CPU's registers. For example:

CLRA sets register A to zero (4F)  
 INX increments the index register by one (08)

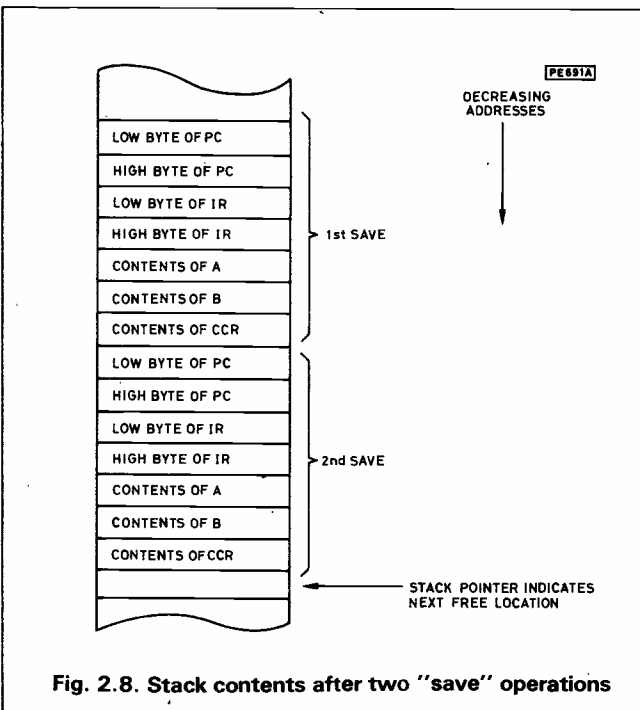

Fig. 2.8. Stack contents after two "save" operations

### Immediate

In this mode, the data value (often referred to as the *operand*) immediately follows the instruction code. The operand may be one

or two bytes, depending on the instruction type, and is usually indicated to the assembler by a "#" sign. Two-byte values are only used for operations affecting the index register and stack pointer. For example:

LDAA #FF loads register A with FF (86 FF)  
 LDX #0300 loads the index register with 0300 (CE 03 00)

### Direct

In this mode, the data is located or to be stored in a memory location which has an address between 00 and FF (hex). This allows the address to fit into one byte only, thereby saving space. For example:

LDAA 7E loads the contents of location 7E into register A (96 7E)  
 CMPB 43 compares the contents of register B with the contents of location 0043 (91 43)

### Extended

This is probably the mode used most often by programmers. The memory address for the operand is contained in the two bytes following the instruction code. The more significant byte comes first, followed by the less significant byte. Extended mode addressing allows the programmer to access the full 65536 bytes of the 6800's address range. This mode will always work for accessing memory, although an "intelligent" assembler may substitute the direct mode where appropriate to keep the program size to a minimum. For example:

LDAB 001F loads register B with the contents of memory location 001F (F6 00 1F)  
 INC 147B increments the contents of location 147B by one (7C 14 7B)

### Relative

This mode is used solely for branching instructions, i.e. ones which may change the sequence of instructions being executed, depending on the state of the flag being tested by the programmer at the time. The instructions for which relative addressing is a valid mode are two-byte instructions, and the value of the operand (in the second byte) indicates the address at which the program will resume execution if the branch occurs. This single byte operand is used to hold a 2's complement number (allowing a range of -80 to +7F) which is added to the current program counter value.

Since the current value of the program counter points to the instruction *after* the branch instruction, this means that the branch can be to any address which is in the range -7E to +81 bytes away. For example:

BRA 23 branches always to an address 25 bytes higher than where the instruction is stored (20 23)  
 BEQ 90 branch if the zero flag is set to an address 6E bytes lower in memory than where the instruction is stored (27 90)

### Indexed

Indexed addressing involves two-byte instructions and makes use of the current contents of the index register. The address used is calculated by adding the value in the second byte of the instruction to the current value in the index register. The value of the index register, however, is unchanged by the instruction. For example, assume in the following that the current value in the index register is 1400:

LDAA 20,X loads the contents of location 1420 into register A (A6 20)  
 CLR 43,X sets the contents of location 1443 to zero (6F 43)

To support indexed addressing, special instructions are provided to manipulate the index register, e.g. LDX, INX, DEX allow it to be loaded, incremented and decremented, respectively. Some of these operations may themselves also use indexed addressing! The use of indexed addressing is particularly useful for manipulating tables of values, but it is worth pointing out that in cases of need, the index register can safely be used for other purposes by the inventive programmer.

**NEXT MONTH: We look at what happens in a 6800 system after you switch the power on, and at peripherals.**

# A GREAT BIRTHDAY BARGAIN FROM

# ALCON

TO COMMEMORATE P.E.'s 21st WE OFFER THE SUPERB

## SUPER 50

for

# ONLY £36.30

This high quality instrument combines high sensitivity (50k ohms per volt on both AC and DC ranges) with foolproof protection. The movement is diode protected on all ranges and the instrument is electronically protected on all of its 39 ranges except the 3 Amp.

### SPECIFICATION

Accuracy: d.c. ranges and  $\Omega$  2% a.c. 3% (off s.d.)  
 39 ranges: d.c. V 150mV, 1V, 3V, 10V, 100V, 300V, 1000V;  
 d.c. I 20 $\mu$ A, 100 $\mu$ A, 300 $\mu$ A, 1.0mA, 3mA, 10mA, 30mA, 100mA, 1A, 3A.  
 a.c. V 10V, 30V, 100V, 300V, 1000V;  
 a.c. I 3mA, 10mA, 30mA, 100mA, 1A, 3A.  
 Ohms 5k $\Omega$ , 50k $\Omega$ , 500k $\Omega$ , 5M $\Omega$ , 50M $\Omega$ .  
 dB from -10 to +61 in 5 ranges.

Dimensions: 105 x 130 x 40mm.

LIKE ALL ALCON INSTRUMENTS THE SUPER 50 COMES COMPLETE WITH A ROBUST CARRYING CASE, LEADS AND INSTRUCTIONS AND IS FULLY GUARANTEED FOR 24 MONTHS.

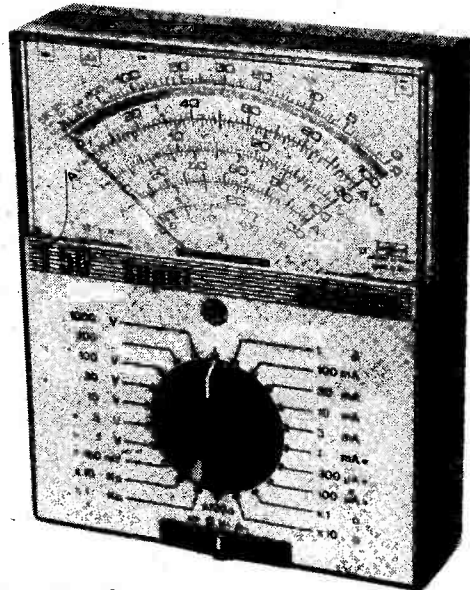

## ★ OTHER STAR BUYS FROM ALCON ★

### TESTER 20

20K $\Omega$ /V AC & DC  
 39 RANGES - DIODE & FUSE PROTECTED

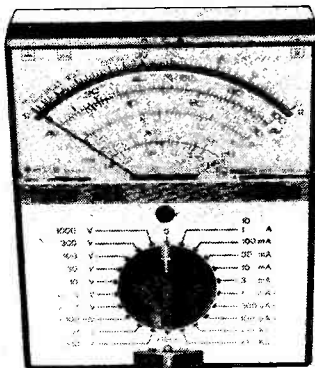

Accuracy: d.c. ranges and  $\Omega$  2% a.c. 3% (of f.s.d.)  
 39 ranges: d.c. V ★ 100mV, 1.0V, 3.0V, 10V, 30V, 100V, 300V, 1000V.  
 d.c. I ★ 50 $\mu$ A, 100 $\mu$ A, 300 $\mu$ A, 1.0mA, 3mA, 10mA, 30mA, 100mA, 1A, 10A.  
 a.c. V ★ 10, 30V, 100V, 300V, 1000V; a.c. I 1.3mA, 10mA, 30mA, 100mA, 1.0A, 10A.  
 $\Omega$  0.5.0k $\Omega$  0-50k $\Omega$ , 0-500k $\Omega$ , 5M $\Omega$ , 50M $\Omega$ .  
 dB from -10 to +61 in 5 ranges.  
 Dimensions: 105 x 130 x 40mm.

ONLY **£29.75**

### SUPER 20

Specification as above but super electronically protected on ranges but 10A - VIRTUALLY INDESTRUCTIBLE! **£33.50**

### MINI 20

20K $\Omega$ /V d.c. & 4K $\Omega$ /V a.c.  
 28 RANGES WITH PROTECTIVE FUSE

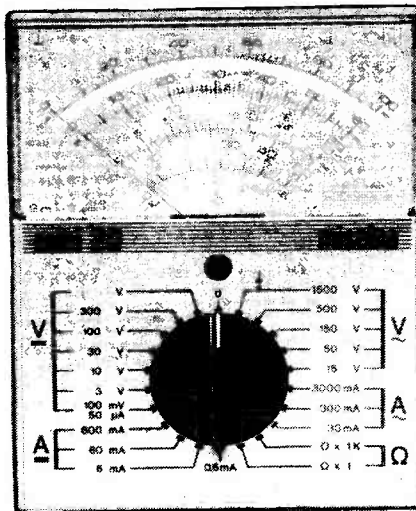

Accuracy: 2% d.c. and resistance 3% a.c.  
 28 ranges: d.c. V 100mV, 3V, 10V, 30V, 100V, 300V, 600V. d.c. I 50 $\mu$ A, 600 $\mu$ A, 6mA, 60mA, 600mA.  
 a.c. V 15V, 50V, 150V, 500V, 1500V; a.c. I 30mA, 300mA, 3.0A. Ohms 0.2k $\Omega$ , 0-2M $\Omega$ .  
 dB from -10 to +62 in 6 ranges.  
 Dimensions: 105 x 130 x 40mm.

THE IDEAL INSTRUMENT FOR THE CONSTRUCTOR **£21.60**

### ELECTRO TESTER

20K $\Omega$ /V AC & DC  
 40 RANGES WITH DIODE & FUSE PROTECTED PLUS 30A FOR THE POWER MAN!

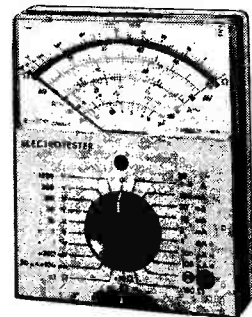

Accuracy: d.c. ranges and  $\Omega$  2.5% a.c. 3% (of f.s.d.)  
 40 ranges: d.c. V ★ 100mV, 300mV, 1.0V, 3.0V, 10V, 30V, 100V, 300V, 1000V.  
 d.c. I ★ 50 $\mu$ A, 100 $\mu$ A, 300 $\mu$ A, 1.0mA, 3.0mA, 10mA, 30mA, 100mA, 1.0A, 6.0A, 30A.  
 a.c. V ★ 10V, 30V, 100V, 300V, 1000V; a.c. I ★ 3.0mA, 10mA, 30mA, 100mA, 1.0A, 6.0A, 30A.  
 $\Omega$  0-10k $\Omega$  0-100k $\Omega$  0-1M $\Omega$ .  
 dB ★ -10 to +61 in 5 ranges.  
 Dimensions: 105 x 130 x 40mm.

ONLY **£32**

### SUPER ELECTRO

Specification as above but super electronically protected despite its high current capability. **£35**

## HIGH QUALITY TEST INSTRUMENTS AT SUPERDEAL PRICES

EACH INSTRUMENT HAS A CLEAR MIRRORED SCALE AND COMES COMPLETE WITH A ROBUST CARRYING CASE, LEADS & INSTRUCTIONS.  
 PRICES: Our prices include VAT and postage and goods are normally despatched by return. Please write or telephone for details of these and the many other instruments in the Alcon range, including multimeters, components measuring, automotive and electronic instruments.

**ALCON** Instruments Ltd.

19 MULBERRY WALK · LONDON SW3 6DZ · TEL: 01-352 1879 · TELEX: 918867

# Bytebox

## PART 2 ... RAY STUART

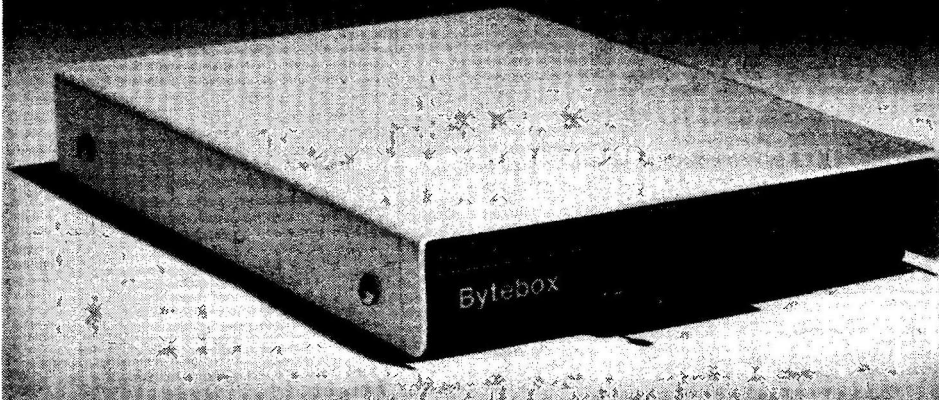

LAST month we took a close look at the design considerations and the circuit operation of the Bytebox. Fig. 7 shows some of the devices the Bytebox can support. This month, we shall complete all the constructional details and look at the other facilities which can be utilised.

### CONNECTOR CABLE

The connector cable details are shown in Fig. 11. It consists of a length of 40-way ribbon cable with a 40-way IDC d.i.l. connector at each end. The cable should be cut to length and offered to one of the two connectors. The connection is made by placing the connector/cable into a suitable tool which is then placed in a vice and tightened until the two halves of the connector mate. This is then repeated at the other end of the cable. Care should be exercised to ensure that the connectors are installed as per the diagram, i.e. the two connectors face the same way. Once the cable is completed it should be formed as shown in Fig. 11.

### PRINTED CIRCUIT BOARD (MAIN BOARD)

The printed circuit board component layout is shown in Fig. 10. The printed circuit board is double sided with soldered link pins

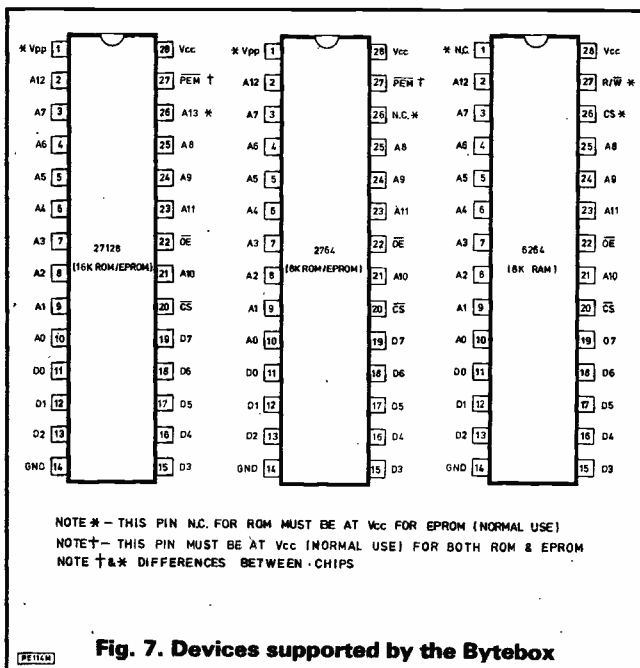

Fig. 7. Devices supported by the Bytebox

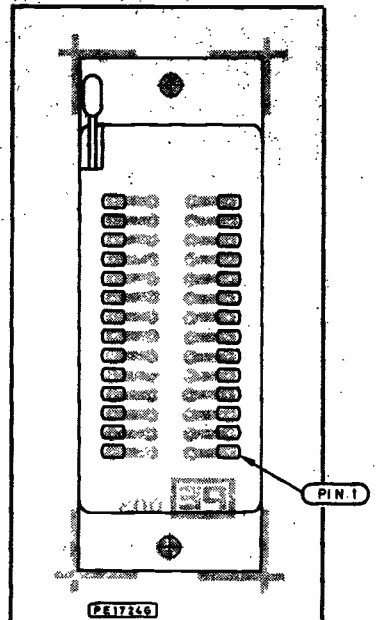
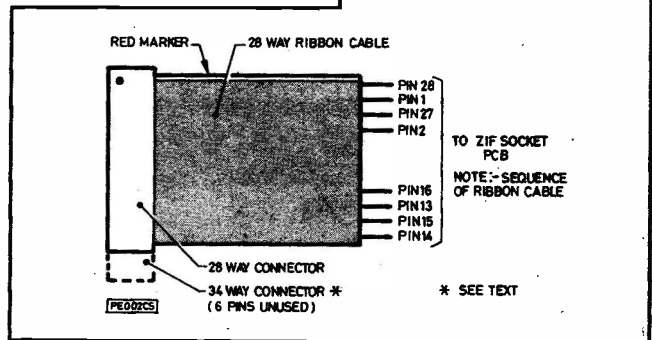

Fig. 8. The z.i.f. socket p.c.b. assembly

Fig. 9. The z.i.f. socket cable assembly



used to connect one side to the other. These should be the first items soldered to the board. These should be followed by the integrated circuit sockets. It is recommended that d.i.l. sockets are used, as it is difficult to remove chips should they be incorrectly fitted or are found to be faulty once soldered. The 40-way ribbon connector should be fitted next, either by being soldered directly to the board or fitted via a 40-way d.i.l. socket. All that remains to be fitted are the twenty decoupling capacitors.

### CASE

The board is housed in an aluminium case consisting of a chassis unit to which the printed circuit board is attached, and a U-section cover retained by four screws. The prototype chassis was sprayed black and the cover honey beige. This produced a colour similar to that of the BBC microcomputer and almost identical to the author's disc drive. The assembled printed circuit board should now be fixed to the chassis unit by means of four insulated pillars, and the ribbon cable connector is passed through the small cutout at the rear of the case.

### ZIF SOCKET

The z.i.f. socket printed circuit board is shown in Fig. 8. The z.i.f. socket can be connected to any of the ROM/EPROM sockets on the board by means of a 28-way IDC d.i.l. connector. This should be constructed as shown in Fig. 9 and in a similar way as was the 40-way ribbon cable, except that one end of the cable is soldered to the z.i.f. printed circuit board. The cutout details on the chassis assembly are intended for a 28-way Tektool z.i.f. socket, others may require a different size cutout. The assembled printed circuit board is fitted to the rear of the chassis front panel, either by two screws or by double sided adhesive tape. The prototype used double sided tape of the foam variety and is still in place despite considerable use.

# COMPUTING PROJECT

## BYTEBOX INSTALLATION

BYTEBOX is now ready to be connected to the BBC microcomputer, but first ensure that it has been turned off. Remove the BBC microcomputer's cover which is held in place by four screws, two on the rear and two under the keyboard. Fig. 11 indicates where the 6502 microprocessor is located on the BBC microcomputer's printed circuit board. This should be carefully removed and placed on a conductive surface to prevent a build up of static charge. It is

also good practice to earth oneself to remove any static charge before removing any integrated circuits. The free end of the 40-way ribbon cable can now be plugged into the now vacant socket and the 6502 inserted into its socket on the BYTEBOX printed circuit board.

NOTE: Take care to install the 6502 the correct way round as it faces in the opposite direction to all the other integrated circuits on this board!

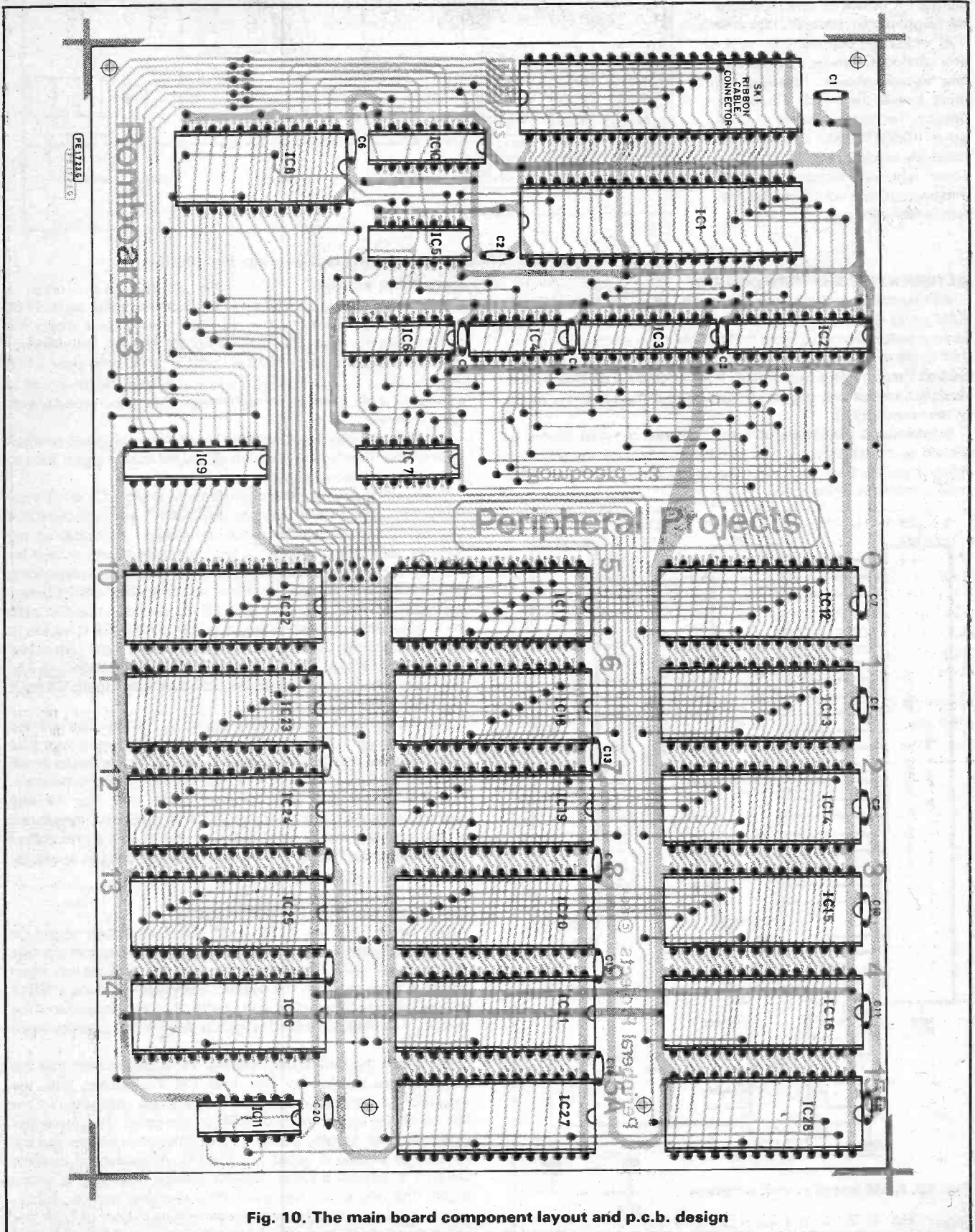

Fig. 10. The main board component layout and p.c.b. design

As BYTEBOX is designed to house all the sideways ROM/EPROMs in the system, those already located on the BBC microcomputer's printed circuit board should be removed and installed in the appropriate sockets in BYTEBOX. Normally BASIC goes in socket 14 unless DFS is fitted, in which case BASIC goes in socket 13 and DFS in socket 14. If RAM is fitted it should be plugged into sockets 15A and 15B whilst the optional z.i.f. socket's connector can be plugged into any vacant socket. However, in most cases the most convenient position for this is socket 9. Any other ROM/EPROMs can now be fitted as required and BYTEBOX's cover replaced. Replace the BBC microcomputer's cover and the system is ready for use.

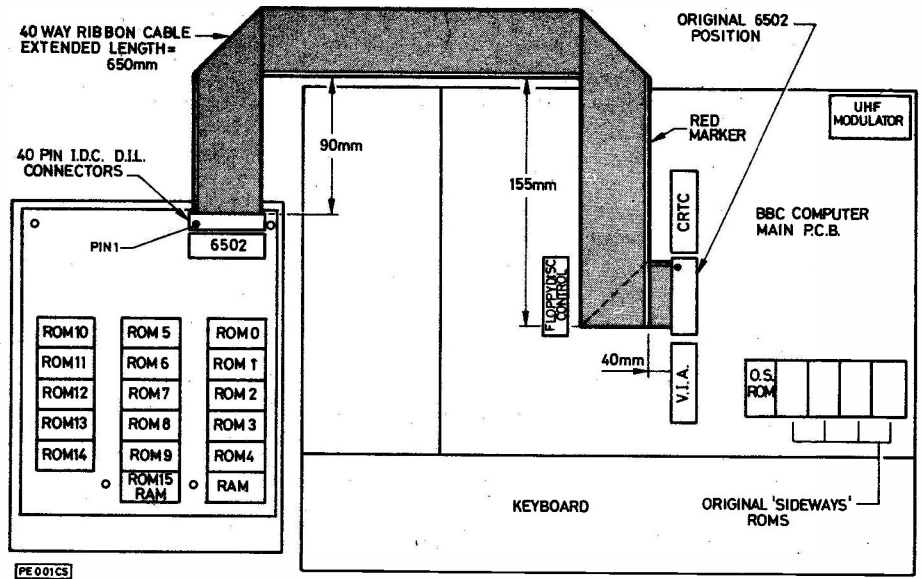

Fig. 11. Ribbon cable details and Bytebox installation

**ALTERNATIVE MEMORY BOARDS**

As mentioned in the design philosophy there are two optional RAM cards that can be used to configure the system to suit user requirements. One uses eight 6116 RAM devices to allow up to 16K bytes to be installed in 2K byte stages, the other is a battery-backed version using two 6264s. Both printed circuit boards are designed so that they can be plugged into the main board in place of the normal RAM.

In addition a third optional board is presented that allows a 27128 to be replaced by two 2764 EPROMs. Like the optional RAM board this board is also designed to allow it to plug into the main printed circuit board.

**6116 RAM BOARD**

This board is designed to allow the system to use eight 6116 type RAMs to provide 16K bytes. This arrangement allows the user to build the system up in blocks of 2K bytes as and when required. In addition the overall cost of this board with eight 6116 devices fitted is less than that for two 6264s. However, as is usually the case, there is a disadvantage, that of increased power consumption.

Its mechanical layout is arranged to allow it to plug into position 15A on the main board, allowing all the necessary signal lines to pass to the additional circuit.

The circuit diagram of this board is shown in Fig. 12. 6116 type RAMs have only 11 address lines (A0 to A10), whereas the 6264 has 14 (A0 to A13). The circuit is arranged such that all the address, data and control lines from the main board, except for A11 to A13 and the chip select line, connect to the corresponding pins of the 6116s. In order to select the correct block of 2K bytes, the upper address lines (A11 to A13) are decoded together with the original 6264 chip select line by IC109, a 74LS138 three line to eight line decoder. This produces the necessary eight chip select lines that ensure that only the correct 6116 device is selected. The eight outputs from the decoder are each connected to the CS input of its associated 6116 device.

The printed circuit board is shown in Fig. 13 together with the component layout. The board is single sided with twelve wire links used to connect tracks. These links should be the first items fitted, followed by the i.c. sockets and then the decoupling capacitors. Turn the board over and carefully solder the four 14-way connectors to the board as shown in the photographs. Installation is then simply a matter of plugging the 6116 board into socket 15A on the main board. The system will now function in exactly the same way as would two 6264s.

**BATTERY-BACKED RAM BOARD**

This circuit, like the 6116 RAM circuit described above, is designed to allow it to plug into the main card in place of the two 6264s. RAM devices are volatile, i.e. their contents are lost when power is removed from the system. However, by using a NiCad battery they can be supplied with power when the remainder of the circuitry has been turned off, allowing the RAM's contents to be preserved.

The circuit diagram is shown in Fig. 14. It can be seen that the address data and control lines from the main board, with the exception of the chip select and +5V lines, are connected to the corresponding pins of the two 6264s in this circuit. The power line passes through a diode, D201, before going to the battery and the RAM. This voltage is called Vcc (BATT). A germanium diode is used as it exhibits a lower forward voltage drop than a silicon diode. The battery is connected via a charging resistor, R201, whose value is selected to produce a charging current of 1mA, the recommended trickle charge current for the type of NiCad battery

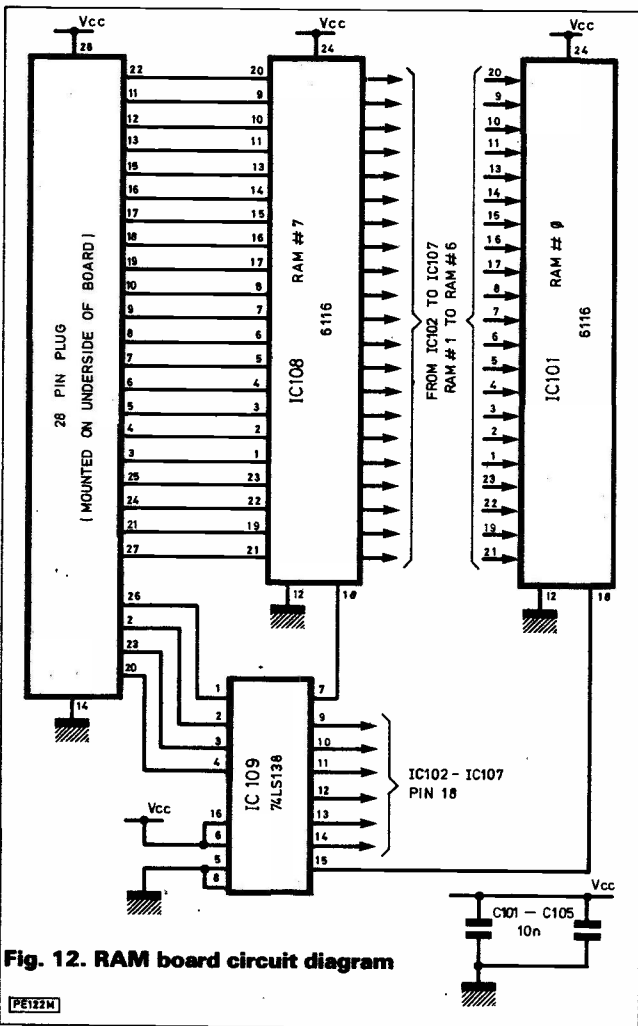

Fig. 12. RAM board circuit diagram

specified. Thus during normal operation the battery is constantly being charged.

However, when the system is turned off, i.e. in power-down mode, the battery is connected to the RAM but isolated from the remainder of the circuit by the diode D201. As the standby current for a 6264 RAM is quoted as 20 microamps per device, the voltage drop across the charging resistor under these conditions is negligible, therefore the RAMs are supplied with sufficient voltage to allow them to retain their data. The battery capacity is quoted as 100mA hours, which should maintain the RAMs for about 100 days.

In order for the circuit to function correctly in the power-down mode it is essential that the two chip select inputs are tied to logic 1, which in this case is Vcc (BAT). If they were left floating, i.e. not connected to any logic level, the circuits would consume more power than the battery can supply, resulting in the memory

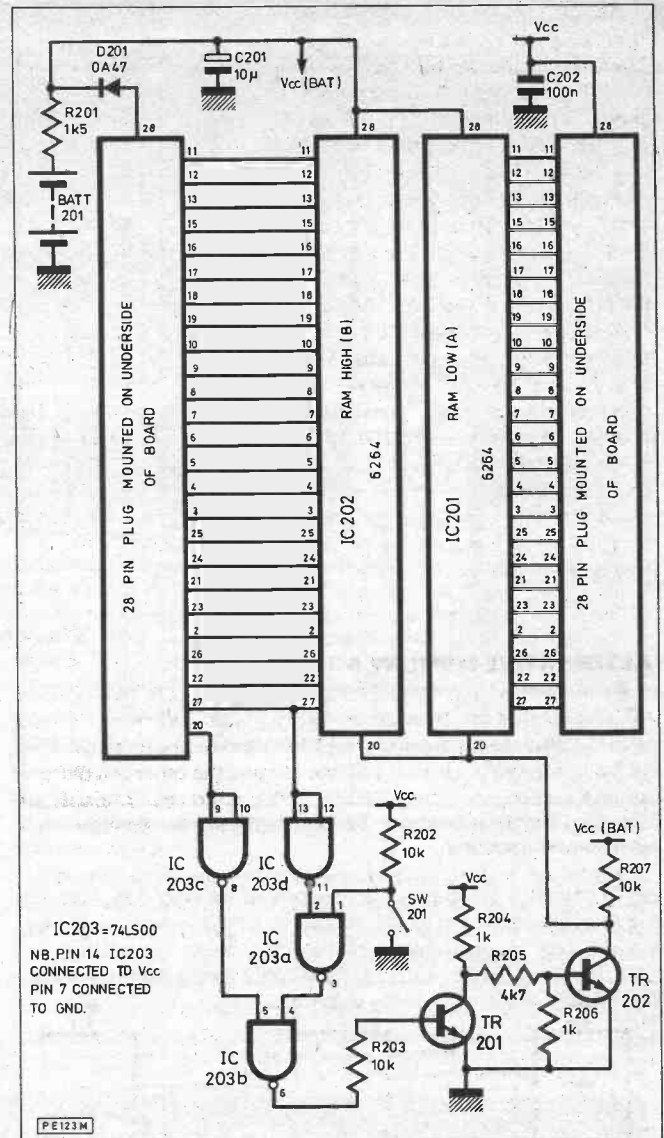
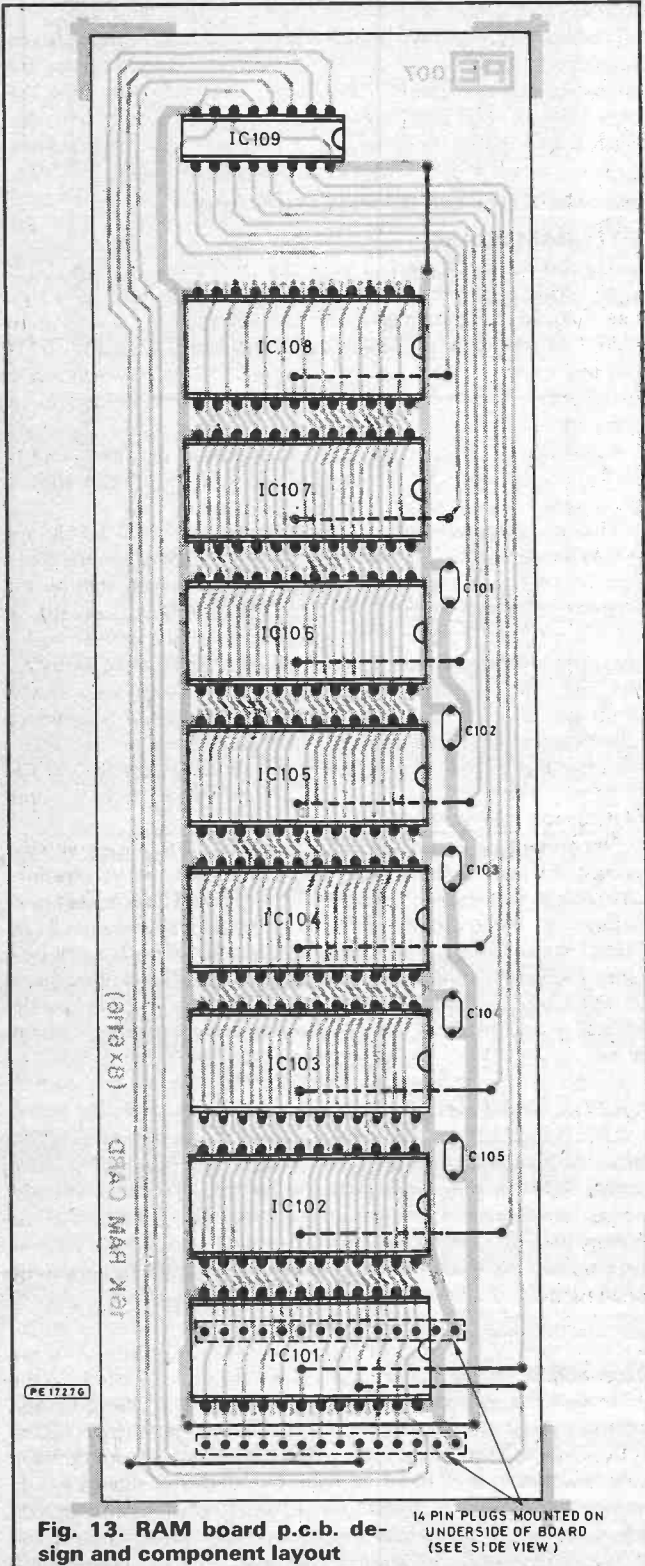

Fig. 14. Battery-backed RAM circuit diagram

contents being corrupted.

To achieve this the chip select line is driven via two transistors, TR201 and TR202. TR201 inverts the chip select line from IC203b pin 6. Thus when its input is a logic 0, i.e. chip select active, the transistor is turned off and its collector is at logic 1. This logic 1 is then used to turn TR202 on thereby putting a logic 0 onto the two 6264 chip select inputs, which enables them. When the power to the board is removed no voltage is available to turn TR201 on. Therefore, the base of TR202 is connected to logic 0 via R206 which turns the transistor off. The two 6264 chip select inputs are therefore tied to Vcc (BAT) via R207, thereby providing the correct power-down mode conditions.

In addition, the circuit is fitted with a write protect switch that can be used to prevent the system writing to the RAM and destroying data that the user may wish to keep. This switch can either be mounted on the board or on the back panel of the case, the latter position allowing the RAMs operating mode to be easily changed.

Write protection is provided by the quad two-input NAND gate, IC203, and switch S201. The chip select signal (CS) from the main board is inverted by IC203c whilst IC203b inverts the R/W signal. The  $\bar{R}/\bar{W}$  signal from IC203d pin 11 is gated with that from the write protect select switch S201 by IC203a. Normal operation occurs when S201 is open, write protection is selected when it is closed. Therefore in normal operation IC203a pin 3 produces the  $\bar{R}/\bar{W}$  signal, i.e. it follows that on the main board. This is then gated with the chip select signal (CS) from IC203c pin B by IC203b to produce a chip select (CS) signal for both read and write modes.

However, when write protection has been selected, i.e. S201 closed, the logic 0 on IC203a pin 1 forces the output of IC203a

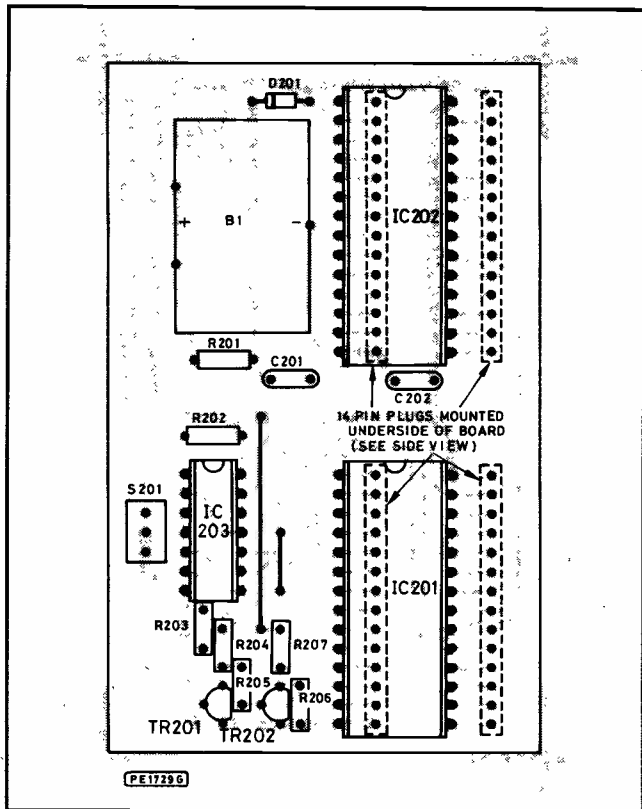

Fig. 15. Battery-backed RAM board p.c.b. design and component overlay

(pin 3) to logic 1 irrespective of the state of the  $R/\overline{W}$  line. This output therefore appears to the following circuitry as a read only signal. Thus, when gated with the chip select signal ( $\overline{CS}$ ) by IC203b the two 6264s can only be enabled during the read mode. The RAMs are therefore write protected.

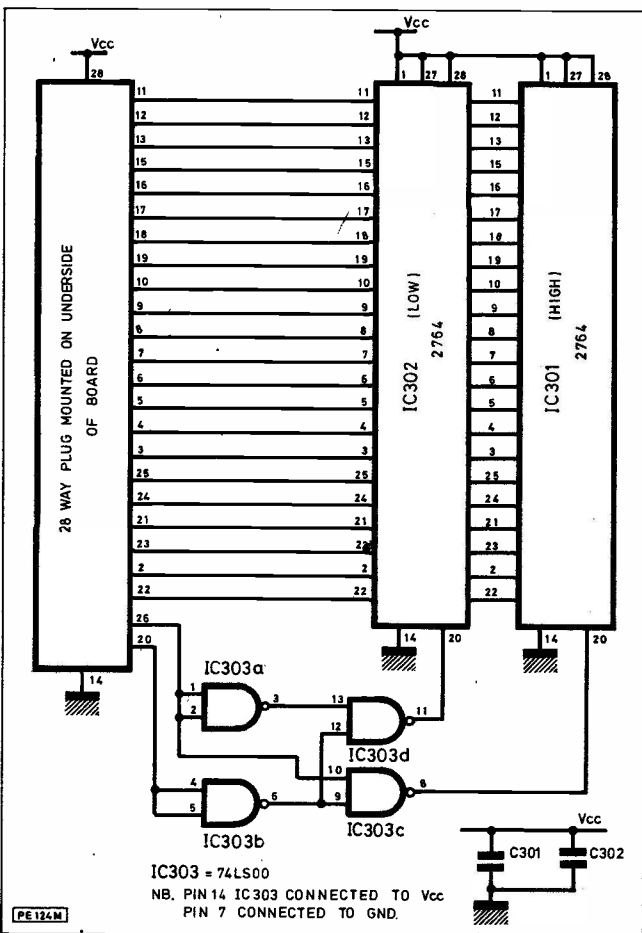

Fig. 16. Alternative EPROM board circuit diagram

The printed circuit board and the component layout is shown in Fig. 15. The board is single sided with two wire links used to connect tracks. These links should be the first items fitted, followed by the IC sockets and then the decoupling capacitors, transistors, resistors, switch and battery. Turn the board over and carefully solder the four 14-way connectors to the underside of the board. This board is then installed in the system by plugging it into the two sockets, 15A and 15B, that would have held the normal RAM.

### ALTERNATIVE EPROM BOARD

The 27128 type EPROMs are sometimes in short supply and are currently more expensive than two 2764 type EPROMs, which provide the same 16K bytes of memory. To enable two 2764s to replace one 27128 an additional printed circuit board is provided. This has been designed so that it can be plugged into a vacant ROM/EPROM socket on the main printed circuit board.

The circuit arrangement is shown in Fig. 16. Address lines A0 to A12 from the main printed circuit board and the eight data lines are connected to both 2764 EPROMs directly via the 28-way plug. As there are two 2764 EPROMs it is necessary to generate two chip select lines from the original 27128 chip select line and address line A13. This is achieved by a quad dual-input NAND gate IC303. The original chip select line is inverted by IC303b, and connected to the other two gates IC303c and IC303d. Thus, when the 27128 chip select line is disabled both IC303c and IC303d have an input at logic 0 which forces both these gates' outputs to logic 1 thereby disabling the two 2764s.

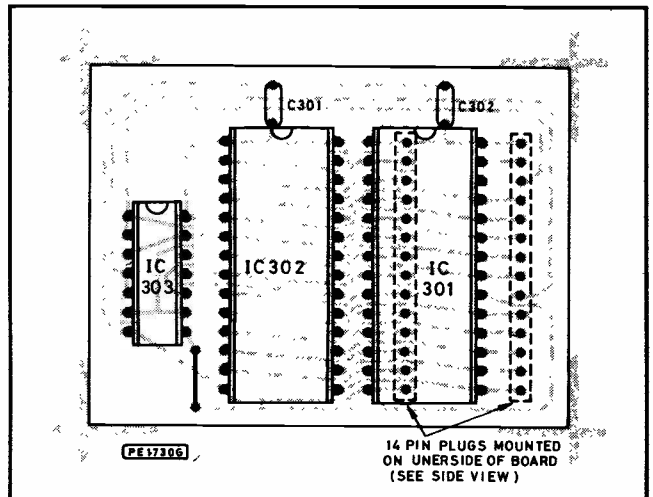

Fig. 17. EPROM board component overlay and p.c.b. design

However, when the 27128 chip select line is active, i.e. at logic 0, both IC303c and IC303d are enabled allowing them to invert the signal on their other input. As one of these gates is connected to A13 and the other to A13 only one 2764 can be enabled at any one time thereby allowing correct operation of the circuit.

The printed circuit board and the component layout is shown in Fig. 17. It can be seen that only one link is required on this board and this, together with the three integrated circuit sockets and the decoupling capacitors should be soldered onto the board. In a similar way to the other auxiliary boards, the two 14-way connectors should be soldered to the underside of the board.

The board can be installed in any position on the main printed circuit board that can normally support ROM/EPROM. The two 2764s should, however, be programmed as required before being fitted.

### RAM APPLICATIONS

To load the system's RAM from either disc or via a BASIC programme all one has to do is to write to memory locations between &8000 and &BFFF, in which case the RAM is automatically selected in preference to ROM as previously described. If, however, one has a file on disc, say a ROM based programme that one is developing, it can be loaded directly into RAM using the command  $\star\text{LOAD} <\text{filename}> 8000$ .



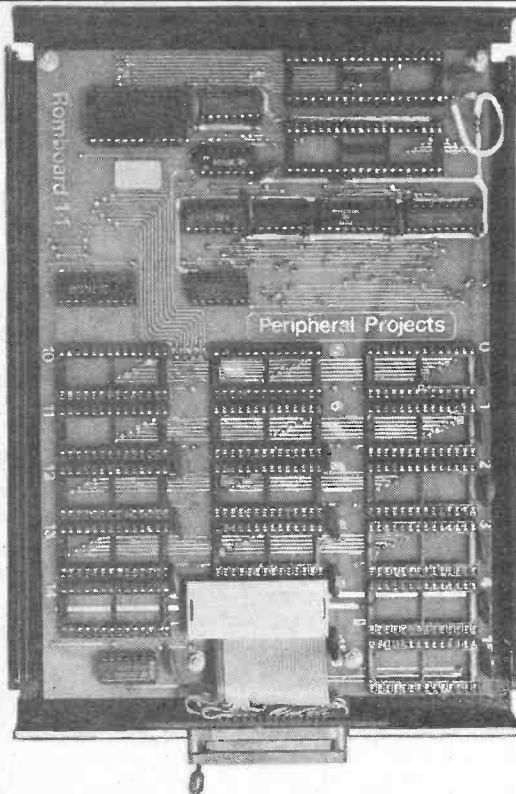

**Constructor's Note:**

The p.c.b.s for the *Bytebox* are available from the **PE PCB SERVICE**, see page 58 for details. Alternatively see below. All parts for the *Bytebox*, including EPROMS, are available from: **PERIPHERAL PROJECTS**, 25 Braycourt Ave., Walton-on-Thames, Surrey, KT12 2AZ. Please send SAE for details.

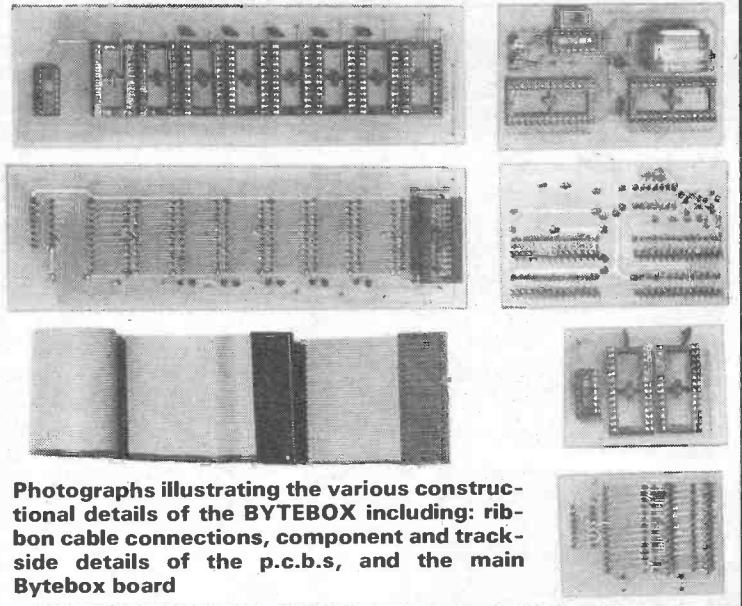

Photographs illustrating the various constructional details of the *BYTEBOX* including: ribbon cable connections, component and track-side details of the p.c.b.s, and the main *Bytebox* board

This "RAM-ROM" can now be used in the same way as ROM/EPROM, i.e. it will respond to any **★**command of that program. If however the program is a language, e.g. PASCAL, it can be started by typing "CTRL-BREAK" as it is in position 15, the most significant, and is therefore the first to be accessed by the operating system.

If the battery backed RAM board has been fitted it should be put into normal mode, i.e. not write protected, allowing data to be sent to it. Once this has been done write protect mode can be selected, thereby preventing the RAM's data from being accidentally overwritten. Should the RAM contain data relating to a language, that language will run when the BBC microcomputer is switched on as RAM is in the most significant sideways position. ★

# MARCO TRADING

SOLDERING AIDS	TELECOM EQUIP	SERVICE AIDS	C-MOS	TRANSISTORS	LINEAR ICs			
Antex 15W Iron £5.25 Antex 18W Iron £5.50 Antex 25W Iron £5.75 Antex Elements £2.75 Antex Bits £0.90 Antex Stands £2.10 Desolder Tool £4.50 Spare Nozzle £0.65 25W kit-iron with 13A plug & stand £10.00 18W kit with 13A plug & stand £9.90	BT Plug & 3M lead £1.25 BT MASTER SOCKET £2.85 BT Sec Sht £1.10 BT 4-core cable 1M £0.15 100M £12.00	POSTED PRICES Switch Cleaner £1.18 Circuit Freezer £1.34 Foam Cleanser £1.16 Silicone Grease £1.10 Plastic Seal £1.18 Ex Polish £1.28 Fire Ex £3.06 Video Cleaner £0.76 Sirdel Mop (std) £0.74 Sirdel Mop (1/2 gauge) £0.74	4000 £0.24 4001 £0.24 4002 £0.25 4007 £0.25 4010 £0.24 4012 £0.24 4013 £0.56 4014 £0.60 4015 £0.60 4016 £0.40 4017 £0.60 4018 £0.60 4020 £0.85 4022 £0.96 4023 £0.35 4024 £0.50 4025 £0.24 4027 £0.45 4028 £0.45 4029 £0.75 4030 £0.35 4031 £1.30 4033 £1.25 4034 £1.46 4035 £0.70 4038 £0.75 4039A £2.80 4040 £0.60 4042 £0.50 4043 £0.42 4044 £0.50 4046 £0.60 4049 £0.38 4050 £0.36 4051 £0.70 4052 £0.60 4053 £0.60	AC128 £0.30 AC176 £0.30 AF239 £0.50 BC107 £0.10 BC108 £0.10 BC109 £0.10 A.B.C. £0.14 BC147 £0.18 BC182 £0.10 BC182L £0.12 BC184 £0.10 BC184L £0.10 BC212 £0.10 BC212L £0.09 BCY70 £0.16 BD131 £0.36 BD133 £0.40 BD135 £0.26 BD136 £0.26 BF115 £0.32 BF184 £0.30 BF185 £0.28 BF194A £0.15 BF195 £0.12 BF200 £0.38 BF224 £0.16 BF244 £0.34 BF244A £0.30 BF244B £0.28 BF259 £0.30 BF262 £0.34 BF263 £0.38 BF337 £0.28 BF338 £0.28	BFX29 £0.28 BFX84 £0.28 BFX85 £0.35 BFX87 £0.44 BFY50 £0.22 BFY52 £0.22 BFY90 £0.80 BSX20 £0.30 BU208 £1.40 BU326 £1.75 OC45 £0.68 OC71 £0.60 OC72 £0.70 TIP31A £0.38 TIP32A £0.35 TIP33C £0.75 TIP34A £0.70 TIP2955 £0.70 TIP3055 £0.58 TIS43 £0.88 TIS88 £0.50 2N3055 £0.65 2SC1096 £0.94 2SC1193Y £1.70 2SC1306 £0.92 2SC1307 £1.50 2SC1957 £0.70 2SC2028 £0.73 2SC2029 £2.70 2SC2078 £1.05 2SC2166 £1.20 3SK88 £0.60 40673 £1.80	CA3011 £2.20 CA3014 £2.70 CA3018 £0.86 CA3020 £2.10 CA3028A £1.10 CA3046 £0.70 CA3080E £0.68 CA3085 £1.50 CA3086 £0.60 CA3090AQ £3.40 CA3130S £2.15 CA3140E £0.60 LM324W £0.45 LM339 £0.40 LM348 £0.60 LM380N (8-pin) £1.15 LM380N (14-pin) £1.80 LM381N £1.75 LM382N £2.00 LM386 £0.99 LM387 £2.00 LM389 £1.60 LM1011N £3.20 LM3900 £0.85 LM3911 £1.85 LM3914N £3.10 NE555 £0.25 NE556 £0.80 SAS5605 £1.85 SAS5705 £1.85 SN7003N £2.50 SN76023N £2.00 TDA1004 £4.95 741 £0.25 TDA2030 £1.90 TL071CP £0.40 UPC1023H £0.60		
NI-CAD CHARGER Universal charger to charge PF3, AA, C, D PRICE £5.95	BT TELEPHONES Viacount £32.00 Statesman £29.50 Sirmel £22.50 Viacount £39.50	L.E.D.s 3mm Red £0.10 10/£0.85 Green £0.13 10/£1.00 Yellow £0.13 10/£1.00 5mm Red £0.10 10/£0.85 Green £0.13 10/£1.00 Yellow £0.13 10/£1.00	DIODES IN916 £0.04 IN4001 £0.05 IN4004 £0.06 IN4005 £0.06 IN4007 £0.07 IN4148 £0.05 IN4149 £0.06 IN5400 £0.12 IN5401 £0.15 IN5402 £0.15 IN5404 £0.16 IN5406 £0.18 IN5408 £0.20 AA119 £0.12 AA129 £0.18 AA330 £0.16 BA100 £0.24 BY126 £0.12 BY127 £0.16 BY133 £0.16 BY184 £0.40 OA47 £0.10 OA90 £0.08 OA91 £0.09 OA95 £0.18 OA200 £0.06	PLASTIC BOXES 3 x 2 x 1" £0.35 3 x 2 1/2 x 2" £0.65 4 x 3 x 1 1/2" £0.83 6 x 4 x 2 1/2" £1.15 8 1/2 x 5 x 3 1/4" £2.15 Colour Black, all boxes with lids and screws.	TRANSFORMERS British made transformers at very attractive prices Primary Secondary Current 1+ 10+ 100+ 240V: 6-0-6V 100mA £0.58 £0.52 £0.43 240V: 6-0-6V 500mA £0.65 £0.60 £0.48 Carriage 45p transformer. £1.60 per 10			
NI-CADS PP3 £4.45, 4/£16.00 AA £0.95, 10/£8.00 HPH £2.30, 4/£8.50 C £1.95, 4/£8.75	VEROBOARDS 2 1/2 x 3 1/4 £0.85 2 1/2 x 5 £1.00 2 1/2 x 17 £3.07 3 1/4 x 17 £1.95 3 1/4 x 5 £3.30 3 3/4 x 17 £4.10 4 3/4 x 17 3/4 £4.95 Pkt of 100 pins £0.30 Spt face cutter £1.48 Pin insert tool £1.85 Vero Wiring Pen & Spoon £3.50 Dip Board £3.85 Vero Strip £1.25	BUZZERS SOLID STATE 6 Volt £0.80 12 Volt £0.80	PRE-SETS Vert + Horiz 100R to 1M £0.10, 100 for £6.50, 0.2 Watts	RESISTOR KITS 1/4W Pack 10 each value E12 10R-1M Total: 610 resistors ONLY £5.75 1/4W Pack 5 each value E12 10R-1M Total: 305 resistors ONLY £3.00 1/2W Pack 10 each value E12 2R2-2M2 Total: 730 resistors ONLY £7.95 1/2W Pack 5 each value E12 2R2-2M2 Total: 365 resistors ONLY £4.75 50v Ceramic Kit 5 each value 125 Per Kit £4.75 Zenner Pack 50FF 400MV £3.50	PLUGS SOCKETS Metal Co-ax Plug £0.18 Plastic Co-ax Plug £0.14 Metal Line Socket £0.30 Single Junc Socket £0.30 Plastic Phone £0.15 F.M. Plugs £3.25 PL259 Plugs £0.50 Reducer £0.15 Low loss splitter 1 in. 2 out £1.00	CERAMIC CAPACITORS All 50V. 1p to 10 nF £0.04 each, 100 for £2.75	COPPER WIRE Tinned + Enamelled Copper Wire. 2oz reels: 14 to 30 swg £1.00 per reel.	ZENER DIODE 400 mW 3v to 75v: £0.08 each, 100 for £6.00. 1 watt 3V3 to 200v: £0.15 each, 100 for £12.50

**MARCO TRADING (DEPT PE11)**  
The Maltings  
High Street  
Wem, Shropshire SY4 5EN  
Tel: 0939 32763 Telex: 35565

ORDERING. All components are brand new and to full specification. Please add 50p postage/packing (unless otherwise specified) to all orders then add 15% VAT to the total. Either send cheque/cash/postal order or send/telephone your Access or Visa number. Official orders from schools, universities, colleges, etc. most welcome. (Do not forget to send for our 1985 catalogue - only £1.00 per copy. All orders despatched by return of mail. (Min order £5.00)  
NEW RETAIL 1,000 sq. ft. shop now open Mon-Fri 9.00-5.00, Sat 9.00-12.00



NEW 1985 CATALOGUE AVAILABLE  
Range of components greatly increased - over 125 pages fully illustrated. Price £1.00 per copy. (Free upon request with orders over £15). Includes 50p Credit Note, Special Offer Sheets, Order Form and Pre-Paid Envelopes.



Launched in the autumn of 1964, *Practical Electronics* was the first UK hobby magazine devoted to this relatively new technology, and committed to explore, unreservedly, all its practical possibilities.

At that time radio enthusiasts were well served by existing periodicals such as *Wireless World*, *Radio Constructor* and *Practical Wireless*. Transmitting amateurs had their specialist publications — the *RSGB Bulletin* and the *Short Wave Magazine*. The first three mentioned had included non-radio projects in their pages for a number of years, but the subjects covered rarely strayed from the audio and test equipment fields.

With the transistor becoming a commonplace and cheap device, possibilities were opening up for new and previously undreamed of opportunities for electronic circuitry. In the early sixties, electronics was the in-thing and had a scintillating image equalled only by those contemporary trendsetters of the pop music world.

# 21 YEARS

## THE FIRST SEVEN YEARS

Constructional projects have had pride of place right from issue No. 1 (Nov. 1964). These articles form the central core of the magazine's structure. They are the reason for its existence and all other features, important as they are, are peripheral and supportive to the prime purpose which is to present detailed information that will enable any constructor to build a wide range of electronic equipment without difficulty. All this for two shillings and sixpence (12½p).

The enthusiast's involvement with modern electronics was well portrayed by the cover of the inaugural issue. This showed a young man holding the Integrated Audio Amplifier, opened up booklike, so that the most interesting details were exposed to the viewer. On the bench top in the foreground stood the associated power unit. Also in view was a Colour Code Calculator for resistors and capacitors which was included as a free gift with the No. 1 issue. The words "Transistorised Equipment" stood out at the foot of the cover—this was obviously considered a very fundamental phrase.

In the centre of the issue were eight supplementary pages containing miscellaneous data. These pages were intended to be withdrawn and folded to produce a 16-page pocket data book.

The opening project was a 5W Integrated Transistor Amplifier designed by K. W. Collins. This contributor was on the staff of Mullard Ltd., and this may have influenced the choice of semiconductors around which the design was based. Yet, in any event, the choice was sound, since Mullard transistors were commonly available on the retail market and were familiar in amateur circles. Mullard had, for a number of years prior to 1964, promulgated much design information relating to the use of their transistors in audio and radio circuits. This information was to be the basis of innumerable PE projects in the coming months.

The Amplifier used four OC71 *pn*p germanium transistors. (This type had become well known as the standard small signal a.f. transistor. It appeared in two other projects in this first issue and was clearly, at the time, the amateur's best

friend.) The Pre-Amplifier and the Power Amplifier sections were built on similar sized boards of laminated plastics (s.r.b.p.). Turret tags or direct wiring of component leads to three rails of 18s.w.g. tinned copper wire were alternative assembly methods suggested. Two U-section heat sinks also acted as linking brackets between the two boards. This project extended over three months.

## FOR BEGINNERS

Right from the start PE made clear its commitment to the newcomer to electronics. Beginners, no less than experienced enthusiasts, would be welcomed to its pages. Carefully planned series giving instruction in theory and practical matters would form an important and essential part of the magazine's contents.

"Beginners Start Here" was the title of the first series for the uninitiated. Without assuming any prior knowledge, this series set out to explain basic principles of electricity and electronics, introducing by way of illustration a number of simple experiments any newcomer could carry out, with just a few tools and components. Theory was at all times closely related to practical matters and examples of real components were introduced as appropriate. The aim was to give the newcomer a "feel" for the material side of electronics and an early introduction to actual circuit components used in projects, as he or she progressed with the study of elementary theory.

The series was to run for 24 months. Perhaps an inordinate amount of time was spent on the groundwork of electricity (electro-magnetism and inductance extended over four parts). Transistors made their appearance in Part 13—in a simple project, a multivibrator, which was to provide a.c. (actually square waves) from a battery supply and would be used in following articles as an aid when examining alternating current.

Transistors used in the early projects were almost always germanium junction types. The superiority of silicon devices was already known and such devices were being used in industry. This was made clear in a feature "Semiconductor

The morning *PE* appeared on the bookstalls, Britain was going to the polls. A "brave new world" to be created through a white-hot technological revolution (based on electronics — what else?) was promised by the new occupant of No. 10, Harold Wilson.

A little more modestly, this new magazine promised an exciting future for the emergent hobby based on modern electronics technology. No denying it, the climate was auspicious when *PE* made its debut in 1964. The immediate reaction was heartening and confirmed the view that a large number of the general public of all ages were fascinated by electronics and welcomed the opportunity to participate in a practical way in this young but rapidly developing field.

The past 21 years have witnessed dramatic changes in the electronics field. The amateur designer and constructor has played no small part in this exciting story of technical advancement, as an examination of past issues of *Practical Electronics* reveals.

**SPECIAL OFFER**  
TO PRACTICAL ELECTRONICS READERS

**SABCHRON DIGITAL**

**LED WRISTWATCH**

As featured in this issue **SAVE ABOUT £8.75\***

(SPECIAL OFFER VALID UNTIL 15th OCTOBER 1975 ONLY)

- SINGLE BUTTON OPERATION.
- DISPLAYS HOURS, MINUTES, SECONDS, MONTH AND DATE (DAY OF MONTH).
- GOLD PLATED SWISS MADE CASE WITH STAINLESS STEEL BACK COVER.
- ACCURACY TO WITHIN 5 SECONDS PER MONTH.
- AUTOMATIC READOUT INTENSITY CONTROL. BRIGHTENS DISPLAY IN BRIGHT LIGHT; DIMS DISPLAY IN SUBDUED LIGHT OR TOTAL DARKNESS.
- BATTERIES LAST UP TO 1 YEAR WITH NORMAL USAGE.
- WATER RESISTANT, SHOCK PROTECTED, ANTI-MAGNETIC.

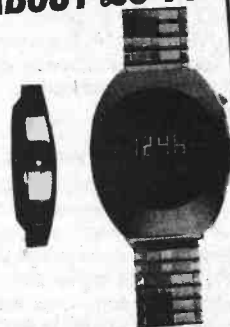

**COMPLETE KIT**  
(with Batteries but without bracelet) **£36.25\***  
(Airmail post paid)

**ASSEMBLED WATCH**  
(with leather band and 12 month guarantee on the electronics) **£45.50\***  
(Airmail post paid)

SABCHRON WATCHES ARE AVAILABLE ONLY FROM THE U.S. MANUFACTURER  
**EURAY TRADING INC.**

# S OF ELECTRONICS **FRED BENNETT PART ONE**

Devices For Automobiles" written by a staff member of Lucas. Here it was explained that in automobile applications the ambient temperature could be in excess of 90 deg. C. Silicon devices are capable of satisfactory operation up to 200 deg. C, whereas germanium devices have an operating temperature limited to 110 deg. C. But, in 1964, silicon transistors were not available to the amateur and germanium reigned supreme in the hobby field.

## ADVERTISEMENTS

Advertisements are an essential part of a publication such as *Practical Electronics*. The home constructor relies considerably upon announcements by those retailers who cater for his particular needs in the way of components, tools, materials and instruments; as well as those that offer other services that can aid him in his hobby.

**The advertisements appearing in the inaugural issue of a magazine can be especially interesting to examine in retrospect.**

We start with Transistor Suppliers for a very good reason. At the time of the launch of *PE* this "active" component had a significance unequalled by any other individual component then in use in electronic circuits. The transistor influenced the physical form and style of electronic equipments as much as the nature of the circuitry.

**Please note: All the advertisements and diagrams illustrated in this article are extracts from previous issues of Practical Electronics which have appeared over the last twenty one years. Unfortunately, they are no longer valid.**

## SUPPLIERS

Ten firms offered specific transistors to our readers in the opening issue of *PE*. Types for sale included the popular small signal a.f. transistor OC71 at prices ranging from 3/- to 5/- (15p-25p), the OC81 at 5/6 (27½p), and the OC171 at 8/6 (42½p).

Technical Trading Co., Brighton were first off the mark. On page one they offered 18 types at prices ranging from 5/- to 15/-, and Mullard matched Output Kits for amplifier and radio at 12/6 and 24/- respectively. They also offered unspecified types: red spot (L.F.) at 1/6 and white spot (R.F.) at 2/-.

listing of transistors was, it must be admitted, rather overshadowed by the 300 odd valve types numerated alongside in this advertisement.

Sinclair Radionics had taken the following four pages to present the X-10 Amplifier, the Micro-6 Receiver (claimed to be the smallest radio set in the world) and other designs. Also included, a list of five types of transistors such as the MAT100 at 7/9 and MAT101 at 8/6 for the constructor.

## VALVES

The number of advertisers offering valves almost equalled those offering transistors. They included three firms already noted above as suppliers of transistors. The valve-exclusive vendors were R&R Radio and TV Service: 40 types of salvaged valves; TRS Radio Component Specialists: 33 types, new, boxed; Padgetts Radio Stores: 58 types Ex equipment, 3 months guarantee; Other advertisers referred to valves without providing detailed lists; for example, Norman H. Field Electronics "thousands of components and valves" and Henry's Radio "800 valves and tubes".

While on the subject of thermionic devices, it should be recorded that TV tubes were readily available. Twelve-inch, 14in, 15/17in and 21in tubes were offered by Technical Trading; Luke & Co., offering 17in and 14in second hand tubes "Ex Rental Service Dept" at 35/- and 15/- respectively; while Television Tube London, SW11 was able to supply unused, guaranteed tubes at prices from 50 per cent to 75 per cent below list price, from a stock of over 2,000 tubes.

## PASSIVE COMPONENTS

Passive components were frequently offered in bargain lots, sometimes as a mixed bag without values specified. For example, "100 Resistors, ¼-2W 6/6". "100 Condensers miniature ceramic and silver mix 10/-". Specific values from the range 10 Ohm to 10 Megohm 20 per cent ¼ and ½ W were priced 3d each. Sub miniature condensers, various values from 1 to 100µ 15V were 2/6 each. Germanium diodes 8d or 6/6 per doz. A large range of silicon rectifiers was available. Test equipment was well featured, notably multimeters and panel meters.

Evidence of the metalwork associated with much electronic circuit construction was to be found in the advertisement of H. L. Smith of Edgware Road, London, a long established provider of blank aluminium chassis and panels—stock sizes or made to order. The well known Q-MAX chassis cutter for

making holes for valveholders and other components appeared in at least two ads, while sheet metal folding machines could be obtained from A. B. Parker of Batley, Yorks.

While the miscellaneous component, materials and accessory needs of the d.i.y. enthusiast were well catered for, a substantial proportion of the ad space in this first issue of *PE* was devoted to complete units, chassis or kits for radio, audio and tape equipment. Heathkit and Martin Audiokits were two of the big names represented in this field. Guitar amplifiers and heavy duty loudspeakers were especially noted and conveyed an impression of contemporary musical trends, while an electronic concert organ kit was available from Stern-Clyne.

Cabinets for hi-fi equipment (Record Housing) and covers to suit some 50 different commercial tape recorders (A. Brown & Sons) seemed to wrap up nicely all this side of the business.

The following famous names were amongst the advertisers to this first issue: Antex; Adcola, AVO, Brenell Engineering, Goodmans, Multicore, Oxley Developments, Telegraph Condenser Co. (TCC), Thorn Electrical Industries and Wharfedale.

Tuition in electronics and other engineering subjects was offered by British Institute of Engineering Technology, British National Radio School and International Correspondence Schools.

### BUILDING METHODS

The early projects employed between them a variety of constructional methods, from the downright "amateur," to the most elegant and professional as represented by the printed circuit board. These were pioneering days for home constructors, who had to improvise with whatever materials and parts were available. Most of these items such as group boards and tag strips were of the valve era and not ideally suited for the smaller semiconductors.

The "New Products" section of *PE* featured an interesting recent development in the form of a wiring board consisting of s.r.b.p. board clad on one side with strips of copper and pierced with a regular hole matrix. This product was called Veroboard, after its inventors and manufacturers, Vero Electronics Ltd.

One of the projects in issue No. 2, Precision Decimal Step Pre-Amplifier by M. L. Michaelis, had the honour to be the very first to employ the Veroboard System. The panel used (VB2503) had 16 parallel strips of copper, 'thickened' and gold plated at one end where the whole card plugged into a linear 16-contact socket. The panel was drilled with a square grid of holes at 0.15in spacing. This particular type of Veroboard had wide applications in industry but rarely used in constructor circles.

The Ultra Sonic Remote Control (Iss. 2.) was notable on two counts. It presented to the general reader, a branch of electronic technology that was not as then, very well known. This project also broke new ground in construction methods. For the second time Veroboard appeared in a *PE* project. However, the product used here was the standard Veroboard of Uniform pattern and which could be cut to any size. The whole matrix was 0.15in. This remained the standard for years, until the closer matrix of 0.1in became the rule.



## Salute to a new Journal

Now that transistors are so freely available to everyone, we feel that *Practical Electronics* had to come. We are confident that this exciting new journal is going to meet the needs of an ever-increasing band of constructors whose interests are taking them into fascinatingly new fields, and who will want more varied and ambitious activities as electronics progress. So good luck to *Practical Electronics*. As a forward looking team ourselves, we wish you every success.

proper was valve-based.

In both of these projects, construction involved the making of a chassis and other items from sheet aluminium and the employment of what would have been described as conventional assembly techniques prior to the advent of transistors.

SEALS SIEMENS HIGH SPEED RELAYS			
H96A, 2.2 ohm ± 2.2	ohm, new	...	12/6
H96B, 50 ohm ± 50	ohm, new	...	12/6
H96C, 145 ohm ± 145	ohm, new	...	12/6
H96D, 500 ohm ± 500	ohm, new	...	12/6
H96E, 1700 ohm ± 1700	ohm, ex-equip.	...	16/6

A.C. AMMETERS			
0-1 amp. F.R. 2 1/2" Dia.	0-15 amp. F.R. 2 1/2" Dia.		
0-5	"	0-20	
0-10	"	"	All at 21/- each

**VAN DE GRAAFF ELECTRO-STATIC GENERATOR**, fitted with Motor drive for 230v. A.C. giving a potential of approx. 5,000 volts. Supplied absolutely complete including accessories for carrying out a number of interesting experiments, and full instructions. This instrument is completely safe, and ideally suited for School demonstrations. Price **£6.6.0**, plus 4/- P. & P.



Van de Graaff electrostatic generator.

Veroboard quickly proved successful as a means for assembling semiconductors and other miniature components, it enabled the amateur to construct units to a professional standard.

### "VEROBOARD—NOW IN STOCK"

In the ensuing months, more and more frequent use was made of Veroboard. The first advertisement by this company appeared in the February '65 issue. Then in March, apart from the manufacturer's own half-page ad, Lasky's Radio announced "Veroboard—now in stock" and Service Trading Co., declared "we are stockists for VEROBOARD".

### VALVE DESIGNS

While all this activity was going on with transistorised designs the valve had not, nor could have been, overlooked. In February '65 appeared a 'Guitar Amplifier by G. S. Chisholm. The complete circuit, which included a vibrato section, was based on valves.

March saw the opening part of an expensive Oscilloscope by P. Cairns. Interesting because whereas transistors were used in the built-in calibration unit, the circuit

Fig. 5. The ratemeter circuit diagram

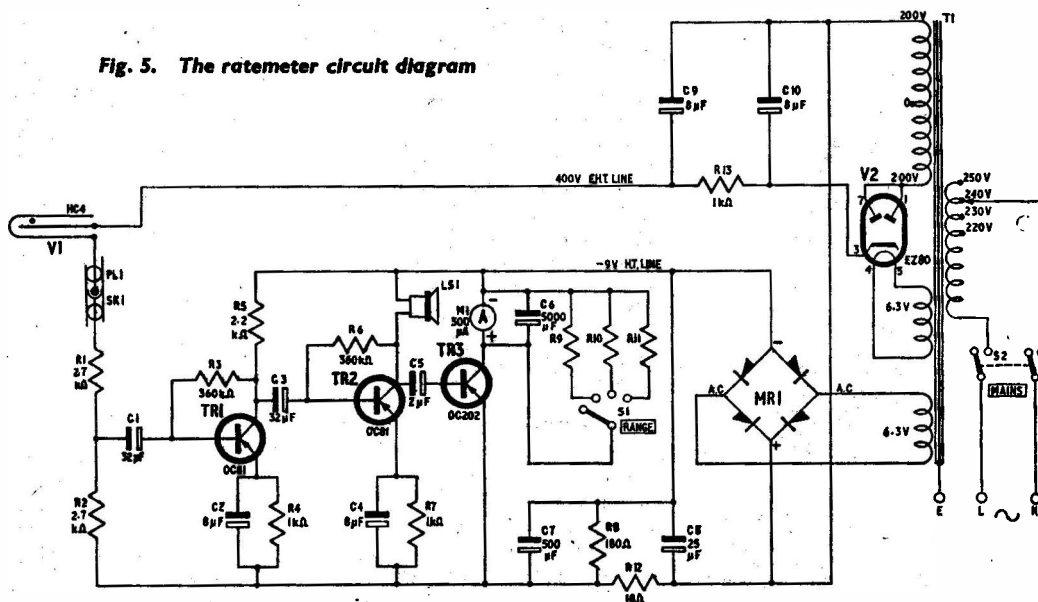

Left: A project from the first issue of *Practical Electronics*, Nov '64. Notice the use of up-to-date technology.

Right: Sinclair, always at the forefront of technology.

In February '65 readers were given a problem, two boxes connected by a pair of wires, with complex switching and counterswitching of a red and a green lamp. What is the secret of the circuitry within the boxes? The answer was given the following month, when "Magic Boxes" appeared as a short and simple project. Mainly for amusement, but nevertheless having practical use when a situation calls for such a remote signalling system and only two wires are available between the two locations.

In the meanwhile our readers had risen to the challenge and over 500 solutions were received during the week following publication of our February issue. An analysis of readers' ideas was published in April. Many ingenious ideas were proposed, but only three readers came close to the actual circuit. Apart from a very gratifying response from our readers, this light-hearted exercise proved exceedingly fruitful and the expression "Ingenuity Unlimited" used as a sub-title to the April article was adopted for a new regular series in which readers offered their own circuit ideas, or commented constructively on published designs.

Thus was given birth to a regular feature which has maintained its appeal and interest throughout the years. Many of the ideas published in this feature have been of considerable merit and have contributed to the general appeal of PE's contents. The first "Ingenuity Unlimited" appeared in May.

### EMERGENCE OF SILICON

In May a small classified advertisement by Longlands, Ascot, offered Transistors, Silicon *pnp* 1/6 (7 1/2 p) and Germanium *npn* 5/- (25p).

In the following month Silicon Planar Transistors were advertised at 4/6 each. Later on, during the course of the year, the following ads were noted.

- August 50 Transistors AF, RF, Silicon and *pnp*. 35/-  
—D & W Ltd., Westcliff.
- October *npn* Silicon for Hi-Fi etc 2N657 35/-; 2N1050 40/-  
—J & J Electronics, London. E18.
- November Silicon Planar *npn* Transistors 5/- and 7/-  
—Longlands, Ascot.  
Silicon Planar 5/-  
—Amatronic Ltd., Croydon.

Silicon Planar devices were most effectively spotlighted by Amatronic. They described the tiny Epoxy encapsulated *npn* devices 2N2926 as being suitable for practically every low power application.

Thus in the course of the last few months of the year (1965) a number of suppliers had become geared up to supply the previously hard-to-get silicon transistors.

Mention of the advantages of silicon against germanium devices had appeared in a feature on "Semiconductors For Automobiles" in the first issue (Nov. 1964). We had to wait until December '65

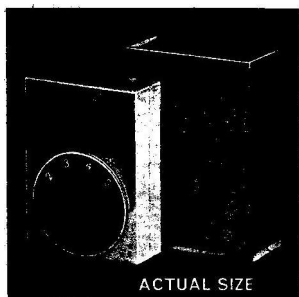

ACTUAL SIZE

## SINCLAIR MICRO-6



MOTORING

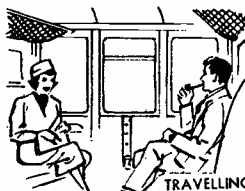

TRAVELLING

### SIX-STAGE POCKET RECEIVER

Build it in an evening!

# 59/6



SPORTS  
EVENTS



### WEAR IT LIKE A WRIST WATCH

A novel and convenient way to use the Micro-6 is to fix it on to the 'Transista' Wrist Strap and wear it like a watch. Particularly useful for sportsmen, travellers, etc.

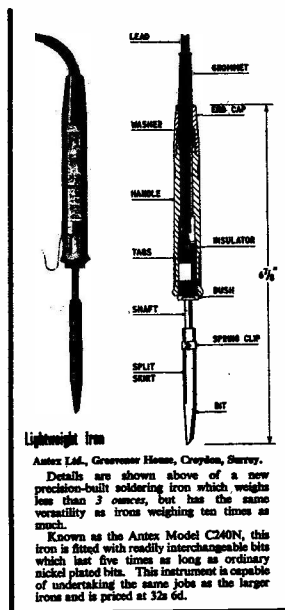

Lightweight Iron

Antex Ltd., Greenway House, Croydon, Surrey.

Details are shown above of a new precision-built soldering iron which weighs less than 3 ounces, but has the same versatility as irons weighing ten times as much.

Known as the Antex Model C200N, this iron is fitted with readily interchangeable bits which last five times as long as ordinary nickel plated bits. This instrument is capable of undertaking the same jobs as the larger irons and is priced at 32s 6d.

Antex and Adcola, still around today producing first class products.

# ADCOLA

PREPARED BY

SOLDERING EQUIPMENT

for the

## DISCRIMINATING ENTHUSIAST

ILLUSTRATED:  
L64 1/4" BIT INSTRUMENT IN  
L700 PROTECTIVE SHIELD

APPLY DIRECT TO:  
SALES & SERVICE DEPT.  
ADCOLA PRODUCTS LTD.  
ADCOLA HOUSE  
GAUDEN ROAD  
LONDON, S.W.4  
TELEPHONE 01-422 0291

for the first practical application of silicon transistors. This was the Fire Alarm System by M. L. Michaelis. The author was emphatic that silicon transistors (BSY53 or 2N1613) be used in this design. The high and temperature-dependent leakage current of normal germanium transistors made them entirely unsuitable, they would give rise to high standing battery drain and also to unnecessary false alarms on warm days.

**Something new in projects was illustrated on the January '66 cover. The Simple Servo System (B. Crank) brought electro-mechanics into association with electronics and offered a good practical introduction to the subject of servomechanisms.**

The first use of the plastic encapsulated *npn* silicon planar transistor type 2N2926 came in February. To those brought up in the valve era, the arrival of *npn* transistors was an additional minor blessing, in that circuit diagrams based on such devices could be drawn with the positive supply at the top as in the conventional valve fashion. But with *pnp* (usually germanium) devices still predominating in amateur designs the reader had to condition himself to some reorientation when studying circuit diagrams.

In March the spotlight was turned on to printed circuits. A detailed account of how to make p.c.b.s was followed by "Bonanza Boards" (A. J. Bassett) which demonstrated how one simple printed circuit board (2in x 2in) could be used to build a number of useful circuits. Four projects were given. A further five appeared the following month.

Amongst the May projects was a Transistor Tester by B. F. Pamplin which was appropriate since a free 24-page Transistor Guide booklet was presented in this issue. The Guide obviously met a long felt need and it became a standard ready reference for amateurs, professionals and retailers alike. Of more than 200 transistors listed only 18 were silicon, 13 *npn*, 5 *pnp*.

A feature "Using Transistor Data" helped the uninitiated with the interpretation of published data relating to these devices. A second part appeared in July and enlarged on more general matters such as cases and encapsulations, comparables and equivalents, and gave the pro's and con's for germanium and silicon.

### TEST GEAR

In the mid-sixty's the growth of electronic technology was making considerable impact upon the constructor field and the standard of performance of amateur built equipment was rising. It was apparent that the amateur was now in need of measuring and testing facilities that only few possessed. PE therefore commissioned the design of a set of test instruments to meet a wide variety of requirements. The result was the Test Gear Trio, which

comprised an a.c. Millivoltmeter, Signal Generator and Stabilised Transistor Power Unit. These three instruments were designed and described by R. Hirst.

It was an impressive set of instruments and would enhance the workbench of any constructor, or for that matter, professional engineer. This was apparent from the August cover which showed the Trio in glorious colour. The series ran from August to October '66.

The Autumn has always been looked upon as the start of a new season for constructors. Certainly the busiest months of the year lie immediately ahead. For this reason the October issue has always been of special importance, and is aimed as much at potential recruits to the hobby as to the regulars. This October issue had enclosed within its pages a Printed Wiring Board, actually a piece of Veroboard 2½ in x 1½ in, 0.15in matrix. Six projects were described, any one of which could be assembled on this board.

A news item in this issue gave details of new silicon planar transistors from Mullard. Of interest to our readers were the BC107, BC108, BC109, BF184 and BF185. The BC108 in particular was destined to become very popular and an indispensable device to the constructor.

**November '66 a whole-page ad from Peak Sound announced Cir-kit—the new wonder circuit system. This was copper strip with heat-resistant adhesive on one side. Lengths were cut off and laid down on laminate board to form the desired pattern.**

Another landmark in designs for amateurs was the Integrated Stereo Amplifier by R. Hirst (of Test Gear Trio fame) which was introduced in December '66. The most modern techniques were incorporated to achieve a high performance compatible with a professional appearance. A unique feature was the use of a field effect transistor to obtain a very high input impedance. Direct interstage coupling and complementary symmetry output stages were incorporated.

#### AND IN 1967

Another innovation in circuit construction was introduced in February '67. A feature entitled "Stick-On Wiring" described a product marketed by Peak Sound (Harrow) Ltd., and named "Cir-kit". (First advertised in the November '66 issue.) This introduction was backed-up by two projects built with "Cir-kit".



**A COMPLETE** page of a newspaper, including pictures and words, was transmitted across the Atlantic on October 17 via satellite from London to San Juan, Puerto Rico. This was the first time that a newspaper page has been sent by satellite.

A complete page of the *Daily Express* was wrapped around a drum on the Muirhead transmitter (above) and a beam of light traversed the drum, illuminating a small square of the page. The drum revolved and the whole page was scanned in the form of a spiral. Light from a minute area of this square was reflected through a precision optical system and used to control the electrical output of a photocell. The amplitude of the output signal depends upon whether the scanning beam falls on white paper or print, including the dots in the half-tone pictures.

The signals were transmitted via a cable and microwave system to Goonhilly where they were directed to the *Early Bird* satellite. The receiver in Puerto Rico converted the signals back to "light" information for processing into printing plates.

### THE BRITISH AMATEUR TAPE RECORDING CONTEST 1967

The above contest, held annually, is open to amateurs only. There are seven different categories for entry. Readers inspired by this article on Electronic Music Techniques may like to know that their own original work can be entered in Class 5 TECHNICAL EXPERIMENT, which embraces sound compositions, electronic music, musique concrète, multi-track music and trick recording. The maximum playing time for a tape is 4 minutes.

Closing date for receipt of tapes is December 30, 1967.

Rules of the Contest and entry forms can be obtained from The British Amateur Tape Recording Contest, c/o The Secretary, 33 Fairlawnes, Maldon Road, Wallington, Surrey.

Sorry—too late to enter.

This year was to see the publication of a considerable amount of information concerning significant developments in semiconductor. First in February a comprehensive account of silicon planar transistors with practical information for the amateur user contributed by G. Wareham. (By mid '67 silicon transistors were being advertised in our pages by many retailers.) In March "Unjunction Transistors" by A. Thomas; in May "Field Effect Transistors" by G. B. Clayton and in July "Tunnel Diodes" by D. G. Whitehead. Then, in August another milestone in semiconductor technology was marked by the commencement of a five-part series by M. J. Hughes, entitled "Microelectronics". The integrated circuit, its mysteries and its potential were about to be revealed.

**In October appeared the very first PE project to incorporate an integrated circuit. This was in a hybrid design. The IC Gram-Amplifier by R. Hirst used a Mullard integrated linear a.f. amplifier type 263TAA followed by a complementary pair of germanium transistors.**

The following year opened with an impressive piece of equipment filling the January front-cover. This was the PE Analogue Computer, one of the most enterprising of projects presented to home constructors. The designer and author of this series had successfully completed a mammoth task. Formidable at first sight, the Analogue Computer was actually arranged in the form of units and broken down in this way the circuitry became easy to assimilate and to build. This was a classic example of unit construction and demonstrated how a complete electronic system could be reduced to manageable proportions. We were to see this technique applied to other large projects in the future as the possibilities of modern solid state electronics became exploited in constructor circles.

With a particularly striking cover, the September issue opened further the door on the new world of microelectronics. "Building Around An Integrated Circuit" was the special feature that introduced a series of five constructional projects all based on the Plessey SL701C Operational Amplifier.

As the i.c. was being introduced into amateur projects, so the steady move from germanium to silicon continued amongst discrete transistors. Further stimulus came in Part 3 of "Transistor Amplifier Design" (April) which was devoted to audio applications for the 2N2926 planar silicon transistor.

*Practical Electronics* has by now established a reputation for reliable designs with meaningful application. Each month appeared a selection of projects covering a variety of interests. Such projects were bringing the influence of electronics into ever increasing areas, in and around the home, in the motor car, in the area of pop music as well as those traditional areas of audio, tape and radio.

This magazine was also at the same time encouraging the reader to explore electronics in the widest sense possible, and to experiment with new devices and circuits, not merely in the quest for knowledge (though the serious or educational side of this hobby was always recognised) but also, for the sheer fun or enjoyment this kind of intellectual pastime could provide.

In November a series called "Bionics" was launched. It was concerned with the design and construction of electronic "animals" or machines with artificial intelligence. G. C. Brown was the enterprising author and he was to create interest in an unusual subject and stimulate thoughts amongst countless readers as the series progressed. We now have many regular robotics features.

## ONE SMALL STEP FOR PE READERS

Not long after man first set foot on the moon (July '69) the PE Wideband Communications Receiver was introduced. This constructional series ran for six months and was an attempt to bring advanced receiver techniques into the amateur field. The author's prototype was an impressive piece of equipment, highly professional throughout. Behind the front panel with its large tuning scale were plug-in modules containing most of the circuitry. This modular design was a boon to the constructor who could tackle this rather formidable building task in reasonably sized bites.

Of appeal to a comparatively limited number of readers the Communications Receiver was nevertheless a most worthy subject for inclusion in PE. The study of these articles, at least, should have been most rewarding revealing as they did some highly advanced electronic circuit techniques and also a most business-like mechanical arrangement of the whole system. The aim throughout these last 21 years has been to help the amateur emulate as far as possible, the best standards of design and construction achieved in industry. Projects such as the Communications Receiver contribute to this aim by making readers aware of these elegant practices—and usually they can be applied elsewhere, to perhaps humbler kinds of projects.

At the close of 1969 further audio designs using i.c.s appeared. These were the work of M. Gay, Plessey Co. In November a Basic Amplifier and also a stereo version built around the Plessey SL402 and SL403. In December and January 1970 a novel high fidelity stereo system based on these i.c.s was published. The unusual feature was the use of a three loudspeaker set-up (bass, middle and treble) with one SL403 feeding each speaker. The part of the frequency spectrum fed to each speaker was selected by an active filter formed around the pre amplifier section of the corresponding SL403.

The first i.c. project, Oct '67—A milestone in our history.

Fig. 1. Circuit diagram of the "hybr:d" gramophone amplifier

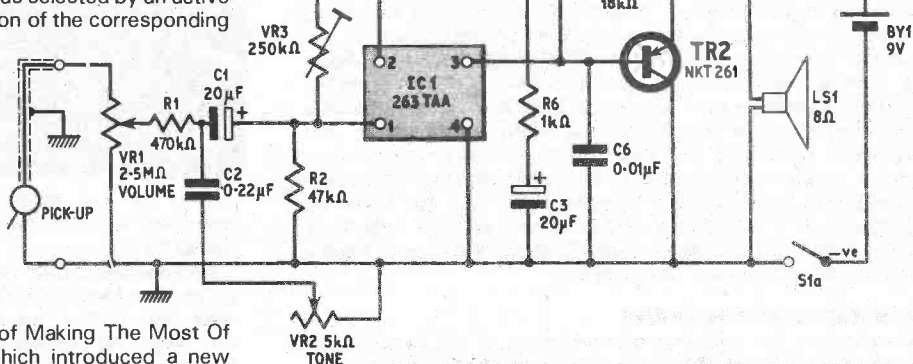

## INTO THE SEVENTIES

July of this new decade saw the start of Making The Most Of Logic I.C.S, a series by R. W. Coles which introduced a new subject to our pages. Silicon monolithic integrated circuits were by now available at a price that made them often cheaper than discrete components. This series was to run to 11 parts and covered the RTL, DTL, TTL, MOS and ECL logic i.c. families.

November saw the appearance of the Gemini Dual Purpose Stereo Amplifier, a design which was to set the standard in this area for a number of years. The design was by D. S. Gibbs and I. M. Shaw of Ferranti Ltd. Discrete transistors were used throughout. The cover for November '70 issue carried the price in the new currency 3/6 (17½ new pence). The actual change to the 'new money' came in February '71.

The first digital i.c. project appeared in December '70 issue with the Digi-Clock, the work of R. W. Coles. This design was based on TTL and used 20 dual-in-line i.c. packages. Readout display was four mini cold cathode indicator tubes. A large project, interesting for the techniques involved and extent of assembly work.

As the first few years passed, the progress of electronic technology made it necessary to publish an increasing amount of technical information to satisfy the interests and aspirations of series enthusiasts, a term which embraces not only hobbyists, but also students and practising technicians and engineers. Our Post-Bag provided evidence of readers' keenness to become deeply involved in electronics, whether as amateurs or professionals. Many requests about subjects and projects came from school teachers who had very quickly appreciated the value of this magazine as a source of ideas and projects for their own classes. The teaching profession has also been well represented amongst our contributors—so it has been a happy two-way relationship between schools and PE, to the advantage of all.

## ENTER EVERYDAY ELECTRONICS

But this increasing need for editorial space to cover the higher end of the "knowledge spectrum" could not be satisfactorily accomplished without some sacrifice in other areas.

After much thought, a decision was finally made in 1971. Practical Electronics would hand over the requirements of newcom-

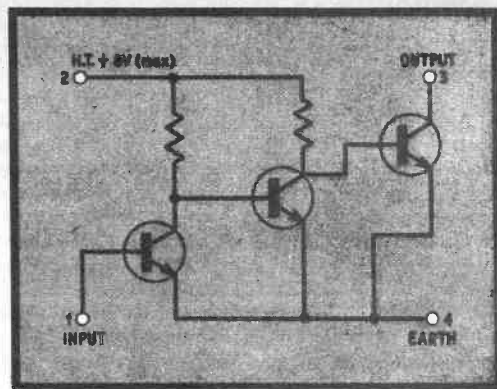

Fig. 2. Circuit diagram of the integrated linear amplifier Type 263TAA

ers to a new magazine, to be run by the same editor, so maintaining a close association with the present publication, while having its own clearly defined policy and purpose. This was announced in the November, 1971 Editorial and the new sister publication *Everyday Electronics* made its bow the next week.

# EXCLUSIVE DIGITAL CLOCK SCOOP!



- MADE ESPECIALLY FOR LASKY'S BY FAMOUS MAKER
- MAINS OPERATION
- 12 HOUR ALARM
- AUTO "SLEEP" SWITCH
- HOURS, MINUTES AND SECONDS READ-OFF
- FORWARD AND BACKWARD TIME ADJUSTMENT
- SILENT OPERATION SYNCHRONOUS MOTOR

**SPECIAL QUOTATIONS FOR QUANTITIES**

This unique DIGITAL CLOCK is now available EXCLUSIVELY FROM LASKY'S in chassis form for you to mount in any housing that you choose. All settings are achieved by two dual-concentric controls at the front including: ON-OFF-AUTO and AUTO ALARM, "sleep" switch, 10 minute division "click" set alarm (up to 12 hour delay), time adjustment. Ultra simple mechanism and high quality manufacture guarantee reliable operation and long life. The sleep switch will automatically turn off any appliance—radio, TV, light, etc., at any pre-set time up to 60 min. and in conjunction with the AUTO setting will switch on the appliance again next morning.

The clock measures 4 1/2" W x 1 3/4" H x 3 1/2" D (overall from front of drum to back of switch). SPEC: 210/240V AC, 50Hz operation; switch rating 250V, 3A. Complete with instructions. HUNDREDS OF APPLICATIONS.

**COMPLETE WITH KNOBS.**

**LASKY'S PRICE £6.19.6** Post 3/6

**KNOBS AVAILABLE SEPARATELY—12/6 per set. Post 1/6**

Digital, but not TTL or CMOS!

## MUSIC AND COLOUR

The April '71 cover was another abstract design introducing Aurora—music inspired light and colour. This project reflected the renewal of interest in lighting schemes controlled by sound. The basic concept was well known and "colour organs" had been described long before *PE* appeared. However, the advent of semiconductor devices such as triacs and thyristors capable of switching power at mains voltage, plus the possibility of sophisticated electronic control circuits brought new impetus to this artistic application of electronics.

The *PE* Aurora system was specially commissioned and was the result of close collaboration between M. J. Hughes who designed the electronics and M. Leonard who was responsible for the artistic presentation. The Aurora was shown at the Audio and Music Fair and at the Electric Theatre exhibition in London.

Amongst covers, that of June 1971 must rate as one of the most spectacular and evocative created by Art Editor, Jack Pountney. The subject itself was exciting: called "XEE" this was an "animal approximation utilising integrated circuits to process optical and tactile sensing together with a random control to give, reasonably life like responses." G. Brown was the designer and he had taken full advantage of the big steps being made in semiconductors. This was the third *PE* project to use digital i.c.s. A total of 7 logic i.c.s were incorporated in what was then a most extensive system arrangement.

### **XEE achieved national fame when it appeared in the BBC TV programme *Tomorrow's World*.**

In November *PE* published what was to become the definitive design for electronic car ignition. Called the *PE* Scorpio, it was designed by D. S. Gibbs and I. M. Shaw and proved an extremely reliable and effective system. It was highly popular and stimulated interest amongst manufacturers as well as constructors.

Also in November appeared another design based on digital i.c.s. The I.C. Digital Dice by J. D. Croft was of special interest being a revised version of a circuit published in *I/U* in the previous April. It showed how effectively i.c.s. could enable smaller and neater units to be built; but also, due to the low price i.c.s now available, was actually cheaper to build than the original discrete transistor version which used 12 transistors. Thus 1971 finished with digital i.c.s established and beginning to take over from discrete devices. Logic devices were in plentiful supply and being advertised at very competitive prices.

## THE SECOND SEVEN YEARS

A mammoth and challenging undertaking for the constructor, but an exciting educational exercise and a worthwhile one was the relatively low-priced *PE* Digi-Cal.

The series ran to 11 parts, finishing in May '73. But Digi-Cal was designed over a period that witnessed feverish developments in the semiconductor field. Large scale integration was under way and hardly had Digi-Cal been launched in our pages when the business world was flooded with commercial desk calculators costing one third of the machines they rapidly replaced. Circuit techniques had taken a gigantic step forward with the practical realisation of whole systems on a chip.

The *PE* Electronic Piano launched in Sept '72 offered a new experience to the music lover. Designed by A. J. Boothman, this

## A FIRST FOR HOME CONSTRUCTORS A POCKET CALCULATOR KIT FROM S.C.S

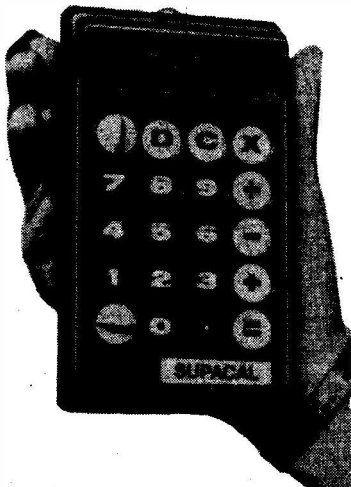

Practical Electronics May 1973

Just look at some of these features:

- 8 digit, fully floating decimal point.
- 4 function with a constant on all functions.
- Does not limit on over or underflow.
- Provides 8 significant figures plus decimal point position over 99 decades.
- Rechargeable batteries.
- Carrying case.
- Charger.
- Touch key board.
- Weighs just 8 oz.
- Measures 5½" x 3" x 1½".
- Full after-sales service.
- 1 year guarantee.

£39  
+  
VAT

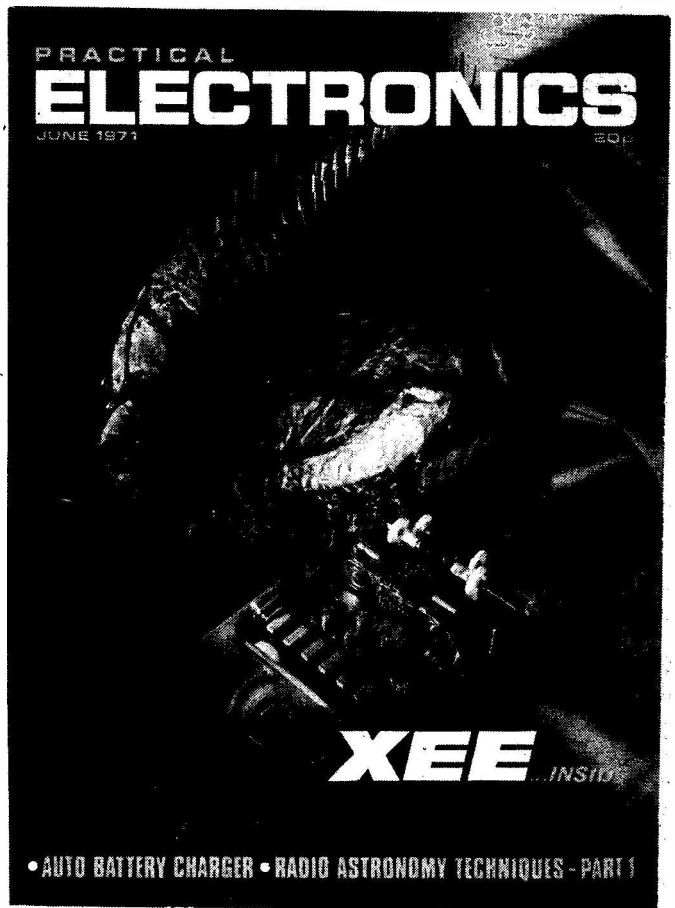

project set out to provide authentic piano sounds from an instrument a quarter the size of a conventional pianoforte, and at a fraction of the cost.

**From around mid 1972 it became the fashion to specify 0.1in Veroboard. The switch to this closer spacing of holes was influenced by integrated circuits. These devices could not be readily accommodated on the 0.15in board because of their pin spacing.**

The "latest" in circuit integration was how the February 1973 issue introduced the *PE* Triffid Single Chip I.C. Radio. The heart of this design was the new ZN414 radio chip produced by Ferranti using CDI, a "new" bipolar integrated circuit manufacturing technique.

The same issue contained the opening part of a block-buster of circuit (or rather system) design. The Sound Synthesiser was designed by G. D. Shaw and represented the latest happening in the electronic-musical field. An assortment of electronic circuitry, including amplifiers, ramp and pulse generators, triangular and square wave generators, reverberation amplifier, ring modulator, envelope shape, noise generator and tone controls—all organised into a system to provide an instrument having exciting possibilities for live performance (with a keyboard), as a sound effects unit or as an audio-visual teaching aid.

## THE 555 TIMER

In June '73 "The 555 Timer I.C." by J. B. Dance brought a new integrated circuit to the attention of readers. Developed by Signetics the 555 could be employed to provide accurate time delays from microseconds to hours. A General Purpose Timer based on this device was also featured in this issue. A few months later (August '73) a Simple Flasher based on the 555 was published. 1973 also marked the 25th anniversary of the announcement of the transistor in 1948.

1974 saw the first use of memory chips by *PE* in the Rhythm Generator by Brice Ward, March 1974. Two SN7489 64-bit bipolar memory i.c.s provided the storage for the programmed rhythms.



The January '75 issue reported under News Briefs the tremendous interest in sound synthesizers as reflected by the massive attendance at the two lectures given at last year's Audio Fair by G. D. Shaw (the author of *PE* articles currently appearing). Part of the lectures dealing with the Minisonic was illustrated with impressive tape recordings made by Malcolm Pointon. Most people were amazed at the range of effects that could be produced by such a simple instrument.

## MICROPROCESSORS

October '75 was notable for including the first comprehensive and authoritative account of microprocessors to be presented to the amateur constructor. Microprocessors by V. Yates (Motorola Inc) was a two-part article explaining how this exciting new device had evolved its operation and applications. The Motorola M6800 was described in some detail as a typical example of the more than 30 types then available to industry.

Also in this issue was a feature Digital Watch which described the assembly of the Sabchron I.e.d. Wrist-watch Kit. The kit was priced at £36.25, or a ready built watch for £45.50. Photographs, blown up to clarify details, accompanied the text which endeavoured to make the way clear for constructors especially those not experienced in such microscopic assembly and soldering operations as demanded. In the December ad pages the Sinclair 'Black Watch' Kit was advertised for £17.95.

April '76 issue contained an 8-page supplement "Sounds Extraordinary" describing principles of operation for the most popular electronic effects used in modern pop music. A special one-shot publication "Sound Design" was announced this month. This publication consisted of a collection of musical projects from *PE*. It included the Joanna Electronic Piano, the Orion Amplifier and the Minisonic Sound Synthesiser; and a variety of sound effects units.

The results of the "How Inventive Are You" Competition appeared in June. The first prize of £250 was awarded to G. G. Hutchieson and B. Ray (Group Entry) for a High Intensity Beacon.

With the May issue was given a piece of Veroboard. An Add-on Capacitance Unit (R. W. Lawrence) had been designed to be built on this board, and was the first example of i.c.s (three in fact) accommodated on a board of these dimensions.

An Audio Compass (M. Kenward) published in May was designed in response to a request for an inexpensive unit to enable a blind person to steer a yacht on a straight course. In the same issue Sinclair offered the Black Watch Kit for £14.95.

In November "Getting to Grips With Microprocessors" by D. Brown (National Semiconductors) featured the SC/MP Development Kit.

An advertisement in October offered the Videomaster Home TV Game Kit for £24.95 ("from 100 TTL devices to one 28-pin chip").

## COMPUTING

With the minicomputer now in full ascendancy it was appropriate for a two-part feature "Memories" (A. Bricer) to appear in the opening month of '77. A Microprocessor Competition presented by A. Marshall, National Semiconductors and *PE* was announced in January. Solar Heating was in the news and a constructional article describing an Electronic Control Unit for Solar Heating Systems was published in February.

**Soon we were back with microprocessors and computers. An interesting feature Computer Hobbies In The U.S. by Roger Woolnaugh revealed the great interest in personal computers and the variety of models available to the public, across the other side of the Atlantic. Will the boom in computing as a hobby come to Britain?**

An important event in February was the microprocessor Forum For Constructors held in London. For three hours a capacity audience listened to National Semiconductor experts D. Brown and S. May both on this topic. Because of great demand, the Forum was repeated the following Saturday. During the first Forum, prizes were presented to the first winners of the *PE* Microprocessor Competition: A. Mackintosh (Brighton) and A. Challinor (Stoke-on-Trent).

The significance of microprocessors was now clear. It was therefore time for an in-depth examination of the subject in our pages. So in March was launched Microprocessors Explained (R. W. Coles). This series ran for six months.

A comprehensive review of the SC/MP Introkit appeared in March.

It was in this issue that Sinclair's Microvision was featured. The review asked if this £200 "pocket" television was a gimmick or a rich man's toy? Britain's leading electronics entrepreneur was not

neglecting the calculator area however. A full-page ad announced Sinclair's 8-digit wrist calculator—available only as a kit for £9.95.

TV Sportcentre (A. M. Marshall) was a project featured in June. Based on the AY-8500 i.c. made by General Instrument Microelectronics, it provided four basic games with sound effects, plus optional extras.

This month it was the turn of the Intercept Junior to be reviewed. This was a microprocessor development and tutorial system based on the Intersil IM6100 CMOS chip.

Such reviews were becoming established features now. In July the Motorola D2 Kit, based on the M6800; and in August the Scrumpi Kit, Bywood's simplified version of the SC/MP, received careful appraisal by experienced contributors.

## BIGGER SIZE

After a 13-year run without change in format, the page size of *PE* was increased as from September 1977. Because of this and to facilitate binding of issues, a new volume was commenced from this date.

The larger cover was immediately put to effective use in displaying the three units that comprised the *PE* Microprocessor System, known, for short, as the *PE* Champ. The co-designers of this impressive equipment and authors of the 10-part series that would cover all details of its design, construction and use were R.W. Coles and B. Cullen. A fitting project to mark the microprocessor revolution, Champ was based on the Intel 4040 micro and was designed expressly for putting microprocessors to work in practical situations. It would help the design of small, cheap dedicated microprocessor boards to run firmware programmes developed by the user to do useful jobs, for example, to control a model train layout or an intruder alarm system.

Recognition of the changing nature of electronics and the increasing emphasis on microprocessors and computing techniques brought into being a new bi-monthly feature Micro-Bus, compiled by D. J. D. This first appeared in October. Its purpose was to present ideas, applications and programmes for the most popular microprocessors.

**Now...the most exciting Sinclair kit ever**

# The Black Watch kit

**At £17.95, it's**

★ **practical**—easily built by anyone in an evening's straightforward assembly.

★ **complete**—right down to strap and batteries.

★ **guaranteed**. A correctly-assembled watch is guaranteed for a year. It works as soon as you put the batteries in. On a built watch we guarantee an accuracy within a second a day—but building it yourself you may be able to adjust the trimmer to achieve an accuracy within a second a week.

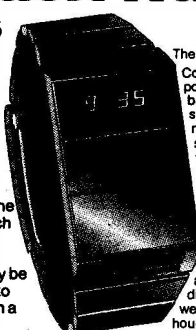

The Black Watch by Sinclair is unique. Controlled by a quartz crystal... powered by two hearing aid batteries... using bright red LEDs to show hours and minutes and minutes and seconds... it's also styled in the cool prestige Sinclair fashion: no knobs, no buttons, no flash.

The Black Watch kit is unique, too. It's rational—Sinclair have reduced the separate components to just four.

It's simple—anybody who can use a soldering iron can assemble a Black Watch without difficulty. From opening the kit to wearing the watch is a couple of hours' work.

### The special features of The Black Watch

Smooth, chunky, matt-black case, with black strap. (Black stainless-steel bracelet available as extra—see order form.)

Large, bright, red display—easily read at night. Touch-and-see case—no unprofessional buttons.

Runs on two hearing-aid batteries (supplied). Change your batteries yourself—no expensive jeweller's service.

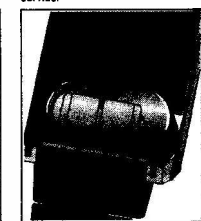
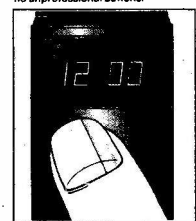
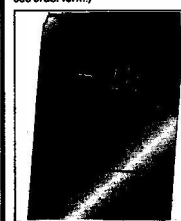

996

Practical Electronics December 1975

A 24-page booklet "A Guide To The Language Of Microprocessors" was presented free with the May issue. Market Place provided news and pictures of the Commodore PET, then available in the UK at £695. Incorporating a 9in. c.r.t. and keyboard the PET was of stylish design and evocative of the new computer age.

**NEXT MONTH: Part 2—The last seven years. *PE* in the age of the micro.**



## SPACE SCAN

During the late summer the two Russian cosmonauts Vladimir Dzhanibekov and Viktor Savinykh have been very busy on the space-station *Salyut 7*. By now the Russians

seem to have their activities down to a fine art; repairs and modifications can be carried out with no trouble at all, and from all accounts the cosmonauts have been in excellent health and spirits.

All this is encouraging for the overall space-station programme scheduled for the 1990s. First, however, we look forward to the Hubble Telescope, a 94-inch reflector to be put into orbit in the near future. If it succeeds (and there is no reason why it should not), it will far surpass any Earth-based telescope.

The *Voyager 2* probe continues its journey towards Uranus, which will be bypassed next January. There are still uneasy doubts about the scan platform, carrying the cameras, which was apparently damaged by a piece of debris after making the closest approach to Saturn, but the space-planners consider that the chances of success with Uranus are at least 60 per cent. Let us hope so; otherwise, we may have to wait

for some time for close-range data from this remarkable world.

Three astronomers at the University of Tasmania—A. R. Klekociuk, P. M. McCulloch and P. A. Hamilton—have reported an abrupt decrease in the period of the Vela pulsar (PSR 0833-45). It apparently happened during mid-July. Pulsars are neutron stars, very small and almost incredibly dense; they are spinning rapidly, which is why we receive the quick-fire, regular radio pulses, and they are slowing down as they lose their energy. Of course, the overall rate of decrease is very slow, and there are occasional "glitches" which may be due to what can only be called starquakes on the neutron star's surface.

The Vela pulsar was the second to be identified with an optical object (the first was the pulsar in the Crab Nebula) and it is excessively faint. It is certainly a supernova remnant, and it has been calculated that the outburst took place about 11,000 years ago,

## The Sky This Month

*It cannot be said that this October is a good month for the planetary observer. Jupiter is still a splendid object in the south-western sky during evenings, but it is rather low down—in Capricornus—and the other giant planet, Saturn, is now to all intents and purposes lost in the evening twilight.*

*Mercury is technically an evening object for the last three weeks of the month, and is well placed for southern-hemisphere observers, but from Britain it will probably not be visible with the naked eye. (Telescopic studies of Mercury are almost always carried out in broad daylight, but this involves using an instrument equipped with accurate setting circles, and in any case virtually all our knowledge of the Mercurian surface has been derived from one space probe, Mariner 10).*

*Venus is still dominant before dawn, and with its magnitude of -3.4 it is much brighter than any other star or planet. The phase is now over 90 per cent., but no telescope will show anything definite upon the upper cloud layer.*

*In early October Venus passes just north of Mars, but the Red Planet is now no brighter than the Pole Star, and its apparent diameter is less than four seconds of arc. It does not come to opposition again until July next year.*

*The Moon is new on 14 October, and full on 28. On the latter date there will be a total lunar eclipse—the second this year, though that of 4 May was not well seen from Britain, partly because the eclipse began well before moonrise and partly because the weather was generally cloudy. The eclipse this month should be more favourable. It is visible from Europe, including the British Isles, as well as from Australasia, Japan, and large areas of Asia. Totality lasts from 17.20 GMT to 18.04 GMT; the eclipse begins its partial phase at 15.55 (again some time before moonrise here) and ends finally at 19.29.*

*It cannot be claimed that lunar eclipses are of great importance astronomically, but they are interesting to watch, and very often there are vivid colours—blues, greens and reds, for example. It is never safe to forecast, however, because all the light from the Sun reaching the eclipsed Moon has to pass through the Earth's atmosphere, and everything depends upon how clear (or otherwise) the air is.*

*At some eclipses the Moon has disappeared so completely for a while that it could not be found even with a telescope, while at other eclipses the disc has remained bright throughout. Major volcanic eruptions, or extensive forest fires, naturally tend to produce "dark eclipses", and it will be worth while taking photographs as*

*well as making visual observations. It will be nearly a year before we in Britain see another lunar eclipse.*

## COMETS

*Halley's Comet is brightening steadily. During October it moves in a retrograde direction through Taurus, and as the magnitude is expected to rise to about 10 the comet is well within the range of most amateur telescopes; whether there will be a detectable tail or not remains to be seen. The distance from Earth has been reduced to less than 150,000,000 miles, and the speed has increased to over 60,000 mph.*

*The other available comet, Giacobini-Zinner, is of about the 9th magnitude, but is moving south. The position on 12 October is expected to be R.A. 7h 8m, dec. -12°28'; not far from Sirius. By the end of November it will have moved so far south that from Britain it will not rise at all.*

*The Great Bear, Ursa Major, is now almost at its lowest, in the north, though it is of course circumpolar from anywhere in the British Isles. Cassiopeia, with its famous W pattern, is almost at the zenith; it is interesting to see which of the five W stars is the brightest, because one of them—Gamma, the middle member—is decidedly variable between magnitude 1½ and 3, and the reddish Shedir is also suspected of variability over a small range.*

*Adjoining Cassiopeia is Perseus, and it is worth finding the Sword-Handle, made up of two open clusters in the same low-power field of view; they can just be seen with the naked eye as a blur of light. The so-called 'Summer Triangle' made up of Vega, Deneb and Altair is now sinking in the north-west, though of the three only Altair actually drops below the horizon.*

*High in the south there is the Square of Pegasus; below it, skirting the horizon, is Fomalhaut in the Southern Fish, which is the most southerly first-magnitude star ever visible from here. Two of the Pegasus stars (Scheat and Markab) point to it, but from North Scotland it is always so low that it is unlikely to be seen. Fomalhaut, one of our nearest stellar neighbours, is of special interest because it was one of the stars found by IRAS, the Infra-Red Astronomical Satellite, to be associated with cool material which may well be planet-forming.*

*In the east Orion is starting to come into view later in the night, and in the late evening some of his retinue, notably the Pleiades cluster and the red Aldebaran, are well on view. As a "preview" of next month, note that on 16 November Halley's Comet will be closely south of the Pleiades. Amateur photographers, lay your plans well ahead of time!*

so that our remote ancestors could have seen it; the maximum brightness may have been as much as that of the half-moon.

**METEOR SHOWER**

During October we are due for the annual Orionid meteor shower. It is of special interest this year, because the Orionids, like the Eta Aquarids of May, are associated with Halley's Comet.

The association between comets and meteors has been known for a long time. (Note that there is no connection with meteorites, which are more related to minor planets or asteroids, and have nothing to do with either comets or shooting-stars.) As a comet moves, it leaves a "dusty trail" of debris behind it; when the Earth plunges through such a trail, we scoop up many meteors, and the result is a shower of shooting-stars.

An old comet, which has been round the Sun many times, will have spread its debris all along its orbit, and the annual meteor shower is predictable in intensity; such as the Perseid shower of early August. In other cases the cometary debris is "bunched up", and we see major displays only when the

Earth is in the right position at the right time; this is the case with the November Leonids, which can be spectacular, as they last were in 1966, but are generally rather sparse. The Orionids have been recorded many times; Chinese reports say that they were very rich, for instance, in the years 288 and 1651. The shower begins about 16 October and ends on 26, with its maximum on the 21.

Meteor activity is listed according to its ZHR or Zenithal Hourly Rate. This is defined as the number of meteors which would be seen with the naked eye by an observer under perfect conditions with the shower radiant at the zenith. In practice, of course, these conditions are never attained, and the observed ZHR is always less than the theoretical, but at least it gives a good general guide.

The usual ZHR of the Perseids is around 75. With the Orionids it is only 20, but there are often long dusty trains which persist for a second or two. There is an unusual multi-radiant structure, and it is now thought that the stream itself is somewhat complex,

made up of four or five "shells" of material which have slightly different orbits and peak at different times.

In past years most of our knowledge of meteor streams was derived from visual observations, mainly amateur. This is no longer true, because radar studies have largely taken over; but visual work is still of value, and the observer can help by counting the number of meteors observed and plotted their tracks against the background of stars. Of course, not all the meteors seen during October will be Orionids; Taurid shower begins on the 20 October, and there are also sporadic meteors, which do not belong to any stream and may therefore appear from any direction at any moment.

It would be wrong to suggest that the Orionids will be particularly rich this year because Halley's Comet is coming in toward perihelion. Last time the comet came round, in 1910, the Orionids were no more spectacular than usual. All the same, one never knows, and meteor enthusiasts will be very much on the alert around the middle of this month.

**FREE! READERS' ADVERTISEMENT SERVICE**

**PE BAZAAR**

**RULES** Maximum of 16 words plus address and/or phone no. Private advertisers only (trade or business ads. can be placed in our classified columns). Items related to electronics only. No computer software. PE cannot accept responsibility for the accuracy of ads. or for any transaction arising between readers as a result of a free ad. We reserve the right to refuse advertisements. Each ad. must be accompanied by a **cut-out valid "date corner"**. Ads. will not appear (or be returned) if these rules are broken.

**WANTED** 16K RAM pack (CE-161) for Sharp PC1500. 4K RAM for part exchange if wanted. Mr. Green, 60 Marlborough Park Avenue, Sidcup, Kent DA15 9DU.

**LYNX** 48K Colour Hi-Res micro one month old £80 ono. Contains £50 worth of socketed chips. Mr. James Fricker, 3 Fairfield Close, Harpenden, Herts AL5 5RZ. Tel: 63729.

**Tandon** TM100-2A 5 1/4" floppy disc drive. BBC compat. D.D. D.S. as new plus 20 discs £140.00. Mr. R. Shettle, 20a Lady Hill Road, Alway, Newport, Gwent, S. Wales NP9 9RY.

**Magazines.** Practical Electronics 69-74; Everyday Electronics 71-73; Practical Wireless 71-74; Radio Constructor 71-73. In binders. Offers? Mr. Derek Andrews, 121 Gladstone Street, Bedford MK41 7RS. Tel: 0234 218973.

**Hewlett-Packard** HP35 calculator and charger—£15. **Wanted**—copy of Radio & Television Engineers reference book. Mr. D.C. Chapman, 6 Pickhurst Green, Hayes, Bromley, Kent BR2 7QT. Tel: 01-462 2178.

**Tektronix** 7603 full professional standard four-trace oscilloscope. Excellent condition. £1250 ono. Barry. Tel: 01-804 5081.

**Tandy** TRS80 Mod 1 48K two disks Lcase sound scripsit edatam visical Newdos80. Much software £300. Mr. P. Short, 5 Hagart Road, Houston, Renfrewshire PA6 7JH. Tel: 0505 613322.

**Books**—as new Prog.Z80 (R. Zaks), Micro Interfacing Techniques (R. Zaks, A. Lesea), Starting Forth (L. Brodie). Others half price. SAE for list to: R.H. Pearce, 8 Holly Oak Road, Cuxford, Southampton SO1 6GD.

**Wanted:** Oscilloscope. Must be cheap and in working order. Write with make, condition and price to: Mike Day, 39 Valnord Lane, St. Peter Port, Guernsey, Channel Islands.

**KIM-1.** Any books or information about this 6502 development system required. Mr. C. Edwards, 53 Southfleet Avenue, Fleetwood, Lancs. Tel: Q3917 5838.

**Riscomp** US5063 ultrasonic detector with case £12.00 + Riscomp US4016 with case £10.00. J. Longley, 28 Canwell, Werrington, Peterborough. Tel: 0733 77918.

**Daisywheel printer** (Diablo) RS232 interface plus typewriter mode fanfold or sheet paper £100. Tel: Twyford 340736.

**Swap** 2532 4K EPROMS for 2716 2K EPROMS (I can't program 4K's), also lenses, Vic/Spectrum bits. Mr. Mel Saunders, 7 Drumcliff Road, Thurnby Lodge, Leicester LE5 2LH.

**Penfriend:** I'm French and I'd like to have an English penfriend. Mazubien La Croix, 50380 St. Pair, France.

**B10** glavanic cells? What are they. Have circuit from 1973 using these—baffled! Eamonn Gibson, 64 Willington Drive, Templeogue, Dublin 12, Ireland.

**Tektronix** Digital Tester (meter), 3 channels, many functions inc. a 5 1/2 digit DMM; probes and manual. Excellent condition. Offers. Tel: 041-552 1160.

**Wanted:** Oscilloscope dual-trace multiplexer adaptor for comparing and contrasting waveforms by superimposition. M.O.A. Chari, Ladersatrvagen 97 3 Tr., 175 70Jarfalla, Sweden.

**Printer,** 110 baud Olivetti TE300 teletype. Upper case only. £30 ono. John Honniball. Tel: 0206 575887.

Please publish the following small ad. FREE in the next available issue. I am not a dealer in electronics or associated equipment. I have read the rules. I enclose a **cut-out valid** date corner.

Signature ..... Date .....

**Please read the RULES** then write your advertisement here—one word to each box. Add your name, address and/or phone no. **COUPON VALID FOR POSTING BEFORE 1 NOVEMBER, 1985** (One month later for overseas readers.)

**SEND TO:** PE BAZAAR, PRACTICAL ELECTRONICS, WEST-OVER HOUSE, WEST QUAY ROAD, POOLE, DORSET BE15 1JG.

**BLOCK CAPITALS PLEASE**

<b>Name &amp; Address:</b>			

For readers who don't want to damage the issue send a photostat or a copy of the coupon (filled in of course) with a **cut-out valid "date corner"**

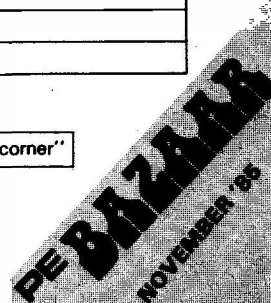

# Experimenting With ROBOTS

Mike Abbott Part 3

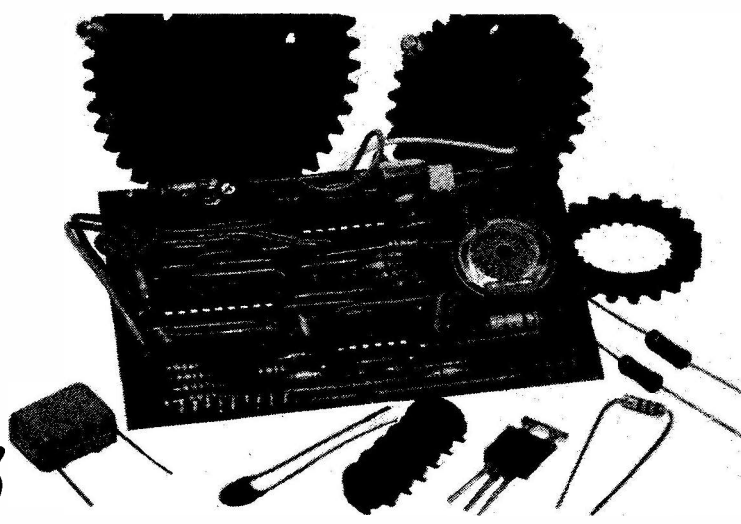

## SQUINT!

*it gives your robot shifty eyes*

OF the various simple robot eye systems that have been devised, such as the flashing I.e.d. circles of the RUR (Reekie Universal Robot), as yet nothing very sinister has emerged.

The circuit in Fig. 1 bestows upon your robot (or Hallowe'en gargoyle, come to that) the power to look left, right, or dead ahead, with no moving parts. It's *not* all done with mirrors. It is done with I.e.d.s and tracing paper. Two groups of three I.e.d.s hidden behind tracing paper, or some other diffuser, create a fairly convincing illusion. A crystal microphone insert fitted in each 'ear' of the robot provides binaural sound sensitivity, allowing the robot to look left when a sound occurs to the left, and right when a sound occurs to the right. In silence the robot stares dead ahead unflinchingly, but will switch gaze to a sound source for as long as that sound persists.

### CIRCUIT DESCRIPTION

The front-end of the robot eye system comprises two identical channels formed around IC1a and b. These op. amp's merely operate as audio amplifiers, but which, due to D1 and D4 act on the positive halves of their input signals only. Their gains are adjustable independently using VR1 and VR2, allowing the ear sensitivities to be balanced relative to each other.

The crystal microphone inserts are coupled to their amplifiers through high-pass filters which reduce sensitivity to mains hum, and meet the input offset requirements of the 741.

The input amplifiers each have a d.c. gain of 1000 maximum, but are decoupled by C1 and C5 to yield a gain some ten times higher at 1kHz, giving *Squint* sufficiently acute hearing to detect local sounds.

Because of the diode pump formed by D2 and C3, a d.c. voltage proportional to the sound level in the left ear is generated across C3. Likewise, C4 stores a voltage proportional to the sound level in the right ear. These voltages take a finite time, or number of cycles, to build up, and therefore should both ears detect sounds simultaneously the sound occurring first will normally attract the eyes to it. However, should the second sound follow closely, and be very much louder, it will gain control of the eyes. This is because the ramp rate of the proportional voltage will be steeper and it will hence reach the Schmitt trigger voltage of IC2 sooner.

A bistable is formed of IC2a and b, and this arrangement, along with IC2c, ensures that only one I.e.d. in each eye is illuminated at any time. Current amplification to drive these I.e.d.s is provided by TR1-TR3.

### THE EYES HAVE IT

As stated, each eye is created from a group of three I.e.d.s mounted on a p.c.b. Because the viewing angle of most I.e.d.s is quite narrow it is advisable to place a piece of frosted glass, or tracing paper, before each eye to create a pleasing glow (see Fig. 2). Of course, the eyes may be of green, yellow or red light, but the high efficiency red I.e.d.s give by far the best result. Make the robot's eye apertures large and round for a friendly, humorous physiognomy; or make them long horizontal slits for the sinister machine.

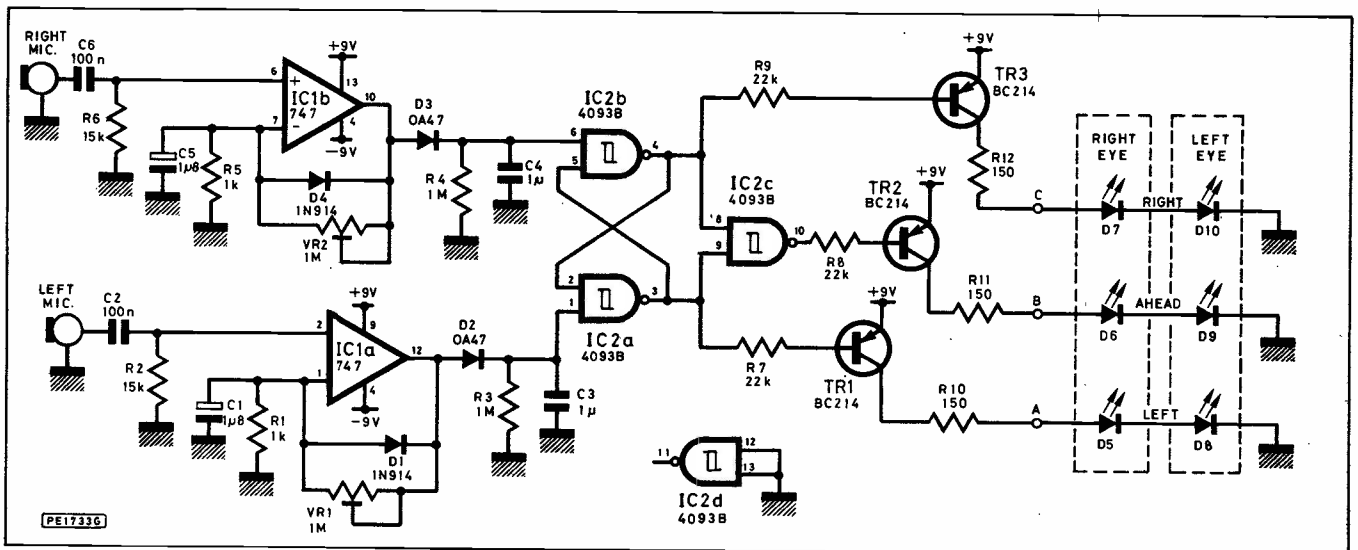
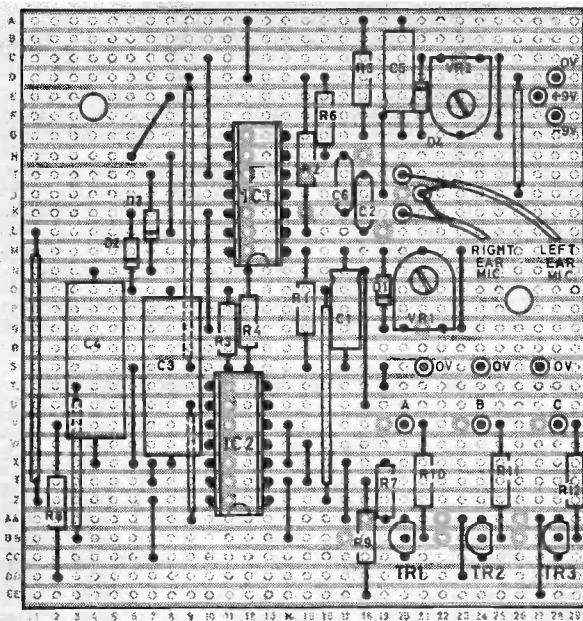
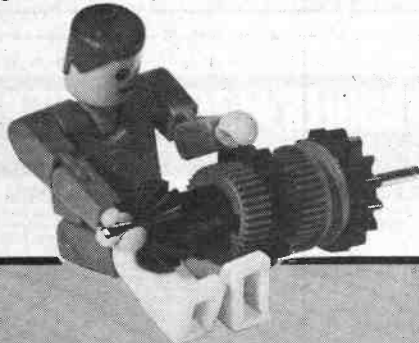

Fig. 1. Circuit diagram of *Squint*



PE17349A PE17326B

**Fig. 2.** Stripboard layout of *Squint*. There are track cuts at L19 and H18 to keep the tracks to ICI pins 2 and 6 no longer than they need be. Op.amp. inputs are extremely sensitive to mains hum and r.f.i., and unnecessary track lengths at these points will act as aerials.



**Fig. 3.** A plan view of a typical layout inside a robot's head once fitted with *Squint*. Wiring is straightforward. Halves of a ping-pong ball make very effective eyeballs but then high intensity red i.e.d.s are recommended. Don't be surprised if *Squint* looks the wrong way occasionally—sounds reflect off different objects at different frequencies around a room! The phenomenon illustrates by contrast the effectiveness of the human brain (which *Squint* does not have the benefit of) at instantly interpreting things seen and heard. Distances of objects and sources of sounds are interpreted as much by experience as by raw data from sensors. Robots have a long way to go and *Squint* like many of today's systems which feign intelligence, however convincingly, is of course merely another prolepsis

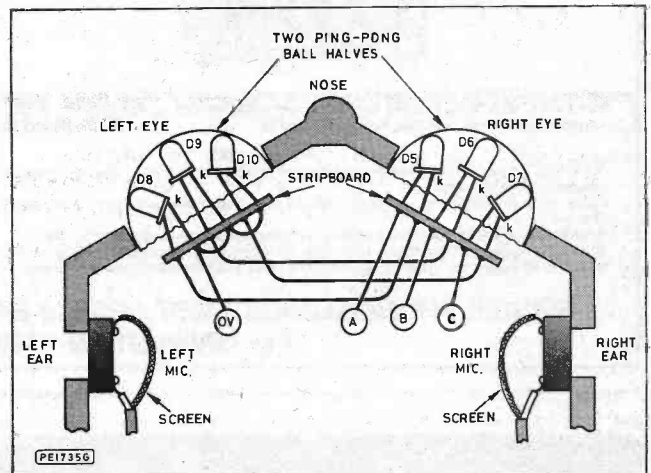

Continued next month

## COMPONENTS . . .

### Resistors

R1,R5	1k (2 off)
R2,R6	15k (2 off)
R3,R4	1M (2 off)
R7-R9	22k (3 off)
R10-R12	150 (3 off)
All resistors ¼W 5%	

### Capacitors

C1,C5	1µ8 (2 off)
C2,C6	100n (2 off)
C3,C4	1µ (2 off)

### Potentiometers

VR1,VR2	1M hor. preset
---------	----------------

### Semiconductors

D1,D4	IN914 (2 off)
D2,D3	0A47 (2 off)
D5-D10*	0.2 in. i.e.d. (high intensity red) (6 off)
TR1-TR3	BC214 (3 off)
IC1	747 dual op-amp
IC2	4093B CMOS Schmitt quad NAND

\* standard i.e.d.s may be used with a less dense diffuser such as tracing paper.

### Miscellaneous

Crystal microphone inserts (2 off), stripboard (3 pieces), ping-pong ball (or tracing paper), instrument wire (screened for mics), PP6 or other 9V source (2 off batteries or +9V & -9V supplies), nuts and bolts or p.c.b. stand-offs.



# DISCO LIGHTS CONTROLLER

John M.H. Becker

Part One

Few discos or parties are complete without a lighting display that can be synchronised with music or follow a chaser sequence. This unit has been designed to satisfy both these needs, and additionally, as so many people now have microcomputers, it can also be computer-controlled. This latter facility even allows the unit to be used for sequential control of shop displays, or house security lighting.

The project has been designed in two sections, consisting of a main 3-channel sound to light controller that can be used on its own, and a set of optional circuits that can be added to the main unit, so providing further versatility. The block diagram of Fig. 1 shows the general arrangement.

The main circuit contains a triple band filter, the response of which can be varied from the panel, separate sensitivity controls for each frequency band, and optically isolated coupling to the output lamp control triacs each of which has a 750 watt capability. Also included in the main part is an integral power supply eliminating the need for batteries, whilst providing further electrical isolation safety via a transformer.

The optional circuits consist of an automatic level control for the input music signal, an interface circuit for coupling the unit to a computer, panel-mounted neons monitoring the output lamps and channel response, and a four mode chaser sequence generator for switching in as an alternative to music control.

## AUTOMATIC LEVEL CONTROL

The use of an ALC ensures that the controlling music remains at roughly equivalent levels irrespective of variations in the level of the music source. The advantage of this is that the lighting response will remain similar even though different music tracks may have different dynamic ranges. The circuit diagram for the full system is shown in Fig. 2: IC6 is a chip primarily designed for such

functions as companding, noise gating and ALC. In ALC mode the input signal level is detected by the chip which provides a feedback level correction to an internal gain stage so that within a given amplitude range, an average constant output level will result.

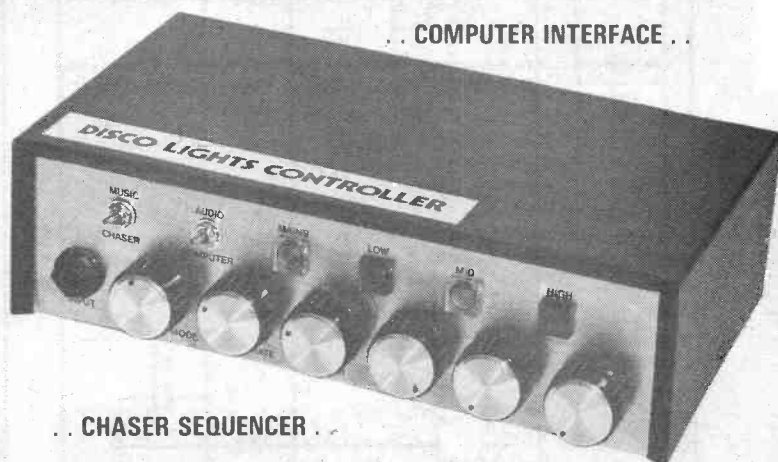

... COMPUTER INTERFACE ...

## ... CHASER SEQUENCER ...

The rate at which the chip responds to varying levels is determined by C3, the value of which has been selected to allow reasonable attack and decay characteristics of the signal to be retained, whilst preserving signal waveform shapes. If too low a value were used, signal peaks would be more restricted, but the envelope characteristics of the signal would be degraded. With a higher value there would be a loss of response time.

The network of R2, R3, C5 and C6 govern the overall gain and frequency range of the chip. R1 sets the minimum level of signal that will produce the average output level. Reducing its value will

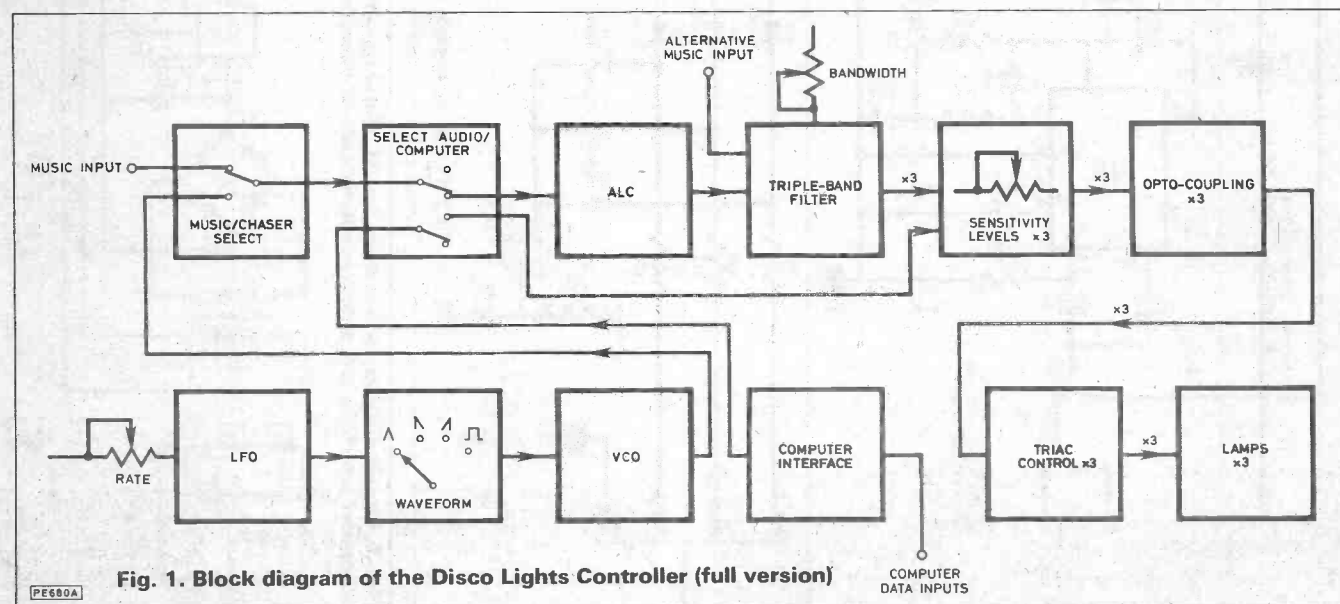
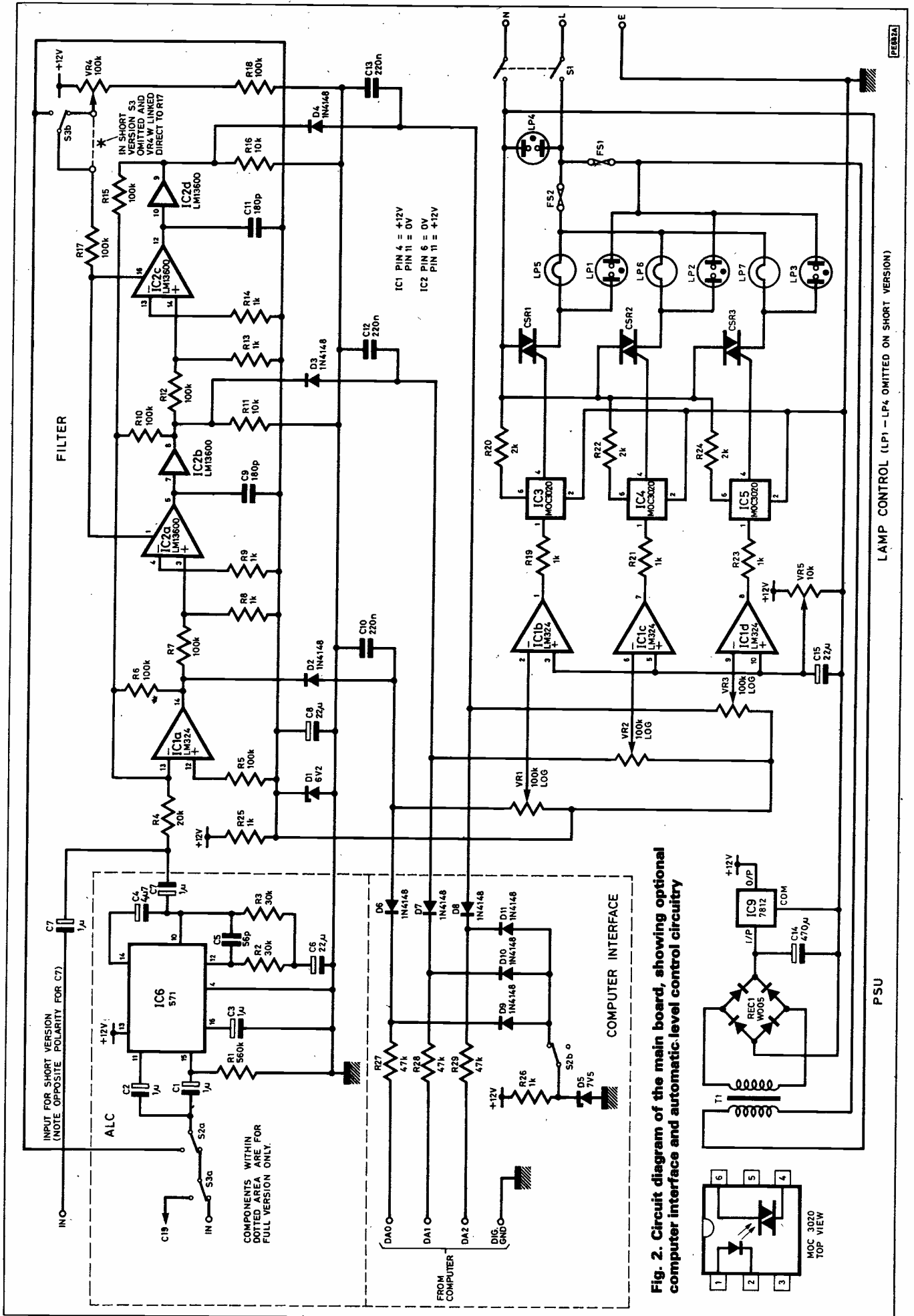

Fig. 1. Block diagram of the Disco Lights Controller (full version)





raise the threshold level, and increasing the value reduce the threshold. With the values chosen for the envelope, gain, and threshold control, input signals from about 200mV peak-to-peak will produce an average output level of about 2.5V p-p. This same average will result with input signals up to about 10V p-p. The chip thus acts as an amplifier for low level signals, and an attenuator for high level ones. This enables the unit to be used with a variety of input sources, from high output microphones, turntables, cassette decks, and direct from many speaker output sockets, with a maximum level of 10V p-p. See photographs 1 and 2.

The actual output level of the chip will however depend upon the waveform shape, and its envelope characteristics. Transient peaks will not be suppressed to the same level due to the response time of C3, (see photographs 3 and 4) and, for example, triangle waveforms will produce a higher p-p level than square waves (see photographs 5 and 6).

If the ALC is not used, the input is brought in direct to C7, and the individual lamp sensitivity controls used to correct for signal amplitude differences.

### FILTER STAGE

Readers of *PE* will be familiar with the use of the LM13600 for various filtering functions. In this circuit IC2 and IC1a are combined to produce a triple band voltage controlled filter, covering low-pass, bandpass, and highpass frequencies. Each of these bands is responsible for controlling one lamp. The stage gain of the filter is set at about 5 by the relationship of R4 to R6, R10 and R15. Increasing R4 will reduce the gain, and vice versa. With R4 at the value chosen, the average level at the three filter outputs will be virtually the maximum permitted by the 12V d.c. power supply. The resultant slightly clipped signal is not undesirable in this instance.

The filter has been made tunable so that different frequency ranges of the signal can be given greater emphasis. The basic filter bandpass frequency is set by the values of C9, C11, and the current seen at IC2 pins 1 and 16. The latter is controlled by varying the voltage at the wiper of VR4. With the wiper fully at its positive end, the bandpass frequency at IC2 pin 8 will be around 7kHz. With the wiper at the R18 end, the centre bandpass frequency will be about 100Hz. Table 1 shows typical characteristics, partly measured, partly calculated, for all three filter outputs at various settings of VR4.

The use of this control allows for the best response of all three lights to be obtained even though the frequency range of the controlling music may emphasise the low end on one record, and the higher end on another. As far as the disco dancer is concerned, it's the rhythmically synchronised fluctuation of all three lights that is more important than whether a particular frequency is corresponding with a particular colour.

Its use also makes it possible for the DJ to select the visual emphasis of a low frequency instrument, such as a bass drum, or a higher frequency one such as a snare, or handclapper.

### FREQUENCY RANGES

Although the frequency range of music may extend well up towards 20kHz, in practice most of the upper range is simply low-power harmonics. The main weight of fundamental information is usually within the frequencies below 4kHz, and often well below 3kHz: For acoustic instruments, some approximate fundamental ranges are: Doublebass 40Hz to 180Hz, Violin 200Hz to 2.5kHz, Clarinet 150Hz to 1.5kHz, Trombone 80Hz to 500Hz, Large Kettle Drum 80Hz to 140Hz, Bass Drum 50Hz to 1.5kHz. Some Pianos may cover 16Hz to 14kHz, but the more usual range is about 30Hz to 4kHz.

For vocals, a Bass voice will probably cover 80Hz to 330Hz, a Tenor 120Hz to 500Hz, and a Soprano 250Hz to 1kHz. The ranges of electronic instruments are less easy to define as their responses are often as much subject to the electronics behind them as to their mechanical qualities. (Reference source: *From Microphone to Ear*, Philips Technical Library).

In practical terms for recorded music, the best settings for the filter control can be roughly summarised as fast heavy beats showing best emphasis with VR4 at about three quarters, speech and slow vocals about one quarter, and those with a good snare drum beat being best with VR4 at about half way.

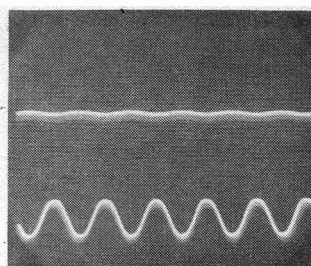

Photo 1: Low level sine

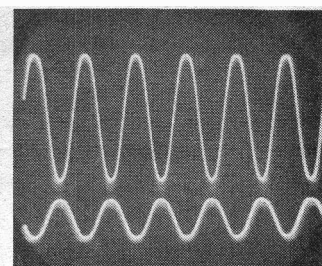

Photo 2: High level sine

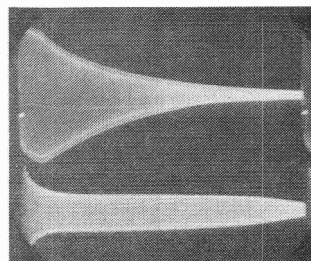

Photo 3: Bass drum

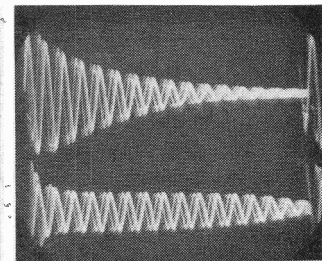

Photo 4: High bongo

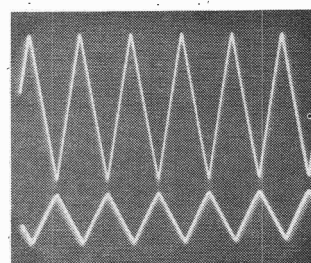

Photo 5: High triangle

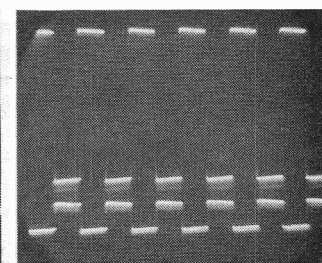

Photo 6: High square

Table 1: Filter outputs for various settings of VR4

VR4	Lowpass		Bandpass			Highpass		
	Full	Half-Level	Half-Level	Full	Half-Level	Half-Level	Full	Half-Level
↑	65Hz	130Hz	30Hz	90Hz	220Hz	60Hz	120Hz	13600Hz
↑↑	160Hz	320Hz	70Hz	210Hz	500Hz	130Hz	260Hz	13600Hz
→	440Hz	880Hz	170Hz	500Hz	1250Hz	300Hz	600Hz	13600Hz
→→	750Hz	1500Hz	300Hz	900Hz	2200Hz	550Hz	1100Hz	13600Hz
↓	1400Hz	2800Hz	530Hz	1600Hz	4000Hz	950Hz	1900Hz	13600Hz
↓↓	2700Hz	5400Hz	1160Hz	3500Hz	8700Hz	2000Hz	4000Hz	13600Hz
←	3500Hz	7000Hz	2060Hz	6200Hz	13600Hz	4500Hz	9000Hz	13600Hz

### SENSITIVITY

Each of the three filter outputs are treated identically. They are each given half wave rectification by D2 to D4 respectively so that only the negative going content of the signal is used. C10, C12 and C13 respectively remove some of the a.c. content, leaving mainly the d.c. level.

Their values, have been deliberately kept small so that the response of the lights to the music control is kept fast. VR1 to VR3 control the level that then reaches the three comparators IC1b to IC1d. These have a common trip point threshold level as set by the preset VR5. As the filter output voltages drop below the threshold level so the comparators change their output state from low to high and in doing so trigger the optically coupled triacs IC3 to IC5.

### OUTPUT COUPLING

In earlier sound-to-light units, mains isolation of the controlling electronic circuitry from the mains driven triacs or thyristors was usually ensured by the use of transformers. However, optically coupled isolation devices such as the MOC3020 are now widely available and offer an excellent alternative. Within them is a light emitting diode and a low current triac. When the l.e.d. is dark, the triac is inoperative, but upon illumination, the triac detects the light from the l.e.d. and is triggered. This particular optotriac is capable of driving a mains voltage load of up to 50mA, and the isolation can withstand up to 7500V a.c.

Each time the comparators IC1d are activated, so the l.e.d. is turned on, and the triac is triggered. The 50mA current is of course inadequate for controlling disco lights directly, but is quite capable of triggering another triac that can cope with the larger load. Although I only use this unit with 100 watt lamps, the rating of the output triacs CSR1 to CSR3 is actually 3-5A, allowing the possibility of lamps up to 750 watts to be controlled.

### CURRENT RATING

With the 100W lamps, heat sinking of the triacs was not found to be necessary, and this will probably be so even with 150W lamps. However, if higher rated lamps are used, heat sinking may be needed. All three may be mounted to the same heat sink as the metal tab on each is connected to the common mains neutral line via the central leg. The heat sink though should be kept isolated from any other part of the circuit or casing.

With higher wattage lamps it is also advisable to increase the current carrying capability of the p.c.b. track delivering the mains neutral line. This can be easily done by soldering copper wire along this track.

Remember also that the rating of the mains lead both into the unit, and out to the lamps must be capable of handling the current used by the lamps. The value of the fuse FS2 must also be selected for the current drawn by the total of all three lamps on together, plus a bit of margin. A 250W lamp will draw a little over 1A. The optional neon indicators LP1 to LP3 that are used for panel monitoring of the frequency bands draw little significant current.

### COMPUTER CONTROL

With so many people now owning microcomputers, it is likely that many DJ's will be able to couple one to the unit, and so generate even more complex lighting control patterns. Consequently a simple computer interface has been included as an optional extra. All that is required is that the unit be coupled to the binary output socket of the computer, and for the relevant binary bit to be taken low then high for the respective lamp to turn on and

off. Only three of the eight available output bits are required, plus the ground connection.

Referring again to Fig. 2, R27 to R29, and D6 to D11 form a simple gating circuit. With the output bits of the computer held high, the voltage across VR1 to VR3 will be at the circuit reference level of about 6V, which is above the trigger threshold of IC1b to IC1d. As the binary outputs go to logic 0, so the voltage levels on the pots will fall below the threshold and the triacs will turn on the lamps.

Although the computer output is only 5V maximum the swing is sufficient to provide the necessary control, providing VR1 to VR3 are turned up sufficiently. The switching arrangement of S2 and S3 is such that priority is given to computer control over both music and chaser control, the input to IC6 being held at a d.c. level whilst in computer mode. Switching S2 from computer control, a bias voltage is applied to D9 to D11 to ensure that even if the computer is still running, the impedance to R27 to R29 will prevent the logic levels from affecting VR1 to VR3.

If you only want computer control of the lights you can omit the filter, chaser, and ALC circuits. In this case VR1 to VR3 can also be left out, and D6 to D8 replaced by link wires. The lamp control circuitry could also be repeated to control eight channels from the eight bit binary port. Such a set up might be ideal for random control of domestic lights.

In these days of unacceptable risk of burglary, observing thieves could be led to believe that premises are occupied since lights can be seen going on and off in an unpredictable fashion. Further details on this are beyond the scope of this article. Shopkeepers also might find benefit from the use of the full circuit, including computer control, for varying their window lighting displays.

### POWER SUPPLY

To avoid interaction between the three channels, the circuit is powered by a stabilised power supply. In the prototype the transformer used has its twin 6V output windings coupled in series as 0-12V a.c. This is rectified by REC1 to about 18V d.c., and stabilised at 12V d.c. by IC9. A separate fuse is given to this part of the circuit to give further electrical safety isolation.

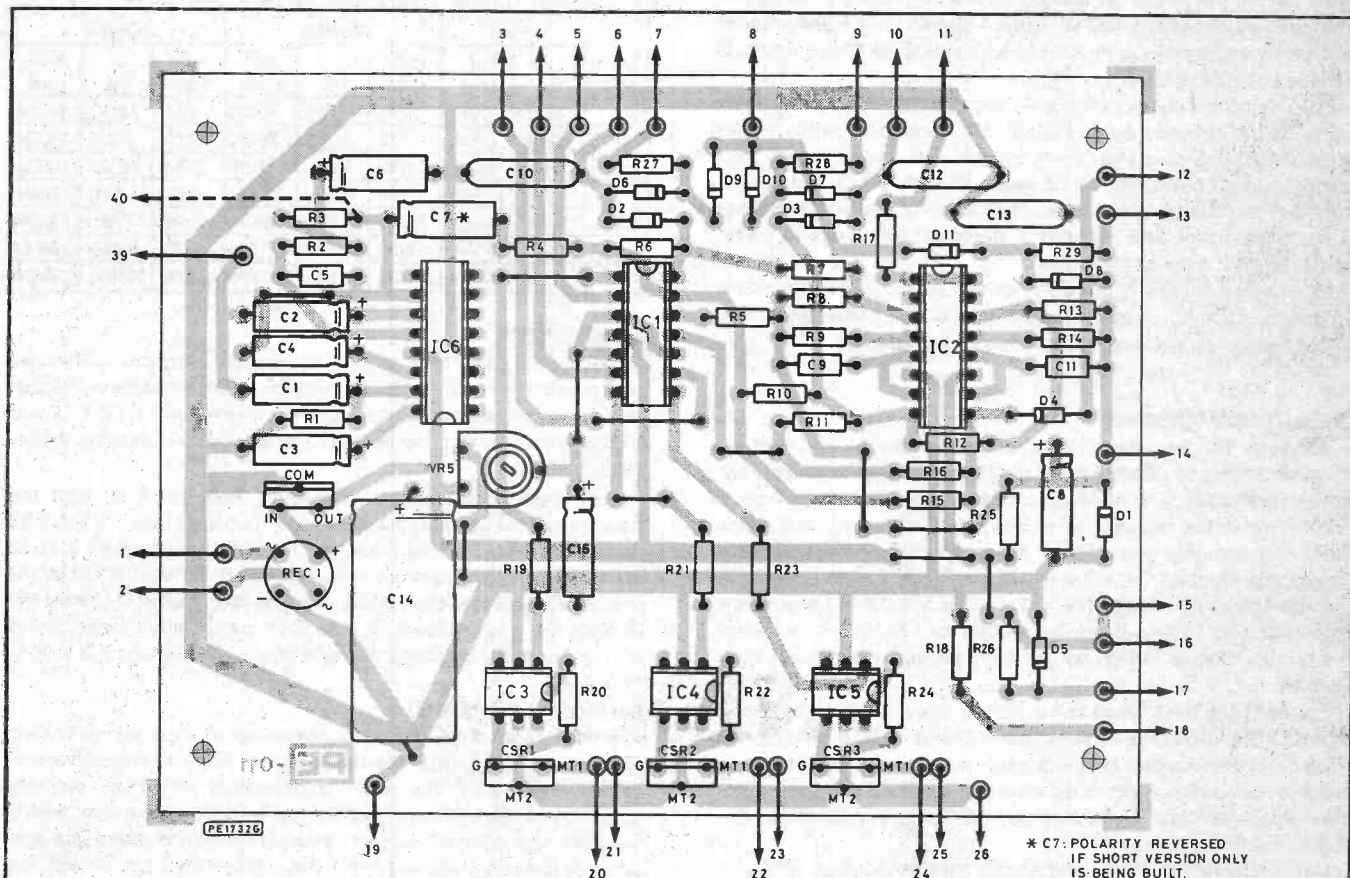

Fig. 3. Main p.c.b., actual size, showing all components mounted, including those for ALC and computer control. The numbered lines from the board relate to numbers on the optional "chaser" board and the interwiring diagram, both of which will be published in the second, and final part next month

## COMPONENTS . . .

### MAIN UNIT

#### Resistors

R4	20k
R5-R7, R10, R12, R15, R17, R18	100k (8 off)
R8, R9, R13, R14, R19, R21, R23, R25	1k (8 off)
R11, R16	10k (2 off)
R20, R22, R24	2k (3 off)
All $\frac{1}{4}$ W $\pm$ 5% carbon film	

#### Capacitors

C7	1 $\mu$ 63V electrolytic
C8, C15	22 $\mu$ 16V electrolytic (2 off)
C9, C11	180p polystyrene (2 off)
C10, C12, C13	220n polyester (3 off)
C14	470 $\mu$ 25V electrolytic

#### Potentiometers

VR1-VR3	100k log mono rotary (3 off)
VR4	100k mono rotary
VR5	10k skeleton

#### Semiconductors

D1	6V2 400mW zener
D2-D4	1N4148 (3 off)
REC1	1A bridge rectifier W005
IC1	324
IC2	LM13600
IC3-IC5	MOC3020 Optotriac (3 off)
IC9	7812
CSR1-CSR3	3-5A Triac (3 off)

#### Switches

S1	Mains d.p.d.t.
----	----------------

#### Miscellaneous

Fuseholder (2 off); p.c.b. clips (4 off); 1A fuse and fuse to suit lamps; knobs (4 off); PCB245A; 6-pin i.c. socket (3 off); 14-pin i.c. socket; 16-pin i.c. socket; mono jack socket; transformer, 2 x 6VA secondaries.

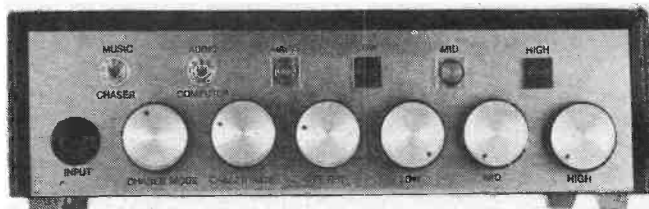

#### OUTPUT SOCKETS

The output sockets for the lamps and for computer control will need to be selected to suit the equipment. In the prototype, as the lamps controlled are only 100W apiece, normal bayonet lamp fittings are used for plugging in separate leads to each lamp. Other connectors can be substituted providing mains safety requirements are met. Remember also never to plug the lamps in while the unit is switched on.

#### ASSEMBLY

The few short link wires on the p.c.b.s themselves can be made from the cut-off wires of the resistors. For the output wires from the p.c.b.s it is preferable to use 1mm terminal pins if they are available. It makes wiring much easier than inserting wires through the holes and then soldering on the other side.

After the components have been inserted and soldered, check very carefully in close up with a strong magnifying glass that no shorts exist between tracks. This is especially important in the areas around IC3 and IC5 and CSR1 to CSR3. Additionally, ensure that all wires below the p.c.b.s are trimmed short so that they cannot touch the bottom of the box. Fig. 3 shows the components mounted on the p.c.b.

#### Constructors' Note

A full kit of parts for this project, or the p.c.b.s on their own, is available from: **Becker Phonosonics**, Dept. DLC, 8 Finucane Drive, Orpington, Kent BR5 4ED. Send a large SAE for full details and prices.

**Note:** the components list above is for the basic system, not including ALC and computer interface. A components list for all auxiliary units will be published in Part 2 next month

**Right, internal details of the complete Controller, showing interwiring. The small p.c.b. on the left is for the "chaser" option. In the prototype unit, shown here, the light sources are simply 100W lamps. However, the unit will drive lamps rated at up to 750W from each channel**

**NEXT MONTH:** The p.c.b. and circuit for the "chaser" option, together with full interwiring details.

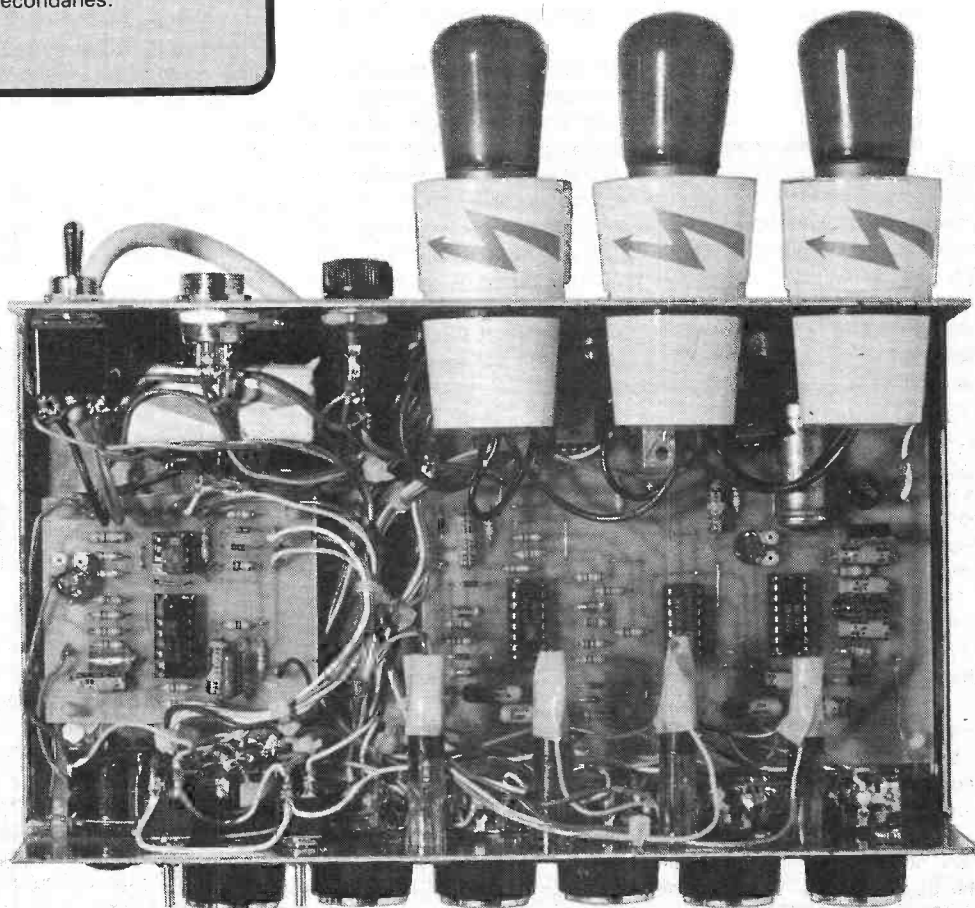

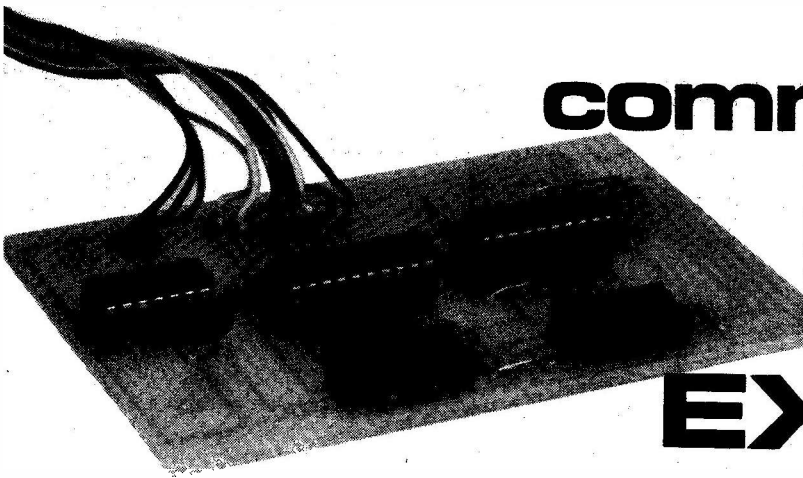

# commodore USER PORT EXPANDER

R.A.PENFOLD

THE Commodore 64 (and VIC-20) has a user port which enables many add-ons to be easily interfaced to this computer. The main features of the user port are eight lines which are individually programmable as inputs or outputs, and three hand-shake lines. While this complement is satisfactory for some applications, it is obviously inadequate for others. In particular, an application that requires eight inputs and eight outputs cannot be accommodated. At least, it cannot be accommodated without a small amount of additional hardware. With the input and output capability of each data line, plus the availability of handshake lines, it is quite possible to latch data into an external eight bit data latch, and to read data via an octal tristate buffer.

This method provides a simple way of expanding the input/output capabilities of the machine, and avoids the slight difficulties and risks associated with adding circuits direct onto the buses by way of the cartridge port. There are only a couple of slight drawbacks, one of which is that care has to be exercised when writing the software in order to make sure that the various pieces of hardware are always in the correct states. In particular, care has to be taken not to have the tristate buffer driving the user port lines while they are set as outputs. This is something that would not necessarily cause any damage, but should obviously be avoided just in case. Provided the specified routines are adhered to there should be no problems of this kind.

The other drawback is that short software routines are needed in order to switch from write operations to read operations, and vice versa. This gives a slight reduction in operating speed when compared to having completely separate input and output ports, but in the vast majority of applications this is of no consequence.

This project is firmly based on the concept outlined above, and it provides the Commodore 64 with eight latching outputs plus eight digital inputs (both having normal LS TTL characteristics). One of the user port handshake lines (PA2) is utilized by the expander and is not available for other purposes, but the other two handshake lines (PC2 and FLAG) are left available. Although the unit was designed specifically for the Commodore 64 it can also be used with the VIC-20, with its very similar user port.

Fig. 1. Block diagram of the User Port Expander

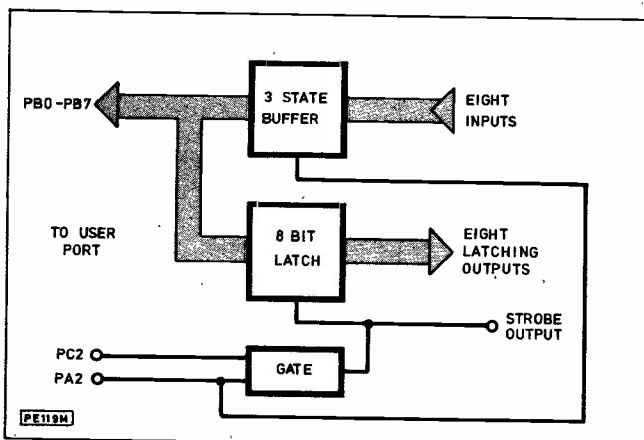

## SYSTEM OPERATION

The block diagram shown in Fig. 1 helps to explain the way in which the unit functions. In order to write data to the eight bit latch the main user port lines (PBO and PB7) are first set up as outputs. The data is then written to the port, after which a strobe pulse is required to activate the latch so that its outputs take up the appropriate states, and remain in these states until fresh data is written. The obvious source for the strobe pulse is handshake line PC2, which is specifically designed for this purpose. It automatically produces a brief negative pulse after each read or write operation to the data lines of the user port.

In this case there is a complication in that the strobe pulse must only be generated after write operations, as otherwise reading the input lines will corrupt the data on the output lines. This is overcome by gating PC2 with another handshake line, PA2. The latter can be used as an input or a latching output, but in this case it operates as an output which is set high for write operations and low during read operations. The gating ensures that a strobe pulse is only fed to the data latch after write operations. This strobe pulse is available from one socket of the interface (if it should be required the straightforward strobe signal from PC2 is still available from the computer, of course).

Incidentally, the third handshake line of the user port, FLAG, is a negative edge triggered input that is not used by this interface, but which could be valuable for use with either the input or output lines.

The eight input lines must be isolated from the user port when the latter is set as output lines, to avoid having two sets of output lines connected together. This is achieved using an octal tristate buffer which is controlled by PA2, and which is taken to the active state when PA2 is low.

## CIRCUIT OPERATION

The full circuit diagram of the User Port Expander appears in Fig. 2. IC1 is the octal data latch, and this is actually a 74LS273 octal D-type flip/flop, but it performs a data latch function with a negative strobe pulse applied to the clock input at pin 11. Gating of PA2 and PC2 is provided by a two input AND gate IC3a. This provides a high output if either of its inputs go low.

During write operations PA2 is high, but PC2 provides a low strobe pulse. The positive output pulse from IC3a is inverted by IC3b to produce the negative latching pulse required by IC1. There are a further two gates in IC3, but these are not needed here and are just ignored.

When PA2 is set low, the output of IC3a goes high, and the strobe pulses from PC2 have no effect on the output. There is a single high-to-low transition which is supplied to IC1, but this does not affect the data on the output of IC1. PA2 is used to directly control IC2, which is the octal tristate buffer. In fact IC2 is a 74LS245 octal transmitter/receiver, but in this circuit it is wired permanently in the "receive" mode, and it acts as a simple tristate buffer. PA2 controls the negative chip enable input, and IC2 is consequently set to the active state when PA2 is set low.

The circuit requires a single five volt supply, and the supply output of the user port is well able to supply the modest current requirement of the circuit.

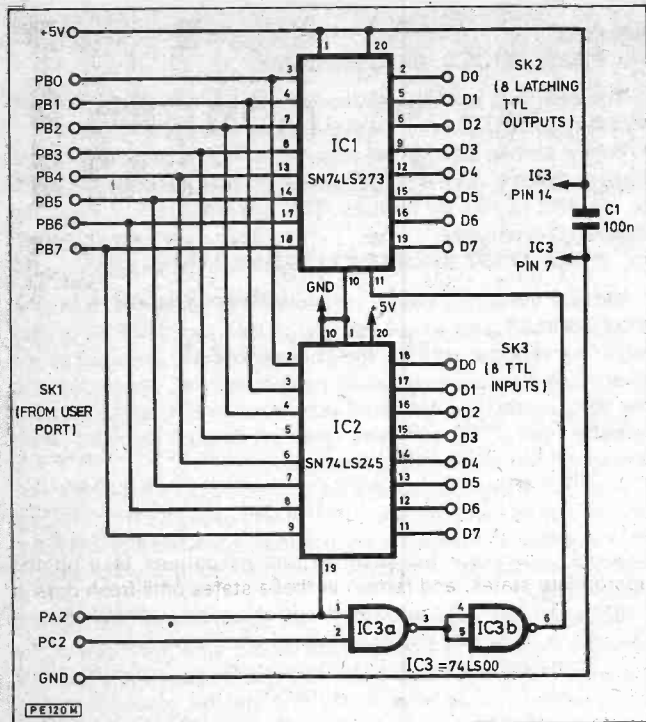

**Fig. 2. Circuit diagram of the expander**

### CONSTRUCTION

The printed circuit design for this project is shown in Fig. 3. None of the integrated circuits are MOS types, but as the devices used in the IC1 and IC2 positions are not amongst the cheapest of integrated circuits and it is advisable to use (20 pin d.i.l.) integrated circuit holders for these. Sockets SK2 and SK3 are the input/output sockets, and are 16 pin d.i.l. integrated circuit holders. Connections to these are made via 16 pin d.i.l. plugs and ribbon cable assemblies. Apart from the eight inputs and eight outputs, five volt positive ground, and strobe lines are also available from these. The current drain from the five volt supply should be no more than about 60 milliamps.

There are a number of link wires to fit on the board, and 22 s.w.g. or similar tinned copper wire is suitable for these. In places there are several link wires running close together and side-by-side. Provided the wires are kept quite taut there should be no risk of accidental short circuits, and there should not be any need to insulate the wires.

The connections to the user port are made using a piece of twelve way ribbon cable about half a metre or so in length. One end connects to the printed circuit board and the other is fitted with a two by 12 way 0.156 inch edge connector. Several component suppliers can provide a connector of this type, but most do not supply a connector fitted with a polarising key. It might be possible to add a suitable polarising key, but a simple alternative is to just mark the top and bottom edges of the connector as such; Fig. 4. gives connection details for the edge connector. This includes the slightly different method of connection for the VIC-20 (which has the same type of user port connector as the Commodore 64, but

**Fig. 4. User Port Expander connections; VIC 20 variations are shown in brackets**

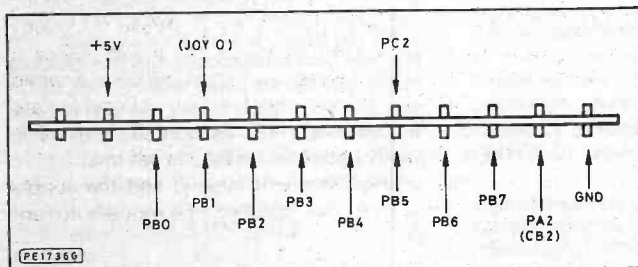

### COMPONENTS . . .

**Capacitor**  
C1 100nF ceramic

**Semiconductors**  
IC1 74LS273  
IC2 74LS245  
IC3 74LS00

**Miscellaneous**  
SK1 2 by 12 way 0.156 inch edge connector  
SK2, SK3 16 pin d.i.l. i.c. holders (2 off)

Printed circuit board available from the *PE PCB Service* order code 006; 12 way ribbon cable; two 20 pin d.i.l. i.c. holders; 14 pin d.i.l. i.c. holder; wire, solder, etc.

has a different user port interface device). With the VIC-20 CB2 is used in place of PC2, and JOY0 is utilised instead of PA2.

### IN USE

With the unit connected to the user port and the computer switched on the normal initial screen display should be obtained. Switch off at once and recheck the wiring if it is not, or if the computer seems to behave in any way abnormally.

If all seems to be well a few simple routines can be used to check the unit. Starting with the routines to enable the unit to operate with the Commodore 64, the first task is to set up PA2 as an output by writing a value of four to the data direction register for port A. This is achieved using the command:

**POKE 56578,4**

**Fig. 3. P.c.b. construction details**

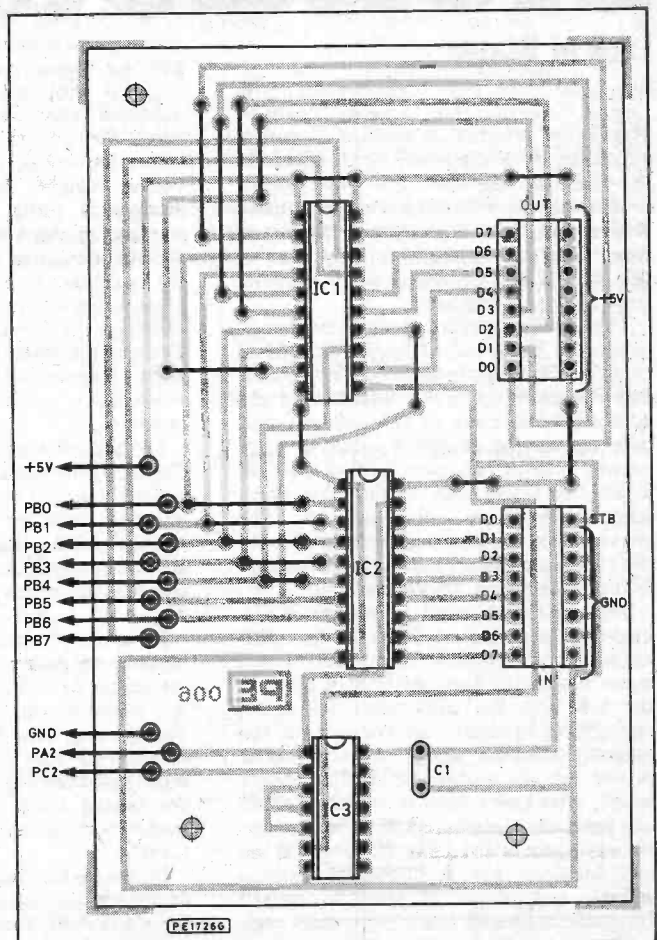

This only needs to be done once at the start of each session. Next a value of zero must be written to the data direction register for port B in order to set lines PBO to PB7 as inputs. Also PA2 (which is at bit two of address 56576) must be set low. This command sets the data direction register and PA2 correctly.

**POKE 56579,0: POKE 56576,0**

The input lines can then be read at address 56577 (i.e. **PRINT PEEK (56577)** will return the value on the input lines). If allowed to float TTL inputs go high, and a value of 255 should be returned if you try this with the input lines left unconnected. As a simple test try wiring input D7 to ground and reading the port again. A value of 127 should be printed on the screen. The input lines can be read repeatedly without having to set up PA2 and data direction register B prior to each reading being taken.

In order to write data to the output lines first PA2 must be set high and then a value of 255 must be written to data direction register B to set PBO to PB7 as outputs. Use the following command to do this:

**POKE 56576,4: POKE 56579,255**

Data for the output lines is then POKEd to address 56577 (e.g. **POKE 56577,15** would set PBO to PB3 high and PB4 to PB7 low). Data can be repeatedly written to the output lines without having to set up PA2 and data direction register B each time. However, both PA2 and the data direction register must be reset each time there is a change from write operations to read operations, or vice versa.

With the VIC-20 line JOY0 must be set as an output before the unit is ready for use. Also, line CB2 must be set for the correct operating mode. JOY0 is set as an output by writing a value of four to data direction register A at address 37139, while CB2 is set to the pulse output mode by writing a value of 160 to the peripheral control register at address 37148. This command therefore provides the necessary setting up:

**POKE 37139,4: POKE 37148,160**

To read data from the input lines things are much the same as for the Commodore 64. JOY0 must be set to the correct mode and a value of zero must be written to data direction register B so that PBO to PB7 are set as inputs. This command provides these functions:

**POKE 37138,0: POKE 37137,0**

The data lines can then be read at address 37136 (i.e. **PRINT PEEK (37136)** will print the returned value on-screen).

Before writing data to the output lines JOY0 must first be set high, and then a value of 255 is written to data direction register B to set PBO to PB7 as outputs. This can be achieved using the following command:

**POKE 37137,4: POKE 37138,255**

Data for the output lines is then written to address 37136 (e.g. **POKE 37136,240** would set PBO to PB3 low and PB4 to PB7 high). As was the case for the Commodore 64, once set to the read mode the input lines can be repeatedly read, and once set to the write mode repeated write operations to the output lines are possible, but JOY0 and data direction B must be reset when changing from one mode to the other.

Line PA2 of the Commodore 64 is only used as a line of the user port, but as its name implies, JOY0 is also used as part of the joystick interface. It is therefore not possible to use this unit and a joystick simultaneously, although it is unlikely that you would wish to do so anyway.

Another point that should be borne in mind is that port A provides the cassette interface and certain other functions of the computer. With the simple routines provided above it is possible that problems could arise if you operate the cassette or disk interfaces while also using the expander. To avoid this it is merely necessary to read port A or data direction register A before writing data to them, so that bits other than bit 2 can be left in their original states.

★

# Readout...

## Lack of Status

Sir—Your July 1985 *Editorial* on "UK Losing Ground" and "Twenty Years of Stagnation" touches on matters of professional status—a subject of much debate in the IEE and elsewhere for more than a decade. An article by Bill Johnstone entitled *Where Have All The British Engineers Gone?* appeared in the May 1984 issue of *IEE NEWS* and provoked much response from Electrical Engineers.

This article identifies the malady in engineering as being caused by the attitude of traditional (usually innumerate) arts graduates who secure the senior management and administrative posts in UK industry and then sustain the projected image of engineering as being of a lower form of academic activity suited only to the "less able" school leavers or undergraduates. The above article coincides approximately with the views expressed by David L. Thomson in the September 1985 *PE Readout*.

The present shortfall in professionally-qualified electrical and electronics engineers can be attributed to the lack of real status within the engineering profession in the UK and the consequent failure of engineering to attract or even interest the majority of school leavers. Who can blame people for not wishing to enter a career which, after many years of intensive study and practical experience and training offers little prospect of any adequate reward at the end? Medicine, law, accountancy, administration, and others all seem to reward successful graduates much better than engi-

neering, and with often much less study and personal commitment.

Faced with this shortfall in engineers qualified (especially) in the new technologies, the Government's answer is to increase the numbers of "engineers" by conversion courses for arts graduates. No attempt is being made to increase the standing of the UK professional engineer, thereby increasing salaries and, eventually, the numbers of school leavers attracted to engineering as a career option. Witness, for example, the Government's refusal to implement the recommendations of the Finiston Enquiry with regard to registration of engineers, as is the case with law and medicine.

I myself left school just over 20 years ago, despite being advised otherwise, to enter engineering as a craft trainee. I was top of my class in most subjects including art, science, maths, English and foreign languages, but opted for engineering (technical subjects) during my 4th year and part of my 5th.

My interest was captivated by electronics because my father (a non-engineer) was a subscriber to *Practical Wireless* and *Wireless World* during the critical years when I was growing up. My science courses at school were very traditional and consisted mostly of chemistry with some physics of the boring kind. The nearest I got to electronics was the definition of OHMS LAW!

In the years following my schooling I undertook day-release and evening classes for C&G Full Technological Certificates,

ONC and HNC and, later, BSc Degree in Electrical & Electronics Engineering.

Eventually, after years of experience and elevation through the grades of technician and technician engineer, I became a Chartered Engineer in the two main disciplines of electrical power engineering and electronics, and currently am conducting research for a higher degree in computer vision systems and robotics.

When I opted for technical subjects at school I did so in the belief that such subjects would better equip me for a career in engineering. I believed that it was better to have practical skills and "real world" tuition in such subjects as engineering drawing, metal engineering and woodwork. This has, in fact, proved to be the case but, for all my wealth of practical skills, academic qualification and engineering middle management experience in local government, I have still not achieved the status of even a moderately qualified administrator.

My conclusion is that, as Mr D. L. Thompson says, the arts hierarchy in UK industry would prefer to have a shortfall in qualified engineers rather than accept students who have been "tainted" by practical-based subjects such as engineering design or electronics project by construction.

This pessimistic view of engineering, however, is not shared by other nations such as Japan, the Soviet Union or our European partners, who accord their engineers the same, or even greater, status than their medical profession. Until this happens in the UK the situation will only get worse and Britain's place in the worldwide technology stakes will decline. We may eventually become a nation of service industries rather than engineering or manufacturing.

Thomas McIndoe, BSc DipIES  
CEng MIEE MIERE MCIBSE,  
Glasgow.

# POWERTRAN

CYBERNETICS LIMITED

## MUSIC

Rugged, reliable and economical - Powertran's range of musical equipment kits has been tried and tested on stages and in studios all over the world.

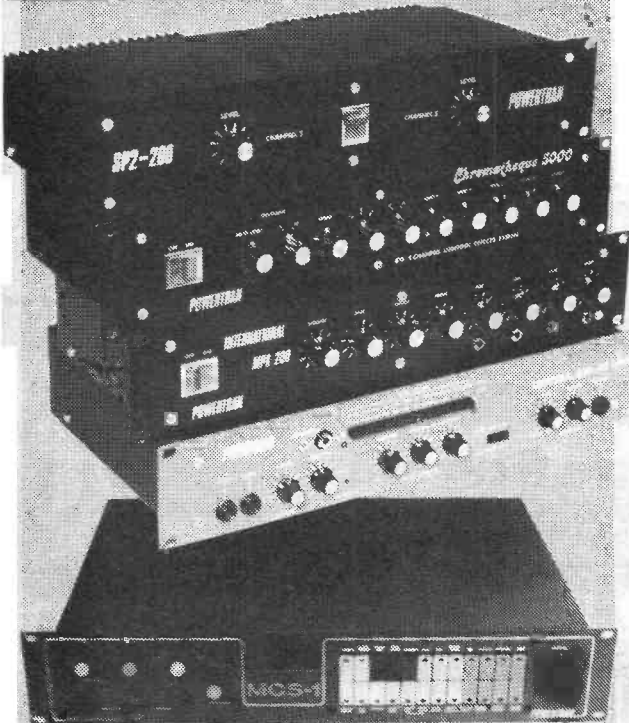

There's a 100W Mixer-Amp, a 2-channel 100W Amp, a 5-channel Lightshow Controller and a Studio Quality Digital Delay Line. Flagship of our Musical range is the MCS-1, a remarkable MIDI controlled Sampling Unit at an equally remarkable price. Available in kit form or ready built, the MCS-1 also doubles as a high-quality effects unit.

## HOME SECURITY

The DRA 100 detects intruders early enough (and loud enough) to afford your home/office/factory/studio real protection.

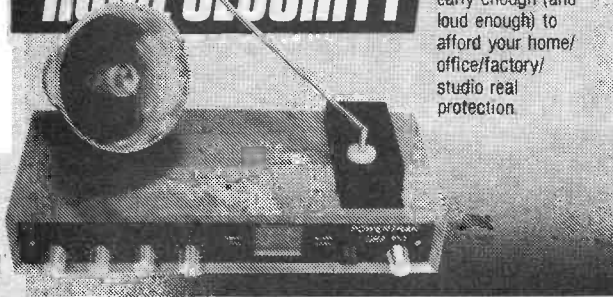

Please supply the following kits:

	Kit	Assembled
Mixer Amp	<input type="checkbox"/> £64.50	<input type="checkbox"/> £79.50
2 Channel Amp	<input type="checkbox"/> £79.00	<input type="checkbox"/> £95.00
Lightshow	<input type="checkbox"/> £79.50	<input type="checkbox"/> £95.00
Delay Line	<input type="checkbox"/> £149.00	<input type="checkbox"/> £199.00
MCS-1	<input type="checkbox"/> £433.90	<input type="checkbox"/> £564.35
Intruder Alarm	<input type="checkbox"/> £119.00	(Kit Only)

V.A.T. Excluded

**POWERTRAN**  
CYBERNETICS LIMITED

Powertran Cybernetics Limited  
Portway Industrial Estate, Andover  
Hampshire SP10 3PE  
Telephone: (0264) 64455



## DIGITAL ELECTRONICS

MADE

EASY



**SUPERKIT** £22.00  
**SUPERKIT II** £16.00  
**(£35.00 if bought together)**

The **SUPERKIT** series introduces beginners to practical digital electronics. **SUPERKIT (SUP I)** is the first kit, which contains an instruction manual, a solderless breadboard, and components (7 integrated circuits, switch, resistors, capacitors, LEDs and wire). It teaches boolean logic, gating, flipflops, shift registers, ripple counters and half adders. **SUPERKIT II (SUP II)** extends **SUPERKIT**. It contains an instruction manual and components (10 integrated circuits, 7-segment display, resistors, capacitors and wire), and explains how to design and use adders, subtractors, counters, registers, pattern recognisers and 7-segment displays.

**DIGITAL COMPUTER LOGIC** £7.00  
**DIGITAL COMPUTER DESIGN** £9.50  
**MICROPROCESSORS & MICROELECTRONICS** £6.50

The **SUPERKIT** series is backed by our theory courses. **DIGITAL COMPUTER LOGIC (DCL)**, the beginners' course, covers the use and design of logical circuits, flipflops and registers. **DIGITAL COMPUTER DESIGN (DCD)**, a more advanced course, covers the design of digital computers both from their individual logic elements and from integrated circuits. **MICROPROCESSORS** and **MICROELECTRONICS (MIC)** teaches what a microprocessor is, how it evolved, how it is made and what it can do.

**GUARANTEE.** If you are not completely satisfied, return the item to us in good condition within 28 days for a full refund. All prices include worldwide surface postage (ask for prepayment invoice for airmail). Orders despatched within 48 hours. Overseas payment by international credit card or by bank draft drawn on a London bank.

**CAMBRIDGE LEARNING LTD.** Unit 26, Rivermill Site, FREEPOST, St. Ives, Huntingdon, Cambs. PE17 4BR, England  
Telephone: 0480 67446.

VAT No. 313026022 Transcash No. 2789159 Reg. No. 1328762

Please send me (initial letters used):

..... <b>SUP I</b>	@ £22.00	..... <b>DCL</b>	@ £7.00
..... <b>SUP II</b>	@ £16.00	..... <b>DCD</b>	@ £9.50
..... <b>SUP I + II</b>	@ £35.00	..... <b>MIC</b>	@ £6.50

Full details of all your courses (please tick)

I enclose a cheque/PO payable to Cambridge Learning Ltd.

for £.....

Please charge my ..... credit card.

No. .... Expiry date .....

Telephone orders from credit card holders accepted on 0480 67446 (24 hrs).

Name .....

Address .....

..... Signature .....

## CAMBRIDGE LEARNING LTD

Unit 26, Rivermill Site, FREEPOST,  
St. Ives, Huntingdon, Cambs PE17 4BR  
England.



# TECHNICIAN ENGINEERS

## COMMUNICATIONS AND ELECTRONICS

A Planned Career in Technology in the Cotswolds  
Salaries up to £11,445

- **VACANCIES** at both **TECHNICIAN ENGINEER** and **ENGINEERING TECHNICIAN** level.
- **CHALLENGING WORK** in the development and support of highly sophisticated communications and computer systems.
- **OPPORTUNITIES** for gaining experience in a wide variety of technical roles.
- **EXTENSIVE ENGINEERING FACILITIES**

- **CAREER PLANNING** aided by regular assessments of performance.
- **ADVANCEMENT** opportunities on the basis of proven ability.
- **OVERSEAS** service (voluntary).
- **FLEXIBLE** working hours with up to six weeks leave.
- **RELOCATION EXPENSES** in most cases.

Applicants for the higher grade of **TECHNICIAN ENGINEER** should normally possess a BTEC Higher National Certificate/Diploma in electronics or other relevant subject; or a City and Guilds Full Technological Certificate, or an equivalent qualification. An aggregate of at least 8 years relevant training and

experience is required. Registration as a Technician Engineer (T.Eng) would be an advantage. **Salary Scale: £9,113 – £11,445** Applicants with BTEC ONC or equivalent and at least 4 years relevant training and experience are eligible for posts at the **ENGINEERING TECHNICIAN** level for which a structured training programme is provided. **Salary Scale: £6,599 – £9,135**

**INTERESTED?** Then for either post send for full details and application form to the address below, quoting Ref: T/6523/85



THE RECRUITMENT OFFICE, GCHQ, ROOM A 1108  
OAKLEY, PRIORS ROAD, CHELTENHAM, GLOS GL52 5AJ  
OR TELEPHONE (0242) 32912 3



## 'RUR' HOBBY ROBOT

### REEKIE INDUSTRIAL & ROBOTIC CONTROL CPU CARD

The electronic Hardware for the Reekie Universal Robot (R.U.R.), as articulated in the June and August 1985 issues of "Practical Electronics" is also very suitable for many other Industrial Applications. It is therefore offered for sale as a stand alone system providing the following:  
Z8 CPU with internal 2K RAM and Tiny Basic/Debug program.  
4 K of RAM/ROM on board expandable to 126K if required, through the Edge Conn.  
20 lines of I/O is available for such functions as; Motor operation, Sonar, LEDs, Sound, Speech Synthesis, Voice Recognition, Burglar Alarm, Smoke and Fire detection and for add-on Logic Board for the Reekie all Belt Robot Arm. RS232/432. The on board options for RAM/ROM expansions means use of Custom Built EPROM Firmware for which Assemblers are available to assist users of the Z8 system to 'Blow' their own EPROMs.

**£130.74 + VAT**  
Carr £8.08 extra. Built & tested as illustrated

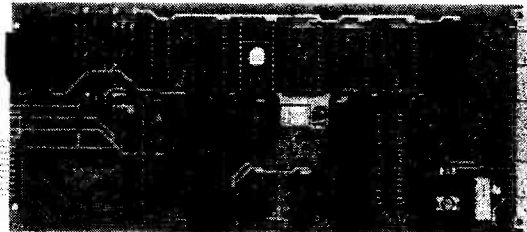

**TERMS:** ACCESS CARDS & OFFICIAL ORDERS from approved industrial or educational establishments accepted, otherwise terms strictly CASH WITH ORDER. Please allow 28 days for delivery

**REEKIE ROBOTS** Beaufort Works, Beaufort Road, Richmond Road, East Twickenham, Middlesex TW1 2PQ

## ★ SECURITY MODULES ★

### A COMPLETE SECURITY SYSTEM FOR ONLY £39.95 + V.A.T.

- contains:
- Control Unit CA 1250
  - Enclosure & mechanical fixings HW 1250
  - Key Switch & 2 Keys KS 3801
  - L.E.D.'s LED 1
  - 5 1/2" Horn Speaker HS 588
  - 4 high quality surface mounting Magnetic Switches MS 1025



With only a few hours of your time it is possible to assemble and install an effective security system to protect your family and property, at the amazingly low cost of £39.95 + V.A.T. No compromises have been made and no corners have been cut. The outstanding value results from volume production and direct supply. Assembly is straightforward with the detailed instructions provided. When installed you can enjoy the peace of mind that results from a secure home. Should you wish to increase the level of security, the system may be extended at any time with additional magnetic switches, pressure pads or ultrasonic sensors. Don't wait until it's too late, order today.

### EXTENDED SYSTEM CS 1480 Price £62.50 + V.A.T.

This system contains, in addition to the CS 1370, an ultrasonic detector type US 5063 + its enclosure, an additional horn speaker and a further 2 magnetic switches. This system represents outstanding value for money for the high level of security provided.

### DIGITAL ULTRASONIC DETECTOR US 5063



- \* Adjustable range up to 25ft.
- \* 3 levels of discrimination against false alarm.
- \* Crystal controlled.
- \* Low-consumption 12V operation.
- \* Built-in delays & fixed alarm time.

An advanced ultrasonic movement detector which employs digital circuit techniques to provide a superior performance for security, automatic light switching and industrial applications.



Suitable metal enclosure £2.95 + V.A.T.

Only £13.95 + V.A.T.

### ALARM CONTROL UNIT CA 1250 £19.95 + V.A.T.



The heart of any alarm system is the control unit. The CA 1250 offers every possible feature that is likely to be required when constructing an installation or simply controlling a single magnetic switch on the front door.

- \* Built-in electronic siren drives 2 loud speakers
- \* Provides exit and entrance delays together with fixed alarm time
- \* Battery back-up with trickle charge facility
- \* Operates with magnetic switches, pressure pads, ultrasonic or I.R. units
- \* Anti-tamper and panic facility
- \* Stabilised output voltage
- \* 2 operating modes full alarm/anti tamper and panic facility
- \* Screw connections for ease of installation
- \* Separate relay contacts for external loads
- \* Test loop facility

Suitable enclosure for CA 1250 as shown in Complete Security System - HW 1250 Price £9.50 + V.A.T.

Add 15% V.A.T. to all prices. U.K. orders at 75p P&P, export postage at cost. Units on demonstration Show hours 9.00 to 5.30 p.m. Closed all day Wednesday Saturday 9.00 to 1.30 p.m.

Write or telephone for full details of our complete range. Please allow 7 days for delivery. Order by telephone or post. **RISCOMP LIMITED** is your credit card.



### INFRA-RED SYSTEM IR 1470

- \* Operates over distance up to 50ft.
- \* LED indicator for easy alignment.
- \* 12V low current operation.
- \* Single hole mounting.

The IR 1470 provides an invisible beam of light which, when interrupted energises a built-in relay in order to operate external switches or equipment. Ideal for use in security, photographic or industrial applications.

Price only £25.61 + V.A.T.



Suitable power supply and timed switching unit for use with IR 1470, etc. Price £13.95 + V.A.T.

**RISCOMP LIMITED**

Dept PE31  
31 Poppy Road  
Princes Risborough  
Bucks HP17 0DB  
Princes Risborough  
0494 441036



# BBC Micro Forum...

David Whitfield MA MSc CEng MIEE

THIS month sees the remaining element of the analogue port, the lightpen input, come under the microscope.

## LIGHTPEN INPUT

The only connection on the analogue port which we have not examined in detail is on connector pin 9 and is labelled "LPSTB". This mnemonic actually stands for Lightpen Strobe, and as you may have guessed by now, the input is provided for connecting a lightpen to the BBC Micro. The signal on this pin is actually connected directly to the 6845 CRT Controller (CRTC) chip in the micro's video display section. The CRTC works closely with Acorn's specially developed video processor ULA, providing the combination which gives rise to the unique versatility of the BBC Micro's display facilities. Although it is not essential to understand the details of the CRTC's operation, a little background does help to understand how the lightpen input operates. The full specification for the 6845, you should be warned, is contained in a data sheet which is almost as dangerous to mental health as the data sheet for the 8271 floppy disc controller!

## CRT CONTROLLER

The CRT controller chip forms the heart of the micro's video display circuitry, and its major function is to control the display of the data held in the screen memory (which varies between 1k and 20k, depending on the mode) on a television or monitor. The 6845 CRTC and the 6502 CPU actually share the system bus and memory on alternative cycles, thereby allowing a continuous display to be produced at the same time as programs are running.

The CRTC controls the conversion of data from the screen memory into the form necessary for the raster scan display used in televisions and monitors. In this type of display, the image is 'drawn' on the screen one line at a time. As the spot moves from left to right across the screen, its brightness is varied to produce the required display. The picture is then built up one line at a time, with the whole screen usually being drawn in two passes, first the odd-numbered lines and then the even-numbered lines; a process known as interlacing, which helps avoid flicker. The whole process is then repeated so that 50 half 'frames' are drawn every second.

The sequence of memory addresses which are accessed to extract the data to be converted into video signals is produced by the CRTC. The actual conversion of the screen memory data into the video line signals is performed by the special Acorn video processor ULA. The overall arrangement for modes 0 to 6 is shown in Fig. 1; in mode 7, a special Teletext character generator replaces the ULA. In addition, the CRTC is also responsible for positioning the cursor, performing the interlace if re-

quired, and for monitoring the lightpen input. The 6845 keeps track of the position of the moving spot, and produces the necessary timing signals to synchronize the display device with the computer. Thus, for example, it produces the horizontal sync pulse for indicating when the end of the line has been reached so that the spot can 'flyback' to the beginning of the next line.

The CRTC itself is controlled in software by means of a set of 18 internal registers, R0 to R17. Most of these are write-only registers, but two are read-only and the remaining two are read/write. The arrangement of these registers is summarised in Table 1. The units used in the registers are usually either characters, character rows or scan lines. As can be seen from this table, the control of the display is indeed a complex business! Readers with an interest in the details of how the display is generated and controlled should consult a reference on the subject (e.g. chapter 18 of the Advanced User Guide), since they are beyond the scope of this column.

## PROGRAMMING THE CRTC

Despite the 18 registers, the CRTC uses only two memory addresses in the I/O address space. This is possible because the

6845 has an address register whose purpose is to select which of the 18 registers will respond when suitably addressed. The CRTC is configured so that Sheila address &00 will access the address register and, when the appropriate 5-bit register address (0 to &11) has been written here, the corresponding internal register can then be read or written at Sheila address &01. From earlier columns, readers may recall that the Sheila I/O address space starts at &FE00, and hence these two addresses are physically located at &FE00 and &FE01, respectively.

Clearly, the simplest approach to interfacing to the CRTC is to manipulate the I/O locations directly. However, as we have seen before, this is not a recommended approach if future software compatibility is to be guaranteed. Instead, as we have seen before, the most reliable way of doing this is to use the \*FX or OSBYTE calls (150 and 151 for reading and writing, respectively). On the other hand, the most convenient way of programming the 6845 registers from Basic is to use the VDU23 command. In the Basic statement:—

```
VDU23;R,V;0;0;0
```

the result will be that the value V will be written into register R of the CRTC. Note the use of semicolons for representing two bytes as an alternative to single byte values separated by commas. As an example of this command in action, the statement:—

```
VDU23;6,10;0;0;0
```

will cause only the top 10 lines of the display to be visible. This can make it difficult to see what you are typing (!), so after experimenting with the result, a mode change (e.g. MODE 7) will restore the display to normal. It is a good idea to set up this command as a function key before starting. The value in register 6 gives the number of character rows to be displayed on the screen; the normal values are 25 and 32.

A similar effect can be obtained by setting the value in register 1 to control the number of characters displayed on each line. The following statement will cause the length of each line to be reduced to 10 characters:—

```
VDU23;1,10;0;0;0
```

As you will soon see, however, this has a slightly different effect to that with the vertical register alteration. The result (in a 40-character mode) is that only the top quarter of the normal screen display appears, but each line is displayed in full, only it is now spread over the (four) shortened display lines. The normal values for register 1 are 20, 40 or 80, and changing mode will restore the normal CRTC settings, as before.

Fig. 1. Video section block schematic

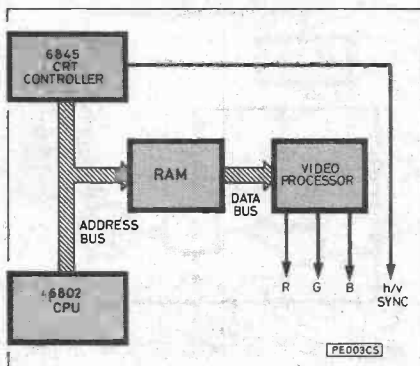

Register	Mode	Contents
R0	W	Horizontal total
R1	W	Horizontal displayed
R2	W	Horizontal sync position
R3	W	Hor/vert sync width
R4	W	Vertical total
R5	W	Vertical total adjust
R6	W	Vertical displayed
R7	W	Vertical sync position
R8	W	Interlace and delay
R9	W	Scan lines per character
R10	W	Cursor start
R11	W	Cursor end
R12	W	Screen start address (H)
R13	W	Screen start address (L)
R14	R/W	Cursor position (H)
R15	R/W	Cursor position (L)
R16	R	Lightpen position (H)
R17	R	Lightpen position (L)

Table 1. 6845 registers

## LIGHTPEN REGISTERS

The lightpen position 'register' is in fact comprised of two CRTC registers, R16 and R17. The two most significant bits of R16 are ignored, and the remaining 14 bits represent the last detected position of the lightpen. This, inevitably, raises the question of how does the CRTC know where the lightpen is pointing? The answer is simply that the CRTC updates this position register every time there is a positive-going pulse on the LPSTB input of the analogue port. The value written into the register gives the CRTC's internal version of the spot's position at the time of the pulse.

## WHAT IS A LIGHTPEN?

Very simply, a lightpen is a small electronic circuit which, when pointed at the surface of a display screen, can detect the electron spot as it moves past the pen's position on the screen. The active element in a lightpen is invariably some form of electro-optical device, such as a phototransistor or diode. This is followed by an amplifier and some form of signal conditioning circuit. The output is presented as a positive-going TTL pulse whenever light triggers the pen circuit.

Inevitably there is some delay in any lightpen between the spot passing under the sensor and the corresponding pulse arriving at the 6845. This is hardly surprising when you consider that each line of the display is separated by only 64  $\mu$ sec. A delay of only 1  $\mu$ sec in a 40-column mode would therefore lead to an error of approximately one character position between the actual pen position and the position stored by the CRTC. The error will usually show the pen to be to the right of its true position. The correction necessary will usually be a constant for a given pen/monitor/computer configuration, but may well be different for different pen designs, and may even vary for different monitors.

Due to the way in which the lightpen position register stores the position value, there is a further correction which must be subtracted from the register contents in order to give the current pen position. This second correction is fixed, and relates to the different screen memory start addresses for different screen modes. The values for this correction are given in Table 2. The resulting value in the lightpen register has a minimum value (of 0) when the pen is detected in the top left of the screen, and a maximum value (which depends on the screen mode) when the pen is in the bottom right of the screen. As we shall see later, the corrected position value can then be converted into the standard character position coordinates, but for now it is time to look at building a lightpen.

Mode	Correction Factor
0	1542
1	1542
2	1542
3	2054
4	2820
5	2820
6	3076
7	10248

Table 2. Correction factors

## BUILDING A LIGHTPEN

The initial stage in building a lightpen is to find a suitable detector to serve as the light sensor. The recent advances in fibre optic technology have produced a number

of devices which now make the construction of a lightpen a much simpler process than used to be the case. The device chosen here is a combined sensor, amplifier and signal conditioning circuit. The SD4324-002 (available from RS as 303-270 for around £10) is a combined 'sweet spot' fibre optic sensor and Schmitt receiver. Although it is a rather expensive device, it is very easy to use and allows us to build a single-component lightpen.

The cross section through the SD4324 in Fig. 2 shows its unique form of construction using a glass focusing bead and a clear lens cap to direct light onto the integrated PIN photodiode. The internal circuit of the device, shown in Fig. 3, produces a TTL-compatible positive-going pulse whenever the photodiode is suitably illuminated. This means that no further signal processing is required in order to make it compatible with the LPSTB input. In practice the greatest difficulty in building a lightpen using the SD4324 is concerned with the mechanical construction of the pen.

Fig. 4 shows the constructional details of this simplest of lightpens. The pen barrel used in the prototype was taken from a

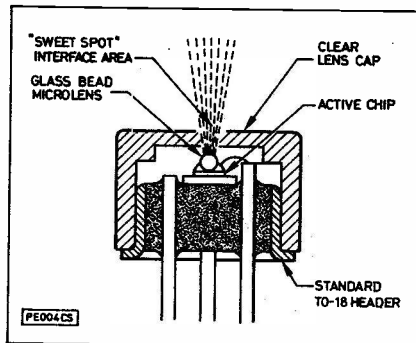

Fig. 2. SD4324 cross section

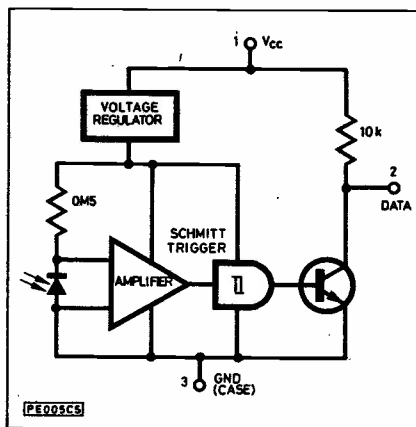
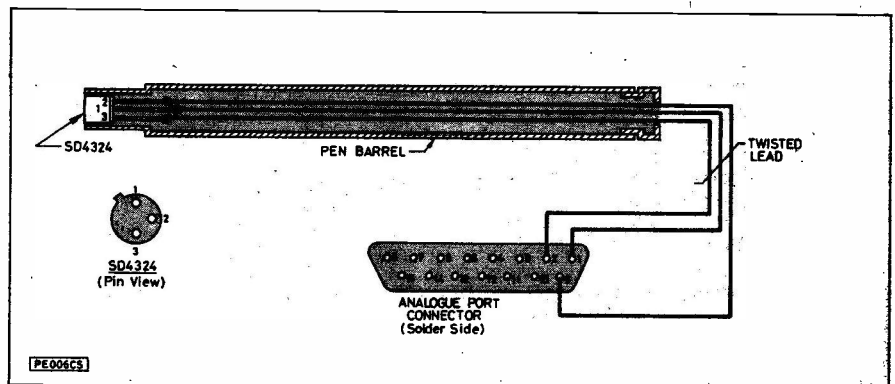

Fig. 3. SD4324 internal circuit

Fig. 4. Lightpen construction



Berol roller-ball type marker, but many other types are suitable. The important point is that the case of the SD4324 should fit into the tip when the ink arrangement has been removed. The first step is to remove the rear cap, ink cartridge, and 'nib' arrangement, discarding all except the rear cap. After washing out the barrel, a 4 mm hole should be drilled in the rear cap, and the pen case is then ready for assembly.

Three lengths (each around 1.5-2 metres) of coded insulated wires should be twisted together to form the connection between the sensor and the micro. Start then at the sensor end, and solder one wire to each of the leads on the SD4324, sleeving at least two of the joints and leads, and keep a note of the connections. Next, remove the tag from the sensor can, and feed the lead through the barrel and end cap until the sensor seats neatly in the end of the pen barrel. It is then a good idea to fix the sensor in place using a suitable non-permanent fixing agent to prevent undue movement. In the prototype this was done by using a piece of large bore rubber sleeving round the sensor to ensure a tight fit, thereby minimising any extraneous light entering the sensor from the side. I recommend some form of strain relief on the lead as it enters the pen barrel as a useful precaution to minimise the number of times the lead becomes disconnected from the sensor. Finally, the far end of the lead should be connected to the 15-pin D-type connector for the analogue port, and the light pen is ready for use.

## A SIMPLE DEMONSTRATION

The program in listing 1 gives a simple demonstration of the lightpen at work. Remember that the pen works best on a bright screen, and does not work at all on a dark screen. The program will change the white screen to black to follow the pen movements. Pressing space will re-paint the screen, and exit is via ESCAPE. If the pen position is not followed by the program correctly, try altering the value of the variable Corr% in Line 40.

### Listing 1. Lightpen test routine

```

10 REM Lightpen Demonstration
20 REM -----
30 ON ERROR GOTO 190
40 Corr%-1542: S=126
50 DIM PK 100
60 [. pos LDX #16:STX #FE00:LDX #FE01
70 LDA #17:STA #FE00:LDA #FE01:RTS:J
80 VDU 23,240,0,S,S,S,S,S,0
90 REPEAT
100 MODE 0: COLOUR 129: GCOL 0,0
110 CLS: VDU5
120 REPEAT: #FX19
130 PenX=(USR(pos)AND#FFFF)-Corr%
140 XX=16*(PenX MOD 80)
150 YX=1024-32*(PenX DIV 80)
160 MOVE XX,YX: VDU 240
170 K#-INKEY$(0): UNTIL K#=""
180 UNTIL FALSE
190 MODE 7

```

## NEXT MONTH

Next month *BBC Micro Forum* will be looking at further uses for the lightpen.

all in your  
**DECEMBER**  
issue!

# HALLEY'S COMET

In 1910 when the famous Halley's comet last returned, the Earth passed right through the tail. People were sufficiently alarmed to buy anti-comet pills from an American entrepreneur. What will happen this time? And will Giotto the European satellite, on course for a head-on rendezvous with the comet, ever return? Join Dr PATRICK MOORE OBE and encounter with him this mysterious celestial body, next month.

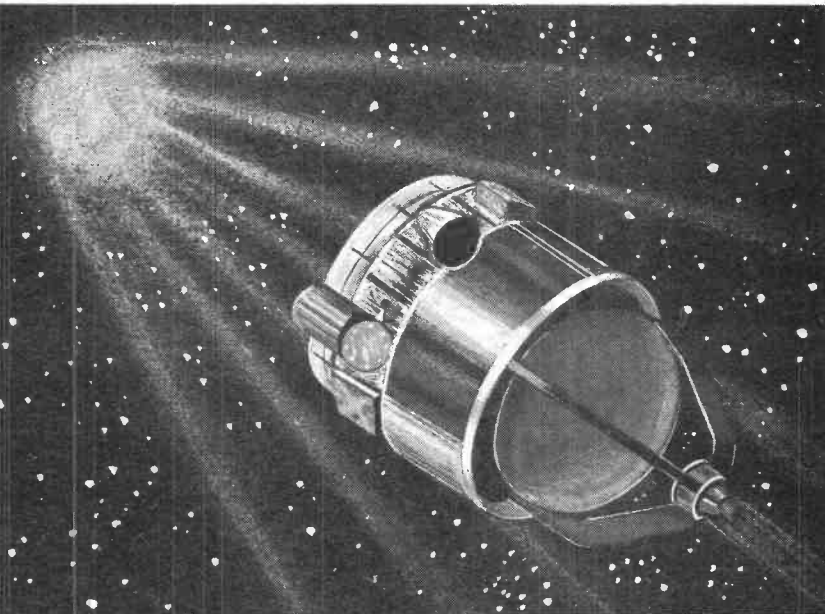

## **FREE** SIEMENS ANALOGUE IC Data Chart

An invaluable reference for analogue design, this double-sided chart, produced in conjunction with Electrovalue, is crammed with application circuits, characteristics and basic specifications for a wide range of Siemens i.c.s. including: op-amps, comparators, oscillators, decoders and drivers.

## Microscope

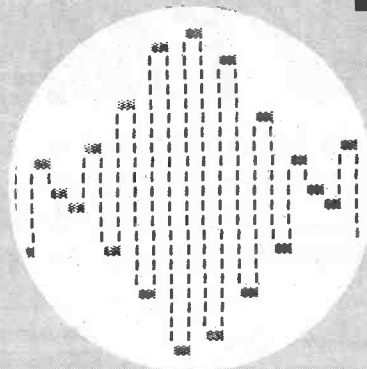

Turns your PET, BBC or any micro with an 8-bit parallel port into an intelligent oscilloscope. Microscope measures from d.c. to 70kHz, 1mV to 25V, also provides digital readout.

PRACTICAL

# ELECTRONICS

ROBOTICS · MICROS · ELECTRONICS · INTERFACING

DECEMBER ISSUE ON SALE FRIDAY, NOVEMBER 1

# PRACTICAL ELECTRONICS PRINTED CIRCUIT BOARD SERVICE

Printed circuit boards for certain PE constructional projects are now available from the PE PCB Service, see list. They are fully drilled and roller tinned. All prices include VAT and postage and packing. Add £1 per board for overseas airmail. Remittances should be sent to: **PE PCB Service, Practical Electronics Editorial Offices, Westover House, West Quay Road, Poole, Dorset BH15 1JG.** Cheques should be crossed and made payable to IPC Magazines Ltd.

Please note that when ordering it is important to give project title, order code and the quantity. Please print name and address in Block Caps. Do not send any other correspondence with your order.

Readers are advised to check with prices appearing in the current issue before ordering.

**NOTE: Please allow 28 days for delivery. We can only supply boards listed here.**

PROJECT TITLE		Order Code	Cost
Spectrum Autosave	MAR '84	403-01	£2.90
Sustain Unit		405-02	£2.90
Audio Signal Generator	MAY '84	405-03	£4.28
"		405-04	£2.90
Cross Hatch Generator	JUNE '84	406-01	£3.52
Simple Logic Analyser I		407-01	£7.73
EPROM Duplicator		407-02	£3.74
Alarm System	JULY '84	407-03	£3.19
Oscilloscope Calibrator		407-04	£4.23
Comm. 64 RS232C Interface		408-01	£3.02
Field Measurement	AUG '84	408-02	£3.19
"		408-03	£2.90
Simple Logic Analyser II		408-05	£2.93
Parallel to Serial Converter		409-01	£2.92
Through the Mains Controller	SEPT '84	409-02	£2.90
"		409-03	£2.90
Logic Probe	OCT '84	410-01	£2.90
Computer DFM Adaptor	NOV '84	411-01	£2.90
Ni-Cad Charger	DEC '84	412-01	£2.90
Outrider Car Computer (Set of 2)	JAN '85	501-01/2	£9.10

Modular Audio Power System				
Pt-1: Power Amp Board	FEB '85	502-01	£4.19	
Spectrum DAC/ADC Board		502-02	£3.69	
Modular Audio Power System				
Pt-2: Pre-Amp/Line Driver		503-01	£5.00	
Main Board		503-02	£5.12	
Heart Beat Monitor	MARCH '85			
Main Circuit Board		503-03	£8.90	
Detector		503-04	£6.62	
Low Cost Speech Synthesiser		503-05	£3.42	
Power Control Interface		504-01	£3.36	
Disc Drive PSU		504-02	£6.54	
Modular Audio Power System	APRIL '85			
Pt-3: Test Signal Source		504-09	£4.20	
Power Supply		504-10	£4.17	
Amstrad Synthesiser Interface		505-01	£4.23	
Rugby Clock Pt-2		504-03	£24.22	
"		504-04	£9.06	
"	MAY '85	504-05	£5.12	
"		504-06	£9.54	
"		504-07	£5.40	
"		504-08	£10.24	
CBM64 Music Keyboard				
Keyboard	JUNE '85	506-02	£4.55	
Main PCB		506-03	£3.50	
MTX 8 Channel A to D	JULY '85	507-01	£3.92	
Voltmeter Memory Adaptor		506-01	£3.28	
Envelope Shaper	AUGUST '85	508-01	£3.73	
Car Boot Alarm	SEPT '85	509-01	£2.90	
RS232 To Centronics Converter		509-03	£4.95	
Touch control PSU		001	£3.17	
Exp. with Robots (double-sided)	OCT '85	004	£16.91	
Modulated Syndrum		005	£3.80	
CBM User Port Expander		006	£3.93	
Model Railway Track Control		010	£5.44	
*Bytebox: ROM Board (double-sided)		002	£12.75	
ZIF Socket	NOV '85	003	£2.90	
RAM Board		007	£4.95	
Battery Backed RAM		008	£3.74	
EPROM Board		009	£2.93	
*Special Price—Complete set of 5 boards		00A	£23.00	

## DON'T MISS A VITAL COPY!

Ever been in the middle of a project only to find the next issue sold out? An annual subscription to **PRACTICAL ELECTRONICS** solves the problem.

Wherever you live you'll receive a copy regularly each month. It's the quick, practical way to solve delivery problems.

### SUBSCRIPTION RATES

U.K. £13.00  
Overseas £15.00

**COMPLETE  
AND POST  
THIS  
ORDER FORM  
TODAY!**

## PRACTICAL ELECTRONICS SUBSCRIPTION ORDER FORM

Annual Subscription Rates  
U.K. £13.00  
Overseas £15.00  
(Students: deduct £1 and quote Student number)

Complete this form and post it, with payment or credit card authorisation to:  
**Practical Electronics**  
Subscription Dept.  
Oakfield House,  
35 Perrymount Road,  
Haywards Heath,  
West Sussex RH16 3DH

POST COPIES TO \_\_\_\_\_

NAME \_\_\_\_\_

ADDRESS \_\_\_\_\_

POST CODE \_\_\_\_\_

I enclose my cheque/PO payable to IPC Magazines Ltd. for £ \_\_\_\_\_  
Charge my credit card A/C at quoted rate

Card valid from \_\_\_\_\_ to \_\_\_\_\_

Signature \_\_\_\_\_

**25**



# GREAT NEW ADVENTURE GAME...



## THE MINES OF MALAGUS IN PROTEUS No. 2

A complete fantasy adventure game magazine for the young and young at heart!

To play the game you just need dice, pencil and paper, plus lots of concentration and luck.

Exciting, entertaining and absorbing. Bound to keep the kids quiet for hours!

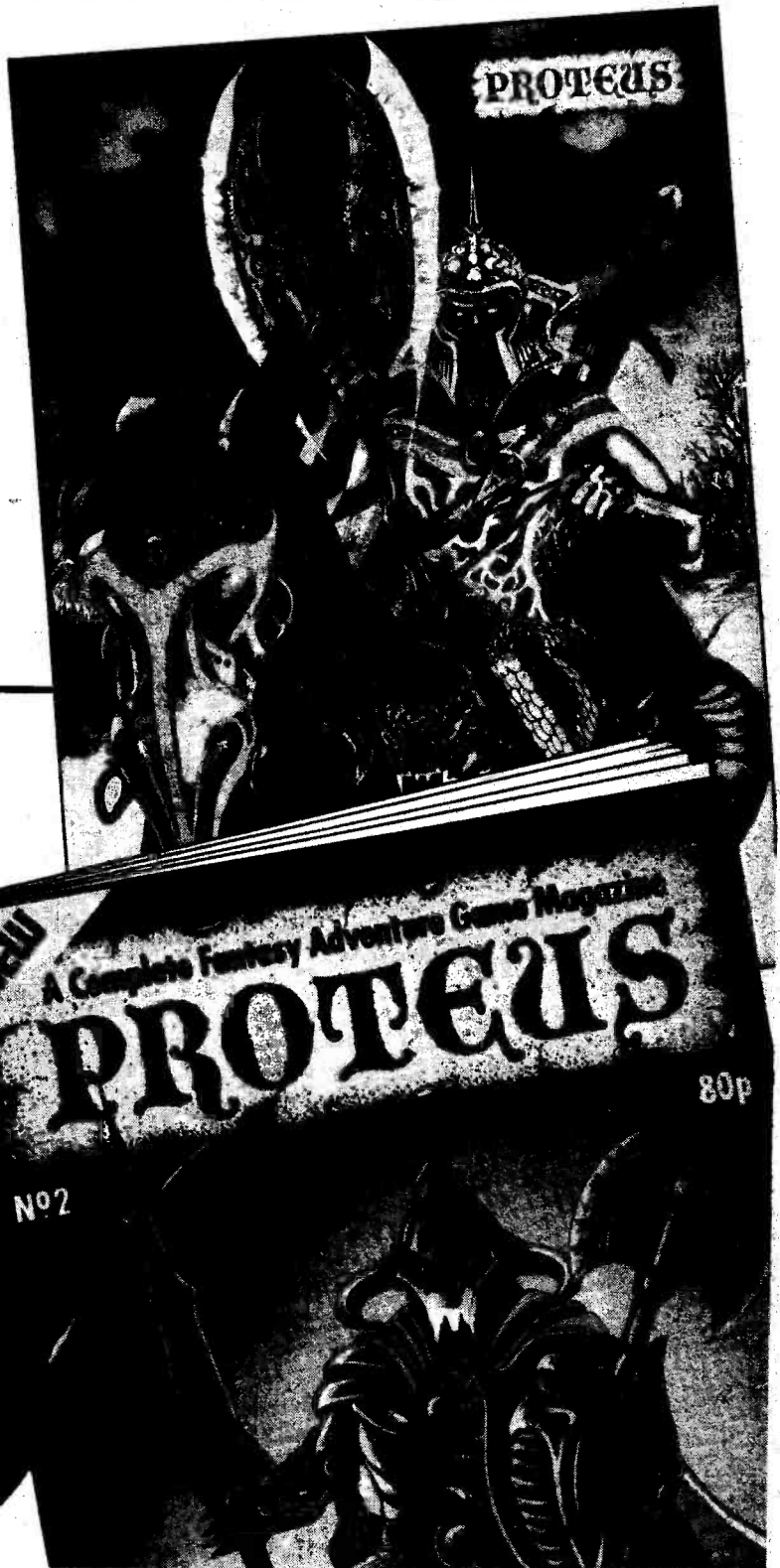

# FREE

## full-colour POSTER

(approx. 40x29 cms)

## AND PAIR OF DICE

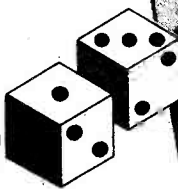

**OUT  
NOW  
ONLY  
80p**

Britain's least  
expensive  
fantasy adventure  
game magazine.





# SMALL ADS

The prepaid rate for classified advertisements is 36 pence per word (minimum 12 words), box number 60p extra. Semi-display setting £12.00 per single column centimetre (minimum 2.5 cms). All cheques, postal orders etc., to be made payable to Practical Electronics and crossed "Lloyds Bank Ltd". Treasury notes should always be sent registered post. Advertisements, together with remittance should be sent to the Classified Advertisement Dept., Practical Electronics, IPC Magazines Limited, King's Reach Tower, Stamford St., London SE1 9LS. (Telephone 01-261 5846.)

## NOTICE TO READERS

Whilst prices of goods shown in classified advertisements are correct at the time of closing for press, readers are advised to check with the advertiser to check both prices and availability of goods before ordering from non-current issues of the magazine.

When replying to Classified Advertisements please ensure:

- That you have clearly stated your requirements.
- That you have enclosed the right remittance.
- That your name and address is written in block capitals, and
- That your letter is correctly addressed to the advertiser.

This will assist advertisers in processing and despatching orders with the minimum of delay.

## RECEIVERS AND COMPONENTS

**BOURNEMOUTH/BOSCOMBE.** Electronic components specialists for 33 years. **FORRESTERS (NATIONAL RADIO SUPPLIES)**, Late Holdenhurst Road. Now at 36, Ashley Road, Boscombe. Tel. 302204. Closed Weds.

**TURN YOUR SURPLUS** capacitors, transistors, etc into cash. Contact **COLES HARDING & CO.**, 103 South Brink, Wisbech, Cambs. Tel. 0945 584188. Immediate settlement.

### OMEGA SERVICES

97 Stricklandgate, Kendal, Cumbria LA9 9AA  
 Resistor 1e 1/4 watt CF 5% 100 plus 1p  
 Capcos 1e 4001 20p 4011 20p  
 Memories 1e 2764 £2.00 6264 LP15 £6.50  
 Regulators 1e 7805 39p 7842 29p  
 Presets 1e 10K HOZ/VRT 10p  
 TV SUB 1e 25W socket angle £2.30  
 Eurocard 1e 32W plug angle £1.00  
 IC Sock 1e 14W 14p 28W 29p  
 PSU 1e 500mA Reg. Adjs 9v £5.00  
 Prices plus 60p carr. plus VAT  
**Telephone 0539 32132 (also indust. supplier)**

### BRAND NEW COMPONENTS BY RETURN

**Electrolytic Capacitors 16V, 25V, 50V.**  
 0-47, 1.0, 2.2, 4.7 & 10 Mfds. — 5p.  
 22 & 47—6p. 100—7p. (50V—8p). 220—8p. (50V—10p).  
 470—11p. (40V—15p). 1000/15V—18p. 1000/25V—28p.  
 1000/40V—35p. 4700V/25V—70p.

**Subminiature bead Tantalum electrolytics.**  
 0.1, 0.22, 0.47, 1.0 @ 35V, 4.7 @ 63V — 14p.  
 2/235V, 4/725V—18p. 10/25V 15/16V—20p.  
 22/16V, 33/10V, 47/16V, 68/3V & 100/3V—32p.  
 15/25V, 22/25V, 47/10V—35p. 47/16V—50p.

**Subminiature Ceramic Caps. E12 Series 100V.**  
 2% 10 pf. to 47 pf.—3p. 56 pf. to 330 pf.—4p.  
 10% 390 pf. to 4700 pf.—4p.

**Vertical Mounting Ceramic Plate Caps. 50V.**  
 E12 22 pf. to 1000 pf. E6 1500 pf. to 47000 pf.—2p.

**Polystyrene E12 Series 63V. Horizontal Mntg.**  
 10 pf. to 820 pf.—3p. 1000 pf. to 10,000 pf.—4p.

**Miniature Polyester 250V Vert. Mtg. E6 Series.**  
 0.1 to .068—4p. 1—5p. .15, .22—6p. .33, .47—10p.  
 .68 — 12p. 1.0 — 18p. 1.5 — 22p. 2.2 — 24p.

**Nylar (Polyester) Film 100V. Vertical Mounting.**  
 .001, .0022, .0047—3p. .01, .022—4p. .04, .05, 0.1—5p.

**High Stability Miniature Film Resistors 5%.**  
 1/4W E24 Series 0.51R—10M0. — 1p.  
 1/2W E12 Series 1R0 to 10M0. — 11/2p.  
 1W E12 Series 10R to 10M0. — 5p.  
 1/4W metal film E12 Series 10R-1M0. 5% — 2p. 1%—E24 — 3p.  
 1N4148—2p. 1N4002—4p. 1N4006—6p. 1N4007—7p.  
 BC107/8/9—12p. BC147/8/9, BC157/8/9, BF196 & 7—10p.  
 8 Pin Ic's 741 Op. amp.—20p. 555 Timer—24p.  
 DIL Holders 8 pin—8p. 14 pin—12p. 16 pin—14p.  
 LED's, red, green, yellow, 3 & 5mm.—10p. 8mm.—35p.  
 Grommets for 3mm.—2p. Grommets for 5mm.—2p.  
 20mm. Q.B. Fuses .15, .25, .5, 1, 2, 3 & 5A—5p.  
 20mm. Anti Surge 100mA to 50A—8p.  
 20mm. Fuseholders P.C. or Chassis Mtg.—9p.  
 Battery Snaps (pairs) PP3—8p. PP9—12p.  
 400mW Zener diodes E24 series 2V7 to 33V—8p.  
 Prices VAT inclusive Post 20p. (Free over £5.00).

**THE C.R. SUPPLY CO.**  
 127, Chesterfield Rd., Sheffield S8 0RN.

Importers wanted for Electronic Components, LEDs, Diodes, Japanese Audio Equipment, Casio Calculators.

Interested please write to:  
**LASERELECTRONICS SDN BHD,**  
 Bldg 67, #03-218 Telok Blangah Drive,  
 Republic of Singapore (0410)  
 or Telex: RS 38615 MANAGE.

## SERVICE SHEETS

**BELLS TELEVISION SERVICES** for service sheets of Radio, TV, etc £1.50 plus SAE. Colour TV Service Manuals on request. SAE with enquiries to B.T.S., 190 Kings Road, Harrogate, N. Yorkshire. Tel. (0423) 55885.

## HOME SECURITY

# CENTURION ALARMS

Manufacturers of Professional Alarm Equipment, for DIY & the TRADE. Send now for our New 16-page Brochure, Full of Information & the Lowest prices.



Tel (0484)  
**21000**  
 or 35527 24 hr.

**CENTURION Dept PE**  
 93 Wakefield Road,  
 Huddersfield,  
 HD5 9AB  
 W. Yorks.

® "CENTURION" is a Registered Trademark of Centurion Alarms

**WHO CAN PUT A PRICE ON A PEACE OF MIND**  
 PROFESSIONAL EQUIPMENT AT LOW/LOW! PRICES  
**HOME SECURITY IS NOW AVAILABLE AT TRADE PRICES**  
**ADVANCED SECURITY PRODUCTS LTD**  
 2 Ealing Road, Aintree,  
 Liverpool L9 0HU, Merseyside.  
**Tel: 051-525 3440**  
**FREE CATALOGUE PHONE OR S.A.E.**

## ORDER FORM PLEASE WRITE IN BLOCK CAPITALS

Please insert the advertisement below in the next available issue of Practical Electronics for .....

insertions. I enclose Cheque/P.O. for £.....

(Cheques and Postal Orders should be crossed Lloyds Bank Ltd. and made payable to Practical Electronics)

NAME .....

ADDRESS .....

## PRACTICAL ELECTRONICS

Classified Advertisement Dept., Room 2612,  
 King's Reach Tower, Stamford Street,  
 London SE1 9LS Telephone 01-261 5846

Rate:  
 36p per word, minimum 12 words. Box No. 60p extra.







# ANTEX a world of soldering

## Tomorrows Soldering Technology Today.

ANTEX has a worldwide reputation for quality & service & for many years has been one of the best known & most popular names in soldering. Always at the forefront of technology, ANTEX is continually researching new and better ways of achieving more accurate, reliable, and cost effective soldering. On ANTEX Soldering Irons, the advanced design of the interface between the element & the bit allows more efficient heat transfer to the bit and improved stability of the temperature at the point of contact with the work. Indeed, experiments have shown that ANTEX irons can be used for tasks where a 40% increase in productivity is possible.

ANTEX Soldering Irons are available in a wide range of models. They are suitable for soldering sensitive devices, and are also controlled by a TCSU-D Temperature Controlled Soldering Unit.

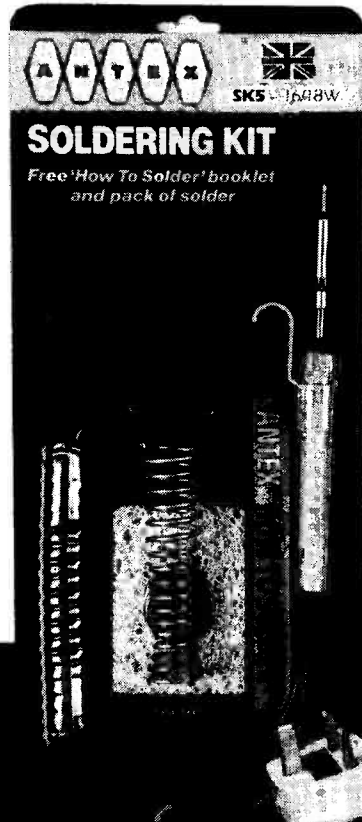

SK5 Soldering Kit

Model XS

Model CS

Model C

TCSU-D Temperature-Controlled Soldering Unit

ST4 Stand

TCSU1 Soldering Unit

**Model C**  
- 15 Watts. Available for 250, 220, 115, 100, 50 or 24 volts.  
**Model XS**  
- 25 Watts. Available for 240, 220, 115, 100, 50, 24 or 12 volts.  
**Model XS-HP**  
- 25 Watts. 240 volts, fitted with British Plug.  
**ST4 Stand**  
- To suit all irons.

**SK5 Soldering Kit**. Contains model CS 240v iron, an ST4 Stand and solder.  
**SK6 Soldering Kit**. Contains model XS240v iron, an ST4 Stand and solder.  
**SK5-HP and SK6-HP** Soldering Kits as above with British Plug.  
**Model CS**  
- 17 Watts. Available for 240, 220, 115, 100, 50, 24 or 12 volts.

**Model CS-HP**  
- 17 Watts. 240 volts, fitted with British Plug.  
**TCSU1**  
- Very robust temperature controlled Soldering Unit with a choice of 30 Watt (CSTC) or 40 Watt (CSTC) miniature irons. Range 65°C to 420°C. Accuracy 2%.

**TCSU-D**  
Elegant Temperature Controlled Soldering Unit with 50 W Iron (CSD) and built around FERMIANT! Custom-made U.S.A. Range Ambient to 450°C. Accuracy ± 5°C. Zero crossing switching. Detachable springs. Easy to use.



**ANTEX (Electronics) Ltd.**  
Plymouth, Devon. Tel: 0752 667377

Made in England  
Telex: 45296

Please send literature, price list and my nearest stockist to:  
Name \_\_\_\_\_  
Address \_\_\_\_\_  
Telephone \_\_\_\_\_

PE/11/85



# Maplin

**WELCOME TO  
THE MAPLIN  
ADVENTURELAND  
IN 1986...**

The new Maplin catalogue for 1986 is a real adventureland for the electronics enthusiast. With hundreds of new lines and details of Maplin's new low low prices, it's the one event in the electronics year that no-one should miss. Packed with data and information on all the latest electronic products. Pick up a copy from any branch of W.H. Smith for just £1.45. Alternatively you can order your copy by post for just £1.85. For overseas customers the prices are as follows: Europe surface mail £2.50; Europe air mail £3.75. Outside Europe surface mail £2.50; Outside Europe air mail depending on distance £4.25/£5.50/£6.25. For surface mail anywhere in the world you may send eleven International Reply Coupons for payment in full.

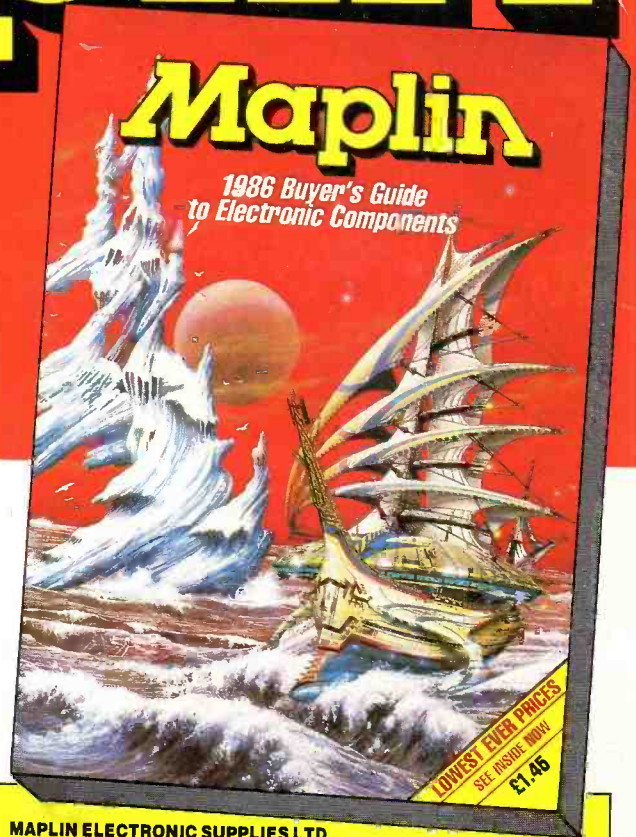

Post this coupon now for your copy of the 1986 catalogue.  
Price £1.45 + 40p post and packing. If you live outside the U.K.  
send £2.50 or 11 International Reply Coupons. I enclose £1.85.

Name .....

Address .....

PE.11.85

**MAPLIN ELECTRONIC SUPPLIES LTD.**  
Mail Order: P.O. Box 3, Rayleigh, Essex SS6 8LR. Tel: Southend (0702) 552911  
SHOPS  
• BIRMINGHAM Lynton Square, Perry Barr, Tel: 021-356 7292.  
• LONDON 159-161 King Street, Hammersmith, W6. Tel: 01-748 0926.  
• MANCHESTER 8 Oxford Road, Tel: 061-236 0281.  
• SOUTHAMPTON 46-48 Bevois Valley Road, Tel: 0703 225831.  
• SOUTHEND 282-284 London Rd. Westcliff-on-Sea, Essex. Tel: 0702-554000  
*Shops closed all day Monday.*

**ON SALE  
9th NOV  
1985**



**ORDER YOUR COPY NOW**