

PRACTICAL ELECTRONICS

JUNE 1967

PRICE 216



**MINIATURE R/C
INSTALLATIONS**

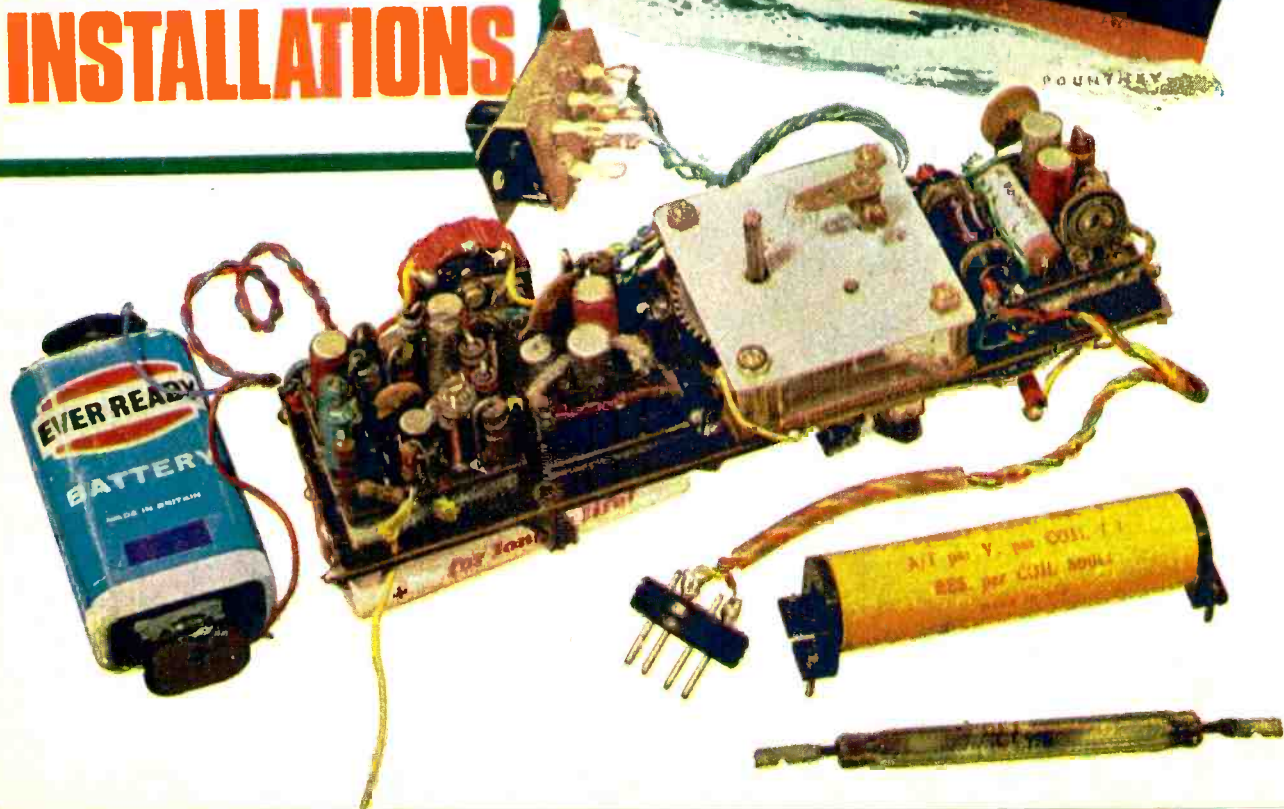

ADCOLA

PRODUCTS LIMITED
(Regd. Trade Mark)

SOLDERING EQUIPMENT

for the

DISCRIMINATING
ENTHUSIAST

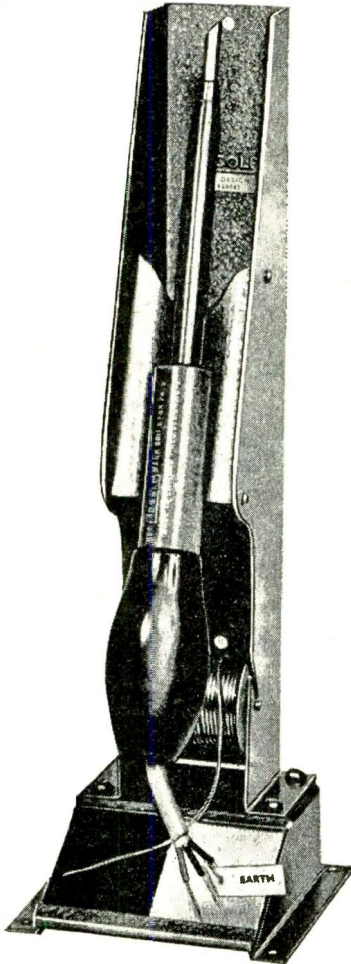

ILLUSTRATED:
L64 $\frac{3}{16}$ " BIT INSTRUMENT IN
L700 PROTECTIVE SHIELD

APPLY DIRECT TO:

SALES & SERVICE DEPT.
ADCOLA PRODUCTS LTD.
ADCOLA HOUSE
GAUDEN ROAD
LONDON, S.W.4
TELEPHONE: MACAULAY 0291/3

OLRUS ELECTRONICS LTD.

PADDINGTON 1515

9 NORFOLK PLACE (off Praed St.) LONDON, W.2

TRANSISTORS — DIODES — ZENER — VALVES
FULLY GUARANTEED — FACTORY NEW. S.A.E. FOR FULL LIST.
P.P. 2/- in £ 1/- min.

2N697 12/6	ANZ20 7/6	NKT228 6/-	OAZ207 9/6	OC122 16/-	GZ34 10/-
2N1304 6/6	ANZ21 15/6	NKT251 5/-	OAZ208 6/6	OC139 7/6	PC86 11/-
2N2926 5/6	ANZ23 30/-	NKT256 6/6	OAZ209 6/6	OC140 9/6	PC88 11/-
2N3819 18/-	BC107 7/6	NKT265 9/6	OAZ210 6/6	OC141 12/6	PC97 7/6
28002 10/6	BC108 5/-	NKT271 5/-	OAZ211 6/6	OC169 5/-	PC94 6/6
28003 9/6	BC109 7/6	NKT272 5/-	OAZ212 6/6	OC170 5/-	PC989 11/-
28004 9/6	BCY31 13/6	NKT273 4/-	OAZ213 6/6	OC171 6/-	PC189 11/-
28012 20/-	BFY17 9/6	NKT274 5/-	OAZ222 9/6	OC200 7/6	PC200 7/6
28012A 25/-	BFY51 8/6	NKT275 5/-	OAZ224 10/-	OC201 10/-	PC286 8/6
28013 20/-	BFY53 7/6	NKT277 5/-	OAZ225 10/-	OC202 13/6	PC287 7/6
28013A 25/-	HPY10 22/6	NKT278 5/-	OAZ226 10/-	OC203 10/6	PC283 8/6
28017 15/-	BNY27 9/6	NKT279A 4/-	OAZ227 10/-	OC204 15/-	PC284 7/6
28018 17/6	BNY61 7/6	NKT279B 4/-	OAZ242 4/6	OC205 15/-	PC285 8/6
28103 20/-	BNY53 7/6	NKT304 7/6	OAZ245 4/6	OC206 22/6	PC286 8/6
28301 12/6	BNY95A 5/6	NKT352 8/-	OAZ246 4/6	OC207 15/-	PC287 8/6
28320 9/6	BY100 4/6	NKT403 12/6	OAZ247 4/6	OC208 7/6	PC288 7/6
28322 7/6	BY100 4/6	NKT404 12/6	OAZ290 9/6	OC209 4/6	PC289 6/6
28323 10/6	GET7 5/6	NKT405 12/6	OAZ291 9/6	OC210 6/6	PC290 6/6
28324 12/6	GET8 5/6	NKT406 12/6	OAZ292 9/6	OC211 6/6	PC291 6/6
28325 12/6	GET9 5/6	NKT407 12/6	OAZ293 9/6	OC212 6/6	PC292 6/6
28326 12/6	GET10 5/6	NKT408 12/6	OAZ294 9/6	OC213 6/6	PC293 6/6
28327 12/6	GET11 5/6	NKT409 12/6	OAZ295 9/6	OC214 6/6	PC294 6/6
28328 12/6	GET12 5/6	NKT410 12/6	OAZ296 9/6	OC215 6/6	PC295 6/6
28329 12/6	GET13 5/6	NKT411 12/6	OAZ297 9/6	OC216 6/6	PC296 6/6
28330 12/6	GET14 5/6	NKT412 12/6	OAZ298 9/6	OC217 6/6	PC297 6/6
28331 12/6	GET15 5/6	NKT413 12/6	OAZ299 9/6	OC218 6/6	PC298 6/6
28332 12/6	GET16 5/6	NKT414 12/6	OAZ300 9/6	OC219 6/6	PC299 6/6
28333 12/6	GET17 5/6	NKT415 12/6	OAZ301 9/6	OC220 6/6	PC300 6/6
28334 12/6	GET18 5/6	NKT416 12/6	OAZ302 9/6	OC221 6/6	PC301 6/6
28335 12/6	GET19 5/6	NKT417 12/6	OAZ303 9/6	OC222 6/6	PC302 6/6
28336 12/6	GET20 10/-	NKT418 12/6	OAZ304 9/6	OC223 6/6	PC303 6/6
28337 12/6	GET21 10/-	NKT419 12/6	OAZ305 9/6	OC224 6/6	PC304 6/6
28338 12/6	GET22 10/-	NKT420 12/6	OAZ306 9/6	OC225 6/6	PC305 6/6
28339 12/6	GET23 10/-	NKT421 12/6	OAZ307 9/6	OC226 6/6	PC306 6/6
28340 12/6	GET24 10/-	NKT422 12/6	OAZ308 9/6	OC227 6/6	PC307 6/6
28341 12/6	GET25 10/-	NKT423 12/6	OAZ309 9/6	OC228 6/6	PC308 6/6
28342 12/6	GET26 10/-	NKT424 12/6	OAZ310 9/6	OC229 6/6	PC309 6/6
28343 12/6	GET27 10/-	NKT425 12/6	OAZ311 9/6	OC230 6/6	PC310 6/6
28344 12/6	GET28 10/-	NKT426 12/6	OAZ312 9/6	OC231 6/6	PC311 6/6
28345 12/6	GET29 10/-	NKT427 12/6	OAZ313 9/6	OC232 6/6	PC312 6/6
28346 12/6	GET30 10/-	NKT428 12/6	OAZ314 9/6	OC233 6/6	PC313 6/6
28347 12/6	GET31 10/-	NKT429 12/6	OAZ315 9/6	OC234 6/6	PC314 6/6
28348 12/6	GET32 10/-	NKT430 12/6	OAZ316 9/6	OC235 6/6	PC315 6/6
28349 12/6	GET33 10/-	NKT431 12/6	OAZ317 9/6	OC236 6/6	PC316 6/6
28350 12/6	GET34 10/-	NKT432 12/6	OAZ318 9/6	OC237 6/6	PC317 6/6
28351 12/6	GET35 10/-	NKT433 12/6	OAZ319 9/6	OC238 6/6	PC318 6/6
28352 12/6	GET36 10/-	NKT434 12/6	OAZ320 9/6	OC239 6/6	PC319 6/6
28353 12/6	GET37 10/-	NKT435 12/6	OAZ321 9/6	OC240 6/6	PC320 6/6
28354 12/6	GET38 10/-	NKT436 12/6	OAZ322 9/6	OC241 6/6	PC321 6/6
28355 12/6	GET39 10/-	NKT437 12/6	OAZ323 9/6	OC242 6/6	PC322 6/6
28356 12/6	GET40 10/-	NKT438 12/6	OAZ324 9/6	OC243 6/6	PC323 6/6
28357 12/6	GET41 10/-	NKT439 12/6	OAZ325 9/6	OC244 6/6	PC324 6/6
28358 12/6	GET42 10/-	NKT440 12/6	OAZ326 9/6	OC245 6/6	PC325 6/6
28359 12/6	GET43 10/-	NKT441 12/6	OAZ327 9/6	OC246 6/6	PC326 6/6
28360 12/6	GET44 10/-	NKT442 12/6	OAZ328 9/6	OC247 6/6	PC327 6/6
28361 12/6	GET45 10/-	NKT443 12/6	OAZ329 9/6	OC248 6/6	PC328 6/6
28362 12/6	GET46 10/-	NKT444 12/6	OAZ330 9/6	OC249 6/6	PC329 6/6
28363 12/6	GET47 10/-	NKT445 12/6	OAZ331 9/6	OC250 6/6	PC330 6/6
28364 12/6	GET48 10/-	NKT446 12/6	OAZ332 9/6	OC251 6/6	PC331 6/6
28365 12/6	GET49 10/-	NKT447 12/6	OAZ333 9/6	OC252 6/6	PC332 6/6
28366 12/6	GET50 10/-	NKT448 12/6	OAZ334 9/6	OC253 6/6	PC333 6/6
28367 12/6	GET51 10/-	NKT449 12/6	OAZ335 9/6	OC254 6/6	PC334 6/6
28368 12/6	GET52 10/-	NKT450 12/6	OAZ336 9/6	OC255 6/6	PC335 6/6
28369 12/6	GET53 10/-	NKT451 12/6	OAZ337 9/6	OC256 6/6	PC336 6/6
28370 12/6	GET54 10/-	NKT452 12/6	OAZ338 9/6	OC257 6/6	PC337 6/6
28371 12/6	GET55 10/-	NKT453 12/6	OAZ339 9/6	OC258 6/6	PC338 6/6
28372 12/6	GET56 10/-	NKT454 12/6	OAZ340 9/6	OC259 6/6	PC339 6/6
28373 12/6	GET57 10/-	NKT455 12/6	OAZ341 9/6	OC260 6/6	PC340 6/6
28374 12/6	GET58 10/-	NKT456 12/6	OAZ342 9/6	OC261 6/6	PC341 6/6
28375 12/6	GET59 10/-	NKT457 12/6	OAZ343 9/6	OC262 6/6	PC342 6/6
28376 12/6	GET60 10/-	NKT458 12/6	OAZ344 9/6	OC263 6/6	PC343 6/6
28377 12/6	GET61 10/-	NKT459 12/6	OAZ345 9/6	OC264 6/6	PC344 6/6
28378 12/6	GET62 10/-	NKT460 12/6	OAZ346 9/6	OC265 6/6	PC345 6/6
28379 12/6	GET63 10/-	NKT461 12/6	OAZ347 9/6	OC266 6/6	PC346 6/6
28380 12/6	GET64 10/-	NKT462 12/6	OAZ348 9/6	OC267 6/6	PC347 6/6
28381 12/6	GET65 10/-	NKT463 12/6	OAZ349 9/6	OC268 6/6	PC348 6/6
28382 12/6	GET66 10/-	NKT464 12/6	OAZ350 9/6	OC269 6/6	PC349 6/6
28383 12/6	GET67 10/-	NKT465 12/6	OAZ351 9/6	OC270 6/6	PC350 6/6
28384 12/6	GET68 10/-	NKT466 12/6	OAZ352 9/6	OC271 6/6	PC351 6/6
28385 12/6	GET69 10/-	NKT467 12/6	OAZ353 9/6	OC272 6/6	PC352 6/6
28386 12/6	GET70 10/-	NKT468 12/6	OAZ354 9/6	OC273 6/6	PC353 6/6
28387 12/6	GET71 10/-	NKT469 12/6	OAZ355 9/6	OC274 6/6	PC354 6/6
28388 12/6	GET72 10/-	NKT470 12/6	OAZ356 9/6	OC275 6/6	PC355 6/6
28389 12/6	GET73 10/-	NKT471 12/6	OAZ357 9/6	OC276 6/6	PC356 6/6
28390 12/6	GET74 10/-	NKT472 12/6	OAZ358 9/6	OC277 6/6	PC357 6/6
28391 12/6	GET75 10/-	NKT473 12/6	OAZ359 9/6	OC278 6/6	PC358 6/6
28392 12/6	GET76 10/-	NKT474 12/6	OAZ360 9/6	OC279 6/6	PC359 6/6
28393 12/6	GET77 10/-	NKT475 12/6	OAZ361 9/6	OC280 6/6	PC360 6/6
28394 12/6	GET78 10/-	NKT476 12/6	OAZ362 9/6	OC281 6/6	PC361 6/6
28395 12/6	GET79 10/-	NKT477 12/6	OAZ363 9/6	OC282 6/6	PC362 6/6
28396 12/6	GET80 10/-	NKT478 12/6	OAZ364 9/6	OC283 6/6	PC363 6/6
28397 12/6	GET81 10/-	NKT479 12/6	OAZ365 9/6	OC284 6/6	PC364 6/6
28398 12/6	GET82 10/-	NKT480 12/6	OAZ366 9/6	OC285 6/6	PC365 6/6
28399 12/6	GET83 10/-	NKT481 12/6	OAZ367 9/6	OC286 6/6	PC366 6/6
28400 12/6	GET84 10/-	NKT482 12/6	OAZ368 9/6	OC287 6/6	PC367 6/6
28401 12/6	GET85 10/-	NKT483 12/6	OAZ369 9/6	OC288 6/6	PC368 6/6
28402 12/6	GET86 10/-	NKT484 12/6	OAZ370 9/6	OC289 6/6	PC369 6/6
28403 12/6	GET87 10/-	NKT485 12/6	OAZ371 9/6	OC290 6/6	PC370 6/6
28404 12/6	GET88 10/-	NKT486 12/6	OAZ372 9/6	OC291 6/6	PC371 6/6
28405 12/6	GET89 10/-	NKT487 12/6	OAZ373 9/6	OC292 6/6	PC372 6/6
28406 12/6	GET90 10/-	NKT488 12/6	OAZ374 9/6	OC293 6/6	PC373 6/6
28407 12/6	GET91 10/-	NKT489 12/6	OAZ375 9/6	OC294 6/6	PC374 6/6
28408 12/6	GET92 10/-	NKT490 12/6	OAZ376 9/6	OC295 6/6	PC375 6/6
28409 12/6	GET93 10/-	NKT491 12/6	OAZ377 9/6	OC296 6/6	PC376 6/6
28410 12/6	GET94 10/-	NKT492 12/6	OAZ378 9/6	OC297 6/6	PC377 6/6
28411 12/6	GET95 10/-	NKT493 12/6	OAZ379 9/6	OC298 6/6	PC378 6/6
28412 12/6	GET96 10/-	NKT494 12/6	OAZ380 9/6	OC299 6/6	PC379 6/6
28413 12/6	GET97 10/-	NKT495 12/6	OAZ381 9/6	OC300 6/6	PC380 6/6
28414 12/6	GET98 10/-	NKT496 12/6	OAZ382 9/6	OC301 6/6	PC381 6/6
28415 12/6	GET99 10/-	NKT497 12/6	OAZ383 9/6	OC302 6/6	PC382 6/6
28416 12/6	GET100 10/-	NKT498 12/6	OAZ384 9/6	OC303 6/6	PC383 6/6
28417 12/6	GET101 10/-	NKT499 12/6	OAZ385 9/6	OC304 6/6	PC384 6/6
28418 12/6	GET102 10/-	NKT500 12/6	OAZ386 9/6	OC305 6/6	PC385 6/6
28419 12/6	GET103 10/-	NKT501 12/6	OAZ387 9/6	OC306 6/6	PC386 6/6
28420 12/6	GET104 10/-	NKT502 12/6	OAZ388 9/6	OC307 6/6	PC387 6/6
28421 12/6	GET105 10/-	NKT503 12/6	OAZ389 9/6	OC308 6/6	PC388 6/6
28422 12/6	GET106 10/-	NKT504 12/6	OAZ390 9/6	OC309 6/6	PC389 6/6
28423 12/6	GET107 10/-	NKT505 12/6	OAZ391 9/6	OC310 6/6	PC390 6/6
28424 12/6	GET108 10/-	NKT506 12/6	OAZ392 9/6	OC311 6/6	PC391 6/6
28425 12/6	GET109 10/-	NKT507 12/6	OAZ393 9/6	OC312 6/6	PC392 6/6
28426 12/6	GET110 10/-	NKT508 12/6	OAZ394 9/6	OC313 6/6	PC393 6/6
28427 12/6	GET111 10/-	NKT509 12/6	OAZ395 9/6	OC314 6/6	PC394 6/6
28428 12/6	GET112 10/-	NKT510 12/6	OAZ396 9/6	OC315 6/6	PC395 6/6
28429 12/6	GET113 10/-	NKT511 12/6	OAZ397 9/6	OC316 6/6	PC396 6/6
28430 12/6	GET114 10/-	NKT512 12/6	OAZ398 9/6	OC317 6/6	PC397 6/6
28431 12/6	GET115 10/-	NKT513 12/6	OAZ399 9/6	OC318 6/6	PC398 6/6
28432 12/6	GET116 10/-	NKT514 12/6	OAZ400 9/6	OC319 6/6	PC399 6/6
28433 12/6	GET117 10/-	NKT515 12/6	OAZ401 9/6	OC320 6/6	PC400 6/6
28434 12/6	GET118 10/-	NKT516 12/6	OAZ402 9/6	OC321 6/6	PC401 6/6
28435 12/6	GET119 10/-	NKT517 12/6	OAZ403 9/6	OC322 6/6	PC402 6/6
28436 12/6	GET120 10/-	NKT518 12/6	OAZ404 9/6	OC323 6/6	PC403 6/6
28437 12/6	GET121 10/-	NKT519 12/6	OAZ405 9/6	OC324 6/6	PC404 6/6
28438 12/6	GET122 10/-	NKT520 12/6	OAZ406 9/6	OC325 6/6	PC405 6/6
28439 12/6	GET123 10/-	NKT521 12/6	OAZ407 9/6	OC326 6/6	PC406 6/6
28440 12/6	GET124 10/-	NKT522 12/6	OAZ408 9/6	OC327 6/6	PC407 6/6
28441 12/6	GET125 10/-	NKT523 12/6	OAZ409 9/6	OC328 6/6	PC408 6/6
28442 12/6	GET126 10/-	NKT524			

LASKY'S RADIO

For the Finest Value and Service to HOME CONSTRUCTORS & ELECTRONICS ENTHUSIASTS

We consider our construction parcels to be the finest value on the home constructor market. If on receipt you feel not competent to build the set, you may return it as received within 7 days, when the sum paid will be refunded less postage.

SPECIAL INTEREST ITEMS!

NEW! LASKY'S CLEAR PLASTIC PANEL METERS

Precision made in Japan by HIOKI. Each meter boxed and fully guaranteed with all fixing nuts and washers. Sizes are of front panel. Add 1/6 Post on each.

Type KR-52 3" x 2" (illustrated)
 1 mA DC 32/6 300 V DC 32/6
 5 mA DC 32/6 500µA 37/6
 1 mA S Meter 39/6

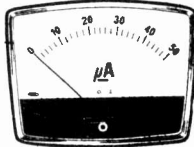

Type MK-38A 2in. square	Type KR-65 3 1/2" x 3in.	1 mA DC 38/-
1 mA DC 22/6	5 mA DC 35/-	5 mA DC 35/-
5 mA DC 22/6	300 V DC 35/-	300 V DC 35/-
300 V DC 27/6	500µA 42/6	500µA 42/6
500µA 27/6	1 mA S Meter 39/6	1 mA S Meter 39/6
1 mA S Meter 29/6		
Type MK-45A 1 1/2in. square	Type MK-65A 3in. square	1 mA DC 36/-
1 mA DC 25/-	5 mA DC 35/-	5 mA DC 35/-
5 mA DC 25/-	300 V DC 35/-	300 V DC 35/-
300 V DC 25/-	500µA 39/6	500µA 39/6
500µA 25/-	1 mA S Meter 37/6	1 mA S Meter 37/6
1 mA S Meter 35/-		

VEROBOARD — High grade laminated board with copper strips bonded to it and pierced with holes.

Boards	Accessories
42/1503 2 1/2" x 5in. 3/11	Terminal pins — pkt. of 50 3/-
43/1504 2 1/2" x 3 1/2in. 3/3	Spot face cutter tool 7/8
45/1507 3 1/2" x 5in. 5/8	Pin inserting tool 9/8
46/1508 3 1/2" x 3 1/2in. 3/11	Post 6d. per item extra.
44/1505 3 1/2" x 17in. 15/6	Orders of 10/- and over post free.

SPECIAL PURCHASE—UHF/VHF T.V. TUNERS

Well known British makers' surplus stocks. Now available for the first time to the Home Constructor. Add 2/6 Post and Packing on each.

VALVE UHF MODEL (illustrated)
 In metal case size 4" x 6" x 1 1/2in. Fully tunable—complete with FCC86 and FCC88 valves. LASKY'S PRICE 29/6. Without valves 12/6

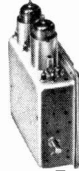

TRANSISTORISED VHF TUNER
 Sub-miniature turret type fitted with 12 sets of coils and 3 Mullard AF102 transistors. In metal case size 3" x 1 1/2" x 2 1/2in. LASKY'S PRICE 37/6
 Add 2/6 Post and Packing on each.

TELEVISION IF AMPLIFIERS

38 Mc/s. Contains a large number of components, IF transformers, resistors, capacitors, etc., and the following valves: 2PCF60, 1XB91, EF80, BF182 and EF184. Overall size 1 1/2" x 3 1/2" x 4" deep. Ideal for servicemen and experimenters. This IF amp. when used with the Valve model UHF Tuner (above) provides a suitable conversion for B.B.C.2. Circuit supplied.

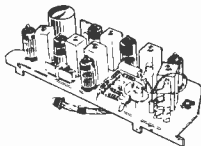

LASKY'S PRICE 29/6 Post 2/6
SPECIAL PACKAGE OFFER

IF AMPLIFIER plus VALVE UHF TUNER (see above), with valves. LASKY'S PRICE 49/6 Post 5/-

EXPORT TTC B4002 FM WIRELESS MIC.

Highly sensitive—suitable for either static or mobile use. Signal can be picked up by any FM radio or tuner which receives frequencies between 96-104 Mc/s. over several hundred yards. Size only 3" x 2 1/2" x 1in. (in leather case). Operates on one FP3 type battery. Complete with neck cord, clip-on dynamic extension mike (1/2" x 1/2" x 1/2in.) and battery.



LASKY'S EXPORT PRICE 10 Gns. Post Free. Anywhere in the World.
TTC 18/500. More powerful version of above—size 7 1/2" x 1 1/2" x 1in. Operates on one FP3 type battery. LASKY'S PRICE 12 Gns. Post Free. Anywhere in the World.
 These cannot be operated in the U.K. owing to G.P.O. regulations.

WATER TEMPERATURE THERMOSTATS

British made—orig. for use in high quality washing machine. range adjustable between 114°F and 230°F. Rating 200/250 V.A.C., 20 amps (also D.C. up to 125 V.A.). Size 2 1/2" x 1 1/2" x 1 1/2" with 18in. capillary tube and 6in. bulb. Single hole fixing—3/16in. spindle.

LASKY'S PRICE 15/- Post 2/-

207 EDGWARE ROAD, LONDON, W.2 Tel: PAD 3271
 118 EDGWARE ROAD, LONDON, W.2 Tel: PAD 9789
 33 TOTTENHAM CT. ROAD, LONDON, W.1 Tel: MUS 2605

The above branches open all day Saturday. Early closing Thursday.
 Please address all Mail Orders and Correspondence to 3-15 Cavell Street, Tower Hamlets, London, E.1.

CONSTRUCTORS BARGAINS

THE SKYROVER

De Luxe

7 transistor plus 2 diode superhet, 6 waveband portable receiver covering the full Medium Waveband and Short Waveband 31-94M and also 4 separate switched bandspread ranges, 13M., 16M., 19M. and 25M., with Band Spread Tuning for accurate Station Selection. The coil pack and tuning heart is factory assembled, and tested. Uses 4 U2 batteries. 5in. Ceramic Magnet P.M. Speaker. Telescopic and Ferrite Rod Aerial. Tone Circuit, wood cabinet, size 11 1/2" x 6 1/2" x 3in. covered with washable material, plastic trim and handle. Car aerial socket fitted.

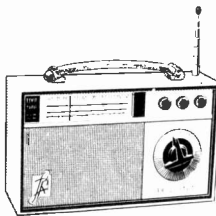

Can be built for **£8.19.6** Post H.P. Terms: 60/- deposit and 11 monthly payments of 12/9. Total H.P.P. £10.0.3. Data 2/6 extra: refunded if you purchase parcel. All parts avail. sep. Four U2 batt. 3/4 A simple additional circuit provides cover of the 1100/1950M Long Waveband. All components with construction data. Only 10/- extra Post Free.

NEW KIT — PEAK SOUND SA-88 TRANSISTORISED STEREO AMPLIFIER AND PRE-AMPLIFIER

A high quality 17 watt, 14 transistor High Fidelity Integrated Amplifier which anyone can easily build using the revolutionary Peak Sound "Cir-Kit" wiring system. Size assembled only 10" x 2 1/2" x 6in. Complete kit with detailed construction data.

LASKY'S PRICE £12.19.6 Post FREE.
 POWER SUPPLY KIT for the SA-88 £3.10.0 Post FREE.

LASKY'S MINIATURE TRANSISTOR AMPLIFIER MODULES

Incorporating the very latest circuitry to provide high sensitivity and good quality in conjunction with extreme small size and compactness. High quality Newmarket transistors used throughout. All designed to operate on 9v. miniature battery. Add 1/- on each for post & packing

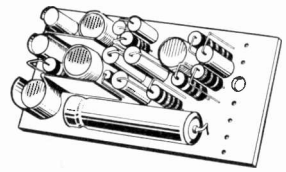

TYPE LRPC 1. 3 transistor. Input sens. 50 mV., output 150 mW, output imp. 40Ω, size 2" x 1" x 1 1/2in. PRICE 27/6

TYPE LRPC 4. 5 transistor. Input sens. 150 mV, output 330 mV, output imp. 15Ω, size 2 1/2" x 1 1/2" x 1in. PRICE 22/6

TYPE LRPC 5. 6 transistor. Input sens. 8mV, output 3W, output imp. 3Ω, size 5 1/2" x 1 1/2" x 1in. PRICE 59/6

FULLY ENCAPSULATED MODULES

Special function modules — all one size 1 1/2" x 1" x 1 1/2in. Complete with detailed function and installation instructions. Send S.A.E. for data.

TYPE PA-1. Public address amp. for use with carbon, crystal or Dynamic microphones. 3Ω output imp. PRICE 30/-

TYPE GR-1. Gramophone amplifier—provides sufficient power to fill average room. 3Ω output imp. PRICE 30/-

TYPE CO-1. Morse code practice oscillator — for use with morse key and 3Ω speaker. PRICE 20/-

TYPE MT-1. Metronome module—provides audible and visual beat from 30 to 240 beats per minute (for use with 3Ω speaker or ind. lamp) PRICE 22/6

SINCLAIR SUPER MINIATURE KITS

We stock the complete range. Write for details of package deals.

THE MICRO-6 miniature radio only 1 1/2" x 1 1/2" x 1 1/2in. £2 19 6

THE MICRO-FM. (tuner/receiver) £5 19 6

THE MICROMATIC mini-radio Kit £2.19.6. Fully built £2 19 6

STEREO 25 pre-amp control unit fully built £2 19 6

THE Z-12 12 watt amplifier and pre-amplifier. Fully built and tested £4 9 6

PZ-3 power pack for Z-12 £3 19 6

TRANSISTORS

ALL BRAND NEW AND GUARANTEED

GET 81, GET 85, GET 86 2/6; 873A, 874P 3/6; OC45, OC71, OC81D 4/6; OC 44, OC 70, OC 76, OC 81 5/6; pair (10/6); AF 117, OC 200 6/6; OC 42, OC 43, OC 73, OC 821 7/6; OC 201, OC 204 15/-; OC 205, OC 206 19/6; OC28 24/6; OC 75 8/-.

TRANSISTORS by BRUSH CRYSTAL CO. Available from stock.

TO—01B 465 kc/s. ± 2 kc/s.	TF—01B 465 kc/s. ± 2 kc/s.	9/6 EACH Post 6d.
TO—01D 470 kc/s. ± 2 kc/s.	TF—01D 470 kc/s. ± 2 kc/s.	
TO—02B 465 kc/s. ± 1 kc/s.		

42 TOTTENHAM CT. ROAD, LONDON, W.1 Tel: 01-580 2573
 152/3 FLEET STREET, LONDON, E.C.4 Tel: FLE 2833

Both open all day Thursday. Early closing Saturday.
 Please address all Mail Orders and Correspondence to 3-15 Cavell Street, Tower Hamlets, London, E.1. Tel.: STE 4821/2

LASKY'S FOR SPEEDY MAIL ORDER SERVICE



I should like a copy of the *Electroniques Hobbies Manual*.
Enclosed is a cheque/P.O. for 10/6.

NAME _____
ADDRESS _____

P.E.6.

COST OF BOOK REFUNDED IF ORDER FOR GOODS FOLLOWS

P. J. Plowman, North Bradley House, Trowbridge, Wilts. Phone: Trowbridge 5306

Introducing

THE NEW RICHARD ALLAN

SARABANDE

RECOMMENDED RETAIL PRICE: £39.17.6

A magnificent triple speaker assembly containing a high flux 15" unit for no compromise bass, and the new

MID RANGE & TWEETER MODULE

(£9.7.10 inc. P.T.)

which has been developed by the same team which produced the brilliant High Fidelity Module.

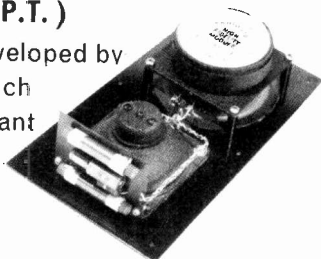

THE SARABANDE OFFERS THE FINEST VALUE OBTAINABLE IN THIS PRICE RANGE OF LOUDSPEAKERS

Richard Allan

RICHARD ALLAN RADIO LTD., BRADFORD ROAD, GOMERSAL, CLECKHEATON, YORKS. TEL.: CLECKHEATON 2442

SAMSON'S ELECTRONICS LTD.

9-10 CHAPEL STREET LONDON, N.W.1

Tel.: PAD 7851 Tel.: AMB 5125

AUTO TRANSFORMERS

For 110 v. equipment. Input 240 v., output 110 v., 3,000 watts. Completely enclosed in strong metal case. Terminal block output. £15, carr. 15/-.

2,000 watts. Enclosed in case fitted with two 2-pin American sockets or terminal blocks. Neon indicator. On/off switch and carrying handle. £10.19.6, carr. 10/-.

Also available. Completely shrouded, fitted with 2-pin American sockets, or terminal blocks. Please state which type required.

Wattage	Price	Carr.
1,500	£7.15.0	8/6
1,000	£4.15.0	7/6
500	£3.15.0	6/6
300	£2.9.6	5/6
150	£1.19.6	4/6
60	£1.12.6	4/-

S.T.C. SELENIUM RECTIFIERS

Type B84-9-1 w. F.W. bridge. Max. A.C. input 162 v. D.C. output 140 v. 2½ amps., 57/6. P.P. 5/-.

Type B67-9-1 w. 1½ amps. output. 37/6. P.P. 5/-.

Type D84-4-3 w. Two required for F.W. Bridge. Max. A.C. input 72 v. D.C. output 60 v. 8 amps., 50/- per pair. P.P. 5/-.

SURPLUS L.T. TRANSFORMERS

ALL BY FAMOUS MAKERS

- A. Pri. 200-240v. Sec. (1) Tapped 38v., 40v. 10A Sec. (2), 6.2, 6.8, 7.3, 7.9, 8.5, 9, 9.5, 10, 10.6v. 18 amps. £7/10/-, Carr. 10/-.
- B. Pri. 240v. Sec. Tapped 53.6, 55.2v. 6 amps. "C" Core, 72/6, Carr. 7/6.
- C. Pri. 200-240v. E.S. Sec. Tapped 32, 34, 38, 40, 44, 46v. 7 amps. 75/-, Carr. 7/6.
- D. Pri. 200-240v. Sec. 8v. 6 amps. 19/6, P.P. 4/6.
- E. Pri. 200-240v. Sec. (1) 25v. 3A. Sec. (2) 10v., 0.1A. Sec. (3) 115v. 0.6A., 29/6, P.P. 4/6.
- F. Pri. 240v. Sec. (1) 45v. 25 M/A. Sec. (2) 1v. ½ amp., 15/-, P.P. 3/6.

MULTI-TAPPED TRANSFORMERS

MOST TYPES, FULLY SHROUDED AND TERMINAL BLOCK CONNECTIONS.

ALL PRIMARIES 220-240 VOLTS

* Denotes Unshrouded Types

TYPE SEC. TAPS AMPS. PRICE CARR.

1A	25-33-40-50	15	£7	19	6	9/-
1B	25-33-40-50	10	£5	19	6	7/6
1C	25-33-40-50	6	£4	19	6	7/6
1D	25-33-40-50	3	£2	19	6	6/-
2A	4-16-24-32	12	£5	7	6	7/6
2B	4-16-24-32	8	£4	2	6	7/6
2C	4-16-24-32	4	£2	12	6	6/-
2D	4-16-24-32	2	£1	15	0	5/-
3A*	25-30-35	40	£12	15	0	15/-
3B*	25-30-35	20	£7	19	6	9/6
3C	25-30-35	10	£5	10	0	7/6
3D	25-30-35	5	£3	5	0	6/-
3E	25-30-35	2	£2	7	6	4/6
4A*	12-20-24	30	£9	15	0	10/-
4B	12-20-24	20	£5	19	6	9/6
4C	12-20-24	10	£3	19	6	7/6
4D	12-20-24	5	£2	15	0	6/-
5A	3-12-18	30	£7	5	0	7/6
5B	3-12-18	20	£5	9	6	7/6
5C	3-12-18	10	£3	5	0	6/-
5D	3-12-18	5	£2	5	0	5/-
6A	48-56-60	2	£2	17	6	4/6
6B	48-56-60	1	£1	19	6	4/6
7A*	6-12	50	£7	15	0	9/6
7B	6-12	20	£4	10	0	7/6
7C	6-12	10	£2	19	6	6/6
7D	6-12	5	£2	2	6	5/-
9A	15-30	1½	£2	19	6	4/6
10A	1-15	2	£1	19	6	4/6
11A	6-3	15	£1	17	6	5/6

Note: By using the Intermediate Taps many other voltages can be obtained. Example:

Range One 7-8-10-15-17-25-33-40-50 v.
Range Two 4-8-12-16-20-24-32 v.
Range Five 3-6-9-12-15-18 v.

SMITH'S 4 MINUTE TIMERS

Switch contacts 15 amp. 250 v. A.C., complete with chrome bezel and control knob. Min. operation time, 30 seconds, max. 4 minutes, brand new 17/6, p.p. 2/6.

Why

NOT BUILD ONE OF OUR PORTABLE TRANSISTOR RADIOS...

FIRST FOR PERFORMANCE, QUALITY & PRICE!

BACKED BY OUR SUPER AFTER SALES SERVICE

"A wonderful range of transistor radios using first grade components guaranteed results."

NEW ROAMER SEVEN Mk IV

7 WAVEBAND PORTABLE OR CAR RADIO

Amazing performance and specification

★ Now with PHILCO MICRO-ALLOY R.F. TRANSISTORS

FULLY TUNABLE ON ALL WAVEBANDS

● 9 stages—7 transistors and 2 diodes

Covers Medium and Long Waves, Trawler Band and three Short Waves to approx. 15 metres. Push-pull output for room filling volume from rich toned 7" x 4" speaker. Air spaced ganged tuning condenser. Ferrite rod aerial for M & L Waves and telescopic aerial for S Waves. Real leather-look case with gilt trim and hand straps. Size 9" x 7" x 4" approx.

The perfect portable and the ideal car radio. (Uses PP7 batteries, available anywhere.)

★ EXTRA BAND FOR EASIER TUNING OF LUXEMBOURG, etc.

Total cost of parts now only **£5.19.6** P. & P. 5/6

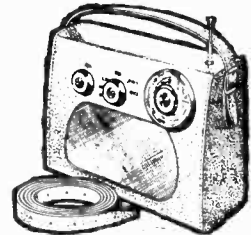

Parts Price List and easy build plans 3/- (Free with kit)

NEW MELODY MAKER SIX

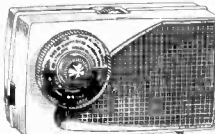

This amazing receiver may be built for only

£3.9.6

P. & P. 3/6

Parts Price List and easy build plans 2/- (Free with kit)

● 8 stages—6 transistors and 2 diodes
Covers Medium and Long Waves and Extra Band for EASIER tuning of LUXEMBOURG, etc. Top grade 3in. Loudspeaker for quality output. Two R.F. stages for extra boost. High 'Q' 6in. Ferrite Rod Aerial. Approx. 350 Milliwatts push pull output. Handsome pocket size case with gilt fittings. Size 6½ x 3½ x 1½in. (Takes long-life PP6 battery).

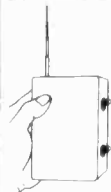

QUICK CHECK TRANSISTOR TESTER.

Checks gain of R.F. and Audio Transistors. Also checks for noise level and dials. All parts ready to be assembled in attractive grey case with red grille, complete with Dial, Knobs, and Dynamic Speaker. Simple assembly instructions free with set of parts. **29/6** P. & P. 2/6.

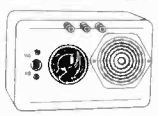

FAULT TRACER.

A versatile Signal Injector. Something no constructor should be without. This ingenious device generates an audible signal through the Audio and R.F. ranges. With variable output. Telescopic Probe. Pocket size slim line case measures 4½ x 3½ x ¾in. Complete set of parts with full instructions. **19/6** P. & P. 2/-.

NOW WITH 3IN. SPEAKER! NEW TRANSONA FIVE

"Home, Light, A.F.N. Lux. all at good volume" G.P., Durham

● 7 stages—5 transistors and 2 diodes

Fully tunable over Medium and Long Waves. Incorporates Ferrite rod aerial, tuning condenser, volume control, new type fine tone super dynamic 3 in. speaker, etc. Attractive case. Size 6½ x 4½ x 1½in. with red speaker grille. (Uses 1289 battery available anywhere.)

Total cost of all parts now only

42/6

P. & P. 3/6

Parts Price List and easy build plans 2/- (Free with kit)

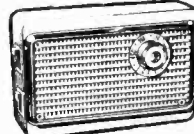

POCKET FIVE NOW WITH 3in. SPEAKER!

● 7 stages—5 transistors and 2 diodes.

Covers Medium and Long Waves. On test Home, Light, Luxembourg and many Continental stations were received loud and clear. Designed round supersensitive Ferrite Rod Aerial and fine tone 3 in. moving coil speaker, built into attractive black and gold case. Size 5½ x 1½ x 3½in. (Uses 1289 battery, available anywhere.)

● Extended M.W. band for easier tuning of Luxembourg etc.

Total cost of all parts now only **42/6**

P. & P. 3/6

Parts Price List and easy build plans 1/6 (FREE with Kit)



STOP PRESS!

Pocket 5 Med and Long wave version with miniature speaker

29/6

P. & P. 3/-

NEW ROAMER SIX

NOW WITH PHILCO MICRO-ALLOY R.F. TRANSISTORS

● 6 WAVEBAND!!

● 8 stages—6 transistors and 2 diodes

Listen to stations half a world away with this 6 waveband portable. Tunable on Medium and Long Waves, Trawler Band and two Short Waves.

Sensitive Ferrite rod aerial and telescopic aerial for short waves. Top grade transistors. 3-inch speaker, handsome case with gilt fittings. Size 7½ x 5½ x 1½in. (Carrying Strap 1/6 extra.)

★ EXTRA BAND FOR EASIER TUNING OF LUX, ETC.

Total cost of all parts now only **£3.19.6**

P. & P. 3/6

Parts Price List and easy build plans 2/- (Free with kit)

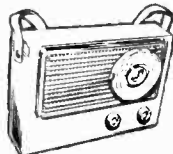

TRANSONA SIX

● 8 stages—6 transistors and 2 diodes

This is a top performance receiver covering full Medium and Long Waves. High-grade 3in. speaker makes listening a pleasure. Push-pull output. Ferrite rod aerial. Many stations listed in one evening including Luxembourg loud and clear. Attractive case in grey with red grille. Size 6½ x 4½ x 1½in. (Uses PP4 battery available anywhere.)

● Extended M.W. band for easier tuning of Luxembourg etc.

Total cost of all parts now only **59/6**

P. & P. 3/6

Parts Price List and easy build plans 1/6 (Free with kit)

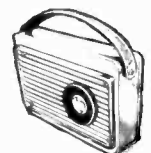

MELODY SIX

● 8 stages—6 transistors and 2 diodes

Our latest completely portable transistor radio covering Medium and Long Waves. Incorporates pre-tagged circuit board, 3in. heavy duty speaker, top grade transistors, volume control, tuning condenser, wave change slide switch, sensitive 6in. Ferrite rod aerial. Push-pull output. Wonderful

reception of B.B.C. Home and Light, 208 and many Continental stations. Handsome leather-look pocket size case, only 6½ x 3½ x 1½in. approx. with gilt speaker grille and supplied with hand and shoulder straps.

Total cost of all parts now only **£3.9.6**

P. & P. 3/6

Parts Price List and easy build plans 2/- (Free with kit)

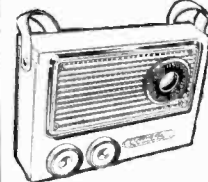
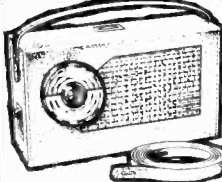

SUPER SEVEN

● 9 stages—7 transistors and 2 diodes

Covers Medium and Long Waves and Trawler Band. The ideal radio for home, car, or can be fitted with carrying strap for outdoor use. Completely portable—has built-in Ferrite rod aerial for wonderful reception. Special circuit incorporating 2 RF Stages, push-pull output, 3in. speaker (will drive large speaker). Size 7½ x 5½ x 1½in. (Uses 9v battery, available anywhere.)

Total cost of all parts now only **£3.19.6**

P. & P. 3/6

Parts Price List and easy build plans 2/- (Free with kit)

Callers side entrance
Barratts Shoe Shop.

RADIO EXCHANGE Ltd

Open 9—5 p.m.
Saturdays 9—12.30 p.m.

61a HIGH STREET, BEDFORD. Phone: 52367

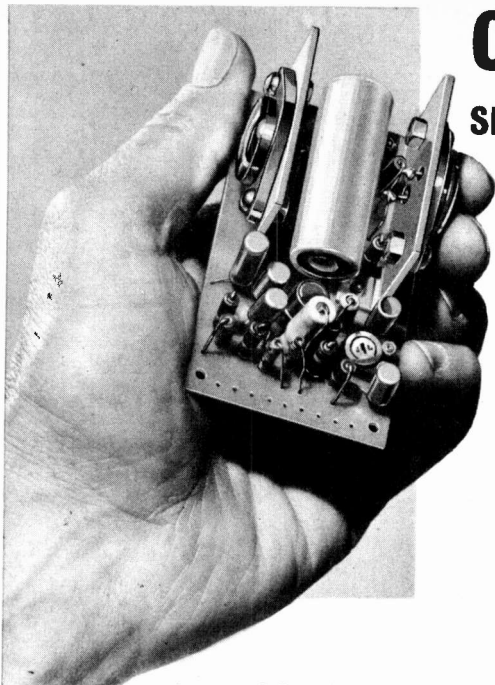

COMPACT, POWERFUL

SINCLAIR

Z.12

COMBINED
12 WATT HI-FI
AMPLIFIER
AND PRE-AMP

- ★ 12 WATTS R.M.S. OUTPUT CONTINUOUS SINE WAVE (24 WATTS PEAK)
- ★ 15 WATTS R.M.S. MUSIC POWER (30 WATTS PEAK)

There has never been an amplifier to touch the Z.12 for adaptability and compactness. It is the embodiment of power, efficiency and reliability. Nothing could be better than this fine unit for use with space-saving plinth-mounted motors and pick-ups. Equally, the light weight of the Z.12 makes it the ideal guitar amplifier, particularly since it operates efficiently on any power supply between 6 and 20 V. D.C. The pre-amp of this 8 transistor masterpiece accepts pick-up, radio and microphone outputs. Details for input matching, control and selector switching circuits are in the manual supplied with every Z.12.

TECHNICAL SPECIFICATION

The Z.12 measures only 3in. x 1½in. x 1½in. and weighs 3 ozs. 8 special transistors are employed in original circuitry developed by Sinclair Radionics. The unit, which includes its own pre-amp, is ruggedly built. Two are ideal in stereo. This versatile amplifier can be powered by batteries or the P.Z.3.

P.Z.3. Transistorised mains power unit. Will power two Z.12's and Stereo 25 with ease.

79/6

- 8 special transistors
- Ultra-linear class B output and generous neg. feedback
- Output suitable for 3, 7.5 and 15 ohm loads. Two 3 ohm speakers may be used in parallel
- Input—2mV into 2K ohms
- Signal to noise ratio—better than 60dB

Built, tested and guaranteed with manual of circuits.

89/6

SINCLAIR MICRO F.M

7 transistor
combined F.M.
tuner/receiver

Less than 3in. x 1½in. x ½in. F.M. Superhet uses pulse counting discriminator for superb audio quality. Low I.F. makes alignment unnecessary. Tunes 88-108 Mc/s. The telescopic aerial suffices for good reception in all but poorest areas. Signal to noise ratio—30dB at 30 microvolts. Takes standard 9v. battery. One outlet serves for feeding to amplifier or recorder, the other allows set to be used as a

pocket portable. Brushed and polished aluminium front, spun aluminium dial. A fascinating set to build which gives excellent reception by any standards.

Complete kit inc. aerial, case, earpiece and instructions

£5.19.6

FULL SERVICE FACILITIES AVAILABLE TO ALL SINCLAIR CUSTOMERS

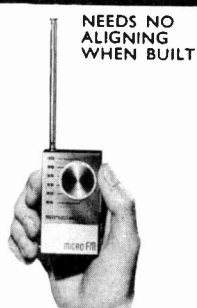

NEEDS NO
ALIGNING
WHEN BUILT



STEREO PRE-AMP AND CONTROL UNIT FOR TWO
Z.12's OR OTHER GOOD AMPLIFIER SYSTEMS

For use with two Z.12's or any hi-fi stereo system. Finest quality components are used in its construction, whilst the overall appearance of this compact de-luxe pre-amp and control unit reflects the professional elegance which characterises all Sinclair designs. The front panel is in solid brushed and polished aluminium with well styled solid aluminium knobs.

Frequency response 25 c/s to 30 kc/s ± 1dB connected to two Z.12's. Sensitivity Mic. 2mV into 50kΩ; P.U. —3mV into 50kΩ; Radio—20mV into 4.7kΩ. Equalisation correct to within ± 1dB on RIAA curve from 50 to 20,000 c/s. Size 6½in. x 2½in. x 2½in. plus knobs.

BUILT, TESTED
AND
GUARANTEED
£9.19.6

sinclair

SINCLAIR RADIONICS LTD., 22 Newmarket Rd., CAMBRIDGE
Telephone 52996 (STD Code OCA3)



The most remarkable letter we have so far received

P.O. Box 43, PAEKAKARIKI,
New Zealand,
27th February, 1967.

Thank you very much for the new Micromatic which arrived safely by Airmail. Our 13 year old son is highly delighted. On the first evening he logged several New Zealand stations. These included our one and only "pirate," Radio Hauraki, stationed in the Gulf of that name well over 400 miles north of here.

His biggest surprise was when 2CY, Canberra (10Kw) identified itself. Australia is more than 1,200 miles away!

I tested the receiver within half a mile of 2YA and 2ZB (just north of Wellington). Selectivity remained perfect. Neither station swamped the other and the customary nul was evident when the set's own ferrite aerial was end on to the transmitters.

In the metal coach of an electric train, the receiver functioned normally even under noise producing conditions.

You have produced a radio receiver which has no equal. Its design, size and performance are such that even you will not easily evolve a successor.

Arnold S. Long

The original of this and countless other letters which enthusiasts send us can always be seen at our Cambridge offices.

- 1 1/4" x 1 3/8" x 1/2"
- NEW SIX STAGE CIRCUITRY
- TUNES OVER M.W. WAVEBAND
- A.G.C.
- AMAZING POWER AND RANGE
- GUARANTEED 5 YEARS

SINCLAIR MICROMATIC

The smallest set in the world

This British made six-stage transistor receiver is a fully fledged radio with all the features essential to reliable listening. It is smaller than anything you have ever used before, yet it gives good choice of programmes anywhere, is selective, powerful, dependable. When, after two or three months or so, the batteries need replacing, new ones are easily obtainable from radio shops,

Boots Chemists, etc. Good listening works out to under a halfpenny an hour. Whether you buy the MICROMATIC in kit form or ready built, you will be the proud owner of a most elegantly styled set brimful of power and ready to keep you in touch with the world wherever you are—in modern town buildings, travelling, walking or anywhere else.



TECHNICAL DESCRIPTION

The Sinclair Micromatic is housed in a neat plastic case with aluminium front panel and spun aluminium calibrated tuning dial.

Special Sinclair transistors are used in a six-stage circuit of exceptional power and sensitivity—two stages of powerful R.F. amplification; double diode detector; a high gain three-stage audio amplifier. A.G.C. counteracts fading from distant stations. The set is powered by two Mallory ZM.312 Cells readily obtainable, for 1/7 each. Plugging in the earpiece switches the set on.

Kit comes complete in see-for yourself easy to check pack with instructions and solder.

MICROMATIC KIT PACK with earpiece, instructions, solder, etc.

59/6

Ready built, tested **79/6** and guaranteed.

GUARANTEE

Should you not be completely satisfied with your purchase when you receive it from us, your money will be refunded in full and at once without question.

FULL SERVICE FACILITIES AVAILABLE

If you prefer not to cut page, please quote PE.6 when ordering.

USE THIS ORDER FORM FOR PROMPT DELIVERY

To: SINCLAIR RADIONICS LTD., 22 NEWMARKET ROAD, CAMBRIDGE

Please send items detailed below:

.....

NAME.....

ADDRESS.....

.....

For which I enclose cash/cheque/money order

PE.6

RADIONIC

RADIO & ELECTRONIC CONSTRUCTION SYSTEM

ABSORBING AND EXCITING!

Unique and brilliantly simple. Hundreds of educational establishments—Universities, Technical Colleges, Schools, the Armed Forces—are already using Radionic for electronic instruction. Enthusiastic owners range from 9 to 82 years of age. Selected by the Council of Industrial Design for all British Design Centres. Featured in Sound and Television broadcasts.

The system is beautifully engineered from top quality British components. No soldering. No mains. No prior knowledge needed. Simply arrange components on perforated transparent panel, position brass connecting strip underneath, fix with 6BA nuts and circuit works with full efficiency. You can then dismantle and build another circuit. Your results are guaranteed by our Technical Department and News Letter Service. All parts available separately for conversion or expansion of sets.

UNIQUE! Our "No soldering" printed circuit board for superhet portable. Simply insert components and tighten nuts.
 No. 1 Set £5.18.6. 14 Circuits (Earphone)
 No. 2 Set £6.19.6. 20 Circuits (Earphone)
 No. 3 Set £10.19.6. 22 Circuits (7 x 4in. Loudspeaker output)
 No. 4 Set £14.19.6. 26 Circuits (include 6 Transistor and reflex superhets)
 Prices (Post Free)
 (PLUS: P.T. Surcharge of 1/8d; 1/11d; 3/1d; 4/2d, respectively.)

Full details from:

RADIONIC PRODUCTS LIMITED
STEPHENSON WAY, THREE BRIDGES
CRAWLEY, SUSSEX

Tel.: CRAWLEY 27028

Trade Enquiries Invited

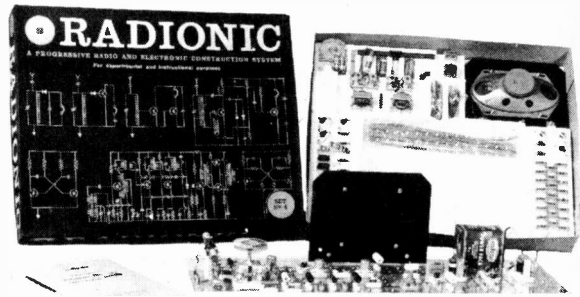

A No. 4 SET and 6-TRANSISTOR SUPERHET

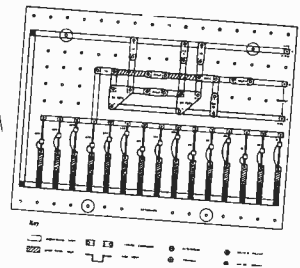
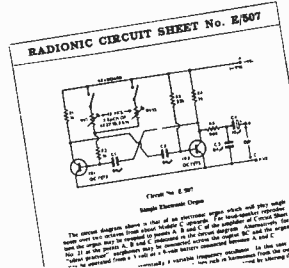

Theoretical Circuit

Practical Layout

Our 'E' Series of basic electronic circuits is available separately. Send for details of E/508, our do-it-yourself computer.

the Wyndors Vanguard...
 the most versatile recorder at its price*
 offering so many outstanding features...

- 4 track-3 speeds — 7 in. spools
- Separate Record and replay amplifiers
- Double play
- Sound-on-Sound
- Detachable lid fitted 8" speaker
- Tape Monitoring facility



- Push button controls
- Recording meter and Playback indicator
- Straight through amplifier facility
- Bass, treble, volume and record gain controls
- Many other features

* All British and full value for money at only 59 gns. inc. 1800 ft. LP tape and Tape manual. (less mike).

Before you buy an ordinary tape recorder write for full details of the Vanguard and other models.

WYNDORS RECORDING CO. LTD. (Dept. PE5)
 Wyndors Works, Bellevue Road, Friern Barnet, London, N.11. ENT. 2226

TWO-YEAR GUARANTEE EX-RENTAL TELEVISIONS

17 in. £11.10.0
 3 star Guarantee

★ Tube

★ Valves

★ Components

Channels for all areas
 Insured Carriage 30/-

FREE ILLUSTRATED LIST

Slim line models
 17" — 19" — 21" — 23"
 A wide range of sizes, models and prices.

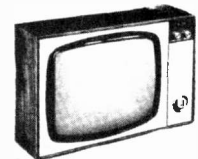

Demonstrations daily

RADIOGRAM CABINETS 19 Gns.

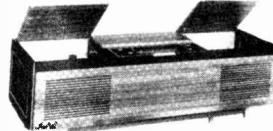

An elegant Stereogram Cabinet in modern Veneered Mahogany and Cloth covered Front Panel
BLACK LEATHERETTE SIDE PANELS
 Dimensions: 52 x 17½ x 12"
 Speaker positions for Twin 10" x 5" Speakers
 OTHER MODELS—SEND FOR LIST



TRANSISTOR CASES
 7/6, 9½" x 6½" x 4½"
 P. & P. 3/6.

TRANSISTOR CASES
 19/6. Cloth covered, many colours. Size 9½" x 6½" x 3½"
 P. & P. 3/6. Similar case in plastic 7/6.



RECORD PLAYER CABINETS 49/6.
 Latest designed covered cabinets. Take any modern Autochanger. P. & P. 7/6.
 SINGLE PLAYER CABINETS 19/6.
 P. & P. 7/6.



T.V. TURRET TUNERS
 2/6.

New Less Valves. Slim Models 5/- Press Button Models 19/6. P. & P. 2/6.

DUKE & CO. (LONDON) LTD.
 621/3 Romford Road, Manor Park, E.12
 Phone: ILFord 600-1-2-3. Stamp for Free List.

HEATHKIT WORLD-FAMOUS ELECTRONIC EQUIPMENT

The Hi-Fi, Radio, Amateur Gear, Test Instruments *anyone* can build

Treat yourself to superb LW, MW entertainment with the
High-Performance Car Radio Kit, CR-1



Complete your motoring pleasure with this small, compact, high-performance car radio. It can be fitted to any make of car having 12 volt positive or negative earth system. Tastefully styled in neutral grey with matching black knobs and chrome trim to harmonise with any car colour scheme.

Features include: Six-transistor, 2-diode circuit. Completely pre-assembled and aligned tuning unit. High sensitivity, combined with wide range automatic gain control (AGC), minimises fading under weak reception conditions. Easy-tune dial. Push button Long, Medium and Tone selection.

The car radio is available for your convenience, in two separate units; RF Amplifier Kit CR-1T £1 . 13 . 6 incl. P.T., IF/AF Amplifier Kit CR-1A £11 . 3 . 6.

TOTAL PRICE KIT (excluding Loudspeaker) £12 . 17 . 0 incl. P.T.
8" x 5" Loudspeaker Pt. No. 401-505 £1 . 16 . 1 incl. P.T.

The Transistor Amplifier you have been looking for!



Low-cost Stereo Amplifier Kit, TS-23
Breaks the price barrier in quality
Transistor Amplifier cost

Incorporates all the essential features for good quality reproduction from gramophone records, radio and other sources.

Its many features include: 3 watts rms (15Ω) each channel. Good frequency response for outstanding fidelity. Compact slim-line styling. Ganged BASS, TREBLE and VOL. controls, 6-position SELECTOR switch for programme sources. Attractive perspex two-tone front panel. 16 transistor, 4 diode circuit. Handsome fully-finished walnut veneered cabinet. Outputs for 8 or

15 ohm loudspeakers. Printed circuit boards. For free-standing or cabinet mounting.
Size 3 7/8" x 13" x 8" deep.

PRICES: Amplifier Kit £17 . 15 . 0
Amplifier Kit and Cabinet £18 . 19 . 0

Walnut Veneered Cabinet
separate £2 . 0 . 0

Hi-Fi performance from a "Mini"

Speaker Kit
with the
"AVON"
BOOKSHELF
SPEAKER
SYSTEM

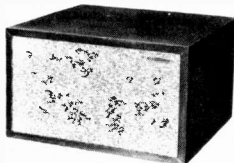

The challenge to our acoustic engineers was to design a speaker occupying the minimum space consistent with first class reproduction. The results of our efforts was this "AVON" compact unit of exceptional quality.

Features: Two special speakers 6 1/2" BASS, 3 3/8" HF unit and crossover network. Good frequency response. Beautiful fully-finished walnut veneered cabinet, size only 7 1/4" x 13 1/4" x 8 3/8" deep.

Supplied in two units. Can be built for a total price.

Kit £13 . 16 . 0 incl. P.T.

A 3" Service Oscilloscope Kit with outstanding features. Model OS-2

The attractively styled OS-2 is a compact, lightweight, portable oscilloscope that fulfills many of the general requirements in Laboratories, Service Departments and Educational Training. It is ideal for use in production line testing where otherwise expensive equipment would be tied up on ordinary routine tests. The bandwidth of the OS-2 is from 2 c/s-3 Mc/s ± 3dB, this 'scope can therefore be used in applications ranging through audio, ultrasonic and radio frequencies. The time base operates from 20 c/s to 200 kc/s in four ranges. Size 5" x 7 1/4" x 12" deep. Weight 9 1/4 lb.



Kit £23 . 18 . 0. Assembled £31 . 18 . 0
Optional extra L/Cap Probe Kit, PK-1 Kit £3 . 12 . 6

Many other models in wide range.

Prices quoted are Mail Order, Retail Prices slightly higher.

Full specification sheets of any model available upon request.

HEATHKIT



FREE!

32 page Catalogue
SEND COUPON FOR
YOUR COPY NOW!

Over 150 models: Hi-Fi, Audio Speaker systems, Intercom, PA Guitar amplifiers, Amateur Radio, Educational, Transistor radios, Test and service instruments. Many shown in full colour.

To:—
DAYSTROM LTD., Dept. P.E.6
GLOUCESTER, ENGLAND. Tel.: Glos. 20217

Please send me
FREE British Heathkit Catalogue

further details of model(s)

NAME

ADDRESS

MOST MODELS CAN BE SEEN AND DEMONSTRATED AT THE LONDON HEATHKIT CENTRE. 233 Tottenham Court Road, W.1 Tel: 01-636 7349.
Retail and Mail Order purchase can be made there.

FULLY GUARANTEED INDIVIDUALLY PACKED VALVES

AC/HL 4/8	EBC41 8/8	EL37 10/-
AC/PA 6/-	EBC80 5/-	EL38 17/8
AC/SPEN 5/-	EBF80 6/8	EL41 8/-
AL60 5/-	EBF83 7/8	EL43 8/-
AR8 5/-	EBF89 6/8	EL50 8/-
AR/3 3/-	EEL31 20/-	EL81 8/-
AR/12 2/8	EC92 4/-	EL83 6/3
AR/P24 10/-	EC53 12/8	EL84 4/3
ART4 2/3	EC70 4/-	EL85 7/8
AT/P 5/8	EC90 4/-	EL91 4/8
AU7 55/-	EC91 4/-	EL95 6/8
AZ31 9/-	ECC81 4/-	EM80 6/-
B6H 15/-	ECC82 5/-	EM81 7/-
BD78 40/-	ECC83 6/-	EM84 6/3
BL63 10/-	ECC84 5/8	EN31 10/-
B84 8/-	ECC85 6/8	ESU74 80/-
B88 20/-	ECC86 6/-	ESU208 6/-
B88A 47/8	ECC189 9/8	EY51 5/8
B2134 16/8	ECF80 7/-	EY86 6/8
CC3L 2/-	ECF82 7/-	EY91 3/-
CF23 10/8	ECH42 9/-	EZ40 6/8
CL3 9/8	ECH81 5/-	EZ41 6/8
CY31 6/8	ECH83 7/8	EZ80 5/8
D1 1/8	ECL89 6/3	EZ81 4/8
D41 3/3	ECL83 10/-	F/6067 5/-
D61 6/8	ECL83 10/-	F/6061 5/-
D77 3/3	ECL86 9/-	F/6063 4/-
DA30 12/8	EF36 3/6	PW4/000 8/8
DA/F96 6/-	EF37A 7/-	PW4800 8/8
DD41 4/-	EF40 8/-	G1/236G29/-
DF3 5/8	EF41 6/-	G50/2G 5/-
DF91 3/-	EF42 6/-	G24 45/-
DF92 3/-	EF52 6/8	GZ32 10/-
DF96 6/8	EF63 4/6	GZ34 10/-
DE96 5/8	EF65 8/-	HK54 22/8
DL92 4/-	EF71 7/8	HL2K 2/6
DL93 4/-	EF72 5/8	HL23 6/8
DL94 5/8	EF73 5/8	HL23DD 5/-
DL96 7/8	EF74 2/-	HL41 4/-
DL10 8/-	EF80 5/-	HVR 8/2
DY86 7/8	EF85 4/6	K3A 30/-
E80F 23/-	EF86 6/8	KT32 8/8
E88CC 12/-	EF89 5/8	KT33C 6/8
E90CC 10/-	EF91 3/8	KT44 5/8
EA50 1/-	EF95 5/-	KT66 18/-
EA73 7/-	EF95 5/-	KT67 25/-
EABC80 5/8	EF183 6/8	KT71 5/8
EAC91 3/8	EF184 6/8	KT76 6/8
EAF42 8/-	EH90 7/8	KT88 22/-
EB34 1/8	EL32 3/8	KTW63 5/-
EB91 3/-	EL34 10/-	KTZ1 6/-
EBC33 6/-	EL35 5/-	KTZ63 6/-

MH4 5/-	S11E12 10/-	UF89 6/-	1D8GT 6/-	3V4 5/9	6AM5 2/6
ML6 6/-	SP1 8/8	UL41 7/8	1E7G 7/8	4C27 35/-	6AM6 4/-
N78 15/-	SP4 1/8	UL84 5/8	1F2 3/8	4D1 4/-	6A85 7/-
NE17 7/-	SP61 4/-	UU5 7/-	1G6GT 8/-	5A173G 5/-	6A85W 9/-
OA2 5/9	SP210 3/8	UU9 8/8	1L4 2/6	5A174G 5/-	6L5M 8/8
OB2 6/-	T41 12/6	UY21 7/8	1LA6 6/-	5B/251M 5/-	6L5G 7/8
OB3 7/-	TP22 5/-	UY85 5/8	1LC6 7/-	5B/253M 40/-	6L5A 3/8
OC3 5/-	TP23 15/-	VP23 3/8	1LH4 4/-	5B/255M 15/-	6L20 5/9
OC4 5/-	TT1 5/8	VP133 9/8	1N21 3/8	5B/254M 40/-	6L20 5/9
OZ4A 5/-	TT15 35/-	VR99 5/8	1N21B 5/-	5B/255M 40/-	6L20 5/9
PC86 9/-	TRR31 45/-	VR105/30 5/8	1N43 4/-	6A76 4/-	6L20 5/9
PC88 9/-	TZ20 16/-	U1 8/-	1N70 4/-	6A76 4/-	6L20 5/9
PC97 7/8	U81 8/-	VR150/36 5/8	1R4 5/-	6A76 4/-	6L20 5/9
PC900 12/-	U12/14 8/8	U15 9/-	1S4 5/-	6A76 4/-	6L20 5/9
PC984 5/6	U17 5/8	VU33A 4/-	1S4 5/-	6A76 4/-	6L20 5/9
PC989 10/-	U18 6/-	VU39 6/-	1T4 3/-	6A76 4/-	6L20 5/9
PC980 8/3	U25 13/-	VX3208 5/8	2A3 5/-	6A76 4/-	6L20 5/9
PCF82 6/8					
PCF84 6/8					
PCF86 8/-					
PCF802 9/6					
PCF805 11/-					
PCL81 9/-					
PCL82 7/8					
PCL83 5/8					
PCL84 7/-					
PCL85 8/8					
PEN25 4/8					
PKN46 3/-					
PFL200 17/8					
PL36 9/-					
PL38 16/-					
PL81 7/-					
PL82 6/8					
PL83 6/8					
PL84 6/8					
PL500 13/8					
PM24A 5/-					
PT15 13/-					
PT25H 7/8					
PT25M 7/8					
PN4 14/-					
PN23 12/8					
PY33 8/8					
PY80 8/8					
YR1 5/8					
YR2 5/8					
YR3 6/8					
YR4 7/8					
YR5 10/8					
YR6 12/8					
YR7 14/8					
YR8 16/8					
YR9 18/8					
YR10 20/8					
YR11 22/8					
YR12 24/8					
YR13 26/8					
YR14 28/8					
YR15 30/8					
YR16 32/8					
YR17 34/8					
YR18 36/8					
YR19 38/8					
YR20 40/8					

TRANSISTORS

OC16 20/-	OC81D 5/-	OC201 12/6	XC141 10/-
OC22 23/8	OC81M 5/-	OC202 13/8	XC142 15/-
OC25 9/6	OC82 10/-	OC203 10/8	XC155 20/-
OC35 12/8	OC82DM 5/-	OC204 17/6	XC156 22/8
OC44 5/-	OC83 5/-	OC206 22/6	2N247 9/6
OC45 6/-	OC83B 5/-	AZ12 6/-	2N412 7/8
OC71 4/6	OC122 5/-	AC126 7/6	2N502 47/-
OC72 5/-	OC127 5/-	AC128 7/6	2N585 10/8
OC73 9/-	OC170 6/-	BCZ11 7/8	2N1090 20/8
OC81 5/-	OC200 7/8	BY38 7/8	2N1091 28/-

U26 13/-	W21 5/-	2B26 8/-	5X4G 8/6
U27 8/-	W118 8/-	2C26 7/-	3Y3GT 5/-
U28 4/6	W119 8/-	2C26A 3/-	3Y3WCTB 6/-
U191 11/6	N66 7/8	2C34 7/-	9/-
OC25 9/6	OC82 10/-	2C45 22/8	5Z4G 6/6
UABC90 6/-	X118 8/-	2C46 20/-	6AB7 4/-
UAF42 9/-	X143 8/-	2C51 12/-	6AC7 3/-
UBC41 6/-	YF 1/-	2D21 5/-	6AG5 2/6
UBF80 5/6	Y63 5/-	2X2 3/-	6AG7 6/8
UBF89 6/6	Y65 4/-	3A4 4/-	6AH6 10/-
UBL21 10/-	Y66 8/-	3B7 5/-	6AJ7 3/-
UCC56 6/8	Z800U 20/-	3BZ4 9/-	6AK5 5/-
UCH42 8/-	Z801U 10/-	3D6 4/-	6AS6 6/-
UCH81 6/-	1A3 3/-	3E29 50/-	6AK7 6/-
UCL82 8/-	1A5GT 5/-	3Q4 6/-	6AK8 5/9
UCL83 9/-	1B22 30/-	3Q5GT 7/8	6AL5 7/-
UF41 8/8	1C5GT 6/-	384 4/-	6AL5W 7/-

P.G. RADIO LTD

170 GOLDHAWK ROAD, W.12
Shepherds Bush 946
Open 9-5.30 p.m. Thursday 9-1 p.m.

6AM5 2/6	6K8G 3/-	12AU7 5/-	60CD6G 27/8
6AM6 4/-	6K8GT 8/3	12AV6 5/8	60L6GT 8/-
6A85 7/-	6L5M 8/8	12AX7 6/-	53A 7/6
6A85W 9/-	6L5G 6/8	12AX7 10/-	67 6/-
6AS6 4/-	6L6A 7/8	12BA6 5/8	58 8/-
6AS6W 9/-	6L34 3/8	12BE6 7/8	59 6/8
6AS7G 15/-	6L34 3/8	12BH7 7/8	76 5/8
6AT6 4/-	6LD20 5/9	12C8 3/-	76 5/8
6AU6 6/8	6L20 5/9	12E6 2/7	77 6/8
6AX4 8/-	6N7G 5/9	12J5GT 2/8	78 5/-
6B4G 17/-	6P25 12/-	12J7GT 6/8	80 5/8
6B7 7/8	6R7 5/8	12K7GT 2/8	81 9/-
6BBG 2/8	6SA7 7/-	12L6M 10/-	82 8/-
6BA6 5/6	6S47GT 6/8	12Q7GT 3/3	84 8/-
6BA7 5/6	6SK7GT 4/-	12S4T 4/8	85A2 5/8
6BE6 4/8	6SK7 7/-	12SC7 4/7	307A 5/-
6BJ6 7/8	68C7GT 5/-	12S7G 3/3	313C 25/-
6BJ7 7/8	68F6GT 5/8	12SH7 3/3	350B 8/-
6BR7 9/-	68H7 3/8	12S7 5/-	367A 70/-
6BW6 7/8	68J7 5/8	12SK7 5/-	368A8 30/-
6BW7 10/-	68J7GT 5/8	12SN7GT5 9/8	393A 27/8
6C4 2/-	68J7V 6/8	12SR7 5/-	446A 8/8
6C5G 2/8	68K7 5/6	12T4 2/-	0080 22/8
6C5GT 6/-	68L7GT 5/6	14L7 7/-	6146 25/-
6C6 4/8	68N7 3/8	1A87 18/-	703A 30/8
6C6G 3/8	68Q7GT 6/-	15D2 6/-	705A 10/8
6C8 3/8	68R7 2/8	20F4 12/8	715B 80/-
6C8H 4/8	68S7 6/8	2N502 47/-	717A 3/8
6CL6 9/8	6V6GT 7/8	2BL6GT 6/8	74A 15/-
6CW4 12/-	6V6M 8/8	2Y5 6/-	757 18/-
6D6 3/8	6X4 3/6	2Z4G 6/8	801 6/-
6E5 6/8	6X5G 5/8	2Z5 7/8	803 22/8
6F5G 5/8	6X6GT 5/8	2Z6GT 8/8	807 8/-
6F5GT 5/9	6X6G 6/8	2D8T 6/-	808 8/-
6F6G 4/8	6X0L2 8/8	30 5/8	813 75/-
6F7 6/8	6Z4 5/8	30C15 9/8	815 35/-
6F7 6/8	7B7 7/8	30C19 11/8	820B 50/-
6F8G 6/8	7C5 10/-	30F5 8/8	832 16/-
6F12 4/6	7C6 7/8	30FL1 10/8	832A 45/-
6F13 5/8	7C7 6/8	30FL12 10/8	866A 14/-
6F13 5/8	7H7 7/8	30FL13 10/8	884 10/-
6F33 20/-	7Q7 7/8	30FL14 13/8	955 2/8
6G6G 6/8	7V7 5/8	30L15 15/8	955 4/8
6H6GT 1/9	7X4 8/8	30P12 9/8	986 2/8
6H6M 1/8	7Z4 4/8	30P19 13/8	987 5/-
6JAWA 10/-	8D2 2/6	30PL1 15/8	988A 4/-
6J5 6/8	9D2 3/8	30PL12 15/8	C.R. Tubes
6J6G 2/8	9D6 2/8	36L6GT 7/8	09J 75/-
6J9 3/8	10F9 9/8	35T 17/8	VCR97 40/-
6J9 3/8	12A6 2/8	35W4 5/8	VCR17 50/-
6J7G 5/8	12A7 5/8	35Z3 10/8	VCR517B5/-
6J7M 8/8	12AT6 5/8	35Z4GT 6/8	VCR517C80/-
6K6GT 5/8	12AT7 4/8	35Z5GT 6/8	3F7 45/-
6K7G 2/8	12AT7WA 3/8	37 4/8	5CP1 30/-
6K7GT 4/9	5/8	38 4/8	5FP7 12/8

MANY OTHERS IN STOCK include Cathode Ray Tubes and Special Valves. U.K. Orders below £1 P. & P. 1/-; over £1, 2/-; over £3, P. & P. free. C.O.D. 2/6 extra. Overseas Postage extra at cost.

Keep those Contacts CLEAN

by using a

DIACROM SPATULA

The "Diacrom" is a metal spatula upon which diamond powder has been deposited by a special process. No deep scratches are possible because density is controlled and the polishing of the contacts is achieved by a gentle brushing motion. With coloured nylon handle for complete insulation and easy size identification.

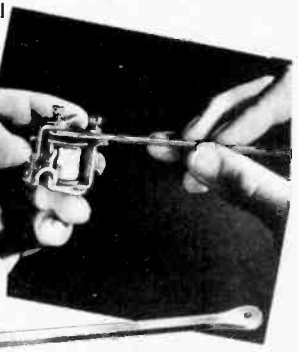

Manufactured in France
British Patents applied for

- Grain size 200, thickness 55/100 mm., both faces diamonded. For quick cleaning of industrial relays and switching equipment, etc.
- Grain size 300, thickness 55/100 mm., both faces diamonded. For smaller equipments, like telephone relays, computer relays, etc.
- Grain size 400, thickness 25/100 mm., one face diamonded. For sensitive relays and tiny contacts. Two close contacts facing each other can be individually cleaned, because only one face of the spatula is abrasive.

Sole Distributors for the United Kingdom
SPECIAL PRODUCTS (DISTRIBUTORS) LTD.
81 Piccadilly, London, W.1. Phone: (01) 629 9556

As supplied to the War Office, U.K.A.E.A., Electricity Generating Boards, British Railways and other public authorities; also to leading electronic and industrial users throughout the United Kingdom.

The most accurate
pocket size
CALCULATOR
in the world

The 66 inch OTIS KING scales give you extra accuracy. Write today for free booklet, or send 75/- for this invaluable spiral slide rule on approval with money back guarantee if not satisfied.

CARBIC LTD. (Dept. PE11)
54 Dundonald Road, London, S.W.19



FREE
BOOKLET ON
REQUEST

BUILD YOUR CIRCUITS on VEROBOARD

—the Universal Wiring Board—
obtainable from your local Retailer

Trade enquiries to:
NORMAN ROSE (ELECTRICAL) LTD.
8 St. Chad's Place, Gray's Inn Road, London, W.C.1

Technical enquiries to:
VERO ELECTRONICS LTD.
Industrial Estate, Chandler's Ford, Hants

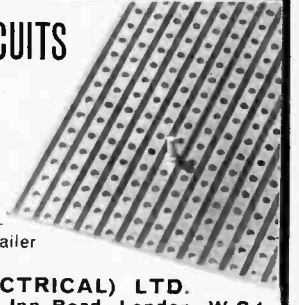

NEW BARGAINS

MOVING COIL METER. 2 1/2 in. flush mounting 5-0-5mA centre zero. 25/- each.

MOVING COIL METER. 2 1/2 in. flush mounting 250-0-250 micro amps. centre zero. 29/6 each.

50 OHM 50 WATT WIRE WOUND POT-METER. 8/6 each.

20K WIRE WOUND POT-METER. 20 watt type made by Colven complete with control knob. 10/- each.

1 MEG MINIATURE. Pot-meter Morganite standard. 1/2 in. spindle 1/- each, 9/- per dozen.

1 MEG MINIATURE. Pot-meter Morganite pre-set screw-driver control. 8d. each, 8/- per doz.

PRE-SET 100K by Welwyn with intricate bakelite knob 1/- each, 9/- per dozen.

100K POT-METER. Miniature type with double pole switch and standard 1/2 in. spindle, by Morganite. 2/- each. 18/- per dozen.

25K POT-METER. Standard size with double pole switch by Egan with full length 1/2 in. spindle. 3/- each. 26/- per dozen.

BLANKETSTAT GLASS. Enclosed, normally closed circuit, will open should blanket overheat. 4/6 each.

THERMAL RELAY. Can be used to delay the supply of HT while heaters warm up, or will enable 10 amp. loads to be controlled by miniature switches or relays. Regular list price over £2, price 7/6 each.

SIEMENS HIGH SPEED RELAY. Twin 1000 ohm coils. Platinum points changeover contacts — Ex equipment, 8/6 each.

ELECTROLYTIC CONDENSER. 500MF, 50 v. working, 2/6 each. 24/- per dozen.

FOOTSWITCH. Two snap-action switches in metal box with flex lead and control tape-recorder, dark room lamps, etc., 18/6, plus 2/9 postage and insurance.

TOGGLE SWITCH BARGAIN. 10 amp. 250 v. normal one hole fitting. 2/9 each, or 30/- per doz.

ELECTRIC LOCK. 24 v. coil, but rewinding to other voltages, 4/8 each.

COMPRESSION CAPACITORS. Twin 100 pF. 1/- each. 9/- per dozen.

MINIATURE RELAY. American make. 630 ohm coil. 20/30 volt operation. 2 pole changeover. 3/- each. 30/- per dozen.

PRECISION WHEATSTONE BRIDGE. Opportunity to build cheaply. 100K wire wound pot. 15 v. rating, only 5/6.

SHEET PAKOLIN. Ideal for transistor projects. 12 panels each 5in. x 8in. 5/-.

3in. PM LOUDSPEAKER. 3 ohm, 12/8, 80 ohm, 13/8.

TRANSISTOR FERRITE SLAB AERIAL with medium and long wave coils, 7/6 each.

SLIDE SWITCH. Sub miniature double pole changeover. 2/- each. 18/- per dozen.

MAGSLIPS (Selsyns). American made repeater motors for transmitter and receiver. 27/6 each, post 4/6 for any one of the pair.

Vacuum Cleaner Flex. Non-kinkable ribbed rubber, most pliable but very tough. 24/36 Cores. Normally 1/9 per yard, offered at 23 per 100 yard coil, post and insurance 8/6.

Sub-Miniature Silicon Diodes. General purpose type with gold-plated, leads, 10/- per doz.

MINIATURE WAFER SWITCHES

	Number of Positions			
	2	3	4	12
1 pole.....	3/6	3/6	3/6	3/6
2 pole.....	3/6	3/6	3/6	3/6
3 pole.....	3/6	3/6	3/6	3/6
4 pole.....	3/6	3/6		

Any 12 switches ordered together 40/-

SEMI-CONDUCTOR BARGAINS

Type	No.	Price	Type	No.	Price	Type	No.	Price
2N1727	15/-	MAT101	8/6	OC71	3/6			
2N1728	10/-	MAT120	7/6	OC72	5/-			
2N1742	25/-	MAT121	8/6	OC75	6/-			
2N1747	25/-	OA5	5/-	OC76	5/-			
2N1748	10/-	OA10	6/-	OC77	7/-			
AC107	8/6	OA47	3/-	OC78	5/-			
AC127	9/-	OA78	2/-	OC78D	5/-			
AC17	8/6	OA79	2/6	OC81	5/-			
AC18	8/6	OA81	2/6	OC81D	5/-			
AC19	8/6	OA85	2/6	OC82	5/-			
AC20	5/6	OA90	2/6	OC83	5/-			
AC21	6/6	OA91	2/6	OC84	6/-			
AC22	4/6	OA200	3/3	OC139	8/6			
AF114	4/6	OA202	3/3	OC140	12/6			
AF115	6/6	OC22	10/-	OC170	5/-			
AF116	7/-	OC23	17/6	OC171	6/-			
AF117	5/-	OC24	15/-	OC200	9/-			
AF118	10/-	OC26	7/6	OC201	12/6			
AF139	12/6	OC28	15/-	OC202	12/6			
AF186	17/6	OC29	17/6	OC203	12/6			
AF212	15/-	OC35	12/6	OC271	15/-			
AS221	15/-	OC36	15/-	ORP12	8/6			
BC107	14/6	OC42	6/6	ORP60	5/-			
BY100	4/8	OC44	4/-	8B078	6/6			
BY213	7/8	OC45	3/6	8B305	8/6			
MAT100	7/9	OC70	4/-	8D251	10/-			

SILICON RECTIFIERS

Tested and guaranteed

750mA	100v.	1/3	1 Amp.	100v.	3/-
	200v.	1/6		200v.	4/-
	400v.	3/6		400v.	6/-
	100v.	3/6		10 Amp.	9/6
3A	200v.	5/-	200v.	12/6	
	400v.	7/8	400v.	14/6	
	600v.	9/8			

Sub-miniature glass encased—only approx. 1/2 in. long wire ends.

750mA	50v.	1/6	100v.	2/6
	200v.	4/6		

CASSETTE LOADED DICTATING MACHINE

Battery operated and with all accessories. Really fantastic offer a British made £31 outfit for only £6/19/6 brilliantly designed for speed and efficiency—cassette takes normal spools drops in and out for easy loading—all normal functions—accessories include:—stethoscopic earpiece—crystal microphone has on/off switch—telephone pick-up—tape reference pad—DON'T MISS THIS UNREPEATABLE OFFER—SEND TODAY £6/19/6 plus 7/6 post and ins. Footswitch 18/6 extra. Spare Cassettes at 7/6 each, three for £1.

NOUGHTS AND CROSSES MACHINE. This machine, described in Sept. '65, is impossible to beat and will provide endless fun at home and considerable attraction (and profit) at charity do's and fetes, etc. It employs 19 switches and 9 bulbs and these and the other components necessary to make this are available. Price £4/10/-, post and insurance. 3/6.



DRILL CONTROLLER

Correct drill speed electronically without loss of power. Complete kit, case, thyristor, rectifiers, wire wound pot, etc. Only 19/6. P. & P. 2/6.

TWO NEW KITS

Multipurpose Audio Switch, 5 transistors and all other components to make this ingenious unit described in last month's issue — only 48/6, plus 2/9 post and insurance.

Analog Computer, all parts including centre zero galvanometer, perspex cursor—8in. dials, to make the unit described in last month's issue. Available at 39/8, plus 2/9 post and insurance.

THIS MONTH'S SNIP

The SRP12 Battery Operated record deck. Made by Garrard unit of proved reliability, ideal if you intend making a portable player. Operates from P.P.9 or similar battery, runs at 33 or 45 R.P.M. Supplied complete with ceramic cartridge, suitable stereo or mono. Limited quantity. Price £3/7/6 plus 6/- post and insurance.

F.M. TUNER

of exceptional quality, giving really fantastic results with virtually no noise. Suitable for mains or battery operation. 6 transistors—three IF stages—double tuned discriminator. Complete, new, and built up all ready to work on chassis. Size 6 4 x 2in. with tuning coil and slow motion drive. A £12/12/- tuner for only £8/10/-.

SOLID STATE IGNITION

Big things are claimed of Electronic ignition systems and if you would like to try for yourself a circuit was described in "Practical Electronics" (Sept., 1966). This requires a silicon controlled rectifier, four transistors and other components available as a kit. Price £6/15/- post free.

OZONE AIR CONDITIONER

For removing smells and generally improving oppressive atmosphere. In neat hammer finish box. Uses Philips ozone lamp and mains unit. Lamp easily replaceable. Only 39/8 plus 6/6 curr. and insurance.

750 mW TRANSISTOR AMPLIFIER

4 transistors including two in push-pull input for crystal or magnetic microphone or pick-up—feedback loops—sensitivity 5 mV. Price 19/6. Post and insurance 2/6. Speakers 3in. 12/6, 5in. 13/6, 6in. 14/6.

CIRCULAR FLUORESCENT

Brings sunshine into your home. 150 watts of light but uses only 40 w. Beautiful fittings with glass, non-plastic centre, fluorescent tube and choke control. Made by Philips. Regular price £4/15/-. Special budget price 69/6 plus 8/6 c. and ins. Please state colour of glass centre, white, pink, blue, red, black, yellow or cream. Also whether plug into lamp holder or metal (normal start), 99/6. 10/- carriage & insurance.

NOW INSTANT START

ELECTRONICS (CROYDON) LIMITED
(Dept. PE), 102/3 TAMWORTH RD., CROYDON, SURREY (Opp. W. Croydon Stn.)
also at 266 LONDON ROAD, CROYDON, SURREY

MAINS TRANSISTOR POWER PACK

Designed to operate transistor sets and amplifiers. Adjustable output 6 v., 9 v., 12 volts for up to 300 mA. (class B working). Takes the place of any of the following batteries: PP1, PP3, PP4, PP6, PP7, PP9, and others. Kit comprises: mains transformer-rectifier, smoothing and load resistor, 5,000 and 500 mfd. condensers. Zener diode and instructions. Real snip at only 14/8, plus 3/6 postage.

9 VOLT PRECISION MOTOR

Intended for driving battery operated tape recorders and record players. Laminated, 6 Pole armature with Brush Gear and rapid start switch. Normally 25/- Our Price 7/6, plus post and insur. 1/6.

SIMPLE RECEIVER FOR LOW VOLTAGE

A TRF transistor set powered from the Sun or a 1 1/2 v. cell. Suitable for children or others who forget to switch off. 4 N.P.N. silicon transistor diode and all other components necessary to build this circuit described in "Wireless World," Oct., are available as a kit. Price 19/6, plus 2/6 post and insurance.

PHOTO-ELECTRIC KIT

All parts to make light operated switch/burglar alarm/counter, etc. Kit comprises printed circuit, Laminated Boards and chemicals, Latching relay, Infra-red sensitive Photo-cell and Hood. 2 Transistors, cond., Terminal block, Plastic case. Essential data, circuits and P.C. chassis plans of 10 photo-electric devices including auto-car parking light, modulated light alarm. Simple invisible ray switch—counter—stray light alarm—warbling tone electronic alarm—projector lamp stabiliser, etc., Only 39/8, plus 2/- post and insur.

HI-FI SPEAKER BARGAIN

12in. High fidelity loudspeaker. High flux permanent magnet type with either 3 or 15 ohm speech coil. Will handle up to 10 watts. 1" and new by famous maker Price 29/8. With built-in tweeter 35/-, plug 3/6 post and insurance.

Multi Purpose Neon Test Unit

Robust, useful and instructive—tests insulation—capacity—continuity—resistor—volume controls—also acts as signal injector and L.T. fault finder —kit comprises neon indicator—4-way water switch—ebonite tubes—resistors—condensers—terminals, etc., with diagram only 9/6, plus 2/- post and insurance.

PP3 Eliminator—play your pocket radio from the mains! Save £s. Complete component kit comprises 4 rectifiers—mains dropper resistances, smoothing condenser and instructions. Only 6/8, plus 1/- post.

SNIPSCOPE

Famous war-time "cat's eye" used for seeing in the dark this is an infra-red image converter cell with a silver caesium screen which lights up (like a cathode ray tube) when the electrons released by the infra-red strike it. A golden opportunity for some interesting experiments, 7/6 each, post 2/- Data will be supplied with cells, if requested.

HALF PRICE OFFER

G.E.C. 13A SWITCHED SOCKETS
Suitable for ring mains, etc., like the modern fused plug surface or gunk (flush) mounting type, 4/8 ea. 54/- doz.

12 V. INVERTER

Fully transistorised for operating a 20-watt fluorescent tube or other 20-watt mains device. Size 6in. long by 1 1/2 in. £3/10/-. Post and insurance. 3/-.

WATERPROOF HEATING ELEMENT

26 yards length 70 W. Self-regulating temperature control, 10/- post free.

Where postage is not definitely stated as an extra then orders over £3 are post free. Below £3 add 2/9. Sem-conductors orders over £1 post free, otherwise add 1/- for post.

CURRENTLY FITTED TO OVER 100 MODELS BY MAJOR MANUFACTURERS

BRING YOUR RECORD PLAYER UP TO DATE WITH

Sonotone TGL

HIGH FIDELITY STEREOHONIC CERAMIC CARTRIDGES

Sonotone 9TA SERIES. Superior quality cartridges offering extremely high compliance for a cartridge with dual styli. Tracking weights as low as 1-3 gm. allow reproduction from heavy modulated records without distortion on most changers. Standard $\frac{1}{2}$ " fixing centres. Prices: Sapphire £2.18.10. Tax paid. Diamond £3.16.7. Tax paid. Other types available. send for leaflet.

metrosound

metrosound manufacturing co. ltd.
bridge works, wallace road,
london, n.1. can 8641/2/3

BAKER 12 in. DE-LUXE Mk II LOUDSPEAKER

Now with high efficiency tweeter cone

Especially designed to provide full range reproduction at an economical cost. Suitable for use with all high fidelity systems.

Maximum Power	15 watts	Available from all Radio & Hi-Fi Dealers
Bass Resonance	32-38 c.p.s.	
Flux Density	14,000 gauss	£9 Post Free
Voice coil diameter	1 1/2"	
Voice coil impedance	15 ohms	Send for New catalogue and enclosure plans
Voice coil material	Copper	
Useful response	25-16,000 c.p.s.	
Cone surround	Plastic	
Chassis material	Alcomax	
Overall diameter	12 1/2"	

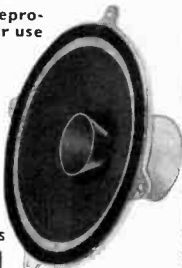

Baker Reproducers Ltd.

(DEPT. P.E.18)

Bensham Manor Road Passage, Thornton Heath, Surrey. THO 1665

ELECTRONICS GALORE! IN THE NEW dca CATALOGUE

THE CONVENIENT WAY TO SHOP FOR ALL YOUR ELECTRONIC NEEDS.

EVERYTHING FROM SINGLE COMPONENTS TO COMPLETE EQUIPMENT ALL AT BEST VALUE PRICES.

SEND 1/6d. NOW FOR YOUR COPY TO Dept. PE/7

dca ELECTRONICS LIMITED
28 UXBRIDGE ROAD, EALING, W.5

YOURS FREE FOR 7 DAYS

The New 'Picture - Book' way of learning

BASIC

ELECTRICITY (5 Vols)
ELECTRONICS (6 Vols)
ELECTRONIC CIRCUITS (2 Vols)
INDUSTRIAL ELECTRICITY (2 Vols)
SYNCHROS & SERVOMECHANISMS (2 Vols)

You'll find it easy to learn with this outstandingly successful new pictorial method—the essential facts are explained in the simplest language, one at a time; and each is illustrated by an accurate cartoon-type drawing.

The books are based on the latest research into simplified learning techniques. This has proved that the Pictorial Approach to learning is the quickest and soundest way of gaining mastery over these subjects.

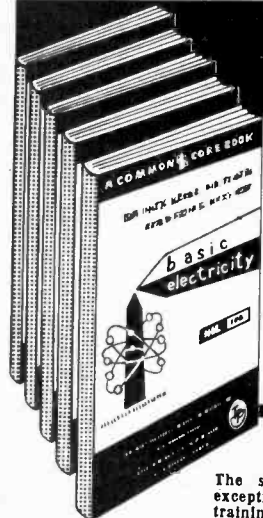

The series will be of exceptional value in training mechanics and technicians in electricity, Radio and Electronics.

WHAT THIS MONTH'S ENTHUSIASTIC READERS SAY

Their appeal is in their simplicity ... E.P., BASINGSTOKE

... An ordinary person like me can soon acquire a first rate understanding of the subject ... C.B., MAIDSTONE

... The technique of learning is such that anyone can become proficient in basic theory ... L.O., BIRCHINGTON

TO SELRAY BOOK CO.
60 HAYES HILL, HAYES, BROMLEY, KENT

Please send me Without Obligation to Purchase, one of the above sets on 7 Days Free Trial. I will either return set, carriage paid, in good condition within 7 days or send the following amounts. Basic Electricity 70/- Cash price or Down Payment of 15/- followed by 4 fortnightly payments of 15/- each. Basic Electronics 82/- Cash Price or Down Payment of 15/- followed by 5 fortnightly payments of 15/- each. This offer applies to U.K. only. Overseas customers cash with order.

Tick set required (only ONE set allowed on free trial)

BASIC ELECTRICITY 70/- BASIC ELECTRONICS 82/-
BASIC ELECTRONIC CIRCUITS 40/-
BASIC INDUSTRIAL ELECTRICITY 40/-
BASIC SYNCHROS & SERVOMECHANISMS 38/-
ALL PRICES INCLUDE POSTAGE

PE 6

Signature (If under 21, signature of parent or guardian)

NAME
FULL POSTAL ADDRESS BLOCK LETTERS BELOW

POST NOW FOR THIS OFFER!

MARCONI TEST EQUIPMENT

TF1440 STANDARD SIGNAL GENERATOR. 85 Kc/s-25 Mc/s. 200/250 v. A.C. £25. Carr. 30/-.
 TF329G 'Q' METER. Brand new with access. £75.
 T.F. 195 M. BEAT FREQUENCY OSCILLATOR. 0-40 Kc/s. 200/250 v. A.C. £20. Carr. 30/-.
 All above offered in excellent condition fully tested and checked and offered at a fraction of original cost.

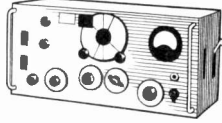

2-WAY RADIOS

Super quality. Brand new and guaranteed.

3 transistor	£6.15.0 pr.
4 transistor	£7.19.6 pr.
5 transistor	£8.4.0 pr.
6 transistor	£9.19.6 pr.
6 transistor De Luxe	£17.10.0 pr.
10 transistor	£22.10.0 pr.
13 transistor 500 MW	£31.10.0 pr.
13 Trans. 1W	£35.0.0 pr. Post extra.

These cannot be operated in U.K.

SINCLAIR TRANSISTOR AMPLIFIERS

Z12 Amplifier 89/6; Z12 Power Pack 79/6; Stereo 25 Pre-Amplifier £9.19.6; Micro FM Radio Kits £5.19.6; Micro 6 Radio Kit 59/6; Micromatic Radio Kit 59/6; Ready built 79/6. Post paid.

GARRARD RECORD PLAYERS

SRP12 Player mono £4.4.0; 1000 changer mono or stereo £5.19.6; 2000 changer mono or stereo £8.19.6; A50 Changer mono or stereo £7.10.0; 3000 Changer stereo £8.19.6; AT6 Mk II £9.19.6; SP25 Player mono or stereo £9.19.6; AT60 Changer mono or stereo £10.19.6; A70 less cartridge £19.19.0; LAB80 Stereo £25.0.0; 401 Transcription 26 gns. Brand new and guaranteed. All plus post and packing 5/-.

LAFAYETTE HI-FIDELITY SOLID STATE STEREO AMPLIFIERS

Latest 1967 models now available. Outstanding performance from modern semi conductors. Provision for all types of inputs and outputs and comprehensive tone controls. Attractive metal cased free standing units.

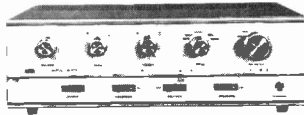

Model LA-224T. 30 watt £25. Carr. 7/6. Model LA-60P. 60 watt £37.10.0. Carr. 7/6. DETAILS ON REQUEST

LAFAYETTE MODEL HA-500 3SB/AM/CW 80 THROUGH 6 METRE RECEIVER



New outstanding Hi-Fi Bands only receiver covering the 80/40/20/15/10/5 metre bands. Incorporates 10 valves, product detector, two mechanical filters, "S" Meter, dual conversion on all bands, crystal calibrator, B.F.O., noise limiter, aerial trimmer, I.F.'s 2,608 Mc/s and 455 Kc/s. Output 8 ohms and 500 ohms. Operations 220/240 volt A.C. Supplied brand new and guaranteed with handbook. 42 gns. Carr. 10/-. 100 Kc/s crystal 85/-.

★ TRANSISTORISED FM TUNER ★

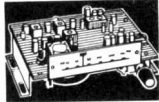

6 TRANSISTOR HIGH QUALITY TUNER. SIZE ONLY 5in. x 4in. x 2 1/2in. 3 I.F. stages. Double tuned discriminator. Ample output to feed most amplifiers. Operates on 9 volt battery. Coverage 88-108 Mc/s. Beautifully finished in ebony. Ready built ready for use. Fantastic value for money. £6.17.6. P.&P. 2/6.

VARIABLE VOLTAGE TRANSFORMERS

Brand New fully Shrouded. Input 230 v. 50/60 c/s. Output 0-260 Volts.

1 Amp	£4.10.0
2 1/2 Amp	£5.17.6
5 Amp	£6.10.0
8 Amp	£9.0.0
10 Amp	£13.10.0
12 Amp	£17.0.0
20 Amp	£32.10.0

2 1/2 Amp Portable Metal Case With Meter. Fuses etc. £9.17.6.

AMERICAN TAPE

First grade quality American Tapes Brand new. Discounts for quantities.

3in. 225ft. L.P. acetate	4/-
3 1/2in. 600ft. T.P. mylar	10/-
5in. 600ft. std. plastic	8/6
5in. 900ft. L.P. acetate	10/-
5in. 1,200ft. D.P. mylar	15/-
5 1/2in. 1,800ft. T.P. mylar	35/-
5 1/2in. 1,200ft. L.P. acetate	12/6
5 1/2in. 1,800ft. D.P. mylar	22/6
5 1/2in. 2,400ft. T.P. mylar	45/6
7in. 1,200ft. std. mylar	12/6
7in. 1,800ft. L.P. acetate	15/-
7in. 1,800ft. L.P. mylar	20/-
7in. 2,400ft. D.P. mylar	25/-
7in. 3,600ft. T.P. mylar	58/6

Postage 2/- Over £3 post paid.

TRANSISTORISED TWO-WAY TELEPHONE INTERCOM.



Operative over amazingly long distances. Separate call and press to talk buttons. 2-way connection. 1000's of applications. Beautifully finished in ebony. Supplied complete with batteries and wall brackets. £5.19.6. P. & P. 3/6.

R.107 RECEIVERS

1-7 17.5 Mc/s. Mans or 12 volt D.C. operation. Perfect condition. £15. Carr. 30/-.

SP.600JX RECEIVERS

Few only of these outstanding receivers 540 Kc/s-54 Mc/s. Cost over £500. Available in excellent condition £100.

CALLERS WELCOME!

Open 9 a.m. to 6 p.m. every day Monday to Saturday. Trade supplied.

Catalogue of Electronic Components and Equipment

Send today 5/- P&P 1/-

G.W. SMITH & CO. (LONDON) LTD.

CATALOGUE

- ★ ELECTRONIC COMPONENTS
- ★ TEST EQUIPMENT
- ★ COMMUNICATION EQUIPMENT
- ★ HI-FI EQUIPMENT

We are proud to introduce our first comprehensive catalogue of Electronic Components and equipment. Over 150 pages, fully illustrated, listing thousands of items many at bargain prices. Free discount coupons with every catalogue. Everyone in electronics should have a copy.

CLEAR PLASTIC PANEL METERS



First grade quality. Moving Coil panel meters, available ex-stock. S.A.E. for illustrated leaflet. Discounts for quantity. Available as follows: Type MR. 38P. 1 1/2"/32in. square fronts.

100-0-100µA	27/6	200mA	22/6	100V D.C.	22/6
500-0-500µA	22/6	300mA	22/6	150V D.C.	22/6
1-0-1mA	22/6	500mA	22/6	300V D.C.	22/6
1mA	22/6	750mA	22/6	500V D.C.	22/6
2mA	22/6	1A D.C.	22/6	750V D.C.	22/6
5mA	22/6	2A D.C.	22/6	15V A.C.	22/6
10mA	22/6	5A D.C.	22/6	50V A.C.	22/6
20mA	22/6	3V D.C.	22/6	150V A.C.	22/6
50µA	29/6	50mA	22/6	10V D.C.	22/6
100µA	29/6	100mA	22/6	20V D.C.	22/6
200µA	27/6	150mA	22/6	50V D.C.	22/6
500µA	25/-				
50-0-50µA	29/6				

POST EXTRA. Larger sizes available—send for lists.

R209 MK. II COMMUNICATION RECEIVER

11 valve high grade communication receiver suitable for tropical use. 1-20 Mc/s on 4 bands. AM/CW/FM operation. Incorporates precision vernier driver, B.F.O. Aerial trimmer, internal speaker and 12 v. D.C. internal power supply. Supplied in excellent condition, fully tested and checked. £15. Carr. 20/-.

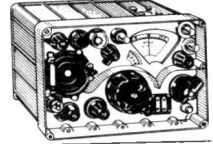

HA-63A COMMUNICATION RECEIVER RECEIVING OUTSTANDING VALUE



High class receiver covering 550 kc/s-31 mc/s on 4 bands. Incorporates 7 valves plus rectifier, RF stage, illuminated "S" meter, 1.5µV sensitivity, electrical bandspread on the 80/40/20/15 and 10 metre bands, slide rule dial, aerial trimmer, B.F.O., noise limiter, Output for phones or speaker. Operates on 115/220/240 v. A.C. Supplied brand new and guaranteed with manual. 24 gns. Carr. 10/-.

LAFAYETTE KT-340 COMMUNICATION RECEIVER SEMI-KIT

Build this wonderful receiver and save Pounds! Supplied semi-completed, main components ready mounted, R.F. section already wired and aligned. Full and precise instructions supplied. Specification: 8 valves + rectifier, 4 bands covering 550 Kc/s-30 Mc/s. Incorporates I.F.P. and 2 I.F. stages, "Q" multiplier, B.F.O., A.N.L. "S" meter, bandspread, aerial trimmer, etc. Operation 115/230v. A.C. Price 25 GNS. Carr. 10/-.

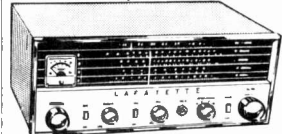

HAM-I. 4 BAND COMMUNICATION RECEIVER

4 wavebands covering 535 kc/s-30 Mc/s 5-valve superhet circuit. Incorporates 8 meter, B.F.O., BANDSPREAD TUNING, BUILT-IN 4in. SPEAKER, FERRITE AERIAL AND EXTERNAL TELESCOPIC AERIAL. Operation 220/240v. A.C. Supplied brand new with handbook. £16/10/0. Carr. 10/-.

NEWLAFAYETTE MODEL HA-700 AM/CW/SB AMATEUR COMMUNICATION RECEIVER

8 valves, 5 bands incorporating 2 MECHANICAL FILTERS for exceptional selectivity and sensitivity. Frequency coverage on 6 bands 150-400 kc/s, 550-1,600 kc/s, 1.8-4.0 Mc/s, 48-400 kc/s, 10-5-30 Mc/s. Circuit incorporates B.F. stage, aerial trimmer, noise limiter, B.F.O., product detector, electrical bandspread, 8 meter, slide rule dial. Output for phones, low to 2KΩ or speaker 4 or 8 ohms. Operation 220/240 volt A.C. Size 7 1/2in. 15in. 10in. Supplied brand new and guaranteed with handbook 36 GNS. Carr. 10/- S.A.E. for leaflet.

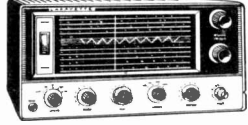

ALL ITEMS AVAILABLE AS PREVIOUSLY ADVERTISED

G.W. SMITH & CO (RADIO) LIMITED

Phone: GERRARD 8204/9155
 Cables: SMITHEX LESQUARE
 3-34 LISLE STREET, LONDON, W.C.2

G

GET A GOLDRING HI-FI TURNTABLE UNIT FOR YOUR AMPLIFIER



GOLDRING-LENCO G.99

Incorporates the unique Goldring-Lenco continuously variable speed control and vertical drive features. Machined 8 lb. non-magnetic turntable. Push-button switching. Neon-lit stroboscope. Speed constant within 1% for up to 13% mains voltage change. £21.19.5d.

GOLDRING-LENCO GL 68

Continuously variable speed control with adjustable click in positions for standard speeds. Arm takes interchangeable head-slides, and is raised and lowered by on/off switch. Wired for mono and stereo. £19.10.7d.



There's a Goldring, or Goldring-Lenco unit to match *any* amplifier—whether you build it or buy it. At the modest end of the scale there's the G.66 integrated hi-fi unit that comes complete with pick-up arm and cartridge for as little as 11 gns. Then there's the highly popular GL 68 (see left) and, for the man who wants the best he can get there's the GL 70 transcription unit with integrated transcription arm at a little under £30, or the sophisticated G 99 without arm, at around £22. Goldring hi-fi equipment includes transcription arms from 7 gns. upwards and a wide choice of cartridges. The coupon will bring you full descriptive leaflets.

GOLDRING HI-FI EQUIPMENT



To: **GOLDRING MANUFACTURING CO. (G.B.) LTD.**, 486-488 High Road, Leytonstone, London, E.11.

Please send me descriptive leaflets on

- TURNTABLE UNITS TRANSCRIPTION ARMS
 MONO & STEREO CARTRIDGES HI-FI ACCESSORIES

Name _____
Address _____

To Goldring Manufacturing Co. (G.B.) Ltd., 486 High Road, Leytonstone, London, E.11. Telephone: Leytonstone 8343

COMMON GROUND

MANY interesting facts are revealed through readers' letters. One point that frequently comes to light is that many newcomers make their very first acquaintance with do-it-yourself electronics because of their interest in some other quite different and seemingly unrelated hobby or pastime.

It is not hard to imagine how such introductions first come about. . . . The amateur photographer decides to build an electronic flashgun to keep up with his more affluent friends with their commercial equipment; the motorist, alert to the dangers of contemporary acquisitive society, decides to install a car alarm system; the amateur horticulturist realises the benefits to be derived from a remote temperature monitoring system for the greenhouse, particularly on those cold winter evenings. Even the more sedentary individual who normally asks nothing more than to be left alone in peace in his armchair with a book or television set as sole companion, suddenly awakens to the fact that a doorphone intercom unit could save all that bother of plodding to the front door on what are often fruitless missions.

Yes, these are representative of some different characters with widely differing ideas as to how best to spend their spare time. But they all can share common ground in amateur electronics.

Some of our new friends will limit their excursion into constructional activities strictly to the one project in mind. Others, the far larger proportion, we trust, will suddenly see the light: what a shame to ignore all the countless other possibilities of using electronics around and about the house. Not that they need become fanatics at the game, to the exclusion or detriment of any other hobby or interest; indeed home constructed electronic devices can enhance the scope and enjoyment of so many other spare time pursuits.

Furthermore, as committed electronics constructors, they will be brought into touch with an even wider range of non-vocational activities as illustrated by the specialised applications of the projects featured regularly in these pages. That common ground may well prove exceedingly fertile—in more ways than one.

THIS MONTH

CONSTRUCTIONAL PROJECTS

VIDEO PATTERN GENERATOR	415
DIAL-A-NAME GAME	420
MODEL CONTROL INSTALLATIONS	432
C.R.O. TRACE DOUBLER	443

SPECIAL SERIES

COMPUTER EVOLUTION—2	425
THE ELECTRONIC ORGAN—7	439

GENERAL FEATURES

PRESS-FIT TERMINALS	414
INGENUITY UNLIMITED	429
FIELD EFFECT TRANSISTORS	448

NEWS AND COMMENT

EDITORIAL	413
MEETINGS	438
BOOK REVIEW	442
ELECTRONORAMA	446
THE 73 PAGE	456
MARKET PLACE	459
DETACHED PARTICLES	463
READOUT	464

*Our July issue will be published on
Friday, June 16*

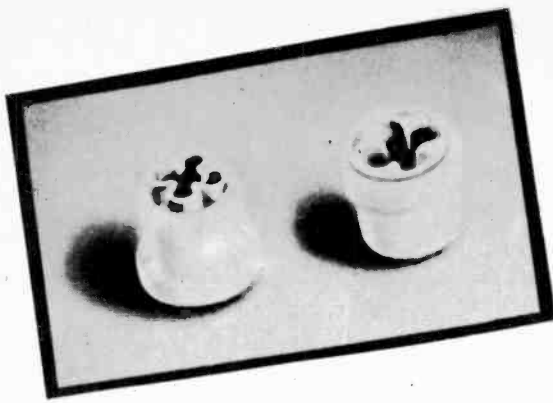

Another wiring technique for the constructor using

PRESS-FIT SOLDERING TERMINALS

OF THE many forms of circuit wiring now open to amateurs and laboratory technicians, each has its inherent advantages.

This month we feature Sealectro "Cloverleaf" press-fit soldering terminals which can be used with Lektrokit perforated chassis plates No. 7 or can be mounted as required on plain aluminium plates.

The "cloverleaf" is a sub-miniature p.t.f.e. insulated press-fit, feed through terminal. P.T.F.E., otherwise known by the trade names of "Teflon" or "Fluon" has an extremely high insulation resistance, and the capacity to withstand large temperature variations.

Although rather costly, this method gives a neat appearance and is particularly suitable for h.f. work.

FITTING THE TERMINALS

The insulators are very slightly tapered so that they are wedge fitted into pre-punched tapered holes in the chassis plates. Two projects are described on pages 415 and 443 using this method, but in order to illustrate the full details of mounting, the photographs on this page show the terminals being mounted on plain aluminium sheet.

The pre-punched plates are ideal for prototype or breadboard circuit assemblies; the components can be simply positioned on the plate so that their junction points are established. These points coincide with the terminals. Modifications or changes can easily be made for

optimum component density; since the system lends itself to above and below chassis wiring, a considerable reduction in circuit area can be affected.

If one intends using a plain 18 s.w.g. aluminium sheet or chassis the circuit components should be laid out the same as in the pre-punched system to establish the junction points. (It is a good idea to sketch a rough plan on paper.) These should be marked with a scribe and holes drilled at these points with a No. 29 drill. The tapered entry for the terminal is achieved by lightly countersinking this hole half-way through the sheet with a No. 22 drill. The p.t.f.e. inserts should then be press fitted into position as in Photo. A.

WIRING

Each "cloverleaf" junction will accommodate four components or wiring leads, with a centre hole for an additional length of 21 s.w.g. bare tinned copper wire.

Soldering is a simple procedure as the "cloverleaf" provides capillary channels so that the solder flows easily when the iron is applied (Photo B). The photographs at the bottom of the page show close up, the soldered components on the board (C) and a cut-away view of a plate (D) with a terminal and components fitted.

The terminals and chassis plates are obtainable from Home Radio (Mitcham) Ltd.

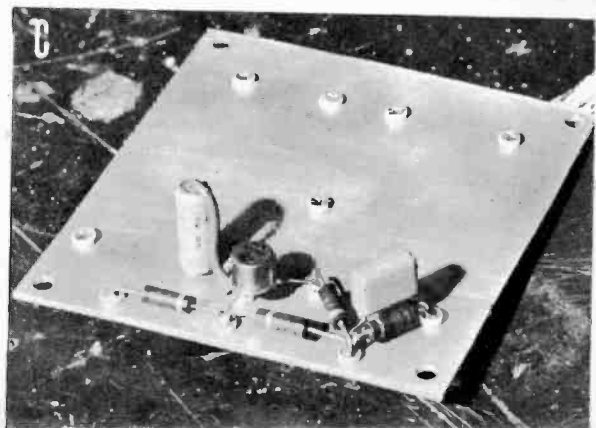
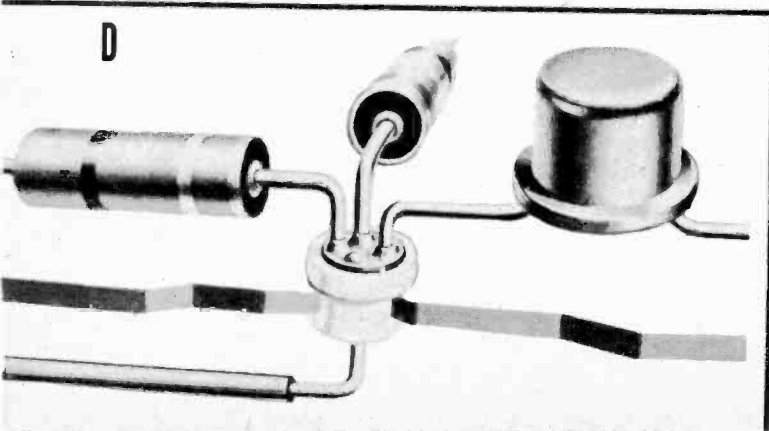
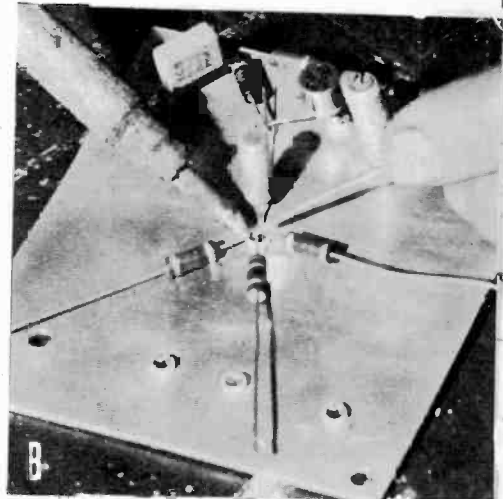
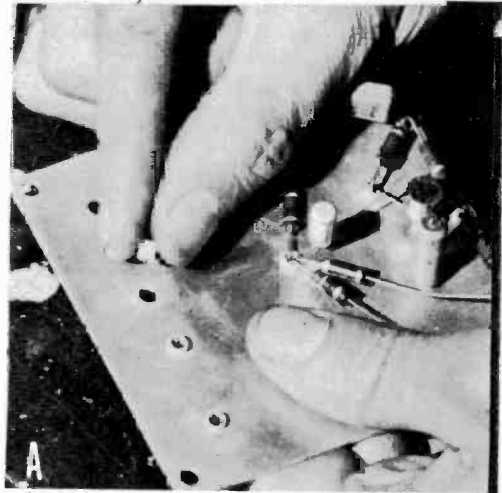

VIDEO PATTERN GENERATOR

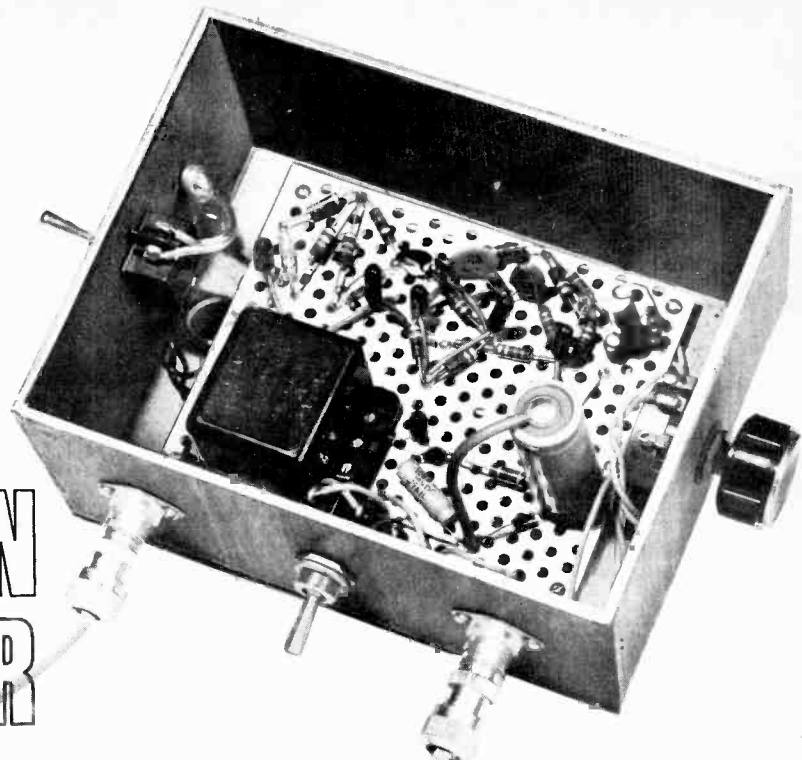

By J.E. KASSER

This simple piece of equipment can be used to provide a pattern on the screen of a television receiver, showing vertical bars. It is suitable for use with such sets that have been converted to receive standard one volt peak-to-peak video signals.

A brief introduction of the theory of pulse circuitry is given in this article, but the reader should consult text books for a fuller explanation of how the various circuits, used in this piece of equipment, work.

PULSE WAVEFORM

The waveform required for displaying vertical lines is a pulse waveform that is synchronised to the line frequency or is capable of locking itself to the line frequency. The block diagram is shown in Fig. 1.

Fig. 2 shows a video pulse waveform. On the 405-line system, the top of the pulse is at the white level, while the bottom is below the black level. The two intermediate levels are shades of grey, the lower one being the darker. The portion of the wave below the black level can be used to lock the signal into the timebase of the receiver if it is of the order of the line timebase frequency.

The waveform generated in an astable multivibrator is given in Fig. 3a. Pulses from this free running square wave generator pass into a bistable multivibrator where it is converted to a castellated waveform (Fig. 3b) which is a factor of the frequency of the pulses in Fig. 3a. This waveform is 1 volt peak-to-peak (the standard video signal).

The number of "battlements" on the castellated waveform is controlled by VR1, which can give from two to about fifty "battlements" per half-cycle. Each "battlement" is of a fixed time duration, and changes the repetition frequency of the wave (Fig. 3c and 3d), and thus the number of bars seen on the screen. It will be found that adjustment of VR1 will lock a picture with say four bars, then with further adjustments the picture goes out of lock, then locks again with three bars.

If the bistable multivibrator divides on both the positive and negative half-cycles of the original frequency a "staircase" waveform (Fig. 3e) would result. This would give rise to bars of different tones of grey from white to black being shown on the screen.

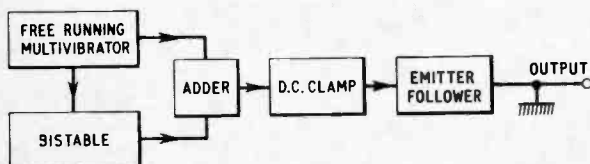

Fig. 1. Block diagram of the video pattern generator

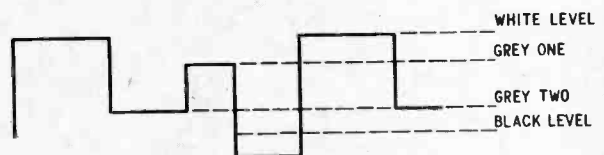

Fig. 2. A typical video monochrome pulse waveform

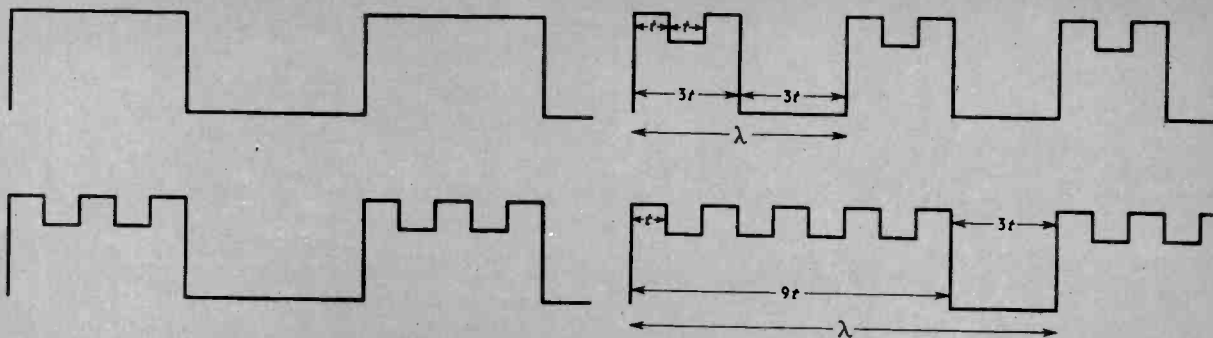

Fig. 3. Square wave conversion to video pattern waveform

3a (top left). Output from the astable multivibrator

3b (lower left). Castellated by the bistable multivibrator

3c (top right). Two "battlements" per half wave. $\lambda = 6t$

3d (lower right). Five "battlements" per half wave. $\lambda = 12t$

3e (left). Staircase waveform

It would give the same effect as viewing colour bars on a monochrome receiver (see photographs).

The astable or free running multivibrator generates a symmetrical square wave at approximately 21.6kHz which is a little more than twice the standard 405-line frequency (10.125kHz). The circuit (Fig. 4) is conventional; the frequency is controlled by C_1 and R_2 .

$$\text{Since } t \approx 0.7(R_2C_1 + R_3C_2)$$

$$\text{and } R_2C_1 = R_3C_2$$

$$t \approx 1.4R_2C_1$$

$$\text{but } f = \frac{1}{t} = \frac{1}{1.4C_1R_2}$$

Circuit values are, C_1 is 2,200pF and R_2 is 15 kilohms.

$$\text{Therefore } f = \frac{10^{12}}{1.4 \times 2,200 \times 15 \times 10^3}$$

$$f \approx 21.6\text{kHz}$$

In theory, the value of C_1 and C_2 would have to be 2,353pF to give a frequency of exactly twice the 405-line standard frequency, but 2,200pF is the nearest preferred value and is close enough.

Trigger pulses are taken from TR2 to the bistable multivibrator. The bistable operates on half the original frequency, i.e. at approximately 10.8kHz. Its rate of division is altered by VR1. This alters the time constant of the circuit and the mark/space ratio.

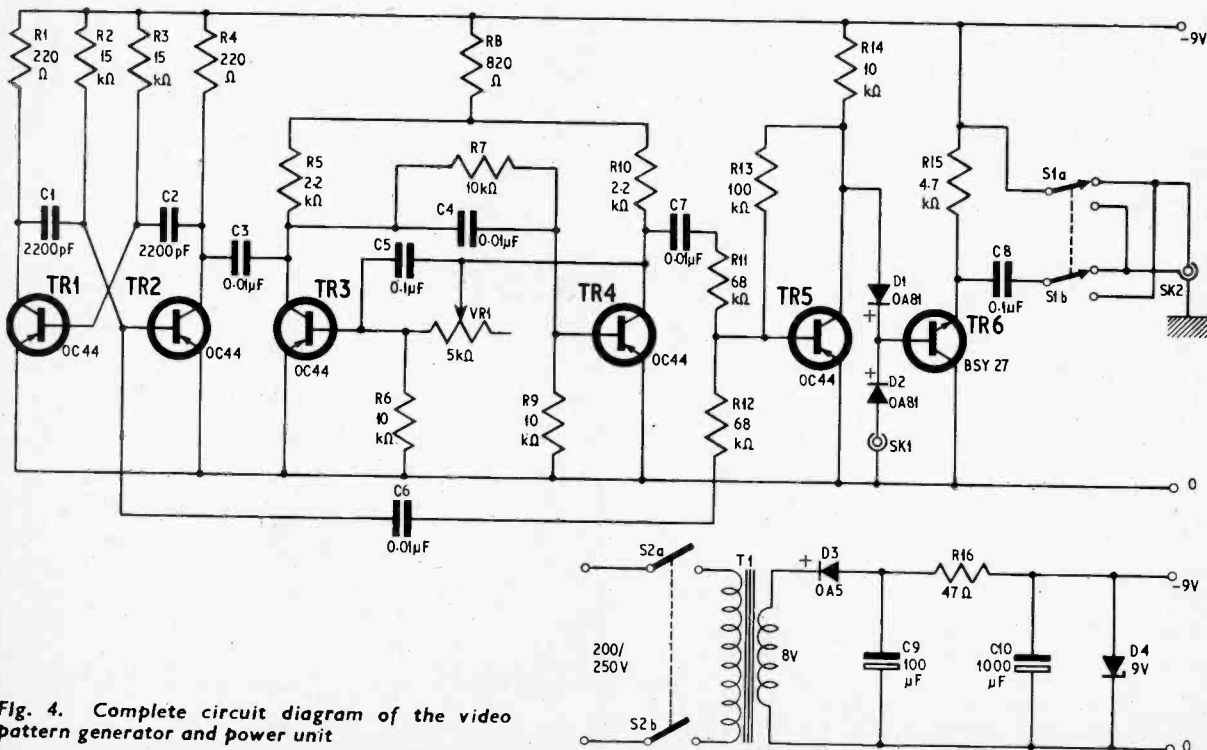

Fig. 4. Complete circuit diagram of the video pattern generator and power unit

ADDER

The outputs from the astable and bistable multivibrators are combined in the adder circuit of TR5. Fig. 5 shows an adder circuit, the gain of which is the ratio R_{13}/R_{12} where R_{11} and R_{12} provide the two inputs and determine the level of voltage injected into the transistor, for assuming a unity stage gain, i.e. $R_{13} = R_{12}$ (resistor R_{14} is R_L in Fig. 4).

$$v_o = -\frac{R_{13}}{R_{12}}(v_1 + v_2)$$

the negative sign showing a 180 degree phase shift.

The values of R_{11} , R_{12} , R_{13} , and R_L have been calculated to give a 1 volt peak-to-peak output waveform. R_{11} and R_{12} can be varied. This will vary the level of each waveform, and will change the shade of the bars seen on the screen. From the collector of TR5 the signal passes through D1, which clamps it to "earth" level (earth being zero volts in this part of the circuit). The clamping process clips the negative going pulse on the output waveform as shown in Fig. 6.

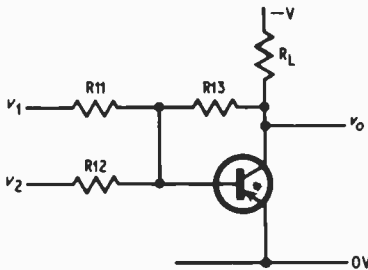

Fig. 5. Basic adder circuit of TR5

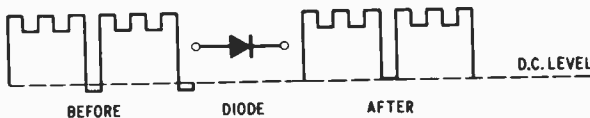

Fig. 6. Effect of clipping negative pulses at the output from TR5

TR6 is an *npn* transistor used as an emitter follower, and is biased by the current flowing through the diode D1. Frame sync pulses can be inserted into the waveform via SK1 and D2. This will enable the frame timebase of the receiver to be tested.

The high frequency transistor used for TR6 ensures a fast rise time on the waveform, and sharp transitions from black to white can be seen. If TR6 is a BSY18, BFY27, BSY27, etc. the fast rise time is an advantage, but an OC139 should work just as well. The output from the emitter follower is taken via a $0.1\mu\text{F}$ capacitor C8 to the phase reversal switch. This enables the signal to be changed from peak white to peak black.

The unit can be made up quite compactly on a piece of perforated board or Lektrokit chassis plate No. 7 using Sealectro press-fit terminals. Figs. 7 and 8 show the layout. Full instructions are given on page 414.

The photographs, taken direct from the television screen, show that different effects may be seen by adjusting VR1, S1 and the line hold control (line timebase frequency) on the receiver. Test Card D gives some idea of the definition of the picture compared with the pattern generator bars.

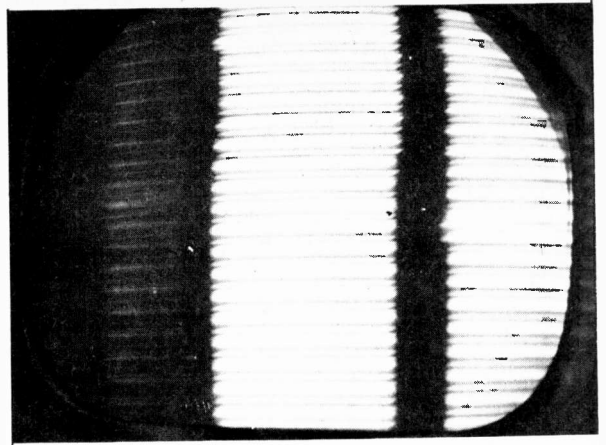

Two pattern bars of horizontal lines shown on the screen. The number of bars is determined by the setting of VR1

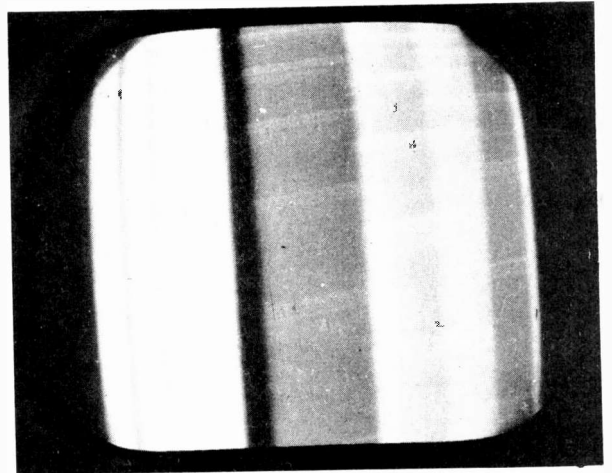

Graduated tones from black to white provided by the staircase waveform when the bistable multivibrator divides on both positive and negative half cycles

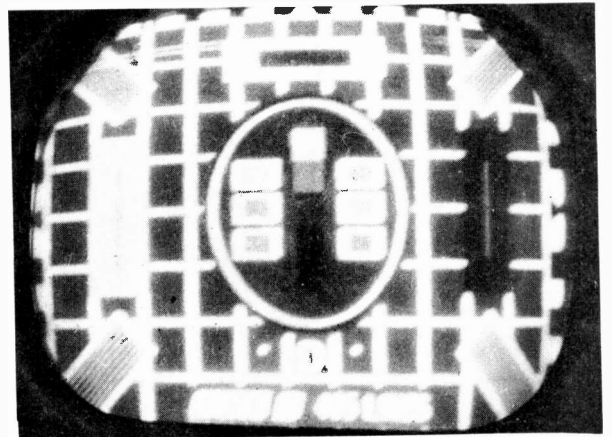

This picture of Test Card D (405 lines) shows poor definition and non-linearity

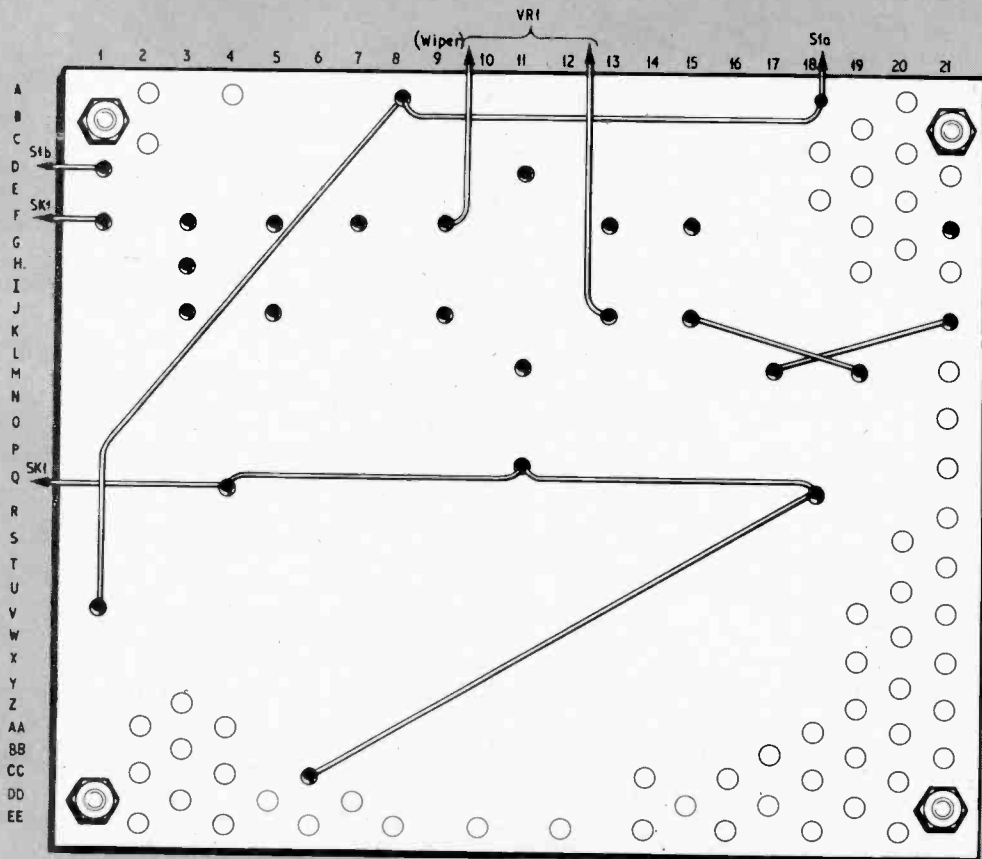
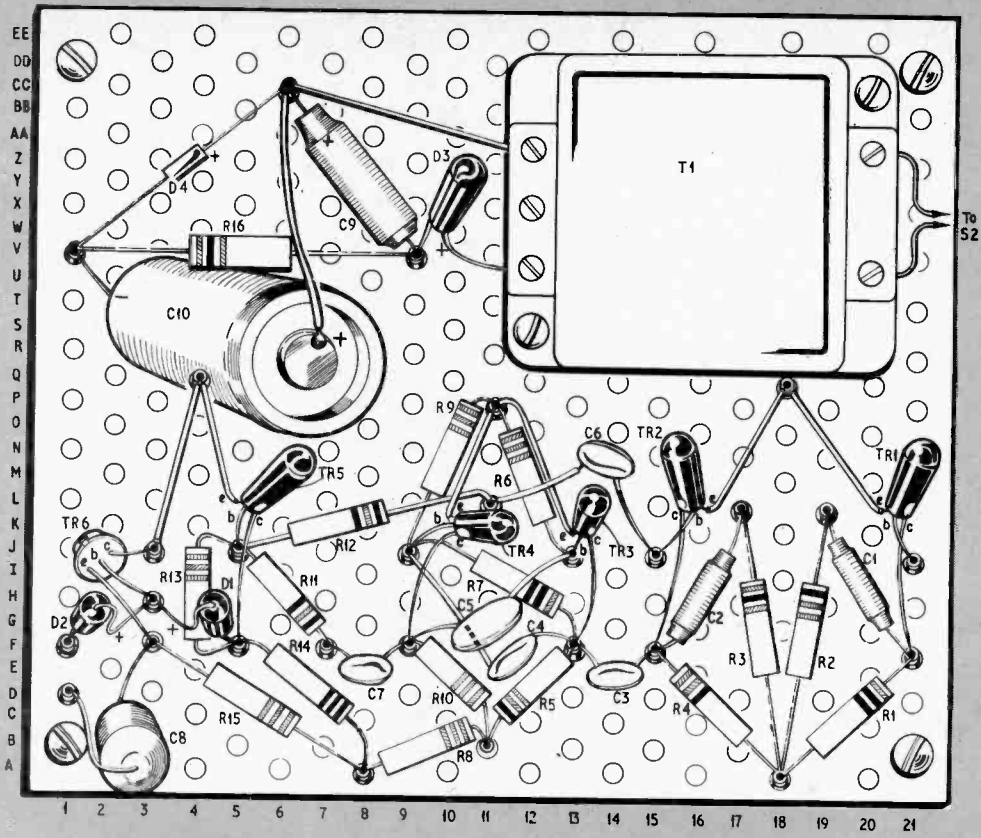

Fig. 7. Top and underside views of the perforated aluminium chassis plate No. 7

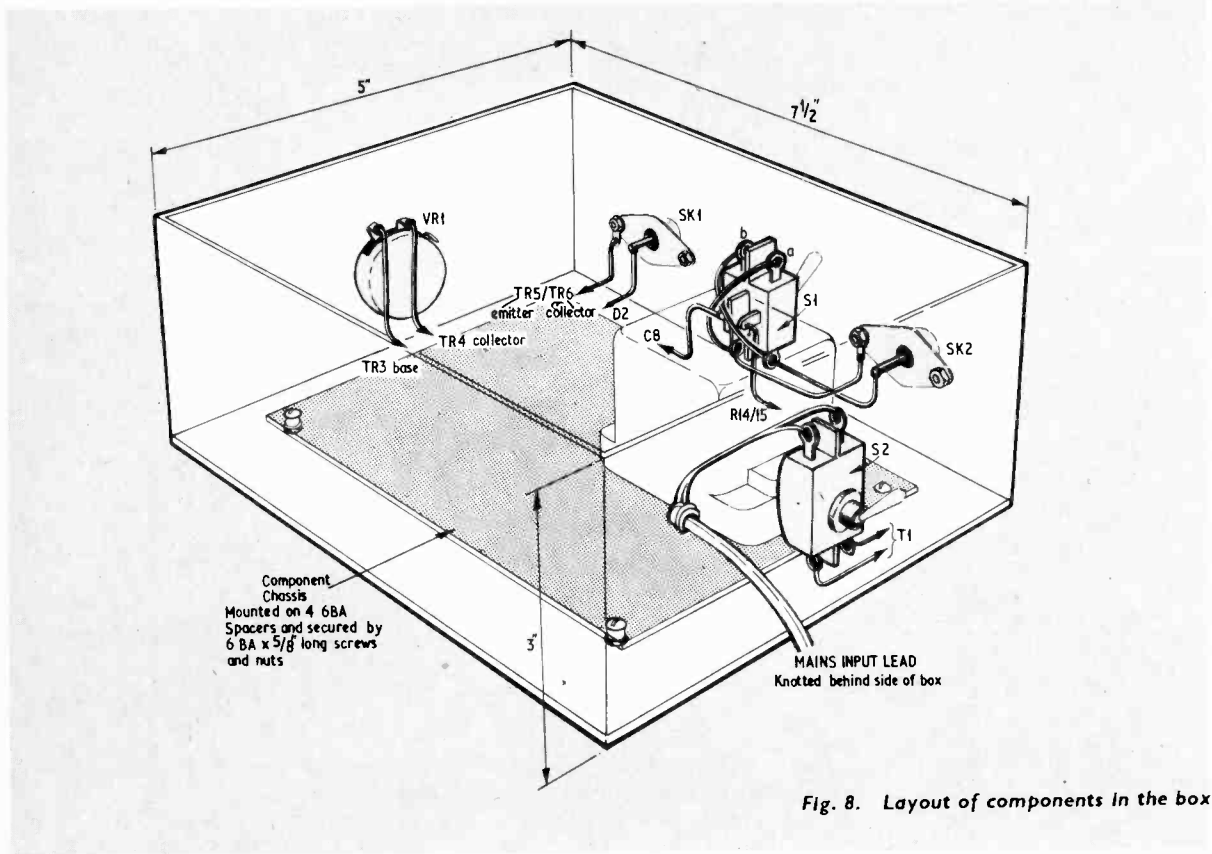

Fig. 8. Layout of components in the box

COMPONENTS . . .

Resistors

R1	220 Ω	R9	10k Ω
R2	15k Ω	R10	2.2k Ω
R3	15k Ω	R11	68k Ω
R4	220 Ω	R12	68k Ω
R5	2.2k Ω	R13	100k Ω
R6	10k Ω	R14	10k Ω
R7	10k Ω	R15	4.7k Ω
R8	820 Ω	R16	47 Ω

All 10%, 1/2 watt carbon

Potentiometer

VR1 5k Ω linear carbon

Capacitors

C1	2,200pF polyester 500V
C2	2,200pF polyester 500V
C3	0.01 μ F disc ceramic 30V
C4	0.01 μ F disc ceramic 30V
C5	0.1 μ F disc ceramic 20V
C6	0.01 μ F disc ceramic 30V
C7	0.01 μ F disc ceramic 30V
C8	0.1 μ F disc ceramic 20V
C9	100 μ F elect. 15V
C10	1,000 μ F elect. 15V

Transistors

TR1 to 5 OC44 or OC42 (5 off) (Mullard)
TR6 BSY27 (Mullard)

Diodes

D1, 2 OA81 (2 off)
D3 OA5
D4 OAZ 247 or ZF9-1 (9V Zener)

Transformer

T1 Pri. 200-250V; see 8V (Bell transformer)

Switches

S1 Double-pole, 2 way toggle switch
S2 Double-pole, on/off toggle switch

Sockets

SK1, 2 Coaxial sockets with plugs

Miscellaneous

Press-fit "cloverleaf" terminals (Sealectro)
Chassis Plate No. 7 (Lektrokrit)
(Home Radio (Mittham) Ltd.)

On some settings of the controls white horizontal lines will be obtained equispaced on the picture to allow one to set the linearity controls.

The unit can be used to test video stages of receivers, transmitters, monitors, etc. and for the budding television "ham" produces an inexpensive electronic test pattern.

The power supply to the generator (9V d.c.) is fairly critical as a higher voltage will not allow the capacitors to charge up properly, and will upset the waveforms in all parts of the circuit. As the unit draws 35mA a mains power pack should be used; Fig. 4 shows a simple one that can be used. D4 is a Zener diode which stabilises the supply to 9 volts.





Dial-a-Name Game

By R. Maker

HERE is a novel idea which can give endless amusement, especially at a party or similar larger gathering. With the summer months rapidly approaching this game would be a great attraction at summer fetes.

The purpose of the game is to score points which are derived from a system of coding for the letters of the alphabet. An element of handicap of sorts is introduced by giving certain letters a "buzz" code. These are shown in Table 1. The numerical and "buzz" codes can be altered to suit the individual, providing allowance is made on the wiring.

CODE COUNTING

Table 2 shows how the code is applied to some examples of christian names. The numbers corresponding to the name letters are added together, but a buzz code, when applicable, cancels all numbers that have gone before.

If two consecutive buzz codes apply, as in "MARY" the cancellation is void, so the previous numbers *do* count. In this case the name has two buzz letters R and Y; this provides a handicap in reducing the number of "counting" letters.

Each letter of each christian name is dialled (using the centre dial scale) against the initial letter of the surname on the outer scale. Let us take an example: JOHN PETER BROWN.

First dial J on the centre scale until it aligns with B on the outer scale. Press the button to indicate in the right-hand boxes what is scored. In this example it will be BUZZ (no score). Likewise dial the second letter O against B and score BUZZ again.

The next letter H will score 50 and N will score 60. The second name PETER will score respectively 4, 2, 750, 2, BUZZ. The last letter BUZZ cancels all that has gone before so the rather disappointing result for this example is nil.

Table 1: CODED LETTERS TO SCORE

A = 3	J = BUZZ	S = 40
B = 8	K = 10	T = 750
C = 30	L = 500	U = 7
D = 200	M = 5	V = 250
E = 2	N = 60	W = 6
F = 1,000	O = BUZZ	X = 6
G = 20	P = 4	Y = BUZZ
H = 50	Q = 1	Z = BUZZ
I = 9	R = BUZZ	

Table 2: EXAMPLES OF CODED NAMES

J = BUZZ	R = BUZZ	J = BUZZ	D = 200
A = 3	O = BUZZ	O = BUZZ	A = 3
N = 60	B = 8	A = 3	V = 250
E = 2	E = 2	N = 60	I = 9
T = 750	R = BUZZ	—	D = 200
—	T = 750	63	—
815	—	—	662
—	750	—	—

M = 5	J = BUZZ	P = 4	F = 1,000
A = 3	O = BUZZ	E = 2	R = BUZZ
R = BUZZ	H = 50	T = 750	E = 2
Y = BUZZ	N = 60	E = 2	D = 200
—	—	R = BUZZ	—
8	110	—	202
—	—	0	—

CASE CONSTRUCTION

The case must be constructed first; it is made in two identical halves 18in × 11in × 2in. The sides are made from planed wood 2in × ½in; 9ft will be needed for the two halves. The top and bottom boards are made from hardboard 18in × 11in.

The bulb compartment is built up on the top by screwing a frame of wood to the hardboard lid. This frame is made from strip wood 1½in × ¾in and is 10½in long, 9in wide, and 1½in deep.

Each bulb holder (m.e.s.) is screwed to the lid in five rows of four. Holes are drilled adjacent to the terminals of all lampholders for the connecting wires to pass through.

Build up a box around each holder, 1½in deep, so that the light from one box does not leak through to another. Flat pieces of white card are glued on top of each holder to reflect the light upward. It is necessary to bore a hole in the centre of each piece of card so that the bulbs can pass through to be fitted into the holders.

DIAL MECHANISM

Leave this part of the construction for a while and make the dial mechanism. The rotating dialling disc is 6in diameter; 25 finger holes, ½in diameter and ⅝in between each hole centre, are drilled around the periphery of the dial. It is best to drill these holes before cutting out the final shape of the dial, which might be plywood, s.r.b.p., or hardboard. The centre

hole in the dial is drilled to accept a Meccano rod 4½in long. Secure the rod to the dial by using a Meccano face plate with boss.

Next comes the fitting of the 7½in diameter wood disc on top of the case. This has the outer scale of letters of the alphabet, although these letters could be stuck straight on the box after finishing. The centre holes of both the dial and disc are concentric and are 5in from the front (handle) side and 4½in from the left-hand side of the box.

Having assembled the dial, face plate and 4½in rod, pass this rod through the centre hole of the disc and through the case lid. On the inside of the case lid another disc is cut to mount the contact strips, there being 25 copper strips each 1in long and ½in wide bent round the periphery of this disc at equal distances apart. This disc is screwed on to two wood battens 2in × ¾in × 10in.

Mount four 2in wooden pillars 1in square on the battens as shown so that they are close to the disc. Two braces are mounted on the ends of the pillars, these being Meccano strips arranged so that two holes coincide with the 4½in rod in the centre of the disc. The rod is passed through this hole. Screw the battens to the inside of the lid.

Fit a bossed face plate to the 4½in rod and bolt to it a copper strip made as a wiper to track over the copper contacts.

Going back to the lamp-display compartment on the right of the lid, wire the bulbs to the correct copper contacts according to the circuit diagram.

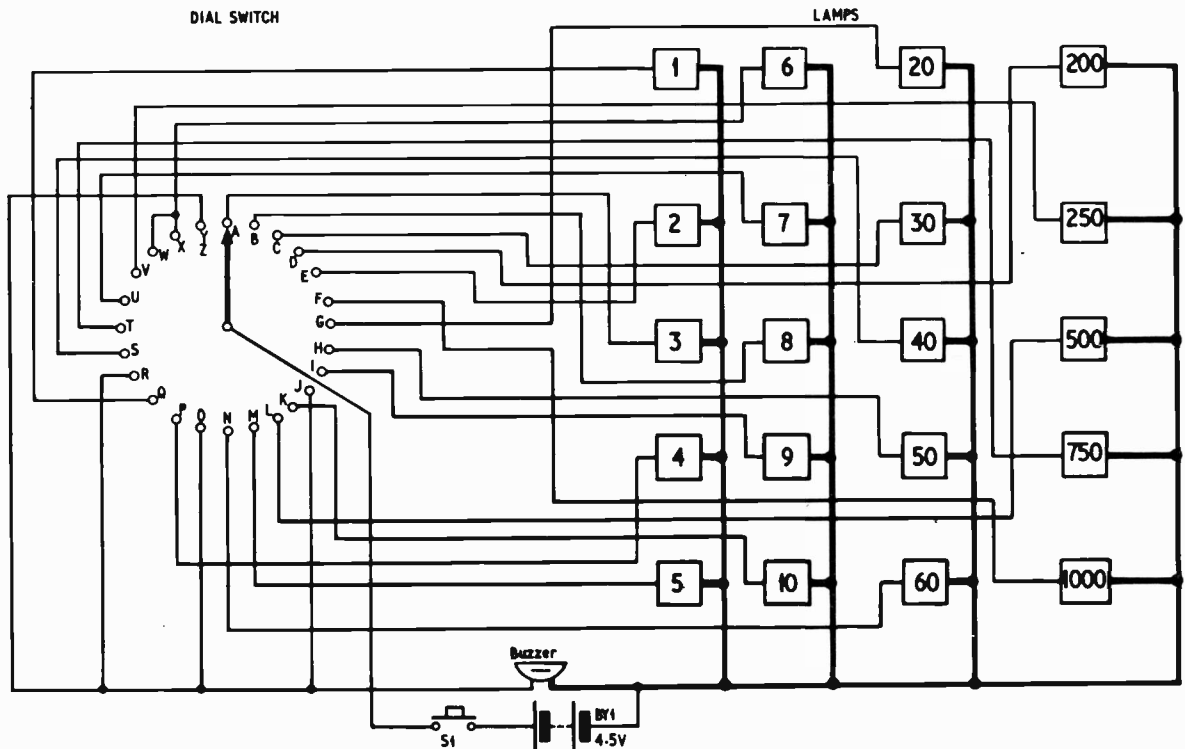

Fig. 1. Complete circuit and wiring of the "Dial-a-name" game

COMPONENTS and MATERIALS . . .

CASE

Wood 2in \times $\frac{1}{2}$ in planed, 9ft long
 Hardboard 18in \times 11in (2 off)
 Attache case handle and fastener
 Hinges 1 $\frac{1}{2}$ in long (1 pair)
 Decorative adhesive plastics sheet
 Quadrant section wood $\frac{3}{4}$ in (6ft) for corner strengthening

DIAL ASSEMBLY

DIAL—Sheet s.r.b.p., plywood or hardboard $\frac{1}{8}$ in thick, 6in diameter
 LETTER DISC—Plywood $\frac{1}{4}$ in thick, 7 $\frac{1}{2}$ in diameter
 CONTACT DISC—Plywood $\frac{1}{2}$ in thick, 6in diameter
 BATTENS—Wood strip 2in \times $\frac{3}{8}$ in (2ft)
 PILLARS—Wood strip 1in square (1ft)
 CONTACTS AND WIPER—Copper strip $\frac{1}{2}$ in wide (3ft)
 DIAL ROD—Meccano rod 4 $\frac{1}{2}$ in long (1 off)
 BRACES—Meccano strips 7 $\frac{1}{2}$ in long (2 off)
 ROD ATTACHMENTS—Meccano face plates (No. 109) 1 $\frac{1}{2}$ in diameter (3 off)
 LETTERS—Alphabet transfers or sticky labels (2 off each)

LAMP COMPARTMENT

WOOD FRAME—Wood strip 1 $\frac{1}{2}$ in \times $\frac{3}{8}$ in (39in)
 CLAMP FRAME—Angle aluminium $\frac{3}{8}$ in (39in)
 LAMPHOLDERS—M.E.S. batten type (20 off)
 LAMPS—3.5V m.e.s. torch bulbs (20 off)
 LAMP BOXES—White card sheet
 COVER—Translucent Perspex sheet 10 $\frac{1}{2}$ in \times 9in and transparent non-inflammable acetate sheet 10 $\frac{1}{2}$ in \times 9in
 MASKING—Black plastics masking tape

MISCELLANEOUS

Buzzer, 4 volt d.c. type
 Switch, single-pole on/off push button or rocker
 Battery, 4 $\frac{1}{2}$ V flat pack
 Wire, p.v.c. covered, single core

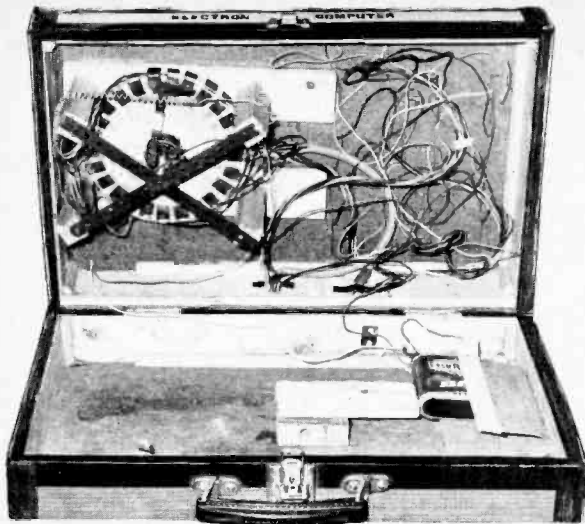

General view of the open case. The dial contacts and wiper are on the left and wiring to the lamps on the right. The 4 $\frac{1}{2}$ V flat pack battery is held firmly in the bottom of the case

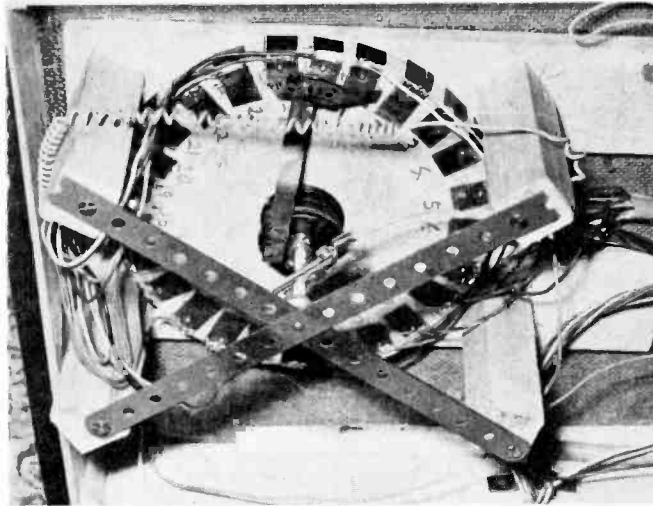

Close-up view of the dial switch mechanism. Contact to the wiper is made by the crocodile clip on the metal spindle which is held in position by the coincident holes in the Meccano strips

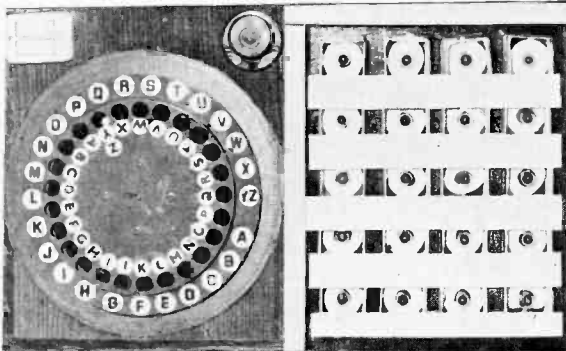

A rocker switch and buzzer are mounted on top of the case. The lampholders are fitted on the top right-hand side and shrouded by cardboard compartments

The lamp compartment is now covered by a sheet of Perspex, preferably translucent. The number transfers are stuck on the Perspex in the right positions. Black masking tape is stuck down to the Perspex between the numbers. To protect these numbers, fit a sheet of non-inflammable celluloid on top of the Perspex and clamp both in place by screwing an angle aluminium frame round the edge to the wooden frame.

All that remains now is to complete the wiring, including the buzzer and switch. A crocodile clip is used to make contact with the wiper by clipping to the rod. Finish of the complete case by covering with adhesive plastics sheet and fix the letters to the dial and disc.



1

TODAY'S MOST ADVANCED AERIAL ROTATORS

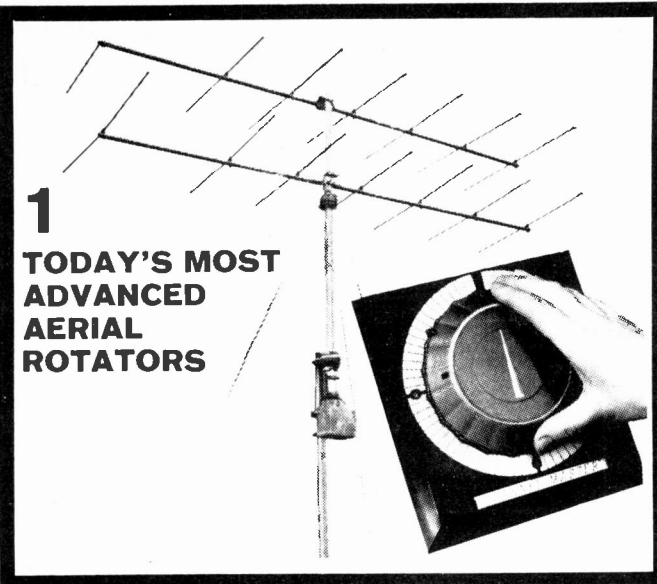

2

BRILLIANT VALVED QOILPAX

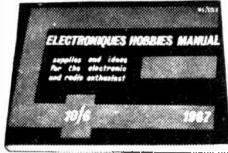
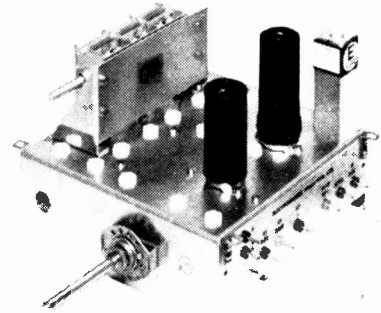

I should like a copy of the Electronics Hobbies Manual. Enclosed is a cheque P.O. for 10 6.

NAME

ADDRESS

P. E. 5

FROM THE ELECTRONICS HOBBIES MANUAL . . .

1 AERIAL ROTATORS. This range of beam rotators and accessories offers more advanced features than any other on the U.K. market—and at a lower price. The rotators can aim an aerial to within one degree of the transmitter location. No guesswork, no irritating gear clicks—just precise fine adjustment through 365 with accurate repeatability. With both models the aerial is held in place in high winds with an ingenious stop-lock brake. **COMPASS MODEL** offering remote fingertip control and continuous direction indication—£12.12.0 plus 3/6 p&p.

AUTOMATIC MODEL (illustrated) offering remote control and facility to pre-set to desired location. A synchronised motor in the control unit gives continuous indication of aerial position—£17.17.0 plus 3/6 p&p.

2 VALVED QOILPAX. If you are building a communications receiver, (whether for general coverage or hambands), why not avoid all the headaches in the front end by purchasing one of our highly sensitive 'QOILPAX' tuners. Sensitivity is 1 μ V for 15dB S:N ratio, and second channel interference is exceptionally low. The high sensitivity RF stage is designed around an EF183 connected in a Miller compensating circuit, followed by an ECH81 triode heptode frequency changer, using oscillator circuits. These give optimum mixing conductance on each waveband without any pulling. Ideal also as a converter, feeding into existing receivers. General coverage and hambands versions are available, each with an IF output of 1620 Kc/s. All units are supplied completely wired, tested and aligned. Either model £12.12.0 each plus 4/- p&p.

FREE Aerial Supplement to the Electronics Hobbies Manual. This publication MG 222S1 supplementing the Manual lists our aerial rotators and wide range of J-Beam aeriels. Send for your copy today.

For the 600 page Electronics Hobbies Manual or further details of the products displayed on this page write to: Electronics (Prop. STC Ltd.) Edinburgh Way, Harlow, Essex. Telephone: Harlow 26777.



High-grade components for amateur communications

electronics

BRAND NEW T.V. U.H.F. TUNER AND SOUND AND VISION I.F. PANEL

By world famous maker. Suitable for use in conversion of T.V. sets to B.B.C.2 (625 line reception). OFFERED (glass valves) AT THE BARGAIN PRICE OF ONLY 27/6. Post Paid. (The components are worth far more than our price for the complete unit and due to the very high value we regret that no correspondence can be entered into regarding this item.)

HIGH GAIN 4 TRANSISTOR PRINTED CIRCUIT AMPLIFIER KIT Type TAI

- Peak output in excess of 1 1/2 watts.
- All standard British components.
- Built on printed circuit panel, size 6 x 3 in.
- Generous size Driver and Output Transformers.
- Output transformer tapped for 3 ohm and 15 ohm speakers.
- Transistors (GET 114 or S1 Mullard OC81D and matched pair of OC81 o/p).
- 9 volt operation.
- Everything supplied, wire, battery clips, solder, etc.
- Comprehensive easy to follow instructions and circuit diagram 1/6 (Free with Kit). All parts sold separately.

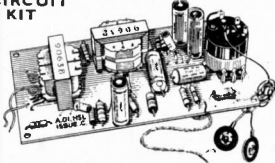

SPECIAL PRICE 45/- P. & P. 3/-. Also ready built and tested, 52/6. P. & P. 3/-. A pair of TAIs are ideal for stereo.

STEREO AMPLIFIER

Incorporating 2 ECL86s and 1 EZ80, heavy duty double wound mains transformer. Output 4 watts per channel into 3 ohm speakers. Full tone and volume controls. Absolutely complete.

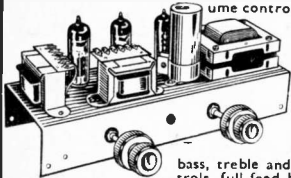

ONLY £4.19.6
P. & P. 8/-

Super Deluxe version with ECL86 valves, sep. bass, treble and balance controls, full feed back. 4 watts per channel into 3 ohm speakers. 8 gns. P. & P. 8/-.

SPECIAL PURCHASE! TURRET TUNERS

By famous maker. Brand new and unused. Complete with PCC84 and PCF80 valves 34-38 Mc/s I.F. Biscuits for Channel 1 to 5 and 8 and 9. Circuit diagram supplied. ONLY 25/- each. P. & P. 3/9.

GÖRLER F.M. TUNER HEAD

88-100 Mc/s 10.7 Mc/s. I.F., 15/-, plus 2/- P. & P. (ECC85 valve, 8/6 extra).

LATEST COLLARO MAGNAVOX 363 TAP DECK DE LUXE. Three speeds, 2 track, takes up to 7 in. spools. 10 gns. Plus 7/6 carr. and ins. on each. (Tapes extra on both.)

QUALITY PORTABLE TAPE RECORDER CASE. Brand new. Beautifully made. Few only at 49/6. P. & P. 8/6.

ACOS CRYSTAL MIKES. High imp. For desk or hand use. High sensitivity, 18/6. P. & P. 1/6.

ACOS HIGH IMPEDANCE CRYSTAL STICK MIKES. Listed at 42/-. Our price, 21/- P. & P. 1/6.

TWIN TELESCOPIC AERIAL. Two 3-section heavily chromed rods. Closed 12-in. each extending to 32 in. Completely adjustable. Universal mounting bracket, coax lead and plug. Ideal for F.M. or T.V. 12/6. P. & P. 2/6.

QUALITY RECORD PLAYER AMPLIFIER Mk II

A top-quality record player amplifier employing heavy duty double wound mains transformer, ECC83, EL84, EZ80 valves. Separate Bass, Treble and Volume controls. Complete with output transformer matched for 3 ohm speaker. Size 7 in. w. x 3 in. d. x 6 in. h. Ready built and tested. PRICE 69/6. P. & P. 6/-.

ALSO AVAILABLE mounted on board with output transformer and speaker ready to fit into cabinet below. PRICE 89/6. P. & P. 7/6.

DE LUXE QUALITY PORTABLE R/P CABINET

Uncut motor board size 14 1/2 in. x 12 in. clearance 2 in. below. 5 1/2 in. above. With take above amplifier and any B.S.R. or GARRARD Autochanger or Single Player Unit (except AT60 and SP25). Size 18 in. x 15 in. x 8 in. PRICE £39/6. P. & P. 9/6.

4-SPEED PLAYER UNIT BARGAINS

All brand new in maker's original packing. **SINGLE PLAYERS**
B.S.R. TU/12 £39/6. Carr. 5/6
GARRARD SP25 De Luxe... £120/0/0. Carr. 5/6
B.S.R. GUT with unit mounted pickup arm. £418/8. Carr. 5/6.

AUTO. CHANGERS

Latest B.S.R. UA25 Super slim £6 2 6
GARRARD 1000 with special Hi-Fi cart. £6 19 6
GARRARD 2000 £7 10 0
GARRARD 3000 £8 15 0
GARRARD AT60 £10.10.0. Carr. 6/6 on each.
All the above units are complete with t/o mono head and sapphire stylus or can be supplied with compatible stereo head for 12/6 extra.

BRAND NEW CARTRIDGE BARGAIN!

ACOS GP69-1 MONO CARTRIDGE. For E.P. and L.P. Complete with stylus. ONLY 12/6. P. & P. 1/-.
BRAND NEW 12" 15w. H/D Speakers, 3 or 15 ohm. Current production by well-known British maker. Offered below list price at 89/6. P. & P. 5/-. Guitars models: 25w. £5.5.0; 35w. £8.8.0.

BRAND NEW 3 OHM LOUDSPEAKERS
5 in., 12/6; 6 1/2 in., 15/-; 8 in., 22/6; 10 in., 27/6; 10 in. x 4 in., 16/-; 10 in. x 6 in., 27/6.
E.M.I. 8 in. x 8 in. with high flux magnet 21/-.
E.M.I. 13 1/2 x 8 in. with high flux ceramic magnet, 42/- (15 ohm, 45/-). P. & P. 4/- 5" 2 1/2" & 8" 2 1/2", 10" & 12" 3/6 per speaker.

E.M.I. PLASTIC CONED TWEETER.
2 1/2" 3 ohm. Limited number: 12/6 each, P. & P. 1/6.

SPECIAL OFFER!
Limited number of 12 in. 10 watt "R.A." Speakers: 3 ohm 25/-; 15 ohm, 27/6. P. & P. 3/6.

YNAIR AND REXINE SPEAKER AND CABINET FABRICS app. 54 in. wide. Usually 35/- yd., our price 13/6 per yd. length (min. 1yd.) P. & P. 2/6. S.A.E. for samples.

7-10 watt OUTPUT TRANSFORMERS to match pair of ECL 86's in push-pull to 3 ohm output. ONLY 11/- P. & P. 2/6.

MAINS TRANSFORMER for resistor power supplies. Tapped pri 200-250v. Sec. 40-0-40 at 1 amp (with electrostatic screen) and 6-3v. at 5 amp for dial lamps etc. Drop thro mounting. Stack size 1 1/2" x 3 1/2" x 3 1/2". P. & P. 4/6.

MATCHED PAIR OF 7 WATT TRANSISTOR DRIVER AND OUTPUT TRANSFORMERS. Stack size 1 1/2 x 1 1/2 x 1 1/2 in. Output trans. tapped for 3 ohm and 15 ohm output. 10/- pair plus 2/- P. & P.

SPECIAL OFFER! FM/AM TUNER HEAD
Beautifully designed and precision engineered by Dormer and Wadsworth Ltd. Supplied ready fitted with twin .0005 tuning condenser for AM connection. Prealigned FM section covers 86 - 102 Mc/s. I.F. output 10.7 Mc/s. Complete with ECC85 (6L12) valve and full circuit diagram of tuner head. Another special bulk purchase enables us to offer these at 27/6 each. P. & P. 3/-. Order quickly!

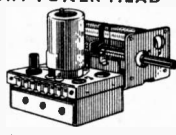
Limited number also available with precision geared 3:1 reduction drive. 30/- P. & P. 3/-.

3-VALVE AUDIO AMPLIFIER MODEL HA34

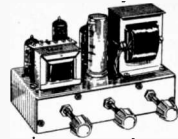

Designed for Hi-Fi reproduction of records, A.C. Mains operation. Ready built on plated heavy gauge metal chassis, size 7 in. w. x 4 in. d. x 4 1/2 in. h. Incorporates ECC83, EL84, EZ80 valves. Heavy duty, double wound mains transformer and output transformer matched for 3 ohm speaker, separate Bass, Treble and volume controls. Negative feedback line. Output 4 1/2 watts. Front panel can be detached and leads extended for remote mounting of controls.

The HA34 has been specially designed for us and our quantity order enables us to offer them complete with knobs, valves, etc., wired and tested for only **£4.5.0** P. & P. 6/-.

HSL 'FOUR' AMPLIFIER KIT

A.C. Mains 200/250v. 4 watt, using ECC83, EL84, EZ80 valves.

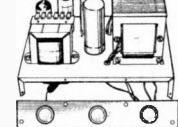

★ Heavy duty double-wound mains transformer with electrostatic screen.
★ Separate Bass, Treble and volume controls, giving fully variable boost and cut with minimum insertion loss.
★ Heavy negative feedback loop over 2 stages ensures high output at excellent quality with very low distortion factor.

★ Suitable for use with guitar, microphone or record player.
★ Provision for remote mounting of controls or direct on chassis.
★ Chassis size only 7 1/2 in. wide x 4 in. deep. Overall height 4 1/2 in.
★ All components and valves are brand new.
★ Very clear and concise instructions enable even the inexperienced amateur to construct with 100% success.
★ Supplied complete with valves, output transformer (3 ohms only), screened lead, wires, nuts, bolts, solder, etc. (No extras to buy.) PRICE 79/6. P. & P. 6/-.
Comprehensive circuit diagram, practical layout and parts lists 2/6 (free with kit).
This kit although similar in appearance to HA34 employs entirely different and advanced circuitry.

10/14 WATT HI-FI AMPLIFIER KIT

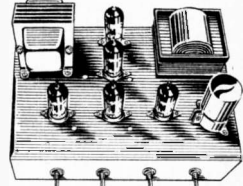

A stylishly finished 'monaural' amplifier with an output of 14 watts from 2 EL84s in push-pull. Super reproduction of both music and speech, with negligible hum. Separate inputs for mike and gram allow records and announcements to follow each other. Fully shrouded section wound output transformer to match 3-15Ω speaker and 2 independent volume controls, and separate bass and treble controls are provided giving good lift and cut. Valve line-up 2 EL84s, ECC83, EF86, and EZ80 rectifier. Simple instruction booklet 1/6. (Free with parts.) All parts sold separately. ONLY £79/6. P. & P. 8/6. Also available ready built and tested complete with std. input sockets, £95/- P. & P. 8/6. Carrying Case for above 28/6. P. & P. 7/6.

MATCHED PAIR AM/FM I.F.'s. Comprising 1st I.F. and 2nd I.F. discriminator. (465 Kc/s/10.7 Mc/s). Size 1" x 1 1/2" x 2 1/2" H. Will match FM/AM Tuner head on left. 11/- pair. P. & P. 2/-.

HARVERSON SURPLUS CO. LTD.

170 HIGH ST., MERTON, S.W.19 ChErwood 3985

Open all day Saturday Early closing Wed., 1 p.m.
A few minutes from South Wimbledon Tube Station. (Please write clearly)
OVERSEAS P. & P. CHARGED EXTRA. S.A.E. with all enquiries

ELECTRONIC ORGAN KITS

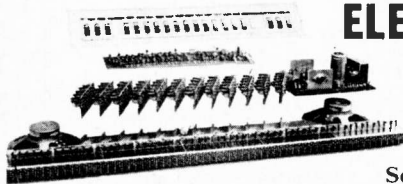

NOW ALSO AVAILABLE IN PARTLY BUILT FORM £105

So easy to build, so delightful to play
Suited to all types of music



The Solette. Precision made, pre-tuned units come to you ready to assemble in only 20 hours. Self-contained amplifier and speakers; perfect tone and generous volume, full 5-octave organ keyboard. Five pitches plus solo and melodic bass. Transistorised, portable. Price £118 complete (terms if needed). Details from:

Harmonics*
(Bromley) Ltd

DEPT. P.E.2, CLARION WORKS, NAPIER ROAD, BROMLEY, KENT. RAVensbourne 2122

★ Also two-manual and pedal organ kits up to £395.

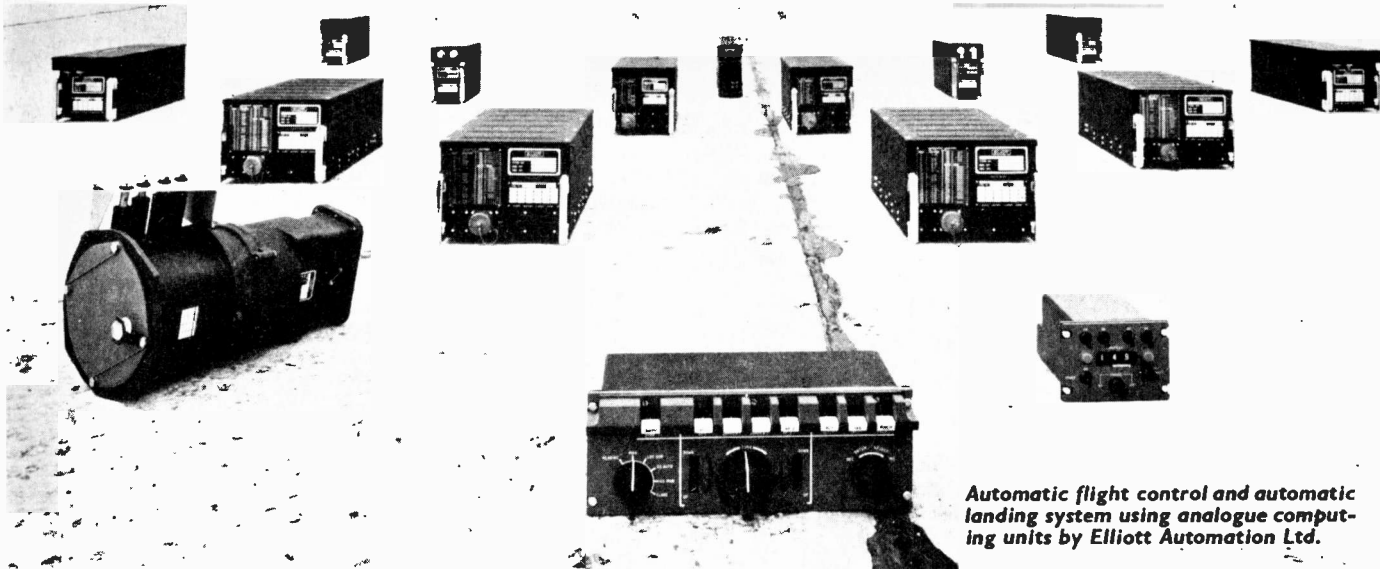

Automatic flight control and automatic landing system using analogue computing units by Elliott Automation Ltd.

COMPUTER EVOLUTION

PART TWO

By S.A. HODSON B.Sc.

BASIC ANALOGUE CIRCUITS

IN the opening article of this series, the differences between analogue and digital computers were explained, and their early development from simple calculating machines was traced. Now we shall come up to date and look at modern analogue computers and some of their uses.

Two important concepts were described in the previous article. The first of these concepts was that of the "model". It should be obvious that a scale model of a ship or an aeroplane will be a great help in predicting its behaviour when it is built full size.

What may not be so obvious is that, especially in these days of electronics, the model need not be a physical scale model at all, but can be a model made in any medium the modeller likes to use. Of course some media are more direct than others, and it is this that directs the attention to the first means of classification of analogue computers: "Direct" and "Indirect". A scale model of an aeroplane in a wind tunnel is a "direct" computer, whereas an electronic analogue computer, programmed to represent the aeroplane in the air flow, would be an "indirect" computer.

In this case, the electronic computer works by representing the air flow over the aircraft; and it does this by means of mathematical equations that can take into account every bump or curve on its skin. What is perhaps more important is that these equations can be altered to take account of a design change without the aircraft having to be hacked about by a welding torch, in fact the performance of the whole plane can be predicted before hacksaw has touched metal.

These mathematical equations or "functions" as they are more properly called, are the second of the two concepts mentioned above: that of being able to represent any physical occurrence by means of an equation.

COMPUTING MEDIA

There are three main computing media in the field of analogue computing. The first of these is that of mechanics. Scale models are a good example of the

direct application of a computing device in this field, while a slide rule serves to illustrate the indirect use of a mechanical device.

The use of the term "computer" about a scale model is not as loose as it may seem. Take for example the case of the model in the wind tunnel. Physical distances and hence velocities have obviously to be scaled, but what about the pressure, the density, and even the composition of the air flowing in the tunnel? These must be scaled too.

A whole science known as "dimensional analysis" has grown up around these scale models, and a lot of time is devoted to the calculation of the correct scaling factors for all the parameters involved in a scale model.

The second medium used in analogue computing is the fluid; here the term fluid includes both liquids and gases, thus embracing the sciences of hydraulics and pneumatics in one term. The fluid medium is mostly commonly used in the direct fashion in scale models of dams and hydroelectric schemes.

It can, however, be used indirectly, and a good example of this is the "electrolytic tank". This device is used mainly in computations involving field theory of one form or another. The details are not important here but the general idea is to have a tank full of an electrolyte and to immerse electrodes in this tank. The arrangement of the electrodes represents the system being investigated, and when they are charged up, the value of the electric field at any point in the electrolyte can be used to calculate the behaviour of the system.

The third, and certainly the most widely used, of the three media that have been mentioned is, of course, that of electronics; and it is the application of this medium that is of interest here.

It should be noted that nearly all the devices described so far can only be used for one purpose. For instance, the model aircraft can only represent one full size machine, any other design will have to have a different model. A computer of this type is known as a "fixed purpose" machine, and as such is limited in its field of operations.

MATHEMATICAL FUNCTION

The great advantage of an electronic computer is that it is a general purpose machine and can be programmed for one job then, when that job is finished, programmed for something entirely different. To achieve this flexibility of operation, the electronic machine works in the realm of the mathematical function, and it is to the explanation of these that the next few paragraphs must be devoted.

Suppose that a capacitor is being charged from a battery, through a resistor. The voltage and current wave-forms will look like Fig. 2.1.

If the graphs of V and I are examined more closely, it will be seen that the actual value of I is directly proportional to the slope of V . That is, near the origin of the graphs, V is sloping upwards quite sharply, and I has a high positive value. As time progresses, V slopes less sharply and the value of I drops away. In mathematical terms this can be expressed

$$I = C \left(\frac{dV}{dt} \right) \quad (1)$$

where the term dV/dt is used to represent the rate of change of voltage V with time. The operation performed on V to get dV/dt is known as "differentiation". The letter d is an arbitrary symbol of differentiation. Similarly, to get back to V from dV/dt the process used is known as "integration", and may be written thus:

$$V = \frac{1}{C} \int I dt \quad (2)$$

Two very similar equations can be written to represent the behaviour of an inductor namely:

$$V = L \left(\frac{dI}{dt} \right) \quad (3)$$

and

$$I = \frac{1}{L} \int V dt \quad (4)$$

The elongated S sign denotes integration.

No apology is made for starting at such an elementary point in the theory of functions, since these equations are by far the most important in the realm of analogue computing. It is in fact possible, with these four equations to set up solutions to the most complex differential equations imaginable.

Just as it is possible to differentiate V once and obtain dV/dt , it is equally possible to do it again and end up with d^2V/dt^2 .

An easy way of understanding this is to consider a car travelling along a road, and to let the distance it has covered be x miles. Then if x were to be differentiated dx/dt would be obtained which is the velocity of the car in miles per hour. A further differentiation would give d^2x/dt^2 which is its acceleration, in miles per hour per hour, and so on. In just the same manner integration may be performed again and again.

In all these examples the function "time" t has been involved and the differentiations and integrations that have been performed have been done with respect to time. Any computations done with respect to time in this manner would be known as "real time" computations.

A great deal of analogue computing is done with respect to time, although, as will be seen, it need not always be real time that is used. In some cases it is very convenient to use "half time" or "quarter time". This gives a very powerful method of speeding up what may be a tedious calculation.

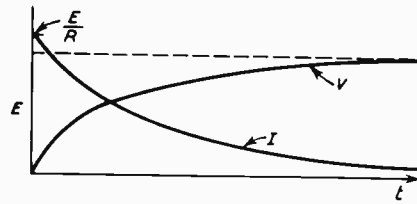
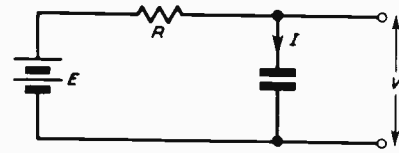

Fig. 2.1. Capacitor charging circuit with voltage and current waveforms

Having described the basic formulae involved in calculus (this is the term used to describe integration and differentiation), it is possible now to turn to the differential equation, which forms the basis of all computations performed on an analogue computer. The general form of such an equation is:

$$a + bx + c \left(\frac{dx}{dt} \right) + d \left(\frac{d^2x}{dt^2} \right) + e \left(\frac{d^3x}{dt^3} \right) + \dots = 0 \quad (5)$$

This looks positively frightening, and as it stands, has no solution. However, if it is broken up into its separate terms, it will be seen that each term is no more than one differentiation of the previous term with a different constant attached. When all the terms are added together they might, for instance, represent the flow of air across an aircraft's wing surfaces, or, in a simplified form, they might, as has already been seen in previous equations, represent the behaviour of a capacitor or an inductor.

Solartron analogue computer in use in the electrical and mechanical research laboratories at the University of Sheffield

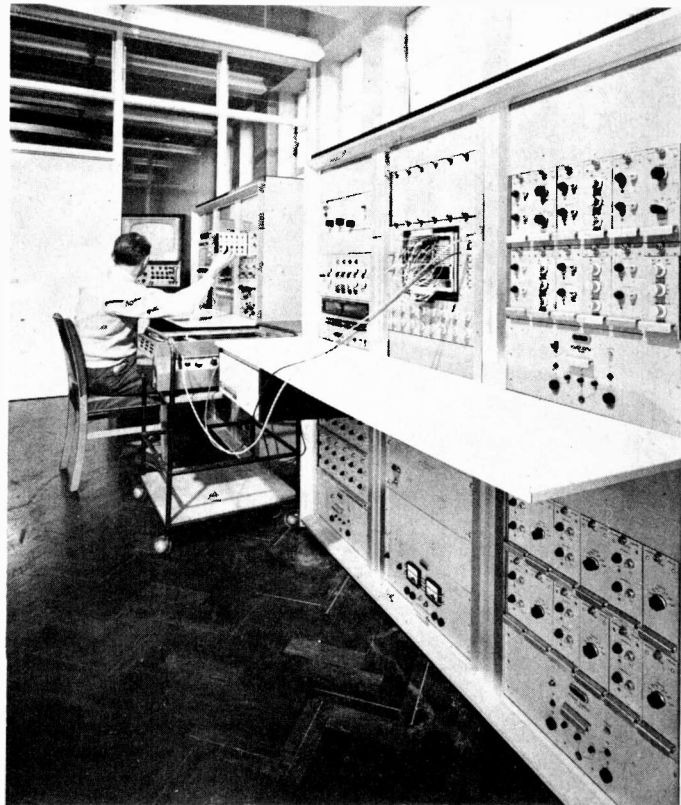

OPERATIONAL AMPLIFIER

To turn now to the actual hardware involved, the basic linear computing unit is the "operational amplifier" (see Fig. 2.2). The amplifier has a very high gain, and its input current is assumed to be zero.

If this is the case, then $I_1 = I_2$, putting this in another form gives

$$\frac{V_1 - V_k}{Z_1} = \frac{V_0 - V_k}{Z_2} \quad (6)$$

Now if the gain of the amplifier is in the thousands or even millions, then V_k can be neglected in comparison with V_1 and V_0 , and this equation becomes

$$\frac{V_1}{Z_1} = \frac{V_0}{Z_2}$$

or

$$\frac{V_0}{V_1} = \frac{Z_2}{Z_1} = G$$

where G is the "closed loop" gain of the unit as a whole. Thus the gain of this device can be controlled at will by the user simply by juggling with the two impedances Z_1 and Z_2 .

Suppose now that Z_1 was a resistance of $10\text{k}\Omega$ and Z_2 a resistance of $100\text{k}\Omega$, then the gain G would be 10 and the output voltage V_0 would be 10 times the input voltage V_1 . This is a simple way of multiplying a variable voltage by a constant. In fact it has performed one of the operations required to form equation 5.

The patch board and analogue control panel on the Solartron basic 24 amplifier equipment

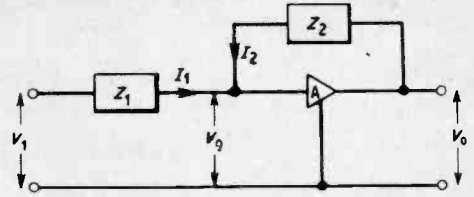
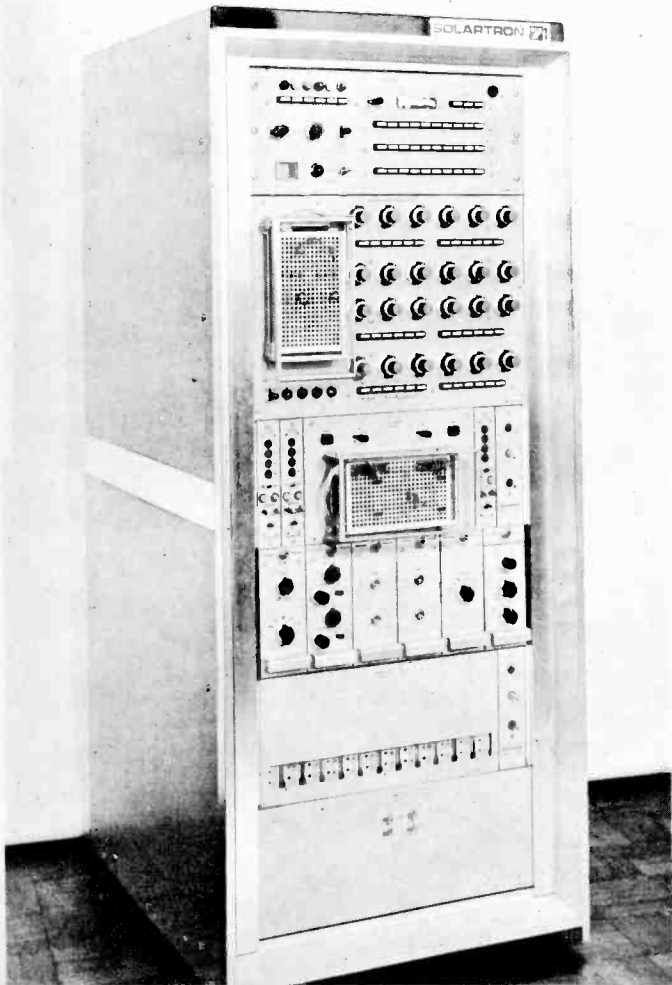

Fig. 2.2. Basic operational amplifier

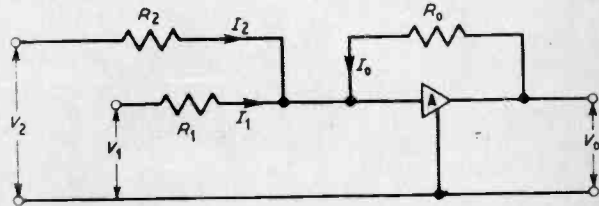

Fig. 2.3. Two inputs fed into a basic amplifier

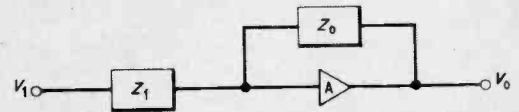

Fig. 2.4. Simplified diagram of an operational amplifier

In the above diagrams A is normally prefixed with a minus sign to denote 180 degrees phase shift

If the input voltage were to represent dx/dt , and $Z_2/Z_1 = c$, then the output voltage will be $C(dx/dt)$; one of the terms in equation 5.

Consider now what would happen if two inputs were added on to a basic amplifier, as in Fig. 2.3.

Now, using the same assumptions as before,

$$I_0 = I_1 + I_2$$

then

$$\frac{V_0}{R_0} = \frac{V_2}{R_2} + \frac{V_1}{R_1}$$

therefore

$$V_0 = \left(\frac{R_0}{R_2}\right) V_2 + \left(\frac{R_0}{R_1}\right) V_1$$

but R_0/R_2 and R_0/R_1 can be varied independently of each other, and hence it is possible to add two variables together. For instance:

Let

$$V_1 = 1 \quad \text{and} \quad R_0/R_1 = a$$

and

$$V_2 = x \quad \text{while} \quad R_0/R_2 = b$$

then $V_0 = a + bx$, which are the first two terms of equation 5. It is easy to see how this technique can be extended to accommodate any number of inputs with different multipliers for each one. The only thing that remains now is to be able to differentiate and integrate electronically. Once this is possible, the whole of equation 5 will be constructed from just one input.

The only type of amplifier that has been dealt with so far is that in which the two impedances, Z_0 and Z_1 (see Fig. 2.4) were both resistances.

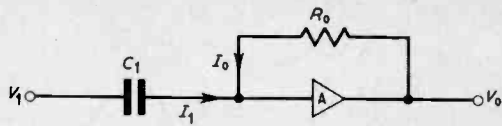

Fig. 2.5. Z_1 is represented by a capacitor

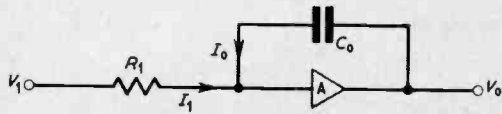

Fig. 2.6. Z_1 is represented by a resistor and Z_2 by a capacitor

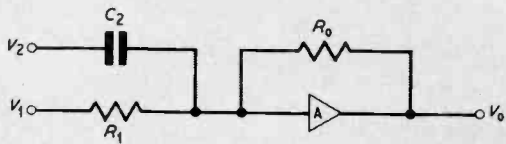
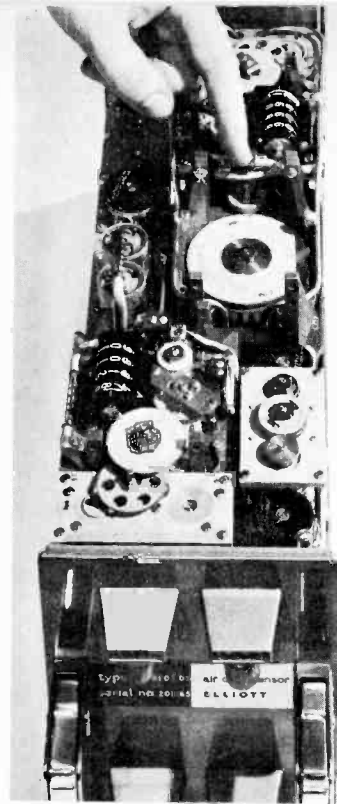

Fig. 2.7. A differentiator C_2 and scaler R_1 are combined

In the above diagrams A is normally prefixed with a minus sign to denote 180 degrees phase shift



Elliott air data analogue computer for aircraft. Signals from the aircraft's sensors are converted for use in flight control

It may have been noted that, in Fig. 2.4, no earth or zero voltage line has been drawn. This is a matter of convenience, and provided that all voltages given on a diagram are given with respect to earth, then no confusion should arise. This makes the drafting of large, more complex circuits, a very much less tedious task.

Having described the results of calling Z_0 and Z_1 resistances, consider now what would happen if one of them, say Z_1 , were to be a capacitance, leaving Z_0 as a resistance, as in Fig. 2.5.

Assuming, as before, that the amplifier draws no current at its input, then $I_0 = I_1$ hence, using equation 1

$$\frac{V_0}{R_0} = I_1 = C_1 \left(\frac{dV_1}{dt} \right)$$

or

$$V_0 = R_0 C_1 \left(\frac{dV_1}{dt} \right)$$

This means that the output of this type of operational amplifier is directly proportional to the differential of the input. It is now that the possibilities of such an amplifier begin to make themselves felt. Given, say, x in equation 5, and this may be the distance that a car has travelled as read from its trip-meter, then solely by using a train of differentiators, as in Fig. 2.5, dx/dt , and all the further derivatives of x , may be found. This gives the speed of the car at any one point; also, its acceleration, its rate of change of acceleration, and so on.

Supposing Z_0 and Z_1 were to be interchanged, making Z_0 a capacitance, and Z_1 a resistance, as in Fig. 2.6.

In this case

$$I_0 = I_1 = \frac{V_1}{R_1} = C_0 \left(\frac{dV_0}{dt} \right) \quad (7)$$

Now, remembering that, to get from dV_0/dt to V_0 , it is necessary to integrate, it is possible to integrate both sides of equation 7, and get

$$C_0 V_0 = \int \left(\frac{V_1}{R_1} \right) dt \quad \text{or} \quad V_0 = \frac{1}{C_0 R_1} \int V_1 dt$$

The dt is included to show that the integration has been performed with respect to time.

Not only is it possible to differentiate and multiply with an operational amplifier, it is also possible to integrate.

The flexibility of these units is such that they can be mixed up together to give more complex results without having to use large quantities of hardware. For instance, Fig. 2.7 shows how a differentiator and a scaler can be mixed together. This dodge can save two operational amplifiers straight away.

It may have been noticed that nowhere in the preceding paragraphs is an inductor mentioned.

The reason for leaving out the inductor is that in practical circuits for this purpose they are never used. Capacitors are cheaper, smaller, easier to obtain, and more stable than inductors. Furthermore, there just isn't any need for them, since all the functions that are needed can be performed using capacitors alone.

In the next article it is intended to describe how these methods are put to use in practical analogue computers; types of d.c. amplifier that can be used; setting up for computation.

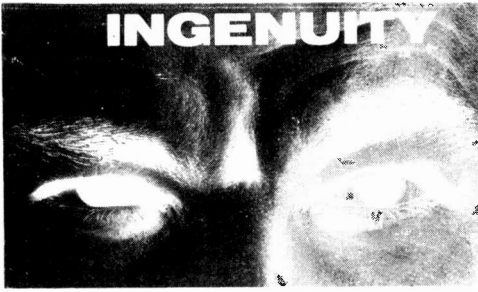

UNLIMITED!

IN THIS feature we hope, from time to time, to be able to publish suggestions submitted by some of our readers on the possible improvement of projects previously described in PRACTICAL ELECTRONICS; short contributions on other subjects may be included. The aim is not to find fault or undermine the abilities or knowledge of our contributors. It may well be that the original article is *par excellence* but it could be improved or adapted to suit individual requirements. The views expressed by readers are not necessarily those of the Editor.

AUTOMATIC SWITCHING OF TAPE RECORDERS

THERE are, of course, alternatives to the method (January 1967 issue) of automatically switching tape recorders. One, basically with less components—and no transistors—is shown in Fig. 1. This unit is simply interposed between the mains supply and the tape recorder. RLA is a Carpenter miniature polarised relay of the twin coil, each-side-stable variety (such as the 5c9, which has 1,600 ohm coils). Coil (b) is connected so that closure of the watch contacts pulls the relay armature “in”. It will, of course, remain “in” after the watch contacts have opened again.

Coil (a) is connected so that the circuit completed by the tape foil moves the armature “out”. So long as the armature is “in” RLB is energised, completing the mains circuit to the tape recorder. Although, normally, the unit will not be used a vast number of times, the loads switched by the watch contacts and RLA contacts are each inductive and it would be desirable to suppress arcing by wiring a resistor (50–100 ohms) and a capacitor (0.05–0.1 μ F) in series across each pair of contacts as shown.

Provided the recording period is to exceed the period of closure of the watch contacts (about 35 minutes) a very short piece of tape foil will result in switching off the mains supply to the recorder. One of the short self-adhesive metallic tabs available from some photographic dealers, fixed temporarily to the back of the tape, will do the job simply and conveniently if the tape deck contacts are suitably arranged. Motor over-run will take the tab past the contacts so that the unit ceases to draw current.

For shorter recordings, a good electrolytic capacitor (say 200 μ F) in series with coil (b) of RLA will allow a “pulse” (whilst the capacitor charges through the coil) to move RLA armature “in”, after which only a minute leakage current will flow—not enough to prevent the foil tab moving the armature “out” again at the required time. Obviously the leakage current will continue to flow only until the watch contacts open.

Since the unit draws current only during the period of watch contact closure or the period of the recording—whichever is the longer—consideration could well be given to battery operation, dispensing with a step-down transformer which would continue to be “alive”. Either way, the d.c. operating voltage is dictated by RLB: the Carpenter relay of the type mentioned, when in good mechanical adjustment, is capable of operation on less than half a volt and little more than a quarter of a milliamp—which means that each coil could have a quite large series resistance, if desired, to keep consumption to a minimum.

If operation via a transformer and rectification is preferred, the circuit of Fig. 2, which uses an additional relay, has the advantage of shutting off the mains supply to both transformer and tape recorder at the end of the recording. Operation is fairly obvious. Depressing the push-button or microswitch (of the biased-off type) closes the mains circuit to the transformer. Rectified low voltage then energises RLC through RLA contacts, and RLC contacts preserve the mains supply to the transformer when the push-button is released.

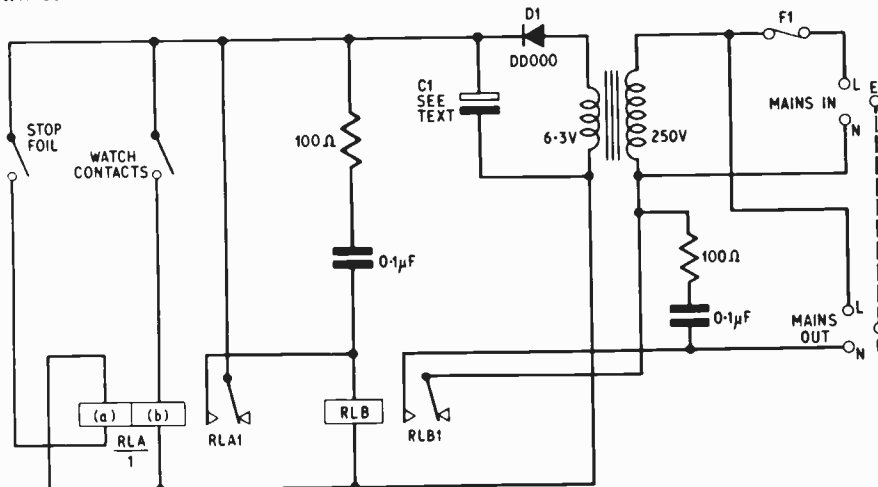

Fig. 1. Simple tape recorder switch using a Carpenter relay

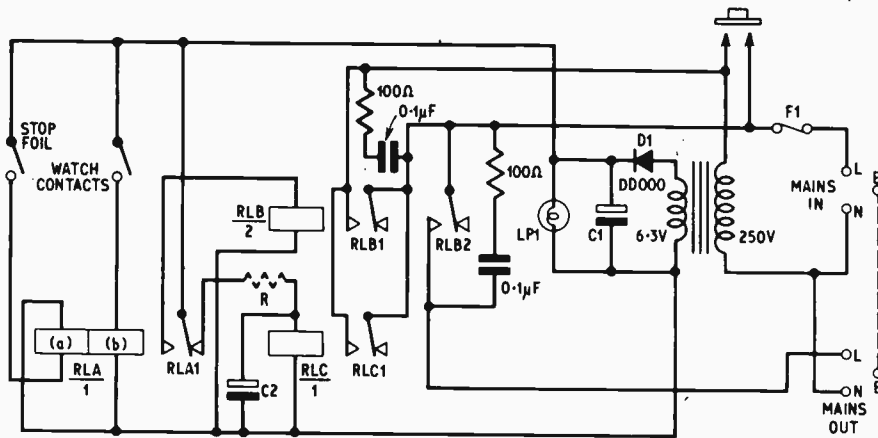

Fig. 2. Improved version of circuit in Fig. 1 to switch off the mains supply at the end of recording

The pilot lamp (which also has another function mentioned later) indicates that the unit is set.

When the watch contacts close, RLA contacts change over, energising RLB in place of RLC, but discharge of the capacitor in parallel with RLC delays its de-energisation long enough for its function to be taken over by RLB, thus preserving continuity of the mains circuit. RLB's second pair of contacts complete the mains supply to the tape recorder.

When the deck contacts are bridged by the foil tab and RLA changes over again there is a fraction of time during which its armature is between its side contacts, touching neither. RLC is already de-energised, and RLB is immediately also de-energised so that the mains circuits to both the transformer and the tape recorder are opened. However, the fraction of time is very small indeed and if sufficient charge remains long enough on the reservoir capacitor C1, RLC will again energise—restoring the mains supply to the transformer, though not, of course, to the tape recorder. During the changeover, RLA (via the foil tab) will briefly take some current from C1 but it will be very little; the pilot lamp will take much more.

On completion of the changeover, C2 presents a temporary virtual short to C1, after which there may be some remanent charge on both capacitors at something less than maximum voltage) draining rapidly away via the pilot lamp and RLC coil. If the capacitance of C1 is chosen to be no greater than is necessary to obviate relay chatter, the probability is that all will be well—so long, at least, as the lamp doesn't fail.

There is a simple way of making sure: a resistance R, will make RLC slow to close without disturbing its slow-to-open function—provided RLC, C2 and R all have fairly high values. A little experimenting with alternative values of C and R, with the pilot lamp removed, should quickly ensure satisfactory operation. If necessary, a bleeder resistance can be fitted across C1. Remarks, in respect of Fig. 1, concerning short recordings and inductive loads clearly apply also to the circuit of Fig. 2. All relays should be capable of operating at the supply voltage (6.3V) and have heavy duty contacts.

If the tape recorder to be used has a three-core mains cable, the earth line can obviously also be used as a connection between the control unit and the "earthed" contact of the pair on the deck which are bridged by the tape foil. This leaves a single line connection to be made (e.g. by banana plug) to the insulated deck contact.

"SOCKET" FOR BANANA PLUG

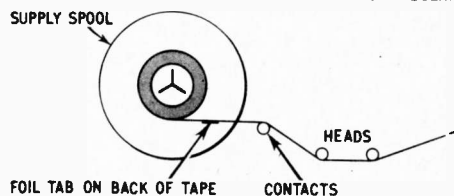
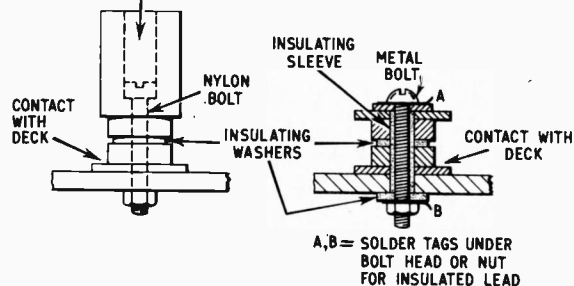

Fig. 3. Insulation of the tape guide and position with respect to the heads

Any rectifier diode rated at about 12V 0.5A will suit for D1.

N.B. Reference to removable self-adhesive foil tabs assumes use of a deck contact assembly similar to those in Fig. 3, which are easily made up. If separately mounted contacts are used, the length of stop foil spliced into the tape should be only marginally longer than the distance between them.

N. G. Dix,
London, W.1.

We would stress that neither this system nor the original system (January 1967) are immune from the possibility of "flats" occurring on the rubber capstan roller if this is mechanically held engaged while the recorder is not running.

SIMPLE SITAR

IN THE "Simple Sitar" (*Ingenuity Unlimited*, March issue) there should be a resistor 220kΩ between TR1 base and the negative supply line. R1 on the published circuit should be 4.7kΩ and R2 220kΩ. The battery voltage is 9V.

FUEL SAVER TIME SWITCH

I HAVE a solid fuel central heating boiler with a mains driven combustion air fan normally controlled by a thermostat. The arrangement as supplied wastes fuel overnight or goes out if the thermostat is set low due to the long waits between "fan on" phases when no heat is abstracted from the primary circuit. To cure this I found that a thirty second puff every half-hour would keep the fire alive without wasting heat. I modified the *Time Switch* (October 1966).

The basic time switch was used to control a power transistor with a 9V relay (with heavy duty contacts) in the collector circuit. The delay period was extended by substituting a 1,000 μ F at C1 and a 10M Ω resistor at R2 and a recycle delay (to keep the relay closed for periods of up to a minute) arranged by discharging C1 through a 100k Ω preset potentiometer switched in by the relay.

Commercial units quoted for the same duty were priced in the £10 region. My switch cost £4 complete with 9V d.c. supply from a mains power unit.

The same system, with slight variations, might be used for intermittent feeds, sampling devices, lighting displays, fountains and the like.

C. Mattingly,
Wormington,
Worcs.

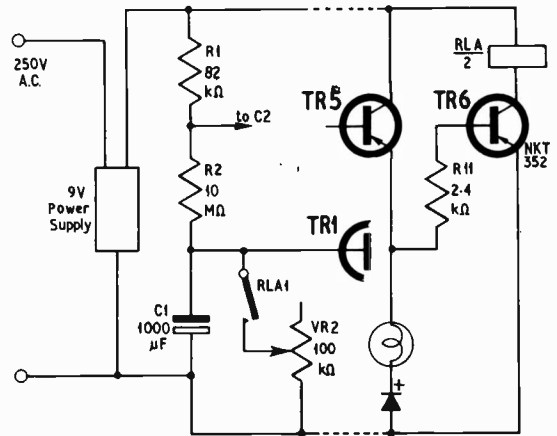

Fig. 1 (above). Modified parts of the original Time Switch circuit

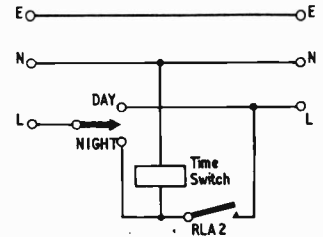

Fig. 2 (right). Mains supply is fed via the "day night" switch and RLA2 to the air fan

THERMAL DELAY

IF THE *Car Burglar Alarm System* in your February issue is wired as shown, when the system is switched off, the mercury switches S1 and S2 will short-circuit the door switch whilst the car is in motion, and thus will flash the interior light.

This can be avoided by inserting a single-pole changeover switch S4 into the circuit as shown in Fig. 1.

It must be remembered when wiring in S4 that there can be up to four door switches; make sure that it is connected correctly.

As it is possible for the alarm to be set off accidentally, the owner may return to find a flat battery.

Fig. 1 also shows a modification to overcome this difficulty.

The system is operated in the conventional manner with mercury and door switches. When the alarm has been set any interference with the car will sound the horn for 30 seconds after which the alarm will reset itself. If the interference continues the alarm will not reset but continue sounding until manually restored.

When the concealed switch S3 is operated the two relays RLA and RLB are connected in series with the door and mercury switches.

When the circuit is completed via S1, S2, or the door switches, RLA operates and holds in via RLA1, relay RLB is a thermal delay relay which will take

30 seconds to operate. The car horn will sound via RLA2 for 30 seconds until RLB operates and RLB1 disconnects the relay circuit. RLA and RLB will release, if S1, S2, or the door switches are operated still. Relay RLA will reoperate and the horn will continue to sound. If the source of interference is removed RLA will not reoperate, thus avoiding the nuisance of flat batteries or having to attend to false alarms.

The thermal delay relay recommended is the P.O. type (Fig. 2). This can be mounted on the PO 3000 type relay, thus if RLA is the PO 3000 type relay the unit will take up very little room.

This thermal relay can be adjusted to give a delay of 10 seconds to 60 seconds in operate lag, the release lag is 1-15 seconds depending on the operate lag and the ambient temperature.

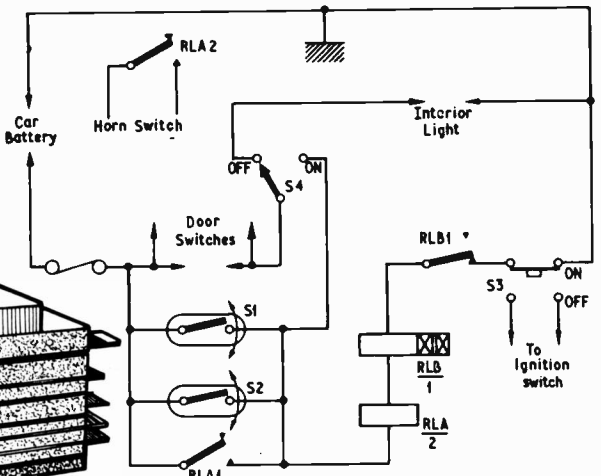
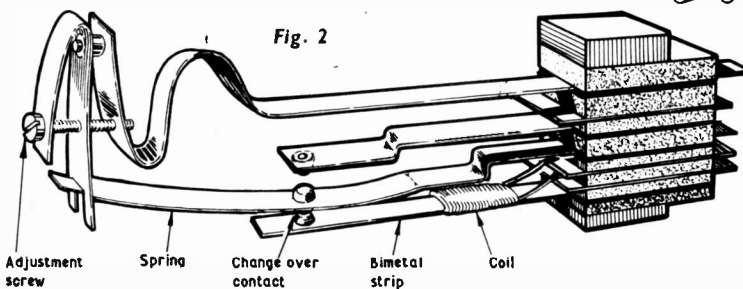
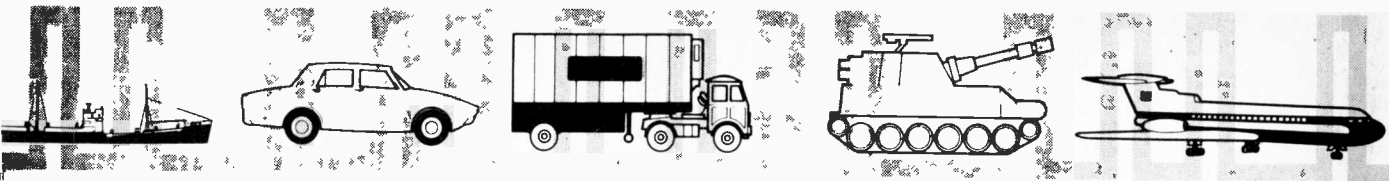

Fig. 1

P. Heal,
Acton,
London, W.3.



MODEL CONTROL

PART ONE

The short series in **PRACTICAL ELECTRONICS on Miniature Model Control** gave constructional details of a transmitter, receiver, and three amplifiers designed specifically for use in small models.

Sufficient information was given to allow the reader to construct and put into operation the basic units of equipment, to the point where a single or multiple on-off function could be obtained in response to a push-button command from the transmitter.

The next stage described here is conversion of a switched function to mechanical operation of various controls within the model itself.

AN IDEAL form of model control system is one where angular rotation of potentiometer spindles at the transmitter is faithfully reproduced by a like rotation of corresponding powered shafts in the model, which are linked to functions such as steering, or engine speed. The majority of existing systems only approximate to this ideal, for the very good reason that a "full house" proportional outfit is rather expensive, and may use as many as 60 or 70 transistors. Nevertheless, it is surprising what can be done with very simple equipment and a skilful operator, particularly in the field of miniature models.

STEERING

The ability to point the model in any desired direction can be claimed as the prime requirement, and it is possible to achieve interesting results with steering alone. Other controls, such as stopping and reversing, can be added later.

Before going on to a description of an integrated steering unit it would be as well to explain first the action of the clockwork escapement. The illustration of Fig. 1 may help to make clear the sequence of events,

which is common to all four-arm escapements, including rubber powered ones.

Referring to Fig. 1, when a pulse is applied to the electromagnet by brief closure of the reed switch in the amplifier module, the latch will move down, releasing arm 1 of the rotor. The rotor is then free to move quickly under power, and drive the crank round, but the top of the latch has moved inwards and blocks the path of approaching arm 3, now on its downward journey. Thus, the rotor stops just before the crank has reached its full control position.

When the pulse ceases the latch is pulled back by its spring against the top stop, releasing arm 3. The bottom of the latch just has time to move in and stop arm 4 when arm 3 is released, and the crank attains full control position.

Therefore, with a single input pulse of indeterminate length, the escapement has unlatched, moved under power to the next position, and relatched on cessation of pulse, ready for the next command to be given. From this it will be clear that a four-arm escapement can provide positive positioning of its crank with the minimum fuss and bother at the transmitter end, and

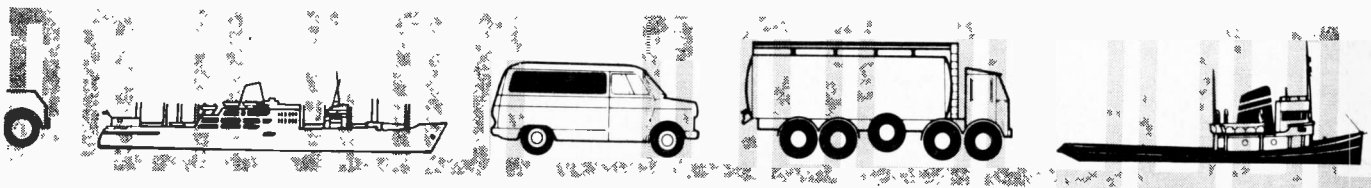

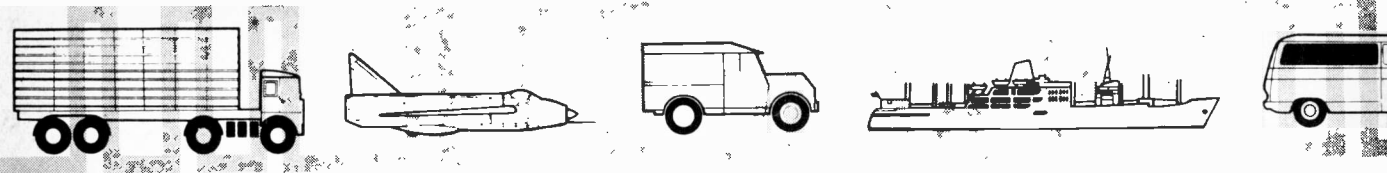

INSTALLATIONS

By D. BOLLEN

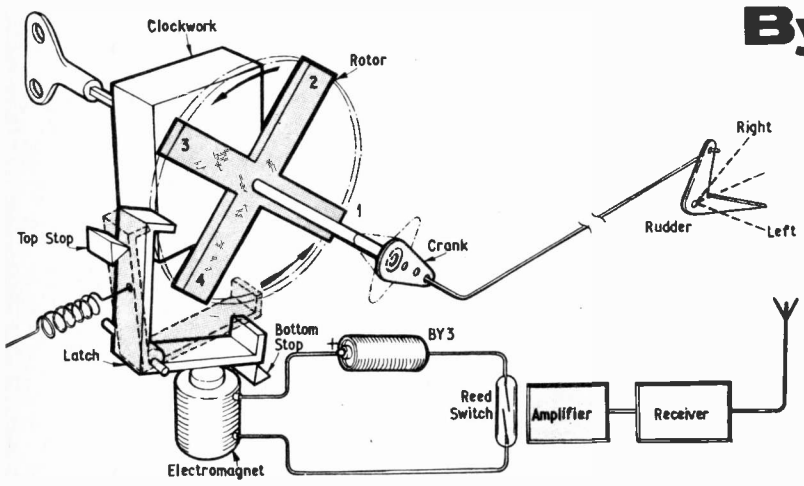

Fig. 1. Simple four-position sequential escapement — pulse operated

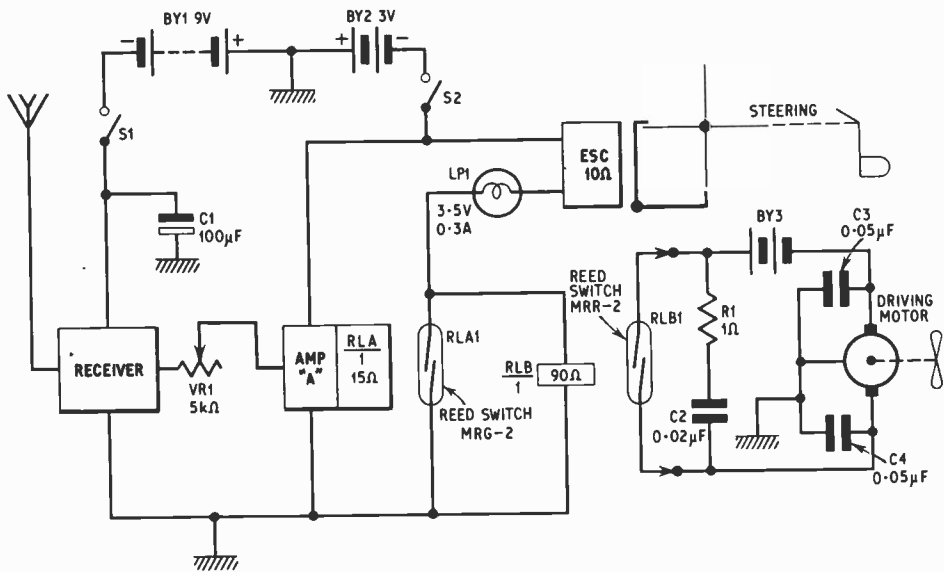
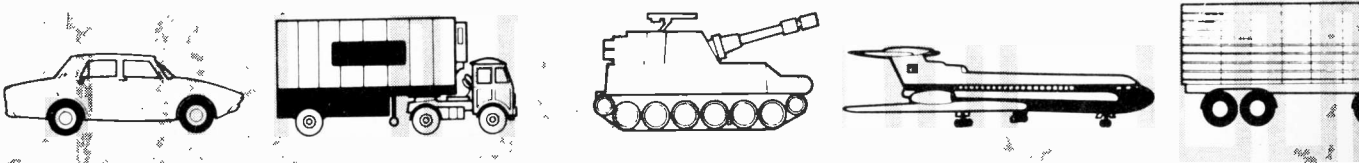
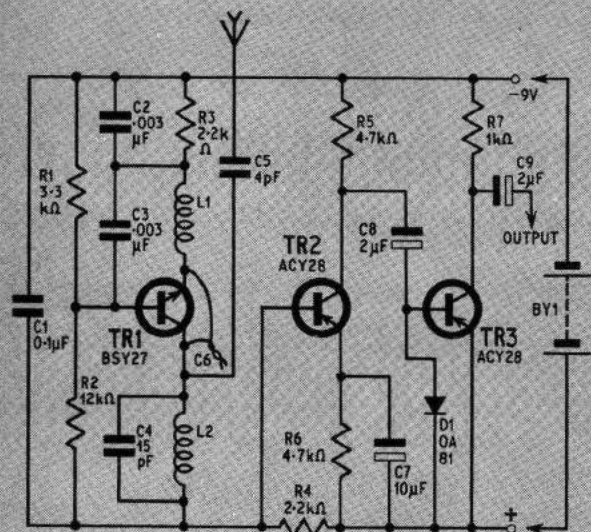

Fig. 2. Addition of stop-start circuit to steering unit



RECEIVER



AMPLIFIER "A"

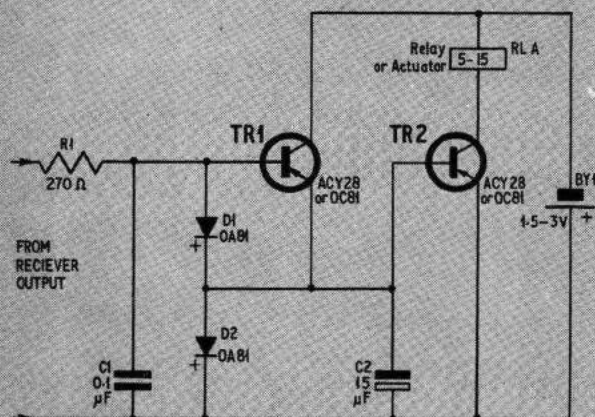

AMPLIFIER "C"

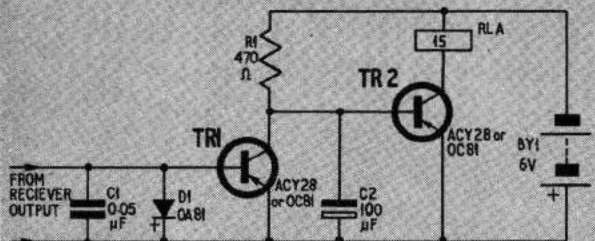

These three circuits are reprinted from the previous series on *Miniature Model Control*. The Transmitter and Amplifier "B" will be given in Part Two

power is only taken from the battery for the duration of the pulse (typically 300-400mA).

It is only necessary to remember the simple sequence *right, neutral, left, neutral* to make the model go straight ahead or to left or right. Two or three fast pulses in succession will cause the escapement virtually to skip positions. Intermediate steering alignment can be approximated by fast work on the transmitter button, so that the escapement only remains at full right or left for a very brief time, sufficient to "twitch" the model in the desired direction; this is where the skill comes in.

The "Rising" Mark 1 four-arm escapement used with the prototype is manufactured by Rising and Schulz, Whissendine, Rutland, and can be obtained from many model shops. There is enough crank power available for a small boat or aeroplane, and the escapement has even been employed by the author to turn the steering wheels on a model car weighing over one pound. The clockwork motor will yield more than 150 complete revolutions of the crank on one winding.

INTEGRATED STEERING UNIT

The integrated steering unit, shown in the photographs, was made with the Receiver and Amplifier "A" module. Being only 3½in long, this unit is small enough to fit inside electrically powered model boats, cars, and tanks. All-in weight, including batteries, is 4 ounces, making the unit suitable for fairly small model aeroplanes. The main reason for having an integrated unit is that it can be quickly transferred from model to model, thus avoiding unnecessary duplication and expense.

Propulsion motors tend to radiate considerable electrical interference, due to sparking on the brushes. One remedy is to wire two 0.05μF capacitors from the brush holders to the metal body of the motor, but even then interference may still be experienced, especially when the Receiver is positioned close to the propulsion motor.

Looking at the circuit in Fig. 2, interference control VR1 has been introduced between the Receiver output and Amplifier "A" input. If interference does cause spurious triggering of the escapement, VR1 can be backed off to just past the point where triggering ceases. There may be some slight loss of range, but not enough to prove troublesome.

VR1 also serves as an accessible connection for a pair of high impedance headphones, which are used to monitor Receiver operation and tone signal from the Transmitter.

Miniature model control receivers do not normally incorporate extensive supply decoupling but, when powered by low impedance Deac type rechargeable batteries, stability is adequate. However, if high gain transistors have been employed in the Receiver circuit there may be instability when it is coupled to a small layer built primary battery, such as the PP5. A simple cure for this instability, which lowers the effective battery impedance, is to wire a sub-miniature 100μF capacitor between the negative supply rail and earth. This is shown in the photograph on the underside of the mounting panel alongside BY2.

The steering unit, receiver and amplifier "A" modules are fixed to a mounting board by means of rectangular pieces of foam plastic, held in place with spots of glue. Although quite firm, the foam will absorb vibration from the propulsion motor, and guard against fatigue of soldered joints.

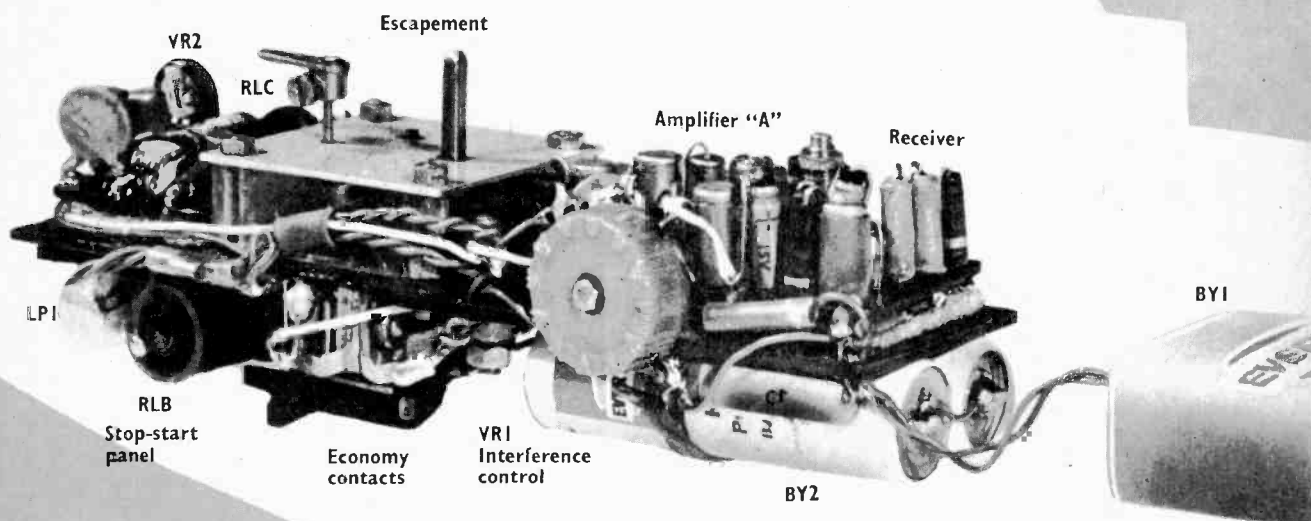

In the event of a very severe jolt, the modules will break free, and this avoids damage to delicate components. The crank can be attached either to the top of the output spindle (as shown in the photograph) or underneath close to the rotor.

High power cells are recommended for BY2 (for example, HP7), and are slung below the mounting board and held with a rubber band. Although a small box equipped with spring contacts could be made up to take the cells, soldered connections are more reliable. Pairs of cells can be quickly taped together and soldered, and it does not take long to connect such a battery to a set of miniature screw terminals on the mounting board. In the pulsed mode, the HP7 will give a surprisingly long life, and battery replacements are infrequent.

BY1 is not fixed to the mounting panel, but is used as ballast to trim the model. Similarly, switches S1 and S2 (Fig. 2) should be conveniently mounted on the outside of the model. BY1 is held by a rubber band, and the two switches can be attached to a sub-panel, designed for quick removal.

If the layout has been well arranged, it should be possible to transfer the integrated unit in a few minutes to another model. One further practical point; the linkage to the rudder or steering can be a piece of wire with a 90 degree bend at the end, to drop into one of the holes in the crank. This is prevented from jumping out again by a short length of tight sleeving slipped on the end of the wire.

STOPPING THE PROPULSION MOTOR

Having constructed and used the integrated steering unit, the enthusiast may wish to introduce other functions, such as "stop-start" and "slow reverse". One virtue of the unit form of construction is that changes can be made without dismantling the original modules.

The only real headache is in finding a bit more space in the model to take extra circuits and batteries. If the intention is to equip one particular model only, better use of available space can be made if the sub-units are dispersed, instead of being assembled in integrated form. It is amazing how much can be stowed away in a tiny model if circuits are built on individual panels less than 1 in square.

The stop-start control can be readily added to the steering unit at the expense of a space measuring $1\text{ in} \times 1\text{ in} \times \frac{1}{2}\text{ in}$, and no extra batteries will be needed. Furthermore, this motor control can be used without any modification to the simple single tone transmitter.

To make the propulsion motor stop, it will be necessary to hold down the tone button on the transmitter. It may seem the wrong way round to keep the model stationary with a continuous tone, but the reason for this becomes apparent when it is considered that the model spends most of its active time going forward, and that stopping is only used for manoeuvring or in an emergency.

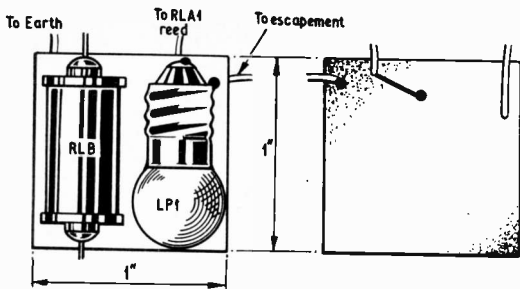

Fig. 3a. Stop-start panel topside and underside

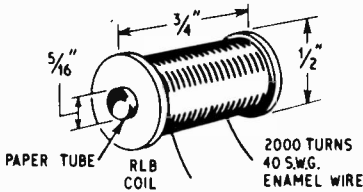

Fig. 3b. Construction details of RLB coil

"Stop-start" circuit details are included in Fig. 2. The bulb LPI is introduced as a battery economiser. If the escapement is to be held on for long periods it will draw a continuous current of some 300mA, but with the bulb in series this is reduced to approximately 150mA. The resistance of a cold filament is much lower than that of a hot filament, therefore, a heavy initial current will flow through the escapement coil when RLA1 contacts close.

Before the bulb has time to warm up, the escapement latch is quickly pulled in, then the bulb glows and the current is reduced. The glow of the bulb is also a clear indication of correct circuit operation, and can be very usefully employed on single-handed range checks.

Unfortunately, although an attractively simple arrangement, the bulb does tend to slow down escapement speed and if pulses are sent in rapid succession, the bulb warms up and escapement current temporarily drops to a point where the latch is no longer pulled in. A preferred form of economy circuit will be given later.

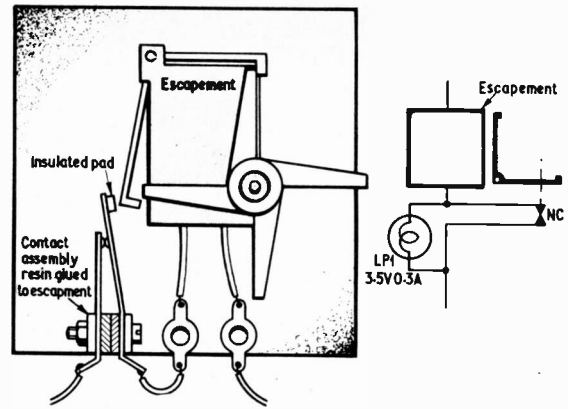

Fig. 4. Fitting economy contacts to the escapement

OPERATION OF "STOP-START" CIRCUIT

Since relay coil RLB (Fig. 2) is wired across the reed switch RLA1, a current will flow through this when RLA1 contacts are open. This is sufficient to close reed switch RLB1 and set the propulsion motor going. RLA1 contacts will therefore remain closed when there is no signal, but a continuous tone from the transmitter will hold them open.

R1 and C2 suppress the arc across the reed switch contacts when switching a heavy load; motor interference suppression capacitors C3 and C4 are also shown. Only the body of the motor is connected to a common earth point, and both brushes are left floating relative to earth. R1, C2, C3, and C4 should be mounted close to the propulsion motor, as permanent fixtures in the model.

"Stop-start" panel details are given in Fig. 3. The unit is very simple indeed, and can be mounted directly on the steering unit. RLB coil is wound with 2,000 turns of 40 s.w.g. enamelled wire, and bobbin constructional details are given in the inset diagram.

REED SWITCH RATINGS

A point well worth considering, which is related to size of model and equipment, is the current rating of miniature and sub-miniature reed switches. Miniature model electric motors have a high stalling current rating, sometimes well in excess of 1A, but the miniature reed switch, depending on type and contact material, has a typical long-life rating of 0.5A. If absolute dependability is called for, the switch rating should not be exceeded.

Although there is no reason why larger armature relays should not be used in bigger models, the reed does offer exceptional reliability and compactness, and an expected life of 100 million operations when not overstressed. Some standard size reeds, encapsulated in 2in glass envelopes, are capable of handling as much as 3A, and can be wound with exactly the number of turns and gauge of wire as a miniature reed in the same circuit. A bobbin for a standard reed need only be 2in long by 3/8in dia. for a 90 ohm coil.

When a heavy current is to be switched it is recommended that larger reeds are used, either to replace the miniature reed or as slave relays. Reed switches were carefully chosen for the circuits given here, bearing in mind cost and current loading. The type numbers in the circuits are for Hamlin switches, and these are obtainable direct from Flight Refuelling Ltd., Industrial Electronics Division, Wimborne, Dorset.

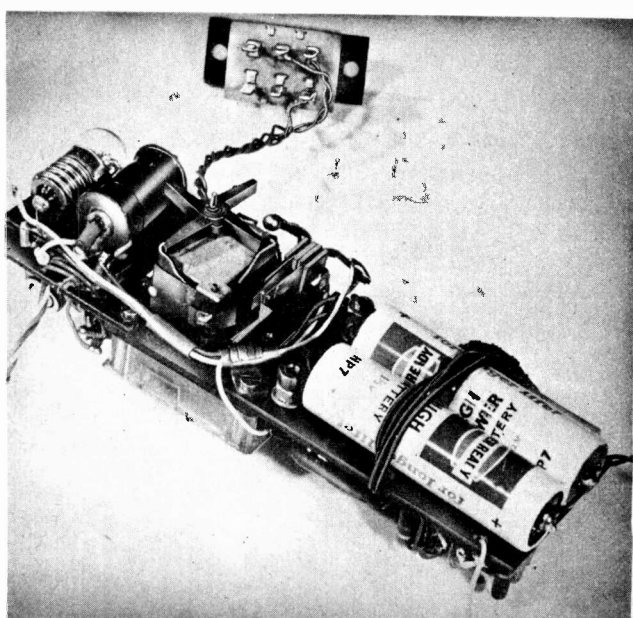

No hard and fast rules can be laid down when so much depends on individual application, but it is sometimes better to retain miniature reeds and replace the motor in the model with a low consumption propulsion unit, where high current is a problem. This will also bring a bonus in model operating time due to lower battery drain. A suitable motor for small boats or cars is the Microperm 2000, which has a stall current of 400mA, a running current of about 150mA, and measures $1\text{in} \times \frac{1}{8}\text{in}$ in diameter case size.

ECONOMY CONTACTS

For a very fast escapement speed with good "hold-on" economy, a set of contacts can be added to an escapement, as shown in Fig. 4. The contacts are normally closed when the escapement coil is not energised. When the latch moves, the contacts open and place LP1 in series with the escapement coil, roughly halving the current consumption. As before, the bulb will light up and can be employed as an indicator.

REVERSING THE PROPULSION MOTOR

Up to this point operation has been confined to one channel, using a modulated carrier only. It is possible to employ the unmodulated carrier virtually as a second channel for a separate function.

Amplifier "C" was originally intended for a 6V supply, but will work on a 3V source if an extra component is added. It may be remembered, from the earlier article, that Amplifier "C" is biased off by noise from the receiver. When a plain carrier is received, the amplifier switches on its relay, but does not respond to modulation.

Equally, Amplifier "A" does not respond to plain carrier, so there are two interaction free channels when both amplifiers are incorporated in a single unit.

The modified Amplifier "C" circuit is shown in Fig. 5. Enough free space exists on the amplifier panel to take not only the extra feedback capacitor C3, but a sub-miniature pre-set potentiometer VR1 and a 15 ohm relay coil identical to that used for Amplifier "A".

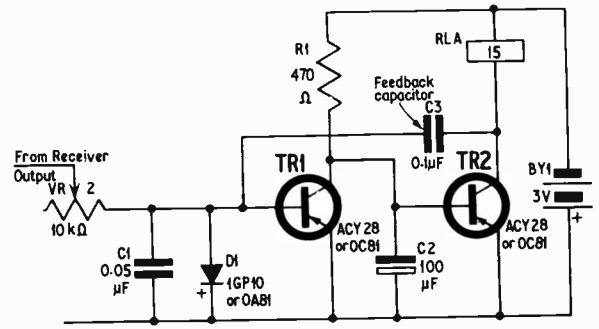

Fig. 5. Modified version of Amplifier "C" to operate from a 3V battery

Amplifier "C" panel, together with the "stop-start" unit, are attached to the "free" end of the escapement, opposite the Receiver and Amplifier "A". The complete control unit is $4\frac{1}{2}\text{in}$ long and weighs 5 ounces.

REVERSING CIRCUIT OPERATION

Fig. 6 gives the complete circuit. A changeover reed relay RLC has been introduced as a simple means of reversing the propulsion motor. BY3 is the main propulsion battery and the smaller battery BY4 is switched in by RLC1 to provide slow reverse when a plain carrier is received. As before, the motor is switched off by RLB1.

Pre-set VR2 allows Amplifier "C" to be trimmed for optimum results without the necessity for altering the value of C1 in Fig. 5 and, at the same time, acts as a series resistor so that the signal from the receiver is equally shared by both amplifiers.

Note the economy contacts on the escapement in Fig. 6, and the new values of suppressor resistors in the motor circuit. The reeds of RLB and RLC can be coupled to the motor circuit with a B7G plug and socket or similar midget connector.

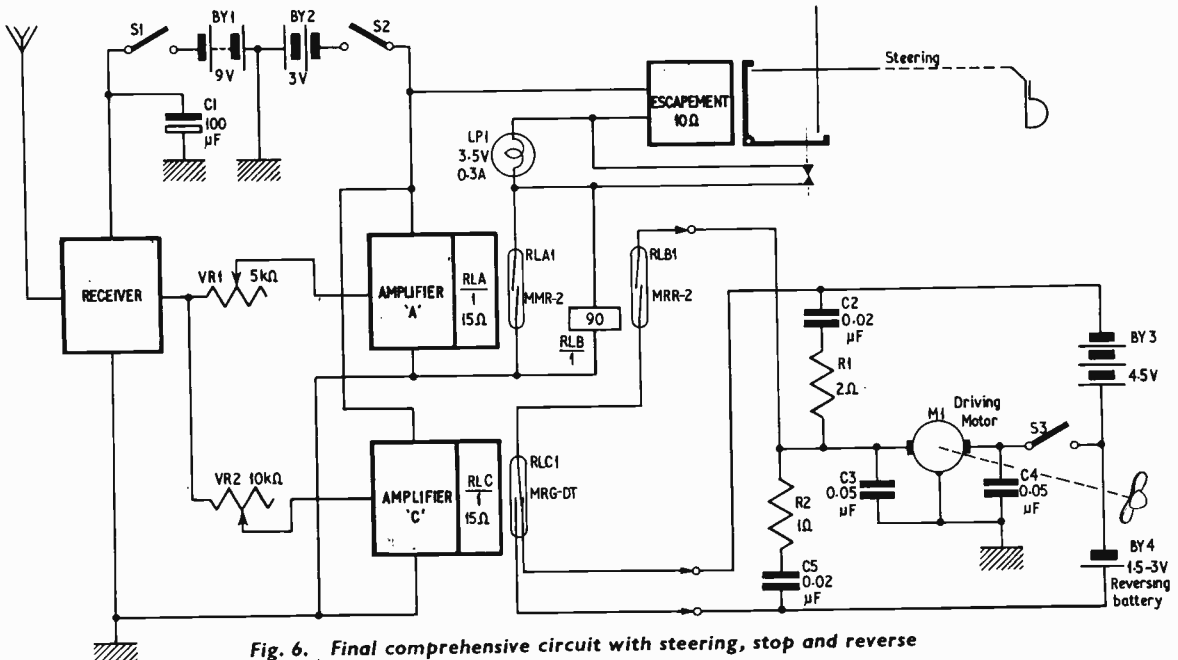

Fig. 6. Final comprehensive circuit with steering, stop and reverse

SETTING UP

Connect a pair of headphones via a $0.1\mu\text{F}$ capacitor between VR1 and earth. Set VR1 to its mid-position and close S1; the hiss from the Receiver should be audible. Check that the Receiver is responding correctly to a tone signal from the transmitter to the limits of range. Retune the Receiver if necessary and slightly advance VR1.

Next, switch on S2 and see if the escapement functions, and does not skip a position when the transmitter button is pressed. It is a good plan to set a small electric motor running close to the receiver to see if there is any interference. If the escapement starts operating of its own accord, back off VR1.

When "stop-start" is included, see that this functions correctly when RLB1 is coupled to a running electric motor. The bulb should light when the transmitter button is held down.

For Amplifier "C" the following procedure is adopted. Having first ensured that steering and stopping circuits are responding well to the transmitter, connect Amplifier "C" to S2 and connect VR2 to the receiver output. Advance VR2 until RLC just operates then back off VR2 slightly. The correct setting is when a very slight noise is just audible from RLC reed switch. A loud noise will denote that the reed contacts are opening and closing spontaneously.

This may be checked with an ohmmeter or a bulb and battery. Key the transmitter button with modulation switched off. If all is well, RLC will change over its reed contact to the reverse position.

Test the plain carrier range, which should be slightly more than half the distance obtained with tone signals. A table of current consumption figures is given as a guide for setting up.

OTHER INSTALLATIONS

It is hoped that the information given here will enable the reader to equip a model, and devise alternative arrangements, with different amplifier and reed switch combinations. For example, if the transmitter is modified to give two tones, at 1kHz and 5kHz, tuned Amplifier "B" can be placed in parallel with Amplifiers "A" and "C" to provide an extra channel, assuming

Table I. CURRENT CONSUMPTION

	No signal (mA)	Tone (mA)	Carrier (mA)
BY1 Receiver	4	5	4.5
Amplifier "A"	2	150	zero
Escapement with economiser	zero	150	zero
RLB	30	zero	30
Amplifier "C"	7	5	150
BY2 total	39	305	180

that two more pen cells are added in series with BY2 to give the 6 volts necessary for Amplifier "B".

The frequency determining ladder network in Amplifier "B" circuit (January issue) is tuned by capacitors C1, C2, C3. If $0.02\mu\text{F}$ capacitors are used, the amplifier will respond to a 5kHz tone. A $0.02\mu\text{F}$ low frequency blocking capacitor should also be added in series with the Amplifier "B" input resistor. As Amplifier "A" cuts off sharply above 2kHz there will be no interaction between "A" and "B" channels.

The circuit diagram of the transmitter and Amplifier "B" will be reprinted in Part Two of this article.

A motorised servo can be used in place of an escapement and the wiring diagram supplied with a new servo will show how to couple to various forms of amplifier output. Although bigger than an escapement, a sequential servo works in a similar manner and its greater crank power is suited to bigger or heavier models.

Several readers have queried the r.f. chokes used in the transmitter and receiver circuits. The prototype chokes were not, in fact, home wound. They were taken from valve type i.f. transformers. There is now available an excellent 97mA 1mH sub-miniature choke, scarcely bigger than a $\frac{1}{2}$ watt resistor and this has been successfully used in both circuits. Manufactured by Painton, the choke is now available from Electroniques (Prop STC) Ltd., Edinburgh Way, Harlow, Essex, with the code number 58-10-0023-10.

Meetings . . .

INSTITUTION OF ELECTRICAL ENGINEERS

LONDON

Date: May 19

Title: Colloquium on "Advances in Measurements Brought About By Recently Introduced Semiconductor Devices"

Time: 9.30 a.m.

Address: I.E.E., Savoy Place, London, W.C.2

Tickets must be obtained from the Secretary, Savoy Place, London, W.C.2

Date: May 24

Title: The Postal Service and the Electronics Engineer

J. Piggott and T. Pilling

Time: 6 p.m.

Address: I.E.E., Savoy Place, London, W.C.2

SOCIETY OF ELECTRONICS AND RADIO TECHNICIANS

GLASGOW

Date: May 19

Title: Computers—A. Coppel (I.B.M.)

Time: 7.30 p.m.

Address: Y.M.C.A. Club, Bothwell Street, Glasgow

INSTITUTION OF ELECTRONIC AND RADIO ENGINEERS

LONDON

Date: May 24

Title: Symposium on "Television Network Switching at the Post Office Tower"

Time: 5.30 p.m.

Address: 8-9 Bedford Square, London, W.C.1

READING

Date: May 23

Title: Astronomical Instrumentation
Prof. P. B. Fellgett

Time: 7.30 p.m.

Address: J. J. Thomson Physical Laboratory, University of Reading



THE ELECTRONIC ORGAN

PART SEVEN

By ALAN DOUGLAS, Sen. Mem. I.E.E.E.

VIBRATO : ELECTRONIC AND MECHANICAL METHODS

MODERN instruments rely greatly on the use of vibrato. This is partly because vibrato is an essential ingredient of romantic music; partly because it enhances the effect of certain tone qualities which would otherwise sound very dull and monotonous; and partly because it is a fashion or symbol of the times.

The word *vibrato* is of comparatively recent origin. It covers a multitude of sins because it can be frequency modulation, amplitude modulation, or a bit of both. Strictly speaking vibrato is equivalent to the tremulant on a pipe organ, first applied by the French; the word tremulant is a corruption of their expression *tremblant*. Because pipes are very sensitive to pressure changes, the device as normally fitted shakes the wind supply to certain selected ranks of pipes and this causes a considerable change in pitch, though not so much in volume. The effect is very agreeable if carefully used and when produced electronically, vibrato should give an equivalent result.

In some instruments only the volume is varied cyclically, and this is described as *tremolo*; an expression of Italian origin, intended to refer to the human singing voice. It is not so effective on organs as vibrato.

METHODS AVAILABLE

We can introduce the vibrato effect in two ways; either something can be done to the circuit to alter its characteristics as required; or a mechanical device can be applied to a loudspeaker to produce the desired result.

On account of the stability in tuning so easily attained with transistor generators, it is not always easy to swing the oscillators to the required extent. Further, in a

frequency divider organ, all notes down to the lowest will be modulated, and as the frequency of vibrato commonly lies between 5 and 6Hz, pedal notes of 16ft pitch may be so modulated. This produces a most objectionable effect.

An alternative electrical method is to use a phase shift circuit following the generators, a necessity if these are of the vibrating reed or gear driven iron wheel type, since generators cannot be made to go off pitch. In such phase shift circuits, the pass band can be so adjusted that the bass is not modulated.

The last method, mechanical control of the sound waves, is the most effective from a truly musical point of view. Although only recently becoming popular, and heralded by some makers as a new invention, it is the oldest type of vibrato and was actually used in reed organs over 100 years ago! The forerunner of the present methods was the Everett Orgatron of 1935, whilst John Compton took out a patent for a rotating horn loudspeaker in 1936. Today, Donald Leslie's design is widely used in various forms, although the rotating unit devised by Jerome Markowitz in 1940 is a standard part of the American Allen organs; and more recently, there is the Compton Rotofon—an almost identical arrangement.

The foregoing represent all the means at present in use, although some ingenious alternatives have been proposed. So let us examine them in turn.

ELECTRONIC METHODS

In the majority of types of electronic organs which are likely to interest readers of this magazine, a Hartley type of oscillator is used as a prime oscillation generator. Although we will deal with transistor methods exclusively so far as the PRACTICAL ELECTRONICS organ is concerned, it must not be forgotten that there are thousands of valve organs in existence; therefore we show one transistor and one valve circuit in this article.

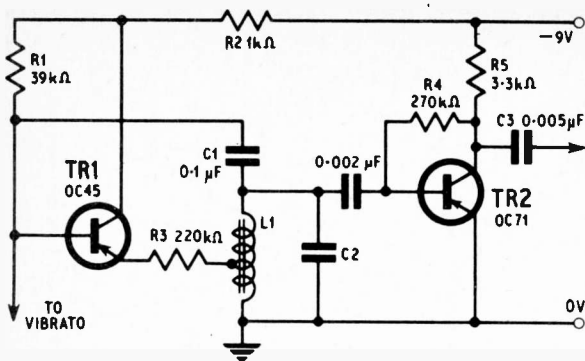

Fig. 7.1. Typical Hartley oscillator tone generator, with buffer and shaping stage to drive dividers

Because a transistor is substantially current operated, it is harder to produce a large change in the bias than in the case of a valve; and the "slope" of a transistor is entirely different from that of a valve. In Fig. 7.1 is shown a popular type of Hartley oscillator for organs. Other types vary only in detail. Differing voltages, etc. are merely due to the use of different kinds of transistor.

The base is the most sensitive element to modulate, so we find a connection which is normally floating, that is, not connected to anything, but which may be connected to a varying voltage supply through a high resistance which will not divert current from the oscillating circuit. Since the circuit shown delivers only a few volts to the load, it is possible to alter the frequency by injecting a few volts into the existing base bias. But this will very much depend on the kind of transistor used. It has long ago been found that there is an optimum value for the frequency of vibrato so produced, and this is about 8Hz. Many people prefer a slower rate of modulation, consequently vibrato oscillators are adjustable for frequency.

It is most important that the vibrato waveform be as sinusoidal as possible, otherwise harmonics may be injected into the oscillator proper and also, the swing must be equal either way. A sine wave vibrato is therefore desirable. This also has the merit that the rise and fall of the sound is truly continuous and is not held up at all during a cycle as can happen with a square wave multivibrator. The phase shift RC oscillator is widely used to provide the vibrato modulation but this kind of oscillator requires high gain transistors.

BRIDGED-T CIRCUIT

A very successful circuit is the tuned bridged-T shown in Fig. 7.2. This was originally described in the *Wireless World* for December 1962 by Mr F. Butler, and can be adjusted to give the frequency for vibrato modulation as shown in the diagram.

One point to note with this circuit is that the feed resistors form part of the oscillator proper, so all must be wired up (probably 12) before tuning. Advantage can be taken of this arrangement to vary the degree of vibrato for different oscillators if desired by raising or lowering the value of these resistors until the effect is judged most pleasing. There is provision for altering both the amplitude and the frequency, and since this latter is very low, the controls can be brought out to

the console stop panel without trouble. The effect of this oscillator on the signal from a tone oscillator is shown in Fig. 7.3.

Turning now to the kind of circuit which follows a tone system, which in itself is not made to alter in pitch or volume, and is therefore applicable to any kind of electrical tone source, it is found virtually impossible to achieve the same simplicity circuit-wise and the simplest arrangement is given in Fig. 7.4. Unfortunately valves are required for this purpose, but there seems little reason why the circuit should not be transistorised. Filters are shown in the output stage to remove the switching transient and also to attenuate the bass.

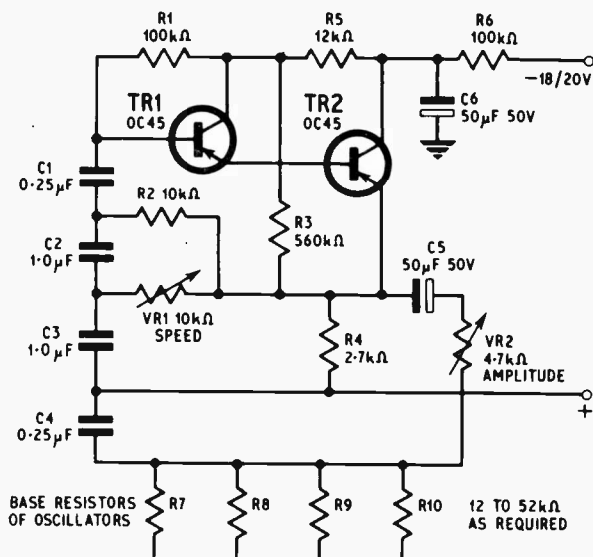

Fig. 7.2. Bridged-T vibrato sine wave oscillator

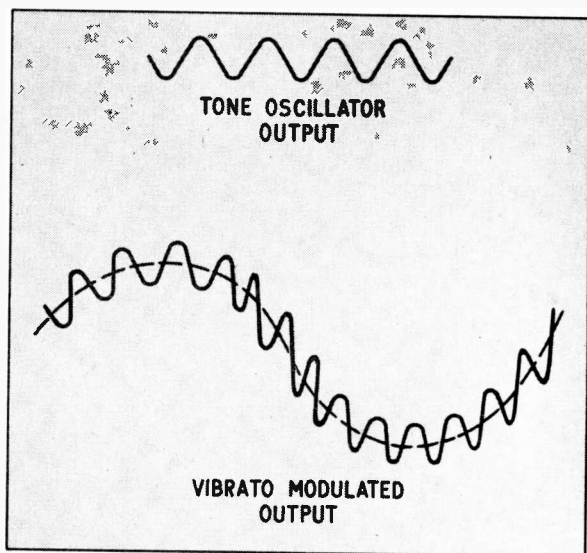

Fig. 7.3. Effect of vibrato circuit of Fig. 7.2 on tone oscillator waveform

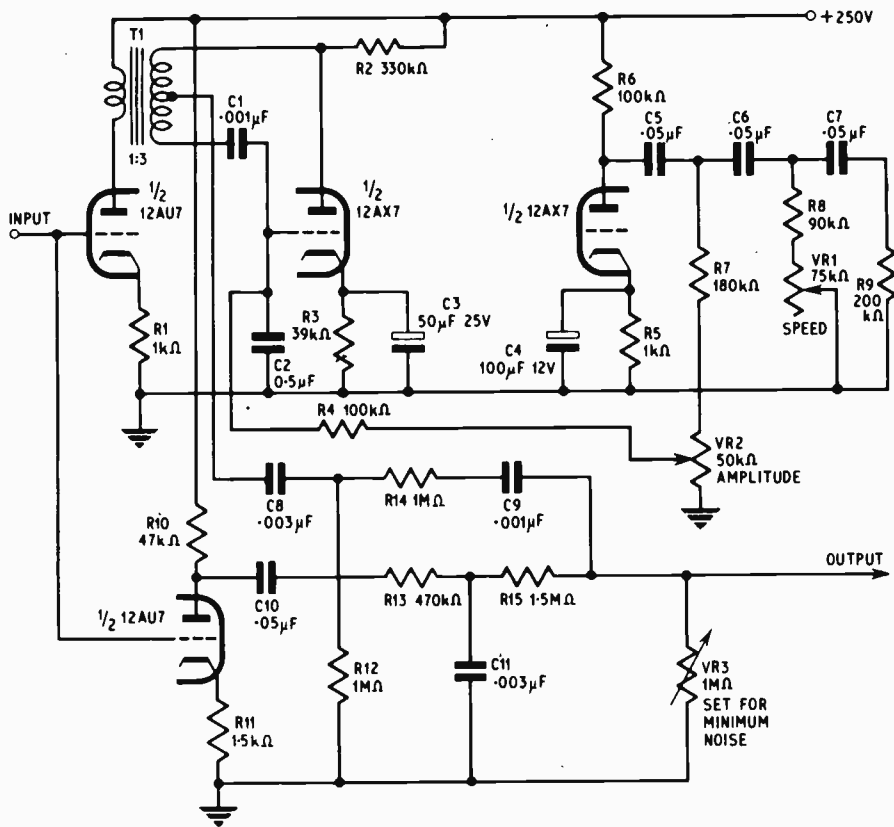

Fig. 7.4. Vibrato circuit suitable for following tone generators of any kind

Such vibratos have been used by Wurlitzer, Kinsman, and Schober, and have the merit that any signal not to be so treated need not be connected to the unit. Thus, one manual need not have vibrato, nor the pedal department, even with a common generator.

MECHANICAL METHODS

Mechanical means for modulating the tone always involve some device which alternately opens and closes the direct radiation path from a loudspeaker. The earliest types used flat paddles revolving in front of a cone, as in Fig. 7.5. This scheme is still very effective, but has the drawback that the vane might stop in such a position that the sound was blocked off. Experimenters who have not tried this very simple idea might like to investigate. The effect is very pleasing, improving of course as the frequency rises. The difference between the fixed rate of rotation and the frequency source will then be greater, since the effect is based on

Doppler's theory which states that:

$$f \text{ (frequency at point of observation)} \\ = \frac{V}{V - V_s} \cdot f_s$$

where V = velocity of sound in the medium (air)
 V_s = velocity of source
 f_s = frequency of source

Unless the vane is shaped to fit the cone, the degree or extent of the vibrato will not be great; and of course some part of the cone will always be exposed and not modulated. Therefore other ideas were investigated.

ROTATING SPEAKERS AND BAFFLES

Since tremulants are always most effective at the upper frequencies, early attempts involved rotating horn loudspeakers. This does away with the difficult problem of a baffle and ensures a high degree of cut off as the horn turns away. However, current must be fed into the circuit by some means and in the first attempts, slip rings proved troublesome. Then, to extend the response of the loudspeaker further down the scale, the size became a problem. This was solved in the Leslie devices, which are as numerous as they are varied.

Two basic types exist; one which rotates a small loudspeaker without a baffle; and one in which the speaker is stationary and a shaped baffle rotates above or below the cone. A baffle is generally used in this arrangement. The small units which themselves rotate are fed with the signal from a transformer with a

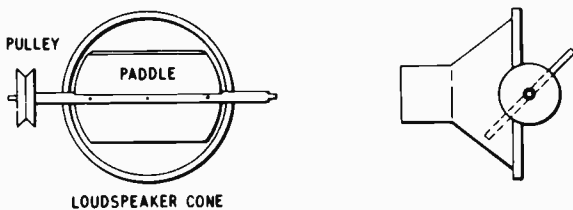
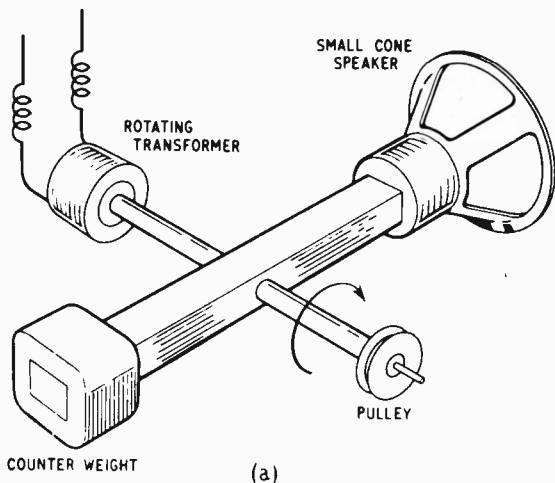
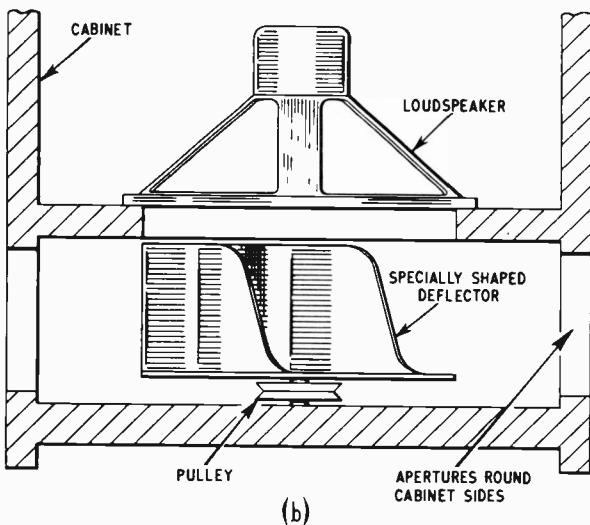

Fig. 7.5. Rotating paddle vibrato system



(a)



(b)

Fig. 7.6. Illustrating the principle of, (a) small and (b) large, Leslie speakers

rotating winding; in the case of the larger units, connections are of course normal. Driving motors may have more than one speed, since except for the American Allen, a.c. motors are used and the speed is not so easily controlled.

Taking the Leslie units first, both patterns are shown in a basic form in Fig. 7.6. The smaller units (Fig. 7.6a) turn rather fast, but produce a very complex radiation pattern which is most effective on high notes. The larger units (Fig. 7.6b) are more generally effective, and some makers fit them inside the console. One obtains true modulation of both pitch and volume, and this is why they sound better than any electrical means of tone modulation. But why they should be so expensive is a mystery.

A rather different approach is taken by the Allen organ company and also the Compton organ company. Here we find several loudspeakers mounted on a circular baffle which must be of large size. This assembly is rotated as a whole inside a large box open at the back and there is no real attempt to make an airtight seal between the rotor and the case. Current is fed in by slip rings. Several channels can be wired

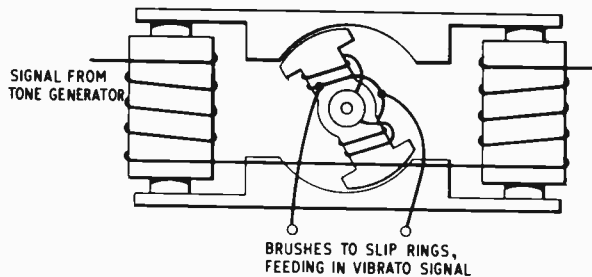

Fig. 7.7. Early Constant Martin tremulant device

into the unit, and because of the large arc described by the loudspeakers, the sound appears to move from side to side rather in the manner observed with a pipe organ when near at hand.

Apart from the main use as a vibrato device, it is found that if the baffle is turned very slowly, the spread of sound has a spacious quality which imparts a suggestion of a large room. Used with reverberation of the right kind it is therefore a useful adjunct to the organ, but it is not effective unless of large size. Of course, electrical vibrato can be added to any of these mechanical devices, when all kinds of effects become possible.

AN EARLY DEVICE

An early attempt to introduce modulation after the tone generators was made by Constant Martin, who used the ingenious little device shown in Fig. 7.7. The signal from the generators passed through the "field" coils on its way to the amplifiers, whilst the vibrato voltage passed through the armature windings, and so was superimposed on the main signals. A small motor drove the armature. ★

Book review

BASIC PRINCIPLES OF ELECTRONICS AND TELECOMMUNICATIONS

By M. D. Armitage

Published by George G. Harrop and Co. Ltd.
390 pages, 5½ in × 8½ in. Price 30s

THIS is the second edition of a popular textbook first published in 1961. Completely revised and with a considerable amount of additional text, this book must be a natural choice for the second-year technical student intending to cover the "Principles A" syllabus of the City and Guilds of London Institute's Telecommunications Technicians' Course (No. 49).

As a class work adjunct, or as a tutor text, for those who might sit this examination as external candidates, this will prove more than adequate in covering the syllabus requirements.

Liberal illustrated and with numerous worked examples, each chapter is completed with a set of questions, many of them from part C.G.L.I. examination papers, and answers which are contained at the back of the book.

G.M.H.

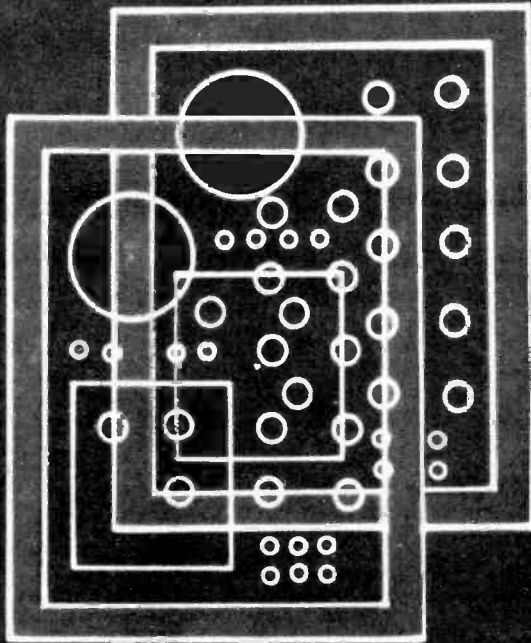

C.R.O. TRACE DOUBLER

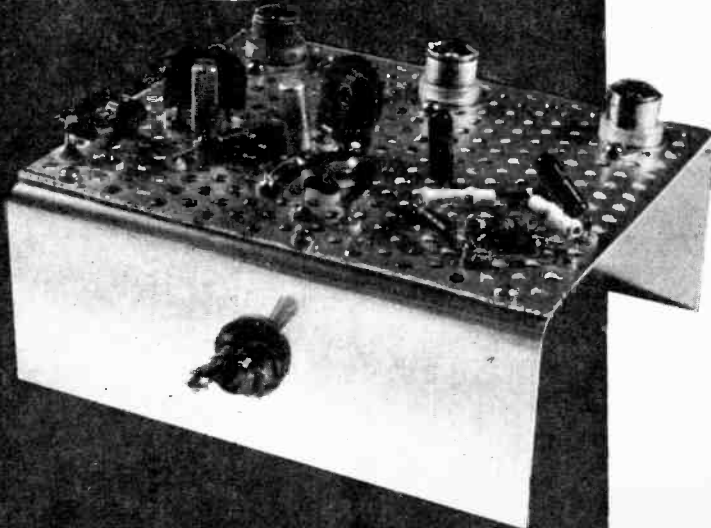

ANY conventional single beam oscilloscope can be quickly and easily converted to dual trace or multiple trace at low cost.

Trace doubling circuits, or "chopping" circuits as they are sometimes called, are by no means new in this application. Most modern oscilloscopes with two or more beams usually employ two quite independent electron beam sources or else resort to the cheaper method of beam chopping.

The chopping method involves deflecting a single beam up and down on the screen by using an internally produced high frequency square wave signal. If the square waves have 1 : 1 mark/space ratio, two distinct horizontal traces are seen instead of one on the screen for low sweep rates.

With switchable internal electronic circuitry these two traces are modulated with the two separate input signals to produce the dual trace effect. For purposes requiring a multiple beam oscilloscope, where measurements of voltage, frequency or phase of several different waveforms are required simultaneously, the enterprising amateur having only a single channel must either use more expensive equipment or resort to modifying his own oscilloscope, an often tedious if not difficult task.

LOW VOLTAGES

The transistor trace doubler described here is suitable for testing transistor circuitry where only low voltages are employed. There is no reason, however, why the circuit could not be adapted for higher input voltages as long as suitable calibrated attenuators are used.

The single circuit shown in Fig. 1 was found to have a frequency response from d.c. up to 50kHz with no relative phase shifts between signals over that range. Upon examination of the circuit it will be seen that its dynamic response to input signals is in fact only determined by the characteristics of the oscilloscope used.

Facility for trace separation also makes it possible for d.c. components of either input-signal to be measured.

The unit shown will divide one channel into two channels. Two such units will provide four channels, when used on a dual beam oscilloscope, and it has been found possible to produce as many as four channels on a single beam oscilloscope, providing that they all operate on the same chopping frequency.

Where there is a need for viewing several different output signals of high output impedance, it was found to be possible using this unit where the current availability was very low.

By B. L. Welsh

THE CIRCUIT

The circuit, containing four transistors, is basically a free running multivibrator producing two sets of negative square waves with a 1 : 1 mark/space ratio, and each in antiphase with the other. The remaining two transistors form a pair of electronic "gates" or low resistance switches.

Each of these transistors has its base negatively biased by one of the square waves from the multivibrator so that it is alternately forward biased, or else forms a high resistance path to earth.

The two input signals are separately applied to the two emitters of the *pnp* transistors, each wired with its emitter as a collector. The two signals are fed via two 5 kilohm potentiometers which are used as gain balance controls. These two signals are alternately shorted to earth at the chopping frequency.

Trace separation is provided by negative d.c. bias on each of the two emitters via two 10 kilohm potentiometers. The emitters of the two transistors are joined together via a pair of 4.7 kilohm resistors with a centre-tap output. These provide the load. The output signal is taken from this point and fed to the oscilloscope.

With the components used the multivibrator frequency was found to be nominally 5-7kHz but jumped to 33kHz when loaded with the circuitry. This provides the unit with a higher frequency response.

ACTION OF THE GATES

In the absence of any base voltage, the first gating transistor can be regarded as a reverse biased diode. Any signal appearing on its emitter is presented with a high impedance to earth via this transistor.

At the same time, however, a negative voltage appears on the base of the second gate transistor, from the antiphased output of the multivibrator. As this voltage is higher than the standing d.c. emitter voltage on gate two, this transistor becomes forward biased and consequently has a low impedance to earth via its emitter.

As there are now two alternative paths to earth, the input signal on the emitter of the first gate now goes via the lowest resistance path to the earth; this is via the second gate.

Current flows through the two 4.7 kilohm resistors and the voltage output is detected as shown, between these two resistors.

As the two d.c. voltages on each gate transistor base are 180 degrees out of phase, the signals appearing

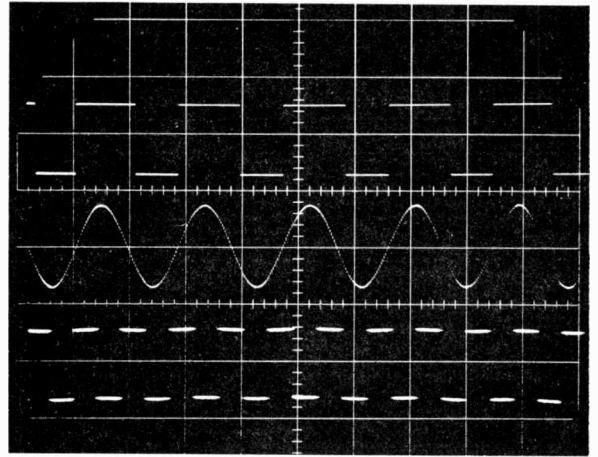

Fig. 2. Top beam direct and d.c. coupled; middle (sine wave) and lower beams a.c. coupled. Very slight differentiation of the lower square wave is just apparent

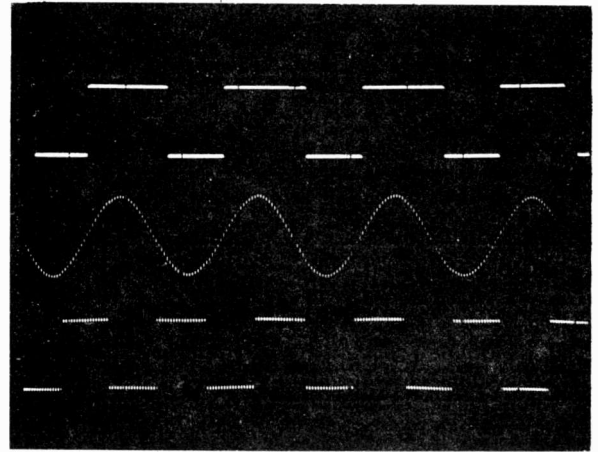
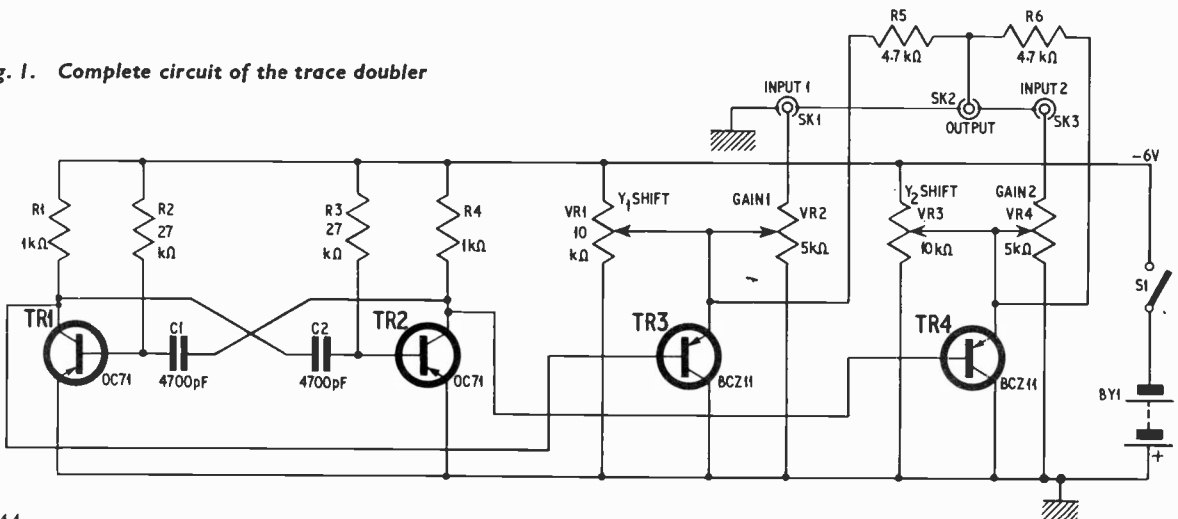

Fig. 3. A square wave and sine wave are injected into the chopper. Both 'scope beams are d.c. coupled

at the two inputs will be alternately shorted to earth, thus producing the switched signal beam at the output.

If Y_1 or Y_2 is at the end of its track, then the whole supply voltage is dropped across the gate transistor.

Fig. 1. Complete circuit of the trace doubler



As long as this is less than 9V the transistors are perfectly safe. Excessive current for this case can produce burning on the end of the resistive tracks of either of the 10 kilohm potentiometers. This could, however, be eliminated by making the potentiometers 5 kilohms each with a 5 kilohm fixed resistor in series. This would give a slightly lesser degree of trace separation, but would protect the potentiometers.

COUPLING

For looking at square waves when using the unit, the output has to be d.c. coupled to the oscilloscope input amplifier, as a.c. coupling will produce differentiation (only slight) of the square wave.

Three traces of signals on a Tetrionix 502A Oscilloscope are shown.

COMPONENTS . . .

Resistors

R1, R4 1k Ω (2 off) wirewound 5% 5W
 R2, R3 27k Ω (2 off) } metal oxide 2% 1W
 R5, R6 4.7k Ω (2 off) } (Radiospares)

Potentiometers

VR1, VR3 10k Ω (2 off) } miniature preset
 VR2, VR4 5k Ω (2 off) } skeleton types

Capacitors

C1, C2 4,700pF

Transistors

TR1, TR2 OC71
 TR3, TR4 BCZ11

Switch

S1 Single-pole on/off toggle switch

Battery

BY1 6 volts (4 pen light cells in plastics container)

Miscellaneous

Lektrokit chassis plate No. 7 and Sealectro "clover-leaf" terminals (Home Radio (Mitcham) Ltd)
 SK1-3 Plugs and sockets coaxial (3 of each)

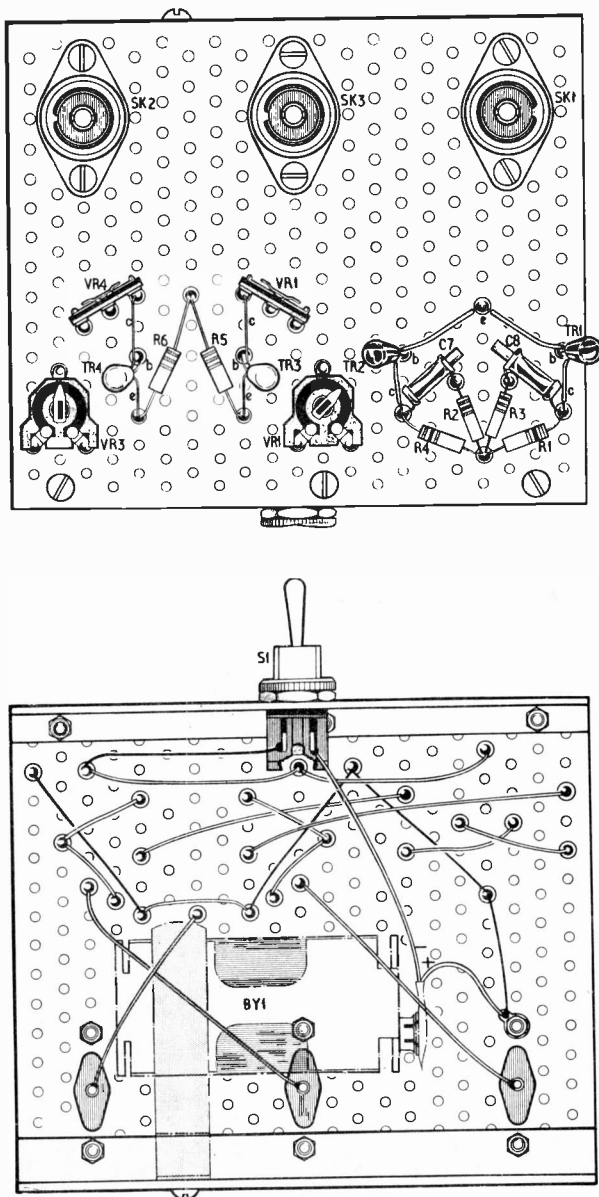

Fig. 4. Top and underside views of the chassis plate

In each case, the two lower signals displayed are chopped, the upper being the remaining beam of the oscilloscope. This top beam is displaying a square wave of about 1kHz frequency. The middle beam is displaying a sine wave of similar frequency and the lower beam a square wave, again of similar frequency.

In Fig. 3 a square wave as well as a sine wave is injected into the chopper to show that the degree of intermodulation between the two differing shapes is only slight.

The chopping frequency on the lower two traces can be seen, but if this is a criterion, the time constants of the multivibrator can easily be changed to produce minimal chopping signal from appearing on high frequency signals.

All three input signals to the oscilloscope are produced from different isolated sources. If it is required to measure phase shift between signals, it can be seen that by putting two identical signals into each channel of the chopper, no phase shift within the device is present, thus it may be possible to measure direct time differences between signal phases.

The author successfully cascaded two such choppers, one into the other, so that simultaneous display of four signals on a dual beam 'scope was achieved. The output of the first chopper can be fed into the second chopper as one of the two inputs.

CONSTRUCTION

The circuit was constructed using standard electronic components readily available, and wired together on Lektrokit chassis plate no. 7 with Sealectro cloverleaf press-fit terminals (see page 414 for full instructions). No care was taken to screen all of the connections, although it would be advisable where very small signals from high output impedance sources are used.

If more than two channels are needed two such units can be used together, but intermodulation will occur between the two different chopping frequencies that would be produced. This can be eliminated by using the one multivibrator to drive as many gates as are needed, via a suitable emitter follower, to match the low input impedance of each set of switches.

The transistors BCZ11 are *pnp* silicon types. Germanium types are not suitable in this part of the circuit.



Electricity Supply Control

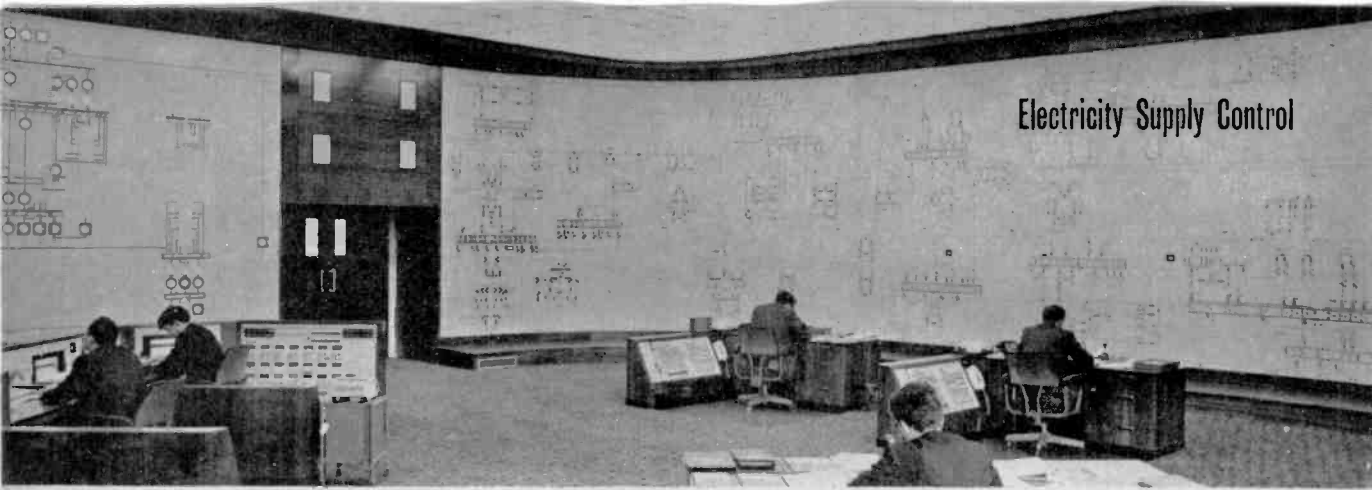

A NEW control centre (above) for the Central Electricity Generating Board at Manchester, this is the first to operate under a three-tier grid control system, and will cover an area from Lancaster to Aberystwyth with a maximum controlled output of 5,480 megawatts. Plessey were responsible for the installation of the control centre.

Above right, we show a close-up view of two electro-hydraulically controlled governor valves, which replace conventional mechanical governors on an A.E.I. 300 megawatt turbine-generator at the West Thurrock power station. The new system incorporates an electrical speed sensing unit, from which a frequency signal is obtained and processed to provide a speed error signal. This is added to a reference voltage to control the governor valves.



Precision Measurement Machine Wins Award

THE Council of Industrial Design has given an award to Ferranti for their co-ordinate inspection machine size 4, a photo-electric control system for measuring component holes and surfaces in two directions to an accuracy of ± 0.001 in over 24 in.

Movements of a probe are measured by an optical grating system whose light pulses are sensed by photocells and translated into a digital readout display.

ELECTRONORAMA

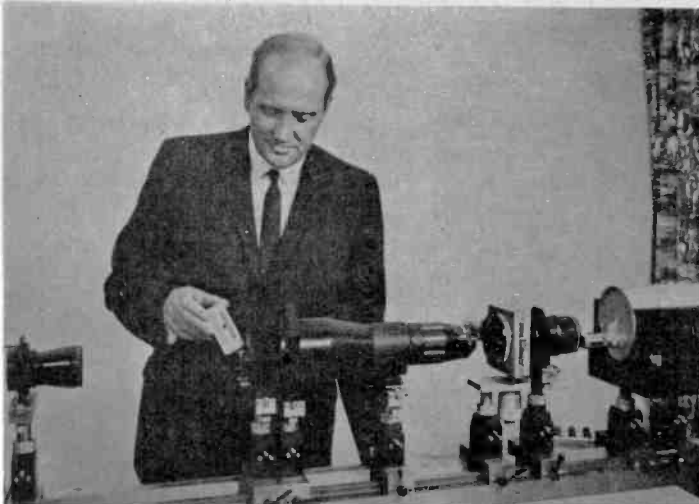

Laser Image Comparison and Display

A FUTURISTIC concept of banking facilities was shown to the Press recently by the National Cash Register Company. The idea is to use holography (a means of detecting and displaying three-dimensional images using a laser beam) to match the shop customer's signature on a credit card to that on his bank account some distance away. It is thought that all shopping using cash can then be replaced by credit card holography systems.

Our picture on the left shows a credit card being inserted into a holograph unit. A photographic reproduction of the signature can be displayed on a terminal unit.

On the right, a laser is used for demonstrating microprinting. Impulses generated by touching the keys of a typewriter keyboard causes the laser beam to form microscopically small characters on a photosensitive plate. The characters can then be printed out by normal photographic means.

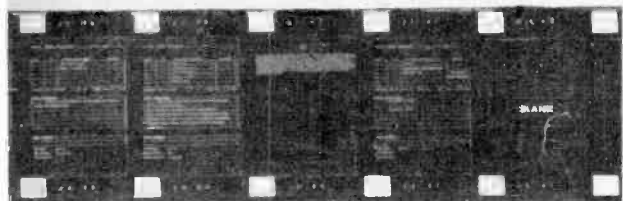
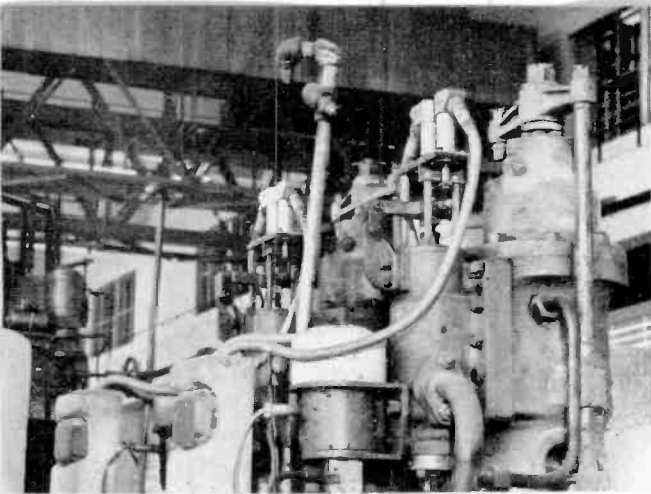

FACE Computer Armament

THE interior of the Royal Artillery's new Battery Command Post showing the Field Artillery Computer Equipment (FACE) is shown above. The computer, an Elliott 920B, is on the left and the operator's console is to the right of the automatic typewriter.

Having FACE, which will be issued on the scale of one per battery, will make the Royal Artillery the first arm of any European army to have computers in the forward battle area.

Our title strip above shows a print of a plate that has been subjected to a laser fed image of book pages. The image has been magnified eight times.

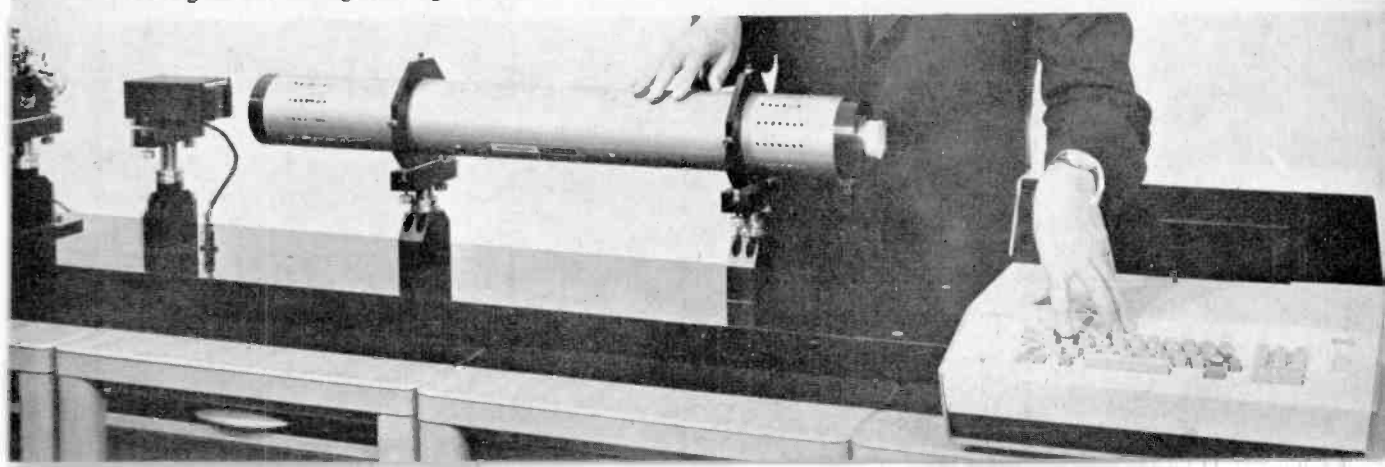

Field Effect



TRANSISTORS

PART TWO

By G. B. Clayton, B.Sc., A.Inst.P

THE electrical characteristics and the theory of operation of f.e.t.s were considered last month; in this article some of the circuitry appropriate to f.e.t.s will be considered. It is not the purpose of the article to suggest that the f.e.t. is superior to the ordinary bipolar transistor, indeed arguments on the relative merits of various devices, like the valve transistor controversy that raged in the early days of transistors, are valueless without first clearly formulating a criterion of superiority.

If one adopts the criterion that the "best" device to use is the one that enables the desired circuit performance to be achieved with the minimum financial expenditure, the greater cost of f.e.t.s will usually favour the use of bipolar transistors, except in certain special circumstances, however, the price of commercially available f.e.t.s is falling so that they may eventually be used in preference to bipolar transistors.

F.E.T.s AS AMPLIFIERS

The f.e.t. like the bipolar transistor is a three terminal device and may be used as an amplifier in three different ways depending upon which of its terminals is made common to both input and output circuits.

The three amplifier configurations are called, common source, common gate and common drain analogous to common emitter, common base and common collector amplifiers respectively. The common gate circuit has a low input impedance and therefore offers no real advantages over bipolar transistor circuits, it will not be considered further.

Only junction gate f.e.t.s will be discussed here; insulated gate f.e.t.s are only just coming out of the development stage and are rather expensive.

COMMON SOURCE AMPLIFIER

A simple self-biased common source amplifier using a *p*-channel f.e.t. is illustrated in Fig. 10. An *n*-channel device would, of course, require a positive voltage supply rail. Readers familiar with valve circuits will notice the close resemblance to a common cathode valve amplifier.

Resistor R_s acts in a manner similar to the cathode resistor in a valve amplifier, source current flowing through R_s being used to produce the desired gate-source biasing voltage. R_s is bypassed by capacitor C_s to prevent degenerative feedback. The magnitude

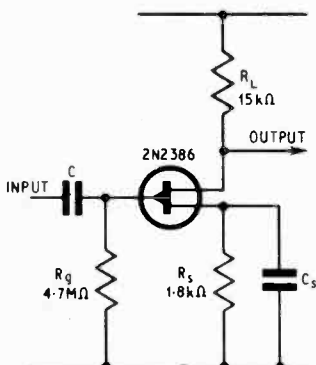

Fig. 10. Simple common source amplifier

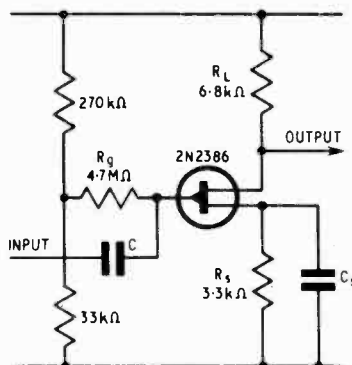

Fig. 11. Common source amplifier with bias

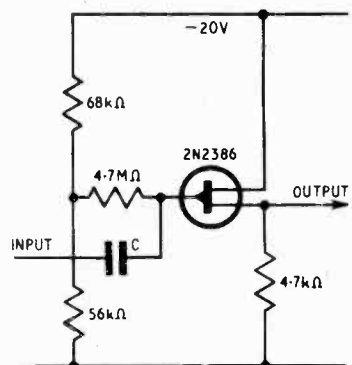

Fig. 12. Common drain amplifier

of the gate resistor (R_g) used should be such that the leakage current which flows through the reverse biased gate junction does not seriously affect the biasing at the highest working temperature.

A circuit giving greater stability of operating conditions is shown in Fig. 11, the method of bias stabilisation being similar to the technique used for stabilising common emitter amplifiers. This method of biasing is preferable for higher temperature working or for compensating for variations in f.e.t. characteristics.

Voltage gains of about 10 are typical for common source amplifiers and because of their high input impedance, the frequency response down to low frequencies may be obtained without the use of very large values of coupling capacitor (C).

Response at high frequencies is limited by a fall of input impedance and a consequent loading of any signal source feeding the amplifier. This is due to the capacitance that exists between gate and source (C_{gs}) and gate and drain (C_{gd}). These capacitances are quite small ($C_{gs} = 10\text{pF}$ and $C_{gd} = 20\text{pF}$ are typical values for currently available f.e.t.s), but the effective input capacitance of the amplifier due to C_{gd} is increased because the signal voltage at the drain is 180 degrees out of phase with the input voltage applied to the gate (the familiar Miller effect). The effective input capacitance is given by the equation

$$C_i = C_{gs} + C_{gd}(1 + A)$$

where A is the voltage gain of the amplifier. Substitution of typical values gives a value of about 230pF for the input capacitance. Thus at a frequency of 10kHz the input impedance will have fallen from its low frequency value of R_g to about 70 kilohms because of C_i . Input capacitance may be reduced at the expense of loss of gain by using smaller values of load resistance. If the load of a common source amplifier is reactive feedback through C_{gd} can cause instability if no neutralisation is used.

COMMON DRAIN AMPLIFIER OR SOURCE FOLLOWER

This amplifier is analogous to the valve cathode follower and the bipolar transistor emitter follower. It is not phase inverting and is characterised by a high input impedance, low output impedance, and voltage gain less than unity, it is very useful for impedance transformation when f.e.t.s are used with bipolar transistors.

An example of a common drain circuit is shown in Fig. 12. The effect of C_{gs} on the input capacitance is reduced in this type of circuit because the signal output voltage at the source varies in phase with the input signal applied to the gate. The effective input capacitance is, given by the equation $C_i = C_{gd} + C_{gs}(1 - A)$ and with A almost unity the input capacitance is not much greater than C_{gd} .

In order that the gain should approach unity the source resistance should be as large as possible. The relatively large voltage drop and power dissipation occasioned by the use of a large source resistance may be overcome by replacing it with a bipolar transistor as shown in Fig. 13. The effective source resistance is then the large dynamic resistance seen looking into the collector of this transistor. The quiescent current is set by the choice of the emitter resistance R_e .

AMPLIFIERS USING F.E.T.s WITH BIPOLAR TRANSISTORS

The outstanding low level characteristics of f.e.t.s are high input impedance and low noise, they are therefore

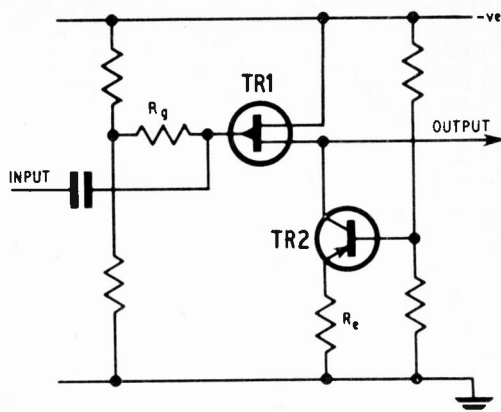

Fig. 13. Common drain amplifier using bipolar transistor instead of load resistor

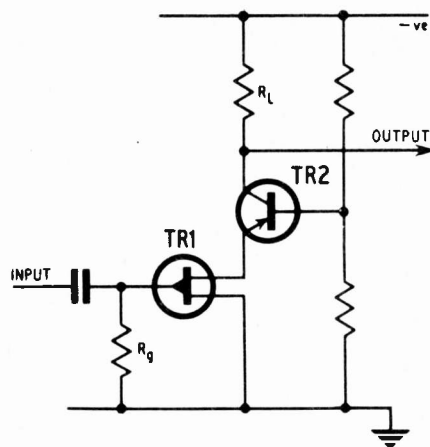

Fig. 14a. Common source amplifier driving a common base pnp transistor amplifier

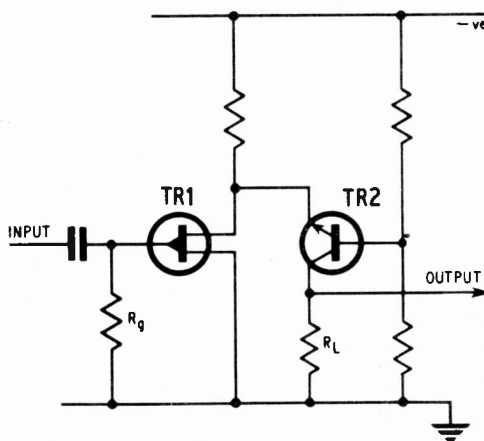

Fig. 14b. Common source amplifier driving a common base npn transistor amplifier

most useful at low level high impedance points in electronic circuits, for example, as a preamplifier for use with a high input impedance transducer. Once the impedance level has been reduced it is more economical to use conventional transistors for further amplification.

Many interesting compound connections of f.e.t.s and bipolar transistors are possible; some increase the bandwidth of the f.e.t. by reducing the effects of inter-electrode capacitance.

An f.e.t. common source or common drain stage may be used to drive any configuration of second stage making six possible circuit configurations. In Fig. 14 a common source amplifier is directly coupled to a common base amplifier, two versions of the circuit are shown. The voltage gain of the common source amplifier is small since it feeds the low input impedance of the common base amplifier. The low voltage gain gives a comparatively small effective input capacitance. The f.e.t. gives a very high current gain. If a large value resistance is used in the collector circuit of the bipolar transistor, high overall voltage and power gains are possible.

The circuit features a great amount of isolation between output and input making it suitable for use as a high frequency tuned amplifier if a tuned load is used instead of the load resistor. The breakdown voltage of currently available f.e.t.s is not large but quite large values of supply voltage can be used with the circuit of Fig. 14a. In this circuit the f.e.t. experiences only the voltage applied to the base of the bipolar transistor.

The effective input capacitance of a common drain amplifier, with gain close to unity, is little greater than C_{gd} , it may be reduced to an even smaller value using the type of circuit shown in Fig. 15.

In this circuit transistor TR3 drives the drain of the f.e.t. in phase with the signal applied to the gate, thus reducing the effective value of C_{gd} . The lower end of the gate resistor is also driven in phase with the signal applied to the gate, thus reducing the current through this resistance and increasing its effective magnitude.

Effective input impedances of many hundreds of megohms are possible; the input capacitance would be less than 1pF. Input capacitance is in fact usually determined by "strays". The circuit is basically a common drain amplifier, so its gain is less than unity.

Another type of compound connection with high effective input impedance, but which can have a voltage gain greater than unity, is shown in Fig. 16. It is sometimes referred to as a "bootstrapped source follower".

The drain of the f.e.t. drives the base of the *npn* transistor whose collector drives the source of the f.e.t. and the lower end of the gate resistor in phase with the input signal. With the component values shown the circuit was found to have a voltage gain of eight and a maximum signal output amplitude of 4 volts. Table 1 shows the input impedance for a wide frequency range.

required by the transistor. Because of the high input impedance of an f.e.t. very high values can be used; long time constants can be obtained in monostable and astable circuits without the need for very large capacitance values.

A circuit for a free running multivibrator published by Semitron is shown in Fig. 17. It is said to have a frequency of one cycle per minute.

A field effect timer circuit using a monostable multivibrator is shown in Fig. 18. In the stable state of the circuit transistors TR1 and TR2 are both conducting;

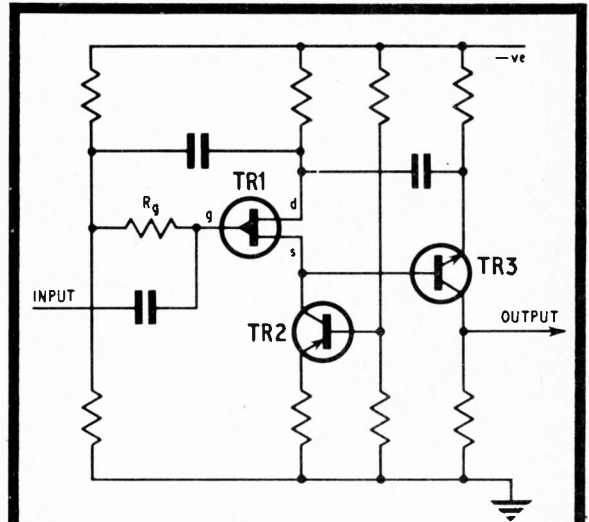

Fig. 15. High input impedance amplifier

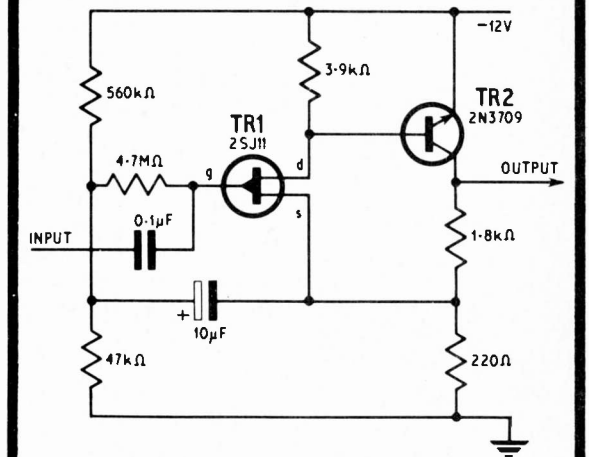

Fig. 16. Boot-strapped source follower

F.E.T. MULTIVIBRATORS

Field effect transistors can be used in multivibrator circuits in a manner similar to bipolar transistors, but if high speed switching and high pulse frequencies are to be used bipolar transistors give better performance. However when repetitive waveforms and timing circuits having periods of several minutes are required the f.e.t. has a marked advantage.

The maximum timing resistance that can be used with a bipolar transistor is determined by the base current

Table I. INPUT IMPEDANCE OF CIRCUIT IN FIG. 16

Frequency	5Hz	1kHz	5kHz	10kHz
Input impedance Z_i (MΩ)	26	26	19	8
Frequency	20kHz	40kHz	100kHz	
Input impedance Z_i (MΩ)	3.1	1.6	0.67	

LOOK!

PRACTICAL!

VISUAL!

EXCITING!



a new 4-way method of mastering
ELECTRONICS
by doing — and — seeing . . .

1 ▶ **OWN and HANDLE a**

complete range of present-day **ELECTRONIC PARTS and COMPONENTS**

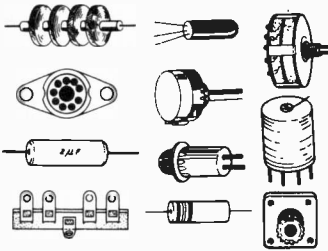

2 ▶ **BUILD and USE**

a modern and professional **CATHODE RAY OSCILLOSCOPE**

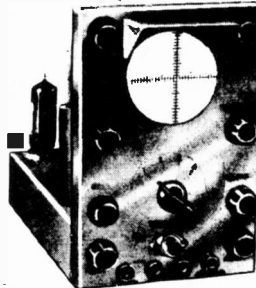

3 ▶ **READ and DRAW and UNDERSTAND CIRCUIT DIAGRAMS**

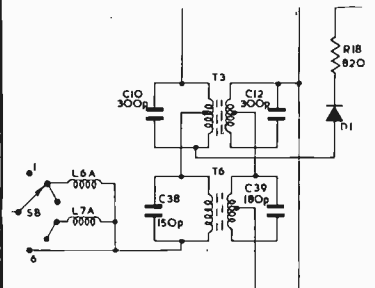

4 ▶ **CARRY OUT OVER 40 EXPERIMENTS ON BASIC ELECTRONIC CIRCUITS AND SEE HOW THEY WORK . . . INCLUDING . . .**

- VALVE EXPERIMENTS
- TRANSISTOR EXPERIMENTS
- AMPLIFIERS
- OSCILLATORS
- SIGNAL TRACER
- PHOTO ELECTRIC CIRCUIT
- COMPUTER CIRCUIT
- BASIC RADIO RECEIVER
- ELECTRONIC SWITCH
- SIMPLE TRANSMITTER
- A.C. EXPERIMENTS
- D.C. EXPERIMENTS
- SIMPLE COUNTER
- TIME DELAY CIRCUIT
- SERVICING PROCEDURES

This new style course will enable anyone to really understand electronics by a modern, practical and visual method—no maths, and a minimum of theory—no previous knowledge required. It will also enable anyone to understand how to test, service and maintain all types of Electronic equipment, Radio and TV receivers, etc.

FREE POST NOW
for
BROCHURE

or write if you prefer not to cut page

To: **BRITISH NATIONAL RADIO SCHOOL, READING, BERKS.** Please send your free Brochure, without obligation, to: we do not employ representatives

NAME BLOCK CAPS

ADDRESS PLEASE PE 6

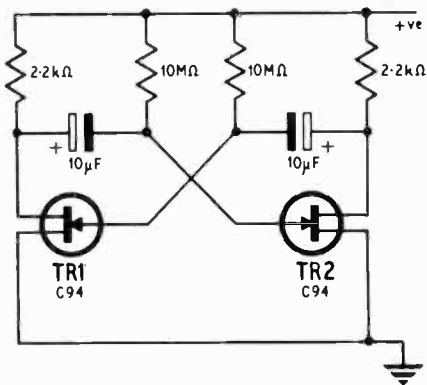

Fig. 17. Very low frequency free running multivibrator

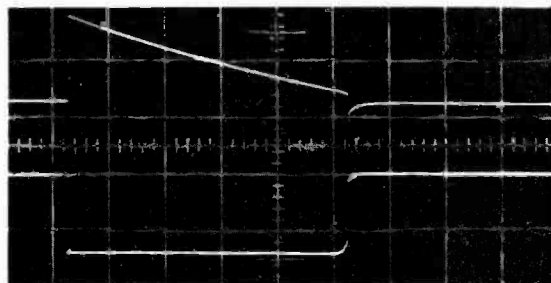

Fig. 19. Gate waveform (top) 5V/cm. TR2 collector (bottom) 5V/cm. Time 0.5 second per centimetre. (Refer to Fig. 18)

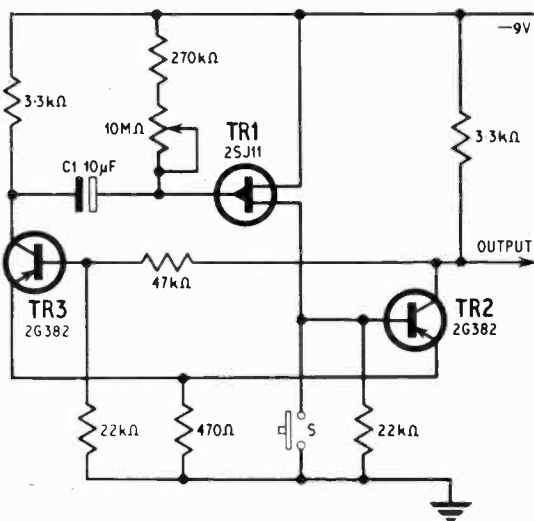

Fig. 18. Field effect timer circuit

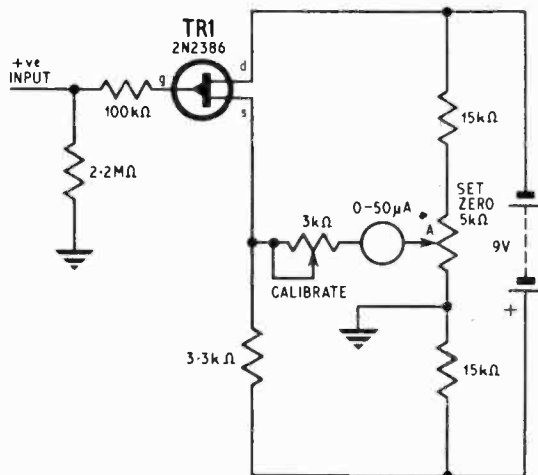

Fig. 20. Simple f.e.t. voltmeter

TR2 is saturated. Transistor TR3 is held cut off by the voltage across the 470 ohm emitter resistor and the potential divider connecting the collector of TR2 to the base of TR3. When the switch S1 is momentarily closed the current through TR2 stops and TR3 suddenly conducts. This causes a sudden change in TR3 collector voltage which is communicated to the gate of f.e.t. TR1 by the capacitor C. TR1 is cut off and this state is maintained until C discharges sufficiently to bring TR1 into conduction again when a regenerative action returns the circuit to its stable state. The waveforms at the gate of TR1 and at the collector of TR2 are shown in Fig. 19. The time delay is proportional to the time constant CR , with the values shown the delay is variable between 3 and 90 seconds.

F.E.T. VOLTMETER

The high input impedance of an f.e.t. may be utilised in the construction of high input resistance electronic voltmeters. The circuit of a simple f.e.t. voltmeter is shown in Fig. 20. With no input voltage applied the potentiometer VR1 is adjusted to bring the potential

of the point A to the same potential as the source of the f.e.t. so that no current flows through the meter. The VR2 calibration control is adjusted to give full scale deflection of the meter when 0.5V is applied to the input. The basic sensitivity of the instrument is then 4.4 megohms per volt; it is a simple matter to make it read higher voltages by using a suitable input multiplier. The reading of the meter is very stable provided no violent fluctuations in temperature take place and the instrument is extremely useful for measuring direct voltages at high impedance points.

F.E.T.s AS VOLTAGE CONTROLLED RESISTORS

The drain characteristics of an f.e.t. in the non-pinched-off region (low values of drain voltage) are almost linear and their slope is dependent on the magnitude of the gate voltage. In this region the f.e.t. acts as a variable resistor; the gate voltage determines the resistance between source and drain. Interesting applications of an f.e.t. operated in this way are possible.

SPECIAL OFFER

For this complete and up to
date work on RADIO and
ELECTRONICS

1,100 PAGES CRAMMED FULL
WITH INFORMATION AND
ILLUSTRATIONS VITAL TO
THE ELECTRONICS STUDENT
AND ENTHUSIAST

If you are an electronics student, teacher, enthusiast, or your business is electronics, these two fact-filled volumes will be an invaluable asset to you. Interested? Complete and send coupon TODAY. WITH NO OBLIGATION.

Application Form

To New Era Publishing Co. Ltd. (Dept. R2A)
39 Parker Street, London, W.C.2

Please send me details of the two-volume work
"Radio and Electronics" together with particulars
of easy payment terms.

Name

Address

Signature

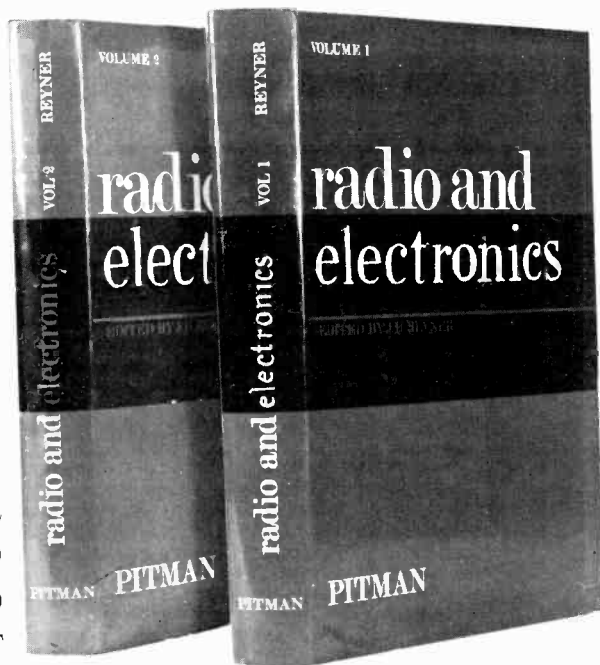

RADIO AND ELECTRONICS

In two volumes

Edited by J. H. Reyner

VOLUME I deals with

Basic Principles of Electrical Engineering
Circuit Design
Electronic Components
Thermionic Valves
Crystal Diodes and Transistors
Cathode-Ray Tubes
The V.H.F. Phenomena
Electric Wave Theory

Plus A practical and readable guide to
Engineering Mathematics indispensable to
the complete understanding of electronic
theory

VOLUME II deals with

Radio Transmission and Reception
Marine and Aeronautical Equipment
Television Transmission and Reception
Sound Recording and Reproducing
(Disc, Film and Tape Techniques)
Radar Principles and Practice
Radio Interference. What causes it?
How can it be controlled?

Plus The application of electronics to medicine
and industry

VARIABLE VOLTAGE TRANSFORMERS



PORTABLE TYPE
£8. 10. 0.

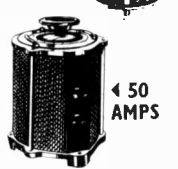

50 AMPS
£3. 3. 0.

INPUT 230/240v. A.C. 50/60—
OUTPUT VARIABLE 0-260v.
BRAND NEW Carriage Paid.
Buy direct from the importer,
keenest prices in the country.
All Types (and Spares) from
1/2 to 50 amp. from stock.
OPEN TYPE (Panel Mounting)
1/2 amp, £3. 3. 0. 1 amp, £4. 10. 0.
2 1/2 amps, £5. 12. 6.

SHROUDED TYPE
1 amp, £4. 10. 0. 2.5 amps,
£5. 17. 0. 4 amps, £8. 7. 6.
5 amps, £9. 0. 0. 8 amps,
£13. 10. 0. 10 amps, £17. 0. 0.
12 amps, £19. 10. 0. 15 amps,
£22. 0. 0. 20 amps, £32. 10. 0.
37.5 amps, £65. 0. 0. 50 amps,
£85. 0. 0.

1.5 amp. portable fitted metal case
voltage meter, lamp, switch, etc. £8. 10. 0.
P. & C. 10/-, similar to above 2.5
amp. £9. 17. 6. P. & C. 10/-

LIGHT SENSITIVE SWITCH

Kit of parts, including ORP12 Cadmium Sulphide Photocell, Relay, Transistor and Circuit, etc., 6-12 volt D.C. op. price 25/- plus 2/6 P. & P. ORP 12 including circuit, 10/6 each, plus 1/- P. & P.

A.C. MAINS MODEL Incorporates Mains Transformer, Rectifier and special relay with 3, 5 amp mains c/o contacts. Price inc. circuit 47/6 plus 2/6 P. & P.

LIGHT SOURCE AND PHOTO CELL MOUNTING
Precision engineered light source with focusible lens assembly and ventilated lamp housing, to take MBC bulb. Separate photo cell mounting assembly for ORP 12 or similar cell. Both units are single hole fixing. Price per pair £2. 10. 0. P. & P. 3/6.

UNISELECTOR SWITCHES

75 ohm coil 24 v. D.C.
6 Bank 25 position, 5 non-bridging 1 Bridging Wiper
6 Bank arranged to give 3 bank, 50 positions. Carefully removed from equipment. All at 35/- each. P. & P. 2/6.

Compact Heavy Duty 6 v. D.C. Relay
2 changeover, 3 ohm coil, 7/6 each. P. & P. 1/6. 3 for 20/- post paid.

BRAND NEW 4 Bank 25 Way Uniselector, 3 Bank Homing 25 ohm coil, 12-24v. D.C. operation £4. 17. 6 plus 2/6 P. & P.

UNIVERSAL DEMONSTRATION TRANSFORMER

A complete composite apparatus, comprising a Transformer and electro-magnet with removable coils and pole pieces. Coil tapped for 230v, 220v, 110v, 115v; 6, 12, 36, 110v. A.C. These coils are also used for D.C. experiments. Complete with all accessories as shown. £17 15/- carriage. Leaflet on request.

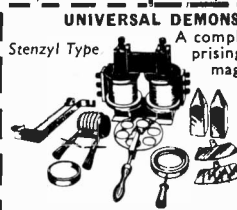

WIMSHURST ELECTROSTATIC GENERATORS
£13/17/6, carr. U.K. (B.R.S.) 10/- Leaflet on request.

ULTRA VIOLET BULBS

Easy to use source of U.V. for dozens of practical and experimental uses. 12 volt 36 watt A.C./D.C. SBC 6/6. 12 volt 60 watt A.C./D.C. SBC 8/6. P. & P. 1/- on above. Transformer to suit the above. Input 200-240 v. A.C., 12 volt 36 watts, 21/-; P. & P. 2/6. Input 200-240 v. A.C. 12 volt 60 watt, 27/-; P. & P. 3/6.

Set of 4 Colours FLUORESCENT PAINT. Red, yellow, green and cerise. In 1/2 oz. tins. Ideal for use with the above Ultra Violet Bulbs. 11/-, plus 2/6 P. & P.

230 VOLT A.C. GEARED MOTORS

5 r.p.m. 1-7 lb. inch £2.9.6. P. & P. 2/6. 13 r.p.m. 1-45 lb. inch £2.17.6. P. & P. 2/6. 80 r.p.m. 2-6 lb. inch £2.2.0. P. & P. 2/6.

DOUBLE WOUND VARIABLE LT TRANSFORMERS

Fully isolated low tension secondary winding. Input 230 v. A.C. Output continuously variable 0-36 v. A.C.
0-36 Volt at 5 Amp. £8.10.0. P. & P. 8/6.
0-36 Volt at 20 Amp. £19.10.0. P. & C. 15/-.
These fully shrouded transformers designed to our specifications are ideally suited for Educational and Industrial Laboratory use.

L.T. TRANSFORMERS

All primaries 220-240 volts.

Type No.	Sec. Taps	Price Carr.
1	30, 32, 34, 36 v. at 5 amps.	£3.5.0 7/6
2	30, 40, 50 v. at 5 amps.	£5.5.0 9/-
3	10, 17, 18 v. at 10 amps.	£3.10.0 7/6
4	6, 12 v. at 20 amps.	£4.17.6 7/6
5	17, 18, 20 v. at 20 amps.	£5.12.6 10/6
6	6, 12, 20 v. at 20 amps.	£5.5.0 9/-
7	24 v. at 10 amps.	£3.15.0 7/6

100 WATT POWER RHEOSTATS (NEW)

AVAILABLE IN THE FOLLOWING VALUES
1 ohm, 10 a.; 5 ohm, 4.7 a.; 10 ohm, 3 a.; 25 ohm, 2 a.; 50 ohm, 1.4 a.; 100 ohm, 1 a.; 250 ohm, .7 a.; 500 ohm, .45 a.; 1,000 ohm, 280 mA.; 1,500 ohm, 230 mA.; 2,500 ohm, .2 a. Diameter 3 3/4 in. Shaft length 3 1/2 in., dia. 3/8 in. All at 27/6 each. P. & P. 1/6.



25 WATT POWER RHEOSTATS

10 ohm, 1.5 a.; 25 ohm, 1 a.; 50 ohm, .75 a.; 100 ohm, .5 a.; 250 ohm, .3 a.; 500 ohm, .2 a.; 1,000 ohm, .15 a.; 1,500 ohm, .12 a.; 2,500 ohm, .1 a.; all at 14/6. P. & P. 1/6.

"GABY" MULTI-RANGE TEST METER

Model B40. D.C. volt, 0-5 v., 2-5 v., at 10,000 ohm per volt. Ideal for transistor circuit testing. A.C. and D.C. volt, 10 v., 50 v., 250 v., 500 v., 1,000 v., at 4,000 ohm per volt. Resistance, 2 K ohm, 200 K ohm, 2 meg., 20 meg. Repair service available. Price includes Test Leads, Battery, Instruction book, Packing and Post (U.K.). £6.2.6. 3 additional models available from 54/- to £14.14.0. Leaflet gladly sent on request.

SOUND POWER OPERATED EX-ADMIRALTY HEAD AND BREAST SETS

Two such sets connected up will provide perfect intercom. No batteries required. Will operate up to 1/2 mile. Price 17/6 each plus P. & P. 3/- or 32/6 per pair. P. & P. 5/6.



36 VOLT 30 AMP AC OR DC VARIABLE LT SUPPLY UNIT

Low voltage supply. Fully isolated. Fitted in robust metal case with Voltmeter, Ammeter, Panel Indicator and Chrome Handles. Input and Output fully fused. Ideally suited for Lab. or Industrial use. £55 40/- CP.

CONSTANT VOLTAGE TRANSFORMER

Input 185-250 v. A.C. Output 230 v. A.C. Capacity 250 watt. Attractive metal case. Fitted red signal lamp. Rubber feet. Weight 17 lbs. Price £11.10.0. P. & P. 15/-.



SERVICE TRADING CO

All Mail Orders—Also Callers—Ample Parking Space
57 BRIDGMAN ROAD, LONDON, W.4 Phone 995 1560
SHOWROOM NOW OPEN CLOSED SATURDAY

Personal callers only
9 LITTLE NEWPORT ST.
LONDON, W.C.2. Tel. GER 0576

LODGE TRADING CO.

SPEAKER UNITS

12" HI/FI 25 watt 15 ohm Heavy Duty (ELAC) £6.6.0
12" Guitar 25 watt 15 ohm Heavy Duty (ELAC) £6.6.0
12" 15 ohm small magnet 8,000 Lines (R & A) £2.5.0
10" Ceramic 11,000 Lines 15 ohm or 3 ohm (ELAC) £1.19.6
10" 6" Ceramic 11,000 Lines 15 ohm or 3 ohm (ELAC) £1.19.6
8" Ceramic 11,000 Lines 15 ohm or 3 ohm (ELAC) £1.17.6
8" small magnet 8,000 Lines 3 ohm only (ELAC) £1.5.0
7" 4" small magnet 7,000 3 ohm only (CELESTION) 17.6
3" Square 4 Hole Fixing 25 ohm only (PLESSEY) 12.6



AERIALS

CAR AERIAL WING FIXING 3 SECTION £15.0
CAR AERIAL LOCKING/DIS-APPEARING 4 SECTION £1.17.6
CAR AERIAL WINDOW FIXING 18.9
CAR AERIAL GUTTER FIXING 18.9
TABLE TOP T.V. AERIALS BBC/I.T.V. FM £1.5.0
TABLE TOP T.V. AERIALS BBC 1/2 I.T.V. FM £2.9.6

Many other lines available—
FULL TRADE DISCOUNT TO BONA FIDE DEALERS
Terms: C.W.O. Please add 5/- Postage on orders under £6
EASY CAR PARKING—A VISIT WILL SAVE YOU MONEY!
21 LODGE LANE, LONDON, N 12 HILISIDE 0749

NEW 1967 Edition

RADIO AMATEUR HANDBOOK

40/- by A.R.R.L. Postage 4/-

DICTIONARY OF RADIO & TELEVISION, by W. E. Pannett. 36/- Postage 1/-.

RAPID SERVICING OF TRANSISTOR EQUIPMENT, by G. J. King. 30/- Postage 1/-.

SUB-MINIATURE ELECTRIC MOTORS, by R. H. Warring. 36/- Postage 1/-.

TRANSISTOR ELECTRONIC ORGANS FOR THE AMATEUR, by A. Douglas & S. Astley. 18/- Postage 1/-.

MATHEMATICS FOR RADIO AND ELECTRONICS TECHNICIANS, by Dr. Ing Fritz Bertgold. 50/- Postage 2/-.

TRANSISTOR POCKET BOOK, by R. G. Hibberd. 25/- Postage 1/-.

RADIO VALVE DATA 8th ed. 9/6. Postage 1/- Compiled "WW".

Inter GEC TRANSISTOR MANUAL. 18/- Postage 2/-.

THE MODERN BOOK CO.

BRITAIN'S LARGEST STOCKISTS of British and American Technical Books
19-21 PRAED STREET
LONDON, W.2
Phone: PADdington 4185
Closed Saturday 1 p.m.

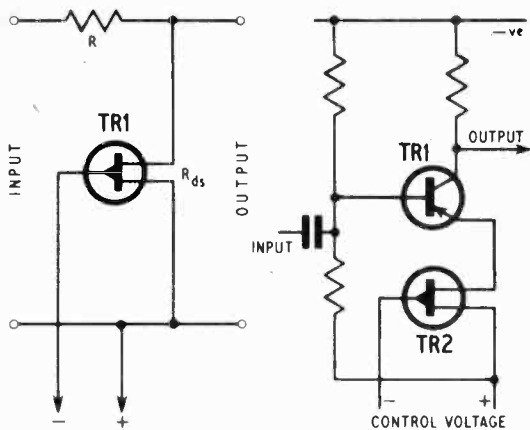

Fig. 21. Voltage controlled attenuator

Fig. 22. Voltage operated gain control

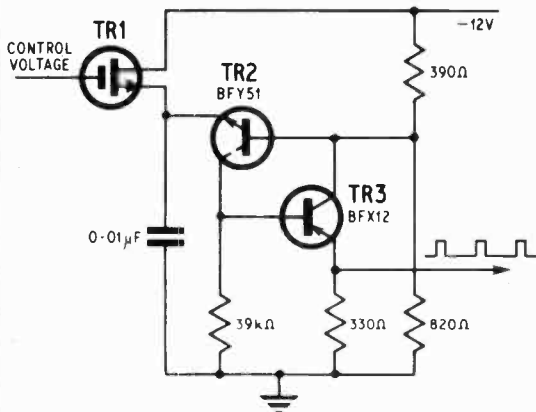

Fig. 23. Voltage to frequency converter

A simple voltage controlled attenuator is shown in Fig. 21. The attenuation ratio is given by

$$N = \frac{R_{ds}}{R + R_{ds}}$$

where R_{ds} is the source drain resistance. The range of attenuation obtainable is dependent on the range over which R_{ds} can be varied and this is a property of the particular f.e.t. in use.

In the circuit of Fig. 22 an f.e.t. is used as a voltage operated gain control. The f.e.t. is used as the emitter resistance of a common emitter amplifier introducing negative feedback. The amount of negative feedback and hence the gain of the amplifier is determined by the value of R_{ds} .

A Mullard circuit using an f.e.t. in a voltage-to-frequency converter is shown in Fig. 23. An insulated gate f.e.t. is used in this circuit although a junction gate f.e.t. could be used in the same way. The f.e.t. is used as the resistive element in a CR *n-p-n-p-n-p* relaxation oscillator, changing the input voltage to the gate of the f.e.t. alters the effective timing resistor and varies the frequency of oscillation. ★

NEXT MONTH!

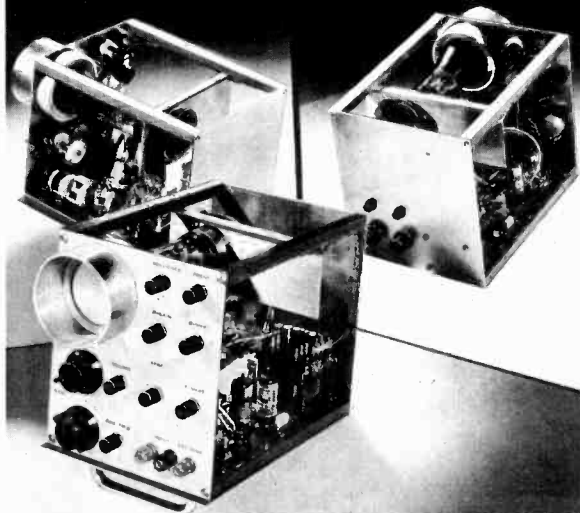

SIMPLE-TO-BUILD OSCILLOSCOPE

Portable single beam oscilloscope with trigger and sync controls and 3in tube. Just right for audio and r.f. monitoring. Simple to make—easy to use!

ALSO

MODEL CONTROL INSTALLATION

The second part of this article shows how to use the P.E. Model Control Amplifier 'B' for relayless operation of servos.

ELECTROMAGNETIC RELAYS

A comprehensive survey of different types of electromagnetic armature and reed relays and how to get the best out of them.

PRACTICAL

JULY ISSUE ON SALE JUNE 16

ELECTRONICS

Reserve your copy and place a regular order!

the 73 page

by Jack Hum
G5UM

Two-Plus-Three

Most short wave listeners keep in the radio room a copy of *The Callbook* to enable them to identify the stations they hear on the amateur bands. But besides functioning as a radio-station directory *The Callbook* can be a source of interesting and at times surprising information. Properly studied, it will in fact reveal a fascinating cross-section of amateur radio history when it is remembered that all two-letter call-signs printed in it are (with a few exceptions in the G4 block) of pre-war origin, while all G3-plus-three call-signs are post-war. And of course all the G6-plus-three and G8-plus-three special u.h.f.-only licences are post-1964, which was the year in which these "Television" and "Sound Licence B" permits came into issue.

What also becomes evident from a study of the pattern of British amateur transmitting licences is that there exists, in contrast to the overwhelming preponderance of G3-plus-three allocations, a small corpus of call-signs in the G2-plus-three series (yes, we said "G2"!), a fact which has prompted many newcomers to amateur radio to ask: What is the special significance of these calls, and why did the series start in the G2AAA block only to peter out somewhere down the G2HAA block? And why are there so few of them?

Which brings us back to the point where we left off last time, and to a word or two about what was once known as the "artificial aerial" transmitting permit.

That Unroyal Road

Before the war there was no royal road to the acquisition of a transmitting licence, as has been amply demonstrated in the last two instalments of *The 73 Page*. It was certainly not possible then, as it is today, to obtain "a ticket" more or less upon request after passing a

Radio Amateurs' Examination: the R.A.E. hadn't been thought of then! No, the procedure which the aspirant to transmitting facilities had to follow was to prove to the licensing authority that the "wireless experiments" on which he was engaged were such that would justify the need to transmit.

It was perhaps not surprising that a majority of applicants said they had experiments with radiating aerials in mind!

Nevertheless, whatever line of experiment was put forward, our (generally young) hopeful would almost certainly not be granted full transmitting authorisation straight away, but—much more likely—would be allocated what was known

probationary period before going on the air. (Today's cynics have been heard to say that judging from the poor quality of some of the signals and operating standards that infest the amateur bands of 1967, it is a pity that the probationary period is no longer the law. "Some of 'em ought to be on probation in a different sense!" growled one.)

"No 'G', Lad"

Up to the time of the war in 1939 artificial aerial permits were allocated in the Figure 2-plus-Three-Letter sequence, e.g. 2AHL. Significantly, the national prefix was not included as part of the callsign as it is today.



Six well-known call-signs in the G2-plus-three series are shown on these QSL report cards. All were issued before the war but none of the holders transmitted on the air until after it. Left to right: G2AHL is General Manager of the Radio Society of Great Britain; G2BLA is a noted ornithologist besides being a radio amateur; G2CDX is Chairman of the Cambridge Radio Club; G2DHV is a Major who travels much on the Continent and holds several overseas call-signs as well as his British one; GM2FNF, a farmer, is one of the few transmitting men on the Isle of Arran; and G2HIF is a leading member of the Radio Club associated with the Atomic Energy Authority

as the artificial aerial (or A.A.) licence. Its purpose: to enable the newcomer to gain experience with the setting up of transmitting equipment on a non-radiating basis, output being fed not to an outside aerial but to a non-radiating artificial aerial—which today we would call a dummy load.

Although derided in some quarters, the A.A. licence system did offer the very practical advantage of allowing the would-be transmitting amateur to master the problem of generating stable r.f. power on the short waves without making himself a nuisance to others with unintended swishes and blurps. It served also the incidental useful purpose of helping to cool the heels of the over-enthusiastic by compelling them to serve a

After all, the A.A. licensee, forbidden to radiate beyond the confines of his home, had no need for national identification. The purpose of his holding his 2-plus-three call-sign was to send it to himself!

One young hopeful, proud possessor of a brand new "Two-plus-Three" call-sign, asked for it to be published in the radio press of the day complete with the prefix "G". Within a mail or two he found himself pulled up smartly by the G.P.O. licensing authority with a reminder that he couldn't—and shouldn't—use "G" until he had earned his full ticket. The lad survived the reproof, and went on to mount the staircase of St Martin le Grand to take his morse test in the fullness of time.

ELECTROLYTIC CONDENSERS

0.25uf. .3V.	4uf. .4V.	16uf. .150V.	64uf. .40V.
1uf. .10V.	4uf. .12V.	20uf. .3V.	100uf. .3V.
1uf. .15V.	4uf. .25V.	20uf. .6V.	100uf. .6V.
1uf. .40V.	4uf. .100V.	20uf. .9V.	100uf. .10V.
1uf. .50V.	5uf. .6V.	20uf. .15V.	100uf. .12V.
1uf. .350V.	5uf. .25V.	25uf. .6V.	100uf. .15V.
1.25uf. .16V.	5uf. .50V.	25uf. .12V.	150uf. .12V.
2uf. .3V.	5uf. .70V.	25uf. .25V.	150uf. .25V.
2uf. .9V.	6uf. .12V.	25uf. .30V.	200uf. .3V.
2uf. .10V.	15uf. .6V.	30uf. .6V.	200uf. .4V.
2uf. .15V.	6.4uf. .40V.	30uf. .10V.	200uf. .16V.
2uf. .70V.	8uf. .3V.	30uf. .15V.	250uf. .2.5V.
2uf. .150V.	8uf. .6V.	32uf. .1.5V.	250uf. .9V.
2.5uf. .16V.	8uf. .50V.	32uf. .25V.	250uf. .15V.
2.5uf. .25V.	10uf. .6V.	40uf. .3V.	320uf. .2.5V.
3uf. .3V.	10uf. .10V.	40uf. .6.4V.	500uf. .4V.
3uf. .12V.	10uf. .12V.	50uf. .6V.	500uf. .25V.
3uf. .25V.	10uf. .25V.	50uf. .9V.	640uf. .2.5V.
3.2uf. .6V.	12.5uf. .4V.	64uf. .2.5V.	750uf. .18V.
3.2uf. .+6.4V.	12.5uf. .40V.	64uf. .9V.	1000uf. .6V.
3.2uf. .40V.	16uf. .16V.	64uf. .10V.	
3.2uf. .64V.	16uf. .30V.	64uf. .16V.	

All at 1/- each, 9/- per dozen. Mixed packet (our selection) 20 for 10/-, 200/100uf., 275V.; 200/200uf., 275V.; 125/300/50uf., 275V.; 5/- each or 3 for 10/-.

PAPER CONDENSERS

0.001uf. .500V.	0.005uf. .750V.	0.1uf. .350V.	0.5uf. .150V.
0.001uf. .1000V.	0.02uf. .600A.C.	0.1uf. .750V.	0.5uf. .350V.
0.002uf. .500V.	0.02uf. .350V.	0.25uf. .350V.	0.5uf. .500V.

All at 15/- per 100, or mixed packet (our selection) 50 for 10/-.

VERY SPECIAL VALUE! CERAMIC CONDENSERS SILVER MICA, POLYSTYRENE, Very well assorted. Mixed types and values. 10/- per 100.

RESISTORS

Very small 1/4 watt, 5% long leads, ideal for transistor work, 10/- for 50, 1/2 watt assorted values including printed circuit types, 10/- for 100, 55/- per 1,000. 1/2 watt to 3 watt mixed values and types, 10/- for 100, 55/- per 1,000. TO CLEAR: 10 Meg. 1/6th watt resistors, £1 per 1,000.

TRANSISTORS

AFZ12, Screened V.H.F. oscillator transistors, 5/- each. OC44, OC45, R.F. Transistors, 4/- each. OC81D, 4/- each. OC71 equivalent, 1/- each, £3 per 100. Switching Transistors ASY22 (npn) or I.B.M. (npn), 6 for 10/-. Car radio type Output Transistors type NKT405, 10/- each.

TELEVISION VALVES. BRAND NEW AND BOXED

PCF80, 7/6; PL81, 7/6; PCL82, 7/6; PCL85, 7/6; PCL84, 7/6; PCC84, 6/6; PY81, 6/-; ECC82, 6/6; PL36, 9/-; EY86, 6/-; PCL83, 9/-; PY33, 9/-; ECL80, 6/6; PCC89, 9/-.

Computer diodes. Make excellent detectors. Also suitable for keying electronic organs. 1/- each or 20 for 10/-. BY100 TYPE TELEVISION H.T. RECTIFIERS, SPECIAL PRICE 5/- each, 30/- dozen.

ORP12 light sensitive resistors, 9/- each. TRANSISTOR BATTERY FLUMINATORS—same size as PP9, 30/-; PP6, 20/- BATTERY CHARGERS, with meter and fuse, 4 amp, 12V., 55/- each. SOLON MODEL 615 Slim Pencil-bit Soldering Irons, 25/- each. WELLER DUAL-HEAT SOLDERING GUN, 57/6. NUTS, SCREWS and WASHERS, very useful assorted packs, 6/- each. WALKIE-TALKIES (not for use in U.K.), £7/10/- pair.

MAGNETIC RECORDING TAPE, BRITISH MADE, FULLY GUARANTEED

Standard Play, 3in., 150ft., 3/6; 5in., 600ft., 10/6; 5 1/2in., 900ft., 13/6; 7in., 1,200ft., 16/3. Long Play, 3in., 225ft., 4/-; 5in., 900ft., 12/9; 5 1/2in., 1,200ft., 15/9; 7in., 1,800ft., 21/6. Double Play, 3in., 400ft., 6/6; 5in., 1,200 ft., 20/-; 5 1/2in., 1,800ft., 28/-; 7in., 2,400 ft., 34/- 2 1/2in., 300ft., 6/9. Triple Play Polyester: 3in., 600ft., 12/6; 4in., 900ft., 16/6.

SIGNAL INJECTOR, parts and circuit to make, 10/- only. SIGNAL TRACER, parts and circuit to make, 10/- only. MOTOR CAR REV. COUNTER (less 1mA meter), parts and circuit to make, 10/- only. TRANSISTORS, COMPONENTS AND CIRCUIT to convert 1mA meter to 0 to 10 Meg. ohm meter, 10/-. TRANSISTORISED RUMBLE AND SCRATCH FILTER (for improving reproduction of old records), all components and circuit, 30/-.

SINCLAIR. All products in stock including latest version of MICRO—World's smallest radio—and only 59/6!

NEEDLES FOR RECORD PLAYERS. HALF PRICE!

All types below at 3/6 each! TC8LP; GC2LP; GC8LP; BF40LP; GP67LP; GP37; GP59; TC8 Stereo LP; Studio O LP.

CARTRIDGES

SONOTONE MONO, 10/-. ACOS, 15/-. ACOS STEREO SAPPHIRE 12/6; DIAMOND, 17/6. All complete with needles!

LAPEL MICROPHONES, Magnetic or Crystal, 10/- each. TAPE RECORDER MICROPHONES, Fantastic value at 12/- each. ACOS MIC. 45, 30/-. Many others, both crystal and dynamic in stock.

THIN CONNECTING WIRE. 10yd., 1/-; 100yd., 7/6; 500yd., 25/-; 1,000yd., 40/-.

LOUDSPEAKERS. 12in. Richard Allen, 37/6d. 12in. Bakers Guitar, £5/5/-, 3in., 4in., 5in., and 5in x 3in., all at 10/- each; 8in. x 2 1/2in., 12/6; 2in. 80 ohm, 7/6.

EARPIECES. Magnetic or Crystal, 5/- each.

VEROBOARD

2 1/2in. x 5in., 3/11; 2 1/2in. x 3 1/2in., 3/3; 3 1/2in. x 5in., 5/6; 3 1/2in. x 3 1/2in., 3/11. Terminal Pins, 50 for 3/-; Spot Face Cutter, 7/3; Pin Insert Tool, 9/6. Special Offer—Cutter and 5 boards, 2 1/2in. x 1in., 9/9.

ELECTRONIQUES DEALER. 600 PAGE CATALOGUE—10s. 6d. **ORDERS BY POST—TO G. F. MILWARD, 17 PEEL CLOSE, DRAYTON BASSETT, STAFFS.**

PLEASE INCLUDE POSTAGE COSTS

For customers in the Birmingham area, goods may be obtained from: **ROCK EXCHANGES, 231 ALUM ROCK ROAD, BIRMINGHAM 8**

EXCEL

in

ELECTRONICS

Through this ICS 3-way Training Method:

1

MASTER THE THEORETICAL SIDE

From basic principles to advanced applications, you'll learn the theory of electronic engineering, quickly and easily through ICS. That's because each course is set out in easy-to-understand terms.

2

MASTER THE PRACTICAL SIDE

ICS show you how to develop your practical abilities in electronic engineering—alongside your theoretical studies. It's the only sure way to success. All training manuals are packed with easy-to-follow illustrations.

3

MASTER THE MATHEMATICAL SIDE

To many this aspect is a bitter problem. Even more so because no electronic engineer is complete without a sound working knowledge of maths. But new ICS teaching makes mathematics easier to learn.

Wide range of courses available include: Radio/T.V. Engineering and Servicing, Closed Circuit T.V., Electronics, Electronics Maintenance, Instrumentation and Servomechanisms, Telemetry, Computers, etc. **NEW! Programmed Course on Electronic Fundamentals**

EXPERT COACHING FOR:
INSTITUTION OF ELECTRONIC AND RADIO ENGINEERS
CITY AND GUILDS TELECOMMUNICATION TECHNICIANS
CITY AND GUILDS SUPPLEMENTARY STUDIES
R.T.E.B. RADIO/T.V. SERVICING CERTIFICATE
RADIO AMATEURS' EXAMINATION
P.M.G. CERTIFICATES IN RADIOTELEGRAPHY

And there are practical "learn as you build" radio courses as well.

Member of the Association of British Correspondence Colleges

FOR **FREE HANDBOOK** POST THIS COUPON TODAY

I.C.S., Dept. 151, INTERTEXT HOUSE, PARKGATE ROAD, LONDON, S.W.11

NAME

ADDRESS

OCCUPATION.....AGE..... 6/67

INTERNATIONAL CORRESPONDENCE SCHOOLS

DIGITAL VOLTMETERS!



For the first time ever, we proudly present a three digit a.c./d.c. voltmeter for less than £100! Manufactured by the world famous Hawker Siddeley Group at its Gloucester Works, the Digimeter Type B.I.E. 2123 is a fully transistorised multi-range instrument possessing the following distinctive features:

Electrical Characteristics:

D.c. Ranges: 10mV to 400V in four ranges (1000V for positive voltages).

Accuracy: the greater of $\pm 0.1\%$ of ± 1 digit.

A.c. Ranges: 100mV to 250V r.m.s. in three ranges.

Accuracy: the greater of $\pm 0.5\%$ or ± 1 digit over the frequency range 30c/s to 10Kc/s.

Range Change is manual.

Input Impedance: D.c. 15 Mohm on two lower ranges, 1 Mohm on two higher ranges.

A.c.-a.c. coupled, approximately equivalent to a shunt impedance of 8 Kohm in series with the parallel impedances 180 Kohm and 550pF.

Input Characteristics: Single ended, floating. The potential between terminal connected to OV and earth should not exceed 400V d.c. or 250V a.c.

Input Filter: 55dB attenuation at 50c/s.

Conversion Time: 300mSec.

Sampling Rate: 1 reading per 2sec or manually controlled.

Power Supply: 100/120V, 200/250V 50c/s.

Mechanical Characteristics:

Dimensions: 10 $\frac{1}{2}$ in high \times 7in wide \times 1 $\frac{1}{2}$ in deep.

Weight: 1 $\frac{1}{2}$ lb.

Display Details: Three digit with decimal point indication. Character Height 1in.

At the price we can offer these instruments no laboratory can afford to be without one! They are ideally suited to production and inspection applications.

Brand new in manufacturer's packing. With Handbook.

£92. 10. 0

Carriage extra at cost

IMMEDIATE DELIVERY!

GENERAL RADIO RF SIGNAL GENERATOR TYPE 804C

Frequency range 8 to 300Mc/s in 5 ranges accuracy 1% directly calibrated. Variable attenuation 1 Micro volt to 20MV. Modulation internal/external incorporates at a glance Carrier and Modulation meters, internal stabilised P.S.U. 110-250 volts a.c. In very good condition and working order. PRICE £22/10/0. p.p. 20/-.

HIVOLT PORTABLE E.H.T. GENERATOR

Variable output from 0 to 10kV d.c., Megohms range 200 to 10 Ω . A small modern completely portable instrument, Fully transistorised C/W batteries. Weight complete 21lb. New condition£35

RELAYS MINIATURE SEALED TYPES

- STC 4186 EA 1.3 volts 1 heavy duty make.
 - STC 4186 EB 6V 45 ohms 1 HD make.
 - STC 4184 GB 6V 45 ohms 2 C/O.
 - STC 4184 GC 12V 170 ohms 2 C/O.
 - STC 4190 GD 24V 700 ohms 2 C/O. (STC 4186ED 24V 700 ohms 1 HD make).
 - STC 4184 GE 48V 2500 ohms 2 C/O.
- All the above types at 8/6 ea. New stock p.p. 1/-.

SANGAMO WESTON MINIATURE MOVING COIL RELAY TYPE 5115

Resistance 90 ohms, nominal operating current 250 micro amps, single C/O. Weighs only 1 $\frac{1}{2}$ oz. Relay C/W base 25/- p.p. 1/- Brand New.

T.M.C. CARPENTERS POLARISED RELAY TYPE 6U32

Double wound coil resistance 1000 + 1000 ohms. Miniature Series. Brand new C/W base. 25/- p.p. 1/6.

MINIATURE LEDEX ROTARY SWITCHES

5 bank single pole 11 way for 24V operation. Brand new stock. PRICE ONLY 30/- p.p. 2/6.

MUIRHEAD REFERENCE CELLS

Type D-845-C. "U" shaped type. Brand new in individual cartons. PRICE 25/- p.p. 1/6.

P. F. RALFE

423 GREEN LANES, HARRINGAY
LONDON, N.4. MOUNTVIEW 6939

AN/APR4 VHF COMMUNICATIONS AND SEARCH RECEIVERS

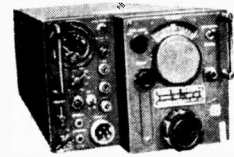

For the first time offered in new, boxed condition. Frequency Range 38-1,000Mc/s. Accuracy 1%. Five I.F. stages. Output impedance 600 or 4,000 ohms. Power supply 115V a.c. (internal). Price complete with three tuning units. NEW £90.

MARCONI POWER OUTPUT METERS TYPE TP340

Measures 5MW-5 watts F.S.D. A small portable instrument in excellent condition. ONLY £12/10/- p.p. 7/6.

BRITISH PHYSICAL LABORATORIES HIGH QUALITY GRADE "I" M/C METER

Sensitivity 1 MA F.S.D. resistance 75 ohms, scale reading 0-200, scale length 5in (mirror for accuracy) being a rectangular flush mounting meter 6 $\frac{1}{2}$ \times 4 $\frac{1}{2}$ makes it very useful for bench work, demonstration purposes etc. where a high accuracy of indication is required, C/W special chrome finish. PRICE ONLY 30/- p.p. 3/6.

GARDNERS V/I "C CORE" TRANSFORMERS

Double wound primary 100-250 volts, secondaries 300-0-300 at 60mA and 6-3V at 4 amps, super high quality, brand new in makers cartons. PRICE 25/- p.p. 3/6.

RELAYS TYPE 3000 BPO

- 25 ohms 3 makes.
 - 500 ohms 2 heavy duty makes (10 amps).
 - 1000 ohms 5 changeovers 2 makes.
 - 1000 ohms 4 C/O.
 - 2000 ohms 4 C/O.
- We have in stock many other types off the shelf, let us know your requirements, all 3000 type relays are priced at 8/6 plus 1/6 p.p.

WESTOOL SOLENOIDS FOR A.C. MAINS OPERATION

230-250V a.c., length of pull $\frac{1}{2}$ inch, base size 1 $\frac{1}{2}$ \times 1 $\frac{1}{2}$, height 1 $\frac{1}{2}$ in, extremely powerful pull. PRICE 25/- each brand new.

HOME RADIO LTD. 187 London Rd., Mitcham, Surrey, CR4 2YQ Phone MIT 3282

What is your time worth per hour?

No doubt you value your time at not a penny less than five pounds per hour . . . but let us settle for an extremely conservative estimate of five shillings per hour! You could save this and much more, on your very first order to Home Radio Ltd. by using our world-famous Component Catalogue. In fact, the time and trouble this catalogue can save you is worth a fortune . . . ask the other 80,000 or so contented customers.

You can save in another way too—although the catalogue costs 7/6 plus 1/6 for post and packing, every copy contains five vouchers each worth 1/- when used as directed. The latest reprint is bigger and better than ever—it lists more than 6,000 items, over 1,000 of them illustrated. Send the coupon today with your 9/- cheque or postal order.

NOW IN STOCK!

Sealectro Clover Leaf Connectors in P.T.F.E. (Lektrokit Part No. LK2031). Price 3/6 per packet of 6, plus 9d. p. & p.

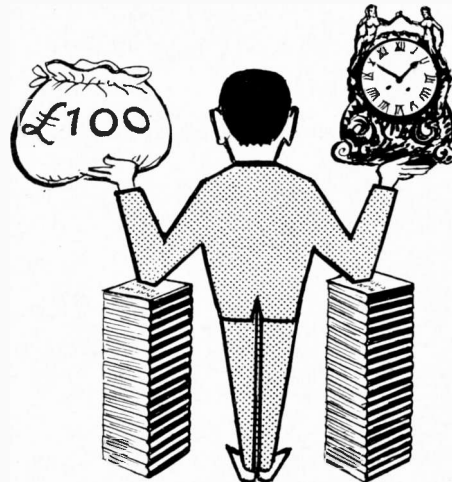

Please write Name and Address in block capitals

NAME

ADDRESS

Home Radio Ltd., Dept. PE, London Rd., Mitcham, CR4 2YQ

MARKET PLACE

Items mentioned in this feature are usually available from electronic equipment and component retailers advertising in this magazine. However, where a full address is given, enquiries and orders should then be made direct to the firm concerned.

AUDIO FAIR

At this year's Audio Fair two companies which made an instant impact were SGS-Fairchild Ltd. and Ferranti Ltd., both first time exhibitors in this show.

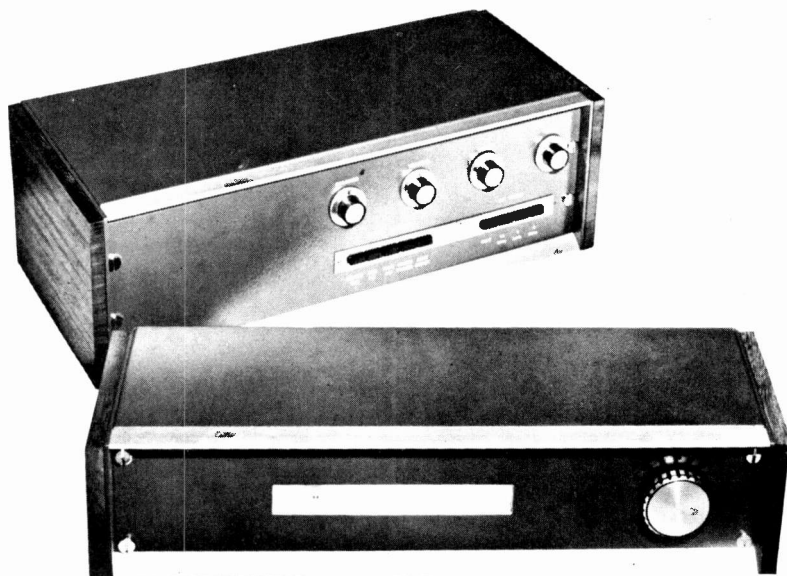

Ferranti pre-amplifier and f.m. tuner

SGS-Fairchild gave details of the AF11 and AF12 "packaged" kits of matched sets of six and seven silicon planar transistors and diodes suitable for building 20 and 30 watt power amplifiers respectively.

The AF11 package is supplied with full circuit and component details for an amplifier having a guaranteed power output of 20W into 15 ohms. Frequency response is 20Hz to 50kHz (-3dB). Harmonic distortion is less than 0.1 per cent and the sensitivity (for maximum output) is 450mV.

The amplifier incorporates design features such as a stable and reliable direct coupled series output circuit, obviating the need for driver and output transformers. Square wave response is said to be excellent, with very fast rise time and no trace of "ringing".

The full matched set of semi-conductors in the AF11 package comprises six transistors for operation at 57 volts and three diodes.

The AF12 consists of seven transistors and one diode; details of a 30 watt amplifier using these are available.

A suitable pre-amplifier design is available for both amplifiers and full details are available from SGS-Fairchild Ltd., Planar House, Walton Street, Aylesbury, Bucks.

An impressive demonstration of audio equipment using silicon planar epitaxial transistors was Ferranti's contribution to the fair. All the pieces of equipment were designed by the Applications Laboratory of the Ferranti Electronics Department and a very good comprehensive 47-page brochure is issued containing all the circuit diagrams, components lists and design notes.

The brochure is entitled "Ferranti High Fidelity Audio Designs", price 5s 0d, and contains chapters on a wide range transistor phase shift oscillator, pre-amplifiers, 7 to 150 watt amplifiers, power supplies, tape recorder pre-amplifiers and amplifiers, tape record level indicator, tape bias/erase oscillator and an f.m. tuner designed to accept BBC stereo broadcasts. For details of where to obtain copies readers should write to Ferranti Ltd., Gem Mill, Oldham, Lancashire.

Ferroglyph Co. Ltd., announced that all Ferroglyph microphones are now supplied complete with stands.

Whilst still on the subject of the Audio Fair, in next month's Audio Trends, Clement Brown will be dealing with some of the exhibits in more detail.

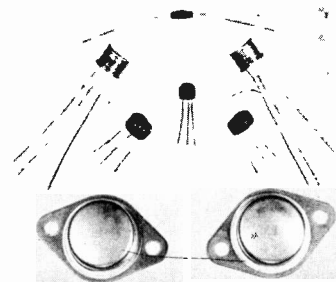

The AF12 Semiconductor pack from SGS-Fairchild

CONSTRUCTORS' AIDS

Surplus or misplaced solder can be speedily removed with a desoldering suction pump, price 65s 0d, from Henri Picard & Frère Ltd., 34/35, Furnival Street, London, E.C.4.

Suction is created by a sprung piston, which is released by pressure on a button catch, the solder being sucked through a pointed nozzle and ejected on the return of the piston. This seems rather expensive for a form of "cycle pump".

A new range of double-sided 0.1in matrix Veroboards have just been introduced by Vero Electronics Ltd., of Chandlers Ford, Hampshire.

These new boards should be ideal for producing prototype "lash-ups" before finalising the intended designs. No special sockets for "bread-boarding" are required and only a spot-face cutter is needed to break the copper strips.

It is strange the number of times faulty readings, malfunctions and general bad performance in pieces of equipment can be traced to dirt. In most cases it is found that the equipment is very delicate, and rather than risk serious damage by



Desoldering Suction Pump imported by Henri Picard & Frère

attempting to clean it, one tends to give a few "puffs" to blow any loose grit clear. This procedure may work the first time but over a period of time the accumulation of dirt, grease and oils tends to solidify and no amount of blowing will shift the waste.

Now a contact cleaner, type CO, is available from **Corrosion Abolition Ltd.**, Camey House, Horton Road, West Drayton, Middlesex. This cleaner is packaged in aerosol cans and dissolves most types of waste and does not damage the base material. The cleaner will penetrate the smallest crack or surface opening and the force from the spray blows away the dirt particles, leaving the contact clean.

A product that retailers, designers and constructors will find useful is the new Electroluminescent Numerical Indicator from **Thorn Bendix Ltd.**, Great Cambridge Road, Enfield, Middlesex, the new name for Thorn Special Products who have merged their interests with Bendix Corporation of the U.S.A.

By applying the principles of the electroluminescent lamp in carefully designed segments, it has been possible to produce a neat numerical indicator that will produce all numerals from 0 to 9 and the letters A, C, E, F, H, J, L, P and U. In addition the letters G, I, O and S may be lit by using the figures 6, 1, 0 and 5 but the possibilities of confusion should be considered before use.

The use of such a light source allows it to be placed directly behind a translucent face, thus eliminating

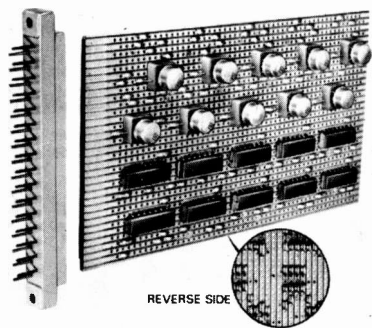

New Veroboard from Vero Electronics

numerical distortion sometimes encountered in conventional indicators with stacked numerals. Also the viewing angle, without distortion, is 160 degrees.

The life of the indicator is not adversely affected by switching on and off, there being no filament or vacuum, and should give many thousands of hours' service. These indicators are housed in either a clear or green polycarbonate case measuring 2 3/8 in by 1 1/8 in and has a maximum overall thickness of 3/8 in.

Also available from the same company is a new midget relay type RA. The relay is a four pole change-over unit with contact ratings of 3 amps at 115 volts a.c. It has standard a.c. and d.c. coils with nominal coil voltages ranging from 6 to 115 volts. The operating time is 9 to 11 milliseconds and the release time 3 to 6 milliseconds.

LITERATURE

The new 1967 Electronics Catalogue from **dca Electronics Ltd.**, 28 Uxbridge Road, Ealing, W.5, contains a very large list of test equipment, receivers, amplifiers, and Radiospares components. The price of the catalogue is 1s 6d including postage, separate price lists of valves and transistors are available free of charge.



CO Contact Cleaner by Corrosion Abolition Ltd.

An enlarged list of semiconductors and diodes is just one of the many additions to the new 1967 Henry's Radio Catalogue. A useful item in the 206 page catalogue is a list of transistor alternatives. The price of the catalogue is 7s 6d plus 1s 0d postage. But this can be offset by the use of five free vouchers each worth 2s. These vouchers are only usable on orders over £1 and should be used as per the instructions given in the catalogue. Copies are obtainable from Henry's Radio Ltd., 303 Edgware Road, London, W.2.

A good components catalogue for the "den" is the Arthur Sallis (Radio Control) Ltd., 1967/68 Mail Order Catalogue No. 17, price 3s 0d. Practically any piece of model control equipment can be obtained direct from stock as well as a large amount of general electronic equipment.

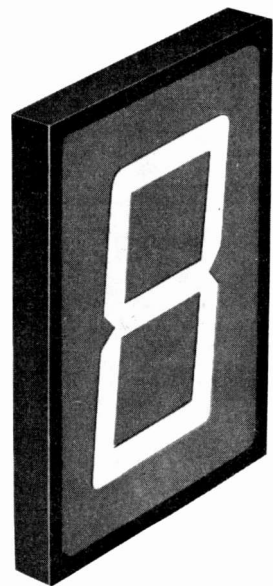

Electroluminescent Indicator marketed by Thorn Special Products

It was noticed, whilst shopping for components, that all recognized International Rectifier distributors are passing on to the public "Pocket Cross Reference Guides". These guides list encapsulated silicon rectifier assemblies and 1-3A silicon diodes with easy cross reference to I.R. equivalents. These guides should prove useful in the selection of diodes and rectifiers. If any readers are unable to locate their nearest I.R. dealers they can write direct to International Rectifier at Hurst Green, Oxted, Surrey, who will notify them of the nearest agent. We are told that supplies are limited.

Three brochures on careers in computers have just been published by **English Electric-Leo-Marconi** to coincide with a major recruiting drive aimed at increasing the company's sales and sales support staff. Particular stress is laid in the new brochures on the fact that it is not necessary to have had a narrowly directed training in the past in order to enter the computer field.

The three brochures are entitled "Careers in Computers", a 20-page publication describing in detail the opportunities now available in research, production, engineering, marketing, systems programming, bureau services and operations research; "Careers in Computers for Arts Graduates"; and "Opportunities for School Leavers". Copies are available from English Electric-Leo-Marconi Computers Ltd., Portland House, Stag Place, London, S.W.1.



POCKET MULTI-METER

Size 3 7/8" x 2 1/4" x 1 1/4". Meter size 2 1/4" x 1 1/4". Sensitivity 1000 O.P.V. on both A.C. and D.C. volts. 0-15, 0-150, 0-1000. D.C. current 0-150mA. Resistance 0-100kΩ. Complete with test prods, battery and full instructions. 42/6. P. & P. 3/6. **FREE GIFT** for limited period only. 30 watt Electric Soldering Iron value 15/- to every purchaser of the Pocket Multi-Meter

3 to 4 WATT AMPLIFIER



3-4 watt Amplifier built and tested. Chassis size 7 x 3 1/4 x 1 in. Separate bass, treble and volume control. Double wound mains transformer, metal rectifier and output transformer for 3 ohms speaker. Valves ECC81 and 6v6. £2.5.0 plus 5/6 P. & P. The above in Kit Form, £1.14.6 plus 5/6 P. & P.

CYLDON U.H.F. TUNER

complete with PC.88 and PC.86 Valves. Full variable tuning. New and unused. Size 4 1/4" x 5 1/4" x 1 1/4". Complete with circuit diagram. 35/- plus 3/6 P. & P.



NEW Transistorised SIGNAL GENERATOR

Size 5 1/4" x 3 1/4" x 1 1/4". For IF and RF alignment and AF output, 700 c/s frequency coverage 460 Kc/s to 2 Mc/s in switched frequencies. Ideal for alignment to our Elegant Seven and Musette. Built and tested. 39/6. P. & P. 3/6.

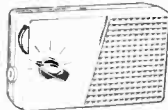

TRANSISTOR INVERTOR

50 v. D.C. Input. Output 240 v. A.C. 40 watts incorporating transformers, choke, condensers and 2 Mullard OC28 in solid 16 gauge Aluminium Case. Size 15" x 6" x 2 1/4" by famous manufacturers. 19/6 plus 7/- P. & P.



40W FLUORESCENT LIGHT KIT

Incorporating GEC Choke size 8 1/4" x 1 3/8" x 1 1/4", 2 bi-pin holders, starter and starter-holder. 11/6. P. & P. 5/6. Similar to above: 80 W. Fluorescent Light Kit incorporating GEC Choke size 11 1/2" x 1 3/8" x 1 1/4", 2 bi-pin holders, starter and starter holder 17/6. P. & P. 6/6. Twin 40 W Choke instant start for 2 x 2 ft. tubes 17/6. P. & P. 5/6.



Special offer ELEGANT SEVEN mk IIa

SPECIAL OFFER. 7" x 4" P.M. Speaker at no extra charge. Power supply kit to purchasers of 'Elegant Seven' parts, incorporating mains transformer, rectifier and smoothing condenser, A.C. mains 200/250 volts. Output 9v. 100 mA. 7/6 extra.

Buy yourself an easy to build 7 transistor radio and save at least £10.0.0. Now you can build this superb 7 transistor superhet radio for under £4.10.0. No one else can offer such a fantastic radio with so many de luxe star features.

★ De luxe grey wooden cabinet size 12 1/2" x 8 1/2" x 3 1/2". ★ Horizontal easy to read tuning scale printed grey with black letters, size 1 1/2" x 2". ★ High 'Q' ferrite rod aerial. ★ I.F. neutralisation on each separate stage. ★ D.C. coupled push pull output stage with separate A.C. negative feedback. ★ Room filling output 350mW. ★ Ready etched and drilled printed circuit board back printed for foolproof construction. ★ Fully comprehensive instructions and point to point wiring diagrams. ★ Car aerial socket. ★ Fully tunable over medium and long wave, 168-535 metres and 1250-2000 metres. ★ All components, ferrite rod and tuning assembly mount on printed board. ★ Parts list and circuit diagram 2/6, free with parts.



ONLY **£4.4.0**
Plus 7/6 Post & Packing

BSR Tape deck

AC 200/250 v., tape speed 3 1/2 twin track.

Special price £5.19.6

Post and packing 7/6



8-VALVE STEREO RADIOGRAM CHASSIS

3-4 WATTS PER CHANNEL

By Famous Manufacturer

Superb new 8-valve chassis covering long, medium and short waves on AM, also VHF transmissions on FM. AM circuit's high sensitivity permits internal aerial for most stations. Well-known Gorler tuning heart in separate FM input. Tone and volume controls. Extra large illuminated dial. External AM and FM aerial inputs. Gram, pick-up socket. Standard 3 ohm speaker. 200/250 volts A.C. **£14. 14. 0**
Size 17 x 7 x 5 1/4 in. deep. P. & P. £1

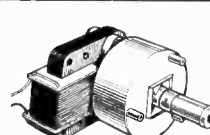

Type E MOTOR

Small A.C. mains motor 230/250 volts complete with gearbox, 6 r.p.m. Price 15/- plus 4/- P. & P. Similar to above motor but without gearbox. Price 9/6 plus 3/- P. & P.

SILICON RECTIFIERS

250 v. P.I.V. 750 milliamps. Six for 7/6, Post paid.

TRANSISTORISED 1 1/2 WATT AMPLIFIER

comprising 2AC 128, 20C 75 and 2 AA129 separate bass and treble volume controls. Complete with Power Supply AC mains 240 v. Size 7 1/2" x 3 1/4" x 2". Price 50/- plus 2/6 P. & P.

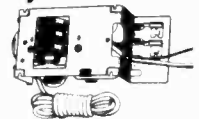

POWER SUPPLY KIT

A.C. MAINS 200-250 V Incorporating "C" core type mains transformer, full wave metal rectification and smoothing condenser. Smooth output 250 v. 250 mA and 6.3v. 4 amp. for Heaters. 25/- P. & P. 9/6.

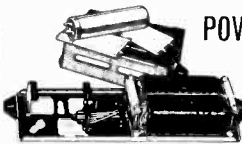

FIRST QUALITY P.V.C. TAPE

5 1/2" Std. 850ft. ...	9/-	5" L.P. 850ft. ...	10/6
7" Std. 1200ft. ...	11/6	3" T.P. 600ft. ...	10/6
3" L.P. 240ft. ...	4/-	5" T.P. 1800ft. ...	25/6
5 1/2" L.P. 1200ft. ...	11/6	5 1/2" T.P. 2400ft. ...	32/6
7" L.P. 1800ft. ...	18/6	7" T.P. 3600ft. ...	42/6
5 1/2" D.P. 1800ft. ...	18/6	4" T.P. 900ft. ...	15/-

P. & P. on each 1/6, 4 or more post free



EXTRACTOR FAN

AC Mains 230/250v complete with pull switch. Size 6" x 6" x 4". Price 27/6 plus 5/- P. & P.

GEC DOORBELL

Complete with mains transformer 240VAC and illuminated bell push. Price 12/6 plus 5/6 P. & P.

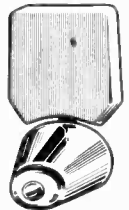

8-WATT 4-VALVE PUSH-PULL AMPLIFIER & Metal RECTIFIER

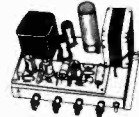

Size 9" x 6" x 1 1/4". A.C. Mains, 200-250 v. 4 valves. For use with Std. or L.P. records, musical instruments. All makes of pick-ups and mikes. Output 8 watts at 5 per cent of total distortion. Separate bass and treble lift control. Two inputs, with controls for gram, and mike. Output transformer tapped for 3 and 15 ohm speech coils. Built and tested. £4.4.0. P. & P. 11/- 8" x 5" Speaker to suit. Price 14/6 plus 1/6 P. & P. Crystal Mike to suit 12/6 plus 1/6 P. & P.

GEC KETTLE ELEMENT

3,000 W WITH AUTOMATIC EJECTION 200/240 v. size of hole required 1 1/8". List Price 32/- Our PRICE 15/- P. & P. 1/6.



RADIO AND T.V. COMPONENTS (ACTON) LTD.

21D HIGH STREET, ACTON, LONDON, W.3

Shop hours 9 a.m. to 6 p.m. Early closing Wednesday. Goods not despatched outside U.K.

All enquiries stamped addressed envelope. Terms C.W.O.

Also at

323 EDGWARE ROAD, LONDON, W.2

Early closing Thursday
PERSONAL SHOPPERS ONLY

All orders by post must be sent to our Acton Address

PRE-PAK SEMICONDUCTORS

DISTRIBUTED EXCLUSIVELY BY

DAVIS & WHITWORTH LTD.
222-224 WEST ROAD, WESTCLIFF-ON-SEA, ESSEX
PHONE: SOUTHEND (0502) 46344

PRE-PAK FOR QUALITY	
No.	PRICE
A1.	6—Silicon rectifiers BY100 type .. 20/-
A2.	10—Relays, mixed types and voltages .. 20/-
A3.	20—Mixed, marked and tested trans. .. 20/-
A7.	1—500 Mc/s epitaxial mesa. PNP 2N700 .. 20/-
A8.	6—Sub. min. zeners, 3.6—15V, 400mW .. 20/-
A9.	1—2N174 real power trans. 80V, 150W .. 20/-
A12.	1—High power, high volts. 25024, 100V, 100W .. 20/-
A13.	25—Assorted trans. and diodes, all new .. 20/-
A14.	4—2N601 p/trans. germ. 30V, 10 Mc/s .. 20/-
B1.	50—Unmarked, untested, trans. new .. 10/-
B2.	4—Solar cells, inc. Book of ins. .. 10/-
B3.	4—OA5 gold bonded diodes, Mullard .. 10/-
B5.	7—Matched set, OC44/45/81D/81 + diode .. 10/-
B8.	2—Power trans. OC26/35 type .. 10/-
B9.	1—Light sensitive cell, ORP12 type .. 9/-
B11.	2—Comp. air, AC128, AC176 .. 10/-
B13.	7—BA115 G.B. diodes T.V. video .. 10/-
B15.	8—Bi-directional trans., ASY66 .. 10/-
B20.	4—Assorted NPN trans., TO-5, TO-18 .. 10/-
B32.	4—1 amp. recs. 200/300P/V .. 10/-
B33.	10—Germ. diodes, assorted types .. 10/-
B34.	8—Silicon diodes, assorted types .. 10/-
B35.	2—2 zener diodes 1jW., 7 and 10 volts .. 10/-
B36.	10—Gold bonded diodes, assorted .. 10/-
B41.	3—2G339A NPN audio, texas .. 10/-
B42.	5—TK22C germ. switching trans. .. 10/-
B43.	4—1500 sil. recs. 100 PIV, 1 amp .. 10/-
B44.	1—Tunnel diode AEY11, 1050 Mc/s, 5mA .. 10/-

PRE-PAK FOR VALUE			
TRANSISTORS	PRICE	TRANSISTORS	PRICE
AC107	6/-	OC81D	2/6
AC126	2/6	OC83	4/-
AC127	2/6	OC139	2/6
AC128	3/-	OC140	5/-
AC17	5/-	OC170	2/6
AF14	4/-	OC171	4/-
AF15	3/-	OC200	5/-
AF116	3/-	OC201	8/-
AF117	4/-	2G301	2/6
AF118	3/6	2G303	2/6
AF119	3/6	2N697	2/6
AF178	10/-	2N706	5/-
ASY66	2/-	2N711	10/-
BCZ11	5/-	2N1302	4/-
BFY50	15/-	2N1303	4/-
BSY25	10/-	2N1304	5/-
BSY26	5/-	2S303	2/6
BSY27	5/-	POWER TRANSISTORS	
BSY28	5/-	OC20	10/-
BSY29	5/-	OC23	10/-
BSY95A	5/-	OC25	8/-
GET102	2/6	OC26	5/-
GET114	2/6	OC28	7/6
NKT213	2/6	OC36	10/-
OC41	2/6	DIODES	
OC44	2/6	AA42	2/-
OC45	2/6	OA10	2/-
OC71	2/6	OA70	1/9
OC72	2/6	OA79	1/9
OC73	5/-	OA81	1/9
OC81	2/6	OA182	2/-
		IN914	1/6

PRE-PAK FOR SERVICE	
No.	PRICE
C1.	15—50 volt. trans., germ. switching .. 15/-
C2.	1—Uni junction, 2N2160 or equiv. .. 15/-
C3.	5—Audio kit, NKT278/275/271/773 + diode .. 15/-
C4.	2—RF. power trans., OC22 and BUY11 .. 15/-
C5.	2—Sil. power recs. 200P/V, 6 amp .. 15/-
C6.	5—Sil. recs., 1 amp, 100/200P/V .. 15/-
C9.	2—100/60V, sil. trans., 200 Mc/s, ZT84/86 .. 15/-
C14.	2—3 watt planar, 2N1613, 2N1893 .. 15/-
C15.	4—Sil. trans., in the 25300 series .. 15/-
C16.	1—Sil. power 85 watts, 25721 series .. 15/-
C17.	2—60v. 160 Mc/s TO-18, 25103/4 .. 15/-
C18.	1—2N1132 sil. planar, pnp trans. .. 15/-
C20.	3—Germ. NPN trans., 2N1302/4/8 .. 15/-
C21.	3—Germ. pnp trans., 2N1303/5/7/9 .. 15/-
C22.	1—300 Mc/s trans. ASZ21, Mullard .. 15/-
C23.	1—35 amp sil. rec., 100P/V, stud .. 15/-
C25.	2—Power trans., germ., OC28/29 type .. 15/-
C27.	4—800P/V, 500mA, sil. recs., 5TC .. 15/-
C28.	5—Sil. recs., 400P/V, 1 amp .. 15/-
C29.	1—200 Mc/s low noise trans., AFZ12 .. 15/-
C30.	2—Sil. trans., narrow gain spread .. 15/-
C31.	4—Sil. recs. 800 PIV, 1 amp .. 15/-
D1.	25—1W iW-stab, resistors mixed .. 5/-
D3.	3—Germ. diodes, OA70, OA79, OA81 .. 5/-
D4.	2—Sil. recs., Sub. min., 400/600P/V 400mA .. 5/-
D7.	2—Zener diodes, 5.1V, 250mW .. 5/-
D9.	10—Assorted capacitors, all types .. 5/-
D10.	20—Transistor heat sinks .. 5/-
D14.	3—Low imp. earphones, less plugs .. 5/-
E1.	2—2N458 matched power trans., 150V, 80W .. 30/-

'FREE' ★ ★
Packs of your own choice to the value of 10/- with all orders over £4 in value.

THE LARGEST RANGE OF LOW PRICED SILICON CONTROLLED RECTIFIERS (THYRISTORS) IN G.B.
SEND FOR FULL RANGE AND PRICES. CIRCUIT DIAGRAMS ISSUED FREE OF CHARGE.

SCOOP PURCHASE!
Pre-assembled logic elements. 2 input gates 2/-, 3 input gates 2/9. Flip Flops and others 5/- each. Send for more details.

GREAT NEWS ★ ★ ★
We now give a written guarantee with all our semiconductors.

FIRST EVER LOGIC KITS. Learn for yourself how computers work, even make one for yourself. Full instructions for a noughts and crosses machine, binary counters, timers, etc. L.1. 5 gns. L.2. 10 gns. No need to purchase both kits, you can start with L.2. which incorporates L.1. DETAILS FREE.

COLOUR TELEVISION ! ! !
First ever correspondence course is now available. 10 lessons fully illustrated. Test questions for student. Marked by experts. Model answers. Total cost 10 gns. Terms at no extra charge. Free details on request.

NO CONNECTION WITH ANY OTHER FIRM. MINIMUM ORDER 10/- CASH WITH ORDER PLEASE. For complete lists and substitution charts send 1/- in stamps, add 1/- post and packing per order. OVERSEAS ADD EXTRA FOR AIRMAIL.

4-STATION INTERCOM



£6/9/6

Solve your communication problems with this 4-Station Transistor Intercom system (1 Master and 3 Subs), in de-luxe plastic cabinets for desk or wall mounting. Call/talk/listen from Master to Subs and Subs to Master. Ideally suitable for Business, Surgery, Schools, Hospital, Office and Home. Operates on one 9V battery. On/off switch. Volume control. Complete with 3 connecting wires each 60ft. and other accessories. P. & P. 0/6.

INTERCOM/BABY ALARM

Usually ~~£6/9/6~~
Our Price **ONLY 49/6**

Modernize business or home with this new two-way Portable Transistor Intercom, consisting of Master and Sub, in strong plastic cabinets with chromium stands. Designed as a two-way instant communication system. Call/talk/listen from Master to Sub and Sub to Master. Operates on one 9V battery. Complete with 60 ft. wire and battery. P. & P. 2/6

Transistor TELEPHONE AMPLIFIER

Why not boost business efficiency with this incredible De-luxe Telephone Amplifier. Take down long telephone messages or converse without holding the handset. A status symbol! Yes, but very useful one. On/off switch. Volume Control. Operates on one 9V. battery supplied for 2/6 extra. P. & P. 2/6.
Full price refunded if not satisfied in 7 days.

WEST LONDON DIRECT SUPPLIES (PE/6)
169 KENSINGTON HIGH STREET, LONDON, W.8

BINARY ADDER/SUBTRACTOR

1011	1101
+1100	-0110
10111	0111

Above are two examples of calculations possible with our Binary circuit. This circuit uses switches and lamps only, and makes an excellent demonstration model for schools and training colleges. All parts are available at a reasonable cost. Full circuit, wiring diagram, price list and text explaining the Binary system—3/6d. post free.

PLANET INSTRUMENT CO.
25(E) DOMINION AVENUE, LEEDS 7



Get a PHOTAIN B-A ELECTRONIC BURGLAR ALARM UNIT

Price **£8.19.6**
complete (P. & P. 3/6)

All equipment and inter-connecting wire included to protect your premises.
★ Easy to install ★ Provides complete protection (Money back guarantee)
Send C.W.O. or get details from
PHOTAIN CONTROLS LIMITED (K)
Randalls Road, LEATHERHEAD, Surrey

NEW HI-GAIN EXPORT VHF/FM AERIALS FOR MONO/STEREO



- Full band width spacing
- High front to back ratio
- Fibreglass moulding
- Universal clamp for up to 2 1/2" masts
- The perfect answer to Mono/Stereo FM reception

● HGFM/3 3 element	60.-
● HGFM/4 4 element	75/- (Illustrated)

ALSO HIGH PERFORMANCE UHF 625 COLOUR AERIALS

Type C 500 3 element	25/-
Type C 570 7 element	32/6
Type C 510 10 element	40/-
Type C 514 14 element	47/6

- Full range of masts and fittings on request
- State channels required when ordering
- C.W.O. or C.O.D. p. & p. 4/6d.

"C" AERIALS LTD.
14-15 QUARRY STREET, GUILDFORD, SURREY
TEL.: GUILDFORD 67704

N.Z. READERS NOTE . . .

All brand new components **LOW** prices.
Silicon Transistors NPN 2N4123, PNP 2N4125 8/- each or 7/8 each in 1/2 dozen lots. FT200-250 MHz/s 50-150 Ic 200ma, 310mw diss. Data sheet with 1/2 dozen extra. Resistors 1/2w high stab 5% 5/8 dozen. Comp. 10% 1/2w 5/8 dozen, 1w 4/8 dozen. Nominate your Values, S.A.B. for price list. 1/- P.&P. Cross all M/Os, Cheques, etc.
Dept. P.E., GUARDALL SERVICES
Sturgess Road, Henderson, Auckland, N.Z.

detached particles

JOHN VALENCE

NEW MANAGEMENT

From America, a county one particularly associates with the all-powerful business tycoon, comes a message of another wind of change. This message was delivered right here in Croydon, England, last month by Robert G. Chollar, Vice-President of the National Cash Register Company of the U.S.A.

For 1 hour 30 minutes Mr Chollar literally held the stage during a demonstration of NCR's long range research and development programme. The aim was to give businessmen from Britain and other countries "a preview of the advanced systems that will shape the future role of management".

An accomplished speaker plus an exceedingly well produced demonstration of some exotic electronic equipment made quite an impression on those present. If there were any complaints, it was that the range of equipment and systems demonstrated was perhaps too large for a single occasion. But if one suffered a little mental indigestion trying to absorb details of the different techniques on show, the desired effect was obviously registered on the audience "... that the information revolution is underway, and cannot fail to have a profound effect in business management circles".

I suspect that another, but less exhilarating, message was that day delivered to our own electronic engineering industry. The visual evidence of actual equipment soon to go into production is rather different to reports one may read about projected developments taking place over the other side of the Atlantic.

Tycoons of the British electronics and computer industry had better get the message—fast! Croydon could well prove to be the jumping off point for another large scale invasion of our markets.

LASERS AND HOLOGRAPHY

And what exactly, are these new aids to management, that are destined "to replace the overrated attribute of intuition". Perhaps the most exciting

are based upon applications of the laser and that even more recent technique called holography.

The laser figures prominently as a communications link, both for speech and for transmitting data from a computer in an on-line banking system.

A specific example of holography in use is the identification of signatures on credit cards. This promises to be a vital component of any "cashless" or "chequeless" society.

The equipment demonstrated how when a credit card is inserted into a machine a photograph of the bearer is located in a central file. This picture is then projected onto a screen and so the identity of the bearer can be confirmed.

The NCR demonstration also included microprinting by laser beam. This beam, focused down to an infinitesimal spot, is controlled by a typewriter keyboard. Microscopically small characters are formed on a light sensitive plate. Thus a large amount of information can be recorded in a small space. Retrieval and reproduction on enlarged scale can be performed at will.



BACK TO BASICS

The armed forces have to be prepared for even the ultimate catastrophe overtaking their electronics.

During a demonstration of FACE (Field Artillery Computer Equipment) it was stated that previously it had taken several months to train an artillery team to carry out the laborious calculations involved before each "shoot". Now the use of FACE meant that an operator could be trained to the requisite standard in just one week.

Nevertheless, a high ranking R.A. officer reassured one rather apprehensive inquirer, the army will continue to provide a certain amount of basic training in triangulation and other relevant sciences for its R.A. crews. Thus, as this officer explained, in the unlikely event of complete electronic failure the crew would be able to perform the essential basic calculations on a slide rule and back of an old envelope! So the shooting would continue—albeit a trifle less accurate than before!

ODD JOTTINGS

Come to think of it, that "old envelope" must have played a significant part in the affairs of man from time to time. How much literature, art, or music would have been lost for ever if that humble item had not been present in the pocket of some genius at the vital moment.

As for the world of science, we might still be waiting for the laser but for the fact that Charles Townes had an inspiration while sitting on a park bench in Washington D.C., way back in 1951.

Speedily he made some calculations on the back of an old envelope. The result suggested a new approach in his experimental work on the production of centimetric waves. This led to the invention of the maser, which as you know was the forerunner of the laser.

So, you budding geniuses, never discard all your old correspondence. You never know when the Muse will descend.

Readout—

A SELECTION FROM OUR POSTBAG

Radiation counter

Sir—With reference to my article *Radiation Counter* in the March 1967 issue. I would draw readers' attention to an error on the e.h.t. circuit Fig. 3.

The base bias resistor (R16) should be shown connected to the negative supply rail and not the collector of the transistor as it appears in the magazine. I would think that the latter configuration would severely damp the oscillatory circuit, however the effect on its performance could only be found by experiment (it may in fact work like this). This error also renders the underside wiring diagram Fig. 5 incorrect.

P. F. Bretherick,
Eastcote,
Ruislip,
Middlesex.

Surprise flash

Sir—In your article *Photoflash Slave Unit* in the March 1967 issue, you suggest adapting an extension lead by reversing the wires to one of the connectors to ensure that the slave unit may be connected to an electronic flashgun with polarities on its trigger lead connector opposite to those required on the slave unit connector. While this is perfectly satisfactory electronically, it should be pointed out that the better quality extension leads have connectors with all metal casings. Adapting such an extension lead would result in the casing of one connector having a polarity opposite to that of the other connector. Touching both connectors with the flashgun switched on would result in one's fingers being effectively shorted across the flashgun's trigger capacitor, which may be charged to a potential of up to 250 volts. While this would constitute no danger to a normal healthy person, the element of surprise might cause the equipment to be dropped, with somewhat disastrous results!

With this in mind, perhaps a better method of ensuring correct

polarity would be to use an extension lead with moulded plastic connectors. As the insides of these connectors are not accessible without destroying the casing, the lead itself would have to be cut and reconnected in reverse, the join naturally requiring careful insulation. This would result in only the actual connecting points of the two connectors having opposite polarities. The chances of touching both these at the same time are only small. However, if metal-cased connectors are employed on the flashgun trigger lead and the slave unit itself the effectiveness of this is reduced considerably.

The most satisfactory arrangement would be to utilise some of the unoccupied space in the slave unit case by fitting a switch to reverse the connections between the slave unit's connector and the thyristor.

A. W. Hawkins,
Lowestoft,
Suffolk.

Quick-blip

Sir—I have been taking this journal for quite a time and have been particularly pleased with the articles on *Radio Control* by Mr D. Bollen. I hope you will persuade him to do some more of this type of article. . . .

My other request is this, could your contributors give general parameters of transistors used in their articles as well as the alternatives. I would like to make up a lot more of the gear described but am often unable to get the transistors listed in the materials lists. Our local dealers have never heard of some of the transistors specified and even famous makes such as Mullard are difficult to obtain. Given some details of the transistors used, one could try and find alternatives among those available locally.

H. C. Wells,
Como,
Western Australia.

We have twisted Mr Bollen's arm and the first part of a new article starts on page 432 this month.

Hot point

Sir—It is with horror that I realise that no emphasis has been placed on the ease with which f.e.t.s can be destroyed. I have in mind all those unsuspecting enthusiasts who are contemplating the building of your *Integrated Stereo Amplifier* (December 1966 issue), in which I note there is no protection of the f.e.t. from lethal transients. The transistor in question, a 2N3819, has a maximum rating of 20 volts gate to any other electrode. Unlike an ordinary transistor, it will be permanently destroyed if any breakdown occurs, and even touching the gate with a finger may cause this if the body has some stray capacity to the mains. After my first disaster, I adopted the following procedure:

Before the transistor is ever brought near mains, batteries, or soldering irons, a length of fine wire (about 36 s.w.g.) is wound round the three leads to short them to each other, and kept in place until construction is complete, and a pair of catching diodes installed. These diodes are reverse biased and connected between the gate and the appropriate voltage sources to limit the range of voltage applied to the gate. In the case of the *Stereo Amplifier*, one is connected to earth (anode end) and the other (cathode end) may be taken to the drain electrode. These catching diodes must be silicon, type OA200 being suitable, and will protect the transistor against transients which can occur when plugging in external signal sources.

James M. S. Hutchinson,
University of Bradford,
Bradford, 7.

While your comments are entirely justified, it must be said that I have designed quite a few circuits for the practical constructor that do in fact contain field effect transistors and have yet to be informed of anyone who has had the misfortune to liquidate one. As long as common sense is used in the handling of these devices, they are quite as tame as the bipolar transistor. As you will no doubt appreciate there was a great deal of trepidation in soldering transistors without a heatsink in the early days, but standard soldering procedure would in fact have caused no trouble at all.

However, do not misunderstand me, there is a real danger of field effect transistor and possibly one of the more pertinent points would be in ensuring that the soldering iron is isolated from the mains earth. No doubt this comment will draw criticism from some people as safety is all a matter of degree.—R.H.

Practical Electronics Classified Advertisements

The pre-paid rate for classified advertisements is 1/- per word (minimum order 12/-), box number 1/6 extra. Semi-displayed setting £3.5.0 per single column inch. All cheques, postal orders, etc., to be made payable to PRACTICAL ELECTRONICS and crossed "Lloyds Bank Ltd." Treasury notes should always be sent *registered post*. Advertisements, together with remittance, should be sent to the Classified Advertisement Manager, PRACTICAL ELECTRONICS, George Newnes Ltd., 15/17 Long Acre, London, WC2, for insertion in the next available issue.

SERVICE SHEETS

SERVICE SHEETS for all makes Radio, T/V, Tape Recorders, 1925-1967. Prices from 1/-. Catalogue 6,000 models, 2/6. Free fault-finding guide with all sheets. Please send stamped addressed envelope with all orders/enquiries. HAMILTON RADIO, Western Rd., St. Leonards, Sussex.

SERVICE SHEETS, Radio, TV, 5000 models. List 1/6. S.A.E. enquiries. TELRAY, 11 Maudland Bank, Preston.

RADIO TELEVISION, over 8,000 Models. JOHN GILBERT TELEVISION, 1b Shepherds Bush Rd., London, W.6. SHE 8441.

T.V. Fault finding guide and unique testing device with servicing instructions. Faults found in minutes 15/-. With service sheets 4/- each extra. Service sheets with guide only 7/6. Radio sheets 3/- all P.P. State model Nos. ELECTRONIC SUPPLIES AND SERVICES (L.W.), 16 Gordon Road, Newport, I.W.

SERVICE SHEETS

4/- each, plus postage.

We have the largest supply of Service Sheets for all makes and types of Radios and Televisions, etc. in the country. Speedy Service.

To obtain the Service Sheet you require, please complete the attached coupon:

From:

Name:

Address:

.....

.....

To: S.P. DISTRIBUTORS

35/36 Great Marlborough Street, London, W.1

Please supply Service Sheets for the following:

Make:

Model No.: Radio/TV

Make:

Model No.: Radio/TV

Make:

Model No.: Radio/TV

I also require the new 1967 list of Service Sheets at 1/6 plus postage. (please delete items not applicable)

I enclose remittance of which includes postage

MAIL ORDERS ONLY June PE

EDUCATIONAL

HOME STUDY COURSES in Practical Electronics. Free Brochure without obligation from: BRITISH NATIONAL RADIO SCHOOL, Reading, Berks.

CHAMBERS GUIDE (New). Details of 293 Careers and spare-time Business, Technical and Examination Courses. A Mine of friendly "know-how" for go-aheads. For free copy write—CHAMBERS COLLEGE (Dept. 856K), 148 Holborn, E.C.1.

A.M.S.E. (Elec.), City & Guilds, G.C.E., etc., on "Satisfaction or Refund of Fee" terms. Wide range of Home Study Courses in Electronics, Computers, Radio, T.V., etc. 132-page guide—FREE. Please state subject of interest. BRITISH INSTITUTE OF ENGINEERING TECHNOLOGY (Dept. 124K), Aldermaston Court, Aldermaston, Berks.

STUDY RADIO, TELEVISION & ELECTRONICS with the world's largest home-study organisation. I.E.R.E., City & Guilds, R.T.E.B., etc. Also practical courses with equipment. No books to buy. Write for FREE prospectus stating subject to I.C.S., Intertext House, Parkgate Road (Dept. 577), London, S.W.11.

MASTER ELECTRONICS THE PRACTICAL WAY! For a sound understanding, knowledge and experience, practical experiments are best. Our Basic Electronics Kit teaches how diodes and transistors work; current, voltage and power operation; basic d.c. and a.c. amplifiers; oscillators; transistor switching; basic computer circuits, etc., etc. Simple instructions; easy assembly—no soldering—no prior knowledge necessary. Price 85/- for kit, instruction manual, and booklet "An Introduction to Electronics". Booklet only sent for 3d. stamp. ELECTRONIC EXPERIMENTS, 49 Heath Lane, Brinklow, Rugby.

ALDERMASTON COURT POSTAL TRAINING for B.Sc. (Eng.) Part 1, A.M.I.E.R.E., A.M.S.E., City & Guilds, G.C.E., etc. prepares you privately for high pay and security as Technician or Technologist. Thousands of passes. For details of Exams and Courses in all branches of Engineering, Building, Electronics, etc. (including latest information on C.Eng.), write for 132-page Handbook—FREE. Please state interest. BRITISH INSTITUTE OF ENGINEERING TECHNOLOGY, (Dept. 125K), Aldermaston Court, Aldermaston, Berks.

TELEVISION SERVICING RADIOTELEGRAPHY RADAR MAINTENANCE COMPUTER TECHNIQUES

Full and Part-time Training Courses

Apply:—Director, British School of Telegraphy, 20 Penywern Road, Earls Court, London, S.W.6

EDUCATIONAL

(continued)

RADIO OFFICERS see the world! Sea going and shore appointments. Trainee vacancies during 1967. Grants available. Day and Boarding students. Stamp for prospectus. WIRELESS COLLEGE, Colwyn Bay, Wales.

FOR SALE

SEE MY CAT. for this and that. Tools, materials, mechanical and electrical gear—lots of unusual stuff. This Cat. is free for the asking. K. R. WHISTON (Dept. CPE), New Mills, Stockport

FOR SALE. Oscilloscopes — Galvanometers — Evershed & Vignoles Meggers. Also other items and components. Free list. Stamp please. R. & E. MART, Box 9, G.P.O., Tunbridge Wells, Kent.

ANALOG COMPUTER

Just think... with this desk-top Mini-Analog Computer you can multiply and divide, take square roots or powers, and do log operations — simply by turning the dials and keeping your eye on the null meter. (And all this from a 1½ volt cell!) The Instruction Manual covers MAC-1's applications in electronics and physics, engineering and trigonometry.

Complete in kit form, MAC-1 is 3 gns — or £3 13s 6d built and ready for use. (For either please add 4s 6d carriage.)

You would probably like more information: just send a 4d stamp to:

I-COR SYSTEMS (File PE.6)
18 Stamford Hill, London, N.16

100 PAGE illustrated catalogue No. 17 of Government and manufacturers' electronic and mechanical surplus, also a complete new section of the latest semi-conductors and miniature components, includes a credit voucher for 2/6. Send for your copy now. Price 3/- Post Free. ARTHUR SALLIS (RADIO CONTROL) LTD., 93 North Road, Brighton.

U.S.A. RELAYS

24 volt totally enclosed and hermetically sealed relays removed from unused U.S.A. computers. These relays are a fine example of modern electronic design. 240 ohm coil rated at 26.5 volts they will operate cleanly down to 12 volts. 6 pole change-over contacts rated at 5 amp D.C. or 4 pole rated at 1 amp.

5/- each. P.P. 1/-. Four for £1 post paid.

Power relays 25 and 50 amp at £1. Time delay relays 1 to 600 secs. at £2. Amphenol plugs and sockets up to 48 pins at 15/- pair.

Of special interest to laboratories and schools, 72 valve digital counters to 10⁶ from £20.

HAXTED MILL, EDENBRIDGE
KENT

FOR SALE

(continued)

LARGE QUANTITY of small Bell Push Type Switches 9d. each. Small 70 V d.c. Solenoids 5/- each. 6 and 12 Gang 12-way lockdown switches 20/- and 30/- each. Double sided printed circuit boards 22 x 27 lines 2/6 each. Emitapes 1/2" x 3 1/2" on 5" dia. reels 5/- each. Cash with order plus postage. **METALO PRODUCTS (CROYDON) LTD.**, 226 Whitehorse Road, Croydon, Surrey, CR9 2NE.

HAMMERITE HAMMER PATTERN BRUSH PAINT FOR PANELS, METALWORK

3/6 TIN • JUST BRUSH ON • WITHSTANDS 150°C, OIL, WATER, Etc.

24 oz. tins	3/6	1 gallon	35/6
1 pint	7/6	1 gallon	58/6
1 pint	15/-	(* sent by road)	

Carriage: Orders up to 5/-, 9d; up to 10/-, 1/9; over 10/-, 3/-. Colours: Blue, Silver, Black or Bronze. Return of post service, Monday to Friday. From your component shop or direct from the manufacturer.

FINNIGAN SPECIALITY PAINTS (PE)
Mickley Square, Stocksfield, Northumberland
Tel. Stocksfield 2280

CRACKLE PAINT. Black or Grey, 1/2 pint tins 4/-, post 6d. from the component specialists. **SERVIO RADIO**, 156-8 Merton Road, Wimbledon, London, S.W.19.

WIRE SCOOP
75,000 YDS. NEW P.V.C.
HOOK-UP WIRE

SINGLE 14/-0076, 100 YARD ROLLS,
7/6 POST PAID.

SINGLE 14/-0048, APPROX. 200 YARD COILS,
7/6 POST PAID.

SINGLE 11/-036, APPROX. 200 YARD COILS,
7/6 POST PAID.

VARIOUS TRACER COLOURS, OUR CHOICE ONLY
112 GROBY ROAD
GLENFIELD, LEICESTER

MORSE MADE EASY !!

FACT NOT FICTION. If you start right you will be reading amateur and commercial Morse within a month. Using scientifically prepared 3-speed records you automatically learn to recognise the code RYTHM without translating. You can't help it, it's as easy as learning a tune. 18 W.P.M. in 4 weeks guaranteed. For full explanatory booklet enclose 8d. in stamps to: G3CHS/H.

45 Green Lane, Purley, Surrey. S.T.D. 01-660 2896

MISCELLANEOUS

CONVERT ANY TV SET into an Oscilloscope. Diagrams and Instructions, 12/6. **REDMOND**, 42 Dean Close, Portslade, Sussex.

"PRACTICAL ELECTRONICS" Milk-O-Stat. Field Strength Meter. Valve Voltmeter and Ohmmeter. Proximity Detector. Photoflash Slave Unit. Doorbell Repeater. Integrated Stereo Amplifier, and all constructional projects going back to Issue 1. Send s.a.e. for your choice of itemised price lists. **AJAX ELECTRONICS**, 18a Rumbold Road, Fulham, London, S.W.6.

HEATHKIT
The World's Largest manufacturer of
ELECTRONIC KITS

We invite you to visit our showrooms at:
233 TOTTENHAM COURT RD., LONDON, W.1
Telephone 01-636 7349

Send for Free catalogue Dept. TC.6

WIRELESS—MICROPHONE. Circuit and details for 5/-. Mr. BOBKER, 64 Choir Street, Lower Broughton, Salford 7, Lancs.

TAPE RECORDERS, TAPES, ETC.

TAPES TO DISC—using finest professional equipment—45 r.p.m. 18/-. S.A.E. leaflet. **DEROY**, High Bank, Hawk Street, Carnforth, Lancs.

20% CASH DISCOUNT on most famous makes of Tape Recorders, Hi-Fi equipment, Cameras, etc. Join England's largest Mail Order Club now and enjoy the advantages of bulk buying. Send 5/- for membership card, catalogues, price lists and ask for quotation on any item. C.B.A. (Dept. A18), 370 St. Albans Road, Watford, Herts.

SAVE UP TO 20% on most new, guaranteed, Hi-Fi and Tape Recorders. Large s.a.e. details. **MICROSERVICE**, Fourways, Morris Lane, Halsall, Lancs.

SITUATIONS VACANT

MINISTRY OF DEFENCE (ARMY DEPARTMENT), HAYES, MIDDLESEX requires **TECHNICIAN** to assist in the supervision of an Approved Firm's Inspection Organisation at a Ministry of Defence Agency Factory manufacturing electronic and electro-mechanical devices. Supervision of Inspectorate of Armament staff, male and female—critical inspection of machined components, moulded items and sub-assemblies.

QUALIFICATIONS: Recognised engineering apprenticeship and practical experience in inspection of armament stores. Good knowledge of modern inspection technique and statistical methods essential. O.N.C., C. & G. Finals or equivalent.

SALARY: £990 (age 26) to £1,179 per annum Outer London.

APPLICATION: Form from the Manager (PE5803), Ministry of Labour, Professional and Executive Register, Atlantic House, Farringdon Street, London, E.C.4.

SITUATIONS VACANT (continued)

RADIO TECHNICIANS

A number of suitably qualified candidates are required for permanent and pensionable employment (mostly in Cheltenham, but from time to time there are some vacancies in other parts of the U.K. including London). There are also opportunities for service abroad.

Applicants must be 19 or over and be familiar with the use of Test Gear, and have had practical Radio/Electronic workshop experience. Preference will be given to candidates who can offer "O" Level GCE passes in English Language, Maths and/or Physics, or hold the City and Guilds Telecommunications Technician Intermediate Certificate or equivalent technical qualifications.

Pay according to age, e.g. at 19—£747, at 25—£962 (highest age pay on entry) rising by four annual increments to £1,104.

Prospects of promotion to grades in salary range £1,032—£1,691. There are a few posts carrying higher salaries.

Annual Leave allowance of 3 weeks 3 days, rising to 4 weeks 2 days. Normal Civil Service sick leave regulations apply.

Application forms available from:

Recruitment Officer (RT)
Government Communications Headquarters
Oakley
Priors Road
CHELTENHAM, Glos.

TECHNICAL TRAINING by ICS IN RADIO, TELEVISION AND ELECTRONIC ENGINEERING

First-class opportunities in Radio and Electronics await the **ICS** trained man. Let **ICS** train YOU for a well-paid post in this expanding field.

ICS courses offer the keen, ambitious man the opportunity to acquire, quickly and easily, the specialized training so essential to success. Diploma courses in Radio/TV Engineering and Servicing, Electronics, Computers, etc. Expert coaching for:

- INSTITUTION OF ELECTRONIC AND RADIO ENGINEERS.
- C. & G. TELECOMMUNICATION TECHNICIANS' CERTS.
- C. & G. SUPPLEMENTARY STUDIES.
- R.T.E.B. RADIO AND TV SERVICING CERTIFICATE.
- RADIO AMATEURS' EXAMINATION.
- P.M.G. CERTIFICATES IN RADIOTELEGRAPHY.

Examination Students Coached until Successful.

NEW SELF-BUILD RADIO COURSES.

Build your own 5-valve receiver, transistor portable, signal generator and multi-meter—all under expert tuition.

POST THIS COUPON TODAY and find out how **ICS** can help YOU in your career. Full details of **ICS** courses in Radio, Television and Electronics will be sent to you by return mail.

MEMBER OF THE ASSOCIATION OF BRITISH CORRESPONDENCE COLLEGES.

INTERNATIONAL CORRESPONDENCE SCHOOLS

A WHOLE WORLD OF KNOWLEDGE AWAITS YOU !

International Correspondence Schools
(Dept. 152), Intertext House, Parkgate Road,
London, S.W.11.

NAME
Block Capitals Please

ADDRESS
.....
..... 6.67

Ferranti EDINBURGH

PUBLICATIONS DEPARTMENT

DEVELOPMENT ENGINEERS

are continually sought—who are prepared to switch their activities from current design and development to writing about these advanced designs and developments.

We are looking for practising engineers with a degree or H.N.C. to join our teams of technical authors for the creation of Technical Manuals, to cover a wide field of new equipments being developed for the Military and Commercial markets.

This is a new profession whose expansion is taxing the rate of entry; thus offering good prospects for the future. It also offers the unique opportunity of obtaining a wide knowledge of the Company's products—design and operational requirements, production techniques, field operation and maintenance and factory overhaul.

Although we do not teach English, we train all new entrants in the science of publications, from the art of gathering information from designers to the printing and binding of the published volume—we back our authors with a complete publishing organisation.

Interviews can be arranged in London, Manchester or Edinburgh, to suit convenience of applicants.

Please send brief details of career to date to the Staff Appointments Officer, Ferranti Ltd., Ferry Road, Edinburgh, 5, quoting Ref. TA/300.

TAPE RECORDER AND HI-FI SERVICING JUNIOR ENGINEER required. Must be willing to study to attain required high standard. Write or phone. HOLDINGS AUDIO CENTRE, Mincing Lane/Darwen Street, Blackburn (Tel. 59595/6).

BOOKS AND PUBLICATIONS

SURPLUS HANDBOOKS

- 19 set Circuit and Notes 4/6 P.P. 6d
- 1155 set Circuit and Notes 4/6 P.P. 6d
- H.R.O. Technical Instructions 3/6 P.P. 6d
- 38 set Technical Instructions 3/6 P.P. 6d
- 46 set Working Instructions 3/6 P.P. 6d
- 88 set Technical Instructions 5/- P.P. 6d
- BC.221 Circuit and Notes 3/6 P.P. 6d
- Wavemeter Class D Tech. Inscr. 3/6 P.P. 6d
- 18 set Circuit and Notes 3/6 P.P. 6d
- BC.1000 (31 set) Circuit & Notes 3/6 P.P. 6d
- CR.100/B.28 Circuit and Notes 8/6 P.P. 9d
- R.107 Circuit and Notes 5/- P.P. 6d
- A.R.88D, Instruction Manual 15/- P.P. 1/6
- 62 set Circuit and Notes 4/6 P.P. 6d
- 52 set Sender & Receiver Circuits 6/- post free
- Circuit Diagrams 3/- each post free.
- R.1116/A, R.1224/A, R.1355, R.F. 24, 25, & 26.
- A.1134, T.1154, CR.300, BC.342, BC.312.
- BC.348, J.E.M.P., BC.624, 22 set.
- Resistor colour code indicator, 1/6 P.P. 6d.
- S.A.E. with all enquiries please.
- Postage rates apply to U.K. only.
- Mail order only to:

Instructional Handbook Supplies
Dept. P.E., Talbot House, 28 Talbot Gardens
Leeds 8

RECEIVERS AND COMPONENTS

R.107 RECEIVER. Overhauled and in perfect condition. £8 delivered. Tel. Cuffley 2459.

R & R RADIO

51 Burnley Road, Rawtenstall

Rossendale, Lancs

Tel.: Rossendale 3152

Salvage Valves	Good Emission Guaranteed		
EF80 1/6	30P4 *7/-	30FL1 5/-	
ECC82 3/-	EB91 1/-	PL82 4/6	
ECL80 3/6	EF85 5/-	PL36 5/-	
30F5 5/-	30PL1 5/-	PCC84 4/-	
PCF80 4/-	EY86 4/-	PY81 3/6	
PL81 5/-	U301 6/-	PY33 6/-	

Speakers, Ex T.V. 5 inch rnd. 3/6. 6 x 4 3/6. 8 inch rnd. 6/-. Min. post 2/6.
BY100 and equiv. rectis. with 10 watt res. 5/6.
Fireball tuners, less cover can 9/-.
Ekco line O/P Trans. U26 type 35/-, post paid.
Push Button tuners, using 30L15 and 30C15 valves, rectangular buttons 27/6, post paid.
Postage on valves 6d, over three, post paid.
S.A.E. with all enquiries.

2N2926 3/6, OC71 3/6, OA81 1/9, 850V, 1/4 Rectifiers 4/-. 1W 5% H.S. resistors 4d. add 6d. pp. Discount on 10 and up. A. P. ROBSON, 41 Thunder Lane, NORWICH.

RECEIVERS AND COMPONENTS

(continued)

SILICON PRODUCTS

- 2N3053. NPN. 60V. 1W. 10/6
- 2N3055. NPN. 100V. .65W. 21/6
- Unijunction 2N2646 13/6
- Computer Diodes 1/-

PREMIT LTD., Components Div.

31 Queen Anne's Gate
London, S.W.1

C.W.O. Add 1/- P. & P.

2N3054 21/-	BC107 7/9	FET.2N3819 25/-
2N3055 22/6	BC108 7/6	FET.2N3820 25/-
2N3702 5/6	BC109 7/6	ALL.2N2926 4/-
2N3704 5/6	ME101 2/6	SCR.2N3525 25/-
ME4001 4/6	ME301 2/6	UJT.T1543 13/-
ME4002 4/9	OC83 4/6	T.D.1N3716 25/-
ME4003 5/3		N-TYPE ECONOMY FET 14/-

MILLTRONICS

1 ULLSWATER ROAD, LEVERSTOCK GREEN
HEMEL HEMPSTEAD, HERTFORDSHIRE
C.W.O. Post Free S.A.E. List Mail Order Only

ECONOMY SEMICONDUCTORS OVER 200 PRICE REDUCTIONS

SILICON TRANSISTORS

BC107 6/-	BC108 5/6	BC109 6/-
2N3241A 7/3	2N3242A 9/9	2N3053 7/9
2N3702 4/6	2N3706 4/6	2N3709 3/3
2N3711 5/-	2N2926 red, orange, yell. 3/6	
40319 13/3	2N3055 4/1	

COMPLEMENTARY MATCHED PAIRS

2N1304/2N1305 8/6	2N2926/2N3702 8/6
2N3705/2N3702 9/9	2N3053/40319 21/6

GERMANIUM TRANSISTORS

2N3730, 200V 10W 3A max. 12/6		
2N3731, 320V 5W 6A max. 16/3		
2N1304 4/-	2N1305 4/-	2N1306 7/6
2N1308 11/-	2N1309 11/-	2G308 6/9

TRIACS

400V 5A (SCR's for AC) 45/-

ZENER DIODES

2.7 to 33V 5% 400mW 6/-

RESISTORS

4.7Ω to 10MΩ, your choice
1W 10%, 2/- doz. 15/- 100
1W 5%, 2/3 doz. 17/3 100

(12 preferred values per decade only)

SKELETON PRESETS

100Ω, 250Ω, 10MΩ, etc. to 10MΩ 1/-
State horizontal or vertical mounting

CIR-KIT

No. 3 Pack 15/-

15ft. x 1", 25ft. x 1/2", 6" x 12", 8/9 each

PEAK SOUND

Stereo Amplifier Kit £12.19.6
Power Supply Kit £3.15.0 P. & P. 5/6

NEW SUB-MINIATURE TRANSISTORS

BC122, similar to BC108, low noise, 7/6

Send for catalogue giving data, equivalents and other information, 6d.

Discount of 10% on orders over £3

ELECTROVALUE

6 Mansfield Place
ASCOT, Berkshire

RESISTORS

1 watt carbon film 5%
All preferred values in stock
from 10 ohms to 10 megohms 2d. each.
Send S.A.E. for free sample.

CAPACITORS

Mullard Miniature Metallised Polyester
P.C. Mounting all 250 v. D.C. working.
.01mf, .022mf, .047mf, .1mf, .22mf,
all 6d. each.

Please include 1/- for postage and packing on all orders under £1.

Dept. P.E.2

BRENAL ELECTRONICS LTD.
CHARLES STREET, BRISTOL 1

RECEIVERS AND COMPONENTS

(continued)

TRANSISTOR PANELS

New boxed, size 9" x 6" x 1 1/2" with "Valvo" transistors type OC45 or similar, with full length leads, also an equal number of OA85 diodes, H/S resistors, etc. Built on perforated board in a metal frame.

Panel of 20 transistors, diodes, etc. 20/-

30 — 25/- 60 — 40/- 90 — 100 — £3
40 — 30/- 70 — 45/-
50 — 35/- 80 — 50/-

Postage 2/- per panel.

Computer boards, two types average 30 planar epitaxial transistors, 27708 or equiv. 300 mags. 30 diodes, Histab resistors. 19/6. P. & P. 1/-.

Polystyrene Capacitors, 350v. 680, 820, 1,800, 2,200, 2,700, 5,600, 6,800, 0.018, 0.022, 0.033, 0.125v. 1,000, 1,200, 1,500, 1,800, 3,300, 3,900, 4,700, 8,200, 0.01, 0.012, 0.015, 2/- dozen any selection. Heat Sinks 10W finned, 5/-. Miniature Relays, 1" x 2" x 1", 950 ohm, 2 pole change over 10/-. Electrolytics, 5,000 MFD, 50v. 6/6, 1,000 MFD, 60v. 5/-. 1,000 MFD, 30v. 4/-. 3,000 MFD, 10v. 2/-. Gold Bonded Diodes, 75v. P.I.V. 75mA. cards of 25, 10/-. Wire Wound Pots 5, 10, 25, 50, 100, 250, 500, 1k, 2k, 2.5k, 5k, 10k, 20k, 25k, 50k, 100k, noc presets, 2/- each. OC23 10/-. NKT452 6/-. NKT453 6/-. NKT216 5/-. OA81 2/-. Minimum order 5/-, post 1/-.

NEW CROSS RADIO

6 OLDHAM ROAD, MANCHESTER 4

AT LAST! THOSE HARD TO GET MICROMINIATURE MICROPHONES

Sensitive dynamic type. Size approx. 3/4" square by 1/4" thick. Impedance approx. 1k. Ideal for external or built in application. LIMITED STOCKS AT ONLY 28/6 post free. C.W.O.

MICRO DATA SYSTEMS

30 Baker Street, London, W.1

MARKET CENTRE

For Semiconductors

RECENTLY SPECIFIED TYPES EX-STOCK

A25	12/6	BCY31	16/-	BFY51	9/6
CR74	23/-	NKT274	3/6	OC71	4/-
OC72	4/6	OCPT7	19/6	25018	8/6
15423	14/9	2N1599	9/6	2N1302	5/-
2N2147	17/-	2N2160	15/-	2N3528	19/-
2N3819	18/-	2N2926	3/9	BC107	5/6

MINIATURE RESISTORS 1/4 WATT 5%
Stock values: 10, 12, 15, 18, 22, 27, 33, 39, 47, 56, 68, 82 and decades to 8.2 Megohm. 1-25 pieces, 4d. each; 25-50, 3d. each; 50-99, 2 1/2d. each; 100 over, 2d. each. Brand new—Not surplus.

VEROBOARD 36 square inches 10/-
0.15" matrix. Pins, 3/- dozen.

SKELETON PRESETS 1/4 WATT, 5K, 10K, 25K, 100K, 250K, 500K. 1 Meg, 2 Meg, 2.5 Meg. 2/- each.

15 VOLT SUB-MINIATURE CAPACITORS
0.5, 1, 2, 4, 6, 8, 10, 16, 25, 32 MFD 2/3; 50, 100 MFD, 2/6; 250, 500, 3/-; 1,000 5/9.

ALL THE ABOVE AND MUCH, MUCH MORE IN OUR CATALOGUE, TRANSISTORS TOO NUMEROUS TO LIST. INTEGRATED CIRCUITS, BARGAIN PACKS, CHEAP TRANSISTOR EQUIVALENTS IN VAST QUANTITY. SEND A LARGE (6" x 10") ENVELOPE OR 1/-.

Postage 9d. Callers very welcome

L.S.T. COMPONENTS

23 New Road, Brentwood, Essex

RECEIVERS AND COMPONENTS

(continued)

EXCLUSIVE OFFER COMPUTER MODULES

- ★ 4 INPUT NOR GATE 6-6
- ★ FLIP FLOP 15-0
- ★ LAMP & RELAY DRIVER 9-0
- ★ 9" x 6" VEROBOARD 0.1" 25-0
- ★ CIRCUIT MANUAL 7-6

SRB BUILD COMPUTER
CIRCUITS, ADDERS,
COUNTERS, GAMES
2/6 P.P. C.W.O.
MODULES 88-90 PALL MALL
LEIGH-ON-SEA, ESSEX

BARGAINS! BARGAINS!

Ex Government Equipment

HRO's, AR88's, 19 SETS and
EQUIPMENT, 31 SETS, B44's, 88,
38 and 18 SETS and miscellaneous
equipment.

Complete List 1/- (S.A.E.)

A. J. THOMPSON (Dept. P.E.)

Elling Lodge, Codicote, Hitchin, Herts.

Tel.: Codicote 242

COMPONENTS

POSTAL SERVICE

★ RECHARGEABLE BATTERIES

(Sealed DEAC Ni-Cad)

PP3 Equiv.: 9v. 37/- (p. & p. 2/-)

U2 Equiv.: 1.25v. 32/6 (p. & p. 2/-)

U7 Equiv.: 1.25v. 12/- (p. & p. 1/6)

U11 Equiv.: 1.25v. 26/- (p. & p. 1/6)

★ TRANSISTORS — Matched Output Kit:

OC81D and 2-OC81 9/6

R.F. Kit: OC44 and 2-OC45 9/6

OC44, 45, 70, 71, 72, 81 and 81D Equivalent, each 3/-

★ SLIDER SWITCH — Miniature Quality 2 pole

changeover 3/-

★ ASSORTED RESISTORS — Hi-Scab, 300 off

(5%, 10%, 1/2 watt, worth £3) 15/-

(P. & P. 1/6 per order) C.W.O.

ELMBRIDGE INSTRUMENTS LTD.

Island Farm Avenue, West Molesey, Surrey

SILICON PRODUCTS

2N696 6/6 2N697 7/-

2N706 4/6 2N3702 4/6

2N3704 5/6 2N3708 4/6

2N3053 11/- 2N3055 22/-

FULL WAVE BRIDGES

100PIV 6 amps 50/ 200V 60/-

100PIV 10 amps 65/- 200V 75/-

RECTIFIERS 1 AMP

50V 6/6 100V 7/- 400V 9/-

800V 14/6

RECTRA COMPONENTS LTD.

25 Victoria Street

LONDON, S.W.1

C.W.O. add postage

RECEIVERS AND COMPONENTS

(continued)

REPANCO Transistor Coils and Transformer, for the Constructor. Send stamp for lists RADIO EXPERIMENTAL PRODUCTS LTD., 33 Much Park Street, Coventry.

'X' LINE Modules you can open !!

X-161	2 Watt Amplifier	35/-
X-191	Guitar Amplifier	35/-
X-141	Record Player Amp.	35/-
X-151	Intercom.	35/-
X-481	Audio Booster	30/-
X-461	Siren	35/-
X-471	Burglar Alarm	35/-
X-661	Metronome	30/-
X-761	Morse Oscillator	20/-
X-671	Lamp Flasher	32/6
X-691	Lamp Flasher (Double)	30/-
X-261	Mic. FM Transmitter	35/-
X-271	Telephone Transmitter	35/-
X-241	R/Player Transmitter	35/-
X-291	Guitar Transmitter	35/-
X-371	Wireless Sentry	35/-

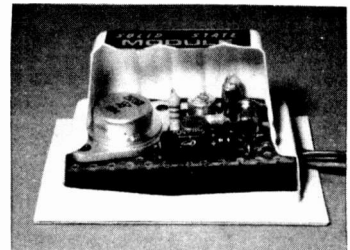

Send a S.A.E. for details to:
L.S.T. COMPONENTS
23 New Road, Brentwood, Essex

SMALL 12 V UNISELECTORS. 10 way 3 bank, plus 1 honing bank, 10/6, post 1/6. Colvern CLR 8011-262, 50 K ohms precision pots, 3 1/2" dia., also CLR 6610-15, 40 K sine/cosine, 5/-, post 1/-. Silicon rectifiers 50 PIV, 1.5 A, 12 V 5%, zeners, 3/6. J. COOPER, 13 Churchfield Road, Outwell, Wisbech, Cambs.

SPECIAL OFFER

1 Watt S.T.C. 300 MC/S N.P.N. Silicon Planer. Transistors. With data. Limited Stocks. £1 for 6.

3/- each. OC44, OC45, OC70, OC71, OC81, OC81D, OC200, Get 16, Get 20.

4/- each. AF114, AF115, AF116, AF117, OC170, OC171.

5/- each. OC139, OC140, Get 7, Get 8, Get 9, XC141, BY100, OA211.

ZENER DIODES

3.9v. to 26 volt, 1/4w. 3/6 each, 1.5w. 5/-, 7w. 6/- each.

Send 6d. for full lists: inc. S.C.R. Zeners.

BSY 27, 7/6 each. OC20, 10/- each.

Cursons

78 Broad Street

Canterbury

Kent

RECEIVERS AND COMPONENTS

(continued)

COMPONENTS FOR A.C. POWER CONTROL

Silicon Bridge Rectifiers 1A 400PIV encapsulated in cylinder 1 cm. by 1 cm. 15/6 p.p. 6d.

Unijunction Transistors 2N2464 suitable for firing SCR's. 12/- p.p. 6d.

The above are first grade components, not seconds or rejects.

'Cir-kit' for instant printed circuits without messy etching processes Kit, No. 3. 15/- p.p. 6d.

SCR's (thyristors) also available 400PIV 1A 10/-, 400PIV 3A 13/- p.p. 6d. Fully tested.

NESLO ELECTRONICS 53 GROSVENOR PLACE NEWCASTLE UPON TYNE 2

PHOTOELECTRIC KIT

Build 12 EXCITING PHOTOELECTRIC DEVICES on a Printed Circuit Chassis

CONTENTS: 2 P.C. Chassis Boards, Chemicals Etching Manual, Infra-Red Sensitive Photocell, Latching Relay, 2 Transistors, Resis. Cond. Pot. Terminal Block, Elegant Case, Screws, etc. In fact, everything you need to build a simple but efficient Photo-Switch/Burglar Alarm/Counter, etc. (Project No. 1) which can be modified for modulated light operation (Projects Nos 2 & 3).

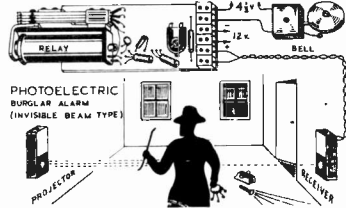

Also Essential Data, Circuits and Plans for building 12 PHOTOELECTRIC PROJECTS. (1) Simple Photo-Switch. (2) Modulated Light Alarm. (3) Long Range Starlight Alarm. (4) Relay-less Alarm. (5) Warbling Tone Alarm. (6) Closed-Loop Photoelectric Alarm. (7) Projector Lamp Stabiliser. (8) Electronic Projector Modulator. (9) Mains Power Supply Unit. (10) Automatic Car Parking Lamp Controller. (11) Super Sensitive Relay-Less Modulated Light Alarm. (12) Car Automatic Headlamp Dipper. Basic Kit: 39/6. Post and Packing 2/6 (U.K.).

OPTICAL KIT

Everything needed (Except plywood) for building 1 Folded-Beam Projector and 1 Photocell Receiver to suit PHOTOELECTRIC PROJECTS. CONTENTS: 2 lenses, 2 mirrors, Infra-Red Filter, 2 45 deg. Blocks, Projector Lamp Holder and Bracket, Plans, etc. Optical Kit: 19/6. Postage and Packing 1/6.

Send S.A.E. for details and photographs

YORK ELECTRICS, 333 York Rd. S.W. 11

Laboratory Components

Resistors. 1W. 10% High Stab. Class 1. Low Noise 3/- per Doz.

Capacitors. Min. Electrolytics, Ass or Single value 9/- per Doz.

Polyethylene sub-min. 26V. 10% Ass. 6/- per Doz.

Transistors. BC108 5/8 each

Matched Output Kit, OC81D + 2 x OC81 7/6 per set

Germanium, Ass, PNP, NPN AP Types 10/6 per doz.

Germanium, Low Leakage, RF Types 12/- per doz.

Type 1020, PNP, Germanium, AF, 50mW 8/- per Doz.

Type 1021, PNP, Germanium, AF, 200mW 12/6 per Doz.

Type 1024, PNP, Low Leakage, RF, 4mc/s Type 17/8 per Doz.

OC44, OC45, OC70, OC71, ACY22, OC81D 2/3 each

Power Transistors. (OC26 7/8) (OC26 8/6) (OC36 10/-)

For complete list of Laboratory Components send S.A.E. to:

**LABORATORY EQUIPMENT (ELEC)
38 Crawford St., London, W.1**

All goods C.W.O. and P.P. 1/6

MODERN DICTIONARY OF ELECTRONICS 50/-

AUTHORITATIVE, COMPREHENSIVE, COMPLETELY UP TO DATE, BY GRAF. POSTAGE 4/6.

Tape Recorder Servicing Manual, by Hellyer. 67/6.

Colour T.V. Servicing Handbook, by Harwich. 51/6.

101 Ways to use your Oscilloscope, by Middleton. 22/-.

Having fun with Transistors, by Buckwalter. 22/-.

Transistor Electronic Organs for the Amateur, by Douglas. 19/-.

Computers, self taught through experiments, by Brayton. 31/-.

Transistor Specification and Substitution Handbook, by Techpress. 22/6.

Hi-Fi Year Book, by Miles Henslow. 16/3.

Transistor Technology, by Middleton. 31/-.

Questions and Answers on Transistors, by Brown. 9/3.

All prices include U.K. postage

Where possible 24-hour service guaranteed

UNIVERSAL BOOK CO.

12 LITTLE NEWPORT ST., LONDON, W.C.2
(Leicester Square Tube Station)

AMATRONIX LTD.

TRANSISTORS—New, First Grade, Perfect.

SILICON MPN: Low-noise a.f. input (N.F. = 2dB). BC109, 6/-; 2N3707, 6/-; Drivers, Class B output: BC107 (100mW, 45V), 6/-; 2N3704 (360mW, 30V), 6/-; 2N3705, 5/-; HK601, 2/6 (5 for 10/-).

H.F.I.F. Amps: T1407/2N3983 low-noise VHF, 6/-; ME101 (f_c = 200MHz); β = 20-120, 2/- (6 for 10/-); 100-200, 2/4 (5 for 10/-); 180-360, 3/- (4 for 10/-); ME301 VHF (f_c = 180MHz, β over 20, COB 1-8P) 2/- (6 for 10/-).

General Purpose: 2N2926, β = 90-180, 3/6; 150-300, 3/9; 235-470, 4/- (18V, 200mW, 120MHz).

SILICON PNP: 2N3702 (300mW), 5/-; HK041 (360mW), 2/6.

GERMANIUM PNP: 2SB187 (sim. OC72, OC75, OC81), 2/- (6 for 10/-) GET 693 (sim. AF117), 10 for 10/-.

AMPLIFIER PACKAGES (Circuits Supplied) All transformerless single-ended push-pull output. FAIRCHILD AF10 8-10W medium-f_c, 15Ω spkr., 30/-; FAIRCHILD AF11 20W hi-fi 0.2% H.D., 15Ω, 67/6. AMAKIT 1: semi-conductors and capacitors for low-power (up to 650mW) miniature amps. Add only two resistors to suit voltage and speaker (data sheet supplied) to complete. Easy, economical, 15/-.

RECTIFIERS: Si 800 pvt 500mA, 3/-; Selenium bridge, 30V rms max input; d.c. output 750mA (contact cooled), 7/-; Miniature, 30V rms 150mAdc, 4/-.

SUBMIN. COMPONENTS: Mains trans. 9-0-9V, 80mA 1 1/2" sq., 11/-; Skeleton pots Egen type 467, 1 1/2" dia., 100mW, 50, 150, 500Ω; 1-5, 5, 15, 150, 500K; 1, 1.5M, 1/6 each. Cash with order. Mail order only. Post paid over 5/-.

396 SELSDON ROAD, CROYDON SURREY, CR1 0DE

BATTERY ELIMINATORS

The ideal way of running your TRANSISTOR RADIO, RECORD PLAYER, TAPE RECORDER, AMPLIFIER, etc. Types available: 9v; 7.5v; 6v; 4.5v (single output) 39/6 each. P. & P. 2/9. 9v + 9v; 6v + 6v; or 4.5v + 4.5v (two separate outputs) 42/6 each. P. & P. 2/9. Please state output required. All the above units are completely isolated from mains by double wound transformer ensuring 100% safety.

R.C.S. PRODUCTS (RADIO) LTD.
(Dept. P.E.), 11 Oliver Road, London, E.17

NEW RANGE U.H.F. AERIALS FOR BBC 2 (625) line transmissions

All U.H.F. aerials now fitted with tilting bracket and 4 element grid reflectors.

Loft Mounting Arrays. 7 element, 35/-; 11 element, 42/6; 14 element, 50/-; 18 element, 57/6. Wall Mounting with Cranked Arm. 7 element, 60/-; 11 element, 67/-; 14 element, 75/-; 18 element, 82/6. Mast Mounting with 2in. clamp. 7 element, 42/6; 11 element, 55/-; 14 element, 62/-; 18 element, 70/-. Chimney Mounting Arrays, Complete. 7 element, 72/6; 11 element, 80/-; 14 element, 87/6; 18 element, 95/-. Complete assembly instructions with every unit. Low Loss Cable, 1/6 yd. U.H.F. Preamps from 75/-. State clearly channel number required on all orders.

BBC · ITV · F.M. AERIALS



BBC (Band 1). Telescopic loft, 21/-; External S/D, 30/-; "H", £2.10.0.

ITV (Band 3). 3 element loft array, 25/-; 5 element, 35/-; Wall mounting, 3 element, 35/-; 5 element, 45/-.

Combined BBC/ITV. Loft 1+3, 41/3; 1+5, 48/9; Wall mounting 1+3, 56/3; 1+5, 63/9; Chimney 1+3, 63/9; 1+5, 71/3. VHF transistor pre-amps from 75/-.

F.M. (Band 2). Loft S/D, 12/6. "H", 30/-, 3 element, 52/6. External units available. Co-ax cable, 8d. yd. Co-ax plugs, 1/3. Outlet boxes, 4/6. Diplexer Crossover Boxes, 12/6. C.W.O. or C.O.D. P. & P. 5/- Send 6d. stamps for illustrated lists.

Quotations for special arrays available on request

K.V.A. ELECTRONICS (Dept. P.E.)

27 Central Parade, New Addington
Surrey—CRO-OJB
LODGE HILL 2266

SPECIAL OFFERS! YOU CAN BENEFIT

H.F. SIRENS: Have you found another use for our powerful yet miniature high frequency horns? Already they are being used in burglar and fire alarms, and for all types of equipment where a clear penetrating sound is required.

AERIAL WIRE: Pure copper, insulated: still available in 76 ft. reels at excellent price of 5/- plus 1/- P. & P.

RELAYS:

1. Miniature plug-in with 2 light duty c/o contacts. Coil 185 ohms. 44/18V. D.C. 16/-.
2. Miniature plug-in with 4 light duty c/o contacts. Coil 130 ohms. 9/15V. D.C. 18/9.
3. Heavy duty car alarm relay 6/12V. D.C. 3 heavy duty c/o contacts. 27/6. P. & P. on above items 1/- each.
4. Base for item (2), 3/0 plus 6d. P. & P.

LOUDSPEAKERS: We carry a range of speakers to suit every application. Typical examples are:

1. Westwell 0.2W.; 8 ohm; 2 1/2in. dia., 7/6.
2. Westwell 0.2W.; 8 ohm; 3in. dia., 9/6.
3. Richard Allen 12in., 3 ohm with tweeter, 37/6 plus 3/- P. & P.

TEST METERS: 171-2. A superb buy for the discerning engineer with a limited budget. 20K. ohms/V.; with all the usual desirable features for testing and experimenting. A snip at 69/6 plus 3/- P. & P.

TEST LEAD KITS: Complete with plastic case. 6/9 plus 1/3 P. & P.

RECORD PLAYER AMPLIFIER: Powerful single valve amplifier (EL84) with metal rectifier. Complete with volume and tone controls. 220/250V. A.C. only 58/6 plus 3/- P. & P. And, of course, all Binclair and Lander products always in stock.

Write or call now for our components list

BOTHWELL ELECTRIC SUPPLIES (Glasgow) LTD.
54 EGLINTON STREET
GLASGOW, G.5. Tel. 041 800th 2904
Member of the Lander Group

BI-PAK SEMICONDUCTORS

8 Radnor House
93/97 Regent St.
London, W.1

★ -VALUE PAKS- ★
★ EXTENDED RANGE ★
★ NEW - UNTESTED ★

TUNNEL DIODES 15/- EACH **AEY11 IN3720**

UNIUNCTION TRANSISTORS 15/- EACH **2N2160 2N2646**

6. 2N2926 SPECIAL OFFER 20/-

TRANSISTOR MANUAL BY G.E.
CIRCUITS, APPLICATIONS, CHARACTERISTICS, THEORY. 30/- EACH P.P. 2/6
INC. L.A. S.C.R.'s, G.T. SWITCHES, THEORY, RATINGS, APPLICATIONS.
S.C.R. MANUAL BY G.E.

FAIRCHILD BRAND NEW FROM U.S.A. 8 LEAD - EPOXY CASE RT/L MICROLOGIC

COMPLETE DATA AND CIRCUITS SEND 1/6. OR FREE WITH ALL IC ORDERS
μ L 900 "Buffer" 19/6
μ L 914 "Gate" 19/6
μ L 923 "J.K." 35/- (FLIP-FLOP)

THESE DEVICES OPEN UP A WHOLE NEW CONCEPT IN THE WORLD OF ELECTRONICS
"INTEGRATED CIRCUITS"

NEW TESTED VALUE PAKS

3 OC139 Trans. NPN Mullard	10/-
2 Drill Trans. 2N1225 100 M/Cs PNP	10/-
6 Matched Trans. OC44/45/81/81D	10/-
4 OA10 Diodes Mullard	10/-
15 Red Spot AF Trans. PNP	10/-
15 White Spot RF Trans. PNP	10/-
4 Sil. Rects. 3A 100/400 PIV	10/-
4 High Current Trans. OC42	10/-
2 Power Trans. OC26/35	10/-
5 Sil. Rects. 409 PIV 250mA	10/-
3 OC71 Trans. Mullard	10/-
3 OC75 Trans. Mullard	10/-
2 10 Amp. Sil. Rect. 50/100 PIV	10/-
8 Diodes OA70	10/-
1 5 AMP SCR 100 PIV	10/-
3 Sil. Trans. 2S303 PNP	10/-
5 GE1884 Trans. eqvt. OC44	10/-
10 Assorted Computer Diodes	10/-
4 Zeners 5, 12 Vols. Mixed	10/-

FREE One 10/- Pack of your own choice free with orders valued £4 or over **FREE**

4 2G417 Trans. eqvt. AF116/117	10/-
2 200 M/Cs Sil. Trans. BSY26/27	10/-
5 OA47 Gold Bonded Diodes	10/-
4 OA202 Sil. Diodes Sub-Min	10/-
3 OC77 Trans. Mullard	10/-
8 OA81 Diodes CV4/8	10/-
3 High vit. AF Trans. PNP ACY17	15/-
3 BSY95A Sil. Trans. STC	15/-
3 Sil. Trans. OC200 Mullard	15/-
2 Sil. Power Rect. 6 Amp. 200 PIV BYZ13	15/-
1 AF139 GERM. Trans. 1500 M/Cs	15/-
1 Sil. Power Trans. 100 M/Cs TE201A NPN	15/-
4 Zener Diodes 3-15 Vols. Mixed 400mW	15/-
5 OA5 Gold Bonded Diodes Mullard	15/-
1 2N1132 PNP PLANAR Trans. Sil	15/-
2 2N697 NPN PLANAR Trans. Sil	15/-
4 GERM. Power Trans. eqvt. OC16 Mullard	15/-
6 Sil. Rect. Type BY100 800 PIV 550mA	20/-
4 BC108 Sil. Trans.	20/-

120 GERM. SUB-MIN. **DIODES 10/-**

50 MIXED **TRANSISTORS 10/-**

16 SILICON 750 mA TOP-HAT **RECTIFIERS 10/-**

20 ALL TYPES MIXED VOLTS **ZENERS 10/-**

25 SIL. NPN 200 M/cs **TRANSISTORS 10/-**

10 STUD. 2 AMP **SILICON RECT. 10/-**

30 NPN MIXED SILICON **TRANSISTORS 10/-**

60 SILICON 200 mA **DIODES 10/-**

40 ZENERS RECTIFIERS MIXED **TOP HAT 10/-**

20 1 Amp GERM. up to 300 PIV **RECTIFIERS 10/-**

40 LIKE OC81 AC128 **TRANSISTORS 10/-**

10 50-400 PIV 1 Amp **SCR's 20/-**

Our vast stocks change daily with hundreds of Semiconductor bargains becoming available. Just send 2/6 to cover 3 months mailing of our latest stock lists, eqvt. charts, circuits, etc.

Minimum Order 10/-. CASH WITH ORDER PLEASE. Add 1/- postage and packing per Order. GUARANTEED by return postal service. Overseas add extra for Airmail.

MAKE 5 DIFFERENT RADIOS FOR 39/6

Amazing Radio Construction Set! Become a radio expert for 39/6. A complete Home Radio Course. No experience needed. Parts including instructions for each design. Step-by-step plan, all Transistors, loudspeaker, personal phone, knobs, screws, etc., all you need. Box size 14" x 10" x 2" (parts available separately). Originally £6. **NOW 39/6** plus 4/6 P. & P.



Frustrated Import Shipment Offered Below HALF PRICE to Clear 500 Only Five Transistor

PERSONAL TRANSCEIVER SETS Our Price £6. 18. 11

You've heard about them, you've read about them, NOW YOUR CHANCE TO OWN THEM. Highly sensitive two-way transistor transceiver sets have individual volume control and talk-listen switch. Telescopic aerial pulls in the voice from the other set over tremendous distances; no wires a genuine transceiver as used by official bodies and forces, 500 sets only at £6. 18. 11, including accessories, batteries etc. Plus 4/6 p.p. These cannot be used in U.K.



UNIQUE NEW PORTABLE RADIOS FULLY TRANSISTORISED READY BUILT

with Full Variable waveband. NOW A FRACTION OF THE NORMAL PRICE **29/6** WHY PAY MORE?

All the latest refinements are packed into this new MULTI-STATION ALL Transistor radio - the internal aerial picks up even the remote stations and the powerful built-in speaker gives room filling volume. Individual tuning, first-class reception. Purchase with confidence - packed in original manufacturer's cartons. (Personal earpiece and battery 4/6). Send 29/6 plus 4/6 p. & p.



HIGH POWERED TRIPOD TELESCOPE ONLY 45/- NO MORE TO PAY

Advantageous Purchase Direct from Importer. 750 only at a fraction of the true value. Special grade A.1 De Luxe model - passed by Japanese Board of Inspection. All Metal construction in Black Crackle finish with plated parts and simulated leather covering. Special polished optical lens gives astounding magnification power of 900x. Large. Single draw focusing tube enables you to study the MOON, PLANETS & STARS. Independent view finder permits you to focus on subjects miles away or just across the road. Brand new, complete with collapsible tripod at unbelievable price of only 45/- plus a post and **SAFE PACKING**. Satisfaction or your money back.

77 NEW BOND STREET LONDON, W.1. Mail Order Only



CONCORD ELECTRONICS LIMITED (Dept. P.E. 32) LONDON, W.1. Mail Order Only

TECHNICAL TRADING Co.

JASON TAPE Top British mylar/P.V.C.

Standard Play		Double Play	
3"	150ft. 2/3	3"	300ft. 4/-
4"	300ft. 4/6	4"	600ft. 8/-
6"	600ft. 7/6	5"	1200ft. 15/-
8"	900ft. 10/8	5 1/2"	1800ft. 19/8
7"	1200ft. 13/8	7"	2400ft. 27/-
Long Play		Triple Play	
3"	225ft. 2/9	4"	900ft. 13/-
4"	450ft. 5/8	5"	1800ft. 25/-
5"	900ft. 10/8	5 1/2"	2400ft. 34/-
5 1/2"	1200ft. 13/-	7"	3600ft. 44/-
7"	1800ft. 18/8		

Post 1/-

ROBOPHONE ORDERS
Your C.O.D. order exceeding £1 can be telephoned to BRIGHTON 680722 at any time day and night

10 TOTTENHAM COURT RD., LONDON, W.1 Tel.: MUS 2639
350/352 FRATTON RD., PORTSMOUTH. Tel: 22034
72 EAST STREET, SOUTHAMPTON. Tel: 25851
132 MONTAGUE STREET, WORTHING. TEL: 2585
ALL MAIL ORDER AND RETAIL SHOP
PARK CRESCENT PLACE, BRIGHTON

YUKAN SO PROFESSIONAL THE YUKAN SELF-SPRAY AEROSOL WAY -

Get these **AIR DRYING GREY HAMMER** or **BLACK WRINKLE (CRACKLE)** Finishes

Yukan Aerosol spraykit contains 16 ozs. fine quality durable easy instant spray. No stove baking required. Hammers available in grey, blue, gold, bronze. Modern Eggshell Black Wrinkle (Crackle) all at 14/11 at our counter or 15/11, carriage paid, per push-button self-spray can. Also Durable, heat and water resistant Black Matt finish (12 ozs. self-spray cans only) 13/11 carriage paid.

SPECIAL OFFER: 1 can plus optional transferable snap-on trigger handle (value 5/-) for 18/11, carriage paid. Choice of 13 self-spray plain colours and primer (Motor car quality) also available.

Other Yukan Air Drying Aerosols include Zinc Chromate Primer. Clear Lacquer. Anti-Tarnish Gold and Metallic Finishes.

Please enclose cheque or P.O. for total amount to: **YUKAN, Dept. PE/5, 307a Edgware Rd., London W.2.** Open all day Saturday. Closed Thursday afternoons.



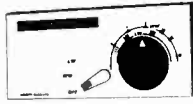

SCR'S (THYRISTORS)

Table listing SCR's (Thyristors) with columns for current (1A, 5A, 15A) and voltage (50 PIV, 200 PIV, 400 PIV, 100 PIV, 400 PIV, 400 PIV).

TUNNEL DIODES

1mA 22/6; 5mA 15/-; 15mA 12/6. Brand new at fraction of normal price. Free Specs. supplied.

Henry's Radio Ltd. 303 Edgware Rd., London, W.2. Addington 1008/19. Open Mon. to Sat. 9-6. Thurs. 1 p.m. Open all day Saturday.

GARRARD DECKS—BRAND NEW, FULLY GUARANTEED

Table listing Garrard decks with columns for model (1000 mono, AT5 mono, 2000 stereo, 3000 1m stereo, SP25 less cart., SP25 mono) and price.

All other makes of decks and cartridge in stock

RADIO CONTROL RECEIVER "TINYTONE" 27 Mc/s band receiver. Printed circuit construction. Sensitive 4-transistor design. Size only 2" x 2" x 1". Complete with circuit and instructions. TOTAL COST 55/- P.P. TO BUILD 1/6 (Circuit, etc. 1/3 separately).

REGENT-6 MW/LW POCKET RADIO TO BUILD 6-Transistor superhet. Geared tuning. Push-pull speaker output. Moulded cabinet 5 1/3 x 1 1/2 ins. Phone socket. TOTAL COST 69/6 P.P. TO BUILD 2/-

MULTI-METERS SCOPE PT34 1kV 39/6 EP30k 30kV £6.10.0 TP10 2kV 75/- EP50k 50kV £9.19.6 ITL-2 20kV 69/6 500 30kV £8.17.6 TP55 20kV £5.19.6 EP100k 100kV £10.10.0 CT52 Scopes £22.10.0, p.p. 10/- Complete range of test equipment in stock

NOMBEX TEST UNITS 150 kc/s—350 Mc/s RF Generator £10.10.0. All Transistor. 10 c/s—100 kc/s Transistor. £16.19.6 Audio Generator.

GARRARD BATTERY 2-SPEED TAPE DECK Brand New with R/P head, erase/osc. head, tape cassette. Specifications and osc. circuits. 2 speed 2-track 9 volt operated. List Price 13 gns.

PRICE £8.19.6 P. & P. 3/6

COMPONENTS AND EQUIPMENT. The largest range in the country. 8/6 buys 1967 200-page catalogue with discount vouchers.

MW/LW QUALITY TRANSISTOR RADIO TUNER Fully tunable superhet with excellent sensitivity and selectivity. Output up to 1/2 volt peak. Complete with front panel, etc. 9 volt operated. For use with any amplifier or tape recorder. TOTAL COST £3.19.6 P.P. TO BUILD 2/6

VHF FM TUNER Supplied as 2 Preassembled Panels, plus mould work Superhet design, 88-108 Mc/s, 9 volt operated. 6 Mullard Transistors. Total cost to assemble £12.17.6, p.p. 2/6

STABILISED POWER SUPPLY Two outputs. 3.6 volt and 9.6 volt up to 250mA each. Transistorised and Zener stabilised. 110 to 250 volt mains input. In case with leads. PRICE 67/6, p.p. 2/6.

5 WATT AMPLIFIER 6-Transistor Push-pull, 3 ohms. 6mV into 1K. 12/18V supply, 2 1/2 x 2 x 1 1/2 in. BUILT AND TESTED 69/6 P.P. (optional mains units 54/-) 2/- 1/2 watt version 59/- Matching Preamplifier, 6 inputs, treble/bass/selector/volume controls. 6-10mV o/p. 9-18V supply. 79/6, p.p. 2/- For use with any Transistor Amplifier LEAFLET ON REQUEST.

FMT41 FM TUNER. 6-transistor, 3 diode design. Com. £6.19.6 p.p. completely built and tested. 79/6, p.p. 2/- AMT31, Med. Wave Tuner. Built ready to use. 79/6, p.p. 2/-.

27 Mc/s BAND RADIO CONTROL Sub-miniature crystals. 17/6 each Matched pairs for superhet. 35/- pair (State 455 kc/s or 470 kc/s I.F.) Complete range of Receiver and Transmitter Kits in stock—see catalogue.



SEE BACK COVER FOR MORE ITEMS OF INTEREST

WENTWORTH RADIO

BAR 3087

104 SALISBURY ROAD, HIGH BARNET, HERTS.

Suppliers of High Quality Semiconductors

Large table listing various semiconductor components (ACX17, ACY18, ACY19, etc.) with columns for part number, price, and other specifications.

SIXPAGE LIST NOW AVAILABLE, S.A.E. TERMS, CASH WITH ORDER. P.P. ADD 9d. SEMICONDUCTORS AND MAIL ORDER ONLY, WE REGRET, NO CALLERS.

YOU CAN AFFORD! AN INDIVIDUALLY MANUFACTURED

ENGRAVED FACIA PANEL

WE OFFER A COMPLETELY NEW SERVICE TO ELECTRONIC ENTHUSIASTS WHO WISH TO MAKE THEIR APPARATUS INDISTINGUISHABLE FROM THE MOST EXPENSIVE PROFESSIONALLY MADE EQUIPMENT.

FOR FREE QUOTATION AND FURTHER INFORMATION SEND S.A.E. AND WORKING DRAWING OF APERTURES AND WORDING REQUIRED TO:—

GREYMEL LTD., 34 PANCRAS RD., LONDON, N.W.1

A BARGAIN FOR ELECTRONICS ENTHUSIASTS BEGINNER'S GUIDE TO ELECTRONICS

By Terence L. Squires, A.M.Brit.I.R.E.

Early chapters explain the nature of electric currents, pulses and waveforms. The components and circuits that are the basis of electronics are then described and illustrated, and their operation clearly explained. Chapters are devoted to test instruments; the principles of and the basic techniques used in the main branches of electronics.

192 pages. 128 line diagrams. 6s. 6d.

From your Bookseller or in case of difficulty 7s. by post from: NEWNES Tower House, Southampton Street, London, W.C.2

VALUABLE NEW HANDBOOK FREE TO AMBITIOUS ENGINEERS

Have you had your copy of "Engineering Opportunities"?

The new edition of "ENGINEERING OPPORTUNITIES" is now available—without charge—to all who are anxious for a worthwhile post in Engineering. Frank, informative and completely up to date, the new "ENGINEERING OPPORTUNITIES" should be in the hands of every person engaged in any branch of the Engineering industry, irrespective of age, experience or training.

On 'SATISFACTION OR REFUND OF FEE' terms

This remarkable book gives details of examinations and courses in every branch of Engineering, Building, etc., outlines the openings available and describes our Special Appointments Department.

WHICH OF THESE IS YOUR PET SUBJECT?

ELECTRONIC ENG.

Advanced Electronic Eng.—
Gen. Electronic Eng.—Applied
Electronics—Practical
Electronics—Radar Tech—
Frequency Modulation—
Transistors.

ELECTRICAL ENG.

Advanced Electrical Eng.—
General Electrical Eng.—
Installations—Draughtsman-
ship—Illuminating Eng.—
Refrigeration—Elem. Elec.
Science—Elec. Supply—
Mining Elec. Eng.

CIVIL ENG.

Advanced Civil Eng.—
General Civil Eng.—Muni-
cipal Eng.—Structural Eng.—
Sanitary Eng.—Road Eng.—
Hydraulics—Mining—
Water Supply—Petrol Tech.

RADIO ENG.

Advanced Radio—General
Radio—Radio & TV Servicing
—TV Engineering—Tele-
communications—Sound
Recording—Automation—
Practical Radio—Radio
Amateurs' Examination.

MECHANICAL ENG.

Advanced Mechanical Eng.—
Gen. Mech. Eng.—Mainte-
nance Eng.—Diesel Eng.—
Press Tool Design—Sheet
Metal Work—Welding—
Eng. Pattern Making—
Inspection—Draughtsman-
ship—Metallurgy—Production
Eng.

AUTOMOBILE ENG.

Advanced Automobile Eng.—
General Auto. Eng.—Auto.
Maintenance—Repair—
Auto. Diesel Maintenance—
Auto. Electrical Equipment—
Garage Management.

WE HAVE A WIDE RANGE OF COURSES IN OTHER SUBJECTS INCLUDING CHEMICAL ENG., AERO ENG., MANAGEMENT, INSTRUMENT TECHNOLOGY, WORKS STUDY, MATHEMATICS, ETC.

Which qualification would increase your earning power?
A.M.I.E.R.E., A.M.I.Mech.E., A.M.S.E., A.M.I.C.E., B.Sc.,
A.M.I.P.E., A.M.I.M.I., A.R.I.B.A., A.I.O.B., A.M.I.Chem.E., A.R.I.C.S.,
M.R.S.H., A.M.I.E.D., A.M.I.Mun.E., C.ENG., CITY & GUILDS, GEN.
CERT. OF EDUCATION, ETC.

BRITISH INSTITUTE OF ENGINEERING TECHNOLOGY
316A ALDERMASTON COURT, ALDERMASTON, BERKSHIRE

THIS BOOK TELLS YOU

- ★ HOW to get a better paid, more interesting job.
- ★ HOW to qualify for rapid promotion.
- ★ HOW to put some letters after your name and become a key man . . . quickly and easily.
- ★ HOW to benefit from our free Advisory and Appointments Depts.
- ★ HOW you can take advantage of the chances you are now missing.
- ★ HOW, irrespective of your age, education or experience, YOU can succeed in any branch of Engineering.

132 PAGES OF EXPERT
CAREER - GUIDANCE

PRACTICAL EQUIPMENT

Basic Practical and Theoretical Courses for beginners in Radio, T.V., Electronics, Etc. A.M.I.E.R.E. City & Guilds Radio Amateurs' Exam. R.T.E.B. Certificate P.M.G. Certificate Practical Radio Radio & Television Servicing Practical Electronics Electronics Engineering Automation

INCLUDING TOOLS

The specialist Electronics Division of B.I.E.T. NOW offers you a real laboratory training at home with practical equipment. Ask for details.

B.I.E.T.

You are bound to benefit from reading "ENGINEERING OPPORTUNITIES"—send for your copy now—FREE and without obligation.

POST NOW!

TO B.I.E.T., 316A ALDERMASTON COURT, ALDERMASTON, BERKSHIRE.

3d. stamp if posted in an unsealed envelope.

Please send me a FREE copy of "ENGINEERING OPPORTUNITIES." I am interested in (state subject, exam., or career).

NAME

ADDRESS

WRITE IF YOU PREFER NOT TO CUT THIS PAGE



THE B.I.E.T. IS THE LEADING INSTITUTE OF ITS KIND IN THE WORLD

NEW SOLID STATE HIGH FIDELITY EQUIPMENT ★ ★ ★ ★

IMPROVED PERFORMANCE — NEW STYLING — NEW MODELS — MONO & STEREO

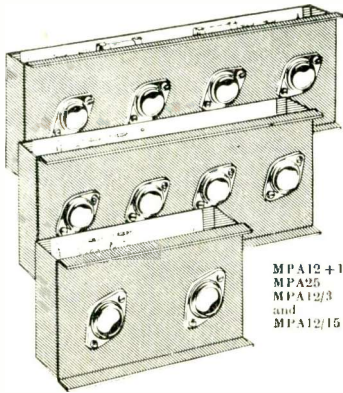

MPA12+12
MPA25
MPA12/3
and
MPA12/15



MP3

SP6-2

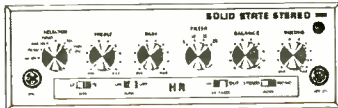

MP3. Mono preamplifier. All silicon low noise zener stabilised circuit. Full range of controls—fully equalised inputs for xtal pu, dyn/xtal mic, radio tuners, tape head and preamp. replay. Supplied built and tested on metal chassis complete with grey/silver front panel, alu. knobs and handbook. Output 250 mV. Supply 12 to 60 volts 3 mA. Overall size 9 1/2" x 1 1/4" in. **MP3 Price £8.19.6, P.P. 3/6**

SP6 2. Mono/stereo preamplifier. Uses 8 silicon/germanium devices. Zener stabilised. Completely new low noise design. Full range of controls and filters. Inputs for magnetic/xtal/ceramic cartridges, radio tuners, tape preamp, microphones, tape head, etc. Record output socket. Supplied built and tested on metal chassis with grey/silver front panel and matching knobs. Complete with input sockets and handbook. Output 250 mV per channel. Supply 9 to 60 volts 4 mA. Overall size 12 x 3 1/4 in. **SP6 2 Price £14.19.6, P.P. 5/6**

SP4. Mono/stereo preamplifier as previously advertised. Complete with front panel and knobs. Size 9 x 3 1/4 x 1 1/4 in. **SP4 Price £10.19.6, P.P. 3/6**

MPA12/3 and MPA12/15. 12 watt power amplifiers for use with above preamplifiers. Improved response and performance with even lower distortion levels. MPA12/3 for 3 to 5 ohm speakers, 24/28 volt supply. MPA12/15 for 10 to 16 ohm speakers, 40/45 volt supply, uses 8 silicon and germanium devices. Inputs 100 mV for 12 watts, response 1 dB, 30 c/s to 20 kc/s. THD 0.2%, at 12 watts. High gain stable push-pull output design. Built on to metal chassis as illustrated. Overall size 5 x 2 x 3 1/4 in. Complete with handbook. **MPA12/3 Price £4.10.0, P.P. 2/6** **MPA12/15 Price £5.0.0, P.P. 2/6**

MPA12+12. Twin amplifier for mono/stereo use with above preamplifiers. Consists of two matched MPA12/15 amplifiers (see above) on single chassis. Output for 10 to 16 ohm speakers. 40/45 volts supply. Overall size 10 x 2 x 3 1/4 in. **MPA12+12 Price £9.19.6, P.P. 4/6**

MPA25. 25/30 watt power amplifier for use with above preamplifiers. New design and layout with improved response and overall performance. Output for 7 to 16 ohm speaker systems. Input 180 mV for full output. Push-pull circuit. Uses 10 silicon and germanium devices. Supply 50/50 volts. Overall size 8 x 2 x 3 1/4 in. **MPA25 Price £7.10.0, P.P. 3/6**

CHOICE OF PREAMPLIFIERS POWER AMPLIFIERS MAINS UNITS

MAINS UNITS
110/240 volt 50/60 c/s input. AC/DC tuned. Fully smoothed and isolated. MU series has additional choke/capacitor filtering and panel voltage selectors. All types on metal chassis. **PS24/40.** Output 24 and 46 volts 1 amp. For use with 1 or 2 MPA12/3, MPA12/15, or 1 MPA12+12. Price 70/-, P.P. 3/6.
MD24/40. Choke smoothed. Output 24 and 46 volts 1 amp. For use with 1 or 2 MPA12/3 and MPA12/15 or 1 MPA12+12. Price 87/8, P.P. 3/6.
MD60. Choke smoothed. Output 50 volts 1 amp. For use with 1 or 2 MPA25. Price 95/-, P.P. 4/6.

RECOMMENDED SYSTEMS

MP3+MPA12/15+PS40	£14.12.6, P.P. 6/6
MP3+MPA12/3+PS24	£13.17.6, P.P. 6/6
MP3+MPA25+MD60	£18.5.0, P.P. 8/6
SP6 2+MPA12+12 or 2MPA12/15 +M140	£28.5.0, P.P. 10/6
SP6 2+2 MPA12/3 +M124	£26.15.0, P.P. 10/6
SP6 2+2 MPA25 +M160	£33.5.0, P.P. 10/6
SP4+2 MPA12/15 +PS40	£24.0.0, P.P. 9/6
SP4+2 MPA12/3 +PS24	£22.15.0, P.P. 9/6
MP3+2 MPA12/15 +M140	£20.17.6, P.P. 8/6
MP3+2 MPA12/3 +M124	£19.7.6, P.P. 8/6

COMPLETE BROCHURE FREE ON REQUEST

THE FINEST VALUE IN HIGH FIDELITY—FULLY GUARANTEED CHOOSE A SYSTEM TO SUIT YOUR NEEDS AND SAVE POUNDS

NEW SCOOP CAR RADIO OFFER

BRITISH MADE. £7.19.6, P.P. 4/6



GLOEMASTER MW/LW/SW PORTABLE RADIO TO BUILD
Full 3-waveband tuning. Push-button wave-change. Superhet printed circuit design. Black-chromed cabinet 11 x 7 1/2 x 3 1/4 in. (SW 17-50 metres). Ear/Record sockets. 1 watt Push/Pull output. 6 Mullard Transistors. Handbook. **TOTAL COST £7.19.6** 3/6 on request. **TO BUILD** 4/6

TOURMASTER TRANSISTOR CAR RADIO British Made
7-Transistor MW/LW Car Radio. 12 volt operated. 3 watt output. Push-button wave-change. RF stage. Supplied built, boxed, ready to use with Speaker and Baffle. Car fixing kit and manufacturers' current guarantee. Special Bargain Offer. Buy Now! **LIST PRICE 15 GNS. £7.19.6** 4/6

BRITISH MADE STEREO TAPE PLAYER FOR CARS 32 gns.
Mono version 28 gns. also P.M./Med. wave/Long wave Car Radio 25 gns. Leaflet on request.

VHF FM TUNER TO BUILD
87/105 Mc/s Transistor Superhet. Geared tuning. Terrific quality and sensitivity. For valve or transistor amplifiers. 4 x 3 1/4 x 2 1/4 in. Complete with dial plate. 5 Mullard Transistors, Plus 4 Diodes. (Cabinet Assembly 20/- extra). Leaflet on request. **P.P. TOTAL COST TO BUILD £6.19.6** 2/6

FM STEREO DECODER
7 Mullard Transistors. Printed Circuit Design with Stereo Indicator. For use with any valve or transistor FM. Uses pot cores to Mullard design and ger. and silicon transistors. Leaflet on request. As used by B.B.C. and G.P.O. **£5.19.6** 2/- Complete Kit Price

BUILD A QUALITY 2 OR 4 TRACK TAPE RECORDER
3-speed version using '363' decks
● TWO-TRACK. Deck £10.10.0. Martin Amplifier. £14.19.6. Cabinet and speaker 7 gns. Complete kits with FREE 7in. 1200Hz. tape, spare spool. **27 gns.** P.P. 15/6
● FOUR-TRACK. Deck £13.10.0. Martin Amplifier £15.19.6. Cabinet and speaker 7 gns. Complete kits with FREE 7in. 1200Hz. tape, spare spool. **30 gns.** P.P. 15/6
Today's Value £50.

DEAC RECHARGEABLE BATTERY
● 9.6 volt 2200mAh 20-. P.P. 1/6
DEAC CHARGER
To charge 3.6 volt and 9.6 volt packs. Fully mains isolated. **45/-** P.P. 2/6 in moulded case.

WE CAN SUPPLY FROM STOCK MOST OF THE PARTS SPECIFIED ON CIRCUITS IN THIS MAGAZINE. SEND LIST FOR QUOTATION OR BETTER STILL BUY THE NEW 1967 CATALOGUE. EVERYTHING YOU NEED IS LISTED AND AVAILABLE FROM STOCK.

See page 472 for further range of stock items

MAYFAIR PORTABLE ELECTRONIC ORGAN

NOW AVAILABLE AS:
● COMPLETE KIT OF PARTS ● BUILT AND TESTED ● PRE-BUILT ASSEMBLIES.
REVERBERATION UNITS AND RECOMMENDED SPEAKERS AND AMPLIFIERS IN STOCK.
Designed by L. W. ROCHE



STRAIGHT FORWARD TO BUILD AND TUNE—EASY TO PLAY—FULLY GUARANTEED. ALL PARTS AVAILABLE SEPARATELY—ASTOUNDING VALUE AND PERFORMANCE. Start to build for as little as £5.

● Plug-in printed circuits ● 170 transistors and devices ● 10 selected tone colours ● Fully sprung keyboard ● Vibrato ● 6 Octaves of generators ● Simple locked-in tuning ● 110/250 volt mains unit ● Cabinet size 30 1/2" x 15 1/2" x 9" ● Weight 35 lb. Cabinet with detachable legs, music stand and foot swell pedal ● Fully detailed building manual with photos, drawings and full circuits.

COMPLETE RANGE OF ORGAN PARTS IN STOCK. H.P. FACILITIES AVAILABLE. TRADE/EXPORT SUPPLIED. FULLY DETAILED LEAFLET AND PRICE LIST ON REQUEST. CALL FOR DEMONSTRATION AND PLAY THE MAYFAIR.

RELAYS, MOTORS, SWITCHES, MINIATURE COMPONENTS, TRANSISTORS AND DEVICES
Complete range in stock all types for every purpose. Also panel and multimeters, precision components, radio control crystals and parts, transistors, tunnel diodes, thyristors, LDR's, zeners, rectifiers and diodes. Everything you need for amateur and professional applications. See 1967 catalogue. The largest range in the country. Suppliers of quality components and equipment for over 20 years.

LISTS AVAILABLE (incorporated in full catalogue)
● Transistors / Rectifiers / SUR's / Valves / Crystals/Zeners, etc. 24 pages, 1/-.
● 4-page hi-fi stock list with discounts.
● All popular makes. Free.
● Car radio and tape recorders. Free.
● Organs and components lists. Free.

1967 CATALOGUE
Have you a copy? Fully detailed and illustrated. Over 200 pages of components, equipment, etc. Over 5,000 stock items. FULLY DETAILED AND ILLUSTRATED. PRICE 8/6, post paid. 5 Free discount vouchers, value 10/- with every catalogue.

HENRY'S RADIO LTD.
303 EDGWARE RD., LONDON, W.2
P 11dington 10093 (extn 01-723 1008)
Open Mon. to Sat. 9-6. Thurs. 1-6pm.
Open all day Saturday
All items fully guaranteed

