

Practical Electronics

JANUARY 1966

PRICE 2'6

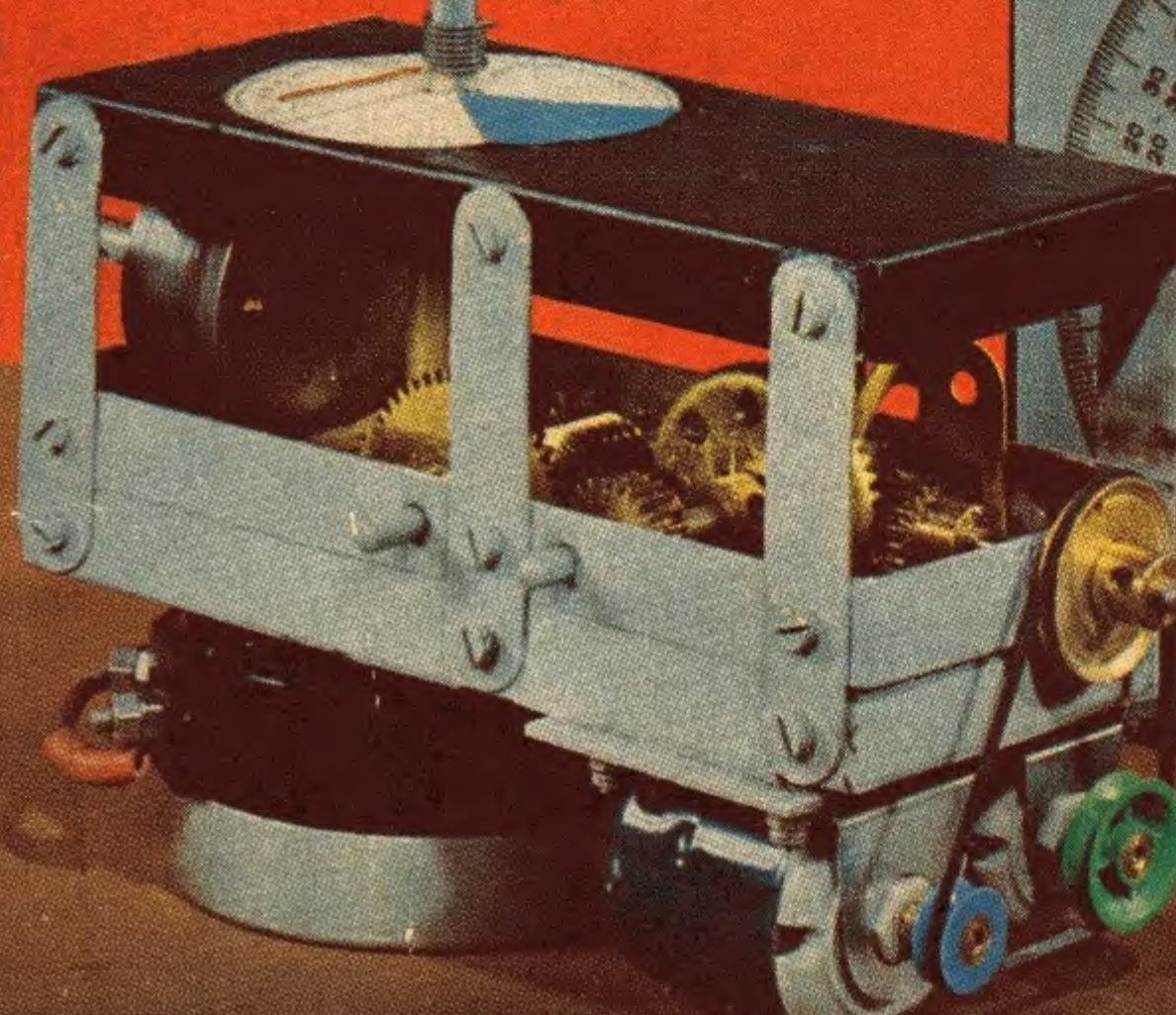
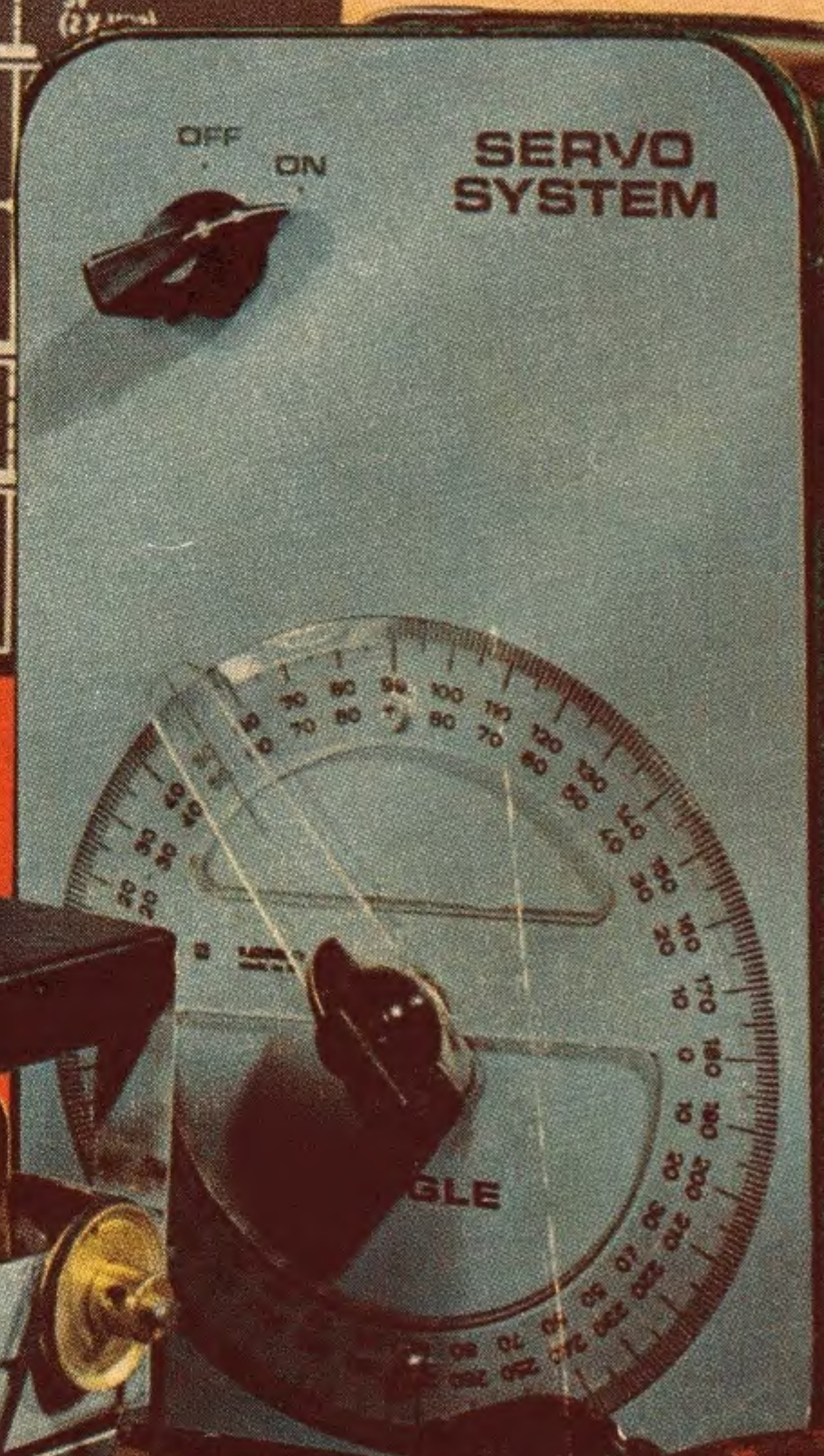
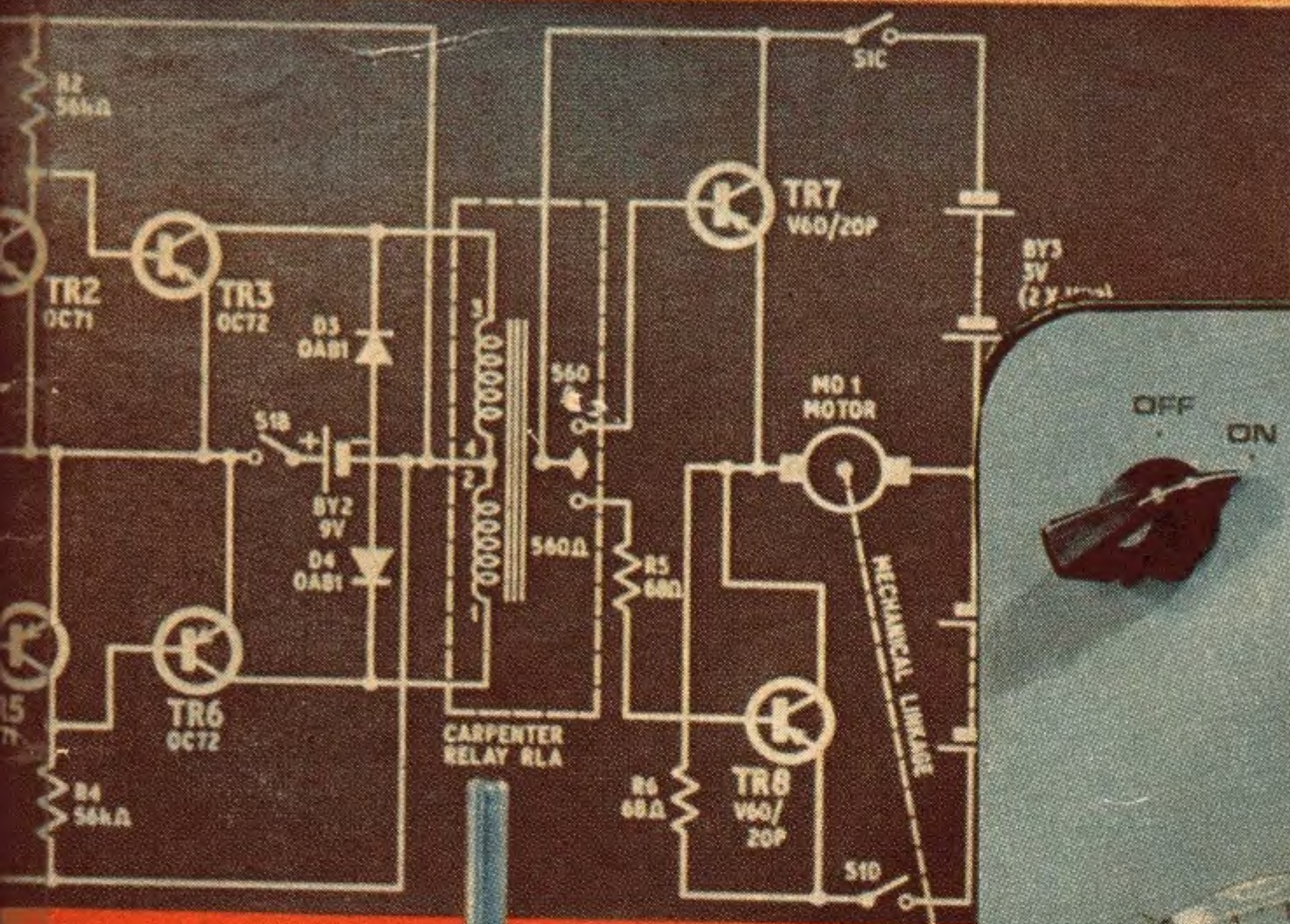

SIMPLE SERVO SYSTEM

FOG BOUND

DESPITE modern scientific and technical aids, travel remains to a considerable extent subject to the vagaries of the weather. In these winter months we experience too often the benumbing and paralysing effects of that great enemy fog. Bewilderment, confusion and a general sense of helplessness descend upon us with dense fog, for this murky vapour obliterates not only our vision but quite a few of the amenities of our modern world. On these occasions it is brought home forcibly and unpleasantly to us how much we are still dependent on the human visual faculty: this is indeed well demonstrated in the case of road transport.

The closing of fogbound motorways is a sensible precaution in view of recent disasters involving sometimes multiple collisions, but this is a purely negative remedy and the present situation cannot be tolerated indefinitely. Modern technology must be brought in to play its full part in combating the catastrophic effects of poor visibility on the roads.

Naturally enough the question is often asked: Can electronic techniques be employed to reduce the hazards of motoring in misty or foggy conditions? Two ideas come to mind in this connection: the setting up of special communications networks to pass general warnings and advice to motorists, and the development of a radar type of device for installation in individual vehicles.

The first of these ideas has in fact been given serious attention in West Germany where a communications system is to be tried out on certain sectors of the autobahn. Inductive loops buried just below the road surface will transmit warnings of hazards ahead such as fog patches, ice, accidents, or traffic jams, and the motorist will receive these messages through an adaptor unit fitted to a standard car radio receiver. These experiments will no doubt be watched with keen interest by our own Ministry of Transport. One suspects that cost alone will inhibit the widespread implementation of this kind of system. It may nevertheless prove worthwhile for certain selected lengths of our motorways.

The equipping of motor cars with some rudimentary form of radar to detect the presence of other vehicles just immediately ahead is an idea that has often been mooted, but so far no practical system has materialised. Considering the present state of the electronic art, we suggest this should not remain much longer a too formidable proposition. Much can be learnt from techniques employed in aeronautical and marine electronics. Perhaps an adaption of the radar altimeter principle might be possible; or maybe an ultrasonic system based on the sonar depth sounder would prove a more likely proposition. Another line of approach surely worth investigating would be the detection of heat radiated from a car's exhaust, by means of infrared sensors.

Much scope obviously exists for developing electronic devices to augment or replace the human eye when visibility conditions deteriorate. Here, surely, is a challenge to our scientists and engineers. The conquering of the fog menace will be one of the great landmarks in technical progress. But this needs immediate, urgent attention. Our present impotency in face of fog is hardly reconcilable with the great technical achievements of this day and age.

THIS MONTH

CONSTRUCTIONAL PROJECTS

PIPE AND CABLE LOCATOR	18
ELECTRONIC CANDLE	22
SERVO SYSTEM	32
MINIPROBE SIGNAL INJECTOR	46
SIMPLE DIGITAL COMPUTER	49

SPECIAL SERIES

NEON NOVELTIES—5	25
BUILDING BLOCKS—10	28
BEGINNERS START HERE—15	42

GENERAL FEATURES

MODERN COMPUTER SYSTEM	14
INGENUITY UNLIMITED	63

NEWS AND COMMENT

EDITORIAL	13
AUDIO TRENDS	26
BOOK REVIEWS	39
ELECTRONORAMA	40
NEW PRODUCTS	44
DETACHED PARTICLES	59
NEWS BRIEFS	60

*Our February issue will be published on
Thursday, January 13*



A MODERN COMPUTER SYSTEM

What Does A Modern Computer System Consist Of? How Does It Work? What Jobs Can It Do?

These are amongst the most common questions asked about computers. With computer systems playing an increasingly important part in our lives, there is good reason to be able to answer these questions accurately. Computers are widely employed in business, industry and scientific research; they are used by borough and county councils and government departments. Universities and colleges have their own installations for teaching, research and administrative tasks.

Computer systems are taking over greater amounts of work every year, and finding their way into more and more commercial and technical concerns. To appreciate their importance in these many spheres of activity, it is necessary to have a basic knowledge of the principles governing their operation and employment. This article aims to give you this. Here you will find answers to some of the questions raised by high speed data processing. Here, in broad detail, is the inside story of a modern computer system.

ALL electronic computers can be divided into two distinct types—*analogue* and *digital*.

Analogue computers represent numbers by the magnitude of physical quantities such as angle of rotation, length along a scale, voltage, magnetic flux, pressure, and so on. They represent numbers by physical analogies—hence their name.

A digital computer represents numbers by discrete digits, whereas the analogues are continuously variable. This is, in fact, the essential difference between the two types of computer. For example, one-third cannot be expressed by a finite number—it is 0.33333..... for ever—but one-third of a distance is easily expressed. In practice, however, the analogue computer is in fact *less* accurate than its digital counterpart, because a scale of convenient length must be very carefully manufactured if it is to be read reliably to just three significant figures.

By contrast, digital systems can handle figures to any number of "places" by duplicating components.

Therefore in the majority of applications digital computers are used because of the precise answers they give. And in commercial applications they are the only practical possibility, since filed information can be set up far more conveniently in digital form. We will therefore consider digital computers only.

WHICH DIGITAL COMPUTER?

The digital computer systems that will be used as illustrations are those of the I.C.T. 1900 Series, designed and produced in Britain. There are a number of reasons why this is an ideal series to use for our explanatory story.

It is modern, having only recently been introduced by International Computers and Tabulators Ltd.

It represents the very latest thinking in computer design and construction. It incorporates many advanced features which will take the system well into the future.

And, as important as any, it is a series of computers which, with its many different combinations, can undertake the widest possible range of automatic data processing and computing tasks.

WHAT DOES A MODERN COMPUTER SYSTEM CONSIST OF?

The Central Processor

The central processor is the heart of a computer. It embodies the arithmetic unit which can add, subtract, multiply and divide, and make logical decisions. These decisions are arrived at by comparing figures and determining whether one is greater than, less than, or equal to the other. Besides calculating, the processor accepts and acts upon the operator's instructions, and controls the working of the system according to the programme or programmes which are being run.

In the I.C.T. 1900 Series there are several central processors varying in size, storage capacity and performance; the user and his advisers will specify the one that best fulfils the various needs. The operator's typewriter is connected to the central processor and is used to pass control instructions to it. These take the form of such commands as "start", "stop", and "load a device", amongst others.

Peripheral Equipment

The "peripheral" equipment, connected around the computer to complete the system, can be divided into input, output, storage, and communications devices.

Input devices include paper tape readers, punched card readers, and document processors capable of reading characters printed in magnetic ink.

Output devices are paper tape punches, card punches and line printers. There are also cathode ray tube display units where the computer's answers are shown on a screen, and a data exchange unit which enables one central processor to pass data to another.

Storage devices include magnetic drums, magnetic tape, magnetic card files, and disc files.

For communications there are various devices which allow data to be fed into the central processor via telephone and telegraph lines from distant points. These also take data from the processor for similar transmission over long distances.

The actual physical electronic circuitry of both central processor and peripheral equipment is termed *hardware*.

Standard Interface

Each item of peripheral equipment on the 1900 Series is connected to the central processor by a special I.C.T. linking device. This is known as Standard Interface, and enables a computer system, of processor and peripherals, to be built up like so many building blocks. With this interchangeable equipment, users can select the exact devices to meet their present needs, knowing it can be changed if and when these need change.

Standard Interface also makes it possible for users to augment their systems with new peripherals and/or central processors produced in the future.

Programmes

The working of a computer system is largely governed by the programmes which are written for it by the user. There are, of course, electronic and manual controls for different sections of the system, but its overall working is dependent on the programme. Each computer task, or application, will have its own particular programme.

Executive Programme

The operation of 1900 Series computers is supervised by a special master programme incorporated in the system. Known as *Executive*, this master programme is stored permanently in the central processor. It controls the flow of work through the system and the transfer of information from one peripheral device to another; it generally oversees the functioning of each component, monitoring its performance to avoid any possibility of error.

A particular feature of certain systems in the 1900 Series is their ability to perform a number of tasks at the same time. This simultaneous working, or multi-programming as it is called, is also governed by the Executive.

The control exercised by Executive in these various ways ensures that the computer is kept as productively occupied as possible, whether on one or more jobs.

Programming Aids

Programmes for a computer are prepared by a programmer. For this work he or she uses programming aids. These are generally termed *software*, and may be regarded as special languages which the computer can understand. Using one of these languages, a programmer will write a programme of working instructions for the computer to obey. The 1900 can almost be said to be multi-lingual, since it is able to understand several major programming languages and operate on instructions written in them.

There are also sub-routines which may be defined as ready-made parts of a programme to be inserted in a main programme.

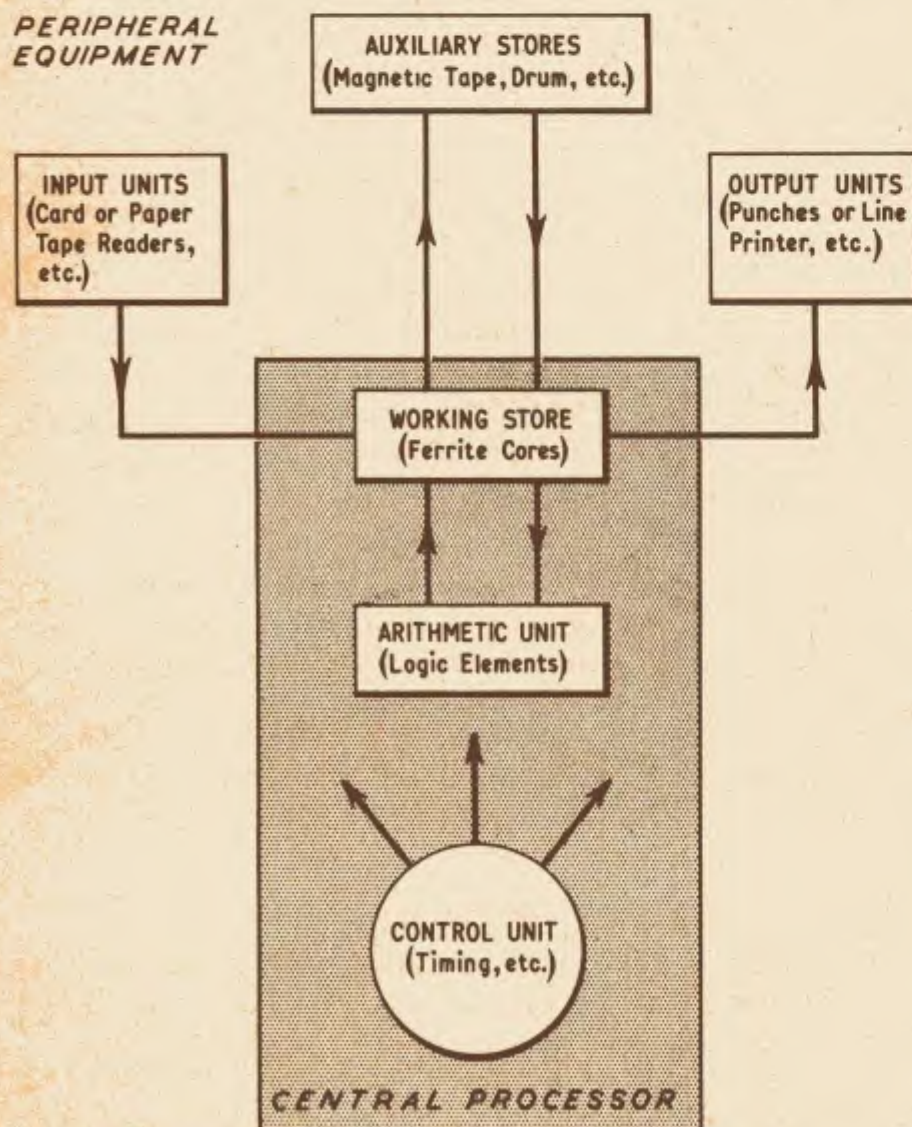

Fig. 1. Basic diagram of a computer system



Fig. 2. An I.C.T. 1903 computer system recently installed at English Sewing Cotton Co. Ltd., Manchester. The picture shows, from left to right, a line printer, paper tape reader, console typewriter, magnetic tape storage units and central processor

HIGH-SPEED DEVICES

The relationship of various 1900 series peripheral devices to the central processor, with Standard interface used to link them, is shown in Fig. 2. An impression of the speed at which a computer works can be obtained from studying the speeds at which input and output peripherals handle paper tape and punched cards, and the time taken for the storage devices to locate characters.

HOW DOES A COMPUTER WORK?

The way a computer system undertakes a job, and the part played by each of its components in the operation is most simply stated by splitting a single task into numbered phases.

(1). A programme, prepared for a particular task by a programmer, will be fed into a computer.

(2). Current data, or information, are presented to the computer on cards or paper tape. These are referred to as input media. These data, whether facts or figures, are represented by holes punched in the cards or paper tape by operators using automatic punches.

If punched cards are being used these will be loaded into the punched card reader, to be read at up to 1,200 characters a second. If paper tape is the input medium, this will be fed to the paper tape reader, and characters will be read at 1,000 a second.

(3). Previously compiled, or existing data—again facts and figures—are loaded into one of the storage devices. The method of storage can be magnetic tape,

magnetic cards, magnetic drum or magnetic discs. These storage devices form the computer's memory, and the data they hold refer to past calculations and information having a bearing on the current task. To indicate the speed at which they work, information contained on magnetic tape can be fed into the central processor at 96,000 characters a second. While with magnetic cards, any one fact contained in 5,000,000,000 characters can be found in one-third of a second.

(4). As the cards or paper tape are accepted by the reader the data they contain are transmitted to the central processor. At the same time existing data from the storage peripherals are fed in.

(5). Acting upon the data from these two sources, the processor carries out the necessary calculations, assembles information, and passes the results of its work to the output devices.

(6). The output devices receive the answers and present them in the required form. A paper tape punch produces the answers in paper tape punched with data holes; a card punch does the same using cards; a line printer produces documents fully printed with the calculated results. Other input devices can be used for visual display of the results, and for passing them to other processors for further work.

(7). The central processor will pass to the storage devices the new data to bring the files up to date. So, when these files are next run, they will contain the new information obtained on this run.



Fig. 4. One of three numerically controlled Milwaukee-Matic machines in operation at I.C.T.'s Stevenage factory. A control tape produced by an I.C.T. computer is used to govern the operation of the machine tools to produce castings for further I.C.T. computer systems

Fig. 3. Backwiring part of an I.C.T. 1900 Series computer. I.C.T. use a semi-automatic method for confirming that every wire has been attached to the correct terminal pins

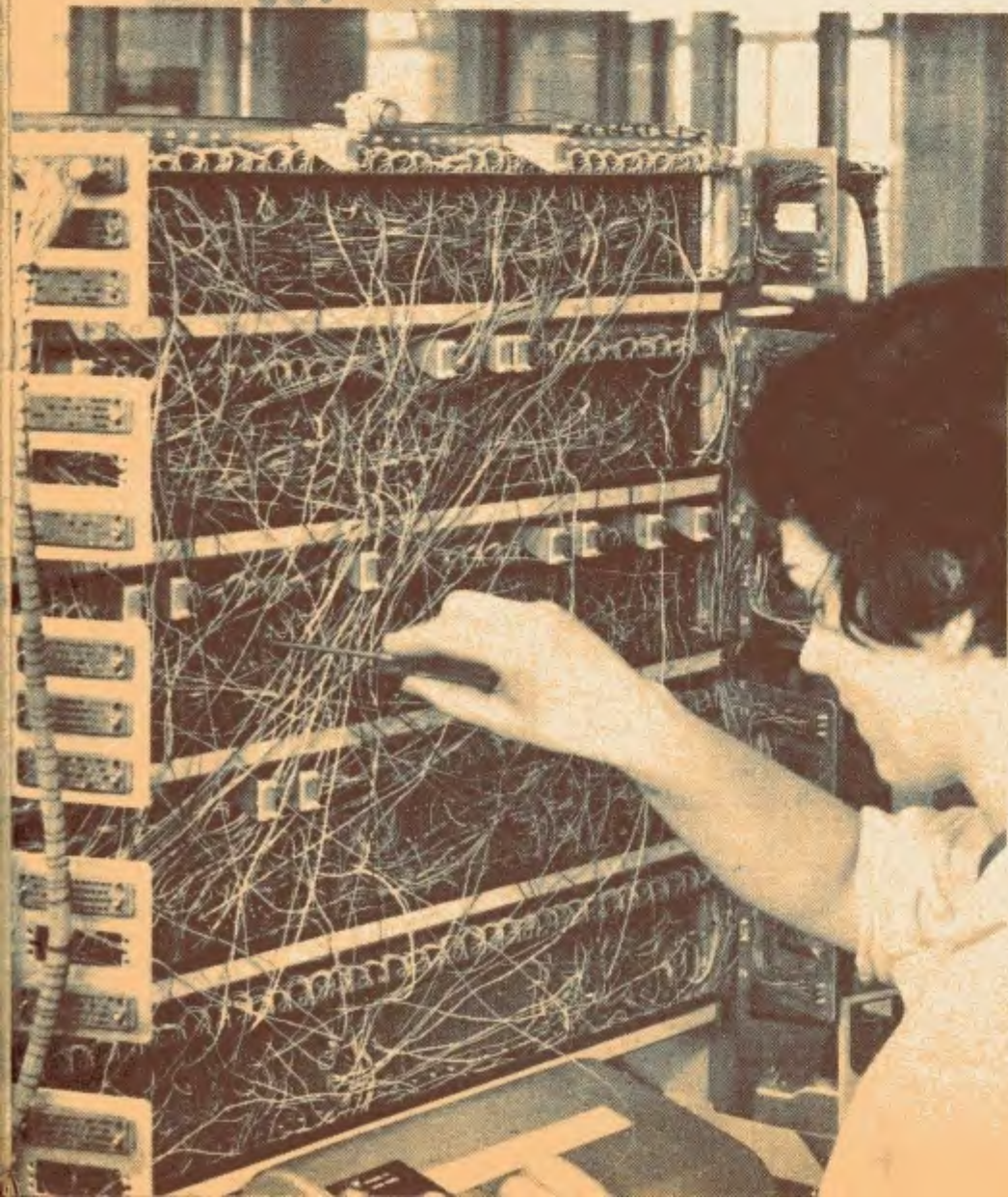

This will have been just one job. It may have involved thousands of punched cards or hundreds of feet of punched paper tape. The results might be hundreds of invoices, fully printed with names and addresses and columns of goods and amounts; or payslips for the staff of a large company, containing basic pay figures with all additions and deductions calculated. The time the job has taken can be judged from the speed of one output device: on the line printer 1,350 lines can be printed in one minute, each line having 160 characters. Impressive as this is though, it is not all. Other jobs could be processed at the same time if the work is being done on one of the 1900 Series computers, since computers in this series are capable of "multi-programming".

WHAT CAN A COMPUTER SYSTEM DO ?

The answer to this question is best given by listing some of the various areas of work for which a computer system can be used, together with tasks in these areas.

Commerce and industry: preparing payroll, invoices, lists and values of stock; controlling production of goods.

Local and national government: keeping medical and social service records; forecasting expenditure; maintaining accounts for large-scale building operations; preparing departmental accounts.

Technology and science: working out the complicated problems involved in many branches of research and manufacturing. For example, the design of a snow plough is being assisted by calculations produced on a computer. A computer system is able to solve complex problems, and accomplish substantial accounting tasks, in only a fraction of the time that they would take large trained staffs to complete.





PIPE and CABLE LOCATOR

GORDON . J. KING

IT IS often a bit of a problem to locate pipes and cables embedded in plaster or brickwork when the time comes for their repair or replacement. This is especially true in old property, where the cable and pipe laying may have occurred subsequent to the erection of the building. Here the routing rarely follows conventional practice and quite a lot of plaster may have to be removed to expose the pipes or cables.

Electric cables can be located by feeding some sort of signal through them while isolated from the mains supply, and then listening for this signal through a very sensitive detector.

TRACING THE HUM FIELD

Cables energised with ordinary mains power radiate a 50c/s electromagnetic field over a small distance, which can be detected. All that is necessary in this case is an electromagnetic pick-up loop, wound on a laminated core of ferrite material and tuned to be sensitive to 50c/s signal. This loop is then connected to the input of a sensitive amplifier which is also tuned to 50c/s; the output could be monitored on headphones. When the pick-up loop is close to a mains carrying cable, hum will be heard in the headphones, and by keeping the pick-up loop on the line of the cable the hum heard will remain at a reasonably consistent volume. When the pick-up loop deviates from the routing of the cable the volume will likewise fall. In this way, the hidden path of the cable can be traced.

This is not a particularly good idea for two reasons. One is that it is not all that easy to hear 50c/s hum unless a very high gain amplifier is used; headphones are not very sensitive to such a low frequency. The second disadvantage is that it may not be possible to apply mains to a cable network as it may be faulty or even short circuiting.

The alternative is to feed into the network a much higher frequency signal of very low power. The signal pick-up amplifier can then be tuned to the frequency of the signal fed into the cable. This method

is also limited by possible short circuits in the cables, for while strong radiation may occur from open circuit cable pairs, the radiation is considerably impaired if the two wires have a short circuit or low impedance load across it.

PROXIMITY INDICATOR

A better method of locating not only electric cables but also metal pipes or, indeed, almost any metal work is by using some sort of proximity indicator. This method does not rely on radiation from the cable or metal work, and it does not make any difference whether a cable is open circuit or completely short circuit; the results are the same. It is this method that is adopted in the device described in this article.

Electronically, the proximity of metal can be indicated either by a change in inductance or by a change in capacitance when near to another conductive material. Take, for instance, an ordinary h.f. oscillator set up to work on a particular nominal frequency.

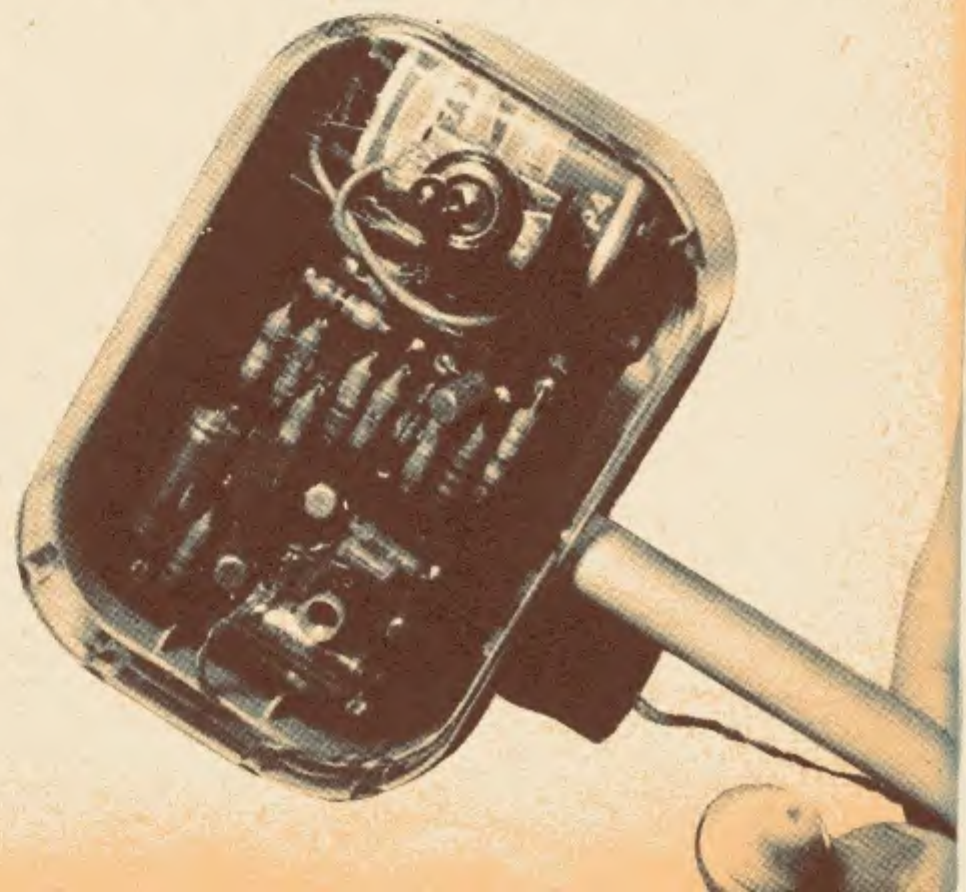

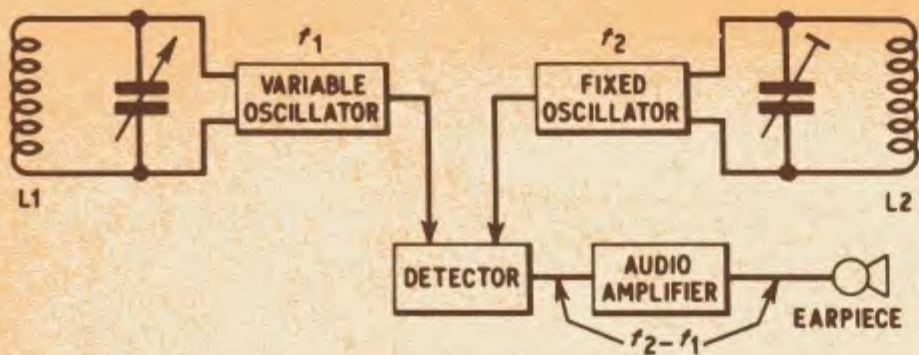

Fig. 1. Block diagram of the pipe and cable locator

This frequency can be altered either by altering the capacitance or the inductance of the tuned oscillator circuit. If the capacitance or inductance is increased, then the oscillator frequency decreases.

The oscillator represents a device which is sensitive to a change in inductance or capacitance. If the frequency of an oscillator is monitored by some simple method, and its tuned circuit is brought near to an electric cable or pipe hidden in the plaster, the oscillator frequency will change by an amount dependent on the proximity factor. The coupling is mainly inductive, but capacitance also has some effect.

To obtain sufficient coupling between the oscillator and the hidden cable or pipe, the oscillator tank coil is wound in the form of a small frame aerial which is tuned by a variable capacitor. The problem remaining is to detect the change in frequency of this oscillator as the oscillator coil is brought into coupling distance of the cable or pipe, etc. This is resolved by means of a second oscillator of fixed frequency.

The signals from the two oscillators are fed into a detector circuit which itself produces signals—due to non-linearity—equal to (a) the sum of the two oscillator frequencies and (b) the difference between their frequencies.

Let us suppose that the variable oscillator is tuned to 1,000kc/s and the fixed oscillator to 1,002kc/s.

Two signals (in addition to the oscillator signals themselves) would then be produced by the detector, one at 2,002kc/s (1,000+1,002kc/s) and the other at 2kc/s (1,002-1,000kc/s). The difference frequency of 2kc/s is selected because this is in the audio range and can be heard in an earpiece connected to the output of the detector. To make this difference signal really audible, it is fed to the earpiece through an amplifier, the whole idea being shown in block diagram form in Fig. 1.

This means that the device can be used as follows: the variable oscillator is adjusted to give a clearly audible note in the earpiece, L1 then "explores" the wall until the note changes substantially in pitch, which indicates, of course, a change in the frequency of the variable oscillator due to the proximity of the hidden cable or pipe.

THE CIRCUIT—HOW IT WORKS

The circuit is shown in Fig. 2 and is worthy of description. It will be seen that it employs three *pnp* transistors and a germanium diode. Transistor TR1 in conjunction with the tank coil L1 and the tuning capacitor VC1, form the variable oscillator. L1 is wound as a small frame aerial to facilitate external "coupling".

Transistor TR2 and the adjustable coil L2 with C2 make up the fixed oscillator. The frequency of this stage can be adjusted over a limited range by setting the dust-iron core in the coil former. L2 is tuned by C2.

Simple single-coil feedback circuits are used in both oscillators, and the h.f. signal appearing at the emitters is fed through C3 (from the variable oscillator) and C5 (from the fixed oscillator) to the detector diode D1. This diode is loaded by R4 and R5. The difference frequency appearing across R5 is fed to the base of the amplifier transistor TR3 through C7. The unwanted h.f. signals at the detector are suppressed by C6.

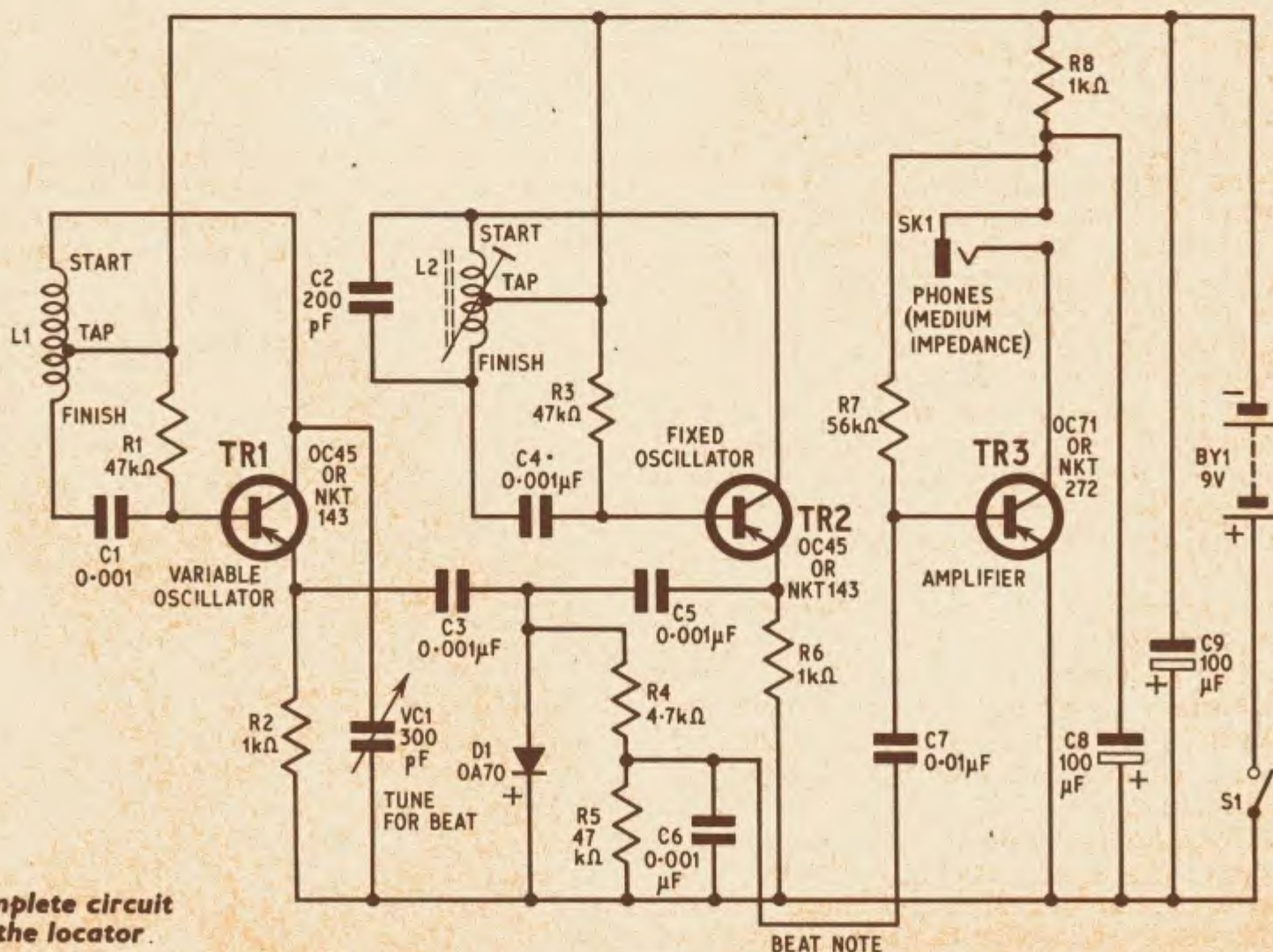

Fig. 2. Complete circuit diagram of the locator.

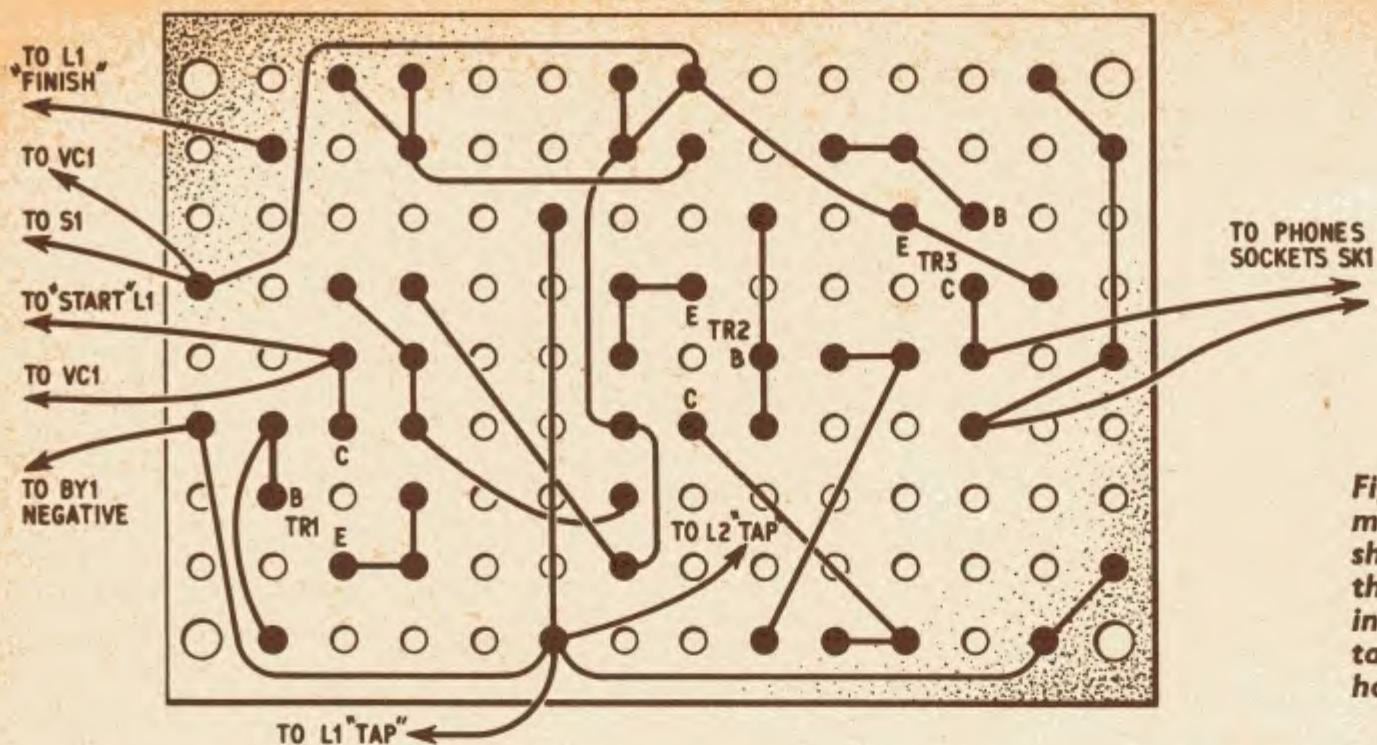

Fig. 3. Underside view of the main component assembly board showing the exact positions of the eyelet tags and interconnecting wires. The wire to "L2 tap" is passed through a vacant hole to the coil winding

The audio amplifier is a very simple common emitter arrangement, with the collector loaded by the headphones or earpiece. The base current is established by R7. Decoupling is provided by C8 and C9, both 100 μ F electrolytics.

The circuit works quite well from a small 9 volt battery. The current consumption is only a few milliamperes, so the battery will have a long life. Either a jack or a two-pin socket can be used for the headphones or earpiece; S1 is an on-off toggle switch which completes the circuit.

CONSTRUCTION

Construction can follow the whims of the experimenter. There is nothing very critical, but care should be exercised on one or two aspects. For instance, the frequency adopted should not be too low to get maximum interaction from a nearby cable. A frequency of about 1,000kc/s (i.e. 1Mc/s) is highly suitable. Both oscillators thus would need to operate at the same frequency.

The variable capacitor, VC1, gives plenty of tolerance in this respect, and it is not difficult to get the fixed oscillator to the same or near frequency by adjusting the dust iron core in L2 former and, if necessary, by adjusting the value of C2. This could be replaced by a small trimmer of the same value.

The transistors for the oscillators can be almost any small-signal type that will oscillate at 1,000kc/s (or at the chosen frequency). The audio transistor is not critical; almost any medium or high gain type will do. Those specified in the components list will serve very well.

The frame aerial configuration for L1 of the variable frequency oscillator must be arranged in such a way that it is not shielded by metal and that it can be held close to and parallel with the plaster wall. It can either be made as a separate item and coupled into the transistor unit through wires or it can be built into the case of the transistor unit. The latter is by far the better way and it is made easy if the unit is built into a plastics box.

In this event, a wooden handle should be attached to the plastic box to avoid "hand" capacitance effects varying the frequency of the beat-note. The prototype is shown in the accompanying photographs.

EYELET BOARDS

The circuit is built up on two pieces of eyelet board measuring about 1 $\frac{3}{4}$ in \times 2 $\frac{3}{4}$ in, with a hole matrix 0.2in square, providing 9 holes by 14 holes (total 126 holes). The eyelet tags should be purchased with the boards to make sure they fit in the holes tightly.

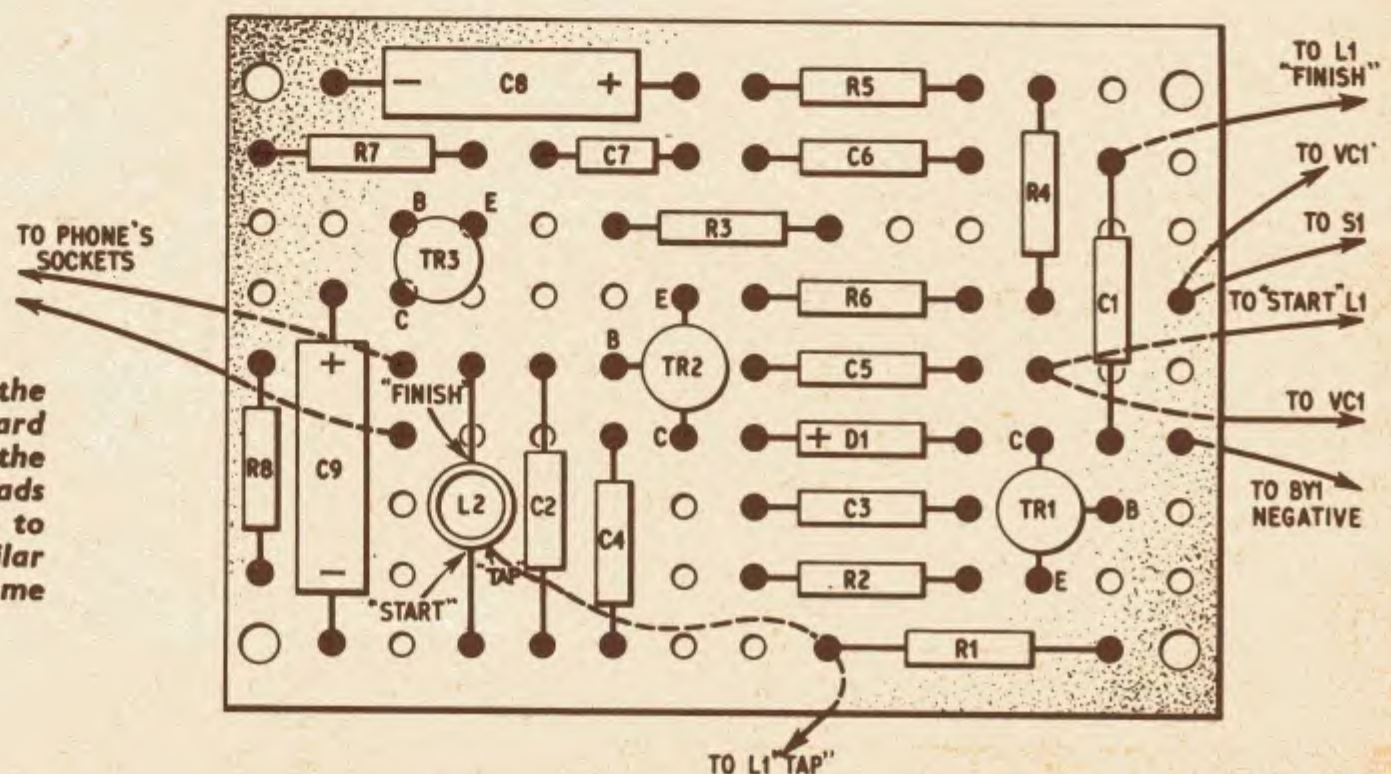

Fig. 4. Topside view of the main component assembly board showing the positions of the components. Notice that leads are taken from this board to VC1 (mounted on a similar board) and L1 which is the frame winding (see text)

COMPONENTS . . .

Resistors

R1	47k Ω	R5	47k Ω
R2	1k Ω	R6	1k Ω
R3	47k Ω	R7	56k Ω
R4	4.7k Ω	R8	1k Ω

All 10%, $\frac{1}{2}$ watt carbon

Capacitors

C1	0.001 μ F	ceramic
C2	200pF	silver mica
C3	0.001 μ F	ceramic
C4	0.001 μ F	ceramic
C5	0.001 μ F	ceramic
C6	0.001 μ F	ceramic
C7	0.01 μ F	ceramic
C8	100 μ F	elect. 15V
C9	100 μ F	elect. 15V

VCI 300pF variable with mica dielectric

Transistors

TR1	NKT143 or OC45
TR2	NKT143 or OC45
TR3	NKT272 or OC71

Diode

DI OA70

Coils

L1 and L2 wound with 30 s.w.g. enamelled wire
Former for L1—see text
Former for L2— $1\text{in} \times \frac{1}{4}\text{in}$ with fixing feet and adjustable dust iron core

Plug and socket

PL1 and SK1 Two-way jack or two-pin miniature type

Battery

BY1 9 volt (Vidor VT3 or VT4 or Ever Ready PP4)

Switch

S1 Single-pole on-off toggle switch

Miscellaneous

Eyelet boards (2 off) each $2\frac{3}{4}\text{in} \times 2\frac{1}{4}\text{in}$, 0.2in matrix, 14 holes \times 9 holes (see text). Eyelet tags to fit the eyelet boards. Earphone (type A) medium impedance (Home Radio). Bolts 1in long, 6 B.A. with nuts, and $\frac{5}{8}\text{in}$ 6 B.A. spacers (4 off each). P.V.C. sleeving to fit over the spacers. Plastics box to accommodate the assembly and battery

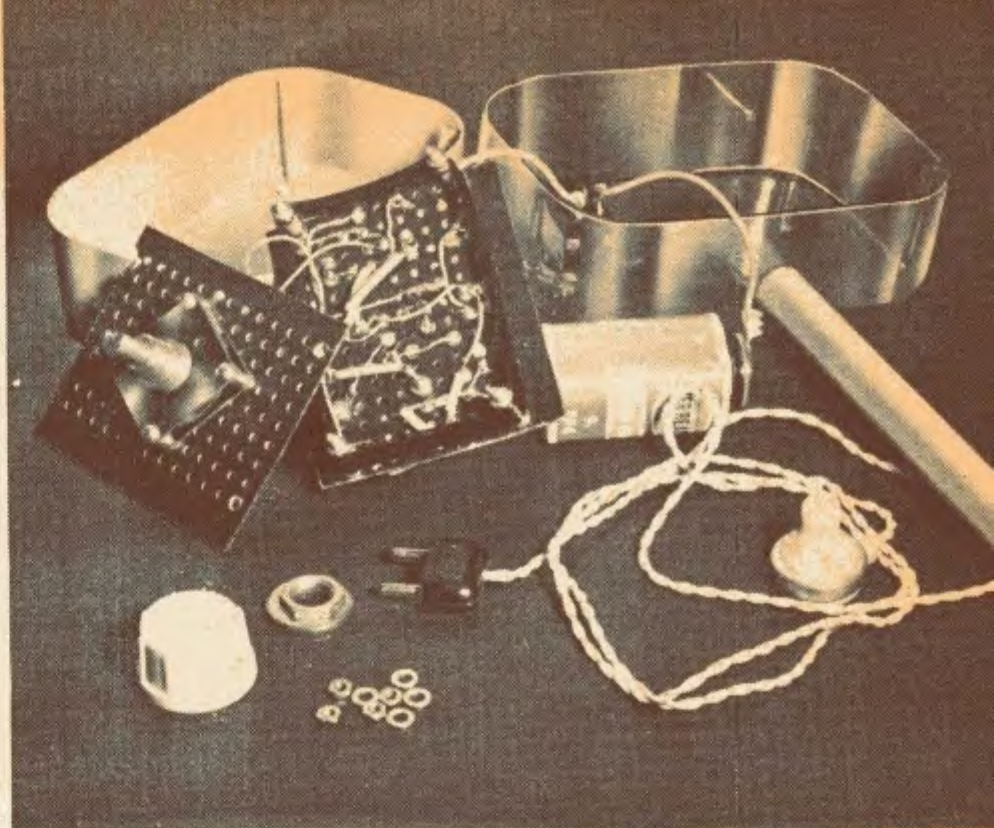

Fit the tags in the required holes as indicated by the filled-in black dots in Fig. 3 (underside view) and Fig. 4 (top view) of the circuit board. The four corner holes are enlarged to secure the boards to the box with nuts and bolts.

The two boards are held away from each other by four spacers approximately $\frac{5}{8}\text{in}$ long. Suitable lengths of plastic sleeving are fitted over the spacers, thereby making an ideal framework for coil L1. The lower board accommodates the variable capacitor VCI and the top board the transistors and the remainder of the circuit, including coil L2 (see photographs).

Coil L2 is wound on an ordinary $\frac{1}{4}\text{in}$ former fitted with an adjustable dust iron core for tuning. The whole assembly can be accommodated in a plastics box of suitable dimensions. Such boxes are available from popular stores and are intended originally for the conveyance of sandwiches. The box used by the author, however, was one which originally contained a small battery-operated photography flash-unit, simply because this happened to be available.

As the photographs show, the box contains the battery and on-off switch so that the device is completely self-contained.

COIL WINDING

The frame coil L1 has dimensions $1\frac{1}{2}\text{in}$ by $2\frac{1}{2}\text{in}$, provided by the framework made up as described above. It consists of 35 turns of 30 s.w.g. enamelled wire, close-wound round the four plastic-sleeved spacers. On completing the 30th turn the wire is looped out about 10 inches, then 5 more turns are added to the frame. The loop represents the tap which is connected to R1 on the circuit board (Fig. 4). The "start" of the coil goes to the collector of TR1 and the "finish" (after the final five turns) to C1, as shown in Fig. 4.

Coil L2 comprises 70 turns of the same kind of wire (30 s.w.g.) wound over the length of the small $\frac{1}{4}\text{in}$ diameter former. It is necessary to layer wind so that all the turns can be accommodated. On the 60th turn the wire is looped out about 10 inches, then 10 more turns are added. The loop represents the tap which is connected to the same tag on the circuit as L1 tap. The "start" and "finish" of the coil are connected to the collector and C4 respectively, as shown in Figs. 3 and 4.

★

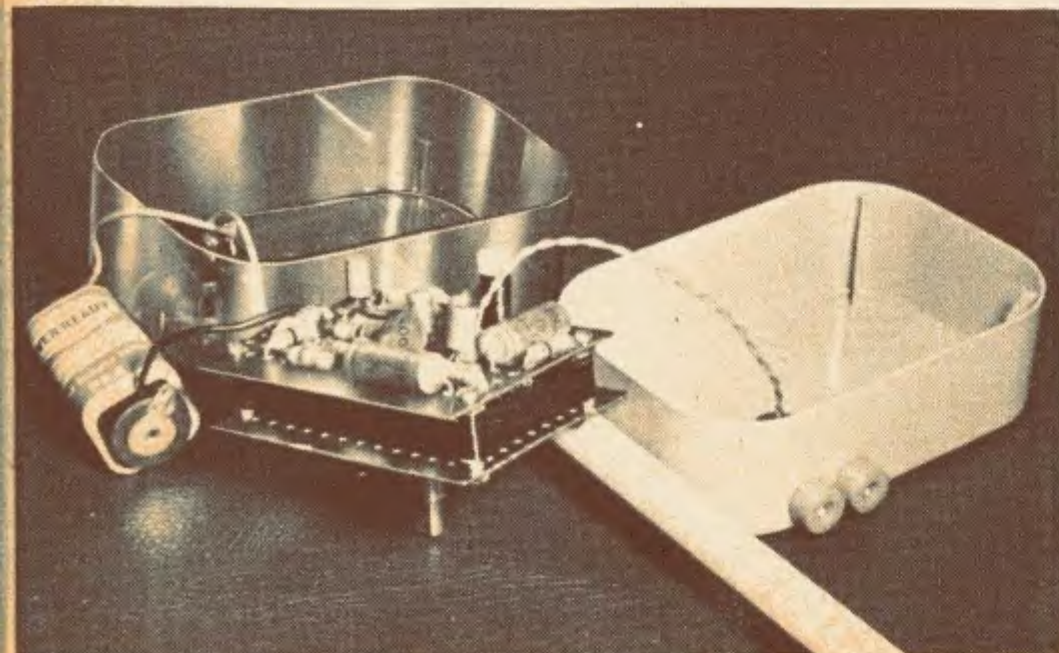

electronic CANDLE

by G. A. Bobker

LIGHT THE BULB WITH A MATCH!

EXTINGUISH IT WITH THE FINGERS!



THE electronic candle is a simple device which can be made up in a very short time and give hours of pleasure to people of all ages. It is fascinating, baffling, and a harmless game for those unversed in the art of electronics.

THE SECRET

In the circuit, shown in Fig. 1, TR1 is a light-sensitive transistor: either an OCP71 or an OC71 with the paint scraped off—but note that this is possible only with the earlier types of OC71. Transistors TR2 and TR3 are both type OC81, but they can be replaced by a *single* OC22 or OC29 or almost any similar power transistor.

The bulb can be any one of several types: for example, 3.5 volts, 0.15A or 0.3A; 2.5V, 0.25A or 0.3A. Lower voltage bulbs are not recommended as their life may be rapidly curtailed.

When light falls on TR1, through the small aperture in the box, the current through it increases, thus increasing the collector current of TR2 and TR3. The current through the bulb is increased and is held on. The bulb is situated close to TR1 aperture so that its light shines on the emitter side of the photo-transistor.

To extinguish the bulb hold it gently by the finger and thumb (as though quenching the wick of a candle) so that the finger is between the bulb and TR1, blocking the light path to TR1. The current will fall again, extinguishing the bulb.

HOW IT IS MADE

The power transistors (TR2 and TR3) are mounted on a small piece of Veroboard or eyelet board with connections as shown in Fig. 2.

The box is constructed of $\frac{3}{8}$ in plywood or obechi, held together by panel pins and glue. It is important that the aperture for TR1 should be in line with the filament of the bulb. TR1 is connected to stiff insulated wires so that it is held near the aperture. See Figs. 3 and 4.

The emitter side of TR1 should face the bulb and can be recognised as the side with the smallest pip on the base element. The bulb holder is mounted such that the bulb is a finger's thickness from the aperture. The bulb filament will be approximately parallel to TR1 for maximum sensitivity; the aperture *must* be left uncovered. It may be necessary to cut away part of the bulb holder as shown, so that the bulb can be reasonably close to TR1. The battery leads are soldered to the terminal strips of the 4.5V flat type battery.

LIGHT UP!

When the wiring has been checked, fit the bulb in position. Light a match or lighter and wave it close to the bulb. The bulb will light and stay on until the light path is interrupted. To prevent unnecessary drain from the battery, remove the bulb after the demonstration. ★

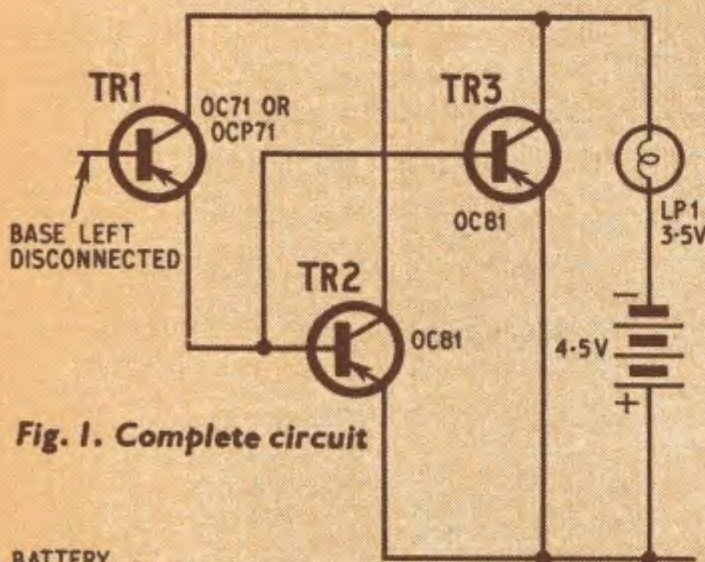

Fig. 1. Complete circuit

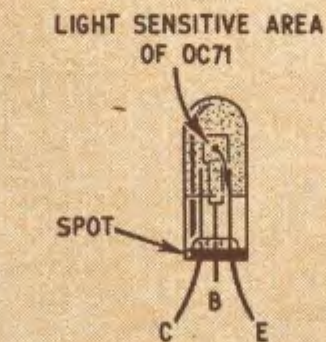
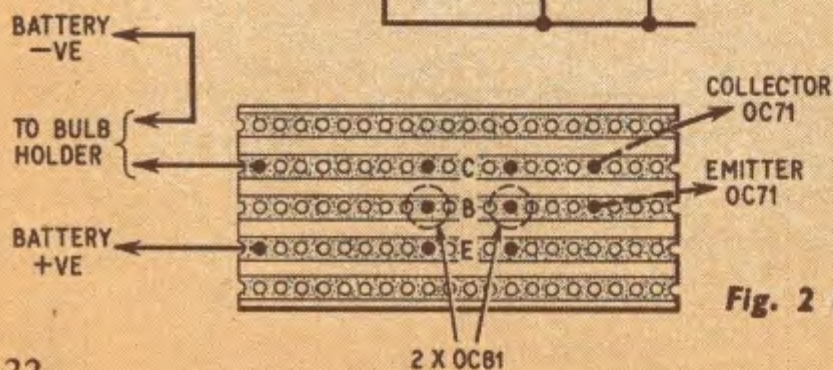

Fig. 3. Connections of the phototransistor

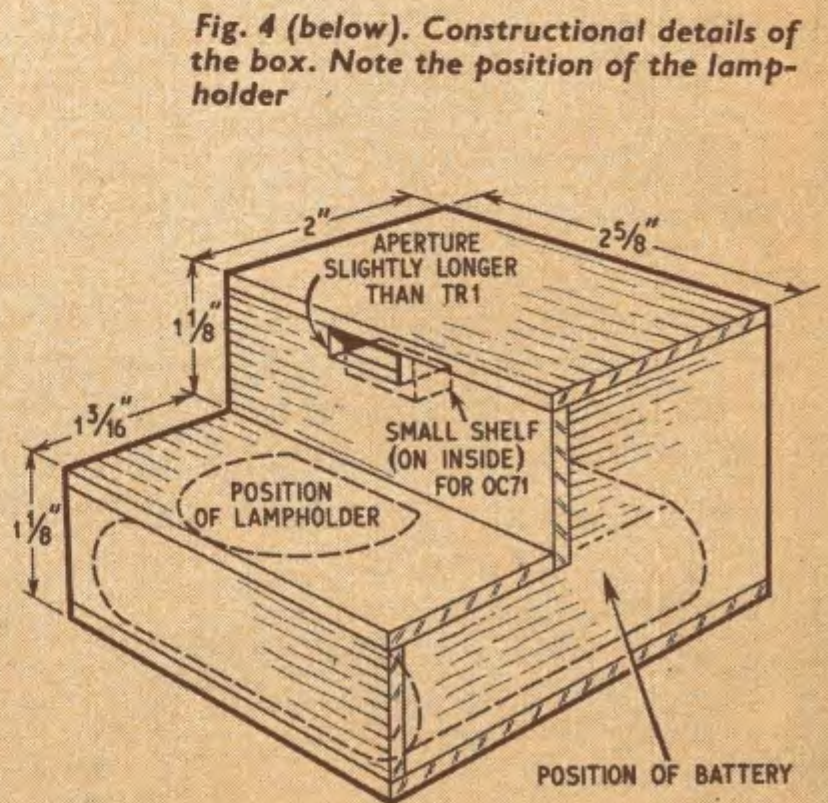
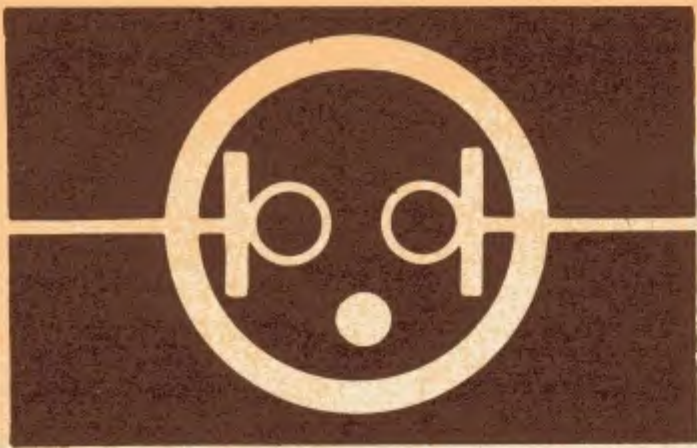
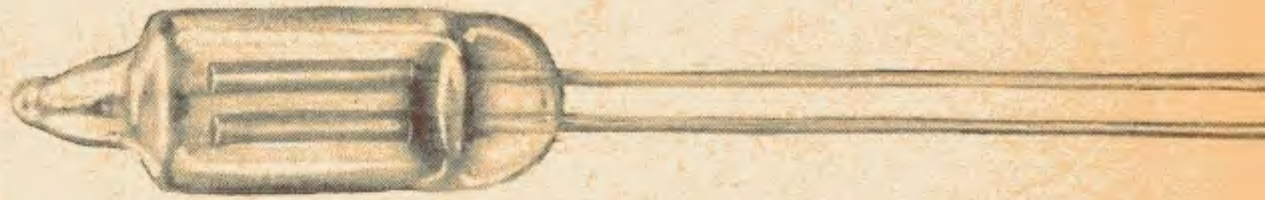

Fig. 4 (below). Constructional details of the box. Note the position of the lamp-holder

Fig. 2 (left). Component wiring



NEON NOVELTIES



THIS is the fifth of a series of short articles illustrating some of the many uses of neon lamps. The neons employed are all miniature wire-ended types as shown above.

Two examples which are ideally suited to these applications are those supplied by Radiospares (striking voltage 65 volts), and the Hivac type 3L general purpose neons. The latter type requires a striking voltage of 80 volts and maintaining voltage of 60 volts.

Some neon indicators have a resistor wired in series with one of the neon wires to make them suitable for mains voltages. These would normally be unsuitable for the circuits described unless the resistor is removed or short-circuited.

FIVE

NEON METRONOME

by **R. Bebbington**
GRAD.I.E.R.E.

A VISUAL indication of musical tempo may be preferable to an audible beat, otherwise conductors may cease to wave their arms and instead stamp their feet. Seriously though, in a noisy environment a visual metronome is extremely useful.

The circuit uses three neons to indicate the tempo in $\frac{3}{4}$ time, or slow compound time $\frac{6}{8}$, or the rarer $\frac{9}{8}$, where there are three basic beats involved. In $\frac{2}{4}$ or $\frac{4}{4}$ time one of the neons is switched out of circuit to leave the remaining two neons to flash alternately.

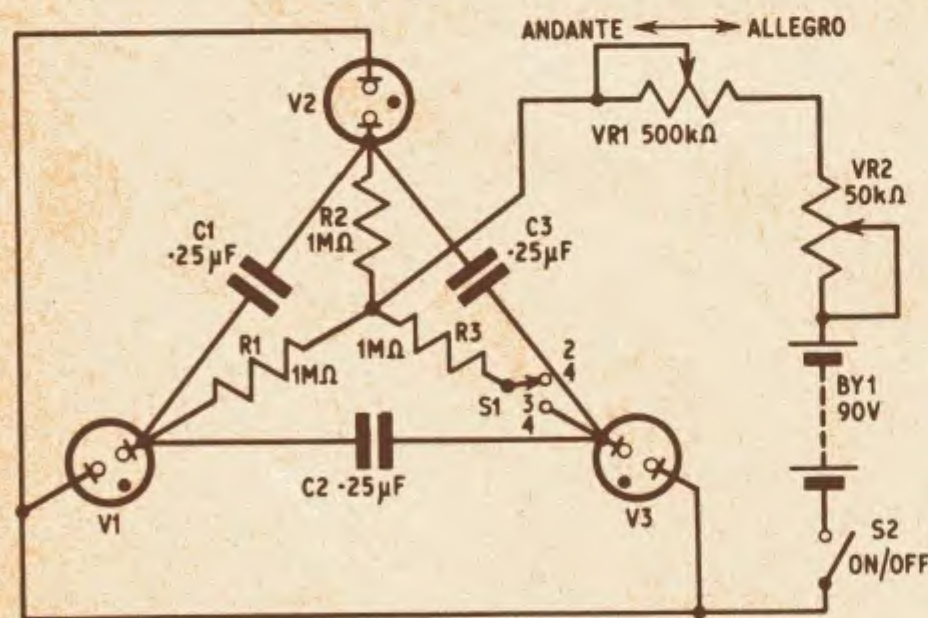

Fig. 1. Basic circuit of the metronome

This switch position is also suitable for fast musical passages in $\frac{6}{8}$ time where a conductor would normally beat two to the bar. Since the total capacitance in the circuit is shared by just two of the neons the flashing rate will be somewhat reduced in this position and a separate scale will need to be scribed. The 500 kilohm potentiometer (VR1) is the speed control and is easily calibrated with a stop-watch or failing this, a watch with a second hand. Metronome markings are of course given as the number of beats per minute.

The 50 kilohm potentiometer (VR2), in series with the speed control, is fitted to allow for changes in supply voltage and, whilst the power demands are very small, the battery voltage will gradually decrease. With this in mind it will be obvious that calibration is best carried out with most of this resistance in circuit.

With a little imagination on the part of the constructor the presentation of the metronome can be made most attractive. The small neons can best be

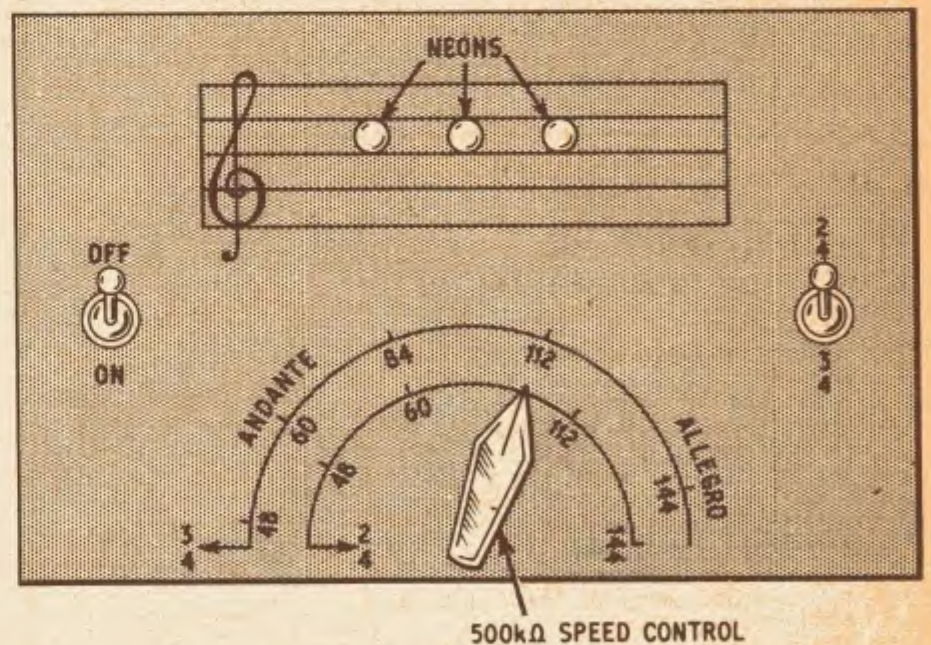

Fig. 2. Suggested layout of the control panel

displayed peeping through holes in a front panel and representing notes on the five lines of a musical staff (see Fig. 2). The on/off and time switches may be two separate single-pole toggle switches as shown or combined as a two-pole three-way rotary switch depending on availability or preference. Whilst the physical lay-out of components is not critical it may be necessary to position the neons to ensure that they fire in the correct order, i.e. from left to right as one would normally read music.

Audio TRENDS...

A Commentary on Sound Reproducing Equipment by Clement Brown

IT IS fairly obvious that some audio equipments are presented in such a way that they attract non-technical users who wish to plug in and enjoy immediate results. This is in the interests of audio enthusiasts as a whole. On the other hand there are many products, in component form, which are of direct interest to amateur enthusiasts who like to make a personal contribution to their installations. Not only can they learn how things work but they can apply the knowledge they gain in order to cut costs.

Perhaps it would be too much to say that a neat division can be made between two categories of user and product; some of the best audio components are of very wide appeal and application, and that is an indication of their merit. Goldring turntables, for instance, are of universal interest, and there are two new models on which to report before going on to some other items for the amateur's shopping list.

TRANSCRIPTION UNITS

The GL68 transcription unit, complete with pick-up arm, has the adjustable drive arrangement which has become familiar through its use in a number of successful Goldring turntables. It is essentially a variable ratio drive in which a rubber tyred idler wheel is moved along the conical motor shaft. This simple and dependable method provides continuous adjustment, but there are click-in positions for the usual record speeds. The 12in turntable weighs $3\frac{3}{4}$ pounds.

Pick-up arm type G65, incorporated in the GL68, together with a raising and lowering device, is also available separately. Its height is adjustable and there is a movable counterweight. A useful feature is the interchangeable cartridge slide: this, rather than the complete head shell, is removed when it is necessary to fit or change the cartridge. Miniature ball races are used for pivot bearings. The G65 arm is priced at £7 6s 6d, including coaxial cable and plugs. The GL68 transcription unit, including the arm, sells at £19 10s 7d.

For those who wish to use a separate arm of their own choosing there is the G99, a robust transcription unit with an 8lb non-magnetic turntable. A wow and flutter figure of less than 0.2 per cent is quoted. The continuously adjustable speed regulator is again a principal feature, and the mains switch controls a neon pilot lamp and disengages the drive when the motor is off. There is also a built-in stroboscope. The price of this model is £21 19s 5d.

COMPACT SPEAKER

Recently a small "infinite baffle" speaker, suitable for shelf mounting, was introduced—at a little over £17—by Richard Allan Radio Ltd. of Gomersal, Yorks.

Known as the "Minette", it is one of those small but potent systems in which a freely suspended, low-resonance bass cone is controlled by the stiffness of the air in the enclosure. It is of special interest to note here that the complete baffle assembly for the speaker is being made available to constructors.

In this form it is called the "Module" and is easily fitted into a home built cabinet of only 340 cubic inches. More than one "Module" could be used in each channel of an ambitious stereo set-up. The assembly, wired and ready to use, consists of the 5in bass unit and 4in tweeter on a metal baffle with a crossover filter. The latter item, based on printed wiring, is an example of the use of dust-cored inductors in audio work.

Before leaving the subject of speaker drive units it should be noted that the Tripletone Manufacturing Company have introduced a couple of inexpensive twin-cone models. These are a 10in unit rated at 8 watts input and an 8in unit rated at 6 watts. Power figures quoted in this way do, of course, apply to speakers mounted in suitable enclosures. Remember also that the amplifier power rating can be a bit bigger than that of the speaker; it is not a critical matter. A response of 30–17,000c/s is claimed for the above speakers.

Headphones are in fashion, it seems, judging by the variety of well designed and reasonably priced examples now available. S. G. Brown of Watford are long established in this field, and their wide range includes headsets for every kind of user. Their latest model, the Dynamic 3C1100, is suitable for listening to stereo, monitoring recordings, and a variety of audio jobs in which the amateur may be involved.

This is a low impedance headset (8 ohms each ear-piece) and the wiring allows for easy changing of connections for stereo and mono use. A sound level of 95 dB, with distortion not exceeding 1 per cent, is produced by an input of 1 mW per ear-piece. The headset, adjustable and with soft earpads, is designed for comfort in use. The price is £6.

Goldring GL68 transcription unit





Reslo microphone boom

FOR TAPE USERS

A microphone boom is an accessory which many experimenters and recording enthusiasts would find useful: professional aids tend to produce professional results. As many amateurs must have found, well designed accessories are often expensive. However, they may agree that the Reslo MS175 boom, at £7, does not divert too much cash. It incorporates a counterweight and its chromium plated tube extends up to 8ft. The illustration shows how it looks on a Reslo floor stand.

Those who use a great deal of tape will probably know that Emitape, among others, has been undergoing material changes. Others may like to note that the revised range has modified oxide coatings for reduced head wear and new base materials for greater strength. Polyester plastics material is used for the new triple-play tape as well as for type 99 long-play and type 100 double-play tape. Dustproof cases, of transparent plastics, are provided.

FURNITURE

There is no doubt that many constructors regard audio furniture as their special province. Most constructors can carve up a sheet of veneered chipboard—or can they? Surely, many must find it difficult to do better than Record Housing, who offer remarkable value in equipment cabinets, speaker enclosures and other items. Among the least expensive examples are



their "Scan" units, which include an equipment cabinet at 8 guineas. This accepts most well-known amplifiers and any turntable. For use with this there is a matching speaker cabinet, also at 8 guineas, which is intended for popular 8in drive units.

A matching record storage unit—capacity 150 discs, price £6 17s 6d—would complete a compact outfit. A pair of "Hi-Rak" frames will carry these "Scan" cabinets and occupy little floor space. Record Housing of Brook Road, London, N.22 will supply full details.

Tripletone speaker units

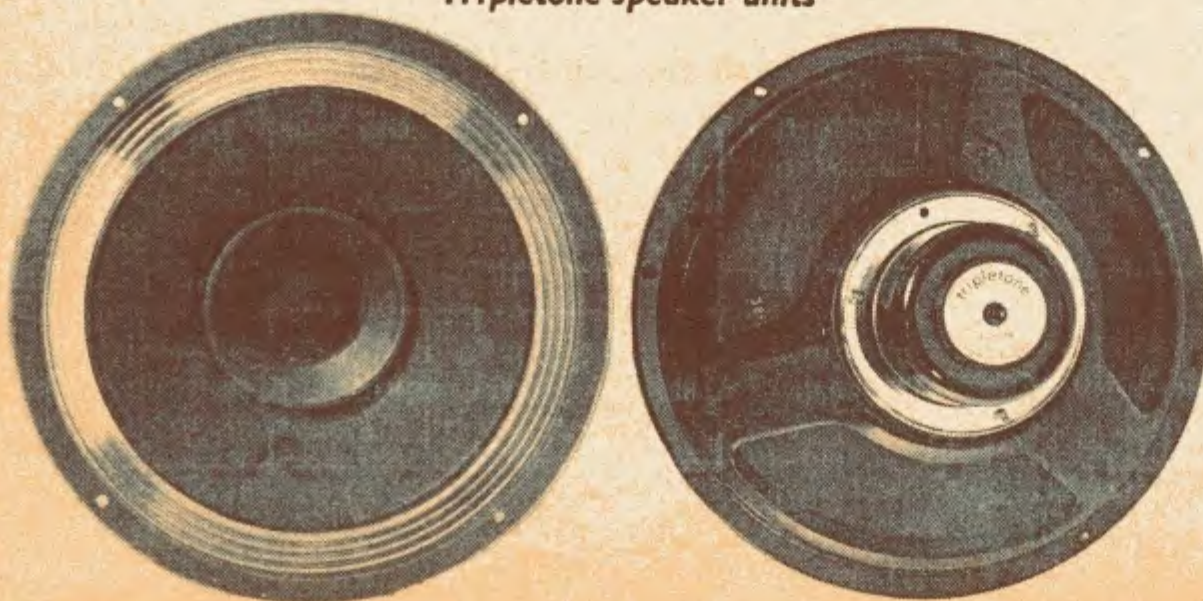

If more luxurious cabinets are required the choice is even wider. Record Housing have several, including a new one at £25, and others are offered by such specialists as GKD and Design Furniture. The "Karelia", by Howland-West Ltd., has a motor board of no less than 44in by 20in.

COMPLETE SPEAKERS

For those who prefer to work on the electronics of audio and buy complete speakers, there is an ever-increasing variety of small but relatively cheap systems. One is the Richard Allan model already mentioned; others include the Celestion "Ditton 10", the Goodmans "Maxim" and "Mezzo", and the Rogers "Wafer". If you wish to get away from the sealed-box principle, there is the "Labyrinth 8 Mk2" by L.N.B. Audio Services, a most successful design which, though quite different from most popular models, sells at just over £20 including the drive unit.

A very good choice of speakers at 20 guineas and under is offered by Bang and Olufsen. They include type B, an attractive model with separate bass and treble units and costing 13 guineas. Frequency response is quoted as 85-16,000c/s ± 3 dB. Type V (15 guineas) is only 3½in deep and is therefore ideal for mounting on a wall. It has a 2½in tweeter and a 7in by 5in bass unit. Others are type S (20 guineas) and type M (16 guineas) both of which are bookshelf style speakers.

Now a tailpiece for those who are interested in following the latest advances in pick-up design. The general aims are of course lower playing weights, reduced record wear and less tracking distortion. The strictest requirements are at present satisfied only at high cost; they include a drastic reduction in the moving mass (the stylus tip and supporting parts), so that the modulations in the groove are subjected to gentler treatment.

A.D.C., the American specialists, say that with their latest cartridge, the 10/E, they have so reduced this mass that deformation of the record groove is eliminated. The playing weight setting can be as low as ½ gramme. The 10/E is likely to join other A.D.C. cartridges on the U.K. market.

Bang & Olufsen type B speaker



ELECTRONIC BUILDING BLOCKS

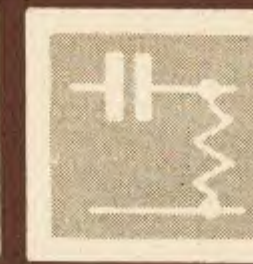

PART TEN

by R. A. DARLEY

FOLLOWING on last month's discussion of the astable multivibrator, we shall continue this month with the two remaining members of the multivibrator family, namely, the bistable and the monostable types.

BISTABLE MULTIVIBRATOR

The basic circuit of the bistable multivibrator is shown in Fig. 10.1. Two transistors are used, with a common emitter load R_7 . Transistor TR_1 has its own collector load (R_1) and its own base bias network (R_3 and R_5), but the negative supply to this bias chain is taken from the collector of TR_2 ; a positive feedback circuit is thus formed. Similarly, the base bias network of TR_2 is taken from the collector of TR_1 via R_2 and R_4 , forming a second positive feedback path. A third feedback path is provided by the common emitter load as explained last month.

The circuit has two stable states, hence the name "bistable". In one state, TR_1 is switched hard on and TR_2 is off, while in the other state TR_1 is switched off and TR_2 is hard on. Once the circuit has taken up one particular state, it will maintain it permanently, unless a suitable signal is applied to cause a transition to occur; unlike the other two members of the multivibrator family, no time elements are deliberately introduced to the circuit.

The method of operation of the circuit is easily understood. When switch S_1 is closed and power is supplied to the multivibrator, the natural unbalance of the components will cause the circuit to take up one or other of its two possible states.

Assume that TR_1 switches hard on and TR_2 switches off; TR_1 collector is at "near-ground" potential. The currents of this transistor are also flowing in R_7 , the common emitter load.

If the emitter and collector potentials of TR_1 are nearly equal, the potential on the base of TR_2 , derived from TR_1 collector, is thus lower than the potential on its emitter. The base-emitter junction of TR_2 is reverse biased and the transistor is cut-off; TR_2 collector is at near full negative rail voltage. The top of the TR_1 base-bias chain is also at near full negative rail voltage, giving sufficient base-bias to TR_1 to hold that transistor hard on. Therefore, TR_1 is switched hard on and TR_2 cuts off.

Now consider what happens when a negative going signal, of sufficient amplitude to cause TR_2 to begin to conduct, is connected to its base. As TR_2 begins to conduct its collector potential becomes less negative. The base-bias of TR_1 , derived via R_3 and R_5 from TR_2 collector, also becomes less negative, resulting in a reduction of TR_1 collector current and making its

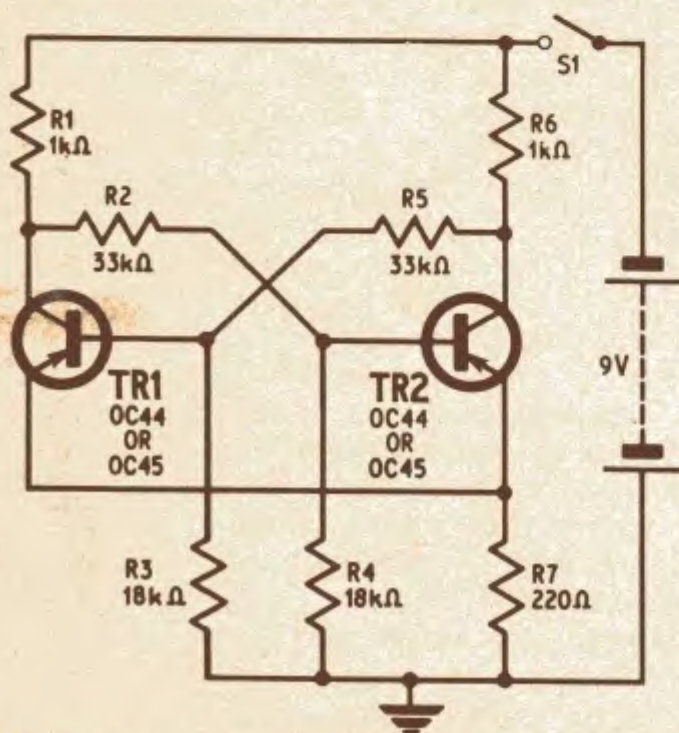

Fig. 10.1. Bistable multivibrator circuit with typical component values

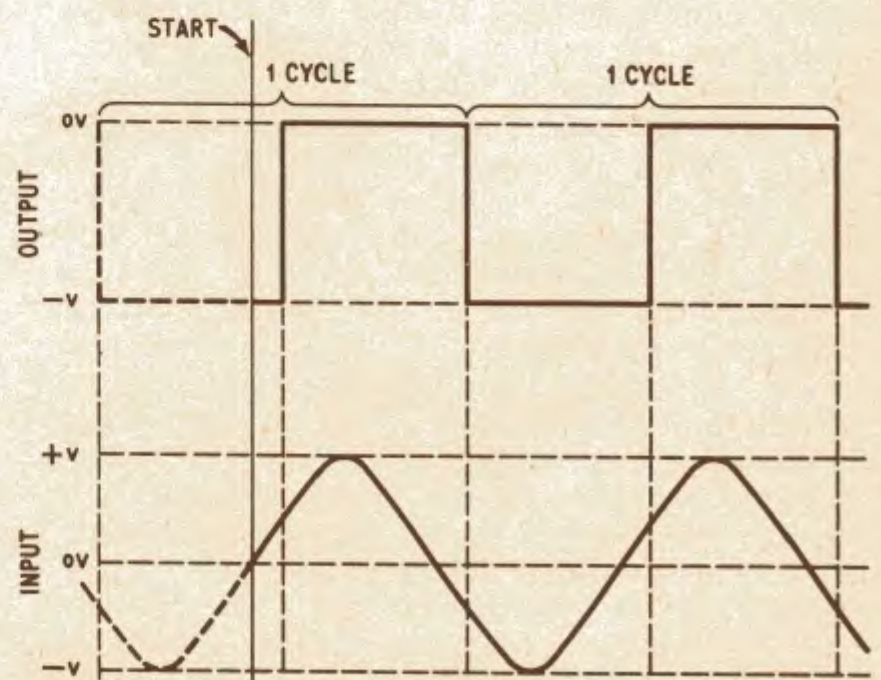

Fig. 10.2. The bistable multivibrator may be used as a squaring circuit

collector go more negative. This increase in negative potential is reflected to TR2 base, making TR2 conduct even more, while TR2 collector becomes even less negative. Regenerative action takes place, in which TR2 switches hard on and TR1 cuts off. The circuit will remain in this state until another trigger pulse is applied to cause it to change.

SQUARING CIRCUIT

In its simplest form (as in Fig. 10.1) the bistable circuit may be used to generate a square wave output from a sine wave input. The input signal is connected to the base of TR1 via a blocking capacitor, and the output is taken from the collector of TR2. The relevant waveforms are shown in Fig. 10.2.

Initially, TR1 is on and TR2 is off; the collector of TR2 is at near negative rail potential. As the input signal rises in a positive direction, a point is reached at which TR1 base current is reduced; a cumulative action takes place and TR1 switches sharply off and TR2 switches on; the output voltage falls to near zero volts. Since TR1 is switched off, the remaining positive part of the input waveform has no effect on the circuit, which remains stable.

As the input waveform goes negative, however, a point is reached where sufficient negative bias is applied to TR1 base to cause that transistor to begin to conduct again. As soon as conduction begins, cumulative action again takes place and TR1 switches hard on and TR2 cuts off, i.e. the circuit reverts to its original condition.

Note that two transition states, or one complete cycle, have taken place, activated by one complete cycle of the input signal. Succeeding cycles of the input signal will cause similar stages of transition to occur.

The output signal is thus a train of square waves with a mark-space ratio of approximately 1 : 1, at the same frequency as the input signal. Although the bistable multivibrator makes a first class squaring circuit, it is more commonly used in more complex forms and applications.

BISTABLE GATE

Sometimes it may be necessary to make an amplifier pass signals for only a pre-determined period, i.e. amplification should start as soon as a *start* signal is given, and cease as soon as a *stop* signal is given. One such application is in electronic timer/counters, where a direct read-out of frequency is obtained by counting the number of cycles that pass through an amplifier within a given period of time, i.e. between the application of the *start* and *stop* signals. The amplifier can be made to act as a "gate" in this way by changing its base-bias or by making and breaking the negative supply rail at the required moments. However, an additional gate circuit is required to correlate the application of the *start* and *stop* signals with the gating of the amplifier. The bistable multivibrator may be adapted for use as such a "gate"; a suitable circuit is shown in Fig. 10.3a. The only way in which this circuit differs from that of Fig. 10.1 is in the use of the two diodes D1 and D2, the two input load resistors R1 and R9, and the two capacitors C1 and C2.

If one of the transistors is switched on, it can be turned off by the application of a positive pulse to its base (assuming the use of *pnp* transistors). If that positive pulse is followed by a negative one, it

will switch on again as soon as the negative pulse arrives. This action is used in the squaring circuit already described, but in the case of the "gate" circuit such action is undesirable.

Only the positive pulses fed to the circuit are allowed to have any effect due to the unilateral paths of D1 and D2; all negative pulses are rejected (see Fig. 10.3a). Since only a short pulse, as opposed to a constant signal, is required to switch the circuit, the trigger pulses can be fed to the circuit via the short time constant circuits, C1-R1 and C2-R9. The pulse length must be as great as, or greater than, the period required to complete the transition between one state and the other. The base of TR1 is externally biased so that when power is initially supplied to the circuit, TR1 is off and TR2 is on; the output (TR2 collector) is at near ground potential. When the positive "start" signal is applied to TR2 base, cumulative action takes place; TR1 switches hard on and TR2 switches off; the output signal rises to near negative rail potential.

Any additional signals that arrive from the "start" terminal will have no effect on the circuit, since all negative pulses will be rejected by D2. No positive pulses can have any effect since TR2 is already switched hard off. The circuit remains in this state, with its output at near the full negative rail potential, until the "stop" signal is fed to TR1 base via C1 and D1.

The resulting positive pulse causes TR1 to switch off and TR2 to switch on. The output at TR2 collector falls to near ground potential. Again, additional signals arriving from the "stop" terminal can have no effect on the circuit. The "gate" sequence of the circuit is now complete.

Fig. 10.3b shows a functional diagram of how this particular circuit can be used with a gated amplifier of the type already mentioned. TR4 is connected as a normal common-emitter amplifier, with base-bias network R10 and R11, emitter load R12 decoupled by C4, and collector load R_L .

The input signal is fed to TR4 base via blocking capacitor C3, and the output signal is taken from the collector of TR3. In series with TR4 collector is a gate transistor TR3, which obtains its base-bias from the output of the bistable gate, which is as shown in Fig. 10.3a.

The operation is as follows. When power is initially supplied to the circuit, it takes up a position such that the bistable output is at near ground potential; TR3 is thus biased to cut-off and passes negligible emitter current. Since TR3 is in series with TR4 collector, the collector line to TR4 can be considered to be open circuit under this condition and TR4 can not amplify.

When the "start" signal is fed to the bistable gate, the output rises to near the full negative rail potential; TR3 conducts heavily and presents negligible resistance to the flow of current between TR4 and R_L . TR3 can thus be considered as a virtual short circuit, and TR4 acts as a normal amplifier with collector load R_L . TR4 continues to act as an amplifier until the "stop" signal is fed to the bistable gate, at which time the output again falls to near ground potential, causing TR3 to become a virtual open circuit again, so destroying the amplifying action of TR4. This completes the cycle of events.

"SPEED-UP" CAPACITORS

It is often required that the output of the bistable should have a very short rise time, i.e. there must be a very sharp transition between the stable states.

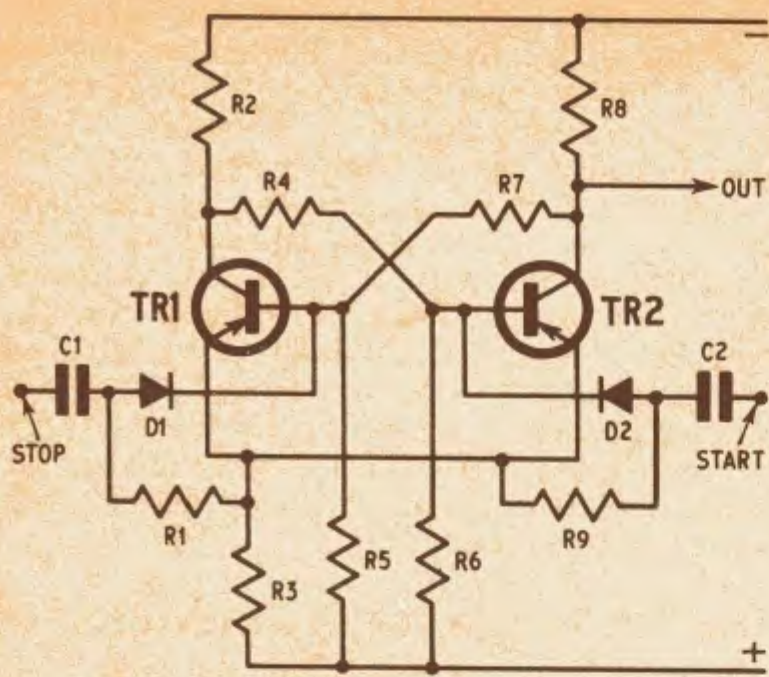

Fig. 10.3a. Bistable multivibrator used as a "gate"

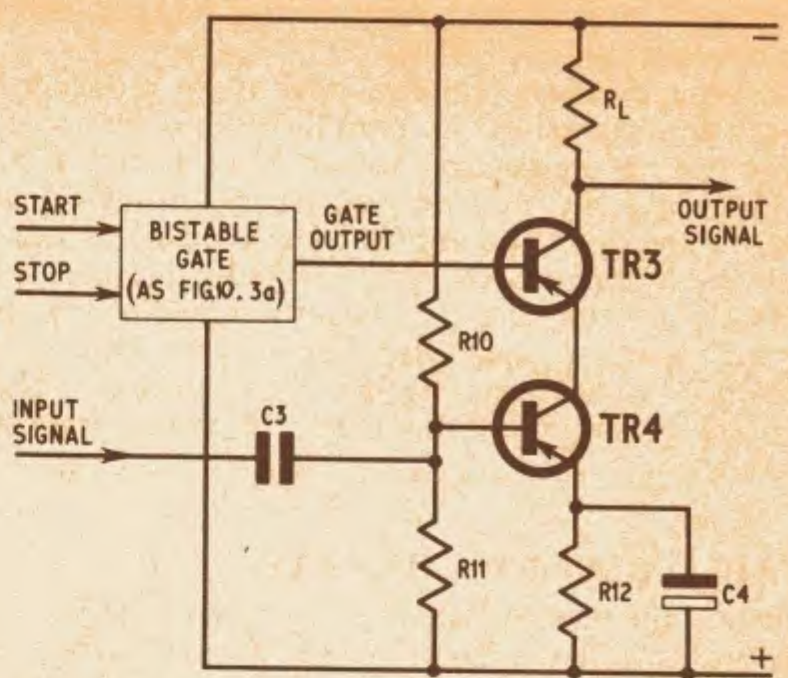

Fig. 10.3b. The bistable "gate" circuit of Fig. 10.3a applied to an amplifier

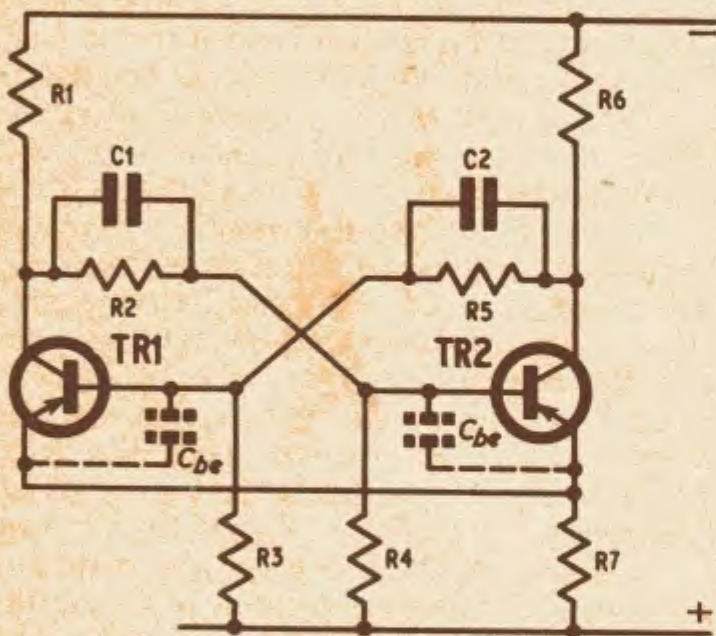

Fig. 10.4. Bistable circuit with C1 and C2 added to "speed-up" or "commutate". C_{be} is the internal base-emitter capacitance

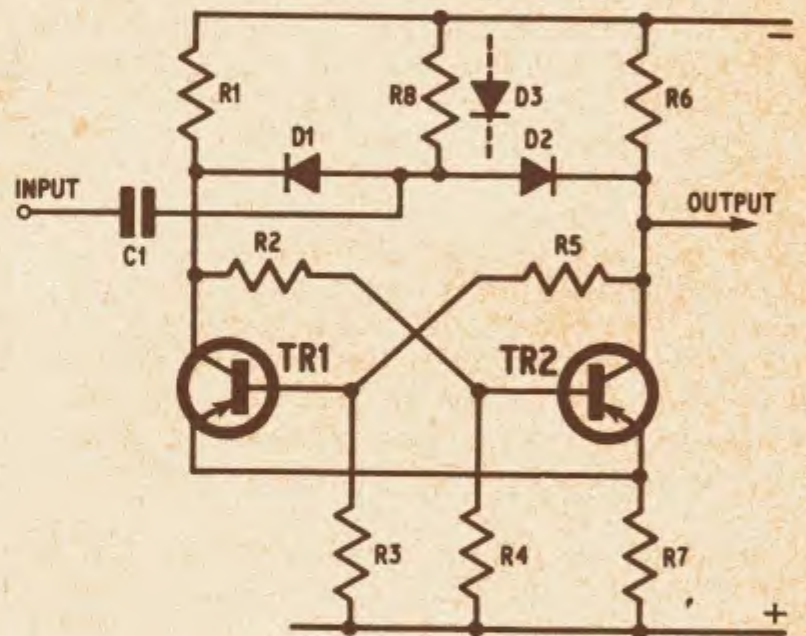

Fig. 10.5a. Collector triggering using "steering" diodes to give binary operation

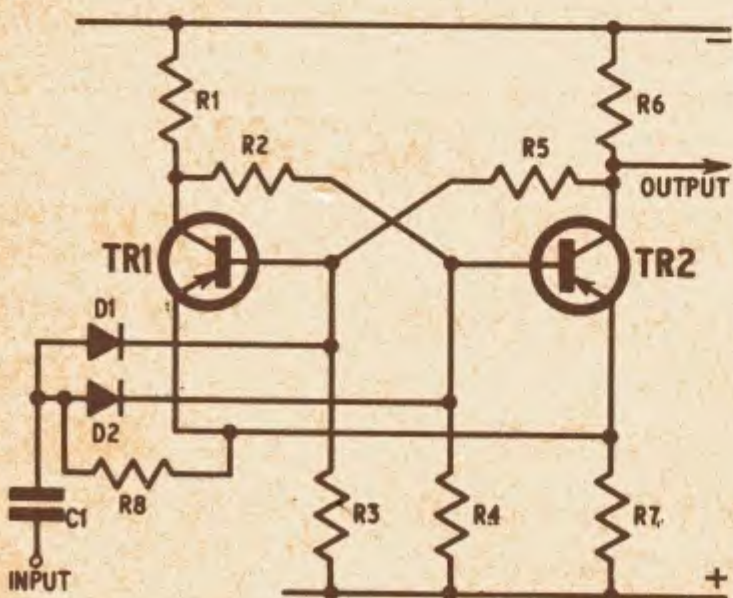

Fig. 10.5b. Base triggering using "steering" diodes to give binary operation

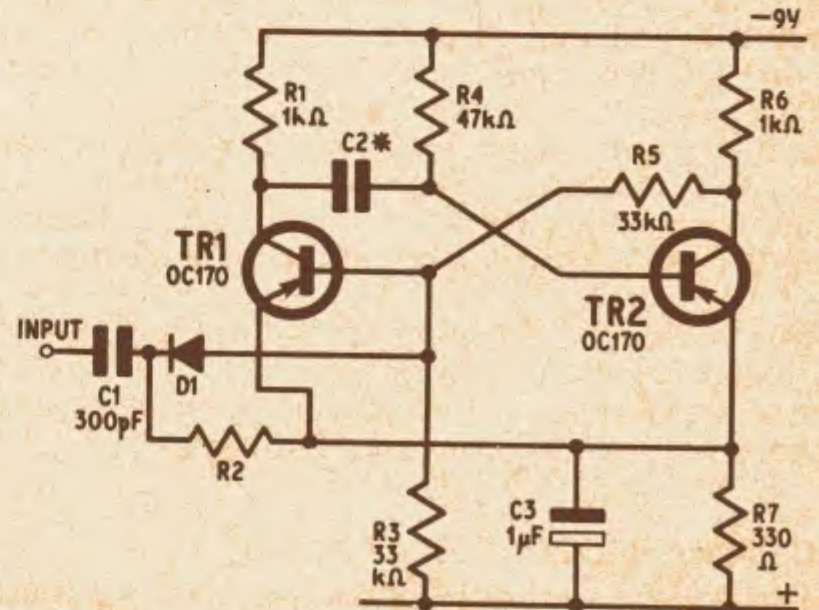

Fig. 10.6. Monostable multivibrator; cross between astable and bistable types

The rise time is largely controlled by the time constant formed by the series resistance of the base-bias network and the internal base-emitter capacitance of the transistors (see Fig. 10.4).

This time constant can be effectively reduced by connecting a capacitor in parallel with each of the main series resistances, as shown by C1 and C2 in Fig. 10.4. At the moment of transition, when the potentials are changing rapidly, the capacitors act as virtual short circuits to a.c., so reducing the time constants involved and appreciably speeding up the transition times. Such capacitors are known as "speed-up" or "commutating" capacitors. Their values are generally in the order of a few hundred picofarads.

BISTABLE BINARY CIRCUITS

Probably the most widely used version of the bistable multivibrator is that known as the "binary" type. As the name implies, the circuit is used to "divide by two", and is a basic unit in many timer/counters, binary computers, etc.

Referring back to Fig. 10.3a, two positive pulses, applied alternatively to the base of one transistor and then the other, are required to cause a complete cycle of events in the circuit. In the binary circuit, the two "trigger" pulses are fed from a single source and "steered" alternatively between one transistor and the other. Two trigger pulses are needed to initiate a complete cycle of events; hence, the circuit "divides-by-two".

This process of "steering" the input pulses is quite simple, but the situation is complicated slightly by the fact that the pulses can be fed to the circuit in a number of alternative ways. The pulses may be positive, or negative, and may be fed to the base, or collector. Consequently, quite a number of steering circuits have been evolved. Two typical circuits are shown in Fig. 10.5.

In Fig. 10.5a the trigger signal is fed via C1 to the junction of D1, D2 and R8. R8 acts as the input load, giving a short time constant with C1, and is sometimes replaced by the diode D3 (shown dotted) in order to give an improved recovery time in high-speed circuits. D1 and D2 pass positive signals only. If TR1 is on and TR2 is off, TR1 collector is at near earth potential, placing a reverse bias across D1, so that when the positive trigger pulse is applied it can have no effect on D1. TR2 collector, on the other hand, is at near negative rail potential, biasing D2 forward, so that when the positive trigger pulse is applied it is steered to TR2 collector and the transition occurs. The change in state of the circuit causes the states of the bias of D1 and D2 to change also, so that when the next positive pulse arrives it is steered to TR1 collector, causing the second transition and thus completing the cycle of events.

Similar steering principles apply in the case of Fig. 10.5b, where base triggering is used. A far lower triggering signal is needed to activate this circuit than is the case with the collector triggered type.

PRACTICAL CONSIDERATIONS

The trigger signal must be of considerable amplitude and short duration if the circuit is to be made to function correctly. The triggering pulse will generally have to be fed to the bistable from a pre-shaping circuit, such as a Schmitt trigger.

Because of the triggering difficulties, the bistable is one of the most difficult circuits for the experimenter to work with. When experimenting with the circuit, an oscilloscope is essential. Beyond certain frequencies, the circuit will operate erratically, dividing by 3, 4, 5, or even higher numbers. The shape of the trigger pulse is critical for satisfactory operation.

The common emitter resistor, in the explanations given in this article, is considered as an additional (third) feedback path. The main function of this resistor, however, is as a biasing resistor, which supplies a voltage which enables the off transistor to be biased beyond cut-off. Since only two feedback paths are required for the operation of the circuit, the common emitter resistor can generally be decoupled with a bypass capacitor, with no deterioration in the performance of the circuit.

THE MONOSTABLE MULTIVIBRATOR

This circuit is a cross between the other two. It has one stable and one semi-stable state. In its stable state, referring to Fig. 10.6, TR1 is on and TR2 is off. The application of a negative trigger pulse switches TR1 off and the transition occurs; the circuit now acts as an astable circuit.

After a time determined by the C2-R4 time constant, the circuit reverts of its own accord to the stable state, with TR1 on and TR2 off. The common emitter resistor, R7, is used to give a biasing voltage to enable the transistors to be biased beyond cut-off, and should be decoupled by a large (1 μ F) capacitor. The points raised in this series about "speed-up" capacitors for the bistable, and the Darlington connection for astable multivibrators, can all be applied to the monostable circuit, no additional explanations being needed.

As in the case of the binary bistable, the triggering pulses used to operate the monostable will have to be pre-shaped in a circuit such as a Schmitt trigger, and the exact form of the pulses is very critical to the satisfactory operation of the circuit. Again, the circuit is a very difficult one for the experimenter to play with and a 'scope is essential if intelligible results are to be obtained. In addition, a good pulse generator is a great asset to any experiments.

The monostable circuit has many uses; it may be used to operate a self-stopping gate, similar to that of Fig. 10.3b; it may be used as a pulse generator or as a pulse restorer, or it may be used as a time-delay device.

Next month: Applications of the binary bistable circuit

PRACTICAL

WIRELESS

◆ SHORT WAVE
DATA
SUPPLEMENT

◆ PUSH BUTTON
MULTIMETER

ON SALE
NOW

TELEVISION

◆ TOWARDS
BETTER TV
RECEPTION

◆ U.H.F. LOFT
AERIAL

ON SALE
23 DECEMBER

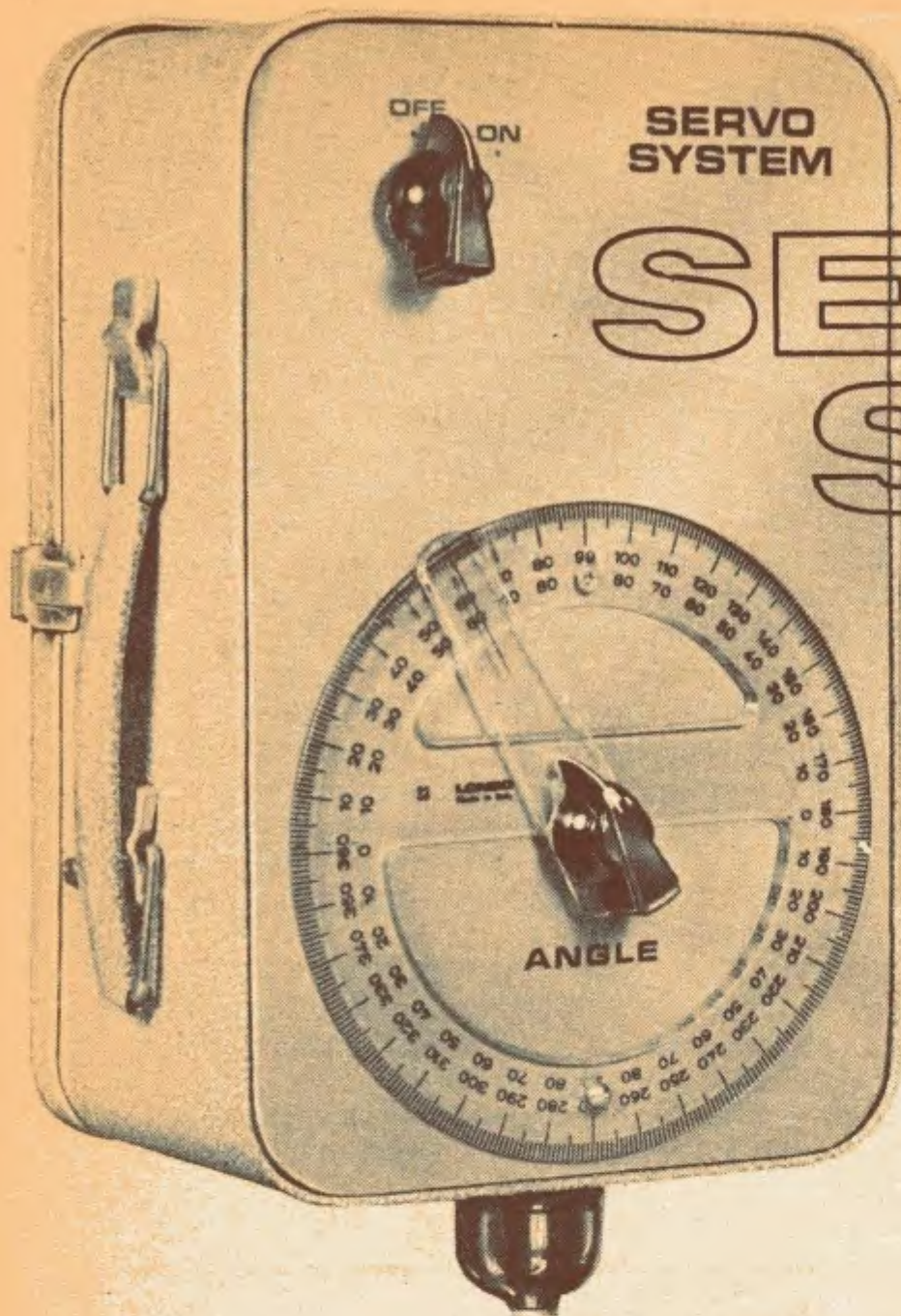

SERVO SYSTEM

by B. Crank

This project affords the amateur an opportunity to become acquainted with the subject of servomechanisms. The resourceful reader will no doubt find many useful applications for the completed model.

When the slider takes up this position the input to the amplifier is reduced to zero and the motor will cease to run. Thus VR3 slider will always follow any movement of VR1. It is for this reason that VR1 is usually termed the *master* potentiometer and VR3 the *slave*. It follows that a shaft coupled to VR3 would follow the movements of VR1.

THIS article describes a simple remote position control servo system recently constructed by the writer after a good deal of experiment using standard easily obtainable parts. Although it is only powered by a small inexpensive motor the output torque is considerable, it being practically impossible to stall the motor by gripping the output shaft. The unit is accurate to one degree.

PRINCIPLE OF THE SYSTEM

A block diagram of the servo system appears in Fig. 1. Ignoring for the present time the function of the generator MO2, it will be seen that this system consists of, essentially, two potentiometers (VR1, VR3), a motor, mechanical gearing, an amplifier, and a motor switching device.

The motor MO1 is connected via reduction gearing to the slider of VR3. This potentiometer is connected in parallel with VR1 located in the control unit. The two potentiometers thus form the familiar Wheatstone bridge and any difference in potential between the two sliders will be fed to the input of the amplifier. If the sliders of VR1 and VR3 are in different positions on their tracks, there will be a potential difference and a current will flow between the sliders via the amplifier. The magnitude of this current will be proportional to the amount of difference between the slider positions, and the direction of this current flow will depend on which way one wiper is displaced relatively to the other.

A much amplified version of this input current is applied to the motor switching device, this causes the motor to run in such a direction as to drive VR3 slider to the same position as that occupied by VR1.

VELOCITY FEEDBACK

Although a system such as described above would work, it would suffer from one major drawback caused by the inertia of the motor and gearing. When the two potentiometers reach the same position, the motor is switched off but its inertia causes it to over-run. Since the sliders are now displaced in the opposite direction, the motor will reverse and at the balance point switch off—but over-run again. And so on. Thus the slider of VR3 will oscillate or “hunt” each side of the balance point.

To prevent this hunting, it is necessary to introduce damping into the system. Frictional damping could be applied, but this presents several problems of design. A far more elegant method is to produce an electrical signal which is proportional to the output velocity of the driven shaft. A small generator, usually called a tachometer-generator, is employed for this purpose. The output from the generator is applied to the input of the amplifier in such a sense as to oppose the normal input. This kind of system is referred to as *output velocity feedback*.

In the actual model described in this article, a small permanent magnet motor serves as a feedback generator. The generator shaft is coupled to the motor gearing and its output is in series with the potentiometer sliders and amplifier input. As VR3 approaches the balance point the generator has the effect of reducing the amplifier input to zero and switching off the motor *before* the balance point is reached, the motor inertia taking it the rest of the way. (A simple analogy is that if one is driving towards a brick wall one applies the brakes before the wall is reached.)

This then is the basic outline of the system.

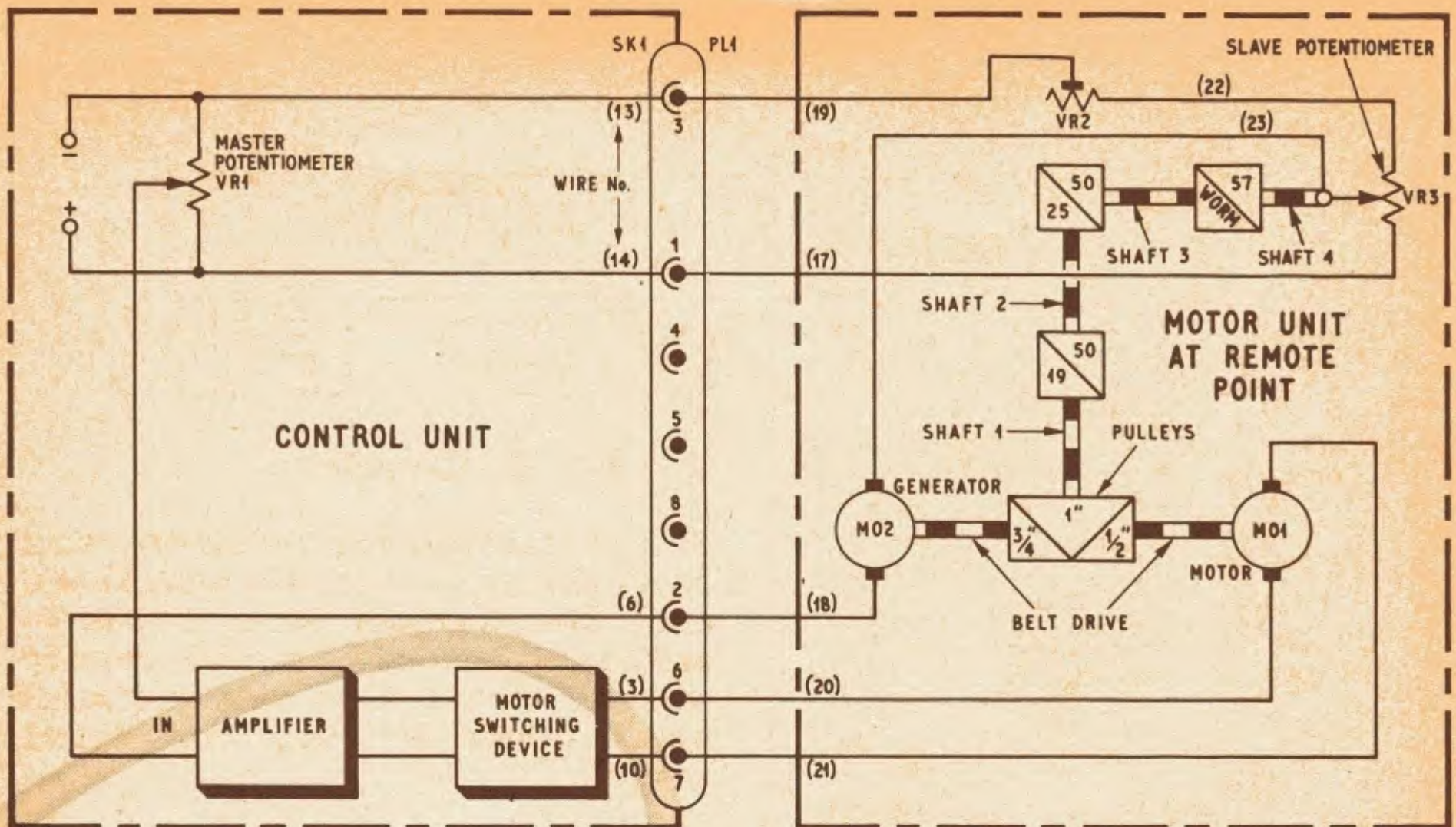

Fig. 1. Block diagram of the remote position control servo system. This diagram also includes the inter-unit wiring details

COMPONENTS . . .

CIRCUIT COMPONENTS

Resistors

R1	1M Ω	$\frac{1}{4}$ W	R4	56k Ω	$\frac{1}{2}$ W
R2	56k Ω	$\frac{1}{2}$ W	R5	68 Ω	2W
R3	1M Ω	$\frac{1}{4}$ W	R6	68 Ω	2W

All $\pm 10\%$, carbon

Potentiometers

VR1, 3	5k Ω wire wound, 3 in dia. (2 off).	G. W. Smith, 3-34 Lisle Street, London, W.C.2
VR2	50 Ω wire wound, preset	

Transistors and Diodes

TR1	OC44	} Mullard
TR2	OC71	
TR3	OC72	
TR4	OC44	
TR5	OC71	
TR6	OC72	
TR7	V60/20P	} Newmarket
TR8	V60/20P	
DI-4	OA81	Mullard (4 off)

Miscellaneous

BY1, 2	9V layer battery.	Vidor VT6 (2 off)
BY3, 4	Two 1.5V cells.	Ever Ready HP2 (4 off)
MO1	Motor,	Ripmax Orbit 505
MO2	Motor,	Mabushi Type TKK35
SI	4-pole on/off switch	
PL1, SK1	Octal plug and octal valveholder	
RLA	Carpenter relay type 5M8 complete with base.	P. F. Ralfe, 423, Green Lanes, London, N.4.

Sundry Items for Control Unit

Metal box 8 $\frac{1}{2}$ in \times 5 $\frac{1}{2}$ in \times 4in. Perforated plastics board 4 $\frac{3}{4}$ in \times 2 $\frac{1}{4}$ in. 360 degree protractor, 5in dia. Small knob. Piece of perspex. Length of 1 $\frac{1}{2}$ in internal diameter cardboard tube. Metal sheet for heat sinks. Plywood and metal strips for battery housing. Two trunnions (Meccano Part No. 126) for battery contacts

MOTOR UNIT

Meccano Parts

Quantity	Part No.	Description
1	22	1in pulley with boss
1	26	Pinion 19 teeth
1	28	Contrate gear 50 teeth
1	25	Pinion 25 teeth
1	27	Gear 50 teeth
1	32	Worm
1	27a	Gear 57 teeth
2	16	Axle rod 3 $\frac{1}{2}$ in
1	16a	Axle rod 2 $\frac{1}{2}$ in
4	59	Collar
1	186a	Driving band 6in
2	53	Flanged plate 5 $\frac{1}{2}$ in \times 2 $\frac{1}{2}$ in
6	5	Strip 2 $\frac{1}{2}$ in
2	2	Strip 5 $\frac{1}{2}$ in
2	10	Fishplate
2	48a	Double angle strip 2 $\frac{1}{2}$ in \times $\frac{1}{2}$ in
1	126	Trunnion

Other Mechanical Parts

Pulley	$\frac{1}{2}$ in Ripmax blue No. 906
Pulley	$\frac{3}{4}$ in Ripmax green No. 907
Shaft Coupler	$\frac{1}{4}$ in Radiospares
Output Shaft	3in \times $\frac{1}{4}$ in spindle
Pointer	Small piece 20 s.w.g. wire
Scale	Paper disc, calibrated 0-280 degrees

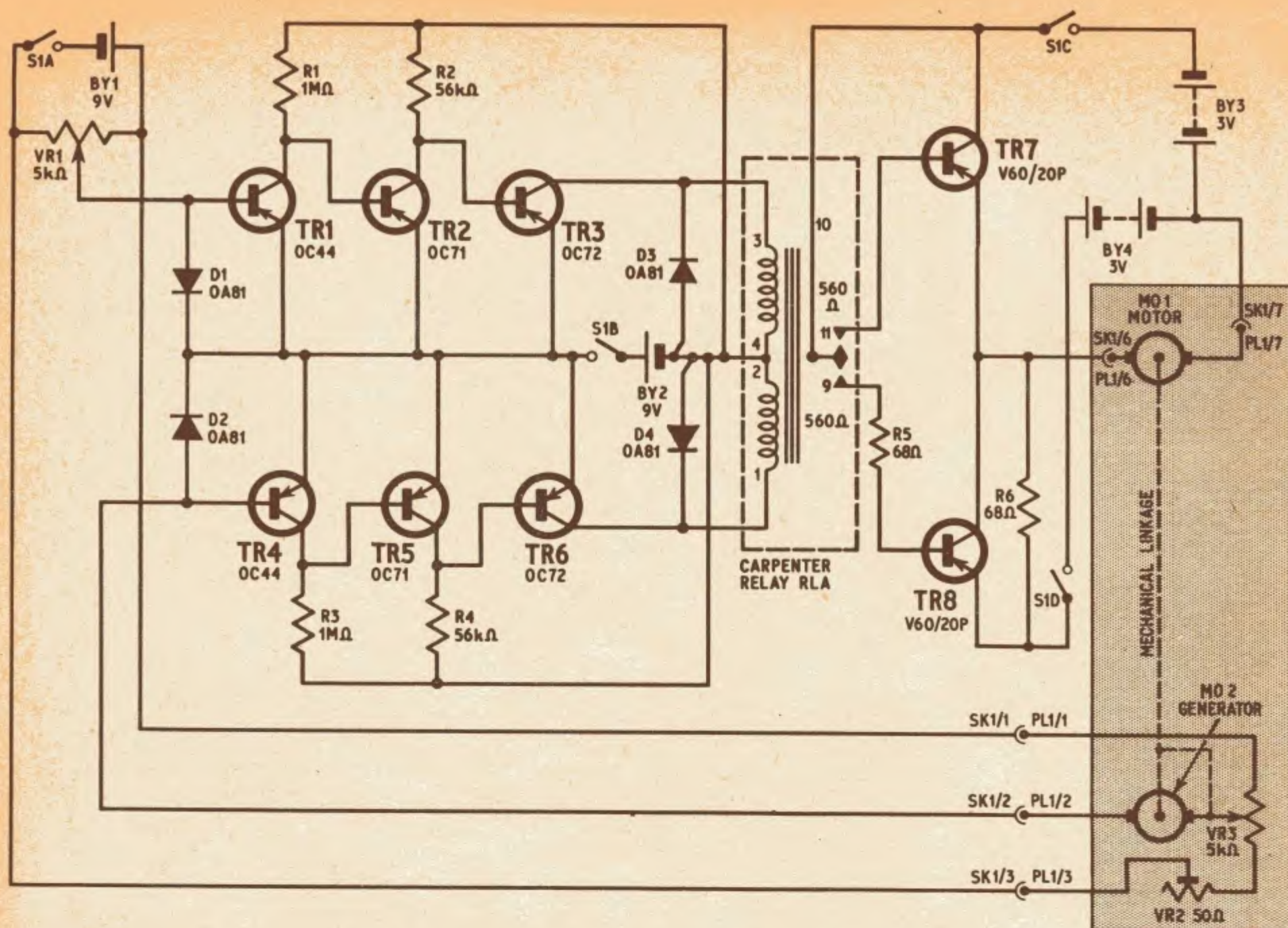

Fig. 2. Circuit diagram of the remote position control servo system. The shaded area represents the motor unit

DESCRIPTION OF THE CIRCUIT

Fig. 2 shows the complete circuit diagram of the servo system. The only component with which readers may not be familiar is the Carpenter relay RLA. The contacts of RLA are of the single pole changeover type, but the centre contact is normally held mid-way between the two other contacts. This is achieved by means of two small bar magnets mounted each side of the centre contact.

The relay is polarised; that is, taking one coil, if a current is passed through this coil in a certain direction the centre contact will touch one of the outside contacts, but if this current is passed through this same coil in the opposite direction the centre contact will make contact with the other outside contact. Because of the polarised property of this relay, it is essential that it is connected as shown in the circuit diagram. The relay specified has three coils, but in this unit only two of these are used.

The transistors TR1 to TR6 inclusive form two simple amplifiers. Under normal static conditions, TR3 and TR6 are in the non-conducting state. If the slider of VR1 goes positive with respect to VR3 there will be a flow of current through D1 and the base emitter junction of TR4, while TR1 will behave as a reversed biased diode. If the input is of the reverse polarity, then D2 and TR1 conduct. Therefore the polarity of the input decides which of the two ampli-

fiers will be operative. The output stage TR3 or TR6 (as the case may be) drives current through one of the relay coils.

The generator MO2 acts as a current limiter and prevents excessive current flowing into the input of the amplifier by providing velocity feedback. At times, when the system is approaching the balance point for instance, the carpenter relay operates at very high speeds and the diodes D3 and D4 prevent the build up of high voltages that might otherwise damage the output transistors TR3 and TR6.

The motor is supplied by the centre tapped d.c. supply provided by batteries BY3 and BY4 and this supply is switched by the transistors TR7 and TR8. It can be seen that the polarity of the supply to the motor depends on which transistor is conducting and this in turn on which way the carpenter relay moves. Resistors R5 and R6 are base current limiters, R6 being connected across BY4, the amount of current taken by this resistor is negligible considering the current taken by the motor. The third potentiometer VR2 is a correction resistor and its purpose will be discussed during the setting up procedure.

COMPONENTS

As has already been stated, all the components are standard, readily procurable items. The particular specified potentiometers were selected because of their large physical size and because of their robustness;

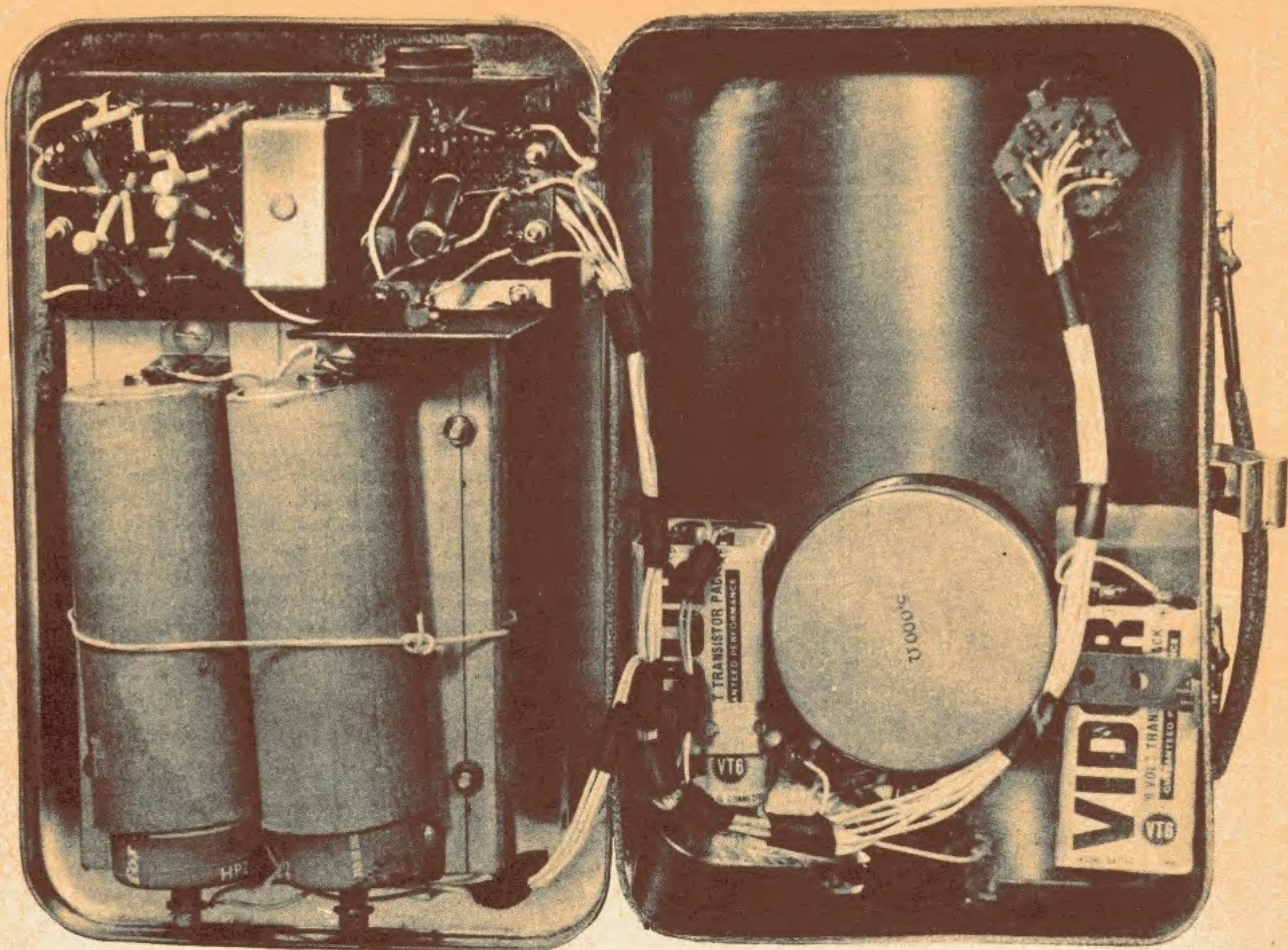

they also have positive end stops and this is a great advantage in a unit of this nature, for should, due to a fault condition, a potentiometer be driven to its limit, damage to the slider will not result. The carpenter relay is a precision piece of equipment and should be treated as such.

CONTROL UNIT

A suitable housing for the electronics, batteries, and control potentiometer—which together make up the control unit—is a metal lunch box, measuring $8\frac{1}{2}$ in \times $5\frac{1}{2}$ in \times $3\frac{1}{2}$ in deep. This type of box is easy to obtain and meets the present requirements very satisfactorily.

As will be seen from the illustrations, part of the equipment is installed onto the inside of the lid and part within the box itself. Thus when the box is opened, all parts and wiring are exposed; this arrangement has obvious advantages—not least being the fact that battery replacement becomes a simple operation.

The amplifier and motor switching circuits are built as a separate sub assembly on a piece of perforated laminated plastics board measuring $4\frac{1}{2}$ in \times $2\frac{1}{4}$ in. Layout of the components and wiring is given in Fig. 4. The two power transistors TR7 and TR8 are mounted on small aluminium plates bolted to the plastics panel. These plates act as heat sinks. A rectangular portion must be cut out from the plastics panel to accommodate the relay socket.

When completely wired up as shown in Fig. 4, the amplifier sub assembly can be fitted to the inside surface of the lid of the metal box. Four stand off pillars about $\frac{3}{4}$ in long should be used for this purpose.

The lid space below the amplifier unit is occupied by four dry cells which make up the batteries BY3 and BY4. A mounting base for these batteries is made from a piece of $\frac{1}{4}$ in plywood, measuring $5\frac{1}{2}$ in \times 4 in. Screwed onto this board are four battery contacts. The uppermost pair of contacts consist of simple L shaped strips of metal. The pair at the bottom of the lid are fashioned from triangular shaped Meccano brackets or trunnions. A 4BA screw passed through the hole at the apex of the bracket provides contact for the battery. A couple of nuts and washers allow the screw head to be locked in close contact with the dry cell. Each pair of cells is housed in a cardboard tube, the two tubes being finally held in place on the wooden board with a loop of insulated wire.

MASTER POTENTIOMETER

The master potentiometer is mounted inside the case proper, and its spindle appears through the bottom—although this is actually the top now, since the box stands lid downwards in the present application.

A 360 degree protractor screwed to the “top” panel makes an ideal scale. A cursor cut from perspex,

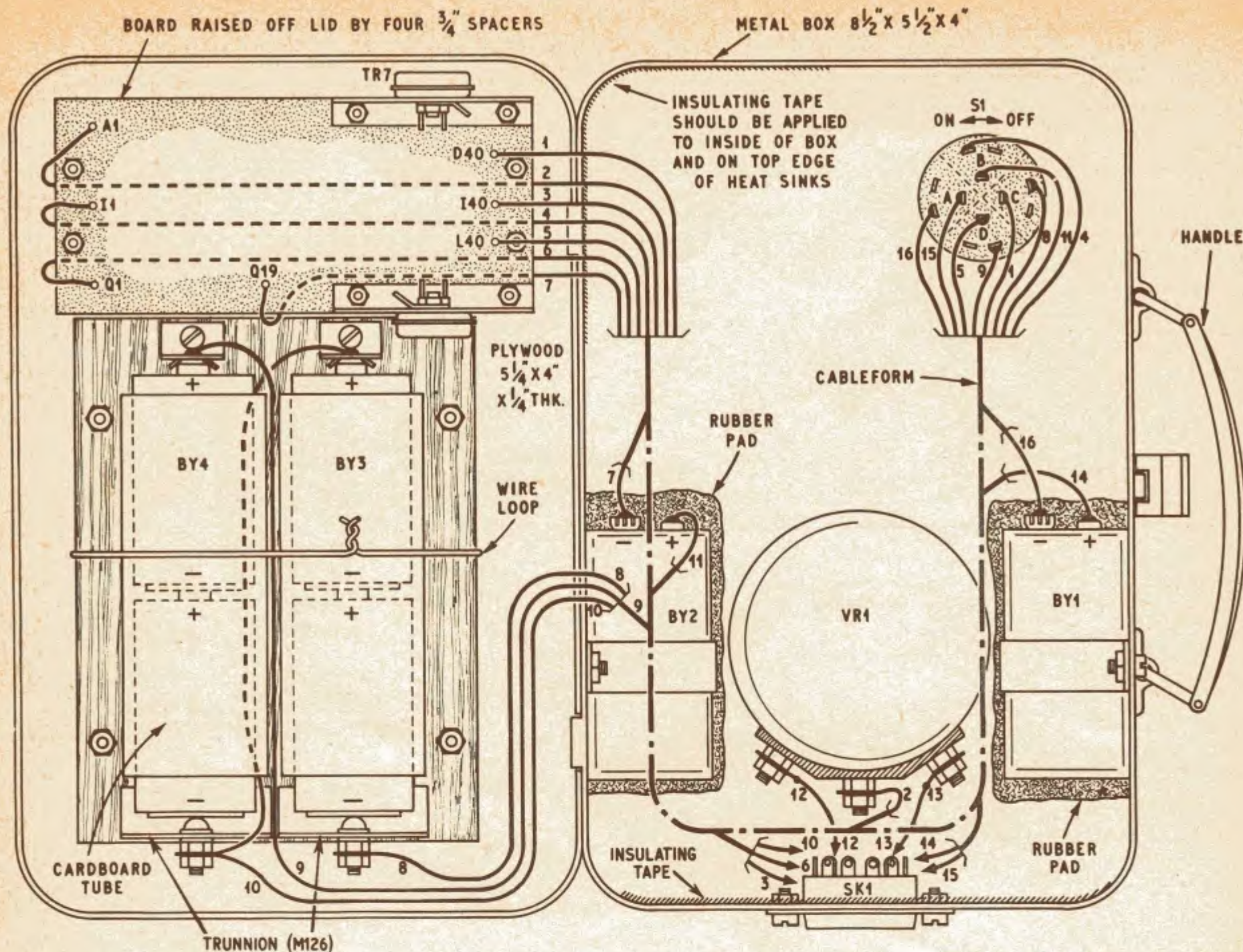

WIRING SCHEDULE					
WIRE No.	FROM	TO	WIRE No.	FROM	TO
1	PB/D40	S1C/ROTOR	9	BY4/+VE	S1D/ON
2	PB/A1	VR1/SLIDER	10	BY4/-VE	SK1/7
3	PB/I40	SK1/PIN6	11	BY2/+VE	S1B/ROTOR
4	PB/I1	S1B/ON	12	VR1	SK1/1
5	PB/L40	S1D/ROTOR	13	VR1	SK1/3
6	PB/Q1	SK1/2	14	SK1/1	BY1/+VE
7	PB/Q19	BY2/-VE	15	SK1/3	S1A/ROTOR
8	BY3/-VE	S1C/ON	16	BY1/-VE	S1A/ON

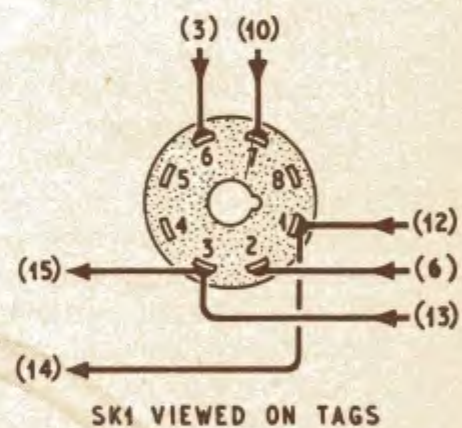

Fig. 3. Control unit. Component layout and wiring

and with a hairline scribed on the underside and filled with black crayon, can be glued to the knob.

One other control remains to be fitted to the front panel—this is the on/off switch S1.

Two 9V layer type batteries BY1 and BY2 fit conveniently one on either side of VR1. They are held in place by means of metal brackets bolted to the sides of the box.

A 1 in diameter hole should be drilled in the bottom side of the case and a octal valveholder (SK1) fitted.

When all these items have been installed in the two portions of the lunch box, the wiring up can be performed. Reference to the illustrations will make clear how various leads are grouped together in neat cable-forms.

It is necessary to apply insulation to certain parts

of the metalwork. The upper l.h. corner and the bottom wall of the case must be covered with insulating tape, and likewise the top edges of the two heat sinks. These areas are indicated in Figs. 3 and 4.

MOTOR UNIT

The motor unit incorporates the servo motor MO1, the feedback generator MO2, the driven potentiometer VR3, and the mechanical system of gearing. All these items are assembled on a chassis built up from standard Meccano parts, and the arrangement is clearly indicated in Fig. 5. The potentiometer VR3 is mounted on the bottom plate of the chassis, and a coupled spindle emerges through the top plate. To this spindle is attached a pointer made from a piece of wire, and this circumscribes a dial calibrated 0 to 280 degrees.

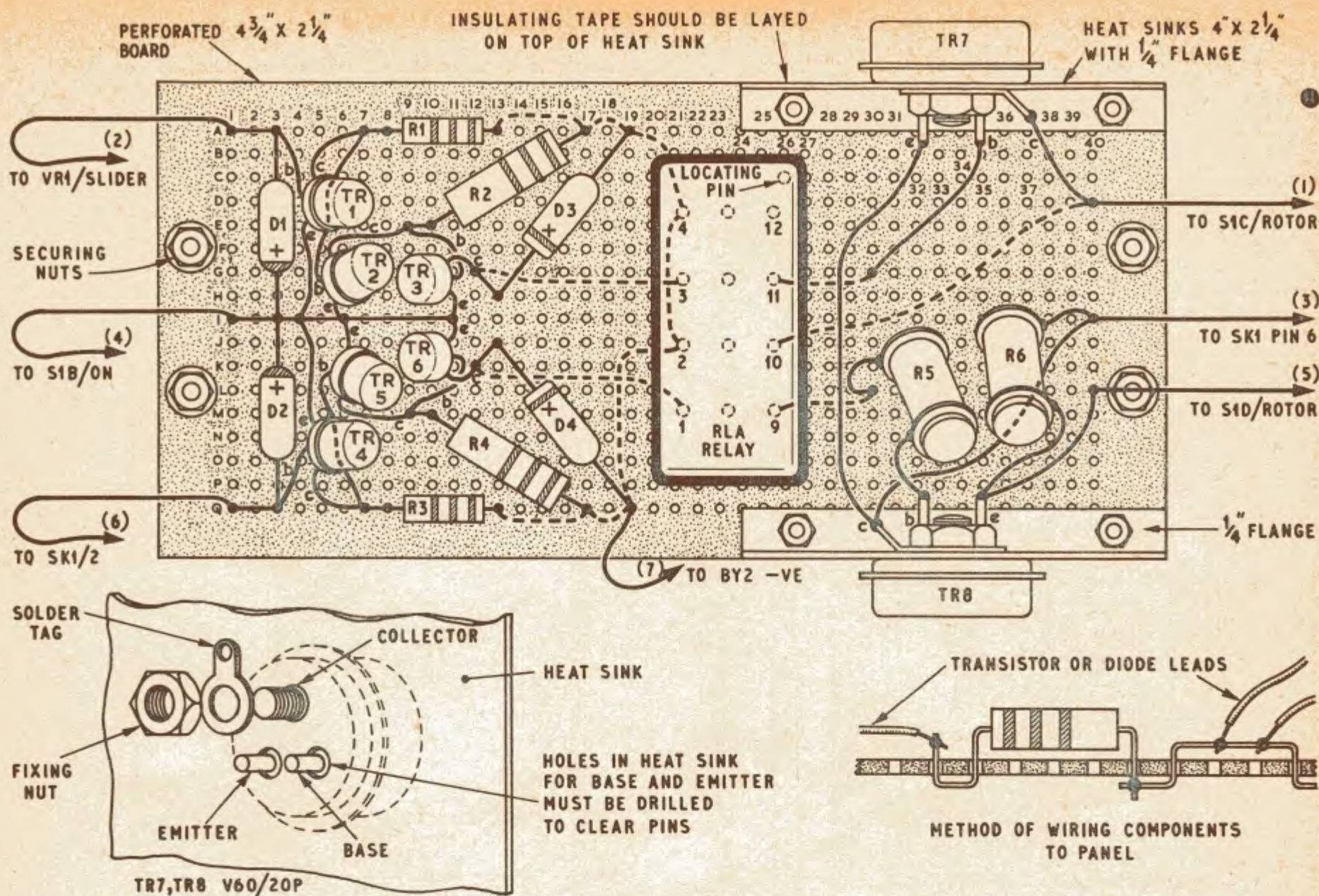

Fig. 4. Amplifier sub-assembly

Also mounted on the bottom plate are the motor and generator. These components and the gearing system are mutually coupled by a rubber band fitted over the three pulleys at the end of the assembly. At the opposite end of the assembly is the "correction" potentiometer VR2.

The motor unit is connected to the control unit by a five-core cable. In practice, a length of three-core and a length of two-core mains cable provide the best solution here; the two separate cables can be taped together at intervals to make a neat cableform, and an octal plug attached to the free end.

METHOD OF ASSEMBLY

With the side strips bolted to the bottom plate (but top plate not yet fitted), assembly of the gearing system can commence. Details of the gearing arrangement are shown in Fig. 5. During this operation the potentiometer VR3 should be mounted in position, and secured by a lock nut on the threaded bush. Care should be taken to ensure that the gears are free and rotate easily. It is a good plan to apply a spot of light oil or grease to each driving surface and bearing hole. Note that it is necessary to drill the 57 tooth gear wheel in order that it will fit the quarter inch diameter output shaft.

Prepare the top plate by fitting a bush to receive the driven shaft from the potentiometer, and also attaching the potentiometer VR2 by means of a small metal strip to one end, then place the top plate in position and bolt to the four corner strips.

The motor and the generator should first be mounted on a piece of metal measuring approximately 3in x 1 1/4in. This small plate is then bolted to the bottom plate of the chassis assembly.

Electrical wiring should be carried out as indicated in Fig. 5, reference also being made to Fig. 1 and Fig. 2 where necessary.

All that remains is to fit a pointer to the extension shaft of VR3, and to prepare a dial calibrated 0 to 280 degrees and glue this to the top plate.

ADJUSTMENT OF SERVO

The Carpenter relay should be first checked to ensure that it is adjusted to be "centre stable". This can be determined visually, i.e. the centre contact should be central between the two outer contacts. If this is not so, slacken off the two bar magnet retaining screws and rotate the magnets until the centre contact is central.

Move the gearing manually to set the slider of VR3 to approximately mid position; also set VR1 to the same position.

After a thorough wiring check, switch on the servo unit. If the motor drives VR3 slider towards its stops, switch off and reverse the motor connections. Switch on again. If the unit "hunts" reverse the generator connections, VR3 should now follow all movements of VR1.

The next step is to adjust the relay contacts. This is done by slackening off the locking screws and adjusting the contact screws in such a way as to reduce the contact gap to the smallest possible. In this condition it will probably be found that the motor will hunt at high

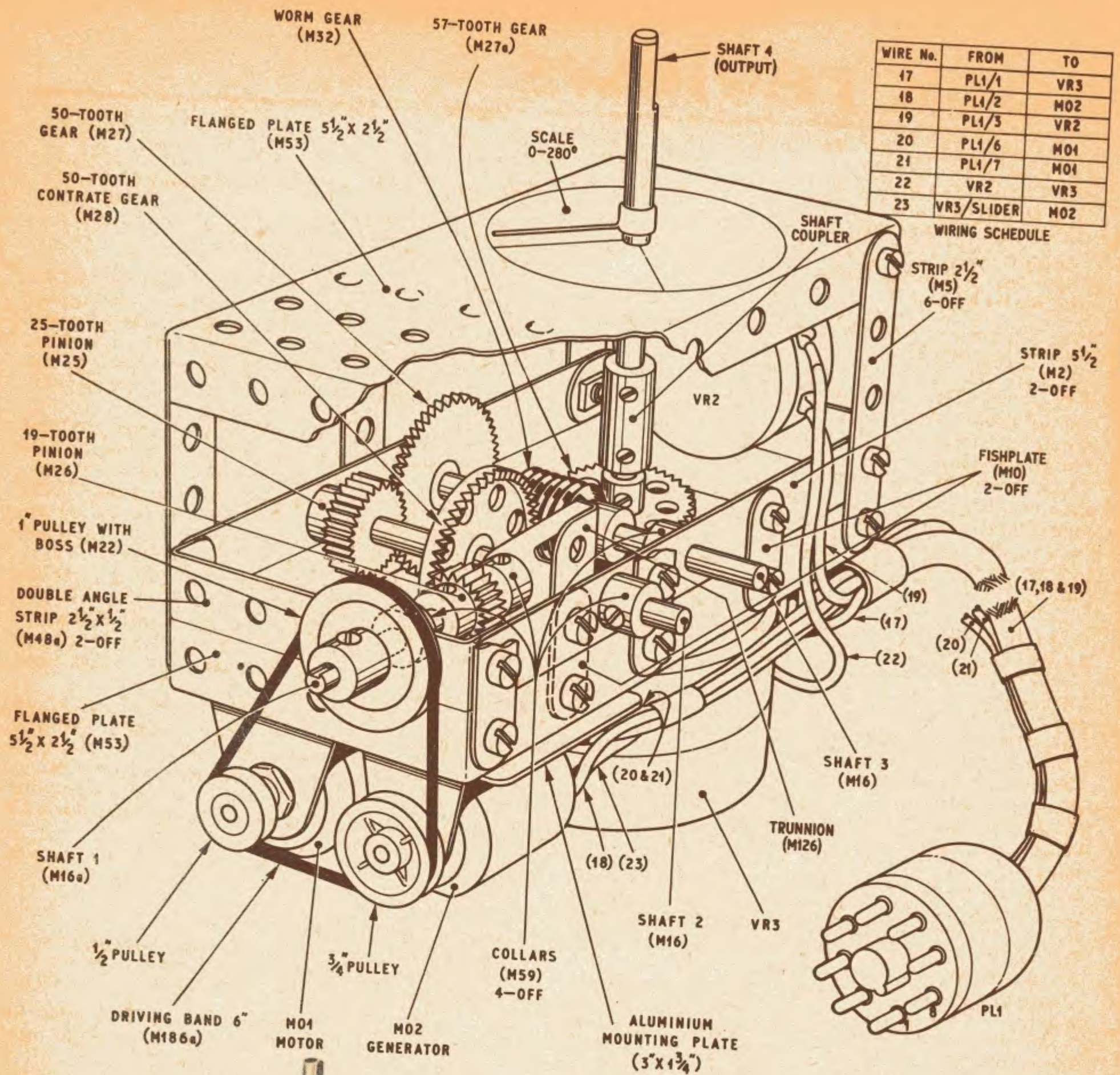

Fig. 5. The servo motor unit. Items identified with "M" prefixed numbers are standard Meccano parts. Refer to Fig. 1 and Fig. 2 for further details of electrical wiring

speed, but it will only hunt by an amount determined by the amount of backlash present in the gearing. If the output shaft will not move, re-lock the contact adjusting screws. The unit is not very accurate at the extreme ends of the scale and VR2 is used to help correct this.

APPLICATIONS

Several applications for the servo unit will no doubt suggest themselves to readers and the system can easily be adapted for different uses. Additional gearing could be employed to give more degrees of rotation, or a push pull type movement. The servo could be used to rotate a v.h.f. or u.h.f. aerial system. Two of the units could be used to provide movement in elevation and azimuth of a camera unit.



Book reviews

J. J. THOMSON and the CAVENDISH LABORATORY in his DAY

By Sir George P. Thomson, F.R.S.
Published by Thomas Nelson & Sons Ltd.
180 pages, 8in. × 5½in. Price 25s.

THIS is one of a series of books dealing with important British men of science.

The central figure of this volume was Professor of Physics at Cavendish Laboratory, Cambridge, from 1884 to 1914. It was during this period that experimental and theoretical discoveries were made which transformed physics.

J. J. Thomson will always be remembered for his discovery of the electron. He made other great contributions to science through his experimental work on the conduction of electricity through gases, and can rightly be considered the father of modern electronics.

The author, himself an eminent scientist and son of J. J., has provided sufficient general biographical matter for the reader to obtain an understanding of J. J.'s personality and his general approach to problems, but it is on the great scientific achievements performed by the Professor and his team at the Cavendish that this book mainly concentrates.

J. J. Thomson's leadership inspired many other brilliant minds. One is dazzled by the great names that contributed to this *Golden Age* at Cambridge: F. W. Aston, E. Rutherford, J. Townsend, H. A. Wilson to mention just a few. A galaxy of talent indeed.

The most significant discoveries of this team are described in detail, frequently with accompanying diagrams of apparatus. In the course of the narrative the universality of science is demonstrated by reference to the work of contemporaries in other countries, showing how one particular discovery influenced another worker.

An introductory chapter gives a background of the ideas on physics prevailing at the time J. J. Thomson started experimental work at Cambridge. This should increase the popular appeal of this book.

There are 20 photographs, many of historical interest.

F.E.B.

Guide to AMATEUR RADIO (Eleventh Edition)

By J. Pat Hawker G3VA
Published by Radio Society of Great Britain
88 pages, 9¼in × 7¼in. Price 5s

FOR anyone wishing to learn about amateur radio this handbook is a must. With this in his possession, the newcomer will find it hard to resist being bitten by "the bug". All aspects of the hobby receive attention—from setting about obtaining a licence to building receiving and transmitting equipment. The technical matter even extends to practical designs for a simple t.r.f. valve receiver, a double superhet, and a 10W phone/c.w. transmitter.

TAPE RECORDER SERVICING MANUAL

By H. W. Hellyer
Published by George Newnes Ltd.
336 pages, 10in × 7¼in. Price 63s

AMONG the profusion of service engineers in the domestic field, it is a sad fact that there is a shortage of personnel who can confidently undertake to repair almost any make of tape recorder entrusted to him. The task is made considerably easier if one has the necessary information on the relevant machine immediately to hand.

This manual is, therefore, a must for any servicing workshop and technical library. Circuits, mechanical systems, dismantling, layouts, and technical information on 281 models of tape recorders and tape decks have been combined in one volume specially for the service man. Models covered include several obsolete as well as very recent types.

The presentation is designed to give the service engineer facilities for quick reference to almost any commercial British and Continental model which has found its way to the U.K. domestic market. The book is lavishly illustrated and common problems on some machines are explained in detail.

The manual is enhanced by the inclusion of an introductory chapter on tape recording principles and practice, giving an insight to some of the problems encountered in designing circuits for tape recorders.

The cost of this manual is very reasonable when one considers the potential saving of time, frustration and repair bills which may be achieved.

M.A.C.

RADIO VALVES

Edited by Edgar J. Black
Published by N.V. Philips Gloeilampenfabrieken
Distributed in the U.K. by Iliffe Books Ltd.
126 pages, 8½in × 5¾in. Price 10s 6d

THIS is one of six paperback books in a series on Radio Servicing which is designed to supplement practical experience with the necessary theory. It is unfortunate that this particular book should be given the title "Radio Valves", for it embraces the basic theory of sound transmission, demodulation, amplification, and rectification as well as that of the thermionic valve itself. Brief notes on transistors are included and, whilst providing a useful comparison with valves, seems a little out of place in a book of this kind. Indeed the brevity of the transistor section precludes its value here.

For readers whose a.c. theory is either rusty or non-existent, then this book will help in understanding these principles and show how they are applied to radio and electronic circuitry.

It goes without saying that the operation of thermionic valves and their associated components is described lucidly. On the whole this book should appeal to those who follow the P.E. "Beginners Start Here" series, and in particular to students. Here, I may add, students can test their knowledge on the various questions which are given after each chapter.

M.A.C.

ELECTRONORAMA

HIGHLIGHTS FROM THE CONTEMPORARY SCENE



Machine Doctor

A NEW instrument, the "Minearscope" has been developed to detect wear in machinery, check the precision fitting of moving parts, and can also detect irregularities in the flow of liquids. It is claimed to be so sensitive that it can "hear" sugar being dissolved in water, and the break-up of molecular structure in a piece of steel under stress.

The "Minearscope", designed by Minear Holdings of Selsey, resembles a stethoscope with a probe unit containing a transducer unit, transistor amplifier and low voltage mercury cells.

Our picture illustrates probably one of the most popular applications: detection of car engine wear without dismantling. The unit is independent of any external power source.

A more sophisticated model, the audiometer, provides both visual and aural evidence of noise and vibration in mechanical and electrical equipment.

Thyristor Controlled Paper Mill

THE FIRST thyristor controlled paper machine sectional drive system has been developed by A.E.I. at Bowater Scott's Northfleet Mill, Kent.

The machine makes tissue paper for domestic use and operates at speeds up to 4,000ft per minute. The eleven drive sections are divided into four groups powered by thyristor converters maintaining 0.1 per cent accuracy, despite supply variations of up to 5 per cent.

The paper machine drive units are shown below; the 540 kilowatt thyristor converter cubicle right.

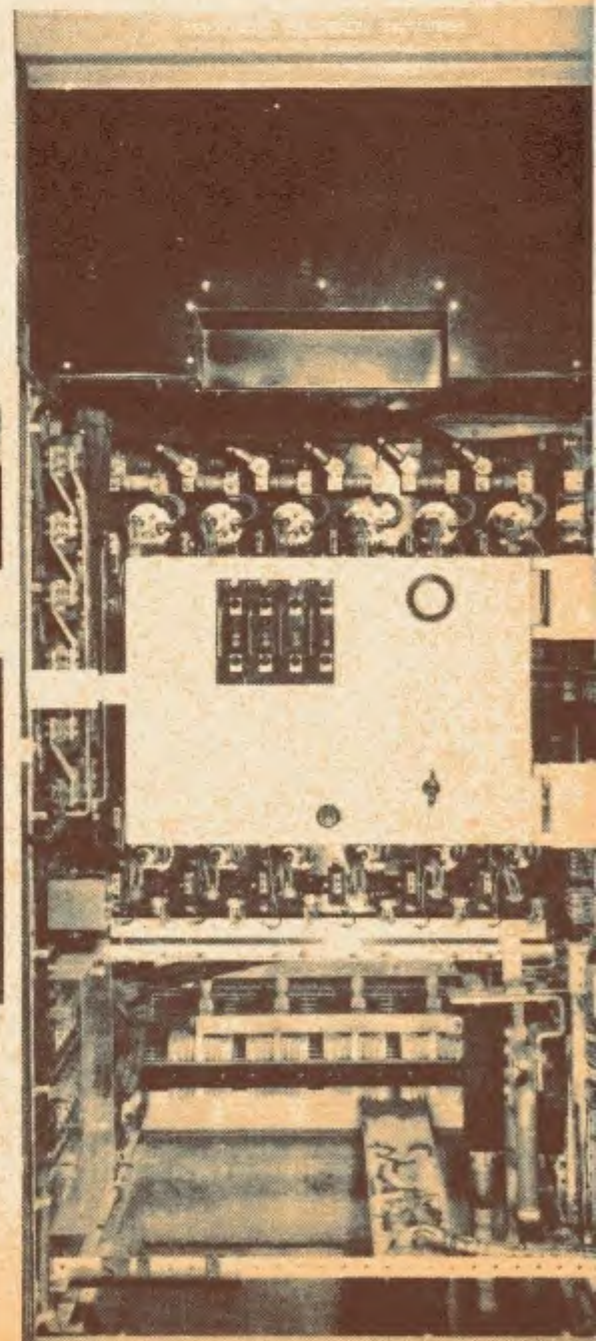
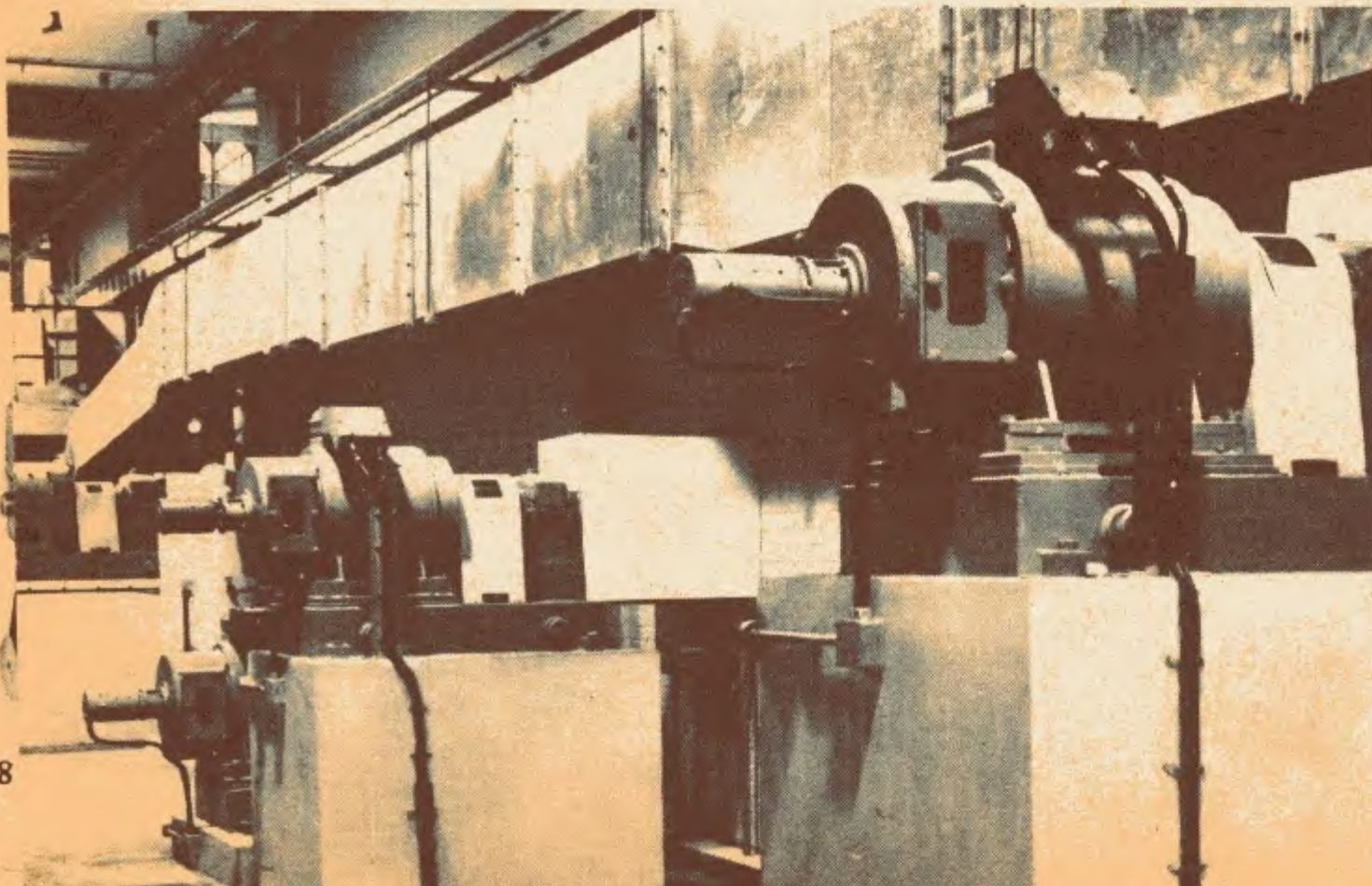

Thermoelectric Generator

ONE OF the most important fields for using thermoelectric generators is in long term space exploration. The 3M Company will design and develop a 50 watt nuclear fuelled thermoelectric generator for operating data instruments on the moon.

Since solar energy to power solar cells is restricted to the lunar daytime and since large quantities of chemical energy would be required for fuel cell operation, NASA decided that a nuclear powered generator would be the most feasible power source for the Apollo project.

The picture is an artist's impression of a lunar landing, showing the SNAP-27 thermoelectric generator in the centre foreground, powering the radio transmission gear on the right.

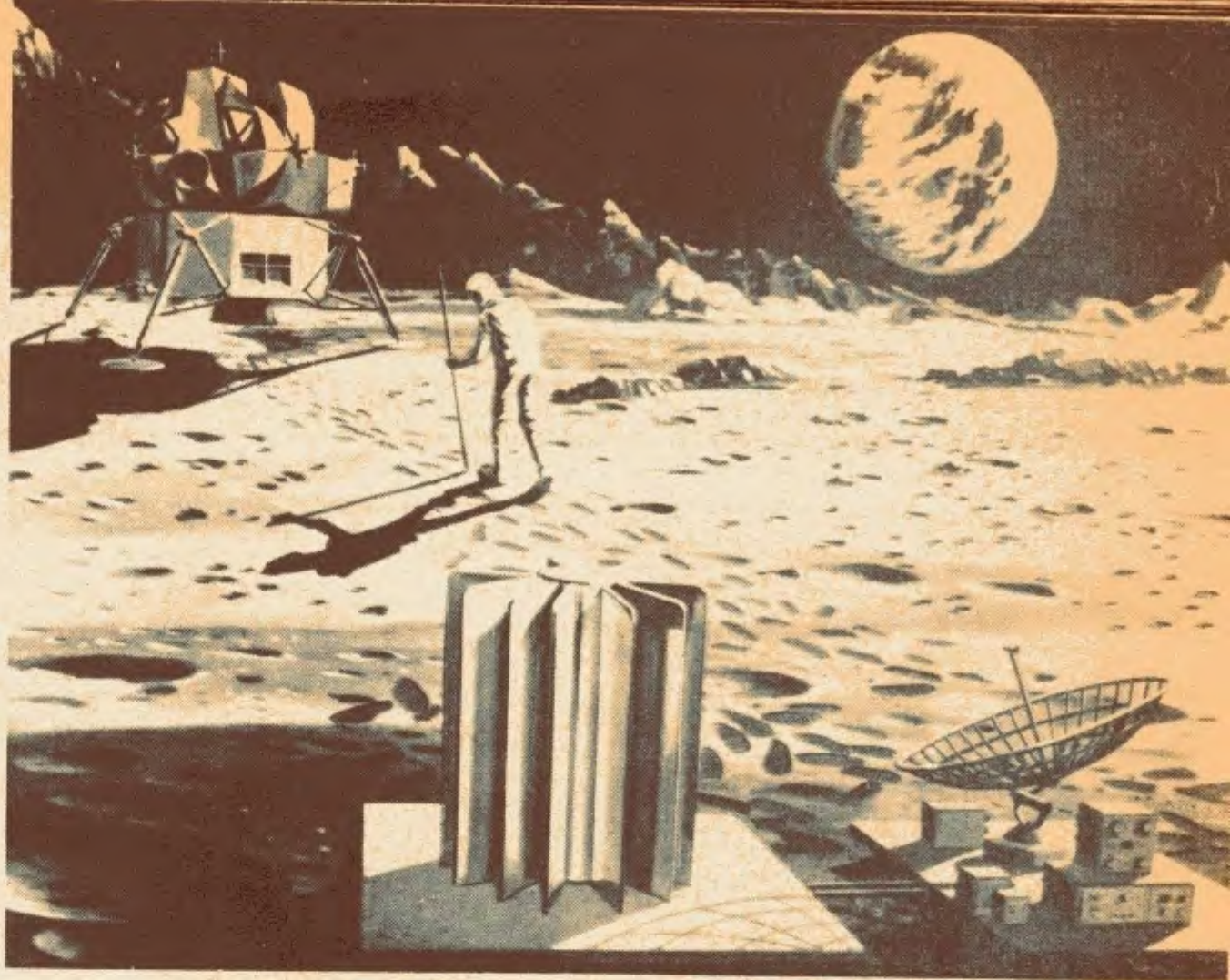

Export Drive

GREAT BRITAIN has sent a gift to Mexico of a complete television studio made by Pye TVT. The equipment will be installed in the Instituto Politécnico Nacional for educational purposes. The gift is the result of an offer made by the Duke of Edinburgh and includes the sound and vision mixing desk shown below.

Other items include two station broadcast cameras, a telecine unit, two record playing consoles, audio tape facilities, six monitors and ancillary equipment.

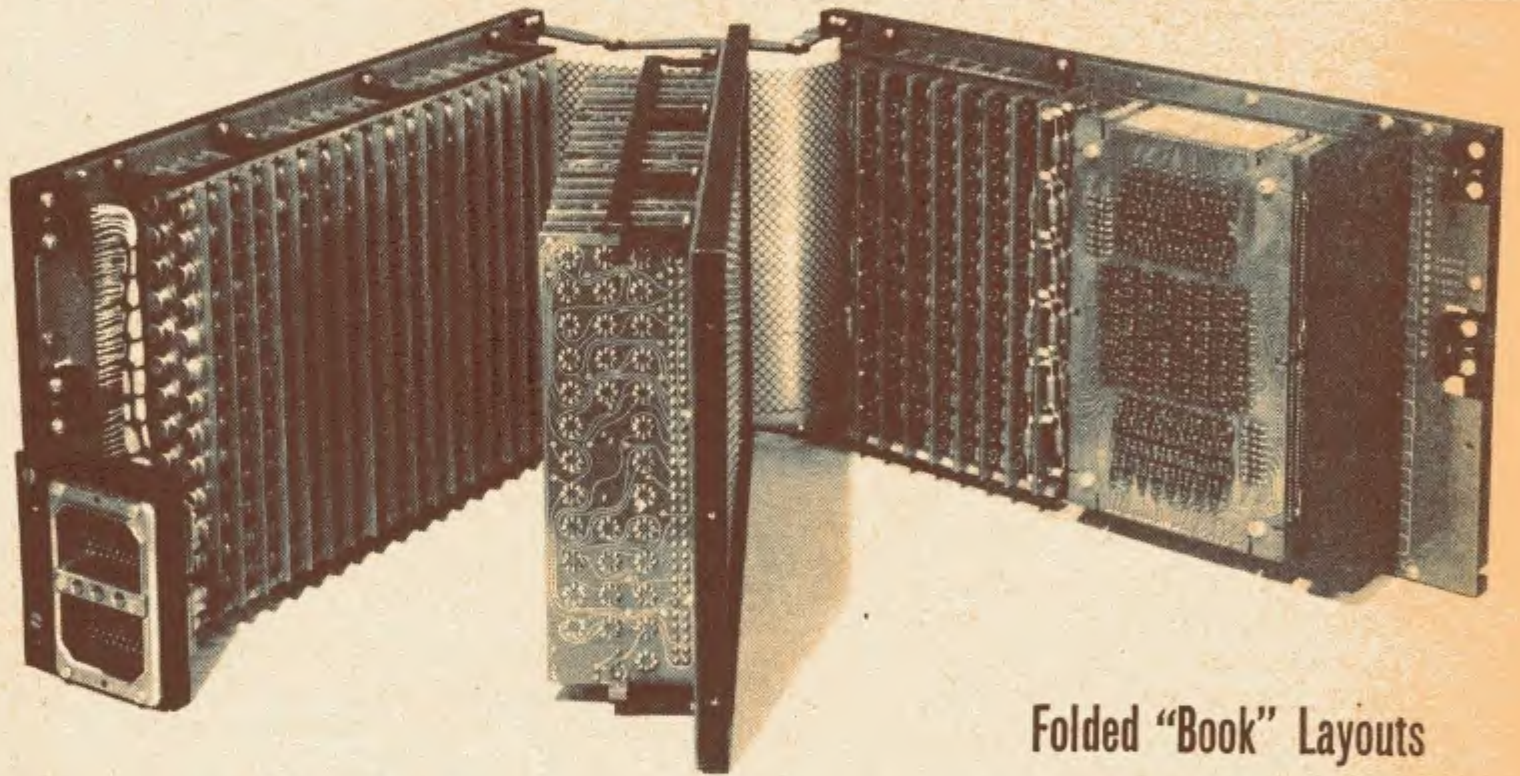

Folded "Book" Layouts



ABOVE IS the new style of computer of the future, the "Argus 400" microminiature digital computer, developed by Ferranti. This unit, built in "book" style, uses single chip silicon integrated circuits, mounted in sealed 8-lead TO5 transistor cases, and ferrite core stores. Interconnection between "leaves" is by the flexible printed circuit card in the centre.

Below is another form of folding system used to house the Marconi TF2100 oscillator.

This unit was recently shown at the "Design in Engineering" exhibition at the Design Centre in London.

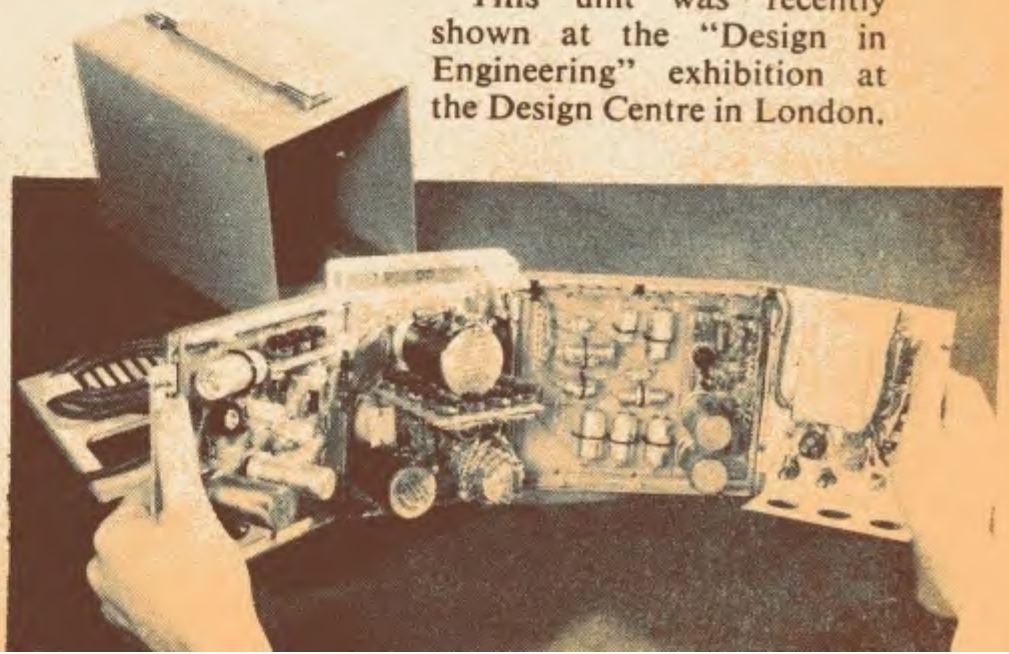

BEGINNERS start here...

15

An Instructional Series for the Newcomer to Electronics

Now to discuss the operation of the three circuit elements *resistance*, *capacitance* and *inductance* and their effects in *d.c.* circuits on the one hand, and in *a.c.* circuits on the other. Perhaps here is the heart of understanding circuit action in all types of electronic devices, so let's see if we can simplify and complete a picture of what goes on, thus enabling us to draw upon this knowledge in future articles.

Right from the start, it is a good idea to distinguish between the *d.c.* and the *a.c.* that flow in all electronic circuits. The *d.c.* part is nearly always the *driving power*, and sets the operation of the circuits at the correct points. It is often called the *bias* that is being applied. The *a.c.* part is usually the *signal* that is being dealt with.

SIGNAL CURRENTS

Signals may consist of currents conveying voice or music information, as in audio and radio equipment. Or they may be pulses, as in radar or computers. Signals may operate machines at a distance such as radio control and *telemetry*, which is the technique of sending data and measurements from such devices as rockets and satellites.

But all these signals are *changing* currents (or voltages) and are therefore alternating. The steady value of *d.c.* cannot convey much information.

Now, although the *d.c.* and *a.c.* parts of a current may flow together, that is, may be mixed up in a particular circuit, it is still best to divide this "mixed" current into these two component parts, and deal with them separately. When discussing the *d.c.* supply, we can forget about the *a.c.* signal. When the signal is in the news, the *d.c.* supply can be "assumed" and thereafter temporarily forgotten. All this simplifies the description of circuit action.

At this point we will move on to the main work, namely, *a.c.* and *d.c.* applied to the three principal circuits components.

RESISTANCE

The difficulty experienced by a current flowing in a circuit is a result of two kinds of opposition. One is called the electrical resistance, and we studied the effects of this in earlier articles in this series. The other effect will come up in connection with capacitance and inductance in a moment. But first let us have a brief closer look at resistance.

By the results of Ohm's Law, the current flowing in a circuit is proportional to the voltage applied to that circuit. We would expect this—the greater the driving pressure then the larger the quantity which is made to flow.

With a direct voltage across the resistor, the current will flow steadily in proportion (Fig. 15.1a). If an alternating voltage is applied, the current will still flow in proportion, i.e. rising with the voltage, reversing when the voltage reverses, and so on (Fig. 15.1b).

The voltage and current are *in phase*. In either case, power is spent in the resistance, and it gets hot. The electrical supply is delivering energy.

CAPACITANCE

A much different action occurs with a capacitor in circuit. Take *d.c.* for instance (see Fig. 15.2a). The capacitor will charge up (as we saw in Part 4), but once charged, everything stops. No current flows whatever the applied voltage (unless the capacitor is broken down by going past its safety limits.) Thus, after the first surge of current, a capacitor becomes a complete block to *d.c.* It is like a switch that is open.

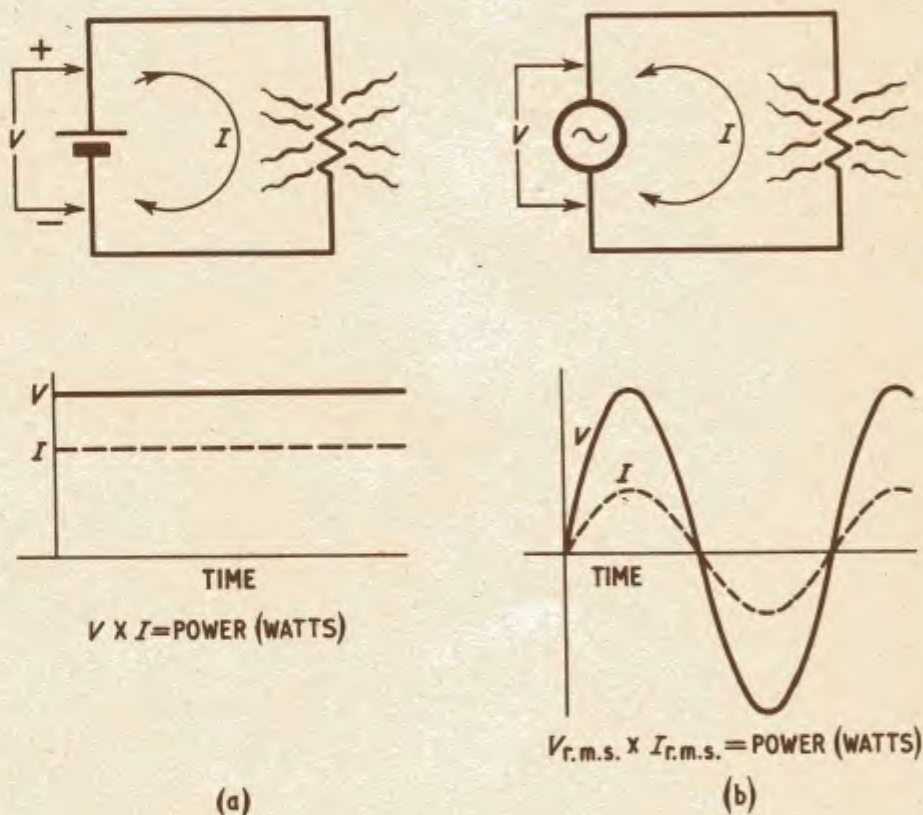

Fig. 15.1 The resistor gets hot when *d.c.* flows through it as shown in (a). The power consumed is the product of the voltage (V) and the current (I).

When *a.c.* is applied to the resistor, see (b), heat is produced on each half cycle, and the resistor gets hot as before, its thermal capacity smoothing out the pulses of heat. As the graph indicates, the voltage (V) and the current (I) are in step or phase

Now with *a.c.* the position is quite different. The capacitor charges and discharges all the time. Current is continually going in and out and this means that an alternating current is able to flow (Fig. 15.2b). It is as though *a.c.* is passing through the capacitor, although it is really an electrical charge going on and off the plates. The faster the changes (or "frequency"), the greater the flow. It is easier for high frequency or rapid changes to pass a given capacitor, than for lower frequency changes.

So we can sum up the effect of capacitance; a complete block to *d.c.* (or "zero frequency"), but an easier and easier path to *a.c.* as the frequency goes up.

You can see at once that capacitors will have a big use in guiding or sorting out the paths of signals, and separating the d.c. and a.c. parts in a circuit.

WATTLSS CURRENT

There is one other point concerning the effect of capacitance on a.c., and that is the remarkable fact that no energy is taken from the supply. The capacitor remains cool (unlike the resistor). When the capacitor charges, it takes energy from the supply: when it discharges, the energy is given back. This effect results in the voltage and current waveforms varying out of step (or out of phase), the maximum current flowing when the voltage is minimum, and vice-versa. Actually, the current leads the voltage by 90 degrees as shown in Fig. 15.2b. Looking at the graph in this Fig. it is easy to see how the average power ($V \times I$) is zero. This is the so-called *wattless current*.

This is a very different state of affairs compared to that occurring with resistance where energy is always absorbed, and it means that although we still measure the opposition presented by capacitors in *ohms*, we cannot call it resistance. This opposition is called *capacitance reactance*, and the symbol X_C is used to denote it.

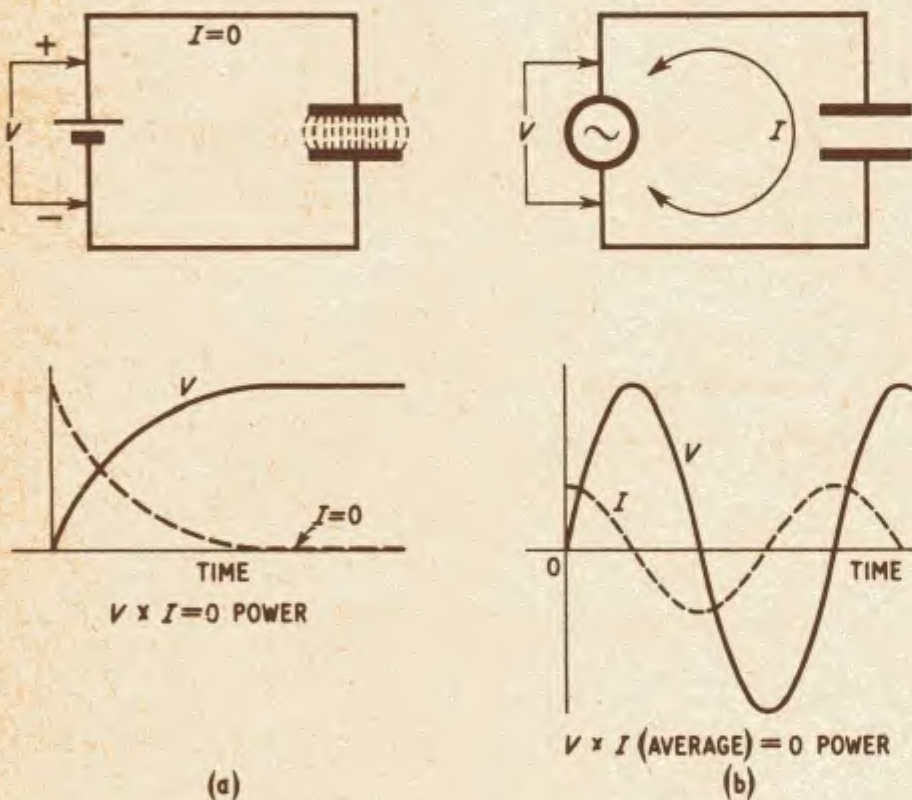

Fig. 15.2. A capacitor passes no current on d.c., except for a brief period when it is charging as indicated by the left-hand portion of the curves in (a). When a.c. is applied to a capacitor, current flows continuously see (b). The current "leads" the voltage as shown. The average product of V and I is zero—hence this is called *wattless current*

INDUCTANCE

There is bound to be a fair amount going on when a.c. is applied to an inductance. Just imagine the rapidly changing magnetic fields. But before discussing a.c., we might first look into the inductance with d.c. applied.

When a d.c. voltage is applied, current immediately tends to flow, and a magnetic field begins to build up around the coil, see Fig. 15.3a. This field moves in such a way as to oppose the current building up, but nevertheless d.c. continues to increase without limit (we

consider the inductance perfect, having no resistance of course). Thus an inductance offers no opposition to d.c.

The same thing, but in reverse, happens when we switch off the current. The field collapses, giving energy to the circuit, and so tending to keep the current flowing. Notice it isn't the d.c. that is opposed, only the *changes* in d.c. (switching on and off).

This gives us a clue immediately to the effect of inductance on a.c., which is changing all the time. The higher the frequency, the faster the changes and opposition *goes up*. Once again the inductance takes no energy from the supply. Energy is taken to build up the field, but is given back when it collapses. The current thus lags behind the voltage as shown in Fig. 15.3b. The average power under these conditions is zero.

Therefore, summing up: inductance offers no opposition to d.c. but opposes a.c., the opposition increasing with the frequency. Notice the fact that inductance is opposite in all respects to capacitance. Again, we cannot call this opposition resistance, but use the term reactance as before. This time it is *inductive reactance*, symbol X_L .

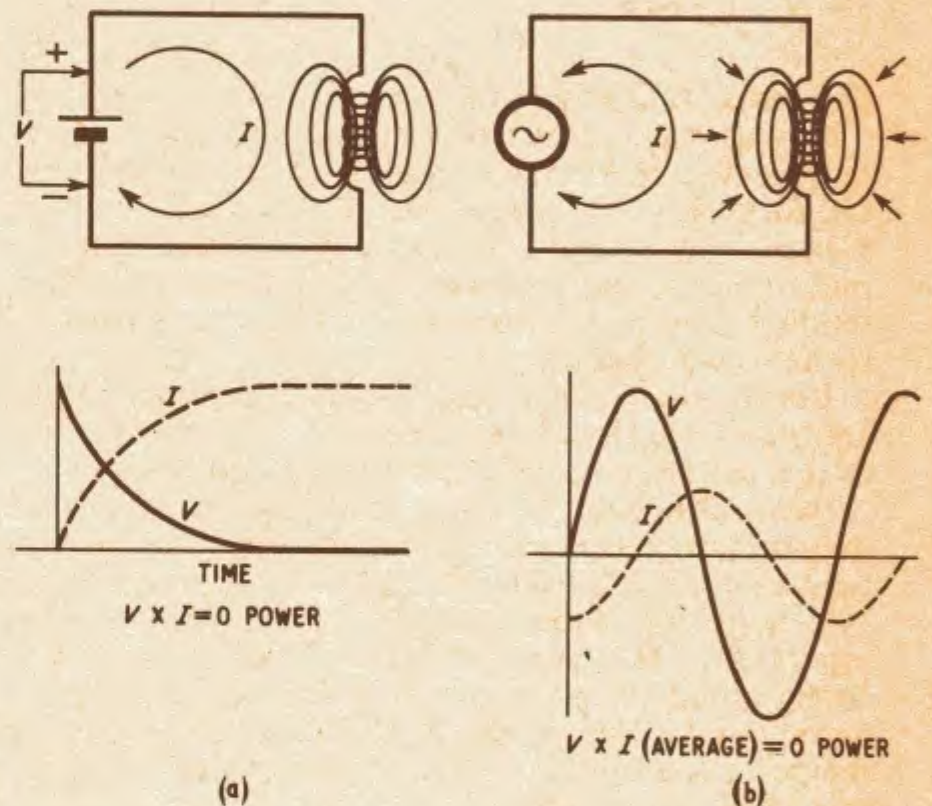

Fig. 15.3. With d.c., the current through an inductor, see (a), grows without limit, theoretically of course (in practice, resistance in the battery and in the coil and connecting wires would limit it). No opposition is offered to d.c., apart from when initially switching on. Thereafter a steady magnetic field is maintained. When a.c. is applied to an inductor, see (b), the flow of current is opposed. The magnetic field alternately builds up and collapses. Current lags behind the voltage as the graph shows. The average power in this circuit is zero

A practical example of how a capacitor and an inductor are used together to separate d.c. and a.c. is the filter or smoothing circuit, commonly found in power supply circuits. Sometimes a resistor takes the place of the inductor—but such an arrangement involves a greater waste of power, this being dissipated in the form of heat.

Next month we will describe the construction of two simple filter units. These units will be used in conjunction with other "building blocks" for future experimental work.

NEW PRODUCTS



Mono/Stereo Tape Pre-amplifier

Brenell Engineering Co. Ltd.,
231/235, Liverpool Road, London, N.1.

The Brenell "Hi Fi Tape Link" contains twin recording amplifiers, 90 kc/s push-pull oscillator, and twin playback pre-amplifiers. It is designed for use with a three-headed stereophonic tape deck and any make of hi fi amplifier equipment capable of supplying a signal level from radio tuners, microphones, pick-ups etc., of at least 75 millivolts; the output from a hi fi pre-amplifier usually ranges from 125 to 500 millivolts.

Whilst recording is in progress, one can listen to the recorded material a fraction of a second after recording has taken place, or the record input signal. Two edgewise scaled illuminated meters indicate the recording signal level and dual concentric gain controls give individual control of the two recording amplifiers. Variable bias enables the recordist to obtain optimum results at all tape speeds with all brands of tape. Mono and stereo recording facilities are provided and frequency correction for four tape speeds, both for recording and replaying, is incorporated. The power unit is on a separate chassis in order that it may be mounted where it cannot introduce hum into the system.

The "Hi Fi Tape Link" is designed to operate with decks having three heads of the following types:

	Erase	Record	Playback
2/2 track (half track)	BL210 or UL290	UK202	UK200
2/4 track (quarter track)	BL216 or UL296	UK207	UK205

The frequency response when used with these heads is very good and enables excellent quality from speech and music to be achieved.

Price including power unit, £46.

Moulded Insulation Switches

A. F. Bulgin & Co. Ltd., Bye Pass Road, Barking, Essex.

The present trend by manufacturers to produce a high standard of finish, as well as maximum reliability, is evident in the new range of double-pole switches being produced by A. F. Bulgin & Co.

This new range of seven double-pole toggle switches has moulded plastic insulation of high grade thermosetting material. The soldering tags are silver plated copper.

The switches are available with various alternative types of operating "dolly" as follows: ball, pear, slotted, push-push, push-pull, and a new insulated "duck-bill" type. The switches will sell at approximately 4s 6d.

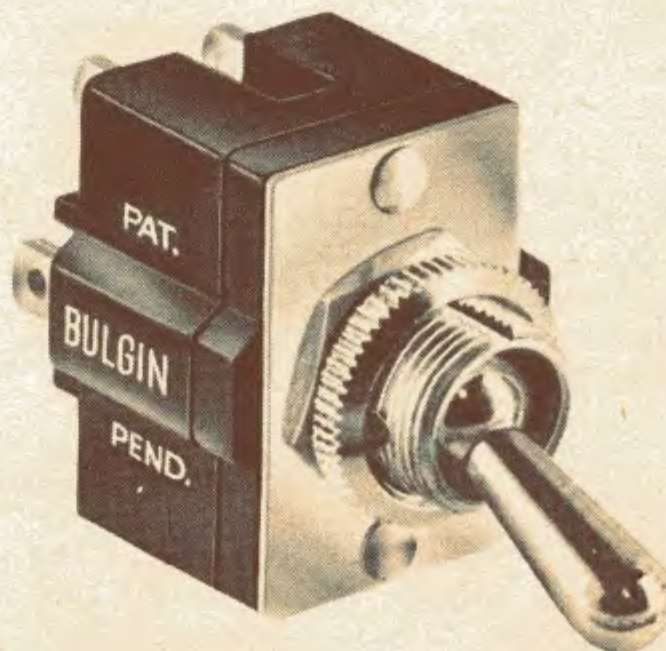

Portable 3 inch Oscilloscope Kit
Daystrom Ltd., Gloucester, England.



The oscilloscope has long been the main test instrument in the workshop of service engineers, experimenters, and amateur constructors. But when confronted with location jobs the 'scope has to be left behind because of its bulk and weight, and perhaps a less versatile instrument used.

The new Heathkit Model OS-2 single-beam service oscilloscope with a 3in tube is ideal for portable use as it weighs only 9½ pounds and measures 5in × 7½in × 12in, making it a useful sensitive alternative to the bench model. The main features are "Y" bandwidth of 2c/s to 3Mc/s; automatic "lock-in" synchronisation; use of printed circuit board; and switched "Ext/Int Y" plate connections.

The vertical amplifier sensitivity is quoted as 100mV r.m.s. per centimetre with a frequency response of 2c/s to 3Mc/s, ± 3dB. Input impedance is 3.3MΩ when shunted by 20pF.

The horizontal amplifier sensitivity is 100mV r.m.s. per centimetre with a frequency response of 2c/s to 300ks/s, ± 3dB. Input impedance is 10MΩ when shunted by 20pF.

The timebase generator is a recurrent type giving a linear sawtooth waveform produced by a multivibrator. The timebase is switched in four steps to cover a range 20c/s to 200kc/s. Voltage calibration of 1V peak to peak is provided using a 50c/s supply.

The Heathkit Model OS-2 is available in kit form with a 40-page constructional and operation manual for £22 18s 0d, or assembled and tested for £30 8s 0d.

Self-cutting Terminal Pin

Vero Electronics Ltd.,
South Mill Road,
Regent's Park,
Southampton.



A new type of terminal pin with self-cutting serrations, to hold it firmly in position during soldering operations, has just been added to the Veroboard range of pin-board products.

The new pin is for boards with 0.052in dia. holes. The collar prevents the pin from being pushed too far into the board.

A pin insertion tool has also been introduced to simplify fitting to the board.

"Mezzo" Loudspeaker Enclosure

Goodmans Industries Ltd., Axiom Works, Lancelot Road, Wembley, Middx.

The new addition to the "M" range of enclosures by Goodmans is the "Mezzo", which is a 15 watt, two speaker system, measuring 10¼in × 18¼in × 8in deep—ideal for standing on a bookshelf. The frequency range is 40 to 20,000 c/s, with an LC crossover network operating at 2,200 c/s. A total harmonic distortion of less than 1 per cent at 55 c/s and above is claimed.

The price of the "Mezzo" is 25 guineas including tax.

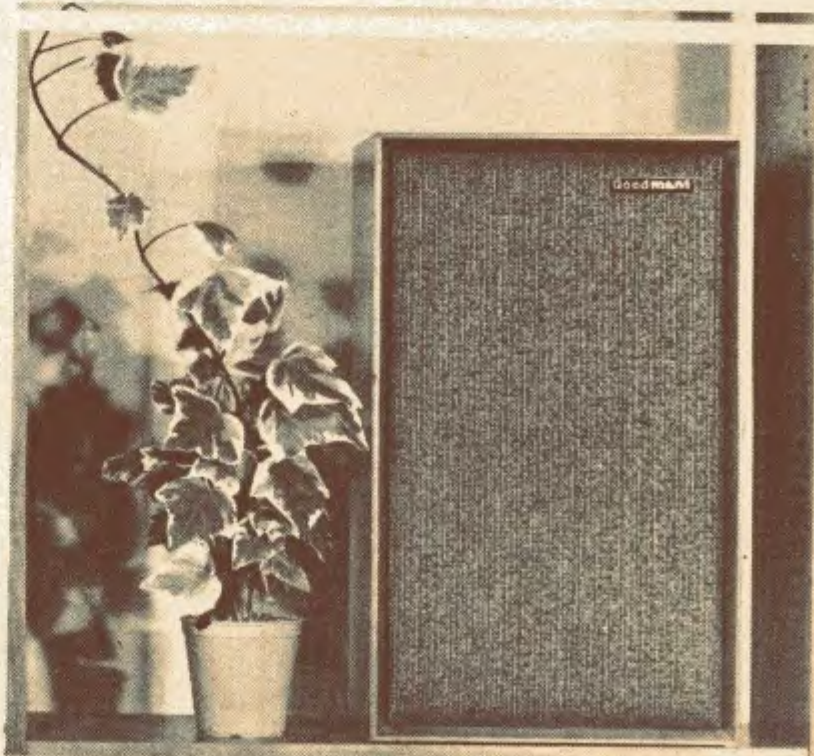

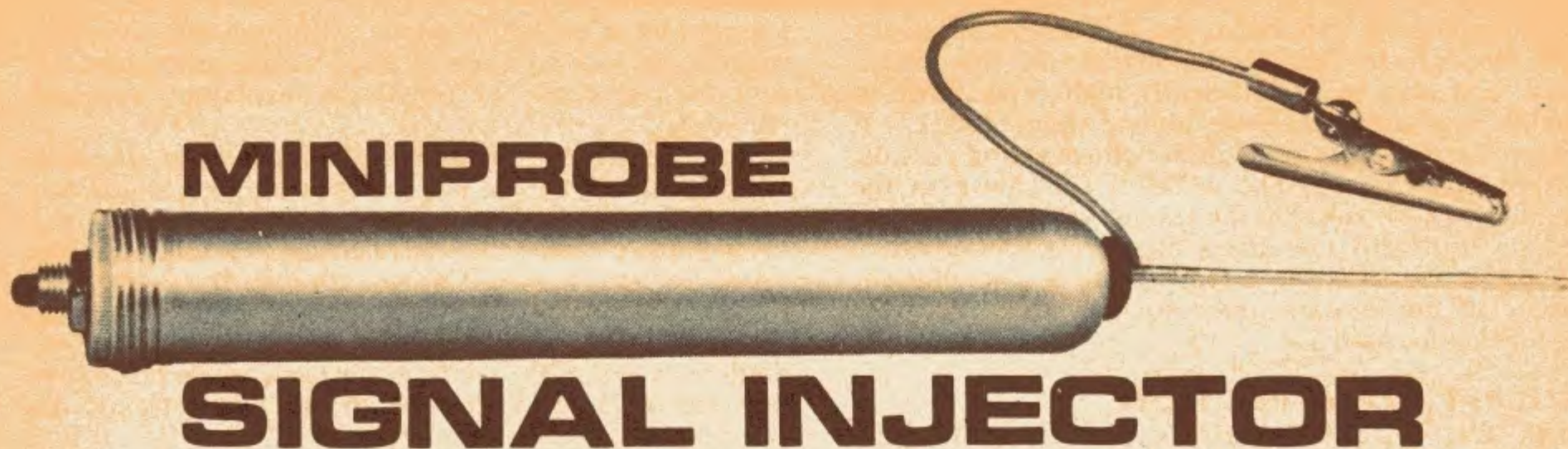

BY A.W. HARTLEY

ONE OF the greatest aids to servicing a radio receiver, or audio amplifier, is undoubtedly a device which will provide a modulated signal for tracing the signal path through the circuit.

The best type of test equipment to do this is a modulated signal generator, but these can be expensive and bulky, also they are not always available at the time and place required.

A somewhat simpler solution is a device so compact that it may be carried around in the pocket, contains its own power supply and will give a modulated signal on frequencies well into the medium waveband. This instrument could be a transistor test probe or signal injector, such as the one to be described here.

The instrument is basically a multivibrator using two transistors. The choice of these is important as they must be capable of generating harmonics of their fundamental operating frequency, which will extend as far as possible into the radio frequency band. The type of transistor which meets this requirement is in the micro-alloy range; for example, either a MAT 100 or MAT 101 (which gives slightly greater output). Other types may in fact suffice, but size is an important factor as well as performance.

CIRCUIT

The circuit used, and illustrated in Fig. 1, is an astable (free-running) multivibrator of common-emitter configuration, which produces at each collector a train of rectangular pulses without external triggering. The two waveform drawings (Figs. 2a and 2b) illustrate the type of signal output produced by this circuit.

In the circuit diagram the collector resistors R1 and R4 are of the same value, but because of component tolerances one transistor will conduct slightly more

than the other, this being an essential requirement of this type of circuit. If TR1 conducts harder, more voltage will be dropped across R1 than R4, making the collector of TR1 more positive than the collector of TR2.

At the moment of switching on, the base of TR2 will be almost the same potential as the emitter; the

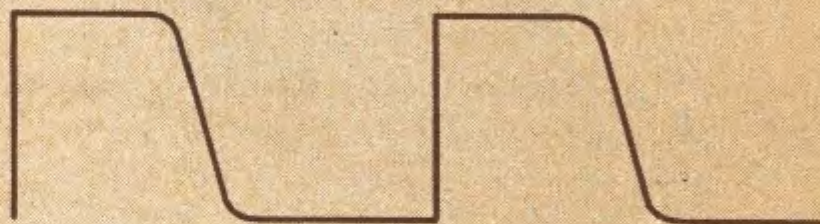

Fig. 2a. Waveform of the output signal

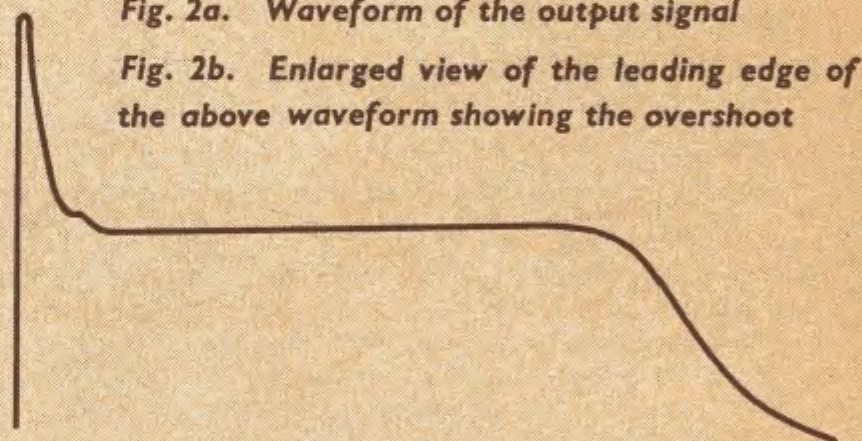
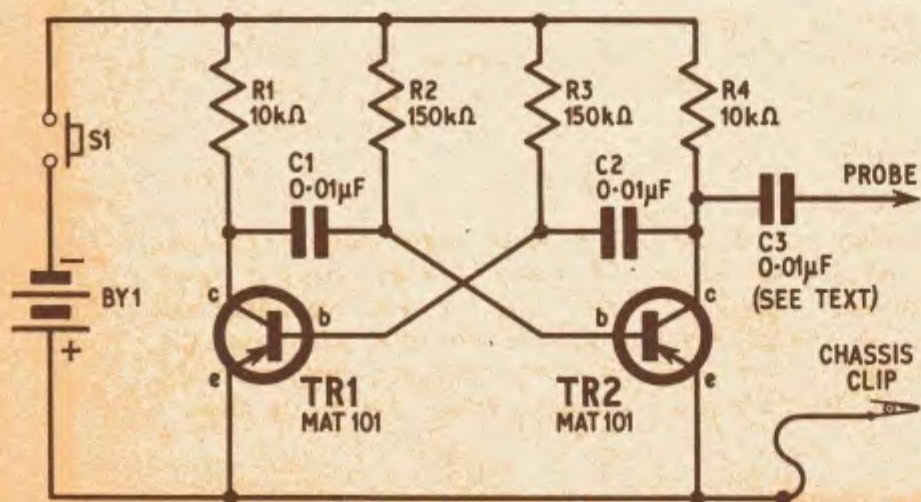

Fig. 2b. Enlarged view of the leading edge of the above waveform showing the overshoot

Fig. 1. Circuit diagram of the signal injector



collector current of TR2 will be reduced, and the collector voltage of TR2 will become more negative. The base of TR1 also rises towards this value and causes TR1 to conduct harder. This action will continue to the maximum value determined by R1, at which time TR2 is completely cut off. The capacitors C1 and C2 have begun to charge as soon as the circuit became operative, with the result that a point is reached where a positive charge is applied to the base of TR1 and negative charge to the base of TR2, which causes an instantaneous switch-over of the transistors due to the changed base potential.

The frequency of the switching action is determined by the discharge of C1 through R2, and C2 through R3; the sequence of switching will continue as long as the power source is applied. The fundamental frequency is in the region of 460c/s.

The capacitor C3 is not an active part of the multivibrator circuit but provides d.c. isolation if the probe is inadvertently touched on a point of high d.c. potential in the apparatus being tested. The choice of a large

value capacitor is important, but it must be physically small enough to be accommodated on the circuit board, and also be of sufficiently high capacitance to provide negligible reactance above about 200c/s. It must, of course, have the highest voltage rating possible consistent with size. The value of C3 shown in the circuit would be suitable for testing valve circuits. If used on transistor circuits, a higher capacitance (e.g. $8\mu\text{F}$ 15V) would be needed to allow the efficient passage of the fundamental frequency to a relatively low impedance load.

GENERAL CONSTRUCTION

The selection of a suitable container for the test probe provided some difficulty. In the first model the circuit board and battery was built into a pen-torch case. Whilst this was convenient for housing the battery and provided a suitable on/off switch, the unit was too tight a fit in the case and being metallic it was not easy to avoid short circuits through the case. Various plastics containers were tried and rejected as being too flimsy, too narrow or too small. The final choice was a discarded cigar tube 5in long and $\frac{3}{8}$ in diameter. A fairly large-stocked tobacconist should be able to

supply one at negligible cost. Although this tube was metallic, it was sufficiently large to accommodate the unit with a sleeve of polythene insulation wrapped round it.

Cut a piece of perforated eyelet board to size (3in long, $\frac{1}{2}$ in wide) using a fine hacksaw blade. Shape one end of the board (Fig. 4) with a fine file to suit the hemispherical shape of one end of the cigar tube. The 3in probe, made from stout tinned copper wire, is attached to this end of the board by fixing in place with a twin tag removed from a miniature component tag board. Solder one end of the probe to the tag's centre hole, then bend the two soldering ends of the tag so that they fit on either side of the eyelet board.

Wire is threaded through the soldering tag holes and the centre hole of the eyelet board at the rounded end. Solder the wire in place to the tag so that the probe assembly is securely held in place.

The remainder of the construction is straightforward if the illustrations are followed. Before fitting any components to the board drill a hole $\frac{3}{8}$ in diameter where shown, using a great deal of care to avoid splitting the board. Fit a grommet (with a $\frac{1}{4}$ in inside hole) into the $\frac{3}{8}$ in hole. This functions as a battery

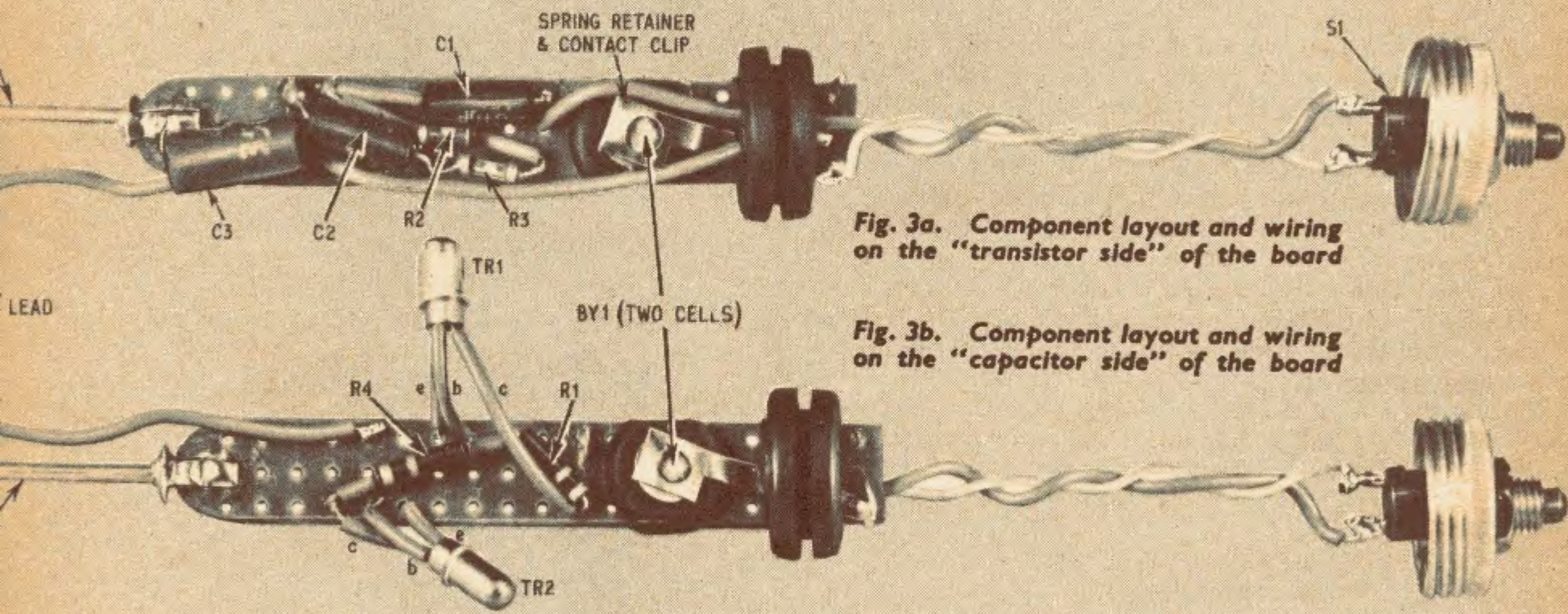

Fig. 3a. Component layout and wiring on the "transistor side" of the board

Fig. 3b. Component layout and wiring on the "capacitor side" of the board

COMPONENTS . . .

Resistors

- R1 10k Ω
- R2 150k Ω
- R3 150k Ω
- R4 10k Ω
- All $\pm 10\%$ $\frac{1}{10}$ watt carbon miniature

Capacitors

- C1 0.01 μF paper 150V
- C2 0.01 μF paper 150V
- C3 0.01 μF paper 350V (see text)

Transistors

- TR1 MAT 101
 - TR2 MAT 101
- (Sinclair)

Batteries

- BY1 1.3V mercury cells (2 off)
- (Mallory type ZM312)

Switch

- S1 Miniature push button press on—release off.
- (e.g. Bulgin type MPI $\frac{1}{4}$ in dia. fixing)

Rubber Grommets

- Hole diameter $\frac{3}{8}$ in, fixing diameter $\frac{1}{2}$ in (1 off)
- " $\frac{1}{4}$ in, " $\frac{3}{8}$ in (1 off)
- " $\frac{5}{32}$ in, " $\frac{1}{4}$ in (1 off)

Miscellaneous

Eyelet board 3in \times $\frac{1}{2}$ in with two soldering pins; 3in length of 12 or 14 s.w.g. tinned copper wire (probe); cigar tube 5in long by $\frac{3}{8}$ in diameter or plastic case of similar size; two-way soldering tag (see text); small spring strips (e.g. ex-relay contact strips); flexible p.v.c. covered wire; crocodile clip.

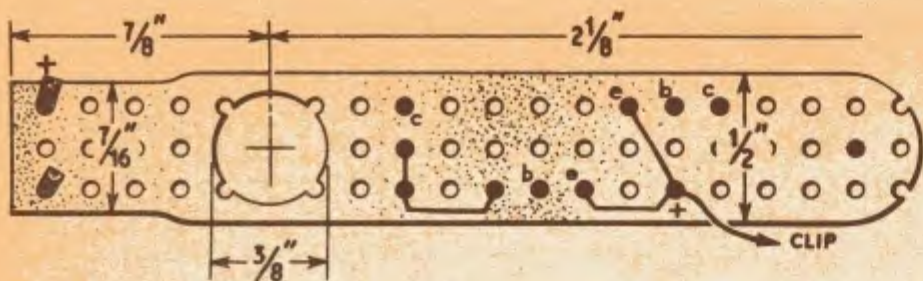

Fig. 4. Constructional details of the eyelet board and probe fixing

retainer for the two mercury cells which are inserted and contact-connected in series. It will be found that they fit snugly and securely if those specified in the components list are used. Observe the polarity of the cells.

Contact with the cells is achieved by using two spring strips, such as relay contact springs. Each strip is soldered to a pin pressed tightly into the "square" end of the component board. Pliers should be used to press each strip firmly to the board around the pins while soldering, thus ensuring a springy contact.

WIRING AND TESTING

The only difficulty in the wiring stage is the positioning of components, since the board area is so small. After some experiment the layout illustrated proved to be the most compact. No more soldering pins are used as it will be found that component leads are firmly held when drawn through the perforations in the board and soldered.

The press switch S1 is mounted in the screw cap of the tube and the flexible leads kept reasonably long (about 4in) for torsional take-up when the cap is screwed on. Before attaching these leads to the unit a grommet with a $\frac{3}{8}$ in diameter inner hole is slid over them. Then the leads are attached to the appropriate points and the grommet is passed over the perforated board so that it assists in pressing on the battery contacts (see photographs). However, the primary function of this grommet is to act as an insulating fender, and to retain the unit firmly within the case.

A $\frac{1}{4}$ in hole is made in the rounded end of the tube to take another smaller grommet. This acts as an excellent push fit retainer for the probe and earth clip lead, which should be about 6 to 9 inches long.

The unit is then pressed into the case and held firmly in place by the large grommet. Final positioning is made by pulling the probe out of the other end as far as possible. The cap, with press switch attached, is screwed on to the tube and the instrument is ready for testing.

It is a worthwhile safety precaution to fit a length of insulating sleeving over the probe to avoid short-circuit dangers. A tight fitting polythene sleeve or tape can be wrapped round the tube.

The finished model can be tested by connecting the probe and earth clip to an oscilloscope, or a working audio amplifier. Press the button S1 to switch on the battery and keep it pressed the whole time the unit is required to operate.

The miniprobe is designed to be used on high impedance inputs, such as valve grid circuits, of greater than 100 kilohms; if a lower impedance circuit is being tested, increase the capacitance of C3 as described earlier.



NEXT MONTH IN Practical Electronics

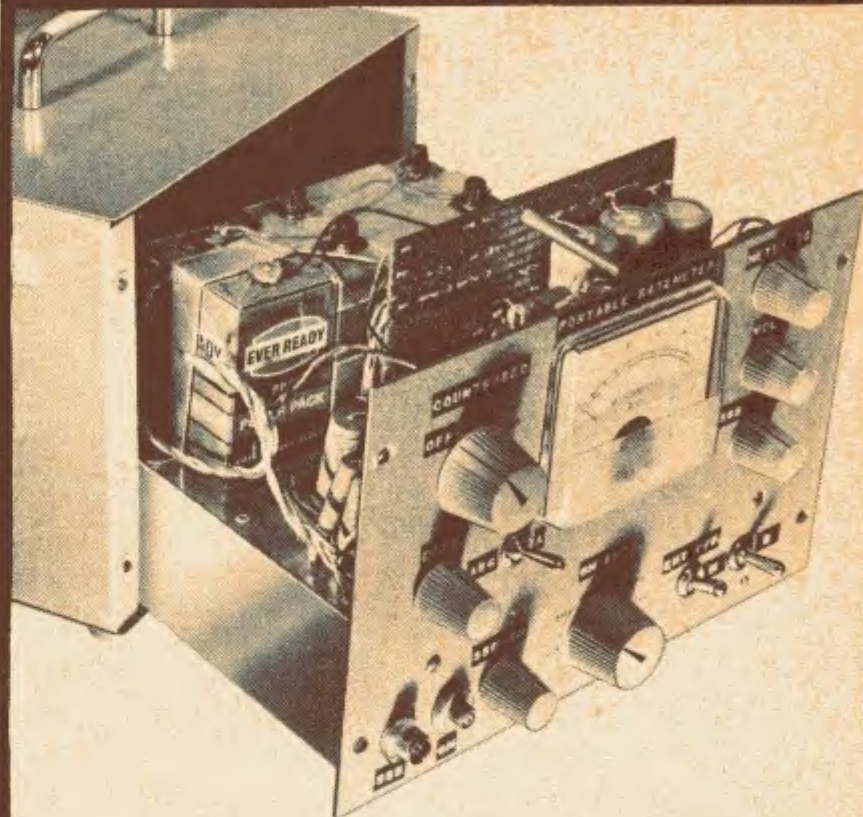

PORTABLE RATEMETER

Self-contained instrument for use with the latest silicon surface barrier radiation detectors and with Geiger-Muller tubes.

ELECTRONIC VIBRATO UNIT

For use with guitars and other electronic instruments.

COMPACT POWER UNIT

General purpose mains operated unit. Outputs 250V 65mA d.c.; 6.3V 3A a.c.

New Series

RADIO CONTROL OF MODELS

First article includes an introduction to remote control systems for model boats and aircraft.

FEBRUARY ISSUE On Sale JAN. 13th

— ORDER YOUR COPY NOW! —

TO _____ (Name of Newsagent)

Please deliver/reserve the February issue of PRACTICAL ELECTRONICS (2/6), on sale Jan. 13th, and continue every month until further notice.

NAME _____

ADDRESS _____

Hand this form to your Newsagent

SIMPLE DIGITAL COMPUTER

$$\begin{array}{r}
 2^5 \quad 2^4 \quad 2^3 \quad 2^2 \quad 2^1 \quad 2^0 \\
 1 \quad 1 \quad 0 \quad 1 \quad 1 \quad 1 \\
 32 + 16 + 0 + 4 + 2 + 1 \\
 = 55
 \end{array}$$



by

J. R. Reid, M.A. and J. R. Reid (Jun), B.Sc.

THE UNIT to be described in this article was originally designed and built to teach students the binary system of counting and simple arithmetic. Simplicity was the key to construction, hence the transparent case so that the switches and wiring can be seen. The unit can be made for an outlay of about £4.

The circuit is made up from identical stages, and, if desired, each stage can be wired by a different person, making it possible to organise a production line, and thus equip a whole class with these adders.

The adder is a type of logical machine and works by direct on-off switching, as opposed to an analogue computer which deals with variations in quantities and is based on the Wheatstone bridge principle. (See the August issue of PRACTICAL ELECTRONICS.)

The machine is "programmed" to display a number, in *binary form*, by a system of lamps. Another number, also expressed in binary code is added to the first; the answer appears again in binary code by using the lamps. It will also multiply any given number by two, and with careful manipulation, it can be made to subtract and divide by two.

The limit on this model is set at $31 + 31$ but, by adding extra stages to the circuit, this can be increased

to almost any value, namely $63 + 63$, $127 + 127$ and so on. This maximum can be evaluated by using the simple formula

$$(2^n - 1) + (2^n - 1)$$

where 2 is the number of the *binary* base, because we are using *binary* code; n is the number of stages employed in the circuit.

BINARY CODE

Full appreciation of the computer's working can only be attained by an understanding of the *binary code* system of numbers. This system is used on many commercial computers and is being taught in many schools to explain the basis for decimal counting.

Logically, mathematically and electrically, the simplest form of communication is one of two states: YES or NO; 1 or 0; ON or OFF. Mathematically it is possible to write any decimal number in terms of "ones" and "noughts" in a logical sequence.

In everyday life the decimal or "denary" counting system is used. This is based on powers of 10 and constitutes a system of ten symbols: 0, 1, 2, 3, . . . 9. By convention, a multiple denary number (such as 6,059) has meaning only because of the "places" of

TABLE 1: DERIVATION OF DENARY AND BINARY NUMBERS

Powers Number	Denary Number				Binary Number					
	10^3	10^2	10^1	10^0	2^5	2^4	2^3	2^2	2^1	2^0
Number	6	0	5	9	1	1	0	1	1	1
Values	(6×10^3)	(0×10^2)	(5×10^1)	(9×10^0)	(1×2^5)	(1×2^4)	(0×2^3)	(1×2^2)	(1×2^1)	(1×2^0)
Denary sum	6000	+	0	+	50	+	9			
Total	6059				55					

the figures. It can be broken down into a sum of powers of 10:

$$6,059 = (6 \times 10^3) + (0 \times 10^2) + (5 \times 10^1) + (9 \times 10^0)$$

In exactly the same way any number can be expressed in terms of powers of 2 (hence the name "binary"). Two symbols are used in this case: 0 and 1. The number is then broken down as follows:

$$55 = (1 \times 2^5) + (1 \times 2^4) + (0 \times 2^3) + (1 \times 2^2) + (1 \times 2^1) + (1 \times 2^0)$$

and written in binary code simply as 110111.

It is important that each power is inserted in the code, even if there are none, as shown above in (0×10^2) and (0×2^3) . Each of these powers equals zero but, as in the denary system, they become essential to the correct evaluation of arithmetic sums.

The "places" of the digits are likewise important since they represent certain values and are normally written as above with high powers of 2 on the left and low powers of 2 to the right. The extreme right-hand power is 2^0 and must always appear. Tables 1 and 2 show how the denary and binary numbers are derived, and some denary numbers that have been converted to binary numbers.

Now let us convert a binary number back to a denary number, but this time we will tabulate as is normal practice in this kind of work. Remember that the binary digits are multiplied by the powers shown above them, the denary answer being given in the third line. The binary number we shall use is 100110.

Binary power	2^5	2^4	2^3	2^2	2^1	2^0
Binary digit	1	0	0	1	1	0
Denary number	32	0	0	4	2	0

The total sum would then be $32 + 4 + 2 = 38$ expressed in denary notation.

When converting from denary to binary, write down the binary values first. Then, starting at the left, write a figure "1" underneath all those values which together total the denary value of the number.

TABLE 2: EXAMPLES OF DENARY TO BINARY CONVERSION

Denary Number	Binary equivalent						
	$2^6=64$	$2^5=32$	$2^4=16$	$2^3=8$	$2^2=4$	$2^1=2$	$2^0=1$
1							1
2						1	0
3						1	1
4					1	0	0
5					1	0	1
6					1	1	0
7					1	1	1
8				1	0	0	0
17			1	0	0	0	1
31			1	1	1	1	1
60		1	1	1	1	0	0
115	1	1	1	0	0	1	1

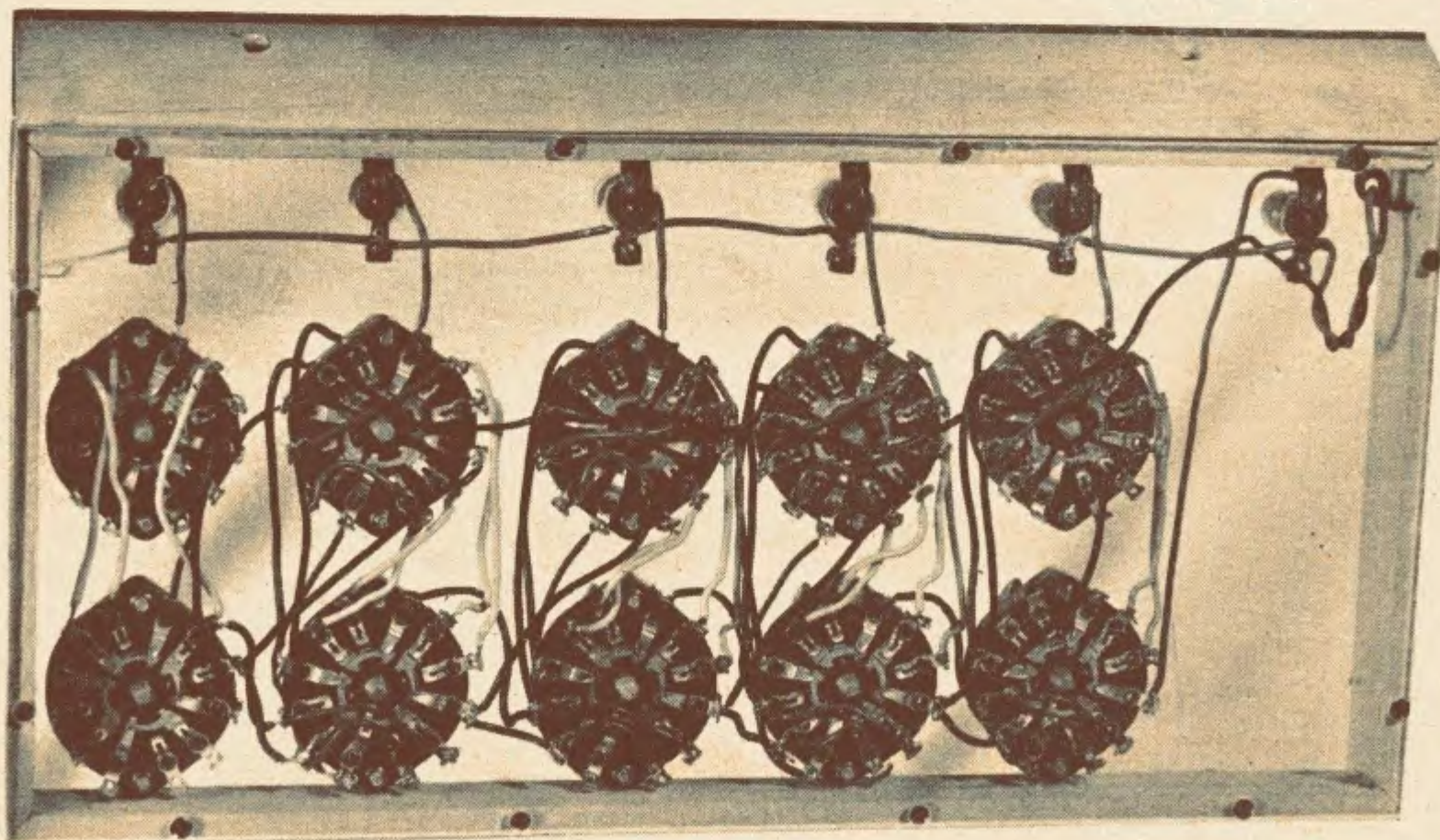

Fig. 1. Underside view of the complete six-stage computer except the external battery

Suppose we wish to convert 43 to binary code: $43 = 32 + 8 + 2 + 1$

Binary powers	2^5	2^4	2^3	2^2	2^1	2^0
Denary values	32	16	8	4	2	1
Numbers totalling 43	(1×32)	$+ (0 \times 16)$	$+ (1 \times 8)$	$+ (0 \times 4)$	$+ (1 \times 2)$	$+ (1 \times 1)$
Binary code	1	0	1	0	1	1
Totals	32	+ 0	+ 8	+ 0	+ 2	+ 1

Therefore 10101 in binary code is equivalent to $32 + 8 + 2 + 1 = 43$ in denary code.

BINARY INDICATORS

We have seen how the binary code system can be represented mathematically; now we will use the binary notation to translate numbers by using electrical conditions ON and OFF. Lamps are used here to denote a "1" when switched on and "0" when switched off (see Tables). Again it is very important to keep to the correct order of digits.

FIRST STAGE, HALF ADDER

Fig. 2 shows one basic stage, the first, for switching a lamp on or off according to the binary code it has received. This particular stage is shown switched to add a "1" and a "0" in the first column, i.e. 2^0 . The total is 1, hence the lamp lights.

The "carry" wires are connected to the second stage 2^1 . As in conventional arithmetic the "carry" numbers are always taken to the next highest column of figures.

For example, let us take

$$16 + 8 = 24$$

In this denary notation the 8 is added to the 6 to give 4 in the right hand column; carry 10 to the left hand column and add to the 1 of 16.

$$\begin{array}{r} \text{Denary } 16 + 8 = 24 \\ \text{Binary } 1 + 1 + 0 + 0 + 0 = 0 \text{ carry } 1 \end{array}$$

Although $1 + 1 = 2$ in denary code, in binary code the highest single digit is 1. Therefore, "2" must be converted back to "0" and carry 1 to the next highest column. This is similar to the denary system where $5 + 5 = 0$, carry 1 to the next highest column.

For any machine programme we must be specific, so two separate circuits are built in, each carrying a current which either informs it to "carry 1" or "carry 0". These "carry" paths pass current to the next highest stages.

The first stage is known as a "half-adder", because it passes information by means of "carry 0" or "carry 1" to the next stage, but does not receive information from any other stage. Table 3 shows the functions of the lamp and "carry" current for the four switched conditions. For these conditions, two switches, each

TABLE 3: FUNCTIONS OF HALF-ADDER CIRCUIT

Switch condition S1 + S2	Lamp	Answer	Carry current to second stage
0 + 0	off	0	carry 0
0 + 1	on	1	carry 0
1 + 0	on	1	carry 0
1 + 1	off	0	carry 1

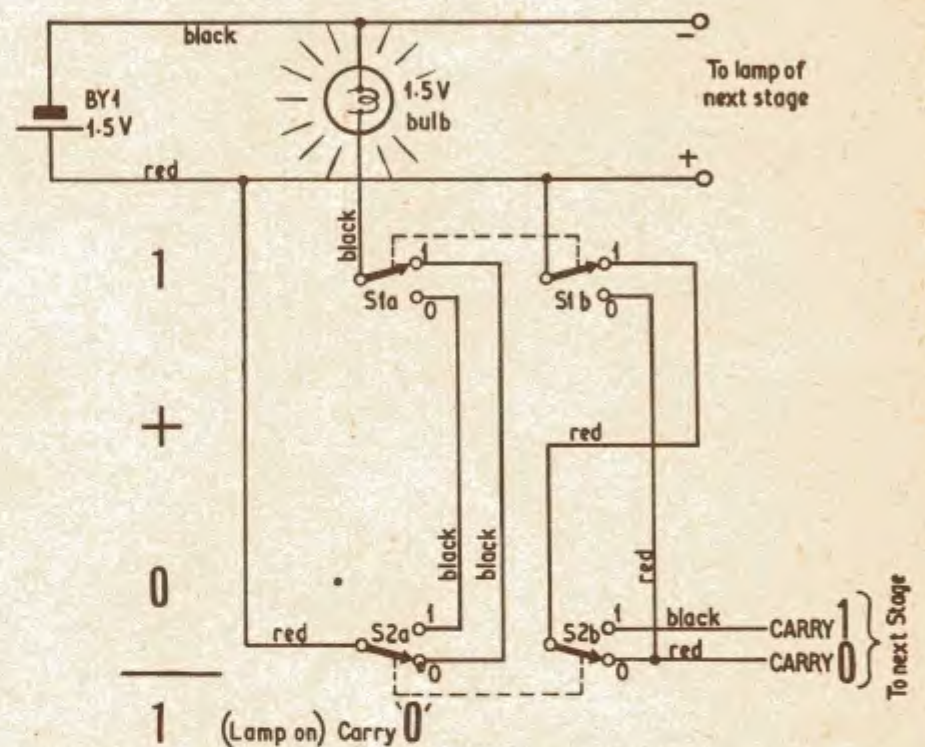

Fig. 2. Basic half-adder stage showing switch functions

being 2-pole 2-way, are required as shown in Fig. 2, although a 4-pole 2 way switch is shown in Fig. 5 for clarity.

INTERMEDIATE STAGE, FULL ADDER

Here we have a similar condition as in the first stage, but the incoming "carry" currents must be inserted and distinguished from the outgoing "carry" currents to the following stage.

Table 4 shows the conditions of the second stage when injected with "carry 0" and "carry 1" currents. Notice that the "carry 0" conditions are the same as those in the first stage.

TABLE 4: FUNCTIONS OF FULL-ADDER CIRCUIT

Incoming carry current from previous stage	Switch condition S1 + S2	Lamp	Answer	Carry current to next stage
carry 0 +	0 + 0	off	0	carry 0
carry 0 +	1 + 0	on	1	carry 0
carry 0 +	0 + 1	on	1	carry 0
carry 0 +	1 + 1	off	0	carry 1
carry 1 +	0 + 0	on	1	carry 0
carry 1 +	1 + 0	off	0	carry 1
carry 1 +	0 + 1	off	0	carry 1
carry 1 +	1 + 1	on	1	carry 1

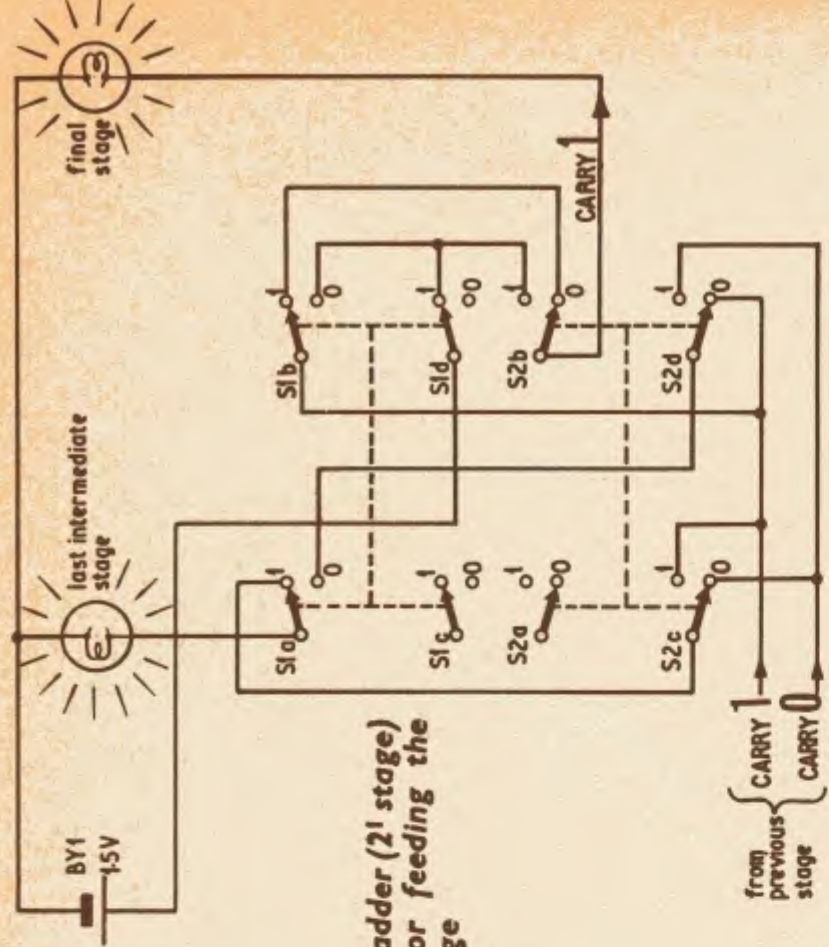

Fig. 4. Full-adder (2¹ stage) modified for feeding the final 2⁰ stage

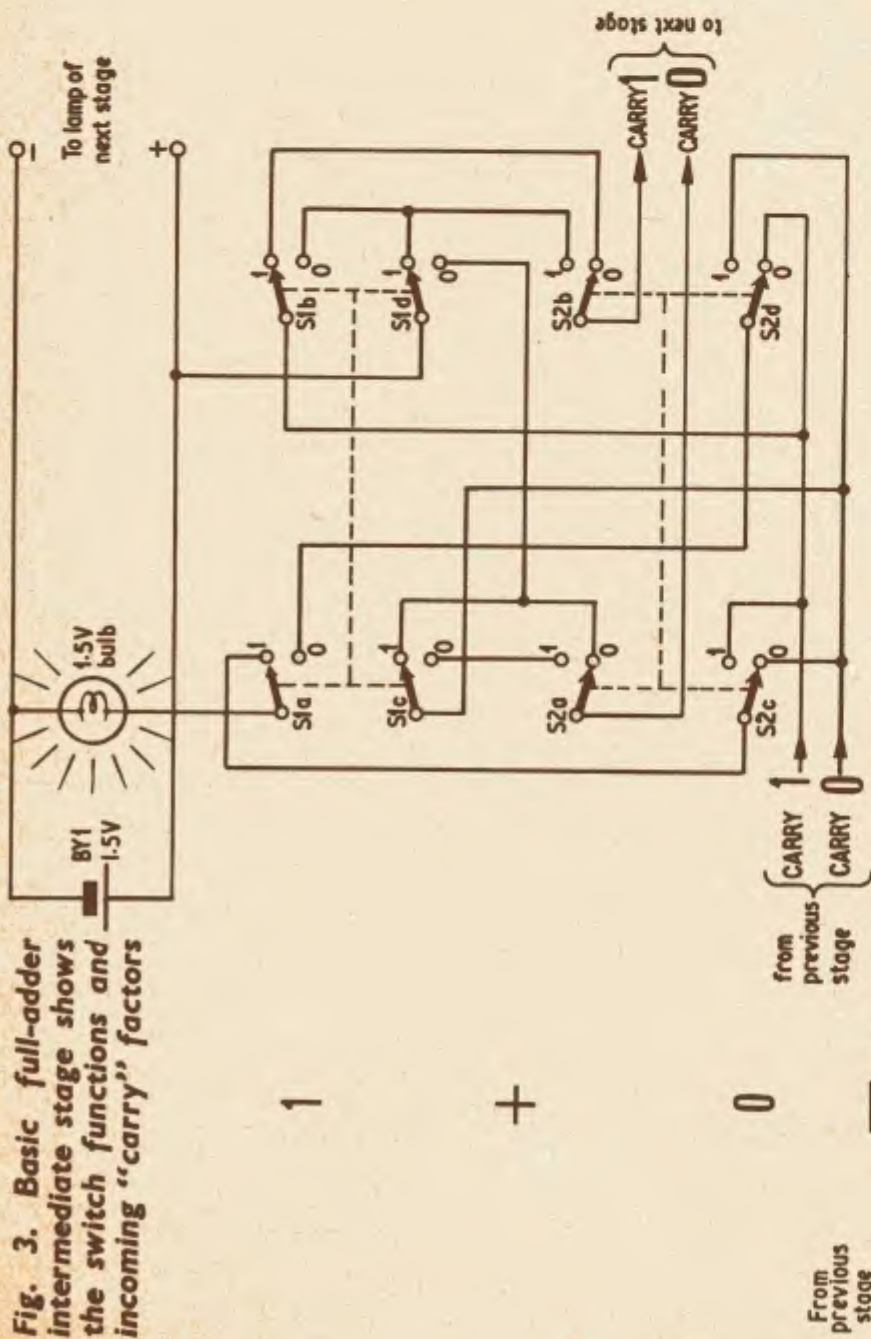
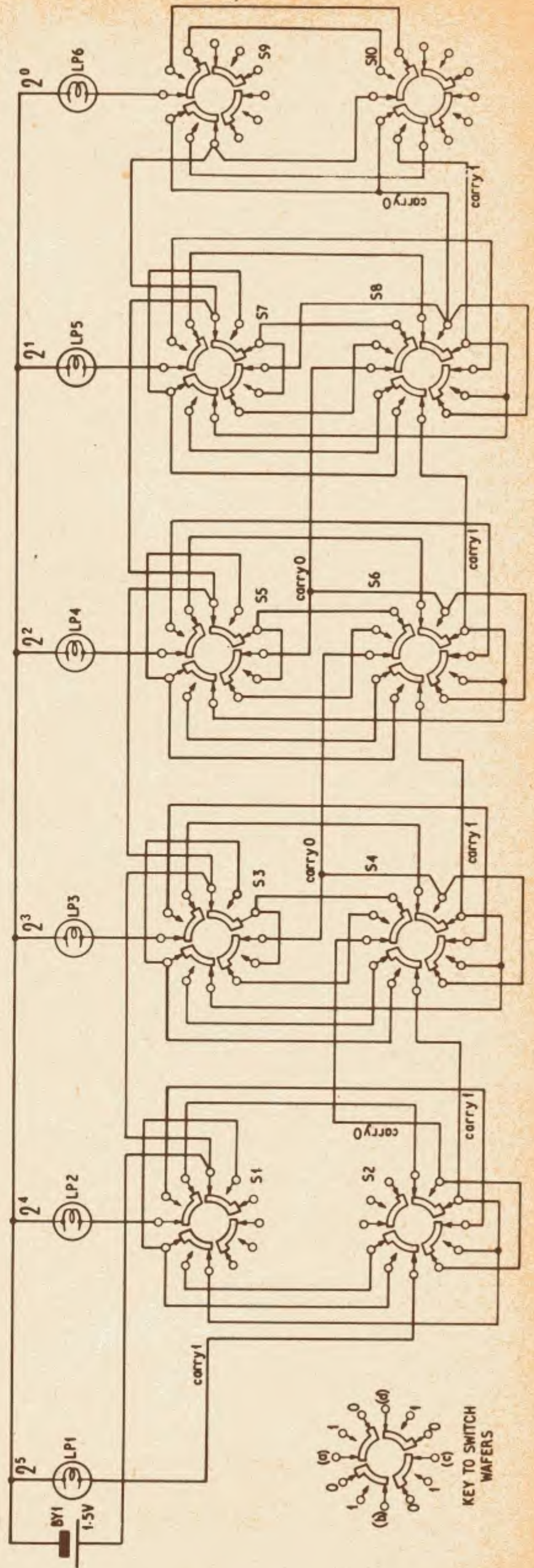

Fig. 3. Basic full-adder intermediate stage shows the switch functions and incoming "carry" factors

From previous stage
 IF CARRY 1 + 1 = 0 CARRY 1 (lamp off this stage)
 IF CARRY 0 + 1 = 1 CARRY 0 (lamp on this stage)

Fig. 5 (below). Circuit of the complete six-stage computer for construction



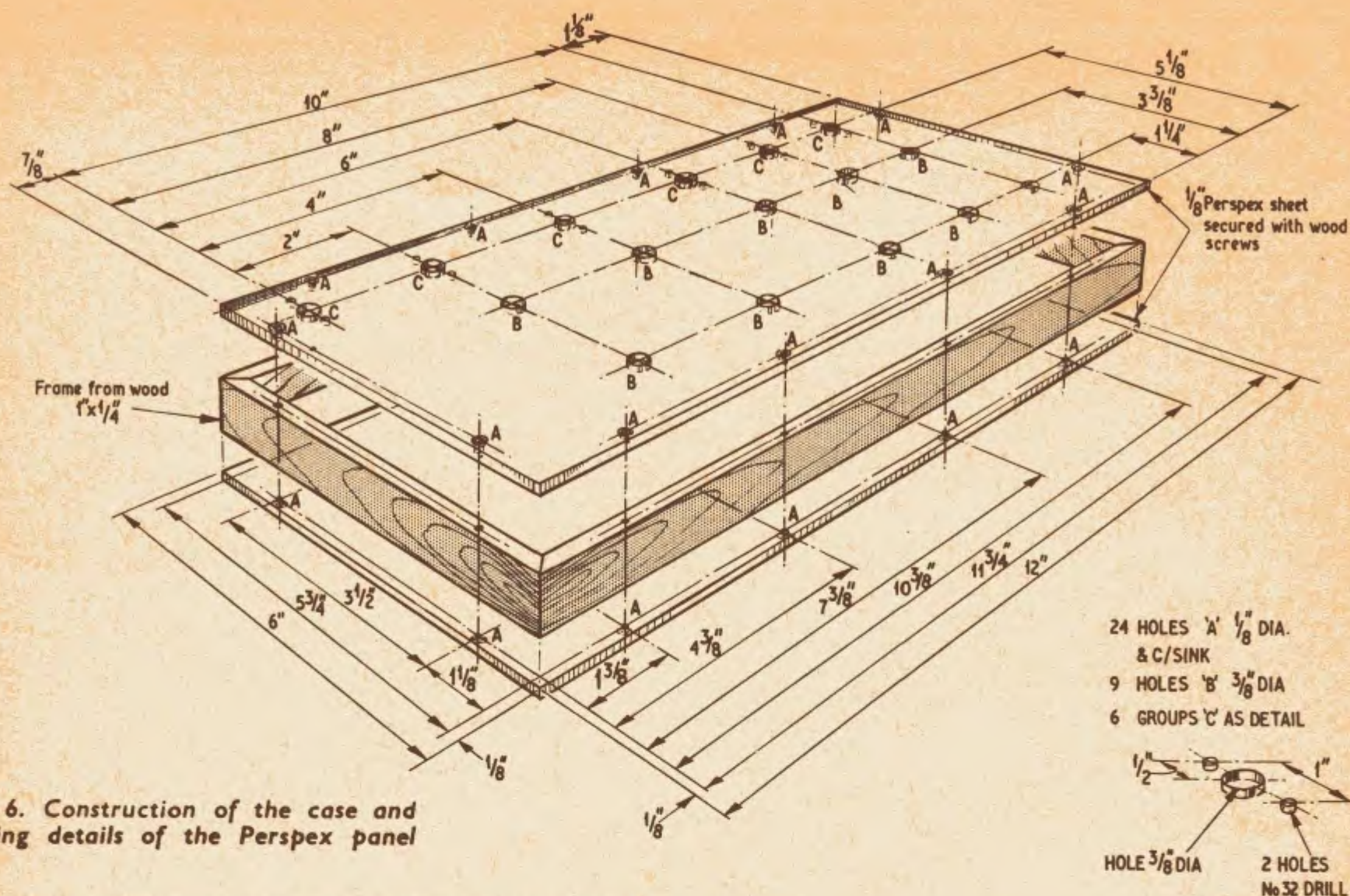

Fig. 6. Construction of the case and drilling details of the Perspex panel

The circuit diagram of one intermediate stage is shown in Fig. 3. Here two additional pairs of switches are added to take the "carry" currents, hence the switches are four-pole two-way types. Any number of these full-adder stages can be used since they would all be identical. In any case they should be preceded by a half-adder and followed by the final stage.

The diagram shows the switches set for $1 + 0$. The answer is indicated for two further conditions: when added to "carry 1" and when added to "carry 0". The last intermediate stage dispenses with S1c and S2a since only "carry 1" is required for the final stage (see Fig. 4).

COMPONENTS . . .

Switches

S1 to S10 4-pole, 2 way rotary wafer switches (10 off)

Lamps

LP1 to LP6 1.5V m.e.s. with batten mounting lampholders (6 off)

Battery

BY1 Heavy duty, 1.5V

Case

Wood 1in \times 1/2in, 3ft length
 "Perspex" sheet 12in \times 6in \times 1/8in thick (2 off)
 Wood screws 2in \times No. 3 csk. head (24 off).

Miscellaneous

P.V.C. covered single-strand wire,
 6 B.A. \times 1/2in bolts and nuts,
 6 B.A. soldering tags

Note: The lamps can be 3.5 volt rating if required to operate from a 3 volt battery. The current rating of the lamps should be as low as possible.

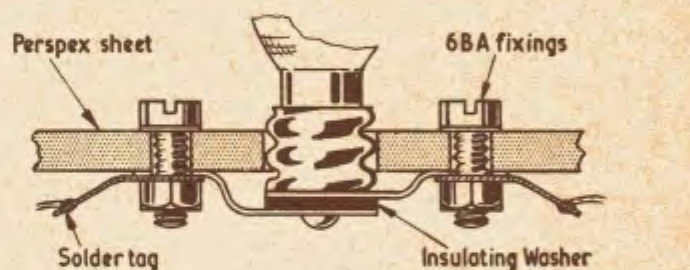

Fig. 7. How the lampholder can be mounted in the panel without using the plastics shroud

CONSTRUCTION

The basic unit is constructed in a "Perspex" case so that all the components and wiring can be seen.

Special care should be exercised when working with "Perspex" as this material is brittle and can be split. It is best to drill small pilot holes in the switch positions before using the larger drill (3/8 in diameter). The switch spindles should be fairly short (about 1/2 in). If they are long when purchased they can be cut with a hacksaw to the required length, holding the spindle in a good vice.

Batten mounting m.e.s. lampholders are used for the bulbs; these can be mounted direct on the case by using the long centre contact screw, and dispensing with the plastic shroud, if a neater appearance is required. Any low voltage torch bulbs will be suitable provided that they are all of the same rating and suit the battery voltage (see suggested types in the components list).

After constructing the case from the drawings in Fig. 6, assemble the components in position. Wire up one stage at a time (see Fig. 5) subsequently checking to see that it functions correctly. Operate the switches to give each condition for each stage (see Table 3).

In each intermediate stage allowance must be made for the incoming "carry" factor from the previous stage (see Table 4).



detached particles

JOHN VALENCE

TOTAL SOLID STATE?

In the last year or so we have seen the transistor invade one of the last remaining strongholds of the valve—the hi fi amplifier. Can it be that solid state is making a bid to take over the whole system, from pick-up to loudspeaker?

An all solid state hi fi system? Well it seems more than likely one of these days. Already at least two American companies are marketing solid state stereo pick-up cartridges. These pick-ups are based on the strain gauge principle. Two semiconductor elements are used and these are energised by a small d.c. power supply. As each element is moved by the stylus, its resistance value alters and so a change in potential appears across the silicon element.

I see that it is claimed that the solid state cartridge is superior in several ways to both the magnetic and the ceramic type cartridge. It is not susceptible to magnetic or electrostatic fields—so there are no hum troubles.

WOT, NO BASS?

Now suppose we take a look at the other end of the hi fi system—at what some people call “the weakest link”. Here again we find our friends across the Atlantic responsible for another innovation—a solid state tweeter with a response from 4,000 to 15,000c/s, announced by Motorola.

The heart of this speaker is a tube of zirconate titanate. This semiconductor material expands or contracts depending on the polarity of the audio signal applied, and so sets into motion an exponential horn attached to one end of the semiconductor tube.

Designing a solid state job to cover the 40 to 4,000c/s part of the audio spectrum is, I presume, rather more tricky. Still I reckon if they can get down to about 200c/s they will be home and dry. The miniature “full range” enclosures now so fashionable will have conditioned the less discerning members of the public to vestigial bass.

FLUID STATE COMPUTER

The meteoric rise to fame of the semiconductor must not blind us to its shortcomings. To demonstrate my own complete detachment in such matters, I draw attention to the fact that the semiconductor has a serious challenger in the field of computer technology.

Sorry, but facts must be faced. The semiconductor does not like certain environmental conditions, for example extremely high temperatures and intense radiation fields. These failings preclude the use of electronic devices in certain applications and therefore extensive research has been made into the use of fluids for control and logic functions.

Last June, a patent for an internally programmed digital computer operating completely with pure fluid (gas or liquid) was granted to the Sperry Rand Corp. of America. By all accounts there is a great future for this system. Fluid devices employ no moving parts, other than the fluid itself. Two principles are involved apparently. First, the fact that if two jets of fluid meet under controlled conditions it is possible to predict the direction of the resultant jet of fluid. Secondly, the phenomenon that when a fixed wall is placed near a jet of fluid, the jet will appear to be attracted to the wall and will actually “lock-on” to the wall.

Using these two principles it is possible to build devices that are analogous to semi-conductor switching and logic function gates.

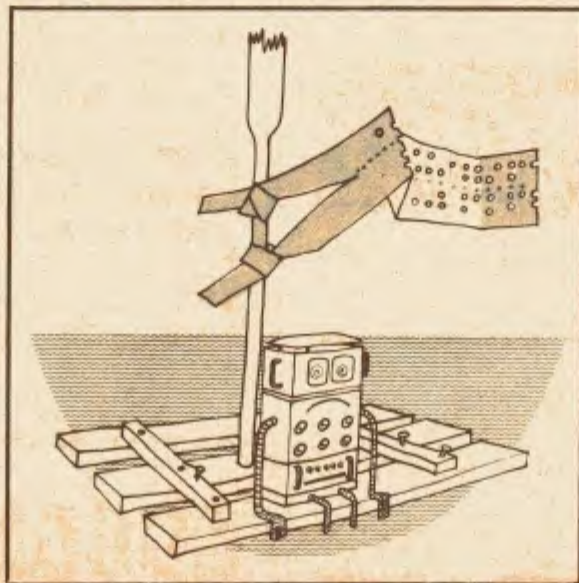

Fluid amplifiers do have one great disadvantage, this is their relatively slow operational speed. Switching times are of the order of a millisecond against a microsecond for an electronic system.

The indications are that fluid logic will be competitive with electronics in many computing fields. But where timing rates in excess of 1kc/s are needed, the semiconductor still has nothing to fear.

ELECTRONIC WATCHKEEPER

After this diversion into an alien field, I return finally to *conventional* computers with a brief mention of automation at sea.

Canadian Pacific's new refrigerated cargo ship *Beaveroak* is the fourth vessel to go to sea this year with an “electronic watchkeeper” installed below deck. This additional crew member is accommodated in an air-conditioned control room within the engine room. Its duty is to continuously scan 200 sensing points throughout the ship.

Any doubts whether this additional crew member earns his keep are dispelled when one learns that “he” carries out a schedule of checks in 101 seconds as against the one hour that would be required for this to be performed manually.

Is this but a forerunner of the completely automated ship?

The computer people seem to have this in mind. At any rate this opinion has been expressed by (another) firm's spokesman during the unveiling of a microminiature process control computer. Possible applications of this compact equipment include use in aircraft and ships.

In the event of the latter, it was suggested that a computer of this kind could be programmed to take over complete control of an unmanned vessel during the voyage, from port to port. One suspects that the National Union of Seamen would be unlikely to object to this extension of automation if it was confined to some of the deleterious and less attractive tropical runs which have to be suffered by some of their members.

NEWS BRIEFS

Milestone in Telecommunications

AT THE inauguration on 8 October of operational working of the Post Office Radio Tower in London, the Postmaster-General, the Rt. Hon. Anthony Wedgwood Benn, M.P., spoke of the tower as a new, bigger Big Ben which captures the spirit of our time. Apart from two obvious puns, the occasion was a serious milestone into the future of telecommunications.

A large proportion of inland trunk calls, broadcasting, and data transmission will be handled by equipment in the tower itself and in the two new trunk exchanges in the building alongside. The incoming signals are converted to microwave radio frequencies for transmission by the tower's aerials.

The tower, which is expected to be open to the public next spring, was inaugurated by the Prime Minister, the Rt. Hon. Harold Wilson, O.B.E., M.P.

Son et Video

THE Slade Radio Society presented its second closed circuit television show on 2 October. Most of the equipment used was built by amateurs and used three cameras. An ambitious programme included comic sketches, an excerpt from "The Importance of Being Earnest", and part of the musical "South Pacific".

Son et Lumière

THIS unusual figure, loaned by Mullard, was the centrepiece of an exhibition on electronic music at Harrods store in London during October. "Nucleus" revolves to the accompaniment of electronic music in a changing dynamic pattern of multi-coloured light.

The electronic music has been composed by Daphne Oram, seen here with John Jedwab (left) the designer of the Electronics Centre.

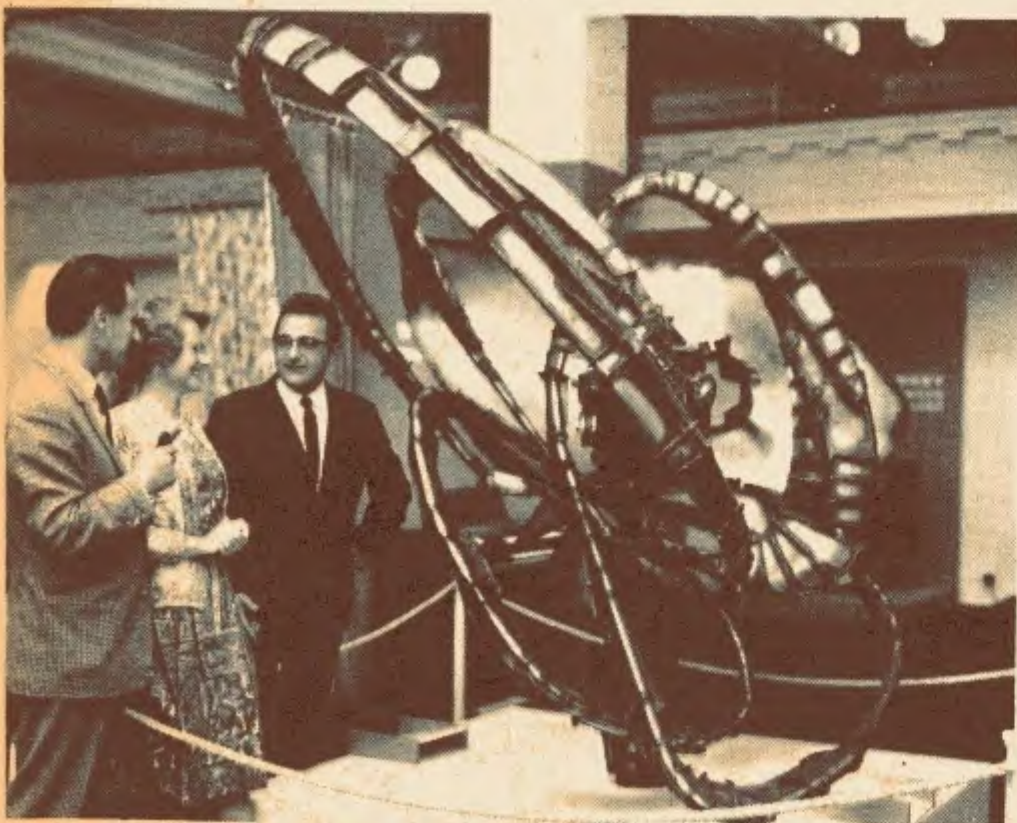

PRACTICAL ELECTRONICS BINDERS



Volume No. 1 of Practical Electronics was completed with the 14th issue last month. Subsequent volumes will run from January to December (12 issues) each year.

The Practical Electronics Easi-binder is designed to hold normally 12 issues, but it will accommodate the two additional copies of Volume 1 quite comfortably.

A new version of the Easi-binder with a special pocket for storing blueprints and data sheets is now available. The price is 14/6d inclusive of postage.

Order your binder from: Binding Department, George Newnes Ltd., Tower House, Southampton Street, London, W.C.2.

LAST MINUTE CHRISTMAS GIFTS

No need to rush out to the shops. Here's one you can arrange now . . . in a few moments . . . in the comfort of your own armchair. A year's subscription for PRACTICAL ELECTRONICS is the ideal gift for friends who are enthusiasts.

But hurry! You must send now to make sure that first copies arrive in time for Christmas. Simply send your friends' names and addresses, together with your own remittance* to cover each subscription to The Subscription Manager (G.3) PRACTICAL ELECTRONICS, Tower House, Southampton Street, London, W.C.2. An attractive Christmas Greetings Card will be sent in your name to announce each gift.

*RATES (INCLUDING POSTAGE) FOR ONE YEAR (12 ISSUES): U.K. AND OVERSEAS £1 16s 0d. U.S.A. \$5.00

To make sure of your own copy why not place a regular order with your newsagent.

INGENUITY

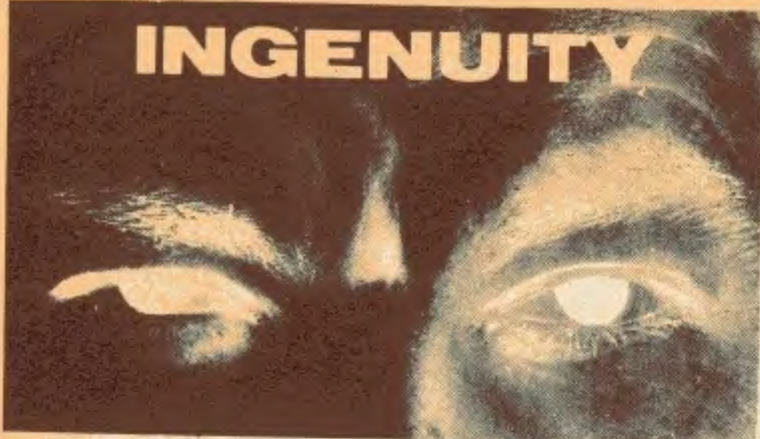

UNLIMITED!

IN THIS feature we hope, from time to time, to be able to publish suggestions submitted by some of our readers on the possible improvement of projects previously described in PRACTICAL ELECTRONICS; short contributions on other subjects may be included. The aim is not to find fault or undermine the abilities or knowledge of our contributors. It may well be that the original article is *par excellence* but it could be improved or adapted to suit individual requirements. The views expressed by readers are not necessarily those of the Editor.

VARIABLE LIGHT FLASHER

HAVING found in past years that Christmas tree decorative light flashers of the thermal type often flashed too slowly, left the lights off too long, or were erratic in operation, I decided to design an electronic flasher with provision for adjusting the duration of the "on" and "off" periods.

With double triodes available very cheaply, and often found in the spares box, a multivibrator circuit was chosen which ensures positive operation of the relay and stable on/off periods. The unit has the additional advantage over the series connected thermal types of being independent of the current consumption of the lights, and can in fact be used to flash any display lamps within the capacity of the contacts of the relay used.

It is recommended that the components be mounted on a panel and enclosed in a case both of insulating material—adequate air circulation should be provided for the valve. A resilient mounting for the relay will give quiet operation. The setting of VR1 determines the period for which the lights are on, and VR2 the

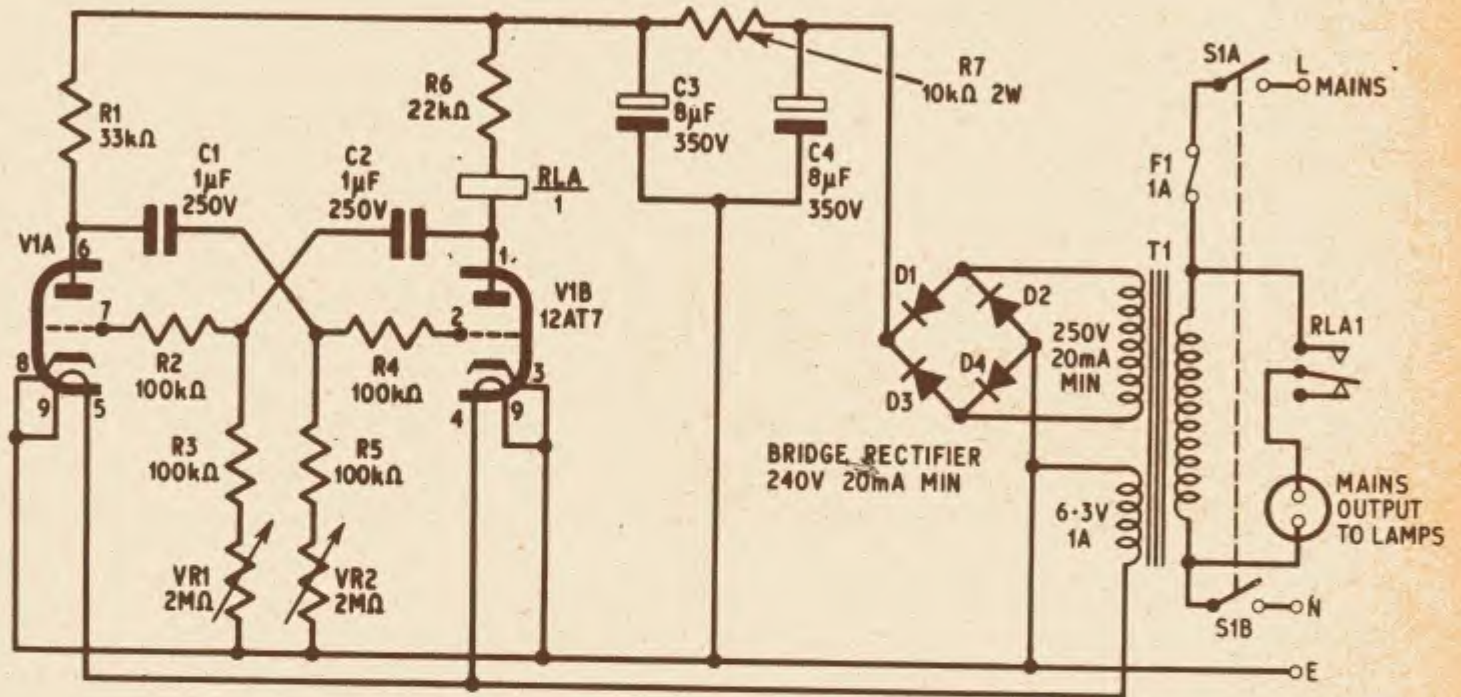

period for which they are off. Both of these are adjustable over a wide range to individual tastes.

The relay used must have contacts rated at mains voltage. The relay coil should have a resistance of between 5,000 and 10,000 ohms, the minimum operating current must be 3mA. Ex-government G.P.O. types are suitable.

Capacitor C2 is quoted in the circuit as 1µF and will provide a nominal maximum "on" period of 3 seconds, but may be altered according to requirements.

J. A. Smith,
Chelmsford,
Essex.

MAGNETIC WATER LEVEL ALARM

IN THE November issue of PRACTICAL ELECTRONICS a water level alarm was described. A magnetic reed switch, a small magnet on a piece of cork or some other material that floats, a bell, and a battery provide a much simpler and cheaper alarm which might be preferred by some readers. A word of caution, though: this alarm is not suitable for use with ferromagnetic containers, so the galvanised or enamelled steel bath is out!

M. Woerner,
Wanstead,
London, E.11.

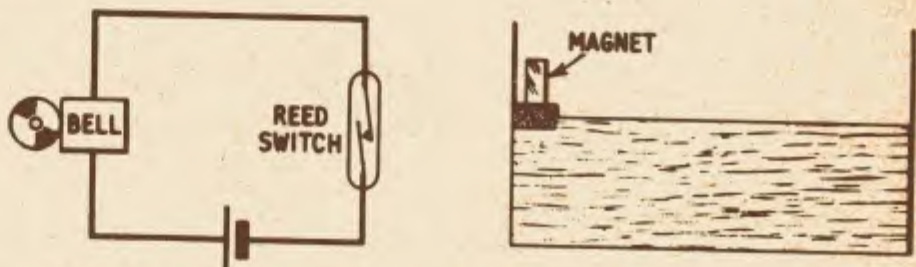

Simpler and cheaper it may well be, but this system may not be as reliable as the original. A guide will be necessary to keep the float rising in a vertical place close to the side of the tank, and the reed switch needs to be very close to the magnetic float to operate well.

FLASH GUN POWER

REFERRING to the Electronic Flash Gun (July, 1965 issue) I should like to make some modifications so that it can be used for close-up work.

The first modification would provide a variable power range, for example, a quarter, half, three-quarters, and full power. I have worked out the switching for this using an extra 16 μ F capacitor to give a little extra full power and to even out the other values. The total capacitance used for each power is as follows:

Full power	1,048 μ F
$\frac{3}{4}$ power	800 μ F
$\frac{1}{2}$ power	532 μ F
$\frac{1}{4}$ power	248 μ F

Could the author tell me if the tube will fire properly on quarter power and if the response to halving the power gives a linear halving of light output?

A. Woolf,
Berkhamsted,
Hertfordshire.

This switching system is a good idea since the new intermediate steps do not deviate from their nominal value by more than 1 $\frac{1}{2}$ per cent; it will only be necessary to calibrate the full power setting.

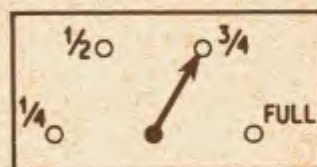
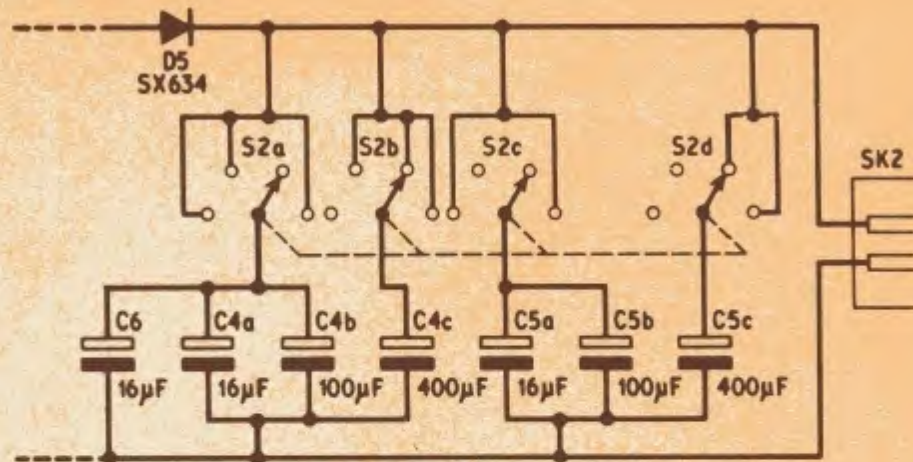

The light output is linear with the capacitance ($L = 50J$ and $J = \frac{1}{2} CV^2$), so that a guide number of, say, 160 on full power would mean guide numbers of 120, 80, and 40 at the intermediate power settings. The tube will fire from almost any reasonable capacitance, provided that the voltage is in excess of 200 volts.

B.J.C.

CLEAN OC71

TRANSISTORS are inherently light sensitive; the old black glass OC71s work as well as photo-transistors when the black paint is removed.

Nowadays, OC71s are filled with an opaque paste which reduces the sensitivity but they can still be used. Carefully file the glass tube near the base, say, $\frac{1}{8}$ in up, until it breaks away.

Dissolve the lump of bluish-white paste by immersing the transistor in alcohol, surgical spirit, or even meths. When the paste is removed give the transistor a rinse in clean spirit and leave to dry thoroughly.

Likewise rinse the paste out of the glass envelope, scrape off the paint, and fit the glass over the transistor carefully, fixing it in place with clear adhesive tape.

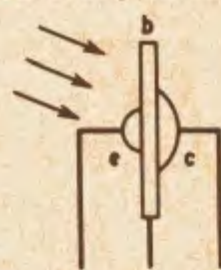

This works very well as a light sensitive device. For maximum sensitivity the light should strike the emitter side—i.e. the smallest "pip".

E. W. Sargent,
High Wycombe,
Buckinghamshire.

HEADS OR TAILS

HAVING a few miniature neons in the spares box, I decided to try the "Heads or Tails" circuit (Neon Novelties, October issue). I used a much larger capacitor (up to 16 μ F) to cause a slow flashing rate and enabling the results of handicapping to be seen easily.

I then decided to extend the circuit to use four neons. The "freeze" switch S2 has three sections in order to short all four capacitors. With component values as shown here, the neons will flash at the rate of about eight flashes per second. Only one neon is on at a time and each remains on for the same duration. Handicapping can be introduced by replacing any pair of resistors by a 2 megohm potentiometer.

Other interesting effects can be obtained by having unequal values for the capacitors.

If ten or more neons are used, a 100 kilohm resistor is recommended between the battery and S1, to reduce the current through the neon which is on in the "freeze" condition. With the multiple circuits the applied voltage not only varies the flashing rate (as in the two-neon circuit) but can also alter the order of flashing.

M. J. Riches,
Leatherhead,
Surrey.

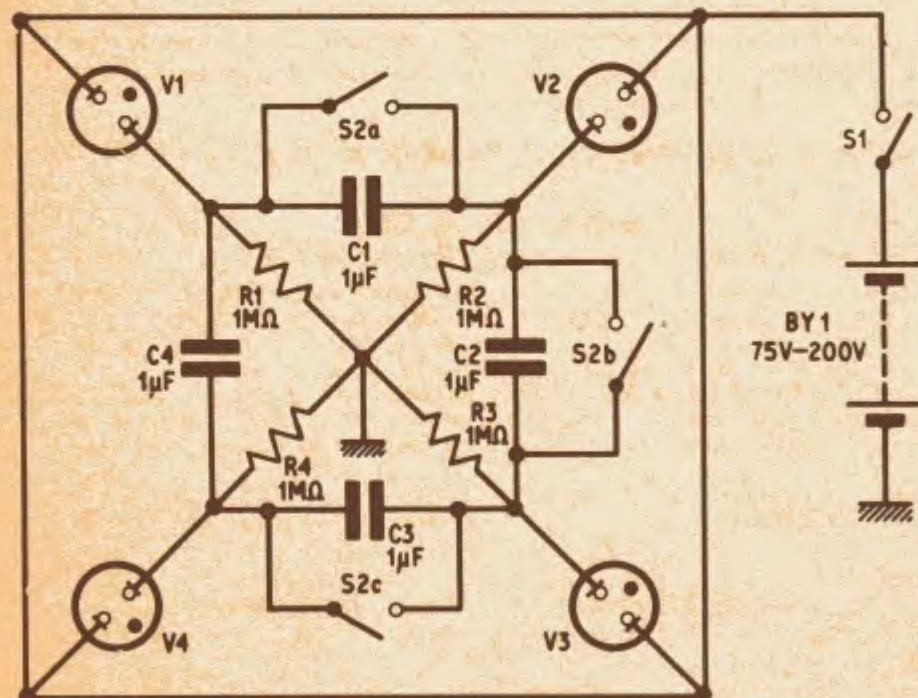

"Heads or Tails" for four players