



# Why

## NOT BUILD ONE OF OUR PORTABLE TRANSISTOR RADIOS...

**BACKED BY OUR SUPER AFTER SALES SERVICE**

### ROAMER SEVEN Mk III

5 WAVEBAND PORTABLE OR CAR RADIO

Amazing performance and specification ★ Now with PHILCO MICRO-ALLOY R.F. TRANSISTORS

● 9 stages—7 transistors and 2 diodes

Covers Medium and Long Waves, Trawler Band and two Short Waves to approx. 15 metres. Push-pull output for room filling volume from rich toned heavy duty "Celestion" speaker. Air spaced ganged tuning condenser. Ferrite rod aerial for M & L Waves and telescopic aerial for S Waves. Real leather-look case with gill trim and shoulder and hand straps. Size 9 × 7 × 4in. approx. The perfect portable and the ideal car radio. (Uses PP7 battery available anywhere.)

Total cost of parts now only **£5.19.6** P. & P.  
Parts Price List and easy build plans 3/- 5/6

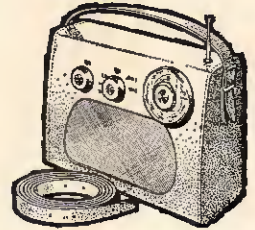

### NEW TRANSONA FIVE

Home, Light, A.F.N., LUX. all at good volume.

G.P. Durham

● 7 stages—5 transistors and 2 diodes

Fully tunable over Medium and Long Waves and Trawler Band. Incorporates Ferrite rod aerial, tuning condenser, volume control, new type fine tone super dynamic 2½in. speaker, etc. Attractive case. Size 6½ × 4½ × 1½in. (Uses 1289 battery available anywhere.)

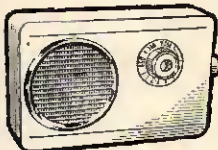

Total cost of all parts now only **42/6** P. & P. Parts Price List and easy build plans 2/-

### POCKET FIVE

● 7 stages—5 transistors and 2 diodes

Covers Medium and Long Waves and Trawler Band, a feature usually found in only the most expensive radios. On test Home, Light, Luxembourg and many Continental stations were received loud and clear. Designed round supersensitive Ferrite rod aerial and fine tone 2½in. moving coil speaker, built into attractive black case with red speaker grille. Size 5½ × 1½ × 3½in. (Uses 1289 battery available anywhere.)

Parts Price List and easy build plans 1/6 Total cost of all parts now only **42/6** P. & P.

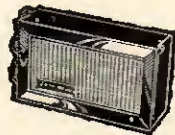

### SUPER SEVEN

● 9 stages—7 transistors and 2 diodes

Covers Medium and Long Waves and Trawler Band. The ideal radio for home, car, or can be fitted with carrying strap for outdoor use. Completely portable—has built-in Ferrite rod aerial for wonderful reception. Special circuit incorporating 2 RF Stages, push-pull output, 3in. speaker (will drive large speaker). Size 7½ × 5½ × 1½in. (Uses 9v battery, available anywhere.)

Total cost of all parts now only **£3.19.6** P. & P. Parts Price List and easy build plans 2/-

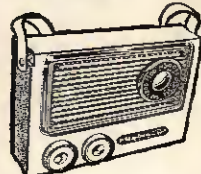

#### COMPONENT BARGAINS

##### TRANSISTORS

PHILCO MADT Type 2N1727  
Maximum frequency of oscillation 150 Mc/s ... 8/6

PHILCO MADT Type 2N1728  
Maximum frequency of oscillation 150 Mc/s ... 9/6

PHILCO MADT (Micro Alloy Diffused) Type 2N503  
Maximum frequency of oscillation over 500 Mc/s ... 15/-

##### TUNING CONDENSERS

Air spaced fine quality German manufacture with slow motion drive. 0.0005 with oscillator section ... 5,6 Post 1/-

##### HEADPHONES

High Fidelity miniature magnetic earpieces (2) on slim band with lead and plug. Easily converted to stereo. American manufacture. 100 ohms impedance. Transformers supplied free for higher impedances P & P 1/6

##### CYLDON PERMEABILITY TUNERS

Full M.W. coverage. Fitted coupling coil, oscillator coil, ferrite slugs and slow motion tuning with cursor, etc. GIVE AWAY PRICE ... 10/- P & P 1/-

### MELODY SIX

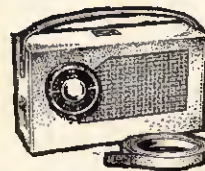

speaker grille and supplied with hand and shoulder straps. Parts Price List and easy build plans 2/- Total cost of all parts now only **£3.9.6** P. & P.

"... amazed at volume and performance, has really come up to my expectations". S.G., Stockton-on-Tees.

● 8 stages—6 transistors and 2 diodes

Our latest completely portable transistor radio covering Medium and Long Waves. Incorporates pre-tagged circuit board, 3in. heavy duty speaker, top grade transistors, volume control, tuning condenser, wave change slide switch, sensitive 6in. Ferrite rod aerial. Push-pull output. Wonderful reception of B.B.C. Home and Light, 208 and many Continental stations. Handsome leather-look pocket size case, only 6½ × 3½ × 1½in. approx. with gill

### TRANSONA SIX

● 8 stages—6 transistors and 2 diodes

This is a top performance receiver covering full Medium and Long Waves and Trawler Band. Push pull output. High-grade speaker makes listening a pleasure. Ferrite rod aerial. Many stations listed in one evening including Luxembourg loud and clear. Attractive case in grey with red grille. Size 6½ × 4½ × 1½in. (Uses PP4 battery available anywhere.) Carrying Strap 1/- extra.

Total cost of all parts now only **59/6** P. & P. Parts Price List and easy build plans 1/6

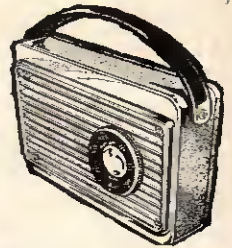

### ROAMER SIX NEW!!

NOW WITH PHILCO MICRO-ALLOY R.F. TRANSISTORS

● 6 WAVEBAND!!

● 8 stages—6 transistors and 2 diodes

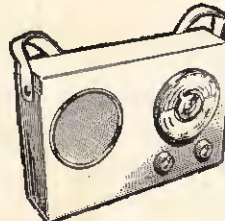

Listen to stations half a world away with this 6 waveband portable. Tunable on Medium and Long Waves, Trawler band and three Short Waves. Push pull output. Sensitive Ferrite rod aerial and telescopic aerial for short waves. Top grade transistors, 3-inch speaker, handsome case with gill fittings. Size 7½ × 5½ × 1½in. ★ Extra band for easier tuning of LUX., etc.

Parts Price List and easy build plans 2/- Total cost of all parts now only **£3.19.6** P. & P. (Carrying Strap 1/6 extra.)

All components used in our receivers may be purchased separately if desired. Parts price lists and easy build plans available separately at fixed prices stated.

**RADIO EXCHANGE Ltd.**  
61a, HIGH STREET, BEDFORD. Phone: 2367

Callers side entrance  
Barratts Shoe Shop  
Open 9—5 p.m.  
Sats. 9—12.30 p.m.

# The NEW Stern-Clyne ELECTRONIC CONCERT ORGAN TO BUILD YOURSELF

## DESIGNED —

- For the Electronic amateur seeking the most fascinating project.
- For the discriminating organist seeking an instrument which DOES sound like a pipe organ.

## NEW —

- Constructional methods introducing "sectional complete instrument" building.
- Extended range of tone colours. Without unrealistic "Gimmick" effects.

**THE MOST COMPREHENSIVE KIT OF PARTS AVAILABLE IN THIS COUNTRY**

**START BUILDING FOR AS LITTLE AS  
£75.15.0 approx. (H.P. Terms Available)**

Send 2/6 for data and information booklet (credited on initial purchase) to: **Electronic Organ Dept., 162 Holloway Road, London, N.7.**

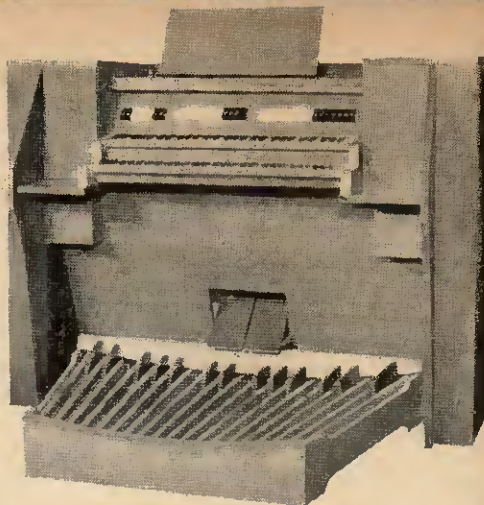

VISIT US AT  
162 HOLLOWAY ROAD, LONDON, N.7  
and hear this fabulous new Electronic Concert  
Organ demonstrated.

# STERN-CLYNE

GREAT BRITAIN'S GREATEST ELECTRONIC HOBBIES ORGANISATION

**HERE'S WHY THOUSANDS OF ELECTRONICS ENTHUSIASTS BUY WITH CONFIDENCE FROM STERN-CLYNE —**

- A wide range of exclusive equipment available including our own speciality — **MULLARD DESIGNS** — for the home constructor or ready assembled.
- The finest selection of Hi-Fi and Audio equipment by all leading manufacturers.
- A comprehensive range of electronic components for the build it yourself enthusiast available at all branches.
- Retail shops, showrooms and demonstration rooms throughout London and the provinces all carry extensive stocks.
- Finest Mail Order Service—geared to give prompt and efficient attention.
- Hire Purchase facilities available on orders of £11 10. 0 and over.
- Hi-Fi advisory service to help you in choosing the right equipment.
- After sales service — complete satisfaction guaranteed.

**VISIT YOUR NEAREST  
STERN-CLYNE ELECTRONICS CENTRE**

### LONDON

18 Tottenham Court Rd., W.1. **MUSEum** 5929-0095. *Half Day Sat.*  
23 Tottenham Court Rd., W.1. **MUSEum** 3451-2. *Half Day Thurs.*  
309 Edgware Rd., W.2. **PADDington** 6963. *Half Day Thurs.*  
109 Fleet St., E.C.4. **FLEET** St. 5812-3. *Half Day Sat.*  
162 Holloway Road, N.7. **NORTH** 7941. *Half Day Thurs.*  
9 Camberwell Church St., S.E.5. **RODNEY** 2875. *Half Day Thurs.*

### BRISTOL

26 Merchant Street, Bristol 1. **Bristol** 20261.  
*Now open 6 days a week.*

### CROYDON

12 Suffolk House, George St. **MUNICIPAL** 3250. *Half Day Wed.*

### LIVERPOOL

52 Lord Street, Liverpool. **ROYAL** 7450. *Open 6 days a week.*

### MANCHESTER

20-22 Withy Grove, Manchester 4. **BLACKFRIARS** 5379-5246.  
*Open 6 days a week.*

### SHEFFIELD

125 The Moor, Sheffield. **SHEFFIELD** 29993. *Half Day Thurs.*

### MAIL ORDERS AND ENQUIRIES TO:

Dept. P.E., 3-5 Eden Grove, Holloway, London, N.7. **NORTH** 8161-5.

# Z & I AERO SERVICES LTD.

Head Office and Warehouse: 44A WESTBOURNE GROVE, LONDON, W.2.

Retail Shop:

85 TOTTENHAM COURT ROAD, LONDON, W.1

Tel.: LANGHAM 8493

Tel.: PARK 5641/2/3

0A2	8/-	6F30L2	10/-	60D6GA17/-	6V6GT	7/8	12F9GT	8/-	
0B2	6/-	6A8	8/-	6CL5	9/-	6X4	4/-	12J6GT	3/-
0C3	6/-	6AB4	6/8	6CW4	12/-	6X9GT	5/8	12K7GT	7/8
0D3	6/-	6AC7	3/-	6D4	15/-	7R8	11/-	12L8	10/-
1A6GT	5/-	6AF4	11/-	6DK6	6/-	7B7	8/-	12Q7GT	5/-
1A7GT	8/-	6AG7	6/-	6DS4	15/-	7C5	10/-	12SA7	7/-
1B3GT	7/-	6AH6	10/-	6EA8	10/-	7C8	7/-	12SB7	4/-
1D6	8/-	6AK5	6/8	6E6	8/-	7D3	8/-	12SC7	4/-
1G6GT	7/-	6AK8	7/-	6F7	5/-	7D5	8/-	12SK7	5/-
1H4GT	7/-	6AL5	3/-	6F8G	5/-	7D8	7/-	12SY7	6/-
1H5GT	7/-	6AM5	2/6	6F11	6/-	7K7	10/-	12QA5	5/-
1L4	2/6	6AM6	4/-	6F13	6/-	7R7	12/-	20F2	15/-
1L8	17/-	6AN5	10/-	6F17	6/-	8BWB	7/-	20L1	14/-
1N6GT	8/-	6AN8	10/-	6F23	9/8	10C1	10/-	20P1	14/-
1Q6GT	8/-	6AQ3	8/-	6F24	11/-	10C2	12/-	20P3	12/-
1R4	6/-	6AQ6	8/-	6F28	10/-	10D1	7/-	20P4	14/-
1R5	5/-	6AR5	6/-	6J4	8/-	10F1	14/-	20P5	12/-
1R6	5/-	6AR6	6/-	6J6	4/-	10F3	8/-	25A5G	5/-
1R8	4/8	6AR6	5/-	6J8	3/8	10F9	10/-	25C5	10/-
1T4	3/-	6AS7G	22/8	6JG	5/-	10F18	9/-	25L5GT	8/-
1T6GT	8/-	6AT8	4/-	6JGT	7/8	10H3	7/-	25Z4G	7/-
1U4	6/-	6AU6	6/-	6K7	5/-	10H13	13/8	25Z5	7/8
1U5	6/-	6AV6	6/-	6K7GT	5/-	10H14	13/8	25Z6GT	8/8
1X2A	7/-	6B7	5/-	6K8	4/-	11D3	7/-	27M1	60/-
1X2B	7/-	6BGT	5/-	6L1	10/-	12A0C	8/-	28D7	7/8
1X3	7/-	6B1GT	5/-	6LGA	7/8	12AH7	5/-	29C1	20/-
1Y4	12/-	6BA4G	4/8	6L7	7/8	12AH8	11/-	30C15	10/-
2D21	6/-	6BA7	15/-	6L18	8/-	12C17	12/-	30E2	9/8
3A4	4/-	6BC4	17/8	6P1	11/-	12A2L3	7/-	30C18	10/8
3A5	7/-	6BD5	5/-	6P25	12/8	12A2G	7/-	30F5	9/8
3B7	4/-	6BR6	6/-	6Q7G	8/-	12A2T	4/-	30FL1	11/-
3Q4	6/8	6BR6	7/-	6QGT	8/-	12A2V	8/-	30L15	12/-
3Q6GT	6/8	6B18	8/-	6SA7	6/-	12AUG	6/-	30L17	23/-
3R4	5/-	6BK7A	8/-	6S07	9/-	12AU7	5/-	30P12	10/-
3V4	5/8	6BN6	7/-	6S07	6/-	12AV6	6/-	30P19	14/-
4D1	4/-	6BQ7A	8/-	6S7J	8/8	12AV7	8/-	30PL1	11/8
4THA	10/-	6BR7	11/8	6SKGT	4/8	12AX7	10/-	30PL13	11/8
FR4GY	9/-	6BR8	5/-	6SLGT	5/-	12AX7	10/-	30PL14	12/8
5U4G	6/8	6B87	18/-	6SN7GT	4/8	12BA8	8/-	30PL15	11/-
5U4GB	6/8	6BWS	9/8	6UAGT	10/8	12BA8	8/-	30C6	6/8
5V4G	8/-	6BW7	9/-	6U8	7/8	12BE6	5/-	35D5	12/-
5Y3GT	8/-	6C4	2/8	6C8A	8/-	12BH7	8/-	35T6GT	7/-
5Z3	8/-	6C6G	7/-	6V6	8/-	12B7	10/-	35W4	5/-
5Z4G	7/8	6C6B	5/-	6V6G	8/-	12E1	20/-	38Z3	10/-



35Z4G	4/-	CY31	8/8
32A0T	8/-	CC32	4/8
32Z5GT	6/-	DAF91	6/8
32Z6GT	6/-	DAF92	6/-
32Z7	4/-	DAF96	6/-
32Z8	4/-	DC090	7/-
32Z9	4/-	DF33	8/-
32Z10	4/-	DF36	8/-
32Z11	4/-	DF39	8/-
32Z12	4/-	DF42	8/-
32Z13	4/-	DF45	8/-
32Z14	4/-	DF48	8/-
32Z15	4/-	DF51	8/-
32Z16	4/-	DF54	8/-
32Z17	4/-	DF57	8/-
32Z18	4/-	DF60	8/-
32Z19	4/-	DF63	8/-
32Z20	4/-	DF66	8/-
32Z21	4/-	DF69	8/-
32Z22	4/-	DF72	8/-
32Z23	4/-	DF75	8/-
32Z24	4/-	DF78	8/-
32Z25	4/-	DF81	8/-
32Z26	4/-	DF84	8/-
32Z27	4/-	DF87	8/-
32Z28	4/-	DF90	8/-
32Z29	4/-	DF93	8/-
32Z30	4/-	DF96	8/-
32Z31	4/-	DF99	8/-
32Z32	4/-	DF102	8/-
32Z33	4/-	DF105	8/-
32Z34	4/-	DF108	8/-
32Z35	4/-	DF111	8/-
32Z36	4/-	DF114	8/-
32Z37	4/-	DF117	8/-
32Z38	4/-	DF120	8/-
32Z39	4/-	DF123	8/-
32Z40	4/-	DF126	8/-
32Z41	4/-	DF129	8/-
32Z42	4/-	DF132	8/-
32Z43	4/-	DF135	8/-
32Z44	4/-	DF138	8/-
32Z45	4/-	DF141	8/-
32Z46	4/-	DF144	8/-
32Z47	4/-	DF147	8/-
32Z48	4/-	DF150	8/-
32Z49	4/-	DF153	8/-
32Z50	4/-	DF156	8/-

RRF83	7/8	EF95	5/8	GZ30	8/8	PEN45DD	U292	13/-	
EBF89	6/8	EF98	10/-	GZ32	10/-	PL36	10/-	U301	14/-
EBL1	14/-	EF183	8/-	GZ34	10/-	PL38	10/-	U403	7/-
FBL21	11/-	EF184	8/-	HABC80	8/-	PL48	18/-	U801	18/-
EC88	12/-	EF760	10/-	HL133DD	PL81	7/-	U4920	7/8	
EC90	2/8	EL74	10/-	KL78C	20/-	PL82	6/-	UABC80	6/-
EC91	5/-	EL35	5/-	KT78	20/-	PL83	6/-	U4842	8/-
EC92	6/8	EL36	9/-	KT85	20/-	PL84	6/8	UBC41	7/-
EC93	5/-	EL37	17/8	KT86	20/-	PL85	6/8	UBC81	7/-
EC94	4/-	EL38	17/8	KT88	20/-	PL86	9/-	UBF80	6/8
EC95	2/8	EL39	10/-	KT89	20/-	PL87	9/-	UBF89	6/8
EC96	6/8	EL40	9/-	KT90	20/-	PL88	9/-	UBL21	11/-
EC97	5/-	EL41	8/8	KT91	20/-	PL89	6/-	UBL42	8/-
EC98	5/-	EL42	8/8	KT92	20/-	PL90	15/-	UCB80	6/8
EC99	5/-	EL43	8/8	KT93	20/-	PL91	15/-	UCB81	7/-
EC100	5/-	EL44	8/8	KT94	20/-	PL92	15/-	UCB89	6/8
EC101	5/-	EL45	8/8	KT95	20/-	PL93	15/-	UCB90	6/8
EC102	5/-	EL46	8/8	KT96	20/-	PL94	15/-	UCB91	6/8
EC103	5/-	EL47	8/8	KT97	20/-	PL95	15/-	UCB92	6/8
EC104	5/-	EL48	8/8	KT98	20/-	PL96	15/-	UCB93	6/8
EC105	5/-	EL49	8/8	KT99	20/-	PL97	15/-	UCB94	6/8
EC106	5/-	EL50	8/8	KT100	20/-	PL98	15/-	UCB95	6/8
EC107	5/-	EL51	8/8	KT101	20/-	PL99	15/-	UCB96	6/8
EC108	5/-	EL52	8/8	KT102	20/-	PL100	15/-	UCB97	6/8
EC109	5/-	EL53	8/8	KT103	20/-	PL101	15/-	UCB98	6/8
EC110	5/-	EL54	8/8	KT104	20/-	PL102	15/-	UCB99	6/8
EC111	5/-	EL55	8/8	KT105	20/-	PL103	15/-	UCB100	6/8
EC112	5/-	EL56	8/8	KT106	20/-	PL104	15/-	UCB101	6/8
EC113	5/-	EL57	8/8	KT107	20/-	PL105	15/-	UCB102	6/8
EC114	5/-	EL58	8/8	KT108	20/-	PL106	15/-	UCB103	6/8
EC115	5/-	EL59	8/8	KT109	20/-	PL107	15/-	UCB104	6/8
EC116	5/-	EL60	8/8	KT110	20/-	PL108	15/-	UCB105	6/8
EC117	5/-	EL61	8/8	KT111	20/-	PL109	15/-	UCB106	6/8
EC118	5/-	EL62	8/8	KT112	20/-	PL110	15/-	UCB107	6/8
EC119	5/-	EL63	8/8	KT113	20/-	PL111	15/-	UCB108	6/8
EC120	5/-	EL64	8/8	KT114	20/-	PL112	15/-	UCB109	6/8
EC121	5/-	EL65	8/8	KT115	20/-	PL113	15/-	UCB110	6/8
EC122	5/-	EL66	8/8	KT116	20/-	PL114	15/-	UCB111	6/8
EC123	5/-	EL67	8/8	KT117	20/-	PL115	15/-	UCB112	6/8
EC124	5/-	EL68	8/8	KT118	20/-	PL116	15/-	UCB113	6/8
EC125	5/-	EL69	8/8	KT119	20/-	PL117	15/-	UCB114	6/8
EC126	5/-	EL70	8/8	KT120	20/-	PL118	15/-	UCB115	6/8
EC127	5/-	EL71	8/8	KT121	20/-	PL119	15/-	UCB116	6/8
EC128	5/-	EL72	8/8	KT122	20/-	PL120	15/-	UCB117	6/8
EC129	5/-	EL73	8/8	KT123	20/-	PL121	15/-	UCB118	6/8
EC130	5/-	EL74	8/8	KT124	20/-	PL122	15/-	UCB119	6/8
EC131	5/-	EL75	8/8	KT125	20/-	PL123	15/-	UCB120	6/8
EC132	5/-	EL76	8/8	KT126	20/-	PL124	15/-	UCB121	6/8
EC133	5/-	EL77	8/8	KT127	20/-	PL125	15/-	UCB122	6/8
EC134	5/-	EL78	8/8	KT128	20/-	PL126	15/-	UCB123	6/8
EC135	5/-	EL79	8/8	KT129	20/-	PL127	15/-	UCB124	6/8
EC136	5/-	EL80	8/8	KT130	20/-	PL128	15/-	UCB125	6/8
EC137	5/-	EL81	8/8	KT131	20/-	PL129	15/-	UCB126	6/8
EC138	5/-	EL82	8/8	KT132	20/-	PL130	15/-	UCB127	6/8
EC139	5/-	EL83	8/8	KT133	20/-	PL131	15/-	UCB128	6/8
EC140	5/-	EL84	8/8	KT134	20/-	PL132	15/-	UCB129	6/8
EC141	5/-	EL85	8/8	KT135	20/-	PL133	15/-	UCB130	6/8
EC142	5/-	EL86	8/8	KT136	20/-	PL134	15/-	UCB131	6/8
EC143	5/-	EL87	8/8	KT137	20/-	PL135	15/-	UCB132	6/8
EC144	5/-	EL88	8/8	KT138	20/-	PL136	15/-	UCB133	6/8
EC145	5/-	EL89	8/8	KT139	20/-	PL137	15/-	UCB134	6/8
EC146	5/-	EL90	8/8	KT140	20/-	PL138	15/-	UCB135	6/8
EC147	5/-	EL91	8/8	KT141	20/-	PL139	15/-	UCB136	6/8
EC148	5/-	EL92	8/8	KT142	20/-	PL140	15/-	UCB137	6/8
EC149	5/-	EL93	8/8	KT143	20/-	PL141	15/-	UCB138	6/8
EC150	5/-	EL94	8/8	KT144	20/-	PL142	15/-	UCB139	6/8
EC151	5/-	EL95	8/8	KT145	20/-	PL143	15/-	UCB140	6/8
EC152	5/-	EL96	8						

# UNUSUAL SINGLE SPEAKER SYSTEM

## A CONCRETE COLUMN

An inexpensive column speaker constructed from a concrete pipe and fitted with a good 8" or 10" unit, has attracted much interest and admiration because of its clean, open sound.

Complete kits of wooden fixtures are available, including absorbent wadding and diffusing cone.

Price £3.15.0 for 8" model. Recommended 8" unit — Super 8/RS/DD £6.14.2 including purchase tax.  
Price £4.18.0 for 10" model. Recommended 10" units — Super 10/RS/DD £10.18.8; Golden 10/RS/DD £7.17.5; 10" Bronze/RS/DD £4.12.9.  
Prices include purchase tax.

Suitable concrete pipes can be purchased from builders' merchants at about 12/6 and 17/6.

Descriptive leaflet free on request from:

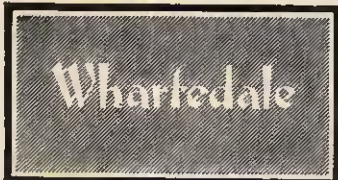

**WHARFEDALE WIRELESS WORKS LTD.**  
Dept. E  
IDLE, BRADFORD, YORKSHIRE  
Grams: "Wharfedale" Bradford  
Telephone: Idle 1235/6

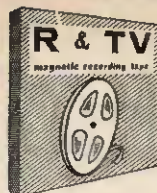

### FIRST QUALITY PVC TAPE

5 1/2" Std. 850 ft. 9/-    5" D.P. 850 ft. 10/6  
7" Std. 1200 ft. 11/6    3" T.P. 600 ft. 8/-  
3" L.P. 240 ft. 4/-    5" T.P. 1800 ft. 20/6  
5 1/2" L.P. 1200 ft. 11/6    5 1/2" T.P. 2400 ft. 27/6  
7" L.P. 1800 ft. 18/6    7" T.P. 3600 ft. 37/6

P. & P. on each 1/6, 4 or more post free.

Complete with McLaren Variable Thermostat 90° to 180°F. 20 amp. A.C. and GEC double pole 20 amp. mains switch. 18", 27", 30" and 36". State length required. £2.0.0 plus 5/- P. & P.

### 3 kW IMMERSION HEATER



### "PREMIER" KETTLE ELEMENT

1000 w., 8/6 + 3/- P. & P. Retaining nut and flange 2/6, switch plug to suit 2/6.

### A.C. MAINS MOTOR



Can be used for a variety of purposes, silent running, satisfactory in every way.

230/250 v.  
A.C. 9/6.  
P. & P. 3/-.

### 3 to 4 WATT AMPLIFIER KIT



comprising chassis 8 1/2" x 2 1/2" x 1 1/2". Double wound mains

transformer, output transformer, volume and tone controls, resistors, condensers, etc. 6V6, ECC81 and metal rectifier. Circuit 1/6 free with kit. 29/6 plus 4/6 P. & P.



### 40w. FLUORESCENT LIGHT

KIT incorporating GEC Choke size 8 1/2" x 1 1/2" x 1 1/2", 2 bi-pin holders, starter and starter holder, 11/6. P. & P. 4/6.

Similar to above: 80w. Fluorescent Light Kit incorporating GEC choke size 11 1/2" x 1 1/2" x 1 1/2", 2 bi-pin holders, starter and starter holder, 17/6. P. & P. 5/6.

### 8-watt 5-valve PUSH-PULL AMPLIFIER & METAL RECTIFIER

Size: 9 x 6 x 1 1/2" A.C. Mains 200-250v. 5 valves. For use with Std. or L.P. records, musical instruments, all makes of pick-ups and mikes. Output 8 watts at 5 per cent total distortion. Separate bass and treble lift controls. Two inputs, with controls, for gram. and mike. Output Transformer tapped for 3 and 15 ohms speech coils. Built and tested. £3.19.6. P. & P. 8/-.

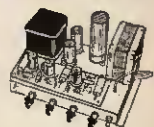

### SPECIAL OFFER!

#### "ELEGANT SEVEN MK. II"

Combined Portable and Car Radio

The Radio with the "Star" Features

- ★ 7-transistor superhet. Output 350 mW.
- ★ Grey wooden cabinet, fitted handle with silver-coloured fittings, size 12 1/2 in. x 8 1/2 in. x 3 1/2 in.
- ★ Horizontal tuning scale, size 11 1/2 in. x 2 1/2 in. in silver with black lettering.
- ★ All stations clearly marked.
- ★ Ferrite-rod internal aerial.
- ★ Operated from PP9 battery.
- ★ I.F. neutralisation on each stage 460 kc/s.
- ★ D.C. coupled output stage with separate A.C. negative feed back.
- ★ All components, ferrite rod and tuning assembly mounted on printed board.
- ★ Fully comprehensive instructions and point-to-point wiring diagram.
- ★ Printed circuit board, back-printed with all component values.
- ★ Fully tunable over medium and long waveband.
- ★ Car aerial socket.      ★ Full after-sales service.

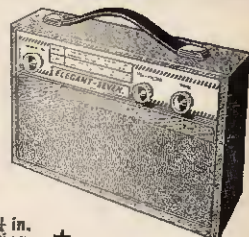

ONLY  
**£4.4.0**

Plus 6/6 Post & Packing

4 in. SPEAKER. Parts list and circuit diagram 2/6. FREE with parts.

Shop Hours 9 a.m. — 6 p.m. Early Closing Wednesday

**RADIO & T.V. COMPONENTS (ACTON) LTD.**  
21D, HIGH STREET, ACTON, LONDON, W.3

*in step with the*

**SINCLAIR**  
20 WATT INTEGRATED

**20 WATTS R.M.S.!**

SIZE  $8\frac{1}{4}" \times 3\frac{1}{4}" \times 1"$  ● WEIGHT  $4\frac{1}{2}$  ozs.

THE SINCLAIR X-20 enables you to enjoy, for the first time ever, the advantages of using a high power, high fidelity audio amplifier truly in step with today's space age electronics. No longer does power mean problems of heat and size, for the X-20 requires neither heatsink nor special ventilation. It measures only  $8\frac{1}{4}" \times 3\frac{1}{4}" \times 1"$ , weighs  $4\frac{1}{2}$  ozs. and will deliver up to 20 watts R.M.S. into a 7-8 ohms loudspeaker—40 watts by U.S.A. standards! A 3-stage pre-amplifier of exceptional efficiency is included within the above dimensions to ensure an overall frequency response from 20 to 20,000 c/s well within  $\pm 1$ dB from input to output. With greatly improved transient response, there is corresponding improvement in the results obtained from other equipment used with the X-20 which itself has an energy conversion factor of better than 95% at the output stage. At no point in the circuitry of the X-20 are components over-run, so that the instrument is both stable and assured of indefinite working life—and it is easier to build and instal than any amplifier you have ever owned. Best of all it costs far less and enables you to have stereo for very modest outlay.

Complete kit of parts  
including transistors  
and X-20 manual in  
sealed carton

**£7.19.6**

Built and tested with X-20 manual  
in sealed carton

**£9.19.6**

X-20 Power Pack sufficient to drive  
two X-20's

**£4.19.6**

FULL SERVICE FACILITIES ALWAYS AVAILABLE TO ALL  
SINCLAIR CUSTOMERS

**SINCLAIR RADIONICS LTD., COMBERTON, CAMBRIDGE**

Telephone  
COMBERTON  
682

# SPACE AGE!

## AIR X-20

### P.W.M. AMPLIFIER AND PRE-AMP

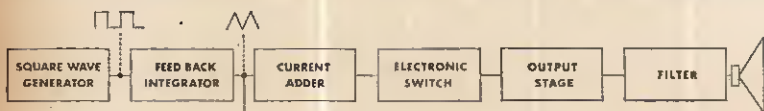

#### WHY P.W.M. IS BETTER

Illustration shows in block diagram form, the principal stages used in the Sinclair X-20 Pulse Width Modulated Amplifier. Use of the latest types of transistors and high quality components combined with unique circuitry achieve outstanding performance whilst retaining all the operational features of conventional quality amplifier design. No other

amplifier in the world can compare for efficiency in the amazingly high energy conversion factor of the X-20—only Pulse Width Modulation used in exclusive Sinclair circuitry gives you this wonderful performance!

### THE ONLY AMPLIFIER IN THE WORLD TO HAVE ALL THESE EXCITING FEATURES

- ★ Easily built in an evening
- ★ No. of transistors—12
- ★ Special silicon epitaxial planar output transistors with a rise and fall time of less than 0.2 micro-seconds
- ★ Frequency response—20 to 20,000 c/s  $\pm$  1dB
- ★ Total harmonic distortion at 10 watts R.M.S.—0.1%
- ★ Input sensitivity—1 mV into 5-K ohms
- ★ Signal-to-noise ratio—better than 70dB
- ★ 20 WATTS R.M.S. MUSIC POWER OR 15 WATTS R.M.S. CONTINUOUS POWER INTO 7.5 OHMS
- ★ 15 WATTS R.M.S. MUSIC POWER OR 12 WATTS R.M.S. CONTINUOUS POWER INTO 15 OHMS
- ★ For use with any type of pick-up, microphone, radio tuner, tape pre-amp, etc.
- ★ Makes an ideal amplifier for guitar or other forms of P.A.
- ★ Built-in low pass filter cutting off above 20 Kc/s makes the amplifier widely tolerant of the load to which it is connected
- ★ Power required—36 V dc at 700 mA preferably from the Sinclair X-20 Power Pack
- ★ 95% ENERGY CONVERSION FACTOR AT OUTPUT
- ★ SUPERB QUALITY AND RELIABILITY
- ★ The simplest ever system of installation, mono or stereo
- ★ The opportunity to connect the tone and control system of your choice

### LISTENERS REQUIRING LESS POWER

This is ideal combined hi-fi amplifier and pre-amp for use in more restricted listening conditions. The X-10 uses P.W.M. with integrated pre-amplifier and offers the same outstanding advantages as the X-20 but with 10 watts peak output. It measures only 6 in. x 3 in. Thousands of these units have been built and are in regular use. For 12-15 volts D.C. operation. Tone control system added to choice.

## SINCLAIR X-10

### P.W.M. AMPLIFIER AND PRE-AMP

Complete kit £5.19.6 Ready built and tested £6.19.6 X-10 power supply unit £2.14.0 with 11 transistors and X-10 Manual

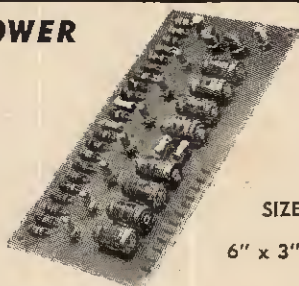

SIZE

6" x 3"

## BUILD IT YOURSELF!

### THE SMALLEST AND MOST EXCITING RADIO IN THE WORLD



SINCLAIR

## MICRO-6

Power • Range • Quality

Smaller than a matchbox, this world-famous receiver brings in stations all over the medium waveband with fantastically good quality and volume. It performs with amazing efficiency in cars, buses, trains and steel-framed buildings, yet measures only 1 1/2" x 1 1/2" x 1/2" complete with self-contained aerial and batteries. Building this smart minute set is enjoyable for expert and beginner alike, its performance is wonderful. All parts including 3 M.A.T. transistors, case, lightweight earpiece, and instructions come to

# 59/6

Mallory Mercury Batteries (2 required)

Type ZM 312, 1/11 each. (6 in pack for 10/6)

## SINCLAIR TR750 POWER AMP

MEASURES only 2" x 2"

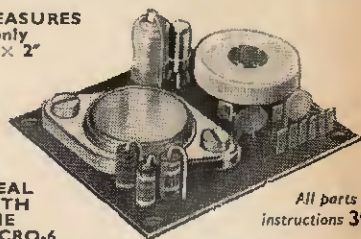

IDEAL WITH THE MICRO-6

All parts and instructions 39/6

Ready built and tested 45/-

With built-in switch and volume control. Output 750mW for feeding into standard 25 to 35 ohm speaker. Input 10mV into 2k $\Omega$ . Operates from 9V d.c. Designed principally for use with the Micro-6 with which it can make a car, portable or indoor domestic radio. This amplifier will also make a record player, intercom, baby alarm, etc. Easily adaptable to stereo.

### LOOKING FOR TROUBLE?

You'll find it more easily with a

## SINCLAIR MICRO-INJECTOR

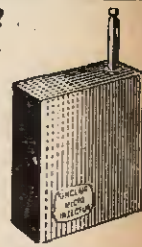

This ingeniously designed device generates and injects a test signal into any part of audio or radio equipment at any frequency from 1kc/s to 30 Mc/s by means of which it becomes easy to locate faults rapidly and accurately. Measures 1 1/2" x 1 1/2" x 1/2", excluding probe and is the smallest and most efficient device of its type ever made available to constructors. With full instructions.

Parts and instructions come to

27/6

Ready built and tested

32/6

## GUARANTEE ORDER FORM

Please send me

NAME.....

ADDRESS.....

For which I enclose Cash/Cheque/Money Order value

£.....s.....d.

## Guarantee

Should you not be completely satisfied with your purchase when you receive it from us, your money will be refunded in full and at once without question. It is important to quote Pr.E.B should you prefer to write your order instead of cutting out this coupon.

## DE LUXE RECORD PLAYER KITS

4-Speed Players 2-tone Cabinets 17" x 15" x 8 1/2". High flux loudspeaker and 3 watt 2-valve 2 stage amplifier ready built. Quality output. Volume and Tone controls. All items fit together perfectly. Special instructions enable assembly in 30 minutes, only 5 wires to join. 12 months' guarantee.



### COMPLETE KITS

As above with B.S.R. Monarch Autochange .....	£10/10/0 P.P. 5/-
Garrard Automim Autochange .....	£10/10/6 P.P. 5/-
Garrard SRP10 Single Play .....	£8/19/6 P.P. 5/-
<b>ALL AVAILABLE SEPARATELY</b>	
Cabinet with board cut to choice .....	£3/9/6 P.P. 3/6
Amplifier with speaker .....	£2/12/6 P.P. 3/6
<b>AUTOCHANGERS (Stereo/Mono 15" extra)</b>	
B.S.R. UA25 Spershim .....	£5/19/6 P.P. 3/6
Garrard Automim Mono .....	£6/10/- P.P. 3/6
Garrard AT6 Mono .....	£10/10/- P.P. 3/6
Garrard A95 Mono .....	£8/19/6 P.P. 3/6
<b>SINGLE PLAYERS</b>	
Garrard SRP 10 auto. stop/start ..	£4/17/6 P.P. 2/6
E.M.I. Latest model auto. stop. ....	£3/19/6 P.P. 2/6
B.S.R. with separate P.U. ....	£3/7/6 P.P. 2/6

## Q MAX CHASSIS CUTTER

Complete: a die, a punch, an Allen screw and key

1/4 in. 14 6	1/2 in. 18 1	1 1/2 in. 22 6
3/8 in. 14 6	1/2 in. 18 1	2 in. 34 3
1/2 in. 15 6	1 1/2 in. 18 6	2 1/2 in. 37 9
3/4 in. 15 9	1 1/2 in. 20 1	2 in. 44 9
1 in. 18 1	1 1/2 in. 20 6	1 in. sq. 31 6

CRYSTAL MIKE INSERTS. 1 1/2 x 1/2 in. ....	8/6
CRYSTAL MIKE RM3 INSERTS. 1 x 1/2 in. ....	7/6
ACOS CRYSTAL MIKE INSERT 1 1/2 x 1/2 in. ....	8/6
ACOS CRYSTAL STICK MIKE 39-1 .....	35/-
PROFESSIONAL MAGNETIC GUITAR MIKE with Vol. and Tone Controls .....	59/6
Moving Coil Mike with Switch 80". Floor Stand. ....	57/-
TANNOY CARBON MIKE with Switch .....	5/6
BARGAIN XTAL PICK-UP ARM Complete with ACOS LP-78 Turnover Head and Stylus .....	30/-

## NEW ELECTROLYTICS FAMOUS MAKES

TUBULAR	TUBULAR	CAN TYPES
1/350 v. ... 2/-	100/25 v. ... 2/-	8/800 v. .... 9/-
2/350 v. ... 2/3	250/25 v. ... 2/6	16/800 v. .... 12/-
4/350 v. ... 2/3	500/12 v. ... 3/-	16-16/500 v. 7/6
6/450 v. ... 2/3	1,000/12 v. 3/-	22-22/350 v. 5/6
16/450 v. ... 3/-	8-8/450 v. 3/6	32-32/450 v. 6/-
32/450 v. ... 3/6	8-16/450 v. 3/6	50-50/350 v. 7/-
25/25 v. ... 1/8	16-16/450 v. 4/3	64-120/350 v. 11/6
50/50 v. ... 2/-	32-32/350 v. 4/6	100-200/275 v. 12/6

### PAPER TUBULARS

350v. 0.1 9d. 0.5 1/9; 1 mid. 3/-
500v. 0.001 to 0.05 8d; 0.1 1/-; 0.25 1/6; 0.5 2/6
1,000v. 0.001, 0.002, 0.005, 0.01, 0.02, 1/8; 0.05, 0.1 2/-; 0.25, 0.5 3/-
2,000 & 0.005, 0.01, 0.02 2/6; 0.05 3/6

### PAPER CONDENSERS, 0.001mfd., 7kV, 8; 20kV., 10/6.

CERAMIC. 500 v. 1 pF. to 0.01 mfd., 9d. Disc Ceramics 1/- Pulse 15 pF. to 155 pF., 12 kV., 2/6.  
SILVER MICA. Close tolerance (plus or minus 1 pF.), 2.2 to 47 pF., 1/-; ditto 1%, 50 to 815 pF., 1/-; 1,000 to 5,000 pF., 1/6.  
TWIN GANG. "C-0" 208 pF., 176 pF., 10/6; 365 pF., miniature 10/-; 500 pF. standard with trimmers, 9/-; midjet, 7/6; midjet with trimmers, 9/-; 500 pF. slow motion, standard 9/-; small 3-rang 500 pF., 17/6. Single "C" 365 pF., 7/6.  
SHORT WAVE. Single 10 pF., 25 pF., 50 pF., 75 pF., 100 pF., 180 pF., 5/6 each. Can be ganged. Couplers 9d. each.  
TUNING. Solid dielectric. 100 pF., 300 pF., 500 pF., 3/6 each.  
TRIMMERS. Compression ceramic 30, 50, 70 pF., 9d.; 100 pF., 150 pF., 1/8; 250 pF., 1/8; 500 pF., 750 pF., 1/8.  
BEST BRITISH P.F. RECORDING TAPES. LP 5in. 900ft., 11/8, DP 1800R, 18/8; LP 6in. 1200ft., 14/8, DP 1800R, 24/8; LP 7in. 1800ft., 19/8, DP 2400ft., 29/6.

## MAINS TRANSFORMERS

250-0-250, 80 mA. 6.3 v. or 4 v. 4a. Rectifier 0.3 v. 1 a. or 5 v. or 4 v. 2 a. 22/6; Ditto 350-0-350, 29/6;	Post 2/- each
300-0-300 v. 120 mA. 6.3 v. CT 4 a. 0.5, 6.3 v. 2 a. 32/6	
MINIATURE 200 v. 20 mA. 6.3 v. 1 a. ....	10/6
MIDGET 220 v. 45 mA. 6.3 v. 2 a. ....	15/6
SMALL 300-0-300 v. 70 mA. 6.3 v. 2 a. ....	19/6
HEATER TRANS. 0.3 v. 1 a., 7.6; 6.3 v. 4 a. ....	10/6
Ditto tapped sec. 1.4 v. 2, 3.4, 4.5, 6.3 v. 1 amp. ....	8/6
GENERAL PURPOSE LOW VOLTAGE. Outputs 3, 4, 5, 6, 8, 9, 10, 12, 15, 18, 24 and 30 v. at 2 a. ....	22/6
Ditto, 1 amp., 5, 10, 18, 20, 25, 30, 35, 40, 45, 50, 55, 60	28/6
Sub-Min. Mains to 9 v. 80 mA. 5 x 1 1/2 x 1 1/2 in. ....	7/6
AUTO TRANS. 150 w. 0.115 v., 230 v., 22/6; 500 w. 82/6	

## GRAM AMPLIFIERS

Valves: UY85 Rectifier and UCL82 Triode/Pentode 31 watts. 5 x 5 1/2 in. disp. New and Tested. 3 ohm output, tone and volume on/off controls. Ready for use 200-250v.A.C. **ONLY 37/6 P. & P. 2/6**

## BAKERS SELHURST LOUDSPEAKERS

### HI-FIDELITY MODELS

12in., 15 w. Stewart 3 or 15 ohms, 46-18,000 c.p.s., 12-18,000 lines **5gns.**  
12in. De Luxe Foam Suspension 14,000 lines, 15 w., 25-17,000 c.p.s. **9gns.**  
12in. Bass 25 w. 25-15,000 c.p.s. **12gns.**  
12in. Super 20 c.p.s. to 25 kw/s **16gns.**



### NEW GROUP MODELS FOR BASS LEAD AND RHYTHM GUITARS

12in. diameter, 25 watt, 12,000 lines ..... **5gns.**  
12in. diameter, 35 watt, 14,000 lines ..... **8 1/2gns.**  
15in. diameter, 50 watt, 17,000 lines ..... **18gns.**

LOUDSPEAKERS P.M. 3 OEMS. 2 1/2 in., 3 in., 4 in., 5 in., 7 in. x 4 in., 15/6 each; 8 in. 17/6; 8 1/2 in. 16/6; 12 in. 30/-; (15 ohms 35/-); 10 in. x 8 in. 22/6; 8 in. x 5 in. 21/-; 9 in. x 6 in. 21/- E.M.I. Double Cone 13; x 8 in., 45/-, Stentorian 10 in. HF1012, 87/8; 8 in. HF512 72/6. Crossover 3,000 c.p.s. 30/-, Horn Tweeter 3 Kc/s. to 16 Kc/s. 29/6.  
**WAVE-CHANGE SWITCHES WITH LONG SPINDLES.**  
2 p. 2-way, or 2 p. 6-way, or 3 p. 4-way or 1 p. 12-way; ea. 3/6  
4 p. 2-way, or 4 p. 3-way; 3/6; 8 p. 4-way, 2 water, .... 6/6  
Wavechange "MAKITS" 1 p. 12-way, 2 p. 6-way, 3 p. 4-way, 4 p. 3-way, 8 p. 2-way. Prices include click spindles, adjustable stops, spacers, etc., 1 wafer, 8/6; 2 wafer, 12/6; 3 wafer, 16/-; 4 wafer, 19/6; 5 wafer, 23/-; extra wafers, 2/6.  
**TOGGLE SWITCHES, s.p., 2/-; d.p., 2/6; d.p.d.t., 4/-**

### BOOKS (Please Add Postage)

"W.W." Radio Valve Data .....	7/6
High Fidelity Speaker Enclosures .....	5/6
At a Glance Valves, CRT Equivalents .....	3/6
TV Fault-Finding .....	6/6
Mallard Audio Amplifier Manual .....	8/6
Radio Valve Guide, Books 1, 2, 3 or 4 ca. ....	5/-
Practical Radio Inside Out .....	3/6
Transistor Audio Amplifier Manual .....	6/-
Shortwave Transistor Receivers .....	5/-

RETURN OF POST DESPATCH Post 1/6, List 1/-, C.O.D. 2/6 extra. (Export. Send remittance and extra postage, no C.O.D.) **CALLERS WELCOME**

# RADIO COMPONENT SPECIALISTS

337 WHITEHORSE ROAD, WEST CROYDON Telephone THO 1665

## TAPE RECORDER COVERS



Smart waterproof cover to give complete protection to your tape recorder. Made from rubberised canvas in navy, wine, tan, grey and bottle green with white contrasting pipings, reinforced base, handy zip microphone pocket and name panel.

Grundig TK 1 ... 49/6	Grundig Cub ... 35/-*
" TK 5 ... 55/-	Telefunken 85 ... 65/-
" TK 6 ... 67/6	" 75/15 & 76K ... 55/-
" TK 8 ... 63/-	" 95 ... 69/6
" & 23, 18 ... 59/6	Philips 8108 ... 57/6
" TK14L, 17L ... 67/6	" 3534 ... 79/6
" 18L & 23L ... 67/6	" 3459 ... 87/6
" TK 20 ... 52/6	" EL3538 ... 63/-
" TK 24 ... 55/-	" EL3542 ... 63/-
" TK 25 ... 55/-	" EL3536 ... 70/-
" TK 30 ... 60/-	" EL3515 ... 57/6
" TK 35 ... 63/-	" EL3541/15 ... 57/6
" TK 40 & 41 ... 66/-	" 3541/H ... 72/-
" TK 46 ... 82/-	" Scarmaker ... 66/-
" TK 55 ... 63/-*	Coscor 1602 ... 57/6
" TK 60 ... 75/-*	



The world-famous copper loaded alloy containing 5 cores of non-corrosive flux, that saves the soldering iron bit. Ersin Multicore Solder is also available in high tin quality alloys. 60/40 in 22 s.w.g. for printed circuits, transistors, etc.



Easy to find in the tool box—simple to use. Virtually a third hand for tricky soldering jobs. 12 feet 5 core 18 s.w.g. ERSIN MULTICORE SAYBIT alloy in a continuous coil used direct from free-standing dispenser. **2/6 each**

SAVBIT ALLOY saves wear on soldering iron bits

SAVBIT SIZE 1 CARTON Contains approximately 30 feet of 18 s.w.g. SAVBIT. It is also supplied in 14 s.w.g. and 16 s.w.g. Obtainable from radio and electrical stores. **5/- each**



BIB WIRE STRIPPER AND CUTTER Strips insulation without nicking wire, cuts wire cleanly, adjustable to most thicknesses. Splits extruded plastic twin flex. **3/6 each**



## MULTICORE SOLDERS LTD.

MULTICORE WORKS • HEMEL HEMPSTEAD • HERTS • HEMEL HEMPSTEAD 3636



**BRAND NEW AM/FM (V.H.F.) RADIO GRAM CHASSIS AT £13.13.0 (Carriage Paid)**

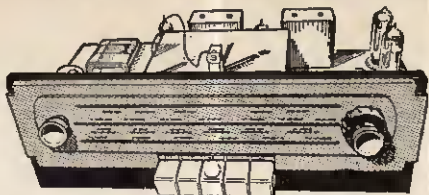

Chassis size 15 x 6 1/2 x 5 1/2 in. high. New manufacture. Dial 1 1/2 x 4 in. in 2 colours, predominantly cream. 200-250V. A.C. only.  
Pick-up. Ext. Spk. 16 $\Omega$ . E.P. and Dipole Sockets. Five pushbuttons—OFF, L.W., M.W., F.M., and Gram. Aligned and tested O.P. Transformer. Tone control. 1000-1000 M.; 200-550 M.; 89-98 Mc/s. Valves EZ80 rect.; EC81, EF89, EABC80, EL84, EC85. 3-ohm speaker required.  
10 x 6 in. ELLIPTICAL SPEAKER 25/- to purchasers of this chassis.  
TERMS: (Chassis) £3.10.0 down and 6 monthly payments of £2.4.0. Cheap Room Dipole for V.H.F. 12/6. Feeder 6d. per yard.  
ALTERNATIVE DESIGN. L.W. 1000-1900 M.; S.W. (0-15 Mc/s); M.W. 190-475 M.; V.H.F. 87-100 Mc/s.; Gram position. Otherwise similar to above chassis. Price £15.15.0 (curr. paid). TERMS: £3.10.0 down and 6 monthly payments of £2.4.0. Total H.P. price £18.14.0. Circuit diagram 2/6.

**AMERICAN BRAND TAPE**

FULLY GUARANTEED AT RECORD LOW PRICES

MYLAR BASE		ACETATE BASE	
7in. Stand. play, 1,200ft. ....	12/6	5in. Stand. play, 600ft. ....	8/-
7in. Long play, 1,800ft. ....	13/6	7in. Stand. play, 1,200ft. ....	11/-
5in. Double play, 1,200ft. ....	15/6	5in. Long play, 900ft. ....	10/-
5in. Double play, 1,800ft. ....	22/6	6 1/2in. Long play, 1,200ft. ....	12/6
7in. Double play, 2,400ft. ....	25/-	7in. Long play, 1,800ft. ....	15/-
3in. Triple play, 450ft. (Plain white boxes) ....	12/6		
3 1/2in. Triple play, 600ft. (Plain white boxes) ....	14/-	<b>MESSAGE TAPES</b>	
4in. Triple play, 900ft. (Plain white boxes) ....	22/6	3in. Stand. play, 150ft. ....	3/6
5in. Triple play, 1,800ft. (Plain white boxes) ....	42/6	3in. Long play, 225ft. ....	4/11
7in. Triple play, 3,600ft. (Unboxed) ....	75/-	3in. Double play, 300ft. ....	7/6
		3in. Triple play, 450ft. ....	12/6

Postage 1/- per reel (4 or more post free)

**SELF-POWERED V.H.F. TUNER CHASSIS.**

Covering 85-95 Mc/s. Mullard permeability tuner. Dims. 6 1/2 x 3 x 3 1/2 in. high. Valves EC85 and 2-EF89's plus 2 diodes with EZ80 rectifier. Mains transformer. Fully wired and tested ONLY £8.17.6 (curr. paid). Room dipole 12/6. Feeder 6d. per yard.



**HIGH GAIN PUSH-PULL OUTPUT AMPLIFIER £5.4.6 (6/- post)**

Valves EZ80, EC85 and 2-EC182 giving 8 watts. Chassis 12 x 3 1/2 x 3 1/2 in. With O.P. Trans. for 3 and 15-ohm speaker. Isolated chassis. Bass and treble cut. Mike, guitar, radio and crystal pick-up input. Facilities for mixing mike and radio, etc. Front panel fixed. Also available as straight 10-watt amplifier with bass, treble and volume controls at £5.5.0. (6/- post). Front panel may be removed on this amp.



**4 TRANSISTOR MINIATURE PUSH-PULL AUDIO AMPLIFIER HIGH IMPEDANCE**

PRINTED CIRCUIT, 4in. x 2 1/2in. x 1 1/2in. over transformers. Output for 3-ohm speaker. Suitable for microphone, record player and intercom. 9 volt battery required. Frequency range 100 cps. to 25 Kcps. Push-pull output class B. Instruction sheet provided. Fully wired ready for use. Three types, 200mW 35/-; 500mW 41/-; 1.2W 57/6. (P. & P. 2/6 each).

**CM21 CRYSTAL MICROPHONE**

With 2.5 mm. Jack plug, 12/6 (Post 1/6.)

**4 TRANSISTOR BABY ALARM.** Attractive walnut veneer speaker cabinet 13 1/2" x 8" front. Bar piece as mike sensitive at 20ft. x 60ft. Ext. Lead. (P.P.6 battery required)—will last for hundreds of hours. Volume Control and On/Off. Price £3.19.6. (P. & P. 5/-).

**GLADSTONE RADIO**

66 ELMS ROAD, ALDERSHOT, Hants.

(2 mins. from Station and Buses.) Aldershot 22240  
CLOSED WEDNESDAY AFTERNOON  
CATALOGUE 6d.  
Regret overseas orders cannot be executed

The little instrument

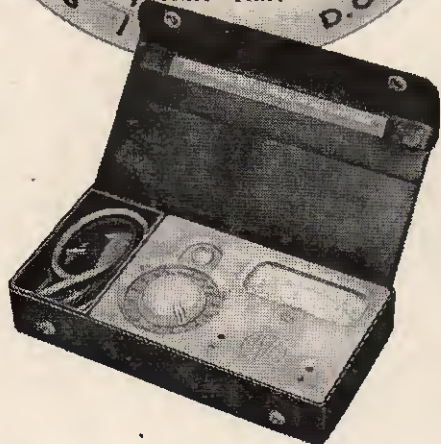

**MULTIMINOR Mk 4**

The newly improved model of this famous AVO pocket size multi-range instrument has been enthusiastically acclaimed in all parts of the world for its high standards of accuracy and dependability as well as for its modern styling, its highly efficient internal assemblies and its resistance to extremes of climatic conditions.

It is simple to use, one rotary switch for instant range selection, only one pair of sockets for all measurements, and a 2 1/2-inch clearly marked scale-plate. It is supplied in an attractive black carrying case complete with interchangeable test prods and clips, and a multi-lingual instruction booklet.



RESISTANCE: 0-2M $\Omega$  in 2 ranges, using 1.5V cell  
SENSITIVITY: 10,000 $\Omega$ /V on d.c. voltage ranges  
1,000 $\Omega$ /V on a.c. voltage ranges

to send you a full specification of this great little instrument. It measures only 7 1/2" x 4" x 1 1/2" in. and weighs only 2 1/2 ozs.

**AVO LTD**  
AVOGET HOUSE • 92-96 VAUXHALL BRIDGE ROAD • LONDON S.W.1  
Telephone: VICTORIA 3404 (12 lines)



THE WORLD-FAMOUS KIT-SETS ANYONE CAN SUCCESSFULLY BUILD



# The practical way to enjoy Electronics

A wide range of well designed kit-sets to choose from

**YOU CAN SAVE £ £'s BY BUILDING ANY HEATHKIT MODEL**



**MALVERN CABINET**



**FM TUNER**



**PORTABLE UXR-2**



**SW RECEIVER RG-1**



**STEREO AMPLIFIER S-99**



**COTSWOLD SPEAKER**

**"MALVERN" HI-FI EQUIPMENT CABINET.** Will house all your Hi-Fi equipment. Left "in the white." Size: 39½ x 32 x 21½ in. Kit £18.1.0 (inc. P.T.)  
A wide range of other cabinets.

**HI-FI FM TUNER.** Range 88-108 Mc/s. Available in two units, sold separately. **TUNER (FMT-4U)** 10.7 Mc/s IF £2.15.0 (inc. P.T.). **IF AMPLIFIER (FMA-4U)** power supply and valves £13.13.0. Total Kit £16.8.0.

**AM/FM TUNER.** Covers FM 88-108 Mc/s, AM 16-50, 200-550, 909-2,000 M. Tuning range (£4.13.6 inc. P.T.) and IF Amp. Case. Total £27.5.0 Kit

**JUNIOR ELECTRONIC WORKSHOP.** Model EV-1. 20 exciting experiments can be made. Special solderless connections. Kit £7.13.6 (inc. P.T.)

**"OXFORD" LUXURY TRANSISTOR PORTABLE.** Model UXR-2. Beautiful solid leather case. LW and MW Coverage. Kit £14.8.0 (inc. P.T.)

**GENERAL COVERAGE RECEIVER.** Model RG-1. Freq. coverage 600 kc/s-1.5 Mc/s. 1.7-32 Mc/s in 6 switched bands. Many features incl. ½ lattice crystal filter. Kit £39.16.0. Assembled £53.0.0.

**5W STEREO AMPLIFIER.** Model S-33H. An inexpensive stereo/mono amplifier. Ideal for use with the Decca Deram lightweight pickup. Modern attractive styling. Kit £15.17.6 Assembled £21.7.6

**50W PUBLIC ADDRESS AMPLIFIER.** Model PA-1. A multi-purpose unit, suitable for vocal and instrumental groups. 4 inputs for guitars, mics, etc. 2 heavy duty speakers, vol. indicator, variable tremolo, modern cabinet. Kit £54.15.0. Assembled £74.0.0. Legs optional extra, 17/6.

**9 + 9W HI-FI STEREO AMPLIFIER.** Model S-99. Ganged controls. Stereo/Mono Gram., Radio, Tape inputs. P.C. board construction. Attractive presentation. Kit £28.9.6. Assembled £38.9.6.

**5W MONO AMPLIFIER.** Model MA-5. A general purpose amplifier based on model S-33. Separate bass and treble controls, gram and radio inputs. Printed circuit. Kit £10.19.6. Assembled £15.10.0.

**"COTSWOLD" HI-FI SPEAKER SYSTEMS.** Std. model. Size: 26 x 23 x 14 in. Kit £25.12.0. MFS "Cotswold" for the smaller room. Size: 36 x 16½ x 14 in. Kit £25.12.0

**SSU-I SPEAKER SYSTEM.** A practical solution to the problem of a low-price speaker system. Two speakers. Without legs £11.7.6 Kit (inc. P.T.) With legs £12.12.0 Kit (inc. P.T.)



**SCOPE, 10-12U**



**POWERSUPPLY, IP-20U**



**TRANSISTOR TESTER, IM-30U**

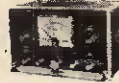

**HARMONIC DIST. METER, IM-12U**



**VVM, IM-13U**



**TV GEN, HFW-1**

## Send for the FREE British Catalogue of Heathkit range of models

Deferred Terms over £10 in U.K.

Extended Deferred Terms in U.K. over £75

Prices quoted include postage in U.K.

**5 in. FLAT-FACE GENERAL PURPOSE OSCILLOSCOPE.** Model 10-12U. An outstanding "scope." "Y" sensitivity, 10 mV rms per cm at 1 kc/s; Bandwidth 3 c/s to 4.5 Mc/s. T/B 10 c/s to 500 kc/s in 5 steps. Kit £35.17.6. Assembled £45.15.0.

**2½ SERVICE SCOPE.** Model OS-1 Light (wt. 10½ lb.), compact, 5 x 8 x 14½ in. The ideal portable for servicemen. Kit £22.18.0 Assembled £30.8.0.

**ELECTRONIC SWITCH.** Model S-3U. Convert your "scope" to dual trace. Kit £12.18.0, Assembled £18.10.0.

**MULTIMETER.** Model MM-1U. Ranges 0-1.5 v to 1,500 v A.C. and D.C., 150 µA to 15A D.C.; 0.2 to 20 MΩ, 4½ in. 50µA meter. Kit £12.18.0 Assembled £18.11.6.

**REGULATED POWER SUPPLY.** Model IP-20U. Transistorised, compact unit. Current range: from 50 mA to 1.5 A f.s.d. Voltage ranges: from 5 to 50 volts f.s.d. Kit £35.8.0. Assembled £47.8.0.

**TRANSISTOR TESTER.** Model IM-30U. Unmatched in quality, performance and price. Provides complete d.c. analysis of PNP, NPN transistors and diodes. Internal battery for tests up to 9 v. Kit £24.18.0. Assembled £35.10.0.

**HARMONIC DISTORTION METER.** Model IM-12U. Freq. cov.: 20 to 20,000 cycles. Meter calibrated in V r.m.s. % distortion, dBs. Kit £24.15.0. Assembled £34.0.0.

**R.F. SIGNAL GENERATOR.** Model RF-1U. Freq. coverage from 100 kc/s-100 Mc/s or six bands, on fundamentals and up to 200 Mc/s on calibrated harmonics. Kit £13.8.0. Assembled £19.18.0.

**DECADE RESISTANCE.** Model DR-1U. Range 1.99-999Ω in 152 steps. Kit £10.8.0. Assembled £14.8.0.

**DECADE CAPACITOR.** Model DC-1U range, 100µF to 0.111 µF in 100 µµF steps. Kit £7.5.0. Assembled £10.8.0.

**INTERNATIONAL MAIL ORDER SCHEME** covering the American Heathkit range of 250 models. Illustrated American catalogue and full details can be obtained from us for 1/- post paid.

**6 in. DE LUXE VALVE VOLTMETER.** Model IM-13U. Measures ac and dc volts 0-1.5 to 1,500 V in 7 ranges. Res. to 1,000 MΩ in 7 ranges. Modern styling, with gimbal mount. Kit £18.18.0. Assembled £26.18.0.

**VALVE VOLTMETER.** Model V-7A. DC volts to 1,500, AC to 1,500 rms and 4,000 V pk. to pk. Res. 0.1-1,000 MΩ. Kit £13.18.6. Assembled £19.18.6. RF Probe 309-CU £1.13.6 kit. HT Probe HV.336 £2.19.6 kit. Will extend range of models V-7A or IM-13U.

**TV ALIGNMENT GENERATOR.** Model HFW-1. 3.6 to 220 Mc/s on fundamentals. Unique electronic sweep oscillator. Built-in fixed and variable marker generators (5 Mc/s crystal). Kit £37.18.0. Assembled £47.10.0.

**AMATEUR TRANSMITTER.** Model DX-100U. With built-in V.F.O. Kit £79.10.0. Assembled £104.15.0.

**REFLECTED POWER METER.** Model HM-11. Indicated TX/antenna match. Kit £8.5.0. Assembled £10.10.0.

**MANY OTHER MODELS** For the home, Hi-Fi enthusiast, Home workshop, Service and Test bench, Laboratory.

**FULL RANGE OF MODELS IN FREE CATALOGUE**  
SIMPLY SEND COUPON TO:—

**To DAYSTROM LTD., DEPT. PM-8, GLOUCESTER, ENGLAND**

Please send me **FREE BRITISH CATALOGUE** (Yes/No).....

Full details of model(s).....

American..... **NAME**

Catalogue..... **(BLOCK CAPITALS)**

(Yes/No)..... **ADDRESS**.....

PM-8

## A BROAD OUTLOOK

THREE international exhibitions held in London, and running in part concurrently during the latter part of May and beginning of June, offered as diverse a choice of interests as one could wish for.

The International Packaging Exhibition at Earls Court brought one the factory floor atmosphere with the food and confectionery industries perhaps predominating. The World Fishing Exhibition at Olympia provided a strong salty flavour of the open seas, and against this the Hospital Equipment Exhibition in the adjoining hall offered a contrast with its clinical setting.

Quite different, yes—but yet there *was* a common link. It was soon plain to see that in all these fields extensive use is already being made of electronic instrumentation and automated systems; and it was equally clear that future improvements in efficiency depend very much (and in some cases, entirely) upon the increased adoption of electronics.

★ ★ ★

Sea fishing is a highly competitive business, and the modern trawler relies upon electronics not only for navigational aids and communications, but as a means for locating the fish. Some modern fish-recording echo sounders can detect a single fish at 200 fathoms, and new sector scanning techniques promise to give even better results over the conventional asdic or sonar systems.

It was not surprising to see how heavily dependent upon automated equipment the food confectionery, cosmetics and other industries have become. For example, electronic checkweighers can weigh 3,000 packages per hour, rejecting over or under weights, while servo systems automatically correct the filler machine. Other electronic systems are employed to detect metal in foodstuffs, to sort peas, nuts, rice, etc., according to colour, and to count articles of irregular shapes.

An automatic patient monitor that will measure and record the blood pressure, pulse rate, and temperature of up to ten patients simultaneously was seen at the Hospital Equipment Exhibition. An automated drip feed system for transfusions, and instruments for remote control temperature measurement were just two further indications that automation is reaching into the hospital service.

★ ★ ★

Here we have merely touched upon a few of the current uses of electronics in just three fields. We think it has been made clear that the student of electronics has much to gain by visiting exhibitions such as these. In so doing, not only will he keep in touch with technical advances of immediate interest, but in the process he will acquire an insight into many other fascinating facets of the modern world. Nothing like an interest in electronics for broadening the mind!

## THIS MONTH

### CONSTRUCTIONAL PROJECTS

SIMPLE ANALOGUE	
COMPUTER	690
ELECTRONIC FLASH GUN	697
TRANSISTOR AND DIODE	
TESTER	715
LOW VOLTAGE BATTERY	
PACK	726

### SPECIAL SERIES

BUILDING BLOCKS—5	709
BEGINNERS START HERE—10	724

### GENERAL FEATURES

U.H.F. RECEPTION	706
INGENUITY UNLIMITED	729
THE DECIBEL	732

### NEWS AND COMMENT

EDITORIAL	689
COMPONENT DEVELOPMENTS	705
THE 73 PAGE	714
ELECTRONORAMA	722
NEWS BRIEFS	736
NEW PRODUCTS	739
DETACHED PARTICLES	743
READOUT	744

Our September issue will be published on  
Thursday, August 12

LOGARITHM TABLES

2	3	4	5	6
---	---	---	---	---

8089	8028	8035	7903	7910	7917
8156	8096	8102	8041	8048	8055
8222	8228	8235	8176	8182	8189
8297	8293	8299	8241	8248	8254
8357	8363	8369	8306	8312	8319
8420	8426	8432	8370	8376	8382
8482	8488	8494	8432	8439	8445
8543	8549	8555	8494	8500	8506
8603	8609	8615	8555	8561	8567
8663	8669	8675	8615	8621	8627
8727	8733	8739	8675	8681	8686
8785	8791	8797	8733	8739	8745
8842	8848	8854	8791	8797	8802
8899	8904	8910	8848	8854	8859
8959	8960	8965	8904	8910	8915
9019	9015	9020	8960	8965	8971
9069	9060	9074	9015	9020	9025
9122	9122	9126	9060	9074	9079
9175	9175	9180	9122	9126	9133
9227	9227	9232	9175	9180	9186
9279	9279	9284	9227	9232	9238
9330	9330	9335	9279	9284	9289
9385	9385	9390	9330	9335	9340
9435	9435	9440	9385	9390	9390
9484	9484	9489	9435	9440	9440
9533	9533	9538	9484	9489	9489
9581	9581	9586	9533	9538	9538
9633	9633	9638	9581	9586	9586
9680	9680	9685	9633	9638	9638
9727	9727	9732	9680	9685	9685
9773	9773	9778	9727	9732	9732
9818	9818	9823	9773	9778	9778
9863	9863	9868	9818	9823	9823
9908	9908	9913	9863	9868	9868
9953	9953	9958	9908	9913	9913
9998	9998	9998	9953	9958	9958
10000	10000	10000	9998	9998	9998

# SIMPLE ANALOGUE COMPUTER

This instrument is capable of carrying out the arithmetical operations of multiplication and division with reasonable accuracy. The evaluation of powers and roots with log. scales may also be achieved.



by H. WEBSTER

**A**LTHOUGH popularly associated with formidable arrays of electronic instruments capable of incredibly complex calculations, computers in one form or another have been with us for a very long time. We have only to recall the familiar abacus or bead bar of our childhood to realise that our acquaintance with computers started at a very early age.

Modern computers are of two major types: the *digital*, which depend on the way we use numbers, and the *analogue*, in which numbers are represented by physical quantities such as length and current. A simple example of a digital computer is the abacus while a good example of the analogue computer is the slide rule.

Although elaborate computers are beyond the scope of the average constructor, quite simple instruments can be made using everyday components. The simple analogue computer described in this article was constructed by the author for classroom demonstration purposes. Although no originality is claimed for the design it was felt that a description of the instrument would be of interest to other constructors, particularly those engaged in teaching.

### BASIC CIRCUIT

The computer is based on the familiar Wheatstone bridge network shown in Fig. 1. Such a network is commonly employed in the determination of an unknown resistance. When the bridge is balanced, for example, when the current through the galvanometer is zero, the following well known relationship holds,

$$R_1 \times R_4 = R_2 \times R_3$$

or transposing,

$$\frac{R_1}{R_2} = \frac{R_3}{R_4}$$

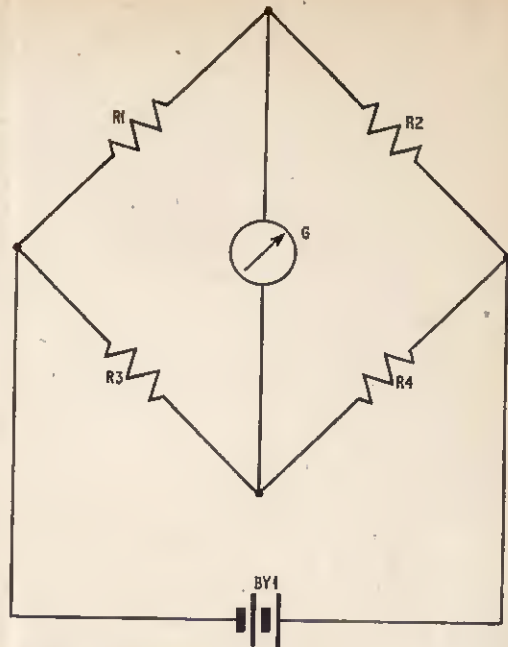
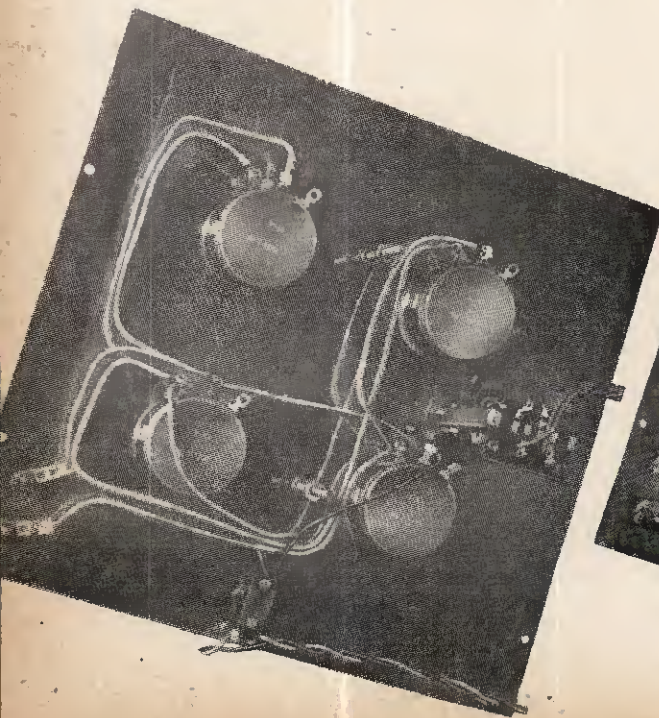

Fig. 1. Basic Wheatstone bridge network on which the computer is based

Generally, R1 and R2 form a calibrated resistance wire system, while R3 is a resistor of known value. R4 is the unknown resistor. When the system is balanced, the ratio R1:R2 is determined, and hence R4 can be calculated. By a reversal of this procedure, the operations of multiplication and division can be carried out.



If the resistors constituting the arms of the bridge are made variable and are accurately calibrated, the two arithmetical operations are easily performed. To multiply two numbers, R4 is set to some power of ten, the multiplicand set on R2 and the multiplier on R3. The bridge is balanced with R1 and the answer automatically read off on the R1 scale. To perform the operation of division, R4 is again set to a power of ten, while the numerator and denominator are set on R1 and R2 respectively. The bridge is balanced with R3 and the answer taken from this scale. For both arithmetical operations it is of course necessary to find the decimal point by inspection.

The scope of the bridge can be further extended by providing logarithmic scales for R3 and R4. Powers and roots may then be evaluated. This application will be discussed at a later stage.

### PRACTICAL CONSIDERATIONS

In common with all other analogue computers the accuracy is limited by the precision of the components employed in the circuit. The author found that ordinary wire wound variable resistors of the type normally employed in radio work were of sufficient precision to enable quite a high degree of accuracy to be achieved.

In the original design the bridge was energised by a battery, the balance point being indicated by a sensitive galvanometer. However, since it was highly likely that the instrument would be subjected to somewhat indelicate handling, the fragile galvanometer was replaced by headphones and a simple but robust transistor audio oscillator used to energise the bridge.

### CONSTRUCTIONAL DETAILS

The computer is mounted on an aluminium panel, the relevant drilling and mounting details being given in Fig. 3. Four 3½ in diameter discs cut from stiff white cardboard, and on which are described 2½ in diameter circles, are used as dials.

The audio oscillator is mounted on a 6 in × 4 in etched wiring board as shown in Figs. 4 and 5. An alternative method using Veroboard may also be used by those constructors who wish to avoid the use of chemicals. For comprehensive examples of this method the reader is referred to the April 1965 issue of PRACTICAL ELECTRONICS.

### ETCHED WIRING BOARD

The copper laminate is polished with metal polish and then washed in warm soapy water. After rinsing and drying, the circuit pattern shown in Fig. 4 is drawn out with cellulose paint of the car "touch up" type. The paint is allowed to dry for approximately 30 minutes and the laminate immersed in a 30 per cent w.v. solution of ferric chloride. This solution is prepared either by dissolving 75gm of the anhydrous salt or 92gm of the hydrated salt in 200ml of water containing 3ml of concentrated hydrochloric acid. The resulting solution is made up to 250ml. For complete dissolution of the unwanted copper a reaction time of roughly 30 minutes at 40 degrees C is required. The etching is done by gentle agitation of the solution.

The prepared board is washed with water to remove all traces of the iron salt and the cellulose paint removed by swabbing with cotton wool soaked in acetone or other suitable solvents.

Fig. 2. Circuit of the simple computer. Additional resistors for calibration (R5-R10) are not shown here but are explained later in Figs. 6, 7, and 10

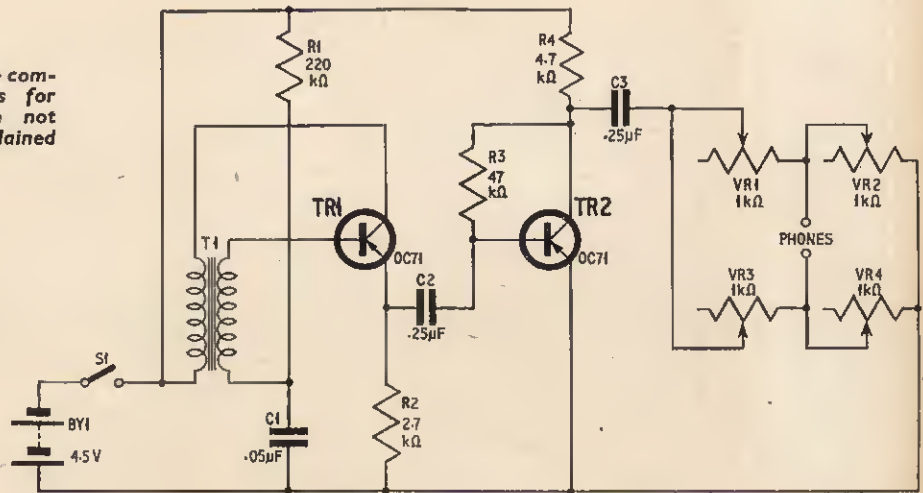

### CIRCUIT DESCRIPTION

The circuit diagram of the computer is given in Fig. 2. Four 1,000 ohm wire wound potentiometers (VR1-4) form the arms of the bridge. The transistor oscillator is of the Hartley type. Oscillation is maintained by feedback in the correct sense through the primary of the audio transformer T1. Although the output of the oscillator may be taken via C2 from the emitter of TR1, an additional stage of amplification may be found advantageous, particularly where noisy background levels are encountered.

Holes are drilled at the points shown in Fig. 5. Wiring of the board is straightforward and the customary heat shunt precautions are observed when the transistors and other closely clipped components are soldered in position.

The audio frequency transformer is temporarily connected to the appropriate points on the board and a check made on the correct functioning of the oscillator. It may be found that the leads to the primary of the transformer require reversal to ensure feedback in the correct sense.

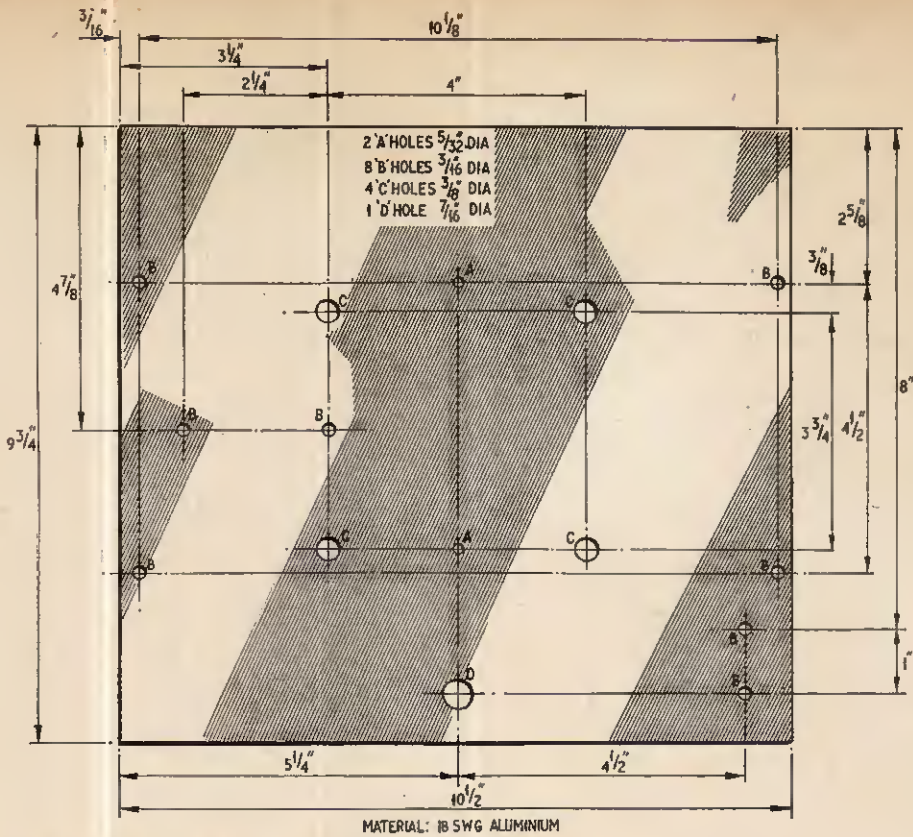

Fig. 3 (above). Drilling details of the aluminium panel to hold the potentiometers

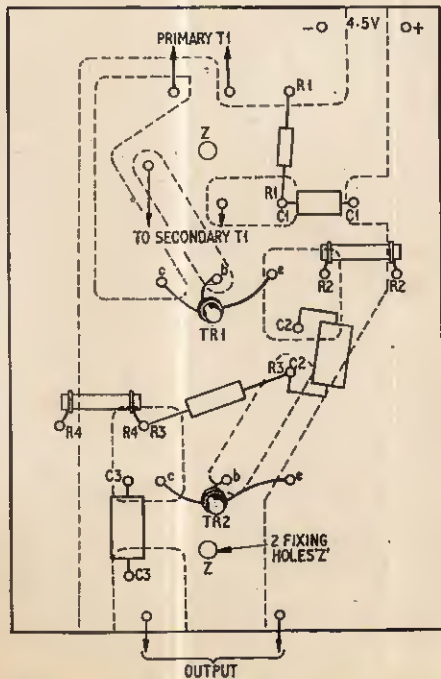

Fig. 4. Component layout on the printed circuit board

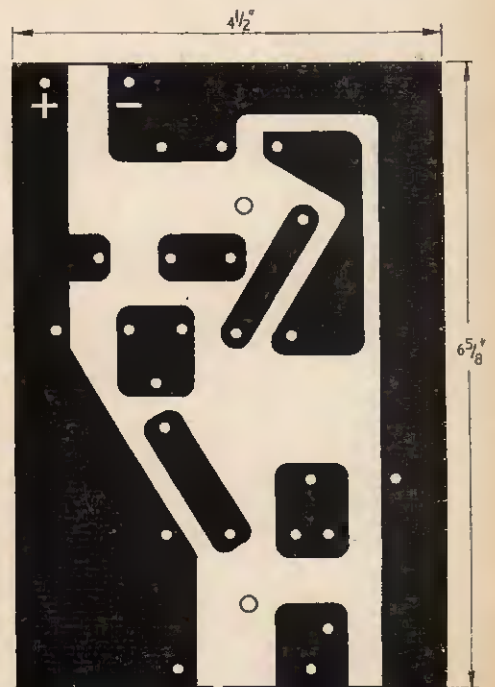

Fig. 5. Plan of the printed circuit board shown half scale

Before the completed audio oscillator is mounted on the main potentiometer panel, the potentiometers are calibrated by the following procedure.

### CALIBRATION OF BRIDGE

A careful calibration of the four potentiometers is essential if accurate results are to be obtained. Although calibration is simplified if a resistance box calibrated in 10 ohm and 100 ohm steps is available, it is possible to use close tolerance fixed resistors as calibration standards. The construction of such a standard is shown later in Fig. 10.

Both calibration methods will be described, the resistance box method being dealt with first.

### VRI CALIBRATION

Two close tolerance resistors, R9 and R10, each of 1,000 ohms, are wired with VR1 and the decade resistance box as shown in Fig. 6. The audio oscillator and headphones are connected to the appropriate points. With the decade box set at 100 ohms, VR1 is adjusted until the null point is observed. The dial of VR1 is carefully marked with pencil at this point. Repetition of the process with the decade box set at 200, 300, 400 ohm etc., followed by balancing with VR1 gives a series of points separated by 100 ohm intervals up to 1,000 ohms. If the decade box is calibrated in 10 ohm steps intermediate points may be filled in.

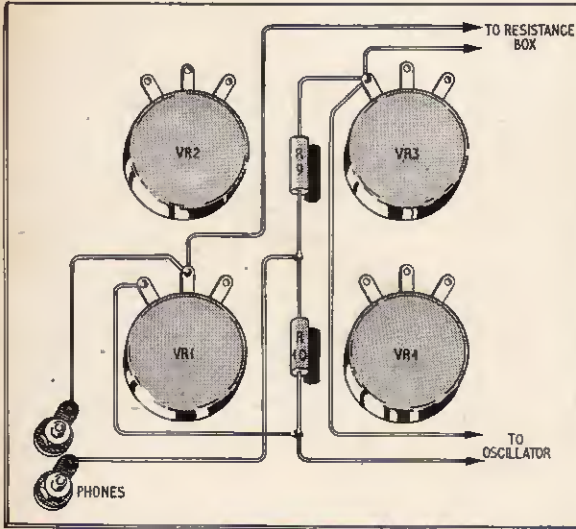

Fig. 6. VRI calibration

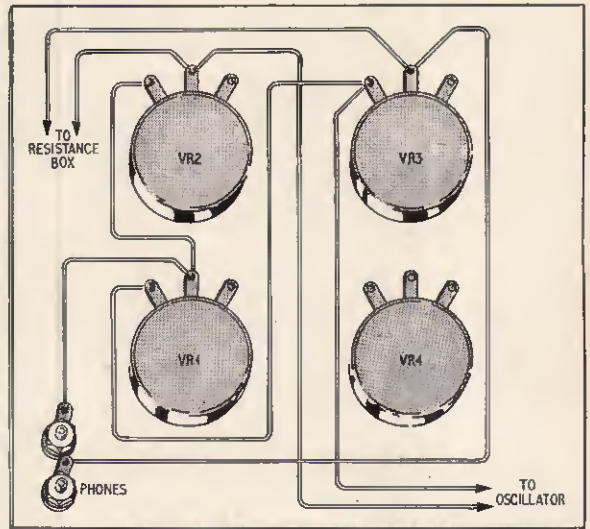

Fig. 8. VR3 calibration

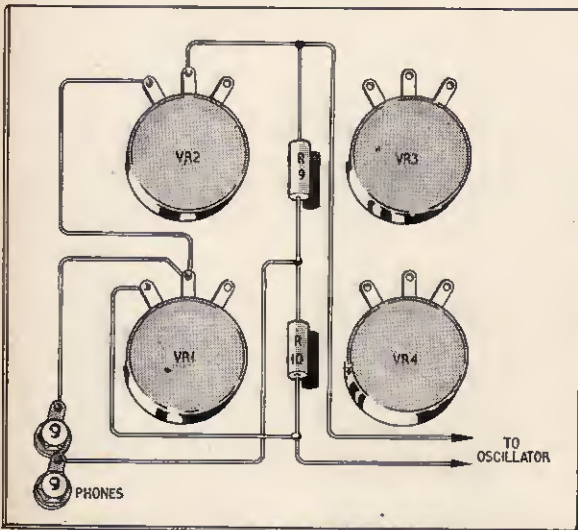

Fig. 7. VR2 calibration

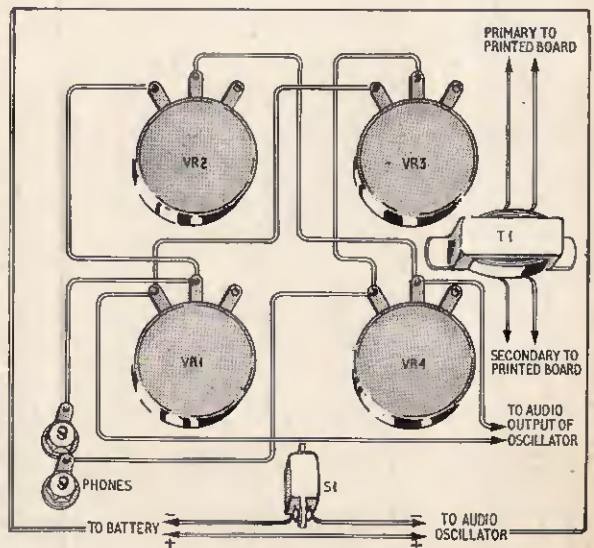

Fig. 9. VR4 calibration

Figs. 6-8. Temporary wiring of the potentiometer panel for calibration. Fig. 9. The final wiring



## VR2 CALIBRATION

The decade box is disconnected and VR2 wired into circuit as shown in Fig. 7.

VR1 is successively set at each of the previously determined points and VR2 balanced against each point. In this way VR2 can be accurately calibrated in terms of VR1.

## VR3 CALIBRATION

The decade box is reintroduced and R9 and R10 deleted. VR1 and VR2 are each set at 500 ohms and VR3 calibrated in 10 or 100 ohm steps against the decade box. Wiring details are shown in Fig. 8.

## VR4 CALIBRATION

Prior to this final calibration the complete panel is wired as shown in Fig. 9. The audio oscillator and transformer may also be permanently attached. Two 3in 4 B.A. bolts serve as stand-off supports for the oscillator panel.

After completing the wiring VR4 is calibrated against VR3 with VR1 and VR2 each set at 500 ohms.

## CALIBRATION WITH FIXED RESISTORS

A simple calibration standard is shown in Fig. 10. Four close tolerance resistors of 100, 200, 300 and 400 ohms respectively, are wired together as shown. By shorting out the appropriate sections a selection of resistance values from 100 to 1,000 ohms may be made. Two leads which terminate in crocodile clips are conveniently used as shorting links. Resistance

TABLE I

Resistance $\Omega$	Short Out
100	3 & 8
200	1 & 2, 6 & 8
300	6 & 8
400	1 & 5
500	3 & 5
600	7 & 8
700	1 & 4
800	3 & 4
900	1 & 2
1,000	none

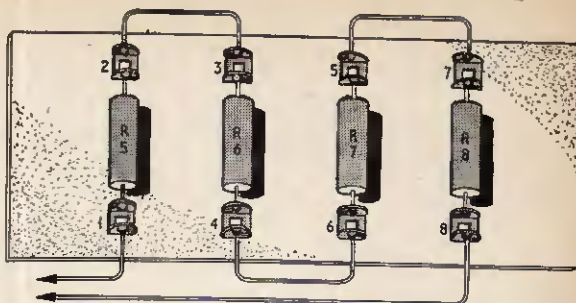

Fig. 10. Assembly and wiring of the calibration resistors. Due to the accuracy required for these resistors, it may be necessary to select and measure to within 1 per cent tolerance of the quoted values from resistors of the nearest "preferred" value available

values obtained when the appropriate sections are shorted are given in Table 1.

Calibration of the bridge using this standard is carried out exactly as before, the standard taking the place of the decade box.

When calibration is complete the dials may be numbered from 0 to 10 and permanently marked with indian ink. If the calibration has been made in 100 ohm steps the intervals may be divided into ten equal parts. No great loss of accuracy will occur since it was found that over small portions of the potentiometer tracks the resistance per unit length was constant enough to warrant this procedure.

## OPERATION OF COMPUTER

A discussion of the operations of multiplication and division was given in the introduction to this article. These operations are summarised at this point.

## MULTIPLICATION

Set VR4 to 1 or 10. The multiplicand is set on VR2 and the multiplier on VR3. The bridge is balanced with VR1 and the answer taken from this scale.

## DIVISION

Set VR4 to 1 or 10. The numerator is set on VR1 and the denominator on VR2. The bridge is balanced with VR3 and the answer taken from this scale.

## COMPONENTS . . .

### Resistors

R1	220k $\Omega$ 10%	} see Fig. 2
R2	2.7k $\Omega$ 10%	
R3	47k $\Omega$ 10%	
R4	4.7k $\Omega$ 10%	
R5	100 $\Omega$ 1%	} see Fig. 10
R6	200 $\Omega$ 1%	
R7	300 $\Omega$ 1%	
R8	400 $\Omega$ 1%	
R9	1,000 $\Omega$ 1%	} see Figs. 6 and 7
R10	1,000 $\Omega$ 1%	

### Potentiometers

VR1, 2, 3, 4 1k $\Omega$  linear, wire wound

### Capacitors

C1	0.05 $\mu$ F paper
C2	0.25 $\mu$ F paper
C3	0.25 $\mu$ F paper

### Transformer

Intervalve type, ratio 3:1

### Transistors

TR1, TR2 OC71 or NKT272

### Switch

S1 Single pole on/off

### Battery

BY1 4.5V battery

### Miscellaneous

Aluminium panel. Copper laminate board. Four pointer knobs. Headphones. Terminals. P.V.C. insulated connecting wire.

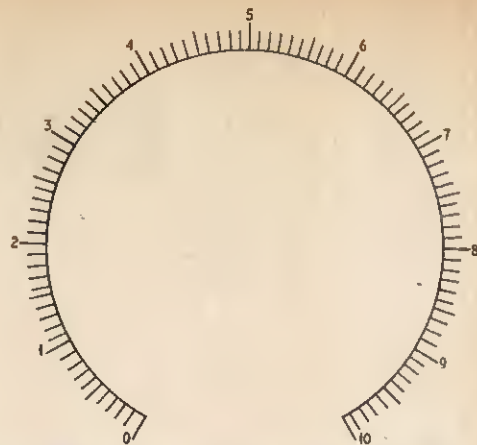
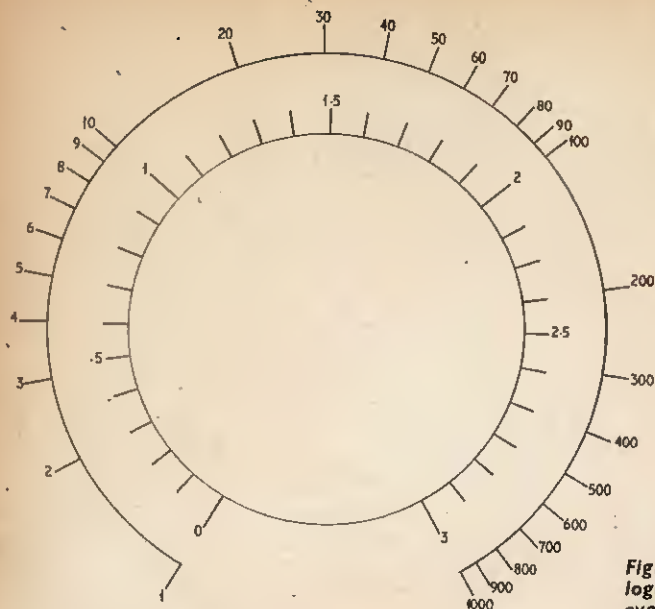

Fig. 12 (above). Example of the linear type of scale that will be produced when the four potentiometers are individually calibrated as described on page 694. This linear scale is used for multiplication and division

Fig. 11 (left). Calibration scale for VR4 drawn on a logarithmic basis to full size. This scale is used for the evaluation of powers and roots

## EVALUATION OF POWERS AND ROOTS

In addition to the operations of multiplication and division, further interesting evaluations may be made if the scales of VR3 and VR4 are calibrated logarithmically.

If we let  $r_3$  be the reading of VR3 such that  $\log r_3 = VR3$  and similarly  $r_4$  the reading of VR4 so that  $\log r_4 = VR4$ , then at the balance point, and recalling that in the basic bridge of Fig. 1,  $R1 \times R4 = R2 \times R3$ , it follows that

$$VR1 \log r_4 = VR2 \log r_3$$

or

$$r_4^{VR1} = r_3^{VR2}$$

or

$$r_4 = r_3^{VR2/VR1}$$

In other words we can determine the value of  $r_3$  to the power  $VR2/VR1$ .

As a simple example consider the evaluation of  $3^4$ . The required power  $VR2/VR1$ , is conveniently obtained by setting VR2 to 8 and VR1 to 2. VR3 is set to 3 and the bridge balanced with VR4. The answer is taken from this scale.

Roots may be evaluated using a similar procedure. For example, suppose we wish to find  $\sqrt[3]{27}$  or, what is the same thing,  $27^{1/3}$ . VR2 is set to 1 and VR1 to 3. After setting VR3 to 27 the answer is read off the VR4 scale.

## LOGARITHMIC SCALES

The logarithmic scales are prepared as follows. A  $2\frac{1}{2}$ in diameter circle is inscribed on a disc. Two points are marked with pencil on the circumference of the circle such that the length of the arc is the same as that of the linear scales. The arc is then divided into three equal portions which in turn are subdivided into tenths. This calibration represents the logarithms of numbers between 1 and 1,000. The resistance scale may now be calibrated by inserting the values whose logarithms correspond to the inner

scale. An illustrative example is given in Fig. 11. This scale can conveniently be used for VR4.

The second logarithmic scale is prepared by calibrating VR3 in terms of VR4. To do this VR1 and VR2 are each set at a dial reading of 5 and VR3 then balanced against each point of VR4 by the usual method. Fig. 12 shows an example of this scale.

Doubtless other evaluations will suggest themselves to the mathematically-minded constructor. Circuit variations are also possible, for example, the audio oscillator may be replaced by a buzzer with a cheapening in the overall cost. As a point of interest the cost of the instrument excluding battery and phones was just over £2. ★

## Contributed Articles

The Editor will be pleased to consider for publication articles of a theoretical or practical nature. Constructional articles are particularly welcome, and the projects described should be of proven design, feasible for amateur constructors and use currently available components.

Intending contributors are requested to observe the style in our published articles with regard to component references on circuit diagrams and the arrangement of components list.

The text should be written on one side of the paper only with double spacing between lines. If the manuscript is handwritten, ruled paper should be used, and care taken to ensure clarity, especially where figures and signs are concerned.

Diagrams should be drawn on separate sheets and not incorporated in the text. Photographic prints should be of high quality suitable for reproduction; but wherever possible, negatives should be forwarded.

The Editor cannot hold himself responsible for manuscripts, but every effort will be made to return them if a stamped and addressed envelope is enclosed.

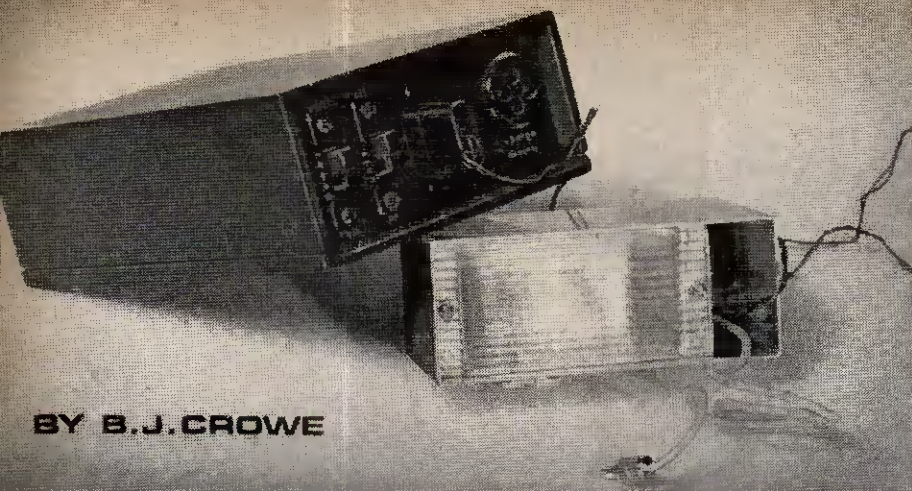

## PART TWO FLASH HEAD

# ELECTRONIC FLASH GUN

*WARNING: High voltages are encountered in this flash gun. Care should be exercised in handling and it is essential that the components and wiring should not be touched until the capacitors are completely discharged (see text later). To avoid any risk of damage or shocks the whole units should be kept dry and carried in a waterproof carrying case.*

**T**HE DESIGN of the flash head posed a rather different problem from that of the power pack. In the latter the innovation was in the circuit design rather than in the hardware; in the flash head, the circuit is well known, but as far as the author is aware a compact mechanical design is not available.

The greatest contribution to miniaturisation in electronic flash has been the introduction of a compact reflector. The author decided, therefore, to attempt the design of a compact flash head incorporating the trigger circuit and cable storage compartment. The construction of the flash head necessarily involves some metal work, but this is kept to a minimum, and alternative designs will be suggested later for those who do not wish to attempt the compact head.

### CIRCUIT

The circuit diagram for the flash head is shown in Fig. 2.1. The output voltage of the power pack is applied across the xenon tube (V2) and a proportion of this voltage appears at the junction of R1 and R2 to charge the capacitor C1 to approximately 250 volts. When the camera shutter is operated C1 is effectively placed in parallel with the primary of the trigger coil (T1) producing a "ringing" circuit, the first spike of which, at about 6 kilovolts, triggers the xenon tube into its conducting state. A smaller portion of the supply voltage (about 70 volts) is tapped off from VR1 to ignite the wire-ended neon indicator V1 when the main capacitors have reached about 90 per cent of their charge voltage. Resistors R2 and R3 are not strictly necessary and may be dispensed with if VR1 is replaced with a 2.5M $\Omega$  preset, but some sensitivity will be lost in setting the ignition point of the neon.

### HOUSING DESIGN

The size of the flash head was dictated primarily by the size of the FA10 xenon tube, and secondly by the requirement that it should fit on top of the power pack and form a compact unit for transportation. The size of the trigger circuit board and the space required for cable storage were also influencing fac-

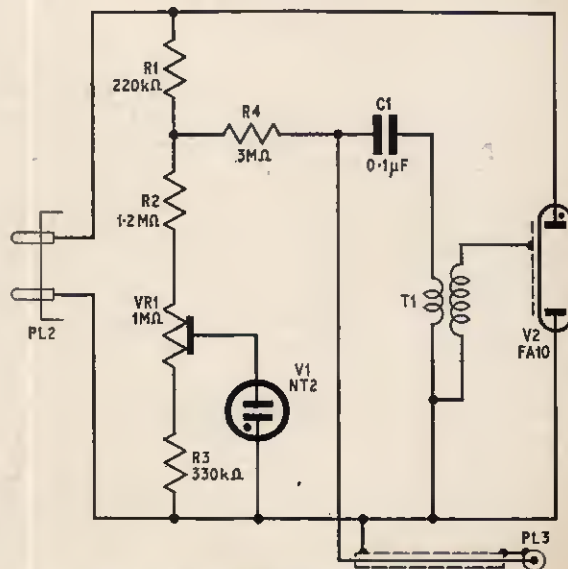

Fig. 2.1 Circuit diagram of the flash head

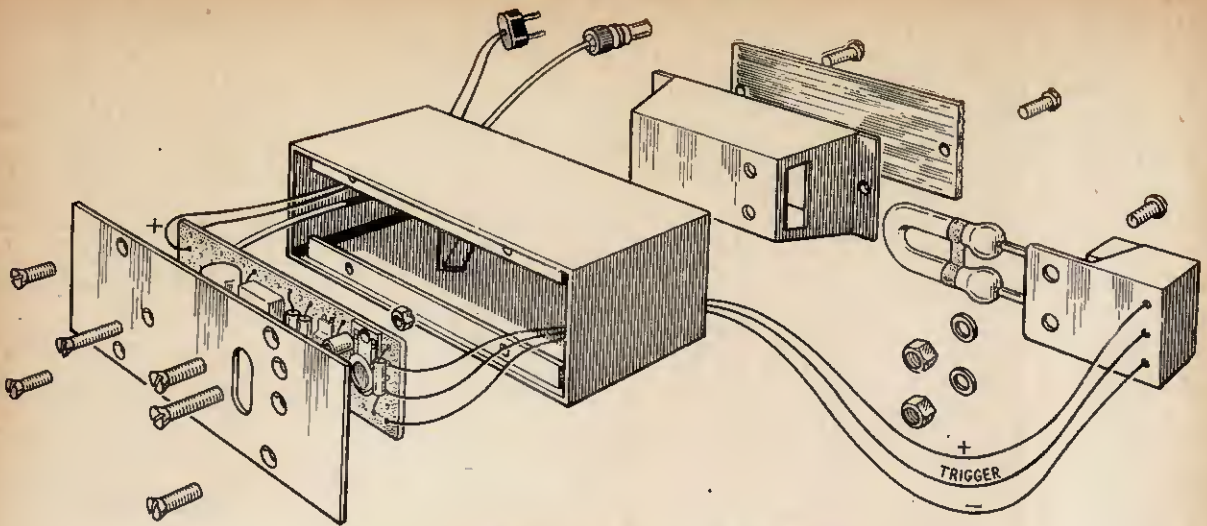

Fig. 2.2 Exploded view of the complete flash head

tors. A pleasing appearance and relatively simple construction is achieved by keeping the mechanical fastening to a minimum by the use of "Araldite" epoxy resin adhesive.

An exploded view of the flash head is shown in Fig. 2.2. The main component is a simple shallow rectangular box of 20 s.w.g. sheet aluminium, open at each end, and carrying two horizontal rails at the back and two short vertical rails at the front.

The front rails carry the lens and reflector, on which is mounted the xenon tube socket. The rear rails carry the backplate which in turn carries the trigger and charge indicating circuit.

The right-hand front rail is set in approximately  $\frac{3}{4}$ in from the edge of the box, forming a space alongside the lens in which the synchronisation and power supply leads may be stored. Only six screws are used as fasteners on the main assembly; all other joints are glued.

### CASE CONSTRUCTION

Since the finished appearance of the flash head is directly dependent upon the accuracy and neatness with which the box is folded, as much care as possible should be exercised at this stage. The box is folded from a sheet of 20 s.w.g. aluminium measuring 11.56in  $\times$  2.10in (Fig. 2.3a) and should be obtained ready cut, or cut by a friend with access to a guillotine, if possible, as this produces neat straight edges. If it is possible to gain access to a folding machine, the task of folding the box is greatly simplified. The box may, however, be folded quite successfully in an ordinary bench vice using the block shown in Fig. 2.3b and protecting the aluminium from the vice jaws with soft jaws or suitable packing, such as wood, on both sides of the sheet.

When the box has been squared up the chamfered edges are cleaned thoroughly with acetone, carbon tetrachloride or trichlorethylene and a small quantity of Araldite applied to each edge. The edges are then brought together and held in position with elastic bands or adhesive tape. A liberal fillet of Araldite is run into the corner as in Fig. 2.4 to ensure a sound joint. The box should now be left for 24 hours to set, preferably in a warm, dry atmosphere.

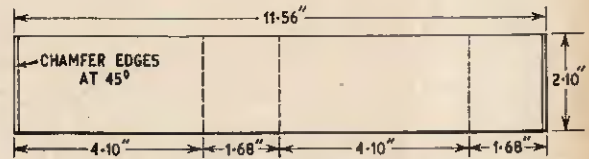

Fig. 2.3a. The main case of the flash head is made from aluminium alloy sheet 20 s.w.g. and folded . . .

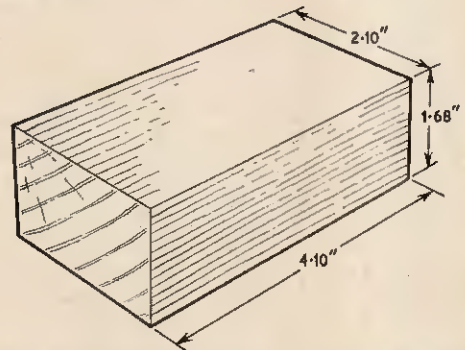

Fig. 2.3b. . . round this block to form an open ended box

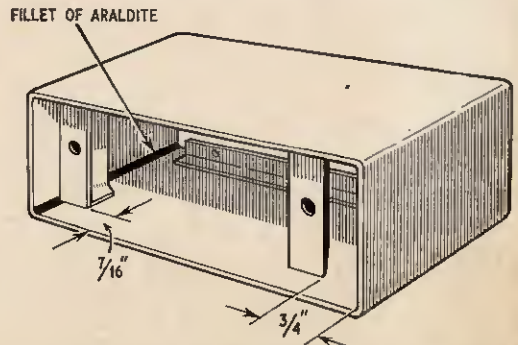

Fig. 2.4. Front view of the completed box with the rails fitted in position



# EXCEL

in

# ELECTRONICS

## Through this ICS 3-way Training Method:

1

### MASTER THE THEORETICAL SIDE

From basic principles to advanced applications, you'll learn the theory of electronic engineering, quickly and easily through ICS. That's because each course is set out in easy-to-understand terms.

2

### MASTER THE PRACTICAL SIDE

ICS show you how to develop your practical abilities in electronic engineering—*alongside* your theoretical studies. It's the only sure way to success. All training manuals are packed with easy-to-follow illustrations.

3

### MASTER THE MATHEMATICAL SIDE

To many this aspect is a bitter problem. Even more so because no electronic engineer is complete without a sound working knowledge of maths. But new ICS teaching makes mathematics easier to learn.

Wide range of courses available include: Radio/T.V. Engineering and Servicing, Colour Television, Electronics, Electronics Maintenance, Instrumentation and Servomechanisms, Telemetry, Computers, etc.

**NEW!** Programmed Course on Electronic Fundamentals

### EXPERT COACHING FOR:

INSTITUTION OF ELECTRONIC AND RADIO ENGINEERS  
CITY AND GUILDS TELECOMMUNICATION TECHNICIANS  
CITY AND GUILDS SUPPLEMENTARY STUDIES  
R.T.E.B. RADIO/T.V. SERVICING CERTIFICATE  
RADIO AMATEURS' EXAMINATION  
P.M.G. CERTIFICATES IN RADIOTELEGRAPHY

And there are practical "learn as you build" radio courses as well.

Member of the Association of British Correspondence Colleges.

FOR FREE HANDBOOK POST THIS COUPON TODAY

I.C.S., Dept. 131, INTERTEXT HOUSE,  
PARKGATE ROAD, LONDON, S.W.11

NAME .....

ADDRESS .....

OCCUPATION.....AGE.....8.65

**INTERNATIONAL CORRESPONDENCE SCHOOLS**



**Semi-conductor module**—cube size encapsulated circuit. Solid state semi-conductor modules—fully transistorised and completely wired and tested circuits that only require a 6-volt battery and connection to input and output to provide a compact ready-made unit. Encapsulated types are shockproof and almost indestructible. Supplied with instructions.

**PUBLIC ADDRESS AMPLIFIER**—needs only crystal microphone and any speaker. Frequency response designed to provide maximum intelligibility. With 15 in. speaker sound covers hundreds of yards. Fully encapsulated. Size only 1½ x 1½ x 2 in. 35/-. P. & P. 1/-.

**CODE PRACTICE OSCILLATOR**—simply connect with morse key, any P.M. speaker and any 1½-6V battery. Fully transistorised and assembled on rigid board size 2 x 1½ in. 12/6. P. & P. 1/-.

**BURGLAR ALARM**—needs only 8-ohm loudspeaker, switch and microswitch (or reed switch and magnet) to complete. Operation of sensing switch trigger upward screaming siren to give instant alarm. For home or motor car protection. 30/-. P. & P. 1/-.

**FIRE ALARM**—module contains temperature sensor and operates in conjunction with 8-ohm loudspeaker and 2-megohm potentiometer. Increase of room temperature above pre-set level immediately triggers screaming siren alarm. 50/-. P. & P. 1/-.

**PHOTO MULTIPLIER POWER TRANSISTOR**—complete photo-electric system in one unit of power transistor amplifier. Photo-electric cell and electronic relay. Make your own photo-control system—door opener, burglar alarm, automatic door chimes, counters, etc. Complete with instruction literature of unusual applications. 25/-. P. & P. 1/-.

**WIRELESS TELEPHONE AMPLIFIER MODULE**—complete, electronic, solid state circuitry ready to amplify and transmit both sides of a telephone conversation into any A.M. broadcast band radio without interconnecting cables. Operates from 9 volts "transistor" battery and requires only telephone pick-up coil to operate. 30/-. P. & P. 1/-.

**MICROPHONE TRANSMITTER MODULE**—contains complete solid state circuitry ready for use as a means of transmitting speech from any high impedance microphone into an ordinary A.M. radio without connecting wires. Requires only 9 volts battery and crystal microphone. 30/-. P. & P. 1/-.

**METRONOME**—requires only 2 megohm potentiometer and any PM speaker to produce accurate repetitive beats at adjustable rates from 40 to more than 208 beats per minute. Low battery drain, simple connections. 22/6. P. & P. 1/-.

**2 WATT GRAM AMPLIFIER**—just connect to any crystal pick-up and 8-ohm speaker for above average output with excellent tonal quality. 1-megohm potentiometer recommended for vol. control. Compact, high quality unit. 35/-. P. & P. 1/-.

## Construct Electronics with NEW VEROBOARD Quickly, Cheaply, Professionally

**VEROBOARDS** supplied by Proops

Brothers Limited have been specially designed to meet the needs of the amateur constructor: hole matrices have been pitched to provide the greatest utility in a wide variety of circuit layouts; purchase price has been kept low by the deliberate selection of one standard board width (22 way) which may be used with almost any circuit but permits large quantity purchase with attendant saving; specially prepared design sheets are provided with each purchase to simplify circuit layout; accessories have been kept to an essential minimum to further reduce cost.

**VEROBOARD SHEETS.** 12/6 each. Post Free. Board size overall: 17 in. long x 3½ in. wide 0.0312 in. thick. Each is clad with 22 x 0.0015 in. thick copper conductors which are fully pierced in line at 0.156 in. intervals across width and 0.2 in. along length. Boards are treated with flux preservative to give protection and ensure satisfactory soldering. A design sheet is supplied with each board.

**SPOT FACE CUTTER.** 8/6. Post Free.

Specially designed hand cutting tool with hole locating spigot. Light turning and pressure removes copper conducting strip locally to make a neat break.

**TERMINAL PINS.** 50 for 3/6. Post Free.

Made specially for Veroboards of pre-tinned brass with a flat head to give maximum contact, and self-cutting serrations near the head to ensure a tight fit when pushed into the hole.

**INTRODUCTORY VEROBOARD KIT.** 24/-. Post Free.

Includes one sheet of Veroboard, Design Sheet, Spot Face Cutter, 50 Terminal Pins, and instruction on design method and layout procedure.

## MINIATURE MERCURY SWITCH

Almost indestructible, Featherlight operation



Encapsulated in copper-plated steel tube only 3/16" dia. x 3/8" long (incl. flange). Tube provides one contact and other contact is 1/8" long wire fused into glass centre of tube base. 20° movement makes or breaks contact; vacuum sealing ensures unchanged contact resistance throughout life. Construction permits switch to be simply clipped into position. Rating 240v. AC mains operation at 1 amp., may also be used with DC current from small torch battery. Can be installed almost anywhere to operate lights automatically or to provide simple warning or safety devices.

TWO  
for  
7/6  
Post free

**PROOPS**  
BROTHERS LIMITED

52 TOTTENHAM COURT ROAD, LONDON W.1  
PHONE: LAngham 0141. HOURS: 9am-6pm  
THURS: 9am-1pm. OPEN ALL DAY ON SATURDAY

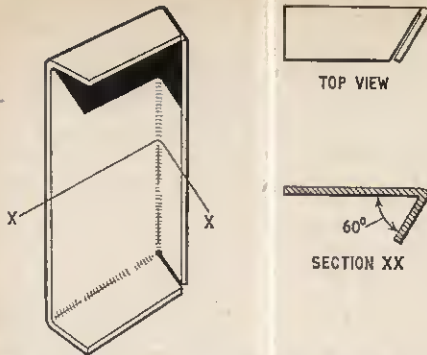

Fig. 2.5. Construction and bending details of the right-hand front rail

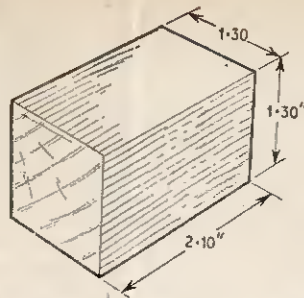

Fig. 2.7. This block is used to form the reflector shape shown in Fig. 2

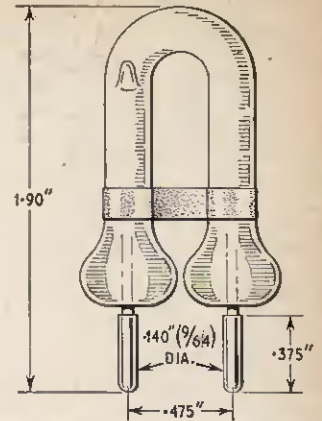

Fig. 2.8. Dimensions of the xenon tube

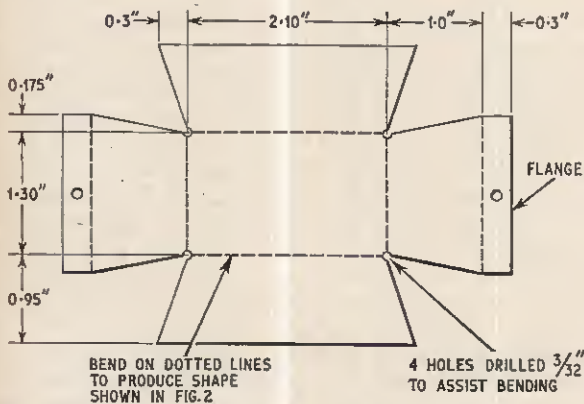

Fig. 2.6. The reflector base is cut from aluminium alloy sheet 20 s.w.g. and folded

The rails may now be constructed while the joint is hardening. The two rear rails and the front left-hand rail are  $\frac{1}{2}$  in  $\times$   $\frac{1}{2}$  in angle sections bent in the vice from  $\frac{1}{2}$  in strips of 20 s.w.g. aluminium and cut to the appropriate lengths to fit inside the case as shown in Figs. 2.2 and 2.4. The right-hand front rail is  $\frac{1}{2}$  in  $\times$   $\frac{1}{2}$  in and is bent to form an acute angle of 60 degrees (see Fig. 2.5) in order to prevent the cables chafing when being withdrawn from the storage compartment. Since it cannot be bonded along the edge like the other rails, the ends are turned over as shown to provide the anchorages. It should be made slightly longer than required and then, when the box is set hard, the ends may be filed until it is a sliding fit in the box.

The surface to be bonded on each rail and the mating surfaces in the box are scored with a sharp point (such as a scriber or hacksaw blade) in a fine criss-cross pattern until the whole surface to be bonded is rough. The surfaces are then cleaned with one of the fluids previously mentioned, smeared lightly with Araldite and each rail offered up to its mating surface. It is better to tackle the rails in pairs and allow one pair to set before fixing the next.

The rear rails may be spaced from the back using a scrap of 20 s.w.g. material to simulate the back-plate.

The front rails are set back  $\frac{3}{8}$  in from the front of the box, and the right-hand rail set  $\frac{1}{2}$  in from the inside of the box (Fig. 2.4). A small card template facilitates the setting of these components.

## REFLECTOR

The reflector base is made from 20 s.w.g. sheet and covered with reflecting material (see later), so that the surface need not be protected during the bending operation. Cut the blank to the template shown in Fig. 2.6, and make the block from a scrap of wood (Fig. 2.7). Bend the flanges down at approximately 60 degrees, and then clamp the blank in the vice with the block, the holes in the blank lying at the corners of the block. The sides are then bent forward until the edges all line up. Square up the flanges, bond the edge joints with Araldite and put on one side for 24 hours to harden.

The backplate is cut from 20 s.w.g. sheet and fitted into the back of the box on the rear rails. The lens is cut from a piece of acrylic sheet to 3.375 in  $\times$  1.65 in. It may be plain or fluted (as in the author's gun) in which case the curves are placed so as to give a "condensing" effect to the light beam. Admittedly no tests have been carried out on this lens to assess its performance compared with a clear lens, but the fluted effect undoubtedly provides a more uniform and diffused light.

The lens and reflector assembly may be fixed with self-tapping screws, or, if a more durable fastening system is required, small pieces ( $\frac{1}{4}$  in  $\times$   $\frac{1}{8}$  in) of 16 s.w.g. mild steel may be glued to the back of the rail and tapped for 6 B.A. screws.

When the necessary preparation has been done, lay the reflector and lens on the rails and drill carefully through all three with a small drill, and then enlarge and tap the holes as required. The backing plate may be glued permanently in position, but in the author's gun it was attached by screws to give greater access to the interior.

## XENON TUBE SOCKET

The FA10 xenon tube (Fig. 2.8) has two pins which are spaced so as to fit a standard two-pin 2 amp socket, but the latter is bulky, and no provision is made for a contact to the trigger strap. Amateur

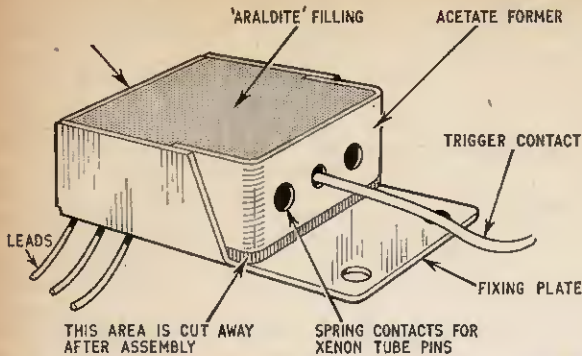

Fig. 2.9 The socket to hold the xenon tube. Note the trigger contact strip which makes contact with the strap across the tube shown in Fig. 8

flash-heads usually use a coil of stiff wire twisted around the pins, and flexible wire twisted round the trigger strap, but with this system the tube is neither rigidly held, nor easily removed. The author has designed a socket in which all three contacts are made and yet the tube may be removed using moderate force.

A word of warning before going into the description—the xenon tube is extremely fragile and should be handled with great care.

The socket (Fig. 2.9) is made from a small piece of celluloid or cellulose acetate and some thin (22 s.w.g. or 24 s.w.g.) beryllium copper or phosphor-bronze sheet (obtainable from any good engineers' suppliers and many model shops).

Cut a piece of phosphor-bronze (or beryllium copper) about  $\frac{3}{8}$  in wide and 3 in long, and wrap it round a nail or drill about  $\frac{1}{8}$  in diameter so that it looks like a clock-spring. When  $2\frac{1}{2}$  turns have been wound, cut off the surplus and solder the coil so that it is held closed. This can be removed from the nail and fitted over one of the pins of the tube. Repeat for the other pins and solder a 6 in length of plastics-covered wire (7/0048) to each one, red and black. Cut a thin strip (about  $\frac{1}{8}$  in wide) of phosphor-bronze about  $\frac{1}{2}$  in long and solder a 6 in length of white covered wire to this. (Phosphor-bronze sheet of this thickness may be cut with ordinary household scissors or tinsman's shears.)

Cut the socket box from 20 s.w.g. aluminium alloy sheet to the shape shown in Fig. 2.10 and fold up the edges. (This may be done by hand with the aid of a pair of pliers or in a small vice.) Cut a piece of celluloid or acetate sheet  $\frac{1}{16}$  in thick (obtainable from model shops) about  $2\frac{1}{2}$  in  $\times$   $\frac{1}{2}$  in and drill and bend as shown in Fig. 2.11. Cement it to the box as shown in Fig. 2.9.

Thread the wires of the three contacts through the appropriate holes in the box, and push the long thin bronze strip (which forms the trigger contact) through the centre hole in the acetate sheet. The spring contacts are held in position while the Araldite sets by the pins of the xenon tube (Fig. 2.12) so these must be lightly smeared with grease to prevent unwanted adhesion.

Insert the tube pins through the outer holes in the acetate sheet and push the spring contacts gently on to them (observe polarity!). The box is then laid on a flat surface with the end overhanging to allow the three wires to clear it, and the xenon tube packed up until it lies parallel to the surface (Fig. 2.12). Mix

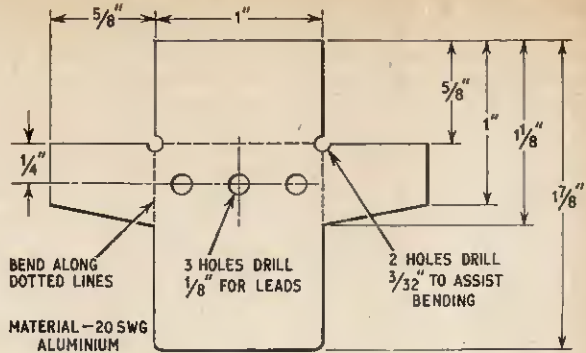

Fig. 2.10. The casing for the xenon tube socket is cut to shape and bent to form the shape shown in Fig. 9

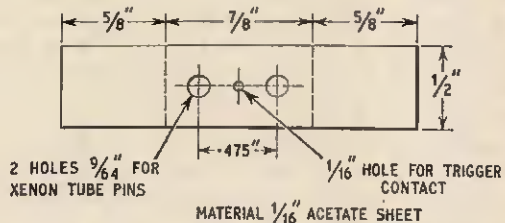

Fig. 2.11. The front plate of the xenon tube socket is cut to the size shown, drilled and bent to the shape shown in Fig. 9

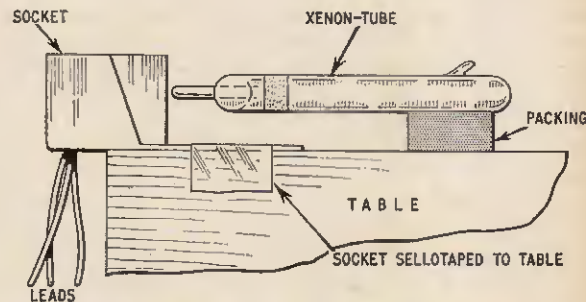

Fig. 2.12. Aligning the xenon tube with the socket by using packing and adhesive tape prior to filling the socket with araldite. The pins should be inserted in the socket.

a good quantity of Araldite (about a third of each tube) on a piece of clean scrap metal or glass and warm it in front of the fire until it runs easily. The Araldite may now be poured round the contacts into the mould formed by the box and the acetate sheet until it is level with the top, and then allowed to set.

After 24 hours, the xenon tube may gently be removed from the socket (the importance of ensuring that no Araldite comes into contact with the pins is obvious) and the shaded portion (Fig. 2.9) cut away with a junior hacksaw and sharp knife. The socket may then be cleaned up with a file and the trigger contact bent to shape as shown in Fig. 2.9, so that it bears on the trigger strap when the tube is inserted.

A hole must now be cut in the reflector base to accept the socket (see Fig. 2.2), either by drilling a series of small holes or using an "Abrafile" saw blade which fits a standard hacksaw frame. The hole is



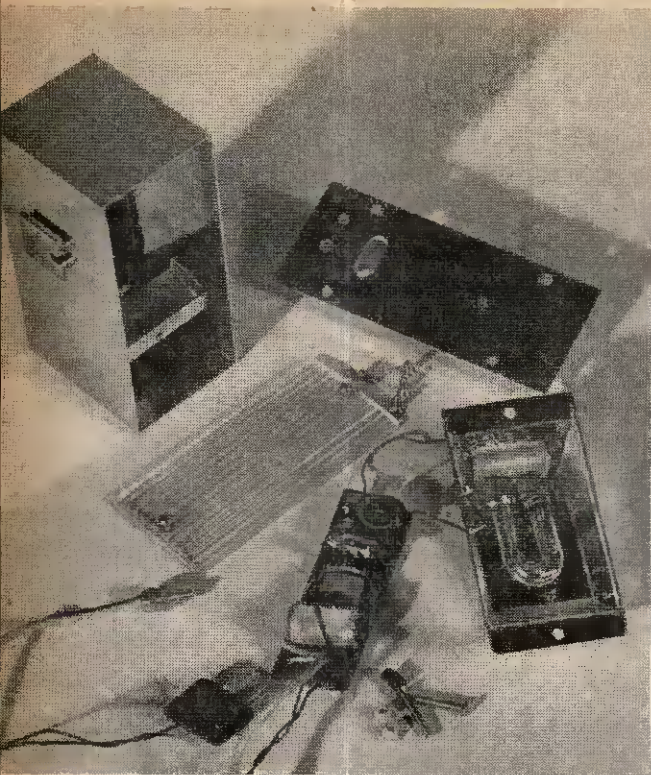

The component parts of the flash head before assembly

carefully enlarged with a file until the socket sits snugly against the back and side of the reflector base. Two holes are then drilled through the reflector base and socket plate to take 6 B.A. countersunk head nickel plated screws.

The reflector base must now have its reflective coating applied. In the author's gun this was a piece of 0.00025in thick aluminised transparent plastic film (Melinex) fixed to the reflector base with clear adhesive, the aluminium side being glued down to leave the

plastic film as a protective coating on the outside. Alternatively, the reflector base may be covered with kitchen foil, or simply polished as it stands, although neither of these surfaces will have as high a reflectivity or durability as the former method provides.

### CIRCUIT BOARD

The circuit is built up on a piece of Veroboard 3in x 1in (matrix of 19 x 6 holes). The component layout is shown in Fig. 2.13, and the component wiring points on the reverse of the board are shown in Fig. 2.14. Cut the board to size and make the breaks in the strips at A7, A9, and E11. Drill  $\frac{1}{16}$ in clearance holes at A3 and C18 and cut the strip well back from the holes.

The author used a preset (skeleton type) potentiometer for VR1, which was modified for use in the horizontal position by bending down the tags and cutting short the centre one. The holes in the Veroboard must be enlarged slightly to take this component,

TABLE I:  
COMPONENT CONNECTION POINTS

Component	Wiring Board Location
R1	D8, A8 & B8
R2	A5, E5
R3	A1, F2
R4	A10, E9
VR1	A2, A4, wiper to C3
C1	A13, E13
T1	Common F15 L.T. winding E16 H.T. winding D13
V1	C7, F6
PL2	B19 (Power in +)
PL2	F19 (Power in -)
V2 positive	B1
V2 negative	F1
V2 trigger	D1
PL3	A18 (Sync inner)
PL3	F18 (Sync screen)

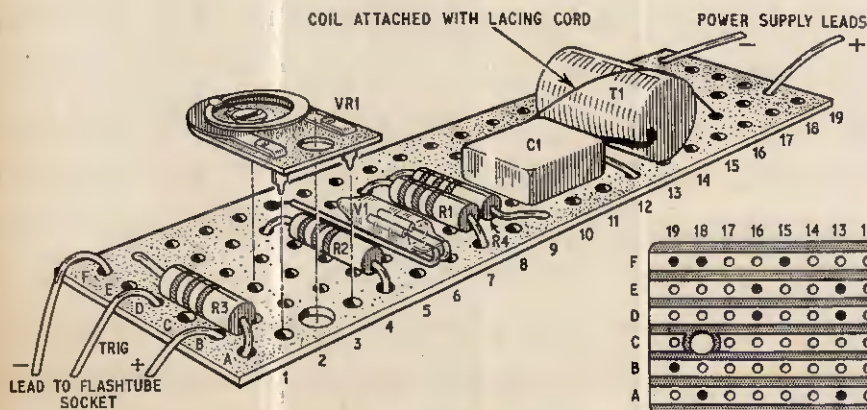

Fig. 2.13. Component layout of the wiring board. VR1 is shown removed from its position to indicate its connections

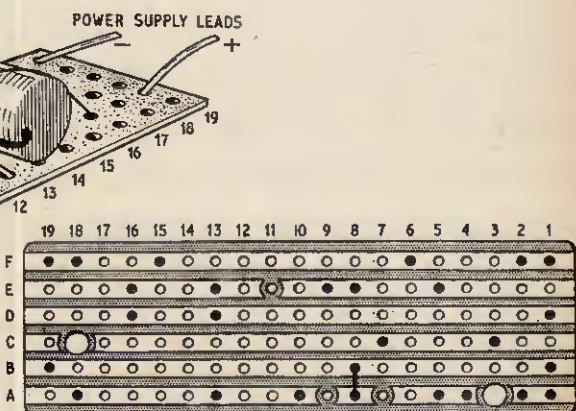

Fig. 2.14. Underside view of the wiring board showing the component connections and cut-outs

but miniature components intended for use on 0.15in matrix board are available and would be preferable here.

The connection points of each component are shown in Table 1. The trigger coil should be strapped to the board using lacing card or p.v.c. covered wire passed through spare holes. Note that the lead of R1 is fed through position A8 and bent up and soldered to strip B at B8. (A miniature resistor could be connected direct to B8 and so avoid this strap.) If the preset potentiometer is used a hole must be drilled through it between the tags to take the mounting screw.

The board is now fitted, components downward, on the inside of the backplate, and holes drilled in the backplate to correspond to holes A3 and C18 in the Veroboard (see Fig. 2.2). A piece of p.v.c. sleeving from coaxial cable serves as a spacer under the circuit board at position A3. Two 6 B.A. screws are pushed through the backplate and board, and secured with nuts. Nylon screws and nuts are obtainable from some component shops and are best used here to prevent shorting adjacent circuit strips.

Mark the position of the neon and potentiometer, remove the circuit board, and cut the holes which allow the neon to be viewed and the preset to be adjusted

from the back (see Fig. 2.2). Attach the socket leads, power supply lead (4ft red and black 7/0048in twisted together) and the synchronisation cable (4mm coaxial plug and coaxial cable, obtainable from photographic dealers) to the appropriate points on the board, and fit the board to the backplate. The copper strip side of the wiring board should be thoroughly cleaned and lightly smeared with a coat of silicon grease. *This is very important to avoid the possibility of shorts if any damp is present.*

Pass the leads through the flash head box from the front, followed by the backplate and circuit board, until the reflector is in position. Place the lens in position and insert the screws. Feed the cables back through the box, through the cable storage compartment until the backplate is in position, and screw down. After fitting the Radiospares flex-connector plug PL2 to the power lead the cables can be coiled and inserted in the storage space. To complete the flash head, make a T-piece from a scrap of aluminium to fit the camera accessory shoe and fix in place with Araldite or screws to the underside of the flash head case (see photograph on page 703).

## CALIBRATION

Plug the power supply lead from the flash head into the power pack and connect the synchronisation cable to a camera or suitable shorting switch. Turn the preset potentiometer in the flash head completely clockwise and switch S2 on the power pack to half power.

*Interior view of the power pack described last month*

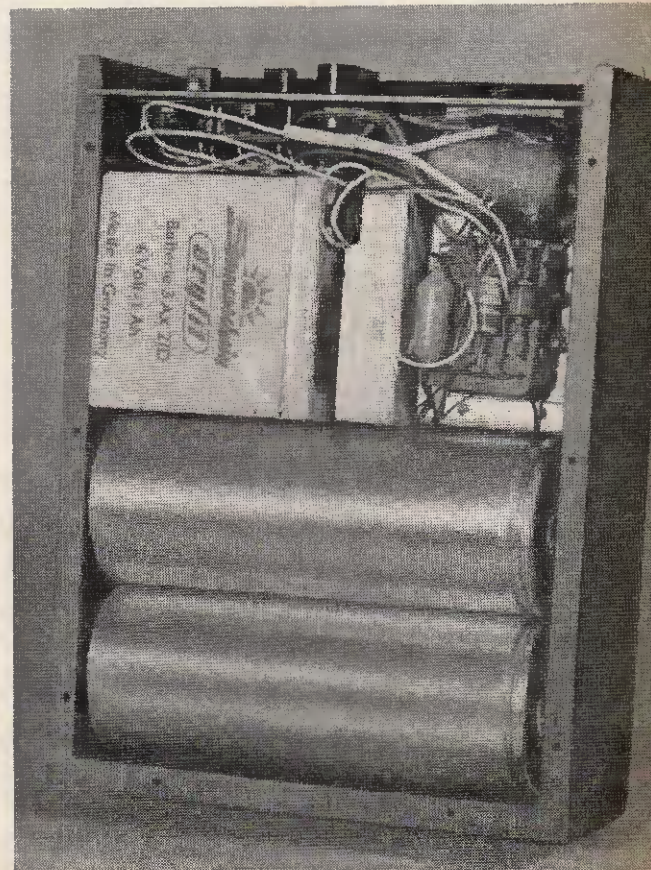

## COMPONENTS . . .

### FLASH-HEAD UNIT

#### Resistors

R1 220k $\Omega$	R3 330k $\Omega$
R2 1.2M $\Omega$	R4 3M $\Omega$

All  $\frac{1}{2}$  watt 10 per cent

#### Potentiometer

VRI 1M $\Omega$  skeleton preset (Radiospares)

#### Capacitor

C1 0.1 $\mu$ F 250V Polyester (Radiospares)

#### Transformer

T1 Trigger coil (General Electronics, 129 Portobello Road, London, W.11)

#### Gas-filled tubes

V1 NT2 Neon indicator (or similar)  
V2 FA10 Xenon discharge tube (A.E.I.)  
(Available from General Electronics, London)

#### Plugs

PL2 Two-pin plug to fit SK2 on the power unit (see last month's article)  
PL3 4mm sync plug and cable for camera (Arrow-tabs)

#### Miscellaneous

Aluminium alloy sheet (half hard grade) 20 s.w.g., 12in  $\times$  12in

Perspex acrylic sheet (clear) plain or fluted, 3 $\frac{1}{2}$ in  $\times$  1 $\frac{1}{2}$ in  $\times$   $\frac{1}{8}$ in thick from Perspex stockists or Fresnal lens (Proops Bros. Ltd)

Aluminised Melinex plastic film, 6in  $\times$  6in  $\times$  0.00025in thick (Utilflex Ltd., Mill Street, Kingston upon Thames, Surrey)

Phosphor bronze or beryllium copper, 3in  $\times$  1in  $\times$  22 s.w.g.

Wood blocks (see text)

P.v.c. covered wire 7/0048

Araldite adhesive (packet of two tubes)

Switch on the power pack, and wait for about one minute, then turn VR1, which controls the neon, gradually clockwise until the neon just strikes. Press the camera shutter release and the gun should fire. If still switched on, the gun will automatically recharge and the neon should strike again after 6 or 7 seconds. Repeat this operation with switch S2 on full power. The gun should now take about 12 to 15 seconds to recharge.

If for any reason the gun fails to fire, it is imperative that the capacitors should be discharged before the power pack is opened. This may be done with a short length of wire in the output socket, but it is better to short with a low value resistor (say 500Ω) to avoid damaging C4 and C5. Touching the capacitor terminals whilst they are charged up will result in a severe shock and possible local burning of the fingers.

## USING THE FLASH GUN

Having ascertained that the gun functions satisfactorily, it is necessary to determine the exact amount of light which the gun provides. This is usually expressed as a pure number called the guide number, and which has the value of the product of the camera aperture and the distance between the camera and the subject, which will give the correct exposure with the film used. A table showing the guide numbers obtained with various film speeds with the author's gun is shown below.

TABLE 2: EXPOSURE GUIDE

Film Speed A.S.A.	Guide Number
50	56
125	88
140	94
200	112
400	158

To determine a guide number, expose several frames at different apertures, and one known camera-to-subject distance. After processing decide from the prints (or transparencies) which aperture gave the best exposure. Multiplying this aperture value by the known distance gives the guide number for the film emulsion in use.

After about 40-50 flashes, it will be found that the recycling time of the gun has increased to 30 seconds or more, and may not even light the neon without resetting the preset potentiometer in the flash head. This indicates that the accumulator needs recharging. If the circuit shown has been incorporated into the power pack, it is only necessary to plug in the mains lead and leave overnight. Alternatively the cell may be charged from any suitable source at 100-150mA for 8-10 hours, with care.

### References

The author has found the following articles helpful in compiling this article:

1. Wakefield, G. Flash Techniques Nos. 6 and 7. *Amateur Photographer*, October 2 and 9, 1963.
2. Shelton, R. J. Novel Electronic Flash Unit. *Amateur Photographer*, October 24, 1962.

## Component Developments

IMPROVED washing machines, television sets (including colour TV), research microscopes and hearing aids are foreshadowed by new electronic "bits and pieces" which were shown at the Radio and Electronic Component Show at Olympia, London in May.

Among the new components shown by 300 members of the industry there was a new colour television tube which will enable bigger and brighter pictures to be shown on a smaller television set.

A field ion microscope, the first to be developed commercially in Britain, has a magnification of more than one million times; for the first time it enables individual atoms to be "seen".

One firm foreshadows the use of thyristors, already proving of great value in industrial control, for making domestic washing machines simpler, more reliable and possibly cheaper. By using a thyristor to control a single motor, gearing is eliminated and the "washing" and "spinning" speeds can be optimised.

## Try and Light the Candle

THIS working exhibit (shown below) on the Mullard stand at the Components Exhibition effectively demonstrates the very high input impedance ( $10^{12}$  ohms) of the recently introduced metal-oxide semiconductor transistor, type 95BFY.

The two bare rods are input connections to a high-gain d.c.-coupled amplifier with an m.o.s. transistor in the first stage. Attempts to light the candle fail because the hot gases produced in the gap by a lighted match are sufficient to reduce the impedance seen by the amplifier. The resulting increase in output current opens a shutter which releases air to extinguish the match before it can light the candle.

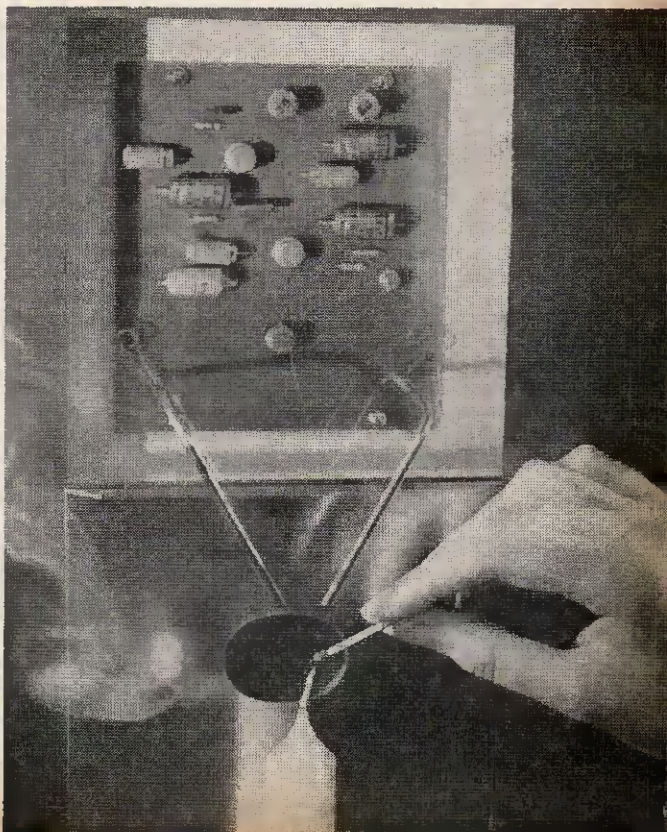

# UHF RECEPTION

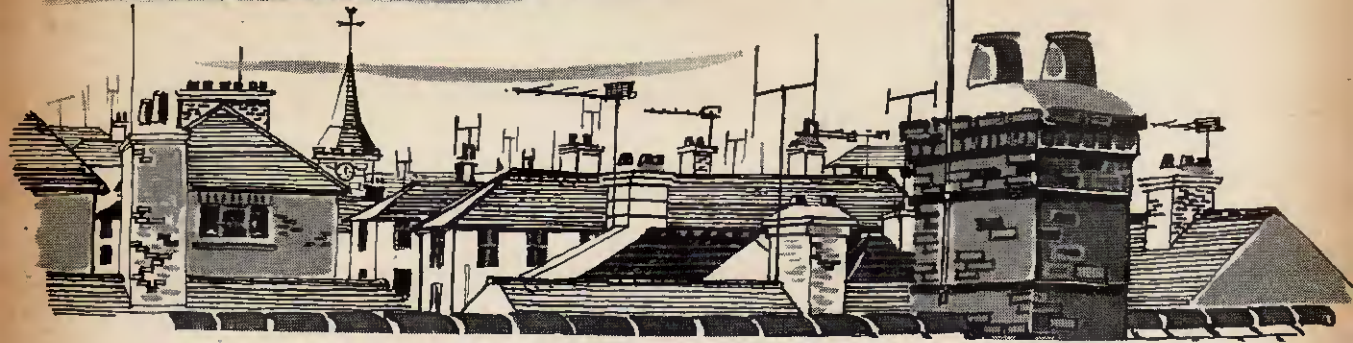

by J. D. Benson

**W**ITH THE rapid expansion of the BBC 2 television service throughout the United Kingdom, television engineers are being faced with an increasing quota of technical problems relating to the reception of these broadcasts in the home. Although this article has been written with service engineers in mind, a large proportion of viewers will probably find many answers to their own problems. To help to explain some of the finer points of u.h.f. reception let us briefly examine some of the fundamentals of radio wave propagation.

## TRANSMISSION

Radio waves consist basically of two components: the electrical field and the magnetic field. These two fields are at right angles to one another and when transmitted are either horizontally or vertically polarised according to which field is parallel with the earth's surface. Irrespective of their frequency, the signals travel at the speed of light, i.e. 186,000 miles per second or 300,000,000 metres per second and from this we can derive the wavelength ( $\lambda$ ) of any particular transmission:

$$\lambda = \frac{300,000,000 \text{ (metres per second)}}{\text{frequency (cycles per second)}}$$

Transmissions in the lower frequency bands are usually referred to by wavelength, whilst those in the higher bands are quoted in frequencies.

When transmitted, radio waves produce three types of waves: the ground wave, sky wave, and direct wave. The effectiveness of these waves depends largely on the frequency at which they are transmitted. The ground wave is produced by the electromagnetic component when the transmission is vertically polarised, that is when the electrical component is vertical to the earth's surface.

The power of the ground wave is determined by the frequency of the transmission; this can be better understood if the earth over which the waves travel is considered as a large capacitor. At low frequencies the earth offers a high impedance and little power is lost; as the frequency increases the impedance offered

decreases until at very high frequencies the ground wave is practically non-existent. A practical case of ground waves transmitted at low frequencies is the BBC Light Programme on 1,500 metres, which can be received hundreds of miles away from its source.

The sky wave is so called because it is reflected from the Kennelly-Heavyside and Appleton layers which exist from about 40 miles to several hundred miles above the earth's surface. These layers are electrically charged (ionised) by the sun's action and deflect radio waves. Unlike a mirror, the waves are not directly reflected, but according to the frequency and state of ionisation are bent (refracted) before reaching the earth again.

It is due to this natural phenomenon that reception of certain frequencies is possible at great distances. It also explains why any change in these ionised layers (sun spots, etc.) results in a great variation in the results received at various times of the year. Very high frequency waves pass through these layers or are absorbed by them.

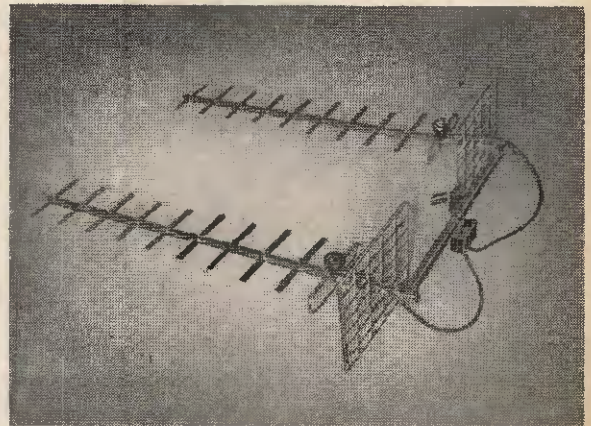

**Fig. 1. Twin 'Yagi' array for fringe reception. The beam width is so narrow that very precise positioning must be carried out to obtain best results.**

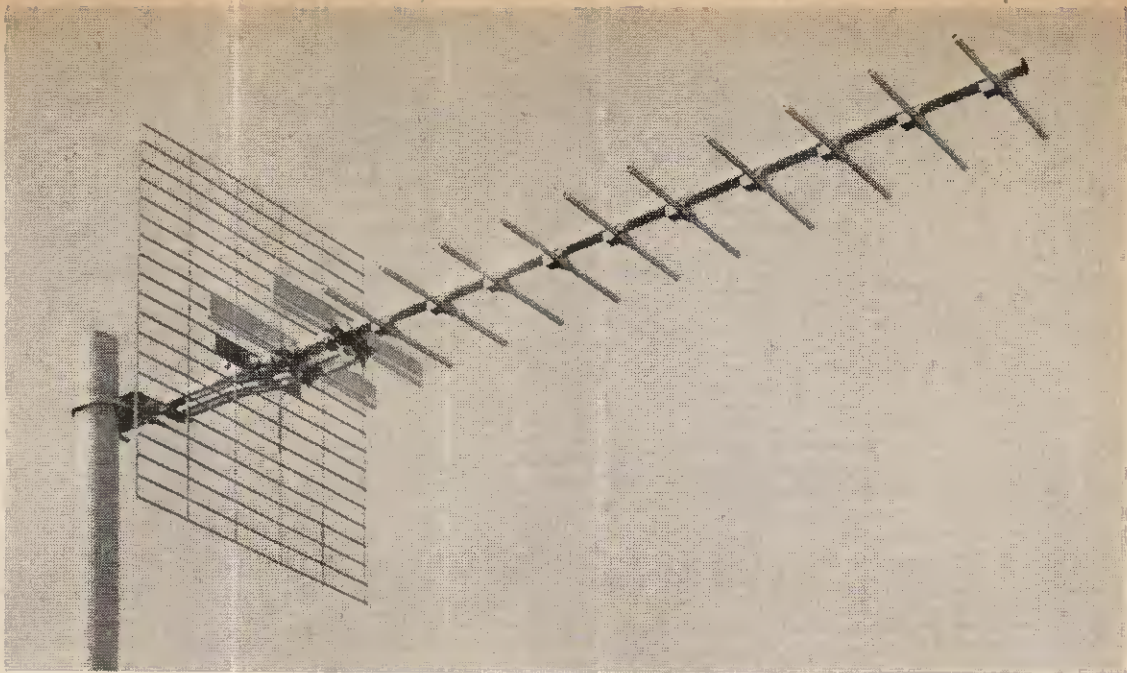

Fig. . A typical commercial 'Yagi' array by Belling & Lee

The long and medium wave stations are therefore very reliable under all climatic conditions because of their powerful ground wave component. The sky wave produced by medium wave stations is greatly reduced in power during the hours of daylight and are very powerful at night, which accounts for the improved reception of the medium wave band Continental stations during the hours of darkness.

#### SKIP DISTANCE

The high frequency band which covers 100-10 metres depends almost entirely on the sky waves for reception and results, according to climatic conditions can be very erratic. At these frequencies another effect called "skip distance" is present. It is the area between where ground waves are non-existent and where the shortest sky waves begin. In the skip distance area, no reception is possible. By the use of directional aerials and choice of frequency, great distances can be covered, but because of the adverse effect of climatic conditions this band is very prone to interference between stations.

Stations transmitting at v.h.f. rely almost entirely on direct waves for communication, i.e. aerial to aerial or line of sight. There is also a small percentage of reflection from the earth. This band is used for f.m. transmissions, television, radar and many other services. These bands, which extend from I to III, have now become so crowded that any new service had to be allocated a frequency on a new band, hence the choice of u.h.f. (ultra high frequency) for BBC 2 in Band IV (470-582Mc/s).

#### SITING AN AERIAL

At these ultra high frequencies communication is almost entirely dependent on direct waves, which necessitates the transmitting aerial being very high above ground (1,000ft or more) if a useful service area is to be covered. In spite of the high power

(500kW) and high aerials, the BBC 2 transmitter will only cover a service area of about 25-30 miles radius from the transmitter and within that area there will be many locations where the signal strength will be greatly reduced due to the impeding effects of hills and tall buildings.

In areas beyond the service limits the service engineer can estimate his chances of receiving a workable signal by studying the contours of the ground between his receiving site and the transmitter. These contours can be obtained from an Ordnance Survey map. By drawing a straight line on the map from the position of the receiving aerial to that of the transmitter, the various heights can be read off and compared with the height of the transmitting aerial. For example, if the viewer's site is, say, 40 miles from the transmitter and directly behind a hill 1,000ft high, then his chances of receiving a workable signal are very small indeed.

U.H.F. waves follow closely the same rules which apply to light, i.e. they travel in straight lines from the source of origin. They are largely absorbed by buildings, so unless the site is very near the transmitter, the use of indoor aerials may be impracticable. In locations where an indoor aerial will give sufficient signal, it will have to be very carefully sited if interference from nearby moving objects is to be avoided.

Loft aerials are a better answer if the location is near the transmitter, but here the engineer must first ascertain whether the roof is lined with metal or not. In positioning the aerial, he must make sure that no piping, tanks, etc. are near the aerial, as at these extremely short wavelengths, they can produce permanent ghosts and reflections which can ruin reception.

#### FEEDER LOSS

It is well to remember that the signal strength required for good reception at these frequencies is at least three times more than those required for Band III (ITA). One of the main contributory factors to

this is that, as frequency is increased, the noise generated within the receiver itself is greater. To suppress this self-generated noise, a much greater signal strength is required. The feeder to the receiver also adds to the loss, but by using standard low loss feeder it has been proved that very little improvement can be gained by fitting other types of cable if the installation is to be kept within practicable limits.

Whilst dealing with the subject of feeder loss, it must not be forgotten that whilst the aerial is a balanced component, the coaxial feeder is not, since one side, the outer sheath, is normally connected to earth. The danger point is near the aerial where currents can be induced in the outer sheath. This will greatly detract from the performance of the aerial. Since it is imperative to avoid all possible losses it is advisable that the cable be joined to the aerial via a "balun", a fitting well-known to the engineer and needing no description here. The mismatch is much more noticeable with horizontal aerials than with vertical aerials by reason of the position of the feeder in relation to the incoming signal.

### ERECTION

Because of the necessity for obtaining as large a signal as possible, the aerials used for u.h.f. reception will be multi-element arrays which will follow the well-known Yagi design. Since the elements of the aerial are physically small, it is possible to increase their number and so effectively boost both the total voltage picked up and their directive qualities. In view of the size of the elements, the aerials are light in weight and can be safely installed in exposed positions where heavier arrays could be unstable. However, it must be borne in mind that u.h.f. arrays must be rigidly constructed, as any inclination to sway in the air when subjected to strong winds can produce variations in the signal strength received.

The erection and positioning of u.h.f. aerials especially in areas of low signal strength, calls for patience. Wherever possible the array should be moved about whilst results are being observed, remembering that at their critical frequencies a matter of inches can mean the difference between a good signal and a poor one. Beyond a certain point there is little to be gained by increasing the size of the array and much better results can be obtained by using a pre-amplifier.

### PRE-AMPLIFIER

With the recent advent of a transistor that is capable of handling the Band IV frequencies, it is now possible to build a pre-amplifier which will give an amplification of about 14dB at low cost. This should give sufficient gain in areas where the field strength is below 100mV. The best position to fit such a pre-amplifier is at the mast head; the power to operate it can be fed via the feeder or it can have a self-contained battery. Amplification of a weak signal in the u.h.f. range is more satisfactory than amplification at lower frequencies since these signals are free from man-made forms of impulsive interference. Although Bands IV and V are free from aircraft flutter, they are subject to disturbance by passing vehicles, so wherever possible the installation should be kept as far away from roads bearing heavy traffic as is possible.

For engineers who construct their own pre-amplifiers it should be noted that at Band IV frequencies all connections should be kept to a minimum length,

since these wavelengths are measured in inches. A point of warning when using transistors with very short leads, do not forget to use a heat shunt or your transistor may be ruined before it is put into service.

### SIGNAL STRENGTH

The following is a list of the signal strengths required to give good results for each of the four television bands from results of research by the BBC.

Band I	.. ..	0.115-0.170mV/metre
Band III	.. ..	0.45mV/metre
Band IV	.. ..	1-2mV/metre
Band V	.. ..	2-4mV/metre

At a glance it will be seen that a much greater signal is required at u.h.f. to obtain comparable results with the other bands. Added to these requirements is the fact that the signal strength delivered to the receiver is only half the signal strength received by the aerial provided *perfect* matching conditions exist.

From these facts it can be more readily understood why an efficient aerial is required even in areas of comparatively high signal strength. There is one more factor which must be remembered when dealing with u.h.f. signals. For every 5 miles from the transmitter the signal strength decreases more than three times as rapidly as Band I.

### AERIAL ARRAYS

The long wire inverted L aerial is well known to all radio experimenters. As the frequency increases, so the wavelength decreases, until at u.h.f. the wavelengths can be measured in inches. The dipole aerials for v.h.f. and u.h.f. are usually made half a wavelength long, which makes the dipole for the lowest channel in Band IV about 12½ inches and for the highest channel in Band V about 5in.

Elements positioned behind the dipole are known as reflectors; elements in front of the dipole are called directors. The complete array is known as a Yagi (see Fig. 2).

*continued on page 713*

**Fig. 3. Antiference 'Uniray' aerial for the Winter Hill area, comprising 3-element Band III plus 9-element u.h.f. arrays**

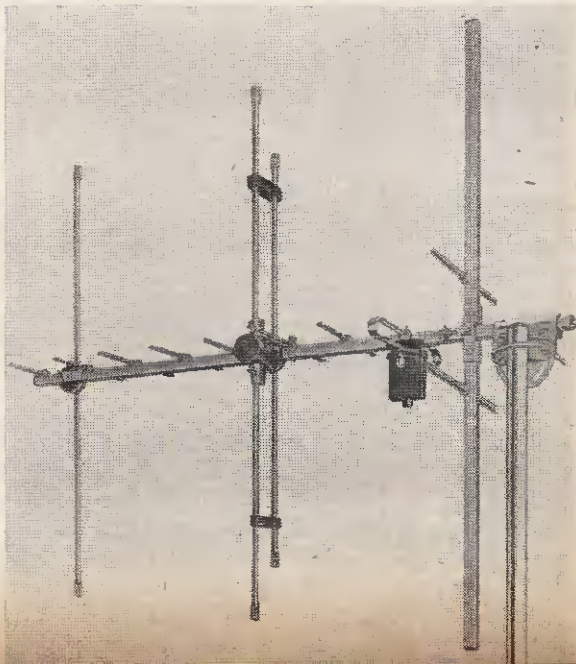



## PART FIVE

by R. A. DARLEY

IT is not the intention in this series to delve deeply into the theory of transistors; information on this aspect has been published recently. This series is mainly concerned with the *application* of transistors. It is assumed throughout that the reader already has some rough idea of how a transistor works. Where it is essential to the text, *simplified* terms are used to indicate certain characteristics of the transistor.

It should be stressed at this point that it is *not* necessary to know all the finer points of transistor theory in order to be able to design complete, and often complex, circuits.

The essential knowledge of transistors that is needed in order to understand this series can be summed up as follows:

### TRANSISTOR CONFIGURATIONS

While it is true that the theory of operation of the valve and transistor are quite different, there are many similarities in their functional operation. In the triode valve, for example, a small grid-to-cathode voltage controls a large anode-to-cathode current flow, while in the transistor a small base-emitter current controls a larger collector-emitter current.

These voltages and currents are illustrated in Fig. 5.1. Note that only the conventional currents are indicated; no reference is made to the flow of electrons.

There are three basic configurations in which the valve can be used: common grid, common cathode, and common anode. Similarly, three configurations are

used in transistor circuits: common base, common emitter, and common collector. These last three circuits are shown in Fig. 5.2, together with details of gain and impedance. *Pnp* transistors are depicted in these, as these are the most widely used of the two main types.

The three configurations are easily remembered if the word "grounded" is substituted for "common", i.e., in the common base circuit, the base is connected directly to "ground" (chassis), and is, therefore, common to both the input and output circuits. A point that must be remembered is that, while the negative line and ground are at different d.c. potentials, they are *effectively* common as far as a.c. is concerned, due to the fact that the power supply has a very low internal impedance. Thus, in the common collector circuit, the collector is effectively shorted to ground, and the term "grounded collector" can be applied.

### PRACTICAL TRANSISTOR CIRCUITS

The circuits shown in Fig. 5.2 are, of course, very much simplified. A practical example of the most widely used of these configurations, that of the common emitter, is shown in Fig. 5.3. Three additional resistors (R1, R2, and R3) are shown.

The working point of a transistor, relative to its characteristics curve, is determined by the amount of base-bias applied. This "bias" may be referred to either in terms of voltage or current, as the two quantities are interdependent. The working point may be set by a simple voltage divider chain, shown as R1 and R2 in Fig. 5.3.

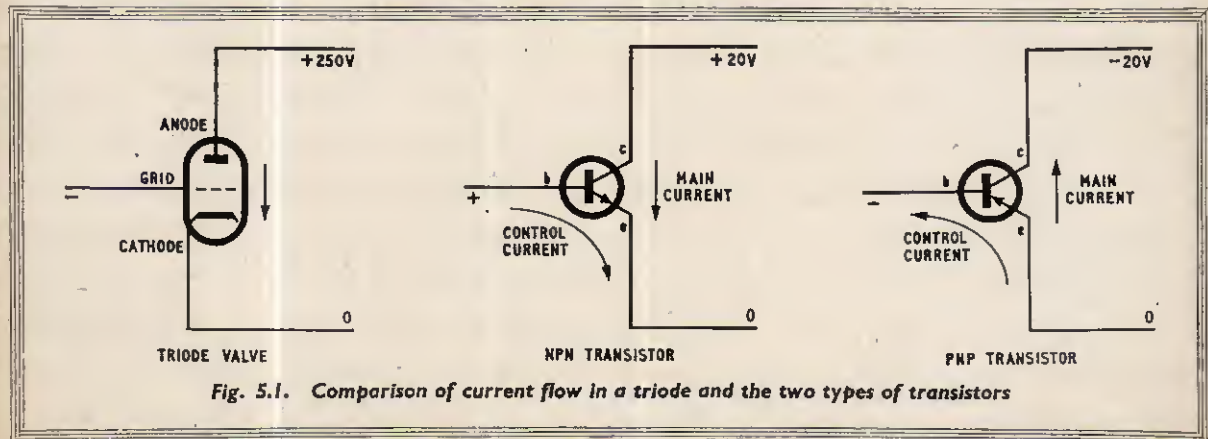

Fig. 5.1. Comparison of current flow in a triode and the two types of transistors

The basic transistor is, unfortunately, notoriously unstable when subjected to temperature changes, and suffers from such ailments as thermal runaway, changing input and output impedances, etc. No complete cure for these troubles exists, as yet, but they can, with careful design, be at least kept under control.

By placing a resistor in series with the emitter (R3 of Fig. 5.3), d.c. negative feedback is obtained; any increase in emitter current results in an increased voltage drop across the emitter resistor. If no corresponding increase in the input voltage to the base has been made, the base-emitter voltage is reduced, thereby

tending to reduce the emitter current. To prevent this feedback acting on signals applied to the transistor input, a decoupling capacitor (C2) is connected in parallel with R3, thus preventing a.c. feedback.

The larger the value of R3, the better will be the stability. A limit is set on the maximum value of R3 by the amount of voltage drop that can be afforded across this resistor; this will depend on the current, and hence peak-to-peak output signal, needed at the collector. In practice, it is adequate to allow for a voltage drop of  $\frac{1}{2}$  to 1 volt across the emitter resistor.

As mentioned above, the transistor input impedance

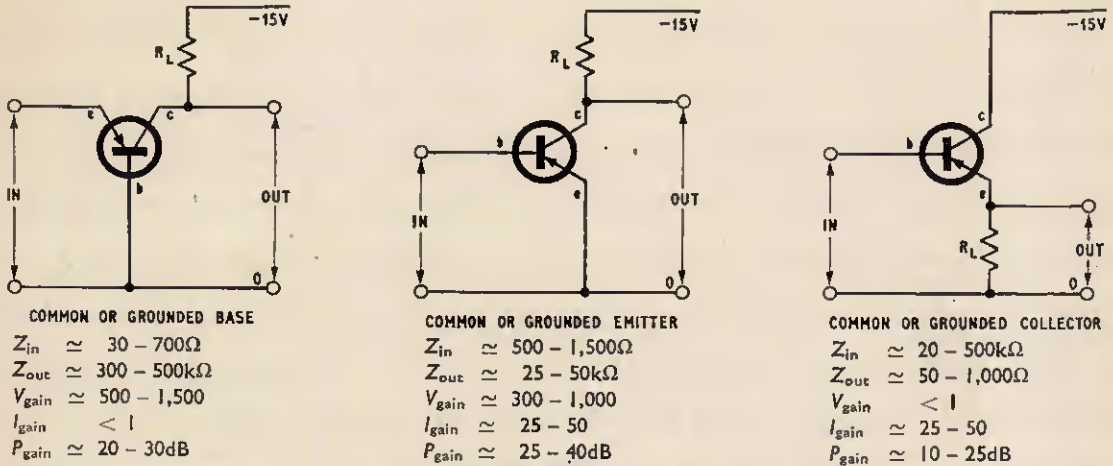

Fig. 5.2. Three basic transistor configurations

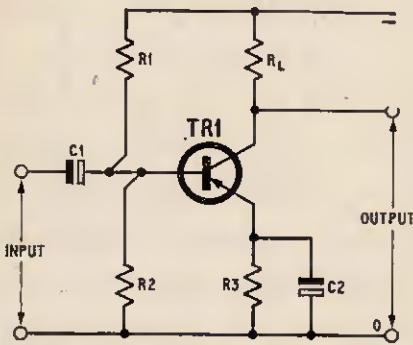

Fig. 5.3. Common emitter single stage transistor amplifier

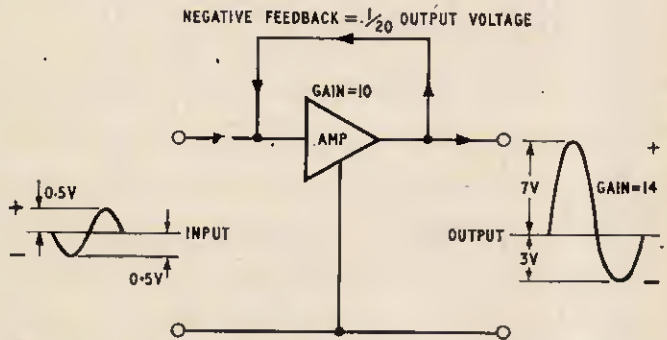

Fig. 5.4a. Block diagram of the circuit shown in Fig. 5.3 and the waveforms of input and output when no negative feedback is applied

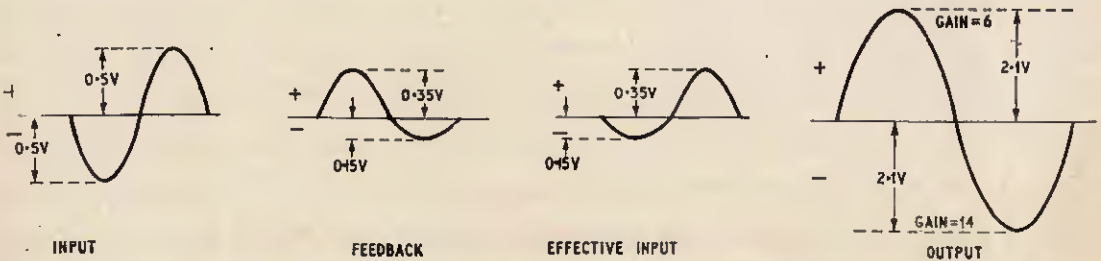

Fig. 5.4b. The effect of applying negative feedback to the circuit shown in Fig. 5.4a



may be subject to change with ambient temperature. The input impedance is effectively in parallel with R2 of the voltage divider chain, and therefore shunts it, so that any changes in input impedance may result in a change in the base-bias voltage, resulting in instability. The current flowing through R1 is shared by R2 and the base and, by ensuring that the current drawn by R2 is about 10 times greater than that of the base, the effect of variations of base current on the bias voltage is considerably reduced and greatly improved stability is obtained. Generally, the lower the values of R1 and R2 for any given voltage divider network, the better the stability will be.

### SINGLE COMMON EMITTER STAGE

When designing a single stage common emitter circuit decide from the manufacturer's literature on the transistors working point. For example, an OC71 transistor should be designed to work with an emitter current of about 1mA, in most cases.

Refer to the manufacturer's literature to find the permissible collector current swing without undue distortion, and from this value select  $R_L$  to give the required output voltage swing.

Now select the emitter resistor R3. Remembering that the recommended voltage drop across this resistor is between  $\frac{1}{2}$  and 1 volt, and that in the case of the OC71, the emitter current is 1mA, R3 will be between 500 and 1,000 ohms. Leakage and base currents have been neglected since they are relatively small and in this calculation are insignificant.

Connect a potentiometer (about 100 kilohms) between the positive and negative supply lines with the wiper connected to the transistor base. Monitor the emitter current and adjust the potentiometer until the emitter current is 1mA. Measure the base voltage between the wiper and chassis and then replace the variable resistor by two fixed value resistors, R1 and R2, with values calculated to give the same base voltage, but with the lower resistor (R2) taking ten times more current than the transistor base. Connect capacitor C2, with a value of about 100 $\mu$ F, in parallel with R3, to eliminate a.c. negative feedback.

This procedure applies ONLY to a single, unloaded stage. When designing the circuit to feed into a specific load, such as the input impedance of a following stage, the value of the collector load,  $R_L$ , is chosen to give an impedance match, since  $R_L$  is effectively in parallel, and shunted by, the output load.

In some cases R2 may be omitted from the circuit, in which case R1 is regarded as a series base current control resistor. Again, it may be found that R1 is replaced by the collector load of a preceding transistor. Stability may be maintained in this case but it is dependent on the stable functioning of the previous stage.

### FREQUENCY RESPONSE

Generally speaking, the frequency response of an RC-coupled transistor a.f. amplifier is limited by two factors. At the low frequency end of the response curve, the limit is set by the time constant of the input coupling capacitor and the base-to-ground impedance of the circuit. For a good low frequency response, a long time constant is required; the input impedance of a common emitter amplifier is generally fairly low, however, and the best way of obtaining a really good low frequency response is to use either a very large value of coupling capacitor, or d.c. coupling between the input and base.

The high frequency response is limited mainly by the characteristics of the transistor. The cut-off frequency of a transistor is usually given in the manufacturer's literature. That of the OC45, for example, is given as about 6Mc/s. It should be noted, however, that this figure applies only to the common base mode of operation, and that in common emitter only a fraction of this figure will be obtained.

### NEGATIVE FEEDBACK

The transistor is basically a non-linear device and, although a practical circuit may be designed to work on the most linear part of the characteristic curve, some distortion of the signal at its output must invariably result. By applying negative feedback over the circuit, both the noise and distortion may be kept low. Unfortunately, the gain is reduced also, so no improvement in signal/noise ratio results. The effective cut-off frequency of the circuit is, in the common emitter mode of operation, increased.

If 6dB of negative feedback is applied over a common emitter stage the noise and distortion are halved and the effective cut-off frequency doubled. Negative feedback is feedback in antiphase to the input, and the action may be understood with reference to Fig. 5.4.

To illustrate this let a sine wave of 1 volt peak-to-peak be fed to the input; the transistor has a mean gain of 10, but the distortion due to non-linearity is such that at the output the positive half-cycles rise to 7 volts peak and the negative ones to 3 volts peak. This is the output signal without feedback.

Now suppose that one-twentieth of the output is fed back to the input, in antiphase. When the positive half-cycle, of 0.5 volts peak, is fed to the input, the output will be a negative half-cycle of 3 volts peak, the true gain at this point of the curve being 6. With one-twentieth of the output fed back to the input, the feedback signal will have an amplitude of  $3/20 = 0.15$  volts, so the actual signal on the base will be  $0.5 - 0.15 = 0.35$  volts. With a gain of 6 the output from an input of 0.35 volts will be 2.1 volts.

Now consider what happens when the negative half-cycle of 0.5 volts peak is fed to the input. The output = 7 volts peak at a gain of 14, and the feedback signal =  $7/20 = 0.35$ . The actual signal on the base is therefore  $0.5 - 0.35$  volts, which gives a base signal of 0.15 volts. The gain is 14, so the output signal = 2.1 volts, exactly the same as was obtained with the other half-cycle. The distortion is thus eliminated.

This explanation of the action of negative feedback is a considerable over-simplification; the gains with feedback would not be the same as those without it. The explanation does, however, serve to indicate the principles involved.

In the case of a single stage common emitter transistor, negative feedback can be obtained by leaving the emitter resistor unbypassed, or by resistive coupling of the base and collector.

### PHASE CHANGERS

It is sometimes required that a phase change of 180 degrees be imposed on the signal in some part of a circuit. Such a phase change can be imparted by a conventional common emitter circuit, and it should be noted that, when reading circuit diagrams, what looks like a conventional amplifier may in fact be a mere phase changer, the stage gain of the circuit being of secondary importance, and quite often very low.

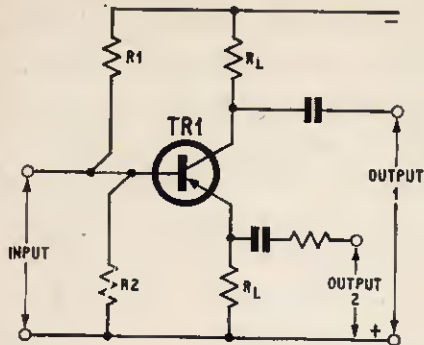

Fig. 5.5. Phase splitter or balanced inverter giving two outputs in anti-phase from a single input

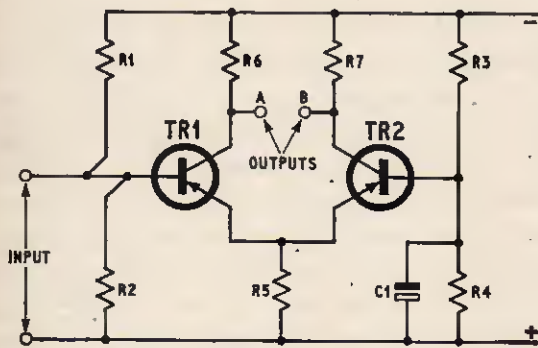

Fig. 5.6a. Another method [of phase-splitting] by using the long-tailed pair paraphase amplifier

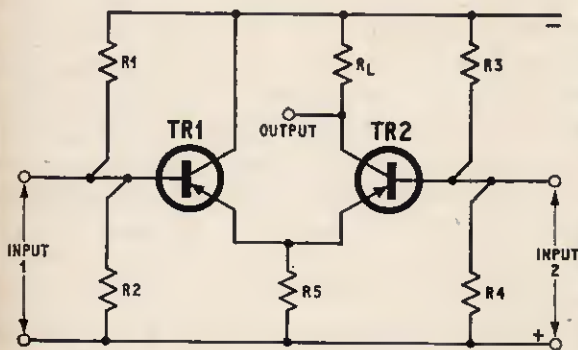

Fig. 5.6b. A variation of the paraphase amplifier known as the differential amplifier in which a single output is obtained from two inputs

## PHASE SPLITTERS

It is sometimes required that two outputs, in anti-phase to each other, be made available from a single input.

One circuit that fulfils this requirement is shown in Fig. 5.5. This circuit, sometimes known as the "balanced inverter", has equal loads on the emitter and collector outputs. Since the current flowing in the collector circuit is practically the same as that flowing in the emitter, the two outputs across the equal value loads will be, for practical purposes, of equal amplitude, but opposite phase.

The unbypassed emitter load resistor introduces considerable negative feedback, and results in a gain of a little less than one at each output.

A disadvantage of the circuit is that the two output impedances are not equal. The output impedance at the collector is roughly equal to the collector load, and is thus fairly high, while the output impedance at the emitter is low, approximating to the input source impedance divided by the transistor current gain. This disadvantage can be overcome by connecting a resistor in series with the emitter output, of a value equal to the difference between the two impedances. When so modified, the circuit gives two outputs of opposite phase, equal magnitude, and with equal output impedances, from a single input signal.

Such a circuit may be used for driving push-pull output stages of an amplifier, or to give symmetrical deflection on the plates of an oscilloscope from a single-ended input.

## THE "LONG-TAILED" PAIR

Another circuit that can be used for phase-splitting is shown in Fig. 5.6a. This circuit is a member of the "long-tailed pair" family, this particular version being known as the "paraphase amplifier". The long-tailed pair circuit is distinguished by the use of a common resistor shared by the two emitters of the circuit.

Referring to the circuit diagram, two transistors are connected in the common emitter mode, each with its own base bias chain ( $R_1$ - $R_2$ , and  $R_3$ - $R_4$ ), but the input is applied to the base of one transistor only (TR1). The base of the other transistor is shorted to a.c. by  $C_1$ . With no signal applied, the two base potentials of the circuit are equal.

Let it be assumed that the transistors TR1 and TR2 have similar characteristics, and that the two collector load resistors,  $R_6$  and  $R_7$ , are of equal value. The current flowing through the common emitter resistor ( $R_5$ ) is shared equally by the two transistors, under "no-signal" conditions.

With an input signal applied to the base of TR1, the negative going part of the input waveform results in an increase of current through TR1 and, therefore, through the common emitter resistor  $R_5$ . The voltage developed across  $R_5$  increases and, consequently, the emitters of the two transistors also move in a negative direction; negative feedback is thus obtained over TR1.

Now, the part of the input signal that really controls the emitter current in a transistor amplifier is the effective difference between the emitter and base potentials resulting from the input signals, i.e. if the emitter is at a potential of 1.5 volts and the base potential is at 1.7 volts, the true control voltage is 0.2 volts. Thus, in the circuit under consideration,

## UHF RECEPTION

continued from page 708

If a half wave dipole were used on its own, the signal strength would be the same from all directions. If the signal strengths from all directions were plotted on paper, the results would be a circle with the dipole as the centre. This kind of graph is known as a polar diagram (see Fig. 4).

the effect of the negative-going movement of the emitter potentials on TR2 is to reduce the difference between the emitter and base potentials (remembering that the base of this transistor is held at a fixed potential and is short circuited to a.c.); the emitter current of TR2 is therefore reduced. The output signals at the two collectors of the circuit are therefore in antiphase.

An increase in collector current through one transistor of a long-tailed pair results in a decrease in the collector current of the other transistor; the total current through the common emitter resistor therefore tends to remain constant. The larger the value of this resistor, the more nearly constant will the current be. It therefore follows that, if the ultimate in stability is to be obtained, an increase of  $I_{mA}$  through TR1 will result in a decrease of  $I_{mA}$  through TR2, and the two signals at the outputs will be of exactly equal magnitude.

Such a circuit will give two output signals of equal magnitude, equal impedance, but in opposite phase, from a single input.

In any common emitter circuit (using *pnp* transistors), the emitter current can be increased either by applying a negative signal to the base, or a positive signal to the emitter.

### THE DIFFERENTIAL AMPLIFIER

A variation of the paraphase amplifier, known as the "differential amplifier", is shown in Fig. 5.6b. The main difference between this and the earlier circuit is that *two* inputs are applied, and only *one* output signal is needed; in view of this last requirement, one of the collector loads can be dispensed with.

The action of the circuit is very similar to that already described; the common emitter resistor results in interaction between the two transistors.

When a negative-going signal is applied to the base of TR1, the emitter current of TR1 increases and that of TR2 decreases. If, simultaneously, a negative-going signal is also applied to the base of TR2, the emitter current of TR2 will increase and that of TR1 will decrease. If the two inputs are of equal amplitude and phase, the increase in emitter current of one transistor due to one input signal will be cancelled by the decrease in emitter current due to the other input; there will be no change in currents and no output signal will result. If the two inputs are not of equal amplitude the currents will not cancel out, and a current that is directly proportional to the difference between the two in-puts will flow in each emitter.

In the circuit shown in Fig. 5.6b, only one collector load has been shown, connected to TR2. If loads are connected to both collectors, the output of TR2 will be in phase with the base of TR1, and the collector of TR1 will be in phase with the base of TR2. The collector loads can be connected to one or both transistors depending on the phase relationship that is required.

The difference between input signals is dictated not only by amplitude, but also by phase. Thus, if the two inputs are of equal amplitude but opposite phase, the output signal will be proportional to twice the value of either of the inputs.

**Next month: Considerations of the effects of impedance in transistor circuits and some practical matching circuits**

A\*\*

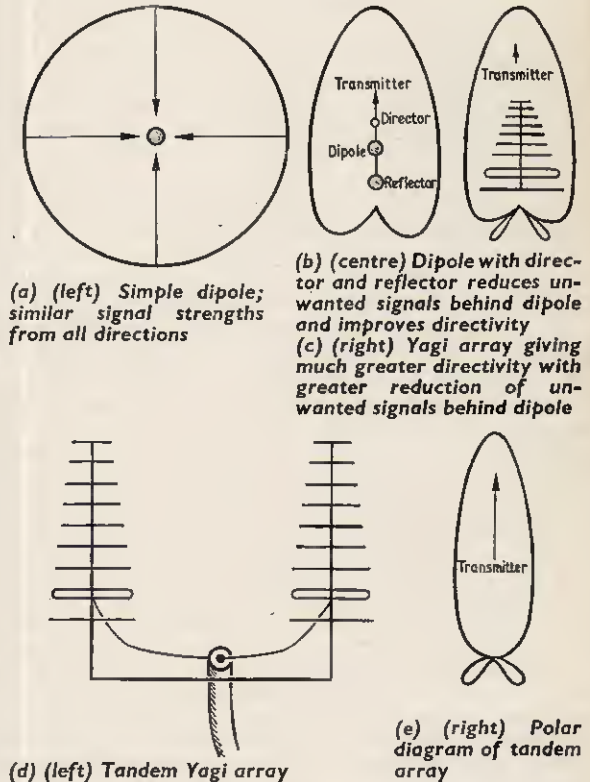

Fig. 4. Polar diagrams of aerial arrays

The addition of reflector and directors has a profound effect on the performance of the aerial as can be seen from the polar diagrams in Figs. 4b and 4c. Broadly speaking, the addition of a reflector greatly reduces the effect of unwanted signals, including man-made interference, from behind the dipole and the addition of reflectors increases the gain of the aerial and also increases the directive qualities of the whole array.

For fringe area reception where two or more arrays may be used to increase the signal strength (Fig. 4d), the directive qualities or beam width is so narrow that very precise positioning of the aerial must be carried out to obtain optimum results. The polar diagram display is shown in Fig. 4e for a twin array. An added characteristic of multi-arrays is excellent selectivity.

**Next month: Some practical guidance on constructing aerial arrays for u.h.f.**

# the 73 page

by Jack Hum  
G5UM

## Competitive

Perceptive readers who examined closely the log extracts reproduced here last time will have noticed two details of some significance: that the contacts logged had been coming thick and fast, and that each was accompanied by a code number.

What in fact was being shown was a portion of a log kept during the course of a transmitting contest. This month we reproduce another such log, this time rather more fully, comprising one page from the written record of a radio club station participating in one of the big annual transmitting contests organised by the Radio Society of Great Britain. It is shown here not so much to illustrate how a log should be kept as to underline the intense activity which such contests produce. Here too, as will be seen, contacts were coming thick and fast.

Transmitting contests today occupy such an important part of the amateur radio scene throughout the world that *The 73 Page* would be failing in its duty did it not invite the attention of its readers to them—if indeed they have not become aware of them already, for barely a weekend passes but one contest or another can be heard in progress somewhere or other in the world.

## Snappy Operating

The immediate evidence by which the short-wave listener gathers that a contest is on is an aura of urgency that seems to dominate the amateur bands. Operators may be heard calling "CQ Contest", sometimes naming the actual event in which they are participating so that no answers will be sent by people who are not! Leisurely conversation is out during contest time: snappy operating is in. Contacts are disposed of in the quickest possible time.

The operator who collects the largest number of contacts, or winkles out the rarest or most distant countries (according to how the rules are framed), will find his call-sign at the top of the list when the results are eventually published.

## The Hard Slog

To achieve this status is the result of sheer hard work. Success in contests calls for nothing less. Nor is a top place simply a brief moment of glory, to be basked in for a month or two before all is forgotten: what is remarkable is how the same call-signs appear time after time in the top positions of the world's competitive transmitting events.

aid of a transmitter-and-aerial combination of hyper-efficiency and reliability used at the psychological moment—and as a rapier, not as a broadsword.

## "Is it worth it?"

Well may the practical electronician enquire "whether it is all worth it", to which he will be inclined to reply "Yes" if he agrees that the development and exercise of a skill are useful ends in themselves. Most people believe that they are.

This belief counterbalances the oft-heard criticisms that contests "clutter up the bands", that "there is no weekend free of them" and that the collecting of code numbers from a myriad of other stations is a

STATION LOG	
Call	Country
G5UM	1006
G5UM	1007
G5UM	1010
G5UM	1013
G5UM	1015
G5UM	1016
G5UM	1021
G5UM	1022
G5UM	1023
G5UM	1024
G5UM	1026
G5UM	1027
G5UM	1028
G5UM	1029
G5UM	1030
G5UM	1031
G5UM	1032
G5UM	1033
G5UM	1034
G5UM	1035
G5UM	1036
G5UM	1037
G5UM	1038
G5UM	1039
G5UM	1040
G5UM	1041
G5UM	1042
G5UM	1043
G5UM	1044
G5UM	1045
G5UM	1046
G5UM	1047
G5UM	1048
G5UM	1049
G5UM	1050
G5UM	1051
G5UM	1052
G5UM	1053
G5UM	1054
G5UM	1055
G5UM	1056
G5UM	1057
G5UM	1058
G5UM	1059
G5UM	1060
G5UM	1061
G5UM	1062
G5UM	1063
G5UM	1064
G5UM	1065
G5UM	1066
G5UM	1067
G5UM	1068
G5UM	1069
G5UM	1070
G5UM	1071
G5UM	1072
G5UM	1073
G5UM	1074
G5UM	1075
G5UM	1076
G5UM	1077
G5UM	1078
G5UM	1079
G5UM	1080
G5UM	1081
G5UM	1082
G5UM	1083
G5UM	1084
G5UM	1085
G5UM	1086
G5UM	1087
G5UM	1088
G5UM	1089
G5UM	1090
G5UM	1091
G5UM	1092
G5UM	1093
G5UM	1094
G5UM	1095
G5UM	1096
G5UM	1097
G5UM	1098
G5UM	1099
G5UM	1100

The station log can be either a self-prepared one ruled up to carry the information required by the G.P.O. licence, or it can be one of the several commercially produced varieties which are on the market. The example shown is from a "G6DS logbook". The extract is from a period of contest-operating on the 2 metre amateur band.

There is an obvious reason for this. The operator who is determined to do well in a contest knows he will be wasting his time if either his skill or his technical facilities are less than one hundred per cent efficient.

He knows that if he can sort out that elusive signal from beneath a pile-up of perhaps half-a-hundred others which are almost zero-beat with it then he stands a fair chance of a top place in the final table.

He knows that this will be possible only if his receiver is better than the next man's—and he knows that "the next man" knows it too!

He knows also that simply to hear them is not enough: he must be able to work them as well, with the

monotonous chore that could be conveniently consigned to a computer—and all of these comments carry some validity.

# the 73 page

by Ja

**Inexpensive  
Versatile  
Simple to  
build**

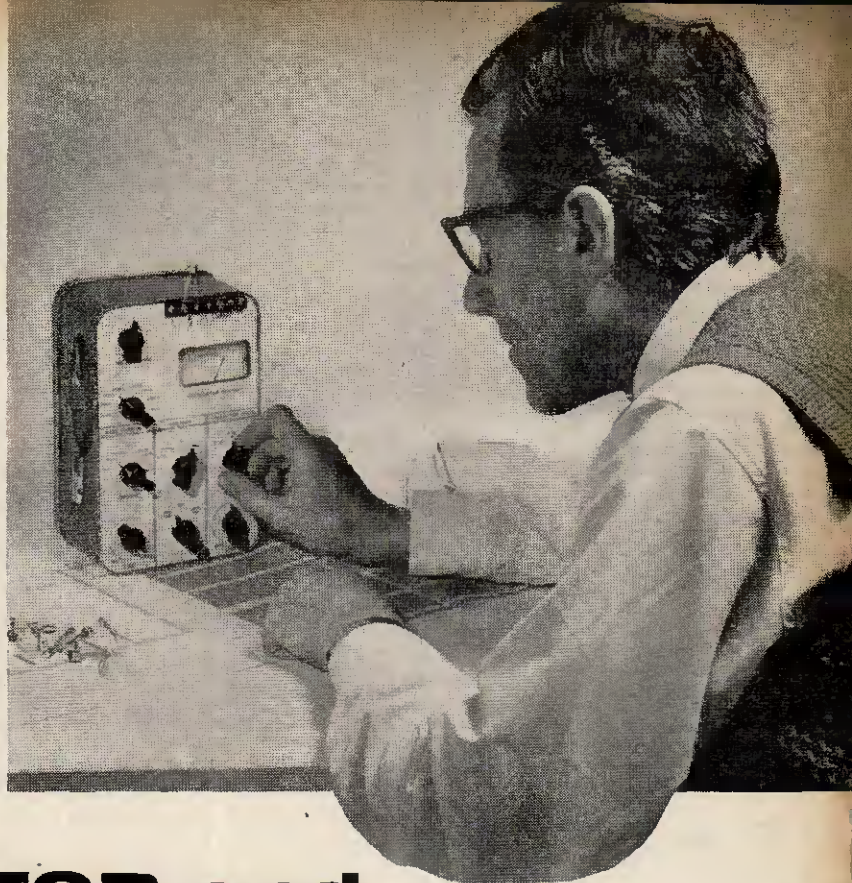
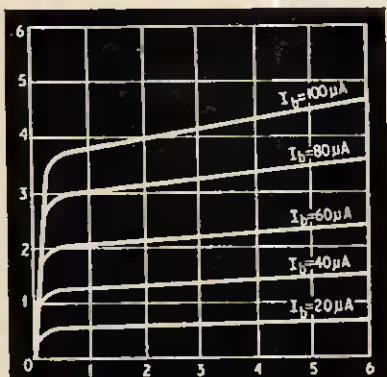

# TRANSISTOR and DIODE TESTER

**By B. Crank**

THIS instrument was designed to provide an inexpensive unit capable of carrying out a series of d.c. tests on various transistors and diodes. It measures leakage current between collector and emitter ( $I_{co}$ ) and between collector and base ( $I_{cbo}$ ). It also enables transfer and collector characteristics to be determined quickly for both *pnp* and *nnp* transistors. Forward and reverse currents for diodes at various applied voltages can be measured; Zener voltage can be determined on silicon Zener diodes.

Indication is by an internal  $50\mu\text{A}$  meter which is provided with fourteen ranges between zero and  $50\text{mA}$ , and between zero and 25 volts. Collector voltage is available up to 18 volts in three ranges, i.e. zero to 1 volt, zero to 9 volts, and 9 to 18 volts. The circuit employed ensures that any value of collector voltage within the above ranges can be easily and accurately set. Base current is available in six continuously variable ranges from zero to  $5\text{mA}$ . Collector currents up to  $50\text{mA}$  can be accommodated.

The unit is housed in a small case  $8\frac{1}{2}\text{in} \times 5\frac{1}{2}\text{in} \times 3\frac{3}{4}\text{in}$ ; the whole unit costs about five pounds to make.

## CIRCUIT

This is best started by looking into the power supply arrangements. As can be seen from Fig. 1 two 9 volt batteries are used these being connected in series

and centre tapped. S6 is the "*pnp/off/nnp*" switch and is shown drawn in the *pnp* position. The negative terminal of BY1 is connected via position 1 of S6c to the top end of VR1. The lower end of VR1 is connected via position 1 of S5a, position 1 of S5d and position 1 of S6d to the positive terminal of B2. Thus VR1 has the full 18 volt supply across it. It will also be noticed that in position 1 of S6a and b that the negative side of the meter is connected to S1b and the positive side to S1a. With S6 in position 2 the batteries are disconnected and a short circuit is placed across the meter to damp the movement of the needle due to its own self-generated current during transit. In the third position of S6, i.e. *nnp* position, the battery and meter connections are reversed.

For the rest of this description it will be assumed that S6 is in the *pnp* position, i.e. position 1. VR1 as has already been shown has 18 volts across it, as long as the unit is switched on, regardless of other switch positions. VR1 forms a potential divider and is the base current fine control. The potential at the wiper of VR1 is fed, via a limiting resistor, selected by the base current coarse control S4, to the base of the transistor under test via S1e. The resistors selected by S4 (R14 to R19) provide the following ranges of base current:  $0\text{--}10\mu\text{A}$ ,  $0\text{--}50\mu\text{A}$ ,  $0\text{--}100\mu\text{A}$ ,  $0\text{--}500\mu\text{A}$ ,  $0\text{--}1\text{mA}$ ,  $0\text{--}5\text{mA}$ .

The action of the collector voltage coarse control (S5) and fine control (VR2) will be discussed next. With S5 in position 1 the negative terminal of BY1, as far as VR2 is concerned, is out of circuit. The negative terminal of BY2 is connected via R20 to VR2; R20 allows about 1 volt to be dropped across VR2, the positive return being S5d and S6d to B1. Therefore a potential of between 0 and 1 volt is available at the wiper of VR2.

With S5 in position 2 the circuit is identical except that R20 is short-circuited. The full nine volts from BY2 is applied across VR2 so that the potential at VR2 wiper can be varied between 0 and 9 volts.

With S5 in position 3 the positive terminal of BY2 is connected via S5a to the earth line of the tester maintaining the 18 volts across VR1. The lower end of VR2 is connected via S5c and S5d to the battery centre-tap and is therefore at 9 volts negative with respect to earth. The upper end of VR2 is connected via S5b to the negative terminal of BY1. Although there is still only 9 volts across VR2 the potential at the wiper is between 9 and 18 volts with respect to battery positive. The extra complication involved in giving VR2 this range of 9-18 volts instead of the much more easily obtained 0-18 volts is well worthwhile as it means that the operator has a much finer control over collector voltage.

The main disadvantage of the system used is that when heavy collector currents are being taken (i.e. over 10mA) and when the switch is in the 9-18 volt position, the collector voltage falls sharply for the first movement of the potentiometer but the voltage soon recovers and still results in finer control being obtained.

S2 and S3 control the meter ranges, provided S1b is at any position except position four, giving eight current ranges with full scale deflections of 50 $\mu$ A, 100 $\mu$ A, 250 $\mu$ A, 500 $\mu$ A, 1mA, 5mA, 10mA and 50mA. With S1 in position four the multiplier resistor selected by S3 is now in the meter circuit to provide up to 0-1V, 0-5V, 1V, 5V, 10V and 25V on each range respectively.

The instrument functions by applying various potentials to the transistor under test and by switching the meter into various parts of the circuit with S1.

### SI IN POSITION 1 $I_{c0}$

In this position the meter is indicating collector to emitter leakage current; the basic test circuit is shown in Fig. 2a. The meter together with a shunt resistor selected by S2 is in series with the negative supply to the collector; the base is open circuit.

Reference to Fig. 1 will show how this is achieved. The negative supply at the wiper of VR2 is fed via position 1 of S1c through the meter and its shunt (selected by S2) to the collector of the transistor under test, via S1a and the external meter socket. The purpose of this socket is to allow collector currents of greater than 50mA to be measured on a more suitable external meter. It also simplifies the process of plotting performance curves, although this can be done without the external meter. Normally this socket is short-circuited when no external meter is used. The emitter of the transistor is connected to the battery positive line via S5a, S5d and S6d.

Fig. 1 (right). Circuit diagram of the complete transistor and diode tester. All switch positions are related to the annotations given in Fig. 7. For example: position 1 of S1 is for measuring  $I_{c0}$ , and so on

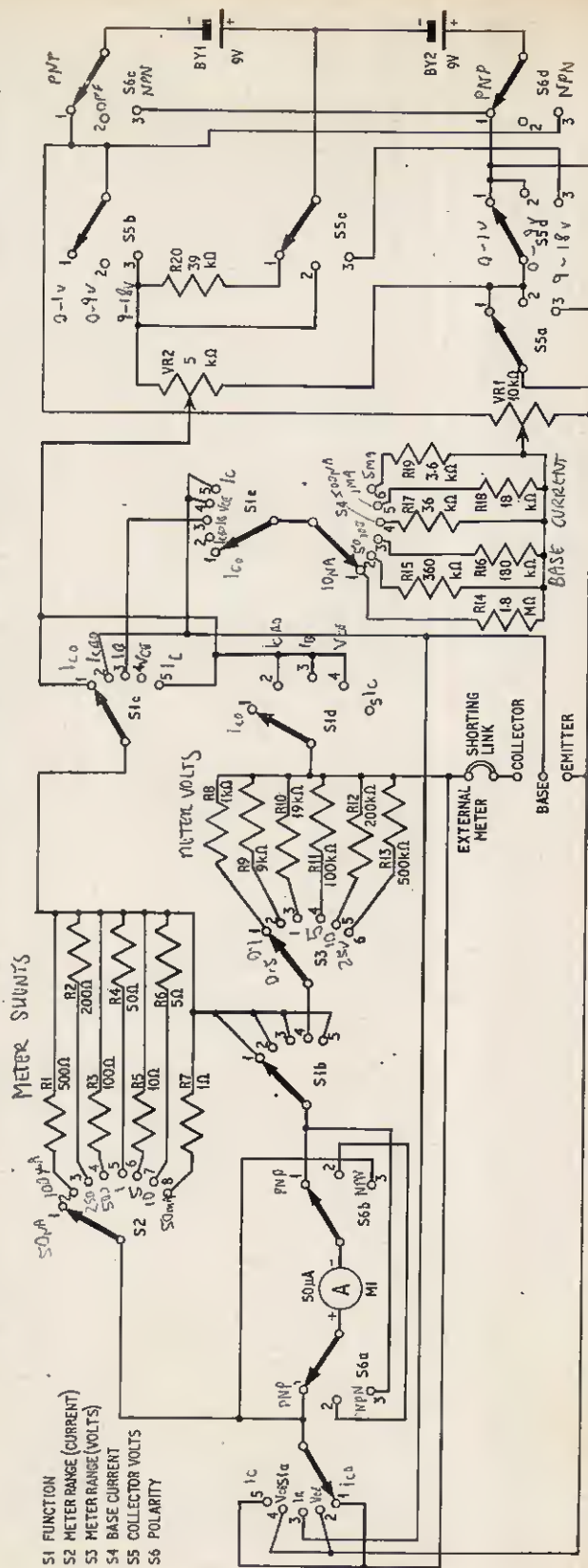

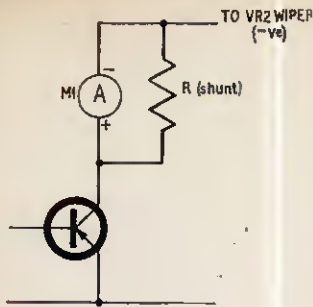

Fig. 2a. Position 1, ( $I_{cb0}$ ) collector to emitter leakage current

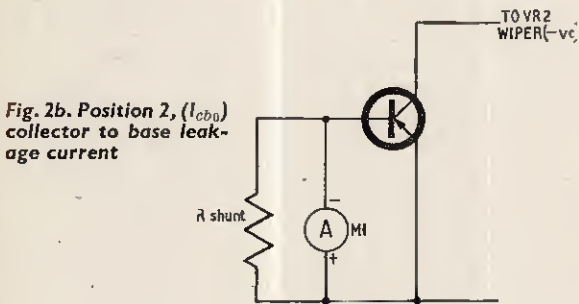

Fig. 2b. Position 2, ( $I_{cb0}$ ) collector to base leakage current

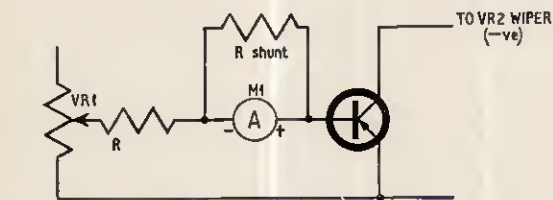

Fig. 2c. Position 3, ( $I_b$ ) base current

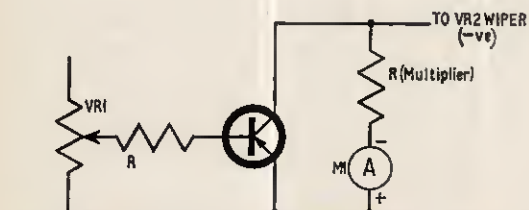

Fig. 2d. Position 4, ( $V_{ce}$ ) collector to emitter voltage

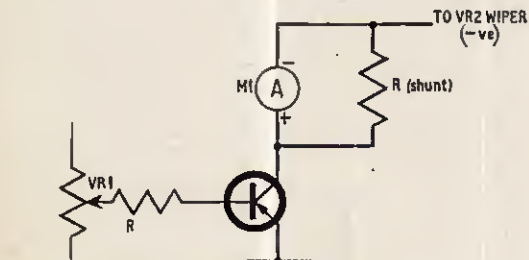

Fig. 2e. Position 5, ( $I_c$ ) collector current

Fig. 2. Basic circuits for each position of S1

### SI IN POSITION 2 $I_{cb0}$

The basic circuit is shown in Fig. 2b. Here the negative supply is fed direct to the collector. The meter and its selected shunt is connected between the base and earth to indicate collector to base leakage current.

The negative supply at the wiper of VR2 is fed via position 2 of S1d direct to the collector. The meter complete with shunt is connected via position 2 of S1c and S1a between the base and emitter.

### SI IN POSITION 3 $I_b$

In this position a measured value of base current is allowed to flow in the transistor. This checks the continuity of the base emitter junction and enables any base current between 0 and 5mA to be preset so that other checks can be carried out. The basic circuit is shown in Fig. 2c. The wiper of VR1 is connected via a limiting resistor selected by S4 to one side of the meter and shunt. The other side of the meter is connected to the base via S6a and S1a. The meter will register base current, the value of that base current being controlled by VR1 and S4. Also the negative supply is still connected to the collector.

The negative supply at the wiper of S4 is fed via position 3 of S1e and S1c to the meter and shunt. The negative supply to the collector is maintained via S1d.

### SI IN POSITION 4 $V_{ce}$

In this position, the collector voltage being applied is measured and set to any value within the range of the instrument. Also the base current preset in the last operation is maintained. This is because variations in base current alters the collector current flowing through the transistor; changes in collector current cause alteration in collector voltage due to the voltage dropped by VR2. In this instrument the value of collector volts required is set after the base current has been set. The basic circuit may be seen in Fig. 2d. The base current is still allowed to flow and the meter, now a voltmeter, is connected with its multiplier resistor, selected by S3, between the collector and earth.

The base supply is maintained via position 4 of S1e and the collector supply by position 4 of S1d. The multiplier resistor selected by S3 is connected to the meter via position 4 of S1b, then to the emitter via S1a.

### SI IN POSITION 5 $I_c$

In this position the collector current is measured and hence the gain of the transistor can be calculated. The basic circuit is shown in Fig. 2e. The collector of the transistor is connected to the negative supply through the meter and its selected shunt, through position 5 of S1c and S1a. The previously set base current is still allowed to flow. The base current supply is maintained by position 5 of S1e.

### METER SWITCHING

The use of separate range switches for voltage and current reduces the number of switching operations during the test of a transistor to a minimum. The voltage range can be preset to a suitable value before the tests commence. Then it is only necessary to alter the current range switch from a suitable range

for base current to one for collector current. If an external meter is employed this need is eliminated. The internal meter range switches can be set to suitable ranges to measure collector voltage and base current, the external meter being switched to a suitable range to measure collector current. If this method is used, collector current can be measured in either the  $I_b$  or  $V_{ce}$  positions of S1, but not in the  $I_c$  position. The alteration of the internal meter to a voltmeter is carried out by the switch S1 to prevent the possibility of too large a voltage being applied across it when on a current range.

Another point worthy of mention is the possible alteration of base current caused by switching the meter in and out of the base current circuit. The actual alteration is very small as the resistance of the meter is very small compared with the series limiting resistance switched in by S4. Once again this possibility is eliminated by using an external meter, as the collector current can be measured in the  $I_b$  position.

### CONSTRUCTION AND COMPONENTS

The instrument was built in a metal case of the type used for sandwiches as shown in Fig. 3. The meter was a surplus item with a full-scale deflection of  $50\mu A$  and internal resistance of about 1,000 ohms. It is obtainable on the surplus market for about 25s. although any similar meter would be suitable. A new scale has to be fitted, this is reproduced in Fig. 4. To do this it is necessary to remove the four screws at the rear of the instrument and remove the case.

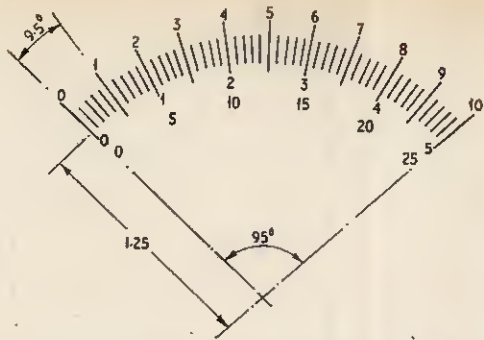

Fig. 4. New scale to suit the ranges of the instrument. This is reproduced full size for the original meter. If a different size or shape of meter is used check that the new scale suitably fits for angle of deflection and length

The scale can then be drawn on paper and glued over the original scale, care being taken to ensure that it is correctly aligned. It is a good plan to smear a little vaseline round the flanges of the case when refitting to prevent the ingress of dust.

Due to the number of different contact arrangements used on the wafer switches it is impracticable to show a point to point wiring diagram, therefore the following constructional procedure is recommended.

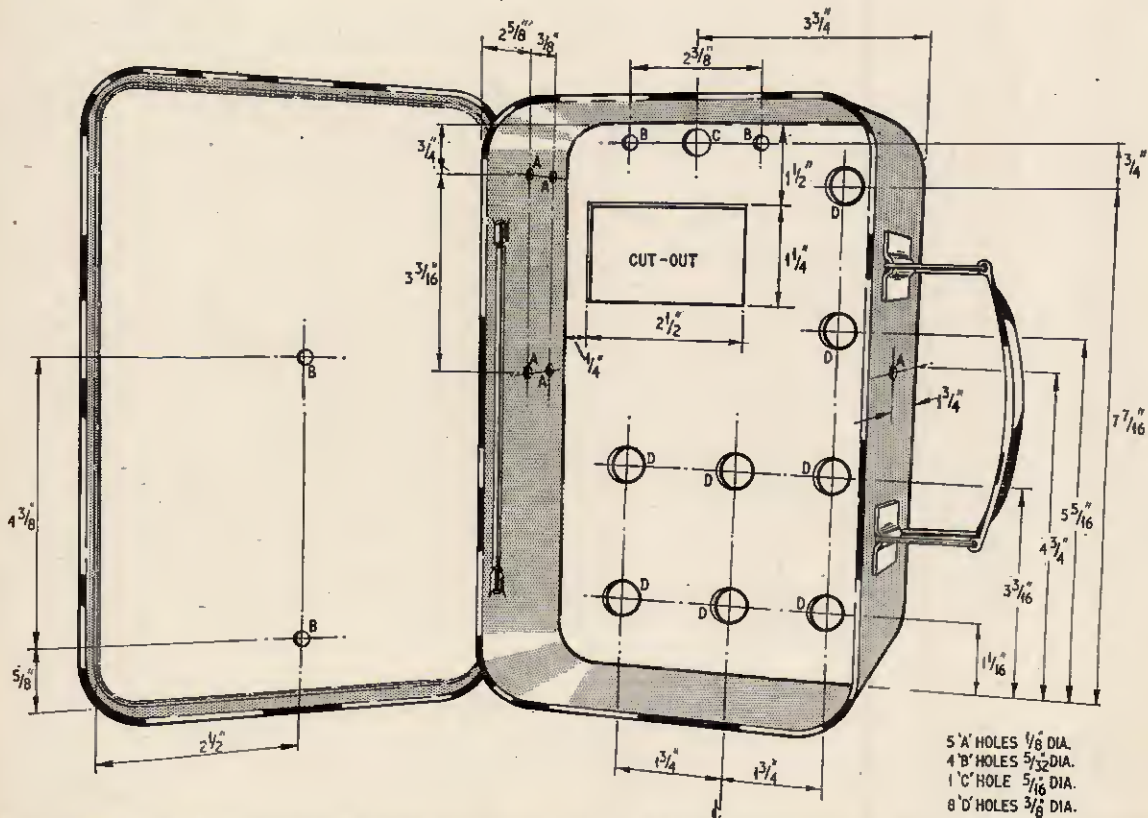

Fig. 3. Drilling details of the metal case used in the prototype. Some adjustments may be necessary if a different shaped meter is used



Sketch each wafer switch used numbering the poles and tags as in Fig. 1. Redraw Fig. 1 in pencil on a separate piece of paper. Mount all switches as shown in Fig. 5 with the exception of S1. S1 is now wired up; as each wire is soldered on it is inked in on the previously made pencil drawing. This method ensures that no wires are omitted. All leads that come from S1 to other parts of the circuit are left about eight inches long and are labelled. When completely satisfied that S1 is correctly wired it can be mounted into the case. The rest of the wiring can now be completed by connecting S1 wires to their appropriate terminations and adding additional wires and components as necessary; mark the circuit diagram as before.

The values of R14 to R20 are not critical and any near values can be used. R11, R12 and R13 should be 1 per cent high stability types. The values given for the meter shunt resistors (R1 to R7) are for guidance only. These are adjusted to their exact value during the setting up procedure. They should be wound on a small piece of s.r.b.p. using suitable resistance wire to a value slightly higher than that specified. R8, R9 and R10 should be high stability types chosen to be slightly lower in value than specified.

The transistor terminals and external meter connections are made up from 4B.A. brass screws and mounted on a paxolin or s.r.b.p. strip about  $\frac{1}{4}$  in.

thick as shown in Fig. 6. The front panel can be reproduced from that shown in Fig. 7.

### ADJUSTING THE METER MULTIPLIERS

After the wiring has been completed and thoroughly checked set the switches to the following positions:

S1	$V_{ce}$	S5	0-9 volts
S2	50mA	S6	off
S3	25 volts	VR1	minimum
S4	10 $\mu$ A	VR2	minimum

Connect an external voltmeter to the emitter and collector terminals with the negative meter lead to the collector. Ensure that there is a shorting link fitted across the external meter terminals. Set S6 to *pn*p. Slowly rotate VR2 to maximum when both meters should read 9 volts. Return VR2 to minimum when both meters should indicate zero. Set S5 to "9-18 volts". Both meters should indicate 9 volts. Rotate VR2 to maximum; both meters should indicate 18 volts. Return VR2 to minimum and S5 to the "0-9 volts" position.

The 10 and 5 volt ranges of S3 can be checked in the same manner, the only difference in this case being that the "9-18 volt" position of S5 is not used. The 1.0, 0.5 and 0.1 volt ranges can now be checked for function only, because the internal meter should read high on these ranges. The appropriate multi-

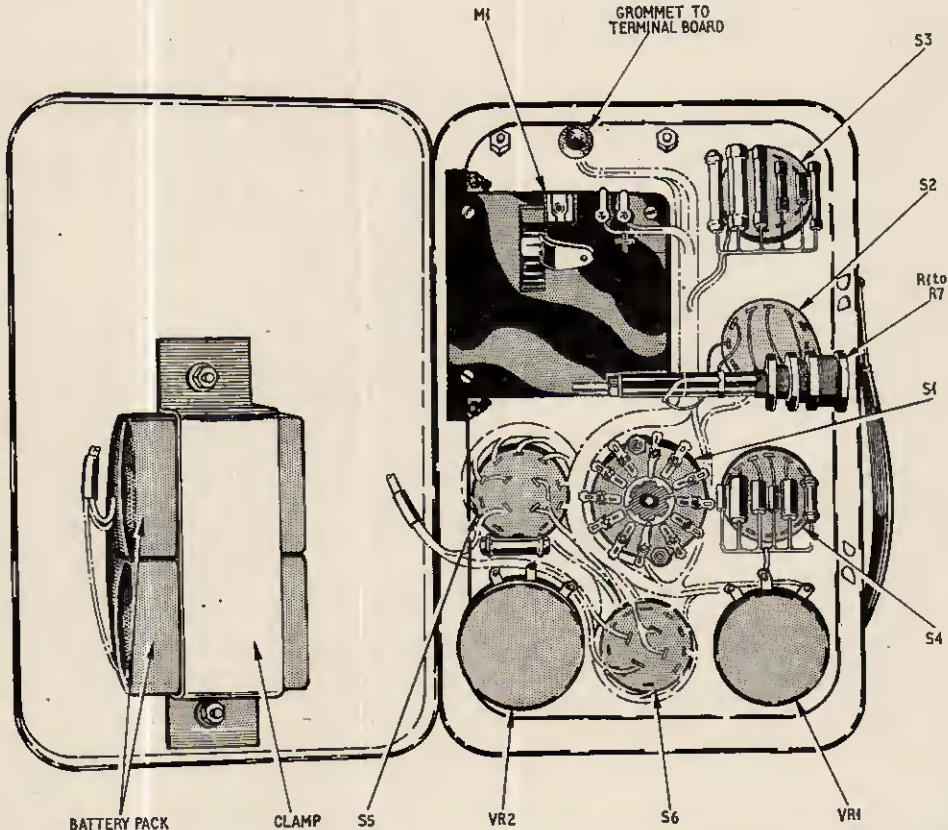

Fig. 5. Interior view of the case with the components assembled. Complete detailed wiring has been omitted for clarity. It is recommended that the system of wiring described in the text is adopted. The wires should be laced into a cable form if possible as shown above

plier resistor is increased in value by careful scraping with a razor blade to reduce its diameter. When the meter is reading accurately on these ranges, the resistors are protected by giving them a coat of clear varnish.

### ADJUSTING THE METER SHUNTS

Set switches to the following positions:

- |    |            |     |           |
|----|------------|-----|-----------|
| S1 | $I_{c0}$   | S5  | 0-9 volts |
| S2 | 50mA       | S6  | off       |
| S3 | 25 volts   | VR1 | minimum   |
| S4 | 10 $\mu$ A | VR2 | minimum   |

Connect an external milliammeter to the external meter sockets, the negative test lead going to the supply terminal and the positive to the terminal connected to the collector. Connect a 150 ohm resistor between the collector and emitter terminals. Set S6 to "ppp". Rotate VR2 slowly clockwise; both meters should indicate a current, the internal meter should read higher than the external meter. This error is corrected by reducing the value of the selected shunt resistor.

## COMPONENTS . . .

### Resistors

- |     |               |   |
|-----|---------------|---|
| R1  | 500 $\Omega$  | } Wirewound (see text)                  |
| R2  | 200 $\Omega$  |   |
| R3  | 100 $\Omega$  |   |
| R4  | 50 $\Omega$   |   |
| R5  | 10 $\Omega$   |   |
| R6  | 5 $\Omega$    | } High stab. 1/4 watt carbon (see text) |
| R7  | 1 $\Omega$    |   |
| R8  | 1k $\Omega$   |   |
| R9  | 9k $\Omega$   |   |
| R10 | 19k $\Omega$  |   |
| R11 | 100k $\Omega$ | } High stab. 1/4 watt 1% carbon         |
| R12 | 200k $\Omega$ |   |
| R13 | 500k $\Omega$ |   |
| R14 | 1.8M $\Omega$ |   |
| R15 | 360k $\Omega$ |   |
| R16 | 180k $\Omega$ | } 1/2 watt 10% carbon                   |
| R17 | 36k $\Omega$  |   |
| R18 | 18k $\Omega$  |   |
| R19 | 3.6k $\Omega$ |   |
| R20 | 39k $\Omega$  |   |

### Potentiometers

- VR1 10k $\Omega$  linear wirewound  
 VR2 5k $\Omega$  linear wirewound

### Switches

- S1 6 poles, 5 ways (3 wafers, 2 poles on each; one pole not used)  
 S2 1 pole, 12 ways (1 wafer; 4 ways not used)  
 S3 1 pole, 6 ways (or 2 poles, 6 ways; 1 pole not used)  
 S4 1 pole, 6 ways (or 2 poles, 6 ways; 1 pole not used)  
 S5 4 poles, 3 ways  
 S6 4 poles, 3 ways  
 All switches are rotary wafer types.

### Batteries

- BY1 and BY2 9 volts each (type PP7 or similar)

### Meters

- M1 50 $\mu$ A 1,000 $\Omega$  Moving coil

### Miscellaneous

- Metal lunch box (Woolworth), eight pointer knobs, s.r.b.p. strip (see text), 4B.A. nuts and bolts

This must not be done while the instrument is switched on. To reduce the resistance of the shunt shorten the length of wire with which it is wound. This should be done a little at a time. This process is repeated for all the other current ranges. For the lower ranges it is advisable to fit a larger resistor

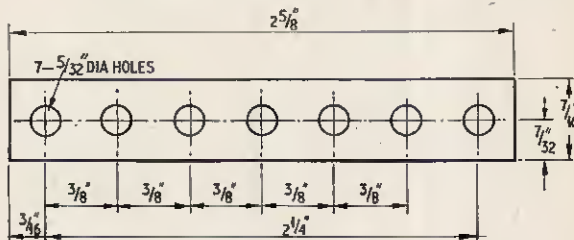

Fig. 6a. Drilling details of the s.r.b.p. strip for mounting the screw terminals

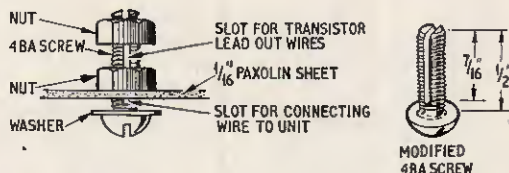

Fig. 6b. The 4 B.A. screw is slotted and mounted as shown above. The transistor wires can be clamped between the two nuts when testing

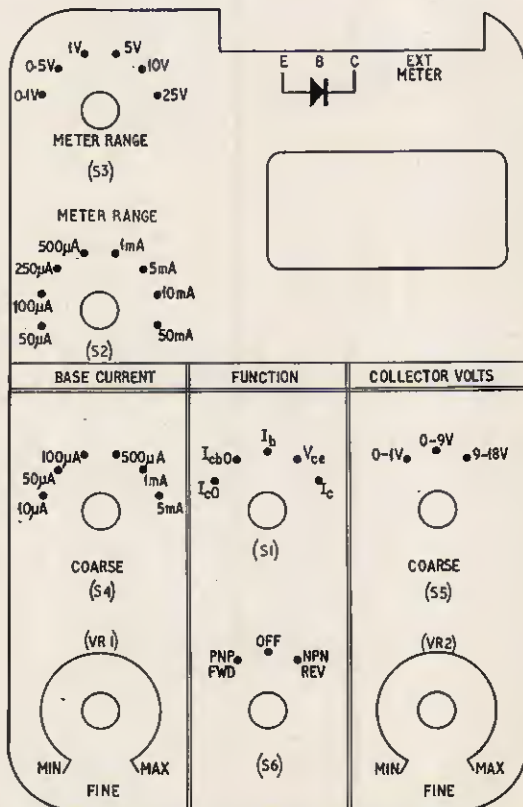

Fig. 7. Suggested design for a front panel made from stiff card and lettered with transfers. This one is reproduced approximately half scale

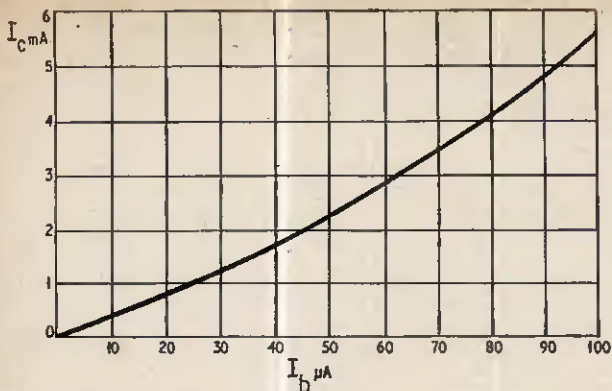

Fig. 8. A typical graph of the transfer characteristic of a medium gain transistor

between the collector and emitter terminals. This is a tedious job but care and patience will be rewarded in the end. Disconnect this resistor and set VR2 to minimum when finished.

### OTHER TESTS

Check that with S5 in the *npn* position the internal meter reads in the correct direction but now the collector terminal is positive with respect to the emitter. Connect a milliammeter between the base and emitter terminals, the negative test lead going to the base. Set S5 to *pnP* and S4 to 1mA. Rotate VR1 towards maximum; both meters should show a reading until 1mA is indicated on both meters at maximum. Set S1 to  $V_{ce}$  and  $I_c$  in turn; the internal meter should not read but the external should still read 1mA.

With a 150 ohm resistor in circuit between the base and collector terminals select  $I_{cb0}$  and ensure that the meter indicates a reading. If the resistor is disconnected the meter reading should fall to zero.

### USING THE INSTRUMENT

**IMPORTANT NOTE:** Care should be taken to ensure that during the following checks the maximum ratings for the transistor under test are not exceeded. The supply voltage should not be switched on until all switches and potentiometers are correctly set.

Set the controls as before when setting up the meter shunts. Connect the transistor to be tested to the test terminals. If an external meter is not being used ensure that the link is in place across the external meter test terminals. Set *pnP* or *npn* as appropriate and switch on. Slowly increase the setting of VR2; if the meter reading climbs rapidly the transistor is short-circuited and the instrument should be switched off. If the meter does not indicate, or indicates very little, all is well. Reduce the meter range until the collector to emitter leakage current can be accurately measured. Increase the meter range. Set VR2 to minimum. Select  $I_{cb0}$  on S1. Proceed as before only this time collector to base leakage current is being measured.

Return VR2 to minimum. Set the meter to a high range. Set S1 to  $I_b$  and with S4 and VR1 set for a  $200\mu A$  base current. Select  $V_{ce}$  on S1 and set the collector to 9 volts. Switch to  $I_c$  and the collector current can be measured. The d.c. gain is given by

$$\frac{\text{collector current}}{\text{base current}} \text{ or } I_c/I_b.$$

This represents the  $\beta$  or  $\alpha'$  of the transistor.

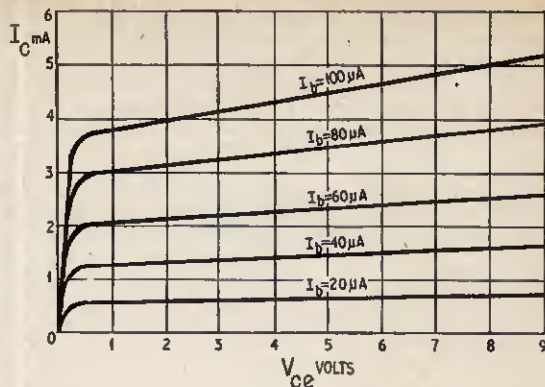

Fig. 9. A typical graph of collector current against collector voltage for given base currents of a medium gain a.f. transistor

### TRANSFER CHARACTERISTIC

The transfer characteristic is plotted easily using the instrument. This is done by drawing a graph as typified by Fig. 8, i.e., base current against collector current.

### COLLECTOR CHARACTERISTIC

Plot the collector current against collector voltage for various preset values of base current as typified in Fig. 9.

### TESTING DIODES

Diodes are tested by connecting them across the collector and emitter test terminals. They can then be checked at various forward and reverse potentials using the *pnP/npn* switch. Voltages and currents flowing are measured in the  $V_{ce}$  and  $I_c$  switch positions.

### OTHER USES

From experience the user may find this instrument invaluable in many other ways. Electrolytic capacitors of low voltage rating may be checked to determine leakage currents by connecting across the collector and emitter terminals and applying voltages and currents as with diodes. The rated working voltage of the capacitor should not be exceeded.

Resistance can be measured by connecting the "unknown" across the collector and emitter terminals, applying a low voltage and measuring as for the collector current condition. The resistance is then calculated by dividing the applied voltage by the measured current.

Once the instrument has been calibrated against a known reliable meter, other meters can be calibrated by connecting to the collector and emitter terminals and following a procedure similar to that described previously.

The tester also becomes an excellent tool in experimental work, for example, when it is required to design a transistor amplifying stage. Various voltages and currents can be applied to find the most suitable working conditions of a transistor.

Care should be exercised in all operations of this tester to avoid undue damage to transistors. One cannot over stress the necessity to watch for rapidly rising currents indicated on the meter. Switch off the instrument *before* such a current rises too high. ★

# ELECTRONORAMA

## HIGHLIGHTS FROM THE CONTEMPORARY SCENE

### Automatic Wiring

ONE of the many interesting features at the Components Show held at Olympia in May was this completely automatic wiring machine developed by Aircraft-Marine Products.

The rack of equipment on the left is a punched paper tape programme console, which provides the wiring machine with information to operate the moving head. Insulated wire is fed into the head from a manufacturer's reel. The insulation is stripped at the end; a gold plated phosphor bronze spring clip (like those shown inset below) is crimped to the wire. The head then locates the required tag post on a large matrix and forces the clip on to it.

The head then finds the corresponding post elsewhere on the matrix to which the other end has to be attached. The wire is threaded between the posts on its way. At its destination the wire is cut, stripped, and again fitted with a clip which is forced on to the next tag post.

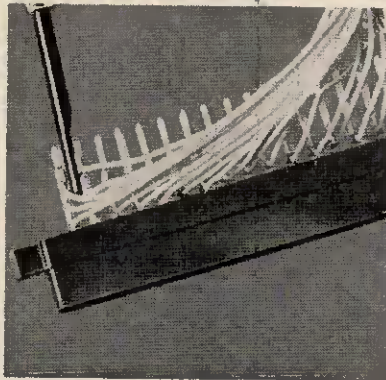
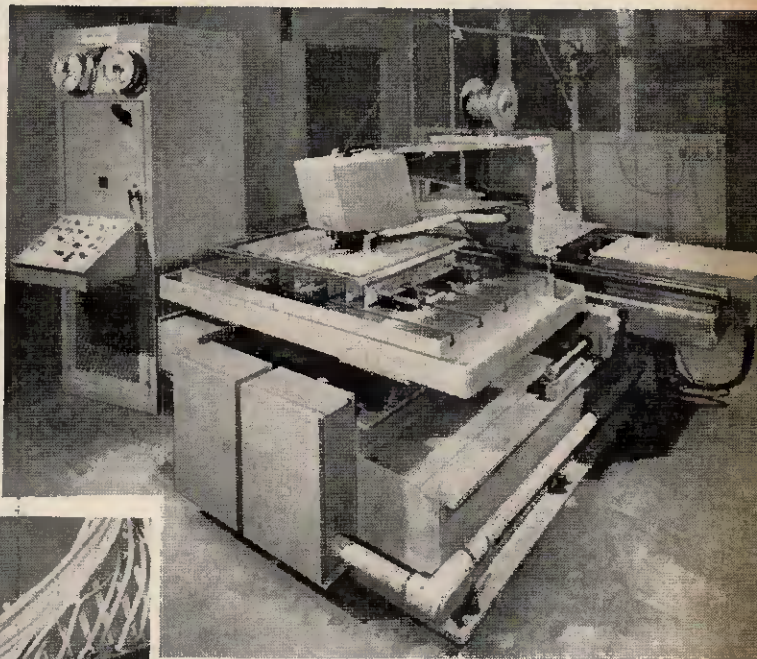

### Painless Activity Recorder

A NEW IDEA in the measurement of body movement is announced by Faraday Electronic Instruments, a company of the Pye Group. Called the "Animal Activity Recorder", it measures and records accurately and electronically many important movements of animals (including humans) under observation. It does this without the use of tilting cages, photo-electric beams or wires attached to the subject.

The sort of things which can now be measured electronically without the "patient" being aware of it include breath-rate and the precise movements of it in its enclosure; even a hiccup is registered. How often a baby moves in its cot and the twitching of the whisker of a rat undergoing drug tests, can all be picked up.

A high frequency low amplitude signal is generated and fed on to the bottom wire grille of the cage containing the animal or to the metal frame of a hospital cot or bed. There is absolutely no danger in this tiny signal and no fear of electric shock. The animal or baby then acts as a "transmitting aerial" within the radiated field deflecting the signals to receiving aerials fastened to the cage or cot.

As the subject moves around, it causes fluctuations in field strength relative to its position.

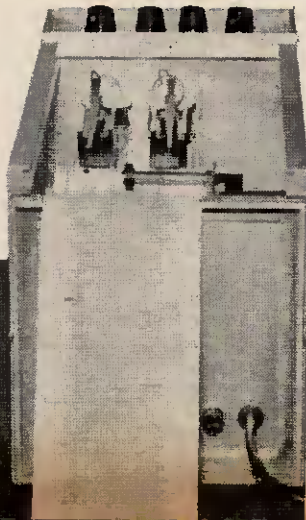

## Count Down

**T**HIS machine (shown in the photograph on the right) counts pills; small pills, large pills, even chocolates, nuts and bolts, seeds, buttons and many other small items. Known as the "Mastercount random path detector," the electronics attached to the front have been developed by Decca Radar to count at the rate of 1,500 to 6,000 per minute by using an OCP71 photo transistor and a beam of light provided by a torch bulb.

The equipment employs an aperture many times larger than the object to be detected, hence the need for a narrow light beam is eliminated.

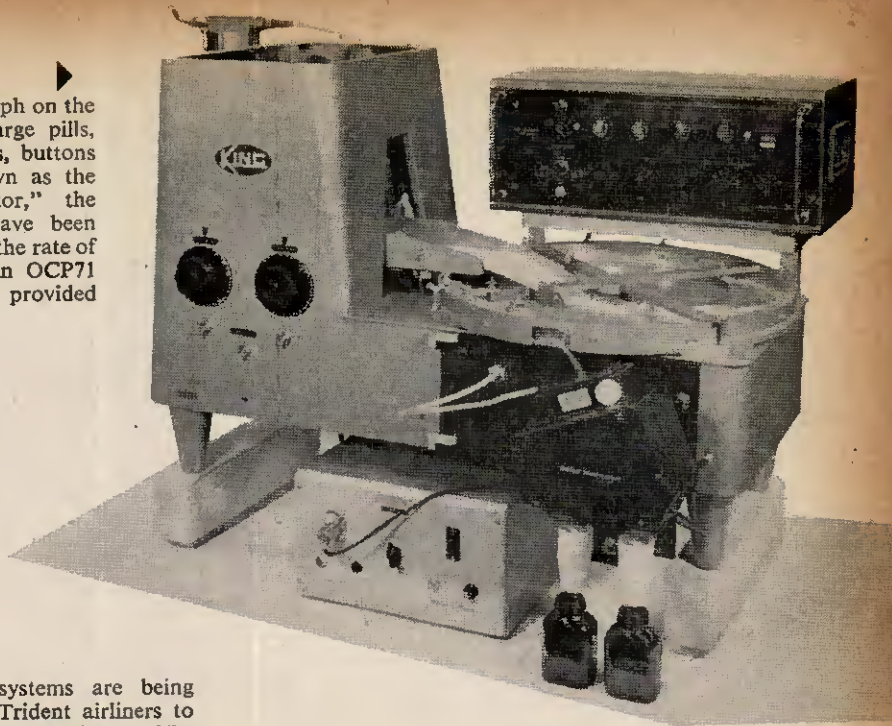

## Automatic Descent

**D**UPLEX automatic flight control systems are being fitted to B.E.A. Hawker Siddeley Trident airliners to provide "autoflare" or automatic touchdown. The execution of the difficult landing phase is shared between the pilot and the electronic equipment developed by Smiths Aviation Division. The equipment is capable of guiding the Trident to a more precise position than can be achieved by a pilot on his own.

At a height of about 150 feet the autoflare equipment is brought into action until touchdown. Aircraft pitch movements and throttle adjustments are controlled automatically while the pilot keeps the aircraft in line with the runway.

An S.T.C. altimeter, emitting a constant sweep frequency

within the 4,200 and 4,400 Mc/s band, measures the height of the aircraft during descent.

The picture below shows the flight deck with duplicated instruments including attitude directors, flight compass, airspeed indicators, altimeter, and vertical speed indicator. The automatic flight control panel is mounted at the front of the pedestal between the pilots' seats.

The system has been approved by the Air Registration Board for use on normal passenger services.

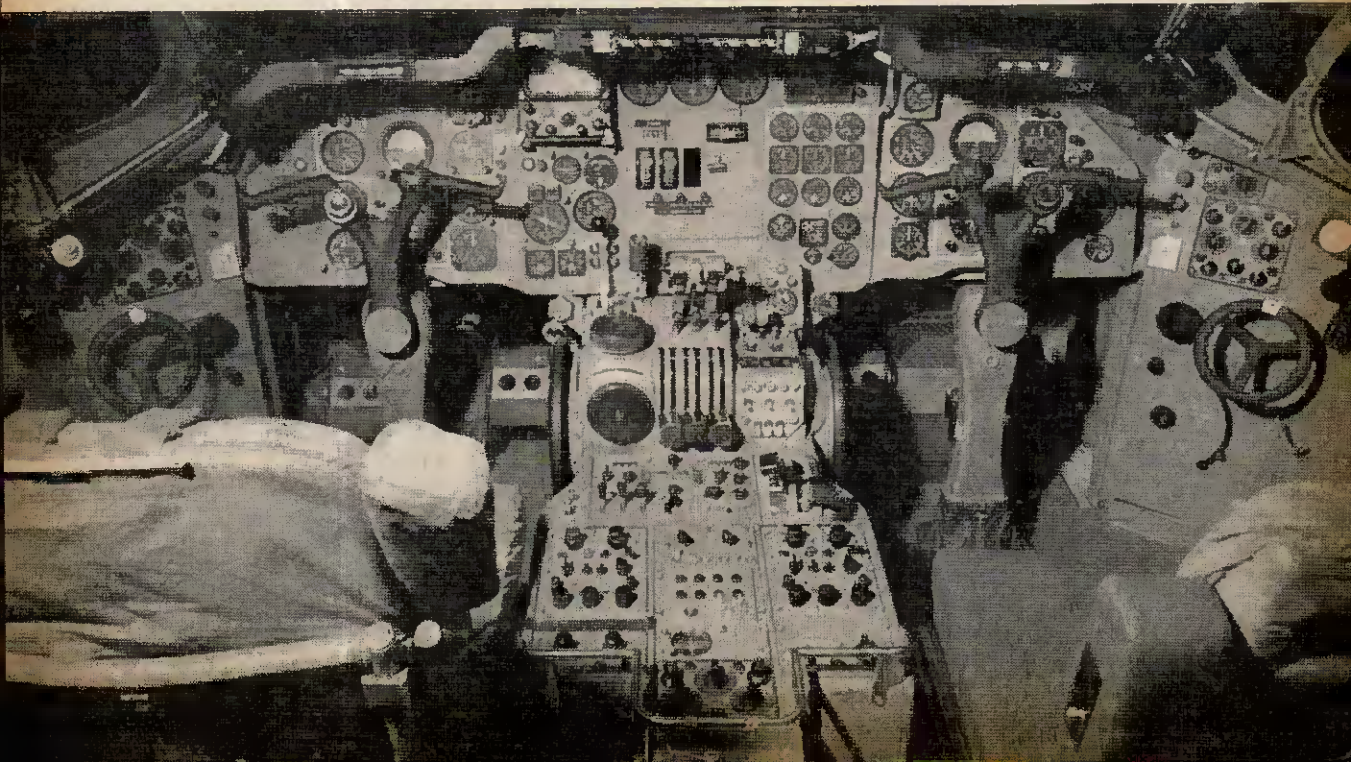

# BEGINNERS start here...

10

## An Instructional Series for the Newcomer to Electronics

THIS month we complete our present look at inductors and transformers by considering two different aspects of energy. First we note how energy can be conserved or stored in a coil, and afterwards we examine the energy losses incurred in iron-cored components.

### STORED ENERGY

One further interpretation of inductor action which is very interesting is the notion that energy is stored in the surrounding magnetic field (see Fig. 10.1). This energy is built up during the current growth: when the current is switched off, this energy is given back to the circuit, and tends to keep the current flowing.

If, in fact, the coil is switched completely off, no current can flow, and the collapsing magnetic field gives rise to a giant voltage peak across the coil. This "inductive surge" is put to good use in high voltage generation for television cathode ray tubes, and in electronic circuits known as "ringing oscillators", "pulse generators" and "blocking oscillators". But, in some circuits, notably transistor designs, these inductive surges are destructive, and must be guarded against. Later on we shall discuss methods of doing this. The storage of energy mentioned above is very similar to a capacitor—except that in the capacitor the energy is stored in the electric field between the plates.

### LOSSES IN TRANSFORMERS

There are some losses in a transformer. For instance, if an output power of 100 watts was being taken from the secondary of a certain specimen, it could easily be the case that 110 watts was being supplied to the primary. Where are the additional 10 watts going?

After some little while, the transformer would feel slightly warm, and this heat produced represents the loss.

Some energy is lost in overcoming the resistance of the windings—this is known as the *copper loss*. Some is lost in eddy current heating of the iron core, even though this is reduced to a minimum by laminating the core.

But, this is not the whole story. It takes energy to continually magnetise and demagnetise the iron in the core. In fact, the *magnetic flux* in the core is a different value while increasing with the growth of current in the windings, compared with that while the current is decreasing.

### MAGNETIC HYSTERESIS

This lag, or "backlash" effect is called *magnetic hysteresis*, and the characteristic "S" shaped loop is often seen in connection with discussions on this topic. Actually, the iron is magnetised by the field produced by the current. The magnetic flux density, set up by a magnetising force, we can call  $B$  to follow convention. The magnetising force is denoted by the letter  $H$ . These quantities are connected by a small equation:

$$B = \mu H$$

This " $\mu$ " is called the *permeability* of the material being magnetised. For iron  $\mu$  can be a very large number, meaning that  $B$  can be considerable even though  $H$  is small. Ferrite rods have a large  $\mu$ , for instance. For iron,  $B$  is not proportional to  $H$ —we say the relation between them is non-linear, hence the distortion that can arise when using cored transformers in amplifiers.

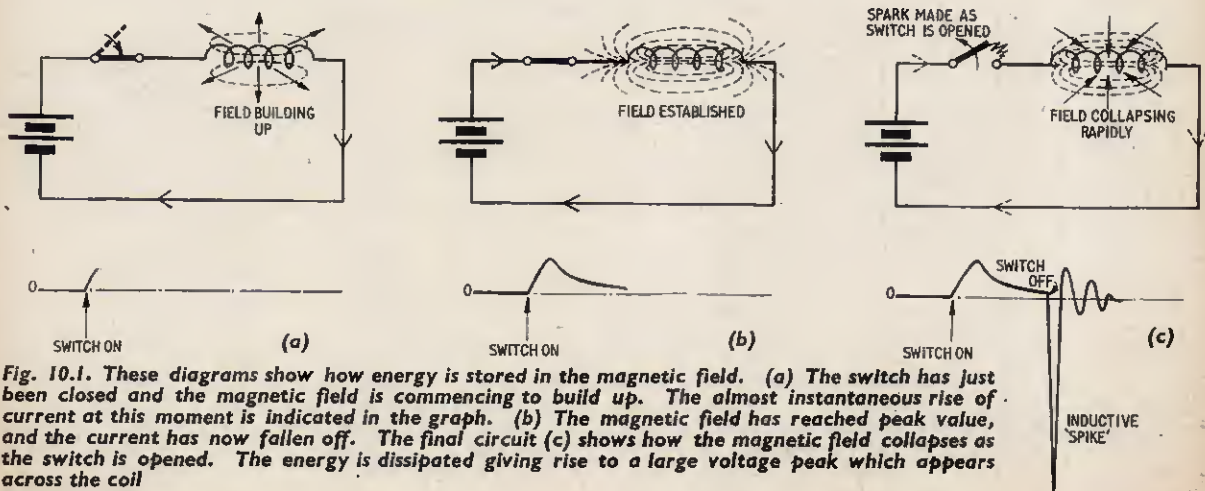

Fig. 10.1. These diagrams show how energy is stored in the magnetic field. (a) The switch has just been closed and the magnetic field is commencing to build up. The almost instantaneous rise of current at this moment is indicated in the graph. (b) The magnetic field has reached peak value, and the current has now fallen off. The final circuit (c) shows how the magnetic field collapses as the switch is opened. The energy is dissipated giving rise to a large voltage peak which appears across the coil

Fig. 10.2a. shows how  $B$  might grow with  $H$ . Notice how the curve flattens off at the top. This means that the iron has the maximum  $B$ , i.e. flux density, that it can take. We say it is saturated. This means that sufficient core area must be used in transformers so that this saturation is not reached while in operation.

Back to hysteresis again. If we reduce the value of  $H$ ,  $B$  will fall, but not so fast as expected. In fact the value of  $B$  will still be something, when  $H$  has been reduced to zero (no current). This means there is some residual magnetism in the core, or *permanent magnetism* as it is commonly known. In order to reduce the value of  $B$  to zero,  $H$  would have to be reversed. If a.c. flows in a winding, the core goes through a complete cycle as above, in step with the changing  $H$  produced by the a.c.

## HYSTERESIS LOOPS

A typical hysteresis loop is shown in Fig. 10.2b, complete with saturation in the two directions. Permanent magnets have a high residual magnetism, as part of their design. The hysteresis loop for the steel in these

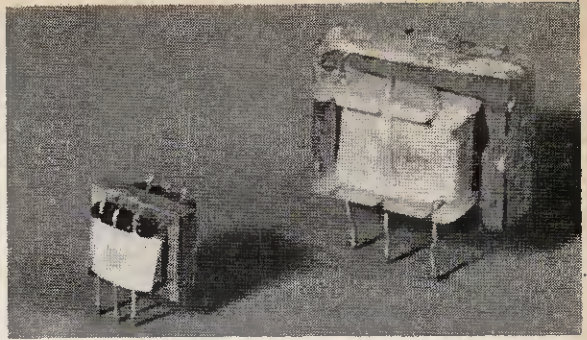

Two iron cored audio frequency transformers. These are reproduced approximately life size and indicate the kind of miniature components now in common use

the core (called the "window"). So, an amateur can fairly easily design and make his own transformers—but the last point above usually makes itself apparent after most of the turns have been put on!

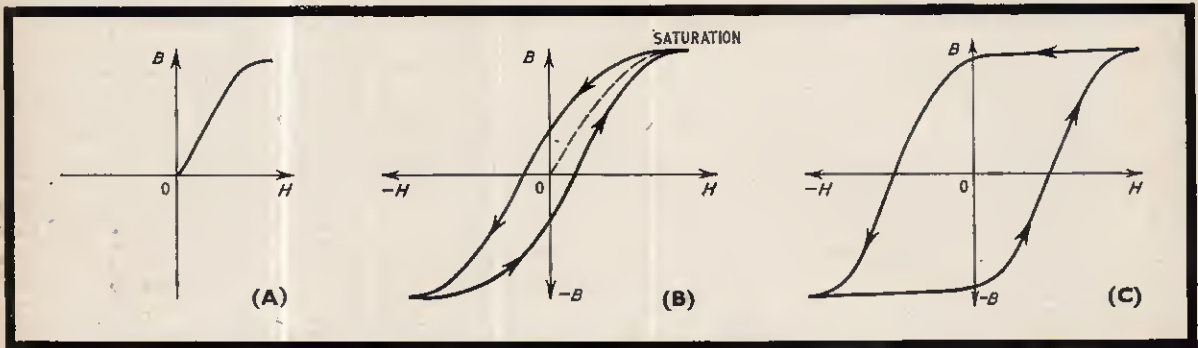

Fig. 10.2a. This shows how the magnetic flux density  $B$  grows as the magnetising force  $H$  increases

Fig. 10.2b. The initial growth of magnetisation goes from '0' to saturation, thereafter the rise and fall "cycles" in the direction shown

Fig. 10.2c. Materials which tend to retain their magnetisation (permanent magnets) have a "flat" hysteresis loop as depicted here

devices resembles Fig. 10.2c. The ferrite ring material, already mentioned in connection with computers in part 7, usually has a very square loop (it is called *square loop material*)—so that the switching over in direction is well defined and sudden.

Now we finish up this discussion with a final point about transformer cores.

Energy is required to go round and round the hysteresis loop, as it were, and this comprises some of the loss in transformers. It can be shown that the energy lost is proportional to the area of the loop, so iron for a.c. cores is chosen to keep the loop narrow and of small area. Thus the *iron losses* in a transformer consist of two parts, the eddy current loss, and that produced by hysteresis. Transformers designed for use on the 50 cycles per second mains must have at least 1 square inch of core for every 50 watts input when operating at the correct load. A good rule is to assume 8 turns per volt for a core area of 1 square inch; 2 square inches would require 4 turns per volt, and so on.

The gauge of the wire is chosen to carry the resultant current. The last point to check is whether the amount of wire needed will go into the space available around

## A USE FOR INDUCTIVE KICKS

We end this month with an example of the use of the voltage pulse produced when the current through a coil is changed rapidly.

In order to set up the discharge in the gas contained inside a photographic flash tube, a very high voltage is required across the starting electrodes to ionise the gas. The main store of energy (contained in a large capacitor) then pours through the ionised gas causing a tremendous burst of light output.

The way to get a pulse of a few thousands of volts for this job is simple, if you remember the theory of inductors. A small charge is passed through the primary winding of a transformer by operating the camera shutter switch contacts. This burst of current produces a rapidly changing magnetic field which links with the large number of turns on the secondary winding, and by Faraday's Law a large voltage (many thousands perhaps) is induced across this winding. Thus the tube is triggered in synchronism with the operation of the camera shutter.

You should now be able to follow Mr. B. J. Crowe's article, using your theoretical knowledge to explain the circuit action.

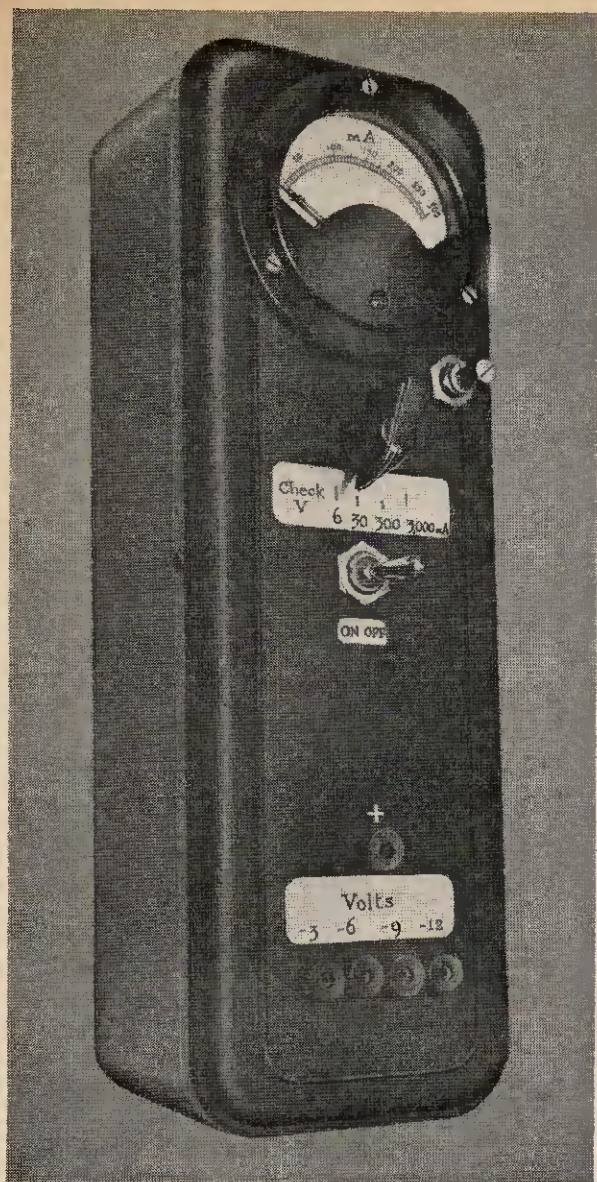

This pack provides a convenient and portable source of power for experimental circuits using transistors, small motors, lamps, and other low voltage devices. It incorporates a fast acting current operated trip, which can be set to any value from 0.5 milliamp to 3 amp. This trip circuit protects the meter, power supply, and any connected load. The actual power source comprises four inexpensive cycle lamp batteries, and these are tapped to provide 3, 6, 9, and 12 volts.

If a moving coil meter is shunted to give a range of current readings, the voltage across the meter terminals will remain constant for any given deflection on any range. The prototype battery pack incorporates a 5 milliamp f.s.d. meter movement with an internal resistance of 15 ohms which, by calculation, shows a terminal voltage of 75 millivolts at full-scale deflection. When this meter is shunted to read 3 amp, for instance, the voltage across shunt and terminals will still be 75 millivolts.

### CIRCUIT DETAILS

By reference to the circuit diagram (Fig. 1) it can be seen that the transistor TR1 is arranged to "read" the voltage developed across the meter, via R7, and pulls in the relay RLA when this voltage exceeds a level predetermined by the setting of VR1.

Under normal circumstances this trip circuit is set to operate at the full scale deflection of the meter, and will therefore cut out at the values set by the range switch S2, namely 6mA, 30mA, 300mA, and 3A. At the most sensitive setting of VR1, the trip functions at lower than 10 per cent of these values.

The circuit is sufficiently flexible to admit other meter movements and the ranges can be altered to suit the existing meter calibration and power supply characteristics. The formula for calculating alternative shunt values is

$$R = \frac{R_m}{n - 1}$$

where  $R_m$  is the resistance of the meter and  $n$  is the desired multiple of its basic current reading. Shunts may, alternatively, be manufactured by the "cut and try" method using a wide range test meter for comparison. Generally speaking, a very sensitive low internal resistance meter would not be suitable for this circuit.

Almost any a.f. transistor could be used for TR1 provided its maximum rated collector-emitter voltage is greater than 12. Variations in gain can be catered

# LOW VOLTAGE BATTERY PACK

BY B. DOUGLAS

for by adjustment of the relay. R9 allows the relay to hold on after the trip operates by permitting a small residual current to pass through the connected load. The trip is automatically reset when the load is disconnected. Capacitor C1 serves to "hold up" the voltage across TR1 and the relay long enough for the trip to function under severe short circuit conditions. The fifth position of S2 checks the battery potential by means of the multiplier resistor R8.





# COMPONENTS . . .

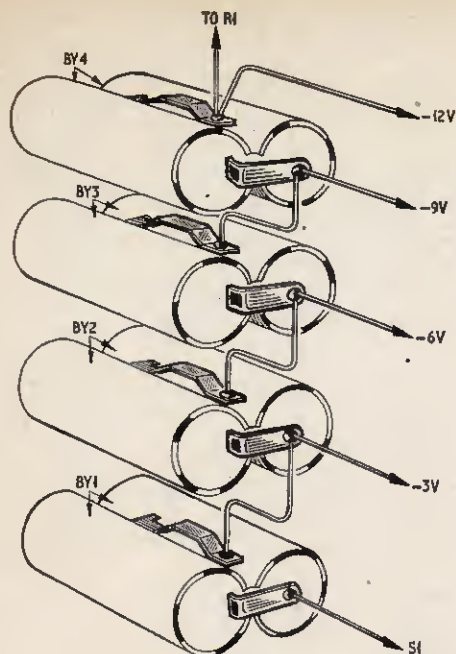

Fig. 3. Wiring details of the batteries to the "negative" sockets

## Resistors

R1	470Ω	R6	75Ω
R2	91kΩ	R7	4.7kΩ
R3	0.025Ω w-w	R8	2.4kΩ
R4	0.25Ω w-w	R9	10kΩ
R5	2.5Ω w-w		

All high stability, cracked carbon except where otherwise indicated.

## Potentiometer

VR1 100kΩ carbon preset

## Capacitor

C1 1,000 μF 12V electrolytic

## Transistor

TR1 OC71 or NKT 272

## Meter

M1 5mA f.s.d., 15Ω, moving coil

## Relay

RLA 1,000Ω coil, single pole changeover contacts, Siemens high speed

## Switches

S1, S3 Double pole on/off  
S2 Single pole, 5 way

## Batteries

BY1-4 Twin cell cycle lamp batteries 3V type (4 off)

## Miscellaneous

Polystyrene lunch box 12in × 4in × 3½in  
Five wander plugs and sockets

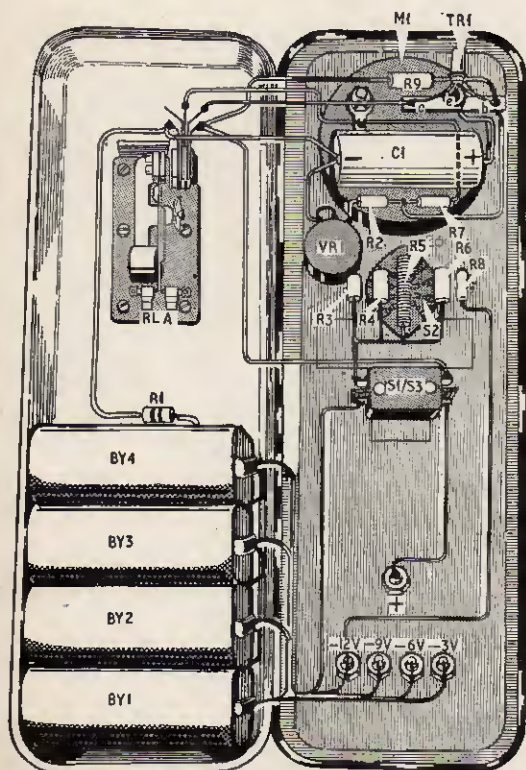

Fig. 4. Internal view of the completed unit

Connect a suitable variable load resistor across the positive and one of the negative output sockets. The meter should show that a current is passing through the load.

Increase the load until the meter reads full-scale, then advance VR1 until the trip operates. A click will be heard from the relay and the meter pointer will drop to zero. If this does not happen, and there is no wiring fault, the relay should be set for greater sensitivity by adjustment of its armature spring tension screw until it pulls in with VR1 set near maximum resistance. Then disconnect, reduce the value of the load resistor and reconnect. It should be found that the trip operates at full scale on all ranges, or at less than full scale, depending on the setting of VR1.

When, say, a transistor receiver is powered by the pack, two points should be noted. If there are high value electrolytic capacitors in the receiver, the switch-on current surge will cause the trip to cut off the supply. This can be avoided by setting S2 to a higher current range initially, then dropping down again to the range consistent with the normal consumption of the receiver. Also, audio peaks, not indicated by the meter, but many times greater than the mean standing current of the receiver, will tend to operate the trip.

In use, the pack allows minor adjustments to be made to experimental circuits while they are functioning, and protects against slow thermal runaway when transistorised circuits are left on and unattended for long periods. This is especially useful in development work and for extended soak tests. ★

# INGENUITY

# UNLIMITED!

IN THIS feature we hope, from time to time, to be able to publish suggestions submitted by some of our readers on the possible improvement of projects previously described in PRACTICAL ELECTRONICS; short contributions on other subjects may be included. The aim is not to find fault or undermine the abilities or knowledge of our contributors. It may well be that the original article is *par excellence* but could be improved or adapted to suit individual requirements. The views expressed by readers are not necessarily those of the Editor.

## PULSE COUNTER

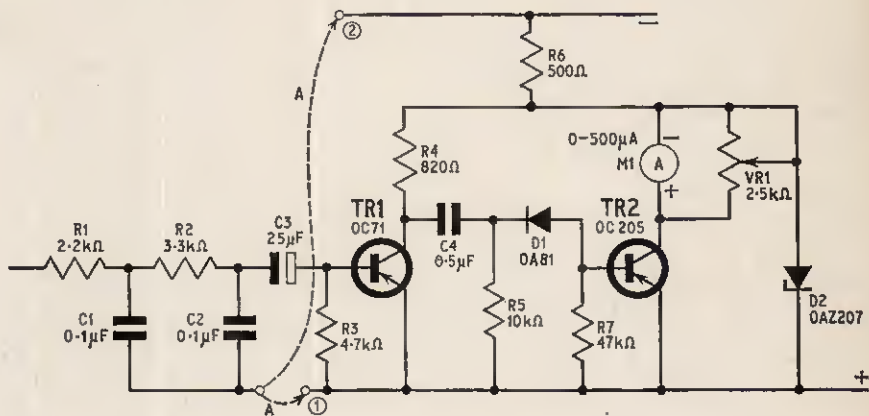

### METER AMPLIFIER

As the output from my version of the pulse counter was only  $50\mu\text{A}$ , I left the Zener diode out and added a meter amplifier. This gives about  $500\mu\text{A}$  enabling a cheaper meter to be used.

To guard against instability through temperature changes, and to obviate non-linearity or zeroing difficulties, a silicon transistor such as an OC205 can be used. If battery variations are troublesome, a simple Zener stabiliser (OAZ207) may be introduced as in the circuit diagram above. This should be effective over the range 11 to 17 volts.

The extra components can be mounted on the sample piece of printed wiring board which was given with the April issue of the magazine. To accommodate them the components to the right of the original Zener diode should be moved to the left by one hole and re-positioned according to the circuit above.

R. L. Mustow,  
Ickenham,  
Middlesex.

### METER ECONOMY

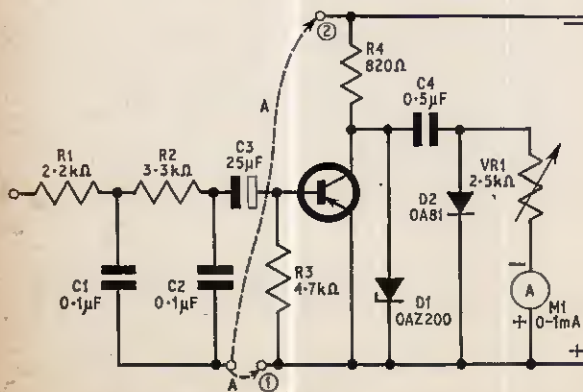

With reference to the "Pulse Counter" in the April issue I would recommend the following modification.

In view of the relatively high cost and fragility of a  $100\mu\text{A}$  meter compared with a  $1\text{mA}$  meter I have modified the circuit as shown to give  $1\text{mA}$  output for  $200\text{c/s}$  input. The performance is very linear but any increase in the value of  $C4$  above  $0.5\mu\text{F}$  leads to non-linearity.

F. M. Gray,  
Rugeley,  
Staffordshire.

Two good ideas well worth considering. Incidentally a few readers noticed in the article that  $C4$  on the original drawing and in the components list should be  $0.47\mu\text{F}$ , and the polarity of the meter in Fig. 1 should be reversed.—Ed.

# PARKING LIGHT

## SIX VOLT PARKING LIGHT

With reference to the "Automatic Parking Light" the circuit shown in the March issue is not sensitive enough for operation on 6 volt car batteries. It may work with a high gain pair of transistors but not with those of low gain.

This can be remedied by a change in the photo transistors. The OCP71 was originally chosen because of its small size, but its sensitive area is only about 7 square millimetres. Light sensitive resistors (cadmium sulphide cells) such as ORP12 have a considerably larger sensitive area and, therefore, give effectively greater output. I am enclosing an alternative circuit which should operate from a 6 volt battery. The value of VR1 may need to be changed to suit different transistors.

A. K. Stevenson,  
Fife,  
Scotland.

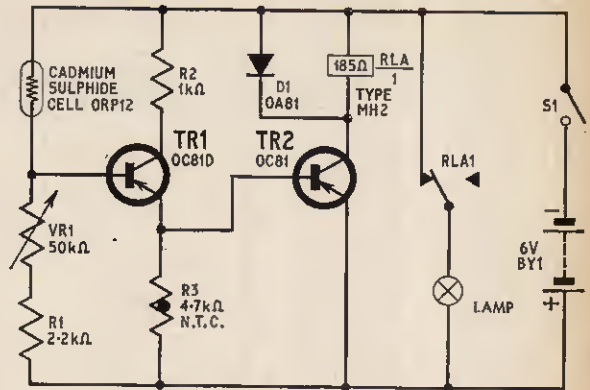

## "MODULE SEVEN"

I used the piece of Veroboard, presented with the April issue, as the circuit board for the construction of the "Automatic Parking Light" described in the March issue.

Specified components were used throughout except for the photo-transistor. Being unable to afford the cost of an OCP71 I used a new OC71 with the metal can removed.

By gently squeezing at the base of the transistor with a pair of long nosed pliers, the glass to metal seal can be broken and the transistor drawn out of the case.

Any glass should be removed (most of it will have powdered when the can was squeezed), and by using a pin the majority of the opaque filling can be cleaned from the transistor junction.

To protect the transistor a small piece of plastic tubing (transparent ink-cartridges are ideal) is placed over the transistor and stuck with a small amount of plastics glue to the transistor lead-out wires. The plastic tubing can be painted black leaving a small area unpainted through which light can pass on to the collector-base junction of the transistor.

An OC71 modified in this manner has been used in the "Parking Light" circuit with complete success. The writer has used the cheap "Red Spot" transistors in place of the OC71, the only difference being that the time delay between the light striking the junction and the operation of the relay is greater.

Nigel Isle,  
Stourport-on-Severn,  
Worcestershire.

## SENSITIVE PARKING LIGHT

I have been experimenting with the circuit from the article "Automatic Parking Light" in the March issue and would like to suggest the following circuit which will operate even a clumsy large relay.

Two OCP71 photo transistors were connected in parallel as shown in the diagram. When VR1 is set to some value between 5 kilohms and 50 kilohms the relay will operate when light falls on the photo transistors. The push button switch (S1) is normally closed and is pressed to reset the required condition between each operation of the circuit.

Battery current consumption is 2mA in the dark and 5 to 15mA in the light depending on its intensity.

R. W. Marshall,  
Belmont,  
Harrow.

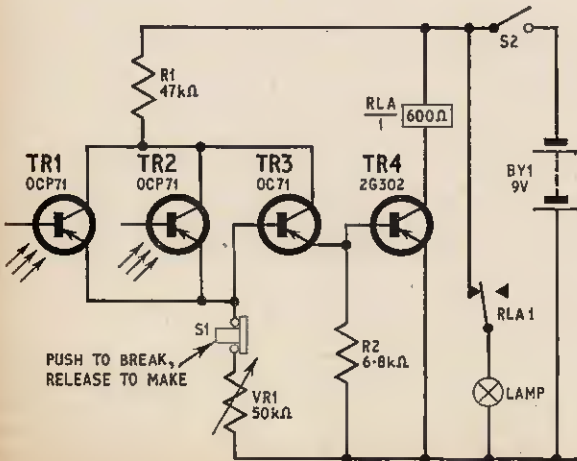

## TESTING DIODES

Further to the "Magic Boxes" articles in the March and April issues, the principle of a diode conducting in one direction only can be applied to a practical unit such as a diode tester. I have made an instrument which will indicate whether a given diode is faulty or not, or if it is open-circuit or short-circuit. The polarity of an unmarked diode can also be determined.

The known diode to be tested is connected across the test terminals—cathode to red and anode to black as shown in the circuit below. Since the test diode and D1 will conduct in the same direction the green lamp LP1 will light. Diode D2 is connected in reverse; no current will flow through it or LP2.

If the test diode is connected in reverse the red lamp (LP2) will light due to the current flowing in the reverse direction through D2.

If the polarity of the test diode is unknown it can be easily determined from the above tests.

If it is found that both lamps light together, this can only be due to a short-circuit in the test diode, which will allow current to flow in both directions. Since the supply is alternating both lamps will be illuminated.

Conversely if both lamps fail to light, this must be due to the diode being open-circuit. Such a diode would not allow current to flow in either direction.

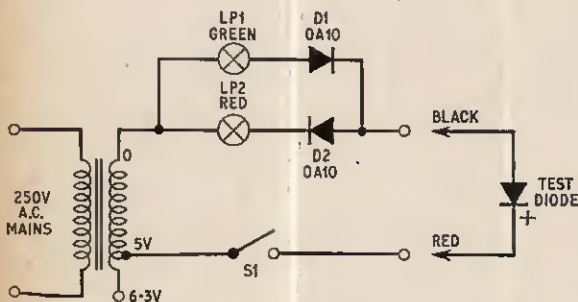

Most types of diodes and rectifiers can be tested with this instrument, e.g., germanium, silicon, selenium, etc., so long as these are above the power rating of this circuit. This is governed by the supply voltage and current rating of the lamps, and should be calculated to ensure low power diodes can be safely tested.

A 6 volt 60mA lamp is most suitable here and gives a calculated power dissipation of 360mW. Clearly any diode rated at about  $\frac{1}{2}$  watt or above could safely be tested. Other lamps and power supplies will work equally well providing this power dissipation does not exceed the rated power of the diode.

A 6.3 volt heater transformer will be the one which is usually to hand and this may be readily employed. Mine had tapings at 3, 5 and 8 volts. The 5-volt tapping was used in conjunction with a 6 volt 60mA lamp, slightly under-running the lamp, and actually permitted diodes down to about 300mW rating to be tested.

The internal diodes, D1 and D2 are not critical so long as they are above the rating of the circuit as mentioned before. Two OA10s were used, since they were readily available, but ones with much lower ratings could have been used.

B. J. McNaughton,  
Sutton Coldfield,  
Warwickshire.



## 3 INTERESTING CONSTRUCTIONAL PROJECTS NEXT MONTH

- **COMMENTARY SYNCHRONISER FOR AUTO SLIDE PROJECTORS**  
Enables a twin track tape recorder to change slides in an automatic slide projector at the appropriate point in the recorded commentary.
- **NOUGHTS AND CROSSES MACHINE**  
You cannot win! An amusing and instructive attraction for Fete, Club, or small Exhibition.
- **A MOTORIST'S AID**  
Audible warning device for the car, having a variety of uses.

SEPTEMBER ISSUE ON SALE AUGUST 12

\* Make sure of your copy by filling in and handing this order form to your newsagent

To \_\_\_\_\_  
(NAME OF NEWSAGENT)

Please reserve/deliver **PRACTICAL ELECTRONICS** (2/6) every month, until further notice.

Name \_\_\_\_\_

Address \_\_\_\_\_

# THE DECIBEL

BY J. R. BRADBURY

OUTSIDE the communications field the decibel is somewhat unfamiliar, yet its value to the hi-fi enthusiast is of far greater significance than some of the more familiar units.

This article sets out to explain the decibel and its practical applications, ending with an exposition of its subjective use in listening which explains its value in assessing fidelity.

## ORIGIN

The decibel (or dB) was originally called the "transmission unit" (itself a development from the "Neper") and was the attenuation of a 886c/s signal in a mile of standard cable such that

$$\frac{\text{input power } P_1}{\text{output power } P_2} = \frac{E_1 I_1}{E_2 I_2} = 10^{0.1}$$

This ratio was easily expressed in common logarithms and, as it is easier to add or subtract rather than multiply or divide when calculating gains or losses, it was adopted as standard for all frequencies.

Later the transmission unit became the "decibel" and expressed the change in power over a given network of equipment.

$$\frac{P_1}{P_2} = 10^{0.1N}$$

and

$$N = 10 \log_{10} \frac{P_1}{P_2} \text{ decibels}$$

The somewhat large unit of the "bel" equals ten decibels and is the common logarithm of the power ratio; the term honouring the inventor of the telephone, Alexander Graham Bell.

## BASIC FORMULAE

The decibel is a comparison ratio between two power levels, one of which is a reference or "zero" level. Zero level is sometimes arbitrary—a value regarded as unity power, of which the other level is either a multiple or sub-multiple, or can be the conventional zero level which, in Europe and the U.K., is a voltage of 0.775 volt r.m.s. across 600 ohms to give a dissipation of 1 milliwatt. In the U.S.A., zero power is regarded as 6 milliwatts.

Amplifier gain, expressed in decibels, is

$$N = 10 \log_{10} \frac{P_2}{P_1} \text{ decibels (power ratio)}$$

$P_1$  being the input or zero reference level and  $P_2$  the output or compared value.

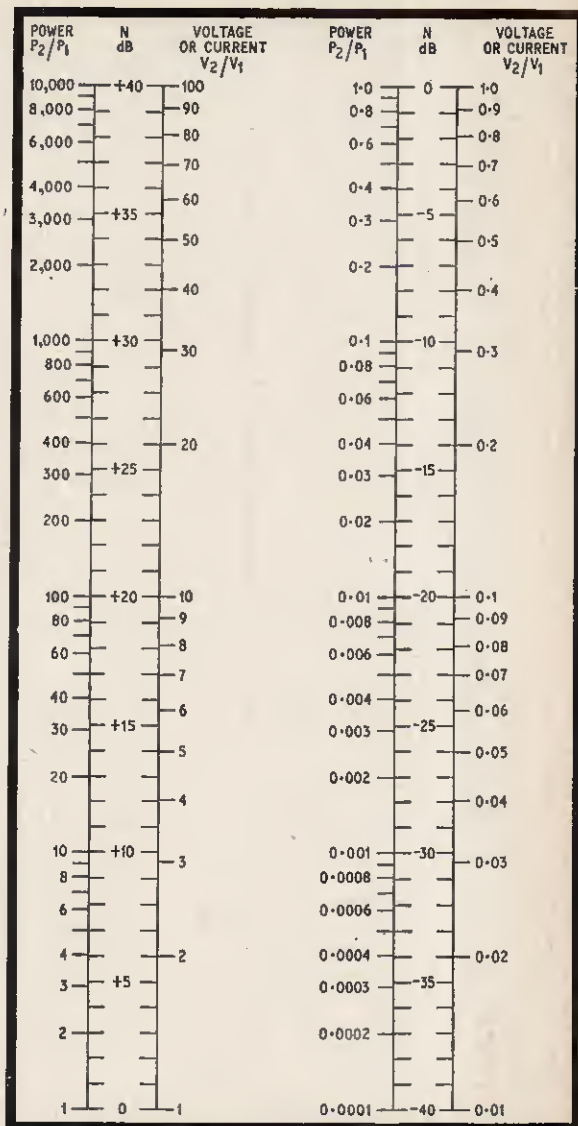

Conversion scales of decibels to power, voltage and current ratios

In this, and other decibel formulae, if the ratio (i.e.  $P_2/P_1$  in the case above) becomes fractional due to a power loss as opposed to a gain, calculations are simplified by inverting the ratio and prefixing the formula with a negative sign:

$$N(\text{loss}) = -10 \log_{10} \frac{P_1}{P_2} \text{ dB}$$

Since the decibel is a power ratio it may be used to express voltage or current ratios. For instance

$P = V^2/R$  and if two voltages are measured across identical impedance values  $Z$ , their decibel ratio is

$$\begin{aligned} N &= 10 \log_{10} \frac{V_2^2/R}{V_1^2/R} \\ &= 10 \log_{10} \left( \frac{V_2}{V_1} \right)^2 \\ &= (2)10 \log_{10} \frac{V_2}{V_1} \\ &= 20 \log_{10} \frac{V_2}{V_1} \text{ dB (voltage ratio)} \end{aligned}$$

$V_1$  being the zero or reference voltage and  $V_2$  the output or compared value. Phase relationships have been ignored here since they would cancel out in the above equations.

This only applies if the resistances or impedances across which  $V_1$  and  $V_2$  are measured are identical in both magnitude and phase.

Because  $P = I^2R$ , the formulae may be similarly applied to current ratios across identical resistances or impedances.

### DISSIMILAR IMPEDANCES

An allowance has to be made in the case where the two impedances, are not the same. Voltage ratios across pure, but dissimilar, resistances are:

$$N = 20 \log_{10} \frac{V_2}{V_1} + 10 \log_{10} \frac{R_1}{R_2} \text{ dB}$$

(Note that resistance ratios are always the inverse of the voltage ratios but are not so for current ratios.)

When impedances differ and cannot be regarded as pure resistances then power =  $VI \cos \phi = I^2Z \cos \phi = V^2/Z \cos \phi$ . Hence

$$N = 20 \log_{10} \frac{V_2}{V_1} + 10 \log_{10} \frac{Z_1 \cos \phi_1}{Z_2 \cos \phi_2} \text{ dB}$$

where  $\cos \phi$  is phase angle between a.c. voltage and current for each respective impedance.

Conversely, the power ratio equivalent to  $N$  dB is

$$\frac{P_2}{P_1} = \text{antilog} \frac{N}{10}$$

and a voltage ratio

$$\frac{V_2}{V_1} = \text{antilog} \frac{N}{20}$$

the decibel equation being transposed and the antilog found, instead of the logarithm, as part of the transposition.

### COMMUNICATION NETWORKS

The simplest network always comprises several components providing gains or losses. Fig. 1 shows a simple communication network between a microphone at A whose output is carried to a transmitter at B.

The microphone level is 60dB below (-60dB) "zero" level and raised to "zero" level by an amplifier having a gain of 60dB. This is followed by a power amplifier which increases the level to 4dB above zero (+4dB) to counteract the noise in the transmission line carrying the signal to the transmitter. During its passage the signal level is distorted by the component quantities (inductance, capacitance and resistance) of the line. To restore the signal to its original quality, an equaliser network is inserted in the system to cut down the least attenuated frequencies to the level of those that have suffered maximum attenuation.

In so doing the overall level of the signal is generally lower (up to about -50dB). To overcome this the receiving amplifier (C) is inserted to raise the signal by 50dB to zero level. A power amplifier boosts the signal to the required level of +10dB to feed the transmitter. Adding the gains and losses in the chain:

$$-60 + 60 + 4 - 54 + 50 + 10 = +10\text{dB.}$$

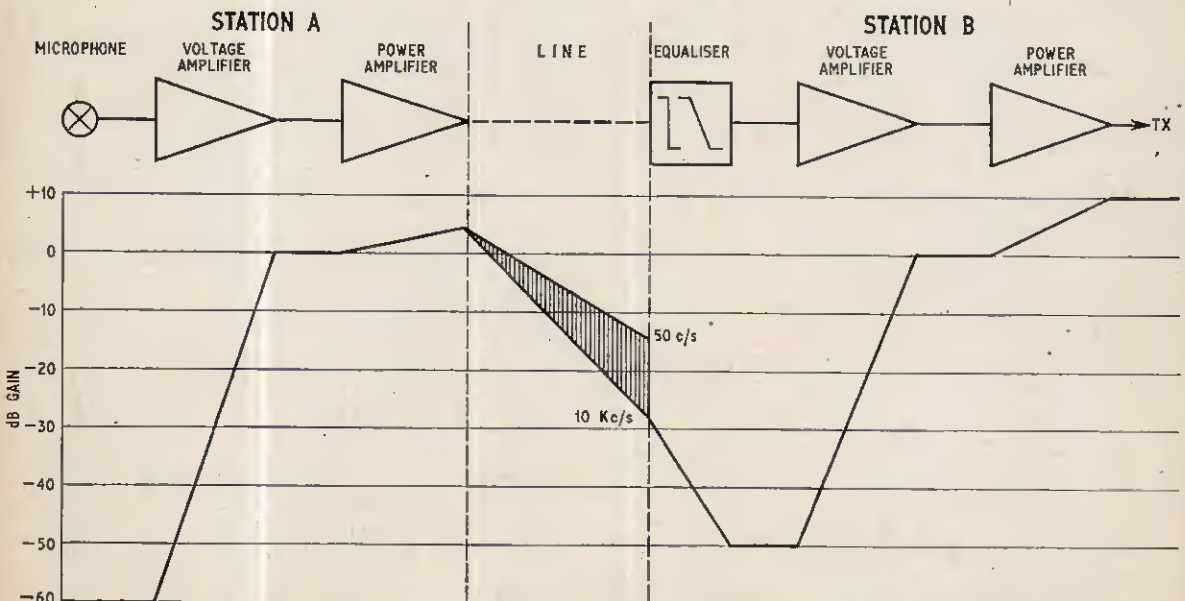

Fig. 1. A simple communications chain. Below it is a graph showing typical levels (in decibels) throughout the chain. The shaded area shows the differences due to line losses between 50 c/s and 10 Kc/s

These levels are used purely to illustrate a typical example but in practice there would be several other items in the circuit whose attenuations and gains would need to be taken into consideration. It is obvious from this example that adding and subtracting decibels is preferable to multiplying and dividing voltages; calculations can be astronomical, even for a simple chain.

Knowing the decibel gains or losses of each item of equipment immensely simplifies the planning of a communications chain, not only to find the gain required in amplifiers but also to assess the power levels and signal/noise ratio anywhere in the chain.

## AMPLIFIER FREQUENCY RESPONSE

The frequency response of an amplifier (or other apparatus) is frequently expressed in decibels which are related to a "zero" reference level at a given frequency (often 1,000c/s) at which the amplifier gain has first been found. The relationship between the power at two different frequencies is

$$N = 10 \log_{10} \frac{P_{f_1}}{P_{f_2}} \text{ dB}$$

where  $P_{f_1}$  is the power at 1,000c/s and  $P_{f_2}$  is the power at some other given frequency.

In this case if  $P_{f_1}$  is greater than  $P_{f_2}$  the answer would be negative and is prefixed by a minus sign. If  $P_{f_2}$  is greater than  $P_{f_1}$  the answer is positive and is prefixed by a plus sign.

In practice it is easier to work in voltages. Hence the relationship would then be

$$N = 20 \log_{10} \frac{V_{f_1}}{V_{f_2}} \text{ dB}$$

assuming that the input voltage is constant at all relevant frequencies. The signs apply as for power.

Some measuring instruments are calibrated in decibels and read the values of level direct in decibels. In such a case the voltage at the reference frequency (say 1,000c/s) is set so that the meter reads 0dB. Hence the relative levels at other frequencies can be read direct in terms of  $\pm N$ dB relative to the level at 1,000c/s.

Frequency responses can be plotted with the y-axis on a linear scale for voltage and decibels, and frequency on the three-cycle log x-axis. The decibel curve is broadly similar to the voltage curve but always flatter, as shown in Fig. 2.

## MEASURING TECHNIQUE

The decibel has been the cause of the introduction of special measuring techniques—because applying decibel theory to voltage readings for each frequency can be time consuming and tedious.

The substitution method is far quicker and has two variations—both being shown in Fig. 3. The first (Fig. 3a) is used for assessing amplifier gain or response, using a calibrated decibel attenuator connected between a test oscillator and the amplifier under test.

A decibel attenuator is constructed of resistors, has a constant impedance and is normally calibrated to vary the attenuation in  $\frac{1}{2}$ dB steps from zero to 55, 60 or 70dB. The meter M is connected to a change-over switch S which selects either the attenuator or the amplifier output, the latter being terminated with a resistance equal to the attenuator impedance.

Initially, the attenuator is set to zero attenuation and the meter switched to it, virtually connecting it to the

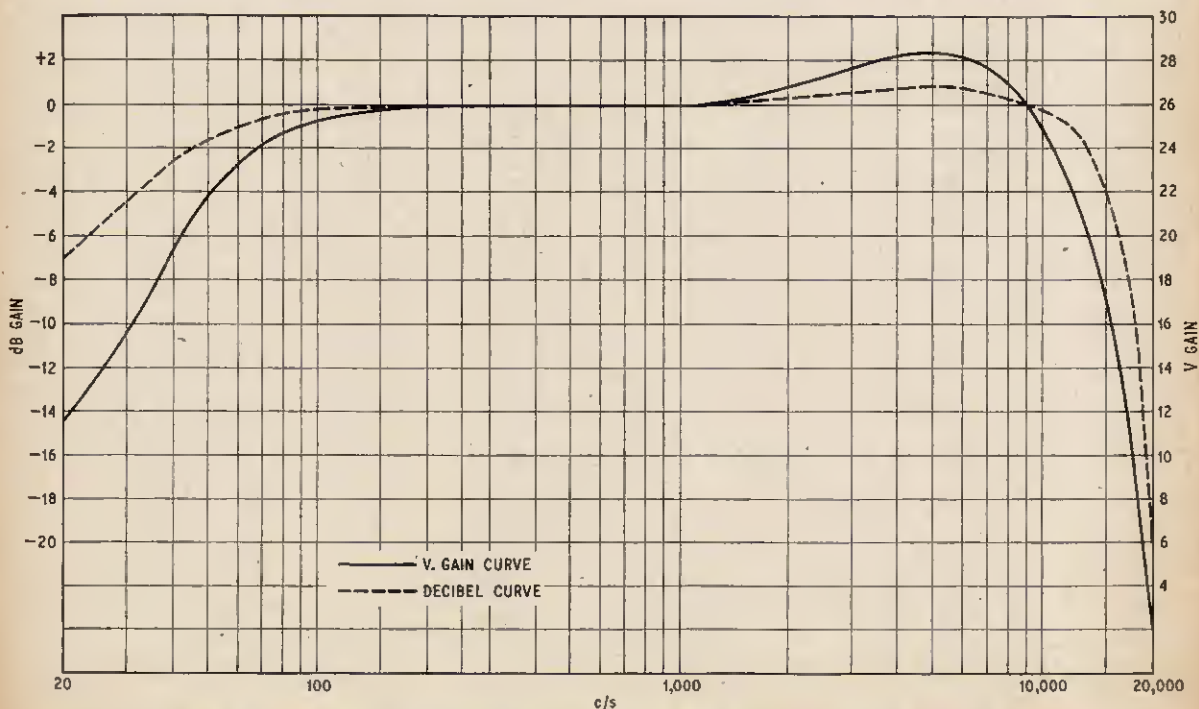

Fig. 2. Frequency response curve for amplifier voltage gain with the equivalent decibel response curve for the same amplifier. The decibels curve shows a characteristically smoother response over the audio frequency range



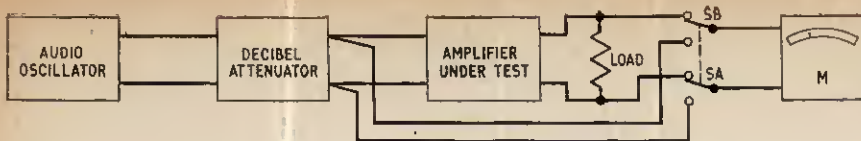

Fig. 3a. Substitution method of measuring the frequency response of an amplifier

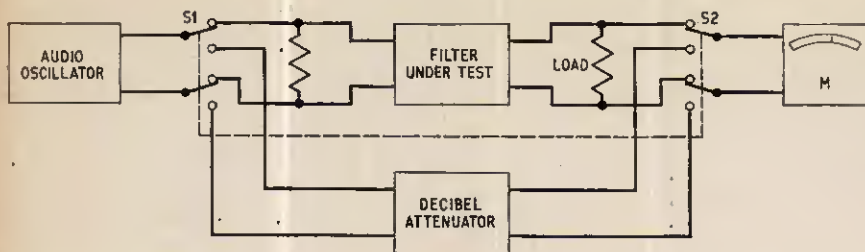

Fig. 3b. Substitution method of measuring frequency response of a filter

oscillator output, the signal from which must be adjusted to give a convenient meter deflection.

The attenuator is then set to maximum attenuation, and the meter is switched to the output of the amplifier under test. The amount of attenuation is gradually reduced until the amplifier gives the same output reading as that obtained in the initial measurement. The amplifier gain then equals the amount of attenuation in use. This is so because the sum of amplifier gain and attenuation must equal unity (the attenuator neutralising the amplifier gain) if the meter deflection is the same for both positions of the switch.

The second application checks the loss in a filter or attenuator which may be just as important as the response of an amplifier. This uses the circuit of Fig. 3b—the decibel attenuator now being connected across the apparatus under test but isolated from it by ganged changeover switches S1 and S2.

The meter is first switched across the filter under

test and the oscillator output adjusted for a convenient meter deflection. Changing over S1 and S2, so that the oscillator output passes to the meter through the decibel attenuator, attenuation is then inserted until an identical meter deflection is obtained. The attenuation inserted equals the filter loss at the particular frequency being used.

The input and output impedances of the apparatus under test should be the same as that of the decibel attenuator.

### LOUDNESS

Loudness is purely subjective and can be defined as the sound heard by the human ear when the aural senses are stimulated by a given sound intensity, i.e. the amount of sound in terms of power and sound wave pressure.

To produce equal changes in loudness the intensity must increase (or decrease) in proportional steps.

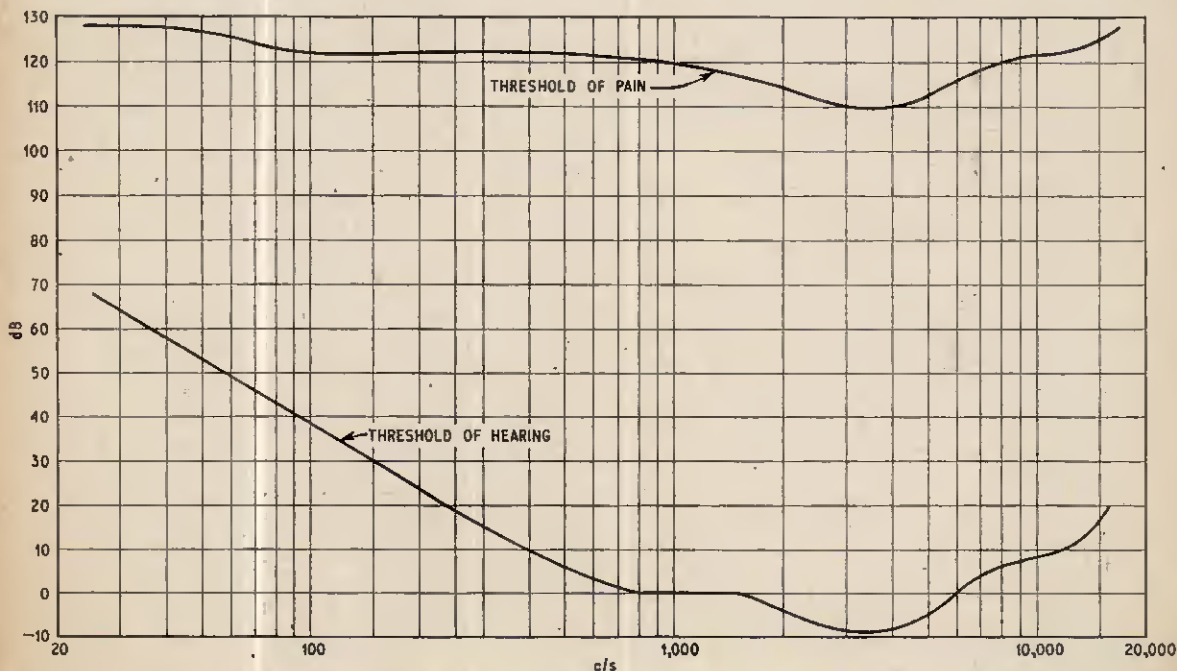

Fig. 4. The upper and lower limit curves of the Fletcher-Munson loudness level responses of the average human ear

Loudness is approximately proportional to the logarithm of the sound intensity.

Because of this relationship, loudness can be measured in decibels related to an acoustic "zero" level. A change in sound intensity of one decibel is the smallest change that can be perceived by the most sensitive human ears, and, in practice, the average person can only detect a change greater than two decibels.

Thus, "electrical" and "acoustical" decibels are linked. For example, an audio system whose response is said to be 3dB down at 5,000c/s will lack treble or "brilliance" to most listeners; if 2dB down this lack of treble might be detected by listeners of average hearing but only the sensitive ear of a musician could detect a change of 1dB.

The decibel therefore offers a useful yardstick for measuring audio "fidelity". The output of an amplifier, record player or other audio system having an overall response within less than 2dB of that of a given reference frequency is considered to be in the range of high fidelity.

### ACOUSTIC DECIBEL

Fletcher and Munson published a set of curves of equal loudness and these are outlined in Fig. 4, the intermediate curves falling broadly between the two limits shown. The upper limit was found to be the tolerable limits above which any further increase causes pain. This limit is known as the "threshold of pain". The lower limit indicates what is generally considered to be where the sound is barely perceptible to the human ear. Any further reduction in level is completely inaudible. This limit is known as the "threshold of hearing". The curves reveal that absolute levels for both thresholds vary with frequency.

The curves also reveal that the human ear is most sensitive in the middle frequency range between about 800c/s and 6,000 cycles, becoming relatively insensitive towards 28c/s and 16,000 cycles—with the lower frequencies being "felt" rather than "heard".

The curves are statistically based and so must be accepted with certain reservations; they vary considerably between different individuals, according to health and age. ★

**In the August  
Practical Television  
A TRANSISTORISED  
E.H.T. VOLTMETER**

*On sale JULY 22*

**In the August  
Practical Wireless  
A SOLAR-POWERED  
POCKET RECEIVER**

*On sale NOW*

**Both only 2/-**

# NEWS BRIEFS

## Brighter Sharper Pictures

FROM January next year, all Mullard monochrome tubes in the 19in, 23in and 25in sizes will be designed to operate at 20kV instead of the present maximum of 18kV. The increased capability will mean brighter pictures, sharper focusing and a reduction in deflection de-focusing.

If all of the extra brightness of the 20kV tube is not required the tube may run at a reduced beam current to obtain a further reduction in spot size and in deflection de-focusing.

A new e.h.t. rectifier has been designed for use with the 20kV tubes. It incorporates special components to guard against flashover and a 3-rod method of anode construction to improve reliability and life expectancy. Numbered DY802, the new rectifier has identical pinning and dimensions to the widely-used DY87.

The extra scanning power required may be obtained with existing Mullard deflection valves, but to provide a reserve of line-output power a new higher dissipation version of the PL500 will be introduced shortly.

To reduce the size of field-output transformers for the 20kV tubes, the field-output valve PCL85 has been re-designed to give an increased dissipation of 8W.

## Young "Hams" Course

ALONGSIDE a week-end course for youth leaders and teachers in Nottinghamshire on "The Hobby of Amateur Radio", at the Residential Youth Centre, Ollerton, Nottinghamshire on 11 and 12 September, there will run a course of lectures for invited established Amateur Radio enthusiasts from the East Midlands and beyond.

The symposium, organised by the Newark and District Amateur Radio Society, is being sponsored by the Radio Society of Great Britain, who are sending speakers of international repute to cover all aspects of amateur radio.

Full details of the course may be obtained from Mr. D. A. Graham, Lower House, South Muskham, Newark, Nottinghamshire.

## I.E.E.T.E. Making Rapid Strides

THE Institution of Electrical and Electronics Technician Engineers is making excellent headway and since April 1st, when membership recruitment began, 5,000 have been admitted to the Institution. Large numbers of membership proposals and enquiries are being received daily.

A specialist committee is now working on a programme of technical lectures and meetings to commence in the Autumn and is selecting technical material for the broadsheet which will be going out to members at regular intervals; this is to be the "pilot" for the I.E.E.T.E. Journal now being designed. Another committee is working on plans for the setting up of Regional Centres, from which a nation-wide chain of Centres will radiate. Inquiries regarding membership should be addressed to The Secretary, I.E.E.T.E. Ltd., 26 Bloomsbury Square, London, W.C.1.

# LEARN ELECTRONICS — AS YOU BUILD

over **25** **CIRCUITS**  
**EXPERIMENTS**  
**TEST GEAR**



including . . .

## ● CATHODE RAY OSCILLOSCOPE

- Valve Experiments
- Transistor Experiments
- Electro-magnetic Experiments
- Basic Amplifier
- Basic Oscillator
- Basic Rectifier
- Signal Tracer
- Simple Counter
- Time Delay Circuits
- Square Wave generator
- Morse Code Oscillator
- Simple Transmitter
- Electronic Switch
- Photo-electric circuit
- Basic Computer Circuit
- Basic radio receiver
- A.C. Experiments
- D.C. Experiments

The full equipment supplied comprises: valves, transistors, photo-tube, modern type chassis board; printed circuit board; full range resistors, capacitors and inductors; transformers; potentiometers; switches; transistors; valves; all hardware, wiring and every detail required for all practical work plus CATHODE RAY OSCILLOSCOPE for demonstrating results of all experiments carried out. All practical work fully described in comprehensive PRACTICAL MANUALS. Tutor service and advice if needed.

*This complete practical course will teach you all the basic principles of electronics by carrying out experiments and building operational apparatus. You will learn how to recognise and handle all types of modern components; their symbols and how to read a completed circuit or schematic diagram. The course then shows how all the basic electronic circuits are constructed and used, and HOW THEY ACTUALLY WORK BY USING THE OSCILLOSCOPE PROVIDED. An application is given in all the main fields of electronics, i.e. Radio; control circuits; computers and automation; photoelectrics; counters, etc., and rules and procedure for fault finding and servicing of all types of electronic equipment.*

- NO PREVIOUS KNOWLEDGE NEEDED
- NO MATHS USED OR NEEDED
- REASONABLE FEE—NO EXTRAS REQUIRED
- SENT IN ATTRACTIVE BOX
- COMPLETE ADVICE SERVICE
- EVERYTHING REMAINS YOUR OWN PROPERTY

A completely **NEW** up-to-date home study experimental course by **BRITISH NATIONAL RADIO SCHOOL** — Britain's Leading Electronic Training Organisation.

### POST NOW FOR FREE BROCHURE

To: BRITISH NATIONAL RADIO SCHOOL, READING, BERKSHIRE. Please send free Brochure, without obligation, to:

NAME.....

ADDRESS.....

OR WRITE IF YOU PREFER NOT TO CUT COUPON

PE 8.65.

## GUITAR AMPLIFIERS WITH TREMOLO

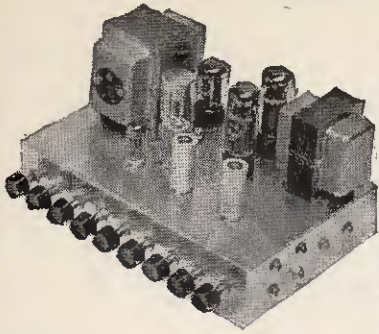

Five jack socket inputs, four with separate mixing volume controls, and one input "straight through". All inputs are of very high sensitivity only 10 millivolts input is required for full output, making them suitable for all types of guitars and microphones. Separate Bass and Treble controls, giving a wide range of lift and cut. Separate master gain control. Tremolo speed and depth controls. Jack socket for remote tremolo switching.

Outputs for 8 and 16 ohms speakers. Valves used in the 30 watt and 50 watt amplifier ECC83, ECC83, EL84, EL84, GZ34. In the 15 watt amplifier ECC83, ECC83, EL84, EL84, EZ81. An extra valve ECC83 is used in the tremolo circuit. The chassis is complete with baseplate and is solidly made of 18 gauge steel, finished silver grey hammer. Size 12 x 8 x 6 1/2 inches high.

**PRICES—**

50 watt with tremolo .....	£20.10.0
50 watt less tremolo .....	£19.10.0
30 watt with tremolo .....	£15.10.0
30 watt less tremolo .....	£14.10.0
15 watt with tremolo .....	£12.10.0
15 watt less tremolo .....	£11.10.0

Add carriage 10/- any amplifier. Send S.A.E. for free descriptive leaflet.

CREDIT TERMS ARRANGED  
EXPORT ENQUIRIES INVITED

**STROUD AUDIO**  
CASHES GREEN ROAD, STROUD, GLOS.

## VALVES

ALL BRAND NEW AND HAVE FULL WRITTEN GUARANTEE

6RL 8/8	DK91 8/-	ECH81 6/6	EZ41 7/-	FL86 9/-
6PL3 8/-	DK92 8/-	ECH83 7/6	EZ80 5/-	PL36 8/-
6P23 7/-	DK96 8/-	ECH84 10/-	EZ81 5/8	PL81 8/-
6P24 8/6	DL91 6/-	EOL80 6/6	GZ34 10/6	PL82 5/-
6/30L2 10/-	DL92 4/6	EOL82 7/6	PC86 9/6	PL83 6/6
20P4 15/-	DL94 6/-	ECL83 9/6	PC88 9/6	PL84 7/-
30C16 10/-	DL96 8/-	EF80 6/-	PC95 7/6	PL80 15/-
30C17 10/-	DY80 7/-	EF85 6/-	PC97 7/6	PY32 8/6
30C18 8/-	DY87 9/-	EF86 7/6	PC98 7/6	PY33 10/-
20PL1 10/-	EABC80 6/6	EF89 6/-	PC99 9/6	PY80 5/6
30L16 9/9	EB01 4/-	EF91 4/6	PC180 10/6	PY81 5/6
30L17 10/-	EB41 7/6	EF92 4/-	PC181 7/-	PY82 5/6
30P4 12/6	ERC81 7/-	EF183 7/-	PCF80 7/6	PY83 8/-
30P13 7/6	RF80 6/6	EF184 7/-	PCF84 6/3	PY88 7/6
30P19 12/6	RF89 8/6	EL34 9/-	PCF86 8/-	PY800 6/6
30PL1 8/8	ECC81 4/6	EL41 8/-	PCF88 10/6	PY801 6/6
30PL13 9/6	ECC82 5/6	EL42 7/6	PCL82 7/-	U28 10/-
30PL14 12/-	ECC83 4/6	EL84 6/-	PCL82 7/-	U29 8/-
DAF91 6/-	ECC84 7/6	EY51 6/6	PCL83 9/6	U26 8/-
DAF96 8/-	ECC85 6/6	EY86 7/-	PCL84 7/6	U181 9/6
DF96 8/-	ECH42 8/6	EZ40 6/6	PCL85 7/6	U301 11/6

BY100 Silicon Rectifiers 7/6 each

Power Transistors equivalent to OC26 6/6 each

**FREE—FREE—FREE—FREE—FREE**

### POWER TRANSISTORISED

Complete instructions to build a 50 watt D.C. Converter. 12-18 volt input, 250 volt output. This is perfect to run H.T. supplies for a T/V in car or caravan. This unit will use transistors as above. We can supply transformer for this at £2.15.0. Power consumption 2 amps.

ALL ITEMS DESPATCHED SAME DAY. MAIL ONLY. NO CALLERS

TERMS—CASH WITH ORDER. ALL ORDERS OVER £1 POST FREE  
POSTAGE ON VALVES—6d. EACH

STAMPED ADDRESSED ENVELOPE ALL ENQUIRIES TO

**BARKERS, 23 HURSTFIELD ROAD  
WEST MOLESEY, SURREY**

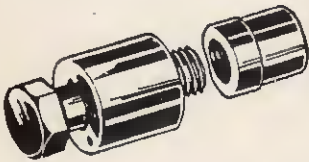

*The PUNCH  
you need!*

### HOLE PUNCHES

<b>Instant Type</b>			
3/8" diameter	...	...	6/10 ea.
<b>Screw-up Type</b>			
3/8" diameter Toggle switch	...	...	8/6 "
" " " " " "	...	...	8/6 "
" " B7G	...	...	9/- "
" " B8A, B9A	...	...	9/6 "
" " " " " "	...	...	10/2 "
" " " " " "	...	...	10/8 "
" " " " " "	...	...	11/8 "
1 1/8" diameter Int. Octal	...	...	13/4 "
" " " " " "	...	...	16/2 "
" " " " " "	...	...	18/10 "
" " B9G	...	...	21/8 "
" " " " " "	...	...	24/4 "
2 1/8" " " " "	...	...	33/2 "

Complete Set £9.3.6.

No extra charge for postage and packing in the U.K.

Now supplied by:

**TOMPkins & LONGMAN LTD.**

237 GIPSY ROAD  
WEST NORWOOD, S.E.27  
Tel.: Gipsy Hill 5000

### MULTI-TAPPED TRANSFORMERS

ALL PRIMARIES 200, 230, 250 v.

Type	Sec. Taps	Amps	
A	3, 4, 5, 6, 8, 9, 10, 12, 15, 18, 20, 24, 30 v.	2	25/- 4/-
B	Dicto	4	39/6 4/6
C	Dicto	5	45/- 5/6
D	Dicto	8	59/6 7/-
E	6, 7, 8, 10, 14, 15, 17, 19, 25, 31, 33, 40, 50 v.	3	45/- 5/6
F	Dicto	6	87/6 7/6
G	12, 18, 20, 24, 30 v.	10	69/6 7/6

### HEAYBERD TRANSFORMERS

Pri. T 200-240 v. Sec. 12 v. 4 a. Brand new. Fraction of maker's price. 15/- P.P. 2/6.

### IBM DOUBLE WOUND TRANSFORMERS

Pri. Tapped 220, 220, 240 v. Sec. Tapped, 110-100 v., 200 v. A. 47/6. Carr. 5/-. Tropicly rated.

### BRAND NEW VENNOR ELECTRIC TIME SWITCHES

200-250 v. 30 amp switch contacts. 24 hour dial. One off, one on. Beautifully finished in bakelite case. Size 5 1/2 x 8 x 4 1/2 ins. Supplied in original cartons at a fraction of maker's price. £3.19.6. P.P. 5/-.

We have London's largest selection of Low Tension Transformers, Variable Voltage Transformers, Smoothing Chokes, Capacitors, Sliding Resistors, Low Tension D.C. Supply Units. Send S.A.E. for lists now, or visit our walk round dept., where we have thousands of genuine electronic bargains.

### SAMSON'S ELECTRONICS LTD.

9-10 CHAPEL STREET, LONDON, N.W.1  
Tel. PAD 7851 Tel. AMB 5125

A must for the beginner's bookshelf...

## BEGINNER'S GUIDE TO ELECTRONICS

by Terence L. Squires, A.M.Brit.I.R.E.

192 pages, 128 diagrams, 15s.

From all booksellers or in case of difficulty 16s. 6d. by post from George Newnes Ltd., Tower House, Southampton Street, London, W.C.2.

NEWNES

### RECORDING TAPE. All Brand New and Boxed. Excellent quality.

7" Double Play	.....	2400 ft. 34/6
7" Long Play	.....	1800 ft. 21/6
5 1/2" Double Play	.....	1800 ft. 24/-
5 1/2" Long Play	.....	1200 ft. 16/6
5" Standard Play	.....	600 ft. 11/3

plus many others

**LOUDSPEAKERS.** New—Top quality.  
2" x 8 ohms 9/9 2 1/2" x 8 ohms 9/9  
2 1/2" x 3 " 15/6 3" x 3 " 15/9  
3 1/2" x 35 " 19/3 5" x 35 " 22/9  
8" x 3 " 26/3 10" x 3 " 32/6  
FANE 12" x 15 ohms (20 watt) 5 GNS.

**CHASSIS** made to your specification. Standard stock sizes available.

**EAR PIECES.** Vast range from 4/11 to 10/6 to suit all transistors.

**TEST METERS.** Panel to multimeters at very keen prices. An excellent "all-rounder" is the Multimeter—20 Kohm/volt, £4.19.6.

**AND HERE'S A SNIP!** 300 x 100 x 100 x 16 MFD. 350 VOLT WKG. CAPACITORS AT ONLY 5/3!

Give yourself the treat you deserve—call at our shop, see our qualified staff and discuss your electronic problems, no matter how simple or complex—we'll do our best to help.

REMEMBER—

**BOTHWELL ELECTRIC SUPPLIES (Glasgow) LTD.**  
54 EGLINGTON STREET  
GLASGOW, G.5  
Member of the Lander Group

has all you need from ferrite rods to electronic security devices. See for yourself!  
P.S. Have you seen our cable prices? Ridiculous, aren't they?

# NEW PRODUCTS

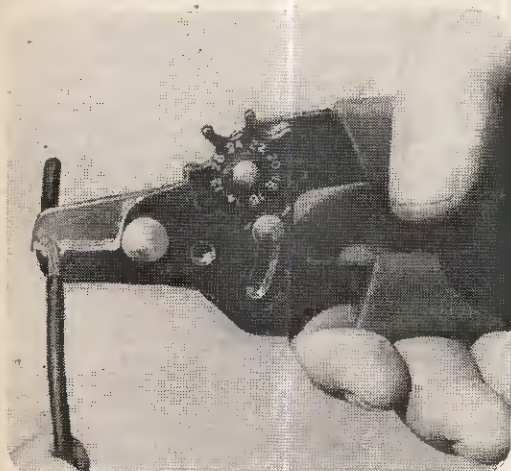

## New Model 8 Wire Stripper and Cutter

Multicore Solders Ltd., Multicore Works, Maylands Avenue, Hemel Hempstead, Herts.

The new Bib Model 8 wire stripper is an improved version of the standard stripper marketed by Multicore Solders Ltd. This new stripper is fitted with a pre-set selector gauge (this can be seen in our photograph) for stripping any standard wire between 12 and 26 s.w.g. It not only strips wire or flex but also cuts when required. The model 8 has plastic handles and retails at 7s 6d.

## Sub-miniature Indicator Lamps

Osram (G.E.C.) Ltd., East Lane, Wembley, Middx.

Our photograph shows one of a range of five new sub-miniature indicator lamps now being manufactured by Osram (G.E.C.) Ltd. The big advantage of these lamps is the ease of fitting, by means of flange clips, and high operating efficiency under conditions of severe vibration and shock. These lamps are obtainable in the following specifications: 28V 0.04A, 12V 0.1A, 6V 0.1A, 6/8V 0.04/0.06A and 12/24V 0.04/0.06A.



## New Coded Label Wiremarkers

Hird-Brown Ltd., Flash Street, Bolton, Lancs.

Probably the most frustrating tasks the service technician and amateur constructor is confronted with is that of sorting out a multitude of wires in a piece of apparatus. To help improve this tedious problem Hird-Brown Ltd. announce two new types of wiremarkers. The first are sets of colour coded, 0 through to 9, markers in the standard international colour code. The second are sets of alphabet letters A to Z printed black on white.

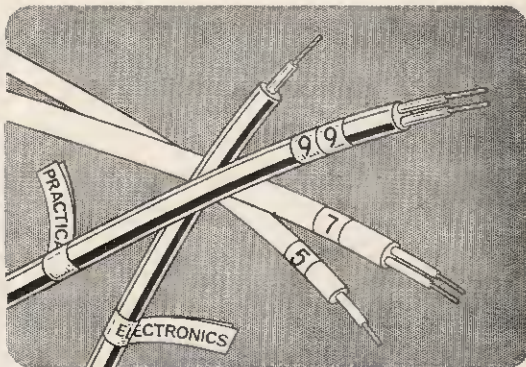

The markers are self-sticking and comprise twenty markers per card. The number or letter is printed six times on each marker, and is therefore visible at all times irrespective of the diameter of the wire to which it is fixed. Each marker measures  $1\frac{1}{2}$  in by  $\frac{1}{4}$  in wide and is impregnated with plastic to be oil, water and wear resistant.

The markers may be removed at any time without damaging the insulation and a full set of cards with numbers plus letters enables wires to be coded with any combination.

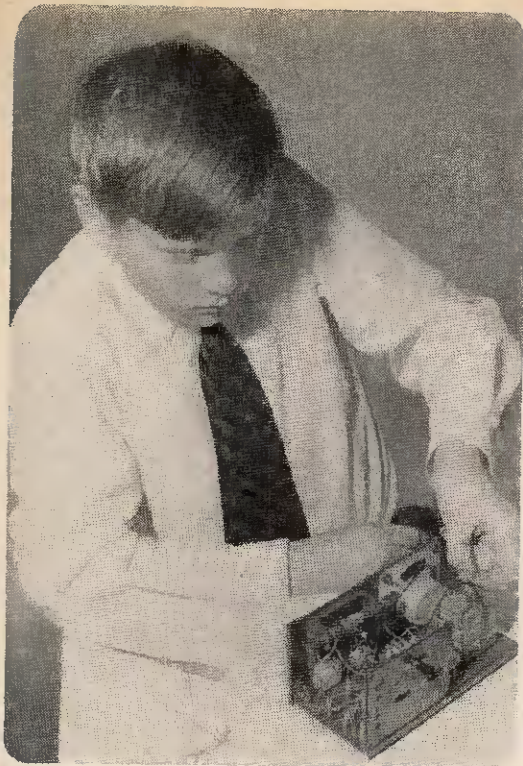

### Radio Engineer's Kit

Philips Electrical Ltd., Century House, Shaftesbury Avenue, London, W.C.2.

The demand and response achieved by Philips Electrical Ltd. to their electronic toy kits has prompted them to produce similar kits for the young radio constructor.

Designed specially for the young would-be future electronics expert these kits offer a good practical exercise in constructing equipment as well as providing a brief theory of radio, which is contained in an instruction book supplied with every kit.

The basic kit RE1 which costs £5 9s 6d is for earphone listening. Kit RE2 which costs £6 19s 6d is a three transistor radio with loud-speaker output. An add-on kit RE1A which costs £1 17s 6d is available to bring the RE1 kit up to the same standard as the RE2 kit.

The basic kits are constructed by means of screw terminals into battery operated medium-wave radios with on/off, volume and tuning controls. Each kit has an internal ferrite rod aerial, but there is provision for attaching an external aerial and earth if required. Both kits have a two-tone plastics cabinet.

Additional features incorporated in the RE2 kit are loudspeaker output and inputs for gramophone pick-up and microphone amplification. The more adventurous teenager can experiment with a tone control and morse code practice.

### Bubble Pack Semiconductors

International Rectifier Co. Ltd., Hurst Green, Oxted, Surrey.

For the first time in this country individual components and semiconductor kits are now being marketed on a self-service bubble pack display board. This form of service, which has been introduced by the International Rectifier Co., is aimed at providing the amateur constructor with a wide range of semiconductor devices, including solar cells, transistors, diodes, Zener diodes, silicon controlled rectifiers and selenium photocells which are easily obtainable. In many cases instruction books giving experiments and practical circuits are attached to the components to encourage the novice, or experienced engineer, to learn to use semiconductors for a variety of functions.

This system of sales promotion, although American in origin, should be of wide appeal especially to the casual purchaser and school science master.

Space is limited in this feature to enable the complete range to be listed, but we recommend anybody interested to call at any of the following retailers where either the full range or a large proportion of it is on display:

D.T.V. Group, 126, Hamilton Road, West Norwood, S.E.27.

Stern-Clyde Ltd., 162, Holloway Road, N.7.

Home Radio (Mitcham) Ltd., 187, London Road, Mitcham, Surrey.

G. W. Smith & Co. Ltd., 3-34, Lisle Street, W.C.2.

A. C. Farnell Ltd., Hereford House, North Court, Vicar Lane, Leeds, 2.

R.S.C. (Manchester) Ltd., 54, Wellington Street, Leeds, 1, and at 326, Argyle Street, Glasgow.

Harmsworth, Townley & Co., 2, Harehill, Todmorden, Lancs.



# JUST ARRIVED !!

## NEW EDITION of the famous Home Radio Catalogue

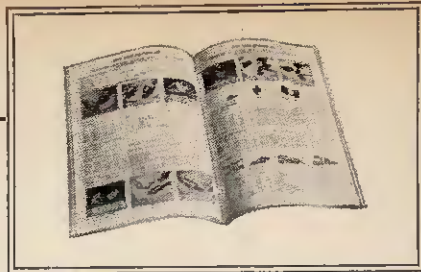

Yes . . . just off the press—Reprint No. 11 of our popular Components Catalogue. It's the *biggest* edition yet . . . an extra 17 pages, listing literally hundreds of new items, plus a supplement! It's better than ever too—as you will certainly agree when you examine it. The prices are listed in the separate supplement. Your catalogue will automatically be kept up to date and will thereby have a much longer life than previous editions.

Due to the greatly increased size of this new edition, plus increased costs of printing and paper, we have regretfully had to raise the price a little. It now costs 7/6, plus 1/- for postage and packing . . . but we are retaining the popular feature of including 5 Coupons in the catalogue, each worth 1/- when used as directed. Send off the attached coupon today, enclosing your cheque or P.O. for 8/6.

Please write your name and address in block capitals

NAME .....

ADDRESS .....

HOME RADIO LTD., Dept. FE. 187 LONDON ROAD, MITCHAM

## RETURN - OF - POST ON CASH OR C.O.D. ORDERS

### ● AMPLIFIER KITS

We have full stocks of all components of the Mullard 510, Mullard 3-3, Mullard 2 and 3 Valve Pre-amp, Mullard Stereo, Mullard Mixer. Fully detailed list on any of these sent upon request. Instruction Manuals: All Mullard Audio Circuits in "Circuits for Audio Amplifiers", 9/5. Post free.

### ● LATEST TEST METERS

	Cash Price	Deposit	Mthly/Pmts.	Credit Price
AVO Model 8 Mark III ..	£24. 0.0	£4.16.0	12 of £1.15.2	£25.18.0
AVO Model 7 Mark II ..	£22. 5.0	£4. 8.0	12 of £1.12.9	£24. 1.0
AVO Multimeter Mark 4 ..	£9.10.0	£1.18.0	12 of 14/4	£10.10.0
T.M.K. TP10 ..	£3.19.6	£1. 3.6	3 of £1. 2.0	£4. 9.6
T.M.K. TP55 ..	£5.19.6	£1.15.6	3 of £1.11.4	£6. 9.6
T.M.K. Model 500 ..	£8.19.6	£1.15.6	12 of 13/8	£9.19.6
TAYLOR MODEL 127A ..	£10.10.0	£2. 2.0	12 of 15/8	£11.10.0
TAYLOR MODEL 88B ..	£23.10.0	£4.14.0	12 of £1.14.6	£25. 8.0

### ● GRAMOPHONE EQUIPMENT

	Cash Price	Deposit	Mthly/Pmts.	Credit Price
ALL LATEST MODELS ALL POST FREE				
GARRARD CHANGERS ..	£6.10.0	£1.15.0	6 of £1. 0.0	£7. 5.0
AUTOSLIM Mono ..	£11. 9.0	£2. 6.0	12 of 16/11	£12. 9.0
AUTOSLIM AT6 ..				
Stereo/Mono ..	£12. 5.4	£2. 9.4	12 of 18/-	£13. 5.0
3000 LM Stereo/Mono ..	£12.15.0	£2.15.0	12 of 18/4	£13.15.0
A70 (with Derran Stereo or Mono cart) ..	£27. 5.6	£5. 9.6	12 of £2. 0.0	£29. 9.6
4HF PLAYER UNIT Mono ..	£16.12.6	£3. 6.6	12 of £1. 4.5	£17.19.6
UA15 Mono (B.S.R. Changers) ..	£6.19.6	£1.14.6	6 of £1. 0.0	£7.14.6
UA15 Stereo/Mono ..	£7.19.6	£1.19.6	6 of £1. 2.6	£8.14.6
UA25 Mono ..	£6.19.6	£1.14.6	6 of £1. 0.0	£7.14.6
UA25 Stereo ..	£7.19.6	£1.19.6	6 of £1. 2.6	£8.14.6

Single Record Players and Transcription Units also available. Send for list.

### ● ARMSTRONG

	Cash Price	Deposit	Monthly Pmts.	Credit Price
127 M. AM/FM TUNER AMP. ..	£26.10.0	£5. 6.0	12 of £1.18.10	£28.12.0
224 FM TUNER ..	£22.10.0	£4.10.0	12 of £1.13.0	£24. 6.0

### ● ILLUSTRATED LISTS

Illustrated lists are available on LOUDSPEAKERS, TAPE DECKS, TEST GEAR, GRAMOPHONE EQUIPMENT, AMPLIFIERS. Any will be sent free upon request.

## WATTS RADIO (Mail Order) LTD

54 CHURCH STREET, WEYBRIDGE, SURREY

Telephone Weybridge 47556

Please note: Postal business only. Callers welcome by appointment.  
CLOSED FOR ANNUAL HOLIDAYS, AUGUST 7th TO 30th.

The

## SUPER 6 LONG & MEDIUM WAVE TRANSISTOR RADIO

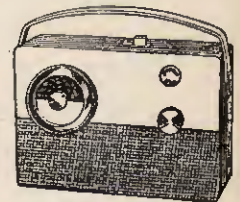

A quality radio available as a kit or ready built. The sparkling performance and superb finish of the completed receiver give you value equivalent to a £12. 12. 0 commercial model.

★ All new parts. ★ 6 transistors and diode. ★ 350mW output, ★ Superhet circuit, Ferrite rod aerial. ★ Weymouth Radio printed circuit board. ★ Component positions and references printed on back of board. ★ Nicely styled wooden cabinet, 11 x 7½ x 3½ in. ★ Vinyl covered in various colours. ★ 6 x 4 in. speaker giving good bass and treble response. ★ Full instruction booklet 2/-. Free with kit. ★ I.F. frequency 470 kc/s. ★ Lining up service if required. ★ All parts supplied separately. Write for list. S.A.E. please. ★ 9v. battery required. VT9 or P.P.9. (3/9 with kit).

COMPLETE KIT ONLY

PLUS 5/- POST

**£4.17.6**

OR FULLY BUILT £6.17.6 Tax & Carr. Paid

V.H.F. Pre-amplifier with high signal-noise ratio and gain of at least 3:1 under average fringe area conditions. Metal container 3½ x 3½ x 1½ in. high, with strap for eaves, loft or skirting fixing. 9 volt battery operated, using transistor AF114. Covers all British and some Continental stations. 88 to 108 Mc/s. Order with confidence of improved reception.

## ELECTRONICS (Camberley) LTD.

15 VICTORIA AVENUE, CAMBERLEY, SURREY

Post Orders Only Please

# VARIABLE VOLTAGE TRANSFORMERS

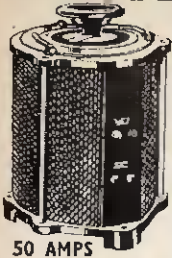

50 AMPS

**INPUT 230 v. A.C. 50/60**  
**BRAND NEW Carriage Paid.** Buy direct from the importer, keenest prices in the country. All Types (and Spares) from 1/2 to 50 amp. available from stock.

*0-260v at 1/2 amp	£3 3 0
*0-260v at 1 amp	£4 10 0
*0-260v at 2.5 amps	£5 17 0
2.5 amps Portable	£9 17 6
*0-260v at 4 amps	£8 7 6
*0-260v at 5 amps	£9 0 0
*0-260v at 8 amps	£13 10 0
*0-260v at 10 amps	£17 0 0
*0-260v at 12 amps	£19 10 0
*0-260v at 20 amps	£32 10 0
*0-260v at 37.5 amps	£65 0 0
*0-260v at 50 amps	£85 0 0

\*These instruments are fully shrouded.

1 AMP



## NEW 1/2 AMP FULL RANGE VARIABLE VOLTAGE TRANSFORMER



Input 230v. a.c. Output continuously variable from 0 to 260v. at 1/2 amp. Size: dia. 3in., depth 3 3/4in. including shaft, single hole fixing. Easily built into equipment. Ideal for manufacturers or Lab. use. £3/3/0.

**1 AMP. OPEN TYPE (Type 1A).** Designed for building into equipment. Complete with voltage panel and knob. Output variable 0-260v. Price £4/17/6 post paid.

**CRATOR 4 Way 16 Amp 250V A.C.** Switch 3 on, 1 off position, complete with knob. 7/6 p. & p. 1/6.

# NOW ANYONE CAN AFFORD TO TRAIN TO BE AN EXPERT IN RADIO and ELECTRONICS

It's the most exciting news of the year! Just imagine. You can get 35 large, fact-packed lessons for little more than 1/- per lesson! The lessons are crystal clear, practical, easy to master and use. Early lessons make fundamentals clear even to the beginner, while other lessons will give you the practical "know-how" of an expert.

Compare favourably with 6000 courses costing ten times as much. You save because you receive all the lessons at one time and are not required to purchase equipment you do not need.

This is a real home-study course that has been bound into one giant 8 x 11in. 216 page manual. Each page is divided into two columns. A wide column features the text, while a narrow column at the side has the instructor's comments, helpful suggestions and additional pictures to simplify the difficult parts.

Everyone can benefit from this practical course. No old-fashioned (or pseudo modern) methods used here, just straight forward, easy to understand explanations to help you make more money in electronics.

The price! Only 30/6 plus postage 1/6.

Terms! Why of course! See Coupon.

OTHER COURSES AVAILABLE

RADIO COURSE (22 lessons, price 36/-)

TELEVISION COURSE (price 36/-)

## UNCONDITIONALLY GUARANTEED TO GIVE COMPLETE SATISFACTION

You must be convinced that this is the best value you have ever seen in Electronics, Radio or T.V. Training, otherwise you can return the course (or have your money refunded if sent with order) after you have examined it in your own home for a full seven days.

**IF YOU SEND CASH WITH ORDER WE WILL INCLUDE A FREE BOOK VALUED 5/-.** Tick on the coupon our book for each course ordered with full cash. These free books are authoritative, and loaded with information. Would cost at least 5/- each if bought separately—by sending cash you reduce book-keeping and other costs which savings we pass back to you.

## --- FREE TRIAL OFFER ---

Pay only 5/- per week if you wish. Clip coupon right now for this special offer.

To: Sim-Tech Technical Books, Dept. ETV10, Gater's Mill, West End, Southampton, Hants.

Please send the following courses for a full seven days' trial.

- No. 1. RADIO COURSE, 37/8, incl. postage.
- No. 2. RADIO & ELECTRONICS COURSE, 41/-, incl. postage.
- No. 3. TELEVISION COURSE, 37/8, incl. postage.

(Free trial customers tick one only please).

If not delighted, I may return the course post-paid without further obligation on my part. Otherwise I will pay cash price or 5/- weekly until paid.

Tick here if enclosing full purchase price.

Please send me

- FREE TRANSISTOR CIRCUITS BOOK.
- FREE OSCILLOSCOPE BOOK.

Amount enclosed £.....

I understand that you will refund this money in full if I am not 100% satisfied. Overseas customers please send full amount (including Ireland).

NAME.....

ADDRESS.....

City..... Country.....

## 100 WATT POWER RHEOSTATS (NEW) AVAILABLE IN THE FOLLOWING 9 VALUES



10 ohm, 3 a.; 25 ohm, 2 a.; 50 ohm, 1.4 a.; 100 ohm, 1 a.; 250 ohm, .7 a.; 500 ohm, .45 a.; 1,000 ohm, 280 mA; 1,500 ohm, 230 mA; 2,500 ohm, .2 a. Diameter 3 1/2 in. Shaft length 3 1/2 in. dia. 1/8 in. All at 27/6 each. P. & P. 1/6.

## INSULATION TESTERS (NEW)

Test to I.E.E. Spec. Rugged metal construction, 500 volt, 500 megohms. Price £22, 1,000 volts, 1,000 megohms, £28.

## TYPE 34R SILICON SOLAR CELL

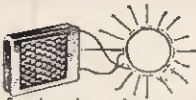

Four .5 volt units series connected in high impact polystyrene case, flying lead connections. Specially designed diffusing lens system to ensure maximum light pickup. Output up to 2v. at 10 to 16 mA in bright sunlight. Wider spectral response, and thirty times the efficiency of selenium cells. As used to power earth satellites! 37/6, and 1/- P. & P.

## SLIDER RESISTANCES

1 ohm, 12 amp, 17/6; 1.2 ohm, 14 amp, 27/6; 75 ohm, 2 amp, 37/6; 200 ohm, 1.25 amp, 37/6; 36 ohm, 6.5 to 2.8 amp, tapered winding, geared drive (less knob), 37/6. P. & P. 3/6.

## INSULATED TERMINALS

available in black, red, white, yellow, blue and green. New, 15/- per doz. P. & P. 1/-.

## VAN DE GRAEFF ELECTROSTATIC GENERATOR



Fitted with motor drive for 230 v. A.C. giving a potential of approx. 50,000 volts. Supplied absolutely complete, including accessories for carrying out a number of interesting experiments, and full instructions. This instrument is completely safe, and ideally suited for School demonstrations. Price £6/6/- plus 4/- P. & P. Leaflet on request.

## VEROBOARD

The perforated Copper Board for Modern Circuitry.

15 x 15 pitch, 2.5 x 3.75.....3/-  
 2.5 x 5.....3/8  
 3.75 x 3.75.....3/8  
 3.75 x 5.....5/-  
 Spot face cutter, 9/-  
 Special Veropins, Pkts. 200.....14/-  
 P.&P. on all items 1/-

## METERS

2 1/2" Flush Round  
**A.C. AMMETERS**  
 0-1, 0-5, 0-10, 0-15, 0-20 Amp. All 21/- each, p. & p. extra.  
**A.C. VOLT METERS**  
 0-25, 0-50, 0-150 V. All 21/- each, p. & p. extra.  
 0-300 V. A.C. m/c Rectifier £19.0.

## BUILD AN EFFICIENT STROBE UNIT FOR ONLY 37/6.

We supply a simple circuit diagram and all electrical parts including the NSP2 Strobe tube which will enable you to easily and quickly construct a unit for infinite variety of speeds, from 1 flash in several seconds to several thousands per minute. 37/6 plus 3/- P. & P.  
**NSP2 TUBE** brand new. I.O. base. Price 15/- P. & P. 1/6.

## 1st grade TRANSISTORS Brand new

OC28 ... 17/-	OC76 ... 6/-	Get 105 ... 10/-
OC29* ... 18/-	OC81* ... 8/-	Get 573 ... 12/6
OC41 ... 7/-	OC83* ... 6/-	2N706A ... 17/6
OC44 ... 6/6	OC139 ... 12/-	25019 ... 30/-
OC45 ... 5/-	OC140 ... 19/-	AC107 ... 14/6
OC71 ... 5/-	OC171 ... 9/-	AF114 ... 11/-
OC72* ... 7/-	OC200 ... 10/6	AF115 ... 10/-
OC73 ... 6/-	OC203 ... 14/-	AF116 ... 10/-
OC75 ... 7/-	Get 104... 6/-	AF117 ... 9/6
		BCZ11 ... 10/-

\*Available in Matched Pairs.

**SOLENOID.** Overall length 3 1/2 in., stroke 1/2 in. to 3/4 in. Maximum push-8 oz. 12-24 v. D.C. operation. D.C. resistance 35 ohm. Price 8/6. P. & P. 1/6.

**SOLENOID.** Heavy Duty 230 v. A.C. Approx. 3lb. pull. 15/- P. & P. 1/6.

**SOLENOID OPERATED MAGNETIC RELAY.** Type Scj3944, 4 Pole c/o., 10 amp. Contacts, 24 volt D.C. operation, 12/6 each. P. & P. 1/6.

**230 v. A.C. RELAY.** Type 1, 2 c/o, 2 amp. contacts, 9/6. Type 2, 2x15 amp. break, 2x2 amp. make, 1x2 amp. break, 11/6. Both types ex new equip. P. & P. 1/6 each.

## ULTRA VIOLET BULBS

Easy to use source of U.V. for dozens of practical and experimental uses.  
 12 volt 36 watt A.C./D.C. SBC 4/6. P. & P. 1/-.  
 12 volt 60 watt A.C./D.C. SBC 8/6. P. & P. 1/-.  
 Transformer to suit the above. Input 200-240 v. A.C., 12 volt 36 watts, 16/6; P. & P. 2/6.  
 Input 200-240 v. A.C. 12 volt 60 watt, 22/6. P. & P. 3/6.  
**Set of 4 Colours FLUORESCENT PAINT.** Red, yellow, green and cerise. In 1/2 oz. tins. Ideal for use with the above Ultra Violet Bulbs. 9/6, plus 1/6 P. & P.

## 0-4 MINUTE MECHANICAL TIME SWITCH

16 Amp D.P. Switch complete with knob. Will switch off any setting between 0-4 minutes. As New, fraction of makers' price. 10/- plus 2/6 p. & p.

**LIGHT SENSITIVE SWITCH.** Kit of parts, including ORP12 Cadmium Sulphide PhotoCell, Relay, Transistor and Circuit, etc., price 25/- plus 2/6 P. & P. ORP 12 including circuit, 10/6 each, plus 1/- P. & P.

**A.C. MAINS MODEL**  
 Incorporates Mains Transformer, Rectifier and special relay with 3, 5 amp mains c/o contacts. Price inc. circuit 47/6 plus 2/6 p. & p.

# SERVICE TRADING CO

All Mail Orders—Also callers:  
 47/49 HIGH STREET, KINGSTON ON THAMES  
 Telephone: KINGSTON 9450

Personal callers only  
 9 LITTLE NEWPORT STREET  
 LONDON, W.C.2 Tel.: GERARD 0576



# DETACHED PARTICLES

By John Valence

## LOUSY BUSINESS

WHENEVER I browse through the small ads in some of our American contemporaries I am struck by the number of different firms selling electronic surveillance devices. True these announcements are always addressed to professional investigators and detectives, but I don't know whether the firms marketing these ultra miniature devices investigate the bona fides of intending purchasers. They certainly ought to!

The thought of these obnoxious snooping aids becoming readily available to all and sundry frightens me, for one at any rate. This growth industry in snooping devices provides an example of how mixed are the blessings of technical progress. There is something revolting and distasteful about eavesdropping in any shape or form. When this is carried out by reputable authorities for law enforcement purposes, it is a practice we can accept—although with some reluctance; but the opportunities these devices present to unscrupulous characters must cause grave concern to anyone who gives the matter some thought.

It is only just and fair to explain that the electronic industry has also come up with the *antidote* to this menace. One often finds other firms urging the reader to safeguard privacy by buying an instrument that detects electronic bugs, wire tapping and snooping devices. I suppose it would be quite funny if it were not for the sinister complications.

It will indeed be a fine state of affairs should it ever become normal routine to check over a room for electronic "bugs" before it is deemed safe for occupancy.

## A SHOCKING TALE

WHEN is a dog a model? This is not a riddle but a legal point the G.P.O. may have to clarify, for I understand that the 27 Mc/s model control band is being used for dog training purposes. Seems a likely story, you say? But perhaps you

haven't heard of the electronic dog collar which made its first public appearance at the recent components exhibition?

By operating the remote control transmitter, the trainer can give the dog a mild electric shock whenever he wishes to correct its behaviour. Apparently this gadget has been used with great success in the training of police and sheep dogs. It is to be hoped that the general dog-owning public do not try to jump on the bandwagon, because the electronic collar is not intended as a substitute for the old fashioned local control as administered through the leash. I know the model control fraternity will echo these sentiments for they have



Switch that confounded thing off and let poor Booboo down at once!

enough trouble as it is from unauthorised (two-legged) users of walkie talkie apparatus operating on the model control frequency.

Tail piece. I am unable to confirm or deny the rumour that the canine world is not over enthusiastic about this gadget, but considers it just a pain in the neck!

## REAL TIME

AROUND about the same time that the World's Fair computer was forging "hands across the sea", as referred to last month, another of its brethren was engaged on rather more sombre business in New York City.

Through evidence compiled by a computer based on betting transactions, eighty-six men were indicted on gambling charges. The significant point of this case is that without the computer the prosecution could not have been made. If left to mere man, the information could not have been compiled within the period of the three year Statute of Limitations. No doubt, as a result of this demonstration of computer against crime, many anti-social types will feel that time is certainly against them now. It only makes the other "time" more certain.

## NO JAM TOMORROW?

MANY brains are busily working on schemes to prevent our town and city centres becoming completely stagnant with hordes of motor vehicles. By far the most sophisticated approach suggested so far is the idea of a sort of "electronic licence".

This would be a small article, about the size of a packet of cigarettes, which the motorist would purchase from a tax office and insert into a special receptacle in the car. Pulses radiated from cables buried just below the road surface would be recorded by this electronic box of tricks. When some predetermined "count" had been reached the electronic unit would indicate "licence expired" by switching on a lamp mounted in a conspicuous position on the vehicle.

With an arrangement of special codes, the count rate could be made to vary for given areas. Thus it would be possible to price motorists out of the more central districts; on the other hand the sparsely populated districts would probably be entirely outside the scheme and motoring in such places would be for free! Well that's the theory at any rate.

# Readout —

## A SELECTION FROM OUR POSTBAG

### Who's old hat!

Sir—When I was reading Readout (PRACTICAL ELECTRONICS, June edition) I felt compelled to comment on D. R. Bowman's letter "Transistors cap valves".

I agree with him when he says that printed circuits are better, in many respects, than chassis construction, but I fail to agree with his statement that valves are "old hat".

I have recently constructed a 20 watt amplifier with total distortion only 0.05% at full output. The frequency response at 1 watt is 2c/s to 150kc/s and the power response (20watt) 10c/s to 30kc/s, each  $\pm 0.5$ dB. Not even P.W.M. type transistor amplifiers, can equal this. Surely the EL34, as I use, cannot be called a special purpose valve?

A. J. Gay,  
Bexhill,  
Sussex.

### All aglow

Sir—When I was sorting out some bits and pieces I found an old night-light bulb. I tried it out and found that it worked, but when I switched it off, I found that if I touched the glass bulb that the filament glowed and as soon as I took my hand off the bulb it stopped glowing.

The slightest touch will make it glow. Could you please tell me the reason for this.

C. D. Cole,  
Kingsbridge,  
S. Devon.

*This is a neon bulb and it seems that when your light is switched off the "live" mains is still present on one contact of the bulb holder (this means that the neutral side of the mains supply is switched, which is incorrect and can be dangerous). By touching the side of the*

*bulb you completed a very high impedance circuit back to earth through your body. This is often sufficient to produce a slight glow in a neon bulb due to gas ionisation.*

### Slave clock

Sir—I was very interested in the article on the Electronic Timer for Sports Events, in the May issue of P.E.

What I would like to do, is to adapt the circuit to operate a slave clock that gives the time of day. To do this an impulse at intervals of 30 seconds is required. Can this be achieved by increasing the size of the capacitors used in the circuit of the timer?

P. E. Huggett,  
Shirley,  
Croydon, Surrey.

*It will require a little experimenting to get the time exactly right, but I would suggest changing the 2 $\mu$ F capacitors to 50 $\mu$ F (ensure polarity is right when connecting) and increase the multi-vibrator charging resistors to about 470k $\Omega$ . This should give about 30 seconds for each impulse.—J. Hillier.*

### Can you help?

Sir—As your magazine is now obviously widely read, might I suggest that a column could, with advantage to many subscribers, be devoted to a "Can You Help?" service. To start the ball rolling I would like to insert the following:

"Can anybody help to locate a replacement motor for a 'Nivico' Radio Phono-graph model TRE-2, made by Victor Co. of Japan Ltd.?"

R. M. F. Clarke,  
Porthcurno,  
Penzance,  
Cornwall.

### Powerless experience

Sir—I had a strange experience recently which you may think worth recording in your columns.

Wishing to match a low impedance microphone into the input of a tape pre-amplifier, I made up a small transistor pre-amplifier as shown in the circuit below.

This did not work very well, and I left it until the next day. To my surprise, it now works perfectly, giving a large increase in volume. On investigating, I found that the 4 $\frac{1}{2}$ V battery had become disconnected! On checking, I find that with no battery, or 10k $\Omega$  collector load, I am obtaining at least 100 times amplification!

I have decided in my own mind why this is, and wondered if your readers would care to theorise?

I am incorporating this "powerless" pre-amp as a permanent feature in my recording set up.

S. C. Hooson,  
Liverpool, 16.

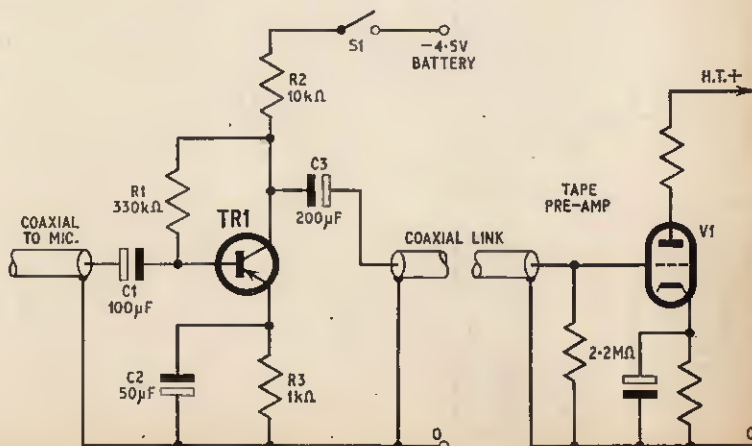

# LASKY'S RADIO

## For the Finest Value and Service to THE ELECTRONICS ENTHUSIAST

We consider our construction parcels to be the finest value on the home constructor market. If on receipt you feel not competent to build the set, you may return it as received within 7 days when the sum paid will be refunded less postage.

### TRANSISTOR PORTABLES

#### THE SKYROVER RANGE

7 transistor and 2 diode superhet portables—covering full mid-plus 6 SW Bands.

#### The SKYROVER Mk III.

(Illustrated). Now supplied with redesigned plastic cabinet in black, grey and chrome with edgewise controls.

Controls: Waveband Selector, Volume Control with on/off Switch, Tuning Control. In plastic cabinet, size 10 x 9 1/2 x 3 1/2 in. with metal trim and carrying handle.

Can now be built for **£8.19.6** Post 5/- extra. H.P. Terms: £1 deposit and 11 monthly payments of 15/6. Total H.P.P. £10.15.6d.

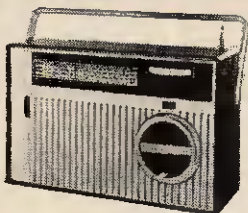

#### The SKYROVER De Luxe

Tone Circuit is incorporated, with separate Tone Control in addition to Volume Control. Tuning Control and Waveband Selector. In a wood cabinet, size 11 1/2 x 6 1/2 x 3 in. covered with a washable material, with plastic trim and carrying handle. Also ear aerial socket fitted.

Can now be built for **£10.19.6** Post 5/- extra. H.P. Terms: 25/- deposit and 11 monthly payments of 20/-. Total H.P.P. £12.5.

Data for each receiver: 2/6 extra. Refunded if you purchase the parcel. Four U2 batteries 2/4 extra. All components available separately.

#### ★ LONG WAVEBAND COVERAGE IS NOW AVAILABLE FOR THE SKYROVER

A simple additional circuit provides coverage of the 1100/1950 M. band (including 1300 M. Light programme). This is in addition to all existing Medium and Short wavebands. All necessary components with construction data.

Only **10/-** extra Post Free. This conversion is suitable for both receivers that have already been constructed. LASKY'S PRICE 2/6 Post 2/-

#### THE "HARROW" POWER PACK

Battery eliminator for portable radios, etc. Converts your battery radio to A.C. mains. Replaces 44 v., 6 v. and 9 v. batts. Size only 2 1/2 in. x 2 1/2 in. State voltage required when ordering. LASKY'S PRICE 2/6 Post 2/-

### SPECIAL INTEREST ITEMS!

#### TEST METER ADAPTOR

Type P.E. 220—this is a fully transistorised device which enables any 50 microamp D.C. Multimeter to be used in place of a valve volt meter. On the IV range an impedance of 1 megohm is offered which increases on the 1000 V. range to 100 megohms. 7 ranges: 1 to 1000 volts. Designed for immediate connection to Avo 7, 8 and similar size meters but quite suitable for use with any other 50 microamp meter. Size 6 x 6 x 5 in. New and boxed. List Price 7/6.

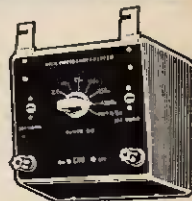

#### LASKY'S PRICE 39/6

Post 2/6. Set of batteries 7/5 extra.

#### VEROBOARD — NOW IN STOCK

A really remarkable time saver in setting out complicated experimental circuits. Vero-board is a high grade laminated board with copper strips bonded to it and pierced with a regular matrix of holes. Ideal for producing single items.

As featured in "Practical Electronics" April 1968 issue.

Boards	Accessories
42/1503 2 1/2 x 5 in. ....	Terminal pins — pkt. of 36 .....
43/1504 2 1/2 x 3 1/2 in. ....	Spot face cutter tool .....
45/1507 3 1/2 x 5 in. ....	Pin inserting tool .....
48/1508 3 1/2 x 3 1/2 in. ....	
44/1505 3 1/2 x 1 1/2 in. ....	

#### TRANSISTORS

#### ALL BRAND NEW AND GUARANTEED

GET S1, GET S5, GET S6 2/6; 873A, 874F 3/6; OC45, OC71, OC81D 4/6; OC 44, OC 70, OC 76, OC 81 5/6; (match pair 10/8); AF 117, OU 75, OC 200 6/6; OC 42, OC 43, OC 73, OC 82D 7/6; OC 201, OC 204 15/-; OC 205, OC 206 19/6; OC 28 24/6.

#### TRANSFILTERS By BRUSH CRYSTAL CO. Available from stock.

TO—01B 465 kc/s. ± 2 kc/s.	TO—02D 470 kc/s. ± 1 kc/s.	<b>6/6 EACH</b>
TO—01D 470 kc/s. ± 2 kc/s.	TF—01B 465 kc/s. ± 2 kc/s.	
TO—02B 465 kc/s. ± 1 kc/s.	TF—01D 470 kc/s. ± 2 kc/s.	<b>P. &amp; P. 6d.</b>

207 EDGWARE ROAD, LONDON, W.2.

Near Praed St. PADDINGTON 3271/2

Open All Day Sat. Erl. Closing Thurs. (43 Tot. Cl. Rd. Erl. Close Sat.) Mail Orders to Dept. P.E., 207 Edgware Rd., W.2

33 & 42 TOTTENHAM COURT ROAD, W.1.

Nearest Stn., Goodge St. MUSEUM 2605

152/3 FLEET STREET, LONDON, E.C.4.

Telephone: FLEET Street 2833

OPEN ALL DAY THURSDAY. Early Closing Sat.

### SEMICONDUCTOR BARGAINS

<b>Silicon Rectifiers</b>	
100 P.I.V. 750 mA .....	1/6
200 P.I.V. 750mA .....	2/-
400 P.I.V. 750mA .....	2/9
600 P.I.V. 750mA .....	4/6
800 P.I.V. 750mA .....	5/9
1,000 P.I.V. 750mA .....	7/6
1/8 watt Zener Diode 12v. ....	4/6
<b>1 watt Zener diodes</b>	
6v., 9v., 10v., 16v., 22v., 28v., 30v., 60v., 95v. ....	6/-
<b>10 watt Zener diodes</b>	
4v., 6v., 8v., 10v., 16v., 19v., 22v., 26v., 32v. ....	8/6
<b>10 watt Double Anode Zeners</b>	
12v. Regulates pos. or neg. or both ....	15/-
<b>Silicon Controlled Rectifiers</b>	
7 amp. 200 P.I.V. ....	18/6
7 amp. 300 P.I.V. ....	21/6
18 amp. 300 P.I.V. ....	25/-
18 amp. 400 P.I.V. ....	28/-
<b>Transistors</b>	
2N1046 p.n.p. 12 amp. 50 watt 10 m/cs. ....	45/-
2N1907 p.n.p. 20 amp. 60 watt 20 m/cs. ....	50/-
8XL 3073 p.n.p. 300m/cs. 150 mw. ....	15/6
<b>NPN Silicon for Hi-Fi etc.</b>	
2N657 100v. 90 gain 4 watts 2 m/cs. ....	35/-
2N1050 120v. 90 gain 40 watts 2 m/cs. ....	40/-
<b>Special Mullard OCP71</b> .....	15/6

Posting and packing 1s. up to any 6 items

Full Data on all items available

### J. and J. ELECTRONICS (CANADA)

ALL ORDERS TO:  
174 Maybank Road, South Woodford,  
London, E.18

Phone: BUC 9315

ALL GOODS NEW AND GUARANTEED  
RETURN OF POST SERVICE

### TRANSISTOR ELECTRONIC ORGANS FOR THE AMATEUR

This book presents not only a detailed design for a full scale organ, but a complete explanation of everything to do with transistorised organs. Profusely illustrated with clear diagrams.

By A. Douglas & S. Astley

18/- Postage 1/-.

#### TRANSISTOR TRANSMITTERS FOR THE AMATEUR, by D. L. Stoner. 21/- Postage 1/-.

#### INTRODUCTION TO ELECTRONICS, by Bureau of US Naval Personnel. 10/- Postage 1/-.

#### ABC'S OF HI-FI & STEREO, by H. Fantel. 16/- Postage 1/-.

#### TROUBLESHOOTING WITH THE OSCILLOSCOPE, by R. G. Middleton. 20/- Postage 1/-.

#### COLOR TV REPAIR, by M. Clifford. 21/- Postage 1/-.

#### WORLD RADIO TV HANDBOOK. 1965 ed. 26/- Postage 1/3.

#### COMPLETE CATALOGUE 1/-.

BRITAIN'S LARGEST STOCKISTS  
of British and American Technical Books

### THE MODERN BOOK CO.

19-21 PRAED STREET  
LONDON, W.2

Phone: PADDINGTON 4185  
Open 6 days 9-6 p.m.

### COMMUNICATIONS RECEIVERS



NATIONAL NC190X

#### INTERNATIONALLY FAMOUS NATIONAL RECEIVERS

NC190X—10 valves, 540 kc/s to 30 Mc/s, 5-meter, noise limiters, product detector, bandspread, double conversion. £99.0.0.

NC121—6 valves, 540 kc/s to 30 Mc/s, 5-meter, noise limiter, bandspread, built-in speaker. £60.8.3.

NC77X—beginner's receiver, 5 valves, 540 kc/s, to 30 Mc/s, built-in speaker. £32.8.9.

Write for illustrated leaflets

WE HAVE A LARGE STOCK OF  
NEW AND SECONDHAND RECEIVERS  
— MANY SECONDHAND BAR-  
GAINS IN MINT CONDITION  
Just write or phone for full details

BRIAN J. AYRES & CO.  
Dept. DW, 21 Victoria Road  
Surbiton, Surrey  
Telephone: Elmbridge 2833

# Practical Electronics Classified Advertisements

The pre-paid rate for classified advertisements is 1/- per word (minimum order 12/-), box number 1/6 extra. Semi-displayed setting £3.5.0 per single column inch. All cheques, postal orders, etc., to be made payable to PRACTICAL ELECTRONICS and crossed "Lloyds Bank Ltd." Treasury notes should always be sent *registered post*. Advertisements, together with remittance, should be sent to the Advertisement Manager, PRACTICAL ELECTRONICS, George Newnes Ltd., Tower House, Southampton Street, London, WC2, for insertion in the next available issue.

## EDUCATIONAL

**HOME STUDY COURSES** in Practical Electronics. Free Brochure without obligation from: **BRITISH NATIONAL RADIO SCHOOL**, Reading, Berks.

**STUDY RADIO, TELEVISION AND ELECTRONICS** with the world's largest home study organisation. I.E.R.E., City & Guilds, R.T.E.B., etc. Also Practical Courses with equipment. All books supplied. Write for **FREE** Prospectus stating subject to I.C.S. (Dept. 577), Intertext House, Parkgate Road, London, S.W.11.

Full-time courses in **RADAR** and **RADIO-TELEGRAPHY** for prospective marine Radio Officers. Govt. approved exam. centre.

Also courses in basic **ELECTRONICS, RADIO, TELEVISION** and **PRACTICAL SERVICING**.

Apply:—Director, British School of Telegraphy, 20 Penywern Road, Earls Court, London, S.W.5

**A.M.I.Mech.E., A.M.I.E.R.E.** City & Guilds, G.E.C., etc. Become a Technician or Technologist for high pay and security. Thousands of passes. For details of Exams. and Courses in all branches of Engineering, Building, Electronics, etc., write for 156-page handbook—**FREE**. B.I.E.T. (Dept. 152), London, W.8.

### INNER LONDON EDUCATIONAL AUTHORITY LONDON COLLEGE OF FURNITURE

Applications are invited for the following part-time posts. **ELECTRONIC MUSICAL INSTRUMENTS**, 2 days per week, 9.15–12.30; 1.30–4.30.

Must be fully conversant with the construction and servicing of electronic organs and amplifiers. **PIANO CONSTRUCTION AND MAINTENANCE**, 1 day, 1 evening (8.30–9.0) per week.

Must be capable of teaching modern construction techniques and repairs to upright and grand pianos of all types.

Remuneration each whole day: 151/3; 1 evening: 62/6.

Full particulars and form of application from the **PRINCIPAL OF THE COLLEGE**, Pitfield Street, Shoreditch, N.1.

## EDUCATIONAL

(continued)

**B.Sc.(ENG.), A.M.I.Mech.E., A.M.I.E.R.E.** City & Guilds, etc., on "Satisfaction or Refund of Fee" terms. Wide range of expert Home Study Courses in Electronics, Computers, Radio, T.V., etc. 156-page Guide—**FREE**. Please state subject of interest. **BRITISH INSTITUTE OF ENGINEERING TECHNOLOGY**, 151a, College House, Wright's Lane, London, W.8.

**THE INCORPORATED PRACTITIONERS** in Radio & Electronics (I.P.R.E.) Ltd., Membership Conditions booklet 1/-. Sample copy of I.P.R.E. Official Journal 2/-. post free. Secretary, Dept F, 32 Kidmore Road, Caversham, Reading, Berks.

## SITUATIONS VACANT

**EXPERIENCED TEST ENGINEERS**  
Vacancies exist for experienced test engineers in the Final Inspection Department of Londex Ltd. Applicants should possess a minimum of O.N.C. or equivalent and have current practical experience of testing and adjusting automatic electrical control equipment.

**JUNIOR TEST ENGINEERS**  
We also require several junior testers. Suitable applicants will be encouraged to study for technical qualifications and a day release scheme is in operation. The work is interesting and demands a methodical and enquiring mind. Reliability, accuracy and integrity are more important than speed. These are important vacancies which have a direct bearing on the Company's reputation and a high sense of responsibility is vital. There are ample opportunities for promotion: many of our senior executives entered the Company through the Test Department.

**FEMALE TESTERS**  
Vacancies exist for women who have had some test experience. Working conditions are attractive and salaries will be in accordance with experience.

In all cases, write in first instance to: Mr. H. G. STERN, Londex Ltd., 207 Anerley Road, London, S.E.20. SYDenham 3111.

## METAL WORK

### CABINETS • CASES CHASSIS

Anything in metal. "One-offs" a pleasure  
Send your drawing for quote

Stove enamelled in any professional finish

**MOSS, WATSON P.E.**

40 Mount Pleasant Street, Oldham  
Lancs. MAIN 9400

## RECEIVERS AND COMPONENTS

**A.1 POST FREE BARGAINS.** Guaranteed reclaimed valves. Send for full list to Dept. MO/E, A.1 RADIO COMPONENTS, 14 The Borough, Canterbury, Kent.

**TRANSISTORS.** PNP from 7d., NPN high gain from 5/-, power types, 20 watt from 7/6, diodes 6d. All guaranteed. SAE Hist, LONGLAND'S, 6 Mansfield Place, Ascot, Berks.

**OVER 300 ELECTRONIC COMPONENTS** in one great parcel including printed circuit panel with condensers, resistors, coils, diodes, transistors, silicon rectifiers, potentiometers IP's, valve base's, tuning condensers, transformers, etc. You can't afford to miss this great bargain offer. Send 10/- plus P. & P. 2/6 to D. & W. LTD., 224 West Road, Westcliff-on-Sea, Essex.

## R. & R. RADIO & TV SERVICE

Dept. P.E.

44 Market Street, BACUP. Tel. 465

### Salvage Valves

6F13	4/6	PCF80	4/-
6F15	5/-	PCL82	6/-
6L18	4/6	PCL83	5/-
6K25	10/-	PL81	5/-
6U4GT	5/-	PL82	4/-
6BV6	5/-	PL83	4/-
630L2	5/-	PY81	3/6
EB91	1/-	PZ30	5/-
6F1	2/6	U801	7/6
EBF80	5/-	U801	6/-
EBF89	5/-	U329	5/-
EF80	1/6	10F1	1/-
EF91	2/6	10LD11	5/-
EF85	5/-	10P13	5/6
ECC81	4/-	10P14	5/-
ECC82	4/-	20L1	5/-
EY86	4/-	20F2	5/6
ECL80	4/-	20D1	2/-
20P3	5/-	20P1	6/6
20P4	7/6	20P5	6/6
30F5	6/-	30FL1	6/6
30PL1	5/-	30P12	5/-
PL38	6/-	30P4	7/6
PL36	7/6	PY32	6/-
PY33	7/6	PY82	5/-
PCC84	4/-		

Postage on valves 6d.—3 or more post free.

Closed for local holidays, July 23rd — August 5th, 1965

1 Pole 8-way switch, complete with 8 resistors 2 @ 1K, 2 @ 15K, one each of 22K, 15K, 18K, 6.8K. 3/6 incl. post.

Panel mounting 8 inch flexible extension shafts for stand 1/2 inch controls, will operate over 180 degrees. 3/6 incl. post.

Speakers ex T.V. 6 x 4 inch 3/6. 8 inch rnd 6/-.  
Resistors New; 1/2 watt 3d., 1 watt 5d., 2 watt 9d. all 10%.

S.A.E. with all enquiries. All goods subject to satisfaction or money refunded.

## RECEIVERS AND COMPONENTS

(continued)

**LIGHT SENSITIVE TRANSISTORS**, hundreds of interesting applications. Unrepeatable at 5/-, P. & P. 6d. while stocks last. MEADOWS, 10 Heolyhan, Barmouth, Merioneth.

"P.E." R/C BRIDGE, V.H.F. Broadcast Receiver, Integrated Transistor Amplifier, Two Band Radio Tuner, Inexpensive Oscilloscope, Mullard Miniature Electrolytics and Hi-stab Resistors, S.a.e. for itemised price lists. AJAX ELECTRONICS, 15a Rumbold Road, Fulham, London, S.W.6.

### GUARANTEED BRAND NEW IN ORIGINAL WOOD PACKING CASE. CANADIAN MARCONI 52 RECEIVERS—FEW ONLY AT £10.10s. 0d.

Mains Power Unit £2.0s. 0d., supplied with outer case and Handbook, circuit set has crystal calibrator, speaker, etc. Range 1.75-16 Mc/s.

### J. T. SUPPLY CO.

38 Meadow Lane, Leeds 11, Yorkshire

**TRANSISTORS AT GIVE-AWAY PRICE!** NKT 124/5 switching transistors. Also capable of being used in all stages of a superhet. 6 for 10/-. Newmarket 405 10/- each. Miniature carbon tubes with plug and lead 5/-. Transistor electrolytics 1/6d. each. Brand-new 4in superhet 10/-. Goods under 10/- add 6d. postage please. G. F. MILWARD, 17 Peel Close, Drayton Bassett, Staffs.

## TESTED TRANSISTORS

1/- each, Red or White Spots.

2/- each, XA101, XA102, XB103, OA90, XA111, XA112, OC430, V101S.

3/- each, OC44, OC45, OC70, OC71, OC81, OC81D, XA151, XB104, XC101, XC101A, OC169, OC200.

4/- each, AF114, AF115, AF116, AF117, OC170, OC171, XA103, XA116, XB102, XB105, XC121, XU611.

5/- each, OC139, OC140, OC204, ORP60, XA701, XA703, GET7, GET8, GET9, XC141, BY100, OA211.

10/- each, OC19, OC22, OC25, OC26, OC28, OC35, 2SO13.

**ZENER DIODES** 4.7 v. to 30 v. ½ watt, 3/6, 1.5 watt, 5/-, 7 watt, 6/- each.

Plus many more, send 6d. in stamps for Full List and Equivalent Chart:

**B. W. CURSONS**  
78 BROAD STREET  
CANTERBURY, KENT

## RECEIVERS AND COMPONENTS

(continued)

## TELEVISION TUBE SHOP

FOR

Unused, Guaranteed Tubes

OVER 2,000 IN STOCK

At prices from 50% to 75% of normal List Price

All tubes tested before despatch and Guaranteed for 12 months

CARRIAGE 10/- via B.R.S. or 15/- via passenger train

TERMS £2 down (plus carriage) and balance at £1 per month

See our advertisement in PRACTICAL TELEVISION for exact prices, or write for details

## TELEVISION TUBE SHOP

48 BATTERSEA BRIDGE ROAD  
LONDON, S.W.11. BAT 6859  
OPEN ALL WEEK AND SATS. UNTIL 4 p.m.

## NOW READY!

A modern way of instrument case assembly using our "Die Strip". The strip has been specially made for us at Birmingham on qty. production, for low price to the public. It is made of high strength alloy and will enable anyone to assemble an instrument case or cabinet in minutes. Full details of these products will be sent free. Please send large envelope self addressed.

88 set transmitter receiver. Chassis less valves 20/- each. Post paid.

Copper Laminate Board, single or double sided, 5/- per square foot panels, either type 3ft. by 4ft. 33/-.

High Stab Resistors, 5% 6d.; 2% 9d.; 1% 1/-, Every six packed in 7-compartment linen finish component box.

Speakers, 3 ohm P.M. 5in., 5½, 6in., 6½, 7 x 4in., 7½, 8in., 8½, 10in., 12½.

Please send S.A.E. for full Lists of other goods on offer.

U.K. ONLY

**E. R. NICHOLLS**

Mail Order and Retail Shop  
46 LOWFIELD ROAD  
off SHAW HEATH, STOCKPORT  
CHESHIRE

## RECEIVERS AND COMPONENTS

(continued)

### L.S.T. COMPONENTS

182B HIGH ROAD, BENFLEET, ESSEX

More bargains from our new lists:

Silicon Power 25012 10/- HF Power Mesa 25025 100 watt 10 mc/s 30/- Red spot NPN transistors 1/- OC71 equivalents 9d. Still available: Our famous 25 for 10/- offer, state 2G371/81 series (AF) or 2G414/7 series (RF). 100 Diodes for 12/-. Post paid over 5/- order. Send 6d. stamp for our latest list.

**50 TRANSISTORS** all tested, marked and guaranteed. A.P.R.F. Silicon and P.N.P. Unobtainable elsewhere at this low price of 35/- plus P. & P. 1/-. D & W LTD., 224 West Road, Westcliff-on-Sea, Essex.

### TRANSISTORS AND DIODES

ALL POST FREE

MULLARD OC45, OC71, OC76, OC81, OC81D, OC84-3/-; OC75-3/6; OC81, OC84 pairs-6/-; OC35-7/6; OA70, OA79, OA81, OA96-1/6; AF115-5/6. TEXAS 2G344a, 2G345b, 2G371a, 2G371b, 2G374a, 2G374b, 2G378b-3/-; 15100-2/3. FERRANTI ZR31C, ZR31CR-15/-, BTH G15.D-2/3. STC Silicon 800 PIV, 500mA-4/6. MA393-3/6.

All amateur requirements supplied. Trade enquiries invited.

### THE RADIO CONSTRUCTORS CENTRE

363 Westborough Road, Westcliff-on-Sea, Essex Phone Southend 49686

**TRANSISTORISED SIGNAL INJECTOR.** Complete kit of components and circuit of injector for testing amplifier or radio, 10/- only. Post free. G. F. MILWARD, 17 Peel Close, Drayton Bassett, Staffs.

## TRANSISTORS AND COMPONENTS

OC71-2/9d. each. OC44. OC45. OC72. OC81. OC81D-3/0d. each. OC42-2/6d. each. OC26. ORP12. GET57-7/9d. each. AF116. AF117. OC170. OC171-3/6d. each. OC82. GET8. BY100-5/0d. each. Lacose Mullard types AC126-8/0d. each. ACY18-7/6d. each. ASY28-8/6d. each. AF186 cut of FREO 800 Mc/s-28/- Silicon Rectifiers 200 volt P.I.V. at 6 amps-5/- each. Branded Mazda ECC85 valves-4/6d. each. 10 watt Transistor driver and output transformers-22/6d. each. Acos Record Player cartridge, suits Collaro, Garrard, B.S.R., etc.-12/6d. each. Latest Mini 2 Motor Transistor Tape Recorder £6. 15. 0d. post paid. Iveslek Signal Injector-22/6d. Transistor Walkie Talkies-9 Gns; pr. Gaby A10 Multi Meter 2000 O.P.V.-£4.17.6d. Bobby 840 Multi Meter 4000 O.P.V.-£5.15.0d. S.E.-200 Min Lab Incorporating A/C D/C Volt Meter, Resistance Measurement, RF Sig. Gen. AF Sig. Gen. R.F. Field Strength, Condenser Check-£8.5.0d. complete.

### ZENER DIODES

OA81, OA91 Diodes-1/6d. each. OA10 Gold Bonded Diode-5/0d. each. Crystal Set Diode-1/3d. each. Matched Pair OC82+1 OC82D-12/6d. set. 3.7V 4-1V 50mA 100Ω 300mW 3/4d. 4-1V 4.5V 50mA 120Ω 300mW " 8-6V 9-5V 45mA 50Ω 300mW " 4-8V 6-4V 45mA 80Ω 300mW " 4-5V 4-9V 250mA 18Ω 1-5W " 4-8V 5-4V 250mA 15Ω 1-5W " 5-8V 6-6V 225mA 12Ω 1-5W " 10-4V 11-6V 125mA 25Ω 1-5W 3/6d. 22-7V 25-5V 55mA 120Ω 1-5W " 28-4V 31-6V 45mA 160Ω 1-5W " 34-2V 37-8V 30mA 125Ω 1-5W " 40-8V 45-2V 30mA 90Ω 1-5W " All types Valves in Stock. S.A.E. all enquiries.

Closed for Holidays 30 July 1965 to 9 August 1965

Mail Order Only!  
All Above Post Paid

**J. ROBINSON**

(Radio & T.V.)

4 Highcliff Road, Blackley, Manchester 9

CONTINUED OVERLEAF

## RECEIVERS AND COMPONENTS

(continued)

**RESISTORS!** You can't resist these! 1,000 assorted wattage and value. Cannot be repeated at **22/10/-** per 1,000. G. F. MILWARD, 17 Peel Close, Drayton Bassett, Staffs.

### WITWORTH TRANSFORMERS LTD.

26 ALL SAINTS ROAD, LONDON, W.11  
Tel.: BAY 9071

260-0-260V. 80mA, 6.3v.2a, 0-5-6. 3v.2a 18/-  
250-0-250V. 160mA, 6.3v.4a, 0-5-6. 3v.2a 27/-  
260-0-260V. 180mA, 6.3v.4a, 0-5-6. 3v.2a 28/-  
400-0-400V. 200mA, 6.3v.4a, C.T.05-6. 3v.3a 50/-

ISOLATING TRANSFORMER, 150 Watt,  
1:1 Ratio. 200-250v. Range ... 50/-

All Transformers have Standard Primaries,  
Screened and are Fully Varnish Impregnated

We Manufacture all types of Transformers small or  
large... quantities at competitive prices

12 Months' Guarantee. S.A.E. All Enquiries  
Postage and Packing 3/- C.O.D. 5/-

## FOR SALE

**CRACKLE PAINT.** Black or Grey, 3 pint tins 4/-, post 6d. from the component specialists, **SERVIO RADIO**, 150-8 Merton Road, Wimbledon, London, S.W.19.

**CONDENSER BARGAIN!** Miniature paper condensers, 1in x 1/2in. Ideal for transistor sets. .0001, .001, .002, .005, .02, .04uF; also small. 500uF and 2.2uF condensers. All 7/6d. per 100. **23** per 1,000. G. F. MILWARD, 17 Peel Close, Drayton Bassett, Staffs.

**CONSTRUCTORS** parcel containing useful assortment of radio and electronic spares, Relays, Switches, Resistors, Condensers, 30/-, Ten times value guaranteed. **AUDIOCRAFT**, 20 Kettering Road, Northampton, NN2 9PL.

**A.C. STANDARD.** Mains Motors Fractional H.P. 3/4in dia x 4in long with 1in spindle. Many uses. Brand new, 25/- each. P. & P. 2/6d. Small Battery Motors 1 1/2in dia x 2 1/2in long - 4 1/2 to 9 volts. Heavy construction; only 7/6d. each. P. & P. 1/-. **WALTON'S WIRELESS STORES**, 15 Church Street, Wolverhampton.

**TRANSISTORS UNMARKED UNTESTED.** 40 for 10/-, P. & P. 1/-. 4 packets post free. Relays, thousands of types, special catalogue free. General Catalogue of Mechanical & Electrical Gear, Tools, etc., 5,000 items, free. **K. R. WHISTON** (Dept. PET), New Mills, Stockport.

**DID YOU KNOW** that Suffolk Tubes, still the largest independent tube rebuilders, give a free delivery service by van or passenger train to all parts of the U.K. Each tube is guaranteed 12 months and all types are always available off the shelf at keenest prices. T-3 Upper Richmond Road, Putney, London, S.W.15. Telephone Vandyke 4304/5267.

**NEW 18 DYNAMOTORS.** Input 12/18 volts. Output 240 V, 120/200 watts, AC/DC, bargain **24.** **J. O'BRIEN**, 1, Hightown, Waterfoot, Rossendale, Lancashire.

**VENNER TIME SWITCHES.** Reconditioned, 14 day clock, once on once off every 24 hrs. jewelled movement, fully guaranteed. 1 amp 25/-, 5 amp 32/6d., 15 amp 39/6d. Post etc. 2/6d. Cast Aluminium Cases 7/6d. **A. R. BATCHELOR**, P.E. Dept. 4 Park Road, Bromley, Kent.

## MISCELLANEOUS

**CONVERT ANY TV SET** into an Oscilloscope. Diagrams and Instructions, 12/6. **REDMOND**, 42 Dean Close, Portslade, Sussex.

**GOVERNMENT SURPLUS** Electrical and Radio Equipment. Our new catalogue No. 16 now ready, 2/6 Post Free, cost refunded on purchase of goods over **22.** **ARTHUR SALLIS RADIO CONTROL LTD.**, 93 North Road, Brighton.

## MISCELLANEOUS

(continued)

**HAMMER FINISH PAINT.** The modern finish for electronics. Can be BRUSHED or sprayed. Blue or silver. 24oz tins 3/6, post 8d., 1/2 pint 7/6, post 1/9, 1 pint 15/-, post 2/9. Retailers supplied, write for details. Amazing results! Return of post service. Orders over 30/- post free. **FINNIGAN SPECIALTY PAINTS**, (PE), Mickley Square, Stocksfield, Northumberland.

**MAINS TRANSFORMERS** rewound. Specials, and Output Transformers to your own specifications. **RATCHIFFS**, 27 Station Road, Holmfirth, Yorks.

## SERVICE SHEETS

**SERVICE SHEETS** for all makes of Radio and TV 1925-1965. Prices from 1/- with free fault-finding guide. S.A.E. inquiries. Catalogue of 6,000 models, 1.6 Valves, modern and obsolete. **Radio/TV Books**. S.A.E. lists, **HAMILTON RADIO**, Western Road, St. Leonards, Sussex.

**TRADE SERVICE SHEETS**, Radio, TV, etc. Mixed dozen @ 4/-, 100-22/6d. p.p. **TELRAY**, Maudland Bank, Preston.

**STATE MODEL NO.** Radio 2/-, TV 2/6. S.A.E. **DARWIN**, 19 George Street, St. Helens, Lancs.

## SERVICE SHEETS

4/- each, plus postage.

We have the largest supply of Service Sheets for all makes and types of Radios, Televisions, Tape Recorders, etc. in the country. Speedy Service.

To obtain the Service Sheet you require, please complete the attached coupon:

From: .....

Name: .....

Address: .....

To: **S.P. DISTRIBUTORS**  
44 Old Bond St., London, W.1  
Please supply Service Sheets for the following:

Make: .....

Model No.: ..... Radio/TV

Make: .....

Model No.: ..... Radio/TV

Make: .....

Model No.: .....

New 1965 List now available.

I also require list of Service Sheets at 1/6.

(please delete items not applicable)

I enclose remittance of .....

MAIL ORDERS ONLY AugPE

"PRACTICAL ELECTRONICS"  
CONSTRUCTIONAL DESIGNS  
All specified 1st grade Components, complete Metalwork, full range of Materials, engraved Panel Plates, Ancillary Equipment and Assembled Units. Comprehensive lists available for each "P.E." Constructional Article.  
Please send 6d. in stamps for each design  
**MALVYN ENGINEERING WORKS**  
Engineers to the Radio and Electronic Industries  
7 CURRIE STREET, HERTFORD, HERTS  
TELEPHONE: HERTFORD 2264

## RADIO AND ELECTRONICS BOOKS ON FREE TRIAL

Then only 5/- weekly for those you keep!

**No. 9C. PIN-POINT TRANSISTOR TROUBLES IN 12 MINUTES.** By Louis E. Garner, Jr. 465 pages. Companion manual to the well-known 'Pin-Point T.V. Troubles in 10 Minutes' using the famous Coyne Check Chart Trouble Shooting Method. Covers all kinds of equipment including radios, T.V.s, audio amplifiers, pre-amplifiers and just about everything. There are hundreds of photos, illustrations, diagrams and check charts; valuable reference sections. Supplies are limited so order your copy now and avoid disappointment. Price, 48/6 including postage.

**No. 12X. RADIO SERVICING.** 351 pages (hard covers), with hundreds of illustrations, circuits and diagrams. By G. E. Patchett and B. Pozzari. Price 28/6d. including postage. A very thorough approach to learning radio servicing, starts with simple explanations and goes on to more advanced radio theory. Doesn't miss a single point. One of the most complete radio manuals ever published. A book you will use for years to come. This is the first time this book has ever been offered on a free trial basis. Order your copy now, see coupon below.

**No. 13N. TELEVISION SERVICING.** 320 pages, hard covers, 296 diagrams. Price, 28/- including postage. As described above, but teaches television repair.

**No. 39. RADIO & ELECTRONICS COURSE.** 210 pages, quarto size, 35 complete lessons. You will find this course easy to understand. The lessons are **CRYSTAL CLEAR, PRACTICAL, EASY TO MASTER AND USE.** Early lessons make fundamentals clear even to the beginner while other lessons will give you the practical knowledge of an expert! This is a modern course, that teaches without resorting to comic strip methods... Thousands of **PRACTICAL ELECTRONICS** and **PRACTICAL WIRELESS** readers have taken this course and enjoyed every minute of it... Why not you? Price for the complete course, 41/- including postage.

**No. 22. PIN-POINT COLOUR T.V. TROUBLES IN 15 MINUTES.** By Robert G. Middleton. 648 pages. 382 check charts. Just about the biggest and most useful manual on Colour T.V. available anywhere. Now is the time to get the complete information on this important new subject. Price, 49/6 including postage.

**No. 8. PIN-POINT T.V. TROUBLES IN 10 MINUTES.** Over 340 cross indexed pages, covers 70 symptoms, 700 trouble spots, has 50 time saving check charts, 250 diagrams. Over 30,000 copies now used in the U.K. alone!

**NOW REPRINTING.** Orders accepted for delivery in four weeks' time. One of the best manuals we have ever handled, well worth waiting for! Price, 41/- including postage. Send coupon today for earliest delivery.

### IRONCLAD GUARANTEE

Any book not satisfactory may be returned within 10 days post-paid for full refund of the purchase price.

### FREE BOOK OFFER!

Send cash with order and qualify for any free book listed on the coupon as follows. Minimum 40/- One book. 80/- or more Two books. 120/- Three books.

**NOTE.** These books are authoritative and loaded with useful information, cost from 4/6 to 5/- each in book stores.

### FREE TRIAL OFFER!

To Sim-Tech Technical Books, Dept. EI, Gater's Mill, West End, Southampton, Hants.

Please send the following books, I have circled.

9C	12N	13N	39
	22	8	

If not delighted I may return any book post-paid without further obligation on my part, otherwise I will pay cash price or 5/- weekly (10/- fortnightly) commencing not later than 10 days after delivery. I am over 21 years of age. (If under 21 parents should place order).

I enclose cash to the sum of £  
I understand you will refund this money if I am not 100% satisfied (provided I return the book in good condition within 10 days).

Please send me the free book(s) I have ticked.

- Oscilloscope Book.
- Electronics Gadgets Book.
- Transistor Book.
- Radio Instruments Book.

Name .....

Address .....

# ASTONISHING LOW PRICED RADIO KITS (all Guaranteed) FROM CONCORD

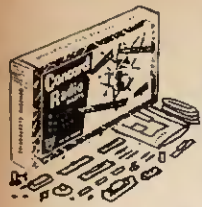

**MAKE 5 DIFFERENT TRANSISTOR RADIOS for 35/-**

Amazing Radio Construction Set! Become a radio expert for 35/-. A complete Home Radio Course. No experience needed. Parts include instructions for each design, Step-by-Step plan, all Transistors, loudspeaker, personal phone, knob screws, etc., all you need. Box size 14" x 10" x 2" (parts available separately). Originally 40. NOW 35/- plus 3/6 p. & p.

**New RADIO Anyone CAN BUILD in 2-3 hours! Only 19/8**  
**EVEN THE CHILDREN BUILD THEM!**  
 ...no soldering—only 16 connections! Then hear it reach out bringing in station after station. 4 1/2" x 2 1/2" x 1 1/2". Many Testimonials:—*M.H. of Bradford, writes: "... I have just completed one of your sets successfully, it is the first time I have ever tackled anything like a radio and I must state and now, I am amazed how easy it is to a layman like me. Your instructions and plan have obviously been very carefully thought out so that even the most dim can follow them ..."* 19/8 plus 2/6 post, etc.



## TRANSISTOR RADIO KITS

— **YOU SAVE 23.15 & Covering all medium long waves with parts including Mullard Semi Conductors.** 48 page instruction manual. Entertaining & educational. No soldering, just plug in, making many different Radios in a few mins. Money back if not delighted.

**OUR PRICE 37/6 P. & P. 3/6 extra**

## ASTONISHING CIGARETTE RADIO!

**ONLY 18/6**

Yes a perfectly ordinary packet of cigarettes—but 18 fetches in station after station, loud and clear! Holds 10 Cigarettes—yet cleverly concealed highly sensitive fully transistorised circuit (incl. tiny battery). Even a young boy can assemble it in under 2 hours. No soldering. No experience necessary. Only 16 Connections. From our bulging testimonial file, Mr. D. B. of Huddersfield writes:—*"... I have fitted the parts in and it is working wonderfully ..."* ALL PARTS including Semi-Conductors, A.B.C. Plans, etc. **ONLY 18/6** plus 2/6 post, etc.



**CONCORD ELECTRONICS LTD (Dept. PE20) 9 Western Road, Hove, Sussex**

### QUALITY RECORD PLAYER AMPLIFIER

A top-quality record player amplifier. This amplifier (which is used in a 29 gm. record player) employs heavy duty double wound mains transformer, ECC83, EL84, E280 valves. Separate Bass, Treble and Volume controls. Complete with output transformer matched for 3 ohm speaker. Size 7in. w. x 2 1/2in. d. x 5 1/2in. h. Ready built and tested. **PRICE 69/6. P. & P. 4/9.**

ALSO AVAILABLE mounted on board with output transformer and 6in. speaker ready to fit into cabinet below. **PRICE 89/6. P. & P. 5/9.**

### QUALITY PORTABLE R/P CABINET

Uncut motor board. Will take above amplifier and B.S.R. or GARRARD Autochanger or Single Record Player Unit. Size 18 x 14 x 8 1/2 in. **PRICE 43/9/6. Carr. 7/6.**

### 4-SPEED PLAYER UNIT BARGAINS

All brand new in maker's original packing.  
**SINGLE PLAYERS**  
 B.S.R. TU12 ..... £3/9/6. Carr. 5/6.  
 GARRARD SRP10 ..... £5/1/11. Carr. 5/6.  
 B.S.R. GU7 with unit mounted pickup arm. £4/18/8. Carr. 5/6.

**AUTO. CHANGERS**  
 B.S.R. UA15 £6/19/6. B.S.R. UA16 ..... £6 19 6  
 Latest B.S.R. UA25 Super slim ..... £6 2 6  
 Latest GARRARD AT5 ..... £8 8 0  
 GARRARD AT6 ..... £10 10 0  
 GARRARD Auto-Slim £6/10.0. Carr. 6/6 on each.  
 All the above units are complete with top mono head and sapphire styli or can be supplied with compatible stereo head for 12/6 extra.

### BRAND NEW CARTRIDGE BARGAINS!

**ACOS 71-5.** Single sided Crystal Cartridge for Stereo and L.P. records. Complete with diamond stylus and universal mounting bracket. List price £2.6.4. Our price 18/6. P. & P. 1/-.

**GARRARD GC2 MONO** complete. List price 24/11. Our price 12/6. P. & P. 1/-.  
**RONETTE STEREO 105 CARTRIDGE** Stereo/LP/78 complete with two sapphire. Original list price 67/8. Our price 24/-. P. & P. 1/-.

### MAINS TRANSFORMERS

Fully shrouded, can be mounted upright or drop through. Tapped pri. 110, 200, 220, 240v. Sec. 250v. 1/4 wave at 85mA and 6-3v. 2 amps. e/c. Stack size 3" x 2 1/2" x 1 1/2". **PRICE 12/6. P. & P. 3/6.** Also Semi shrouded drop thro' type. Pri. 200, 220, 240v. Sec. 250v. 1/4 wave at 70mA and 6-3v. at 2 amp. e/c. Stack size 3" x 2 1/2" x 1 1/2". **PRICE 11/-. P. & P. 3/-.**

### BRAND NEW 3 OHM LOUSPEAKERS

5in., 12.6/61 in., 15" 8 in., 21" 10 in., 25" 12 in., 27" 8; (12 in. 15 ohm, 30"/-), 10 in. x 6 in., 26"/-.  
 E.M.I. 13" x 8 in. with high flux ceramic magnet. 42"- (15 ohm, 45"/-).  
 P. & P. 5" 21"-61" & 8" 2/6, 10" & 12" 3/6 per speaker.  
**4in HIGH FLUX TWEETER.**  
 3 ohm and 15 ohm imp. Famous British make. Few only 12/6.

### ROLA CELESTION.

Approx. 9 in. x 6 in. 3 ohm. Middle register speaker, 18/6. P. & P. 3/-.

### ACOS CRYSTAL MIKES.

High imp. For desk or hand use. High sensitivity, 18/6. P. & P. 1/6.

### TSL CRYSTAL STICK MIKE.

Listed at 45/- Our price, 18/6. P. & P. 1/6.

### BRAND NEW. 12" 15w. H/D Speakers.

Current production by well-known British maker. Offered below list price at 89/6. P. & P. 5/- (25w. guitar model £5.5.0).

### MATCHED PAIR OF 21 WATT TRANSISTOR DRIVER AND OUTPUT TRANSFORMERS.

Stack size 1 1/2 x 1 1/2 x 1 in. Output trans. tapped for 3 ohm and 15 ohm output. 10/- pair plus 2/6 P. & P. **BRAND NEW PLESSEY 12 v. 4 pin non-sync. vibrators.** Type 12 1.45D. **ONLY 8/6. P. & P. 1/6**  
**4-WAY NON-TANGLE TELEPHONE CABLE** Latest spring-back coil type, extends 12 in. to 5 ft. Complete with rubber bushes, 4/6 each. P. & P. 1/6.  
**WYNAIR AND REXINE SPEAKER AND CABINET FABRICS** app. 54 in. wide. Usually 35/- yd., our price 13.6p per yd. length (min. 1 yd.) P. & P. 2/6. S.A.E. for samples.

### STEREO AMPLIFIER

Incorporating 2 ECL82s and 1 E280, heavy duty, double wound mains transformer. Output 4 watts per channel. Full tone and volume controls. Absolutely complete.

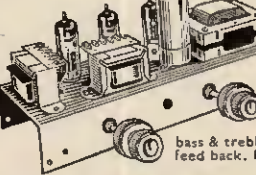

**ONLY £4.19.6 P. & P. 6/6**

Super Deluxe version with ECL86 valves, sep. bass & treble controls, full feedback. 8 gns. P. & P. 6/6

### HIGH GAIN 4 TRANSISTOR PRINTED CIRCUIT AMPLIFIER KIT



● Peak output in excess of 1 1/2 watts.  
 ● All standard British components.  
 ● Built on printed circuit panel, size 6 x 3in.  
 ● Generous size Driver and Output Transformers.  
 ● Output transformer tapped for 3 ohm and 15 ohm speakers. ● Transistors (GET 114 or SI Mullard OC81D and matched pair of OC81 or P) ● 9 volt operation, ● Everything supplied, wire, battery clips, solder, etc. ● Comprehensive easy to follow instructions and circuit diagram 1/6 (Free with Kit). All parts sold separately. **SPECIAL PRICE 45/-.** P. & P. 3/-. Also ready built and tested, 52/6. P. & P. 3/-. A pair of TAIs are ideal for stereo.

### TAPE DECKS

**B.S.R. MONARDEK (Single speed)** 32in. per sec., simple control, uses 54in. spools, £6/15/6 plus 7/6 carr. and ins.  
**GOLLAARD STUDIO DECK 3 motor 3, 3 speeds** push button control. Up to 7in. spools £10/10/- P. & P. 7/6. (Tapes extra on both.)

### 10/14 WATT HI-FI AMPLIFIER KIT

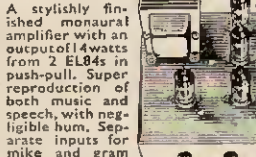

A stylishly finished monaural amplifier with an output of 4 watts from 2 EL84s in push-pull. Super reproduction of both music and speech, with negligible hum. Separate inputs for mike and gram allow records and announcements to follow each other. Fully shrouded section wound output transformer to match 3-15Ω speaker and 2 independent volume controls, and separate bass and treble controls are provided giving good lift and cut. Valve line-up 2 EL84s, ECC83, EF86, and E280 rectifier. Simple instruction booklet 1/6. (Free with parts.) All parts sold separately. **ONLY 46/19/6.** P. & P. 8/6. Also available ready built and tested complete with std. input sockets, £8/15/-. P. & P. 8/6.

### 3-VALVE AUDIO AMPLIFIER MODEL HA34



Designed for Hi-Fi reproduction of records. A.C. Mains operation. Ready built on plated heavy gauge metal chassis, size 7 1/2 in. w. x 4 in. d. x 4 1/2 in. h. Incorporates ECC83, EL84, E280 valves. Heavy duty double wound mains transformer and output transformer matched for 3 ohm speaker, separate Bass, Treble and volume controls. Negative feedback line. Output 4 1/2 watts. Front panel can be detached and leads extended for remote mounting of controls. The HA34 has been specially designed for us and our quantity order enables us to offer them complete with knobs, valves, £4.5.0 etc., wired and tested for only P. & P. 6/-.  
**ONLY £4.19.6 P. & P. 6/6**

### HSL 'FOUR' AMPLIFIER KIT.

A.C. Mains 200/250v., 4 watt, using ECC83, EL84, E280 valves.



★ Heavy duty double-wound mains transformer with electrostatic screen.  
 ★ Separate Bass, Treble and Volume controls, giving fully variable boost and cut with minimum insertion loss.  
 ★ Heavy negative feedback loop over 2 stages ensures high output at very low distortion factor.  
 ★ Suitable for use with guitar, microphone or record player  
 ★ Provision for remote mounting of controls or direct on chassis.  
 ★ Chassis size only 7 1/2 in. wide x 4 in. deep. Overall height 4 1/2 in.  
 ★ All components and valves are brand new.  
 ★ Very clear and concise instructions include even the inexperienced amateur to construct with 100% success.  
 ★ Supplied complete with valves, output transformer (3 ohms only), screened lead, wire, nuts, bolts, solder, etc. (No extras to buy.) **PRICE 79/6. P. & P. 6/-. Comprehensive circuit diagram, practical layout and parts list 2/6 (free with kit).**

### HARVERSON'S F.M. TUNER Mk. I

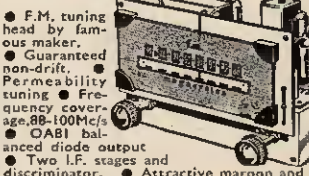

● F.M. tuning head by famous maker.  
 ● Guaranteed non-drift.  
 ● Permeability tuning.  
 ● Frequency coverage, 88-100Mc.  
 ● OABI balanced diode output  
 ● Two I.F. stages and discriminator.  
 ● Attractive maroon and gold dial (7 x 3in. glass)  
 ● Self powered, using a good quality mains transformer and valve rectifier.  
 ● Valves used ECC85, two EF80s, and E280 (rectifier).  
 ● Fully drilled chassis.  
 ● Size of completed tuner 8 x 6 x 5 1/2 in. ● All parts sold separately. Set of parts if purchased at one time £5/19/6, plus 8/6 P.P. and ins. Circuit diagram and instructions 1/6 post free. Mark II version as above but complete with magic eye, front panel and brackets, £6/12/6. P. & P. 8/6.  
 Mark III version as Mark I but with output stage (ECL82) and tone control, £7/7/-. P. & P. 8/6.  
**Handsome Metal Cabinets.** Choice of Black, or Green. To fit Mark I, 25/- P. & P. 3/-. To fit Mark II, 17/6. P. & P. 3/-.

## HARVERSON SURPLUS CO. LTD.

170 HIGH ST., MERTON, S.W.19. CHerrywood 3985  
 Open all day Saturday Early closing Wed. 1 p.m.  
 A few minutes from South Wimbledon Tube Station. (Please write clearly)  
**OVERSEAS P. & P. CHARGED EXTRA. S.A.E. with all enquiries.**

### SPECIAL PURCHASE TURRET TUNERS

By famous maker. Brand new and unused. Complete with PCC84 and PCC80 valves, 34-36 Mc/s I.F. Bands-cuits for Channels 1 to 5 and 8 and 9. Circuit diagram supplied. **ONLY 25/- each.** P. & P. 3/9.

# Essential books for the serious enthusiast

## RADIO ENGINEERING FORMULAE AND CALCULATIONS

by W. E. Pannett

Problems in radio, radar and television engineering are usually presented either in the form of examination questions and answers, omitting many intermediate steps, or are framed solely for the instruction of the student. In this book, examples have been selected from everyday practice in design, installation and operation and are shown fully worked and generously illustrated. Although it is intended primarily for the practising engineer, it will be found equally valuable to the technical assistant and the student about to embark on an engineering career.

Covers 1. Aids to Engineering Calculations—2. Formulae and Examples; Resistors and Voltage Dividers—Inductors—Capacitors—A.C. Applications of Ohm's Law—Circuit Theorems—Gains and Losses—Electrical Tolerances—Frequency and Wavelength—Resonant Circuits—Coupled Circuits—Attenuators and Filters—Thermionic Amplifiers—Amplifier Noise—Receivers—Oscillators—Transmitters—Signalling and Modulation—Valve Cooling and Ventilation—Aerials and Propagation—Radio-frequency Transmission Lines—Power Supply—A.C. Rectifiers and Smoothing Filters—Transformers and Reactors—Cables and Lines—Tests and Measurements—Transistors—Principles of Television—Radar Fundamentals—Great Circle Bearings—3. Unit and Symbols—4. Mathematical Formulae, Data and Tables Index.

208 pages 163 figures 17s. 6d. (19s. by post)

"PRACTICAL WIRELESS"

## RADIO AND TELEVISION REFERENCE DATA

compiled by J. P. Hawker

This handy book provides the practical reference data that radio and television servicemen, radio constructors, enthusiasts and amateurs always need. It has been compiled with the day-to-day requirements of servicemen particularly in mind.

Contents include: full details of colour codes; a comprehensive collection of practical, everyday formulae for calculating the values of biasing components, potential dividers, etc.; aerial dimensions; a quick frequency-wavelength conversion table; full lists of radio and television broadcasting stations and frequencies; common symbols and abbreviations; notes on Amateur radio and a list of call-sign prefixes; communication receiver I.F.s; mathematical data including logarithm tables; wire and cable data; battery equivalents; and a full and up-to-date listing of valve, transistor and cathode-ray tube pin connections, bases, ratings and equivalents, including selected CV types.

96 pages 62 pages of tables 10s. 6d. (12s. by post)

## ELECTRONICS POCKET BOOK

edited by J. P. Hawker and J. A. Reddihough

Fully covers . . . FUNDAMENTALS: Behaviour of Electrons in Electric and Magnetic Fields—Emission of Electrons—Conduction and Current—Voltage Relationships. CIRCUIT ELEMENTS: Diodes—Thermionic Triodes—Tetrodes and Pentodes—Thyratrons—The Transistor—Four-layer Semiconductor devices—Cathode-Ray Tubes—Electron Multipliers—Hall Multiplier—Thermistors and Non-Linear Elements—Photo-Electric Cells—Transducers. ELECTRO-MAGNETIC DEVICES: Solenoids—Relays. AMPLIFIER CIRCUITS: Voltage Amplification—Distortion—Bandwidth—Power Amplifiers—Classification of Amplifiers—Feedback—Special Circuits—D.C. Amplifiers. PULSE CIRCUITS: Self-Oscillating Pulse Generators—Single-Stroke Pulse Generators—Sawtooth Voltage Generators—Wide-Range Pulse Generators. FURTHER ELECTRONIC CIRCUITS: Electronic Switching—Diode Clamps—Phase-Sensitive Detectors—Pulse Modulation. COUNTING DEVICES AND CIRCUITS: Counting Circuits—Radiation Detectors. POWER SUPPLIES: A.C. Rectification—Rectifier Circuits—Ripple Reduction—Voltage Regulation—D.C. Converters. THE MAGNETIC AMPLIFIER. ELECTRONIC MEASUREMENT AND TEST GEAR. INDUSTRIAL ELECTRONIC CONTROL. ELECTRONIC COMPUTERS. INSTALLATION AND MAINTENANCE UNITS.

294 pages 203 diagrams 21s. (22s. 6d. by post)

Order now. Complete the order on facing page to receive books by return of post.

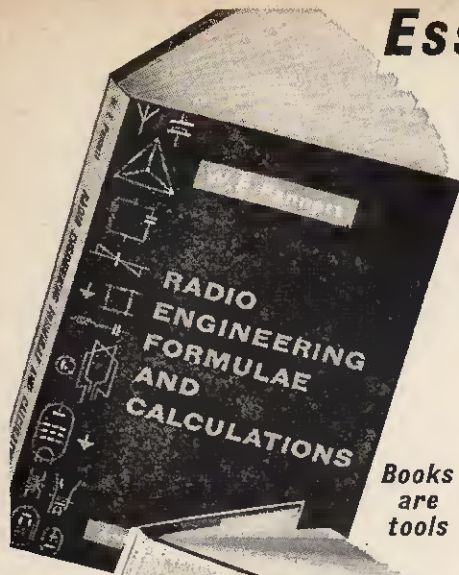

Books are tools

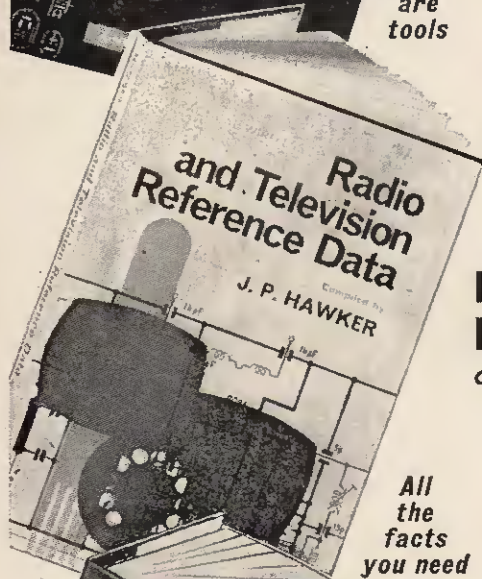

All the facts you need

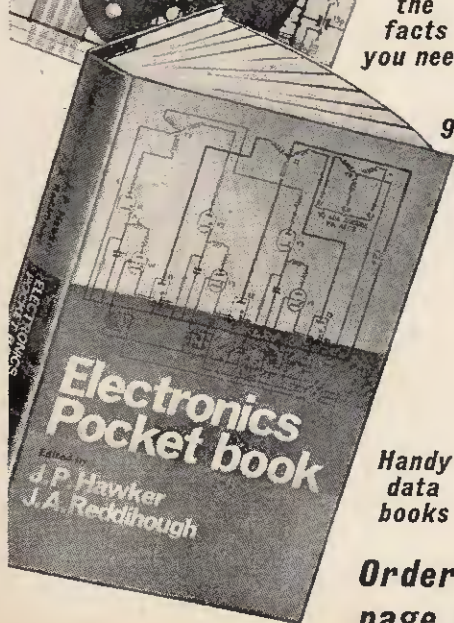

Handy data books



# Authoritative, practical, inexpensive. Add them to your technical bookshelf

## BEGINNER'S GUIDE TO ELECTRONICS

by Terence L. Squires

This book provides a "short-cut" for those wishing to obtain a quick acquaintance with modern electronics. It is not intended to replace "text" or "course" books on the subject that take the student through detailed theory and calculations: what it does is to describe as simply as possible the basic concepts of importance in electronic engineering, and the various components used in electronic equipment, so that the reader gains an understanding of the terms used and the practical side of the subject. No prior technical knowledge is assumed, mathematics being avoided and emphasis placed on numerous illustrations. The book will enable the reader to go on to more specialised works or courses with confidence.

Contents: Electric Currents—Direct and Alternating Currents—Electronic Components—Basic Electronic Circuits—Test Instruments—Radar—Medical Electronics—Electronics in Space—Television—Electronics in Industry—The Future of Electronics—Training to be an Electronics Engineer.

192 pages 128 diagrams 15s. (17s. by post)

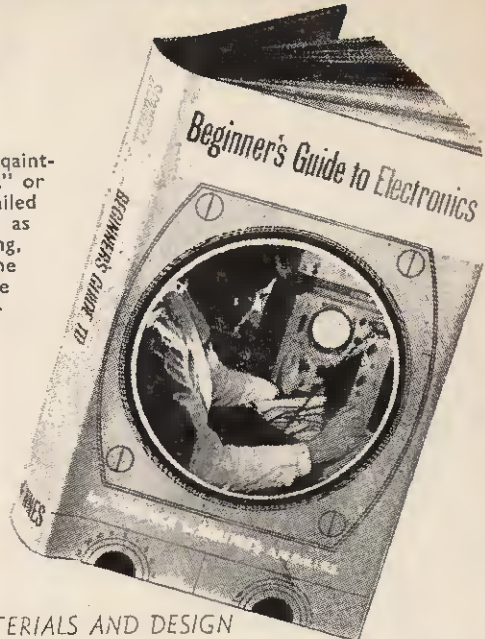

"The subject has been thoroughly and wisely treated"

ENGINEERING MATERIALS AND DESIGN

## HIGH FIDELITY SOUND REPRODUCTION

edited by E. Molloy

The high quality reproduction of disc and magnetic tape recordings and of radio programmes has made remarkable strides in the past decade. The introduction of long-playing gramophone records, V.H.F./F.M. broadcasts and the availability of first-rate amplifiers, loudspeakers and pickups have all created a growing interest in the faithful reproduction of music in the home. The aim of this book is to bring together authoritative and balanced information on the technique of Hi-Fi in terms that will be readily understood.

Contents: Introduction—Subjective and Objective Judgement of Performance—The Acoustics of Sound Reproduction—Multiple Channel Systems—Amplifiers and Pre-Amplifiers—Dynamic Loudspeakers—Loudspeaker Enclosures—Electrostatic Loudspeakers—Record Reproduction—Tape Recordings—Radio Reproduction.

212 pages 151 illustrations 20s. (22s. by post)



order here

Please send me.....copy/copies of the following books

- ..... RADIO ENGINEERING FORMULAE AND CALCULATIONS 17s. 6d. (19s. by post)
- ..... RADIO AND TELEVISION REFERENCE DATA 10s. 6d. (12s. by post)
- ..... ELECTRONICS POCKET BOOK 21s. (22s. 6d. by post)
- ..... BEGINNER'S GUIDE TO ELECTRONICS 15s. (17s. by post)
- ..... HIGH FIDELITY SOUND REPRODUCTION 20s. (22s. by post)

Name.....  
Address.....

**FROM ALL BOOK SELLERS**

... or in case of difficulty use this handy order form today P.E.18/65-

Simply complete this order form and send with your remittance to George Newnes Ltd., Tower House, Southampton Street, London, W.C.2

**NEWNES.**

## 4-STATION INTERCOM

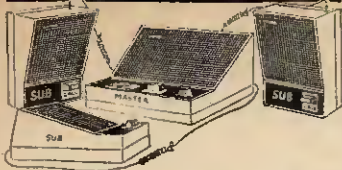

Solve your communication problems with this latest 4-STATION TRANSISTOR INTERCOM system (1 MASTER and 3 SUBS), in do-luxe plastic cabinets for desk or wall mounting. Call/talk/listen from MASTER to SUBS and SUBS to MASTER. Buzzing system operates to call when switched off, thus saves battery. Operates on one small 9V battery which lasts months. On/off switch. Volume control. 210. dynamic speakers. Fully transistorized to last for years. Ideally suitable to modernize Office, Factory, Workshop, Warehouse, Hospital, Shop, etc. for instant inter-departmental contacts. Complete with long connecting wires and other accessories. Nothing else to buy. P. & P. 5/.

## INTERCOM/BABYALARM



Usually ~~£12.00~~  
Our Price ONLY

57'6

Modernize your Office, Shop, Warehouse, Workshop, Surgery, Nursery and Home with this latest two-way TRANSISTOR INTERCOM. Consists of two units MASTER and SUB, in strong plastic cabinets with chromium stands. Elegantly designed to use as two-way instant communication system. Call/talk/listen between two persons anywhere indoors or outdoors. Both units operate on one 9V battery. Fully transistorized. Complete with accessories. Ready to operate. P. & P. 2/6.

## BATTERY ELIMINATOR & CHARGER Price 27/6

Use your TRANSISTOR RADIO or INTERCOM from domestic A.C. mains, and charge dry battery FF3 or 006P 9 volts thus boost battery's life many times. Unbeatable value. Saves you pounds on batteries. P. & P. 2/6. Complete with Plug, Lead and Snap cord. Full price refunded if not satisfied in seven days.

WEST LONDON DIRECT SUPPLIES (PE/11)  
6 Chignell Place, West Ealing, London, W.13

O / X your move!

Unless you put your X between the two O's the machine will win at the next move. Even if you do the machine puts the next O in the centre square, which not only stops you winning but also guarantees the machine's win at the next move. Try it and see.

As Brian Trueman of Granada TV said after demonstrating the machine on television on April 12th, "I'm glad I wasn't playing it for money". One machine that did play for money, at 3d a go, refunded for a drawn game, raised £3 in three hours for charity. Full circuit, wiring diagram, instructions for this fabulous unbeatable machine, 3/6d post free. Built for about £6.

PLANET INSTRUMENT CO.  
25 DOMINION AVE., LEEDS 7

## BATTERY ELIMINATORS

The ideal way of running your TRANSISTOR RADIO, RECORD PLAYER, TAPE RECORDER, AMPLIFIER, etc. Types available: 5v; 6v; 4½v (single output) 39/6 each. P. & P. 2/9. 9v + 9v; 6v + 6v; or 4½v + 4½v (two separate outputs) 42/6 each. P. & P. 2/9. Please state output required. All the above units are completely isolated from mains by double wound transformer ensuring 100% safety.

R.C.S. PRODUCTS (RADIO) LTD.  
(Dept. P.E.), 11 Oliver Road, London, E.17

## DUKE & CO. (LONDON) LTD.

621/3 Romford Rd., Manor Park, E.12  
Ilford 6001-2-3 Stamp for list

## T.V. TUBES

17in. — 35/- 14in. — 15/-  
Most makes and types available. Set Tested. Guaranteed good picture. Ex Rental Service Dept. Stock. Carriage 5/- extra  
RESISTANCES 10/- per 100. Brand new, mostly High Stabs. Assorted parcels. P. & P. 2/-.

## BBC2 (625 LINE) TV AERIALS



MAST MOUNTING ARRAYS, 9 element 45/-; wide spaced high gain, 11 element 55/-; 14 element 62/6. WALL MOUNTING WITH CRANKED ARM, 9 element 60/-; wide spaced high gain, 11 element 67/6; 14 element 75/-. CHIMNEY ARRAYS COMPLETE, 9 element 72/-; wide spaced high gain, 11 element 80/-; 14 element 87/6. LOFT ARRAYS, 7 element 32/6; wide spaced high gain, 11 element, WITH TILTING ARM 62/6; 14 element 70/-. ALL HIGH GAIN UNITS HAVE SPECIAL MULTI-ROD REFLECTOR. LOW LOSS CO-AXIAL CABLE 1/6 yd. VHF transistor pre-amps from 75/-.

## BBC + ITV + F.M. AERIALS



B.B.C. (BAND 1). Telescopic loft 21/- External S/D 30/-.  
I.T.V. (BAND 3). 3 Element loft array 25/- 5 element 35/- Wall mounting, 3 element 35/- 5 element 45/-.  
COMBINED B.B.C./I.T.V. Loft 1+3, 41/3; 1+5, 48/9. Wall mounting 1+3, 56/3; 1+5, 63/9. Chimney 1+3, 63/9; 1+5, 71/3.

VHF transistor pre-amps from 75/-.

F.M. (BAND 2). Loft S/D, 12/6. "H", 30/-. 3 element, 52/6. External units available. Co-ax. cable 8d. yd. Co-ax. plugs, 1/3. Outlet boxes, 4/6. Diplexer Crossover Boxes 12/6. G.W.O. or G.O.D. P. & P. 3/6. Send 6d. stamps for illustrated lists.

K.V.A. ELECTRONICS (Dept. 2)  
3b, Godstone Road, Kenley, Surrey.  
CRO 2527

## Advertisers' Announcement

Readers will be glad to know that catalogue transistors suitable for use in the circuits discussed in this issue are:

ARTICLE	POSITION	NKT TYPE NO.	LIST PRICE
Low Voltage Battery Pack	TR1	NKT 272	8/-
Simple Analogue Computer	TR1 & TR2	NKT 272	8/- Postage Extra

They can be purchased from any of the following:

EASTERN AERO ELECTRICAL SERVICES LTD  
BUILDING 424, EASTERN PERIMETER ROAD  
LONDON (Heathrow) AIRPORT,  
HOUNSLOW, MIDD.X.

ELECTRICAL & HARDWARE MARKETING CO  
LTD, 10 KING STREET MEWS, BELFAST 1.

JAMES SCOTT (Electronic Agencies) LTD  
90 WEST CAMPBELL STREET, GLASGOW C2.

S.D.S. (Portsmouth) LTD, 67/69 COMMERCIAL  
ROAD, PORTSMOUTH, HANTS.

Now in its 11th Revised edition . . .

## ELECTRICAL ENGINEER'S REFERENCE BOOK

A revised edition of this comprehensive thirty-three section standard reference work covering all branches of electrical engineering. New and thoroughly revised sections include materials; cables and wires; wiring and installation; applied electronics; instruments and measurements, etc. References are also made to many new aspects including germanium and silicon; printed circuits; transformer windings and design; electronic motor control; cold-cathode lighting, etc. The "Progress" section is again entirely new and includes an authoritative survey of recent extensions to power-station generating plant.

2,212 pages, 2,096 diagrams, over 300 photographs,  
76 specialist contributors, 33 sections, 11th Edition. 120s.

FROM ALL BOOKSELLERS

. . . or in case of difficulty 120s. post free from GEORGE NEWNES LTD., TOWER HOUSE, SOUTHAMPTON STREET, LONDON, W.C.2

NEWNES

# VALUABLE NEW HANDBOOK FREE TO AMBITIOUS ENGINEERS

Have you had your copy of "Engineering Opportunities"?

The new edition of "ENGINEERING OPPORTUNITIES" is now available—without charge—to all who are anxious for a worthwhile post in Engineering. Frank, informative and completely up to date, the new "ENGINEERING OPPORTUNITIES" should be in the hands of every person engaged in any branch of the Engineering industry, irrespective of age, experience or training.

On 'SATISFACTION OR REFUND OF FEE' terms

This remarkable book gives details of examinations and courses in every branch of Engineering, Building, etc., outlines the openings available and describes our Special Appointments Department.

WHICH OF THESE IS YOUR PET SUBJECT?

**MECH. ENGINEERING**  
Gen. Mech. Eng.—Maintenance Eng.—Diesel Eng.—Press Tool Design—Sheet Metal Work—Welding—Eng. Pattern Making—Inspection—Draughtsmanship—Metallurgy—Production Eng.

**RADIO ENGINEERING**  
General Radio—Radio & TV Servicing—TV Eng.—Telecommunications—Electronics—Sound Recording—Automation—Practical Radio—Radio Amateurs' Exam.

**CIVIL ENGINEERING**  
General Civil Eng.—Municipal Eng.—Structural Eng. Sanitary Eng.—Road Eng. Hydraulics—Mining—Water Supply—Petrol Tech.

WE HAVE A WIDE RANGE OF COURSES IN OTHER SUBJECTS INCLUDING CHEMICAL ENG., AERO ENG., MANAGEMENT, INSTRUMENT TECHNOLOGY, WORKS STUDY, MATHEMATICS, ETC.

Which qualification would increase your earning power?  
A.M.I.Mech.E., A.M.S.E., A.M.I.C.E., A.M.I.E.R.E., B.Sc., A.M.I.P.E., A.M.I.M.J., A.R.I.B.A., A.I.O.B., A.M.I.Chem.E., A.R.I.C.S., M.R.S.H., A.M.I.E.D., A.M.I.Mun.E., CITY & GUILDS, GEN. CERT. OF EDUCATION, ETC.

BRITISH INSTITUTE OF ENGINEERING TECHNOLOGY  
155 COLLEGE HOUSE, 29-31 WRIGHT'S LANE, W.8

## THIS BOOK TELLS YOU

- ★ HOW to get a better paid, more interesting job.
- ★ HOW to qualify for rapid promotion.
- ★ HOW to put some letters after your name and become a key man . . . quickly and easily.
- ★ HOW to benefit from our free Advisory and Appointments Depts.
- ★ HOW you can take advantage of the chances you are now missing.
- ★ HOW, irrespective of your age, education or experience, YOU can succeed in any branch of Engineering.

156 PAGES OF EXPERT CAREER - GUIDANCE

### PRACTICAL EQUIPMENT

Basic Practical and Theoretical Courses for beginners in Radio, T.V., Electronics, Etc., A.M.I.E.R.E. City & Guilds Radio Amateurs' Exam. R.T.E.B. Certificate P.M.G. Certificate Practical Radio Radio & Television Servicing Practical Electronics Electronics Engineering Automation

### INCLUDING TOOLS

The specialist Electronics Division of B.I.E.T. NOW offers you a real laboratory training at home with practical equipment. Ask for details.

## B.I.E.T.

You are bound to benefit from reading "ENGINEERING OPPORTUNITIES", and if you are earning less than £30 a week you should send for your copy NOW—FREE and without obligation.



## POST NOW!

TO B.I.E.T., 155 COLLEGE HOUSE,  
29-31 WRIGHT'S LANE, W.8.

3d. stamp if posted in  
an unsealed envelope.

Please send me a FREE copy of "ENGINEERING OPPORTUNITIES." I am interested in (state subject, exam., or career).

NAME .....

ADDRESS .....

WRITE IF YOU PREFER NOT TO CUT THIS PAGE

THE B.I.E.T. IS THE LEADING INSTITUTE OF ITS KIND IN THE WORLD

Published about the 15th of the month by GEORGE NEWNES LIMITED, Tower House, Southampton Street, London, W.C.2. Printed in England by THE CHAPEL RIVER PRESS LIMITED, Andover, Hants. Sole Agents for Australia and New Zealand: GORDON & GOTCH (A/sia) Ltd.; South Africa and Rhodesia: CENTRAL NEWS AGENCY LTD.; East Africa: STATIONERY & OFFICE SUPPLIES LTD. Subscription rate including postage for one year: To any part of the World £1 16. 0.

FULLY DETAILED AND ILLUSTRATED  
**CATALOGUE**

Over 90 big pages. The largest PRICE range available in the country. 2/6  
All types of components and (post paid) equipment at competitive prices.

**PROVED AND TESTED DESIGNS**  
FULL AFTER SALES SERVICE AND GUARANTEE



★ **CALL IN FOR DEMONSTRATIONS** ★  
DETAILED LEAFLETS FREE ON REQUEST

**MW/LW POCKET SUPERHET RADIO**

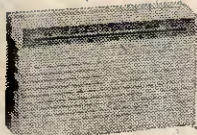

TOTAL COST TO BUILD

**85/-** P.P. 2/6

(Battery 2/6 Phone 5/-)

★ All parts sold separately.

- ★ 6-Transistor design. Push-pull output.
- ★ 2 1/2 in. Cleartone speaker. Printed circuit.
- ★ Attractive moulded cabinet.
- ★ Slow motion tuning.
- ★ Full med. and long waves.
- ★ Size: 5 x 3 x 1 1/4 in.

● **AMAZING SENSITIVITY & SELECTIVITY** ●

- ★ 6-Transistor push-pull design.
- ★ Uses factory built panels.
- ★ Permeability geared tuning.
- ★ Full med./long wave tuning with push-button wave change.
- ★ Double tuned IFT's.
- ★ Chromed front panel plate.
- ★ Size: 7 x 4 x 2 in. Fits any car.
- ★ Pre-built units sold separately.

TOTAL COST TO BUILD

**£8.19.6** P.P. 3/6



**TWO WAVEBAND ALL TRANSISTOR CAR RADIO TO ASSEMBLE**  
● **HIGH PERFORMANCE SUPERHET** ●

**2- AND 4-TRACK TAPE RECORDERS TO ASSEMBLE**

Pre-built Equipment—6 Valves—Collaro Studio Decks—Portable Cabinets with Speakers.



Complete record and playback.

★ 2-track deck 10 gns. P.P. 5/- Amplifier 11 gns. Cabinet with speaker 5 gns.

OR SPECIAL PRICE **£26** P.P. 8/6 **TWO TRACK**

★ 4-track deck £13. 19.6. P.P. 5/- Amplifier 12 gns. Cabinet with speaker 5 gns.

OR SPECIAL PRICE **£30** P.P. 8/6 **FOUR TRACK**

Prebuilt and tested units. Low distortion, low noise

**10 Watt & 20 Watt HI-FI AMPLIFIERS**

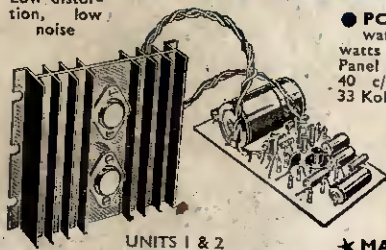

UNITS 1 & 2



UNIT 5

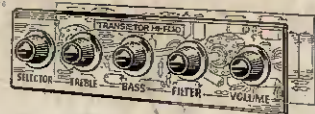

UNIT 3

**THE FINEST QUALITY HI-FI AT UNBEATABLE PRICES**

● **POWER AMPLIFIERS.** 10 watts R.M.S. music power. 20 watts peak. 6-Transistor design. Panel size 4 x 2 1/4 x 1 1/4 in. Response 40 c/s to 20 kc/s. 100mV into 33 Kohm input.

**UNIT 1.** For 12/15 ohm speakers. 40 volt supply. PRICE **£5.19.6** P.P. 2/6

**UNIT 2.** For 3 to 5 ohm speakers. 24/28 volt supply. PRICE **£5.10.0** P.P. 2/6

★ **MAINS UNITS.** 59/6. To power one amplifier or 69/6 to power two amplifiers (State 24 or 40 volt version).

**PREAMPLIFIERS.** Mono and stereo versions, 8 inputs, 1 1/2 to 300mV at 1k to 500k. Response 30 c/s to 20 kc/s. Complete range of controls. Mains unit or battery operated. For pickups, tuners, tape, microphones, etc.

**UNIT 3.** Mono full-function pre-amplifier. Size: 9 1/2 x 2 1/4 x 2 in. PRICE **£5.10.0** P.P. (Brown/Gold front panel plate 8/6)

**UNIT 4.** Simplified version of Unit 3. Price 65/-. P.P. 1/6. Panel plate 3/6

**UNIT 5.** Stereo preamplifier for use with two units 1 or 2. Size 9 x 3 1/2 x 1 1/4 in.

PRICE **£10.19.6** P.P. 3/6  
(Front panel plate 12/6)

We stock:

- TRANSISTORS
- RECTIFIERS
- VALVES
- CRYSTALS
- MICROPHONES
- TEST GEAR
- TAPE DECKS
- SPEAKERS
- MULTI-METERS
- RADIO CONTROL AMPLIFIERS
- RECORDERS
- TUNERS
- RECORD DECKS
- TWEETERS
- RECEIVERS
- GENERATORS
- COMPONENTS AND ACCESSORIES

**SINCLAIR DESIGNS**

- ★ Micro-6 MW/ radio 59/6
- ★ TR750 "Addon" power amp. 39/6
- ★ Micro injector 27/6
- ★ Micro amp. 28/6
- ★ X10 Amp. kit £5.19.6



BUILT **£6.19.6**

**4 WATT AND 1 1/2 WATT PACKAGED AMPLIFIERS**

- ★ 6-Transistor push-pull printed circuit designs
- ★ Size only 2 1/2 x 2 x 1 1/4 in
- ★ 4 watt 12/18 volt, 1 1/2 watt 9/12 volt
- ★ For 3 to 5 ohm speakers
- ★ 7mV into 1 Kohm, 40 c/s to 15 kc/s

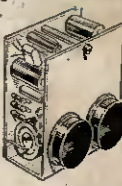

PRICES BUILT **1 1/2 W. 65/-** P.P. 1/6 **4W. 79/6** P.P. 1/6

**4-CHANNEL MICROPHONE MIXER**

Transistorised, 4 inputs up to 100 Kohm. Full mixing. PRICE **49/6** P.P. 1/6



**VALUE FOR MONEY DESIGNS**

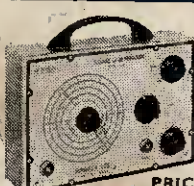

**TRANSISTOR PORTABLE TEST EQUIPMENT**

All units size: 6 1/2 x 4 1/2 x 2 1/4 in.  
★ RF generator, 150 kc/s to 350 mc/s in 8 ranges. RF, Mod. RF, AF outputs.  
★ Resistance/capacitance bridge. £8.5.0.

PRICE **£9.10.0** P.P. 2/6

★ Audio generator 10 c/s—100 kc/s. 4 ranges. **£16.15.0** P.P. 2/6



**VHF/FM TUNER TO ASSEMBLE**

★ Two pre-built units, plus metal work and front panel  
Total Cost **£12.17.6** P.P. 2/6

- ★ Size: 9 1/2 x 3 1/2 x 4 in
- ★ 88 to 108 mc/s tuning
- ★ 100mV to 100Kohm cutout
- ★ 6-Transistor printed cct. superhet design (All units available separately)

**TWO WAVE BAND PUSH-BUTTON TRANSISTOR PORTABLE TO BUILD**

TOTAL COST

**£7.19.6** P.P. 3/6

(Batteries 6/-)

- ★ 5in. speaker
- ★ 6-Transistor push-button design



- ★ Easy to follow printed circuit
- ★ Bin. ferrite aerial. D/T IFT's
- ★ Push button wave change
- ★ Geared tuning. Full Med./LW
- ★ Attractive sturdy cabinet with handle. Size: 10 x 7 x 3 1/4 in.

**SENSITIVE SUPERHET RADIO**

Let us quote for parts for your circuit. Send a list for quick reply. Quality components at realistic prices

**VHF/FM TRANSISTOR TUNER TO BUILD**

TOTAL COST

**£6.19.6**

P.P. 2/6 (complete with frontplate)

(Gold sprayed cabinet 20/- extra).

- ★ 5-Transistor 4 diodes
- ★ Printed circuit superhet
- ★ Geared tuning 87 to 105 mc/s FM
- ★ RF stage and double tuned IFT's
- ★ Output up to 1 volt peak up to 100 Kohm
- ★ 9 volt 9mA supply
- ★ Size in cabinet 4 x 3 1/2 x 2 1/4 in.
- ★ All parts sold separately

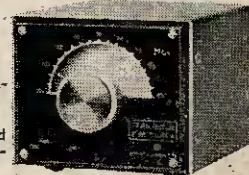

**HENRY'S RADIO LTD.**

303 EDGWARE RD., LONDON W2  
PADDINGTON 1008/9

Open Mon. to Sat. 9-6. Thurs. 1 p.m.  
Open all day Saturday