

THE No.1 MAGAZINE FOR ELECTRONICS TECHNOLOGY & COMPUTER PROJECTS

EVERYDAY

NOVEMBER 2005

PRACTICAL ELECTRONICS

£3.30

TEACH-IN '06 - PART 1

Find out how circuits work and what really goes on inside them

SPEED CAMERA WATCH Mk2

Improved early warning and speed alert system



CHROMATONE

Colour-To-Sound experimenter's project

PLUS

BACK TO BASICS - 8

Noughts & Crosses Enigma
Weather Vane



www.epemag.co.uk



Colour CCTV camera, 8mm lens. 12vdc 200ma a 582x628 Res 380 lines Automatic aperture lens Mirror function PAL Back Light Comp MLR. 100x40x40mm ref EE2 £75.90

Built in Audio .15lux CCD camera 12vdc 200ma 480 lines s/n ratio >48 db 1v P-P output 110x60x50mm ref EE1 £108.90



Metal CCTV camera housings for internal or external use. Made from aluminium and plastic they are suitable for mounting body cameras in. Available in two sizes 1-100x70x170mm and 2-100x70x280mm Ref EE6 £22 EE7 £26 Multi position brackets Ref EE8 £8.80



Excellent quality multi purpose TV/TFT screen, works as just a LCD colour monitor with any of our CCTV cameras or as a conventional TV ideal for use in boats and caravans 49.75mhz-91.75mhz VHF channels 1-5. 168.25mhz-222.75mhz VHF channels 6-12, 471.25mhz-869.75mhz. Cable channels 112.325mhz-166.75mhz Z1-Z7, Cable channels 224.25mhz-446.75mhz Z8-Z35 5" colour screen, Audio output 150mW. Connections, external aerial, earphone jack, audio/video input, 12vdc or mains. Accessories supplied Power supply Remote control Cigar lead power supply Headphone Stand/bracket. 5" model £139 Ref EE9.



Self cocking pistol picro02 crossbow with metal body. Selfcocking for precise string alignment Aluminium alloy construction High tec fibre glass limbs Automatic safety catch Supplied with three bolts Track style for greater accuracy Adjustable rear sight 50lb draw weight 150ft sec velocity Break action 17" sling 30m range £23.84 Ref PLCR002



Fully cased IR light source suitable for CCTV applications. The unit measures 10x10x150mm, is mains operated and contains 54 infra red LEDs. Designed to mount on a standard CCTV camera bracket. The unit also contains a daylight sensor that will only activate the infra red lamp when the light level drops below a preset level. The infra red lamp is suitable for indoor or exterior use, typical usage would be to provide additional IR illumination for CCTV cameras. £53.90 ref FF11



Colour CCTV camera measures 60x45mm and has a built in light level detector and 12 IR leds. 2lux 12 IR leds 12vdc Bracket Easy connect leads £75.90 Ref EE15



A high quality external colour CCTV camera with built in infra red LEDs measuring 60x60x60mm Easy connect leads colour Waterproof PAL 1/4" CCD542x588 pixels 420 lines. 05lux 3.6mm F2.78 deg lens. 12vdc 400ma Built in light level sensor. £108.90 Ref EE13



A small colour CCTV camera just 35x28x30mm Supplied with bracket, easy connect leads. Built in audio. Colour 380 line res. PAL 0.2lux+18db sensitivity Effective pixels 628x582 6-12vdc Power 200mw £39.60 Ref EE16

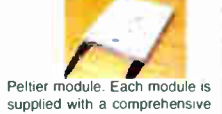

Peltier module. Each module is supplied with a comprehensive 18 page Peltier design manual featuring circuit designs, design information etc etc. The Peltier manual is also available separately Maximum watts 56.2 40x40mm I max 5.5A V max 16.7V T max (c-dry N2) 72 £32.95 (inc manual) REF PELT1. just manual £4.40 ref PELT2



COMPAQ 1000mA 12vdc power supplies, new and boxed. 2 metre lead DC power plug 2.4mmx10mm £5.25 each, 25+ £3.50 100+£2.50



1.2ghz wireless receiver Fully cased audio and video 1.2ghz wireless receiver 190x140x30mm metal case, 4 channel, 12vdc Adjustable time delay, 4s, 8s, 12s. 16s. £49.50 Ref EE20

The smallest PMR446 radios currently available (54x87x37mm). These tiny handheld PMR radios look great, user friendly & packed with features including VOX, Scan & Dual Watch. Priced at £59.99 PER PAIR they are excellent value for money. Our new favourite PMR radios! Standby - 35 hours Includes:- 2 x Radios, 2x Belt Clips & 2 x Carry Strap £59.95 Ref ALAN1 Or supplied with 2 sets of rechargeable batteries and two mains chargers £93.49 Ref Alan2

The TENS mini Microprocessors offer six types of automatic programme for shoulder pain, back/neck pain, aching joints, Rheumatic pain, migraines headaches, sports injuries, period pain. In fact all over body treatment. Will not interfere with existing medication. Not suitable for anyone with a heart pacemaker. Batteries supplied. £21.95 Ref TEN327 Spare pack of electrodes £8.59 Ref TEN327X

Dummy CCTV cameras These motorised cameras will work either on 2 AA batteries or with a standard DC adapter (not supplied) They have a built in movement detector that will activate the camera if movement is detected causing the camera to "pan" Good deterrent. Camera measures 20cm high, supplied with fixing screws. Camera also has a flashing red led. £10.95 REF CAMERAB

INFRA RED FILM 6" square piece of flexible infra red film that will only allow IR light through. Perfect for converting ordinary torches, lights, headlights etc to infrared output using standard light bulbs. Easily cut to shape. 6" square £16.50 ref IRF2 or a 12" sq for £34.00 IRF2A

THE TIDE CLOCK These clocks indicate the state of the tide. Most areas in the world have two high tides and two low tides a day, so the tide clock has been specially designed to rotate twice each lunar day (every 12 hours and 25 minutes) giving you a quick and easy indication of high and low water. The Quartz tide clock will always stay calibrated to the moon. £23.10 REF TIDEC

LINEAR ACTUATORS 12-36VDC BUILT IN ADJUSTABLE LIMIT SWITCHES POWDER COATED 18" THROW UP TO 1,000 LB THRUST (400LB RECOMMENDED LOAD) SUPPLIED WITH MOUNTING BRACKETS DESIGNED FOR OUTDOOR USE. These brackets originally made for moving very large satellite dishes are possibly more suitable for closing gates, mechanical machinery, robot wats etc. Our first sale was to a company buying solar panels that track the sun! Two sizes available, 12" and 18" throw. £32.95 REF ACT12.

Samarium magnets are 57mm x 20mm and have a hole (5/16th UNF) in the centre and a magnetic strength of 2.2 gauss. We have tested these on a steel beam running through the offices and found that they will take more than 170lbs (77kgs) in weight before being pulled off. With keeper. £21.95 REF MAG77

New transmitter, receiver and camera kit. £69.00 Kit contains four channel switchable camera with built in audio, six IR leds and transmitter, four channel switchable receiver, 2 power supplies, cables, connectors and mounting bracket. £69.00 Wireless Transmitter Black and white camera (75x50x55mm) Built in 4 channel transmitter (switchable) Audio built in 6 IR Leds Bracket/stand Power supply 30 m range Wireless Receiver 4 channel (switchable) Audio video leads and scart adapter Power supply and Manual £69.00 ref COP24

This miniature Stirling Cycle Engine measures 7" x 4-1/4" and comes complete with built-in alcohol burner. Red flywheel and chassis mounted on a green base, these all-metal beauties silently running at speeds in excess of 1,000 RPM attract attention and create awe wherever displayed. This model comes completely assembled and ready to run. £106.70 REF SOL1

High-power modules using 125mm square multi-crystal silicon solar cells with bypass diode Anti reflection coating and BSF structure to improve cell conversion efficiency: 14%. Using white tempered glass, EVA resin, and a weatherproof film along with an aluminum frame for extended outdoor use. system Lead wire with waterproof connector 80 watt 12v 500x1200 £315.17, 123w 12vdc 1499x626x46 £482.90 165 w 24v 1575x826x46mm £652.30

BULL GROUP LTD
UNIT D HENFIELD BUSINESS PARK
HENFIELD SUSSEX BN5 9SL
TERMS: CASH, PO, CHEQUE PRICES+VAT
WITH ORDER PLUS £5.50 P&P (UK) PLUS VAT.
24 HOUR SERVICE £7.50 (UK) PLUS VAT.
OVERSEAS ORDERS AT COST PLUS £3.50
Tel: 0870 7707520 Fax 01273491813
Sales@bullnet.co.uk
www.bullnet.co.uk



Ultra-compact, lightweight, easy to use and comfortable to hold, the new NVMT is unique for a night scope in offering a tactile, suregrip plastic bodyshell and, for extra protection/grip, partial rubber armouring. Currently the top of the range model, the NVMT G2+ features a 'commercial' grade 'Gen2+' Image Intensifier Tube (IIT). The NVMT has a built-in, powerful Infrared (IR) Illuminator for use in very low light/total darkness. Power for the scope and IR is provided by 1 x 3V Lithium CR123A battery (not supplied). A green LED next to the viewfinder indicates when the Image Intensifier Tube is switched on while a red LED indicates when the IR Illuminator is switched on. Type Gen Weight Size Lens Mag 2x. Weight 400g, 125x82x35mm angle of view 30deg, built in infra red, rang 3 - 400m. supplied with batteries £849 ref COB24023.

55 - 200 WATT INFRA RED TORCHES Search guard 1 infrared torch Plastic bodied waterproof infrared rechargeable lamp. 100mm diameter lens, 200mm body length. 55 watt bulb 1,000,000 candle power (used as an indication of relative power) Supplied complete with a 12v car lighter socket lead/charger and a 240v mains plug in charger. £49 REF sguard 1. Also available, 70watt @ £59, 100 watt @ £79, 200watt @ £99.



B2 AIR RIFLE Available in 177 and 22+19" Tapered Rifled Barrel Adjustable Rear Sight Full Length Wooden Stock Overall Length 43" approx Barrel Locking Lever • Also available in CARBINE Grooved for Telescopic Sight model with 14" barrel - no front sight for use with scope. Weight approximately 6lbs Extremely Powerful .22 £28.90, .177 £24.70, pellets (500) £2.55, sights 4x20 £6.80, 4x28 £15.32 Other models available up to £250. www.airpistol.co.uk

12V SOLAR PANELS AND REGULATORS
9WATT £58.75
15WATT £84.25
22WATT £126.70
Regulator up to 60 watt £21.25
Regulators up to 135 watt £38.25

The combination of multi-crystal cells and a high-reliability module structure make this series of solar panels the ideal solar module. For large-scale power generation hundreds or even thousands of modules can be connected in series to meet the desired electric power requirements. They have a high output, and highly efficient, extremely reliable and designed for ease of maintenance. Separate positive negative junction boxes and dual by-pass diodes are a few examples of some of its outstanding features. Supplied with an 8 metre cable. Perfect for caravans, boats, etc. Toughened glass.



This set is deluxe in every way! It includes a nice assortment of balls, rakes, hooks, diamonds, two double ended picks, a broken key extractor, and three tension wrenches. And just how do you top off a set like this? Package it in a top grain leather zippered case. Part: LP005 - Price £45.00 This 32 piece set includes a variety of hooks, rakes, diamonds, balls, extractors, tension tools ... and comes housed in a zippered top grain leather case. If you like choices, go for this one! Part: LP006 - Price £65.00 If your wants run toward the biggest pick set you can find, here it is. This sixty piece set includes an array of hooks, rakes, diamonds, balls, broken key extractors, tension wrenches, and even includes a warded pick set! And the zippered case is made, of course, of the finest top grain leather. First Class! Part: LP007 - Price £99.00

Mamod steam roller, supplied with fuel and everything you need (apart from water and a match!) £85 REF 1312 more models at www.mamodspares.co.uk

Mamod steam roller, supplied with fuel and everything you need (apart from water and a match!) £130 REF 1318 more models at www.mamodspares.co.uk

PEANUT RIDER STIRLING ENGINE This all metal, black and brass engine with red flywheel is mounted on a solid hardwood platform. comes complete with an alcohol fuel cell, extra wick, allen wrenches, and Owner's Manual. Specifications: Base is 5-1/4" x 5-1/4", 4" width x 9" height, 3-1/4" stroke, 3-1/2" flywheel £141.90

SHOP ONLINE
WWW.BULLNET.CO.UK

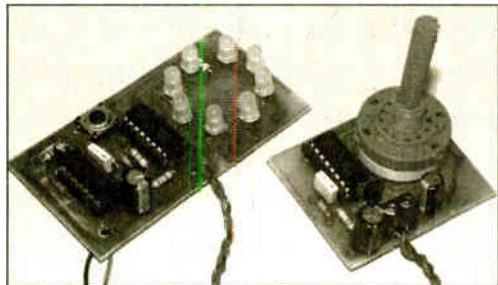
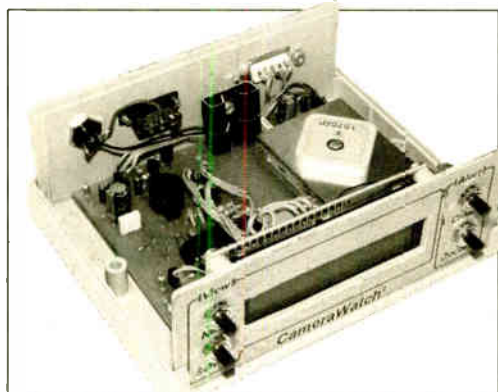

Projects and Circuits

- SPEED CAMERA WATCH Mk2** by Mike Hibbett **748**
 Improved early warning and speed alert system
- MULTI-FUNCTION R/C SWITCH** by Ken Ginn **777**
 A four-channel switcher for your radio controlled models
- INGENUITY UNLIMITED - Sharing your Ideas with others** **783**
 Noiseless Switch
- BACK TO BASICS - 8 Noughts and Crosses Enigma and Weather Vane Repeater** by Bart Trepak **785**
 Simple, easy-to-build circuits based on one or two CMOS logic chips
- PIC CHROMATONE** by John Becker **801**
 Colour-to-Sound experimenter's project

Series and Features

- TECHNO TALK** by Mark Nelson **754**
 Tardic antennas and metamaterialism
- PIC N' MIX** by John Becker **758**
 Using the MAX118 8-channel ADC with a PIC
- TEACH-IN 2006** by Mike Tooley BA **760**
 Find out how circuits work and what really goes on inside them
 Part 1: Introduction
- CIRCUIT SURGERY** by Ian Bell **791**
 Our consultant surgeon looks at analogue switch i.c.s
- PRACTICALLY SPEAKING** by Robert Penfold **798**
 Getting to grips with stripboard
- NET WORK - THE INTERNET PAGE** surfed by Alan Winstanley **809**
 Climb aboard EPE's website and a case for Roboform

Regulars and Services

- EDITORIAL** **747**
- NEWS** - Barry Fox highlights technology's leading edge **755**
 Plus everyday news from the world of electronics
- READOUT** John Becker addresses general points arising **773**
- SUBSCRIBE TO EPE** And save money **775**
- BACK ISSUES CD-ROMs** Did you miss these? **782**
- CD-ROMS FOR ELECTRONICS** **794**
 A wide range of CD-ROMs for hobbyists, students and engineers
- SHOPTALK** with David Barrington **808**
 The *essential* guide to component buying for *EPE* projects
- PLEASE TAKE NOTE** **808**
 Ingenuity Unlimited - Cybervox Light Interface
- DIRECT BOOK SERVICE** **810**
 A wide range of technical books available by mail order, plus more CD-ROMs
- PRINTED CIRCUIT BOARD SERVICE** **813**
 PCBs for *EPE* projects
- ADVERTISERS INDEX** **816**

© Wimborne Publishing Ltd 2005. Copyright in all drawings, photographs and articles published in **EVERYDAY PRACTICAL ELECTRONICS** is fully protected, and reproduction or imitations in whole or in part are expressly forbidden.

Our December 2005 issue will be published on Thursday, 10 November 2005. See page 739 for details

Readers Services • Editorial and Advertisement Departments 747

New PIC Products from Forest Electronics Low Cost Development Boards, New Programmer, Lite version of our C Compiler

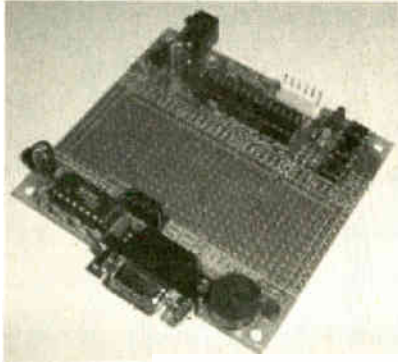

A range of New PIC development boards priced from just £4.00 !

We have a range of 5 new PIC project boards - all available as bare PCB's or as pre-built boards with components. They all have space for the PIC microcontroller, (from 8 to 40 pins). Support circuitry includes the 5V power regulator, decoupling components, reset circuitry and a crystal oscillator. Included are basic I/O components including, LEDs, push-buttons, and a piezo buzzer plus RS232 drivers and DB9F serial connectors. All boards have a large circuit prototyping areas for your designs. The boards all feature a compatible 6 pin in circuit programming connector.

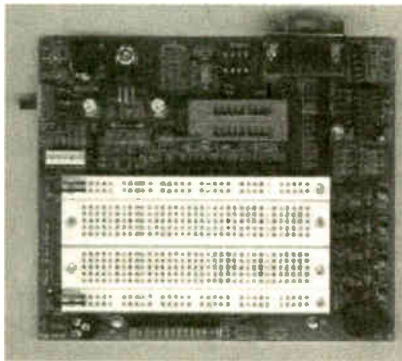
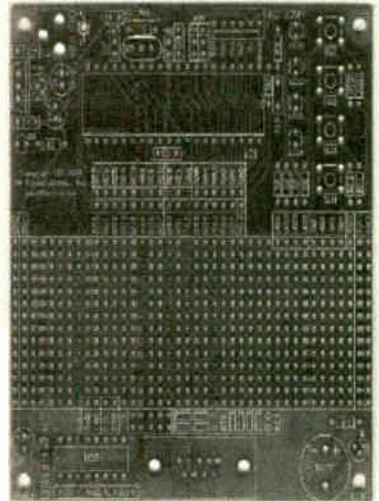

The most comprehensive board (lower left) offers a ZIF socket and breadboard area, plus LCD connection which is ideal for experimental and educational users.

Ideal for use with WIZ-C Lite (below).

See www.fored.co.uk for further details



Serial+ Programmer (Right). New programmer handles 12C, 12F, 16C, 16F, 18F devices from 8 to 40 pins includes In Circuit Serial Programming connector and In Circuit Debugger function. Fully built and tested at just £35.00

WIZ-C Lite – complete ANSI C Compiler for the PIC together with RAD front end Lighting fast C development at an affordable price



- WIZ-C is more than a C Compiler for the PIC – it is a complete development environment with rapid access to library components with point and click set up.
- Ideal for beginners, includes full tutorial manuals and an introductory manual to the C language.
- Syntax highlighting editor.
- Full ANSI C Compiler
- Large libraries included for displays, ports, data transfer, keypads, graphics, bootloader and C standard functions.
- Extensive simulation capabilities, very rapid program execution, includes simulation of LCD, LED, switches, I2C, RS232 terminals etc. Inspect C variables in C format
- Logic analyser can display waveforms of PIC pins and internal registers simplifying debugging.
- Includes assembler to allow you to develop assembler projects in their own right, or as part of C projects
- LITE version supports the most popular PIC devices – academic users may choose these types.
- UK written and supported.
- **LITE Version available for only £35.00**

We accept major credit cards and Switch.

Order securely from our site www.fored.co.uk or contact us by phone or fax on 01590-681511. email info@fored.co.uk
Forest Electronic Developments, 12 Buldowne Walk, Sway, Lymington Hampshire, SO41 6DU

www.fored.co.uk

info@fored.co.uk

NEXT MONTH

PROPELLOR MONITOR

This design demonstrates a way in which the rotation rate of a propellor on a model boat or aircraft can be measured, and the propulsion force that it develops.

As the prop rotates, its blades cut the light beam reaching an optosensor, causing an electronic pulse to be developed. The rotation rate is the number of pulses counted in a given time, divided by the number of blades on the prop, which can be set by the user.

Sensing the prop's force is spring-based in conjunction with a coil that is part of an oscillator circuit. The spring is compressed by the force of the model pushing against a plunger within the coil, so changing the inductance and varying the frequency of the oscillator.

A PIC microcontroller calculates the revolution rate and relates the coil's frequency to a pressure value in kilograms or pounds. The values are displayed on an I.c.d. module.

The unit can be used for testing various propellers and/or tuning engines etc. It will also have a wide range of uses for checking force generated by different means.

VEHICLE FROST BOX

Another update of a previously published circuit. This PIC-based design gives seven different warning signals from a single dual colour I.e.d. corresponding to air temperatures between 0°C (when ice might occur on the road) and 5.4°C when it is very unlikely. The range and 1°C steps, indicated by various output signals, can be easily changed to suit individual requirements.

Make sure you know when ice might occur on road surfaces when driving this winter.

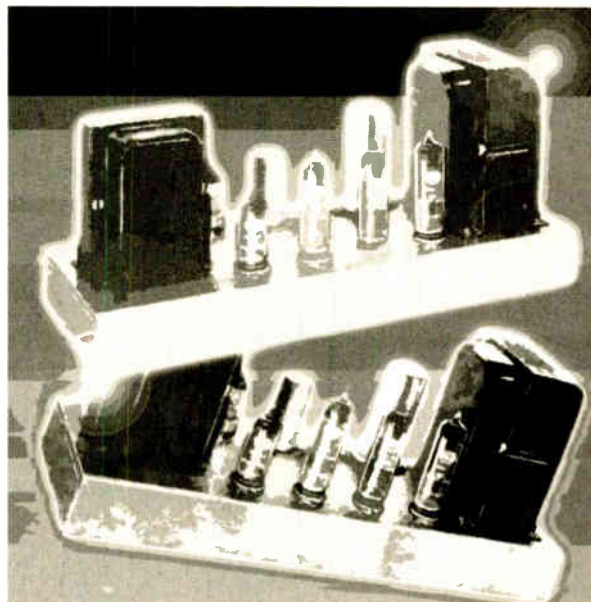

VALVE P.S.U.

Not a power supply employing valves but a modern solid-state design which will supply valve equipment. The unit can supply up to 200V h.t. at 100mA plus 6V and 12V at 1A for the heaters, all from a 12V battery. A standard 12V-0-12V mains transformer is used in an inverter circuit, thus avoiding the need for a special "valve" transformer. The design is just right for those building or repairing a wide range of valve equipment, including vintage radios, amplifiers etc.

TEACH-IN 2006 – Part 2

The next instalment covers: Circuit Diagrams, Series and Parallel Circuits, Kirchhoff's Laws, Voltage and Current Dividers, Analogue and Digital Meters, Energy and Power, plus Circuit Construction Techniques and, of course, another on-line test.

NO ONE DOES IT BETTER

**EVERYDAY
PRACTICAL
ELECTRONICS**

**DON'T MISS AN
ISSUE – PLACE YOUR
ORDER NOW!**

see page 759

Or take out a subscription and save money.

see page 775

DECEMBER 2005 ISSUE ON SALE THURSDAY, NOVEMBER 10



Quasar Electronics Limited
 PO Box 6935, Bishops Stortford,
 CM23 4WP
 Tel: 0870 246 1826
 Fax: 0870 460 1045
 E-mail: sales@quasarelectronics.com

Postage & Packing Options (Up to 2kg gross weight): UK standard 3-7 Day Delivery - £3.95; UK Mainland Next Day Delivery - £8.95; Europe (EU) - £6.95; Rest of World - £9.95 !Order online for reduced price UK Postage!
 We accept all major credit/debit cards. Make cheques/POs payable to Quasar Electronics Limited.
 Prices include 17.5% VAT. MAIL ORDER ONLY.
 Call now for our FREE CATALOGUE with details of over 300 high quality kits, projects, modules and publications.



QUASAR 0871 CREDIT CARD 717 7168 electronics SALES

Helping you make the right connections!

PIC & ATMEL Programmers

We have a wide range of low cost PIC and ATMEL Programmers. Complete range and documentation available from our web site.

Programmer Accessories:

- 40-pin Wide ZIF socket (ZIF40W) £15.00
- 18VDC Power supply (PSU010) £19.95
- Leads: Parallel (LDC136) £4.95 / Serial (LDC441) £4.95 / USB (LDC644) £2.95

NEW! USB 'Flash' PIC Programmer

USB PIC programmer for most 'Flash' devices. No external power supply making it truly portable. Supplied with box and Windows Software. ZIF Socket and USB Plug A-B lead not incl.



Kit Order Code: 3128KT - £34.95

Assembled Order Code: AS3128 - £39.95

"PICALL" ISP PIC Programmer

"PICALL" will program virtually all 8 to 40 pin serial-mode* AND parallel-mode (PIC16C5x family)* Programmed PIC micro controllers.

Free fully functional software. Blank chip auto detect for super fast bulk programming. Parallel port connection. Supply: 16-18V dc.

Assembled Order Code: AS3117 - £24.95

ATMEL 89xxx Programmer

Uses serial port and any standard terminal comms program. 4 LEDs display the status. ZIF sockets not included. Supply: 16VDC.



Kit Order Code: 3123KT - £29.95

NEW! USB & Serial Port PIC Programmer

USB/Serial connection. Header cable for ICSP. Free Windows software. See website for PICs supported. ZIF Socket and USB Plug A-B lead extra. 18VDC.

Kit Order Code: 3149KT - £34.95

Assembled Order Code: AS3149 - £49.95

USB Flash ICSP PIC Programmer

Fully assembled version of our 3128 USB Flasher PIC Programmer but WITHOUT the pre-programming socket. It just has 5-pin ICSP header (GND, VCC, CLK, DAT, VPP) and cable. No external PSU required. Free Windows software.



Order Code: AS3182 - £37.95

ABC Maxi AVR Development Board

The ABC Maxi board has an open architecture design based on Atmel's AVR AT90S8535 RISC microcontroller and is ideal for developing new designs.



Features:

- 8Kb of In-System Programmable Flash (1000 write/erase cycles) • 512 bytes internal SRAM • 512 bytes EEPROM
- 8 analogue inputs (range 0-5V)
- 4 Opto-isolated Inputs (I/Os are bi-directional with internal pull-up resistors)
- Output buffers can sink 20mA current (direct I.e.d. drive) • 4 x 12A open drain MOSFET outputs • RS485 network connector • 2-16 LCD Connector
- 3.5mm Speaker Phone Jack
- Supply: 9-12VDC.

The ABC Maxi STARTER PACK includes one assembled Maxi Board, parallel and serial cables, and Windows software CD-ROM featuring an Assembler, BASIC compiler and in-system programmer.

Order Code ABCMAXISP - £89.95

The ABC Maxi boards only can also be purchased separately at £69.95 each.

Controllers & Loggers

Here are just a few of the controller and data acquisition and control units we have. See website for full details. Suitable PSU for all units: Order Code PSU445 - £8.95

Rolling Code 4-Channel UHF Remote

State-of-the-Art. High security.

4 channels. Momentary or latching relay output. Range up to 40m. Up to 15 TXs can be learned by one Rx (kit includes one Tx but more available separately). 4 indicator LEDs.

Rx: PCB 77x85mm, 12VDC/6mA (standby).

Two & Ten Channel versions also available.

Kit Order Code: 3180KIT - £39.95

Assembled Order Code: AS3180 - £47.95



Computer Temperature Data Logger

Serial port 4-channel temperature logger. °C or °F. Continuously logs up to 4 separate sensors located 200m+ from board. Wide range of free software applications for storing/using data. PCB just 38x38mm. Powered

by PC. Includes one DS1820 sensor and four header cables.

Kit Order Code: 3145KT - £16.95

Assembled Order Code: AS3145 - £23.95

Additional DS1820 Sensors - £3.95 each



NEW! DTMF Telephone Relay Switcher

Call your phone number using a DTMF phone from anywhere in the world and remotely turn on/off any of the 4 relays as desired. User settable Security Password, Anti-Tamper, Rings to Answer, Auto Hang-up and Lockout. Includes plastic case. 130 x 110 x 30mm Power: 12VDC.



Kit Order Code: 3140KT - £39.95

Assembled Order Code: AS3140 - £59.95

Serial Port Isolated I/O Module

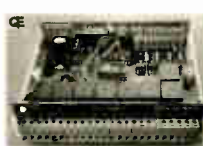

Computer controlled 8-channel relay board. 5A mains rated relay outputs and 4 opto-isolated digital inputs (for monitoring switch

states, etc). Useful in a variety of control and sensing applications. Programmed via serial port (use our new Windows interface, terminal emulator or batch files). Serial cable can be up to 35m long. Includes plastic case 130 x 100 x 30mm. Power: 12VDC/500mA.

Kit Order Code: 3108KT - £49.95

Assembled Order Code: AS3108 - £59.95

Infra-red RC 12-Channel Relay Board



Control 12 on-board relays with included infra-red remote control unit. Toggle or momentary. 15m+ range. 112 x 122mm. Supply: 12VDC/0.5A.

Kit Order Code: 3142KT - £39.95

Assembled Order Code: AS3142 - £49.95

PC Data Acquisition & Control Unit

Monitor and log a mixture of analogue and digital inputs and control external devices via the analogue and digital outputs. Monitor pressure, temperature, light intensity, weight, switch state, movement, relays, etc. with the appropriate sensors (not supplied). Data can be processed, stored and the results used to control devices such as motors, sirens, relays, servo motors (up to 11) and two stepper motors.



Features

- 11 Analogue Inputs - 0-5V, 10 bit (5mV/step)
- 16 Digital Inputs - 20V max. Protection 1K in series, 5-1V Zener
- 1 Analogue Output - 0-2.5V or 0-10V. 8 bit (20mV/step)
- 8 Digital Outputs - Open collector, 500mA, 33V max
- Custom box (140 x 110 x 35mm) with printed front & rear panels
- Windows software utilities (3-1 to XP) and programming examples
- Supply: 12V DC (Order Code PSU203)

Kit Order Code: 3093KT - £64.95

Assembled Order Code: AS3093 - £94.95

Most items are available in kit form (KT suffix) or pre-assembled and ready for use (AS prefix).

Hot New Kits This Summer!

Here are a few of the most recent kits added to our range. See website or join our email Newsletter for all the latest news.

NEW! EPE Ultrasonic Wind Speed Meter



Solid-state design wind speed meter (anemometer) that uses ultrasonic techniques and has no moving parts and does not need calibrating. It is intended for sports-type activities, such as track events, sailing, hang-gliding, kites and model aircraft flying, to name but a few. It can even be used to monitor conditions in your garden. The probe is pointed in the direction from which the wind is blowing and the speed is displayed on an LCD display.

Specifications

- Units of display: metres per second, feet per second, kilometres per hour and miles per hour
- Resolution: Nearest tenth of a metre
- Range: Zero to 50mph approx.

Based on the project published in *Everyday Practical Electronics*, Jan 2003. We have made a few minor design changes (see web site for full details). Power: 9VDC (PP3 battery or Order Code PSU345).

Main PCB: 50 x 83mm.

Kit Order Code: 3168KT – £34.95

NEW! Audio DTMF Decoder and Display



Detects DTMF tones via an on-board electret microphone or direct from the phone lines through the onboard audio transformer. The

numbers are displayed on a 16-character, single line display as they are received. Up to 32 numbers can be displayed by scrolling the display left and right. There is also a serial output for sending the detected tones to a PC via the serial port. The unit will not detect numbers dialled using pulse dialling. Circuit is microcontroller based.

Supply: 9-12V DC (Order Code PSU345).

Main PCB: 55 x 95mm.

Kit Order Code: 3153KT – £17.95

Assembled Order Code: AS3153 – £29.95

NEW! EPE PIC Controlled LED Flasher



This versatile PIC-based LED or filament bulb flasher can be used to flash from 1 to 160

LEDs. The user arranges the LEDs in any pattern they wish. The kit comes with 8 superbright red LEDs and 8 green LEDs. Based on the Versatile PIC Flasher by Steve Challinor, *EPE Magazine* Dec '02. See website for full details. Board Supply: 9-12V DC. LED supply: 9-45V DC (depending on number of LED used). PCB: 43 x 54mm. Kit Order Code: 3169KT – £11.95

Most items are available in kit form (KT suffix) or assembled and ready for use (AS prefix)

FM Bugs & Transmitters

Our extensive range goes from discreet surveillance bugs to powerful FM broadcast transmitters. Here are a few examples. All can be received on a standard FM radio and have adjustable transmitting frequency.

MMTX' Micro-Miniature 9V FM Room Bug



Our best selling bug! Good performance. Just 25 x 15mm. Sold to detective agencies worldwide. Small enough to hide just about anywhere.

Operates at the 'less busy' top end of the commercial FM waveband and also up into the more private Air band. Range: 500m. Supply: PP3 battery. Kit Order Code: 3051KT – £8.95
Assembled Order Code: AS3051 – £14.95

HPTX' High Power FM Room Bug

Our most powerful room bug.

Very Impressive

performance. Clear and stable output signal thanks to the extra circuitry employed.

Range: 1000m @ 9V. Supply: 6-12V DC (9V PP3 battery clip supplied). 70 x 15mm.

Kit Order Code: 3032KT – £9.95

Assembled Order Code: AS3032 – £17.95

MTTX' Miniature Telephone Transmitter



Attach anywhere along phone line. Tune a radio into the signal and hear

exactly what both parties are saying.

Transmits only when phone is used. Clear, stable signal. Powered from phone line so completely maintenance free once installed. Requires no aerial wire – uses phone line as antenna. Suitable for any phone system worldwide. Range: 300m. 20 x 45mm.

Kit Order Code: 3016KT – £7.95

Assembled Order Code: AS3016 – £13.95

3 Watt FM Transmitter

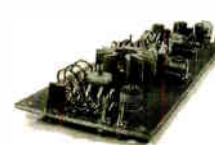

Small, powerful FM transmitter. Audio preamp stage and three RF stages deliver 3 watts of RF power. Can be used with the electret

microphone supplied or any line level audio source (e.g. CD or tape OUT, mixer, sound card, etc). Aerial can be an open dipole or Ground Plane. Ideal project for the novice wishing to get started in the fascinating world of FM broadcasting. 45 x 145mm.

Kit Order Code: 1028KT – £23.95

Assembled Order Code: AS1028 – £31.95

25 Watt FM Transmitter

Four transistor based stages with a Philips BLY89 (or equivalent) in the final stage. Delivers a mighty 25 Watts of RF power. Accepts any line level audio source (input sensitivity is adjustable). Antenna can be an open dipole, ground plane, 5/8, J, or YAGI configuration. Supply 12-14V DC, 5A. Supplied fully assembled and aligned – just connect the aerial, power and audio input. 70 x 220mm.

Order Code: AS1031 – £134.95



QUASAR
electronics

Helping you make the right connections!

**CREDIT
CARD
SALES**
0871
717
7168

Electronic Project Labs

Great introduction to the world of electronics. Ideal gift for budding electronics expert!

500-in-1 Electronic Project Lab

This is the top of the range and is a complete electronics course taking you from beginner to 'A' level standard and beyond! It contains all the parts and instructions to assemble 500 projects. You get three comprehensive course books (total 368 pages) – *Hardware Entry Course*, *Hardware Advanced Course* and a micro-computer based *Software Programming Course*. Each book has individual circuit explanations, schematic and assembly diagrams. Suitable for age 12 and above. Order Code EPL500 – £149.95

30, 130, 200 and 300-in-1 project labs also available – see website for details.

Number 1 for Kits!

With over 300 projects in our range we are the UK's number 1 electronic kit specialist. Here are a few other kits from our range.

1046KT – 25W Stereo Car Booster £29.95

3087KT – 1W Stereo Amplifier £6.95

3105KT – 18W BTL mono Amplifier £9.95

3106KT – 50W Mono Hi-fi Amplifier £23.95

3143KT – 10W Stereo Amplifier £10.95

1011-12KT – Motorbike Alarm £12.95

1019KT – Car Alarm System £12.95

1048KT – Electronic Thermostat £9.95

1080KT – Liquid Level Sensor £6.95

3003KT – LED Dice £7.95

3006KT – LED Roulette Wheel £9.95

3074KT – 8-Ch PC Relay Board £24.95

3082KT – 2-Ch UHF Relay £30.95

3126KT – Sound-Activated Relay £8.95

3063KT – One Chip AM Radio £11.95

3102KT – 4-Ch Servo Motor Driver £15.95

3155KT – Stereo Tone Controls £11.95

1096KT – 3-30V, 5A Stabilised PSU £32.95

3029KT – Combination Lock £7.95

3049KT – Ultrasonic Detector £14.95

3130KT – Infra-red Security Beam £13.95

SG01MKT – Train Sounds £6.95

SG10 MKT – Animal Sounds £5.95

1131KT – Robot Voice Effect £9.95

3007KT – 3V FM Room Bug £6.95

3028KT – Voice-Activated FM Bug £11.95

3033KT – Telephone Recording Adpt £8.95

3112KT – PC Data Logger/Sampler £18.95

3118KT – 12-bit Data Acquisition Unit £49.95

3101KT – 20MHz Function Generator £69.95

www.quasarelectronics.com

Secure Online Ordering Facilities ● Full Product Listing, Descriptions & Photos ● Kit Documentation & Software Downloads



Learn About Microcontrollers

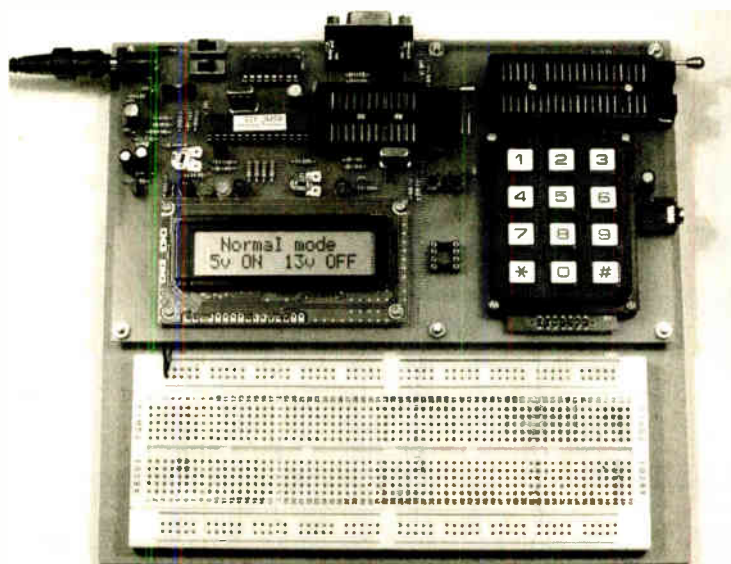

PIC Training & Development System

The best place to start learning about microcontrollers is the PIC16F84 with its simple easy to understand internal structure. Then continue on using the more sophisticated PIC16F877 family.

At the heart of our system are two real books which lie open on your desk while you use your computer to type in the programme and control the hardware. Start with four simple programmes. Run the simulator to see how they work. Test them with real hardware. Follow on with a little theory....

Our PIC training course consists of our mid range PIC programmer, a 298 page book teaching the fundamentals of PIC programming in assembly language, a 274 page book introducing the C programming language for PICs, and a suite of programmes to run on a PC. The module is an advanced design using a 28 pin PIC16F870 to handle the timing, programming and voltage switching requirements. Two ZIF sockets and an 8 pin socket allow most mid range 8, 18, 28 and 40 pin PICs to be programmed. The plugboard is wired with a 5 volt supply. The programming is performed at 5 volts, verified with 2 volts or 3 volts applied and verified again with 5.5 volts applied to ensure that the PIC is programmed correctly over its full operating voltage. UK orders include a plugtop power supply.

- Universal mid range PIC programmer module
 - + Book *Experimenting with PIC Microcontrollers*
 - + Book *Experimenting with PIC C*
 - + PIC assembler and C compiler software suite
 - + PIC16F84 and PIC16F870 test PICs. £159.00
- (Postage & insurance UK £10, Europe £15, Rest of world £25)

Which Language to Learn

Everyone should start programming PICs using assembly language. That is the only way to fully understand what happens. Then there are good arguments in some applications to change over to using a high level language, but, BASIC or C? At the beginning BASIC is easy to learn while C can seem very strange, but the weakness of BASIC comes from its ease of use, while the power of C lurks in its strangeness. Once the early stages are past programmes are easier to write in C than in BASIC.

Experimenting with PIC Microcontrollers

This book introduces PIC assembly language programming using the PIC16F84, and is the best way to get started for anyone who is new to PIC programming. We begin with four easy experiments, the first of which is explained over ten and a half pages assuming no starting knowledge of PICs. Then having gained some practical experience we study the basic principles of PIC programming, learn about the 8 bit timer, how to drive the liquid crystal display, create a real time clock, experiment with the watchdog timer, sleep mode, beeps and music, including a rendition of Beethoven's *Fur Elise*. Finally there are two projects to work through, using the PIC16F84 as a sine wave generator and investigating using the PIC16F88 (from the PIC16F877 family) to monitor the power taken by domestic appliances. In the space of 24 experiments, two projects and 56 exercises the book works through from absolute beginner to experienced engineer level.

Web site:- www.brunningsoftware.co.uk

PIC C Language

The second book *Experimenting with PIC C* starts with an easy to understand explanation of how to write simple PIC programmes in C. The first few programmes are written for a PIC16F84 to keep continuity with the first book *Experimenting with PIC Microcontrollers*. Then we see how to use the same C programmes with the PIC16F627 and the PIC16F877 family.

We study how to create programme loops using C, we experiment with the IF statement, use the 8 bit and 16 bit timers, write text, integer and floating point variables to the liquid crystal display, and use the keypad to enter numbers.

Then its time for 25 pages of pure study, which takes us much deeper into C than is directly useful with PICs as we know them - we are studying for the future as well as the present. We are not expected to understand everything that is presented in these 25 pages, the idea is to begin the learning curve for a deep understanding of C.

In chapter 9 we use C to programme the PIC to produce a siren sound and in the following chapter we create the circuit and software for a freezer thaw warning device. Through the last four chapters we experiment with using the PIC to measure temperature, create a torch light with white LEDs, control the speed of one then two motors, study how to use a PIC to switch mains voltages, and finally experiment with serial communication using the PIC's USART.

Some of the programmes towards the end of *Experimenting with PIC C* are shown in assembler and C to enable the process to be fully explained, and in the torch light experiments, due to the fast switching speed, the programmes are written only in assembler.

As you work through this book you will be pleasantly surprised how C makes light work of calculations and how easy it is to display the answers.

Ordering Information

The programmer module connects to the serial port of your PC (COM1 or COM2). All our software referred to in this advertisement will operate within Windows 98, XP, NT, 2000 etc.

Telephone with Visa, Mastercard or Switch, or send cheque/PO. All prices include VAT if applicable.

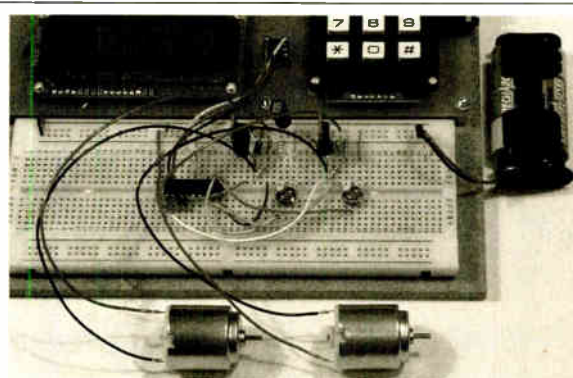

White LED and Motors

Our PIC training system uses a very practical approach. Towards the end of the second book circuits need to be built on the plugboard. The 5 volt supply which is already wired to the plugboard has a current limit setting which ensures that even the most severe wiring errors will not be a fire hazard and are very unlikely to damage PICs or other ICs.

We use a PIC16F627 as a freezer thaw monitor, as a step up switching regulator to drive 3 ultra bright white LEDs, and to control the speed of a DC motor with maximum torque still available. A kit of parts can be purchased (£30) to build the circuits using the white LEDs and the two motors. See our web site for details.

Mail order address:

Brunning Software 138 The Street, Little Clacton, Clacton-on-sea, Essex, CO16 9LS. Tel 01255 862308

MAIL ORDER ONLY • CALLERS BY APPOINTMENT

EPE PROJECT PICS

Programmed PICs for *EPE Projects

12C508/9 - £3.90; 16F627/8 - £4.90

16C84/16F84/16C71 - £5.90

16F876/877 - £10.00

All inc. VAT and Postage

(*Some projects are copyright)

EPE MICROCONTROLLER P.I. TREASURE HUNTER

The latest MAGENTA DESIGN - highly stable & sensitive - with I.C. control of all timing functions and advanced pulse separation techniques.

- High stability drift cancelling
- Easy to build & use
- No ground effect, works in seawater



- Detects gold, silver, ferrous & non-ferrous metals

- Efficient quartz controlled microcontroller pulse generation.
- Full kit with headphones & all hardware

KIT 847£63.95

68000 DEVELOPMENT TRAINING KIT

- NEW PCB DESIGN
- 8MHz 68000 16-BIT BUS
- MANUAL AND SOFTWARE
- 2 SERIAL PORTS
- PIT AND I/O PORT OPTIONS
- 12C PORT OPTIONS

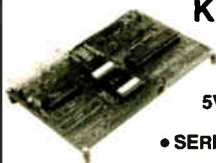

KIT 621

£99.95

- ON BOARD 5V REGULATOR
- PSU £6.99
- SERIAL LEAD £3.99

Stepping Motors

MD100...Std 100 step...£9.99

MD200...200 step...£12.99

MD24...Large 200 step...£22.95



PIC PIPE DESCALER

- SIMPLE TO BUILD
- HIGH POWER OUTPUT
- AUDIO & VISUAL MONITORING
- SWEPT FREQUENCY

An affordable circuit which sweeps the incoming water supply with variable frequency electromagnetic signals. May reduce scale formation, dissolve existing scale and improve lathering ability by altering the way salts in the water behave.

Kit includes case, P.C.B., coupling coil and all components. High coil current ensures maximum effect. L.E.D. monitor.

KIT 868 £22.95 POWER UNIT.....£3.99



MICRO PEST SCARER

Our latest design - The ultimate scarer for the garden. Uses special microchip to give random delay and pulse time. Easy to build reliable circuit. Keeps pets/pests away from newly sown areas, play areas, etc. uses power source from 9 to 24 volts.

- RANDOM PULSES
- HIGH POWER
- DUAL OPTION

Plug-in power supply £4.99

KIT 867.....£19.99

KIT + SLAVE UNIT.....£32.50



WINDICATOR

A novel wind speed indicator with LED readout. Kit comes complete with sensor cups, and weatherproof sensing head. Mains power unit £5.99 extra.

KIT 856.....£28.00

★ TENS UNIT ★

DUAL OUTPUT TENS UNIT

As featured in March '97 issue.

Magenta have prepared a FULL KIT for this excellent new project. All components, PCB, hardware and electrodes are included. Designed for simple assembly and testing and providing high level dual output drive.

KIT 866. . Full kit including four electrodes £32.90

Set of 4 spare electrodes £6.50

1000V & 500V INSULATION TESTER



Superb new design. Regulated output, efficient circuit. Dual-scale meter, compact case. Reads up to 200 Megohms.

Kit includes wound coil, cut-out case, meter scale, PCB & ALL components.

KIT 848. £32.95

EPE TEACH-IN 2000

Full set of top quality NEW components for this educational series. All parts as specified by EPE. Kit includes breadboard, wire, croc clips, pins and all components for experiments, as listed in introduction to Part 1.

*Batteries and tools not included.

TEACH-IN 2000 -

KIT 879 £44.95

MULTIMETER £14.45

SPACEWRITER

An innovative and exciting project.

Wave the wand through the air and your message appears. Programmable to hold any message up to 16 digits long. Comes pre-loaded with "MERRY XMAS". Kit includes PCB, all components & tube plus instructions for message loading.

KIT 849£16.99

12V EPROM ERASER

A safe low cost eraser for up to 4 EPROMS at a time in less than 20 minutes. Operates from a 12V supply (400mA). Used extensively for mobile work - updating equipment in the field etc. Also in educational situations where mains supplies are not allowed. Safety interlock prevents contact with UV.

KIT 790£29.90

SUPER BAT DETECTOR

1 WATT O/P, BUILT IN SPEAKER, COMPACT CASE 20kHz-140kHz NEW DESIGN WITH 40kHz MIC.

A new circuit using a 'full-bridge' audio amplifier i.c., internal speaker, and headphone/tape socket. The latest sensitive transducer, and 'double balanced mixer' give a stable, high performance superheterodyne design.



KIT 861£34.99

ALSO AVAILABLE Built & Tested. . . £48.99

MOSFET MKII VARIABLE BENCH POWER SUPPLY 0-25V 2.5A

Based on our Mk1 design and preserving all the features, but now with switching pre-regulator for much higher efficiency. Panel meters indicate Volts and Amps. Fully variable down to zero. Toroidal mains transformer. Kit includes punched and printed case and all parts. As featured in April 1994 EPE. An essential piece of equipment.



Kit No. 845£64.95

ULTRASONIC PEST SCARER

Keep pets/pests away from newly sown areas, fruit, vegetable and flower beds, children's play areas, patios etc. This project produces intense pulses of ultrasound which deter visiting animals.

- KIT INCLUDES ALL COMPONENTS, PCB & CASE
- EFFICIENT 100V TRANSDUCER OUTPUT
- COMPLETELY INAUDIBLE TO HUMANS



- UP TO 4 METRES RANGE
- LOW CURRENT DRAIN

KIT 812..... £15.00

SIMPLE PIC PROGRAMMER

KIT 857... £12.99

Includes PIC16F84 chip disk, lead, plug, p.c.b., all components and instructions

Extra 16F84 chips £3.84 Power Supply £3.99

PIC LCD DISPLAY DRIVER

16 Character x 2 Line display, pcb, programmed PIC16F84, software disk and all components to experiment with standard intelligent alphanumeric displays. Includes full PIC source code which can be changed to match your application.

- Learn how to drive the display and write your own code.
- Ideal development base for meters, calculators, counters, timers --- just waiting for your application!
- Top quality display with industry standard driver, data and instructions

KIT 860.....£19.99

PIC STEPPING MOTOR DRIVER

PCB with components and PIC16F84 programmed with demonstration software to drive any 4 phase unipolar motor up to 24 Volts at 1 Amp. **Kit includes 100 Step Hybrid Stepping Motor**. Full software source code supplied on disc.

Use this project to develop your own applications. PCB allows 'simple PIC programmer' 'SEND' software to be used to reprogram chip.

KIT 863.....£18.99

8 CHANNEL DATA LOGGER

From Aug/Sept.'99 EPE. Featuring 8 analogue inputs and serial data transfer to PC. Magenta redesigned PCB - LCD plugs directly onto board. Use as Data Logger or as a test bed for developing other PIC16F877 projects. Kit includes lcd, prog'd. chip, PCB, Case, all parts and 8 x 256k EEPROMs

KIT 877.....£49.95

PIC16F84 MAINS POWER CONTROLLER & 4 CHANNEL LIGHT CHASER / DIMMER

- Zero Volt Switching
- Opto-Isolated 5 Amp **HARD FIRED** TRIACS
- 12 Way keypad Control

- With program source code disk
- Chase Speed and dimming potentiometer controls
- Reprogram for other applications

KIT 855.....£39.95

PIC TUTOR 1 EPE MARCH APRIL MAY '98 PIC16F84 STARTER SERIES

The original PIC16F84 series by John Becker. Magenta's Tutor board has individual switches and leds on all portA and PortB lines, plus connectors for optional 4 digit seven segment led display, and 16 x 2 intelligent lcd. Written for newcomers to PICs this series. Disk has over 20 tutorial programs. Connect to a PC parallel port, send, run, and experiment by modifying test programs - *Then Write and Program your Own*

KIT 870... £27.95, Built...£42.95

16x2 LCD..£7.99. LED display..£6.99. 12VPSU..£3.99

SUPER PIC PROGRAMMER

Magenta's original parallel port programmer. Runs with down-loaded WINDOWS 95 - XP software. Use standard Microchip .HEX files. Read/Prog/Verify wide range of 18,28, and 40 pin PICs. Including 16F84/876/877, 627/8, (Inc. 'A' versions) + 16xx OTPs.

KIT 862... £29.99 Power Supply £3.99

ICEBREAKER

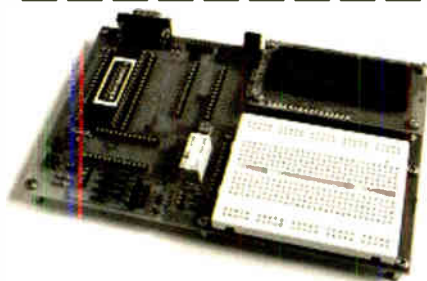

PIC Real Time In-Circuit Emulator

- ICEbreaker uses PIC16F877 in-circuit debugger.
- Links to standard PC Serial port (lead supplied).
- Windows (95 to XP) Software included
- Works with MPASM assembler
- 16 x 2 LCD display, Breadboard, Relay, I/O devices and patch leads.

Featured in EPE Mar'00 Ideal for beginners & experienced users.

KIT 900...£34.99 With serial lead & software disk, PCB, Breadboard, PIC16F877, LCD, all components and patch leads.

POWER SUPPLY - £3.99 STEPPING MOTOR 100 Step £9.99

Programs can be written, downloaded, and then tested by single-stepping, running to breakpoints, or free run at up to 20Mhz.

Full emulation means that all ports respond immediately - reading and driving external hardware.

Features include: Run; set Breakpoint; View & change registers, EEPROM, and program memory; load program; 'watch window' registers.

20W Amp. Module

EPE May '05 -- Superb Magenta Stereo/Mono Module

Wide bandwidth Low distortion 11W /channel Stereo 20W Mono True (rms) Real Power

Short Circuit & Overheat Protected. Needs 8 to 18V supply.

Stable Reliable design

Latest Technology IC with local feedback gives very high performance.

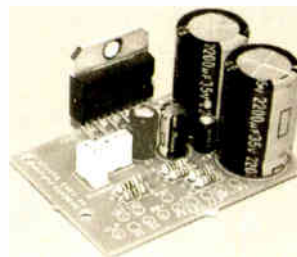

KIT 914 (all parts & heatsink for stereo or mono) **£11.90**

Magenta BrainiBorg

A super walking programmable robot with eyes that sense obstacles and daylight: BrainiBorg comes with superb PC software CD (WIN95+ & XP) and can be programmed to walk and respond to light and obstacles on any smooth surface.

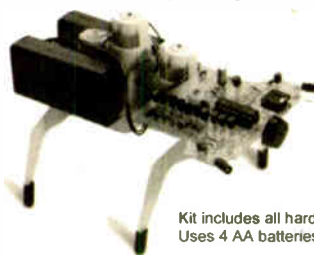

CD contains illustrated constructional details, operating principles, circuits and a superb Educational Programming Tutorial.

Test routines give real-time 'scope traces of sensor and motor signals. Connects to PC via SERIAL port with the lead supplied.

Kit includes all hardware, components, 3 motor/gearboxes. Uses 4 AA batteries (not supplied). An Ideal Present!

KIT 912 Complete Kit with CD rom & serial lead **£49.99**

KIT 913 As 912 but built & tested circuit board **£58.95**

EPE PIC Tutorial

EPE Apr/May/June '03 and PIC Resources CD

- Follow John Becker's excellent PIC toolkit 3 series.
- Magenta Designed Toolkit 3 board with printed component layout, green solder mask, places for 8, 18, 28 (wide and slim), and 40 pin PICs. and Magenta extras.
- 16 x 2 LCD, PIC chip all components and sockets included.

KIT 880 (with 16F84) **£34.99**, built & tested **£49.99**

KIT 880 (with 16F877) **£39.99**, built & tested **£55.99**

EPE TEACH-IN 2004

THE LATEST NOV 03 SERIES All parts to follow this new Educational Electronics Course. Inc. Breadboard, and wire, as listed on p752 Nov. Issue.

Additional Parts as listed in 'misc.' Section (less RF modules, Lock, and Motor/g.box)

Reprints: £1.00 per part.

KIT 920.....£29.99

KIT921.....£12.99

MAGENTA BRAINIBOT I & II

- Full kit with ALL hardware and electronics.
- As featured in EPE Feb '03 (KIT 910)
- Seeks light, beeps, and avoids obstacles
- Spins and reverses when 'cornered'
- Uses 8 pin PIC chip
- ALSO KIT 911 - As 910 PLUS programmable from PC serial port leads and software CD included.



KIT 910....£16.99 **KIT 911....£24.99**

MAGENTA

All prices include VAT. Add £3.00 p&p. Next day £6.99

Tel: 01283 565435 Fax: 01283 546932 email: sales@magenta2000.co.uk

112005



Station Road, Cullercoats, Tyne & Wear, NE30 4PQ

Prices Exclude Vat @17½%.
UK Carriage £2.50 (less than 1kg)
£5.50 greater than 1kg
Cheques / Postal orders payable to
ESR Electronic Components.
PLEASE ADD CARRIAGE & VAT TO ALL ORDERS

See Next / Last Months Ad. for **ELECTRONIC COMPONENTS**

PCB Production - Processing Equipment

We carry a large range of the photographic & chemical processing equipment for PCB production, a full list with full technical specifications is available in our catalogue or visit our web site.

UV Exposure units
2 x 8W Tubes, 6 min timer £88.78
229 x 159mm working area
Model 332-002
4 x 15W Tubes, 7½ min timer £194.51
330 x 260mm working area
Model 332-004

Chemical Processing
Low cost plastic tray £1.80
Process tanks feature electrically operated pumps and/or heaters with thermostat control, suitable for boards upto 320 x 260mm.
Universal Tank with heater Model 333-007 £161.60
Bubble etch Tank with heater & bubble pump Model 333-004 £198.50

Any of these items, carriage £5.50

PCB Production - Laminates

Copper clad - paper
Single sided low cost paper composite board
100 x 160mm Board £0.44
100 x 220mm Board £0.62
160 x 233mm Board £1.02
220 x 233mm Board £1.40
8" x 12" Board £1.70

Copper clad - glass fibre
Single & Double 1.6mm 305g/m²
100 x 160mm Single £0.85
100 x 220mm Single £1.49
160 x 233mm Single £2.29
220 x 233mm Single £2.88
8" x 12" Single £3.44
100 x 160mm Double £0.88
100 x 220mm Double £1.25
160 x 233mm Double £2.30
220 x 233mm Double £2.90
8" x 12" Double £3.50

Photoresist Coated
1.6mm 35 micron Pre-coated with a high quality photoresist layer. Available in low cost paper composite or Glass fibre, Single & Double sided. Other sizes also available.

Size	Paper	Double	Glass Fibre	Double
4 x 6"	£1.47	£1.82	£1.89	£2.17
6 x 12"	£4.20	£5.04	£5.60	£6.23
9 x 12"	£6.30	£7.70	£8.40	£9.38
10 x 12"	£8.19	£10.01	£10.78	£11.83
12 x 12"	£8.26	£10.08	£10.99	£12.25
100 x 160mm			£2.38	£2.66
203 x 114mm			£3.01	£3.43
220 x 100mm			£3.08	£3.71
233 x 160mm			£4.83	£5.32
233 x 220mm			£6.83	£7.70

PCB Production - Development

0.1" Copper Stripboard

Size	Tracks/Holes	£0.24
25 x 64mm	9T / 25H	£0.24
64 x 95mm	24T / 37H	£0.87
95 x 127mm	36T / 50H	£1.41
95 x 432mm	36T / 170H	£4.39
100 x 100mm	39T / 38H	£1.40
100 x 500mm	39T / 199H	£6.20
119 x 455mm	46T / 179H	£5.40

Stripboard track cutter £1.99

Solderless Breadboard
Tie Points & Size Power Rails
390 81 x 60mm 2 £2.75
840 175 x 67mm 2 £4.86
740 175 x 55mm 1 £4.03
640 175 x 42mm 0 £3.08
Many other sizes available, also jump wires & matrix board.

PCB Production - Tools

Drill Bits
HSS parallel shank bits available in sizes from 0.3mm to 2.0mm
0.3-0.95mm in 0.05mm steps £0.60ea £4.00/10
1.0-2.0mm in 0.1mm steps £0.40ea £3.60/10
HSS Reduced shank (2.35mm) bit available in sizes from 0.6mm to 1.7mm in 0.1mm steps £0.84ea £7.60/10
Reground Tungsten carbide reduced shank (3.2mm) available in sizes from 0.6 to 1.6mm in 0.1mm steps £1.90

Drilling Machines
Expo reliant 12V drill, 3.8mm capacity, 8400rpm £12.78

Minicrof MX1 230V, 8000 - 21000rpm with chuck & collet.
Model EPE270-390
Normal price £48.51

**** SPECIAL OFFER PRICE £31.02 ****

PCB Production - Chemicals

100ml	Aerosol Photoresist spray, covers 2m²	£4.25
50g	Powder developer, makes 1lt	£1.09
500g	Powder developer, makes 10lt	£7.08
250g	Ferric Chloride Pellets, makes 500ml	£1.68
500g	Ferric Chloride Pellets, makes 1lt	£3.04
1.5kg	Ferric Chloride Pellets, makes 5lt	£9.84
1.1kg	Clear Fine etch crystals, makes 5lt	£17.58
90g	Tin Plating Powder, makes 1lt	£11.58
200ml	Aerosol Flux spray	£3.41
110ml	Aerosol PCB Laquer spray	£3.63

PCB Production - Drafting Materials

A4 Artwork Film (per 10 sheets)
Clear Manual Film £1.20
Clear Laser Film £1.75
White HQ Laser Film £4.62

Etch Resist Pens
"Dalo" Pen £2.98
"Sigaretter" Fine Pen £0.88

Etch Resist Transfers
Seno mixed DIL pads £2.24
Seno mixed Rnd pads £2.24
Alfac mixed pads £1.84
Transfer Spatular £1.25

We carry the full range of Seno & Alfac PCB transfers, see our catalogue for full details.

Servisol Products

Aerosols

200ml	Switch Cleaner	£1.96
200ml	Freezer	£3.97
400ml	Foam Cleanser	£2.13
400ml	Cleaner / Lubricant	£2.79
75ml	Wide Head Cleaner	£1.94
200ml	Aero Klene	£2.85
200ml	Aero Duster	£4.66
250ml	Cold Clean	£3.14
200ml	Label remover	£3.52
400ml	Isopropyl alcohol	£3.36

Tubes

10g	Heatsink Compound	£1.66
25g	Heatsink Compound	£2.60
50g	Silicone grease	£3.16

Magnifying Desk Lamp

A high quality scratch resistant magnifying glass fitted to a balanced swivel arm and desk mount. An integral fluorescent tube provides illumination. Magnification: 3x Lens: 120mmØ Tube: 22W Daylight simulation.

Model: 028-205 £28.80

Soldering Irons

We carry in stock a wide range of soldering iron and soldering accessories. Irons from 12 to 100 Watts.

20W 240V Basic	£3.74
25W 240V Ceramic	£7.14
30W 240V Basic	£4.68

Desolder Pumps

Basic 165 x 18mmØ	£2.85
Antistatic 195mm	£3.92
Antex Mini 195mm	£6.02
Antex Pro 210mm	£10.26

NEW CATALOGUE OUT NOW

available from www.esr.co.uk

Tools - Cutters & Strippers

We carry a wide range of specialist tools for the electronics industry including:

Side Cutters

130mm Low cost	£1.99
115mm Dropper	£2.38
115mm Box Jointed	£4.26
145mm Long reach	£3.40

Wire Strippers

130mm Low cost	£2.30
150mm Dropper 5mmØ	£5.86

Digital Multimeter

Model: 121-120
Price: £11.47

A highly featured digital multimeter for professional use. Offers 30 ranges and 8 functions including temperature, capacitance, diode, continuity and hFE measurement. Large 3.5 digit LCD display with automatic polarity indicator. Supplied with shrouded test leads, K type temperature probe and shock proof rubber holster.

Technical Specifications
DC voltage 200mV - 1000V (±0.5%)
AC volts 2V - 700V (±0.8%)
DC current 2mA - 20A (±1.2%)
AC current 200mA - 20A (±1.8%)
Resistance 200 Ohms - 20M Ohms (±0.8%)
Capacitance 2000pF - 20µF (±2.5%)
Temperature 0 C - 1000 C (±1.5%)
Frequency 20kHz (±1%)
Max display 1999
Power supply 9V (PP3 battery)
Dimensions 88 x 173 x 40 mm

Educational Kits

These kits are an ideal way to start your interest in electronics. They feature re-useable components which are attached via springs & wires and easy step by step guides to make a range of exciting projects. The 300-in-1 features a breadboard for more complex circuits.

30-in-1	£13.18
50-in-1	£16.80
130-in-1	£32.29
300-in-1	£55.20

Tools - Ratchet Crimping Pliers

High quality ratchet crimping pliers for various terminals including Automotive, Data, Power and Data connections.

Red / Blue / Yellow	£15.80
BNC / TNC RF series	£15.08
RJ11/12 Data Series	£22.32
RJ45 Data Series	£20.43
RJ11/12 & 45 Series	£12.64

CK® Tools Crimp Pliers

Green/Red/Blue	£24.38
Red/Blue/Yellow	£22.88
0.24-2.5mm crimps	£26.01
0.5-6.0mm crimps	£26.01
Non insulated crimps	£24.38

CCTV - Complete Systems

We carry the full range of Micromark Black & White and Colour CCTV systems for the home or office.

These complete easy install systems are supplied complete with power supply, cables and all fixings. Simple plug-in connections, for use with any TV or Video with a scart socket.

Black & White Systems from £22.97

Panel Meters

High quality analogue panel meters, class 2, zero point correction, mirror scale and prewired for panel illumination. Meter size 46 x 60mm, Cutout size: 38mmØ.

Range	Int Ω	All meters £5.89 each
0-50uA	6k5	6V Lamps £1.23 / pair
0-100uA	1k0	
0-500uA	430Ω	
0-1mA	200Ω	
0-10mA	2Ω6	
0-50mA	1Ω2	
0-100mA	0Ω265	
0-1A	60mΩ2	
0-3A	20mΩ2	
0-5A	12mΩ2	
0-15A	4mΩ2	
0-10V	10k	
0-15V	15k	
0-30V	30k	
+50uA	1k9	

Tools - Cable - Ribbon

7/0.127mm Grey ribbon cable on a 0.05" 1.27mm pitch with a red identifying stripe. Supplied by 305mm (1ft) or on full 30.5m (100ft) reels.

Size	per 305mm	per Reel
10 Way	£0.10	£5.36
14 Way	£0.14	£7.50
16 Way	£0.16	£8.58
20 Way	£0.20	£10.72
24 Way	£0.26	£13.94
34 Way	£0.34	£18.22
40 Way	£0.40	£21.44
50 Way	£0.50	£26.80
60 Way	£0.64	£33.92
IDC Crimp tool		£11.80

CCTV - Black & White Module

A miniature CMOS camera module with a 3.6mm F2 Lens, video output & power via connectors provided.

Specs (660-800)
Power: 12Vdc 50mA
Video System: CCR
Pixels: 352 x 288
Min Illumination: 0.5Lux
Video Output: 1 Vpp, 75Ω
Dims: 35 x 35 x 28mm 20g

£16.60

CCTV - Colour Module

A miniature colour CMOS camera module with a 3.6mm F1.2 Lens, video output & power via connectors provided.

Specs (660-842)
Power: 12Vdc 150mA
Video System: PAL
Pixels: 628 x 582
Min Illumination: 3Lux
Video Output: 1 Vpp, 75Ω
Dims: 28 x 28 x 28mm 20g

£36.33

CAT5e Networking

UTP Cable
Conforms to CAT5E
100MHz standard,
ETA verified TIA/EIA 568-B.2

305m Box	£23.93
100m Reel	£13.33

exc carriage.

RJ45 Outlet Kit
Backing Box
2 Gong Plate
RJ45 Module
Blank Module
Colour coded id inserts.

special price £2.99

Tools
Plastic punch down tool & cable stripper £1.40
Professional punch down IDC & trim tool £7.38

NOW IN STOCK
Patch & Cross-over leads from £0.50, Full range of outlet modules/keystone outlets, switches & accessories.

Tel: 0191 2514363 Fax: 0191 2522296 Email: sales@esr.co.uk <http://www.esr.co.uk>

EVERYDAY PRACTICAL ELECTRONICS

THE No.1 MAGAZINE FOR ELECTRONICS TECHNOLOGY & COMPUTER PROJECTS

VOL. 34 No. 11 NOVEMBER 2005

Editorial Offices:
EVERYDAY PRACTICAL ELECTRONICS EDITORIAL
Wimborne Publishing Ltd., 408 Wimborne Road East, Ferndown,
Dorset BH22 9ND
Phone: (01202) 873872. Fax: (01202) 874562.

Email: enquiries@epemag.wimborne.co.uk
Web Site: www.epemag.co.uk
EPE Online (downloadable version of *EPE*): www.epemag.com
EPE Online Shop: www.epemag.wimborne.co.uk/shopdoor.htm
See notes on **Readers' Technical Enquiries** below – we regret lengthy technical enquiries cannot be answered over the telephone.

Advertisement Offices:
EVERYDAY PRACTICAL ELECTRONICS ADVERTISEMENTS
408 Wimborne Road East, Ferndown, Dorset BH22 9ND
Phone: 01202 873872 Fax: 01202 874562
Email: stewart.kearn@wimborne.co.uk

Teach-In Again

Teach-In is here again and our new series promises to be one of the most popular ever with many students, hobbyist and educators expressing an interest in the course. We are also very pleased to welcome Rapid Electronics to our pages. Rapid have very generously sponsored the series and will present over £600s worth of prizes to 22 *Teach-In 2006* "students" who achieve top marks in our end of term on-line test – see the *Teach-In* pages for full details.

It is great to see a large distributor like Rapid recognising the importance of the hobbyist/student market and investing in future customers who could well go on to be important individuals within large electronics companies. We know that many who started their interest in electronics through the pages of *EPE* have gone on to have excellent careers in the industry or in associated industries.

Face Lift

Like myself and the staff at *EPE* no doubt regular readers will feel at home with our general look, feel and layout. However, the magazine has become rather stuck in a time warp and we feel it must now get "with it" rather more. We are planning to improve the paper quality and go full colour throughout the magazine with effect from the January 2006 issue. Whilst the look and layout of the magazine will change with a much greater use of colour all the regular *EPE* items will continue, so those of you who love the present magazine will still get a mix of projects plus theory, news and comment, much the same as in the past. It will mean getting used to a new, and we believe improved look, which should help us to appeal to new readers more used to seeing magazines in full colour on better paper. This does *not* mean an increase in cover price, we are planning to hold the price for some time yet.

You can, of course, get your magazine for the equivalent of just under £2.59 a month if you take out an annual subscription now (even less if you buy a two year subscription!) but don't wait, we will have to increase the subscription price very soon due to increased postage charges; we have managed to hold the old price for some time but something has to give now. You will find our subscription offer on page 775.

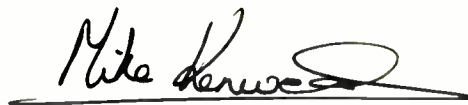

Editor: MIKE KENWARD
Deputy Editor: DAVID BARRINGTON
Technical Editor: JOHN BECKER
Business Manager: DAVID J. LEAVER
Subscriptions: MARILYN GOLDBERG
General Manager: FAY KEARN
Editorial/Admin: (01202) 873872
Advertising Manager:
STEWART KEARN (01202) 873872
On-Line Editor: ALAN WINSTANLEY
EPE Online (Internet version) **Editors:**
CLIVE (MAX) MAXFIELD and ALVIN BROWN

READERS' TECHNICAL ENQUIRIES

E-mail: techdept@epemag.wimborne.co.uk
We are unable to offer any advice on the use, purchase, repair or modification of commercial equipment or the incorporation or modification of designs published in the magazine. We regret that we cannot provide data or answer queries on articles or projects that are more than five years old. Letters requiring a personal reply *must* be accompanied by a **stamped self-addressed envelope** or a **self-addressed envelope and international reply coupons**.

PROJECTS AND CIRCUITS

All reasonable precautions are taken to ensure that the advice and data given to readers is reliable. We cannot, however, guarantee it and we cannot accept legal responsibility for it. A number of projects and circuits published in *EPE* employ voltages that can be lethal. **You should not build, test, modify or renovate any item of mains powered equipment unless you fully understand the safety aspects involved and you use an RCD adaptor.**

COMPONENT SUPPLIES

We do not supply electronic components or kits for building the projects featured, these can be supplied by advertisers (see *Shoptalk*). **We advise readers to check that all parts are still available before commencing any project in a back-dated issue.**

ADVERTISEMENTS

Although the proprietors and staff of EVERYDAY PRACTICAL ELECTRONICS take reasonable precautions to protect the interests of readers by ensuring as far as practicable that advertisements are *bona fide*, the magazine and its Publishers cannot give any undertakings in respect of statements or claims made by advertisers, whether these advertisements are printed as part of the magazine, or in inserts.

The Publishers regret that under no circumstances will the magazine accept liability for non-receipt of goods ordered, or for late delivery, or for faults in manufacture.

TRANSMITTERS/BUGS/TELEPHONE EQUIPMENT

We advise readers that certain items of radio transmitting and telephone equipment which may be advertised in our pages cannot be legally used in the UK. Readers should check the law before buying any transmitting or telephone equipment as a fine, confiscation of equipment and/or imprisonment can result from illegal use or ownership. The laws vary from country to country; readers should check local laws.

AVAILABILITY

Copies of *EPE* are available on subscription anywhere in the world (see opposite), from all UK newsagents (distributed by COMAG) and from the following electronic component retailers: Omni Electronics and Yebbo Electronics (S. Africa). *EPE* can also be purchased from retail magazine outlets around the world. An Internet on-line version can be purchased and downloaded for just \$14.99US (approx £8) per year available from www.epemag.com

SUBSCRIPTIONS

Subscriptions for delivery direct to any address in the UK: 6 months £16.50, 12 months £31, two years £57; Overseas: 6 months £19.50 standard air service or £28.50 express airmail, 12 months £37 standard air service or £55 express airmail, 24 months £69 standard air service or £105 express airmail. To subscribe from the USA or Canada see the last magazine page. Online subscriptions, for downloading the magazine via the Internet, \$14.99US (approx £8) for one year available from www.epemag.com. Cheques or bank drafts (in £ sterling only) payable to *Everyday Practical Electronics* and sent to EPE Subs. Dept., Wimborne Publishing Ltd. 408 Wimborne Road East, Ferndown, Dorset BH22 9ND. Tel: 01202 873872. Fax: 01202 874562. **Email:** subs@epemag.wimborne.co.uk. Also via the **Web** at: <http://www.epemag.wimborne.co.uk>. Subscriptions start with the next available issue. We accept MasterCard, Amex, Diners Club, Maestro or Visa. (For past issues see the *Back Issues* page.)

BINDERS

Binders to hold one volume (12 issues) are available from the above address. These are finished in blue p.v.c., printed with the magazine logo in gold on the spine. Price £7.95 plus £3.50 p&p (for overseas readers the postage is £6.00 to everywhere except Australia and Papua New Guinea which cost £10.50). *Normally sent within seven days but please allow 28 days for delivery – more for overseas.*

Payment in £ sterling only please. Visa, Amex, Diners Club, Maestro and MasterCard accepted. Send, fax or phone your card number, card expiry date and card security code (the last 3 digits on or just under the signature strip), with your name, address etc. Or order on our secure server via our UK web site. Overseas customers – your credit card will be charged by the card provider in your local currency at the existing exchange rate.



Speed Camera Watch Mk2

Mike Hibbett

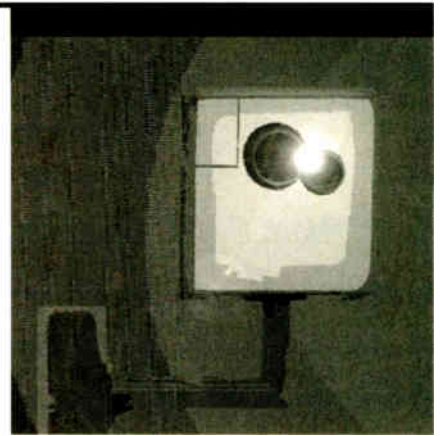

An enhanced version of a sophisticated unit to improve your road safety when driving.

SPEED cameras have become a common sight on our roads, and while they serve a valuable deterrent to dangerous driving, they are also a bane; the slightest, shortest exceeding of the limit can result in fines, points and an increase in insurance costs.

Devices to detect speed cameras have been available on the market for some time, and their interesting use of GPS technology lead to the *EPE Speed Camera Watch* project being published in Jan '05. The publication of that article generated a lot of interest, and many suggestions for enhancements. The unit had a simple l.e.d. bargraph and acoustic alerter for proximity warning, and a database of up to 1000 camera positions.

Speed Camera Watch Mk2 (CW2) addresses those suggestions. It has been given the ability to store up to 10,000 camera positions, and has a fast microcontroller that can scan all of these within one second. An l.c.d. provides the visual feedback and enables the display of additional GPS related information, including useful things like where you are and at what altitude!

RS232 Interface

Another frequently requested addition was for an RS232 PC interface. This has been provided and the database in the unit can now be extracted, uploaded to the internet and shared with other users. You can also download other users' databases and merge them with your own.

To facilitate this, the author has set up a website (www.drivesentinel.co.uk) specifically to provide a central point for people to exchange databases. The website also provides help, forums and even a map with satellite pictures (courtesy of *Google*) showing the positions of all the recorded camera locations.

There is also a previously-existing website, www.pocketgps.co.uk, that has its own database which contains about 6000 known camera positions and is updated every month. PocketGPS have kindly allowed the author to enable support for this database; the file can be freely downloaded from their website and imported into the unit.

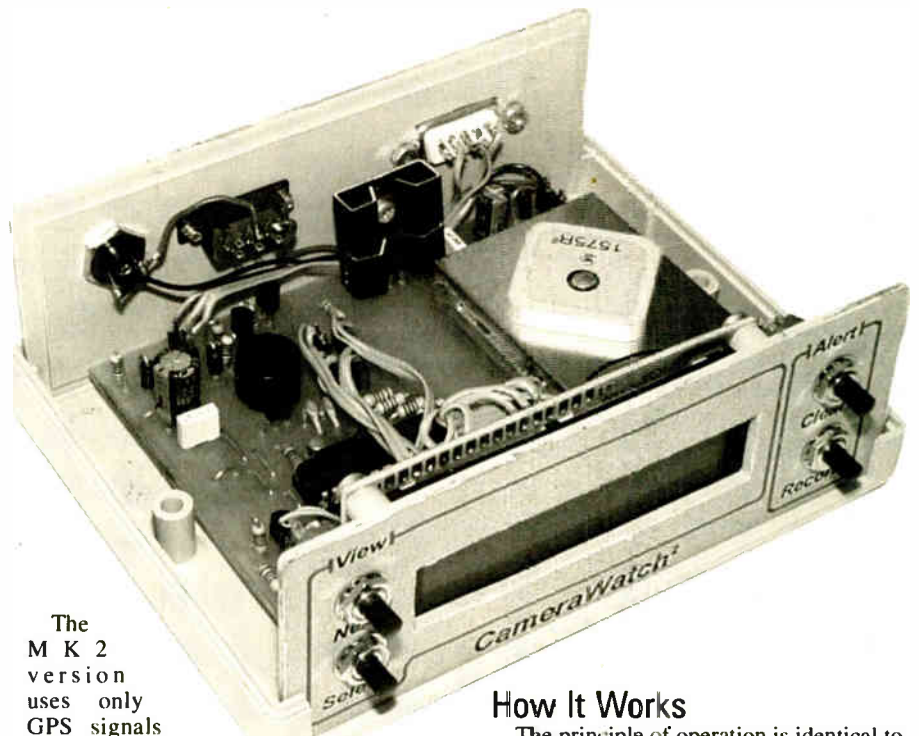

The M K 2 version uses only GPS signals to "detect" the location of speed cameras.

Detection of radar signals is technically illegal in the UK and so equipment that includes detection facilities is of dubious merit. It is the author's understanding that other European countries take an even dimmer view of such devices, and so radar detection is not included in this unit.

Speed Alert

What has been included, however, is the ability to set an acoustic warning for exceeding preset speeds (30, 40, 50, 60 and 70mph). Surprisingly, since we all have speedometers in our vehicles, this has proved very useful – when travelling on a motorway, for example, and then entering a 30mph zone, the author has sometimes found it difficult to maintain the correct speed without constant reference to the console.

Now, with an acoustic alert, you can concentrate on the road without having to worry about your speedometer. You will find the results surprising!

How It Works

The principle of operation is identical to that of the original *Speed Camera Watch*, and in fact much of the software has been reused, and simply optimized for the new microcontroller – the PIC18F2420. This PIC is twice as fast as the PIC16F873 used in the original. It also offers hardware multiply instructions which help provide the improved processing capability.

The other change that provides the final speed improvement is a change from IC to SPI-based EEPROM memory for the database storage. This memory can be read at 10 times the speed of the former, enabling the unit to read 10,000 camera locations and solve a two-dimensional trigonometric problem on all of them every second. Not bad for a humble PIC!

Two GPS modules are supported: The Holux-UK GM-21 and the RF Solutions LS-40CM. Other modules may well work, possibly with a little tweaking of the software. Interested parties are welcome to contact the author for help if needed via the [drivesentinel](http://drivesentinel.co.uk) web site. The GPS module has an integral antenna which should work in most cases. If your car is fitted with a heated front windscreen, however, or you

frequently drive in heavily built up areas, then you should consider using a module with an external antenna. The RF-Solutions module has a connector for an external antenna.

Initially, when the unit is first switched on, the GPS will start to search for satellite data. The acquisition time depends on when the unit was last used; it can take from one second to approximately one minute if stationary. If you are driving it may also take longer since the GPS module must compensate for the vehicle movement.

Every second the unit calculates the distance to the closest camera, the vehicle's speed, the direction of travel and the altitude above mean sea level. The user can choose from a number of different displays, and be alerted on close proximity to a camera or on going over a selected speed limit. As the algorithm used is so similar to the original unit, readers are referred to the original article for the mathematics involved.

The final benefit from using the PIC18F2420 microcontroller in this unit is that this PIC supports "self programming",

where the software is able to erase and change program memory while running. This means that a "bootloader" could be integrated into the unit, enabling the downloading of new software into it without even having to disassemble the case. New software can be downloaded via the RS232 interface, making experimentation easier and quicker.

Circuit Diagram

The complete circuit diagram for Speed Camera Watch Mk2 is shown in Fig.1. Signals from the GPS Receiver come in

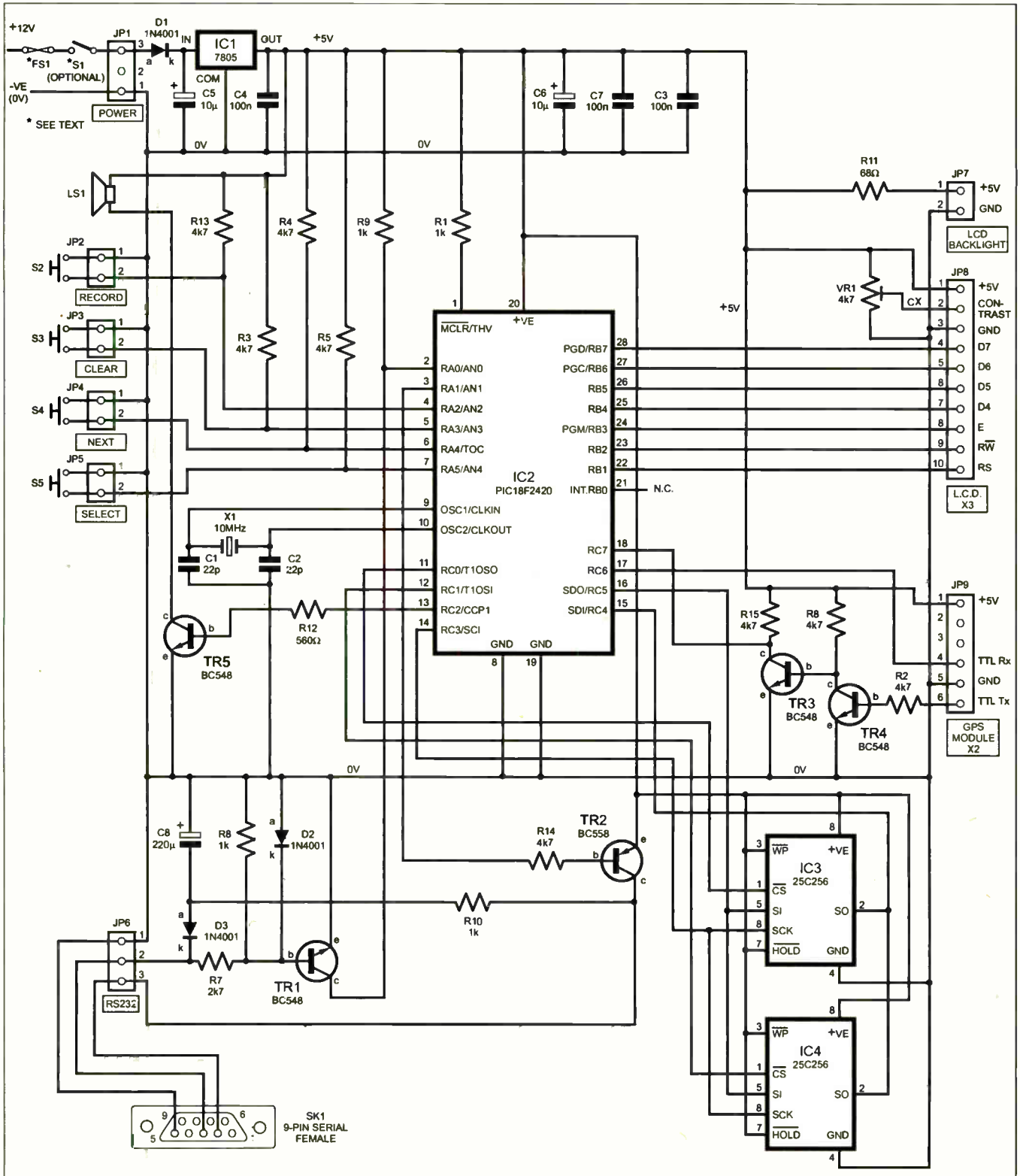

Fig.1. Full circuit diagram for the Speed Camera Watch Mk2. The GPS module is connected in circuit at junction point JP9



via connector JP9. However, the GPS data output pin only supplies 3V, which is insufficient for the PIC. Transistors TR3 and TR4 level shift this signal to give 5V into the processor's UART port via PIC pin RC7.

The processor's UART output pin (RC6) is connected to the GPS module but is currently unused. A second serial port connection on JP6 serves as the PC interface. The signals are level shifted and inverted from RS232 format to TTL levels by transistor TR1 and TR2. Capacitor C8 and diode D3 "steal" negative voltage from the PC's transmit signal to provide the RS232 output voltage swing.

This saves the use of the more usual MAX232 RS232 interface device, and requires less printed circuit board space. The PC interface uses a "bit-bashed" UART implementation.

IC3 and IC4 are SPI mode serial EEPROMs which provide the non-volatile memory for the camera database. Each camera location requires six bytes – two 24-bit signed numbers to hold the latitude and longitude values. The i.c.s. are surface mount devices.

On Display

An alphanumeric l.c.d. module is connected to the PIC in 4-bit interface mode. Preset VR1 provides Contrast control. It is recommended that an l.c.d. with an l.e.d. backlight is used, the power for which comes from connector JP7. Series resistor R11 is used to reduce the brightness of the backlight, since at night a full backlight can be quite distracting. The values specified here gives a very dim glow; you may reduce the value for a brighter backlight if desired.

The PIC modes are controlled by push-switches, S2 to S5, their functions are described later. Resistors R3 to R5, plus R13, bias the PIC pins to which they are connected normally-high.

Power at 9V to 14V d.c. is input to the unit via connector JP1. Voltage regulator IC1 reduces this to provide 5V to the circuit. It is recommended that a small heatsink be fitted to IC1 since it can run quite hot, especially on hot summer days. A small rectangle of aluminium approximately 30mm x 10mm would be sufficient.

Audible alerts are software-generated via PIC pin RC2. The signal is buffered by resistor R12 and amplified by TR5 before driving a small loudspeaker, LS1. The tiny speaker used in the prototype produces a fairly "tinny" sound; however, TR5 is capable of driving a standard 8ohm loudspeaker – if you can find somewhere in your case to put it!

Construction

Due to the extensive peripherals built into the PIC18F2420, allowing for design simplicity, the circuit has been built onto a single-sided p.c.b. that also holds the GPS module. To keep the p.c.b. small and low cost a number of link wires have been used.

Component and track layout details for this board are shown in Fig.2. It is available from the *EPE PCB Service*, code 541.

Assemble the p.c.b. in the usual order of ascending component size, leaving the d.i.l. i.c.s. until last. Use a socket for the PIC.

COMPONENTS

Resistors

R1, R8 to R10	1k (4 off)	See SHOP TALK page
R2 to R6, R13 to R15	4k7 (8 off)	
R7	2k7	
R11	68Ω	
R12	560Ω	
All 0.25W 5% carbon film		

Potentiometer

VR1	4k7 preset, round
-----	-------------------

Capacitors

C1, C2	22p ceramic (2 off)
C3, C4, C7	100n polyester (3 off)
C5, C6	10μF radial elect. (or tantalum bead) 16V (2 off)
C8	220μ radial elect. (or tantalum bead) 16V

Semiconductors

D1 to D3	1N4001 rectifier diode (3 off)
IC1	7805 +5V 1A regulator
IC2	PIC18F2420 microcontroller, preprogrammed (see text)
IC3, IC4	25C256 SO-08M (surface mount) serial memory (2 off)
TR1, TR3 to TR5	BC548 npn transistor (4 off)
TR2	BC558 npn transistor

Miscellaneous

JP1, JP6	3-way header pin connector 2.54mm pitch (2 off)
----------	---

JP2 to JP5, JP7	2-way header pin connector 2.54mm pitch (5 off)
JP8	10-way header pin connector 2.54mm pitch
JP9	6-way header pin connector 2.54mm pitch
LS1	T70P015H min. loudspeaker, (see text)
X1	10MHz crystal
X2	Holux-UK GM21 GPS module plus CA21 cable or LS-40CM plus CBA-LS-40M cable (RF Solutions) alphanumeric l.c.d. module, 2 line x 16 character (per line), with back light (see text)
S1	s.p.s.t. slider switch (see text)
S2 to S5	min. momentary push-to-make switch (4 off)
SK1	9-pin D-type connector, female, panel mounting

Printed circuit board, available from the *EPE PCB Service*, code 541; plastic case 128mm(w) x 50mm(h) x 98mm(d); 28-pin d.i.l. socket; d.c. power socket (optional, see text); cigarette lighter plug and lead, with suitable terminating plug

Approx. Cost
Guidance Only

£90
excl case

SPEED CAMERA WATCH Mk2 – CIRCUIT BOARD CONSTRUCTION

IC3 and IC4 are surface mount (SM) devices and as such are soldered to the *trackside* of the board. Use a fine-tipped soldering iron for this, plus fine (say 18 s.w.g.) solder and take extreme care that solder does not short between the narrowly-spaced pins.

If you are not used to handling SM components, you may find it best if you solder just one corner pin of each device first. Check then that the other i.c. pins are in contact with their tracks, then *very carefully* apply solder to them.

Use a close-up magnifying glass to check that your soldering is satisfactory, not only for the SM i.c.s., but also for the rest of the board. Also check the board thoroughly for general correctness of assembly.

Case Assembly

Drill and cut the holes in the front and rear panels of the case for the off-board components. The mounting holes for the l.c.d. should be countersunk, and countersunk bolts used for securing it.

Prepare the GPS module for assembly into the box. The cable (supplied separately from the module) comes with a tiny 6-pin connector and flying lead.

Cut the cable to a short enough length for easy wiring in the enclosure but do not leave too much cable otherwise it may flap about and obscure the module antenna. Strip the individual wires back by about 3mm and tin them. Connection details for the two suggested GPS modules are shown in Fig.3 and Fig.4.

First Checks

Connect a 12V d.c. power supply to JP1 and check that there is 5V at the PIC's power pins. If not, check for shorts or diode D1 being fitted the wrong way round. Now fit the preprogrammed PIC and wire the l.c.d. (X3) to JP8 and JP7.

Again apply power; within a second you should hear a few notes from the speaker. Now adjust preset VR1 to get a suitable contrast setting on the l.c.d.

If you did not hear any sound and cannot get anything displayed on the l.c.d., check the l.c.d. wiring and that power is reaching its allocated pins. If you can see text on the display but heard no sound, check the orientation of transistor TR5.

Once you have confirmed basic operation, mount the GPS module onto the p.c.b., socket pointing towards JP7. Secure the module with double-sided foam or Velcro tape, or hot melt glue. You can now complete the assembly and final soldering of switches and connectors.

Power is typically supplied from an in-car cigarette lighter socket, so you should create a lead for this, correctly terminated with a suitable d.c. power plug. You can purchase cigarette lighter plugs with integral fuses but if you are using one without a fuse it is recommended that an in-line 1.25A slow blow fuse, with holder, is inserted. The cigarette lighter socket is capable of supplying 10A continuously, which is sufficient to melt the p.c.b. tracks if you have a p.c.b. short in the wrong place!

You should also make sure you have a 400mA 9V d.c. unregulated power supply (the plug-top type) so that you can use the

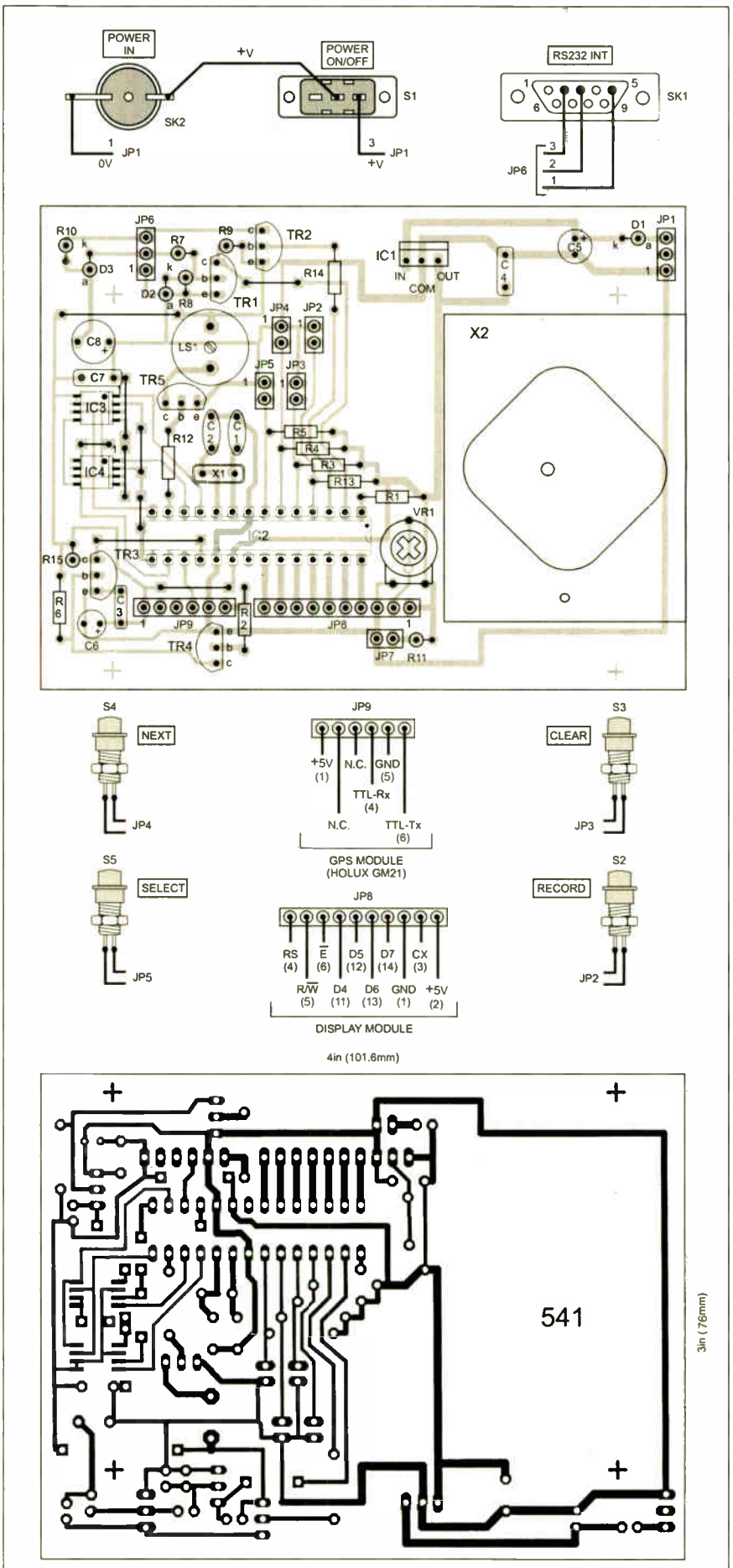
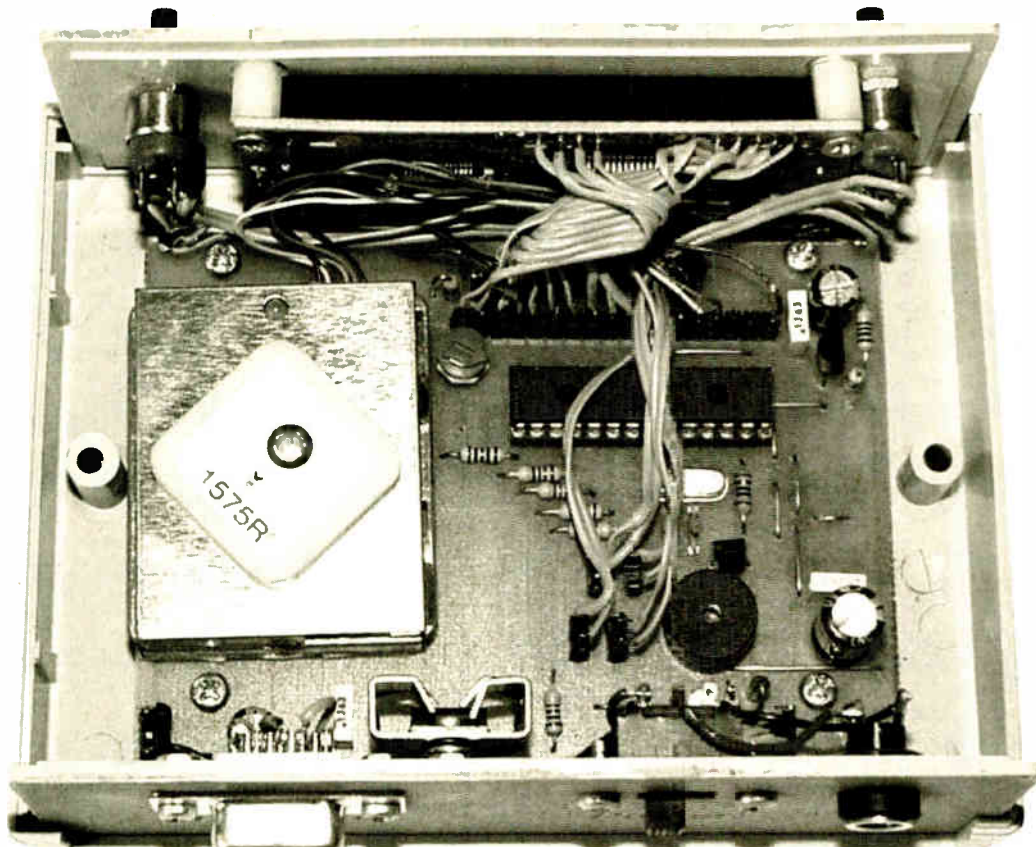

Fig.2. Component and copper track layout details for Camera Watch Mk2. Note that the surface mount devices, IC3 and IC4, are soldered directly on the copper tracks



Interior view showing the position of the Holux GPS Receiver and the display module bolted to the rear of the front panel

unit away from the vehicle when making database updates. Cheap radio mains adaptors are perfectly suited, so long as they have the correct d.c. plug termination and polarity.

In Use

Place the unit on the vehicle dashboard where it can get as much view of the sky as possible, without affecting your driving vision. Plug the unit into the cigarette lighter socket, and away you go! Note that some vehicles provide continuous power to the cigarette socket even when the engine is turned off. If this is the case in your car, you should install an off-switch (S1) in the power supply lead so you can turn the unit

off when the engine is off to save draining the car's battery.

On initial power up the unit will give a short series of notes (the author thinks it's a tune...) and then show the default display. Once the unit has acquired all the necessary satellite data it will give two short beeps. It will give a lower frequency beep if it should lose lock (for example, in a tunnel). The display will warn you if it does not have any valid location information, but you will quickly become accustomed to the sounds made by the unit.

On The Button

The device has several displays that you can cycle through using the Next switch (S4). After five seconds of inactivity, the display returns to the default display. Pressing Select (S5) will cause the currently viewed display to become the new default display. The Clear button (S3) can be used to silence an alert. Pressing Clear when an alert is not sounding will cause the closest camera position to be deleted from your database.

The Record button (S2) can be used to log the current location into the database. You should press this at the moment that you pass a new camera, if it is safe, roadwise, to do so.

The first display shows a simple bargraph of proximity.

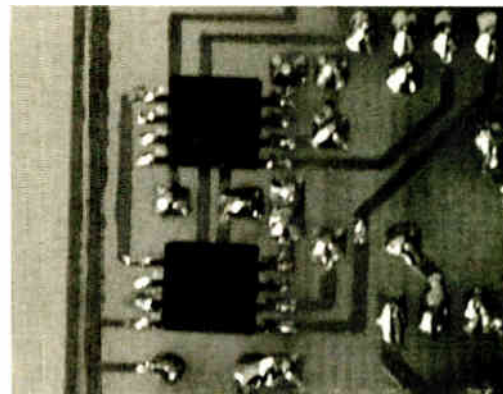

The two surface mount serial memory i.c.s soldered directly onto the underside copper pads. Use a fine-tipped soldering iron for this and take care that solder does not bridge any of the copper pads

As you get close to a camera the unit will start to beep, and the frequency of the beeps will increase as you get closer. The

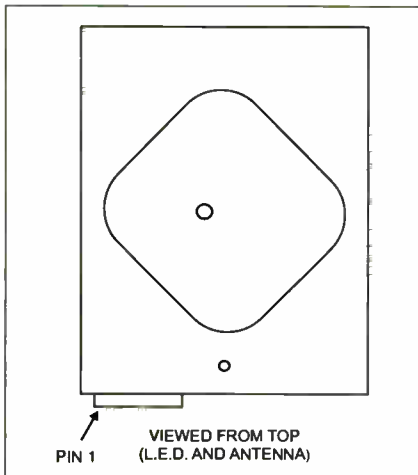

GM21	
CONNECTOR	PCB JP9 PIN
1	1
4	4
5	5
6	6

Fig.3. Connection details for the Holux GM21 GPS module

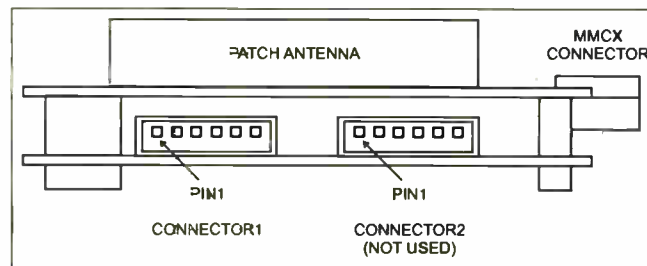

I.S-40CM	
CONNECTOR 1	PCB JP9 PIN
5	1
2	4
6	5
7	6

Fig.4. Connection details for the RF Solution GPS module



Front and rear views of the Speed Camera Watch Mk2. The function buttons (S2 to S5) are mounted either side of the front panel display window. The PC Interface socket is located on the back panel as indicated

next five displays provide the bargraph but also a distinctive acoustic warning if the speed exceeds the displayed limit. Slowing down will stop the alert.

The next display shows altitude above sea level in metres and the direction of travel in degrees. The following display shows your position, latitude on the top, longitude on the bottom. Another screen displays the software version, and finally there is a screen for accessing the PC link.

PC Interfacing

The RS232 cable for interfacing with a PC should be a "straight through" 9-pin male to 9-pin female.

The project files (downloading details later) include a program called **cw2link.exe**. This can be used to manage the database on your unit, allowing you to merge it with databases from other users. To install the program open the **cw2link.zip** file and extract the files to your PC. Double click on the **cw2link.exe** program to start it up.

Select the Options menu to choose the correct COM port that you will be using. Under the Database menu you have four options for managing the camera database. These allow you to transfer a database into the program (Read) or output the database to the unit or a file on your PC.

To upload your unit's database to the internet, select Read From Unit, followed by Write to File. To transfer a database that you have downloaded from the Internet select Read From File, followed by Write To Unit.

Whenever you read a database into **cw2link** the camera locations will be indicated on the map with red dots, rather like a rash. Quite appropriate! When the program reads data from a file or the unit, it always merges that data with any already in the program; identical camera positions are discarded. This way you will not lose any information that you have recorded.

DriveSentinel Web Site

The DriveSentinel website provides an area for you to share your database with others, and to download new updates. Using a browser, navigate to the website and select the Camera Database page. Run the **cw2link** program and read the database from your unit, saving it to a file.

Back in the browser, click on the Browse button and locate your file, select it then click Upload. This will copy your database to the website. After a day or two any new

camera locations will be transferred to the main database. To download the main database from the website simply click on the link Latest Database and select Save. Once saved, you can load that file into the **cw2link** program and then program it into your unit.

Downloading Other Locations

There is a website, www.pocketgps.co.uk, that maintains an extensive database of camera locations. The **cw2link** program has an import facility (under the Advanced menu) that can read this file. To use it, first download the zip file from the website by clicking on its Download The Database link and store the file on your PC.

Unzip this file and extract the files. On the **cw2link** program select the Import Camera Database from the Advanced menu, click Browse and select the file **pocketgps_uk_sc.csv** in the directory **single file version\csv file\other** then click Import to load it. A message box will appear stating the number of locations loaded, and when you press OK, the map will update showing the camera positions. You may now write this data to your unit.

Software Upgrading

The process for changing the software in the unit, either to fix bugs (should any come to light) or to add new features, has been simplified by the inclusion of a bootloader in the unit's software. A bootloader is an independent piece of software that can re-write the main application software without the need to access the p.c.b. directly.

The bootloader is started by pressing the Next switch (S4) while switching the unit on; the display will indicate that it is in Bootloader mode and waiting for the PC to send it a file. If this should happen by accident simply turn the unit off and then on again.

The software update can be performed by the **cw2link** program through the Advanced menu. It should be noted that the bootloader is part of the application software, so it is still necessary to program the PIC in the normal way first.

Going Further

With the bootloader facility, changes to the software are very easy to test and mistakes easy to rectify, which we hope will encourage experimentation. The different displays are implemented in a single source file, **displays.inc**, which is relatively easy to read because all the complex maths and low level driver code is hidden away in other source files.

There are forums and FAQs (frequently asked questions) on the **drivesentinel** website that will help answer any questions. The tunes and alerts that are created can also be easily modified. These are defined and documented in the source file **melody.inc**

Resources

All the software for Speed Camera Watch Mk2 can be downloaded free from the **EPE UK** web Downloads site, access via www.epemag.co.uk. Preprogrammed PICs are available as stated in the *Shoptalk* page.

References

Original *Speed Camera Watch*, *EPE* January 2005

DriveSentinel: www.drivesentinel.co.uk

Microchip AN617 – Fixed point math routines: <http://www1.microchip.com/downloads/en/AppNotes/00617.pdf>

Dr Math – several explanations of the mathematics involved: www.mathforum.com/library/drmath/view/51711.html

Pocket GPS World – database of speed camera locations: www.pocketgps.co.uk/uksafetycameras.php □

ASSISTANT MAINTENANCE ENGINEER (London)

Mayfair Recording Studios is seeking an assistant engineer to complete our staff due to an expansion programme.

The person must have an electronics qualification and/or have previous experience repairing studio equipment and be able to work late hours and weekends.

Send CV and a short presentation letter to

bookings@mayfair-studios.co.uk (Subject: Job Prospect)



TARDIC ANTENNAS AND METAMATERIALISM

Larger than its physical size, the science fiction *TARDIS* defies the rules of science. Microwave antennas can do this for real, as Mark Nelson reveals

EVER since David and Goliath, history has recorded examples of the puny outstripping the gigantic. It's a theme that recurs repeatedly and always seems to give us a warm feeling when little gets the better of large.

It happens in electronics too when clever design achieves mega-bang for mini-buck. Radio astronomers have been doing it very successfully for quite some time, exploiting a technique known as linked interferometer networks to create huge "virtual" antennas for their radio telescopes. These systems are utterly fascinating (we'll return to them shortly), highly ingenious and extremely effective. But you need an area at least the size of a football pitch for each element in the network, so they are not the kind of technology you can apply to a mobile phone.

Metamaterials, on the other hand, look set to transform the efficiency of mobile phone antennas and perhaps improve all manner of other wireless entertainment systems in the home, so this month we will also investigate the promise that these hold out. It's a case of little and large but in the reverse order.

MERLIN's Magic

You don't need to be a professional astronomer or mariner to know that the more powerful your telescope, the clearer the view you gain of distant objects. The larger the lens, the better the view. This law of optics applies equally well to radio; the larger the antenna, the more signal it picks up. A set-top TV antenna is never as good as a multi-element beam on the chimney and a big satellite dish always picks up a better signal than a tiddler does.

Radio astronomy works with signals far weaker than terrestrial or satellite transmitters. You start to get decent results only when you use an antenna dish the size of Jodrell Bank and the cost and size of arrays like this limit the number of radio observatories you can erect. Frustrated scientists looking for other ways of expanding their radio vision of the skies came up with the notion of a "virtual" antenna and one of the most successful examples is MERLIN, operated by Jodrell Bank observatory.

MERLIN stands for Multi-Element Radio Linked Interferometer Network and is an array of radio telescopes distributed around Great Britain, with separations of up to 217km. A series of microwave links brings back the signals from each outstation to a central site, where these are combined into a single product. The resulting signal is equal to what would be achieved by a single giant antenna of fea-

sible proportions, giving an accuracy (resolution) better than 50 milliarcseconds (at 5GHz operating frequency), greater than that of the Hubble Space Telescope.

Effectively the network of smaller aeriels creates, or rather simulates, an antenna 230km across and since it was first put into service in 1980, the images it produces have helped shed light on the mysterious processes going on inside radio galaxies and quasars. MERLIN can also be linked up to other radio telescopes around the world to create virtual antennas of utterly monstrous proportions in a technique known as Very Long Baseline Interferometry (VLBI).

Networks like MERLIN have not yet attained the ultimate in astronomical resolving power and, provided that suitable arrangements can be made for combining the signals, there is no limit on how far apart the individual telescopes can be placed. The greater the distance, the greater the resolving power.

With VLBI, real-time links are not required between sites either: the radio signals are recorded on tape at each telescope together with a synchronizing signal giving precise timing information from an atomic clock. The tapes are then sent to a correlating centre, where they are played together and combined just as if the signals were coming direct from the telescopes in real time. The correlated data can then be turned into images using similar software to that used by MERLIN.

You can read more about the way MERLIN works and what it achieves at www.merlin.ac.uk.

Metamaterialism Made Known

The term metamaterials may well be new to you (it certainly was to me) you'll doubtless be hearing more of them soon. An American military website describes them as a new class of ordered nanocomposites that exhibit exceptional properties not readily observed in nature.

It continues, "The physics of 'small-scale' lies at the heart of the metamaterial advantage. The physics at small scale is different than bulk physics and, from a performance standpoint, often significantly better. Quantum confinement, exchange-biased ferromagnetism, and effective media responses are all examples of how the physics at small-scale can result in enhanced electromagnetic properties."

That's quite a lot to take in but the phrase "enhanced electromagnetic properties" is what is enthusing scientists. Certain parameters can be fine-tuned to create negative values, allowing researchers to create materials with some very unusual properties, such as

amplifying radio waves without electrical power. Continues the DARPA website, "Some researchers claim that materials with such novel properties could transform wireless communications as well as microwave, optical and magnetic imaging."

Fine business, but what does this mean in plain language? John Byrne of the Institute of Physics (IoP) puts it simply: metamaterials can create antennas that behave electrically as if they are larger than in reality. These exotic properties could be harnessed to increase antenna efficiency and performance, deliver greater bandwidth and minimize size and weight.

His report quotes Chris Taylor, an analyst with the market-research firm Strategy Analytics, who believes there are many potential applications for metamaterials. "In mobile handsets metamaterials could be used for small, high-gain planar antennas. These could help improve reception, downlink data rates and network capacity through diversity." At cellular base stations the large sector antenna arrays used at present could be replaced with a single smaller antenna made from metamaterials.

Work in Progress

Whilst metamaterials appear to hold out considerable promise, it may be some time before they appear in consumer electronics and right now research is confined mainly to academic and military laboratories. The only mainstream manufacturer noted in the IoP report is Nortel (Northern Telecom), which is working with the University of Toronto in exploring the potential of metamaterials in future wireless broadband networks.

A company spokesperson said, "Our work is focused on the design of compact antennas for terminals. We are looking at single-feed and multiple-feed antenna elements, and their performance on PDAs and laptops. However, we are not in a position to talk about any product plans or development because we are still evaluating the technology."

Long-term prospects for metamaterials look bright to Chris Taylor of Strategy Analytics nevertheless. He is quoted as stating, "Given the annual volume of handsets – which is greater than 650 million per year – I would expect products to first appear here rather than in network infrastructure. Multiple antennas and smaller, cheaper front-end modules for handsets are probably the most exciting areas. This is a potential market of about 500 million units per year. I cannot really judge when these might appear, but they would appear to be at least several years away."

RENEWABLE COPY PROTECTION

The latest attempts at defeating DVD hackers aim at zero awareness of the consumer – Barry Fox reports

THE new High Definition DVD blue laser system, due for launch in the 4th quarter this year, will be the first consumer product to use “renewable” copy protection that self-repairs when pirates hack its secrets. But the DVD Forum, which is backing HD-DVD against the rival Blu-Ray blue laser system, has still not decided on the final specifications for renewable protection.

Renewable Systems

There are two renewable systems for HD-DVD on offer. Advanced Access Content System was developed by companies that also developed HD-DVD, and is thus the preferred protection for HD-DVD. (http://aacsla.org/specifications/AACS_Spec-Common_0.90.pdf).

Says Mark Knox, spokesman for the HD-DVD Group in the US: “AACS was adopted for HD-DVD by a vote of the DVD Forum Steering Committee ... all that remains for it to become final and official is completion of the ‘Compliance and Robustness Rules’ – that’s expected imminently, in time for this Fall’s launch of HD-DVD products.”

The other option is an independent system dubbed Self Protecting Digital Content. SPDC works together with AACS, to try and avoid upsetting innocent consumers who find that legitimate playback of legitimate discs has suddenly and mysteriously stopped as a side effect of Hollywood’s ongoing fight against hackers (www.cryptography.com/index.html)

Intel, IBM, Panasonic, Microsoft, Sony, Toshiba, Disney and Warner developed the Advanced Access Content System for next generation players, such as HD-DVD. Because DVD’s supposedly unhackable copy protection, the CSS Content Scrambling System, was defeated. A hacker simply sucked the de-encryption keys out of a legitimate player and grafted them into simple free software called DeCSS.

DeCSS now lets anyone with a PC copy a DVD movie to a blank disc. Changing DVD’s encryption keys to beat DeCSS would stop millions of legitimate DVD players playing any new discs – which is clearly impractical.

War of the Hackers

Adopting AACS lets Hollywood change the keys used for discs and players, as soon as a pirate hacks them. All this will be done without a phone line or

wireless connection to home players and without their owners even knowing it.

This is possible because the player stores its de-encryption keys in non-volatile flash memory, similar to that used in an MP3 player. This memory can be automatically updated to blacklist any keys that have been hacked. When a consumer buys or rents a new movie disc – like *War of the Worlds* in HDTV – software hidden on the disc silently modifies the player while the movie is playing.

From then hacked keys will stop working. The risk is that after updates some legitimate players will be unable to play some legitimate discs they previously played.

The Motion Picture Association of America, which represents Hollywood and supports AACS, has so far been unable to clarify what playback problems innocent consumers risk as an unwanted side effect of AACS key blacklisting.

Self Protection

Cryptography Research Inc. of San Francisco has developed Self-Protecting Digital Content to reduce this risk. SPDC works hand in hand with AACS. SPDC software on the movie disc sniffs the player for hacked keys and disables playback, just like AACS. But it also puts a message on screen telling the owner of the player how to go on

line or phone the movie studio for advice on how to cure any innocent playback problems.

“Professional pirates, or Joe Sixpack with an unauthorised disc copy program on their PC, will not phone”, says Paul Kocher, CRI’s President and Chief Scientist. “Owners of players and PCs that are legitimate but bugged will get a free fix.”

Technical advisers to the DVD Forum met in Venice at the beginning of July to “decide whether to adopt SPDC in addition to AACS”. No formal announcement has yet been made but leaked reports suggest the experts are split on using SPDC and the Forum may well reject it. (www.cptwg.org/Assets/Presentations%202005/WG9_CPTWG_2005_06_02.pdf).

“The only question is when, not if, pirates will find and exploit a security hole”, says CRI’s VP Kit Rodgers. “Our aim is zero consumer awareness unless you are trying to commit a crime.”

An even bigger question mark hangs over the commercial success of HD-DVD, though. Philips, Panasonic and Sony are still planning to launch the incompatible Blu-Ray blue laser system in head-on competition, and probably with similar renewable protection. All efforts at unifying the two rival formats have failed – and look likely to fail because the optical construction of the discs is so different.

Kempton Park Fair

The Kempton Radio and Electronics Fair will be held at Kempton Park Racecourse in the main exhibition centre on Sunday 13 November 2005. The attractions this time will be:

- RSGB Train the Trainers lectures (sponsored by Kenwood and ML&S)
- RSGB bookstall
- New Raynet communications vehicle demonstration
- HF special events station (sponsored by Kenwood)
- VHF talk-in
- CATS Bring and Buy sale
- Morse proficiency testing

Checkout the www.radiofairs.co.uk website for floor plans, last minute news and updates, or contact Paul Berkley, tel: 01737 279108, fax: 01737 211836, email: paul@radiofairs.co.uk.

Free P.C.B. Software

PCB-Pool have teamed up with Friedrich Engineering to offer electronic engineering students the ideal opportunity to learn a simple yet professional p.c.b. layout software package. This is available to download free of charge and contains the following powerful functions: p.c.b. layout and design, schematic simulation, auto-placer, autorouter, and EMC analysis.

The software is a full license and not just a sketch version. It has no pin or size limitations, and has a full component library.

Once a design has been completed, students can have their designs manufactured to a high quality standard for a fraction of the usual costs.

For more information visit www.pcb-pool.com.

Email: sales@pcb-pool.com. Tel: 0800 3898560. Please mention EPE if you can.

Rapid Literature

Rapid Electronics have sent us two publications – their New Products catalogue and the Winter 2005 Secondary Education edition of *Focus*. The former is a 64-page A4-size well-illustrated catalogue, in full colour, in which they detail over 200 products from leading suppliers.

Specially featured is the introduction of Kingbright I.e.d.s, such as SnapLEDs, XPower and an extended range of Superflux I.e.d.s. The latter range offers new opportunities in lighting design with high-current capabilities having efficient optical packaging.

Focus highlights the new products which have been specifically chosen to cater for teachers' curriculum requirements within subjects such as Science, Design and Technology, and much, much more.

Rapid have been a supplier to schools, colleges and universities for over 25 years, "providing a fast and efficient service of affordable, best value products and components".

For more information contact Rapid Electronics Ltd., Dept EPE, Severalls Lane, Colchester, Essex CO4 5JS. Tel: 01206 751166. Fax: 01206 751188. Email: sales@rapidelec.co.uk. Web: www.rapidelectronics.co.uk, and www.rapideducation.co.uk.

Dimensioned Regulators

Dimension Engineering have introduced two switchmode voltage regulators – the DE-SWOXX and DE-SWADJ. The DE-SWOXX regulators are designed to be the easiest possible way to add the benefits of switch-mode power regulation to a new or existing project. They are pin-compatible with the common 78xx family of linear voltage regulators and the voltage ranges available are 3.3V, 4.2V and 5V. Efficiency is typically 83%, which means that heat sinks will not be needed.

The DE-SWADJ is an adjustable version of the SWOXX. Using a small screwdriver, the output voltage can be adjusted to between 1.3V and 13V, with greater than 90% efficiency.

Both ranges can be used to run servos or other high current loads.

For more information contact Dimension Engineering, 899 Moe Drive #21, Akron, OH 44310, USA. Tel: (330) 634-1430.

Web: www.dimensionengineering.com.

WCN Cat

WCN Supplies have sent us their latest mini-catalogue, issue 22A. In its 16 pages they list their latest good-value offerings, including fibre-optic cable at £1 per 2ft (60cm) to 12V 2.3Ah sealed lead acid gel-type batteries at only £4.95, a whole variety of capacitors, semiconductors, etc., and this time they are "having a clear out" – for £6 per 3kg pack, you can buy "junk" packs of components – items which have been purchased as job lots but which are too small to list. They cannot guarantee what

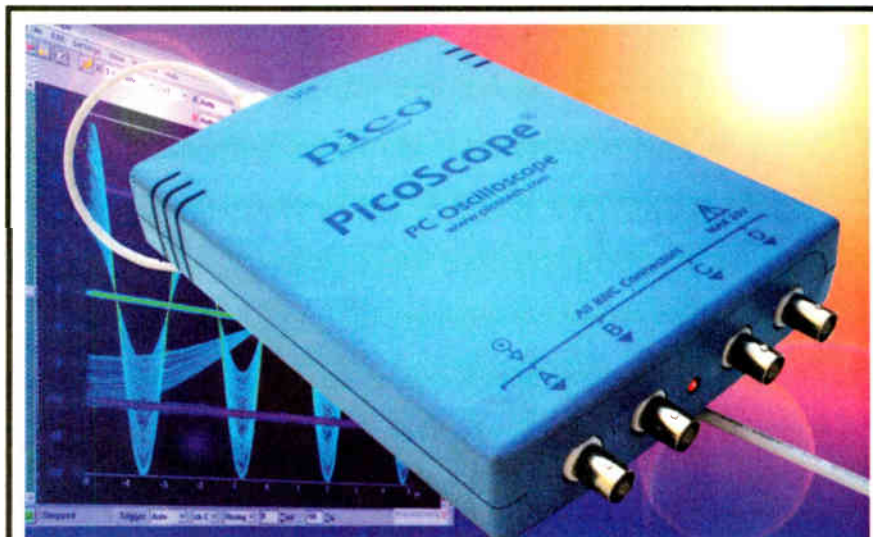

PicoScope 3424 PC Scope

Pico Technology have introduced another virtual scope – the 3424. This is a 4-channel PC scope which has a 12-bit resolution 20MS/s sampling rate and a 512K memory buffer. The addition of a USB 2.0 connection makes using the oscilloscope easy, and enables rapid display updates. The USB interface also powers the unit, eliminating the need for an external supply.

Its large memory buffer allows even long duration signals to be captured at its top sampling speed. Timebases

from 500ns/div to 50s/div and voltage ranges from $\pm 20\text{mV}$ to $\pm 20\text{V}$ make it suitable for a wide range of applications.

Pico have also released a two-channel version, the 3224.

The PicoScope 3424 is priced at £699, and the 3224 at £399, both prices plus VAT. For more information contact PicoScope Technology Ltd, Dept EPE, The Mill House, Cambridge Street, St Neots, Cambs PE19 1QB. Tel: 01480 396395. Fax: 01480 396296. Email: sales@picotech.com. Web: www.picotech.com.

will be in each pack, but say "you sure won't be disappointed"!

For more information, contact WCN Supplies, Dept EPE, The Old Grain Store, Rear of 62 Rumbidge Street, Totton, Southampton SO40 9DS. Tel/fax: 023 8066 0700. Email: info@wcnsupplies.fsnet.co.uk. web: www.wcnsupplies.com.

USBWiz Chip

Crownhill tells us that thanks to USBWiz Chip you can now add USB keyboard, mouse, joystick and printer to your system very easily. USBWiz also includes the FAT file system so that you can use USB thumb drives and external USB (FAT formatted) harddrives. Moreover, USBWiz knows TCP/IP, enabling you to connect your product to the internet or LAN, either through wires or wirelessly.

No USB knowledge is necessary – just plug and play, say Crownhill. The USBWiz manual can be downloaded from www.usbwiz.co.uk.

For more information contact Crownhill Associates, Dept EPE, The Old Station, Station Road, Wilburton, Ely, Cambs CB6 3PZ. Tel: 01353 749990. Fax: 01353 749991. Email sales@crownhill.co.uk.

USB Sees Red

Lascar Electronics Ltd have introduced their USB to InfraRed Converter, USB-Link-IR. Powered from the USB port, this device is designed to work on any PC with

USB compatibility. With the royalty-free driver installed on the host computer, all the user needs to do is connect the ISB-Link-IR to a free USB port to communicate with an IrDA device.

USB-Link-IR offers support for Windows 98SE/2000/XP, MAC OS-X and Linux 2.40. The device is compatible with IrDA 1.4 specifications and is designed to work with existing COM port applications. The Baud rate is fixed at 9600 Baud, although speeds up to 115200 Baud are available on request. The transmission distance between the device and IrDA devices is up to 1.0 metres.

USB-Link-IR is available immediately at a unit price of £35.85, with quantity discounts available.

For more information contact Lascar Electronics Ltd., Dept EPE, Module House, Whiteparish, Salisbury, Wilts SP5 3SJ. Tel: 01794 884567. Fax: 01794 884616. Email: sales@lascar.co.uk. Web: www.lascarelectronics.com.

EOCS Magazine

The latest magazine from the Electronic Organ Constructors Society (EOCS) has been received. If you are interested in knowing more about this long-standing Society, contact:

Don Bray, Editor, EOCS, 34 Etherton Way, Seaford, Sussex BN25 3QB. Tel: 01323 894909. Email: editor@eoocs.org.uk. Web: www.eoocs.org.uk.

TRY IT, A **FREE LITE EDITION** PROTON DEVELOPMENT SUITE

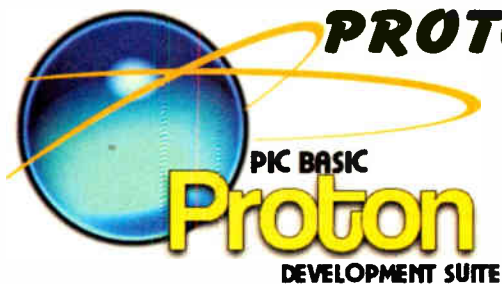

"I find the Proton+ compiler to be absolutely excellent, I've played with others and they don't come anywhere close to Proton+, and it's very reassuring to hear that there's continual development going on. I can honestly say that this is one program that I believe is worth every penny, and unfortunately I don't honestly think I can say that about any other computer program out there at all."

Samuel Hunt,

www.picbasic.org

Wireless made easy, add wireless connectivity to your project, with easyBlue Bluetooth modules. A simple "AT style" serial command set allows integration of wireless communications to your project using serial commands in plain ascii. Connect your project to a desktop or laptop computer or to other Bluetooth enabled devices with easyBlue



Through simple serial commands you can read/write files from your thumb drive, compact flash or SD/MMC card. Accessing USB Human Interface Devices (HID) and USB printers is also as simple.

No USB knowledge is necessary - just plug and play!



Add Global Positioning to your projects with this high sensitivity ultra low power consumption, plug & play GPS module board. This product is based on the proven technology found in the 16 channel GPS NEMERIX chipset solution. The GPS module receiver will track up to 16 satellites at a time while providing fast time-to-first-fix and 1Hz navigation updates. Its far reaching capability meets the sensitivity & accuracy requirements of car navigation as well as other location-based applications, such as AVL system. Handheld navigator, PDA, pocket PC, or any battery operated navigation system.

www.crownhill.co.uk/gps

www.crownhill.co.uk/gps



Visit us on the web, FREE downloadable demos of Software Data sheets and Code Examples, projects and offers.

www.crownhill.co.uk

Established for over a decade supplying Government, Education, Industry and home developers.



www.virtualworkbench.co.uk

PIC N' MIX

JOHN BECKER

Our periodic column for your PIC programming enlightenment

Using the MAX118 8-channel ADC with a PIC

THIS month we take a look at how Maxim's MAX118 8-channel analogue-to-digital converter (ADC) can be used with a PIC. For the sake of demo, a PIC16F877 is used, though the principles described here can be used with many other members of the PIC family.

This ADC and the DS1267 digital potentiometer discussed in the last two issues are being used by the author in a moderately complex workshop instrument he is working on. He had not used either before and inevitably there were some aspects of their datasheets which were not immediately clear. Discussing their resolution here should hopefully help other potential users.

MAX118 ADC

The Maxim MAX118 is a multiplexed 8-channel ADC which can be used at a faster rate than, say, the PIC16F877's own built-in 8-channel ADCs. It is described by Maxim as being microprocessor-compatible (e.g. usable with PICs), operating from a +5V supply and using a half-flash technique to achieve a 660ns conversion time (1MSPs).

Although described as eight-channel, in fact only seven channels have external access pins, the eighth-channel being reserved for internally monitoring the reference voltage. The input voltage range is 0V to +5V (negative-going voltages are not permitted).

The device includes a track and hold facility, enabling it to digitize fast analogue signals. Although it only provides 8-bit resolution, compared to the PIC16F877's 10-bit, its faster conversion rate makes it better suited to those applications requiring greater speed when finer definition is not needed.

PIC or other microprocessor interfacing is simplified because the ADC can appear

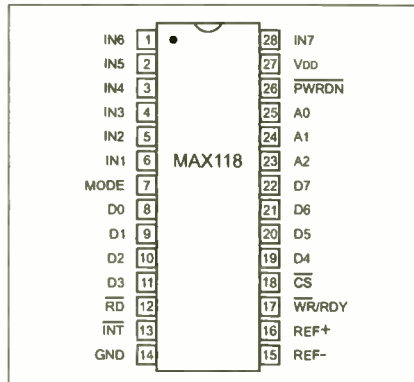

Fig.2. Pinouts of the MAX118

as a memory location or an I/O (input/output) port without external interface logic. The data outputs use latched tri-state buffer circuitry for direct connection to an 8-bit parallel data bus or input port.

There is also a 4-channel version, the MAX114, whose basic use is identical to that of the MAX118.

The functional block diagram for the MAX118 is shown in Fig.1, and the pinout diagram is given in Fig.2. The download source for the full data sheet is Maxim's website at www.maxim-ic.com.

Operation Modes

The datasheet describes four modes of operation, but the one chosen for the author's application is ordinary Read Mode, as selected by holding the Mode pin low (0V connection). The timing diagram for this mode is shown in Fig.3.

In Read Mode, conversions and data access are controlled by the RD input. The ADC's comparator inputs track the analogue input voltage for the duration of timing parameter t_{ACQ} . Conversion is initiated by taking CS and RD low.

There are two techniques for monitoring when the conversion has been completed. In the first one, the WR/RDY pin can be used as a status-monitoring output (RDY). It is an open-collector output and so requires an external pull-up resistor of, say 10k Ω , connected to the +5V line. Alternatively, one of the PIC's PORTB pins could be used with its internal light-pullup option enabled. RDY goes low after the CS pin has been taken low, and goes high again at the end of the conversion.

It is legitimate, though, to ignore RDY and to leave it unconnected. In this case the INT pin can be used instead. This is normally held high internally, but goes low at the end of the conversion, and then goes high again on the rising edge of CS or RD. It is the INT pin that the author uses in the design referred to above.

Demonstration Circuit

A demo program has been prepared which illustrates how this ADC can be used. It is based on a PIC16F877 under crystal control at between 3.2768MHz and 20MHz. The Toolkit TK3 p.c.b. can be used as part of the overall demo assembly.

The ADC is connected to the PIC as shown in Fig.4. This can be assembled on stripboard or a breadboard and then connected to the PIC.

It is also necessary to connect a 2-line 16-character per line alphanumeric l.c.d. display to the PIC via PORTB. The pin arrangement is that which is commonly used by the author in almost all of his programs that use an l.c.d. The TK3 p.c.b. has the correct l.c.d. connections built into it.

Demo Program

The program has been written to repetitively sample each of the ADC channels, as selected by PORTE. PORTC controls the

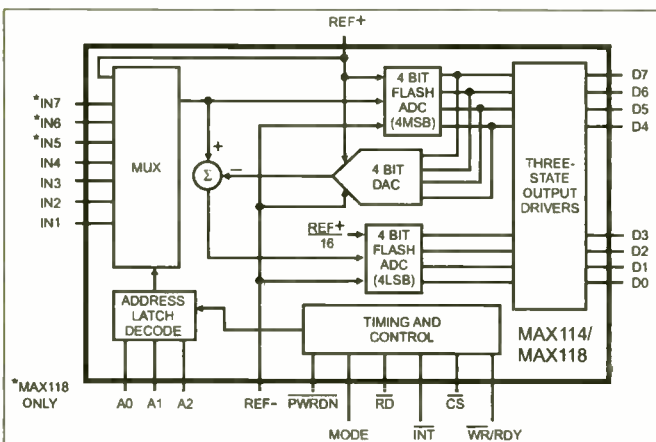

Fig.1. Functional diagram of the MAX118

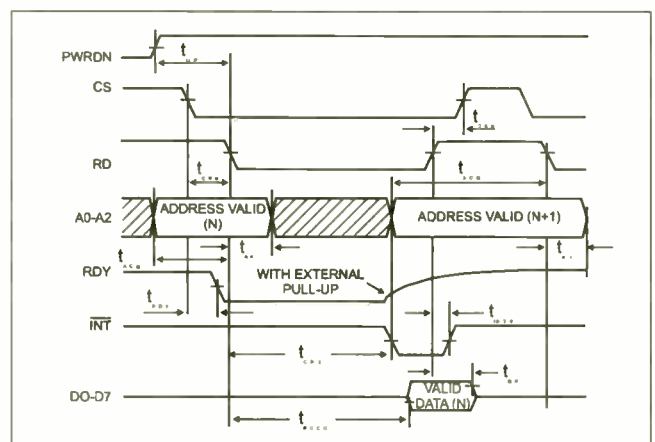

Fig.3. Read Mode timing diagram

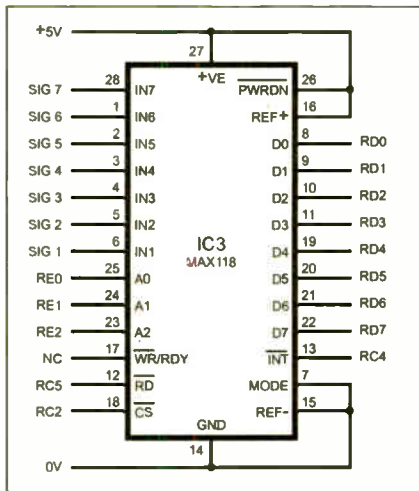

Fig.4. ADC connections to a PIC 16F877 for the demo program

ADC's conversion, and PORTD receives the converted data from it.

It is basically a repeating cycle of eight samples, at the end of which the received data bytes are converted from binary to decimal for display on the l.c.d. Channels one to four are shown on l.c.d. line one, and channels five to eight on l.c.d. line two.

There is a brief pause between each 8-sample batch to allow the l.c.d. screen to be viewed at a reasonable rate.

The complete demo program, PNM05NOV11.ASM, is available for free download via www.epemag.co.uk, from within the PICnMix folder. The hex file is available with the ASM in standard MPASM format and includes the embedded configuration values.

An extract from the program, showing the sampling loop, is shown in Listing 1.

The repetitive loop starts at MAIN, in which first several calls to PAUSIT are made to slow the rate at which each batch of samples is taken. Variable CHANE is the counter which causes the required ADC channel to be selected.

Sampled data is stored in eight consecutive registers, ADCSTORE0 to ADCSTORE7, but accessed using the PIC's indirect register (via FSR and INDF).

At ROUTECHANS, two commands are shown temporarily deleted – more on those shortly. The next command is MOVF CHANE,W in which the value of the

LISTING 1: Sampling Loop

```

MAIN:      call PAUSIT
             call PAUSIT
             call PAUSIT
             call PAUSIT
             clrf CHANE
             movlw ADCSTORE0
             movwf FSR

ROUTECHANS:
             ; movlw 7
             ; movwf PORTE
             movf CHANE,W
             call GETCHAN
             movwf INDF
             incf FSR,F
             incf CHANE,F
             btfss CHANE,3
             goto ROUTECHANS
             call SHOWCHANS
             goto MAIN

GETCHAN:  movwf PORTE
             nop
             bcf PORTC,ADCCS
             nop
             bcf PORTC,ADCRD

WAITADC: btfsc PORTC,ADCINT
             goto WAITADC
             movf PORTD,W
             bsf PORTC,ADCRD
             bsf PORTC,ADCCS
             return

```

counter for selecting the ADC is pulled into W. A call to GETCHAN is then made, in which the value in W is output to PORTE, so selecting the ADC channel.

ADC conversion is then started by taking the ADC's pins \overline{CS} and \overline{RD} low. There are two NOP pauses inserted here. They just add a little extra time to allow the ADC to respond, but they have not been proved to be essential, and it is likely that they can be omitted in programs run at under 20MHz.

Next, the status of the ADC's INT pin is polled until it is taken low at the end of the conversion. Having gone low, PORTD is read into W for the converted value now presented to it by the ADC.

The ADC's \overline{CS} and \overline{RD} pins are then returned high and a return made to the calling routine, where the received value is stored into the required register via INDF.

CHANE and FSR are then incremented, after which CHANE is tested to see if eight samples have been taken. If they have not, the ROUTECHANS loop is repeated for the next channel.

If eight samples have been taken, their values are then converted to decimal and displayed on the l.c.d. through a grouped set of routines (not shown here) accessed by the call to SHOWCHANS.

Image Ghosting

Data acquisition times are quoted in the datasheet, but tests showed that adhering to these did not totally block the superimposition of the sampled voltage from one channel on the next channel's sample. This resulted in the second sample being affected by the first. The effect was only small, but felt to be undesirable.

It was found that setting the channel control to channel 8 (the reference voltage monitor) immediately prior to any other change of ADC channel cured this effect. In applications where one of the seven externally accessed channels is not used, a similar result can be achieved by setting for that channel instead of channel 8. The unused channel must, of course, be connected to the 0V or +5V line and not left floating.

The reasoning behind this logic is that taking the sample and hold aspect of the ADC to a known level before the required channel is sampled, standardises the initial voltage at this point before the new voltage is applied to it.

Using the ADC

The use to which you put the ADC and the converted values is entirely up to you. They could for example be read and then another aspect of your program amended as the result of those values. For example, the setting of the digital potentiometer (see P'n'M Sept/Oct '05) could be controlled depending on the value of an input voltage.

In the author's case, he currently samples seven external analogue signal sources, and stores the values to an addressed SRAM memory, also controlled by the PIC. When the SRAM is full, the stored data is then output serially to a PC, where it is processed and displayed as oscilloscope-type waveforms. The unit under development also offers frequency spectrum analysis displays.

Obtaining EPE

An initiative in the UK is designed to help you obtain your favourite magazines from newsagents. Called *Just Ask!* its aim is to raise awareness that newsagents can stock, order and often home deliver magazines.

Don't Miss Out

Just Ask!

Your local newsagent to order this magazine



NEWSAGENTS ORDER FORM

Please reserve/deliver a copy of *Everyday Practical Electronics* for me each month

Signed

Name and Address

Post Code Tel

Everyday Practical Electronics is published on the second Thursday of each month and distributed S.O.R. by COMAG
Make sure of your copy of *EPE* each month – cut out or photostat this form, fill it in and hand it to your newsagent.



TEACH-IN 2006

Part One – Introduction, Multiples, Atoms, Electrons and Electric Current, Voltage, Resistors, Batteries, Switches

MIKE TOOLEY BA

In this Teach-In 2006 series we provide a broad-based introduction to electronics for the complete newcomer. The series will also provide the more experienced reader with an opportunity to “brush up” on topics with which he or she may be less familiar. We begin this month by introducing the series and some of its innovative features before delving into some of the basics

WELCOME to the fascinating and exciting world of electronics! Are you starting electronics for the first time? Or perhaps you are a little more experienced but have missed out on some aspects of electronics?

Do you wonder about how circuits work and what really goes on inside them? Do you want to be able to design and build your own circuits and get them to work first time? Are you a student or thinking about gaining a formal qualification in electronics?

If the answer to any one or more of the above questions is “yes” then our *Teach-In 2006* series is going to be just right for you!

This series has been designed to provide you with a gentle but thorough introduction to the world of electronics. We won't assume that you have any previous knowledge but we will assume that you are keen to get to grips with the subject.

We will include the relevant theory but we won't bore you with a lot of mathematics. Instead, we will be emphasising the practical aspects of electronics; how the basic parts and components work and what they can do when they are connected together.

Special Features

We've also included some special features in Teach-In. For example, to help you quickly and easily grasp the main points we've included a number of Check Points in the text. These serve to emphasise the key points and important principles introduced in the series and provide you with a quick (and hopefully memorable) summary of the text. So, if you do find that you need to recap a particular section of the text, all you need to do is to read the Check Points!

To get you started with building and testing electronic circuits, each part includes a number of “Practical Investigations”. These are designed to reinforce the theory and provide an

- ### List of Topics
- Units, Multiples and Sub-multiples. Atoms, Electrons and Electric Current. Periodic Table. Introducing Resistors. Introducing Batteries. Introducing Switches. Current, Voltage and Resistance. Potential Difference. Ohm's Law.
 - Circuit Diagrams. Series and Parallel Circuits. Circuit Construction Techniques. Basic Measurements – The Multimeter. More Circuit Theory. Power and Energy. Voltage Divider. Current Divider.
 - Charge and Capacitance. Introducing Capacitors. Magnetism and Inductance. Introducing Inductors.
 - Introducing Transformers. Semiconductors. Diodes. Rectifiers. Introducing Diodes. Power Supplies.
 - Transistors. Transistor Circuits. Introducing Transistors. Basic Concepts of Amplifiers. Gain and Frequency Response. Single and Multi-stage Amplifiers. Coupling.
 - Test and Measurement. Waveforms. The Oscilloscope. Signal Sources and Signal Generators. Optoelectronics. Introducing Light Emitting Diodes. L.E.D. Circuits.
 - Digital Electronics. Logic. Introducing Logic Circuits.
 - Microprocessors. PICs. Programming. Introducing Microprocessors. Introducing PICs. Interfacing. Typical Applications.
 - Analogue Electronics. Operational Amplifiers: Inverting, Non-inverting, and Differential Amplifiers. Introducing Operational Amplifiers. Filters. Comparators. Typical Applications.
 - Radio and Communications. Tuned Circuits. Modulation and Demodulation. Transmitters and Receivers. Aerials. Introducing Quartz Crystals. Typical Applications. Radio Constructional Project.

opportunity for you to make measurements and understand how real circuits work.

Because electronic components are fundamental to the operation of electronic circuits, we've incorporated sections in the text designed to introduce you to a wide range of electronic components. For example, in Part 1, we've included sections on Introducing Resistors, Introducing Switches, and Introducing Batteries. These summarise each type of component, what they do and how they work, and include representative photographs and component symbols. Likewise, Part 3 will feature Introducing Capacitors, and so on.

In order to test your knowledge (and find out how much you really know!) there is also a short multiple choice Quiz (10 to 20 questions) on-line for you to enter for each part of the series. Your score is generated automatically.

For those of you who would like some formal recognition that you have completed the *Teach-In 2006* series, a Final Test will also be available on-line. This test will be based on multiple-choice questions that are similar to those used in the quizzes but will cover the entire series. Successful completion of the Final Test will lead to the award of a personalised *Everyday Practical Electronics Teach-In Certificate*. This is a real “first”

for any magazine and is something that will provide you with lasting recognition of your success. Rapid Electronics have also donated over £600s worth of prizes for successful students – see opposite.

Topics Covered

In this first Teach-In 2006 part we begin with information on how to get started and some guidance for how to get the best out of the series. We shall be explaining some units, multiples and sub-multiples that are commonly used in electronics as well as introducing basic components such as resistors, switches and batteries.

We shall describe the components, materials and test equipment required to carry out our Practical Investigations before providing information on how to make basic measurements of *current*, *voltage* and *resistance*. We also explain some basic circuit configurations based on series, parallel and series-parallel connections.

The full list of topics covered in each part of the series is shown in the List of Topics panel. Note that length restrictions may cause some topics to be deferred until the next issue.

How to Use Teach-In 2006

Our Teach-In 2006 series can be used in different ways. If you are a complete newcomer to electronics or if you are studying electronics as part of a course at school or college, you will probably want to work systematically through each part of the series, working through the examples and problems and carrying out each of the Teach-In Practical Investigations.

You will need to allow adequate time for each section and ensure that you fully understand each topic before you move on to the next. At the end of each part you will be able to use the on-line Teach-In Quiz as a means of checking your understanding. You can attempt the quiz as many times as you like and you will be able to improve your score by looking back through the text. To assist you in this process, your answers will remain checked in the on-line site until you decide to change them.

If you already have some knowledge, you will be able to just go to the topics that you need to “brush up” on. To help you do this, each main topic has been designed to be reasonably self-contained and you will be able to select just those examples, problems and Teach-In Practical Investigations that relate to the areas that you wish to study.

If you are not sure whether you need to study a particular topic or not, you can always jump ahead and attempt the on-line Teach-In Quiz to see how much you really know! The results of the quiz will help you to identify those topic areas on which you need to concentrate as well as those with which you are already familiar.

Practical Investigations

Our Teach-In Practical Investigations are based on readily available components and a low-cost breadboard system. We have aimed to keep the total cost of components and materials as low as possible but we have added a few recommended

OVER £600s WORTH OF TEACH-IN '06 PRIZES DONATED BY RAPID ELECTRONICS

At the end of the Teach-In '06 course there will be an on-line multiple-choice test covering the entire series. Successful completion of the final test will lead to the award of a personalised certificate and students with the highest marks will go forward to a tie-break for the award of tool kits, kindly donated by Rapid Electronics. Just follow the course and you could be a winner.



1st Prize: 72-piece tool kit worth £323.00

The kit comprises a very wide range of high quality hand tools that should last a lifetime. Everything from a professional digital l.c.d. multimeter with capacitance, frequency, temperature and transistor h_{FE} measurement in addition to a.c. and d.c. voltage and current and resistance ranges – 32 ranges in all – to a Nimrod butane gas soldering iron, soldering and desoldering aids, screwdrivers, files, pliers, sidecutters, wire strippers, even hex keys and combination spanners etc. The

set is ideal for commonly encountered electronic, electrical and hardware tasks and comes in a rugged ABS/aluminium carrying case.

Runners Up Prizes: 21 tool kits in zipped cases each worth £13.51

The kits each comprise eight commonly used hand tools, including pliers, side cutters, a wire stripper, screwdrivers, a stripboard cutter and trimming tool in a black reinforced, zip fastening, padded carrying case. Ideal for the student, hobbyist or technician to keep handy for electronic or electrical tasks.



See www.miketooley.info/teach-in/quiz1 for this month's on-line test.

items which, whilst not essential, will make the Practical Investigations easier and more fun. To also keep the cost down, we have chosen components that keen experimenters and enthusiasts should already have as well as those that will almost certainly be available in most schools and colleges.

Several of our regular advertisers are providing kits of components to support the series so it's well worth checking the advertisement pages before you decide to buy.

Getting Started

In this first section we explain some of the units, multiples and sub-multiples that are commonly used in electronics, as well as explaining atoms, electrons and electric current. Having dealt with the basics we introduce three of the most common electronic components.

In today's world, electricity is something that we all take for granted. So, to get us started, it's worth thinking about what electricity means to you and, more importantly, how it affects your life.

Think, for a moment, about where and how electricity is used in your home, car, workplace, school or college. You will quickly conclude that electricity is a means of providing heat, light, motion and sound. You should also conclude that electricity is invisible – we only know that it's there by looking at what it does!

In this section we explain electricity in terms of electric charge, current, voltage and resistance. We begin by introducing you to some important concepts, including the Bohr model of the atom and the fundamental nature of electric charge and conduction in metals. Next we look at three important components found in electronic circuits; *resistors*, *batteries* and *switches*.

Units

You will find that a number of units and symbols are commonly encountered in electronic circuits so let's get started by introducing some of them. In fact, it's important to get to know these units and also to be able to recognize their abbreviations and symbols before you actually need to use them. Later we explain how these units work in much greater detail but for now we simply list them so that at least you can begin to get to know something about them, see Table 1.1.

Multiples and sub-multiples

Unfortunately, because the numbers can be very large or very small, many of the electronic units can be cumbersome for everyday use. For example, the voltage present at the aerial input of an f.m. radio could be as little as 0.000002V. At the same time, the resistance present in an amplifier stage could be as high as 2,000,000Ω.

To make life a lot easier we use a standard range of multiples and sub-multiples.

Table 1.1: Units, Abbreviations and Symbols

Unit	Abbrev.	Symbol	Notes
Ampere	A	I	Unit of electric current (a current of 1A flows in a conductor when a charge of 1C is transported in a time interval of 1s)
Coulomb	C	Q	Unit of electric charge or quantity of electricity (a fundamental unit)
Farad	F	C	Unit of capacitance (a capacitor has a capacitance of 1F when a charge of 1C results in a potential difference of 1V across its plates)
Henry	H	L	Unit of inductance (an inductor has an inductance of 1H when an applied current changing uniformly at a rate of 1A/s produces a potential difference of 1V across its terminals)
Hertz	Hz	f	Unit of frequency (a signal has a frequency of 1Hz if one complete cycle occurs in a time interval of 1s)
Joule	J	J	Unit of energy (a fundamental unit)
Ohm	Ω	R	Unit of resistance (a fundamental unit)
Second	s	t	Unit of time (a fundamental unit)
Volt	V	V, E	Unit of electric potential (sometimes referred to as e.m.f. or p.d. – see text)
Watt	W	P	Unit of power (equal to 1J of energy consumed in a time of 1s)

Table 1.2: Multiples and Sub-multiples

Prefix	Abbrev.	Multiplier
giga	G	10^9 (= 1,000,000,000)
mega	M	10^6 (= 1,000,000)
kilo	k	10^3 (= 1,000)
(none)	(none)	10^0 (= 1)
milli	m	10^{-3} (= 0.001)
micro	μ	10^{-6} (= 0.000,001)
nano	n	10^{-9} (= 0.000,000,001)
pico	p	10^{-12} (= 0.000,000,000,001)

These use a prefix letter in order to add a multiplier to the quoted value, as shown in Table 1.2.

Converting to and from multiples and sub-multiples is actually quite easy, as the following examples show:

Check Point 1.1

It's sometimes possible to confuse the symbols and abbreviations that we use for units. For example, V is used as both the abbreviation for voltage and for its unit symbol (the volt). This isn't the same for other quantities.

For example, L is used to denote inductance but the units of inductance are Henry (H). Similarly, C is used to denote capacitance but the units of capacitance are Farad (F). Try not to let this confuse you too much!

Example 1.1

A cathode ray tube operates from a power supply of 8,500V. To express this in kV (kilovolt) we move the decimal point three places to the left. So 8,500V = 8.5kV.

Example 1.2

A resistor has a resistance of 3,900,000 Ω . To express this in M Ω (megohm) we move the decimal point six places to the left. So 3,900,000 Ω = 3.9M Ω .

Example 1.3

A transistor operates with a current of 0.005A. To express this in mA (milliamp) we move the decimal point three places to the right. Thus 0.005A = 5mA.

Example 1.4

A resistor dissipates a power of 275mW. To express this in W (watt) we move the decimal point three places to the left. Thus 275mW = 0.275W.

Example 1.5

An inductor has a value of 270nH. To express this in μ H (microhenry) we move the decimal point three places to the left (because there are 1,000nH in 1 μ H). Hence 270nH = 0.27 μ H.

Example 1.6

A capacitor has a value of 0.56nF. To express this in pF (picofarad) we move the decimal point three places to the right (because there are 1,000pF in 1nF). Hence 0.56nF = 560pF.

Check Point 1.2

Multiplying by 1,000 is equivalent to moving the decimal point three places to the right, whilst dividing by 1,000 is equivalent to moving the decimal point three places to the left.

Similarly, multiplying by 1,000,000 is equivalent to moving the decimal point six places to the right, whilst dividing by 1,000,000 is equivalent to moving the decimal point six places to the left.

Questions 1.1

Here are a few questions for you to try (answers later):

- Q1.1. State the units for electric current
- Q1.2. State the units for frequency
- Q1.3. State the symbol used to represent capacitance
- Q1.4. An amplifier requires an input signal of 0.0025V, express this in mV
- Q1.5. A current of 75mA flows in a resistor, express this in A
- Q1.6. A resistor has a value of 0.22M Ω , express this in k Ω

Atoms, Electrons and Electric Current

To understand what electricity is we need to take a look inside the atoms that make up all forms of matter. Since we can't actually do this with a real atom we will have to use a model. Fortunately, understanding how this model works isn't too difficult – just remember that what we are talking about is very, very small!

All matter is made up of atoms or groups of atoms (*molecules*) bonded together in a particular way. In order to understand the nature of electricity and what causes an electric current, we need to consider a simple model of the atom. This model is known as the *Bohr model* and our simplified diagram in Fig. 1.1 shows a single atom consisting of a central *nucleus* with just two orbiting *electrons*.

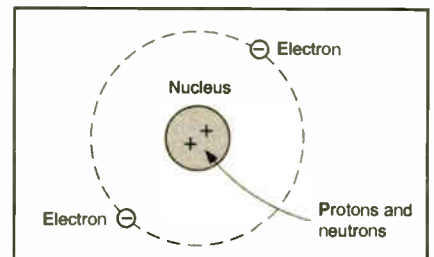

Fig. 1.1. The Bohr model of the atom

Within the nucleus there are *protons* which are *positively charged* and *neutrons* which, as their name implies, are electrically neutral and *have no charge*. Orbiting the nucleus are a number of electrons that each have a *negative charge*, equal in magnitude (size) to the charge on the proton. These electrons are approximately two thousand times lighter than the protons and neutrons in the nucleus.

In a stable atom the numbers of protons and electrons are equal, so that overall, the atom is neutral and has no charge.

However, when an atom within a material loses an electron from its outer shell, it becomes positively charged and is known as a *positive ion*. Conversely, when an atom gains an electron it has a surplus negative charge and so is known as a *negative ion*.

These differences in charge can cause *electrostatic* effects. For example, combing your hair with a nylon comb may result in a difference in charge between your hair and the rest of your body, resulting in your hair standing on end when your hand or some other differently charged body is brought close to it.

Periodic Table

The number of electrons occupying a given orbit within an atom is predictable and is based on the position of the element within the *periodic table*. The electrons in all atoms sit in a particular position (shell) dependent on their energy level. Each of the shells within the atom is filled by electrons from the nucleus outwards.

A material which has many free electrons available to act as *charge carriers* and thus allows current to flow freely, is known as a *conductor*. Examples of good conductors include metals like aluminium, copper, gold and iron. With such materials, only a small amount of external energy is necessary to overcome the attraction of the nucleus and, once detached from the atom, electrons are able to move relatively freely around the crystal lattice structure of the material. Each of these *free electrons* carries a tiny negative electric charge.

The motion of free electrons in a conductor (without any external field applied) is random and the electrons simply drift around with no consequent effect. However, if an external electric field is applied to a conductor by connecting a battery or other source of *electromotive force* (e.m.f.) to it, and since like charges repel and unlike charges attract, the motion of the electrons will change such that the negatively charged electrons will drift towards the positive end of the conductor (see Fig.1.2). This leads us to the conclusion that, in a metal conductor, electric current is simply the organised movement of electrons.

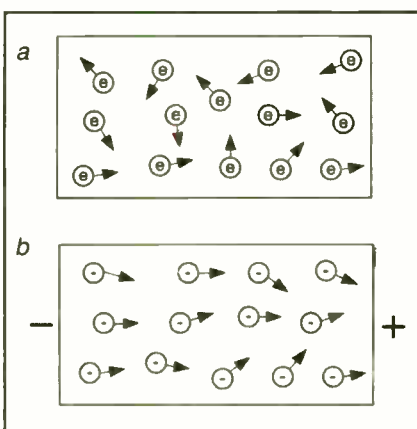

Fig.1.2. a) Free electrons, b) the application of an external force (an e.m.f.) produces current flow in a conductor

Metals are the best conductors, since they have a very large number of free electrons available to act as charge carriers. Materials that do not conduct charge are

Check Point 1.3

Metals, like copper and silver are good conductors of electricity and they readily support the flow of current. Plastics, rubber and ceramic materials are insulators and do not support the flow of current.

Check Point 1.4

In a metal conductor, electric current results from the organised motion of electrons and each electron carries a tiny negative charge that drifts towards the point with most positive potential.

At this point it's worth noting that some materials combine some of the electrical characteristics of conductors with those of insulators. They are known as *semiconductors*. In these materials there may be a number of free electrons sufficient to allow a small current to flow.

It is possible to add foreign atoms (called *impurity atoms*) to the semiconductor material that modify the properties of the semiconductor. Varying combinations of these additional atoms are used to produce various electrical devices such as diodes and transistors that we will meet in Part 3. Common types of semiconductor material are silicon, germanium, selenium and gallium.

Check Point 1.5

Semiconductors are pure insulating materials with a small amount of an impurity element present. Typical examples are silicon and germanium.

called *insulators*, their electrons are tightly bound to the nuclei of their atoms. Examples of insulators include plastics, glass, rubber and ceramic materials.

Unfortunately, we can't "see" an electric current but we can sense its presence from the effects that it causes. Depending on the type of conductor, these effects can include any one or more of the following: heat, light, magnetism, pressure and chemical action.

Introducing Resistors

The amount of current that will flow in a conductor when a given e.m.f. is applied to it is inversely proportional to its resistance. Resistance may therefore be thought of as an opposition to the flow of electric current. In other words, the larger the resistance, the greater the opposition to current flow when an e.m.f. is applied.

Various types of fixed, preset and variable resistor are found in electronic circuits, including carbon film, metal film, and wirewound types, see Photos 1.1, 1.2, 1.3. Resistors are used for determining the voltages and currents in circuits, as "loads" to consume power, and in preset and variable form for making adjustments (for example, volume and tone controls). Typical circuit symbols for various types of resistor are shown in Fig.1.3.

The terms *potentiometer* and *variable resistor* are often used interchangeably. However, strictly speaking, preset and variable resistors have only two terminals whilst *potentiometers* (either preset or rotary types) have three terminals. Note also that a preset or variable potentiometer can be used as a variable resistor by simply ignoring one of its end terminals, or by connecting its moving contact to one of its outer terminals.

Photo 1.1. Various types of fixed resistor. From left to right: high-power metal-clad resistor, ceramic-coated wirewound, and three carbon film types with power ratings from 2W to 0.25W

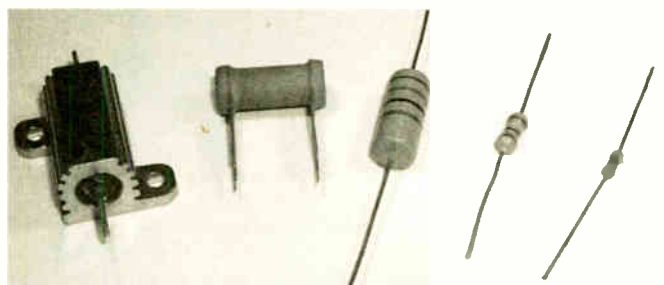

Photo 1.2. Various types of preset potentiometer. From left to right: sub-miniature multiturm, miniature open-skeleton preset, adjustable rotary preset, multiturm, and miniature sealed types

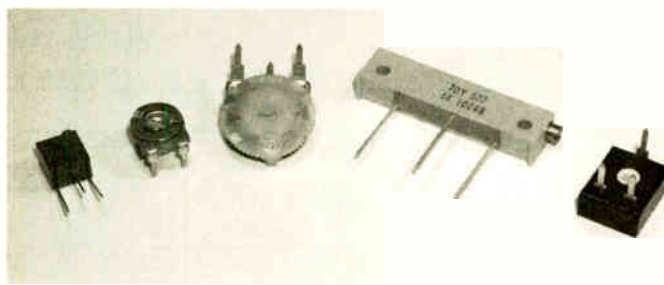

Photo 1.3. Various types of rotary potentiometer. From left to right: miniature wirewound, carbon track rotary, wirewound, carbon track with p.c.b. mounting tags



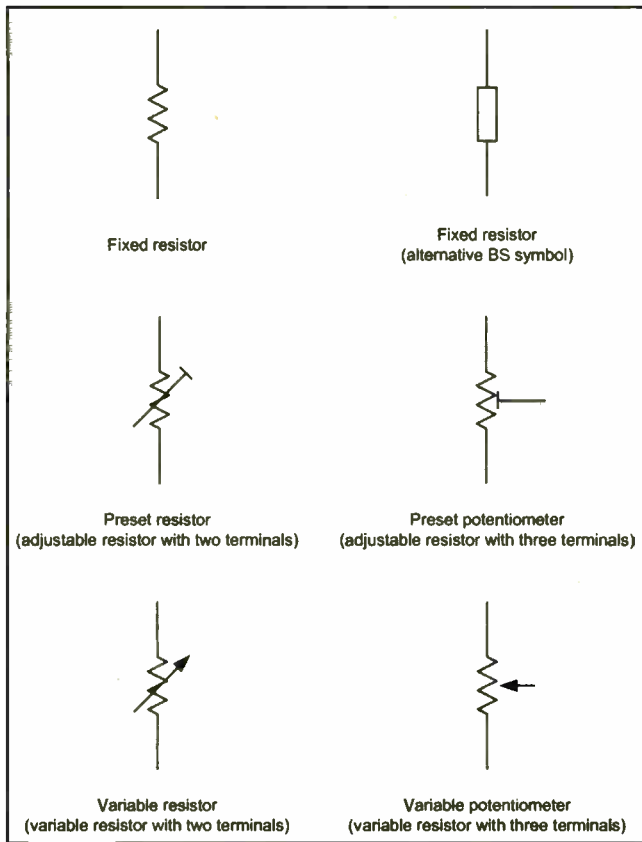

Fig. 1.3. Circuit symbols used for various types of resistor

The specifications for a resistor usually include the value of resistance (expressed in Ω , $k\Omega$ or $M\Omega$), the accuracy or tolerance of the marked value (quoted as the maximum permissible percentage deviation from the marked value), and the power rating (which must be equal to, or greater than, the maximum expected power dissipation). Temperature coefficient and stability are also important considerations in certain applications.

Fixed resistors are available in several series of fixed decade values, the number of values provided with each series being governed by the tolerance involved. In order to cover the full range of resistance values using resistors having a $\pm 20\%$ tolerance it will be necessary to provide six basic values (known as the E6 series).

More values will be required in the series that offers a tolerance of $\pm 10\%$ and consequently the E12 series provides twelve basic values. The E24 series for resistors of $\pm 5\%$ tolerance provides 24 basic values and, as with the E6 and E12 series, decade multiples (i.e., $\times 1$, $\times 10$, $\times 100$, $\times 1k$, $\times 10k$, $\times 100k$ and $\times 1M$) of the basic series. Table 1.3 gives typical characteristics of common types of fixed resistor.

Table 1.3: Common types of Fixed Resistor

		Resistor Type					
		Carbon Film	Metal Film	Metal Oxide	Ceramic Wirewound	Vitreous Wirewound	Metal Clad
Characteristics	Resistance Range	10 Ω to 10M Ω	1 Ω to 10M Ω	10 Ω to 1M Ω	0.47 Ω to 22k Ω	0.1 Ω to 22k Ω	0.05 Ω to 10k Ω
	Typical Tolerance	$\pm 5\%$	$\pm 1\%$	$\pm 2\%$	$\pm 5\%$	$\pm 5\%$	$\pm 5\%$
	Power Rating	0.25W to 2W	0.125W to 0.5W	0.25W to 0.5W	4W to 17W	2W to 4W	10W to 300W
	Temp. Coefficient	+250 ppm/ $^{\circ}C$	+50 to +100 ppm/ $^{\circ}C$	+250 ppm/ $^{\circ}C$	+250 ppm/ $^{\circ}C$	+75 ppm/ $^{\circ}C$	+100 ppm/ $^{\circ}C$
	Stability	Fair	Excellent	Excellent	Good	Good	Good
	Temp. Range	-45 $^{\circ}C$ to +125 $^{\circ}C$	-55 $^{\circ}C$ to +125 $^{\circ}C$	-55 $^{\circ}C$ to +155 $^{\circ}C$	-55 $^{\circ}C$ to +200 $^{\circ}C$	-55 $^{\circ}C$ to +200 $^{\circ}C$	-55 $^{\circ}C$ to +200 $^{\circ}C$
	Typical Applications	General purpose	Low-noise amplifiers, oscillators	General purpose	Power supplies, loads	Power supplies, loads	High power applications

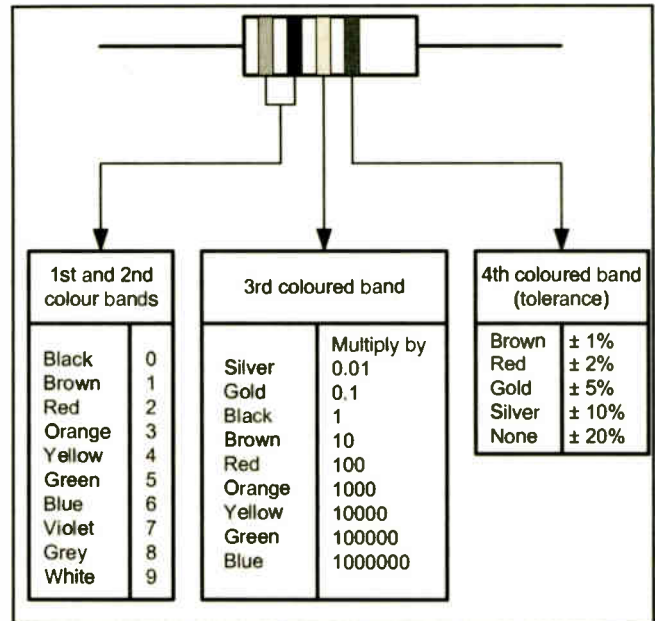

Fig. 1.4. The four-band resistor colour code

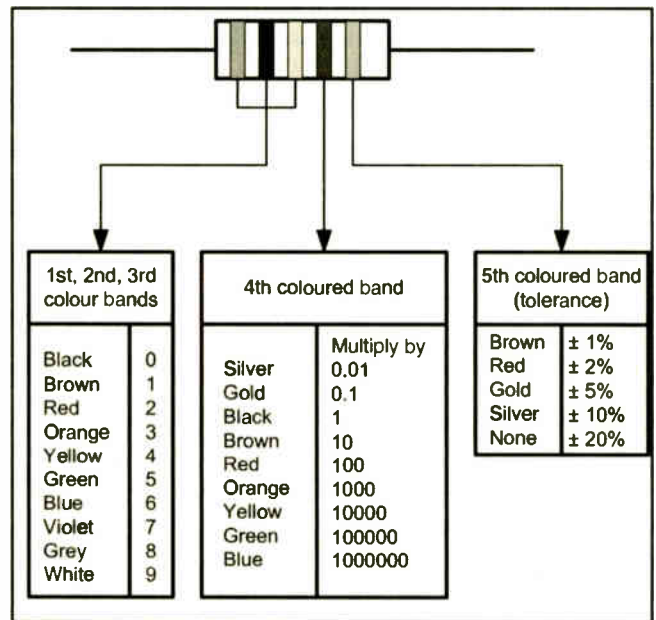

Fig. 1.5. The five-band resistor colour code

Carbon and metal oxide resistors are normally marked with colour codes that indicate their value and tolerance. Two methods of colour coding are in common use; one involves four coloured bands (see Fig. 1.4) whilst the other uses five colour bands (see Fig. 1.5).

Example 1.7

A resistor is marked with the following coloured stripes; brown, black, red, gold. What is its value and tolerance?

This resistor uses the four-band colour code in which:

- First band = first digit: brown = 1
- Second band = second digit: black = 0
- Third band = multiplier: red = 2 (i.e. $\times 100$)
- Fourth band = tolerance: gold = $\pm 5\%$

From which the value is:
 $10 \times 100 = 1,000 = 1k\Omega$, 5%

Example 1.8

A resistor is marked with the following coloured stripes; blue, grey, orange, silver. What is its value and tolerance?

This resistor uses the four-band resistor colour code in which:

First band = first digit: blue = 6
 Second band = second digit: grey = 8
 Third digit = multiplier: orange = 3
 (i.e. $\times 1,000$)
 Fourth band = tolerance: silver = $\pm 10\%$

From which the value is:
 $68 \times 1,000 = 68,000 = 68k\Omega, 10\%$

Example 1.9

A resistor is marked with the following coloured stripes; yellow, violet, silver, silver. What is its value and tolerance?

This is yet another resistor that uses the four-band colour code in which:

First band = first digit: yellow = 4
 Second band = second digit: violet = 7
 Third band = multiplier: silver = $\div 100$
 Fourth band = tolerance: silver = $\pm 10\%$

Hence the value is:
 $47/100 = 0.47\Omega, 10\%$

Example 1.10

A resistor is marked with the following coloured stripes; violet, green, black, black, brown. What is its value and tolerance?

This resistor uses the five-band colour code in which:

First band = first digit: violet = 7
 Second band = second digit: green = 5
 Third band = third digit: black = 0
 Fourth band = multiplier: black = $0(\times 1)$
 Fifth band = tolerance: brown = $\pm 1\%$

Hence the value is:
 $750 \times 1 = 750\Omega, 1\%$

Questions 1.2

Here are a few questions on colour codes for you to try (answers later):

- Q1.7. Brown, black, orange, silver
- Q1.8. Red, red, green, gold
- Q1.9. Orange, orange, silver, gold
- Q1.10. Red, violet, gold, gold
- Q1.11. Brown, black, black, black, brown
- Q1.12. Green, blue, green, brown, brown

Tolerance

Some minor variation in resistance value is inevitable due to manufacturing tolerance and thus the value marked on the body of a resistor is not its exact resistance.

For example, a resistor marked 100Ω and produced within a tolerance of $\pm 10\%$ will have a value which falls within the range 90Ω to 110Ω . If a particular circuit requires a resistance within this range, a $\pm 10\%$ tolerance resistor of 100Ω will be perfectly adequate. If, however, we need a component within the range 99Ω to 101Ω , then it would be necessary to obtain a 100Ω resistor with a tolerance of $\pm 1\%$.

Photo 1.4. Various types of battery. From left to right: a 3V lithium (Li) battery, a 1.2V nickel-metal hydride (Ni-MH) cell, a 9V alkaline battery, a 3V lithium (Li) button cell



Example 1.11

A resistor has a marked value of 220Ω and a tolerance of 5%. Determine the maximum and minimum possible values for the resistor.

Now 5% of 220Ω is 11Ω so the maximum value possible is $220\Omega + 11\Omega = 231\Omega$ and the minimum value possible is $220\Omega - 11\Omega = 209\Omega$.

Power Ratings

The power rating (or "wattage rating") of a resistor is the maximum power that the resistor can safely dissipate. Power ratings are related to operating temperatures and resistors should be derated at high temperatures.

For this reason, in all situations where reliability is important, resistors should be operated at well below their nominal maximum power rating. We introduce power (and how it is calculated) in Part 2.

Introducing Batteries

Most portable electronic circuits operate from direct current (d.c.). This is the current that flows in one direction only and the most commonly used method of providing it is from a battery which itself is made up from a number of electrochemical cells. Circuit symbols are shown in Fig. 1.6.

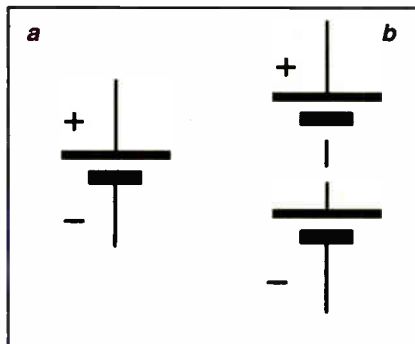

Fig. 1.6. Circuit symbols used for cells (a) and batteries (b)

There are two basic types of cell, *primary* and *secondary*. Primary cells produce electrical energy at the expense of the chemicals from which they are made and once these chemicals are used up, no more electricity can be obtained from the cell. An example of a primary cell is an ordinary 1.5V AA alkaline battery.

In secondary cells, the chemical action is reversible. This means that the chemical energy is converted into electrical energy when the cell is discharged whereas electrical energy is converted into chemical energy when the cell is being charged. An example of a secondary cell is a 1.2V AA Nickel Cadmium (NiCad) battery.

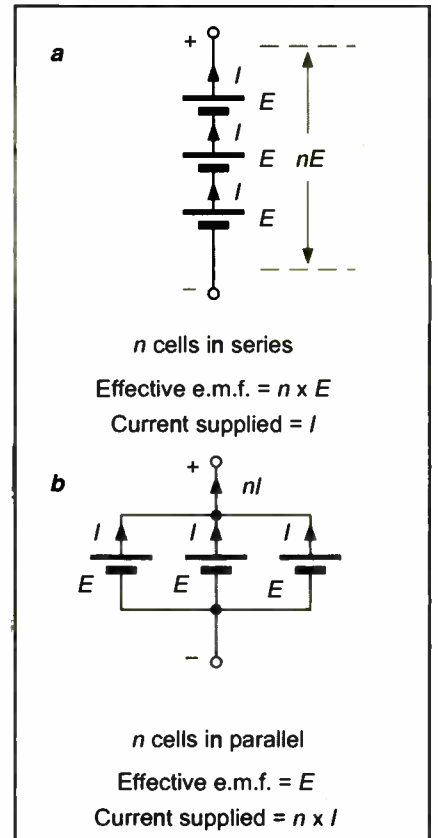

Fig. 1.7. Cells connected in series (a) and parallel (b)

In order to produce a battery, individual cells are usually connected in series with one another, as shown in Fig. 1.7a. Cells can also be connected in parallel (Fig. 1.7b).

In the series case, the voltage produced by a battery with n cells will be n times the voltage of one individual cell (assuming that all of the cells are identical). Furthermore, each cell in the battery will supply the same current. Series connected cells are often used to form batteries. For example, the popular PP3, PP6 and PP9 batteries are made from six "layered" 1.5V alkaline cells which are effectively connected in series. A 12V car battery, on the other hand, uses six 2V lead-acid cells connected in series.

In the parallel case, the current produced by a battery of n cells will be n times the current produced by an individual cell (assuming that all of the cells are identical). Furthermore, the voltage produced by the battery will be the same as the voltage produced by an individual cell. Batteries are rarely constructed with parallel connected cells because it is possible for a cell to fail in which case a "good" cell may discharge into a faulty cell, rendering the battery as a whole useless.

Table 1.4: Principal characteristics of various common types of cell

Cell Type	Primary or Secondary	Wet or Dry	Positive electrode	Negative electrode	Electrolyte	Output Voltage (nominal)	Notes
Zinc-carbon (Leclanché)	Primary	Dry	Zinc	Carbon	Ammonium chloride	1.5V	Used for conventional AA, A, B and C type cells (now obsolete)
Alkaline dry cells	Primary	Dry	Manganese dioxide	Zinc	Potassium hydroxide	1.5V	Used for conventional AA, A, B and C type cells
	Secondary	Dry	Manganese dioxide	Zinc	Potassium hydroxide	1.5V	Can be recharged a limited number of times
Lead-acid	Secondary	Wet	Lead Peroxide	Lead	Sulphuric acid	2.2V	For general purpose 6V, 12V and 24V batteries
Nickel-iron (NiFe)	Secondary	Wet	Nickel	Iron	Potassium and lithium hydroxide	1.4V	Rugged construction for industrial use
Nickel-cadmium (NiCad)	Secondary	Dry	Nickel	Cadmium with cadmium hydroxide	Potassium hydroxide	1.2V	Can be recharged about 400 times. Used for high-power applications requiring AA, A, B and C type cells
Nickel-metal Hydride (NiMH)	Secondary	Dry	Nickel	Lanthanum - Nickel or Zirconium - Nickel	Potassium hydroxide	1.2V	Can be recharged more than 500 times. Used for high-power applications requiring AA, A, B and C type cells

Internal Resistance

Every practical source of e.m.f. (for example a cell, battery or power supply) has some internal resistance. This value of resistance is usually extremely small but, even so, it has the effect of limiting the amount of current that the source can supply, and also reducing the e.m.f. produced by the source when it is connected to a load (i.e. whenever we extract a current from it).

The idea of an “invisible” internal resistance can be a bit confusing, so when we need to take it into account we show it as a fixed resistor connected in series with a “perfect” voltage source. To clarify this point, Fig.1.8a shows a “perfect” source of e.m.f. whilst Fig.1.8b shows a practical source of e.m.f. It’s important to note that the internal resistance, r , is actually inside the cell (or battery) and is not actually something that we can measure with an Ohmmeter!

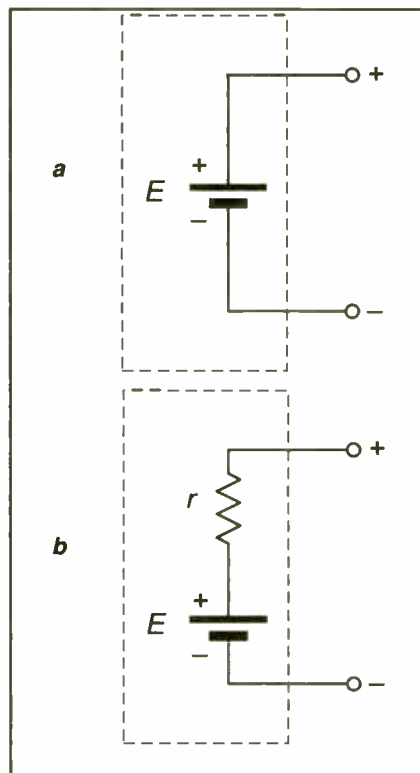

Fig.1.8. a) a perfect source of e.m.f., b) a practical source of e.m.f.

Introducing Switches

Switches provide us with a means of interrupting the current in a circuit. An obvious application for a switch is that of connecting or disconnecting the supply to a circuit. Switches come in many shapes and forms according to the application concerned. Photo 1.5 shows various common types of switch whilst Fig.1.9 shows a selection of circuit symbols used for switches.

The most basic form of switch is the single-pole, single-throw (s.p.s.t.) switch. This switch has a simple on/off action when respectively closed and opened (see Fig.1.10). The double-pole, single-throw

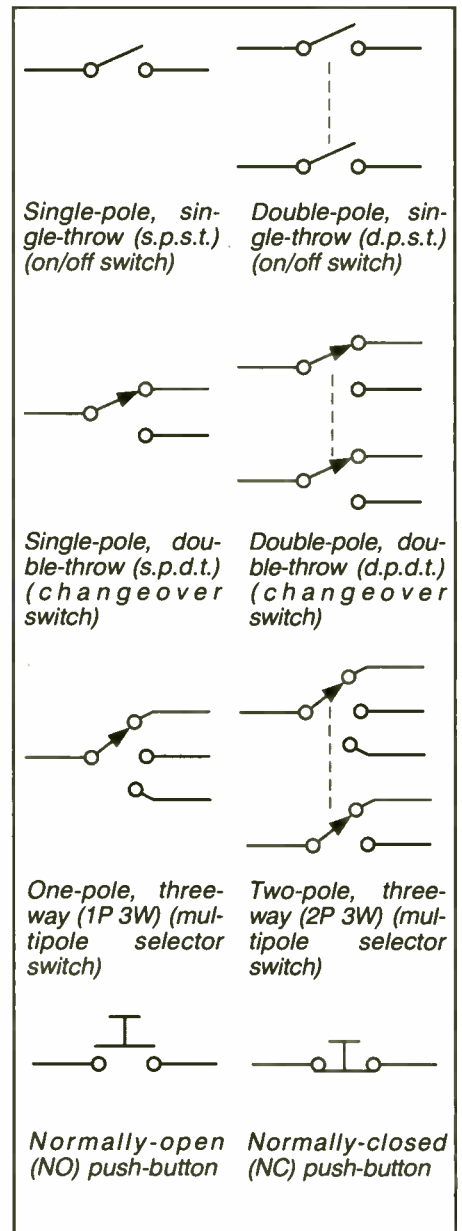

Fig.1.9. A selection of circuit symbols used for switches

Check Point 1.6

In a primary cell the conversion of chemical energy to electrical energy is irreversible and so these cells cannot be recharged. In secondary cells, the conversion of chemical energy to electrical energy is reversible. Thus these cells can be recharged and reused many times.

Check Point 1.7

Every practical source of e.m.f. (for example a cell, battery or power supply) has some internal resistance which limits the amount of current that it can supply. When we need to take the internal resistance of a source into account (for example, in circuit calculations) we show the source as a perfect voltage source connected in series with its internal resistance.

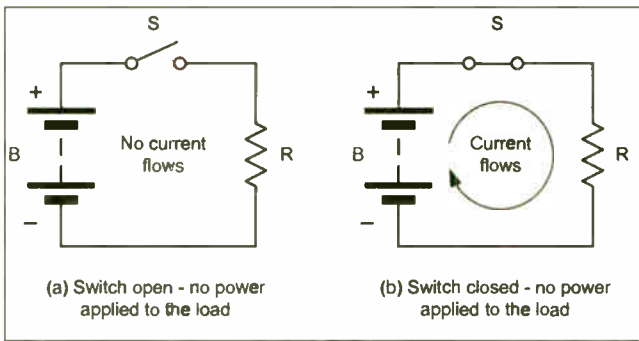

Fig. 1.10. A simple s.p.s.t. switch application. The circuit (load) has power applied to it when the switch contacts are closed (b)

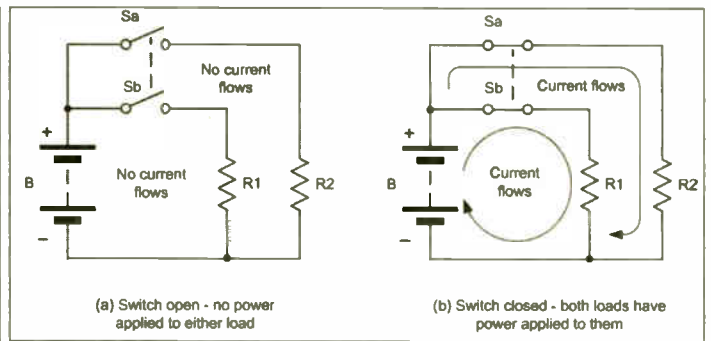

Fig. 1.11. A simple d.p.s.t. switch application. Both circuits (loads, R₁ and R₂) have power applied to them when the switch contacts are closed (b)

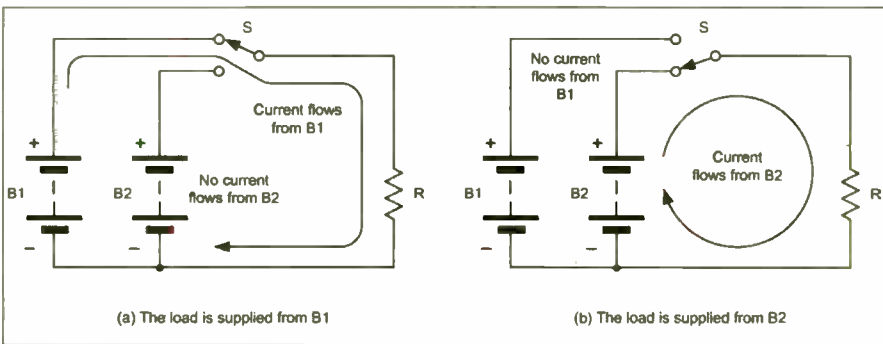

Fig. 1.12. A simple s.p.d.t. switch application. The supply to the load is changed over when the switch is operated

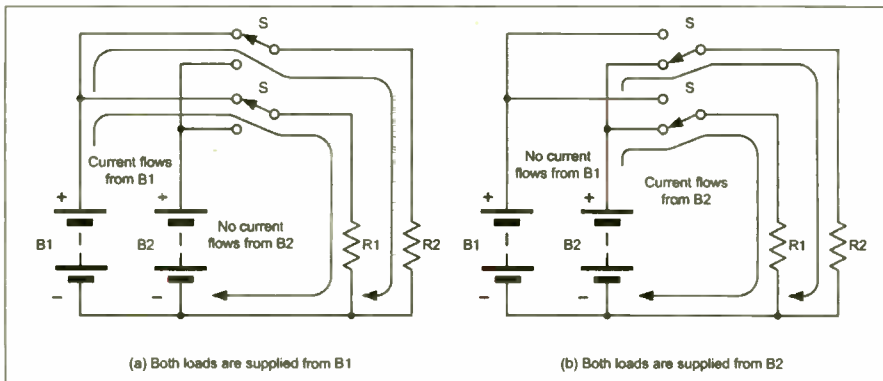

Fig. 1.13. A simple d.p.d.t. switch application. The supply to both loads is changed over when the switch is operated

(d.p.s.t.) switch is similar to the s.p.s.t. switch with its on/off action but is capable of switching two circuits independently (see Fig. 1.11). A further switch type has a changeover action and is available in both single-pole double-throw (s.p.d.t.) and double-pole double-throw (d.p.d.t.) variants (see Fig. 1.12 and Fig. 1.13).

Many more complex types of switch are available including multipole rotary and pushbutton types. Switches of these types are frequently used for selecting signal sources in amplifiers, changing ranges on test equipment, and selecting wavebands on radio receivers.

The specifications for a switch are usually quoted in terms of the switch function (the number of poles and the number of ways), the style of the switch (rotary, toggle, slide, pushbutton etc), and the maximum current and voltage that can be applied to the switch.

Practical Investigation 1.1

Objective: To investigate the relationship between the resistance in a circuit and the current that flows in it.

Components and materials required: Plug-in breadboard; 9V d.c. power source (PP9 9V battery or a.c. mains adapter with a 9V 400mA output); digital multimeter with test leads; resistors of 100Ω, 220Ω, 330Ω, 470Ω, 680Ω and 1kΩ; insulated wire links (various lengths); assorted crocodile clip leads; short lengths of black, red, and green insulated solid wire.

Circuit diagram: Fig. 1.14

Wiring diagram: Fig. 1.15

Photograph: Photo 1.6

Tip: You need resistors of several different values for this investigation. These will often be supplied in batches of five or ten of the same value connected by tapes. These have been cut from much larger reels used by equipment that automatically inserts resistors into printed circuit boards. To make life a little easier (and to avoid having to spend a lot of time working out the values of resistors) it can be useful to check each batch of resistors and mark the value on the tape.

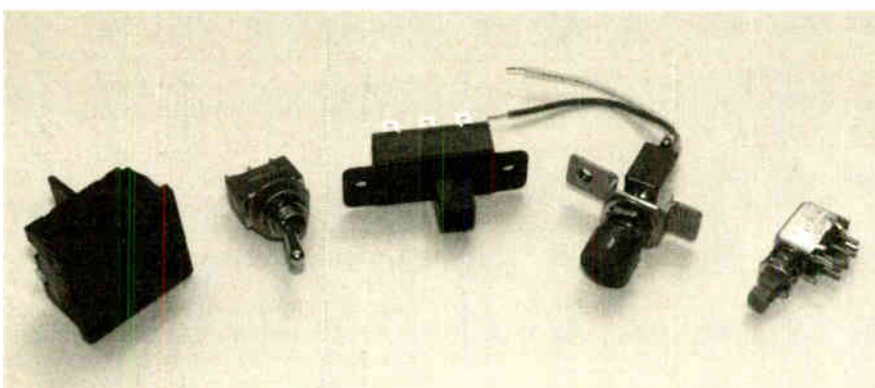

Photo 1.5. Various types of switch. From left to right: a mains d.p.s.t. rocker switch, a s.p.d.t. miniature toggle (changeover) switch, a d.p.d.t. slide switch, a s.p.d.t. pushbutton (wired for use as a s.p.s.t. pushbutton), a miniature p.c.b. mounting d.p.d.t. pushbutton (with a latching action)

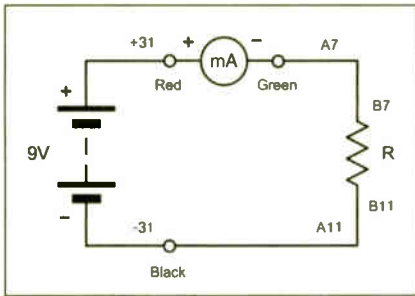

Fig.1.14. Circuit diagram for Practical Investigation 1.1

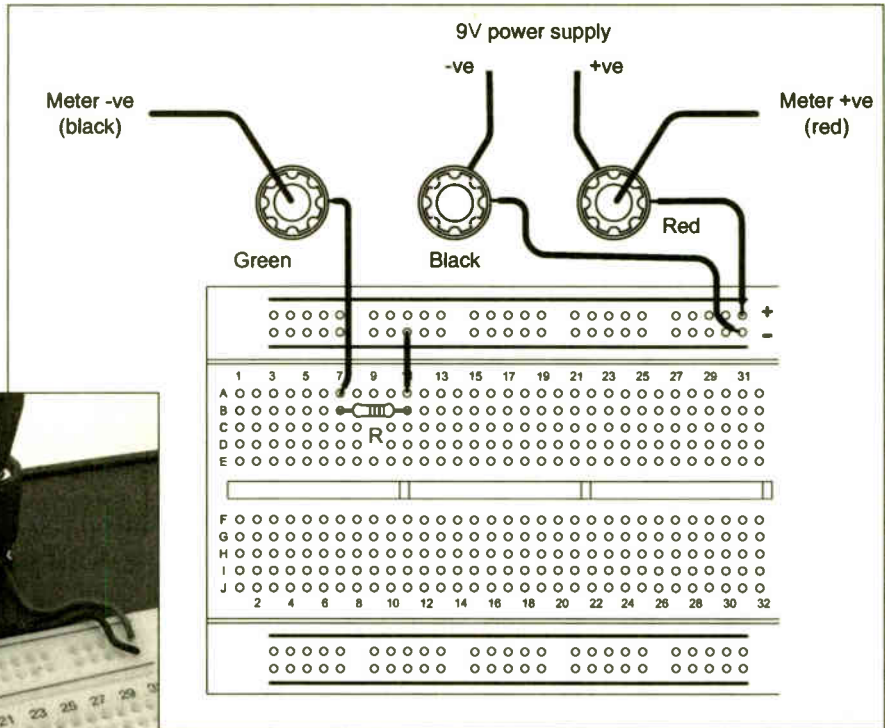

Fig.1.15. Wiring diagram for the Practical Investigation 1.1

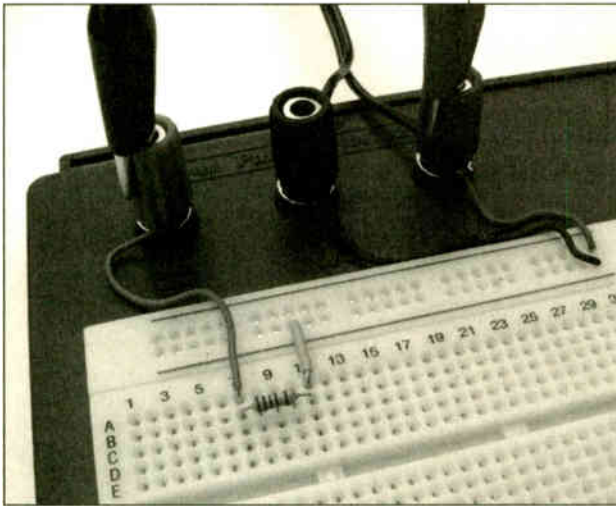

Photo 1.6. The completed breadboard wiring

Table 1.5: Breadboard wiring for Practical Investigation 1.1

Step	Connection, link or component	From	To
1	-9V supply	-9V	Black terminal
2	+9V supply	+9V	Red terminal
3	Green wire	A7	Green terminal
4	Yellow link	A11	-11
5	Red wire	Red terminal	+31
6	Black wire	Black terminal	-31
7	100Ω resistor	B7	B11

Table 1.6: Meter connections

Step	Connection, link or component	From	To
8	mA (red)	Red	Red terminal (via red croc lead)
9	COM (black)	Black	Black terminal (via black croc lead)

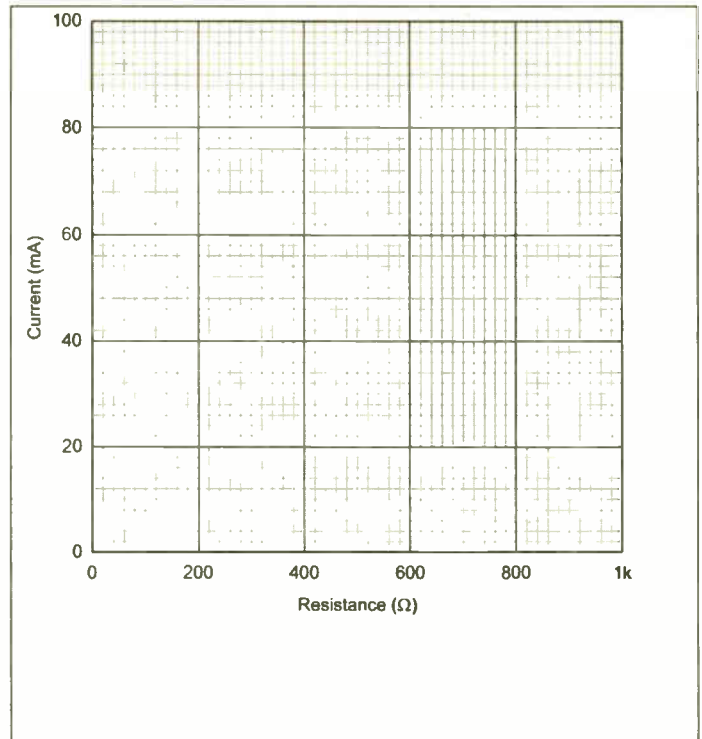

Fig.1.16. Graph sheet for plotting the results of Investigations 1.1 and 1.2. We suggest you enlarge this using a photocopier

Before switching on the d.c. supply or connecting the battery, check that the meter is set to the 200mA d.c. current range. Switch on (or connect the battery), switch the multimeter on and read the current.

Note down the current on a photocopy of Table 1.7 and repeat for resistance values of 220Ω, 330Ω, 470Ω, 680Ω and 1kΩ, switching off or disconnecting the battery between each measurement. Plot corresponding values of current (on the vertical axis) against resistance (on the horizontal axis) using an enlargement photocopy of the graph sheet shown in Fig.1.16.

Conclusion: Comment on the shape of the graph. Is this what you would expect? Does this confirm that the current flowing in the circuit is inversely proportional to the resistance in the circuit? It should do!

Table 1.7: Measurements

Resistance (Ω)	Current (mA)
100	
220	
330	
470	
680	
1k	

Current, Voltage and Resistance

In this section we explain the relationship between current, voltage and resistance in a circuit. This important relationship is known as *Ohm's Law*.

As mentioned earlier, all electrons and protons have an electrostatic charge but the charge carried by an individual electron is so small that a more convenient unit of charge is needed for practical use, we call this the *coulomb*. A charge of one coulomb (1C) is the same charge as that possessed by 6.21×10^{18} electrons. Putting this another way, a single electron has a charge of $1.61 \times 10^{-19}C$.

Electric current (the “organised movement of electrons” that we referred to earlier) is the rate of flow of charge and its unit is the Ampere, A. The Ampere is defined as follows:

One Ampere is equal to one coulomb per second, or 6.21×10^{18} electrons passing a point in a circuit in a time interval of one second. Thus current can be thought of as the “rate of flow of charge”, hence:

$$\text{Current} = \text{Charge/Time, or } I = Q/t$$

where I = current in Amps, Q is the charge in coulombs, and t is the time in seconds.

So, for example, if a steady current of 2A flows for five minutes, then the amount of charge transferred will be:

$$Q = I \times t = 2A \times (5 \times 60)s = 2 \times 300 = 600 \text{ coulombs}$$

Direction of Current Flow

Because of their negative charge, electrons will flow from a negative potential to a more positive potential (recall that like charges attract and unlike charges repel). However, when we indicate the direction of current in a circuit we show it as moving from a point that has the greatest positive potential to a point that has the most negative potential.

We call this *conventional current* and, although it may seem to be odd, you just need to remember that it flows in the *opposite* direction to that of the motion of electrons!

Check Point 1.8

Current is the rate of flow of charge. Thus, if more charge moves in a given time, more current will be flowing. If no charge moves then no current is flowing.

Check Point 1.9

Electrons move from negative to positive whilst conventional current is assumed to flow from positive to negative.

Potential Difference

The force that creates the flow of current (or rate of flow of charge carriers) in a circuit is known as the *electromotive force* (or *e.m.f.*) and it is measured in volts (V). The *potential difference* (or *p.d.*) is the voltage difference (or voltage drop) between two points. Note that one volt (1V) is the potential difference between two points if one Joule of energy is required to move one coulomb of charge between them.

Ohm's Law

The most basic d.c. circuit uses only two components; a cell (or battery) acting as a source of e.m.f., and a resistor (or *load*) through which a current is passing. These two components are connected together with wire conductors in order to form a completely closed circuit, as shown in Fig.1.17.

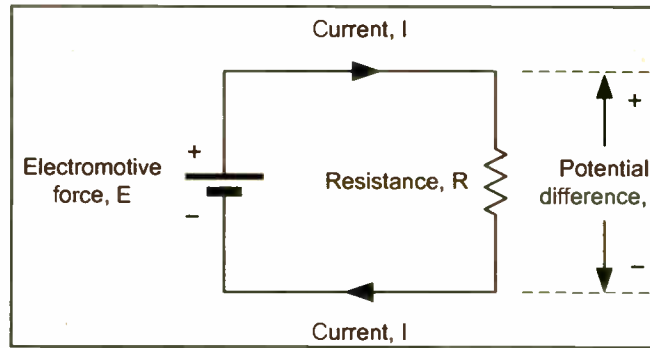

Fig.1.17. A simple d.c. circuit consisting of a battery (source) and resistor (load)

For any conductor, the current flowing is directly proportional to the e.m.f. applied. The current flowing will also be dependent on the physical dimensions (length and cross-sectional area) and material of which the conductor is composed.

The amount of current that will flow in a conductor when a given e.m.f. is applied is inversely proportional to its resistance (as we saw from Practical Investigation 1).

Now, provided that temperature does not vary, the ratio of p.d. across the ends of a conductor to the current flowing in the conductor is a constant. This relationship is known as *Ohm's Law* and it leads to the relationship:

$$\text{Voltage/Current} = \text{a constant, thus } V/I = \text{a constant} = R$$

where V is the potential difference (or voltage drop) in volts (V), I is the current in amps (A), and R is the resistance in ohms (Ω).

The formula may be arranged to make V , I or R the subject, as follows:

$$V = I \times R \quad I = \frac{V}{R} \quad \text{and} \quad R = \frac{V}{I}$$

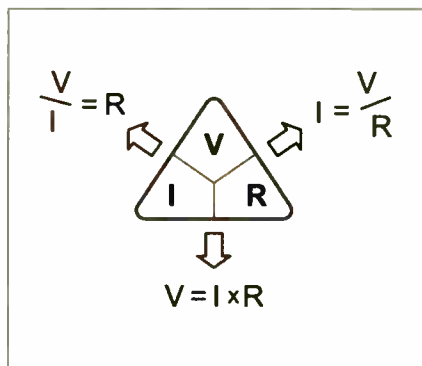

Fig.1.18. The Ohm's Law triangle

The triangle shown in Fig.1.18 should help you remember these three important relationships. It is important to note that, when performing calculations of currents, voltages and resistances in practical circuits it is seldom necessary to work with an accuracy of better than $\pm 1\%$ simply because component tolerances are invariably somewhat greater than this. Furthermore, in calculations involving Ohm's Law, it is sometimes convenient to work in units of $k\Omega$ and mA (or $M\Omega$ and μA) in which case potential differences will be expressed directly in V.

Example 1.12

A current of 0.5A flows in a 12Ω resistor. What voltage drop (potential difference) will be developed across the resistor?

Here we must use and ensure that we work in units of volts (V), amps (A), and ohms (Ω):

$$V = I \times R = 0.5A \times 12\Omega = 6V$$

Example 1.13

A 150Ω resistor is connected to a 9V battery. What current will flow in the resistor?

Here we must use $I = \frac{V}{R}$ (where $V = 9V$ and $R = 150\Omega$):

$$I = \frac{V}{R} = \frac{9V}{150\Omega} = 0.06A = 60mA$$

Example 1.14

A voltage drop of 15V appears across a resistor in which a current of 5mA flows. What is the value of the resistance?

Here we must use $R = \frac{V}{I}$ (where $V = 15V$ and $I = 5mA = 0.005A$)

$$R = \frac{V}{I} = 15V/0.005A = 3,000\Omega = 3k\Omega$$

Note that it is often more convenient to work in units of mA and V which will produce an answer directly in $k\Omega$, i.e.

$$R = \frac{V}{I} = \frac{15V}{5mA} = 3k\Omega$$

Questions 1.3

Here are a few questions that can be solved using Ohm's Law (answers appear later):

Q1.19. A 6V battery is connected to a 24Ω resistor. How much current is supplied?

Q1.20. A current of 20mA flows in a resistor of $1.2k\Omega$. What voltage drop will appear across the resistor?

Q1.21. A 15V supply delivers a current of 0.4A to a load. What is the resistance of the load?

Practical Investigation 1.2

Objective: To investigate Ohm's Law and plot a graph of voltage against current for two different values of resistance.

Components and materials: Breadboard; 9V d.c. power source (either a PP9 9V battery or an a.c. mains adapter with a 9V 400mA output); digital multimeter with test leads; resistors of 470Ω and $1k\Omega$; $10k\Omega$ potentiometer; insulated wire links (various lengths); assorted crocodile leads; short lengths of black, red, and green insulated solid wire.

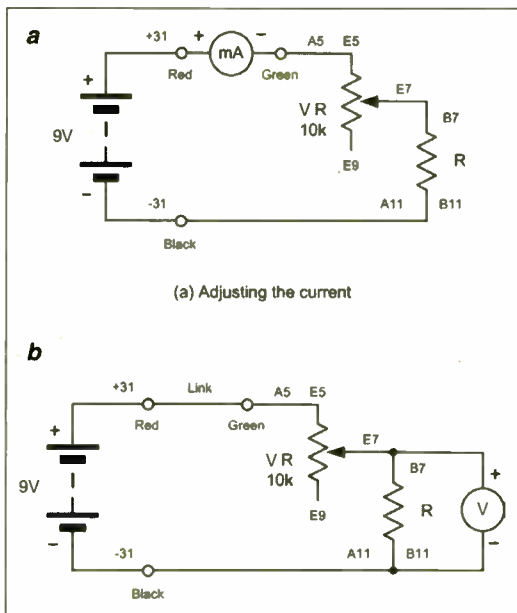

Fig.1.19. Circuit diagram for the Ohm's Law Practical Investigation, (a) adjusting the current, (b) measuring the voltage

Table 1.9

Step	Meter connection	Meter leads	To
11	mA (red)	Red	Red terminal (via red croc lead)
12	COM (black)	Black	Green terminal (via black croc lead)

Table 1.10

Step	Meter connection	Meter leads	To
13	V (red)	Red	B7 (via red croc lead)
14	COM (black)	Black	B11 (via black croc lead)

Circuit diagram: See Fig.1.19

Wiring diagram: See Fig.1.20 and Fig.1.21

Procedure: Table 1.8

To adjust the current, the required meter connections are as in Table 1.9.

To measure the voltage, the required meter connections are as in Table 1.10.

Connect the circuit as shown in Fig.1.20 and the meter as described in Steps 11 and 12 of Table 1.9. Before switching on the d.c. supply or connecting the battery, check that the meter is set to the 200mA d.c. current range. Switch on (or connect the battery), switch the multimeter on and read the current.

Adjust VR to obtain a current of exactly 1mA. Switch off (or disconnect the battery) and connect the circuit as shown in Fig.1.21 and the meter as described in Steps 13 and 14 of Table 1.10. Select the d.c. 20V range on the multimeter, switch the supply back on (or connected the battery) and read the voltage. Record the voltage indication on a photocopy of Table 1.11.

Switch off the d.c. supply (or disconnect the battery). Repeat the procedure, adjusting the current in 1mA steps from 2mA to 8mA, and at each step measure the voltage.

Finally, replace the 1kΩ resistor with one of 470Ω and repeat the measurements, recording the new set of values in the appropriate column of Table 1.11.

On a photocopy of Fig.1.16, plot graphs of voltage (on the vertical axis) against current (on the horizontal axis) using the same set of axes for both sets of measurements.

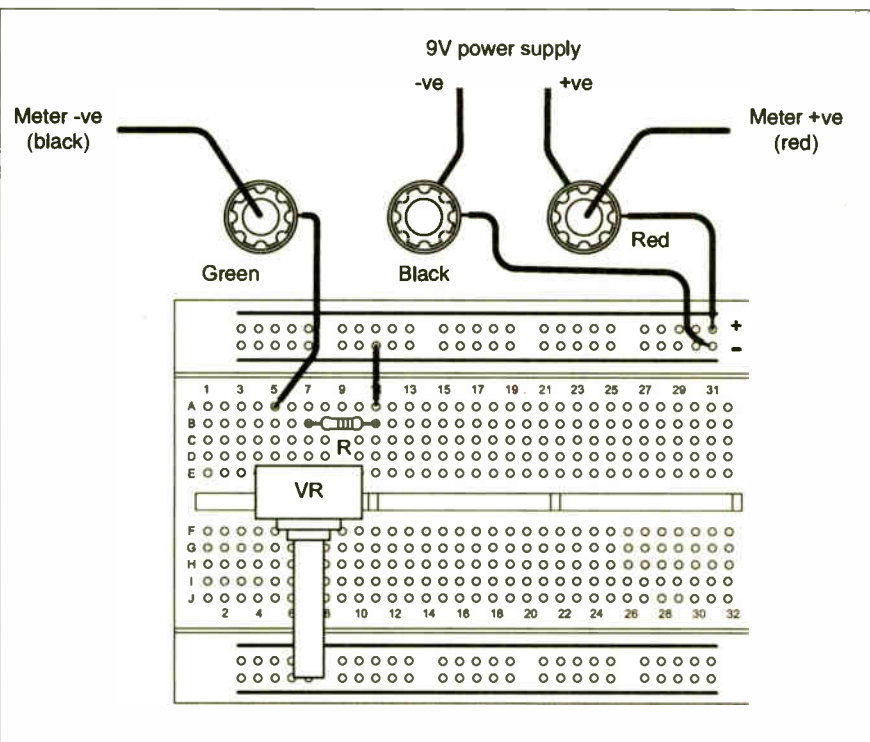

Fig.1.20 Wiring diagram for adjusting the current in the Ohm's Law Practical Investigation

Table: 1.8

Connection Procedure Investigation 1.2

Step	Connection, link or component	From	To
1	-9V Supply	-V	Black Terminal
2	+V Supply	+9V	Red Terminal
3	Green Wire	A7	Green Terminal
4	Yellow Link	A11	-11
5	Red Wire	Red Terminal	+3
6	Black Wire	Black Terminal	-31
7	VR Pot.	E5	
8	VR Pot.	E7	
9	VR Pot.	E9 (not used)	
10	1kΩ Resistor	B7	B11

Table 1.11 Measurements

Current (mA)	Voltage (V)	
	R = 1kΩ	R = 470Ω
1.0		
2.0		
3.0		
4.0		
5.0		
6.0		
7.0		
8.0		

Tip: In order to provide some protection when a multimeter is inadvertently set to a current range and used to make a voltage measurement, a fuse (of typically 200mA rating) is often fitted inside the multimeter. If you find that the meter stops working on the current ranges (but still works on the voltage ranges) it could well be that the fuse has blown. You can avoid this unfortunate situation by taking care to ensure that you *always* select the correct range and meter connections before switching the d.c. supply on!

Conclusion: Comment on the shape of the two graphs. Is this what you would expect? What does the slope of the graph indicate? How does the slope differ for the two values of resistance?

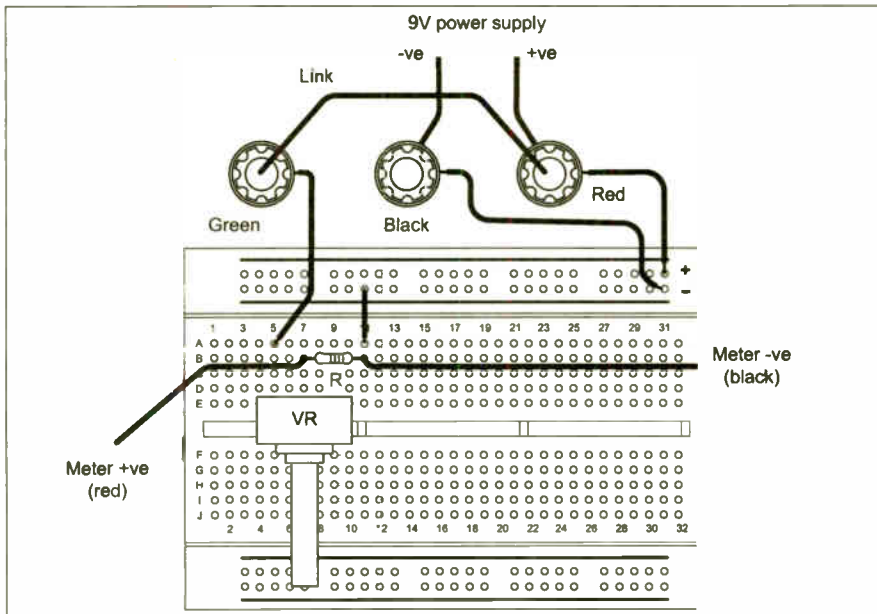

Fig.1.21. Wiring diagram for measuring the voltage in the Ohm's Law Practical Investigation

Answer to Questions

- Q1.1. Amps
- Q1.2. Hertz
- Q1.3. C
- Q1.4. 2.5mV
- Q1.5. 0.075A
- Q1.6. 220k Ω
- Q1.7. 10k Ω 10%
- Q1.8. 2.2M Ω 5%
- Q1.9. 0.33 Ω 5%
- Q1.10. 2.7 Ω 5%
- Q1.11. 100 Ω 1%
- Q1.12. 5.65k Ω 1%
- Q1.13. C1
- Q1.14. R2, R4, R6
- Q1.15. s.p.s.t.
- Q1.16. True
- Q1.17. 220 Ω
- Q1.18. 10 μ F
- Q1.19. 0.25A (or 250mA)
- Q1.20. 24V
- Q1.21. 37.5 Ω

Teach-In 2006 Full Components List

Resistors

10 Ω , 47 Ω , 100 Ω , 220 Ω , 330 Ω , 470 Ω , 680 Ω , 1k, 2k2, 3k3, 4k7, 6k8, 10k, 22k, 33k, 47k, 68k, 100k, 220k, 470k, 680k, 1M (5 to 10 of each value. All 0.25W 2%)

Potentiometer

10k linear potentiometer, panel mounting

Capacitors

100p, 470p ceramic
1n, 2n2, 4n7, 10n, 47n, 100n, 220n, 470n polyester
1 μ , 4 μ 7, 10 μ , 47 μ , 100 μ , 220 μ , 470 μ radial electrolytic, 16V minimum working voltage (4 of each value)

Semiconductors

1N4148 signal diode (2 off)
1N4001 rectifier diode (2 off)
Red i.e.d. (2 off)
Green i.e.d. (2 off)
BZX79C 3V9 Zener diode
BZX79C 5V1 Zener diode
BC548B npn transistor (4 off)
741 op.amp (2 off)
555 timer (2 off)
4001 quad NOR gate (2 off)
4011 quad NAND gate (2 off)

Hardware and Miscellaneous

6V d.c. 25mA sounder
Plug-in breadboard, with base-plate attachment having at least three screw terminals, preferably coloured red, green and black
9V d.c. 400mA power supply or 9V PP9

battery with battery clips

Flexible leads with crocodile clips at each end

Low-cost digital multimeter (a.c., d.c., resistance and capacitance ranges), with test leads

Recommended Additional Items (not essential)

For all parts:

Jump wire kit
Bench magnifier or small magnifying glass
Portable component storage box

For Parts 7 and 8:

Low-cost logic probe

For Part 10 (Radio project):

OA91 germanium diode
2N3819 n-channel JFET
LM386N-1 audio amplifier
Standard slide switch
Min. low-impedance loudspeaker
10k linear potentiometer with d.p.s.t. switch
Stripboard, 0.1-inch matrix, with at least 40 copper strips \times 40 holes
LW/MW ferrite rod aerial
Miniature AM tuning capacitor
8-pin d.i.l. socket
Insulated solid wire (various colours)
Miniature soldering iron, pliers, cutters and screwdriver

Part 1 Quiz

An on-line quiz is available which you are invited to try. This quiz consists of 15 multiple-choice questions that will allow you to check your understanding of the topics contained in the first part of our *Teach-In 2006* series. Please note that the quiz can only be taken on-line, and requires Microsoft Internet Explorer, version 6.0 or greater. Your answers will be automatically marked and the score returned to you by going to:

www.miketooley.info/teach-in/quiz1

Next Month

In next month's *Teach-In* we shall be taking a look at some more circuit theory including the classic voltage and current divider circuits as well as introducing some important concepts relating to power and energy. We shall also be explaining how to read a circuit diagram and introducing circuit construction techniques and the multimeter.

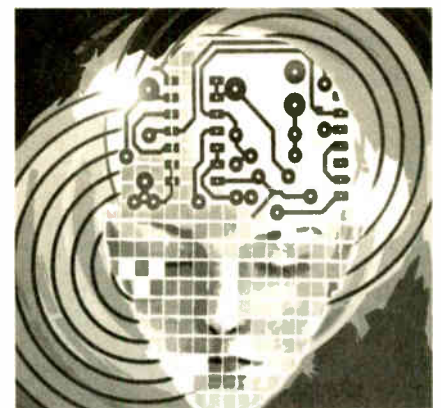

EP
Online
www.epemag.com

Get your magazine "instantly" anywhere in the world
– buy and download from the web.

TAKE A LOOK, A FREE ISSUE IS AVAILABLE

A one year subscription (12 issues) costs just \$14.99

(US)

www.epemag.com

Rapid

Proud to be this year's
prize sponsor for the
EPE Tutorial Series 'Teach-In' 2006

- Competitive prices on the Components Kits and all our products
- Dedicated technical team
- Over 32,000 products in stock
- Same day despatch
- No minimum order value
- Free carriage for orders over £25 – excluding VAT (UK mainland only)
- Product quality and service guaranteed

FIRST PRIZE

72 piece
Electronics
Tool Kit

worth £275

plus 21
runner-up prizes

Order code:
85-0075



KIT 1

Set of general
components
(including free
Digital
Multimeter)

Order code: **£17.50***
70-1252 +VAT
* inc p&p

KIT 2

Recommended
additional
items, including
logic probe

Order code: **£13.00***
70-1254 +VAT
* inc p&p

KIT 3

Components for
the radio
project

Order code: **£19.00***
70-1256 +VAT
* inc p&p

KIT 4

The complete
set
(Kits 1, 2 and 3
together)

Order code: **£41.95**
70-1258 +VAT
FREE Despatch

www.rapidelectronics.co.uk

Rapid Electronics Limited
Severalls Lane, Colchester,
Essex CO4 5JS

Telephone: 01206 751166

Fax: 01206 751188

Email: sales@rapidelec.co.uk

Website: www.rapidelectronics.co.uk

defining the standard

READOUT

Email: john.becker@wimborne.co.uk

John Becker addresses some of the general points readers have raised. Have you anything interesting to say? Drop us a line!

All letters quoted here have previously been replied to directly.

WIN AN ATLAS LCR ANALYSER WORTH £69

An Atlas LCR Passive Component Analyser, kindly donated by Peak Electronic Design Ltd., will be awarded to the author of the *Letter Of The Month* each month.

The Atlas LCR automatically measures inductance from 1 μ H to 10H, capacitance from 1pF to 10,000 μ F and resistance from 1 Ω to 2M Ω with a basic accuracy of 1%.



★ LETTER OF THE MONTH ★

Net Work - Spyware

Dear EPE,

I have just read Alan's latest *Net Work* article in Oct '05 about his woes of Spyware infections again. Having seen his previous article, it was interesting to see him "attacked" again, even after his previous experiences.

I work as a mobile IT trouble shooter for a large corporate throughout the UK. I have worked with IT and computer systems for many, many years, and yet, even with the serious investment of my employer with defence tools against such attacks, even we fail. I all too often pin down PC issues to "additional" software installations that make it through the corporate defences. I also spend a reasonable amount of time and effort in clearing systems of private individuals.

It is interesting to see how well Spyware is getting in defending itself against removal and detection tools available on the market. After experiencing similar situations of continued "sticky" Spyware applications, I developed an improved method of removal that's maybe of interest to you and the readers of *Net Work*. By the way, it works well for those stubborn virus infections as well.

First of all I need to point out that not all users will be able to employ this method. However, with the assistance of an old PC laying around, the solution

can provide a far better cleansing approach to the infected system. But also, it does require the removal of the infected hard drive from the PC that may be technically beyond some users, and this may also affect the warranty.

I have discovered that if the infected hard drive is not booted up, then it is impossible for the Spyware infection and defences to become active and hence it can no longer defend itself. To achieve this, remove the hard drive from the infected PC and install it as a "slave" in another Spyware free "helper" system with an identical or higher level of operating system to that of the infected system. XP NTFS partitions are really difficult to access via Win9x.

Boot up the "helper" system if needed. I often use an IDE/USB, SATA/USB or SCSI/USB interface cables to hook the infected drive to an alternative system, so booting up/down, and case removal etc. are kept to a minimum with the "helper" system. These can be purchased for around £30 and are well worth the investment. Once the "helper" system is booted, you may use as many different packages as you like to clean the infected drive. This is so successful, that over 95% of the time, a good single removal tool will generally suffice. Because the problem package has not had any chance to "hook" itself in, cleaning is amazingly reliable with the first pass. But generally I run a second just as a verification.

This will clean out all the executable content that could be loaded during a normal system boot up. However, it does not remove the hooks from any registry hives. I have been talking to several Spyware products, but few of them are interested in locating registry hives, mounting them and cleaning them.

The "dirty" registry is not a problem, because it cannot contain any executable content, only references to something executable. The hard drive can be returned to the original system, booted and a final "clean" to remove any remaining markers from the registry.

So, perfect Spyware removal method for even the most stubborn of system "stains". Although it requires a little more skill, the results speak for themselves – a system restored to being "whiter-than-white" ...

Adam Sharp, via email

Alan replied to Adam:

This is an interesting approach that I have not come across before, though as you rightly say, the warranty of commercial PCs will be affected if the drive is removed, so this technique is strictly for those confident in PC assembly. USB hard drive adaptors can be useful and can be sourced from eBay. Remember that data should be backed up first.

Alan Winstanley

Will the Bulldog C to Oz?

Dear EPE,

Even down under we enjoy your mag. There is a group of us that anxiously awaits the newsagent delivery.

In *Readout* June '05 there's a letter from Dale Stewart regarding C programming. We Aussies must just be so much further advanced. We all program in C and would love some more articles and code for C. Why program in assembler these days? All the chips have so much memory that I have never run out of memory in any application. Using C is just so quick and easy. The compilers are great and most have wizards, so you can be up and running in no time. The code is just so transportable too.

Whilst you are very focused on PICs, we would also like to hear a little about Atmel. They too are just so easy to use,

and becoming more and more popular.

I know the Bulldog moves slowly, but we live in hope.

John O'Hagan, Australia, via email

Thanks for your comments John. Yes we know we have many faithful Down-Underers – greetings all!

There are also many readers who have a preference for C, though my own choice is for PIC assembler as it achieves more compact code and consequent reduction in PIC program space use – though admittedly that's less of a problem these days.

We are unlikely to get into Atmel as most readers are kitted for PICs and for them to use Atmel would require considerable extra expense, and learning curves! We did try an Atmel chip some years back and there was little interest.

Radio Cones?

Dear EPE,

Referring to your comment on disguised mobile phone masts in Aug '05, our pensioners club frequently takes coach trips around the M25 from junction 26 to the Dartford Tunnel and quite near the junction with the M11 one can see many of these plastic trees thinly disguised as hat stands littering the roadside. They must be dropping seeds because the numbers are increasing rapidly. They are easy to spot – whoever heard of a tree with uniform short stubby branches and bright reddish brown shiny bark?!

George Chatley, via email

Thanks George. Apart from the Orpington one I mentioned, I've not seen any more.

Ghost Buster?

Dear EPE,

I have a small dot-matrix I.e.d. display with scrolling messages. The problem is with the ghosting effect on the display (columns are kept illuminated when they should be off). Any ideas or references to documents about this issue will be appreciated.

Suheil Bukhzam, Senior System Engineer, Riyadh, Kingdom of Saudi Arabia, via email

If the controlling program has been correctly written and multiplexing turns I.e.d.s off properly before turning others on, ghosting should not happen. If the design is your own, re-look at your software in this context, and at the choice of the components used to multiplex the display.

Ensure that unwanted capacitance is eliminated to allow an I.e.d. to turn off fully before the next turns on. Question whether you have chosen the best devices to drive I.e.d.s, e.g., don't use 4000 series CMOS, which is slow, but choose faster drivers, such as HC or LS.

But do keep in mind that the human eye has "persistence of vision", and I.e.d.s may "appear" to glow for a fraction of a second after they have turned off while the eye readjusts itself – cinema films work on this principle, images changing at 25 frames per second appear to change smoothly. Your software should be written to avoid this conflict, i.e. don't scroll too fast.

If the design is not yours – I regret you're stuck with what you've got!

Suheil came back following my above reply, saying:

I am actually using my own design with a C18 compiler, PIC18 micro, 64 × 8 dot matrix I.e.d.s, and standard I.e.d. drivers: 74HCT245, 74LS377, 74HC574 and ULN2803.

From my software programs, I can ensure that the I.e.d.s are turned off before moving to the next columns (next frame). The problem arises when trying to make higher speed scrolling of a message on the display, for example, I want the message to scroll in three seconds from right to left, then with 64 columns the frame period should be $3/64 = 46.875\text{ms}$ per frame, this implies each I.e.d. column would stay on for about 46ms and then move to the next column, but I think because of the persistence of light effect the 46ms between columns will keep the eyes seeing the previous column on for sometime and this will create the ghosting effect.

One work around solution is to light up one column for 33ms for example and then turn it off for 13ms before moving to next frame, but this will noticeably reduce the brightness of the I.e.d.s per each frame.

Maybe you can answer these questions: is it normal that light brightness should be reduced as we scroll faster? Or are there some ways to keep high intensity even with high scrolling speeds? Are there some guidelines or best practices documents (or web links)

on how to make animated frames with dot matrix I.e.d.s?

To which I replied: I regret it's a fact of life that perceived brightness will reduce with multiplexing. To compensate, brighter I.e.d.s must be used. But I am not aware of any guideline documents on this. I'm just applying my own logical thinking to the question.

Have any readers more information on this intriguing problem?

Footprints and USB

Dear EPE,

Yours is a great magazine through which I have learned from many projects on PICs.

Recently I bought the p.c.b. for TK3. It was unfortunate that many of the components bought locally in Malaysia were far too big to fit into the footprint of the board.

I also note that TK3 makes use of the parallel port for interfacing with the computer. Parallel ports will soon become obsolete and replaced by USB. When will the USB version of TK3 be available?

Tey Meng Tah, Malaysia, via email

Thanks for your kind comment Tah.

Footprints in this context are not an issue for us as all components used in our published designs are available from UK suppliers – who you can also use. Ask them for their overseas delivery details if they are not quoted in their adverts.

Sorry to disappoint you, though, but I think it is unlikely that I shall upgrade TK3 for USB in the short-term as I don't currently use a USB PC in the workshop. That situation may change in the future!

Xport Praises

Dear EPE,

I would like to bring your attention to Xport (www.charmedlabs.com). This system could open up a whole new world of projects. For example FPGAs, C/C++ programming, RTOS, etc. You can get this thing out of the box take a working example and immediately you are up and running, and able to expand the example with ease. Everything except for the hardware is free.

Just take a look at the Gameboy spec (www.work.de/nocash/gbatek.htm) to realise how much more computing power you would have than with a PIC. You do not have to buy a Gameboy or Xport to evaluate the tools. Just download Xport Development Kit Software Package (Windows version) and VisualBoy Advance (Game Boy emulator for Windows), and you're away.

David Drummie, BEng (Hons), via email

Thanks for the info David, the specs you quoted make it look an interesting system, but we decided long ago that we cannot support several varieties of programmer etc, and have standardised on PICs. Readers who are interested in the Xport are recommended to follow up directly via the web address you quote.

Laser Ranges with PICs

Dear EPE,

Reading the August '05 *Readout*, I thought you might like to ponder the way radio altimetry worked. The frequency of transmission is linearly swept so that the return is at a slightly different frequency to the transmission, and the difference gives the range. If the difference frequency is small enough it could be handled by a PIC? But I don't know if the frequency of a laser can be swept.

John Waller, Plainfield, USA, via email

That's intriguing John! I'll think on it.

Timing the Speed of Light

Dear EPE,

In the August issue John asks about timing the speed of light. From my days as a Radar Technician in the US Navy I can tell you that it takes $1.2\mu\text{sec}$ (microseconds) for a pulse of r.f. or light to travel one mile downrange and return. We called this a "radar mile".

A bit of work with my calculator reveals that it takes roughly 1ns for light to travel 1ft (30cm actually). Of course it then takes another 1ns for the pulse to return to be detected. A 3-metre range would thus take about 20ns; 10ns there and 10ns to return.

George Martin, Austin, Texas, via email

Thanks George, it's a topic which deserves further investigation, like, is a PIC (and my brain) up to it?!

PC Scopes

Dear EPE,

I was interested to read Lynden McIntyre's letter in the June issue as I have recently been sizing up PC-based oscilloscopes myself. I came across one company that could be of interest called Bitscope (www.bitscope.com). Their main attraction to me is that they fully support my operating system of choice, Linux, but I do reluctantly accept that installing SUSE is not everyone's idea of a perfect solution to XP woes.

However, in true open source spirit, Bitscope also publish schematics for their instruments, freely downloadable from their site along with their software suite, and will sell p.c.b.s and kits. The article by Norm Jackson, linked to at the bottom of Bitscope's main page, is a good starting point for those interesting in learning more.

Gavin Wheeler, Pembrokeshire, via email

Thanks for the advice Gavin.

Cybervox

Dear EPE,

I am having trouble sourcing exact parts for your Cybervox (July '05). Is it possible to replace certain electrolytic capacitors, e.g. 16V with 25V?

Jon, via email

Yes Jon, 25V will do instead of 16V – you can always go upwards (within reason) in working voltage, size permitting.



EVERYDAY
PRACTICAL ELECTRONICS
 INCORPORATING ELECTRONICS TODAY INTERNATIONAL



UK readers you can
SAVE 71p
 on every issue of *EPE*

How would you like to pay £2.58 instead of £3.30 for your copy of *EPE*?
 Well you can – just take out a one year subscription and save over 71p an issue,
 or £8.60 over the year

You can even save over 92p an issue if you subscribe for two years
 – a total saving of £22.20

Overseas rates also represent exceptional value

You also:

- Avoid any cover price increase for the duration of your subscription
- Get your magazine delivered to your door each month
- Ensure your copy, even if the newsagents sell out

Order by phone or fax with a credit card or by post with a cheque or postal order, or buy on-line from www.epemag.co.uk (click on “Subscribe Now”)



EPE SUBSCRIPTION PRICES

Subscriptions for delivery direct to any address in the UK: 6 months £16.50, 12 months £31, two years £57; Overseas: 6 months £19.50 standard air service or £28.50 express airmail, 12 months £37 standard air service or £55 express airmail, 24 months £69 standard air service or £105 express airmail. Cheques or bank drafts (in £ sterling only) payable to *Everyday Practical Electronics* and sent to *EPE* Subs. Dept., Wimborne Publishing Ltd., 408 Wimborne Road East, Ferndown, Dorset BH22 9ND. Tel: 01202 873872. Fax: 01202 874562. Email: subs@epemag.wimborne.co.uk. Also via the Web at <http://www.epemag.co.uk>. Subscriptions start with the next available issue. We accept MasterCard, Amex, Diners Club, Maestro or Visa. (For past issues see the *Back Issues* page.)

ONLINE SUBSCRIPTIONS

Online subscriptions, for downloading the magazine via the Internet, \$14.99US (approx. £8) for one year available from www.epemag.com.

USA/CANADA SUBSCRIPTIONS

To subscribe to *EPE* from the USA or Canada please telephone Express Mag toll free on 1877 363-1310 and have your credit card details ready. Or fax (514) 355 3332 or write to Express Mag, PO Box 2769, Plattsburgh, NY 12901-0239 or Express Mag, 8155 Larrey Street, Anjou, Quebec, H1J 2L5. Email address: expsmag@expressmag.com. Web site: www.expressmag.com.

USA price \$60(US) per annum, Canada price \$97(Can) per annum – 12 issues per year.

Everyday Practical Electronics, periodicals pending, ISSN 0262 3617 is published twelve times a year by Wimborne Publishing Ltd., USA agent USACAN at 1320 Route 9, Champlain, NY 12919. Subscription price in US \$60(US) per annum. Periodicals postage paid at Champlain NY and at additional mailing offices. POSTMASTER: Send USA and Canada address changes to *Everyday Practical Electronics*, c/o Express Mag., PO Box 2769, Plattsburgh, NY, USA 12901-0239.



SUBSCRIPTION ORDER FORM



- 6 Months: UK £16.50, Overseas £19.50 (standard air service), £28.50 (express airmail)
- 1 Year: UK £31.00, Overseas £37.00 (standard air service) £55 (express airmail)
- 2 Years: UK £57.00, Overseas £69.00 (standard air service) £105 (express airmail)
- To: *Everyday Practical Electronics*,
 Wimborne Publishing Ltd., 408 Wimborne Road East,
 Ferndown, Dorset BH22 9ND
 Tel: 01202 873872 Fax: 01202 874562
 E-mail: subs@epemag.wimborne.co.uk

I enclose payment of £ (cheque/PO in £ sterling only), payable to *Everyday Practical Electronics*

My card number is:
 Please print clearly, and check that you have the number correct

Signature

Card Security Code (The last 3 digits on or just under the signature strip)

Card Ex. Date Maestro Issue No.

Name

Address

Post code Tel.

Subscriptions can only start with the next available issue.



the Atlas DCA55

- Automatically analyse most 2 and 3 leaded semiconductors.
- Automatically identify all leads, just connect any way round!
- Measures lots of parameters too such as gain, V_{BE} , V_{GS} , etc...



LCR40
£69.00

DCA55
£49.00

SCR100
£99.00

Passive components, semiconductors,
power devices, network cabling
Choose your perfect analyser

New Low Prices!

limited time only

the Atlas LCR40

- Automatically identify Inductors, Capacitors and Resistors.
- Inductors from $1\mu H$ to 10H.
- Capacitors from 1pF to 10,000 μF .
- Resistors from 1Ω to 2M Ω
- 1% Basic accuracy.
- Automatic frequency selection.



"Star Pack"
LCR and DCA
in carry case
£118.00

Carry cases
£15.00

SMD Tweezer
Probes for LCR
£19.00

Spare Battery
£1.75



Triac and Thyristor Testing



Multi-Function R/C Switch



Ken Ginn

A single channel radio controlled transceiver can control four peripheral functions

THE single function radio controlled (R/C) switch which has just one set function and one relay, has limited usefulness. Described here is the construction of an R/C interface unit which has four switched outputs. The unit responds to the transmitter's joystick movement, controlling the four outputs, switching them on or off. As the joystick is pushed from one extreme to the other, so the outputs are switched in sequence.

The unit could form part of a crude speed controller, giving one or two speeds each in forward or reverse. It can also be part of a model's effects facilities, such as in the case of a model car with working indicator lights. The unit could also be connected in parallel with the steering servo signal and as the model turns in one direction, the unit would switch on the indicator lights on the appropriate side. There are numerous other possible uses specific to a model's needs.

R/C Matters

Radio control systems generally rely on a signal format from an R/C Receiver that feeds a switch, a speed controller or a

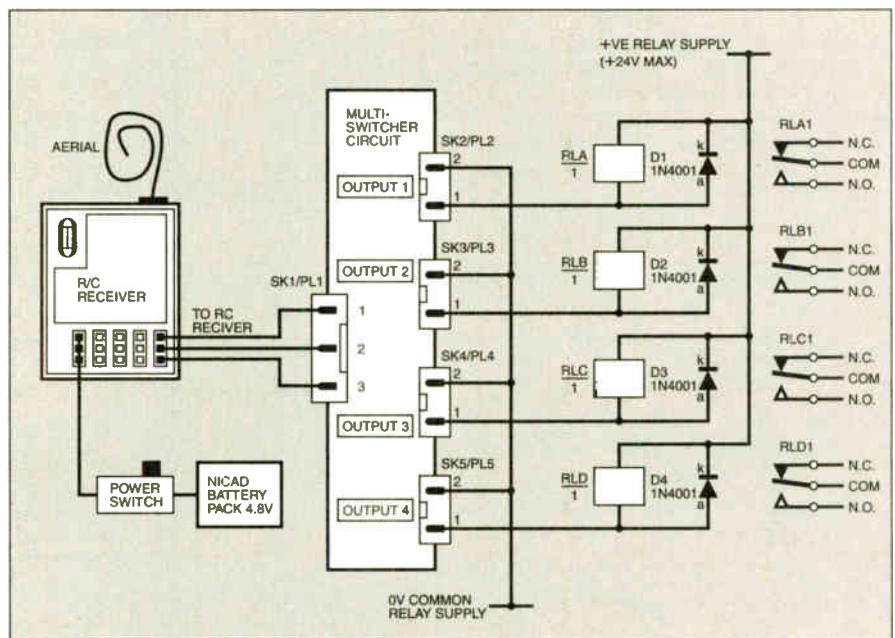

Fig. 1. Block diagram of the Multi-Function R/C Switch's operation

servo. A valid signal is a positive-edged pulse having a duration in the region of 1.0ms to 2.0ms. This pulse is updated regularly at 20ms intervals. The transmitter joystick position controls the pulse width.

With this circuit, the pulse width is measured and the software controls the outputs, setting them on or off accordingly. The pulse amplitude is typically 4V. The switching points for each output are set as in Table 1.

Table 1: Pulse Width Response

1.0ms to 1.2ms (output 1)
1.2ms to 1.4ms (output 2)
1.4ms to 1.6ms (neutral - no action)
1.6ms to 1.8ms (output 3)
1.8ms to 2.0ms (output 4)

Note that between 1.4ms and 1.6ms there is a neutral zone where none of the outputs are activated.

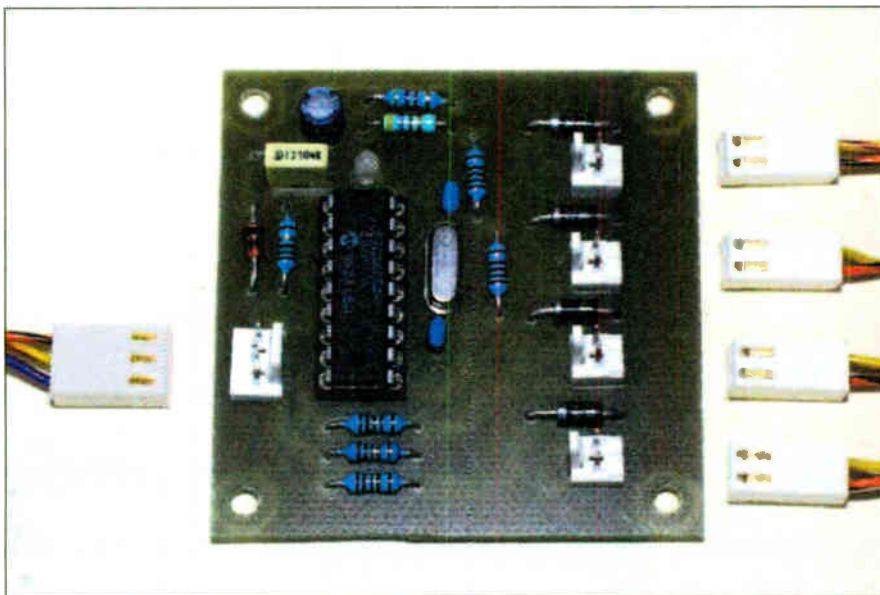

Should the transmitter system fail, the unit turns off all outputs, providing a fail-safe condition.

Circuit Description

A block diagram of the switcher unit's operation is shown in Fig.1. The relays are optional (see later).

As shown in the circuit diagram of Fig.2, the circuit uses a PIC16F84A microcontroller, IC1, as its workhorse. It takes the signal output from the R/C Receiver and, depending on its pulse width, switches the four outputs on or off. (Components in the far right dashed box are for "testing" circuit operation only.)

Power for the unit is supplied by the R/C Receiver itself, at about 5V d.c. Resistor R1 limits the current drawn from the receiver, and Zener diode D1 limits any supply voltage variations and transients to a maximum limit of 5.6V, to prevent possible damage to IC1. Power supply decoupling is provided by capacitors C1 and C2.

The signal and power supply from the receiver are input to the unit via connector pair SK1/PL1. The signal is fed to PIC pin RB0, which is biased normally-low by resistor R2.

PIC pins RB5, RB6, RB2 and RB1 are used in output mode and control the four power field effect transistors (f.e.t.s), TR1 to TR4, via buffer resistors R5 to R8.

Each transistor is protected against back-e.m.f. transients when switching inductive loads (e.g. relays) by the inclusion of diodes D3 to D6.

Construction

Printed circuit board component and track layout details for the Multi-Function

COMPONENTS

Approx. Cost
Guidance Only

£17

excl case and relay

Resistors

R1	10Ω
R2	100k
R3	4k7
R4	470Ω
R5 to R8	100Ω (4 off)
R9 to R12	560Ω (4 off) (for test only)

All 0.25W 5% carbon film

Capacitors

C1	100n ceramic disc, 5mm pitch
C2	22μ radial elect. 16V
C3, C4	22p ceramic disc, 2.5mm pitch (2 off)

Semiconductors

D1	5V6 1.3W Zener diode
D2	min. bi-colour l.e.d. (red/green)

See
SHOP
TALK
page

D3 to D6	1N4002 1A 100V rect. diode (4 off)
D7 to D10	red l.e.d. (4 off) (for test only)
TR1 to TR4	BSP295 power f.e.t. (surface mount) (4 off)
IC1	PIC18F84A micro- controller, prepro- grammed (see text)

Miscellaneous

X1	4.0MHz crystal
----	----------------

Printed circuit board, available from the *EPE PCB Service*, code 540; 18-pin d.i.l. socket, 3-pin connector pair, to suit R/C system, p.c.b. mounting; 2-way pin-header plug (4 off) plus matching socket and cable; p.c.b. plug and cable socket (4 off); connecting wire; solder etc.

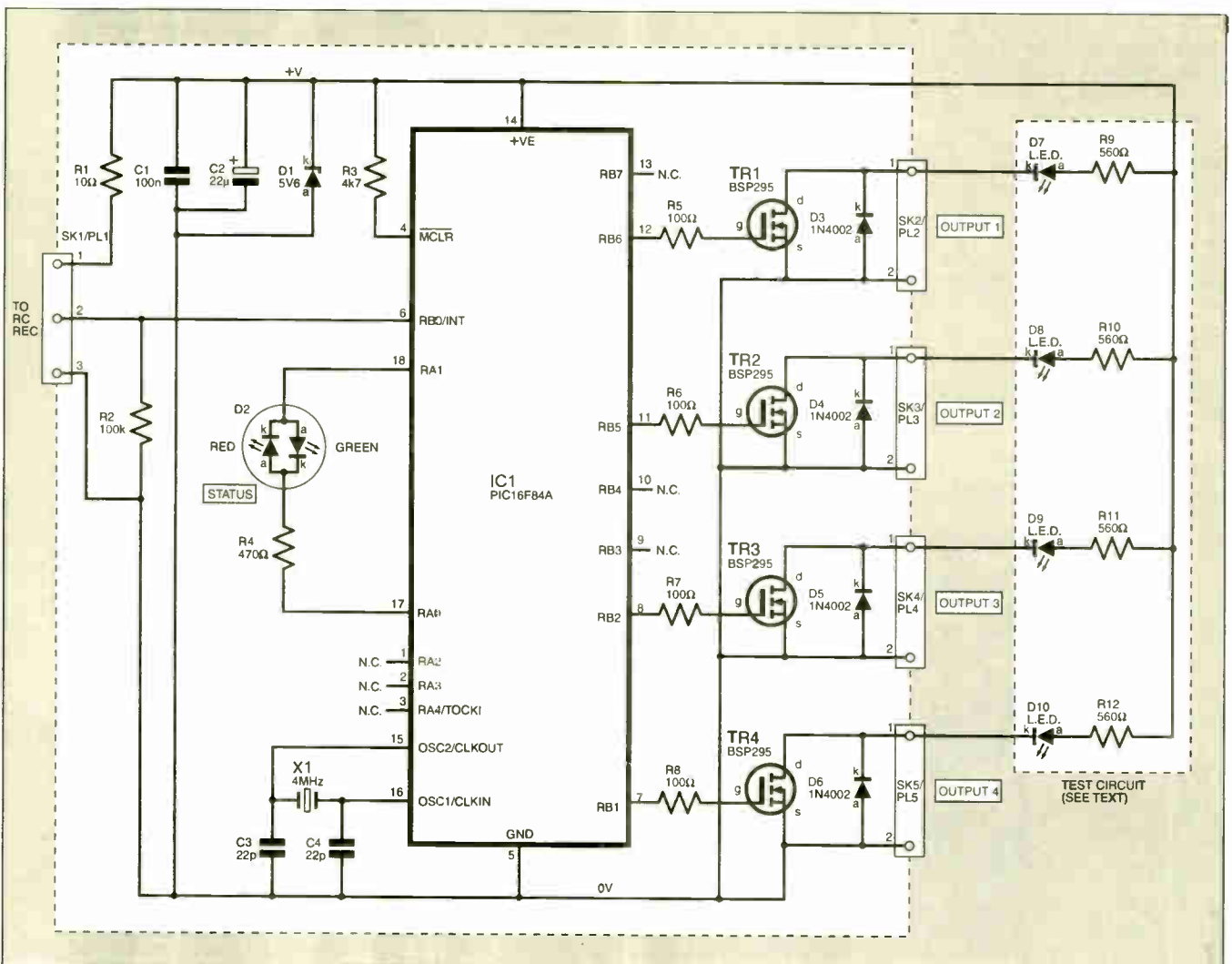

Fig.2. Full circuit diagram for the Multi-Function R/C Switch

R/C Switch are shown in Fig.3. This board is available from the *EPE PCB Service*, code 540.

Note that whilst the majority of the components are mounted on the topside of the p.c.b., the four f.e.t.s are all surface mount devices (SMD) and are soldered to the copper trackside.

Although the f.e.t.s are static sensitive, and would ordinarily be installed last, it is probably easier to install them first, and from then on treat the whole assembly as one sensitive device, touching a grounded item each time before handling it.

The topside components should be mounted last, using an 18-way d.i.l. socket for the PIC.

Before applying power to the board (or inserting the pre-programmed PIC – see later), check for the correct placement of components, and the correct orientation of capacitor C2, the l.e.d., and all other semiconductors. If the l.e.d. is connected the wrong way around, the colours indicated will be reversed for the valid and non-valid conditions. The longer lead of the l.e.d. should be to the right-hand side of the p.c.b. as shown in Fig.3.

Apply 5V d.c. power (ideally from a separate current-limited source) to the unit and note the current drawn, this should not exceed 10mA. Disconnect the supply when satisfied.

Testing

For testing purposes, connect a series of l.e.d.s (D7 to D10), external to the circuit board, between the four outputs and the +5V line via 560Ω current limiting resistors (R9 to R12) – anode (a) to +5V, cathode (k) to transistor drain (d). These will give a clear indication of which outputs become switched on.

Connect the unit to the R/C Receiver. Switch on the receiver and the transmitter. The PIC unit now receives its power from the receiver.

After switch on, there is a delay of half a second while the software goes through an initialisation routine. The program then looks at the incoming signal (if any) from the receiver. The pulse width is measured and translated to a numerical value. Should this be outside what is considered to be a valid pulse width, the unit goes into a failsafe state, with none of the four outputs switched on.

If the pulse is absent, or invalid, and assuming that bi-colour l.e.d. D2 is in the correct way round, the l.e.d. should glow red and remain red. Valid signals are acknowledged by the l.e.d. glowing green.

The PIC looks for a pulse width that matches those in Table 1, and responds accordingly. Be aware that if the pulse width is between 1.4ms and 1.6ms (neutral), a valid signal has still been received and D2 still glows green, but none of the four outputs will be switched on.

The transmitter's joystick can now be used to switch the four outputs as it is moved back and forth. As soon as the circuit receives a valid signal from the receiver, l.e.d. D2 will switch from red to green, showing the circuit is operating and receiving a valid signal within the required range.

While pushing the joystick back and forth, the test l.e.d.s on the outputs will illuminate in sequence. If the sequence is incomplete, i.e. one or more outputs not operating, there is either a problem with the circuit or the joystick. With the former, switch off and find the reason. With the latter, it may be necessary to adjust the joystick's timing response (consult its manual).

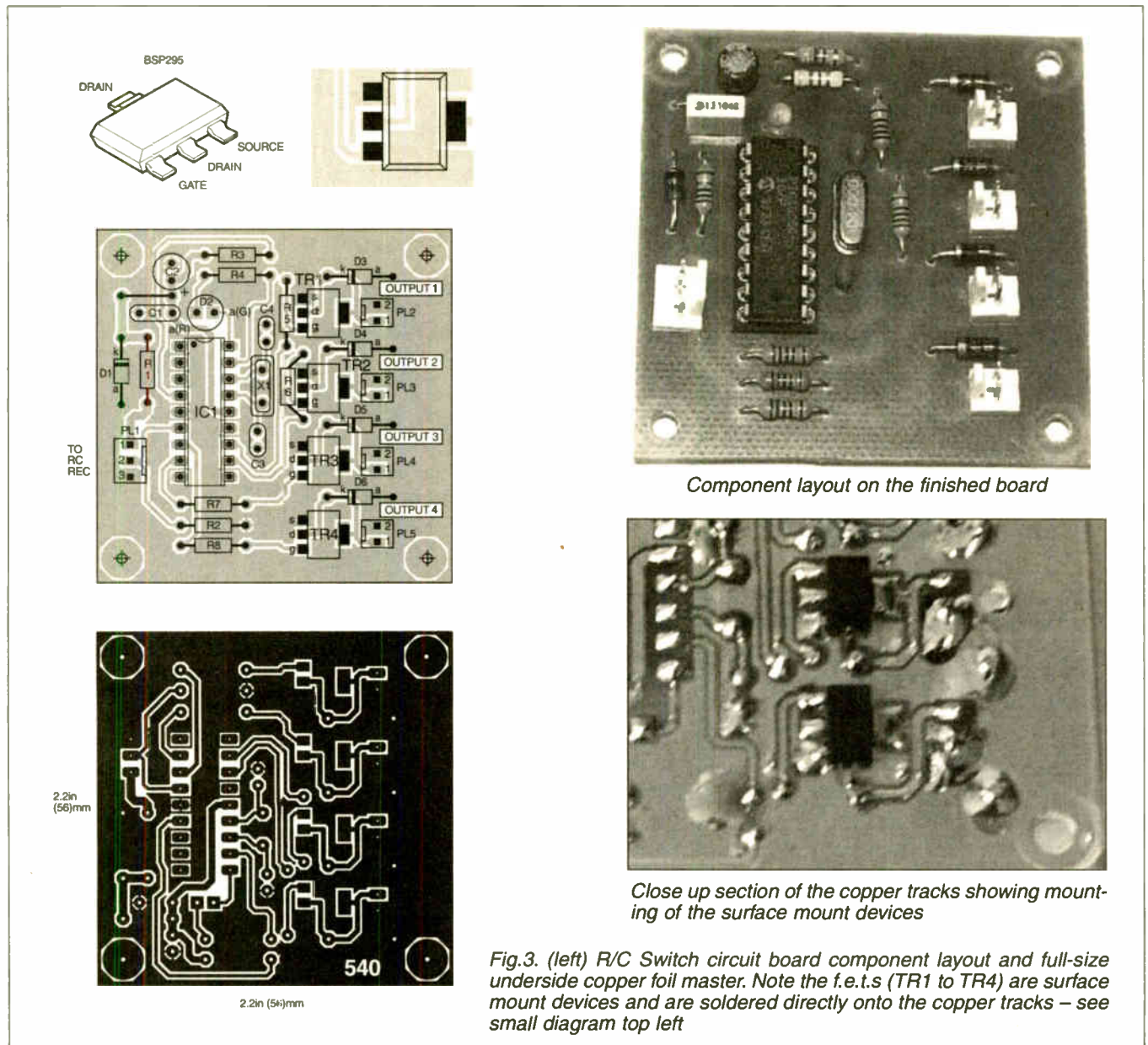

Fig.3. (left) R/C Switch circuit board component layout and full-size underside copper foil master. Note the f.e.t.s (TR1 to TR4) are surface mount devices and are soldered directly onto the copper tracks – see small diagram top left

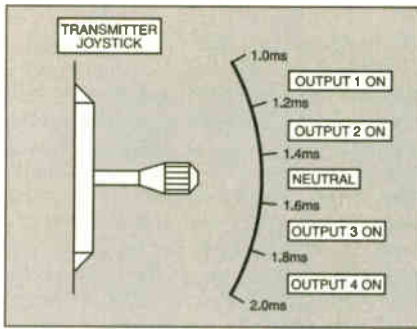

Fig. 4. Relationship between transmitter joystick position, switching pulse width value and switched output operation – see also Table 1

Typical positions and timings for the joystick are shown in Fig. 4.

Suggestions For Use

There are two suggestions offered for how the unit can be used: first, as the indicator system for a model car; second, as a simple single speed controller, with one speed forward, one speed for reverse, and a neutral position. No constructional details are offered.

Car Indicator

The model car indicator system can be configured such that this circuit's input is connected in parallel with the model's steering servo input – see circuit Fig. 5.

There are two l.e.d.s for each side of the model (D1 to D4), buffered by resistors R1 and R2. On each side, one of the l.e.d.s has to be of the flashing variety, the other should be a standard type. This way the flashing l.e.d. when activated will ensure the standard l.e.d. will also flash.

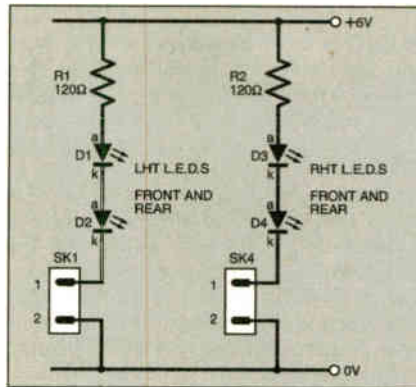

Fig. 5. Use of the R/C Switcher to effect an automatic direction indicator on a radio control model car using amber l.e.d.s. The input (R/C Receiver servo output) is connected in parallel with the steering servo.

Speed Controller

A suggested speed controller circuit diagram is shown in Fig. 6. The circuit is arranged so that when outputs one or two are activated, current is drawn through the motor. When outputs three or four are activated the motor current reversing relay (RLA) is activated, causing the motor to rotate in the opposite direction.

The maximum current that can be controlled is 1A, the limit of the chosen f.e.t.s.

If you wish to extend the current capability of the circuit beyond the 1A limit, then it is possible to drive a relay, using it to switch the higher current. The relays could be powered at a voltage greater than the 5V provided by the circuit, up to a maximum of 50V (again a limit set by the f.e.t.s).

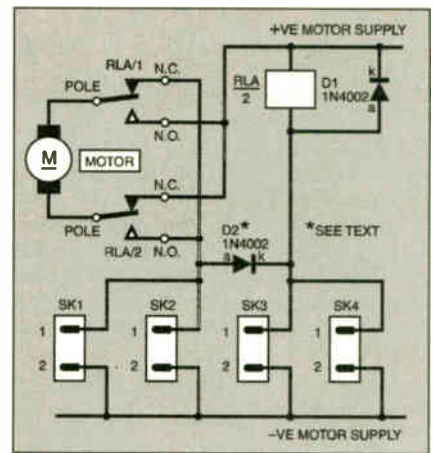

Fig. 6. Use of the R/C module to produce a simple speed controller. With the aid of a relay the controller can provide; forward/stop and reverse functions to a small electric motor. The current rating of diode D2 has to be sufficient to take the drive current of the motor

Resources

Software for the PIC microcontroller, including source code files, can be downloaded *free* from our UK Downloads website, accessible via www.epemag.co.uk. It is held in the PICs folder. For information about obtaining pre-programmed PICs and component buying, see the *Shoptalk* page.



The affordable PC oscilloscope from the market leaders



PicoScope 2202

- 2 channels
- Fast 20 MS/s sampling
- 2 MHz bandwidth
- 32,000 sample buffer memory
- No power supply required
- USB 2.0 for fast screen updates

pico
Technology Limited

The PicoScope 2202 is an entry-level PC Oscilloscope with spectrum analyser and meter functions at a surprisingly affordable price.

Just £199 + VAT



Complete with software and lifetime technical support.

www.picotech.com/scope

Pico Technology Limited, The Mill House, Cambridge Street, St. Neots, Combs, PE19 1QB, UK +44 (0) 1480 396395



Switch on to Conrad and get **10% OFF**

From power supplies and components to circuits and accessories, if you need the latest technology, there's only one place to look.

Europe's favourite electronics and technology retailer, Conrad offers a huge selection of over 15,000 of the most popular products at the best prices.

Place any first order over £30 and we'll reward you with a 10% saving. That's right, 10% OFF! And you'll also get the chance to win a Voltcraft Multimeter worth £139 in our exclusive Prize Draw.

So why go anywhere else?

Plus WIN A Voltcraft Multimeter worth £139

- Large display
- Backlight
- Optical interface
- Professional performance
- 40,000 counts LCD



Switch on to Conrad today and visit
www.conrad-direct.co.uk/multimeter

CONRAD
www.conrad-direct.co.uk
Electronics. Technology. Tradition.

STORE YOUR BACK ISSUES ON MINI CD-ROMS



**VOL 12
NOW AVAILABLE**

**ONLY
£14.45** each
including VAT
and p&p



A great way to buy **EPE Back Issues** – our mini CD-ROMs contain back issues from our **EPE Online** website plus bonus articles, all the relevant **PIC** software and web links. Note: no free gifts are included. All this for just £14.45 each including postage and packing.

- VOL 1: BACK ISSUES** – January 1999 to June 1999
Plus some bonus material from Nov and Dec 1998
- VOL 2: BACK ISSUES** – July 1999 to December 1999
- VOL 3: BACK ISSUES** – January 2000 to June 2000
- VOL 4: BACK ISSUES** – July 2000 to December 2000
- VOL 5: BACK ISSUES** – January 2001 to June 2001
- VOL 6: BACK ISSUES** – July 2001 to December 2001
- VOL 7: BACK ISSUES** – January 2002 to June 2002
- VOL 8: BACK ISSUES** – July 2002 to December 2002
- VOL 9: BACK ISSUES** – January 2003 to June 2003
- VOL 10: BACK ISSUES** – July 2003 to December 2003
- VOL 11: BACK ISSUES** – January 2004 to June 2004
- VOL 12: BACK ISSUES** – July 2004 to December 2004

Order on-line from
[www.epemag.wimborne.co.uk/
shopdoor.htm](http://www.epemag.wimborne.co.uk/shopdoor.htm)
or www.epemag.com (USA \$ prices)
or by phone, Fax, E-mail or Post

NOTE: These mini CD-ROMs are suitable for use on any PC with a CD-ROM drive. They require Adobe Acrobat Reader (available free from the Internet – www.adobe.com/acrobat)

WHAT IS INCLUDED

All volumes include the **EPE Online** editorial content of every listed issue, plus all the available **PIC Project Codes** for the PIC projects published in those issues.

Note: Some supplements etc. can be downloaded free from the Library on the **EPE Online** website at www.epemag.com. No advertisements are included in Volumes 1 and 2; from Volume 5 onwards the available relevant software for **Interface** articles is also included.

EXTRA ARTICLES – ON ALL VOLUMES

BASIC SOLDERING GUIDE – Alan Winstanley's internationally acclaimed fully illustrated guide. **UNDERSTANDING PASSIVE COMPONENTS** – Introduction to the basic principles of passive components. **HOW TO USE INTELLIGENT L.C.D.s**, by Julyan Ilett – An utterly practical guide to interfacing and programming intelligent liquid crystal display modules. **PhyzyB COMPUTERS BONUS ARTICLE 1** – Signed and Unsigned Binary Numbers. By Clive "Max" Maxfield and Alvin Brown. **PhyzyB COMPUTERS BONUS ARTICLE 2** – Creating an Event Counter. By Clive "Max" Maxfield and Alvin Brown. **INTERGRAPH COMPUTER SYSTEMS 3D GRAPHICS** – A chapter from Intergraph's book that explains computer graphics technology. **FROM RUSSIA WITH LOVE**, by Barry Fox – Russian rockets launching American Satellites. **PC ENGINES**, by Ernest Flint – The evolution of Intel's microprocessors. **THE END TO ALL DISEASE**, by Aubrey Scoon – The original work of Rife. **COLLECTING AND RESTORING VINTAGE RADIOS**, by Paul Stenning. **THE LIFE & WORKS OF KONRAD ZUSE** – a brilliant pioneer in the evolution of computers. A bonus article on his life and work written by his eldest son, including many previously unpublished photographs.

Note: Some of the **EXTRA ARTICLES** require WinZip to unzip them.

BACK ISSUES MINI CD-ROM ORDER FORM

- Please send me (quantity) BACK ISSUES CD-ROM VOL 1
 - Please send me (quantity) BACK ISSUES CD-ROM VOL 2
 - Please send me (quantity) BACK ISSUES CD-ROM VOL 3
 - Please send me (quantity) BACK ISSUES CD-ROM VOL 4
 - Please send me (quantity) BACK ISSUES CD-ROM VOL 5
 - Please send me (quantity) BACK ISSUES CD-ROM VOL 6
 - Please send me (quantity) BACK ISSUES CD-ROM VOL 7
 - Please send me (quantity) BACK ISSUES CD-ROM VOL 8
 - Please send me (quantity) BACK ISSUES CD-ROM VOL 9
 - Please send me (quantity) BACK ISSUES CD-ROM VOL 10
 - Please send me (quantity) BACK ISSUES CD-ROM VOL 11
 - Please send me (quantity) BACK ISSUES CD-ROM VOL 12
- Price £14.45 each – includes postage to anywhere in the world.

Name

Address

..... Post Code

I enclose cheque/P.O./bank draft to the value of £

Please charge my Visa/Mastercard/Amex/Diners

Club/Maestro

£

Card No.

Card Security Code (The last 3 digits on or just under the signature strip)

Valid From Expiry Date

Maestro Issue No.

SEND TO: **Everyday Practical Electronics,
Wimborne Publishing Ltd.,**

408 Wimborne Road East, Ferndown, Dorset BH22 9ND.

Tel: 01202 873872. Fax: 01202 874562.

E-mail: orders@epemag.wimborne.co.uk

Payments must be by card or in £ Sterling – cheque or bank draft drawn on a UK bank.

Normally supplied within seven days of receipt of order.

Ingenuity Unlimited

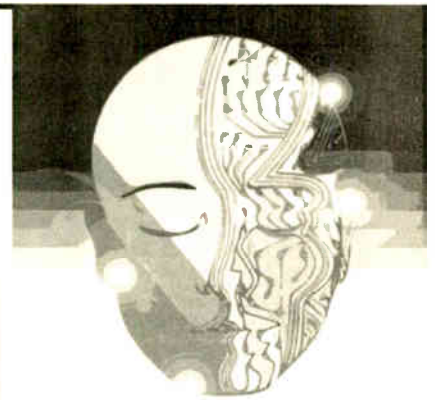

WIN A PICO PC BASED OSCILLOSCOPE WORTH £586

- 5GS/s Dual Channel Storage Oscilloscope
- 50MHz Spectrum Analyser
- Multimeter
- Frequency Meter
- USB Interface.

If you have a novel circuit idea which would be of use to other readers then a Pico Technology PC-based oscilloscope could be yours. Every 12 months, Pico Technology will be awarding a PicoScope 3205 digital storage oscilloscope for the best IU submission. In addition a DrDAQ Data Logger/Scope worth £59 will be presented to the runner up.

Our regular round-up of readers' own circuits. We pay between £10 and £50 for all material published, depending on length and technical merit. We're looking for novel applications and circuit designs, not simply mechanical, electrical or software ideas. Ideas *must be the reader's own work* and **must not have been published or submitted for publication elsewhere**. The circuits shown have NOT been proven by us. *Ingenuity Unlimited* is open to ALL abilities, but items for consideration in this column should be typed or word-processed, with a brief circuit description (between 100 and 500 words maximum) and include a full circuit diagram showing all component values. **Please draw all circuit schematics as clearly as possible**. Send your circuit ideas to: *Ingenuity Unlimited*, Wimborne Publishing Ltd., 408 Wimborne Road East, Ferndown, Dorset BH22 9ND. (We **do not** accept submissions for IU via email). Your ideas could earn you some cash **and a prize!**

Noiseless Switch – *Switched-On Puff*

THERE is no doubt that a hand-clap switch is a useful device to operate various appliances around the home but the sudden and unexpected clap or shout is liable to damage a marital relationship! Would it not be better to use a noiseless switch?

By adopting the circuit diagram shown in Fig.1, just a light puff on electret microphone MIC1, even from around nine inches away, will enable you to switch on a mains appliance. A second puff will switch it off. The circuit is unaffected, to a large extent, by general household noise emanating from, say, a TV or radio so is ideal for operating a bedside radio without having

to reach out to it whilst still in a comatose state.

The first amplifier stage, comprising transistor TR1 and its associated components, responds only to alternating currents picked up from microphone MIC1. The amplified a.c. signal output is then coupled, via capacitor C2, to a rectifier/smoothing network made up of diodes D1 and D2 and capacitor C3 which converts it to d.c. and switches on transistor TR2.

A conventional 555 timer, IC1, arranged delivers a quick pulse at its output (pin 3) when trigger pin 2 is momentarily grounded by transistor TR2. The output at

IC1 pin 3 is connected, via resistor R6, to the clock (CLK) input of IC2, a JK flip-flop.

Each pulse received at IC2's input alternately switches its output high and low, so switching relay driver transistor TR3 on and off. Which means, of course, relay RLA is also switched. The diode across the relay coil is for protection against any back e.m.f. when the relay switches off.

The unused pins of IC2 should be connected to the positive and negative rails as shown in Fig.1. The values of components were chosen for convenience of construction and are not critical.

Tony Lee,
Old Reynella, Australia

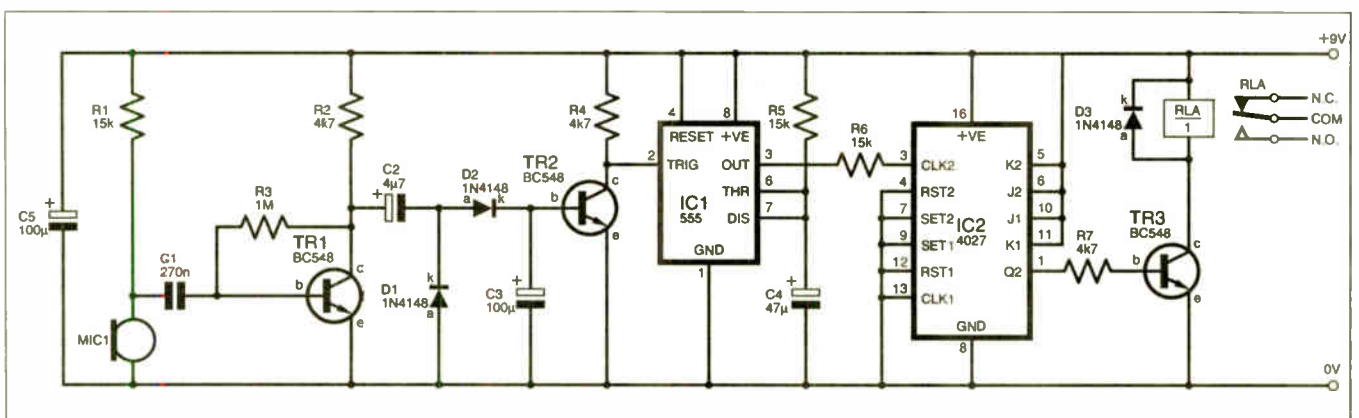

Fig.1. Complete circuit diagram for the Noiseless Switch

MikroElektronika

MICROCONTROLLER DEVELOPMENT TOOLS

from Breadboarding Systems

Make PICmicro® development easy with the EasyPIC3 - *only £99!*

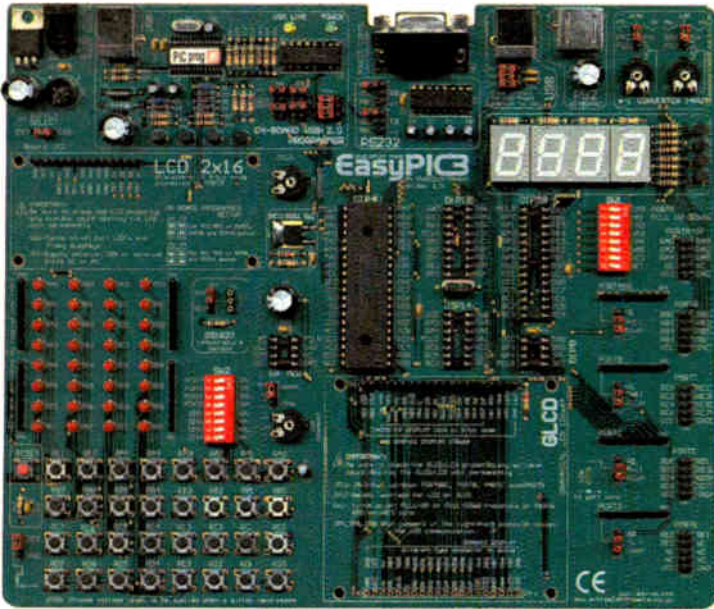

EasyPIC3 Development Board features:

- High quality development/experiment board with built-in USB 2.0 high-speed programmer.
- Programming software compatible with Windows operating systems including 2000 and XP.
- Comes with a PIC16F877A microcontroller but compatible with virtually all 8, 14, 18, 28 and 40-pin PICmicro® devices in the 10F, 12F, 16F and 18F families.
- On-board I/O devices including switches, LEDs, seven-segment displays, potentiometers and RS-232 interface. Now also features USB and PS/2 keyboard interface connectors.
- Provision for easy fitting of optional DS18S20 temperature sensor, and LCD and GLCD displays.
- All I/O lines available for off-board expansion.
- Wide range of optional add-on boards available including ADC, DAC, EEPROM, Compact Flash, MMC/SD, Keypad, RTC, RS-485, CAN and IrDA. Additional add-ons available soon.
- Powered from your PC's USB port or optional mains adapter.
- Supplied with example programs written in assembly language, BASIC, C and Pascal.
- Supplied with Microchip Technology's MPLAB development software and demonstration versions of MikroElektronika's mikroBASIC, mikroC and mikroPascal compilers.

The new EasyPIC3 Development Board combines a versatile development/experiment board with a built-in USB programmer. With its wealth of on-board I/O devices and support for virtually all 8, 14, 18, 28 and 40-pin PICmicro® microcontrollers in the 10F, 12F, 16F and 18F families, we're certain you won't find a more versatile high quality board at such a low price. The EasyPIC3 Development Board is supplied with USB programming/power cable, programming software and useful example programs.

Also available are similar boards for the 8051, AVR and dsPIC, each at the same great price of £99 including UK delivery and VAT—please telephone or see our website for further details.

Learn about microcontrollers with our EasyPIC3 Starter Pack - *just £149!*

We've taken the EasyPIC3 Development Board and added a 16x2 character LCD display, 128x64 graphical LCD, DS18S20 temperature sensor, RS-232 serial communications cable and our own easy-to-follow microcontroller tutorial to form a complete and self-contained Starter Pack—everything you need to learn about and experiment with microcontrollers! With this pack you will quickly become proficient in microcontroller programming and interfacing. Please see our website for full list of covered topics.

Make programming easy too with mikroBASIC, mikroC and mikroPascal

Three incredibly easy-to-use yet powerful compilers for PICmicro® microcontrollers, each featuring a user-friendly code editor, built-in tools and routines and source-level debugger. Supplied libraries facilitate rapid development and include ADC, CAN, Compact Flash, EEPROM, Ethernet, Graphic LCD, I²C, LCD, 1-wire, PWM, RS-485, sound, SPI, USART, USB routines and many more. mikroBASIC and mikroPascal—£99 each, mikroC—£149.

Call **0845 226 9451** or order online at www.breadboarding.co.uk

All prices include UK delivery and VAT. Major credit and debit cards accepted. Secure online ordering.

Back to Basics – CMOS Logic Devices

Bart Trepak

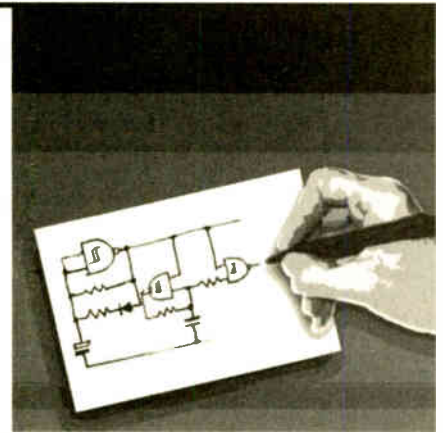

Part 8 – Noughts and Crosses Enigma and Weather Vane

Illustrates how useful circuits can be designed simply using CMOS logic devices as the active components

SMALL electronic games have always been popular constructional projects and no series featuring CMOS i.c.s would be complete without one! Whilst this Noughts & Crosses Enigma game is simple enough to construct, it requires a good deal of logical thinking as well as a good memory to win.

It is based on the familiar game of Noughts and Crosses (a.k.a. Tic-Tac-Toe) which is played on a 9-cell grid, but the similarity ends here – hence “Enigma” in the name. Instead of taking turns to place a O or X in each cell to form a winning pattern, in this version the game is already won, so to speak, and the players take turns to try to guess what the winning pattern was.

This makes paper and pencils unnecessary and greatly simplifies the electronics as well as making the game much more interesting. In its simple form, it is more akin to a detective game, while in the more complex version it has some of the attributes of the wartime *Enigma* machine which the German forces used to encode secret messages, although it does not require a computer, which the Allies developed to decode Enigma!

Game Play

To start a game, a switch is pressed, which selects at random one of the winning patterns (see Fig.8.1) although this of course remains hidden from the players. The players now take turns to press one of the nine switches (S1 to S9) and if the switch pressed forms part of the hidden pattern, the relevant l.e.d. in the display will light. If it does not form part of the pattern the l.e.d. will remain off. From this information, a logically-thinking player can deduce the hidden pattern. The first player to guess this correctly is the winner.

A simple-minded way of finding the hidden pattern would be to press each button in turn and see which ones cause the l.e.d.s to light and thus deduce the stored pattern. A good player, however, can be much cleverer than that.

There are only eight winning patterns and these are labelled P1 through P8 in Fig.8.1.

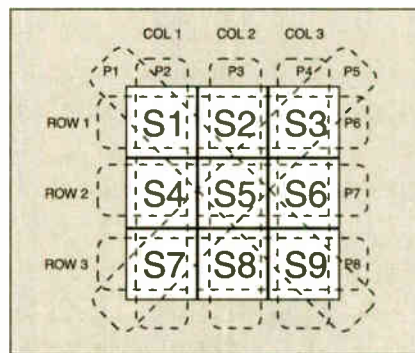

Fig.8.1. The eight winning patterns

Thus pressing switch S2, for example, and noting the result provides far more information than simply that this switch/l.e.d. is or is not part of the hidden pattern. If the l.e.d. lights, then the hidden pattern must be either Row 1 or Column 2 (i.e. pattern P3 or P6) and all of the other patterns and their switches can be discounted.

Similarly, if the l.e.d. lights when switch S9 is pressed, patterns P2, P3, P5, P6 and P7 can be ignored, while if it remains off, then one of these must be the hidden pattern. In this way, the player with the most logical thought process and best memory (together with a bit of luck) can beat the opponent player.

When players think they have guessed the pattern, they press the three switches simultaneously, which should result in the three l.e.d.s lighting, thus revealing the pattern as correct. If the guess is wrong, the opponent gets an extra turn. This is the simple game!

Advanced Call

To make the game more “interesting”, a switch selects between “standard” play and a more advanced version in which the pattern changes cyclically, just as the *Enigma* machine encoded each letter of the alphabet into a different one each time the letter was used in a message. Here, each time a correct guess is made and an l.e.d. lights, the circuit selects the next pattern when the switch is released, giving each player even more to remember.

Thus, in the above example, if the l.e.d. lights when S2 is pressed revealing that the current hidden pattern is P3 or P6, when the switch is released the hidden pattern will become P4 or P7. The players must therefore also take this into account when considering their next move.

Basic Operation

The block diagram in Fig.8.2 shows what is involved in the design.

A counter is used to store the randomly selected hidden pattern, which is generated by an oscillator that is switched on

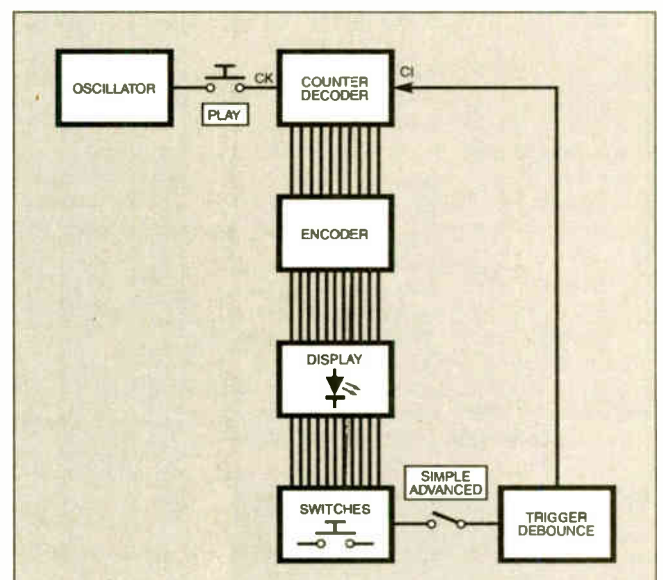

Fig.8.2. Noughts and Crosses block diagram

when the Play button is pressed. The count reached when the oscillator is switched off is decoded into one of eight states, corresponding to the eight winning patterns. These outputs are encoded to drive nine l.e.d.s arranged in the familiar grid pattern.

Each l.e.d. has a corresponding push-switch associated with it (again arranged in the grid pattern) so that pressing the switch will light the l.e.d., provided that the l.e.d. is one of those selected by the encoder.

In the advanced setting of the game a simple switch debouncing circuit is activated, to prevent the pattern change being triggered unexpectedly.

Circuit Diagram

The simplicity of the block diagram is matched by that of the Noughts and Crosses Enigma circuit diagram in Fig.8.3, except that it contains rather a lot of diodes. IC1a forms a familiar gated oscillator which is activated when Play switch S10 is pressed, producing a series of pulses which are fed to the clock input of decade counter IC2, connected as a divide-by-eight counter.

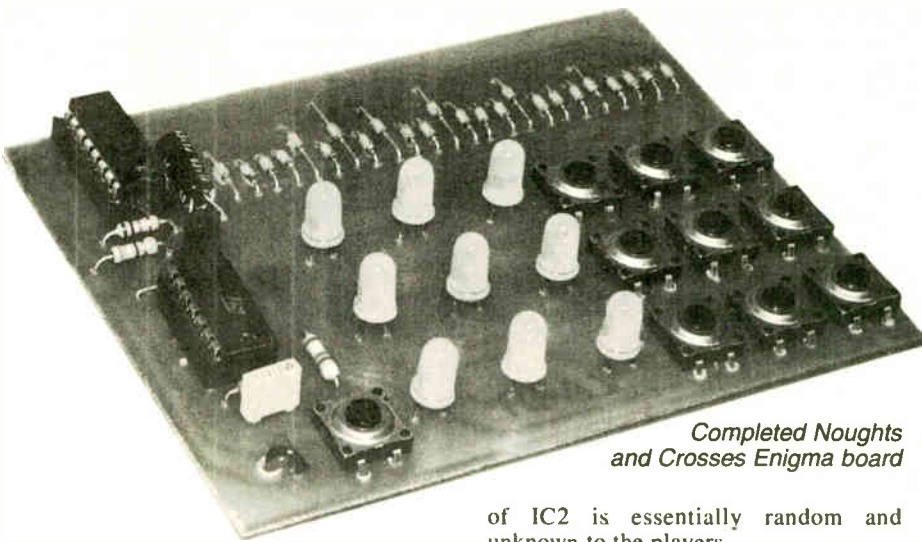

Completed Noughts and Crosses Enigma board

of IC2 is essentially random and unknown to the players.

Depending on the instant when S10 is released, one of the outputs of IC2 will be high, defining one of the eight winning patterns. The high speed of the oscillator, set by capacitor C1 and resistor R2, and the variable time for which S10 is pressed ensure that the final state

The outputs are encoded by diodes D10 to D33 to produce nine outputs driving nine l.e.d.s and switches arranged in a grid pattern. For example, l.e.d. D1 only lights when winning pattern P1, P2 or P6 has been selected by the counter, so diodes are connected to D1 from outputs Q0, Q1 and Q5.

COMPONENTS

Noughts and Crosses

Resistors

R1	100k	See SHOP TALK page
R2	10k	
R3	1M	
R4	390Ω	

All 0.25W 5% carbon film

Capacitors

C1	10n ceramic disc, 5mm pitch
C2	1μ radial elect. 16V

Semiconductors

D1 to D9	red l.e.d. (9 off)
D10 to D33	1N4148 signal diode (24 off)
TR1	2N3904 npn transistor
IC1	4093 quad Schmitt NAND gate
IC2	4017 decade counter

Miscellaneous

S1 to S10	min. push-to-make switch, p.c.b. mounting (10 off)
S11	min. s.p.s.t. toggle switch (see text)

Printed circuit board, available from the *EPE PCB Service*, code 538; 14-pin d.i.l. socket; 16-pin d.i.l. socket; 9V PP3 battery and connector; connecting wire; solder, etc.

Approx. Cost

£16

excl case and batt

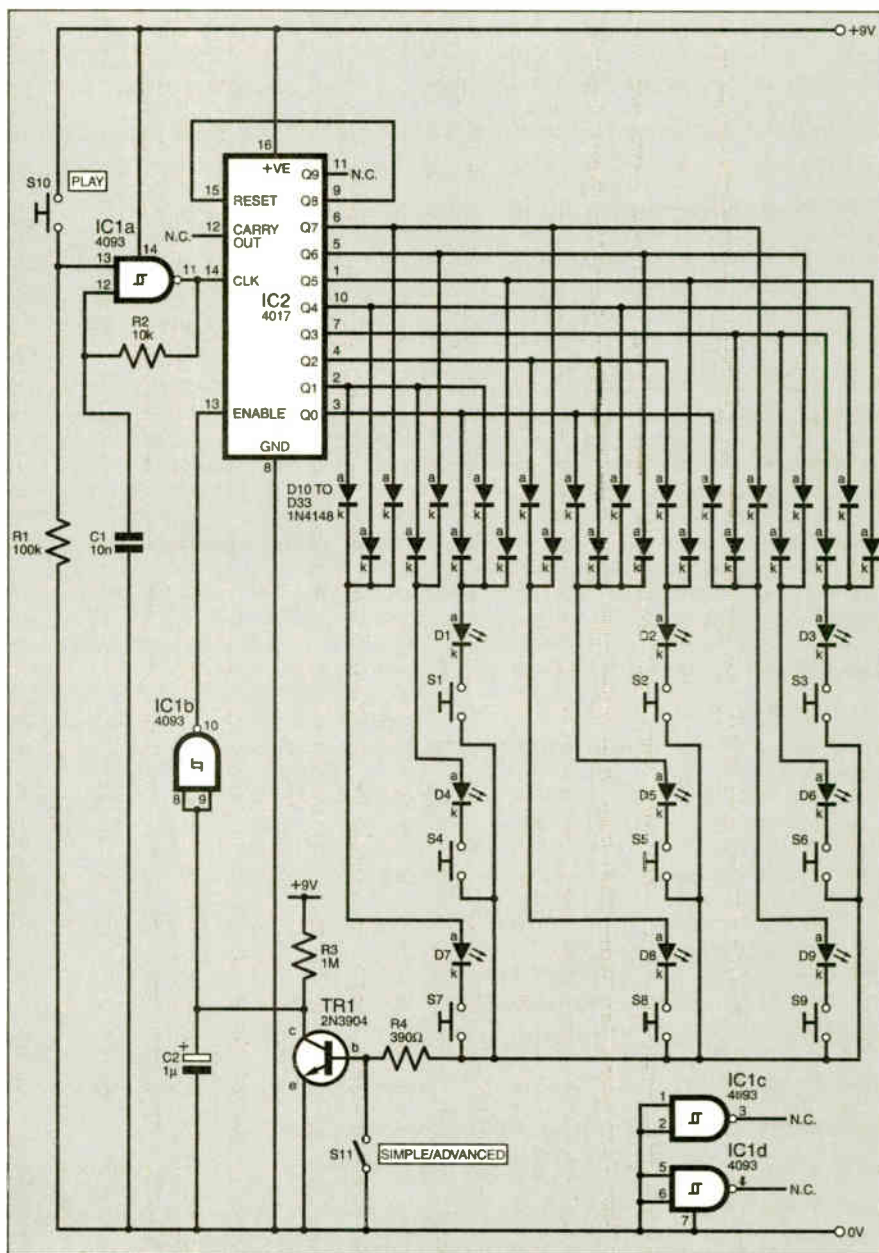

Fig.8.3. Completed circuit diagram for the Noughts and Crosses Enigma

NOUGHTS & CROSSES ENIGMA – CIRCUIT BOARD

Each l.e.d. is also connected to a switch so that an l.e.d. can light only if it is selected by the encoder and the associated switch is pressed, thus enabling the players to determine if a particular l.e.d. is part of the hidden pattern.

Resistor R4 serves to limit the l.e.d. current and is either connected to the 0V supply via switch S11, or, in the advanced version of the game, to the base of transistor TR1. In this latter case, if a switch is pressed and an l.e.d. is lit, the transistor will switch on and its collector voltage will fall, discharging capacitor C2.

Consequently, any switch bounce will not appear at this point because the relatively long time constant of C2/R3 will prevent the collector voltage from rising appreciably until the base current is switched off when the switch is released.

The collector voltage is inverted by IC1b which causes IC2's Enable input to go high when TR1 is switched on, and low again when it is switched off. Since this input causes the counter to advance when it goes low, the next counter state is selected only when the switch is released.

As with the other projects in this series, this circuit is powered by a 9V battery. As the current consumption is very low (except when a switch that results in a l.e.d. switching on is pressed), no on/off switch is included.

Construction

Printed circuit board component and track layout details are shown in Fig.8.4. This board is available from the *EPE PCB Service*, code 538.

Switches S1 to S9 and the l.e.d.s are mounted in a 3 x 3 matrix pattern. Except for the battery, all components are mounted on the board. Ensure that polarity-sensitive components such as l.e.d.s, diodes, i.c.s and electrolytic capacitor C2 are inserted correctly. The i.c.s are static sensitive and the usual precautions should be observed. Do not fit them in their sockets until the board has been fully checked.

As mentioned, the game can be played in two versions. You can allow for both to be played by using switch S11. Alternatively, you could replace the switch by a link wire (advanced version) or omitting the connection (standard version).

Testing

No adjustment or setting up is necessary and provided the circuit has been correctly assembled, it will be ready to play as soon as a battery has been connected.

A simple way to determine if all of the diodes have been correctly fitted and that there are no faults is to set the unit for the Advanced game and then press each switch in turn until one l.e.d. is found to light. Keeping this switch pressed, determine which winning pattern is active by pressing two other switches until all three l.e.d.s selected light. When these switches have been released, the next pattern will be selected and this may be confirmed by pressing the relevant switches. In this way all eight patterns can be checked.

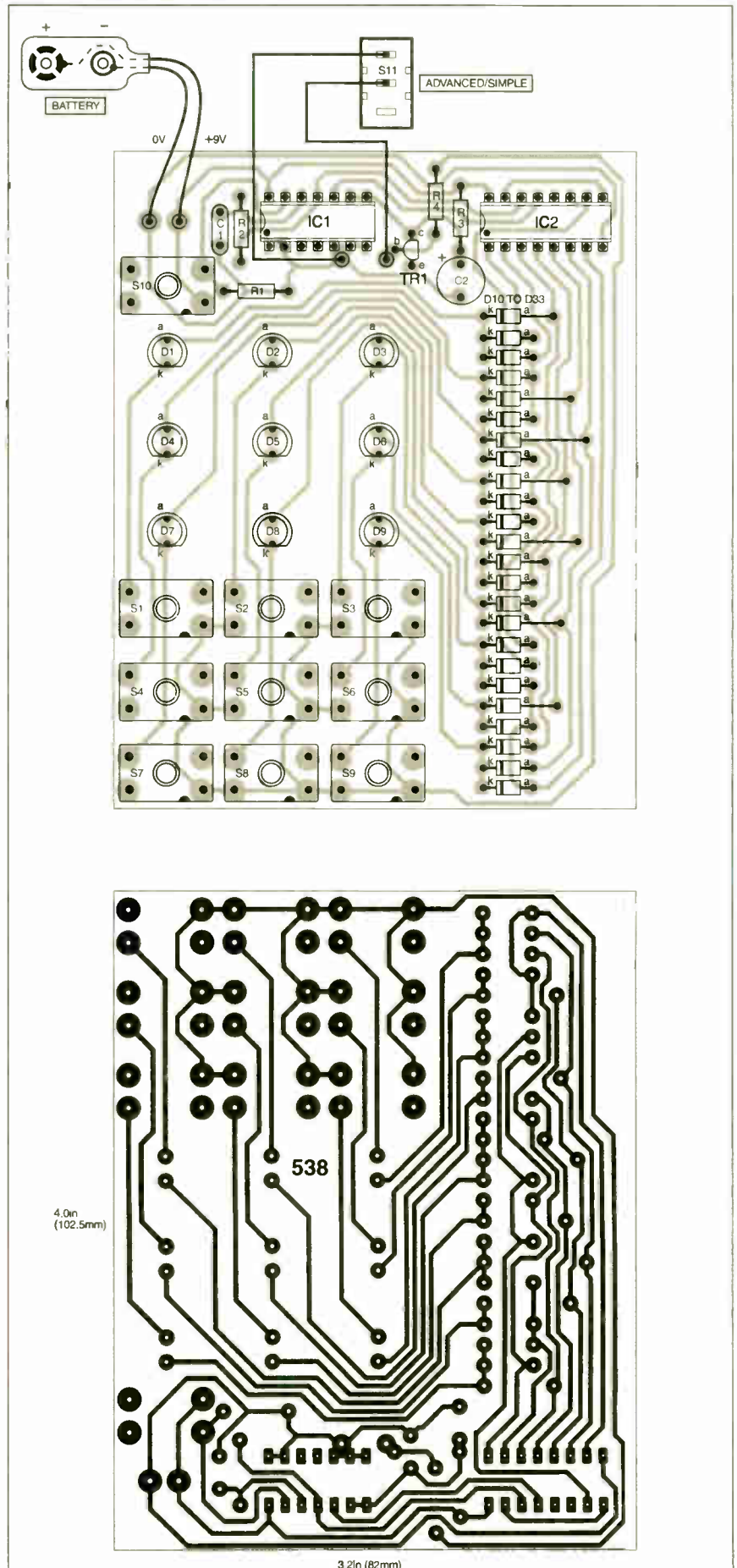

Fig.8.4. Printed circuit board component layout and copper foil trackside master for the Noughts and Crosses Enigma

ELECTRONIC WEATHER VANE

It is always good to know which way the wind is blowing, both in the figurative and the literal sense! While this device can be of little help with the former, it will be of much more use with the latter.

Weather vanes or wind direction indicators are traditionally ornate pieces of ironmongery, shaped as cockerels or other livestock, placed on rooftops together with arrows showing the four main points of the compass (NESW).

Unfortunately, the roof and hence the vane cannot normally be seen from within the house so unless your neighbour is thoughtful enough to place one on his roof for your benefit, determining the wind direction will normally involve going outside, whatever the weather.

Viewpoint

To get around this, some form of indicator mounted in a convenient place indoors is useful. The simplest scheme for such a device would consist of an 8-way switch, to which the vane is attached, feeding eight l.e.d.s which display the position of the switch. A typical arrangement is shown in Fig.8.5.

To achieve this, a switch capable of rotating through 360 degrees is required and, although such switches are not generally available, it is a relatively simple matter to modify a standard 12-way rotary switch to perform this function.

A bigger problem is the fact that a 9-way cable is required to connect the switch to the display and since the length of this is likely to be considerable, the cost of such a system would be quite high with the cable costing more than the indicator.

This circuit allows a relatively inexpensive 2-way cable to be used instead and could also be useful in many other signalling applications.

Basic Operation

The weather vane presented here consists of two units; an indoor Display and a Wind Vane mounted on the roof. These are shown in the block diagram in

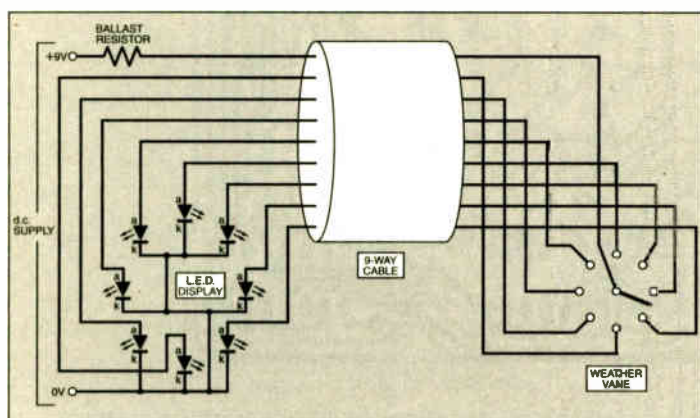

Fig.8.5. Conventional weather vane repeater set-up

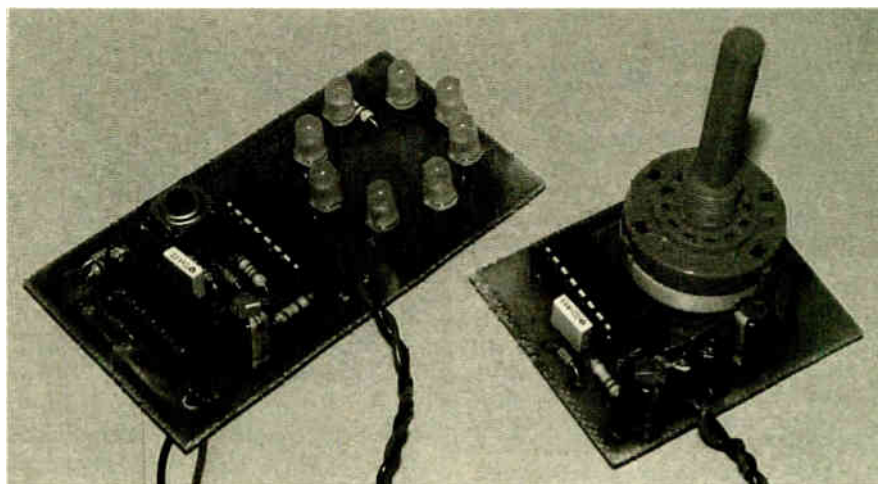

Fig.8.6. The system basically consists of two counters which are fed with clock pulses via a common line. One counter, together with the clock pulse generator and display, is mounted indoors while the other counter with an 8-way switch attached to the weather vane is mounted on the roof.

Both counters are initially reset and since they are advanced by the same clock signal, both counters keep in step. When the output of the roof-mounted counter, to which the weather vane switch is pointing, goes high, a monostable is triggered, forcing the clock line low, inhibiting further counting. The count reached at that moment by the counter mounted indoors is displayed by l.e.d.s, indicating the relative direction in which the weather vane is pointing.

Time Out

When the monostable times out, the counter's clock terminal goes high again. As long as no more clock pulses are received, the Vane counter is reset, ensuring that it always starts with output Q0 high. The Display counter is reset independently at the beginning of each count cycle (controlled by a separate oscillator)

so that it too starts with its Q0 output high, thus ensuring that both counters remain in step.

The low power requirements of CMOS are exploited here to allow power for the roof-mounted Vane to be supplied through the same wire as the clock signal, allowing a simple two-wire connection between the two units. The positive supply for the Vane is derived from the Display unit when the clock line goes high. This is made possible by ensuring that the clock terminal is taken low for a very short time compared to the time it spends in the high state.

This also means that the counting period is very much shorter than the display period (when the clock line is high) so that although some or even all of the l.e.d.s in the Display unit may light in turn, only the final one will be lit for long enough to be visible. To save battery power, the l.e.d. display is only enabled when a switch is pressed.

Circuit Diagram

The circuit diagram for the Electronic Weather Vane is shown in Fig.8.7. The operation is best considered by assuming that a transmission has just ended and transistor TR1 has switched off. One of

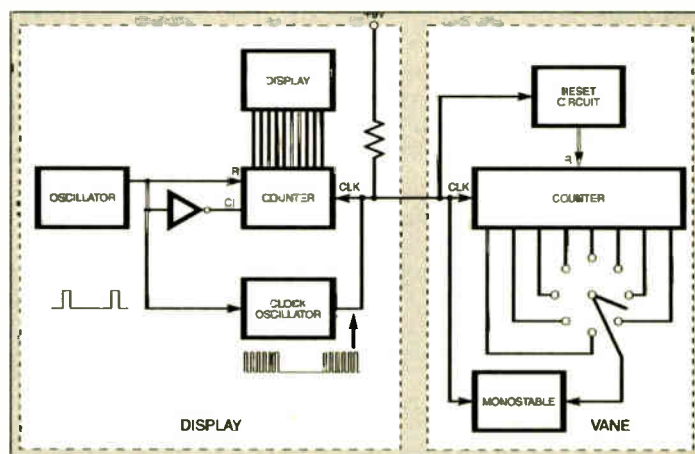

Fig.8.6. Block diagram for the Electronic Weather Vane Repeater

the outputs of decade counter IC2 will be high causing the corresponding l.e.d. (D1 to D8) to light if the Display switch S1 is closed.

With TR1 off, capacitor C7 can charge via resistor R6 and diode D11, thus providing the d.c. voltage to power the Vane circuit. Capacitor C5 will also charge via R7, thus resetting counter IC3, but this will have no effect on IC2 or the l.e.d. which is lit.

Master Oscillator

The master oscillator in the Display circuit is built around IC1a and produces a short positive pulse (about 10ms) every few seconds or so defined by the time constants set by the relationship between capacitor C2, resistors R3 and R4, and diode D9. When the output of IC1a goes high, counter IC2 is reset via C1, and the oscillator formed around IC1b is enabled, providing clock signals to both counters. Resistor R5 and capacitor C3 set the clocking rate.

The Enable input of counter IC2 is also taken high via inverter IC1c so that counting can proceed. Diode D10 ensures that the output of IC1b can only pull the clock line low, while R6 pulls it high when the output goes high.

As soon as the clock line goes low, C5 will discharge via D12, removing the reset on counter IC3. The values of R7 and C5 are chosen to ensure that the reset input of IC3 remains low during the short positive periods of each clock pulse, so that the i.c. is not reset and can continue to count. Since the counters are initially reset and they receive the same clock pulses, both counters will advance on the positive clock transition and will therefore remain in step.

When the output of IC3, to which the rotor or pole of switch S2 is connected, goes high, transistor TR1 will be switched on by the resulting pulse across C6, grounding further clock pulses so that counting stops even though IC1b will still be oscillating.

When the output of IC1a goes low again, clock oscillator IC1b switches off

COMPONENTS

Approx. Cost **£14**

excl cases and batts

Electronic Weather Vane		Semiconductors			
Resistors R1 56k R2 1k R3, R5 10k (2 off) R4 1M R6 1k8 R7 560k R8 56k All 0.25W 5% carbon film Capacitors C1 47p ceramic disc, 5mm pitch C2 2μ2 radial elect. 16V C3 10n ceramic disc, 5mm pitch C4, C6, C7 47μ radial elect. 16V (3 off) C5 100 ceramic disc, 5mm pitch		D1 to D8 red l.e.d. (8 off) D9 to D13 1N4148 signal diode (5 off)			
		TR1 2N3904 <i>npn</i> transistor			
		IC1 4093 quad NAND gate			
		IC2, IC3 4017 CMOS decade counter (2off)			
		Miscellaneous		S1 min. push-to-make switch, p.c.b. mounting S2 1-pole 12-way rotary switch, p.c.b. mounting	
		Printed circuit board, available from the <i>EPE PCB Service</i> , code 539; cases to suit (see text); 14-pin d.i.l. socket; 16-pin d.i.l. socket (2 off); 9V PP3 battery and connector; connecting wire; solder, etc.			
				See SHOP TALK page	

and IC2's Enable input (pin13) goes high, preventing any further advancement of the counter, which will therefore continue to display the position of the Vane switch S2.

Capacitor C6 will eventually charge up, causing TR1 to switch off and allow the clock line to go high. Since both counters respond to the positive going transition of the clock signal, this would essentially form another clock pulse but the count reached by IC2 will not change as the Enable pin is now high. The count of IC3 advances by one but this does not matter as the counter will be reset as soon as capacitor C5 charges via resistor R7.

With TR1 off and IC3 reset, capacitor C6 discharges via one of the outputs of

IC3 making the circuit ready for another run. Meanwhile, IC2 will remain in its final state, turning on the appropriate l.e.d. when Display switch S1 is pressed, until the output of IC1a again goes high and the process is repeated.

Construction

Printed circuit board component and track layout details are shown in Fig.8.8. This board is available from the *EPE PCB Service*, code 539. Cut the board into its two sections as indicated.

All of the components including both switches are mounted on the board although S1 (Display switch) may need to be mounted on the front panel of the enclosure if one is used. In this case a suitable panel mounted push switch

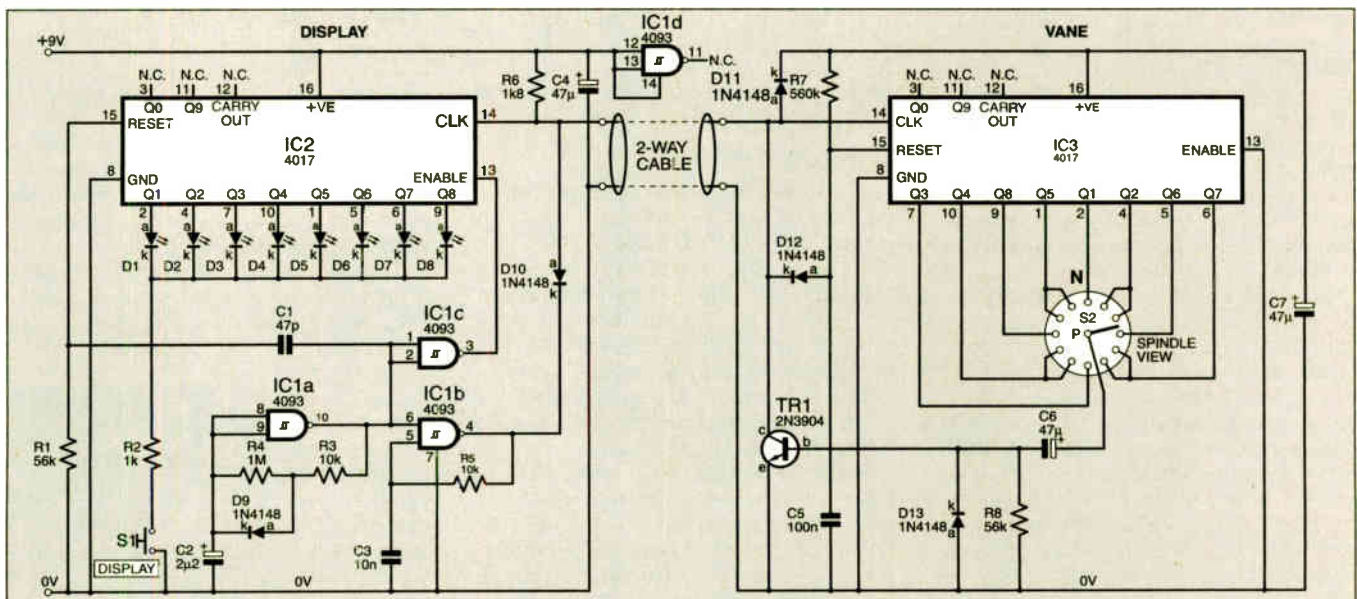

Fig.8.7. Complete circuit diagram for the Electronic Weather Vane

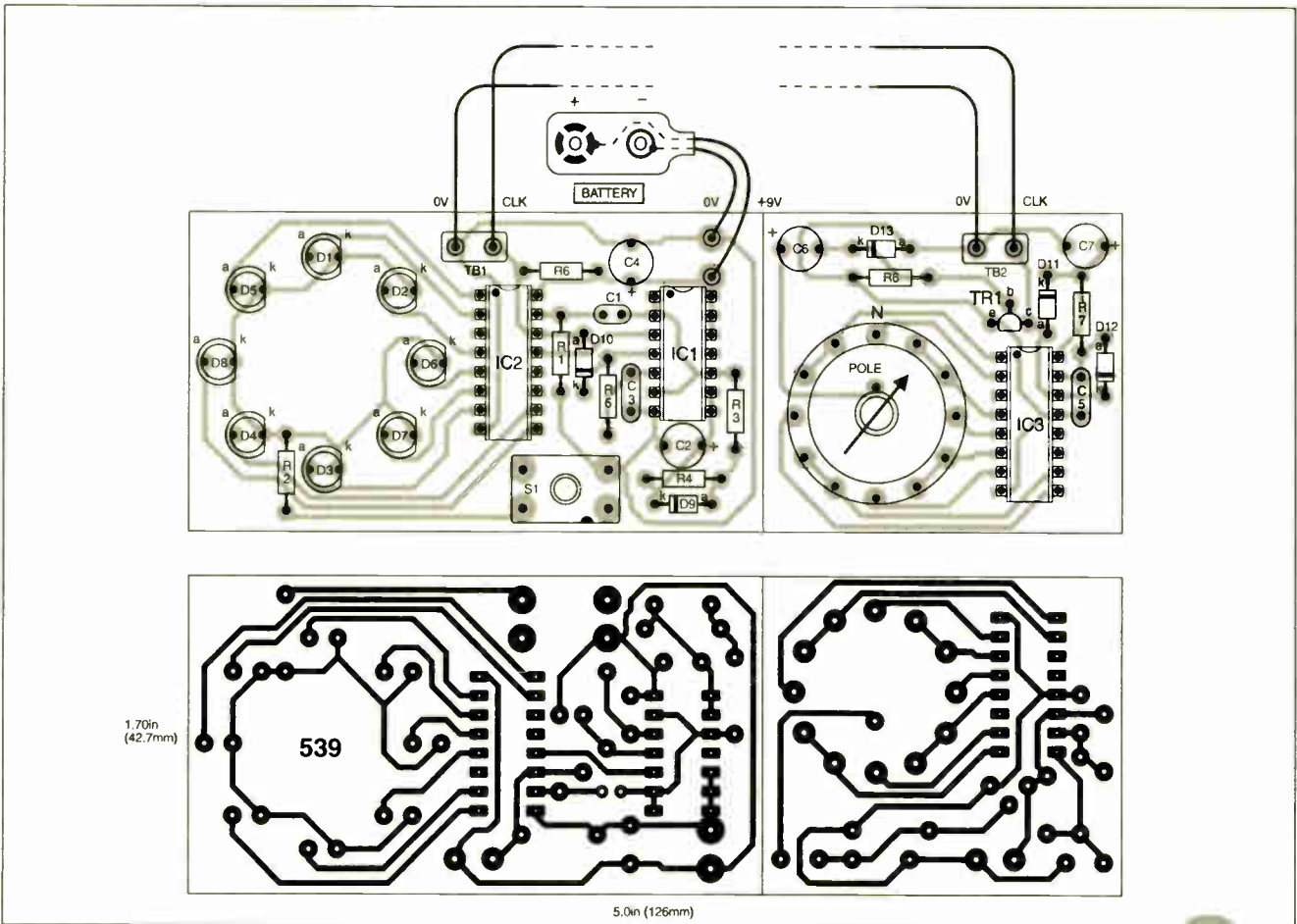
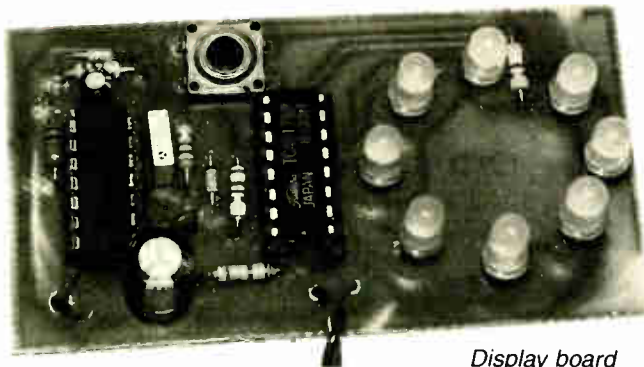

Fig. 8.8. Printed circuit board (p.c.b.) component layout, wiring details and full-size copper track master for the Electronic Weather Vane. The p.c.b. is cut into two sections making up the Display and Vane boards – see below

connected to the board on flying leads would be more appropriate.

The rest of the electronics construction should not pose any problems provided the normal precautions with device orientation and CMOS handling are observed.



Display board

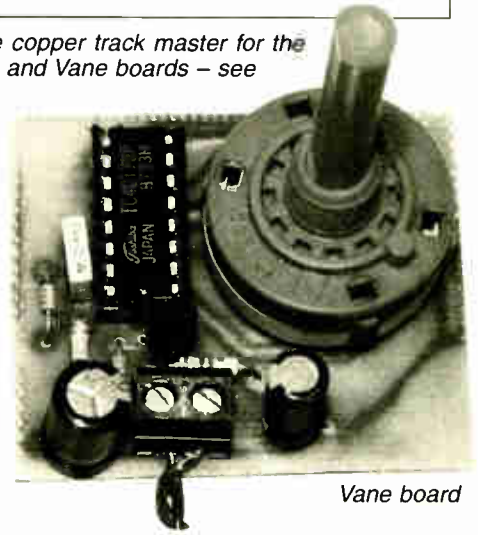

Vane board

Vane Unit

As the Vane board will be mounted on the roof and thus exposed to the elements, some thought must be given to the box in which it is to be mounted. This can range from proprietary mast mounting boxes specifically designed for such applications, to homemade equivalents such as an empty tin.

Whatever is chosen it should obviously be weather resistant and waterproof and, as an added precaution, the circuit board can be given a few coats of varnish or conformal spray (after it has been tested). Care should be taken to ensure that the freedom of Vane switch S2 to rotate is not impaired. Metal boxes should be painted with suitable oil based paint.

Since no battery is required in the roof mounted unit, the box may be permanently sealed leaving only the cable emerging. Another alternative is to pot the entire circuit, or at least the areas where water may

penetrate, in mastic such as is used for sealing around baths and sinks.

Vane Switch

The author was unable to source 8-way 360-degree rotary switches and so instead an easily available 12-way unit was used. These normally have an adjustable end stop so that rotation can be limited to the number of ways required and this should be removed. The permanent end stop at position 12, consisting of a protrusion in the moulded plastic switch body, must be removed to enable full 360 degree rotation.

Rotary switches also often have a click action imposed by two ball bearings. These must also be removed to enable the switch shaft to rotate freely. Gently prize back the four retaining lugs, taking care not to break them, removing the spring, ball bearings and

end stop, and snap the switch back together again.

A suitable vane needs to be attached to the shaft and this could be made from an aluminium or plastic sheet but the details of this are left to the taste and artistic capabilities of the reader.

The two units should be interconnected using a suitable length of twin cable. Once the system is working there are no adjustments to be made other than mounting

switch S2 and the l.e.d.s with the same orientation so that when the vane points north, the l.e.d. marked N is lit.



Circuit Surgery

Ian Bell

In response to a reader's prompt, our "consultant surgeon" switches his attention to analogue switch i.c.s

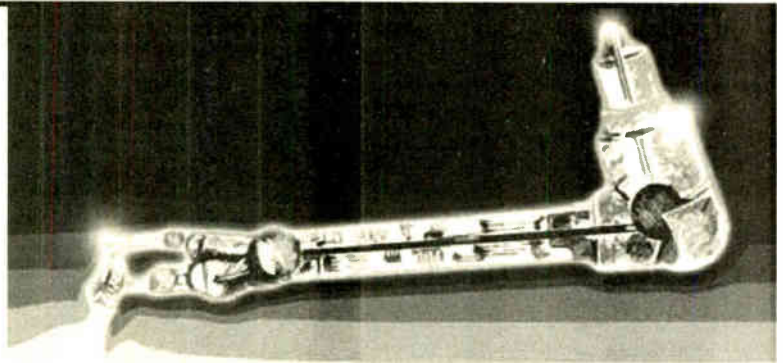

THIS month we will be looking at analogue switch i.c.s in response to a post by *Malcolm* on the EPE Chat Zone.

"At home I have a fairly complicated audio cable network – various radio tuners, DVD thingies, VHS machines, PC sound cards, Freeview boxes, tape decks etc – which need to be connected to each other and to a couple of hifi amplifiers as well.

At present I select the various routes I need via three separate switch boxes using mechanical toggle switches. The problems with this are that it's complicated, it's a pain to update as kit changes, and as the toggle switches age they cause noise and signal dropouts etc.

I am thinking of rationalising the whole lot into one box using electronic switches such as the 4052, controlled by a PIC. That way I could program the various signal routings I need and set them up with a single buttonpush.

Are 4052s OK for preamplifier audio signals? I was hoping the circuit could be powered with a couple of small 9V batteries to provide the \pm rails, to minimise any noise problems. I presume the CMOS will draw very little current, and the PIC can be put to sleep when not actually needed to do switching? Or will I need to think in terms of a good quality mains power supply?"

The on-line discussion on this topic included a debate on the relative merits of various devices such as 4016, 4051, 4052, 4053, 4066, DG417 to 419, and DG201A. The effect of on-resistance and available supply voltage range was also discussed.

There are in fact a very large number of analogue switch and multiplexer i.c.s available – some individual manufacturers produce hundreds of different switch i.c.s. There is likely to be one to suit your requirement, but how do you choose?

We will start by looking at the theory of how CMOS analogue switches work and then consider the key datasheet parameters and features that will determine their performance in real applications.

Before that, a quick comment about the power supply. It would seem worthwhile looking at the battery supply option. PICs

can certainly be put into a sleep mode, and as this application is relatively undemanding of processing power you should be able to use a slow clock speed to keep the operational power consumption low. Analogue switch i.c.s are available with a wide range of power supply voltages including several types which support the voltages needed. Analogue switch i.c.s optimised for low power operation are also available.

Transistor Switch

MOS transistors can behave like electronically controlled on/off switches. A single MOS transistor can be used in this way as shown in Fig.1. Such switches can be used to control the routing of signals in both analogue and digital circuits.

Unfortunately, the transistor switches off when the voltage being switched gets close to the control voltage because the gate-channel voltage falls below the switch-on threshold. The channel is the path from source(s) to drain(d) within the transistor. The gate(g) covers the channel and is separated from it by a very thin insulating layer.

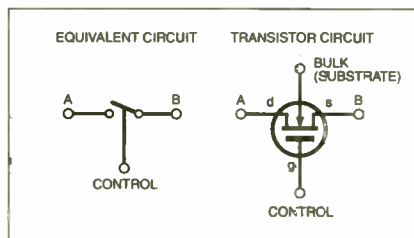

Fig.1. Circuit representation of the MOS transistor as a switch

The voltage difference between the gate and channel must be equal to or greater than the transistor's threshold voltage along the whole channel for the device to operate as a switch which is on. Note that when the transistor is acting as a switch which is on, the voltages at the source and drain should be approximately equal – you do not expect a lot of voltage to be dropped across a switch when it is operating properly.

Dual Switching

An NMOS (*n*-channel) transistor switch connecting two circuits together, in which we will assume that the transistor has a threshold voltage of 1V, is shown in Fig.2. If we have a single supply of 5V with logic control for the switch, 0V off and 5V on, then the possible range of switched analogue signal voltage is from 0V to 4V. Once the signal gets over 4V the gate voltage to source/drain voltage drops below the threshold and the transistor starts to switch off.

For correct operation the bulk or substrate connection of the transistor must be connected to a voltage equal to or more negative than the most negative signal voltage. The bulk or substrate is the silicon in

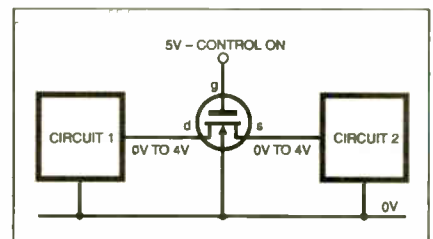

Fig.2. The switch voltage range when connecting two circuits together

which the transistor is formed. It is often connected to the source in discrete devices (so they have three pins rather than four).

A PMOS (*p*-channel) device used in a similar way would be on with 0V on the gate and off with 5V, it would have a signal range of 1V to 5V, and require the bulk to be connected to 5V.

Having Potential

How the on resistance of the switch could form a potential divider with a load resistor (e.g. the input resistance of the next circuit) is shown in Fig.3. When R_L is much bigger than R_{ON} the potential divider formed by R_{ON} and R_L has little effect on the signal voltage. For example if R_{ON} is 40 Ω and R_L is 40k Ω then output would be 3.4965V. Unless R_L is small and comparable with R_{ON} the attenuation of the signal caused is

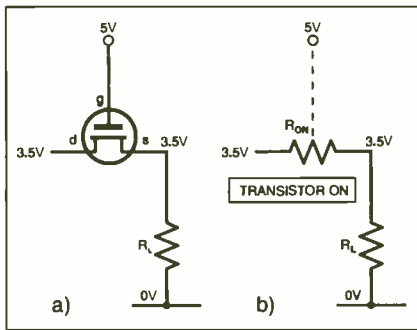

Fig.3. Potential divider formed by transistor and load resistance; a) actual circuit and b) equivalent circuit

unlikely to be a problem, however the value of R_{ON} varies with the difference between the signal and control voltage to the attenuation varies with signal level. This results in distortion of the signal which may be unacceptable in applications such as high quality audio.

Transmission Gate

The voltage range problem of the single MOS switch can be overcome by using two MOS transistors, one *p*-channel and one *n*-channel as shown in Fig.4., an arrangement which is often referred to as a transmission gate. Here at least one of the transistors is On when the control signal is high for all in/out voltages within the supply range. However, the value of R_{ON} for both transistors varies with signal level and at the ends of range (near the supply voltages) only one transistor is on causing R_{ON} of the whole switch to be relatively high at these voltages.

As indicated in the question, transmission gates are available in the 4000 series of CMOS devices. The 4016 and 4066 both contain four such switches with individual control inputs. The 4066 has lower and less variable on resistance.

For high performance use with analogue signals it is usually better to use switch i.c.s specifically designed for accurate handling of analogue signals, rather than the 4000 series devices. Unfortunately, the on resistance of the 4066 (and other 4000 series devices) depends quite strongly on supply voltage, input voltage and temperature and much better performance is available from other devices.

Other Parameters

In addition to on resistance the many parameters that might be of interest to the user of analogue switches include: signal range, on resistance matching and crosstalk of multiple switches, leakage current, noise, distortion, bandwidth, switching time, charge injection and logic compatibility of the control inputs.

Different devices may provide the best performance in one or more of these categories. You also get a variety of switch configurations to choose from, from basic s.p.s.t./s.p.d.t switches with either normally open or closed "contacts" to multiplexers and crosspoint switches.

Signal range specifies the voltages over which reasonable accurate switching will take place. Other parameters such as R_{ON} are often specified over a smaller input range, and often tend to get worse if the full range is used.

Resistance flatness is defined as the difference between the maximum and minimum value of on resistance (under specified conditions). Poor resistance flatness causes signal distortion and is obviously to be avoided. The problem can be reduced a lot by using circuit configurations where the value of R_{ON} has little or no influence on the gain.

Crosstalk indicates how much signal is coupled through from one switch (or multiplexer channel) to another on a chip with multiple switches. Crosstalk is caused mainly by unwanted (known as "parasitic") capacitances within the chip. It could occur between stereo channels, or between different signal sources (CD, tuner etc) in the proposed audio switch.

On resistance matching. For chips with multiple switches this indicates how similar the on resistances of the switches will be to one another. This is important in multi-channel systems where you would hope each channel is processed equally.

Off isolation indicates how much unwanted signal comes through an off switch.

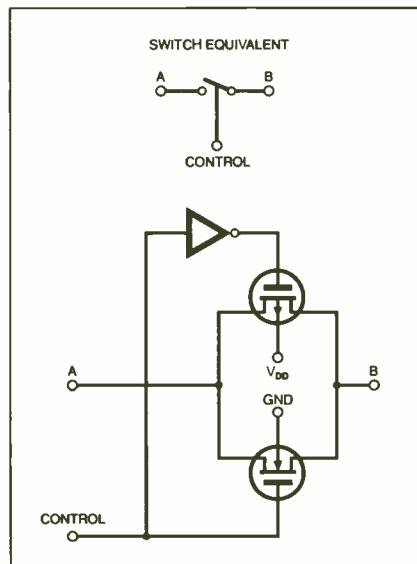

Fig.4. A CMOS transmission gate

Leakage current is the current that flows through the switch when it is off – it is more accurate to think of an off CMOS switch as a very small current source than a very large resistor. Leakage current can upset some circuit configurations especially where it causes unwanted charging or discharging of capacitors.

Charge injection is the glitch transferred from the digital control input to the analogue output during switching, this is more important in circuits where a lot of switching takes place all the time, and less so where signals are occasionally rerouted (as in our current discussion).

Switching time indicates how fast the switches turn on and off. Values for real devices vary widely, from nanoseconds to microseconds or more. For audio routing slow switches are possibly better as they are less likely to produce audible clicks. Some switches are specifically slowed (soft switched) for this reason.

Bandwidth has its conventional meaning, but is unlikely to be an issue for audio use – many CMOS switches are suitable for video applications.

Logic compatibility indicates what type of logic signals can be used to control the switch (e.g. CMOS or TTL). It obviously also helps if the switch i.c. has a supply voltage compatible with the control logic system (PIC etc).

Make or Break

What happens when you change over a switch or switch one switch on and another off at the same time is critical in some circuits (what you need depends on the circuit configuration). For example, if you are switching the feedback around an op.amp and open all the switches at once (during changeover) causing the op.amp to go open loop for a moment it will saturate with its output at one of the supply rails, possibly causing a massive disturbance of circuit voltages.

As to which devices to use from the many that are out there, one possibility from the vast range of basic switches (but not necessarily the best as we have not done an extensive search!) is the ADG451 to ADG453 range of switches from Analog Devices. These have a low on resistance (45Ω) and good resistance flatness (0.2Ω) A 44V supply maximum rating is well above the 9V required (the analogue signal range $\pm 15V$). For use with bipolar analogue signals, they can be operated from a dual power supply ranging from $\pm 4.5V$ to $\pm 20V$ (so $\pm 9V$ is fine). They have ultra-low power dissipation ($18\mu W$) which is great for battery operation. The control inputs are TTL and CMOS-compatible. Their suggested applications include audio and video switching as the on resistance is very flat over the full analogue input range, providing good linearity and low distortion when switching audio signals.

The ADG451/ADG452/ADG453 contain four independent single-pole single-throw (s.p.s.t) switches. The 451 and 452 differ only in that their digital control logic is inverted. The ADG453 has a break-before-make switching action for use in multiplexer applications. These devices are available in a 16-pin d.i.l. package.

More Complex

More complex switch i.c.s are also available, usually targeted at more specific applications. One example that may be appropriate to our current discussion is the MAX4571 to MAX4574 serial-interface controlled range of "clickless audio switches" from Maxim. These are described as being ideal for multimedia applications. Each device has a 35Ω maximum on-resistance, $-90dB$ audio off-isolation, ($-60dB$ for video) and $-90dB$ audio crosstalk.

Different devices from the range have different combinations of s.p.s.t. and s.p.d.t. switches (e.g. the MAX4571/MAX4573 contains eleven s.p.s.t. switches) and provide different serial interfaces such as SPI and I²C. The serial interfaces would make control from a PIC easy as PICs also support these protocols. Unfortunately they are not available in d.i.l. packages and feature single-supply operation from $+2.7V$ to $+5.25V$ so a regulator would be required if 9V batteries were used.

The chips we have described so far all have basic switches such s.p.s.t. and s.p.d.t, however more complex arrangements such as crosspoints and multiplexers are available. As we said earlier the choice in analogue switch i.c.s is very large.



New B² Spice V5 Our hottest Spice ever

New B² Spice Version 5 has all the power and functions you expect from a professional Spice package, but without the high cost:

- Real design flexibility with over 30,000 models, unlimited circuit size and a huge range of new virtual instruments
- New Circuit Wizard saves time by auto-generating many designs for you
- Sweep all parameters for any component and simulation type with the powerful new Scenario Editor
- Live Circuit feature allows values to be adjusted while simulations are running, displaying the results in real time

Professional standard Spice simulation for just £229 + VAT. Plus educational and multi-user licence discounts available and FREE comprehensive telephone technical support. **Try the full version completely free for 30 days.**

www.spice-software.com
Tel: 01603 872331

Research House, Norwich Road, Eastgate
Norwich, NR10 4HA. Fax: 01603 879010
Email info@looking.co.uk



RD Research

EPE IS PLEASED TO BE ABLE TO OFFER YOU THESE ELECTRONICS CD-ROMS

ELECTRONICS PROJECTS

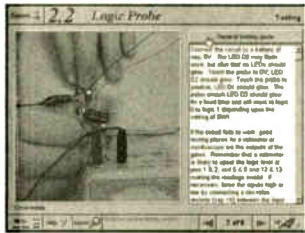

Logic Probe testing

Electronic Projects is split into two main sections: **Building Electronic Projects** contains comprehensive information about the components, tools and techniques used in developing projects from initial concept through to final circuit board production. Extensive use is made of video presentations showing soldering and construction techniques. The second section contains a set of ten projects for students to build, ranging from simple sensor circuits through to power amplifiers. A shareware version of Matrix's CADPACK schematic capture, circuit simulation and p.c.b. design software is included.

The projects on the CD-ROM are: Logic Probe; Light, Heat and Moisture Sensor; NE555 Timer; Egg Timer; Dice Machine; Bike Alarm; Stereo Mixer; Power Amplifier; Sound Activated Switch; Reaction Tester. Full parts lists, schematics and p.c.b. layouts are included on the CD-ROM.

ELECTRONICS CAD PACK

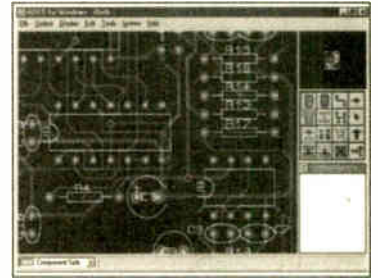

PCB Layout

Electronics CADPACK allows users to design complex circuit schematics, to view circuit animations using a unique SPICE-based simulation tool, and to design printed circuit boards. CADPACK is made up of three separate software modules. (These are restricted versions of the full Labcenter software.) **ISIS Lite** which provides full schematic drawing features including full control of drawing appearance, automatic wire routing, and over 6,000 parts. **PROSPICE Lite** (integrated into ISIS Lite) which uses unique animation to show the operation of any circuit with mouse-operated switches, pots, etc. The animation is compiled using a full mixed mode SPICE simulator. **ARES Lite** PCB layout software allows professional quality PCBs to be designed and includes advanced features such as 16-layer boards, SMT components, and an autorouter operating on user generated Net Lists.

ELECTRONIC CIRCUITS & COMPONENTS V2.0

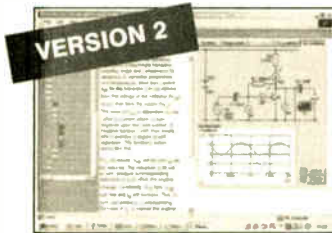

Circuit simulation screen

Provides an introduction to the principles and application of the most common types of electronic components and shows how they are used to form complete circuits. The virtual laboratories, worked examples and pre-designed circuits allow students to learn, experiment and check their understanding. Version 2 has been considerably expanded in almost every area following a review of major syllabuses (GCSE, GNVQ, A level and HNC). It also contains both European and American circuit symbols. Sections include: **Fundamentals**: units & multiples, electricity, electric circuits, alternating circuits. **Passive Components**: resistors, capacitors, inductors, transformers. **Semiconductors**: diodes, transistors, op.amps, logic gates. **Passive Circuits**. **Active Circuits**. **The Parts Gallery** will help students to recognise common electronic components and their corresponding symbols in circuit diagrams. Included in the Institutional Versions are multiple choice questions, exam style questions, fault finding virtual laboratories and investigations/worksheets.

ANALOGUE ELECTRONICS

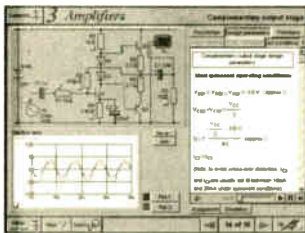

Complimentary output stage

Analogue Electronics is a complete learning resource for this most difficult branch of electronics. The CD-ROM includes a host of virtual laboratories, animations, diagrams, photographs and text as well as a SPICE electronic circuit simulator with over 50 pre-designed circuits.

Sections on the CD-ROM include: **Fundamentals** – Analogue Signals (5 sections), Transistors (4 sections), Waveshaping Circuits (6 sections), **Op.Amps** – 17 sections covering everything from Symbols and Signal Connections to Differentiators. **Amplifiers** – Single Stage Amplifiers (8 sections), Multi-stage Amplifiers (3 sections). **Filters** – Passive Filters (10 sections), Phase Shifting Networks (4 sections), Active Filters (6 sections). **Oscillators** – 6 sections from Positive Feedback to Crystal Oscillators. **Systems** – 12 sections from Audio Pre-Amplifiers to 8-Bit ADC plus a gallery showing representative p.c.b. photos.

DIGITAL ELECTRONICS V2.0

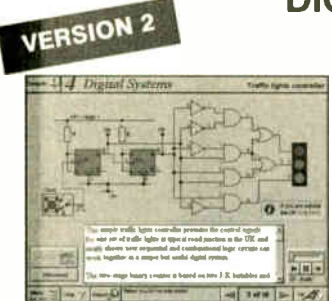

Virtual laboratory – Traffic Lights

Digital Electronics builds on the knowledge of logic gates covered in *Electronic Circuits & Components* (opposite), and takes users through the subject of digital electronics up to the operation and architecture of microprocessors. The virtual laboratories allow users to operate many circuits on screen.

Covers binary and hexadecimal numbering systems, ASCII, basic logic gates, monostable action and circuits, and bistables – including JK and D-type flip-flops. Multiple gate circuits, equivalent logic functions and specialised logic functions. Introduces sequential logic including clocks and clock circuitry, counters, binary coded decimal and shift registers. A/D and D/A converters, traffic light controllers, memories and microprocessors – architecture, bus systems and their arithmetic logic units. Sections on Boolean Logic and Venn diagrams, displays and chip types have been expanded in Version 2 and new sections include shift registers, digital fault finding, programmable logic controllers, and microcontrollers and microprocessors. The Institutional versions now also include several types of assessment for supervisors, including worksheets, multiple choice tests, fault finding exercises and examination questions.

ANALOGUE FILTERS

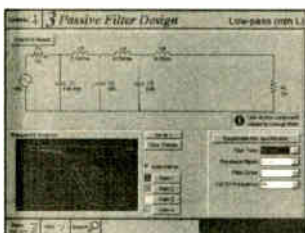

Filter synthesis

Analogue Filters is a complete course in designing active and passive filters that makes use of highly interactive virtual laboratories and simulations to explain how filters are designed. It is split into five chapters: **Revision** which provides underpinning knowledge required for those who need to design filters. **Filter Basics** which is a course in terminology and filter characterization, important classes of filter, filter order, filter impedance and impedance matching, and effects of different filter types. **Advanced Theory** which covers the use of filter tables, mathematics behind filter design, and an explanation of the design of active filters. **Passive Filter Design** which includes an expert system and filter synthesis tool for the design of low-pass, high-pass, band-pass, and band-stop Bessel, Butterworth and Chebyshev ladder filters. **Active Filter Design** which includes an expert system and filter synthesis tool for the design of low-pass, high-pass, band-pass, and band-stop Bessel, Butterworth and Chebyshev

ROBOTICS & MECHATRONICS

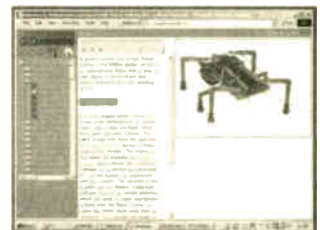

Case study of the Milford Instruments Spider

Robotics and Mechatronics is designed to enable hobbyists/students with little previous experience of electronics to design and build electromechanical systems. The CD-ROM deals with all aspects of robotics from the control systems used, the transducers available, motors/actuators and the circuits to drive them. Case study material (including the NASA Mars Rover, the Milford Spider and the Furby) is used to show how practical robotic systems are designed. The result is a highly stimulating resource that will make learning, and building robotics and mechatronic systems easier. The Institutional versions have additional worksheets and multiple choice questions.

- Interactive Virtual Laboratories
- Little previous knowledge required
- Mathematics is kept to a minimum and all calculations are explained
- Clear circuit simulations

PRICES

Prices for each of the CD-ROMs above are:

(Order form on third page)

Hobbyist/Student	£45 inc VAT
Institutional (Schools/HE/FE/Industry).....	£99 plus VAT
Institutional 10 user (Network Licence)	£249 plus VAT
Site Licence.....	£499 plus VAT

(UK and EU customers add VAT at 17.5% to "plus VAT" prices)

PICmicro TUTORIALS AND PROGRAMMING

HARDWARE

VERSION 3 PICmicro MCU DEVELOPMENT BOARD

Suitable for use with the three software packages listed below.

This flexible development board allows students to learn both how to program PICmicro microcontrollers as well as program a range of 8, 18, 28 and 40-pin devices from the 12, 16 and 18 series PICmicro ranges. For experienced programmers all programming software is included in the PPP utility that comes with the development board. For those who want to learn, choose one or all of the packages below to use with the Development Board.

- Makes it easier to develop PICmicro projects
- Supports low cost Flash-programmable PICmicro devices
- Fully featured integrated displays – 16 individual i.e.d.s, quad 7-segment display and alphanumeric i.c.d. display
- Supports PICmicro microcontrollers with A/D converters
- Fully protected expansion bus for project work
- USB programmable
- Can be powered by USB (no power supply required)

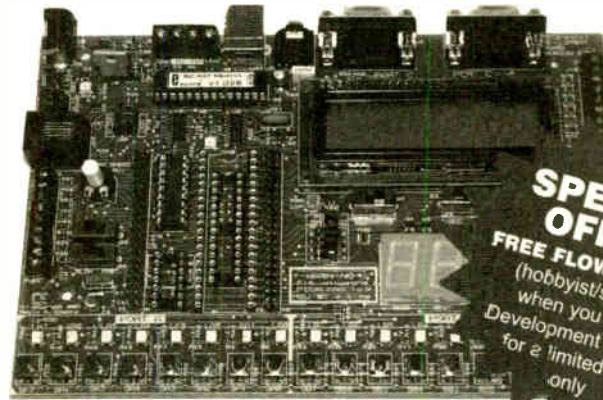

SPECIAL OFFER
FREE FLOWCODE V2
(hobbyist/student)
when you buy a
Development Board –
for a limited time
only

£158 including VAT and postage

supplied with USB cable and programming software

SOFTWARE

Suitable for use with the Development Board shown above.

NEW V3

ASSEMBLY FOR PICmicro V3 (Formerly PICtutor)

Assembly for PICmicro microcontrollers V3.0 (previously known as PICtutor) by John Becker contains a complete course in programming the PIC16F84 PICmicro microcontroller from Arizona Microchip. It starts with fundamental concepts and extends up to complex programs including watchdog timers, interrupts and sleep modes. The CD makes use of the latest simulation techniques which provide a superb tool for learning: the Virtual PICmicro microcontroller. This is a simulation tool that allows users to write and execute MPASM assembler code for the PIC16F84 microcontroller on-screen. Using this you can actually see what happens inside the PICmicro MCU as each instruction is executed which enhances understanding.

- Comprehensive instruction through 45 tutorial sections
- Includes Vlab, a Virtual PICmicro microcontroller: a fully functioning simulator
- Tests, exercises and projects covering a wide range of PICmicro MCU applications
- Includes MPLAB assembler
- Visual representation of a PICmicro showing architecture and functions
- Expert system for code entry helps first time users
- Shows data flow and fetch execute cycle and has challenges (washing machine, lift, crossroads etc.)
- Imports MPASM files.

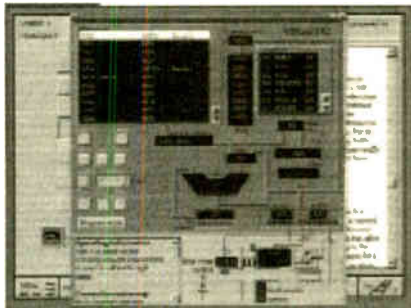

Virtual PICmicro

'C' FOR PICmicro VERSION 2

The C for PICmicro microcontrollers CD-ROM is designed for students and professionals who need to learn how to program embedded microcontrollers in C. The CD contains a course as well as all the software tools needed to create Hex code for a wide range of PICmicro devices – including a full C compiler for a wide range of PICmicro devices.

Although the course focuses on the use of the PICmicro microcontrollers, this CD-ROM will provide a good grounding in C programming for any microcontroller.

- Complete course in C as well as C programming for PICmicro microcontrollers
- Highly interactive course
- Virtual C PICmicro improves understanding
- Includes a C compiler for a wide range of PICmicro devices
- Includes full Integrated Development Environment
- Includes MPLAB software
- Compatible with most PICmicro programmers
- Includes a compiler for all the PICmicro devices.

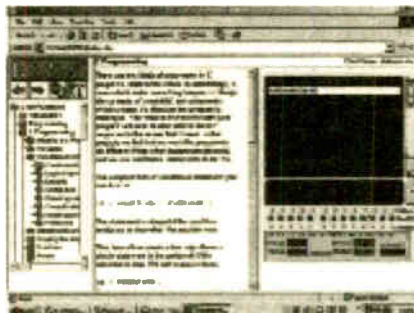

Minimum system requirements for these items: Pentium PC running Windows 98, NT, 2000, ME, XP; CD-ROM drive; 64MB RAM; 10MB hard disk space.

FLOWCODE FOR PICmicro V2

Flowcode is a very high level language programming system for PICmicro microcontrollers based on flowcharts. Flowcode allows you to design and simulate complex robotics and control systems in a matter of minutes.

Flowcode is a powerful language that uses macros to facilitate the control of complex devices like 7-segment displays, motor controllers and i.c.d. displays. The use of macros allows you to control these electronic devices without getting bogged down in understanding the programming involved.

Flowcode produces MPASM code which is compatible with virtually all PICmicro programmers. When used in conjunction with the Version 2 development board this provides a seamless solution that allows you to program chips in minutes.

- Requires no programming experience
- Allows complex PICmicro applications to be designed quickly
- Uses international standard flow chart symbols (ISO5807)
- Full on-screen simulation allows debugging and speeds up the development process
- Facilitates learning via a full suite of demonstration tutorials
- Produces ASM code for a range of 18, 28 and 40-pin devices
- Professional versions include virtual systems (burglar alarm, buggy and maze, plus RS232, IrDa etc.).

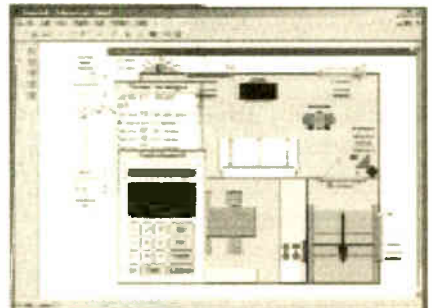

Burglar Alarm Simulation

PRICES

Prices for each of the CD-ROMs above are:

(Order form on next page)

(UK and EU customers add VAT at 17.5% to "plus VAT" prices)

Hobbyist/Student
Flowcode V2 Hobbyist/Student
Institutional (Schools/HE/FE/Industry)
Flowcode Professional
Institutional/Professional 10 user (Network Licence)
Site Licence

£45 inc VAT
£57 inc VAT
£99 plus VAT
£99 plus VAT
£300 plus VAT
£599 plus VAT

TEACH-IN 2000 – LEARN ELECTRONICS WITH EPE

EPE's own Teach-In CD-ROM, contains the full 12-part Teach-In series by John Becker in PDF form plus the Teach-In interactive software (Win 95, 98, ME and above) covering all aspects of the series. We have also added Alan Winstanley's highly acclaimed *Basic Soldering Guide* which is fully illustrated and which also includes *Desoldering*. The Teach-In series covers: Colour Codes and Resistors, Capacitors, Potentiometers, Sensor Resistors, Ohm's Law, Diodes and L.E.D.s, Waveforms, Frequency and Time, Logic Gates, Binary and Hex Logic, Op.amps, Comparators, Mixers, Audio and Sensor Amplifiers, Transistors, Transformers and Rectifiers, Voltage Regulation, Integration, Differentiation, 7-segment Displays, L.C.D.s, Digital-to-Analogue. Each part has an associated practical section and the series includes a simple PC interface (Win 95, 98, ME ONLY) so you can use your PC as a basic oscilloscope with the various circuits.

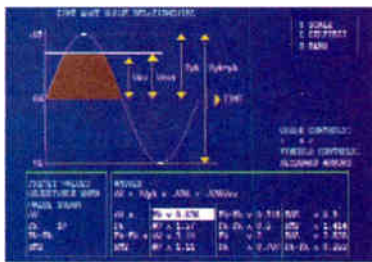

Sine wave relationship values

A hands-on approach to electronics with numerous breadboard circuits to try out.

£12.45 including VAT and postage. Requires Adobe Acrobat (available free from the Internet – www.adobe.com/acrobat).

FREE WITH EACH TEACH-IN CD-ROM – *Electronics Hobbyist Compendium* 80-page book by Robert Penfold. Covers Tools For The Job; Component Testing; Oscilloscope Basics.

FREE BOOK WITH TEACH-IN 2000 CD-ROM



DIGITAL WORKS 3.0

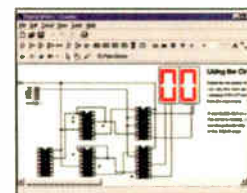

Counter project

Digital Works Version 3.0 is a graphical design tool that enables you to construct digital logic circuits and analyze their behaviour. It is so simple to use that it will take you less than 10 minutes to make your first digital design. It is so powerful that you will never outgrow its capability ● Software for simulating digital logic circuits ● Create your own macros – highly scalable ● Create your own circuits, components, and i.c.s ● Easy-to-use digital interface ● Animation brings circuits to life ● Vast library of logic macros and 74 series i.c.s with data sheets ● Powerful tool for designing and learning. **Hobbyist/Student £45 inc. VAT. Institutional £99 plus VAT. Institutional 10 user £249 plus VAT. Site Licence £599 plus VAT.**

PROJECT DESIGN WITH CROCODILE TECHNOLOGY

An Interactive Guide to Circuit Design

An interactive CD-ROM to guide you through the process of circuit design. Choose from an extensive range of input, process and output modules, including CMOS Logic, Op-Amps, PIC/PICAXE, Remote Control Modules (IR and Radio), Transistors, Thyristors, Relays and much more.

Click Data for a complete guide to the pin layouts of i.c.s, transistors etc. Click More Information for detailed background information with many animated diagrams.

Nearly all the circuits can be instantly simulated in Crocodile Technology* (not included on the CD-ROM) and you can customise the designs as required.

WHAT'S INCLUDED

Light Modules, Temperature Modules, Sound Modules, Moisture Modules, Switch Modules, Astables including 555, Remote Control (IR & Radio), Transistor Amplifiers, Thyristor, Relay, Op-Amp Modules, Logic Modules, 555 Timer, PIC/PICAXE, Output Devices, Transistor Drivers, Relay Motor Direction & Speed Control, 7 Segment Displays. Data sections with pinouts etc., Example Projects, Full Search Facility, Further Background Information and Animated Diagrams.

Runs in Microsoft Internet Explorer

*All circuits can be viewed, but can only be simulated if your computer has Crocodile Technology version 410 or later. A free trial version of Crocodile Technology can be downloaded from: www.crocodile-clips.com. Animated diagrams run without Crocodile Technology.

Single User £39.00 inc. VAT.

Multiple Educational Users (under 500 students) £59.00 plus VAT. Over 500 students £79.00 plus VAT.

(UK and EU customers add VAT at 17.5% to "plus VAT" prices)



Over 150 pages
Over 600 images

ELECTRONIC COMPONENTS PHOTOS

A high quality selection of over 200 JPG images of electronic components. This selection of high resolution photos can be used to enhance projects and presentations or to help with training and educational material. They are royalty free for use in commercial or personal printed projects, and can also be used royalty free in books, catalogues, magazine articles as well as worldwide web pages (subject to restrictions – see licence for full details).

Also contains a FREE 30-day evaluation of Paint Shop Pro 6 – Paint Shop Pro image editing tips and on-line help included!

Price £19.95 inc. VAT



Minimum system requirements for these CD-ROMs: Pentium PC, CD-ROM drive, 32MB RAM, 10MB hard disk space. Windows 95/98/NT/2000/ME/XP, mouse, sound card, web browser.

Please send me: **CD-ROM ORDER FORM**

- Electronic Projects
- Electronic Circuits & Components V2.0
- Analogue Electronics
- Digital Electronics V2.0
- Filters
- Electronics CAD Pack
- Robotics & Mechatronics
- Assembly for PICmicro V2
- 'C' for PICmicro V2
- Flowcode V2 for PICmicro
- Digital Works 3.0

Version required:

- Hobbyist/Student
- Institutional
- Institutional/Professional 10 user
- Site licence



- PICmicro Development Board V2 (hardware)
- Development Board UK plugtop power supply
- Development Board 25-way connecting lead

- Teach-In 2000 + FREE BOOK
- Electronic Components Photos
- Project Design – Single User
- Project Design – Multiple User (under 500 students)
- Project Design – Multiple User (over 500 students)

Note: The software on each version is the same, only the licence for use varies.

Full name:

Address:

Post code: Tel. No:

Signature:

I enclose cheque/PO in £ sterling payable to WIMBORNE PUBLISHING LTD for £

Please charge my Visa/Mastercard/Amex/Diners Club/Switch: £

Valid From: Card expiry date:

Card No: Switch Issue No.

Card Security Code (The last 3 digits on or just under the signature strip)

ORDERING ALL PRICES INCLUDE UK POSTAGE

Student/Single User/Standard Version price includes postage to most countries in the world
EU residents outside the UK add £5 for airmail postage per order

Institutional, Multiple User and Deluxe Versions – overseas readers add £5 to the basic price of each order for airmail postage (do not add VAT unless you live in an EU (European Union) country, then add 17½% VAT or provide your official VAT registration number).

Send your order to:
Direct Book Service
Wimborne Publishing Ltd
408 Wimborne Road East
Ferndown, Dorset BH22 9ND

To order by phone ring
01202 873872. Fax: 01202 874562

Goods are normally sent within seven days

E-mail: orders@wimborne.co.uk

Online shop:
www.epemag.wimborne.co.uk/shopdoor.htm

EASYSYN C™ Test and Measurement Solutions

USB Instruments

PC Oscilloscopes & Logic Analyzers

Our range of PC Instruments may be budget priced but have a wealth of features normally only found in more expensive instrumentation. Our DSTM-2 and PS40M10 oscilloscopes have sophisticated digital triggering including delayed timebase and come with our EasyScope oscilloscope / spectrum analyzer / voltage and frequency display application software and our EasyLogger data logging software. We also provide Windows DLLs and code examples for 3rd party software interfacing to our scopes. Our ANT8 and ANT16 Logic Analyzers feature 8/16 capture channels of data at a blazing 500MS/S sample rate in a compact enclosure. Detailed specifications and software downloads for these products can be found at <http://www.usb-instruments.com>

EasySync Ltd
 373 Scotland Street,
 Glasgow G5 8QB
 United Kingdom
 Tel: 0141 418 0181
 Fax: 0141 418 0110
 Web: <http://www.easysync.co.uk>
 E-Mail: sales@easysync.co.uk

* Prices shown exclude PD and VAT where applicable

YOU WON'T GET YOUR FINGERS BURNT

It may surprise you but buying an Antex soldering iron costs less than you think in the long run. British made to exacting standards, they last significantly longer than imported brands. And with a wide range of thermally balanced soldering irons, you can pick up a "fixed temperature" or "in-handle" temperature model that will suit your needs perfectly.

None of which will burn a hole in your pocket.

If your hobby demands the best iron for the job but you don't want to get your fingers burnt by the cost, visit our website or your electronics retailer for the coolest models around.

Pick up an

ANTEX
 Not just any old iron.



www.antex.co.uk

2 Westbridge Industrial Estate Tavistock
 Devon PL19 8DE Tel 01822 613565

PCB-POOL®

SERVICING YOUR COMPLETE PROTOTYPE NEEDS

- Prototypes at a fraction of the cost
- Industry standard quality
- Tooling and setup included
- Follow up series runs
- Any contour
- CAM / CAD consulting
- Fr4 1.6mm, 35µm Cu

1 EUROCARD (5 PTH)
 + Tooling
 + Photoplot
 + VAT
 = £ 29.89*

*Starting rates may vary. Price = D 49

€49

FREE

Beta

Freephone
0800-389 8560

Simply send your files and order details to:

WWW.PCB-POOL.COM

Protel ORCAD EPLAN GraphiCode

PRACTICALLY SPEAKING

Robert Penfold looks at the Techniques of Actually Doing It!

STRIPBOARD is a product that revolutionised electronic project building. Older methods of construction such as using tag boards and hardwiring were not really suited to what at that time were the new components, such as transistors and integrated circuits. Building your own custom printed circuit boards tended to be difficult and expensive, and ready-made printed circuit boards were not available for most projects.

Stripboard was an immediate success as it provided a universal board that could be used to construct practically any project. Unlike many forms of prototyping board it provided a finished product that was reasonably neat and tough. This made it suitable for testing prototype circuits and for producing the final "real thing".

Although stripboard has many advantages, it is probably not the best choice for complete beginners building their first project. A custom printed circuit board (p.c.b.) has to be regarded as the more foolproof option. However, despite a few limitations it is perfectly suitable for the vast majority of projects, and before too long it is likely that you will wish to build a project that uses this method of construction.

Perfect Pitch

Like most good ideas, stripboard is basically a very simple product. It consists of a thin board made from a piece of insulating material and drilled with a matrix of small holes (Fig.1-right). With modern boards the holes are 1mm in diameter and the pitch of the matrix is 2.54mm. This arrangement suits the vast majority of components, but there are obviously a few "awkward customers" that cannot be fitted directly to the board. Using adaptors or a bit of ingenuity it is possible to fit most types of component onto standard stripboard.

There are also thin copper strips running along rows of holes on what is generally considered to be the underside of the board (Fig.1-left). Stripboard is used in what is essentially the same manner as the custom printed circuit board. Components are mounted on the plain (top) side of the board with the leadout wires being threaded through the holes, trimmed to length on the underside of the board, and then soldered to the copper strips.

There is actually a "plain" version of stripboard that lacks any copper strips, and it

is used by hardwiring everything on the underside of the board. This type of board is very good for prototyping and building high-frequency circuits, but in practice it is little used these days. It will not be considered further here.

Problems, Problems

Although stripboard is less straightforward in use than a custom printed circuit board, it is not particularly difficult to use. However, in order to avoid frequent problems you have to be aware of a few potential traps. It would be unreasonable to expect stripboard to be very tough, bearing in mind that a fair percentage of each board consists of empty holes. This means that you have to use the "kid glove" approach when drilling and cutting it.

Stripboard is sold in several standard sizes, and practically every project requires a standard board to be cut down to the appropriate size. Numerous methods of cutting stripboard have been suggested over the years, often using essentially the same methods and tools that are utilized for cutting glass and ceramic tiles.

Some makes of stripboard are quite brittle and can be used with these methods, but with other makes results can be disastrous. Even when used with a suitable make of board there is still a risk of these methods producing unusable results.

Experience suggests that the most reliable approach to cutting stripboard is to use a saw that has a thin blade and fine teeth. In practice this means using a junior hacksaw. Cut carefully and slowly along rows of holes and do not try to cut between the rows. The spacing between them is so small that this is not a practical way of doing things.

Make sure that the board is held firmly in place and use no more pressure on the saw than is really necessary. Cutting along rows of holes is guaranteed to produce some pretty rough edges, but they are easily filed to a neat finish.

A Stand-off

Some stripboards are mounted in the case using guide rails, but in most instances the board must be drilled to take mounting bolts or plastic stand-offs. In general, it is best to use mountings that require relatively small holes to be drilled in the board. The result should be quite neat and usable if one of the existing holes in the board is drilled out to only about 2.5mm to 3mm in diameter.

Making a mounting hole much larger than this tends to result in it merging with the four surrounding holes in the board. This does not produce a neat-looking end result and is unlikely to provide a reliable method of fixing the board in place.

Most types of stand-off do not work well with stripboard, so it is probably best to use mounting bolts and spacers. A mounting hole of 3mm in diameter or a little less can be used with M2.5 mounting bolts, which will fix the board in place reliably. Even if the board is mounted in a plastic case, do not be tempted to omit spacers from between the board and the case. The underside of the board will be far from flat due to the protruding solder joints. Failing to use spacers tends to result in the board buckling and distorting when the mounting nuts are tightened.

This is something that must be avoided with any circuit boards, but it is especially important when using one of the more brittle types of stripboard. There would be a real danger of the board cracking or even shattering into several pieces. Short spacers or some extra nuts used between the board and the case should ensure that the board does not come to harm.

However, make sure that the mounting holes are drilled very accurately in the case. A lack of accuracy will result in stresses being placed on the board, and there would again be a risk of it coming to grief. Using the circuit board as a template is an easy way of marking the positions of the mounting holes very accurately.

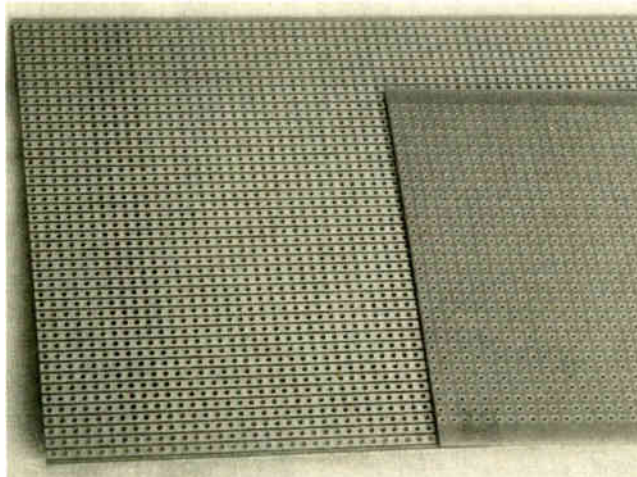

Fig.1. The two faces of stripboard; on the left the copper "strip" underside, and on the right the plain component topside

Quick Break

On the face of it there is a big limitation with strip-board in that each copper strip can only carry one set of connections. In practice the copper strips are often broken in several places so that each section can carry a different set of interconnections. There is a special tool available for making the breaks in the strips (Fig.2), which is sometimes called a "spot face cutter" in electronic component and equipment catalogues.

The proper tool provides the easiest means of making the breaks, but a twist drill bit of around 5mm in diameter also does the job quite well. Carving out pieces of copper strip using a modelling knife is not a good way of doing things. It is quite difficult to cut away the pieces of copper strip properly and very easy to cut yourself.

When making the breaks you have to make sure that the cuts are deep enough to properly sever the strips across their full width. On the other hand, it is important not to cut too deeply into the board. Particularly when there are a lot of cuts close together, cutting deeply into the board could seriously weaken it. Cut deep enough to make reliable breaks, but no more than this.

Togetherness

An inherent problem with stripboard is that the gap between the adjacent copper strips is extremely small at about 0.3mm. This makes it very easy to produce accidental short-circuits between adjacent strips due to excess solder on a joint.

While this is a potential problem with most modern circuit boards, in practice it seems to be worse with stripboard. Using a soldering iron fitted with a bit having a diameter of 2.5 millimetres or less helps to minimise the problem.

Most short-circuits are easily spotted as soon as the joint has been made, and small pieces of excess solder can be wiped away with the bit of the iron. With larger solder blobs it is better to use a desoldering pump to clean away all the solder and then redo the joint "from scratch".

The real problem comes from pieces of solder that are minute, especially if they are also buried in some excess flux. Having completed any circuit board it is a good idea to clean the underside and check for short circuits with the aid of a magnifier. Special cleaners are available, but vigorous scrubbing with an old toothbrush seems to do the job just as well.

When a completed stripboard fails to work properly it is quite likely that the problem is due to a minute piece of solder causing a short-circuit, or because there is an incomplete break in a copper strip. Some checks with a continuity tester will soon confirm the presence of either problem.

Out of Place

Getting the components fitted in the right places is trickier with stripboard than when using a custom p.c.b. With a custom board there is one hole per

Fig.2. Commercial "spot face cutter" hand tool

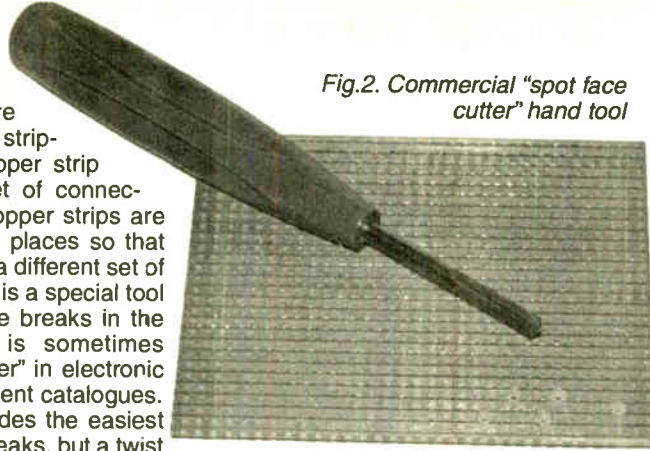

leadout wire, but stripboard has numerous unused holes. It is very easy to get one lead or even a complete component shifted one hole out of position. At the very least, the position of each component has to be double-checked prior to soldering it in place.

Take particular care with components that have a number of pins, such as integrated circuit holders and relays. Even with the aid of the correct equipment, desoldering them from the board is likely to be difficult. With this type of thing there is always a risk of damaging components and the board itself.

Make Your Mark

Many stripboard layout diagrams, including all those featured in *EPE*, are marked with letters to identify the copper strips and numbers to identify the columns of holes. It can be very helpful if the same markings are added to the board itself. It is then very easy to match any point on the board with the corresponding position on the layout diagram. It also greatly reduces the likelihood of an error being made.

There is only a very limited amount of space available for the labels, which makes it a bit awkward to mark them on the board. It can be done using a fibre-tip pen having a suitable fine tip, but the pen must be a type that is suitable for writing on non-porous surfaces such as glass. Pens having ordinary water based inks will not mark the board properly, and the ink will soon rub off when you start handling the board. Marking the numbers for every column of holes can be difficult, but this system still works well even if every fourth or fifth column is labelled.

A neat way of doing things is to use a computer drawing program and a printer to produce labels that can be glued to the board (Fig.3). Any drawing program should be able to produce lettering with an accurate spacing of 2.54mm (0.1in.). Use a water soluble adhesive such as a glue-stick so that the labels are easily removed once the board has been finished.

There are often blank areas at the top and bottom of a circuit board that can be used to accommodate the column num-

bering label. The board can be made one or two extra holes too wide to provide space for the row lettering label.

Missing Links

Most stripboard layouts rely on a fair number of link-wires. The copper strips of a custom p.c.b. can be routed here, there, and everywhere, but stripboard has only straight pieces of copper track running in the same direction. The link wires are required to compensate for this limitation.

Trimblings from the leadout wires of resistors and capacitors are ideal for the shorter links, but some 22 or 24 gauge (around 0.8mm dia.) tinned copper wire is needed for the longer ones. Where a board has a large number of links it is easy to miss out one or two, so meticulously check that all the links have been added.

While some constructors prefer to insulate all the link wires, there is little risk of accidental short-circuits occurring if the shorter ones are left as bare wires. However, make sure that the wires are neatly formed so that they run straight from one hole to the other. It is definitely a good idea to use p.v.c. sleeving over wires that are more than about 25mm long, especially at places where several links run side-by-side.

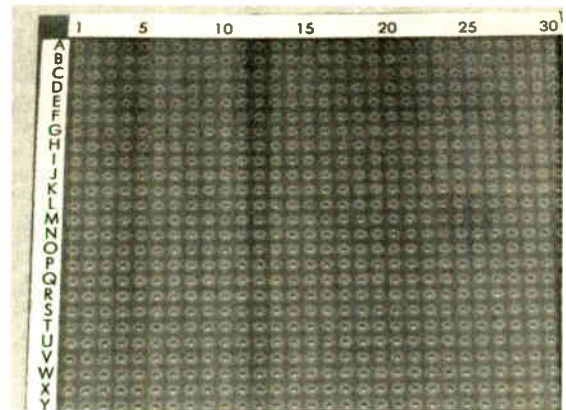

Fig.3. Labelling the stripboard with letters for strips and numbers for columns

Standard lead spacing is sometimes used for stripboard layouts, but it can result in a large number of links being needed and a sprawling layout. It is more usual for resistors to span anything from four to ten or more holes. This helps to keep the layout simple but can make building the board a little awkward.

Over the years there have been various gadgets and methods for forming the leads to fit a certain hole-spacing. The obvious method, and one that works very well, is to simply hold the resistor, link-wire, or whatever on the stripboard so that the board can be used as a simple measuring guide. With experience it becomes quite easy to guesstimate the lead spacing with sufficient accuracy.

Whether you are using a custom board or stripboard, always make the external connections via solder-pins. Any 1mm diameter solder-pins should be compatible with normal stripboard.

AVIT Research

www.avitresearch.co.uk

USB has never been so simple...



Special Price
£29.99

USB to TTL Serial Cable

- Simple and Easy way to give USB support to your designs
- Connects directly to microcontroller UART or I/O pins
- PC communicates as a standard serial device
- All circuitry integrated into sleek, moulded USB plug
- 4 way connector (Gnd, RX TX and +5v)
- Supplied with PC drivers, example code and tutorial
- Special Price of only £29.99 including VAT

AVIT Research also supply:

I²C Bus Tool - Allows your PC to monitor and control the I²C Bus

- Invaluable tool for developers using the I²C Bus
- See website for full details



www.avitresearch.co.uk

info@avitresearch.co.uk

0870 741 3636

Build Your Own Weather Station



- ▶ Measure Wind Speed
- ▶ Measure Wind Direction
- ▶ Measure Temperature
- ▶ Easy Build Kit
- ▶ FREE Software
- ▶ USB or RS232
- ▶ Optional Humidity Module
- ▶ Optional Pressure Module
- ▶ Optional Rainfall Gauge
- ▶ Simple 1-wire[®] connection
- ▶ Build and add your own devices

- Weather Starter Kit £59
- RS232 Interface £25
- USB Interface £29
- Humidity Module £39
- Pressure Module £49
- Rainfall Gauge £59

Prices exclude VAT and delivery

For more information, manuals and downloads on this and other interesting products see www.audon.co.uk

audon Electronics

www.audon.co.uk | +44 (0)115 925 8412 | Fax +44 (0)115 925 9757

PicoScope 3000 Series PC Oscilloscopes

The PicoScope 3000 series oscilloscopes are the latest offerings from the market leader in PC oscilloscopes combining high bandwidths with large buffer memories. Using the latest advances in electronics, the oscilloscopes connect to the USB port of any modern PC, making full use of the PC's processing capabilities, large screens and familiar graphical user interfaces.

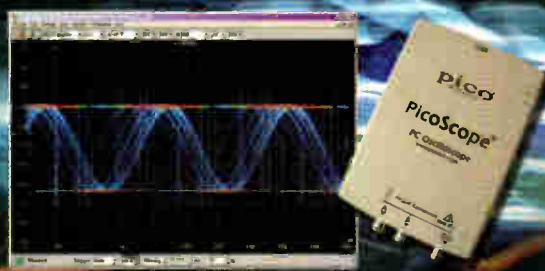

- High performance: 10GS/s sampling rate & 200MHz bandwidth
- 1MB buffer memory
- High speed USB 2.0 interface
- Advanced display & trigger modes
- Compact & portable
- Supplied with PicoScope & PicoLog software

PicoScope	3204	3205	3206
Bandwidth	50MHz	100MHz	200MHz
Sampling rate (repetitive)	2.5GS/s	5GS/s	10GS/s
Sampling rate (single shot)	50MS/s	100MS/s	200MS/s
Channels	2+Ext trigger	2+Ext trigger Sig gen	2+Ext trigger Sig gen
Oscilloscope timebases	5ns/div to 50ns/div	2ns/div to 50ns/div	1ns/div to 50ns/div
Timebase accuracy	50ppm	50ppm	50ppm
Spectrum ranges	0 to 25MHz	0 to 50MHz	0 to 100MHz
Buffer memory size	256KB	512KB	1MB
Resolution / accuracy		8 bits / 3%	
Ranges		±100mV to ±20V	
PC Connection		USB2.0 (USB1.1 compatible)	

Tel: 01480 396395

www.picotech.com/scope305

pico
Technology Limited

PIC Chromatone

John Becker

Be entertained by a light controlled musical novelty



YOU'VE all experienced Sound-to-Light displays – haven't you – discos, parties, raves, etc? But what about Light-to-Sound? Bet that's probably a new one to you – but not any longer if you read on!

Light-to-sound? Well it's just a matter of turning thoughts on their head a bit. Given the infinite variety of colour tones around us, all we do is to electronically sense what colours they are and produce frequency tones specific to them.

Easier said than done, though, once theory began to be turned into reality! And it must be said, the resulting design presented here is a gimmick. But it's a fun gimmick, and should provide much musical entertainment.

PIC the Rainbow

These days there's only one route the author wishes to take when designing something – via a PIC microcontroller. In this case it's the PIC18F252 device which is put into service. The PIC is fed with colour data, which it converts into a single value representing the colours sensed, and causes a "musical" note to be sounded, from across several octaves.

First, though, let's examine the sensors, of which there are four. Three sensors have coloured filters in front of them, red, green and blue (RGB), and so only respond to light that contains those colours. The fourth is unfiltered and so sees the light "as is".

The sensors are the type IS474, manufactured by Sharp and described as human eye linear output OPIC light detectors. They have a built-in linear amplifier giving a spectral sensitivity similar to that of the human eye, and have an illuminance range from 50 lux to 50,000 lux.

Sharp's spectral sensitivity graph for the IS474 is shown in Fig.1. The graph covers the light wavelength range of 400nm (nanometres) to 900nm. The wavelength bands for colours as we describe them are given in Table 1.

The colours in the table will be recognised as those which we can distinguish in a rainbow. The order can be memorised from the acronym ROYGBIV – which

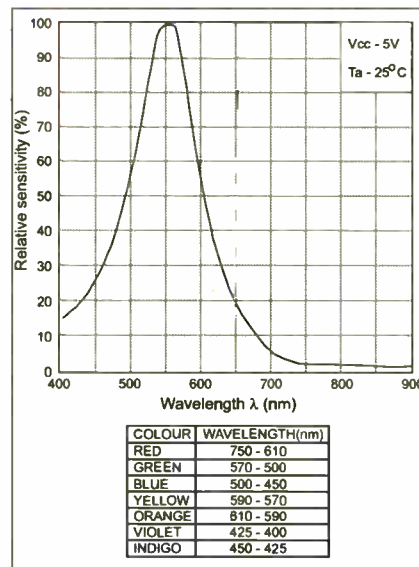

Fig.1. Spectral sensitivity graph for the IS474 light detector

letters some people remember as Richard Of York Gained Battles In Vain. Others relate them to the name of a fictitious Roy G. Biv. (Web browsing revealed that poor Mr Biv has now lost his eye – indigo, apparently, no longer being recognised as a separate colour, and so the "I" has been dropped by some academics.)

Internally, the IS474 can be represented by the diagram in Fig.2. In response to illumination of its photodiodes, the device develops an output current at pin 2. By connecting a resistor between this pin and the 0V (GND) line, the current can be converted to a voltage which, when the sensor is fully illuminated, is 1.5V less

Table 1: Colour Wavelengths

Red	750nm	to	610nm
Orange	610nm	to	590nm
Yellow	590nm	to	570nm
Green	570nm	to	500nm
Blue	500nm	to	450nm
Indigo	450nm	to	425nm
Violet	425nm	to	400nm

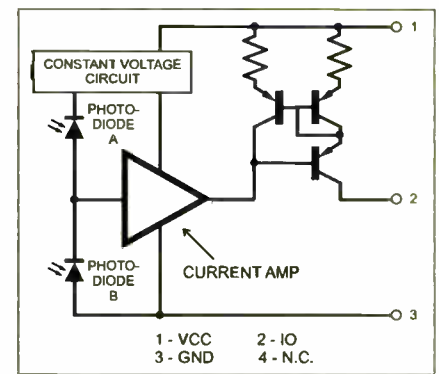

Fig.2. Internal schematic of the IS474

than the supply voltage (4.5V to 5.5V).

The output current generated by an IS474 when exposed to different light intensities, in lux, is given in Fig.3.

Sensor Interface

The circuit diagram for the amplifiers (IC1a to IC1d) to which the sensors (X1 to X4) are coupled is shown in Fig.4. Taking sensor X1 as an example, light-generated current flows into resistor R1, and the resulting voltage on the sensor's output is fed to the non-inverting input of IC1a (pin3). This provides a signal gain of $\times 11$ ($R3 / R2 + 1$).

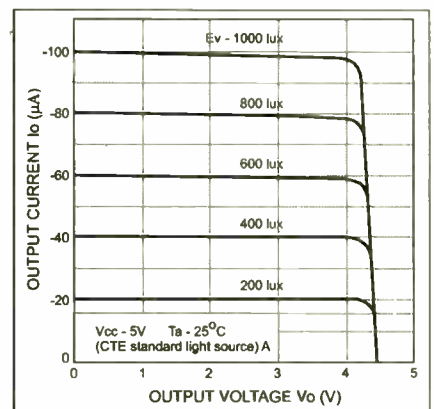

Fig.3. Output current, voltage and lux relationship

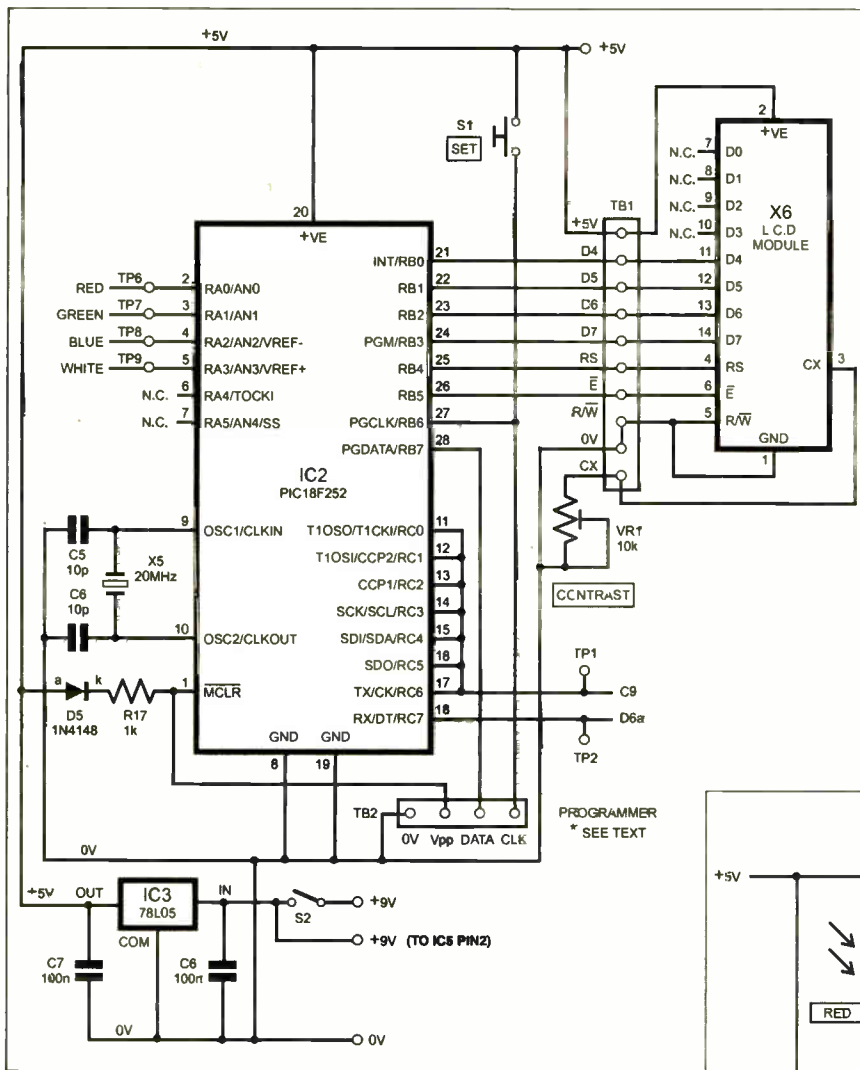

Fig.5. Controller and l.c.d. module circuit diagram

From IC1a, the amplified voltage is fed to the fast-attack, slow-decay stage formed by resistor R4, diode D1 and capacitor C1. Any upwards swing of the output voltage is immediately received by C1 via D1. If the output voltage falls, the charge on C1 decays only slowly, via R4.

All four sensor stages are identical, except for the filters in front of sensors X1 to X3. The voltage on the capacitors, C1 to C4, is fed to four analogue-to-digital converter (ADC) pins on the PIC, RA0 to RA3, as shown in the main control circuit diagram, Fig.5.

Colour Notation

The PIC's job, purely but not-so-simply, is to determine what voltage is generated by the colour-filtered sensors, and to produce musical tones according to the relationship between the values. The unfiltered sensor has a different purpose, as will be seen.



It is at this point in design that the complications arose, and put the author's mathematical skills into uncharted waters!

The design concept has at its root the notion that the three filtered colours can be represented on the peaks of a "colour triangle", as in Fig.6a. The strength of the colours can be represented by the lines extending from the centre of the triangle, point O, each of the colour "forces" pulling outwards from O in the direction indicated, R, G, B.

The net result when the three colours have equal intensity is that the triangle is "in balance". Suppose, though, that there is no red present in the light detected, and that green and blue have equal values. Now with these two forces pulling against each other in the directions shown in Fig.6b, without the balance previously provided by red, a fictional "force" in the direction of point L is developed.

Similarly, if blue is not present, though red and green are, albeit with different intensities as shown by the line lengths in Fig.6c, then L now points in a different direction. If only one colour is active, then force L points out from the apex of that colour angle.

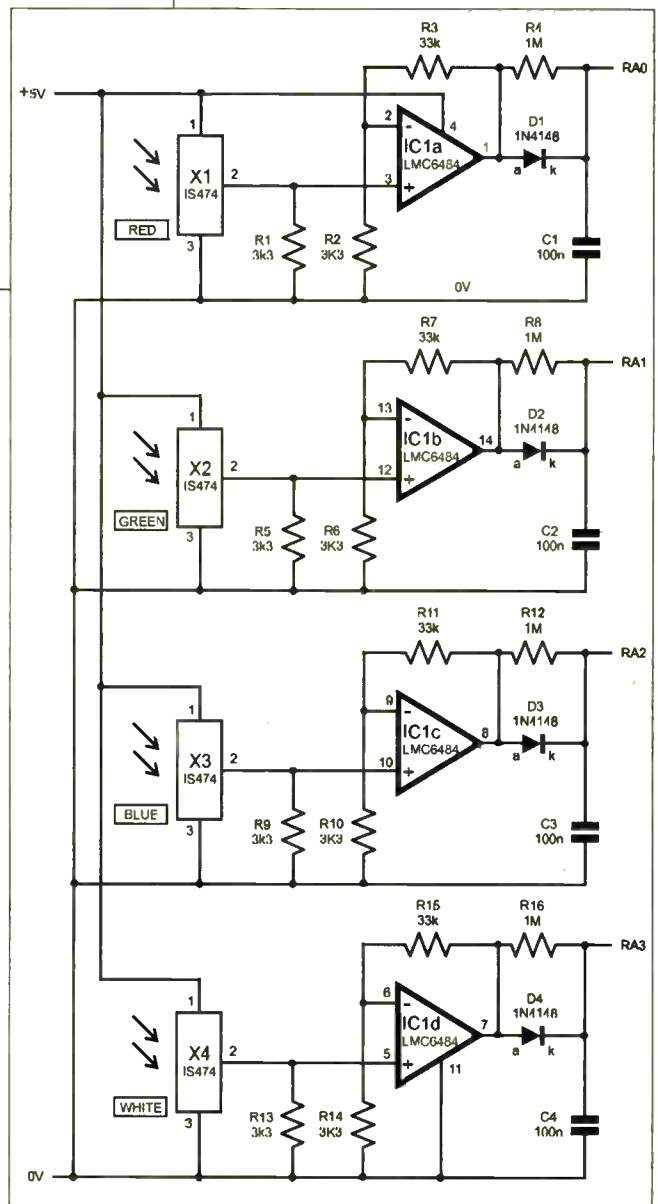

Fig.4. Circuit diagram for the four light sensor amplifiers

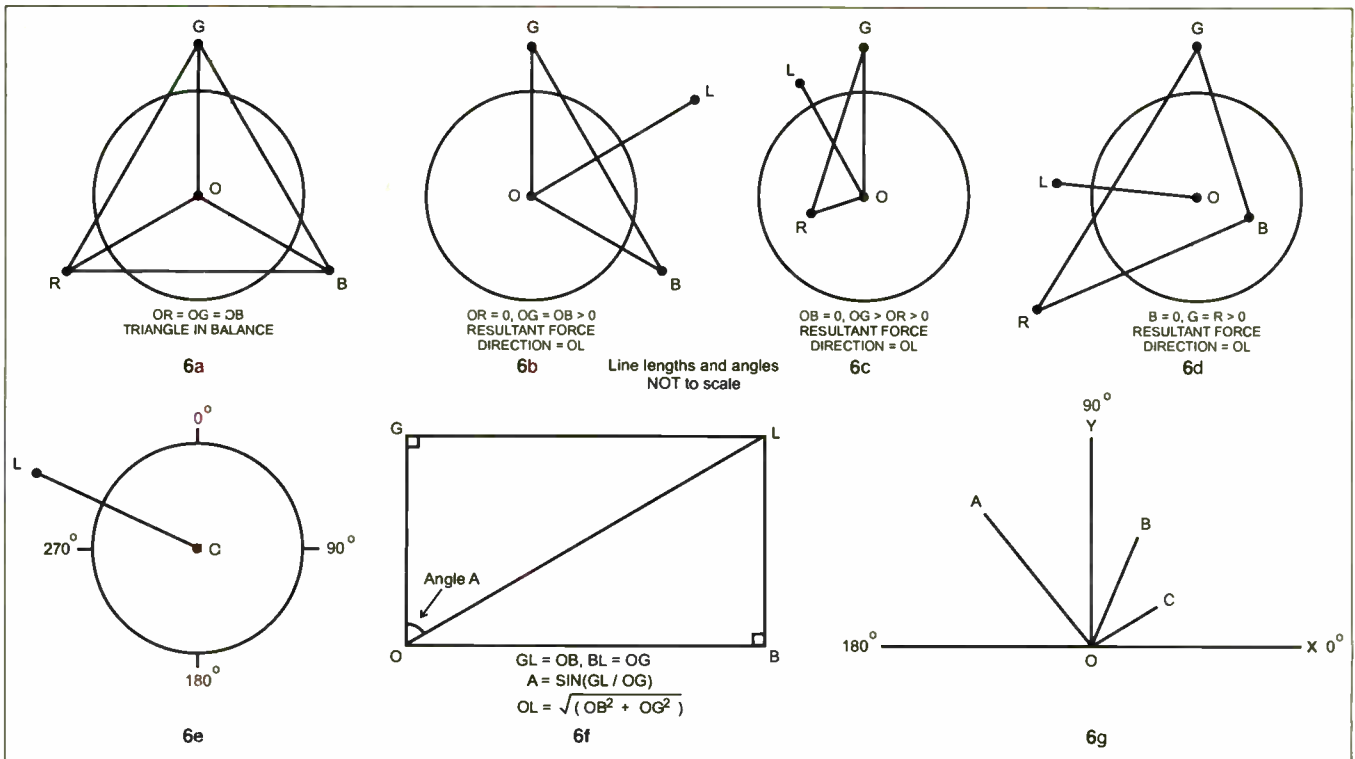

Fig.6. Geometric relationship of the sensor "forces" to be evaluated

If all three colours are present, at different intensities, as in Fig.6d, then the force direction and intensity reflect those conditions.

If the circle shown, having its centre at point O, is notated in degrees, as in Fig.6e, then for each filtered colour combination, the resulting force direction can be expressed as an angle, clockwise from 0°, right round and back to 360°, which is the same as 0°.

Coloured Geometry

It will be obvious to those of you who did geometry at school, that the solution for two angular colour directions/strengths, can be found by using the parallelogram of forces rule, as shown by the example in Fig.6f.

For simplicity in Fig.6f, green and blue are shown as pulling at 90° to each other and the angle of line OL (angle A) is easy to calculate according to normal right-angled triangle rules:

$$A = \sin(GL / OG)$$

and the length of OL can be calculated as:

$$OL = \sqrt{(OB^2 + OG^2)}$$

In reality, the three colours are 120° apart, but the solution can still be found by using variations on these rules, and breaking the picture down to its several right-angled constituents (too lengthy a process to show here).

The situation is not straightforward, though, when three (or more) forces are all pulling in different directions, and you need to find the single value that represents their resulting angular force direction, and its strength.

It was obvious to the author that the result would still be according to a variant of the parallelogram of forces rule, but

was not one which his pre-Ark school curriculum covered – time for research!

Polygons of Forces

Google, of course, was the research engine. But astonishingly a relevant equation for this multi-directional poser could not be found, despite using many different search phrases, including "triangle of forces".

The author knew that such an equation must exist for what must be a common situation in mechanics where a multitude of forces and directions prevail in a given construction.

The answer was eventually found in the book *Intermediate Mechanics*, dated 1930 and previously owned by the author's father. It turned out that the search term really needed should have been based around the phrase "polygon of velocities".

Referring to the illustrative example in Fig.6g, the equations for the resultant directional angle and length are astonishingly simple:

$$\begin{aligned} \tan(A) &= T_{\cos} / T_{\sin} \\ L^2 &= T_{\cos} + T_{\sin} \end{aligned}$$

where:

A is the resultant directional angle
L is the resultant directional length
Tcos = sum of the products of each line length × the cosine of its angle
Tsin = sum of the products of each line length × the sine of its angle

For example, in Fig.6g assume the lines represent forces in the directions shown and that the line lengths and angles are:

Line	Length	Angle
OA	8	120°
OB	6	60°
OC	2	30°

First, the cosines of the angles along OX are multiplied by the lengths, and added:

$$T_{\cos} = (8 \times \cos(120)) + (6 \times \cos(60)) + (2 \times \cos(30)) = 0.732$$

Next, the sines of the angles along OY are multiplied by the lengths, and added:

$$T_{\sin} = (8 \times \sin(120)) + (6 \times \sin(60)) + (2 \times \sin(30)) = 13.124$$

$$\text{Then } L = \sqrt{(T_{\cos}^2) + (T_{\sin}^2)} = 13.144$$

If A is the angle made by L with OX, then:

$$A = \arctan(L / T_{\cos}) = 87^\circ \text{ approx.}$$

Although too complex to show here, this principle can be extended to cover multiple forces at different angles through a full 360° by taking into account the signs of each component result.

During development, the author set up a QBasic program to check the basic maths, and then a Visual Basic 6 (VB6) program through which the principle could be observed in action. The QBasic program is shown in Listing 1. An example screen dump of the VB6 program is shown in Fig.7. A copy of the VB6 program, including its source code, is available as detailed later.

Although the strength of the resulting force direction is obtained through the above equations, experiments showed that its use had no benefit to the Chromatone. It was purely the angular value that turned out to have any relevance.

PIC Maths Involved

Before that conclusion was reached, though, the software for translating the equations into PIC coding had to be resolved. Whilst the PIC18F family have

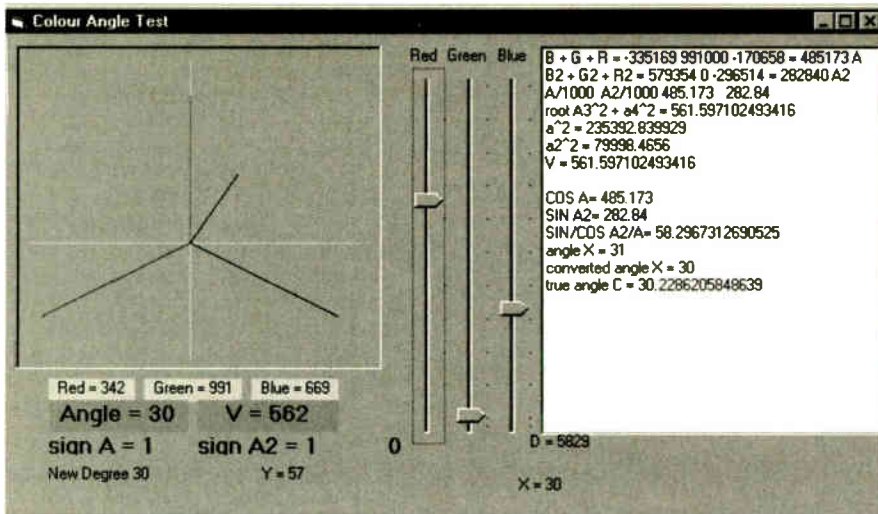

Fig.7. VB6 demonstration program for proving the polygon of forces calculations

LISTING 1 QBasic Polygon Test

```
CLS
CONST pi = 3.141593 ' value of PI
p2 = pi / 180 ' angle to radians multiplier
p3 = 180 / pi ' radians to angle multiplier
TOA = COS(120 * p2) * 8
TOB = COS(60 * p2) * 6
TOD = COS(30 * p2) * 2
Tcos = TOA + TOB + TOD
TOA = SIN(120 * p2) * 8
TOB = SIN(60 * p2) * 6
TOD = SIN(30 * p2) * 2
Tsin = TOA + TOB + TOD
L = SQR((Tcos ^ 2) + (Tsin ^ 2))
A = ATN(Tsin / Tcos) * p3
PRINT "Tcos = "; Tcos
PRINT "Tsin = "; Tsin
PRINT "L = "; L
PRINT "A = "; A
```

multiply and divide commands, these are too restricted to have any applicability to the equations.

Fortunately, Peter Hemsley has written an excellent suite of 32-bit maths routines for the PIC16F family. These were published as *32-bit Signed Integer Maths for PICs* (Jan '05). They are incredibly powerful, as the author has proved in many of his published designs.

They include very efficient and fast routines for the functions: add, subtract, multiply, divide, round, square root, binary to decimal conversion, and decimal to binary conversion.

Very heavy use of Peter's routines has been made in the Chromatone, although they had to be translated to PIC18F first (not too difficult a task). It's probably true to say that the Chromatone would have been practically impossible to create without Peter's codes.

What Peter's code does not do, however, is to provide routines for calculating sines, cosines and tangents etc. A web search was made for such, but none of those tried were suitable, for a variety of reasons – wrong language, incomprehensible, wouldn't work, too slow, etc.

Eventually, the author wrote a simplified routine in VB6 using look-up tables. This was then further simplified and translated into PIC. The Chromatone simply calls various aspects of these routines

and their tables, and then performs calculations based on the results. The results are not precision, but they meet the needs of this design.

Listing 2 shows the main calls made from the Chromatone to the various sub-routines. The comments in the listing give a brief guide, but the routines themselves are too complex to describe here.

Calling the Tune

Calling the musical notes generated by the Chromatone a *tune*, is probably open to challenge. It is in reality just a sequence of different notes musically tuned within seven octaves, eight notes per octave. The note for octave 7, though, is the same as for octave 6. The true frequency for octave 7 would be too low to be meaningful.

LISTING 2 Main Chromatone Routine Calls

```
MAIN2: call GETWHITE ; read the sensor values
call GETRED
call GETGREEN
call GETBLUE
call CORRECTRED ; initial colour processing
call CORRECTGREEN ; for sine/cosine values
call CORRECTBLUE
call PROCESSRED ; secondary colour processing
call PROCESSGREEN ; for sine/cosine values
call PROCESSBLUE
call ADDSINES ; add the sine values
call ADDCOSINES ; add the cosine values
call DIVIDECOSBSYNE ; divide the cosine total by sine total
call GETHYPFORCE ; get angular force strength - not used
call GETANGLE ; allocate the answer to an angle
call CORRECTFOR360 ; relate that angle to 360^
call SHOWCOLOURVALS ; show colour values on l.c.d.
call GETMAINNOTES ; get additive value for creating frequency
bsf TRIGGER,7,A ; set envelope shaper trigger
clrf ENVELOPELSB,A ; clear frequency counter LSB and MSB
clrf ENVELOPEMSB,A
call WAITNOTETIME ; perform and output note generation
goto MAIN ; start again
```

Table 2:

Basic Chromatone Note Frequencies

Note	Frequency
A	1760.00Hz
B	1975.53Hz
C	2093.00Hz
D	2349.32Hz
E	2637.00Hz
F	2739.84Hz
G	3135.96Hz
A	3520.00Hz

The primary notes are basically generated to be as close as possible to the frequencies shown in Table 2:

The frequencies are then divided by factors of two depending on the octave required.

The division is not actually done directly in software, rather it is done by feeding the frequency into a counter whose value is output via PIC Port C.

Referring back to Fig.5, it will be seen that the first seven pins of Port C (RC0 to RC6) are connected together. Internally, the software selects which of the seven pins is to be used as the frequency output, holding the other pins as inputs (high-impedance) so that the pins do not conflict with each other. The note frequency is only capable of being output from the selected pin.

Envelope Shaper

To give interest to the notes, an envelope shaper is used to make the notes sound somewhat as though they are created by a piano. Its circuit diagram is shown in Fig.8.

The envelope shaper is created around one half of an LM13700 dual transconductance op.amp, IC4. This has an inverting signal input at pin 4, and a control input at pin 1.

When each note value has been calculated from the sensor data, a loop is entered which outputs the related frequency from Port C to IC4's pin 4, via C9 and R19. Immediately prior to starting the loop, a trigger signal is sent from RC7, via diode D6 to IC4's control input

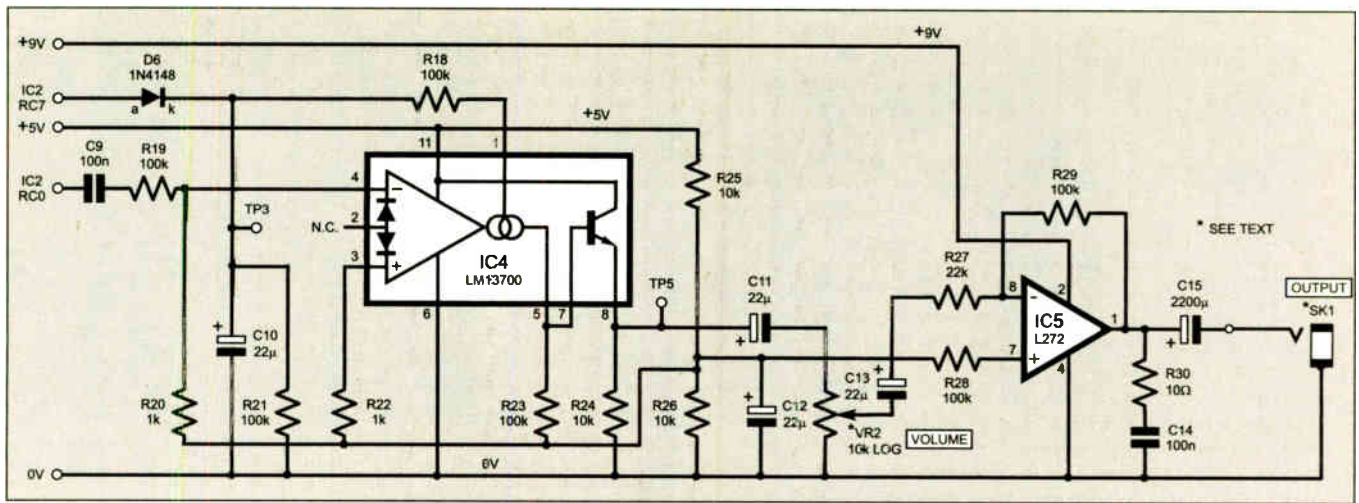

Fig.8. Envelope shaper and audio output circuit diagram

and to capacitor C10. This sets IC4 to full gain as determined by the current flowing via R18 into pin 1, and that flowing out of pin 5 into resistor R23.

The positive pulse from RC7 is held high only briefly and when it ceases the voltage on C10 starts to ebb, through R18 and R21. As it does, so the current flowing into IC4 pin 1 starts to fall, and so does the signal amplitude at pin 5, until it fades fully to zero.

The output from IC4 pin 5 is coupled, via pin 7, directly to IC5's internal Darlington buffer, and output to pin 8 across R24. The signal here is capacitively coupled by C11 to Volume control VR2. From there it is fed to the power op.amp stage around IC5.

Power op.amp IC5 can deliver an output current of up to 1A, making it suitable for driving headphones or a speaker of 4Ω upwards. Capacitor C15 provides capacitive coupling for the output signal. Capacitor C14 and resistor R30 provide stability to the signal, which could oscillate at high frequency without them.

The network comprising R25, R26 and C12 provides bias to IC4's inputs, and to the non-inverting input of IC5.

Other Aspects

The PIC is controlled at 20MHz as set by crystal X5 together with capacitors C5 and C6.

The Chromatone is intended to be powered from a 9V d.c. source, e.g. a 9V battery. The battery voltage directly powers output op.amp IC5, but it is reduced by regulator IC3 to 5V to suit the PIC and the other circuits.

The use of liquid crystal display module X6 is optional. It simply shows the values of the sensors and the resulting note frequency. It may be omitted if preferred. Preset VR1 sets the l.c.d.'s screen contrast.

Switch S1 is used to select different note playing modes, as itemised later.

Connector pins notated as TB2 allow the PIC to be programmed in situ by those who have suitable programming facilities, such as *Toolkit TK3*. Diode D5 and resistor R17 protect the 5V power line during programming.

Construction

Component and track layout details for the Chromatone printed circuit board are shown in Fig.9. This board is available from the *EPE PCB Service*, code 537.

COMPONENTS

Resistors

R1, R2, R5, R6,	
R9, R10, R13, R14	3k3 (8 off)
R3, R7, R11, R15	33k (4 off)
R4, R8, R12, R16	1M (4 off)
R17, R20, R22	1k (3 off)
R18, R19, R21,	
R23, R28, R29	100k (6 off)
R24 to R26	10k (3 off)
R27	22k
R30	10Ω

All 0.25W 5% carbon film or better

Potentiometers

VR1	10k min. preset, round (optional, see text)
VR2	10k rotary carbon log, panel mounting, or 10k min preset, round (see text)

Capacitors

C1 to C4, C7 to C9, C14	100n ceramic disc, 5mm pitch (8 off)
C5, C6	10p ceramic disc, 5mm pitch (2 off)
C10 to C13	22μ radial elect. 16V (4 off)
C15	2200μ radial elect. 16V

Semiconductors

D1 to D6	1N4148 signal diode (6 off)
IC1	LMC6484 quad op.amp, rail-to-rail
IC2	PIC18F252 microcontroller, pre-programmed (see text)

IC3	78L05 +5V 100mA voltage regulator
IC4	LM13700 dual transconductance op.amp
IC5	L272 dual power op.amp

Miscellaneous

X1 to X4	IS474 human eye light detector (4 off)
X5	20MHz crystal
X6	2-line 16-character (per line) alphanumeric l.c.d. module (optional, see text)
SK1	min. mono jack socket, for headphones (see text)
S1	min. push-to-make switch
S2	s.p.s.t. min. toggle switch

Printed circuit board, available from the *EPE PCB Service*, code 537; optically clear gelatine or celluloid (or similar) filters, one sheet each red, green, blue, yellow (see text); 8-pin d.i.l. socket; 14-pin d.i.l. socket; 16-pin d.i.l. socket; 28-pin d.i.l. socket; knob for VR2 (see text); 9V battery and clip; plastic case 150mm x 80mm x 50mm (see text); headphones or loudspeaker (see text); connecting wire; solder, etc.

Approx. Cost
Guidance Only

£27

excl case and
batts

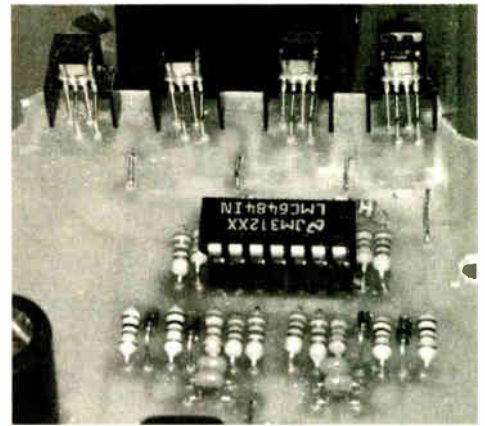
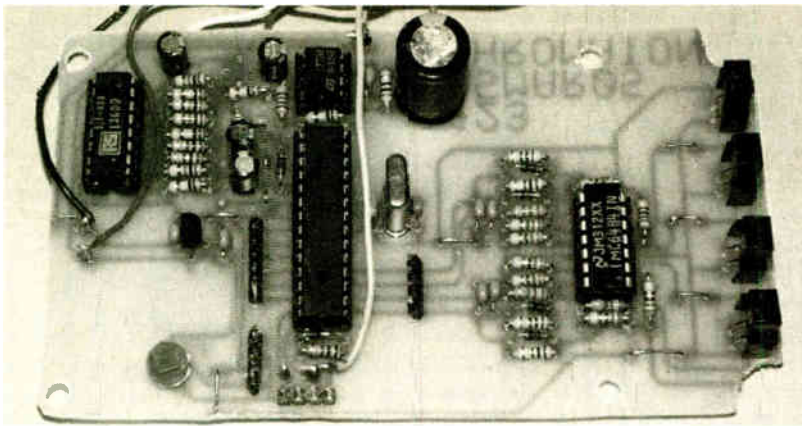
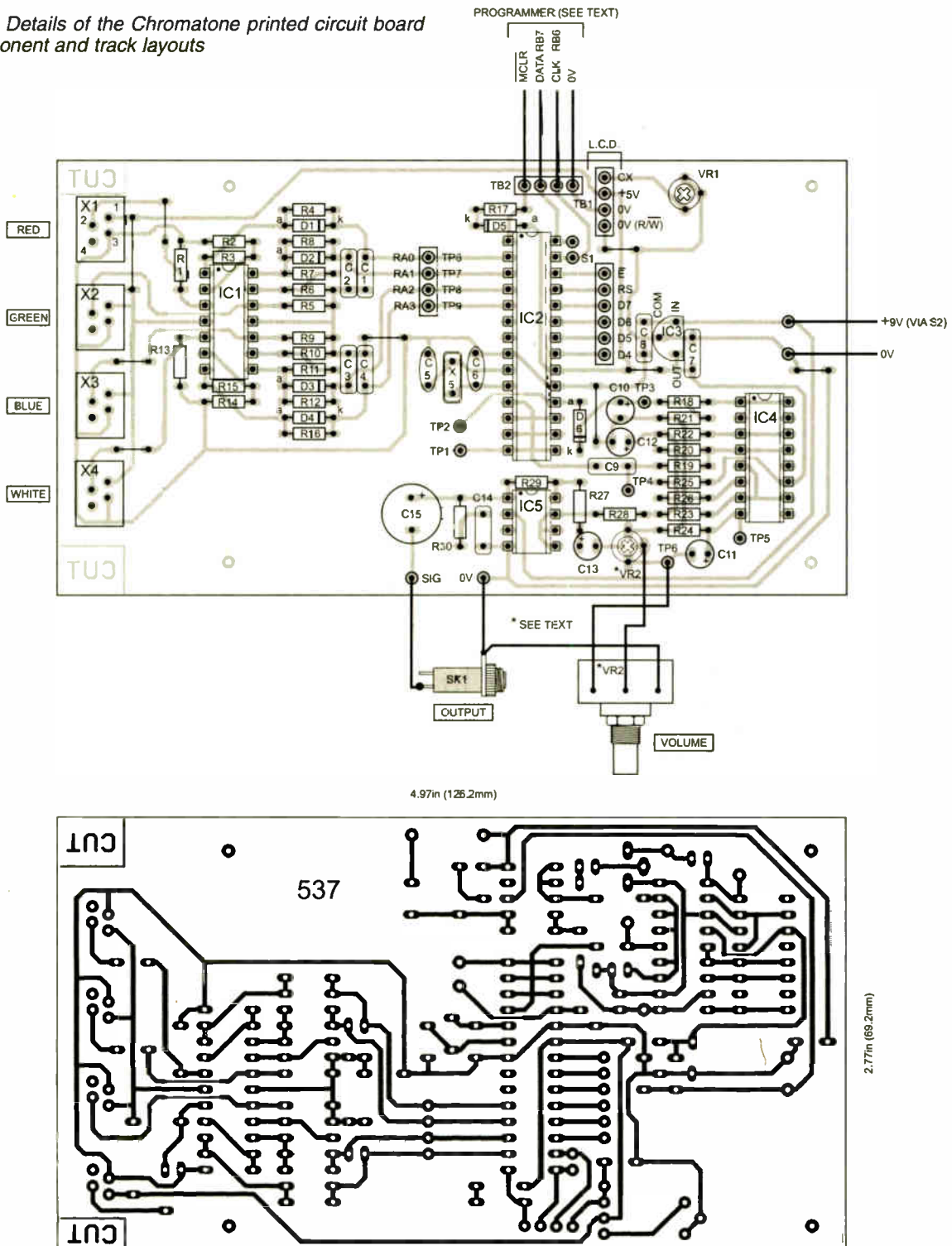
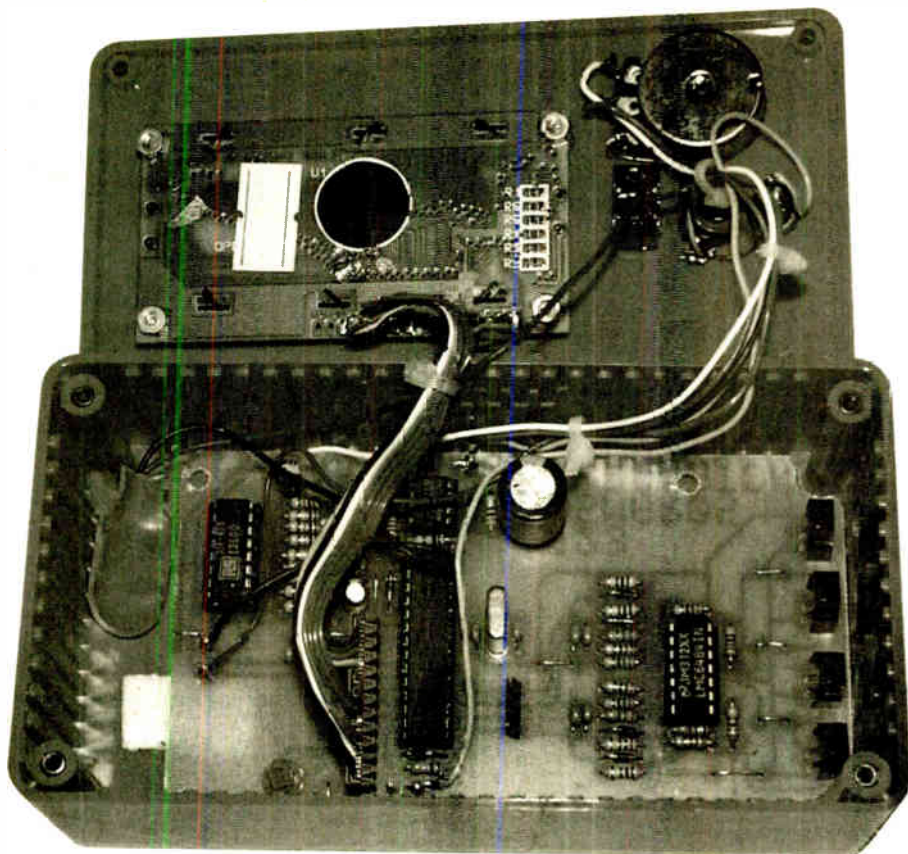

Fig.9. Details of the Chromatone printed circuit board component and track layouts





Assemble the board in the usual order of ascending component size, from link wires upwards. Use sockets for the d.i.l. (dual-in-line) i.c.s, but do not insert those i.c.s. until the assembled board has been fully checked and the correctness of the 5V output from regulator IC3 has been proved.

Note that the sensors have two plastic "legs" at their sides and these may be cut off carefully with wire clippers.

Potentiometer VR2, the Volume control, may be mounted on the board as a preset, or on the case as an external panel control.

The prototype was housed in a plastic case, measuring 150mm x 80mm x 50mm, and drilled as indicated in the photographs.

Note that the four sensor holes are in one end face of the case, drilled so that the sensors get an unobstructed view through them. A 0.25in (6.35mm) drill bit was used for the prototype, but there may be advantage in using slightly larger holes. However, do not allow light through any hole to reach the adjacent sensors, which would upset the colour response.

Cut a small square of each coloured filter material and secure it behind the appropriate hole using double-sided adhesive tape. Don't let the tape itself cover the hole.

Mount the p.c.b. using self-adhesive supports so that the sensors are close to and in alignment with the holes.

In Use

As soon as the unit is switched on in a moderately lit room, the PIC Chromatone will start generating notes whose frequency varies depending on what the sensors see, both in terms of colour and of the light intensity.

If the l.c.d. is installed, a display similar to that in Fig.10 should be seen (although the values may differ greatly).

The bottom line shows the values read from the colour sensors, suffixed by the letters R, G and B. The values can range from



Fig.10. Initial l.c.d. display screen

0 to 1023, depending on the light level sensed. On the top line is shown the angle that has been calculated in relation to the colour values' mathematical combination. It is followed by the value read from the unfiltered (White) sensor, again with a value between 0 and 1023, and suffixed W.

To the right of this the letter M is shown, plus a value, 0 at present, representing the note generation mode selected by pushswitch S1 (more in a moment).

At the far right of line 1 is another letter and a value. The letter can be between A and G, representing the note's musical notation. The value beside it is the octave selected, from 0 to 6, although this is not the octave number as "officially" regarded as musical notation, rather it is the value allocated to suit the PIC's software.

Move the unit around the room or outdoors, and listen to the notes produced as the lighting conditions change. Also observe the values on the l.c.d. screen. You might find it entertaining to variously shade off one or more sensor holes and so create your own musical sequence.

The only way to stop notes being played is to switch off the Chromatone! (Although you could just turn down the volume using VR2.)

Sequence Options

There are eight musical sequence options which can be selected using switch S1, all random, depending on the prevailing light.

Press and release S1, noting the M1 value now shown on l.c.d. line 1. In this mode, the angle values are "turned

upside-down" and so different notes are generated for the same lighting conditions.

Press S1 again for mode M2. This mode generates the notes in the same fashion as mode M0, but at a different rate, which depends on the value read from the "white" sensor.

Mode M3 is at the same rate as with M2 but with notes inverted as in M1.

Modes 4 to 7 are only available if requested at the moment of power switch on. With the power switched off by S2, press S1 and hold it pressed. Switch on S2, wait a moment for the PIC to initialise itself and the l.c.d. When the screen shows the message OK, release S1. Modes 4 to 7 are now available in sequence following mode 3. (If you are not using the l.c.d., just wait a couple of seconds or so.)

With these extra modes, the notes generated are now relative not only to the values read from the filtered sensors, but also the white value sensed at the moment of switch on. Their operation, though, is otherwise identical to that for modes 0 to 3.

Pointing the unit at different lighting conditions when setting for modes 4 to 7, will achieve different note responses.

What Else?

It's worth commenting on a few factors encountered during the Chromatone's development.

It had been thought that the Chromatone would probably sound good if the tones simply "slid" from one frequency to another as lighting conditions changed. That proved to be an impossible task because of the amount of processing that needs to be done by the PIC. It is not a device that is ideally suited to such complex maths routines as it has been coaxed to process.

Furthermore, no way could be found to avoid a brief delay in audio output while each new block of sensor samples was processed. An attempt was made at note generation triggered by timed interrupts, to avoid the breaks. This proved impossible to achieve without overheads such as unreliable frequency stability.

It was because of the inherent pauses that the envelope shaper was introduced. This makes a virtue out of the fact, actually extending the pause to give greater credibility to the piano-like hard start and slow decay of the note.

Experiments were also made with 12 notes to the octave instead of eight, to include sharps and flats as well. The result was appallingly untuneful! Because lighting

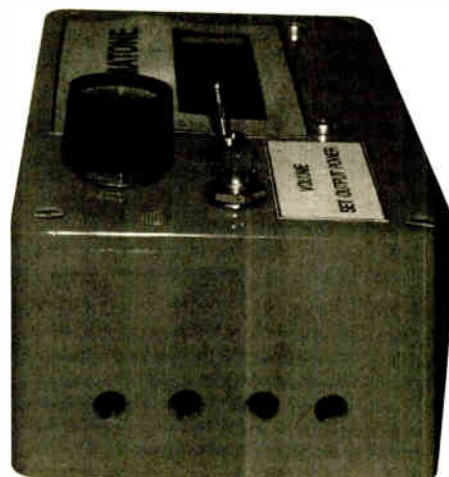

conditions can cause any note to be generated following any other, inharmonious note progressions were found to occur.

By cutting back to just the major eight notes of an octave, juxtapositions of these notes turns out to be quite melodic! Some might think it reminds them of progressions found in Chinese traditional music. It can become quite hypnotic after a while.

It would have been nice to have changed the note tempo a bit more frequently, but modes 2/3 and 6/7 provide a nod in that direction.

One thing the author found while "Chromatonologically" examining the garden's spring colours was that dangling the unit in a breeze caused intriguing note sequences at random. Perhaps hanging a waterproofed version from a tree might prove fascinating to the young at heart!

You could also experiment with using a yellow filter in place of the green one – it might even be educational to do so.

As a final thought, you might find that you can actually get to recognise what colours the

Chromatone is seeing by the notes that it plays. It could be a fun game to try!

Resources

Software for the PIC and the VB6 demo, including source code files can be downloaded free from the *EPE* Downloads site, accessible via the home page at www.epemag.co.uk. It is held in the PICs folder, under Chromatone. Download all the files within that folder.

The PIC program source code (ASM) was written using *EPE Toolkit TK3* software (also available via the Downloads site) and a variant of the TASM dialect. It may be translated to MPASM via *TK3* if



preferred. The run-time assembly is supplied as an MPASM HEX file, which has PIC18F configurations embedded in it. If you wish to program the PIC yourself, simply load this HEX file into the PIC using your own PIC programming software and hardware. □

SHOP TALK

with David Barrington

Teach-In 2006 – Part 1

Using the in-vogue football parlance, we should like to "kick-off" this month's roundup on components sourcing by looking at the new *Teach-In 2006* series.

As you will see from their advertisement (see page 772), and the news on the Editorial page, not only are *Rapid Electronics* sponsoring this important new series by donating over £600s worth of prizes for "end of term" on-line tests they are producing a range of kits for the *Teach-In '06* series: Kit 1 includes a set of general components, plus a *Free* digital multimeter; Kit 2 contains additional items, including a logic probe; Kit 3 a set of components for a radio project and finally Kit 4 contains all three kits together.

Also producing some kits geared towards the *Teach-In* series is *Sherwood Electronic*, Dept EPE, 7 Williamson Street, Mansfield, Notts, NG19 6TD. The kits consist of: Kit 1 all components, excluding power supply, £30; Kit 2 Tools, soldering iron, pliers, cutter and screwdriver, £18; Kit 3 Test (multimeter, with capacitance range, and a logic probe) £45.

Speed Camera Watch Mk2

We will start the component supply roundup for the *Speed Camera Watch Mk2* with the two main components, namely, the satellite GPS module and the PIC microcontroller.

The author chose the Holux GM-21 module and the construction is based around this unit. The GM-21 module, together with the CA21 cable, was purchased direct from *Holux-UK Ltd*, Dept EPE, Navigation House, Lady Lea Industrial Estate, Lady Lea Road, Horsley Woodhouse, Ilkestone, Derly, DE7 6AZ (☎ 0870 321 6929 or www.holux-uk.com/oem.shtml).

At the time of going to press, we have just received the news that Holux are about to discontinue the GM-21 module and replace it with a smaller compatible and more sensitive GR-23 model. The price for the GR-23 will be £70 including the cable and VAT, plus a £5 delivery charge. We have been asked to make it clear they will only accept credit card payments from readers.

For details of prices and stockists of the *RF Solutions* LS-40CM module and CBA-LS-40M cable, readers are directed to www.rf-solutions.co.uk/acatalog/board_level_gps_module.html or ☎ 01273 898000.

The PIC18F2420 microcontroller used in this enhanced version is claimed to be twice as fast as the one used in the original design. For those readers unable to program their own PICs, a ready-programmed 18F2420 can be purchased from *Magenta Electronics* (☎ 01283 565435 or www.magenta2000.co.uk) for the inclusive price of £10 each (overseas add £1 p&p). The software including source code files, is available for free download via the Downloads link on our UK website at www.epemag.co.uk.

The tiny surface mount 25C256 serial memory chip is obtainable from *Farnell* (☎ 0870 7200 100 or farnellonline.co.uk), code 880-3625. They also supplied the sub-miniature p.c.b. mounting speaker, resembling a small piezo sound transducer, code 224-479. If you wish to use the same case as shown in the photographs, this also came from the above company, code 491-6591.

The printed circuit board is available from the *EPE PCB Service*, code 541 (see page 813). The choice of alphanumeric I.c.d. modules on the market is fairly large and no doubt most of our components advertisers will be able to offer a suitable display, such as the LM016 or similar. You should check the pinout arrangement when purchasing.

PIC Chromatone

To date, we have located only one source for the Sharp IS474 "human eye linear output OPIC light sensor" used in the *PIC Chromatone* project. This detector has a built in linear amplifier giving a claimed spectral sensitivity similar to that of the human eye.

The IS474 was purchased (*credit card only*) from *RS Components* (☎ 01536 444079 or rswww.com), code 267-8447. They also supplied the LMC6484 quad rail-to-rail op.amp, code 310-925.

The LM13700 dual transconductance op.amp is available from *Rapid Electronics* (☎ 01206 751166 or www.rapidelectronics.co.uk), code 82-5038. They also list the L272 8-pin dual audio op.amp, code 82-0172.

For those readers unable to program their own PIC18F252 microcontroller, a programmed xF252 can be purchased from *Magenta Electronics* (☎ 01283 565435 or www.magenta2000.co.uk) for the sum of £10 each (overseas add £1 p&p). The software, including source codes, is available for free download via the Downloads link on our UK website at www.epemag.co.uk.

The printed circuit board is obtainable from our *PCB Service*, code 537. The coloured filter sheets are probably best purchased from a local arts supplies shop.

Multi-Function R/C Switch

The Multi-Function R/C Switch is another project this month which calls for the use of a surface mount device (SMD). In this case, it's the BSP295 power f.e.t. (field-effect transistor). Some readers may have problems locating this device but it is currently listed by *Maplin* (☎ 0870 429 6000 or www.maplin.co.uk), code N91AG.

For readers who are unable to program their own PICs, a preprogrammed PIC18F84A is obtainable from *Magenta Electronics* (☎ 01283 565435 or www.magenta2000.co.uk) for the sum of £5.90 (overseas add £1 for p&p).

The small printed circuit board is available from the *EPE PCB Service*, code 540 (see page 813).

If you elect to use a relay switching circuit, the choice of relay will, of course, depend largely on the application envisaged and its contact ratings noted accordingly.

Back To Basics – Noughts and Crosses Enigma/Weather Vane Repeater

No puzzles or storms should be encountered when shopping for parts for the *Noughts and Crosses Enigma* or *Weather Vane Repeater*, this month's *Back To Basics* projects. Like the previous projects in this series, all the semiconductor devices should be generally available.

When mounting the small "click effect" pushbutton switches on the N&C p.c.b., take care to get them the right way round as the contact tags are in pairs and some are used to complete the circuit tracks. If in doubt, a continuity check with a meter should establish their pairings.

The most tricky task will be to modify the mechanics of a single-pole 12-way rotary switch to give a relatively smooth 360 degree rotation. You need to work slowly and have lots of patience.

The adjustable end-stop should be removed and the moulded fixed stop at position 12 trimmed off. If the switch has a click action, then two ball-bearings will have to be removed carefully, as outlined in the article, to enable the switch spindle to rotate freely.

The two printed circuit boards are available from the *EPE PCB Service*, codes 538 (N&C) and 539 (Vane) – see page 813.

PLEASE TAKE NOTE

Cybervox Light Interface (I/O Oct '05)

Page 698 Fig.1. Transistor TR2 should be shown as a *npn* device, not *npn*. The type number of TIP32 is correct.

Net Work

Alan Winstanley



Climb Aboard EPE's Web Site!

Welcome to this month's *Net Work* – the column that brings you news, hints and tips from the Internet world. Regular readers will be aware of the online support provided via our web site at www.epemag.wimborne.co.uk. (A shortcut that takes you to the home page is to type www.epemag.co.uk instead.) The first distinction to make is that *EPE* also offers a downloadable version of the printed magazine called *EPE Online*, available from our USA-based sister web site at www.epemag.com.

Essential for all PICmicro constructors is our *Download Area* which links to the *EPE* file server, from where almost all PIC source code files are available for download. A "Downloads" link further down the home page takes you to our web-based interface at <http://www.epemag.wimborne.co.uk/downloads.html>. The latest PIC file additions are highlighted in bold. Those with FTP software (e.g. see www.ipswitch.com) can access the file server via anonymous FTP at <ftp://ftp.epemag.wimborne.co.uk/pub>. To receive an email when changes and updates are made to the Downloads page, use the ChangeNotes link supplied. You will be emailed usually within 24 hours of updates being made.

A web-style PIC Project Mirror is maintained separately, due entirely to the tireless work of Thomas Stratford (thanks Thomas!). The Official *EPE* Mirror Site is at <http://homepages.nildram.co.uk/~starbug/epemic2.htm> or via the Mirror link on the Downloads page.

Our web site also summarises briefly this month's magazine contents, details can be checked via various links on the homepage. The *EPE Project Index* outlines the contents of each issue for at least the last five years. This is an important – and often overlooked – part of our web site because it highlights details of any updates or "Please Take Note" amendments (look for the red cross icon). Legacy project updates are also available, dating back to at least the 1998 magazine year, though we regret we cannot provide support for older circuits.

A server-based search engine enables you to locate details of an individual project or magazine issue by searching for keywords. For example, suppose you are looking for details of a "motor controller". Type this expression into the Search box and a number of links will be displayed. Clicking any link displays details of the corresponding issue, including stepper motor projects. If you decide to buy, the place to go is the *Online Shop*, which is conveniently arranged into sections including *EPE Back Issues*.

Delivering worldwide, there is no minimum order charge in our Online Shop. The shopping cart checkout system was recently upgraded from a Java applet-based system and it now uses a secure server to capture credit/debit card details. After completing your order, be sure to have your printer online, ready to print your receipt. An acknowledgement is then emailed to you.

Before buying a back issue, please read the Frequently Asked Questions at <http://www.epemag.wimborne.co.uk/back-issues-faq.html> noting that we can only supply or support projects in back issues for the past five years.

Also on the *EPE* web site is the *Chat Zone* forum, which is running very smoothly after a total rebuild earlier this year. You can click through directly at www.chatzones.co.uk or via the *Chat Zone* buttons on the main web site. All users are able to read messages but need to register in order to post: an automated registration email will be sent out, but we find that these are sometimes screened out by over-zealous spam filters, so you may need

to contact the *EPE* webmaster if your registration email doesn't arrive within a few minutes. Then check the forum's Help page for formatting and usage guidance, and try your hand in the Test Area practice forum. Have fun!

Queries about the web site or *Chat Zone* can be emailed to webmaster@epemag.demon.co.uk.

On Top Form

If there's one thing guaranteed to obstruct one's web surfing, it's a combination of a user/password fill-in form, and sudden memory block. So many web site addresses, usernames and passwords to remember!

One of the most indispensable software tools that money can buy is Roboform (www.roboform.com), which will automatically log you into a web page with a single mouse click. The latest version has evolved into a superb program with excellent usability. Roboform calls a username/password combination a "passcard" and their free trial version limits users to ten passcards.

To start using Roboform, simply log in to a web page as normal. A toolbar will then prompt if you want to remember that passcard for the future. If so, it then encrypts the details onto your hard drive. If you want to deliberately block an automatic login (perhaps for online banking) it can obediently Always Block upon request.

Say you have an initial ID login screen (e.g. HSBC's lengthy User IDs for Internet Banking) – it has a separate feature called SafeNotes that can encrypt such data so that you can recall it and paste it automatically into a form field before using the passcard to log in. This also helps to defeat phishing attempts. Can't think of a password? It has a character string generator that produces a random login (it just offered "n3F6iZZB" when I tried it). Let it remember n3F6iZZB so that you don't have to. Password protection is also available to restrict overall access to your Roboform program.

One of the best features is the single-click accessibility of all key functions. Simply mouse over its toolbar in the web browser, and a dropdown list of your "passcarded" web sites appears – just single-click on the target site and it will go to that web site and log you in automatically. This is a terrific timesaver.

Roboform also offers a Portable version intended for a USB memory key. These popular Flash memory storage devices are universally available (e.g. try eBay), so you could carry your encrypted Roboform passcards and SafeNotes around with you for use as a secure form filler on any computer. Some memory keys (e.g. Sony Biometric MicroVault) even include a fingerprint scanner as well, offering you the ultimate in data security.

This fantastically useful program integrates perfectly into MSIE as a toolbar, and the good news is that it's also available for Pocket PC, Firefox and Palm. After a few days of using the trial version, you will find that adding and recalling passcards is a real cinch and web surfing becomes a pleasure once again. The purchase price is \$29.95, and Portable Roboform adds just \$9.95 to the bill. It is one program worth spending time getting to grips with. Other products to consider include Symantec Password Manager (free trial available from www.symantec.com/passwordmanager) and KeyChain from www.cyberscrub.com.

Of course, anti-virus, anti-keylogger and anti-spyware countermeasures are as important as ever. Next month: why pay for a so-so anti-virus program? I'll suggest one of the best free a/v downloads available. You can email feedback or comments to alan@epemag.demon.co.uk

FREE *Electronics Hobbyist Compendium* book with Teach-In 2000 CD-ROM



EPE TEACH-IN 2000 CD-ROM

The whole of the 12-part *Teach-In 2000* series by John Becker (published in *EPE* Nov '99 to Oct 2000) is now available on CD-ROM in PDF form. Plus the *Teach-In 2000* interactive software (Win 95, 98, ME and above) covering all aspects of the series and Alan Winstanley's *Basic Soldering Guide* (including illustrations and Desoldering).

Teach-In 2000 covers all the basic principles of electronics from Ohm's Law to Displays, including Op.Amps, Logic Gates etc. Each part has its own section on the interactive software where you can also change component values in the various on-screen demonstration circuits.

The series gives a hands-on approach to electronics with numerous breadboard circuits to try out, plus a simple computer interface (Win 95, 98, ME ONLY) which allows a PC to be used as a basic oscilloscope.

ONLY **£12.45** including VAT and p&p

THE AMATEUR SCIENTIST CD-ROM

The complete collection of The Amateur Scientist articles from *Scientific American* magazine. Over 1,000 classic science projects from a renowned source of winning projects. All projects are rated for cost, difficulty and possible hazards.

Plus over 1,000 pages of helpful science techniques that never appeared in *Scientific American*.

Exciting science projects in: Astronomy; Earth Science; Biology; Physics; Chemistry; Weather . . . and much more! The most complete resource ever assembled for hobbyists, and professionals looking for novel solutions to research problems.

Includes extensive Science Software Library with even more science tools.

Suitable for Mac, Windows, Linux or UNIX. 32MB RAM minimum, Netscape 4.0 or higher or Internet Explorer 4.0 or higher.

Over 1,000 projects

CD-ROM **Order code ASICD-ROM £19.95**

PROJECT CONSTRUCTION

IC 555 PROJECTS

E. A. Parr

Every so often a device appears that is so useful that one wonders how life went on before without it. The 555 timer is such a device. Included in this book are over 70 circuit diagrams and descriptions covering basic and general circuits, motor car and model railway circuits, alarms and noise makers as well as a section on 556, 558 and 559 timers. (Note. No construction details are given.) A reference book of invaluable use to all those who have any interest in electronics, be they professional engineers or designers, students or hobbyists.

167 pages **Order code BP44 £5.49**

POWER SUPPLY PROJECTS

R. A. Penfold

This book offers a number of power supply designs, including simple unregulated types, and variable voltage stabilised designs, the latter being primarily intended for use as bench power supplies for the electronics workshop. The designs provided are all low voltage types for semiconductor circuits. The information in this book should also help the reader to design his own power supplies. Includes cassette PSU, Ni-Cad charger, voltage step-up circuit and a simple inverter.

91 pages **Order code BP76 £5.49**

HOW TO USE OSCILLOSCOPES AND OTHER TEST EQUIPMENT

R. A. Penfold

This book explains the basic function of an oscilloscope, gives a detailed explanation of all the standard controls, and provides advice on buying. A separate chapter deals with using an oscilloscope for fault finding on linear and logic circuits, plenty of example waveforms help to illustrate the control functions and the effects of various fault conditions. The function and use of various other pieces of test equipment are also covered, including signal generators, logic probes, logic pulsers and crystal calibrators.

104 pages **Order code BP267 £5.49**

DIRECT BOOK SERVICE

The books listed have been selected by *Everyday Practical Electronics* editorial staff as being of special interest to everyone involved in electronics and computing. They are supplied by mail order direct to your door. Full ordering details are given on the last book page.

FOR A FURTHER SELECTION OF BOOKS SEE THE NEXT TWO ISSUES OF EPE.

All prices include UK postage

RADIO

SETTING UP AN AMATEUR RADIO STATION

I. D. Poole

The aim of this book is to give guidance on the decisions which have to be made when setting up any amateur radio or short wave listening station. Often the experience which is needed is learned by one's mistakes, however, this can be expensive. To help overcome this, guidance is given on many aspects of setting up and running an efficient station. It then proceeds to the steps that need to be taken in gaining a full transmitting licence.

Topics covered include: The equipment that is needed; Setting up the shack; Which aerials to use; Methods of construction; Preparing for the licence.

86 pages **Order code BP300 £4.45**

EXPERIMENTAL ANTENNA TOPICS

H. C. Wright

Although nearly a century has passed since Marconi's first demonstration of radio communication, there is still research and experiment to be carried out in the field of antenna design and behaviour.

The aim of the experimenter will be to make a measurement or confirm a principle, and this can be done with relatively fragile, short-life apparatus. Because of this, devices described in this book make liberal use of cardboard, cooking foil, plastic bottles, cat food tins, etc.

Although primarily a practical book with text closely supported by diagrams, some formulae which can be used by straightforward substitution and some simple graphs have also been included.

72 pages **Order code BP278 £4.00**

25 SIMPLE INDOOR AND WINDOW AERIALS

E. M. Noll

Many people live in flats and apartments or other types of accommodation where outdoor aerials are prohibited, or a lack of garden space etc. prevents aerials from being erected. This does not mean you have to forgo shortwave-listening, for even a 20-foot length of wire stretched out along the skirting board of a room can produce acceptable results. However, with some additional effort and experimentation one may well be able to improve performance further.

This concise book tells the story, and shows the reader how to construct and use 25 indoor and window aerials that the author has proven to be sure performers.

50 pages **Order code BP136 £2.25**

TICKLING THE CRYSTAL Domestic British Crystal Sets of the 1920's

Ian L. Sanders

The first book dedicated to the topic of British crystal sets to be published in the last 25 years. For a very brief period during the early 1920's, these simple receivers played a crucial role in the expansion of domestic wireless throughout the United Kingdom. For many families, rich and poor, the crystal set provided an introduction to the new pastime of listening-in to broadcast programmes. Rapidly made obsolete from homes as suddenly as it had arrived, but not without leaving its mark on the history of wireless.

Written by a long-time authority and enthusiast, *Tickling the Crystal* is the most comprehensive work on the subject ever assembled. Containing almost two hundred excellent quality photographs and a wealth of previously unpublished material, it cannot fail to be an invaluable reference for anyone interested in the history of early wireless receivers.

256 pages hardback **Order code TC1 £34.00**

ELECTRONIC PROJECT BUILDING FOR BEGINNERS

R. A. Penfold

This book is for complete beginners to electronic project building. It provides a complete introduction to the practical side of this fascinating hobby, including the following topics:

Component identification, and buying the right parts; resistor colour codes, capacitor value markings, etc; advice on buying the right tools for the job; soldering; making easy work of the hard wiring; construction methods, including stripboard, custom printed circuit boards, plain matrix boards, surface mount boards and wire-wrapping; finishing off, and adding panel labels; getting "problem" projects to work, including simple methods of fault-finding.

In fact everything you need to know in order to get started in this absorbing and creative hobby.

135 pages **Order code BP392 £5.49**

TEST EQUIPMENT CONSTRUCTION

R. A. Penfold

This book describes in detail how to construct some simple and inexpensive but extremely useful, pieces of test equipment. Stripboard layouts are provided for all designs, together with wiring diagrams where appropriate, plus notes on construction and use.

The following designs are included:- AF Generator, Capacitance Meter, Test Bench Amplifier, AF Frequency Meter, Audio Multivoltmeter, Analogue Probe, High Resistance Voltmeter, CMOS Probe, Transistor Tester, TTL Probe. The designs are suitable for both newcomers and more experienced hobbyists.

104 pages **Order code BP248 £4.49**

COMPUTING

COMPUTING FOR THE OLDER GENERATION

Jim Gatenby

Especially written for the over 50s, using plain English and avoiding technical jargon. Large clear type for easy reading.

Among the many practical and useful ideas for using your PC that are covered in this book are: Choosing, setting up and understanding your computer and its main components. Writing letters, leaflets, invitations, etc., and other word processing jobs. Keeping track of your finances using a spreadsheet. Recording details of holidays and other ideas using a database. Using the Internet to find useful information, and email to keep in touch with family and friends. Making 'back-up' copies of your work and checking for viruses. How to use Windows XP to help people with impaired vision, hearing or mobility.

Provides the basic knowledge so you can gain enough confidence to join the local computer class.

308 pages **Order code BP601 £8.99**

THE INTERNET FOR THE OLDER GENERATION

Jim Gatenby

Especially written for the over 50s. Uses only clear and easy-to-understand language. Larger type size for easy reading. Provides basic knowledge to give you confidence to join the local computer class.

This book explains how to use your PC on the Internet and covers amongst other things: Choosing and setting up your computer for the Internet. Getting connected to the Internet. Sending and receiving emails, photographs, etc., so that you can keep in touch with family and friends all over the world. Searching for and saving information on any subject. On-line shopping and home banking. Setting up your own simple web site.

228 pages **Order code BP600 £8.99**

THEORY AND REFERENCE

BEBOP TO THE BOOLEAN BOOGIE

Second Edition

Clive (call me Max) Maxfield

This book gives the "big picture" of digital electronics. This in-depth, highly readable, up-to-the-minute guide shows you how electronic devices work and how they're made. You'll discover how transistors operate, how printed circuit boards are fabricated, and what the innards of memory ICs look like. You'll also gain a working knowledge of Boolean Algebra and Karnaugh Maps, and understand what Reed-Muller logic is and how it's used. And there's much, MUCH more. The author's tongue-in-cheek humour makes it a delight to read, but this is a REAL technical book, extremely detailed and accurate.

Contents: Fundamental concepts; Analog versus digital; Conductors and insulators; Voltage, current, resistance, capacitance and inductance; Semiconductors; Primitive logic functions; Binary arithmetic; Boolean algebra; Karnaugh maps; State diagrams, tables and machines; Analog-to-digital and digital-to-analog; Integrated circuits (ICs); Memory ICs; Programmable ICs; Application-specific integrated circuits (ASICs); Circuit boards (PWBs and DWBs); Hybrids; Multichip modules (MCMs); Alternative and future technologies.

470 pages - large format **Order code BEB1** £26.95

BEBOP BYTES BACK (and the Bebop Computer Simulator) CD-ROM

Clive (Max) Maxfield and Alvin Brown

This follow-on to *Bebop to the Boolean Boogie* is a multimedia extravaganza of information about how computers work. It picks up where "Bebop I" left off, guiding you through the fascinating world of computer design... and you'll have a few chuckles, if not belly laughs, along the way. In addition to over 200 megabytes of mega-cool multimedia, the CD-ROM contains a virtual microcomputer, simulating the motherboard and standard computer peripherals in an extremely realistic manner. In addition to a wealth of technical information, myriad nuggets of trivia, and hundreds of carefully drawn illustrations, the CD-ROM contains a set of lab experiments for the virtual microcomputer that let you recreate the experiences of early computer pioneers. If you're the slightest bit interested in the inner workings of computers, then

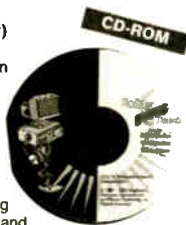

don't dare to miss this!

Over 800 pages in Adobe Acrobat format

CD-ROM **Order code BEB2 CD-ROM** £21.95

RADIO! RADIO! (Third Edition)

Jonathan Hill

A celebration in words and pictures of the development of the British wireless set from its experimental beginnings in Victorian England, to the foundation of a domestic wireless manufacturing industry and the inception of broadcasting in the early 1920's. The story continues on through the design-conscious 1930's (where the radio really came into its own as a piece of furniture), to the war-torn and austere days of the 1940's.

The first transistor radios began to appear in the second half of the 1950s and in this new edition, this rather neglected area has been fully covered by a section all of its own which includes a directory listing of nearly 3,000 different transistor models. The book finishes after the 1960s, by which time our long established and once great radio industry had all but been destroyed by foreign imports.

Now with 320 pages and over 1,000 illustrations, informative captions and carefully researched text *Radio! Radio!* is the first and still the only truly comprehensive book of its kind ever to be published.

320 pages (A4 Hardback) **Order code RR1** £40.95

SCROGGIE'S FOUNDATIONS OF WIRELESS AND ELECTRONICS - ELEVENTH EDITION

S. W. Amos and Roger Amos

Scroggie's Foundations is a classic text for anyone working with electronics, who needs to know the art and craft of the subject. It covers both the theory and practical aspects of a huge range of topics from valve and tube technology, and the application of cathode ray tubes to radar, to digital tape systems and optical recording techniques.

Since *Foundations of Wireless* was first published over 60 years ago, it has helped many thousands of readers to become familiar with the principles of radio and electronics. The original author Sowerby was succeeded by Scroggie in the 1940s, whose name became synonymous with this classic primer for practitioners and students alike. Stan Amos, one of the fathers of modern electronics and the author of many well-known books in the area, took over the revision of this book in the 1980s and it is he, with his son, who have produced this latest version.

400 pages **Temporarily out of print**

GETTING THE MOST FROM YOUR MULTIMETER

R. A. Penfold

This book is primarily aimed at beginners and those of limited experience of electronics. Chapter 1 covers the basics of analogue and digital multimeters, discussing the relative merits and the limitations of the two types. In Chapter 2 various methods of component checking are described, including tests for transistors, thyristors, resistors, capacitors and diodes. Circuit testing is covered in Chapter 3, with subjects such as voltage, current and continuity checks being discussed.

In the main little or no previous knowledge or experience is assumed. Using these simple component and circuit testing techniques the reader should be able to confidently tackle servicing of most electronic projects.

96 pages **Temporarily out of print**

DIGITAL GATES AND FLIP-FLOPS

Ian R. Sinclair

This book, intended for enthusiasts, students and technicians, seeks to establish a firm foundation in digital electronics by treating the topics of gates and flip-flops thoroughly and from the beginning.

No background other than a basic knowledge of electronics is assumed, and the more theoretical topics are explained from the beginning, as also are many working practices. The book concludes with an explanation of microprocessor techniques as applied to digital logic.

200 pages **Order code PC106** £9.95

PRACTICAL ELECTRONICS HANDBOOK - Fifth Edition. Ian Sinclair

Provides a practical and comprehensive collection of circuits, rules of thumb and design data for professional engineers, students and enthusiasts, and therefore enough background to allow the understanding and development of a range of basic circuits.

Contents: Passive components, Active discrete components, Circuits, Linear I.C.s, Energy conversion components, Digital I.C.s, Microprocessors and microprocessor systems, Transferring digital data, Digital-analogue conversions, Computer aids in electronics, Hardware components and practical work, Micro-controllers and PLCs, Digital broadcasting, Electronic security.

440 pages **Order code NE21** £19.99

MUSIC, AUDIO AND VIDEO

QUICK GUIDE TO ANALOGUE SYNTHESIS

Ian Waugh

Even though music production has moved into the digital domain, modern synthesizers invariably use analogue synthesis techniques. The reason is simple - analogue synthesis is flexible and versatile, and it's relatively easy for us to understand. The basics are the same for all analogue synths, and you'll quickly be able to adapt the principles to any instrument, to edit existing sounds and create exciting new ones. This book describes: How analogue synthesis works; The essential modules every synthesiser has; The three steps to synthesis; How to create that bass sound; How to generate filter sweeps; Advanced synth modules; How to create simple and complex synth patches; Where to find soft synths on the Web.

If you want to take your synthesiser - of the hardware or software variety - past the presets, and program your own sounds and effects, this practical and well-illustrated book tells you what you need to know.

60 pages **Order code PC118** £7.45

QUICK GUIDE TO MP3 AND DIGITAL MUSIC

Ian Waugh

MP3 files, the latest digital music format, have taken the music industry by storm. What are they? Where do you get them? How do you use them? Why have they thrown record companies into a panic? Will they make music easier to buy? And cheaper? Is this the future of music?

All these questions and more are answered in this concise and practical book which explains everything you need to know about MP3s in a simple and easy-to-understand manner. It explains:

How to play MP3s on your computer; How to use MP3s with handheld MP3 players; Where to find MP3s on the Web; How MP3s work; How to tune into Internet radio stations; How to create your own MP3s; How to record your own CDs from MP3 files; Other digital audio music formats.

60 pages **Order code PC119** £7.45

ELECTRONIC PROJECTS FOR VIDEO ENTHUSIASTS

R. A. Penfold

This book provides a number of practical designs for video accessories that will help you get the best results from your camcorder and VCR. All the projects use inexpensive components that are readily available, and they are easy to construct. Full construction details are provided, including stripboard layouts and wiring diagrams. Where appropriate, simple setting up procedures are described in detail; no test equipment is

needed.

The projects covered in this book include: Four channel audio mixer, Four channel stereo mixer, Dynamic noise limiter (DNL), Automatic audio fader, Video faders, Video wipers, Video crispener, Mains power supply unit.

109 pages **Order code BP356** £5.45

ELECTRONIC MUSIC AND MIDI PROJECTS

R. A. Penfold

Whether you wish to save money, boldly go where no musician has gone before, rekindle the pioneering spirit, or simply have fun building some electronic music gadgets, the designs featured in this book should suit your needs. The projects are all easy to build, and some are so simple that even complete beginners at electronic project construction can tackle them with ease. Stripboard layouts are provided for every project, together with a wiring diagram. The mechanical side of construction has largely been left to individual constructors to sort out, simply because the vast majority of project builders prefer to do their own thing in this respect.

None of the designs requires the use of any test equipment in order to get them set up properly. Where any setting up is required, the procedures are very straightforward, and they are described in detail.

Projects covered: Simple MIDI tester, Message grabber, Byte grabber, THRU box, MIDI auto switcher, Auto/manual switcher, Manual switcher, MIDI patchbay, MIDI controlled switcher, MIDI lead tester, Program change pedal, Improved program change pedal, Basic mixer, Stereo mixer, Electronic swell pedal, Metronome, Analogue echo unit.

124 pages **Order code PC116** £5.45

THE INVENTOR OF STEREO - THE LIFE AND WORKS OF ALAN DOWER BLUMLEIN

Robert Charles Alexander

This book is the definitive study of the life and works of one of Britain's most important inventors who, due to a cruel set of circumstances, has all but been overlooked by history.

Alan Dower Blumlein led an extraordinary life in which his inventive output rate easily surpassed that of Edison, but whose early death during the darkest days of World War Two led to a shroud of secrecy which has covered his life and achievements ever since.

His 1931 Patent for a Binaural Recording System was so revolutionary that most of his contemporaries regarded it as more than 20 years ahead of its time. Even years after his death, the full magnitude of its detail had not

been fully utilized. Among his 128 patents are the principal electronic circuits critical to the development of the world's first electronic television system. During his short working life, Blumlein produced patent after patent breaking entirely new ground in electronic and audio engineering.

During the Second World War, Alan Blumlein was deeply engaged in the very secret work of radar development and contributed enormously to the system eventually to become 'H2S' - blind-bombing radar. Tragically, during an experimental H2S flight in June 1942, the Halifax bomber in which Blumlein and several colleagues were flying, crashed and all aboard were killed. He was just days short of his thirty-ninth birthday.

420 pages **Order code NE32** £17.99

VIDEO PROJECTS FOR THE ELECTRONICS CONSTRUCTOR

R. A. Penfold

Written by highly respected author R. A. Penfold, this book contains a collection of electronic projects specially designed for video enthusiasts. All the projects can be simply constructed, and most are suitable for the newcomer to project construction, as they are assembled on stripboard.

There are faders, wipers and effects units which will add sparkle and originality to your video recordings, an audio mixer and noise reducer to enhance your soundtracks and a basic computer control interface. Also, there's a useful selection on basic video production techniques to get you started.

Complete with explanations of how the circuit works, shopping lists of components, advice on construction, and guidance on setting up and using the projects, this invaluable book will save you a small fortune.

Circuits include: video enhancer, improved video enhancer, video fader, horizontal wiper, improved video wiper, negative video unit, fade to grey unit, black and white keyer, vertical wiper, audio mixer, stereo headphone amplifier, dynamic noise reducer, automatic fader, pushbutton fader, computer control interface, 12 volt mains power supply.

124 pages **Order code PC115** £5.45

HIGH POWER AUDIO AMPLIFIER CONSTRUCTION

R. A. Penfold

Practical construction details of how to build a number of audio power amplifiers ranging from about 50 to 300/400 watts r.m.s. includes MOSFET and bipolar transistor designs.

96 pages **Temporarily out of print**

FAULT FINDING, CIRCUITS AND DESIGN

DISCOVERING PICS

W.D. Phillips

A good introduction to PIC programming, covering everything you need to know to get you started. No previous knowledge of microcontrollers is required, but some previous experience with electronic circuits is assumed. Covers the basic concept of a microcontroller, fundamentals of a PIC-based circuit and using the MPLAB program. Further chapters introduce binary, PIC architecture, the instruction set, the PIC memory map and special registers plus real world programming. Four simple projects are also fully described; a Wavy Wand, an Electronic Dice, a Games Timer and a Pulse Monitor.

The associated CDROM contains the book in PDF format, MPLAB (plus instruction manuals in PDF format) and all the programs covered in the book as assembler (ASM) files.

In addition a p.c.b. based hardware kit is also available that makes up into the Wavy Wand which will spell out a short message via a line of l.e.d.s when waved through the air.

190 pages, A4 spiral bound

**BOOK + CDROM
+ HARDWARE**

Book + CDROM Order code DOC1 £22.00

Book + CDROM + Hardware Order code DOC2 £28.50

PRACTICAL OSCILLATOR CIRCUITS

A. Flind

Extensive coverage is given to circuits using capacitors and resistors to control frequency. Designs using CMOS, timer i.c.s and op.amps are all described in detail, with a special chapter on "waveform generator" i.c.s. Reliable "white" and "pink" noise generator circuits are also included. Various circuits using inductors and capacitors are covered, with emphasis on stable low frequency generation. Some of these are amazingly simple, but are still very useful signal sources.

Crystal oscillators have their own chapter. Many of the circuits shown are readily available special i.c.s for simplicity and reliability, and offer several output frequencies. Finally, complete constructional details are given for an audio sine wave generator.

133 pages

Order code BP393

£5.49

PIC IN PRACTICE

David W. Smith

A graded course based around the practical use of the PIC microcontroller through project work. Principles are introduced gradually, through hands-on experience, enabling hobbyists and students to develop their understanding at their own pace. The book can be used at a variety of levels. Contents: Introduction to the PIC microcontroller; Programming the 16F84 microcontroller; Using inputs; Keypad scanning; Program examples; The 16C54 microcontroller; Alphanumeric displays; Analogue to digital conversion; Radio transmitters and receivers; EEPROM data memory; Interrupts; The 12C5XX 8-pin microcontroller; The 16F87X microcontroller; The 16F62X micro-

controller; Projects; Instruction set, files and registers; Appendices; Index.

272 pages

Order code NE39

£17.49

COIL DESIGN AND CONSTRUCTIONAL MANUAL

B. B. Babani

A complete book for the home constructor on "how to make" RF, IF, audio and power coils, chokes and transformers. Practically every possible type is discussed and calculations necessary are given and explained in detail. Although this book is now twenty years old, with the exception of toroids and pulse transformers little has changed in coil design since it was written.

96 pages

Order code BP160

£4.49

PRACTICAL ELECTRONIC FAULT FINDING AND TROUBLESHOOTING

Robin Pain

To be a real fault finder, you must be able to get a feel for what is going on in the circuit you are examining. In this book Robin Pain explains the basic techniques needed to be a fault finder.

Simple circuit examples are used to illustrate principles and concepts fundamental to the process of fault finding. This is not a book of theory, it is a book of practical tips, hints and rules of thumb, all of which will equip the reader to tackle any job. You may be an engineer or technician in search of information and guidance, a college student, a hobbyist building a project from a magazine, or simply a keen self-taught amateur who is interested in electronic fault finding but finds books on the subject too mathematical or specialised.

The fundamental principles of analogue and digital fault finding are described (although, of course, there is no such thing as a "digital fault" - all faults are by nature analogue). This book is written entirely for a fault finder using only the basic fault-finding equipment: a digital multimeter and an oscilloscope. The treatment is non-mathematical (apart from Ohm's law) and all jargon is strictly avoided.

274 pages

Temporarily out of print

OPERATIONAL AMPLIFIER USER'S HANDBOOK

R. A. Penfold

The first part of this book covers standard operational amplifier based "building blocks" (integrator, precision rectifier, function generator, amplifiers, etc), and considers the ways in which modern devices can be used to give superior performance in each one. The second part describes a number of practical circuits that exploit modern operational amplifiers, such as high slew-rate, ultra low noise, and low input offset devices. The projects include: Low noise tape preamplifier, low noise RIAA preamplifier, audio power amplifiers, d.c. power controllers, opto-isolator audio link, audio millivolt meter, temperature monitor, low distortion audio signal generator, simple video fader, and many more.

120 pages

Order code BP335

£5.45

A BEGINNERS GUIDE TO CMOS DIGITAL ICs

R. A. Penfold

Getting started with logic circuits can be difficult, since many of the fundamental concepts of digital design tend to seem rather abstract, and remote from obviously useful applications. This book covers the basic theory of digital electronics and the use of CMOS integrated circuits, but does not lose sight of the fact that digital electronics has numerous "real world" applications.

The topics covered in this book include: the basic concepts of logic circuits; the functions of gates, inverters and other logic "building blocks"; CMOS logic i.c. characteristics, and their advantages in practical circuit design; oscillators and monostables (timers); flip/flops, binary dividers and binary counters; decade counters and display drivers.

119 pages

Order code BP333

£5.45

AUDIO AMPS

BUILDING VALVE AMPLIFIERS

Morgan Jones

The practical guide to building, modifying, fault-finding and repairing valve amplifiers. A hands-on approach to valve electronics - classic and modern - with a minimum of theory. Planning, fault-finding, and testing are each illustrated by step-by-step examples.

A unique hands-on guide for anyone working with valve (tube in USA) audio equipment - as an electronics experimenter, audiophile or audio engineer.

Particular attention has been paid to answering questions commonly asked by newcomers to the world of the vacuum tube, whether audio enthusiasts tackling their first build, or more experienced amplifier designers seeking to learn the ropes of working with valves. The practical side of this book is reinforced by numerous clear illustrations throughout.

368 pages

Order code NE40

£21.99

VALVE & TRANSISTOR AUDIO AMPLIFIERS

John Linsley Hood

This is John Linsley Hood's greatest work yet, describing the milestones that have marked the development of audio amplifiers since the earliest days to the latest systems. Including classic amps with valves at their heart and exciting new designs using the latest components, this book is the complete world guide to audio amp design.

Contents: Active components; Valves or vacuum tubes; Solid-state devices; Passive components; Inductors and transformers; Capacitors, Resistors, Switches and electrical contacts; Voltage amplifier stages using valves; Valve audio amplifier layouts; Negative feedback; Valve operated power amplifiers; Solid state voltage amplifiers; Early solid-state audio amplifiers; Contemporary power amplifier designs; Preamplifiers; Power supplies (PSUs); Index.

250 pages

Order code NE24

£25.99

AUDIO AMPLIFIER PROJECTS

R. A. Penfold

A wide range of useful audio amplifier projects, each project features a circuit diagram, an explanation of the circuit operation and a stripboard layout diagram. All constructional details are provided along with a shopping list of components, and none of the designs requires the use of any test equipment in order to set up properly. All the projects are designed for straightforward assembly on simple circuit boards.

Circuits include: High impedance mic preamp, Low impedance mic preamp, Crystal mic preamp, Guitar and GP preamplifier, Scratch and rumble filter, RIAA preamplifier, Tape preamplifier, Audio limiter, Bass and treble tone controls, Loudness filter, Loudness control, Simple graphic equaliser, Basic audio mixer, Small (300mW) audio power amp, 6 watt audio power amp, 20/32 watt power amp and power supply, Dynamic noise limiter.

A must for audio enthusiasts with more sense than money!

116 pages

Order code PC113

£10.95 £5.45

VALVE AMPLIFIERS

Second Edition. Morgan Jones

This book allows those with a limited knowledge of the field to understand both the theory and practice of valve audio amplifier design, such that they can analyse and modify circuits, and build or restore an amplifier. Design principles and construction techniques are provided so readers can devise and build from scratch, designs that actually work.

The second edition of this popular book builds on its main strength - exploring and illustrating theory with practical applications. Numerous new sections include: output transformer problems; heater regulators; phase splitter analysis; and component technology. In addition to the numerous amplifier and preamplifier circuits, three major new designs are included: a low-noise single-ended LP stage, and a pair of high voltage amplifiers for driving electrostatic transducers directly - one for headphones, one for loudspeakers.

288 pages

Order code NE33

£32.99

BOOK ORDERING DETAILS

All prices include UK postage. For postage to Europe (air) and the rest of the world (surface) please add £2 per book. For the rest of the world airmail add £3 per book. CD-ROM prices include VAT and/or postage to anywhere in the world. Send a PO, cheque, international money order (£ sterling only) made payable to **Direct Book Service** or card details, Visa, Mastercard, Amex, Diners Club or Switch/Maestro to: **DIRECT BOOK SERVICE, WIMBORNE PUBLISHING LIMITED, 408 WIMBORNE ROAD EAST, FERNDOWN, DORSET BH22 9ND.**

Books are normally sent within seven days of receipt of order, but please allow 28 days for delivery - more for overseas orders. Please check price and availability (see latest issue of Everyday Practical Electronics) before ordering from old lists.

For a further selection of books see the next two issues of EPE.

Tel 01202 873872 Fax 01202 874562. E-mail: dbs@wimborne.co.uk

Order from our online shop at: www.epemag.co.uk

BOOK ORDER FORM

Full name:

Address:

..... Post code: Telephone No:

Signature:

I enclose cheque/PO payable to DIRECT BOOK SERVICE for £

Please charge my card £ Card expiry date:

Card Number Switch/Maestro Issue No.

Card Security Code (the last three digits on or just below the signature strip)

Please send book order codes:

Please continue on separate sheet of paper if necessary

PCB SERVICE

Printed circuit boards for most recent *EPE* constructional projects are available from the PCB Service, see list. These are fabricated in glass fibre, and are fully drilled and roller tinned. All prices include VAT and postage and packing. Add £1 per board for airmail outside of Europe. Remittances should be sent to **The PCB Service, Everyday Practical Electronics, Wimborne Publishing Ltd., 408 Wimborne Road East, Ferndown, Dorset BH22 9ND. Tel: 01202 873872; Fax 01202 874662; Email: orders@epemag.wimborne.co.uk. On-line Shop: www.epemag.wimborne.co.uk/shopdoor.htm.** Cheques should be crossed and made payable to *Everyday Practical Electronics* (Payment in £ sterling only).

NOTE: While 95% of our boards are held in stock and are dispatched within seven days of receipt of order, please allow a maximum of 28 days for delivery – overseas readers allow extra if ordered by surface mail. Back numbers or photostats of articles are available if required – see the *Back Issues* page for details. We do not supply kits or components for our projects.

Please check price and availability in the latest issue. A large number of older boards are listed on our website.

Boards can only be supplied on a payment with order basis.





PROJECT TITLE	Order Code	Cost
In-Car Lap-Top PSU	MAY '04 443	£4.60
Beat Balance Metal Detector	444	£4.60
Teach-In '04 Part 7 – Transmitter Receiver	445 446	£4.91 £4.75
Moisture	447	£4.44
★PIC Quickstep	JUNE '04 448	£5.71
Body Detector MkII	449	£4.91
★Teach-In '04 Part 8 – Software only	–	–
★MIDI Synchronome – Software only	–	–
Hard Drive Warbler	JULY '04 450	£4.60
★Bongo Box	451	£6.02
Portable Mini Alarm – Sensor	452	£5.23
– Counter	453	£5.07
★Teach-In '04 Part 9	–	–
PIC Combination Lock Alarm Monitor	454	£5.07
★EPE Magnetometry Logger	455	£5.71
Keyring L.E.D. Torch	AUG '04 456	£4.12
★Teach-In '04 Part 10 – PIC Curtain or Blind Winder	457	£5.39
Simple F.M. Radio – F.M. Tuner	458	£5.07
– Tone Control	459	£4.75
– Audio Power Amp (TDA2003)	347	£4.60
– Power Supply	460	£5.39
★EPE Scorer	– Control Board 461	£6.66
– Display Board 462	£7.93	
– Slave Board 463	£5.55	
★PIC to Mouse/Keyboard – Software only	–	–
EPE Wirt Zapper	SEPT '04 464	£4.60
★Radio Control Failsafe	465	£4.76
★AlphaMouse Game	466	£4.60
★Rainbow Lighting Controller – Software only	–	–
★Moon and Tide Clock Calendar	OCT '04 467	£5.55
Volts Checker	468	£4.20
★Smart Karts – Software only	–	–
Logic Probe	NOV '04 469	£4.76
Thunderstorm Monitor	470	£5.39
MW Amplitude Modulator	– V.F.O./Buffer 471	£4.76
– Modulator/PA 472	£5.07	
– Power Supply 473	£4.76	
Super Vibration Switch	DEC '04 474	£4.75
Wind Director Indicator	475	£6.18
★PIC Flasher Mk2 – Control Board	476	£4.75
– Transmitter 477	£4.44	
– Multipurpose Board 478	£4.75	
– Simple Cyder 479	£4.44	
– Luxeon V Controller 480	£4.44	
– Power Supply 473	£4.76	
Light Detector	JAN '05 481	£4.44
★Camera Watch 482	£6.03	
Gate Alarm – Oscillator	483	£4.92
– Delay/Timer 484	£4.92	
★Sneaky – Transmitter	FEB '05 485	£4.60
– Receiver 486	£4.91	
★PIC Electric Mk2 – Control	487	£5.87
– Sensor 488	£5.71	
Sound Card Mixer	489	£7.29
Headphone Monitor	MAR '05 490	£5.71
EPE Cat Flap	491	£6.02
★Bingo Box – Main	492	£9.04
– Big Digit Display 493	£10.31	
Spontaflex Radio– Tuner	APR '05 494	£5.55
– Coil Pack 495	£5.71	
– Audio Amplifier 496	£5.55	
– Tuning Capacitor Board 406	£4.28	
★Safety Interface	497	£6.18
Back-To-Basics 1– Fridge/Freezer Door Alarm	498	£5.39
★Crossword Solver	MAY '05 499	£6.66
20W Amplifier Module	500	£5.14
Back-To-Basics 2 – Water Level Alarm	501	£5.39
– Burglar Alarm 502	£5.87	

PROJECT TITLE	Order Code	Cost
★PIC Ultrasonic Scanner	JUN '05 503	£6.66
★Radio Control Model Switcher	504	£5.87
Back-To-Basics 3 – Scarecrow	505	£5.55
– Digital Lock 506	£6.66	
CompactFlash Interface Board	507	£6.66
LF/VLF Converter	JUL '05 508	£5.71
– Fixed Capacitor Board 509	£5.86	
– Mixer/Oscillator Board 510	£5.23	
– Buffer Amplifier 511	£5.23	
– Q-Multiplier 406	£4.28	
– Tuning Capacitor Board 512	£6.34	
Back-To-Basics 4 – Doorchime	513	£6.02
– Electronic Dice 514	£6.82	
★Cybervox Multi-Clap Switch	515	£6.66
Audio System	AUG '05 516	£6.02
– Preamplifier 517	£5.23	
– Mic. Supply Board 518	£6.02	
– Power Amp 519	£7.14	
★Pain Monitor	520	£7.45
MotorAmp 521	£5.87	
Back-To-Basics 5 – Kitchen Timer	522	£6.02
– Room Thermometer	–	–
All-Band Radio – Full Version	SEPT '05 523	£5.71
– Mini Version 524	£5.23	
★Multicore Cable Tester – Main	525	£6.19
– Active 526	£5.55	
Back-To-Basics 6 – Daily Reminder	527	£6.19
– Whistle Switch 528	£5.87	
★Model Railway Signal Control	529	£6.19
★Snooker/Darts Scoreboard	530	£8.72
Photic Phone – Transmitter	OCT '05 531	} pair £6.98
– Receiver 532		
Back-To-Basics 7 – Parking Radar	533	£5.71
– Telephone Switch 534	£5.55	
★Halloween Howler	535	£6.02
★PIC-Based USB Interface	536	£6.19
★PIC Chromatone	NOV '05 537	6.82
Back-To-Basics 8 – Noughts and Crosses Enigma	538	£6.66
– Weather Vane Repeater 539	£6.18	
★Multi-Function R/C Switch	540	£5.87
★Speed Camera Watch Mk2	541	£6.35

EPE SOFTWARE

★ All software programs for *EPE* Projects marked with an asterisk, and others previously published, can be downloaded *free* from our Downloads site, accessible via our home page at: www.epemag.co.uk.

EPE PRINTED CIRCUIT BOARD SERVICE

Order Code	Project	Quantity	Price
Name			
Address			
Tel. No.			
I enclose payment of £..... (cheque/PO in £ sterling only) to:			
 Everyday Practical Electronics 		 MasterCard, Amex, Diners Club, Visa or Switch/Maestro  	
Card No.			
Valid From		Expiry Date	
Card Security Code		Switch/Maestro Issue No	
(The last 3 digits on or just under the signature strip)			
Signature			
<p>NOTE: You can also order p.c.b.s by phone, Fax, Email or via our Internet site on a secure server:</p> <p style="text-align: center;">http://www.epemag.wimborne.co.uk/shopdoor.htm</p>			

Everyday Practical Electronics reaches twice as many UK readers as any other UK monthly hobby electronics magazine, our sales figures prove it. We have been the leading monthly magazine in this market for the last twenty years.

If you want your advertisements to be seen by the largest readership at the most economical price our classified and semi-display pages offer the best value. The prepaid rate for semi-display space is £10 (+VAT) per single column centimetre (minimum 2.5cm). The prepaid rate for classified adverts is 40p (+VAT) per word (minimum 12 words).

All cheques, postal orders, etc., to be made payable to Everyday Practical Electronics. **VAT must be added.** Advertisements, together with remittance, should be sent to Everyday Practical Electronics Advertisements, 408 Wimborne Road East, Ferndown, Dorset BH22 9ND. Phone: 01202 873872. Fax: 01202 874562. Email: epeads@wimborne.co.uk

For rates and information on display and classified advertising please contact our Advertisement Manager, Stewart Kearn as above.

TOTALROBOTS

ROBOTICS, CONTROL & ELECTRONICS TECHNOLOGY

High quality robot kits and components
 UK distributor of the OOPic microcontroller

Secure on-line ordering
 Rapid delivery
 Highly competitive prices

Visit www.totalrobots.com

Tel: 01737 371688

The Versatile, Programmable On Screen Display System

www.STV5730A.co.uk



- Fully programmable
- PIC 16F628 microcontroller
- Demo software code available
- OSD IC 28 by 11 screen
- I/O lines free to connect sensors or buttons
- Serial or PC keyboard interface versions

Your own complete eCommerce 24/7 site for only £10 per week!

Domain, secure hosting, emails, shopping basket, etc, included.
 details: www.eConcept.co.uk

Miscellaneous

MAKE YOUR HOBBY A BUSINESS. Earn money making a unit for the partially sighted. Exclusive areas. Outlets provided. Full assembly Instruction manual and suppliers. DETAILS 02392 830158

VALVES AND ALLIED COMPONENTS IN STOCK. Phone for free list. Valves, books and magazines wanted. Geoff Davies (Radio), tel. 01788 574774.

FREE! PROTOTYPE PRINTED CIRCUIT BOARDS! Free prototype p.c.b. with quantity orders. Call Patrick on 028 9073 8897 for details. Agar Circuits, Unit 5, East Belfast Enterprise Park, 308 Albertbridge Road, Belfast BT5 4GX.

PRINTED CIRCUIT BOARDS - QUICK SERVICE. Prototype and production artwork raised from magazines or draft designs at low cost. PCBs designed from schematics. Production assembly, wiring and software programming. For details contact Patrick at Agar Circuits, Unit 5, East Belfast Enterprise Park, 308 Albertbridge Road, Belfast BT5 4GX. Phone 028 9073 8897, Fax 028 9073 1802, Email agar@argonet.co.uk

KITS, TOOLS, COMPONENTS. S.A.E. catalogue. SIR-KIT ELECTRONICS, 52 Severn Road, Clacton, CO15 3RB. www.geocities.com/sirkituk

LPG ELECTRONICS Solar Charging Specialists. Rugged 4A Solar Shunt Regulator £24.99. Solar Boost Trickle Regulator - Charge 12V Gel Cells, even when sun is hiding! £14.99. Prices Inc for UK. Cheques Payable to S Taylor. 76 Queensdown Gardens, Brislington, Bristol, BS4 3JF.

WANTED - GRUNDIG YACHT BOY RADIO. Must be Model 210 from between 1970-1974. Must be in mint condition. Will pay very good money for a set in mint condition. Contact Peter Tankard on Tel 0114 2316321

X-10® Home Automation We put you in control™

Why tolerate when you can automate?

An extensive range of 230V X-10 products and starter kits available. Uses proven Power Line Carrier technology, no wires required.

Products Catalogue available Online.
 Worldwide delivery.

Laser Business Systems Ltd.

E-Mail: info@laser.com
<http://www.laser.com>
 Tel: (020) 8441 9788
 Fax: (020) 8449 0430

VVT TRANSFORMERS

Transformers and Chokes for all types of circuits including specialist valve units
 Custom design or standard range
 High and low voltage

Variable Voltage Technology Ltd
 Unit 3, Sheat Manor Farm, Chillerton, Newport, Isle of Wight, PO30 3HP
 Tel: 0870 243 0414 Fax: 01983 721572
 email: sales@vvt-cowes.freeseerve.co.uk
www.vvttransformers.co.uk

BARGAIN PRICES.

1000's of electrical components, motors, transformers, switches, capacitors plus many more. Please phone, write or email for a catalogue.

J & N Electrical, Pilgrims, Stairbridge Lane, Bolney, West Sussex, RH17 5PA.

Tel: 01444 881965.
 Email: jnfactors@aol.com

www.pawbooks.co.uk

Using ICs. Pinout diagrams.
 Numeric control.
 Interactive Demonstrations.
 Write, save, load your own programs.
 See ICs working on screen.

BOWOOD ELECTRONICS LTD

Suppliers of Electronic Components
 Place a secure order on our website or call our sales line
 All major credit cards accepted
 Web: www.bowood-electronics.co.uk
 Unit 1, McGregor's Way, Turnoaks Business Park, Chesterfield, S40 2WB. Sales: 01246 200222
 Send 60p stamp for catalogue

BTEC ELECTRONICS TECHNICIAN TRAINING

NATIONAL ELECTRONICS VCE ADVANCED ICT HNC AND HND ELECTRONICS FOUNDATION DEGREES NVQ ENGINEERING AND IT DESIGN AND TECHNOLOGY

LONDON ELECTRONICS COLLEGE
 20 PENYVERN ROAD
 EARLS COURT, LONDON SW5 9SU
 TEL: (020) 7373 8721
www.lec.org.uk

SQUIRES MODEL & CRAFT TOOLS

100 London Road, Bognor Regis,
West Sussex, PO21 1DD.
Tel 01243 842424, Fax 01243 842525.
email: sales@squirestools.com

The Squires 2006 Mail Order Catalogue has just been published. It features over 10,000 tools, materials and components all available by POST FREE mail order. If you would like to receive a copy of our catalogue, please contact us at the above address.

Our Shop is open 9.00 - 5.30 Monday to Saturday.

EPE BINDERS

The EPE ring binder uses a special system to allow the issues to be easily removed and re-inserted without any damage. A nylon strip slips over each issue and this passes over four rings in the binder, thus holding the magazine in place.

The binders are finished in hard-wearing royal blue p.v.c. with the magazine logo in gold on the spine. They will keep your issues neat and tidy but allow you to remove them for use easily.

The price is £7.95 plus £3.50 post and packing. If you order more than one binder add £1 postage for each binder after the initial £3.50 postage charge (overseas readers the postage is £6.00 each to everywhere except Australia and Papua New Guinea which costs £10.50 each).

Send your payment in £'s sterling cheque or PO (Overseas readers send £ sterling bank draft, or cheque drawn on a UK bank or pay by card), to **Everyday Practical Electronics, Wimborne Publishing Ltd, 408 Wimborne Road East, Ferndown, Dorset BH22 9ND. Tel: 01202 873872. Fax: 01202 874562.**

E-mail: editorial@epemag.wimborne.co.uk. Web site: <http://www.epemag.co.uk>
Order on-line from www.epemag.co.uk/shopdoor.htm

We also accept card payments. Mastercard, Visa, Amex, Diners Club or Maestro. Send, fax or phone your card number, card expiry date and card security code (the last 3 digits on or just under the signature strip), plus Maestro Issue No. with your order.

Easy Components

10% OFF



£9.99



£4.99

Our components sets are so useful you'll wonder how you coped without! Buying a component set is simply the easiest way to keep stock of those project building essentials!

1/2W Precision Metal Film Resistors evenly distributed over 73 E12/E24 values from **10Ω** to **10MΩ**. Pure convenience! Just **£9.99** for a set of 1040 resistors.

Electrolytic Capacitor set? CAP-001 has 105 Grade A electrolytics, in 14 values from **0.47µF** to **2200µF** (16v - 63v). Perfect for power supply / filter experiments and only **£4.99**.

But wait, there's more! **Veroboards** from **£2.99**. **100 63v Polyester Capacitors** for **£4.99**, and **SMD-001** boasts 1130 **Surface Mount Resistors** in 1206 & 0805 packages for **£12.99**.



It's time to get smart about buying components. Visit our website or write to us and ask for a free catalogue!

10% off for EPE readers. Codeword: FARADAY

Mail order P&P: £2.50 (Free P&P orders over £20)

www.fastcomponents.co.uk

Tel: 0870 750 4468 Fax: 0870 137 6005

Winchester House, Winchester Road, Walton-on-Thames, Surrey. KT12 2RH

ANDRE LAMOTHE'S
XGAMESTATION
LEARN STEP-BY-STEP HOW TO DESIGN
AND BUILD YOUR OWN VIDEO GAME CONSOLE!

Design inspired by the Atari 800/2600,
Sinclair ZX Spectrum, Apple II & Commodore 64!

Complete Package eBook Integrated IDE

SX52 CPU 80 MIPS! OPEN SOURCE!

FEATURES:

- Great for Hobbyists AND Students!
- Complete Software Development Kit!
- eBook on Designing the XGS Console!
- Parallax SX-Key Compatible!
- Fully Assembled XGS Micro Edition Unit!
- The Fun Way to Learn Embedded Systems!

PAL & NTSC COMPATIBLE!

WWW.XGAMESTATION.COM
SUPPORT@NURVE.NET | PH 925.736.2098(USA)

Europe's Largest Surplus Store

20,000,000 Items on line NOW!
New items added daily

Established for over 25 years, UK company Display Electronics prides itself on offering a massive range of electronic and associated electro-mechanical equipment and parts to the Hobbyist, Educational and Industrial user. Many current and obsolete hard to get parts are available from our vast stocks, which include:

- ◆ 6,000,000 Semiconductors
- ◆ 5,000 Power Supplies
- ◆ 25,000 Electric Motors
- ◆ 10,000 Connectors
- ◆ 100,000 Relays & Contactors
- ◆ 2000 Rack Cabinets & Accessories
- ◆ 4000 Items of Test Equipment
- ◆ 5000 Hard Disk Drives

We Ship Worldwide

Surplus Wanted

www.distel.co.uk

Display Electronics
29 / 35 Osborne Road
Thornton Heath
Surrey UK CR7 8PD

Telephone
[44] 020 8653 3333
Fax **[44] 020 8653 8888**

PROTEUS

The Complete Electronics Design System

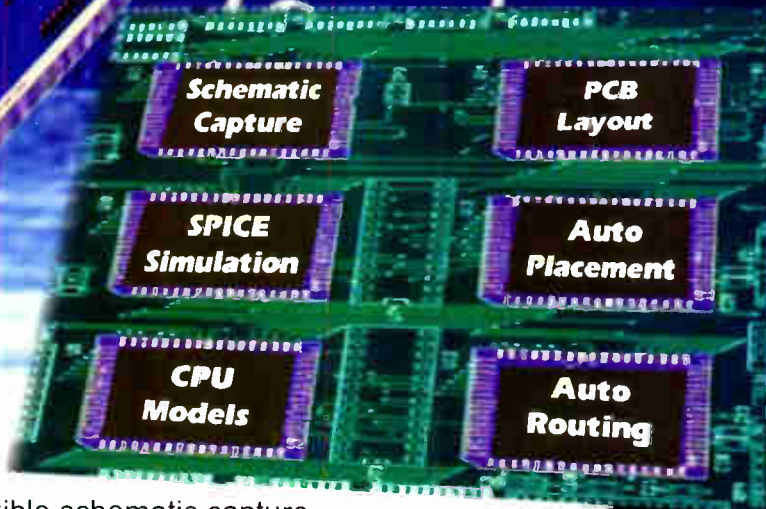
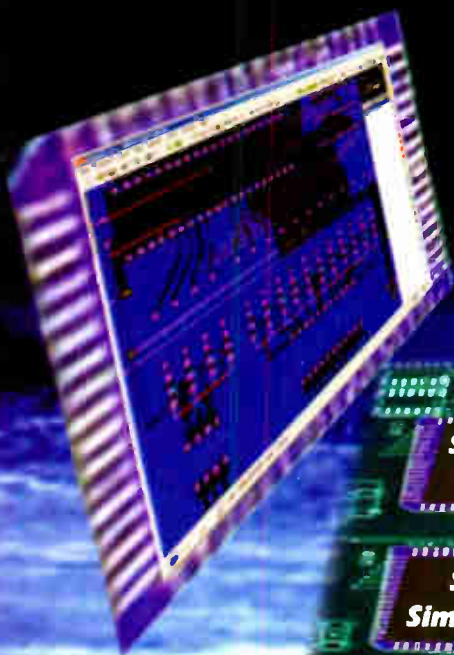

VSM
Virtual System Modelling

Schematic & PCB Layout

- Powerful & flexible schematic capture.
- Auto-component placement and rip-up/retry PCB routing.
- Polygonal gridless ground planes.
- Libraries of over 8000 schematic and 1000 PCB parts.
- Bill of materials, DRC reports and much more.

Mixed Mode SPICE Circuit Simulation

- Berkeley SPICE3F5 simulator with custom extensions for true mixed mode and interactive simulation.
- 6 virtual instruments and 14 graph based analysis types.
- 6000 models including TTL, CMOS and PLD digital parts.
- Fully compatible with manufacturers' SPICE models.

- Interactive Design Rule Check.
- Mitring / Unmitring.
- Enhanced track editing.
- Struct/Array expansion.
- ELF/DWARF file loader.
- Expanded model libraries.

New Features in Version 6.8

Call Now for Upgrade Pricing

Proteus VSM - Co-simulation and debugging for popular Micro-controllers

- Supports PIC, AVR, 8051, ARM7 and BASIC STAMP micro-controllers.
- Co-simulate target firmware with your hardware design.
- Includes interactive peripheral models for LED and LCD displays, switches, keypads, virtual terminal and much, much more.
- Compatible with popular compilers and assemblers from Microchip, Crownhill, IAR, Keil, and others.



labcenter

Electronics
53-55 Main Street, Grassington. BD23 5AA

Tel: 01756 753440
Fax: 01756 752857

Contact us for
Free Demo CD

www.labcenter.co.uk
info@labcenter.co.uk

This is where we live!

Jaycar Electronics

Yes that's right, down-town, down under in Sydney Australia. We are a bunch of electronics enthusiasts who sell a great range of goodies through our FREE 400 page catalogue (see below) - don't be frightened! You can purchase on the Net from us 24/7/365 through our secure encrypted system. Post and packing charges are modest and you can have any of 8,000 + unique products delivered to your door within 7 - 10 days of your order. Some specific products are shown below.

Remote Control Extender - MKII

KC-S209 £6.70 + post & packing



Many households have two or more TV sets which are linked to a single VCR via antenna cable. The problem is, you can't directly control the VCR from another room in the house. So, if you want to fast forward or freeze frame the action, you

have to get up and walk to the other room to where the VCR lives. Not any more! This amazing kit will let you control a VCR or hi-fi system using a remote control from another room in the house. It picks up the signal from the remote control and sends it via a 2-wire cable to an infrared LED located close to the VCR or IR receiving equipment. The kit is a breeze to construct and will work with virtually any remote control system. The Jaycar kit is complete with case, silk screened front panel, PCB, hardware plus all electronic components.

A 9VDC power supply (Maplin #GS74R £9.99) and a 2-wire cable are required.

3 Stage FM Transmitter Kit

KJ-8750 £5.80 + post & packing



The circuit board may measure just 2"(L) x 1.06"(W), but it can transmit signals over half a mile in the open. It has flexible power requirements, with 6 to 12VDC input voltage (so a 9V battery would be suitable). It is quick to build, and fun to use. Kit supplied with circuit board, electronic components, and clear English instructions.



Theremin Synthesiser Kit

KC-S295 £17.50 + post & packing

The Theremin is a weird musical instrument that was invented early last century but is still used today. The Beach Boys' classic hit "Good Vibrations" featured a Theremin. By moving your hand between the antenna and the metal plate, you create strange sound effects like in those scary movies! Kit includes a machined, silk screened, and pre drilled case, circuit board, all electronic components, and clear English instructions.

9VDC power supply required (Maplin #GS74R £9.99).



Get the Video Quality you Paid for!

KC-S390 £29.00 + post & packing

Copy protection is put in place on videos and DVDs for a good reason, but this robs you of the true high quality reproduction that it is capable of. Get the quality you paid for and strip out these annoying signals! It supports composite and S-video signals and can be configured for NTSC or PAL format. Kit includes case, circuit board, all electronic components & clear English instructions. Note: Some SMD soldering required.

Caution. During signal conditioning, this unit removes copyright protection. Piracy is a crime & Jaycar Electronics takes no responsibility for its potential for unlawful use.

9VAC power supply required (Maplin #GU09K £9.99)



We Stock...

Electronic Components, Sub-Assemblies & Electronic Kits

Power Products & Accessories

Audio & Visual Equipment & Accessories

Computer & Telecoms Accessories

Burglar Alarms & Surveillance Equipment

Lighting Products & Accessories

Gadgets & Unique Gifts

KITS FOR HIGH PERFORMANCE CARS

Independent Electronic Boost Controller

KC-S387 £23.20 + post & packing

Change between 2 completely different boost maps at the flick of a switch. Map across a maximum of 64 different engine loads. Boost curve selection is via a dashboard switch, and it is all programmed using the Handheld Digital Controller - KC-S386. Kit supplied with PCB, machined case, and all electronic components. Suitable for EFI and engine management systems only.



Hand Controller for Digital Adjusters

KC-S386 £23.75 + post & packing

Used to program the Independent Electronic Boost Controller circuits. It features a 2 line backlit LCD, and easy to use push buttons. It is designed as an interface and display, and is not required for general adjuster functions after they have been programmed. Kit supplied with screen printed and machined case, a quality solder masked PCB with overlay, backlit LCD, and all electronic components. Requires serial interface lead 5ft D25 plug to plug (Jaycar Cat. WC-7502 £2.30)



400+ page Catalogue

Post and Packing Charges:

Order Value	Cost
£20 - £49.99	£5
£50 - £99.99	£10
£100 - £199.99	£20
£200 - £499.99	£30
£500+	£40

Max weight 12lb (5kg) - heavier parcels POA.
Minimum order £20.

Log on to
www.jaycarelectronics.co.uk/catalogue
for your FREE catalogue!

0800 032 7241

(Monday - Friday 09.00 to 17.30 GMT + 10 hours only).

For those who want to write:
100 Silverwater Rd Silverwater NSW 2128
Sydney AUSTRALIA