

THE No.1 MAGAZINE FOR ELECTRONICS TECHNOLOGY & COMPUTER PROJECTS

EVERYDAY

JULY 2002

**PRACTICAL**

# ELECTRONICS

£2.85

## STYLOPIC

A hand-held musical instrument

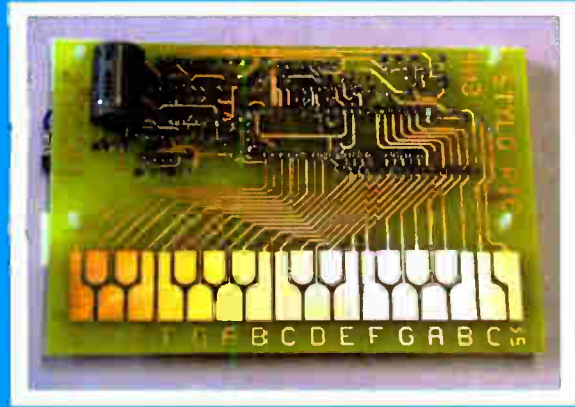

**INFRA-RED AUTOSWITCH**  
An easy to build project

**AUDIO CIRCUITS - 3**  
Power supplies, loudspeakers & signal filtering

**PLUS**  
**USING THE PIC's PCLATH COMMAND**

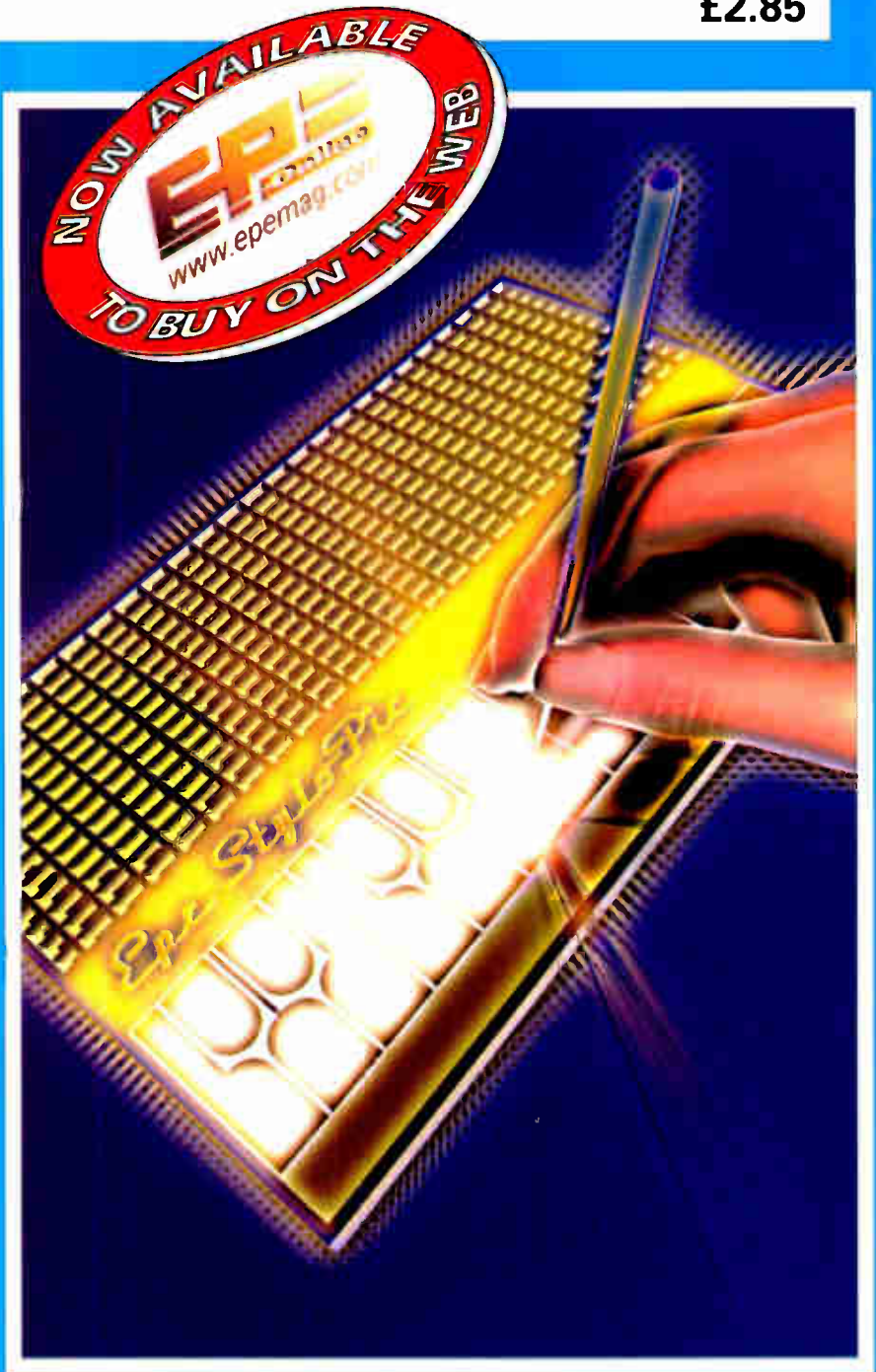

<http://www.epemag.wimborne.co.uk>



ISSN 0262 3617  
PROJECTS ... THEORY ... NEWS ...  
COMMENTS ... POPULAR FEATURES ...

VOL. 31. No. 7 JULY 2002  
Cover illustration by Jonathan Robertson

# EVERYDAY PRACTICAL ELECTRONICS

INCORPORATING ELECTRONICS TODAY INTERNATIONAL

[www.epemag.wimborne.co.uk](http://www.epemag.wimborne.co.uk)  
EPE Online: [www.epemag.com](http://www.epemag.com)

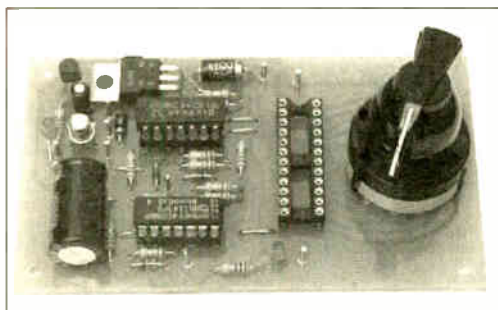
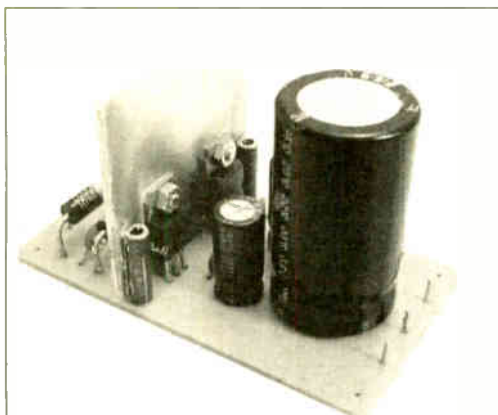
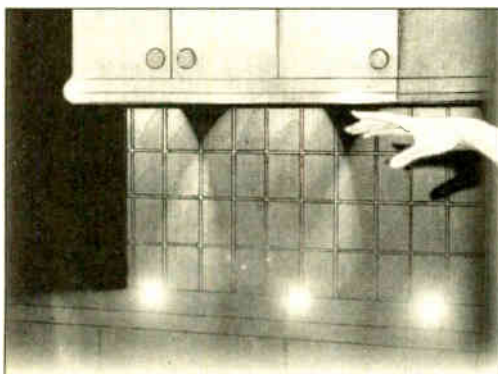
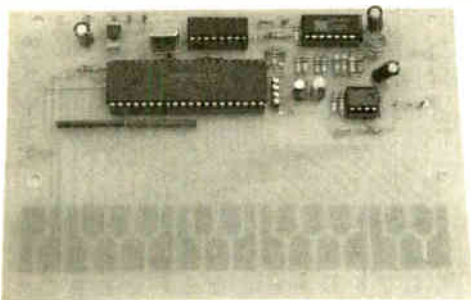

© Wimborne Publishing Ltd 2002. Copyright in all drawings, photographs and articles published in EVERYDAY PRACTICAL ELECTRONICS is fully protected, and reproduction or imitations in whole or in part are expressly forbidden.

Our August 2002 issue will be published on Thursday, 11 July 2002. See page 467 for details

## Projects and Circuits

- INFRA-RED AUTOSWITCH** by Max Horsey 476  
Keeps work-surface lights turned on only while you are near to them
- INGENUITY UNLIMITED** hosted by Alan Winstanley 486  
Velocity Detector; Car Battery Trickle Charger
- EPE STYLOPIC** by John Becker 488  
Have fun with a modern interpretation of a classic musical instrument!
- SIMPLE AUDIO CIRCUITS – 3. Power Supplies, Loudspeakers, Crossover Networks and Filters** by Raymond Haigh 500  
A compendium of useful audio amplifier circuits for the experimenting constructor
- ROTARY COMBINATION LOCK** by Thomas Scarborough 512  
Pure logic and a “stack of cards” function enhance security

## Series and Features

- NEW TECHNOLOGY UPDATE** by Ian Poole 484  
Holographic techniques could revolutionise computer data storage
- USING THE PIC'S PCLATH COMMAND** by John Waller 509  
How to access PIC addresses beyond 2K and place tables outside the basic 256 byte block
- CIRCUIT SURGERY** by Alan Winstanley and Ian Bell 519  
Bandgap Voltages; More on X and Y capacitors; Yaesu Battery Charger again
- PRACTICALLY SPEAKING** by Robert Penfold 522  
A practical look at interpreting component codings
- NET WORK – THE INTERNET PAGE** surfed by Alan Winstanley 527  
Search Engines; Tiscali 10.0
- TEACH-IN 2002 – 9. Filters, Analogue-to-Digital Conversion, Sampling and Nuclear Radiation Sensing** by Ian Bell and Dave Chesmore 528

## Regulars and Services

- EDITORIAL** 475
- NEWS** – Barry Fox highlights technology's leading edge Plus everyday news from the world of electronics 482
- READOUT** John Becker addresses general points arising 495
- BACK ISSUES** Did you miss these? Many now on CD-ROM! 498
- SHOPTALK** with David Barrington, The essential guide to component buying for EPE projects 507
- PLEASE TAKE NOTE**  
World Lamp; L.E.D. Sequencer; Toolkit TK3 507
- CD-ROMS FOR ELECTRONICS** 524  
A wide range of CD-ROMs for hobbyists, students and engineers
- DIRECT BOOK SERVICE** 536  
A wide range of technical books available by mail order
- PRINTED CIRCUIT BOARD AND SOFTWARE SERVICE** 539  
PCBs for EPE projects. Plus EPE software
- ELECTRONICS MANUALS** 540  
Essential reference works for hobbyists, students and service engineers
- ADVERTISERS INDEX** 544

Readers Services • Editorial and Advertisement Departments 475



# NEXT MONTH

## PIC WORLD CLOCK

Inspired by a display originally seen in a hotel lobby, this design graphically shows calendar, clock and global timezone data. Based on a PIC16F877 microcontroller and a graphics I.c.d., the following functions are available:

- Simplified World map
- Current UK clock and calendar data
- Clock data for any other timezone, adjustable via switches
- Flashing marker for sun's current highest position, i.e. true noon at that longitude (angle in relation to 0°, GMT)
- Marker's position vertically (latitude) varies with the weeks and months throughout the year, spanning the Tropics of Capricorn and Cancer
- Multi-paged text display of 150 major cities and their timezone displacements in relation to GMT (e.g. New York -5 hours, Sydney +11 hours)
- Additional city timezones can be readily added by readers who have PIC Toolkit Mk2 or Mk3 (TK3 V1.2)
- Accuracy of clock time-keeping adjustable via switches
- Principal clock and calendar data stored in the PIC's non-volatile EEPROM for recall in the event of power failure.
- Runs from a mains powered 9V battery adaptor, plus standby battery back-up.

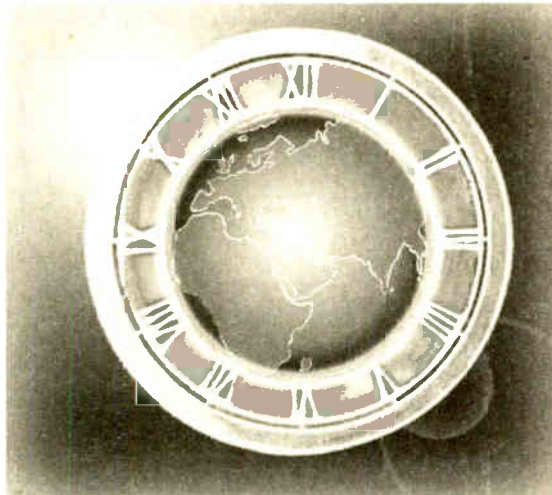

## A REVOLUTION IN EVOLUTION

We hear about advances in electronics all the time – smaller circuits, faster chips, new devices and technologies. But there's another revolution happening, one that in a few years may change electronics forever and perhaps even lead to the development of the first truly intelligent machines. This new revolution is called Evolutionary Electronics. One of the most interesting and unusual attributes of this revolution is its accessibility to hobbyists. The answers to the big questions aren't clear yet and the rewards for getting it right are immense. The experiments don't need million dollar machines or laboratories, just access to some good computing equipment and a degree of ingenuity.

We all know what evolution is: it is a simple and elegant concept. If you take a population of animals which have random genes and leave them in a particular environment, those with good traits will survive and those that are not as fit will die. The better-suited members of the population survive to breed and to mix and pass on their good traits to the next generation. So, why not do the same with circuits? Set them up randomly, test how good they are (their fitness), and allow the best ones to survive and mix their traits (to breed!). Well, this can be done and it has been done with some very interesting results, as you will see next month.

## BIG-EARS BUGGY

A simple fun buggy that will move towards a sound – speak to it and it will turn and move towards you. Uses inexpensive circuitry bolted to a simple chassis. The circuit could find a number of other applications where the direction of sound needs to be monitored.

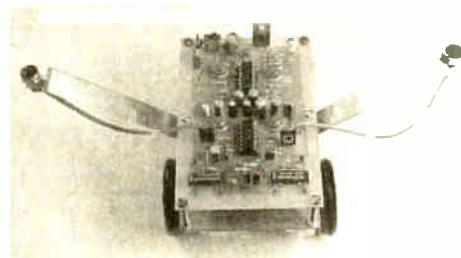

# NO ONE DOES IT BETTER

EVERYDAY  
**PRACTICAL**  
**ELECTRONICS**

**DON'T MISS AN  
ISSUE – PLACE YOUR  
ORDER NOW!**  
Demand is bound to be high

**AUGUST 2002 ISSUE ON SALE THURSDAY, JULY 11**



## Enhanced 'PICALL' ISP PIC Programmer

Kit will program virtually ALL 8 to 40 pin\* serial and parallel programmed PIC micro-controllers. Connects to PC parallel port. Supplied with fully functional pre-registered PICALL DOS and WINDOWS AVR software packages, all components and high quality DSPTH board. Also programs certain ATMEL AVR, SCENIX SX and EEPROM 24C devices. New devices can be added to the software as they are released. Blank chip auto detect feature for super-fast bulk programming. Hardware now supports ISP programming. \*A 40 pin wide ZIF socket is required to program 0-3in. devices (Order Code AZIF40 @ £15.00).



3144KT	Enhanced 'PICALL' ISP PIC Programmer	£64.95
AS3144	Assembled Enhanced 'PICALL' ISP PIC Programmer	£74.95
AS3144ZIF	Assembled Enhanced 'PICALL' ISP PIC Programmer c/w ZIF socket	£89.95

## ATMEL AVR Programmer



Powerful programmer for Atmel AT90Sxxxx (AVR) micro controller family. All fuse and lock bits are programmable. Connects to serial port. Can be used with ANY computer and operating system. Two LEDs to indicate programming status. Supports 20-pin DIP AT90S1200 & AT90S2313 and 40-pin DIP AT90S4414 & AT90S8515 devices. NO special software required – uses any terminal emulator program (built into Windows). The programmer is supported by BASCOM-AVR Basic Compiler software (see website for details).

3122KT	ATMEL AVR Programmer	£24.95
AS3122	Assembled 3122	£39.95

Atmel 89Cx051 and 89xxx programmers also available.

## PC Data Acquisition & Control Unit

With this kit you can use a PC parallel port as a real world interface. Unit can be connected to a mixture of analogue and digital inputs from pressure, temperature, movement, sound, light intensity, weight sensors, etc (not supplied) to sensing switch and relay states. It can then process the input data and use the information to control up to 11 physical devices such as motors, sirens, other relays, servo motors & two-stepper motors.



### FEATURES:

- 8 Digital Outputs: Open collector, 500mA, 33V max.
- 16 Digital Inputs: 20V max. Protection 1K in series, 5-1V Zener to ground.
- 11 Analogue Inputs: 0-5V, 10 bit (5mV/step.)
- 1 Analogue Output: 0-2.5V or 0-10V. 8 bit (20mV/step.)

All components provided including a plastic case (140mm x 110mm x 35mm) with pre-punched and silk screened front/rear panels to give a professional and attractive finish (see photo) with screen printed front & rear panels supplied. Software utilities & programming examples supplied.

3093KT	PC Data Acquisition & Control Unit	£99.95
AS3093	Assembled 3093	£124.95

**See opposite page for ordering information on these kits**

## ABC Mini 'Hotchip' Board



Currently learning about microcontrollers? Need to do something more than flash a LED or sound a buzzer? The ABC Mini 'Hotchip' Board is based on Atmel's AVR 8535 RISC technology and will interest both the beginner and expert alike. Beginners will find that they can write and test a simple program, using the BASIC programming language, within an hour or two of connecting it up.

Experts will like the power and flexibility of the ATMEL microcontroller, as well as the ease with which the little Hot Chip board can be "designed-in" to a project. The ABC Mini Board 'Starter Pack' includes just about everything you need to get up and experimenting right away. On the hardware side, there's a pre-assembled micro controller PC board with both parallel and serial cables for connection to your PC. Windows software included on CD-ROM features an Assembler, BASIC compiler and in-system programmer. The pre-assembled boards only are also available separately.

ABCMINISP	ABC MINI Starter Pack	£64.95
ABCMINIB	ABC MINI Board Only	£39.95

## Advanced 32-bit Schematic Capture and Simulation Visual Design Studio



## Serial Port Isolated I/O Controller

Kit provides eight relay outputs capable of switching 4 amps at mains voltages and four optically isolated inputs. Can be used in a variety of control and sensing applications including load switching, external switch input sensing, contact closure and external voltage sensing.



Programmed via a computer serial port, it is compatible with ANY computer & operating system. After programming, PC can be disconnected. Serial cable can be up to 35m long, allowing 'remote' control. User can easily write batch file programs to control the kit using simple text commands. NO special software required – uses any terminal emulator program (built into Windows). All components provided including a plastic case with pre-punched and silk screened front/rear panels to give a professional and attractive finish (see photo).

3108KT	Serial Port Isolated I/O Controller Kit	£54.95
AS3108	Assembled Serial Port Isolated I/O Controller	£69.95





# New – Professional versions of WIZ-C and our PIC C Compiler

WIZ – C, The new name for FED's PIXIE development system

## What is the WIZ-C Rapid Application Environment ?

- Our PIC C compiler including a new front end.
- An application designer for the FED PIC C Compiler
- Drag a software component on to your design & set up the parameters using check boxes, drop down boxes and edit boxes (see shot right).
- Connect the component to the PIC pins using the mouse
- Select your own C functions to be triggered when events occur (e.g. Byte received, timer overflow etc.)
- Generate the base application automatically and then add your own functional code in C or assembler
- Simulate, Trace at up to 10x the speed of MPLAB
- Supports 14/16 bit core PICS  
16F87x, 16C55x, 16C6x, 16F8x, 16C7xx 18Cxx etc.
- C Compiler designed to ANSI C Standards

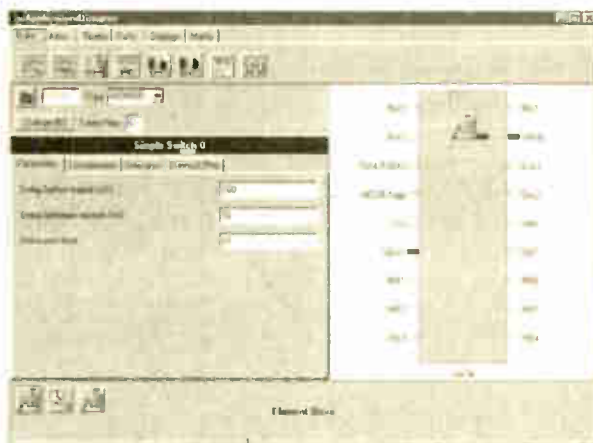

## Professional Version Enhancements to our C Compiler and WIZ-C Rapid Application Environment

- Manage and simulate multiple projects together
- Connect PIC pins across projects to allow simulated devices to communicate
- Handle assembler and C projects
- View and inspect variables in native C format
- Inspect all local variables and their values in native C format
- Maintain a history within simulation to back track and determine the past leading up to an event

### Prices

WIZ – C Standard - £70.00,  
Professional £100.00. Upgrade for existing WIZ-C owners £30.00  
PIC C Compiler Standard - £60.00,  
Professional £90.00. Upgrade for existing Compiler owners £30.00  
**Other upgrade options are available together with reduced price bundled packages – see our web site for details**

## In Circuit Debugger

Operates with FED PIC Development apps (WIZ-C, WIZASM, C Compiler)

### What is In-Circuit Debugging (ICD) ?

In Circuit Debugging is a technique where a monitor program runs on the PIC in the application circuit. The ICD board connects to the PIC and to the PC. From any of our applications it is then possible to set breakpoints on the PIC, run code, single step, examine registers on the real device and change their values. The ICD makes debugging real time applications faster, easier and more accurate than simulation tools available for the PIC.

### Features

- Allows real hardware to be examined & programs to be debugged and to be run in real time on your application

- Powered from the application circuit (3.3V to 5V)
- The FED ICD requires only one data I/O pin on the PIC which can be chosen from any of ports B, C or D.
- Can program and re-program applications in circuit
- Up to 3 breakpoints
- Run, single step and step over, run to cursor line, set PC to any value in the program
- Trace execution in the original C or Assembler source files
- Animate operation to trace variables at breakpoints or watch the program executing
- Auto Run application if ICD not connected
- View and change values of PIC special function and general purpose registers, W and the ports.
- Uses a standard (3 wire) serial interface to a PC
- Operates on our development board (right)

Price - £30.00, Requires a copy of WIZASM, our PIC C Compiler, or the WIZ-C applications

## Other PIC Products

### Development Board

- Handles 40 pin PIC devices
- Includes on board Programmer – no separate programmer required
- 4 LED's on board, Analogue on trimpot, 2 duplex serial ports
- 1A 5V regulator
- 20MHz crystal
- Interfaces for LCD, hex keypad, 32 I/O pins on IDC connectors
- Will run FED PIC BASIC (included on CD)
- 12C EEPROM socket



Price - £45.00 Built and Tested. 16F877-20P £6.00, 18C452/JW £30.00. CD with BASIC & Programmer £5.00

### PIC Serial Programmer including 18Cxxx

Handles serially programmed PIC devices in a 40 pin multi-width ZIF socket.  
16C55X, 16C6X  
16C7X, 16C8x, 16F8X,  
12C508, 12C509,  
16C72XPIC 14000,  
16F87X, 18Cxxx etc

Also In-Circuit programming. Operates on PC serial port.  
Price : £45/kit £50/built & tested

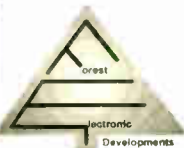
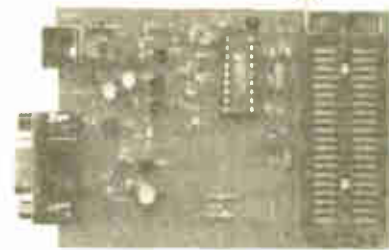

**Forest Electronic Developments 01590-681511 (Voice/Fax)**

12 Buldowne Walk, Sway, LYMINGTON, HAMPSHIRE, S041 6DU.

Email – info@fored.co.uk, or sales@fored.co.uk

Web Site – http://www.fored.co.uk

Prices are fully inclusive, Add £3.00 for P&P and handling to each order.

Cheques/POs payable to Forest Electronic Developments, or phone with credit card or Switch details.



MAIL ORDER ONLY • CALLERS BY APPOINTMENT

## EPE MICROCONTROLLER P.I. TREASURE HUNTER

The latest MAGENTA DESIGN - highly stable & sensitive - with I.C. control of all timing functions and advanced pulse separation techniques.

- High stability drift cancelling
- Easy to build & use
- No ground effect, works in seawater



- Detects gold, silver, ferrous & non-ferrous metals

- Efficient quartz controlled microcontroller pulse generation.
- Full kit with headphones & all hardware

**KIT 847 ..... £63.95**

## PORTABLE ULTRASONIC PEST SCARER

A powerful 23kHz ultrasound generator in a compact hand-held case. MOSFET output drives a special sealed transducer with intense pulses via a special tuned transformer. Sweeping frequency output is designed to give maximum output without any special setting up.

**KIT 842.....£22.56**

## 68000 DEVELOPMENT TRAINING KIT

- NEW PCB DESIGN
- 8MHz 68000 16-BIT BUS
- MANUAL AND SOFTWARE
- 2 SERIAL PORTS
- PIT AND I/O PORT OPTIONS
- 12C PORT OPTIONS

**KIT 621**

**£99.95**

- ON BOARD 5V REGULATOR
- PSU £6.99
- SERIAL LEAD £3.99

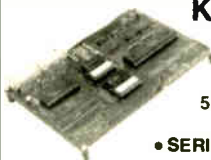

## Stepping Motors

MD38...Mini 48 step...£8.65

MD35...Std 48 step...£9.99

MD200...200 step...£12.99

MD24...Large 200 step...£22.95



## PIC PIPE DESCALER

- SIMPLE TO BUILD
- HIGH POWER OUTPUT
- AUDIO & VISUAL MONITORING
- SWEPT FREQUENCY

An affordable circuit which sweeps the incoming water supply with variable frequency electromagnetic signals. May reduce scale formation, dissolve existing scale and improve lathering ability by altering the way salts in the water behave. Kit includes case, P.C.B., coupling coil and all components. High coil current ensures maximum effect. L.E.D. monitor.

**KIT 868 ..... £22.95 POWER UNIT.....£3.99**



## MICRO PEST SCARER

Our latest design - The ultimate scarer for the garden. Uses special microchip to give random delay and pulse time. Easy to build reliable circuit. Keeps pets/pests away from newly sown areas, play areas, etc. Uses power source from 9 to 24 volts.

- RANDOM PULSES
- HIGH POWER
- DUAL OPTION



Plug-in power supply £4.99

**KIT 867. .... £19.99**

**KIT + SLAVE UNIT. .... £32.50**

## WINDICATOR

A novel wind speed indicator with LED readout. Kit comes complete with sensor cups, and weatherproof sensing head. Mains power unit £5.99 extra.

**KIT 856. .... £28.00**

## ★ TENS UNIT ★

### DUAL OUTPUT TENS UNIT

As featured in March '97 issue.

Magenta have prepared a FULL KIT for this excellent new project. All components, PCB, hardware and electrodes are included. Designed for simple assembly and testing and providing high level dual output drive.

**KIT 866. . Full kit including four electrodes £32.90**

Set of 4 spare electrodes £6.50

## 1000V & 500V INSULATION TESTER



Superb new design. Regulated output, efficient circuit. Dual-scale meter, compact case. Reads up to 200 Megohms. Kit includes wound coil, cut-out case, meter scale, PCB & ALL components.

**KIT 848. .... £32.95**

## EPE TEACH-IN 2000

Full set of top quality NEW components for this educational series. All parts as specified by EPE. Kit includes breadboard, wire, croc clips, pins and all components for experiments, as listed in introduction to Part 1.

\*Batteries and tools not included.

**TEACH-IN 2000 -**

**KIT 879 £44.95**

**MULTIMETER £14.45**

## SPACEWRITER

An innovative and exciting project. Wave the wand through the air and your message appears. Programmable to hold any message up to 16 digits long. Comes pre-loaded with "MERRY XMAS". Kit includes PCB, all components & tube plus instructions for message loading.

**KIT 849 .....£16.99**

## 12V EPROM ERASER

A safe low cost eraser for up to 4 EPROMS at a time in less than 20 minutes. Operates from a 12V supply (400mA). Used extensively for mobile work - updating equipment in the field etc. Also in educational situations where mains supplies are not allowed. Safety interlock prevents contact with UV.

**KIT 790 .....£29.90**

## SUPER BAT DETECTOR

1 WATT O/P, BUILT IN SPEAKER, COMPACT CASE 20kHz-140kHz NEW DESIGN WITH 40kHz MIC.

A new circuit using a 'full-bridge' audio amplifier i.c., internal speaker, and headphone/tape socket. The latest sensitive transducer, and 'double balanced mixer' give a stable, high performance superheterodyne design.

**KIT 861 .....£24.99**

ALSO AVAILABLE Built & Tested... £39.99



## MOSFET MkII VARIABLE BENCH POWER SUPPLY 0-25V 2.5A

Based on our Mk1 design and preserving all the features, but now with switching pre-regulator for much higher efficiency. Panel meters indicate Volts and Amps. Fully variable down to zero. Toroidal mains transformer. Kit includes punched and printed case and all parts. As featured in April 1994 EPE. An essential piece of equipment.



Kit No. 845 ..... £64.95

## EPE PROJECT PICS

Programmed PICs for all\* EPE Projects 16C84/18F84/16C71 All **£5.90 each** PIC16F877 now in stock **£10 inc. VAT & postage** (\*some projects are copyright)

## ULTRASONIC PEST SCARER

Keep pets/pests away from newly sown areas, fruit, vegetable and flower beds, children's play areas, patios etc. This project produces intense pulses of ultrasound which deter visiting animals.

- KIT INCLUDES ALL COMPONENTS, PCB & CASE
- EFFICIENT 100V TRANSDUCER OUTPUT
- COMPLETELY INAUDIBLE TO HUMANS



- UP TO 4 METRES RANGE
- LOW CURRENT DRAIN

**KIT 812. .... £15.00**

## SIMPLE PIC PROGRAMMER

INCREDIBLE LOW PRICE! Kit 857 **£12.99**

INCLUDES 1-PIC16F84 CHIP  
SOFTWARE DISK, LEAD  
CONNECTOR, PROFESSIONAL  
PC BOARD & INSTRUCTIONS

Power Supply £3.99

EXTRA CHIPS:  
PIC 16F84 £4.84

Based on February '96 EPE. Magenta designed PCB and kit. PCB with 'Reset' switch, Program switch, 5V regulator and test L.E.D.s, and connection points for access to all A and B port pins.

## PIC 16C84 DISPLAY DRIVER

INCLUDES 1-PIC16F84 WITH DEMO  
PROGRAM SOFTWARE DISK, PCB,  
INSTRUCTIONS AND 16-CHARAC-  
TER 2-LINE  
**LCD DISPLAY**

Kit 860 **£19.99**

Power Supply £3.99

FULL PROGRAM SOURCE CODE  
SUPPLIED - DEVELOP  
YOUR OWN APPLICATION!

Another super PIC project from Magenta. Supplied with PCB, industry standard 2-LINE x 16-character display, data, all components, and software to include in your own programs. Ideal development base for meters, terminals, calculators, counters, timers - Just waiting for your application!

## PIC 16F84 MAINS POWER 4-CHANNEL CONTROLLER & LIGHT CHASER

- WITH PROGRAMMED 16F84 AND DISK WITH SOURCE CODE IN MPASM
- ZERO VOLT SWITCHING MULTIPLE CHASE PATTERNS
- OPTO ISOLATED 5 AMP OUTPUTS
- 12 KEYPAD CONTROL
- SPEED/DIMMING POT.
- HARD-FIRED TRIACS

Now features full 4-channel chaser software on DISK and pre-programmed PIC16F84 chip. Easily re-programmed for your own applications. Software source code is fully 'commented' so that it can be followed easily.

Kit 855 **£39.95**

LOTS OF OTHER APPLICATIONS

## 8-CHANNEL DATA LOGGER

As featured in Aug./Sept. '99 EPE. Full kit with Magenta redesigned PCB - LCD fits directly on board. Use as Data Logger or as a test bed for many other 16F877 projects. Kit includes programmed chip, 8 EEPROMs, PCB, case and all components.

KIT 877 **£49.95** inc. 8 x 256K EEPROMS

## ICEBREAKER

□□□□□□□□□□

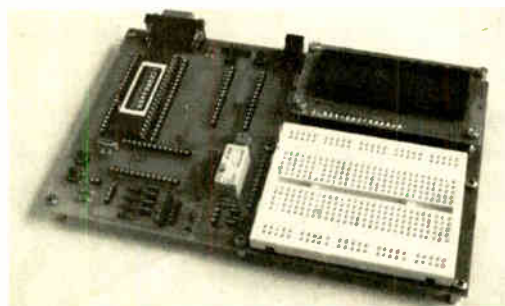

## PIC Real Time In-Circuit Emulator

- Icebreaker uses PIC16F877 in circuit debugger
- Links to Standard PC Serial Port (lead supplied)
- Windows™ (95+) Software included
- Works with MPASM and MPLAB Microchip software
- 16 x 2 L.C.D., Breadboard, Relay, I/O devices and patch leads supplied

As featured in March '00 EPE. Ideal for beginners AND advanced users. Programs can be written, assembled, downloaded into the microcontroller and run at full speed (up to 20MHz), or one step at a time.

Full emulation means that all I/O ports respond exactly and immediately, reading and driving external hardware.

Features include: Reset; Halt on external pulse, Set Breakpoint; Examine and Change registers, EEPROM and program memory; Load program, Single Step with display of Status, W register, Program counter, and user selected 'Watch Window' registers.

KIT 900 . . . **£34.99**

POWER SUPPLY £3.99 STEPPING MOTOR £5.99

## EPE PIC TOOLKIT 3

NEW

- THE LATEST TOOLKIT BOARD - 8, 18, 28 AND 40-PIN CHIPS
- MAGENTA DESIGNED P.C.B. WITH COMPONENT LAYOUT AND EXTRAS
- L.C.D., BREADBOARD AND PIC CHIP INCLUDED
- ALL TOP QUALITY COMPONENTS AND SOFTWARE SUPPLIED

KIT 880 . . . **£34.99** with 16F84 . . . **£39.99** with 16F877

## PIC TOOLKIT V2

- SUPER UPGRADE FROM V1 • 18, 28 AND 40-PIN CHIPS
- READ, WRITE, ASSEMBLE & DISASSEMBLE PICS
- SIMPLE POWER SUPPLY OPTIONS 5V-20V
- ALL SWITCHING UNDER SOFTWARE CONTROL
- MAGENTA DESIGNED PCB HAS TERMINAL PINS AND OSCILLATOR CONNECTIONS FOR ALL CHIPS
- INCLUDES SOFTWARE AND PIC CHIP

KIT 878 . . . **£22.99** with 16F84 . . . **£29.99** with 16F877

## EPE PIC Tutorial

At last! A Real, Practical, Hands-On Series

- Learn Programming from scratch using PIC16F84
- Start by lighting l.e.d.s and do 30 tutorials to Sound Generation, Data Display, and a Security System.
- PIC TUTOR Board with Switches, l.e.d.s, and on board programmer

## PIC TUTOR BOARD KIT

Includes: PIC16F84 Chip, TOP Quality PCB printed with Component Layout and all components\* (\*not ZIF Socket or Displays). Included with the Magenta Kit is a disk with Test and Demonstration routines.

KIT 870 .... **£27.95**, Built & Tested .... **£42.95**

Optional: Power Supply - **£3.99**, ZIF Socket - **£9.99**

LCD Display ..... **£7.99** LED Display ..... **£6.99**

Reprints Mar/Apr/May 98 - **£3.00** set 3

## SUPER PIC PROGRAMMER

- READS, PROGRAMS, AND VERIFIES
- WINDOWS® SOFTWARE
- PIC16C6X, 7X, AND 8X
- USES ANY PC PARALLEL PORT
- USES STANDARD MICROCHIP • HEX FILES
- OPTIONAL DISASSEMBLER SOFTWARE (EXTRA)
- PCB, LEAD, ALL COMPONENTS, TURNED-PIN SOCKETS FOR 18, 28, AND 40 PIN ICs

• SEND FOR DETAILED INFORMATION - A SUPERB PRODUCT AT AN UNBEATABLE LOW PRICE.

Kit 862 **£29.99**

Power Supply £3.99

DISASSEMBLER SOFTWARE **£11.75**

## PIC STEPPING MOTOR DRIVER

INCLUDES PCB, PIC16F84 WITH DEMO PROGRAM, SOFTWARE DISC, INSTRUCTIONS AND MOTOR.

Kit 863 **£18.99**

FULL SOURCE CODE SUPPLIED ALSO USE FOR DRIVING OTHER POWER DEVICES e.g. SOLENOIDS

Another NEW Magenta PIC project. Drives any 4-phase unipolar motor - up to 24V and 1A. Kit includes all components and 48 step motor. Chip is pre-programmed with demo software, then write your own, and re-program the same chip! Circuit accepts inputs from switches etc and drives motor in response. Also runs standard demo sequence from memory.

# MAGENTA

All prices include VAT. Add £3.00 p&p. Next day **£6.99**

Tel: 01283 565435 Fax: 01283 546932 E-mail: sales@magenta2000.co.uk



# EVERYDAY PRACTICAL ELECTRONICS

THE No.1 MAGAZINE FOR ELECTRONICS TECHNOLOGY & COMPUTER PROJECTS

VOL. 31 No. 7 JUNE 2002

## RIP OFF!

It's a pity when a few spoil it for everyone – we see it all too often in modern society with football hooligans, young vandals, hackers and virus writers and, of course, those that are prepared to rip someone else off for their own gain and glorification. Why is this relevant to *EPE*, well, of course, it should not be – but then we exist in today's world just like everyone else.

## SERIOUS OFFENCE

Over the last twenty years or so we have had just one or two instances where items we have published have turned out to have been copied from other magazines, but this month two such items have come to light – both have been published in our *Ingenuity Unlimited* column and both have been copied from other magazines. This has happened even though both readers have signed a legal form to say: "I hereby confirm that the above-mentioned submission for publication in the *Ingenuity Unlimited* column is my/our own work and has not been published or currently submitted for publication elsewhere. I have read and understand the Notice appearing below." The Notice referred to reads: "This is a legally-binding agreement. Breach of copyright is now a serious offence. Material which is accepted for inclusion in *Ingenuity Unlimited* must not have been published or be currently submitted for publication elsewhere. In signing this form you agree to indemnify us from any damages and costs arising as a consequence of any breach of copyrights held by any other parties."

So these *EPE* readers are apparently quite happy to commit a serious offence and to take all of us for a ride.

The items in question were previously published in *Practical Wireless* and *Elektor* magazines and we apologise to them for breaching their copyright. Fortunately, the Editors of both magazines have been very understanding – possibly because they, too, are well aware of the problems caused by a few unscrupulous readers, so hopefully we will not need to go after these readers for damages, although that might make others think before they copy. In one case the reader has not been paid and in the other we are taking steps to recover the payment made.

## REVIEW

We are now in the process of reviewing the future of our *IU* page, a pity but then, as I have said, so often the few spoil it for everyone. I hope those responsible are suitably shamed – you will find a special notice on our *IU* page this month.

I guess after 30-odd years on *PE/EE* and *EPE* I should not be surprised, but I am rather sad.



## AVAILABILITY

Copies of *EPE* are available on subscription anywhere in the world (see below), from all UK newsagents (distributed by COMAG) and from the following electronic component retailers: Omni Electronics and Yebo Electronics (S. Africa). *EPE* can also be purchased from retail magazine outlets around the world. An Internet on-line version can be purchased and downloaded for just \$9.99 (US – approx £7.70) per year available from [www.epemag.com](http://www.epemag.com)

## SUBSCRIPTIONS

Subscriptions for delivery direct to any address in the UK: 6 months £15, 12 months £28.50, two years £52; Overseas: 6 months £18 standard air service or £27 express airmail, 12 months £34.50 standard air service or £52 express airmail, 24 months £64 standard air service or £99 express airmail.

Online subscriptions, for downloading the magazine via the Internet, \$9.99 (US – approx £7.70) for one year available from [www.epemag.com](http://www.epemag.com).

Cheques or bank drafts (in £ sterling only) payable to *Everyday Practical Electronics* and sent to EPE Subs. Dept., Wimborne Publishing Ltd, 408 Wimborne Road East, Ferndown, Dorset BH22 9ND. Tel: 01202 873872. Fax: 01202 874562. Email: [subs@epemag.wimborne.co.uk](mailto:subs@epemag.wimborne.co.uk). Also via the Web at: <http://www.epemag.wimborne.co.uk>. Subscriptions start with the next available issue. We accept MasterCard, Amex, Diners Club, Switch or Visa. (For past issues see the *Back Issues* page.)

## BINDERS

Binders to hold one volume (12 issues) are available from the above address. These are finished in blue p.v.c., printed with the magazine logo in gold on the spine. Price £5.95 plus £3.50 p&p (for overseas readers the postage is £6.00 to everywhere except Australia and Papua New Guinea which cost £10.50). Normally sent within seven days but please allow 28 days for delivery – more for overseas.

Payment in £ sterling only please. Visa, Amex, Diners Club, Switch and MasterCard accepted. Send, fax or phone your card number and card expiry date with your name, address etc. Or order on our secure server via our UK web site. Overseas customers – your credit card will be charged by the card provider in your local currency at the existing exchange rate.

## Editorial Offices:

EVERYDAY PRACTICAL ELECTRONICS EDITORIAL  
WIMBORNE PUBLISHING LTD., 408 WIMBORNE ROAD EAST,  
FERNDOWN, DORSET BH22 9ND  
Phone: (01202) 873872. Fax: (01202) 874562.

Email: [enquiries@epemag.wimborne.co.uk](mailto:enquiries@epemag.wimborne.co.uk)

Web Site: <http://www.epemag.wimborne.co.uk>

EPE Online [www.epemag.com](http://www.epemag.com)

EPE Online Shop: [www.epemag.wimborne.co.uk/shopdoor.htm](http://www.epemag.wimborne.co.uk/shopdoor.htm)

See notes on **Readers' Technical Enquiries** below – we regret lengthy technical enquiries cannot be answered over the telephone.

## Advertisement Offices:

EVERYDAY PRACTICAL ELECTRONICS ADVERTISEMENTS  
MILL LODGE, MILL LANE  
THORPE-LE-SOKEN, ESSEX CO16 0ED  
Phone/Fax: (01255) 861161

Editor: MIKE KENWARD

Deputy Editor: DAVID BARRINGTON

Technical Editor: JOHN BECKER

Business Manager: DAVID J. LEAVER

Subscriptions: MARILYN GOLDBERG

Administration: FAY KENWARD

Editorial/Admin: (01202) 873872

Advertisement Manager:

PETER J. MEW, Frinton (01255) 861161

Advertisement Copy Controller:

PETER SHERIDAN, (01202) 873872

On-Line Editor: ALAN WINSTANLEY

EPE Online (Internet version) Editors:

CLIVE (MAX) MAXFIELD and ALVIN BROWN

## READERS' TECHNICAL ENQUIRIES

E-mail: [techdept@epemag.wimborne.co.uk](mailto:techdept@epemag.wimborne.co.uk)

We are unable to offer any advice on the use, purchase, repair or modification of commercial equipment or the incorporation or modification of designs published in the magazine. We regret that we cannot provide data or answer queries on articles or projects that are more than five years old. Letters requiring a personal reply must be accompanied by a stamped self-addressed envelope or a self-addressed envelope and international reply coupons. All reasonable precautions are taken to ensure that the advice and data given to readers is reliable. We cannot, however, guarantee it and we cannot accept legal responsibility for it.

## COMPONENT SUPPLIES

We do not supply electronic components or kits for building the projects featured, these can be supplied by advertisers (see *Shoptalk*). We advise readers to check that all parts are still available before commencing any project in a back-dated issue.

## ADVERTISEMENTS

Although the proprietors and staff of EVERYDAY PRACTICAL ELECTRONICS take reasonable precautions to protect the interests of readers by ensuring as far as practicable that advertisements are *bona fide*, the magazine and its Publishers cannot give any undertakings in respect of statements or claims made by advertisers, whether these advertisements are printed as part of the magazine, or in inserts.

The Publishers regret that under no circumstances will the magazine accept liability for non-receipt of goods ordered, or for late delivery, or for faults in manufacture.

## TRANSMITTERS/BUGS/TELEPHONE EQUIPMENT

We advise readers that certain items of radio transmitting and telephone equipment which may be advertised in our pages cannot be legally used in the UK. Readers should check the law before buying any transmitting or telephone equipment as a fine, confiscation of equipment and/or imprisonment can result from illegal use or ownership. The laws vary from country to country; readers should check local laws.



## Constructional Project

# INFRA-RED AUTOSWITCH

MAX HORSEY



Simply waving your hand near this versatile IR switch will cause lights to switch on for a timed period. If you stay in the area the unit will remain triggered.

**T**HE Infra-Red Autoswitch described here will, no doubt, find many applications, but it was designed initially to switch on the concealed lighting around a set of kitchen units. Simply waving your hand near the unit will cause the lights to switch on for a timed period. Also, if you stay in the area the unit will remain triggered.

The sensor employed here is similar to the auto-switches used in up-market public wash handbasins and handdriers, where the water or air is switched on when your hand is in place.

It is important not to make the unit too sensitive otherwise false triggering will occur. The system is triggered when your hand is about 30cm from the unit. The prototype was concealed underneath a kitchen cupboard, the distance between the unit and the worksurface being too large to cause false triggering.

The project was designed for maximum ease of assembly and fitting, with all components including the transformer being housed on a printed circuit board (p.c.b.). The only connections required are the mains supply input, and lighting output.

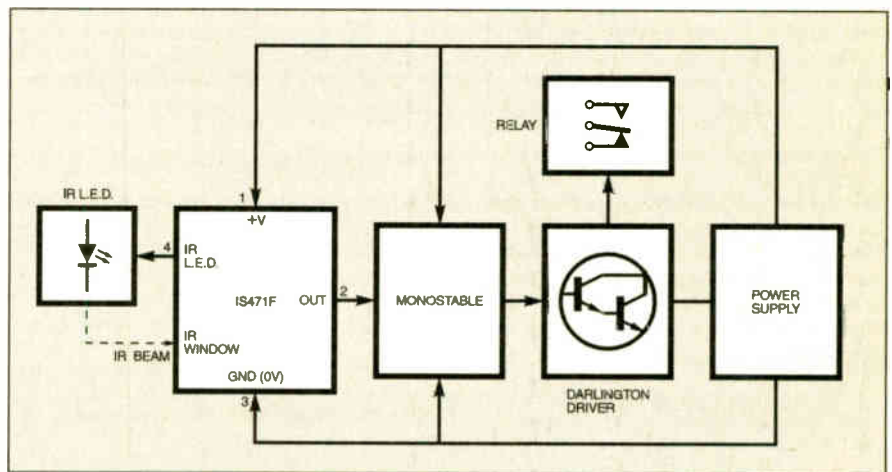

Fig. 1. Block schematic diagram for the Infra-Red Autoswitch.

### INTELLIGENT SENSOR

The infra-red system is based on the inexpensive but intelligent IS471F infra-red sensor i.c. This i.c. provides a signal, which may be used to directly drive one or two infra-red l.e.d.s.

A coded signal is applied to the IR l.e.d.s, and having transmitted the beam,

the i.c. waits for the signal to be reflected. The reflected signal is detected by a window built into the i.c., and when the signal is received the output switches from positive to zero volts.

A basic block schematic diagram is shown in Fig.1. The IS471F is a 4-pin device; pin 1 and pin 3 connect to the power supply, which should be between 4.5V and 16V. Pin 4 acts as a sink to provide the coded signal for the IR l.e.d.s. and pin 2 is the output.

When a reflected signal is detected, the output at pin 2 switches from positive to 0V. This is used to trigger a monostable (timer). The monostable switches on a transistor and relay, which in turn switches on the lights or any other device.

### CIRCUIT DETAILS

The full circuit diagram for the Infra-Red Autoswitch is shown in Fig.2. The IS471F infra-red sensor (IC1) is connected to a pair of infra-red l.e.d.s D1 and D2 as shown. Note that no series resistor is required since the current is regulated by the i.c. In tests, two l.e.d.s provided a longer detection range than one, but three made no difference. If a shorter range is required a single l.e.d. could be employed, it is also possible to reduce the range by adding a resistor in series with the l.e.d.s.

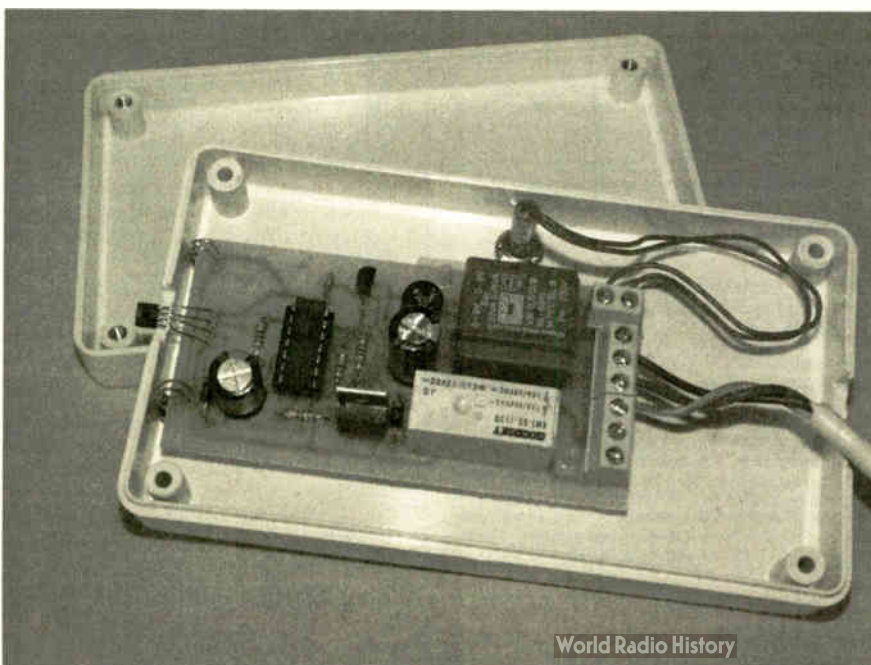

The monostable is based around the well-tried-and-tested CMOS 4001B chip, which houses four NOR gates. Gates IC2b and IC2c are configured as a monostable and a positive signal is required at pin 5 of gate IC2b to trigger the time period.

As stated, IC1 provides an output which switches to 0V when an object is detected. So it is necessary to invert this signal, and this is achieved by means of gate IC2a, whose inputs (pin 1 and pin 2) are connected together thus making it behave as a NOT gate or inverter.

When an object is detected, pin 2 of IC1 switches to 0V, and this causes output pin 3 of IC2a to switch to positive (high). This signal is fed to input pin 5 of IC2b, so triggering the monostable formed by IC2b and IC2c.

When triggered, pin 4 of IC2b switches to 0V, and this sudden change of voltage is transferred to the other side of capacitor C1, so reducing the voltage at pin 8 and pin 9 to 0V. Hence output pin 10 of IC2c switches to positive, and this is fed back to input pin 6 of IC2b, so latching the monostable into its new state.

output pin 2 of IC1 switches to 0V (object detected), capacitor C1 is discharged.

With this addition, timing is from the last time that an object was detected. So, if you stand near the sensor, the lights will remain on. Diode D3 prevents current flowing towards capacitor C1 when IC1 pin 2 is positive, and resistor R1 is needed to reduce the surge of current that might damage IC1.

When the circuit is being tested, a time period of more than five minutes can be tedious! So resistor R3 was included together with solder pads P1 and P2. Terminal pins or a wire link may be soldered to these pads so that at the testing stage the time period can be reduced to just a few seconds. When the system is working, the link can be cut, so reverting to the full time period.

If you wish to have a variable time period, then resistor R2 may be omitted, and a variable resistor (potentiometer) can be connected across pads P1 and P2. A value of 1 megohm will provide a sufficient range of times.

## COMPONENTS

### Resistors

R1	680Ω
R2	680k
R3	10k
R4	4k7

All 0.25W 5% carbon film

See  
**SHOP  
TALK**  
page

### Capacitors

C1, C3	1000μ radial elect. 25V (2 off)
C2	100n disc ceramic

### Semiconductors

D1, D2	infra-red light-emitting diode (2 off)
D3, D4	1N4001 1A 50V rect. diode (2 off)
TR1	TIP122 npn Darlington transistor
IC1	IS471F infra-red sensor
IC2	4001 quad 2-input NOR gate
IC3	78L12 +12V voltage regulator
REC1	W005 1.5A 50V bridge rectifier

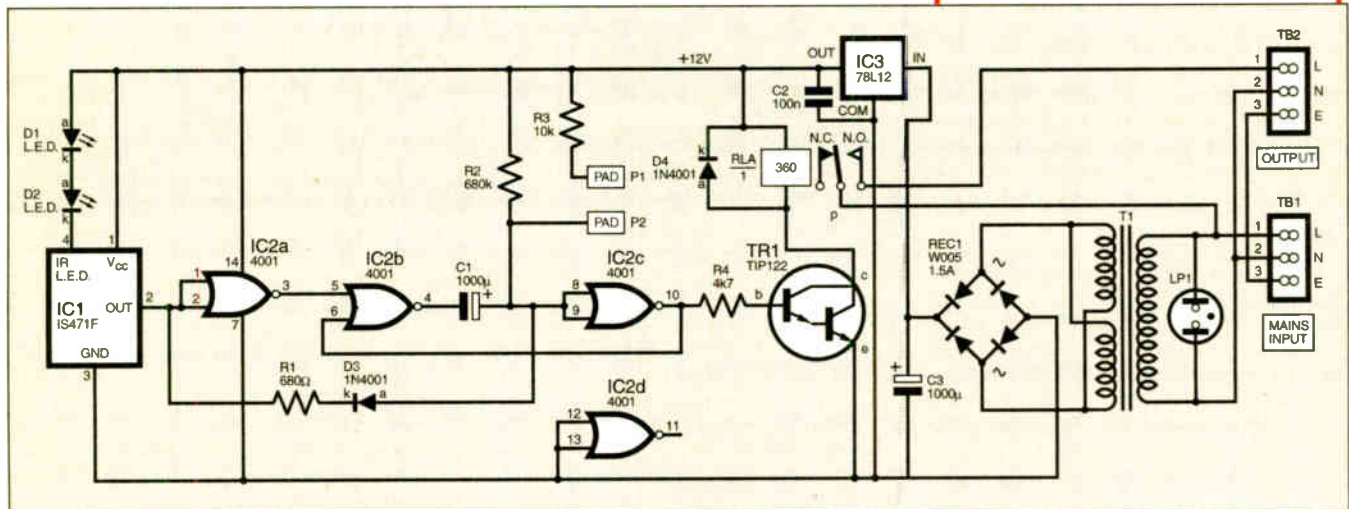

Fig.2. Complete circuit diagram, including mains power supply, for the Infra-Red Autoswitch.

The monostable is not stable in its new state, since there is a voltage difference across resistor R2. Current therefore flows through R2, slowly charging up capacitor C1. So the voltage rises at IC2c pin 8 and pin 9 and as it crosses the half-way point, gate IC2c changes state and completes the time period.

Now the change of logic level is fed back to IC2b pin 6 which causes IC2b output pin 4 to switch back to positive. This change of voltage is transferred across capacitor C1, so reinforcing the change already taking place. All this happens very quickly so producing a clean change of state to 0V at pin 10 of IC2c.

Once the monostable is triggered, further triggering has no effect, and the time period is fixed from the first moment that triggering occurred. This can be irritating in this application, since the lights will switch off even if your hand is still near the sensor.

Although they will be re-triggered immediately, this is not ideal, especially since kitchen units are generally fitted with fluorescent lights which flicker as they switch on. Hence resistor R1 and diode D3 were added so that every time

## OUTPUT DRIVER

Little current is available from the output of a CMOS gate, and so transistor TR1 is employed to amplify the current available. In fact, Darlington transistors cost little more than normal ones, and so a Darlington transistor was used in the prototype. The massive gain and power rating of a Darlington allows the use of almost any type of low voltage relay, and allows the value of resistor R4 to be sufficiently high not to adversely affect the logic level at the output.

A relay with a 12V coil voltage should be employed for the output, and its contacts must be rated at 230V a.c., 5A or more. Note that many relays on sale have contacts rated at 120V. These are likely to burn out or fuse together in a short time.

It is much easier and safer to house the relay directly on the p.c.b., and so check that the type obtained will fit. There seem to be two slightly different pin spacings in common use, and the p.c.b. has been designed to accommodate either. Diode D4 removes any back e.m.f. produced by the relay.

### Miscellaneous

T1	230V a.c. mains transformer, p.c.b. mounting, with twin 9V 0.028A secondaries; total rating 0.5VA
RLA	mains p.c.b. mounting, low-profile relay with 12V d.c. 360 ohm coil and 12A 250V a.c. single-pole change-over contacts. The relay height should be 19mm or less to fit inside the specified case
LP1	mains neon indicator, with integral resistor

Printed circuit board available from the EPE PCB Service, code 358; plastic case, size 143mm x 82mm x 30mm; 14-pin d.i.l. socket; 3-way, p.c.b. mounting screw terminal block (2 off); multistrand connecting wire; mains cable; nylon self-adhesive p.c.b. supports (3 off); solder pins; solder etc.

Approx. Cost  
Guidance Only

**£19**  
excluding case

## POWER SUPPLY

A regulated mains power supply is included in the circuit diagram of Fig.1 and is made up of the components to the right of relay RLA1 contacts. The supply was included to simplify installation of the system. The main components are the mains transformer T1, bridge rectifier REC1, smoothing capacitor C3 and the +12V voltage regulator IC3.

The Autoswitch circuit consumes very little power and so a fully encapsulated p.c.b. mounting mains transformer was employed. The specified transformer supplies a limited current and its secondary can be short-circuited without the transformer being damaged. Note that there are two separate secondary windings, and these are connected in *parallel* to double the current available. Select the transformer with care, so that its pins fit the p.c.b..

When the a.c. supply from transformer T1 secondaries is full-wave rectified by REC1, and smoothed by capacitor C3, the resulting d.c. voltage is increased by a factor of about 1.4 times, though this is subject to a voltage drop caused by the "bridge" diodes. The current available is reduced by the same percentage.

So a transformer rated at 9V 28mA per secondary winding was employed, the two coils being connected in parallel to achieve 9V 56mA. After rectification and smoothing the voltage available is around 12V and the current around 40mA.

## REGULATION

The original prototype design used this unregulated supply to drive the circuit, and all was well. However, the *actual* voltage produced by the transformer depends upon the current flowing, and when the circuit is in standby mode, the current is very small and so the voltage rises well above its nominal value. Small transformers of the type employed here are particularly bad in this respect.

The i.c.s in the circuit can tolerate up to 16V, but there was a danger that the voltage may rise beyond this when in standby mode. So a +12V voltage regulator, IC3, was added. This limits the supply to 12V regardless of whether the circuit is in standby mode, or activated.

The current required by the relay coil when activated will make the regulated supply dip a little below 12V, but this should not be a problem since a 12V relay should be capable of operating on 9V or less. Capacitor C2 is needed to remove any spikes from the supply line.

No fuse was included though it is assumed that the circuit is driven from a fused supply. If this is not the case, then a fuse *must* be added in series with the Live connection on the mains input side; terminal block TB1. Neon indicator (with integral resistor) LP1 is included on the mains input side to provide a warning that the system is live.

## TIME OUT

The period for which the output of the monostable (IC2b/IC2c) is positive is set by resistor R2 and capacitor C1. The formula is:

$$\text{Time (secs)} = R \text{ (ohms)} \times C \text{ (farads)} \times 0.7$$

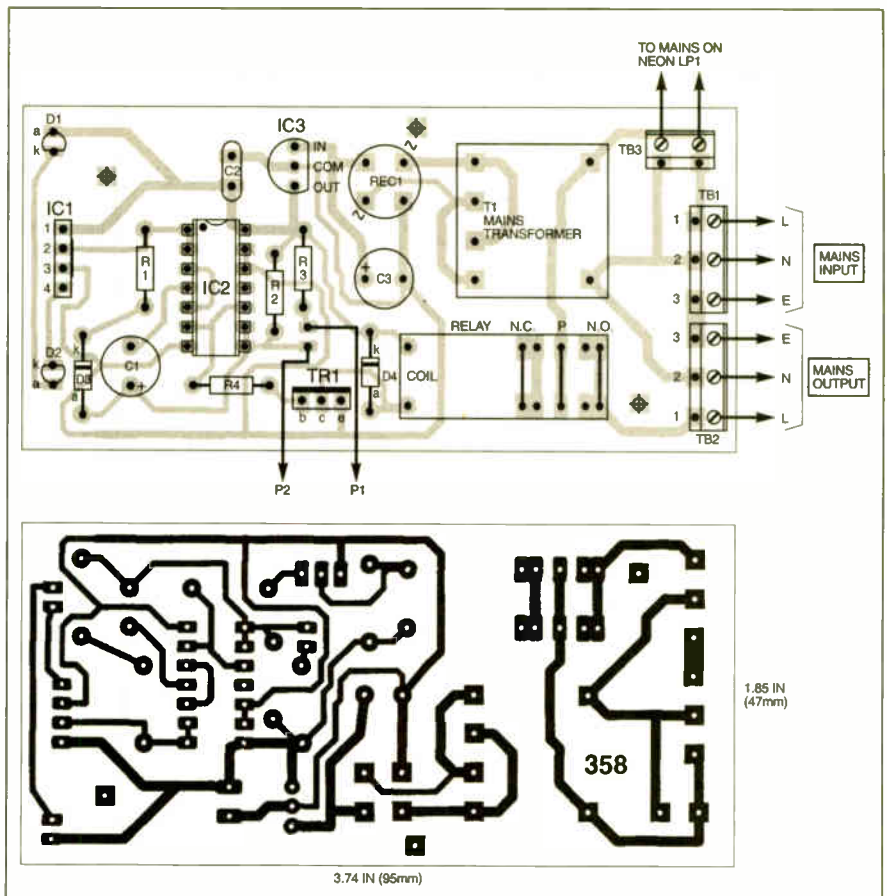

Fig.3. Printed circuit board topside component layout, lead-off wires and full-size underside copper foil master.

The numbers can be simplified by taking  $R$  in megohms and  $C$  in microfarads  $\mu\text{F}$ .

Hence using the values in the circuit diagram (Fig.2):

$$\text{Time} = 0.68 \times 1000 \times 0.7 = 476 \text{ secs.} = \text{almost 8 minutes.}$$

Remember that this is the time for which the switch remains on, after the last time it was triggered. If the pads P1 and P2 on the p.c.b. are joined with a wire link, then resistor R3 reduces the time period considerably. Resistor R3 is so much lower than R2 that R2 can be ignored in the calculation, so the time is given by:

$$\text{Time} = 0.01 \times 1000 \times 0.7 = 7 \text{ secs.}$$

Note that all these times are approximate as they depend upon the accuracy of the components used, particularly the capacitor. Some electrolytic capacitors may have a tolerance (error) of as much as 50 per cent, though most modern ones can do better!

As stated earlier, if precise times are required, a potentiometer (wired as a variable resistor) could be employed so that the exact time may be set. The "variable resistor" should be connected to the p.c.b. pads P1 and P2 so that it is in series with resistor R3; this ensures that if the variable resistor is reduced to zero, there is not a direct link to the positive supply.

The value of resistor R3 could be reduced to 1k if shorter times are required. The maximum resistance permitted is 1M, beyond that, timings may be unstable.

If very long timings are required the value of capacitor C1 could be increased, though be cautious, as large value electrolytics can be very "leaky" and you may find that C1 never charges sufficiently to complete the timing cycle. Some experimentation may be necessary.

## CONSTRUCTION

Apart from the mains neon indicator LP1, all the components for the Infra-Red Autoswitch are mounted on a small single-sided printed circuit board. The topside component layout and full-size copper foil master pattern are shown in Fig.3. This board is available from the *EPE PCB Service*, code 358.

Begin construction by soldering in position the 14-pin i.c. socket followed by the resistors and diodes D3 and D4, checking that the diodes are fitted the correct way round.

Now fit the larger components including bridge rectifier REC1 and the capacitors. Again, all must be fitted the correct way round, except C2 which may be either way. Fit transistor TR1 with its metal tab away from the edge of the board, and regulator IC3 with the flat side the way shown.

Fit solder terminal pins into copper pads P1 and P2, or use a wire link (which will later be cut) to join these two pads together. This will help with testing as explained later.

The infra-red l.e.d.s D1 and D2 must be fitted the correct way round (see Fig.3), and must stand proud of the board so that they may be bent over the edge later. Leave their wires as long as possible.



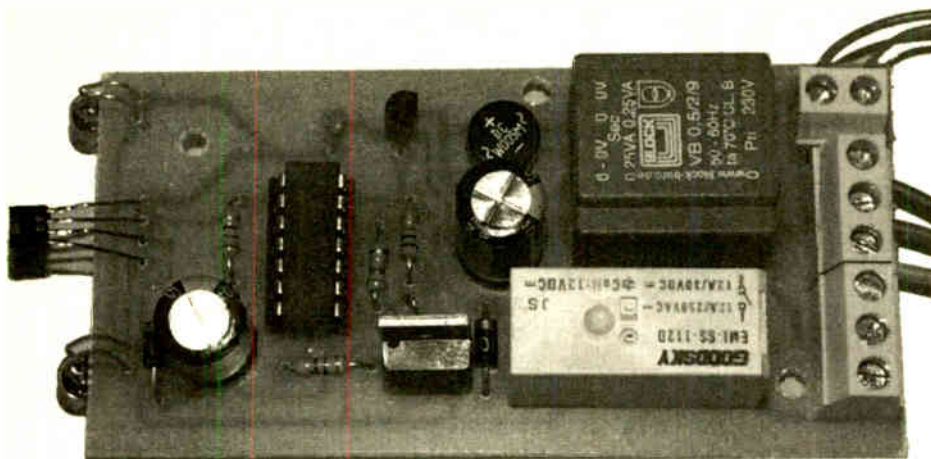

Component layout on the completed printed circuit board. The infra-red sensor and diode emitters are mounted on the lefthand edge. Note the two infra-red light-emitting diodes are "looped" over the edge of the p.c.b.

**WARNING:** The IR I.e.d.s used in the prototype were supplied with their longer leads indicating cathode (k). This is very unusual, normally long indicates anode (a). So take care with the orientation of the I.e.d.s.

Round I.e.d.s have a flat mark on the base of the plastic, and this also indicates cathode. In the prototype the flat mark was – correctly – on the cathode side. If you only require a single IR I.e.d. (for a shorter detection range) then fit a wire link in place of the I.e.d. not required.

The infra-red sensor IC1 must also be fitted correctly. The "bump" on the surface of the I.C. indicates the rear (non-sensing) side (see Fig.4). Hence, it should be fitted with the smooth flat side towards the edge of the p.c.b.

Touch an earthed surface (such as the case of a metal appliance which is plugged into the mains) in order to remove any static electricity in your body before handling IC1. Fit the sensor, allowing it to stand proud of the p.c.b. so that it can be folded over the edge later.

Now fit the relay to the p.c.b., noting that double holes are provided for some of the relay tags, since – annoyingly – relays do not always conform to a standard layout. Similarly the transformer should be soldered into place. Neither the specified relay nor transformer will fit the wrong way round.

If you employ a relay or transformer which is not designed for p.c.b. mounting, then you must use insulated wires to make the appropriate connections. However,

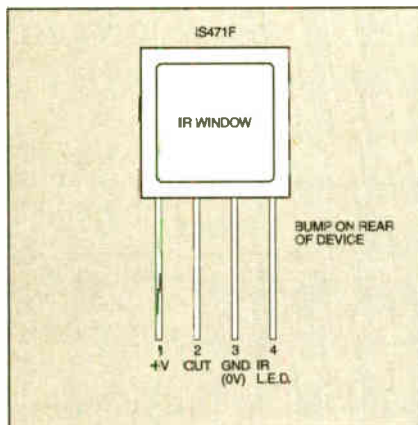

Fig.4. Pinout details for the IS471F infra-red sensor.

using the components specified will be easier and safer.

The mains and lighting cables are connected via 3-way terminal blocks (TB1 and TB2). These are soldered to the p.c.b., and provide a convenient way of connecting leads at a later stage. Likewise a 2-way block (TB3) can be used to connect the mains neon indicator LP1. Alternatively, the mains neon may be soldered directly to the appropriate p.c.b. pads, but before fitting the neon, check which way it passes through the case; if fitted from the outside, you will need to attach it to the case before soldering or screwing in its leads.

Finally, fit IC2 into its socket, checking that its notch (or dot) is at the correct end, and taking the same anti-static precautions as described earlier.

## TESTING

It is strongly recommended that the circuit board should first be tested on a separate 9V or 12V battery supply before connecting it to the mains, otherwise, house the circuit in its case first, and return to testing later.

Connect a separate battery supply by clipping a pair of leads to the appropriate tracks on the circuit board. Check that the correct polarity is observed. The track at the top, leading to IR diode D1 is the positive supply, and the track at the very bottom of the p.c.b. is the negative (0V) supply line. If terminal pins have been fitted to pads P1 and P2, then join these together for testing.

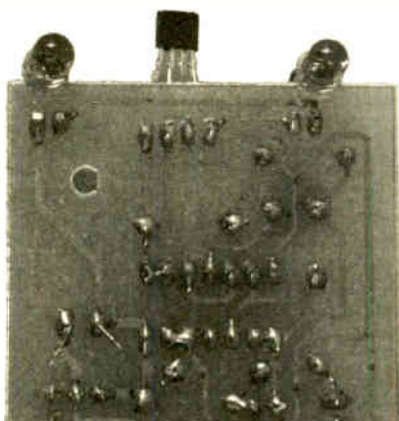

IR sensor (centre) and diodes mounted at one end of the p.c.b.

Switch on. The relay should click on. Assuming that you have not connected a mains supply, you can verify that the relay is working by connecting a multimeter set to "resistance" to the terminals marked "L" on TB1 and "L" on TB2. When the relay contacts close, the meter should give a reading of about zero, or bleep.

When power is first applied to the board the relay should switch on. Assuming that pads P1 and P2 are joined together, the relay should remain on for about 7 seconds. If the relay remains on for longer, it may be because the IR receiver IC1 is being triggered by the IR I.e.d.s. Try shielding the sensor with thick paper, card or Blu-Tack.

If all is well, disconnect the multimeter and temporary low voltage supply. Do not connect the mains supply until the p.c.b. is safely housed and secured into its case.

## FAULT FINDING

Fault finding should *only* be carried out if the circuit is powered from a separate 9V or 12V battery supply as described earlier, i.e. do not connect the circuit to a mains supply. A voltmeter is the only test instrument required; connect the negative lead of the voltmeter to the 0V track (the very bottom) on the p.c.b.

Begin at the sensor (IC1) end of the circuit, and take readings with the positive lead of the voltmeter, starting with the power pins of IC1, pin 1 (positive) and 3 (0V). Now test pin 2 (output) of IC1. This should be positive when a signal is *not* received, switching to 0V when the IR beam is reflected from an object. A constant 0V signal may indicate that the beam is reaching the sensor directly, so try covering D1 and D2 with thick paper or Blu-Tack (front, sides and back) to find out whether this is the case.

Remember that when the circuit is housed in its case, direct transmission from infra-red I.e.d.s D1 and D2 to sensor IC1 should not be a problem. A constant positive signal may indicate that the I.e.d.s are not working at all. Check their connections carefully, and remember that the longer lead indicates cathode (k) on certain infra-red I.e.d.s. If you have employed only one I.e.d., you should have fitted a wire link in place of the other one.

If the output pin (2) of IC1 is working correctly, its logic levels should be copied to pin 1 and pin 2 of IC2. Pin 3 of IC1 should do the opposite.

The best test point on the monostable IC2b/IC2c is pin 10. This should normally be around 0V switching to positive during the timed period. If its input side is working, but the output fails, check carefully the values of the components, and whether diode D3 is fitted the correct way round.

If you have joined pads P1 and P2 then the timed period should be about 7 seconds. If the monostable never completes its timed period, try using a smaller capacitor for C1 since some electrolytic capacitors leak current. The value suggested should not suffer in this way, unless very old or connected the wrong way round.

If the voltage at IC2c pin 10 is near positive, then TR1 and the relay should switch on. Failure at this point suggests that the transistor may be the wrong way round, or

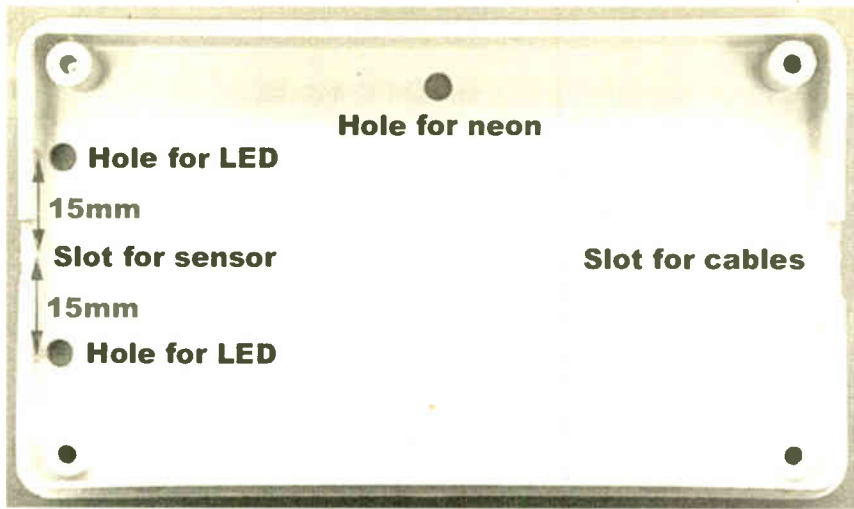

*Suggested drilling and component positioning details for the case lid.*

the wrong type etc. You can check the operation of the relay by shorting together the two right hand pins (c and e) of TR1. This should trigger the relay.

### CASING UP

A neat white plastic case, measuring 140mm x 80mm x 30mm, was used in the prototype as shown in the photographs. Decide which of the two halves will be used to house the circuit. If required for a kitchen unit, it is best to fit the p.c.b. in the lid i.e. the side where you can see the lid retaining screws. The base of the case can be fastened to the underside of a kitchen cupboard by means of one or two small wood screws. Begin case preparation by drilling holes for these screws in the base of the case.

Turning your attention to the lid, cut a slot in the end for the sensor IC1. The use of a slot at the side of the case ensures that the IR beam cannot be received from the rear of the l.e.d.s, or by reflections inside the case. If you change the design, do ensure that this point is observed, otherwise use large amounts of Blu-Tack to protect the sensor from stray reflections!

Now drill two holes for the IR l.e.d.s near the edge of the case as shown in the above photograph, plus a hole for the

mains neon LP1. The latter can fit anywhere providing it does not foul the p.c.b. Check the position of the p.c.b. before drilling. You will also need a slot for the mains input and light output cables.

The printed circuit board may be housed by means of nylon self-adhesive p.c.b. supports. Before removing the protective

cover on these supports, check that the sensor and l.e.d.s will fit into place. The l.e.d.s D1 and D2 should be neatly folded over the edge of the p.c.b. as shown in the photograph, so that they fit into the holes.

You could have soldered the l.e.d.s to the copper side of the board, but exact alignment is much more difficult and it is hard to judge how long the leads should be to make a good fit. The method suggested is much easier.

Having fixed the p.c.b., the mains wiring can be completed, but do not plug in, until the base is fixed to the lid.

### FINAL TESTING

When the two halves of the case are screwed together, connect the unit to a fused mains supply. On switch-on, the relay should switch on with a click. If pads P1 and P2 are still joined, the timed period will be about 7 seconds. Test the system to ensure that the "trigger" range is satisfactory.

Now disconnect from the mains supply, and remove or cut the link between pads P1 and P2. The timed period will now be about 8 minutes. When the case is safely back together, re-connect the mains supply.

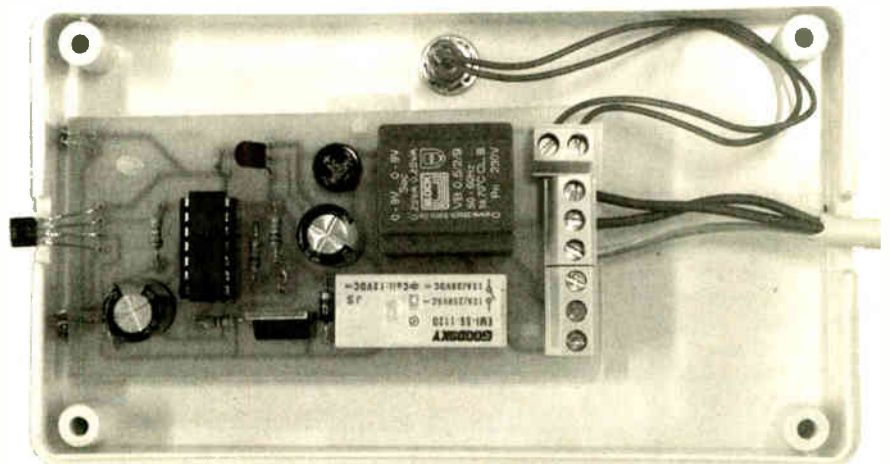

*The printed circuit board should be positioned in the lid of the case using nylon self-adhesive pillars. Note the cutout slot for the IR sensor.*

EVERYDAY  
**PRACTICAL**  
**ELECTRONICS**

## NEWSAGENTS ORDER FORM

Please reserve/deliver a copy of *Everyday Practical Electronics* for me each month

Signed.....

Name and Address.....

.....

.....

Post Code .....

*Everyday Practical Electronics* is published on the second Thursday of each month and distributed S.O.R. by COMAG  
Make sure of your copy of *EPE* each month – cut out or photostat this form, fill it in and hand it to your newsagent.

SPECIAL  
READER -  
SEE WEBSITE  
FOR DETAILS

# PROTEUS VSM

Virtual System Modelling

Build It In Cyberspace

[www.labcenter.co.uk](http://www.labcenter.co.uk)

**Develop and test complete micro-controller designs without building a physical prototype. PROTEUS VSM simulates the CPU and any additional electronics used in your designs. And it does so in real time. \***

- CPU models for PIC and 8051 and series micro-controllers available now. 68HC11 coming soon. More CPU models under development. See website for latest info.
- Interactive device models include LCD displays, RS232 terminal, universal keypad plus a range of switches, buttons, pots, LEDs, 7 segment displays and much more.
- Extensive debugging facilities including register and memory contents, breakpoints and single step modes.
- Source level debugging supported for selected development tools.
- Integrated 'make' utility - compile and simulate with one keystroke.
- Over 4000 standard SPICE models included. Fully compatible with manufacturers' SPICE models.
- DLL interfaces provided for application specific models.
- Based on SPICE3F5 mixed mode circuit simulator.
- CPU and interactive device models are sold separately - build up your VSM system in affordable stages.
- ARES Lite PCB Layout also available.

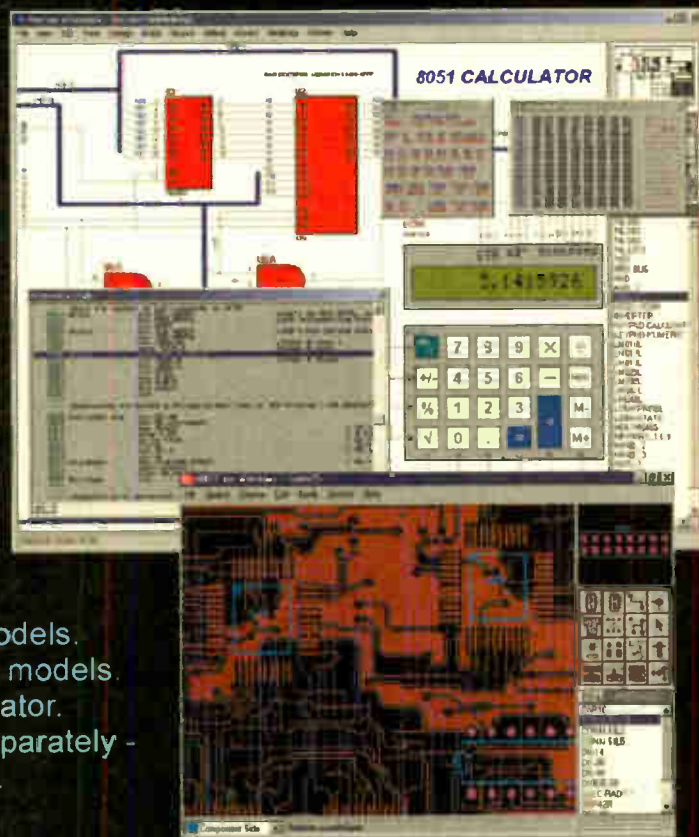

labcenter

Electronics

\*E.g. PROTEUS VSM can simulate an 8051 clocked at 12MHz on a 300MHz Pentium II

Write, phone or fax for your free demo CD - or email [info@labcenter.co.uk](mailto:info@labcenter.co.uk).  
Tel: 01756 753440. Fax: 01756 752857. 53-55 Main St, Grassington, BD23 5AA.

## TV HISTORY REVISITED

### Big business ethics do not always favour the creative inventor, as Barry Fox reports.

**C**ONTRARY to popular belief, the world very seldom beats a path to an inventor's door, waving a cheque book; pioneers die broke and forgotten, and big business lawyers make mincemeat of lone inventors.

The tragic story of how Edwin Howard Armstrong invented FM radio in 1933, and committed suicide in 1954 out of despair, is well documented in *Man of High Fidelity* by Lawrence Lessing, Bantam Books (although, be warned, the book is a eulogy and lacks any index). Armstrong struggled first to win frequencies for FM broadcasting from the Federal Communications Commission and then to win royalties on radio equipment from the giant RCA and its ruthless Chairman, David Sarnoff.

#### Boy Genius

The equally bitter struggle between David Sarnoff and US TV pioneer Philo Farnsworth, has so far been a lot less well documented. But a new book by Daniel Stashower just published in the USA (*The Boy Genius and the Mogul, the Untold Story of Television*, Broadway Books, ISBN 0-7679-0759-0), fills the gap. And of course the Internet now makes it much easier to buy books internationally.

Stashower's book also provides a useful reminder that no-one really invented television; the technology emerged as two competing streams of development, mechanical and all-electronic, converged. Although the mechanical systems were all doomed to failure, they put pictures on screen much earlier than the electronic systems could do, and so whetted the public's appetite for "seeing by radio".

Paul Nipkow began it all with his 1884 idea for a spinning disc to scan an image. This was taken up by Charles Francis Jenkins in the USA in 1922, John Logie Baird in the UK in 1926 and Bell Labs in 1927. In 1928 Ernst Alexanderson at RCA switched from disc to mirrored drum.

It was 1908 when A. A. Campbell Swinton proposed a cathode ray tube and inspired Edouard Belin who was experimenting in Paris by 1921. Karl Ferdinand Braun, Boris Rosing and Vladimir Zworykin took up the idea of displaying pictures on a CRT. Philo Farnsworth was a fifteen year old Idaho farm boy when, in 1922, he started to formulate plans for a television set with no moving parts while ploughing fields with a raster of furrows. Farnsworth filed

his key patents (USP 1,773,980 and 981) in 1927.

Jenkins died in poverty in 1934 and although Baird lived until 1946, his mechanical system had long since been ousted in the UK by the all-electronic technology developed by EMI and Marconi, with a team including Alan Blumlein, the inventor of stereo sound recording.

Baird had called on Farnsworth in 1934 to help him convert his mechanical system to an electronic one. The deal collapsed, because Baird's operation was shut down by a disastrous fire at his Crystal Palace research labs in South London in 1936.

At the time Farnsworth was also working with German broadcasters on televising the Berlin Olympics. And by then Philo Farnsworth and his small, under-funded company, were in head-on confrontation with David Sarnoff and RCA, who were backing Vladimir Zworykin's approach. Zworykin had told RCA in 1929 it would cost \$10,000 and take two years to make electronic television work. Sarnoff was later to complain it had taken ten years and cost \$50 million.

#### Breaking Patents

RCA's policy under Sarnoff was that RCA collected royalties, and did not pay them. So although Farnsworth's Image Dissector camera worked better than Zworykin's Iconoscope (while Zworykin's Kinescope display worked better than Farnsworth's tube) Sarnoff was not willing to cut a deal. Instead, after Zworykin visited Edouard Belin in 1928 and Farnsworth in 1930, Sarnoff set out to break Farnsworth's patents.

RCA had vast financial resources from the pool of several thousand radio patents the company had accumulated through the 1920s, so could afford prolonged legal action, with the best lawyers. When Farnsworth won a round they just appealed. In 1935 RCA had hardened its commitment to television, instead of FM radio. RCA's PR machine swung into action to tell the public what RCA was achieving. At the World's Fair in New York in 1939, RCA made the headlines, with Farnsworth and his system nowhere to be seen.

Farnsworth's research had been starved of funds, despite a deal with Bell and AT&T in 1937; the inventor was on the breadline and in mental and physical decline. Sarnoff was earning \$100,000 a year. In 1939, after ten years of legal battle, RCA finally took a licence from

Farnsworth, the first ever for the company. But war was coming and by the time it was over, Farnsworth's patents were dead.

Ten years later, ITT took over what was left of the Farnsworth company and the inventor lived on until 1971 dreaming up ideas for nuclear power generation. Stashower's story makes a good read and a timely antidote to some of today's adverts for invention brokerage agencies which can lead the innocent into expecting too much, too easily from filing a patent.

But although the story hangs on patents, they are not identified by number; this is a surprising omission. It is also clear that the author is much better at telling a story than analysing and explaining competing technologies. He would have benefited from some technical assistance. And I would add a final irony: some of the original mechanical technology has recently found a new life; the digital micro-mirror projectors which use a Texas Instrument chip often rely on a spinning filter wheel to add colour to the picture.

### WELLBERRY CASES



MOST of you are no doubt familiar with the "WB" range of project cases that has been around for many years. Wellberry Cases have reminded us that in fact it was in 1971 that these aluminium/steel cases with simulated leatherette texture finish were first introduced. In 1974 the same company also introduced the familiar EB range that so many readers have used for instrumentation-type housings.

The good news is that not only are the cases still available after all these years, but that they are now available direct from the manufacturer, Wellberry, at a good price advantage! Not only that, Wellberry will also punch panels to your design if you have a requirement for at least 50 of them (kit suppliers take note!), and at a low price.

For more information contact Wellberry Cases, Dept. EPE, Ion Farm, Lower Gravenhurst, Bedfordshire MK45 4HH. Tel: 01462 814788.

Fax: 01525 860081.

Web: [www.wellberry.co.uk](http://www.wellberry.co.uk).

## PICtutor V2

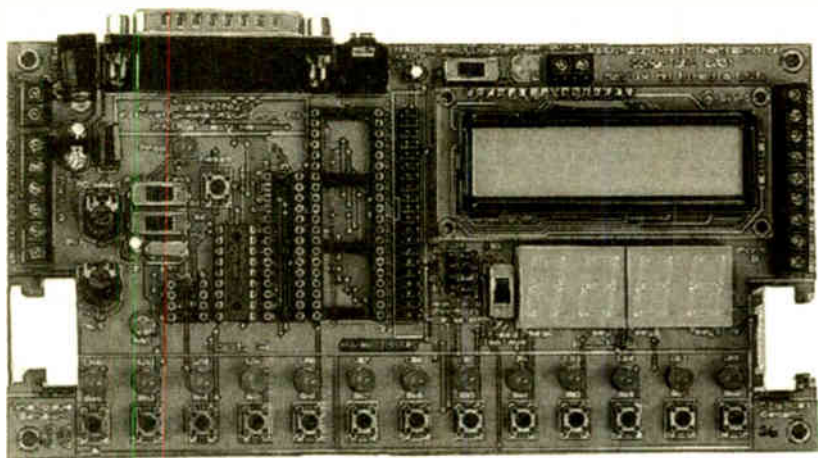

BACK in '98 we published John Becker's well-acclaimed *PIC Tutorial* series of articles explaining to newcomers how to understand and use PIC microcontrollers. The success of that series led to the production of a CD-ROM based version in conjunction with Matrix Multimedia Ltd, and known as *PICtutor*, complete with its own simulator and development board.

A new version of *PICtutor* has been introduced with many beneficially enhanced features. First, whereas the original was based on the TASM assembly dialect, John has revised V2 so that it is totally based upon the industry-standard MPASM dialect, giving a much more universal appeal to the tutorials, demonstrations and development exercises.

Secondly, the development board through which PICs can be programmed during the tutorials, and in the user's own later applications, has been totally redesigned with many new interface features, and allowing four different PIC sizes to be programmed. Of great significance, too, is the improvement that does away with the programming switches of V1. All program downloading is now fully under control of the PC computer, via a specially developed suite of software that is included on the CD.

We are extremely pleased that Microchip, the manufacturers of PICs, has given its support to the new version. To suit their marketing recommendations, it has been renamed as *Assembly for PICmicro Microcontrollers V2.0*. For further details see the *CD-ROMs for Electronics* pages in this issue.

## Weather Instruments

IT is well known that in the UK we are pretty much obsessed with the weather. Hardly surprising, perhaps, as despite the worthy efforts of our met forecasters, it is so irrationally changeable and seemingly unpredictable. Mindful of this, no doubt, American company Davis Instruments have sent a catalogue of their Precision Weather Instruments that will delight the heart of any weather watcher.

Davis Instruments is a California-based manufacturer of high quality marine, weather and automotive products. They have a wide range of weather stations and accessories for many purposes, from education, agriculture, industry and expeditions, to "just for the hobbyist".

The Weather Wizard III Station, for example, is said to be "everything you need for measuring inside and outside temperature, wind speed and direction, wind chill, and daily and accumulative rainfall". It is priced at US \$250, although there are other units from \$195 to \$995.

In the higher price range are included advanced stations that are solar powered and have radio links to a base station, which can include a PC interface and a suite of analytical software.

For more information contact Davis Instruments, 3465 Diablo Ave., Hayward, CA 94545, USA. Tel: (510)732-9229. Fax: (510)732-9188. Web [www.davisnet.com](http://www.davisnet.com). Also browse [www.sierracom.com](http://www.sierracom.com) and [www.icselectronics.co.uk/icsnet](http://www.icselectronics.co.uk/icsnet).

*Everyday Practical Electronics, July 2002*

## Greenweld E-bargains

GREENWELD Electronics, who are noted for their bargain offers, tell us that their E-Newsletters may become a more regular item "thanks to a new member of staff who has got it into her head that we ought to actually tell all our customers about the latest bargains when they come in, instead of just sitting here drooling over them!"

So, readers, get yourselves on Greenweld's E-newslist and get to the bargains before they are snapped up by those just sitting at home waiting for the postman to deliver news about them through snail-mail!

For more information email: [bargains@greenweld.co.uk](mailto:bargains@greenweld.co.uk), or browse [www.greenweld.co.uk](http://www.greenweld.co.uk).

## Networks Expo

NETWORKS *Telecom Europe 2002* takes place at Birmingham NEC from 25 to 27 June 2002 and provides a platform to explore new products, network with leading vendors and keep abreast of the latest issues facing the networking industry.

There will be over 200 exhibitors, offering demonstrations and advice relating to new products and services.

For more information visit: [www.networks-telecom.com](http://www.networks-telecom.com).

## Attractive Connections

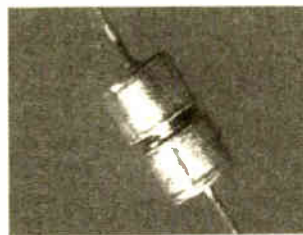

THE new Magtrix Connectors caused a bit of a stir on the newsdesk! They are magnetic and are said to be "an irresistible connection". Indeed so, for their size they probably have the strongest permanent magnet we've encountered.

A pair of them is shown in the photo, in which the two end surfaces are in strong magnetic connection to each other. The other ends have rigid wires attached to enable the magnets to be p.c.b. mounted so that they make strong electrical and physical contact with ferrous-based components, such as fuses and some types of battery casing, for instance.

They really have an extremely powerful semi-permanent bonding effect, allowing components to be securely retained yet removed from a circuit without desoldering. They can even pick up two D-type batteries weighing in at 300g!

The Magtrix connectors can also be used as the component part of actuators, Hall effect devices and generators. It seems that they must have many more applications in a hobbyist's workshop as well! They are supplied as five pairs to a pack (code MC/53GNS) for £3.75.

For more information contact Magtrix Connectors, Dept. EPE, 17 Larch Drive, Brinscall, Chorley PR6 8QN. Tel: 01254 830761. Fax: 01254 830408.

Email: [sales@victorignition.co.uk](mailto:sales@victorignition.co.uk).

## Magnifico

FOR a bigger view of those tiny electronic components and their identities, you should "look into" Magnifico UK Ltd. They tell us they offer Britain's best online selection of magnifiers, loupes and low-vision aids.

On their website are over 100 products in six key categories, including handheld, illuminated, desk, sheet and handsfree. There is also a useful guide, *Choosing A Magnifier* to help with your selection.

Prices range from £2.75 to £120, so there's bound to be something for everyone. Prices include free delivery to any mainland UK address.

For more information contact Magnifico UK Ltd., Dept. EPE, 12 Sussex Road, Harrow HA1 4LX. Tel/fax: 020 8891 6966.

Web: [www.magnifyingglasses.co.uk](http://www.magnifyingglasses.co.uk).

Email: [sales@magnifyingglasses.co.uk](mailto:sales@magnifyingglasses.co.uk).

## Magfield Sensors

OVER recent years we have published three constructional projects that use the FGM-3 magnetic field sensor from Speake & Co. Bill Speake, the proprietor, tells us that he now has a website through which you can browse the company's full range of products. It can be accessed by either of the following:

[www.speakesensors.co.uk](http://www.speakesensors.co.uk), or  
[www.speakesensors.com](http://www.speakesensors.com).

# New Technology Update

*Holographic data storage promises to revolutionise the way the computer industry stores data and could even spell the end for the trusty disk drive, reports Ian Poole.*

**M**EMORY and in particular long term memory such as that supplied by disk drives, tape drives and the like is a key element in electronics technology. Storage is being used at an ever increasing rate as software becomes more complicated and takes up more storage space. Also with the growing reliance on computer technology there is a greater need to take back-ups and have long term archive systems.

Instead of requiring disk sizes in megabytes, the storage sizes will be measured in terabytes. Whilst there is plenty of room for development using today's technologies, new ideas will be required for years into the future.

Many of these new ideas are emerging even now. This is a necessity as often they require many years of development before they can be made successfully on a commercial scale.

A company that is making some very significant inroads into storage developments that offer a quantum leap increase is called Polight Technologies. A Cambridge University spin-out, it has some interesting ideas that, it is claimed, are capable of revolutionising the way in which data is stored.

In fact, its ideas could sound the death knell for some existing forms of mass storage and may even spell the end for the trusty disk drive that has been at the centre of computer technology for so many years.

## New Technology

The idea is based around a group of semiconducting glasses known as chalcogenides that contain Group VI elements. These exhibit some significant changes when they are illuminated by a particular form of light. These can include changes in structure, volume, and various optical properties including the refractive index and level of light absorption. As a demonstration of some of the effects that can be created, it has been shown that a bi-layer cantilever can be deflected up and down by exposing it to polarised light.

However, it is the change in refractive index that is of particular importance as this can be used to enable vast amounts of data to be stored. Up until now it has not been possible to use this form of optical storage commercially as a result of material problems.

## Holographic storage

Now with the introduction of the new chalcogenides, a way forward is available and it is expected that it will be possible to commercialise this form of data storage using holographic techniques. This

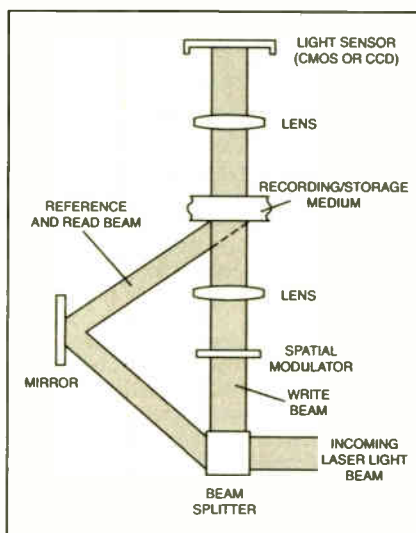

*Fig.1. Basic concept of the new data storage system being developed by Polight Technologies.*

involves optically writing data into a volume of photosensitive material.

This is achieved using a laser. The data is encoded into the laser beam using what is known as a spatial light modulator. This beam is combined with a reference beam and the combined light is then projected into the material.

To read the data the reference beam is projected into the material and emerging light contains the data that was written into the material and this can be converted into an electrical format using a CCD or CMOS sensor (see Fig.1).

The amount of data that can be stored is enormous. This is due to the fact that multiple images can be stored in the recording material.

This can be achieved because of the holographic nature of the images and the fact that the material has a very large dynamic range, each of the individual images uses up a portion of this range. To enable multiple images to be stored the angle of the reference beam is changed.

Only when the angle of the reference beam used to read the data matches the angle of the reference beam used to write the data match can the data be retrieved. By enabling a large variety of angles to be used, the amount of data that can be stored can be multiplied many times.

## Work

A wide variety of work is being undertaken to fully investigate the new materials. Computer simulations of the atomic vibrational characteristics of real glasses

and of the new chalcogenides are being performed.

Thus a greater understanding of the way in which light phonons are related to the vibrational modes can be gained. In turn this can be used to gain a better understanding of the way data can be stored using these materials.

It is interesting to note that the early thermionic valve developments were greatly hindered by a lack of understanding of the way in which valves worked. This team are aiming to gain as full an understanding as possible.

## First units

Polight's first storage product is being developed with investment partners. Called the Holodisc, this first product is a 500 Gbyte storage unit and uses a 250 to 500 micron thick element of chalcogenide. This gives it a memory data density of around 110Gbit/cm<sup>2</sup>, a figure which is many times that of current disk drive technology.

It is expected that it will revolutionise the corporate back-up and archive storage markets. The unit offers read and write speeds of 750Mbytes per second in comparison to a DVD which offers a capacity of only 4-7Gbytes and speeds of 3Mbytes per second.

The market for the new product is expected to be huge, with sales in excess of \$25 billion by the year 2005. This shows the potential that can be realised when investors and academia come together.

Indeed, Professor Stephen Elliott commented: "This is an excellent example of Cambridge University and investors coming together to turn academic research into a real business opportunity. I'm delighted to see Polight complete this round: this company has a very exciting future in front of it".

## Future

For the future, holographic data storage is highlighted by industry experts as offering the prospect of a revolution in data storage. Until now commercialisation has not been possible for lack of a suitable media. Now Polight has the challenge to resolve the last problems with its inorganic glasses that are given the name "Holonide".

Michael Ledzion, Polight's CEO commented: "Holographic data storage is the next big step forward for the removable data storage industry". It will now be very interesting to see how this new and exciting technology develops over the next few years, and the impact it makes on the computer industry.

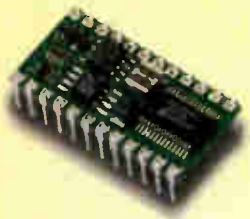

BS2-IC



BS2-SX

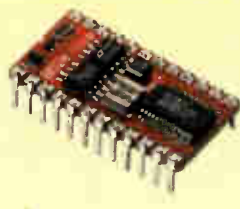

BS2E-IC

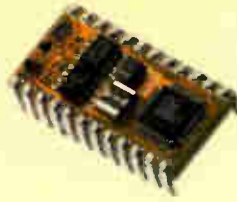

BS2P/24

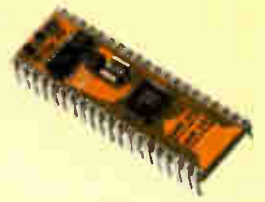

BS2P/40

**Parallax BASIC Stamps - still the easy way to get your project up and running!**

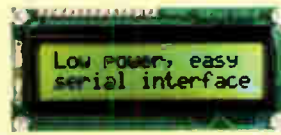

**Serial Alphanumeric and Graphic Displays, Mini-Terminals and Bezel kits**

# www.milinst.com



Animated Head



3-Axis Machine



Six-Legged Walkers



Robotic Arms



Bipeds

**Robotic models for both the beginner and the advanced hobbyist**



Servo Drivers



Motor Drivers



On-Screen Displays



DMX Protocol

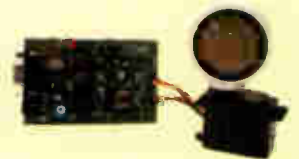

U/Sound Ranging

**Animatronics and Specialist Interface-Control Modules**



Quadvox MP3 & Speech Systems



SensoryInc Voice Recognition



Parallax Ubicom Tool Kits



Tech-Tools PIC & Rom Emulators



BASICMicro PIC BASIC Compilers

**Development Tools**

Milford Instruments Limited Tel 01977 683665, Fax 01977 681465, sales@milinst.com

# INGENUITY UNLIMITED



Our regular round-up of readers' own circuits. We pay between £10 and £50 for all material published, depending on length and technical merit. We're looking for novel applications and circuit designs, not simply mechanical, electrical or software ideas. Ideas *must be the reader's own work and must not have been submitted for publication elsewhere*. The circuits shown have NOT been proven by us. *Ingenuity Unlimited* is open to ALL abilities, but items for consideration in this column should be typed or word-processed, with a brief circuit description (between 100 and 500 words maximum) and full circuit diagram showing all relevant component values. **Please draw all circuit schematics as clearly as possible.** Send your circuit ideas to: Alan Winstanley, *Ingenuity Unlimited*, Wimborne Publishing Ltd., 408 Wimborne Road East, Ferndown Dorset BH22 9ND. (We do not accept submissions for *IU* via E-mail.) Your ideas could earn you some cash and a prize!



## WIN A PICO PC BASED OSCILLOSCOPE WORTH £586

- 100MS/s Dual Channel Storage Oscilloscope
- 50MHz Spectrum Analyser
- Multimeter • Frequency Meter
- Signal Generator

If you have a novel circuit idea which would be of use to other readers then a Pico Technology PC based oscilloscope could be yours. Every 12 months, Pico Technology will be awarding an ADC200-100 digital storage oscilloscope for the best *IU* submission. In addition, a DrDAQ Data Logger/Scope worth £69 will be presented to the runner up.

## Velocity Detector – Speed of Light

**A**N optically-triggered counter/timer, which can be used to measure the time taken for a moving object to break two light beams in succession, is shown in the circuit diagram of Fig.1. It is suggested that a pair of budget-price laser pointers could be used as precision light sources, with the beams shining onto a pair of small light-dependent resistors R2 and R4. The moving body interrupts the beams in succession, and a period is displayed by a timer circuit.

When the object crosses "A" it sets the bistable formed from IC2a and IC2b which triggers a 555 timer, via IC3. The output waveform is sent to a dual decade counter IC5 and IC7. The number of pulses produced is counted, passed to a digital decoder driver IC6 and IC8. Common anode 7-segment displays are used to display tens and units. Clearly the accuracy of the design is determined by that of the 555 astable which may need trimming or adjusting with the aid of an oscilloscope.

In Fig.1, the multivibrator IC4 is wired as a gated astable to produce pulses of 50ms duration per pulse. The decade counters IC5 and IC7 are wired to produce BCD (binary coded decimal) outputs which are decoded by the BCD decoder/drivers IC6 and IC8. Common anode 7-segment displays are used to display tens and units. Clearly the accuracy of the design is determined by that of the 555 astable which may need trimming or adjusting with the aid of an oscilloscope.

If the number of 50ms pulses clocked by a moving body is  $n$  (say 40 for example) and the distance between "A" and "B" is, for example, 10 metres, then its velocity in metres per second is  $10/50 \times 10^{-3} \times n = 5$  metres per second (obviously it takes two seconds to travel ten metres in this example).

R. Subramaniam (age 18), Kodambakkam, India.

Fig.1. Circuit diagram for the Velocity Detector. Don't forget to ground the unused inputs of IC3.

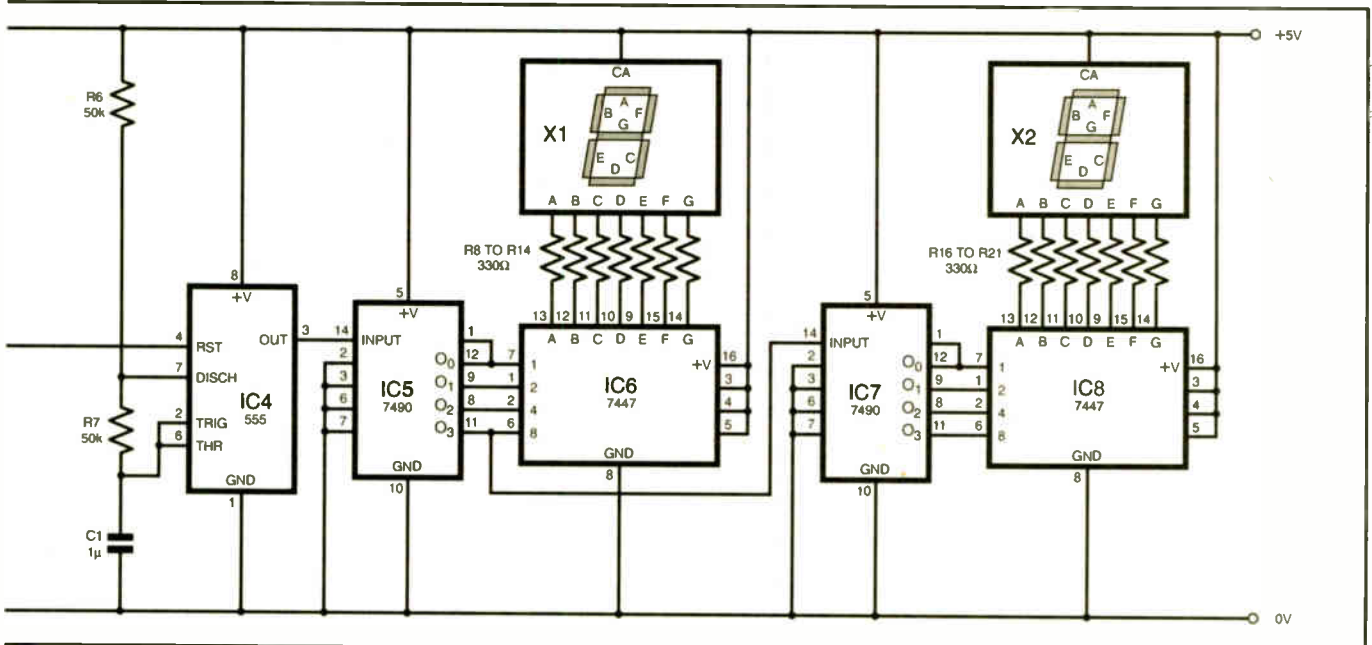
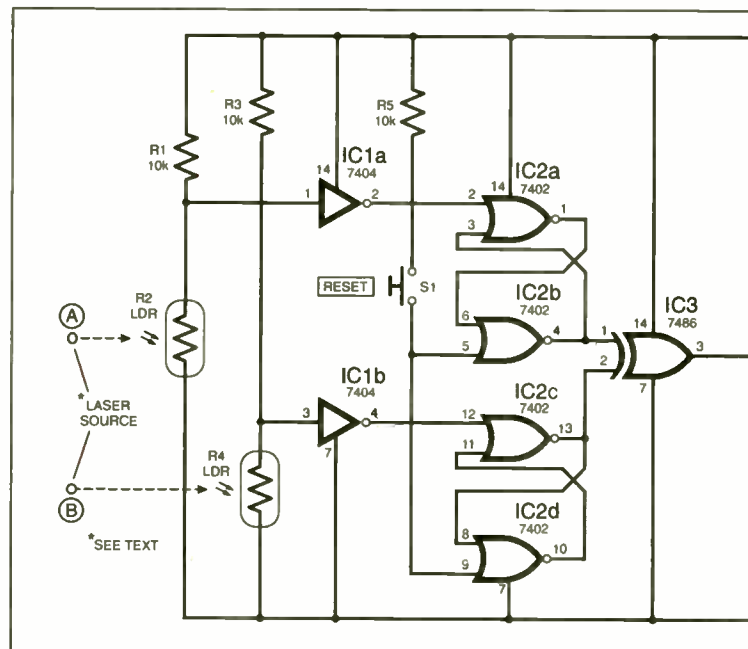



# Car Battery Trickle Charger

## - A Sure Start

WORKING away out of the country for long periods often resulted in the writer returning home to find his car battery "dead". Whilst proprietary trickle chargers are available, they tend to be rather expensive and very bulky. The simple trickle charger shown in the circuit diagram of Fig.2 was made from scrap components for just a couple of pounds. The prototype has been in use for 18 months and has provided "first time" starts to a 3.5 litre sports car after standing for a 2½ month period, and a diesel saloon after six weeks in winter.

A discarded mains adapter from an old answering machine formed the heart of the unit, which produced an (unregulated) d.c. output of 17V at 500mA. An LM317 voltage regulator IC1 was built into the adapter casing, the device then being connected to the car via the cigar lighter socket.

The regulator provides a constant voltage under all conditions, and therefore a charging current inversely proportional to battery terminal voltage. A state of equilibrium is eventually reached between the charger output and the trickle charge requirement of the battery along with any loads formed by the car clock, alarm etc. A 200mA fuse near the cigar plug guards against shorts.

The prototype was set up by connecting an ammeter in the output circuit, connecting to car and mains supply and advancing the preset trimmer VR1 until a current of approximately 60mA was displayed. This corresponded to an output voltage of

approximately 14V. This value will need to be altered to suit the standing current drain from any car accessories permanently connected to the battery, but in practice a trickle current of around 50mA into the battery was found to be sufficient.

Not all cigar lighter sockets may allow such a connection, so consider a direct connection to the battery as an alternative,

observing all the usual precautions when dealing with lead acid batteries.

David-John Gibbs,  
Southport.

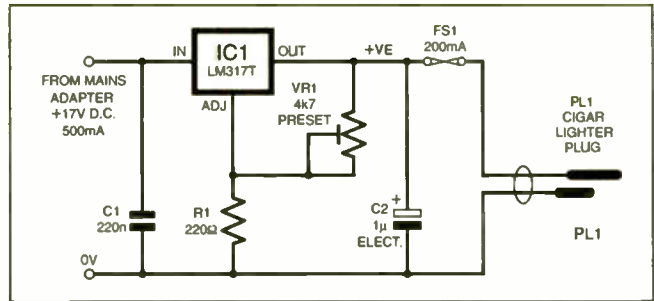

Fig.2. Circuit diagram for the Car Battery Trickle Charger. A novel application of a standard circuit.

### APOLOGY

We regret to say that the item *Battery Discharger* (EPE May 2002 issue) was not an original item. EPE has since received an apology from Liao Jian Mei, the author concerned. Our thanks to the reader who notified us promptly and EPE duly apologises to the publishers of *Elektor* magazine who published the original circuit.

Additionally we are told that the item *Emergency Light Unit* by Steve Cartwright shown in the November 2001 issue is the same as a circuit devised by Alan Ainslie in *Practical Wireless* January 1976 and for this we apologise to *PW Publishing*.

*Everyday Practical Electronics* publishes readers' own circuits in good faith with a view to encouraging more efforts in circuit design, providing an outlet for ideas and

inspiring readers to develop ideas for themselves. EPE does everything possible to authenticate the circuits and contributors are required to sign a written legal disclaimer and confirmation of originality. Copyright infringement is a serious matter and readers who copy material and claim it is their own could be prosecuted.

Those who would attempt to defraud the column would do well to remember that EPE has many tens of thousands of very loyal readers around the world, some of them with extremely long memories. Any attempt to pass off a deliberately copied circuit as "original" will be exposed without mercy - both by upset readers as well as EPE.

**NOTE:** The *Emergency Light* circuit in the May 2002 issue (which is original) was sent in by Thomas Scarborough.



**80-046 Electronic digital caliper** for both imperial (0-6 inches) and metric (0-150mm). Accuracy +/-0.001". Simple touch button facility to change from metric to imperial (and vice versa). On/off and zero button, inside and outside measuring plus locking screw to hold measurement. Uses a standard watch battery (included). Metal construction. Supplied in a neat plastic storage case. **£34.95**



**56-067 CR2016 lithium battery.** 3V. 20mm diameter x 1.6mm high. **£1.00**  
**56-068 CR2025 lithium battery.** 3V. 20mm diameter x 2.5mm high. **£1.00**  
**42-544 Lithium button cell, CR2032.** 3V, 20mm diameter x 3.2mm thick. Brand new (not surplus). **£1.00**



**80-078 Mains PSU,** 220-240V AC input, 15V DC, 800mA output. Plug in the wall type. 2m flying lead to a 2.1mm power socket. **£3.95**



**80-045 12V, 17Ah, lead acid, sealed rechargeable battery.** Gel type. Brand new. 180 x 165 x 75mm. These are usually around £45.00 each to buy. **£14.95**



**80-042 Switch mode PSU** (ATX type) for computers. Mains input to DC output. +5V @ 32A, +3.3V @ 25A, +12V @ 8.5A, -5V @ 0.4A, -12V @ 0.7A, +5V (aux) @ 0.75A, maximum 330W. Made by AC Bel, Part No. API7506. Case size 150 x 145 x 105mm. Fan cooled. **£12.95**



**48-111 Vibrating motor** designed for pagers and mobile phones. 20mm long x 7mm diameter. Works between 3V and 6V. Very small and excellent quality. **£2.50**



**80-102 IDE hard disk drive cable** with 3 x 40 way IDC sockets so you can have two hard drives running off the same motherboard. 580mm long. **£1.50**



**80-103 Floppy disk drive cable** to enable the use of up to 2 floppy disk drives. Has 3 x 34 way IDC sockets and 2 x 34 way card edge connectors mounted on a 650mm long ribbon cable. **£1.50**



**80-104 Ribbon cable lead,** 450mm long with 3 x 40 way IDC sockets for use with hard drives and CD ROM's. Also included is a 4 pin in-line socket to a 4 pin in-line socket lead for internal CD ROM audio connection. **£2.00**



**38-484 MES lamp holder** with two screw fixing holes for mounting. Screw terminals for connection. White. **£1.00**  
**For Pack Of 4**



**56-155 KBPC3501 bridge rectifier** 100V, 35Amp. **£2.50 each**



**48-140 PVC electrical tape,** 19mm wide x 0.15mm thick x 33 metres long. Flame retardant, BS3924. **75p**



**56-006 Brand new 12V DC fan.** 80 x 80 x 25mm with 10" red and black lead. **£2.95**



**WGN SUPPLIES**

WGN Supplies  
 Dept EE · The Old Grain Store  
 Rear Of 62 Rumbidge Street  
 Totton · Southampton · SO40 9DS  
 Telephone or Fax On  
 Southampton 023 8066 0700  
 Email: info@wcnsupplies.fsnet.co.uk

**SEND FOR OUR FREE CATALOGUE CONTAINING EVEN MORE BARGAIN ITEMS!**

**ALL PRICES INCLUDE VAT  
 ADD £2.25 FOR P & P**

# EPE STYLOPIC

## JOHN BECKER

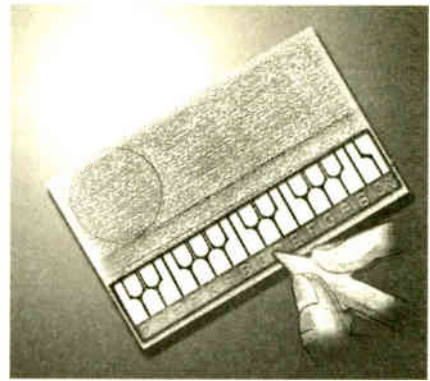

*Have fun with a modern interpretation of a classic musical instrument!*

**R**OLF Harris is well known these days for his concern for sick animals. Back in the 1970s (and later) though, he was popular as an entertainer who would delight his audience by (amongst many other activities) playing the didgeridoo, wobble-board and the *Stylophone*. The latter was a compact hand-held electronic musical instrument having a built-in keyboard which was activated by an electrically conductive stylus.

The *EPE StyloPIC* pays homage to this classic design, which is now relegated to the depths of history and enthusiast's web sites (although we know some readers still have the real thing, and second-hand ones can still be found!). It is really simple in its concept, yet remarkably fun to play!

### HISTORY

Some of you familiar with the original *Stylophone* can be forgiven for perhaps thinking that Rolf Harris actually invented this superb little instrument. In fact, his involvement was purely promotional, but this was to prove crucial to the *Stylophone*'s success.

The *Stylophone* came about as a result of a certain Brian Jarvis having been asked to repair his young niece's toy piano. Not only did he do so, but added a modification that led to the idea of a completely new hand-held electronic instrument.

Brian was one of a team who in 1967 had founded a company providing dubbing and recording services to the broadcast and film industry, from which services the company name Dubreq was derived.

Brian and his partners, Bert and Ted Coleman, recognised that this instrument had great potential, if only it could be marketed effectively, with television being the obvious medium.

With this in mind, the team also recognised that the popularity of Rolf Harris made him the ideal celebrity to help promote their innovative instrument. Bert demonstrated the *Stylophone* to Rolf, who is said to have been "very impressed".

This ultimately led to the instrument making its debut on Rolf's BBC TV *Saturday Show*, in which a renowned support troupe of the era, *The Young Generation*, played along with Rolf on six additional *Stylophones*. The Rolf Harris connection was to lead to the *Stylophone* becoming known as the "greatest little instrument of the century!"

### EXPANSION

Initially, *Stylophones* were hand-made and (in "pre-decimal money") sold at £8 18s 6d (£8.92 "modern"), which is estimated to be the equivalent of £95 in today's money. Production soon expanded and a move was made from Dubreq's basement premises to a proper factory in Cricklewood, London. Staff numbers would eventually grow to around 75 during the company's full production life.

The original *Stylophone* was a monophonic instrument which comprised a metal keyboard, a stylus to play the notes, vibrato and on-off switches, plus a line-out socket. There was also a spindle underneath for fine tuning. Although there were only two basic models made, there

were many variants, including the components used, and in the finish, colour, keyboard and packaging.

Dubreq licensed the *Stylophone* to America, Germany, France and Hong Kong. Its major success, though, brought the inevitable copies and copyright infringements. During its production lifetime approximately four million units were sold in the UK alone.

Developments in technology eventually caused the demise of the *Stylophone* in the early 1980s. The simple electronics around which it was based were superseded by the far more sophisticated technology being used in instruments originating from the Far East.

Dubreq ceased manufacture in 1977 and was wound up in 1980. The original prototype *Stylophone* is said to still exist!

### STYLOPIC CONCEPT

Whereas the original *Stylophone* had 20 keypad zones, the *EPE StyloPIC* has been extended to cover two full octaves – 25 notes including sharps and flats (C to C – 261Hz to 1046Hz). It too, of course, is activated by a stylus, which makes contact with the integral keyboard-style printed circuit board that also holds the electronic components. Its tuning accuracy is superb, the software making use of a technique hitherto unpublicised through *EPE*.

Apart from the PIC microcontroller, there are only three active integrated circuits – a waveform converter, an envelope shaper and an amplifier. The circuit diagram in Fig.1 shows the detailed connections between the *StyloPIC*'s keyboard and the microcontroller, IC1, along with the waveform converter, IC2, and the simple regulated power supply, derived via IC3. The envelope shaper and amplifier are discussed later, referring to Fig.2.

The keyboard contacts are formed on the printed circuit board (p.c.b.) in the style of a 25-note keyboard, plus an additional "mode-change" contact which causes a change in the tonal quality of the notes produced. All contacts are connected to individual inputs of the PIC16F877 microcontroller.

Note that in Fig.1, the keyboard notation is shown in the order best suited to illustrating the PIC's port connections in an appropriate visual order. On the p.c.b., of course, the keyboard connections are in the correct musical order!



Rolf and the *Stylophone* – "The greatest little instrument of the century!" Courtesy [www.stylophone.fsnet.co.uk](http://www.stylophone.fsnet.co.uk)

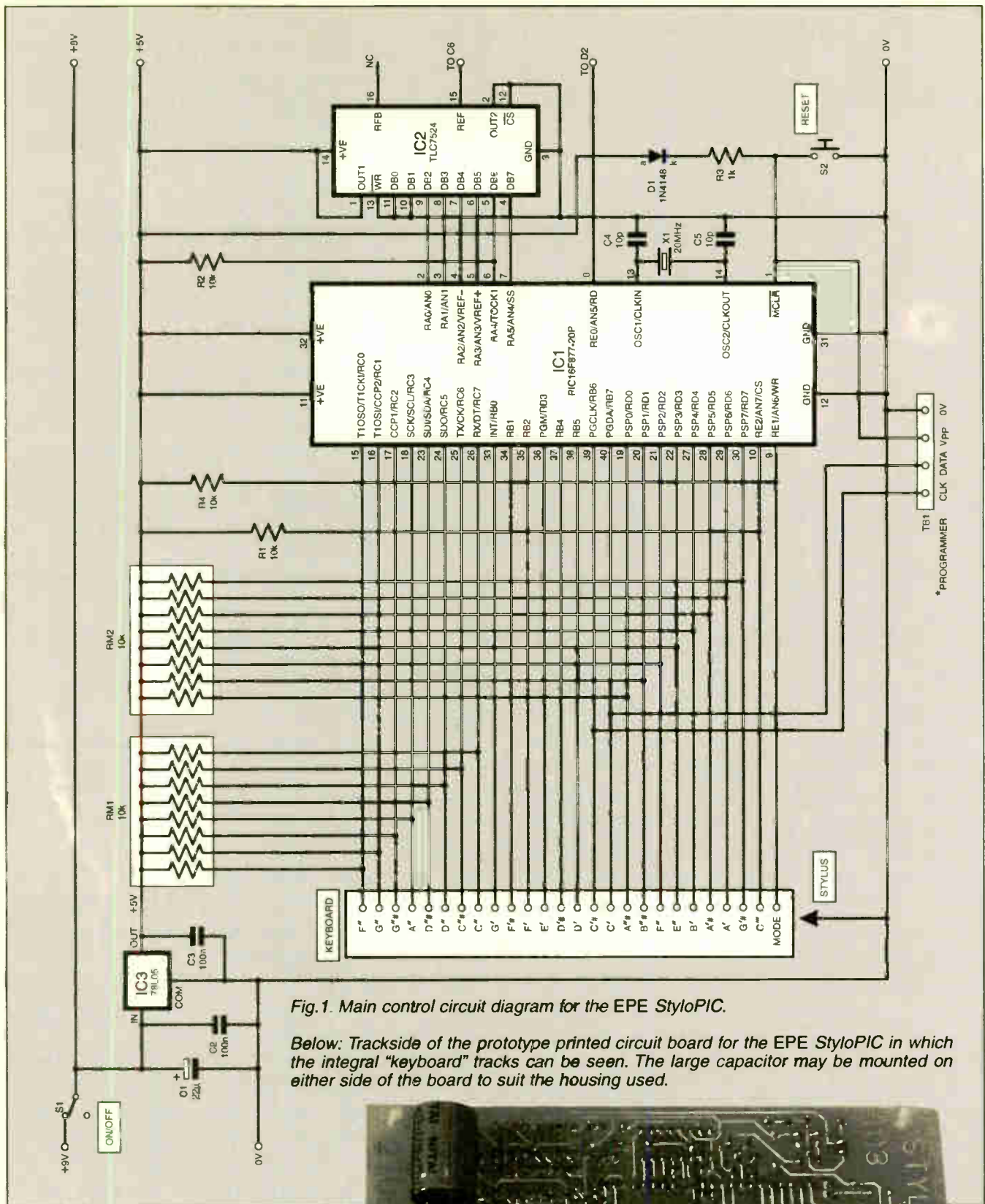
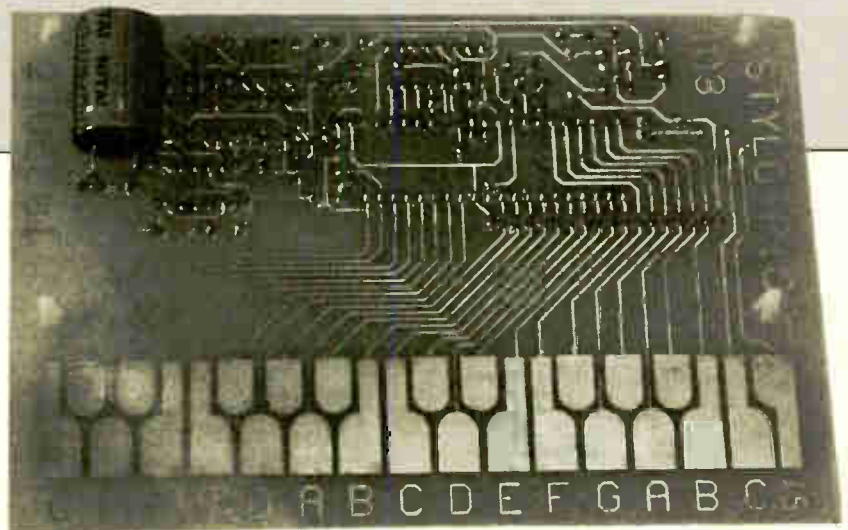

Fig.1. Main control circuit diagram for the EPE StyloPIC.

Below: Trackside of the prototype printed circuit board for the EPE StyloPIC in which the integral "keyboard" tracks can be seen. The large capacitor may be mounted on either side of the board to suit the housing used.



All contacts except for the eight connected to the PIC's Port B are biased normally-high via individual resistors, eight within each of resistor modules RM1 and RM2, plus two designated as R1 and R4. The connections to Port B (RB0 to RB7) are held normally-high by the PIC's eight internal pull-up resistors.

The stylus which causes the notes to be triggered is connected to the 0V line. When it connects with a note key, the respective PIC line is taken low, the PIC responding according to which line has been affected.

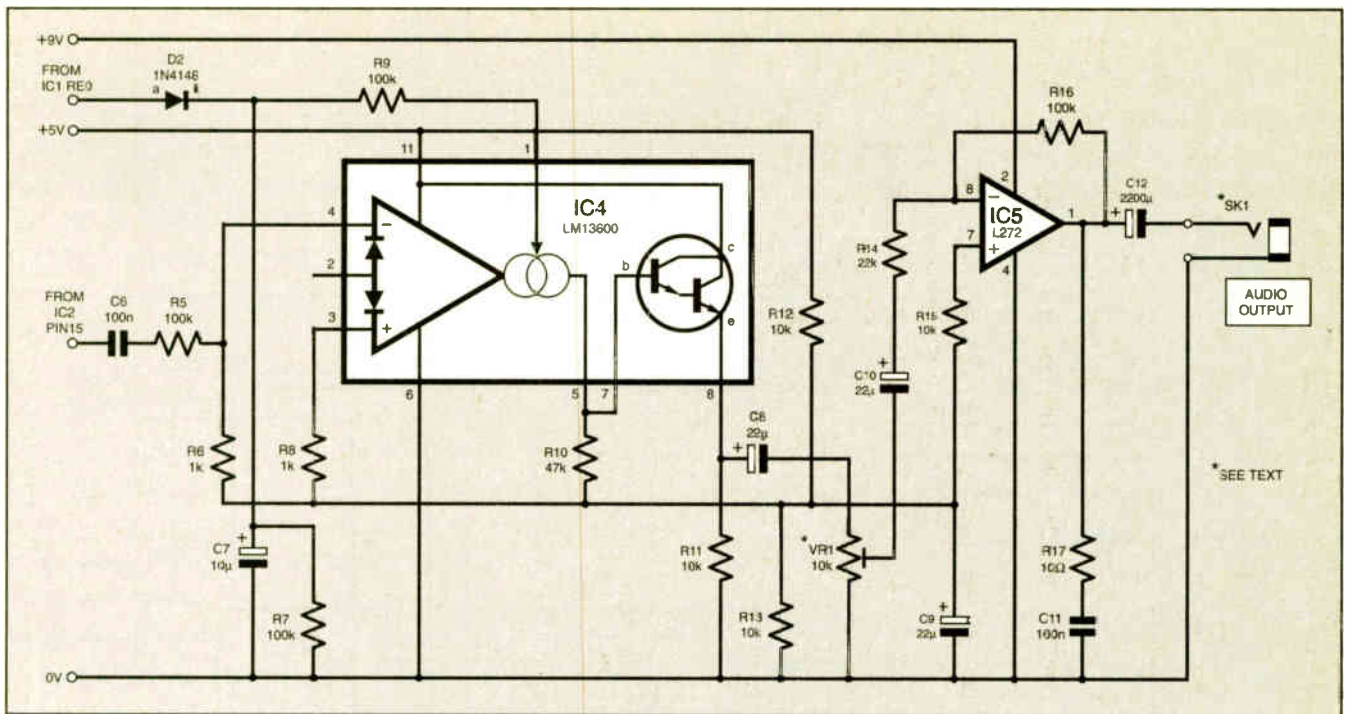

Fig.2. Circuit diagram for the envelope shaper and output amplifier.

In response to music keys being activated (as opposed to activating the Mode Change key) the PIC increments an internal counter at a rate related to the note frequency required. The counter's value is output via Port A (RA0 to RA5) to six inputs of the 8-bit digital-to-analogue converter (DAC) IC2, whose other two inputs are held permanently low.

The manner in which the counter's value is output determines the tone of the note produced. This stage and the subsequent envelope and amplifier stages are essentially the same as used in the author's *PIC Magick Musick* design of *EPE Jan '02*. However, whereas that design always generated a rising ramp waveform via the DAC, the option to output a square waveform has been provided here.

This tone-change function is triggered via the Mode key feeding into PIC pin RE1. Each time the key is activated the mode changes, alternating between the ramp and square options.

It is believed that the original *Strylphone* probably output a squarewave, but the author finds the ramp (sawtooth) waveform more harmonious to the ear. Indeed, as shown through *Magick Musick*, when envelope shaping is applied as well, a very piano-like sound is created.

The DAC is used in the mode which allows a voltage-related output to be generated in respect of digital input values (it can also generate current related outputs). In the voltage output mode, the voltage signal is taken from the device's REF (reference) pin, with the two "normal" outputs (OUT1 and OUT2) connected to +5V and 0V respectively. If you wish to explore this

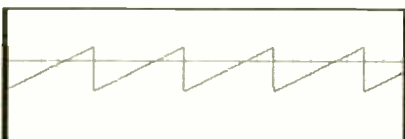

Fig.3. Sawtooth waveform created via DAC IC2.

device's attributes in detail, its datasheet can be download free from [www.ti.com](http://www.ti.com).

An example of the ramp waveform generated is shown in Fig.3.

## ENVELOPE SHAPING

Referring now to Fig.2, envelope shaping is performed by transconductance amplifier IC4, an LM13600 device, whose datasheet can be download from [www.nsc.com](http://www.nsc.com) (it was also discussed in *Circuit Surgery Dec '01*).

As in *Magick Musick*, it is used as a voltage controlled amplifier (VCA) that is under pulsed control as an envelope shaper (varying the amplitude of a frequency signal across a specific period). In this application, the pulse control is applied from PIC pin RE0 to IC4 pin 1.

The pulse is modified by the action of diode D2, capacitor C7 and the combined resistance of R7 and R9. As will be seen from the waveform in Fig.4, the voltage at IC4 pin 1 rises rapidly when the pulse arrives from RE0. When it ceases, the voltage across C7 decays at a rate determined by the current flowing through R7 and R9.



Fig.4. The envelope shaping pulse at capacitor C7

It is the current that flows into IC4 pin 1 that determines the amplitude of the audio signal "transconducted" through IC4, from pin 4 to pin 5, and secondarily governed by the value of resistor R10. The signal at R10 is then buffered by IC4's internal Darlington transistor and output via capacitor C8 to potentiometer VR1, and thence to the audio amplifier stage around IC5.

A typical waveform as seen at IC4 pin 8 is shown in Fig.5. It clearly illustrates the

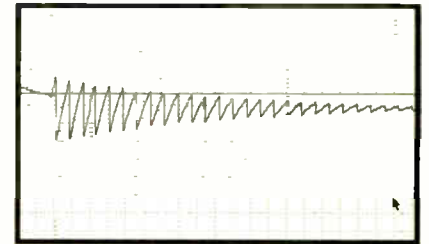

Fig.5. The attack and decay of a note as controlled by the envelope shaper.

"attack" as a note is triggered by a pulse from the PIC, and the subsequent "decay" of the amplitude when the pulse has ended. Note that the software has been written so that the PIC's trigger pulse remains high for as long as stylus contact with the key is maintained. This allows a certain amount of "colour" to be introduced to the musician's playing.

Whilst VR1 is shown as a preset potentiometer (mounted on the p.c.b.) an external rotary pot could be used instead, mounted in the chosen case. In this instance, a logarithmic (log) potentiometer is recommended.

An L272 audio amplifier (IC5) is used for the final output stage. This device is capable of outputting about 1W and is suitable for coupling into loudspeakers or headphones having impedances as low as 8Ω.

The output is a.c. coupled via capacitor C12 and may also be fed to the line-input of a normal domestic amplifier.

The device has been given a gain of about x5 and the maximum output level is around 3V peak-to-peak. Resistor R17 and capacitor C11 give stability to this power op.amp (which is actually a dual channel device, although only one channel is used).

## POWER SUPPLY

The circuit is basically run at 5V as regulated by IC3 (Fig.1), except for the power amp IC5, which is powered at the full voltage of the power supply. The latter may be any d.c. source between about 7V and 15V.

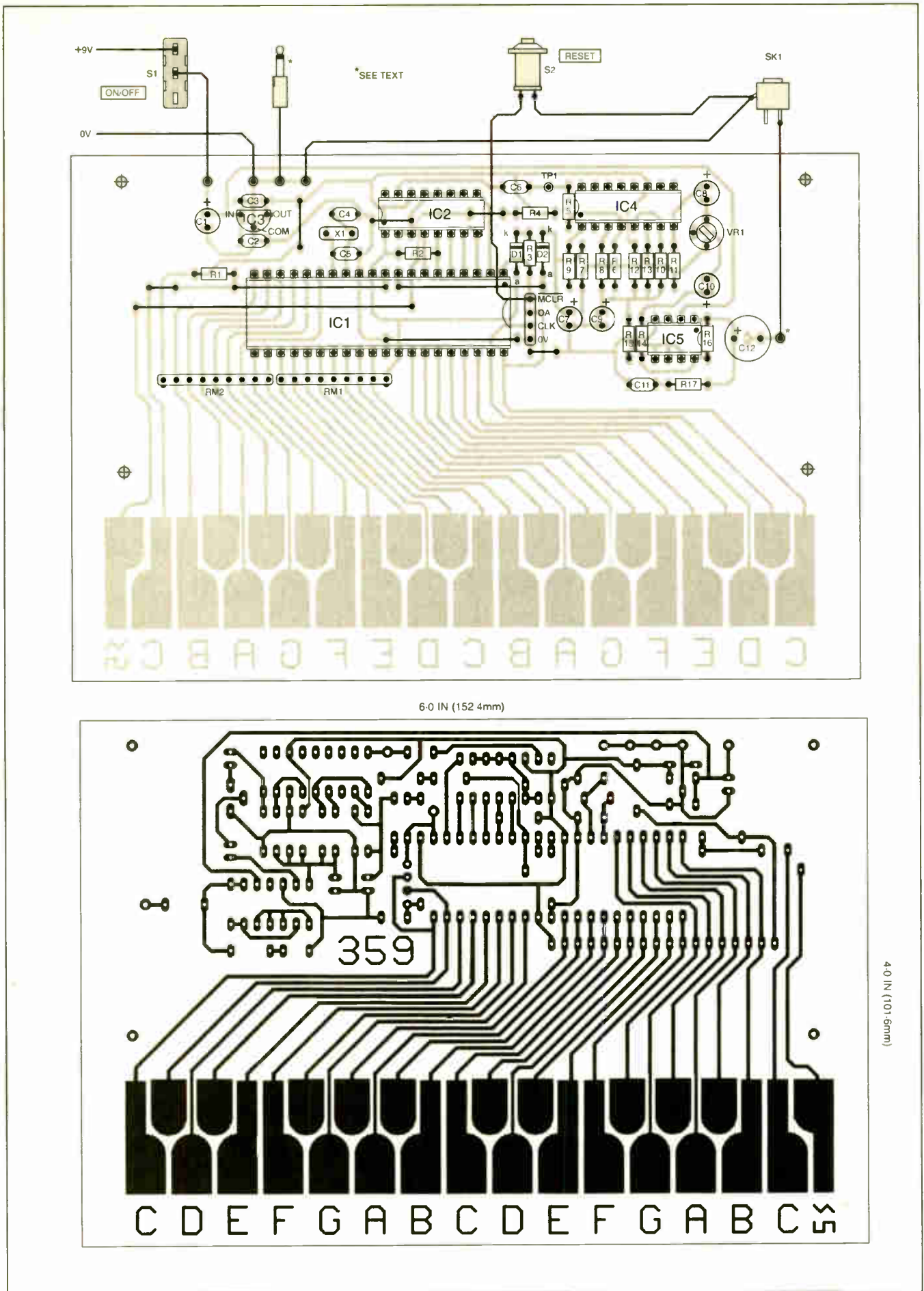

Fig.6. Component layout and full-size master track pattern for the EPE StyloPIC printed circuit board. Note that capacitor C12 may be mounted on either surface of the board to suit the housing used, and is best positioned "lying down" rather than vertically. Also note that several on-board link wires are required below the i.c. sockets, and that resistor modules RM1 and RM2 have "orientation" marks on their bodies which must correspond in position to the indications in the top figure.

A 9V battery may be used (e.g. PP3). Capacitor C1's voltage rating should be increased to 25V for supply voltages above 12V.

Maximum current consumption will depend on the amplitude output from the power amp. In the prototype, the current was about 14.5mA with no audio output, rising to about 80mA when driving an 8Ω speaker at full amplitude with IC5 powered at 9V.

## CONSTRUCTION

The printed circuit board component layout and tracking details are shown in Fig.5. This board is available from the *EPE PCB Service*, code 359. Assemble in any convenient order you prefer, using sockets for the d.i.l. (dual-in-line) i.c.s, and observe the correct orientation for the polarity sensitive components (including resistor modules RM1 and RM2).

Note that capacitor C12 is physically large. It may be mounted flat on either side of the board to suit the type of housing in which the StyloPIC is housed. It seems likely that in most instances mounting on the trackside would be more suitable (as done with the test model).

Treat all i.c.s as static sensitive and discharge static electricity from your body before handling them (touch a water pipe or the bare metal of a grounded item of workshop equipment). Do not insert them until the correctness of the regulated 5V power supply has been proved.

If you intend programming your PIC *in situ* (see later) do not connect Reset switch S2 until you have done so (it uses one of the programming terminals).

## STYLOPIC CASING

The test model was not mounted in a case and is simply enjoyed as an unprotected fun instrument on the author's workbench. No definitive suggestions for housing your own are offered, but you may find inspiration from the earlier photograph of an original *Stylophone*.

A plastic slim-line case measuring about 180mm × 120mm × 40mm might also be considered. In this instance, the p.c.b. could perhaps be mounted so that it slides in and out of the front aperture, protruding just so far as is required when actually playing the keyboard.

It is strongly recommended that the outer corners of the keyboard should be filed so that they are rounded and smoothed to avoid damage to your playing hand as it frantically keys-out *Tie me Kangaroo Down Sport*, or some other "Rolfarian refrain" or similar!

You may need to glue a wooden or plastic support under the front of the keyboard area to prevent the board from tilting while playing.

If using an internal speaker, the size of the above mentioned case would probably allow it to be mounted either under the lid, or above the base, with suitable holes drilled to let the sound out adequately. A rotary volume control and jack socket for external sound output could be mounted on the rear panel, along with switches S1 and S2.

It seems likely that a PP3 battery will fit comfortably to the side of the p.c.b. Those are just idle thoughts, though – let not the author impose his will on your creativity!

A word of caution, though. It is unusual for a p.c.b. to be used trackside upwards. Do ensure that the tracks around the i.c.s. cannot be shorted by inadvertent contact with anything conductive. However, the keyboard tracks themselves may (and must!) remain open and electrical shorts between them are permissible (and unavoidable when playing glissando).

It is also important that undesirable external voltage sources are not applied to the unit, which could cause a safety hazard. If you are plugging the unit into another item of equipment, full consideration must be given to whether or not that equipment could potentially cause high voltages (e.g. mains a.c.) to be applied to the StyloPIC tracks.

## DURABILITY

With the prototype, the stylus principally used is a round-ended probe from a multimeter. Occasionally the rounded tip of a 3.5mm jack plug has been used. Whatever your choice of stylus, ensure that the contact area is as smooth as possible to avoid damage to the p.c.b.

It is acknowledged that the long-term durability of the p.c.b. tracks will be significantly lower than that provided by the

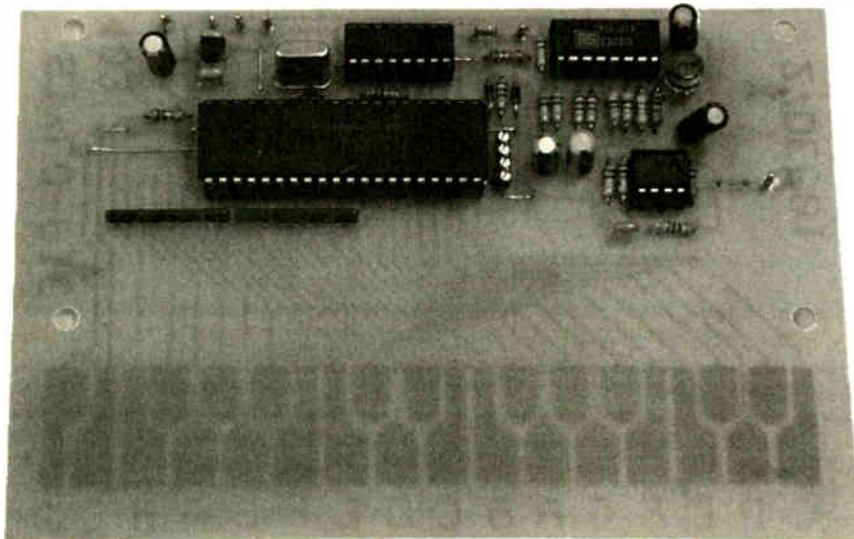

Component side of the StyloPIC. It is turned the "other-way-up" to play the keyboard!

# COMPONENTS

## Resistors

R1, R2,		<b>See SHOP TALK page</b>
R4, R11 to		
R13, R15	10k (7 off)	
R3, R6, R8	1k (3 off)	
R5, R7,		
R9, R16	100k (4 off)	
R10	47k	
R14	22k	
R17	10Ω	
RM1, RM2	10k, 8-common resistor module (2 off)	

All 0.25W 5% carbon film except RM1 and RM2.

## Potentiometer

VR1	10k min. preset, round, or rotary log (see text)
-----	--

## Capacitors

C1, C8	
to C10	22μ radial elect. 16V (4 off)
C2, C3,	
C6, C11	100n ceramic, 5mm pitch (4 off)
C4, C5	10p ceramic, 5mm pitch (2 off)
C7	10μ radial elect. 16V
C12	2200μ radial elect. 25V

## Semiconductors

D1, D2	1N4148 signal diode (2 off)
IC1	PIC16F877-20 microcontroller (20MHz), preprogrammed (see text)
IC2	TLC7524 digital-to-analogue converter
IC3	78L05 +5V 100mA voltage regulator
IC4	LM13600 transconductance amplifier
IC5	L272 dual power op.amp

## Miscellaneous

S1	min. s.p.d.t. switch
S2	min. push-to-make switch
SK1	3.5mm mono jack socket (see text)
TB1	1mm terminal pins or pin-header (optional)
X1	20MHz crystal

Printed circuit board, available from the *EPE PCB Service*, code 359; 8-pin d.i.l. socket; 16-pin d.i.l. socket (2 off); 40-pin d.i.l. socket; stylus (see text); loud-speaker or headphones (see text); case to suit (see text); supports for p.c.b. (see text); connecting wire; solder etc.

Approx. Cost  
Guidance Only  
excluding speaker, case & batts

**£25**

steel-based keyboard of the *Stylophone*. Readers using the ready-made board from the *EPE PCB Service* should fare better in this respect since the boards are roller-tinned, unlike the bare copper boards that (usually) result from making your own.

Nonetheless, whilst you will periodically get carried away with rapid glissandos and staccato keying, try not to dig holes into the keyboard pads, and certainly avoid contact with the connections leading from

them to the PIC. Probably, though, a touch of the soldering iron will repair minor damage.

## SOFTWARE HIGHLIGHT

It was mentioned earlier that the tuning accuracy of the StyloPIC surpasses that for any PIC-controlled music design previously published in *EPE*.

You may recall that in *PIC Magick Musick* there was a brief discussion about the difficulty of accurately generating exact frequencies when using a PIC. That discussion related to "conventional" frequency generation in a which a counter is incremented by whole values (minimum of one unit) within a loop whose length is varied to change the resultant output frequency.

There is another technique whose principle has been used by the author in other non-musical PIC applications in which fractional values can be added in the loop. Once such instance was with his bike computer (*PIC-Agoras*) of April '87 in which distance was calculated in relation to precise wheel diameters, and required the use of binary fractions.

However, the author had not thought to relate this technique to music generation until Peter Hemsley (of renown for his many *PIC Tricks*) pointed out the possibility. Thank you, Peter, it's a superb way of achieving accuracy, and is used here in the StyloPIC!

To achieve it, though, a much higher clock frequency is required to control the PIC than is usually employed for many designs. As you will see from Fig.1, the rate used here is 20MHz – effectively the top rate at which a PIC16F877 is designed to operate (although as many readers will have found, PICs can often be driven at rates in excess of their specifications – but we would be reluctant to actually publish over-driven designs).

In "conventional" frequency-generating PIC software the following technique is typically used:

```
START:    clrf COUNTER
FREQ:    movf COUNTER,W
          movwf PORTB
          nop
          incf COUNTER,F
          goto FREQ
```

In this routine the value of COUNTER is repeatedly incremented and output to one of the ports, Port B in this instance. The rate at which Port B bit 0 oscillates would be the highest frequency available from this loop. That at Port B bit 7 would be the slowest, at eight octaves below that at bit 0 (i.e. 256 times slower). The actual frequency range would be controlled by the number of NOP instructions included in the loop.

In the "fractional" technique, a binary word (two bytes) holds a constant 16-bit value which is repeatedly added to a 3-byte counter (23 bits) within a loop. It is the value of the most significant byte (counter bits 16 to 23) which is output to the port. This technique provides a far greater potential for tuning accuracy due to the ability to change the additive value by as little as 1/65536.

## TUNING ADJUSTMENT

In the StyloPIC tuning values for all 25 notes are held in two blocks within the PIC's data Eeprom. When the PIC has been

newly programmed, the two blocks are identical, the second being regarded as holding the "author's default" values, i.e. those which held true with the prototype unit.

There will be slight differences between clock rates of individual versions of the StyloPIC due to the crystal-generated frequency not being at exactly 20MHz. This is a perfectly natural situation with crystals. As with other component types, crystal values have a manufacturing tolerance spread.

Not only that, if the StyloPIC is to be used alongside other instruments, it may be desirable to change its pitch to suit the pitch set for the other instruments. Consequently, a pitch adjustment option has been provided within the software.

Pitch tuning can be shifted symmetrically across all 25 notes, both upwards and downwards. The author's default values can also be recalled to replace the user's own values should the need arise. Tuning of individual notes is not allowed for, nor is it desirable since the frequency relationship between each note is mathematically derived (ideal note frequencies are shown in Table 1). Consequently, any frequency shift has to be applied equally relative to each note's mathematical ideal.

**Table 1. Mathematically calculated ideal frequency values for the notes covered by the StyloPIC.**

Note	Frequency (Hz)
C'	261-625
C#	277-182
D'	293-664
D#	311-126
E'	329-627
F'	349-229
F#	369-994
G'	391-995
G#	415-304
A"	440-000
A#	466-163
B"	493-883
C"	523-251
C#	554-364
D"	587-328
D#	622-252
E"	659-254
F"	698-458
F#	739-988
G"	783-990
G#	830-608
A"	880-000
A#	932-326
B"	987-766
C"	1046-50

Thus, if you increase note Concert A from 440Hz to 441Hz, A at the next octave up is automatically increased to 882Hz, exactly twice that of the lower note.

To change the pitch of the entire 25-note block, Reset switch S2 is pressed (while the unit is fully powered) and the stylus applied to one of three keys. Keeping the stylus on the selected key. Reset is released and the program restarts from the beginning. During the initialisation it recognises which key is active and the program jumps to an appropriate correction routine. The interception routing is shown in Listing 1.

As you will see, if top C is keyed, an increase in pitch is required. Keying bottom C causes a reduction in pitch, while

## LISTING 1

```
btfss PORTE,2      ; is increase in tuning
                   ; freq needed?
                   ; (top C keyed)
call TUNEUP        ; yes
btfss PORTB,7      ; is decrease in
                   ; tuning freq need-
                   ; ed? (bot C keyed)
call TUNEDOWN     ; yes
btfss PORTD,6      ; is restore of orig
                   ; tuning freq need-
                   ; ed? (A 440 key)
call RESTORETUNE  ; yes
call GETNOTES
```

keying Concert A 440Hz (A nearest to the left of the keyboard) results in the author's defaults being restored.

Readers having TK3 and its board could actually change the pitch by as little as one least significant bit via the MSG file amendment/programming option.

## RESTORING

Any changes actioned are automatically stored back to the first block in the Eeprom, where they remain even after power has been switched off, being recalled again when the unit is next switched on.

Tuning adjustment is in relation to the value held in the MSB (most significant byte) of the 2-byte tuning value in the author's default block. For example, if tuning upwards is needed, the author's MSB is retrieved from the Eeprom, halved and added to the LSB (least significant byte) of the value for the equivalent note in the user's block, automatically incrementing the user's note MSB if a Carry (roll over of the LSB) results from the addition. The process is automatically repeated by the software routine for all 25 notes.

Similarly, if a decrease in pitch is required, half the value of the author's MSB is subtracted from the user's LSB/MSB. Restoration of the author's defaults simply entails copying these values into the user's data Eeprom block.

Each adjustment is only performed once for any call via the Reset option. As soon as the adjustment has been made, the PIC waits until the stylus has been removed from the selected key. It then stores the new values back to the user's Eeprom block.

Having done so, and even if adjustment has not been called, the software extracts all values from the user's Eeprom (GETNOTES routine called in Listing 1) and stores them into a 50-byte wide block (25 pairs of note values) of the normal data registers (NOTEVAL, commencing at \$30). These are the tuning values then accessed by the software when the StyloPIC is in normal use.

When the values have been extracted following switch-on or Reset, Concert A 440Hz is triggered, and will be heard from the loudspeaker or headphones as a hard-attack, slow decay audio output (assuming you have turned up volume control VR1!). Although the audio output decays, the note itself continues to be generated at the pin 15 output of DAC IC2. This may be monitored by a frequency counter at test point TP1. To establish its true accuracy, use a frequency counter that shows the result to at least one decimal place. The frequency

for *true* Concert A should be exactly 440.0Hz.

Should you decide that a further adjustment of the pitch is required, repeat the Reset procedure as just described.

## GENERATION GAME

The software has been written so that all lines from the keyboard are constantly scanned to see if any is being touched by the stylus. If one has, a lookup table is used to determine which note frequency it refers to. If the note is different to the previous one called, that note's 2-byte tuning value is then copied from the NOTEVAL block and stored into registers *FREQHI* and *FREQLO* (MSB and LSB respectively). Simultaneously, the envelope shaper is triggered via PIC output *RE0*.

It is the *FREQHI/LO* value that is added to the frequency generation counter pair *WAVEHI* and *WAVELO* in routine *PLAYIT*. Each time the added value causes *WAVEHI* to rollover (Carry flag set), another counter, *OUTPUT* is incremented. It is the value of this counter that is output to Port A and DAC IC2. Listing 2 shows the structure of the *PLAYIT* routine.

There are two points especially worth noting in Listing 2. First, it will be seen that the status of the Carry flag is not actually tested (e.g. *BTFSS STATUS,C*), but its status is extracted as a value which is then added to *WAVEHI*, regardless of whether the answer is 0 or 1.

One of the most import aspects of music generation software is that all functions are absolutely consistent in their timings, irrespective of any intermediate actions that have to be performed during them. To have actually tested the Carry flag would have resulted in different loop timings, depending on the result of the test. This would probably be heard as a brief "hiccup" (unevenness) in the note. The process shown in Listing 2 avoids this brief deviation.

Secondly, it is in the *PLAYIT* routine that the output waveform is set to either ramp or squarewave. Towards the end of Listing 2 is the command *BTFSC MASK,0*. Register *MASK* is that which holds the waveshape flag as triggered by touching the stylus on the keyboard's right-hand pad (marked with a triangle and squarewave) below it.

If *MASK* bit 0 is set (= 1) then the ramp waveform is required and the routine jumps to label *PLAY2* and then at *OUTIT* outputs the full value of the *OUTPUT* counter to Port A.

If *MASK* bit 0 is not set (= 0), the squarewave output is required. This is generated by outputting a value of 0 or 31 (binary 00111111), depending on the state of the count. If bit 5 of *COUNTER* is high then 31 is output, otherwise the output value is 0. In both instances the four *NOP* commands at *PLAY2* are bypassed.

The *NOPs* are again there for timing balance, this time between the different times it takes to process the ramp waveform compared to the squarewave.

If you study the full listing for the *StyloPIC* you will find numerous *NOP* commands inserted, all to maintain the timing balance between various stage aspects. **IT IS IMPERATIVE that you do NOT change the number of *NOPs*.** You will lose tuning consistency if you do.

## LISTING 2

```

PLAYIT:  movf FREQLO,W      ; get freq LSB and add it to WAVE LSB
         addwf WAVELO,F
         movf STATUS,W     ; add Carry (if any) to WAVE MSB
         andlw 1
         addwf WAVEHI,F
         movf STATUS,W     ; add Carry (if any) to OUTPUT register
         andlw 1
         addwf OUTPUT,F
         movf FREQHI,W     ; get freq MSB and add it to WAVE MSB
         addwf WAVEHI,F
         movf STATUS,W     ; add Carry (if any) to OUTPUT register
         andlw 1
         addwf OUTPUT,F
         movf OUTPUT,W
         btfsc MASK,0      ; is MASK = 1 (ramp)?
         goto PLAY2       ; yes
         movlw 0           ; no, so square needed
         btfsc OUTPUT,5    ; should output be low?
         movlw %00111111  ; no, it should be high
         goto OUTIT
PLAY2:   nop               ; timing balance delay
         nop
         nop
         nop
OUTIT:   movwf PORTA      ; output value to PORTA
         goto MAIN

```

## SOFTWARE

The *StyloPIC* software was written in TASM grammar on *Toolkit TK3*, through which it can be translated to MPASM grammar for use with such software as MPLAB, for example. It is available on 3.5in disk (for which a small handling charge applies) from the *EPE* Editorial office, or by free download from the *EPE* ftp site.

The easiest access to the ftp site is via our main web site at [www.epemag.wimborne.co.uk](http://www.epemag.wimborne.co.uk). At the top of the main page click on the ftp option, then select in order of PUB - PICS - *StyloPIC*.

There are four files involved: *ASM* (TASM), *OBJ* (TASM), *HEX* (MPASM) and *MSG*. The latter holds the data Eeprom tuning values in the format specific to *Toolkit TK3* (whose software is also available for free download via our ftp site). Non-*TK3* users will need to incorporate these values into the *HEX* file so that during programming they are loaded into the PIC's data Eeprom commencing at location 0.

*PIC* configuration is embedded into the *HEX* file. *OBJ* users should configure the *PIC* for HS crystal, *WDT* off, *POR* on.

The printed circuit board includes connections through which the *PIC* can be programmed using *TK3* and its *MK3* board. The connections are in the author's standard order (via *TB1*, see Fig.1). Remember to connect switch *S2* after you have completed the programming.

Programmed *PICs* are available as discussed in this month's *Shoptalk* column (which also provides essential information on component sourcing for the *StyloPIC*).

## STYLOPHONE WEBSITES

Doing a search on *Stylophone* via [www.google.com](http://www.google.com) revealed that at the time of writing it provides access to 2260 *Stylophone*-related sites, while [www.yahoo.com](http://www.yahoo.com) has 1610 sites available.

Some other sites not only offer history and other information about the

*Stylophone*, but also offer second-hand ones for sale (for about US \$70 on one site). There are also sites that allow you to download and play with simulations of the *Stylophone* on your PC.

Other sites deal with the spin-offs that resulted from the *Stylophone* craze, including information on the musicians and groups who used the instrument on their recordings, such as David Bowie, for example, on his *Space Oddity* (spelled *Odyssey* on some sites - never mind, it's a superb track whatever its name!).

There are too many sites for the author to provide a list of the most interesting ones, but one in particular is worth highlighting:

[www.stylophone.fsnet.co.uk](http://www.stylophone.fsnet.co.uk)

which the author found especially fascinating, and from which the earlier "history" paragraphs were distilled (there is much more, and very interesting, information in the original - browse it!). The images of a *Stylophone* also came from this site.

## PUTTING ON THE STYLE

Whilst the heyday of the *Stylophone* is long gone, it continues to live on as an excellent example of how someone's innovative brainwave materialised as a product that really caught people's imagination. It is hoped that many of you will find enjoyment through playing with the author's modern re-interpretation of the original simple yet very effective idea. □

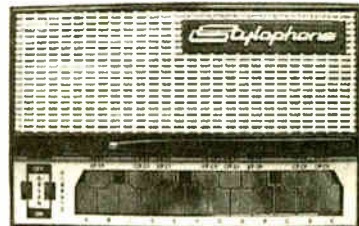



# READOUT

E-mail: [editorial@epemag.wimborne.co.uk](mailto:editorial@epemag.wimborne.co.uk)

**John Becker addresses some of the general points readers have raised. Have you anything interesting to say? Drop us a line!**

## WIN A DIGITAL MULTIMETER

A 3½ digit pocket-sized I.c.d. multimeter which measures a.c. and d.c. voltage, d.c. current and resistance. It can also test diodes and bipolar transistors.

Every month we will give a Digital Multimeter to the author of the best *Readout* letter.



## ★ LETTER OF THE MONTH ★

### P.C.B. SIZES AGAIN

Dear EPE,

Regarding the enquiry by Dave Stacey on p.c.b. sizes (*Readout* June '02), I have also had re-sizing problems with pdf file p.c.b. sizes, and with trying to import pdf files into Photo Suite, Photo Studio and Photo Plus for editing. The ubiquitous free Adobe Acrobat Reader unfortunately allows no graphics editing. Not only that, but scanning poor quality paper magazine layouts produces unwanted image artifacts, and can cause closely placed tracks and pads to merge on the final printout, making the scan unusable as a p.c.b. master image.

I have found a solution: it is so simple, quick and easy, and produces such accurate and high quality p.c.b. masters from both pdf files and scanned images, that at first I could not believe that it worked. It is also free!

Obtain a copy of Paint Shop Pro (PSP). I use version 4.15 but an evaluation copy of Paint Shop Pro 3.0 may be downloaded from [www.jasc.com](http://www.jasc.com), and works just as well, although the toolbars are better on V4.15. (Other graphics packages may work with the following procedure, but I have no such experience. Maybe other readers can advise.)

Install PSP, open to full screen size, and minimise. Open Acrobat to full screen size, load the relevant p.c.b. layout page and centralise the layout on the screen. Press the Print Screen key on the keyboard (this sends the screen image to the clipboard). Minimise Acrobat and maximise PSP and make it the active window. Press Ctrl-V (simultaneously), which pastes the clipboard to PSP.

Select the p.c.b. layout, crop and zoom to 10:1. A bit map image in pixels is produced which may be manipulated in all forms. Pixels can be deleted or added as required

by the various tools available, tracks and pads can be removed, or added to make minor additions to the layout, the printout can be re-sized and even specified for placement on the page (which can save valuable acetate). Don't forget to save regularly while editing. My 1280 x 1024 screen gives a resolution in PSP of about 150 pixels/inch which is adequate for good resolution printouts with a manageable number of pixels to edit.

Poorly reproduced magazine layouts are as simple, and the cheapest scanner should be adequate. Open PSP, go to File, Acquire and use the TWAIN interface to scan the magazine copy. Use Lineart, Resolution 200. Then edit the layout as above.

Three additional points for making best p.c.b. production:

1. Mirror the layout before printing on acetate to allow the printed tracks to be in intimate contact with the photosensitive layer when exposing the board.

2. Special ink-jet (sand finish) acetate can produce acceptable masters with ink jet printers, but the cartridge and printer must be perfect. Any missing scan lines will etch hair line track breaks on the final board.

3. For consistent high quality masters a cheap 600 lines-per-inch laser printer is worth the investment.

I also recommend *Paint Shop Pro in Easy Steps* by Stephen Copestake, £8.99. The publisher in UK is Computer Step - tel: 01926 817999.

**Roger Lucas,  
via email**

*That appears to be very useful info, Roger. Whilst I have not tried it, it seems that the technique should also work with the standard Paint program supplied in the Accessories folder of all Windows-based PCs.*

### PIC627/8 DEVICES

Dear EPE,

I assume you're aware that the price of the PIC16F84 and 16F84A has recently increased quite dramatically.

Checking Farnell's web site, I found that the 16F627 (and 628) were, by comparison, a bargain. If the price differential is likely to persist (which, I suspect, will be the case), then might it be time to make the cheaper 16F627/8 the entry-level PIC in *EPE*?

However I'm well aware that the additional complexity of these PICs might put beginners off. The 16F84(A) is, at least, fairly simple.

**Phil Cadman, via email**

*The differential is likely to continue and I have experimented with the F627 and found that at its simplest level it can readily be used in place of the F84, with a simple software modification if Port A is to be used as normal I/O:*

*First, add the equates:*

```
CMCON EQU H'1F'
```

*Then prior to the initialising commands for the ports etc, make the statement (within Page 0):*

```
MOVLW 7  
MOVWF CMCON
```

*Port A will then behave in the normal way. You must also ensure that all variables (user registers) start at H'20' or later, not at H'0C' as allowed by the C84 and F84.*

*Toolkit TK3 software has been upgraded to handle F627/8 and is now on our web site as V1.3. A short article looking at basic F627/8 use and various mods made to TK3 to handle them will be published in the near future. TK3 has also been modified to allow users to add their own specified PICs (14-bit command types) to the list of those it handles.*

### TK3 AND PIC12C508

Dear EPE,

Here's a handy tip for readers who have built the Toolkit TK3 programmer board and want to program 12C508 or other 12-bit code PICs. TK3 software only programs 14-bit code.

First go to [www.ic-prog.com](http://www.ic-prog.com) and download the free programmer software and helpfile. Now the hard bit, on the TK3 circuit board you must cut the track between printer connector pin 6 (DA4) and TP4. Then unsolder the ends of resistors R7 and R3 connected to TP3 and lift them off the board. Now connect TP3 to TP4. I also took out the wire link connecting TP6 to IC2c pin 2 (but maybe not needed, try leaving it in first).

Now run the ICPROG programmer you downloaded and under hardware select PROPIC2. ICPROG will treat TK3 like PROPIC2, and can program PICs TK3 software cannot. It's easy to reverse these circuit changes.

**Stanley Cartwright, via email**

*That's useful Stanley, thanks. I have not yet found a situation where I wanted to use a 12C device. Should I ever do so I'll probably upgrade TK3 to cope with it.*

### DIGITAL MULTIMETER

Dear EPE,

Could you please send me any information you might have on digital multimeters. I am building a multimeter and I heard your magazine did an issue several years ago. I do not have this particular magazine and you not do back issues. Thank you for your support and great magazine.

**Meme, via email**

*We have not done anything on them in many years and cannot offer you any info. However, they are so cheap that it seems hardly worthwhile building one.*

*But why do you believe we do not sell back issues? We certainly do, as our regular Back Issues pages prove. We also sell back issues on CD-ROMs. Even if we no longer have a back issue containing a particular project, we can provide a photocopy of that article, providing it is less than five years old. See the Back Issues page in this issue for prices.*

### FED WIZPIC

Dear EPE,

I have been learning PIC assembler over the last few months with a regard to several projects I have been wanting to design/build for years. Last month, I came across Forest Electronic Developments ([www.fored.co.uk](http://www.fored.co.uk)) who sell a PIC development/simulation system, for Windows, called WIZ-ASM. This product is fantastic value for money, and it has allowed me to move on in leaps-and-bounds.

I now write code and test it (with appropriate simulated hardware) before I get near a programmer or a single "real" component. Fantastic. I rate this product 10/10 for value and usefulness. Well done, FED.

**Geoff Sim,  
via email**

*Yes, Geoff, we know that FED do good products, and that they are a very helpful company.*

## VIRUS ZAPPING

Dear EPE,

I have used a virus zapper of the type designed by Andy Flind and published in your March '02 issue, but do not know whether or not it helped a virus infection I had for several weeks in an ear canal last year. I like to keep an open mind on these matters. Antibiotics had not been able to heal this infection.

However, I recently had an identical infection in the same ear canal, and it hurt just the same, too much to ignore! So it happened with this new infection that a highly experimental "brain wave stimulator" I designed and built about 15 years ago forcibly came out of retirement to act as a source of capacitor-discharge spikes for a six-inch diameter coil I hurriedly wound. (Andy Flind's *Moodloop*, Aug '00 - Andy is a good source of information on brainwaves and why you would want to stimulate them.)

I did this because I wanted a Rife-type of "magnetic pulser" and I was in too much discomfort to bother with making a proper one, with a proper frequency feed of squarewave a.c. (as per Aubrey Scoon's *The End to all Disease*, April '01).

I knew from years earlier that my brain wave machine when fed into a one-turn room loop coil could influence the mood of people in the room. I was hoping that the d.c. spikes from it at 16.7Hz when fed into my small coil held close to my ear, would be powerful enough to ease possible weeks of pain such as I had last year. And it worked. The pain was mostly gone within 24 hours and in 48 hours I was a happy man.

Why 16.7Hz? That's the only Rife frequency that any brain wave machine can reach (it's in the "beta" brain wave range). Allegedly (from Rife supporters) that frequency is totally wrong for infections but I was - again - hoping that it would work. It wasn't a forlorn hope, as readers who follow alternative electrotherapy will realize that, while Rife has large numbers of frequencies, one for each ailment, a certain Dr Robert Beck offers a similar coil-type magnetic pulser, but in Beck's case one 4Hz squarewave frequency does the lot!

So now I have just helped myself with a d.c. train of spikes, not a.c., at an "unapproved" frequency!

Which leaves me thinking: many people in the Rife and Beck camps apparently swear that their system is the right one. Therefore one must conclude that the choice of frequency is/isn't important. And when I put my pennyworth in, we also understand that the supply should be a.c./d.c. Yes, they are silly statements, but how can they be refuted? I am not lying, and I am sure that the Rife and Beck supporters are not lying either! Are we mistaken then, as to what really heals us? Could be. I look forward to other readers' opinions.

May I also comment that the *EPE PIC Virus Zapper* carries no health warning and point out that Dr Hulda Clark in her book states "Do not zap if you are pregnant or wearing a pacemaker".

**Stan Hood,  
Christchurch, New Zealand,  
via email**

*Andy Flind replies:*

I recently had two really bad colds in quick succession. My original zapper has been loaned to a chap in Scotland, so I knocked up a generator for a zapper output, only this one can do both 2.5kHz and 20kHz. I applied it through adhesive electrodes on my wrists, and manually timed the sessions, not having a PIC programmed for this.

The sore throat cleared up overnight, and on the day after the first treatment I felt a bit thick-headed (no, really!) as they say you sometimes will when you first use a zapper on a problem. Like Stan, I can't say whether I'd have got better anyhow or the zapper did the job, but something fixed my problems.

The first zapper circuit I built was Hulda's original, from her book. It has a truly horrible

output waveform, and ran at about 18kHz if I recall. I used the bipolar 555 in case the rise and fall times of the output were significant, being faster than CMOS types. However, I've since found that the body appears to behave a bit like a capacitor, if the output drive current isn't available it'll slow the rise and fall times significantly. Hulda's design has a 1kΩ resistor in its output, which would be enough to cause the problem.

Frequencies . . . I've used both, and didn't notice any significant difference between them. One commercial supplier now claims that they work by achieving resonance with the target organisms and "bursting" them, but I think there's some confusion with Rife here. They offer a unit which sweeps its output between 10kHz and 100kHz, though if it's swept as fast as their 'scope picture suggests, it misses most of the intermediate ones.

Yes, we should have had warnings.

**Andy Flind**

## PIC INTERRUPTS

Dear EPE,

Referring to Malcolm Wiles' *Using PIC Interrupts* articles (Mar/Apr '02), the RETFIE instruction is by no means the only possible return from an ISR, RETURN and RETLW can also be used but will not set the GIE bit. This proved useful to me on one occasion when I needed to measure the width of an external pulse. The ISR in conjunction with TMR0 measured the pulse width and returned to the main program using a RETURN instruction. The main then tested GIE to be clear indicating a valid reading was available.

Malcolm's Listing 6 highlights the problem of reading a 2-byte value that is continually changing. Here is a solution that does not require interrupts to be disabled. Read and save the high byte, read and save the low byte, re-read the high byte and check if it is the same as the previous read, if not start over again. This translates to the following pic code.

```
LOOP MOVF ISRCH,W
      MOVWF COUNTH
      MOVF ISRCL,W
      MOVWF COUNTL
      MOVF ISRCH,W
      XORWF COUNTH,W
      BTFSF STATUS,Z
      GOTO LOOP
```

Malcolm is correct in respect of Microchip having fixed Murphy's last trick. Here is an extract from the document 31008a.pdf which, as far as I know, does not appear elsewhere:

"When an instruction that clears the GIE bit is executed, any interrupts that were pending for execution in the next cycle are ignored. The CPU will execute a NOP in the cycle immediately following the instruction which clears the GIE bit. The interrupts which were ignored are still pending to be serviced when the GIE bit is set again."

So if you clear GIE and are also counting instruction cycles for a timing critical section, beware! - the CPU may slip in an extra NOP instruction. The moral of this story? Read every Microchip document you can find, and read it very carefully!

Finally, despite a few minor shortcomings an AVR is a programmer's dream when compared to a PIC.

**Peter Hemsley,  
via email**

*That's useful, Peter, thanks.*

*AVRs - that's another story. A while ago we tried readers on an Atmel microcontroller design and no-one was significantly interested. Also, despite AVRs periodically being discussed in Readout, there's not a great deal of interest coming in on correspondence. We have therefore concluded that PICs, which do have a good following, are the microcontroller that we should principally support.*

## PIC, SHIFT REG AND L.C.D.

Dear EPE,

Thanks to John Becker for all his hard work in producing *TK3*. There are many expensive programmers and tutors etc. that fall far short of what *TK3* will do, a confusing minefield for people who wish to start using PICs. How about a comparison feature in *EPE*? I have used *TK3* with John's excellent *PIC Tutorial* text downloaded with the *TK3* software, with a bit of thought most tutorial examples can be run on the *TK3* board. I found ASM easier to pick up this way than Basic.

My own projects are being slowly thought out, worked out and programmed. The splendid *Teach-In* series is helping me with a weather station project, and an inverter project is also under way. Both have small programs that need only a 16F84. I did not want to use (waste) an F87x or buy a serial l.c.d. (too dear for alphanumeric) so I extended a routine for 8-bit shift registers I developed, added some of your l.c.d. bits and ended up with a routine to talk to intelligent l.c.d.s. it only uses three I/O pins and although not optimised, works ok.

I would recommend *TK3*, as a tutor and development tool, excellent value, well done, many thanks. Thanks also to Malcolm Wiles for a very informative and (for me) timely article on interrupts.

**Graham Card,  
via email**

*Very many thanks for the kind words and software offering - it looks interesting. It's too long to quote in Readout, but I have put the code in the PIC Tricks folder on our FTP site.*

*Regarding comparison articles - that would be extremely difficult for us to do in a meaningful manner since it would require someone to acquire and learn the various programmers that are available. No-one is realistically ever going to have the time to do this, nor would it be cost-effective in respect of the research and equipment costs. It's a nice idea, and a pity we could not undertake it.*

## HIGH VOLTAGE GENERATORS

Dear EPE,

I want to build a high voltage generator of sufficient power and voltage to kill rodents. I built something in kit form some years back using a Darlington circuit which was used as a car ignition amplifier. Perhaps I could follow the same tack, but what I really want is a unit powered by about 6V to 12V d.c., storing voltage of the maximum that could be generated from this source, but perhaps not exceeding 30kV, until it is delivered through a short circuit that occurs when a rodent treads on a plate (earth) and the voltage discharged from an electrode through the rodent. I envisage something in solid state form.

At present I am using mains voltage for this purpose. It fries the rodents, but each time I have to reset the 6A circuit breaker, and the unit is inconvenient as it cannot be used out of doors. Any idea where I can look for information?

**Anthony Banksie, via email**

*Goodness, Anthony, I dread to think what animal (and human) welfare organisations might think of your extermination practice and intent! I will refrain from comment on this, but if you wish to investigate high voltage generation in a broad sense, the technology used in the Tesla coil generator for the DIY Tesla Lightning of March '01 might be of interest to you. There are also many web sites devoted to Tesla coils - do a search on Tesla via [www.google.com](http://www.google.com). Such voltages aare, of course, highly dangerous.*

## RUGBY CLOCK

Dear EPE,

I am thinking of decoding the time-signals from Rugby to use in a data logger. Has anybody made a program for a PIC?

**Dave, via email**

*My PIC Time Machine (Nov '97 plus Aug '98) does it. The software's on our FTP site.*

# Measure pH, Voltage, Humidity, Sound & Light, on your PC!

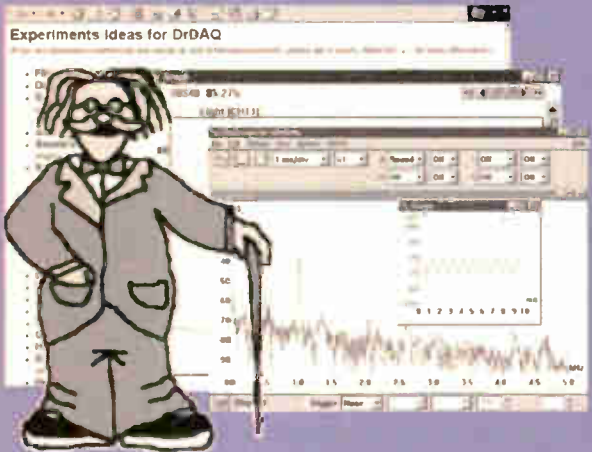

- ✓ Very low cost
- ✓ Built in sensors for light, sound (level and waveforms) and temperature
- ✓ Use DrDAQ to capture fast signals (eg sound waveforms)
- ✓ Outputs for control experiments
- ✓ Supplied with both PicoScope (oscilloscope) and PicoLog (data logging) software

**Only £59!**  
+ VAT

The DrDAQ is a low cost data logger from Pico Technology. It is supplied ready to use with all cables, software and example science experiments.

**DrDAQ represents a breakthrough in data logging.** Simply plug DrDAQ into any Windows PC, run the supplied software and you are ready to collect and display data. DrDAQ draws its power from the parallel port, so no batteries or power supplies are required.

As well as the built in sensors, DrDAQ has two sockets for external sensors. When a sensor is plugged in, the software detects it and automatically scales readings. For example, if a temperature sensor is plugged in, readings are displayed in °C. Details are provided to allow users to develop their own sensors.

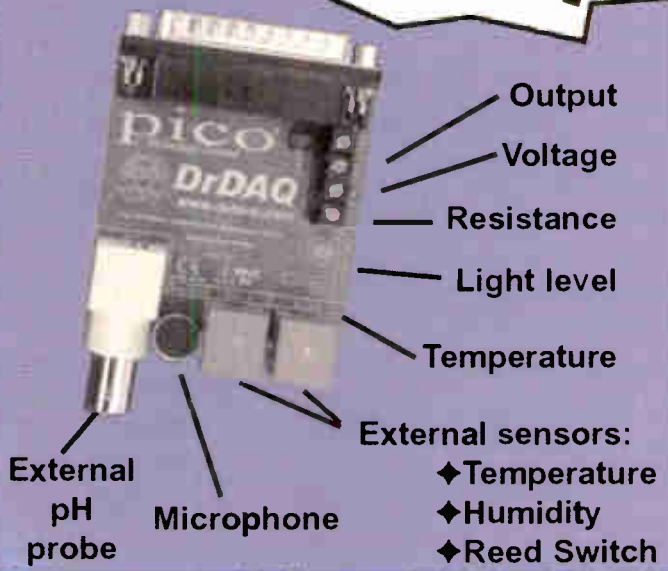

To order the DrDAQ please choose one of the following options:

- i) Visit our web site and place an order over the Internet,
- ii) Place an order over the phone by ringing the number below, or,
- iii) Fill out the order form and either fax it, or post it back to Pico Technology.

DrDAQ Order Form:			
Quantity	Package	Price inc VAT	Total
	DrDAQ + Software	£69.32	
	DrDAQ + 2 Temp Sensors	£92.85	
	DrDAQ + 2 Temp, pH Electrode, Humidity + Reed Switch Sensors	£175.08	
	Delivery	£4.11	£4.11
Grand Total		£	

Name			
Address			
Post code			
Phone			
Credit Card	<input type="checkbox"/> Visa / Mastercard / Switch / Amex		
Card Number			
Expiry Date	/	Start Date & or Issue No.	
Cheque with order	<input type="checkbox"/>		

Pico Technology Ltd, The Mill House, Cambridge Street, St Neots, Cambridgeshire. PE19 1QB  
 Tel: 01480 396395, Fax: 01480 396296, E-mail: [post@picotech.com](mailto:post@picotech.com), Web: [www.drdaq.com](http://www.drdaq.com)

World Radio History

**PICO** A Data Logging Breakthrough  
 Technology Limited

THE No.1 MAGAZINE FOR ELECTRONICS TECHNOLOGY & COMPUTER PROJECTS

We can supply back issues of *EPE* by post, most issues from the past three years are available. An *EPE* index for the last five years is also available – see order form. Alternatively, indexes are published in the December issue for that year. Where we are unable to provide a back issue a photocopy of any *one* article (or *one* part of a series) can be purchased for the same price. Issues from Jan. 2002 onwards are also available to download from [www.epemag.com](http://www.epemag.com).

## DID YOU MISS THESE?

### MAR '01

**PROJECTS** • Doorbell Extender • Body Detector • DIY Tesla Lightning • Circuit Tester  
**FEATURES** • Understanding Inductors • The Schmitt Trigger-Part 5 • Circuit Surgery • Interface • New Technology Update • Net Work – The Internet Page.

### APRIL '01

**PROJECTS** • Wave Sound Effect • Intruder Alarm Control Panel-Part 1 • Sound Trigger • EPE Snug-Bug Pet Heating Control Centre.  
**FEATURES** • The Schmitt Trigger-Part 6 • Practically Speaking • Ingenuity Unlimited • Circuit Surgery • Net Work – The Internet Page • **FREE** supplement – An End To All Disease.



### MAY '01 Photostats only

**PROJECTS** • Camcorder Mixer • PIC Graphics L.C.D. Scope • D.C. Motor Controller • Intruder Alarm Control Panel-Part 2.  
**FEATURES** • The Schmitt Trigger-Part 7 • Interface • Circuit Surgery • Ingenuity Unlimited • New Technology Update • Net Work – The Internet Page.

### JUNE '01

**PROJECTS** • Hosepipe Controller • In-Circuit Ohmmeter • Dummy PIR Detector • Magfield Monitor.  
**FEATURES** • Controlling Jodrell Bank • PIC1687x Extended Memory Use • Practically Speaking • Ingenuity Unlimited • New Technology Update • Circuit Surgery • Net Work – The Internet Page.

### JULY '01

**PROJECTS** • Stereo/Surround Sound Amplifier • PIC to Printer Interface • Perpetual Projects 1 – Solar-Powered Power Supply and Voltage Regulator • MSF Signal Repeater and Indicator.  
**FEATURES** • The World of PLCs • Ingenuity Unlimited • Circuit Surgery • New Technology Update • Net Work – The Internet Page.

### AUG '01

**PROJECTS** • Digitimer • Lead-Acid Battery Charger • Compact Shortwave Loop Aerial • Perpetual Projects 2 – L.E.D. Flasher – Double Door-Buzzer.  
**FEATURES** • Controlling Power Generation • Ingenuity Unlimited • Interface • Circuit Surgery • New Technology Update • Net Work – The Internet Page.

### SEPT '01

**PROJECTS** • Water Monitor • L.E.D. Super Torches • Synchronous Clock Driver • Perpetual Projects 3 – Loop Burglar Alarm – Touch-Switch Door-Light – Solar-Powered Rain Alarm.  
**FEATURES** • Controlling Flight • Ingenuity Unlimited • Practically Speaking • Circuit Surgery • New Technology Update • Net Work – The Internet Page.

### OCT '01 Photostats only

**PROJECTS** • PIC Toolkit Mk3 • Camcorder Power Supply • 2-Valve SW Receiver • Perpetual Projects 4 – Gate Sentinel – Bird Scarer – In-Out Register.  
**FEATURES** • Traffic Control • Ingenuity Unlimited • New Technology Update • Circuit Surgery • Interface • Net Work – The Internet Page • **Free** 2 CD-ROMs – Microchip 2001 Tech Library.



### NOV '01

**PROJECTS** • Capacitance Meter • Pitch Switch • Lights Needed Alert • Teach-In 2002 Power Supply.  
**FEATURES** • Teach-In 2002 – Part 1 • Practically Speaking • Circuit Surgery • New Technology Update • Ingenuity Unlimited • Net Work – The Internet Page • **Free** 16-page Supplement – PIC Toolkit TK3 For Windows

### DEC '01

**PROJECTS** • Ghost Buster • PIC Polywhatsit • Twinkling Lights • Mains Failure Alarm.  
**FEATURES** • Teach-In 2002 – Part 2 • Marconi – The Father of Radio • Interface • Ingenuity Unlimited • Circuit Surgery • New Technology Update • Net Work – The Internet Page • 2001 Annual Index.

### JAN '02

**PROJECTS** • PIC Magick Musick • Time Delay Touch Switch • Versatile Bench Power Supply • Forever Flasher.  
**FEATURES** • Teach-In 2002 – Part 3 • Practically Speaking • Ingenuity Unlimited • New Technology Update • Circuit Surgery • Net Work – The Internet Page.

### FEB '02

**PROJECTS** • PIC Spectrum Analyser • Guitar Practice Amp • HT Power Supply • Versatile Current Monitor.  
**FEATURES** • Teach-In 2002 – Part 4 • Ingenuity Unlimited • Russian Space Shuttle Revisited • Circuit Surgery • Interface • New Technology Update • Net Work – The Internet Page.



### MAR '02

**PROJECTS** • MK484 Shortwave Radio • PIC Virus Zapper • RH Meter • PIC Mini-Enigma.  
**FEATURES** • Teach-In 2002 – Part 5 • Ingenuity Unlimited • Programming PIC Interrupts-1 • Circuit Surgery • Practically Speaking • New Technology Update • Net Work – The Internet Page.

### APR '02

**PROJECTS** • Electric Guitar Tuner • PIC Controlled Intruder Alarm • Solar Charge and Go • Manual Stepper Motor Controller.  
**FEATURES** • Teach-In 2002 – Part 6 • Interface • Programming PIC Interrupts-2 • Circuit Surgery • Ingenuity Unlimited • New Technology Update • Net Work – The Internet Page • **FREE** Giant Op.Amp Data Chart.



### MAY '02

**PROJECTS** • PIC Big-Digit Display • Simple Audio Circuits – 1 • Freezer Alarm • Washing Ready Indicator.  
**FEATURES** • Teach-In 2002 – Part 7 • Ingenuity Unlimited • Practically Speaking • New Technology Update • Circuit Surgery • Net Work – The Internet Page.

### JUNE '02

**PROJECTS** • Biopic Heartbeat Monitor • Frequency Standard Generator • Simple Audio Circuits – 2 • World Lamp.  
**FEATURES** • Teach-In 2002 – Part 8 • Interface • New Technology Update • Circuit Surgery • Ingenuity Unlimited • Net Work – The Internet Page.

**BACK ISSUES ONLY £3.30** each inc. UK p&p.  
Overseas prices £3.80 each surface mail, £5.25 each airmail.

We can also supply issues from earlier years: 1998 (except Jan. to May, July, Nov., Dec.), 1999, 2000 (except Feb., July), 2001 (except May, Oct.). Where we do not have an issue a photocopy of any *one* article or *one* part of a series can be provided at the same price.

#### ORDER FORM – BACK ISSUES – PHOTOCOPIES– INDEXES

- Send back issues dated .....
- Send photocopies of (article title and issue date) .....
- Send copies of last five years indexes (£3.30 for five inc. p&p – Overseas £3.80 surface, £5.25 airmail)

Name .....

Address .....

.....Tel: .....

I enclose cheque/P.O./bank draft to the value of £ .....

Please charge my Visa/Mastercard/Amex/Diners Club/Switch £ ..... Switch Issue No. ....

Card No. .... Card Expiry Date .....

SEND TO: Everyday Practical Electronics, Wimborne Publishing Ltd., 408 Wimborne Road East, Ferndown, Dorset BH22 9ND.

Tel: 01202 873872. Fax: 01202 874562.

E-mail: [croers@epemag.wimborne.co.uk](mailto:croers@epemag.wimborne.co.uk) On-line Shop: [www.epemag.wimborne.co.uk/shopdoor.htm](http://www.epemag.wimborne.co.uk/shopdoor.htm)

Payments must be in £ sterling – cheque or bank draft drawn on a UK bank. Normally supplied within seven days of receipt of order.

Send a copy of this form, or order by letter if you do not wish to cut your issue.

M07/02

# STORE YOUR BACK ISSUES ON MINI CD-ROMS



**VOL 6  
NOW AVAILABLE**

**ONLY  
£12.45 each**  
including VAT  
and p&p

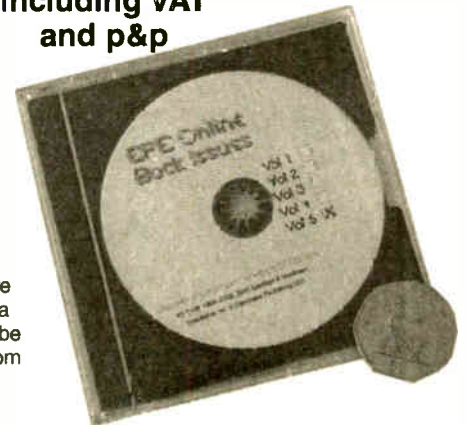

A great way to buy *EPE* Back Issues – our mini CD-ROMs contain back issues from our *EPE Online* website plus bonus articles, all the relevant PIC software and web links. Note: no free gifts are included. All this for just £12.45 each including postage and packing.

## VOL 1 CONTENTS

**BACK ISSUES** – November 1998 to June 1999 (all the projects, features, news, IUs etc. from all eight issues). Note: No advertisements are included. **PIC PROJECT CODES** – All the available codes for the PIC based projects published in these issues.

## VOL 2 CONTENTS

**BACK ISSUES** – July 1999 to December 1999 (all the projects, features, news, IUs, etc. from all six issues). Note: No advertisements are included. **PIC PROJECT CODES** – All the available codes for the PIC-based projects published in these issues.

## VOL 3 CONTENTS

**BACK ISSUES** – January 2000 to June 2000 (all the projects, features, news, IUs, etc. from all six issues). **PIC PROJECT CODES** – All the available codes for the PIC-based projects published in these issues.

## VOL 4 CONTENTS

**BACK ISSUES** – July 2000 to Dec. 2000 (all the projects, features, news, IUs etc. from all six issues). **PROJECT CODES** – All the available codes for the programmable projects in these issues.

## VOL 5 CONTENTS

**BACK ISSUES** – January 2001 to June 2001 (all the projects, features, news, IUs etc. from all six issues). **PROJECT CODES** – All the available codes for the programmable projects in these issues, including those for *Interface*.

## VOL 6 CONTENTS

**BACK ISSUES** – July 2001 to December 2001 (all the projects, features, news, IUs etc. from all six issues). **PROJECT CODES** – All the available codes for the programmable projects in these issues, including those for *Interface*.

## EXTRA ARTICLES – ON ALL VOLUMES

**BASIC SOLDERING GUIDE** – Alan Winstanley's internationally acclaimed fully illustrated guide. **UNDERSTANDING PASSIVE COMPONENTS** – Introduction to the basic principles of passive components. **HOW TO USE INTELLIGENT L.C.D.s**, By Julyan Ilett – An utterly practical guide to interfacing and programming intelligent liquid crystal display modules. **PhyzyB COMPUTERS BONUS ARTICLE 1** – Signed and Unsigned Binary Numbers. By Clive "Max" Maxfield and Alvin Brown. **PhyzyB COMPUTERS BONUS ARTICLE 2** – Creating an Event Counter. By Clive "Max" Maxfield and Alvin Brown. **INTERGRAPH COMPUTER SYSTEMS 3D GRAPHICS** – A chapter from Intergraph's book that explains computer graphics technology in an interesting and understandable way with full colour graphics.

## EXTRA ARTICLE ON VOL 1 & 2

**THE LIFE & WORKS OF KONRAD ZUSE** – a brilliant pioneer in the evolution of computers. A bonus article on his life and work written by his eldest son, including many previously unpublished photographs.

NOTE: These mini CD-ROMs are suitable for use on any PC with a CD-ROM drive. They require Adobe Acrobat Reader (available free from the Internet – [www.adobe.com/acrobat](http://www.adobe.com/acrobat))

Order on-line from  
[www.epemag.wimborne.co.uk/shopdoor.htm](http://www.epemag.wimborne.co.uk/shopdoor.htm)  
or [www.epemag.com](http://www.epemag.com) (USA \$ prices)  
or by phone, Fax, E-mail or Post

### BACK ISSUES MINI CD-ROM ORDER FORM

Please send me ..... (quantity) BACK ISSUES CD-ROM VOL 1  
Please send me ..... (quantity) BACK ISSUES CD-ROM VOL 2  
Please send me ..... (quantity) BACK ISSUES CD-ROM VOL 3  
Please send me ..... (quantity) BACK ISSUES CD-ROM VOL 3  
Please send me ..... (quantity) BACK ISSUES CD-ROM VOL 5  
Please send me ..... (quantity) BACK ISSUES CD-ROM VOL 6

Price £12.45 each – includes postage to anywhere in the world.

Name .....

Address .....

.....

Post Code .....

I enclose cheque/P.O./bank draft to the value of £ .....

Please charge my Visa/Mastercard/Amex/  
Diners Club/Switch

£ .....

Card No. ....

Expiry Date ..... Switch Issue No. ....

SEND TO: **Everyday Practical Electronics,  
Wimborne Publishing Ltd.,**

**408 Wimborne Road East, Ferndown, Dorset BH22 9ND.**

Tel: 01202 873872. Fax: 01202 874562.

E-mail: [orders@epemag.wimborne.co.uk](mailto:orders@epemag.wimborne.co.uk)

Payments must be by card or in £ Sterling – cheque or bank draft drawn on a UK bank.

Normally supplied within seven days of receipt of order.

Send a copy of this form, or order by letter if you do not wish to cut your issue.

# SIMPLE AUDIO CIRCUITS



## Part 3 – Power Supplies, Loudspeakers, Crossover Networks and Filters

RAYMOND HAIGH

*A selection of "pic-n-mix" low-cost audio circuits – from preamplifier to speaker!*

If a modest output from one of the smaller power amplifiers (May '02) is all that is required, dry batteries represent a suitable power supply. However, when the output is expected to exceed the half-watt level for sustained periods, a mains power unit is more appropriate. Savings in the cost of batteries will quickly cover expenditure on components.

Compromises, inherent in the design of loudspeakers, give rise to limitations which are normally overcome by the use of two or more units and a crossover.

Power supplies, loudspeakers and associated networks are the topics to be covered this month.

### SUPPLY REGULATION

A simple mains power supply comprising a full-wave rectifier and capacitor input filter will deliver an off-load voltage of around 1.4 times the transformer secondary voltage.

With a secondary rated at 12V a.c., the off-load d.c. output voltage will, therefore,

be almost 17V. If the power supply output is close to the maximum safe operating voltage of the amplifier i.c., there is a danger that, under no-signal conditions, the device will be ruined.

When fully loaded, the d.c. output voltage will fall to around 14V with an adequately rated transformer; lower when the transformer specification has been skimped. Voltage will, therefore, be low at the very moments when the power amplifier is being called upon to deliver a high output.

These voltage variations are a cause of distortion and impair the performance of the power amplifier. Moreover, when high-gain preamplifiers or radio tuners are fed from the same supply, the variations can also result in instability, even when substantial decoupling is provided.

### POWER SUPPLY

These problems can be avoided by regulating the output of the power supply, and a versatile circuit, which can be adapted

for single or stereo pairs of any of the amplifiers described in Part 1 (May '02), is given in Fig.1. The mains voltage is stepped down by transformer T1, and a full-wave bridge rectifier arrangement, D1 to D4, produces the d.c. output. Reservoir capacitor C5 reduces supply ripple.

Voltage regulators IC1 and IC2 virtually eliminate any voltage swings caused by load variations. The regulators also remove any residual 100Hz ripple on the supply voltage rails and permit the use of a lower value reservoir capacitor (C5). Low level electrical noise, extending into the r.f. spectrum, is present in the output of the i.c.s, and bypass capacitors, C6, C7, C8 and C9, shunt this to the 0V rail.

The voltages required by amplifiers, preamplifiers and auxiliary equipment are often different, and provision is made for two regulated outputs. Alternatively, each output can supply a separate channel of a stereo system in order to double the current rating.

The switching action of the rectifier diodes (D1 to D4) modulates any r.f. (radio frequencies) present in the mains input. This modulated r.f. can be picked up by radio receivers connected to the supply and it manifests itself as a 100Hz hum which only appears when a station is tuned in. Capacitors C1 to C4, connected across the diodes, suppress this interference, which is known as modulation hum. If radio tuners are to be powered from this circuit, these capacitors must be fitted.

### COMPONENT RATINGS

#### Fuse

It is good practice to protect the equipment with an internal fuse of the lowest possible rating. Because of the nature of the load, this should be of the anti-surge or slow-blow type, and a component rated at one amp (1A) would be suitable for power supplies serving the amplifiers described in this series of articles.

#### Transformer

The rectified d.c. voltage across the reservoir capacitor (C5) must be at least 3V more than the regulator output when

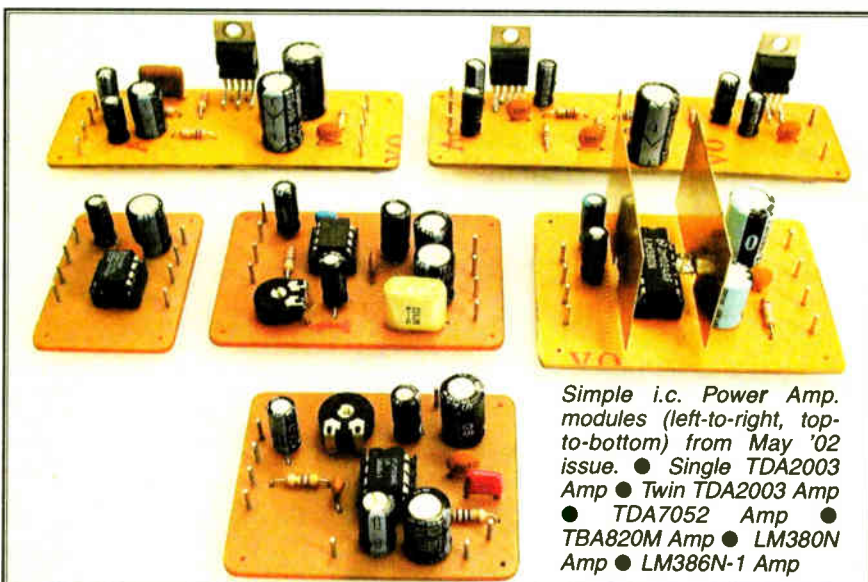

Simple i.c. Power Amp. modules (left-to-right, top-to-bottom) from May '02 issue. ● Single TDA2003 Amp ● Twin TDA2003 Amp ● TDA7052 Amp ● TBA820M Amp ● LM380N-1 Amp

maximum current is being drawn from the supply. Further, the maximum input voltage to the regulator i.c., which is usually 35V for devices with a 2A rating, *must not* be exceeded. It is also desirable for the voltage drop across it to be no more than 10V or so, or power dissipation within the chip will be increased and more elaborate heatsinking will be required.

These requirements can best be met if the mains transformer secondary voltage is 3V more than the regulated d.c. output.

To determine the required current rating of the secondary winding, add together the demands of the amplifiers and ancillary equipment to be connected to the power supply, and increase this by at least 25 per cent to allow for the reactive load presented by the reservoir capacitor (C5). The current requirements of the power amplifiers were given in Part 1. For convenience, they are repeated here in Table 2.

Manufacturers usually indicate the current delivering capacity of their mains transformers by quoting a VA rating. This is, of course, the secondary output voltage multiplied by the maximum current which the transformer can supply.

In Europe, mains transformers often have two 115V primary windings and two identical secondary windings. The primary windings must be series or parallel connected to suit the local supply voltage, and the secondary connected to deliver the desired output. Parallel connecting the secondary will, of course, double the current available. *Connect the windings in phase or the transformer will be short circuited.*

### Rectifiers

With a capacitor input filter, the rectifiers (D1 to D4) must have a p.i.v. (peak inverse voltage) rating at least three times the secondary voltage of the mains transformer. Their current rating should be at least 50 per cent greater than the maximum load on the power supply.

### Reservoir Capacitor

The value of the reservoir capacitor, in microfarads ( $\mu\text{F}$ ), should be at least 2500 times the maximum load current in amps when the supply is regulated, and double this value when unregulated. The working voltage should be at least double the secondary voltage of the mains transformer.

### Regulators

The current rating of the voltage regulators (IC1 and IC2) must, of course, be equal to or greater than the maximum current demand on the power supply. The maximum input voltage rating (usually 30V to 35V) must be at least 1.5 times the secondary voltage of the mains transformer.

Regulator i.c.s are available in a range of output voltages suitable for the audio amplifiers (May'02) and preamplifiers (June'02) described in this

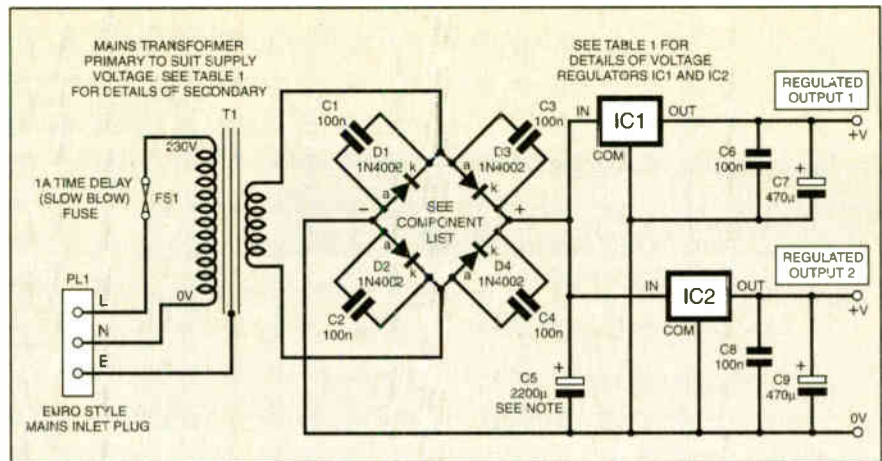

Fig.1. Circuit diagram for a Dual Output Regulated Power Supply.

Table 1: Component Ratings

Regulated Output V d.c.	Transformer Sec. V r.m.s.	Regulator I.C. (1A max output)	C5 Working Voltage
6	9	L7806	25
9	12	L7809	25
12	15	L7812	35
15	18	L7815	35

### NOTES:

- (1) To determine the transformer current rating, add together the current demands of pre and power amplifiers and any ancillary equipment, then increase the total by at least 25% to allow for the reactive load presented by C5.
- (2) A bridge-connected pair of TDA2003 i.c.s with a 4 ohm load will draw 1.7A from a 15V supply and the ratings of the rectifiers, regulator and reservoir capacitor must be increased. Use 1N5401 rectifiers, an L78S15 regulator and a 4700 $\mu\text{F}$  capacitor for C5 (35V working).
- (3) For two, bridge-connected pairs of TDA2003 i.c.s in a stereo combination, fit a 10000 $\mu\text{F}$  (or two 4700 $\mu\text{F}$ ) 35V reservoir capacitor, two L78S15 regulators, (one for each stereo channel) and use P600D rectifiers.

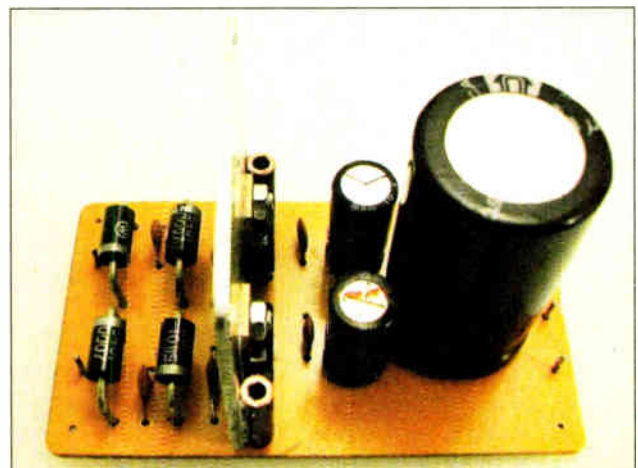

Completed power supply board.

Table 2: Power Amplifier Current Requirements

Power Amp I.C.	Speaker Imp Ohms	Supply volts V d.c.	Current drain A	Power output W
LM386N-1	4	6	0.13	0.32
LM386N-1	8	9	0.12	0.56
TDA7052	4	6	0.42	0.78
TDA7052	8	9	0.39	1
TBA820M	4	9	0.23	0.98
TBA820M	8	12	0.17	1.1
LM380N	4	12	0.23	1.12
LM380N	8	15	0.19	1.32
TDA2003	4	15	0.5	3.92
TDA2003	8	15	0.27	2.1
TDA2003 x 2	4	15	1.7	12.5
TDA2003 x 2	8	15	0.96	8.2

series. Maximum current ratings are 5A for 12V and 3A for 15V units, but chips rated at more than 2A can be difficult to obtain. When the current demand exceeds 2A; e.g. when two, bridge-connected, pairs of TDA2003 audio power amplifier modules are used in a stereo combination, fit a 2A regulator to each output of the power supply and use one for each stereo channel.

### Suppressor Capacitors

The working voltage of capacitors C1 to C4, connected across the rectifier diodes, should be at least four times the secondary voltage of the mains transformer. Bypass capacitors C6, C7, C8 and C9, should have a working voltage at least 1.5 times the transformer secondary voltage to protect them in the event of regulator failure.

Current drain and power output measured just before the onset of clipping.

# DUAL OUTPUT REGULATED POWER SUPPLY

## COMPONENTS

### POWER SUPPLY

#### Capacitors

- C1 to C4 100n ceramic, 100V (4 off)
- C5 2200 $\mu$  radial elect. (see Table 1)
- C6, C8 100n ceramic, 50V (2 off)
- C7, C9 470 $\mu$  radial elect. 50V (2 off)

See  
**SHOP  
TALK**  
page

#### Semiconductors

- D1 to D4 1N4002 rect. diode for 1A max. output (4 off)
- 1N5401 rect. diode for 3A max. output (4 off)
- P60D rect. diode for 4A max. output, limited by regulators (4 off)
- IC1, IC2 78 series for 1A; 78S series for 2A maximum output. See Table 1 (2 off)

#### Miscellaneous

- T1 mains transformer – see text and Table 1
- FS1 1A 20mm slow-blow fuse to suit holder
- PL1 Euro fused mains inlet, chassis mounting, plug with line socket

Printed circuit board available from the EPE PCB Service, code 356 (PSU); metal case, size and type to choice; multistrand connecting wire; mains cable; aluminium sheet or proprietary heatsink and heatsink compound; solder pins; nuts, bolts and washers; stand-off pillars (4 off); solder etc.

Approx. Cost  
Guidance Only

**£20**  
excluding case

## CONSTRUCTION

Any readers who have no experience of building or commissioning mains-powered equipment are reminded that the voltages involved can kill! Anyone who feels unsure of his or her ability to complete a project of this kind **MUST** seek help and guidance from an experienced constructor.

The small components are assembled on the printed circuit board (p.c.b.) as illustrated in Fig.2, together with a full-size copper foil master and the interwiring to off-board components. This board is available from the *EPE PCB Service*, code 356.

Commence construction by first soldering in position on the p.c.b. the rectifier diodes and non-electrolytic capacitors. This can be

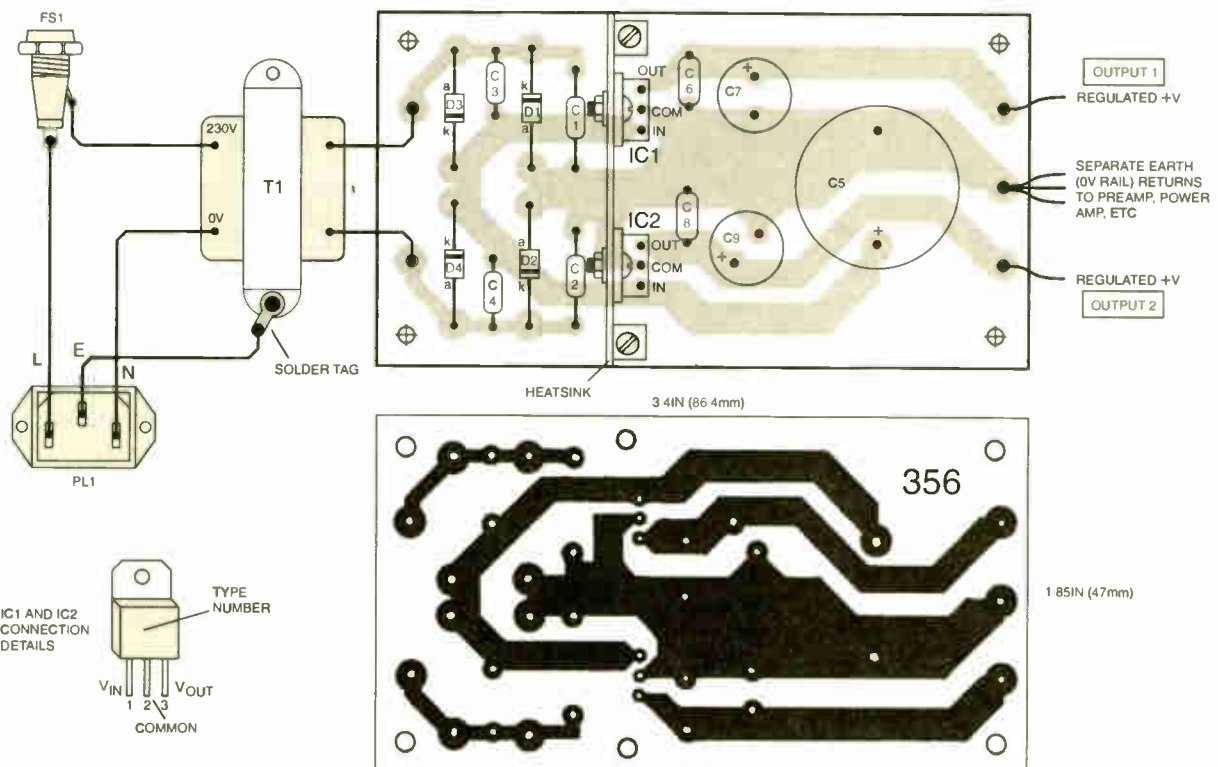
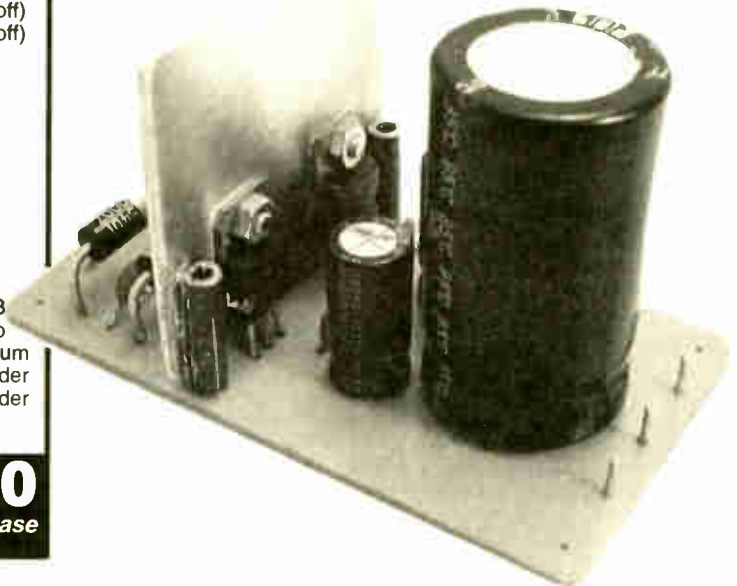

Fig.2. Power Supply printed circuit board, full-size copper master and suggested mains transformer and separate panel fuseholder interwiring. The 16 s.w.g. aluminium heatsink measures 45mm x 45mm.



# LOUDSPEAKERS

followed by the larger electrolytic types and the voltage regulators IC1 and IC2. Finally, you will need to bolt a heatsink to the regulators and details of choosing a suitable heatsink will be given shortly. Solder pins, inserted at the lead-out points, simplify the task of off-board wiring.

Diodes D1 to D4, the reservoir capacitor, C5, and the regulators, IC1 and IC2, have to be chosen to suit the voltage and current to be delivered by the power supply. The requirements are summarised in Table 1 and the associated notes. Details of the modest current needs of the various preamplifiers were given in Part 2 of the series, and the current demands of the power amplifiers are scheduled in Table 2.

Dimensions and fixing arrangements for mains transformers vary and this heavy component should be mounted directly into or on the metal equipment case bottom or chassis panel. A Euro-style mains inlet plug, with a built-in fuseholder for FS1, is strongly recommended. You can, of course, use a separate panel-mounting fuseholder if you wish, see Fig.2.

Mains Earth should be connected to any metal case and to the core and cladding of the transformer. (A solder tag bolted under one of the mains transformer mounting lugs makes a good earthing point for the mains Earth lead.)

Interwiring details to off-board components are also shown in Fig.2. Leads connecting the mains transformer to the inlet plug and the p.c.b., and any mains switch wiring, should be tightly twisted to minimise external fields. Keep the transformer at least 150mm (6in.) away from signal input wiring.

Toroidal transformers have a smaller external field than units with conventional cores. They are the component of choice when the equipment is particularly compact and/or high gain preamplifiers are used.

## HEATSINKING

Unless the current drain is to be very low (say 20mA or less), the regulator i.c.s must be bolted to a heatsink. The 45mm x 45mm sheet of 16s.w.g. aluminium shown on the drawing (Fig.2) is sufficient for current drains up to 1A when the voltage drop across the regulators is not too extreme.

For larger current loads it is suggested that the heatsink be extended and bolted to the metal case or chassis of the unit to ensure adequate heat transfer. Failure to properly dissipate heat from the regulators will result in the devices shutting down.

## COMMISSIONING

Once construction has been completed, check the p.c.b. for poor soldered joints and bridged tracks. Check the orientation of electrolytic capacitors, diodes and regulators.

Make sure that the primary windings of the mains transformer are connected to suit the local supply voltage, and that the secondary windings are connected, in phase, to deliver the correct voltage to the power supply p.c.b. It is a good idea to connect the transformer to the mains and check the secondary voltage with a test meter before linking it to the p.c.b. **Extra care must be taken when carrying out this last task.**

Check the voltage across the reservoir capacitor C5, and that the voltages delivered by regulators (IC1 and IC2) are correct before using the supply to power any equipment.

Loudspeaker (speaker) designers have to make compromises. Sensitivity, good transient and good high frequency response call for a lightweight cone and speech coil assembly. Power handling and an extended low frequency response require a large, strong (and heavy) cone and coil.

For good sensitivity, the magnetic field cutting the voice coil must be intense. Unfortunately, this increases the impedance at the cone's resonant frequency. However, this impedance rise can be controlled by the speaker enclosure, and a powerful magnet is always preferable.

The reproduction of low frequencies involves large cone excursions and the suspension must be highly compliant. High compliance also lowers the cone's resonant frequency, and this extends the speaker's low frequency response. However, the need to maintain control of the position of the voice coil in the magnet gap imposes limits on how free the suspension can be.

Cone movement for a given sound output reduces with increasing speaker size but, as we have seen, greater diaphragm mass impairs transient and high-frequency response.

## HORSES FOR COURSES

To avoid performance being excessively degraded by these conflicting requirements, domestic "hi-fi" systems usually combine two or more speakers, each being designed to reproduce part of the audio frequency spectrum.

The low frequency unit, or *bass* speaker, has a comparatively heavy cone and voice coil with a highly compliant suspension. Clever designers have managed to obtain reasonable results with small speakers, but an extended low frequency response and good power handling are more easy to achieve with speakers of 200mm (8in.) or more in diameter.

Mid-range units are sometimes provided when the low frequency speaker is large (300mm to 450mm or 12in. to 18in. diameter). As one would expect, cones are lighter, the compliance is often stiffer, and the chassis can form a sealed enclosure.

High-frequency units, or "*tweeters*", have a very small diaphragm, which is commonly dome shaped to improve sound dispersal. Units of this kind always have sealed backs.

Whilst moving coil tweeters are the preferred option for hi-fi applications, horn-loaded piezoelectric units are often fitted in the high power speaker systems used by musicians. The impedance of these devices rises, and their power consumption falls almost to zero, as the applied frequency is lowered. They do not, therefore, require a "crossover unit", and are easy to connect into multiple speaker systems.

## COMMUNICATIONS

Loudspeakers intended primarily for speech reproduction in communications equipment have to perform well over a restricted frequency range, usually around 300Hz to 3000Hz.

Inexpensive speakers of the type manufactured for portable receivers are better suited for this purpose, and, if space is available, a 102mm (4in.) diameter unit is

to be preferred. Clarity will be impaired if low frequencies are allowed to excite the cone of a speaker of this kind, and measures to prevent this were discussed in Part 1 (May '02).

## IMPEDANCE

Speech coil impedance is usually measured at around 400Hz. At this frequency, the inductance of the coil has a minimal effect, and its impedance is only one or two ohms more than its d.c. resistance. As frequency rises, the inductance of the speech coil has a growing impact and impedance mounts steadily.

The movement of the speech coil in the magnetic field induces in it a voltage which opposes the signal voltage. At the cone's resonant frequency, very little energy is needed to sustain it in motion, and it vibrates readily, over larger distances, for a comparatively small power input.

These larger cone excursions generate a greater opposing voltage, or back-e.m.f., and speech coil impedance, at resonance, increases by as much as a factor of ten over its nominal value. The more powerful the magnetic field, the more dramatic the rise in impedance.

Impedance peaking at cone resonance (between 30Hz and 100Hz for low frequency speakers), and the gradual rise in impedance with increasing frequency, makes the response of the speaker non-linear. (The power which can be fed to a speaker system falls as its impedance rises). Fortunately, the former can be tamed by good enclosure design, and the latter can be overcome by the use of filter networks and the addition of a tweeter.

Care must always be taken to ensure that the rated impedance of a speaker system is not too low for the power amplifier. Too low an impedance will cause excessive dissipation in the output transistors and, if there is no overload protection circuitry, the power amplifier will be ruined.

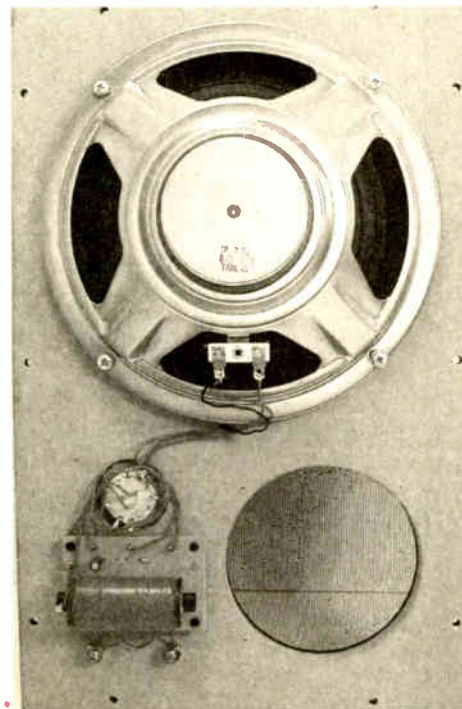

Safe supply voltage and speaker impedance combinations for the various i.c. power amplifiers were given in Part 1. They are summarised here in Table 2.

## CROSSOVERS

When two or more speakers are used to improve performance, arrangements must be made to allocate the audio spectrum between them.

The resistance presented by capacitors to the flow of alternating current decreases as frequency rises. With inductors, resistance increases with rising frequency. This frequency-dependant opposition to current flow is known as *reactance*.

Capacitors and inductors can be combined in simple networks which utilise this phenomenon to allocate frequency bands to different speakers. Circuits and design data are given in Fig.3 and inductor and capacitor values for common speaker impedances, and a range of crossover frequencies, are set out in Table 3. The reactances of standard value capacitors, at

**Table 3: Crossover Network Inductor and Capacitor Values**

Crossover frequency Hertz		500	1000	1500	2000	2500	3000	3500	4000	4500
4 ohm Speaker 1st Order Filter	L	1.3	0.63	0.42	0.32	0.25	0.21	0.18	0.16	0.14
	C	80	40	26	20	16	13	11	10	8
4 ohm Speaker 2nd Order Filter	L	1.8	0.9	0.6	0.5	0.35	0.3	0.25	0.22	0.2
	C	56	28	18	14	11	9	8	7	6
8 ohm Speaker 1st Order Filter	L	2.6	1.26	0.84	0.64	0.5	0.42	0.36	0.32	0.28
	C	40	20	13	10	8	6.5	5.5	5	4
8 ohm Speaker 2nd Order Filter	L	3.6	1.8	1.2	1	0.7	0.6	0.5	0.44	0.4
	C	28	14	9	7	6	4.5	4	3.5	3

Inductance values, L, are given in mH (millihenries).

Capacitor values, C, are given in  $\mu\text{F}$  (microfarads).

See text for guidance on rounding figures up or down to nearest standard value.

various audio frequencies, were tabulated in Part Two.

## FILTER ORDERS

The simple "first order" filters shown in Fig.3a and Fig.3d are perfectly suitable for domestic systems rated at up to 15W.

Low frequency roll-off above the crossover frequency is 6dB per octave and this may not be sufficient to protect some tweeters when higher powered amplifiers are used. In these cases, the second order filters, shown in Fig.3b and Fig.3e, which produce a 12dB roll-off, are safer options.

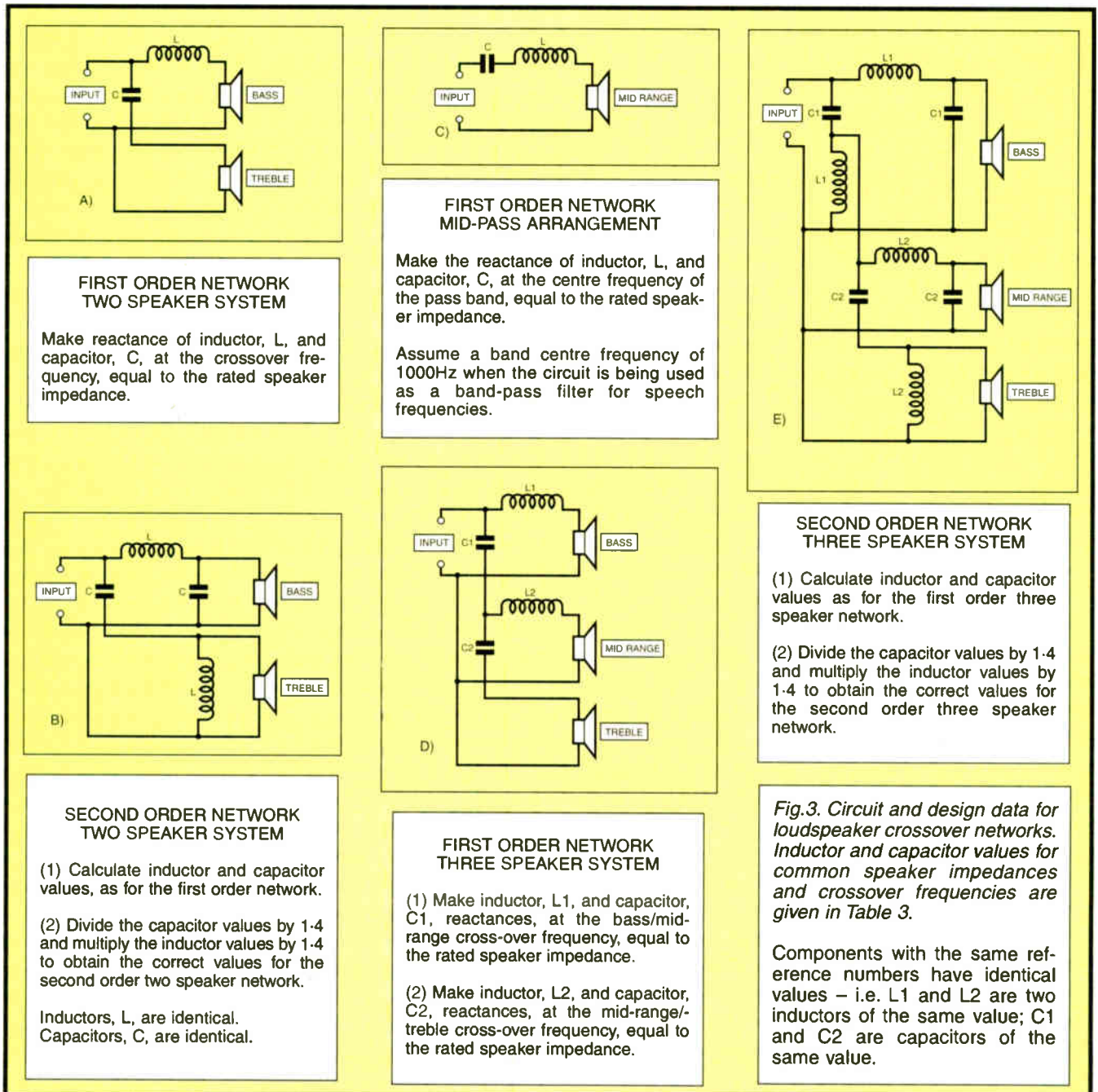

**Fig.3. Circuit and design data for loudspeaker crossover networks. Inductor and capacitor values for common speaker impedances and crossover frequencies are given in Table 3.**

Components with the same reference numbers have identical values – i.e. L1 and L2 are two inductors of the same value; C1 and C2 are capacitors of the same value.

## CROSSOVER FREQUENCY

With two-speaker systems the crossover frequency is usually between 1kHz and 4.5kHz, and the tweeter manufacturer's recommendations should be followed. If the unit is of uncertain origin, adopt a crossover frequency of around 2.5kHz: this will normally be satisfactory.

When the bass speaker is large (12 inches diameter or more), a crossover at 1kHz or even lower can produce a more even frequency response. Suitable tweeters tend to be rather costly, but an inexpensive alternative will be described later.

## THREE SPEAKERS

Another way of ensuring a more even response when a large bass speaker is used is to install a third, mid-range unit. Suitable circuits are given in Fig.3d and Fig.3e.

The bass/mid-range crossover point is usually around 500Hz with open chassis mid-range speakers, and 1000Hz with sealed back units. The mid-range/treble crossover is generally between 4.5kHz and 6kHz. Again, the recommendations of the speaker manufacturer should be followed.

## PHASING

Parallel connected bass speakers must be wired in phase to avoid cancellation of the lower audio frequencies. Use a 1.5V dry cell to test for phasing on unmarked speakers by noting the battery positive connection for the outward movement of the cone.

Crossover networks introduce phase shift, but, as frequency increases, phasing becomes less important. Readers can try reversing the connections to mid-range units. However, unless they have a very refined ear, they are not likely to detect any difference.

## CROSSOVER COMPONENTS

### Inductors

Inductors for home-made crossovers have to be hand wound. The amount of wire, and the resistive losses, can be greatly reduced by winding the coils on short lengths of ferrite aerial rod. Core saturation problems should not arise at the power levels encountered in domestic installations.

Bobbin construction is illustrated in Fig.4. Winding details for the inductor values likely to be encountered are given in Table 4.

The wire should be wound on evenly, and masking tape, applied over each layer, will make the task a little easier. Constructors who have difficulty producing neat windings should increase the diameter of the bobbin ends for the larger inductance coils.

### Capacitors

The bipolar electrolytic capacitors used in crossover networks are available in a limited range of values. Capacitors of this kind can be formed by connecting two ordinary electrolytics back-to-back, and this makes possible the production of non-standard values. The details are given in Fig.5. Capacitors rated at 50V working

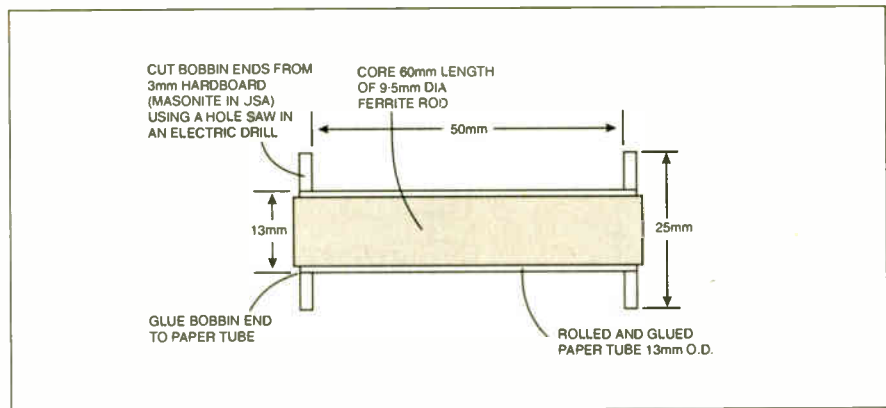

Fig.4. Inductor bobbin construction details.

Table 4: Inductance of Ferrite-cored Coils

Induct mH	0.1	0.2	0.3	0.4	0.5	0.75	1	1.5	2	2.5	3	3.5
No. of turns	45	60	75	90	100	125	150	175	200	225	250	275

Use 20 s.w.g. (19 a.w.g.) enamelled copper wire for coils up to 2mH.

Use 22 s.w.g. (21 a.w.g.) enamelled copper wire for 2.5mH to 3.5mH coils. See illustration for details of bobbin and core.

will be suitable for all of the power amplifiers described in Part 1.

The performance of electrolytic capacitors can become uncertain at high audio frequencies, and the best crossover networks use components with a paper, polyester or polypropylene dielectric.

### Tolerances

Variations in the composition of ferrite rod will affect the tabulated inductor values shown in Table 4 by plus or minus 10 per cent or so. Bipolar electrolytics, whether purchased or homemade, have a tolerance, at best, of plus or minus 20 per cent.

Fortunately, loudspeaker crossover networks are very forgiving, and component spreads even greater than this produce no audible difference. When calculated values are being rounded up or down, it is prudent to err on the high side with inductors and on the low side with capacitors.

## BANDPASS FILTERS

Mention has already been made of the desirability of restricting the audio bandwidth of speakers used primarily for speech communication. An inductor and capacitor can be combined to produce a bandpass effect, and a typical circuit is given in Fig.3c.

As a starting point, select the inductor and capacitor values for a centre frequency of 1000Hz (1kHz). If a more severe attenuation of frequencies below 300Hz and above 3000Hz (3kHz) is required, reduce the capacitor and increase the inductor value. When using this network with earphones, connect both earpieces in parallel to produce an impedance of 16 ohms, and perform the calculations on this basis.

Although extremely simple, this measure will greatly improve the clarity of speech, especially when signals are overlaid by received or generated noise within the amplifiers.

## CROSSOVER UNIT

The circuit diagram for an inexpensive 8ohm Crossover/Filter unit suitable for a multi-purpose workshop speaker is shown

### FORMULAE FOR THE REACTANCE OF INDUCTORS AND CAPACITORS

$$X_L = 0.00628 f L \text{ ohms}$$

$$X_C = \frac{159000 \text{ ohms}}{f c}$$

where

f is in Hertz  
L is in millihenries (mH)  
and C is in microfarads ( $\mu F$ )

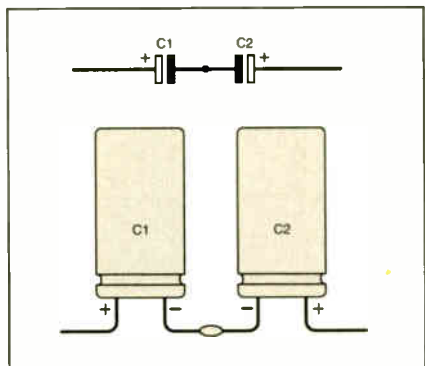

Fig.5. Creating a bipolar electrolytic from two capacitors.

### FORMULAE FOR COMBINING CAPACITORS

Two capacitors in series:

$$C_x = \frac{C_1 \times C_2}{C_1 + C_2}$$

Capacitors in parallel:

$$C_x = C_1 + C_2 + C_3 \dots$$

The working voltage of each capacitor should be at least 1.5 times the peak-to-peak signal voltage developed across the loudspeaker at maximum input.

# CROSSOVER/AUDIO FILTER

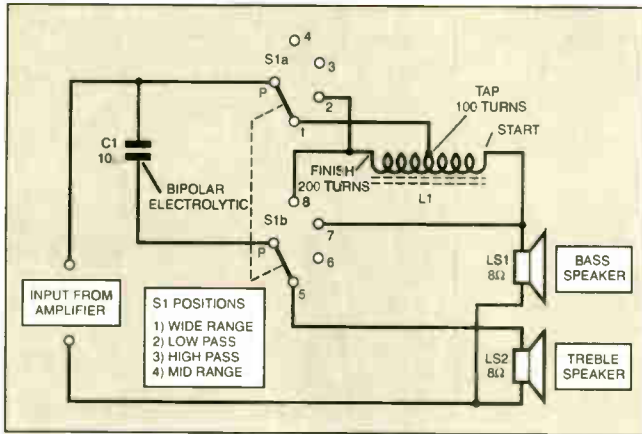

Fig.6. Circuit diagram for the Loudspeaker Crossover/Audio Filter.

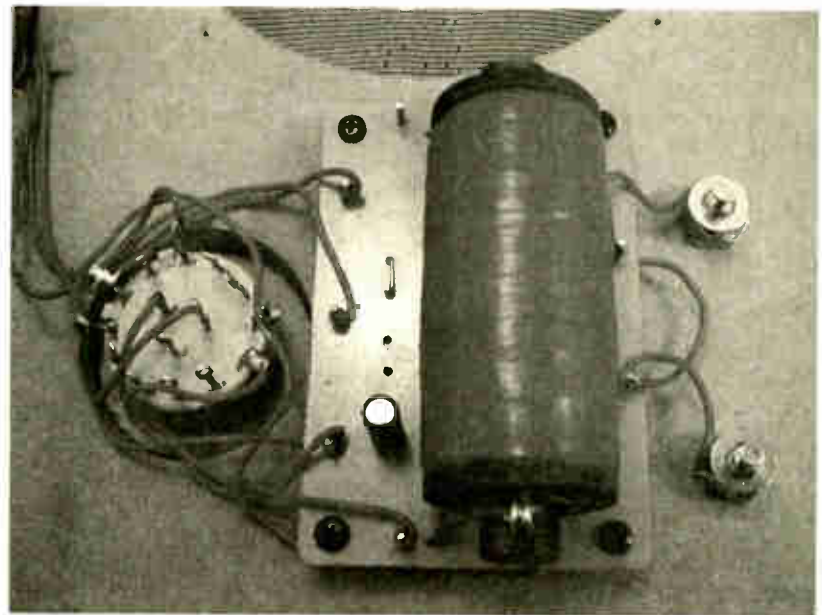
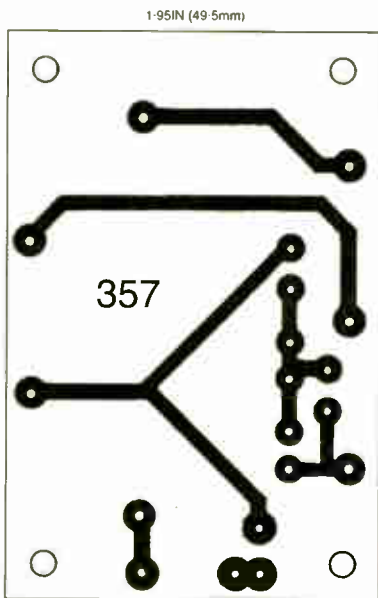
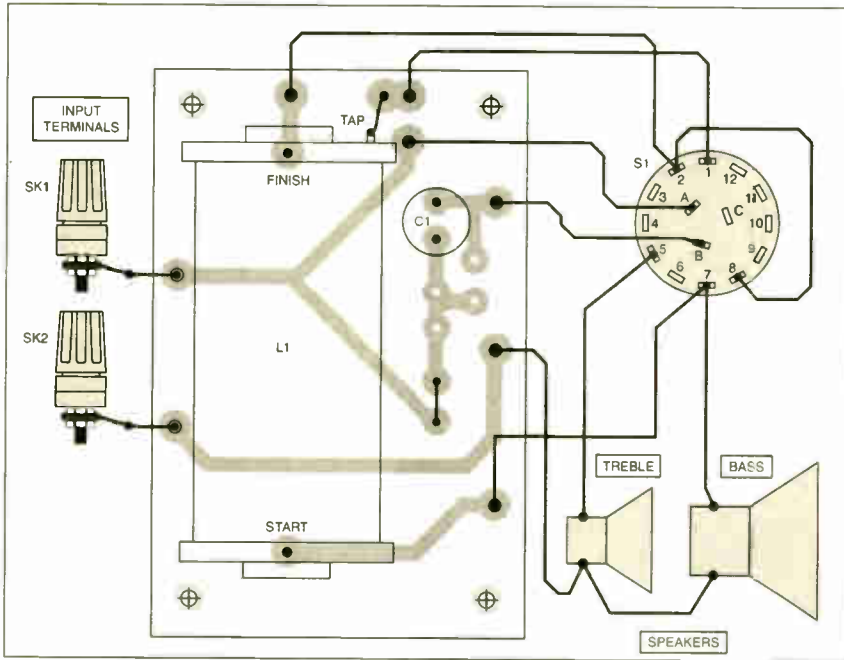

Fig.7. Crossover/Audio Filter printed circuit board component layout, interwiring to off-board components and full-size copper foil master. The completed crossover is shown in the above photograph.

## COMPONENTS

### CROSSOVER/AUDIO FILTER

#### Capacitors

- C1 10µ bipolar radial elect. 50V (Alternatively, two 22µ standard elect. connected back-to-back – see text and Fig.5)

#### Inductor

- L1 9.5mm (3/8in.) dia. ferrite rod, length 63mm (2½in.); card, hardboard and glue for bobbin. Enamelled copper wire: Crossover only – 100 turns 20 s.w.g. (19 a.w.g.), Crossover and Filter – 200 turns 22 s.w.g. (21 a.w.g.). See Fig.4 and text

#### Miscellaneous

- S1 3-pole 4-way rotary switch (only two poles used)  
SK1, SK2 4mm screw terminal post/socket (2 off)

Printed circuit board available from the *EPE PCB Service*, code 357 (Crossover/Filter); multistrand and connecting wire; plastic control knob; speaker terminals; solder pins; solder etc.

Approx. Cost  
Guidance Only

**£9**  
excluding speakers

in Fig.6. The first order filter serves as a basic crossover when the speaker is being used for testing or listening to "hi-fi" equipment.

Switching out the Treble speaker and connecting the inductor in series with the Bass speaker gives a low-pass (top cut) effect. Connecting the capacitor in series with the speaker provides a high-pass (bass cut) arrangement. With the inductor and capacitor in series with the speaker, response to speech frequencies is emphasised, making the unit suitable for use with a communications receiver or for surveillance work.

Rotary switch S1 selects the required function, and the inductor is tapped to provide appropriate values for the crossover and speech filter.

## CONSTRUCTION

Construction of the Crossover/Filter Unit is based on a small single-sided printed circuit board (p.c.b.). This board is available from the *EPE PCB Service*, code 357.

The topside component layout, full-size copper foil master and off-board wiring details are illustrated in Fig.7. Again, solder pins at the lead-out points will simplify off-board wiring. The p.c.b. makes provision for series and parallel combinations of capacitors, and a wire link must be inserted

if capacitor C1 is a single, bipolar electrolytic.

Constructors interested only in "hi-fi" applications can ignore the switching arrangements and simply connect a 100-turn (0.5mH) inductor and the capacitor as shown in Fig.3a.

**Next Month: The final part will deal with speaker enclosures and include a low-cost, high-performance design**



Low Frequency Oscillator for loud-speaker resonance checking.

which incorporates this month's Crossover/Filter unit.

The construction of a simple and inexpensive oscillator and resonance detector, which can be used to match any speaker to an enclosure and optimise performance, will also be described.

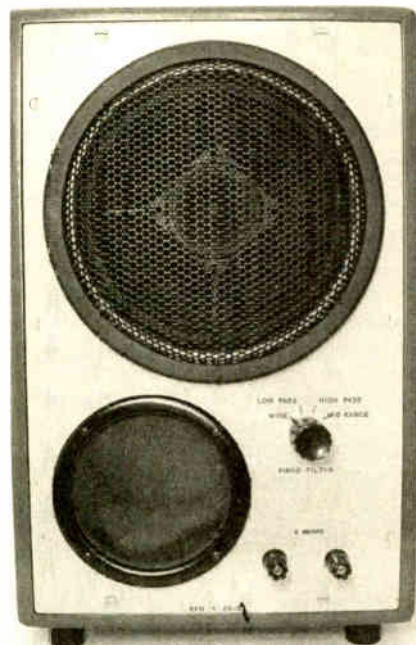

## SHOP TALK

with David Barrington

### Infra-Red Autoswitch

As the *Infra-Red Autoswitch* project is mains powered, all the components have been specially selected to fit directly on the small printed circuit board (p.c.b.). If alternative, non-board mounting components, such as the mains transformer and relay, are used you *must* take extra care when building and testing this unit. In this case, it is very important that the p.c.b. and any off-board parts be mounted in its case *before* testing and that a separate *battery* supply is used for checking its operation, prior to mains connection.

The special Sharp IS471F infra-red sensor/detector came from **RS Components** and carries the order code 564-396. They also supplied the p.c.b. mounting, short-circuit proof, mains transformer with twin 9V 0.027A (0.5VA total) secondaries, code 310-1263. These components can be ordered from any *bona-fide* RS stockists, including some of our advertisers. You can order direct (*credit card only*) on ☎ 01536 444079 or on the web at [rswww.com](http://rswww.com). A post and handling charge will be made.

The 12V d.c. low-profile relay, with 12A 250V a.c. rated single-pole changeover contacts, used in the model was purchased from **Rapid Electronics** (☎ 01206 751166 or [www.rapid-electronics.co.uk](http://www.rapid-electronics.co.uk)), code 60-4630. We understand that RS (see above) also stock a similar relay, code 198-6933.

The specified low-profile case came from **CPC** (*credit card only*), ☎ 08701 202530, code EN55028. A post and packing charge is made on all orders under £30. The Autoswitch printed circuit board is available from the *EPE PCB Service*, code 358 (see page 539).

### Teach-In 2002 - Lab 9

Once again, it's only the sensor and semiconductor devices called for in this month's *Teach-In 2002 Lab Work* that will give some readers sourcing grief. Starting with the Nemoto NAP-7AU gas sensor/compensator pair, these were obtained from **Maplin** (☎ 0870 264 6000 or [www.maplin.co.uk](http://www.maplin.co.uk)), code FM87U and are sold as a pair.

We have found two listings for the precision low off-set op.amp type OP177 and it can be ordered from **Rapid Electronics** (☎ 01206 751166 or [www.rapidelectronics.co.uk](http://www.rapidelectronics.co.uk)), code 82-0092, or **RS Components** (☎ 01536 444079 or on the web at [rswww.com](http://rswww.com)), code 127-2868. Expect to pay a handling and postage charge.

If readers experience any difficulty in finding a local source for the 4093 quad 2-input NAND Schmitt trigger (Rapid 83-0420) and the ADC0804 8-bit analogue-to-digital chip (Maplin QQ0CA or RS 411-674) they should contact the above mentioned companies. The relevant code numbers are shown in brackets.

The Linear Technology LTC1062CN8 5th order switched capacitor low-pass filter i.c., used in the *Anti-aliasing Filter* (Lab 9.5), appears to be listed only by RS (see above), code 633-880.

### EPE Stylopic

A couple of items proved hard to find when tracking down parts for the *EPE StyloPIC* project. The National Semiconductor LM13600 transconductance amplifier i.c. and the SGS-Thompson L272 dual power op.amp i.c. only appear to be listed by RS, codes 304-453 and 635-167 respectively. You can order

them direct from RS (*credit card only*) on ☎ 01536 444079 or on the web at [rswww.com](http://rswww.com). A post and handling charge will be levied.

The above company supplied the Texas TLC7524CN 8-bit digital-to-analogue converter chip, code 650-087. It is also currently listed by **Rapid** (☎ 01206 751166 or [www.rapidelectronics.co.uk](http://www.rapidelectronics.co.uk)), code 82-0764, but double check it is the 16-pin device being supplied.

For those readers unable to program their own PICs, a ready-programmed PIC16F877-20 microcontroller can be purchased from **Magenta Electronics** (☎ 01283 565435 or [www.magenta2000.co.uk](http://www.magenta2000.co.uk)) for the inclusive price of £10 each (overseas add £1 p&p). It is the 20MHz version you require. The software is available on a 3.5-in. PC-compatible disk (*EPE* Disk 5) from the *EPE* Editorial Office for the sum of £3 each (UK), to cover admin costs (for overseas charges see page 539). It is also available *Free* from the *EPE* web site: [ftp://ftp.epemag.wimborne.co.uk/pub/PIC/STYLOPIC](http://ftp.epemag.wimborne.co.uk/pub/PIC/STYLOPIC).

The printed circuit board/keyboard is available from the *EPE PCB Service*, code 359 (see page 539).

### Simple Audio Circuits - 3

Most of our components advertisers should be able to supply all the parts needed to construct the circuits in this month's instalment of the *Simple Audio Circuits*. A suitable Bulgin fused Euro-style mains inlet, chassis mounting, plug (code MK18U or FT37S) together with an insulation, rear tag, protective cover (code JK67X) and line socket (UL16S) is listed by **Maplin** (☎ 0870 264 6000 or [www.maplin.co.uk](http://www.maplin.co.uk)). They also list the 6A 200V P600D rectifier diode for one version of the Power Supply Unit, code UK60Q.

If problems are experienced in obtaining a ferrite rod for the Crossover unit, we understand, from the author, that one is obtainable from **JAB, PO Box 5774, Birmingham, B44 8PJ** (*mail order only*), and **J. Birkett** (☎ 01522 520767). You will need to cut the rod down to size (take care, it is brittle!). These two firms can also supply 50g (2oz) reels of enamelled copper wire for the Crossover.

The two printed circuit boards are available from the *EPE PCB Service*, codes 356 (PSU) and 357 (Crossover) - see page 539.

### Rotary Combination Lock

Probably the most expensive item when purchasing components for the *Rotary Combination Lock* project is likely to be the heavy-duty power solenoid. The one in the model cost about £15 and came from **RS** (☎ 01536 444079 or [rswww.com](http://rswww.com)) and is their 12V d.c. standard pull action, spring return type, code 250-1303. They also supplied the Omron 12V d.c. ultra-min., p.c.b. mounting relay, code 369-359.

The two printed circuit boards are available from the *EPE PCB Service*, code 260 (Lock) and 361 (Interface).

### PLEASE TAKE NOTE

**L.E.D. Sequencer** (Ingenuity Unlimited) June '02  
Page 406. To prevent the i.c. outputs (IC2, IC3) from adversely affecting each other, 1N4148 signal diodes should be inserted between each i.c. pin and the respective i.e.d. The anode on the pin and cathode on the i.e.d.

**World Lamp** June '02  
Where it is said that VR1 should be turned clockwise, this should read anti-clockwise, and where anti-clockwise, clockwise.

**Toolkit TK3**  
Updated files for V1.2 are now on our FTP site. Only files Disk 1 and Disk 3 are affected.



## A COMPLETE RANGE OF INVERTERS

150W TO 2500W - 12V & 24V

A Complete range of regulated inverters to power 220V and 240V AC equipment via a car, lorry or boat battery. Due to their high performance (>90%) the inverters generate very little heat. The high stability of the output frequency (+/-1%) makes them equally suitable to power sensitive devices.

These inverters generate a modified sine wave, which are considerably superior to the square waves which are produced by most other inverters. Due to this superior feature they are capable of powering electrical equipment such as TV's, videos, desktop & notepad computers, microwave ovens, electrical lamps, pumps, battery chargers, etc.

### Low Battery Alarm

The inverters give an audible warning signal when the battery voltage is lower than 10.5V (21V for the 24V version). The inverter automatically shuts off when the battery voltage drops below 10V (20V for the 24V version). Fuse protected input circuitry.

Order Code	Power	Voltage	Price
651.581	150W Continuous	12V	£36.39
651.578	150W Continuous	24V	£36.39
651.582	300W Continuous	12V	£50.64
651.585	300W Continuous	24V	£50.64
651.583	600W Continuous	12V	£101.59
651.593	600W Continuous	24V	£101.59
651.587	1000W Continuous	12V	£177.18
651.597	1000W Continuous	24V	£177.18
651.602	1500W Continuous	12V	£314.52
651.605	1500W Continuous	24V	£314.52
651.589	2500W Continuous	12V	£490.54
651.599	2500W Continuous	24V	£490.54



ILLUSTRATION SHOWN IS 651.583 600W VERSION.

All prices are inclusive of V.A.T. Carriage (B.D) Per Order

Many uses include:- . Fetes . Fairgrounds . Airshows . Picnics . Camping . Caravans . Boats . Carnivals . Field Research and . Amateur Radio field days \* Powering Desktop & Notepad Computers.

DELIVERY CHARGES ARE £6.00 PER ORDER. OFFICIAL ORDERS FROM SCHOOLS, COLLEGES, GOVT. BODIES, PLC.S ETC. PRICES ARE INCLUSIVE OF V.A.T. SALES COUNTER. VISA AND ACCESS ACCEPTED BY POST, PHONE OR FAX, OR EMAIL US AT SALES@BKELEC.COM ALTERNATIVELY SEND CHEQUE OR POSTAL ORDERS MADE PAYABLE TO BK ELECTRONICS.



**B.K. ELECTRONICS**



UNIT 1, COMET WAY, SOUTHEND-ON-SEA, ESSEX. SS2 6TR  
TEL.: +44(0)1702-527572 FAX.: +44(0)1702-420243

For Full Specifications View our web site at:-  
**WWW.BKELEC.COM/INVERTERS.HTM**



## 20% discount for EPE readers

digimess® power supplies from £99.00 inc vat & del



**Vann Draper Electronics Ltd**  
The test & measurement specialists  
www.vanndraper.co.uk  
Test equipment from Grundig, digimess, Kenwood, Hameg, Tektronix, Avo and more.

Vann Draper is offering over 20% discount to readers of *Everyday Practical Electronics* on their new range of low cost digimess® power supplies.

The range includes single, dual, triple and high current output types. All feature LED displays of voltage and current and can be operated in constant voltage or constant current modes. Dual and triple types have switching for independent, series, parallel and tracking modes. All models are supplied complete with mains lead, operating manual and a 1 year guarantee.

Model number	HY3003	HY3003-2	HY3003-3	HY3010	HY3020
Price (inc vat & del)	£99.00	£169.00	£199.00	£275.00	£375.00
No of outputs	Single	Dual	Triple	Single	Single
Output voltage	0-30V	2 x 0-30V	2 x 0-30V, 5V	0-30V	0-30V
Output current	0-3A	2 x 0-3A	2 x 0-3A, 3A	0-10A	0-20A
Load regulation	<0.01%	<0.01%	<0.01%	<0.02%	<0.02%
Ripple & noise	<1mV rms	<1mV rms	<1mV rms	<3mV rms	<3mV rms
Dimensions (mm)	291x158x136	365x265x164	365x265x164	365x265x164	365x265x164

To order, simply post the coupon to:  
**Vann Draper Electronics Ltd, Stenson House, Stenson, Derby DE73 1HL.**  
Or Tel 01283 704706 Fax 01283 704707 Email sales@vanndraper.co.uk

Use this coupon for your order

Please supply me:

(Qty) ..... (Model) ..... (Price) .....

(Qty) ..... (Model) ..... (Price) .....

Name: \_\_\_\_\_

Address: \_\_\_\_\_

Tel No: \_\_\_\_\_

Total £ \_\_\_\_\_

Cheques payable to Vann Draper Electronics Ltd or debit my visa, mastercard or switch card:

Card type: \_\_\_\_\_

Card No: \_\_\_\_\_

Expiry date: \_\_\_\_\_ Switch Issue No: \_\_\_\_\_

Signature: \_\_\_\_\_

Overseas readers can still obtain this discount but carriage charges vary according to country. Please telephone, fax, email or write to Vann Draper.

# USING THE PIC'S PCLATH COMMAND

## JOHN WALLER

*How to use PCLATH to access a PIC's higher program addresses and place tables where you want them.*

**J**OHN Becker described extended data memory bank use in *EPE* June 2001, with particular reference to the PIC16F87x devices which contain up to 512 bytes of data memory. The data memory is divided into "banks" of 128 bytes, and John explained how to cope with the complexity of up to four banks.

In a similar way, the program memory scope varies from 2K to 8K bytes, depending on the device, and is partitioned into 2048 (2K) byte-wide pages. Normally, the use of the term *page* would apply to sections of data memory and program memory; Microchip has chosen *bank* to apply to data memory (special function and general purpose registers), and has reserved the term *page* for program memory. It is convenient here to divide pages into *sub-pages* of 256 bytes each, with eight sub-pages to a page.

The extension of program memory across page boundaries is somewhat transparent (of no concern) to the programmer, but there are constraints on setting the program counter which must be complied with for correct operation of the program.

### PAGE ALLOCATION

Most readers are probably very familiar with the PIC16x84, which has 1K of program memory in a single page. All the tables used in the *PIC Tutorial* series (Mar to May '98), for example, are placed in the first 256 bytes of program memory in the 'x84, a constraint imposed for a reason that may not immediately be apparent.

In fact, tables may be put anywhere in program memory space, once the operation of the PCLATH function is understood, and the table is wholly contained within a sub-page. The number of bits

required to access different spans of program memory is shown in Table 1.

The program counter (PC) value is held in a 13-bit special function register, which can be regarded as having two parts – PCH (Program Counter High) and PCL (Program Counter Low), for the high and low bytes, respectively. PCH resides in the upper five bits of the PC, whereas PCL resides in the lower eight bits.

PCL can be written to directly, as is done when normally accessing tables, for example, and the response to amending PCL takes immediate effect. PCH, though, can only be written to via the lower five bits of special function register PCLATH. Writing to PCLATH, however, only takes effect when the **CALL**, **GOTO** or arithmetic operation involving PCL is performed.

It is worth noting that PCLATH is a write-only buffer. It is not safe to read PCLATH in order to (perhaps) do PC arithmetic (although Microchip's MPSIM simulator lets you do this).

Table 2 shows starting addresses for pages and sub-pages which are accessed under PCLATH control.

**Table 2. Starting Addresses for Pages and Sub-Pages (Addresses are in hexadecimal.)**

Sub-page	Page 0	Page 1	Page 2	Page 3
0	0000	0800	1000	1800
1	0100	0900	1100	1900
2	0200	0A00	1200	1A00
3	0300	0B00	1300	1B00
4	0400	0C00	1400	1C00
5	0500	0D00	1500	1D00
6	0600	0E00	1600	1E00
7	0700	0F00	1700	1F00

**Table 1. Number of Program Counter Bits Required in Relation to PCLATH**

Number of bytes in program memory	Number of bits required in program counter	Number of bits required in PCLATH
2048 (2K)	11	0
4096 (4K)	12	1
8192 (8K)	13	2

### SETTING PROGRAM COUNTER VALUE

There are three ways in which the programmer can set a value into the program counter (PC):

- An instruction which carries out an arithmetic operation on the PC. The most commonly used such instruction is adding a value to the PC from the working register when accessing a table, such as **ADDWF PCL,F** as used in the example program listings.
- A **CALL** or **GOTO** instruction which places the address of a label into the PC.
- A **RETURN** instruction which places the contents of the stack top into the PC.

### ARITHMETIC OPERATIONS

Arithmetic operations on the PC involve the working register and other 8-bit wide registers. It therefore follows that only PCL can be set with an arithmetic instruction. PCH remains at whatever value it holds at the time of the instruction.

It is possible to place a table anywhere in program space by setting PCLATH before the call to the table is made. As explained presently, the purpose of PCLATH is to set PCH for the call itself. Then, at the arithmetic instruction, it is used again to set PCH, but with an important distinction:

The call itself only requires bits 3 and 4 of PCH to be set, whereas the arithmetic instruction requires bits 0 to 4 to be set, for 8K program memory devices. For 4K program memory devices, bit 4 of PCH is ignored.

The program example shows how this is done. Fortunately, the value may be set into PCLATH for all 5 (4) bits and need not be changed again until after the table has returned its value. Fig.1 illustrates this process.

### CALL AND GOTO

The operation code for **CALL** and **GOTO** instructions sets 11 bits of the destination address, which is all that is needed in 2K program memory devices. The additional bits are set from PCLATH bit 3 for 4K program memory devices, and bits 3 and 4K for 8K devices. This is shown in Fig.2.

## LISTING 1

```

MOVLW %00001000 ; Set up for page 1
MOVWF PCLATH    ; sub-page 0
MOVLW 2         ; Get third line from
CALL TABLE1    ; first table
MOVWF PORTB     ; Display it on Port B
CLRF PCLATH     ; Set for page 0 and sub-page 0
LOOP1: BTFSS PORTA,0 ; Loop until button 0
      GOTO LOOP1   ; pressed
    
```

## LISTING 2

```

.ORG %0000100001111111 ; 087Fh (hex), page 1
                          sub-page 0
TABLE1: ADDWF PCL,F
      RETLW %00100100
      RETLW %01011100
      RETLW %10000110
      RETLW %00011001
    
```

## LISTING 3

```

MOVLW %00001011 ; Set up for page 1
MOVWF PCLATH    ; sub-page 3
MOVLW 1         ; Get second line from
CALL TABLE2    ; second table
MOVWF PORTB     ; Display it on port B
CLRF PCLATH     ; Set up for page and sub-page 0
LOOP2: BTFSS PORTA,1 ; Loop until button 1
      GOTO LOOP2   ; pressed
    
```

## LISTING 4

```

.ORG %0000101101011001 ; 0B59h, page 1
                          sub-page 3
TABLE2: ADDWF PCL,F
      RETLW %11010001
      RETLW %01110101
      RETLW %10100000
      RETLW %11000010
    
```

## RETURN INSTRUCTION

A **CALL** instruction pushes PCL and PCH values onto the stack. A **RETURN** instruction pops those PCL and PCH values and puts them into the PC, and no manipulation of PCLATH is required. It might be necessary, however, to set PCLATH *after* the return, as shown in the following example.

## PROGRAM EXAMPLE

This program example (the software for which is available as stated later) is designed for a PIC16F877 device plugged into the *Toolkit Mk3* board (Oct '01) with Port B connected to the l.e.d.s and Port A bits 0 to 3 connected to the four push-button switches. It can equally well be simulated through other equivalent hardware assemblies (as a breadboard assembly for instance). Throughout the example, program memory span is artificially extended by the use of **ORG** (origin) statements.

The uncommitted switch inputs are connected to Port A bits 0 to 3 in active high mode. Button "X" will be used to refer to the switch connected to Port A bit X. The

uncommitted l.e.d. outputs are connected to Port B. Ports A and B are initialised accordingly. The program comprises a series of table calls and jumps, with pauses waiting on a button press to allow the value returned from a table to be viewed on the l.e.d.s.

The first operation from the example program, after initialisation, is shown in Listings 1 and 2 (the grammar used is TASM).

The first two lines in Listing 1 set all bits in PCLATH to zero, except bit 3. The table in Listing 2 starts at address 087Fh. Table 2 shows this address is in page 1, sub-page 0, meaning only bit 3 in PCLATH should be set, to make it equal to 08h. The third line in Listing 1 sets the table line access parameter. The fourth line calls the table, whereby bits 3 and 4 of PCLATH are prepended to (placed in front of) the opcode to give the full table address, as in Fig.2.

Execution now passes to the first line in Listing 2. There the first five bits in PCLATH are prepended to the ALU result of the arithmetic operation, as in Fig.1.

Since the value in the working register (W) is 2, the program counter jumps to the third data line in the table and returns a value of %10000110, which is then shown on the l.e.d. display at the fifth line of Listing 1.

The sixth line returns PCLATH back to its original value, an essential step if the following **GOTO** is to work correctly. The program now loops indefinitely until button 0 is pressed, whereby execution passes to Listings 3 and 4.

The operation of the second pair of Listings (3 and 4) is almost the same as the first pair. The table address is still in page 1, but is in sub-page 3, since 0B59h - 0800h = 0359h, and 0359h / 256 = 3.35, or 3 rounded down to the nearest integer; this may also be determined from Table 2. In Listing 4 the second line from the table, %01110101 is returned and displayed, and the program loops until button 1 is pressed, whereby execution passes to Listing 5.

## TABLES BEYOND SUB-PAGE 0

Listing 5 shows how a table could be placed in the 16F84, for example, outside of the first 256 bytes of program memory within a page. Here the table is at address 0564h, or page 0, sub-page 5, as set by the first two lines. The next two lines call for the fourth line from the third table, which returns %01100110 for display on Port B, similarly to before.

Since the **GOTO** destination address is in the same page as the third table address, there is no need to reset PCLATH before entering the loop, which may be subsequently exited by pressing button 2. On exit, the following three lines set up and execute a jump to page 3, as shown in Listing 6.

Note that in Listing 6 it was sufficient to set bits 3 and 4 (in Listing 5) only of PCLATH for the jump to occur correctly; in other words, the sub-page is immaterial for this particular operation, as in Fig.2. But for the second and third lines of Listing 6, where preparations are made to access the table at TABLE4, setting sub-page 2 is material, and this is done simply by setting bit 1 of PCLATH.

The first line in the table is then accessed, and a value of %10010111 is returned for display on Port B. Pressing button 3 exits from the loop to the final,

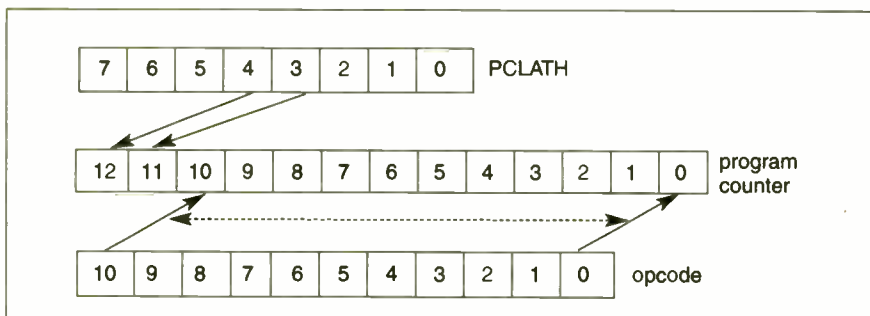

Fig.1. Setting the Program Counter for an Arithmetic Instruction

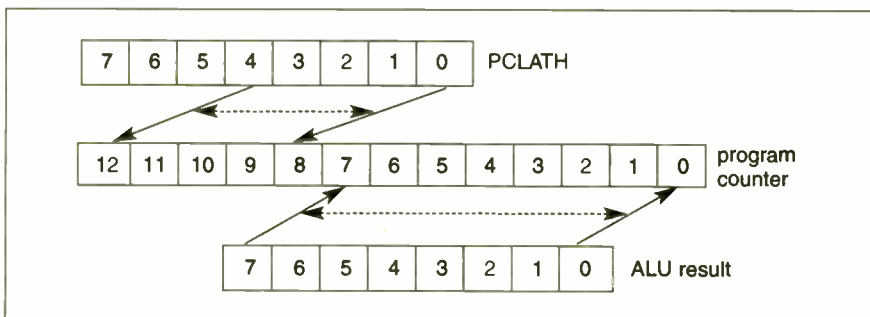

Fig.2. Setting the Program Counter for a CALL or GOTO Instruction



## LISTING 5

```
MOVLW %00000101 ; Set up for page 0
MOVWF PCLATH ; sub-page 5
MOVLW 3 ; Get fourth line from
CALL TABLE3 ; third table
MOVWF PORTB ; Display it on port B
LOOP3: BTFSS PORTA,2 ; Loop until button 2
GOTO LOOP3 ; pressed
MOVLW %00011000 ; Set up for page 3
MOVWF PCLATH ; sub-page 0
GOTO JUMP1 ; Go there

.ORG %0000010101100100 ; 0564h, page 0
sub-page 5.

TABLE3: ADDWF PCL,F
RETLW %00110111
RETLW %11001101
RETLW %11100001
RETLW %01100110
```

and infinite, loop whereby %11111111 is shown on Port B.

## PROGRAMMER'S TASK

Every **CALL** and **GOTO**, and every arithmetic operation affecting the PC, requires that **PCLATH** contains the correct value for the operation concerned. Sometimes, for example, **GOTO** is used in a timing loop, which might have to allow for two additional **PCLATH**-setting instructions, and this loop might lie across a page boundary.

Somehow these matters must be catered for in PIC programs, whether they are written in "normal" PIC code, or in a high level language, such as BASIC or C. As with so much in programming, there are diverse opinions on which is the best technique. A useful strategy, for instance, could be:

1. Assign a functionality to each of the pages which minimizes **CALL** and **GOTO** instructions across page boundaries.
2. If possible, provide buffer zones, with no instructions, near page boundaries.
3. Write a first pass for the code ignoring the need to set **PCLATH**; have it assembled and examine the listing.
4. Determine where **CALL** and **GOTO** instructions cross page boundaries, and where table calls (or other arithmetic operations on **PCL**) cross sub-page boundaries.
5. Readjust tables so they are completely contained in a sub-page.
6. Include **PCLATH** setting instructions where required.
7. Repeat steps 4, 5, and 6 until no further corrections are required.

In an automatic program to do the above, steps 1, 2, and 3 would mostly be done by the programmer, and the automatic program would do the rest. The programmer might have to try again if the process does not converge.

## PRACTICALITIES

In practical terms, though, manual inspection and iteration during program development is at the very least tedious and time consuming. At worst, it can be highly error prone. Each time a program is modified, you need to repeat the fix-up process, and on subsequent occasions the chances are that you have mostly forgotten how large chunks of the program work in detail.

## LISTING 6

```
.ORG %0001101010011100 ; 1A9Ch, page 3
sub-page 2
JUMP1: MOVLW 0 ; For first line of table
BSF PCLATH,1 ; Set up for sub-page 2
CALL TABLE4 ; fourth table
MOVWF PORTB ; Display it on Port B
LOOP4: BTFSS PORTA,3 ; Loop until button 3
GOTO LOOP4 ; pressed
FINAL: MOVLW $FF
MOVWF PORTB
GOTO FINAL
TABLE4: ADDWF PCL,F
RETLW %10010111
RETLW %00111111
RETLW %01101011
RETLW %10101010
```

Alternatively, every relevant instruction that might involve page boundaries could be preceded by **PCLATH**-setting instructions, whether they are needed or not, a brute-force approach. Whilst it can be argued that it would be cumbersome and consume valuable program memory space to set **PCLATH** for every such instruction, there is a lot to be said for the "brute force" approach if programming space permits it and there are doubts about where page boundaries might lie.

The use of **PCLATH** is essential in many larger PIC programs, and it is a command that you should familiarise yourself with through experiment. Perhaps the best advice is to use it in a fashion you feel comfortable with, and which you have proved through experimentation to be reliable. While evolving that technique, remember that you have to keep your wits about you – but then, don't you always in programming!

## STRUCTURED PROGRAMMING

Program structure, whether in the PIC language, or a high-level language, is the province of the program author(s), although there are guide lines. For example, this author's policy is:

- a. Where something seems to be overwhelmingly complex, break it down into chunks of manageable size.
- b. Try and write separate routines (terminated in a **RETURN**) for each of the chunks, and aim to keep routine size to a page or less; avoid what is called "spaghetti code" which goes on and on without a break.
- c. Make a routine self-contained with as few links to other routines as possible. Do not use **GOTO** instructions between routines (but remember the PIC's stack only allows a limited number of "nested" calls).
- d. All variables (general purpose registers) in the PIC language are "global", that is, visible to all routines. Be careful to reduce the number of routines which alter variable values to as small a number as possible, preferably one only, perhaps by defining more variables than is strictly necessary. Be especially cautious where variable values are altered in interrupt routines. Read Malcolm Wiles articles on *Using PIC Interrupts* (Mar/Apr '02) carefully.
- e. Insert comments at the head of each routine which describe what the routine

does, what routine(s) it calls, and where it is called from.

f. Nearly every line, or group of lines, in the code deserves its own comment, even if trivial. Define what each variable does. When mystified by some lines of code, or things seem to be ambiguous, a seemingly trivial comment can help. Use capitalisation or punctuation to make it clear how many lines comments apply to. In the listings shown in this article, comments start with a capital letter, and continue over more than one line where appropriate, to the line before another headed by a capital letter. For example, in Listing 1, the first comment applies to the first two lines. Check your spelling!

g. Remember: comments are written once but read many times. Test your comment writing quality by reviewing what you wrote six months ago to determine if it still makes sense!

h. Where appropriate, put things in alphabetical order.

## RESOURCE

The full illustrative software listing for this article is available from the *EPE* Editorial office on 3.5in disk (*EPE* Disk 5 – for which a nominal handling charge applies, see *PCB Service* page), and is also available for free download from our ftp site, accessible via the top of the main page at [www.epemag.wimborne.co.uk](http://www.epemag.wimborne.co.uk) and held in folder **PUB/PICS/PCLATH**.

Note that only the software for *Toolkit TK3 V1.2* and higher version numbers can handle addresses above 2K and the **PCLATH** command. □

## COMING SOON!

We have a number of short PIC programming features in the pipeline. These are just two to look out for:

**Using PICs and Square Roots Algorithm.** Peter Hemsley again shows us a programming routine that is extremely well thought-out, is neat and compact, and works beautifully – it is a superior maths function that the PIC family lack, yet which is often needed in a variety of applications (next month).

**TK3, Win2000 and WinXP.** Mark Jones has unravelled the secrets of getting our *Toolkit TK3* programming software running under the Windows 2000 and XP platforms.

# ROTARY COMBINATION LOCK

THOMAS SCARBOROUGH

*Pure logic and a "stack of cards" function help to maintain the security of your cherished possessions.*

THE purpose of this design is to emulate as closely and as simply as possible the traditional rotary combination lock. Full emulation would be possible with a complex design – close emulation is possible with a remarkably simple circuit – in this case using just two CMOS i.c.s and three transistors.

Pseudo-rotary combination locks are well known. These usually use a combined dial and pushbutton, with limited rotation of the dial. The dial is usually turned to a number in the sequence, then a pushbutton is pressed to register the number. Both this and the characteristics of the standard wafer rotary switch (its rotation-limit-stop and snap-action) make such locks seem poor substitutes for the real thing.

This design has smooth 360° rotation, does not use a pushbutton switch, and offers roughly twice the security of a 4-digit keypad lock. It also prevents aimless turning of the dial, and is able to send a secret panic (*duress*) signal to another location.

The last two features are optional, and may be built onto an additional printed circuit board, which may also be interfaced to a standard intruder alarm system.

### SYNC LOCKING

The Rotary Combination Lock has one significant difference to the old mechanical lock – it needs to be turned "in sync" with a pulsed l.e.d. That is, the lock's dial must point to each number in sequence at the moment that an l.e.d. pulses.

Once opened, the lock is closed again by turning the dial to a Reset digit. Assuming that the rotary dial has twelve positions, there is one chance in 20,736 (that is  $12^4$ ) that a prospective thief would randomly hit the right combination.

In practice, however, due to the construction of the wafer rotary switch, the chances of randomly hitting the right combination are much less than this. On the

other hand, there is better than one chance in two that the would-be thief's *first* move will trigger an alarm.

A particular advantage of the Rotary Combination Lock is that its fascia may be artistically altered to suit every taste. In fact the lock need not even be rotary – the circuit would also work with a standard keypad, or with various arrangements of momentary-action, normally-open switches. These switches need not even be mounted together in the same place.

### CIRCUIT DESCRIPTION

The Rotary Combination Lock is based on a standard cascaded latch using four AND gates, IC2a to IC2d, as shown in Fig.1.

Let us consider the action of just one of these gates. According to AND logic, output terminal pin 3 will remain low (logic 0)

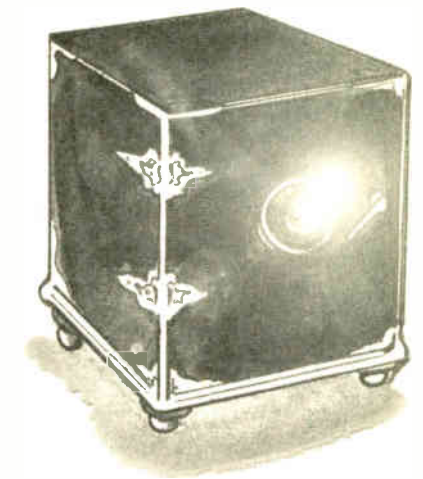

for all combinations of inputs at pins 1 and 2, except when *both* inputs go high (logic 1) together. In this case, output terminal pin 3 also goes high.

Normally, pin 2 is held low through resistor R8 and pin 1 is held high through R14, consequently IC2a's output pin 3 is held low. When IC2a pin 2 is taken high through the 12-way rotary switch S1 (see later) both inputs are now high, so pin 3 also goes high. As pin 3 is fed back to pin 2, the gate becomes "latched" with its output high.

As a result, IC2b's input pin 6 is also held high. This gate's input pin 5 is normally held low through R9 and the same logic applies as with IC2a, so it too can be triggered when a pulse is received from switch S1, which enables IC2c to be triggered via S1, and so on through IC2d.

Next, consider what happens when a negative-going (logic 0) pulse is applied to IC2a pin 1. This causes output pin 3 to go low and each of the four latches IC2a to IC2d now resets – collapsing, as it were, like a stack of cards, in accordance with AND logic.

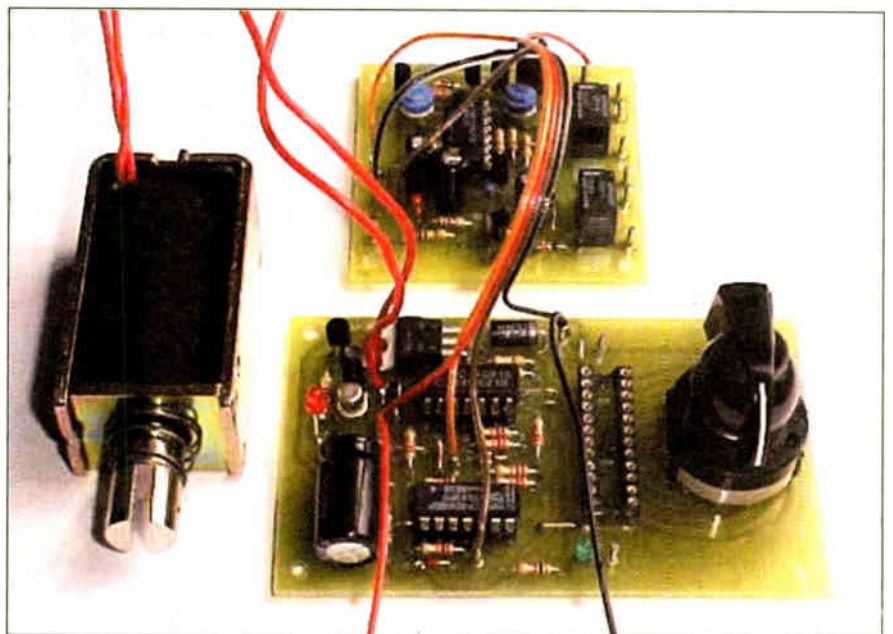

This reset action is triggered if switch S1 is set to any position other than the four which connect to the IC2 gate chain. The pulses from these other positions control the opening and closing of electronic switches IC1a and IC1b. Their control inputs are normally held low via resistors R4 and R6 and their "gate paths" remain open (very high impedance). When either of them receives a pulse from switch S1, the respective gate path closes, causing IC2a pin 1 to be pulled low via diode D3 or D4, so resetting the IC2 gate chain.

If it is IC1b that is triggered, the negative-going pulse generated at the junction of R7 and IC1b pin 3 is used to activate the Interface alarm discussed later. However, IC1a is not connected to the alarm controller, and this allows one switch position to be used as a Reset digit, to close the lock after it has been opened, as well as six digits to trigger an alarm in the case of aimless turning of the dial.

Diode D5 in IC2d's feedback path prevents the possibility of a brief positive-going pulse from S1 reaching the gate (g) of transistor TR3.

When the third digit of the 4-digit code has been set by switch S1, IC2c pin 9 goes high, as does pin 12 of IC1d, causing this bilateral switch to close. This means that

switch IC1c is now potentially able to conduct. When IC1c's control pin 6 goes high, this causes a high pulse at IC1d pin 11. This pulse may also be sent to the Interface unit as a Duress signal.

The Duress switch position may either replace the 4th digit in the 4-digit sequence, or add a 5th digit to the 4th. Thus someone who knows that this is a 4-digit system would not notice anything out of the ordinary when the Duress position is selected. The Duress signal may also be sent after the 4th digit has been selected, e.g. on closing the lock again.

### UNIUNCTION OSCILLATOR

The positive-going pulses which are routed through the 12-way rotary switch S1 are produced by a unijunction transistor (u.j.t.) oscillator based on TR2. The u.j.t. oscillator is chosen for its simplicity – it uses just four components to flash I.e.d. D2 and provide a positive pulse at its base 1 (b1).

A u.j.t. has a low "off" resistance (called its "inter-base" resistance, or  $R_{BB}$ ), and this would cause this I.e.d. to glow continuously if it were wired to base 1 or base 2. For this reason, it is wired to the emitter (e), which has a high emitter-to-base "off"

resistance. Current through the I.e.d. is modest, so a high brightness I.e.d. would serve best in this position. Do not change the value of resistor R3.

A u.j.t. is similar in its design to an n-channel field effect transistor (f.e.t.), but with some important differences. Perhaps most importantly, its n-type material is only slightly doped, which creates an "avalanche" effect when the emitter potential reaches the transistor's "peak point" (in this case just over 8V), causing the u.j.t. to conduct simultaneously between its emitter and both bases.

When the u.j.t. conducts, the potential at base 1 rises sharply, and a positive pulse is sent to transistor TR1, which now conducts. TR1 ensures that the u.j.t. oscillator

Fig.2. Minor circuit change for "releasing" the lock

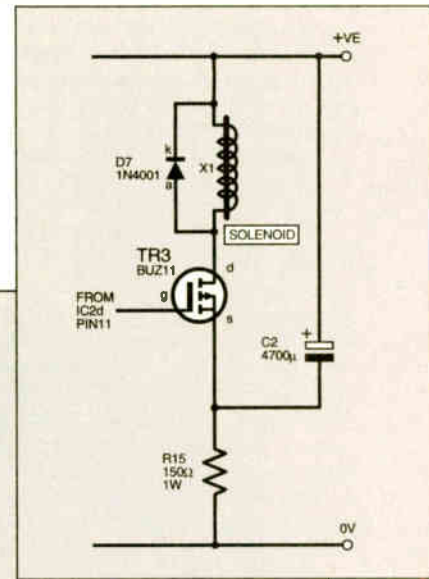
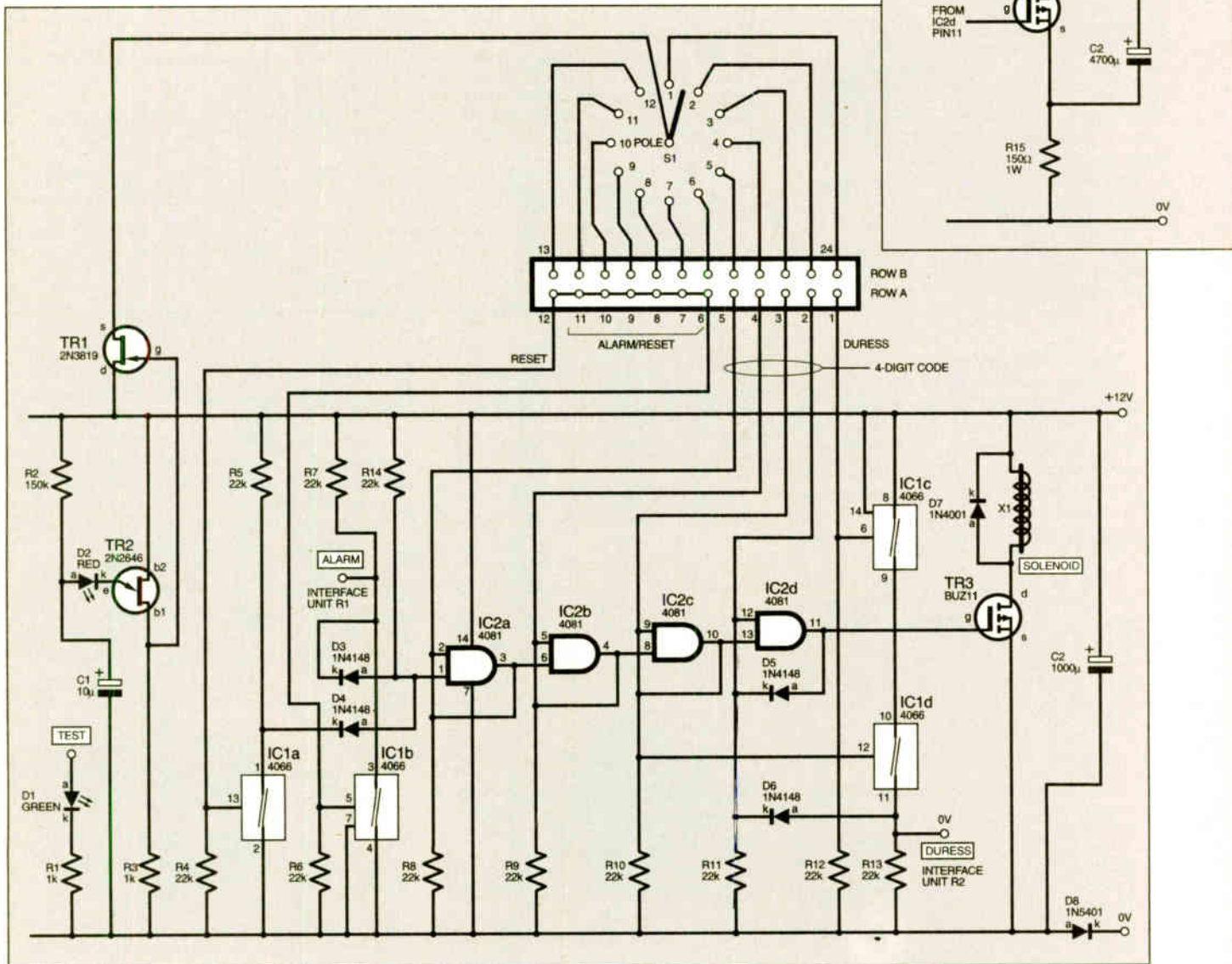

Fig.1. Circuit diagram for the Rotary Combination Lock. Note how positive pulses are routed through the 12-way rotary switch S1, via the 24-pin "combination" d.i.i. socket.

is not unduly loaded, and also that no negative-going pulses will reach the circuit and so unbalance it.

## SOLENOID

The solenoid is powered by power MOSFET TR3, which conducts when the potential at its gate rises above about 4V, as provided by the output of IC2d. When IC2d latches, TR3 conducts, and the solenoid retracts with a convincing whack. The solenoid's integral spring enables the lock to close again when the circuit receives a Reset pulse from switch S1.

The specified MOSFET has an extremely low "on" resistance (0.04Ω), and this ensures that there is minimal power dissipation in the device, and therefore minimal generation of heat. In fact TR3 remains cool without any heatsinking.

Note that TR3 should not be substituted with "any old" power MOSFET, since a power MOSFET with a higher "on" resistance will dissipate more power, thus generating more heat, which would then need the use of a suitable heatsink.

A momentary action pushswitch may be wired between IC1a pin 13 and the +12V line if desired, so that the lock may be closed again with a button-press. Thus this lock could be used, for example, to open a door, and the pushbutton switch used to reset the lock after entering.

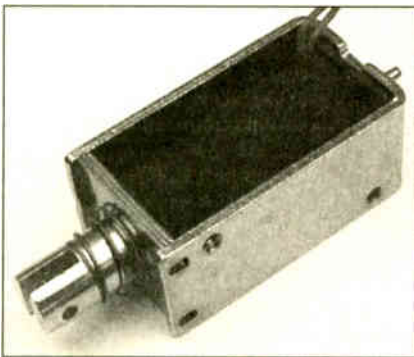

The specified solenoid consumes nearly 10W, and this means that a 12V 1A power supply is required. The solenoid could also be replaced with a relay if this would better suit the requirements of the application. Although the solenoid is rated for a continuous 12V, with the prototype it was found that after 15 minutes or so it generated an uncomfortable amount of heat (it is supposedly permitted to warm to 105°C)!

If the lock is likely to remain opened (solenoid active) for long periods, a simple modification to the circuit can be made as shown in Fig.2. This changes the lock from one that simply opens to one that briefly "releases". A tapered plunger may then be used to click the lock shut. This arrangement may be used also where only a smaller 12V power supply (100mA upwards) is to hand.

Note that diode D8 in the 0V line, which prevents reverse polarity power supply connection, warms as well when the lock is opened, and this is normal.

If desired, a number of solenoids may be wired in parallel. In this case, separate MOSFETs must be used in place of the single one used as TR3, and their gates are commoned. The power supply's rating *must* be suitably increased, as well as the rating of diode D8.

# COMPONENTS

Approx. Cost  
Guidance Only

**£40**  
excluding batts

## ROTARY COMBINATION LOCK

### Resistors

R1, R3	1k (2 off)
R2	150k
R4 to R14	22k (11 off)
R15	150Ω 1W

All 0.25W 5% carbon film, except R15.

### Capacitors

C1	10μ sub-min radial elect. 16V
C2	1000μ sub-min radial elect. 16V (see text)

### Semiconductors

D1	green l.e.d., 3mm
D2	ultrabright red l.e.d. (3mm)
D3 to D6	1N4148 signal diode (4 off)
D7	1N4001 50V 1A rect. diode
D8	1N5401 100V 3A rect. diode
TR1	2N3819 f.e.t. transistor
TR2	2N2646 u.j.t. transistor
TR3	BUZ11 power MOSFET
IC1	4066 or 4016 quad bilateral switch
IC2	4081 quad AND gate

### Miscellaneous

S1	1-pole 12-way rotary switch, p.c.b. mounting
X1	Solenoid, standard pull action, spring return, 12V d.c.

Printed circuit board, available from the *EPE PCB Service*, code 360; knob and dial for switch S1; 24-pin d.i.l. socket; 14-pin d.i.l. socket (2 off); connecting wire; solder pins; solder, etc.

See  
**SHOP  
TALK**  
page

## INTERFACE MODULE

### Resistors

R1 to R3	100k (3 off)
R4, R7	4k7 (2 off)
R5	470Ω
R6	220k
R8, R10	1k (2 off)
R9, R11	22k (2 off)

All 0.25W 5% carbon film

### Potentiometers

VR1, VR2	1M cermet preset (2 off)
----------	--------------------------

### Capacitors

C1	100n min. polyester
C2, C4, C5	220μ sub-min. radial elect. 16V (3 off)
C3	1μ sub-min. radial elect. 16V
C6	100μ sub-min. radial elect. 16V

### Semiconductors

D1, D4, D5	1N4148 signal diode (3 off)
D2	red l.e.d., 3mm
D3	green l.e.d., 3mm
D6	1N4001 50V 1A rect. diode
TR1	BC337 npn transistor
TR2	2N3819 f.e.t. transistor
TR3, TR4	BC547 npn transistor (2 off)
IC1	7556 dual CMOS timer

### Miscellaneous

RLA, RLB	ultra-min, s.p.c.o. relay, 12V, low-power, p.c.b. mounting (2 off)
S1	min. s.p.s.t. pushswitch, p.c.b. mounting

Printed circuit board, available from the *EPE PCB Service*, code 361; 14-pin d.i.l. socket, connecting wire, solder pins, solder, etc.

Finally, l.e.d. D1 is provided to test rotary switch S1. A test lead can be connected between the anode (a) of the l.e.d. and any position of S1 (row B). The switch is then turned until D1 pulses. This is very helpful in setting up the circuit (more later).

## CONSTRUCTION

Begin construction by making modifications to the rotary switch, S1, to provide full and smooth 360° rotation. Without this, the switch would fail to give the "feel" of a genuine rotary combination lock, although the circuit would still work perfectly well.

Remove the switch's rotation-limit washer and clip off its tab. Carefully prise open the switch, observing where each part fits. To cancel the snap-action of the switch, so that it will rotate smoothly, take out the spring and the two ball-bearings – if they have not shot out already! The author opens up such items inside a glass jar – the pieces can be awfully hard to find if they shoot into the air!

Internally, there is a rotation-limit stop which is an integral part of the plastic moulding, which is to be found at the bottom of the switch's well. Cut or chisel this out, then test to see that there is a smooth

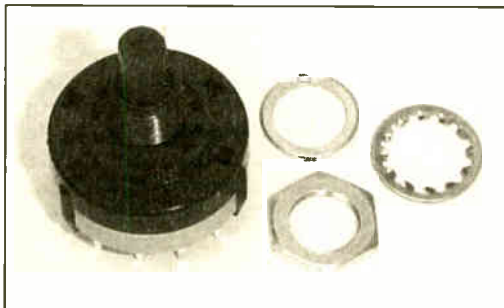

The rotary switch, before modification, showing the external limit washer and fixing nut and washer. Part of the switch body showing the internal rotation limit stop "pip" – which has to be removed to allow 360 degrees rotation.

360° rotation. Now snap the switch shut again, *carefully*, so as not to jog the small metal contacts out of place.

### MAIN BOARD

Details of the main printed circuit board (p.c.b.) for the Rotary Combination Lock are shown in Fig.3. This board is available from the *EPE PCB Service*, code 360.

Solder the link wires, solder pins, and the three dual-in-line (d.i.l.) sockets. Note that some of the link wires are soldered beneath the d.i.l. sockets, and that the two link wires beneath MOSFET TR3 should be sheathed to prevent contact with its body when it is mounted flat with the board.

Next solder in position the resistors, diodes, and l.e.d.s, continuing with the capacitors and transistors. Transistor TR3 is static sensitive, and anti-static precautions should be observed, the most important being to ground your body immediately before handling (via a metal water tap for example). In the author's experience, f.e.t. TR1 is also a fragile device, and should be handled with care.

Be careful to observe the correct orientation of the electrolytic capacitors, transistors, diodes and i.c.s.

Attach the solenoid and l.e.d. D2 to the allocated solder pins. Finally, solder rotary wafer switch S1 into place on the p.c.b.

Thoroughly check the accuracy of your assembly and soldering and then insert the CMOS i.c.s IC1 and IC2, again observing anti-static precautions.

No case is specified, since the Rotary Combination Lock could be used in any number of applications, and thus mounted in various places. Ensure that the p.c.b. and switch are well protected from the elements.

The solenoid may be used as is, so that its plunger normally resides in a corresponding hole in a door frame. Alternatively, a mechanical arrangement may be used as shown in Fig.4. A suitable cover may then be used to enclose the mechanics.

Firmly fix a dial with a pointer to the shaft of rotary switch S1 – if the pointer slips out of place, your combination could be lost!

### SETTING UP

Having ensured that there are no solder bridges or short-circuits on the board, connect it to a 12V 1A power supply. Check first that power MOSFET TR3 remains cool. If it does not, turn off the power immediately, and re-check the circuit.

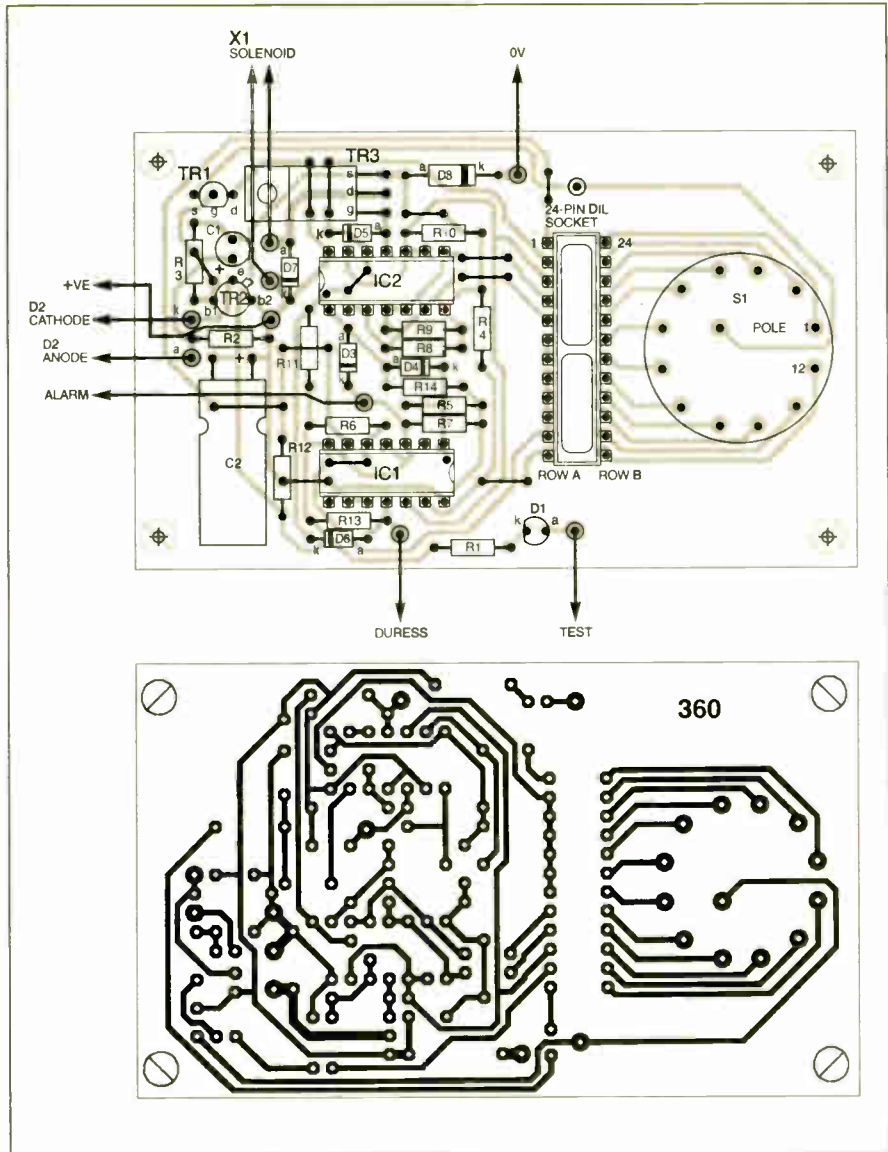
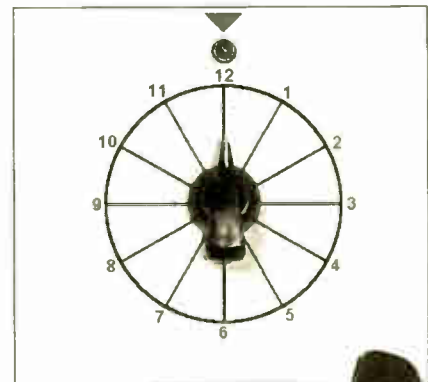

Fig.3. Rotary Combination Lock printed circuit board component layout, full-size copper foil master and lead-off wires.



Check that l.e.d. D2 is flashing. The solenoid should at this point not have closed yet.

One of the most important aspects of setting up is to configure rotary switch S1. A 24-pin d.i.l. socket (two rows of 12 holes) is used for this purpose, with sheathed link wires being used to set the combination. This is relatively simple to do, and permits easy changing of the combination at a later stage.

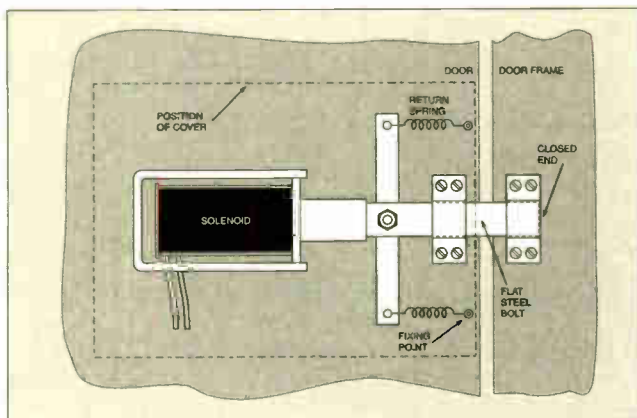
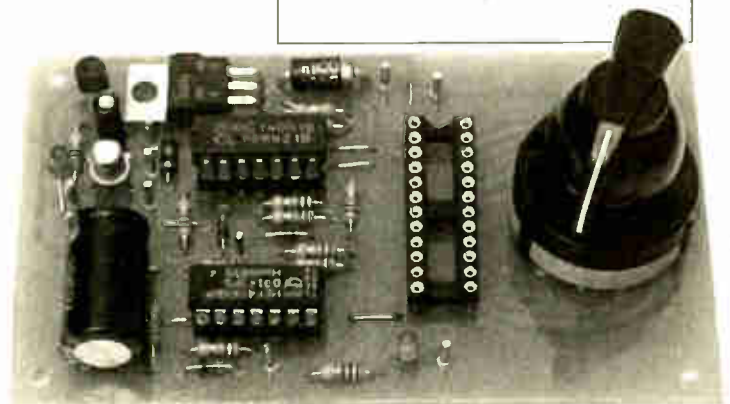

Fig.4. Mechanical "bolt" arrangement using a solenoid.



Completed prototype lock p.c.b. and suggested "combination" display scaling (above).

Alternatively, 24-pin plug-in sockets could be used to swap combinations in and out. Twelve sheathed link wires are used, with bared, untinned ends, each between 2cm and 4cm in length, as required. These are "jumped across" from Row A to Row B to set the combination.

For example, suppose we want to set the first digit of the 4-digit code, which is pin 5 of the 24-pin d.i.l. socket (pins 5, 4, 3 and 2 are used for the 4-digit code – see Fig.1). Plug in a sheathed link wire at pin 5 (Row A). Next, turn the rotary dial more or less to the position you would prefer for this first digit. Temporarily connect the solder pin adjacent to D1 to each hole in Row B (pins 13 to 24), until you find which of these lights i.e.d. D1. You might need to give the dial a little "play" to find the exact position. Now plug in the spare end of this first digit's wire into this hole.

The same procedure is now followed for the remaining eleven wires (refer to Fig.1). When all twelve wires have been plugged in at both sides of the socket (Row A to Row B), test the lock by turning the dial to the correct 4-digit sequence in synchronisation with the flashing of i.e.d. D2 (that is, the dial must be pointing to each number at the moment that D2 flashes).

The solenoid should operate decisively when the correct code has been selected. Turn to the Reset digit position that you have chosen to release the solenoid again. If it does not release, turn off the power and carefully re-check the circuit. Check again for warming in TR3 when the solenoid operates – there should be virtually no perceptible warming.

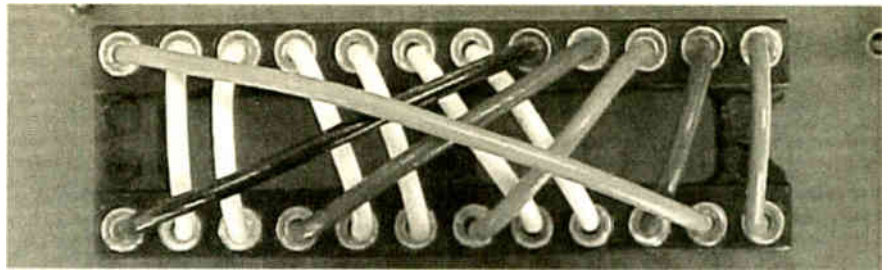

Using plastic-covered wires to set up the lock's combination in the board-mounted 24-pin d.i.l. socket.

Note that a fairly precise turning of the switch dial is required. This is not difficult, but if you are a few degrees out of true when turning to a position on the dial, this could reset the lock, or send Alarm or Duress pulses to the Interface board.

### WORKED EXAMPLES

Suppose you are using a dial marked with 12 positions (as on a clock face), and have selected 1-2-3-4 on the dial as your 4-digit code (not recommended!), with 5 as the Reset digit, and 6 as the Duress digit. Digits 7, 8, 9, 10, 11, and 12 now remain, and these are therefore used as Alarm digits. The options include the following:

- The 4-digit code (1-2-3-4) opens the lock.
- Reset (5) closes the lock.
- 1-2-3 (the first three digits of the 4-digit code) followed by Duress (6) opens the lock and simultaneously sends a secret Duress signal to the Interface p.c.b.

- The 4-digit code (1-2-3-4) followed by Duress (6) opens the lock, then sends a secret Duress signal.

- Duress (6) followed by Reset (5) sends the secret Duress signal just before closing the lock.

Note that Duress *only* works as a substitute 4th digit, *or* as an additional 5th digit at the end of the 4-digit code. This feature remains disabled until the third digit of the 4-digit code has been selected.

- Positions 7, 8, 9, 10, 11 and 12 (Alarm) all trigger the alarm.
- Selecting 1-2-2-3 would have no effect, since four separate digits are required for the 4-digit code, each one different from the other.
- Finally, 2-1-5-3 (as an example) would represent a very lucky would-be thief! Each one of these digits misses both the Alarm and Duress digits. The chance of such a 4-digit lucky miss is about 1 in 33 (that is  $1 / (5 / 12)^4$ ).

## ALARM INTERFACE

**T**HIS Interface circuit may be used not only to interface the Rotary Combination Lock just described to a standard intruder alarm system, but will also serve as a simple stand-alone, two-zone alarm system. It is also capable of switching powerful alarm sounders and beacons directly.

Besides this, the Interface is capable of a variety of standard switching options, of which four are described. These include:

- A "single-action" pushbutton
- A "dead man's handle" (strictly speaking, this term has been superseded by more politically correct terminology!)
- A "conditional" switch
- A timer

### INTERFACE CIRCUIT

The circuit for the Interface is relatively straightforward and its schematic diagram is shown in Fig.5. It uses a 7556 CMOS dual monostable timer (IC1) which is used to close relays RLA and RLB for specific periods when pulses are received from the lock's main circuit board.

Presets VR1 and VR2 are used to set the duration of triggering of each of the monostable timers between about 0.7 seconds and two-and-a-half minutes with the component values shown. The values of capacitors C2 and C5 may be increased for longer timing periods.

IC1 requires a negative pulse at each of its trigger inputs, pin 6 and pin 8. A negative-going Alarm pulse is applied to IC1's trigger pin 6 from the main lock circuit.

However, the lock's Duress pulse is positive-going, so this needs to be inverted before it is presented to IC1b's trigger pin 8. This is accomplished with the help of transistor TR1, which is wired as a standard inverter.

The purpose of capacitor C1 at TR1's base is to damp any possible mains transients, since these may even pass through a regulated power supply. One would not want to rouse a rapid-reaction squad with a small mains transient (from a hairdryer, say!)

The specified relays are rated at 60V d.c. 1A, with a maximum switched power of 30W, or 125V a.c. 1A, and a

maximum switched power of 62.5VA. This means that they may be used to switch powerful alarm sounders and beacons directly – so long as their ratings are not exceeded.

Alternatively, they could be used to switch power relays, which in turn could switch even bigger loads.

### OBLIGATORY INHIBITION

The Interface circuit includes a significant inhibition, in the form of field effect transistor (f.e.t.) TR2. Assuming that a would-be thief would abandon the Rotary Combination Lock at the moment

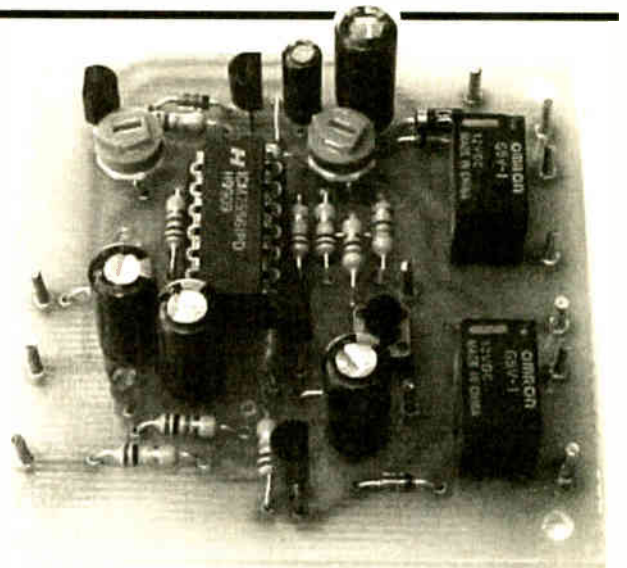

of triggering the alarm, the rotary dial would then remain set to the Alarm position, and would thus continue to send trigger pulses to the Interface p.c.b. In short, the alarm would never stop sounding.

Local regulations will usually set a limit to the amount of time that a public alarm may sound. In the UK this is 20 minutes. Therefore, when output pin 5 goes high capacitor C3 charges up through diode D1, the potential at TR2's gate (g) rises – and so also does the potential at its source (s).

Trigger pin 6 is now held high, and further trigger pulses are inhibited. Diode D1 prevents any rapid discharge of C3 through output pin 5, D3, and TR4. With the value shown for C3 (1μF), further triggering is

tactile type which is provided so that an alarm sounder or beacon may be manually cancelled. This takes IC1's reset pins 4 and 10 low, thus simultaneously resetting both monostable timer IC1a and IC1b, and instantly opening both relays, RLA and RLB. An alternative switch (perhaps a keyswitch) may be wired to the two solder pins on the p.c.b. at either side of S1, and taken to a convenient location.

Resistor R6 and capacitor C4 are used to send a negative pulse of a few seconds to reset pins 4 and 10 at switch-on. This prevents any spurious triggering at switch-on, on condition that the Alarm and Duress inputs are not left "floating", or disconnected. To keep them from floating, take these inputs high or low through 22kΩ resistors.

be orientated so that each of its "commoned" sides is closest to the solder pins to either side of it.

Alternative 12V miniature relays may be used in place of those specified. In this case, their coil resistances should be 250Ω or more so as not to overload transistors TR3 and TR4.

As with the main p.c.b., no case is specified, since the unit could be mounted in various places as the situation dictates. Only four wires need to be taken from the Interface p.c.b. to the main p.c.b., namely 0V, +VE, Alarm and Duress. Make sure that there are no shorts where these wires are connected.

As soon as these wires are connected, the Interface is ready to receive Alarm and Duress pulses from the lock.

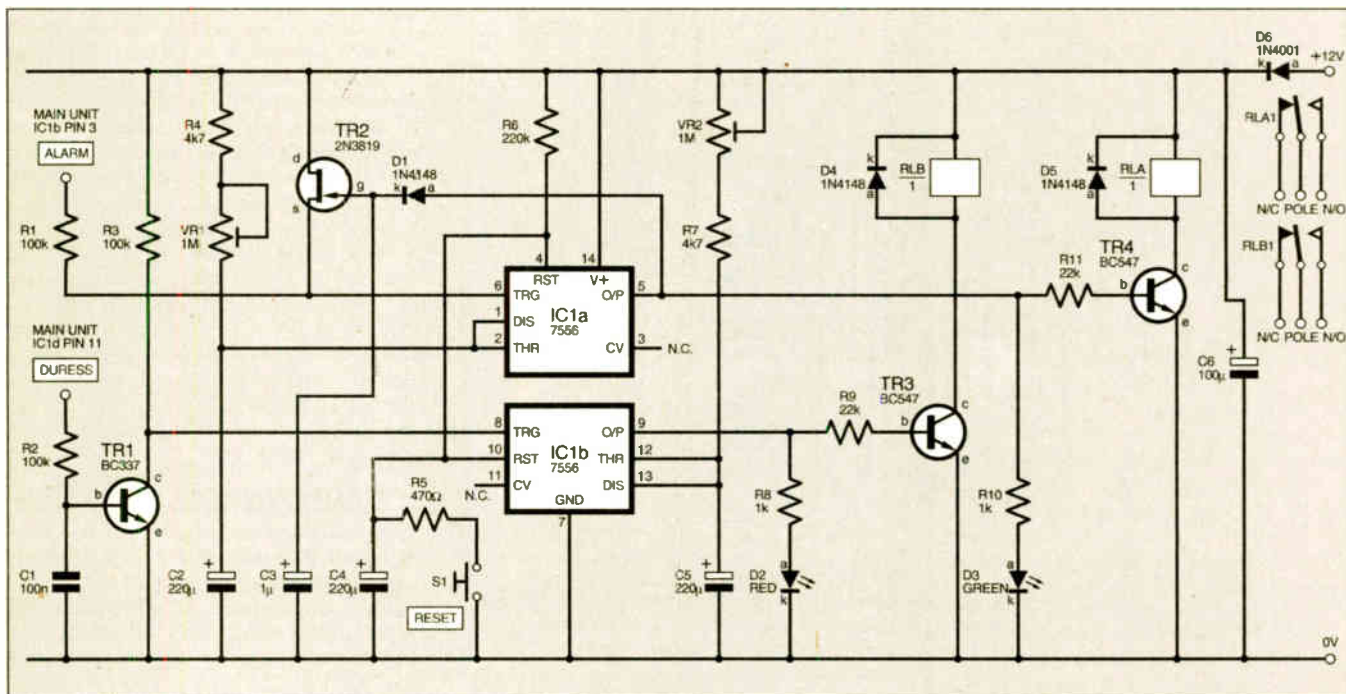

Fig.5. Complete circuit diagram for the Interface and "stand-alone-alarm" system. Note the TR2 "inhibit" function. The two sets of relay contacts can be used for a variety of switching applications.

inhibited for about half an hour, which should allow ample time to reset the lock. This period would increase to about two hours with a value of 4μ7, and would be reduced to about two-and-a-half minutes with a value of 100n.

This inhibitory feature may be used to good effect with a front doorbell, so that the doorbell is only permitted to sound once during a specific time period (this is the "single-action" switch mentioned earlier). If you have callers who maddeningly press the doorbell every so many seconds, the Interface will permit only one bellpress to get through every so many seconds or minutes.

### UNDER DURESS

The same feature is not provided for the Duress input, since Duress pulses can only reach the Interface board should at least three correct digits of the lock be selected beforehand. It, therefore, seems highly unlikely that anyone should accidentally send a Duress pulse to the Interface board – and besides, one may not want this to be cancelled until help has arrived.

Switch S1 is a miniature pushbutton

Finally, l.e.d.s D2 and D3 are provided so as to give a visual indication of whether a relay has closed or not. A green l.e.d. lights on an Alarm pulse, and a red l.e.d. on Duress.

Remember, the Alarm input is inhibited as long as capacitor C3 retains a certain charge, and will not work while inhibited.

### INTERFACE CONSTRUCTION

Details of the topside component layout of the Interface p.c.b., together with the underside tracking details, are shown in Fig.6. This board is available from the EPE PCB Service, code 361.

First solder in position the link wires, solder pins and the 14-pin d.i.l. socket, then the resistors, diodes and l.e.d.s, continuing with the capacitors and transistors. IC1 is a CMOS device and anti-static precautions are again advised.

Be careful to observe the correct orientation of the electrolytic capacitors and the transistors, diodes and the i.c.

Switch S1 is of the kind that has two commoned terminals at each side. It should

### INTERFACE SETTING-UP

As the circuit stands, when an Alarm pulse is received, IC1a's input at pin 6 is inhibited for about half an hour after the alarm has ceased sounding. This period may be altered by changing the value of C3 (see earlier).

Beyond this, the only setting-up that is required is the adjustment of the timing periods of IC1a and IC1b, which may be set between about 0.7 seconds and two-and-a-half minutes with the component values shown. The timing periods are calculated with the following formulae:

$$t = 0.69 \times (VR1 + R4) \times C2$$

$$t = 0.69 \times (VR2 + R7) \times C5$$

Where *t* is the timing period in seconds  
Resistance is in ohms  
Capacitance is in farads

If you have an existing intruder alarm system, this would normally make provision for normally-closed loop inputs. The POLE and N/C outputs of the two relays

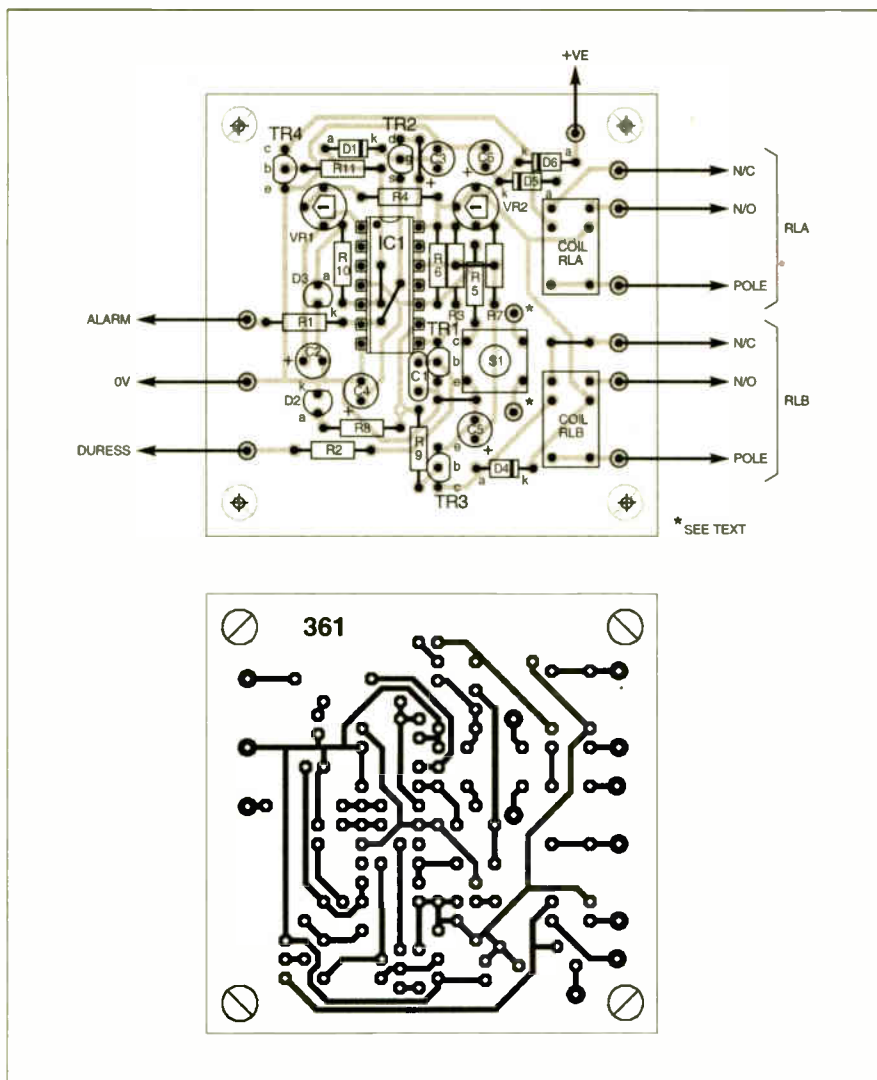

Fig. 6. Interface topside component layout, lead-off wiring details and full-size underside copper foil master pattern.

on the Interface p.c.b. are taken to these inputs of the intruder alarm system – or the POLE and N/O outputs are taken to normally-open inputs of the intruder alarm system.

### STAND-ALONE ALARM

The Interface p.c.b. may also be used as a simple stand-alone, two-zone alarm system. In this case, normally-closed switches may be wired in series (these would protect, for instance, doors and windows) and connected between the Alarm input and the positive power line, with a “pull-down” resistor of 22kΩ taken from the input to 0V (see Fig. 7a).

Note that “normally-closed” refers to switches that are closed when the door, for example, is closed, but open when the door opens.

The Duress input may serve the same purpose, only the switches are now wired between the Duress input and 0V, while a “pull-up” resistor of 22kΩ is taken from this input to the positive power line (see Fig. 7b).

Bear in mind that the Alarm input has the Inhibit function, while the Duress input reacts immediately to every positive pulse it receives. The Inhibit function may be removed simply by taking out diode D1 from the p.c.b.

Normally-open switches may also be used. These are wired in parallel, and in

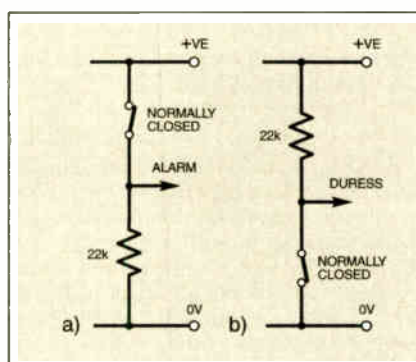

Fig. 7. Circuit details for a stand-alone alarm system.

this case, the positions of the 22kΩ resistors and the switches are swapped around.

### OTHER USES

The “single-action” switch was described earlier. A “dead man’s handle” can perform a vitally important function in certain situations.

In a recent highly publicised case near the author, a pump attendant left his pump (apparently for lunch), and a team in some water-filled caves below nearly lost their lives. A “dead man’s handle” could prevent such incidents by sounding an alarm if, for instance, a pump is abandoned for too long

– or if, as the term suggests, the pump attendant should drop dead!

This is accomplished as follows: the alarm sounder is connected to relay RLA’s POLE and N/O connections. The Interface’s Alarm input is then tied low with a 22kΩ “pull-down” resistor, which is wired between the Alarm input and 0V.

This means that monostable IC1a would continually be triggering, and the alarm would always be sounding – if TR2 were not there to inhibit incoming negative-going pulses. Then the anode of D1 should be disconnected from its existing position and connected to IC1 pin 9 instead. A hole is provided for this purpose on the p.c.b., at the junction of R8 and R9 (see Fig. 6).

Now, every time a Duress pulse is received, the Alarm trigger is disabled. If, however, no Duress pulse is received, TR2’s Inhibit feature times out, monostable IC1a triggers, and RLA pole contact switches over to the normal open contact – sounding the alarm. The Duress input may be tied low with a 22kΩ resistor, and a normally-open switch (perhaps a lever switch) wired between the input and the positive line to operate the “dead man’s handle”.

All that now remains is for you to decide how soon you would like the alarm to sound after the unit has been abandoned (this is determined by capacitor C3 – see earlier), and how long you would like the alarm to sound (which is set by VR1). Adjust preset VR2 to its minimum value, since IC1b merely serves as a trigger in this application. Switch S1 serves to instantly cancel the alarm.

### CONDITIONAL SWITCH

A “conditional” switch is one which switches on condition that another switch has (or has not) been activated during a predetermined period beforehand. This would have a wide variety of possible uses. For instance, it could be used to “authorise” the use of another switch for a predetermined period. It could also be used to disable another switch for a predetermined period, or be used as a form of double-handed switch.

The logic required to do this is simple, and the author leaves the details to the ingenuity of the constructor. In short, one set of relay contacts is wired in series with the opposite monostable timer’s input, so making one input dependent on the state of the opposite relay. Remember to use 22kΩ “pull-up” or “pull-down” resistors where necessary, so that no inputs are left “floating”.

### TIME OUT

Finally, the Alarm input may be used as a timer. This begins to time the instant that a pushbutton is pressed, and will receive no further trigger inputs until the timing period has ended. It may be instantly reset at any time by means of switch S1.

For this purpose, the value of capacitor C3 may be reduced to nF, so that the pushbutton is disabled only for two or three seconds after the timing period has ended. A 22kΩ “pull-up” resistor is wired between the input and the positive rail, and a momentary-action pushbutton is wired between the Alarm input and 0V.

The instant the pushbutton is pressed, the timing period begins. The output is taken from relay RLA. □



# CIRCUIT SURGERY

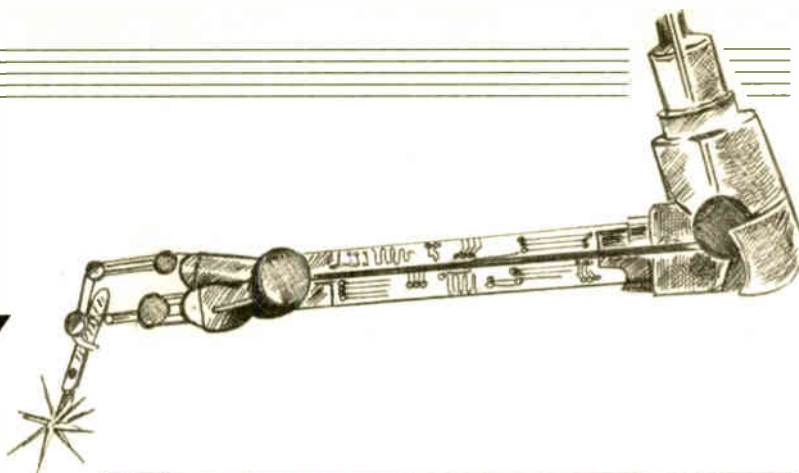

**ALAN WINSTANLEY  
and IAN BELL**

*Our monthly surgeons examine the fundamentals of bandgap references, revisit Y-class capacitors and a supply surprise.*

## Mind the Bandgap

Regular *EPE* reader *Gerard Galvin* asks by email: *What does the term 'bandgap voltage' mean? I've seen the term in data sheets and I think it relates to reference voltages.*

First of all, **bandgap** is a term relating to the physics of semiconductors and electrical conduction in general. In order for a material to be an electrical conductor the electrons must detach themselves from their atoms so that they can move around and form an electric current.

"Attached" electrons near the "outside" of the atom possess a certain range of energy values known as the **valence band**. "Unattached" electrons, which are free to move around and hence take part in conduction, also have a range of possible energy values, known as the **conduction band**.

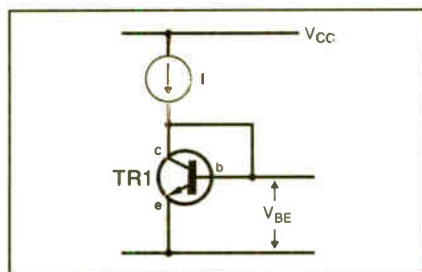

**Fig.1.** Basic  $V_{BE}$  voltage reference using a diode-connected transistor supplied with a constant current.  $V_{BE}$  has a negative temperature coefficient.

It is not possible for an electron to have an energy value between the valence and conduction ranges. The separation between these allowed energy ranges, that is from the top of the valence range to the bottom of the conduction range, is the **bandgap**.

For insulators the bandgap is very large so conduction does not take place. For conductors such as metals the valence and conduction bands overlap so electrons can easily move between them and conduction readily takes place. For semiconductors the bandgap is small so things get interesting: we can significantly change the electrical properties by adding "impurity" atoms as we do with diodes and transistors.

Effects such as light-dependent conduction are related to the bandgap too – e.g. if a photon provides the correct amount of energy to an electron in a semiconductor valence band, it can jump into the conduction band.

A full understanding of bandgaps and related issues requires some advanced physics and is therefore beyond the scope of this column. We will therefore move on to look at bandgap reference circuits.

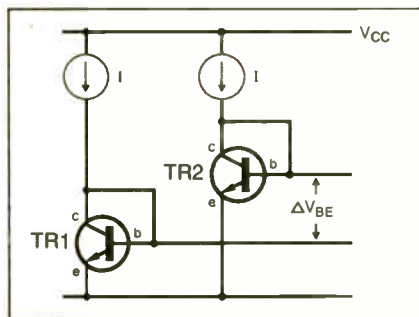

**Fig.2.** Two diode-connected transistors of different physical sizes provide a voltage,  $\Delta V_{BE}$ , with a positive temperature coefficient.

## Band of Circuits

In circuits such as analogue-to-digital converters it is essential to have an accurate and stable reference voltage if an accurate and stable conversion is required. We touch on this in *Teach-In 2002 Part 9*, but we did not have space to go into reference circuits in detail.

A number of possibilities spring to mind when considering how we might design a voltage reference, with the most obvious perhaps being to use the diode voltage drop (or transistor base-emitter voltage of a diode-connected transistor – see Fig. 1) or a Zener diode. These approaches are used in circuits that do not have to be particularly stable, but they are not suitable for high precision applications because of the high sensitivity of these voltages to changes in temperature. The Zener diode is more stable than the  $V_{BE}$  voltage by about a factor of three, but Zener diodes are noisy and the stability is simply not good enough for many critical applications.

Note that the "arrow in a circle" symbol in Fig. 1 is a constant current source, which we have discussed before in *Circuit Surgery*. In this case we could simply use a resistor, on the assumption that the supply voltage and  $V_{BE}$  voltages do not change much.

The  $V_{BE}$  voltage of the circuit in Fig. 1 would typically be about 0.6V at room temperature but it has a *negative* temperature coefficient – in fact  $V_{BE}$  decreases by about 2mV per degree Celsius increase. Some temperature sensor circuits actually make use of this very characteristic.

We can use the diode-connected transistor as long as we compensate for the temperature change. One way of doing this is to add  $V_{BE}$  to another voltage which has the *opposite* temperature coefficient. If we take two transistors of *different physical sizes* supplied with the same current, as shown in Fig. 2, it turns out that the temperature coefficient of the *difference* between the two  $V_{BE}$  voltages (labelled ( $\Delta V_{BE}$  or "delta  $V_{BE}$ ") is positive. So if we build a circuit with an output  $V_{ref}$  given by

$$V_{ref} = V_{BE} + k \Delta V_{BE}$$

and we choose the right value for the constant  $k$ , then we get a temperature-stable voltage reference.

We can obtain a current that is proportional to the difference in  $V_{BE}$  using the

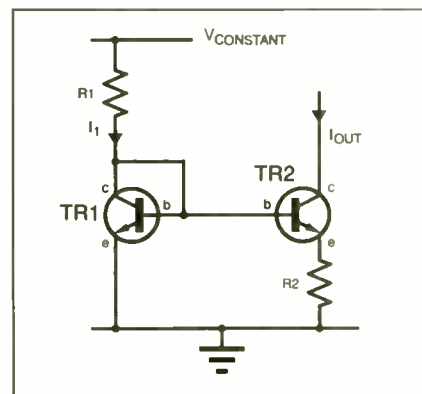

**Fig.3.** Here,  $I_{OUT}$  is proportional to the difference between the transistors'  $V_{BE}$  voltages and it has a positive temperature coefficient.

circuit in Fig.3. Here resistor R1 acts as a current source as both  $V_{\text{CONSTANT}}$  and  $V_{\text{BE}}$  of TR1 are fixed. The value of  $I_{\text{OUT}}$  is equal to the current in resistor R2 (ignoring TR2's base current).

The current in R2 is set by the voltage across it, which is the difference in the  $V_{\text{BE}}$  values ( $\Delta V_{\text{BE}}$ ) of the two transistors. Thus  $I_{\text{OUT}}$  is proportional to  $\Delta V_{\text{BE}}$ . To get a voltage proportional to  $\Delta V_{\text{BE}}$  we just pass  $I_{\text{OUT}}$  through a resistor.

The collector (c) of TR2 is the output of a current source and can therefore be set to any voltage within the operating range of the source. If we connect it to a voltage equal to  $V_{\text{BE}}$  (supplied from the base of a conducting transistor with its emitter connected to ground – see Fig.4) then the voltage at the other end of a resistor, R3, carrying  $I_{\text{OUT}}$  will be at  $V_{\text{BE}} + R3 \cdot I_{\text{OUT}}$ . As  $I_{\text{OUT}}$  is proportional to  $\Delta V_{\text{BE}}$  this gives us a reference voltage in the form we were looking for.

After choosing component values which give the correct value for k the voltage obtained is around 1.2V and is related to the band gap for silicon. The voltage stability is about ten times better than a Zener and can be further enhanced by more sophisticated circuits.

To get a practical reference circuit we note that the  $V_{\text{CONSTANT}}$  we require for the current source input can be  $V_{\text{ref}}$  – our reference output voltage (clever isn't it!). The same voltage can also be used for  $V_{\text{BIAS}}$  for the transistor supplying the  $V_{\text{BE}}$  voltage. Current to the whole circuit can be supplied via a resistor (R4) from the power supply which gives us a basic temperature-compensated voltage reference (see Fig.5).

This circuit was published in 1971 by Robert Widlar (a highly respected engineer whose name often headed up many National Semiconductor application notes), and is one of the many implementations of the bandgap reference that are now available. The output from Fig.5. would usually be buffered by an op.amp to prevent loading effects. Other bandgap circuits put the op.amp and reference in a feedback loop to further stabilise the circuit. Bandgap references are available as integrated circuits such as the LM113 and LM10 from National Semiconductor. *IMB.*

## Capacitors: Class of Y2

Roger Warrington writes:

*With respect to Circuit Surgery in the June issue and the discussion about X-Class and Y-Class capacitors, the statements you made are essentially correct. However, I feel that the effect of the difference between Y1 and Y2 caps ought to have been pointed out since getting it wrong could be lethal. I speak as a retired safety test engineer for the British Standards Institute.*

*There are various different standards for complete equipment but they all require TWO levels of insulation between dangerous voltage and the operator. The two levels can be "basic" and earth, or "double" or "reinforced".*

*Note for the purposes of all standards, both Live and Neutral sides of the mains are considered as dangerous for two reasons: (a) the spikes referred to in the article which are with respect to earth and (b) there is the possibility of reversing the Live and Neutral as occurs with some continental wall plugs etc.*

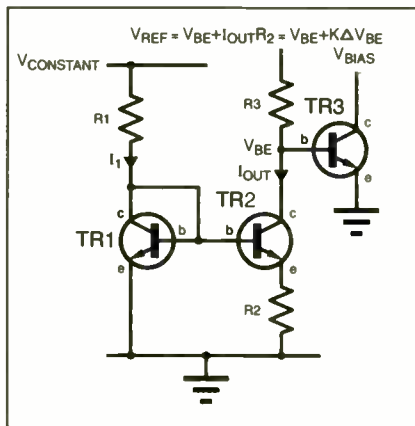

Fig.4. Concept circuit for bandgap reference.

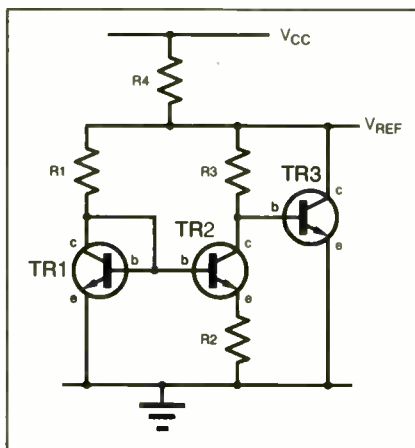

Fig.5. Practical circuit of Fig.4 – The Widlar Bandgap Reference.

or the two-pin "figure eight" type of mains power cord used on some appliances.

*Now to the crux of the matter: a Y2 capacitor is only considered to be the equivalent of "basic" insulation. Thus it is suitable for use between mains and a safety earth because the safety earth provides the second level of protection in the event of failure. It is NOT suitable for use between mains and an unearthed ground or secondary circuit that may be touchable by the user.*

*Generally speaking it is safer to consider that any secondary circuitry or conductive parts will be touchable by the operator (though there are plenty of exceptions in these days of plastics), but in order to confirm it one has to have a detailed knowledge of the spacing requirements for the particular voltage. In any case it's safe to assume that your readers will have their fingers in the secondary circuit workings with the power on. After all that's why they read the magazine.*

*A number of switch-mode power supplies use Y capacitors between floating secondary circuits and the mains as an aid to suppressing interference or even to detect the presence of the mains. Since there is no safety earth, the requirement is for "double" or "reinforced" insulation. This requires the use of two equal Y2 capacitors in series, or one Y1 type.*

*Note that there is an earth leakage current flowing through these caps and in the case of using two Y2 caps, the current through a single one should not exceed the limit. The limit varies with the standard, medical standards being much more critical for instance.*

*However, for non-medical use in Class II equipment (Class II means no safety earth) the limit is normally 0.25mA. Thus one can do the sums of  $E / Xc$  and deduce a maximum value of Y capacitance for 250V 50Hz of about 3nF. Of course, putting two in series will halve the effective capacitance so a single Y1 cap may be preferable.*

*Roger Warrington C.Eng MIEE by email.*

Thank you for filling us in with this technical information. As we mentioned previously, Y-Class capacitors are rated for direct connection to earth although they effectively bypass the mains insulation of the apparatus. X-Class capacitors are not permissible in that mode.

Clearly, it is difficult to cover this in any depth without reference to the lengthy technical standards, something that I feel goes beyond the remit of *Circuit Surgery*. Nevertheless, even though *EPE* is a hobbyist magazine, where relevant we do try to set a good example by applying standards used by experts. *ARW.*

## More Supply Surprises

Back in April 2002 *Circuit Surgery* we recounted the tale, with hopefully a happy ending, of a reader who had purchased a Yaesu transceiver but couldn't locate a suitable Battery Charger for it. After talking to the manufacturers we suggested the RS 250-1397 basic charging unit. I then heard back from *George Jacobs* who writes:

*I was ever so relieved to hear that my battery problem had been solved – thank you ever so much! I went along with your opinion and decided to buy the suggested power unit. However, when I rang RS Components they said they could not help me because they do not supply individual customers, only companies and business etc. That really flattened me. I have written twice to Yaesu but they have not replied. I may have to sell the Transceiver and buy another model instead.*

I was dismayed to hear that you had been turned away when you tried to buy the recharger. Firstly for the benefit of readers in the USA and elsewhere, RS Components has nothing to do with the vendor you may know as Radio Shack (or Tandy). You will see RS Components part numbers quoted frequently in our constructional articles as well as in *Shoptalk*. RS Components (<http://rswww.com>) is a vast UK-based component supplier that over the years has built up an excellent reputation for delivering a high quality service to industry.

Even so, the information you received from RS Components was incorrect. A very apologetic RS advisor confirmed that although they are strictly speaking a "trade only" organisation they are still happy to deal with individuals on a credit card basis (only). They were keen to phone you to sort out your order.

Readers should note that the only other way to buy from RS is via their web site, which is what I do if I need an RS part in a hurry. I suggested you give RS another try, this time asking for the New Customer Reception department if you have any further problems. *ARW.*

# Video Surveillance



- C-MOS B/W Camera 15mm/15mm £29.00
- C-MOS Colour Camera 15mm/15mm £65.00
- PCB B/W Camera 32mm/32mm £24.00
- PCB Colour Camera w/Audio 32mm/32mm £65.00
- 23cm (1.3GHz) Video/Audio Transmitter £35.00
- 13cm (2.4GHz) Video/Audio Transmitter £35.00
- 1.2 Watt 2.4GHz Video/Audio Transmitter £120.00
- 4" TFT Boxed Colour Monitor w/Audio £110.00
- Video to VGA Converter £65.00
- VGA to Video Converter £90.00
- External USB Video Capture Box £55.00

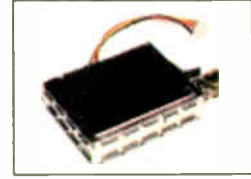

All prices exclude VAT.

Many more products on our website:

[WWW.BITZTECHNOLOGY.COM](http://WWW.BITZTECHNOLOGY.COM)

Tel: 01753 522 902 Fax: 01753 571 657

# Wireless Remote Controls



**RC-11**  
3 channels RC-11 Key fob  
Control Transmitter with  
Rolling Code technology.

RC-11 Price: £14.99



**UC-216**  
3 channels receiver with 2 relays  
output working from 9V to 12vdc  
UC-216 with learning mode and  
rolling code technology.

UC-216 9-12Vdc £29.00  
UC-222 240 Vac £29.00

Also

- Wireless pager alarm PG-4W £125.00
- Wireless PIR alarm JA-60S £49.00
- Wireless door magnet alarm £39.00
- Wireless smoke alarm £49.00
- Wireless glass break alarm £49.00
- Wireless alarm control panel £99.00
- Wireless alarm control panel with digital /voice dialler £149.00

Distributors Welcome.

All prices exclude VAT and carriage. All transmitters are licence exempt working on 433.92Mhz. All transmitters work with rolling code technology.

**Bitz Technology Ltd**  
sales@bitztechnology.com  
+44 (0) 1753 522 902

# PRACTICALLY SPEAKING

Robert Penfold looks at the Techniques of Actually Doing It!

It is generally conceived that it is the colour-coded components that should give the most identification problems to beginners at electronic project construction. However, once you have learnt the basic resistor colour code and one or two variations on it, there should be little difficulty in determining the value of any colour-coded component. Components that are marked with values or type numbers using letters and numbers should leave even less room for error, and each one should be exactly what it says on the casing.

## Clear as Mud

It is clear from readers' letters that things are not as straightforward as this in practice. Readers having problems with a project often include descriptions of some of the components that they suspect of being the wrong thing. Semiconductors in general, and integrated circuits in particular, are probably the worst offenders when it comes to spurious markings. Even experienced project builders can sometimes take a while to sort out the "wheat from the chaff". Matters are certainly easier if you understand the fundamentals of semiconductor type numbers.

Understandably, most semiconductor manufacturers like their name or logo to be prominently displayed on their products. Virtually all integrated circuits carry a manufacturer's name such as "MAXIM" or (more usually) a logo - see Fig.1. One or other of these is often squeezed onto small semiconductors such as low-power transistors. These are usually easy to spot and should not give any major problems.

In addition to the name or logo of the manufacturer and the type number, most semiconductors usually have some additional letters and numbers.

Over the years there has been a tendency for the logos and additional markings to become more prominent at the expense of type numbers, etc. This can be very confusing for beginners, but the secret of success is to look for meaningful markings and ignore everything else.

The extraneous markings are usually just things like batch numbers, the date of manufacture in some obscure form, a code number indicating the particular factory where the component was made, and things of this general type. They are, of course, of no relevance to the project builder.

The secret of success with component markings is to avoid panicking if you are faced with a jumble of digits,

and look for something that could be a type number or value. Things like batch numbers are usually in a form that avoids them being easily confused with type numbers or values.

It helps to bear in mind that the convention with integrated circuits is for the type number to be given first, followed by any batch number, etc. Hence the eight-pin device shown in Fig.1 is an NE602AN and not an FSH4930 or 9501nA. Similarly, the 16-pin device is a MAX232CPE and not a 9450N. Unfortunately, the same convention is not used with capacitors and most other components.

## Numbers Up

Even if you manage to ignore the spurious markings, there can still be problems with the type number or value. Integrated circuits are undoubtedly the worst offenders, since the same chip can be sold under different

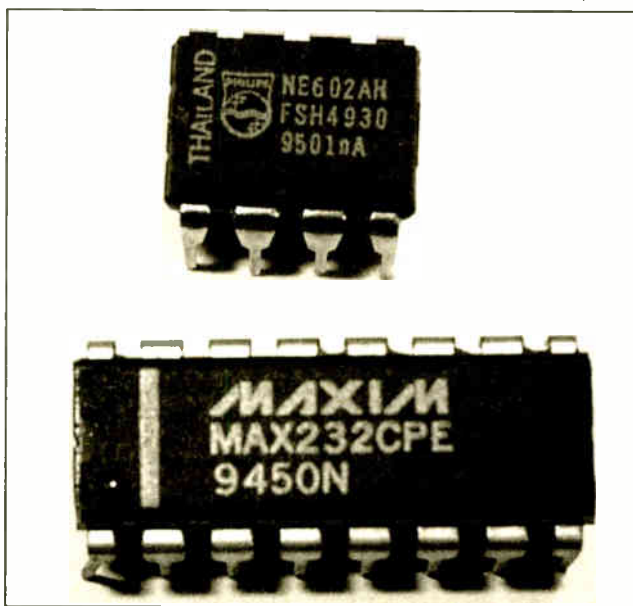

Fig.1. The markings on integrated circuits usually include a lot of "excess baggage".

type numbers. In general, the basic type number is the same, but it is preceded by the manufacturer's code letters and followed by a suffix that denotes the case style.

Having several manufacturers producing the same chip might seem a little odd, but equipment producers do not like being tied to a single source for components. Having a second source of supply, or even several sources, makes a component more marketable.

Unfortunately, it also results in the same component being marketed under several slightly different type numbers. Provided you obtain the correct chip, it should not matter which particular manufacturer it was produced by.

Not all integrated circuits are available with multiple prefixes. Some devices are only produced by one manufacturer, and this is particularly common with the more specialised types. Others are produced under the same type number regardless of which company actually made the device. The "NE" suffix for the eight-pin chip in Fig.1 suggests it was made by Signetics, but the logo clearly indicates that it was made by Philips.

## Logic

The devices that are most likely to have a variety of prefixes are the popular operational amplifiers and logic devices, both of which are commonly used in projects for the home constructor. In components lists it is normal for only the basic type number to be specified, or perhaps the basic type number plus a suffix.

With the 4000 series CMOS logic devices for example, a type number such as 4066BE might be specified. Here "4066" is the basic type number, and "BE" is the suffix. The same method of identification is often used in component catalogues, with no particular manufacturer being mentioned.

Some of the very large suppliers do offer devices from a specific manufacturer, and may even offer a choice of manufacturers in some cases. Where there is a choice, simply opt for whichever one is the cheaper.

There is a further complication with the 74\*\* series TTL logic devices, because various families of improved chips have been introduced over the years. The original devices had basic type numbers that started with "74" and then had a two or three digit number (e.g. 74245).

The original TTL logic integrated circuits are now largely obsolete. Later logic families are identified by adding two or three letters after the "74" part of the type number. These are the identification letters for some common TTL logic families:

HC	high-speed CMOS (e.g. 74HC02)
HCT	high-speed CMOS using normal TTL logic levels (e.g. 74HCT02)
LS	low-power Schottky (e.g. 74LS02)
LCX	low-voltage and high speed (e.g. 74LCX02)
LVX	low-noise, low current and high-speed (e.g. 74LVX02)

There have been many other TTL logic families, but these have not stood the test of time and you are unlikely to encounter them. It is the first three in the list that are most commonly used in EPE projects.

In general, compatibility between various TTL logic groups is not very good. They have different supply voltage ranges, logic voltage requirements, drive currents, and input currents. Some are more tolerant of supply noise than others.

Unless you are sure you know what you are doing it is definitely not a good idea to use a device from the wrong logic family. A substitute of this type will sometimes work, but it is more likely to fail. There is also a risk of the supply voltage being inappropriate for the substitute device, which could result in it being damaged.

### Tail Piece

On the face of it, the suffix is more crucial than the prefix. These days most integrated circuits are available in a variety of case styles, but only the dual in-line (d.i.l.) variety is normally used in do-it-yourself projects. In practice there is less than total uniformity in the suffixes, so what appears to be the wrong suffix can appear on a perfectly suitable device. On the other hand, an increasing range of surface-mount devices is listed in most component catalogues, so you have to be careful to order the right type.

The original 4000 CMOS devices had an "AE" suffix, but the improved "B" series devices that are still in use today and have a "BE" suffix superseded these. The "E" simply means that the device is in a plastic d.i.l. encapsulation.

A few devices are available with a "UBE" suffix, and the "U" stands for unbuffered. The "UBE" version should always be used if it is specified in a components list, but the standard "BE" variety should otherwise be used.

An "E" in a suffix is not the only letter used to indicate a plastic d.i.l. encapsulation. Both "P" and "N" are commonly used to indicate this type of encapsulation, and there are further variants such as "G" or "H". There are often two or three letters in the suffix, and some manufacturers seem to use one letter to denote the case material (plastic or ceramic) and another to indicate the pinout configuration. More commonly an additional letter is used to indicate whether the device is a commercial grade component or a higher-grade type such as an industrial or military type.

Most EPE projects normally require the "bog standard" commercial variety and these normally have "C" in the suffix. Higher-grade devices should work perfectly well if used instead of a standard commercial grade component, since they are all basically the same chip. The superior versions have wider operating temperature ranges, and may be superior in other respects.

### Euro ICs

Some integrated circuits have European type numbers, and these start with a "T" followed by two letters, a serial

number, and a suffix letter (e.g. TBA820M). Devices of this type have the same type number regardless of the manufacturer concerned, so it is important to obtain a component that has precisely the right type number. It is otherwise virtually certain that you will obtain completely the wrong device, or the right chip but in the wrong encapsulation.

### Transistors and Diodes

Transistors and diodes do not have the same type number variations as integrated circuits. The prefix does not usually indicate the manufacturer, although there are some exceptions such as the "TI" and "TIL" prefix used by Texas Instruments.

Devices having European codes start with two letters that indicate the semiconductor material used and the type of component, as detailed below:

First Letter	Meaning
A	Germanium
B	Silicon
C	Gallium Arsenide
R	Compound materials
Second Letter	Meaning
A	Small signal diode
B	Rectifier or variable capacitance diode
C	Small signal audio transistor
D	Power transistor
E	Point contact diode
F	Low power high frequency transistor
K	Hall-effect device
L	High frequency power transistor
N	Opto-isolator
P	Photo diode
Q	LED
T	Thyristor or triac
U	High-voltage transistor
X	Rectifier
Y	High-power rectifier
Z	Zener diode

A BC109 for example, is therefore a small silicon transistor for audio use. The number is simply a serial type, starting from 100.

American semiconductors have a "1N", "2N", or "3N" prefix. The number is one less than the number of leads the device has, so diodes and rectifiers have 1N\*\*\* type numbers, and transistors mostly have 2N\*\*\* type numbers. A few transistors have four leads and a 3N\*\*\* type number. Again, the number following the suffix is a serial type.

Devices having Japanese Industry Standard (JIS) type numbers are occasionally used in EPE projects. These start with a number that indicates the number of leads in the same way as the American system. The next digit is always an "S", and the third digit indicates the type of component using a code letter ("D" for a low-frequency npn transistor for example). This is followed by the usual serial number.

One slightly confusing aspect of Japanese type numbers is that the first two digits are often absent from the actual components. A "2SC646" for example, would probably just be

marked "C646". Fig.2 shows two more examples. Since the first two digits are of little practical value, their absence is of no real importance.

### Transistor Suffixes

Clearly, small semiconductors have rigidly standardised type numbers and there is not the "free-for-all" associated with integrated circuits. The only variations are in the suffixes applied to some transistors.

With the American devices there is sometimes an "A" on the end of the type number, and this is used to indicate that the device concerned is an improved version of the basic device. The original and improved versions are effectively two different devices and it is not a good idea to use one in place of the other.

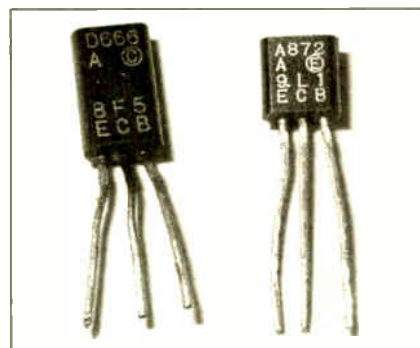

Fig.2. The device on the left is a 2SD666A and the one on the right is a 2SA872A

A more common variation is where a suffix letter is added to a European transistor type number. This letter indicates that the device is in a particular gain group, as follows:

Letter	Gain Range
A	110 to 220
B	220 to 450
C	420 to 800

If no suffix is given in a components list it does not matter which gain group you use, and it is also all right to use a device that lacks the suffix. Where a particular gain group is specified it will usually be the highest ("C" suffix) group. It is quite likely that the project will not work properly if you use a transistor from the wrong gain group or one that is not graded.

A few American devices, and the 2N2926 in particular, use coloured spots on the device to indicate its gain group. This method is based on the resistor colour code, with brown representing the lowest gain group, and red, orange, yellow, etc., representing progressively higher gain ranges. Again, if a particular colour is specified it is important to use a device from the correct gain group.

Colour coding is little used with semiconductors, but there are some American diodes that use a variation on the resistor colour code to indicate the serial number. For example, a 1N914 diode would have white, brown, and yellow bands to respectively indicate the 9, 1, and 4 part of the type number. No multiplier band is used with this system. There should be no difficulty with this type of coding provided you know the resistor colour code.

# EPE IS PLEASED TO BE ABLE TO OFFER YOU THESE ELECTRONICS CD-ROMS

## ELECTRONICS PROJECTS

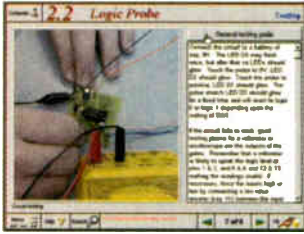

Logic Probe testing

*Electronic Projects* is split into two main sections: **Building Electronic Projects** contains comprehensive information about the components, tools and techniques used in developing projects from initial concept through to final circuit board production. Extensive use is made of video presentations showing soldering and construction techniques. The second section contains a set of ten projects for students to build, ranging from simple sensor circuits through to power amplifiers. A shareware version of Matrix's CADPACK schematic capture, circuit simulation and p.c.b. design software is included. The projects on the CD-ROM are: Logic Probe; Light, Heat and Moisture Sensor; NE555 Timer; Egg Timer; Dice Machine; Bike Alarm; Stereo Mixer; Power Amplifier; Sound Activated Switch; Reaction Tester. Full parts lists, schematics and p.c.b. layouts are included on the CD-ROM.

## ELECTRONICS CAD PACK

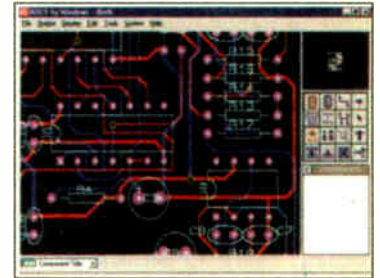

PCB Layout

Electronics CADPACK allows users to design complex circuit schematics, to view circuit animations using a unique SPICE-based simulation tool, and to design printed circuit boards. CADPACK is made up of three separate software modules. (These are restricted versions of the full Labcenter software.) **ISIS Lite** which provides full schematic drawing features including full control of drawing appearance, automatic wire routing, and over 6,000 parts. **PROSPICE Lite** (integrated into ISIS Lite) which uses unique animation to show the operation of any circuit with mouse-operated switches, pots, etc. The animation is compiled using a full mixed mode SPICE simulator. **ARES Lite** PCB layout software allows professional quality PCBs to be designed and includes advanced features such as 16-layer boards, SMT components, and an autorouter operating on user generated Net Lists.

## ELECTRONIC CIRCUITS & COMPONENTS V2.0

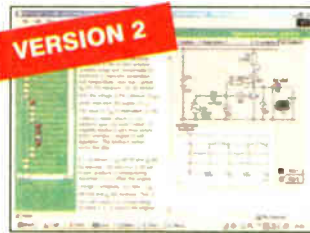

Circuit simulation screen

Provides an introduction to the principles and application of the most common types of electronic components and shows how they are used to form complete circuits. The virtual laboratories, worked examples and pre-designed circuits allow students to learn, experiment and check their understanding. Version 2 has been considerably expanded in almost every area following a review of major syllabuses (GCSE, GNVQ, A level and HNC). It also contains both European and American circuit symbols. Sections include: **Fundamentals:** units & multiples, electricity, electric circuits, alternating circuits. **Passive Components:** resistors, capacitors, inductors, transformers. **Semiconductors:** diodes, transistors, op.amps, logic gates. **Passive Circuits. Active Circuits. The Parts Gallery** will help students to recognise common electronic components and their corresponding symbols in circuit diagrams. Included in the Institutional Versions are multiple choice questions, exam style questions, fault finding virtual laboratories and investigations/worksheets.

## ANALOGUE ELECTRONICS

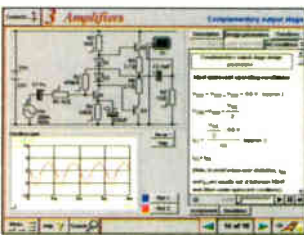

Complimentary output stage

*Analogue Electronics* is a complete learning resource for this most difficult branch of electronics. The CD-ROM includes a host of virtual laboratories, animations, diagrams, photographs and text as well as a SPICE electronic circuit simulator with over 50 pre-designed circuits. Sections on the CD-ROM include: **Fundamentals** – Analogue Signals (5 sections), Transistors (4 sections), Waveshaping Circuits (6 sections), **Op.Amps** – 17 sections covering everything from Symbols and Signal Connections to Differentiators. **Amplifiers** – Single Stage Amplifiers (8 sections), Multi-stage Amplifiers (3 sections). **Filters** – Passive Filters (10 sections), Phase Shifting Networks (4 sections), Active Filters (6 sections). **Oscillators** – 6 sections from Positive Feedback to Crystal Oscillators. **Systems** – 12 sections from Audio Pre-Amplifiers to 8-Bit ADC plus a gallery showing representative p.c.b. photos.

## DIGITAL ELECTRONICS V2.0

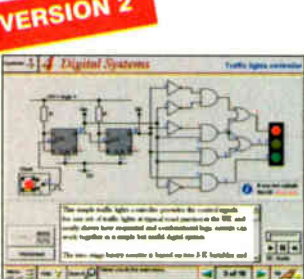

Virtual laboratory – Traffic Lights

*Digital Electronics* builds on the knowledge of logic gates covered in *Electronic Circuits & Components* (opposite), and takes users through the subject of digital electronics up to the operation and architecture of microprocessors. The virtual laboratories allow users to operate many circuits on screen. Covers binary and hexadecimal numbering systems, ASCII, basic logic gates, monostable action and circuits, and bistables – including JK and D-type flip-flops. Multiple gate circuits, equivalent logic functions and specialised logic functions. Introduces sequential logic including clocks and clock circuitry, counters, binary coded decimal and shift registers. A/D and D/A converters, traffic light controllers, memories and microprocessors – architecture, bus systems and their arithmetic logic units. Sections on Boolean Logic and Venn diagrams, displays and chip types have been expanded in Version 2 and new sections include shift registers, digital fault finding, programmable logic controllers, and microcontrollers and microprocessors. The Institutional versions now also include several types of assessment for supervisors, including worksheets, multiple choice tests, fault finding exercises and examination questions.

## FILTERS

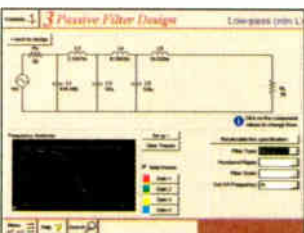

Filter synthesis

*Filters* is a complete course in designing active and passive filters that makes use of highly interactive virtual laboratories and simulations to explain how filters are designed. It is split into five chapters: **Revision** which provides underpinning knowledge required for those who need to design filters. **Filter Basics** which is a course in terminology and filter characterization, important classes of filter, filter order, filter impedance and impedance matching, and effects of different filter types. **Advanced Theory** which covers the use of filter tables, mathematics behind filter design, and an explanation of the design of active filters. **Passive Filter Design** which includes an expert system and filter synthesis tool for the design of low-pass, high-pass, band-pass, and band-stop Bessel, Butterworth and Chebyshev ladder filters. **Active Filter Design** which includes an expert system and filter synthesis tool for the design of low-pass, high-pass, band-pass, and band-stop Bessel, Butterworth and Chebyshev op.amp filters.

## NEW ROBOTICS & MECHATRONICS



Case study of the Milford Instruments Spider

Robotics and Mechatronics is designed to enable hobbyists/students with little previous experience of electronics to design and build electromechanical systems. The CD-ROM deals with all aspects of robotics from the control systems used, the transducers available, motors/actuators and the circuits to drive them. Full case study material (including the NASA Mars Rover, the Milford Spider and the Furby) is used to show how practical robotic systems are designed. The result is a highly stimulating resource that will make learning, and building robotics and mechatronic systems easier. The Institutional versions have additional worksheets and multiple choice questions.

- Interactive Virtual Laboratories
- Little previous knowledge required
- Mathematics is kept to a minimum and all calculations are explained
- Clear circuit simulations

## PRICES

Prices for each of the CD-ROMs above are:

(Order form on third page)

(UK and EU customers add VAT at 17.5% to "plus VAT" prices)

Hobbyist/Student .....£45 inc VAT  
 Institutional (Schools/HE/FE/Industry).....£99 plus VAT  
 Institutional 10 user (Network Licence) .....£199 plus VAT  
 Site Licence.....£499 plus VAT

# PICmicro TUTORIALS AND PROGRAMMING

## HARDWARE

### VERSION 2 PICmicro MCU DEVELOPMENT BOARD

*Suitable for use with the three software packages listed below.*

This flexible development board allows students to learn both how to program PICmicro microcontrollers as well as program a range of 8, 18, 28 and 40-pin devices. For experienced programmers all programming software is included in the PPP utility that comes with the development board. For those who want to learn, choose one or all of the packages below to use with the Development Board.

- Makes it easier to develop PICmicro projects
- Supports low cost Flash-programmable PICmicro devices
- Fully featured integrated displays – 13 individual I.e.d.s, quad 7-segment display and alphanumeric I.c.d. display
- Supports PICmicro microcontrollers with A/D converters
- Fully protected expansion bus for project work
- All inputs and outputs available on screw terminal connectors for easy connection

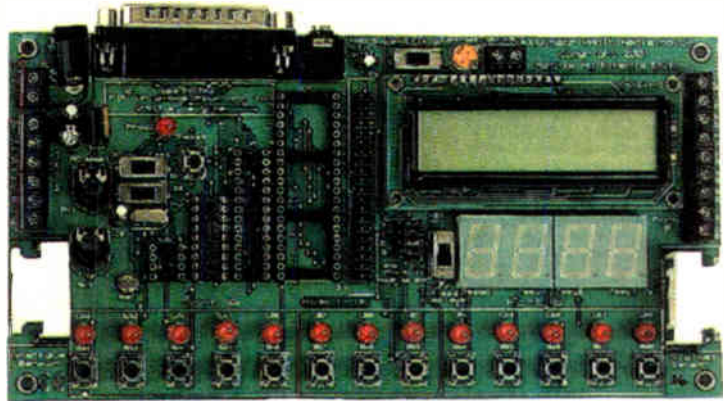

**£145 including VAT and postage**  
**12V 500mA plug-top PSU (UK plug) £7**  
**25-way 'D' type connecting cable £5**



## SOFTWARE

*Suitable for use with the Development Board shown above.*

### ASSEMBLY FOR PICmicro V2 (Formerly PICTutor)

Assembly for PICmicro microcontrollers V2.0 (previously known as PICTutor) by John Becker contains a complete course in programming the PIC16F84 PICmicro microcontroller from Arizona Microchip. It starts with fundamental concepts and extends up to complex programs including watchdog timers, interrupts and sleep modes. The CD makes use of the latest simulation techniques which provide a superb tool for learning: the Virtual PICmicro microcontroller. This is a simulation tool that allows users to write and execute MPASM assembler code for the PIC16F84 microcontroller on-screen. Using this you can actually see what happens inside the PICmicro MCU as each instruction is executed which enhances understanding.

- Comprehensive instruction through 39 tutorial sections
- Includes Vlab, a Virtual PICmicro microcontroller: a fully functioning simulator
- Tests, exercises and projects covering a wide range of PICmicro MCU applications
- Includes MPLAB assembler
- Visual representation of a PICmicro showing architecture and functions
- Expert system for code entry helps first time users
- Shows data flow and fetch execute cycle and has challenges (washing machine, lift, crossroads etc.)
- Imports MPASM files.

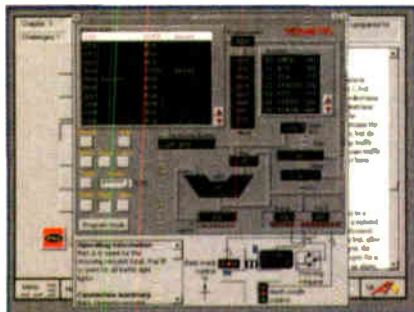

Virtual PICmicro

### 'C' FOR PICmicro VERSION 2

The C for PICmicro microcontrollers CD-ROM is designed for students and professionals who need to learn how to program embedded microcontrollers in C. The CD contains a course as well as all the software tools needed to create Hex code for a wide range of PICmicro devices – including a full C compiler for a wide range of PICmicro devices.

Although the course focuses on the use of the PICmicro microcontrollers, this CD-ROM will provide a good grounding in C programming for any microcontroller.

- Complete course in C as well as C programming for PICmicro microcontrollers
- Highly interactive course
- Virtual C PICmicro improves understanding
- Includes a C compiler for a wide range of PICmicro devices
- Includes full Integrated Development Environment
- Includes MPLAB software
- Compatible with most PICmicro programmers
- Includes a compiler for all the PICmicro devices.

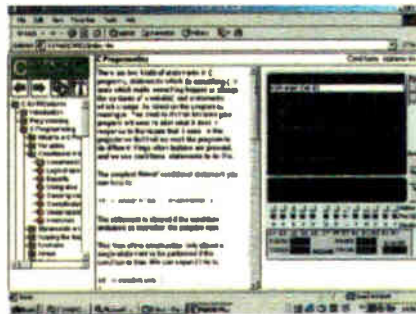

Minimum system requirements for these items: Pentium PC running Windows 95, 98, NT, 2000, ME, XP; CD-ROM drive; 64MB RAM; 10MB hard disk space.

### FLOWCODE FOR PICmicro

Flowcode is a very high level language programming system for PICmicro microcontrollers based on flowcharts. Flowcode allows you to design and simulate complex robotics and control systems in a matter of minutes.

Flowcode is a powerful language that uses macros to facilitate the control of complex devices like 7-segment displays, motor controllers and I.c.d. displays. The use of macros allows you to control these electronic devices without getting bogged down in understanding the programming involved.

Flowcode produces MPASM code which is compatible with virtually all PICmicro programmers. When used in conjunction with the Version 2 development board this provides a seamless solution that allows you to program chips in minutes.

- Requires no programming experience
- Allows complex PICmicro applications to be designed quickly
- Uses international standard flow chart symbols (ISO5807)
- Full on-screen simulation allows debugging and speeds up the development process
- Facilitates learning via a full suite of demonstration tutorials
- Produces ASM code for a range of 8, 18, 28 and 40-pin devices
- Institutional versions include virtual systems (burglar alarms, car parks etc.).

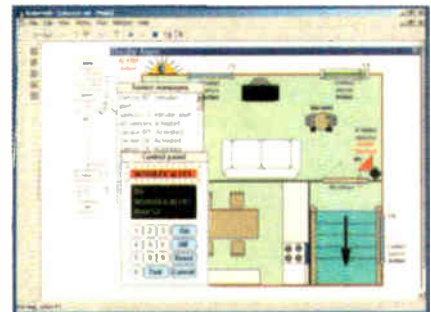

Burglar Alarm Simulation

## PRICES

Prices for each of the CD-ROMs above are:

*(Order form on next page)*

*(UK and EU customers add VAT at 17.5% to "plus VAT" prices)*

Hobbyist/Student  
 Institutional (Schools/HE/FE/Industry)  
 Flowcode Institutional  
 Institutional 10 user (Network Licence)  
 Site Licence

£45 inc VAT  
 £99 plus VAT  
 £70 plus VAT  
 £249 plus VAT  
 £599 plus VAT

# TEACH-IN 2000 – LEARN ELECTRONICS WITH EPE

EPE's own *Teach-In* CD-ROM, contains the full 12-part *Teach-In* series by John Becker in PDF form plus the *Teach-In* interactive software covering all aspects of the series. We have also added Alan Winstanley's highly acclaimed *Basic Soldering Guide* which is fully illustrated and which also includes *Desoldering*. The *Teach-In* series covers: Colour Codes and Resistors, Capacitors, Potentiometers, Sensor Resistors, Ohm's Law, Diodes and L.E.D.s, Waveforms, Frequency and Time, Logic Gates, Binary and Hex Logic, Op.amps, Comparators, Mixers, Audio and Sensor Amplifiers, Transistors, Transformers and Rectifiers, Voltage Regulation, Integration, Differentiation, 7-segment Displays, L.C.D.s, Digital-to-Analogue.

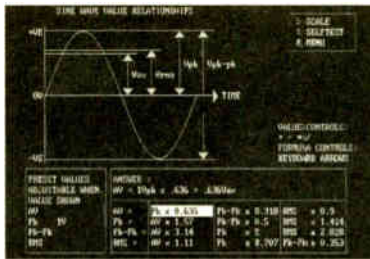

Sine wave relationship values

Each part has an associated practical section and the series includes a simple PC interface so you can use your PC as a basic oscilloscope with the various circuits. **A hands-on approach to electronics with numerous breadboard circuits to try out.**

**£12.45 including VAT and postage.** Requires Adobe Acrobat (available free from the Internet – [www.adobe.com/acrobat](http://www.adobe.com/acrobat)).

**FREE WITH EACH TEACH-IN CD-ROM** – *Electronics Hobbyist Compendium* 80-page book by Robert Penfold. Covers Tools For The Job; Component Testing; Oscilloscope Basics.

**FREE BOOK WITH TEACH-IN 2000 CD-ROM**

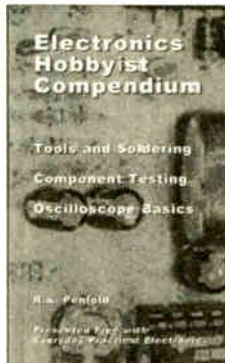

# DIGITAL WORKS 3.0

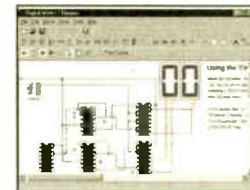

Counter project

*Digital Works Version 3.0* is a graphical design tool that enables you to construct digital logic circuits and analyze their behaviour. It is so simple to use that it will take you less than 10 minutes to make your first digital design. It is so powerful that you will never outgrow its capability ● Software for simulating digital logic circuits ● Create your own macros – highly scalable ● Create your own circuits, components, and i.c.s ● Easy-to-use digital interface ● Animation brings circuits to life ● Vast library of logic macros and 74 series i.c.s with data sheets ● Powerful tool for designing and learning. **Hobbyist/Student £45 inc. VAT. Institutional £99 plus VAT. Institutional 10 user £199 plus VAT. Site Licence £499 plus VAT.**

## ELECTRONICS IN CONTROL

Two colourful animated courses for students on one CD-ROM. These cover Key Stage 3 and GCSE syllabuses. **Key Stage 3:** A pictorial look at the Electronics section featuring animations and video clips. Provides an ideal introduction or revision guide, including multi-choice questions with feedback. **GCSE:** Aimed at the Electronics in many Design & Technology courses, it covers many sections of GCSE Electronics. Provides an ideal revision guide with Homework Questions on each chapter. Worked answers with an access code are provided on a special website.

**Single User £29 inc. VAT. Multiple User £39 plus VAT**  
**Student copies (available only with a multiple user copy) £6 plus VAT**  
*(UK and EU customers add VAT at 17.5% to "plus VAT" prices)*

## MODULAR CIRCUIT DESIGN

Contains a range of tried and tested analogue and digital circuit modules, together with the knowledge to use and interface them. Thus allowing anyone with a basic understanding of circuit symbols to design and build their own projects. Version 3 includes data and circuit modules for a range of popular PICs; includes PICAXE circuits, the system which enables a PIC to be programmed without a programmer, and without removing it from the circuit. Shows where to obtain free software downloads to enable BASIC programming. Essential information for anyone undertaking GCSE or "A" level electronics or technology and for hobbyists who want to get to grips with project design. Over seventy different Input, Processor and Output modules are illustrated and fully described, together with detailed information on construction, fault finding and components, including circuit symbols, pinouts, power supplies, decoupling etc.

**Single User £19.95 inc. VAT. Multiple User £34 plus VAT**  
*(UK and EU customers add VAT at 17.5% to "plus VAT" prices)*

**VERSION 3**

## ELECTRONIC COMPONENTS PHOTOS

A high quality selection of over 200 JPG images of electronic components. This selection of high resolution photos can be used to enhance projects and presentations or to help with training and educational material. They are royalty free for use in commercial or personal printed projects, and can also be used royalty free in books, catalogues, magazine articles as well as worldwide web pages (subject to restrictions – see licence for full details).



Also contains a **FREE** 30-day evaluation of Paint Shop Pro 6 – Paint Shop Pro image editing tips and on-line help included!

**Price £19.95 inc. VAT**

Minimum system requirements for these CD-ROMs: Pentium PC, CD-ROM drive, 32MB RAM, 10MB hard disk space. Windows 95/98/NT/2000/ME/XP, mouse, sound card, web browser.

Please send me:

## CD-ROM ORDER FORM

- Electronic Projects
- Electronic Circuits & Components V2.0
- Analogue Electronics
- Digital Electronics V2.0
- Filters
- Electronics CAD Pack
- Robotics & Mechatronics
- Assembler for PICmicro
- 'C' for PICmicro
- Flowcode for PICmicro
- Digital Works 3.0

- Version required:
- Hobbyist/Student
  - Institutional
  - Institutional 10 user
  - Site licence



- PICmicro Development Board (hardware)
- Development Board UK plugtop power supply
- Development Board 25-way connecting lead

- Teach-In 2000 + FREE BOOK
- Electronic Components Photos
- Electronics in Control – Single User
- Electronics in Control – Multiple User
- Modular Circuit Design – Single User
- Modular Circuit Design – Multiple User

Note: The software on each version is the same, only the licence for use varies.

Full name: .....

Address: .....

Post code: ..... Tel. No: .....

Signature: .....

I enclose cheque/PO in £ sterling payable to WIMBORNE PUBLISHING LTD for £ .....

Please charge my Visa/Mastercard/Amex/Diners Club/Switch: £ ..... Card expiry date: .....

Card No: ..... Switch Issue No. ....

## ORDERING

**ALL PRICES INCLUDE UK POSTAGE**

Student/Single User/Standard Version price includes postage to most countries in the world  
 EU residents outside the UK add £5 for airmail postage per order

**Institutional, Multiple User and Deluxe Versions** – overseas readers add £5 to the basic price of each order for airmail postage (do not add VAT unless you live in an EU (European Union) country, then add 17½% VAT or provide your official VAT registration number).

Send your order to:  
**Direct Book Service**  
**Wimborne Publishing Ltd**  
**408 Wimborne Road East**  
**Ferndown, Dorset BH22 9ND**

To order by phone ring  
**01202 873872. Fax: 01202 874562**

Goods are normally sent within seven days

**E-mail: [orders@wimborne.co.uk](mailto:orders@wimborne.co.uk)**

**Online shop:**  
**[www.epemag.wimborne.co.uk/shopdoor.htm](http://www.epemag.wimborne.co.uk/shopdoor.htm)**



# SURFING THE INTERNET

# NET WORK

## ALAN WINSTANLEY

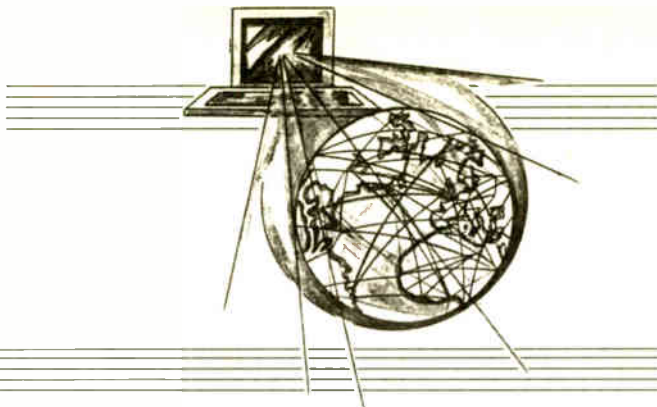

### A Fistful of Dollars

WELCOME to *Net Work*, our column written for Internet users. As regular readers will know, ever since its beta days Google ([www.google.com](http://www.google.com)) has been my preferred search engine for hunting down elusive information on the Internet. It is a "pure" search engine that runs on a whole farm of computers and it returns results almost instantaneously.

Compare this with Yahoo! ([www.yahoo.com](http://www.yahoo.com)), one of the world's most popular directories: while Google searches the Internet, Yahoo! searches its own database of web sites instead, which it has organised in a highly structured manner. The same is true of the popular Open Directory Project, the largest human-edited directory on the web at [www.dmoz.org](http://www.dmoz.org). Web sites are included in the Yahoo! directory only with the permission of Yahoo! editors, and it's an expensive affair: new business entries pay \$299 per year to have their web site listed in Yahoo! Entry into the ODP is free.

If you search Yahoo! but fail to find a result in its directory, Yahoo! will politely offer you more results gleaned from the rest of the Internet courtesy of... Google. This is typical of the way in which major search engine databases are used to feed results into other web sites such as AOL. Click the Directory tab on Google and you will see the similarity to the ODP.

### For a Few Dollars More

This month I highlight some other useful search tools that Google has to offer. Not only can Google search web pages but it can also hunt down *images*: simply click the Images tab on the Google main page then enter a search phrase. Google Images will return thumbnails of all the relevant images it finds on the web. (It is not quite clear why a microscopic close-up of a creepy crawly should appear under a listing of CMOS chip, but there you are.)

Stuck for an answer to something? Google Answers is a new beta development whereby you can actually commission a little research to help you answer a thorny problem. Presently, Google Answers is hosted at <https://answers.google.com/answers/main>. For a small fee (you decide how much) Google researchers promise to supply a paragraph or more of information that answers your question as well as links to websites that can provide more material.

The more you bid, the quicker the reply is likely to be, and the more research that is needed, the more you should offer to pay. You could even apply online to be a Google researcher yourself, though you shouldn't book an exotic holiday on the prospect of any rich rewards.

Some interesting new developments from Google are presently on show at <http://labs.google.com>. The most interesting one for *EPE* readers will be the new Google Glossary: just type in an obscure acronym or phrase and Google will seek out a definition on the web.

A test for typical electronics terms including *TTL*, *mcu*, *vlsi* and *CMOS* rapidly returned definitions together with a corresponding lists of web sites. Google Glossary is not America-centric either: it immediately defined HMCE (Her Majesty's Customs and Excise) and DVLA (the UK's Driver and Vehicle Licencing Authority) with

its usual speed. Voice-controlled searches by phone are also on the cards.

Other tools under development include Google Sets, an interesting attempt to return "sets" of terms that relate to a number of words or phrases that you enter. This can be great fun to play with.

### In the News

One of the most important search functions provided is Google News (<http://news.google.com>). This searches their entire archive of Usenet, including those it inherited from Deja News. This is a priceless information resource that all readers should become familiar with. It works extremely well and runs directly in your web browser as an online newsreader.

Still on the subject of Usenet archives, there is a fascinating archive of the last twenty years of Usenet posts at [http://www.google.com/googlegroups/archive\\_announce\\_20.html](http://www.google.com/googlegroups/archive_announce_20.html). Read about the first mention of Microsoft (May 1981), the first fax machine in February 1983, and the first mention of Tim Berners-Lee's "world wide web" project (August 1991). On the 30 March 1998 we see the first mention of Google itself, which has since evolved from the Stanford University mathematical model into today's indispensable research tool.

Lastly, if you are at all keen on using the Internet for research you

should download the extremely handy web browser toolbar from Google, which runs in Windows and needs Microsoft Internet Explorer version 5 or later.

### Tiscali 10.0

Despairing of spiralling phone bills and resigned to the fact that broadband access will not arrive in the neighbourhood any day now, I finally ditched a LineOne (now Tiscali) Surftime tariff which was paid for with the quarterly phone account. I signed up for a FRIACO account (flat rate internet access call origination – i.e. an unmetered connection) with Tiscali instead. This offers a £14.99 fixed price service with no minimum call charge and unlimited access with a two-hour cut-off.

Tiscali's heavily advertised "10.0" package – the "great new service that gives you instant access to our key products" – is just a consolidation of some ISP portal offerings of dial up access, web space, mail, text messaging and more. Bundle ten services together, add some lifestyle-type TV advertising marketing and you get a trendy new account that, in my case, took a whole afternoon to set up, and suffered from incomprehensible error messages on the web site that needed several support calls at 50p/minute to resolve. This in turn cancelled out any likely savings for the first month.

In practice, access is not always proving that reliable, especially after dark, but overall it is quite workable. Remember that whichever ISP you dial up through, you will usually be using their SMTP servers for your outgoing mail. I was quite shocked to suffer lengthy delays (several days) due to a broken mail server, which made communications very garbled at times and made it more efficient to actually write a letter.

See you next month for more *Net Work*. You can reach the author by email at [alan@epemag.co.uk](mailto:alan@epemag.co.uk).

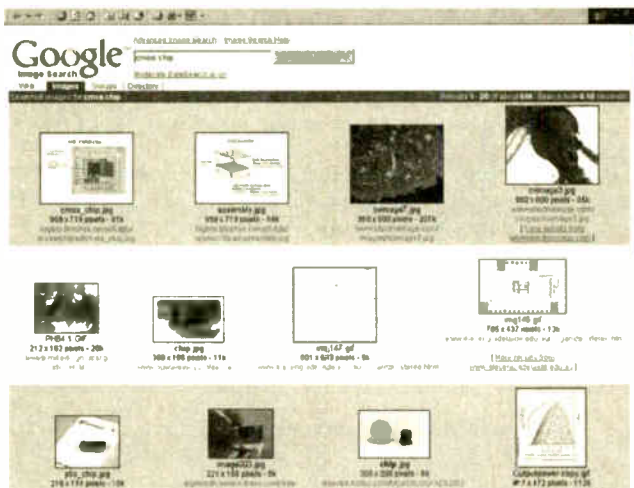

Google's Image Search will find and display a gallery of images that are published on the world wide web.

# TEACH-IN 2002

## Part Nine – Analogue-to-Digital Conversion, Sampling and Nuclear Radiation Sensing

IAN BELL AND DAVE CHESMORE

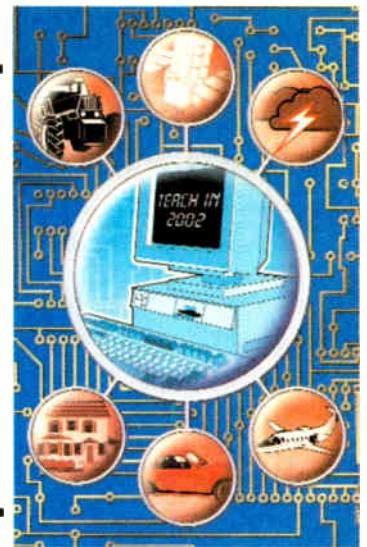

### Making Sense of the Real World: Electronics to Measure the Environment

#### GOING DIGITAL

**T**HE main aim of this series has been to look in depth at sensors and the circuitry connected directly to them. However, apart from their use in very basic measurement instruments, sensors are usually part of larger systems where their signals are interpreted or processed in some form of computer or other complex digital circuit.

For *EPE* readers, the PIC microcontroller is likely to form the heart of many sensor-based systems, but in general, a large range of microcontrollers, PCs, DSPs (digital signal processors) and custom designed integrated circuits are used to process sensor data.

We will not be covering PIC programming or PIC interfacing in this series, but this month we look at the fundamental issues involved in converting sensor data from analogue to digital (A-to-D) form. As usual we will be looking at some sensors and this month it is the turn of nuclear radiation sensing. Since it is difficult to design labs for nuclear radiation sensing, we will be looking at analogue-to-digital conversion, problems and solutions.

#### WHY GO DIGITAL?

Up to now, nearly all of our circuits have been analogue in nature, so why change to digital? There are several reasons why digital signals are better than analogue:

- Digital signals are better for transmitting down long cables since an analogue signal is degraded due to the wire's resistance and the addition of noise. So, at the end of the wire, the analogue signal's SNR (signal-to-noise ratio) is lower. A digital signal also has a lower SNR but as long as it can still be detected as a logic 1 (high voltage), it can be reconstructed – a method known as **regeneration**. This becomes important when very long cables are used, such as undersea telephone cables for example.
- Digital signals can be processed many ways in microcontrollers and specialized **digital signal processors** (DSPs) when the equivalent analogue circuits would be extremely complex. Just think how

many op.amps would be needed for a low-pass filter with a roll-off of 240dB per octave – at one op.amp per 24dB, we would need 10 op.amps plus 40 resistors and 20 capacitors! It is possible to implement such a filter in digital form using arithmetic on a DSP.

- Digital signals can be stored in memory whereas analogue signals cannot easily be stored unless on tape.
- Digital signals can be **encrypted** against interception and in theory can be made totally secure. Analogue signals can only be **scrambled**, i.e. the spectrum and/or the time domain waveform is mixed up and reconstructed when received. Scrambling is not secure since many of the signal's characteristics (e.g. speech) are preserved and it is relatively easy to unscramble.

Digital signals are not always good, though, especially if we are going to transmit them over, for example, radio because they need a much wider bandwidth than the original analogue signal. This so-called **bandwidth expansion** can be such that it is not always possible to use digital transmission. We will illustrate this later when we have introduced the concepts needed.

#### SMART AND INTELLIGENT SENSORS

Up to now, we have been looking at sensors separately from associated circuitry such as linearising and amplifying circuits. Advances in technology, particularly in integrated circuit fabrication, provide us with the ability to include most if not all signal conditioning circuitry on the same piece of silicon as the sensor. Such devices are called **integrated sensors** and we have already used some of these – TSL250 photodiode and integrated amplifier and LM35 temperature sensor are two examples.

We can go further and add a microcontroller creating a so-called **smart sensor**. This allows much more functionality including:

- data logging – storing values in memory at intervals

- digital signal processing such as filtering, calculating averages, maximum and minimum values, transforming data into meaningful units, e.g. voltage from a temperature sensor into degrees Celsius; transmitting data, e.g. RS-232 or formatting data for a printer, display, etc.

All this requires us to convert voltages, currents, etc. into a digital form, i.e. using an A-to-D converter. We can go one stage further and add "intelligence" to create **intelligent sensors**. By *intelligence* we mean artificial intelligence such as expert systems or artificial neural networks.

These allow the intelligent sensor to perform tasks that normal microcontrollers cannot. Examples include detecting and sometimes "repairing" (or ignoring) faults in sensors, performing difficult signal analysis and actually recognizing different signals. We will be discussing intelligent sensors next month.

#### ANY NUMBER YOU LIKE?

A numerical value held in a digital circuit consists of a binary number with a fixed number of digits (bits). For example, if we have eight bits we can have binary numbers ranging from 00000000 to 11111111 (0 to 255) in decimal.

We have a specific maximum and minimum value (0 and 255 in this case), and we also have a finite number of possible different values (256 in this case). This limits the step size in moving from one possible value to the next, for example, starting at two the next possible value is three.

Compare this with an analogue signal. We would also usually have a fixed maximum and minimum, possibly set by the supply voltage or the characteristics of a sensor, but the number of possible values is effectively infinite.

For example, starting at 2.0V we could step to 2.1V, 2.01V, 2.001V, 2.0001V and so on. There are practical limits, of course, due to how small a step we could either control or detect, but from the perspective of an ideal circuit the number of possible analogue values is infinite, whereas even for an ideal digital circuit it is specifically limited.

The mapping of an infinite range of analogue values onto the limited number of digital values is called **quantisation**. A circuit called an **Analogue-to-Digital Converter (ADC)** is used to obtain the digital representation of an analogue signal.

ADCs come in many types and forms; they are available as individual i.c.s but are also built into some microcontrollers. To convert a digital signal to analogue we use a **Digital-to-Analogue Converter (DAC)**. Similarly, these have a variety of forms and may be built into microcontrollers.

We stated earlier that an 8-bit binary number gives us a range of 0 to 255. Does this mean that it would only be useful for a signal of 0V to 255V? The answer is *no* because we can **scale** the range of values represented by the binary number in any way we like. A range of 0 to 255 could represent 0V to 255mV in 1mV steps, 0V to 1V in 3.91mV steps, 0 to 1.02V in 4mV steps, 10V to 25V in 0.0588V steps, -3.55V to -1V in 0.01V steps, and so on. Note that the **span** of the signal represented by the binary number does not have to start at 0V.

We can also represent both negative and positive numbers using our binary digits. The simplest way is to designate one of the bits as the sign (e.g. 0 for positive, 1 for negative) and use the remaining bits for the numerical value. For eight bits this would give a range of -127 to +127, which again could be scaled to represent any actual range of voltages or currents.

Other ways of representing negative numbers in digital circuits and computers are in use (such as two's complement), but a discussion of these is outside the scope of this series.

As this series is mainly concerned with getting data from sensors we will look at the ADC in detail, however similar concepts (such as resolution) apply to DACs.

## ADC CHARACTERISTICS

In Fig.9.1 are shown a schematic symbol of an ADC and the signals typically associated with it. There is the analogue input, the *n*-bit digital output, a reference voltage (which may be fixed for some ADCs), and a clock or "start conversion" control (which may not always be present).

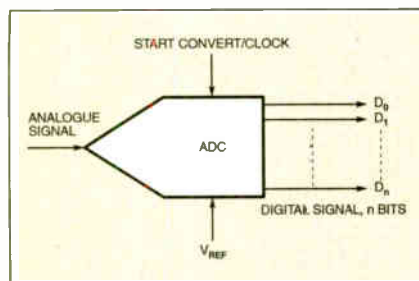

Fig.9.1. Signals associated with an ADC.

The example shows parallel digital output, but some converters output the digital data in serial form. The ADC converts the range of voltages between 0V and the reference voltage,  $V_{REF}$ , known as the **full scale range (FSR)** into a binary number 0 to  $2^n - 1$ .

Obtaining an accurate, stable (with time and temperature), and low noise voltage reference is quite difficult, but fortunately

such references are often built in to ADC chips. If not, separate voltage reference i.c.s are available for this purpose.

Output codes other than binary (e.g. Gray code) are used by some ADCs, but we will only consider binary converters. To change the scaling of input voltage to output code,  $V_{REF}$  can be changed within limits specified for the ADC.

To change the span of voltages converted, shifting the converted range away from starting at 0, or to change the scaling beyond that controllable via  $V_{REF}$ , requires external level shifting, gain or attenuation circuitry (e.g. using the shift and amplify circuits described in *Teach-In 2002* Parts 2 and 3).

The binary output has *n* bits labelled  $D_0$  through to  $D_n$ .  $D_0$  represents the units column of the binary number and is called the **Least Significant Bit (LSB)**.  $D_n$  represents the two-to-the-power-*n* column of the binary number (e.g. for eight bits this would be the  $2^7$ s or 128s column).

$D_n$  is called the **Most Significant Bit (MSB)**. The binary number output by the ADC changes by one (that is, by an LSB) for an input voltage change of  $V_{REF}/2^n$ . This voltage is also referred to as an LSB.

The dynamic range of the ADC indicates the difference between the largest and smallest output code and is given by the ratio of FSR to LSB and is equal to  $2^n$ . Expressed in decibels it is approximately  $6n$  dB. Example dynamic range figures are given in Table 9.1.

Table 9.1 – ADC resolution

Number of bits (n)	Number of Levels ( $2^n$ )	Dynamic Range/dB	Resolution/%
3	8	18	12.5
4	16	24	6.3
8	255	48	0.4
10	1024	60	0.98
12	4096	72	0.0224
16	65536	96	0.0015
20	1048576	120	0.00010

In some applications, such as sound processing (voice, music, etc.), dynamic range is particularly important. The perceived (by humans) dynamic range can be improved by using a non-linear conversion characteristic.

The **resolution** of an ADC, which determines the smallest analogue change which it can distinguish with respect to its range, is specified by the number of bits, or by the percentage of full scale that the LSB represents. Resolutions as a percentage of full scale for various numbers of bits are also given in Table 9.1.

It is instructive to compare these resolutions with the accuracy available from sensors and their associated analogue circuits. For example, there would be little point in using a 16-bit converter with a sensor and measurement circuit which had an inherent (and acceptable) accuracy of two percent.

In Fig.9.2 is shown the output of an ideal 3-bit ADC plotted against the input voltage.

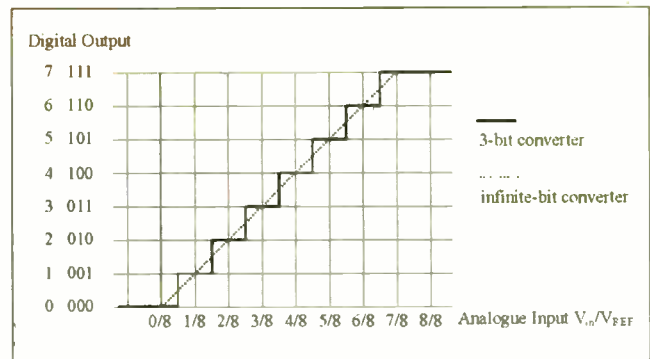

Fig.9.2. Input-Output characteristics of a 3-bit DAC.

The graph also shows the output characteristic of a converter with infinite resolution (dotted line). The difference between the actual characteristic and the infinite resolution characteristic is known as the **quantization error**, and results in **quantization noise** in the digital representation of the signal.

## SAMPLING

So far we have only considered the voltage response of the ADC, but we also need to look at the time and frequency aspects of converters. ADCs take a finite time to convert an analogue voltage to digital form, this means that there is a finite number of conversions per second – this is the **sampling frequency**.

There is a very important rule that states that we **must sample a waveform at a rate of at least twice the highest frequency in the waveform**. If we fail to do this, the sampled waveform will be a distorted and inaccurate representation of the original – in the worse cases the sampled waveform may end up completely different from the original.

The rule is known as the **Nyquist criterion** (or **sampling theorem**) and the process by which distortion occurs due to inadequate sampling is called **aliasing**. The minimum sampling frequency of twice the signal frequency is known as the **Nyquist rate**. Later we do a

Lab experiment to illustrate this.

The illustration in Fig.9.3 shows an analogue waveform and three sampled versions of the waveform at different sampling rates. Waveforms (b) to (d) are obtained using a **sample and hold circuit**, which would form part of an ADC. In an ADC it is the **stable** value from the sample and hold output that is converted to digital form.

The signals in Fig.9.3 are all analogue in nature, they are not digital codes. The flat (held) parts of waveforms (b) to (d) can still take an infinite number of possible levels. Signals like this – which are analogue in terms of levels, but which only change value at specific points in time – are called **discrete time analogue signals**, the usual analogue signal (as in Fig.9.3a) is referred to as a **continuous time analogue signal**.

There are some types of circuit that directly process discrete time analogue

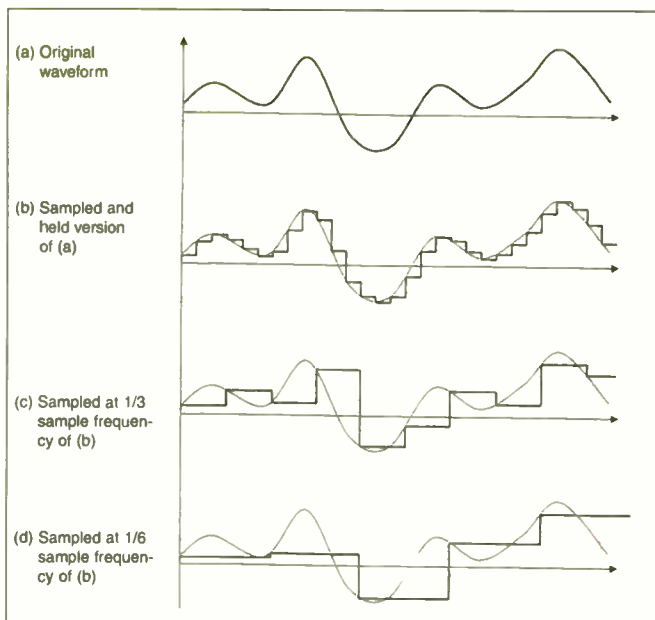

Fig.9.3. Example of the effect of sampling frequency.

signals. Perhaps the most well-known of these are **switched capacitor** circuits, which have several important uses, including filters.

Returning to the Nyquist sampling theorem, and looking at Fig.9.3, we conclude that waveform (b) is at a reasonable sampling rate – you can see that it resembles the original. Waveform (c) is either two slow or very close to the minimum sample rate. Waveform (d) is definitely too slow – the sampled waveform bears little resemblance to the original.

If we only dealt with sinewaves it would be easy to ensure that we were sampling at the Nyquist rate, but real signals are complex and have a spectrum of frequencies present in them – and we may not always be sure exactly what to expect.

In order to make sure that aliasing cannot lead to distortion of a converted waveform when using an ADC, we often need to filter the signal to remove all frequencies above half the ADC conversion rate. A low pass filter, preferably with a nice sharp cut-off and minimal pass-band distortion, is typically required (see last month for information on filters).

Although we are concentrating on ADCs it is worth noting that the analogue signal obtained directly from a DAC would look something like Fig.9.3b. In order to obtain a smooth continuous time analogue signal the DAC output is filtered using a low pass filter with a cutoff at half the sample frequency. This would restore (b) to the form shown in (a).

### NYQUIST FORMULA

The Nyquist sampling criterion is written mathematically as:

$$f_s \geq 2f_{MAX}$$

where  $f_{MAX}$  is the maximum frequency in the signal. As we mentioned earlier, this is an extremely important concept and needs more explanation. Fig.9.4 shows three identical sinewaves sampled at exactly  $2f_{MAX}$ ,  $1.5f_{MAX}$  and  $f_{MAX}$ . The sampling points are denoted by the vertical lines and the dots.

If we try to reconstruct the signal by putting the sampled signals through a low

Right: Fig.9.4. Illustration of aliasing.

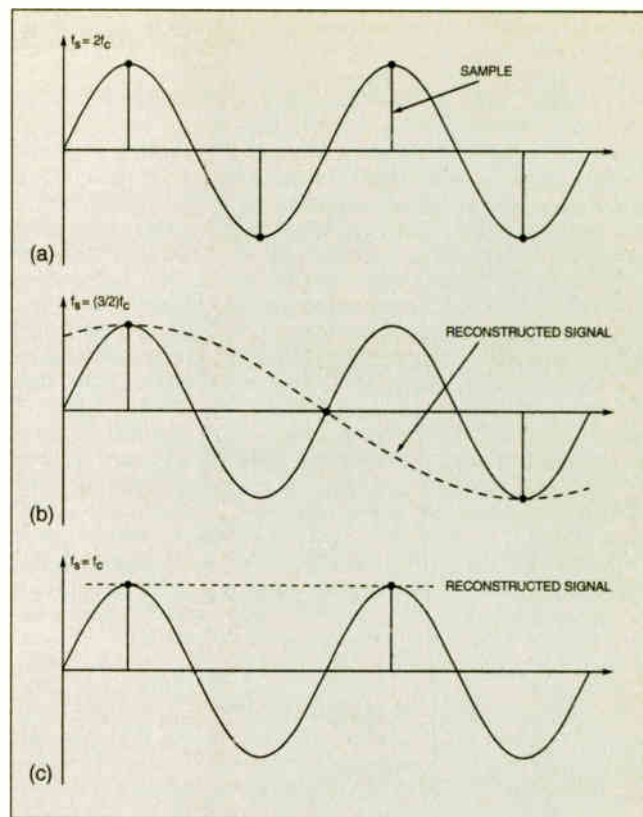

pass filter then we can see that in (a), the signal can be reconstructed successfully but in (b) we get a lower frequency. In the worst case, when  $f_s = f_{MAX}$  we get a d.c. signal!

We can look at this another way by examining what happens in the frequency domain. Fig.9.5a shows an amplitude-versus-frequency graph for a signal with energy present up to  $f_{MAX}$ . Note that we have *negative* frequencies to  $-f_{MAX}$  – don't worry about this, it is a consequence of the mathematics!

When we sample this signal, we get a graph like that in Fig.9.5b which is a repeated (to infinity) series of spectra centred at  $\pm f_s, \pm 2f_s, \pm 3f_s, \pm 4f_s$ , etc. Now, if  $f_s$  is greater than  $2f_{MAX}$  the spectra are separated, but if  $f_s$  is smaller, the spectra overlap (Fig.9.5c). This is aliasing and it means that the original signal cannot be reconstructed.

If the signal is a single frequency sine-wave then, as its frequency is increased up to  $f_s/2$ , it will be correctly sampled. Between  $f_s/2$  and  $f_s$  the signal will appear to have a frequency of  $f_s - f$  until  $f = f_s$  when the output will be d.c. If the frequency is increased further then it will appear to start again at d.c. and increase. We will be looking at this in the Lab experiments.

In practice, the sampling frequency is usually quite a bit larger than  $2f_{MAX}$  to

guarantee a good representation of the signal. Obviously, the higher the sampling rate, the better the representation (see Fig.9.3) but this has an immediate consequence – more samples per second equates to more memory storage!

So, there is a compromise between quality and memory storage. Audio CDs are a good example of this. The maximum input frequency is typically 16kHz which means that the theoretical minimum sampling frequency is 32kHz but the actual frequency is 44.1kHz. There are some very clever ways of reducing the sampling rate – **compression** (e.g. MP3) but these rely on a knowledge of the way in which sounds are produced and only work on the correct types of signal. MP3 only works for speech

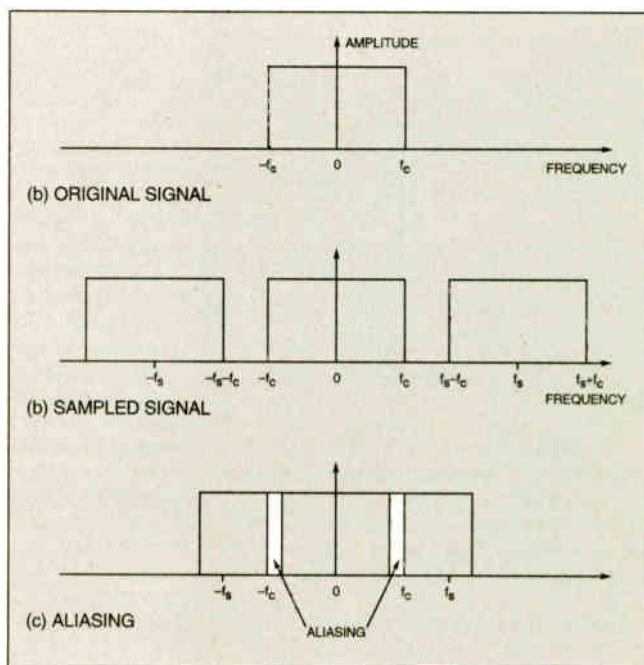

Fig.9.5. Aliasing in the frequency domain.

and music and would not work for compressing video.

## ANTI-ALIASING FILTERS

As we see from the experiments, the Picoscope ADC-40 exhibits this behaviour which means that we can get incorrect results for high frequencies. How do we stop this? We use a low pass filter called an **anti-aliasing filter** which is placed between the input signal and the ADC as shown in Fig.9.6.

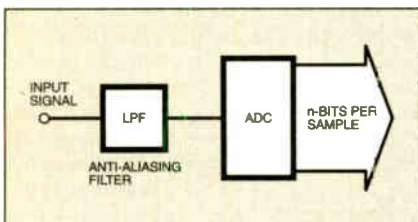

Fig.9.6. Preceding an ADC by an anti-aliasing filter.

The filter must have a sharp roll-off and have a cut-off frequency at less than  $f_s/2$ . One of the most common filters used nowadays is the switched capacitor filter, similar to that used last month. One of the Lab experiments this month uses a filter to stop aliasing on the Picoscope.

## BANDWIDTH EXPANSION

Now we have all the requisite concepts, let us return to the idea that digital signal transmission needs a much wider bandwidth than transmitting the analogue signal directly. We will use the transmission of speech as an example. Human speech has frequency components up to 10kHz but we can reduce the bandwidth to around 3.4kHz without reducing the overall intelligibility. This 3.4kHz is the bandwidth of common analogue telephones.

In order to turn the signal into a digital form, we need to sample it. According to the Nyquist sampling criterion, the minimum rate is 6.8kHz. However, a higher value of 8kHz is used since the anti-aliasing filter will not have an infinite roll-off. Once sampled the signal is then converted into digital form using an ADC. The smallest number of levels needed to give good quality is around 200 and an 8-bit ADC has 256 levels.

We now have a signal sampled 8,000 times per second and converted into 8-bit samples. This gives  $8 \times 8,000$  bits per second = 64,000 bits per second. A transmission path needs to have a bandwidth at least 64kHz to accommodate this. Compare this with the original of 3.4kHz – we need nearly 19 times the bandwidth!

## RADIATION SENSING

Our main sensing topic this month is nuclear radiation. Obviously we won't be able to carry out any experiments but we can look at the principles of nuclear radiation and how it can be measured. Before discussing sensors, we need to examine the causes of nuclear radiation.

All elements are made up of a nucleus surrounded by a cloud of negatively charged electrons. The nucleus of any atom contains positively charged protons and neutrons (no charge), with the exception of hydrogen which consists of a proton.

The chemical properties of an atom are determined by its **atomic number**, which is the number of protons in its nucleus. The **atomic mass** is the number of protons plus the number of neutrons. An **isotope** of an element has the same number of protons but a different number of neutrons. Some isotopes are stable and do not decay, but many are unstable and undergo spontaneous disintegration forming another element and releasing electromagnetic radiation (gamma rays or X-rays) or elementary particles such as beta or alpha particles:

**Alpha particle.** An alpha particle is a helium nucleus (positively charged) which is relatively heavy compared with other particles and is easily absorbed by the air or materials such as paper. The alpha particle is changed into a helium atom by capturing two electrons from other atoms, such as nitrogen and oxygen atoms in the atmosphere.

**Beta particle.** Beta decay is characterized by a nuclear reaction in which the atomic number changes but not the atomic mass. Beta particles can be negatrons (electrons) or positrons which have the mass of an electron but with a positive charge.

**Gamma ray emission.** Many alpha and beta emission processes leave the nucleus in an excited state which then returns to its non-excited state accompanied by the release of a gamma ray. Gamma rays are electromagnetic in nature.

We can write nuclear decay as an equation. For example, the decay of uranium-238 into thorium-234 is written as:

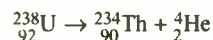

The top number is the atomic mass and the bottom the atomic number. This decay produces an *alpha particle* which, as just said, is a helium nucleus. As another example, the conversion of carbon-14 to nitrogen-14 produces a negatron and a neutrino ( $\nu$ ) and is written as:



## ENVIRONMENTAL NUCLEAR RADIATION

Nuclear radiation always makes the news because of an inherent fear of radiation-induced diseases such as leukaemia and cancers. Radiation is always present in very small quantities and it is calculated that 87 percent of the radiation to which we are exposed each year comes from natural sources such as rocks, soil, space (cosmic rays) and food (source *This Common Inheritance – Britain's Environmental Strategy*, Government White Paper, 1990). Most of the remainder is from medical uses.

Our exposure to radiation also depends on where we live – granite-bearing rocks produce radon (Rd), an inert but radioactive gas. In fact, it is estimated that 50 percent of radiation in the UK is from radon. If you are interested in radon, browse

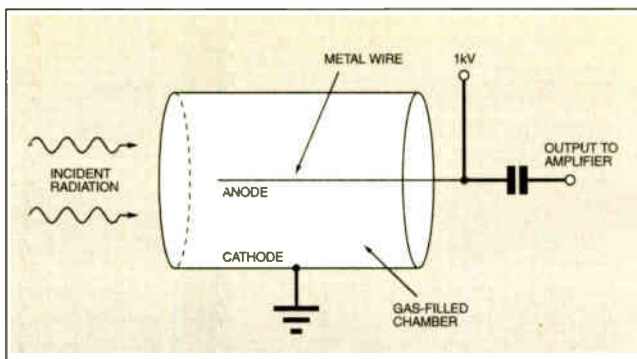

Fig.9.7. Geiger-Muller tube construction.

[www.bre.co.uk/radon/links.html](http://www.bre.co.uk/radon/links.html). This is the Building Research Establishment and the page referred to has links to bodies such as the DETR (Department of Transport and the Regions).

Astronauts receive large doses of radiation ranging from solar X-rays and solar particles to cosmic rays. Electronic equipment in space is very susceptible to radiation and only **radiation-hardened** electronics can be used.

The *Galileo* spacecraft orbiting Jupiter has encountered high levels of radiation during its tour of Jupiter's moons and as the spacecraft has become older, increasing numbers of faults have been occurring due to radiation damage. It has apparently endured more than twice its designed amount of radiation and is still operational.

The two major areas where we are likely to hear of or encounter radiation are nuclear power stations and in medicine. Nuclear power stations are widespread in the world and in some countries such as Belgium and France they produce as much as 69 percent of the country's electricity. In Britain, this is around 20 percent.

Power stations can be highly dangerous and most of us will remember Chernobyl, where caesium released by the explosion settled on grazing land in the UK and entered the human food chain, mainly via sheep.

The other worry is the disposal of waste which may remain radioactive for thousands of years. It is ironic that nuclear power would appear to be the most environmentally friendly if we think about global warming as it does not produce carbon dioxide, but the waste products are certainly not environmentally friendly!

In medicine, X-rays are well known but radioactive isotopes are used for many purposes, such as labelling, where the radioactive material is used to **label** a chemical (e.g. iodine) and its movement through the body can be traced.

## NUCLEAR RADIATION DETECTORS

Perhaps the most well known radiation detector is the Geiger-Muller (GM) tube. A schematic diagram of a typical GM tube is shown in Fig.9.7 consisting of a tube filled with argon through which passes a wire. The outside of the tube is grounded and the wire has about 1kV on it. Any radioactive particles (this includes X-rays and gamma rays) entering the tube ionize the gas, creating ions and electrons. The electrons are attracted to the wire whilst the ions are attracted to the grounded tube. The resulting drop in voltage at the wire is detected

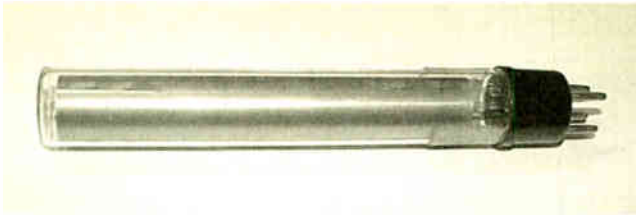

Example of a Geiger-Muller tube.

and amplified to produce a digital pulse which can be counted.

One problem with GM counters is that it takes time for the charge built up to dissipate, meaning that it exhibits a **dead time**, producing an upper limit to the number of counts per second. The dead time is of the order of 50ms to 200ms.

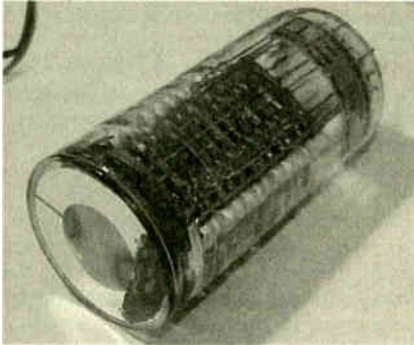

Example of a photomultiplier.

A second method is known as **scintillation** where X-rays and nuclear particles striking a special screen produce flashes of light. These flashes are extremely faint but can be amplified using a **photomultiplier** tube. One of the most common scintillation materials is sodium iodide; others include zinc sulphide, anthracene and terphenyl.

The photomultiplier is a device in which an incoming photon causes an electron to be emitted from a surface, this is accelerated towards a cathode at, say, 100V potential. When the electron hits the cathode it releases many more electrons which are then accelerated to another cathode at, say, 200V, and so on. A typical photomultiplier may have 10 cathodes.

The resulting current at the final electrode is many times more than one electron and can be detected. Fig.9.8 shows a schematic diagram of a scintillation detector.

A third method is to use semiconductors, sometimes known as **lithium-drifted silicon detectors**. Germanium is sometimes used. Fig.9.9 shows a diagram of such a device. It consists of three layers of doped silicon – a *p*-type layer facing the radiation to be sensed, an **intrinsic** zone and an

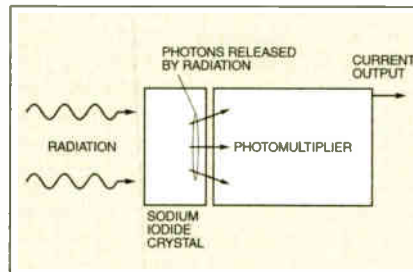

Fig.9.8. Scintillation detector.

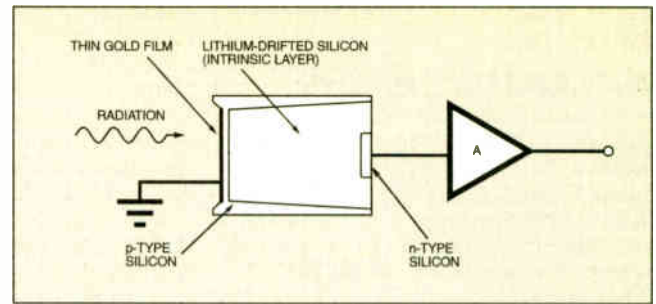

Fig.9.9. Lithium-drifted sensor.

*n*-type layer. The outer surface of the *p*-type layer is coated with a thin gold layer to act as an electrical contact. The output is taken from the *n*-type layer and amplified.

The intrinsic layer, which is *p*-type silicon, is doped with lithium in an unusual way. A lithium layer is deposited onto the *p*-type layer and the whole device heated to around 400°C, at which point the lithium diffuses into the silicon and converts the *p*-type into *n*-type silicon.

While it is still at 400°C, a d.c. potential is applied, which causes the lithium ions to drift into the *p*-type layer and replace holes. The overall effect is for the intrinsic layer to act in a similar manner to the gas in a GM tube and when a particle impinges on the sensor, a current spike is produced.

One other thing – the sensor is cooled by liquid nitrogen to –196°C to reduce electrical noise. In fact, if the sensor is allowed to reach room temperature, its performance is degraded because the lithium will diffuse rapidly in the silicon.

If you have any queries directly related to this series, you can write to the authors c/o the Editorial address, or you can email them at [teach-in@epemag.demon.co.uk](mailto:teach-in@epemag.demon.co.uk) (no file attachments or general electronic queries please).

## TEACH-IN 2002 – Lab Work 9

DAVE CHESMORE

### GAS SENSING, DIGITAL SAMPLING AND EXPERIMENTS WITH AN ADC

#### Lab 9.1 Gas Sensor Circuit

**L**AST month we discussed the principles of gas sensing. Here, we present a circuit capable of sensing butane, ethanol, hydrogen and methane. It is based on the Nemoto NAP-7AU sensor.

The sensor consists of two separate devices – the sensor itself and a compensator which has the same characteristics as the sensor but its resistance doesn't change with the presence of gases. The sensor and compensator are resistive and placed in two arms of a bridge circuit. When a gas is present, the sensor's

resistance changes and the bridge becomes unbalanced.

The complete circuit diagram of the Gas Sensor is shown in Fig.9.10. The bridge is powered from a 2.2V power supply derived from an LM317 variable voltage regulator (IC1). The output voltage is set by preset potentiometer VR1. The sensor and compensator are notated as X1 and X2 respectively. The other arms of the bridge are formed by 30Ω resistors (in our case 2 × 15Ω) and balanced by potentiometer VR2.

Since the output of the bridge is a difference voltage, we need to use a difference

amplifier, which is formed by IC2. The gain is set to 21 but can be changed if the ratio between resistors R6, R7 and R8, R9 is changed. You can also use an instrumentation amplifier instead of IC2 to give a better CMRR.

It is advisable to construct and set the 2.2V supply before attaching it to the bridge as the sensor X1 may be damaged by higher voltages. Once constructed, monitor the voltage at point A and vary VR1 until it reads 2.2V.

Build the rest of the circuit and connect the 2.2V supply. Monitor the output and

# COMPONENTS

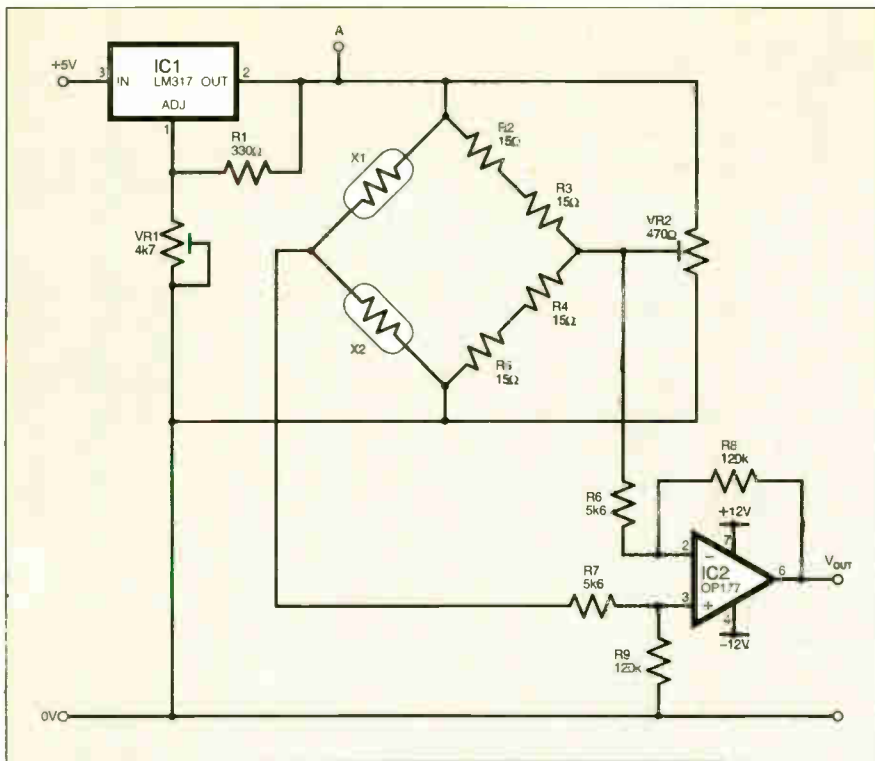
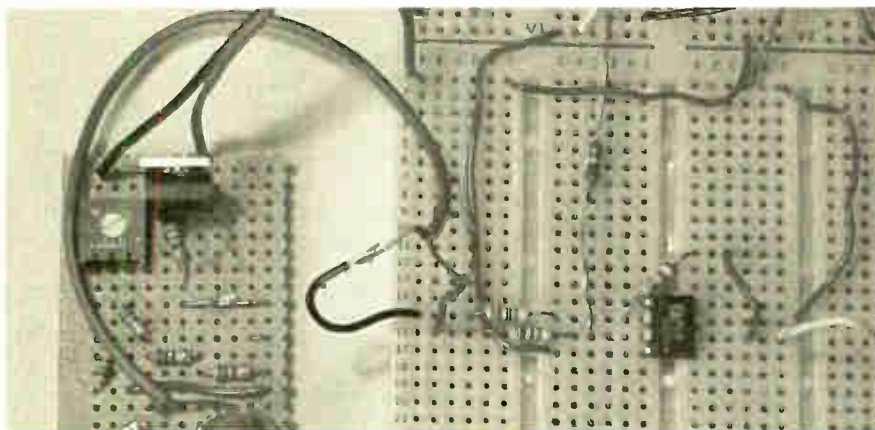

Fig.9.10. Gas Sensor: circuit diagram.



The sensor circuit in Fig.9.10 is assembled on stripboard.



The stripboard is then connected to the op.amp on the breadboard.

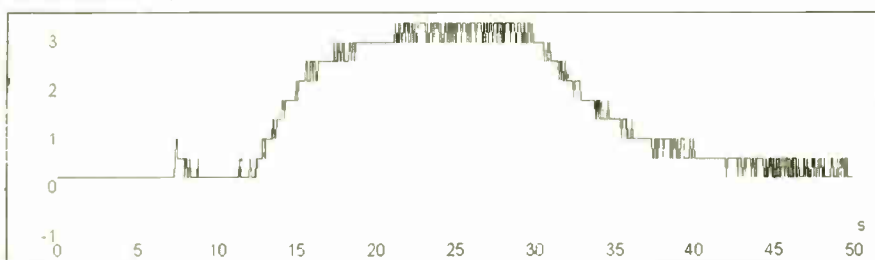

Fig.9.11. Response of Gas Sensor to alcohol.

## Lab 9.1

### Resistors

R1	330Ω
R2 to R5	15Ω (4 off)
R6, R7	5k6 (2 off)
R8, R9	120k (2 off)

All 0.25W 5% carbon film.

### Potentiometers

VR1	4k7 sub.min preset
VR2	470Ω sub.min preset

### Semiconductors

IC1	LM317 variable voltage regulator, 1.5A
IC2	OP177 op.amp
X1/X2	NAP-7AU gas sensor/compensator pair

### Miscellaneous

Stripboard section (see photo).

## Lab 9.2

### Resistors

R1	120k
R2, R3	2k2 (2 off)
R4	12k
R5 to R12	470Ω (8 off)

All 0.25W 5% carbon film.

### Potentiometer

VR1	10k rotary carbon, lin
-----	------------------------

### Capacitors

C1	10μ tantalum, 16V
C2	100n polyester
C3	150p ceramic/ polystyrene

### Semiconductors

D1 to D8	red l.e.d. (8 off) (see text)
IC1	4093 quad 2-input NAND Schmitt trigger
IC2	ADC0804 8-bit ADC

## Lab 9.5

### Resistors

R1	6k8
R2	15k
R3, R4	27k (2 off)
R5	470k

All 0.25W 5% carbon film.

### Capacitors

C1	82p ceramic/ polystyrene
C2	100p ceramic/ polystyrene
C3, C5	10n polyester (2 off)
C4	10μ tantalum, 16V

### Semiconductors

IC1	4093 quad 2-input NAND Schmitt trigger
IC2	LTC1062 5th order switched capacitor low-pass filter

N.B. Some components are repeated between Lab Works.

Approx. Cost  
Guidance Only

**£26**  
excl. hardware

vary VR2 until the output is 0V. The circuit is then ready to be tested with gases.

Testing is straightforward as long as you are careful. Ethanol (alcohol) is probably the best to use as it is readily available! Soak a piece of cotton wool in some alcohol (e.g. vodka) and place it close to the sensor. The output of the circuit should change as indicated in Fig.9.11. The output for our test circuit reached about 3.5V. The reaction time is about 10 seconds.

You can repeat the tests with other gases such as butane. Note that this circuit is not calibrated. Also note that the output will be negative if you have the sensor and compensator the wrong way round!

### Lab 9.2 A-D Converter Demonstration Circuit

It is beyond the scope of these articles to provide complete circuits for ADCs, partly because there are so many available! Here, we will show how to control a common ADC at low speed so that the binary output can be observed for different input voltages.

The complete circuit is shown in Fig.9.12 and it uses a readily available National Semiconductor ADC0804 8-bit ADC (IC2). The ADC has three control inputs, chip select (CS), write (WR) and read (RD), together with two analogue inputs,  $V_{in(+)}$  and  $V_{in(-)}$ . The final input is for a reference voltage and is denoted as  $V_{ref/2}$ .

The binary output goes from 00000000 at  $V_{in(-)}$  to 11111111 at  $V_{ref}$ . For example, if  $V_{in(-)}$  is 0V and the voltage at  $V_{ref/2}$  is 2.0V then the 00000000 is equivalent to 0.0V and 11111111 equivalent to 4.0V.

In our demonstration circuit, the reference voltage is set at half the supply by potential divider R2 and R3; this makes 11111111 equal to 5V. Chip select (CS) is set low to permanently enable the device and Read (RD) set low to enable the outputs (D0 to D7). Control of the ADC is via the Write input (WR) which is active low and is derived from a low frequency squarewave oscillator (IC1) operating at about 200Hz.

The internal operation of the ADC is controlled by an internal high speed oscillator operating at a frequency set by resistor R4 and capacitor C3. This means that each conversion takes place over about 100ms but at 200 samples per second.

The input voltage to be converted to digital output is provided by VR1 and the binary output is displayed on l.e.d.s D1 to D8, which are buffered by resistors R5 to R12. (An l.e.d. array was used in the test model, but individual l.e.d.s. can be used instead.)

Construct the circuit in Fig.9.12 and vary potentiometer VR1. You should see the l.e.d.s changing in a binary manner. The accompanying photograph shows a binary value of 01011111 which is equal to 95 in decimal (least significant bit is at the top of the array).

Using the signal generator from Part 8, you could input a low frequency sinewave and watch the binary values changing. You can also vary the value of  $V_{ref/2}$  and show that the range can be changed.

A full datasheet for the ADC0804 can be found at the National Semiconductor web site ([www.natsemi.com](http://www.natsemi.com)).

### Lab 9.3 Illustration of Aliasing – Time Domain

We can illustrate aliasing very easily using the Picoscope and the sinewave

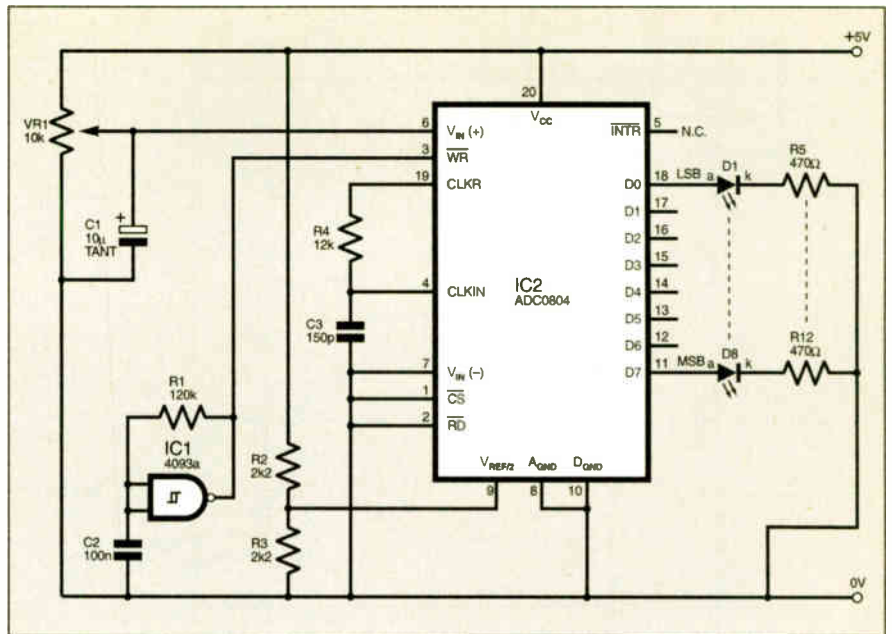
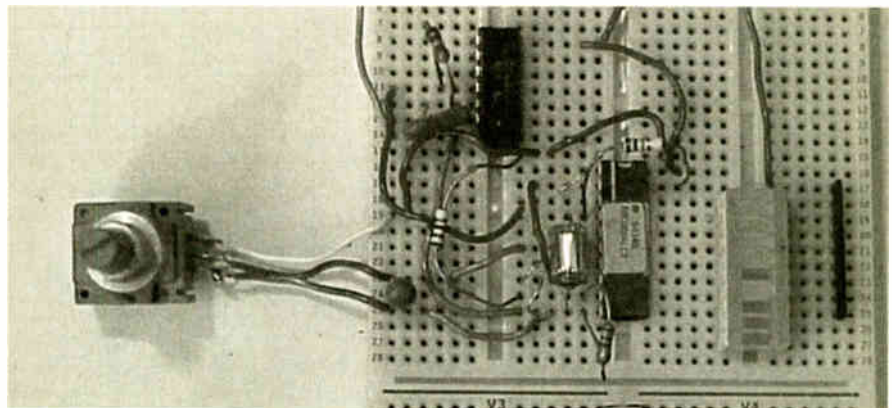

Fig.9.12. A-to-D converter demonstration circuit.



Breadboard assembly for the circuit in Fig.9.12.

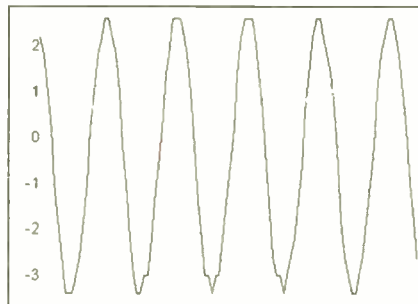

Fig.9.13. Picoscope display of a sinewave at 1kHz.

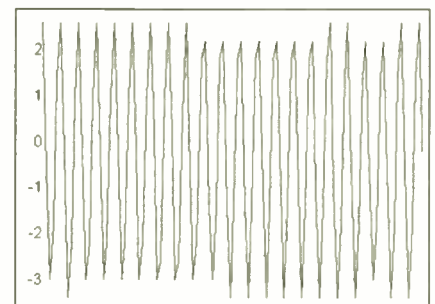

Fig.9.14. Picoscope display at 4kHz, beginning to show a small amount of aliasing.

generator from Part 8 (Fig.8.11). Connect the generator to the Picoscope input and set the frequency to about 1kHz. The Picoscope display should be similar to that in Fig.9.13, showing that the signal is almost correctly displayed.

Now increase the signal to 4kHz; again the almost correct waveform should be displayed, but with a small amount of aliasing just beginning to appear (Fig.9.14). Increase the input frequency further until it is about 10kHz – you

should see something like that in Fig.9.15. It does not look much like a pure 10kHz sinewave! It is the sampling rate fixed inside the Picoscope software that causes this.

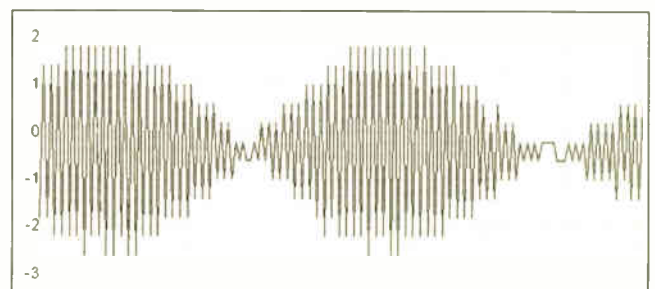

Fig.9.15. Picoscope display at 10kHz, dramatically showing how aliasing has disrupted the signal quality.



### Lab 9.4 Illustration of Aliasing - Frequency Domain

Aliasing can also be seen by using the Picoscope Spectrum Analyser. See Panel 9.1 for details of how to operate the analyser. Select the Spectrum Analyser, set the sampling rate to 10kHz and FFT size to 1024. Input a 1kHz sinewave and observe the display - you should see a peak in the spectrum at about 1kHz.

Increase the frequency to 4kHz; the peak in the display should correspond (Fig.9.16). Now increase it to 5kHz and then 6kHz. The peak will go from the far right hand side of the display (5kHz) and move to the left, reading 4kHz as shown in Fig.9.17!

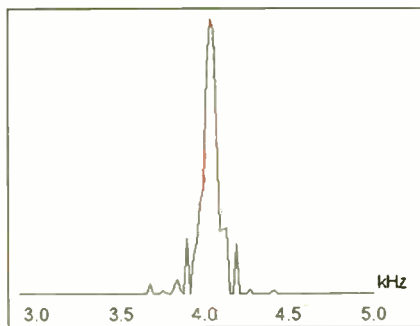

Fig.9.16. Spectrum analysing a 4kHz sinewave at 10kHz.

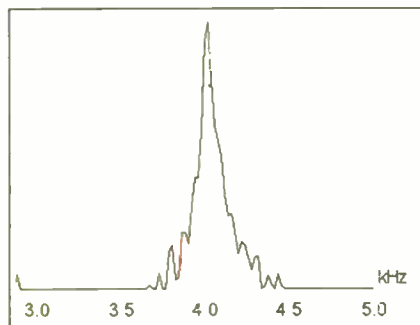

Fig.9.17. When spectrum analysing a 6kHz sinewave at 10kHz, aliasing causes the waveform to be shown as representing a 4kHz signal.

Carry on increasing the frequency and see what happens. When the frequency is 10kHz, the peak should read 0Hz (Fig.9.18). Further increasing the input frequency continues to increase the displayed spectrum, which goes up again.

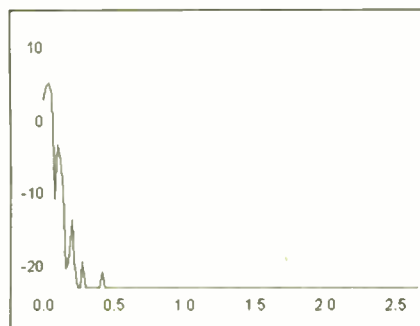

Fig.9.18. When spectrum analysing a 10kHz sinewave at 10kHz, the display indicates that the signal is occurring at around 0Hz!

## PANEL 9.1. Picoscope Spectrum Analyzer

The Picoscope Spectrum Analyzer can be started from within the oscilloscope display either by clicking the button on the panel (second button from the left) or via the View drop-down menu - select *new spectrum*. The spectrum is shown with frequency on the x-axis and signal power in dB on the y-axis. The default set-up is for a maximum frequency of 10kHz and an FFT (Fast Fourier Transform) size of 256 points.

The number of points in the FFT determines the frequency resolution of the display - the higher the number of points (always a power of 2) the better the resolution, *but* the slower the update of the display because it takes longer to calculate the spectrum.

The Spectrum Analyzer operates on *blocks* of data and calculates the FFT for each block. One problem with this is that the division of the signal into blocks introduces distortion in the form of side-lobes in the spectrum because the end of a block is abrupt, giving rise to additional false frequency components.

This is overcome by multiplying the data by a *window* which reduces the data at the beginning and end of the block progressively to zero to remove the abrupt ends. There are many windows available which can be selected via the *settings*:

*options menu* (F5). The default set-up is *Blackman*, which is best for reducing sidelobes.

FFT size can be changed to between 128 and 4096 using the same menu option. In addition, you can change the display from dB to volts and display current spectrum, average spectrum or capture the spectrum peaks.

Finally, the sampling frequency can be changed on the main display from a maximum of 10kHz to 100Hz. The default is 10kHz. The timebase option (*settings: timebase*, F2) also allows you to change the frequency.

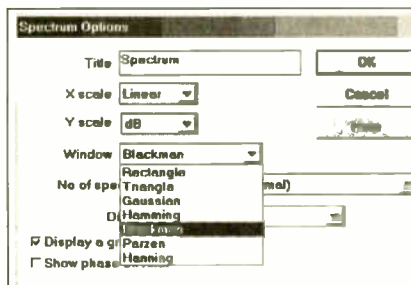

This behaviour can be explained by Nyquist: the sampling frequency is 10kHz and the maximum input frequency is therefore 5kHz. For an input frequency  $f$ , below  $f_s/2$  the output is  $f$ ; between  $f_s/2$  and  $f_s$ , the output is  $f_s - f$ .

### Lab 9.5 Anti-aliasing Filter

Build the circuit of Fig.9.19, which is nearly identical to Fig.8.16 in last month's Lab Work. The filter has a cut-off frequency of 4kHz, determined by the oscillator formed around IC1a, which has an output at approximately 400kHz.

Placing this filter between the input signal and the Picoscope should stop all

aliasing problems. Try repeating Labs 9.3 and 9.4 with the filter in place.

Note that the filter has a cut-off frequency of 4kHz and not 5kHz; this is because the filter is not perfect and some energy is passed above the cut-off frequency which would be aliased if it were set to half of the sampling frequency. Also note that the cut-off frequency should be changed if the sampling frequency is changed.

### NEXT MONTH

In Part 10 next month we conclude the *Teach-In 2002* series by discussing smart and intelligent sensors, telemetry systems and sensor networks.

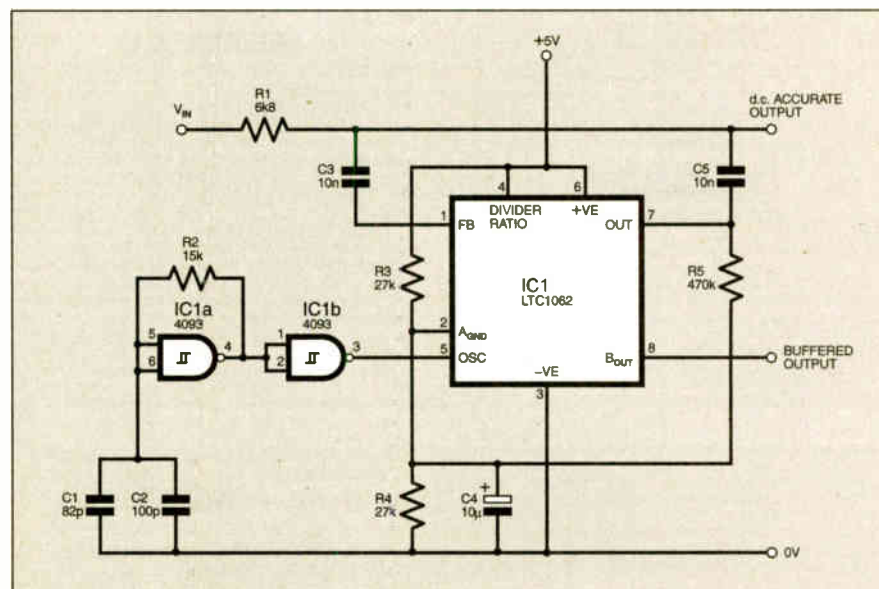

Fig.9.19. Anti-aliasing filter, having a cut-off frequency of 4kHz.









**WHETHER ELECTRONICS IS YOUR HOBBY  
OR YOUR LIVELIHOOD . . .  
YOU NEED THE MODERN ELECTRONICS MANUAL  
and the ELECTRONICS SERVICE MANUAL**

## **THE MODERN ELECTRONICS MANUAL (CD-ROM VERSION ONLY)**

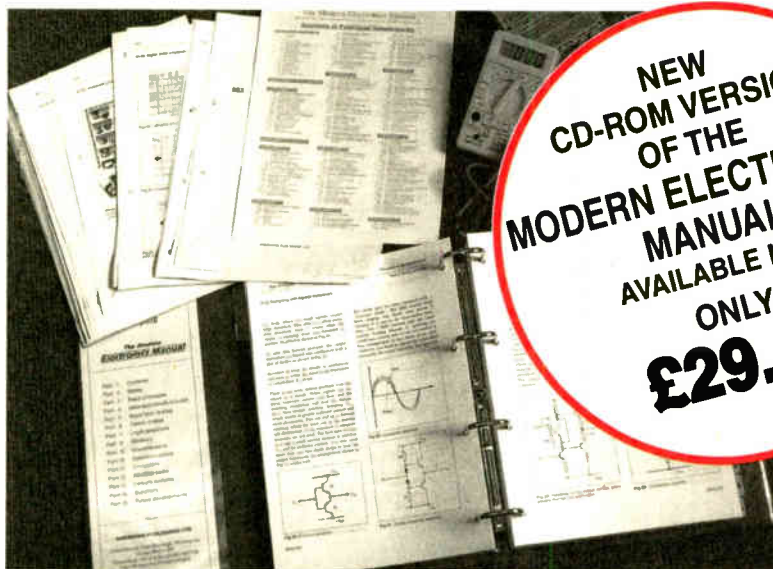

**NEW  
CD-ROM VERSION  
OF THE  
MODERN ELECTRONICS  
MANUAL  
AVAILABLE NOW  
ONLY  
£29.95**

*The essential reference  
work for everyone  
studying electronics*

- Over 800 pages
- In-depth theory
- Projects to build
- Detailed assembly instructions
- Full components checklists
- Extensive data tables
- Manufacturers' web links
- Easy-to-use Adobe Acrobat format
- Clear and simple layout
- Comprehensive subject range
- Professionally written
- Regular Supplements

## **EVERYTHING YOU NEED TO GET STARTED AND GO FURTHER IN ELECTRONICS!**

The revised CD-ROM edition of the Modern Electronics Base Manual (MEM) contains practical, easy-to-follow information on the following subjects:

**BASIC PRINCIPLES:** Electronic Components and their Characteristics (16 sections from Resistors and Potentiometers to Crystals, Crystal Modules and Resonators); Circuits Using Passive Components (10 sections); Power Supplies; The Amateur Electronics Workshop; The Uses of Semiconductors; Digital Electronics (6 sections); Operational Amplifiers; Introduction to Physics, including practical experiments; Semiconductors (5 sections) and Digital Instruments (3 sections).

**CIRCUITS TO BUILD:** There's nothing to beat the satisfaction of creating your own projects. From basic principles, like soldering and making printed circuit boards, to the tools needed for circuit-building, the Modern Electronics Manual and its Supplements describe clearly, with appropriate diagrams, how to assemble a radio, loudspeaker circuits, amplifiers, car projects,

a computer interface, measuring instruments, workshop equipment, security systems, medical and musical circuits, etc. The Base Manual describes 12 projects including a Theremin and a Simple TENS Unit.

**ESSENTIAL DATA:** Extensive tables on diodes, transistors, thyristors and triacs, digital and linear i.c.s.

**EXTENSIVE GLOSSARY:** Should you come across a technical word, phrase or abbreviation you're not familiar with, simply look up the glossary included in the Manual and you'll find a comprehensive definition in plain English.

The Manual also covers **Safety** and provides web links to component and equipment **Manufacturers and Suppliers**. The most comprehensive reference work ever produced at a price you can afford, the CD-ROM edition of **THE MODERN ELECTRONICS MANUAL** provides you with all the **essential** information you need.

## **THE MODERN ELECTRONICS MANUAL (MEM - CD-ROM version only)**

**Revised CD-ROM Edition of Basic Work:** Contains over 800 pages of information in Adobe Acrobat format. Edited by John Becker.

**Regular Supplements:** Additional CD-ROMs each containing approximately 500 pages of additional information on specific areas of electronics will be available for £19.95 each. Information on the availability and content of each Supplement CD-ROM will be sent to you as they become available.

**Presentation:** CD-ROM suitable for any modern PC. Requires Adobe Acrobat Reader which is included on the MEM CD-ROM.

**Price of the Basic Work: £29.95 POST FREE.**

## **ORDER BOTH MANUALS TOGETHER AND SAVE £10**

*A mass of well-organised and clearly explained information is brought to you by expert editorial teams whose combined experience ensures the widest coverage  
Regular Supplements to these unique publications, keep you abreast of the latest technology and techniques if required*

# ELECTRONICS SERVICE MANUAL

(PRINTED VERSION ONLY)

## EVERYTHING YOU NEED TO KNOW TO GET STARTED IN REPAIRING AND SERVICING ELECTRONIC EQUIPMENT

**SAFETY:** Be knowledgeable about Safety Regulations, Electrical Safety and First Aid.

**UNDERPINNING KNOWLEDGE:** Specific sections enable you to Understand Electrical and Electronic Principles, Active and Passive Components, Circuit Diagrams, Circuit Measurements, Radio, Computers, Valves and Manufacturers' Data, etc.

**PRACTICAL SKILLS:** Learn how to identify Electronic Components, Avoid Static Hazards, Carry Out Soldering and Wiring, Remove and Replace Components.

**TEST EQUIPMENT:** How to Choose and Use Test Equipment, Assemble a Toolkit, Set Up a Workshop, and Get the Most from Your Multimeter and Oscilloscope, etc.

**SERVICING TECHNIQUES:** The regular Supplements include vital guidelines on how to Service Audio Amplifiers, Radio Receivers, TV Receivers, Cassette Recorders, Video Recorders, Personal Computers, etc.

**TECHNICAL NOTES:** Commencing with the IBM PC, this section and the regular Supplements deal with a very wide range of specific types of equipment – radios, TVs, cassette recorders, amplifiers, video recorders etc..

**REFERENCE DATA:** Detailing vital parameters for Diodes, Small-Signal Transistors, Power Transistors, Thyristors, Triacs and Field Effect Transistors. Supplements include Operational Amplifiers, Logic Circuits, Optoelectronic Devices, etc.

## The essential work for servicing and repairing electronic equipment

- Around 900 pages
- Fundamental principles
- Troubleshooting techniques
- Servicing techniques
- Choosing and using test equipment
- Reference data
- Easy-to-use format
- Clear and simple layout
- Vital safety precautions
- Professionally written
- Regular Supplements
- Sturdy gold blocked ring-binder

## ELECTRONICS SERVICE MANUAL (ESM - Printed version only)

**Basic Work:** Contains around 900 pages of information. Edited by Mike Tooley BA  
**Regular Supplements:** Unlike a book or encyclopedia, this Manual is a living work – continuously extended with new material. If requested, Supplements are sent to you on approval approximately every three months. Each Supplement contains around 160 pages – all for only £23.50+£2.50 p&p. You can, of course, return any Supplement (within ten days) which you feel is superfluous to your needs. You can also purchase a range of past Supplements to extend your Base Manual on subjects of particular interest to you.

**Presentation:** Durable looseleaf system in large A4 format

**Price of the Basic Work: £29.95**  
(to include a recent Supplement FREE).



### Guarantee

Our 30 day money back guarantee gives you complete peace of mind. If you are not entirely happy with the *Electronics Service Manual*, for whatever reason, simply return it to us in good condition within 30 days and we will make a full refund of your payment – no small print and no questions asked. All we ask is that you pay the return postage. (Overseas buyers also have to pay our overseas postage charge). Sorry, but we can only make exchanges on the *Modern Electronics Manual* (CD-ROM version) if the CD-ROM is faulty, we cannot offer a money back guarantee on this product as the content can be printed out.

Wimborne Publishing Ltd., Dept Y7, 408 Wimborne Road East, Ferndown, Dorset BH22 9ND. Tel: 01202 873872. Fax: 01202 874562.  
 Online shop: [www.epemag.wimborne.co.uk/shopdoor.htm](http://www.epemag.wimborne.co.uk/shopdoor.htm)

**PLEASE** send me



- THE MODERN ELECTRONICS MANUAL (CD-ROM version only)
- ELECTRONICS SERVICE MANUAL plus a FREE SUPPLEMENT (Printed version only)
- I enclose payment of £29.95 (for one Manual) or £49.90 for both Manuals (saving £10 by ordering both together) plus postage if applicable.
- I also require the appropriate ESM Supplements four times a year. These are billed separately and can be discontinued at any time. (Please delete if not required.)

FULL NAME .....  
(PLEASE PRINT)

ADDRESS .....

.....POSTCODE .....

SIGNATURE .....

- I enclose cheque/PO in UK pounds payable to Wimborne Publishing Ltd.
- Please charge my Visa/Mastercard/Amex/Diners Club/Switch Switch Issue No.....

Card No. .... Card Exp. Date .....

### ORDER FORM

Simply complete and return the order form with your payment to the following address:

Wimborne Publishing Ltd, Dept. Y7, 408 Wimborne Road East, Ferndown, Dorset BH22 9ND

We offer a 30 day MONEY BACK GUARANTEE on ESM – see the panel above for details.

### POSTAGE CHARGES FOR ESM

MEM CD-ROM POST FREE TO ALL COUNTRIES  
(Note we use the VAT portion of the MEM CD-ROM payment to pay for overseas postage)

Postal Region	Price PER ESM PRINTED MANUAL	
	Surface	Air
Mainland UK	FREE	–
Scottish Highlands, UK Islands & Eire	£7 each	–
Europe (EU)	–	£23 each
Europe (Non-EU)	£23 each	£30 each
USA & Canada	£28 each	£39 each
Far East & Australasia	£35 each	£43 each
Rest of World	£28 each	£52 each

Please allow four working days for UK delivery.  
 NOTE: Surface mail can take over 10 weeks to some parts of the world. Each ESM weighs about 4kg when packed.

mem-cd









# PIC BASIC COMPILERS

Crownhill Associates  
smart electronic solutions

## PIC Basic Plus & PIC Basic Pro Compilers

**P**IC BASIC Plus, supports the popular 14 bit Microchip PIC-Microcontrollers, allowing the user to write professional programs in BASIC. The compilers produce fast, tight machine code to load directly into the PIC-Microcontroller. The Compiler produces code that is guaranteed 100% compatible with Microchips MPASM assembler. The compiler allows direct comparison between the BASIC program and the assembly listing. Two compilers are available, the PIC Basic Pro, entry level compiler and PIC BASIC Plus, professional compiler. Both produce fast assembly code from BASIC. The Compilers run under Windows 95,98,NT,ME and XP and are supplied with a comprehensive, Windows based editor with Syntax highlighting and just two key clicks to compile and program and detailed manuals with worked examples. The Compilers support a range of programmers including the Microchip PICStart-plus and our own development programmers. For a free demo of the Pro compiler visit our web site [www.letbasic.com](http://www.letbasic.com), or join our web based forum to hear what other users think of our compilers and supporting products... (PIC BASIC Pro is supplied with the book "Experimenting with the LET Basic Pro compiler" by Les Johnson, an invaluable guide for the beginner. See the web site for an example chapter).

Technical support is provided online via our web based forum, [www.picbasic.org](http://www.picbasic.org), or to tutors via telephone direct from the Author. Additional support can be provided to tutors using our development system for educational purposes.



### Development system



### Prototype PCB system



Supplied with source code and documentation for 20 Educational projects. Supports LCD displays from 2x16 Chrs to 128x64 dot matrix Graphics panel

### Programmers



All supporting components stocked at competitive prices  
e.g PIC 16F84 04 /P - £1.80 each, PIC 16F877 04 /P £3.95 each  
LCD 2x16 Chrs, £7.50 each LCD 128x64 dot matrix £15.95 each  
Many more items stocked, email [sales@crowhill.co.uk](mailto:sales@crowhill.co.uk) for prices

WorldRadioHistory

£49.95 - PRO  
£99.95 - PLUS

Visit our web sites: [www.picbasic.org](http://www.picbasic.org)

[www.letbasic.com](http://www.letbasic.com)

32, Broad Street, Ely  
Cambridge, CB7 4AH

Tel: +44 (0) 1353 666709  
Fax: +44 (0) 1353 666710  
[sales@crowhill.co.uk](mailto:sales@crowhill.co.uk)

All prices exclude:  
VAT, postage and packing

