

OCTOBER

The PRACTICAL ELECTRICAL ENGINEER

A MONTHLY MAGAZINE FOR PRACTICAL MEN

VOL. I—No. 2

OCTOBER, 1932

**SPECIAL
ARTICLE**

BY

**SIR RICHARD
GLAZEBROOK, F.R.S.**

ALSO

**CAR ELECTRICAL
CIRCUITS**

TRAFFIC SIGNALS

**FAULT LOCATION ON
2 CORE FEEDER
ETC., ETC.**

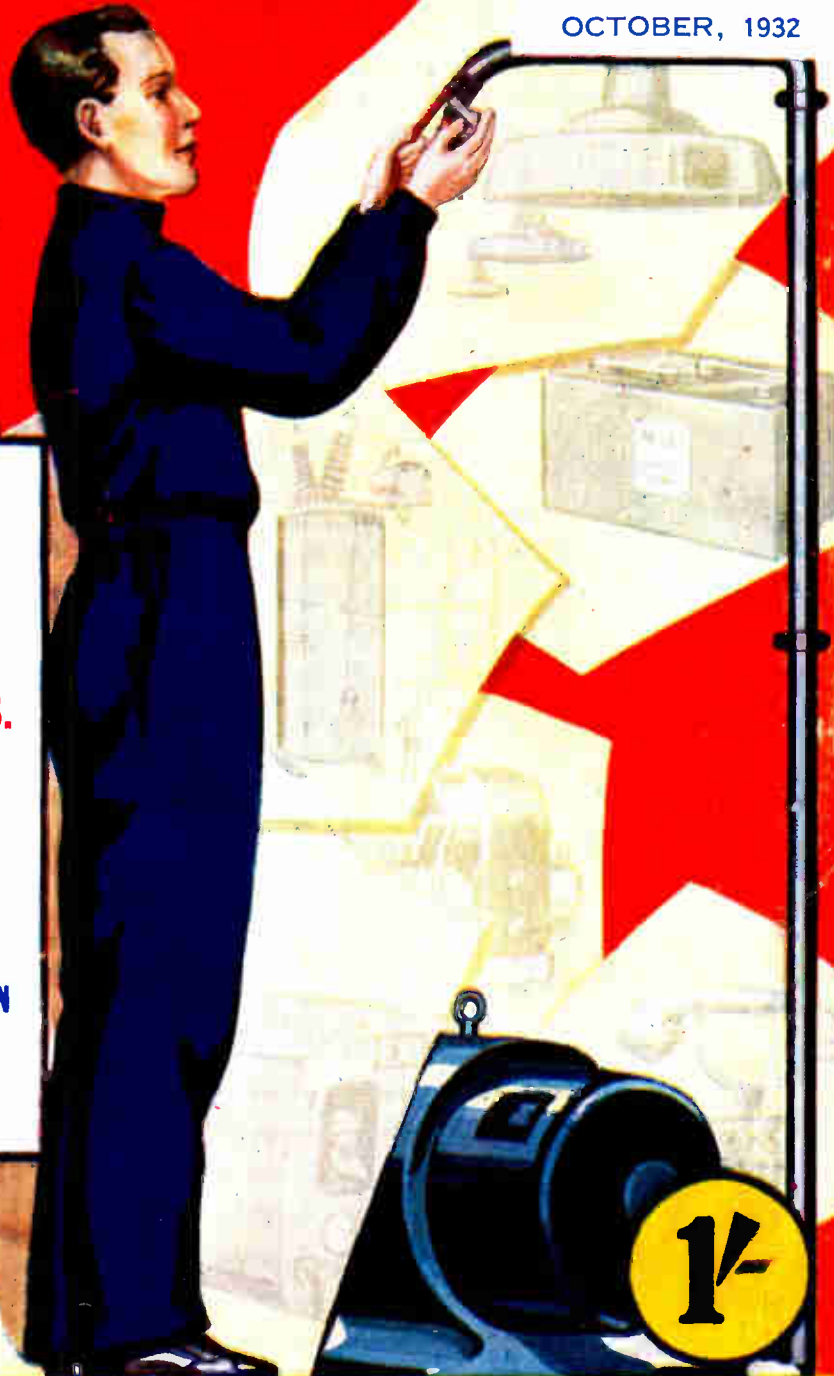

1½

GEORGE NEWNES LIMITED

STUDY
AT
HOME

YOU CAN HAVE A COLLEGE
TRAINING IN ALMOST ANY
CAREER FOR A FEW
SHILLINGS MONTHLY

IN
YOUR
SPARE
TIME

LET ME BE YOUR FATHER

Unless you are in touch with all branches of industry, you cannot see the possibilities of employment, but with our gigantic organisation we are in touch with every sphere of activity and we know that in many trades and professions there are more vacancies than there are trained men to fill them.



WE DO NOT PROFESS TO ACT AS AN EMPLOYMENT AGENCY, BUT WE CERTAINLY ARE IN A POSITION TO GIVE FATHERLY ADVICE ON ALL CAREERS AND THE POSSIBILITY OF EMPLOYMENT THEREIN.

WE teach by post all branches of the following vocations and specialise in all examinations connected therewith. Our advice is always Free.

J.B. Bennett

THE MOST SUCCESSFUL AND MOST PROGRESSIVE CORRESPONDENCE COLLEGE IN THE WORLD

Aviation Engineering.
Boiler Engineering.
Boiler Making.
B.Sc. (Engineering).
Civil Engineering :
A.M.I.C.E.
Quantities—Specifications.

Commercial Art.
Concrete and Steel.
Draughtsmanship :
Electrical or
Mechanical.
Electrical Engineering :
A.M.I.E.E.
City and Guilds.
Engineering Mathematics.
Foundry Work.

Heat Engines.
Heating, Ventilating and
Lighting.
Internal Combustion Engines
Machine Designs :
Theory of Machines.
Mechanical Engineering :
A.M.Inst.B.E.
A.M.I.Mech.E.
City and Guilds.
Pattern Making.
Mechanics.
Metallurgy of Steel.

Mine Electrician :
A.M.E.E.
Mining (all examinations).
Motor Engineering
A.M.I.A.E.
Municipal and County
Engineers :
M. and C.E.
Naval Architecture.
Pumps and Pumping
Machinery.
Radio Reception.
Ship Building.
Structural Engineering.
Telegraphy and
Telephony.

IF YOU DO NOT SEE YOUR OWN REQUIREMENTS ABOVE, WRITE TO US ON ANY SUBJECT.

WE TEACH BY
POST IN ALL PARTS
OF THE WORLD

DO NOT DELAY
THERE MAY BE CHANCES FOR YOU
TO-DAY FOR WHICH YOU MAY BE
TOO LATE TO-MORROW. EVERY
DAY COUNTS IN A MAN'S CAREER

IT COSTS
NOTHING TO
ENQUIRE

Also ask for Our New Book
(FREE OF CHARGE)

THE HUMAN MACHINE

SECRETS OF
SUCCESS

Note Address Carefully

The BENNETT COLLEGE, Ltd., Dept. 190, Sheffield



The PRACTICAL ELECTRICAL ENGINEER

A MONTHLY SURVEY OF MODERN PRACTICE IN ELECTRICAL ENGINEERING

VOL. I

OCTOBER, 1932

No. 2

Published by GEORGE NEWNES, Ltd.,
8-11, Southampton Street, Strand, London, W.C. 2.

Telephone—Temple Bar 7760
Telegrams—"Newnes, London"

Price - 1/- Monthly
Yearly Subscription, 14/- Post Free
6 months' Subscription, 7/- Post Free
Registered for Transmission by Canadian Magazine Post
Canadian Rate: Yearly Subscription, 13/6 Post Free
6 months' Subscription 6/9

OUR first number has been given a very good reception by electrical engineers. Amongst the many congratulatory letters received, were several asking for advice on technical matters and others making valuable suggestions for articles to appear in subsequent issues.

Here are a few items which have been suggested: Fault Location on Underground Cables, Rotary Converters with reference to switching for straight and inverted runnings, Control of Motor Converters, Transformer Protection, Pole-mounted Substations, Modern Methods of House and Factory Wiring, Safety Regulations, Electric Welding.

These letters are especially valuable as they provide the very best possible guide as to the kind of information which is likely to be most useful to readers.

Value for Money The object of this magazine so far as the editorial side is concerned can be stated in a very few words. It is to give the electrical engineer the best possible value in technical information. We

want every reader to feel that the contents have been planned to suit the reader and that in buying the magazine he is getting real value for money.

We welcome advertising from reputable firms in the industry, but we believe that their interests can best be served by including in the editorial pages only that information and those articles which are likely to be of real value to the reader without whose support the magazine would not exist.

We shall be very pleased to include useful practical information relating to any new product, but the usual descriptive "write-up" from the maker's catalogue will not find a place in the editorial pages.

A Noteworthy Article We are publishing in this issue an important article by Sir Richard Tetley Glazebrook, M.I.E.E., F.R.S., one of the few remaining old students of the illustrious Clerk Maxwell.

In this article Sir Richard explains Clerk Maxwell's fundamental ideas concerning electro magnetic theory and shows how these are reconciled with the most modern discoveries regarding the nature of electricity.

We are sure that every reader will appreciate the value of this article which has been specially written for the magazine by one of the foremost physicists of the day. We hope from time to time to include further articles by some of the most eminent men in the profession.

Technical Advice Service

As already mentioned we have received a number of letters from readers asking for technical advice on some particular matter which has cropped up in their everyday work. We have decided to offer to registered readers a Free Technical Advice Service. Every reader who wishes to avail himself of this should to detach the coupon herewith, fill up and forward it to the address given.

So long as he remains a reader of the magazine he will be entitled to receive, free of charge, advice or information connected with electrical engineering.

All queries submitted by registered readers will be answered by an expert technician. If your query relates to telephony you will receive the advice of an expert telephone engineer. If it relates to extra-high-tension transmission it will be dealt with by a transmission engineer and so on. If you wish the enquiry to be treated as confidential this will be done.

Enquiries should relate to problems encountered in actual practice, and should be kept as concise as possible.

A STUDY IN ILLUMINATION

The two photographs below afford striking proof of the value of scientifically applied knowledge, as compared with rule-of-thumb methods



A STREET IN BROMLEY—OBSOLETE LIGHTING.

Compare this with the second picture, which shows the same street after Mr. W. G. Trend, the Borough Electrical Engineer, in collaboration with the General Electric Co., had set to work to devise the highest possible lighting efficiency at all points.



THE SAME STREET—UP-TO-DATE LIGHTING.

This installation consists of totally enclosed Wembley lanterns with asymmetric prismatic glass refractors and 500-watt lamps. The supporting cables are of copper-weld wire, i.e., steel-cored with copper covering.

CLERK MAXWELL'S ELECTRO-MAGNETIC THEORY

IN THE LIGHT OF PRESENT-DAY KNOWLEDGE

By SIR RICHARD TETLEY GLAZEBROOK, F.R.S.

In recent times there has been much discussion as to the bases on which to build any account of electro-magnetic action. We have been fortunate in securing from one of the last survivors of Maxwell's pupils this interesting statement of what he understands to be involved in Maxwell's views.

TO the practical electrical engineer, magnetic force and the magnetic field are generally regarded as important effects which follow the passage of an electric current through a coil of insulated wire, effects which are markedly modified and usually greatly magnified by the presence of iron in the neighbourhood of the coil.

Iron filings sprinkled on a sheet of cardboard or paper arrange themselves in definite curves; the needle of a compass is deflected; variations of the current in the coil produce, while they are in progress, currents in neighbouring coils, while a second coil, suspended near the first in a manner free to move, when carrying a current tends to set itself in a definite position.

The space near the coil appears to be in a special state and to this state, or to its

changes, these effects are assigned. The motion of the iron filings, the compass needle or the suspended coil shows that certain bodies in the field are acted on by forces: the force at any point has direction and magnitude and its direction is indicated by the curves, lines of force they are called, in which the iron filings set themselves.

Employing somewhat vague and not very scientific language, we may say that the magnetic conditions in the neighbourhood of the coil are disturbed and, to quote one writer, the disturbance is said to be in the form of *flux* while "the magnetic flux can be defined as the sum total of magnetic disturbance through a cross section perpendicular to the lines of force."

The physicist is inclined to ask what is it that is disturbed and constitutes this



JAMES CLERK MAXWELL.

Whose brilliant mathematical researches into the nature of electro-magnetic action enabled him in effect to calculate the properties of wireless waves before these had actually been discovered.

flow—flux means flow—along the lines of force. What in fact is this flux ?

Faraday's Discovery.

Now Faraday showed that if a coil be placed in a magnetic field there is some quantity linked with the coil to which these effects are due; variations in this quantity set up an electromotive force round the coil; this electromotive force is measured by the rate of decrease of the quantity; calling it ϕ we have an equation which we may write as

$$E = - \frac{d\phi}{dt}$$

and hence, by the use of a ballistic galvanometer or other suitable appliance we can measure ϕ . To do this we require to develop the theory of the galvanometer and this involves a consideration of the action between a current and a magnet.

Attempts have been made, somewhat unconvincingly it appears to me, to build up a theory of magnetic or electromagnetic action on the basis of "flux" identifying it with the quantity whose variation was shown by Faraday to be proportional to the E.M.F. set up round the circuit, thus avoiding any reference to the idea of a magnetic pole which by some authors is dismissed as inadequate and artificial, avoiding also any attempt to analyse "flux."

Clerk Maxwell's View.

Now this was not the view of Clerk Maxwell; the Treatise on Electricity and Magnetism was published fifty-nine years ago and there have been many advances in our electrical knowledge since that date, but Maxwell's equations of the electrical field have been, and still are, the foundations on which most of those advances rest, and when developing these equations it is necessary I consider to start from the conception of magnetic poles. Here are his words, after describing how certain bodies, e.g., the iron ore called loadstone and pieces of steel which have been subject to a certain treatment and are known as magnets, have, when suspended freely, directional properties and can exert forces of attraction or repulsion. He states :

"The ends of a long thin magnet are commonly called its poles. In the case of an indefinitely thin magnet uniformly magnetised throughout its length the extremities act as centres of force and the rest of the magnet appears devoid of magnetic action. In all actual magnets the magnetisation deviates from uniformity so that no single points can be taken as poles. Coulomb, however, by using long thin rods magnetised with care succeeded in establishing the law of force between two magnetic poles."

It is true of course that we cannot isolate a single pole. Any magnet contains a series of pairs of equal and opposite poles, and if we suppose that a pole possesses its attractive or repulsive properties because a quantity of magnetism is concentrated in its immediate neighbourhood it follows that the total quantity of magnetism in the magnet is zero.

If a long thin magnet is broken into a number of pieces each of these is found to be a magnet, and thus we come to regard any magnet as composed of chains of molecular magnets, dipoles they are some times called. The ends of each such molecule carry equal and opposite charges of magnetism.

Now we know that we can magnetise a piece of steel by bringing it near to a coil carrying a current, while, moreover, magnetic effects due to a magnet can be replaced by those due to a coil suitably placed and carrying a current of definite amount.

How Maxwell's View Can Be Reconciled with Modern Theory.

The electric currents that light our lamps or drive our trams are due, we believe, to the motion of electrons in the conducting circuits; may it not be the case that the molecular magnets of Maxwell are due, as suggested long ago by Ampère, to molecular currents within the substance of the magnet? Do we need to suppose that there is anything of the nature of free magnetism distributed throughout a magnet? I take it that the answer to the first question is in the affirmative, that to the second in the negative. It may be that magnetic action is the means by which we appreciate the existence of these

molecular currents and that free magnetism, regarded as attracting and repelling material distributed throughout a magnet, has no existence. At present we do not know. Following Maxwell again, we must therefore seek for a mode of expression which shall not be capable of expressing too much and which shall leave room for the introduction of new ideas as these are developed from new facts. This he finds in the statement that the particles of a magnet are polarized.

So far as we are at present aware each molecule of a magnet may itself be a molecular magnet with equal quantities of opposite magnetism, at its ends, and the state of polarization may consist in causing the axes of these molecules to set more or less exactly in the same direction, or it may be that round each molecule there flows an electric current—a rapidly moving electron or stream of electrons—and the polarization consists in setting the planes in which these currents flow more or less nearly parallel. According to modern views this is the more probable explanation of the effects observed.

Provided there is a suitable relation between the quantity of magnetism and the strength of the current the effects so far as we can measure them by the forces which the magnet exerts on external bodies or the reactions to which it is subject when in a magnetic field, are the

same. The assumption that these forces arise from magnetism distributed in a definite manner throughout the magnet enables the physicist to calculate their effect in many cases. Maxwell by this means arrived at equations from which far-reaching consequences verified by experiment have been shown to follow.

Electro-magnetic theory as developed by him starts from the assumption of the existence of magnetic poles attracting and repelling according to a certain law of force discovered by Coulomb.

Our belief in the truth of this law does not depend on the accuracy of Coulomb's experiments but on the fact that the complex consequences we can deduce from the assumption are borne out by experiment.

This process satisfied Maxwell. It satisfied also Lord Kelvin, while in more recent years Lorentz defines magnetic field

strength or force as a vector which measures the force exerted on a north magnetic pole of unit strength, and after stating some of the properties of this vector, states that it can easily be proved that the magnetic force in a field due to one or more magnets, if calculated according to Coulomb's law, satisfies these conditions.

If dS be the area of one of the molecular circuits and i the current then each circuit may be replaced by a magnet of moment M with its axis normal to the circuit given by the relation $M = i dS$.



SIR RICHARD TETLEY GLAZEBROOK, F.R.S.

Former Director of the National Physical Laboratory and one of the few remaining pupils of the illustrious Clerk Maxwell. In this article Sir Richard describes what he understands to be involved in Maxwell's views.

I would urge therefore, that the fact that we cannot realize an isolated pole, since magnets in every case are dipolar, and that it is very probable that free magnetism nowhere exists, should not lead us to forsake the historic basis of magnetic theories for the vague idea of "flux" but that this basis should still be accepted as the means whereby we can best co-ordinate the experimental facts and through them advance to new knowledge.

It may be of interest that I should state the lines along which it seems to me, as an old pupil of Maxwell, our teaching may best proceed.

The Fundamental Statements.

We imagine the electric charges and magnetic poles with which we are to deal are situated in a medium—air or a vacuum will serve—which is a non-conductor of electricity and incapable of magnetization.

In such a medium Coulomb's laws hold and we may write these (1) for two electric charges e, e' at a distance r apart

$$\text{Force} = \frac{ee'}{k_0 r^2} \text{ and}$$

(2) for two magnetic poles m, m'

$$\text{Force} = \frac{mm'}{\mu_0 r^2}$$

where k_0 and μ_0 are constants which depend on the medium.

But there is a force between a magnet pole and a wire in which an electric current flows; it is convenient for purposes of calculation to analyse this into a series of forces between each element ds of the wire and the magnet pole and it was shown by Ampère that the resultant effect was consistent with the assumption that the force between a pole m and an element of current ids at a distance r apart is proportional to the expression $mids \sin \theta / r^2$ where θ is the angle between the directions of r and ds . This force acts in a plane perpendicular to r and ds .

We therefore write

$$\text{Force} = \frac{1}{A} \frac{mis \sin \theta ds}{r^2}$$

where A is a third constant.

It can be shown from these three equations that $A^2/\mu_0 k_0$ must represent the square of a velocity, and experiment

teaches us that this velocity is the velocity with which electromagnetic waves travel. moreover it can be shown that A is necessarily the same in all non-magnetisable media; it is a universal constant and Maxwell assumes it to be unity; according to other theories it is the velocity of electro-magnetic waves in free space.

According to Maxwell then $1/\mu_0 k_0 = c^2$, if c represents the velocity of an electro-magnetic wave in the medium considered. Thus either μ_0 or k_0 both have dimensions. For the present we assume both to be dimensional quantities.

Magnetic Field Strength.

Now since the force between two poles is $mm'/\mu_0 r^2$ and the strength of a magnetic field is the force on a unit pole, the field strength due to a pole m at a distance r is $m/\mu_0 r^2$, and so long as μ_0 is a constant, the field strength due to any number of poles, any distribution that is of magnetism, can be calculated by compounding the forces due to each of the poles.

Magnetic Induction.

The quantity m/r^2 is defined as the magnetic induction due to a single pole m ; it is obtained from the force by multiplying the field strength by μ_0 and takes place in the direction of the force. It thus can be compounded in the same way as the force, and if H_0 be the field strength at any point, B_0 the value of the induction, we have $B_0 = \mu_0 H_0$.

MAGNETIC FLUX.

The total amount of induction passing through an area, measured by the surface integral of the induction normal to the area, is known as the magnetic flux through the area.

Thus, if we are dealing with a single pole the flux through an area S of a portion of a sphere with its centre at the pole is mS/r^2 and since the area of the complete sphere is $4\pi r^2$ the flux across the whole sphere is $4\pi m$.

From the expression mS/r^2 the flux across any surface due to a given distribution of poles can be calculated.

Magnetic Media.

A magnetic medium is one, such as iron

steel and some few other substances, which becomes magnetised when placed near a permanent magnet or a coil carrying a current.

Intensity of Magnetisation.

Here it is convenient to introduce the term intensity of magnetisation. By this is meant the ratio of the magnetic moment of any small volume of a magnetised substance to that volume. If we take as the volume a cylinder of cross sectional area dS and length a in a direction parallel to that of the magnetisation the volume is $a.dS$ and the magnetic moment is ma where m is the strength of a pole of the elementary magnet thus formed. Thus I the intensity of magnetisation is given by the equation

$$I = ma/adS = m/dS$$

$$\text{or } m = IdS.$$

Hence I may be regarded as the surface density with which magnetism is distributed over the area dS , and if we now suppose this cylinder to be removed, it follows that the magnetism is distributed over one end of the hollow cylinder thus left in the material with density I , over the other end with density $-I$.

Magnetic Field Strength in a Magnetised Material.

To obtain a measure of this we imagine a small portion of the material removed and a magnetic pole introduced into the cavity thus formed, which is filled with material of permeability μ_0 . Owing to the magnetic force to which the material is subject the surface of the cavity will be coated with magnetism and the force on the pole will be made up of the external force H_0 to which this magnetisation is due and the force due to the surface magnetism. This will depend on the shape and size of the cavity; in practice it is convenient to consider two cases. In each of these the cavity is supposed to be very small, cylindrical in form, with its axis parallel to the direction of magnetisation, in the first case it is supposed to be long compared with its cross section, tunnel-shaped in fact; in the other it is assumed to be short compared with the cross section, disc or crevasse shaped. In neither case is there any magnetism on the sides

of the cylinder; since these are parallel to the magnetisation, the additional force is that due to the ends.

In the tunnel the ends are small compared with their distance from the pole and contribute as a result an addition to the unpassed field strength H_0 , which is negligibly small. In the other case the ends are large compared with the distance, each may be treated as a plane of infinite extent, exerting force on a particle very close to its surface, and magnetised with densities I and $-I$ respectively. The one repels the magnetic pole with a force equal to $\frac{m \times 2\pi I}{\mu_0}$ the other attracts it with the same force. The effect of the crevasse therefore is to add to the field strength H_0 a quantity $\frac{4\pi I}{\mu_0}$.

Thus we arrive at the result* that the field strength in the tunnel is H_0 , that in the crevasse is $H_0 + \frac{4\pi I}{\mu_0}$ or as it may be written $H_0 \left(1 + \frac{4\pi I}{\mu_0 H_0} \right)$

This last quantity is defined to be the field strength in a magnetic material when magnetised to intensity I under a magnetising force H_0 .

If we call this quantity H_1 , we have

$$H_1 = H_0 \left(1 + \frac{4\pi I}{\mu_0 H_0} \right).$$

Now we have seen that in a medium in which the field strength due to an isolated pole is given by $m/\mu_0 r^2$ the magnetic induction is found by multiplying the force by μ_0 . The pole which is now under consideration is surrounded by such a medium. Hence in the medium the magnetic induction which we denote by B_1 is equal to $\mu_0 H_1$.

Thus $B_1 = \mu_0 H_1 = \mu_0 H_0 \left(1 + \frac{4\pi I}{\mu_0 H_0} \right)$, and if we write B_1 as $\mu_1 H_0$, we have

$$\mu_1 = \mu_0 \left(1 + \frac{4\pi I}{\mu_0 H_0} \right).$$

In this expression the quantity μ_0 is known as the permeability of the unmagnetisable medium in which we suppose

*This assumes that H_0 and I are co-linear. It may happen that this is not the case and the statements made would then require modification

the forces with which we are dealing are measured ; it is a constant and is found by experiment to have very nearly indeed the same value in all but the few media which are capable of magnetisation.

The quantity μ_1 on the other hand is not constant but depends on I and H_0 ; it is the permeability of a medium such as iron or steel which is capable of magnetisation. In such a medium the magnetic induction is given by the relation $B_1 = \mu_1 H_0$, and the ratio of the induction to the field strength is no longer constant.

The above relation can be written

$$B_1 = \frac{\mu_1}{\mu_0} (\mu_0 H_0) = \frac{\mu_1}{\mu_0} B_0 \text{ or } \frac{B_1}{B_0} = \frac{\mu_1}{\mu_0}.$$

So that μ_1/μ_0 measures the ratio of the induction in the medium to the induction in air—or a vacuum—which is produced by the same magnetising force.

Electrostatic and Electromagnetic Systems.

We have seen that in the above development of Maxwell's theory three constants k_0 , μ_0 , and A are introduced and that these are connected by the equation,

$$\frac{A^2}{\mu_0 k_0} = c^2 \text{ where } c \text{ is the speed of radio waves in the medium considered.}$$

Of the three Maxwell assumed, for the reasons already given, that A is unity.

Since then $1/\mu_0 k_0 = c^2$ one at least of the other two must involve the units of space and time, provided we assume, as Maxwell does, that all the quantities we deal with in Physics can be expressed in terms of the units of mass, length and time.

As, however, we are entirely in ignorance of the actual values of k_0 and μ_0 , and know only that they are connected by a single equation we may, in the development of our subject, make any assumptions we like as to these quantities, consistent with this one equation, and investigate the conclusions, to which these assumptions lead.

The equations we have hitherto relied on, have been called in Germany magnitude equations. They are true in whatever consistent system of units the quantities involved are measured ; we wish for the purposes of measurement and calculation to turn them into numerical equations

implying the measurement of the quantities involved in terms of units defined by the equations themselves ; to do this we must fix on numerical values for μ_0 and k_0 , and we have an infinite choice.

One obvious solution is to assume that k_0 is unity ; then μ_0 must be equal to $1/c^2$; we obtain what is known as the electrostatic system of units and we are able by the aid of our fundamental equation to decide in what way the electrical quantities depend on the units of length, mass, and time, what are their dimensions in terms of these fundamental units.

A different assumption which we can make is that μ_0 , the magnetic permeability of air—or a vacuum—is unity. Then k_0 is equal to $1/c^2$.

We have then Maxwell's electromagnetic system and can again determine from our fundamental equations the dimensions of our electrical quantities. These will clearly differ from the values found previously since they are based on a different assumption on the electrostatic system.

On that system a unit quantity of electricity placed a distance of 1 cm. from an equal quantity repels it with a force of one dyne, while a unit magnetic pole placed at a distance of one cm. from an equal pole repels it with a force of c^2 dynes.

On the electromagnetic system these statements are reversed ; the force between the two units of electricity is c^2 dynes, that between two unit magnetic poles is one dyne. This does not mean any change in the actual value of a given quantity of electricity or a given pole. It merely involves a change in the unit in terms of which we choose to make our measurement ; it is as though at one time we measured a mass of matter in tonnes, at another time in milligrammes.

It may, of course, be true that we cannot express a quantity of electricity in terms of mass, length and time. It may be preferable to realise that it is, like these, a quantity of its own kind and to include in our dimensional equations some symbols to indicate the unit of electrical charge or to retain in our equations the symbols k_0 and μ_0 to indicate quantities of unknown dimensions, as has been done in the above

brief account of the development of a theory. We should, of course, no longer be able to state the dimensions in mass, length and time of a magnetic pole; we should on the other hand avoid the apparent inconsistency of the statement that a magnetic pole has different dimensions in the two ordinary systems of measurement.

Maxwell's Definition of Induction.

As has already been stated the magnetic induction B_1 in a magnetisable medium is given by the formula

$$B_1 = \mu_1 H_0 = \mu_0 \left(1 + \frac{4\pi I}{\mu_0 H_0}\right) H_0 = \mu_0 H_1$$

where H_1 is the field strength in a crevasse, H_0 in a tunnel.

On Maxwell's electromagnetic system we are to put $\mu_0 =$ unity and we have

$$B_1 = H_1.$$

Thus on this system magnetic induction is equal to the field strength in a crevasse normal to the direction of magnetisation. It is therefore a quantity of the same kind as magnetic force. If on the other hand we adopt a more general view and retain μ_0 as a quantity of unknown dimensions, we have $B_1 = \mu_0 H_1 = \mu_1 H_0$, and then B_1 and H_1 are quantities of different kinds.

In our practical methods of measurement it is the ratio B_1/B_0 , the induction relative to air, that we require and since $B_1/B_0 = \mu_1/\mu_0$, the result we obtain is the ratio of the permeability of the medium to that of air; it is the relative permeability and is a pure number.

FULL LOAD CURRENT AND MINIMUM LINE CABLE SIZES FOR THREE-PHASE A.C. MOTORS

H.P. Output.	Volts per Phase 100 or Line Volts 173		Volts per Phase 230 or Line Volts 400		Volts per Phase 290 or Line Volts 500	
	Amps.	Cable.	Amps.	Cable.	Amps.	Cable.
		In.		In.		In.
¼	1.3	1/.044	.56	1/.036	.45	1/.036
½	2.5	3/.029	1.1	1/.044	.87	1/.044
1	3.9	3/.029	1.7	1/.044	1.35	1/.044
2	7.8	3/.036	3.4	3/.029	2.7	3/.029
3	11.7	7/.029	5.1	3/.029	4.1	3/.029
4	14.3	7/.029	6.2	3/.029	4.9	3/.029
5	18	7/.036	7.8	3/.036	6.2	3/.029
10	34.5	7/.052	15	7/.029	12	7/.029
15	51	19/.052	22	7/.036	17.5	7/.036
20	66	19/.064	28.5	7/.044	22.5	7/.036
25	84	19/.072	36.6	7/.052	28.5	7/.044
30	99	19/.083	43	7/.064	34	7/.052
35	113	19/.083	49	19/.044	39	7/.064
40	127	37/.064	55	19/.052	43.5	7/.064
45	139	37/.072	60.5	19/.052	48	19/.044
50	154	37/.083	67	19/.064	53	19/.052

LOCATING A SIMPLE FAULT ON A TWIN-CORE FEEDER CABLE

NO attempt will be made in this short article to deal with the whole subject of fault location, but the following example of the method of applying the loop test to a twin-core feeder cable will, it is hoped, be interesting to most readers. In later issues we hope to deal in much greater detail with this very important branch of distribution work.

The Problem.

It is known that there is an earth fault on one of the cores of a twin-feeder cable between two junction boxes, and it is required to find the approximate position of the fault.

The Method of Procedure.

After the suspected portion of the line has been made safe, one end of the sound core should be connected to the end of the faulty core at the first junction box. The consumers' premises along the faulty portion of the feeder must next be disconnected.

Locating the Fault.

The loop test is now applied at the other end of the twin-core cable as shown in the diagram attached. The method is quite simple and it consists in connecting the sound core and the faulty core to the two ends of a potential divider.

A fairly sensitive galvanometer is also connected across the terminals of the divider in series with a tapping key. The slide of the potentiometer is connected

to one terminal of the battery and the other terminal of the battery is connected to earth.

First place the slider about mid position and close the tapping key. Note the direction in which the galvanometer needle is deflected. Now move the slider to one end of the potentiometer. Close the key and note whether the galvanometer needle is deflected in the same direction as before. If so the slider must be moved towards the other end of the potentiometer until a position is found at which no deflection is obtained when the key is closed. Then if a_1 and a_2 are the values of the two portions into which the potentiometer

scale has been divided and l is the distance in feet between the two junction boxes and x the distance of the fault from the junction box at which the ends of the sound and faulty cores have been connected together then, using the

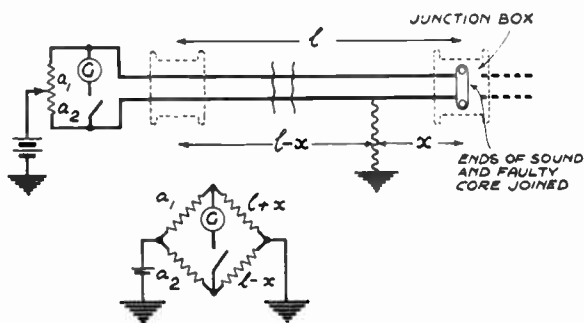

CONNECTIONS FOR LOCATING A SIMPLE FAULT ON A TWIN-CORE FEEDER CABLE.

well-known principle of the Wheatstone Bridge, we get

$$\frac{a_1}{l+x} = \frac{a_2}{l-x} \text{ so that } x = \frac{l(a_1 - a_2)}{a_1 + a_2}$$

In practice the calculation is quite a simple one. For instance, suppose the potentiometer scale is 10 in. long and the zero position of the slide is found at a point 2 in. from the end to which the faulty core is connected and the distance between the junction boxes 330 ft. then :-

$$x = \frac{8 \times 330 - 2 \times 330}{10} = \frac{6 \times 330}{10} = 198 \text{ ft.}$$

from the other junction box.

HOW A D.C. MOTOR IS MADE

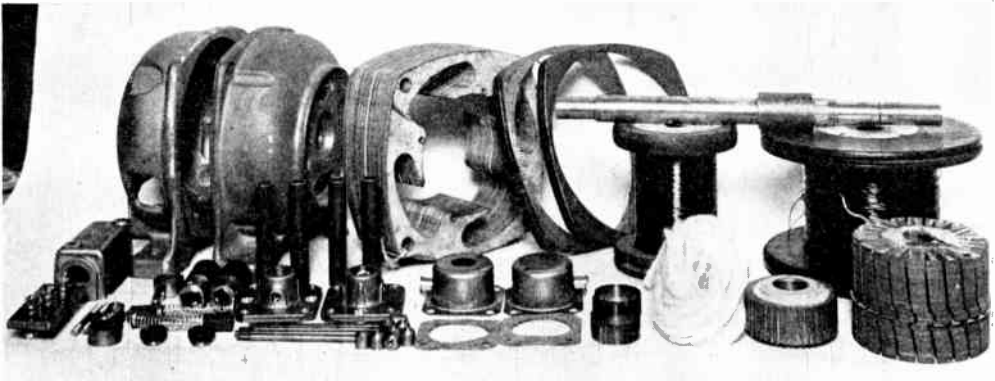

THE COMPONENT PARTS BEFORE ASSEMBLY.

Here we see the complete set of parts used in the manufacture of a typical D.C. motor. It will be seen that the field magnets are four-pole, built up of laminations, whilst the armature has 23 slots, with a 45-section commutator.

BY the courtesy of the Lancashire Dynamo and Crypto, Ltd., we have been enabled to secure a most interesting series of photographs which illustrate the whole process of building a fractional horse-power D.C. motor.

The particular motor here illustrated is compound wound, the series turns being added to enable the motor to be switched direct on to the line by means of a double-pole switch without the need for a starting resistance. Another advantage obtained by compounding is the high starting torque which enables the motor to speed up quickly under a moderate load.

When the power is switched on, the series turns carry a heavy current. This produces a strong magnetic field

which serves the double purpose of limiting the current flowing in the armature and also providing a powerful starting torque.

The curve below shows armature current, in relation to speed. The exact shape of the curve depends on the proportion between the shunt and series windings.

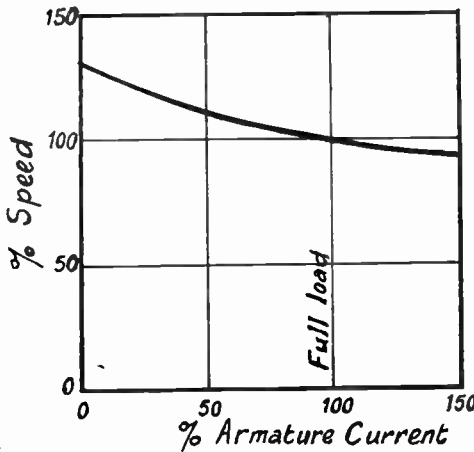

A TYPICAL CHARACTERISTIC CURVE FOR A COMPOUND-WOUND MOTOR.

When the motor has reached its normal running speed, the back-E.M.F. of the armature opposes the flow of current through the series coils and the field magnets are therefore energised chiefly by the shunt windings.

The photographs which follow illustrate the whole process of assembly of a ¼-h.p. direct current motor. In a later series we shall show in the same detail the method of assembling an alternating current motor of similar size.



ASSEMBLING THE ARMATURE STAMPINGS.

Note the rod which is placed in one of the slots to ensure proper alignment during assembly. Note also that the shaft is gripped between lead pads placed on either jaw of the vice, so as to avoid accidental damage.

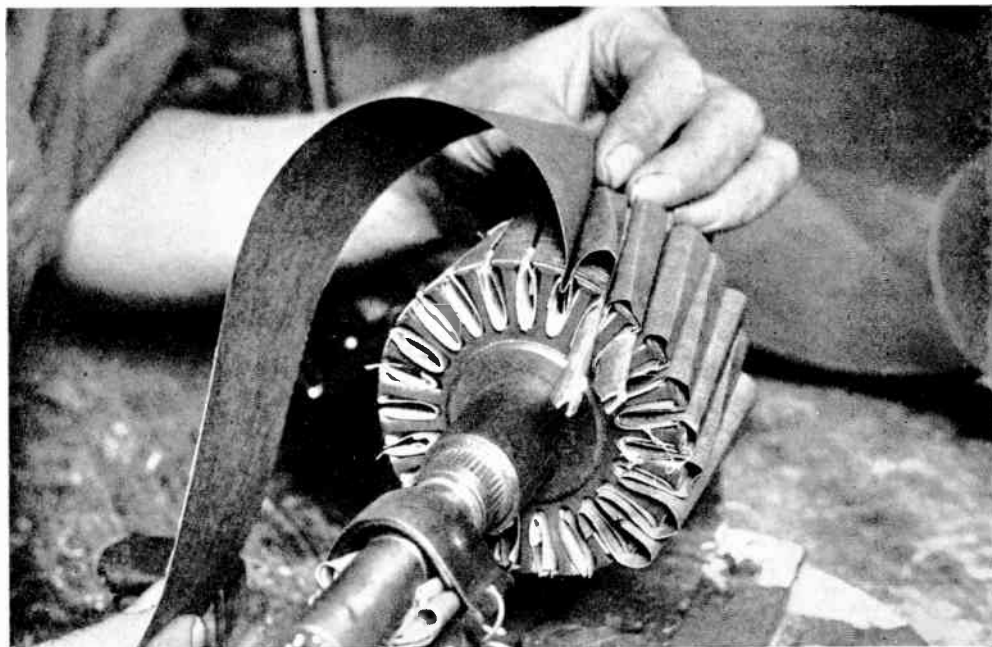

INSULATING THE ARMATURE SLOTS.

Note that three layers of insulation are used for this purpose. First a sheet of Leatheroid, next a sheet of Empire cloth. Finally, a second sheet of Leatheroid. The superfluous insulation is cut away after the slots have been lined.

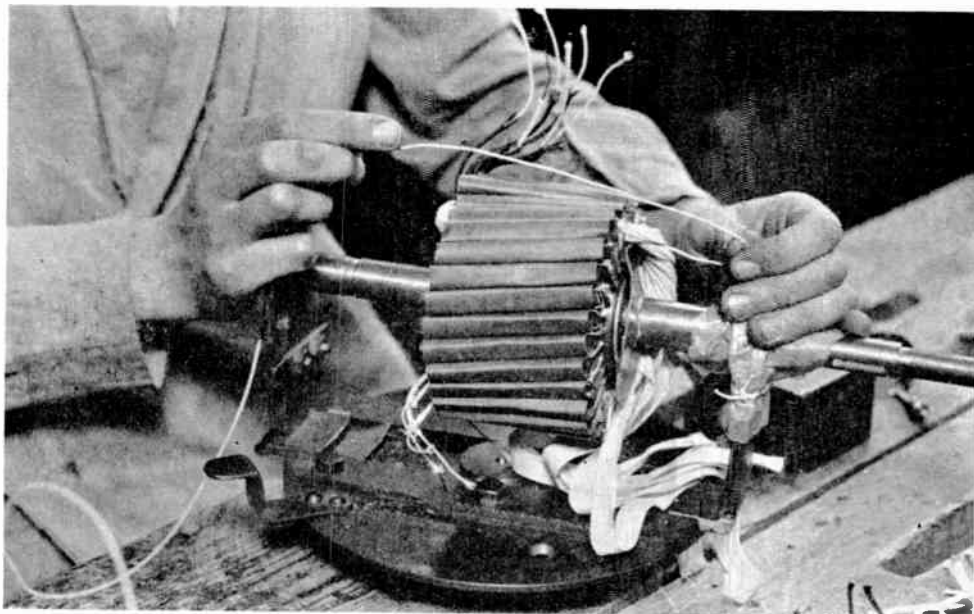

WINDING THE ARMATURE.

Here we see the armature being wound with single cotton-covered wire. Special care is taken to distinguish the ends of the various coils, so that there shall be no confusion when these are to be soldered to the commutator segments. After winding, the armatures are impregnated and baked for twenty-four hours.

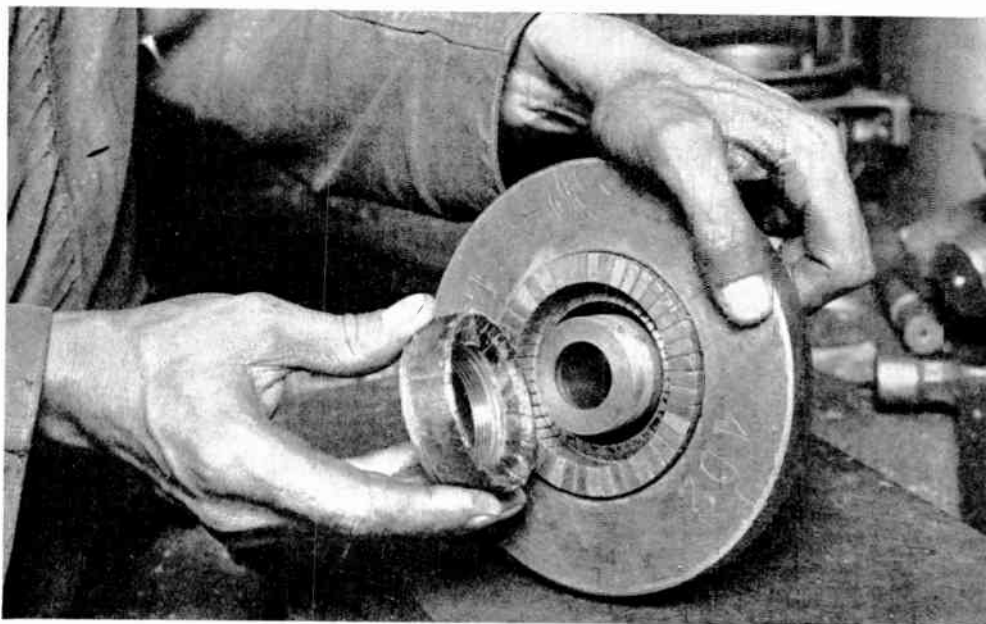

ASSEMBLING THE COMMUTATOR.

This shows how a jig is used for positioning the segments whilst the centre is inserted.

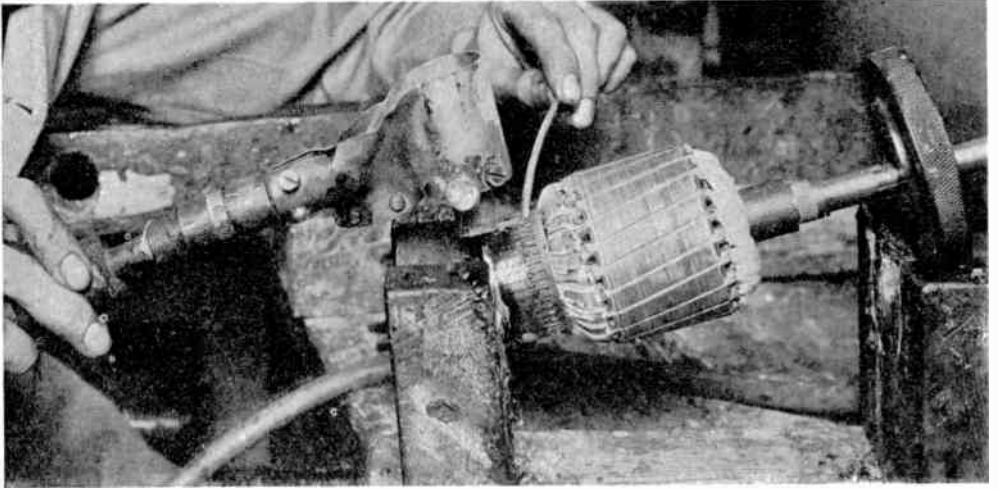

(Above)

CONNECTING THE ARMATURE COILS TO COMMUTATOR SEGMENTS.

Here we see the ends of the armature coils being soldered to the respective segments of the commutator.

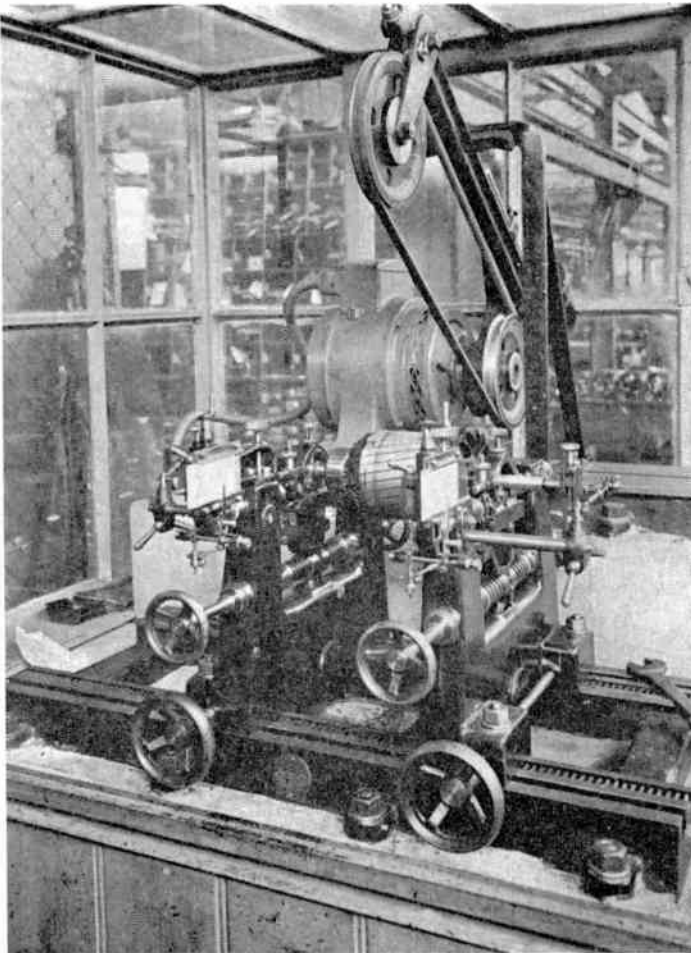

(Left)

TESTING THE ARMATURE FOR BALANCE.

The armature is mounted up on ball races in the testing machine. The motor-driven belt, which is shown above the machine, is then lowered on to the armature. When the motor is started up, this belt, pressing on the armature, causes it to revolve. At a speed of about 3,000 r.p.m. the belt is lifted off and the armature allowed to slow down. As the critical speed is reached, any vibration of the armature is recorded by pointers on two chalked glass plates which can be seen on each side of the machine. If the armature is out of balance, weight is put in the slots of the armature until no vibration is recorded. Plasticine is used to provide weight. After the test, this is removed, weighed and equal weights of copper strip substituted.

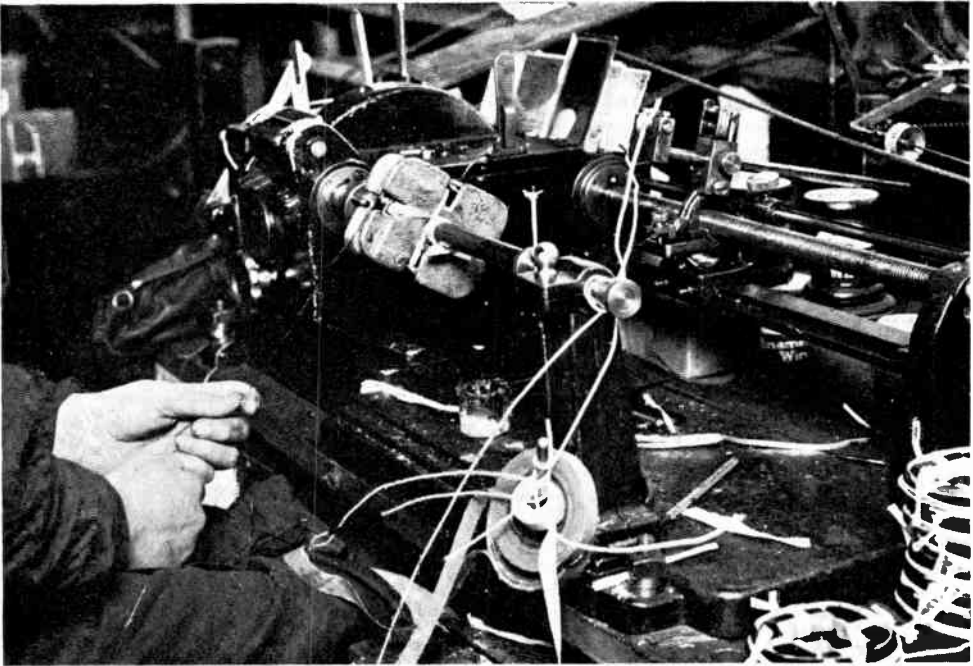

(Above)

WINDING THE FIELD COILS.

It will be seen that the field coils are wound on a former, thin wire being used for the shunt winding and stouter wire being used for the series turns.

The number of turns and size of wire depend on the size of the motor and also the voltage at which it is to be run. When a machine has to be rewound owing to a burn-out, the easiest method is to "copy wind" it, i.e., count the number of turns and note the sizes of wire for the various coils and replace exactly as previously. To rewind for a different voltage the new windings must carefully be calculated.

(Right)

PLACING THE FIELD COILS IN POSITION.

After winding, the field coils are carefully taped and placed over the poles. Note that the slots between the poles are insulated with Leatheroid and Empire cloth in a similar manner to the armature slots. It will be seen that each coil has four leads coming out from it. Two of these are the ends of the shunt winding and the other two are the ends of the series winding. The shunt turns of the four coils are connected together in series and the series turns are also joined up in a similar manner.

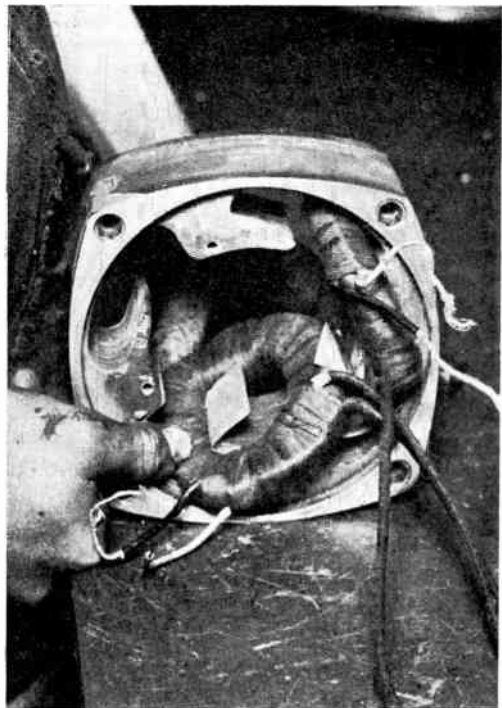

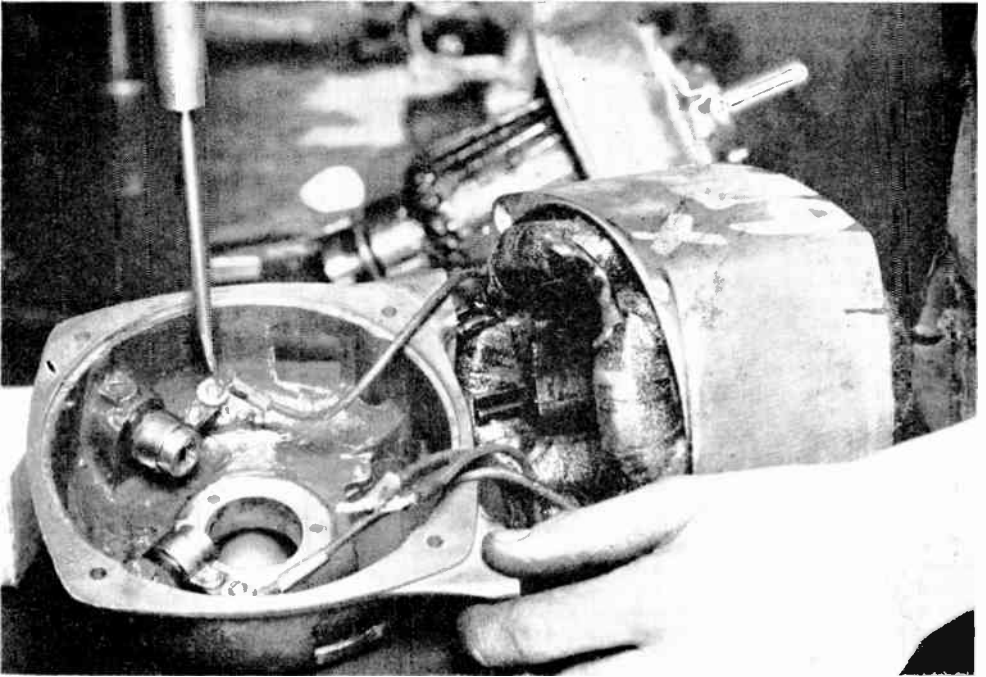

CONNECTING THE FIELD COILS TO THE BRUSH HOLDERS.

The picture shows the shunt windings connected across the brushes. The ends of the series winding have still to be connected.

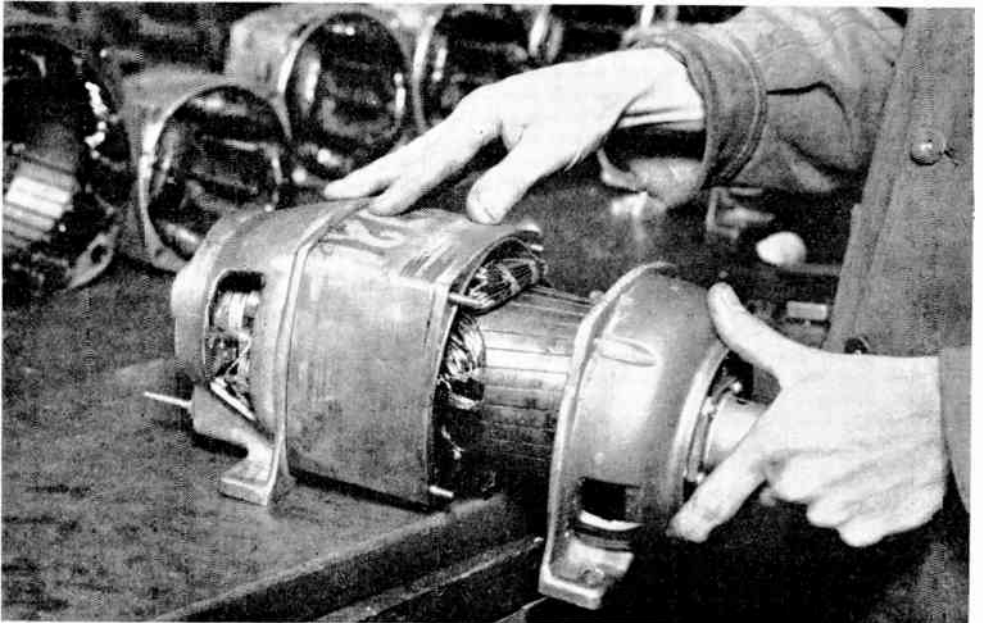

ASSEMBLING THE ARMATURE AND END PLATES.

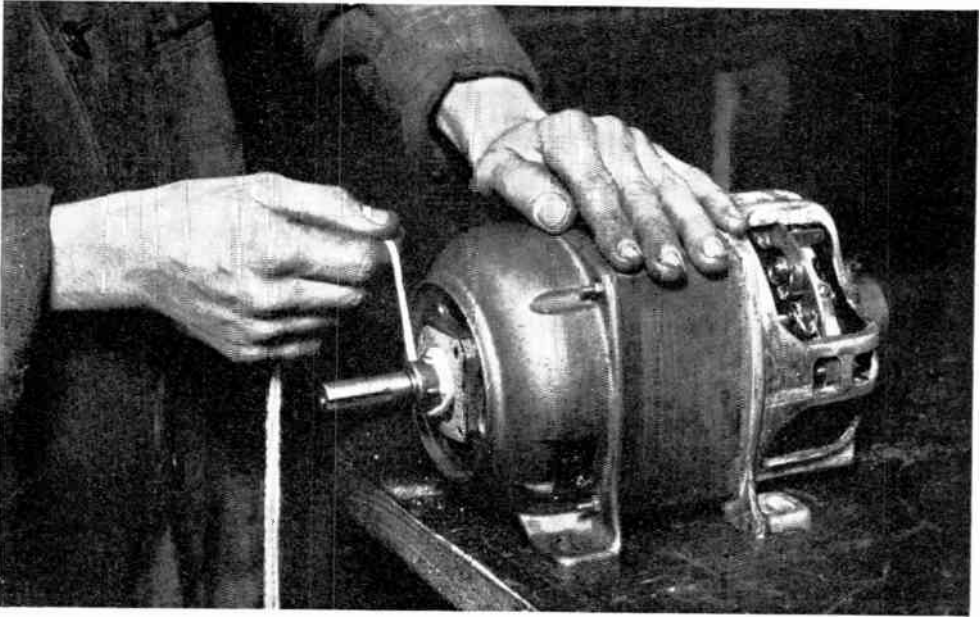

WINDING BEARING WITH YARN.

Note that after the gaskets have been placed in position and before the end covers are put on, the end of the spindle is wound with yarn which acts as a retaining medium for the lubricant.

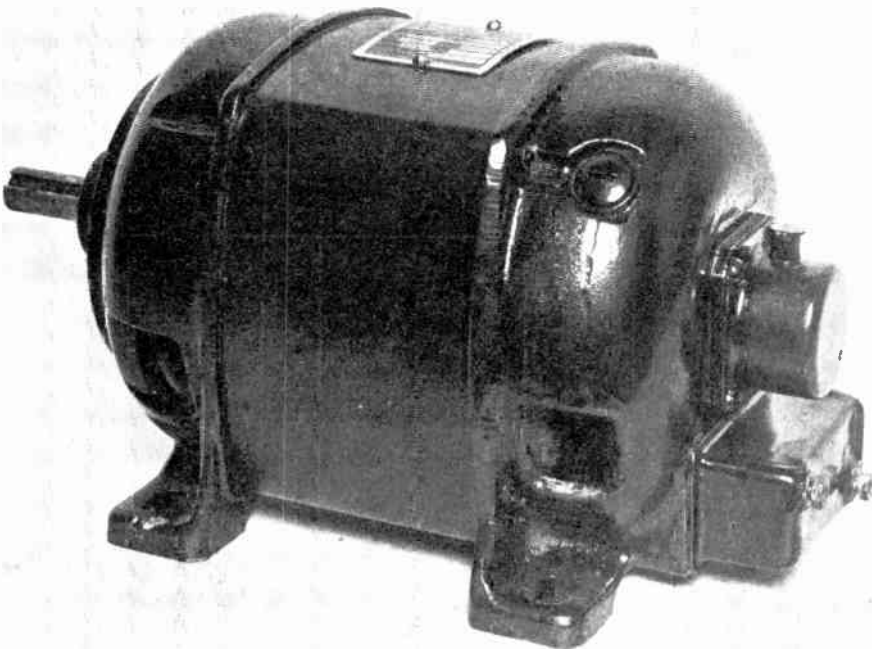

THE FINISHED MOTOR.

F

FULL LOAD CURRENT AND MINIMUM CABLE SIZES FOR D.C. MOTORS

H.P. Out- put.	100 volts.		230 volts.		460 volts.		500 volts.	
	Amps.	Cable.	Amps.	Cable.	Amps.	Cable.	Amps.	Cable.
		In.		In.		In.		In.
$\frac{1}{4}$	2.5	3/.029	1.1	1/.044	.51	1/.036	.5	1/.036
$\frac{1}{2}$	4.9	3/.029	2.1	3/.029	1.1	1/.044	1.0	1/.044
1	9.2	3/.036	4.0	3/.029	2.0	1/.044	1.8	1/.044
2	18	7/.029	7.8	3/.036	3.9	3/.029	3.6	3/.029
3	27	7/.044	11.7	3/.036	5.9	3/.029	5.4	3/.029
4	35.5	7/.055	15.5	7/.029	7.7	3/.036	7.1	3/.036
5	44	7/.064	19.1	7/.036	9.6	3/.036	8.8	3/.036
10	85	19/.072	37	7/.064	18.5	7/.036	17	7/.029
15	126	37/.064	55	19/.052	27.5	7/.044	25	7/.044
20	166	37/.083	72	19/.064	36	7/.054	33	7/.052
25	205	37/.093	89	19/.072	44.5	7/.064	41	7/.064
30	244	61/.093	106	19/.083	53	19/.052	49	19/.052
35	283	61/.093	123	37/.064	61.5	19/.052	57	19/.052
40	322	61/.103	140	37/.072	70	19/.064	65	19/.064
45	362	91/.093	157	37/.083	78.5	19/.064	72	19/.064
50	400	91/.103	174	37/.083	87	19/.072	80	19/.064

DYNAMO FULL LOAD CURRENT AND POWER REQUIRED TO DRIVE

Output.	Effi- ciency.	Power to Drive	Full-load Current, Amperes.						
			6 volts.	12 volts.	50 volts.	110 volts.	220 volts.	440 volts.	500 volts.
Kilowatts.									
.1	.7	$\frac{1}{4}$	16.6	8.3	2	.91	.45	.227	.2
.2	.75	$\frac{1}{2}$	33.4	16.7	4	1.8	.91	.45	.4
.5	.8	1	83	41	10	4.5	2.25	1.1	1
1	.85	1 $\frac{1}{2}$	166	83	20	9.1	4.5	2.3	2
1.5	.88	2 $\frac{1}{2}$	250	125	30	13.6	6.8	3.4	3
2	.88	3	334	167	40	18	9.1	4.5	4
5	.89	7 $\frac{1}{2}$	835	417	100	45	22.7	11	10
10	.9	15	1,666	833	200	91	45	23	20
15	.92	22	2,500	1,250	300	136	68	34	30
20	.92	30	3,340	1,666	400	182	91	45	40
25	.93	36	4,166	2,083	500	227	113	57	50
30	.93	43	5,000	2,500	600	272	136	68	60
40	.94	57	6,666	3,333	800	364	282	141	80
50	.95	70 $\frac{1}{2}$	8,350	4,170	1,000	450	227	113	100
60	.95	85	—	5,000	1,200	545	272	136	120
70	.955	98	—	5,833	1,400	635	318	159	140
80	.955	112	—	6,666	1,600	725	364	182	160
90	.957	126	—	7,510	1,800	817	408	204	180
100	.96	140	—	—	2,000	910	454	227	200

ELECTRICAL CIRCUIT DIAGRAMS

CAR ELECTRICAL EQUIPMENT.

THE diagrams which follow deal with a typical car electrical installation.

The first diagram shows a typical car wiring system in a conventional form, while the second diagram is a pictorial representation of the same circuit. Note that the system employed is coil ignition. The dynamo has the usual third brush control, and an insulated return is employed. All the return wires are shown dotted.

How the Circuit is Divided Up.

It may be mentioned that no two makes of cars are wired in exactly the same manner, but a careful study of the diagrams given herewith will enable the reader to analyse the circuit of any car with which he may have to deal. It will be seen that the method employed here is to divide up the circuit as below:—

- (a) The starting circuit for the motor.
- (b) The charging circuit, which includes the dynamo, the cut-out, control switch and battery.
- (c) The lighting circuit, consisting of battery, switch, ammeter and lamps.
- (d) The ignition circuit, consisting of battery, ignition switch, distributor and contact breaker and plugs. An earth return is, of course, always employed on the high tension side.
- (e) Ignition circuit, in the case of magneto ignition. This consists of magneto primary and contact breaker, ignition switch, magneto secondary, distributor and plugs.

The separate study of each of these sub-sections of the main wiring diagram will be found invaluable whenever a fault in the electrical circuit has to be traced.

Charging Connections.

In the third and fourth diagrams the dynamo is of the third-brush type, and the charging switch is shown open, or in the "off" position. When it is turned clockwise into the "on" or "charge" position, its upper blade connects the dynamo positive and dynamo field terminals, thus enabling the dynamo to build up or excite and so furnish current when its speed is high enough.

It will be seen that the dynamo positive terminals on the cut-out and dynamo are connected by being joined together at the switchboard charging switch terminal; the dynamo negative terminal connections join on the negative bus-bar; while the battery positive terminal leads are connected to the positive bus-bar.

Starter Connections.

In the diagram showing the remote control circuit for the starting motor, A is the starter positive terminal, B the battery positive terminal and C the push-button switch terminal. With this particular system of connections, the remaining push-switch terminal is connected to the negative bus-bar of the switchboard.

Lighting Connections.

In the diagram showing the typical lighting circuit the switch is shown in the "off" position. Turning it clockwise, the first stage of the movement puts it into the "side and tail" position, in which the positive bus-bar is connected to the side and tail terminal block ST. A further clockwise movement preserves the positive bus-bar to side and tail block connection and, in addition, connects the positive bus-bar with the headlamp terminal block H.

Ammeter Connections.

In most of these diagrams it will be seen that the ammeter shows the current which is passing into or out of the battery, apart from the starter current. An ammeter able to measure the starter current

relating to the coil ignition, the ignition switch is the same as the charging switch; but the charging blade of the switch is insulated from the ignition blade. The coil is switched on by turning the switch clockwise.

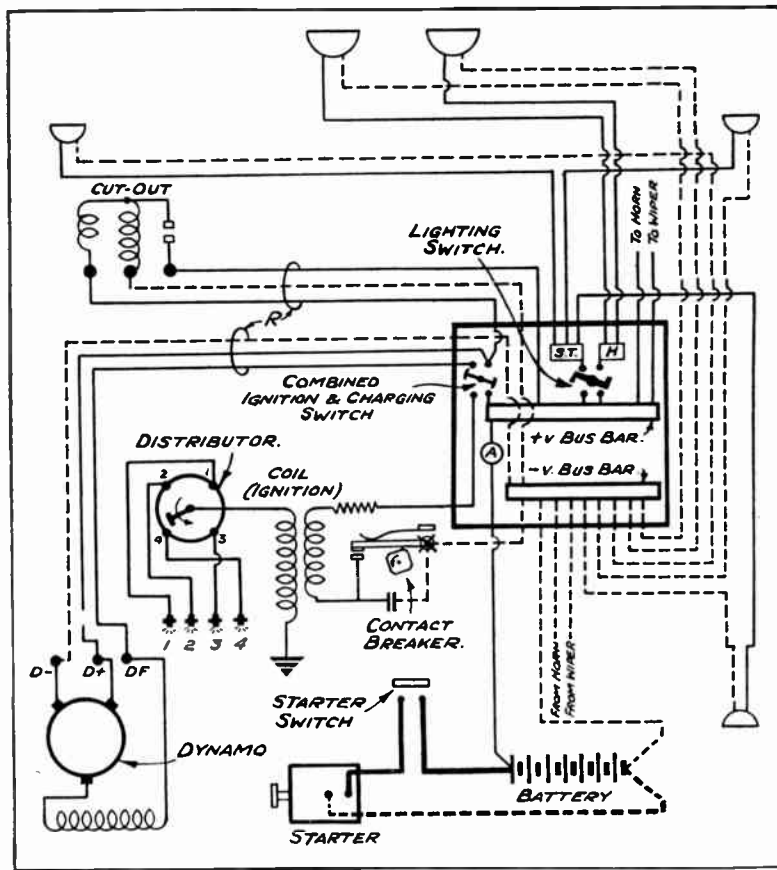

A TYPICAL WIRING DIAGRAM.

The above circuit shows all the parts of a modern car lighting equipment, viz., lamps, cut-out, switchboard and instruments, coil ignition, dynamo, battery and starter. Compare with diagram on facing page.

would be of interest to comparatively few people and would not show the much smaller charging and lighting currents with reasonable accuracy, if, indeed, the ammeter needle moved at all. The ammeter, in fact, is in the lead connecting battery positive with switchboard positive bus-bar.

Coil Ignition.

In the diagram showing the wiring

In this example the primary winding of the coil is entirely insulated from the secondary winding; and one end of the secondary winding is earthed, to provide a return path from the sparking of the sparking plugs.

The primary and secondary coils are sometimes connected as shown by the dotted line X; the earth connection shown on the left is then omitted and the secondary is earthed through the contact breaker.

Magneto Ignition.

In the case of the diagram showing the ignition connections of a magneto, the magneto is switched off by earthing one end of the primary winding when required; the other end is always earthed and is connected to one end of the secondary winding.

Compare the switch in this figure with that in the diagrams of the coil ignition circuit and the typical wiring diagram to obtain a clear idea of its several functions. Notice the position of the charging blade B

with reference to the ignition blade of the switch.

Accessories.

Accessories such as an electric horn are usually wired to the positive bus-bar of the switchboard through the appropriate operating switch of one terminal, and by the other to the negative bus-bar or to earth.

Other Wiring Diagrams.

One of the chief sources of difference between one wiring diagram and another is the construction of the switchboard, and, in particular, the construction of the switches. Some of the rotating parts of combination switches are not easy to draw in diagram form if examined by themselves; but if the connections to the fixed contacts be traced and plotted on a diagram the difficulty usually disappears at once.

Wiring diagrams for most of the chief makes of motor-cars are published by *Automobile Electricity*, 53, Shorts Gardens, London, W.C. 2, and whenever these can be obtained it is a simple matter to split up the circuit into component parts as shown in the diagrams which follow.

How to Trace Out the Circuit of an Old Car.

When an old car is under consideration and it is not possible to obtain a circuit diagram either from the makers or from any other source, the best plan is to take the circuit in which the internal trouble

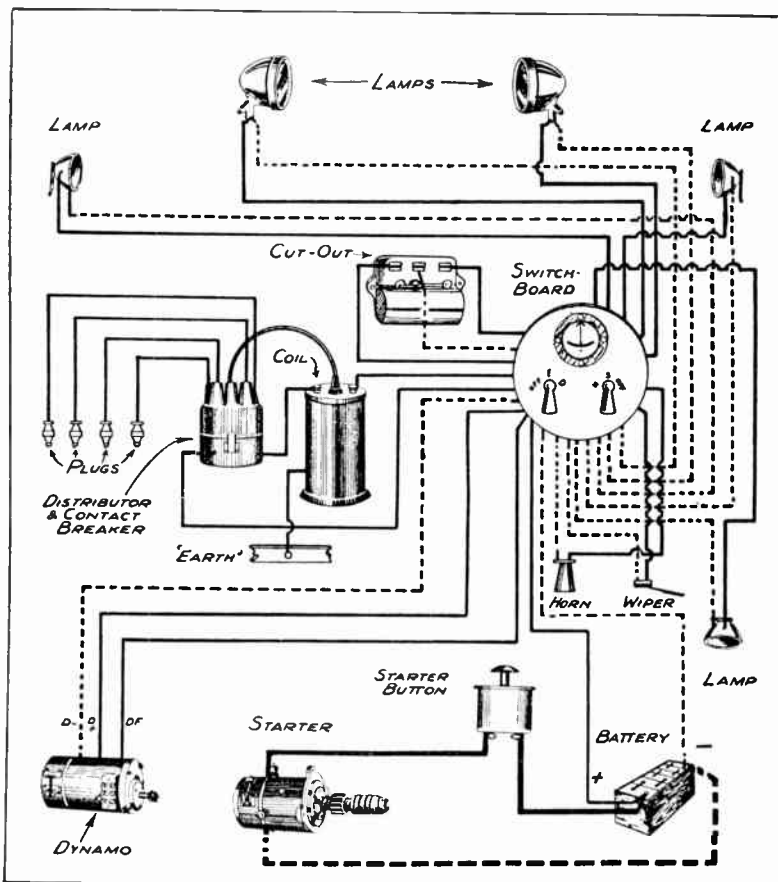

PICTORIAL DIAGRAM OF TYPICAL WIRING SYSTEM.

By comparing this diagram with the technical circuit diagram shown opposite, the reader will be able to follow the connections of the various components without difficulty. The horn and windscreen wiper switches are not shown.

is suspected and trace it out wire by wire and make a systematic diagram for this alone. This procedure can be carried out with other parts of the circuit until the fault is traced. Usually it is not necessary to construct the entire diagram before the fault is found.

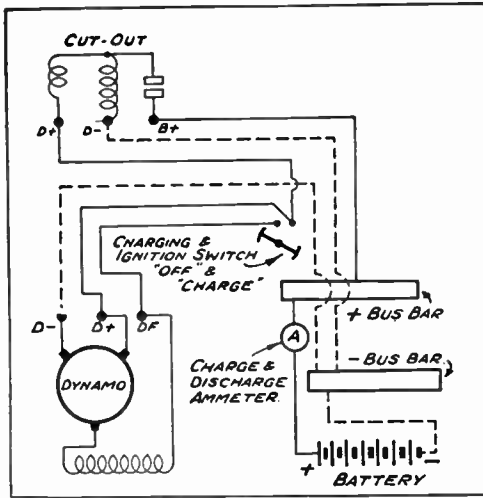

CHARGING CIRCUIT.

This shows the main parts of the dynamo and battery circuit, including the cut-out.

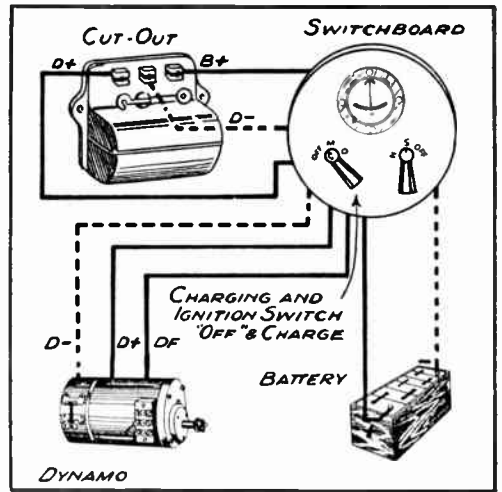

PICTORIAL DIAGRAM OF CHARGING CIRCUIT.

Compare this with the diagram on the left.

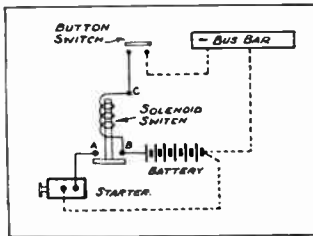

REMOTE CONTROL CIRCUIT FOR THE STARTING MOTOR.

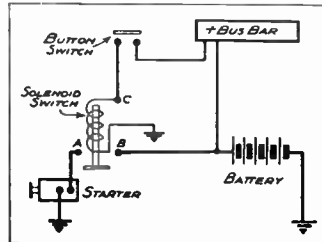

REMOTE CONTROL STARTER CIRCUIT (EARTH RETURN SYSTEM).

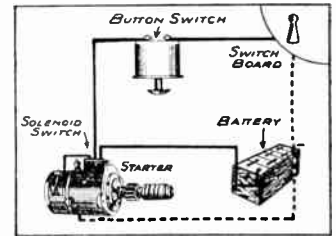

PICTORIAL DIAGRAM OF THE REMOTE CONTROL CIRCUIT FOR THE STARTING MOTOR.

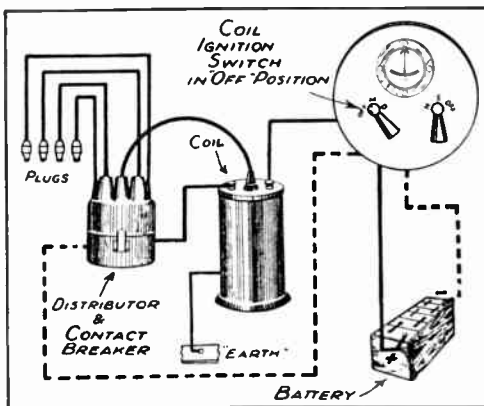

PICTORIAL DIAGRAM OF A COIL IGNITION CIRCUIT.

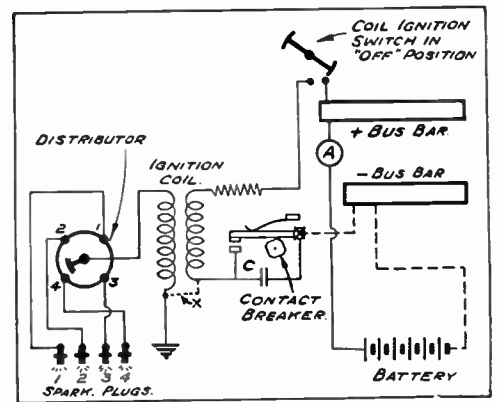

TECHNICAL DIAGRAM FOR A COIL IGNITION CIRCUIT.

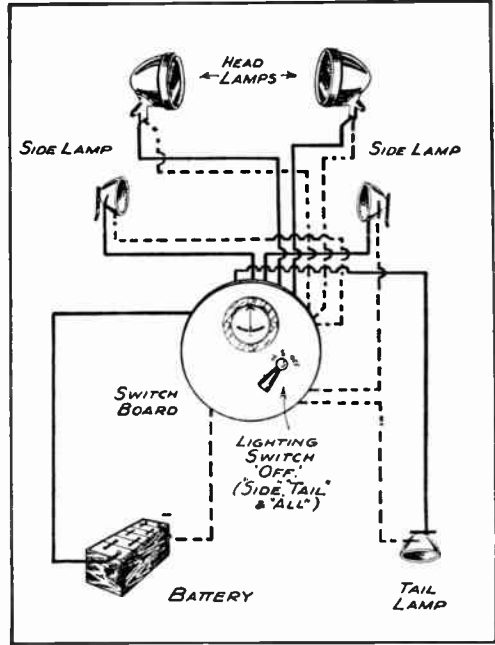
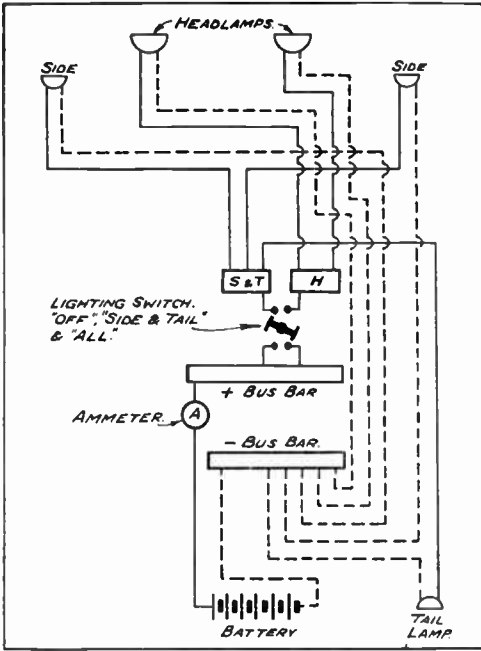

(Above)
TECHNICAL DIAGRAM FOR A TYPICAL LIGHTING CIRCUIT FOR A MOTOR-CAR.
The switch is shown in the "off" position.

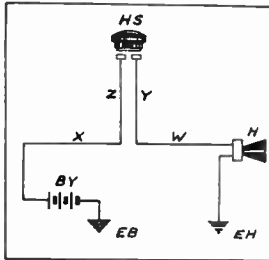

ELECTRIC HORN CIRCUIT (SINGLE-POLE SYSTEM).

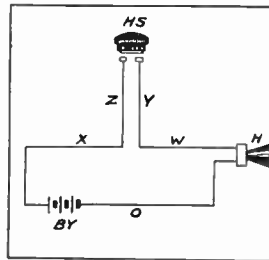

ELECTRIC HORN CIRCUIT (DOUBLE-POLE SYSTEM).

(above)
PICTORIAL DIAGRAM OF A TYPICAL LIGHTING CIRCUIT FOR A MOTOR-CAR.
Compare this with the technical diagram.

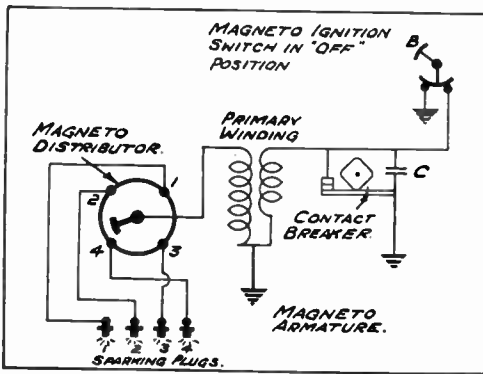

TECHNICAL DIAGRAM OF MAGNETO IGNITION CIRCUIT.

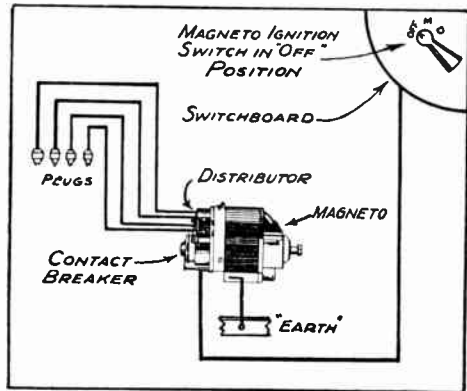

PICTORIAL DIAGRAM OF MAGNETO IGNITION SYSTEM.

THE GRID SYSTEM AND THE ELECTRICAL ENGINEER

IN a few words, the grid scheme involves the closing down of a fair number of the smaller power stations so that the remaining stations can generate at higher efficiency with fewer standby units. Its development tends to restrict the field

for advancement for the man engaged strictly on the power generation side as there will be fewer worth-while jobs available.

There is, however, always room at the top and the man who determines to get

there can still do so. He will need to acquire a good knowledge of E.H.T. work if he wishes to make good in this sphere in the future. The boiler house is becoming more important because economy in steam generation is of greater importance now than ever before. The inefficient stations will eventually be closed down.

Another effect of the grid is the great increase in the demand for engineers capable of dealing with the E.H.T. transmission side. There is splendid scope here for the young ambitious man. New problems of all kinds have to be solved and the man who acquires a good knowledge of this side should make rapid progress.

The most important effect of the grid

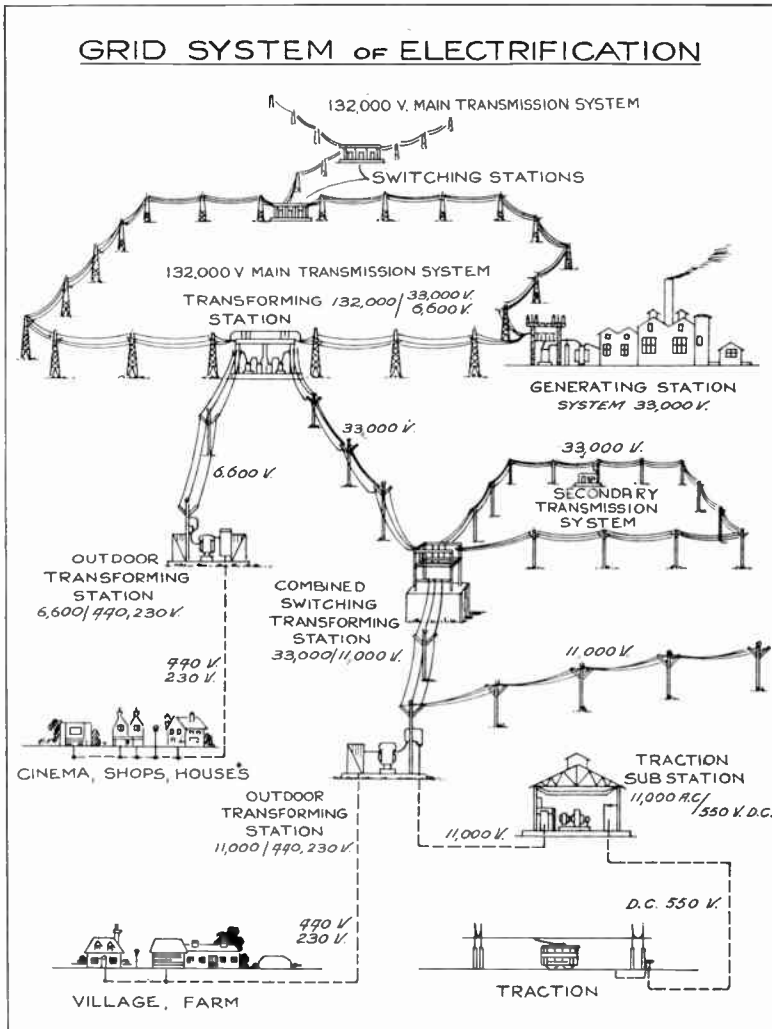

This diagram and that opposite show only two variations. They will, however, serve to show the surprising flexibility of the Grid scheme.

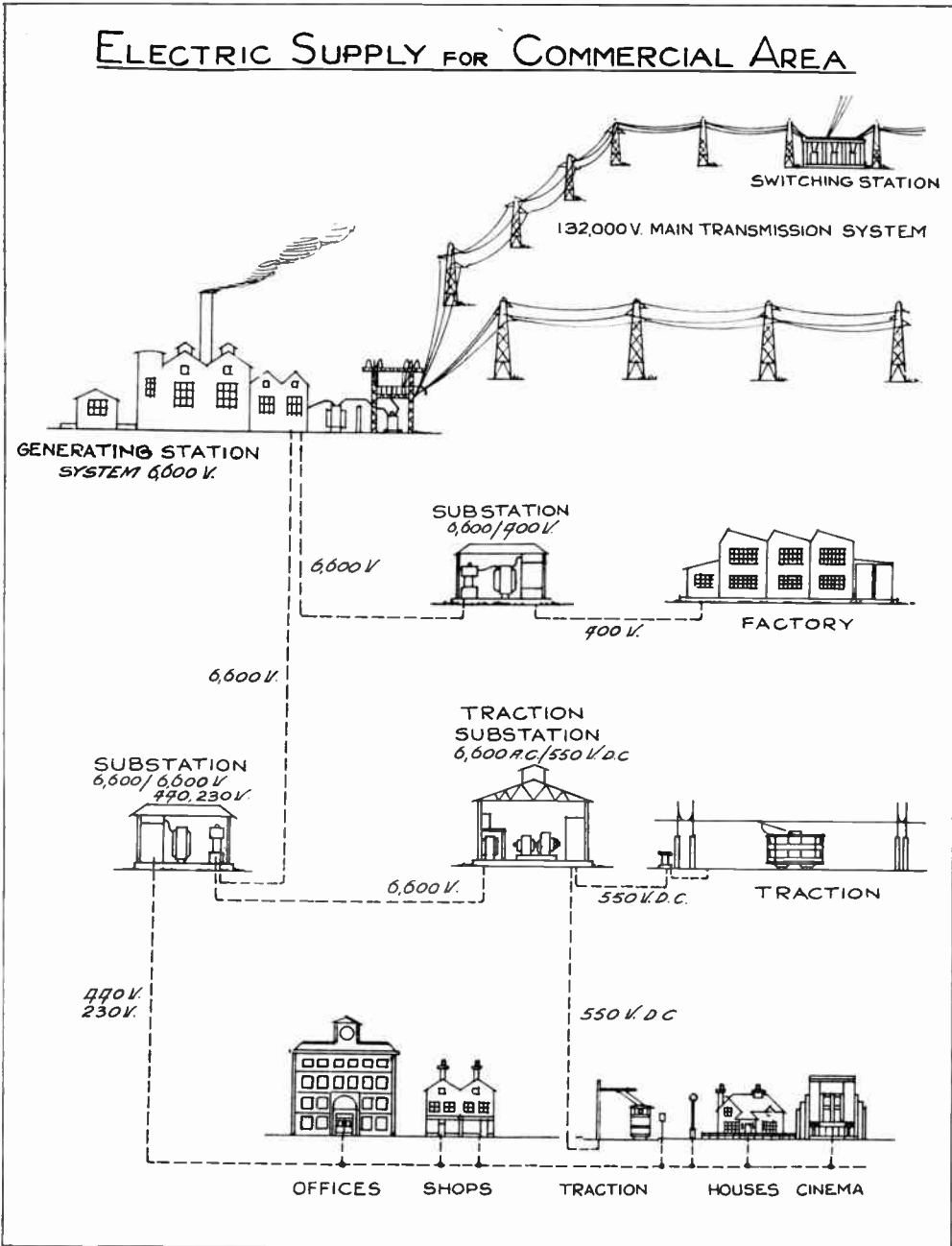

A TYPICAL ARRANGEMENT SHOWING IN PICTORIAL FORM HOW THE EXTRA HIGH VOLTAGE GRID SUPPLY IS STEPPED DOWN FOR INDUSTRIAL, COMMERCIAL AND DOMESTIC PURPOSES.

scheme has not yet been felt in full. This is the great development which is sure to follow on the distribution side of the industry. A recent survey of 12,000,000 houses showed that 8,000,000 were still without an electric supply of any kind. *Millions of new consumers will be secured in the next few years.*

Premises will have to be wired, service connections made; lamps, fires, irons, cookers, fans, refrigerators, will be required

by the million, and electric motors, switch-gear and transformers by the thousand.

What a wonderful opportunity for men with vision to look ahead and secure the advantage of this inevitable expansion in the industry. It almost seems as if the day may come when electrical engineers will receive from the rest of the community an adequate recompense for the study and skill which they must give to their work.

HOW IS AN EXCITER STABILISED?

For the purpose of stabilising exciters when alternator rheostats are not provided, a separately excited field winding is wound on the main poles in addition to the shunt field, the current required being not more than 0.125 amp. This stabilising winding is energised off a constant D.C. supply of anything up to 250 volts, and may be regarded as increasing the residual magnetism of the magnetic system. A series resistance consisting of six resistance units (250, 500, 1,000, 2,000, 3,000 and 4,000 ohms respectively) is provided, suitably encased for mounting on the back of the switchboard, and should be adjusted

so that on the descending saturation curve, with the exciter field rheostat cut "all in," the alternator line volts will be between 35 per cent. to 40 per cent. of the normal value. The stabilising winding must be continuously energised when the machine is in service, and its controlling switch must always be closed before, and opened after, the main field switch.

On large machines a separate small exciter is sometimes arranged on the same shaft as the main exciter and provides excitation for the main exciter, thus ensuring absolutely stable and quick operation under all conditions of load.

CURRENT CONSUMPTION OF LAMPS

Watts Rating.	Units per Hour.	Hours per Unit.	Current Consumption, Amperes.									
			6 volts.	12 volts.	100 volts.	110 volts.	200 volts.	210 volts.	220 volts.	230 volts.	240 volts.	250 volts.
15	.015	66.6	2.5	1.25	.15	.136	.075	.0715	.068	.065	.0625	.06
25	.025	40	4.17	2.08	.25	.227	.125	.119	.114	.108	.104	.1
40	.04	25	6.7	3.3	.4	.36	.2	.19	.18	.174	.167	.16
60	.06	16.6	10	5	.6	.55	.3	.286	.27	.26	.25	.24
75	.075	13.3	12.5	6.25	.75	.68	.375	.357	.34	.326	.312	.3
100	.1	10	16.7	8.35	1	.91	.5	.475	.455	.435	.415	.4
200	.2	5	—	—	2	1.8	1	.95	.91	.87	.835	.8
300	.3	3.3	—	—	3	2.7	1.5	1.44	1.36	1.3	1.25	1.2
500	.5	2	—	—	5	4.5	2.5	2.38	2.27	2.17	2.08	2
1,000	1	1	—	—	10	9.1	5	4.75	4.55	4.35	4.15	4
2,000	2	.5	—	—	20	18.2	10	9.5	9.1	8.7	8.35	8
3,000	3	.33	—	—	30	27.2	15	14.4	13.6	13	12.5	12
4,000	4	.25	—	—	40	36.4	20	19	18.2	17.4	16.7	16
5,000	5	.2	—	—	50	45.5	25	23.8	22.7	21.7	20.8	20

OPERATION OF TRAFFIC SIGNALS

By C. CAMERON KIRBY, A.M.I.C.E., A.M.I.E.E.

In this article Mr. C. Cameron Kirby describes how traffic signals are operated by manual and automatic means



A TYPICAL TRAFFIC SIGNAL INSTALLATION.
This shows four two-way traffic signals in operation.

THE increasing density of road transport in recent years and the congestion that already exists in city thoroughfares has grown to such dimensions that free movement of traffic has been considerably hampered. The limitations of the "point duty" policeman are well known, and in the nature of things unavoidable, and in consequence the demand has arisen—and is being supplied—for automatic means to control and direct traffic at many points on our highways. Light signals for traffic control were first installed in New York in 1918, and were manually operated by the police from control towers by special switches. This has since been developed into the completely automatic equipment in use to-day.

The Flexible Progressive System.

A system that has been found to possess many advantages is known as the "Flexible Progressive System." The period for a complete cycle of changes must be of the same duration for all the intersections controlled, but the total time at each intersection may be divided between "main" traffic and cross traffic to suit the volume of each. The timing of the signals as a whole may be adjusted to meet the varying traffic conditions during the day and to permit the continuous movement of traffic at predetermined speed.

Location of the Signal Posts.

The actual location of the signal posts

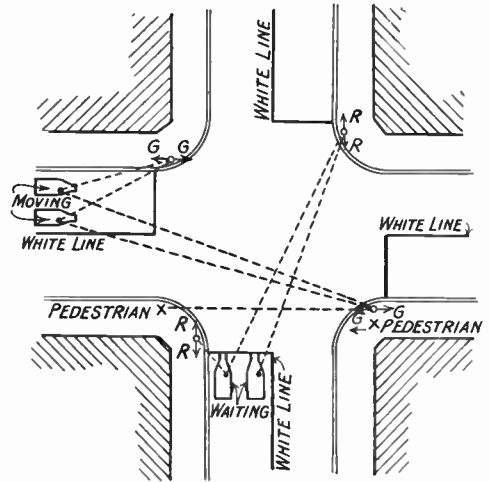
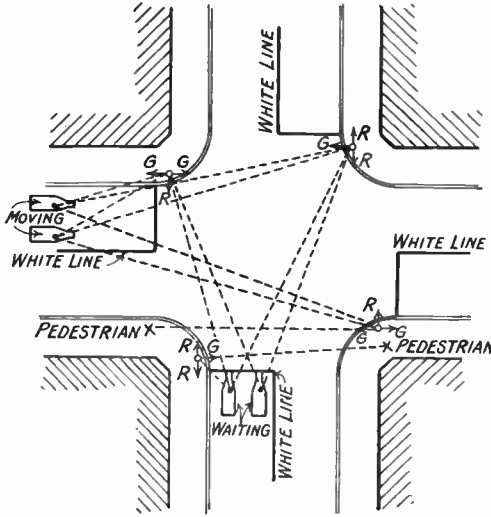

POSITION OF SIGNALS FOR A THREE-WAY SYSTEM ON EACH CORNER.

R = Red light. G = Green light.

<i>Vehicles—</i>		<i>Signals Visible.</i>	
Moving	One or both of the signals on the left, and the far-side signals on the right, if not obscured by traffic.	
Waiting	Two far-side signals and possibly near-side signal on left.	
<i>Pedestrians</i>	..	Correct signal straight ahead at all points.	

POSITION OF SIGNALS FOR TWO-WAY SIGNALS AT 180° ON EACH NEAR CORNER.

R = Red light. G = Green light.

<i>Vehicles—</i>		<i>Signals Visible.</i>	
Moving	Signal on near side to left and/or far side signal on right, if not obscured by traffic.	
Waiting	Far-side signal on right and possibly near-side signal on left.	
<i>Pedestrians—</i>		Crossing on right hand of intersections. Correct signal straight ahead.	
		Crossing in other directions. No correct indication visible ahead.	

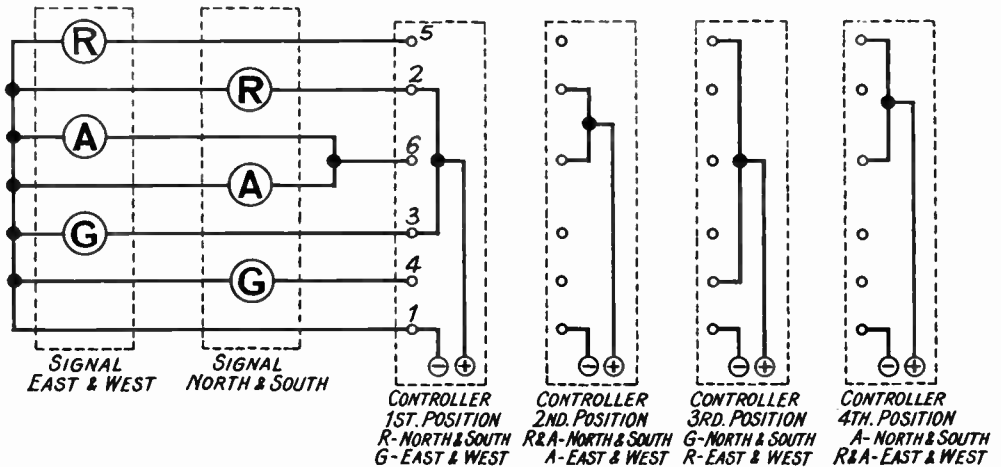

AUTOMATIC TRAFFIC SIGNAL.
Sequence of controller switching operations for one complete cycle.

at a crossing obviously has a direct effect on their utility, and the diagrams show respectively the lay-outs recommended for two-way and three-way signals, the latter type being recommended where it is advisable to afford a guide to pedestrians.

How the Signal Indications are Given.

Each signal consists of three lenses arranged vertically — Red, Amber and Green, with the Red at the top. The signal indications are given in the following order during any complete cycle: (1) Red, (2) Red and Amber together, (3) Green, (4) Amber, and so on. With the majority of signal controllers the time for a complete cycle may be adjusted from about 40 seconds to three minutes, and the periods for Red and Green signals from 25 per cent. to 75 per cent. of the total cycle in either direction. The duration of the Amber signal is adjustable from 2 to 10 seconds, depending on the width of the crossing and speed of the traffic.

Details of the Electrical Control.

From the above it is clear that the electrical control deals with repetitive cycles, each of which contains four distinct periods. Moreover, there are two distinct sets of electric light signals, namely, the North and South light signals, and the

East and West light signals. Further, the duration of each light signal period per cycle has to be capable of variation, and the duration of the cycle itself has also to be capable of alteration. The end of the first period coincides exactly with the beginning of the second period, and the beginning of the third period occurs at the same instant as the end of the second period, etc.

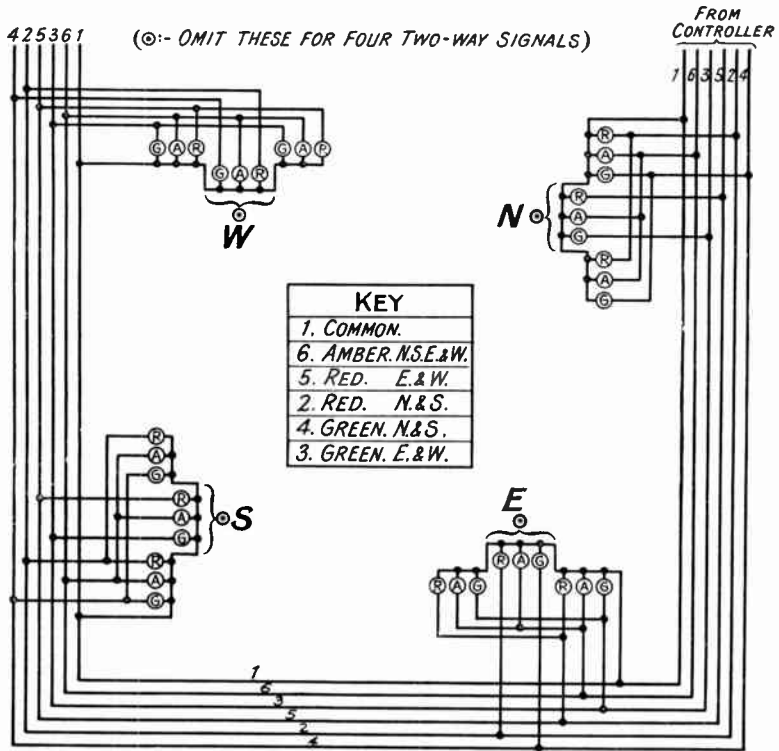
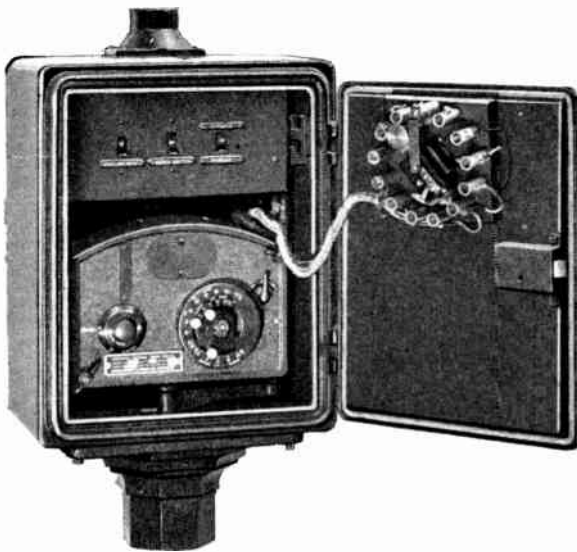

DIAGRAM OF CONNECTIONS OF AUTOMATIC TRAFFIC SIGNALS. This is for four three-way signals to give red-amber change period.

The Switches.

Consequently four switches are required, each one to light up the lamps required for the particular period. These switches are interlocked, either mechanically or electrically according to the particular make of control mechanism, so that this definite sequence of switching operations is performed. The schematic diagram of connections for these operations shows a



VIEW OF TIMER OF TRAFFIC SIGNAL CONTROL BOX.

The three white knobs shown in the lower right-hand side are for varying the relative positions of the cams.

main road signal (i.e., North and South) and a cross-road signal (i.e., East and West) with the connections to each of the four positions comprising one complete cycle. The polarities have been marked with a + and a - sign to facilitate tracing out the flow of current and do not necessarily indicate that direct current is used. Signals are made to work satisfactorily on both A.C. and D.C. circuits.

How the Four Switching Positions are Obtained.

These four switching positions may be obtained by the use of four individual switches, or as is adopted in some cases, by the use of a "drum" controller.

This sequence may be briefly tabulated as follows :—

No. 1 switch closed, or controller 1st position :—

Red showing north and south streets.

Green showing east and west streets.

No. 2 switch closed or controller 2nd position :—

Red and amber showing north and south streets.

Amber showing east and west streets.

No. 3 switch closed or controller in 3rd position :—

Green showing north and south streets.

Red showing east and west streets.

No. 4 switch closed or controller in 4th position :—

Amber showing north and south streets.

Red and amber showing east and west streets.

How Signal Posts are Connected to the Control Box.

For the actual connections from the control box to the signal posts a six-core cable is run; this usually consisting of conductors of 3/.029 in. or 3/.036 in. soft tinned copper wires. Each core is covered

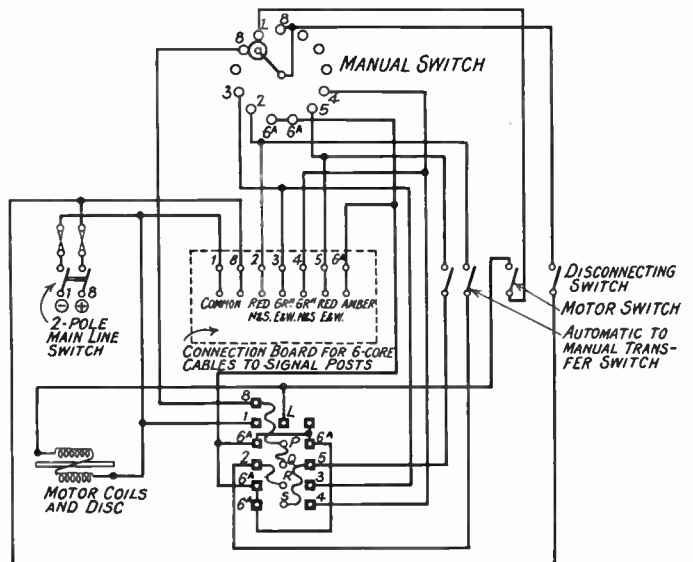

INTERNAL WIRING OF CONTROL BOX FOR AUTOMATIC OR MANUAL OPERATION.

with a distinctly coloured braiding which facilitates the connection of the signal post wiring to the correct terminals in the control box. The wiring diagram shows the various cores to which individual signal lights are connected in order to give the correct sequence of signals. This diagram should be studied in conjunction with the diagram of connections.

The Barcol Controller.

There are many types of control boxes on the market and various methods are employed to achieve the same final result. One type which has been in successful operation for some years is the Barcol controller, which consists of a motor driving a camshaft through reduction gearing, the various cams operating the four switches necessary to work the signal lights.

Motor Used in A.C. Systems.

In the case of alternating current systems the motor consists of a Foucault or eddy current disc similar to those in use in ordinary A.C. house service meters, with two field coils, one above and one below the disc, and these are connected in opposition. The interaction of the energised field coils, each having the same magnetic polarity at any instant, induce a current in the disc of opposite magnetic polarity, and accordingly the disc rotates like a simple single-phase motor.

Varying the Speed of a Complete Cycle of Operations.

One of the two field coils is attached to a movable bracket and this can be adjusted to bring the field either nearer the centre of the disc or farther from this point. If the field is moved out to the circumference, the effect is that of a retarding force acting with a larger arm or fulcrum, and the motor slows down. This lengthens the time for a complete cycle of operations. Moving the coil towards the centre of the disc shortens the cycle. This adjustment is made by hand on the face of the control box, whilst the installation is in operation.

Adjusting the Timing of the Signals.

In addition to varying the total cycle, it is necessary to allot varying proportions of the cycle to the N.S. street and the E.W. street, and to vary these according to the volume of traffic existing at any



EXTERIOR VIEW OF TRAFFIC SIGNAL CONTROL BOX.

Showing where the handle fits when manual working is employed.

particular time of the day without shutting down the signals. This is accomplished by varying the relative positions of the cams. The three white knobs shown in the lower right-hand side of the controller photograph are for this purpose, two being for the period of duration of amber light in each direction, and the third enabling the proportion of time for main street traffic to be varied from 75 per cent. to 35 per cent. of the total period.

Working the Signals by Hand.

The tubular pillars shown on the inside of the door are contactors brought into use when the signals are manually operated. The external view of the box shows where the handle fits when manual working is employed.

Internal Connections of Controller.

At the top of the diagram of the internal connections for the Barcol controller are shown the connections to the hand-operated controller, which is normally in the position indicated, i.e., making

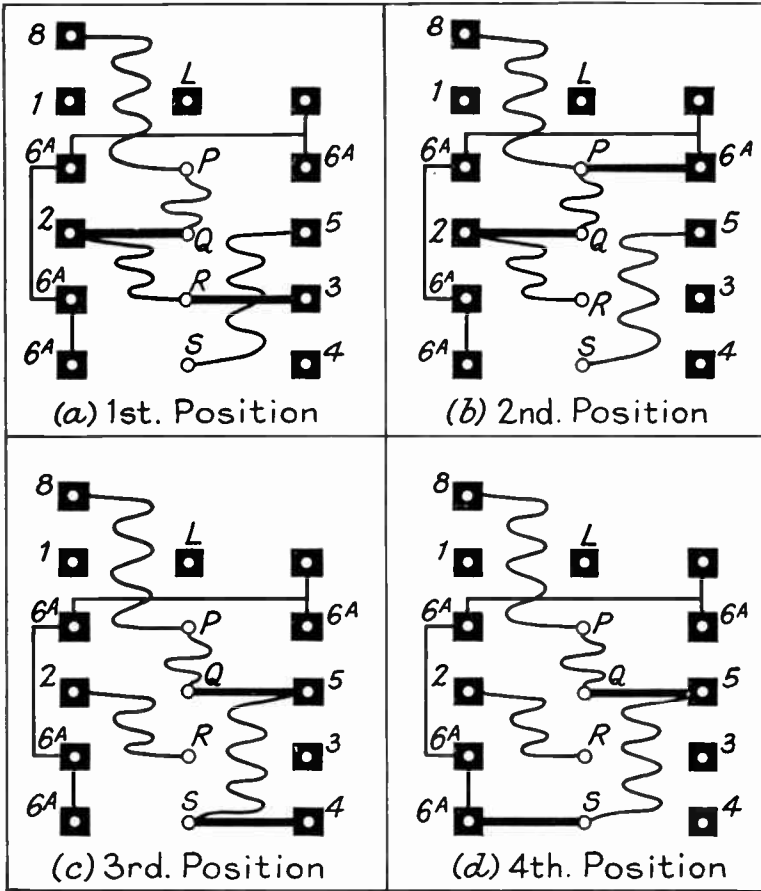

CAM-OPERATED SWITCHES.

Showing sequence of switching operations for one complete cycle.

connection between contacts L and 8, and the handle is so interlocked mechanically with the contactor spindle which it operates, that it cannot be taken off in any other position. For manual operation the handle is moved downwards from the position shown in an anti-clockwise direction, pausing at position 3, 2, to give the right of way to E.W. traffic, moving on to 2, 6A, to show Amber, etc., for clearing the crossing and moving on to the 5, 4, studs in favour of the N.S. traffic. Having reached this position the handle is brought back in a clockwise direction, and after the 5, 6A, studs are cleared the cycle is repeated.

Position of Control Box.

The control box is always placed in

such a position that the policeman operating the signals manually can observe the movement of vehicles and give a longer or shorter period in favour of each street as may be required. When changing over to the signals to automatic operation, the officer opens the double-pole switch shown on the middle left, and switches in the motor switch.

Cam - operated Switches.

The cam-operated switches are depicted at the bottom of the diagram. P, Q, R and S are switches connected to the supply by flexible leads and are moved by the cams either to the right, or left, in an horizontal direction, making contact with the fixed studs as shown. The supply

connection is brought to No. 8 contact and conducted via the flexible leads to the moving contacts or switches. These switches take the current for lighting the signals to five of the cores of the six-core cables, only two of these cores being alive at any one time. The sixth core, that numbered 1 in the diagram is the common return, and may be assumed to be at earth potential. This core is connected directly to the connection board shown in the centre of the diagram and has no switch in circuit with it, apart from the main switch.

The last illustration shows diagrammatically the four positions of these cam-operated switches which occur during the operation of a complete cycle.

THE C.T.S. WIRING SYSTEM

The C.T.S. wiring system is too well known to electrical engineers to need a lengthy description. We hope, however, that these notes will prove useful to those who have occasion from time to time to estimate for outdoor and factory wiring schemes, and also for temporary wiring installations

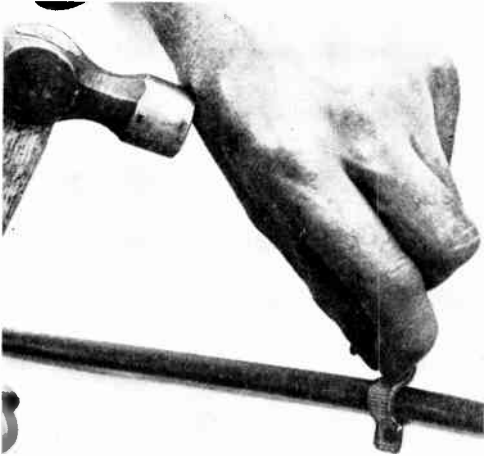

SHOWING THE RUNNING OF THE CABLE AND FIXING WITH LEAD SADDLES.

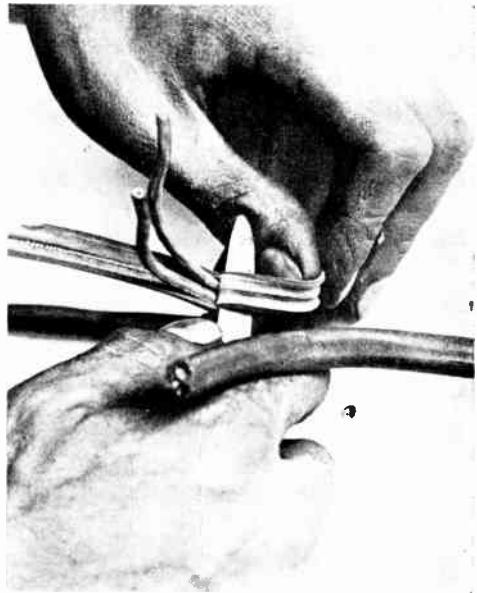

TWO CABLE ENDS BEING TRIMMED READY FOR PASSING THROUGH PATERAS BLOCK.

THE illustrations given in the following pages show at a glance the work involved in using this particular system on wiring schemes. This class of wiring is particularly suitable for use in factories and workshops, especially where flexible leads are required for supplying current to accessories such as electric drills, inspection lamps, electrically driven air compressors, etc. It is also ideal for use in wiring outdoor extensions such as garages, home workshops, etc. Very little description of the system is necessary for the practical man, but there are just one or two points to which special attention may be drawn.

It may be remarked that this system, unlike the metal sheathed surface systems,

requires no bonding at switches, junction boxes and other fittings.

Running the Wires.

The simplest method of running the wires is by using lead saddles as shown in the first illustration. These are usually cut from lead strip on the job. Ordinary nails are quite suitable for securing the saddles if the wiring is being carried along a wooden partition, but in the case of brick or stone walls Rawlplugs can be used most effectively.

It will be seen from the second illustration above that the twin or multi-cored wire has an outer sheath which must be removed before the separate wires can be

G

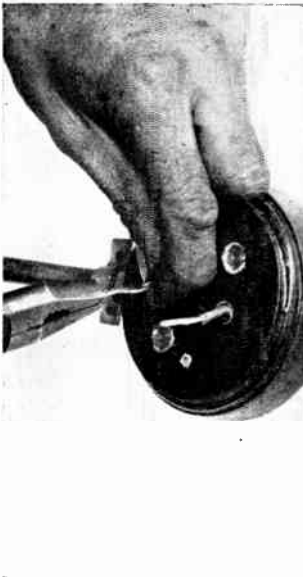

TWISTING CABLE ENDS AFTER PASSING THROUGH AND FIXING WOOD BLOCK.



FIXING CEILING ROSE TO BLOCK AND MAKING CONNECTIONS.

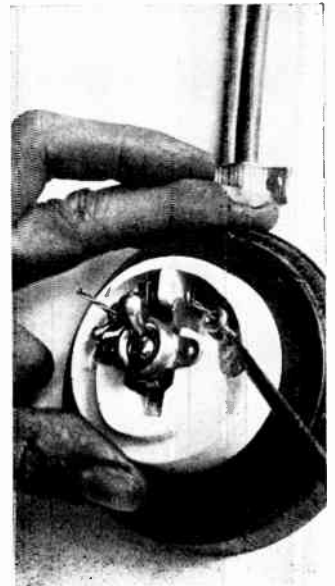

STANDARD TUMBLER SWITCH (ASSEMBLED), SHOWING WIRES BEING CONNECTED.

prepared for insertion into the ceiling rose or switch. In making all terminal connections, care should be taken to twist the strands together as shown so as to get the best possible contact.

Composition Fittings.

The illustrations show 2-way and 4-way junction boxes suitable for use with this system of wiring. The last illustration shows one of the commonest applications, viz., for supplying power to portable electric tools. The sturdiness of the insulation renders this cable much more suited to workshop conditions than the ordinary twin flex. It is unaffected by moisture, acid fumes or paint. It is extremely flexible, and owing to the fact that the outer covering is of tough rubber there is practically no danger of accidental shocks.

Uses in Chemical Works.

In situations where corrosive fumes or specially damp atmosphere is likely to be met with it is important to use with this system corrosion proof fittings and a sealing compound should be used for protecting the exposed ends of the wires.

The metal fastenings for the saddles should be painted.

For Greater Safety.

Wherever C.T.S. cables are used for supplying current to portable electric tools, small D.C. or single-phase motors, etc., 3-core cables should be used. Two of the cores are for supplying the appliances with current, and the third core should be used for earthing the casing of the machine.

Improving the Appearance.

Wherever the appearance of a job is of importance, for instance in offices attached to works, where this system is in use, it is recommended that the wiring should be run in wooden casing. A special type of casing can be obtained for this purpose. The cable is held in position by special clips which take the place of the ordinary lead saddles, and each clip is provided with side extensions which grip the sides of the wood casing.

We are indebted to the St. Helen's Cable and Rubber Co., Ltd., for facilities for staging the illustrations which accompany this brief description of the C.T.S. cable systems.

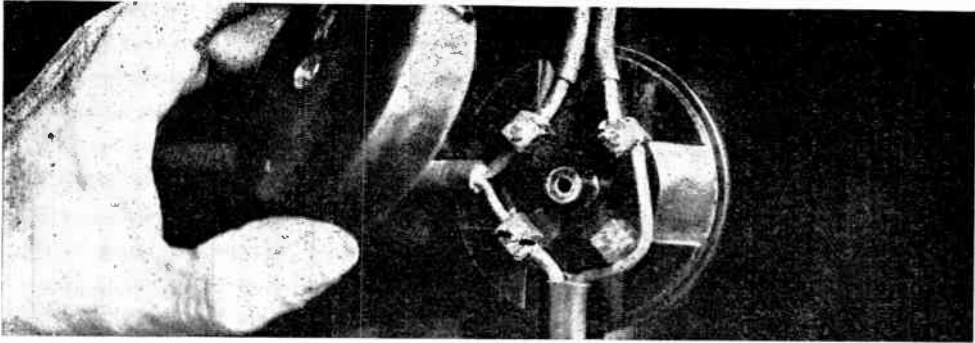

STANDARD C.R. FOUR-WAY CONNECTOR BOX, WITH VARIOUS SIZES OF SINGLE AND TWIN CABLES, COMPLETE WITH COVER.



HOW TO MAKE A JOINT, USING THE STANDARD C.R. STRAIGHT-THROUGH (TWO-WAY) CONNECTOR BOX.

This method has superseded the old method of twisting cable ends together after stripping, insulating and taping, and is now a standard practice.

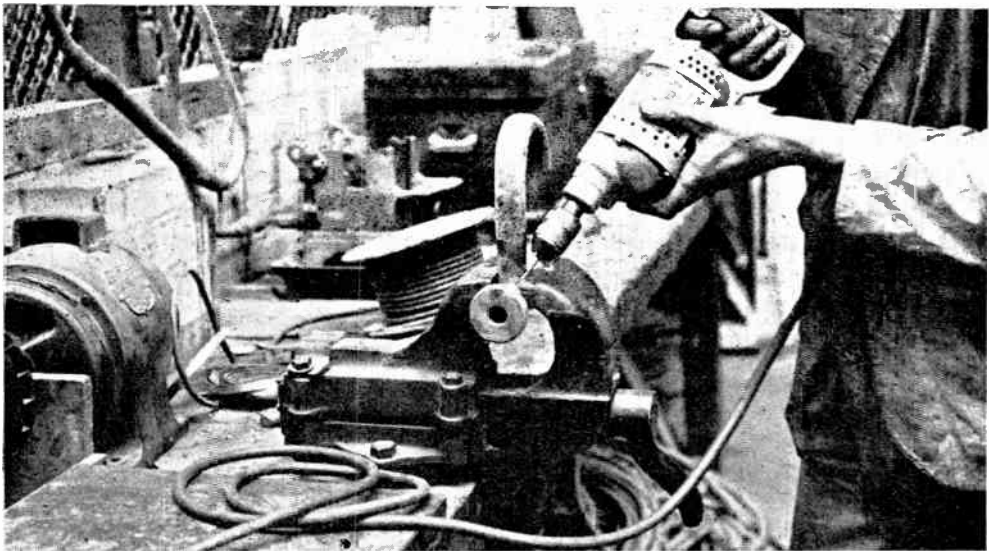

USING CAB TYRE SHEATHED FLEXIBLE CABLE IN CONNECTION WITH PORTABLE TOOLS, I.E., BENCH DRILL IN WORKSHOP.

HOW TO EXPLAIN ELECTRICAL TERMS IN A SIMPLE MANNER

This article is intended to show electrical engineers how they can explain electrical terms in a simple manner when the occasion arises

THE electrical engineer, especially the man who is connected with the commercial side of the industry, often has occasion to explain electrical terms in a simple manner to householders who may be contemplating the use of electric irons, fires, etc. The following notes will prove very useful in helping people to visualise what terms such as "amperes," "kilowatts" mean in relation to the cost of using electrical accessories.

Water as an Analogy for Electric Current.

Visualise your electric current as water passing along a pipe. A pipe will only convey according to its size a certain number of gallons per hour. Similarly, an electric cable will only take a certain flow, in this case known as amperes. The following will be helpful in roughly estimating the cost of installing points:—

Size of Cable.	Maximum Current.
1.045	6 amps.
3.036	12 "
7.029	18 "
7.036	24 "
7.044	31 "

These figures are for normal runs of not more than 40-50 feet from the plug to the fuse board. If the length is much greater intermediate fuse boards should be fixed or the size of the cable increased.

Electrical Terms in Simple Language.

Continuing the idea that electricity in a cable corresponds to water in a pipe, you can easily explain the following electrical terms to the non-technical customer.

Ampere.—This is the volume of electricity flowing down the main.

The Volt.—This is the pressure of the electricity, and corresponds to the pounds

per square inch of water pressure in a pipe. The voltage, of course, is determined by the supply authority for the district.

The Watt.—This is a term of measurement. It is found by multiplying the "volts" by the "amps." One thousand watts is known as one kilowatt, or usually one KW.

Explaining the "Ohm."

Water flowing along a pipe encounters a certain amount of friction. Electricity flowing along a cable also encounters friction, which is known as the ohm. This was named after a celebrated scientist who evolved what is known as "Ohm's Law." This simple equation is one which will help the electrical engineer in practically every visit he makes when explaining his particular appliance, and it is that:

$$\text{Amperes} \times \text{Volts} = \text{Watts.}$$

Finding the Cost of Using an Electrical Appliance.

From this he will be able to explain how to arrive at the cost of using any electrical appliance, for example:—

An electric iron, on which the makers put "2 amperes; 200 volts will consume $2 \times 200 = 400$ watts."

Electricity is measured by units, and the Board of Trade have set out a standard which lays down that 1,000 watts used for one hour constitute one unit. Taking the above example, in which it was found that the iron consumed 400 watts, this means that the iron consumes 400 watts in one hour, or one unit in

$$\frac{1,000}{400}$$

or just over two hours; in other words, the householder could be told the iron will use a unit of electricity in just over two hours' use.

Giving Advice About Heating.

In estimating the size, or advising on the size of fire or heating appliance necessary, a fair basis to take is that one kilowatt will raise 800 cubic feet of air approximately 7° in one hour, or, allowing for the average position and window space of the ordinary room, 1½ watts per cubic foot of space will be sufficient.

Local conditions, of course, will vary this, but here a higher technical knowledge and study of heating will be necessary to arrive at definite and accurate results, but for ordinary purposes the figures given above will suffice.

Water Heating.

The average family of four to five persons require approximately 50 gallons of hot water daily, at an average temperature of 120° to 150°.

Temperatures.

The following will be found useful data:—

Cold water temperature ..	50° F.
Room temperature	60° F.
Bath temperature	100° F.
Washing-up temperature ..	120° F.
Boiling temperature	212° F.

With the average electric appliance one kilowatt will boil two gallons of water in one hour.

To ascertain the capacity of a rectangular tank:—

$$\frac{\text{Height} \times \text{Width} \times \text{Depth}}{276} \text{ (in ins.) = galls.}$$

1 gallon = 276 cubic in.

1 lb. water = 27.6 cubic in.

Hints About Cooking Appliances.

The average cost of cooking for domestic purposes for the average family up to six persons is one unit per person per day.

For hotels and restaurants the cost varies with the type of meals produced, but for the average meal it is half a unit per person per meal. This is for a standard two or three-course dinner.

STAND-BY LIGHTING SUPPLY FOR CINEMAS

The idea that gas, oil lamps or candles provide a satisfactory secondary lighting system in cinemas is rapidly being dispelled in most places, but there are still a few diehards who are not well disposed to electricity.

As a result of an intensive campaign by the battery makers to influence licensing authorities favourably to regard electricity as the best medium for the cinema safety lighting system which the Home Office regulations demand, large numbers of cinemas are being equipped with storage battery installations.

The Accumulator Makers' Association has gone further by issuing the neat lantern slide shown here to the cinemas so equipped,

which informs the audience that the cinema management has assured the public safety and comfort by installing a storage battery which will maintain the light in the building even though the surrounding district may be in darkness.

Apart from the expressions of appreciation of this service from cinema managers it is another step in the direction of bringing the public to that state of "electrical mindedness" which will help in the loading of the distribution centres of the grid.

Cinema engineers who would like to have fuller details can obtain them from the Accumulator Makers' Association, 66, Victoria Street, S.W. 1.



THE LANTERN SLIDE.

THE ILLUMINATION OF STAGE PLAYS

By FENTON J. HURST

Stage lighting is a subject of great importance to electrical engineers. In this article will be found an outline of the apparatus used and the effects that can be obtained by stage lighting electricians

THE art of illuminating stage plays in this country—although fairly well established—has not received the amount of attention that its importance warrants.

Especially is this so in circles devoted to the production of amateur theatricals, concerts and other functions which are presented from a staging and viewed from the usual auditorium or balcony of what often purports to be a first-class hall. The legitimate theatre, especially in provincial districts, is also frequently sadly lacking from a production point of view as regards stage lighting and its control.

The Art and Science of Stage Lighting.

The lighting of stage plays is a science and an art. It is a many sided art, but there are certain fundamentals that must be observed if stage plays are to be presented successfully. Light on the stage is not only necessary in order to permit the audience to follow the action of the play, but it is also a medium whereby certain mental efforts may not only be created to follow the play as the author planned it, but to make the playgoer yield himself body and soul—for the time being—to the intricacies of the plot and the machinations of the different characters

Efficient Apparatus Necessary.

This cannot be done without efficient apparatus, which must be capable of covering the whole of the principles of correct illumination. Glaring sources of visible light on the stage, for example, would tend to focus attention on the lighting and not on the presentation. It would also fatigue the eye and cause irritation to the audience.

All sources of light must carefully be concealed, and where it is necessary to provide a visible "property

light" such, for example, as a lighting standard in a supper table or bedroom scene, this must merely be rendered sufficiently luminous to fulfil its apparent function. In no sense must it form a part of the general illumination of the stage.

Standardised Stage Lighting Equipment.

The aim of stage lighting is to provide lighting of any intensity, hue or tint, whenever it is required. This needs efficient apparatus and capable control. Most of this equipment, although it is not generally known, is standardised, and can be bought and installed in the same way as the more widely known home electrical fittings, such as switches, lampholders and the like. In the main it consists of some

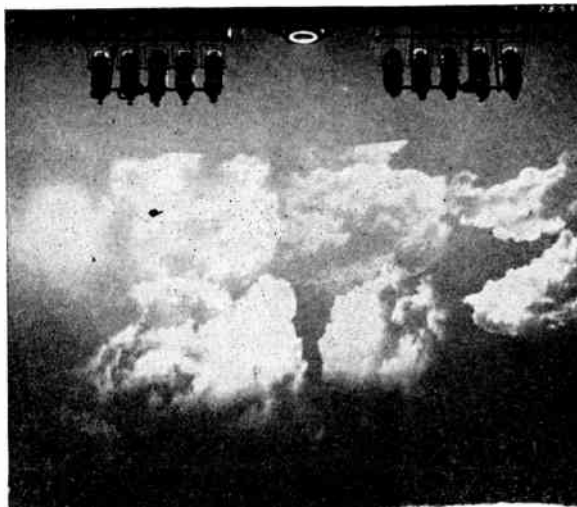

A CLOUD PICTURE, SHOWING BOTTOM TIER OF HORIZON COLOUR FLOODS.

This effect is obtained by using a cyclorama.

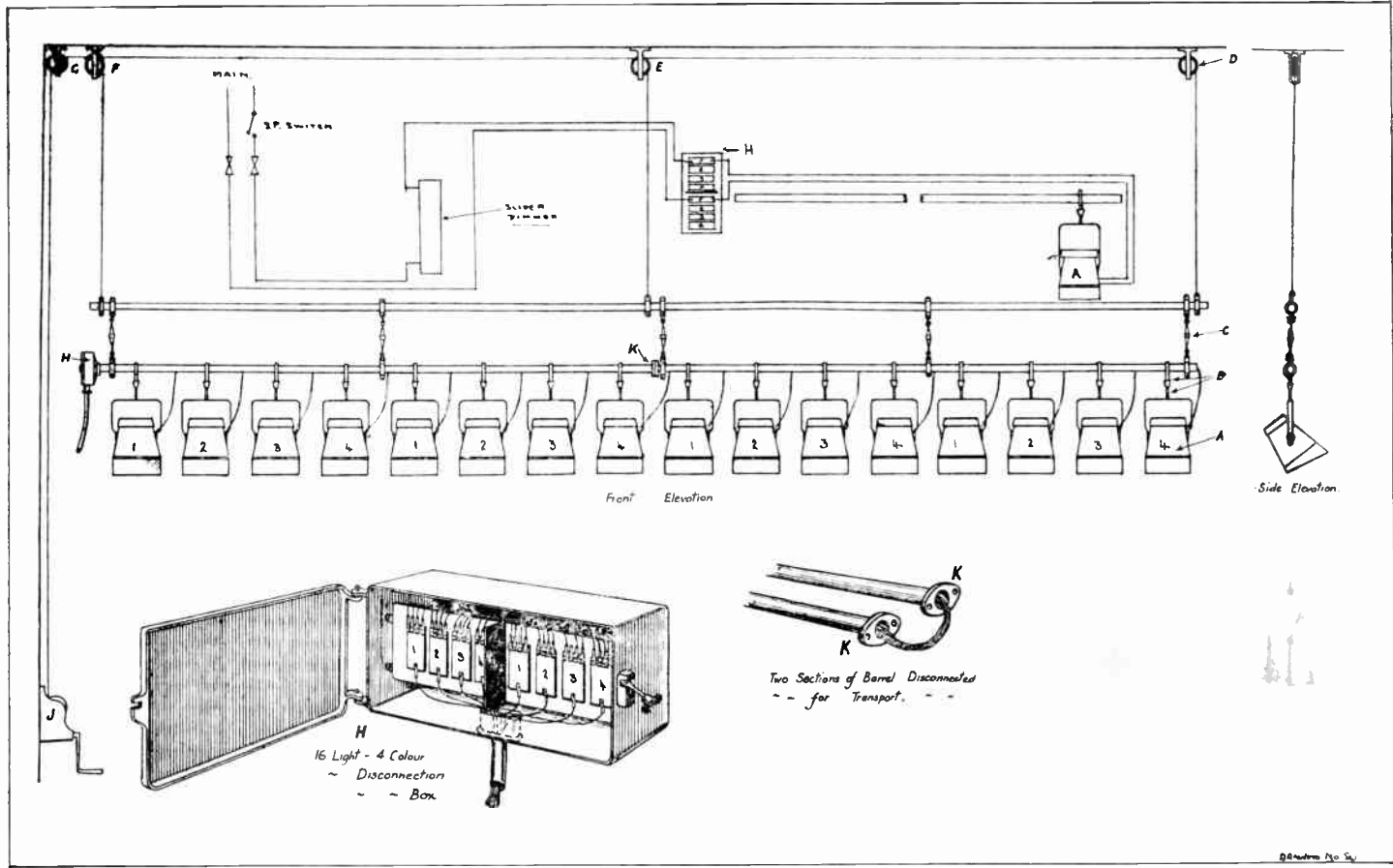

ARRANGEMENT OF SUSPENSION FOR GENERAL ELECTRIC CO. FLOOD BATTEN.

A, S.L. 166, 500-watt box type floods; B, pipe clip and adaptor; C, batten suspension gear; D, E, F, one-way batten pulley; G, three-way batten pulley; H, disconnection box; J, three-compartment batten winch; K, oval flanges for disconnecting two pieces of barrel for transport and for assembly.

DIAGRAMATIC LAYOUT OF
STAGE LIGHTING SWITCH-
BOARD AND LIGHTING
EQUIPMENT.

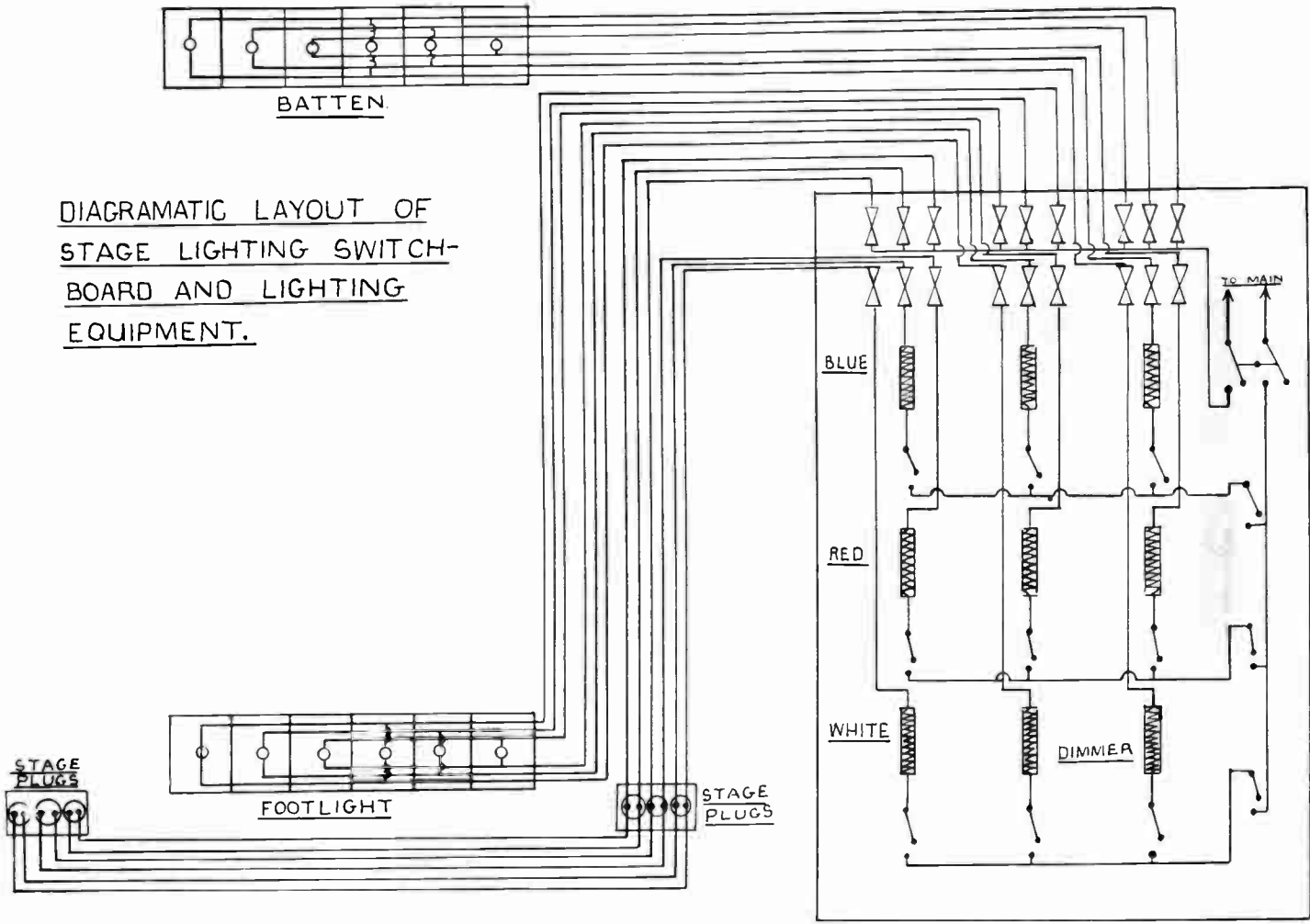

DIAGRAM OF SWITCHBOARD TO DIMMER WIRING FOR STAGE LIGHTING.

half a dozen items which will be found suitable for both large and small halls. Generally speaking, these may be summarized as follows: footlights, battens or border lights; wing floods, acting area floods and spotlights of various orders according to the size of the hall or stage. Provision must also be made for the control of the lighting by this equipment, such as by a switchboard, dimming apparatus, etc. This plant should be installed in a convenient operating chamber from which the electrician can command a full view of the stage in order that he may control the lighting in accordance with the instructions of the producer.

The Cyclorama.

Other and more costly apparatus may here be cited, such, for example, as the cyclorama, for producing an artificial sky or horizon, the latter consisting of a creaseless white cloth running on a curved rail at the extreme rear of the stage, and which is easily folded up whenever required. By the aid of special projectors with motor-driven optical effects, many charming horizon settings are easily produced.

Effects Produced by Using the Cyclorama.

The projections may simulate a clear blue sky across which fleecy clouds float gently by, a darkened storm sky, or a pleasant twilight evening. Rain, lightning and other effects are also easily contrived by auxiliary "effect" attachments. Where a cyclorama is used there is necessarily less scenery required, so that, although it is fairly costly to install, the cost may easily be covered by substantial savings in outlay on scenic items. When cyclorama scenes are being operated, the usual standard stage lighting is usually reduced by means of dimming or blacking out, so that the lighting from the footlights or overhead battens does not overwhelm the delicate colour tones that form so pleasing a feature of a cyclorama background or horizon setting.

Footlighting Apparatus.

But let us return to what we may call the "bread and butter" necessities of stage lighting. First, every stage must

have footlights. Footlights to-day are usually sunk in a trough below stage level and their function is to provide strong general illumination from the stage level to intensify the facial expression of the performers, and as a set-off against shadows cast by the overhead frontal lighting battens or border lights.

Footlights are usually of one of three types, viz., trough, magazine or combined direct-indirect.

Trough-type Footlights.

The first is a simple metal trough fitted with a given number of lampholders, each of which must be lamped, usually spaced about six inches apart. The inner reflective surface may be painted white or lined with a polished metal reflector element. Its principal merit is cheapness, and although now almost obsolete, will answer quite well for small stages of church halls and the like, where the more elaborate magazine type is considered too expensive.

Using Coloured Lamps.

The trough type may be wired on any number up to four circuits, and can be equipped with coloured lamps, spaced in the order white, red, blue and amber, or colour screens, when very telling effects can be obtained. Suitable wattage lamps must, however, be employed, or there will be a lack of light owing to absorption by the colours.

Magazine-type Footlights.

The magazine or compartment type footlight has now largely superseded its predecessor, the simple trough type. As its name implies, it is made up in a series of compartments, each with its own individual reflector containing a single lamp. Each lamp is usually spaced at 6 in. centres which, fitted in front of reflectors of polished aluminium, stainless steel or glass, provides a higher intensity of illumination than the trough type.

Again, three or four colour circuits may be employed, the wiring being carried in a separate channel at the rear of the fitting. Colour mediums, either of glass—in which case strips should be employed in preference to one piece glasses—allowing for expansion by heating—or what are more

generally used nowadays—gelatine colour mediums. Either are held in position by wire frames. As modern practice decrees that footlights should be let in flush with the stage, it is necessary that the fittings should be amply ventilated, either by a series of holes or louveres.

Combination Direct-Indirect Footlights.

The direct-indirect type is little used in this country. It possesses certain merits however, but could not be recommended for installing around a curved stage. It is essentially a straight front stage footlight. It is not elaborate in character. In the main it consists of separate lamp sections mounted on a spindled framework which can be rotated through 180° the whole length of the fitting. Normally it functions directly, but when rotated its light impinges on to a curved metallic reflector which re-reflects light of slightly lower intensity upwards. By rotation, of course, the intensity varies through this half-circle.

This type is frequently wired for five circuits and usually the lamps are spaced at 4 in. centres. Rotation through its orbit with different coloured lamps gives great variation of lighting, and dimmer control is not absolutely essential. This type is eminently suitable for cyclorama presentations. Usually footlights are subdivided into 3 ft. or 5 ft. sections depending, of course, on the number of connections it is desired to control from the switchboard.

Battens.

These are generally used for frontal curtain lighting also in conjunction (with footlights). They are wired similarly to footlights and suspended on barrellings with raising and lowering adjusters, but for fear of falling glass on to the stage, gelatine colour mediums only must be employed.

Floodlights.

Next we come to floodlights. These are of various kinds. Acting area or box floods for providing downward illumination over the acting area of the stage, and wing and perch floods. Wing floods are

portable and are designed to be plugged into conveniently situated sockets on the stage. They may be single, double or triple floods, mounted on a telescopic stand on a heavy base equipped with 500, 1,000 or 1,500 watt lamps. Perch floods are installed in fixed positions overhead and above the proscenium opening. Mobile ground floods are also used extensively for supplying lower stage lighting from the wings. These may have colour screens if it is desired to introduce colour at the base of the scenery.

Spotlights.

Spotlights come next, and they are designed, as their name implies, to throw a concentrated beam of light on to a performer or a setting. In small halls what are known as "baby spotlights" are used. These are very inconspicuous, quite effective and can be installed almost anywhere. Long throw spotlights, familiarly known as "front of house projectors," are necessary for large halls where throws of 100 ft. and upwards are necessary, but they are so practical nowadays for illuminating either one performer or the whole stage, or introducing effect lighting, that they are always worth investing in. In fact, apart from the footlights and battens, they are almost a lighting installation in themselves.

Switchboards and dimmers, both liquid and metallic, and control apparatus, although governing stage lighting, are frequently harnessed to the general lighting.

Regulations Regarding Stage Lighting.

It will be appreciated that only the barest fringe of the art and science of stage lighting has been touched on, and readers who desire more detailed enlightenment on this fascinating subject, particularly as to wiring details and control, would do well to study the official handbooks issued by the Institution of Electrical Engineers, containing the many regulations applying to this subject, as it is impossible to quote the whole of the regulations here—varying as they do for different types of halls according to their seating capacities.

RESISTANCE NETS FOR ELECTRICAL PURPOSES

In this article will be found some practical advice on using resistance nets for building up resistance units for use with motor starters, accumulator-charging plant, etc.

AN excellent method of building up electrical resistance units for accumulator-charging plant, motor starters, dimmers, and similar appliances, is to utilize resistance nets as clearly explained and illustrated in the following article.

Description of Nets.

The nets consist of resistance wire woven between asbestos yarn, the complete net being perfectly rigid and free from vibration.

The wire used is nickel-copper alloy. Flat-ribbon is also used in place of wire for nets of large current capacity.

Ohmic Value and Range.

Regarding the accuracy of the ohmic value of the resistance nets, for ordinary commercial purposes, the nets are usually wound within plus or minus 5 per cent., but for special requirements they can be calibrated to within 1 per cent. accuracy.

The standard range of resistance nets is from .093 to 54 amperes for single nets,

but by connecting several nets in parallel, resistances up to 700 amperes capacity have been successfully constructed and operated with entire satisfaction.

Method of Connecting to Obtain Requisite Value.

Standard resistance nets are provided with two flexible connections. They can also be supplied with the addition of "short loops" for short circuiting a few turns to cut out some of the resistance. Selvedges or "fixing margins" are provided on two opposite sides of each net.

For regulating resistances, shunt and series regulators, the nets are supplied with tappings —5, 7 and 8 steps according to requirements. A combination of resistance nets will make up a shunt regulator resistance of any conceivable capacity.

PRACTICAL EXAMPLES.

A Typical Motor Starter.

To make up a resistance suitable for a 5-H.P., 400-volt direct current motor starter, five type A.C.1 nets connected

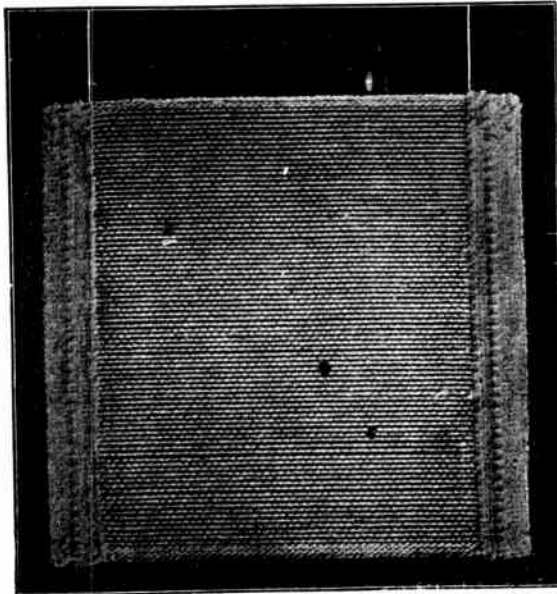

AN ASBESTOS WOVEN WIRE RESISTANCE NET.

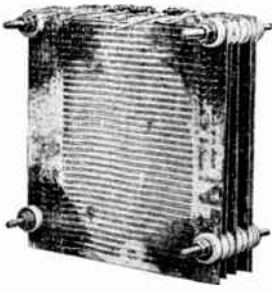

HOW A MOTOR STARTER OR SHUNT REGULATOR IS MADE UP.

This shows the bank of nets (or resistance bank) ready for mounting.

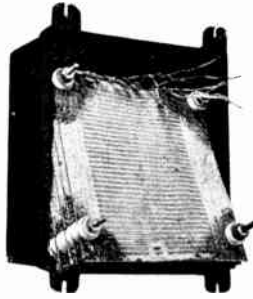

SECOND STAGE IN MAKING UP A MOTOR STARTER OR SHUNT REGULATOR.

Showing the resistance unit being fitted with the box.



THE MOTOR STARTER OR SHUNT REGULATOR COMPLETED.

Showing the complete resistance unit mounted in ventilated box.

in parallel would be required. The nets would have seven tappings and are suitable for a starter having 8 studs, i.e., seven equal steps.

First Build up the Nets to Form a Complete Resistance.

These nets are made in different sizes to suit the starter case and assuming that the correct size nets have been obtained (in this case $7\frac{3}{8}$ in. by 8 in.) the next step is to build up the nets to form a complete resistance ready for mounting inside the starter case.

First, four pieces of mild steel rod 6 in. long and threaded throughout, are obtained. On to each piece of rod mica tubing $\frac{1}{4}$ in. hole by $\frac{3}{8}$ in. outside diameter are threaded.

Placing the Nets on Mica-insulated Rods.

The resistance nets are now placed on the four mica-insulated rods, care being taken to see that a porcelain spacing washer of the

correct size is placed between each net and one at each end.

An ordinary washer and nut is then slipped over each piece of steel rod still projecting (about $\frac{1}{2}$ in. to $\frac{3}{4}$ in.) and the whole screwed up tight. The resistance is now complete and ready for fitting into the starter case.

The connections between contact studs on the starter and the corresponding tappings on the resistance nets can now be completed and the starter made ready for service.

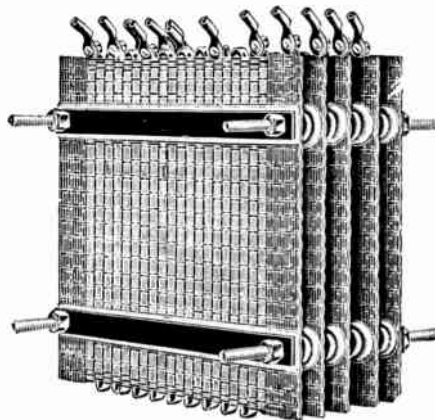

DETAILS OF A COMPLETE RESISTANCE.

Comprising five resistance nets. Note the tappings at the top of the nets for motor starter or shunt regulator.

An Accumulator Charging Resistance.

Resistance nets of the type described in the foregoing paragraphs form an ideal resistance unit for accumulator charging and are made up in exactly the same way as for motor starters, assuming that it is desired to vary the charging rate and that a radial type battery charging resistance is to be employed.

When a battery charging resistance with a fixed charging

rate is decided on, ordinary resistance nets with two flexible connections (no tappings) are employed. The nets are then suitably connected and mounted inside the resistance case and the connections completed.

A Lamp Dimming Resistance.

This type of dimming resistance is similar in appearance to the standard protected type front-of-board shunt regulator and is operated in the same way.

The method of building up the resistance from the nets is again precisely the same as in a motor starter.

It should be noted, however, that for all

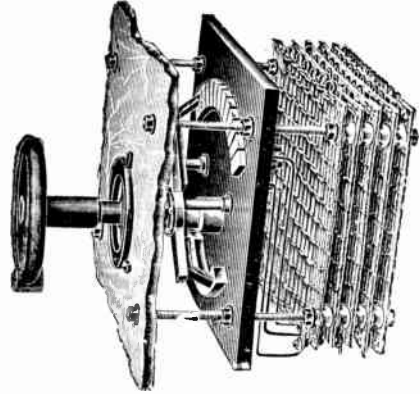

VIEW OF BACK-TO-BACK BOARD TYPE REGULATOR, WITH COVER REMOVED.

This shows the resistance nets fitted and connected at the back.

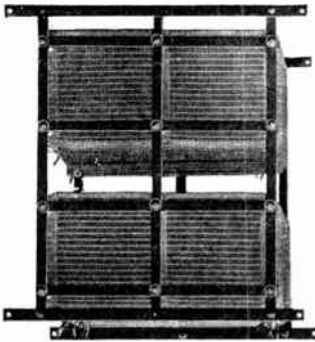

DOUBLE RESISTANCE BANK MOUNTED IN IRON FRAMEWORK.

apparatus in which the resistance is to be in circuit for long periods, continuously rated nets for cool running must be employed, otherwise there is the danger of the resistance getting hot.

Making up a Heater for Drying-out Transformers.

A typical electric heater for drying-out transformers would be made up as follows: The heating elements consisting of standard resistance nets (with two copper flexible connections only) would be fitted into

insulated iron frames. As many nets as required would be made up in this way and connected in parallel until the total loading of the heater would be, say, 5 K.W.

The frames holding the nets are now bolted together or dropped into grooves or slots which form the frame of the heater.

Where Obtainable.

These nets are manufactured in all required sizes by the Cressall Manufacturing Company, of 31 Tower Street, Birmingham, 19, who will be glad to answer any technical enquiries on the subject.

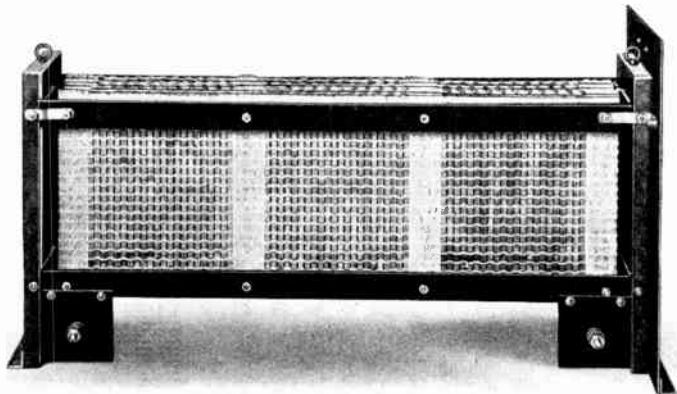

A TYPICAL ELECTRIC HEATER FOR DRYING OUT TRANSFORMERS. The heating elements consist of standard "Cressall" heating nets.



The Editor invites correspondence from readers on any subject of general interest to members of the electrical engineering profession. Letters should be addressed to THE EDITOR, The Practical Electrical Engineer, 8-11, Southampton Street, Strand, W.C.2.

The Diesel Electric Generator.

SIR,—The problem your correspondent A.P.Q. mentions is of considerable importance and is many-sided.

Undoubtedly the efficiency and reliability of the Diesel or other oil engine driven generator will steady any tendency of the "Grid" supply to overcharge consumers who use a fair amount of power.

This is undoubtedly necessary, as one or two syndicates, controlled to some extent by American capital, are attempting to form a closed ring round all industrial districts with the object of squeezing from the consumer every farthing he can be made to pay.

The small and medium oil-driven set will give the manufacturer and the large city store an alternative method of obtaining power and light, and for a time at perhaps a lower cost.

When, however, the powerful interests which are now seeking to make a monopoly of electricity supply between the Grampians and the South Coast feel this competition acutely they will undoubtedly work to get a stiff tariff placed on fuel oil; this point must be remembered. This attempt to tax fuel oil would also be supported by the colliery interests on behalf of British coal: for it is not yet possible to produce commercially the requisite quantity of fuel oil from coal.

Thus, if the "Grid" supply is made too stiff, it can only be defeated by using foreign oil in place of British coal.

There is another side to the question.

A manufacturer may find that to purchase energy costs him £1,500 a year, whilst to generate it costs him only £1,350 a year; but he may actually be out of pocket on the deal. In order to make sure of the soundness of his policy, he must calculate how many manufacturing machines of his special trade could be accommodated in the space devoted to his power house, oil fuel store, engine and generator stores, together with the small workshop space necessary to maintain properly the oil engines, generators and accessories. He then has to place the profit the machines which could occupy the generating plant space would earn in a normal year against the saving he has made in the cost of electrical power, by generating it himself.

In the case quoted, if the manufacturing plant which occupied the generating station could earn £250 a year clear profit, it would pay the manufacturer to buy power rather than generate himself.

Speaking generally, where purchased electricity is over 0.75d. a unit, and profits earned per square foot of factory space are high, it will pay to buy and not generate.

Again, if special current applications are required in the factory, it may pay to generate even at a higher cost. Whilst on the score of absolute reliability the outside supply is inferior to a well-planned single set private supply.

A.M.Inst.E.E. (SHEFFIELD).

Cost Figures of Heavy Oil Engines.

SIR,—The question raised by your correspondent, A.P.Q. (Yeovil), is an important one to electrical engineers.

I am sure the cost figures given below will be of much interest to your readers.

Typical figures of cost of Petter 250 B.H.P. two-stroke heavy oil engine for industrial drive.

CAPITAL COST.	
Engine and Pipes, Air Comp. Equipment, etc.	£1,700
Erection Complete	140
Water Tanks	140
Foundations, 47 cub. yds. at 45s.	105
	£2,085

OPERATING COSTS.

Based on full load operation.

10 hours per day 300 days per year = 3,000 hours per year.

No. of H.P. hours per year = 750,000.

	Per Year.	Per B.H.P. hour	Pence.
INTEREST AND DEPRECIATION AT			
11 PER CENT.	£229		.073
Repairs and Renewals	35		.011
Insurance Fire	15		.004
Insurance against Breakdown and ex. £1,000.	42		.013
Water and Stores	47		.015
Attendance—52s., 40 hours	150		.048

LUBRICATING OIL.

Cons. .005 pint per B.H.P. per hour at 3s. per gallon. . . . 68 .022

FUEL OIL.

.43 lb. per B.H.P. per hour at £5 7s. 6d. per ton 774 .247

£1,360 .433

Typical costs for a "Crossley-Premier" 200-K.W. four-stroke heavy oil engine set working under conditions as follows:—

Average load	164 K.W.
Hours per annum	2,444
Units supplied at switchboard	400,000
Fuel at £5 per ton. Lubricating Oil at 3s. per gallon.	
Water—No Charge.	
Fuel	£550
Lubricating Oil	25
Stores	10
-Maintenance	25
Wages	155
	<u>£765</u>

Nett Cost per Unit46d.
Capital Charges on Engine, Generator and Equipment—	
Interest at 5 per cent.	£160
Depreciation at 5 per cent.	160

Gross Cost	£1,085
Gross Cost per Unit650d.

The following data refers to a factory installation using a Rushton oil engine set. Current was metered on the switchboard and the other figures of cost are taken from invoices, etc.

52 weeks from March 31st, 1925, to April 1st, 1926.

47 hours per week = 2,444 hours.

The total number of Units generated = 176,390 K.W.-hour.

The initial total cost of the Plant was £3,542 0 0

Interest on initial outlay, 5 per cent. on £3,542. 117 2 0

Depreciation on Engine 7½ per cent., and Dynamo 7½ per cent. 265 13 0

Wages 193 13 10

Insurance 55 2 0

Fuel Oil (Specific Gravity .87), 60 tons 2 cwt. 3 qrs. 25 lb. at £4 17s. 6d. per ton 293 4 3

Hauling Fuel Oil from Station 16 1 2

Lubricating Oil, 257½ gallons at 3s. 11d. 50 8 7

£1,051 4 10

176,390 K.W.H. = 1.43d. per K.W.-hour. The working cost per unit (exclusive of capital charges, etc.) is roughly .75d. per unit, a figure which compares with an average of rather over .75d. per unit in the case of a number

of public supply generating stations, of all sizes, using oil engines, where the conditions may not be so favourable to low costs as in the case of a factory plant.

Yours, etc.,

J. Y. (MOTHERWELL).

Radio Interference from Bell Wiring.

SIR,—With reference to the letter of your correspondent W. H. C. (Farnham) in your September issue, radio interference from bell-wiring circuits is not at all unexpected. General wireless interference from supply mains and mains apparatus has recently occupied a good deal of attention, chiefly because it is more prominent and also because it is possibly less under the listener's control than the use of electric bells in his own house.

It is extremely difficult to specify what may be a complete remedy in any particular case, but it is not so difficult to indicate general palliative methods that may give adequate relief.

First, of course, in these days of sensitive radio sets, all bell wiring should be done in metal-cased bell-wire such as is now available at no great cost from many of the cable makers. The metal sheath should naturally be bonded and earthed just like the heavier mains wiring. This type of wiring is additionally to be recommended because of the neatness of the job that can be done with it.

A condenser across the contacts of the bell would most probably give considerable relief. A standard method of improvement is a filter unit consisting of two H.F. chokes and two condensers. The chokes are inserted in series in the leads, while the two condensers are joined in series with each other and put across the wiring pair with their mid-point earthed. This should alternatively be tried in the leads immediately next to the battery, but is more likely to be effective close up to the bell. The condensers should be of not less than 4 microfarads.

Reliable information on interference-prevention can be got from the Engineer-in-Chief's Department of the G.P.O.

"ELECTRODE" (WINDSOR).

Car Dynamo Control.

SIR,—I should be glad if you could inform me through the medium of your magazine on the following point: What is the value and cost of the resistance to insert between the positive brush and field winding of a car dynamo to obtain half charge when the switch is open? Can this system be fitted to any 12-volt, 120-watt machine?

H. W. T. (SUTTON COLDFIELD).

It is impossible to give the value for the "half charge" resistance unless the resistance of the shunt windings is known. For a case in which the shunt windings have a resistance of 5 ohms, the value of the additional resistance would be about 1½ ohms.—[ED.]

A MAGNETO MAGNET MAGNETISER

THE magneto magnet magnetiser described in this article will be found invaluable for automobile engineers. It can be constructed and wound from the particulars given in the diagram and the accompanying table

The windings are wound on spools made of brass tubing and sheet metal for the flanges. If the windings are wound on the spools with the circular iron core assembled in the spool, the spools will be a tight fit on the core.

Insulation.

The windings are entirely insulated from the spools and if the magnetiser is intended for operation on a voltage of 100 or over, very great care must be taken in regard to insulations. In such case, three turns of varnished cambric should be wound round the tubing and in addition to cambric on the flanges, sheet fibre or presspahn insulation at least equal in thickness to the diameter of the wire should be used.

Cut a Slot in the Fibre Flange.

Since the beginning of each winding

must be brought out, a slot should be cut in the fibre flange used at the end of the spool where the winding is started. It is also advisable to cover the lead out wire, when located in the slot, with another cambric washer or flange insulation. This will prevent any possibility of a short-circuit between this wire and any of the successive and adjacent end turns of the winding.

Well treat each winding with shellac varnish and finally wrap with cotton taping for protection, giving the magnetiser a coat of shellac varnish.

Check the Windings.

The windings are connected in series, and before finally soldering and taping the connections, check with a compass needle to see that the magnetiser poles are of opposite polarity.

Larger magnetisers for magnetising assembled magnetos may be purchased from various manufacturers (see adverts. in motor trade journals). These are, however, too large to be made except by manufacturers.

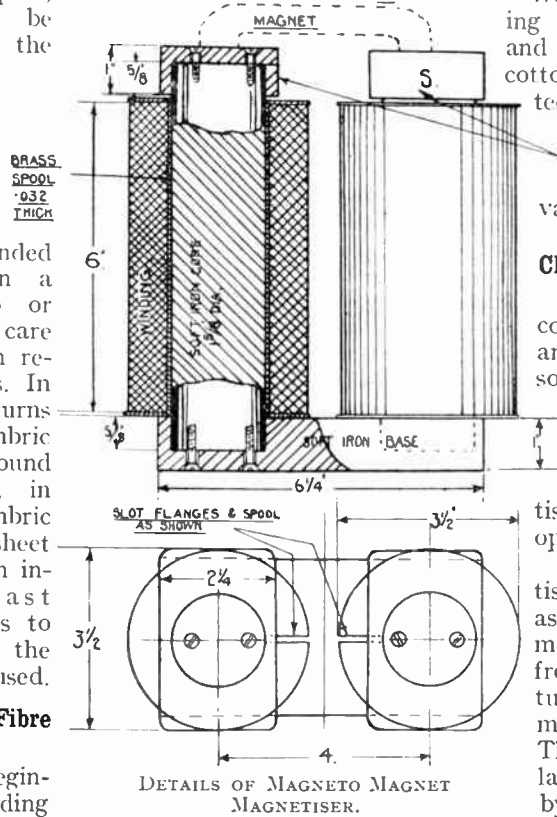

PARTICULARS OF MAGNETISER WINDINGS.

Voltage.	460	230	200	100	50	25	12	Volts.
Size of wire ..	.018"	.026"	.028"	.040"	.056"	.072"	.104"	D.C.C.S.F.
Approx. turns per coil ..	8400	4680	4260	2250	1180	730	365	
No. of layers ..	35	26	25	18	13	10	7	Amperes Lbs.
Current consumption ..	1.27	2.5	2.63	5.15	9.6	12.7	25.4	
Approx. wt. of wire	11.5	13.0	14.0	14.75	15.25	15.75	16.5	

NOTE.—The windings on the two limbs of the magnetiser are connected in series.

*Insulation troubles you can forget
by using Spicers' Sistoflex*

SISTOFLEX

(REGD.)

BRITISH MADE

INSULATING SLEEVING

0.5 m.m. to 30 m.m.

USUAL COLOURS

SUPPLIED ONLY BY

SPICERS

LIMITED

INSULATION DEPARTMENT

19, New Bridge St., London, E.C.4

Telegrams:
"Nykoping Lud,
London"

Telephones:
City 6251
Extension 49

THE BEST OF OPPORTUNITIES

More than 430,000 men have studied I.C.S. Electrical Courses since 1894. A very considerable percentage of them now hold important and well-paid positions. The reason for this is that these Courses are absolutely the best in the world, having been specially prepared and constantly revised for correspondence tuition by many experts of very high standing at a cost, exclusive of printing, of more than £80,000.

If you wish to make rapid progress in the wonderful and fascinating field of electricity, you owe it to yourself to obtain all particulars of I.C.S. Training and what it can do for you. Among our Courses are the following—

Complete Electrical Engineering
Electrical Designers
Hydro-Electric
Electric Lighting
Electric Traction
Steam Electric
Gas Electric

Engine and Dynamo Running
Lift Operation and Maintenance
Water-Power Electrical
Mining Electrical
Practical Telephony
Wireless Engineering

Professional Exams.

Write to-day for our 80-page FREE BOOKLET,

"ELECTRICAL ENGINEERING" stating the subject in which you are most interested

International Correspondence Schools, Ltd.
238 International Bldgs., Kingsway, London, W.C.2.

**TO BE COMPLETED IN ABOUT
48 WEEKLY PARTS**

NEWNES

ENGINEERING PRACTICE

This fine new work will form a reliable reference book on up-to-date engineering in all its branches.

Written throughout from the point of view of the practical man. Illustrated by hundreds of drawings and action photographs which have been specially taken for the work.

Invaluable to everyone engaged or interested in any branch of engineering.

**ORDER YOUR
COPY TO-DAY**

of all Newsagents and Bookstalls or by post from George Newnes, Ltd., 8 11, Southampton Street, Strand, W.C.2

**PART 1
READY
SEPT. 28th**

**ONE
SHILLING
WEEKLY**

Geo. Newnes, Ltd.

THE ENGINEER'S WATCH

Unbreakable. Shock Proof. Guaranteed

5/- each, Post Free

**CASH RETURNED
IF NOT SATISFIED**

THE GEM WATCH CO.,
180, Cemetery Road, Sheffield, 11

The NEW Paper for the NEW Hobby

Everyone interested in Home Movie Making will welcome this brightly written and fully illustrated monthly magazine

HOME MOVIES
and HOME TALKIES
SIXPENCE

Obtainable at all Newsagents, Bookstalls and Dealers, or post free 7d. (Subscription rates: Inland and Abroad, 7 6 per annum; Canada, 7/- per annum) from George Newnes, Ltd., 8-11, Southampton Street, Strand, London, W.C.2

Geo. Newnes, Ltd.

Something **NEW** for
Amateur and Expert



**PART
ONE
NOW ON
SALE**

FREE INSIDE

a fine Design Chart containing full and clear instructions for making a Double Cone Portable Set.

If You Earn Your Living in the Wireless Industry this work is worth pounds to you as an ever-ready source of reliable information.

If You are a Keen Amateur you will find this is just the work you have been looking for. Explains wireless theory in a way never before achieved. Packed with really practical articles. Not a square inch of padding in the whole work. **Get your copy to-day.**

**NEWNES
COMPLETE
WIRELESS**

At all Newsagents and Bookstalls.

IN ABOUT 24 WEEKLY PARTS

1/6

George Newnes, Ltd.

Geo. Newnes Ltd.

**New
Wireless
Weekly**

FOR THE
PRACTICAL MAN

THIS publication marks an important development in the wireless home-constructor market. As indicated by the title, it will be essentially practical in its contents, which will be designed and presented in an attractive and popular manner. All those interested in the construction of sets and in the development of the practical side of wireless will find PRACTICAL WIRELESS invaluable. Everything new in the field of wireless construction will be dealt with in plain and simple language by experts thoroughly acquainted with the needs of the home-constructor.

FREE INSETS are a special feature

**No. 1
on Sale
Wednesday,
Sept. 21st**

**1/6
BLUE
PRINT
Inside**

**Practical
Wireless**

ON SALE EVERY
WEDNESDAY

3^D

At all Newsagents' and Bookstalls, or obtainable by post 4d. from George Newnes, Ltd., 8-11, Southampton St., Strand, London, W.C.2.

Geo. Newnes, Ltd.

Printed in Great Britain for the Proprietors, GEORGE NEWNES, LTD., 8-11, Southampton Street, Strand, W.C.2, by WILLIAMS, LEA & CO., LTD., Clifton House, Worship Street, E.C.2. Sole Agents: Australasia: GORDON & GOTCH (Australasia), LTD. South Africa: CENTRAL NEWS AGENCY, LTD.