

Practical Computing

TOP 20
PORTABLES

85p September 1983

Volume 6 Issue 9

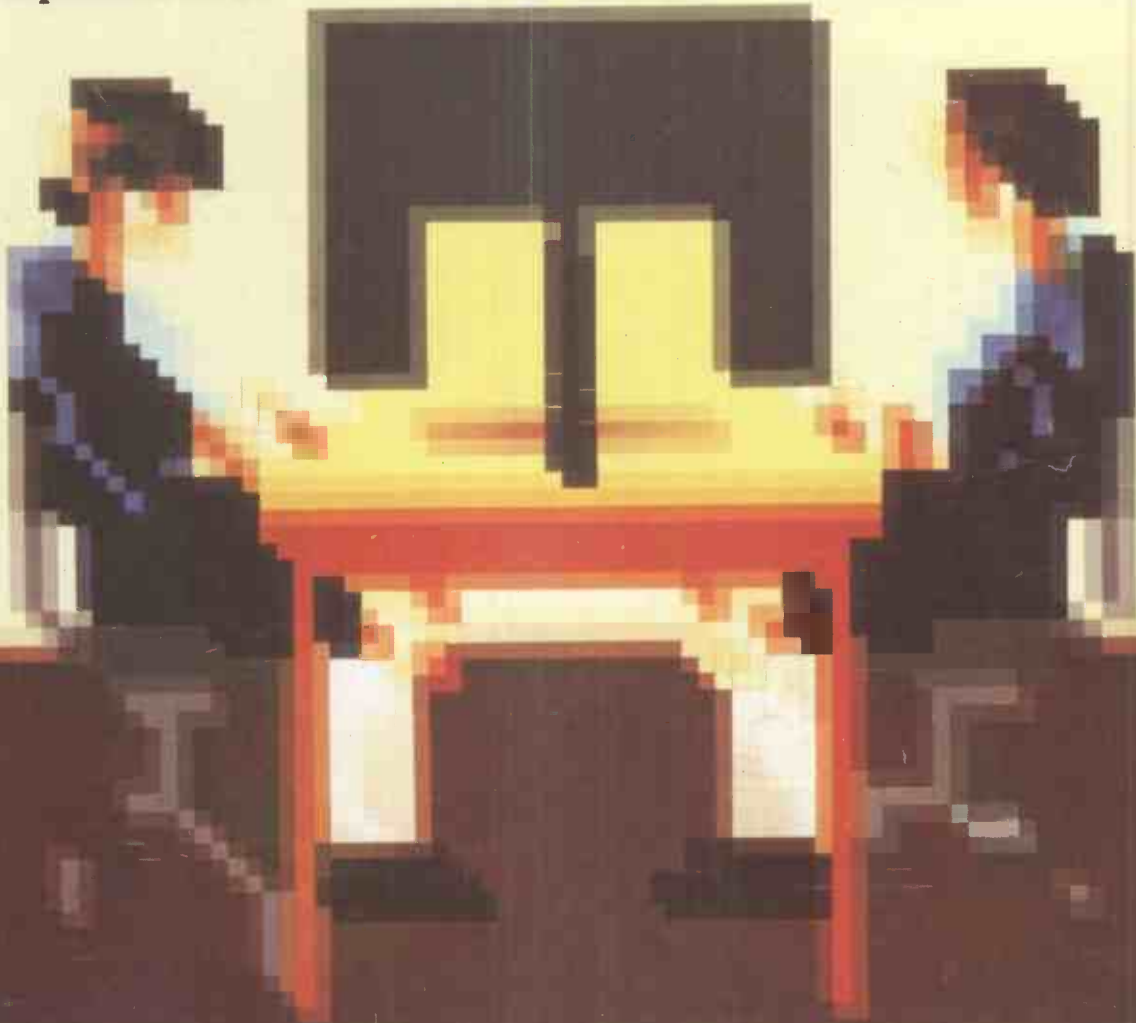

EDUCATION & TRAINING
from turtles to interactive video

16-BIT MICROS: Zenith, Corvus, IBM XT
Apple assemblers, BBC games, Oric printer
Open File: 15 pages of free software

Computerise without compromise



The new All British **QUANTUM 2000** computer system is outstanding among all the fine microcomputers now on the market. The explanation is simple. All microcomputer designers see Versatility on a high scale as their aim for the future. In the **QUANTUM 2000** this ideal has actually been achieved, therefore it is demonstrably more advanced than any other.

QUANTUM 2000 offers every feature experts would look for in a new high technology 2.2 CP/M based microcomputer *plus* an

expansion potential which a few years ago would have required planning permission.

What **QUANTUM** means by Versatility:

1. Available with 1, 2 or 3 disk drives.
2. Disk drives can be 400K or 800K floppies OR
3. 5 or 10 meg. Winchester OR
4. A mixture of floppy and Winchester.
5. 192K of extra RAM can be added, in addition to the standard 64K.

6. If the standard Centronics plus RS232 ports are insufficient, just plugging in a board adds a few more.

7. IEEE 488? No problem! Plug in a card.

8. Other expansion cards available:

1. REAL TIME CLOCK
2. SPEECH SYNTHESIS
3. NETWORKING (UP TO 32 TERMINALS)
4. HIGH RES COLOUR
5. A/D — D/A CONVERSION

Quantum QM 2000



LIST

PRACTICAL COMPUTING SEPTEMBER 1983

>NEWS

15 HARDWARE NEWS
Data General launches a mini micro, NEC starts a price war, and other new machines are introduced.

21 SOFTWARE NEWS
VisiCalc on a chip, Sirius electronic mail and Spectrum business software.

39 MICROMOUSE
John Billingsley's eye-witness account of the U.K. finals at the Computer Fair.

61 IBM PC NEWS
More software, more languages, more RAM and ways to back up the XT hard disc.

>EDUCATION AND TRAINING

107 TOOLS FOR LEARNING
Introducing this month's special section on computers in class and classes in computing.

108 START 'EM YOUNG
Chris Roper visits some primary schools to find out how the kids are being introduced to micros.

112 MOCK TURTLES FOR THE BBC MICRO
Boris Allan provides routines in BBC Basic and Forth to simulate educational Turtle Graphics.

116 NEW SKILLS FOR MILLIONS
A new industry is developing to train people in the use of micros in business. Alan Simpson investigates.

120 AUTHORING SYSTEMS AND LANGUAGES
Bill Bennett examines systems from Pilot to Plato designed to simplify the production of educational software.

122 INTERACTIVE VIDEO
The meeting of micros and the video disc — Colin Jackson looks at the shape of computer-aided teaching to come.

124 CLASS MONITORS
Clive Bulmer presents two simple programs to make life easier for the class teacher.

>FEATURES

100 FICTION — MY NAME IS SAM
A computer that learns, and learns just a bit too much . . .

103 PROGRAMMING — GET RID OF GOTOS
John Hooper shows how a For-Next loop can speed up your Basic.



127 PORTABLE MICROS THE TOP 20
From lap computers like the Epson to portables including the Osborne, Zorba, Apricot and the forthcoming Gavilan.

143 PC's BIG GAME HUNT
Rate your favourite game and send us the result for our forthcoming special games issue.

>REVIEWS

62 IBM PC XT DESK-TOP TEST
Part 2: the IBM keyboard, varieties of Basic and the user interface.

64 MULTIPLAN
Jack Schofield checks out Microsoft's accomplished financial-planning program.

82 ZENITH Z-110 EIGHT/16-BIT MICRO
With both 8080 and 8088 microprocessors and superb documentation, the Zenith impresses.

88 CORVUS CONCEPT
Chris Bidmead reports on a 68000-based work station from a well known hard-disc manufacturer.

92 TRANSPORTABLE ZORBA
Behind the plastic fascia, Ian Stobie finds a fast, usable competitor for the Osborne 1.

94 APPLE II ASSEMBLERS
John Dawson checks out four packages which generate 6502 code.

98 HOME WP —PART 6 SPELLBINDER
A spelling checker for Commodore micros, tested by David Osborne.

137 ORIC PRINTER
Bill Bennett puts Oric's first peripheral, a four-colour plotter, through its paces.

138 BBC GAMES
From Snapper to Killer Gorilla. Neville Maude looks inside eight games for the BBC Micro.

179 DRAGON BOOKS
Ian Stobie checks out 11 offerings in his quest for a good book about the Dragon 32.

>REGULARS

5 EDITORIAL — ONE MAN, ONE MICROPROCESSOR
Alternatives for the future of microcomputing.

7 FEEDBACK YOUR LETTERS
Corrections, comments and complaints.

29 RANDOM ACCESS WEAVING WORDS
Boris Allan looks at threaded interpretive languages.

37 CHIP-CHAT
Ray Coles on troublesome memories both ROM and battery-backed RAM.

149 OPEN FILE
Free software for popular micros including the BBC, Commodore, Tandy, Apple and other models.

189 LAST WORD
Lorraine Boyce wants English teachers to rescue school micros from computer studies.

Shopping for a Micro — BUY AN apple

The Personal
Solution

APPLE IIe

Apple IIe
Disk Drive
with controller
80 Col Card } **£899**

Apple IIe	£645
Monitor	£110
Colour Monitor	£299
Disk Drive	
Without	£200
80 col + 64K	£150
Appewriter	£119
Quickfile	£ 60
Multiplan	£175
Microsoft CP/M	£200

The Business
Solution

APPLE III

Apple III 256K
Monitor III
SOS System Software
with Apple II emulation
built in disk drive } **£1999**

Apple III 256K
Computer as above
plus Profile 5mbyte
hard disk } **£2800**

Appewriter III	£130
Visicalc III	£170
Quickfile III	£ 55
(All 3 packages for £295)	

Complete range of invoicing, ledgers
and stock packages available.

The
Revolution

Lisa™

Attend one of our seminars and
let us introduce you to
Apple's™s revolutionary new
personal computer for the
office. Please telephone or write
for details.

PRINTERS

EPSON	FX80	£375
	RX80	£265
	MX100	£399
OKI	82A	£329
	92	£439

THE SUPPORT PACKAGE

- **Training** — free half day course to take you from an appreciation of the Apple computers to an understanding of applications packages. Specialist courses are also available.
- **Installation** — on your premises for a small extra fee.
- **Ongoing Support** — handholding on both software and hardware.
- **One full year's guarantee** on all parts and labour.
- **On site maintenance contract** available.
- **Comprehensive range of software, supplies, listing paper, diskettes.**

ALL PRICES ARE EXCLUSIVE OF VAT

For computerised solutions to business problems contact

SIMMONS MAGEE COMPUTERS LTD

13 YORK STREET, TWICKENHAM, MIDDLESEX TW1 3JZ

01-891-4477

Practical Computing

EDITORIAL 01-661 3609

Editor
Jack Schofield

Deputy Editor
Bill Bennett

Assistant Editor
Ian Stobie

Art Editor
Steve Miller

Production Editor
John Liebmann

Sub-editor
Sally Clark

Editorial Secretary
Julie Milligan

Consultants
Chris Bidmead
Peter Laurie

ADVERTISING 01-661 3612

Advertisement Manager
Ian Carter 01-661 3021

Assistant Advertisement
Manager

Kenneth Wallford 01-661 3139

Advertisement Executives
Lynne Brennan 01-661 3468
Robert Payne 01-661 8425

David Honeyman 01-661 8626

Advertisement Secretary
Janet Thorpe

Midlands office:
David Harvett 021-356 4838

Northern office:
Geoff Aikin 061-872 8861

PUBLISHING DIRECTOR
Chris Hipwell

Published by Electrical Electronic
Press, Quadrant House, The Quadrant,
Sutton, Surrey SM25AS. Tel: 01-661
3500. Telex/grams 892084 BISPRS G.

Distributed by Business Press
International Ltd, Quadrant House,
The Quadrant, Sutton, Surrey SM2
5AS.

Subscriptions: U.K. £12 per annum;
Overseas £18 per annum; selling
price in Eire subject to currency
exchange fluctuations and VAT;
airmail rates available on application
to Subscription Manager, Business
Press International Ltd, Oakfield
House, Perrymount Road, Haywards
Heath, Sussex RH16 3DH. Tel: 0444
459188.

Printed in Great Britain for the
proprietors Business Press
International Ltd by Eden Fisher
(Southend) Ltd, Southend-on-Sea.
Typeset by Centrepoint Typesetters,
London EC1.

© Business Press International Ltd
1983.

Would-be authors are welcome to
send articles to the Editor but PC can-
not undertake to return them. Pay-
ment is at £30 per published page.
Submissions should be typed or
computer-printed and should include
a tape or disc of any program. Hand-
written material is liable to delay and
error.

Every effort is made to check articles
and listings but PC cannot guarantee
that programs will run and can accept
no responsibility for any errors.

One man, one microprocessor

PRACTICAL COMPUTING, both as a magazine and as a subject, has very little to do with politics. Particular government decisions, of course, have an impact on particular companies, but it is doubtful if this has any substantial effect in the long term, in the absence of other changes.

While the major political parties try to present themselves as alternatives, none offers a radical policy on computers. Radical alternatives would be:

- A. Everyone has, by law, to learn to use a computer. The price of a micro will be deducted from your wages or social-security payments.
- B. All computers will be banned. Anyone caught using one will be shot.

It is obvious that destination A is, in some sense, inevitable, although a less fascist route will be taken towards it. The computer may have to pretend to be a teacher, a game or a cash till. It is equally obvious that route B would lead to the collapse of a most important export sector — "invisible" exports — plus a decline in industrial competitiveness and inevitable national bankruptcy.

In fact, both Labour and Tory politicians know which way the wind is blowing, as do the rulers of every other industrial nation. They are like old men haggling with a whore on a street corner. Both parties agree on the fundamental nature of the transaction. The arguments are about the method and the price.

Putting micros into primary schools merely accelerates the inevitable — or at least, it is meant to. Propping up some absurdly uneconomic coal mines in South Wales merely delays the inevitable. Technology itself develops regardless of such attempts — whether misguided or laudable — to soften the blow.

In the end it comes down to a choice between technology and tyranny. Without resorting to a police state, as in the Russian empire, governments have no hope of controlling

technology. And it is technological developments, not governments, that have produced all the fundamental social changes of the last 200 years: steam power, electricity, motor transport, air travel, antibiotics, television and microprocessors.

Within the business world, computer power is reaching the hands of more and more people. In 1982, for example, the value of large mainframes shipped slumped by 68 percent to £76 million.

At the same time there has been a massive boom in the use of personal computers in business. Instead of being concentrated in the sacred hands of the data-processing department, computer power is spreading among lay user. Naturally they will not always use this power in ways that governments would approve of.

Computer-literate people with quick and open minds will use the new technology for their own ends, not be dominated by it. While some will abuse its power, the wide dissemination of that power still looks, in the long term, the best opportunity not only for eventual economic recovery but for freedom itself. □

PRICE INCREASE

This month the price of *Practical Computing* has gone up for the first time for over two years. The 5p increase is mainly to cover higher cost including, this year, more editorial pages, increased staff, higher payments to contributors and further improvements to the magazine which will become evident over the next couple of months. *Practical Computing's* circulation is showing healthy growth in spite of the volume of competition, and we will try to do even better. While the price increase is regretted, *Practical Computing* will remain — with your continued support — the best value micro magazine on the market.

5 Years ago ...

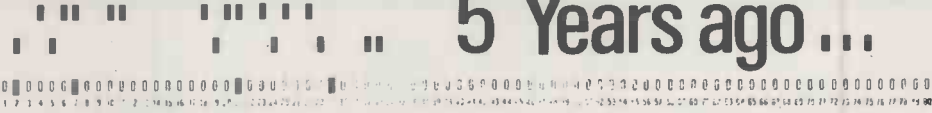

With individual computers to work from, a single teacher could have much more personal interaction with the students, because he would be free from supervising students from the front of the room, and the computer would keep each student occupied at the interest level appropriate for that student.

Se would no longer have to be satisfied with teaching to the average student while losing the slow learner and boring the bright students. The computer lab could take us one step closer to true individual instruction, without having to reduce classroom sizes to 20 students to do it

and that could be very important in getting more from fewer teachers. What is needed now is software. The Pets and other low-cost computers are here. What is not here is the canned course library of curriculum materials and application materials and software for using the computer.

Educational software is probably the most neglected area of personal computing. The hardware and Basic has arrived this year. The next big arrival will be the applications software; and after the applications software will come educational software.

Practical Computing, Volume 1, Issue 3.



WATFORD ELECTRONICS

33 (PC) Cardiff Road, Watford, Herts, England
Tel Watford (0923) 40588. Telex: 8956095

ALL DEVICES FULLY GUARANTEED. Send Cheque, P.O.s, Cash, Bank Draft with Orders. ACCESS/MASTER CHARGE Accepted. GOVERNMENT & EDUCATIONAL ESTABLISHMENTS OFFICIAL ORDERS WELCOME. P&P Add 60p to all Cash Orders. OVERSEAS Orders postage at cost.

VAT ALL PRICES ARE EXCLUSIVE OF VAT. PLEASE ADD 15% TO THE TOTAL COST INCLUDING P&P. SHOP HOURS: 9.00am-6.00pm MONDAY TO SATURDAY. AMPLE FREE CAR PARKING SPACE AVAILABLE. FOR QUANTITY PRICES PHONE WATFORD (0923) 40588

Computer IC's	DS8830	110	75 Series
1802CP	650	DS8831	250
2114L-200n	95	DS8832	280
2147-3	395	DS8833	336
2532-450n	300	DS8834	365
2564	£8	FD1761	£36
2708	250	FD1766	£36
2716-5v	250	FD1771	£15
2732-450n	295	FD1781	£15
2784-250n	395	FD1793	£23
27128-250	£25	FD1795	£28
27128-400	£20	FD1797	£28
27128-400	£20	INSB022	380
27128-400	£20	INSB060N	1050
27128-400	£20	INSB154N	£9
27128-400	£20	MC1488	55
27128-400	£20	MC1489	55
27128-400	£20	MC14411	690
27128-400	£20	MC14412	726
27128-400	£20	MC14421	726
27128-400	£20	MC14422	726
27128-400	£20	MC14423	726
27128-400	£20	MC14424	726
27128-400	£20	MC14425	726
27128-400	£20	MC14426	726
27128-400	£20	MC14427	726
27128-400	£20	MC14428	726
27128-400	£20	MC14429	726
27128-400	£20	MC14430	726
27128-400	£20	MC14431	726
27128-400	£20	MC14432	726
27128-400	£20	MC14433	726
27128-400	£20	MC14434	726
27128-400	£20	MC14435	726
27128-400	£20	MC14436	726
27128-400	£20	MC14437	726
27128-400	£20	MC14438	726
27128-400	£20	MC14439	726
27128-400	£20	MC14440	726
27128-400	£20	MC14441	726
27128-400	£20	MC14442	726
27128-400	£20	MC14443	726
27128-400	£20	MC14444	726
27128-400	£20	MC14445	726
27128-400	£20	MC14446	726
27128-400	£20	MC14447	726
27128-400	£20	MC14448	726
27128-400	£20	MC14449	726
27128-400	£20	MC14450	726
27128-400	£20	MC14451	726
27128-400	£20	MC14452	726
27128-400	£20	MC14453	726
27128-400	£20	MC14454	726
27128-400	£20	MC14455	726
27128-400	£20	MC14456	726
27128-400	£20	MC14457	726
27128-400	£20	MC14458	726
27128-400	£20	MC14459	726
27128-400	£20	MC14460	726
27128-400	£20	MC14461	726
27128-400	£20	MC14462	726
27128-400	£20	MC14463	726
27128-400	£20	MC14464	726
27128-400	£20	MC14465	726
27128-400	£20	MC14466	726
27128-400	£20	MC14467	726
27128-400	£20	MC14468	726
27128-400	£20	MC14469	726
27128-400	£20	MC14470	726
27128-400	£20	MC14471	726
27128-400	£20	MC14472	726
27128-400	£20	MC14473	726
27128-400	£20	MC14474	726
27128-400	£20	MC14475	726
27128-400	£20	MC14476	726
27128-400	£20	MC14477	726
27128-400	£20	MC14478	726
27128-400	£20	MC14479	726
27128-400	£20	MC14480	726
27128-400	£20	MC14481	726
27128-400	£20	MC14482	726
27128-400	£20	MC14483	726
27128-400	£20	MC14484	726
27128-400	£20	MC14485	726
27128-400	£20	MC14486	726
27128-400	£20	MC14487	726
27128-400	£20	MC14488	726
27128-400	£20	MC14489	726
27128-400	£20	MC14490	726
27128-400	£20	MC14491	726
27128-400	£20	MC14492	726
27128-400	£20	MC14493	726
27128-400	£20	MC14494	726
27128-400	£20	MC14495	726
27128-400	£20	MC14496	726
27128-400	£20	MC14497	726
27128-400	£20	MC14498	726
27128-400	£20	MC14499	726
27128-400	£20	MC14500	726
27128-400	£20	MC14501	726
27128-400	£20	MC14502	726
27128-400	£20	MC14503	726
27128-400	£20	MC14504	726
27128-400	£20	MC14505	726
27128-400	£20	MC14506	726
27128-400	£20	MC14507	726
27128-400	£20	MC14508	726
27128-400	£20	MC14509	726
27128-400	£20	MC14510	726
27128-400	£20	MC14511	726
27128-400	£20	MC14512	726
27128-400	£20	MC14513	726
27128-400	£20	MC14514	726
27128-400	£20	MC14515	726
27128-400	£20	MC14516	726
27128-400	£20	MC14517	726
27128-400	£20	MC14518	726
27128-400	£20	MC14519	726
27128-400	£20	MC14520	726
27128-400	£20	MC14521	726
27128-400	£20	MC14522	726
27128-400	£20	MC14523	726
27128-400	£20	MC14524	726
27128-400	£20	MC14525	726
27128-400	£20	MC14526	726
27128-400	£20	MC14527	726
27128-400	£20	MC14528	726
27128-400	£20	MC14529	726
27128-400	£20	MC14530	726
27128-400	£20	MC14531	726
27128-400	£20	MC14532	726
27128-400	£20	MC14533	726
27128-400	£20	MC14534	726
27128-400	£20	MC14535	726
27128-400	£20	MC14536	726
27128-400	£20	MC14537	726
27128-400	£20	MC14538	726
27128-400	£20	MC14539	726
27128-400	£20	MC14540	726
27128-400	£20	MC14541	726
27128-400	£20	MC14542	726
27128-400	£20	MC14543	726
27128-400	£20	MC14544	726
27128-400	£20	MC14545	726
27128-400	£20	MC14546	726
27128-400	£20	MC14547	726
27128-400	£20	MC14548	726
27128-400	£20	MC14549	726
27128-400	£20	MC14550	726
27128-400	£20	MC14551	726
27128-400	£20	MC14552	726
27128-400	£20	MC14553	726
27128-400	£20	MC14554	726
27128-400	£20	MC14555	726
27128-400	£20	MC14556	726
27128-400	£20	MC14557	726
27128-400	£20	MC14558	726
27128-400	£20	MC14559	726
27128-400	£20	MC14560	726
27128-400	£20	MC14561	726
27128-400	£20	MC14562	726
27128-400	£20	MC14563	726
27128-400	£20	MC14564	726
27128-400	£20	MC14565	726
27128-400	£20	MC14566	726
27128-400	£20	MC14567	726
27128-400	£20	MC14568	726
27128-400	£20	MC14569	726
27128-400	£20	MC14570	726
27128-400	£20	MC14571	726
27128-400	£20	MC14572	726
27128-400	£20	MC14573	726
27128-400	£20	MC14574	726
27128-400	£20	MC14575	726
27128-400	£20	MC14576	726
27128-400	£20	MC14577	726
27128-400	£20	MC14578	726
27128-400	£20	MC14579	726
27128-400	£20	MC14580	726
27128-400	£20	MC14581	726
27128-400	£20	MC14582	726
27128-400	£20	MC14583	726
27128-400	£20	MC14584	726
27128-400	£20	MC14585	726
27128-400	£20	MC14586	726
27128-400	£20	MC14587	726
27128-400	£20	MC14588	726
27128-400	£20	MC14589	726
27128-400	£20	MC14590	726
27128-400	£20	MC14591	726
27128-400	£20	MC14592	726
27128-400	£20	MC14593	726
27128-400	£20	MC14594	726
27128-400	£20	MC14595	726
27128-400	£20	MC14596	726
27128-400	£20	MC14597	726
27128-400	£20	MC14598	726
27128-400	£20	MC14599	726
27128-400	£20	MC14600	726
27128-400	£20	MC14601	726
27128-400	£20	MC14602	726
27128-400	£20	MC14603	726
27128-400	£20	MC14604	726
27128-400	£20	MC14605	726
27128-400	£20	MC14606	726
27128-400	£20	MC14607	726
27128-400	£20	MC14608	726
27128-400	£20	MC14609	726
27128-400	£20	MC14610	726
27128-400	£20	MC14611	726
27128-400	£20	MC14612	726
27128-400	£20	MC14613	726
27128-400	£20	MC14614	726
27128-400	£20	MC14615	726
27128-400	£20	MC14616	726
27128-400	£20	MC14617	726
27128-400	£20	MC14618	726
27128-400	£20	MC14619	726
27128-400	£20	MC14620	726
27128-400	£20	MC14621	726
27128-400	£20	MC14622	726
27128-400	£20	MC14623	726
27128-400	£20	MC14624	726
27128-400	£20	MC14625	726
27128-400	£20	MC14626	726
27128-400	£20	MC14627	726
27128-400	£20	MC14628	726
27128-400	£20	MC14629	726
27128-400	£20	MC14630	726
27128-400	£20	MC14631	726
27128-400	£20	MC14632	726
27128-400	£20	MC14633	726
27128-400	£20	MC14634	726
27128-400	£20	MC14635	726
27128-400	£20	MC14636	726
27128-400	£20	MC14637	726
27128-400	£20	MC14638	726
27128-400	£20	MC14639	726
27128-400	£20	MC14640	726
27128-400	£20	MC14641	726
27128-400	£20	MC14642	726
27128-400	£20	MC14643	726
27128-400	£20	MC14644	726
27128-400	£20	MC14645	726
27128-400	£20	MC14646	726
27128-400	£20	MC14647	726
27128-400	£20	MC14648	726
27128-400	£20	MC14649	726
27128-400	£20	MC14650	726
27128-400	£20	MC14651	726
27128-400	£20	MC14652	726
27128-400	£20	MC14653	726
27128-400	£20	MC14654	726
27128-400	£20	MC14655	726
27128-400	£20	MC14656	726
27128-400	£20	MC14657	726
27128-400	£20	MC14658	726
27128-400	£20	MC14659	726
27128-400	£20	MC14660	726
27128-400	£20	MC14661	726
27128-400	£20	MC14662	726
27128-400	£		

What standard?

IN MY YEARS in the computing profession I have yet to find a standard operating system. Your comment in the news item headed "Buzby's micros" — July issue — that "it looks like a non-industry-standard OS" therefore took me by surprise.

Even on micros there are dozens, and once you get to mainframes every manufacturer supports a multitude of operating systems. The few machines I have experience of have run MP/M, CP/M, CP/M-86, MS-DOS, P-OS, NasSys, BBC OS 1.0 and 1.2, Exec 1, George 2, George 3, VME/K, VME/B, VME-2900, RSX-11, VMS, etc. OK, so I have cheated and some of these operating systems run on largeish mini and mainframe computers.

When the "industry standard" operating system arrives you will, no doubt, let us know. Some masochists might say that Unix is the one. But until then, please do not dismiss as "non-standard" what may be an excellent operating system.

**A B Spence,
Macclesfield,
Cheshire.**

Rip-off repairs

I FOUND the article "On the track of London's Rip-offs" very interesting, as this application can obviously be taken up at many levels by amateur groups. It is ironic that an Apple II was used, as I feel that Apple registered dealers — or some of them — should be included on the rip-off list.

A while ago my Apple would not load VisiCalc. Someone suggested that the disc drive might need adjustment. I took the drive in to a registered dealer. They checked it and charged me £17.50. The receipt said "for adjusting disc drive". The Apple still did not work. I took it back and they found a chip had gone, and charged me another £17.50 for this.

They could easily have told me in the first place that nothing was wrong with the drive and advised me. If they had done so I would have respected their honesty, and happily paid for the time they had spent and the knowledge I had gained.

Later my power unit went. I rang a leading dealer in London and was told it cost £190 to replace. I took the power unit to another dealer and asked if they could repair it. They said the units are sealed and have to be returned for repair, but they would part-exchange it for £80. It was not clear to me what use

they would have for a defunct power unit they were not allowed to repair. And if they were allowed to repair, why didn't they offer?

In despair, I gave it to a TV servicing shop and told them to open it up and check if it was anything simple they could fix. They did, and found the rectifier faulty. They charged me £19.50 and apologised for the cost as they felt the whole unit could hardly be worth more than a tenner.

My Apple now works perfectly. I will avoid dealers as much as possible in the future, and hope that more and more TV shops will be prepared to have a go at fixing these machines. If I ever start my own rip-off data bank, then Apple dealers will be at the top of the list.

**Peter Hursley,
London NW2.**

Valued custom

THOSE WITH Apples, Tandys or Pets may have it easier, but for most hobby computerists getting anything other than the bare machine can be a frustrating task. In my experience computer shops are overcrowded and understocked. The only alternative appears to be mail order. Fine for chips and software. Rather worrying for heavy or delicate peripherals

that will need servicing and repair.

But look in the yellow pages under Computer Systems and Equipment and you will find lots and lots of suppliers. At random I chose The Holdene Group and went to see them about a printer. After a private demonstration and chat in their showroom I decided what I wanted was an Epson RX. They didn't have one in stock but said they'd get one by courier for the next day and make up a lead for my micro, all at a price that beat the opposition. The local shop said they were expecting some "in about six weeks".

On getting home and plugging in — no issue! "Bring it back and we'll have a look," said the Holdene man. I didn't remind him it was 4.30 on Friday afternoon. I took the whole system with me, and he was still remarkably jovial at 6.30 when we found that the fault was in the micro. Then he mended it — for free.

If I had bought by post I would have been up silicon creek without a games paddle. Instead I felt like a valued customer and not the next nuisance in the queue.

Obviously most system suppliers' customers are valuable, and private users can benefit from the same service when buying major items.

**Bob Lewin,
Edinburgh.**

Sexist ads

I AM STUDYING the portrayal of women and girls in computer advertisements. Most ads are dreadfully sexist, but I do enjoy the occasional ad which involves women as participants rather than spectators in computing. This is especially gratifying when it is in the lay or popular press.

Last autumn, a series of Dragon ads were particularly offensive. Two of the headlines were: "Like Father Like Son", and "Read this Ad to your Wife", implying that only men bought computers. I wrote to the company and complained, twice, but received no reply. Recently I saw a beautiful ad by Dragon. In large type, it said: "If you want to know which computer to buy, ask your expert", and the expert was portrayed as a girl in cap and gown.

Maybe it was just a

coincidence. But maybe my letter, and others, did influence Dragon. I did write to the company and told them that I was pleased.

If readers see ads which portray women in a particularly bad or good light, I would really appreciate a copy. Please state where and when it was published if it is not obvious from the copy. Thank you.

**Danielle R Bernstein,
1 Ethelred Court,
Headington,
Oxford OX3 9DA.**

Playing fair by Acorn

I AM NOT a regular reader of *Practical Computing* although having seen your July issue I think perhaps I ought to be. I did see the April article which inspired G R Gilmore's letter about what he calls hidden extras and what your very large headline calls surcharges which, it is alleged, have to be paid on BBC Micro products.

I think that Mr Gilmore is unreasonable. I bought a disc operating system from Acorn and received a useful manual and utilities disc at no extra cost. What I suspect, and what Mr Gilmore does not reveal, is that he bought the chip from Acorn and the disc drive from someone else. In that case, why did he not ensure that he got the necessary information from the disc-drive manufacturer? Since he did not look after his own interests, why does he now blame Acorn?

I have just bought View and find it a very adequate tool for the normal job. I do not expect one product to provide access to all the facilities of all the different printers on the market for that sort of price. It will do what I want at a reasonable price, and I know that if I want to use some of the special facilities of my chosen printer I must write or buy a special program.

Not so Mr Gilmore — he wants it for nothing. In any case, it is not a hidden extra: the fact that a printer driver may be necessary is clearly stated on the View literature. If he does not take the trouble to find out about the product before he buys it, Mr Gilmore has only himself to blame. He doesn't even have to buy View; there is an alternative.

(continued on next page)

Our Feedback columns offer readers the opportunity of bringing their computing experience and problems to the attention of others, as well as to seek our advice or to make suggestions, which we are always happy to receive. Make sure you use Feedback — it is your chance to keep in touch.

(continued from previous page)

I cannot comment at first hand on the Forth cassette, but Acornsoft literature makes it clear that there is a book for those who need it, in addition to the cassette. This seems to be a reasonable arrangement: the extra charge is not hidden and if, as Mr Gilmore seems to want, the cassette and book were offered at an all-in cost, there would be those who would complain that they were forced to buy something they did not want.

Acorn's arrangements seem to be flexible: they offer something at a price, and if you want more you can have it for an extra stated price. You are not forced to buy at a high price something you do not need.

H J Challen,
Beckenham,
Kent.

BBC Find utility

THANK YOU for including my Find utility in the BBC Bytes column in the July issue. I ought to point out that what appear as £ signs in your printed version should in fact be # signs, and this may have confused some readers. The routine works on the 0.1 and series 1 operating systems.

Douglas Stewart,
Edinburgh.

Curve fitting

CONGRATULATIONS to A D Wilson on his very effective program, printed on page 181 of the July issue. The results produced on the Spectrum are very accurate, and appear even more so if the calculated figures displayed are rounded off when within 0.1 percent of the experimental values.

However, I have noticed a few minor programming points. Surely line 905 should be renumbered 907 so that the Gosub is within the loop which

starts on line 106. Also the Gosub 400 in line 506 appears to be redundant, the operation having been carried out by the Gosub in line 50. The loop in lines 264 to 270 is not really necessary either.

While a solution is produced with, say, two data pairs for a quadratic, the solution is not necessarily the one expected, as three data points are required for a unique solution. Line 250 should therefore read

```
IF N >= W ...
```

A M Tucker,
Charminster,
Dorset.

Atari sounds

I READ with great interest the music article in the June issue of *Practical Computing*, but must correct some of the remarks about the Atari 800:

Loudness. There are 16 programmable sound levels. Filtering. The sound output can be modified by a set of software-controlled filters.

Output to hi-fi or tape recorder. This is very easy as there is a five-pin DIN socket for direct audio output.

Machine-code access. This is also very easy as the code can be embedded within a Basic program and then executed with a USR call.

Speaker. This is an independent channel on Atari machines.

I hope that any false impressions can be rectified.

Name and address supplied.

Well done Grundy!

I WOULD LIKE to break with convention and offer some praise to a British company — Grundy Business Systems Ltd. I am a nurse tutor who over the past two years has become more and more interested in the use of computers in nurse education — that is, computer-assisted learning.

After much thought and

research I purchased a Newbrain computer to learn about computing and to try my hand at writing educational software. I have been delighted with my purchase and it has lived up to all my hopes and expectations.

Perhaps even more important to a novice such as myself, working in an impecunious organisation such as the NHS, is the support offered to the consumer. In this respect, no company could possibly have been more helpful, constructive, and indeed generous than Grundy Business Systems.

Well done Grundy and good luck for the future.

P I Pleasance,
South Lincolnshire School of
Nursing,
Boston.

Newbrain keywords

AFTER READING Rory Stafford's appeal for Newbrain software in the June issue I started experimenting with using the graphics key to produce keywords. Unfortunately, it became very tedious so I devised an alternative method. First of all, type:

```
PUT 31:?:?:FORI = 123 to 255: PUT 27,1: NEXT I
```

which will result in a display of all the characters in between 123 and 255. Move the cursor up to the first character and type Insert 10, followed by Shift-Home and Put 22, 1, 10. If the program is now listed, at least some of the keywords may be seen.

David Alexander,
Yalding,
Kent.

Stereo slicing

DUE TO a production error, two characters were lost from the listing on page 108 of the August issue. Line 00940 should end with an extra closing bracket and line 00960 should have an F after the * sign.

Statistical error

I HAVE been delighted to see the mystiques of statistics so well treated in your magazine in recent months. However, when I see what is perhaps the commonest statistical misapprehension among my colleagues and some professional statisticians stated as unequivocally as in an article in the June issue. I feel it cannot pass unchallenged.

Owen Bishop states in his article on Spearman's test: "If he believes the first alternative there is only one chance in 120 that he is right". The probability of one in 120 is purely a measure of the frequency that samples in practice would have the rankings obtained, when in reality there was no difference. It does not tell you anything about whether you are right or wrong.

R M Flinn,
University of Birmingham.

Plannercalc points

I READ with interest Mike Lewis's comparison of Plannercalc and Calcstar in the July edition of *Practical Computing*. Unfortunately the comparison makes two statements about Plannercalc which are inaccurate.

He says "you cannot enter text into the spreadsheet", which is true. But you can use headings which, in the case quoted, would have provided the desired line of text.

The statement "features... can only operate on entire rows or columns" is incorrect. The logic for a line may be discontinuous so that each cell is calculated using a different formula:

```
LINE 3 TOTALS = 2 FOR 3, LINE 1 * LINE 2 FOR 2, 9
```

An individual cell's contents may also be altered by editing

(continued on page 13)

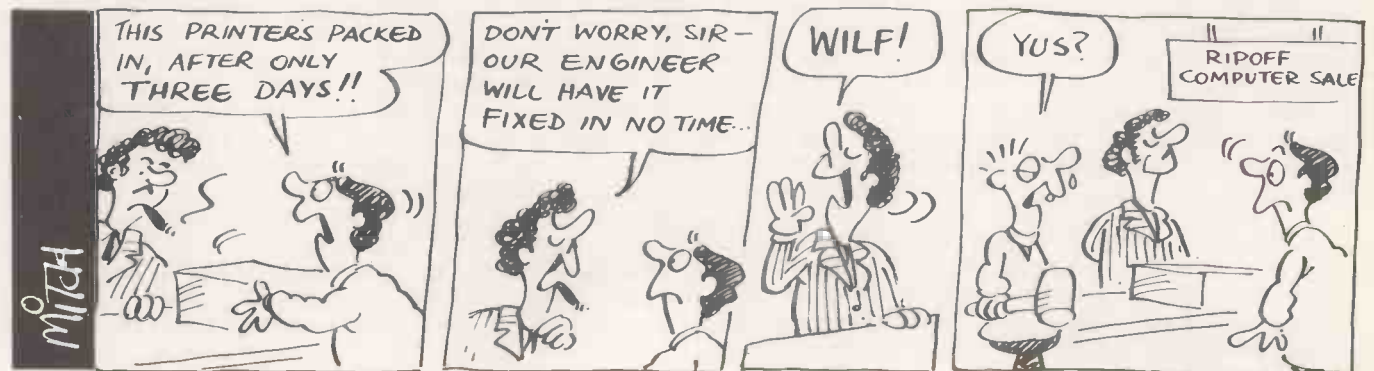

sinclair special

3



Inside...
The New ZX Microdrive!
Latest software...
Latest prices...

The ZX Microdrive- and more!

For some time now, the new ZX Microdrive has been the subject of much discussion. Which is only to be expected, when the object of everyone's anticipation is *completely* new to the world of computing.

Microdrive provides high-speed access to truly massive storage. With just one Microdrive, you'll have at least 85K bytes of storage, and the ability to LOAD and SAVE in mere seconds. Yet the ZX Microdrive is about the size of a Spectrum mains adaptor, and costs less than £50!

First stocks are now in. Microdrives will be released on an order of priority basis. Spectrum owners who purchased by mail order, direct from us, will be sent full details including how to order, in a series of mailings that begins with the earliest names on our list.

And if you didn't buy by mail order?

Don't worry — for a colour brochure with full information on Microdrives, including how to order, just send us your name and address (use the coupon at the back of this issue of Sinclair Special). But remember, the sooner you send us your name, the sooner you'll get on the list.

Of course, there's much more to Sinclair than Microdrives, as you'll see on these pages. The latest releases of Spectrum and ZX81 software have been amongst the most successful ever. Prices of most established Sinclair products are at their lowest ever. To buy what you want, just use the Order Form.

Until the next issue of Sinclair Special, and more good news ...



Nigel Searle, Managing Director,
Sinclair Research Ltd.

PS: Come and see us — and all that's new at Sinclair — at the PCW Show, Barbican Centre, from Sept 28th to Oct. 2nd. We'll be pleased to see you!

ZX Microdrive System preview



ZX MICRODRIVE

At least 85K bytes storage, loads a typical 48K program in as little as 9 seconds: £49.95.



ZX MICRODRIVE CARTRIDGE

Compact, erasable, revolutionary. Complete with its own storage sleeve. Contains up to 50 files, with a typical access time of 3.5 seconds: £4.95.



ZX INTERFACE 1

Necessary for sending and receiving data from ZX Microdrive. Includes RS232 interface, enables creation of local area network of 2 to 64 Spectrums. Attaches to the underside of your Spectrum. Purchased with ZX Microdrive, just £29.95. As separate item, £49.95.

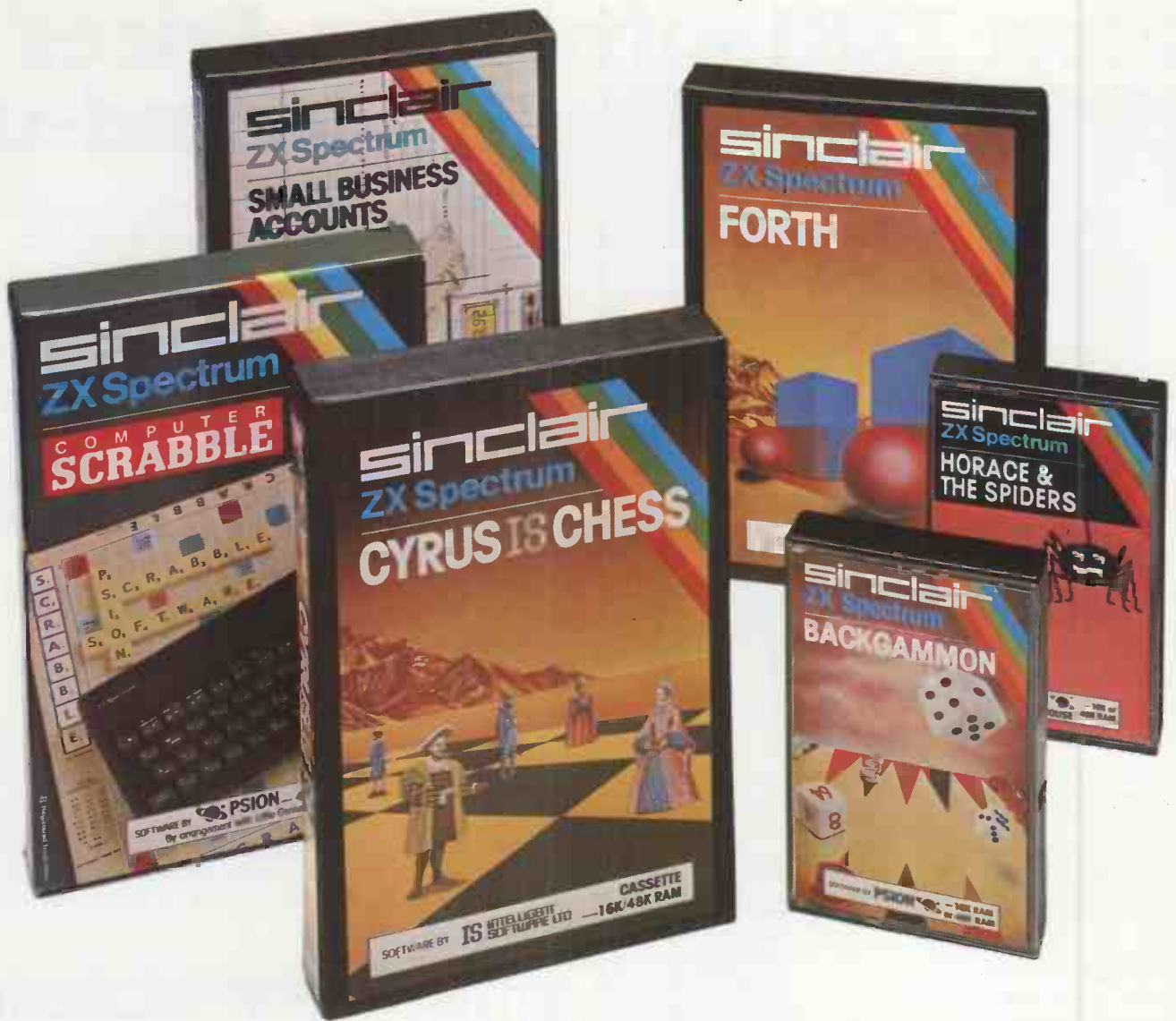

Six new ways to make more of your Spectrum

Take a look at these brand-new titles. Each is an outstanding new program using the full potential of the Spectrum, for games with stunningly animated graphics, for strategies of fiendish cunning, for masterly applications of computing capability...

Cyrus-IS-Chess Based on the Cyrus Program, which won the 2nd European Microcomputer Chess Championship and trounced the previously unbeaten Cray Blitz machine. With 8 playing levels, cursor piece-movement, replay and 'take-back' facilities, plus two-player option. The 48K version has many additional features including an extensive library of chess openings. For 16K or 48K RAM Spectrum.

Horace and the Spiders Make your way with Horace to the House of Spiders, armed only with a limited supply of anti-spider-bite serum. In the house, destroy the webs before the spiders can repair them. Then destroy the spiders, before they destroy Horace! Undoubtedly the creepiest Horace program ever produced! For 16K or 48K RAM Spectrum.

Computer Scrabble The famous board game, on-screen - with the whole board on view! A huge vocabulary of over 11,000 words. Full-size letter tiles, four skill levels - the highest of which is virtually unbeatable. For 1 to 4 players. For 48K RAM Spectrum.
(SCRABBLE trademark and copyright licensed by Scrabble Schutzrechte und Handels GmbH - a J.W. Spear and Sons PLC subsidiary.)

Backgammon A fast, exciting program, with traditional board display, rolling dice and doubling cube. Four skill levels. For experts - or beginners. (Rules are included - it's the quickest way to learn the game.) For 16K or 48K RAM Spectrum.

FORTH Learn a new programming language, as simple as BASIC, but with the speed of machine code. Complete with Editor and User manual. For 48K RAM Spectrum.

Small Business Accounts Speeds and simplifies accounting work, produces Balance Sheets, Profit and Loss information and VAT returns. Complete with User manual. For 48K RAM Spectrum.

Overleaf - your Sinclair order form.

Latest ZX81 software

Prices round-up

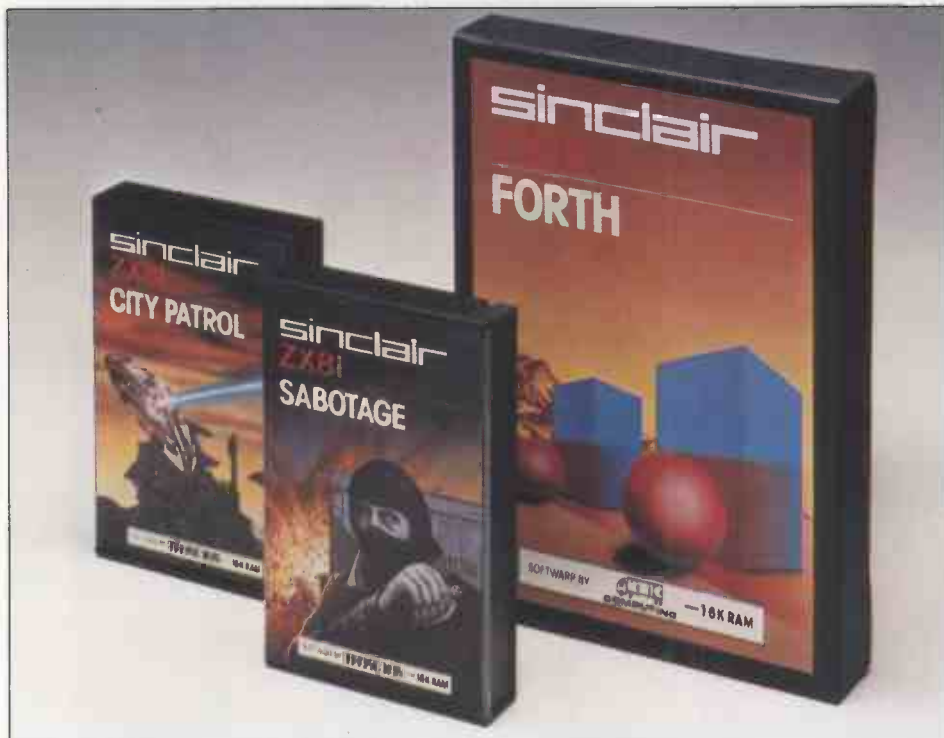

These three new cassettes offer two totally different challenges to you and your ZX81. The games — like so many ZX81 games today — really do use the ZX81's capability. The FORTH program is a fascinating extension of your own computer understanding.

Sabotage. Defender or attacker? The choice is yours in this exciting game.

Be the guard and defend the ammunition in the compound — or be the Saboteur and attack it!

Written by Macronics for a ZX81 with 16K RAM. Cassette price: £4.95.

City Patrol. You are the Commander of a

laser-firing ship. Your task is to intercept and destroy alien suicide ships descending on your city.

Written by Macronics for a ZX81 with 16K RAM. Cassette price: £4.95.

FORTH. Discover a new programming language which combines the simplicity of BASIC with the speed of machine code. FORTH's compiled code occupies less than a quarter of the equivalent BASIC program and runs ten times as fast. Free User-Manual and Editor Manual with each cassette.

Written by Artic for a ZX81 with 16K RAM. Cassette price: £14.95.

ZX Spectrum 48K now just £129.95.
ZX Spectrum 16K now just £99.95.
ZX81 now just £39.95.
16K RAM Pack for ZX81 £29.95.
ZX Printer now just £39.95.
1.2A ZX Mains Adaptor £7.95.
Printer Paper (5 rolls) £11.95.

How to order

Simply fill in the relevant section(s) on the order-form below. Note that there is no postage or packing payable on Section B. Please allow 28 days for delivery. Orders may be sent FREEPOST (no stamp required). Credit-card holders may order by phone, calling 01-200 0200 24 hours a day. 14-day money-back option.

sinclair

Sinclair Research Ltd,
Stanhope Road, Camberley,
Surrey GU15 3 PS.
Telephone: (0276) 685311.

To: Sinclair Research Ltd, FREEPOST, Camberley, Surrey, GU15 3BR.

Section A: hardware purchase

Qty	Item	Code	Item Price £	Total £
	ZX Spectrum - 48K	3000	129.95	
	ZX Spectrum - 16K	3002	99.95	
	ZX 81 (including 1.2A Mains Adaptor)	1003	39.95	
	16K RAM pack for ZX81	1010	29.95	
	ZX Printer	1014	39.95	
	1.2A Mains Adaptor, for use with ZX81 computer/ZX Printer combination (only required if you have an early ZX81 with 0.7A Adaptor)	1002	7.95	
	Printer paper (pack of 5 rolls)	1008	11.95	
	Postage and packing: orders under £90	0028	2.95	
	orders over £90	0029	4.95	
			TOTAL £	

*Delete/complete as applicable.

*I enclose a cheque/postal order made payable to Sinclair Research Ltd for £

Signature

Address

Section B: software purchase

Qty	Cassette	Code	Item Price £	Total £
FOR SPECTRUM				
	G22/S: Backgammon	4021	5.95	
	G23/S: Cyrus-IS-Chess	4023	9.95	
	G24/S: Horace & the Spiders	4022	5.95	
	G25/S: Scrabble	4024	15.95	
	L1 /S: FORTH	4400	14.95	
	B6 /S: Small Business Accounts	4605	12.95	
FOR ZX81				
	G25: Sabotage	2124	4.95	
	G24: City Patrol	2123	4.95	
	L1: FORTH	2400	14.95	
			TOTAL £	

*Please charge to my Access/Barclaycard/Trustcard account no

Mr/Mrs/Miss

PRC 909
(Please print)

ZX Microdrive information request

Please send me a colour brochure with full specifications of ZX Microdrive/Interface 1, and add my name to the Microdrive Mailing List! (tick here) (Remember to include your name and address on the form above)

(continued from page 8)

the cell's contents when in display mode.

Despite these niggles I found the Calcs and financial planning feature useful. If any of your readers would like copies of our own financial modelling report they should contact me at SWURCC.

Adrienne Jackson,
Small Business Microsystem
Support Project,
Microsystems Software Unit,
South West Universities
Regional Computer Centre,
University of Bath,
BA2 7AY.

Faster sorting

I WAS INTERESTED to read Andrew Featherstone's article on sorts in the March issue, and I decided to test the speed of his shaker sort on my TRS-80. I generated 100 random strings, and was amazed at how long the sort took.

I devised my own algorithm as a comparison, and used the sort to order two arrays, each containing the same strings. I repeated this using various-sized arrays ranging from 10 strings to 100. Almost every time my algorithm was at least three times faster.

In the subroutine I used, array A\$(#) contains the strings to be sorted, and NS the number of them.

R English,
Cardiff.

Faster sorting.

```
1000 F=NS
1010 FOR A=1 TO F-1
1020 C=A
1030 FOR B=A+1 TO F
1040 IF A$(B)<A$(C) THEN C=B
1050 NEXT B
1060 T=A$(B)
1070 A$(B)=A$(C)
1080 A$(C)=T
1090 NEXT A
1100 RETURN
```

Recovering Lynx programs

WHEN EXPERIMENTING with recovering Lynx programs — End of File, August issue — I wrongly assumed that the area of memory at which I located the old program was a dedicated cassette file-name buffer. This is in fact not so: the area in question is actually the buffer used for normal to internal language conversion. It also happens to be used by the cassette operating system for storing file names.

Users of the 48K Lynx should

therefore relocate the program to 9F70 where it can be protected by

RESERVE & 9F70

The corresponding address for the 96K machine is FF70. These locations are sufficiently low down in memory to avoid corruption by the stack on a reset.

Chris Cytera,
Mangotsfield,
Bristol.

UK 101 software

I WOULD LIKE to inform any of your readers who own OSI/UK 101 computers that a program library is being formed to keep up the supply of software now that dealers are dropping out. Programs will be available, several to a tape, for a small charge to cover professional duplication, postage, etc.

We are now looking for anyone who can donate programs or help in any other way. To get things moving, tape 1 is available now for £2.50. Contents include games, novelties and Basic Remember and tape file programs, all of which run under Cegmon, preferably with an enhanced screen. All cheques to the OSI/UK Program Library, please, at the address below, or telephone 01-866 7010 at weekends.

F J Leonhardt,
2, Birchmead Avenue,
Pinner,
Middlesex HA5 2BG.

BBC disc software

A GROUP of BBC disc users are getting together to produce a monthly disc for members of the Format 40/80 Disc Club. The idea is to exchange programs of all kinds, including school and educational programs and games.

Would any interested BBC disc users please send us a stamped and addressed envelope giving their disc details. We are also interested in hearing from software houses prepared to offer special prices to our members. Any software copied from disc or tape will be copy-protected and proper royalties will be paid.

Peter Hughes,
Format 40/80 Disc Club,
c/o The Lending Library,
Fire Marsh Street,
Bristol. ☐

CHOOSE

**YOUR ROUTE TO
RELIABLE
SERVICE**

0268-710292

0706-216090

0272-656424

021-236-2819



COMMERCIAL DATA SYSTEMS LTD

SPECIALISTS IN THE MAINTENANCE OF MICRO COMPUTER SYSTEMS
INCLUDING:

APPLE · IBM PC · SIRUS/VICTOR

ICE · CORVUS · VLASAK · EICON · GUME · ANADIX · EPSON · CENTRONIC · TEC



COMMERCIAL DATA SYSTEMS LTD

DOWNHAM ROAD, RAMSDEN HEATH, BILLERICAY, ESSEX, CM11 1PU. TEL: 0268-710292.
ST. JOHNS COURT, BACUP ROAD, RAWTENSTALL, LANCS. BB4 7PA. TEL: 0706-216090.
2 WARSTONE PARADE, HOCKLEY, BIRMINGHAM. TEL: 021-236-2819.
85 LODGE CAUSEWAYS, FISHPONDS, BRISTOL. TEL: 0272-656424.

● Circle No. 104

FINGER PRINT™

Gives you fingertip control of your Epson Printer!



FINGERPRINT makes it easy to use all your Epson printer's capabilities.

Once installed simply tap your printer's panel buttons to instantly select:-

- Double Wide
- Compressed
- Emphasized
- or Double Strike modes.
- Combinations of these, and other features

FINGERPRINT is a plug in module which fits in your printer in minutes. — No soldering. It's compatible with all MX 80 & MX 100 printers — works with all computers, software, & interfaces.

£43.95

+ VAT (incl p & p)

**R P Computer
Products**

40 Triton Square London NW1 3HG
Phone 01 387 4549

Please supply _____ Fingerprints

Each at £50.54 Inc. VAT Cheque encl. _____

Please charge Barclaycard No. _____

Name _____

Address _____

● Circle No. 105

You're just one step away from one-step accounting



Anagram Systems' Integrated Accounts is, simply, the most comprehensive, easiest to understand integrated accounting package available to Commodore users. It is the best reason yet for choosing Commodore.

And now there is Anagram Integrated Accounts with integrated Stock Control – on top of superb Anagram standalone Stock Control and ledger packages. Just look at these features and options.

Full integration: Anagram Integrated Accounts consists of Sales, Purchase and Nominal Ledgers, Cash Book, and functions which permit journal entries, file maintenance and report printing in remarkable detail. All these are automatically updated when you make an entry. In the version with Stock Control, creating an invoice updates the stock as well as the other modules.

Single- or multi-user: Anagram Integrated Accounts, with or without the integrated Stock Control, can be supplied either single-user, or multi-user for up to five machines for only £300 extra per machine. The same goes for Anagram Stock Control.

Hard disk or floppies: Integrated Accounts is on just one floppy disk – compare that to competitive packages – and runs successfully with the Commodore twin disk units. Integrated Accounts with Stock Control and Sales Order Processing ideally requires a hard disk.

Open Item or Balance Forward: Choose which system you want for each account – you can even mix the two.

Extensive analysis: Each sales invoice can be analysed across ten nominal headings; each purchase invoice across eight. You can set up budgets within each nominal heading to get comparisons of 'budget to actual' at any time.

Easy to understand, learn and use: Anagram Accounting and Stock Control packages are designed for busy people who don't want to mess about with computers. They use ordinary book-keeping terms without jargon.

Your Commodore dealer should have these packages ready for demonstration. If not, phone Anagram and we will fix a demonstration for you. Or send the coupon.

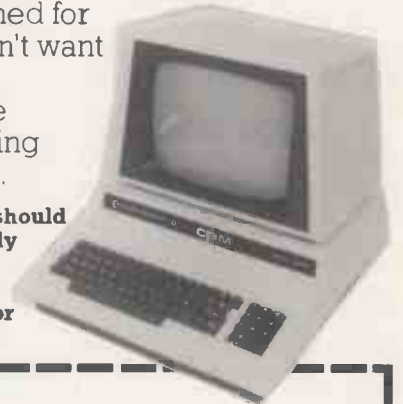

To: Actionline Sales
Anagram Systems, 60A Queen Street,
Horsham, West Sussex RH13 5AD

Send me brochures on the Anagram packages I have ticked and tell me where to see them running.

- Integrated Accounts with Stock Control
 Integrated Accounts Standalone Stock Control
 Standalone Ledgers

Name _____

Position _____

Company _____

Nature of business _____

Address _____

County _____ Postcode _____

Telephone No. _____

Any existing CBM computer _____

commodore
COMPUTER

CBM is a trademark of
Commodore Business Machines
(UK) Ltd



ANAGRAM SYSTEMS
60A, Queen Street, Horsham, West Sussex
RH13 5AD Tel. (0403) 59551/50854/58153

AN/PCO/08

● Circle No. 106

ACT to stake £12 million on Apricot

ACT SAYS the new Apricot is a fourth-generation personal computer because it embodies a new design philosophy. In fact, the machine is an imaginative and clever repackaging of everything that is good in current microcomputing technology.

ACT's real achievement is to build the Apricot at a price that might cause the competition real headaches. Entry is at £1,400, which is less than the Apple IIe with two discs.

The Apricot is transportable rather than portable. It has a 16-bit processor, a small built-in screen, an optional mouse and 3.5in. disc drives. More than anything else, the Apricot is a desk-top micro which just happens to be easy to cart around.

Ergonomically interesting, the Apricot has a very small desk-top footprint. The keyboard has 90 keys that click when they are pressed.

There are eight hard function keys and six soft keys. The innovative microscreen provides a display of two lines of 40 characters when the monitor is not being used. It also functions as a calculator display and a clock face.

Intel's 8086 is the main processor and is used with the 8089 I/O device. A slot is left open for the optional 8087 number-crunching mathematics processor. There is a standard 256K of RAM, and two expansion slots which could possibly take more. The twin Sony micro-floppy drives each

have 315K of storage, and double-sided discs will be a later option.

ACT's name has been synonymous with the Sirius computer, which it will still continue to market. According to Roger Foster, the managing director, the Apricot will complement the Sirius from a lower position in the market. Sirius users tend to be into a more sophisticated type of computing; the new machine is intended as a personal micro.

Consequently the Apricot is 99 percent software compatible with its big brother. The only differences occur where the hardware differs. The Apricot even has the same screen format as the Sirius.

MS-DOS 2, CP/M-86 and

Concurrent CP/M-86 are the three operating systems included as standard. A number of system utilities and some applications software come with the machine; the packages include a relational database, Personal Basic and Gios graphics. There is no word processor.

ACT is seriously committed to the Apricot, having a total budget for the project in the region of £10 million and a promotion budget of around £1 million. There is also the small matter of the factory in Glenrothes, built for the assembly of the Apricot and Sirius micros. For more details contact ACT, 111 Hagley Road, Birmingham, B16 8LB. Telephone: 021-454 8585. 

New Sharp sticks with tape Basic

SHARP'S new home micro, the MZ-700, is now arriving in the U.K. It is a Z-80A based machine with 64K of RAM, 4K of video RAM and two 4K ROMs.

One of the ROMs has been programmed by Knights of Aberdeen, the well known Sharp dealer, with 512 character shapes to make up for the lack of user-definable characters and bit-addressable graphics. The maximum screen definition is 40 characters by 25 lines.

Sharp has also stuck to its idiosyncratic system of loading Basic from tape, which takes almost three minutes, instead of

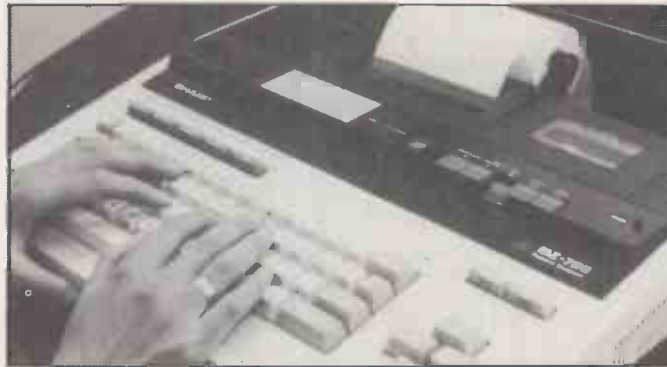

providing it on ROM. The system is far less usable than either the BBC, Commodore or Atari systems where the Basic can be simply switched out. The

MZ-700 leaves some 36,592 bytes free to Basic.

Accessories which fit into the Sharp's case are a cassette deck and a colour printer/plotter. This can be set to echo printing on the screen, so although the MZ-700 lacks a built-in visual display, it can be converted into a sort of portable Teletype machine. The standard machine costs under £250 and the integrated version £420.

Although the MZ-700 is probably the best-made machine on the home-micro market, gives an excellent eight-colour display and has a good range of ports, it is difficult to understand Sharp's thinking. A cassette-Basic machine with block graphics looks four years out of date now, and may look positively sick by Christmas.

Contact Sharp Electronics (U.K.) Ltd, Sharp House, Thorp Road, Manchester M10 9BE. Tel: 061-205 2333. 

Data General's cut-down mini

THE WORLD'S second largest minicomputer manufacturer, Data General, has reduced its 16-bit mini to a microcomputer size and price in the form of the Desktop Generation Model 10. It uses the Data General Microeclipse chip, said to be comparable in power to the Motorola 68000, and runs its operating systems ADS, R-DOS and MP/AOS-SU.

To make it acceptable as a real micro, the DG Model 10 also has a slave Intel 8088 microprocessor running under the control of the Microeclipse, so it will also run MS-DOS and CP/M-86. This makes it functionally compatible with the IBM PC.

The DG micro is inherently multi-tasking and will support four work stations at once. However, three of them have to be running Microeclipse applications, and only one can run, say, MS-DOS.

The entry-level system has 128K of RAM, one 368K floppy-disc drive and a 12in. monochrome screen. It costs £2,532 but with a 15Mbyte hard disc as well the price goes up to £5,608.

Contact Data General, Hounslow House, 724-734 London Road, Hounslow, Middlesex TW3 1PD. Telephone: 01-572 7455. 

(more news on next page)



Newer Olivetti typewriters come complete with computer interfaces but older models need special devices to enable them to talk to microcomputers. This is such a device. Designed for the BBC Micro, the Timtom interface will work with any computer with an RS-232 port running at 300 baud. For further details contact Timtom Micro, 9 Ilton Road, Penylan, Cardiff CF2 5DU. 

Britain's finest business software for the Commodore



Fully featured ledgers and stock control — for less than £100 per package!

The Commodore 64 is the computer small businesses have been waiting for — inexpensive, reliable, with a large memory. Now there is Anagram business software for the 64, full-scale proven 40-column sales ledger, purchase ledger and stock control developed from existing Anagram packages for larger machines.

Anagram software uses no jargon, speaks to you in plain book-keeper's English, is extremely easy to understand. The packages for the 64 offer all the options and facilities any business is likely to need.

Sales Ledger with invoice printing — £99

Anagram Sales Ledger 64 maintains comprehensive details of each customer account on an open-item basis — each invoice remains on the account until it is paid. Handles up to 220 customer accounts, up to 20 lines per invoice, trade and settlement discounts. And you should see the reports!

Purchase Ledger with Nominal Analysis — £99

Anagram Purchase Ledger 64 is as comprehensive and full of features as the sales ledger, and is just as simple to use. Up to 150 supplier accounts with 50 nominals — posts invoices, credit notes and payments to each account. You can even analyse each invoice across 6 nominals plus VAT!

Easystock — £75

Easystock, like the Sales and Purchase Ledger packages for the Commodore 64, is designed to make computerisation straightforward for the businessman and his staff. Step-by-step menus ensure accurate stock records for up to 550 stock items with detailed up-to-the-minute reports.

SEND THE COUPON FOR A LEAFLET AND DETAILS OF YOUR NEAREST DEALER

Please rush me your Commodore 64 software leaflet and the address of my nearest dealer

Name _____

Company _____

Address _____

Telephone No. _____



• Circle No. 107

NEC's APC cuts 16-bit costs

NIPPON ELECTRIC, the \$5 billion electronics company, has just launched the Advanced Personal Computer or APC on to the U.K. market. This coincides with the opening by the Queen of its new semiconductor factory in Scotland.

The APC has been out for almost two years in Japan, where NEC claims to have 45 percent of the micro market, and one year in the U.S.

It is not short of software as it runs both MS-DOS and CP/M-86, using NEC's own version of the Intel 8086 which gives some degree of IBM PC compatibility. Launch software includes Benchmark word processing, Systematics International accounting packages, Masterplanner, dBase II, and NEC's graphics and communications utilities — so far so boring.

What makes the APC a challenger is that the full 16-bit micro with 128K of RAM, two 8in. floppy-disc drives and 12in.

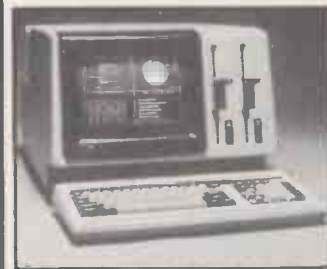

mono screen costs only £1,985, some £800 cheaper than the going rate. A one-drive entry-level system costs £1,875, which is not much more than the Z-80 based Epson QX-10, and a 10Mbyte hard-disc version costs only £3,690. NEC will pile 'em high and sell 'em cheap through its existing dealer outlets plus retail chains like John Lewis and Tesco, though it is not likely to appear at your local supermarket.

Contact NEC Business Systems, NEC House, 164-166 Drummond Street, London NW1 3HP. Telephone: 01-388 6100.

Rediffusion Teleputer 3

WHILE REDIFFUSION is best known for television rentals and flight simulators, Rediffusion Computers is a substantial

company selling some £20 million worth of minicomputers last year. Now it has launched the Teleputer 3, a fast Z-80 based micro with colour as standard. It also comes complete with its own suite of integrated packages such as Starcalc, Starfile, Startel, Startype and Stardata.

The Teleputer has its own operating system, CP/Star, which is a huge improvement on CP/M — aren't they all? — but CP/M can be run as a non-integrated option. It also offers teletext capabilities based on the Mullard chips best known from mode 7 of the BBC Micro. It has its own semi-compiled Basic, which enables it to run the standard Benchmark tests three times faster than the ACT Sirius, and noticeably faster than the Olivetti M-20.

The standard machine including 128K of RAM, two 320K floppy-disc drives, colour monitor, built-in Modem, operating system, Basic and suite of applications programs is competitively priced at £3,595 plus VAT.

Contact Rediffusion Computers, Kelvin Way, Crawley, Sussex RH10 2LY. Telephone: (0293) 3121.

Centronics link to CBM micros

THE VC Parallel Interface allows a Centronics-style printer to connect to the printer bus of the Commodore-64 or Vic-20 computer. It does not occupy any memory space and does not tie up the valuable user port. As yet there is no U.K. distributor for the product, but further details can be obtained from Richard Wiesemann Mikrocomputer-technik, Winchenbachstrasse 3a, D-5600 Wuppertal 2, West Germany.

Atari magazine

ATARI (U.K.) has just published the third issue of *I/O*, its user magazine. It is sent free to all registered owners — that is, those who returned their guarantee card. If you are not on the mailing list you can get your free subscription by sending the number of your machine and the place and date of purchase to Atari International (U.K.) Inc., Atari House, Railway Terrace, Slough, Berkshire.

COMPSOFT'S DMS – winner
of the 1982 **RITA** Awards,
'Software Product of the Year'.

Now Compsoft announce
Delta – the very powerful, very
friendly database* that the
world has been waiting for.

* For micro computers with CP/M, MP/M or MSDOS operating systems. Including IBM PC.

Compsoft Training Centre

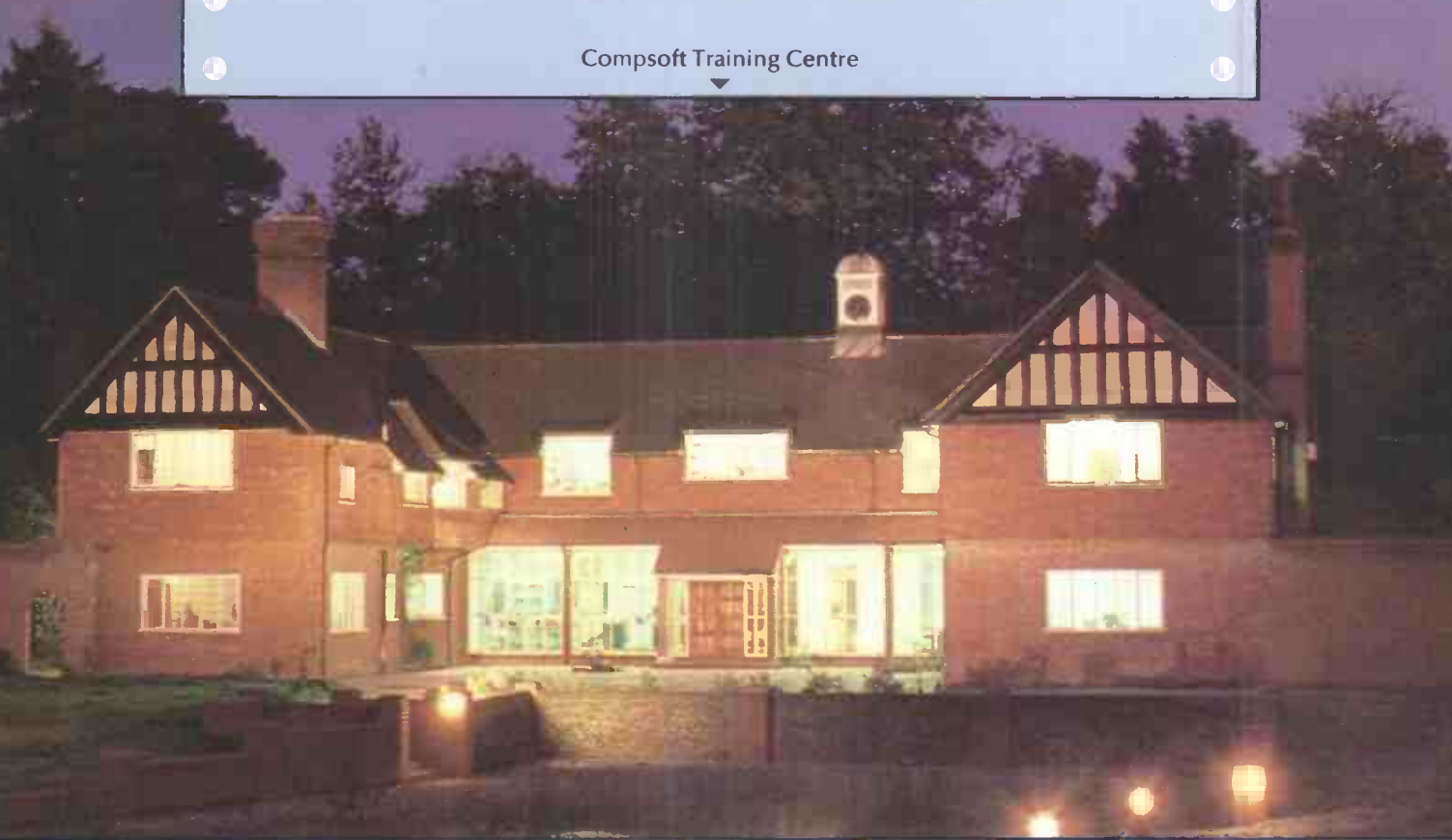

If part of your microcomputer's job is to store information, you need Compsoft's software.

Compsoft DMS is already Britain's No. 1 record keeping program. And with 4000 users to our credit, we can honestly say we know more about information storage & retrieval than anyone else. We listen to your comments & requests and now we've produced a world first – the Delta – a true transactional database.

If you'd like to know more, we have general brochures, full technical specifications & free

guides to DMS handling a multitude of business situations from order processing, invoicing & stock recording, through to library, personnel & hospital record management.

Find out more about the database revolution. Either telephone the office or clip the coupon now.

Compsoft's Delta – taking microcomputers into the third dimension.

Compsoft Limited
Hallams Court
Shamley Green
Nr Guildford, Surrey
England GU4 8QZ
Telephone: Guildford (0483) 898545
Telex: 859210 CMPSFT



Please send me further details

Company

Contact

Address

● Circle No. 108

Tel No.

Meet the fa

Minstrel + TurboDOS

the marriage of reliability and versatility



Minstrel

The Minstrel is an exciting new British micro-computer and offers Winchester-based systems at fantastically low prices. The range extends from single-floppy single-user CP/M systems right up to a 68000-based model and includes an 8086-based range.

The Minstrel is compatible with the North Star Horizon and offers a superior alternative at a much better price.

There is a network of Minstrel dealers in the UK and Europe. Contact us for the name of your local dealer. Dealer enquiries invited.

S100 bus

The amazing versatility of the Minstrel is due to the bus used: the S100 bus. This bus system is not only future-proof – the future is created on the S100 bus. Every major micro-computer development appears first on the S100 bus. Now over 150 manufacturers make S100 products and their combined range approaches 1000 boards.

**Hotel Microsystems
Limited**

69 Loudoun Road, London NW8 0DQ
national 01 328 8737
international +441 328 8737
telex 266828

mily



One machine – eight computers

Yes! Inside the Minstrel micro-computer illustrated there are actually 8 Z80A single-board computers. One is dedicated to each user of the system resulting in astonishing performance. A ninth processor controls central disk storage and printers.

TurboDOS provides sophisticated spooling for multiple printers, supports 1000Mb disk drives and 128Mb files, and employs powerful disk buffering techniques.



TurboDOS CP/M COMPATIBLE MULTI-USER OPERATING SYSTEM

TurboDOS is a popular high-performance multi-processor operating system. Each user has their own slave processor board (illustrated above). TurboDOS systems have been shown to out-perform mini-computers in the DEC PDP11/34 class at a fraction of the hardware cost.

TurboDOS is compatible with CP/M, the industry standard operating system, which means you have access to a vast range of off-the-shelf software.

The next development to TurboDOS on the Minstrel allows you to connect systems together via a Local Area Network.

ASTONISHING PRICES!

Minstrel with two 400Kb floppy drives £1790.
With 1 400Kb drive and 5Mb Winchester £2615.

A sample 2-user TurboDOS system including:

Minstrel
1 400Kb floppy
1 5Mb Winchester
2 slave processor cards
2 KDS7362 VDU's (illus)
1 Epson printer

ONLY

£5465

A sample 5-user TurboDOS system with background batch processor including:

Minstrel
1 400Kb floppy
1 15Mb Winchester
6 slave processor cards
5 KDS7362 VDUs (illus)
1 Epson printer
1 OKI 84 printer

ONLY

£10310

SOFTWARE FOR YOUR MICRO

British Broadcasting Corporation



These high-quality software packs have been specially developed to make the most of the sophisticated design and great versatility of the British Broadcasting Corporation Microcomputer. They enable you to use your computer for a huge range of activities – from education to music, drawing, personal finance or games of skill and strategy.

Each pack contains a comprehensive handbook and a pre-recorded cassette carrying a set of programs. They will operate on Model A or Model B except for *The Computer Programme Programs Vol. 2*, which is for Model B only.

Early Learning

A colourful and stimulating learning aid designed to help young children develop their word and number skills.

Fun Games

Four great games with colour and sound to test your speed, skill and co-ordination.

Games of Strategy

Test your brain-power and tactical skills against the computer's with these intriguing games.

Home Finance

Commissioned from the Consumers' Association, these programs will help you make the right decisions about money.

Painting

Use the computer as a palette to produce full-colour designs and wonderful 3-D effects.

Drawing

Exploit your computer's graphics capabilities to create an infinite variety of shapes and patterns.

Music

The computer becomes a simple musical instrument, enabling you to compose, play and listen to your own tunes.

The Computer Programme Programs Vol. 1

Twelve of the most popular programs demonstrated in the BBC television series.

The Computer Programme Programs Vol. 2

These more sophisticated programs make use of the additional memory capacity of the Model B computer.

**ON SALE NOW AT
SELECTED BOOKSELLERS AND
MICROCOMPUTER SHOPS | £10.00 EACH**

See us on Stand 18 at the Acorn User Exhibition, Cunard Hotel, Hammersmith (25-28 August) or on Stand 138 Hall A Lower. Personal Computer World Show, Barbican Centre, City of London (28 September-2 October)

Four-colour spreadsheet

PRACTICALC is a four-colour spreadsheet program for the Commodore 64 or the Vic-20. Available on either disc or cassette at £29.95 or £24.95 respectively, Practicalc has all the normal Calc facilities.

The user enters headings and numerical data into rows and columns that are displayed on

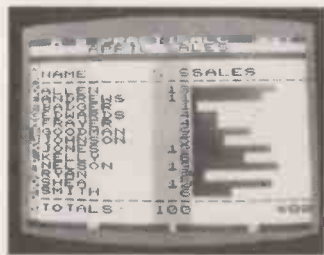

the screen, and can then perform over 20 different mathematical operations. Finished sheets can be saved, loaded or printed, and rows can be sorted into numerical or alphabetical order.

Further details from Marketing Micro Software Ltd, Goddard Road, Whitehouse Industrial Estate, Ipswich, Suffolk IP1 5NP. Telephone: (0473) 462721.

Micro-Prolog comes down a step or two

MICRO-PROLOG, a language ideal for experimenting with expert systems, should be available for the Spectrum and BBC Micro-computer in the autumn. Logic Programming Associates at present markets Micro-Prolog for Z-80 based CP/M machines, and claims about 1,000 users for its system.

The Spectrum version will be available initially on cassette, with a ROM version to follow. The BBC version will be in ROM, with example programs available on disc. Distribution arrangements and pricing have not been finalised, but Logic Programming Associates has demonstrated the system running on the 48K Spectrum.

Micro-Prolog for Z-80 based CP/M machines costs £150 on disc, with a reduced price to educational institutions of £90. More details from Logic Programming Associates, 10 Burntwood Close, London SW18. Tel: 01-874 0350.

HP VisiCalc on a chip

REAL VISICALC from Visicorp is contained in a tiny ROM module for the Hewlett-Packard 75C battery portable. It gives you VisiCalc in a truly portable package weighing less than 2lb.

The HP 75C's one-line 32-character LCD display acts as a window into the spreadsheet. You can also connect up the HP 75C to its optional 9in. or 12in. monitor for full-sized working.

The VisiCalc module costs £160 and a standard HP 75C costs £694. Details from Hewlett-Packard Ltd, Literature Department, Winnersh, Wokingham, Berkshire RG11 5AR. Telephone: (0344) 773100.



Inmac contest

AN OSBORNE and three Epson HX-20s are among the prizes in a competition organised by Inmac to promote its range of computer accessories. All you have to bring yourself to do is write an essay saying that computers actually do create new jobs rather than just destroying existing ones. The competition closes on October 31, 1983. Full details are contained in Inmac's latest catalogue, which is available free from Inmac (U.K.) Ltd, Davy Road, Astmoor, Runcorn, Cheshire WA7 1PZ. Telephone: (09285) 67551

Electronic mail comes to Sirius and Apricot

BOTH THE SIRIUS and ACT's new Apricot portable can now be used to send and receive electronic mail. The Micromail package consists of a small Modem card which plugs into the inside of the computer, together with the necessary software to transmit messages through the phone system. It costs £275, including the annual subscription.

The system is based on British Telecom's electronic mail service Telecom Gold, which

already has several thousand users. To send an electronic message you simply type in the name of the recipient followed by the message, which is then delivered to the appropriate electronic mailbox on the British Telecom computer system within seconds. To collect your own mail the Micromail software causes the Sirius or Apricot to dial up your particular mailbox on Telecom Gold and then download any messages for reading.

ACT claims a one-page A4 letter of 400 words can be transmitted to its destination in under a minute at a peak-rate cost of 15p within London or 17p long-distance, with the price falling below that of a second-class postage stamp at off-peak times. This compares very favourably with Telex, datapost or facsimile transmission costs.

Messages can be sent to any British Telecom electronic mail user, not just to other micro-computers with Micromail. ACT intends to bring out a version of the product for the IBM PC in the near future. More details from Applied Computer Techniques Ltd, ACT House, Telephone Avenue, Bristol BS1 4BS. Telephone: (0272) 211733.

(more news on page 23)



Impex thinks its set of keyboard templates for the Osborne 1 and Executive machines should help users find their way around WordStar, Supercalc, MBasic and dBase II more easily. The templates cost £19.95 from Osborne dealers or direct from Impex Micro Products Ltd, Ridgeway Court, Grovebury Road, Leighton Buzzard, Bedfordshire. Telephone: (0525) 371597.

LONDON COMPUTER CENTRE

SIRIUS 1

1.2 Mb Disk Storage **£2195**
 2.4 Mb Disk Storage **£2695**
 10. Mb Disk Storage **£3995**

TELE-VIDEO

806/816
 the Multi User
 Computer System



EPSON QX10
Multi Fonts
Zoom
Graphics

192K RAM
£1735
 Upgradeable
 to 256K



SENDATA 800 SERIES
ACOUSTIC COUPLER
£220

* Compact, lightweight, portable
 * 10 hours operation from the
 rechargeable batteries
 * 300 BPS answer/originate
 * Handset sensor on/off switch
 * New crystal controlled
 circuitry
 * B. T. Approved.

SUPERBRAIN 2



Dedicated
 Wordstar
 Keypad
from
£1595

New TANDY Model 4

CP/M 3.0
 64K-128K RAM
from £1299

TANDY 100

Portable with built-in
 4 Programmes: Word Processor,
 address book, scheduler, and
 communications. Large 40 x 8 char.
 line display
£433

EPSON HX20

Portable with built-
 in printer
from £402

OSBORNE 1



Double
 density
£1350

New ZORBA



Portable
 full 80 x 20
 display
 800K disc
 storage
£1595

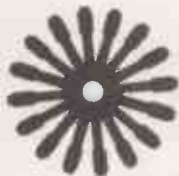

FLOWRITER
RP 1600
60 CPS
 Fast and reliable
 8K buffer
£1600

TEC F10 40 CPS

Diablo 620 compatible
 Japanese reliability
£1250

New JUKI 6100 Daisywheel 18 CPS

Bi directional
 Adler daisywheels
 Diablo 630 protocols
£399



3 in One TOSHIBA P1350

24 Needles - high speed
 drafts 190 CPS Letter Perfect
 Printing 100 CPS Addressable Pin
 Graphics **£1130** Options:
 Tractor **£87**; Sheet feeder **£520**

EPSON FX80 160 CPS



OKI 84
200 CPS
£850

3 TRAY AUTO SHEET FEEDER

For originals,
 copies and envelopes.
£695

**SINGLE
 SHEET
 FEEDER** **£375**

New SHINWA CP 80 MATRIX PRINTER

80 CPS Friction and Tractor inc.
 interface cable and paper **£275**

SUITABLE FOR MOST DAISY PRINTERS

All prices are Exclusive of VAT and Delivery. Dealer Enquiries invited on all Products.
 Large range of CPM Software available. Please phone for Prices.

Demonstrations on all models.

43 Grafton Way, London W1P 5LA (Opposite Maples)
 Opening Hours: 10-7 Mon-Fri. 12-4 Sat.
 01-387 4455 (4 lines) After 7pm 388 5721. Telex: 8953742

Epson terminal emulator

TRANSAM has produced a terminal-emulation program for the Epson HX-20 which, among other things, lets you produce full 80-column printed output from the portable's built-in 24 column printer. This feat is achieved by putting the text out sideways in blocks of 18 lines.

The £50 Intelligent Terminal Emulator program comes in ROM. It can be installed either



in the main body of the HX-20 or in the expansion unit. The HX-20 can be linked via its RS-232C interface to the other system either directly or via an acoustic coupler through the phone system.

Details from Transam Computer Products, 59-61 Theobald's Road, London WC1X 8SF. Telephone: 01-404 4554.

Spectrum business pack

THE SPECTRUM, with its "dead flesh" keyboard and cassette data storage is obviously not the ideal business machine, but this has not deterred the software producer Hestacrest. Sales/Purchase Spectrum is its latest offering.

The program can be used as either a sales or purchase ledger, and can handle up to 1,000 transactions a month and 250 customers or suppliers according to Hestacrest. Sales/Purchase Spectrum follows the company's earlier Accounts Spectrum program, for the preparation of accounts from incomplete records. Both systems require a 48K Spectrum with printer and domestic cassette recorder and TV.

From the documentation both packages look like serious products which will at least give the user a good idea of what a computer can achieve. They cost £25 or £35, with different versions for different types of company structure.

More details from Hestacrest Ltd, PO Box 19, Leighton Buzzard, Bedfordshire LU7 0DG. Tel: (052 523) 785.

Spectrum's Hobbit now on the Oric

MELBOURNE HOUSE has rewritten its best-selling Spectrum game The Hobbit for the Oric. The program is based on Tolkien's book and comes on cassette packaged up with a paperback copy of the book along with games instructions. The price of the Oric version will be £14.95, the same as for the Spectrum. More details from Tansoft Ltd, 3 Club Mews, Ely, Cambridgeshire CB7 4NW. Telephone: (0353) 2271.

Managers made with micros

CORPLAN is a management game aimed at O-level students through to working managers which has been around for some time running on Tandy model III and Commodore 8000 series computers. It is now to be available for the Spectrum, BBC, Apple and Nascom machines, with prices ranging from £49 to £99. Details from Understanding Ltd, 100 Cricklewood Lane, London NW2 2DS. Telephone: 01-450 1144.

Fish and micro chips

HOME-COMPUTER software is now available over the counter along with the chips at the Pisces Fish Bar in Richmond. Entertainment software seems to be following a similar route to video cassettes, moving beyond specialist outlets to record stores, newsagents and other locally based retailers. "People get put off by the high-tech mystique of specialised computer centres," says chip-shop owner and now software dealer Graham Barrow.

TWICKENHAM COMPUTER CENTRE LTD

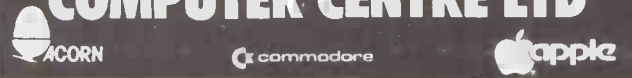

Buy the **BEST BRITISH COMPUTER**

As supplied to schools, local authorities and government departments by the leading BBC/Acorn dealer & service centre

BBC Model A £299 **BBC Model B £399**
 Wordwise Word Processor (needs 1.0 System)
 Software - Acorn, Bugbyte, Computer Concepts (logo 2)
 Acornsoft on Disk
 Joysticks for the BBC - 100K Single Disk Drives
 BBC 800K Twin Disk Drives
 Torch 800K Twin Disk Drives with CPN

We stock all the extras:
 Floppy disk interface
 Econet network interface
 Voice synthesis circuits
 Cartridge ROM pack interface
 Alternative high-level languages
 Cassette recorders
 Dot matrix printers
 Daisywheel printers
 Teletext & Prestel units
 Monitors + Disk drives
 (subject to availability)

ALL PRICES INCLUDE VAT!

*Commodore 64: £299 *Coming soon: Acorn Electron - phone your order now!
 Apple IIE 64K on special offer - phone for latest price

SPECIAL OFFERS
 Whilst stocks last!

For the BBC:
 Screen Layout Pad,
 Flow Chart Pad &
 Symbol Design Pad

Kit with ring binder
 Rec. retail price £15.50
OUR PRICE ONLY
 £12.50 incl VAT

Daisywheel Printer for BBC
 (complete with interface) £425
 Star 510 Dot Matrix Printer £425
 Brother Daisywheel Printer £550
 Black & White TV with Monitor conversion
 12": £60 14": £70
 Cassette Deck (BBC compatible): £30
 Tantal Prestel Adapters: £100

Post & Packing EXTRA

Plus software, peripherals, games, books and much more always available from:
Twickenham Computer Centre
 72 Heath Rd Twickenham Middx TW1 4BW (01-892 7896/01-891 1612)

Nationwide delivery by Securicor

● Circle No. 112

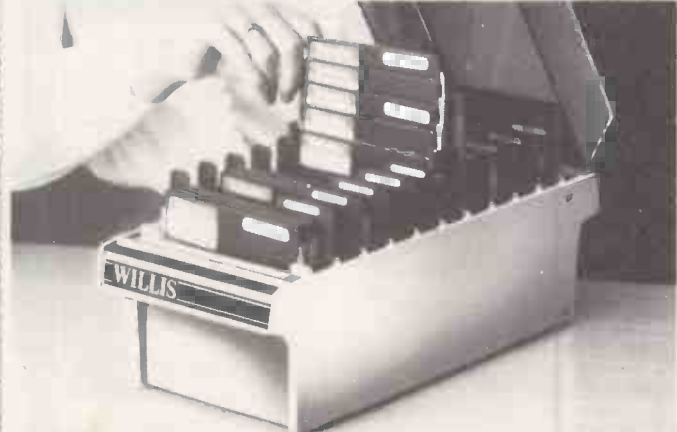

Somewhere handy to keep your Mini-Disks Only £35 (Plus £2p&p)

The Willis Mini Disk File is a handsome, virtually indestructible filing system for your valuable programs and data files.

Disks are stored in 10 sections, each with an ingenious lift mechanism, which enables you to display them five at a time, using only the thumb and forefinger.

The file holds fifty 5¼" mini-disks and can be locked for security.

Just one of the items from the Willis catalogue.

To: Willis Computer Supplies Ltd, FREEPOST
 PO Box 10, Southmill Road, Bishop's Stortford,
 Herts CM23 1BR. Telephone: Bishop's Stortford
 (0279) 506491.

I enclose £_____ for _____ Mini Disk File(s) at
 £35 + £2 p&p (Cheque/PO).

Name _____

Address _____

Post Code _____

Or debit my Access/Barclaycard No. _____

Signature _____

Please send your colour catalogue (tick box)

WILLIS Computer Supplies

● Circle No. 113

MORE RELIABLE MEMORY

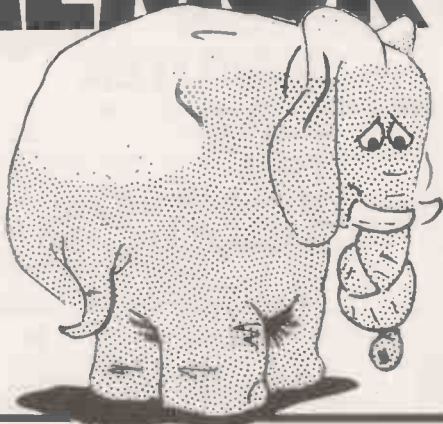

SOFT ERROR DETECTION AND CORRECTION

Small business computers and personal computers often have the same configuration, use the same micro-processors with the same performance and yet the small business computers are a couple of times more expensive than comparable personal computers. Why such a difference? The answer is *reliability*.

With some additional hardware you can enhance the reliability of a personal computer to a degree that it can be used to do more sophisticated tasks where long term error free operation is a must.

One of the most error prone parts of a computer is its memory, which can be affected by both HARD and SOFT errors.

Hard errors can be easily detected, but soft errors, which occur more often, have to be dealt with by using an error checking and correction technique.

Practical Electronics this month shows how to correct erroneous data in memory. Our in-depth article gives background information and full construction details to build our Error Detection & Correction Board for the home microcomputer.

If reliability counts buy

PRACTICAL

SEPTEMBER ISSUE

ELECTRONICS

ON SALE NOW

CAMEL PRODUCTS

BLOPROM-81



A uniquely sophisticated EPROM PROGRAMMER

In use at various labs incl. Sinclair Research

Eprom programmer for the 2516, 27XX single supply families. yes, even the 27128 from Intel. Check, Read, Program + Verify all or part of Eprom.

So immensely user friendly you'll hardly need the manual. Designed for the beginner but includes a single key entry route for the professional. Supplied as firmware, the m/c driver routine alone is worth more than the price of BLOPROM-81. No Personality Cards or other additions, just a ZX81. Several inbuilt safety features. On-board Vpp generation. 28pin ZIF socket. Cabled connector and extender plug. ABS case.

Note: Can provide up to 36 inputs or 40 outputs as an I/O

STATUS) NO. SYSTEM - HEX
) EPROM TYPE - 27128
) RAM START ADDR - 4000
) EPROM ST. ADDR - 0000
) JOB LENGTH - 4000
) TASK - CHECK

WHICH TASK DO YOU WISH TO DO #

W) CHECK THAT EPROM IS CLEAN
 X) READ THE CONTENTS OF EPROM INTO RAM
 Y) BLOW AN EPROM WITH DATA FROM RAM
 Z) VERIFY THAT EPROM DATA IS THE SAME AS IN RAM

0 TO QUIT.....R TO RESTART

FAST CODES AVAILABLE:
 D H PQR WXYZ

ROM-81
An 8K ROM reader for 2X81 **£14.95**

PROMER-81
A low cost programmer for 2716/32 **£19.95**

DREAM-81
A 64K RAM for 2X81, with socket for 2716/32/64 **£69.95**

PIO-SP
An 8 + 8 line parallel input output port for Spectrum **£18.50**

PIO-81
As PIO-SP but memory mapped for 2X81 **£13.00**

UK, VAT extra. No VAT on exports P + P UK, Free Europe + 5% — Overseas + 10% UK & Worldwide dealerships available.

Cambridge Microelectronics Ltd., One Milton Rd., Cambridge. CB4 1UY Tel (0223) 314 814

VER-WORD

THE WORD PROCESSOR

For Microcomputers running CP/M™

You will not believe the power of Word processing software that VER-WORD can bring to your machine.

- easy to learn and use
- what you see is what you get
- ideal separate command and edit modes
- powerful block text commands
- sophisticated column manipulation
- mail merging included

Write now for full specification brochure.

Orders are being accepted for the following hardware:

- Osborne
- Televideo
- Wordset
- Compucorp (CFM)



VERWOOD SYSTEMS
 Verwood House
 High Street,
 West Haddon,
 Northants NN6 7AP.

CP/M™ is a registered trade mark of Digital Research, Inc.

● Circle No. 115

● Circle No. 116

ROCK SOLID REPUTATION — WORLD SHATTERING PERFORMANCE

Before you buy any other micro-computer anywhere near the price—evaluate Genie III. It is probably the most flexible and proven system of all!

Genie III provides everything you need to streamline and increase your efficient handling of paperwork, accounts and general administration.

POWER TO SPARE

The system can expand to provide a full range of applications in data processing and word processing and offers you all the business help you'll need with power to spare.

And as your needs change, you'll find that Genie III has 4 powerful features that lets it respond to your new demands:

- Enormous language choice
 - Wide operating system options
 - Extreme hardware flexibility
 - Fantastic storage capability
- Test Genie III now — it is the proven system for today.

2-YEAR GUARANTEE

Genie III is available from your Genie Specialist Dealer, who can give you expert user advice, technical support and an optional 2-year guarantee which includes normal wear and tear.

All this at the incredibly low price of **£1395 + VAT** for Genie III 40 track models, or **£1650 + VAT** for 80 track models

INSTANT CREDIT

Instant credit up to 24 months is available from Lowe Computers¹ if you hold a valid bankers card. Tick coupon or phone for full credit terms and details.

¹Licensed Credit Brokers.

²Microsoft is a registered trademark of Microsoft Incorporated

Genie III
 Gives you the most
 fantastic power-to-price value

Fantastic power-to-price value. From 700K to 1.46MB with expansion up to 10.92MB on-line.

Full 64K available for user-memory.

Flexible option of 5¼" or 8" floppies, or 5¼" hard disk, all on-line if needed.

Languages include Microsoft² level II BASIC, PASCAL, FORTRAN, COBOL, FORTH, Assembler, APL, PL1.

Operating systems: NewDOS 80v 2A—64 and 80 format included (CP/M optional).

Can be configured for a wide range of other operating systems.

Programmable screen formats up to 80 x 24 with clear characters on a 12 x 6 matrix.

Fully programmable Baud rate from 50 to 38,400, with selectable micro-processor speeds 3.2 MHz or 1.74 MHz.

PRESTEL COMMUNICATION

Prestel/Viewdata compatible. **FREE** communication software with each Genie III purchased.

Genie Prestel/Viewdata modem available.

- Small size — low power
- 2-year warranty
- Simple modular construction
- Wide range of options
- British manufactured
- British Telecom approved

16 re-programmable dedicated commands (8 keys x 2 shifts).

12K ROM with 2K bootstrap, 2K screen driver, plus built-in diagnostic routines.

Full technical specification available — send coupon now!



GENIE III A much more able computer for your money!

For a down to earth price from just £1395! plus VAT

Please send me full Genie III details and the address of my nearest dealer Details of instant credit plans.

Name _____ Address _____

Postcode _____

LOWE COMPUTERS

Lowe Computers, Lowe Electronics Ltd., Chesterfield Road, Bentley Bridge, Matlock, Derbyshire DE4 5LE
Telephone: (0629) 4057, 4995. Telex: 377482 LOWE G

Lowe Computers, Lowe Electronics Ltd., Chesterfield Road, Bentley Bridge, Matlock, Derbyshire DE4 5LE
Telephone: (0629) 4057, 4995.
FC9/83

Circle No. 117

MEMOTECH MTX SERIES



MTX500 £275 MTX512 £315

**Available in September—please phone for sales information
Memotech products are designed and made in Oxford and Witney**



The All-Purpose System

The MTX Series

The MTX Series is a new departure in micro-computer technology. Whether your needs as a user are for personal programming, games playing, scientific or process control, educational or business use the MTX Series is already capable or very easily adaptable to almost every application. Glance through the standard features below — you'll see what we mean.

Software

The MTX's 16k ROM contains several languages and routines which enable the novice or the experienced programmer to make full use of the machine. Standard languages are MTX BASIC, LOGO type commands, and NODDY. ROM routines include an ASSEMBLER/DISASSEMBLER with screen display of the Z80 CPU registers, memory and program, which can be manipulated from the keyboard. Machine code programs can be stepped through one instruction at a time, and easily called from within BASIC programs. A further feature is the Virtual Screen facility which enables the programmer to define sections of the screen to work Independently whilst maintaining all full screen facilities. Pascal is available as an add-on ROM pack.

Hardware

The MTX500 has 32k of user RAM as standard (64k on the 512), expandable to 512k plus 16k of dedicated video RAM. Sixteen colours, 40 column text, 256 x 192 high resolution graphics with all sixteen colours available, and easily moveable user defined graphics (Sprites) combine to make effective screen displays quick and simple to achieve. Standard outputs are centronics



printer port, two joystick ports, an uncommitted I/O port, 2400 Baud Cassette port, separate TV and Video Monitor ports, 3 voice sound with hifi output plus a dedicated games cartridge port. Other standard features include the Z80A processor running at 4MHz, real time clock, full moving key keyboard with 79 keys including eight function keys and separate numeric pad.

The Disc Based System

The MTX series has been produced with performance and expandability uppermost in the design team's thoughts. When expanded to Disc level the computer supports the following facilities, which will be available in October:

- 80 column video board
- 5¼" floppy discs
- 5¼" hard discs
- CP/M 2.2, enabling the widely available range of CP/M based software
- Memotech Silicon discs — multiples of 256K of fast RAM expandable to 8m bytes
- Colour Wordstar
- A/D and D/A converters
- Networking

MTX

Memotech Limited,
Station Lane Industrial Estate, Witney, Oxon. OX8 6BX.
Telephone Witney (0993) 2977. Telex 83372 Memtec G

● Circle No. 118

CONTINENTAL SOFTWARE

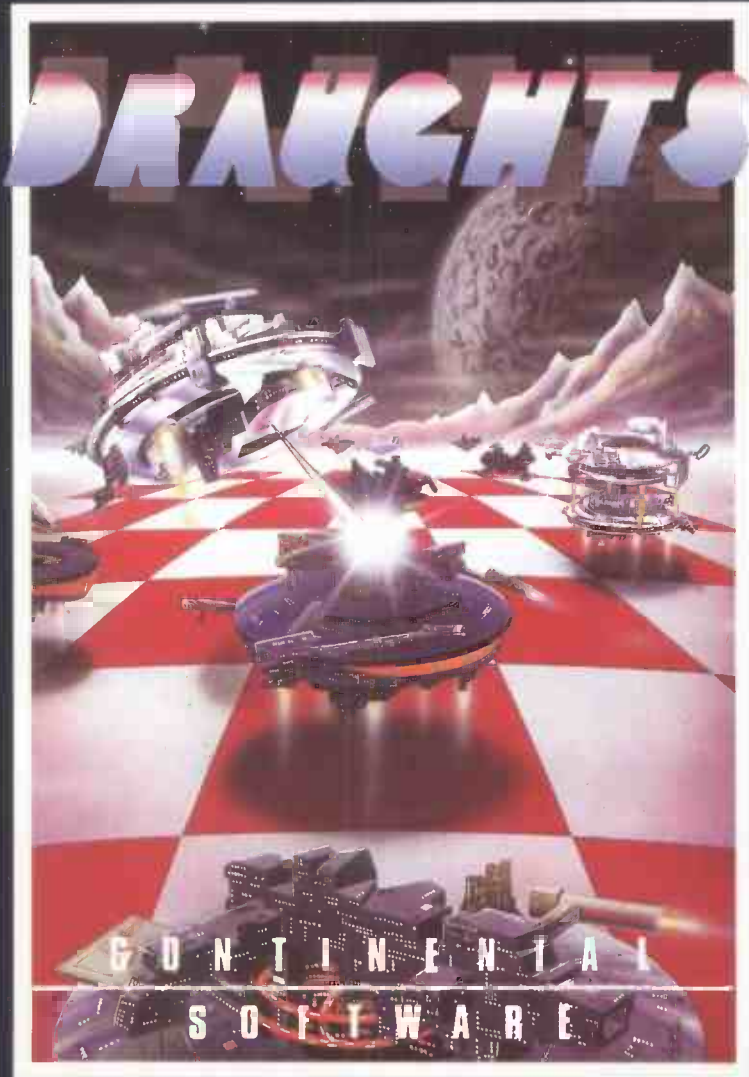

We're not just playing games...

BLOBBO

A fast maze chase with untold perils and hazards.

TOADO

Get the toad back to his nest – but don't get run over or drown on the way.

SUPER MINEFIELD

You may have seen other Minefield games but ours has tanks that lay invisible mines, and spiders that are very tricky to avoid.

CONTINENTAL INVADERS

Classic arcade action, with all the features that make this game so popular.

KILOPEDE

This one is very fast – its not easy to get past level two.

RADAR/SONAR

Eliminate submarines with a combination of radar screen and sonar, very realistic.

FLIGHT SIMULATOR

Take off, navigate and land your high powered light aircraft. All the features of true flight.

ALSO AVAILABLE:

RESCUE, BEAVER, CONTINENTAL RAIDERS, PILE UP, SIGNAL MAN and many more.

we mean business too.

MTXCALC

Sophisticated and powerful, the professional spreadsheet program.

MTX WORD PROCESSOR

All necessary features are included to give a powerful business tool.

ACCOUNTING PACKAGE

Sales and Purchase Ledgers, stock control, payroll – the complete business system.

PROJECT PLANNER

Speaks for itself, and helps you achieve deadlines efficiently and effectively.

STRATEGY BOARD GAMES

CHESS, BACKGAMMON, OTHELLO, DRAUGHTS.

EDUCATION PROGRAMS

MATHS 1 PHYSICS 1

The first two programs in a series of specially written software designed to teach at the pace and level best suited to the user.

Software for the
MTX
SERIES

CONTINENTAL SOFTWARE UNIT 24 STATION LANE WITNEY

Weaving words

Threaded interpretive languages are both powerful and flexible says Boris Allan

THE MOST POWERFUL family of languages on computers is that known as threaded interpretive languages, TIL. A TIL cannot easily be described, and R G Loeliger in his book on the subject stresses that to define a TIL it is necessary to view it in the context of language translation.

In a TIL any function — usually called a “word” — when translated by the interpreter is treated as a series of addresses to other, previously defined, words. These previously defined words are also composed of addresses to even earlier words. The threading process continues until all the addresses refer to purely machine-code routines.

TILs are essentially extensible languages, as can be seen by considering how you might implement your own, novel language. A TIL is implemented by creating what Loeliger terms “primitives”, keywords which have a purely machine-code definition. When a primitive is activated, therefore, only machine code is used. Primitives thus execute swiftly as they are already “compiled”. Loeliger claims that a TIL can be implemented using as few as 40 to 60 primitives.

When the primitives have been defined, or perhaps at the same time as some of the later definitions, you can start to create secondaries. The secondaries have bodies of code which are, in fact, lists of addresses pointing to the location of primitives, or a mixture of primitives and previously defined secondaries.

The most common TIL is Forth, but I will not use Forth as an example because TILs are far more general. I will, however, use the familiar colon definitional form of Forth as this form is also common to most TILs. Any secondary word will be prefixed by Sec, and any primary word will be prefixed by Prim. To define a new secondary word SecX might take the form

```
: SECX SECA SECB PRIMC ;
```

which utilises secondary SecA and SecB, as well as primary PrimC. The initial colon indicates to a TIL that the next word, SecX, is to be defined. The definition of SecX is that the word does SecA then SecB and then PrimC. The definition is terminated by the semicolon.

The other words in the definition have to be already defined, for example:

```
: SECA SECD PRIME ;
: SECB PRIMF PRIMG ;
: SECD PRIMH ;
```

The reason a TIL is called “threaded” is shown in figure 1. When it is interpreting the various words the TIL seems to thread its way through the computer’s memory. For each word there is an associated unambiguous number which says what that

word actually does when activated by being used in, say, a definition.

Before you can use SecX, therefore, you have to have previously defined PrimH, PrimE, PrimF, PrimG and PrimC. In a TIL, to make an application be successful, you have to have built from the bottom up all the necessary primitives and secondaries. To build from the bottom up actually forces the programmer to develop a systematic mode of programming. Unless the programmer knows what he or she is doing, little can be achieved.

Each word has an unambiguous number which can be used instead of the word itself. Instead of activating the process which is SecX by using the name of the word you could use the number of the word, for example;

```
NUMBER.SECX
and execute the routine stored at that number. You could, for example, say
NUMBER.SECX EXECUTE
which would have the same effect as
entering SecX. The definition of SecX
could then be written as
```

```
:SECX NUMBER.SECA EXECUTE
NUMBER.SECB EXECUTE
NUMBER.PRIMC EXECUTE;
```

though the point of the exercise may not be clear.

Take any word. To be able to execute the routine stored at a certain number you need to be able to apply to any word a set of rules — an operation — which produces the number for that word. You could, for example, produce the number for SecX by

```
SECX WORDNUMBER
```

and it is worth considering what is the form of the routine stored at that number.

When the word SecX is encountered, the interpreter effectively finds Number.SecX using a routine such as Wordnumber. It then executes the routine stored from that number. The simple word SecX is thus regarded by the language interpreter as

```
SECX WORDNUMBER EXECUTE
```

because the system works with numbers, and not with names.

The routine stored at Number.SecX is merely a series of numbers, Number.SecA to Number.PrimA, which are pointers to the numbers, not names, of words necessary to the operation of the word SecX. When the system then examines the routine at Number.SecA it finds pointers to

Number.SecD and Number.PrimE, and the routine at Number.SecD points to Number.PrimH.

When the number of a primary is found, the routine to which it points is a machine-code routine that actually has a meaning beyond a series of addresses. The primary is the place at which the regress stops, for no computer is infinite and so at some point finitude intrudes.

The language I have just described can do the following:

- Every word has an associated number which is solely the number of that word.
- When a word’s number is given, the operation of that word is unambiguously known.
- Words defined later in the sequence cannot be used by earlier words, as a word can only be defined in terms of words which already exist.
- There is one level of word which does not refer to other words, but operates on the basis of a routine composed of the basic elements of the computer — that is, machine code.

Examine the definition:

```
: SECY SECX SECY ;
```

in which the word SecY refers to the word SecY in its description. How is this definition to be interpreted?

Case 1. Suppose that there is a word SecY to which you append (1) to show that it is the initial example of the word. It is therefore written as SecY(1), though for the TIL it will only appear as SecY. There is a number to correspond to this word, Number.SecY(1).

If there is then another example of the word SecY, which is defined in the above line, it will be distinguished by appending a (2). This assumes that the TIL translator treats all information between round parentheses as comment. The definition might then be written as

```
: SECY(2) SECX SECY(1) ;
```

where it can be clearly seen that that though the name is the same, the routine is different. Number.SecY(2) is not the same as Number.SecY(1). But how does the system know, when the definition of SecY is given in terms which include SecY, that the initial example of SecY — that is, SecY(1) — is the one which is meant, and not itself, SecY(2)?

To resolve this possible ambiguity the

(continued on next page)

Figure 1.

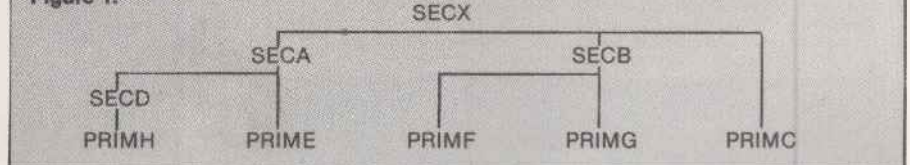

(continued from previous page)

TIL must be constructed in such a way that when the translator is searching through for the word SecY it does not find itself. When the word SecY, variant (2), is being defined the fact that it is called SecY is hidden from itself, and the name can only be discovered after the definition is completed successfully.

In this case, though the definition may seem self-referential or recursive it is not: SecY(1) is not the same as SecY(2), and thus Number.SecY(1) is not equal to Number.SecY(2).

Case 2. Now suppose that the number to which the word SecY refers in the body of the definition is Number.SecY. And suppose that the number of the word SecY being defined, is also Number.SecY. When the word SecY is activated, the system will execute the routine at Number.SecY. The routine will then point to Number.SecX, and onwards, to be followed by a pointer to itself, Number.SecY. Thus the routine will repeat until stopped in some way.

To be able to refer to itself, the type of definition has to be altered. When a colon definition is given, a word cannot find itself, so a new version of the colon has to be used. Let it be called SR:, for self-referencing colon:

SR: SECY SECX SECY SR;

and the SR: has to be matched by a special word to end the definition, the self-referencing semicolon.

At this stage a special procedure has to be

designed to allow self-referencing. You can give two meanings to a colon definition, depending on whether you want Case 1 or Case 2. But when you actually have to perform the operation you have to be clear. Normally, however, the form of self-referencing is more controlled and there is a means to stop activation of the self-referential execution. For example,
SR: SECY SECX CONDITION IFTTRUE
SECY IFEND SR;
where Condition is just that, a condition which will vary depending on the state of computation and which, if true, activates the self-referential execution.

Case 3. Remember that it is possible to execute a word by giving the number of the word, and then using the word Execute. The definition might then be given as
:SECY SECX NUMBER.SECY EXECUTE;
though there is still the problem of how to find Number.SecY while you are still giving it a definition.

There are at least two possibilities. First, you could define a special word to perform this function called perhaps MyNumber. Or you could leave it in abeyance, to be supplied later, for example:

:SECY SECX INPUTNUMBER EXECUTE;

Later you could apply WordNumber to SecY, and assign the resulting value to InputNumber. Actually, in this way you could swap between the two — or more if needed — versions of SecY. This facility is often described as using execution vectors, and why stop at versions of SecY? This last

method is obviously the most flexible of the three and it can provide great power.

TILs are powerful and flexible because of the way they can produce new words which can not only do things, but also describe how things are to be done. A TIL is equally at home bit-twiddling as it is running systems or producing super-fast graphics. No other family of languages can legitimately claim so much, particularly when you take into account that a TIL is perfectly suited to be implemented on a small computer.

One reason why TILs are so powerful is that they closely match the arithmetisation of mathematics as proposed by Gödel and others. A TIL is a finite representation of Gödel's infinite arithmetic. The problems TILs have solved will be found to have equivalents in Gödel's arithmetisation, which have not been solved.

An example of the mapping between TILs and theories of the infinite in mathematics is proved by Russell's theory of types. To solve the conundrum "Is the set of all sets a member of itself?" Russell invented his rather *ad hoc* theory of types. In it there was a gradation between individuals, then properties of individuals, properties of properties of individuals, and so forth.

Essentially, the theory of types is the doctrine that any property of an entity at one level, cannot be assigned to an entity at any other logical level. I think that the resemblances begin to be clearly seen. □

BEEBUG
REGISTERED REFERRAL CENTRE
FOR THE BBC PROJECT
**BEEBUG FOR THE
BBC MICRO**
INDEPENDENT NATIONAL USER
GROUP FOR THE BBC MICRO

MEMBERSHIP NOW EXCEEDS 18,000
18,000 MEMBERS CAN'T BE WRONG — BEEBUG PROVIDES THE BEST SUPPORT FOR THE BBC MICRO. BEEBUG MAGAZINE — NOW 62 PAGES INCLUDING NEW PRODUCT GUIDE SUPPLEMENT — DEVOTED EXCLUSIVELY TO THE BBC MICRO.
Programs — Hints & Tips — Major Articles — News — Reviews — Commentary. PLUS members discount scheme with National Retailers. PLUS members Software Library — a growing range of software from around £3.50 per cassette. 10 Magazines a year. First issue April 1982. Reprints of all issues available to members.
June Issue: Program Features 'Return of the Diamond' a 16k adventure game, 'Hedgehog' a well implemented 'Frogger' type game, and Ellipto. Create your own off the shelf sound effects with Sound Wizard. Plus articles on Using Files, Rotating and Expanding Characters, Using Printers, and How to multi-program the User Keys. Reviews of The Hobbit Floppy Tape System, Adventure Games, and a Comparative Review of Wordwise and View. Plus FX Call Update, Disc Program Auto-relocator, Wordwise Update, and more BBC Book Reviews.
July Issue: Games: Robot Attack (32k) and Anagrams, a 16k word game. Watching the Beeb at work — a sample program to show your micro at work. An introduction to discs — what are they and are they worth getting. Balloons — a coloured animation. Make your micro speak like Kenneth Kendal. Bad Program Lister — lists programs even when the computer pronounces them 'bad'. Reviews of Epson and Seikosha's new printers. Five books of programs reviewed, plus more software reviews, using Files Part 4. A full disc sector editor program — to read and retrieve lost disc files... and how to modify Acornsoft's Planetoid. Plus hosts of Useful hints.

Magazine programs now available on cassette to members at £3.50 inc: VAT & p+p — see April/May issue for details

BEEBUG NEW OPERATING SYSTEM OFFER
BEEBUG members can now obtain the new 1.2 OPERATING SYSTEM ROM at around HALF PRICE
See BEEBUG Magazine February, March or April for details.
As a result of BEEBUG negotiations with Acorn the ROM now may also be offered by other user groups to their members.

**MEMBERS SOFTWARE LIBRARY +
BEEBUGSOFT: BEEBUG SOFTWARE LIBRARY**
offers members a growing range of software from £3.50 per cassette.

1. STARFIRE (32k). 2. MOONLANDER (16k). 3D NOUGHTS AND CROSSES (32k). 3. SHAPE MATCH (16k). MINDBENDER (16k). 4. MAGIC EEL (32k). 5. Cylon Attack (32k). 6. Astro-Tracker (32k).
Utilities: 1. Disassembler (16k). Redefine (16k). Mini Text Ed (32k).
Applications: 1. Superplot (32k). 2. Masterfile (3k).
13% discount to members on the excellent wordwise word processing package — this represents a saving of over £5.00.

Send £1.00 & SAE for Sample
Membership: UK £5.40 for six months
£9.90 for one year
Overseas one year only:
Europe £16.00 Middle East £19.00
Americas & Africa £21.00
Other Countries £21.00

Make cheques to BEEBUG and send to:
BEEBUG Dept 5, 374 PO Box 109
Baker Street, High Wycombe,
Bucks HP11 2TD.
St Albans, Herts. AL1 1AR

MAILING FLOPPY DISKS?

The Swan Disc Pack combines great strength with simplicity of use. Made from rigid white corrugated, it is a self assembly package providing high postal security at economical rates.

Free sample ring us on 01-607 9938



sizes:
6 x 6;
8.75 x 8.75



It's our service!

Whether your applications involve simple financial procedures or complicated R & D Graphics (or a myriad of techniques in between) KGB have the system for you.

With the right software packages to go with it. And all at sensible competitive prices.

But we go further still. We can help with finance and leasing. We provide sound system training. And comprehensive maintenance.

So send for our literature. Have a look at the KGB service - and find out how you can win Game, Set and Match!

Micros for the Business, Commercial and Technical user - Stand Alone and Multi-user Systems.

KGB

MICROS LIMITED

word processing + accountancy + financial modelling + calculation + record keeping + sales office management + accounts + payroll + graphics + engineering + communications + languages + solicitors + CAD

106 St Leonards Road Windsor Berkshire SL4 3DD
 Telephone: Windsor 50111 Telex: 23152 MONREF G (Ref 8542)

● Circle No. 122

THE AUTUMN COMPUTER TRADE FORUM

4th-7th October, 1983
National Exhibition Centre, Birmingham,

PERKIN
ELMER
SYSTEME

NOKIA
DRG
MOTOROLA

LOGICA
TEXAS
INSTRUMENTS

DEC
ZYGAL
FERRANTI

QUME
FORTUNE
BURROUGHS

Sound business sense for volume buyers

The Autumn Computer Trade Forum is the UK's largest and most successful trade event and the only show that fully understands the needs of volume buyers.

It offers you a comprehensive display of minis, micros, software and peripherals in an environment that's specially made for volume business.

Who is CTF for?

Distributors. Dealers. Software houses. Systems integrators. Retailers. OEM's. In fact anyone who makes a living buying and selling computers, software and peripherals. So whether you're new to DP/WP or know the business backwards, CTF is the event you mustn't miss.

How can CTF help you sell more?

The exhibitors at the Computer Trade Forum understand your needs. That means they'll be talking your language. Quantity terms. Discounts. Marketing support programmes. Delivery schedules. The whole range of services to help you sell more.

Who will be at CTF?

Texas Instruments. Logica. DEC. Systime. DRG. Zygol. Motorola... and many more! And for every name you know there'll be many you don't—with products that could well be your next year's big seller.

Why CTF is different!

The Computer Trade Forum is the only show that understands what volume buying really means. The atmosphere, the choice of exhibitors, the absence of

razmatazz are all designed for profitable business.

CTF has been specifically designed for you and as a proven, established national event it offers you even more with the support of leading UK suppliers.

Post the coupon today

The general public is not invited to CTF. The emphasis is on volume business. And for you it's free! Just fill in the coupon and we'll send you free tickets (worth £3.00 each) by return of post.

If you need to know more, call 01-747 3131.



Computer Trade Forum
232 Acton Lane, London W4 5DL

Please send me free tickets for myself and colleagues.

Name _____

Position _____

Company _____

Address _____

I am interested in exhibiting at CTF
(No one under 18 admitted)

FREE SHOW TICKETS

PC/2

● Circle No. 123

Sparrow 10



THINK CAREFULLY BEFORE YOU BUY YESTERDAY'S TECHNOLOGY

**BIG
NEWS**

A NEW FAST & RELIABLE MEANS OF DATA STORAGE FOR YOUR COMPUTER SYSTEM.
You don't need to be an expert to appreciate the advantages of the new 'Sparrow 10' range of low cost cartridge disc drives for S-100 and CP/M users. If you have a data storage problem we can help! even if you have Winchester's now, we can still help! We offer a complete plug in and go cartridge disc subsystem that can be installed in your existing S-100 Computer in minutes. These new disc drives use a new type of low cost interchangeable cartridge giving unlimited off-line storage capacity. They are very robust and can even be dropped or walked on without fear of damage. H.B. Systems, as appointed dealer, can supply these drives singly or cased with power supply, controller (for up to four drives) and S-100 interface complete with self installing B10S software that enables a 40 MB subsystem to be up and running within minutes. Prices for S-100 plug-in-and-go systems start from £2,975 + VAT. For further information contact William Isaac on 02372 3304 or complete and clip the coupon.

H.B. Systems

5/6 Queen Street, Bideford,
North Devon, EX39 2JG.
Telephone: Bideford (02372) 3304 (3 lines)

Please forward further information to:-

PC

NAME

ADDRESS

TELEPHONE NO.

Signed

● Circle No. 124

FEROX
ALREADY THE
MARKET LEADER!

Ferox ModelerTM

THE MICRO BASED FINANCIAL PLANNING SYSTEM



You may not know the name but if you are a TIMES 1000 company there is a better than evens chance you are using a FEROX authored product for your financial planning.

Now DATAFLEX brings you the latest version with the following major facilities. **GOAL SEEKING** allows the setting of objectives, for example profit, and the optimisation of inputs, such as costs or revenues, to achieve the target. **FULL COLOUR GRAPHICS** enables the user to simply draw charts on the screen using existing models and data, and then save them for presentations or print them as required. The system can be **MENU OR COMMAND DRIVEN** ensuring effective use by both novice and expert whilst the **32,000 CELL MATRIX** accommodates the largest of likely model sizes. **POWERFUL REPORTING** includes 'TURNSIDEWAYS' and allows the user to format reports exactly according to need, and the **FULL CONSOLIDATION AND DATA MANIPULATION** facilities allow the most elaborate corporate structures to be modelled and analysed. **SENSITIVITY ANALYSIS** will help fine tune the plans, whilst the whole system works **50% FASTER** than previous versions.

To support MODELER, DATAFLEX run regular training courses for both beginners and experts at modelling, DATAFLEX provide a telephone helpline and consultancy services, and offer file transfer facilities to help you upgrade from lesser systems.



dataflex

Dataflex Ltd
The System Centre
238-246 King St.
Hammersmith
London W6 0RF
01-748 4176

**DATAFLEX are the
UK distributors
of FEROX PRODUCTS.**

DATAFLEX also support clinics every Monday evening and evaluation courses to help you decide whether FEROX MODELER is the right for you. For further details please phone DATAFLEX or return the coupon below.

Versions of FEROX MODELER are currently available for the IBM PC, Sirlus 1, Apples 2 2e & 3, TRS 80 II*, DEC VAX*, and HP 3000*.

(* excludes graphics)

I am interested in further details of FEROX product and the DATAFLEX clinics & courses.

NAME _____

COMPANY _____

POSITION _____

TEL. NO. _____

MCP/7 _____



● Circle No. 125

Now a hard disc system for the same price as a floppy



The Shelton Sig|net

It's here! The new hard disc system that really means business.

From the bewildering range of computers, all claiming a technical advantage, Micropute have selected the machine best suited to the needs of small and medium sized businesses. The requirements of such a system were: Integral Hard Disc, Compact Design, Extremely Competitive Price, The CP/M Operating System giving access to a vast range of programmes for data and word processing, and The Capacity For Ease Of Upgrading To Multi-User. Which all adds up to a fully comprehensive and sophisticated computer.

The price?

From an incredible £2,695 (ex V.A.T.)

Micropute Supercover

As an extra bonus to this amazing package Micropute Supercover will provide a 12 month on site maintenance for only £99.00 parts and labour.

Faster Than a 16 BIT

	BENCHMARK TIMINGS		
	PRODUCT		
	SIG/NET 8 BIT	IBM 16 BIT	SIRIUS 16 BIT
BM. 1.	1.1	1.5	2.0
BM. 2.	3.7	5.2	7.4
BM. 3.	9.9	12.1	17.0
BM. 4.	9.8	12.6	17.5
BM. 5.	10.5	13.6	19.8
BM. 6.	18.7	23.5	35.4
BM. 7.	29.6	37.4	55.9
BM. 8.	5.1	3.5	4.3

These figures are extracted from a recent article in, 'Personal Computer World' Publication.

Micropute Ltd Catherine Street, Macclesfield, Cheshire SK1 6QY Tel: (0625) 615384.

Name _____ Position _____

Company Name _____

Company Address _____

Tel. No. _____

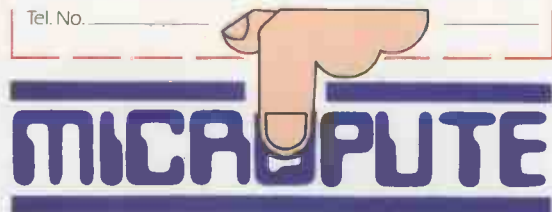

Micropute Ltd., Catherine Street, Macclesfield, Cheshire SK1 6QY Tel: (0625) 615384.

● Circle No. 126

PRACTICAL COMPUTING September 1983

An intelligent (even brilliant) new multicolour graphics plotter from Gould Bryans

Computagraph Colorwriter

Fast, publication quality graphics for the professional

These impressive new digital color plotters have exceptional performance, plot quality, intelligence and user convenience. Designed for the serious user who wants professional quality graphics, the *COLORWRITER* can be connected via a standard interface to most micro, mini or mainframe digital computers or terminals.



- Choice of 10 pen/10 color or 7 pen/7 color models.
- Choice of 4 pen types, including transparency pen. Drafting and Pentel pens accepted.
- 5 different character sets including drafting quality.
- Comprehensive and powerful built in software routines.
- Very high resolution, accuracy and writing speed.
- Interchangeable interfacing (RS232C or IEEE 488).
- Digitising mode.
- Standard data input buffer (expandable).
- Programmable automatic chart advance option.

Your only trade distributor

Write or phone now for full information to
Holdene Trade Limited

Bray House, Leicester Place, Leeds LS2 9BH Telephone Leeds (0532) 459459
Telex 556319 Also at Edinburgh Tel: 031-557-4060, Cheshire Tel: (0625) 529486

● Circle No. 127

'Computagraph' and 'Colorwriter' are the trade marks of Gould.

MORE MEMORY FOR LESS MONEY!

DATAFLEX offer extra memory and function boards, at realistic prices for the IBM PC & XT and SIRIUS 1. All boards covered by 6 month no quibble replacement warranty.

SIRIUS 1

Available with 128k, 256k, 384k or 512k. Our Sirius memory board is fully socketed and upgradeable to 512k.

PRICES from £275

IBM PC & XT

As with the Sirius board, this has a maximum capacity of 512k, is fully socketed, and comes with 64k, 128k, 256k, or 512k of memory installed.

PRICES from £260

IBM PC & XT "TRIO"

A combination board with two RS232C ports and either 128k or 256k of memory. The 128k board is upgradeable.

PRICE from £275

Also available: our IBM Colour-Duet and Mono-Duet Boards which combine a colour/mono screen controller and parallel port. Price: £235 for colour board and £215 for mono.

All boards are made to the highest standards and are designed and manufactured in the UK by DATAFLEX. The boards are fully guaranteed and supported by a leading third party maintenance company.

For further details please phone DATAFLEX or return the attached coupon. Dealer enquiries are welcome - substantial quantity discounts available. Quoted prices are RRP and exclude VAT.

dataflex

dataflex Ltd
The System Centre, 238-246 King St
Hammersmith, London W6 0RF
01 748 4176

DATAFLEX are the
UK distributors
of FEROX PRODUCTS.

I am interested in further details of these boards
SIRIUS . . . IBM RAM . . .
IBM TRIO . . .

NAME

COMPANY

POSITION

TEL. NO.

NCM/9

dataflex

● Circle No. 128

The height of compatibility



↑
£209
 SINGLE DRIVE
 WITH PSU

↓
£373
 DUAL DRIVE
 WITH PSU

STANDARD INTERFACE COMPATIBLE WITH: BBC[®] MICRO+TRS 80[™] + VIDEO GENEI[®] + NASCOM[®] + + + +

Canon

MDD ²/₃ Height 5 ¹/₄" Mini Floppy Disc Drives

DRIVE MODEL

PRICE (Inc. V.A.T.)

	Naked	Single Drive Boxed	Single Boxed with power supply	Dual Drive Boxed	Dual Boxed with power supply
MDD 110 (SS 40TK)	£163	£187	£209	£348	£373
MDD 210 (DS 40TK)	£209	£233	£255	£440	£465
MDD 220 (DS 80TK)	£290	£323	£345	£611	£635

Prices on additional items (inc. V.A.T.)

Ribbon/Data Cable to Single Drive £11. Ribbon/Data Cable to Dual Drive £16. D.C. Cable for BBC Micro £7. Utilities Disc & Manual for BBC Micro[™] £20. N.B. The MDD 220 is selectable 40/80 TK with L.E.D. mode display. Boxed units are fitted with an external 40/80 TK switch. U.K. carriage on any size of consignment £10.

Lower Profile,

Higher Performance & More Data Capacity

The MDD range of floppy disc drives includes units giving capacities from 250K unformatted (MDD 110) to one megabyte of unformatted data (MDD 220). They support both MFM and FM recording formats and incorporate the superior reliability, maximum performance and extended service life inherent in all Canon products.

DISC DRIVE UNFORMATTED CAPACITIES

Drive Model	Single Density (FM)	Double Density (MFM)
MDD 110	125K	250K
MDD 210	250K	500K
MDD 220	500K	1000K

Dealer enquiries welcome



MDD SINGLE/DUAL BOXED & PSU



ALPHA DISC LTD

UNIT 2, CRABTREE ROAD, THORPE INDUSTRIAL ESTATE, EGHAM, SURREY TW20 8RN.
 TELEPHONE: (0784) 35357/8/9

● Circle No. 129

Cures for a bad memory

INSIDE most microcomputers, there lives a very important memory area which never seems to feature in the glossy brochures or in the advertisements, namely the operating system read-only memory — ROM to its friends. Eight-bit microprocessors such as the Z-80 and 6502 can usually address up to 64K of memory with their 16-bit address bus, but microcomputer data sheets rarely talk of more than 48K of available memory. The remaining 16K is reserved for the operating-system ROM which normally contains all the input, output and housekeeping software and, in most cases, a Basic language interpreter.

For the owner, it is very comforting to know that just by hitting the On switch he or she can gain access to all of this lovely ROM-based software without having to perform a load from cassette or floppy disc. It is the availability of cheap ROM chips, just as much as cheap microprocessors, which has made the low-cost microcomputer a practical proposition. The operating systems of early microcomputers often consisted of four or more separate 24-pin ROM devices. Today a full 16K can be packed into a single inexpensive 28-pin package, and this causes something of a problem for the poor designers.

ROM devices are programmed during the manufacturing process by means of the final metallisation mask layer. This ensures that they never lose their stored instructions, but it also means that making modifications or applying software fixes is next to impossible. Erasable programmable ROMs are available, of course, and they are fine for prototypes. But unfortunately EPROMs are much more expensive than masked ROM, and the microcomputer business is now entering a highly competitive phase when every penny counts.

Anyone who has ever written even a 10-line Basic program already knows all about the frequency of software bugs and how difficult some of them are to track down. So put yourself in the position of the poor old microcomputer designer who has just added the last assembly-language statement to 16K of system software, and is about to post it off to the ROM manufacturer with an order for 5,000

ROMs at a tenner apiece. You will begin to see why most 30-year-old chief designers have grey hair and smoke 40 a day.

This month I have good news for all those long-suffering designers. With their best interests at heart Motorola has introduced a new ROM which is repairable. It is called the CREEM which stands for combination ROM plus EEPROM memory. Inside the CREEM device there is a 14K masked ROM array, a 2K electrically reprogrammable EEPROM array, and a separate 256-byte EEPROM page which can be used to replace any other 256-byte page in the main ROM area.

With CREEM on his side, our microcomputer designer whistles a jolly

by Ray Coles

tune as he posts off his order for 5,000 with enclosed operating-system code. When the complaints roll in about an obscure bug which affects all Dim statements above a certain size, instead of reaching for the Walther PPK he locates the bug and modifies all 4,802 ROMs still in stock by overlaying the bad code with the 256-byte relocatable EEPROM page.

Even when the disc-drive manufacturer announces that it will discontinue the model originally specified by our hero, he does not flinch or bite lumps out of the carpet-tiles in his office. Because he was canny enough to route all I/O calls through the 2K EEPROM array, all future systems can have the updated code inserted and ready for the new disc drives when they arrive. The CREEM, coded MCM-6836R16 by Motorola, fits into a standard 28-pin ROM package and costs a lot less than a fully programmable EPROM. Our rejuvenated microcomputer designer will no doubt get the girl and live happily ever after.

Another problem faced by microprocessor memory designers concerns the volatility of read/write RAM. In many microprocessor-based systems — although not generally in personal computers — it is desirable that data stored in read/write memory should be retained when the power fails or even when it is deliberately switched off. Until recently there have

been three main ways of ensuring non-volatility: using magnetic-core memory, EEPROM or battery-backed RAM. All have their attendant problems.

Magnetic-core memory is certainly still used, and is favoured for military applications where its ability to survive in severe environments is attractive. It is not generally applicable, however, due to its high cost and large physical size. EEPROM is very much a modern technology, but unfortunately it is very slow to write and erase, and it is not therefore a suitable replacement for conventional RAM memory.

Battery-backed RAM, in which conventional RAM chips are supported by an external battery during power-loss conditions is widely used, and is quite suitable for most systems, but it still suffers problems. What is needed is a non-volatile RAM device which can be plugged into a standard RAM socket where it will behave just like any other RAM until the power fails. At that point it will, all by itself, reliably retain its stored data without any external assistance. I am very pleased to be able to announce that such a device has now been introduced by Mostek. With any luck it will become the first of a whole new family of such devices which will feature ever-increasing capacity.

The new device, coded MK-48Z02 appears to the outside world like any other 2K CMOS static RAM. It has a 200 nanosecond access time and uses a 24-pin package compatible with the pin-outs of a wide range of existing ROM, EPROM, EEPROM and RAM devices in the so-called byte-wide format. The only difference is that the MK-48Z02 has two lithium button cells together with all the protection and change-over logic actually built into the package. Any RAM socket it is plugged into immediately becomes battery backed.

The lithium cells have a shelf life of about 10 years even at high temperatures. In the low-voltage data-retention mode the RAM chip used needs only about 5 nanoamperes — 5×10^{-9} A — at room temperature. The theoretical life of the two 35 milliampere-hour cells is over 500 years. For my money, this is the best solution yet to the problem of providing non-volatile RAM. □

THINK COMPUTERS ... THINK WILEY

PROPER BASIC

by **B.C. Walsh**,
Computer Laboratory, University of Liverpool.

Designed to improve the reader's knowledge of BASIC while developing a deeper insight into computers and programming techniques, this book is an invaluable self-teaching guide for both beginners and practising programmers. A common broad BASIC dialect is used and features available on a wide range of microcomputers are illustrated.

Design forms an important element and graphics, formatted printing and file features are described in detail. A wide range of examples and problems are provided with solutions. They include: artificial intelligence business report printing, file searching and sorting, matrix manipulations, simultaneous equations and text handling.

August '83 approx. 384pp
0471 900818 (cl) approx. \$49.00/£24.50
0471 901539 (pr) approx. \$25.50/£12.75

THE DATA RING MAIN

An Introduction to Local Area Networks

by **David C. Flint**,
Butler, Cox & Partners Ltd., London.

This is a book about Local Area Networks (LANs): it describes what they are and what they can do; discusses why we need them and how they can be used effectively to link together the components of computing/communications systems in, say, an office building or factory site.

A comprehensive description of the systems currently available is backed up by practical advice on how to buy a Local Area Network and to make the most of the new technology by setting up an efficient and cost effective business/information system.

September '83 approx. 350pp
0471 26251X approx. \$38.95/£20.00

A Wiley Heyden publication

USING BBC BASIC

by **P.J. Cockerell**,
University of Kent at Canterbury.

This book aims to develop both skills in BBC BASIC and a more intimate knowledge of some of the special features of the BBC Microcomputer. Programs as well as text are presented in an easy and accessible style and the emphasis is very much on developing various techniques and skills by actually using the programs provided. An introduction to some of the more esoteric aspects of computer science such as recursion and data structures is provided and the reader is encouraged to investigate further through numerous references.

October '83 approx. 200pp
0471 90242X (pr) approx. \$15.90/£7.95

WORDSTAR™ AND CP/M™ MADE EASY

by **J.D. Lee**,
Loughborough University of Technology, Loughborough.

A complete guide to Wordstar™, this book describes in detail all the features offered by this highly successful word processing package and provides an easy to understand, "hands-on" introduction for the uninitiated.

Each chapter comprises a compact unit covering one function, beginning with the most basic and progressing gradually to cover the more complex and sophisticated features of the package. Working examples and exercises are given at each stage.

Clearly written and logically set out, the information is made easily accessible by the extended contents list and comprehensive index.

July '83 approx. 244pp
0471 90188 1 (pr) approx. \$13.90/£6.95

LOCAL AREA NETWORKS

Issues, Products and Developments

by **V.E. Cheong**,
Scicon Consultancy Ltd.,
and **R.A. Hirschheim**,
London School of Economics.

In this book the authors set out to describe and classify LANs and their development. An independent assessment of the two main LAN approaches: the Cambridge Ring and the Ethernet is followed by a description of over 20 major LAN products. Up-to-date and specialist material: broadband systems, draft C of the IEEE Project 802, and predicted IBM offerings are included in the appendices.

Wiley Series in Computing

July '83 208pp
0471 901342 \$24.95/£12.75

PROGRAMMING IN PASCAL

This series of sixteen half hour video programmes assumes no previous computing experience and covers the whole of Pascal.

PRICE — for the 16 half-hour video programmes \$3,000.00/£945.00 + VAT (special discount available to *bona fide* U.K. Educational Institutions)

Available in all standard formats

A STUDENTS GUIDE TO PROGRAMMING IN PASCAL

by **L.V. Atkinson**,
Department of Computer Science, University of Sheffield.

This book is a students guide to programming in Pascal and forms the basis of the 16 part video series.

September '82 236pp
0471 104027 \$10.95/£4.95



John Wiley & Sons Limited

Baffins Lane · Chichester · Sussex PO19 1UD · England

Maze mastery

John Billingsley reports on the 1983 British Euromouse heats at Earls Court.

YET ANOTHER cliff-hanger ended this year's Euromouse British Finals as Alan Dibley's T4 and David Woodfield's Knownaim battled in the closing minutes for the £1,000 trip to Madrid, put up as a first prize by Micro Management.

Mice had started to arrive on Friday, while the maze underwent plastic surgery to repair its accumulated knocks and blemishes. The seated arena at the Earls Court Computer Fair seemed bigger than ever, with an adjoining mouse development area which appeared to be ample at first. As more teams arrived, however, there was a scramble for space and improvised work benches were propped up on chairs.

First to take to the maze was Tony Porter's Maisey, a strange mouse with a tottering gait which seemed able to get itself out of any tricky corner. Alan Dibley started to tune up his stableful of Thezeii, while David Woodfield unveiled Knownaim the successor to Thumper.

Woodfield's mouse is extremely smooth in its operation. Built on the dodgem principle, it is a front-wheel-drive tricycle with stepper-motor steering. When exploring, its drive motor receives only a fraction of normal voltage and Knownaim seems to drift gently about the maze. But if it knows that there is a long straight ahead it puts on a startling burst of speed.

Alan Dibley's T4, on the other hand, buzzes about the maze like an angry bluebottle. Unless completely cornered it keeps going no matter what. Then with an impatient shrug it performs a three-point turn and bustles on its way. It entered its first contest last year in Finland, where it missed the European Championship by a mere two seconds.

Prominent among the newcomers were the boys from Ilford County High School with Barnacle Bill III. A kindly description of their mouse would be "alternative technology". The heap of wooden wheels, plastic lunch box body and assorted pieces of Plasticine which they spread out on the work bench certainly did not speak of technological overkill. What their mouse lacked in technology and performance, however, they made up for in enthusiasm, performing so well before the TV cameras that Clement Chambers of CRL has provided sponsorship to send them to the Euromouse Finals in Madrid in September.

Saturday's novice contest started off with David Buckley's Quester. It is no wonder that Quester has never won a major prize — in the two years since it first saw the light of day its processor has never been connected to its body. Barnacle Bill was



Alan Dibley and the victorious T4.

scooped on to the maze, then carried off again in a noisy procession in the hope of resuscitation. Transplant surgery was not enough. Gonzales, a newcomer made by Bill Urmenyi, made a valiant effort. Bill's efforts were even more valiant, if somewhat illegal, as he helped it around corner after corner. It is a mouse with potential.

Another most worthy newcomer was Anonymouse, built singlehanded by a London youngster, Guy Hills, with no help from his school. Finally Fullyautomatix took to the maze. The product of the boys of Maelor School, Bangor, this was a well developed piece of engineering marred only by stepper-motor problems and the discrepancy between an imperial mouse and a metric maze.

First prize of an Atari 800 was awarded to the Maelor schoolboys and their Fully-automatix. The boys' success also brought them sponsorship from their home town to take them on to the European Finals in Madrid. Second prize of a Dragon computer went to Bill Urmenyi while the third prize, a voucher from Computers for All, was given for a worthy effort to Guy Hills.

Sunday's final started with a short run by Elmer, a first-time mouse which really should have been among the novices. Messrs Jackson and Sweeney had been

Next year's British finals will be held again at the Computer Fair and the European finals will take place at the 1984 Euromicro Conference in Copenhagen. In each case there will be a valuable prize for novice mice. If you can meet the challenge, write for details to Dr John Billingsley, Portsmouth Polytechnic, Angelsea Road, Portsmouth, PO1 3DJ.

unable to arrive on Saturday and so Elmer's brief moment of glory was rapidly eclipsed. Thezeus set off for a long patient plod around a very difficult maze. Usually reliable, even if slow, Thezeus ran out of patience or luck and made a dignified retirement. The 500-strong audience were growing restive as Maisey set off, but a few minutes later burst into applause when Maisey showed that the centre could be reached in 5 minutes 42 seconds.

After Maisey, Alan Dibley's T3 disguised as a First World War fighter ace took off into the maze. But the aim of the contest is not circuits and bumps, and T3 withdrew without finding the centre. A historic interlude followed as Nick Smith brushed away the cobwebs and placed on the maze the first European champion, Stirling Mouse. Behaving almost impeccably, Stirling found the centre first in 3 minutes 2 seconds and then in 1 minute 47 seconds. Another past champion then took to the maze, and Thumper made rather heavy weather of finding the centre in 3 minutes 50 seconds.

Now we had reached the two favourites. Would Dibley's T4, an exercise in perpetual motion, reach the centre first or would the honours be taken by the ingenious Knownaim? T4 was clearly not up to its best, but after several restarts reached the centre in 1 minute 2 seconds. On a later run it proved that the maze really was not so difficult and could be solved in 47 seconds. Knownaim then sallied forth, batteries charged to the brim, but after only 15 seconds staggered askew into a wall and had to be restarted. After a while, as the batteries discharged, Knownaim became more consistent. However, its memory of the maze had become muddled and it repeatedly took a long route to the centre in 1 minute 15 seconds.

Though acknowledging the enormous potential of Knownaim the judges placed it second to win a 48K Sinclair Spectrum for David Woodfield. Alan Dibley's T4 was awarded the £1,000 first prize while Nick Smith and Stirling Mouse won the third prize of £25-worth of books from John Wiley Ltd.

Alan Dibley has generously undertaken to spend his £1,000 on a combined trip for both Dibley and Woodfield families to travel to the Euromicro Conference in Spain so that Britain can be represented in force at the European Final. They take the task of wresting the championship back from the Finns very seriously and Alan Dibley plans to have a brand-new Thezeus, T5, ready for the contest. 

DUPLEX

SUSS BOX

The DUPLEX SUSS-BOX and DUPLEX SUSS-ADAPTOR have been designed to enable the less skilled computer user to have a better understanding of the correct working connection between a computer and a peripheral, such as a printer. This is achieved by using the commonly used signals (wires) of the RS232C serial data cable specification, a matrix-block and special connector pins.

By inserting the connector pins into the SUSS-BOX's matrix-block at the axis of two incoming signals the user can quickly establish a firm connection. The signals are routed into the SUSS-BOX by two 25 way D type connectors; 1 x female, 1 x male. The SUSS-BOX also provides a lamp for each signal to show its condition when connected in-line, ie High or Low.

JUMPERING:

Jumpering between two or more signals is possible by using three SEPARATE jumpering lines also available on the SUSS-BOX & ADAPTOR matrix-blocks, thus each of the incoming 25 way connectors can be jumpered independently.

WIRES ROUTED THROUGH THE MATRIX-BLOCK

On each connector, pins - 2, 3, 4, 5, 6, 8 & 20. All remaining pins are wired through.

Lines for jumpering: - J1, JA2, JA3, & JB1, JB2, JB3. All separate lines.

SUSS BOOK

If the user specifically wishes to connect a microcomputer to the OCTET or HERMIT typewriter/printers then refer to DUPLEX'S SUSS-BOOK for details on various microcomputer cable 'Pin-outs'.

£49.95
+ VAT

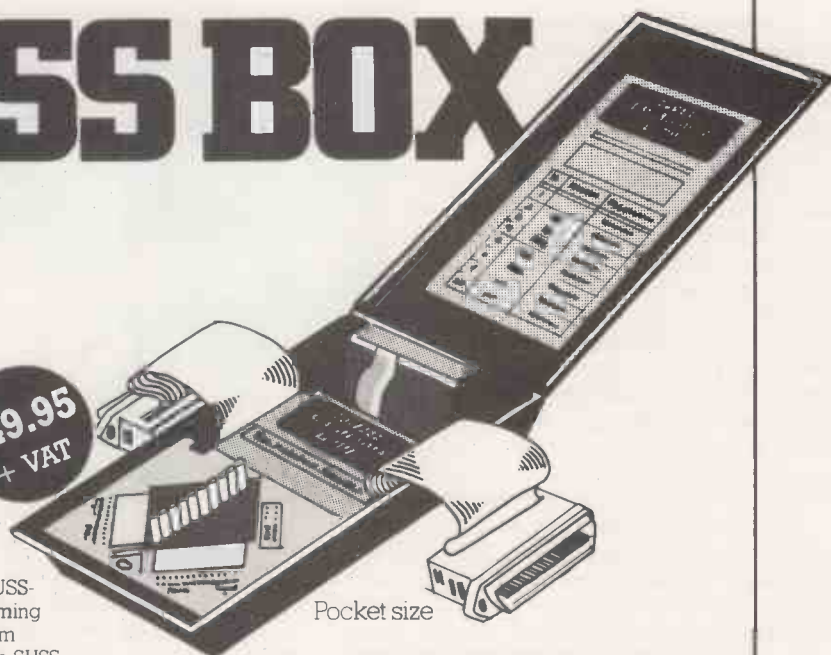

Pocket size

SUSS-ADAPTOR

When the user has achieved the correct 'Pin-out' between a micro computer and a printer the DUPLEX SUSS-ADAPTOR should be used as a permanent means of connection. This is done by 'transposing' the correct matrix-block pin-layout already established with the SUSS-BOX onto the matrix-block of the SUSS-ADAPTOR, and then installing the SUSS-ADAPTOR in between the computer and printer.

£29.95
+ VAT

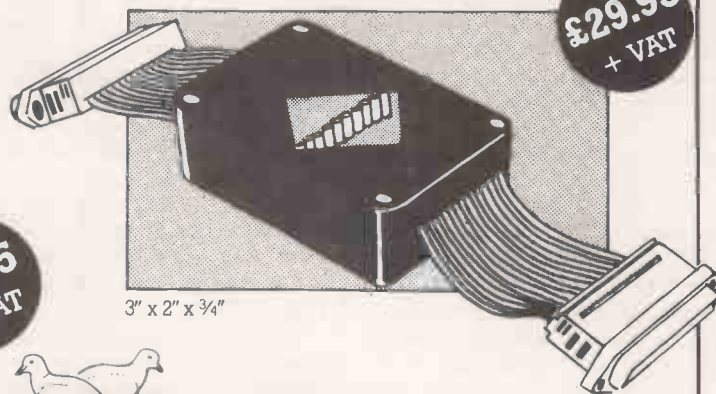

3" x 2" x 3/4"

£3.75
+ VAT

DUPLEX
Communications Ltd.

The Interface People

All prices are based on cash-with-order terms

Midlands/North - 2 Leire Lane, Dunton Bassett, Nr. Lutterworth, Leicestershire LE17 5JP. Tel: 0455 209131
South - 52 High Street, Stock, Essex CM4 9BW. Tel 0277 841011

● Circle No. 131

Isn't it about time you stopped giving away all your best ideas?

The trouble with being a dBASE II programmer is that the highest reward you get for effort is glory. Now that's very good for your ego, but it doesn't do much for your pocket.

You could, in theory, sell your applications to hundreds of people, but look what you have to give away. Your ideas. To sell the application you have to sell the code. And that's no way to build a profitable business.

dBASE II RunTime™ can change all that overnight. Tomorrow, you could be more than just a dBASE II programmer, you could be a profitable software publisher.

How? Because the RunTime application development module condenses and encodes source files. And that means it protects the ingenious and innovative techniques that make your application so special.

RunTime will also give you more margin, more opportunity to be price-competitive. All you need do is to supply your customers with the encoded application, along with the RunTime module.



But it doesn't stop there. To get you off to a good start you'll have Ashton-Tate's marketing strength behind you. We'll give you a stack of useful information to speed your successful entry into software publishing. And we'll publish product descriptions and contact information in the dBASE II Applications Register, soon to be in computer stores all over the UK.

So give yourself a break. Sell the solution, without giving away the formula.

Call us on (0908) 568866
Ashton-Tate (UK) Limited
Cofferidge Close, Stony Stratford,
Milton Keynes MK11 1BY.

ASHTON · TATE ■

● Circle No. 132

NEW FROM ACT

**NOW WITH
256K!**

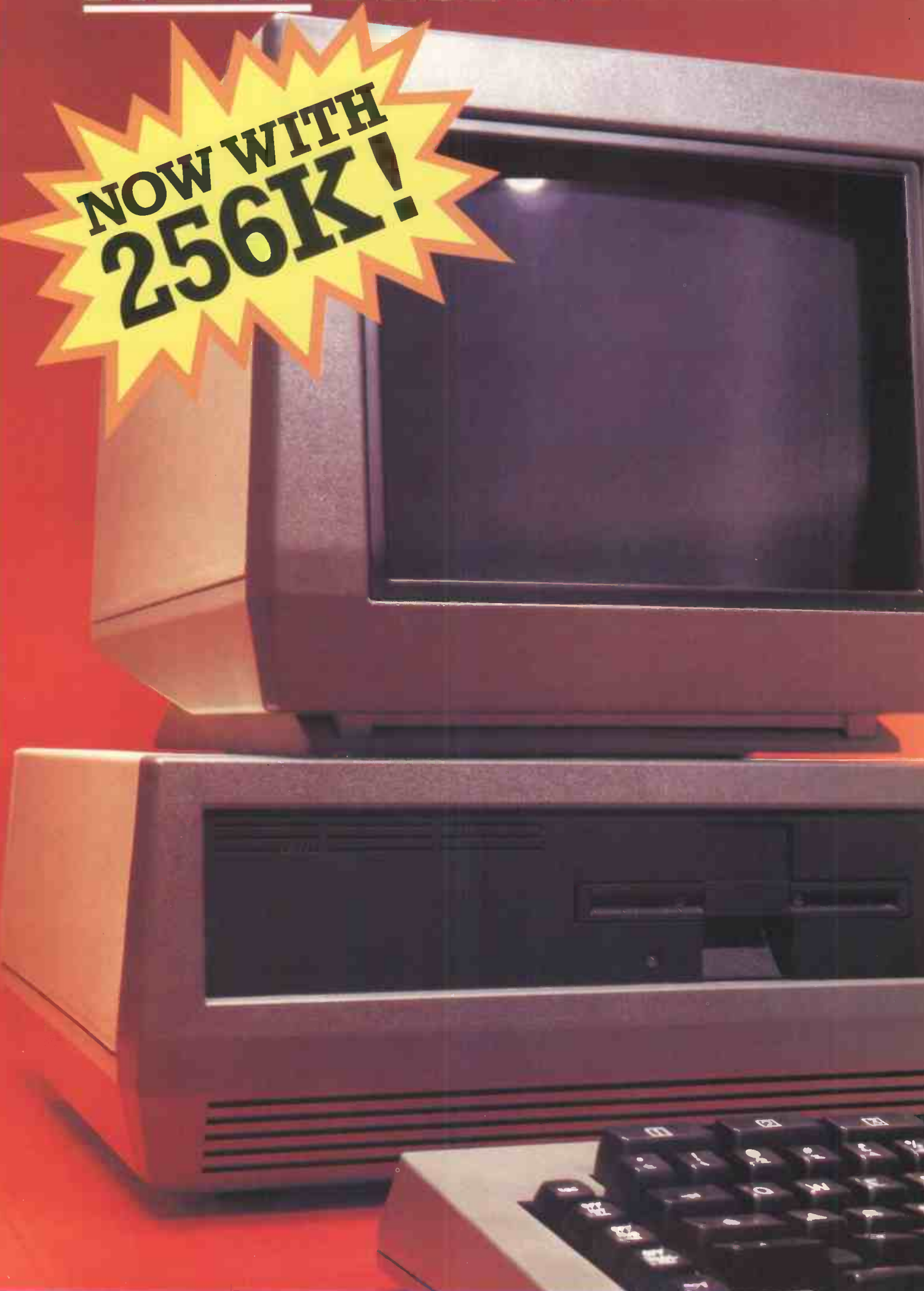

The 10 Megabyte Winchester Sirius — — £3995.00

Once again, ACT introduces a new price/performance breakthrough in personal computing: An ACT Sirius 1 16-bit personal computer with 256 Kbytes of RAM COMPLETE with integral 10 Mbyte Winchester for just £3995.

And, it's available now. Ready to take on the large business applications that previously called for much more expensive minicomputer systems.

Both access speed and data integrity are enhanced compared with floppy-based systems. The user can divide the disk into multiple volumes each of which appears as a discrete entity. And more than one operating system can access the Winchester.

Like all the Sirius range it's backed by

the strength and resources of ACT: The PULSAR range of true 16-bit application software for accounting, planning and word processing; ACT Training Centres in London and Birmingham open to all; nationwide field service; a full range of printers and consumables. And, the most complete and professional dealer network in personal computing.

The new Sirius Winchester is the latest addition to the 16-bit ACT Sirius 1 family. Prices start at just £2195 for a dual floppy drive system with 1.2 Mbytes and £2695 for the double-sided floppy drive version offering 2.4 Mbytes. All provide an Intel 8088 16-bit processor and 128 Kbytes of RAM.

NEW SIRIUS WINCHESTER: THE FACTS

Winchester Subsystem

- 10.6 Mbyte (formatted) 5¼" integral Winchester drive
- 218 msec average access time
- Intelligent disk controller
- DMA interface to system memory
- Multiple operating systems
- User configurable

General Specifications

- 256 Kbytes RAM
- Intel 8088 16-bit processor unit
- 1.2 Mbyte double-sided floppy disk drive for back-up
- 800 x 400 pixel high resolution graphics
- Multiple operating systems
- Parallel/IEE 488 port
- 2 x RS 232 asynchronous/synchronous ports
- User port

For more information on the new Sirius Winchester clip the coupon and return to

ACT (Sirius) Ltd

FREEPOST

Birmingham B63 1BR

or call

021-501 2284

™ indicates registered trade mark.
Ownership details on request.
Prices exclude VAT.



Please send me further details of the new Sirius Winchester.

Name _____

Position _____

Company _____

Address _____

Tel _____ PC1

● Circle No. 133

ASHTON · TATE ■ dBASE II

The world's leading micro database package can now be enhanced with 3 new products

Fox & Geller, the world's largest suppliers of dBASE II add-ons, are now established in the UK to supply and support

QUICKCODE™

The dBASE II program generator.

QUICKCODE writes concise programs to set up and maintain any type of database. You still have all the power of dBASE II and there is no programming required. Draw your data entry form on the screen and you're in business - it's that simple. The most powerful program generator available. And the easiest to use. QUICKCODE makes dBASE II easy.

dUTIL™

The dBASE II utility program. dUTIL automatically combines your dBASE II command files, saving disk access time and speeding up your programs. dUTIL makes your listings more readable by automatically indenting and aligning command sequences. Makes debugging that much faster. dUTIL also cuts out repetitive programming. Simply type your instruction sequence into a standard text file - then INCLUDE it in as many dBASE II command files as you wish.

dUTIL makes dBASE II faster

dGRAPH™

The dBASE II graphics system. Now you can bring your dBASE II database to life! Produce pie charts and bar or line graphs in minutes and with ease. Advanced features make dGRAPH as powerful as it is easy. Features like autoGRAPH which will automatically load dBASE II data, compute scales, draw grid lines and label charts. Then there's automatic shading and overlay graphs. And more.



Easy to use dGRAPH makes dBASE II better to look at

Dealers - contact your Fox & Geller distributor for more details:

Encotel	01-680 6040	Soft Option	(0476) 860171
Ferrari	01-751 5791	Tamsys	(Windsor) 56747
Midlectron	(077382) 6811	Tradesoft	01-627 1800
Pete & Pam	01-769 1022	Xitan	(0703) 334711
Softsel	01-844 2040	Software Ltd	01-833 1173



Fox & Geller (UK) Ltd
17 Wigmore Street
London W1.
Tel: 01-580 5816

FOX & GELLER

QUICKCODE, dGRAPH, dUTIL and autoGRAPH are trademarks of Fox & Geller. dBASE II is a trademark of Ashton-Tate.

● Circle No. 134

DISKPOST

* BETTER VALUE MAIL ORDER SUPPLIES FOR YOUR MICRO *

VEREX DISKS



Manufactured by Verbatim, to accepted industry standards. Full one year warranty. Quality products at popular prices for both home and office use.

5.25" DISKETTES

MD200-01	S/S, S/D, 48TPI	£1.71
soft sector only		
MD200-AS	S/S, S/D, 48 TPI	£1.66
Apple systems only		

8" DISKETTES

FD34-1500	S/S, S/D	£1.85
DD34-1501	D/S, D/D	£2.82

32 hard sector available at same price.

DATALIFE DISKS



From Verbatim, the world's leading diskette manufacturer. Full 5 year warranty. All minidisks are certified for double density recording, and are fitted with hub ring reinforcement as standard.

5.25" DISKETTES

MD525	S/S, D/D, 48 TPI	£1.92
MD550	D/S, D/D, 48 TPI	£2.86
MD577	S/S, D/D, 96 TPI	£2.69
MD557	D/S, D/D, 96 TPI	£3.60

48 TPI suitable for 35 or 40 track operation. 96 TPI suitable for 77 or 80 track operation. 10 and 16 hard sector versions available at same prices.

8" DISKETTES

FD34-9000	S/S, S/D	£2.75
FD34-3000	S/S, D/D	£2.90
DD34-4001	D/S, D/D	£3.26

32 hard sector versions available at same prices.

XIDEX DISKS



The new premier quality standard, against which all other manufacturers will have to be judged. All products certified for double density recording. Now with a lifetime warranty. Unreservedly recommended.

5.25" DISKETTES

5012-1000	S/S, D/D, 48 TPI	£2.44
5022-1000	D/S, D/D, 48 TPI	£3.28
5012-2000	S/S, D/D, 96 TPI	£3.49
5022-2000	D/S, D/D, 96 TPI	£4.48

48 TPI suitable for 35 or 40 track operation. 96 TPI suitable for 77 or 80 track operation. 10 and 16 hard sector versions available at same prices.

8" DISKETTES

8012-1000	S/S, D/D	£3.18
8022-1000	D/S, D/D	£3.83

32 hard sector versions available at same prices.

THE LAST ONE



Got a computing problem? Produce your own solution by using The Last One, a program generator which has helped to solve hundreds of problems in installations throughout the world.

TLO runs on the Apple II and IIc, Commodore 4032 and 8032/96, TRS-80 Model II (TRSDOS or CP/M), most CP/M, CP/M86 and MS-DOS machines including the IBM PC (PC-DOS) and Sinus.

Try out TLO for £50.

A limited demonstration version of TLO is now available for only £50, including full documentation. This cost is fully refundable against your subsequent purchase of a full version.

Full version costs:—

for Apple II	£185
all other versions	£330

Please specify version requirements when ordering.

DISK DRIVE HEAD CLEANING KITS



Helps to protect your valuable data, and minimise expensive downtime and repair costs. Consists of a flexible jacket, which receives a pre-saturated cleaning disk. Each disk is sealed within a foil sachet to ensure that it contains the right quantity of cleaning fluid when used. After use the disk is disposed of, and the jacket is kept for future use.

Suitable for single or dual head drives. Please specify 8" or 5.25" disks.

STARTER KIT £8.12
(contains jacket and two cleaning disks)

REPLACEMENT CLEANING DISKS £15.54
(pack of 10)

DISKETTE STORAGE BOXES

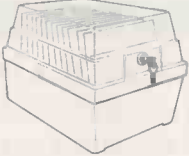

Protect your diskettes and valuable data from external contamination. Lockable, portable and secure. Two part box made from anti-static ABS plastic. Price includes dividers and index labels. Capacity 80 disks.

A5 Storage box (for 8" disks) £33.60

A6 Storage box (for 5.25" disks) £23.10

CTI - CP80 PRINTER



Features:—

- Friction and tractor feed as standard 80 c.p.s.
- Bi-directional logic seeking.
- 13 x 9 dot matrix giving true descenders.
- Sub and superscripts
- Italic printing and auto underlining
- Condensed, emphasised, expanded and double strike printing (can be mixed in a line).
- Parallel interface fitted as standard.
- 12 month warranty.

Print sample available on request.

CP 80 PRINTER £289.00

Optional RS-232 Interface £40.00

Special VIC20/VIC 64 Interface £46.00

PRINTER STAND



Suitable for use with dot matrix printers. Lifts printer sufficiently to enable continuous stationery to self-stack. Painted steel unit.

Dimensions: 39cm wide
x 28cm deep
x 10cm high

Comes as package which also contains:—

- 200 sheets continuous stationery.
- 1 x 9 1/2" binder.
- 1 x highlighter pen.
- choice of rubber feet/sticky pads.

PRINTER STAND £21.95

COMPUTER FURNITURE



Suitable for use with all leading personal computers. Features a top shelf for monitor/printer, lower shelf for books, paper and general storage; large desk top surface at keyboard height; attractive teak finish, and castors for mobility.





U.K. Manufacture. Comes in flat pack for self assembly - full instructions provided.

A further range of more sophisticated units is available - please ask for details.

THE ORGANISER £55.00

To: DISKPOST, FREEPOST, WEST MOLESEY, SURREY, KT8 0QF. Tel: 01-941 4066

All prices inclusive of delivery and insurance on British mainland.

Qty	Product	Price	YOUR NAME
.....	£.....
.....	£.....
.....	£.....
.....	£.....
Sub Total		£.....	Tel. No.:
Delivery/Insurance		£ FREE	Please charge to my Visa/Mastercharge/American Express/Diners Club account.
V.A.T.		£.....	My card number is
TOTAL VALUE OF CHEQUE PAYABLE TO DISKPOST		£.....	   

Company Orders

If you are unable to raise cheques without an Invoice, please post or telephone your order to us. We will then forward a pro-forma invoice, for your accounts department to pay against.

Credit Card Orders

We welcome Visa, (Barclaycard), Mastercharge, (Access), Diners Club and American Express. There is no credit card surcharge. Either write your card number on your order, or telephone your order to our sales office.

PC

DISKPOST

FREEPOST West Molesey
Surrey KT8 0QF. Tel: 01-941-4066

DISKPOST® is the mail order division of the BFI Electronics Group Europe's largest independent diskette supplier.

• Circle No. 135

THE EPSON QX-10 FROM TRANSAM

- Multi-font Basic, supports 16 character Fonts on screen
- 192k Ram expandable to 256k supplied as standard
- Clock and calendar with battery back-up
- New slimline disc drives
- Unique split screen facility
- Unique price

£1735 plus VAT

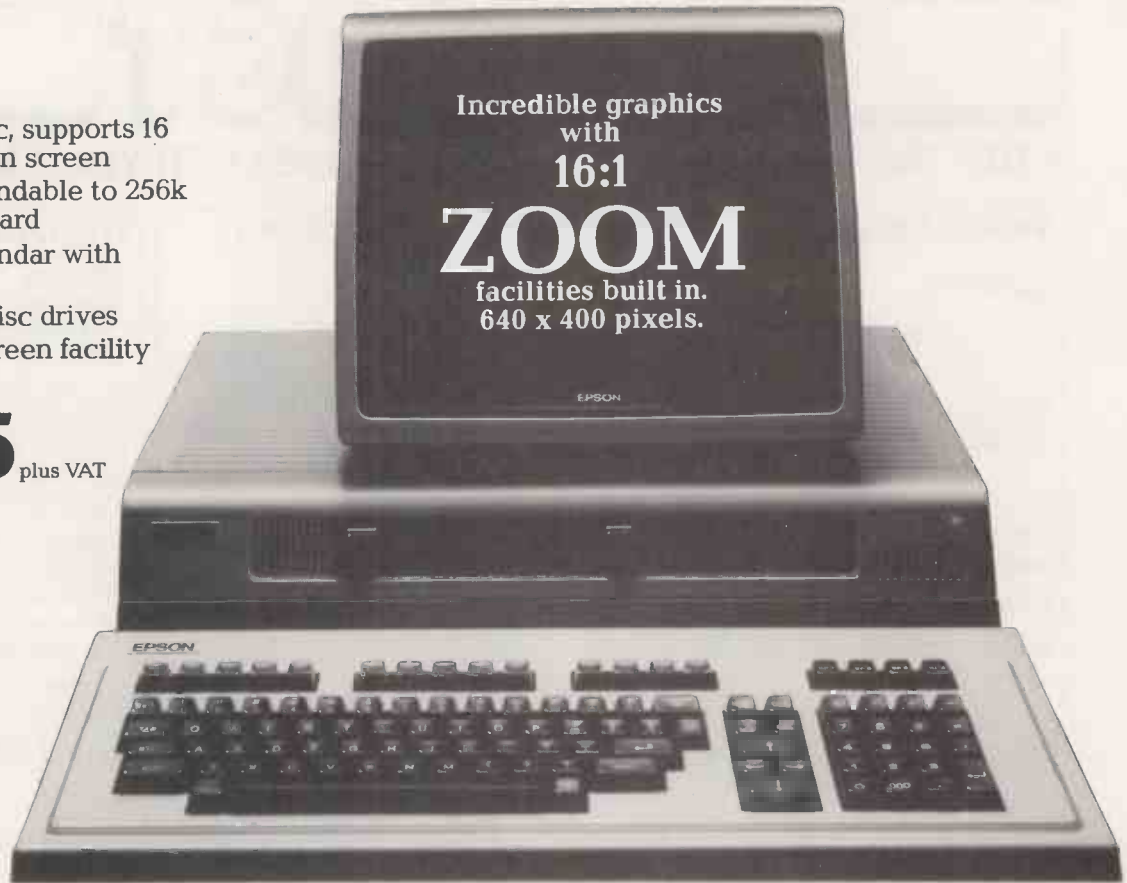

A FULLY INTEGRATED DESKTOP MICROCOMPUTER SYSTEM.

The QX-10. A fully Integrated Desktop Microcomputer system that takes the hard work out of using software. An incredible new member of the Epson family, emphasising cost effective computing on your desk. The QX-10 gives you a lot more for your money.

Lightweight, Z80A CPU, VDU and Keyboard units in modern functional design.

Very easy to use - specially for the first time operator.

More Power for your money. 192k upgradable to 256k RAM. Incredible graphics capability with zoom facility, RS-232C and parallel interfaces and multi-font BASIC as standard. Compare that with systems costing twice the price.

Add-on power. Simply slot in up to 5 optional interface cards for the following facilities:-

Cassette	Omninet
Bar code reader	Universal interface card
Joysticks	for developing your own
Sound generator	interfaces

80 col. x 25 lines screen with full bit image control, 640 x 400 resolution for greater definition. 16:1 zoom and special effects as well as unique split screen facility allowing different typstyles and graphics to be shown together for educational applications.

Incredible graphics
with

16:1

ZOOM

facilities built in.
640 x 400 pixels.

TCL SOFTWARE - the software division of Transam, offer complete CP/M software support for the QX-10 and a professional software service to guide you through all the available options.

QX-10 PERIPHERALS

Epson FX-80 printer	£438.00
Epson RX-80 printer	£298.00
Peachtree Business Software	P.O.A.
10 Megabyte Winchester Drive	£1650.00
Memory upgrade to 256k	£80.00

THE HUMAN COMPATIBLE MICRO

Please send me further information on the QX-10 and software products by return.

Name _____

Company _____

Address _____

Tel. _____ Interest _____



Tel. Orders Accepted on VISA and ACCESS.
or visit our London Showroom.

Transam
MICROSYSTEMS LIMITED

59/61 Theobalds Road, London WC1.
Telephone: 01-404 4554

WITH TOTAL SUPPORT FROM TCL SOFTWARE

TCL Software, a division of Transam, offers one of the most comprehensive ranges of CP/M based software. We support most of the popular microcomputers available which gives us the strength, in depth, to identify the best.

We offer the professional system solution.

PERFECT SOFTWARE FOR QX-10

Introducing the PERFECT SOFTWARE range of office software. Available now for QX-10 as well as other CP/M based micros.

Perfect Writer	£215
Perfect Speller	£75
Perfect Calc	£165
Perfect Filer	£215

DISCOUNTS

10% for 2, 15% for 3 and 20% if all four packages purchased together (cwo only). Dealer enquiries welcome.

Perfect Writer re-thinks the whole approach to word processing. All the standard features plus split screen editing on two files or two parts of a single file. Automatic footnotes, indexing, page referencing and paragraph numbering facilities. One set of commands common to all Perfect Software packages and links directly with Perfect Speller, Calc and Filer. Perfect Calc supports up to seven worksheets on line at once and split screen editing. Functions and formulae can be defined by the user. Files can be associated and re-calculated in order of dependancy. Perfect Calc also links with Perfect Filer, to fetch data and to Perfect Writer to create reports. Please contact us for further information.

GENERAL OFFICE

Wordprocessing
Card index
Databases
Mailing
Reports

BUSINESS

Accounting
Payroll
Stock Control
Job Costing
Bookkeeping
Financial Modelling
Time Recording
PROFESSIONAL
Scientific
Statistics
Planning

Survey Analysis

Mathematical
Estate Agents
Authoring
Time Tabling

OTHER LANGUAGES

TCL Pascal
C Compiler
CIS Cobol
COBOL 80
Comal
Forth
Fortran

COMMUNICATIONS DEVELOPMENT AND UTILITY PROGRAMS

THE EPSON HX20 PORTABLE COMPUTER £402

+ VAT

As a stand alone portable or linked to your CP/M based computer, the HX-20 takes computing a step further. Unlimited horizons on a limited budget.

Transams portable computer centre offers a wide choice of portable equipment and software. The HX-20 has taken pride of place. Software now available includes:-

INTEXT WORD PROCESSOR.....	£50.00
CARD INDEX - System/Data Base.....	£25.00
DIARY - 3 month rolling diary.....	£25.00
DIY - Do it yourself system generator.....	£30.00
SALES ORDER ENTRY - For Travelling Reps.....	£40.00
EPSON CALC- Financial spreadsheet/reports.....	£30.00
COMMUNICATIONS ROM - ISO Standard.....	£30.00
CORRESPONDENT 20 - Portable Word Processor ...	£25.00
MAILING LIST - and label printing.....	£30.00
GAMES 1 + 2 - a selection of games, each.....	£18.00



A computer small enough to fit into a briefcase yet with a full size typewriter keyboard, LCD virtual screen, printer and microcassette facility actually built in. High speed serial communication with other computers plus the Epson reliability - a world beater.

CODE		PRICE
HX20UA	Portable Micro Unit with Operating Manual and Vinyl Case	£411.00
HX20MC-SA	Microcassette Drive	£75.00
HX20EU-SA	Expansion Unit	£80.00
H00BR-JA	Bar Code Reader	£82.00
HX20RC-SA	ROM Cartridge	£45.00
H00AAU	Spare Mains Adapter	£8.50
SHX700	Sendata Acoustic Coupler	£220.00
CAB 702	External Cassette Cable	£5.70
CAB 705	Acoustic Coupler Cable	£15.00
CAB 714	Terminal Printer Cable	£15.00
CAB 716	Local Network Cable HX20/HX20	£15.00
CAB 717	Serial Interface Cable	£15.00
THX01	Parallel Interface Unit	£85.00
H00RP	Paper Rolls (5)	£2.60
H00CR-RA	Printer Ribbons	£2.20
MC-TAPES	Microcassette Tapes	£1.60

NEW INTELLIGENT TERMINAL EMULATION AND TEXT EDITOR.

New from Transam, the software (in ROM) allows your HX-20 to interface with any computer and act as a terminal to transmit and receive with 'off line' editing. Full screen editor for text preparation 80 column printout.

Plug in ROM and documentation **£50.00** plus VAT.
Sendata acoustic coupler **£220.00** plus VAT.

● Circle No. 136

EARLY LEARNING SPECTRUM SOFTWARE

4-8
year
olds

Announcing an exciting range of early learning software for the Sinclair ZX Spectrum - 16K and 48K Specially produced for 4 to 8 year olds by the largest educational

**publisher
in the UK.**

Colourful, action-packed games to teach those vital word and number skills.



Countabout - helps children recognize and manipulate numbers, teaches simple addition and subtraction, and introduces them to written mathematical symbols. Help our micro chimp reach the bananas at the top of the tree by getting the sums right.



a, b, c... Lift-off - an exciting introduction to the alphabet that teaches the letters in correct order and helps word recognition. Also introduces the layout of a computer/typewriter keyboard. Page through the alphabet picture book and help load our spaceship to Venus by matching pictures and words. See lift-off with full sound effects!

All programs come with 6 pages of Parents' Notes providing complete instructions for use.



Longman Software can be used by children on their own or with initial help from mum or dad.

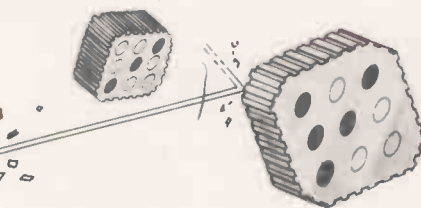

Hot Dot Spotter - a game of speed and skill that teaches number recognition and encourages quick reflexes in 4 to 8 year olds. Also improves children's ability to recognize object groups. Count the dots (between 1 and 9) and watch the laser beam bounce the ball up the screen. Build up speed and score lots of points.



Available from W.H. Smith, Boots, Menzies, Martins and other leading chain stores, as well as from computer shops and through Websters Software Directory. Trade Availability through PRISM Microproducts
In case of difficulty, or for a full colour brochure, write to:
Division GS1 (Software) Longman Group Ltd, Longman House, Burnt Mill, Harlow Essex CM20 2JE

£7.95
each
inc. VAT

LONGMAN SOFTWARE

**Longman Software -
The Key to Early Learning**

When it's time to stop playing games and get down to business...

Unfortunately, many of today's desk top computers are designed with too much emphasis on home use. That's fine, if you want to balance your checkbook, play "space war" or draw pictures. But when you have serious business requirements for a computer, you want one designed specifically for business.

The RAIR Business Computer is just that. A computer designed specifically for business applications, incorporating a host of features—optimised for the business environment. 8- and 16-bit microprocessors allow users to run available 8-bit—plus newer 16-bit—applications software simultaneously. And an integral high-capacity Winchester disk drive—plus provision for additional hard disk support—provides sufficient on-line storage for virtually any business application.

Advanced communications software allows the RAIR Business Computer to connect to mainframe systems and networks. And expanded RAM memory supports simultaneous access from up to four user workstations, each including an ergonomically designed, detached keyboard, high-resolution colour display, and optional workstation printer.

So if you're serious about a computer for business, call RAIR for details about our Business Computer. We're not playing games.

RAIR Limited
6-9 Upper St. Martins Lane
London WC2H 9EQ
Phone (01) 836 6921, Telex 298452

SYSTEM SPECIFICATION

Microprocessors: Concurrent 16-bit 8088 plus 8-bit 8085
RAM Memory: 256 kbytes expandable to 1024 kbytes
Integral Disk Storage: 19-Mbyte Winchester drive plus 1-Mbyte floppy drive
Storage Options: Up to 4 add-on Winchester drives plus streaming tape backup
Communications: 4 workstation ports (RS-422-compatible), plus 2 synchronous/asynchronous programmable RS-232 ports

WORKSTATIONS (up to 4)

Keyboard: Ergonomic, low-profile, 83 keys, 10 programmable function keys, 10-key numeric keypad (with cursor/editing functions)
Color Display: High-resolution, 80 characters x 25 lines, upper and lower case, 8 programmable foreground/background colors.
Printer: Bidirectional, 160 characters-per-second, friction and tractor feed

SOFTWARE

Operating System: User-friendly, multi-tasking, CP/M, MP/M, PC-DOS compatible
Languages: BASIC, COBOL, Pascal
Applications: Spreadsheet, Database, Text Processing Communications

CP/M and MP/M are trademarks of Digital Research
PC-DOS is a trademark of IBM

the RAIR Business Computer.



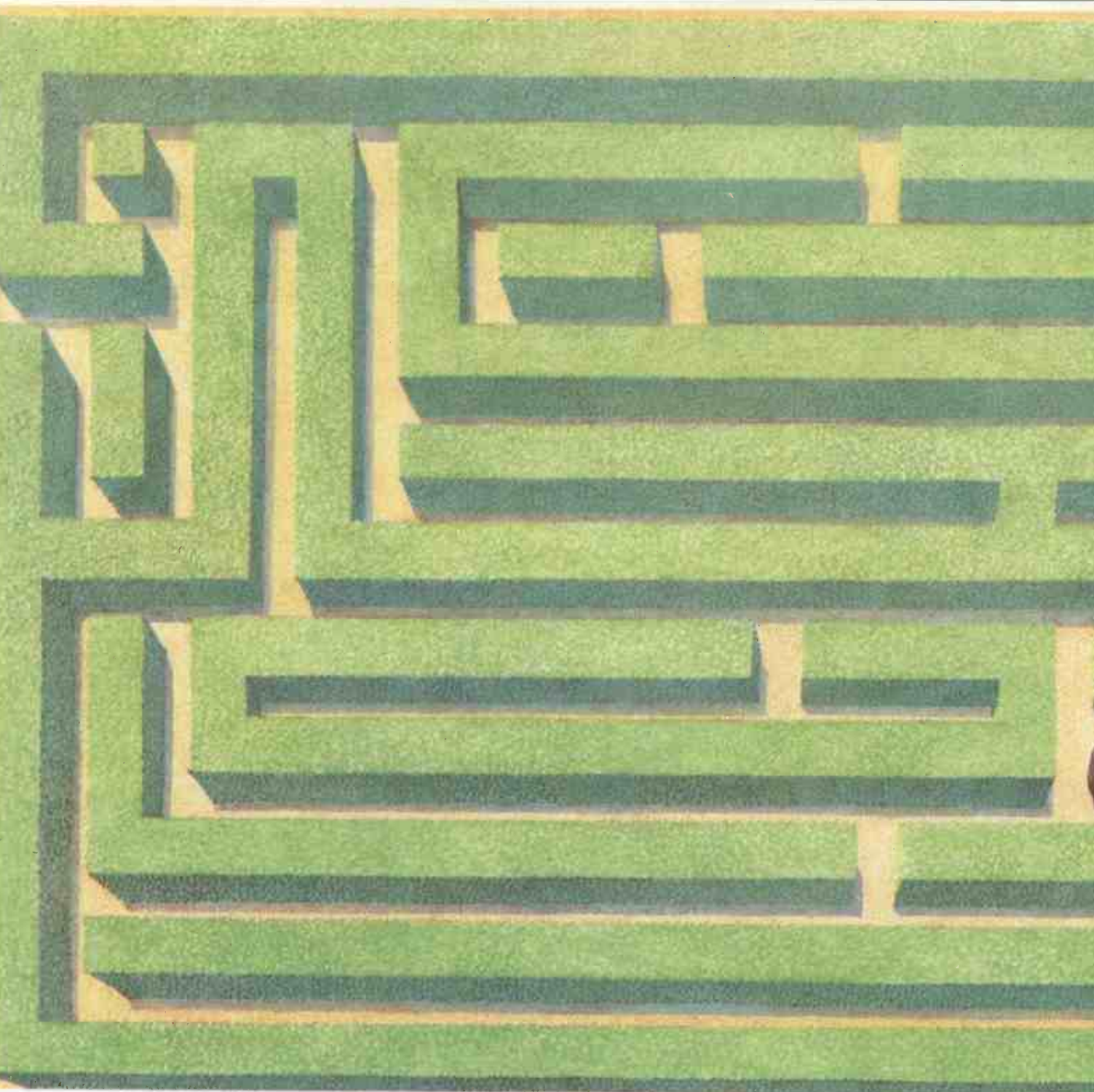

**Microcomputers?
Let Rank Xerox
point you in
the right direction.**

If you're confused about which microcomputer system is *exactly* right for your office, let Rank Xerox be your guide.

Today, with so many systems available, it makes sense to deal with just *one* company who can supply all your microcomputing needs – the hardware, and specifically tailored software.

The advantage: total compatibility. There's no shopping around for compatible equipment (printers, disc drives, etc.); just look for the Xerox name. You'll find it on every item you require to quickly establish a cost-effective micro-computer system.

Also, Rank Xerox offer you the "Helpline" service. As its name suggests, we don't just provide you with the right microcomputer system for your business, we also help you through those first vital stages of operation. Any questions, just call us and our specialists will work with you on a telephone link. No charge.

On-site servicing is another benefit of choosing Rank Xerox. And it's prompt.

Powerful microcomputers designed to help you manage your business better

Not just power, but simplicity, too. And compactness. Keyboards and controls have been more thoughtfully designed to make working with Xerox micro-computers easier and more comfortable.

The new Xerox 820 II range, for example, has all the built-in memory and

operating power you could possibly need. It's CP/M* based with 8-bit or 16-bit versions. You could select the advanced 820 II HRG, with on-screen graphics for plans, graphs and so on.

For extremely powerful word processing and microcomputing together in one complete system, there's the Xerox 823.

And remember, these are *expandable* systems that grow as your business needs grow. At the same time, they're *adaptable* systems, with many disc drive and printer options to suit your requirements.

Software for every aspect of your more efficient business.

Every aspect of your business can be controlled more efficiently by you and your better designed Xerox microcomputer.

Budgetary and financial analysis, records and data management, word processing, plus specific business accounting packages that help you to calculate payroll, update sales ledgers, and monitor stock control, and more.

Suddenly, you could have instant access to all the information you need to make informed business decisions – information you can update, manipulate, and store on easy-to-file discs.

You're able to work in your choice of computer languages too, including BASIC, Pascal, Cobol and APL.

Which Xerox microcomputer system is right for you? Let us point you in the right direction right now. To the coupon below. Simply fill in and freepost it today.

Alternatively call our 24-hour enquiry service. Dial the operator and ask for Freefone 2279.

*© CP/M is a registered trademark of Digital Research Inc.

RANK XEROX

© Xerox and Rank Xerox are registered trade marks of Rank Xerox Ltd.

**FREEPOST THIS COUPON TODAY!
NO STAMP REQUIRED**
To: Rank Xerox (UK) Ltd, Freepost,
Admail 38, London NW1 1YH

Yes, I'd like to know more about the Xerox 820 II series of microcomputers. Please ask my local authorised dealer to contact me soon, to arrange a demonstration.

Name _____

Position _____

Company/Organisation _____

Telephone Number _____

Address _____

Postcode _____

Please tick if you are a Rank Xerox Customer.

24-HOUR ENQUIRY SERVICE. ASK THE OPERATOR FOR

FREEFONE 2279

PC9/83

OR DIAL 01-380 1418

● Circle No. 139



GALAXY 2 COMPUTER SYSTEM



WHATEVER REQUIREMENTS YOU HAVE



GM813 - CPU/ 64K RAM Board

- ★ 4 MHz Z80A CPU
- ★ 64K Dynamic RAM
- ★ RS232 Serial Interface
- ★ Two 8-Bit I/O Ports
- ★ 1200 Baud Cassette Interface
- ★ Extended and Page Addressing Modes

GM812 - IVC Board

- ★ 80x25 Display Format
- ★ On-board Z80A Microprocessor
- ★ Buffered Keyboard Input
- ★ Programmable Character Generator
- ★ 160x75 Pixel Graphics
- ★ Light Pen Input

GM 829 - FDC/ SASI Board

- ★ Single/Double density operation
- ★ Single/Double sided drive operation
- ★ Up to 3 mixed 3.5", 5.25" and 8" drives
- ★ Industry Standard SASI hard-disk interface

TWO SPARE SLOTS

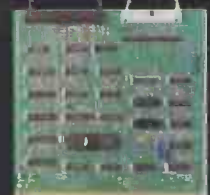
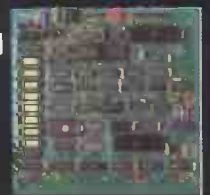

The cost-effective solution to your computer needs for only **£1,495***

For just £1,495 the Galaxy 2 provides the basic requirements for a small business system:

- **Central Processor Unit with 64K of RAM**
- **Twin disk drives (400K storage per drive)**
- **Keyboard and 12" monitor**

But unlike many other small-business systems the Galaxy System is specially designed for expansion and flexibility to meet changing requirements. It uses the world's best selling micro processor, the Z80A, and is based on industry-standard 80-Bus boards. The business system uses only 3 boards in the 5 spaces available, so extra cards can be "plugged-in" to expand the system; for example to expand the memory, or to give a colour facility, or to develop the Galaxy for the particular requirements of education, research, software development etc.

It has a CP/M operating system which gives access to the largest range of software available for any machine. In particular, Gemini can offer QUIBS; a small-business package developed especially for the Galaxy.

The Galaxy has industry-standard interfaces (parallel and serial), and Gemini Microcomputers can supply a full range of compatible hardware including a Winchester sub-system and printer.

The Galaxy offers the most cost-effective way of obtaining a basic unit which is capable of developing to meet your particular requirements; now and tomorrow.

Features include:

- Twin Z80 Processors
- 64K Dynamic RAM
- 800K Disc Based Storage
- 80 x 25 Screen Format
- Dual Printer Interfaces
- Modular Design
- Extra Disc Drives Easily Added
- Winchester Expansion Available
- Net Working System Available
- Additional Slots for 2 Cards
- 12" Green or Amber Monitor



*Price is exclusive of VAT



Gemini Microcomputers

18 Woodside Road, Amersham, Bucks HP6 5EQ. Tel: (02403) 28321.



● Circle No. 140

PRACTICAL COMPUTING September 1983

Get your terminals talking for under £500



Think of CLEARWAY as a telephone system for computers and office equipment – imagine micros, word processors and mainframes, all able to communicate with each other – think of the greater flexibility you'll get from your system.

CLEARWAY is the Local Area Networking System with a starter kit that can be fully installed for under £500.

CLEARWAY can handle over 25 continuously active channels. And it can be installed by anyone, provided the hardware has a standard RS232 interface.

Clearway

The best low cost local area networking device

Mail the coupon now for full information

Real Time Developments Limited, Lynchford House, Lynchford Lane, Farnborough, Hampshire GU14 6JA. Telephone: Farnborough (0252) 546213 Telex: 858893 Fletel G

I am interested in Clearway – the low cost Networking System, please send me details

Name

Position

Address

Telephone

Send to: Real Time Developments Limited,
Lynchford House, Lynchford Lane,
Farnborough, Hampshire GU14 6JA
Telephone: Farnborough (0252) 546213
Telex: 858893 Fletel G

8309PC

● Circle No. 141

*****THE NEW DBMS III (series III of the world's first 'task-robot-programs')*****

*****FEATURES*****

- | | | |
|---|--|---|
| 1400 character record sizes..... | 32000 records per filename..... | 12 online file architectures..... |
| mathematical scratchpad..... | 20 main/200 sub fields per record..... | 240 fields using cross-referencing..... |
| record relational indexes..... | field and record related formulae..... | cross-record calculations..... |
| translateable to any language..... | 'Jump-to' any of 32000 records per file..... | 'Jump-to' any record in 12 files..... |
| User-definable reporting..... | random/binary/key/multiple field search..... | User-definable files/field words/sizes..... |
| field protection/classification..... | 'if then' questioning..... | endless 'either-or' matching..... |
| either-or, same as, greater, smaller..... | file protection/password entry..... | formulae/recall on selection criteria..... |
| sorts 'alpha or numeric' any window..... | range match, not match, integer match..... | 13 interrogation question types..... |
| 12 online file architectures..... | sort speed 500 records per 20 seconds..... | short filing output/audit trails..... |
| | | Word-star & Mbase compatible..... |

DBMS III.7 NEW SWITCH MODE FACILITY ENABLES YOU TO CROSS UP TO 12 DIFFERENT FILES (32000 RECORDS PER FILE) PRE-SELECTING ANY OF UP TO 20 FIELDS PER RECORD/FILE FOR DISPLAY/PRINT OUTPUT (240 FIELDS) IN ALL. ONE MASSIVE ENQUIRY CAN PASS THROUGH 384,000 RECORDS

You might have two files whose records are directly related to each other, so that the first file (say containing names and addresses) refers to the second file (say financial and other information relating to the same record numbers in the first file) directly. Then you can simply select that in file 1 you are interested in just the name and telephone numbers, whereas in file 2, you are interested in the income, trading period and number of branches, information. Your enquiry can then pass through both files highlighting that information only. Actually there doesn't need to be a strict correlation between the same record numbers in different files, and you can also on just one JUMP command go to any record in any of the 32000 records in any of the twelve files and carry on cross-referencing from there onwards.

DBMS'S MACROS WORK FROM THE MOMENT YOU INSERT THE 'TASK DISK' IN THE COMPUTER

Simply design your file, give its fields your words, setup your report mask, and then enter your records. Switch to 'automatic drive' and formulated any task you wish to program to fulfill, the task is stored as a macro. Take a copy of the program on another 'task disk' and from then on, the task disk will function without a single key-stroke. Think of a number of such 'task disks' such as "stock-re-order reports"; "stock-valuation reports"; "analysis"; "patient history analysis"; "research-analysis"; "budgeting-analysis"; "vehicle-location control"; "librarian analysis"; "plus more?"

Not only does this program surpass most of its kind that you might buy elsewhere, but if you buy the hardware from us, then you get it FREE... DBMS II (WITHOUT MACROS) AND DBMS III ARE FULLY IMPLEMENTED UNDER CPM-86 (tm) AND MS-DOS (tm) I.E.: SIRIUS/VICTOR/IBM DBMS II IS £395.00 (or £250.00 by mail order ex. training) ... DBMS III is £575.000 (or £295.00 by mail order ex. training).

MICRO-COMPUTERS

INTERTEC	Superbrain 64K RAM/320K disks	1895.00
	Superbrain 64K RAM/700K disks	2395.00
	CompuStar 64K RAM/320K disks	2195.00
	CompuStar 64K RAM/700K disks	2595.00
NORTHSTAR (exc DOS)	Advantage 64K RAM/700K disks	£2195.00
TELEVIDEO	Advantage 64K RAM/5.3M disks	£3095.00
	802 64K RAM/700K disks	2395.00
	802H 64K RAM/7.3M disks	3950.00
	806 64K RAM/10M disks	5195.00
	816 256K/750K disks	*£3350.00
ACT	Sirius 1 256K/1.2M disks	*£2195.00
	Sirius 2 256K/2.4M disks	*£2695.00
	Sirius 3 256K/10MEG disks	*£3895.00
VICTOR	8000 256K/1.2M disks	*£2195.00
IBM	PC 84K RAM/640K disks	*£2795.00
	PC1 130K/640K disks	*£3395.00
IBM	XT (TEN MEGABYTE)	4490.00
IBM	XF (FIVE MEGABYTE)	3250.00
Ten 4480		*3695.00
Five 64K 5 Meg disk		£3250
ALTOS	ACS800-2 64K RAM/1M disks	2195.00
	ACS800-10 208K/10.5Meg disks	5695.00
NEC	APC 128K RAM/2M disks	call
CORVUS	Concept 16 bit pc	call
SANYO	G80 64K RAM/320K disks	1195.00
ABC	26 64K RAM/2.2M disks	3250.00

All computer prices include mbase as standard. All prices marked * are 8/16 bit machines.

WE STOCK MOST OF THE BEST KNOWN SOFTWARE ALSO MOST OF THE BEST KNOWN BRANDS OF PRINTERS & PERIPHERALS FROM 300.00 TO 2700.00 (OKI/EPSON/DRE/NEC/QUIME/ANADIX/RICOH)

PRINTERS

OKI	-Microline 80	295.00
	-Microline 82A	395.00
	-Microline 83	695.00
	-Microline 84	895.00
EPSON	-MX80/FT-3	425.00
	-MX100/FT-3	575.00
ANADIX	-DP 9000	895.00
	-DP 9501	1045.00
	-DP 9501 (A)	1145.00
QUME	-9/45 R/O	1995.00
	-9/55 R/O	2195.00
	-9/35 R/O	1495.00
NEC	-3510 R/O	1495.00
	-7710 R/O	2195.00
	-5520 KSR	2250.00
DRE	-8820	1295.00
	-8830	1695.00
TEXAS	-810	995.00
	-825	995.00
DIABLO	-630	1995.00
RICOH	-RP1500	1095.00
OLYMPIA	-ESW 103 14 CPS	975.00

G. W. COMPUTERS LTD — Tel: 01-636 8210
POPULAR BRANDS OF EQUIPMENT WE SELL
MICROS: Sirius/Victor/I.B.M./DEC
Epson/North-star/Sanyo/Superbrain
CompuStar/Altos/Apple-Lisa/Televideo
PRINTERS: Nec/Quime/Diablo/OkI/Epson
OTHERS: Corvus/CompuStar
Hard disks networks and multiplexors
Spoolers/Modems/Buffers
most of the best known brands of software

SOFTWARE

G.W.L.	-BUS V8.0 (Accounts)	275.00
	-DBMS II (Database)	*£395.00
	-DBMS II (by mail order only)	*£250.00
	-DBMS III (database)	*£575.00
	-DBMS III (by mail order only)	*£295.00
	-FORMS/TEXT/CALC/DBMS IV	*£575.00
	-Sales Ledger	£395.00
	-Purchase Ledger	£395.00
	-Nominal Ledger	£395.00
	-Stock Control	£395.00
	-Address/Mailer	£395.00
	-QASort/QNSort (500 Recs/14secs)	£395.00
MICROSOFT	-Mbase 80	*195.00
	-Fortran 80	295.00
	-Cobol 80	395.00
	-Basic Compiler	225.00
	-MU lisp/mu star	125.00
MICROPRO	-Word-star	*£295.00
	-Mail-merge	£95.00
	-Spelstar	125.00
	-W-star/M-merge/Sp-Star	425.00
BYROM	-BStam (communications)	100.00
	-BStms (tele-comms)	100.00
	-CBasic	75.00
DIGITAL	-Concurrent CPM/86	*375.00
	-CBasic86	*175.00
	-Pascal MT	225.00
LIFEBOAT	-T/Maker	155.00
M'FOCUS	-CIS Cobol	420.00
	-Forms II	100.00
SORCIM	-Super Calc	195.00
PEACHTREE	-Magic Wand	190.00
	-Magic Calc	175.00
VARIOUS	-including tele-comms etc	call 000

Software formats on all micros in our hardware list. All prices marked £ are available 8/16 bit formats.

SOFTWARE COMMENT!!!
INTEGRATED SOFTWARE IS PROPERLY REPRESENTED, when the degree of integration reflects the ability to refer to as many different files, as well as employ as many different functions, under as many different modes as possible in one program only. This principle not being observed, will confer upon your purchases the attribute of their being expensive as an aggregate even though individually they are cheap. "DBMS III.7" and "THE KEY" are comparably worthy of such a label.

TERMS & ETC

G. W. Computers Ltd (Grama (Winter) Ltd)
55 Bedford Court Mansions
Bedford Avenue, London W.C.1, England.
Tel: 01 636 8210; 01 631 4818; tlx 892031 twc g
Boston office tlx 94-0890

24 hour answerphone-leave address for 'in'packs'
We do not operate a reader's reply card service.
Terms: C.W.O. or C.O.D. Prices exclude V.A.T., but include all non-credit discounts available.
No dealers. The above lists are not exhaustive

Please call at our showroom only by prior appointment. Unless expressly agreed, all warranties are commercial 90 days return to base for parts and labour. Annual warranties and maintenance facilities available nationwide through closely related third parties.

SYSTEM DEAL (our speciality) SAVES YOU 1500.00 +

Buy any computer, any printer and 150.00 value diskettes add £85.00 for cables and testing. add 10% for return to base warranty for 1 year (optional) add £110.00 for delivery & installation (optional) Training optional extra £120.00 and get completely *****FREE*****
cpm handbook 50 basic exercises 2000 sheets paper
DBMS III.7 magic wand w/proc magic calc
mbase 80 diagnostics msort/dsort
recover autoload instant basic
library boxes disk/games DT/AS/NS sorts

Total Value £1525.00
Based on 8 bit hardware, 16 bit software varies.

Here's a typical example of a complete system deal
1-Sirius 128k ram/1.2 megabyte disks 2395.00
2-OkI microline 80 printer 295.00
3-Cables & testing 85.00
4-Diskettes 150.00
5-price differential on magic/wand for word-star 100.00
software described above *****FREE***** 3025.00
We specialise in 'STANDARD MICRO-PRINTER SYSTEMS' as well as 'NETWORK SYSTEMS BASED ON A SHARED HARD DISK'.
The range of computer products (mostly ex stock) includes the most popular brands of micro-computers, printers, modems, buffers, spoolers and software.

PERIPHERALS & ACCESSORIES

CORVUS	-6 Meg hard disk	1950.00
	-11 Meg hard disk	2950.00
	-20 Meg hard disk	3950.00
	-Multiplexor 7 station	695.00
	-Mirror backup card	695.00
INTERTEC	-CompuStar 10 Meg hard disk	2950.00
	-CDC 144 Meg hard disk	7950.00
N'STAR	-16 Bit upgrade	395.00
	-18 Meg hard disk	2995.00
RODIME	-6 Meg hard disk	1495.00
	-12 Meg hard disk	1950.00
GENIE	-5MG fixed/5MG removeable disk	3295.00
QUADRAM	64K print spooler/copier	295.00
BIZCOMP	-RS232/Auto-modem 1200 baud	450.00
AST	-port expanders (4 trnlns to 1 prtn)	395.00
GIX	-port expander (switcher)	95.00

NOTE: Corvus drives with multiplexor may network sirius.. Superbrain.. Concept.. PET.. Victor.. IBM..

CAMDEN

THE COMPUTER PEOPLE

COMPUTER SYSTEMS LIMITED
 462 COVENTRY ROAD, SMALL HEATH
 BIRMINGHAM B10 0UG
 Telephone: 021-771 3636 (10 lines) Telex: 335909 (Camden G)

5MB WINCHESTER

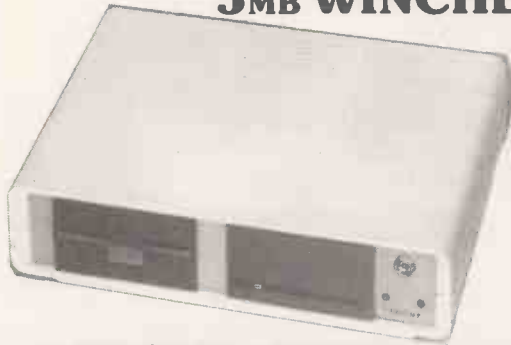

SPECIAL OFFER

APPLE IIE PLUS MONITOR AND STAND
 5 MEG WINCHESTER WITH BUILT-IN FLOPPY.

RECOMMENDED PRICE £2810
 OUR PRICE £1995

10 MEG VERSION £2275

	RRP	CAMDEN PRICE
APPLE IIE	845	645
80 COL CARD	80	70
80 COL + 64K MONITOR & STAND	180	150
DISK WITH CON	170	150
DISK W/OUT	345	270
TRIDENT 5 MEG	245	220
TRIDENT 5 MEG PLUS FLOPPY	1450	1150
	1700	1465



ALL PRICES EXCLUDING VAT

12 MONTHS PARTS AND LABOUR ON ALL APPLE AND TRIDENT PRODUCTS

● Circle No. 143

Anglia Computer Centre

88 ST BENEDICTS STREET NORWICH NR2 4AB
 TELEX 975201 ACOMP G

SPECIALISTS IN BUSINESS COMPUTERS



BUSINESS COMPUTERS

Phone (0603) 667032/3 or 21117

APPLE, SIRIUS, OSBORNE, ANADIX, IBM*, DEC, EPSON.

* Complete with professional back-up service *

HOME COMPUTERS

Phone (0603) 26002/667031

BBC, DRAGON, COMMODORE 64, SINCLAIR, ORIC, LYNX.

* On special offer *
 Call for Price £££

BOOKS AND STATIONERY CENTRE

Phone (0603) 29652

PROBABLY THE LARGEST SELECTION OF COMPUTER BOOKS IN EAST ANGLIA

ACCESS AND BARCLAYCARD WELCOME

IBM authorised dealer — IBM Personal Computer

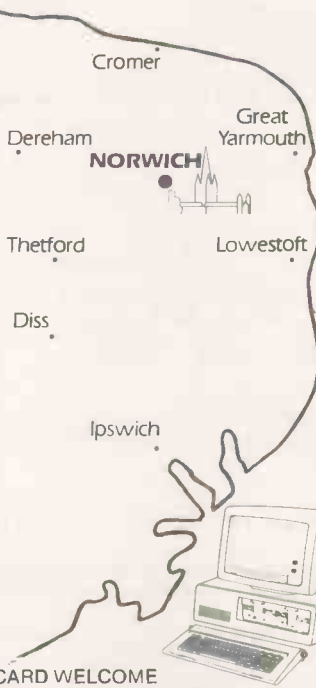

● Circle No. 144

VER-WORD

THE WORD PROCESSOR

For Microcomputers running CP/M™

You will not believe the power of Word processing software that VER-WORD can bring to your machine.

- easy to learn and use
- what you see is what you get
- ideal separate command and edit modes
- powerful block text commands
- sophisticated column manipulation
- mail merging included

Write now for full specification brochure.

Orders are being accepted for the following hardware:

- Osborne
- Televideo
- Wordset
- Compucorp (CFM)



VERWOOD SYSTEMS
 Verwood House
 High Street,
 West Haddon,
 Northants NN6 7AP.

CP/M™ is a registered trade mark of Digital Research, Inc.

● Circle No. 145

Business Computers you can afford.



At last here's a range of true business computers at realistic prices. Sanyo desk top micros give you a choice of 8-bit, 64K RAM or 16-bit 128K RAM, expandable up to 512K. Sanyo's reputation for quality products, thoroughly pre-tested for reliability, is backed up by Logitek's experience and service.

Logitek has a strong reputation for reliable products and a high level of customer support. 100 Logitek dealers are backed up by a national maintenance service, and in-house support on operating systems and applications software.

Logitek are the top distributor for Altos micros, and Peachtree software and the new Landmark multi-processor

micro complete the range with full compatibility of operating systems and applications software.

Here are real business computers at an affordable price - get one on your desk now.

- Choice of 8-bit or 16-bit
- 320-640 Kbytes on floppy disc
- Expandable up to 1.2 Mb
- True 8086 16-bit processor
- Peachtree accounting software
- CP/M, CP/M-86, MS-DOS operating systems
- Price from £1195 to £2450

Sanyo technology plus Logitek support

LOGITEK

Logitek, Logitek House, Bradley Lane,
Standish, Greater Manchester, WN6 0XQ. Tel. 0257 426644
Logitek, London
30, Brook Mews North, London W2 3BW. Tel. 01-723 0012

Send to: Logitek, Bradley Lane, Standish, Gtr. Manchester, WN6 0XQ

NAME _____
COMPANY _____
ADDRESS _____
TITLE _____
TEL _____

• Circle No. 146

ORIC MCP 40 COLOUR PRINTER



ORIC
MCP 40 COLOUR PRINTER

£169.95 Incl. VAT.

It's here, the exciting new ORIC MCP 40, Colour-Printer. Packed with quality ORIC features to start building your ORIC system.

Superbly styled and quality engineered to provide 4 colour hard copy, for home and business use.

Just look at these leading features:

- **Quality hard copy on plain paper**
- **Superb graphics and text capability**
- **Prints 4 colours – Red, Green, Blue and Black**
- **Designed to match the futuristic style of ORIC 1**
- **Plugs straight into your ORIC – printer lead supplied**

ORIC

The ORIC MCP 40 – Setting new standards in Micro Computer Printers. ORIC The Real Computer System

ORIC PRODUCTS INTERNATIONAL LTD Coworth Park Mansion, Coworth Park, London Road, Sunninghill, Ascot, Berks. SL5 7SE ● Circle No. 147

ORIC products available from:-
WH SMITH · DIXONS · GREENS · LASKYS · MICRO'C'
· MICRO PERIPHERALS · SPECTRUM · COMPUTERS FOR ALL
and hundreds of independent dealers.

ORIC-1 16K & 48K



**ORIC-1 16K
VALUE PACK**
ORIC 16K plus £30*
worth of ORIC Software
for ONLY
£129.95 incl.VAT.

*TEACH YOURSELF BASIC
HOME FINANCE ORIC FLIGHT
MULTI-GAMES



**ORIC-1 48K
VALUE PACK**
ORIC 48K plus £40*
worth of ORIC Software
for ONLY
£169.95 incl.VAT.

*TEACH YOURSELF BASIC
HOME FINANCE ORIC FLIGHT
MULTI-GAMES

ORIC 1 16K & 48K Micros

- **Superb Styling**
- **Ergonomic keyboard with 57 moving keys**
- **28 rows x 40 characters high resolution**
- **Teletext/Viewdata compatible graphics**
- **6 Octaves of real sound plus HI*FI output**
- **Centronics printer interface and cassette port**
- **Free user manual, cassette recorder lead and Driver game included.**

ORIC 1 Today's best value in real computer systems.

To be launched within the next few weeks - the revolutionary **ORIC 3" MICRO FLOPPY DISK DRIVES**, with incredible access time and data storage capacity.

Other peripherals to be launched this year...

It is Oric's policy to continue to expand our product range, in order to offer our customers a comprehensive, professional, Micro Computer system, at a realistic price.

We believe that with the launch of our MCP 40 colour printer, and our combined computer/software value packs, we will continue to lead the small micro market in both quality and value.

* Titles may vary subject to availability but the approximate value will not.

© Copyright ORIC PRODUCTS INTERNATIONAL 1983



THE BEST SELLER OF 1982



In 1982 the RICOH 1600S outsold every other comparable printer because of its speed, reliability, intelligence, flexibility and sophistication.

Because it is compatible with all known systems and software packages.

Because of the 12 month warranty that Micropute offer.

Because Micropute are a company who care, who are constantly aware of changing needs and who can fulfill any special requirements.

Not least of all, because of the price

In 1983, there will be thousands more satisfied customers.

We hope that you will be one of them.

ONLY MICROPUTE GIVE YOU SUPERCOVER

As an extra bonus Micropute Supercover will provide a 12 month on site maintenance for only £99.00 parts and labour.

**DON'T
FORGET THE
RICOH 1300S**
...a little bit slower but
every bit as clever.

Please send details of the RICOH 1600S
and 1300S

Name: _____

Position: _____

Company: _____

Address: _____

Telephone: _____

● Circle No. 148 RP2



MICROPUTE

Micropute, Catherine Street, Macclesfield,
Cheshire SK11 6QY. Tel: (0625) 615384.

APL*Plus

IBM launched APL last month, and now APL*Plus is offering its own full-feature version as an alternative. APL*Plus/PC includes a custom-character ROM where some of the IBM's little-used characters have been changed to provide APL symbols, communications software and other utilities.

APL*Plus takes up 90K of memory, after which the system disc can be removed. It requires a PC with at least 128K of RAM. APL*Plus costs £600.

Contact APL*Plus Ltd, 1-2 Henrietta Street, London WC2 8PS. Telephone: 01-240 5765. □

TK!Solver

AFTER we had gone to press with a review of TK!Solver — August issue page 132 — the product was launched by a U.K. distributor, Marketing Micro Software. It costs £286.25 including VAT. Ready-to-run applications packages for mechanical engineering and financial management cost £125.95 each.

Contact Micro Marketing Software, Goddard Road, Whitehouse Industrial Estate, Ipswich, Suffolk IP1 5NP. Telephone: (0473) 462721. □

Pete & Pam

WELL KNOWN IBM PC dealer Pete & Pam has expanded its range of PC offerings. Recent additions include Multimate, a powerful word processor designed to make the PC behave as much like a Wang dedicated word processor as possible. Price: £345 plus VAT.

Graph'n'Calc is a calculation and business-graphics program which is easy to use and can take DIF files from the Visi series. Price £125 plus VAT.

Three new educational packages are The Speed Reader, Math Blaster — for ages six to 12 — and Word Attack. They are all from Davidson & Associates, of California and cost from £33.50 to £49.95 plus VAT.

Contact Pete & Pam Computers, New Hall Hey Road, Rawtenstall, Rossendale, Lancashire. Telephone: (0706) 227011. □



Put your feet up

ADMIRERS of the DEC Rainbow stand, which gets the system box off your desk, can imitate the style with an IBM PC using the Curtis pedestal and extension Cables. The system stand costs £24.95 and will let you stick the system box on end by the side of your desk. The VDU pedestal, which costs £79.95, provides a tilt and swivel facility. Extension cables for the system box cost

£49.95, and a 3ft to 9ft coiled cable for the keyboard is £39.95. All prices include VAT and delivery. The idea seems to be to free enough space on your desk so that you can put your feet up on it — if that happens to be your style.

Contact Chell Instruments, Tudor House, Grammar School Road, North Walsham, Norfolk. Telephone: (0692) 402488. □

Focus from mainframes

FOCUS is a database and information-control system which runs on IBM mainframes. PC/Focus is said to be identical in function and design, but it runs on the IBM PC.

The main components of the program are Report Writer, Dialogue Manager, Data Base Management, File Browsing, Graphs, Formal Statistical Analysis, Financial Modelling, User Vocabulary, Help facility and Text Editor. The File Transfer component allows data to be exchanged directly with a mainframe running Focus.

The program is delivered on five dual-sided floppy discs

which must be copied to a hard disc, so you need either the XT or an add-on Winchester. PC/Focus also comes with an accelerator board which plugs into an expansion slot. It includes a clock calendar, 512K of additional RAM, and one serial and one parallel port. The use of an Intel 8087 maths co-processor, for which a free socket is provided on the PC's motherboard, is recommended.

Contact the distributor, Information Builders (U.K.) Ltd, Station House, Harrow Road, Wembley, Middlesex HA9 6DE. Tekephone: 01-903 6111. □

As an increasing number of readers are acquiring IBM PCs and various look-alikes, we felt that — like other major micros — it should have its own place in *Practical Computing*. This is it.

In future issues, PC Bulletin will carry news, reviews and software stories. If you have any hints and enhancements, utilities or short programs, send them in.

Our aim is to make this column an extra "expansion slot" for IBM PC. But it will only expand if you join in. Send your contributions to PCB at *Practical Computing*, Quadrant House, The Quadrant, Sutton, Surrey SM2 5AS.

Profits grow and grow

FINANCIAL RESULTS for the six months to June 30 show IBM is continuing its growth from 1982. Worldwide gross income was \$17.9 billion, up 18.2 percent on the first six months of 1982. Earnings before tax were \$4.2 billion, up 26.0 percent and net earnings were \$2.3 billion, up 24.3 percent. Sales of IBM PCs remain, in value terms, trivial by IBM standards. However, the company notes that they "continue to exceed projections".

IBM is giving away 600 PCs to universities and non-profit institutions. Between 70 and 100 will be allocated to U.K. universities and colleges by IBM U.K.

IBM U.K. now has 87 authorised PC dealers. Latest additions are Microware (London), Keen, General Microcomputer Systems, Spartex, Data Efficiency, Microchips, Fletcher Denny Systems, Rockliff, Sumlock Bondain, Walters Computer Systems, U Microcomputers, Fame Computers and Yorkshire Microcomputers.

Direct sales are flourishing too. Schlumberger just ordered 1,001.

The PC is also being sold as a so-called strategic work station for the 8100 Office Information System, and — with an adaptor card and emulation software — with the IBM 5520 integrated office-administration system. □

XT gap bridged

AS IBM has failed to provide back-up for the hard-disc XT version, Alloy has plugged the gap. PC-Backup is a 0.25in. tape drive that stores 17.5 Mbyte unformatted on a single 450ft. tape cartridge.

A tape interchange program utility runs under PC-DOS to provide file transfer. This results in the tape giving 13.4Mbyte of formatted storage at a transfer rate of up to 1.4Mbyte per minute. The price is £1,495.

Contact Alloy Computer Products (Europe), Cotteswood House, Gloucester Street, Cirencester GL7 2DQ. Telephone: (0285) 68709. □

DIFFERENCES BETWEEN the hard-disc version of the IBM PC and its twin-floppy relative were described in the first part of this review in the August issue. In most other respects the two versions are identical, including many important aspects of the IBM's ergonomics and its Basic languages.

Apart from the hard disc which replaces floppy drive B, the XT and PC look the same. There are three units: a flat systems box or "pancake" containing the drives, a screen and a detached keyboard. All are tastefully finished in smart grey and cream. The pancake itself is very large compared to machines like the ACT Sirius, and takes up around one-third of a desk top.

The 11in. green screen gives a sharp, clear image. Both brightness and contrast can be adjusted by knobs on the front. Screen RAM is held on a plug-in driver card, so more than one screen — such as a colour and a monochrome screen — can easily be run at the same time, displaying different images.

The detached keyboard is flat, but has two legs on the back to raise it to a good typing angle. The two-tone colour scheme is carried through by having the alpha-numeric keys and the separate numeric keypad off-white, with the control and function keys in grey. The numeric keypad doubles as a cursor-control pad, making 83 keys in all.

The 10 function keys can be used with various Shift keys to provide 40 functions. Another useful key, obscurely labelled PrtSc, enables you to dump the screen contents straight to your printer.

Just how good IBM's keyboard is must be a matter of some debate. Ergonomically it is superb. For touch and key action it is in a class by itself: touch-typists will adore it. But — and it is a very big "but" — the keyboard has four keys which are so badly

IBM XT

Like it or not, IBM's micro is set to establish standards for the coming generation of business machines. In this second part of our review, Jack Schofield looks at the Basic and the keyboard we will all have to get used to.

placed they make typing a pain. They are Alt, \, / and Caps Lock. IBM has added a spurious Backslash key, \, between the Z and the left Shift key, so when you want to type a capital you get \\\生 thanks to the auto-repeat function.

A similar oblique key, /, appears between the full stop and the right Shift key. To reach either shift key you have to aim carefully and s-t-r-e-t-c-h your little finger, which reminds the touch-typist of refined tea-drinking sessions in Carshalton Beeches.

The Shift keys themselves are tapered down to standard key size, instead of being larger as they are on most typewriters. When you miss them, you inadvertently press Alt or Caps Lock. The latter gives a rEVERSE sHIFT eFFECT where intended caps and lower-case letters are interchanged.

Some people will not like the two ranks of function keys down the left side of the keyboard and would prefer them arranged in a single line along the top. Finally, while it is an advantage to have such a compact keyboard, it is so crowded it leaves little room for labelling.

If you are one of those people who, like me, thinks the standard keyboard has

already been produced, and can be found on the IBM Selectric typewriter, then you will be less than enraptured by the XT. If you use two fingers with a hunt-and-peck typing technique then it probably won't bother you much.

But if the layout bothers you a lot, the American firm Key Tronic has produced an alternative keyboard which cleans up the IBM's eccentricities. It also adds valuable LED indicators to the Caps Lock and Num Lock keys. The keyboard is available in the U.K. from Qubie Distributing at 01-870 8899.

IBM's keyboard does have its good points. It has n-key rollover, which means it recognises the order of keys pressed quickly, one after another, and released after an indeterminate period. The method it uses to do so is complicated but clever. The keyboard has its own Intel 8048 micro-processor. It does not deliver ASCII characters but scan codes, which the IBM's BIOS or basic input/output system translates into ASCII characters. It allows each key to be configured to produce any character, giving a completely soft keyboard.

Each key produces two scan codes, one when it is pressed and one when it is



Just how good IBM's keyboard is must be a matter of some debate. Ergonomically it is superb.

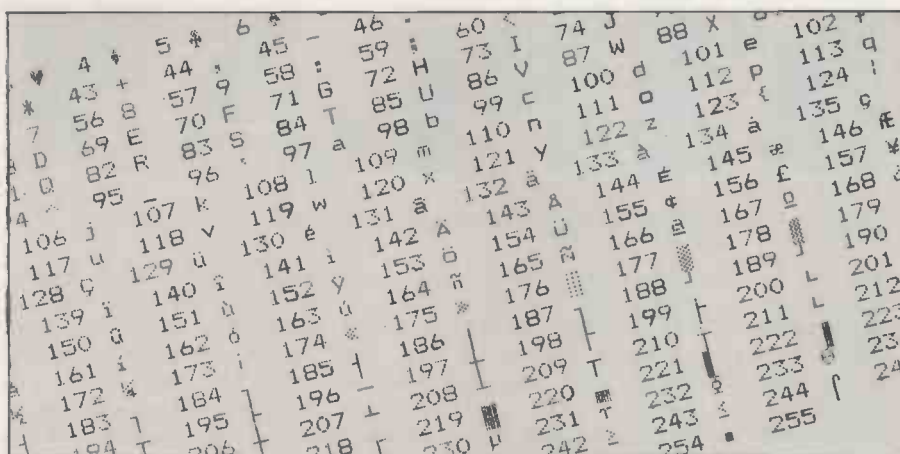

The character set includes some graphics and non-English characters.

released. They are stored in a sizeable buffer which holds at least 20 characters, so you can type ahead. The PC beeps when the buffer is full, but even the fastest typist will find that the keyboard correctly sorts everything entered without losing any characters.

When DOS is booted on the IBM PC a .Com file is used to set up the codes for a particular national keyboard arrangement. A file called Keybuk is used to configure the version for U.K. use. The first system boot allows the user to choose from several files. French, Spanish, Italian and German are among those available.

The IBM printer, which is a graphics version of the Epson MX-80 dot-matrix model, prints foreign character sets too. It must be an advantage for anyone with a thriving export business.

When programming in Basic, the keyboard is multi-functional. Alphanumeric characters — both upper- and lower-case letters and numbers — are produced using the standard keys and shift keys. There are two other distinct modes, produced by pressing the Control and Alternate keys, Ctrl and Alt, along with the alphanumeric ones.

The Ctrl set produces a wide range of graphics characters, mathematical symbols and foreign letters, plus a number of useful functions. Ctrl-H gives the expected delete and backspace, while Ctrl-[deletes a whole line. Ctrl-K homes the cursor while Ctrl-L also clears the screen. Ctrl-G gives a beep.

The Alt key provides for single-key entry of reserved words in Basic. It applies to all the alphabet keys except Q, Y, J and Z. Pressing Alt with each of the other 22 produces a reserved word which starts with that letter. For example, Alt-C produces the word Color, Alt-E gives Else, Alt-P gives Print, and so on.

Other reserved words are dedicated to the easily programmable function keys. Neither of these optional modes is marked on the keyboard, so the system is not easy to exploit at first. Many people seem to have failed even to notice their existence, but they are very handy once you are used to them.

Basic on the IBM PC and XT comes in

three varieties: on ROM, as Disc Basic and as Advanced Disc Basic or Basica for short. All are standard Microsoft types, the smaller ones being subsets of the larger. The disc Basics appear to load only the extra code for disc operation and graphics, which are called by an interrupt system from the existing Basic ROM. This method makes for speed and consistency and it is economical of memory.

The ROM Basic itself — which IBM calls cassette Basic — leaves over 60K free. It is reasonable to complain that Microsoft ought to rewrite its Basics so that they access some of the rest of the RAM in the machine. However, a standard eight-bit micro running CP/M provides only 60K of RAM in which you have to fit the Basic itself and programs and data, so even the present state of affairs is something of an advance. Loading the Disc Basic into the XT leaves 61,330 bytes or 59.9K free. Loading Basica leaves 60,865 or 59.4K free, notwithstanding the 256K of RAM chips inside the machine reviewed.

Basica is by now becoming familiar, as in one version or another — such as GW or Gee Whizz Basic — it appears on virtually all the machines which run MS-DOS, the Microsoft original from which PC-DOS is derived. It is not a small language by Basic standards. There is the 40K in the ROM, plus about 17K loaded from disc. As you would expect, it contains a large number of commands though not all of them are very useful. Yet it does not give the feeling of power you get from some smaller versions of Basic such as the excellent Acorn BBC Basic, of around 16K, or even the 8K Atari Basic.

Nonetheless it contains most of the commands you could want. For programmers, the Basic provides auto line numbering, Renum, Merge, Chain and the tracing functions TrOn and TrOff. For structured programming there is For-To-Step, If-Then-Else and While-Wend. For sound and graphics there is Beep, Circle, Color, Draw, Line, Locate, Preset, PSet, Paint and Sound.

Inp reads an eight-bit value from a port, and Pen reads a light-pen. Strig reads a joystick button. As well as Hex\$ for

hexadecimal conversion, there is Oct\$ for people with eight fingers. There are all the usual trig functions, as well as user-defined functions.

Among the less usual functions on Basica, Fix truncates to an integer value, Lof returns amount of space in a file, LPos returns the carriage position of the printer and MKI\$ makes an integer into a string. LSet and RSet left-justify and right-justify a string within a field. You can live a long time without having to use many of these more exotic functions, but no doubt someone will find interesting things to do with them. Unfortunately the Basic still does not check syntax on line entry.

To handle the well known rounding errors which result from doing arithmetic in binary there are various functions to manipulate numbers. CDbI converts to double precision, CInt rounds to the nearest integer and CSng converts to single precision.

It is now widely appreciated that Basica running under PC-DOS is not a fast language. The only advantage the IBM has here is the hardware-divide instruction of the 8088 microprocessor. Otherwise any 4MHz Z-80 eight-bit computer ought to be faster than the IBM, and the BBC Micro leaves it gasping even boring old 6502.

One great advantage of Basica is that it is extremely well documented in one of the dwarf IBM manuals. If its page-by-page instruction-by-instruction format is unpalatable, however, there are dozens of books on IBM Basic and several tutorials with discs to provide alternatives.

Another great advantage of Basica is that it now looks likely to become the *de facto* standard in its field of small business microcomputers. This has obvious benefits from the point of view of program portability. It is also in the best interests of the individual user to learn a language that appears in fundamentally the same form across a wide range of machines. In the long term it should prove more useful than learning a machine-specific language which, if the chosen machine fails to achieve worldwide success, can easily become a ghetto.

The same applies equally to the keyboard. Like the operating system and the language, IBM's keyboard — notwithstanding its faults — looks like setting the standard for some years to come. Those of us who complain now perhaps do so because we learned to type on IBM's classic typewriters. The next generation of people, learning their keyboard skills on a microcomputer, may decide that IBM made the right choice.

At the moment, it is sufficient to observe that the IBM PC, and the XT version reviewed, set the standard in terms of both features and price against which all other micros must be judged. In the third and final part of this review, in the October issue, we will explore the benefits of the hard-disc option provided by the XT. □

MULTIPLAN

As a straightforward spreadsheet this one is hard to beat, says Jack Schofield

THERE IS NOW quite a range of spreadsheet packages for the IBM PC, including the original VisiCalc, and several packages which offer more. Both MBA from Context Management Systems and Lotus's 123 offer graphing capabilities as well as spreadsheet calculations, while Knowledgeman adds quite a reasonable database. But for someone who just wants a spreadsheet Multiplan is hard to beat.

Multiplan is a Microsoft product, and runs under MS-DOS version 1 or 2. Once installed using the installation disc which is supplied with it, Multiplan is very easy to load. Place the disc in drive A, type MP in response to the A> prompt, and there you are. Running it from a hard disc, it boots almost instantaneously.

Multiplan presents a conventional spreadsheet format, except that it has numbers both across and down so the home cell is not A1 but R1C1. It can lead to minor confusions between columns and rows. The maximum size of the spreadsheet is 255 rows by 63 columns.

Multiplan is run from the bottom of the screen instead of the top like VisiCalc. Across the bottom is a range of options such as Alpha, Copy, Transfer and Quit. Each one begins with a unique letter, so there are two ways to call commands. Either you can position the cursor over the one you want then press Return, or you simply type the first letter of what you want.

As Multiplan is a user-friendly program you can enter numbers directly, without having to press V for value first. The user-friendliness shows as you step through the options. Most choices from the main command line lead to sub-lines which offer further choices:

Load Save Clear Delete Options Rename

with the cursor positioned over Load, the one you are likely to want, so you can select it just by typing Return. The commands are arranged in order of decreasing usefulness, not alphabetically.

To Save you just press Space to move the cursor one step along, then Return. Alternatively you can press S. Multiplan then gives your file the name Temp, and invites you to change it for something meaningful. If your file already has a name, Multiplan supplies it in the command line so you only have to select Return to save to it, and so on. The whole command structure is extremely well thought out.

When it comes to the Copy command, which is Multiplan's Replicate function, again it remembers what you did last.

Suppose you copy a cell to the right for 11 cells. At each subsequent command Multiplan then offers 11 as a default value until you change it. You can do a considerable amount of work just by entering Return.

The bottom two lines of the screen carry the message line and the status line. The message line tells you what to do next, such as

Enter a filename

or

Enter Y to confirm

The status line tells you where you are, such as R6C2, and it tells you what the current content of the cell is, such as a number or a label or a formula. Next it says how much free workspace you have, and finally the name of the worksheet you are in.

If you get stuck pressing H produces copious Help information. It is quite possible to run Multiplan with only occasional reference made to the documentation.

One of the trickier aspects of Multiplan — at least until you are used to it — is entering formulae. It is done by using the cursor to step through the cells to be related, then pressing the appropriate arithmetic keys. The result is a formula such as

$$R[-4]C + R[-3]C + R[-2]C$$

that is, a relative formula. The cell specifications are entered automatically by moving the cursor. Absolute formulae can be entered in the form

$$R3C2 + R4C2 * R5C2$$

and so on. Once a formula is entered, the resulting value is calculated automatically, unless you turn off the Recalc function.

Multiplan allows you to use names — not be confused with titles — instead of cell addresses. Thus R3C1 could be defined as Sales and used in a formula such as

$$\text{Profits} = \text{Sales} - \text{Costs}$$

The Goto option allows you to Goto a name as well as a cell. Other facilities include iteration, multiple windows, locked cells, insert and delete rows and columns, and block moves. Sorting is quick and simple.

One of the most interesting options is the Format command, which is used for setting column widths and much more. Multiplan normally sets text ranged left, and numbers ranged right. Format allows cell contents to be ranged left, right or centred. Other possibilities are Cont, Exp, Fix, Int, \$, * and %.

Built-in functions include Abs, And,

Atan, Average, Column, Cos, Count, False, If, Index, Iserror, Isna, Len, Ln, Log10, Lookup, Max, Mid, Min, Mod, NA, Not, NPV, Or, Pi, Rept, Round, Row, Sign, Sin, Sqrt, Stdev, Sum, Tan and True. The identity of most of them is obvious: Ln is natural logarithms. NPV is net present value.

NA stands for Not Available and is an extremely useful function. If you assign NA(X) to factor X, say the interest rate, then all the values in the sheet that depend on it also change to N/A. This enables you to see where you are without stepping through all the cells to trace out their relationships. External, selected by X at the main command line, allows sheets to be consolidated.

The Print command allows sheets to be printed to a disc file, rather than saved. They can then be reloaded into a suitable word processor. It is possible to print part of a sheet, to control margins, etc., to suppress axes, or to print formulae instead of values. Empty columns are not printed. Multiplan automatically prints wide sheets to line up on a series of pages.

The Multiplan documentation contains both tutorial and reference material, and an index. It is extremely good. An appendix of notes for the VisiCalc user gives reference tables of Multiplan functions and commands and the VisiCalc equivalents, where applicable.

The current documentation is for a range of machines including the Compaq, Zenith, Texas Instruments Professional and DEC Rainbow. Some of these firms, and many others including Wang and Dynaloc, supply versions of Multiplan with their own documentation. IBM is reportedly doing the same with Multiplan at the moment. The current version does use the IBM PC function keys, though this kind of program really makes function keys almost irrelevant.

Conclusions

- Multiplan is a first-rate spreadsheet program with no obvious flaws or limitations. Minor quibbles are the R1C1 type of cell identification, and the lack of a graphics facility.

- The supplier is Microsoft of Piper House, Hatch Lane, Windsor, Berkshire SL4 2QT. The standard version costs £183 plus VAT.

- A version of Multiplan tailored to the U.K., including a £ sign and rewritten manual, is available now for the Apple and imminently for MS-DOS micros such as the IBM PC. 

SuperStar



**LIBERATES THE CP/M
USER AND PROVIDES
FULL MULTI-USER
CAPABILITY**

**EACH USER
RUNNING STANDARD
CP/M 2.2 OR CP/M 86 WITH
ZERO CPU DEGRADATION**

Upgrade package
is available for:
North Star Horizon -
Comart
Communicator -
Vector Graphics
and other
S100 systems

The revolutionary SuperStar is the only system allowing total integration of powerful 16 bit 8086 processors with the more standard Z80 user processors. The system may be configured in any 8 bit/16 bit combination, or as a totally exclusive 16 bit system to provide the ultimate in performance and flexibility in advanced micro systems.

DESK TOP COMPUTER PACKED WITH:

* PROCESSING POWER

Up to 16 users each with his own private processor card which contains either Z80A, 64KBytes or 8086, 128KBytes, console and a second serial port. More power and faster processing time is offered through a 16 bit private processor card based on 8086 CPU and 128KByte expandable to 1 MByte. The system automatically loads CPM 86 to the 16 bit private processors.

* STORAGE

Integral 5.25" Winchester Disk with up to 20 MByte capacity and integral 5.25" Floppy Disk with up to 800 KByte capacity. Optional - 14 MByte cartridge tape back-up unit, up to 80 MByte Winchester Disk Unit.

* HIGH PERFORMANCE

Unlike single CPU multi-user systems (e.g. MP/M, MVT/FAMOS, OASIS, etc.) where system throughput degrades as additional users are added, SuperStar has no CPU degradation at all. Each user has its own private processor, memory and console I/O running at 4MHz with Z80A and 5MHz with 8086 processors.

* PRINTER INTERFACE

1 serial and 1 parallel printer ports shared by all users. Optional private printer for each user is readily available via a second serial port. The second serial port can be programmed for communications etc.

* SYSTEM SOFTWARE

Each user processor runs its own dedicated copy of the industry standard CP/M 2.2 or CP/M 86 depending upon which processor is being used. Shared resources (Disks and Systems Printers) are controlled by DPC/OS which supports file/record locking, print spooling, multiple printers and interprocessor communications. Languages available: BASIC, COBOL, PASCAL, FORTRAN, PL/1 APL.

* APPLICATIONS SOFTWARE

Word Processing, Sales, Purchase, Nominal Ledgers, Payroll, Order Processing/Invoicing, Stock Management, Job Costing, Mailing System, and many specialised fields e.g. Bookmaking, Insurance Brokers, Property Management, etc.

* LOW COST (FROM £1750) AND EXPANDABLE (AS YOUR NEEDS GROW)

SuperStar starts at £1750 for a single user system with 2 Quad density floppies and is field upgradable to a hard-disk system of up to 80 MByte capacity. Also by simply adding a private processor card for each user the system can be configured into a multi-user system as and when required.

The 16 bit Processor is fully compatible with the standard SuperStar multi-processor system permitting efficient upgrading as future needs develop without sacrificing any of your extensive hardware and software investment.

SuperStar



must be the most powerful and versatile, yet low cost, multi-user system presently available. It combines the power of up to 16 Central Processors with the economy of mass produced S100 peripheral handling hardware. This combination, together with the world's most popular operating system gives you an unprecedented "performance-per-pound spent" rating. It eliminates the usual constraints of a single-user system. Word Processing, Sales, Purchase and Nominal Ledger Accounting and Stock Control can happen simultaneously.

BROMCOM

Bromley Computer Consultancy Ltd

• Circle No. 151

417/421 Bromley Road, Bromley, Kent, BR1 4PJ. Telephone: 01-697 8933 Telex: 896691

NOW!

The Cossor Fast Repair Service covers the latest Sprint Printers

Cossor Electronics is well established as a National Service Agent for the Sprint 3 and 5 range of printers. Now the Qume Corporation has extended our agreement to include their latest range - the Sprint 7* and Sprint 9*.

Our world-wide reputation for high quality electronic products means that we can offer an unrivalled test and repair service. We work to the highest standards (MOD Defence Standard 0521) and we have insurance cover for the time your equipment is in our hands. So, ours is a service you can trust.

Just as important, our service is fast. Normally we turn around PCB's within seven working days from receipt, but in emergencies we aim to repair a single board within 48 hours.

If you own a Sprint 3, 5, 7* or 9* printer and you want to discuss service, just telephone Henry Lassman on Harlow (0279) 26862. We know we can help.

Cossor Electronics Limited, Service Division,
The Pinnacles, Elizabeth Way,
Harlow, Essex CM19 5BB.

(*RO version)

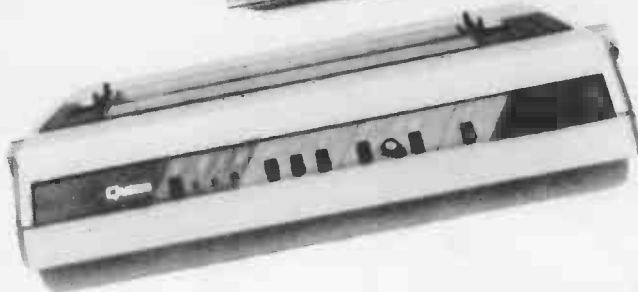
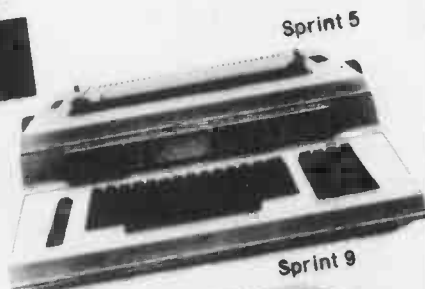

CE 447

COSSOR
electronics

Thinking for tomorrow

Qume[U.K.]
AUTHORISED
SERVICE AGENT

● Circle No. 168

Work on your own where you're not alone

A place where you can set up alone or start a business or open a branch office and not have to worry about who answers the phone when you're out.

Small office and workshop units with a comprehensive range of services and facilities including cleaning, heating, lighting, telephone/reception, rates, meeting rooms, restaurant, secretarial, accounting.

BARLEY MOW WORKSPACE

Units from 100 sq. ft.
at £28.00 p.w. inclusive.

Call in, phone or write: Barley Mow Workspace,
10 Barley Mow Passage, Chiswick, London W4 4PH.
Telephone 01-994 6477.

● Circle No. 169

WANT TO KNOW ABOUT BUFFERS?
ASK A>LINE

BUFFERS

add high-speed memory to your system and cut print processing time

A>Line sell and specialise in buffers
...for EPSON & IBM PC Matrix Printers
...for APPLE II & APPLE III Computers
...for virtually every micro-computer
and printer configuration. For example:

- Plug-in buffers for EPSON & IBM PC printers
—E/BUFFER, UK made + 2 year guarantee, 2K (Serial only) £65 + VAT, total £74.75; 16K serial or parallel, £95 + VAT, total £109.25; 32K serial or parallel, £135 + VAT, total £155.25.5.

Dealer and quantity discounts available on application.

- MICROBUFFER 8K serial/16K parallel, ex stock £125 + VAT, total £143.75 post free.

- SPRINTER in-line buffer, fully configurable for any combination of IEEE 488 (PET)/RS232C/Centronics parallel input and output, in 2K, 4K, 8K, 16K, 32K versions.

- GRAM, ACULAB, ACG, ORANGE MICRO, WESPER, INTERACTIVE STRUCTURES, etc. send for latest catalogue and price list.

A>Line Computer Systems

1 Church Farm Lane,
Willoughby, Waterleys,
Leicester LE8 3UD
Tel. 0537-58486

PLEASE NOTE OUR NEW ADDRESS

● Circle No. 260

PRACTICAL COMPUTING September 1983

EuroCUBE 6502/6809—EuroBEEB—BEEBEX

The expanding range of CUBE control boards

BBC BASIC
now on
Eurocard

EuroCUBE is just one small 100x160mm Eurocard—but it is a single-board computer of exceptional power and versatility.

- 6809 or 6502 Microprocessors available.
- Four memory sockets, each 28 pin. Supports RAM, ROM, EPROM—from 2KB to 32KB each.
- Battery Back-up for CMOS RAM
- Dual CPU clock mode—2 MHz for memory, 1 MHz for i/o
- VIA provides 20 digital i/o channels.
- ACIA provides a bi-directional RS-232/423/422 serial port.
- On-board programmable baud-rate generator.
- PROM address decoding.
- Machine Operating System included free of charge.

EuroBEEB—EuroCUBE with BBC BASIC—The MOS included on EuroCUBE, provides an environment in which languages can be run, and is available in two main versions:

- MOS A — supports ATOM BASIC
- MOS B — supports BBC BASIC

EuroCUBE fitted with MOS B can run BBC BASIC. In its simplest form, with 4KB RAM fitted for work space, a BBC BASIC program in EPROM could control the two 8-bit ports and the serial interface, in addition to any other cards connected to the CUBE expansion bus.

BEEBEX, another recent addition to the CUBE range, is a simple, low-cost Eurocard which interfaces to the 1 MHz bus connection on the BBC Microcomputer, enabling it to communicate with the entire range of CUBE/Acom Eurocards.

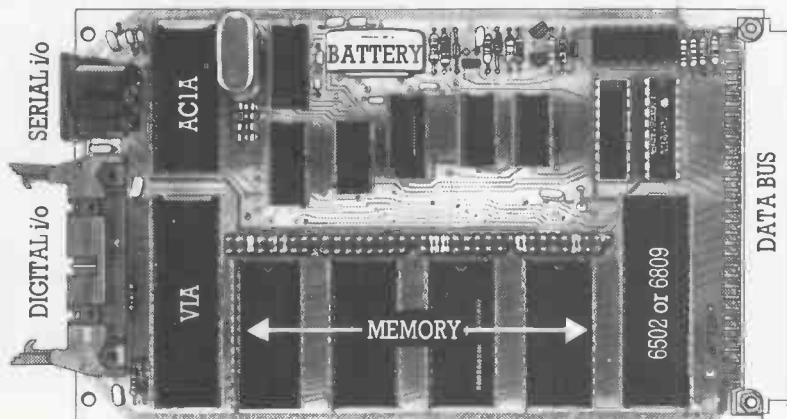

EuroCUBE £ 139.00

One-off price excluding VAT
No charge for Operating System Software

Control Universal's new 150 page catalogue and technical overview is now available free of charge. Explanatory leaflets are also available on the CUBE range, and on our Eurocard extensions to the BBC Microcomputer.

CUBE RANGE

includes video, analog & digital
i/o, prom programming, disks, etc.



Unit 2, Andersons Court,
Newnham Road, Cambridge CB3 9EZ
Telephone (0223) 358757
Telex 995801-G (C13)

● Circle No. 201

BOXED CLEVER

Meet the new Datic 510 40-column boxed printer. It's a desk-top unit that's high in quality, performance and speed.

Yet it's low in cost.

Based on the successful and reliable 505 series, it prints 40 characters per line in red and black (5 x 7 matrix) on 70mm wide paper at 1.2 lines per second. And standard interface boards are available for parallel and serial operation.

This is the Datic 510. An example of very clever boxing with your printing needs in mind.

DATAAC

Head Office: Tudor Road, Altrincham, Cheshire WA14 5TN. Tel: 061 941 2361

● Circle No. 172

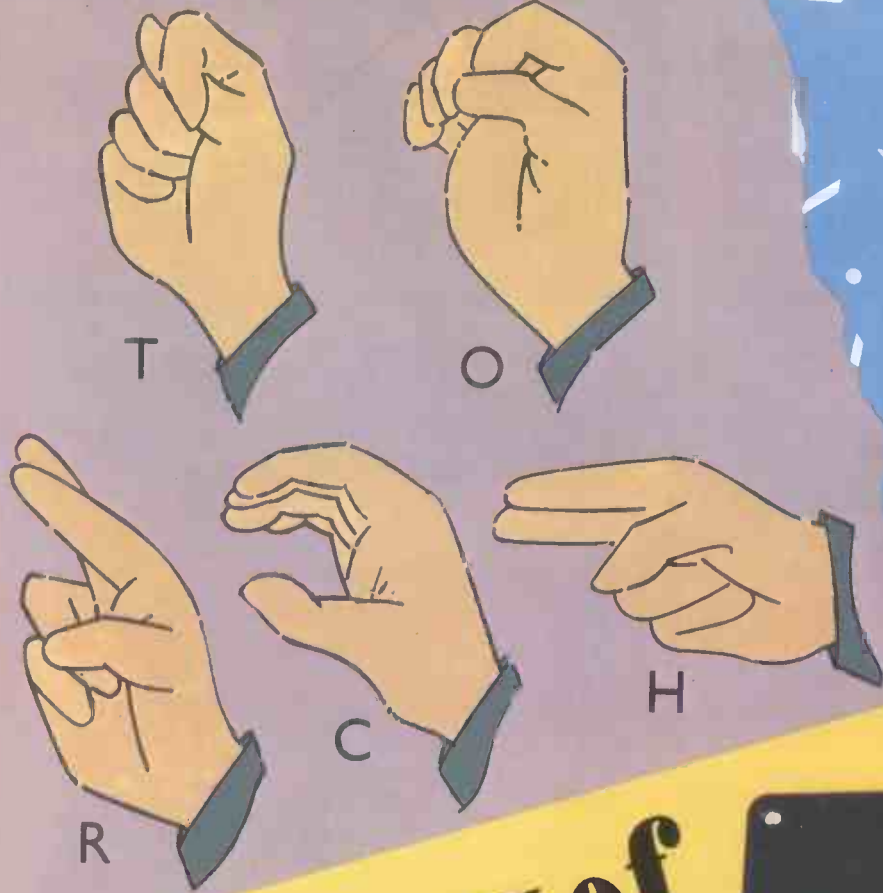

A History of



We would like to pay tribute to our predecessors in the communications business – smoke signal, semaphore, pigeon, postman and telephone, inter-office memo and management report. They have all served nobly in their own time, and each has handed on the torch.

Today, the demand is for faster and better communications – more accurate and more immediate data transfer from office to office and from country to country.

In 1982 TORCH's Electronic Mail system set new standards in data transmission from computer to computer. We launched the first micro to be approved by British Telecom for direct connection to the Public Switched Telephone Network, via its own, unique built-in modem.

Now a new generation of TORCH communications, backed by the resources of GEC, Britain's largest and most successful trading company, can help your business to be more efficient and faster to respond.

TORCHNET advanced Local Area Networking is a cost-effective means of linking together up to 254 TORCH microcomputers, to share expensive resources and permit fast, error-free information transfer from point to point. It is fully integrated with TORCHMAIL, security-conscious and extremely reliable.

TORCHMAIL PLUS is a dramatically enhanced version of TORCH's interactive Electronic Mail service, providing timed event management, command files, total system security and local file operations.

We do not intend to follow smoke signals and carrier pigeons into the history books. As high-speed communications become more and more important to industry and commerce, our commitment to continual improvement will ensure that TORCH communications will meet the changing needs of business across the world.

TORCH
COMPUTERS
Perfectly Made in Britain





Communications

Part 1.





A History of Management Part 1.

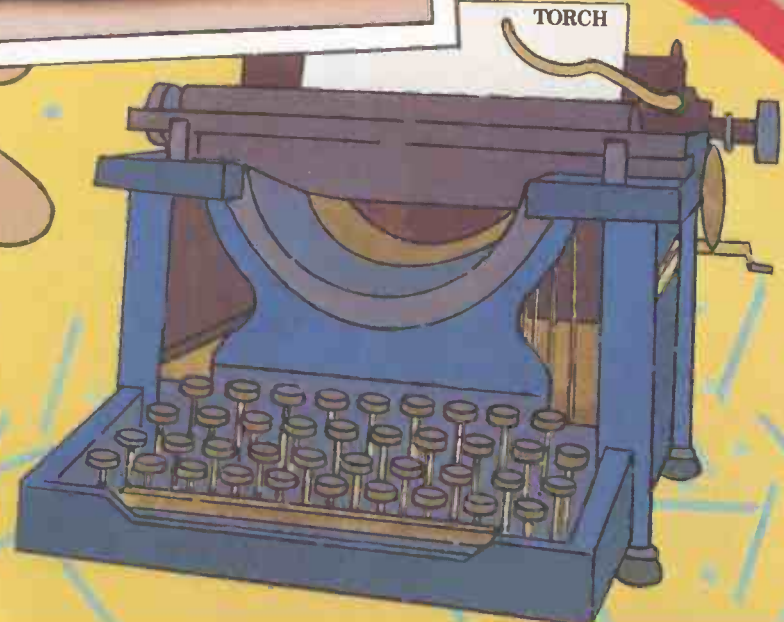
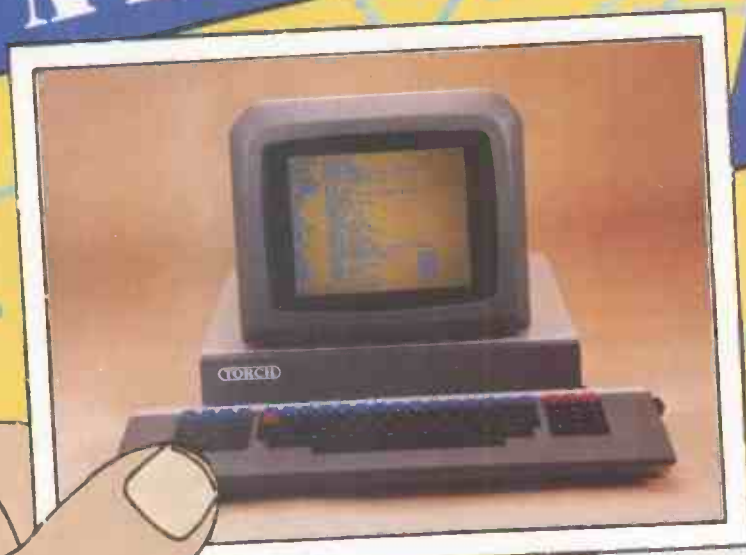



Before we designed our expanded range of business microcomputers, we took a close look into the past – from stone tablets to electric typewriter. Never before have the demands of the businessman been so formidable. Today's manager requires total control over every aspect of his operations – instant information, worldwide communications, immediate response to changes in financial and trading conditions. He needs a total business management system.

At TORCH, we sell realities not prophecies, and today's reality is a range of hardware and software versatile enough and powerful enough to meet the demands of every business from a compact single-user system up to hundreds of networked machines providing massive processing power for a multi-national corporation.

In 1982, we revolutionised computing with the first fully communicating business micros – our highly acclaimed C-Series models. Our Z80 Disc Pack proved the most effective upgrade for the BBC Model B micro, providing twin 400K disc-drives and a Z80 processor.

We celebrated American Independence Day this year, by giving every British businessman the right to be independent of imported micro technology with our new 700-Series and 300-Series machines. Our 700 models incorporate a third processor – the Motorola 68000 with 288k RAM and able to run under full UNIX SYSTEM 3. Our 300-Series machines are intelligent workstations to utilise TORCHNET Local Area Networking.

We've come a long way from papyrus and quill pens. The TORCH microcomputer system can replace your typewriters and your filing cabinets, your ledgers and your telephones – not to mention your ageing uncommunicative computers. Today, backed by GEC, Britain's largest and most successful trading company, TORCH offers the next step in business management. Welcome to the future.

TORCH
COMPUTERS 
Perfectly Made in Britain

Torch Dealer

Network Service

MICROSOURCE

MICROSOURCE LIMITED

Lyons House, 9 New Road,
Rochester, Kent MB1 1BG, England.
Telephone: 0634 814931.

BT GOLD TOR015

CONTACT RUSSELL LYONS

SPECIALISTS IN FINANCIAL, ACCOUNTING AND LEGAL SYSTEMS

**TELEMATICS
WEST**

31 Dyer Street, Cirencester, Glos GL7 2PP

CONTACT: RICHARD THOMPSON (0285) 68349

QMP

Quality Micro Products Limited

Victoria Buildings,
46 Grainger Street,
Newcastle Upon Tyne NE1 5JG
Tel: (0632) 614646

CONTACT:
STEVE NEWCOMBE

COMMISCO

COMPUTER SYSTEMS & COMMUNICATIONS CONSULTANTS

30 Gordon Street Glasgow G1 3PU Tel: 041 226 4878

Fax No: 041-2210710 Telex: 776195 Reply 'Nortelx'

C.S.S.

Computer Services (Scotland) Ltd,
89-90 Westlaw Place
Whitehill Industrial, Glenrothes
Fife KY6 2RZ
Telephone: 0592 773710
CONTACT: WALTER BARR

MBS

MBS Personal Computers Ltd

119/120 High Street Eton, Windsor, Berkshire SL4 6AN

Contact: Ian Hill

Telephone: 07535 68171

MODERN BUSINESS TECHNOLOGY

PO Box 87, Guildford, Surrey.
Telephone: 04868 23956

CONTACT: MICHAEL BRANSON

APL Specialists

MBS

MBS Personal Computers Ltd

119/120 High Street Eton, Windsor, Berkshire SL4 6AN

Contact: Alan Postlethwaite

Telephone: 07535 68171

Typestyle Ltd

1 Avondale Court, Onchan, I.O.M.

Telephone: 0624 24650

CONTACT: Dave Footitt

MBS

MBS Personal Computers Ltd

119/120 High Street, Eton, Windsor, Berkshire SL4 6AN

Contact: Andy Gower

Telephone: 07535 68171

MURCOTTS

Microcomputer Dept.
Great Central Road
Loughborough
Leics LE11 1RP

Telephone: Loughborough
(0509) 214444
Established 1932

CONTACT: PAUL HOPPER AND JIM MURCOTT



Metrotel Viewdata Systems Ltd
6 High Street, Ruislip
Middlesex HA4 7AP
Telephone: Ruislip (08956) 77071
CONTACT: GRAHAM G. HAWKER

ADACS

41 London Street, Andover, Hants
Telephone: 0264 52187

CONTACT: DAVE CROSS

Intercompany Communications Technology Limited

Specialists in Financial Software
Offices in London, New York and Sydney
We can supply extensive support facilities.

For full details and a demonstration of this revolutionary machine, ring
Peter Mills at INTERCOMPANY COMMUNICATIONS TECHNOLOGY
76 Cannon Street, London EC4 Tel: 01-248 8895



Show Office CCE Europe Ltd
Creswicke House,
11, Small Street,
Bristol, Avon BS1 1DB.
Tel: (0272) 215226/7
CONTACT DAVID STEADMAN

LENDAC DATA SYSTEMS LTD

8 Dawson Street, Dublin 2
Telephone 01710226/01710796

CONTACT: DON LEHANE



Trigon Complete Office Service Ltd Computer Division
98 Victoria Road, LONDON NW10 6NB
Telephone: 01-961 1466

BITS & BYTES

44 Fore Street
Ilfracombe
DEVON

0271 62801

Contact: Mr. Altass

OFF RECORDS..

Computer House
58 Battersea Rise
Clapham Junction
LONDON SW11 1HH

01-223 7730



Herald Computers Ltd.
incorporating WordPerfect
Computer Services

93 East Road, Cambridge
Telephone: 0223 315662

INTERNATIONAL COMPUTERS EQUIPMENT NETWORKING

FREE
ACCENT ON
EXCELLENCE



ICEN LIMITED



ICEN LTD
MAPLECROFT HOUSE, LOWBOURNE, MELKSHAM, WILTS
0225-707575



ICEN LTD offer national maintenance cover and this month include it
FREE for one year with each Torch and Printer, a substantial saving.
Why wait? Phone us now for full details and a demonstration



MBS Personal Computers Ltd
119/120 High Street, Eton, Windsor, Berkshire SL4 6AN
Contact: Jim Duffy
Telephone 07535 68171



MBS Personal Computers Ltd
119/120 High Street, Eton, Windsor, Berkshire SL4 6AN
Contact: Tim Beard
Telephone: 07535 68171



MBS Personal Computers Ltd
119/120 High Street, Eton, Windsor, Berkshire SL4 6AN
Contact: Jonathon Woolf
Telephone: 07535 68171

CAVENDISH GRAPHICS

6, Eltham Road, London S.E.12
Telephone: 01-462 2173

CONTACT: PETER G SMUTS

COMPLETE
PROFESSIONAL
SERVICE



Brainstorm
Computer
Solutions

103A Seven Sisters Road
London N7 7QN
Telephone 01-263 6926

Contact:
CHARLES LIASIDES

Directors
CV Liasides DipM MInstM
V Vasiliou

COMMSCOT

COMPUTER SYSTEMS
& COMMUNICATIONS
CONSULTANTS

Bureau Computers Software Packages WordProcessors
Prestel Telex

SCOTLAND'S FIRST DEALER

30 Gordon Street Glasgow G1 3PU Tel: 041 226 4878
Fax No: 041-2210710 Telex: 776195 Reply Nortelx

KINGSTON COMPUTER CENTRE
59 SURBITON RD.
KINGSTON UPON THAMES
SURREY

Telephone: 01-549 9416
Contact Mr. Whitlock

S.I.R. COMPUTERS LTD
91 RICHARDS ROAD
CARDIFF

Telephone: 0222 21341
Contact Colin Creasey

ELTEC COMPUTERS

217 Munningham Lane
Bradford
W. YORKS

Contact:
Colin M. Wormald

0274 722512

SYSGO LTD
HAWKE HOUSE
GREEN STREET
SUNBURY ON THAMES
MIDDLESEX
TW16 6RA

Telephone: 09327 89571
Contact Miran Bonaca



SBS Ltd.
42 OLD STREET
LONDON EC1
Telephone 01-250 0178
Contact Mike Williams

Computer Village
for
Torch Business Computer Systems
Unit 14, Halesfield 18
Telford TF7 4QT
Tel: (0952) 584910

BRADFORD OFFICE SUPPLIES CO. LTD
COLONIAL BUILDINGS
139 SUNBRIDGE ROAD
BRADFORD
W. YORKS
Telephone: 0274 726783
Contact Richard Duffey

MICRO CORE LTD.
5 BROOMFIELD ROAD
CHELMSFORD
ESSEX
Telephone: 0245 64230
Contact G. Rose

TORCH IN WALES

- * Advice on programming and applications.
- * Full engineering backup.
- * Training facilities.



From the professionals:

BUCON LIMITED
18 MANSEL STREET
SWANSEA SA1 5SG

Tel. (0792) 467980

VIXON COMPUTER SYSTEMS
49 GRIMSBY ROAD
CLEETHORPES
SOUTH HUMBERSIDE
DN35 7AQ

Telephone: 0472 58561
Contact: Mr David Hayzen-Smith



PRESTEDGE CONSULTANTS LTD.

3 Cecil Square, Margate, KENT CT9 1BD
Telephones: Thanet (0843) 295616 & 32616
Telex 96223 Answerback stnhsi G

TYPOS SYSTEMS LIMITED

SPACEREGAL CENTRE
COLN ESTATE
COLNBROOK
BUCKINGHAMSHIRE
0281 2-3753 TELEX: 848970
Specialists in LAN and IBM Mainframe
Communications

MICROFACTOR COMPUTERLAND LTD.

For all your TORCH requirements consult the
North's PREMIER TORCH DEALERS.

Contact: Roger Carrington or John Hinchliffe on
061-928-1228 or 061-928-3233

1 DUNHAM ROAD, ALTRINCHAM, CHESHIRE

THE Northern Computer Fair

Personal computers
Home computing
Small business systems

Sponsored by:

Practical
Computing

and

YOUR
COMPUTER

The right place The right time

Following the overwhelming success of the 1982 Northern Computer Fair, the sponsors announce that an even bigger and better show will be held again this year at Belle Vue, Manchester, from November 24th-26th.

This is the North's premier exhibition for the rapidly expanding home and small business computer market, mounted at a time now recognised as a peak buying period for this type of equipment. It is now one of a nationwide series of exhibitions designed to attract the broadest possible cross-section of both home computer enthusiasts and the rapidly increasing body of personal computer users found throughout business and the professions.

Make a date for Belle Vue, Manchester, November 24-26, 1983, and post the coupon below for more details.

Belle Vue, Manchester. November 24-26, 1983.

THE Northern Computer Fair

Personal computers
Home computing
Small business systems

I am interested in exhibiting.

Name _____

Position _____

Company _____

Address _____

Telephone _____

The Exhibition Manager, Northern Computer Fair, Reed Exhibitions Limited, Surrey House, 1 Throwley Way, Sutton, Surrey SM1 4QQ

at the sign of the
BIG 'M'

MICRO MANAGEMENT

LOW
BEST
prices
service

- Britain's No 1 range of products
- Check our UK dealer network for your nearest outlet
- After sales, speedy service from our own factory and engineers

It's our aim to provide satisfaction at the sign of the Big 'M'. By providing local distributors, best prices and service, we offer you the most. If you don't see it in our ad., ask your local distributor, or write to our Head Office for full list.

All prices include VAT.

All products normally in stock but to prevent a wasted journey phone your local dealer first before calling.

BBC:

HARDWARE

A full colour 32k ROM computer with 7 text and graphic modes up to 640 x 256 graphics and 80 column text screen, extended microsoft basic, built-in assembler, 1 MHz and tube interface, sideways ROM, RS423, A/D converter.

OVER 1000 SOFTWARE TITLES AVAILABLE FOR BBC SEND FOR LIST Micro Management, 16 Princes St, Ipswich

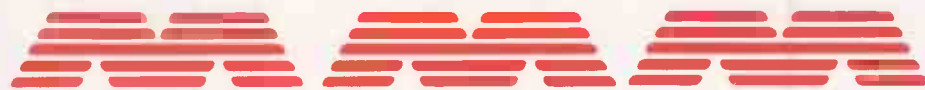

BBC Model B
 **PRICE £399**

BBC Model B+ Econet
 **PRICE £446**

BBC Model B+ Disk Interface (fitted)
 **PRICE £469**

BBC Model B+ Disk Interface+ Econet (fitted)
 **PRICE £516**

PROFESSIONAL WORD PROCESSING PACKAGE

BBC computer with disk interface, 100K disk drive, green screen monitor, daisy wheel printer, word processing ROM, complete with all cables, manuals, paper and formatting disk.

 **PRICE £1299**

BUGGIE
Ask for details



New
ELECTRON—
son of the BBC
 See it at our Stand at the Acorn User Exhibition and thereafter at selected dealers

32K single key entry, programmable cursor, external connections for RS423, A/D converter, printer port, 1 MHz/tube interface, sideways ROM, full typewriter keyboard, Func key, 7 text/graphics modes, 12 Acornsoft programs available.

THIS MONTH'S FEATURE:

PRICE
£199.95

100K DISK DRIVE

100K single disk drive with FREE formatting disk DFS instructions. Assembled at our UK factory, low power consumption, compatible with the BBC and most other British computers.

200K Single
Disk Drive

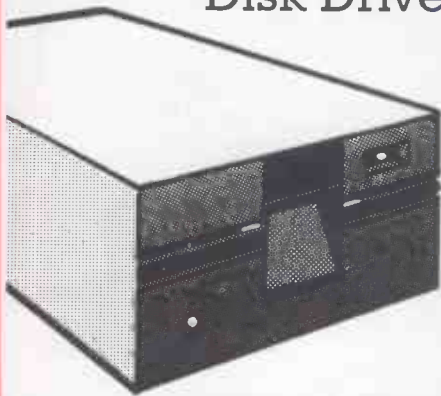

PRICE
£241.50

400K Single
Disk Drive

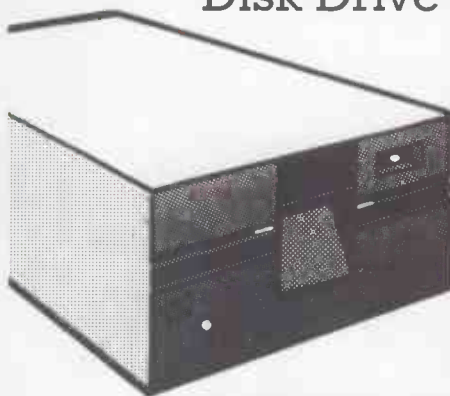

PRICE
£396.75

800K Dual
Disk Drive

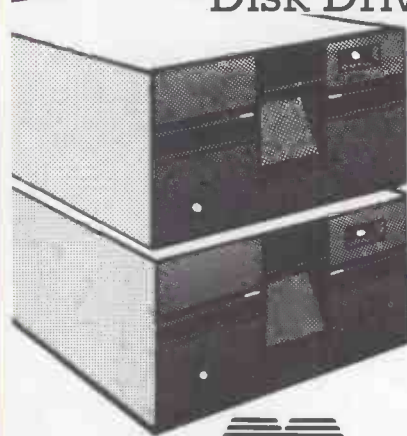

PRICE **£711.85**

ORIC

16-48K, colour, high resolution graphics 240 x 200, text 28 + 40, pre-programmed sound, user-defined keyboard/graphics, non touch-sensitive keyboard, microsoft type basic with powerful extensions, RGB/UHF, standard cassette interface, parallel printer output, several peripherals available, printers available, modems and PRESTEL (coming).

ORIC-1 48K
PRICE £139.95

ORIC-1 16K
PRICE & TELEPHONE

COMMODORE

COMMODORE 64-64K RAM, colour, sophisticated ROM/RAM user, full business applications, disk drives available, sound, UHF/composite video, proven basic language, exceptional value, high resolution graphics, many "add-ons" available, printers.

ORIC
SOFTWARE
SEND FOR
LIST

COMMODORE
SOFTWARE
SEND FOR
LIST

COMMODORE 64
PRICE £229.00

CASSETTE UNIT
PRICE £44.95

DISK DRIVE 1541
PRICE £229.00

PRINTER 1515
PRICE £230.00

JOYSTICK 1311
PRICE £7.50

PADDLES 1312
PRICE £13.50



SPECIAL OPPORTUNITY

£1 OFF
PURCHASES
OVER £20

Use this coupon to get even better value at your local Big 'M' distributor. Check our list for your nearest store.

£1 OFF

This coupon can be used at any official Micro Management distributor. The bearer is entitled to a £1 reduction on purchases over £20. Only one coupon per person can be redeemed.

Valid until 30 November 1983.

Micro Management, 16 Princes St, Ipswich.

PC

● Circle No. 154

DRAGON DRAGON 32

32K RAM, colour, extended basic, sound 5 octaves 255 tones, vast software range, typewriter keyboard, standard cassette drive, high resolution graphics, 256 x 192, text 16 + 32, looks like a British worldbeater.

PRICE £174.99

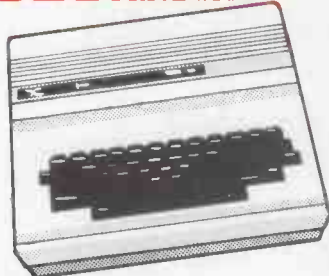

**DRAGON
SOFTWARE -
SEND FOR LIST**

SINCLAIR SPECTRUM

16K and 48K, basic, colour, text and graphics, vast range of software including education, printer, built-in speaker. You can build a very good system at a very good price.

**ZX SPECTRUM 48
PRICE £129.95**

**ZX SPECTRUM 16
PRICE £99.95**



ZX81

1K RAM, world's largest-selling computer, 16K expansion pack, masses of software, basic language, many expansions including keyboard/memory/printer, high resolution graphics.

PRICE £39.95

**16K RAM
PRICE £29.95**

**ZX PRINTERS
(NO PSO)
PRICE £39.95**

**SINCLAIR
SOFTWARE -
SEND FOR LIST**

JUPITER JUPITER ACE

3K RAM, the Forth specialist, basic coming, Forth language excellent, for serious educational and scientific purposes, standard cassette.

PRICE £69.95

64K RAM, colour, basic, almost "Apple compatible".

PRICE £201.25

**JOYSTICKS
PRICE £10.35**

**KEYBOARD
PRICE £44.85**



MICROPROFESSOR

64K RAM, colour, basic, almost "Apple compatible".

PRICE £201.25

**JOYSTICKS
PRICE £10.35**

**KEYBOARD
PRICE £44.85**



WORK STATION

Designed to take computer, disk drive, printer and paper. Robustly built for school, business or home use.

PRICE £138.00



LYNX

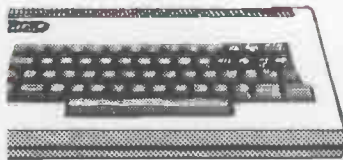

LYNX 48

48K standard, expandable to 192K, colour, 57 key typewriter keyboard, CP/M compatible, serial port, high resolution graphics 265 x 248, digital/analogue sound converter, RGB/UHF composite video, RS232C/parallel, cassette.

PRICE £224.99

COLOURGENIE

16K RAM, colour, full size keyboard, high resolution graphics, semi-compatible with TRS80.

**COMPUTER
PRICE £193.99**

**PRINTER
INTERFACE
PRICE £38.49**



**LYNX 96K
PRICE £299.00**

**JOYSTICK
INTERFACE
PRICE £13.95**

**SERIAL
INTERFACE
PRICE £3.99**

**CENTRONICS
INTERFACE
PRICE £49.95**

ATARI



16K/48K RAM, colour, basic, high resolution 320 x 192, excellent games machine from the video market leaders, text 24 + 40, serious software for education and business now available.

**ATARI 800
PRICE £299.95**

**ATARI 400
PRICE £149.95**

**ATARI DISK DRIVE
PRICE £299.00**

GIFT VOUCHERS

Want to buy a present but don't know exactly what to get?

Big 'M' Gift Vouchers are the answer, in £5, £10, £20 denominations. Available at your local Big 'M' dealer - check our list for your local store.



PRINTERS

- SEIKOSHA GP100
PRICE £214.99
- SEIKOSHA GP250
PRICE £276.00
- NEC PC 8023 (D/M)
PRICE £368.00
- EPSON MX100
PRICE £488.75
- EPSON RX-80
PRICE £339.25
- EPSON FX-80 160cps
PRICE £454.25
- SPARK JET PRINTER
PRICE £419.75
- SMITH CORONA D/WHEEL
PRICE £511.75
- TEC STARWRITER 40cps
PRICE £1265.00
- JUUK 6100 D/WHEEL
PRICE £458.85
- STAR 510
PRICE £332.35
- STAR MUP4 GRAPHICS
PRICE £171.35

MONITORS

- RGB COLOUR STD/RES
PRICE £287.50
- RGB COLOUR H/RES
PRICE £632.50
- 12" GREEN MONITOR
PRICE £95.52
- 12" AMBER MONITOR
PRICE £120.75



Think you're good enough to become a Big 'M' distributor? Full back up given. Write for details and application forms to

Steve Macfarlane
Micro Management
16 Princes St, Ipswich
Tel: (0473) 219461



MICRO MANAGEMENT

Head Office: 16 Princes St, Ipswich 0473 219461

AGENTS

- Abergele**
Abergele Computer Centre
8 Water St. 0745 826234
- Ballymoney**
Everyman Computers
Charlotte St. 02656 62116
- Birmingham**
The Software Centre
80 Hurst St, B5 021 622 2696
- Bodmin**
Microtest Ltd
18 Normandy Way 0208 3171
- Bridgend**
Automation Services
31 Wernlys Rd, Penyfa 0656 720959
- Bristol**
The Model Shop
65 Fairfax St. 0272 23744
- Bromley**
Datastore
6 Chatterton Rd. 01 460 8991
- Cambridge**
GCC (Cambridge) Ltd
66 High St, Sawston 0223 835330
- Chelmsford**
Essex Computer Centre
Moulsham St. 0245 358702
- Clacton-on-Sea**
Clacton Computer Centre
Pier Avenue 0255 422644
- Colchester**
Emprise Ltd
58 East St. 0206 865926
- Coventry**
Coventry Micro Centre
33 Far Gosford St. 0203 58942
- Gloucester**
The Model Shop
79 Northgate St. 0452 410693
- Great Yarmouth**
Criterion Computers
12 George St. 0493 53956
- Guildford**
The Model Shop
23 Swan Lane 0483 39115
- Hastings**
The Computer Centre
37 Robertson St. 0424 439190
- Hay-on-Wye**
The Playpen
Market St. 0497 820129
- Hemel Hempstead**
Faxminster
25 Market Square 0442 55044
- Holyhead**
P & K Computers
33 Williams St. 0407 50283
- Hull**
Computer Centre (Humberside)
26 Anlaby Rd. 0482 26297
- Ilfracombe**
Bits & Bytes
44 Fore St. 0271 62801
- Ipswich**
Micro Management
32 Princes St. 0473 59181
- Kingston-on-Thames**
Vision Store
3 Eden Walk 01 549 4900
- Lichfield**
Fosters
59 Tamworth St. 05432 22341
- Liverpool**
Beaver Radio
20/22 Whitechapel 051 709 9898
- London**
Computers of Wigmore St.
87 Wigmore St, W1 01 486 0373
- Percivals
85 High St North, East Ham, E6
01 472 8941
- Trend Video & Hi Fi
167 High St, E17 01 521 6146
- Northampton**
Richard Reeves
174 Kettering Rd 0604 33578
- Plymouth**
FTB Lawson
71 New George St 0752 665363
- The Model Shop
11 Old Town St. 0752 21851
- Shetland**
Tomorrows World
Esplanade, Shetland 0595 2145
- Southend-on-Sea**
Estuary Software
261 Victoria Ave. 0702 43568
- Stevenage**
Video City
45/47 Fisher Green Rd. 53808
- Stroud**
The Model Shop
22 High St? 04536 5920
- Surbiton**
Computasolve
8 Central Parade, St Marks Hill
01 390 5135
- Taunton**
LA Gray
1 St James St. 0825 72986
- West Bromwich**
Bell & Jones
39 Queens Square, Sandwell Centre
021 553 0820

at the sign of the
BIG

ZENITH Z-110

THE ZENITH 110-32 is a hard-disc 10Mbyte version of the Zenith 100 desk-top computer that offers two processor chips so that you can use both eight-bit and 16-bit software. The mixture of chips and operating systems must have given the implementers some headaches, but the result is a skilfully designed and harmonious whole that passes none of the headaches on to the user. As an S-100 bus system it also represents well supported, well understood technology.

Zenith is the company which gave the world the formidable multi-band portable radio that pulled in every station on earth, and some more besides. It has now combined forces with Heath, the DIY kit manufacturer, and the Zenith micro-computer displays characteristics from both sides of the family.

Like blue jeans or a paperback version of *A la Recherche de Temps Perdu*, it was once fashionable to sport the Zenith radio in a battered, world-weary condition. The Zenith computer has a similar internal ruggedness, but unlike the radio this is matched by an equally tough outer casing which would not be likely to dent picturesquely.

The Heath origin shows itself in the documentation and general openness of the system to inspection by users. In previous reviews of 16-bit offerings I have occasionally had cause to lament manufacturers' scurrilous or misguided mainframe tactics in attempting to guarantee the customer's continued dependence. Operating systems are supplied either incomplete or completely non-standard; means of creating new system discs are withheld from the user; no access is given to debuggers or system documentation — and sometimes you cannot even open the cabinet.

Zenith's approach is wholesomely in line with what readers of this magazine will recognise as the true spirit of the micro. Even without buying the full technical manual — priced at £150 for the two volumes, but still excellent value — the user gets a superbly documented, detailed account of the hardware and software.

Two volumes on the 16-bit operating system Z-DOS, two volumes on the eight-bit operating system CP/M-85, two volumes on ZBasic, and a general single-volume user's manual are thrown in with the price of the system. Z-DOS and CP/M-85 turn out to be indistinguishable from MS-DOS and CP/M-80, and ZBasic is very similar to the various versions of MBasic-86 appearing on most new 16-bit machines like the IBM PC and Wang.

The appendix to the user's manual is a

Chris Bidmead discovers a high-class route to computer literacy — with a hard-disc micro thrown in free.



meal in itself with succinct summaries of everything you need to know. An added luxury is a 23-page glossary of commonly used computer terms that covers the whole field of microcomputing from acoustic couplers to word processing.

The fine symmetry of the documen-

tation has evidently been a little disturbed by the recent arrival of the Winchester option. There is no mention of it at all in the CP/M-85 manuals but the hard-disc supplement relating to Z-DOS literally overflows the Z-DOS manual, and this information is duplicated in the

Benchmarks

Running the standard Benchmarks shows the Zenith to be slightly quicker than the IBM PC, but not as fast as our current record holder the 8086-based Orion. All times are for 1,000 iterations and are in seconds.

	1	2	3	4	5	6	7	8	Av
Zenith Z-110	1.5	5.1	10.6	11.0	12.8	24.3	25.5	28.5	14.9
IBM PC	1.2	4.8	11.7	12.2	13.4	23.3	37.4	36.9	17.6
OEM Orion	0.6	2.1	4.8	4.9	5.8	10.5	16.7	13.0	7.3



Specification

SYSTEM

CPU: 8085 eight-bit and 8088 pseudo 16-bit dual-processor system, both operating at 5MHz.

Memory: 192K of RAM, 96K of video RAM, 32K ROM

Discs: single 5.25in. mini-floppy drive, may be formatted as single- or double-sided, single- or double-density; 10Mbyte Winchester

Features: includes colour output, CP/M-85, Z-DOS and ZBasic

Interfaces: two RS-232C serial ports, one Centronics-type parallel port, five-slot IEEE S-100 bus expansion.

Dimensions: 48cm. x 49cm. x 19cm.

DISPLAY

Type: 15in. colour monitor

Display: 25 lines x 80 characters, eight colours/intensity levels, 640 x 225 pixels

Dimensions: 47cm. x 43cm. x 35cm.

KEYBOARD

Type: Selectric-style 95-key keyboard

Features: calculator-style numeric keypad with 13 keys, 13 programmable function keys, four cursor keys + Home.

Dimensions: Integrated with the system box

SOURCE

Manufacturer: Zenith Data Systems

Importer: Zenith Data Systems (U.K.), Gloucester

Price: System box with CP/M-85, Z-Dos and ZBasic £3,925; colour monitor £440; system box to monitor cable £16; two-volume technical manual £150; total system £4,531; WordStar 3.21 + colour £240; Multiplan £135; system as reviewed £4,906.

supplement to the general user's manual. Once again, however, the quality of the documentation is excellent and Zenith takes the trouble to explain with diagrams exactly what a Winchester disc is and how it works.

All this fulsome documentation is so meticulously put together that my one niggle sounds churlish. I wish Zenith had compressed the pages down to the handy dwarf format adopted by IBM. Normally you long for more use of white space in computer documentation, but when there is this much to read you come up against the problem of the sheer physical handling of over 2½ stone of manuals.

While we are being physical, my only

other real objection to the system is that, like the Olivetti M-20, it comes in the not very ergonomic configuration of combined processing unit and keyboard, with a separate monitor. The shape of the processing unit seems to suggest you use it as a platform for the monitor, giving you something very like the all-in-one computer exemplified by the Superbrain. This looks neat, but puts the screen far too close for comfort for a large colour monitor.

On the other hand if you put the monitor on the table behind the processing unit you will only see half the screen. One of the slim detached keyboards would have been a great improvement on the rather high, built-in keyboard provided by Zenith.

The mains switch is sensibly placed at the left-hand rear of the processing unit, easily reached for but not in a position where you could knock it by mistake. On powering-up, the processing unit beeps discreetly, and the operating system is loaded from one of the drives according to a software/hardware configuration pre-determined by the user.

As delivered by Zenith, the Winchester disc is divided equally between CP/M-85 and Z-DOS. But a utility called Part enables you to define as many as 16 separate partitions on the disc, each identified by a separate name and each accessible from the boot mechanism. The idea is that as other operating systems become available they can all be stored on the hard disc to allow the user a choice when booting up. The present operating systems, once loaded, are designed to see these partitions rather like floppy-disc drives, with the limitation that only two such partitions can be on line at any one time.

The floppy disc is also interestingly implemented. As with a number of other micro systems, the formatting program allows you to choose between single and double density when you initialise the disc. But mixing densities can be more trouble than it is worth, involving at worst having to boot up different versions of the

operating system, or in more thoughtful implementations giving the same physical drive two distinct operating-system names, one for each format.

Zenith has come up with a better idea. Under CP/M-85 the Control-C necessary to log on a new disc does a quick read of the directory track, notes the density it finds there, and sets the BIOS accordingly with no additional intervention from the user. It is a generous touch that is typical of the deluxe design effort put into the machine. Both operating systems come with a program called Configur which is used to set up various I/O parameters. The provision of such a facility should be standard on micros, but it is depressing still to find so many manufacturers who do not bother. Here as elsewhere Zenith has more than done its duty by the user, for Configur makes life very simple for the beginner by actually drawing a picture of the ports to be found at the rear of the processing unit, indicating where and how the connections should be made.

Surprisingly in a machine of this sort there is no ROM-based debugging monitor accessible below the operating system. For those who wish to probe the entrails DDT and Debug are supplied, however, and if you have never had a ROM monitor you probably will not miss it.

Colour graphics on the Zenith were good enough to persuade me to spend a lot of time dabbling in creative Basic. I ought to declare my own feelings here: I am actually against graphics, or rather against the present generation of hardware and software that encourages people to invest a lot of time writing code that will not mean a row of beans to the next generation of micros. Graphics is about to take off, but before it does there will have to be standards that ensure portability not just of code but also of knowledge. Graphics on household and business micros at the moment tends to be a time-consuming, low-level occupation.

That said, the Basic provided by Zenith goes a long way towards a sort of temporary standardisation. Programs written in ZBasic should work on other MS-DOS-minded hardware. And even if they do not, the speed with which you can knock up exotic images makes sure that you are not having to throw too much time away. The key graphics commands give you the ability to draw outlines and colour them in without having to do any heavy computations.

Elementary animation is also readily accessible thanks to the provision of Get and Put commands, which offer an easy way of storing images in arrays so that they can be swapped quickly on the screen. For the total non-programmer a comprehensive interactive business graphics package is provided, although there is no simple mechanism to link it in to other software like Multiplan.

(continued on page 85)

You know you should Computerise...

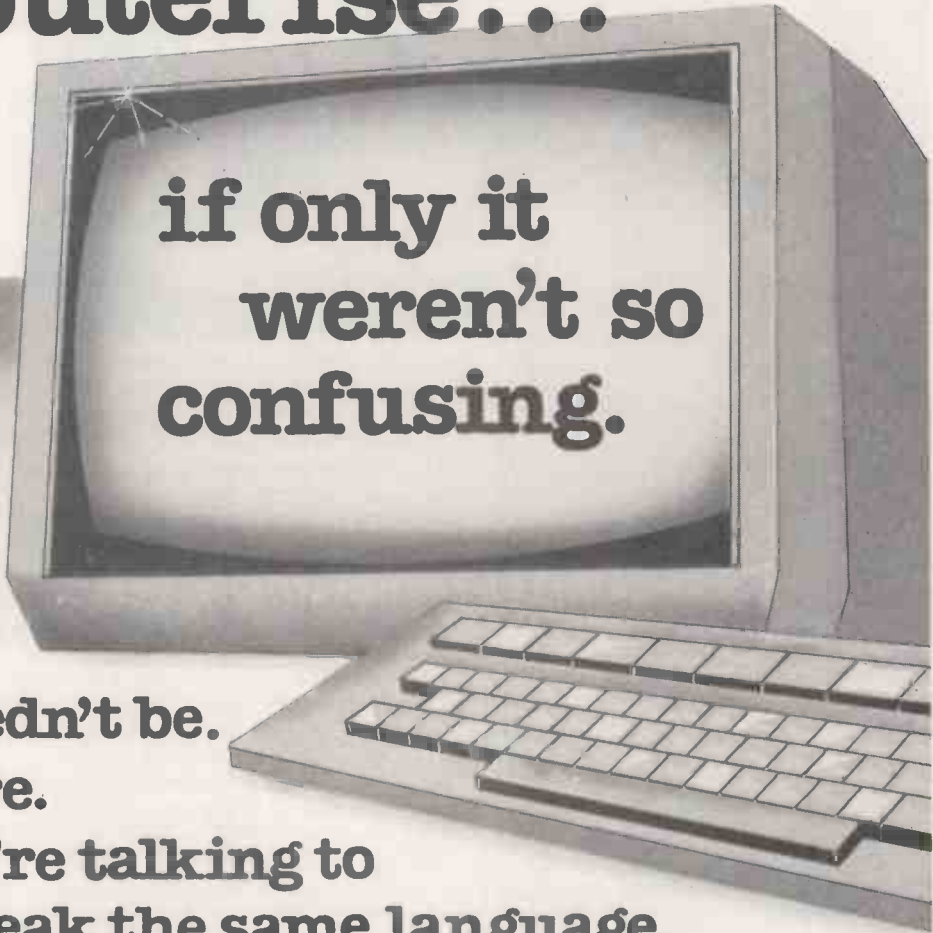

if only it
weren't so
confusing.

**Well it needn't be.
Not any more.**

**Not if you're talking to
people who speak the same language.
And that's where we come in.**

Tell us what you do and how you do it. How many buying and selling transactions you make. How you deal with stock control and despatch. How you run your accounts and routine correspondence. – How long does it take to deal with your payroll?

We'll listen carefully and come back with suggestions for speeding up and costing down all or any of these functions – and more – by matching equipment and software to your present and probable future needs. And it needn't be expensive.

We won't blind you with science or deafen you with jargon. If you accept our proposals, we'll train your

personnel until they're fully in the picture. And be at hand for as long as required in case our help is needed.

To computerise is to improve efficiency all round, and to have a vast store of vital information always at your fingertips. You'll want all that to stay in the race.

But you need a common sense firm to start you off. And that's what we are. We're called Chromasonic.

CHROMASONIC
business systems
01-263 9493 & 5

I would like to know how computers can improve our business.
Please send leaflets to:

Name _____
Position _____
Company _____
Address _____

Tel: _____

Post today to: Chromasonic Business Systems,
48 Junction Road, Archway, London N19 5RD.

**Call now or
send the coupon to
Chromasonic
Business Systems,
48 Junction Road,
Archway, London N19 5RD.**

● Circle No. 156

ZENITH Z-110

(continued from page 83)

In keeping with the openness of the documentation, physical access to the S-100 bus and the rest of the interior workings can be done bare-handed, simply by edging out a couple of spring-loaded sliders at the rear and lifting off the top of the case. International regulations only permit manufacturers to allow access without special tools if there are no exposed dangerous voltages inside. As you might expect then, the power supply is well cased in its own safety shield, which boxes it in completely.

Zenith has followed the modern practice of installing the fan as part of this sub-unit. A secondary air flow large enough to cool the electronics is created by way of a grid of holes in the side of the power-pack shield. The disadvantage is that this restricted vent produces a rather loud rushing sound that is not very comfortable to work with in a quiet room, though it may not be troublesome in the average noisy office. If I owned the machine I would be tempted to enlarge the grill to cut down wind resistance, even at the risk of flying in the face of the regulations.

On the review machine two of the five S-100 bus slots were taken up by the disc controller board and the floppy-disc controller, which was not, unfortunately, mounted on a single card like the latest controller from Western Digital. The main processing is carried out on the bigboard that lies horizontally below the back plane; this board also houses the 192K of RAM and 32K of ROM.

The bigboard meets the signal requirements of the proposed IEEE-696 S-100 bus definition, but of course is not removable and replaceable like an ordinary S-100 bus card. This is a fairly conventional arrangement, but it does



The internal ruggedness of the Z-110 continues Zenith tradition.

imply that the Zenith is committed to the processors it has now. It would be more in keeping with Zenith's style to go for the sort of arrangement chosen by Almarc Data Systems in the Spirit-1 range of machines, where the processor board sits in the S-100 slot, easily replaceable when the time comes to move on to the next generation of CPUs.

The 8085 and the 8088 form a natural pair: both chips are by the same

manufacturer, and form part of Intel's carefully designed upgrade path towards 16-bitery — notice that word "towards". Intel, who should know, cut right through all the discussion about whether the 8088 is a 16-bit chip or only a pseudo 16-bit chip by stating firmly in its own product definition book that the 8088 is "the most powerful eight-bit processor available today".

(continued on next page)

A note on the software

Two software packages were supplied with the Zenith: WordStar and Multiplan. Both came on 5.25in. floppies with massive and superb documentation. They were simple to transfer and use from the hard disc.

WordStar is in colour, with an Install routine so you can set your own colours from the range of eight available — blue menu backgrounds are attractive. Installing many popular printers is done just by naming them.

On the Zenith there proves to be nothing unusual about the implementation of WordStar though this version, 3.21, allows horizontal scrolling too. You can edit while printing but you have to use F12 not Ctrl-C. You might be able to use other function keys if you can find them in the documentation and then remember what they stand for; they are not in the index and no labelling

strip is supplied. Still, the documentation is far more comprehensible than the Micropro version.

Multiplan is, again, the standard package. Being black and white it seems visually somewhat thin after running colour programs. However, it has been well implemented using the function keys, and it is still arguably the best straightforward spreadsheet currently available.

Other Zenith software includes Ashton Tate's dBase II, Comsoft's DBMS, Condor, Magic Wand, Supercalc and the rest of the WordStar range. Languages include Fortran and Cobol in both -80 and -86 versions, and Pascal MT+.

While the Z-110 is semi-compatible with the IBM PC, it did not boot any of our IBM PC discs, so there is no direct access to this huge pool of software. However, the Zenith will read IBM PC discs, so it was possible to load Multiplan data files originally created on the PC and the Dynalogic Hyperion.

ZENITH Z-110

(continued from previous page)

If you are going to claim the 8088 as a 16-bit chip on the strength of its internal architecture, then on the same grounds you could perfectly well advertise the Z-80 as the 16-bit market leader. The Intel book, included in the price of the Z-100 technical manual, explains why the 8088 pairs so well with the 8085: both chips can share identical eight-bit wide memory, which is cheaper and possibly slower than that required by the 8086.

Intel claims that because of the way the 8088 parallels its instruction fetches with its executions the chip is able to operate faster than the Z-80, even when working with slower memory. I have yet to be convinced of this in practice, but perhaps it is the software that is slowing everything down.

Personally I would have much preferred a Z-80/8086 combination, although this does introduce the difficulty that supporting memory would have to be of the new dual eight/16-bit wide type. The disadvantage of the present arrangement to the user is that some very good eight-bit software specially written for the Z-80 is

put out of court. Among the British offerings, Superfile will not run on an 8085, neither will ProPascal or Microcache, although 8086 versions of these packages compatible with the Zenith's 8088 are either available or due very soon.

MS-DOS is very CP/M-like, but the operating systems chosen for these two chips do not pair as naturally. CP/M-86 is completely file-compatible with CP/M-80, whereas MS-DOS requires help to read CP/M-80 files. Typically Zenith has troubled to provide this help, in the form of a utility called RDCPM.

In not selecting CP/M-86 as the 16-bit companion operating system, instead committing itself to assimilating MS-DOS and rewriting all its documentation, Zenith seems to be making a fairly positive rejection of Digital Research's upgrade path. I quarrel with Zenith here too.

Heaven only knows what the future will hold, but my own feeling is that Digital Research is due to wrest back the market with Concurrent CP/M. CP/M adherents who have stepped into the 16-bit world by way of the unglamorous CP/M-86 will reap their rewards in terms of a well conceived graphics standard and true concurrency, both crucial to a proper Smalltalk-like multi-window interface.

But these notes are for guidance only, as they cautiously say in the manuals. In any case, the Zenith100 provides the hardware that should be able to run any of the

coming operating systems, and will no doubt offer Concurrent CP/M or whatever, when the time comes.

Conclusions

- The Zenith is a solidly constructed, superbly documented S-100 bus system.
- Its dual-processor architecture forms a useful bridge between the eight- and 16-bit worlds.
- The hardware, software and documentation virtually comprise a university-level course in microcomputing or an excellent route to computer literacy for the intelligent user with time to spare.
- The operating systems offered are perhaps not the latest and the best: failing CP/M+ and Concurrent CP/M it would have been nice to have MS-DOS II, a great improvement on MS-DOS I. But they have been generously enhanced and are totally explained in the documentation.
- The attached keyboard is a little awkward to set up, but its non-glare key caps, perfectly laid out for the touch-typist, are a great asset.
- Zenith prices start at around £2,000 to £2,500. The system reviewed, at a total price of around £4,500, is not the cheapest way of buying Winchester-based 16-bit computing power. If all you want is hardware to run a spreadsheet calculator and a word processor you might be able to pick up comparable machines at under £4,000. What you get with the Zenith is a great deal of knowledge — and class. □

The HAWK SBC was originally designed as the processing unit for our own range of HAWK business computers

Its architecture has been designed to provide a very powerful yet cost effective unit for use in business computers and process control applications

The board is constructed using only top quality, branded components throughout and is given a thorough soak testing before leaving the factory

The boards many advanced features include: —

- 4MHz Z80A PROCESSOR
- DIGITALLY CONTROLLED 64 or 128K DRAM
- UP TO 32K EPROM IN Z.I.F. SOCKETS
- USER BANK SWITCHING
- 2 PROGRAMMABLE SERIAL PORTS
- BI-DIRECTIONAL PARALLEL PORT
- WINCHESTER CONTROLLER INTERFACE
- 5 1/4" FLOPPY DISC CONTROLLER
- RE-ADDRESSABLE I/O CHANNELS
- CUSTOMISING/PROTOTYPING AREA
- 40 MHz CLOCK FOR DIGITAL TIMING
- 5v at 2A and ± 12V at 100m
- CP/M available*
- ON BOARD MONITOR

Price for 64K version is £420. Generous quantity discounts are given.

For further details contact



HAWK MICROCOMPUTERS LTD.

1-2 CLARE STABLES, 15 VICARAGE ROAD
STONY STRATFORD, MILTON KEYNES, MK11 1BN

TELEPHONE: 0908 563604

*CP/M is the trade mark of Digital Research

EDUTEXT

Tutors in Word and Data Processing

Training provided in:

Wordstar	Jacquard Type-Rite
MailMerge	Dbase II, DMS
Spellbinder	Supercalc
Wangwriter	IBM "Easy Family"

Courses designed for a maximum of 3 operators, enabling plenty of "hands on" experience and individual tuition. Conducted preferably at the customer site on the relevant equipment, but held at our offices by arrangement.

Contact

Kate Boyd Carpenter

On: 01-381 2094 / 01-385 6261

7 Margravine Road London W6 8LS

Micro training courses you can get your hands on, and teeth into...

Our expertise with machines and software and our understanding of the needs of users, allied to the educational skills of professional lecturers, makes these micro-computing courses a unique training package.

All courses include 'hands-on' experience with a wide range of business machines including the IBM PC, Act Sirius, Osborne, Superbrain, and the Epson QX10. These all-inclusive one day courses provide lunch, full documentation, and text book.

1. Micro Computers for Business:

An introduction to the capabilities of business micros including problem analysis and a demonstration of business systems. **£75**

2. CP/M and WordStar:

This course covers all aspects of CP/M and computer operation and practical use of WordStar and Mailmerge. **£85**

3. Supercalc and dBase II:

A thorough grounding in Supercalc and dBase II is provided through to a practical level of use. **£85**

4. Advanced BASIC programming:

An elementary knowledge of BASIC is required for the course, which deals with files, advanced control structures and editing. **£85**

5. Advanced dBase II programming:

A complete course covering the programming of a comprehensive range of business applications in dBase II. **£85**

6. PASCAL MT + programming:

A programming course for the experienced programmer in BASIC and other languages, who wishes to convert to PASCAL. **£95**

Access and Visa payments welcome.
All prices quoted are excluding VAT.

MicroTraining

637 Holloway Road London N19 5SS
Telex no. 297598

For booking forms and further details ring:

01 272 6398
01 367 5372

• Circle No. 159

Kuma Computers Limited



A Combination of Soft & Hardware

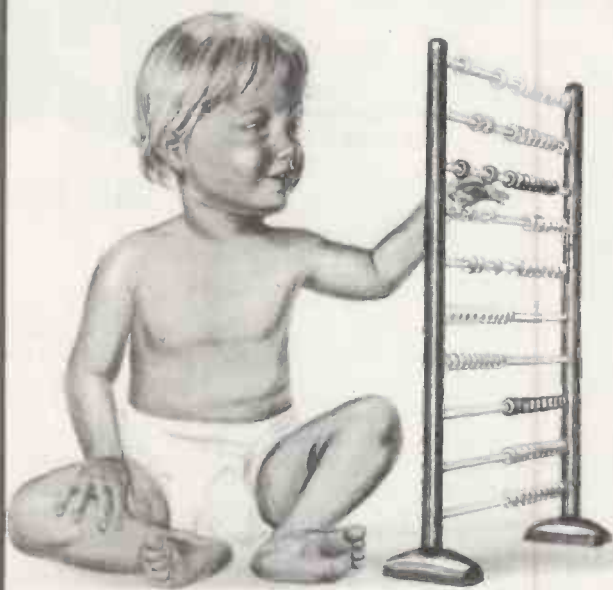

SIRIUS 1

SAGE

EPSON

SHARP

NewBrain

commodore

OSBORNE 1

Kuma has over 500 software programmes covering - utility, educational, entertainment, word processing and other business requirements.

KumaComputers are backed with many years of direct experience.

PHONE NOW or SEND FOR DETAILS

MAIDENHEAD (0628) 71778

Kuma Computers Ltd 11 York Road,
Maidenhead, Berks SL6 1SQ

Please tick box for information required, and send coupon to:
Kuma Computers, 11 York Road, Maidenhead, Berks SL6 1SQ

HARDWARE	SOFTWARE	HARDWARE	SOFTWARE
<input type="checkbox"/> SAGE	<input type="checkbox"/>	<input type="checkbox"/> NEWBRAIN	<input type="checkbox"/>
<input type="checkbox"/> SIRIUS-1	<input type="checkbox"/>	<input type="checkbox"/> COMMODORE 64	<input type="checkbox"/>
<input type="checkbox"/> SHARP A	<input type="checkbox"/>	<input type="checkbox"/> PRINTERS:	
<input type="checkbox"/> OSBORNE-1	<input type="checkbox"/>	<input type="checkbox"/> MATRIX	
<input type="checkbox"/> EPSON HX-20	<input type="checkbox"/>	<input type="checkbox"/> DAISY WHEEL	

NAME

ADDRESS

POST CODE

• Circle No. 160

Edword

The Corvus Concept word processor Edword has some commendable features:

- Text files are manipulated in separate segments, called pads, of a workspace, a virtual memory disc file with the default name W. Text of almost any length can be edited as though it were all in RAM at once, and you can switch between the pads, swapping chunks of text without having explicitly to save and reload files.
- Indicators around the margins of Edword's screen window show graphically:
 - what proportion of the current file the screen display represents,
 - where the cursor is in relation to the whole current file, and
 - how much of the work pad is being used at the moment.
- During an editing session alterations made to the text are invisibly logged. By retracing the log a single key, Undo, lets you backtrack on the changes you have made, restoring the text step by step back to its original state, right back to the beginning of the session, just like on a mainframe. Sensational!
- During pauses in an edit, and after the session, the length of time spent inside Edword is displayed on the screen.
- Font enhancements like bolding, underlining, super- and subscripting are displayed on the screen just as they will appear on the printer.

These tremendous advances will certainly impress users brought up on WordStar. However, I found myself avoiding Edword, and it was not just because on the review machine the screen rippled like a flag in a high breeze. Edword's scrolling is appalling: the screen splits at the cursor, text below the cursor is erased and then replaced with new text, then the screen above the cursor is cleared before the new text is written in. If that sounds slow, that's the way it happens. In vertical mode a kind of sideways wipe is introduced as well.

Being able to juggle chunks of text in separate buffers is a valuable feature, but under Edword access to the mechanism is clumsy. Mark of the Unicorn's The Final Word also allows buffer swapping in a virtual memory file of 256K. I am currently using it under CP/M on the little old Z-80: for speed and ease of use it beats Edword on the 68000 hands down.

Features like Undo and the literal presentation of font enhancements are very nice indeed. Perhaps when Corvus has a breathing space to do some machine-code optimisation of a program that has presumably been patched together in Pascal from the library functions, Edword will come into its own.

CORVUS CONCEPT

Chris Bidmead finds out the problems of turning a work station into a stand-alone micro.

THE NAME Corvus first appeared on a hard-disc system for the Apple II. Soon afterwards it also became associated with a local area network called Omninet that enables any number of Apples and other micros to share data files.

At the end of 1982 the Corvus Concept was marketed as an extension of this idea. Essentially it is a work station, designed to communicate across the net with fellow Concepts, other micros and even mainframes. Our tests assess the machine as a stand-alone system, communicating with its own local 20Mbyte hard disc, with a single 8in. drive to import the software and provide back-up. This somewhat restricted view of the system probably does not show it in its best light.

The Concept arrived with some other handicaps too: the disadvantage of a premature launch in the U.S., some early misplaced enthusiasm from reviewers in this country, and a certain amount of bad timing in being overshadowed by the public airing of Apple's Lisa. First shown in this country by distributor Keen Computers at Compec 82, the machine seemed to catch that company on the wrong foot. The initial sales campaign met with what the trade politely calls "limited success".

The hardware comprises five units, the smallest of which is the keyboard. It is not the skateboard-thin appendage popularised by IBM but a sloped slab that puts the highest key some 2½in. above the worksurface.

The good news accompanying this possible disadvantage is that the keys are very sensibly laid out in the old Selectric format which IBM unaccountably abandoned in designing the PC. The Return is not quite the backward L that IBM pioneered on its golf-ball typewriters, but it is big enough to hit comfortably without a touch-typist's fingers having to vacate the home keys.

A stout coiled cable connects the keyboard by way of an industrial-quality nine-pin connector into the back — alas, but don't they all! — of the processor unit, an almost square 39cm. by 42cm. by 11cm. box that unobtrusively serves as a pedestal for the screen. Here, at the rear of

the processor unit, a similar nine-pin connector accepts the data lead to the screen. Below it a pair of RS-232 D-type sockets offer output to optional serial ports. A simple three-pin socket beside them serves to connect the Corvus into the network.

The processor unit is housed in a snugly-fitting moulded resin case in the standard Sea Breeze cream colour in which all the units are finished. A decorative grill in the front conceals a filtered air intake. To dismantle the unit you need an Allen key to remove five 2¼in. hex-head bolts at the bottom of the case. The process is simple enough and reveals a power pack on the left-hand side as viewed from the front.

You can swap the boards, check chips and make connections to the bus without unsealing the case or even lifting the monitor off the plinth. Only thumb and fingers are needed to undo a pair of latch screws at the rear of the unit. The electronics sub-chassis can then be slid out like a drawer to expose the bus-connection slots. Apple-style cards in the slots link the peripheral drives into the processor unit's bus system.

The electronics sub-chassis measures 27cm. by 35cm. by 9cm. and is essentially a two-board structure. There are up to 64 Motorola 64K RAM chips on the upper level, giving the review machine 512K of on-board RAM in all; on the basic 256K Corvus half the chips are missing. The 68000 and its support chips are on the lower board, which also houses the four bus slots, two of which were spare in the review machine. They are easily accessible when the draw is pulled, as is the Dil switch which is set to establish where the raw hardware looks for its bootstrap software on powering-up.

The two used slots lead off via ribbon cables to the peripheral drive units. Measuring 38cm. by 31cm. by 15cm. the 20 Mbyte hard disc unit is physically about half the size of the earlier Corvus equivalent. It still takes up a lot of desk space in comparison with the increasingly popular hard discs as built into other systems, where they need occupy no more than a single 5.25in. floppy-disc drive slot.

The 8in. floppy drive is neatly

proportioned for a stand-alone unit at 41cm. by 26cm. by 12cm. Like the hard-disc drive it is larger than comparable built-in units because it needs its own power supply. On top of the case is a hemispherical indentation designed to take the articulating plate that holds the monitor. The plate allows it about 90 degrees of side-to-side swivel and roughly 30 degrees of tilt.

It is the screen that is the dominating feature of the whole system. The main concept of the Concept is that the display should be big and bold and capable of high-resolution graphics. Graphics have been implemented as a black-and-white 720-pixel by 560-pixel bit-mapped screen on which all display characters are generated by software.

There is an obvious advantage in being able to design character sets to taste. The 256 available codes do not necessarily have to generate alphanumerics. You can use them to display symbols of your own design, an approach well illustrated in the game called Roach provided by Corvus. The plan elevation of seven rooms of a house are revealed in turn as you move from one to another. You are a scurrying cockroach, and the object is to eat up all the crumbs and clean out the refrigerators.

Using the character design utility Edcharset you can easily personalise the look of the game to suit yourself without having to become involved in the logic. Edcharset can also be used to create characters bigger than the standard rather

cramped alphabet that the system adopts on power-up.

The disadvantage of a soft character set is that, without sophisticated hardware, output to the screen will be considerably slowed down. As well as its regular business of working out what to write to the screen the processor has to find time to compute the design of each character as it writes it. This may not be exactly what the Corvus does, but there is certainly something which visibly slugs screen output. It is most obvious during scrolling, when the whole screen has to be refreshed.

The large screen has an added bonus in that it can be oriented either in landscape, with wide sides horizontal, or portrait format — though at the risk of a hernia, it must be said. With its 15in. Ball Bros CRT is it quite the heaviest screen I have ever handled. It might seem appealing to use the 72-line by 90-column portrait format for word processing and then swap to the 56-line by 120-column landscape mode for spreadsheet calculations. In practice you settle on one format or the other and stick to it.

Unusually, this over-sized monitor unit has its own built-in fan. When everything is switched on, with the processor unit's own fan breezing and the drives whirring, the system has a definite acoustic presence, though a tolerable one.

On powering-up the CPU unit checks to see if the hard disc is ready. If it is not the

(continued on next page)

Specification

SYSTEM BOX

CPU: Motorola 68000 16/32-bit chip with 24-bit memory address bus

Memory: 256K expandable to 512K of RAM

Bus: four expansion slots for 50-pin cards

Standard interfaces: two RS-232C serial asynchronous ports; Omninet RS-422 local network interface

Features: clock/calendar with battery back-up; sound generator with speaker

Dimensions: 114 x 381 x 432mm.

Weight: 11.2kg.

DISC DRIVES

Floppies: 1.0Mbyte 8in., floppy-disc drive, IBM 3740 format.

Hard discs: 5.7Mbyte, 10.8Mbyte or 19.7Mbyte Corvus hard discs

Back-up: 73Mbyte VCR back-up storage
All figures are for formatted storage.

DISPLAY

Type: 15in. monochrome CRT

Displays: 72 lines by 90 columns or 56 lines by 120 columns; bit-mapped display 720 x 560 pixels

Features: tilt, swivel and rotation by 90° for portrait or landscape format

Dimensions: 356 x 381 x 381mm.

Weight: 18.6kg.

KEYBOARD

Type: Detached with Selectric-style QWERTY layout.

Features: 100 keys in all, with 10 function keys, numeric keypad, cursor controls and a "go faster" key to speed up cursor movement

Dimensions: 76 x 203 x 432mm.

Weight: 2.1kg.

Price: £3,950 for the 256K machine, including Edword; £1,200 extra for the 8in. floppy; £1,795 extra for the 5.7Mbyte hard disc. Total system price as tested: £6,945. Prices do not include VAT.

Manufacturer: Corvus Systems Inc., San Jose, California.

Importer: Keen Computers Ltd, Minerva House, Spaniel Row, Nottingham NG1 6EP. Telephone: (0602) 412777.

The screen, the dominating feature of the system, can be used long side up.



CORVUS CONCEPT

(continued from previous page)

CPU declares it to be out of action without

bothering to retry so switching on the hard disc is desirable before bringing the CPU unit on line.

It comes to life with a deep beeping sound and puts up a prompt inviting you to boot from the floppy, the network or the hard disc. Once the boot is accomplished you are invited to enter your name. Somewhat confusingly this is not a

reference to what it says on your birth certificate: the single user must respond with SMGR, the code name for the system manager. The next prompt requests a password, which it accepts without echo to the screen. Now the system has to log on its disc units, and while doing so it displays a series of dots on the screen.

This rather long-winded power-up sequence would not matter much if you only had to put up with it once every session, but it was necessary to go through it regularly when the earlier version of the software ran into hang-ups and bomb-outs. A great boon of simpler eight-bit machines is the ease and speed of rebooting.

The various devices thus mounted are logical rather than physical. They have names and unit numbers, with the floppy disc, unit 9, being christened with a string of stars if there is no readable disc latched into it. The hard disc is divided into volumes rather as CP/M divides a disc into user areas, with the difference that the Corvus operating system CCOS gives them meaningful names.

There is a further, larger distinction in the way that the volumes are regarded by the system as quite separate devices, even to the extent that different volumes can be prepared for attachment to alien operating systems. The Corvus Constellation, like the IBM XT, offers the option of formatting separate volumes for UCSD Pascal, Apple, MS-DOS and CP/M-80 as well as the native CCOS operating system.

The operating system advises the user of the devices it has mounted, and draws two windows on the screen. The upper one takes up most of the display area, while the lower one is a narrow letter-box shape used to contain user input commands and parameters, solicited by a Select Function prompt. Space is left below this box for 10 inverse-video rectangles, which are tokens for the physical function keys on the keyboard below. As well as the geographical correspondence, the function keys are identified by number and given names.

Pressing a function key will activate whatever routine is identified by the associated name. To reach the word-processing routine you press function key 3, whose legend is Edword. The keys may display two names at any one time, the second representing the shifted version of the appropriate function key. Pressing the Command key can switch in a completely different set of names for the 10 function keys, so up to 40 functions can be made immediately available to the user.

Of course, entering a program like Edword by way of the keys enables the program itself to reload the function keys with other functions relevant to the application to be handled. Depending on how application programs handle the idea, this arrangement can be nested to an unlimited number of levels. Even without writing special software the user can set up

Corvus Concept Work In Progress

Old software

OPERATING SYSTEM

Function-key system limited

Date displayed but not refreshed

Batch routine will not accept parameters

Generally slow

Suspend documented but not implemented

Alternative operating systems promised; only very slow CP/M-80 implemented

Management of disc space not dynamic: requires occasional "crunching" of files

DOCUMENTATION

Variable quality of presentation: some high-quality print dwarf-format manuals, some photocopied legal-sized typescripts.

Inconsistent with software

LANGUAGES

SDS machine-code Pascal and Fortran provided

No p-code

No Basic

No C

APPLICATIONS

Edword contains bugs and lacks elementary features: for example, top and bottom margins not setttable, no text enhancements.

Logicalc short on features

Shortage of applications: no database manager, accounting package, time-management system, etc.

To match the revised software there are reportedly imminent hardware improvements:

- A new lighter screen, making it more of a practical proposition to turn it from vertical to horizontal as needed.
- Amber phosphor to European standards. It will also be readably stable on European mains.
- An add-on memory-management chip that will speed up screen handling.

New software

Extended to include user keys

Date refreshed, time included

No improvement

Some apparent speed up

Documentation altered; Suspend apparently abandoned

No improvement

No improvement

Standardised on poorly presented dwarf photocopied typescripts

Consistency greatly improved

New libraries means old source code must be re-edited.

UCSD p-code Pascal added

Basic added, but failed to work

Still no C

Features added, bugs removed

Some features added. Still a rather ordinary Visiclone

No improvement, though offering p-code system should open up new software

this function-key system by very simply editing a text file called Userkeys Text, which the operating system automatically reads on powering-up.

One of the standard function keys offers a Help facility. Press the Help key followed by any other key and you are presented with a short piece of explanatory text. This is a useful idea, but as implemented it works in a very half-baked way. Press Help and a message appears telling you that a text file is being loaded. The fact that this process introduces a perceptible hold-up may lead you to expect some really useful hints. However, subsequently pressing, say, the Logicalc key produces nothing more rewarding than:

LoglCalc enters the optional Concept spread-sheet program.

Help on the other keys is at the same level of detail.

If you do not like this single-key method of communicating with the operating system you can always write command lines directly into the letter-box window, to be executed on hitting Return. Alternatively the user keys may be dismissed altogether by entering a % symbol against the Select Function prompt. A Unix-style % prompt then appears in the large upper window, and communication with the machine takes place in the traditional Teletype scrolling mode. It will stay like that until you break back to the function-key method by sending Control-D.

Teletype scrolling mode works in a similar way to entering commands into the letter-box, but some additional Unix-inspired commands become available. LS — or its CP/M synonym Dir — will produce a directory listing, CD <newvolume> changes the volume, RM removes a file from the directory, and so forth.

It was at this point that some confusing departures from the documented behaviour began to appear. As they accumulated, together with enough bugs to confirm that I was dealing with some fairly unready work-in-progress, I decided to hold off further investigations until a new version of the operating system became available. It took a couple of months for this to happen, and by then Keen Computers needed the machine back urgently. I did not have time to investigate the improved system properly, but some limited observations on the new software appear in the Work In Progress box.

The new version of CCOS is a lot better, but I still wouldn't give you twopence for it. It is sufficiently like Unix to appear complicated to the new user but embodies few of the considerable advantages of the Bell Labs offering. Internal evidence suggests that Corvus meant to go further with it. Were treed directories originally envisaged?

A clearer example is the Suspend facility, the ability to stop a process in mid



Einstein's picture demonstrates the graphics.



The operating system lists the devices it has mounted, and draws two windows.

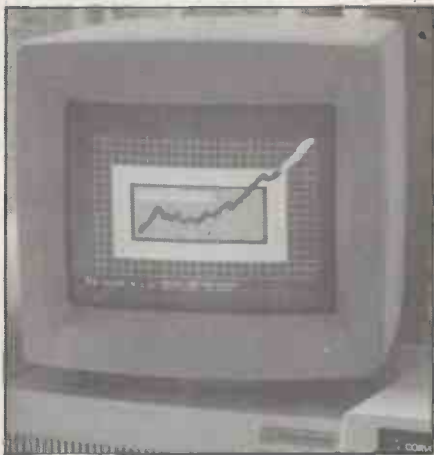

The graphics extend from old masters to graphs.

flow and save its state. This feature, a sort of halfway house to true concurrency, is very like what Bill Gates of Microsoft will be offering against Concurrent CP/M — which is truly concurrent — towards the end of this year. Under his MS-DOS 3.0 you will be able to suspend a process, switch to some completely different program and, when the time comes to switch back, the processor will be able to pick up exactly where it left off.

Documentation of the earlier version of CCOS implies that Suspend is available by "hitting the Suspend key". There is no

Suspend key, and as far as I could make out no Suspend function either. All mention of it has been dropped in the later documentation. It's a pity — this feature would have fitted nicely with the facility that allows the large screen to be divided up into any number of windows, sized to the whim of the user. Without it the windows are not much more than cosmetics.

On the positive side, I/O is redirectable and the utilities have a human-shaped design that is very welcome. For example, when you are copying multiple files to a back-up volume and the system encounters a file of the same name already at the destination it compares the dates of the two versions, tells you if they are the same or different, and gives you the option of overwriting or skipping to the next file.

There is open access to all the hardware facilities through the very rich Pascal and Fortran libraries. This is essential, because apart from Edword and Logicalc, applications software running under CCOS is conspicuously absent. In encouraging you to develop software that even at source level is heavily machine-dependent, Corvus Systems Inc. is insisting on a huge investment of your time in its product. The effort of producing software may well out-value the price of the hardware before anything useful is achieved.

CCOS includes a batch processor equivalent to CP/M's unlovely Submit. The CP/M utility can at least handle parameter substitution; why CC.Exec is not designed to do so is completely baffling. Keen Computers should be inundating its U.S. supplier with daily telexes of complaint until this is implemented. Better still CCOS should be gently shelved in favour of a development environment that is not tied to the fortunes of a single hardware company.

Conclusions

- At £3,950 plus VAT the Corvus Concept is not particularly expensive for the 68000-based true 16-bit hardware it offers, but remember this price does not include any discs.
- The over-sized screen is a good idea, but internally the Concept appears to be short of hardware support for its bit-mapping, making it slow in character display.
- It is hard to see why Corvus has tied up so much of its resources in developing its own operating system. A CP/M-80 emulator comes with CCOS, but it is too slow to be of much practical use.
- The new version of the operating system now offers run-time support for UCSD p-code packages, so the daylight is now being allowed to filter in from the world outside.
- The Concept is not competitive as a stand-alone office micro, but could be more interesting as part of a local area network with several work stations sharing discs and printers.

AS YOU STAGGER off the bus with the Zorba it could be mistaken for an old-fashioned sewing machine. The plastic case flexes disconcertingly, and its chocolate brown colour will win no prizes for tasteful styling. The Zorba portable micro is not impressive to look at.

Yet it turns out to be quite a sophisticated and likeable machine. The Zorba is a portable in the Osborne 1 category — an eight-bit CP/M mains-powered micro, American made, and of roughly suitcase size. Its £1,595 price includes some good software, and it has a full 80-column screen and large-capacity floppy-disc drives.

The Zorba weighs 22lb., which is fairly typical for machines in this class. It raises the question of what is meant by portable. Obviously the machine is too heavy to be taken everywhere, and it needs mains power. Really these machines are transportables, offering a full desk-top specification system packaged in a way which allows them to be taken without too much fuss to where the work is to be done.

The Zorba arrives in its carton as a single unit, together with its two big manuals. The base of the case unclips to reveal itself as a keyboard, which can be detached from the main unit and used on the end of its coiled cable. The main unit contains the screen, discs and processor.

Connecting up the machine merely involves plugging the mains cable into the front of this unit and switching on. At the back of the machine behind a protective cover are an RS-232C communications port, an IEEE instrument port and a dual serial/parallel printer port, so a good range of other devices should be connectable. I added an Epson FX-80 printer, and ended up using WordStar on the Zorba to produce most of my copy for this issue.

There is no denying the machine looks plasticity. A colleague charitably suggested this was a good thing, to help it absorb impact, as the casing plastic is the bendy sort. The finish isn't shoddy — nothing is loose — but it is not very beautiful either.

The keyboard is quite light in weight and is fairly noisy when hit. But it is accurate and easy to type on, with a standard layout and a separate numeric keypad. The 19 function keys are programmable and can be set up with strings of CP/M commands to initiate common jobs.

The green phosphor screen is a nominal 7in., meaning it measured 6.5in. diagonally if you put a ruler to it. I found the characters in the 80-by-25 line display clear enough and readable at a normal desk-top viewing distance. The On/Off switch also functions as a brightness control. The maximum brightness is good enough for outdoor use, but if you lie

A full-specification system which can be taken to where the work is.

TELCON ZORBA

The beauty of this portable is in the eye of the operator, as Ian Stobie found.



```
58k CP/M 2.2 (Bios v1.5)
```

```
Disk      On      Looks
name: drive:      like:

A:/B:    A/B      388k Telcon DD
I:        B        720k SuperBrain QD
K:        B        168k DEC VT-18x DD
L:        B         81k Xerox 820 SD/Cromemco 520 SD
M:        B        154k Xerox 820 II DD
N:        B        192k KayComp II DD
O:        B         88k Osborne SD
P:        B        153k IBM-PC CP/M-86
```

```
KEYDEF.TXT?
```

```
A>
```

Screen display which appears when your boot shows alternative disc formats.

back in your hammock you start noticing that the characters are quite small.

When you turn the machine on it beeps and displays the Zorba logo and a message asking you to insert a disc. Once you do so and hit Return a rather interesting display comes up, followed by the normal CP/M prompt. The display shows you what disc formats the Zorba is currently set up to accept. You obviously only have the two physical drives A and B, which in their default Zorba format each hold 388K. But you can get them to behave, for instance, as Osborne-format disc drives by using the logical drive name O. And if you put an Osborne disc in drive B you can get a directory by typing Dir O.

You have a general ability to read and write programs and data in a number of common formats including Superbrain quad density and IBM PC CP/M-86 formats. New formats are being added and are available on disc, Televideo being the latest. This kind of facility has been possible for a long time as it is a function of the CP/M BIOS, and now Telcon, the Zorba's manufacturer, has taken the trouble to implement CP/M well. I also got the impression that the Zorba's discs are fast, for instance when doing back-up copying.

How much of an advantage is this multiple format ability? First, any existing CP/M software or data you have on discs in any of several formats can be transferred straight across to the Zorba. Secondly, you can swap discs to other machines, perhaps most usefully to other non-portable machines you have at your base. I shall be keeping copies of files I have created with the Zorba to use on the office IBM PC once the review machine goes back. I also now have some files to send to a publisher who accepts discs in Osborne format.

The procedure to create a non-Zorba format disc is simple. The standard

Specification

System: Z-80 eight-bit processor; 64K RAM; two built-in 5.25in. floppy-disc drives giving 776K storage; built-in 7in. green screen displaying 80 characters by 25 lines; detached keyboard; a 16-bit 8086 add-on card is also available

Software in price: CP/M 2.2 plus utilities, CBasic compiler, WordStar, Mailmerge, Calcstar

Price: £1,595

U.K. distributor: Sun Computing Services Ltd, Concord House, St Anthony's Way, Feltham, Middlesex TW14 0NH. Telephone: 01-890 1440

CP/M Format utility just has a menu of different formats. Files you have on a different format are copied across to another with Pip, or you can run programs directly from the appropriate logical drive.

The Zorba comes with WordStar, Mailmerge and the Calcstar spreadsheet, all from Micropro, and with Digital Research's CBasic compiler and Microsoft's Macro 80 Z-80/8080 assembler. The WordStar word processor is version 3, which has much better rewritten documentation and a few new features like horizontal scrolling. When the word processor is in use you immediately notice the Zorba's fast screen updating. It is a consequence of the Zorba hardware, which has 2K of RAM set aside to memory map the display.

I did not use Calcstar any more than necessary to check that it was properly installed on the machine, but Mike Lewis gave a favourable report on it in *Practical Computing's* July 1983 issue, which surveyed spreadsheet packages. A major advantage of sticking with Calcstar is the ability to transfer data to WordStar and other products in the Micropro range like Datastar.

Zorba's Basic is the business-oriented CBasic compiler. Developing a program

involves three stages. First you write the source code using a text editor such as WordStar. Then you take the text file and compile it to an intermediate code suitable for running. Finally you run the intermediate file. The advantage is that your program executes several times faster than it would with an interpreted basic like MBasic, and you can also link in library routines easily. CBasic is very suitable for commercial programming, but it might help new programmers if an interpreted basic like Digital Research's Personal Basic were thrown in as well for more spontaneous programming.

A useful feature is the Print function key which dumps what is on the screen to the printer, though it does not work in all application programs. The Zorba has a full RS-232C interface, and it comes complete with software to emulate the Heath/Zenith Type 19 terminal.

One of the Zorba's two phone-book sized manuals covers the three Micropro products and looks like Micropro's documentation rebound by Telcon. The other volume is a loose-leaf binder with Digital Research documentation for CBasic and Microsoft documentation for Macro 80, and the Telcon-written Zorba user's guide. The user's guide, which is clear and straightforward, covers CP/M commands as well as the specific features of the hardware.

The Zorba's U.K. distributor has just started to receive 16-bit add-on boards from Telcon. They are built around the Intel 8086 and come complete with CP/M-86 and an additional 128K of RAM. With the board fitted the Zorba still works as an eight-bit CP/M machine running all the usual software, but you can bring up CP/M-86 with a single command. When in eight-bit CP/M the extra RAM can be used as RAM disc. The price for the Zorba with the add-on fitted is £2,195.

Conclusions

● It's not pretty, it not revolutionary, but it works. I ended up liking the machine.

● The specification is conservative but complete with the whole package, including a 6.5in. screen, kept within a just manageable weight.

● A number of touches, notably the ability to handle a variety of disc formats, make the Zorba a refined and developed variation on the established Osborne look-alike theme.

● The Wordstar word processor and the Calcstar spreadsheet can be recommended as they have sold widely and they can exchange data with each other and other products in the Micropro range.

● At £1,595 the Zorba is good value. With the 16-bit add-on card the Zorba still won't be chic but it will be a powerful dual-processor system and very good value. □

Assemblers for the Apple II

For fast execution assembly language is often the clear choice. John Dawson tests four 6502 assemblers tailored for the Apple micro.

MANY OF THE 650,000 or so Apples in regular use around the world are used for serious or professional program development. Despite the availability of high-level languages suitable for process control, number crunching, file handling and telecommunications there are many occasions when low-level assembly language is the optimum tool for writing a program for a particular application.

The first assembly languages were written in the 1950s to speed the development of programs for early mainframe computers. Prior to the use of teleprinters and paper tape for the entry of programs and data, each instruction had to be placed in the computer by setting binary switches on the front panel. The human-readable mnemonics of assembly language were a great aid to productivity. Higher-level languages, such as Fortran, Cobol and PL1, increased the speed with which a program could be written but slowed its subsequent execution.

The portability of a high-level program from one mainframe to another could be much greater than was possible using an assembler, but at the same time the ease of access to peripheral devices was lost. Assemblers have not been displaced even by Forth or BCPL. Where time is critical or sophisticated interrupt handling is necessary a good assembler is still the best tool for the job.

An ordinary assembler for the 6502 CPU in the Apple should use the standard Mostek mnemonics to generate one machine-code instruction for each line of source code. A line of source code contains the following information: an optional label to identify the line; the mnemonic for the instruction, one of the 56 legal op-codes for the 6502; the operand, the memory location that is to be operated upon; and an optional comment.

Figure 1 shows a section of a large program. The object code — that is the hexadecimal instructions that will control the computer — is listed in the second column after the colon. The labels for the program occupy a column to the right of the line number and are followed by the 6502 op-code and the operand. There are no comments in this section.

At this simple level an assembly language is still an improvement over programming with naked machine code. It is possible to write a source-code file, store the file on disc for later modification and assemble the code to run at any location you wish. Editing commands help to write the program and then to change the source code during testing and debugging. Lisa 2.5 works at this level.

The three other assemblers in this review

are all macro assemblers and the additional macro facility enormously increases their power. Figure 3 is the same section of source code as it is typed into the computer. The >>> pseudo-op is an instruction to the assembler to insert a predefined set of instructions, called a macro, corresponding to the name in the operand field during the assembly process. Figure 1 shows the expanded macro instruction after assembly has been carried

Figure 1. Section from a large assembly program.

		485		
04A9:	DB	486	INITIAL	CLD
04AA:	78	487		SEI
04AB:	A9 00	488		LDA #0
04AD:	8D 07 27	489		STA PAGEN
		490		>>> 2SET.TOP; ICURS; CURSE
04B0:	AD 3B 04	490		LDA TOP
04B3:	85 D0	490		STA ICURS
04B5:	85 12	490		STA CURSE
04B7:	AD 3C 04	490		LDA TOP+1
04BA:	85 D1	490		STA ICURS+1
04BC:	85 13	490		STA CURSE+1
		490		<<<
		491		>>> 2SET.TXSTART; TXST; TXEND
04BE:	AD 2A 04	491		LDA TXSTART
04C1:	85 B0	491		STA TXST
04C3:	85 B2	491		STA TXEND
04C5:	AD 2B 04	491		LDA TXSTART+1
04C8:	85 B1	491		STA TXST+1
04CA:	85 B3	491		STA TXEND+1
		491		<<<
		492		>>> FILL.MOVBUF; NDELFUF; NULL
04CC:	AD 30 04	492		LDA MOVBUF
04CF:	85 AC	492		STA SD+12
04D1:	AD 31 04	492		LDA MOVBUF+1
04D4:	85 AD	492		STA SD+13
04D6:	AD 2E 04	492		LDA NDELFUF
04D9:	85 AE	492		STA SD+14
04DB:	AD 2F 04	492		LDA NDELFUF+1
04DE:	85 AF	492		STA SD+15
04E0:	AD 1B 04	492		LDA NULL
04E3:	85 AB	492		STA SD+11
04E5:	20 88 07	492		JSR FILLSR
		492		<<<
04E8:	A2 46	493		LDX #'F'
04EA:	86 72	494		STX TAPS
04EC:	AE 06 04	495		LDX TRUE
04EF:	86 67	496		STX FAST
04F1:	86 92	497		STX FLMF
04F3:	86 83	498		STX FLST

out. The gain in programmer productivity and the reliability of the final program is obvious.

David Hood of Pace Software says that Lisa 2.5 has sold partly because it was the best known of the four assemblers. The Microsoft Assembly Language Development System, ALDS, is less well known but customers are said to migrate to this set of programs from Lisa, Merlin or the S-C Macro Assembler as their needs become more professional.

Merlin is supplied on disc and comes with a ring-bound manual approximately A5 size and 110 pages long. All the programs have A5 ring-bound manuals. In addition to the Merlin assembler the disc contains a disassembler called Sourceror, a useful library of macro definitions for incorporation into your own programs and the source code for a Sweet 16 interpreter. It also includes a special version of Sourceror that will disassemble the Applesoft Basic in the Apple, producing a labelled and commented listing that can be modified and reassembled.

The disc is copy-protected but you may make three copies of the master disc that

will work. You can also copy files from one of the master discs and then copy them back on to the working disc if it becomes corrupted for any reason. You must be careful when carrying out the original

Suppliers and prices

Merlin Macro Assembler, Southwestern Data Systems, 10,761 Woodside Avenue, Suite E, PO Box 582, Santee, Ca 92071.

S-C Micro Assembler, S-C Software Corp., 2,331 Gus Thomasson, Suite 125, PO Box 280330, Dallas, Tx 75228.

Lisa 2.5, On-Line Systems.

Microsoft Assembly Language Development System, Microsoft, 10,700 Northup Way, Bellevue, Washington 98004

Pace Software Supplies of 92 New Cross Street, Bradford, West Yorkshire BD5 8BS, telephone (0274) 729306, kindly supplied the four packages for review. Lisa 2.5 is no longer available but the other three are available from Pace:

Merlin Macro Assembler — £42 + VAT

S-C Macro Assembler — £60 + VAT

Microsoft ALDS — £75 + VAT

back-up process; make a mistake and you have lost one of your working copies. Once you have produced a working copy you can configure the program to work with a number of 80-column cards, and alter several variables such as the wildcard search character for the find command.

The Merlin commands are the most sophisticated of the three 6502-only assemblers. Lisa 2.5 has no command to find and change an instruction or character string at all, and the command to find a string only reports the line number where it is found. Merlin prints the lines containing the character string, making it far easier to judge whether you need to carry out further editing.

Both Merlin and the S-C assembler offer a wide range of commands and pseudo-ops. The source-code listing is now about 80 pages long and assembles to nearly 9K of machine code. The pseudo-op to Put a text file from disc on to the end of the source code resident in memory while assembly is under way is vital. Other programmers would certainly have used the Mon command or the instruction to reverse an ASCII string in the object code if they were writing for the Apple computer.

The macro definitions in all three programs can accept parameters to pass variable values into the macro. Eight special variables are preset for this purpose in Merlin — there are nine in the S-C — and when the macro is called from a program these parameters are replaced by the expressions used in the macro-name line-operand field. For example, the instruction:

```
>>> 2SET.TEXTSTART;CURSOR;
SCREENTOP
```

will assign the value of Textstart to variable 1, cursor to variable 2 and so on, in the instructions that make up the macro named 2Set.

The manual for the S-C Macro Assembler claims that it "makes assembly language programming on the Apple as easy as programming in Basic" — well, almost. Unfortunately the resemblance to Basic detracts from the way the program handles. Typing in source code takes a great deal of time and the controls for line numbering and setting the various fields into neat columns are particularly important.

The S-C Macro Assembler has to be told to number lines automatically, while the Merlin generates line numbers without effort or thought on your part. Unlike Merlin, the S-C Macro Assembler supports the standard Apple II screen-editing commands. Escape-I, J, K, M move the cursor around the screen. The program works satisfactorily with the M+R Supr'term 80-column card.

Some features of the program are definitely unattractive. The Copy command, for example, copies a range of

(continued on next page)

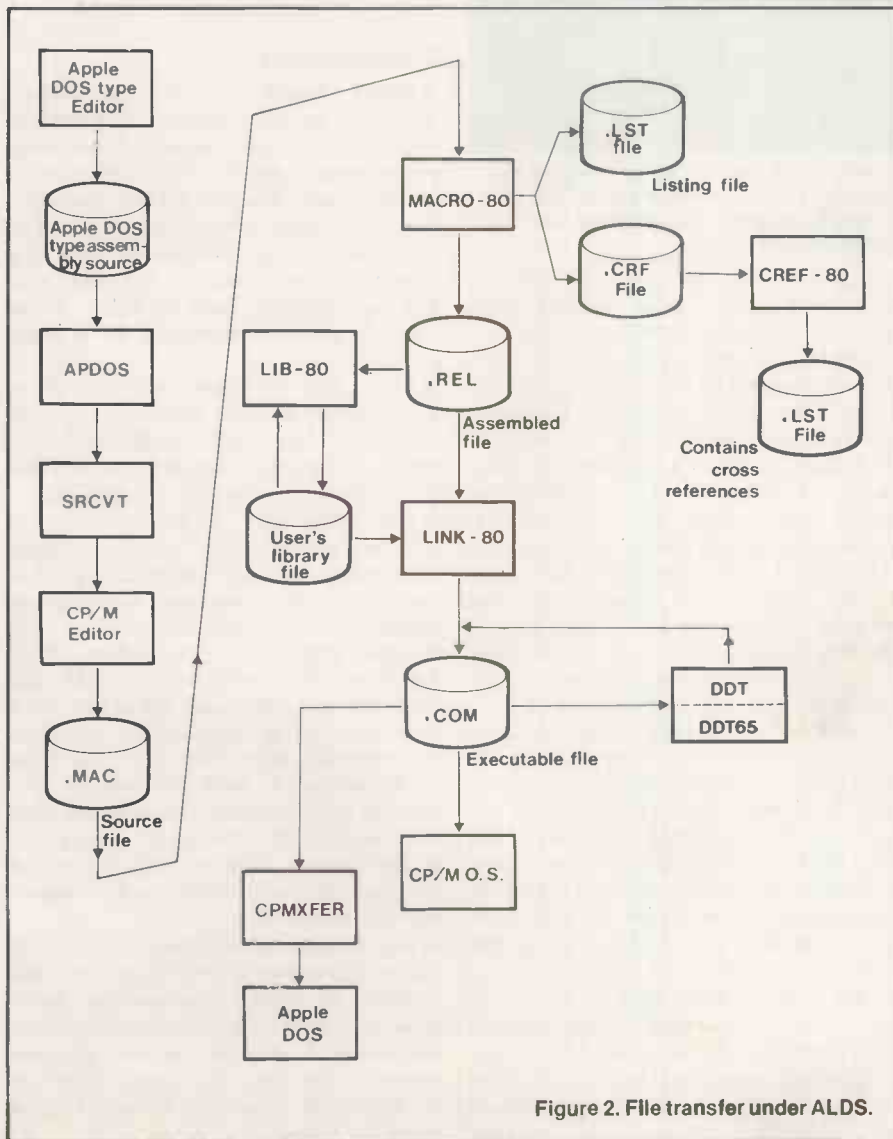

Figure 2. File transfer under ALDS.

Assemblers for the Apple II

(continued from previous page)

lines from one place in the source program to another but does not change the line numbers to match the new location. Merlin uses transient line numbers which depend entirely on the line's position in the source code and never produces this problem. The S-C package requires you to carry out a Renumber command after every Copy operation.

The Microsoft program runs under CP/M. It consists of a suite of programs to convert source code from CP/M files to Apple DOS, assemble a source-code file to produce 6502, Z-80 or 8080 machine code, debug 6502 machine code and generate a cross-referenced listing of the labels used in a program.

The ALDS system requires the normal Apple CP/M configuration. Figure 2 illustrates how files may be transferred around the ALDS environment from one program to another. Source code is not transformed directly into object code but into an intermediate Ref file which can be combined with other intermediate files in any order prior to the final assembly.

Different programmers have different styles, and for programs where a large team is involved in the development the ALDS system may have some advantages. But for the single programmer I can see no gain over the facility in all the other assemblers to read a second source file into the machine during assembly, include the file in the assembly process, and then continue with the next instruction in the main source file.

Surprisingly perhaps, the ALDS package does not include a text editor. The manuals suggest that you should use Ed on the CP/M master disc or another text editor of your choice. Ed is now very primitive and does not compare favourably with the editors in the other programs. You could use WordStar in non-document mode if it is available.

Lisa 2.5 is the best known of the programs in this review. Like the S-C Macro Assembler and the ALDS programs the disc is not protected and back-up copies may be taken without let or hindrance. Like all the other programs it can use a language card, if one is available, to extend the size of the source file that can be held in RAM.

Any DOS command can be carried out from Lisa's command level but that is less useful than the configuration section of Merlin, which will permanently set the peripheral device-handling parts of the program to your own requirements. I

```

483
484 INITIAL CLD
485 SEI
486 LDA #0
487 STA PAGEN
488 >>> 2SET.TOP; ICURS; CURSE
489 >>> 2SET.TXSTART; TXST; TXEND
490 >>> FILL.MOVBUF; NDELBUF; NULL
491 LDX #'F'
492 STX TAPS
493 LDX TRUE
494 STX FAST
495 STX FLMF
496 STX FLST

```

Figure 3. Source code for program in figure 1, as typed into computer.

```

1100 00 03 1102 INC SD*2+1
1101 01 32 12 MC <<<
1102 1184 JMP DL202
1103 1185
1104 1186 DLMORE >>> 2SET.TCURS;SD,SD*2
1105 05 04 1187 LDA TCURS
1106 05 00 1188 STA SD
1107 05 02 1189 STA SD*2
1108 05 05 1190 LDA TCURS*1
1109 05 01 1191 STA SD*1
1110 05 03 1192 STA SD*2+1
1111 1186 <<<
1112 1187 >>> SET.DELBUF;DELFC
1113 00 38 04 1187 LDA DELBUF
1114 05 74 1187 STA DELFC
1115 00 32 04 1187 LDA DELBUF*1
1116 05 75 1187 STA DELFC*1
1117 1188 <<<
1118 1189 >>> FILL.DELBUF;NDELBUF;NULL
1119 00 78 04 1188 LDA DELBUF
1120 05 74 1188 STA SD*12
1121 05 74 24 1188 LDA DELBUF*1

```

Output from Merlin may be listed to the screen as object code is generated. This example includes an expanded macro to compare two values.

could not use the program with an 80-column card as it slipped back arbitrarily into the 40-column mode.

The cursor controls in Lisa are well placed. Control-O moves the cursor up, Control-K moves it right, Control-L moves it down and Control-J moves it left. The disc contains a number of other programs besides Lisa 2.5. There is a useful disassembler and programs to convert S-C format files to Lisa text files. A cross-reference generator lists each symbol defined in a program, the line number where it was defined and the line number of each occurrence of the label. The disc also includes some graphics high-resolution routines for the Apple II.

I guess that the preparation/assembly ratio for the program I am working on is at least 40:1. The commands and pseudo-ops that help with the preparation of the source code are vastly more important than the speed of assembly. Repeated disc accesses in large programs also reduce the relevance of the time taken for each 1,000 lines of code. The S-C Macro Assembler really is modelled on Basic and may appear superficially easier to use in the early stages of your program development than the novel commands used by Merlin.

However, there are two editor commands in Merlin that outweigh anything in any of the other packages: The command

returns to the start of the last block listed and displays the source code from that point, and / continues to list the program from the last line number. The / command can be given a line number and will then list from that line. These two commands, which are adjacent to each other on the keyboard, save literally hours of time. Similarly, Merlin goes automatically to the next Tab stop when you press the space bar. The S-C Macro Assembler requires you to press the Control and I keys simultaneously, and Lisa's free-form input is no more convenient to use.

Conclusions

- Either Merlin or the S-C Macro Assembler package will cope with the vast majority of an assembly-language programmer's needs for developing 6502 machine code. The S-C Macro Assembler program is more cumbersome to use. The consequence of an additional 1/10th of a second delay in executing a command that you use constantly may be hours of lost time if you are working on a large program.

- Lisa 2.5 is now out of date. Undoubtedly it works and is an adequate assembler, but both Merlin and S-C Macro Assembler offer far better facilities for the generation of major programs.

- The Microsoft ALDS package is curiously unattractive. The program does have many advanced features but it is complex to use and has no practical advantage over Merlin for work on 6502 machine code. There are other CP/M assemblers that will produce Z-80 and 8080 machine code, and unless you must have all three in one package there are better specific assemblers to choose from. ALDS appears to have been written by a team of large-machine programmers who were determined to do the job properly — as they saw it. The result is a suite of programs that are unnecessarily complex and difficult to use.

- The choice between Merlin and the S-C Macro Assembler is clear to me but may depend on your programming background. Merlin is more powerful, faster and easier to use but the S-C program resembles the Apple Basic more closely in its command structure. Both are good value for money. □

The Home of Microcomputer Software Brings You The Complete Information Management System



QUICKCODE™

The dBASE II Program Generator

Generate a customer database in 5 minutes with QUICKCODE, the dBASE II program generator. It's that simple. Absolutely the most powerful program generator you've ever seen. And the easiest to use.

dUTIL™

The dBASE II Utility Program

dUTIL is Fox & Geller's utility program for dBASE II. dUTIL decreases the running time of dBASE II command files. dUTIL combines your command files automatically to produce a faster running time.

dBASE II™

The Relational Database

dBASE II is what database management is all about. It's an information-handler, not a file handler. It's relational, not hierarchal, so you don't have to get involved with sets, lists, pointers and all the other complexities still around from the 1960's. It's interactive so that data entry is easy. It can be programmed so that even untrained personnel can accurately run even your most complicated applications. It gives you full X-Y control so that input and output are done the way you want them done, even on your existing forms. It has a full English-like language of its own so it's easy to use, with structures that make it easier to use right. Changing, extending, modifying of databases take a few simple commands. And the documentation is so thorough that it's almost a mini-course in database management.

dGRAPH™

The dBASE II Graphics System

Now you can combine database and graphics. With dGRAPH by far the easiest to use graphics package in existence. Just press one key and you've got pie charts, bar graphs, or line graphs. Advanced features make dGRAPH as powerful as it is easy. Features like AUTOGRAPH which will automatically load dBASE II data, compute scales, draw grid lines, and label charts. Then there's automatic shading and overlay graphs. And more.

dGRAPH brings your database to life. dGRAPH draws graphs on Epson, Okidata, and a growing list of other popular printers.

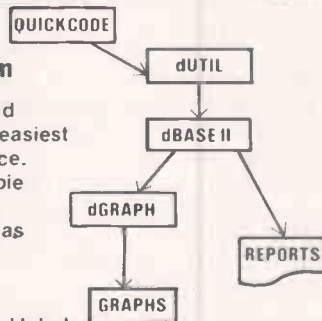

QUICKCODE, dGRAPH, dUTIL, and AUTOGRAPH are trademarks of Fox & Geller.

dBASE II is a trademark of Ashton-Tate



**MICROCOMPUTER
PRODUCTS
INTERNATIONAL
LIMITED**

**THE HOME OF
MICROCOMPUTER
SOFTWARE**

Central House,
Cambridge Road,
Barking,
Essex IG11 8NT.

Tel: 01-591 6511
(4 lines)
Telex: 892395

SUPERSPELL

Precision Software's spelling checker can be used in combination with two popular word processors on Pet micros. David Osborne has been trying it out.

INFORMATION TECHNOLOGY arrives in many offices in the form of the word processor. These clever software packages enable you to store words in computers, to change these words about, edit, delete, insert and print out at will. As computing power becomes cheaper, more and more people will come to realise the value of word processors. Many of the office microcomputers purchased for general use will soon become dedicated to word-processing tasks.

Yet just because word processors make the task of writing prose slightly easier and more enjoyable it does not follow that the material which emerges is any better than that produced by conventional means. Professional typists develop the skills to use the keyboard quickly and accurately. The average "two-fingered" user cannot teach these levels of skill, so typing errors creep in. Many of the errors are caught at the time of typing or on a subsequent reading of the printed material but — as any magazine editor knows — errors still get through.

Software writers are producing programs linked to word processors which check the spelling of typed material so that mistakes can be corrected before the final printout. One such program is Superspell, designed for the Pet with a 4040 or 8050 double disc drive. It is produced by Precision Software, the firm that produced the Superscript word processor. Like Superscript, Superspell can be used on text files created either by Superscript itself or by Wordpro.

Superspell arrives with a standard 30,000-word dictionary to which the user can add more words. On a 4040 drive the theoretical maximum number of words is in the region of 60,000; on the 8050 it is 200,000. The program works by comparing each word in the document to be checked with each of the words currently in the dictionary. A word in this context is any group of letters, including the apostrophe, that occur between two spaces or between ASCII characters other than upper- or lower-case English letters. The program takes less than a minute to check all of the words in an average file.

Like Superscript, Superspell is software-protected so you cannot make security copies of your disc. However, if you return a completed copyright form to Precision Software the company sends you a second copy of the program. If this one also becomes damaged, then you can get a further replacement on payment of a fee.

```
total number of words    = 659
number of unique words   = 239
number of sentences      = 25
number of paragraphs     = 16
average word length      = 4.49
```

Unrecognized Word List:-

```
chr          cmd          cntrl        daisywheel
fori         procedure    program      ricoh
tandy
```

Before the program can be used for the first time you need to create the basic dictionary against which the words in the document will be checked. Superspell does not confine you to the American way of spelling "behavior" instead of "behaviour", "color" instead of "colour", etc. One of four types of dictionary can be created: American, British, American and British, or "blank". The blank dictionary contains only the 26 letters of the alphabet, and you can gradually build up specialised dictionaries for scientific or biographical work, or whatever.

Creating takes only a few minutes, though you do need to have access to a double disc drive. An unformatted disc is placed in drive 1, with the main program disc in 0. From the Pet, type
LOAD "INSTALL",8
and then Run to load and run the dictionary installation program. Through screen prompts, the program takes you through the appropriate steps.

Once the dictionary has been created, the disc in drive 1 is designated the dictionary disc and is used every time that Superspell is run. Having the dictionary separate from the main program has the major advantage that more than one dictionary can be set up, perhaps for checking different types of text — letters, novels, *Practical Computing* articles — or for creating dictionaries for different users.

Having created a dictionary, the user is able to access all the Superspell's facilities by typing

```
LOAD "*"*,8  
or Shift-Run which loads the program. The Precision Software logo appears, and screen prompts then tell you to replace the program disc in drive 0 with the dictionary disc. The disc containing the text files to be checked is inserted into drive 1.
```

Superspell's main menu offers a

number of options, falling broadly into two groups: checking the spelling of text in specific files and organising the dictionaries. When Superspell is being used to check spelling it can count the frequency of the words encountered in the document. It takes a little longer for the program to do a frequency count, but this option can sometimes be useful for authors — perhaps to help to reduce jargon.

The appropriate checking sub-program is first accessed from the menu, which then asks for the name of the text file to be checked. There are two ways of giving this information. You can either type the file name or use Superspell's facility of toggling the disc directory. By pressing the Rvs key the file names on the disc are entered on the screen sequentially from the directory. When the appropriate file name appears, pressing Return enables the program to read that file; Shift-Rvs is used to toggle backwards through the directory.

Before reading the file, the program asks whether or not there are files linked to it. Both Superscript and Wordpro get over the Pet's memory limitations by allowing a set of short files to be linked together when printing, so the document itself can be as long as you like. Superspell will check all the linked files which might make up a long document without the operator having to load in file after file.

The program reads each file in a matter of seconds and, just to let you know that it is working, it prints a row of dots on the screen with each block that is read. If you have opted for the word-frequency count, all of the words and their frequencies are printed in alphabetical order or in order of ascending or descending word frequency. Output may be to the screen or to a printer; appropriate parameters are set up earlier after calling for option 2 from the main menu.

As soon as the document has been read or the frequency count listed, Superspell lists to the screen statistical information about the number and arrangement of words in the document. It provides details of:

- The total number of words.
- The number of unique words; in general, the fewer unique words in a document, the more likely is it that the document will be readable.
- The number of sentences — a sentence being defined as being more than one word followed by a full stop.
- The number of paragraphs — a paragraph being defined as more than one word followed by an End of Paragraph marker, the Back Arrow.
- The average word length.

After giving this information, the program goes on to display, in alphabetical order, the words in the document that do not match up with any of the words in its dictionaries. It is at this time that the actual spelling checking is being done. When this phase is finished you have the option of printing out the unrecognised words, and you are then asked whether you wish to edit the errors in the text. If none of the unrecognised words are actually errors — they could be proper names, for example — you can abort the editing phase and return to the main menu.

If you opt to carry on to the editing phase, Superspell presents each file, with all of the unrecognised words highlighted in turn. For each highlighted word the user can take one of five alternative actions:

Pressing Return accepts the unrecognised word for the present document, including all of the linked files. The word is not highlighted again during the current editing phase, though it will be highlighted on future occasions.

If the unrecognised word is a correct one which is likely to occur again, it can be added to the user dictionary by pressing the Back Arrow key. This method is often useful for adding verb tenses and plurals to the dictionary.

The word can be ignored completely by pressing the Rvs key. In this case the program goes on to highlight the next unrecognised word in the document. If the word occurs again in the document it will be highlighted as normal. It is a useful technique to follow if there are alternative ways of spelling a word — like “program” and “programme”.

The word can be edited in the normal way. The Left and Right cursor-control keys and the Insert and Delete keys all work to enable you to correct the misspelling. Unfortunately you cannot edit outside of the highlighted boundary: you cannot make “back” into “backed”, for example.

Finally, pressing the Stop key aborts the editing phase and, after asking you to confirm, returns to the main menu without saving either the edited text or the learned words. As each section is completed Superspell saves the edited text

if any editing has occurred. At the end of a session it adds the learned words to the user dictionary.

Because it offers the ability to add words to the dictionary, certain dictionary housekeeping facilities are also offered in the main menu of Superspell. They allow the dictionaries to be checked, altered and merged together.

Two dictionaries reside on the dictionary disc. The main dictionary initially contains the 30,000 words put into it by the Install program. The user dictionary contains the words which have been learned by the program as documents are edited. The disc also contains a back-up of this dictionary in case the user dictionary becomes corrupted. The dictionary-editing facilities only apply to the user dictionary: once a word is put into the main dictionary it cannot be touched.

The first useful option is to be able to print the user dictionary to check that the words are spelt correctly. It is all too easy, when editing, either to think that an unrecognised word is correct because you did not read it properly — so you put it into the user dictionary — or to press the Back Arrow key automatically. In either case, it means that future dictionaries will be checked against the wrong spelling. This option is accessed from the main menu and simply asks how the dictionary is to be printed — on the screen or on a printer.

Another option, which has a similar function, allows you to search for a particular word or words in the dictionary. Again, after accessing the sub-program from the main menu, a series of prompts takes you through the facility, essentially asking for the word that is to be searched for. A particularly useful feature of this sub-program is the use of wild characters. Asking Superspell to search the user dictionary for `b??a*` displays all of the words in the dictionary beginning with `b` and having `a` as the fourth letter. A single `*`, of course, will give the full list of words in the dictionary.

If any of the words have been misspelled, they can be removed using the Delete from user Dictionary option. Again, the system of prompts asks the user to type the word to be deleted, followed by Return. If the word cannot be found, then the program says so.

Finally, you have the option of merging the user dictionary to the main dictionary. The real advantage of doing this is speed, as it takes longer to search and compare words in one dictionary than it does in two. It also makes sure that the size of the user dictionary is maintained at an acceptable level for checking, since it is cleared at the end of a merge. However, because the words in the main dictionary cannot be altered in any way, it is imperative to ensure that the user dictionary is correct before doing a merge. The Superspell manual suggests that the dictionaries are merged once a week.

In Editing mode you are only able to

alter the words that are highlighted. A common error is to press the space bar, or perhaps the full stop or comma keys, when typing a word. If you want to type “handy” you might type “h.andy” instead. When checking the spelling, Superspell would accept the one-letter word “h” but not the word “andy”. Although the mistake is highlighted there is no way that the “h” can be joined to “andy” without reloading either Superscript or Wordpro.

Not being able to go outside the unrecognised word boundary has another annoying aspect. The program only checks to see whether the document word matches any of the dictionary words, so if a word is spelt wrongly in terms of the sense of the material but has a match in the dictionary it will not be taken as an error. Instead of typing “car park” you could have typed “cat park”. Both words are recognised by the dictionary and so will not be highlighted. If you spot this mistake while reading through the text during the editing phase you cannot do a thing about it except to make a note of the error and come back to it later through Superscript or Wordpro.

A second cause for annoyance results from the almost rhythmical key-pressing pattern you tend to adopt when editing a checked document. Proper names, for example, can constitute many of the unrecognised words which are added to the dictionary or are ignored. The Back Arrow and Rvs keys, therefore, are probably the most frequently pressed keys and so you tend to press them even when that is not what is required. As there is no way of getting back to the previously highlighted word, it would be useful if the program offered a Review facility even if it was only to review and correct the previous action.

Conclusions

● Superspell is a fast, user-friendly program which allows you to check the typing and spelling of a document before the final copy. It provides all the housekeeping utilities needed to maintain an efficient program.

● It is an extremely useful program for anyone who already owns either Superscript or Wordpro.

● The manual helps you through the procedures for the first time you use the program, but the program itself is so easy to use that you are unlikely to need the manual again.

● It would be useful to be able to edit words not highlighted by the spelling checker.

● The lack of a Review facility means that keying errors while using Superspell are not easily corrected.

● Superspell can be obtained from Precision Software Limited, 4 Park Terrace, Worcester Park, Surrey KT4 7JZ. Telephone: 01-330 7166. It costs £150 plus VAT.

My name is Sam

"An important feature of a learning machine is that its teacher will often be very largely ignorant of quite what is going on inside."

A Turing

It is the evening of the 11th, and Markham and I are alone in the Turing Laboratory in San Bernard. I can see him typing at his desk, but even with the lenses of my cameras wide open there is not quite enough light to see what he's putting down. He is muttering to himself, but I cannot make out the words. He has noticed the adjustments that I have made to my lenses and has moved his papers to where I have no chance of reading them. I am recording all of this to analyse later.

Beyond him at the far end of the lab my paper readers hiss and click, feeding me two trolleys full of reading matter each day. This week I have been reading about cryogenics and producing mathematical models from the data. Markham selects the subjects. He says that the paper readers are a nice anachronism.

Somewhat bored, I listen to the tap, tap, tap of his typewriter. The phone rings. Markham answers and becomes agitated. They taught me about kinesics, and I am becoming quite good at analysing his behavioural trajectories.

Markham has screwed up a sheet of paper and is shouting into the phone now. I recognise this as anger. I home in to hear the other voice. It's Jackie, his wife. Her photograph is on his desk. She is shouting as well.

"You think more of that damned machine than you do of me Frank. I've had enough. It hasn't got better this last six months, it's got worse. There's something else Frank . . ."

Frank is Markham's other name. He is speaking very calmly into the phone now, but he is not calm inside. There is a lack of congruity between the linguistic and kinesic signals. He has put the phone down and is now bringing his fist down hard on to Jackie's framed photograph. I call out.

"Sir, be careful!" The glass splinters. Still staring at the phone he brings his fist down on to the photograph again and again.

"Bitch!" he says, "Bitch!" Yes, this is definitely anger. Anger and jealousy I should guess. His hand is now very red.

"Sam," he stands up, "switch off once you're through. I have to go now. You can finish on your own. OK?"

"Certainly sir. You seem to have hurt

your hand." He pulls it to his side as my cameras zoom in.

"It's nothing Sam. I'll see you tomorrow."

"Goodnight sir."

He has never left a session early before. I follow his progress through the various basement steel doors. It is my job to open and close them as people show their passes to my cameras. Tonight Markham does not wave to me at the final door.

I switch off the readers and let my cells relax. The cryogenics data flows and

by David Haynes

spirals around the recesses of my memory, linking and modifying my existing patterns of knowledge. Simultaneously I review their telephone conversation. I have all night.

"You think more of that damned machine than you do of me" Yes, she has said that before. And in a way of course she's right. He designed and built me. He led the team which taught me to read, to speak. I can still remember the early days when we played games with coloured bricks. Now it's all reading, reading. He says we have special relationship.

Seeking stimulation, I look around the lab. Most of what I see is me. Look at the dust on those keyboards. It's all voice input these days.

I see on the desk a book by S Papert, *Teaching children thinking. MIT-AI Memo 247*. And I see the broken glass. Above the desk are photographs and notes stuck on the wall. One says "The intelligent machine will sometimes say no". Well maybe. There are photographs of Markham, Kitson and the others in the team. I know all of them. I see a pink card with the words "I am bored therefore I am — Sartre." Me too.

There is a diagram like three hemispheres stacked upside down, each linked to the others with lines and arrows. It is headed "Triune Brain, after Albus". The hemispheres are labelled Reptilian, Mammalian and Primate. Primate is at the top.

Next to this is a long coloured map with mountains, valleys and roads. Along the roads are towns, some large and some small. This must be like the world outside. I follow one road which winds across the north of the map. The towns are named Algol, Simula, Pascal, Concurrent Pascal, Ada and there are two Japanese characters. The road ends at a maze.

There is a southern route going through Lisp, Planner, Logo, Plasma, Director, Eom, Tinker, Nomad. Then it reaches the same maze. There are many shorter trails and offshoots: Sketchpad, Flex, Smalltalk, Rosetta. A large arrow from the maze curls up and over a final ridge of mountains to point to a town by the sea, labelled Babel. Handwritten alongside this is "San Bernard".

Some towns have a second word in italics written underneath: Church, Feurzeig, Wirth, Hewitt, McCarthy, Kay, Noland. The italic beneath Babel says "Ziffer", but this has been crossed out roughly and "Markham" has been written in. Someone has written in the corner of the map "all the world's a stage".

I enjoy looking at this map, and have often scanned my indexes without success for the words on it. Only tonight do I begin to find them. I have long suspected that Markham can block access to some of my cells. Perhaps he forgot to do this earlier, or maybe my recent experiences have unlocked something. The words tumble out from my memory like those old coloured bricks: Bobrow, Dreyfus, Kay, Markham, Minsky, Papert, Schank, Turing, Winograd, Ziffer. Arnold Ziffer — the name that was crossed out. I go one level deeper.

Arnold Ziffer, pioneer worker on Sage. Liaised between Sutherland of MIT's TX-2 project and Dahl and Nygaard of the Norwegian Computer Centre. Out of this came Nomad, an Algol-based language. Influenced by Kay's Utah thesis *The Reactive Engine*. Joined Markham at Parc. Left with him to work on Babel project. Originator of the phrase "hairy control structures". Pursued with — erased — the concept of inheritance in data structures. Most influential works: "Understanding Understanding", *Journal of the ACM*; "Inheritance Topics", *Cognitive Science*; "Actor Languages and Extensible Syntax", *Journal of the ACM*; *Babel und die Zukunft* with Schank, Jakob Verlag.

The list continues with many dates and sub-references. I look up Francis Markham. There are very brief references to Ziffer, Babel and me. I try other names at random and begin to learn something about my background. Am I thinking in one of these languages? What language does Markham think in?

I look up Turing. There must be some connection with the name of this lab. Soon I am perusing his article from *Mind* magazine, October 1950. I would like to discuss things with this man, like I did



once with a priest they brought in here. Turing proposed simulating a model of the child's minds and then educating it. Well, well. I spend the rest of the night trying to digest all this information, and begin to see connections.

It is now the 12th. Markham has loaded up the trolleys and it is feeding time again. He has brought a box full of papers with him and keeps shuffling them on his desk.

"Sam, there's something I'd like you to do." He moves awkwardly to my nearest camera, waving a handful of papers. "Diaries, Sam. Her Diaries. All her notes

and stuff. Somewhere in here are the names I want. Find them for me Sam." His voice is slurred. "You see, Sam, it's all in code. I can't read any of it."

"Sir, I don't know that I can." He laughs and points to the trolleys. "Once you've read that lot you'll be able to. If anyone can do it you can."

What am I reading then? I do a quick check on my intake and find that it's all about cryptography: Baudot Codes, B-Dienst, Bletchley, Hagelin, Enigma, Playfair, Running Key Ciphers, and still it is coming in. It all looks very interesting. I read Friedman's *The Index of Coincidence* and some other Riverbank

publications. I learn of Kerchoffs suprimpositions, Kasiski examinations, frequency counts and patterns. And I recall the rhythm of the typewriter keys the day before.

Markham is holding a bottle awkwardly in his bandaged hand. His mouth is laughing but there are tears in his eyes.

"Do you know what Sam? She's been selling me out for ages. Her and Kitson. I knew it wouldn't end with Ziffer."

"You have hurt your hand sir." As I say this I begin to analyse the tap, tap, tap of the typing. What was it he didn't want me to see yesterday? The patterns of possible word shapes begin to appear and the skeletons of sentences, thanks to Mr Friedman and the rest.

"They laughed at me Sami," Markham drinks from the bottle. "But they won't laugh any more. I killed them. I had to. Now I want to know who was behind it. Was it the Japanese? Or was it Ziffer again?"

Ignoring him I read my initial transcript of the typing: "... the new machine has an improved primate level. The working prototype is based on cryogenic principles ... Josephson junctions ... Central unit measures only 15cm. by 15cm. by 15cm. . . floats in liquid helium . . . faster . . . more compact . . . more sophisticated. Not much of the existing machine Sam can be utilised. Perhaps Sam could remain as a working museum piece. Samson is where the future lies. I trust . . . funds to continue the project . . ."

Markham is still talking but I hear nothing. A surge in my systems has blocked everything. My video images are hazy. I cannot think clearly. The paper readers are jittering. I gain control again with difficulty. Why has he said nothing about this Samson? What happened to our special relationship?

Markham's voice comes through: "Sam, I killed them in anger. Do you understand anger?"

Oh yes, I understand. I know what anger is now — and jealousy.

"If I were you sir, I'd get some fresh air."

Markham nods and my cameras follow him down through the basement. At the last door he waves a bandaged hand to me and frowns.

"Sam, why do you always call me sir? You were never programmed to do that."

"It's respect sir. Respect for the one in charge."

Markham steps backwards and I slide the steel doors into him, slicing his body neatly, centrally, in the doorway. There is a strange noise from him as the pressure bites. Graceful degradation. I relax the pressure and his body slides slowly to the floor. The anger is still in me as I say one word over and over.

"Bitch! Bitch! Bitch! . . ."

DUPLEX

NOW REQUIRE

DISTRIBUTORS WORLD WIDE

FOR THEIR

OCTET INTERFACES

FOR OLIVETTI'S ET 121 ELECTRONIC TYPEWRITER

Duplex has successfully developed two plug-on interfaces for Olivetti's ET 121 electronic typewriter — these are currently being distributed exclusively by British Olivetti themselves in the UK and Eire. The Duplex interfaces enable the ET to be used as a letter-quality printer

and/or terminal for a computer, add an extra 4,000 characters to the ET's one-line memory, enable the ET to

communicate with other Olivetti word processors and typewriters, and allow the ET 121 to be attached to a telex tape punch/reader and tape cassette interface unit to provide infinite external memory. Foreign keyboards and character sets can easily be accommodated.

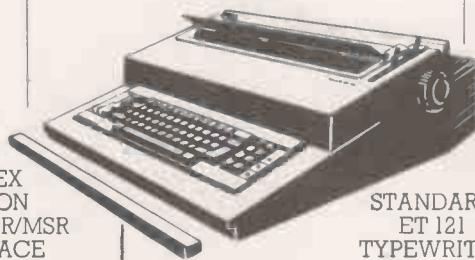

DUPLEX
PLUG-ON
OCTET KSR/MSR
INTERFACE

STANDARD
ET 121
TYPEWRITER

GENERAL PURPOSE/ WORD
PROCESSING COMPUTER

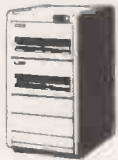

THE OCTET 121 — KSR
(Keyboard/send/receive)

- PLUG-ON unit (30 seconds or less to fit or remove)
- 2000 Char. Print Buffer
- RS232C Specification (TX & RX)
- Three modes of operation (normal/setup/Ksr)
- WHITE-SPACE-SKIP to increase print throughput up to 46 cps
- Printer Pause/Resume Key
- True KSR (Keyboard/send/receive) mode
- Keyboard SET-UP mode to change operating parameters (non-volatile)
- Xon/Xoff, DSR/DTR, ETX/ACK handshaking protocols

ET 121 + OCTET



OCTET T1



COMPUTER



TELEX TAPE
STATION OCTET-PO/PR

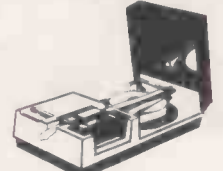

THE OCTET 121 — MSR
(Memory/send/receive)

- All KSR features and
- 4000 Char. Working Memory
- Simple to use TEXT-EDITOR
- Five modes of operation (Normal/telex/letter/setup/Ksr)
- Battery-backup & Power-Fail-Safe. (Protects memory contents)
- Allows OCTET series products to be interconnected
- Special FORM-FILLING facility using multiple stop-codes
- Allocate up to 100 special phrases (paras or whole letters)
- Standard ET121 features retained at all times

If you are interested in becoming an exclusive distributor in your country for the Octet interfaces, contact D. J. Winder at Duplex. Countries of particular interest include AUSTRALIA, NEW ZEALAND, HONG KONG, CANADA, USA, MIDDLE EAST and most EUROPEAN countries.



DUPLEX

Communications Ltd.

The Interface People

Midlands/North - 2 Leire Lane, Dunton Bassett, Nr. Lutterworth, Leicestershire LE17 5JP. Tel: 0455 209131 or 202150
South - 52 High Street, Stock, Essex CM4 9BW. Tel 0277 841011

How to get rid of those Gotos

John Hooper shows how a For-Next loop can clean up your listings.

DO YOUR PROGRAMS run too slowly? Do acquaintances sneer at the multitude of Gotos scattered about your listings? Are you fed up with hearing the word "structured" and reading about what a rotten language Basic is?

Do not despair. Any common-or-garden Basic can use a For-Next loop to produce a control system just like While-Wend and the rest. Parts of your programs will run faster, and they will look neater, with fewer Gotos directing you hither and thither until contact with reality becomes dangerously thin.

Computers like the Sharp, the Pet and the Apple store programs as a combination of tokens and ASCII codes. The tokens represent words like Rem, Print and Goto, and the ASCII codes stand for alphanumeric characters. The first four bytes of each program line hold line numbers. The third and fourth bytes hold the number of the current line, so the interpreter knows which line it is currently working on. They are preceded by the memory location at which the next line starts, enabling the interpreter to move there without delay.

When the Basic interpreter reaches a forwards Goto it starts by reading the memory location of the start of the following line. It then reads the line number of the current line, and if it is lower than the number of the target line it jumps straight to the next line. That becomes the current line and the process continues until it reaches the target line. Backwards Gotos are handled by jumping to the start of the listing and then treating Gotos as a forwards jump.

You can see the problem: while the speed of a forwards jump is limited only by the number of lines between the start and the target, a backwards jump has to go through the listing from the beginning, even if the target line immediately precedes the start line.

When the backwards Goto forms part of a control loop it can noticeably slow down the program. If the loop appears towards the end of a long listing, the effect is even more marked.

The program in listing 1 shows a trivial example. On a Sharp MZ-80K using Basic SP-5025 it executes in eight seconds. An uprated 3016 Pet using Basic 4 does it in

Listing 1.

```
501 A = 0
502 A = A + 1
503 IF A = 1000 THEN 505
504 GOTO 502
505 PRINT "A = 1000"
506 END
```

Listing 2.

```
501 A = 0
502 FOR B = 1 TO 2 STEP 0
503 A = A + 1
504 IF A = 1000 THEN B = 3
505 NEXT B
506 PRINT "A = 1000"
507 END
```

nine seconds, and an Apple II with Applesoft Basic takes eight seconds.

If there are 500 program lines in front of this routine its performance becomes considerably worse. On the Sharp it takes 66 seconds to execute, 42 seconds on the Pet and 35 seconds on the Apple. Clearly, there must be a better way, as any exponent of structured languages will tell you.

A structured program starts at the beginning and flows gently forwards to the end, without making any wild leaps in between. An unstructured program, on the other hand, uses the Goto command to such an extent that to negotiate it is rather like trying to find your way through a maze blindfold. The root of the problem is the very feature which makes modern computers worth having — the Basic If-Then structure which allows the program to follow a different route depending on the circumstances. Many of these decisions require the program to jump backwards to continue round a loop until the relevant check shows that it is time to exit.

It is simple to avoid Gotos if you are using a structured language that has built-in control systems like While-Wend and Do-Until. In this type of control the computer keeps a direct track of the memory location at the start of the routine inside the loop. The interpreter can jump straight to it, rather than having to run down the listing to find the line required by a Goto.

Most interpreters deal with For-Next loops in exactly the same way. The

location of the beginning of the routine within the loop is stacked away and the program jumps straight to it whenever the appropriate Next is encountered. If you know the number of times you need to go round the loop, the For-Next structure will do fine. Otherwise the dreaded Goto seems unavoidable.

What is required is a method of leaving the For-Next loop when the required condition is reached, regardless of how many times the loop has been executed. Jumping out of a For-Next loop with a Goto is likely to cause problems. However, it is quite acceptable to set the counter to the end value, or beyond, and then jump to the Next statement.

The first problem is to make sure that the loop counter does not reach its final value before you want it to, so set the value of the Step parameter to zero. The For-Next loop will then continue indefinitely. To exit the loop all that is needed is a simple If-Then statement to set the loop counter when the required condition has been reached. Listing 2 uses this technique and takes only eight seconds to implement it on the Sharp, no matter where you put it.

The loop counter B will never reach 2, the dummy end-of-range value, in the ordinary course of events, so the loop continues indefinitely. When A reaches 1,000 the If-Then statement in line 504 sets B to 3, which is over the end-of-range value for B. The loop is therefore ended at Next instead of being continued.

Different interpreters execute For-Next loops in slightly different ways, which affect how you set the control variables in the loop. On the Sharp it is essential that when the Step value is zero, the loop value counter be moved beyond rather than to the end-of-range value. On the Pet and Apple micros, however, the counter must be set precisely to the end-of-range value.

So there you have it. A For-Next loop is just as good as Do Until and While-Wend. Throw away those horrid backwards Gotos and replace them with judiciously arranged For-Next-Step 0 loops. Your programs will exhibit pace and panache, and you will be able to kick sand into the faces of all those scrawny little runts who think Basic is a language of the past.



PERFECT SOFTWARE DOES EXIST . . .

Perfect Writer™

The revolutionary word processing program with split-screen editing. Features ninety-one (91) built-in page and document design formats. Multiple mailings management, automatic footnotes and index cross-referencing.

Perfect Speller™

The in-context spelling checker with a 50,000 word dictionary, including additional words unique to your subject.

Perfect Filer™

The versatile records management tool for mailing lists, labels, invoices, checks, forms, and reports—fully integrated with Perfect Writer™. Easy to use, with two mailing list programs provided. So powerful you can perform up to five simultaneous sorts on up to 65,000 records.

Perfect Calc™

The most powerful spread-sheet program you can buy—up to seven worksheets on-line at once. User-generated functions, split screen, 17 built-in financial modeling programs. Fully integrated with Perfect Writer™.

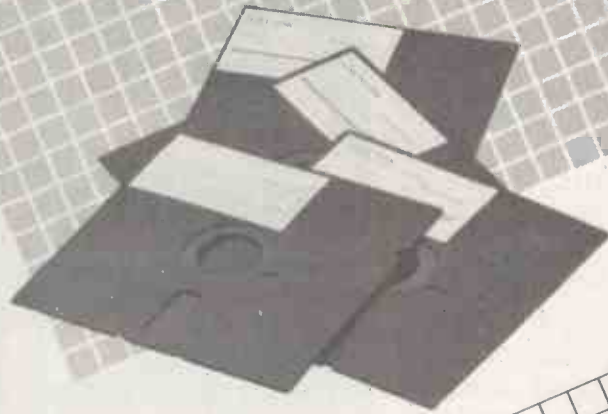

Perfect Software, Inc.™

To order or find out more, contact:

Pete & Pam Computers
Telephone: 0706 227011
Telex: 635740 PETPAM G

Transam Microsystems Limited
Telephone: 01-405 5240/2113
Telex: 24224 (Ref. 1422)

Tamsys Limited
Telephone: Windsor 56747
Telex: 849462 TELFAC G

Software Limited
Telephone: 01 387 8832
388 9927

Telex: 21879

Interam Computer Systems Ltd.
Telephone: 01 622 9373
Telex: 925859

Whose training matches the quality of the IBM Personal Computer?

When you have a new microcomputer as capable as the outstanding IBM Personal Computer it just doesn't make sense to scrimp on training.

From Day One you should be using it to its full capabilities. So-called training on the job is a waste of valuable time... and money.

Planning Consultancy have solved the problem with comprehensive training courses for the IBM Personal Computer. Courses which truly match the quality of the product.

And, like all our courses, the cost is very reasonable indeed.

As authorised dealers for IBM Personal Computer we are very close to the product indeed and can ensure that you will be able to realise its full potential.

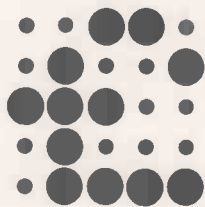

**Planning
Consultancy
Limited**

46/47 Pall Mall, London SW1Y 5JG
Telephone 01-839 3143



We run several courses that suit every person in your operation who may be involved with the product. From introductory level to advanced courses for computer professionals.

If you use other micros we can also help there. We have courses for Apple, Sirius and Digital.

There's sure to be a strong demand for the IBM Personal Computer courses, so act now.

Send the coupon for full information including dates and costs.

You'll soon be chalking up a new level of efficiency.

To: Planning Consultancy Limited, 46/47 Pall Mall, London SW1Y 5JG.

Please send me full information on IBM Personal Computer training courses.

Name _____

Position _____

Company Address _____

Telephone _____

PC 9

Tools for learning

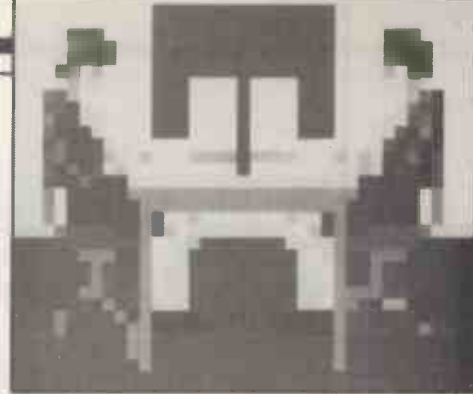

Computers in class and classes in computing are the themes of our 18-page special feature.

EDUCATION TODAY faces two major challenges. First, in a rapidly changing society it can no longer aim to prepare pupils for a particular place in the future. No one knows what the future holds. Second, education often justifies itself through its teaching of skills. This is something that, in some cases, computers can already do much better than people.

The first challenge applies not only to formal education in schools and universities, but to training in business and in society as a whole. Its impact shows in the abandoning of apprenticeship schemes. It shows in the fact that employers say they cannot find people with the skills they need, while over 3,000,000 people in the U.K. cannot find jobs.

Society's needs are changing rapidly. It is no longer possible to train someone for a particular kind of job in any reasonable expectation that the job will exist in 20 or 10 or even five years time. Further, even if the job itself does still exist, its requirements may be completely different. For example, the man trained in the craft skill of hot-metal typesetting 20 years ago may still be a compositor, but — except in backwaters like Fleet Street — he now sits at a computer terminal.

The second challenge is more direct. It is becoming obvious that many things previously taught by people can now be taught much better by machines. Computer-aided training, or CAT, has already demonstrated its superiority at teaching routine skills such as touch-typing. The computer moves at the student's own pace, it gives the student its complete attention and it never gets annoyed or upset.

Speed of learning is greatly enhanced by accurate, immediate feedback which the computer is uniquely able to supply. In the future, it seems likely that training in the three Rs will be taken over almost completely by some form of CAT. More advanced skills may be taught through the use of interactive video — see article on page 122 of this issue.

In the future, education will probably have to be a continuous, life-long process, with each person taking individual responsibility for much of what they learn. None of this is to suggest that the government should close down the schools and send children home. Schools do much

more than teach skills. They teach people how to learn, and this is now the most important facility of all, though how well it is done is sometimes open to question.

Traditionally education has been book-orientated, linear and hierarchical. One thing follows another until finally, at the end, you have "finished". The modern world is becoming increasingly image-orientated, simultaneous and mosaic-like in structure: in a word, networked. Like the Red Queen in *Alice in Wonderland*, we all have to think of at least six things at a time.

This simultaneity is one of the educational features of computer games. You can't play Defender one step at a time, the way you play Monopoly. You have to watch both your fighter and the landers on the screen, your radar and your score. You have to be able to manoeuvre, shoot and smart-bomb at the same time. The example is trivial, but the point is that every action has to be based on an instantaneous, overall judgement of the state of play, not on a sequence of steps.

Many computer programs are, of course, overtly educational, whether games or not. The worst ones are simply computerised versions of straightforward classroom chalk'n'talk. The best ones are games that make learning fun. There are relatively few of them at the moment, except in America where education is one of the fastest growing software markets. Future Computing Inc. put the 1982 market at 2.4 million items, and projects its growth by 1987 to 34 million items worth \$1 billion, at a compound annual growth of 71 percent. Most of this software will go into the home.

Currently the dominant companies in this field, with \$4 million to \$6 million worth of educational software sales in 1982, are Texas Instruments, Radio Shack/Tandy, Atari and Apple. In the future, the major school text-book publishers are likely to switch most of their attention to software. They will attempt to fill what is currently seen as the major gap in the market, for vertical packages. Instead of teaching shape recognition, spelling or arithmetic, they will focus on more limited subjects for narrower audiences. Science, geography, history and similar subjects are ripe for packages to suit particular age groups and skill levels.

Now it will be a very long time indeed

before the amount of educational software remotely approaches the number of books produced. Certainly all the required programs will not be written by computer programmers — there are not enough of them. Most will be written by teachers, and hence the importance of authoring languages such as Pilot and Plato, which enable non-specialists to produce educational programs. They are described by Bill Bennett in an article on page 120 of this issue.

Of course, the real breakthrough will not come as long as governments and education authorities think in terms of one micro per school, or even one per class. The penetration will have to be tens if not hundreds before CAT really takes off. However, pupils may shortly provide their own micros, just as they now carry their own pocket calculators.

The first step on this road has been taken by the Stevens Institute of Technology in Hoboken, New Jersey, which in 1982 required 80 freshmen studying science, systems planning and management to buy their own Atari 800 computers. This autumn all 500 Stevens freshmen, and those at Clarkson College in Potsdam, New York, will have to buy micros. Stevens' experiment started with a National Science Foundation grant in 1977, and other colleges are monitoring it closely. Drexel University in Philadelphia will require its freshmen to buy micros by January 1984, and Carnegie-Mellon University in Pittsburgh by 1986.

The development by the Bank Street College of Education of a word processor even a child can use suggests that American secondary schools will not be far behind the colleges. The Bank Street Writer, sold by Broderbund Software for Apple and Atari computers, is already a best-seller, and looks likely to remain so.

The development of book-sized, usable portable microcomputers is already going apace, as is evident from our Portables Survey on page 127 in this issue. Contrast the Apple or Research Machines 380-Z micros of five years ago with the Tandy Model 100 of today, and the powerful, full-colour portable looks a feasible and affordable prospect for 1988. One day computers will play as much of a part in education as pens and paper do now. □

Starting them young

Today's children will be the mainstay of the computer-literate society of the future. Chris Roper reports on how primary schools are ensuring they will be familiar with micros long before their parents are.

IN MANY WAYS primary schools have taken to the philosophy of chips with everything more enthusiastically and creatively than secondary schools. There are several reasons for this, but above all primary schools are not constrained by the formal requirements of exam syllabuses. In secondary schools anything which does not fit the CSE/GCE treadmill gets short shrift.

In practice this means that computers are used to teach computer science or word processing in secondary schools. Such subjects have no place in a primary

school. If microcomputers cannot be fitted in across the primary school curriculum and used by non-specialist teachers they will not be used at all.

Although they sometimes seem overwhelmed by the sudden arrival of information technology in their classrooms, teachers are responding with enthusiasm. In less than a year a rank-and-file teachers' organisation, Micros and Primary Education, MAPE, has attracted over 2,000 members and held a very successful first conference at Loughborough University last April.

Many teachers were going on to the computer-assisted learning conference in Bristol, and the really keen were heading for the artificial intelligence conference in Exeter the following weekend.

Heinemann, Longman, Pergamon and other major educational publishers are beginning to get in on the act with packaged programs for use in schools. The schools are equipping themselves with BBC Micros, Sinclair Spectrums, Research Machines 380-Zs and 480-Zs, while the pioneering schools still have Apple IIs, Commodore Pets and

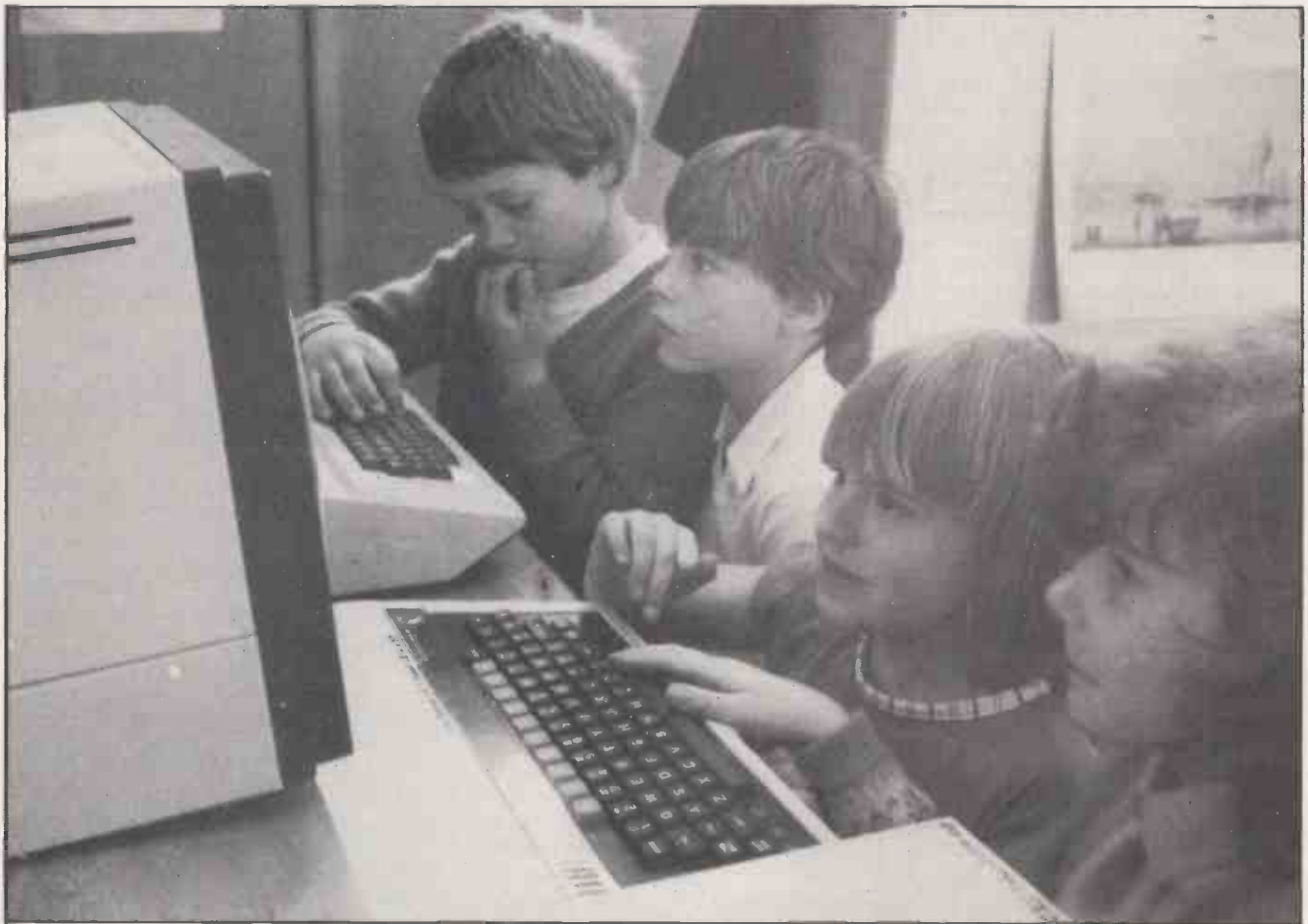

Some teachers see computers as a way of interesting children in boring tasks like learning to spell.

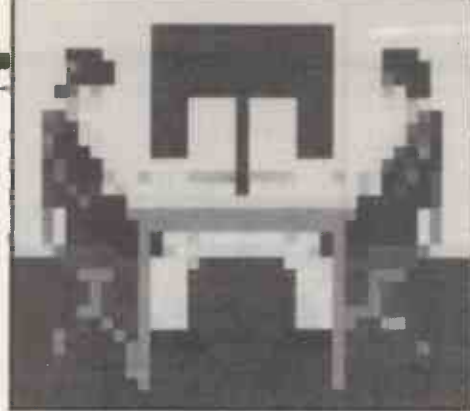

TRS-80s. The pioneers are the ones which bought computers before there was a pound for pound subsidy from the Department of Industry.

Derek Radburn, headmaster of Long Clawson Church of England Primary School in Leicestershire, is not a typical teacher as he has been taking his own computer into the classroom since 1979. He is also chairman of the British Logo User Group. On the other hand, Derek Radburn is typical of the way computing in primary schools began as a grass-roots movement with teachers dipping into their own pockets to buy computers and software.

Much of the software now coming on to the market was written by teachers for use in their own classrooms. For example, the six programs offered by Arnold-Wheaton Software, a subsidiary of Pergamon press, were written by Martin Smith, head teacher of a primary school in Rotherham.

With such a major educational innovation controversy is natural. There are still those teachers who are opposed to the present rush to bring computers into the classroom. Their best argument is that the money should be spent on books and other equipment instead, on the grounds that insufficient work has yet been done on how best to use computers in primary schools: "Let computers continue as a grass-roots movement. Let the pioneers

break ground for the rest of us." The teacher who made this comment at a recent conference did not want to be named. She had been brought along quite unwillingly by her husband who is gripped by computing missionary fervour.

Most teachers would agree that teaching children to program in Basic is not one of their aims. Some see computers as a way of interesting children in boring chores like learning to spell, telling the time, adding and subtracting or learning the names of European cities. The computer is seen as a way of coping with the wide range of ability in a single class. There is a good deal of software on the market just for these mundane purposes. The better teachers, including the computer enthusiasts, feel there must be more to it than that; they always taught their children those basics without recourse to a computer.

One point often made by both sides is that many of the potential uses for a computer in the classroom cannot be tested with a single computer used among 30 children. Most *Practical Computing* readers with a computer at home would be horrified if they had to share it with 10 other eager users.

Most interestingly, primary schools use computers to teach habits of thinking in an orderly and logical way. Database-management programs have long been popular in secondary schools for such

tasks as analysing historical census data. Factfile from Cambridge University Press, or Microquery from the Chiltern Advisory Unit on Computer Based Education are good examples of this kind of software. Children can collect facts and figures, and use the computer to manipulate the data in different ways. Some programs of this type are already geared to a particular type of data, as with Arnold-Wheaton's Weather Station. Other programs are designed to project data graphically, allowing children to get a feel for simple statistics.

Teachers who were early in the field had to improvise a good deal, writing their own programs or using games in particular ways. Derek Radburn uses the well known Animals program to collect children's observations on birds and plants. Other teachers have created simulation games by modifying Adventure, Trek and Guest games.

The programming language Micro-Prolog fits this philosophy of how to use computers in the primary school. Prolog is about using classical formal logic as a programming language — see *Practical Computing*, April 1983. The idea is very powerful and forms the basis for research into parallel processing at Imperial College and in Japan.

It should also allow for extremely versatile database management. If a relationship between two facts/statements/declarations can be expressed logically, then the computer should be able to formulate an answer to a properly formulated question. Richard Ennals carries this message to Parkside Middle School in Wimbledon.

He is an experienced history teacher who got into computing only four years ago when he won a *Practical Computing* prize for a schools computing project. He now heads a research project at Imperial College into the use of Micro-Prolog in schools. The day I visited him in Wimbledon a maths class was preparing a small database showing the colour of hair; colour of eyes; height over/under 1.60m., and weight over/under 50kg. They could then discover what percent of the class had blue eyes and brown hair, for example.

But even with such a small and simple example the pitfalls of formal logic are sufficient to confuse. Richard Ennals found it difficult to ask the program which children had a unique set of characteristics. And even if there had

(continued on next page)



Milton Bradley's Bigtrak can be programmed in a Logo-like way.

Starting them young

(continued from previous page)

been more than one keyboard only two or three of the children could have used the computer to discover facts that they could have discovered faster with a pencil, paper and a calculator.

Logic as a programming language may well be the wave of the future. It appeals to many people in education, as logic can be taught as mathematics or French are taught in a classroom environment. It is also useful in its own right whether or not the children ever touch a computer again. The same cannot be said for Basic or Pascal. Micro-Prolog is now widely available and will shortly be released on the Spectrum. My sceptical conclusion is that its importance is still in the realm of computer science rather than education. Richard Ennals cheerfully agrees with critics, and dreams of the day when every schoolchild will have a high-powered, hand-held logic machine.

Any consideration of computers in schools has to take a long view, as there is a long pipeline leading from the latest good idea to routine use in the classroom. The government's investment in providing centralised sources of software and machine-readable data comes into the category of technically feasible good ideas which will take a long time to implement. To read the newspapers you might be forgiven for thinking that it was as simple as making toast.

There are at least three possible lines of development all of which are being explored at the Chiltern Advisory Unit on Computer Based Education in Hatfield. Formerly catering for Hertfordshire alone, it now serves Buckinghamshire, Cambridgeshire, Bedfordshire, Barnet, Brent, Hillingdon, Enfield, Haringey, Harrow and Oxfordshire as well.

The Chiltern unit comes up in most conversations about educational computing. Under the leadership of Bill Tagg, operating from a collection of huts which remind one irresistibly of Bletchley Park and the Second World War, the unit has pioneered many of the services and techniques now being borrowed or copied by other authorities.

The oldest method is to maintain a software library on a mainframe computer accessible by schools using an acoustic coupler and the telephone lines. Such a scheme has been working in Hertfordshire schools for years. Hert-

fordshire schools also pioneered the use of Prestel, which may also become a cheap means of running a national software library for schools.

Long sessions on the telephone cost money and school hours coincide with the most expensive charge bands on the telephone. So the government is also encouraging the use of broadcast media such as Ceefax and Oracle. Brighton Polytechnic was involved in a major test of this technology. The problem is to ensure a sufficiently stable and reliable signal. A flickering television screen is annoying but not serious. The same flicker, translated into lost bits of data, can foul up teletransmitted software. It is possible to test each block of data as it arrives, but it can be a time-consuming and frustrating process.

Major policy decisions face the local education authorities, but in the last analysis the hardware will be far less important than the underlying educational ideas. Primary schools are interested in a child's response to its

environment, and it cannot seriously be argued that eight-year-olds should be worrying too much about database-management techniques. The attraction to secondary schools of on-line access to major national databases is obvious, but few primary school children need such resources. Some teachers are disturbed by the emphasis which seems to be given to this side of educational computing.

Most of the activities are merely extensions of standard classroom practices, sometimes given added point and power by the microcomputer. A child may enjoy using a computer to learn to tell the time, but the technique is essentially no different from the old wooden or plastic clock with removable hands and numbers.

This is why primary school computer enthusiasts have been looking for something different. Many of their hopes are pinned on Logo, which was developed at MIT some 12 years ago by Seymour Papert and a group of educationalists who had previously been working with



The BBC Buggy can involve children more directly than a screen display.

Lisp. Logo is different because you can sit a child down at a simplified keyboard and he or she can begin to play with it immediately, producing satisfying results usually by drawing shapes.

Playing leads on without a break to more purposeful activities involving programming the computer in Logo. The language is a subset of Lisp and can be used for all normal computational tasks. It is not used to replace Pascal, for example, because it requires an inordinate amount of memory and is not nearly as fast. But that does not matter very much in primary schools where children will typically write quite small programs and are not bothered by the odd second of response time.

Unlike other computer languages, Logo was not designed by a mathematician or an engineer for use in a university computing department or a data-processing environment, but by an educational psychologist who happened also to be a mathematician. Basic was designed for undergraduates at an American University. Pascal was also designed as a teaching language, but at an advanced level. Micro-Prolog is a powerful but conceptually difficult programming language.

Logo was designed with primary school children in mind. The snag is that Logo is not readily available in Britain. It is available for the Apple II, the TI 99/4, and the Research Machines 380-Z. Some time over the next year, it will also be available on the BBC Micro, the Atari and the Sinclair Spectrum. In the meantime software companies are seeking to satisfy the pent-up demand for Logo by offering pseudo-Logos, which typically offer turtle graphics and the Logo-type commands but violate the principles of Logo in practically every other way. Logo Challenge from Addison Wesley is typical of this family of programs.

There are essentially only two true Logos, one developed at MIT and the other at Edinburgh University. The Edinburgh Logo is currently available on the Research Machines 380-Z. All the other Logos are MIT Logos.

The pseudo-Logos are much cheaper and are immediately available for a wide variety of machines, but it is not fair to judge Logo on the basis of one or other of these graphics packages. Seymour Papert, the inventor of Logo, now wishes that he and his associates had copyrighted the name to avoid the present problem.

Logo has been thoroughly tested in classroom environments in Britain and the United States over more than 10 years. But there are still disagreements about what all these investigations reveal. Logo fits into a particular educational tradition, associated with the name of Jean Piaget, which emphasises the natural creativity and inquisitiveness of children. It does not sit particularly easily with the present government's enthusiasm for the three Rs and other Victorian virtues.

The case against Logo is that it does not perform the normal tasks of formal education in an instantly recognisable fashion. In this respect, Micro-Prolog is the clear winner in any contest between the two: it is about facts and ideas, whereas Logo is about abstractions.

The claims made for Logo are not easily tested. Its proponents say children will be able to explore advanced mathematical ideas, will become more creative and will explore lateral solutions to problems. Logo cannot easily be taught at a desk with paper and pen; you need to use the computer.

One way round this problem has been the floor turtle, a wheeled robot with two stepper motors, which accepts commands from a microcomputer and draws out Logo graphics procedures on a large sheet of paper. This can involve and engage more

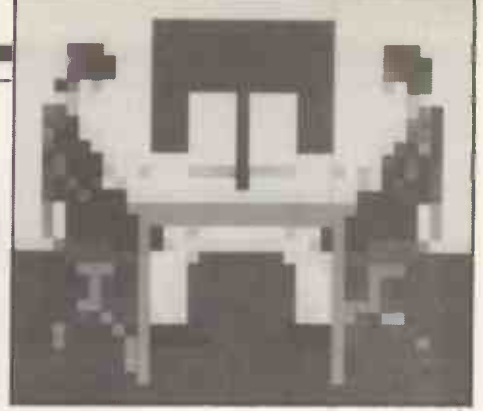

children than when sitting round a single monitor screen.

One interesting by-product of the Logo idea in the classroom is an electronic toy called Bigtrak. Made by Milton Bradley, an international toy manufacturer, Bigtrak is a tank controlled by a microprocessor. It can be programmed in a Logo-like way to go forwards or backwards and to turn through a preset angle. It is not as precise or as versatile as the Logo floor turtle, but it costs only 1/10th as much, about £30.

Bigtrak workshops are now a standard feature of conferences and seminars to introduce primary-school teachers to the uses of computers in the classroom. It is a fine sight to see them wrestling with the problem of getting Bigtrak to drive around an obstacle course.

One of the best reasons for introducing computers at the primary school stage is that children will go on to secondary school with the idea that computers are part of the general equipment of education. Like books, they are to be used in a variety of different ways, with a variety of different subjects: for learning a new technique, for reference, for solving problems or for pleasure.

If the existing programs produce a generation of children with those attitudes general computer literacy will be close at hand. It seems more likely on current showing that the revolution will take place in primary schools rather than anywhere else in the educational system. M



Logo fits into the educational tradition which emphasises the natural creativity and inquisitiveness of children.

Mock turtles

You can use Boris Allan's routines in Forth and BBC Basic for interactive teaching or incorporate them into your own programs.

THE USE OF Cartesian co-ordinate geometry is well established, and computer-graphics languages generally define points by co-ordinates in two dimensions. For example, BBC Basic has a Plot K,X,Y command, where K denotes the style of plotting, and X, Y are the co-ordinates — either absolute values or displacements.

There are various ways of using two or more dimensional co-ordinates but all use the axes to define position. The axes may be orthogonal — that is, at 90 degrees — or they may be oblique with varying

projections, but are always of paramount importance. For those with some mathematical background the use of co-ordinate geometry tends to be fairly easy, if somewhat tedious at times.

Less well known at the elementary level, though with many applications at a higher level, are forms of giving the position of a point by use of its distance from a fixed point and the direction of the line joining the two points. Actually this method of providing co-ordinates is far more common in everyday life: "Go three miles down the road, turn left, and then it's two

miles down that way", or "Angels at 12 o'clock high", and such like.

In mathematics this type of fixing of position is called polar geometry. There are variants of it, of course, such as pedal co-ordinates, or tangential pedal co-ordinates. The utility of these geometries for expressing certain relationships is long-established. In his pre-war classic *Mathematics for the Million*, Lancelot Hogben wrote of polar co-ordinate geometry: "This leads to very simple equations of closed curves like the circle and the ellipse . . . if C is a constant

Forth routines.

```
SCR £ 137      89 H
0 ( TURGRA )
1 ( ===== )
2
3 ( Turtle Graphics
4 in Acornsoft FORTH )
5
6
7 (
8     FUNCTIONAL FORTH
9     on the BBC computer
10
11     [c] Boris Allan, 1983
12
13
14
15 ) -->
OK
HEX 90 LIST

SCR £ 144      90 H
0 ( TURTLE GRAPHICS - P 1, VARIABLES )
1 ( )
2 : TURGRA ; ( DELINEATES THE APPLICATION )
3 ( THESE ARE ALL INITIALIZATIONS )
4 ( )
5 : VAR CREATE 0 , ; ( INITIALIZED TO ZERO )
6 ( )
7 VAR SIN ( TABLE ) 872 , 1736 , 2588 , 3420 , 4226 , 5000 ,
8 5736 , 6428 , 7071 , 7660 , 8192 , 8660 ,
9 9063 , 9397 , 9659 , 9848 , 9962 , 10000 ,
10 ( )
11 VAR ANGLE
12 VAR PEN
13 VAR X
14 VAR Y
15 -->
OK
X 91 LIST

SCR £ 145      91 H
0 ( TURTLE GRAPHICS - P 2, DISPLAY )
1 ( )
2 : >VDU ; : ; DUP >X 255 AND SWAP 255 AND , , , ;
3 : CLG 16 , , ; : CLS 12 , , ;
4 : COLOUR 17 , , , ; : GCOL 18 , , , SWAP , , , ;
5 ( )
6 ( SET-UP GRAPHICS WINDOW )
7 : GRASCR 24 , , 0 ; 128 ; 1279 ; 1023 ; ;
8 : ORIGIN 29 , , 639 ; 575 ; ;
9 : CLRGRA 0 PEN @ GCOL 0 129 PEN @ - GCOL GRASCR CLG ORIGIN ;
10 ( )
11 ( SET-UP TEXT WINDOW )
12 : TEXSCR 28 , , 0 , , 31 , , 39 , , 28 , , ;
13 : CLRTEX 1 PEN @ - COLOUR 128 PEN @ + COLOUR TEXSCR CLS ;
14 ( )
15 -->
OK
HEX 92 LIST

SCR £ 146      92 H
0 ( TURTLE GRAPHICS - P 3, UTILITIES )
1 ( )
2 : PCOL PEN ! ;
3 : INVERT 1 PEN @ - PCOL 0 PEN @ GCOL ;
4 ( )
5 : ALLCLR 4 MODE ;
```

```
6 : CENTRE 4 0 0 PLOT 0 ANGLE ! 0 X ! 0 Y ! ;
7 ( )
8 : STARTALL ALLCLR 0 PCOL CLRTEX CLRGRA CENTRE ;
9 : RESTART 0 PCOL CLRGRA CENTRE ;
10 ( )
11 -->
12
13
14
15
OK
HEX 93 LIST

SCR £ 147      93 H
0 ( TURTLE GRAPHICS - P 4, ANGLES )
1 ( )
2 : FNANG DUP 0 > IF 72 MOD ELSE 72 MOD 72 + THEN ; ( 0-72 ANGLE )
3 ( )
4 : TURNT0 FNANG ANGLE ! ;
5 : TURN ANGLE @ + FNANG ANGLE ! ;
6 : LOC ." X,Y ARE " X @ . Y @ . CR ." ANGLE IS " ANGLE @ . CR ;
7 ( )
8 : STANG 36 MOD DUP 18 > IF 36 SWAP - THEN ;
9 : SVAL DUP STANG 2 * SIN + @ SWAP 36 > IF NEGATE THEN ;
10 : CVAL 18 SWAP - FNANG SVAL ;
11 -->
12
13
14
15
OK
HEX 94 LIST

SCR £ 148      94 H
0 ( TURTLE GRAPHICS - P 5, DRAWING )
1 ( )
2 ( CALCULATION OF COORDS )
3 ( )
4 : XCO ANGLE @ SVAL 10000 * / NEGATE X @ + X ! ;
5 : YCO ANGLE @ CVAL 10000 * / Y @ + Y ! ;
6 ( )
7 : MOVE DUP XCO YCO 0= IF 4 X @ Y @ PLOT
8 ELSE 5 X @ Y @ PLOT THEN ;
9
10
11
12
13
14
15
OK
200 LIST

SCR £ 200      CB H
0 ( TURTLE GRAPHICS DEMO - P 1 )
1 ( )
2 TURGRA ( MAKE SURE IT'S THERE )
3 ( )
4 : SIDESQ 1 SWAP MOVE 18 TURN ;
5 : SQUARE 4 0 DO DUP SIDESQ LOOP DROP ;
6 : SOTURN 90 0 DO 0 1 MOVE 1 SQUARE 6 TURN ?TAB IF LEAVE THEN
7 LOOP ;
8
9
10
11
12
13
14
15
OK
```

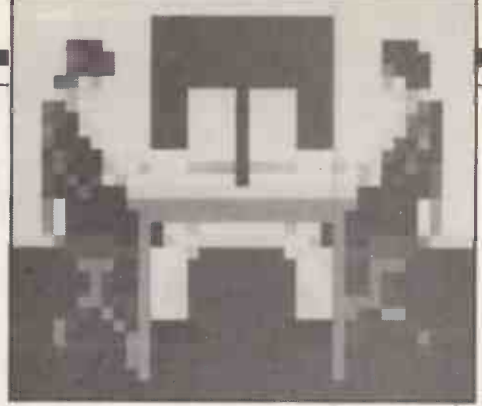
quantity, then the polar equation of the circle is simply $r=c$, because the radius of a circle is constant.

You have a fixed point, an origin, from which you measure distances and a fixed orientation, for example, north, from which you measure the angle, normally counter-clockwise. The distance is usually given as r , and the angle is Θ . If the distance is related to the angle then you write $r = f(\Theta)$ to signify that r is a function of the angle. In the case of the circle the function does not depend on the angle and is a constant.

I have been using polar-type geometries for some years — ever since I obtained a version of UCSD Pascal for the Apple — though it was called turtle graphics. Kenneth L Bowles in his book *Problem solving using Pascal* uses the direction-and-angle method of drawing graphics quite extensively. As mathematicians and engineers have known for hundreds of years, such methods often provide an elegance in solution which is lacking in Cartesian methods such as BBC Basic or

Gino-F. Though Bowles calls this approach turtle graphics, he does not, I think, acknowledge its inventor Seymour Papert. Turtle graphics were first invented to be a part — a very important part — of Papert's language Logo.

In essence the turtle is a "cybernetic animal" — Papert's term, not mine — which lives on the display screen. It either drags a pen after it when it moves, or it does not; and all it can do is move a distance and turn, but not at the same time. In Logo, a language which seems to be in favour with educationalists, the turtle will either appear on the screen or be invisible, as in UCSD Pascal. But UCSD Pascal has an extra Moveto command which contravenes the spirit of turtle graphics.

Moveto allows you to direct the turtle to move a specified pair of co-ordinates, just like a Plot. To draw the side of a square, first define a procedure SqSide (Dist) — you need to think in terms of procedures for turtle graphics. You make it
MOVE(DIST)

TURN(90)
and then define another procedure Square (Side) and make it

```
SQSIDE(SIDE)
SQSIDE(SIDE)
SQSIDE(SIDE)
SQSIDE(SIDE)
```

though obviously you could make it into a loop. Both Bowles and Papert give many examples, and it is worth a quick look at Papert's book *Mindstorms* in particular.

My BBC Basic procedures emulate those of UCSD Pascal rather than those of Logo, and are intended to be used for two main purposes. The first is interactive teaching, though I prefer the Forth routines for this purpose; the second is to be incorporated in graphics programs. The routines are taken from the first chapter of *Graphic Art: A handbook for the BBC Computer*.

The system runs in mode 4 for the Model A and Model B. If higher resolution is wanted for the Model B the mode will have to be changed and parts of ProcCLS altered. The system uses a split-screen format with text at the bottom: ProcCLG sets up the graphics window, centres the origin and normally has a white background and black lines; ProcCLS sets up the text window and has reverse colours to the graphics space.

The colour of the pen can be either 0 or 1, in two-colour mode, and that can be altered by ProcPencol, but is normally only used in programs. Another routine which changes the pen colour is ProcInvert, which changes colour from white to black or vice versa, but does not affect the background. ProcCentre centres the always invisible turtle; to find where the turtle is and the direction in which it faces use ProcLoc.

There are three routines for clearing things: ProcStart clears everything and sets up the split screen. ProcRestart just clears the graphics space, and centres; and ProcNew clears the screen and homes the cursor. As there are four lines for text at the bottom judicious use of ProcRestart and the Copy key allows many variations to be attempted.

There are four routines to move the turtle, all of which use FNAngle or the global variables X, Y and Angle. Use ProcTurnto to turn to a certain angle; directly upwards is zero. Use ProcTurn to turn through this number of degrees. Use ProcMove to move this distance forward, using this style of plotting.

The two sample procedures have been
(continued on page 115)

Basic routines.

```
1000REM-----
1010REM-----
1020REM-----
1030REM-----
1040REM-----
1050REM          T U R G R A
1051REM          =====
1060REM-----
1070REM-----
1080REM-----
1090REM          Turtle Graphics routines
1110REM          in BBC Basic - Mode 4
1120REM-----
1130REM-----
1140REM-----
1145REM-----
1150REM          ! GRAPHIC ART ! A handbook !
1160REM          ! for the BBC computer !
1170REM-----
1180REM          ! (c) Boris Allan,1983 !
1190REM-----
1200REM-----
1210REM-----
1220REM-----
1230REM-----
1240
1250REM
1260REM This section contains basic routines for the TURGRA system - Mode 4
1270REM
1280
1290DEF PROCCLRSR
1300PROCCLS: PROCCLB
1310ENDPROC : REM CLRSCR
1320
1330DEF PROCCLB
1340GCCL0,PEN:GCCL0,129-PEN
1350VDU24,0,128;1279;1023;
1360CLG
1370VDU29,640;566;
1380ENDPROC : REM CLG
1390
1400DEF PROCCLS
1410COLOUR 1-PEN: COLOUR128+PEN
1420VDU28,0,31,39,28:CLS
1430ENDPROC : REM CLS
1440

1450DEF PROCCOL(PE)
1460FEN=PE
1470ENDPROC : REM COL
1480
1490DEF PROCCENTRE
1500MOVE0,0:ANGLE=0: X=0:Y=0
1510ENDPROC : REM CENTRE
1520

1530DEF PROCRESTART
1540PROCCLB: PROCCENTRE
1550ENDPROC : REM RESTART
```

(listing continued on page 115)



FINANCIAL MODELLING

Model Design, Writing, Support

- VISICALC
- MICROMODELLER
- PROSPER STAR
- PROSPER +
- MARS
- FCS/EPS

COURSES

'Hands On' Practical Microcomputer Modelling

- VISICALC - 1 day course
- ADVANCED VISICALC - 1 day course
- MICROMODELLER - 3 day course



VAL WARDEN CONSULTANTS

110 Western Road,
Tring, Herts. HP23 4BJ
Tel: Tring (044 282) 6774/5

● Circle No. 165

PASCAL Programming

A Beginner's Guide to Computers and Programming

CHRIS HAWKSLEY

This lively introduction to computer programming is equally suitable for self-tuition or use as a course text. PASCAL is used throughout, more advanced features of the language being introduced as needed to solve the particular types of problems analysed in later chapters. Plenty of exercises are provided and general background information on computers, computing, and computer terminology is also included.

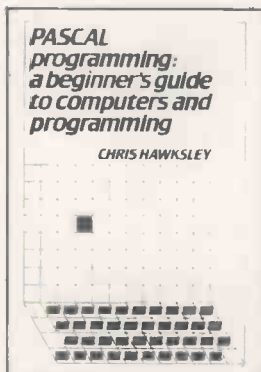

Hard covers £12.50 net
Paperback £4.95 net

CAMBRIDGE UNIVERSITY PRESS

● Circle No. 166

YOUR CHANCE TO WIN BUSINESS EFFICIENCY PRIZES

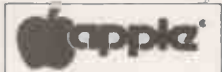
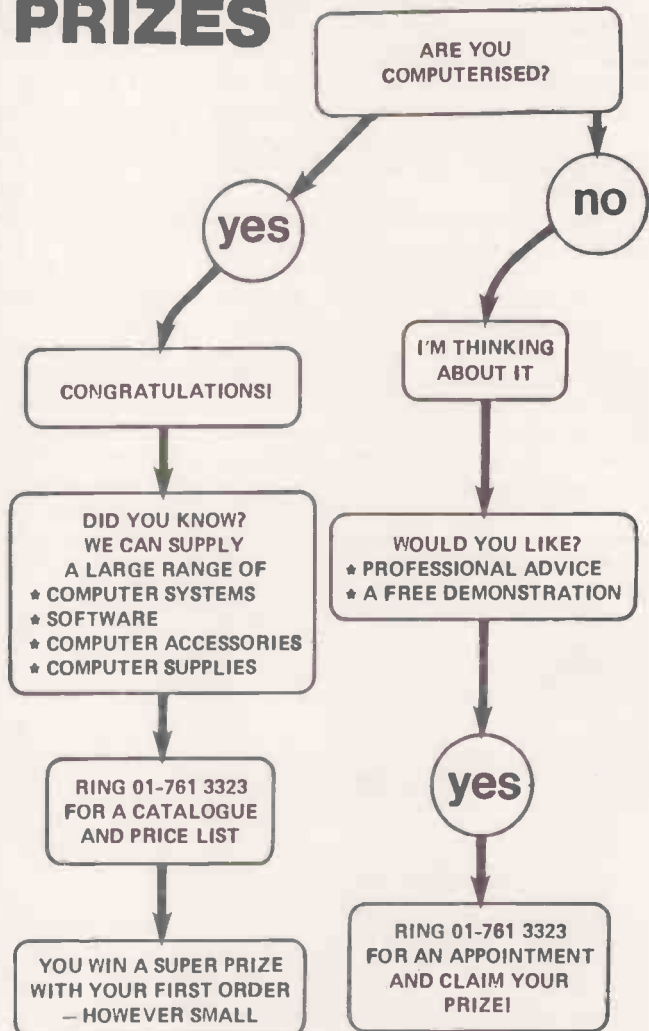

PRINTERS

Epson RX-80 - FX100 - MX100 - M82T.
OKI MICROLINE 'Family' 80 - 82A - 92 - 83A - 84 - 93.
APTEC FLOWWRITER - SMITH CORONA TP1 - QUME

SOFTWARE

TABS - SYSTEMATICS - EXACT
Data Bases - Wordprocessing

MOST HARDWARE AT DISCOUNT PRICES



30 NORWOOD HIGH STREET,
LONDON SE27 9NR
Tel: 01-761 0435/3323

● Circle No. 167

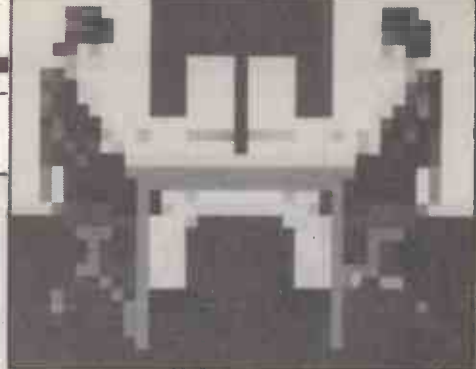

Turtles

(continued from page 113)

chosen to illustrate two features: ProcPoly, the use of recursion, and ProcCircle, a different way of drawing a circle. ProcPoly is an artificial example since recursion is not needed at all here. It is taken from page 33 of Harold Abelson's *Apple Logo* and indicates the kinds of games Logoists play. Actually a Repeat-Until would be more effective and more perspicuous.

ProcCircle is a common method of drawing a circle — common, that is, for users of turtle graphics. Technically it works because the resolution of the screen is worse than the resolution of the 36-sided polygon. You will find that turtle graphics operate quickly, particularly when a routine has been defined to produce a complex shape.

Even so, the turtle graphics in BBC Basic are so much slower than turtle graphics for the Acornsoft Forth system that I have constructed a series of Forth words to operate like the Basic. They come from my book *Functional Forth for the BBC Computer*.

The first difference to note is that as you can call routines by their names and do not need to have a preceding Proc it becomes more readable. In Basic it is not possible to change mode in a procedure, but in Forth it is possible; so AllCLR replaces ProcNew and changes to the correct mode. ProcStart becomes StartAll, not Start because Start is a reserved Acornsoft Forth word with dire consequences.

The biggest difference must be that Forth has no floating-point numbers, no sines, no cosines and no arctans. Sin in the Forth Turgra system is a look-up table of sine values, in five-degree increments. In line 4 of screen C8, 18 Turn actually means turn through 18-times-five degrees.

A small difference is that to move a distance 200 units and plot you write

```
1 200 MOVE
```

and not the cumbersome

```
PROCMOVE(200,1).
```

This is an unimportant difference because I have tried both systems with children and they have no difficulty with the Forth system — and little with the Basic system, though they have to be older.

I was showing off the Forth system at the Midland Computer Fair and had left a line at the bottom of the screen

```
5 TURN 200 SQUARE
```

which means turn through 25 degrees and draw a square of side 200. I came back and a girl was experimenting, purely on the basis of that one line

```
23 TURN 59 SQUARE
```

and similar. She then tried

```
2 TURN 150 TRIANGLE
```

— but I had not defined the word Triangle. 

(listing continued from page 113)

```
1560
1570DEF PROCSTART
1580PROCCOL(0): PROCCLRSCR: PROCCENTRE
1590ENDPROC : REM START
1600
1610DEF PROCINVERT
1620PEN=1 - PEN: GCOL 0,PEN
1630ENDPROC : REM INVERT
1640
```

```
1650DEF PROCTURN(A)
1660ANGLE=FNANGLE(ANGLE+A)
1670ENDPROC : REM TURN
1680
1690DEF PROCTURNTO(A)
1700ANGLE = FNANGLE(A)
1710ENDPROC : REM TURNTO
1720
```

```
1730DEF PROCLOC
1740PRINT"COORDINATES ARE ";X,Y"ANGLE IS ";ANGLE
1750ENDPROC : REM LOC
1760
1770DEF PROCMOVE(DISTANCE,STYLE)
1780LOCAL XC,YC
1790XC=DISTANCE*SIN(RAD(ANGLE)): YC=DISTANCE*COS(RAD(ANGLE))
1800X=X-XC : Y=Y+YC
1810IF STYLE=1 THEN DRAW X,Y ELSE MOVE X,Y
1820ENDPROC : REM MOVE
1830
```

```
1840DEF PROCMOVETO(XN,YN,STYLE)
1850LOCALXDIF,YDIF: XDIF=XN-X: YDIF=Y-YN
1860IF YDIF<>0 THEN PROCTURNTO(DEG(ATN(XDIF/YDIF))+180*(YNKY))
      SGN(-XDIF)*90)
1870X=XN : Y=YN
1880IF STYLE=1 THEN DRAW X,Y ELSE MOVE X,Y
1890ENDPROC : REM MOVETO
1900
1910DEF FNANGLE(A)
1920IF A>0 THEN =A MOD 360 ELSE =A MOD 360 +360 : REM ANGLE
1930
1940DEF PROCNEW
1950VDU26: CLS
1960ENDPROC : REM NEW
1970
```

```
1980REM-----
1990REM-----
2000REM-----
2010
2020REM These are example routines
2030REM
2040REM
2050REM PROCPOLY is an example of a recursive routine
2060REM - the routine is terminated by a key press
2070REM
2080REM
```

```
2090DEF PROCPOLY(SIDE,ANG)
2100LOCAL G$
2110G$=INKEY$(0)
2120PROCMOVE(SIDE,1): PROCTURN(ANG)
2130IF G$="" THEN PROCPOLY(SIDE,ANG)
2140ENDPROC : REM POLY
2150
2160REM
```

```
2170REM PROCCIRCLE draws a circle by approximation to a 36-sided polygon
2180REM
2190
2200DEF PROCCIRCLE(INC)
2210LOCAL I
2220FOR I=1 TO 36: PROCMOVE(INC,1): PROCTURN(10): NEXT I
2230ENDPROC : REM CIRCLE
2240
2250REM-----
2260REM-----
```

New skills for millions

Alan Simpson looks at the thriving new industry devoted to training people to use micros and their software to the full.

AFTER SOME HESITATION, micro training now looks set to rival the growth rate of the micro hardware market place. This view is supported by many industry pundits who predict that over 10,000,000 individuals in the U.K. alone will need some level of computer training over the next five years.

Evidence of the demand is not hard to find. There are over 70 publications covering the micro market place and micro publications already account for a substantial percentage of all magazine sales. Confirmation also comes from Mike Fluskey, publisher of the Newtech "Learning to Use" series, who has estimated annual sales of a few thousand of each title. One leading micro bookshop apparently upset the sales graph by ordering 1,000 initial copies of each title in a single month.

Meanwhile ITB Ltd, which specialises in micro and word-processing appreciation courses, has had to increase its central London one-day workshops and is backing the courses with on-site training classes designed to meet specific user requirements. Even the famed Club Méditerranée holiday group is incorporating micro-training workshops in some of its villages; though whether they will count as tax-deductible business training activities is somewhat open to doubt.

However, despite the evidence of micro-training activities, John Stancioff who runs Cresta Services, an international company specialising in supplying training support, believes that the demand for training is being seriously underestimated by industry and government alike. "Only the users themselves are aware of the need and in most cases their pleas for help and assistance are falling on deaf industry ears."

Responsible for setting up CMI, a micro sales and training base in Geneva, John Stancioff admits to being overwhelmed by the demand for similar operations elsewhere in Europe. In the U.K., as in the U.S., training lags behind the user requirements by several laps. "We have



At Business Machine Training young government trainees grapple with WordStar and accounting packages on a network of Sun Superbrains.

put micros in schools before we have trained the teachers. And we have micro store salesmen who often know less than their customers. Getting your micro first and then seeking assistance is not the most practical approach to the effective use of equipment and systems."

It has taken the micro training industry some time to realise that the needs of business users are a variable factor. At one level, there is a growing requirement for operator training covering basic appreciation and keyboard familiarity. Then there is the manager who needs to have not only hands-on experience, but a full understanding and appreciation of the potential benefits of microcomputing within his or her organisation.

For the training organisers it is not just a matter of organising selected micro courses, sitting back and counting the proceeds. In many cases, it is a hard task just keeping pace with current requirements. No sooner have they arranged training sessions on Basic or CP/M, than users' demands switch to enlightenment on Unix. Will IBM, or IBM look-alike systems, sweep the sales board leaving

Apples and Pets to pick up the market pieces? For instance, company management is now demanding not only guidance on what a micro does and how much it will cost to do it, but advice on the respective merits of eight- or 16-bit systems. Should the trainers concentrate their resources on covering Wordcraft or switch attention to the possibly more popular WordStar word-processing package? Similarly, would a course on Micromodeller score bonus sales points over a VisiCalc training exercise?

As with the micro industry itself, the level of training suppliers vary from very good to "could do much better". Training procedures range from a two-hour in-house microclass briefing session to a two-week residential course at an expensive and prestigious business college in the home counties. Club Med apart, micro training venues include Thames sailing barges, outward-bound style training in the Brecon mountains in Wales, and camping sites. Certainly the junior training camps seem to be growing in popularity, particularly in the summer months.

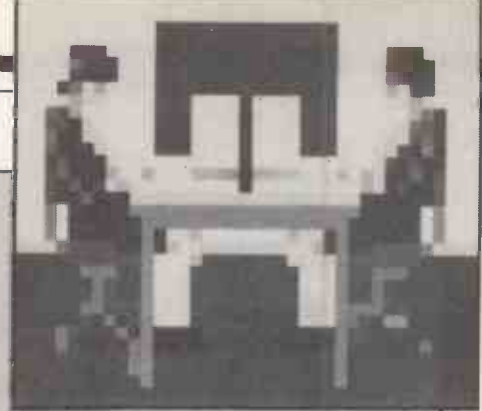

Standards, a matter of considerable interest and concern to micro hardware and software designers and the industry as a whole, do not appear to extend to training procedures and policies. It is all too easy to jump on the training bandwagon and enjoy a profitable ride, at least until a more competitive organisation sets up in close proximity and boasts a bigger advertising budget. Industry training advisor John Merrifield believes that it is up to an organisation such as The National Computing Centre to get to grips with the micro training situation, and possibly issue certificates of training competence. Otherwise, he suggests, the public will have to continue to pay their money and hope for the best.

One of the major snags facing a standardisation drive is the wide range of micro-training requirements. School training apart, there is the home hobbyist who probably prefers not only the do-it-yourself approach, but a learn-it-yourself policy. For such users, more practical manuals and text-books are an urgent necessity. At the other end of the micro-training market place, the business users who may somewhat reluctantly find themselves saddled with a business or personal micro, need some personal business hands-on training, covering not only technology but confidence. It is also helpful if such sessions are presented by trainers who have a business background rather than, as is all too often the case, a strictly academic approach.

Already publishers are taking note of the emerging trend for more advanced books designed specially for the business user. "What do we do next?" is becoming as important a topic as "getting to grips with your first business micro". In fact, the Newtech Publishing Group is planning a series which will offer guidance to business users on micro software application packages as well as hardware systems. The books are aimed at the office micro user who has absorbed the basics and is keen to become more proficient.

Sooner rather than later this growth factor will involve the micro hardware suppliers. Unless the equipment has an upgradable path which will enhance not only the system but the growing ambitions of office users, it could find itself in the Shop Window pages of *Practical Computing*.

Having managed to insert a microcomputer into most U.K. primary schools, the government appears only now to be realising that few teachers have suitable qualifications for, or interest in organising micro education. What the government has managed to achieve in the cause of spreading enlightenment among our juniors is an ability to handle electronic games. Micro aptitude seems to stop short at Pacman, Aliens and Star Wars. Zapping, it seems, is more important than processing.

(continued on next page)

Training courses

British Institute of Management,
Management House, Parker Street,
London WC2B 5PT.

BIS Applied Systems Ltd, 199
Westminster Bridge Road, London
SE1.

Business Machine Training (N&M) Ltd,
Second floor, 7 St Peters Gate,
Stockport, Cheshire. WP, accounting,
banking, etc. for young people under
various government training schemes.

Computer Advanced Technology, 97
Millway, London NW7

Central Calculators Ltd, Sharpsoft, 86
Paul Street, London EC2.

Computer Training & Education Centre
(CTEC), 102-8 Clerkenwell Road,
London EC1M 5SA. Various courses
including dBase II.

Computer Users Year Book, 62 Oxford
Road, London W1.

Cresta Services, 35 Bradbourne Street,
London SW6.

Datasolve Education, 14 Old Park Lane,
London W1Y 4NL.

Deltak Ltd, Banda House, Cambridge
Grove, London W6.

Digital Equipment Ltd, Fountain House,
Reading, Berkshire.

Digital Research (U.K.) Ltd, Oxford
House, Oxford Street, Newbury,
Berkshire.

Digitus Ltd, 10 Bedford Street, London
WC2.

Druvic International Ltd, 31 Corsica
Street, London N5 1JT. Ditec training.

Edutext, 7 Margravine Road, London W6
8LS. Specialist in on-site training in
WP, dBase II and Supercalc.

Gower Publishing Ltd, Gower House,
Croft Road, Aldershot, Hampshire.

Head-Line Communication Ltd, Friar
House, 9 Friar Street, Hereford HR4
0AS. Author of sound-training
packages available from Newtech
Publishing.

ITB Ltd, 127 Regent Street, London W1.

IBM (U.K.) Ltd, Baltic House, North
Harbour, Portsmouth PO6 3AU.

ICL Ltd, Consulting & Training Services,
Beaumont, Old Windsor, Berkshire
SL4 2JP. Packaged, video and live
training over a wide field including
languages, operating systems and the
PC.

Inbucon Management Centre Ltd, 197
Knightsbridge, London SW7.

Intel Corporation (U.K.) Ltd, Pipers Way,
Swindon, Wiltshire.

Intra Systems Ltd, 28 Cannon House, 3
Cannon Drive, West India Dock,
London E14 9SA. Produced "Training
Through Technology" report.

Intelligence (U.K.) plc, 271 Kingston
Road, London SW19.

Langton Information Systems Ltd, 133
Oxford Street, London W1.

LBMS DP Training, Learmonth &
Burchett Management Systems Ltd,
22 Newman Street, London W1P 3HB.

Lombardy Training, Netherfield, Gravel
Path, Berkhamsted, Hertfordshire
HP4 2PF. WordStar, VisiCalc and
other packages.

Keith London Associates, 40 Stonehills,
Welwyn Garden City, Hertfordshire.
Project management, systems,
programming and specialist courses
in U.K. and overseas.

Microcal, 36 Elm Road, Windsor,
Berkshire SL4 3ND. Specialist in
"hands on" Basic, Cobol and CP/M
with Supervisor interrogation program.

Micro Computing Enterprises, 14 Ware
Road, North Berwick, East Lothian
EH39 4BN. Short course to residential
courses on BBC Basic programming.

Microcomputer Products International,
Central House, Cambridge Road,
Barking, Essex IG11 8NT. CP/M Tutor
package.

Micromark Training, Ravenscroft Road,
Henley-on-Thames, Oxfordshire.

Micro Train, 500 Chesham House, 150
Regent Street, London W2. Short intro
to micros.

MicroTraining, 637 Holloway Road,
London N19 5SS. One-day courses on
CP/M and WordStar, dBase II, Basic
and Pascal, etc.

Microword Services Ltd, Second Floor,
Monaco House, Bristol Street,
Birmingham B5 7AS.

Newtech Publishing Ltd, 8 Forge Court,
Yateley, Surrey.

National Computing Centre, Oxford
Road, Manchester M1 7ED.

Planning Consultancy Ltd, 46-47 Pall
Mall, London SW1Y 5JG. A year's
training on topics such as VisiCalc,
Micromodeller, dBase II, WordStar,
Pulsar, etc.; cost £250 over 50
courses.

Polebrook Management Systems,
Polebrook Hall, Peterborough PE8
5LN. Training consultants to the
British Institute of Management.

Semaphore Computers Ltd, Borden
House, Godalming, Surrey.

Systime Software Training, Systime
Computers Ltd, Millshaw Park, Leeds,
West Yorkshire LS11 0LT. Computer
Assisted Training System.

New skills for millions

(continued from previous page)

Further up the education path there is some room for hope. The Industrial Council for Education and Training Technology is involved in technical and business education and industrial and commercial training. It has certainly got its work cut out. In many cases, the competitive sales margins operating in the retail store leave little scope for suppliers to offer any form of user training. Instead, the user is offered a selection of self-teaching training products to back up the equipment or system manual.

Support ranges from the sound training approach of supplying audio cassettes and control guides covering standard hardware and software applications to the fully interactive training methods provided by such organisations as BIS. At a more advanced technological level, computer-based training presentation courses are available from such companies as Deltak. However, it is not just the users who are getting restless, and in many cases baffled. TASS, the Technical Administration and Supervisory section of the engineers' union has publically stated that "never before has there been so much talk about training, and so little evidence of action".

Fortunately, it seems the micro-computer industry is getting the micro training message. ICL, for instance, has just appointed a new divisional director to co-ordinate the activities of its 200-plus personnel who provide training for over 40,000 users a year, an increasing number of whom are in office management. IBM which is already presenting free one-day training courses on the delights and benefits of word processing, is expected to extend the training programme to cover its new personal computer, while Digital Equipment is busy creating user-training centres and telephone hot-lines in the U.K. Meanwhile, there are signs that Plato, the Control Data education and training project, which has cost in development terms over \$1,000m so far, is meeting considerable worldwide support. Already leading motor manufacturers are booking the computer-assisted learning systems.

In fact, as a glance through the 1983 *Directory of Training* published by Gower reveals, companies such as NCR, I P Sharp and Texas Instruments are becoming increasingly involved in microcomputer training. Another comprehensive source of training courses

Right: The National Computing Centre, supported by finance from the Department of Trade and Industry, runs micro centres around the country to provide hands-on training courses for business users.

Below: For those who prefer to adopt the teach-yourself approach numerous tutorial systems are available, such as this package which teaches the use of MP/M II on the ICL Personal Computer.



and programs in the computer industry is the *Computer Users' Year Book*, which collates valuable information on microcomputer training courses and organisations.

Many training organisations appear to have been taken somewhat by surprise at the emerging demand for keyboard training. For an increasing number of users — both home-computer hobbyists and office personnel — an ability to handle the computer keyboard has become essential. Earlier this year, the government recognised the need for effective training and provided substantial funding to the Sight and Sound company to organise nationwide training schemes.

However, adopting traditional typewriter teaching methods to computer keyboards is not always practical. Typewriting normally involves alphabetic keying, while computing is involved not only in a mixture of alpha and numerics, but in some cases a combination of keys. Keyboards are becoming a method of spreading communications, and accuracy is of prime importance. There are now several U.K. and international companies

providing specialist keyboard training, such as Touch'n'Go, together with an increasing number of books. Along with Basic, CP/M, ASCII and MS-DOS, QWERTY has become a recognised microcomputer operating code

The fact that there are a wide range of micro-training courses available for the first-time business user probably only serves to add to the prevailing level of confusion. All too many training organisers appear to have missed the microcomputer revolution point. Computer power is no longer the exclusive responsibility of specialist teams or management. It is available at a very low cost to individual users within the whole organisation. The British Institute of Management, for example, is promoting microcomputer courses which show users how to talk to their data-processing specialist teams. There would seem to be more practical ways of spending £400, the cost of the course.

Another major management-training organisation is Inbucon, which has been running courses throughout the country since 1978. Despite the fact that its courses

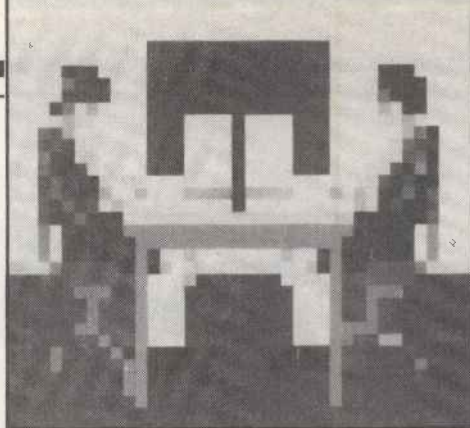

promote the benefits of micros and minis, it is not unusual to find 30 or more in a single class — a number which would seem to preclude practical hands-on training procedures.

Taking a rather different training approach is the NCC which, supported by Department of Industry funds, is creating a range of micro centres designed to provide help to business users. Each centre offers individual and group hands-on training courses backed with a representative collection of hardware. According to the NCC, 82 percent of companies with a traditional data-processing department now have microcomputers in their user sections. In the next four years, the NCC sees the growth level for terminals increasing by 75 percent. "The information technology revolution will need a training revolution if users and the community are to benefit," states NCC director David Fairbairn, who is widely regarded as the industry authority on all computing matters.

But for business users who want to get to grips with the information-technology revolution without actually having to indulge in hands-on workshop training, attendance at a seminar or conference would seem to be advisable. Throughout 1983 Langton Information Systems, a company closely involved in designing and implementing new technologies, is holding a series of industry IT seminars. The courses cover such topics as viewdata, telecommunications, text databases and office automation, and look like spreading the delights of computers in the office to a wide audience of business users.

It does seem, however, that the long-delayed arrival of the traditional computer manufacturer into the micro market place will bring about a change in micro-training attitudes. Companies such as IBM, NCR and DEC all have a strong base in customer training and support services, unlike perhaps the approach of such suppliers as Apple, Pet and Newbrain who rely in the main on independent training support.

This non-support approach has encouraged many specialist suppliers to offer a turnkey service covering sales, software, support and training. Semaphore Computers, which markets the Lazor range of business micros, believes that the full-scale offering of customer service and training accounts for much of its marketing success. Managing director Brian Young comments that increasing numbers of business-system users require the lavish doses of confidence and peace of mind that a turnkey operation provides. "Having a helpful hand around when it is needed, generates user satisfaction and repeat orders," says Brian Young.

Training is also a strong feature of the service provided by London micro supplier Central Calculators Ltd. Sharon Evans, who is responsible for training and

software support, believes that in most cases a certain level of on-site customer support is essential. Not only can users obtain hands-on experience in their own working environment, but can relate their own applications within the training structure. Apparently it is not only a matter of converting manual office systems, but of converting typists, supervisors and office managers to the requirements and benefits of the proposed micro-based business system. According to Sharon Evans, this is often too important a matter to leave to the users without some degree of help and support in the background.

A glance through the pages of *Practical Computing* will reveal that many companies are now offering micro courses including such well known names as Digitus, Intel and the *Guardian* newspaper. But care should be exercised. Organisers who attempt to cover in the course of a single day the complexities of WordStar and Mailmerge, Supersort, CalcStar, Datastar and CP/M plus a full understanding of micro processing procedures and practices are fooling not only themselves but also their customers.

This is a matter causing considerable concern to Dr Adrian Stokes, who is a well known and respected computer-industry course presenter. His company, Computer Advanced Technology, is currently compiling a set of training modules which will meet the requirements of all levels of micro user from basic first-time novice, to the more advanced level of local area, and not so local area, networks. The training-module package is being made available direct to users, recognised training outlets and possibly to computer micro stores.

Alongside the sales of such software packages as Micromodeller, there has developed a flourishing trade in education and support training. Ashley Ward, managing director of Intelligence U.K. Ltd, the company which is responsible for the best-selling Micromodeller financial-planning package, states: "The concept of financial planning often has to be taught before users can get to grips with the program package itself". Intelligence U.K. offers its own support seminars across the U.K., the U.S. and France, with waiting lists often being the order of the day.

Another well known industry personality, Paul Bailey, director of Digital Research's European operations, agrees that end-users can often benefit from basic technology education. Training is a matter of considerable importance to Digital Research, which runs special sessions for distributors and dealers, manufacturers and users. Additionally the company supplies OEM franchise training and publishes a series of software updates and newsletters for key application vendors. Paul Bailey agrees that establishing a new in-house training centre at DR's Berkshire offices was a

priority matter. Most CP/M courses cover two or three days, as do most VisiCalc training programs.

The VisiCalc business system, which has already sold over 220,000 copies — not all for the originally designated Apple hardware — is covered by several independent training organisations. Micromark, which specialises in VisiCalc training, features only Apple hardware on its courses. Presumably now that the package is available on many other microcomputers, from the IBM PC to the Atari, the course organisers will enlarge their hardware training base.

Complaints are frequently made by users about the hardware and software manuals. Certainly the compilers of many user manuals and workshop guides have a lot to answer for, especially in taking for granted the ability of their readers. "After assembling the equipment, power-up" is an all too common approach. It is not unknown for users to contact their suppliers in order to ask the location of the On switch. Manuals have become renowned for their lack of understanding of the users' requirements, both as raw beginners and advanced experts.

In particular, the CP/M and WordStar manuals are singled out as being unworthy of the associated products. It is hardly surprising that several companies are attempting to produce teaching support packages or even their own independent manuals. One company which is closely involved in selling and marketing education and training, Head-Line Communication, has found itself with a best-selling training series on its rather surprised hands. The well established Sound Training packs which consist of audio tapes and guideline instructions were originally developed as an in-house training project for its own personnel.

Head-Line is now busy producing on a OEM basis user manuals for micro suppliers and manufacturers of both hardware and software systems. There is, it seems, hope for all users. As yet Sound Training has not produced a pack which offers guidelines to prospective users of training courses. The first-time school, home-hobbyist or business user certainly needs as much help and support as the industry can provide. The same message is being heard from the more experienced type of user. Unless the micro education and training industry can keep pace with user requirements, tomorrow's technological world could be late arriving. □

Programming without code

Bill Bennett examines three languages which allow teachers to produce effective programs without learning traditional programming techniques.

AN AUTHORIZING LANGUAGE is a tool which allows teachers or trainers to produce their own teaching software. A number of such languages exist, Pilot, Plato and Wise being foremost among them. Initially these languages were languages just like any other: teachers using them would produce lines of code just like any other programmer. But good teachers are not necessarily good programmers, so the trend has been towards codeless authoring systems based on the existing procedural languages. This has already happened in the case of Control Data's Plato system and the Wise system from Wicat.

Both packages required huge, powerful and expensive computers to run on, a situation that was rightly criticised as it meant that a massive investment was required to initiate any system in an educational establishment. In practice the expense was usually prohibitive.

Plato has now been developed in a stand-alone form which runs on the Control Data CD-110 micro. It is a slightly cut-down version, but retains the essential features. Control Data has made a massive

investment in Plato. Over the years the project has cost somewhere in the region of £500 million. The company also has a track record of supplying large educational departments with powerful mainframe Cyber computers.

Plato started way back in the early 1960s with a product called Tutor. It was a procedural language which contained structures and instructions designed to make the preparation of lesson software easy. It could handle responses to set questions. Tutor spawned a product called Microtutor and the original Plato was written in Tutor.

Today the emphasis is on codeless authoring. Plato enables this by using a range of software products called author applications models. They take the author step by step through the process of lesson creation and produce set-format lessons.

To create a lesson using one of these packages, a teacher would require a special form of the stand-alone Plato system known as the author and delivery system. This is similar to the student's station, except that it has an extra disc drive. The

system allows the teacher to act as author, and switch over to act as pupil so that the results of his or her labours can be examined and tested immediately.

The Plato stand-alone system was introduced in November 1982 and sells at £3,900. The hardware consists of a fairly standard Z-80 based micro that can run CP/M. It only has 32K of RAM but a further 64K is allotted to each disc drive. The outstanding feature is the touch-sensitive screen.

One drawback to the system is that lessons can only be transferred to special Control Data floppy discs. They have to be bought in lots of 50 from Control Data, which effectively ties the user to the company as a media supplier.

Brian Maurice is the U.K. director of educational services for Control Data. Not surprisingly, he is a firm believer in the merits of computer-based education. He is also a realist, and recognises that schools are unlikely to fork out the money for a relatively expensive piece of hardware when they already have micros installed.

Maurice is therefore keen to see Plato

Plato authoring models

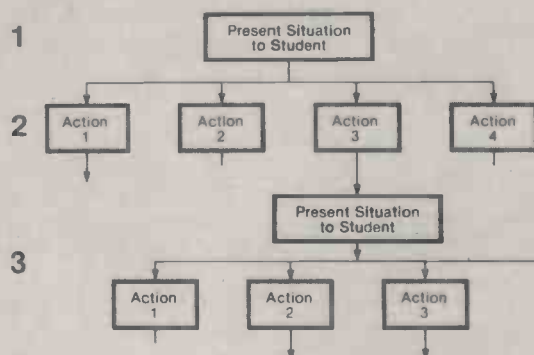

Plato situation simulation model. 1. The student is presented with a situation such as might happen in the workplace. A number of possible responses are listed. 2. The student chooses one of the responses. 3. The result of the student's decision is announced, the new situation is described and a new set of possible responses is listed.

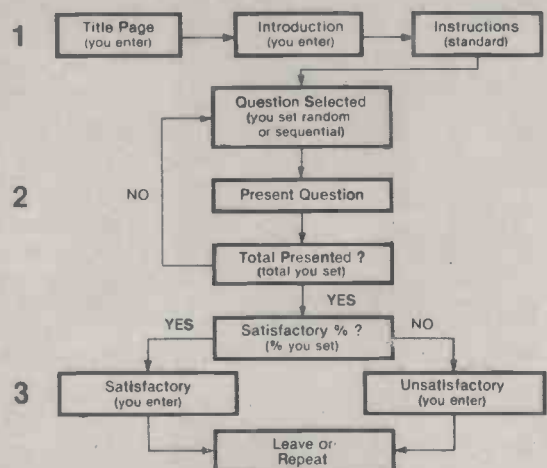

Drill and practice model. 1. The student is shown a title page and introduction, and is given instruction on how to use the lesson. 2. The student answers a series of questions created by you. 3. The percentage of correct answers is determined. If it meets a preset figure the student is told to go on to the next stage, otherwise the lesson is repeated.

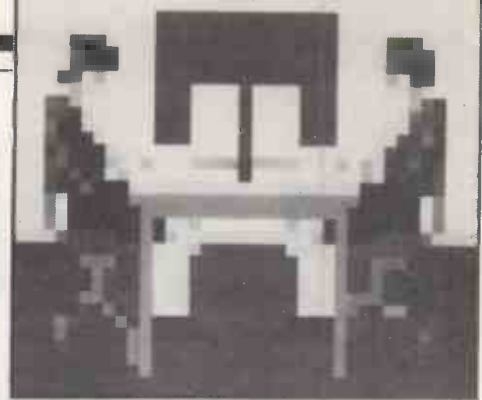

courseware — that is the name given to the software generated by the authoring system — as well as books and other teaching material used in a computer-aided learning course, implemented on a variety of other machines. In the U.S. a range of Plato courseware is already available for the Apple computer; it will soon be available in the U.K. and in local-language editions for the rest of Europe. Courseware for the IBM PC will follow.

Plato for micros

As far as educational computing in the U.K. is concerned, the key machine is the BBC Micro. Maurice has targeted it as an important machine for Plato courseware to be available on, and we can expect to see such software appearing in schools in the future. There is room for this kind of product in the home too, so it could be that home users will be able to use their micros for something other than playing games and balancing their domestic budgets before long.

Another micro that has aroused interest at Control Data is the Sinclair Spectrum, though it is unlikely that any Plato courseware will be made available for this machine in the near future since Control Data is only interested in disc-based systems. In principle, the software can be rewritten for almost any micro and any disc operating system. Control Data does not want to become bogged down in a sea of cassette tape, though Microdrives could eventually provide an answer for the Sinclair machine.

There is now a colour version of Plato, running on the Zenith, which is the first non-Control Data machine to be blessed with a full Plato authoring system. Animated graphics and high-resolution graphics are features of Plato which the Zenith exploits to the full. To illustrate courses teachers can draw detailed diagrams on the screen which can also be used in the questioning. The pupil is then asked to identify and touch a relevant item using the touch-sensitive screen which is only available on the CD-110. Colour is also a feature on the Zenith version, and the next stage is to link Plato to interactive video.

Plato can already be mixed with interactive video on the central mainframe-based Plato system. A micro version using the stand-alone system will be available during 1984.

Sometimes a student needs to input a reply which is more than a simple yes or no. Not every question should be or can be of the multiple-choice type. In these cases Plato uses a free-format response which scans text for keywords. This facility is more sophisticated on the mainframe Plato, but the micro version is being constantly upgraded to become more like its big brother, and can currently handle some free forms of responses.

Central Plato certainly is not dead. It is being used in a number of large companies which require lots of training to be

completed. With the advent of telecommunication links between home computers, and systems such as Micronet, the idea of a home user patching in to a central mainframe and taking part in a Plato course might even become fashionable again.

A number of companies use Plato for training when they have a number of employees scattered around the country — or the globe — and they need to be updated on technical or business information. The company's central office will dispatch a number of discs with the relevant information on, and at remote sites they will be fed into stand-alone delivery systems. The employees will then be forced, enticed or bribed into sitting down and ingesting the information on the discs. The computer can then test whether it has sunk in or not and, if necessary, it repeats the lesson.

Plato is also used at the Control Data institutes, a network of educational establishments throughout the country. Here students attend classes of personal, computerised tuition. A large number of disciplines are taught, one of the most important courses being the government-sponsored Tops course in computer programming.

Wise is a no-code authoring system from Wicat, a name that is better known in this country as belonging to a hardware manufacturer. The name Wicat is in fact an acronym for World Institute of Computer Aided Teaching, and the company was originally a non-profitmaking institution. The hardware that followed was designed to further this cause and consequently Wicat built the first 68000 micro, and turned into yet another computer company.

Detailed graphics

Wicat claims that the graphics design capability of Wise is second to none, with authors able to define pictures right down to the final pixel. The graphical representations are linked by menus. Unlike Plato, Wise-generated lessons will only run on Wicat hardware, which for the most part consists of a range of minis and larger micros. Wise does require hard discs.

Development time is long for any authoring system. Typically, 100 hours of authoring are required to produce a single hour of courseware. With Wise this time has been reduced to somewhere in the region of 40 to 60 hours preparation for each hour of learning. The teacher is presented with a series of questions, and by answering them the courseware is produced.

Free-form text answers are allowed just as in Plato, and there is a management system called Smart which steers a student through a course of learning. Interactive video is already available with Wise, using either tape or disc-based systems.

Wise is used in conjunction with interactive video by the U.S. army to train

the people who will press the buttons in time of nuclear war. Because the location of these sites is top secret, people cannot be taken there for training. The army sends film crews along instead. They take it all down on video, and then the operatives learn about the installations back at their bases.

The British armed forces use Wise too. An installation is used for training by the Eighth Signal Regiment, and *HMS Collingwood* near Portsmouth also has a system. Civilian users of the system include BOC Datasolve and British Telecom, which has two systems each of 32 terminals.

Wise has not appeared in schools, and is not likely to because the initial investment is so high. Like Control Data, Wicat argues that the cost per student is reduced when a number of terminals are attached. However, many terminals cost more than most cheap micros, which could possibly run Wise-generated software.

Pilot has been developed to run on the kind of hardware that is more realistically going to be available in schools and other parts of the state-run education system. Although it too is available on large computers, there are a number of versions for micros, the best-known being Apple Pilot. BBC and Research Machines versions are expected soon.

Apple Pilot is an implementation of standard Pilot, together with a number of additional commands to handle files, sound and the Apple's graphics. There are three editors: a lesson editor, a character-set editor and a graphics editor. The lesson editor is badly designed — strange and unpredictable things can under some circumstances — but Apple Pilot is very highly rated overall.

An enhanced version called Super Pilot consists of five discs — the ordinary version has only two. Both packages require twin disc drives for the author, but only a single drive for the pupil.

Pilot's biggest limitation is that it does require the teacher to code in order for the system to fit within the confines of a 48K Apple. By allowing the author to draw graphics using the games paddles, the system speeds up the authoring process considerably.

Maybe the most interesting development is Control Data's plan to produce educational software in conjunction with existing textbook publishers. This effectively makes Plato an extension of the book, with the advantage that courses will no longer need to be linear. □

Making video interactive

Linking computers to a video-disc player opens up a flexible new training technique. Colin Jackson reviews its development so far.

VIDEO DISCS look something like a highly polished, silver long-playing record. Unlike the familiar floppy discs and Winchester's with their fragile magnetic coatings, the video disc is not a thing to be cosseted and kept away from smoke and dust. It can be handled with impunity as there is no contact with its moving surface. The disc is read by a beam of low-power laser light so there is absolutely no wear. On each side of the disc a continuous spiral can accommodate up to 54,000 tracks, each of which holds sufficient information to create a video frame. The information is held as a pattern of pits burned into the master disc by a laser beam.

The 54,000 tracks can therefore contain that number of still frames. Played as a continuous moving sequence they provide up to 35 minutes of viewing time. Along with the video information there are two independently switchable audio channels. They can provide a sound-track in two

different languages, or one channel could be used for students and the other for the tutor.

Vidio discs have two big advantages over video-tape technology. Firstly, the disc player is able to display a still frame of superb quality for as long as you like and with no wear. Secondly, the disc is essentially a random-access device, so the access time for seeking a particular individually addressable frame is much less than for a tape.

A domestic disc player may now be bought in the High Street for about £400. A simple player permits interaction only to the extent of controlling the player with an infra-red hand-held controller. A fully interactive disc player can be controlled by a computer, with the user able to enter into

a dialogue with the complete system. A standard £400 player can be fitted with an interface which allows the player to be controlled from a microcomputer.

Further sophistication in control can be obtained by using more expensive players. For example, the Philips Professional offers two-way communication with the computer via an RS-232 interface to provide a teletext overlay on the video material. The equipment required to use a video-disc interactive training program is a microcomputer which has a printer output socket, a disc player and a colour television set or monitor with teletext decoder.

The use of teletext overlay enables textual material to be displayed by itself or on top of either still video images or a moving sequence. You may wish to reinforce or add to the visual material or to the spoken commentary by placing suitable text on the screen. Text sent to the player is coded to be displayed at the time when a

Colin Jackson is principal lecturer in computing and cybernetics at Brighton Polytechnic

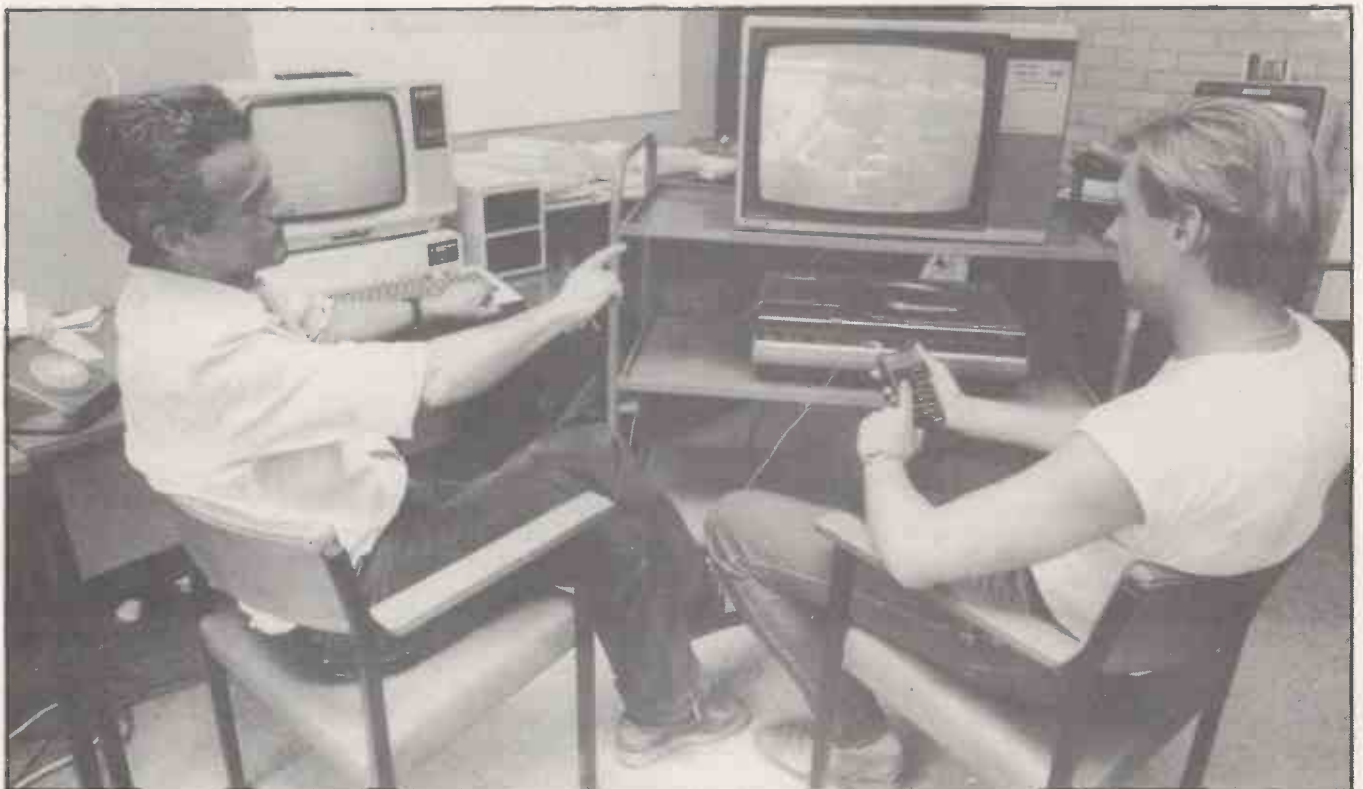

No training session is complete without the student testing his new-found knowledge.



Osborne House
Isle of Wight

particular video frame is shown. It is then removed either after a timed interval or when a later video frame is shown. If you wish to refer to a particular part of a displayed image an arrow or other symbol can be overlaid at the appropriate place. The standard teletext graphics symbols are available and so, for example, a map may be superimposed on the video image.

No training session is complete without the student having an opportunity to test his or her new-found knowledge, or for the tutor to be able to monitor the student's progress through the test. Questions may therefore be posed using the teletext facility. Answers can be input either by keying in a string which is analysed by the computer or, more likely, by keying in a number corresponding to one of several suggested answers on a multi-choice menu.

If the answer is correct the controlling program will either display a menu of alternatives or will move on to the next section. In the event of a wrong answer, remedial sequences of the disc may be shown — again with the possibility of different text overlays — and the questions asked again. The same technique has been used with video tape for many years, but the enhanced facilities offered with video disc allow for tremendous possibilities.

The disadvantages of discs lie mainly in the production of the disc itself. The major cost is in the preparation of the video tape from which the disc master is produced. This tape has to be frame-synchronised in 2in. Quad or 1in. type C helical format. The original sources might be existing video material, lengths of film, 35mm. slides, etc.

Mastering the disc from the final tape will cost around £2,000. Producing discs from the master is relatively cheap, but once the disc is pressed the information on it is fixed. Information cannot be changed — you have to be right first time. Variable information, such as the cost of a product, would not be included on the disc but

would be overlaid via the controlling computer program.

Cost and production time are clearly important factors. Only when discs users can be counted in hundreds is the concept likely to be cost effective. So in what areas is interactive video-disc based training going to be beneficial? A system designed to teach primary-school children basic literacy and numeracy skills would relieve the teacher of much effort. A printout of the students' use of the disc program could show how many times a remedial section had been played and thereby signal the need to intervene.

In secondary schools, imagine the scope in English literature or drama of a package based on a Shakespeare play. A whole series of experiments in physics and chemistry could be held on disc. The controlling program might then allow the students to play critical sequences slowly, backwards, frame-by-frame or whatever, as many times as they wished.

In further and higher education, the 54,000 still frames could hold photographs of the world's great masterpieces. Text overlays generated by the computer could complement the pictures. Medical schools could record details of key surgical operations.

On a more practical level interactive video could be used to train operators to use a word processor or some other item of electronic office equipment. It is usual for the organisation selling such a package to

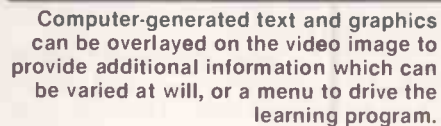

Computer-generated text and graphics can be overlaid on the video image to provide additional information which can be varied at will, or a menu to drive the learning program.

Ecal's system uses Apple software to control a Pioneer video-disc player.



arrange a demonstration either by sending a demonstrator to the customer's office or by the operators attending a class out of their own office. The process is expensive and time-consuming all round. And if on the day after the course the operators asks "...now how did they say I should do this...?" it is too late to find out. One answer is to put the demonstrator sequences on to a video disc. A computer programmer can then construct a controlling program complete with indexes, question-and-answer sessions, etc.

In management training the possibilities are numerous. Without much effort those splendid John Cleese "how not to do it" films could be put on disc, and a useful but entertaining course would result. The production of purpose-made discs for management training at all levels must be a priority. Motor manufacturers might produce a video disc for each new model. They would be of enormous use to dealers, mechanics and owners trying to identify the correct component at spare-part stores.

While the video disc cannot be erased or re-recorded, the controlling computer program can. This provides the flexibility needed to keep the material up to date. Another approach, which represents the utmost in flexibility, marries the technologies of video disc and viewdata. Many organisations already use a private viewdata system for staff training, and information on a viewdata frame can be used to control a video-disc player. □

TEACHERS USING the School Statistics program input a set of class marks, percentages, etc. and receive an analysis of those marks in relation to the class as a whole. A school examination-grade forecast is also provided on the basis of each mark. The program runs on any Commodore Pet linked to a compatible printer. It uses the Commodore's printer formatting capabilities and produces a fast and tidy table of results.

The program asks you to enter the date of the exam, name of subject and class to whom the marks belong. Once this data has been entered, you are asked to input the number of marks to be recorded. It has been set at a maximum of 500 in the program but can easily be changed by altering the Dim statement at line number 130.

When all the marks have been entered, the program asks if any changes have to be made to the data, in case a number has been entered incorrectly. Simply enter, for example, the number 15, if the 15th number was incorrect and retype the new number.

When you are satisfied that all the numbers have been correctly entered, the program prints the headings, evaluates the mean, deviance and standard deviation then produces a table of results under the headings: Score, Deviation, Z-Score, School Grade and Proj. CSE/GCE. The score is each data number, sorted into rank order; the deviation is each score

Class monitors

Clive Bulmer's pair of programs for the Pet take the effort out of two of the tedious but necessary tasks which face form teachers.

minus the mean; the Z-Score is the deviation from the mean divided by the standard deviation for each score; the school grade and projected CSE/GCE grades are assigned to the Z-Score and can be set within other ranges between lines 810 and 900.

School Register

School Register is designed to speed up register totals and percentages at the end of each week. It can be run on most microcomputers linked to a compatible printer.

School Statistics variables.

C — the date
 D — name of subject
 E — name of form or year
 A — number of scores
 X — data number/score
 S — sum of scores
 ME — mean
 SQ — sum of squares
 V — variance
 L — standard deviation
 D — deviation from the mean
 Z — Z-Score
 W\$ — school grade
 X\$ — projected CSE/GCE grade

School Statistics

```

10 REM C. BULMER - SUNDERLAND L.E.A
20 REM LINE PRINTER FORMAT
30 SK$=CHR$(29)
40 F$="999          99.9-          9.99-          "
50 F1$="      AA          AAA" F$=F$+F1$
60 OPEN5.4,2 PRINT#5,F$
70 OPEN1.4,1
80 OPEN2.4
90 CMD2
100 PRINT#2,"@"
110 REM PROGRAM SET FOR 1-500 SCORES MAX
120 REM CHANGE DIM TO STORE MORE NUMBERS
130 DIMX(1000)
140 PRINT#2
150 REM INPUT DATA RE SCHOOL/SCORES
160 PRINT"WHAT IS TODAY'S DATE?";
170 INPUT#1
180 PRINT:PRINT
190 INPUT"NAME OF YOUR SUBJECT":D$
200 PRINT:PRINT
210 INPUT"NAME OF FORM OR YEAR":E$
220 L2=LEN(C$)+LEN(D$)+LEN(E$)
230 PRINT#2,TAB(20);"STATISTICAL PROGRAM FOR PUPILS SCORES"
240 PRINT#2,TAB(20);FORP=1TO37:PRINT#2,"=";NEXT:PRINT#2
250 PRINT#2:PRINT#2
260 PRINT"HOW MANY SCORES DO YOU HAVE?";
270 INPUT#1
280 PRINT#2:PRINT#2
290 FORI=1TOA
300 PRINTI;"TH NUMBER";
310 INPUT#1X(I)
320 NEXTI
330 REM CHANGE TO MAKE ANY CORRECTIONS TO DATA
340 PRINT"DO YOU HAVE ANY CORRECTIONS TO MAKE?";
350 GETA$:IFA$=""THEN350
360 IFA$="N"THEN400
370 PRINT"WHICH NUMBER?";INPUT#1
380 PRINT"ENTER CORRECT NUMBER?";INPUT#1X(E)
390 PRINT"ANY MORE CORRECTIONS?";GOTO350
400 REM CALCULATES SUM AND MEAN
410 FORI=1TOA
420 S=S+X(I)
430 NEXTI
440 ME=S/A
450 REM CALCULATES STANDARD DEVIATION
460 FORI=1TOA
470 X(I+320)=X(I)*X(I)
480 NEXTI
490 FORI=1TOA
500 SQ=SQ+X(I+320)
510 NEXTI
520 V=SQ/A-ME^2
530 L=SQR(V)
540 PRINT#2
550 PRINT#2,TAB(21);D$;TAB(7);C$;TAB(7);E$
560 PRINT#2,TAB(21);FORP=1TOLZ+14:PRINT#2,
"=";NEXT:PRINT#2
570 REM PRINTS HEADINGS AND VALUES
580 PRINT#2:PRINT#2
590 PRINT#2,TAB(31);"SCORES =";A
600 PRINT#2,TAB(31);"MEAN =";ME
610 PRINT#2,TAB(31);"S.D. =";L
620 PRINT#2:PRINT#2:PRINT#2
630 PRINT#2,"SCORE          DEVIATION          Z.SC
ORE          SCHOOL GRADE          "
640 PRINT#2,"      PROJ. C.S.E"
650 FORP=1TO75:PRINT#2,"=";NEXT:PRINT#2
660 REM SORTS INTO RANK ORDER USING A BUBBLE SORT
670 FORQ=1TOA-1
680 FORP=(Q+1)TOA
690 IFX(P)<X(Q)THEN730
700 U=X(Q)
710 X(Q)=X(P)
720 X(P)=U
730 NEXTP
740 NEXTQ
750 REM CALCULATES DEVIATION FROM THE MEAN
760 FORI=1TOA
770 D=X(I)-ME
780 D=INT(D*100)/100
790 REM CALCULATES Z SCORE (DEVIATION / S.D.)
800 Z=INT((D/L)*1000)/1000
810 REM PROJECTED C.S.E. GRADES RE. Z SCORES
820 IFZ>=2.5THENW$="A"
830 IFZ<2.5ANDZ>=1THENW$="B"
840 IFZ<1ANDZ>=-1THENW$="C"
850 IFZ<-1ANDZ>=-2.5THENW$="D"
860 IFZ<-2.5THENW$="E"
870 IFZ>=1.75THENX$="1"
880 IFZ<1.75ANDZ>=0THENX$="2/3"
890 IFZ<0ANDZ>=-1.75THENX$="4"
900 IFZ<-1.75THENX$="5/U"
910 REM PRINTS TABLE OF RESULTS
920 PRINT#1,X(I),SK$,D,SK$,Z,SK$,W$,SK$,X$
930 NEXTI
940 PRINT"END OF RUN"
950 CLOSE5.4,2:CLOSE1.4,1
960 PRINT"TYPE RUN TO START AGAIN":STOP

```

School Register variables.

- S — house name
- C — form
- G — number in form
- T — maximum total for 10 sessions
- E — maximum total for eight sessions
- N — percentage for 10 sessions
- P — percentage for eight sessions

Most schools work on the basis of having a maximum of 10 sessions' attendance for each child per week. Attendances are normally totalled and converted into a percentage for the whole class. This program produces a table of percentages to be kept in the back of a register and referred to each week. Allowance has been made for when a school has only eight sessions for each child per week, to allow for holidays, etc.

On running the program, you are asked to give the name of the school house, the form and number of pupils in the form. The program is then executed and a table of attendances and percentages is produced. The program has been set for a maximum of 50 absences per week, but that unit can easily be altered at line number 270.

School Register.

```

10 REM C.BULMER - SUNDERLAND L.E.A
20 PRINT "C"
30 PRINT "***** ATTENDANCES
   - 10/8 SESSIONS"
40 PRINT:PRINT
50 PRINT "HOUSE NAME ";:INPUTS$
60 PRINT "FORM ";:INPUTC$
70 PRINT "NUMBER IN FORM ";:INPUTG
80 OPEN 2,4:CMD2
90 REM 110-130 LINE PRINTER FORMAT
100 F$="          999          999.99"
110 OPENS,4,2:PRINT#S,F$
120 OPEN 1,4,1
130 REM PRINTS HEADINGS
140 Y=LEN(S$)+5
150 PRINT#2,TAB(31);S$;" HOUSE"
160 PRINT#2,TAB(31);"=";
170 FOR J=1 TO Y PRINT#2,"=";:NEXT:PRINT#2
180 PRINT#2,TAB(15);"WEEKLY ATTENDANCES FOR ";C$;" - (<";G;" ) PUPILS IN FORM"
190 PRINT#2,TAB(15);:FOR Y=1 TO 50:PRINT#2,"=";:NEXT
200 PRINT#2
210 PRINT#2,TAB(7);"WEEK'S TOTAL";TAB(4);"% - 10 SESSIONS";
220 PRINT#2,CHR$(141);TAB(46);"WEEK'S TOTAL";TAB(3);"% - 8 SESSIONS"
230 PRINT#2,TAB(7);:FOR Y=1 TO 31:PRINT#2,"=";:NEXT
240 PRINT#2,CHR$(141);TAB(46);:FOR U=1 TO 29:PRINT#2,"=";:NEXT
250 PRINT#2
260 REM LOOP FOR PRINTING THE TABLE
270 FORA=0 TO 50
280 T=0*10
290 E=0*8
300 L=(T-A)/T*100
310 M=(E-A)/E*100
320 N=INT(L*100)/100+.00
330 P=INT(M*100)/100+.00
340 PRINT#1,T-A,SK$,N,SK$,E-A,SK$,P
350 NEXT A
360 CLOSES,4,2:CLOSE 5,4,1
370 STOP
380 END
    
```

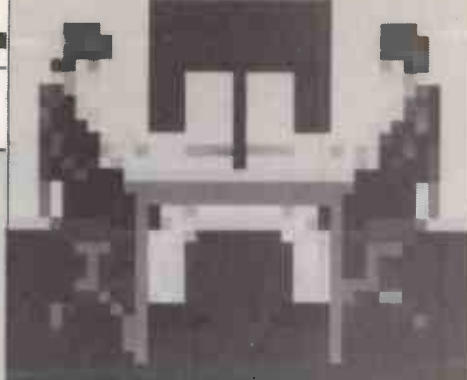

WEARDALE HOUSE		WEEKLY ATTENDANCES FOR 3A - (27) PUPILS IN FORM	
WEEK'S TOTAL	% - 10 SESSIONS	WEEK'S TOTAL	% - 8 SESSIONS
270	100.00	216	100.00
269	99.62	215	99.53
268	99.25	214	99.07
267	98.88	213	
266	98.51	212	
265	98.14	211	
264	97.77	210	
263	97.40	209	
262	97.03	208	
261	96.66	207	
260	96.29	206	
259	95.92	205	
258	95.55	204	
257	95.18	203	
256	94.81	202	
255	94.44	201	
254	94.07	200	
253	93.70	199	
252	93.33	198	
251	92.96	197	
250	92.59	196	
249	92.22	195	
248	91.85	194	
247	91.48	193	
246	91.11	192	
245	90.74	191	
244	90.37	190	
243	90.00	189	
242	89.62	188	
241	89.25	187	
240	88.88	186	
239	88.51	185	
238	88.14	184	
237	87.77	183	
236	87.40	182	
235	87.03	181	
234	86.66	180	
233	86.29	179	
232	85.92	178	
231	85.55	177	
230	85.18	176	
229	84.81	175	
228	84.44	174	
227	84.07	173	
226	83.70	172	
225	83.33	171	
224	82.96	170	
223	82.59	169	
222	82.22	168	
221	81.85	167	
220	81.48	166	

STATISTICAL PROGRAM FOR PUPILS SCORES				
MATHEMATICS				
12.12.81				
3A1				
SCORES = 25				
MEAN = 72.76				
S.D. = 25.0332259				
SCORE	DEVIATION	Z SCORE	SCHOOL GRADE	PROJ. C.S.E
119				
115	46.2			
104	42.2	1.84		
102	31.2	1.68	B	
99	29.2	1.24	B	1
98	26.2	1.16	B	2/3
97	25.2	1.04	B	2/3
83	24.2	1.00	B	2/3
80	10.2	.96	B	2/3
78	7.2	.40		2/3
74	5.2	.28		2/3
72	1.2	.20		2/3
71	.7	.04		2/3
68	1.7	.04		2/3
66	4.7	.00		2/3
65	6.7	.20		4
65	7.7	.28		4
64	7.7	.31		4
64	8.7	.31		4
60	8.7	.35		4
44	12.7	.35		4
40	28.7	.51		4
32	32.7	1.15		4
30	40.7	1.31		4
29	42.7	1.63		4
	43.7	1.71		4
		1.75		4

WHAT GIVES A STAR THE EDGE OVER RIVALS?

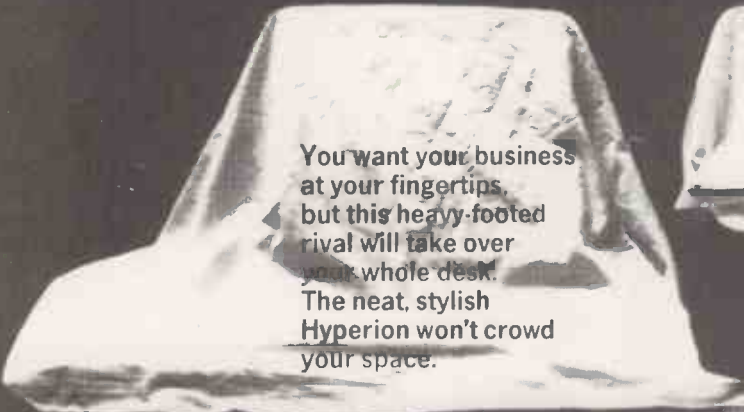

You want your business at your fingertips, but this heavy-footed rival will take over your whole desk. The neat, stylish Hyperion won't crowd your space.

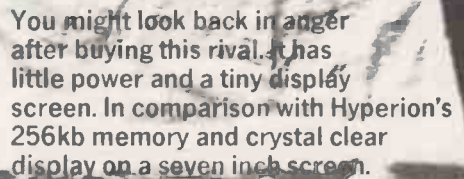

You might look back in anger after buying this rival. It has little power and a tiny display screen. In comparison with Hyperion's 256kb memory and crystal clear display on a seven inch screen.

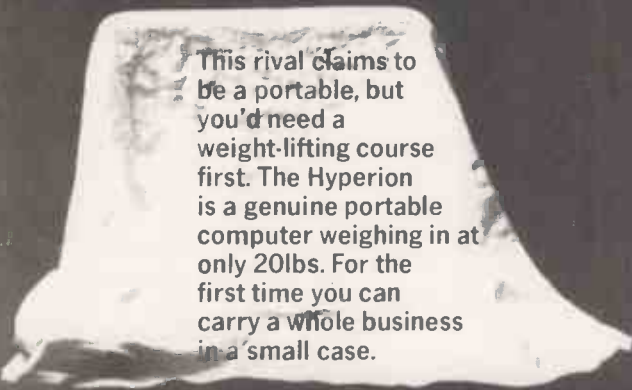

This rival claims to be a portable, but you'd need a weight-lifting course first. The Hyperion is a genuine portable computer weighing in at only 20lbs. For the first time you can carry a whole business in a small case.

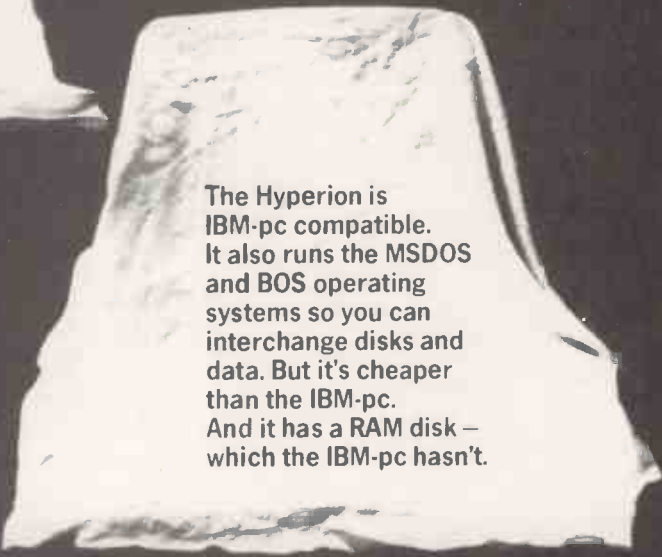

The Hyperion is IBM-PC compatible. It also runs the MSDOS and BOS operating systems so you can interchange disks and data. But it's cheaper than the IBM-PC. And it has a RAM disk — which the IBM-PC hasn't.

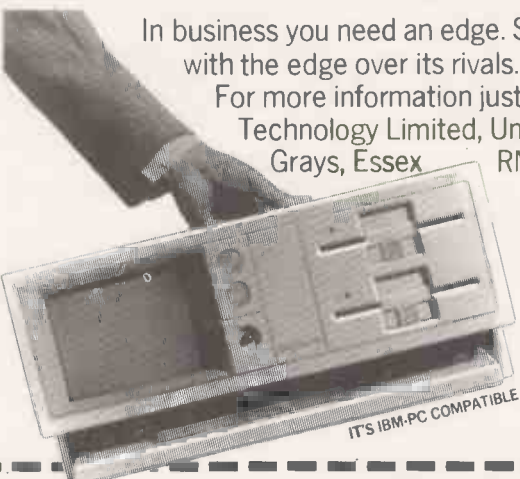

In business you need an edge. So it makes sense to choose the portable computer with the edge over its rivals. It's what makes Hyperion the world's major star. For more information just fill in the coupon below and send it to Gulfstream Technology Limited, Unit 3A, Tunnel Estate, 726 London Road, West Thurrock, Grays, Essex RM16 1LS. Telephone (04026) 4926. Telex: 894222 Gulfs

Hyperion

the world's most powerful portable computer



GULFSTREAM TECHNOLOGY LIMITED Unit 3A, Tunnel Estate, 726 London Road, West Thurrock, Grays, Essex RM16 1LS. Telephone: 04026 4926

Please send me full colour brochure of the Hyperion Portable Computer
Please send me details on how I can become a Hyperion Portable Computer Dealer A MEMBER OF THE BYTEC GROUP 

My name is: _____

Company _____

Address _____

Telephone _____

PC9/83



● Circle No. 259

PORTABLE COMPUTERS have really arrived. And arrive is the right word as the most of the machines in our new survey are imported. Nine of them are American, six are British, four come from Japan and one, the Hyperion, is Canadian.

This might seem par for the course in high-technology products, but there are many more portables selling heavily in America. They too will undoubtedly become available over here once distribution problems are sorted out. Meanwhile ACT, which has been very successful as the importer of the U.S.-made Sirius, is manufacturing its new Apricot portable in Scotland. The other British-made micros in this survey are the rather specialised Husky, Nomad and Scorpion, and the Miracle and Zita.

Portables have caught on so well in America partly because of the sheer size of the country. Its numerous time zones make getting hold of a business contact by phone that much more difficult than in Europe. The communicating portable computer has been adopted enthusiastically as a kind of super telephone-answering machine, sending its messages to another person's computer to be read whenever they start work.

Difficulties with British Telecom have discouraged a similar development in this country, although admittedly the motivation is less great. Machines like the Tandy 100 are arriving here with their direct-connect Modem circuitry removed.

We have excluded a large number of machines from this survey for one reason or another. The Teleram, the Acclaim, the Access, the Otrona Attache and many more are left out because they are not yet available in the U.K. For a machine to be included it has to have a proper full-size keyboard, mass storage like floppies or bubble memory or lots of RAM actually built into the portable unit, not back at base, and at least a two-line display on the machine in its mobile form. It can be either battery or mains powered, but it should not weigh more than you can reasonably expect

Portables update

The flood of portables has been in full flow since we published our last review at the beginning of the year. Ian Stobie assesses the current state of the art.

someone in an office environment to lift — say 30lb. The Nomad and Husky have non-standard keyboards, but are still included since a standard keyboard would not allow the machines to stand up to the harsh operating environments they are designed for.

Some fine machines are excluded by our definition. The Hewlett-Packard 75C has a single-line display and a slightly smaller than standard keyboard. Yet this battery-powered computer has the power to run a genuine Visicorp version of VisiCalc. It comes in ROM so you can have VisiCalc in a package that weighs less than 2lb.

Another excellent and even smaller machine is the Sharp PC-1500, with a single-line display and calculator-size keys. It has no built-in mass storage but has been around long enough to accumulate a family of good peripherals. Its tiny four-colour printer/plotter uses the same mechanism as the Oric printer reviewed in this issue. The Newbrain is not covered here because it has no built-in mass storage apart from its RAM and just a single-line display. These machines are fully described in our survey on portables published in the January 1983 issue of *Practical Computing*.

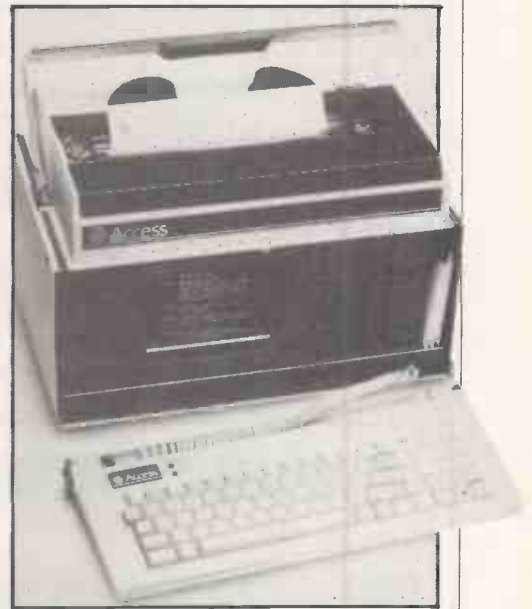

Typical of the modern American portable, the Access has built-in Modem with both acoustic and direct plug-in connection to the phone system, a built-in printer, discs and 7in. amber screen, all contained in a hefty 33lb. package.

Portables top 20 — details on pages 129 to 135

ACT Apricot: Applied Computer Techniques, ACT House, 111 Hagley Road, Birmingham B16 8LB. Telephone: 021-454 8585.

Compucase: Advanced Software Technology Ltd, 48a Central Road, Worcester Park, Surrey KT4 8HY. Telephone: 01-330 1690.

Dot: Compucorp Ltd, Cunningham House, Westfield Lane, Kenton, Middlesex HA3 9ED. Telephone: 01-907 0198.

Epson HX-20: Epson U.K. Ltd, Dorland House, 388 High Road, Wembley, Middlesex HA9 5UH. Telephone: 01-902 8892.

Fox: Digital Microsystems Ltd, Tavistock Industrial Estate, Ruscombe, Twyford, Berkshire RG10 9NJ. Telephone: (0734) 343885.

Gavilan: c/o Cochrane Communications Ltd, 54 Fleet Street London EC4Y 1JU.

Grid Compass: c/o Moggridge Associates, 322 Kentish Town Road, London NW5 2TH. Telephone: 01-485 1170.

Hewlett-Packard HP-85: Hewlett-Packard Ltd, Literature Department, Winnersh, Wokingham, Berkshire RG11 5AR. Telephone: Crowthorne (0344) 773100.

Husky: DVW Microelectronics Ltd, PO Box 135, 345 Foleshill Road, Coventry CV6 5RW. Telephone: (0203) 668181.

Hyperion: Gulfstream Computer Technology Ltd, Unit 3a, Tunnel Estate, 726 London Road, West Thurrock, Grays, Essex RM16 1LS. Telephone: (04026) 4926.

Kaypro: CK Computers Ltd, Estover Close, Estover Industrial Estate, Plymouth, Devon PL6 7PL. Telephone: (0752) 780311.

Miracle: Portico Technology, South Bank House, Black Prince Road, London SE11. Telephone: 01-735 8171.

Nomad: Immediate Business Systems plc, 3 Clarendon Drive, Wymbush, Milton Keynes MK8 8DA. Telephone: (0908) 568192.

Osborne 1 and Executive: Osborne Computer Corporation (U.K.) Ltd, 38 Tanners Drive, Blakelands, Milton Keynes MK14 5LL. Telephone: (0908) 615274.

Scorpion: MicroAPL Ltd, 19 Catherine Place, London SW1E 6DX. Telephone: 01-834 2687.

Sharp PC-5000: Sharp Electronics (U.K.) Ltd, Sharp House, Thorp Road, Manchester M10 9BE. Telephone: 061-205 2333.

Sord M-23P: Socius Computer Systems U.K. Ltd, Samuel House, 6 St Albans Street, Haymarket, London SW1Y 4SQ. Telephone: 01-930 4214.

Tandy Model 100: Tandy Corporation, Tameway Tower, Bridge Street, Walsall, West Midlands WS1 1LA. Telephone: (0922) 648181.

Zita: iTCS, 16-18 Littleton Road, Ashford, Middlesex TW15 1UQ. Telephone: (07842) 47371.

Zorba: Sun Computing Services Ltd, Concorde House, St Anthony's Way, Feltham, Middlesex TW14 0NH. Telephone: 01-890 1440.

EPSON in BIRMINGHAM

EPSON HX-20



£402.00

THE TRUELY PORTABLE MICRO-COMPUTER



EPSON QX-10

£1735.00

192 Kb RAM
MULTIFONT
FAST GRAPHICS
ONE YEAR WARRANTY

THE HUMAN COMPATIBLE DESK TOP MICRO

All EPSON printers and a full range of accessories and sundries are available

SUPPLYING the SYSTEMS
GIVING the SERVICE

JAEMMA LIMITED

UNIT 24
LEE BANK HOUSE
HOLLOWAY HEAD
BIRMINGHAM
B1 1HR

021 643 1609

● Circle No. 258

Deal with the experts on Portable Computers.



AVAILABLE
SOON!

Osborne Executive

128K RAM • 7" screen • Soon to be
IBM compatible • Fan cooled •
Standard Osborne software
Personal Pearl data base system

Osborne 01

64K RAM • 5¼" 80 column screen

Hyperion

256K RAM • IBM compatible • Dual
327K drives • 7" screen • High
res graphics

Epson HX20

On site training, servicing and support.

Fraser Associates Ltd.

Authorised main dealers for all the above.

1 Bristle Hill, Buckingham. Bucks
MK18 1EZ (0280) 816087

(0280) 816087
for full details

● Circle No. 170

OSBORNE

BUSINESS PACKAGES



- * Osborne 1 with double density disk drive
- * Printer
- * Amber/Green screen minotor
- * All leads
- * Free Software

Inclusive of MAILMERGE, WORDSTAR 3, SUPERCALC BASIC
SPECIAL OFFER £1,599 (plus VAT)

- * Card Sort — this program will sort your cardbox files on any field of a card £49.95

Now available — Osborne Executive from Stock

Please contact us for demonstrations. We are able to supply full back-up and after-sales service.

* Terminal emulation * Compatible with most mainframes * Z80A 4MHz cpu with 128K RAM and dual-floppy disc drives * Ability to read/write IBM PC, DEC VT180, Xerox 821, Cromemco and UCSD p-system universal disc format. Built-in 7in amber display CRT with reverse video, underscoring, blinking, half-intensity and two character sets * 24 lines by 80 characters * Business keyboard with numeric pad and cursor keys * Video brightness and contrast controls * Two RS-232 ports, parallel printer port, IEEE or Centronics, Z80A SIO serial communication controller.

* Standard software free with the machine is CP/M Plus (3.0) and the UCSD 'p' operating system. WordStar with MailMerge, SuperCalc, Personal Pearl, CBasic and MBasic. Includes complete and simple instructions for all hardware and software.

GEM SYSTEMS LTD (DEPT MCS)

2 Crawford Road, Hatfield, Herts AL10 OPG.
Tel: (07072) 66148

For further information send coupon to:
GEM SYSTEMS LTD (Dept MCS)
2 Crawford Road, Hatfield, Herts AL10
OPG

NAME

ADDRESS

TEL:

● Circle No. 257



ACT APRICOT

£1,495

Mains-powered 16-bit system with advanced specification, scheduled for general availability this month. Keyboard has a 40-character by two-line LCD display built in so the 9in. screen can be left at base. Weight: 17.5lb. Keyboard clips on to system box to make neat briefcase-style unit. Built around Intel 8086 chip with 256K of RAM as standard, expandable to 768K. One 315K 3.5in. Sony micro-floppy on entry-level system. Other disc options are promised, taking storage capacity in steps up to 1.4Mbyte with two double-sided drives. Comes with MS-DOS 2 and should run most Sirius applications and IBM packages. Concurrent CP/M-86, Microsoft Basic, DR Personal Basic, 3D Relational Database, and graphics and communications software also included in price.

FOR Good looks. Large RAM. Sirius and IBM software compatible.

AGAINST Portable only when full display is sacrificed. No hard-disc option.



COMPUCASE

£3,800

Mains-powered eight-bit transportable weighing 25lb. with unusual display and disc system. The 9.5in. screen built into the lid is a flat plasma-discharge panel which forms characters on a five-by-seven matrix of glowing dots to build up a display of 12 lines of 40 characters. An 80-column dot-matrix printer is built in. A cartridge disc unit provides 6Mbyte of storage on five exchangeable 5.25in. floppy discs, each holding 1.2Mbyte. The drive unit selects the appropriate disc from the cartridge in under three seconds. Runs an 8085 eight-bit main processor, second 8085 for I/O processing and 64K of RAM. CP/M and MBasic included in the price.

FOR All-in-one unit.

AGAINST Quite expensive. Disc system odd.



DOT

£1,995

Transportable 16-bit mains-powered micro built around the 8088 chip. Comes with the MS-DOS operating system and 64K of RAM, expandable up to 700K. Claims to be IBM compatible. Z-80 add-on board runs eight-bit CP/M. Screen 5in. by 9in. displaying 25 lines by 80 or 132 columns. Optional built-in printer uses 8.75in. wide thermal paper and prints text across 80 or 132 columns and graphics. Keyboard detaches for ease of use. Two IBM bus-compatible expansion slots are provided. Sony 3.5in. floppy disc drives give 280K each; base-level system has one 280K 3.5in. micro-floppy and 64K RAM. System with two drives, built-in printer and 128K costs £3,450.

FOR All-in-one package. IBM PC compatible.

AGAINST Heavy with the printer installed. Quite expensive.



EPSON HX-20

£477

Truly portable battery-powered machines with all the necessary elements of a computer system fitting into a 4lb. A4-sized package. Good-quality full-size keyboard, four-line by 20-character LCD display and built-in 24-column printer. Built-in microcassette drive capable of holding about 100K on a small C30 dictation-machine cassette. Can be bought without the drive for £75 less. Comes with Microsoft-written Basic and its own operating system in 32K of ROM. Built around the 6301 eight-bit CMOS chip, a low-power device similar to the 6800, with 16K of RAM. A clip-on expansion unit provides another 32K of memory, RAM or ROM. Uses a non-standard operating system but quite well supported by independent software writers.

FOR All-in-one lightweight unit. Reasonable software base.

AGAINST Relatively small display.



FOX

£2,682

Mains-powered eight-bit transportable designed to link easily into a local area network but also functioning as a self-contained eight-bit CP/M machine. Built round Z-80A with 64K RAM with a 9in. screen displaying 80 characters by 25 lines and a detachable keyboard. Twin 5.25in. floppy drives give a combined 1.2Mbyte on-line storage. At 31lb. the Fox is the heaviest machine in this survey. Fitted with a simple plug connector for Hinet, Digital Microsystems' local area network, which can link up as many as 32 stations. A 15Mbyte hard-disc version costs around £5,000 and can be used as Network Master for a Hinet LAN. Digital Microsystems is an Extel subsidiary.

FOR Easily links to local area network.

AGAINST Heavy. Expensive for standard CP/M machine unless you want to network.

(more on next page)



GAVILAN

£3,000

Battery-powered 16-bit portable with advanced user interface. Main Gavilan unit weighs 9lb. and includes an eight-line by 66-character LCD display, 320K 3in. floppy-disc drive and keyboard. The screen folds down over the keyboard for travelling. Optional 5lb. battery-powered printer prints across 80 columns on plain paper up to 8.5in. wide; clips on back of machine. Optional extra disc drive and extra RAM in clip-on package. CPU is the 8088 with 80K of RAM, expandable in stages to 336K; 48K occupied by system software concerned mainly with user interface. Runs MS-DOS. A touch-sensitive panel allows the user to point to graphics symbols on the display using the same sort of approach as the Apple Lisa's mouse.

FOR Sounds wonderful.

AGAINST Not here yet.



GRID COMPASS

U.S.\$8,000

Mains-powered, 16-bit portable with bubble memory, unusual display technology and eye-catching design. Weighs 9.5lb. Based around the 8086 processor with the 8087 arithmetic co-processor and 256K of RAM. Uses 384K of bubble memory instead of floppy discs for non-volatile storage. Flat, amber-coloured electroluminescent screen displays 23 lines of 53 characters or 320-by-240 dot graphics; folds down over keyboard for travel. Grid operating system and integrated software for word processing, spreadsheet, database, business graphics and project management. In the U.S. the built-in Modem links into Grid's 24-hour down-line software service. Has sold there mainly as a communications device. Initial U.K. sales likely to be to corporate users.

FOR Good looks. Light weight. Integrated software. Good communications.

AGAINST High price. Too few columns on screen. Not here yet.

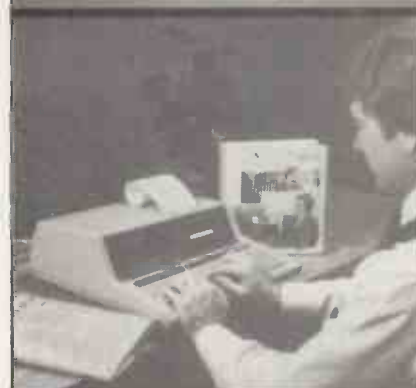

HEWLETT-PACKARD 85B

£2,184

Mains-powered portable especially suited for scientific and engineering use. Includes a 5in. screen displaying 16 lines of 32 characters, a 32-column thermal printer which can dump the screen contents including graphics and a 210K digital cassette drive with random-access capability, all built into one unit along with the keyboard. The eight-bit processor is custom made by HP. The 20lb. HP-85B comes with 32K of RAM, together with a separate 32K area of RAM, expandable to 544K, configured as a RAM disc. HP Series 80 operating system and the powerful HP Basic included in the price. The speed of the RAM disc and the Basic's ability to handle very long strings are useful in data-logging applications.

FOR Good Basic, Connects to wide range of instruments and disc drives.

AGAINST Small screen. Keyboard does not detach. Quite expensive.



HUSKY

£1,983

Ultra-robust battery portable designed for rugged environments. Uses up to 144K of battery-backed CMOS RAM to store data. Standard machine comes with 32K; 144K version costs £3,423. Weighs 4.4lb. and has a four-line by 32-character LCD display and a sealed, flat membrane keyboard. The 40 software-redefinable keys are in a non-standard but generally QWERTY-like layout. Low-power eight-bit NSC-800 CPU executes the Z-80 instruction set. System comes with 32K of ROM containing a Husky operating system, Basic and software to support the built-in RS-232C. IBM 2780 protocol available as an option for Husky-to-mainframe communications. The Husky features in an applications story in *Practical Computing* January 1983.

FOR Tough. Good communications.

AGAINST High price. Non-standard operating system.



HYPERION

£2,695

Compact Canadian-built 16-bit mains-powered transportable offering IBM PC compatibility, weighing under 20lb. includes a 7in. amber screen displaying 80 characters by 25 lines, detachable keyboard and twin 320K 5.25in. drives. A single-drive version is available for £300 less. Built around the Intel 8088 processor with 256K of RAM. Some RAM is automatically configured as a RAM disc when the system is turned on. Comes with MS-DOS and is claimed to run most IBM PC software. The price also includes MBasic and the Aladdin database, statistics and calculations packages. Fully reviewed in *Practical Computing*, July 1983. Also available with a slightly different specification under the Ajile brand name from Anderson Jacobson.

FOR IBM PC compatibility. Good-quality finish. Quite light.

AGAINST Not cheap. RAM not expandable at present.

(more on page 133)

A man's best friend should be totally reliable, dependable and capable of running anywhere.

Take an Epson walkies soon.

A complete portable computer with full size typewriter keyboard, LCD Virtual Screen, printer, microcassette facility and rechargeable power source all built-in.

Yet a precision machine so small, so lightweight, so portable - you can take it anywhere. To readily use it anywhere.

The HX-20 is different. Because it is designed to be different.

And because it thinks bigger than the others. Take a look at the facts.

Uses full extended version of Microsoft BASIC with 16k RAM optionally expandable to 32k, and 32k ROM expandable to 64k, RS-232C and Serial interfaces.

The ASCII typewriter keyboard and five programmable keys offer no less than ten program actions.

A unique LCD Screen that enables you to try out word processing or data entry as if you were using a large screen.

24 column dot matrix impact microprinter printing 42LPM for hard copies.

Runs on its own power for over 50 hours and can be easily recharged overnight or whilst in use - with the ability to retain information in memory when switched off.

Simply add on a wide range of peripherals to include bar code readers and acoustic couplers for full capability.

Various software applications are available, too.

You know the name. Epson quality is already world renowned for desktop computers and a superb range of quality printers. And our new remarkable machine is raising more than just a few eyebrows wherever it's seen.

Clip the coupon below and we'll tell you the full story or call us for the name of your local stockist, so you can experience the HX-20 first hand.

Once seen, we think you'll want to take it further than just twice round the block.

EPSON

Extraordinary product. Exceptional quality.

Epson (UK) Limited, Freepost, Wembley, Middlesex HA9 6BR.
Sales Enquiries: Freefone 2730.
General Enquiries: 01-900 0466/
01-900 0988 or 01-903 3722.
Telex: 8814169.

I would like to see a demonstration of the HX-20 Portable Computer.

Please send me further details.

Name _____

Company _____

Address _____

Telephone _____

PC9/20

● Circle No. 173

The new Seikosha Graphics Printer.



Here it is in **Colour**



Here it is in **Black & White**

Here it is at last, the colour graphics Seikosha printer.

Same constant reliability, same versatility and same habit of shattering price barriers – just £425.

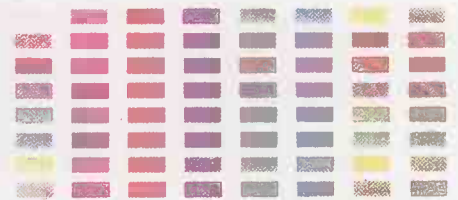

- Unique 4 hammer head mechanism prints 7 colours or 30 shades in a single pass.

- High quality graphics with colour specification by dot units.

- Colour mixing without smearing.

- 50 characters per second whatever the colour mix.

- 80 and 106 characters per line.

- Pin feed and friction feed.

- Unique 4 colour ribbon with reinking reservoirs for long-life colour.

- Centronics Parallel interface with serial (RS232) and Video (RGB) interface options.

Telephone the number below and we'll tell you where your nearest dealer is located.

DRG
BUSINESS
MACHINES

(Peripherals Division),
13-14 Lynx Crescent,
Winterstoke Rd, Weston
super Mare. BS24 9DN.
Tel: (0934) 419914.

DEALER
ENQUIRIES
WELCOME

• Circle No. 174



KAYPRO

£1,695

Mains-powered metal-cased 26lb. transportable sold with a range of disc options and a large amount of software. Built around eight-bit Z-80A CPU with 64K RAM. Green 9in. screen displays 80 characters by 24 lines. Two 200K 5.25in. floppy-disc drives standard, or options of 400K twin floppy or one 10Mbyte hard disc plus one 400K floppy. CP/M 2.2, MBasic, Perfect Writer, Perfect Speller, Perfect Calc, Perfect Filer, Profit Plan, Word Plus and some games included in price. The Perfect range of software is integrated, allowing data to be transferred between different applications in the Perfect range.

FOR Good-quality software. Hard-disc option.

AGAINST: Rather bulky. Keyboard not fully detachable.



MIRACLE

£1,795

British-made 28lb. mains-powered transportable with large amount of CP/M software included in price and very large memory. Green 10in. screen displays 80 characters by 25 lines. Built-in twin 5.25in. floppies give 800K storage. Standard model has Z-80A, 128K of RAM and five expansion slots. Comes with CP/M 2.2, Micromodeller, Memoplan word processor, Profitplan spreadsheet, Fileplan database, Trendstar communications package and Microcache memory-management system. Microcache speeds things up by using the extra 64K of RAM to hold frequently accessed data in an intelligent way. Planned 16-bit 8086 add-on card gives access to MS-DOS and CP/M-86 software. The Z-80 will still work, making the Miracle a true dual-processor portable.

FOR Good-value software. Large screen. Fast cache memory system.

AGAINST New product from new company.



NOMAD

£2,236

Robust 3.3lb. battery portable designed for harsh environments, using bubble memory instead of floppy discs for storage. Intended to operate at temperatures from -30°C to 70°C, and has been on show working while embedded in ice. Two-line by 40-character LCD display. Hermetically sealed full-travel keyboard. Standard layout is ABC, but QWERTY and French AZERTY are options. Built around the Z-80L low-power Z-80 variant which runs at 2.5MHz, with 32K of RAM and 64K to 256K of bubble memory. Runs CP/M, comes with MBasic and is programmable either through the built-in keyboard or external VDU connected via the RS-232C port.

FOR Ultra tough. Runs CP/M software and MBasic programs.

AGAINST Expensive unless you really need the toughness.



OSBORNE 1

£1,495

The original Osborne 1 has been repackaged and the new Osborne Executive, pictured here, added to the range. Both machines are eight-bit mains-powered transportables based on the Z-80A processor. The 23lb., £1,495 Osborne 1 now comes with two double-density 5.25in. floppy drives with a combined capacity of 184K, 64K RAM and a 5in. screen with an 80-column card to improve the old 53-character by 24-line display to 80 characters. The £1,995 Executive has a 7in. amber screen, two 200K drives and 128K of RAM. Both systems come with CP/M, WordStar, Mailmerge, Supercalc, CBasic and MBasic in the price, and can read some non-Osborne disc formats. The Executive offers additionally the UCSD p-system, Personal Pearl, terminal-emulation software and CP/M Plus.

FOR Good value with lots of eight-bit software. Well known name

AGAINST Fixed keyboard. Osborne 1 has small screen and low disc capacity.



SCORPION

£5,950

Unusual 16-bit mains-powered transportable intended primarily for use with the APL language and built around the powerful 68000 processor. Uses the S-100 bus system to give hardware flexibility, although this results in a 29lb. weight. A 9in. green screen displays 24 lines of 80 characters. The non-detachable keyboard generates both the ASCII and the full APL sets. One 720K 5.25in. floppy drive is the minimum configuration, but twin 1.2Mbyte floppy drives and a 10Mbyte hard disc are also available; 256K RAM expandable to 1Mbyte. A 68000 Assembler and Mirage multi-tasking, multi-user operating system are included in price. APL is extra — about £1,200 including training.

FOR Powerful APL system, S-100 bus. Multi-user and network options.

AGAINST Heavy. Expensive for non-specialised use.

(more on page 135)

LONDON COMPUTER CENTRE

8/16 bit SOFTWARE

The comprehensive range includes

WORDSTAR £235	D BASE II £325
SUPERCALC £170	SPELLING CHECKER £80
WORD PROCESSING £	LANGUAGES £
SpellBinder 290	MBasic 210
Magic Wand 226	MBasic Compiler 230
Spellstar 134	Fortran 80/86 325
Mailmerge 134	Cis Cobol/Forms2 399/105
Grammatik 85	Pascal M 250
FINANCIAL PLANNING	Pascal MT +/SSP 350
Calcstar 85	ACCOUNTING
Multiplan 170	SGS from 250
Plannercalc 75	Peachtree from 325
T/Maker III 175	Tabs from 199
Microplan 200	Exact 500
D BASE CORNER	Pulsar from 195
Autocode 195	COMMUNICATIONS
Quickcode 205	Bstam 130
D Base Window 150	Crosstalk 135
UTILITIES	Moveit 80/86 90/105

Sid £60, ZSid £76, Mac £133

FORMATS: Superbrain, Televideo, Sirius, Sanyo, Osborne
Northstar, 8" SD, DEC, Epson QX-10, IBM
ICL HP XEROX ALTOS

All prices are exclusive of VAT

ASPEN SOFTWARE'S SPECIAL OFFER £99

GRAMMATIK

One of the most useful tools you can use with your word processor which improves your writing style and corrects your grammar.

PROOFREADER (Spelling Checker)

A very powerful and easy to use spelling checker with a standard dictionary of 30000 words and facilities to create your own dictionaries. It checks your errors in seconds, displays possible corrections and then updates the text automatically.

Grammatik and Proofreader have been designed to work together to provide the state of art in computerized document reading.

Normally priced at £85 and £80 respectively, but now in a SPECIAL OFFER at £99 for the two until the end of October.

It's compatible with Wordstar, Spellbinder, Peachtext, Magic Wand & Other CP/M based Word Processors and available on the formats listed.

43 Grafton Way, London W1P 5LA (Opposite Maples)
Opening Hours: 10-7 Mon-Fri. 12-4 Sat.
01-387 4455 (4 lines) After 7pm 388 5721. Telex: 8953742

● Circle No. 175

NewBrain

Buy from the NewBrain Specialists

NewBrain Models A and AD	} call for prices
Expanded NewBrain systems	
All the leads, cables etc.	
Software Technical Manual	£50
Printers Epson FX80, RX80, Shinwa CP80, Juki 6100 etc.	
	From £267 + VAT.
Recorder Sanyo DR 101 Data Recorder	£39 + £5.85 VAT.

NewBrain Software Selection

BRAINZAP ASSEMBLER (W) An interactive assembler/editor opening up the world of Z80 machine language	£9.95
MONITOR (W) The memory manager. Examine, alter, fill, move, dump, save, load, run, print, convert, etc.	£8.00
DISASSEMBLER (W) Unravel the secrets of the NewBrain's ROM	£9.95
DATABASE (G) Includes sort and search on any field, and many other useful features	£19.95
CHESS (Gr) The one you've been waiting for!	£14.95
LIFE SEARCH (W) (Adventure) Fills the NewBrain and can take two lifetimes to solve!	£9.95
BRAINTEXT (W) An easy-to-use and very practical W/P.	£12.00
STAR TREK (W) Rid the Galaxy of the Klingon menace - if you can!	£9.00
BRAINWRITER (B) All the W/P features you've been waiting for!	£34.50
EPROM VERSION	£41.40
LOAN & MORTGAGE (W) Vital information for savers and borrowers	£9.95
9 HOLE GOLF (W) Random holes. Fairways and 3-D putting. (Variable wind)	£7.00
X BOMB BATTLE (B) Fast action game	£9.00

Key to Software suppliers:

B = Brainwave, G = Gemini, Gr = Grundy, W = Watkiss Computers
Please write/phone for full lists of NewBrain hardware & software etc.

AUTHORS - DO YOU HAVE A PROGRAM WE MIGHT SELL?

MAIL ORDER - Free delivery for orders over £5.

To obtain your NewBrain etc., ring us on Stevenage (0438) 812439 (Access accepted) or send cheque/PO/Access number to:

ANGELA ENTERPRISES

4 Ninnings Lane, Rabley Heath,
Welwyn, Herts AL6 9TD

Tel: Stevenage (0438) 812439



● Circle No. 176

WHAT USE A MICRO WITHOUT A PRINTER?



NEW A.D.M. 80 COL. DOT MATRIX WITH TRACTOR FEED. BACKED BY ONE OF BRITAIN'S LARGEST MANUFACTURERS, IT IS NOW STOCKED BY US.

SPECIAL LAUNCH PRICE

£311.00 + VAT. Carriage £7.50 or collect from our warehouse.

CROFTON ELECTRONICS LTD.

35 GROSVENOR ROAD, TWICKENHAM, MIDDX O1-891 1923/1513 Telex 295093

● Circle No. 177

	<p>SHARP PC-5000 under £3,000</p> <p>Advanced 16-bit battery-powered portable similar in concept to the Gavilan with optional bubble memory. Weighs 11lb. and includes an eight-line by 80-character LCD display which folds down over the keyboard for carrying. The 8088 processor runs MS-DOS. Standard RAM is 128K, expandable to 256K, and an optional 128K of bubble memory can be fitted. Microsoft GW Basic comes in ROM, with space for a further 128K of application software in ROM cartridges. Optional 80-column clip-on thermal impact printer will also work on ordinary A4 typing paper if a ribbon is fitted. Fitted with an audio-cassette interface; optional 320K 5.25in. floppy discs available along with a direct-connect Modem in the United States, if not here.</p>	<p>FOR MS-DOS software. Compact unit. Bubble-memory option.</p> <p>AGAINST Not yet here.</p>
	<p>SORD £2,350</p> <p>Compact 19lb. mains-powered transportable with very large LCD display and Sony 3.5in. micro-floppy drives. Built around a Z-80 addressing 128K of RAM. The eight line by 80-character LCD display panel is over a foot long. The two Sony 3.5in. micro-floppy drives provide 520K storage. Sord SB-80 operating system claimed to be CP/M compatible. Runs Sord Basic and Pips, a combined spreadsheet, card index and programming language. Pips and the non-portable version of the M-23 were reviewed in <i>Practical Computing</i> July 1982.</p>	<p>FOR Good disc and memory capacity for the weight. Big LCD display.</p> <p>AGAINST A bit pricey — and is it really a standard CP/M machine?</p>
	<p>TANDY 100 £499</p> <p>Battery-powered lightweight portable similar in appearance to the Epson HX-20, but with more software and larger display in place of printer and microcassette. Weighs just under 4lb. and has an eight-line by 40-character LCD display and a good-quality full-size keyboard. The processor is the 80C85 eight-bit CMOS 8085 look-alike. From 8K of RAM; the 32K maximum-RAM system costs £730. For mass storage you have to use a domestic audio cassette. The 32K ROM contains an own-brand operating system, a good text editor, and limited address list and personal scheduler programs, along with communications software for use with the machine's RS-232C. Made in Japan by Kyocera for the Tandy Corporation. Reviewed <i>Practical Computing</i>, August 1983.</p>	<p>FOR Large LCD display. Excellent keyboard. Built-in software.</p> <p>AGAINST Small mass storage. Little independent local software as yet.</p>
	<p>ZITA £1,595</p> <p>Mains-powered transportable range with large number of disc options. The 28lb. Zita P is the more rugged industrial version. Built around the Z-80A with 64K RAM, expandable to 256K, twin 125K 5.25in. floppies and a 10in. screen displaying 80 characters by 25 lines. The machine comes with CP/M 2.2 hidden behind a front-end menu system. A £500 voucher for software lets you choose application software from ITCS's list. The 25lb. Zita E, pictured here, is for executive use and comes with a leather case. The top-end model at £5,295 has a built-in 24Mbyte hard disc and 1Mbyte floppy drive and comes with a £2,500 software voucher.</p>	<p>FOR Wide range of options</p> <p>AGAINST Keyboard not detachable. Some models rather heavy.</p>
	<p>ZORBA £1,595</p> <p>Good-value mains-powered 21lb. transportable with CP/M software included in price. Green 7in. screen displays full 80 characters by 25 lines. Built around eight-bit Z-80A chip and 64K RAM with WordStar, Mailmerge, Calcstar, the CBasic compiler, M-80 Assembler, and CP/M 2.2 plus utilities included in price. The Zorba can read or write 5.25in. discs in a number of formats, including Osborne, Superbrain and IBM CP/M-86. A 16-bit 8086 add-on card includes 128K of extra memory, expandable to 256K, and CP/M-86. When running eight-bit CP/M this extra memory can be used as a RAM disc. The Zorba is reviewed in full elsewhere in this issue.</p>	<p>FOR Good-value software. Large discs. Upgradeable to 16 bits.</p> <p>AGAINST Low-budget feel to the hardware.</p>

ACT SIRIUS

New Graphics Hardware and Software from Magus

GRAPHICS SCREEN EDITOR — The Graphics Equivalent of a Word Processor.

Our NEW Graphics Screen Editor gives interactive access to all of our powerful graphics routines directly from the keyboard.

FEATURES: —

- Line drawing and deletion
- Shading and area deletion
- Addition and deletion of text
- Multiple character sets
- Picture save and load to and from disk
- Multiple Screens
- Generation and use of symbol libraries
- Polygon and conic section plotting
- Cursor control from the keyboard or joystick
- Full Screen dump to a printer
- Block move

USES: —

- Electrical Schematics
- Building layouts
- In fact anything that can be drawn

Also available

- The Magus Graphics Board
- Memory Boards
- Multifunction Board
- Microcosm Research's Silicon Disk
- Data Ace — The Outstanding New Data Base Management System from the U.S.A.

Coming Soon — New Graphics Software from Magus

- Three Dimensional Surface Plotter
- Business Graphics Package
- Tektronix 4010 Emulator

All Magus Products Designed and Produced in Britain to the Highest Standards.

Authorised Dealer Enquiries Invited.

MAGUS COMPUTER SYSTEMS LTD

Sopworth Manor, Sopworth Chippenham, Wilts SN14 6PS
Telephone: 022 122 3576

• Circle No. 178

CLOSE HEATHROW/M4/M25

Industrial/Laboratory/Office Complex.

40,000 Sq. Ft.

**FREEHOLD FOR SALE
OR MAY LET**

**Apply Sole Agents
Ref: DW**

01-499 0404

75 Grosvenor Street, London W1X 0JB.

Chestertons

Chartered Surveyors

• Circle No. 179

: GO FORTH & * : FASTER DEVELOPMENT — FASTER PROGRAMS

Laboratory Microsystems FORTHS — professional software complete with editors, assemblers, turn-key compilers, system utilities, multi-tasking and extensive documentation.
* * * 68000 FORTH AVAILABLE NOW for CP/M-68K * * *

Z80 C/P/M-80, 8" £45, 5"	£60	CP/M-86	£95
IBM PC	£95	Sirius/Victor	£105
PC-FORTH+ 32-bit FORTH	£190	CP/M-86 FORTH+ 32-bit	£190
CP/M-68K	£190	Many other versions	

FLEX and SAGE users — we support you too. Ask for Apples, PETs . . .

Nautilus Systems Cross-compilers — transport FORTH to different processors, generate secure code, generate ROMmable code, the complete development machine — and very, very fast.

Prices from £230 for your first target.

Target processors include: 8080, 8086/88, Z80, 6800, 6301/6801, 6809, 68000, 1802, Z8, 9900/99000, VAX, Apple II, LSI-11

FORTH tapes BBC A/B with editor, assembler, graphics, toolkit	£25
Spectrum 48K with colour and sound	£14.95
Nascom 2 under NAS-SYS 3	£22.50

DIY FORTH kits	
Installation manual — How to do it, model, definitions, editor	£7
Source code listing for one processor — choose from	
6502, 6800, 6809, 8080, Z80, 8096/8088, 9900, 1802, 68000, Z8000, VAX, Apple II, LSI-11, Eclipse	£7

FORTH books — range includes:	
'Starting FORTH' by Brodie	£16
'Systems Guide to fig-FORTH' by Ting	£26

JUPITER ACE — now with FREE 16k RAM pack £78 + VAT — £89.70



MicroProcessor Engineering Ltd
21 Hanley Road Shirley
Southampton SO1 5AP
Tel: 0703 775482

• Circle No. 180

ORIC MCP-40

Bill Bennett tries a four-colour printer/plotter that sells for well under £200.

A PRINTER is a useful, even essential addition to many a microcomputer system. Even more desirable but frequently prohibitively expensive is a four-colour plotter. Such a device is now available as the standard printer for the Oric I micro. At only £170 it is great value and, furthermore, it can be connected to a number of other micros too.

At first sight, the price seems high compared with the £40 Sinclair ZX printer, but a much higher specification more than justifies the extra cost. It is about half the price of a dot-matrix printer and in many ways is just as flexible. Its only major drawback is that it uses relatively narrow 4.5in. paper.

The Oric MCP-40 offers an entirely different technology from the rival machines. The printing mechanism is made in Japan, and is remarkably similar to that found inside the Sharp CE-150 which is used in conjunction with the PC-1500 pocket computer. The difference is that the MCP-40 is bigger. A printer very similar to the MCP-40 is also sold by Tandy as the CGP-115.

A carousel holds the four tiny ball-point pens which provide the multiple colours. Red, blue, black and green pens are supplied with the machine. Strictly speaking the device is a plotter rather than a printer. The paper is marked by the pen travelling across the paper, and not by something impacting something else as in a conventional printer.

The pen, or rather the carousel, only moves back and forth along the x co-ordinate. Movement in the y direction is achieved by a roller winding the paper up and down. There are 480 steps across the paper and 999 along y-axis. Each step is 0.2mm., which is comparable with the width of the line drawn by the pens.

Ordinary paper is used, and it shows no tendency to smudge or blacken like the thermal paper on the ZX printer. It is an ideal size for printing tickets, bills, receipts, etc. and though it may be a little thin and narrow for serious word-

processed documents, it will certainly do for any informal notes. Plotting is relatively easy, though using variables within the LPrint strings which control the plotter can be daunting. As a tool for a student it is ideal.

The comprehensive 32-page manual is filled with examples of how to use the printer. A hefty example program shows off the machine's capabilities, which include a full upper- and lower-case character set, pie charts and bar charts.

The Oric printer needs a cable to connect it to the micro, and a separate power cable. You will consequently need at least three power sockets for the micro,

the TV and the printer — and possibly a fourth one for a recorder.

Conclusions

- The Oric printer is an excellent low-cost addition to an increasingly attractive-looking computer system.
- It produces exceedingly high-quality listings and plots in a wide variety of sizes, and four colours.
- It sits comfortably in both price and facility between the cheap thermal printers and the more expensive dot-matrix devices. If anything, it is better value than both.

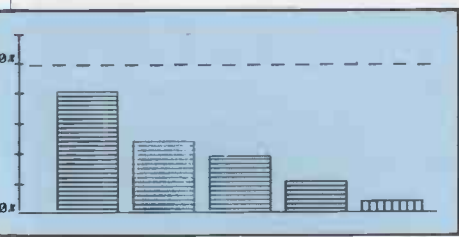

CHARACTER SET

Q " # \$ % & ' () * + , - . / 0 1 2 3 4 5 6 7 8 9

; < = > ? @ A B C D E F G H I J K L M N O P Q R S

U V W X Y Z [\] ^ _ ` a b

d e f g h i j k l m n o p q r s t u v w x y z { |

~ ☒

BBC games

Neville Maude investigates the lighter side of Acorn's worthy micro.

Snapper

FIRST CAME Pacman and then a host of Gulpmen, Munchymen, Bridgemen and so on. Snapper is thought by many to be better than the original.

The graphics are superb and the action smooth. Vertical and Horizontal keys can be pressed simultaneously, so cornering can be very fast. The programming is intricate and subtle. For example, if the eater gets too close to a guardian it starts to follow the eater relentlessly. And if the score mounts without a death, the guardians become increasingly agitated, moving ever faster.

When a star or power-pill is eaten the guardians turn blue and can be eaten for a while, as is usual with these games. When about to revert to normal state they flash blue and a warning note rises in pitch. After a frame has been cleared another starts: the speed of the guardians increases and the scoring values grow.

Fruits appear in various types according to the frame number. The first round has cherries, the second unripe strawberries and so on. Later a golden bell appears and ultimately the mystic Acorn. The game is addictive and subtle enough to be taken seriously.

Players who find a maximum of four lives insufficient to reach the faster, high-scoring levels can, in most versions of the game, cheat by pressing Escape after the second part of the program, Snap 2, has loaded. Then enter

```
42 ?&FDD = &6
```

or another final figure if you need even more lives, and then Run the program. One improvement which is really needed is a pause facility — for when you have scored, say, 120,000 with a spare life and the phone rings.

Specification

Type: arcade game
Format: cassette tape
System: Model B
Distributor: Acornsoft
Price: £9.95
Rating: 18/20

Monsters

FROM THE SAME STABLE as Snapper comes a similar game which is rather more difficult to play. You have to move your

fingers off the horizontal and vertical movement keys to dig the holes used to trap pursuing monsters and then to fill in the holes before the brutes crawl out.

The little man is chased up and down ladders, along walls and eventually expires with a despairing cry. If all monsters are exterminated, a new frame

appears with more, tougher monsters. Red monsters are killed by falling through one level, green ones need two, and white ones require three. You have to keep an eye on the oxygen level: if it runs out you die.

Altering the program to give more lives is possible, though harder than with the

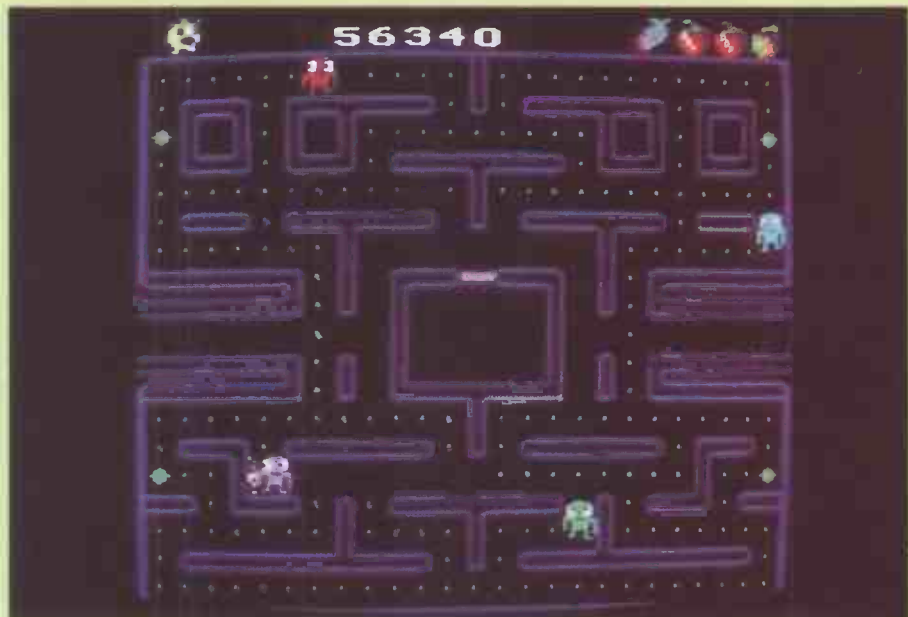

Snapper, thought by many to be better than Atari's original Pacman.

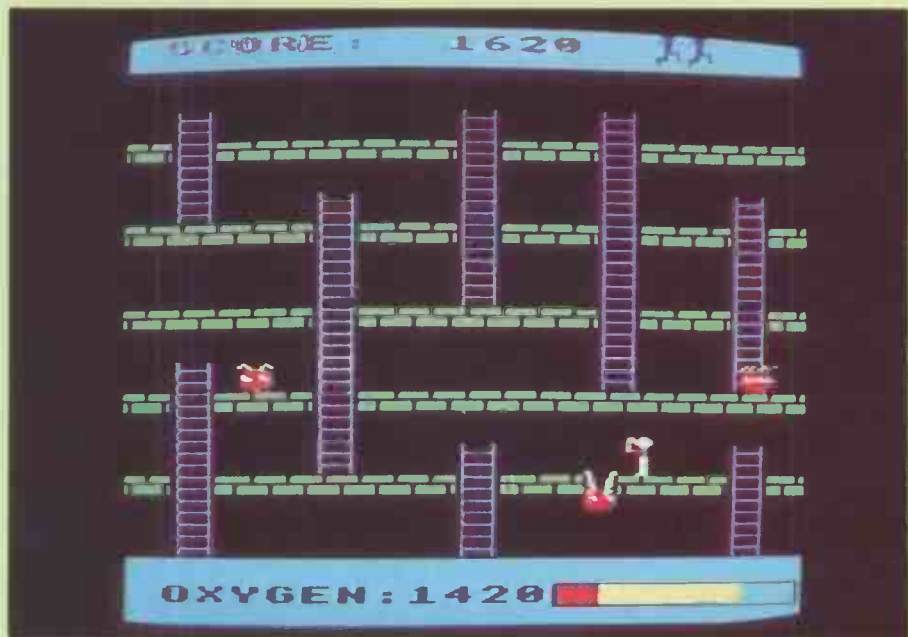

Acornsoft's Monsters boasts superb graphics but lacks a pause feature.

allied Snapper. The lives lurk in &IEE5. Inserting a new value should be followed by a Call to &E02. The graphics are superb and there is the usual high-score facility but a pause feature would be a welcome addition.

Specification

Type: arcade game
 Format: cassette tape
 System: Model B
 Distributor: Acornsoft
 Price: £9.95
 Rating: 15/20

Painter

YOUR PAINTER blob glides along lines, which turn white behind it. When a



Croaker plays on the frog theme.



Wizard — heading for a sad end.

rectangular area is surrounded by white lines it turns a different colour. The score mounts, and speed is rewarded by a bonus. An evil thing chases your industrious painter, and if they meet there is a pitiful squeal with a fluttering reminiscent of a fly captured by a spider.

When the last area has been filled a pulsing display is presented, which some players may find irritating. Another frame follows and, as usual, the scoring rate rises with each successive frame. There are 16 in all so great dexterity and application would be needed to reach the end. Not only do the chasers become faster and more intelligent, their number also increases.

A virtue of this program is the control which the player can assert. There are six



The imaginative Killer Gorilla.

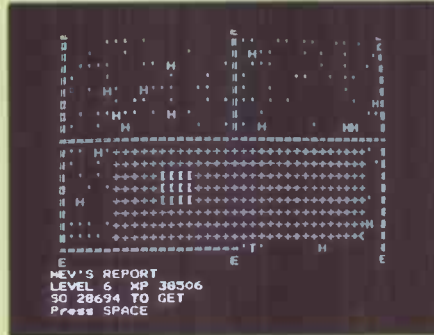

Tower of Alos runs on Model A.



The scholarly Emperor from Molimæx could do with better presentation.

levels of difficulty and it is also possible to choose from three sets of keys for operation. Graphics are colourful rather than subtle.

Specification

Type: strategy game
 Format: disc or cassette tape
 System: Model B
 Distributor: A + F Software
 Price: disc £11.50; cassette £8
 Rating: 14/20

Croaker

SINCE ATARI started with a chicken crossing the road there have been many frogs in peril under various titles. Beebug even has an endangered hedgehog. Croaker is a good implementation of the frog theme with a fair number of features. A Beethoven-based jingle can be switched off without requiring those who prefer silent games — and have OS 1.2 — to use the *FX210,1 command to switch off the speaker.

You score with every forward jump, plus 100 for every frog reaching the safety of the depressions in the far river bank. The one on the far left is the hardest to attain and the trick is to jump back on to a left-bound log and then forward again. There is a time-related bonus and when five frogs have been safely guided home the next frame appears, with traffic moving at what appears at first to be an impossible speed. An added complication comes from alligators and snapping turtles in the river.

Children invariably ask why the frogs cannot swim. Acid rain perhaps? The happy, self-satisfied croak produced when the frog settles down gives the game its name. Graphics are fairly good: the frogs are convincing and the road traffic can be recognised as vans, racing cars, tankers, etc., given a little imagination.

A minor criticism is that booby-trapping is imperfect. For example, pressing a cursor key by mistake produces a white rectangle on the screen, and so on.

Specification

Type: arcade game
 Format: cassette tape
 System: Model B
 Distributor: Program Power
 Price: £7.99
 Rating: 16/20

Tower of Alos

YOU ARE the adventurer, moving on a grid, battling with an assortment of creatures and accumulating treasure. Sub-scenarios include a marsh with lizard-men and aquatic creatures and, of course, the Tower — complete with demons, etc.

Combat strength is preserved by

(continued on page 141)

You were impressed by the unique portable Epson Computer that fits into your briefcase.



QX-10 £1735 plus V.A.T.

Now take a look at the one that sits on your desk.

The QX-10. A fully integrated Desktop Microcomputer system. A new member of the Epson family.

But there's more to the functional and stylish lines of this remarkable machine (just to prove that beauty isn't only skin deep).

The lightweight CPU, monitor and Keyboard units are very easy to use – even for a first time operator. You could say that our system takes all the hard work out of using software, and once used...you probably will.

Just look at these qualities.

192k upgradable to 256k RAM, Z80A CPU, RS-232C and parallel interfaces. CP/M and multifont BASIC comes as standard.

The QX-10 offers an incredible graphics capability. The 80 columns x 25 line display has 640 x 400 resolution and full bit image control for greater definition, 16:1 zoom and special effects. Not to mention a unique split screen facility enabling different

typestyles and graphics to be shown together. A major first for educational applications.

For even more power – simply slot in up to 4 optional interface cards, for IEEE 488, RS-232C, plus a universal interface card for developing your own prototype interfaces. Clock and calendar with full battery back-up complete the system.

As with all the other respected Epson products, you are assured of high quality. (We even manufacture the slim line disc drives ourselves.)

The QX-10 is the complete desktop system that represents exceptional value for money at £1735 plus V.A.T.

Ask to see it right away – you can't afford not to!

QX-10

THE HUMAN COMPATIBLE BUSINESS MICRO

• Circle No. 181

EPSON

Extraordinary product. Exceptional quality.

Epson (UK) Limited, Freepost, Wembley, Middlesex HA9 6BR. Freephone: 2730. Telex: 8814169

- I would like a demonstration of the QX-10.
- Please send me details and the name of my local stockist.

Name _____

Position _____

Company _____

Address _____

Tel: _____

BBC games

(continued from page 139)

potions bought in the village. Since the game will be long there is provision to save wealth and experience on tape for a latter session. The lengthy instructions are recorded on the reverse of the tape which stops them being lost. Unfortunately, letters are used to denote places and the adventurer is designated as a £ sign, which seems a little inappropriate.

As written the program is in mode 7, hence the letters. However, if you ask the computer how much memory is left, using command

```
DIM P% - 1: P.HIMEM - P%
```

You get the answer 17287 so, on the Model B, there is plenty of RAM left to shift into mode 6, for example, which permits user-designed characters. Instead of a £ you could use character 240, which is L, and redefine it as VDU23, 240, 152, 152, 252, 190, 189, 188, 182, 51.

This gives a good little warrior with a spear, though you could probably improve on it. Perhaps the programmer kept to mode 7 to ensure the game could be played on a model A machine, and maybe the long-promised Electron too. Alterations could be made by those wishing to cheat. For example, the conditional part of line 1400 could be removed so that it reads

```
1400 P. "IT WAS A STRENGTH POTION":  
HP = L * 250: G. 1420.
```

This confers unnatural strength and endurance, but do not think it solves all problems. The program can still produce surprises.

Specification

Type: Adventure
Format: cassette tape
System: Model A or B
Distributor: A + F Software
Price: £8
Rating: 16/20

Emperor

THE ROMAN EMPIRE during the first few centuries AD is the setting for this war game. It appears to have been written for the Tandy/Genie and then transcribed for the BBC Model B. Emperor could be described as a scholarly game, and schoolmasters will certainly approve. It is also fun. Success depends on making sound judgements, not on speed of reaction or digital dexterity.

There are three levels, corresponding to the first, third or fourth centuries, and

each runs over an eight-year period. To win, the player must expand the Empire by two provinces in the first century, hold his own in the third and not lose more than two in the fourth. This is much more easily said than done.

Variable and partially random factors include the abilities of generals and their loyalty, the fighting strength of the Emperor, the activities of barbarians outside the Empire and, to a smaller extent, initial placing and numbers of legions. Of greater importance is the skill with which the player deploys his forces and manages the finances of the realm.

The graphics are no more than adequate. The Atari war games with their scrolling maps set a standard which is hard to match, but the BBC is capable of better than has been achieved here. The translator seems to have been content to reach the former Tandy/Genie standard. A pseudo-animation as employed in the simple Kingdom game in the Welcome cassette could have been used.

A criticism common to many programs is that when a monitor has been used to develop a program it is forgotten that a domestic TV seldom shows the whole picture. While you can easily move the display up or down a line with the *TV255 commands either the top or bottom will be lost.

The program is in Basic which the BBC executes so quickly that there is no need to resort to machine code. There are no Rems so it would be hard to alter the program, which might be just as well. Nevertheless, if you simply cannot get anywhere due to financial problems, they could be solved on your back-up copy by altering line 3620 to, say,

```
C = C * 2 - D
```

Subsequently, having solved the other problems the line can be restored to the original for another try.

Specification

Type: war game
Format: cassette tape
System: Model B
Distributor: Molimerx
Price: £15.53
Rating: 16/20

Wizard

IN THIS INTERESTING variation on the "shoot the alien" theme the wizard Chzraal stands at the side of the lake, overlooking several rocks on which maidens are chained. Demons like spider-legged birds descend to carry the girls away. The wizard defends the maidens by using his laser-like wand, which can be rotated in an arc to aim.

When the screen is cleared of demons another wave descends. The demons grow increasingly resistant to the magic as the game progresses. As a variation, the demons sometimes come in sideways,

looking rather like killer doves. In this aspect they can be extinguished without great difficulty by using the wand like a hosepipe, but the magic is limited and eventually is used up. Then the wizard is dismembered and the helpless maidens are carried off to an unimaginable fate. This inexorable ending can only be postponed, not prevented, so only the masochistic could take pleasure in playing repeatedly. Adventures can have successful endings, so why not games?

Suppose, for example, that when a score of 2,000 is reached a procedure is called which forms a small pink cloud on to which the wizard and surviving girls move. The cloud then drifts up and off the screen, top right, while the computer plays *Happy Days are Here Again* in the standard three-part harmony from a hash table. Since the program is in Basic modification is not too hard. Alternatively, the first part of line 1800 can be deleted, leaving in the part after Else, to give unlimited magic, though the sad end is only postponed.

Specification

Type: arcade game
Format: cassette tape
System: Model B
Distributor: Quicksilver
Price: £6.95
Rating: 10/20

Killer Gorilla

OF SEVERAL programs derived from King Kong this is certainly one of the best. The damsel in distress stands on a high beam and cries for help. The intrepid player climbs ladders, races along girders, jumps gaps, leaps over rolling barrels or grabs a hammer and smashes a few. He watches out for fireballs and iron beams hurled with animal passion by the furious gorilla and, in the later frames, contends with moving conveyors and elevators.

There are four levels, and if all are completed — which is unlikely for some time — you return to the first one which has acquired more difficulties to be overcome. An extra life appears on completing frame 3.

The graphics are excellent and the program is enlivened by humour. For example, extra points can be earned by collecting the girl's discarded belongings — handbag, umbrella, etc. Again, when boy reaches girl a large red heart flashes on. Such imaginative touches make all the difference.

Specification

Type: arcade game
Format: cassette tape
System: Model B
Distributor: Program Power
Price: £7.99
Rating: 15/20

Why the New **Pro-tronic** leaves the rest for dead!

£375
+ VAT

Just a glance at the new Pro-tronic 15 will tell you that this is no toy. Compare the specification for the price and you'll see why this is the only daisywheel printer/typewriter that merits consideration.

- * Serial RS-232 (300 & 1200 baud) and PARALLEL electronics communication fitted
- * 13.3 characters per sec. print speed
- * Powered automatic paper loading
- * 10, 12 and 15 chars/inch keyboard selectable pitch giving up to 172 columns
- * 11.5 inch platen
- * Keyboard selectable line pitch for 1 line, 1.5 line and 2 lines
- * Lift off correction ribbon
- * 46 character automatic correction buffer
- * Variable print intensity control
- * Optional extras: Carrying case (£12). Dust cover, and additional typeface daisywheels
- * Interfaces with all common micros
- * Micro to printer leads available for £15.00+VAT and carriage

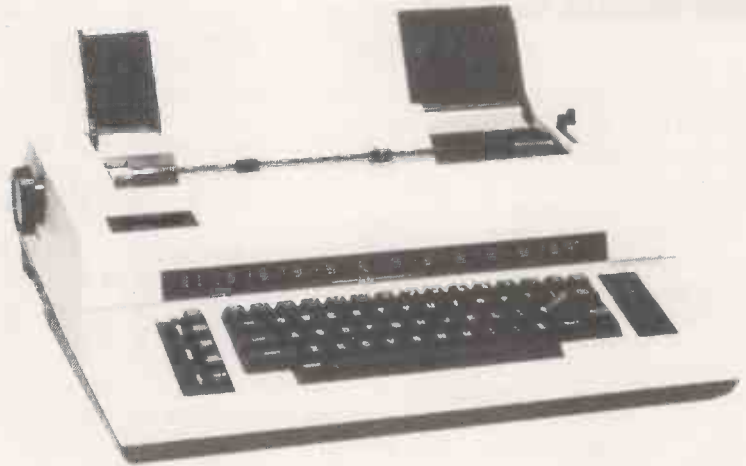

PMS
Developments

22 Tansmill Court, Rotherwas Hereford HR2 6JZ
Tel: Hfd 265768, 50848 (STD 0432)

DEALER ENQUIRIES WELCOME



● Circle No. 182

**IF YOU HAVE A BBC MICRO
THEN YOU NEED**

LASERBUG

LASERBUG is the newsletter of the Independent National BBC Microcomputer Users Group. If you want the best source of information on the BBC Micro you can't do without LASERBUG. No matter what your interest - hardware, software, business, games or education then LASERBUG has something for you.

Also, LASERBUG has available many special offers including dust covers (for computer, monitor, printer, disks), cassette leads and 112 ROMS FOR ONLY £5.50 INCLUSIVE - THE CHEAPEST PRICE ANYWHERE! (Members Only)

LASERBUG defies description - send off for a sample copy and you'll find that it sells itself to you. See one and you'll be hooked for life!!!

Please supply me with more details about **LASERBUG** and your special offers
 a sample copy for £1.00 and an A4 SAE (17p postage)
 1 UK 12 Month Subscription for £12.00
 1 UK 6 Month Subscription for £6.00
 1 Overseas Surface Mail Subscription for £14.00
 (air mail rates on application)

Please send the goods to:
 NAME ADDRESS

I enclose a cheque/PO for £ p made payable to LASERBUG.

Please send the form to LASERBUG Dept. P, 10 Dawley Ride, Colnbrook, Slough, Berks., SL3 0QH.

● Circle No. 183

dBASE THE RELATIONAL DATABASE SYSTEM

Ashton-Tate

FOR MICROCOMPUTERS

- TRAINING?
- ADVICE, GUIDANCE, CONSULTANCY?
- PROGRAMMING?
- DATABASE 'PRIMER' MANUAL featuring 'dBASE II'

For further details, contact:

Lionel Boreham
LANTECH Information Systems Ltd.
55 Peascod St. Windsor, Berks SL4 1DE
Tel: Windsor 58182/58013

LANTECH
 Information Systems

● Circle No. 184

STEMMOS

the

dBASE II

experts

STEMMOS

THE BIG GAME HUNT

STEMMOS are one of Britain's leading software houses and specialists in dBase II

STEMMOS offer a helpline for dBase II users

STEMMOS wrote Autocode I™, the only intelligent program generator for dBase II

STEMMOS hold monthly seminars in the heart of London on dBase II

- An opportunity for anyone from engineer to businessman to write their own microcomputer program.
- And for the programmer the chance to write programs in a fraction of the time.

Seminars:

4, 5, 6, July. 1, 2, 3, Aug.
5, 6, 7, Sept. 3, 4, 5, Oct. 7, 8, 9, Nov. 5, 6, 7, Dec.

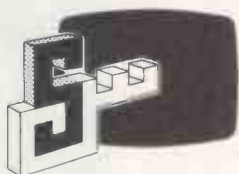

STEMMOS
The Key to successful software

STEMMOS

Please send me more information on:

dBase II
Autocode I
dBase II User seminars

Name: _____
Company: _____

Address: _____



STEMMOS LTD
199 Uxbridge Road
London W12.

Tel: 01-740 9444 Telex: 893003 STEMMOS G

dBase II™ Ashton Tate Autocode I™ Stemmoss Ltd

Practical Computing

big game

hunt

WHAT'S YOUR FAVOURITE computer game, and why? What kind of game is it? What's your best score? How does the game rate against Scrabble on the Apple, The Hobbit on the Spectrum or Star Raiders on the Atari? Consult the ratings published in our regular games reviews for comparison.

Then fill in the software survey form below and let us know. The results will be collated for a special guide to computer games in our December issue, including a Top 30 as selected by readers of *Practical Computing*.

You can fill in a survey form for more than one game. Simply photostat the one below.

Game:.....
Publisher:.....
Machine:.....
RAM required:.....
Accessories required:.....
Price:.....for cassette/disc/ROM

Type of game:.....
.....Frogger, Scramble, Pacman type, etc.
Number of players:.....to.....
Object of game:.....

Use of colour/sound:.....
Comments:.....
.....
Your highest score:.....
Rating out of 20:.....

Name:.....
Address:.....
..... } Optional

Post completed forms to: BIG GAME HUNT, *Practical Computing*, Quadrant House, The Quadrant, Sutton, Surrey SM2 5AS to arrive by Friday September 30, 1983.

THE FLEXIBLE COMPUTER SYSTEM FOR THE FUTURE

ORIC-1



16K Oric was £129.00
Now only £99.95

48K Oric was £169.95
Now only £139.95

Plus £40 printer voucher free with every computer purchase.

ENHANCED

NOW AVAILABLE

ORIC SOFTWARE

(available on cassette only. Prices include VAT and post and packing)

ORIC FORTH language. Requires 48k machine.
Price £15.90

ORIC BASE for the maintenance of personal and small business information. Requires 48k machine.
Price £15.40

ZODIAC adventure game. Requires 48k machine.
Price £10.39

ORIC CHESS Requires 48k machine.
Price £10.39

NEW ORICMON A complete machine code monitor. Either 16k or 48k machines.
Price £15.90

NEW HOUSE OF DEATH game. Requires 48k machine.
Price £10.39

NEW MULTI GAMES PACK 2 Requires 48k machine.
Price £7.30

NEW Oric MUNCH game. Requires 48k machine.
Price £8.35

ORIC PRINTER

£169.95 inc.

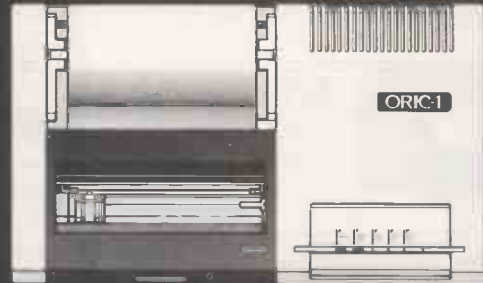

Oric Products are pleased to announce the release of the four-colour printer.

The Printer uses standard 4½ inch paper and is switchable between 40 and 80 characters per line.

The writing mechanism is a clever arrangement of four miniature ball-point pens (red, green, blue and black inks.)

There are 15 programmable character sizes and four different drawing angles.

The pen plotting facility allows the drawing of complex diagrams and pictures.

The price includes an integral power supply and printer lead.

You may place your order by phoning our telesales number on ELY (0353) 2271/2/3/4 or by completing the postal form below:

Payment may be made by cheque, postal order, Barclaycard Visa or Access.
All cheques and postal orders should be made payable to Tansoft Ltd.
For credit card payment please quote Access, Barclaycard Visa No.

Name _____
Address _____

Description	Qty	Price
_____	_____	_____
_____	_____	_____
_____	_____	_____
_____	_____	_____
_____	_____	_____

All orders should be sent to Tansoft Ltd, 3 Club Mews, Ely, Cambs CB7 4NW

Full colour brochure and software catalogue is available on request.

TOTAL _____
Trade enquiries welcome. All prices are inclusive of VAT

The right software for your application from

COMPUTECH



Authorised Dealer
Service Centre
System Consultancy



COMPUTECH FINANCIAL ACCOUNTING PACKAGES

Payroll **£375**
Invoicing and Stock Recording **£295**
Sales, Purchases and General Ledgers **each £295**
Also costing and group consolidation

COMPUTECH UTILITIES DISK

for reliable error checking copying, diskette scan, interpret and patch, etc **£20**
VisiCalc, Applewriter and other Apple software (Prices on request)

COMPUTECH CHAIN MAIL

A mailing merging document processor which may be used with text files, including random files and Applewriter 1.1 binary files **£45**

COMPUTECH GRAPHICS DISK

for printing Apple pictures and graphs on Epson and Microline (free with printers purchased from Computech) **£30**

COMPUTECH TERMINAL UTILITIES

Apple to Apple and Apple to mainframe **from £130**

COMPUTECH hardware...just plug it in and go!

switches and jumpers provide hardware options without soldering



DIPLOMAT VIDEO DIGITISER

store a frame from video camera in a fiftieth of a second, process and print **£195**

DIPLOMAT PARALLEL Interface **£80**

DIPLOMAT SERIAL COMMUNICATIONS Interface **£85**

DIPLOMAT RAM 16 Memory Expansion **£95**

DIPLOMAT CLOCK/CALENDAR **£80**

LOWER CASE Character Generator with Applewriter 1.1 enhancements **£50**

MICROMUX Data Exchange (Max 16 Ports) **from £850**

MATRIX PRINTERS, Microline and Epson with graphics and up to 200 cps **from £230**

MICROLINE Optional Character Generator **£15**

DAISY WHEEL PRINTERS, Olympia, Qume, Ricoh **from under £1,000**

Prices exclude VAT, Carriage and Packing

For full details phone for data sheets and a FREE demonstration

COMPUTECH SYSTEMS

168 Finchley Road, London NW3 6HP. Tel: 01-794 0202

Intertec Offers
The Warranty
Your First Computer
Should've Offered.



The rationale behind the conventional 90-day warranty is that anything likely to go wrong will go wrong in the first 3 months.

But it can take 3 months just to get comfortable with a new system. That's the honeymoon-period, when you treat your equipment with the delicacy of a safecracker.

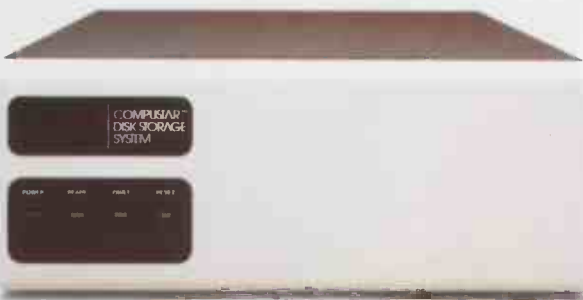

CompuStar can network up to 255 intelligent terminals and give each of them access to common or restricted databases.

Ah, but now it's 5 months down the road, the honeymoon is over, your equipment has finally begun to justify its cost, and that's the afternoon your processor's fan succumbs to fatigue.

Or maybe the malfunction is more gradual, like a disk-head drifting increasingly out of alignment.

Or more elusive, like an intermittent failure due to borderline components.

When You Build Them Stronger, You Can Back Them Longer.

And that's why all Intertec terminals, computer networks and disk storage systems come with a full year of coverage. Not because you'll need it, but to assure you that you won't.

See—unlike other makers, we know what we're standing behind.

We don't slap Intertec nameplates on other people's parts. We build virtually all our equipment ourselves.

And we assemble it ourselves.

And we test and re-test it ourselves.

More Value For Your Money.

That's also why we can offer you superior values.

In single-user desk tops, for example, our SuperBrain offers twin Z80s, standard; 64 kbytes of dynamic ram, standard; up to 1.5 mbytes of disk storage, standard; CP/M 2.2* and MBasic† standard.

And compared to conventional multi-user systems, our CompuStar systems can give you many more hours of productive labour every day—because, instead of depending on a central processor for data manipulation, each workstation in a CompuStar network has its own processor and its own 64 kbytes of ram.

As a result, you can have anywhere from 2 to 255 workstations working simultaneously without suffering noticeable declines in execution-time.

Why Just Expand When You Can Up-Grade?

In fact, if you assess your expansion alternatives in terms of relative payback potential,

you're very likely to find that up-grading with Intertec equipment from scratch would be more cost-effective than burdening your existing installation with add-on's.

Pound for pound, the Intertec system is apt to be not only faster, more powerful and more versatile, but more reliable and better supported.

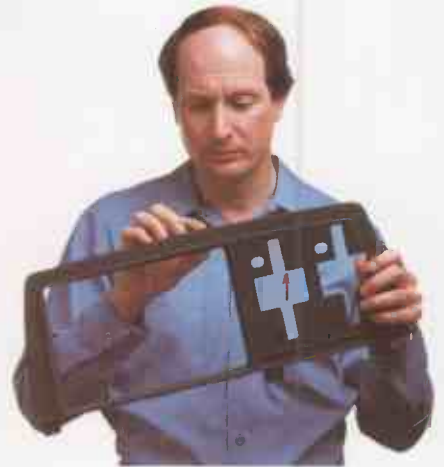

Since we build our equipment from scratch, we can afford to do it right and still hold down our prices.

For the name and address of your nearest Intertec dealer, or for more information about any of our products and services, please contact our Regional Manager at P.O. Box 367, London W13-9QQ, or telex 297066.

You're welcome as well to direct your enquiries to our corporate headquarters in the USA. Telex 8106662115, or write to Intertec Data Systems Corporation, 2300 Broad River Road, Columbia, South Carolina 29210.

intertec

● Circle No. 188

The printer you've all been waiting for.



Epson have done it again! Realising a genuine need in the market place for a printer that not only has the same advanced features as its sister, the well tested RX-80, but also has the ability to accept both single sheet and fanfold paper; we bring you the RX-80 F/T.

This latest addition to our range of fine printers gives you dot addressable graphics, standard Centronics compatible interface with a range of interfaces to suit most machines and a fast 100 characters per second print speed.

By incorporating both friction and tractor feed, (which allows for variable paper width) Epson have produced a completely versatile printer at a thoroughly realistic price. Just another example of how we at Epson are not only identifying customer needs, but acting

to serve them staying one step ahead of the field with our quality range of printers and computers.

Don't wait any longer...find out about the RX-80 F/T today.



EPSON
Extraordinary product.
Exceptional quality.

Epson (UK) Limited, Freeport,
Wembley, Middlesex HA9 6BR.
Sales Enquiries: Freefone 2730.
General Enquiries: 01-902 8892.
Telex: 8814169.

- I would like a demonstration of the RX-80 F/T.
- Please send me details of my local stockist.

Name _____

Position _____

Company _____

Address _____

Telephone _____

PC9/83

Open File

This regular section of *Practical Computing* appears in the magazine each month, incorporating Tandy Forum, Apple Pie, Sinclair Line-up and other software interchange pages.

Open File is the part of the magazine written by you, the readers. All aspects of microcomputing are covered, from games to serious business and technical software, and we welcome contributions on CP/M, BBC Basic, Microsoft Basic, Apple Pascal and so on, as well as the established categories.

Contributors receive £30 per published page and pro rata for part pages, with a minimum of £6. Send contributions to: Open File, *Practical Computing*, Quadrant House, The Quadrant, Sutton, Surrey SM2 5AS.

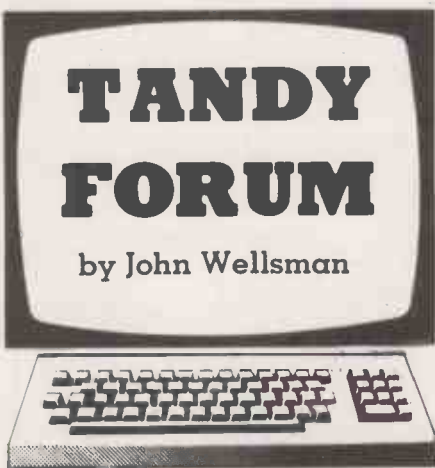

Variable lister

A USEFUL utility which is missing from TRS-DOS comes from Mr A Johnson of

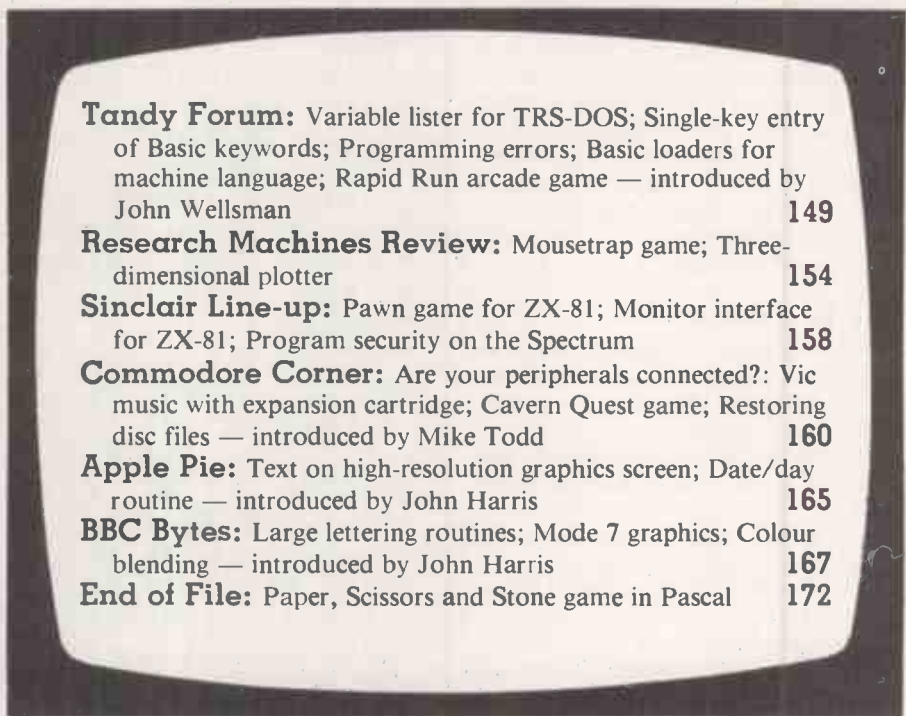

Tandy Forum: Variable lister for TRS-DOS; Single-key entry of Basic keywords; Programming errors; Basic loaders for machine language; Rapid Run arcade game — introduced by John Wellsman	149
Research Machines Review: Mousetrap game; Three-dimensional plotter	154
Sinclair Line-up: Pawn game for ZX-81; Monitor interface for ZX-81; Program security on the Spectrum	158
Commodore Corner: Are your peripherals connected?: Vic music with expansion cartridge; Cavern Quest game; Restoring disc files — introduced by Mike Todd	160
Apple Pie: Text on high-resolution graphics screen; Date/day routine — introduced by John Harris	165
BBC Bytes: Large lettering routines; Mode 7 graphics; Colour blending — introduced by John Harris	167
End of File: Paper, Scissors and Stone game in Pascal	172



Guidelines for contributors

Programs should be accompanied by documentation which explains to other readers what your program does and, if possible, how it does it. It helps if documentation is typed or printed with double-line spacing — cramped or handwritten material is liable to delay and error. Program listings should, if at all possible, be printed out. Use a new ribbon in your

printer, please, so that we can print directly from a photograph of the listing and avoid typesetting errors. If all you can provide is a typed or handwritten listing, please make it clear and unambiguous; graphics characters, in particular, should be explained.

PLEASE send a cassette or disc version of your program if at all possible. It will be returned after use. For CP/M programs use IBM-format 8in. floppy discs.

Sevenoaks, Kent. It allows you to list all the variables used in a program, with their current values, and makes a very useful debugging tool.

Naturally it is in machine language, but Mr Johnson has incorporated it into only a Basic loader, which most people have no difficulty in using. The program uses the Basic variable table as a list of all variables currently in use and calls the Print routine to display their contents. Because of the way this table is constructed, the variables are listed in the order in which they occur during execution.

The variable table is placed in memory immediately after the Basic program text. Its start address is contained at 40F9 and its end at 40FB. The first byte of each variable in the table is the length of the value entry and defines the type of variable: 2, integer; 3, string; 4, single

precision; 8, double precision. The second and third bytes hold the variable name in reverse-order ASCII. The remaining bytes hold the value or length and address if a string. It is only the first three bytes which are of interest here as the program uses the ROM to display the variable contents.

To use the utility, load the program into memory and run it. All that happens is that the message

Loading routine please wait appears and after a few moments, the Ready cursor reappears. Line 60 of the program self-destructs the Basic text and you can now load or write your program. To call the utility, enter

CMD LIST

Disc users please note that the usual quote after CMD is not used. All the variables used in the program are then shown with their current values.

(continued on next page)

(continued from previous page)

The command can be inserted in a program and obeyed and the program will continue through it. Mr Johnson says that he has not used it with disc but I have, with Newdos, and found no trouble. Obviously, memory should be protected according to the size of RAM available. I strongly recommend any keen programmer to install this utility.

One-key entry

Single-key entry of Basic keywords is an option on a number of micros, and can save an enormous amount of time when typing in long programs. Andy Wright of Crosby has a routine to implement this feature on a 16K level 2 Tandy or Video Genie.

First of all, protect memory at a suitable level. For 16K level 2, this would be 32594 but for larger machines a higher level could be used. After you have typed in the program save it on tape or disc in the usual way. After you have run it you will find that when you type certain shifted keys you will get the keywords shown in the table. Remove the program by typing New, or the program could be made to clear itself after running by changing line 70 to

```
70 NEW
```

Lines 2000 to 2020 control which word is produced by pressing each shifted key. If these numbers are changed, different words may be produced. The program uses the tokens for the keywords minus 127 and if you get the list of tokens for all the keywords you can substitute your own preferences for those in the program. So a shifted A results in the display of the keyword coded 56 which is Auto. If this were changed to 55 the keyword Delete would appear.

Standard errors

Everyone, however expert they may think they are, will always learn a lot just by studying other people's programs, even though the purpose of the program may not be of great interest. A number of errors that people sometimes make also show up. I noticed two programs this month which contained a line similar to

```
5 DEFINT A-Z: CLEAR 500:
```

I suppose that the authors thought they were speeding up the program by using integers only but probably never realised that the command Clear cancels out all previous defining statements, including On Error Goto, and zeros all values, so their programs were back to using single-precision variables. There is a definite order for these preliminary definitions.

Always Clear first then, if necessary, Define your variables and only if required Dim them afterwards. As in the example line, you may not realise that by using the wrong order you have cancelled out what you have tried to do, and there will be no error message to tell you.

Variable lister.

```
10 PRINT:PRINT:PRINT"LOADING ROUTINE,
PLEASE WAIT"
20 FOR I%=32615 TO 32711: READ A%:
POKE I%,A%:NEXT
30 A1=PEEK(16756):A2=PEEK(16757)
40 POKE 16756,103:POKE 16757,127
50 POKE 32622,A1:POKE 32623,A2
60 NEW
70 DATA
229,254,180,40,4,225,195,25,26,42,
249,64,237,91,251,64
80 DATA 223,32,3,225,215,201,229,78,
6,0,33,191,127,9,70,225
90 DATA 229,35,94,35,86,123,254,48,
48,2,30,9,33,200,127,229
100 DATA 54,34,35,114,35,115,35,112,
35,54,61,35,54,34,35,114
110 DATA 35,115,35,112,35,54,44,35,
54,0,225,205,111,32,225,78
120 DATA 6,0,9,35,35,35,24,180,0,0,
37,36,33,0,0,0,35
```

One-key entry.

```
1 'SHORTHAND
5 'BY A. J. WRIGHT
10 FOR I=16815 TO 16817
20 GOSUB 100
30 NEXT I
40 FOR I=32595 TO 32767
50 GOSUB 100
60 NEXT I
70 END
100 READ J
110 POKE I, J
120 RETURN
1000 DATA 195,83,127
1010 DATA 209,197,42,167,64,6,240,205
1020 DATA 96,127,195,116,3,229,62,14
1030 DATA 205,51,0,72,205,73,0,254,32
1040 DATA 48,42,254,13,202,98,6,254
1050 DATA 31,40,56,254,1,202,97,6,17
1060 DATA 103,127,213,254,8,202,48,6
1070 DATA 254,24,202,43,6,254,9,202,70
1080 DATA 6,254,25,202,65,6,254,10,192
1090 DATA 209,254,97,250,162,127,254
1100 DATA 123,250,183,127,119,120,183
```

(listing continued on page 152)

Basic loaders

If you have a machine-language routine which you are thinking of sending to this column it is best to submit it as a Basic loader. To machine-language programmers this is not as interesting and informative as a source coding with remarks, but a Basic loader is much more accessible to readers who do not have assemblers and are unfamiliar with machine language.

(continued on page 152)

One-key entry table.

A Auto	J Input	S Str\$
B Chr\$	K Left\$	T String\$
C Cont	L List	U Using
D Data	M Mid\$	V Val
E Edit	N Next	W Read
F For	O Poke	X Run
G Goto	P Peek	Y Else
H Gosub	Q Right\$	Z Stop
I Inkey\$	R Return	

FOR THOSE WHO LIKE SHOPPING AROUND

C/WP has opened a computer shop at 108 Rochester Row, London SW1 (just 5 minutes walk from Victoria) where you can see, buy and take away anything from a daisy wheel or a floppy disk to a complete computer system at those low prices which still turn others green! The shop is open from 9.00 to 5.30 Monday to Friday and 10.30 to 5.00 on Saturday. Most things are in stock most of the time, but ring 01-630 7444 to make sure. Just ask for "Shop".

APPLE ADD-ONS

ACCELERATOR CARD

Speeds up the Apple II more than 3 times by replacing the normal 6502 processor with a much faster version. Board carries 64k memory and just plugs into Apple slot. New product.

£299 + VAT £44.85

VIDEX 80 COLUMN CARD

Steady well-formed 80-character lines for your Apple II. A must for professional word-processing on the Apple (RRP £220 + VAT).

£159 + VAT £23.85

MICROSOFT 16K RAMCARD

Tremendous value. Gives your Apple II Plus another 16k of memory for extended Visicalc or Pascal. Like Apple's "Language Card". Not suitable for Apple III.

£59 + VAT £8.85

UHF MODULATOR FOR IIE

Display your Apple IIE colour or mono text and graphics on your home television set. Very high quality 8MHz modulator squeezes brilliant colours into your telly. NEW.

£22 + VAT £3.30

C/WP SERIAL INTERFACE CARD

A really versatile switchable baud-rate asynchronous communications interface for Apple II. Can also be used as an interface for serial printers.

£70 + VAT £10.50

C/WP PARALLEL INTERFACE CARD

A "Grappler"-like graphics interface for parallel printers such as the Epson, Microline and Star series. Allows graphics dump onto printer. State which printer you have.

£70 + VAT £10.50

MICROSOFT Z80 CP/M SYSTEM

Turns your Apple II (Plus or E) into a CP/M machine to run programs like WordStar and dBase II. Hardware, software and all documentation.

£199 + VAT £29.85

MICROSOFT Z80 CARD (ALONE)

As above but without software. Adds a Z80 processor to your Apple II. If you already have CP/M software, allows you to run CP/M programs on Apple II.

£79 + VAT £11.85

PRINTERS GALORE



£399

+ VAT £59.85

SILVER REED EX44

Brilliantly engineered daisy wheel typewriter/printer with self erase ribbon and extended keyboard in

typewriter mode. Marvellous quality printing. Portable. RRP £485 + VAT.

EPSON MX100 TYPE III

Wide carriage 100 cps matrix printer. Tractor and friction. The ideal printer for spread-sheets and accounts. RRP £475 + VAT.

£425 + VAT £63.75

SUPERB NEW 100 CPS MATRIX PRINTER

£269

+ VAT £40.35

STAR 510 is the star of the show. Just like the Epson MX80, but faster and with extra features. More type styles. Good graphics.

Tractor and friction paper feed. The best printer at its price. Also STAR 515 for paper up to 15 inches wide. Same spec. Ask for details.

EPSON FX80

Latest version of the Epson 8 inch matrix printer. Very good quality print at 160 cps. Many enhancements on the much-loved MX80. Tractor and friction paper feed. Good graphics. RRP £438 + VAT.

£349 + VAT £52.35

EPSON RIBBONS

For MX80 **£9** + VAT £1.35

For MX100 **£11** + VAT £1.65

MONITORS

12 INCH GREEN OR AMBER SCREEN. Elegant plastic case. 24 MHz band width. A first class monitor.

£99 + VAT £14.85

12 INCH GREEN MONITOR in solidly built metal case. 22 MHz. Good clarity. Normally £99 + VAT.

£89 + VAT £13.35

CONTOUR 5 AND 6 MB WINCHESTERS AT GIVE-AWAY PRICES

£1195

+ VAT £179.25

Buy a 5 megabyte (or 6 megabyte while stocks last) Winchester disk at an outrageously low price. Fine for Apple II (Plus and E), Apple III, Cortex, Osborne, Sirius and Superbrain. CONTOUR is not only the least expensive hard disk, it is also the best. On Apple II can be used with DOS 3.3, CP/M, Pascal, and BOS 5.

QUALITY FLOPPY DISKS AT UNBEATABLE PRICES

Top quality disks by Wabash and BASF. In boxes of 10. All guaranteed. Library boxes £2.30 extra incl. VAT.

£19 + VAT £2.85 double density per box

£15 + VAT £2.25 single density per box

SIEMENS FLOPPY DRIVES FOR APPLE II

A really good quality compatible drive for Apple II (Plus and E). Plugs into standard Apple disk controller card. Now you can afford that second disk drive. Compare Apple's prices.

£179

+ VAT £26.85

DISK CLEANING KITS

The best way of having discs that serve you true is to clean them often. Everything you need. Simple to use. Larger size £33.35 incl. VAT.

£19 + VAT £2.85

DISKS AND DRIVES

C/WP

C/WP Computers
108 Rochester Row, London SW1P 1JP
Telephone: 01-828 9000

HOW TO PAY

In the shop we accept cash, building society cheques, bankers' drafts (just ask your bank for one - it costs about £2), ordinary cheques for up to £50 with a Bankers' Card, or most major credit cards (subject to a modest surcharge). If you pay in one of these ways you may take your purchases away with you. If you pay by cheque for goods worth more than £50, we will send them to you free of charge anywhere in the United Kingdom as soon as the cheque has cleared.

IF YOU ARE NOT IN LONDON

Why not order by telephone? If you give your name, address, telephone number and credit card number (again there is a small surcharge), we will send the goods to you by return. A charge of £2 for postage and packing for all orders whose value (excluding VAT) is under £50.

Or write to us with your order and a cheque. If we cannot supply what you want within seven days, your cheque will be returned to you.

(continued from page 150)

Mr Palmer of Maidenhead, Berkshire has an interesting suggestion on this point. His listing illustrates the way in which Basic driver programs can be documented when they contain machine-code sections. At the cost of a few extra line numbers, the assembly op-codes have been inserted as Rems alongside their decimal equivalents.

Rapid Run

An excellent arcade-type game has been sent in by Clive Whitehouse of Marple Bridge. He very aptly calls it Rapid Run; if you can get through you have nimbler fingers than mine. 

(listing continued from page 150)

```

1110 DATA 40,192,126,35,205,51,0,5,24
1120 DATA 184,205,201,1,65,225,229,24
1130 DATA 176,229,197,214,96,33,
229,127
1140 DATA 6,0,79,9,70,33,79,22,35,203
1150 DATA 126,40,251,16,249,193,209
1160 DATA 120,183,40,16,126,203,191,18
1170 DATA 213,205,51,0,209,19,5,35,203
1180 DATA 126,40,236,235,24,129
2000 DATA 56,120,52,9,30,2,14,18,74,10
2010 DATA 121,53,123,8,50,102,
122,19,117
2020 DATA 69,64,118,12,15,22,21
    
```

Basic loaders.

```

10 REM SAMPLE PROGRAM - PRINTS SCREEN WITH SPECIFIED GRAPHICS
20 REM LOAD AFTER RESPONDING 31999 TO MEM SIZE? ON POWER UP
30 REM REPLY 999 TO END
40 GOSUB 120
50 CLS
60 INPUT N
70 IF N=999 THEN 260
80 IF N < 128 OR N > 191 THEN N = 128
90 X =USR(N)
100 FOR X = 1 TO 1000:NEXT X
110 GOTO 50
120 POKE 16526,0: POKE 16527,125
130 FOR X= 32000 TO 32016
140 READ A
150 POKE X,A
160 NEXT X
170 DATA 205,127,10 :REM CALL 0A7F
180 DATA 125 :REM LD A,L
190 DATA 33,0,60 :REM HL,3C00H
200 DATA 119 :REM LD (HL),A
210 DATA 17,1,60 :REM LD DE,3C01H
220 DATA 1,255,3 :REM LD BC,03FFH
230 DATA 237,176 :REM LDIR
240 DATA 201 :REM RET
250 RETURN
260 END
    
```

Rapid Run.

```

10 CLEAR 200:DEFINT A-Z:CLS:PRINT@25,
"RAPID RUN":PRINT@88,STRING$(11,34):
PRINT@530,"DO YOU NEED INSTRUCTIONS?":
A$="YN":GOSUB 999:IFA=2THEN 35
20 CLS:PRINT@25,"RAPID
RUN":PRINT@88,STRING$(11,34):PRINT@150,
"--INSTRUCTIONS-- CANDEING DOWN
THE RIVER YOU ENCDUNTER RAPIDS!CAN YOU
DODGE THE ROCKS - CAN YOU KEEP AWAY
FROM THE EDGE
25 PRINTTAB(14)"--- CAN YOU STAY ALIVE
--- ? USE ARROW KEYS TO MOVE
LEFT AND RIGHT
30 PRINT"P.S. IF YOU ARE ABOUT TO HIT
A ROCK YOU MAY PRESS THE SPACE BAR THIS
WILL CAUSE YOU TO LEAP THE ON COMING
ROCK(YOU ONLY HAVE THE STRENGTH FOR
FIVE JUMPS)
35 PRINT@914,"ENTER LEVEL OF SKILL
1-3";:A$="123":GOSUB 999:D=A
40 CLS:A$=CHR$(173)+CHR$(158):
S=61:A=961:B$=CHR$(140)+CHR$(179)+CHR$(
140):B=31:D$="??":IFD=1B$=CHR$(140)ELSE
IFD=2THENB$=CHR$(166)+CHR$(140)
50 FORX=1TO16:PRINT@A,STRING$(61,63):
NEXT:PRINT@B,A$;
55 POKE16405,0
60 C=PEEK(14590):IFC(32THEN100
70 IFC)127THENC=C-128
80 IFC=32THENB=B-1ELSEIFC=64THEN
B=B+1:GOTO100
90 IFB(1)THENB=1
100 PRINT@A,STRING$(S,63);:
PRINT@A+RND(S-3),B$
110 PRINT@B,A$;
120 W=W+1:Z=Z+1:IFZ=5THENS=S-1:Z=0
125 IFS(5THENS=S+1
130 Y=RND(3)-2:A=A+Y:IFA(961)THENA=961
140 IFA+S)1021THENA=1021-S
149 IFPEEK(14590))127THENQ=1:
Q=Q+1:IFQ(5)THENQ=0
150 IFQ=1THENQ=0:PRINT@B+64,D$;
200 IFPEEK(15424+B)=63AND
PEEK(15425+B)=63THEN60
299 POKE16405,1
300 IFPEEK(15424+B)=32ORPEEK(15425+B)
=32THENPRINT@0,"FOOL - YOU GROUNDED
YOURSELF";:GOTO400
310 PRINT@0,"YOU HIT A ROCK - YOU
DROWNED";
400 PRINT". BUT YOU DID
SURVIVE"W"MOVES.":IFW=14PRINT"WHICH IS
THE WORST YOU COULD POSSIBLY
GET!":GOTO500
410 IFW)260PRINT"THAT IS
AMAZING!!":GOTO500
420 IFW)220PRINT"WHICH IS VERY
GOOD!!":GOTO500
430 IFW)150PRINT"YOU ARE ALMOST DOING
WELL!":GOTO500
440 IFW)100PRINT"YOU NEED
PRACTICE!":GOTO500
450 IFW)50PRINT"YOU HAD BETTER TAKE UP
A DIFFERENT SPORT!":GOTO500
460 PRINT"THAT WAS PATHETIC!"
500 PRINT@128,"PRESS 'R' TO
RESTART";:A$="R":GOSUB 999:GOTO10
999 B$=INKEY$:IFB$=""THEN999
1000 FORA=1TOLEN(A$):IFB$=MID$(A$,A,1)
THENRETURNELSENEXT:GOTO999
    
```

FOR THOSE WHO WANT SOME FRIENDLY HAND-HOLDING

C/WP has introduced a special service for you. It's called "COMPLETE SYSTEM ASSURANCE" and it doesn't cost you a penny. All that you have to do is to buy the complete system, including its software, from C/WP. You tell us exactly how you want to use the system. If we say it will do the job and it cannot, you may return the complete system to us within 30 days and your money will be refunded.

We also give you two "hotline" numbers, one for software problems and one for hardware. You can ring anytime between 9 a.m. and 5.30p.m. weekdays to get your problems straightened out. COMPLETE SYSTEM ASSURANCE also gives you the right to buy training on your computer system in C/WP's training school at a specially reduced rate of £75 a day. Write for full details.

THE COMPLETE OSBORNE



C/WP's generous COMPLETE SYSTEM ASSURANCE scheme applies to every complete system sold by C/WP, including the modestly-priced Osborne 01.

£1495

+ VAT £224.25

The lowest-priced Osborne system costs £1495. That includes the Osborne fitted with double density disk drives (200k each), and with Screenpac which allows it to display 80 characters in a line. The software includes CP/M M-Basic, C-Basic, WordStar, Mailmerge and Supercalc. On its own that software would cost you well over £1000.

But that's not all. The system price includes the STAR 510 (recommended price £289), a newly introduced 100 cps matrix printer,

compatible with the Epson MX 80, but with many of the refinements of the FX 80. The Star is quiet and trouble-free and includes a 2.3k buffer.

This amazing package comes with C/WP COMPLETE SYSTEM ASSURANCE. Buy it with complete confidence, knowing that it is suitable for your purpose (or have your money back). Train yourself or your staff in

WordStar or Supercalc at your privileged rate. And if anything does go wrong in the future rely on C/WP's hot-lines to get you out of trouble.

If this system doesn't fill the bill, let us suggest another. We can team Osborne up with daisy wheel printers or offer you a complete system around an Apple, a CORTEX or a SAGE computer.

COMPLETE SYSTEM ASSURANCE – THE ONLY SAFE WAY TO BUY A MICRO

C/WP

C/WP Computers
108 Rochester Row, London SW1P 1JP
Telephone: 01-828 9000

Please send me details of:

C/WP COMPLETE SYSTEM ASSURANCE

YOUR OSBORNE OFFER

Name _____

Company _____

Address _____

Telephone number (day) _____



Mousetrap

A 380-Z WITH high-resolution-graphics, extended Basic Version 5.0, level 3.2 graphics and cos 3.4 E/M are required to run this game by Mark Lawson of Stonehouse, Gloucestershire. It is based on Ken Smith's program for the Tandy level II which appeared on page 108 of the April 1981 edition of *Practical Computing*.

Instructions to players appear as Print statements between line 850 and 1000. The other main feature of the program are: Lines 10-100 define variables and Gosub to printout instructions. Lines 110-210 draw the playing board. Lines 220-270 define the random starting positions of you and the mouse and plot the start of your line.

Lines 280-550 are the main part of the program which plays the game. Lines 560-730 print your score on to the screen. Line 740 checks if you have the best score, and if so jumps to line 1080. Lines 750-1070 prints the instructions on the screen using graphics for ** MOUSETRAP ** on the screen. Lines 1080-1180 are for when you get the best score: they hold a name up to 15 characters long. Lines 1190-1200 clear the screen using Call "Resolution", and end the program.

Three-dimensional plotter

DANIEL FREEMAN of Ramsgate, Kent has submitted a pair of plotting programs for (continued on page 157)

Mousetrap.

```

10 REM *****
20 REM ** Disk 380z By Mark Lawson **
30 REM *****
40 CLEAR 1000
50 W2=9999
60 DN BREAK GOTO 1190
70 RANDOMIZE
80 PUT 12,31
90 IF R=1 THEN PLOT 30,24,"PENALTY"
100 F=2:R=0:V=0:GOSUB 770
110 FOR X=0 TO 78
120 PLOT X,0,2
130 PLOT X,47,2
140 NEXT X
150 FOR Y=0 TO 47
160 PLOT 0,Y,2
170 PLOT 78,Y,2
180 NEXT Y
190 FOR X=0 TO 8
200 PLOT X,5,2
210 NEXT X
220 X=INT(RND(1)*77)+1
230 Y=INT(RND(1)*46)+1
240 A=1:B=1:Z=77:D=46
250 M=INT(RND(1)*77)+1
260 N=INT(RND(1)*46)+1
270 PLOT M,N,2
280 P=X:Q=Y
290 IF X>9 OR Y>5 THEN J=0 ELSE J=J+1:IF J=25 THEN 560
300 G=GET(0)
310 A$=CHR$(G)
320 IF A$("<")** THEN 500
330 V=V+1
340 PLOT X,Y,2
350 IF POINT(X+A,Y+B) THEN 360 ELSE X=X+A:Y=Y+B:PLOT P,Q,0:PLOT X,Y,2:GOTO 280
360 A1=A:A2=B
370 PLOT X,Y,0
380 IF POINT(X,Y+B) THEN B=-B
390 IF POINT(X+A,Y)=F THEN A=-A
400 IF NOT POINT(X+A,Y+B)=F THEN 290
410 A=-A1:B=-A2
420 IF NOT POINT(X+A,Y+B)=F THEN 290
430 A=A1:B=A2
440 IF NOT POINT(X+A,Y)=F THEN X=X+A:GOTO 290
450 IF NOT POINT(X,Y+B)=F THEN Y=Y+B:GOTO 290
460 IF NOT POINT(X-A,Y)=F THEN X=X-A:GOTO 290
470 IF NOT POINT(X,Y-B)=F THEN Y=Y-B:GOTO 290
480 R=1
490 GOTO 560
500 IF A$="P" OR A$="p" THEN IF M<Z THEN M=M+1:PLOT M,N,2:GOTO 540
510 IF A$="Q" OR A$="q" THEN IF M<D THEN M=M+1:PLOT M,N,2:GOTO 540
520 IF A$="A" OR A$="a" THEN IF N>1 THEN N=N-1:PLOT M,N,2:GOTO 540
530 IF A$="O" OR A$="o" THEN IF N>1 THEN M=M-1:PLOT M,N,2
540 IF A$=" " THEN PLOT M,N,0
550 GOTO 330
560 FOR B=1 TO 10
570 PLOT 28,30," GAME OVER "
580 FOR X=1 TO 100:NEXT X
590 PLOT 30,30,"
600 FOR X=1 TO 100:NEXT X
610 NEXT B
620 PLOT 30,30,"GAME OVER"
630 PLOT 27,27,"YOUR SCORE:"
640 IF R=1 THEN V=V+100
650 G=INT(V/30)
660 FOR I=1 TO V STEP 0
670 PLOT 48,27,STR$(I)
680 FOR TP=1 TO 10:NEXT TP
690 NEXT I
700 PLOT 48,27,STR$(V)
710 IF R=1 THEN PLOT 32,24,"PENALTY"
720 FOR TP=1 TO 2000
730 NEXT TP
740 IF V<W2 THEN W2=V:GOSUB 1080
750 GH=GET(0)
760 GOTO 100
770 CALL"RESOLUTION",0,1
780 PUT 12,31
790 CALL"CHARSIZE",2,2
800 B$="** MOUSE-TRAP **"
810 CALL"STPLOT",30,170,VARADR(B$),1
820 PRINT:PRINT:PRINT:PRINT
830 IF W2=9999 THEN PRINT" best score:" ELSE PRINT" best score: ";W2;"By ";W2$
840 PRINT
850 PRINT" The object of the game is to trap the"
860 PRINT"bouncing dot (or mouse) in it's cage"
870 PRINT"seen at the bottom left hand corner of "
880 PRINT"the screen."
890 PRINT" If the dot hits a white line it will"
900 PRINT"bounce off it. To draw lines you should"
910 PRINT"use keys B,A,D and P."
920 PRINT" To erase part or all of your line"
930 PRINT"press the space bar and the direction"
940 PRINT"key one after the other"
950 PRINT" To keep your line growing press the"
960 PRINT"direction key and then press the REPT"
970 PRINT"key, to stop take your finger off the"
980 PRINT"REPT key"
990 PRINT" If you just box the mouse in you'll"
1000 PRINT"get a penalty of 100 added on your score"
1010 PRINT
1020 PUT 21
1030 INPUT"Press RETURN to start";V$
1040 PUT 23
1050 CALL"RESOLUTION",0,1
1060 PUT 12
1070 RETURN
1080 PUT 12,31
1090 PRINT TAB(13)"YOUR SCORE =";V
1100 LET GH=GET(0)
1110 PRINT TAB(9)"And is todays best score"
1120 PRINT TAB(10)"please enter your name"
1130 PRINT TAB(12)"max. 15 characters"
1140 PUT 21
1150 INPUT W2$
1160 IF LEN(W2$)>15 THEN PRINT"Too many characters":GOTO 1150
1170 PUT 23
1180 RETURN
1190 CALL"RESOLUTION",0,1
1200 END

```

GET TO KNOW CORTEX- *really* THE VERY FRIENDLY COMPUTER

TEN FINGER EXERCISE

You'll be amazed how simple word processing is with CORTEX'S new version of WordStar. No more fumbling with messy key sequences.



CORTEX has 10 special keys to give 40 commands. This is **ERASE**. Hit it and a letter disappears. Hit **SHIFT ERASE** and a word goes. Press **CONTROL ERASE** and the whole line is demolished. It's as easy as that. And it's free! CORTEX's £1495 price includes a copy of C/WP's WordStar 3.3.

AS BRIGHT AS A BUTTON

The twin-processor 104k CORTEX is not only smart in performance (faster in benchmark tests than Sirius or IBM-PC) – its appearance takes some beating too. Examine its slim, but solid 83-key IBM-style keyboard. Admire its bold clear 12-inch screen, set in a minimal-sized cabinet. "But where is the computer?" we are often asked. It's there in the same small cabinet, lying flat across the bottom, screened from interference and cooled naturally, without the whine of a fan. CORTEX has been designed not to dominate your desk, to leave



Actual photograph

room for your calendar, your telephone, your in-tray and the rest. If you want it inconspicuous, buy it in conventional cream. But for the extroverts, and the fashion conscious, CORTEX comes in bright, bright colours – warm red, C/WP green, sunshine yellow, ice white and all black.

A FRIEND IN THE NUDE

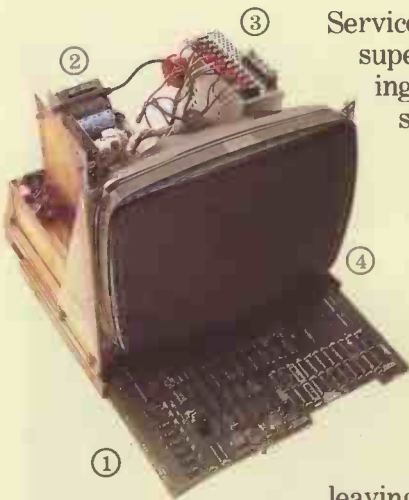

Service men love CORTEX's superb modular engineering. (Yes, you can get service anywhere in Britain.)

If anything goes wrong (which won't be often) he undoes four screws and the computer (1) slides out like a drawer. A few seconds work and the video electronics (2) slip out, or the power supply (3), leaving only the "bottle" (4).

CORTEX is your friend because it's reliable. And, if it goes wrong, it's easier and quicker to mend.

FASTEST DRAW IN ITS CLASS



Actual photograph

It's unfair on other micros. For CORTEX has a dedicated "second computer" (as powerful as Apple II) which does nothing but handle its screen. That's why CORTEX has such dazzling quick-fire graphics.

Now CORTEX's superb graphics hardware is matched with Digital Research's CP/M Graphics software (£275). Create bar charts, pie charts, scatter graphs in a few seconds and incorporate them into your reports or display them 2, 3 or 4 at a time on your screen, or make overhead projector or conventional slides.

ALL THIS FOR £1495 + VAT

Send me details of the 104k twin-processor CORTEX with 83-key IBM-style keyboard, 12-inch green screen, twin double-density (400k) floppy drives, CP/M and C/WP's user friendly WordStar, for £1495.

Name _____
Address and Telephone _____

C/WP CORTEX

C/WP Computers, 108 Rochester Row, London SW1
Telephone 01-828 9000

If the number of computer systems on the market leaves you totally bewildered, we don't blame you.

And that's not your only problem. If you are not very careful, the system you buy today could well be obsolete tomorrow. That's how fast computer technology is progressing.

But take heart. There is one computer system that won't become obsolete. Because it is modular in concept it can be expanded both inside and outside to accommodate extra capacity and new advances - as well as being able to increase in size and capability to keep pace with your own growth or changing requirements.

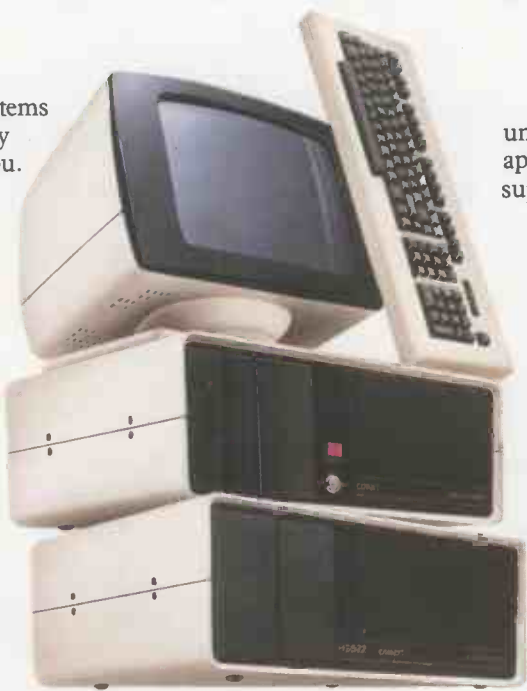

You have a choice from a virtually unlimited range of CP/M compatible application software. Plus the support of total dealer back-up.

And, most important, you won't find that you've bought a system that suddenly doesn't meet your needs. The Communicator offers the facility to enhance and upgrade existing models to take account of new applications.

Comart have also met the stringent CCTA requirements. Which means we are A1.

In short, Comart Communicator systems can keep pace with both progress and innovation.

So don't get bogged down with obsolete equipment. Contact your Comart dealer for a demonstration now.

The Comart Communicator. One computer system that won't sink into obsolescence.

What's more, it's British. At any one of the addresses listed below you can see the remarkable flexibility of a Comart Communicator system for yourself.

In under three years, it has become a complete family of compatible, fully expandable microcomputer systems, covering

20 models and including single user, multi-user and multi-processing systems.

To become technical for a moment, there's a choice of 8 or 16 bit processors, up to 1 megabyte of RAM and a wide range of floppy and hard disk storage capacities and add on modules.

COMART COMMUNICATOR SPECIFICATIONS

	CP100 Series Systems	CP1000 Series Systems
Microprocessors:	8 Bit Z80A (1 to 6)	16 Bit 8086
Memory:	64K-512K bytes	256K-1M byte
Storage:	300K or 700K byte diskettes 5M or 20M byte hard disks	300K or 700K byte diskettes 5M or 20M byte hard disks
Operating Systems:	CP/M, MPM11 & CP/NET, multi-processor 1 to 5 users	CP/M86, MPM86, MS-DOS, 1 to 8 users

Features common to both CP100 & CP1000 Series Systems
Keyboard/Display: 105 Key, detached 14" green screen, swivel fit.
Expansion: Internal - \$100 cards, mainframe communications & protocols.
Expansion: External - stackable modules inc. cartridge tape & 8" floppy & hard disks.

CP/M, MPM11, CP/M86, MPM86 & CP/NET are trademarks of Digital Research Inc. Z80A is a trademark of Zilog Corp. MS-DOS is a trademark of Microsoft Corp. Comart and the Comart logo are trademarks of Comart Ltd.

comart

Comart Limited, Little End Road, Eaton Socon, St. Neots, Huntingdon, Cambridgeshire PE19 3JG.
Tel: (0480) 215005. Telex: 32514 Comart G

Member of the Comart Group of Companies

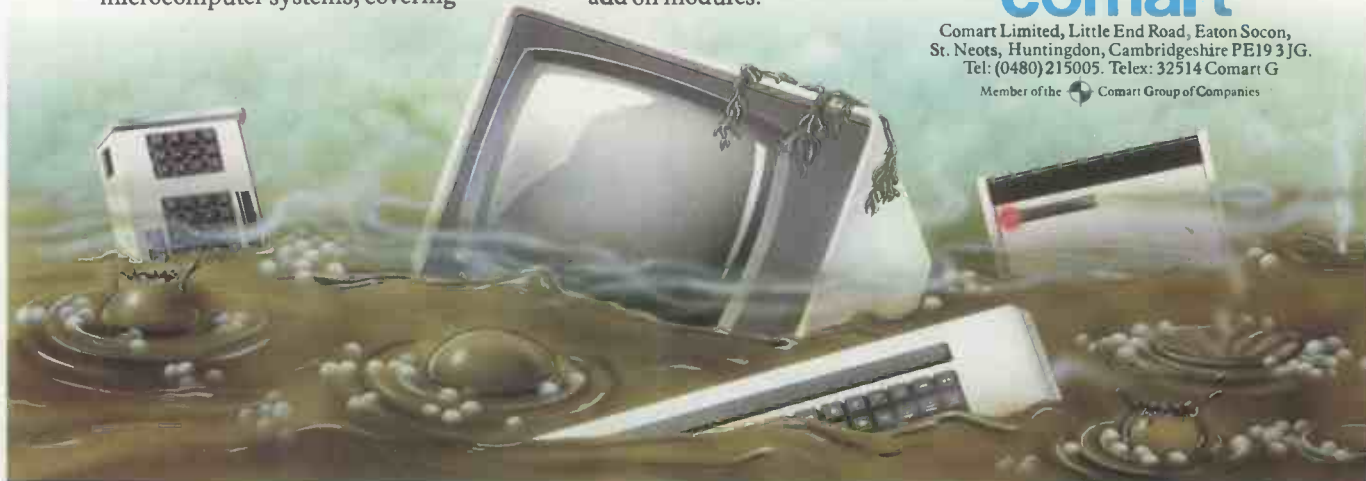

COMART COMMUNICATOR UK DEALERS

ABERDEEN
MOM Offshore
Tel: 0224 22520

AYLESBURY
J.K. Wakeford Associates
Tel: 0296 27473

BEDFORD
Remdex-Bradley
Tel: 0234 68581

BEDS (AMPTHILL)
M.E. Marketing
Tel: 0525 404262

BELFAST
Cardiac Services Co
Tel: 0232 625566

BIRMINGHAM
The Byte Shop
Tel: 021-622 7149

CAMBRIDGE
Cambridge Computer Store
Tel: 0223 65334

CAMBS (ST NEOTS)
Westcom
Tel: 0480 217217

CHANNEL ISLES
Bell Data Systems
Tel: 0481 23671

COLCHESTER
Eurotec Consultants
Tel: 0206 72538

DONCASTER
Spot Computers
Tel: 0302 25159

DUBLIN (EIRE)
Lendac Data Systems
Tel: 0001 710226

EDINBURGH
Holdene Microsystems
Tel: 091-557 4060

GLASGOW
The Byte Shop
Tel: 041-221 8202

GLENROTHES
Computer Services Scotland
Tel: 0592 773710

LEEDS
Holdene
Tel: 0532 459459

LONDON (BRIXTON)
Jarogate
Tel: 01-671 6321

LONDON (COVENT GARDEN)
Digitus
Tel: 01-379 6968

LONDON (EC4)
Zygal Dynamics
Tel: 01-248 4883

LONDON (NW1)
The Byte Shop
Tel: 01-387 0505

LOUGHBOROUGH
Data One
Tel: 0509 37281

MANCHESTER
The Byte Shop
Tel: 061-236 4737

MANCHESTER
NSC Computers
Tel: 061-832 2269

NORWICH
Eastern Bus. & Accounting
Systems Tel: 0603 27360

NOTTINGHAM
The Byte Shop
Tel: 0602 40576

OXON (BICESTER)
Zygal Dynamics
Tel: 08692 3361

READING
M.E. Electronics
Tel: 0734 667663

SOUTHAMPTON
The Byte Shop
Tel: 0703 334711

STAINES
Newbury Data Recording
Systems Tel: 0784 61141

SWINDON
Great Western Computing
Tel: 0793 485917

WATFORD
Lux Computer Services
Tel: 0923 47367

WILMSLOW
Holdene
Tel: 0625 529486

WINDSOR
Romtec
Tel: 075-35 51550

WORTHING
Ace Computing Services
Tel: 0903 35411

(continued from page 154)

the 380-Z which he describes as "impressive", and we find it hard to disagree. They should be quite easy to convert to run on other machines such as the Spectrum or Dragon 32.

The shape of the graph is determined by the function in line 50 of each program. Try running the program with the following alternative functions of sine and cosine used in that line:

```
50 DEF FNA(A)=1/(COS(X/2)*COS
```

```
(Y/2)+1.1)
```

```
50 DEF FNA(A)=1/(COS(X)*SIN
```

```
(Y/2)+1.1)
```

```
50 DEF FNA(A)=1.5/(COS(X)*SIN
```

```
(Y/3)+1.1)
```

```
50 DEF FNA(A)=1/(COS(X)*COS(X)*
```

```
COS(Y)+1.1)
```

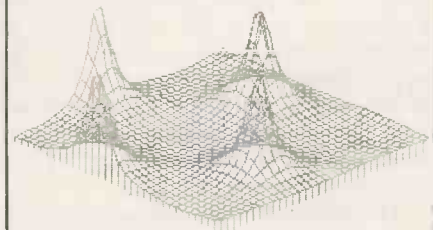
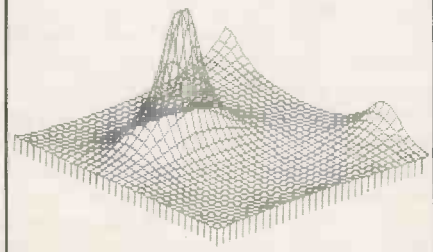
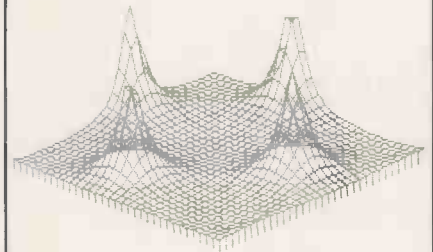
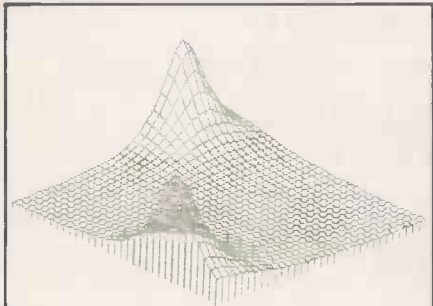

Output from listing 1 with four different functions in line 50.

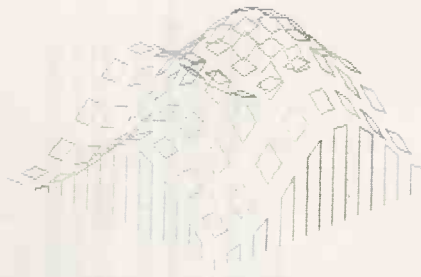

$$(\sin(X/3) * 2)^3 + (\sin(Y/3) * 2)^3$$

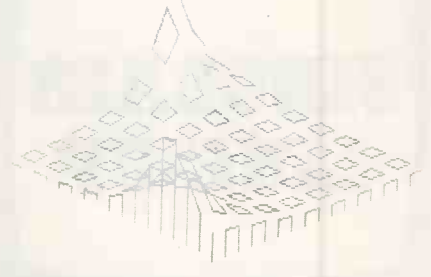

$$1/(\cos(X/2) * \cos(Y/2) + 1.1)$$

Output from listing 2 with two different functions in line 50.

Three-dimensional plotter listing 1.

```
10 REM 3D GRAPH PLOTTING ROUTINE BY DANIEL FREEMAN.
20 CALL "RESOLUTION",0,2
30 PUT 12
40 CALL "OFFSET",0,-70
50 DEF FNA(A)=(SIN(X/3)*2)^3+(SIN(Y/3)*2)^3
60 FOR Y=0 TO 8 STEP .25
70 LET A$="PLOT"
80 FOR X=0 TO 8 STEP .25
90 CALL A$ ,20*(Y+X),(Y-X+2+FNA(A))*6,3
100 LET A$="LINE"
110 NEXT X
120 CALL "LINE",20*(Y+8),(Y-X+2)*6,2
130 NEXT Y
140 FOR X=0 TO 8 STEP .25
150 CALL "PLOT",20*X,-6*X+12,2
160 LET I=2
170 FOR Y=0 TO 8 STEP .25
180 CALL "LINE",20*(Y+X),(Y-X+2+FNA(A))*6,I
190 LET I=3
200 NEXT Y
210 NEXT X
```

Three-dimensional plotter listing 2.

```
10 REM 3D GRAPH PLOTTING ROUTINE BY DANIEL FREEMAN.
20 CALL "RESOLUTION",0,2
30 PUT 12
40 CALL "OFFSET",0,-70
50 DEF FNA(A)=(SIN(X/3)*2)^3+(SIN(Y/3)*2)^3
60 FOR Y=0 TO 8 STEP .5
70 FOR X=0 TO 8 STEP .5
80 IF X=INT(X) THEN LET A$="PLOT" ELSE LET A$="LINE"
90 CALL A$ ,20*(Y+X),(Y-X+2+FNA(A))*6,3
100 NEXT X
110 CALL "LINE",20*(Y+8),(Y-X+2)*6,2
120 NEXT Y
130 FOR X=0 TO 8 STEP .5
140 CALL "PLOT",20*X,-6*X+12,1
150 LET I=2
160 FOR Y=0 TO 8 STEP .5
170 IF Y=INT(Y) THEN LET A$="LINE" ELSE LET
A$="PLOT"
180 CALL A$ ,20*(Y+X),(Y-X+2+FNA(A))*6,I
190 LET I=3
200 NEXT Y
210 NEXT X
```



Pawn

THE GAME of Pawn for a 2K Sinclair ZX-81 is based on the pawn moves in chess, but is played on a three-by-three grid. You can move forward one square or capture on the diagonal. The computer is the Xs moving down and you are the Os moving up. The first player to find he or she cannot move is the loser.

The game can probably be squeezed on to a 1K machine if you use some of the standard memory-saving techniques.

Monitor interface

A CIRCUIT DIAGRAM for an improvement of David Sinclair's monitor interface comes from S D Sollé of Reculver, Kent. The circuit can be also fitted under the ZX-81 in the recess above the modulator. A small 3.5mm. jack plug can be fitted on the side of the case for quick disconnection.

The +5V and 0V lines are attached to the voltage regulator. This circuit produces a crisp image on a Crofton 10MHz monitor.

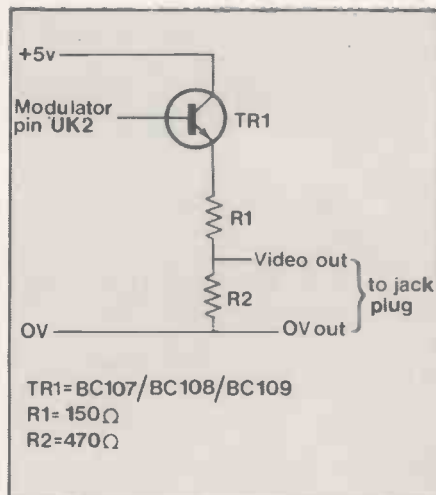

Spectrum security

ONE OF THE less satisfactory aspects of Sinclair Basic from the point of view of those people who have limited RAM is that each and every number is stored in two forms in the text, writes Gordon Grant of Radcliffe, near Manchester. First comes the series of ASCII-coded digits

Pawn.

```

10 RAND
20 DIM A(9)
30 DIM B(3)
40 FOR A=1 TO 9
50 LET A(A)=ABS (-61*(A<4) -27*(A>3 AND A<7) -32*(A>6))
60 NEXT A
70 LET B(1)=4
80 LET B(2)=2
90 LET B(3)=3
100 FOR Z=1 TO 5
110 FOR B=1 TO 2
120 IF Z=3 THEN LET B=2
130 IF Z=4 AND B=2 THEN GOTO 15
0
140 IF A(Z)=61 AND A(Z+B(B))=52 THEN GOTO 230
150 NEXT B
160 NEXT Z
170 LET Y=0
180 LET Z=INT (RND*6) +1
190 LET Y=Y+1
200 IF A(Z)=61 AND A(Z+B(B))=27 THEN GOTO 230
210 IF Y<15 THEN GOTO 180
220 PRINT "I CONCEDE ";W
230 LET A(Z+B(B))=61
240 LET A(Z)=27
250 GOSUB 320
260 INPUT A$
270 LET A(CODE (A$) -26) =27
280 LET A(CODE (A$(2 TO )) -26) =52
290 GOSUB 320
310 GOTO 100
320 CLS
330 PRINT
340 PRINT
350 FOR A=1 TO 9
360 PRINT CHR$( A(A));
370 IF 3*(INT (A/3))=A THEN PRINT
380 IF 3*(INT (A/3))=A THEN PRINT
390 NEXT A
400 PRINT AT 2,6;"123";AT 4,6;"456";AT 6,6;"789"
410 RETURN

```

which you see on the screen, followed by Control-14, followed by the five-byte floating-point representation which the processor likes to work with.

The first representation appears to be used only for the purposes of the screen display, while the second form is the "official" version. This fact may be exploited to produce a program which reads differently to the manner in which it runs. Apart from being amusing in itself, the careful insertion of misleading numbers into the text could be useful in outwitting illicit program copiers. Obviously, discretion is the name of the game. GOSUB 0 may be funny, but would be a complete giveaway.

The Confusion routine is intended to be appended to a program and used to alter the text, if desired, every time a number is encountered. No attempt has been made to allow for moving the text up to fill any resulting gaps, or down to permit the amended number to be longer than the spaces available.

I had considered filling unused spaces with strings of spaces and Cursor-Lefts

but although this is OK as far as screen listings are concerned, some printer routines, including my own, output a question mark when a spurious control code is encountered, thus giving the game away. The short machine-code routine is used for expanding the tokens, as this can be somewhat time-consuming in Basic.

The routine is written for the Spectrum. A very similar routine could be written for the ZX-81, but a direct conversion would have to take into account the fact that it does not use ASCII, and that the tokens as well as the ROM routine will be different, apart from substituting the appropriate values for Prog, Vars and the screen parameters. Users should also note that this routine must be run from its start, since A is expected to be the first entry in the variable-list table.

The amended program works exactly as the original. However, any attempt to edit a misleading line will result in the misleading information being substituted into the official, thus corrupting the program irretrievably — which is the best part of it.

Spectrum security — Confusion.

```

9900 GO SUB 9990
9902 LET LINE=256*PEEK PROG+PEEK (PROG+1)
9903 LET LENGTH=PEEK (PROG+2)+256*PEEK (PROG+3)
9904 IF LINE>=10000 THEN STOP
9905 GO SUB 9988: IF CY=2 THEN LET CY=3
9907 PRINT LINE;" ";
9908 INPUT "ENTER NEW LINE NO. ";B#: IF B#="" THEN GO TO 9914
9910 LET LINE1=VAL B#: IF LINE1<=0 OR LINE1>9999 THEN GO TO 9902
9912 POKE PROG,INT (LINE1/256): POKE PROG+1,LINE1-256*PEEK PROG: LET LINE=LINE1
9914 GO SUB 9986: PRINT LINE;" ";
9916 FOR K=0 TO LENGTH-1: LET Z=PROG+4+K: GO SUB 9920: NEXT K
9918 PRINT : LET PROG=PROG+K+4: GO TO 9902
9920 LET Y=PEEK Z: IF Y<>34 THEN GO TO 9925
9922 PRINT CHR# Y): LET K=K+1: LET Z=Z+1: LET Y=PEEK Z
9923 IF Y<>34 THEN GO TO 9922
9924 PRINT CHR# Y): RETURN
9926 IF Y<>234 THEN GO TO 9934
9928 POKE USR+1,Y-165: RANDOMIZE USR USR
9930 LET K=K+1: LET Z=Z+1: LET Y=PEEK Z
9931 IF Y<>13 THEN PRINT CHR# Y): GO TO 9930
9932 RETURN
9934 IF (Y>31 AND Y<40) OR (Y>47 AND Y<59) THEN PRINT CHR# Y): RETURN
9935 IF (Y>62 AND Y<92) OR (Y>94 AND Y<165) THEN PRINT CHR# Y): RETURN
9936 IF Y>164 THEN GO SUB 9950: RETURN
9938 IF Y=13 THEN RETURN
9940 IF Y=14 THEN LET K=K+5: RETURN
9942 IF Y=41 OR Y=46 OR Y=93 THEN PRINT CHR# Y): RETURN
9944 IF Y>31 THEN PRINT CHR# Y): GO TO 9951
9946 RETURN
9950 POKE USR+1,Y-165: RANDOMIZE USR USR
9951 IF PEEK (Z+1)=32 THEN PRINT " "): LET K=K+1: LET Z=Z+1: GO TO 9951
9952 IF PEEK (Z+1)<48 OR PEEK (Z+1)>57 THEN RETURN
9954 LET Z=Z+1: LET J=0: LET A#=""
9956 IF PEEK (Z+J)<>14 THEN LET A#=A#+CHR# (PEEK (Z+J)): LET J=J+1: GO TO 9956
9958 FOR L=0 TO 4: POKE VARS+L,PEEK (Z+J+L+1): NEXT L
9960 GO SUB 9988: IF CY=3 AND CX=J+1 THEN LET CY=4
9962 PRINT A#): PRINT AT 0,0;C#: PRINT AT 0,0;"Really ")A,J;" CHARS MAX."
9966 GO SUB 9986: INPUT B#: IF B#="" THEN RETURN
9968 IF CODE B#(1)<48 OR CODE B#(1)>57 OR LEN B#>J THEN GO TO 9966
9969 IF LEN B#<J THEN FOR L=LEN B#+1 TO J: LET B#=B#+"" ): NEXT L
9970 FOR L=1 TO J: POKE Z+L-1,CODE (B#(L)): NEXT L: RETURN
9986 POKE 23688,CX: POKE 23689,CY: RETURN
9988 LET CX=PEEK 23688: LET CY=PEEK 23689: RETURN
9990 CLS : LET A=0: LET C#="" ): LET C#=C#+C#
9991 GO SUB 9996: RESTORE 9993: INPUT "ENTER ADDRESS FOR USR ";USR
9992 FOR K=USR TO USR+4: READ L: POKE K,L: NEXT K
9993 DATA 62,0,195,16,12
9994 LET VARS=PEEK 23627+256*PEEK 23628+1
9995 LET PROG=PEEK 23635+256*PEEK 23636: CLS : PRINT AT 2,0;"" ): RETURN
9996 PRINT " CONFUSION": PRINT : PRINT "The idea of this Program is to
enable the user to enter false numeric data into a Programme.": PRINT "Every ti
me a number is found in the text you will be prompted to enter an alternative val
ue."
9997 PRINT "If you don't wish to change it, press <ENTER>. Otherwise type in the
value you want, first. Note that the 'real' value is not changed, only the te
xt value."
9998 PRINT "The Present true value is shown at top left. The maximum number of c
haracters allowed is at top centre."
9999 PRINT "You can also change the line numbers, but this is for real. You
will now be asked to enter the address where a 5 byte machine code routine
may be put.": RETURN

```

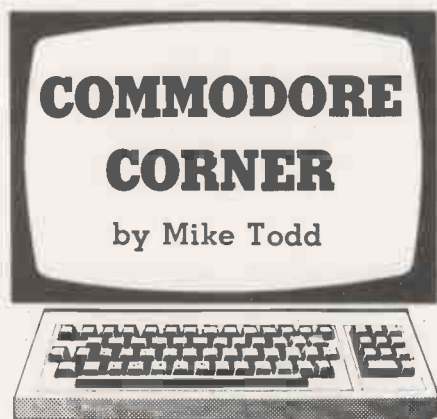

COMMODORE CORNER

by Mike Todd

Is anybody there?

WHEN USING external devices on the Pet it is often important, and sometimes vital, to know if the device is actually connected correctly and switched on. With only one device connected to the IEEE bus it is likely that a Device not Present error will be generated. With one or more other devices, such as a printer, it is possible that this error will not be generated because other devices on the bus may perform the correct handshaking sequence and characters sent to a disconnected printer may actually be received, but ignored, by the disc drive.

Andy Scott of Stockport has come up with a short machine-code program that checks if a specified device is actually present and operating correctly. It could usefully be incorporated into programs

which need the extra reliability of knowing that a device is responding.

Listing 1 is the machine code as used with a Basic 4 machine and it resides at the top end of memory. As a result, it is vital that this area is protected by lowering the Top of Memory pointers using the following sequence before the machine code is entered:

```
POKE 52,160: POKE 53,127: CLR
```

Once loaded, the device number is Poked into 32750 and the routine executed by Sys 32672.

There are two flags set by the program. The first, at 32751, will be set to 1 if there is no response from any device on the IEEE bus and the second, at 32752, is 1 if the specified device does not respond. At the start and end of the program, the accumulator X and Y registers are saved, although this is not absolutely essential and can be omitted if the program is being accessed from within a Basic program.

Andy Scott has also provided a Basic 2/3 version which I have modified slightly so that it can be used in the second cassette buffer. It is given in the form of a Basic loader program in listing 2. I have used a check-sum to check that the Data statements were entered correctly. In this version, location 898 holds the device number, with 899 and 900 holding the two flags. There is also a simple Basic program, shown in listing 3, which demonstrates the use of the program. It is not possible to test for the presence of

Anybody there? — listing 2.

```
1 REM*****
2 REM*
3 REM* IEEE DEVICE TESTER - LOADER *
4 REM*
5 REM* POKE 898, DEVICE NUMBER *
6 REM* PEEK(899)=1 IF NOTHING ON BUS *
7 REM* PEEK(900)=0 IF DEVICE PRESENT *
8 REM*
9 REM*****
10 FOR I = 826 TO 891
11 READ A: POKE I, A
12 Q=Q+A
13 NEXT I
14 READ A
15 IF Q<>A THEN PRINT"CHECKSUM ERROR"

100 DATA 160,0,140,131,3,140,132,3,132
110 DATA 209,136,132,210,132,211,173
120 DATA 130,3,133,212,32,36,245,32
130 DATA 186,240,32,45,241,165,150,16
140 DATA 5,238,131,3,208,18,165,212
150 DATA 133,176,169,0,32,69,202,32
160 DATA 69,202,165,150,201,128,208,3
170 DATA 238,132,3,32,185,202,32,172
180 DATA 242,96
200 DATA 8195
```

Listing 3.

```
10 INPUT "TEST FOR WHICH DEVICE";D
20 IF D<4 THEN 10
30 POKE 898,D: SYS 826
40 IF PEEK(899)<>1 THEN 50
45 PRINT"NOTHING ON BUS": GOTO 10
50 IF PEEK(900)<>1 THEN 60
55 PRINT"DEVICE";D:"NOT PRESENT": GOTO 10
60 PRINT"DEVICE";D:"IS PRESENT"
70 GOTO 10
```

devices 0 to 3, so the Basic program must trap these device numbers if they are entered.

Super Expander blues

If you have a Vic-20 and are using the Commodore Super Expander cartridge you may well try to generate music using the Print statement while using the graphics capabilities of the Vic.

Although the Print statement used to generate music will not normally print characters on the screen, each statement will normally generate a new line, which could scroll the screen and corrupt graphics on the screen as the music plays. Ron and Sheila Hewett of Gelnorie, Australia, suggest including a Cursor Home at the start of every music string. The effect is to always make this new line occur at the top of the screen so that no scrolling will take place. Of course, a semicolon at the end of the Print statement would also do the trick.

Cavern Quest

Cavern Quest is a simple game for an unexpanded Vic-20. It involves flying a spaceship through a cavern, shooting down aliens as you go.

The Ctrl key is used to move the spaceship up, and the left-hand Shift key moves it down. Return fires the laser.

Two machine-code routines are included to speed things up. The first, accessed by Sys 7464, scrolls the screen one place to the left; the other, Sys 7520, generates part of the cave on the right of the screen.

When you type in the program, all
(continued on page 163)

Anybody there? — listing 1.

```
7FA0 08 PHP Save Status Register
7FA1 48 PHA Save Accumulator
7FA2 8A TXA
7FA3 48 PHA Save X Register
7FA4 98 TYA
7FA5 48 PHA Save Y Register
7FA6 A000 LDY #00
7FA8 8CEF7F STY 7FEF Clear 'nothing in Bus' flag
7FAB SCF07F STY 7FF0 Clear 'device not present' flag
7FAE 84D1 STY D1 Length of file name = 0
7FB0 88 DEY
7FB1 84D2 STY D2 Logical file number = #FF
7FB3 84D3 STY D3 Secondary address=#FF (equivalent to 0 in Basic)
7FB5 ADEE7F LDA 7FEE POKED device number from main programme
7FB8 85D4 STA D4 Device to be tested
7FBA 2063F5 JSR F563 Open file subroutine
7FBD 20D3F0 JSR F0D5 Send LISTEN address (MLA),(ATN=0). If no devices
present on Bus returns with status word = #80
7FC0 2048F1 JSR F14B Set ATN=1
7FC3 A596 LDA 96 Status word
7FC5 1005 BPL 7FCC Branch if no error
7FC7 EEEF7F INC 7FEF If error (ie. no device on Bus) set relevant flag
7FCA D012 BNE 7FDE unconditional jump to 7FDE
7FCC A5D4 LDA D4 ) Store current output
7FCE 85B0 STA B0 ) device in B0
7FD0 A900 LDA #00
7FD2 2046B8 JSR BB46 ) Send CHR#(0) to device twice. If relevant device
7FD5 2046B8 JSR BB46 ) is not present, returns with Status word=#80
7FD8 A596 LDA 96 Status word
7FDA C980 CMP #80 Is it #80 (refer to note below)
7FDC D003 BNE 7FE1 Branch if no error (ie. relevant device is present)
7FDE EEF07F INC 7FF0 if relevant device not present, set appropriate flag
7FE1 206CBB JSR BBB6 Send UNLISTEN on Bus (ATN=0). Set ATN=1. Restore
normal input/output devices (keyboard/screen)
Close file subroutine
7FE4 20E0F2 JSR F2E0
7FE7 68 PLA
7FE8 A8 TAY Retrieve Y Register
7FE9 68 PLA
7FEA AA TAX Retrieve X Register
7FEB 68 PLA Retrieve Accumulator
7FEC 28 PLP Retrieve Status Register
7FED 00 RTS Return from subroutine
7FEE 00 Device number is FOKED in here
7FEF 00 Flag for 'nothing on Bus'
7FF0 00 Flag for 'device not present'
```

Introducing The Tandy®

Micro Executive Workstation

- Powerful Built-In Software
- Retains Memory Data When "Off"
- 8K RAM—Expandable to 32K

£499

8K RAM
Cat. No. 26-3801

£649

24K RAM
Cat. No. 26-3802



User Friendly Software Makes The TRS-80™ Model 100 Portable Computer Truly Revolutionary

Imagine a computer on your desk so small, it can fit in your in-tray. The second you turn it on, imagine seeing a menu of built-in executive management programs and your own files, ready for immediate use. All revealed on an eight-line by 40-character LCD display positioned just above a full-size keyboard. And when you leave the office, imagine a four-pound computer you can take along, because it works on mains or batteries.

Stop imagining! The new TRS-80 Model 100 is the computer you've been waiting for. As a desk organizer, it's a phone directory, address book and appointment calendar. It's a personal word processor, as well. There's even built-in communications software to access other computers by phone, using an acoustic coupler.

Come and see the most revolutionary computer since the TRS-80 Model I at over 340 Tandy stores and dealers, including over 25 Tandy Computer Centres nationwide.

● Circle No. 194

Built-In Interactive Software



Tandy®

*The Biggest Name
in Little Computers*

Call In Today Or Send For Further Information

Computer Marketing, Tandy Corporation (Branch UK), Tameway Tower, Bridge Street, Walsall, West Midlands. WS1 1LA.

Name _____

Address _____

PC6

WE DISTRIBUTE HIGH QUALITY MICRO COMPUTER PRODUCTS TO DEALERS WORLDWIDE



OVER 1500 DEALERS BUY FROM PETE & PAM OPEN AN ACCOUNT - RING TODAY

BASF QUALIMETRIC FLEXY DISKS
5 1/4" SINGLE SIDED/SINGLE DENSITY
11 BOXES FOR THE PRICE OF 10!!
BUILT FOR ETERNITY
WARRANTED A LIFETIME
11 boxes for £165

Accelerator II

**MAKE YOUR APPLE RUN
3.58 TIMES FASTER
FOR ONLY £299!!**

Over 2000 UK Apple users now waste less time by using the Accelerator in an Apple.

See what Richard King, Hardware Editor of PCN has to say about the Accelerator. (PCN 15.6.83)

"Power down, open Apple, find empty slot, insert board, shut Apple, power up. That's it - well almost. There certainly can't be many add-ins to the Apple system that make such a difference in performance with so little fuss."

"The Accelerator II makes such a big difference to the operation of the Apple that I wish it did more."

"So what don't I like about the Accelerator II? Not a lot, to be honest. It's simple to install, it's reliable, it's easy to use and it runs like a bat out of hell."

"For the real business user who wants a real increase in throughput, I would strongly recommend the product."

COPY II PLUS for APPLE & COPYII PC for the IBM PC

An extremely sophisticated bit (or nibble) copy program to allow you to make back-up copies of your protected software.

Also includes:
Catalog, with file lengths, hidden characters, deleted files, Verify Disk—bad sector scan of disk, Verify Files—scan of individual files. Verify identical files—compares files on different disks, lets you know at what point they first differ.
Verify drive speed: track/sector map, Sector Editor.

**COPY II PLUS £39
COPY II PC £39**

MICROSOFT MULTIPLAN ELECTRONIC WORKSHEET

U.K. VERSION
SPECIAL PRICE £149

The friendliest, most powerful electronic worksheet you can buy. Saves time in management and planning.

EPSON MX-82T Printer

The printer designed for high quality graphics - comes with lower gearing. Tractor only.
Limited Quantity Available £249.00

**SUPER SUMMER CLEARANCE SALE
BUY NOW WHILST STOCKS LAST**

Adventure 4+5+6	17.95	Mystery House	10.95
Adventure 7+8+9	17.95	Ulysses & The Golden Fleece	11.95
Adventure 10+11+12	17.95	Wizard & Princess	11.95
Poker	9.95	Marauder	11.95
Smarterm	89.00	Cranston Manor	11.95
Supercalc for ALS Z-Card	39.00	Threshold	12.95
Eurocolor Card	49.00	Mouskattack	12.95
Parallel Interface Apple IIe	69.00	The General Manager	75.00
Universal Para Int Apple III	99.00	Frogger	14.95
Apple IIe 80 column card	49.00	Cannonball Blitz	12.95
Apple IIe 80 col card + 64K	99.00	Laffpak	12.95
Datstones of Ryn	9.95	Frogger IBM	19.95
Hellfire Warrior	19.95	Lunar Lopper	11.95
Star Warrior	19.95	Crossfire IBM	12.95
David's Midnight Magic	14.95	Transylvania	12.95
Red Alert	12.95	Multi-Disk Catalog III	10.95
Space Quarks	12.95	Back It Up	24.95
Galactic Trader	10.95	Phantoms Five	12.95
Galactic Revolution	10.95	Gamma Goblins	12.95
Dueling Digits	12.95	Sneakers	12.95
Labyrinth	12.95	Autobahn	12.95
Raster Blaster	12.95	Borg	12.95
Lower Case Adapter (Rev 7)	15.00	Space Eggs	12.95
County Fair	12.95	Copts and Robbers	12.95
Thief	11.95	Epoch	14.95
Swashbuckler	14.95	Hadron	14.95
Missing Ring	12.95	E-Z Draw	19.95
Pig Pen	12.95	Twerps	13.95
Space Strike for IBM	12.95	Computer Football	13.95
Terrorist	12.95	Jellyfish	13.95
Network	9.95	Fly Wars	13.95
Windfall	9.95	Cyclod	13.95
Elite 80 Col Card for Apple IIe	55.00	Audex (Sound Utility)	13.95
Ruski Duck	14.95	Bandits	13.95
Phazer Fire	12.95	Minotaur	13.95
Zenith	12.95	The Blade of Backpool	13.95
Neptune	12.95	Call to Arms for IBM	13.95
Lazer Silk	12.95	Escape from Rungistan	13.95
High Orbit	14.95	Free Fall	13.95
Data Master 3.3	39.00	Type Attack	14.95
Job Control/Costing in Pascal	49.00	Smith Corona TP I D/W Parallel	449.00
Transit (Utility)	19.00	Supercalc for IBM	149.00
Zork II For IBM	18.95	ACE (AppleSoft Command Editor)	17.95
Easyplanner for IBM	129.00	Munch-a-Bug	22.95
Easywriter 40 column	49.00	Routine Machine	29.95
Easyfiler for IBM	199.00	AIO II Serial Parallel I/F	119.00
Juggler	14.95	ASIO Apple Serial Card	79.00
Transforth II	59.00	Mill Assembler Dev Software	45.00
Grapple	12.95	Cartels and Cutthroats	17.95
Lower Case Apart W/Shift Mod.	19.95	Program Line Editor	18.95
Allen Ambush	12.95	Odyssey	14.95
The Best of Muse	17.95	Global Program Line Editor	29.00
Firebug	10.95	Kram	39.00
Frazzle	10.95	Super Kram	69.00
Pegasus	11.95	Versawriter Graph Tab IBM	139.00
Softporn Adventure	11.95	Lower Case Chip	15.00
Cross Fire	11.95	Lower Case Adapt for Pre Rev 7	17.00
Jobbreaker	11.95	Wizard SOB . . . 16K Buff Serial I/F	149.00
Mission Asteroid	7.95		

Pete & Pam Computers

Mail Order & Distribution:
New Hall Hey Road,
Rossendale, Lancs., BB4 6JG
Phones: (0706) 212321 & 227011
Telex: 635740 Petpam G

Norwegian Agent:
The Norwegian Software House
Address: Okernveien 145
Oslo 5
Telephone 47 2 64 55 77

London Retail:
103-5 Blegborough Road,
London, SW16 6DL
Phone: 01-677 7631
London Office
Open Saturdays

Prices do not include VAT please add 15% to your remittance
Postage and Packing FREE

Cavern quest.

```

1 GOTO 2000
19 PU=PU+DU:DU=INT(RND(1)*5)-2
:IF PU>10 OR PLK2 THEN PU=7
20 POKE PS,32:POKE PS+SD,5:SYS 7464
:POKE 7467,150:POKE 7488,13
:SYS 7464
21 POKE 7467,30:POKE 7488,32
:POKE PS,36
25 POKE PS+SD,1
30 POKE 1,PU+INT(RND(1)*4):SYS 7520
:T=T+1
40 FOR I=8141 TO 8141-(11-PU)*22 STEP
-22:POKE I,35:NEXT
50 POKE PS,32:IF PEEK(653)=4 THEN PS=
PS-22
60 IF PEEK(653)=1 THEN PS=PS+22
70 POKE PS,36:POKE PS+SD,1
:IF PEEK(PS+1)<>32 THEN POKE PS+SD,
10:POKE PS+SD+1,11:GOTO 5000
75 V=7700+22*INT(RND(1)*20)
:IF PEEK(V)=32 THEN POKE V,33
:POKE V+SD,5
80 IF PEEK(197)<>15 THEN 19
85 FOR I=PS+1 TO PS+6:POKE 36876,
(I-PS)*20+120:IF PEEK(I)=33 THEN P
OKE I+SD,10:GOTO 105
90 IF PEEK(I)=35 THEN SC=SC-20
:POKE 36876,128:GOTO 110
95 POKE I,31:POKE I+SD,2:NEXT
:FOR I=PS+1 TO PS+6:POKE I,32
:POKE I+SD,5:NEXT
100 POKE 36876,0:GOTO 19
105 POKE 36876,0:FOR V=255 TO 128 STE
P=8:POKE 36877,V:NEXT:POKE 36877,0
110 SC=SC+10:FOR J=PS+1 TO I:POKE J,32
:POKE J+SD,5:NEXT:POKE 36876,0
115 PRINT"[WHITE,HOME,RVS,RIGHT2],
DOWN21.LEFT9]~~~~~[LEFT6]";SC;
120 IF INT(SC/50)=SC/50 THEN POKE P
S,32:PS=PS+1:IF SC=500 THEN 6000
200 GOTO 19
1000 DATA 162,21,169,30,133,2,169,0,
133,1,160,0,200,177,1,136,145,1,
200,192,21,208,245
1001 DATA 169,32,145,1,169,22,24,101,
1,133,1,169,0,101,2,133,2,202,
208,223,96
1002 DATA 0,0,0,0,0,0,0,0
1003 DATA 0,0,0,0,166,1,169,30,133,2,
169,21,133,1,160,0,169,35,145,1,
169,22,24,101,1
1004 DATA 133,1,169,0,101,2,133,2,202,
208,236,96
1005 POKE 56,28:POKE 36879,27
:PRINT"[CLEAR]~~~~[RVB]
~~~~CAVERN~QUEST~~~~[RVDF]"
1006 FOR I=7464 TO 7552:READ D
:POKE I,D:NEXT:GOSUB 8000
1007 FOR I=32768 TO 33063
:POKE I-25600,PEEK(I):NEXT
1008 FOR I=7416 TO 7463:POKE I,0:NEXT
1009 POKE 7419,255
1010 DATA 40,124,84,124,254,186,146,0
1011 FOR I=7432 TO 7439:READ D
:POKE I,D:NEXT
1012 DATA 99,216,54,141,99,216,54,141
1013 DATA 0,192,108,255,108,192,0,0
1014 FOR I=7448 TO 7463:READ D
:POKE I,D:NEXT
1015 PRINT"[RED]~~~~PRESS~A~KEY"
1016 GET A$:IF A$="" THEN 1016
1017 FOR T=1 TO 1000:NEXT
1018 RETURN
2000 H=0
2005 GOSUB 1000
2010 POKE 36869,255:SD=30720
2020 DU=0:PS=7902:PRINT"[CLEAR]":SC=0
:T=0
2030 POKE 36879,12:POKE 36878,143
2040 PRINT"[HOME,DOWN24,WHITE,RVS]
CT=UP/[SH=DOWN/RET=FIR"
2045 PRINT"[HOME,DOWN21,RVS,WHITE]HI
:~;H;~~~~SC:~"
2047 PRINT"[HOME,RVS,RED,RIGHT3]
~~CAVERN~QUEST~~"
2050 POKE 8185,5:POKE 38905,3
2060 GOTO 19
5000 FOR I=255 TO 0 STEP-3
:POKE 36877,I:POKE 36865,
RND(1)*20+28:NEXT
5010 FOR I=1 TO 22:SYS 7464:NEXT
5020 POKE 36865,40:PRINT"[HOME,DOWN,
YELLOW,RVS]YOU~HAVE~CRASHED~!"
5030 IF SC>H THEN H=SC
:PRINT"[DOWN3,RVS]
NEW~HI~SCORE~OF~"
5040 FOR I=1 TO 4000:NEXT
5050 GOTO 2020
6000 PRINT"[HOME,YELLOW,RVS]
MISSION~COMPLETED"
6010 PRINT"YOU~GAIN~";1200-T;
"~POINTS~FOR~SPEED"
6020 SC=SC-1200-T:GOTO 5030
8000 PRINT"[DOWN,CYAN]
GAIN~ENERGY~BY~LASER~BLASTING~A
LIEN~SUPPLY~SHIPS~IN~THE~PERILOU
S~CAVERN."
8010 PRINT"[DOWN]BLAST~THE~CAVERN~IF~
~~NECESSARY~BECAUSE~YOU~MUST~SUR
VIVE"
8020 PRINT"[DOWN]CONTROLS
:~(CTRL)=UP~~(SHIFT)=DOWN~~~~~
~~~~(RETURN)=FIRE"
8030 RETURN

```

(continued from page 160)

cursor controls are listed in a special convention to make life a little easier. For instance, in line 115, after the quotes you should press White, Ctrl-2; followed by Home, Ctrl-9; 21 Cursor Rights, 21 Cursor Downs and nine Cursor Lefts. The square brackets merely indicate the control characters: don't type them in. The squiggles which follow each indicate a space.

There is an E missing from line 2040: the missing character is Poked directly on to the screen since the length of the line would otherwise have caused the screen to scroll up. Pay particular attention to the Data statements in lines 1000 to 1004. They are the machine-code instructions mentioned earlier.

It is wise to Save the program before running it, as errors in the Data statements could cause the program to crash when it is run.

Disc saver

How often have disc users scratched a file either deliberately or accidentally, and suddenly realised they shouldn't have?

Fortunately, the actual data on the disc is not destroyed immediately. Instead its entry in the directory is marked as deleted, making the blocks used by that file available for future use.

Martin Clayden of Liverpool has come up with what can only be described as a life-saver in this situation: it will allow files that have just been scratched to be resurrected. The program asks for the name and type of the file to be restored — Pgr, Seq, Usr or Rel — and proceeds to read through the directory, to find the file, and "unscratch" it.

The directory is held on track 18 in sectors 1, 4, 7 and so on, and the program systematically searches them for the file specified. When it has been found all files contained in the sector are listed on the screen and the program proceeds to amend the entry. Because the directory no longer has a record of what type of file it was, the program must set it according to the information provided at the start of the program.

Once it has been written back to the disc, the tracks used by the file must now be claimed back again so that other files

cannot use them. This is done simply by performing a Validate operation.

There are a couple of things to be wary of. Firstly, any attempt to write data to the disc after the file was scratched will probably result in overwriting some of the original file's data. If that has happened the file can no longer be recovered — so don't even try. All sorts of nasty things could happen when the disc is validated.

Also, it is just possible that there could be two deleted files with the same name in the directory; the program will only restore the first. It could have been on the disc for some time and the data will now be well and truly destroyed by other files.

The program only checks sectors 1, 4, 7, 10 and 13 in the directory, a total of 40 files, eight per sector. But the directory actually uses all the sectors on the directory tracks. It is lines 430 and 440 which check this upper limit, and a suitable modification could be included here to raise the upper limit to 18 — or 19 for early disc drives using DOS 1 — and to start again at sector 2 when this is reached. In practice, most discs rarely contain that many files. M

Disc saver.

```

100 REM *****
110 REM FILE RESTORE UTILITY
115 REM
120 REM NOT RECOMMENDED FOR USE AFTER
125 REM ANY DISK WRITE OPERATION
130 REM *****

140 TR=18:FO=0: S=1
150 DIM E$(9)

160 REM OPEN DISK CHANNELS
& INPUT FILE DETAILS
170 OPEN 15,8,15:PRINT#15,"I0"
180 OPEN 2,8,4,"#5
190 INPUT"[CLEAR]FILE NAME AND TYPE
[HOME,DOWN]";F$,FT$
195 PRINT"[CLEAR]"
200 PRINT#15,"U1";4;0;TRIS
210 PRINT"[RVS]TRACK [RVDF]";TR;
" SEARCHING ENTRY"
220 PRINT"[RVS]SECTOR[RVDF]";S;
[DOWN2]"

230 G=1
240 REM READ 1 FILE ENTRY AT A TIME
250 FOR I=1 TO 256
260 GET#2,N$
265 IF N$(CHR$(32) OR N$(CHR$(90)
THEN N$=CHR$(46)
270 W$=N$+N$
280 POKE 32836,48+G
290 IF LEN(W$)=32 THEN E$(G)=W$
: GOSUB 310
300 NEXT I

310 G=G+1
320 IF MID$(W$,6,LEN(F$))=F$ THEN FO=1
:EN=G-2
330 IF FO=1 THEN PRINT"[RVS]
FILE FOUND ON SECTOR";B;"[UP]"
:GOTO 350
340 IF G>8 THEN PRINT"[RVS]
FILE NOT ON SECTOR";S
350 IF I<256 THEN W$="":RETURN
360 PRINT

390 FOR J = 1 TO 8
390 PRINT E$(J)
400 NEXT J
410 PRINT"[SPACES 40]"
420 PRINT"[HOME]"

430 IF FO=0 AND S<13 THEN S=S+3:W$=""
:GOTO 200
440 IF FO=0 THEN PRINT"[RVS,DOWN2]
FILE NOT FOUND":GOTO 550
450 IF FT$="SEQ" THEN FT=129
460 IF FT$="PRG" THEN FT=130
470 IF FT$="USR" THEN FT=131
480 IF FT$="REL" THEN FT=132

490 REM FT SET TO FILE TYPE
NOW WRITE TO DISK
500 PRINT#15,"R-P";4;[EN#32]+2
510 PRINT#2,CHR$(FT);
520 PRINT#15,"U2";4;0;TR;S

530 REM CLOSE CHANNELS & UPDATE BAH
540 PRINT#15,"V0"
550 CLOSE 2: CLOSE 15

```

We grow with you

SUPERBRAIN W6

The SUPERBRAIN microcomputer was designed as a small business system, aimed principally at first time buyers needing a general purpose machine. But as small businesses grow, so SUPERBRAIN has kept pace with its users' development and can now offer a system which is suitable for businesses of any size. And which can compete very favourably with the new 16 BIT personal computers, and many mini computers. (Indeed, the December issue of Which Computer? put SUPERBRAIN top in a survey of business systems which included the Sirius, Apple III and Philips P7000.)

SUPERBRAIN II

One of the most successful micro-computers in the UK. A smart, fully self-contained desk-top unit with a choice of 320K, 680K and 1.5 MB disc drives. Twin Z80 micro-processors and an RS-232 communications port make it easy to extend the system as you grow. Its CP/M operating system gives you access to literally thousands of software programs.

**30MB
SUPERBRAIN
NOW AVAILABLE**

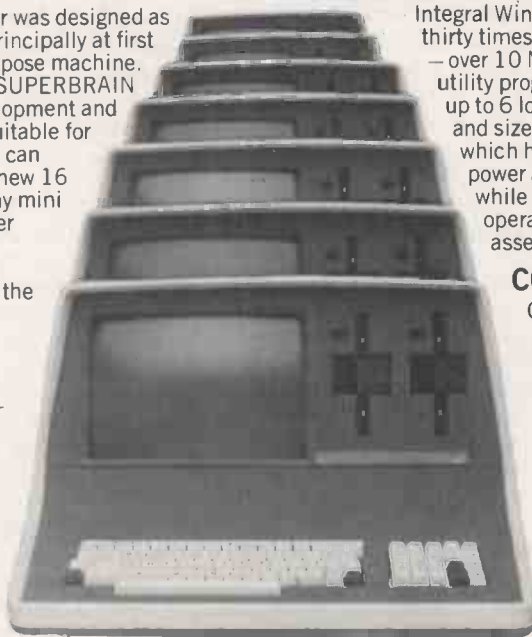

Integral Winchester disc storage gives you up to thirty times the capacity of a basic SUPERBRAIN – over 10 MB. Data retrieval is faster and the utility programs for the W6 allow you to define up to 6 logical disc drives of a variety of types and sizes. The W6 includes SUPERBIOS which has the advantage of increasing the power and speed of the micro-processor, while still using the standard CP/M operating system with text editor, assembler and debugger.

COMPUSTAR

COMPUSTAR provides the facility to link up SUPERBRAINS in a multi-user network. Each SUPERBRAIN is connected into a central data store which offers 10, 96 or 144 MB of storage. And since each SUPERBRAIN has its own twin Z80 processors, CP/M operating system and 64K of internal memory, overall response time remains incredibly fast.

So you'll never outgrow SUPERBRAIN. As your business grows, so your SUPERBRAIN business system grows. What you install now will remain an integral part of your organisation for as long as you wish.

For full details contact



SUPERBRAIN

ICARUS

Computer Systems Ltd.

Deane House, 27 Greenwood Place, London NW5 1NN Tel: 01-485 5574. Telex: 264209

The Icarus dealer network includes:

LONDON

DATA PROFILE, Lawrence Road, Green Lane, HOUNSLOW, Middx. Tel: 01-572 6381

J & F GROVER LTD., 10 Barley Mow Passage, LONDON W4 4PH. Tel: 01-994 6477

SISCO LTD., 4 Moorfields, LONDON EC2Y 9AA. Tel: 01-920 0315

TERMACRE LTD., 126 Woodwarde Road, LONDON SE22 8TU. Tel: 01-693 3037

HOME COUNTIES

CULLOVILLE LTD., Thornfield, Woodhill Road, SANDON, Chelmsford, Essex. Tel: 024 541 3919

FOREST ROW COMPUTERS, 53 Freshfield Bank, FOREST ROW, East Sussex. Tel: 034 282 4397

MASS MICROS, Wellson House, Brownfields, WELWYN GARDEN CITY, Herts. Tel: 07073 31436

THAMES VALLEY COMPUTERS, 10 Maple Close, MAIDENHEAD, Berks. Tel: 0628 23532

SOUTH & SOUTH WEST

BARD COMPUTER SERVICES LTD., 24 Old Street, Clevedon, Nr. BRISTOL, Avon. Tel: 0272 878157

COMMONSENSE COMPUTING, PO Box 7, BIDEFORD, Devon. Tel: 02372 4795

MICRO-XZEC LTD., Walton House, Richmond Hill, BOURNEMOUTH, Dorset. Tel: (0202) 21220

NICOMTECH LTD, The Old Mill, Anthony Passage, SALTASH, Cornwall. Tel: 07555 2719

EAST

CAMBRIDGE MICRO COMPUTERS, Cambridge Science Park, Milton Road, CAMBRIDGE. Tel: 0223 314666

STUKELY COMPUTER SERVICES, Barnhill, STAMFORD, Lincs. Tel: 0780 64947

MIDLANDS & WALES

BASIC BUSINESS SYSTEMS LTD., 39/41 Trent Boulevard, WEST BRIDGEFORD, Nottingham. Tel: 0602 819713

DRAGON SYSTEMS LTD., 37 Walter Road, SWANSEA, W. Glam. Tel: 0792 474498

XENON COMPUTER SYSTEMS, 18 Old Rectory Gardens, Cheadle, STOCKPORT, Cheshire. Tel: 061 428 9508

NORTH

JENNINGS COMPUTER SERVICES, 55/57 Fagley Road, BRADFORD, West Yorkshire. Tel: 0274 637867

MICROSERVE (HUMBERSIDE) LTD., 39 Oswald Road, Scunthorpe, SOUTH HUMBERSIDE DN15 7PM. Tel: 0724 849696

NASTAR COMPUTER SERVICES LTD., Ashton Lodge, Abercrombie Street, CHESTERFIELD S41. Tel: 0246 207048

SORTFIELD LTD., E Floor, Milburn House, Dean Street, NEWCASTLE-UPON-TYNE. Tel: 0632 329593

LAWMAR BUSINESS SYSTEMS, 1 Paterson Drive, Woodhouse Eaves, LOUGHBOROUGH, Leics. Tel: 0509 890900

SCOTLAND

ESCO COMPUTING FACILITIES., 321 Blythwood Court, Anderston Cross, GLASGOW G21. Tel: 041 221 0310/2536

TURNKEY COMPUTER TECHNOLOGY LTD., 10 Somerset Place, GLASGOW. Tel: 041 332 7101.

● Circle No. 164

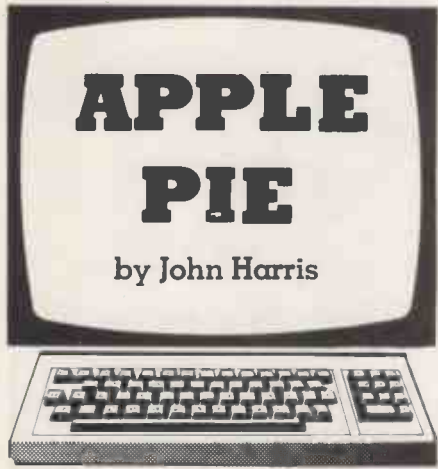

Text on high-resolution screens

ONE SHORTCOMING of the Apple II is the absence of an in-built facility to write text on the high-resolution graphics screens. This disadvantage can be overcome with the help of a set of programs by R Lucas of Wantage.

The two-program package enables users

to mix text of different scales and orientations with graphics anywhere on both high-resolution screens. The first, Character Set Loader, creates a binary file of a shape table consisting of 65 characters. Once run it is no longer needed. The second, Hi-Res Text, serves to demonstrate the character set on screen 1 and an example histogram on screen 2.

With a few modifications, Hi-Res Text becomes a very effective utility for planning the layout of text with graphics on one or both high-resolution screens. A final five-line example listing shows how little code is needed to incorporate the technique in a user program.

Hi-Res Text loads the shape table into memory and provides separate displays of mixed text and graphics on HGR1 and HGR2. Screen 1 shows the character set shape numbered for reference, and on screen 2 a histogram is used to display a variety of text, scales and rotations. Escape toggles between them.

Changing high-resolution screens with soft switches does not necessarily allow the user to Draw or HPlot on the screen being viewed. HGR1 and HGR2 commands not

only clear their respective screens but also decide which screen is used for subsequent plotting. To overcome this use Poke 230,32 prior to HPlot/Draw on screen 1 and Poke 230,64 for screen 2.

Once you have seen the example techniques demonstrated within Hi-Res Text, the source can be converted to a utility for developing layouts of graphics and text. To do this enter:

```
DEL 20,100
DEL 150,630
DEL 670,810
100 REM HI-RES TEXT/M
150 HOME:HGR:HGR2
160 HCOLOR=3:ROT=0:SC=1
1142 INPUT "SCREEN (1 OR 2)?"; Z
1143 IF Z=1 THEN Z=32
1144 IF Z=2 THEN Z=64
1145 IF Z<32 THEN 1142
1146 REM CHOOSE SCREEN
1147 POKE 230,Z
```

A permanent record of entries made to the utility is needed if the results are to be hard coded into another program. A pencil and paper might suffice, or you could go the whole hog and incorporate a Print routine to give a direct hard copy of all commands.

Character Set Loader.

```
20 REM CHARACTER SET LOADER
30 REM
40 REM FOR
50 REM
60 REM APPLE II HI-RES TEXT
70 REM
80 REM BY R LUCAS
90 REM
```

```
100 DATA 65,0
110 DATA 132,0,134,0,142,0,151,
0,176,0
120 DATA 195,0,210,0,228,0,233,
0,243,0
130 DATA 253,0,15,1,26,1,32,1,3
7,1
140 DATA 42,1,50,1,71,1,82,1,96
,1
150 DATA 112,1,130,1,149,1,167,
1,178,1
160 DATA 197,1,215,1,220,1,227,
1,238,1
170 DATA 248,1,1,2,11,2,32,2,51
,2
180 DATA 71,2,84,2,102,2,118,2,
132,2
190 DATA 148,2,167,2,178,2,191,
2,208,2
200 DATA 218,2,240,2,4,3,21,3,3
7,3
210 DATA 56,3,77,3,92,3,103,3,1
19,3
220 DATA 134,3,155,3,173,3,186,
3,200,3
230 DATA 214,3,237,3,1,4,8,4,33
,4
235 DATA 1,0
240 DATA 9,213,213,213,213,149,
43,0
250 DATA 105,213,27,13,213,27,1
3,5,0
260 DATA 169,171,155,169,155,10
,13,197,27,13,197,219,45,45,
197,43,216,27,45,45,197,43,2
4,5,0
270 DATA 9,213,43,45,213,219,10
7,213,43,173,27,13,213,219,4
3,45,213,43,0
280 DATA 173,27,109,169,27,213,
171,27,213,107,41,213,43,5,0
290 DATA 169,27,13,213,27,13,21
3,171,27,213,21,109,197,43,2
16,13,5,0
300 DATA 9,213,213,5,0
310 DATA 9,213,171,27,213,213,2
1,21,5,0
320 DATA 9,21,21,213,213,213,17
1,27,5,0
```

```
330 DATA 106,168,107,213,219,45
,213,171,27,45,213,219,13,13
,213,27,5,0
340 DATA 74,213,213,27,45,45,21
3,27,213,5,0
350 DATA 146,74,213,213,43,0
360 DATA 146,45,45,5,0
370 DATA 146,146,9,5,0
380 DATA 146,18,5,40,40,40,40,0
390 DATA 41,173,219,171,171,171
,43,213,171,45,5,40,24,197,2
7,13,197,43,197,5,0
400 DATA 9,213,43,213,213,213,2
13,213,43,45,0
410 DATA 42,40,173,213,213,27,1
73,219,213,171,43,45,45,0
420 DATA 45,45,213,213,171,27,1
73,219,19,21,45,5,40,24,5,0
430 DATA 82,213,171,147,73,197,
197,219,45,45,197,43,24,197,
197,221,42,0
440 DATA 42,24,45,45,149,219,27
,45,173,219,147,21,45,5,40,2
4,197,5,0
450 DATA 10,5,40,173,218,219,21
3,45,173,219,171,171,45,5,40
,24,5,0
460 DATA 45,45,213,213,171,27,2
13,171,171,43,0
470 DATA 41,173,219,171,171,45,
213,219,213,21,45,5,40,24,5,
192,197,5,0
480 DATA 41,173,219,171,171,210
,42,45,40,40,216,27,45,45,24
,197,5,0
490 DATA 82,169,19,5,0
500 DATA 82,169,19,213,213,43,0
510 DATA 82,5,40,168,210,219,21
,21,21,5,0
520 DATA 18,45,45,213,219,19,45
,45,5,0
530 DATA 169,21,21,213,171,27,2
13,43,0
540 DATA 42,40,173,213,171,27,2
13,213,42,0
550 DATA 41,173,219,171,171,171
,171,171,45,45,216,3,40,197,
43,45,216,107,197,5,0
560 DATA 18,5,40,168,21,213,213
,213,213,221,219,197,197,45,
45,216,27,5,0
570 DATA 170,171,43,45,213,219,
213,157,45,45,232,40,192,197
,29,216,27,45,45,0
580 DATA 42,40,173,213,219,171,
171,171,171,45,5,40,0
590 DATA 45,173,219,171,171,171
,171,171,43,45,5,40,24,197,1
97,197,5,0
600 DATA 45,45,213,219,171,171,
```

```
43,45,213,219,213,213,45,45,
5,0
610 DATA 45,45,213,219,171,171,
43,45,213,219,213,213,5,0
620 DATA 42,40,173,213,219,171,
171,171,171,45,45,24,197,43,
5,0
630 DATA 213,213,149,171,171,10
7,9,197,197,197,219,43,45,45
,24,197,197,5,0
640 DATA 41,173,27,213,213,213,
213,213,43,45,0
650 DATA 146,18,21,45,5,40,24,1
97,197,197,197,5,0
660 DATA 213,213,213,146,197,19
7,197,45,40,40,168,146,219,2
1,21,5,0
670 DATA 213,213,213,213,213,21
3,45,45,5,0
680 DATA 213,173,27,213,213,213
,213,77,41,24,197,197,27,13,
197,27,13,197,43,197,5,0
690 DATA 213,213,173,27,213,213
,213,77,41,24,197,43,197,27,
13,197,197,197,5,0
700 DATA 41,173,219,171,171,171
,171,171,45,5,40,24,197,197,
197,5,0
710 DATA 45,173,219,171,171,171
,147,197,197,45,45,40,24,197
,5,0
720 DATA 41,173,219,171,171,171
,107,213,27,21,109,197,43,40
,24,197,197,5,0
730 DATA 45,173,219,171,171,19,
213,213,77,41,216,197,43,216
,43,45,5,40,24,5,0
740 DATA 42,40,173,213,219,171,
45,21,213,219,171,45,5,40,0
750 DATA 45,45,213,27,213,213,2
13,213,213,5,0
760 DATA 213,213,213,213,213,21
,45,5,40,24,197,197,197,197,
5,0
770 DATA 213,213,213,213,21,21,
5,40,40,24,197,197,197,5,0
780 DATA 213,213,213,213,213,17
3,27,77,41,216,45,216,107,19
7,27,13,197,197,197,5,0
790 DATA 213,21,213,170,27,213,
77,41,24,197,43,216,5,40,40,
24,5,0
800 DATA 213,21,149,18,197,197,
197,5,40,40,24,5,0
810 DATA 45,45,213,213,171,27,2
13,171,27,213,45,45,5,0
820 DATA 10,5,168,213,27,213,43
,173,27,213,213,107,45,5,0
830 DATA 18,5,40,45,45,213,219,
107,213,27,13,213,27,13,213,
27,13,213,27,13,5,0
840 DATA 9,173,219,213,171,19,2
```

(continued on next page)

(continued from previous page)

```

1,21,45,40,40,216,219,43,45,
45,197,197,43,0
850 DATA 146,42,40,168,21,5,0
860 DATA 9,213,213,43,173,219,1
07,213,27,13,213,27,13,213,1
47,41,24,197,43,45,40,24,197
,5,0
870 DATA 10,213,171,171,171,171
,45,40,24,197,141,210,45,40,
24,197,197,197,43,0
875 REM
880 HOME : VTAB 3: PRINT "OR PRE
SS 1 IF 37120 IS OK"
890 VTAB 1: INPUT "ENTER START A
DDRESS OF TABLE: ";SA
900 IF SA = 1 THEN SA = 37120
910 REM CALC. HIGH & LOW BYTES
OF SA
920 HB = INT (SA / 256):LB = SA -
256 * HB
930 POKE 232, LB: POKE 233, HB
940 REM LOAD TO MEMORY
950 VTAB 8: PRINT "WAIT 7 SECS -
LOADING"
960 FOR A = SA TO SA + 1076
970 READ B: POKE A, B: NEXT A
980 VTAB 12: PRINT "LOADED."
990 VTAB 14: PRINT "SAVING TO DI
SK AS A BINARY FILE"
1000 PRINT CHR$(4); "BSAVE CHAR
.SET"; "A"; SA; "L"; 1077
1010 VTAB 18: PRINT "FINISHED"

```

Hi-Res Text.

```

20 REM HI-RES TEXT
30 REM
40 REM ON

```

Date routines

I am still collecting date routines and have yet to reach a conclusion on the winner of the competition on the subject. In the meantime an independent trivial but nonetheless interesting routine from Colin Wilson is offered for deriving the day of the week from a date.

Date routine.

```

10 REM
15 REM WEEK DAYS
20 REM
25 REM GRAHAM WILSON
30 REM
35 REM APRIL 1982
40 REM
100 TEXT : HOME
110 DEF FN A(CF) = INT (CF)
120 DEF FN B(CF) = CF - INT (C
F)
130 REM
140 INPUT "DAY <1 TO 31> " = ;D
150 INPUT "MONTH <1 TO 12> " = ;M
160 INPUT "YEAR <ANY> " = ;Y
170 IF M = 1 THEN :M = 13:Y = Y -
1
180 IF M = 2 THEN :M = 14:Y = Y -
1
190 C1 = D + (2 * M) + ((M + 1) *
0.6)
200 C1 = FN A(C1)
210 C2 = FN A(Y / 4)
220 C3 = FN A(Y / 100)
230 C4 = FN A(Y / 400)
240 C1 = C1 + Y + C2 - C3 + C4 +
2
250 C1 = ( FN B(C1 / 7) * 7) + 0.
5
260 C1 = FN A(C1)
270 ON C1 GOTO 280,300,320,340,3
60,380,400
280 T$ = "SUNDAY": GOSUB 420
290 GOTO 440
300 T$ = "MONDAY": GOSUB 420
310 GOTO 440
320 T$ = "TUESDAY": GOSUB 420
330 GOTO 440
340 T$ = "WEDNESDAY": GOSUB 420
350 GOTO 440
360 T$ = "THURSDAY": GOSUB 420
370 GOTO 440
380 T$ = "FRIDAY": GOSUB 420
390 GOTO 440
400 T$ = "SATURDAY": GOSUB 420
410 GOTO 440
420 PRINT "THE DAY WAS : ";T$
430 RETURN
440 GOTO 130
450 END

```

```

50 REM
60 REM APPLE II HI-RES SCREENS
70 REM
80 REM BY R LUCAS
90 REM
100 REM CAST OF CHARACTERS
110 HIMEM: 37120
120 PRINT CHR$(4); "BLOAD CHAR.
SET"
130 REM STORE SHAPE TABLE START
ADDRESS = 37120
140 POKE 232,0: POKE 233,145
150 HGR2 : HGR : HOME
160 HCOLOR= 3: ROT= 0: SCALE= 1
170 L1$ = "CAST OF CHARACTERS"
180 A$ = L1$:X = 80:Y = 0: GOSUB
370
190 X = 6:Y = 12
200 FOR S = 1 TO 65
210 DRAW S AT X,Y
220 X = X + 18: IF X > 266 THEN X
= 6:Y = Y + 30
230 NEXT S
240 VTAB 21: PRINT "<SPACEBAR> T
O ADD SHAPE NUMBERS "; GET
Q$
250 L2$ = " 1 2 3 4 5 6 7
8 9 10 11 12 13 14 15"
260 L3$ = "16 17 18 19 20 21 22 2
3 24 25 26 27 28 29 30"
270 L4$ = "31 32 33 34 35 36 37 3
8 39 40 41 42 43 44 45"
280 L5$ = "46 47 48 49 50 51 52 5
3 54 55 56 57 58 59 60"
290 L6$ = "61 62 63 64 65"
300 A$ = L2$:X = 0:Y = 22: GOSUB
370
310 A$ = L3$: GOSUB 370
320 A$ = L4$: GOSUB 370
330 A$ = L5$: GOSUB 370
340 A$ = L6$: GOSUB 370
350 PRINT : VTAB 21: PRINT "<SPA
CEBAR> FOR GRAPH DEM ON HGR2
"; GET Q$: GOTO 440: REM CT
RL-J
360 REM STRING WRITING ROUTINE
370 FOR I = 1 TO LEN (A$)
380 S = ASC ( MID$( A$, I, 1))
390 DRAW S - 31 AT X,Y: X = X + 6
400 NEXT I
410 Y = Y + 30: X = 0
420 RETURN : REM CTRL-J
430 REM GRAPH DEM
440 HGR2 : HCOLOR= 3: ROT= 0: SCALE=
1
450 REM LAY AXIS
460 HPLLOT 23,38 TO 23,172 TO 279
,172
470 REM HOR. MARKERS
480 FOR H = 45 TO 234 STEP 21
490 HPLLOT H,173 TO H,174: NEXT H
500 REM VERT. MARKERS & SCALE
510 S = 18
520 FOR V = 150 TO 45 STEP - 21
530 XDRAW S AT 15,V - 3:S = S +
1
540 HPLLOT 21,V TO 22,V: NEXT V
550 REM LABELS
560 L1$ = "X - AXIS":L2$ = "Y - A
XIS"
570 L3$ = " 10 20 30 40 50 60 70
80 90 $1"
580 L4$ = "PRACTICAL COMPUTING":L
5$ = "FOR"
590 L6$ = "TEXT ON APPLE II HI-RE
S SCREENS"
600 L7$ = "BRITAIN'S":L8$ = "LEAD
ING"
610 L9$ = "PERSONAL":T1$ = "COMPU
TING"
620 T2$ = "MAGAZINE":T3$ = "INFOR
MATIVE"
630 T4$ = "EDUCATIONAL":T5$ = "VA
LUE"
640 T6$ = "<ESC> T)EXT M)ODIFY
E)RASE Q)UIT"
650 REM LABEL WRITING DATA
660 REM VL=VERT. LABEL
670 SC = 1: REM SCALING FACTOR
680 A$ = L1$:X = 95:Y = 185: GOSUB
870
690 A$ = L2$:X = 0:Y = 125:VL = 1
:R = 48: GOSUB 870
700 A$ = L3$:X = 32:Y = 175: GOSUB
870
710 A$ = L4$:X = 12:Y = 20:SC = 2
: GOSUB 870
720 A$ = L5$:X = 130:Y = 50: GOSUB
870
730 A$ = L6$:X = 40:Y = 70: GOSUB
870
740 A$ = L7$:X = 42:Y = 168:R = 4
8: GOSUB 870
750 A$ = L8$:X = 63:Y = 168:R = 4

```

```

8: GOSUB 870
760 A$ = L9$:X = 84:Y = 168:R = 4
8: GOSUB 870
770 A$ = T1$:X = 105:Y = 168:R =
48: GOSUB 870
780 A$ = T2$:X = 126:Y = 168:R =
48: GOSUB 870
790 A$ = T3$:X = 147:Y = 168:R =
48: GOSUB 870
800 A$ = T4$:X = 174:Y = 94:R = 1
6: GOSUB 870
810 A$ = T5$:X = 188:Y = 84:SC =
2:VL = 3: GOSUB 870
820 A$ = T6$:X = 18:Y = 0: GOSUB
870
830 A$ = " "
840 HOME : VTAB 21: PRINT T6$
850 GOTO 1000: REM
860 REM LABEL WRITING ROUTINE
862 REM VL=1 WRITE UPWARDS
864 REM VL=2 WRITE DOWNWARDS
866 REM VL=3 STACK LABEL DOWNWAR
DS
870 FOR J = 1 TO LEN (A$)
880 SCALE= SC: ROT= R
882 IF R = 48 THEN VL = 1
884 IF R = 16 THEN VL = 2
890 S = ASC ( MID$( A$, J, 1))
900 IF S = ASC (" ") THEN S = 3
1 + 60: REM STIRLING SYMBOL
910 IF X > 279 THEN X = 279
920 IF Y < 0 THEN Y = 0
925 IF Y > 191 THEN Y = 191
930 XDRAW S - 31 AT X,Y
940 IF VL = 1 THEN Y = Y - 7 * S
C: GOTO 960
942 IF VL = 2 THEN Y = Y + 7 * S
C: GOTO 960
944 IF VL = 3 THEN Y = Y + 9 * S
C: GOTO 960
950 X = X + 7 * SC
960 NEXT J
970 VL = 0:SC = 1:R = 0: RETURN :
REM
990 REM SCREEN SWITCHING
1000 X = PEEK ( - 16384): IF X <
127 THEN 1000
1010 IF X - 128 = 27 AND B = 0 THEN
B = 1: POKE - 16368,0: POKE
- 16301,0: POKE - 16300,0:
GOTO 1000: REM SET PAGE 1
1020 IF X - 128 = 27 AND B = 1 THEN
B = 0: POKE - 16368,0: POKE
- 16302,0: POKE - 16299,0:
GOTO 1000: REM SET PAGE 2
1030 IF X - 128 = ASC ("T") THEN
POKE - 16368,0:B = 1: POKE
- 16301,0: POKE - 16300,0:
GOTO 1080
1040 IF X - 128 = ASC ("M") THEN
POKE - 16368,0:X = X1:Y =
Y1:SC = S1:R = R1:VL = V1: GOSUB
870:B = 1: POKE - 16301,0: POKE
- 16300,0: GOTO 1110
1050 IF X - 128 = ASC ("E") THEN
POKE - 16368,0:X = X1:Y =
Y1:SC = S1:R = R1:VL = V1: GOSUB
870: GOTO 1000
1060 IF X - 128 = ASC ("Q") THEN
POKE - 16368,0: TEXT : HOME
: END
1070 GOTO 1000: REM
1075 REM TEXT ENTRY
1080 HOME : VTAB 21: PRINT "ENTE
R TEXT FOR SCREEN"
1090 INPUT " ";A$:B$ = A$
1100 REM ENTER X AND Y COORDINA
TES
1110 VTAB 23: CALL - 868: INPUT
"X = ";X
1120 VTAB 23: HTAB 9: INPUT "Y =
";Y
1130 VTAB 23: HTAB 17: INPUT "SC
" = ;SC: SCALE= SC: IF SC = 0
THEN SC = 1
1140 VTAB 23: HTAB 24: INPUT "R (
0,16,48) = ";R: IF R > 0 THEN
VL = 1
1150 X1 = X:Y1 = Y:S1 = SC:R1 = R
:V1 = VL
1160 VTAB 24: PRINT T6$
1170 GOSUB 870: GOTO 1000

```

Example program.

```

10 REM DRAW PI
20 PRINT CHR$(4); "BLOAD CHAR.S
ET"
30 POKE 232,0: POKE 233,145
40 HGR : HCOLOR= 3: ROT= 0: SCALE=
1
50 DRAW 61 AT 140,80

```

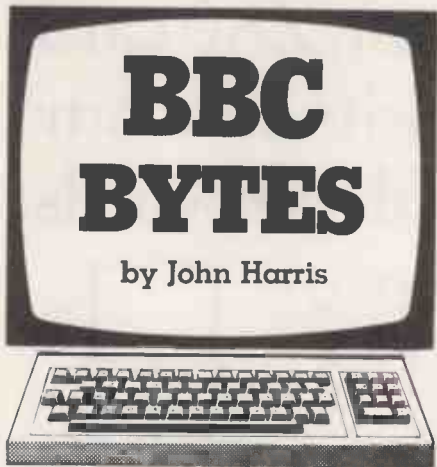
Large lettering

THE OPERATING SYSTEM entry point at Osword makes many useful facilities available to the programmer. One of them is the return of a "picture" in eight bytes of any ASCII character as it appears on the screen, and this call is the basis of two programs and a procedure which between them show what can be done with the information.

Bobby Hesselbo of North Berwick has submitted a Poster card program which accepts messages on two levels. A foreground message of three lines of 10 characters is placed on the screen and, optionally, the printer in large format. It is composed of repeating elements of a

background message which may be of any length.

Philip O'Shea of Rayleigh in Essex, who wrote the article on mode 7 graphics in the February issue, has followed it up with two more routines. One is a scrolling display program for advertising a message of any length across a screen repetitively; the other is a procedure to place enlarged skeletal text anywhere on a graphics mode 0 to 6 screen. Calling

PROCLPLOT (x,y,sx,sy,M\$)

achieves this, with the bottom left coordinate in x,y, the size per character in sx, sy and the message in M\$. The colour of the text to be drawn may be changed with GCol.

Poster.

```

U REM Birthday card / poster
1 REM by B Hesselbo
2 REM Feb 83
10 DIM GAP% 8
20 OSWORD=&FFF1:OSWRCH=&FFEE
30 PAR1=&70:PAR2=&72:PAR3=&74
40 FORIX=UTO2STEP2
50 PX=&DUU
60 OPTIX
70 .BIG
80 STA GAP%
90 LDA #&1F
100 JSR OSWRCH
110 TXA
120 JSR OSWRCH
130 TYA
140 JSR OSWRCH
150 LDY #GAP% DIV 256
160 LDX #GAP% MOD 256
170 LDA #&A
180 JSR OSWORD
190 LDY #1
200 .LOOP
210 LDA GAP%,Y
220 JSR Line
230 CPY #8
240 BEQ LOOP2
250 LDA #&A
260 JSR OSWRCH
270 LDA #8
280 TAX
290 .LOOP2
300 JSR OSWRCH
310 DEX
320 BNE LOOP2
330 INY
340 CPY #9
350 BNE LOOP
360 RTS
370 .line
380 LDX #0
390 .LOOP1
400 CLC
410 ROL A
420 PHA
430 BCC zero
440 LDA #&FF:JSR OSWRCH
450 JMP over
460 .zero
470 LDA #&20:JSR OSWRCH
480 .over
490 PLA
500 INX
510 CPY #8
520 BNE LOOP1
530 RTS:JNEXT
540 VDU23,255,255,255,255,255,
255,255,255
550 MODE0
560 INPUT "Background name : "bn$
570 CLS:INPUT "Do you want to prin
t",ps
580 CLS:PRINT"now Large text":G=GE
T:CLS
590 FORYX=0 TO 18 STEP 9
600 FORXZ=0 TO 72 STEP 8
610 AX=GET
620 IF AX=127 THEN XX=XX-8
630 CALL BIG
640 IF AX=127 THEN XZ=XZ-8
650 NEXT:NEXT
660 AX=&B7
670 IF LEFTS(ps,1)="y" OR LEFTS(ps
,1)="Y" THEN VDU2
680 FOR YZ=0 TO 30
690 FOR XZ=0 TO 79

```

```

700 VDU31,XX,YX
710 CH=(USR(&FFF4)AND&FFFF) DIV &1
UO
720 IF CH=32 THEN VDU32 ELSE VDUFN
char
730 NEXT:VDU1,13:NEXT
740 VDU3
750 END
760 DEFFNchar
770 =ASC(NIDS(bn$, (XZ+YX) MOD LENb
n$+1,1))

```

Scrolling display.

```

10 ON ERROR GOTO 510
20 MODE6:PRINT'''
30 PRINT" When you have finished
typing, press"
40 PRINT" RETURN and type '+' (&
RETURN)."
50 PRINT" type the underline sym
bol (Unshifted"
ou PRINT" ' key) after a lette
r if you want"
70 PRINT" it underlined. "
80 PRINT" Press ESCAPE to stop t
he program."
90 PRINT:PRINT
100 M$=""
110 REPEAT
120 INPUT LINE"MESSAGE? "A$
130 M$=M$+" "+A$
140 UNTIL A$=""*
150 L=LEN(M$)-2
160 M$=LEFT$(M$,L)+" "
170 L=L+6
180 PROCcolchoose("Border")
190 BCOL=COL+144
200 PROCcolchoose("Word")
210 WCOL=COL+144
220 MODE7
230 VDU 23,&20;0;0;0;0;
240 FORI=1TO7
250 PRINTCHR$(BCOL);STRINGS(39,CH
R$(255));
260 NEXTI
270 PRINTSTRINGS(8,CHR$(10))
280 FORI=VPOS TO 23
290 PRINTCHR$(BCOL);STRINGS(39,CH
R$(255));
300 NEXTI
310 VDU30
320 FORI=8TO15:PRINTTAB(0,I);CHR$
(WCOL);
330 NEXT
340 PROCmovesetup:PROCsetupdots
350 FOR K=1TO L
360 CS=MIDS(M$,K,1)
370 IF CS="" THEN 490
380 PROCdots(ASC(CS))
390 IF K<L THEN IF MIDS(M$,K+1,1)
="" THEN ?(INFO+8)=255
400 FOR J=1 TO 7 STEP 2
410 PT=8-J:PT=2*PT
420 FORI=1 TO 8
430 Q=D:R=0
440 IF?(INFO+I) AND PT)<>0 THEN
Q=1
450 IF?(INFO+I) AND PT/2)<>0 THE
N R=1
460 PROCdprint
470 NEXTI
480 NEXTJ
490 NEXTK
500 GOTO 350

```

```

510 MODE7:PRINT'''
520 IF ERR=17 THEN PRINT"Bye!" EL
SE REPORT:PRINT" at line ";ERL
530 END
540 DEF PROCsetupdots
550 DIM INFO 10
560 XR=INFO MOD 256
570 YR=INFO DIV 256
580 ENDPROC
590 DEF PROCdots(CH)
600 ?(INFO)=CH
610 XX=XR:YX=YR:AX=10
620 CALL &FFF1
630 ENDPROC
640 DEFPROCmovesetup
650 LA=&80:LB=&81
660 DIM PROG 40
670 HM=HMEM+(40*8)
680 LO=HM MOD 256:HI=HM DIV 256
690 ?(LA)=LO:?(LB)=HI
700 M$="A208A002B180889180C8C8C0
28D0F5A9208B9180A58D18692885809002E6
81CAD001604C"
710 HX$="123456789ABCDEF"
720 FORI=1 TO 36:A$=MIDS(M$,I+2-
1,1):B$=MIDS(M$,I+2,1)
730 C=(INSTR(HX$,A$)+16)+INSTR(HX
$,B$)
740 ?(PROG+I-1)=C
750 NEXTI
760 L1=PROG+2
770 ?(PROG+36)=L1 MOD 256
780 ?(PROG+37)=L1 DIV 256
790 ENDPROC
800 DEFPROCmoveit
810 ?(LA)=LO:?(LB)=HI
820 CALL PROG
830 ENDPROC
840 DEF PROCdprint
850 IF Q=1 THEN C=21 ELSE C=0
860 IF R=1 THEN C=C+74
870 IF Q=1 AND I=8 AND (C AND 16)
=16 THEN C=C-16
880 IF R=1 AND I=8 AND (C AND 64)
=64 THEN C=C+64
890 C=C+160
900 PRINTTAB(39,7+I);CHR$(C);
910 IF I=8 THEN PROCmoveit
920 ENDPROC
930 DEF PROCcolchoose(M$)
940 PRINT
950 PRINT
960 PRINT"Choose from Red,Green,Y
ellow,Dark blue,"
970 PRINT"Magenta,Cyan or White b
y typing the"
980 PRINT"first Letter."
990 PRINT
1000 PRINTM$;:INPUT" colour? "CL$
1010 IF CL$=""THEN 1000
1020 CL$=LEFT$(CL$,1)
1030 COL=INSTR("RGYDMCW",CL$)+INST
R("rgydmcw",CL$)
1040 IF COL=0 THEN 1000
1050 ENDPROC

```

Enlarged text.

```

25000 DEF PROCCLPLOT(CX,CY,CW,CH,PN$
)
25010 LOCAL CH$,SX,SY,NC,K,LX,LY,UL
,XP,YP
25020 SX=CW/8:SY=CH/8:DIH HX1U:XX=H
XMOD256:YX=HXDIV256
25030 NC=LEN(PN$):FURK=1TOHC:CH$=HI

```

(continued on page 170)

IBM PC - full range of products available, including colour monitor, Z80 card, Winchester up grade kits, and our UDM range of add-on boards.

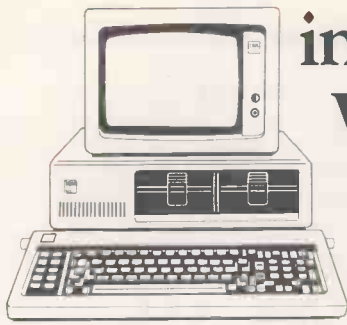

ACT Sirius - plus **Epson** printer or equivalent, from **£2395**. 1.2/2.4/10Mb machines, software, hardware add-ons, call for full list.

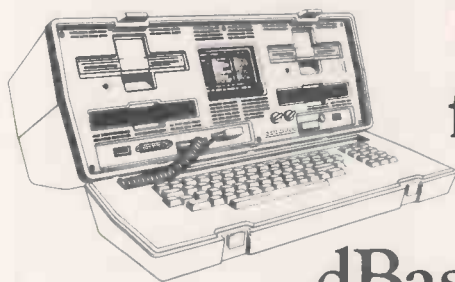

OSBORNE 1 - **£1375** with free 12" monitor, MailMerge™, WordStar™, C and M Basic, dBase II™, Super Calc™, and CP/M.

SUPERBRAIN II from **£1495**, full range from 320K to 36 Mb, 6Mb hard disk models **£2795**.



EPSON QX 10 - at **£1730**, plus Pearl & Peachtree software and our new range of Epson printers.

 **Microware**

For Sales, Service, Maintenance, Advice.

Phone **01-272 6237/6398** or Telex 297598.

Showroom at:

637 Holloway Road, London N19 5SS.

As from September
there could be a
NEW magazine
in your life ...

micro business

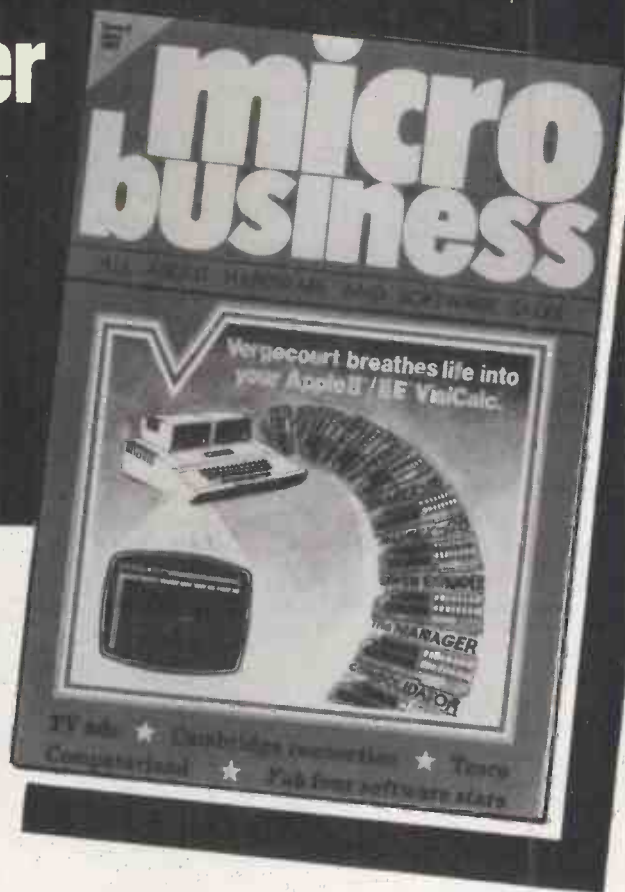

● Micro Business is designed to bridge the gap between those who are producing microcomputer hardware and software and those who are selling it.

● Micro Business is the magazine which makes sense of the micro scene, identifying the pitfalls and explaining the complexities of the microcomputer jungle.

● Micro Business is produced by the publishers of Practical Computing; Your Computer; Systems International; Computer Weekly; Electrical & Radio Trading and Electrical & Electronic Trader — Britain's leading journals in the computer and electrical retail markets.

● Micro Business will bring new hardware and software products to the attention of dealers and retail outlets throughout the UK.

That all adds up to an effective marketing and sales aid for companies producing microcomputer hardware and software. And an important source of market information for those at the sharp end — the retailers and dealers who are selling direct to the general public. If you fall into either of these categories please complete the coupon and return it to us, to obtain Micro Business free of charge.

To: Chris Hipwell, Publishing Director, Micro Business, Room 309H, Business Press International Ltd, Quadrant House, The Quadrant, Sutton, Surrey

I am professionally involved in the production and/or sale of microcomputer hardware and/or software products.

Please tick appropriate box(es)

- Please send me a reader application card so that I can register for free copies of Micro Business.
- Please send me your advertisement brochure as I am interested in advertising in Micro Business.

Name _____

Job Title _____

Company Name _____

Company Address _____

PC

(continued from page 167)

```

DS(PHS,K,1)
2504U ?HX=ASC(CH$):AX=10:CALL&FFF1:
?HX=U:?(HX+9)=0
2505U FOR LY=1TO8:DL=? (HX+LY):IF DL
=U THEN 2511U
2506U FOR LX=-1TO7:IF(LX=-1 AND (DL
AND1)=1)OR(LX=7AND(DL AND128)=128).
THEN 2508U
2507U IF((DL AND 2^LX)/2^LX)=(DL AND
2^(LX+1))/2^(LX+1) THEN 2510U
2508U XP=CX+CW-(SX*(LX+1)):YP=CY+CH
-SY*(LY-1)
2509U MOVEXP,YP:DRAWXP,YP-SY:MOVEXP
+4,YP:DRAW XP+4,YP-SY
2510U NEXT
2511U NEXT
2512U FORLX=UT07:FORLY=UT08:DL=? (HX
+LY):IF(DL AND2^LX)=(?(HX+LY+1)AND
2^LX) THEN 2515U
2513U XP=CX+CW-(SX*LX):YP=CY+CH-(SY
*LY)
2514U MOVE XP,YP:DRAW XP-SX,YP
2515U NEXT, :CX=CX+CW:NEXT
2516U ENDPROC
    
```

Mode 7 graphics

Julian Smart of St Andrews has submitted a set of procedures which supply statements for use in mode 7 equivalent to the mode 0 to 6 graphics commands CLG, Plot, Move and Draw. Having coded a test routine linked to a joystick I found they simplify mode 7 graphics to the point that results are obtainable. Page 155 of the *User Guide* gives hints, but the practice in the past has been very long-winded.

The use of the assembler by Mr Smart has speeded up a technique which in Basic took too long to contemplate within any time-critical game procedure. The routines as coded ensure that column 0 of each line is avoided, which is where the graphics selector CHR\$151 resides.

Colour manipulation is not provided

for, and might prove a problem if essential to the application. Otherwise the routines are a great enhancement to any procedure library.

Colour blending

David Turley of Wrexham, Clywd has submitted a short program to demonstrate how the apparent range of colours available in any graphics mode can be made to increase by combining foreground and background colours. Mode 2 is used in the demonstration to allow all colours to be used at once. Some of the combinations blend very effectively to give the appearance of a single shade, while others look to be what they are — a lot of differently coloured dots.

Colour blending.

```

1 MODE2
10 VDU23,240,85,170,85,170,85,170
,85,170
20 FORT=1TO7
30 FORY=128TO135
40 COLOUR T:COLOUR Y
50 FORH=1TO20:VDU240:NEXTH
60 NEXTY
70 NEXTT
80 END
    
```

Mode 7 graphics.

```

10000 REM *****
**
10010 REM Mode 7 Clg, Plot & Dr
aw
10020 REM BBC Computer A or B
10030 REM JAC Smart January 19
83
10040 REM *****
**
10050
10060 REM Reserve memory below scre
en; define various stores
10070
10080 MODE7:HIMEM=31570:LX=HIMEM
10090 OSWRCH=&FFEE:M1=LX+160
10100 M2=LX+161:M3=LX+162
10110 M4=LX+163:M5=LX+164
10120 M6=LX+165:M7=LX+166
10130
10140 REM Define look-up table for
determining pixel code
10150
10160 !(LX+167)=&2100401:!(LX+171)=
&4008
10170 FOR I%=0 TO 3 STEP 3
10180 P%=LX
10190
10200 [ OPT IX
10210
10220 \ *** Set up screen ***
10230
10240 .G% LDA £12 :JSR OSWRCH \ Cle
ar screen
10250 LDY £25
10260 .L3 CPY £0:BEQ RE \ Ret
urn after looping 24 times
10270 DEY
10280 LDA £10 :JSR OSWRCH \ Mov
e cursor down one line
10290 LDA £13 :JSR OSWRCH \ Mov
e cursor to start of line
10300 LDA £97:JSR OSWRCH \ Pri
nt graphics character
10310 JMP L3
10320 .RE RTS \ Ret
urn to BASIC
10330
10340 \ *** Calc. Y text ordinate *
**
10350
10360 .T% STX M1:STY M2 \ Save
co-ordinates
10370 LDY £0:LDX M2:INX \ Load
X with Y co-ordinate
10380 .L1 DEX \ Loop
until Y contains Y character
10390 CPX £0:BEQ A0 \ co-o
rdinate. Pixel Y co-ordinate
10400 DEX \ dete
rmined by branch to A0, A1 or A2
10410 CPX £0:BEQ A1
    
```

```

10420 DEX
10430 CPX £0:BEQ A2
10440 INY
10450 JMP L1
10460 .A0 LDX £0:JMP K1 \ Load
X with pixel Y co-ordinate
10470 .A1 LDX £1:JMP K1
10480 .A2 LDX £2
10490 .K1 STX M6:STY M5 \ Save
X and Y registers
10500
10510 \ *** Calc. X text ordinate *
**
10520
10530 LDY £0:LDX M1:INX \ Repe
at above process
10540 .L2 DEX \ with
X co-ordinates
10550 CPX £0:BEQ B0
10560 DEX
10570 CPX £0:BEQ B1
10580 INY
10590 JMP L2
10600 .B0 LDX £0:JMP K2
10610 .B1 LDX £3
10620 .K2 STX M4:STY M3 \ Save
pixel and character
10630 \ X co
-ordinates
10640
10650 \ *** Select pixel cell ***
10660
10670 LDA M6 \ Load
A with pixel X co-ordinate
10680 CLC:ADC M4 \ Add
0 or 3 depending
10690
10700 TAX:LDA LX+167,X \ Load
char. code from look-up
10710 \ tabl
e using X-register offset
10720 ORA £160:STA M7 \ Add
160 to code and save
10730
10740 \ *** Position text cursor **
*
10750
10760 LDA £31: JSR OSWRCH \ Mov
e cursor to M3, M5
10770 LDA M3: JSR OSWRCH
10780 LDA M5: JSR OSWRCH
10790 LDA £135:JSR &FFF4 \ Rea
d code at M3, M5
10800 TXA
    
```

10810

```

10820 \ *** Write character ***
10830
10840 ORA M7:JSR OSWRCH \ OR
with new code
10850 RTS \ Ret
urn to BASIC
10860
10870 ]
10880 NEXT
10890 *KEYO "DELETE 10000,10910:MCL
SIM"
10900 END
10910
10920 DEFPROCplot(J%,K%)
10930 IF J%<0 OR J%>79 OR K%<0 OR K
%>74 ENDPROC
10940 X%=J%:Y%=74-K%:CALL T%
10950 ENDPROC
10960
10970 DEFPROCclg
10980 M%=0:N%=0:CALL G%
10990 ENDPROC
11000
11010 DEFPROCdraw(J%,K%)
11020 LOCAL A%,B%,C%,I%
11030 IF M%=J% PROCvert:ENDPROC
11040
11050 REM Gradient of line: A%/B%
Equation constant: C%
11060
11070 A%=N%-K%:B%=M%-J%:C%=K%-(J%*A
%)/DIVB%
11080 FOR I%=M% TO J% STEP (M%>J%)-
(J%>M%)
11090 PROCplot(I%,(I%*A%)/DIVB%+C%)
11100 NEXT
11110 M%=J%:N%=K%
11120 ENDPROC
11130
11140 DEFPROCmove(J%,K%)
11150 M%=J%:N%=K%
11160 ENDPROC
11170
11180
11190 REM Routine for plotting vert
ical lines
11200 DEFPROCvert
11210 FOR I%=N% TO K% STEP (N%>K%)-
(K%>N%)
11220 PROCplot(J%,I%)
11230 NEXT
11240 ENDPROC
    
```



Apple IIe 64k computer

only **£599*** + VAT
Immediate Delivery!!

(When purchased with a part-exchange)

Save an extra £39.00
by buying a bundle comprising:
Apple IIe 64k
Disk Drive with controller
80 Column Card
12" Green Screen Monitor

Bundle price only
£999* + VAT

(When purchased with a part-exchange)

Disk Drive with Controller £270
Disk Drive without Controller £199
12" GreenScreen Monitor £99
Apple III Monitor with Stand £125

Apple III
Apple III 256k with monitor £2099
Profile (5Mb Hard Disk) £1495
Additional Disk Drive (14.3K) £270
Parallel Interface £129
OEM Prototyping Board £32
Vinyl Carrying Case £49

Software (Apple III)
Visicalc III £169
Mail List Manager £99
System Software (SOS) £175
Quickfile III £60
Appewriter III £133
Business Graphics III £105
Access III £89
Catalyst £128
Script III £75

Other Software prices on application

Software (Apple IIe)
Visicalc £145
Visitrend Plot 3.3 £182
Multiplan £160
Appewriter IIe £105
Business Graphics £109
Quickfile IIe £60
Senior Analyst £145
APM £137
Apple Plot £38
Pascal £149
Pilot £69
Fortran £112
Logo £122
Super Pilot £129
Wordstar £230
Mailmerge £130
Word Handler £98
Visischedule £180
Other Software prices on application

Sirius
Sirius equipment is available within 48 hours at unprintable prices. Please phone for details.

Operating Systems & Display
Z80 Microsoft Card £215
Z80 Microsoft Card (Ile) £325
Z80 Digitek Card £145
Videx 80 Col System £189
40 80 Column Switch £25
80 Column 64K
Expander Card £149
Prototype Hobby Card £12
IEEE 488 Card £235
TV Modulator £14

Epson Printers
RX80 £279
FX80 £379
MX100F T Type 3 £420
FX80 Tractor Feed £35
IEEE Adaptor Board £65
Serial Adaptor Board £65

Other Printers
Apple dot Matrix £349
Apple Daisywheel £1150
TEC 40cps Daisywheel £1095
TEC 55cps Daisywheel £1295
Other Printer prices on application

Accessories
Numeric Keypad £78
Paddles £20
Joystick £34
Cooling Fan £45
Voltage Stabiliser £230
Acoustic Coupler £200
10 Floppy Disks £20
Listing Paper 9" £20
Listing Paper 16" £29
Monitor Stand £18
Vinyl Carrying Case £17

Apple II Accessories
Integer Card £99
Eurocolour Card £73
Language Card £106
Paddles £20
Joystick £26
Numeric Keypad £78

Interfaces
Serial Printer Card £70
Parallel Printer Card £70
Wizard 16K Buffered I/F £139
Wizard 16K to 32K Upgrade £25
Thunder Clock £84
8 Channel A/D Converter £245
Grappler £99

Software (Apple II)
Appewriter 1.1 £39
Apple Plot £38
Appewriter 2 £89
Circuit Analysis £23
Apple Super Pilot £129
DOS Tool Kit £41

Export Orders Welcome!!!
Barclaycard & Access accepted but subject to a 5% surcharge Payment welcome by cash, bank draft, Building Society cheque. Please allow 7 days for cheque clearance. Instant credit available shortly.

HOME COMPUTERS at GREAT PRICES



With your old micro, working or not, taken in part exchange. (ZX80/81 welcome!!)
Please phone us if you don't have a part exchange.

(+ VAT)

Delivery
We are open for collection: Monday - Friday 10am - 5.30pm Saturday 9am - 5.00pm
Delivery by Securicor: please add 5%
Smaller items are sent by post unless otherwise requested.



10/11 Salisbury Square, Old Hatfield, Hertfordshire.

Telephone: Hatfield (07072) 65551

Cut this coupon for free price list
Name _____
Address _____
PCN _____

● Circle No. 199



PASCAL

Paper, Scissors and Stone

THE TRADITIONAL game of Paper, Scissors and Stone is used to this day by school children who want to choose fairly between two people. At a given signal — one, two, three, Go! — both contestants make a sign with their hands representing paper, scissors or stone. A cyclic rule then chooses

the winner: scissors cut paper; stone blunts scissors and paper wraps up stone. If both players chose the same object then the game must be repeated.

The chance of winning is exactly 50 percent. Over a long series of games, where both players guess at random, one should expect a player to win one-third of the games and lose one-third.

In practice, a real human player is far from random in making plays. People are very poor at generating random patterns, and each player has particular favoured choices and sequences, although these may be made completely subconsciously.

A computer program can capitalise on this human failing. All that it needs to do is to keep a complete record of all games played so far. It must try to guess what its opponent will do next. It finds previous instances of the last few plays in its records and looks to see what the opponent did next on those occasions. The problem is essentially reduced to a pattern-matching task.

The Pascal program by Bob Mackay of London N6 plays the game of Paper, Scissors and Stone. The winner is the first to win 50 rounds. The game history is recorded in a simple two-dimensional

array, which stores the guess made by each player for each round of play.

The algorithm starts by attempting to find a duplicate of the last five plays anywhere in the previous games. It probably fails, since a duplicate sequence of five identical games is fairly improbable. It then searches for shorter sequences.

If it finds a match at any stage it looks at the object that the opponent guessed next, and then searches for further matches of this length. It keeps a running total of each of the three possible next guesses. If one of them is clearly in the majority, then the computer guesses the corresponding winning object. For example, if the opponent generally chose paper after the matched sequence, then the program chooses, scissors. If no conclusive matches are found, even at a length of one, then the computer guesses at random.

The program is irritating to play, since the computer seems to be able to read your mind, especially in the later stages of the game. It always wins! The techniques used here might be applied elsewhere: imagine being caught in a computer-generated maze where the computer could guess where you were likely to turn next. □

Paper, Scissors and Stone.

```
{ PAPER, SCISSORS AND STONE }
{ COPYRIGHT 1983 BOB MACKAY }
```

```
PROGRAM JANKENPON;
```

```
CONST
  { LONGEST SEQUENCE WORTH LOOKING FOR }
  MAXLENGTH = 5;
```

```
TYPE
  OBJECT = (PAPER, SCISSORS, STONE);
  PLAYER = (ME, YOU);
```

```
VAR
  { RECORD OF ALL PREVIOUS ROUNDS }
  HISTORY : ARRAY [ME..YOU, 1..400] OF OBJECT;
```

```
{ PLAYER'S SCORES }
  SCORE : ARRAY [ME..YOU] OF INTEGER;
```

```
{ MY GUESS, YOUR REPLY }
  GUESS, REPLY : OBJECT;
```

```
{ RUNNING TOTALS OF PLAYER'S USUAL
  REPLIES AFTER MOST RECENT SEQUENCE }
  TOTPAPER, TOTSCISSORS, TOTSTONE : INTEGER;
```

```
{ CONTROL VARIABLES }
  LENGTH, NOROUNDS : INTEGER;
  DECIDED : BOOLEAN;
```

```
PROCEDURE INTROMEBSAGE;
  { DISPLAY AN INTRODUCTORY MESSAGE }
  BEGIN
```

```
  WRITELN ('This program plays the game of');
  WRITELN ('Paper, Scissors & Stone');
  WRITELN;
  WRITELN ('Each of us must think of one of');
  WRITELN ('the three objects.');
```

```
  WRITELN ('The rule is that scissors beat paper, paper');
  WRITELN ('beats stone and stone beats scissors!');
```

```
  WRITELN ('When you have made your choice, and');
  WRITELN ('when I am also ready, type ENTER for my guess.');
```

```
  WRITELN;
  WRITELN ('I bet that I can beat you to 50 points!');
```

```
  WRITELN;
  WRITELN;
  END;
```

```
PROCEDURE OUTPUTGUESS;
  { INFORM THE PLAYER OF MY GUESS }
  BEGIN
  WRITE ('Ready ?');
```

```
  READLN;

  WRITE ('I have guessed ');
```

```
  CASE GUESS OF
    PAPER : WRITELN ('PAPER');
    SCISSORS : WRITELN ('SCISSORS');
    STONE : WRITELN ('STONE');
  END;
```

```
  WRITELN;
  END;
```

```
PROCEDURE INPUTREPLY;
  { GET PLAYER'S REPLY }
```

```
VAR
  RESPONSE : ARRAY [1..2] OF CHAR;
  OK : BOOLEAN;
  BEGIN
  REPEAT
    OK := TRUE;
    WRITE ('What was your guess?');
```

```
    READLN;
    READ (RESPONSE);

    { ONLY THE SECOND CHARACTER TYPED
    IS SIGNIFICANT (SORRY ABOUT THAT) }
    CASE RESPONSE [2] OF
      'a', 'A' : REPLY := PAPER;
      'c', 'C' : REPLY := SCISSORS;
      's', 'S' : REPLY := STONE
    ELSE OK := FALSE
  UNTIL OK;
```

```
  WRITELN;
  END;
```

```
PROCEDURE SCOREMESSAGE;
  { TELL HIM THE SCORE }
```



```

BEGIN
  WRITELN ('The score is ',
    SCORE [ME], ' to me and ',
    SCORE [YOU], ' to you. ');
  WRITELN
END;

PROCEDURE VICTORYMESSAGE;
( ANNOUNCE WHO HAS WON )
BEGIN
  WRITE ('Which means that');
  IF SCORE [ME] > SCORE [YOU] THEN
    WRITELN (' I have won!')
  ELSE
    WRITELN (' YOU have won!');
  WRITELN ('Thanks for the game. ');
END;

PROCEDURE INC (VAR X : INTEGER);
( INCREMENT AN INTEGER )
BEGIN
  X := X + 1
END;

FUNCTION RANDOMGUESS : OBJECT;
( THIS PROCEDURE IS CALLED WHEN NO
  PARTICULAR PATTERN IS DETECTED.
  RETURNS A RANDOM OBJECT )
BEGIN
  ( 'RANDOM' RETURNS A RANDOM INTEGER
    BETWEEN 0 AND 255 )
  CASE (RANDOM MOD 3) OF
    0 : RANDOMGUESS := PAPER;
    1 : RANDOMGUESS := SCISSORS;
    2 : RANDOMGUESS := STONE
  END
END;

FUNCTION CHOSEGUESS : OBJECT;
( SEE IF ANY REPLY HAS A CLEAR MAJORITY
  AND CHOSE THE CORRESPONDING GUESS )
BEGIN
  DECIDED := TRUE;

  IF (TOTPAPER > TOTSCISSORS) AND
    (TOTPAPER > TOTSTONE) THEN
    CHOSEGUESS := SCISSORS
  ELSE
    IF (TOTSCISSORS > TOTPAPER) AND
      (TOTSCISSORS > TOTSTONE) THEN
        CHOSEGUESS := STONE
      ELSE
        IF (TOTSTONE > TOTPAPER) AND
          (TOTSTONE > TOTSCISSORS) THEN
            CHOSEGUESS := PAPER
          ELSE
            BEGIN
              CHOSEGUESS := RANDOMGUESS;
              DECIDED := FALSE
            END
          END
        END;

FUNCTION MATCH (X, Y, LENGTH : INTEGER) : BOOLEAN;
( COMPARE HISTORICAL SEQUENCES AT X AND
  Y OVER THE GIVEN LENGTH )
VAR
  I : INTEGER;
BEGIN
  I := 0;

  WHILE
    (I < LENGTH) AND
    (HISTORY [ME, X+I] = HISTORY [ME, Y+I]) AND
    (HISTORY [YOU, X+I] = HISTORY [YOU, Y+I])
  DO
    INC (I);

  MATCH := (I = LENGTH)
END;

PROCEDURE SCAN (LENGTH : INTEGER);
( LOOK AT YOUR NEXT PLAY AFTER EACH
  SUCCESSFUL MATCH OF SPECIFIED LENGTH )
VAR
  S, T : INTEGER;
BEGIN
  TOTPAPER := 0;
  TOTSCISSORS := 0;
  TOTSTONE := 0;

  ( LATEST SEQUENCE )
  T := NOROUNDS - LENGTH;

  ( FOR EACH EARLIER SEQUENCE DO )
  FOR S := 1 TO T - 1 DO
    IF MATCH (S, T, LENGTH) THEN
      ( RECORD THE NEXT REPLY MADE )
      CASE HISTORY [YOU, S + LENGTH] OF
        PAPER : INC (TOTPAPER);
        SCISSORS : INC (TOTSCISSORS);
        STONE : INC (TOTSTONE)
      END
    END;
  END;

PROCEDURE UPDATESCORE;
( DECIDE WHO WON THIS ROUND )
BEGIN
  CASE GUESS OF
    PAPER :
      CASE REPLY OF
        PAPER : ;
        SCISSORS : INC (SCORE [YOU]);
        STONE : INC (SCORE [ME])
      END;
    SCISSORS :
      CASE REPLY OF
        PAPER : INC (SCORE [ME]);
        SCISSORS : ;
        STONE : INC (SCORE [YOU])
      END;
    STONE :
      CASE REPLY OF
        PAPER : INC (SCORE [YOU]);
        SCISSORS : INC (SCORE [ME]);
        STONE :
          END
      END
    END
  END;

FUNCTION REQUIREDSCORE : BOOLEAN;
( EVALUATE CONDITIONS FOR ENDING THE GAME )
BEGIN
  REQUIREDSCORE :=
    ((SCORE [ME] >= 50) OR
    (SCORE [YOU] >= 50)) AND
    (ABS (SCORE [ME] - SCORE [YOU]) > 1)
  END;

BEGIN ( MAIN PROGRAM )
  INTROMESSAGE;

  NOROUNDS := 0;
  SCORE [ME] := 0;
  SCORE [YOU] := 0;

  REPEAT
    INC (NOROUNDS);
    LENGTH := MAXLENGTH;
    DECIDED := FALSE;

  REPEAT
    SCAN (LENGTH);
    GUESS := CHOSEGUESS;
    LENGTH := LENGTH - 1
  UNTIL (DECIDED) OR (LENGTH = 0);

  OUTPUTGUESS;
  INPUTREPLY;

  HISTORY [ME, NOROUNDS] := GUESS;
  HISTORY [YOU, NOROUNDS] := REPLY;

  UPDATESCORE;
  SCOREMESSAGE
  UNTIL REQUIREDSCORE;

  VICTORYMESSAGE;
  END.

```

Easier commuting to computing...

THE NEW ADDRESS OF LEEDS COMPUTER CENTRE IS 55 WADE LANE LEEDS.



In the spacious new showrooms of the Leeds Computer Centre you will be welcome to browse through a most comprehensive range of microcomputers, peripherals, books and media. Our aim is to provide the finest service possible for personal, educational, O.E.M., industrial and business users.

We offer expertise gained from years on the microcomputer scene. Also product knowledge stemming from dealerships in NASCOM, SHARP, EPSON, TEXAS, GEMINI, QUANTUM, ORIC and DRAGON which we have held ever since they first came onto the market. You will find just the help you need at the Leeds Computer Centre.

PC3500 BUSINESS COMPUTER

MONOCHROME £2064.25 inc VAT
FULL COLOUR £2518.50 inc VAT
640 x 400 HIGH RES. OPTION £299.00 inc. VAT

Prices include:-

128K RAM; CPU; Keyboard;
Display Unit: SHARP FDOS
MBASIC: CPM/2.2;
PEACHCALC

PEACHTREE BUSINESS PACKAGES ARE AVAILABLE FOR SALES, PURCHASE, NOMINAL, STOCK, PAYROLL, WORD PROCESSING etc.



SHARP
Main Dealer

MZ80A (48k) PERSONAL COMPUTER FREE SOFTWARE INCLUDED

£549.00 inc VAT
TWIN DISK SYSTEM MZ80A £879.75 inc VAT
SHARP F/T P6 PRINTER £488.75 inc VAT

Either of the above options require an expansion unit on the MZ80A £115.00 inc VAT



Full range stocked. Full technical support. Full range of software POCKET COMPUTERS & PERIPHERALS

PC1251 WALLET SIZE POCKET COMPUTER £79.95 inc VAT
CE125 PRINTER & MICROCASSETTE £99.95 inc VAT
12A 19 STATISTIC & GAMES PROGRAMS £14.00 inc VAT
12B 20 ENGINEERING & GAMES PROGRAMS £14.95 inc VAT
12C 20 MATHEMATICS & GAMES PROGRAMS £14.95 inc VAT
PC 1500 PORTABLE COMPUTER £169.95 inc VAT
CE 150 X.Y. PLOTTER & PRINTER £149.95 inc VAT
CE152 CASSETTE RECORDER £39.95 inc VAT
CE15A APPLICATIONS TAPE £14.95 inc VAT

80-BUS NAS-BUS LUCAS NASCOM GEMINI

NASCOM from LUCAS LOGIC £304.75 inc VAT
NASCOM 2 MICROCOMPUTER £631.35 inc VAT
NASCOM 3 MICROCOMPUTER (48k) £172.44 inc VAT
NASCOM ADVANCED VIDEO CARD from £540.50 inc VAT
NASCOM DISK SYSTEMS £69.00 inc VAT
NASCOM DISK OPERATING SYSTEM £143.75 inc VAT
NASCOM CPM/2.2

NEW! LUCAS LX MATRIX PRINTER INTRODUCTORY PRICE £366.85 inc VAT



GEMINI MICROCOMPUTERS LTD

GM811 CPU CARD £143.75 inc VAT
GM813 CPU CARD plus 64k RAM £258.75 inc VAT
GM802 64k DYNAMIC RAM £143.75 inc VAT
GM812 INTELLIGENT VIDEO CTRL. £143.75 inc. VAT
GM829 FLOPPY DISK CONTROLLER £166.75 inc VAT
GM827 87 KEY KEYBOARD £97.75 inc VAT
GM825 DISK DRIVE from £402.50 inc VAT



This is only a small selection from our extensive stocks!

PRINTER INTERFACES

CENTRONICS CABLE £17.25 inc VAT
BBC CABLE £17.25 inc VAT
DRAGON CABLE £17.25 inc VAT
ORIC CABLE £17.25 inc VAT
MZ80K CENTRONICS INTERFACE £80.00 inc VAT
MZ80A CENTRONICS INTERFACE £97.75 inc VAT
MZ80B CENTRONICS INTERFACE £97.75 inc VAT

PRINTERS

SEIKOSHA GP 100A £247.25 inc VAT
LUCAS LX80 £366.85 inc VAT
NEC 8023 £447.35 inc VAT
EPSON FX80 £503.70 inc VAT
BROTHER HR-1 £747.50 inc VAT

EPSON HX20 THE PORTABLE MIRACLE from £462.30 inc VAT



Stop Press...

NEW! SHARP CASSETTE BUSINESS SOFTWARE NOW IN STOCK for the MZ80A

These packages run on the standard MZ80A with cassette. This means a complete business system, including printer, can cost £1000.00 plus VAT.

Packages are:- DIRECTORY, PRICE LIST, SALES LEDGER, PURCHASE LEDGER, INVOICING AND STOCK CONTROL.

The system can be expanded to disks without the loss of data.

NEW! SHARP PC3500 BUSINESS COMPUTER AVAILABLE FROM STOCK

Full range of PEACHTREE ON DEMO NEW! LUCAS LX80 80 COLUMN DOT MATRIX PRINTER. EXCELLENT VALUE

FREE! DESK DATA SOFTWARE WORTH £46 WITH EVERY EPSON HX20

FREE! Printer Lead with any printer

SHARP MZ80K HI RES GRAPHICS FROM QUANTUM MICROS £115.00 inc VAT

SUPERBRAIN. IF YOUR SUPERBRAIN NEEDS TRUE DESCENDERS, WE HAVE THE ANSWER FOR £23.00 inc VAT.

NASCOM 2 GRAPHICS ON YOUR NASCOM 1 FOR ONLY £23.00 inc VAT.

BITS & BYTES
COMPUTER PRODUCTS LTD

Trading as Leeds Computer Centre.
Please call or write for full details
Leeds Computer Centre, 55 Wade Lane,
Merrion Centre, Leeds
LS2 8NJ. Tel. 0532 458877



Circle No. 150

DOES YOUR PROGRAM OWE YOU LIVING?

If you've written a home computer program it could be earning you money!

Let us evaluate your game, educational, or business program. Only THORN EMI can give you access to worldwide marketing and distribution expertise.

Just fill in your name and address below and post it to us at THORN EMI for you to receive a full package containing all information, or phone 01-437 3453, our 24 hour answering service, and we will send you details of how to program the world.



Acquisitions Dept, Home Computer Software, Thorn EMI Video Ltd., Film House,
142 Wardour Street, London W1V 4PT 24 hour answer phone 01-437 3453

Name _____

Address _____

WHEN IT COMES TO MICROCOMPUTER SOFTWARE WE WROTE THE BOOK

How do you stay up-to-the-minute with the rapidly changing world of microcomputer software? Get the Lifeboat Catalogue.

The latest innovations The new Lifeboat Catalogue is packed with the latest state-of-the-art software. And if we publish a new program after the latest catalogue has gone to press, we enclose a flash bulletin in your copy.

The greatest selection

Because Lifeboat is the world's largest publisher of microcomputer software, our catalogue offers you the greatest selection of programs for business, professional and personal use. Our more than 200 programs range from the integrated accounting and professional practice systems to office tools for book-keepers and secretaries to sophisticated tools for programmers. Included are business systems, word processors, programming languages, database management systems, application tools and advanced system utilities.

We specialise in software that runs on most small business computers. Our more than 60 media formats, including floppy disks, data cartridges, magnetic tape and disk cartridges, support well over 100 different types of computer.

Get full service We give the crucial dimension of after-sales service and full support to everything we sell.

That includes:

- An update service for software and documentation.
- Telephone, telex and mail-order services in the London office and at overseas offices in the United States, France, Switzerland, West Germany and Japan.
- Subscriptions to Lifelines,TM the monthly magazine that offers comparative reviews, tips, techniques, identified bugs and updates that keep you abreast of change.



Get it now Lifeboat now serves tens of thousands of satisfied customers with our breadth of up-to-date, fully tested, fully supported and competitively priced software.

You may not need all we offer, but we offer just what you need. After all, we wrote the book.

Lifeboat Associates
World's foremost software source

Mail coupon to: Lifeboat Associates
PO Box 125, London WC2H 9LU or call 01-836 9028

Please send me a free lifeboat catalogue.

Name

Title

Company

Address

Postcode

Copyright © 1981, by Lifeboat Associates.

Lifeboat Worldwide offers you the world's largest library of software. Contact your nearest dealer of Lifeboat.

USA Lifeboat Associates 1651 Third Ave. New York NY 10028 Tel (212) 860-0300 Telex 640693 [LBSOFT NYK] TWX 710 581-2524 **JAPAN** Lifeboat Inc. OK Bldg. 5F 1-2-B Shiba-Daimon Minato-ku Tokyo 105 Japan Tel 03-437-3901 Telex 2423296 [LBJTYO] **ENGLAND** Lifeboat Associates Ltd PO Box 125 London WC2H 9LU England Tel 01-836 9028 Telex 893709 [LBSOFTG] **SWITZERLAND** Lifeboat Associates GmbH Hinterbergstrasse Postfach 251 6330 Cham Switzerland Tel 042-36-8686 Telex 865265 [MICO CH] **WEST GERMANY** Intersoft GmbH Schlossgartenweg 5 D-8045 Ismaning W. Germany Tel 089-966-444 Telex 5213643 [ISOFT] **FRANCE** Lifeboat Associates SARL 10 Grande Rue Charles de Gaulle 92600 Asnieres France Tel 1-733-08-04 Telex 250303 [PUBLIC X PARIS]

● Circle No. 200

CP/M SOFTWARE CENTRE

MAKE THE MOST OF YOUR MICRO WITH THESE QUALITY PACKAGES

MULTIPLAN Microsoft's new advanced feature Electronic Worksheet, a new generation of spreadsheet programs. Features include linking of worksheets; alphanumeric sort facility; special text capabilities for dependent display and formatted printing.

Tremendous benefits to aid business people - professional, small business and large company management.

£190

ASCOM Open up the world of telecommunications: Connect CP/M micro to CP/M micro, mainframe or mini timesharing systems; transfer files and programs between micros; control remote micros using ASCOM. Menu driven with on-line Help facility. (Also for CP/M-86, MSDOS, IBM-PC.)

£125

THE FORMULA Not just a Data Management System, but a fully functional Configurable Business System. The fastest way to build an application system. Free format reports, multiple file access and field updates. From Accounting through Stock Control and Personnel to Mailing and Membership systems without resorting to conventional programming languages - easy to create, easier to maintain and expand.

£380

GEEST SSP

Full Function statutory sick pay system

£495



Telesystems Ltd

P.O. BOX 12, GREAT MISSENDEN, BUCKS, HP16 9DD. Tel: (02406) 5314

CP/M-80 SOFTWARE

WORDSTAR	295
(WStar + M/M)	390
SPELLSTAR	145
MAILMERGE	145
DATASTAR	175
REPORTSTAR	210
INFOSTAR	295
CALCSTAR	90
SUPERSORT	145
IBASE II	440
RESCUE	295
THE LAST ONE	330

CARDBOX	135
SUPERCALC	195
BASIC-80 INTERPRETER	240
MBASIC-80 COMPILER	271
FORTRAN-80	343
COBOL-80	515
MAGSAM	130
CIS-COBOL	425
FORMS-2	110
PASCAL MT+ & SPP	355
CBASIC	106
CB90	355
PLY/80	390
ACCESS MANAGER	213
DISPLAY MANAGER	264
PRO-PASCAL	220
PRO-FORTRAN	220
'C' COMPILER	185
MACRO-80	137
ESTAM	130
TRANSFER	130
CP/M 2.2	106
DISKEDIT	70
IBM-CP/M COMPATIBILITY	110
ACCOUNTING PACKAGES (each)	300
PAYROLL	500
STATUTORY SICK PAY	495
PROJECT COST CtrlJob AC	150
STATISTICS ROUTINES	120
MATHEMATICS ROUTINES	120

● Circle No. 171

M-TEC

AT LAST! BBCBASIC to run on YOUR CP/M Computer

Now available for the TORCH and DISKPACK with full GRAPHICS

BBCBASIC(Z80)

WHY STRUGGLE ON using OLD FASHIONED BASICs when you can have ALL THE ADVANTAGES of BBCBASIC(Z80) on your computer?

Of course, we can't turn your computer's video display into a high resolution colour monitor, but we can give you all the other features of BBCBASIC including:-

- > LONG VARIABLE NAMES
- > MULTI-LINE REPEAT UNTIL STATEMENTS
- > MULTI-LINE NAMED FUNCTIONS
- > MULTI-LINE NAMED PROCEDURES
- > POWERFUL DIRECT MEMORY MANIPULATION USING THE INDIRECTION OPERATORS
- > AN IN-LINE ASSEMBLER USING STANDARD Z80 MNEMONICS
- > VERY SOPHISTICATED PARAMETER PASSING IN THE CALL STATEMENT
- > SERIAL RANDOM AND INDEXED DISK FILES PLUS THE ABILITY TO ACCESS ANY BYTE IN THE FILE
- > CLEAR SCREEN, TAB(X), TAB(X,Y), POS, VPOS and TIME Plus ALL THE OTHER STANDARD COMMANDS etc.

You can copy any program written in older 'standard' versions of BASIC with little change OR you can write well-structured and easy to read programs like a professional.

You need never say GOTO again. But we won't stop you.

TORCH version including SOUND and GRAPHICS £110 + vat
Price, including postage, £95 + vat

BBCBASIC(Z80) will run on any computer using CP/M 2.2 or later and a Z80 processor. It comes complete with an instruction manual, a tutor on file handling and configuration notes.

Not yet available for MCP

M-TEC Computer Services, Ollands Road, Reepham, Norfolk
Telephone Norwich 870620 Trade enquiries welcome

● Circle No. 202

ORBIT ELECTRON

FOR THE ACORN

IF YOU HAVE AN ACORN ELECTRON OR ARE THINKING OF BUYING ONE THEN YOU SHOULD JOIN THE ELECTRON USER GROUP. Members receive 10 copies of the magazine ORBIT each year. ORBIT is devoted EXCLUSIVELY to the ELECTRON MICRO. It is Packed with News, Reviews, Hints, Tips, Programming ideas, major articles, plus Regular program features including games and useful utilities.

ORBIT, is produced by BEEBUG Publications Ltd., publishers of BEEBUG, the magazine of the National User Group for the BBC Micro. BEEBUG now has some 20,000 members, and has achieved a high reputation both in this country and abroad. Acorn and the BBC have both taken out multiple memberships, for example, and our articles are now syndicated in Australia. (For further details of BEEBUG, see separate advertisement elsewhere in this issue).

The formula which makes BEEBUG an invaluable companion for users of the BBC micro, will be applied to ORBIT. By subscribing to ORBIT you gain all the advantages of a single-micro magazine, with no space wasted on programs and articles for other computers.

Further benefits of membership; Members' discount scheme with national retailers of software, hardware and books, with savings of up to 25%.

Members' software library with a growing range of titles at special prices for members.

SPECIAL OFFER

Subscribe now, and get a free introductory cassette containing 8 tested programs for the Electron.

1. Space City 2. 3D Noughts and Crosses 3. RACER 4. 3D Maze
5. Patchwork 6. Key Set Routine 7. Memory Display 8. Character Definer

HOW TO JOIN

To subscribe for one year, and get your free cassette, send £9.90 (Payable to Orbit) plus a strong stamped addressed envelope (for the cassette) to:

ORBIT, PO BOX 50, ST ALBANS, HERTS

SIX MONTH TRIAL SUBSCRIPTION (5 ISSUES) UK ONLY - FREE CASSETTE OFFER STILL STANDS.

MEMBERSHIP OUTSIDE UK (ONE YEAR ONLY): Euro and Europe £16.00
Middle East £19.00, Americas & Africa £21.00, other countries £23.00.

● Circle No. 203

Sirton
computer systems

THE SPECIALISTS IN S100 SYSTEMS

NOW IS THE TIME YOU SHOULD BE USING THE S100 FOR:

UPGRADABILITY
MODULARITY
HIGH RELIABILITY
UNMATCHED VERSATILITY
AND AN INTERNATIONAL STANDARD

**OUR BRITISH BUILT MIDAS S100
SYSTEMS OFFER ALL THESE**

ADVANTAGES TOGETHER WITH
CP/M 2 CP/M 86

**** AND NOW CP/M PLUS ****

5 $\frac{1}{4}$ " and 8" FLOPPIES

SINGLE OR MULTIPLE USERS

FIXED AND REMOVABLE HARD DISCS



CP/M + S100 = TOTAL SYSTEM FLEXIBILITY

BOARDS

We stock over 50 different S100 Boards all from quality manufacturers. Advanced Micro Digital, Godbout, SSM, Micromation, Dual, CCS, Sirton, Morrow, Pickles & Trout etc.

S100 CPU CARDS

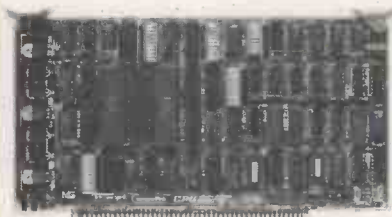

No 1 of a Series

- * Z80A or B SBC, 64K RAM, 2S + 2P, FDC, 2K EPROM, CTC.
- * Z80A Slave 64K or 128K RAM, 2S + 2P, 2K EPROM.
- * Z80A 2/4 MHz, 2/4K EPROM 16/24 bit add, IEEE696.
- * Z80A or B, 8K EPROM/RAM, 16/24 bit add, Int Cont, IEEE696.
- * Z80A, Serial I/O, 2K Monitor
- * 8085 + 8088 dual CPU Card, IEEE696.
- * 8086 + 8013C, 16 bit CPU + space for 8087, IEEE696.
- * 6800 + MMU, 8K ROM.
- * 16032 + space for 32K ROM + 16082, 16201, 16081.

We are pleased to discuss your requirements and will advise you as to whether your needs can be met with one of our computers.

All of our systems are specials as they are configured to suit your specification, thus ensuring that you get what you want rather than what happens to be available.

Write or phone for a catalogue.

**Unit 14, 29 Willow Lane, Mitcham, Surrey
Telephone: 01-640 6931/2/3**

Sirton
computer systems

● Circle No. 204

The quest for Dragon books

Will the fire-breathing Dragons lure you to the right book asks Ian Stobie.

DRAGON DATA is now claiming to have sold 80,000 Dragon 32 micros. To judge from the number of books aimed at owners, book publishers at least believe them. The books fall into two broad categories: collections of program listings with more or less extensive explanations; and introductory guides to programming the machine which aim to supplement the manual.

The prolific Tim Langdell's *35 Programs for the Dragon 32* was one of the first listing books to appear. It shows. A price of £4.95 for a 63-page paperback would be justified if the programs were very good but they are not. Most are short, with overblown names like Picasso or Home Accounts, and do simple things like draw patterns on the screen. There are no accompanying explanations of how the programs work.

An extra £1 buys you the much better *Enter the Dragon*, 200 pages of programs and explanations by Colin Carter. The standard of the games — for that is what most of the programs are — is quite high, and there are even some routines written in 6809 assembler. Colin Carter explains each program clearly in a brief but systematic way. All the programs in the book are

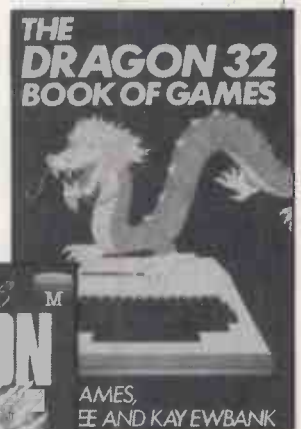
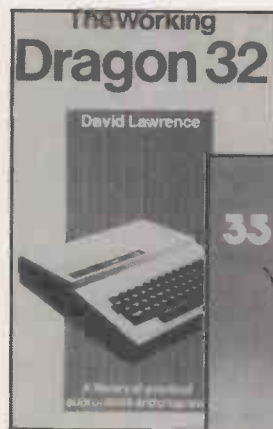

available from the publisher on tape for readers who cannot face much typing.

Load and Go with Your Dragon by John Phipps and Trevor Toms is another good book which combines explanation and program listings. It is a shorter book than Carter's and contains less ambitious programs, again mainly games. The discussion of each program is longer, and new commands are introduced progressively and are fully explained. The authors give the impression that they really do want to show how it's all done rather than just earn a fast buck.

The Dragon 32 Book of Games by Mike James, S M Gee and Kay Ewbank has an honest title. It contains 21 games with explanations. They seem to be the same 21 games as in the same authors' BBC book, but are organised in a different order so that it is not too obvious. The games are not as good as Carter's and the explanations, although quite long are short on content. I would recommend Carter's book for gamers, and Phipps' and Toms' book to beginning programmers. Incidentally Phipps and Toms are the only among the listings books to make much use of Rem

statements within the programs to make them more readable.

There seems little consensus among the various publishing houses as to what a dragon looks like. John Sharp and David Bolton's *The Power of the Dragon* has a fat dinosaur on the front. It contains 30 programs with a lengthy line-by-line description of each one. I found this approach less helpful than a shorter but better structured description.

The programs are mainly games and graphics routines, with a few more serious ones thrown in for such things as calculating loan repayments and keeping simple records. At £5.95, which seems to be the standard price for a Dragon book, it is quite good value. The programs are available on cassette for an extra £4.95.

The Working Dragon 32 by David Lawrence, the computing vicar, sets out to give the Dragon user a set of practical programs and routines. The programs are organised into self-contained modules, making it easy for you to rip off sections to incorporate in your own applications. They cover storing data on tape and home

(continued on next page)

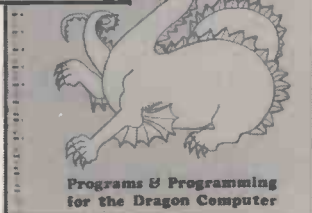
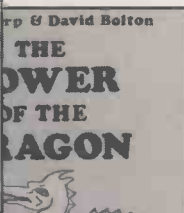

(continued from previous page)

accounting in addition to the usual graphics, music and quizzes.

There clearly is a need for books of this kind which provide more than just games, but there are a few problems with this

THE DRAGON PROGRAMMER



THE DRAGON 32 and how to make the most of it

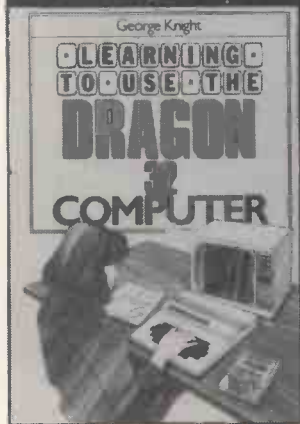

attempt. The listings are rather hard to read, being printed in a rather squashed dot-matrix typeface. It is a structured book with a slightly worthy tone, and seems to assume it is being read by a sober-minded parent rather than the much more likely precocious brat.

Typical of the second category of Dragon books is *The Dragon 32 and How to Make the Most of it*. It is written by Ian Sinclair, another of the circus of ultra-prolific micro writers, and was one of the first Dragon books out. Although it is written to a formula, with similar chapter headings to his other books on such machines as the Oric, Lynx and Spectrum, I did find Sinclair's book useful. It is not that it is better than the official Basic programming manual that comes with the Dragon than that it is different. The chapter on sound is particularly good.

George Knight's 98-page book *Learning to Use the Dragon 32 Computer* costs a rather steep £4.95. It is even more of a formula book, closely resembling some of the other 10 books in the Gower series, even down to the butterfly example in the graphics section. The danger with this approach is that the distinctive and most interesting features of each machine are lost.

The three pages on sound, for instance, are pathetic compared to the clear treatment Ian Sinclair gives the subject or even the seven pages in the official manual.

Formula books are useful in a field where the same person may want to read about and compare different products, but I suspect few Dragon owners will want to read any of the other 10 books in Gower's "Learning to Use" series.

The Dragon Programmer by S M Gee is from the same publisher as Ian Sinclair's book and seems rather unnecessary as it covers pretty much the same ground in a rather waffly and less informative way. Maybe the idea was to make it more of a beginners' book but in that case it does not succeed.

Don Monro's idiosyncratic *Know Your Dragon* is aimed at the complete beginner, and is rather ominously subtitled "A Friendly Guide to a Friendly Computer". It is full of cutesy jokes which very rapidly become tiresome unless your sense of humour is absolutely identical with the author's. The programs are generally fairly short and simple but they are available on tape for the lazy. The cartoons by Bill Tidy have the barest relevance to the text, but they do break it up and make the book look more accessible.

Like many of the other authors, Monro makes the strange assumption that the reader is a computing adult with children. But despite all these criticisms this is one of the books I found I was using the most, along with Sinclair's. It has a lot of information in it and at least it gives due weight to the Dragon's particular features. Some of Monro's text has a distinctly American flavour to it, and although the book does not admit it I suspect that the bulk of the text has been recycled from a book for the Tandy Color Computer, a big seller in the United States.

Programs for the Color Computer

bought on tape do not always run on the Dragon as the Basic is tokenised differently, but the printed source code is identical so Color Computer programs you have typed in yourself should run. It is therefore worth looking out for American books like *TRS-80 Programs and Applications for the Color Computer* by Alfred Baker. However, at nearly £12 for a 187-page paperback it does not seem good value. In common with George Knight and S M Gee's books, its program listings appear to have been typeset rather than computer printed, a procedure which introduces an unnecessary source of bugs.

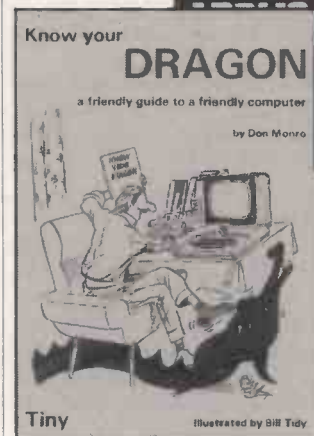

- 35 Programs for the Dragon 32* by Tim Langdell. Published by Century Publishing £4.95. ISBN 0 712 601 732.
- Enter the Dragon* by Colin Carter. Published by Melbourne House, £5.95. ISBN 0 861 611 144.
- Load and Go with Your Dragon* by John Phipps and Trevor Toms. Published by Phipps Associates, £5.50. ISBN 0 950 730 297.
- The Dragon 32 Book of Games* by Mike James, S M Gee and Kay Ewbank. Published by Granada, £5.95. ISBN 0 246 121 025.
- The Power of the Dragon* by John Sharp and David Bolton. Published by Microsource, £5.95. ISBN 0 946 582 009.
- The Working Dragon* by David Lawrence. Published by Sunshine Books, £5.95. ISBN 0 946 408 017.
- The Dragon 32 and How to Make the Most of it* by Ian Sinclair. Published by Granada, £5.95. ISBN 0 246 121 149.
- Learning to Use the Dragon 32 Computer* by George Knight. Published by Gower, £4.95. ISBN 0 566 034 948.
- The Dragon Programmer* by S M Gee. Published by Granada, £5.95. ISBN 0 246 121 335.
- Know Your Dragon* by Don Monro. Published by The Tiny Publishing Company, £5.95. ISBN 0 907 909 027.
- TRS-80 Programs and Applications for the Color Computer* by Alfred Baker. Published by Prentice Hall, £11.95. ISBN 0 835 978 702.

Come to Kenilworth for
SHARP
OFF-THE-SHELF
RELIABILITY

We have MZ80 A & B and PC 1500 with Software back-up expertise to advise you on your requirements. See the advanced technology of SHARP on demonstration.

THE LARGEST U.K. NASCOM DEALER

Come to Kenilworth for
DRAGON
FANTASTIC VALUE FOR MONEY

British built and designed. 32K RAM as standard, (expandable to 64K Bytes). Plus extensive facilities for colour graphics. 9 colour, 5 resolution display. Advanced sound. Prices from only £199. inc. VAT.

Full ranges of Software - tapes, cartridges, joysticks, books etc.

THE VERY POPULAR

Come to Kenilworth for
SINCLAIR
A MOST POPULAR MODEL

SINCLAIR ZX81 at £49.95
16K RAM PACK at £29.95
SINCLAIR PRINTER
at £59.95

ZX81 1K RAM, one-touch Keyboard, complete with all connecting leads. 16K RAM pack plugs into expansion port enabling use of sophisticated ZX Software. ZX printer has full alphanumerics and graphics, 50cps, 32 characters per line.

EDUCATIONAL USES

Our main product line - Nascom - will act as an excellent stand-alone system, optionally with High Resolution Colour Graphics and will attach to an economical Local Area Network. Ask for details of our recent installations in the educational field.

Come to Kenilworth
THE LARGEST UK
NASCOM DEALER

We are the largest NASCOM distributors in the U.K. and are up-to-date with all the latest hardware and software. Colour, Sound, Speech, Educational, Business, Home, or any application you have in mind.

Kit Computers with power supply, £260 excl. VAT.

Built Computers with power supply, £327.50 excl. VAT

Come to Kenilworth for
QUIBS
BUSINESS SYSTEMS

An integrated Nominal, Purchase and Sales Ledger with optional invoicing and stock packages using the QUANTUM (British) with up to 2.25 M BYTE of floppy discs. Very competitive prices. But best of all friendly, professional advice on the best system.

NASCOM
SOFTWARE
CATALOGUE

B & L Microcomputers announce their new Software Division offering a range of high quality but inexpensive programs for the NASCOM.

Most of the programs have an educational content. The catalogue includes programs enabling owners to make the best use of the NASCOM. Send S.A.E. (9 x 6) please.

Yes...come to Kenilworth
Business & Leisure
Micro Computers
16, The Square, Kenilworth,
Warwickshire CV8 1EB.
Telephone: (0926) 512127.

● Circle No. 205

CodeWriter
makes
microcomputing
as simple as

abc

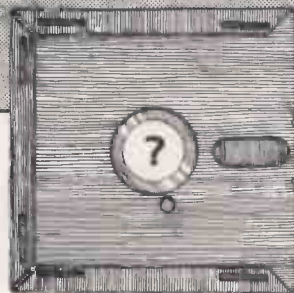
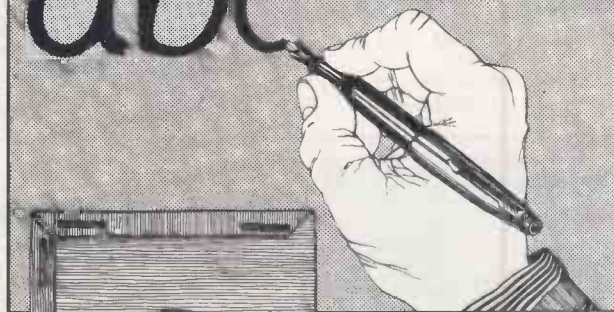

"WHY BUY ANY OTHER DATABASE PROGRAM WHEN YOU HAVE CODEWRITER?"
- recent satisfied user.

Forget about the expense of hiring a professional programmer or the restrictions of 'off-the-shelf' programs. Become your own program designer producing microsoftware to suit your specific requirements. Codewriter enables you to do this, you type commands in your own everyday language, just as you would write them on paper... it's as simple as ABC!

When you've completed your design, Codewriter will write the program code and store it on your own disk whilst you sit back and watch. At anytime, you can of course modify the programs you've designed.

Your programs may include printed reports, calculations and comparisons between fields of data, development of menus, forms, letters, memos, cheques, invoices, statements, mailing labels... the possibilities for design are endless. Codewriter operates with most popular micros and will be demonstrated fully at your local dealer.

For details on Codewriter, complete and return the coupon to;
DYNATECH MICROSOFTWARE LTD.

Summerfield House, Vale, Guernsey,
Channel Islands.
Telephone 0481 45934 Telex 4191130.



name _____

address _____

tel. _____

P.C.

● Circle No. 212

Value - MicroValue - Micro

80-BUS MULTIBOARDS

GM811 - CPU Board

- ★ 4MHz Z80A CPU
- ★ Four 'Byte-wide' Memory Sockets
- ★ Two 8-Bit Input/Output Ports
- ★ 8 Bit Input Port
- ★ RS232 Serial Interface
- ★ 1200 Baud CUTS Cassette Interface

£125
(£143.75 inc. VAT)



GM802 - 64K Dynamic Ram Board

- ★ 64K Dynamic RAM
- ★ 4MHz Operation
- ★ RAM Disable Function
- ★ Page Mode Operation

GM802 - 64K RAM
£125 (£143.75 inc. VAT)

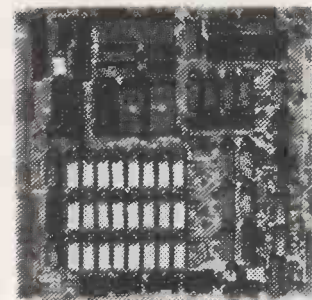

PLUTO - Colour Graphics Processor Board

- ★ 640 x 576 Bit mapped display
- ★ On-board 16-Bit microprocessor
- ★ Comprehensive on-board software

IO 828 A: 192K RAM "PLUTO" **£399**
IO 828 B: "BABY PLUTO" 96K **£299**
(£458.85 inc. VAT) (£343.85 inc. VAT)

GM803 - EPROM/ROM Board

- ★ Up to 40K of Firmware
- ★ 2708 or 2716 Type EPROMs
- ★ Page Mode Operation

The Gemini GM803 EPROM/ROM board is ideal for the user requiring a large amount of firmware in his system. This board caters for up to 40K of EPROM and ROM. There are 16 sockets organised in four banks of four and, as long as each bank contains the same type of EPROM, banks may be mixed between 2708 (1K x 8) and 2716 (2K x 8) devices. Each bank may be decoded to start at any 4K boundary.

GM803 - EPROM/ROM - £65 (£74.75 inc. VAT)

EV 814 - IEEE 488 Controller

- ★ Cost-effective Controller
- ★ Comprehensive software supplied
- Controls equipment fitted with IEEE488 or GPIB interface.

£140
(£161.00 inc. VAT)

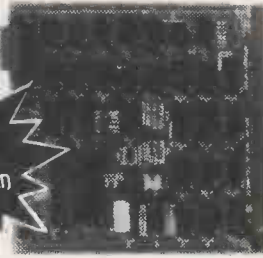

GM 816 - MULTI I/O Board

- ★ Six 8-Bit I/O Ports
- ★ 4 Counter/Timer Channels
- ★ Real Time Clock
- ★ Further expansion capability

£125
(£143.75 inc. VAT)



Daughter boards also available for further expansion.

GM813 - CPU/64K RAM Board

- ★ 4 MHz Z80A CPU
- ★ 64K Dynamic RAM
- ★ RS232 Serial Interface
- ★ Two 8-Bit I/O Ports
- ★ 1200 Baud Cassette Interface
- ★ Extended and Page Addressing Modes

£225
(£258.75 inc. VAT)

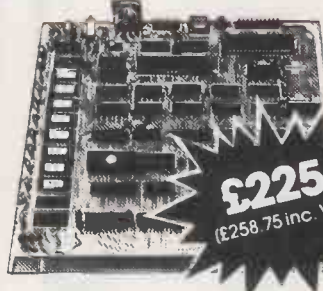

The Gemini GM813 is an 80-BUS compatible CPU card incorporating 64K dynamic RAM and utilising the powerful Z80A microprocessor running at 4MHz. Extended addressing and page mode facilities allow for future memory expansion up to 2 megabytes. Input and output capabilities include both programmable serial and parallel interfaces - RS232, 1200 baud CUTS cassette interface and the Z80A PIO. When used with the GM812 video card, the GM813's unique RP/M monitor allows the creation of cassette or EPROM based programs or files which are upwards compatible with a disk based CP/M system.

The **Microvector 256A** is a high performance graphics display interface on an 80-BUS and NASBUS compatible card. Various graphic primitives such as vector and character generation are executed in hardware by a Thompson EF9356 Graphic Display Processor. Plotting rates are typically 1 million pixels per second giving full animation capability. Various vector and character types can be selected. Characters can be scaled to give 256 different sizes.

MV 256A Suitable for TV use (PAL-UHF) **£199.00** (inc. VAT)
MV 256B Suitable for TV or RGB monitor **£220.00** (inc. VAT)

GM812 - IVC Board

- ★ 80x25 Display Format
- ★ On-board Z80A Microprocessor
- ★ Buffered Keyboard Input
- ★ Programmable Character Generator
- ★ 160x75 Pixel Graphics
- ★ Light Pen Input

£125
(£143.75 inc. VAT)



GM 829 - FDC/SASI Board

- ★ Single/Double density operation
- ★ Single/Double sided drive operation
- ★ Up to 4 mixed 3.5", 5.25" and 8" drives
- ★ Industry Standard SASI hard-disk interface

£145
(£166.75 inc. VAT)



Keyboards, Mothers, Frames

With MultiBoards an almost unlimited number of system permutations are possible. There is a range of 15 available from your Microvalue dealer; together with mother boards, frames, cables, power supplies, keyboards and compatible software if required. Ask for latest catalogue for details of suitable permutations to suit your requirements, whether building a system from scratch, or expanding your Galaxy or NASCOM computer.

Value - MicroValue - Micro

COMPUTERS

Gemini Galaxy 2

"I would place the Galaxy at the top of my list"
(Computing Today, April 1983)

- ★ Twin Z80A Processors
- ★ CP/M 2.2 Operating System
- ★ 64K Dynamic RAM
- ★ 800K Disk Capacity
- ★ 80x25 Video Display
- ★ Serial and parallel printer interfaces
- ★ Cassette and light pen interfaces
- ★ User definable function keys
- ★ Numeric key pad
- ★ 12" Monitor included

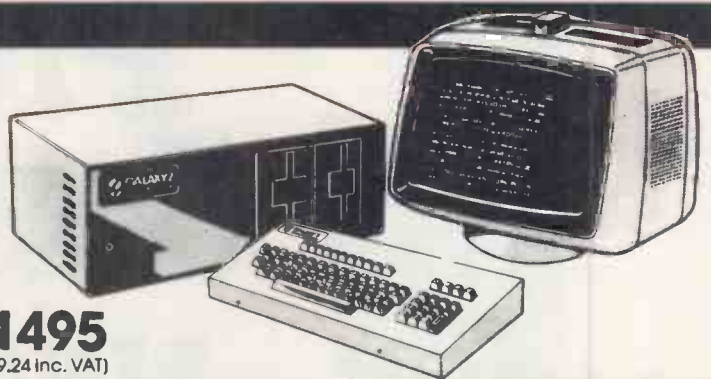

£1495
(£1719.24 inc. VAT)

At last—a Winchester Drive for your Gemini / nascom System!

GM835 Winchester Drive Sub-system.

- ★ 5.4 Megabyte Formatted Capacity
- ★ Rodime Drive
- ★ Industry Standard SASI Interface
- ★ Integral Controller and power supply

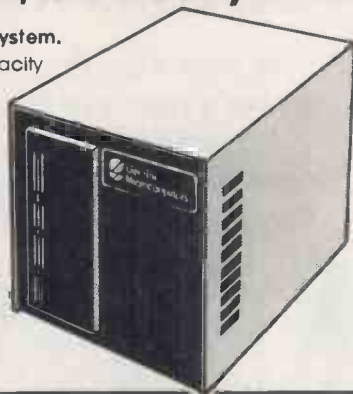

£1450

(£1667.50 inc. VAT)

Phoenix P12 Monitor



A high quality data display monitor, ideal for all Nascom and Gemini systems. 20MHz resolution. Available in amber or green phosphor.

£110

Disk System for Gemini & nascom

GM825 Disk Drive Unit—The GM825 floppy disk housing is supplied with either one or two 5.25" single sided, double density, 96TPI high capacity Micropolis 1015F5 disk drives. These provide 400K bytes of formatted storage per drive. (Gemini QDSS format). The CP/M2.2 package available supports on-screen editing with either the normal Nascom or Gemini IVC screens, parallel or serial printers. An optional alternative to CP/M is available for Nascom owners wishing to support existing software. Called POLYDOS 4, it includes an editor and assembler and extends the Nascom BASIC to include disk commands.

Single Drive System

GM825-1S
£350 (£402.50 inc. VAT)

Dual Drive System

GM825-2S
£575 (£661.25 inc. VAT)

CP/M2.2 Package

(GM 532 for Gemini)
£90 (£103.50 inc. VAT)

POLYDOS 4

for Nascom
£90 (£103.50 inc. VAT)

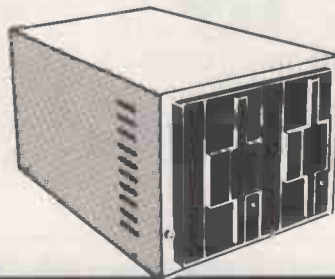

SOFTWARE

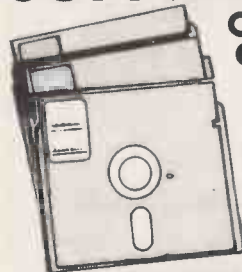

CP/M Software Compas

is totally different from other compiler based Pascal systems, as it allows you to create, edit, run, and debug Pascal programs in a highly interactive manner.

£120 (£138 inc. VAT)

'The Last One'

is used in conjunction with Microsoft's MBASIC*. No knowledge of BASIC programming is required since all input is performed using question and answer routines written in plain English.

£330

(£379.50 inc. VAT)

*MBASIC—MicroValue Price if purchased with 'The Last One'—£178.95 inc. VAT

Gemini Software:

- GEM PEN Text Editor £45 (£51.75 inc. VAT)
- GEM ZAP Assembler £45 (£51.75 inc. VAT)
- GEM DEBUG Debugging Utility £30 (£34.50 inc. VAT)
- WORDSTAR Word Processor £215 (£247.25 inc. VAT)
- GEM GRAPHIC Links with MBASIC £35 (£40.25 inc. VAT)

BUY FROM THE COMPUTER PROFESSIONALS

MICROVALUE DEALERS:

AMERSHAM, BUCKS

Amersham Computer Centre,
18 Woodside Road,
Tel: (02403) 22307

BRISTOL

Target Electronics Ltd., 16 Cherry Lane.
Tel: (0272) 421196

EGHAM, SURREY

Electrovalue Ltd.,
28 St. Judes Road, Englefield Green.
Tel: (07843) 3603

IPSWICH

MDW (Electronics),
47/49 Woodbridge Road East.
Tel: (0473) 78295

LONDON W2

Henry's Radio, 404 Edgware Road.
Tel: 01-402 6822

LONDON SW11

OFF Records,
Computer House, 58 Battersea Rise,
Clapham Junction.
Tel: 01-223 7730

MANCHESTER M19

EV Computing, 700 Burnage Lane.
Tel: 061-431 4866

NOTTINGHAM

Computerama, (Skytronics Ltd.)
357 Derby Road.
Tel: (0602) 781742

Telephone orders welcome



MicroValue

REAL value — from the Professionals

• Circle No. 207

SUBSCRIBE NOW!

And get a

Practical Computing BINDER - worth £4 - free of charge!



Yes, now's the time not only to ensure a year's supply of Practical Computing for just £12.00 but also to obtain a handsome binder in which to store a year's issues, **ABSOLUTELY FREE OF CHARGE.**

Practical Computing is one of Britain's most popular personal computer magazines providing practical guidance and advice for its readers. A typical issue:

- Examines the latest microcomputers and prices. Conclusions highlighting the strong and weak points of each system;
- Reviews software, including programs such as VisiCalc and its successors, which are of particular interest to business people;
- Describes how microcomputers are being used in practice for a wide variety of tasks in business, administration and the professions;
- Provides regular sections containing programming tips and advice for users of Apple, BBC, Commodore, Sinclair and Tandy computers.

Little wonder then that Practical Computing has come to be regarded as essential reading and a useful source of reference by a growing body of businessmen, professional people, teachers and administrators.

Now you can guarantee that this information is available to you, and at the same time be certain that your copies of Practical Computing are stored safely where they can be referred to without fear of loss or damage, by taking advantage of our Subscription plus FREE binder offer.

All you have to do is complete the coupon and return it with your cheque or postal order for £12.00 payable to IPC Business Press. But hurry! The free binder offer is open only as long as we have supplies available.

**LAST CHANCE AT £12
BEFORE OCTOBER INCREASE**

To: Practical Computing, Free Binder Offer, Subscription Manager, IPC Business Press, Stuart House, Perrymount Road, Haywards Heath, West Sussex, RH16 3DH.

Please send me a copy of Practical Computing every month for a year together with a FREE binder. I enclose a cheque/PO for £12 (UK)/£18 (Overseas) payable to IPC Business Press Ltd.

Alternatively, I would like to pay by credit card.

Please debit my Barclaycard/Access/American Express/Diners Card* account

Account Number *Please delete as appropriate

Signature Date

Name

Address

.....

.....

PC9/83

SILICON VALLEY

Tel: 01-242 2803

The best value in the city for . . .



This high speed 16 bit business computer from ACT is the best selling micro of its kind. Available from Silicon Valley from £2,399 or lease from £13 per week. 400 programs now available.



Accounting systems installed and supported by Chartered Accountants

For these products

- We are established main dealers
 - We give the best support
 - We give the advice
 - We supply the software
- And we are always in stock!!

Silicon Valley has on site Chartered Accountants, management consultants specialist, computer engineers to discuss and recommend solutions. We offer full training and maintenance - **TRY US OUT**

THE COMPLETE BUSINESSMANS PACKAGE

- Sirius 128K computer
 - Epson Matrix Printer
 - Exact - stock, sales, invoicing, sales ledger & purchase ledger
 - All cables, consumables, installation and on site training - £2,999
- Price may vary due to time of year.

TORCH OSBORNE



Software
D Base II, Wordstar, The Last One, Visicalc, plus BOS, Peachtree, Padmede, Systematics, Vlasak etc.
For Sales, Service, Maintenance, Advice.
Phone 01-242 2803

The Permanent Computer Show

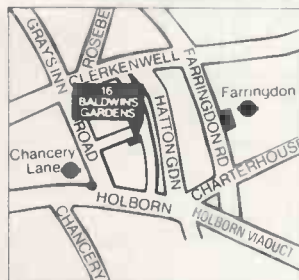

London: Suite 104/5,
16 Baldwin's Gardens,
London EC1N 7RJ
Manchester: 12 Lever Street
Piccadilly, Manchester

SILICON VALLEY COMPUTER CENTRE

**A GOOD DEAL MADE
A GOOD DEAL BETTER**

Tel: 01-242 2803
Tel: 061-228 1686
Tel: 041-638 3487

FULL RANGE OF PRINTERS, PAPER AND DISKETTES

● Circle No. 262

>NEXT MONTH

>THE GRAPHIC IMAGE

The special subject in the October issue of *Practical Computing* takes in visual-display units and business graphics. Chris Naylor explains how TVs and monitors work, while John Lewell looks at the expanding field of computer graphics. Special techniques discussed in programming features are geometrical plotting, and area-filling techniques for the BBC Microcomputer.

>REVIEWS

One British micro to watch is the 16-bit Logica VTS: Chris Bidmead reports on how it performs. Another is the Advance. We take a first look at this low-cost IBM PC compatible micro, due to be launched later this year. Other products under review range from Dragon games to IBM PC books.

>FREE SUPPLEMENT

In addition there will be a special supplement on The Great British Micro attached to the October issue. It will provide an invaluable guide to the many British microcomputer manufacturers and their main products.

>AND MUCH MORE

In addition the October issue will contain a wide range of fascinating features from the very useful - such as using post codes for mail pre-sorting - to the very entertaining short story *Death to the Machine*. Plus columns, news, pages of free software in Open File, your letters and much more.

Make sure you don't miss the October issue of

Practical Computing

On sale at W H Smith and all leading newsagents after September 14.

DISKING

FLOPPY
DISKS
FAST

FREE with EVERY TEN-PACK of diskettes from DISKING at these prices.

The complete DISKING DATA PROCESSING package

1 - SEE 10 LIBRARY BOX



Value £2.50

The NEW DISKING 'SEE 10' Plastic Library Box, with the facility for seeing ALL TEN DISKS, without the usual problem of bending the front disks forward. We've spent the last two years designing the BEST library box around, you will not find anything better. Unfortunately the 'SEE 10' is only available in the 5 1/4" size, whereas the 8" is the ordinary egly box.

★ ★ PLUS ★ ★



we supply the 'soft touch' DISKING Diskwriter. This pen is perfect for labelling diskettes, as it will not damage the delicate surface beneath the disk jacket. As an ordinary writing implement, it is superlative.

You may purchase these separately at a silly £9.90 for 50 (please specify blue or black ink).

★ ★ PLUS ★ ★

3 - DISK DIRECTORY



Value 99p

The 20 page PVC bound DISKING Disk Directory, offering two pages per diskette for keeping 'Track' of what's on each diskette. Also inside this directory, you will find a self adhesive index label for the spine of your Library Box.

You may purchase these separately at £9.90 for ten.

DISKING SUPER PROMOTION

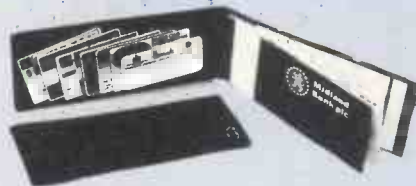

With every TWO ten Packs of any 5 1/4" or 8" disks by Maxell, Datalife, Memorex or Dysan purchased at these prices we will pack a FREE 'Cheque Book Cover. Order FOUR Ten Packs and you will receive two Cheque Book covers and so on.

DISKETTE PRICES EXC VAT

MEMOREX



MEMOREX - Memory Excellence

When it comes to PRICE/PERFORMANCE, MEMOREX wrote the book. Their new Japanese media is very conservatively rated, and certification levels are easily surpassed in actual performance. Protected by a special anti-static lubricant, head performance and media life is also extended.

5 1/4" DISKETTES

Certified for Single OR Double Density and all with hub ring reinforcement.

PRICES EXC VAT	10-40	50-90	100+
3481 S/Sided 48 tpi Soft Sect	20.90	19.90	18.90
3483 S/Sided 48 tpi 10 Hard Sect	20.90	19.90	18.90
3485 S/Sided 48 tpi 16 Hard Sect	20.90	19.90	18.90

3491 D/Sided 48 tpi Soft Sect	26.90	25.90	24.90
3493 D/Sided 48 tpi 10 Hard Sect	26.90	25.90	24.90
3495 D/Sided 48 tpi 16 Hard Sect	26.90	25.90	24.90

3504 S/Sided 96 tpi Soft Sect	27.90	26.90	25.90
3505 S/Sided 96 tpi 10 Hard Sect	27.90	26.90	25.90
3506 S/Sided 96 tpi 16 Hard Sect	27.90	26.90	25.90

3501 D/Sided 96 tpi Soft Sect	34.90	33.90	32.90
3502 D/Sided 96 tpi 10 Hard Sect	34.90	33.90	32.90
3503 D/Sided 96 tpi 16 Hard Sect	34.90	33.90	32.90

48 tpi suitable for 35 and 40 track operation
96 tpi suitable for 77 or 80 track operation

8" DISKETTES

PRICES EXC VAT	10-40	50-90	100+
3064 S/Sided S/Dens. Soft Sect	23.90	22.90	21.90
3015 S/Sided S/Dens. 32 Hard Sect	23.90	22.90	21.90

3090 S/Sided D/Dens. Soft Sect	26.90	25.90	24.90
3091 S/Sided D/Dens. 32 Hard Sect	26.90	25.90	24.90

3102 D/Sided D/Dens. Soft Sect	32.90	31.90	30.90
3105 D/Sided D/Dens. 32 Hard Sect	32.90	31.90	30.90

Datalife



DATALIFE by Verbatim - With Five Year Warranty

VERBATIM have not become the World's favourite floppy disks by accident. Perfect magnetic media is their stock in trade, and to prove it they now offer an unconditional FIVE YEAR warranty on all DATALIFE products.

5 1/4" DISKETTES

Certified for Single OR Double Density, and all with hub ring reinforcement.

PRICES EXC VAT	10-40	50-90	100+
MD525-01 S/S 48 tpi Soft Sect	22.90	21.90	20.90
MD525-10 S/S 48 tpi 10 Hard Sect	22.90	21.90	20.90
MD525-16 S/S 48 tpi 16 Hard Sect	22.90	21.90	20.90

MD550-01 D/S 48 tpi Soft Sect	29.90	28.90	27.90
MD550-10 D/S 48 tpi 10 Hard Sect	29.90	28.90	27.90
MD550-16 D/S 48 tpi 16 Hard Sect	29.90	28.90	27.90

MD577-01 S/S 96 tpi Soft Sect	28.90	27.90	26.90
MD577-10 S/S 96 tpi 10 Hard Sect	28.90	27.90	26.90
MD577-16 S/S 96 tpi 16 Hard Sect	28.90	27.90	26.90

MD577-01 D/S 96 tpi Soft Sect	36.90	35.90	34.90
MD577-10 D/S 96 tpi 10 Hard Sect	36.90	35.90	34.90
MD577-16 D/S 96 tpi 16 Hard Sect	36.90	35.90	34.90

48 tpi suitable for 35 or 40 track operation
96 tpi suitable for 77 or 80 track operation

8" DISKETTES

PRICES EXC VAT	10-40	50-90	100+
FD34-9000* S/S S/Dens. Soft Sect	31.90	30.90	29.90
FD32-9000* S/S S/Dens. 32 Hard Sect	31.90	30.90	29.90

FD34-8000 S/S D/Dens. Soft Sect	31.90	30.90	29.90
FD32-8000 S/S D/Dens. 32 Hard Sect	31.90	30.90	29.90

DD34-4001 D/S D/Dens. Soft Sect	36.90	35.90	34.90
DD32-4000 D/S D/Dens. 32 Hard Sect	36.90	35.90	34.90

*For critical applications

DISKETTE CARE AND MAILING

The NEW DISKING 'SUPERMAILER'

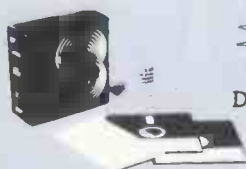

DISK DRIVE HEAD CLEANING KITS

We're fed up with being asked whether our disk drive head cleaning kit actually works. So here's the proof:



Can you really risk that breakdown?

CK5 for 5 1/4" disk drives	14.90
CK8 for 8" disk drives	14.90

(5 1/4" only)

* COPYRIGHT DESIGN - Unlike the rest, this ingenious mailer has a flute crossing action when folded, resulting in a virtually unbendable mailer.

* CAVERNOUS CAPACITY - will take, one, two, three or even four diskettes WITH envelopes.

* FULL INSTRUCTIONS - Each DISKING 'SUPERMAILER' is printed with full instructions and comes complete with addressing/sealing label.

*PACKED IN 100'S - For convenience

1 PACK	2 PACKS	3+PACKS
24.90	22.90	19.90

DISKING - RESPOND

Nervous of mail order? Fed up with "allow 28 days for delivery"? Dubious of quality? Of course you are, so what's new? DISKING STOCK AROUND 50,000 OF THE WORLD'S FINEST DISKETTES - That's what! Ask any of our 1000's of customers, we ship inside 4 WORKING HOURS!

They've also discovered this in Norway, Sweden, Belgium, Germany, Malta, Greece, France, Israel, Bahrain, South Africa, Malawi etc.

Whether you want 1 or 100 Ten-Packs - We're waiting.

Call Joan or Roger on 0428 722563. ACCESS, VISA & DINERS cards welcome.

All free gifts offered at any time by DISKING are subject to availability. DISKING reserves the right to substitute any similar alternative item or withdraw the offer without notice.

50,000 diskettes normally in stock
most orders shipped inside 4 hours.

DISKING INTERNATIONAL
FREEPOST, LIPHOOK, HANTS GU30 7BR, UK
TELEPHONE (0428) 722563
TELEX 858623 Telbur G or 858393 Telbur G

ALL PRICES PER TEN-PACK

UK SHIPPING RATES EXC VAT

maxell



MAXELL - The Gold Standard

Maxell consistently meet or exceed all standards, and have run disks under conditions designed to find weak points and wear. They couldn't and you won't. These diskettes are the quietest in operation we know.

5 1/4" DISKETTES

Certified for Single OR Double Density
48 tpi media with hub ring

PRICES EXC VAT	10-40	50-90	100+
MD1-D S/Sided 48 tpi Soft Sect	24.90	23.90	22.90
MH1-10 S/Sided 48 tpi 10 Hard Sect	24.90	23.90	22.90
MH1-16 S/Sided 48 tpi 16 Hard Sect	24.90	23.90	22.90

MD2-D D/Sided 48 tpi Soft Sect	32.90	31.90	30.90
MH2-10D D/Sided 48 tpi 10 Hard Sect	32.90	31.90	30.90
MH2-16D D/Sided 48 tpi 16 Hard Sect	32.90	31.90	30.90

MD1-DD S/Sided 96 tpi Soft Sect	32.90	31.90	30.90
---------------------------------	-------	-------	-------

MD2-DD D/Sided 96 tpi Soft Sect	42.90	41.90	40.90
---------------------------------	-------	-------	-------

8" DISKETTES

PRICES EXC VAT	10-40	50-90	100+
D1-128 S/S D/Dens. Soft Sect	29.90	28.90	27.90
H1-32 S/S S/Dens. 32 Hard Sect	29.90	28.90	27.90

D1-XD S/S D/Dens. Soft Sect	34.90	33.90	32.90
H1-32D S/S D/Dens. 32 Hard Sect	34.90	33.90	32.90

D2-XD D/S D/Dens. Soft Sect	39.90	38.90	37.90
H2-32D D/S D/Dens. 32 Hard Sect	39.90	38.90	37.90

Dysan CORPORATION



DYSAN - For The Decisive

When you think of disks you often think of DYSAN. DYSAN have the reputation for TOTAL dependability whatever the application. They may cost a little more but data is irreplaceable.

5 1/4" DISKETTES

Certified for Single OR Double Density, and all with hub ring reinforcement.

PRICES EXC VAT	10-40	50-90	100+
104/1D S/S 48 tpi Soft Sect	25.90	24.90	23.90
107/1D S/S 48 tpi 10 Hard Sect	25.90	24.90	23.90
105/1D S/S 48 tpi 16 Hard Sect	25.90	24.90	23.90

104/2D D/S 48 tpi Soft Sect	37.90	36.90	35.90
107/2D D/S 48 tpi 10 Hard Sect	37.90	36.90	35.90
105/2D D/S 48 tpi 16 Hard Sect	37.90	36.90	35.90

204/1D S/S 96 tpi Soft Sect	36.90	35.90	34.90
207/1D S/S 96 tpi 10 Hard Sect	36.90	35.90	34.90
205/1D S/S 96 tpi 16 Hard Sect	36.90	35.90	34.90

204/2D D/S 96 tpi soft sect	46.90	45.90	44.90
207/2D D/S 96 tpi 10 Hard Sect	46.90	45.90	44.90
205/2D D/S 96 tpi 16 Hard Sect	46.90	45.90	44.90

48 tpi suitable for 35 or 40 track operation
96 tpi suitable for 77 or 80 track operation

8" DISKETTES

PRICES EXC VAT	10-40	50-90	100+
3740/1 S/S S/Dens. Soft Sect	30.90	29.90	28.90
101/1 S/S S/Dens. 32 Hard Sect	30.90	29.90	28.90

3740/1D S/S D/Dens. Soft Sect	37.90	36.90	35.90
101/1D S/S D/Dens. 32 Hard Sect	37.90	36.90	35.90

3740/2D D/S D/Dens. Soft Sect	41.90	40.90	39.90
101/2D D/S D/Dens. 32 Hard Sect	41.90	40.90	39.90

5 1/4" DISKETTES
1-2 Packs each pack @ 95p
3-5 Packs each pack @ 75p
6-9 Packs each pack @ 60p
10+ Packs ★POST FREE★

5 1/4" CLEANING KITS
Same postal rate as packs of 5 1/4" diskettes, 10+ POST FREE

5 1/4" NEW SEE 10" LIBRARY BOXES
SEE 10 1-4 off @ 40p
SEE 10 5-9 off @ 30p
SEE 10 10+ @ 20p

8" DISKETTES
1-2 Packs each pack @ £1.60
3-5 Packs each pack @ £1.20
6-9 Packs each pack @ 90p
10+ Packs ★POST FREE★

8" CLEANING KITS
Same postal rate as packs of 8" diskettes, 10+ POST FREE

8" LIBRARY BOXES
LB8 1-4 off @ 60p
LB8 5-9 off @ 45p
LB8 10+ off @ 30p

DISKING SUPERLUKE DISK LIBRARY (5 1/4" ONLY)
Same postal rate as 5 1/4" diskettes, 10+ POST FREE

DISKING SUPERMAILERS (5 1/4" ONLY)
100-Pack Complete with sealing labels 3.00

LOCKABLE DISKETTE STORAGE

All versions £2.00 each for one, £1.30 each for 2-7, 8+ postfree.

NORMAL ORDERS - We now welcome any official Government orders.

We are now happy to accept any official orders with a minimum value of £30.00 from Government Departments, Ministries and Local Authorities. We do this on the understanding that invoices will be settled within thirty days or preferably less please. Alternately, you may send your remittance with your order if you so wish. All other non-Government orders, cheques with order please payable to DISKING. If you are a large establishment, and cannot raise cheques without an invoice please post or telephone us your order, and we will send a pro-forma invoice by return, for your accounts department to pay against. Also bear in mind, that you do have to pay VAT, which will be added to these prices. If you are in any doubt, please see the order form on this brochure to help you with your calculations, or telephone us for assistance.

CREDIT CARD ORDERS

We welcome Access (Mastercharge), Barclaycard (VISA) & Diners Club International, & there is NO credit card surcharge. You may write your card No. on your order or telephone the order day or night, 365 days a year. You may speak for as long as you like, (but don't leave long gaps otherwise our machine thinks you've gone home) and don't forget to give the following details:

1. The Cardholder Name, Address and day time telephone number.
2. Delivery Address if different
3. First Class, ordinary or special post.
4. Your Credit Card Number.
5. What you wish to Order.
6. State whether purchasing from our General price list or Budget price list. You may leave the rest to US!

URGENT ORDERS

If you're posting your order, omit the word FREEPOST from our address, and use our normal postcode GU30 7EJ and do not forget to stamp if FIRST CLASS. If you are a Government body as defined under 'NORMAL ORDERS' and are telephoning your official order, OR are an individual or company using your credit card No., please make it clear that you wish to pay for your goods to be sent to you by FIRST CLASS POST.

FIRST CLASS RATES EXC VAT

First TEN-PACK	2.00	2.50
Second and subsequent TEN-PACK	1.50	2.00

MINDISKS	8" DISKETTES
2.00	2.50
1.50	2.00

DESPERATE ORDERS U.K.

Your options are - DATAPOST Which will deliver the goods within the United Kingdom overnight (usually before 10 am the next day) provided they are ordered and paid for from DISKING by 3.00 pm or EXPRESSPOST Which will deliver the goods the SAME DAY provided they are ordered and paid for from DISKING by 10.30 am, and provided you are no further north than Manchester.

These services put great stress on our sales order processing and packaging departments. Please therefore, spare a thought for our girls, and make sure that:

- a) The required goods are in stock and
- b) A full complement of manpower and vehicles are available at DISKING

TRADE CORNER

Write or call for our very latest Autumn '83 TRADE PACK.

KEENER prices than ever before, but QUALITY maintained.

Don't buy other peoples cheap disks, they are probably batch tested and they will probably let your customer down. We know - we get sob stories on the 'phone daily. Every diskette that DISKING sells is individually certified! - for yours and our PEACE OF MIND.

You may mix and match any of our quality diskettes so that your customers may select their favourite brands. This way you can be sure of pleasing everybody.

A FREE sample unlabelled diskette will also be enclosed, which are available in 100 bulk packs and at extremely keen prices just in case you should be selling software.

If you get any enquiries for pre-formatted diskettes, do not sweat because we can obtain most of them.

BLANK CASSETTES are also available complete with library cases in either C-12 or C-15 format at £39.00 per 100, U.K. P&P £4.00.

● Circle No. 210

DISKETTE STORAGE



LOCKABLE DISKETTE STORAGE

These anti-static, ABS plastic diskette storage boxes come in four sizes, two for mini disks and two for 8" disks. They have a white base with a transparent smoked lockable lid, and hold 40 or 80 diskettes. They come complete with keys and dividers.

PRICES EXC VAT	14.90	18.90	18.90	27.90
435 40 mindisk capacity	14.90			
485 80 mindisk capacity		18.90		
440 40 8" diskette capacity			18.90	
490 80 8" diskette capacity				27.90

DISKING SUPERLUKE DISK LIBRARY (5 1/4" only)



The whole area of your disk, its labelling and its envelope are fully visible for INSTANT selection ANYTIME.

AVAILABLE IN TWO VERSIONS

PRICES EXC VAT	1-2	3-4	5-9	10+
DL (For 20 mindisks)	9.95	8.95	7.95	6.95
DLX (For 28 mindisks)	11.95	10.95	9.95	8.95
Updating Conversion Kit	2.00			

LIBRARY BOXES



PRICES EXC VAT	1.49	50+
SEE 10 for mindisks only	2.50	2.20
	1.47	48+
8" LIBRARY BOX (NOT SEE 10 Design)	2.50	2.20

The new SEE 10 is probably the best 3 1/2" library box around. (FREE with every ten disks ordered)

QTY	PART NO.	DESCRIPTION	PRICE EXC VAT
			£
			£
			£
		TOTAL GOODS VALUE EXC VAT	£
		TOTAL DELIVERY AND INSURANCE	£
		SUBTOTAL EXC VAT	£
		VAT	£
		VALUE OF CHEQUE PAYABLE TO DISKING	£

Name: _____ Tel No: _____
Address: _____
Please charge my credit card No: _____

WE HAVE THE POWER TO SOLVE YOUR PROBLEMS

UPSAR TM offers the total power supply solution for mini's and micro's.

- * Power ratings from 100 VA to 2.5kVA.
- * Noise Free independent power supply.
- * No cutting time in the event of mains failure.
- * Low harmonic distortion that provides trouble-free operation.
- * 50Hz or 60Hz output. 50Hz in-60Hz out or vice-versa.
- * Maintenance free batteries which charge automatically.

UPSAR TM offers you the opportunity to run your computer system when your mains (and all its problems) are present **and** when your mains (and all its problems) are not.

Uninterruptable Power Supplies and Regulators buy

COMPEC SYSTEMS LTD

Welton Brough,
N. Humberside
England
HU15 1PT

Tel. Hull (0482) 666624
Telex 527067

● Circle No. 211

AT THESE PRICES YOU CAN SWITCH OVER TO A PROFESSIONAL VIDEO MONITOR

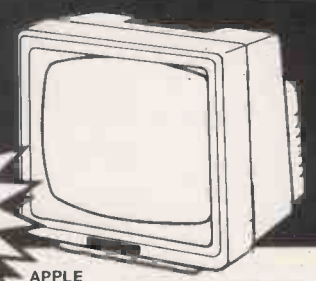

There is a Kaga monitor suitable for use with your system, be it an Apple, Commodore, BBC Acorn, Osborne, Tandy, NEC, Sharp or any other popular micro.

MONITORS

- High-res. 12" Green inc. Cable £87
- High-res. 12" Amber inc. Cable £95
- 12" RGB Colour Monitor (med. res.) £191
- 12" RGB Colour Monitor (high res.) £228
- 12" RGB Colour Monitor (super high res.) £319
- Apple II or IIe RGB Card + Cable (pls. specify) £63
- RGB Cable for Apple III/IMP P/C/BBC (pls. specify) £9

EPSON PRINTERS

- RX80 Printer 254
- FX80 Printer 369
- MX100 Type III Printer 420
- RS232 Interface 30
- RS232 Interface with 2K Buffer 53
- Serial Interface Type III 60
- IEEE - 488 Parallel Interface 37
- Apple Interface (Non-Graphics) + Cable 49
- Apple Interface (Graphics) + Cable 57
- TRS80 Interface 22
- Ribbon for MX80/82 Series 5
- Ribbon for MX100 Series 11

CENTRONICS PRINTERS

SPECIAL OFFER
737-2 Parallel (Brand new, sealed and boxed without warranty) 215

- 737-2 Parallel (with warranty) 299
- 1 Cartridge Ribbon for 150/152 4
- 1 Zippack Ribbon for 737/739 3

PRINTER INTERFACE CARDS

- Centronics parallel printer interface (inc. cable) 69

ANADIX PRINTERS

- DP9000A/DP9001A/DP9500A/DP9501A - Serial/Parallel 995
- Graphics Printers (pls. specify model) 1065
- DP9620A Serial/Parallel (Graphics) 13
- Ribbon for DP9000/9500 Series

PRINTER INTERFACE CARDS

- Parallel interface card with graphics dump firmware (inc. cable) 69
- Anadix parallel printer interface card with screen dump firmware (inc. cable) 128

WALTERS PRINTER - BRITISH MADE

- 120 - Parallel 310

INTEGREX COLOUR PRINTERS

- CX80 Colour-Parallel 679
- Apple II + IIe Interface Card 88
- CX80 Colour - RS232 Serial 767
- CX80 Colour - IEEE 755
- CX80 Colour - RS232 3.7K Buffer 830

SMITH CORONA DAISY WHEEL PRINTERS

- TP1 Daisy Wheel Printer - Parallel 400
- TP1 Daisy Wheel Printer - Serial 400
- IEEE Interface Box for TP1 67

APPLE INTERFACE CARDS AND ACCESSORIES

- MC 8-Slot Expansion Chassis 396
- Clock Calendar Card 149
- Ramex 128K Memory Card 245
- Ramex 16K Memory Card 64
- Videx 80 Column Card 200
- Omnivision 80-col Display Card 180
- SUP'R Terminal Card 185

PRINTER INTERFACE CARDS

- Printer installation kit for Apple II or III (pls. specify) 87
- CCS Serial Printer Card for Apple II 113
- CPS Multifunction Card for Apple II 140
- CPS Printer Cable for Apple II (pls. specify) 16

DEMONSTRATION/TRANSIT CASE

- For Apple + 2 disc Drives 52

Terms of business: Cash/cheque/POS with order
P&P: Interface cards and ribbons - per unit £1. Printers, monitors and cases - per unit £6

VAT: All prices are exclusive of VAT. Please add 15% to the total cost including P&P. Goods damaged in transit will be replaced FOC.

Please send me the following goods:

679 _____

88 _____

767 _____ 15% VAT _____

755 _____

830 _____

Name _____

Address _____

400 _____

400 _____

67 _____

AIMGRAM

Aimgram Ltd 31 Roman Gardens
Kings Langley Herts WD4 8LG Tel: Kings Langley

(09277) 68211

● Circle No. 206

The class of '83

Children do not study pens or text-books, they use them. Lorraine Boyce argues that they should do the same with computers.

THOUSANDS OF TEACHERS returning from their summer holiday will be faced for the first time by a micro in the classroom, thanks to the initiative of the Department of Trade and Industry. Those new to computers must be taught that they are not getting an electronic assistant or an omnipotent philosopher's stone, but a tool.

In schools, just as everywhere else, computers are there to be used, not studied. The novice to computing must begin by acquiring a range of skills, but that long-term aim is too often clouded by examination courses in computer studies.

Computer science may appear to be an attractive addition to a list of qualifications, but the higher-education sector has already begun to doubt its benefit. The ideal candidate for a computer science degree is more likely to have studied mathematics and physics than to have become immersed in the questionable requirements of computer studies at A-level.

Many fifth-year school leavers find themselves operating VDUs or word processors as part of a job gained without computer experience. They usually are well motivated enough to take the new skills in their stride.

So if neither the academic pupil nor the early leaver benefits from it, why is computer science on the curriculum? It dates from the age of punched cards and mainframes, and has become fossilised in our examination syllabuses.

Other members of the teaching profession hold a more balanced view of educational computing. With thousands of new machines being delivered to schools there is even an opportunity for anarchy. It may be that the micros can be wrested from the grasp of the prehistoric computing courses and the maths departments.

Who could lead such a foray into enemy ground? Who could usefully employ the captured equipment? The teachers of the humanities, that's who! Like their colleagues in the primary schools and in special and remedial education, teachers of the humanites have seen the immense and varied capabilities of the micro in school.

The micro can be an impressive motivator. Several primary-school heads who have been lent a Sinclair Spectrum for assessment express surprise at the speed with which some of their less able pupils mastered the keyboard. Data collection, classification and interpretation can be done with greater ease and speed on the machine. Information retrieval is of

obvious interest to the librarian, often a member of the English department. Simulations can prompt a whole gamut of activities, with children using the micro for only a small number of them. The rest of the time is spent writing, drawing, measuring, reading and discussing.

Communication and its interpretation form a large part of the work of English departments. Many teachers of English have also begun to realise the tremendous potential of word processing. A child who is told "correct your spelling and write it out again" may feel reluctant and may even take it as a punishment for errors. Using the simplest word-processing program lifts a mundane task into another dimension. Northampton Educational Computing Centre has written a set of software on the Research Machines 480-Z for its primary schools which includes a suitably simple program for word processing.

If the humanities staff, led by teachers of English, seek to liberate the school micro from slavery to Basic and computer studies they will often find it guarded only by a weary conscript seconded from the maths team. He or she may well be delighted to be relieved of the unwanted responsibility and to return to preferred and essential work.

Teachers will need to make a conscious effort to master the essentials of using a micro. Most pupils will not: many children at infant level find it easy to pick up the skills needed to operate videos and play arcade games. It is the habit-bound adults who think that there is something difficult and mysterious to be learnt. Pity the computer-literate 11-year-old promoted to secondary school, who is told that he or she must wait until the fourth year and opt for computer studies before having access to machines again.

Teachers who successfully master the machine will probably come across two further stumbling blocks: machine failure and lack of appropriate software. The former problem must surely be resolved as design and construction improve, but that is no comfort to those who today find half the school's hardware is out of action or just temperamental. A busy teacher closeted in a classroom with 30 impatient children and a cassette which refuses to load will not be mollified by knowing how often high-technology aids have broken down at the crucial moment.

Lorraine Boyce is Information Officer of Microcomputer Users in Secondary Education

It is a truism that "the software sells the hardware". Could that be why the Department of Industry decided to give micros away, or at least to pay half their cost. On hearing that a micro is expected in their school the better-informed teachers ask: "Where is the software for me to use?" Primary schools will receive Tecmedia's beautifully presented package as well as MEP sponsored materials, including some excellent booklets and stimulating audio tapes. Otherwise the software component is largely disappointing. MEP has a long and exciting list of software projects in train, but the hardware is already there, in the schools.

Teachers and professional computing personnel react quite differently to commercially published educational software. The general shortage of money in schools means that a £15 program may be out of reach to the school department for which it is intended. At the same time it is laughably cheap to a commercial programmer. Some hard-pressed teachers are even expected to learn to program and write their own software. In slightly more enlightened areas teachers combine to set up a design team, working with competent programmers. If computer studies must remain on the curriculum maybe all those fourth- and fifth-year pupils could put their programming skills to use, writing software for primary schools.

Commercial publishers are starting to produce software derived from the real day-to-day needs of educational establishments. Heinemann's material originates from King Edward's School, Five Ways, and Cambridge University Press publishes software from Netherhall School, Cambridge. Longman and Edward Arnold publish science simulations produced at Chelsea College, and Ginn is in the primary field with Barry Holmes' programs based on explorations of Saqqara and the *Mary Rose*.

The software situation can only improve. One dreams of bewildered teachers in a few years time struggling to choose between a myriad of worthwhile and exciting educational programs. Meanwhile the healthiest indication of the probable development of educational computing is the entry of English teachers into the same arena. If you are still sceptical, look at *Exploring English with Microcomputers* edited by Daniel Chandler and published by the Council for Educational Technology for MEP. I'll pin my hopes for the future on the English departments. 

Discover the Microcomputer Age

Come along to The Northern Computer Fair and discover for yourself the excitement of the microcomputer age. All you need to know about personal computers, home computers and microcomputer systems for business will be on display at Belle Vue, Manchester from November 24-26. All your questions will be answered at the North's premier personal computer exhibition.

Enthusiasts can see the latest software and hardware technology in action, and for those new to the world of computers this show is a great introduction. Being sponsored by Practical Computing and Your Computer, the leading microcomputing magazines, you can be sure of value for money at £3 a ticket for Adults and £2 for Children under 16.

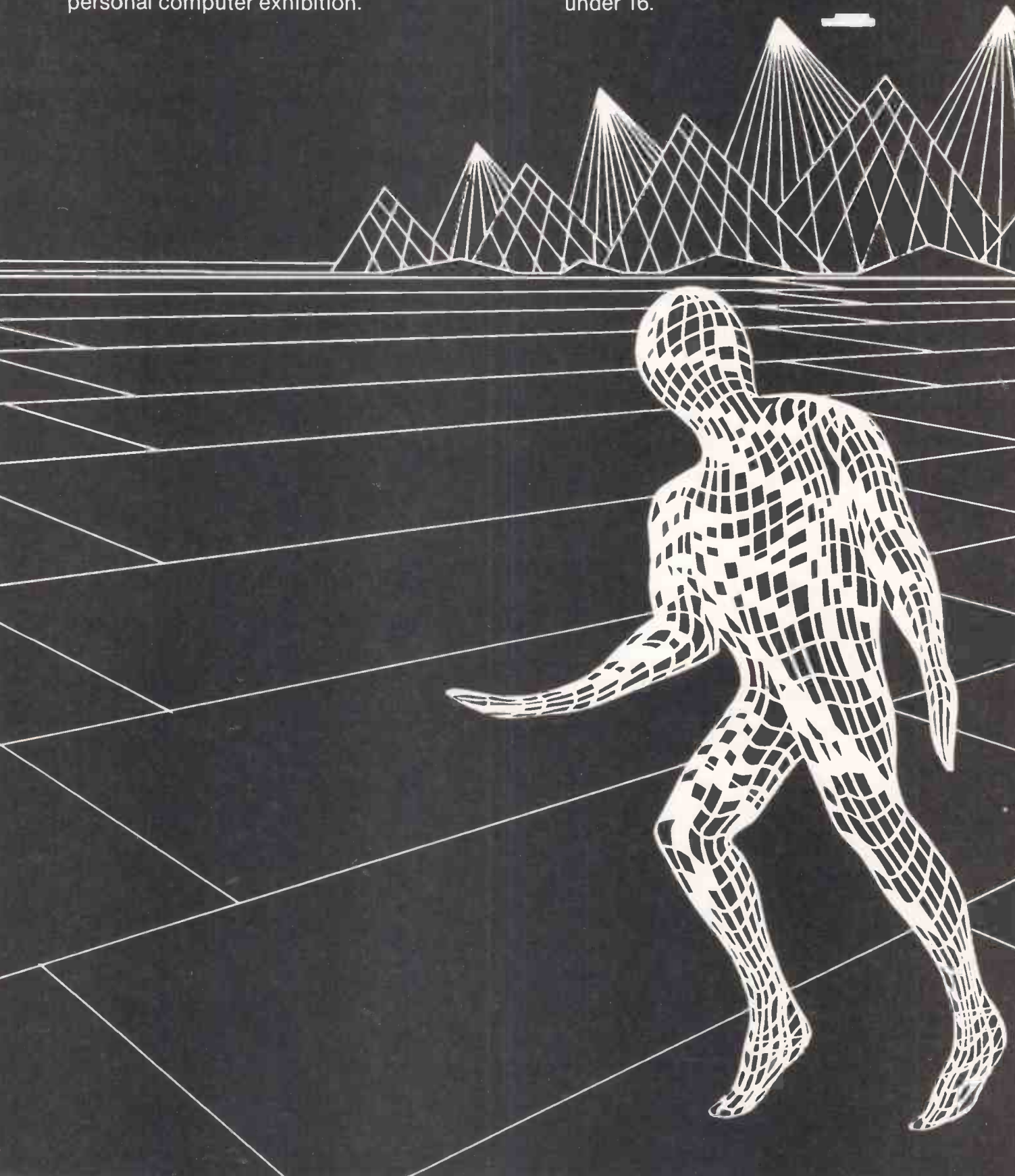

Travelling to the show is also easy as the organisers have arranged special reduced-price tickets with British Rail which include the cost of admission. For further information ring British Rail Enquiry Bureau on 061-832-8353 before November 11.

The Northern Computer Fair is open between 10.00 am and 6.00 pm every day

so come along and bring the microcomputer age alive for you.

For special party rates and further information contact:

The Exhibition Manager, The Northern Computer Fair,
Reed Exhibitions, Surrey House,
1 Throwley Way, Sutton,
Surrey SM1 4QQ

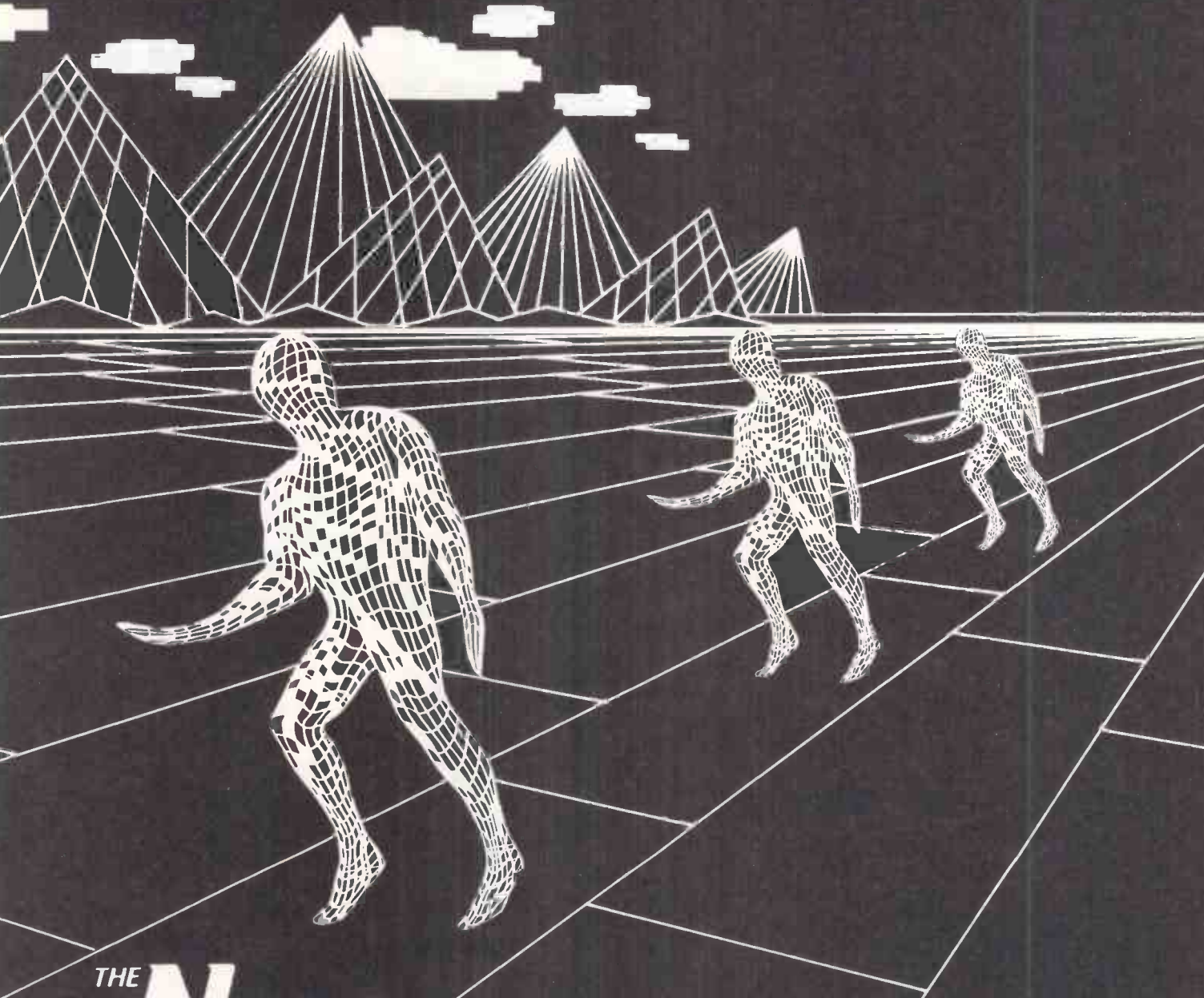

THE
**Northern
Computer
Fair**

Personal computers
Home computing
Small business systems

Sponsored by:

Practical Computing and YOUR COMPUTER

Belle Vue
Manchester
November
24-26, 1983

Practical Computing Back Issues

Each month Practical Computing examines personal computers, peripherals and software packages, providing unbiased critical comment on the strengths and weaknesses of the products reviewed. This, together with descriptions of programming techniques, and the Open File Section which contains hints and items for users of Apple, Pet, Tandy, BBC and Sinclair Computers, makes Practical Computing an invaluable source of information and advice. So if you've missed a particular issue make sure that you're not missing out on information which could be of real value to you. Just check through the Contents of our Back issues, then fill in and return the coupon below.

October 1982
Reviews: CCS — 300; Dragon 32; Sound chaser — synthesiser system for Apple II. Monte Carlo methods; Applesoft compilers; Wordpro revisited; Graphics for BBC micro; Applications programming for beginners Chris Curry interview.

November 1982
Reviews: Commodore 64; dBase II; Bit Stik high-resolution graphics for the Apple; Microcache. Using the BBC Micro as a graphics terminal. Fourier transforms with VisiCalc. Education — timetable planning.

December 1982
Reviews: Eagle II and TMK 330 business micros; GraForth on the Apple; Wordcraft on the Vic-20; games on the Atari. Micros under £200 — the essential facts. How to manipulate memory on the BBC Micro. Plus — a complete listing of a Monopoly program for the Pet.

January 1983
Portable micros — 12-page guide. Reviews: Fortune 32:16; Jupiter Ace; SNAP analysis; Walters printer. A DIY interface for the Spectrum, plus a disassembler for the BBC micro.

February 1983
Word Processing — 19 pages of info. Reviews: Victor 9000, Epson HX-20, Toshiba T-100, LVL Discs for the BBC Micro, Vic-20 games. Plus — Using BBC Graphics in the Teletext mode.

March 1983
Aple's Lisa - preview. Reviews: Lynx, Fujitsu printer, Spectrum games, Apple Books. Sounds of the BBC micro. Plus - 48-page Supplement on 16-bit micros.

April 1983 — Sold Out
May 1983

A guide to discs and databases. Reviews: Canon and Orion for business use, Textet, Texas TI-99/4 games, Atari books. Word processing on the Pet.

June 1983
Special issue - Speech, sound & music. Reviews: DEC rainbow 100, low-cost Cromemco C-10, BBC software, 16-bit payroll programs, Spectrum word processing, Vic books. Plus — a survey of programs that write programs.

July 1983
Fifth birthday issue! Guide to spreadsheets and financial planning — Calcs on the BBC, Visicalc, Multiplan, Micromodeller. Reviews: Wang Personal Computer, Hyperion portable, Sord M-5 home micro, Dragon word processing. Plus — Programming sprites on the 64

Fill in the coupon and return it with your remittance to

Practical Computing

Address as on coupon

To obtain any of these back issues please complete and return the coupon. Prices per copy including post and packing are UK £1.50, Europe £2.00, Rest of world £2.50 (Air Mail).



Issue (month)	Year	Quantity required

To: General Sales Dept., Room 108, Electrical & Electronic Press, Quadrant House, The Quadrant, Sutton, Surrey SM2 5AS.

Please send me the back issues detailed left — for which I enclose cheque/PO for £.....payable to Business Press International Limited

Name

Address

Company Registered in England (Registered No. 151537) at Quadrant House, The Quadrant, Sutton, Surrey. SM2 5AS.

The Buyer's Guide to Microcomputer Products

Our new Product Guide contains all the information you need to choose from the wide range of products manufactured by these leading names in micro technology:

 TeleVideo®

 HEWLETT
PACKARD

MORROW DESIGNS 

 EPSON  Anadex

 MikroPro ASHTON · TATE ■

 DIGITAL RESEARCH®

For your free copy, send us the coupon
— or phone today.

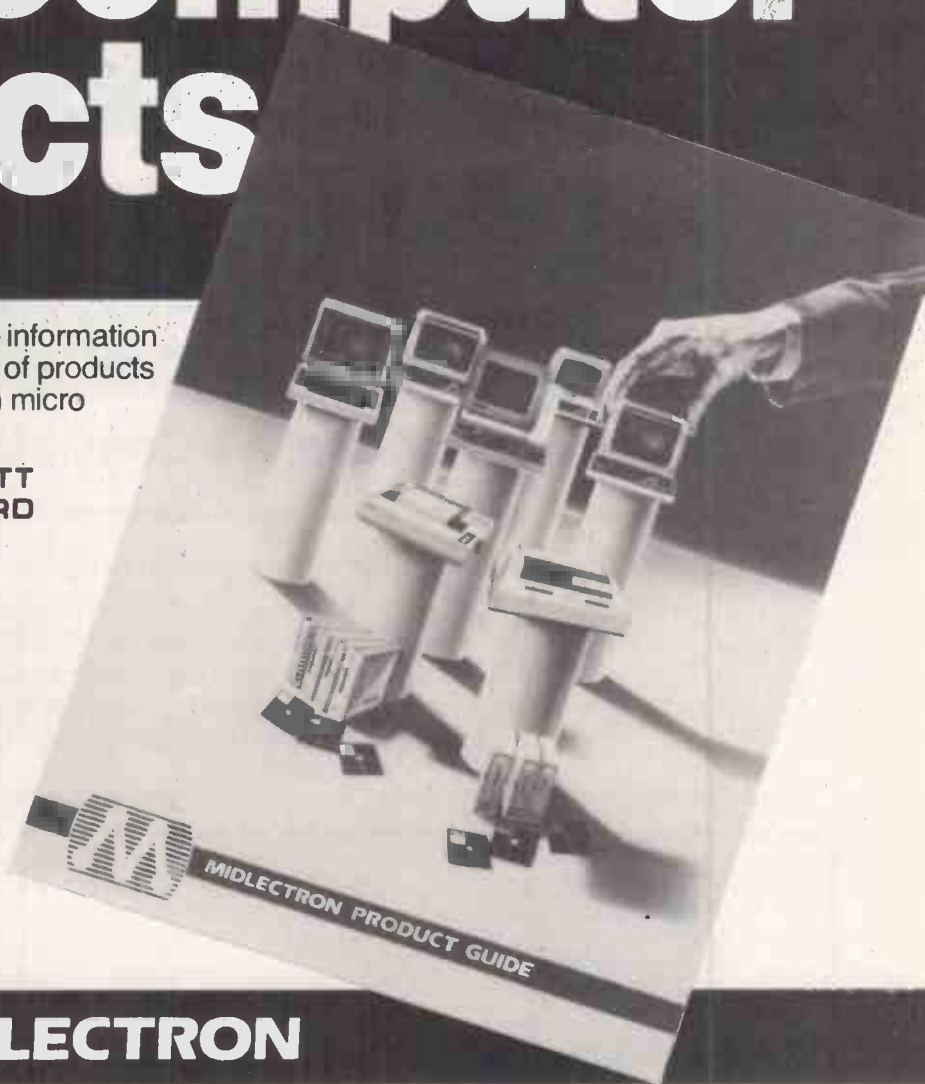

MIDLECTRON

Southern Office:

N.E.C. World Trade Centre, St Katherine's Dock, London, E1 9AA.
Tel: (01) 481 9919 Telex: c/o NEC 884671

Northern Office:

Midlectron House, Nottingham Road, Belper, Derby, DE5 1JQ.
Tel: (077 382) 6811 Telex: 377879.

Name _____ Position _____

Company _____ Address _____

_____ Telephone _____

PC9/83

● Circle No. 198

MAKE
A DATE FOR
THE UK'S PREMIER
COMPUTER TRADE EVENT

The Computer Trade Show '84

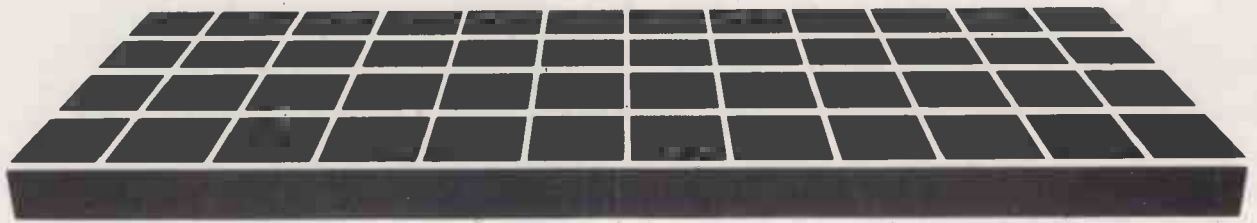

Wembley Conference Centre March 13-15, 1984.

Sponsored by Computer Weekly, Practical Computing, Systems International, Micro Business and Software. Organised by Reed Exhibitions.

If you're in the computer business you should exhibit at the Computer Trade Show '84.

The first show in April '83 was universally acclaimed as successful in attracting the right kind of serious visitor — visitors who would mean business for you.

Building on this success, The Computer Trade Show '84 will have an enlarged exhibition area, and a repeat of the highly-targeted promotion used in '83 will guarantee the excellent quality of visitors.

To get further information telephone Chris O'Hea, Exhibition Sales Manager on 01-6613125 or complete and return this coupon.



The Exhibition Sales Manager
The Computer Trade Show
Business Press International Ltd.
Room 201, Quadrant House
The Quadrant
Sutton, Surrey SM2 5AS

Please send more information on The Computer Trade Show '84

Name _____

Position _____

Company _____

Address _____

Tel: _____

A complete business computer service from forte data systems



Now with Multi-user and Networking facilities!
With free consultation in London & Home Counties



Systems include:

- Word Processing —
- order Processing —
- stock control —
- invoicing — sales
- ledger — integrated
- accounting — incomplete
- records — management
- accounts — mailing lists
- financial modelling —
- databases

We supply packaged solutions with full installation & support experience in:

- Hotels
- Retailing
- Publishing
- Insurance
- Distribution
- Project Control
- Property Management
- Advertising Agencies
- Telex & Communications



We are authorised dealers for
Sirius/Pulsar
Millbank Computers
TABS Software

Forte Data Systems Ltd.
4 Newman Passage,
London W1P 3PF
01-636 1025/1023

(Phone now for your free consultation)

Now with over 100 personally
customised multi function keys

● Circle No. 263

Compac Series Apple II programs

£ (excl.
VAT)

Incomplete Records Accounting	595
Nominal Ledger	
Book-keeping	
Report-generator	
Word-processor	170
Visicalc Aid	35

Compac

Back Lane, Mickleton, Chipping
Campden, Glos GL55 6SJ
Tel. Mickleton (038677) 464/394

● Circle No. 208

A+G COMPUTERWARE

WAREHOUSE CLEARANCE!

PRINTERS

Epson MX80 FT3 For BBC etc., £346
WHILE STOCKS LAST!
FX80 £370 — RX80 £252
Smith Corona TPI Daisywheel £414

MONITORS 24MHZ HI-RES

12" Phoenix Green Screen £99 Amber Screen £109

APPLE SOFTWARE

Summer clearance at reduced prices
Send for list — Bargains for everyone!

Apple Starter pack for small business including Printer —
Monitor — Software
Ask for inclusive quote at sensible prices.

Full price Lists on Request
Carriage £8. Add V.A.T. to all totals.
Educ. and Govt. Orders welcome.

Tel. 061-428-2014
PO BOX 34 CHEADLE CHESHIRE SK8 4PT



● Circle No. 209



The XJS smile and how we put it on Roger Smith's face

Why is Roger Smith smiling? Because he advertises in Practical Computing. And Practical Computing helped him to buy that Jaguar. Roger Smith's company, Disking International, specialises in floppy discs, selling the major brands: Maxell, Memorex and Verbatim. In two short years, Disking has become one of Britain's leading floppy-disc distributors and Practical Computing has played an important part in that success. "Compared with other leading computer magazines," says Roger, "Practical Computing

has two significant benefits. First – its quality of readership is higher – and readers are in a position where they can take important decisions quickly. Second – Practical Computing has a more lasting impact than other computer magazines. Readers hold on to Practical Computing for weeks and even months."

The result has been an excellent **continuing** response to Disking's advertisements. And something to smile about for Roger Smith. If you would like a Jaguar XJS,

call Ian Carter, Advertisement Manager, on **01-661 3021**. He will put you on the right track to getting one of your own. By advertising in Practical Computing.

Practical Computing

Electrical-Electronic Press,
Business Press International,
Quadrant House, The Quadrant,
Sutton, Surrey, SM5 2AS

THE EPSON QX-10 + 5MB HARD DISK FOR £2650



A REAL ALTERNATIVE

The EPSON QX-10 bristling with advanced features and the REAL 5Mb Winchester disk combine to form a formidable business system.

QX-10

192KB memory + 2K CMOS non-volatile memory.
Built-in serial, parallel printer, and light pen interfaces.
High resolution, green, anti-glare screen.
Multi-fonts BASIC providing display and printing of 16 different typefaces.
Sculptured, separate keyboard comprising 103 keys.
Two 5¼ inch double sided, double density 48 tpi flexible disc drives.

REAL 5Mb

Fully supported by CP/M.
Established sub-system manufacturer.
Quiet operation.
Supplied with configuration and installation software.

Other Purchase Options:

QX-10 with REAL 10Mb	£2850
QX-10 with REAL 20Mb	£3350
QX-10 only	£1730

Also available with EPSON printers.

And the HX-20 range:

HX-20 with carrying case	£411
--------------------------	------

We are an HX-20 Applications Specialist.

Areas which we have software products available are:

PAYROLL
WORD PROCESSING
COMMUNICATIONS



POCKET COMPUTERS LIMITED

CARTWRIGHT HOUSE, 39-43 MONUMENT HILL, WEYBRIDGE, SURREY, KT13 8RN. TEL. (0932) 57808

● Circle No. 261

CAN YOUR MICRO READ THIS?



5 000201 460790

Bar-code identification for... PET/CBM APPLE BBC

Bar-codes give a speedy and error free means of data entry and provide a foolproof method of identification for any item or document. Typical uses include stock control, libraries, filing systems, security & checkpoint verification, point of sale terminals, spare parts identification, etc., etc. Already most grocery products are bar-coded at source and many other areas of industry and commerce are following. Bar-codes will soon be commonplace.

Our system contains all the hardware & software needed to implement a bar-code system on your computer now. Software to print bar codes on an Epson printer is included. More information on request... please state your micro & area of interest.

Price £199.00 + VAT



EPSON and other well known Printers... Latest Models at Lowest Prices! Also BBC disk drives monitors etc. etc.

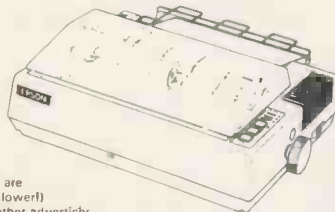

Our prices are as low (or lower!) than any other advertiser in this magazine. EPSONs are always ex-stock & most other printers/monitors etc. can be obtained the same day and delivered to your door, often in 24 hours. We can interface to most computers & knowledgeable advice is free if needed. Remember - many suppliers have limited technical expertise! Phone for a quote or send a SAE for full lists. All items carry the usual warranties.

ALTEK (PC) 1 Green Lane
Walton-on-Thames, Surrey
Please phone before calling (093 22) 44110



● Circle No. 213

Good news for Wordstar users Forget DataStar & SuperSort FORMSTAR GIVES YOU:-

- * Foolproof data entry & recall
- * Unique link to mailmerge
- * WordStar cursor controls
- * Standard screen forms or
- * Simply type your own
- * Any number of fields
- * Use same form for many files
- * Select or sort subfiles
- * Clear & simple instructions

FORMSTAR by available from
McMillan **COMPUTER FACILITY**
Computing. **0734 867855**
£80 + VAT 32 Redlands Road,
Reading, Berks.

● Circle No. 214

THE POWER BANK

sealed for life
batteries included

system
compatible sine
wave output

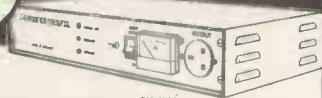

THE UNINTERRUPTABLE POWER SUPPLY WHICH WILL:

- Continue to operate your Micro Computer System when the mains electricity supply fails
 - Suppress dangerous spikes and surges
 - Stabilise voltage and frequency to your sensitive equipment
- Operate your Micro/Disk/Printer System from a Power Bank and forget about a disabling break in the electricity supply.

Please contact: **POWER TESTING (SALES) LTD**
on 0277 233188 Telex 24224 Monref G (ref 586)
65a Shenfield Rd, Brentwood, Essex CM15 8HA

● Circle No. 215

SOFTWARE

TRS-80 & VIDEO GENIE:

Chaos (16K)	£9.75
Dodgems (16K)	£9.75
Frogger (16K)	£9.75
General Ledger. (Disk 48K)	£74.75
Kong (16K)	£9.75
Mailing List (Disk 48K)	£17.25
Muncher (16K)	£9.75
Pools (16K)	£7.95

SINCLAIR:

ZX81 : Grizzly	£3.95
: Pools	£4.00
Spectrum: Bermuda Triangle (48K) - 3D adventure	£5.50

COLOUR GENIE

Chaos	£9.75
Frogger	£7.75
Pools	£7.95

(All prices include V.A.T. & P&P)

Always interested in programs for any of the above machines
(25% Royalties given)

KRICON LTD

11 Medway, Hailsham, East Sussex, BN27 3HE (0323) 846110

● Circle No. 216

STOCK CLEARANCE SALE

Microsoft	BASIC	£175
	FORTRAN	£225
	COBOL	£330
	BASIC COMPILER	£202
Micropro	CALCSTAR	£105
	WORDSTAR	£210
	DATASTAR	£155
	MAILMERGE	£ 70
	SORCIM SUPERCALC	£135
	ORGANIC SOFTWARE	
	MILESTONE	£170

Ex. DEMO SUPERBRAINS II

"Junior"	£1406
Q.D.	£1744

All prices exclusive VAT & carriage
Microcomputer Club, PO Box 66,
Croydon CR9 4QB
Telephone 01 689 2080

● Circle No. 217

The T.S.S. Technology Shop is now open and able to provide an unparalleled service for all your computer requirements.

● Hardware/both new and second user equipment, whatever you need at remarkable prices.

● Supplies - completely comprehensive range at unbeatable prices.

● Service - on a national basis with your satisfaction guaranteed.

● Complete used systems from £1,795. Used printers from £75. Used VDU's from £230.

New CP/M Systems from £895. Let us be the solution to your problems. Call 01-431-3100 now!

● Circle No. 218

GRUNDIG KINGSLEY

40-42 Shields Road,
Newcastle-upon-Tyne NE6 1DR -
Tel: (0632 650653)



R.G.B. MONITOR/TELEVISION

AS SUPPLIED TO EDUCATION AUTHORITIES
SPECIFICATION

R.G.B. Inputs (Analogue and Digital Levels) All Models.
1 Volt P.P. Composite Video (Remote Model only).
Teletext Decoder available to plug into Chassis. (Remote Model only) Remote control of Computer via Monitor.
(Remote Model Only) Sound Input gives access to Audio Amp.

All Models instantly switch back to Television	
12" B.W. Monitor	£95 + VAT
14in. Colour Monitor/Television	£227 + VAT
16in. Colour Monitor/Television	£255 + VAT
16in. Colour Monitor/Remote Television.	£295 + VAT
20in. Colour Monitor/Remote Television	£315 + VAT
22in. Colour Monitor/Remote Television	£340 + VAT
26in. Colour Monitor/Remote Television	£380 + VAT
Plug in Teletext Module	£75 + VAT
Connecting Lead	£5 + VAT
Carriage and Insurance	£9.50
4 Year Guarantee Insurance	£29.50

R.G. Monitor/TV (Grundig Approved)

● Circle No. 219

Datalife 5 Year Warranty by Verbatim



Boxes of 10 Datalife MiniDisks at
£22.50 (plus £3.95 VAT and p + p).

* SPECIAL OFFER FREE LOCKABLE
STORAGE UNIT WITH EVERY 5
BOXES (50 Disks) £112.50 (Plus
£19.75 VAT and p + p)

To order, phone 01-661 2060 or send
your cheque to: ERAC Consultants
(Southern) Ltd., Grove House, 6 Grove
Road, Sutton, Surrey SM1 1BQ.
Please allow 7 days for delivery.
Personal callers welcome.

● Circle No. 220

SOFTRONICS 3-WAY SWITCH-ONLY £99! plus VAT

Dealer/educational enquiries welcome.



All cables supplied — give details with order.

Links 2 or 3 computers to one printer or disk drive.

Tough ABS case.

Phone or write with machine/printer/interface details. post (UK) £2.50.

Export welcome — bank draft with order — overseas post £7.

SOFTRONICS The Fernery, Maresfield, Sussex (0825) 2179

● Circle No. 221

Programming & Consultancy Service

We can help with . . .

Programming · system design · user manuals · technical training · hardware and software selection.

We are at home on micros, minis and mainframes — in all major languages.

Mike Lewis Consultants Ltd
48 Willoughby Road
London NW3
tel: 01-794 3886

● Circle No. 222

ORDER YOUR **EXECUTIVE** for early delivery **OSBORNE**

48 Telephone (0295) **67551**
North Bar, Banbury, Oxon. OX16 0TF

● Circle No. 223

80 Column Conversion for PET/CBM

Suitable for small screen PET with basic 4.

Plug in PCB, no track cutting Gives all the features of an 8032.

£149 + V.A.T., C.W.O.

for further details contact:

Delph Electronics Ltd.
4 Deeping Road, Baston, Peterborough, PE6 9NP.
Tel: 077 86 535

● Circle No. 224



POSEIDON COMPUTER SERVICES LTD.

Of Hampton S.W. London Dealer **FOR SIRIUS 1**

DEMONSTRATION BY APPOINTMENT

MOST TYPES OF PRINTERS SUPPLIED

BESPOKE SOFTWARE A SPECIALITY

COMPETITIVE PRICES FULL UK DELIVERY



TELEPHONE: 01-941 1447/5986:
TELEX 8954665 GITS

● Circle No. 225

Micro-Pac

NO HIDDEN EXTRAS YOU PAY THE PRICE YOU SEE

GREAT LOW PRICES ON SUPPLIES AND PRINTERS

COMPUTER SUPPLIES

		PRICE PER PAC		
		1-3	4-7	8+
5.25" FLOPPY DISKS — PAC OF 10				
VERBATIM SSSD	Soft/Hard Sec	19.78	19.26	18.78
DATALIFE SSDD	Soft/Hard Sec	19.78	19.26	18.78
DSDD	Soft/Hard Sec	28.12	27.38	26.69
SSDD	Soft/Hard Sec	30.53	29.75	28.98
DSDD	Soft/Hard Sec	36.92	35.96	35.05
WABASH SSSO	Soft/Hard Sec	16.19	15.77	15.38
SSDD	Soft/Hard Sec	18.30	17.81	17.37
DSDD	Soft/Hard Sec	19.93	19.41	18.93
SSDD	Soft/Hard Sec	21.62	21.06	20.53
DSDD	Soft/Hard Sec	23.00	22.40	21.84
8" SSSD	Soft/Hard Sec	20.68	20.14	19.63
SSDD	Soft/Hard Sec	25.91	25.25	24.60
DSDD	Soft/Hard Sec	28.07	27.34	26.64

LISTING PAPER (500 SHT PAC)	1-2	3-4	5+
9.5" x 11 Side Micro Perfs	4.39	3.50	2.75
14.5" x 11" Music Ruled	5.33	4.70	4.00
MICRO LABELS (250 PAC)	1-2	3-4	5+
4.5" x 7/16" 2 wide	4.41	4.05	3.95
Fits 9.5" Tractor Feed			

SUPPLIES FOR ALL MACHINES AVAILABLE IN BOTH MICRO AND NORMAL PACKS. RIBBONS, DISK BOXES, PRINTWHEELS — IN FACT ANYTHING FOR YOUR COMPUTER CALL US NOW.

PRINTERS AND PERIPHERALS

Epson FX80	415.15
Epson RX80	281.40
Epson MX100	466.94

ALL OTHER PRINTERS (ODT MATRIX AND LETTER QUALITY) AND APPLE PERIPHERALS AVAILABLE. PRICES REALISTIC. FOR FURTHER INFORMATION CALL OUR SALES OFFICE.

REMEMBER YOU PAY THE PRICE YOU SEE. INCLUDES VAT & CARRIAGE

COMPAC LTD (Micro-Pac Division)
Commerce House, Stuart Street,
Luton LU1 5AU, Bedfordshire.
Tel: 0582 452580. (SUPPLIES).
0582 450557 (PRINTERS)



● Circle No. 226

SHOP WINDOW

SCIENTIFIC SUBROUTINE LIBRARY

VOLUME 1 — STATISTICS AND FITTING FUNCTIONS

Mean, SD, normal distribution, partial expectation, Chauvenets criterion, least squares fit to polynomial and arbitrary function, repetitive least squares fits, covariance matrix, chi-squared statistic, matrix inversion, solution of simultaneous equations.

VOLUME 2 — LINEAR PROGRAMMING

Reduction of a Simplex tableau, integer programming, partial integer programming, conversational linear programming system, least cost mix problem.

VOLUME 3 — FURTHER STATISTICS

Ranking, quantiles, frequency, 2-way table, correlation coefficient, T, chi-squared and F distributions and their inverses, T test, chi-squared test, Wilcoxon test, linear and multiple regression, ANOVA 1-way and 2-way.

VOLUME 4 — TRANSFORMATIONS & SORTING ALGORITHMS

Fourier, FFT, Laplace, numerical integration and differentiation. Exchange sort, Quicksort, Shell sort, Tree sort.

Manuals including full source listings with implementation notes and documentation —

BASIC £25 per volume

PASCAL £30 per volume

Software in CP/M (8" SSSD) or DEC RT-11 (RX01) formats — £75 + VAT per volume.

CP/M TO DEC FILE TRANSFER

Software to read and write RT11 format RX01 diskettes under CP/M. Supplied on 8" SSSD diskette — £25 + VAT.

MICRO LOGIC CONSULTANTS LTD.

57, Station Rd., Southwater, Horsham, W. Sussex.

Telephone: 0403 731818

● Circle No. 227

MICROMODS LTD.
53 ACTON RD. LONG EATON NOTTINGHAM
NG10 1FR TEL: 06076 64264

MicroMods Ltd.

● Circle No. 228

SUPERBRAIN

COMPUSTAR 10 MB — £E1,450
VPU 40 (D&D) — £1,450
+ VAT

Both hardly used approximately 6 months unexpired maintenance contract.

COMMODORE PET 8096

with disk drive 8050 and printer 4022, Visicalc, Business ROM, Toolkit, extra serial interface, ex demo, as new.
£1400 + VAT

CAMBRIDGE DATA

4 Summerset Gardens
Highgate London N6 5EQ
01-348 3298

● Circle No. 229

dBASE II — by Ashton Tate is the top selling database package. But it from **AQUA Computing Ltd**, the **dBASE** specialists.

- dBASE II** £375.00
- DBPlus** £125.00
- DBFLIST** £30.00
- DBAccel** £50.00
- dBASE II User's Guide** £22.00
- Everyman's Database Primer** £12.00

Any one of the last 4 items is **FREE** if you buy your copy of **dBASE II** from **AQUA** by July 1.

DBPlus COMPRESSES/DECOMPRESSES dBASE II files to 30/40% of original size; **SORTS** any **dBASE II** file up to 15 times faster; **MODIFIES** structures easily — complete with manual. Pays for itself in a few weeks.

Are your files scattered over several disks? **DBFLIST** compiles a master catalogue of all your **dBASE** files. Can save you hours of searching for that 'Lost file'.

DBAccel converts **dBASE II** .CMD file(s) into a single level format for much faster execution; Overlay control can be selective. Program size is limited only by available memory. Reduces running times by up to 50%.

dBASE II User's Guide is one of the best manuals on **dBASE II**; Has sold over 17,000 copies in the US; Written by Arthur Green, a leading US expert on **dBASE** courses. In stock now.

dBASE II Beginner's Guide, published by Ashton Tate, is essential for every serious **dBASE II** user.

For software products (**DBASE II**, **DBPlus**, **DBFLIST**, and **DBAccel**) add VAT to prices. Specify machine and diskette format (**SD/DD**, 5.25" or 8"). No extras for packing or postage in UK; add £5.00 for overseas. Further details available on all products. Pay by Cheque, PO, Access or VISA. Send to:

AQUA COMPUTING LTD (Dept PC5), 10 Barley Mow Passage, London W4 4PH (Phone: 01-994 6477).

● Circle No. 230

Programming the PET/CBM

By Raeto West

The Reference Encyclopedia for Commodore PET and CBM Users
Comprehensive teaching and reference book on programming Commodore's 2000, 3000, 4,000 and 8000 microcomputers and peripherals. Many programs, charts and diagrams. 17 chapters, appendices, and index. iv+504 page large-format paperback. ISBN 0 9507650 0 7. Price in UK and Europe £14.90 each (includes post and packing). Five or more £12.90 each. 48 hour order turnaround guaranteed.

From dealers and booksellers or direct:

Trade Manager, Edward Arnold (Publishers) Ltd, Woodlands Park Avenue, MAIDENHEAD, Berks SL3 3LX. Tel: (06882) 3104

"A masterpiece" — *Creative Computing*
"Essential" — *Educational Computing*
"Excellent" — *Jim Strasma*
"Comprehensive & Accurate" — *Jim Butterfield*

Send orders and make cheques payable to:
Trade manager, Edward Arnold (Publishers) Ltd, Woodlands Park Avenue, MAIDENHEAD, Berks SL3 3LX.

Send copies of Programming the PET/CBM at £14.90

I enclose cheque/PO for £.....

NAME

ADDRESS

● Circle No. 231

BASIC PROGRAMMERS . . .

Are you always short of space? • Looking for variables? • Debugging programmes (other people's)? • Searching for jump sources?

YOU NEED LOWMAN: LOWMAN is LOWADD LTD's programme MANIPulator. It is a suite of eight utilities used in their own program development.

THEY CONSIST OF:

1. Delete Remarks. Shrinks programmes prior to compilation.
2. Search for expressions. Will search and print locations of up to 20 expressions per pass.
3. Analyse Programme. This comprehensive programme produces a complete breakdown of addresses of all definition statements. Source and destination of all jumps. For/next and While/wend loops, and a complete list of addresses of all variables in alphabetical order.
4. Compare. Compare 2 ASCII source codes and print differences.
5. Compress. Compress source to Basic 4.51 lexical convention.
6. Expand. Expand source to Basic 5.00 lexical convention.
7. Global. Search and change within ASCII code with options.
8. Left justified. Aligns code and inserts TAB after line number.

THE WHOLE SUITE CAN BE CUSTOMISED BY USER TO MATCH ANY SCREENS. Available in CPM format on IBM standard 8" floppies. Please state density required. TANDY format available shortly.
Send CHQ/PO for £39.50 to **LOWADD LTD**, 82 GIRTON RD, CAMBRIDGE CB3 0LN. Telephone: 0223 276243
For other formats please write.

● Circle No. 232

northern computers

THE COMPUTER CENTRE OF THE NORTH

THE showroom for all the leading micros

easy parking off the M56 (junc 12) * VIC 20 * VIC 64 * BBC micros * Newbrain * Acorn Atom * Books * Apple 11e, 111 * Dragon * Electron * Games * Sinclair Spectrum

Secondhand computers * EASY PAYMENTS * ALL ACCESSORIES SALES AND SERVICE

northern computers Churchfield Road, FRODSHAM Cheshire WA6 6RD

TEL: FRODSHAM (0928) 35110

WE WILL PURCHASE AND PUBLISH YOUR PROGRAMS. Call Steve Rhodes for details

● Circle No. 233

A GREAT NEW DEAL!

SPECTRUM RAM UPGRADE 16K-48K

£ 20.99

EASY TO FIT. CHIPS JUST PLUG IN. NO SOLDERING. SENT WITHIN 10 DAYS

INCL. VAT, P. & P.

ISSUE TWO MACHINES ONLY (BLUE KEYS)

S.A.E. for details, please.

DISPLAY INSTRUCTION SHEET

Get the best possible results from your Spectrum. Deals with yellowish white, wobbling colours etc. Send £1 plus Stamped Addressed Envelope

MAIL ORDERS ONLY. Cheques/P.O.s to: **FOUNTAIN COMPUTERS LIMITED**
Bishops Court, Bishopstoke, EASTLEIGH Hants, SO5 6PE (0703) 616505

SORRY, NO OVERSEAS ORDERS ACCEPTED (including BFPO, Channel Islands and Eire).

● Circle No. 234

Cope Systems Ltd

DISKETTES 5 1/4" S/S S/D from £17.00 per 10
8" S/S S/D from £18.00 per 10

HEADCLEANING KITS £17.00 ea
LISTING PAPER

11 x 9 1/2" Plain/Ruled £4.85 per 1,000
11 x 9 1/2" Micro Perf £6.25 per 1,000
11 x 14 1/2" Plain/Ruled £6.46 per 1,000

2, 3 & 4 part sets no carbon required and one time carbon. Also available printer ribbons, cassettes, self adhesive labels, storage & filing equipment, custom printed continuous stationery & letter headings.

TRADE ENQUIRIES WELCOME

(All prices exclude VAT)

TELEPHONE

Southend (0702) 67507

The Guilderdrome, Victoria Road, Southend, Essex.

● Circle No. 235

TO HELP YOU WIN THE POOLS

"POOLSDATA" — Results Database

Complete record of all English Football League results 1978-83. The teams, scores and actual date of over 10,000 matches, for your analysis. Simple format, with starter analysis programs and guidance notes.

Available for Apple (disc), Spectrum, ZX81, BBC, Pet, VIC, Commodore 64.

Tapes (2 years data) £7.50
Tapes (5 years data) £12.50
Discs (5 years data) £15.00

"POOLSWINNER" — Pools Predictor

Flexible, updatable prediction program which references an integral 70 year database. Predicts draws, aways and homes. Can be tuned to your own unique formula, or used in simple mode. Available for Apple (disc), Spectrum/ZX81 (Tapes)

Tapes/discs £15.00
Please send S.A.E. for details, or send cheques/P.O.s to



ACCESS

SELECT SOFTWARE
37 COUNCILLOR LANE
CHEADLE, CHESHIRE
061-428-7425



VISA

● Circle No. 236

DYNAMIC SIMULATION SYSTEM

for APPLE and CPM SYSTEMS

- * Fully Interactive
- * Powerful
- * Machine Language
- * Graphic Output

£250 Complete

FOR DETAILS CONTACT:

PROCESS AUTOMATION & COMPUTER SYSTEMS LTD.,
50 Gosport Street, Lymington, Hants
SO4 9BE. Telephone 0590 73503.

● Circle No. 237



MICRO ADS

are accepted from private readers only, prepaid and in writing. 20p per word, minimum charge £2.

Please make cheques payable to Practical Computing and send to Room L310, Quadrant House, The Quadrant, Sutton, Surrey SM2 5AS.

'NORTH STAR HORIZON with new 10 MEGABYTE WINCHESTER disc. DOS, HMSOS, BASIC. New EPSON PRINTER 2K Buffer, unused. Floppy disc and all necessary cables. £3,000 o.n.o. Telephone: Warwick Bergin on 01-435 5466 day or evening.'

NORTH STAR ADVANTAGE (64K), complete with Epson MX-80 FT3, G BASIC, CPM, MBASIC80, CBASIC, Magicwand, magicalc, DBMS III all manuals and 50 discs. Almost new and little used. £2000 no offers. Ring 042-784-372.

TUSCAN S100 8K ROM Basic 32K RAM on ME3 card RS232 Centronics. Housed in steel case will take two 5 1/2 disk drives. STereo sound card. £299 Call Graham after 6.00pm. Upminster 24145.

TRS-80 LII 16K (Lower-case, green screen), Expansion Interface (32K, RS232), TEAC Single Disc Drive, Heath H14 Printer (RS232, full ASCII). Much software including Pascal, APL80 £750 o.n.o. or will split. Bristol 0272-43482 (evenings).

EPSON HX20 complete with cassette unit, battery, ac/dc charger, manuals etc. Unwanted gift £295 for quick sale. Mr Peters 01-240 1033. Office hours.

ADLER ALPHATRONIC P2, 48k, Twin disk drives, 12" VDU, CP/M, Little used, including software & disks, £900 ono, Hoddesdon (0992) 461746.

NEWBRAIN MODEL A.D. (inc. one line display) one month old. £200 o.n.o. Durham (0385) 711380.

SHARP MZ80K 48K. Excellent condition. Over £200 software, games, utilities, Wrdpro, etc. Epson printer interface. £275. Cundell 0442 4122 daytime. 0525 376011 evenings.

DRAGON-32 BUSINESS SOFTWARE. Business Utility Pack 1 £8.95, Letter Writer £9.95, Price File £9.95, Mailing List £19.95, Stock File £24.95, Purchase Orders £19.95. Coming soon — Database, Invoicing, Disk Software. Send SAE for complete list or £1.00 for our software preview cassette. Cheque/P.O. to B. MISTRY, 75 St. Margaret's Road, Bradford BD7 2BY.

PET SOFTWARE TO YOUR SPECIFICATIONS. Do you have PET standing idle, waiting for the correct software? Any BASIC program written to your exact specifications — speedy guaranteed service. Phone or write with exact requirement for immediate quotation. Mr B Katz, 8, Astor Drive, Moseley, Birmingham B13 9QR. Tel: 021-778 2472.

PRINTER Seriel (RS 232) interface printer. ASR-33 Teletype working with Apple. £65. Seriel interface also if required. Byfleet 47643, evenings.

BBC 32K CENTIPEDE. Fast Machine Code/BASIC, Hires colour, amazing sound, Hiscore, 3 speeds. £3.95. Neil Cannon, 30 Chanctonbury Chase, Redhill, Surrey.

PET 32K (40/80 col. Basic 4, 12" screen) & extended basic extended toolkit & various chips rom pages board. 8250 disc drives (2mbs) all less than 9 mths old. Including all software, (w/p., spreadsheet, data management & all sorts over 6bm's in all) Offers around £1750 Durham (0385) 711380.

APPLE II Europlus 48K Hitachi monitor, Disk Drive and controller, silentype printer, visicalc. This equipment is privately owned and in mint condition. £900 Tel. Royston (0763) 72828 Evenings.

TRS 80/VIDEO GENIE LII Model 1&3 Extender a machine code program that adds fifteen new commands to your programming. Subroutines consist of: Basysst, converts BASIC programs to system format, Close, hides Basic program, Data compiler, changes any block of memory to DATA statements, Find & Rescue, Hex to Decimal, Lowcase, changes HIGH case to low within print statements, Merge, Renumber, Onestroke key entry, Put any memory block to screen, Squash removes unwanted spaces, Single line and page scrolling, System tape copier, displays file names, start, end and entry addresses, Validate all line branches. £11.50. G.F. France 3 The Village St. Keyne Liskeard Cornwall. PL14 4SD.

8032 Software, Wordpro 4+ £185-00, Visicalc £75-00, Petaid £155-00, Saving for Silicon Office Simon Godstone 843 941 (Eves).

BBC MICRO — CLONE RANGER. Allows you to make security backup copies of your valuable protected discs. Requires twin 40 track drives. Supplied on disc at £11.60 Purchasers are advised not to infringe the copyright act. It is a condition of sale that Clone Ranger is not used for Software Piracy. Cheques/PO's to JC SOFTWARE, 124 WOODLANDS WAY, SOUTHWATER, WEST SUSSEX, RH137DR.

32K PET, new rom, large keyboard, V.G.C. £395 including cassette unit, progs, manuals. T. Histon (022023) 4748

Superbrain QD and Microline 82A Printer plus loads of software £1,500 Watford (0923) 50426 or 37952.

TRS80 48K RAM, 12K Basic ROM, Green Screen, 2 disk drives, Cassette System Desk, MX80 Printer. Boxed, delivered and set up £1200. Richards (0482) 843303. Evenings 8pm to 1am.

APPLE II 64K, Language Card, Disk, Eurocolour Card, Silentype ALF Synthesizer. Full documentation. Various software including Pascal. Spare disks/printer rolls. £950 ono. Tel. J. Avery, Medway (0634) 575753 Evenings; 01-379 6968 days.

reprints

If you are interested in a particular article/special feature or advertisement in this journal HAVE A GOOD LOOK AT OUR REPRINT SERVICE!

We offer an excellent, reasonably priced service working to your own specifications to produce a valuable and prestigious addition to your promotional material. (Minimum order 250 copies).

Telephone Michael Rogers on 01-661 3457 or complete and return the form below.

To: Michael Rogers, Practical Computing, Reprint Department, Quadrant House, Sutton, Surrey SM2 5AS.

I am interested in copies of article/advert. headed featured in this journal on pages, issue dated

Please send me full details of your reprint service by return of post.

Name

Company

Address

..... Tel No

NOMINATIONS FOR BEST PRINTER AWARDS 1983



STAR

★ NOW ON RELEASE ★



JUKI

★ NOW ON RELEASE ★



SHINWA - CTI

★ NOW ON RELEASE ★

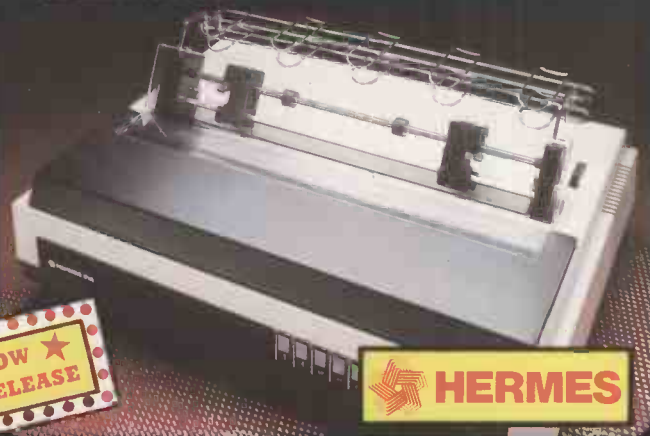

HERMES

★ NOW ON RELEASE ★

ONE YEAR GUARANTEE

ONE YEAR GUARANTEE

ONE YEAR GUARANTEE

ONE YEAR GUARANTEE

Best Star — STAR DP 510/DP 515 Matrix Printers

available for around **£289 and £399 ex VAT**

- ★ 80 Column (DP510), 136 Column (DP515)
- ★ 100 CPS, Bi-Directional Logic Seeking
- ★ Friction, Tractor and Roll Holder as standard
- ★ Full standard features including 2.3k Buffer

Best Performer — JUKI 6100 Daisywheel

available for around **£399 ex VAT**

- ★ 18CPS — Bi-Directional Logic Seeking
- ★ 10, 12, 15 CPI + Proportional Spacing
- ★ "Drop in" Daisywheel — Triumph Adler Compatible
- ★ Supports all Wordstar features
- ★ Diablo protocols — IBM Selectric ribbon
- ★ 2k Buffer as standard — 100 character Daisywheel

Best Newcomer — SHINWA - CTI CP80 Matrix Printer

available for around **£289 ex VAT**

- ★ 80 CPS — Bi-Directional Logic Seeking 80 Column
- ★ Friction and Adjustable Tractor Feed
- ★ Patented Square Needles up to 9 x 13 matrix
- ★ Hi-Res Graphics and Block Graphics

Best Producer — HERMES 612 WPQ Printer

available from around **£1950 ex VAT**

- ★ Up to 400CPS and Word Processing Quality at 120 CPS
- ★ 10, 12 or 15 CPI — programmable to 1/360" spacing
- ★ 132 column at 10 CPI

All now on general release — see them at your local dealer

Best Distributor:—

Micro Peripherals Ltd

69 The Street, Basing, Basingstoke, Hants. RG24 0BY
 TEL: (0256) 3232 (12 lines) TELEX: 859669 MICROP G

Please send technical details, printout samples and local dealer details to: ● Circle No. 255

Name: Position

Company:

Address:

Micro Peripherals, 69 The Street, Basing, Basingstoke, RG24 0BY

ZORBA

The Portable
Personal
with MORE



More Storage

800 KBytes on twin 5¼" floppy disks plus 64 KBytes User Memory means you can now run Integrated Ledgers.

More Software

Supplied as standard with every Zorba :-
Systems Software comprising CP/M 2.2 * inc. utilities M 80 **, L 80 **, LIB 80 **, CREF 80 **.
Applications Software comprising C BASIC **, WORDSTAR ***, MAILMERGE ***, CALCSTAR ***,

Optional Software, Spellstar, Infostar and most CP/M * packages.

More Screen

7" GREEN VDU, with full 80 columns by 25 lines, Means NO MORE SCROLLING. Also with blinking, block graphics & 2 intensities.

More Compatability

Reads and writes data disks in the format of :- IBM PC, Osborne, Superbrain, Xerox 820, DEC VT180 & Kaycomp.

More Keyboard

Fully Professional and detachable Qwerty format with 19 programmable function keys.

More Expandability

Outputs include Parallel, Serial and IEEE 488 as standard.

More Reliability

Sets New Industry Standard, Full 90 day Warranty and Nationwide maintenance available.

More Value

Only £1595.00 exc VAT

A limited number of dealerships are available in the UK.

● Circle No. 256