

# POPULAR WIRELESS

THE FIRST AND FOREMOST RADIO WEEKLY FOR THE CONSTRUCTOR & AMATEUR EXPERIMENTER

Scientific Adviser: SIR OLIVER LODGE, F.R.S.  
 Technical Editor: C. V. DOWDING, Associate I.E.E.  
 Assistant Editor: P. ROBERT BIRD.

Managing Editor:  
 N. F. EDWARDS.

Chief Radio Consultant: P. P. ECKERSLEY  
 Assistant Editor: A. JOHNSON-RANDALL.  
 Chief of Research: K. D. ROGERS.

BROADCAST PROGRESS  
 SIR AMBROSE FLEMING  
 UNSOLICITED  
 A PECULIAR  
 PHENOMENON

## RADIO NOTES & NEWS

TIME BY TELEPHONE  
 JAPANESE TELEVISION  
 POOR BERMUDA  
 RADIO OR  
 GRAMOPHONE ?

It's All-British.

AS a neat rejoinder to the complaints of the "too-much-foreign-music" patriots the B.B.C. has begun a series of six Queen's Hall concerts of British music covering the work of thirty-one composers. I suppose that this series is intended to be "highbrow," for neither German nor Sullivan is represented, being men who wrote music to gladden the heart. Coleridge Taylor, too, and Eric Coates are amongst those absent.

"The March of Time."

IT is a simple matter to cite instances to illustrate the evolution of broadcasting during the past ten years, but I would suggest that the change in its development is really strikingly brought into relief by the fact that in December last listeners here were enabled to hear a song by Bai Sunderabai, a Sitar solo by Pandit Madhoalal and a Sanai solo by Mr. Madhu Oomaji, all being accompanied by Tablas and Sarangis and broadcast by Bombay.

In 1923 the saxophone was an exciting thing. And now we have a Sarangi and an Electronde! I forgot to mention the Jaltarang played by Prof. Deodhar, and the Tamboora. Henry Hall evidently has more worlds to conquer yet.

We Live and Learn.

KENNETH LESLIE-SMITH, who wrote eight numbers for the revue "After Dark," was once a piano salesman in America, and as a result is able to reveal the remarkable fact that the most successful piano salesmen knew very little about music.

My brother says gloomily that he could quote a parallel fact about motor-car salesmen. After pianos Leslie-Smith joined a New York telephone company and used to go round the business houses trying to make the Big Chiefs "telephone minded."

And then, in 1930, he wrote a song which Rudy Vallée put into the "Vagabond Loyer." Since then, like the boy in the dark lane, he has not looked back.

A Great Opportunity.

IN connection with the twenty-fourth annual exhibition of scientific instruments arranged by the Physical Society, Sir Ambrose Fleming is to lecture at the Imperial College of Science and Technology, Imperial Institute Road, South Kensington, at 8 p.m. on Jan. 11th.

Sir Ambrose's subject will be "The History and Development of the Thermionic Valve," and I advise all those who are able to try to attend. A great physicist and a great topic! In years to come you will treasure the memory and tell your grandchildren: "Yes, I remember hearing Fleming."

### THERE'S ONLY JUST OVER A WEEK

before the long-awaited wavelength changes will compel you to recalibrate your receiver.

"POPULAR WIRELESS," ever to the fore, has recognised the difficulties which such recalibration presents to its readers, and has prepared a complete and authoritative Supplement dealing with this matter from the point of view of the constructor with his home-made set and the listener with his commercial receiver. This Supplement has been prepared in conjunction with the set manufacturers concerned, and is, therefore, entirely official.

"POPULAR WIRELESS" ALWAYS LEADS!

A Club Announcement.

I AM asked by the Hon. Sec. of the Rodney Radio Club to state that the club holds weekly meetings at the L.C.C. Schools, Victory Place, Rodney Road, Walworth, S.E.17, at 8 p.m.—day of the week not mentioned.

Lectures and discussions on subjects embraced by wireless and domestic electrical matters are held under the direction of Mr. S. Harris (G 5 S H). Mr. S. Parr is the Hon. Sec., 18, Harris Street, Camberwell, S.E.5.

An Unsolicited Testimonial.

A GOOD story is told of Eric Greene, the well-known tenor. Whilst on holiday in Cornwall recently he decided to give his voice a trial in order to see whether he was deriving benefit from the rest.

Finding the hotel's music-room vacant, he sang several songs, and was then amazed to hear a voice saying: "Thank you! That was very charming. You ought to ask the B.B.C. for an audition. I have heard much worse than that on my set." It was an old lady, sitting mouse-quiet in a corner, who had spoken.

Another Humble Suggestion.

WITH due modesty I beg to point out that more than one suggestion which I have made in "Notes and News" has become reality—though, of course, the B.B.C. "thought of it first." Well, that Seymour Hicks masterpiece, "Scrooge"—I saw him do it at, I think, the Coliseum before the war—proves that Dickens was a first-class dramatist.

Why not produce other pieces of Dickens, such as the unmasking of Uriah Heep by Micawber, the death of Bill Sikes or the prison scene in which Fagin "stars"? Heaps more thrilling drama in Dickens. Give him "a break," as the Americans so mysteriously say.

Do "Earths" Decompose?

A CORRESPONDENT of a contemporary has started a very interesting line of inquiry and speculation, arising from his observation that the range of a new radio station gradually decreases after a few months and is never regained unless the apparatus is altered.

He suggests that this phenomenon may be due to the action of the electricity on the soil surrounding the "earth" connection, and points out, in indirect support of this theory, that he has never noticed a similar falling off in a ship station, whose "earth" is, of course, always changing.

Why Not Test Droitwich?

I HAVE never noticed the deterioration of signals from new stations—never troubled particularly, so long as I got all the "punch" I needed—but evidently others have; therefore I would suggest that the B.B.C. might let us know whether  
 (Continued on next page.)

# IF YOU WANT TO KNOW THE TIME, ASK—THE 'PHONE

the "field strength" of Droitwich, measured at a number of places, is the same three or four months after the station opens as it was on the opening day.

Again, I suggest that a chemical and physical examination of the soil round one of Droitwich's "earths" be made before the station functions and a few months after it has opened.

## "Howlers": First Crop.

YOU expect a few school-kid "howlers" at this time of the year, don't you? Well, I have never failed you yet—except that I didn't get clear to the bottom of the piano-tuner's trouble. "Potential drop is what a condemned murderer waits three weeks for." "Television is scanning people with specially painted faces." "Polarity means which pole, north or south, and there are also magnetic poles in the earth."

And, lastly, this perfect gem: "Broadcasting is like throwing good seed on barren ground; example, the sower who went forth to sow and the thorns sprang up and choked him."

## Talking Time Signals.

I DO not know whether the watches which are carried by French people are erratic or whether watches are scarce over the water, but one or other must explain the extraordinary demand for Paris's famous "talking clock," which tells telephone subscribers the correct time. It is said that this clock spoke the time to 4,000,000 inquirers during its first year of operation, at the average rate of 11,000 calls a day, and thereby earned £25,000. It is not unnatural that the busiest time for this service is 8 a.m., when folk are thinking about catching trains.



Hats off to the B.B.C.'s time signals, Big Ben and the "pips"!

## Engineering Employment Prospects.

I AM all too frequently asked by parents whether they would be wise to train their sons as electrical engineers (including radio men).

One dodges the issue, if possible, or advises with great diffidence, for although the world is rapidly becoming all-electric and engineers will be wanted in increasing numbers, the beginner has "a hard row to hoe" and no certainty of employment.

I am inclined to think that the production of electrical engineers ought to be restricted for a time. In America 10,000 graduates of 1932 and 10,000 of 1933 are not yet employed, and altogether some 50,000 engineers are out of work.

## A Legal Note.

IN the matter of the Gramophone Company versus S. Carwardine & Co. it has been established that the performance of a gramophone record in public can be

restrained unless it is done by agreement with the record manufacturer.

In this test case the record in question was one of "The Black Domino," composed 100 years ago; but though there were whiskers on the piece there were no flies on the record makers—hence this case.

"Hello, Folks! This is——"

THE annual award for the clearest diction, open to American radio announcers, has recently been won by a Mr. Wallington, who is employed by the National Broadcasting Company. They say that his execution of "Oh, yeah" and "Nerts" are most finished pieces of *maestria*.



But, joking apart, I think that the report which I read used the wrong word. What is wanted in announcers is not so much clear diction as clear enunciation—two somewhat different things.

## SHORT WAVES

A German complains of the reception his countrymen are getting from Britain. British radio fans have been complaining for years.—"Punch."

"Who owns the air?" asks a headline. We don't know. Hitler hasn't told us yet.

It is claimed that Hilversum is the most musical broadcast centre in the world. But there's a very charming Ayr in Scotland.

## THE RADIO HUSBAND.

To the radio microbe a victim he fell,  
And had such a case that he never got well  
Till he bought him a peach of a radio set  
And sat down to listen to what he could get;  
And the dishes from dinner are now made to wait  
Until after the concert at quarter to eight.

Then his wife is accustomed to enter the place  
With a painful expression adorning her face.  
"Just a minute, my dear," says he, waving his hand.

"I've got a new station. Isn't it grand?"  
But, in spite of his willing and hopeful reply,  
He'll forget that the dishes are waiting to dry.  
"Radio News."

## Television in Japan.

PROGRESS in television in Japan is such that it has been thought desirable to found a Television Society. The organisers were the Nippon Radio Broadcasting Association, the Waseda University, the Hamamatsu Technical College, the Electro-Technical Laboratory and the Engineering Bureau of the Ministry of Communications.

That looks like business indeed. Which nation is going to win the race and produce the first system capable of giving domestic "entertainment" results?



The television battle is becoming extremely interesting, and I for one look forward with eager anticipation to the first signs of popular television.

## Japan Jibs at Noise.

AS proof that radio has conquered Japan I may cite the fact that the public there has at last admitted that it can no longer suffer the excess of noise from loudspeakers.

After attempting to find peace by running madly to the summit of Fujiyama, the victims have petitioned the authorities for help, with the result that strict anti-noise rules have been made and will be enforced by the police.

## Radio Thumbs Up.

OFFICIAL returns of radio exports and imports for November are just to hand, and they have that healthy look which cheers this old heart. (*Immature babbler!—Ed. "P.W.": Sez which?—Ariel.*) We will now proceed.

The November figures show a favourable balance of over £40,000, whereas November, 1932, showed an adverse balance of £10,943. Imports from America fell, except those of radio-gramophones, whilst imports from Canada rose.

## A "Wet" U.S.A. and the Empire.

BERMUDA, though not "dry," believes wholeheartedly in prohibition. Consider! When America went "dry" it discovered that our Bermuda was a beautiful "wet" island.



So Bermuda and its hotels flourished. Now that America has returned to its original humidity, Bermuda trembles for its prosperity: trembles so much that its Government has decided to spend £1,000 in advertising the glories of the island by broadcasting over one or other of the American national "chains" from the excellent radio-telephone station worked by Imperial and International Communications' local branch.

I fear that it will need a lot of scenery and climate to drag Uncle Sam away from his new-found absorption liberties.

## She Prefers "Canned" Music.

IN an interview Dame Clara Butt is reported to have said of broadcasting that it has developed in some people an attitude which "is destructive of all the finer qualities of musical art," because they play bridge or talk, with the music as a sort of background. I believe that a lot of people do that.

But Dame Clara goes on to declare that the influence of gramophone records is not in general so evil. Hence she will not broadcast, but she will make records. Yes, and then the records will be broadcast like billio—and people will play bridge meanwhile. And so we come to the same end in the long run—as the two last in the Marathon race said.

ARIEL.

# TELEVISION

## BREAKING UP THE PICTURE

By  
**G.P. KENDALL**  
B.Sc.

**W**E discovered last week that the basic process used in all the present systems of television depends on splitting up the picture into little pieces which are transmitted separately in quick succession.

At the receiving end we saw that if these separate pieces are popped on to a screen in the right positions the phenomenon called "persistence of vision" causes us to see the picture as a whole, although only a single spot is really present at any given instant.

The lag effect of the eye causes it to go on seeing the spot in all its earlier positions when it has just finished tracing out the complete picture, and we therefore see the view as a whole.

### The Question of Detail.

We learned also that directly the moving spot of light has covered the picture area once it must immediately set to work and repeat the process. In the present B.B.C. transmissions the complete picture is traced out twelve and a half times in every second.

This is sufficiently rapid to bring persistence of vision to our aid once more and make the eye imagine that it is seeing the picture continuously. Actually, it

★.....★  
The "mechanics" of television—the moving spot of light, the rapid repetitions, and so on—are all extremely interesting, especially as recounted by Mr. G. P. Kendall. His gift for clear presentation is admirably shown in this lucid account of the important process of scanning.  
★.....★

mission, the rating in lines being a common one in television work, since it gives one an approximate idea of the quality of a given transmission.

The greater the number of lines per picture the better the detail which can be obtained. Some idea of the detail which can be got from a 30-line system can be formed from the series of half-tone illustrations given last week.

The coarsest of these was made up of 20 dots to the inch, and in making the

home constructor. Room for improvement there is, admittedly, but the picture quality is now sufficient to provide us with a basis for fascinating experimental work.

Now let us tackle the next step. Before we can get much farther we must learn how the separate pieces of a television picture are assembled in their correct positions on the receiving screen.

Here we make the acquaintance of an important principle called "scanning."



### A BRITISH PIONEER

Mr. John Logie Baird, whose original television system employed an ingenious scanning disc with lenses

This term simply means a process whereby the spot of light is made to chase about on the receiving screen in such a way that at any given instant it is in exactly the right place to reproduce the corresponding detail of the picture.

It will be remembered that the light and shade, appropriate to the detail of the picture at any given point, are produced by variations in the

brightness of the spot on the screen. These variations are achieved by making a locally produced beam of light fluctuate in strength in accordance with the electrical impulses received from the distant transmitting station.

### Assembling the Scene.

Just how this is done we must leave for a future occasion. For the moment we must content ourselves with assuming that it is possible to produce the required "modulated" beam of light. For the moment we must concern ourselves with the

(Continued on next page.)

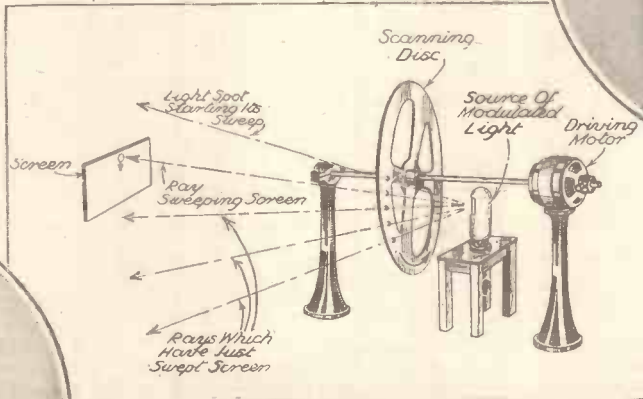

### THE MOVING SPOT OF LIGHT

The underlying principle of scanning is clearly shown by this simplified sketch. Note how the direction of rotation of the disc sweeps the spots of light down the screen, and how the spiral arrangement of the holes causes each successive spot of light to line up with its predecessor as the disc rotates.

comparison it must be remembered that the 30 lines of the television picture may be spread over a screen 3 inches wide, so that there are then actually only 10 lines to the inch.

This might seem to promise a very crude picture with little detail, but the results actually obtained are considerably better than one would expect. The half-tone block is not really a perfect analogy, and the television picture behaves differently in several respects.

The pictures now obtainable from the B.B.C. transmission are, in my opinion, good enough to be of real interest to the



### AUTHOR OF OUR REVIEW

A recent portrait of the author of "P.W.'s" Television Survey, Mr. G. P. Kendall, B.Sc.

is only just fast enough, and it is usual to notice a slight flicker effect. (Increased picture frequency is one of the tendencies of present research.)

Another important fact about this transmission is that the spot of light covers the whole picture in thirty sweeps. This is what is called a "30-line" trans-

—TELEVISION—  
BREAKING UP THE PICTURE

*(Continued from previous page.)*

problem of making that beam "scan" the screen correctly.

The first thing we must understand is that there is a very similar process going on at the transmitter.

To get proper "assembly" of the pieces of the picture at the receiving end we must do two things: first we must see that we do our scanning on the same plan as that used at the transmitter when the picture was originally being broken up into the constituent pieces which we now want to put together again.

This simply means that we must arrange our scanning device in such a way as to make the spot of light sweep across the screen in the right direction—i.e. from top to bottom or from one side to the

THE REVOLVING SPIRAL

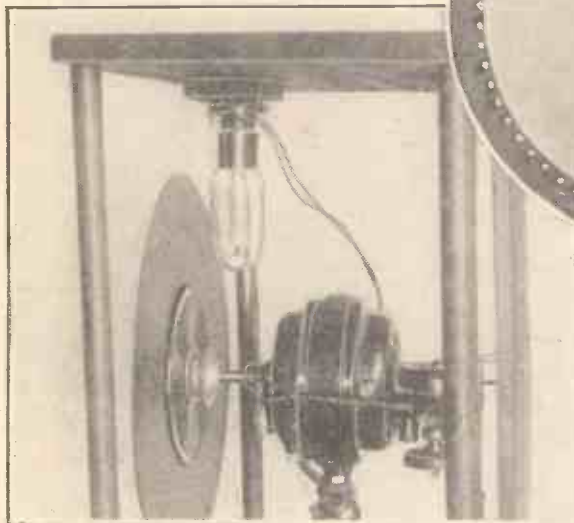

other—and also cover the screen in the same number of sweeps or "lines."

This is comparatively easy, for the right arrangement is known, and it is merely a question of the design of the scanning mechanism.

The second requirement is an obvious one: we must arrange to do

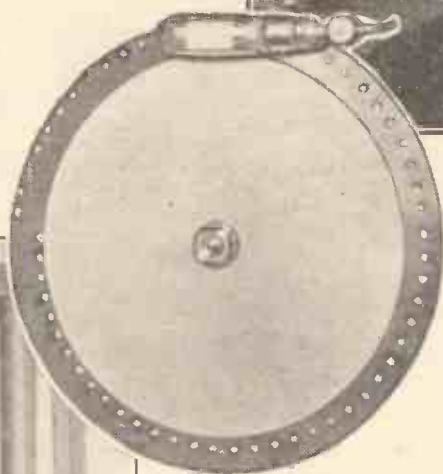

To the left is an amateur's scanning disc mounted in position, and the picture above shows the spiral in detail, and how it is illuminated by a neon lamp in a typical arrangement.

our scanning exactly in step with the corresponding process going on at the transmitter.

This is usually called "synchronising" a television receiver, and is by no means

ANOTHER TYPE OF DISC

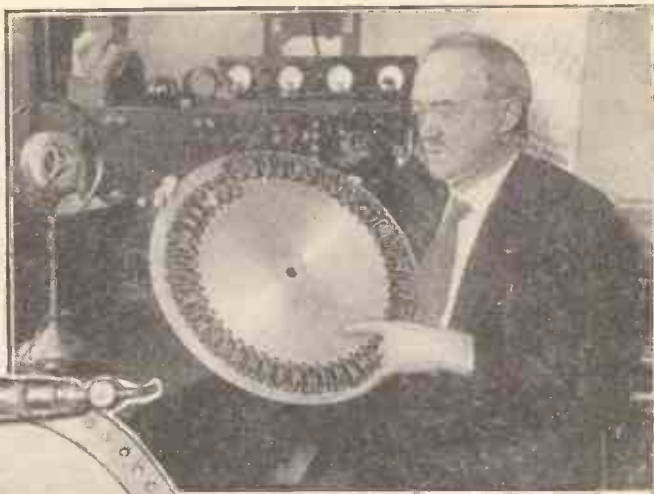

In this lens-scanning disc the spiral arrangement is again clearly depicted. It is being inspected by G. Francis Jenkins, the American television inventor.

such an easy matter. Indeed, it represents one of the most difficult of the practical problems involved in television.

You see, we have not merely to get our apparatus in step, but we must *hold* it in this condition indefinitely with great accuracy. A very slight error is sufficient to send our collection of pieces into the hopeless confusion of a jig-saw puzzle which has been well shaken up in its box!

An Important Subject.

The subject is such an important one that I shall have to devote the whole of one of these articles to this alone.

Probably the easiest way to arrive at an understanding of the basic principle of scanning is to investigate in detail the working of one particular method. If we grasp this thoroughly we shall find it simple enough to understand the other ways of producing the same result.

For our example we will take what is called the "scanning disc," which was

*(Continued on page 806.)*

ONE of the most significant tendencies in present television research and experiment seems to me to be found in the determined attempts which are being made in many quarters to increase the number of scanning lines in use.

More lines, of course, mean more detail and better picture quality and the ability to transmit a much less limited range of subjects. That, in turn, means more interesting programmes, with more varied subjects.

The transmission now available gives us a picture of thirty lines, and it is really surprising what detail and quality the B.B.C. manage to get with it. When, therefore, we learn that successful tests have been made, both here and abroad, with apparatus giving as many as 120 or even 180 lines per picture, it seems as though the future might have something really exciting in store for us.

A Radio Problem.

Pictures so finely divided as this give a wealth of detail and a perfection of gradation which puts them definitely in the same class as, say, home "movies," which, as some of my readers will no

**RECENT DEVELOPMENTS**

Reviewed by G. P. KENDALL, B.Sc. doubt know, are not far short of the professional standard.

Interesting as the prospect may be, it is important that we should realise the existence of certain limiting factors if we are to understand exactly what is going on. Only thus shall we really be able to feel that we are keeping abreast of developments. Now, the point really is that the main difficulty in transmitting these many-lined pictures is not so much a television problem as a radio one.

To devise apparatus which will deal with the television part of the process is not such a very formidable matter, and the real snag is only encountered when an attempt is made to send these fine-detail pictures from place to place via ether.

This arises from the fact that the electrical impulses which are equivalent to these pictures involve a range of extremely high audio frequencies which it is not practical to include in the modulation of a transmitter working on the ordinary broadcast wavelengths. To do so would mean such a broad belt of "side-bands" that severe interference would be caused, and great difficulty would be experienced in designing a receiver to cope with them.

Ultra-short Wavelengths.

It seems, therefore, that if we are to be able to exploit the possibilities of these fine-detail pictures on the present systems of television we shall be compelled to use some ultra-short wavelength. That, of course, is the explanation of the short-wave tests which are being made from the Crystal Palace and elsewhere.

The wavelengths which have so far been used in experimental work have been so short that there will, obviously, be considerable difficulty in the way of participation by the general public, but that need not worry seasoned constructors like the readers of "P.W." For them I can see a very interesting time in the offing.

# Recommended WRINKLES

## DAMPING VIBRATION.

WHEN incorporating a speaker in the same cabinet as the set, we sometimes find that the vibrations set up by the speaker causes the detector valve to emit a ringing sound.

A very effective method of damping out the vibrations is to tack on to the underside edges of the baseboard lengths of draught-excluding rubber. Another advantage of doing this is that any under-board wiring is kept clear of the cabinet shelf.

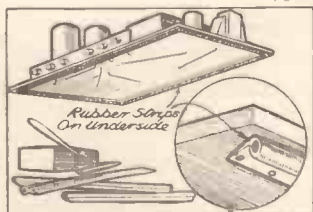

A "draught excluder" tacked round the bottom of a baseboard serves two useful purposes.

The rubber can be bought in various sizes, but 1/4 in. is large enough for this job.

## PORTABLES IN WINTER-TIME.

THE portableness of the portable is not of nearly so much importance in the winter-time as in the summer. Because of this, and because the set gets used for much longer hours, many listeners who have mains in their house run their portables in the winter from a mains unit.

The supply of a comparatively large current from such a unit is neither expensive nor undesirable, so when working a portable from a mains unit it is often a great improvement to substitute the output valve by one of a larger type. Portable set power valves are of necessity restricted in the power they can handle, so the change of valve suggested will doubly improve the set by making bigger volume and better quality available.

## ADDITIONAL VENTILATION.

ADDITIONAL ventilation is often thought advisable in a mains receiver—or the metal containers in which the eliminator is contained, as they sometimes become abnormally warm, due to varying causes. There are several methods of enlarging the present ventilation holes, but even

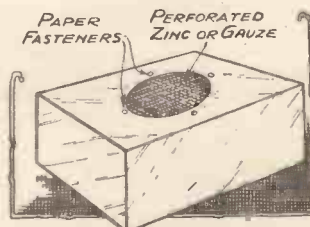

Perforated zinc held by paper fasteners provides better ventilation for a mains receiver.

when enlarged to their maximum, only a slight increase in ventilation is obtained.

It is suggested in such a case that the whole of the metal surrounding the ventilation holes be removed, and a piece of perforated zinc or wire gauze fitted. There is no need to screw or solder the zinc or gauze into position—four ordinary brass paper-fasteners will do the trick.

## MAKING SMALL BOX-SPANNERS.

SMALL box-spanners to suit the B.A. sizes are easily made up from small brass tubing. The tubing can be softened by heating and plunged into cold water.

Only one end of the tube should be softened. The nuts for each particular size should be inserted in the soft end; they should just fit on the corners in the tube. Then the end of the tube is knocked gently to shape with a small hammer while resting the tube on a flat surface.

with insulating tape. A simple way of making sure that the joint cannot part is to tie the ends together, as at B.

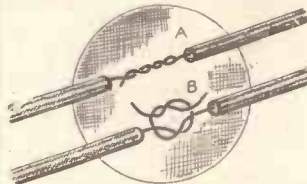

"A" shows how not to join wire. "B" is the best method.

The resulting joint may be a little more bulky, but it is strong and, electrically, just as good as the normal method.

## VARIABLE-MU BIAS.

IT is important to use the correct value of maximum bias with a battery variable-mu valve in order to

The D.C. resistances of the above will be very much lower than that of an equally effective resistance.

If these precautions are taken practically the full available voltage will be obtained on the anode.

## REGARDING D.C. SETS.

ON a receiver which has its H.T. taken from D.C. mains it is advisable as a precaution to have an output filter in order to prevent any possibility of a serious shock from touching the speaker terminals. It should be noted that when a choke is used a fixed condenser in each lead ought to be used to be entirely effective.

Where a pick-up is in use, it is also desirable to insert a condenser in each lead, otherwise there is the chance of a shock if the terminals of the pick-up are not insulated.

The condensers should be of a large value of, say, 2 mfd.

## A USEFUL DRILL GAUGE.

THE set builder frequently wastes time deciding which is the most suitable drill for the bolt or screw to be used.

So keep a small piece of bakelite, say 3 in. by 1 in., with holes drilled, therein by all the drills in one's tool

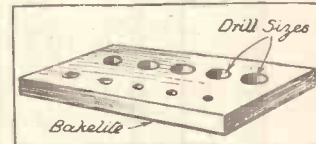

A permanent drill-gauge is made by drilling a piece of ebonite with all the drill sizes in one's tool kit.

kit and in order of size, and each hole marked with its relative drill size. By slipping the bolt to be used in its most suitable hole the drill size required is readily decided.

## COPPER-COVERED BASEBOARDS.

AFTER a time wires that are screwed direct to a copper-covered baseboard sometimes fail to make perfect contact owing to the copper becoming oxidised.

To solder the wires on direct is generally a little difficult to many. However, if the holes in the copper made by the screws are tinned all

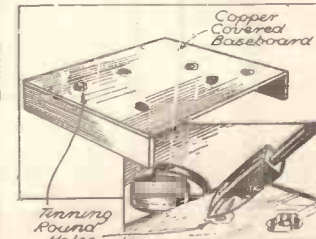

Tinning round the holes through which wires are screwed to a copper-covered baseboard ensures a good connection.

round for about a quarter of an inch, so that the usual wire loop is screwed down on to the tinning, the result is a perfect contact.

## ONE GUINEA FOR THE BEST WRINKLE!

Readers are invited to send a short description, with sketch, of any original and practical radio idea. Each week £1 is paid for the best Wrinkle from a reader, and others published will be paid for at our usual rates.

Each hint must be on a separate sheet of paper, written on one side of the page only. Address your hints to the Technical Editor, "Popular Wireless," Tallis House, Tallis Street, E.C.4, marking the envelope "Recommended Wrinkles."

Will readers please note that the Editor cannot, in any circumstances, guarantee to return rejected Wrinkles, and that payment for published hints is not made until ten days after they appear?

The best Wrinkle in the December 30th issue was sent by Mr. Henry Hackett, 10, Netherthorn Road, St. Margarets, Twickenham, to whom a guinea is being awarded.

The tubes can be made as long as needed to get into awkward corners, but short pieces can be utilised by cutting a slot across the opposite end for the insertion of a screwdriver, which

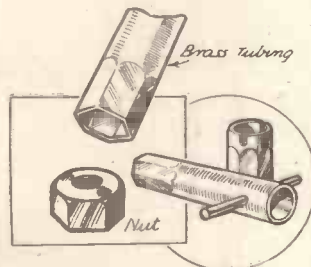

Brass tubing stands up well to the work of a box-spanner.

takes the place of the lengthened tubing and thereby effects an economy. On such small sizes there is not a great amount of wear, and the brass tubing stands up very well.

## SECURE JOINTS.

FLEXIBLE leads usually are subjected to a certain amount of strain, and it is not an infrequent occurrence for a joint to break down under this strain and for the ends of the wire to be pulled apart.

The usual way of twisting the wires is shown at A, and it is not surprising that the ends sometimes unravel themselves, even when the joint is covered

obtain a satisfactory "distributed" control of volume through the rotation of the potentiometer knob.

If too large a bias is employed a small movement of the potentiometer knob will cut signals out completely, while if the bias is too low the control will not be sufficiently effective.

The actual value will depend upon a number of circumstances—the type of valve used, the distance from nearest station, efficiency of the aerial, etc.

Some short-base variable-mu valves require a maximum bias of only 4 1/2 volts or so, while other types of valves require as much as 12 or more for full control.

When situated some distance from the the "local" less bias would be needed, of course, for any particular valve than would be the case when situated fairly close.

## CHANGING TO POWER-GRID DETECTION.

IN order to change the ordinary leaky-grid detector to a power-grid detector, apart from alterations in the values of the grid leak and condenser, the anode voltage must be increased very considerably. If the maximum H.T. voltage available is no more than 200 to 250 volts, it means that any high D.C. resistance in the anode circuit must be avoided.

Consequently, the use of resistance-capacity coupling in any form must be avoided. Transformer coupling should be used with the primary connected direct in the anode circuit, the usual decoupling resistance being replaced by an L.F. choke.



# FURTHER

The "S.T. 500," Mr. Scott-Taggart's latest triumph, is now firmly established as the greatest masterpiece of modern set design. Ever since the details of this magnificent receiver were published in "Popular Wireless," letters of appreciation and congratulation have been pouring in from all parts of the United Kingdom and from distant countries of the world.

Many of these letters have already been printed in "P.W.," and here is another large selection from satisfied constructors of the "S.T. 500," the receiver which ably deals with the most difficult of present-day ether conditions.

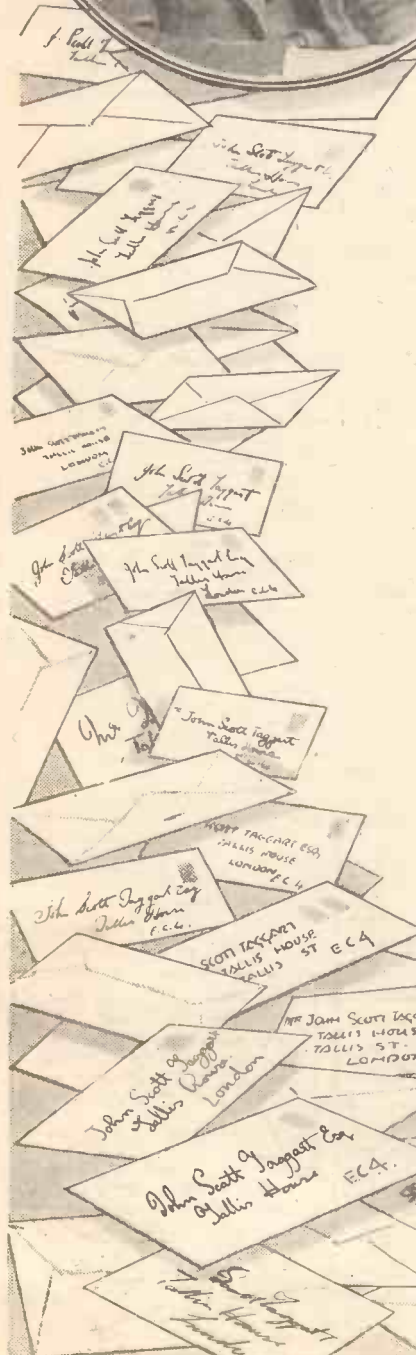

## BROCKLEY

**"VERY PLEASSED WITH THE PERFORMANCE."**

[From W. Corbett, Brockley Grove, Brockley, S.E.4.]

"On the appearance of your 'S.T.500' in 'Popular Wireless' I built the set, and am very pleased with the performance which I get, coupled with the control possible by means of double reaction."

**"SINCERE THANKS."**

[From A. C. Godbold, St. Asaph Road, Brockley, S.E.4.]

"As you have made the best gift to constructors for years, I send my sincere thanks for the 'S.T.500.' The long waves give me a new source of entertainment, and I endorse all the testimonials. But no one has mentioned what a marvel has been invented without 'cans.'"

## LEICESTER

**"IT IS CERTAINLY GREAT."**

[From E. Waterfield, Houghton Street, Leicester.]

"I have just completed the 'S.T.500,' and at first try-out it is certainly great."

## LIVERPOOL

**"SO PLEASSED WITH IT."**

[From J. Mackenzie, Essex Street, Liverpool, 8.]

"I have built the 'S.T.500' for a friend, and am so pleased with it that I will certainly convert my 'S.T.400.'"

**"A WONDERFUL SET."**

[From T. Reyner.]

"I have finished the 'S.T.500,' and think it is a wonderful set. Its tone is great; it has a punch like Carnera! I previously had a good make of four-valve set (two screen-grid valves) which I thought was good, but it has to take second place to the 'S.T.500.'"

## ISLE OF MAN

**"RESULTS ALL THAT ARE CLAIMED."**

[From James Boyd, Stanley Mount, Ramsey, I.O.M.]

"You will be interested to learn that I have just completed an 'S.T.500' set as described in 'Popular Wireless,' and the results are all that are

claimed for it. As this is the first set I have built, it says a great deal for the conciseness of your instructions."

## KENLEY

**"IT IS WONDERFUL."**

[From F. Bucknell, 49, Lower Road, Kenley, Surrey.]

"Having built the 'S.T.500,' I am very proud of it. It is wonderful."

## DUNDEE

**"THE TONE IS SUPERB."**

[From Wm. C. Ramsay, Rankin Street, Dundee.]

"My sister had a three-valve set which was certainly good, and we all enjoyed the entertainment immensely, but my assistant drew my attention to your articles in 'Popular Wireless' on your 'S.T.500,' and nothing would keep me back from trying my hand at building the set."

"I have never in all my life—and I am now beginning to feel the toll of the years—handled any mechanical tools of any kind. I have no acquaintance with wireless names and signs, and I may say that this puzzled me, as my kit often differed in minor particulars from the components you used."

"It took the whole week, starting at 9 p.m. every evening. I came up at 2.30 p.m., and found my sisters enjoying glorious music on the 'S.T.500.' The volume and purity of tone are superb, and the reproduction of singers and speakers is marvellously natural. I tender you my sincere thanks, and we are all looking forward to enjoying the good things in the world of wireless this winter as never before. It beats anything I have yet heard."

## PECKHAM

**"A PERFECT RECEIVER."**

[From H. R. Heywood, Sidmouth Grove, Peckham, S.E.15.]

"I thank you for your memo, and have made the necessary alteration, and am very pleased to say how delighted I am with such pure tone and wonderful reproduction which I have never heard so well before. Please accept my sincere thanks for such a perfect receiver."

[This constructor was applying negative grid bias to a Class B valve other than the B21. Ed.]

## MAIDA HILL

**"ABSOLUTELY ASTOUNDED."**

[From T. Jefferiss, Bravington Road, Maida Hill, W.9.]

"I am pleased I persuaded two of my friends to build your 'S.T.500,' with the greatest results, as they are absolutely astounded, to use their own words, at the tremendous volume and loads of stations they receive."

# CONTRIBUTES TO S.T. 500

## WALLASEY

"MORE THAN REPAID ME."

[From J. L. Read, Cross Street, Wallasey, Cheshire.]

"I saw the announcement of your 'S.T.500,' and decided to indulge, and am pleased to say that it has more than repaid me for my trouble. Splendid results."

## BRISTOL

"DELIGHTED WITH IT."

[From C. Arthur Prideaux, West Street, Oldland Common, Bristol.]

"Having put these faults right, I really must say that the 'S.T.500' is all that you claim for it, and I am delighted with it."

## LOWESTOFT

"SPLENDID PERFORMANCE."

[From F. Jenkerson, Royal Avenue, Lowestoft.]

"I have just completed the 'S.T.500,' and I am very pleased with its splendid performance. It is the first set I have ever built, but as the instructions were so clear I had no difficulty in following them. I think you deserve all the praise that has been given you by home constructors in 'Popular Wireless.'"

## TUNBRIDGE WELLS

"EVERYTHING YOU CLAIM."

[From G. J. Merritt, Park Street, Tunbridge Wells, Kent.]

"Have made the 'S.T.500' and wish to thank you for such an efficient circuit. It is everything you claim."

## LEEDS

"A VERY FINE SET."

[From J. Crossley, Birstall, Nr. Leeds.]

"I should like to add a little more praise towards your latest success, the 'S.T.500.' I am about 12 miles from Moorside Edge. I regard it as a very fine set."

[Details are given of programmes heard on the speaker from five American stations received with the aid of double reaction.—Ed.]

## LEICESTER

"THANK YOU HEARTILY."

[From Wm. Hartshorn, Birstall, Leicester.]

"Thank you heartily for the 'S.T.500,' which gives me a greater pleasure in listening than I have had before."

## LIVERPOOL

"VOLUME IS TERRIFIC."

[From E. A. T., September Road, Liverpool, 6.]

"I have just built the 'S.T.500' exact to specification, and would like to say that I am very pleased with it. The volume is terrific and the tone beautiful. I have used a Rola Class B speaker and left the output choke out of the set."

## PERTH

"FINEST SET I HAVE EVER HANDLED."

[From D. Horn, 12, North William Street, Perth, Scotland.]

"I have built your 'S.T.500,' and it is just the finest set that I have ever handled. I have been one of your followers ever since

you designed the 'S.T.100,' and home-built every S.T. set as it came along. I may also mention that I have built dozens of 'S.T.300's' and 'S.T.400's,' and they have all turned out to be a great success.

"May I say now how much I appreciate all you have done in the way of helping the amateur to attain many hours, weeks and months of joy and amusement, and, whatever may turn up in other sets, S.T. sets still remain far ahead."

## PENZANCE

"AN EXCEPTIONAL SET."

[From W. L., Market Jew Street, Penzance.]

"I have made up the 'S.T.500,' and am pleased at the powerful way it brings in stations which I previously thought were not receivable in Penzance except on a two-H.F. set. With thanks for an exceptional set."

## CORNWALL

"A1 RESULTS."

[From A. K. Creber, Liskeard, Cornwall.]

"'S.T. 500.' A1 results."

## LLANELLY

"REMARKABLY FINE SET."

[From E. S. Chubb, Llanelly.]

"As a constructor of the 'S.T.500' I should like to express my appreciation to the designer for a remarkably fine set.

"Up to the present my experience has not gone farther than a "straight" set, but my decision to build the 'S.T.500' has opened up a new era in wireless as far as I am concerned.

"Hitherto unheard stations come in at fine volume, and multiply the entertainment value of wireless to me many times."

## UNIVERSALLY ACCLAIMED

A photograph of the 'S.T.500' about which constructors have sent thousands of enthusiastic letters.

★ ★

## SWINDON

"DELIGHTED WITH ITS PERFORMANCE."

[From L. W. Allford, Brunswick Street, Swindon.]

"I have built the 'S.T.500' and am delighted with its performance, both on radio and gramophone. I am working from an Ekco A.C.25 eliminator, using no stabiliser, and there is no trace of instability or distortion."

## GLAMORGAN

"ALL HAVE BEEN SUCCESSFUL."

[S. J., Douclais, Glamorgan.]

"I should like to say I have built many 'S.T.300's,' 'S.T.400's' and 'S.T.500's' for my many radio friends, and, of course, it does not need any comment from me as to how successful they have all been."

## FALMOUTH

"REALLY PLEASSED WITH MY 'S.T.500.'"

[From E. W. Wright, Woodland Terrace, Falmouth.]

"I am at present in England on leave from Nigeria, and have just built your 'S.T.500.' Being aware of the fact that conditions in Cornwall are generally considered to be bad, I was prepared to make allowances, but it was not necessary.

"If you can build a short-wave set which is as big an advance on present practice as the 'S.T.500' is over the usual good broadcast receiver, and don't do it—well, my thoughts turn in the direction of boiling oil!

"If you have read as far as this you will have gathered that I am really pleased with my 'S.T.500.'"

(Continued on page 812.)

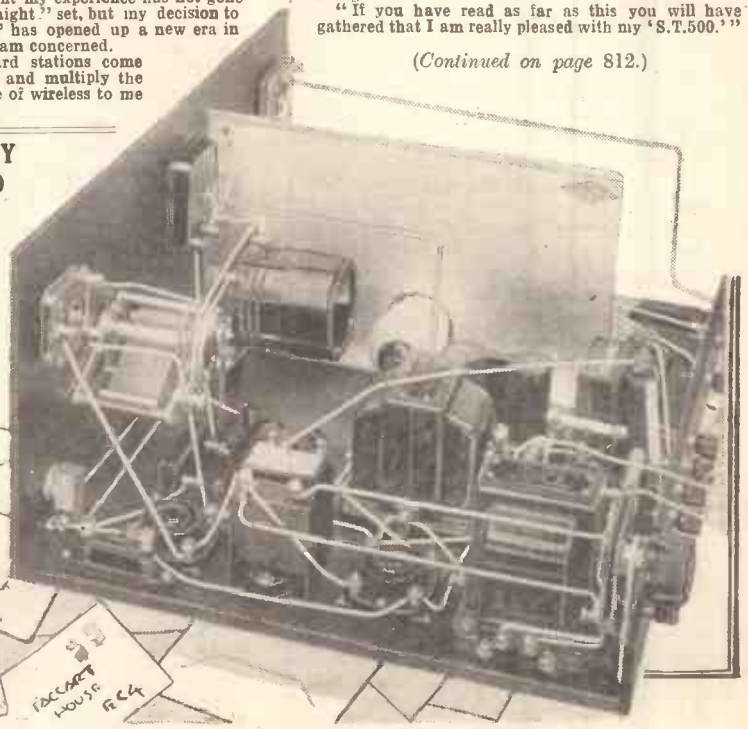
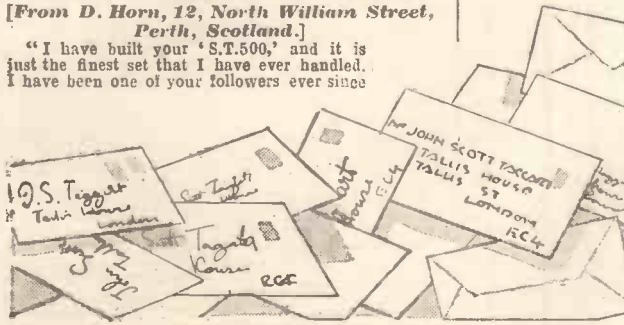

THE MIRROR OF THE B.B.C.

## THE PROBLEM OF B.B.C. FINANCE

More Trouble about Studios — Mr. A. P. Herbert's Saturday Night Discussions — Disatisfaction Regarding Staff Anonymity — West Region Director Coming to Portland Place? — Broadcasting and Travel

REFLECTIONS BY O. H. M.

THERE is a good deal of anxious thought being given to B.B.C. finance these days. The chief problem, of course, is to try to estimate the "saturation point" of licence revenue, and to give this a "date." Although licences are up by about a million in the past twelve months, the programme officials are not so foolish as to expect a continuance of this sort of increase indefinitely.

Meanwhile, programme expenditure has gone steadily ahead. Also capital requirements impose a great and persistent strain. No sooner is the regional scheme finished than it requires adapting to new needs. Also the factor of obsolescence of other equipment is an absorber of a good deal of money.

I hope that the result of the deliberations that will take place early in the year will be a clearer recognition than in the past of the priority of the claims of entertainment. If expenditure is to be checked here and there, and obviously it will have to be, let it be in the "luxury" services of education and not in the real service of entertainment.

### The "B.H. Crisis."

What has come to be known as the "B.H. Crisis" has blown up again in Portland Place. This time the cause is something like an ultimatum from those responsible for the disposition of studios for rehearsals and performances. It has been known for some time that Broadcasting House has proved rather more than inadequate for programme requirements. Those who planned it apparently worked out their scheme on the basis of Savoy Hill experience.

No account was taken of the probability of greater attention to rehearsals as the service developed. The result is quite a serious state of affairs, which is not being solved by the expedients of "Maida Vale" or the adjoining houses in Portland Place. The time is approaching when Sir John Reith and the Governors will have to step in and settle the matter on a big scale. Also it would not surprise me to hear that Parliament will show some curiosity as to why the original plans were so lacking in foresight and vision.

### A. P. Herbert's New Feature.

One of the most intriguing departures in the programmes for 1934 is the A. P. Herbert Saturday night feature. Mr. Herbert has been charged with the task of organising and compèring "Fireside" discussions with eminent leaders and thinkers on topics of the moment.

The list is impressive, including H. G. Wells and Winston Churchill. Mr. Herbert

himself is tremendously keen but still a little apprehensive about the degree of freedom he will be given. He holds, and rightly, that normal censorship should be lifted, the talkers being allowed to say pretty well what they like.

This principle has neither been conceded nor denied. I dare say the B.B.C. Talks officials are hoping to "try it on the dog";

## BILLY MERRIN AND HIS COMMANDERS



The popular dance band which Billy Merrin directs from Nottingham has come back on the air to the delight of thousands of listeners. This "round-table conference" shows Billy himself with his ten "Commanders."

in other words to discover by experiment. If this is the case, I sincerely trust they will not be influenced by the adverse correspondence they may well receive from that section of the public that has a natural abhorrence of free speech.

On the whole, however, I think Mr. Herbert's ingenuity can be trusted to carry through the thing in the way listeners would like. If so, he will create an important new

IT should cause no alarm to listeners if they find themselves momentarily assailed by feelings of flatness. It is obvious that the normal broadcast fare to which the B.B.C. has again reverted should pale alongside the special riches lavished on us during the Christmas and New Year festivities. I've said it before and I'll say it again: "The B.B.C. does its big jobs well."

It is, perhaps, just as well that there are the fat and lean kine in broadcasting. Having the lean kine makes us appreciate the fat when it comes along. The Christmas programmes to me began with the Eric Maschwitz production of Dickens' "A Christmas Carol."

Despite the familiarity of this adaptation, it was as fresh as ever. Seymour Hicks' performance as Scrooge was superlative. Added to this was Robert Chignell's charming music, a multiplicity of effects, the seasonable church bells ringing out their Christmas message, all of which moved along as on the oiled of oiled wheels. The whole thing was a triumph.

The Christmas Day programme approached the marvellous. That direct contact with Jerusalem passed my understanding.

I am not sorry that I still possess an acute sense of wonder. I always enjoy a speaker better if I know him, or know of him. I like to think I know the Bishop of Jerusalem. Anyhow, I met him last

landmark in the history of British broadcasting.

### "Anonymity" Again.

One result of the attempt to tighten up the anonymity rule for programme officials and others engaged on the B.B.C. staff is growing dissatisfaction wherever the rule is applied. There is also a feeling of unfairness and frustration. While, on the one hand, it is allowable and in fact encouraged for band and orchestra conductors to have publicity, announcers and programme builders are subject to an impenetrable impersonality.

In the case of announcers the rule has been applied to ridiculous lengths. Most of the announcers are known by name to millions of listeners through the enterprise of journalism. The rule means simply that new announcers get no chance of being similarly known.

### Mr. Appleton for London?

Mr. E. R. Appleton, the energetic and popular West Regional Director of the B.B.C., may be transferred to London during the spring. Mr. Appleton is the founder and conductor of "The Silent Fellowship," the "Joan and Betty" stories, and the Carolare series. He has felt for a long time that he would like a wider field in which to develop his special ideas.

First of all it was a possibility that he might take over all the educational and children's activities of Head Office. This, however, did not materialise, and it is thought now that Mr. Appleton will come to London as a specialist adviser on his subjects, the West Region being handed over to Mr. Sutthery, the present Director of Programmes at Cardiff.

### Transport and Holidays

This year the B.B.C. is likely to do much more for travel and holidays than ever before. Both Sir Frank Wedgwood, head of the L.N.E.R., and his opposite number (Continued on page 806.)

## THE LISTENER'S NOTEBOOK

Frank comment on recent programme and on microphone personalities of the moment.

year in a Cambridge college hall, and I remember he kept us all in fits of laughter throughout a lengthy and amusing after-dinner speech.

Last week I looked back. This week I shall look ahead. One scarcely looks for any changes in music. In any case, it were possible. But talks are a different proposition. The new programme of talks for the next quarter, now published, look very much the same in substance as the one it has succeeded. But the people to give the talks are different, and they sound attractive.

The group of talks under the title of "Taking Stock," arranged by the Central Council for Broadcast Adult Education, is in the hands of a number of celebrities, including Mr. H. G. Wells, Mr. Churchill, Mr. Lloyd George, Mr. Ernest Bevin, Mr. Israel Sieff, Mr. Bernard Shaw, Mr. Walter Elliot and Mr. Quintin Hogg.

Interesting as all this sounds, my fancy is the talks on spiritualism, or as the B.B.C. have named the series, "Inquiry into the Unknown."

Sir Oliver Lodge, whose subject is to be "Do We Survive?" is a fine broadcaster, and he can be certain that all Britain will be tuned in on his night. Among the other speakers are Professor C. G. Seligman, Mrs. W. H. Salter, Dame Edith Lyttleton and Professor C. D. Broad.

(Continued on page 806.)





P. P. Eckersley's opinions on foreign listening are changing somewhat. His dislike of distant-station reception is diminishing because, as he puts it, "The receiver is so much tamer than it was." That is why he devotes his page this week to a brief study of Automatic Volume Control—outlining its advantages and touching upon its methods of operation.

**N**OW is the time for listening to far-away stations and for oscillating on Sunday evenings. Now the Heavside layer does its best for us, and signals are readable with loudspeakers in the linen cupboard while I was upstairs having a bath strength.

But delayed auto-gain circuits help enormously to tame all the many things which tend to make it all rather hideous and noisy. I think the delayed auto-gain circuit the most important practical adaptation we have had since mains power was made usable to energise receivers.

**Intrigued by the Technique.**

My dislike of distant listening is diminishing, not only because my dislike of local listening is increasing, but also because the receiver is so much tamer than it was. I have given up hoping that wireless programmes would give me pleasure in themselves, so now, more and more, I am becoming intrigued by the technique of wireless reception. I am changing my mind, but then I have a mind to change, besides which circumstances are altering.

In early days one felt one was just going to hear something really good and forgave what was bad. Distant stations were very weak and receivers could only be handled by the very patient.

I was never one of these. The noises, too, however patiently one fiddled for them, were ridiculous if weak and barbaric if loud. It was so important in the early days to foster the idea that wireless should interest people in terms of the programme received and not by the method by which that programme was received.

The best receiver I then said was the one which was easiest to handle and brought in the clearest signals. But the clearest signals were local signals. The local programme was free from noise, gave good quality and was just going to be interesting. So I said, "Listen locally——" But lots laughed.

**Selectivity and Quality.**

But to-day people won't buy a receiver unless it gets foreign stations, because they feel they want to use it on Sunday. So the simple commercial receiver cuts off most top—some say that a selective receiver cuts around a frequency of 3,500! So the quality is just as good (bad) on the local as on the distant; it has to be.

Moreover, the distant has come up in power tenfold—a hundredfold. And with the Heavside helping is for quite long periods as loud as the local. And, be it whispered, usually more interesting.

But, in spite of all these things, I would not listen to distant stations if (1) I could get my local up to 10,000 a second and have real quality; (2) I could rely upon finding a modicum of the proper spirit behind my local; (3) I had to use a volume control for distant stations, or, in other words, could not use the (D.) A.V.C. (delayed automatic volume control).

**Simplifying Distant Reception.**

But it is so lovely to be able to turn a knob and hear this and that and the other with no bother in further twiddling. No!

**SELF-CONTAINED UNITS**



There are several makes of commercial Automatic Volume Control units on the market. All of these are self-contained, making use of a Westector for the rectification of A.C. as explained by our Chief Radio Consultant. Readers who think of converting their own receivers to use A.V.C. should remember that considerable high frequency amplification is necessary to ensure the satisfactory working of such a control, and it should not, as a rule, be incorporated in a set having less than two H.F. stages. Circuits incorporating A.V.C. have been published from time to time in "POPULAR WIRELESS."

I don't like twiddling, perhaps because I do so much of it "researching" into bits of problems in my workaday life; perhaps because I know that the set of the future is one which gives the user no bother to use. And whatever the morals of it all, that is the fact.

I heard a set the other day on a fair-sized aerial which wasn't too noisy in the condenser intervals, where no station carrier reduced the sensitivity, and it certainly was a joy to handle—and it WASN'T A SUPER!

How does A.V.C. work? Of course, that's the question I set out to answer and explain.

Of course, you know that a variable-mu valve is one which varies its magnification

as its negative grid bias is varied. The more negative on the grid the less does the variable-mu valve magnify.

Suppose we start with a very sensitive arrangement, very little or no negative on grids of the H.F. variable-mu valves. We then turn the tuning condenser. Along comes, let us say, a very weak station. Then the receiver, being very sensitive, will receive it.

**How the System Works.**

But it's a dull station, and so we go on searching. Suddenly the local station, very powerful. If nothing is done about it, it blows up the set, scares the cat and shatters the nervous system. Here's where A.V.C. comes in. A.V.C. takes part of the signal and makes it put negative on the grid of the H.F. valves to make them less sensitive. The stronger the signal the more the negative, the less sensitive the set. A balance is obtained.

But A.V.C. has a disadvantage, because the arrangement desensitises the set directly any signal comes along. Even the weakest signals desensitise the set a bit. So delayed A.V.C. has been invented where the grids are left in a condition for maximum sensitivity until a certain strength of signal comes in, that strength being equal to or above a level which would overpower the set.

In other words, delayed A.V.C. makes the set have a given and proper sensitivity for all strong signals, while it is as sensitive as it can possibly be for weak signals.

How is it done? How questions do go on getting asked! Well, it's done by taking the amplified signal and rectifying it and turning it into a D.C. current and passing the D.C. current through a resistance and tapping the variable-mu valve grid on to that resistance.

**Delaying the Action.**

Then the more the signal the more the D.C. current and the more negative along the resistance. Delayed A.V.C. is achieved by backing off a voltage to act against the rectified signal voltage so that no current can flow, and so no negative can get on the grids until the rectified signal exceeds a certain amount.

Try to work out some ways of doing this, and then have a look at the standard diagrams procurable from the rectifier makers. Dry or metal rectifiers are used—G.B.D.A.V.C. (G.B. does not stand for grid bias).

I AM asked by Mr. Art Bates (W 9 F O) to refer back to "P.W." for March 4th, when my page of Short-Wave Notes was illustrated by a photo of the veteran operator of the Swedish station, S M 6 U A, under the query "The World's Oldest Ham?" Mr. Bates asks me to mention that the operator of the American station, W 8 A R J, is over eighty! This beats S M 6 U A, who is only a youngster of sixty-five, by a handsome margin. I wonder whether I shall still be enthusiastic over "ham" radio when I am eighty, if I ever reach that venerable figure.

#### Loss to Short-Wave Work.

Short-wave enthusiasts all over the country will be sorry to hear of the death of Mr. F. T. Carter, who for so long has been the agent in this country for the Amateur Call-Book. I, for one, shall miss my regular correspondence with one who, though I never had the privilege of meeting him, was quite an "old friend."

Those of you who take a pride in keeping logs systematically might well copy the example of "C. H. H." (Calstock), who has evolved a very neat log-pad for his own use. It takes the form of a small duplicate-entry book, the top leaves being torn off and sent to the stations, when verification is required or reporting is thought useful, the second sheet being kept as a permanent record.

The International DX-ers' Alliance announces some special transmissions as follows: January 6th, 5-7 a.m. G.M.T., O A 4 B, Lima, Peru, on 42-10 metres. This is a special "gesture of goodwill" by the Peruvian Government.

January 14th and 28th, from 4-6 a.m. G.M.T., P A o A S D, Amsterdam, on 79-57 metres.

#### A Matter of Course.

These special transmissions are very valuable as a means of maintaining short-wave interest

## Short Wave Notes

News and comment by radio's foremost short-wave expert.

in these days, when we all seem to receive just what we want to and to take it rather as a matter of course. Reports should be sent to the stations concerned or to the International DX-ers' Alliance, 1018, North Prairie Street, Bloomington, Ill., U.S.A.

Full particulars of the I.D.A. may be obtained from Mr. R. L. Rawles, Blackwater Corner, Newport, I.O.W.

W. W., of Exeter, comes back into the

news again after a long absence due to illness and overwork. His recent loggings confirm my own experience, particularly with regard to the stations on the shorter waves, such as W 3 X A L on 16-87 and the 19-metre group.

He mentions that he has logged W 2 X E on 19-64—between W 8 X K and W 2 X A D. I have a feeling that I may have been listening to W 2 X E several times without knowing it, but I have never heard a definite announcement. All these stations, of course, vanish at or before sunset, so don't waste time looking for them after tea!

#### Look on the 49-metre Band.

W. W. mentions the Radio Club of Brazil's station, P S K, on 36-65 metres, asking in English for reports to be sent to the club at Rio de Janeiro. This clears up one or two recent queries. He also says that Nairobi is usually R 7 on Saturdays between 7 and 8 p.m. Don't forget to look for him in the 49-metre band, although one generally thinks of that band in terms of "Yanks" late at night.

#### Not Yet Logged.

I should imagine that there are very few readers of "P.W." who can claim to have heard a transmission from Bolivia. They may make up for this short-coming by listening hard for station C P 5, the property of the Compania Radio Bolivian at La Paz. He may be heard from 11.30 p.m. onwards on 49-3 metres, and I don't fancy that he has yet been logged in this country.

There is soon to be a short-wave broadcast from K Z R M, Manila, Philippine Islands, the manager of that station having announced the acquisition of a 5-kw. short-wave transmitter.

W. L. S.

### BERLIN'S RADIO NERVE CENTRE

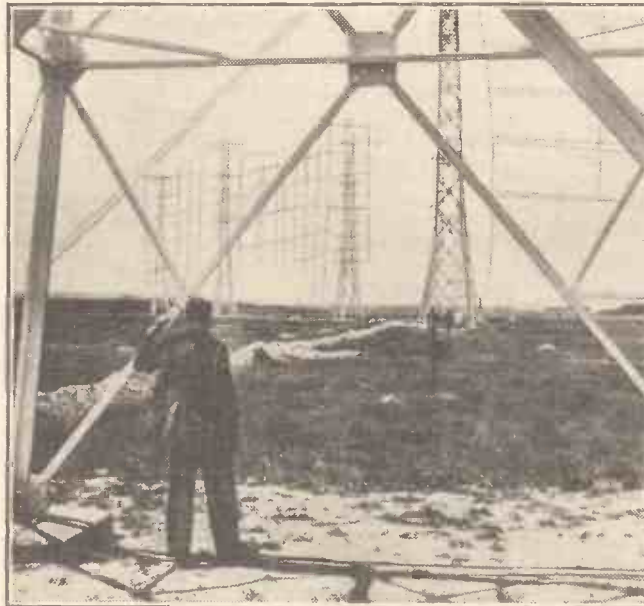

A view of some of the masts at Berlitz, near Berlin, which forms the central receiving station for German overseas radio communication. All transatlantic radio-telegraphic and telephonic messages will converge upon this station.

THE latest issue of H.M.V. records covers a remarkably varied range, from re-recordings of Caruso to a series of three discs incorporating a complete Gracie Fields "turn" at the Holborn Empire.

The new Caruso records are "For You Alone" and "A Dream" on DA1349, and "The Lost Chord" and the famous Handel's Largo, "Ombra mai fu" on DB2073.

Gracie's records are C2625-7, and are unique. Made under conditions of secrecy, they give practically every moment of a complete turn at the Holborn Empire, where the famous comedienne sings nine songs amid scenes of great enthusiasm.

For the making of these records a number of microphones were secreted in the footlights and in the wings of the theatre; special wiring connected these microphones with the "His Master's Voice" mobile recording laboratory which was parked at the side entrance of the theatre.

#### Disguised as a "Plain Van."?

In order not to arouse suspicion, the laboratory was disguised as a furniture pantechnicon, special canvas covers bearing the name of a well-known furniture store being mounted on the laboratory for the evening.

Naturally, Gracie Fields, during the act, moved about the stage, and it was necessary to keep the engineers in the recording laboratory aware of her movements. In order that a successful monitoring of the microphone might be achieved, a sound expert was accommodated in the wings of the theatre and controlled a system of coloured light signals whereby the engineers in the laboratory were kept *au fait* with Gracie's movements.

More serious records are those by various orchestral combinations. The B.B.C. Symphony Orchestra gives Sir Edward Elgar's "Cockaigne Concert

### ROUND the RECORDS

Old Sam's Party—"Why Build a Wall Round a Churchyard?"—Our "Gracie" at the Holborn.

Overture" on DB1935-6, on the last side of which is the famous "Pomp and Circumstance" No. 4. Then there is Grieg's "Concerto in A minor" by a full symphony orchestra with Wilhelm Backhaus (DB2074-6), and conducted by John Barbirolli.

A light vein is struck in "Old Sam's Party" by Stanley Holloway on a Columbia disc. Everybody knows "Sam" of musket fame, and here he gets together all the famous folk with whom he has been associated in other Holloway sketches.

This is no highfalutin fare—just old ale and sandwiches—but the party is graced by the "Dook," and by George the Fourth and his Queen, who hang up their crowns in the hall. The Queen meets Mr. and Mrs. Ramsbottom, who, on inquiry after their son Albert, tell of the unfortunate adventure of Blackpool.

#### A Valuable Addition.

It is good fun all round, and the listener is left with the impression that these characters, fantastic though they are, really do live, and that he has been eavesdropping on a party that has actually taken place.

I am particularly fond of Stanley Holloway's "Sam" series, and make a point of not missing any

records he brings out. This last (DX512) will be a valuable addition to a collection of records unique in their characterisations.

Another fun-maker is Will Hay's latest disc (Col. DX558)—another "Fourth Form at St. Michael's" sketch in which the aged Harbottle is still very much in evidence.

Anona Winn is one of my favourite broadcast and gramophone artists. She has a versatility that is amazing, and one of the cleverest recordings she has made is just released by Columbia (DB1285). "Tuning In" is the title, and it relates the experiences of a refined lady who switches on her radio and wanders from station to station, at home and abroad.

The result is merciless in its characterisation of the various vocal items rendered from the loudspeaker, including a realistic ballad soprano on the "National," whose song is duly punctuated by the inevitable "six pips." Everything is done by Anona, who has not only marvellous powers of mimicry but a really fine voice—and uses it.

#### "Nobody Wants to Go In."

Of all the tricks a trumpet can play I have seldom heard such a variety of effects as those provided in "The Nightmare" by the trumpet player. The record is a very amusing one by a new dance combination—Clyde McCoy and his Orchestra—and is well worth hearing. (CB679.)

Finally, let me recommend to him who has a morbid side to his nature an inexpensive record by Leslie Sarony. It is on Imperial "Trax," and is entitled "Why build a wall round a churchyard," advancing in doleful fashion the irrefutable reasons that the aforesaid structure is completely unwarranted, for "nobody wants to go in" and nobody wants (or can) to come out. Terrible and true; but it will make you laugh.

K. D. I.

# THE GREAT WAVELENGTH SHUFFLE

## "P.W.'s" OFFICIAL GUIDE TO THE 1934 CHANGES

THE re-arrangement of European wavelengths, which is to take place on January 15th in accordance with the recommendations of the Lucerne Convention, is one of the most drastic wavelength shuffles that has ever taken place in the whole history of radio. Even so, the "panicky" attitude of a certain section of the daily press is wholly unfounded, and with proper guidance on the matter there is not the slightest need or alarm as to the consequences.

First and foremost, let us endeavour to remember that whatever the temporary inconveniences at first, the materialisation of the Plan cannot but react to the good. With the ever increasing number of stations in the European zone, the conditions for satisfactory broadcast reception have become little short of chaotic, and it is with intent to "sort out the mess" that the present plan has been evolved.

For satisfactory transmission and reception, it is desirable for each station to have a band of frequencies ten kilocycles wide, and there are already far more stations requiring these ten-kilocycle bands than can possibly be accommodated within the lower and upper extremities



of the frequency spectrum set aside for broadcasting.

There is only one way out of the difficulty, and that is to place on adjacent channels stations which are separated by the widest possible margin geographically. It sounds easy, but there is little doubt that the present plan has only been drawn up after months of endless discussion, and if it only partially succeeds

The Lucerne Plan for the revision of wavelengths, which comes into force on January 15th, will more or less affect every receiver in this country—an enormous total of something like five or six million sets. For the guidance of its readers and with the official co-operation of the manufacturers, "P.W." has pleasure in presenting in this special supplement full details of the modifications that will be necessary to large numbers of sets when the change-over takes place.

in clearing up the present chaotic conditions, then it will, indeed, have been worth while.

January 15th is the red-letter day,

**YOU CAN BRING YOUR SET INTO LINE IN A FEW MINUTES!**

but do not assume that the present plan necessarily reaches finality. It is only when the change has actually taken place that the complete success or other-

## MANUFACTURERS' COMPLETE PLANS TO MEET THE NEW CONDITIONS

wise of the re-arrangement can be determined. In general, there is every indication that the scheme will be entirely successful, and that any modifications that may be necessary will be of a trivial nature. At any rate, let us all regard it as for the best.

It is inevitable, of course, that with such a drastic change-over as is to take place, a certain amount of temporary inconvenience will be caused to the listening public. But that is where "P.W." steps into the limelight with this special supplement.

The exact procedure to be adopted for practically every set—whether commercial or home constructed—is outlined in the pages which follow. The supplement has been prepared with the official co-operation of all manufacturers concerned, and it tells in a clear and concise manner their plans to meet the new conditions. Whether your set is commercial or home-constructed, the great January "shuffle" need hold no terrors, for "P.W.," in pursuance of its policy of being first with the news, enables you to overcome your own particular troubles with the minimum amount of trouble and inconvenience.

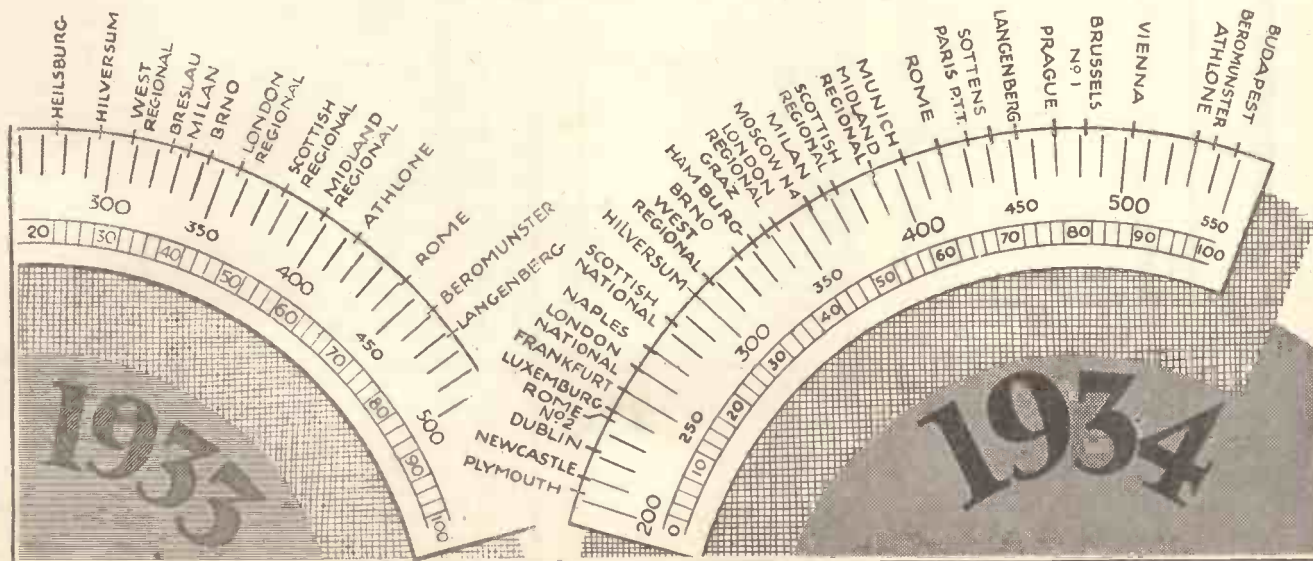



# How the HOME-MADE SET is AFFECTED

The Lucerne Wavelength Plan, which comes into operation on January 15th, will not make a great deal of difference to owners of home-made receivers. How they will be affected is discussed in the following article.

**W**HENEVER there is a big change in radio the home constructor usually comes off best. Not that he is always capable of making better use of a new development or of taking fuller advantage of a fresh scheme of broadcasting than the manufacturer, but he can adapt himself and his set to the new requirements very much sooner than the factory-set maker.

It is only natural, therefore, that the home-constructor receiver should lead the way in the practice of new ideas. Screened-grid valves, pentodes, A.V.C., Class B and so on are all examples of the versatility of the home constructor and of his adaptability. These radio advances were incorporated in home-constructors' sets and were in use in their homes long before commercial receivers of a like ilk were on the market.

## "General Post" in Wavelengths.

Therein lies no aspersion on the commercial-set maker. He takes up the worthwhile advances and adapts for the important radio changes as soon as he can; but obviously a factory-made article is not in itself so adaptable as the home-made variety, nor is it possible to swoop on a new thing and put it into immediate practice when factory conditions of layout, die stamping and so forth have to be satisfied.

So now, as ever, the home constructor is least affected by the new wavelength changes taking place at midnight on January 14th. In many cases the commercial-set owner will not be greatly affected; but whereas the set maker has in many instances incorporated named-station tuning in his receiver, this normally valuable asset has not been possible in the case of home-made sets unless the dials have been appropriately marked by the set builder himself.

So that, with a "general post" in the wavelengths, the home constructors can, with few exceptions, sit back and be practically unaffected. Naturally, the new positions of the stations on the wavelength or degree-marked scales will have to be noted, but apart from that there should be little trouble.

## Minor Annoyances will Occur.

The answer to the question, "Will the home-made set be affected by the Lucerne Plan?" can therefore be, to all intents and purposes, "No."

Minor annoyances are bound to occur with such wide alterations as have been

decided. Bournemouth and Plymouth listeners, for instance, may have difficulty in some cases in tuning low enough to reach their new wavelength of 203.5 metres, while the apparent relegation of Fécamp to a common wave may upset many "fans" of that station.

A few may lose Athlone when he moves up to 531 metres owing to inability to get their sets to tune high enough; while those who can get him may find him heterodyned by the Italian common-wave stations and Palermo, who share 531 metres with Athlone.

## London's Small-Power Neighbours.

The shifting of Sottens to 443.1 metres takes that interfering station which used to worry Midland Regional well out of its way, but this 25-kw. station is now going to a position only 9 kes. from the North Regional, whose listeners may now experience trouble instead.

Luxembourg is supposed to come down from the long waveband to 240.2 metres,

entered into for future long-wave sponsored programmes.

The first thing for the home constructor to do is, of course, to calibrate his set, if he has not done so, making a graph of the dial readings of the most constant condenser (the one not affected by aerial changes) against wavelengths. On this (or on his old one, if he has already made such a graph) he can mark the positions of the main stations in which he is interested.

As the long waves also are affected, another graph should be marked out for long-wave readings. These graphs are more useful than lists of stations and dial readings, for if carefully done they allow new stations to be found easily by reference to the chart and subsequent setting of the dials in agreement with the readings taken from it.

A simple way of marking old and new wavelengths on a graph is shown in one of the diagrams, which is intended to show how an already existing curve can

be utilised, or copied, to show where the main changes, as they affect the listener in question, have been made.

## Added Capacity.

But graph making is not all that will have to be done by some constructors. Those who cannot get up to such a favourite as Athlone will have to take steps to increase the tuning ranges of their sets.

The simplest way is to add small pre-set condensers, .0003 max., across the main condensers (carefully trimming them if ganged tuning is employed), in series with switches, so that they are only

connected when the top of the tuning band is to be explored. If they are left in circuit all the time the lower end of the band will be lost.

This alteration can be carried out successfully in all sets, provided care is taken

## KEEP THESE AT MINIMUM

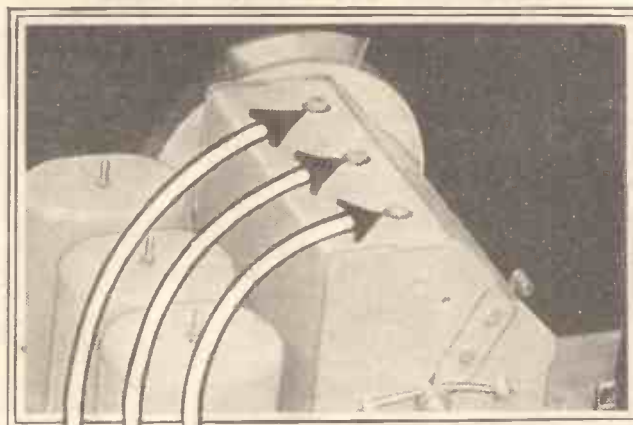

Bournemouth and other low-wavelength listeners will do well to see that any trimmers in their receivers are set to as low a capacity value as possible, in order that the minimum capacity across the tuned circuits shall be low. Added capacity in the form of trimmers carelessly adjusted is often the cause of a set employing ganged tuning refusing to go "well down." Very often the trouble experienced due to too much trimming capacity originates in the fact that an aerial circuit not needing any added capacity is given some owing to the mistaken idea that all the trimmers must be employed. More often than not one circuit needs no such capacity, while the others require a little to bring them into line.

where he will shake things up pretty well—if he does come down. We understand, however, at the time of writing, that his shift from his present "unauthorised" wavelength is unlikely, owing to his success there and the contracts he has

not to upset trimming when switching in the condensers where ganged tuning is employed.

Those who cannot get down in wavelength have a more awkward time, but few will be affected by the change in this regard—that they will not be able to get down to their favourite (or local) station. Bournemouth listeners will be among those thus affected, of course, and the problem is a difficult one to solve.

Unless simple coils and tuning circuits are used, nothing can be done of any great avail should the set fail to get anywhere near the required wavelength.

In cases of ganged sets, careful setting of the trimmers so that they are set at their minimum effective capacities will help, but apart from this little can be done.

**New Coils must be Substituted.**

In simple coils a few turns can be taken off the secondary winding of the medium-wave coil, but this step is very inadvisable when gang circuits are concerned. New coils that will go down (Colvern are excellent in this regard) will have to be substituted.

In superhets with one-dial tuning the trouble may exist if the oscillator is set to give its "upper" readings. Where a separate oscillator tuning control is used it will in many cases be found that the low-wave stations can be obtained by using the upper channel reading instead of the lower one when searching below 220 metres. The success of this, of course,

**THE OSCILLATOR DIAL**

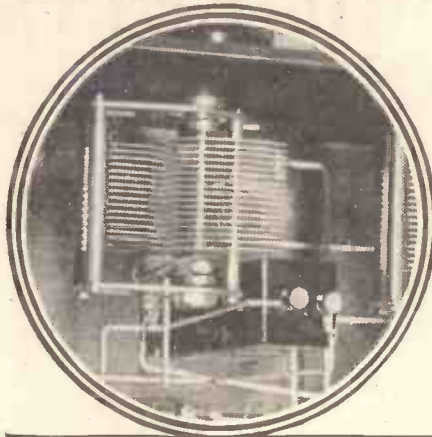

Where superheterodynes with separate oscillator dials are concerned it will be found that the lower of the two oscillator readings will be required for listening to some of the new wavelengths, notably Bournemouth and Plymouth, which are to be on 203.5 metres after the change. Single-dial supers cannot of course, be tuned in this way, as the oscillator control is fixed, and the choice between upper or lower setting of the oscillator condenser is made when the receiver is designed.

programmes can be obtained from Daventry on the long waves, while the apparent loss of Fécamp (we hope it is not really so) would affect a great number of "low" station fans.

If Fécamp goes to the French common wavelength he will be found on 215.4 metres, and if he uses the nearest International wave to his present wavelength he will be even lower—209.9 metres. In either case he would be badly heterodyned where British listeners to his programmes were concerned.

On the long waves, present home-constructor sets will not be affected, for no vital changes other than position within the normal limits of wavelength have been made. Huizen comes down to 1,345 metres and Radio Paris goes up to 1,796, Moscow taking 1,714 for its "number one" 500-kw. broadcaster.

**The Home Constructor Scores.**

These alterations should not worry listeners at all, other than slowing down searching until the new positions are memorised. The home constructor has come out of the whole business extremely well. He will be very little affected electrically, though we cannot yet say how much he will be concerned from the point of view of reception conditions.

In this, however, he will naturally be in the same boat as the manufactured-set owner—at first. But if he does not like the new conditions he can easily rebuild or alter his receiver, a comparatively simple matter.

And now, in answer to many who will be asking, "Why change the wavelengths?" a few words about the Lucerne Plan, as explained by the officials who have fostered the idea.

In the first place, the benefits accruing have to be looked upon from an international point of view, and not from that of any one country. So we find that some countries gain at the expense of others.

These latter are to be found among the older broadcasters with well-established systems, who have made sacrifices in the ether so that "younger" countries can establish better national broadcasting facilities.

In order to preserve peace in the European ether it is essential that some sort of fixed plan be arranged and agreed on by all countries. This the Lucerne Plan attempts to create, but unfortunately at the moment there are still broadcasters who will have none of it, and it is from them that interference may be expected. Actually, 27 countries signed the Plan and 8 abstained from acknowledging it.

**The Meaning of "Common Waves."**

To obtain adequate broadcasting service all over Europe certain countries have agreed to have common waves on which some of their smaller relay (and therefore local only) stations will broadcast. In addition there are International Common waves for small stations it may be found necessary to employ, but all these are to be of low power, and therefore incapable (?) of interfering with other broadcasters on the same wavelengths.

In certain bands, notably above 600 metres, it has been necessary to restrict the kilocycle separation between stations, and it remains to be seen how this works out in practice. The restriction has limited certain wavelength neighbours to as little as 7 kcs., but here again sufficient distance and power "separation" has been arranged.

**CAPACITY!**



In order to "get down" well in wavelength, all added capacities to tuning circuits—series and parallel—should be kept as low as possible.

In most cases the standard separation of 9 kcs. applies, but by later mutual arrangement between some countries certain broadcast channels have been increased to 10 or 11 kcs. An example of this is the widening of the gap between the North Regional and Langenberg, which will now be 10 kcs. instead of the previous, and insufficient, 9 kcs., and also between Milan and the Scottish Regional.

On the whole there should be less interference on the medium waveband if the stations stick closely to the rules laid down at Lucerne, but the long waves may not be so lucky. Here we have Luxembourg, which we believe intends to remain in its long-wave position instead of coming into line with Lucerne and taking up a position in the medium band. It may come down, but at the time of writing it seems unlikely.

**TO AID TUNING**

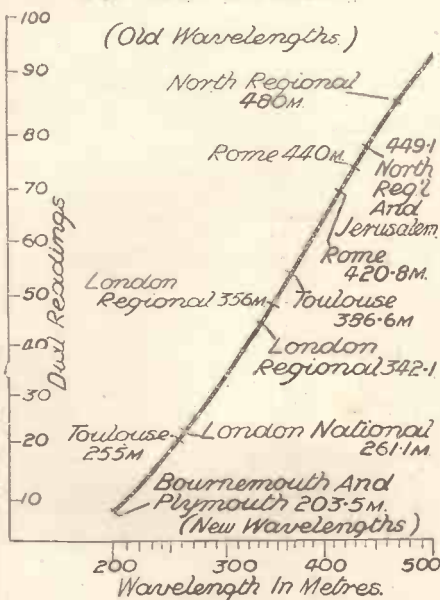

A specimen graph showing how the main tuning dial of your set can be calibrated. It shows both old and new wavelength dial-readings.

depends on the capability or otherwise of the aerial and other tuning circuits to go down below 220.

Series-aerial condensers, care in eliminating high-capacity wiring, all help to achieve a low minimum wavelength, while tuning condensers with low minimums should be used by those anxious to get right down.

These will be few, probably, for the British stations using the lower wavelengths are relay stations, and their

# The NEW WAVELENGTHS On Your Set

It is inevitable that the drastic revisions of wavelengths taking place on January 15th will cause temporary inconvenience to a great army of listeners in this country. With the details given below "P.W." seeks to reduce this to a minimum.

### ADEY PORTABLE RADIO.

Sets affected : None.  
Sets not affected : Adey Portable Four. Adey Portable One.

In the case of both of the sets manufactured by Adey Portable Radio, the dials are calibrated in degrees, and in consequence no changes to the actual sets will be necessary. It is the exception rather than the rule for a portable set to be calibrated other than in wavelengths or degrees, and when the revision comes into force on January 15th it will simply be necessary for owners of sets of this type to determine the new dial readings of stations in accordance with the details given on page 792.

### BALCOMBE, A. J., LTD.

Sets affected : Models 23, 34, 45, 54, 56, 67, 75 and 78.

Sets not affected : Models 22, 222, 444, 50 and 70. The sets affected in the "Alba" range comprise the complete superhet range, the dials of which are calibrated both in wavelengths and station names. A new dial is available from the makers at a nominal cost of two or three shillings, and it is not a difficult matter to effect the exchange. The chassis must first be removed from the cabinet when the dial, which will then be easily accessible, will be found to be connected to the rotor plate by four metal eyelets. The old dial can easily be ripped off and the eyelets removed with a pair of pliers, and the new dial, which will have the fixing holes already punched, can be fixed in position by means



The Blue Spot Pedestal Class B receiver is calibrated in wavelengths and needs no alteration.

of four small nuts and bolts. In the case of "Alba" sets, the non-technically-minded users are advised to leave it to a retailer as the makers guarantee would not hold good in the event of breakdown at a later date.

### BEETHOVEN RADIO.

Sets affected : S.G. Minor Four Portable.  
Sets not affected : S.G. Four Transportable. Twin A.C. S.G. 3.

The Beethoven S.G. Minor Four Portable is affected only in so far as the tuning indicator, which is fitted to the panel, is concerned. A new tuning indicator to meet the modified wavelengths is available from the makers at the cost of one shilling.



This supplement has been prepared with the full co-operation of the set manufacturers concerned, and gives clear and concise details of their plans to meet the modified conditions. See how your set is affected.

### BRITISH BLUE SPOT CO. LTD.

Sets affected : None.  
Sets not affected : Class B Four (Table model). Class B Four (Pedestal model).

Although one or two of the principal stations are marked on the dials of these two Blue Spot receivers, we are advised by the makers that they are arranged in such a manner that there is a sufficient margin to avoid complications when the re-arranged wavelengths come into force. The main calibration is in wavelengths in each case, and it will, therefore, only be necessary to revise the settings at which stations come in when the change-over takes place.

### BRITISH LUMOPHON CO.

Sets affected : Models W.D.23, G.D.23, W.D.76, and G.D.76.  
Sets not affected : Models W.30, D.C.3, K.400, W.300 and W.440.

The four sets which are affected in the British Lumophon range are not of the type that can easily be altered by the ordinary listener. A new scale for these sets is, however, available at the modest price of 1s. 6d. and the fitting can be undertaken by the makers. The charge for fitting will be 2s. 6d. With regard to the sets in this range which are not affected, the "W.30" and the "D.C.3" are calibrated in degrees, and the remainder are marked in wavelengths. With the

## WE DEAL WITH THE PRODUCTS OF ALL THESE FIRMS!

	Page No.
Adey Portable Radio	
Balcombe, A. J., Ltd.	794
Beethoven Radio	
British Blue Spot Co. Ltd.	
British Lumophon Ltd.	
Brunswick Ltd.	
Burgoyne Wireless (1930) Ltd.	
Burrell Radio Ltd.	
Burton, C. F. & H.	795
Bush Radio Ltd.	
Clarke, H., & Co. (M/C.), Ltd.	
Climax Radio Electric Ltd.	
Cole, E. K., Ltd.	
Columbia Graphophone Co., Ltd.	
Consolidated Radio Co., Ltd.	796
Cossor, A. C., Ltd.	
Cromwell (Southampton) Ltd.	
Decca Gramophone Co., Ltd.	
Edge Radio Ltd.	
Eldeco Radio Ltd.	
Faraday Allwave Wireless Ltd.	797
Faudels Ltd.	
Ferranti Ltd.	
Gambrell Radio Ltd.	
General Electric Co., Ltd.	
Grampian Reproducers Ltd.	
Hart Collins Ltd.	
Hicker, H., & Sons	798
Higgs (Gt. Britain) Ltd.	
His Master's Voice	
Hustler, Simpson & Webb, Ltd.	
Kolsier Brandes Ltd.	
Lissen Ltd.	
Majestic Electric Co., Ltd.	
Manufacturers Accessories Co., Ltd.	799
Marconiphone Ltd.	
McMichael Radio Ltd.	
Murphy Radio Ltd.	
Philco Radio & Telvn. Corpn.	
Philips Lamps Ltd.	
Portadyne Radio Ltd.	
Pye Radio Ltd.	
Radiogram Development Co. Ltd.	
Radio Instruments Ltd.	800
Rees Mace Mfg. Co., Ltd.	
Regentone Ltd.	
Six-Sixty Radio Co., Ltd.	
Sunbeam Electric Ltd.	
Tannoy Products Ltd.	
Telsen Electric Co., Ltd.	801
Ultra Electric Ltd.	
United Radio Manufacturers	
Varley (Oliver Pell Control) Ltd.	



All Climax receivers are station-calibrated as well as having wavelengths marked on the dials. The example shown is the T.C. III.

help of the list given on page 796, users of these sets will experience no difficulty when the plan comes into operation.

### BRUNSWICK LIMITED.

Sets affected : Models 280, 350, 360, 430, 480 and 550.  
Sets not affected : All models previous to 1933/34. Brunswick are producing a new scale for their sets which are affected, and it can be obtained from them at a cost of 2s. 6d. Fitting is not difficult providing the following procedure, which applies to models 280, 350, 360, 430, 480 and 550, is carefully followed. First of all remove the main tuning knob, an operation which consists simply of pulling it off, since it is held on to the spindle by means of a friction spring.

Next, carefully mark the position of the chassis on the chassis board. This is very important, since it affects the focusing of the light on to the dial. This done, the four chassis bolts underneath the motor board can next be removed, when it will be found possible to draw the chassis back sufficiently far to remove the dial. Immediately under the dial, and actually touching it, it will be found that there are two small rollers held in position by a spring. Both of these rollers have to be removed, carefully noting the position of the dial on the shaft. If the two grub screws holding the dial to the spindle are next slackened off the dial will be free to be removed.

The new dial should be slipped on in exactly the same position as marked, the two rollers replaced and the two dial-fixing screws tightened up just sufficiently to bite. Before putting the chassis bolts back, slide the chassis into position and try the set on one or two well-known stations. It may be found necessary to move the dial slightly to the right or left, as the case may be, in order to show these stations at their correct positions. That operation over, the dial-fixing screws should be properly tightened and the chassis bolts put back. The set is then re-calibrated for the new conditions.

**BURGOYNE WIRELESS (1930) LTD.**

Sets affected : None.  
Sets not affected : The Class B Three, Portable de-Luxe, Dreadnought Three, Olympic Three, Olympic de-Luxe, Popular Three, Popular de-Luxe, Portable Five and Class B Portable de-Luxe.

Users of Burgoyne sets will only be affected to the extent of plotting the new dial readings of stations, for all their sets are calibrated in degrees, wavelength, or both. In this connection the list of stations given on page 796 will be found invaluable, since not only does it give the new wavelengths of all the old stations, but the very latest additions as well.

**BURRELL RADIO LIMITED.**

Sets affected : None.  
Sets not affected : Three-valve A.C. and Radiogram, Four-valve A.C. and Radiogram.

Although the practice of naming stations round the dial is a boon when it comes to identifying distant stations, the owners of sets calibrated only in wavelengths or degrees will come off best when the change-over takes place. It is into this category that owners of Burrell sets fall, for all the receivers produced by this firm are calibrated both in wavelengths and degrees. It will be necessary, of course, to re-locate the stations, but this should not be difficult if use is made of the completely up-to-date list given elsewhere in this supplement.

**BURTON, C. F. & H.**

Sets affected : None.  
Sets not affected : Straight - Three Receiver, Class B Straight Three, The Empire Two, Three-Valve S.G., Four-Valve S.G., Class B, Three-Valve A.C. Mains, and Four-Valve A.C. Mains.

Without exception the dials of the receivers produced by Messrs. C. F. & H. Burton are marked in degrees. The makers advise us that they anticipated the present position and purposely refrained from calibrating their dials in any way which might ultimately call for revision. From this point of view, the idea is a sound one, but, of course, it does not dispense with the need for re-plotting the positions at the new conditions. Any difficulties in this connection can soon be overcome with the help of our guide to the new wavelengths on pages 796 and 797.

**BUSH RADIO, LTD.**

Sets affected : None.  
Sets not affected : A.C. Three Receiver, Q.P.P.5 Battery Receiver, S.A.C.4 Bush Ranger, and the S.A.C.6 Receiver.

The system of dial calibration in wavelengths has been adopted in all of the sets manufactured by Bush Radio, and sets of this type will be least affected by the revision. Most of the stations, of course, will come in after January 15th at different settings, but since the dial markings are actually in wavelengths, the process of sorting them out should not be a difficult one. You certainly won't go wrong if you refer to our special tuning guide.

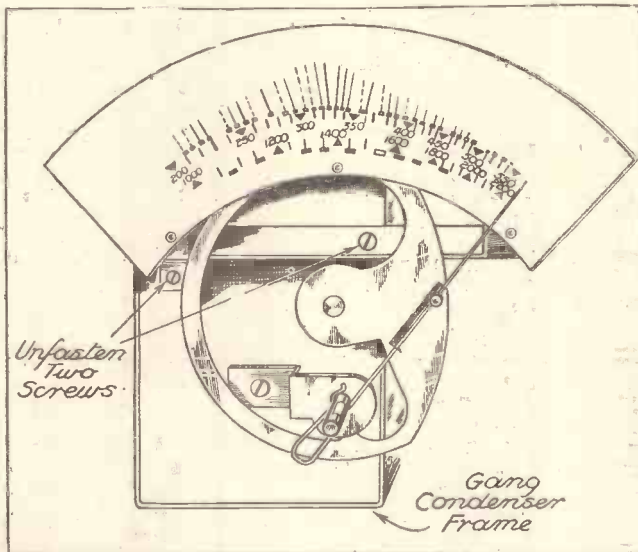
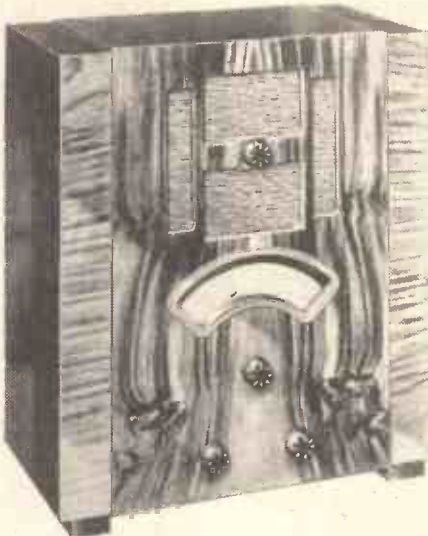

The G.E.C. table model Superhet Five is shown above, and below the photograph is a sketch of the dial which should be consulted in conjunction with the changing details given elsewhere in this supplement.

**CLARKE, H., & CO. (M/C) LTD.**

Sets affected : Atlas A.4, Atlas B.4, and Atlas 3-valve All-Mains (Table model).  
Sets not affected : Atlas "Lambda" 3-valve Battery Receiver.

Owners of Atlas sets which are affected by the shuffle are particularly fortunate in that the whole operation of changing the dial is one which the makers claim can be carried out in about ten seconds! But unfortunately this only applies to the A.4 and the B.4, for which new scales are available from the makers at 2s. 6d. each. Their plans with regard to the three-valve all-mains table model are not yet announced, although there is little doubt that some provision will be made at an early date.

With regard to the A.4 and the B.4, the present scale is a separate unit which simply slides into slots in the clips attached to the front of the tuning condensers. This is easily accessible from

the back of the set, and in changing the scale all the user has to do is to pull out the old one and slide in the new one. No screws, no rivets, just like taking your old season ticket out of its case and putting in a new one and the job is done! The designer of those sets certainly had one eye on Lucerne when the question of the scale fixing arose!

The only other set in the Atlas range—the well-known "Lambda" battery set—is calibrated in wavelength, and does not, therefore, require any modification other than that of determining the new tuning positions of the stations.

**CLIMAX RADIO ELECTRIC LTD.**

Sets affected : Model M.C.111 (Battery), the A.C. Superhet, model S.4 and the model T.C. 111 (A.C.).  
Sets not affected : None.

On account of the fact that the dials of all Climax receivers are marked with wavelengths as well as station names, it is not the intention of the makers to prepare a new scale until the revised wavelengths become permanent. In this connection, it is only fair to point out that the revision on January 15th does not necessarily mean finality. It is only when the stations are actually working on the new wavelengths that the complete success of the new plan can be determined, and any minor difficulties after that date may lead to still further alterations. In general, however, there is every indication that, apart from one or two minor alterations which may be found in practice to be necessary, the new scheme will be completely practicable.

As and when absolute finality is reached, it is the intention of Climax to produce a new scale for existing receivers. The price of these new scales will be approximately 2s. 6d., and fitting will have to be carried out by your local dealer.

**COLE, E. K., LTD.**

Sets affected : Models A.C.74, D.C.74, B.74, S.H.25, R.S.3, Consoles 74, C.25, and R.C.4, and Radiograms R.G.25 and R.G.5.  
Sets not affected : None.

To render existing Ekco receivers suitable for the new conditions, the makers—enterprising as usual—have prepared replacement scales for every model affected.

The procedure to be adopted in the A.C.74, D.C.74, B.74 and Console Model 74 is not difficult, and is as follows: Remove the receiver back, the four screws and washers underneath the cabinet and the three control knobs at the front and after having removed the L.S. plug at the top of the chassis, withdraw the receiver chassis from the cabinet. At the top edge of the scale, it will be found that there are two screws, and, in some cases, a clamping bar, and these should all be removed. It will now be found that the scale can be withdrawn, although it may be necessary slightly to ease the metal edge. The fitting of the new scale is simply a reversal of the procedure adopted when taking the old one out.

In the case of the S.H.25 console the operation of changing the dial is quite simple, but the order of the instructions which follow should be carefully followed. First remove the speaker fret by undoing the six small domed hexagon-head screws which secure it to the cabinet, and when the fret comes away, it will be found that two grey-board vibration damping pieces are also released. Next remove the four small screws and the two hexagon clamping bolts which secure the scales, and slack off the four counter-sunk-head screws which secure the cabinet front to the chassis, but in doing so, be careful to hold the appropriate nuts inside the cabinet to prevent them falling into the receiver. It

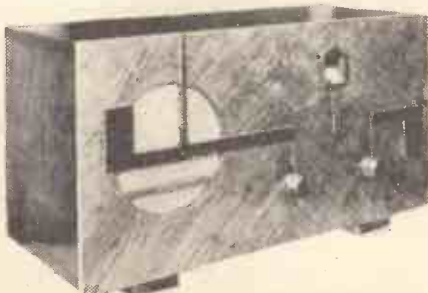

Lissen receivers are not affected by the wavelength shuffle. Here is one of their A.C. superhets.



A very easy modification is possible with the Atlas B.4, the whole scale sliding out.

will now be found possible to slip out the old scales, and to slip in the new ones, the fixing of which is simply a reversal of the procedure outlined above.

In this particular model it is important to note that if the old scales are found to be sticking to the speaker baffle, it will be necessary to remove the four control knobs and to withdraw the six screws which clamp the under edge of the cabinet to the chassis. This will allow the cabinet and baffle to be eased away from the scales. After the new scales have been put into position, the six screws holding the base of the cabinet should be inserted before the four counter-sunk screws referred to above are finally tightened.

The procedure to be adopted for changing the scales in the models R.G.25 and C.25 is the same as for the above except that the fret in these cases is mounted by six round-head wood screws, and the chassis is secured to the cabinet base by four screws only.

To change the scales in the R.S.3, first remove the speaker fret, and, incidentally, the two greyboard vibration pieces, by undoing the four small domed hexagon-head screws. To remove the actual scales, unscrew the six small screws which hold the semi-circular scale clamps in position. These scale clamps should next be replaced with the new scales in position, but be careful to observe that the outer edges of the clamps go underneath the four small clips in the chassis face plate, and make quite certain that the six small screws are quite tightly in position. To complete the operation it is simply necessary to replace the greyboard pieces, the fret, and the four fixing screws.

# The Old

THE NEW	STATION	THE OLD
203.5	Bournemouth	288.5
203.5	Plymouth	218.5
209.9	Newcastle	211.3
209.9	Cork	224.4
222.6	Dublin	217
222.6	Aberdeen	214.3
238.5	San Sebastian	453.1
238.5	Rome No. 2	—
238.5	Riga	525.3
240.2	Luxemburg	1191
243.7	Gleiwitz	253.1
245.5	Trieste	247.7
247.3	Lille	265.8
251	Frankfurt	259.3
259.1	Moravska Ostrava	263.8
261.1	West National	261.6
261.1	London National	261.6
263.2	Turin	278.7
265.3	Horbj	257
267.4	Belfast	242.3
271.7	Naples	319
274	Vinnitsa	—
278.6	Barcelona	348.4
283.3	Bordeaux	304
285.7	Barj	269.8
288.5	Scottish National	288.5
291	Leningrad No. 2	—
293.5	Heilsberg	270.5
	Madrid No. 2	424.3

period, however, they have produced a special tuning guide for use in conjunction with their sets, and it may be had by Columbia users free of charge from any of their appointed dealers, or direct from head office.

### CONSOLIDATED RADIO CO., LTD.

Sets affected: None.  
Sets not affected: "Ranger" Junior Battery Three, "Ranger" Suitcase S.G. Portable Four, "Ranger" Battery Three, "Ranger" de-Luxe Transportable Four, Rolls Caydon Class B Transportable Four, Rolls Caydon All-Wave A.C. Three, Rolls Caydon A.C. Two, and Rolls Caydon de-Luxe Class B Transportable Four.

With the exception of the "Ranger" Junior Battery Three and the "Ranger" Suitcase S.G. Portable Four, the complete range of sets manufactured by Consolidated Radio has dials calibrated in both degrees and wavelengths. The first two mentioned have dials marked only in degrees.

The re-plotting of the settings at which stations on their new wavelengths come in is all that concerns the owner of any one of these sets, and that can best be done by reference to the tables given on this and the succeeding page. Here will be found both the old wavelengths and those coming into force on the 15th.

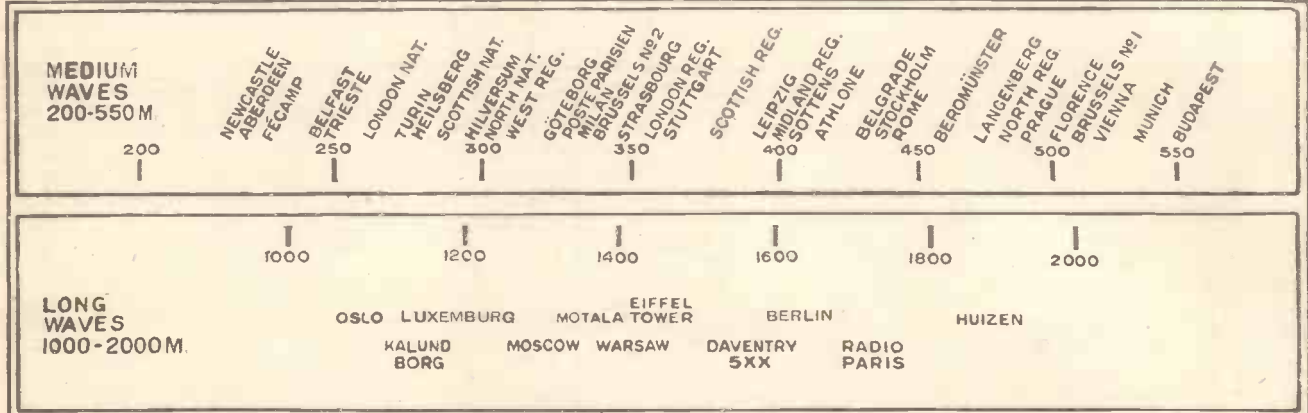

The above details apply also to the R.G.4 and the R.C.4, except that in these two sets the fret is mounted without vibration damping pieces.

Although all the new scales have been very accurately prepared, the makers strongly recommend a calibration check to determine that the scale has been mounted in the correct position. If the mounting is correct, then, of course, the stations on their new wavelengths will be received in the correct positions as indicated by the pointer. Should the pointer be slightly out, the error may be corrected quite easily by tuning the receiver carefully to a known station somewhere in the middle of the dial (the London Regional, for instance) and by sliding the scale in one direction or the other until the station name is under the pointer. Model R.S.3 may be checked in this way before the speaker fret is replaced, but in the case of all other models the chassis must be replaced in the cabinet and the back put on before the check is carried out.

For those who would prefer not to carry out the alterations themselves, any Ekco stockist will be able to make the necessary modification.

### COLUMBIA GRAPHOPHONE CO., LTD.

Sets affected: Models 640, 631, 629, 1001, and 1003.

Sets not affected: Models 307, 331, 332, 304, 306, 310, 308, 302, 301, 352, 355, 602, 603, 604, 356, 354, 1005, 380, 303.

The Columbia Graphophone Company is to follow the procedure of one or two other firms in that it will not produce a new scale for their sets that are affected until finally in regard to the new wavelengths is reasonably assured. In the interim

296.2	North National	301.5
298.8	Bratislava	279.5
301.5	Milversum	296.1
304.3	Genoa	312.8
307.1	West Regional	309.9
316.8	Breslau	325
318.8	Göteborg	322
318.8	Algiers	363.3
321.9	Brussels No. 2	337.8
325.4	Brno	342
331.9	Hamburg	372
338.6	Graz	352.1
342.1	London Regional	356
345.6	Poznan	334.4
349.2	Strasbourg	345
356.7	Berlin	419
369.6	Moscow No. 4	424.3
368.6	Milan	332.2

(Continued on next page.)

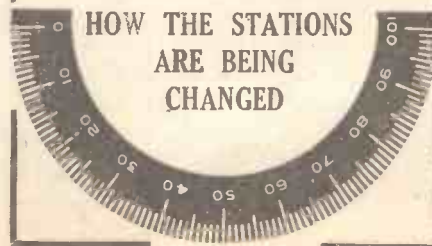

### COSSOR, A. C., LTD.

Sets affected: None.  
Sets not affected: Models 3456, 3468, 3469, 533A, 735, 634, 635, 233, and 222A.

With the sole exception of the Model 233, the fine range of receivers produced under the Cossor Trade Mark are all calibrated in wavelength. For users of any of these sets, the change-over will hold no terrors at all, for it will simply mean the re-plotting of stations in their new positions. Again, our lists, in which the new and the old wavelengths are arranged conveniently side by side, will prove invaluable for this purpose.

### CROMWELL (SOUTHAMPTON) LTD.

Sets affected: None.  
Sets not affected: Models B.34, S.H.8 B, R.F.A.B, A.C./D.C., and S.H.8.

Wavelength calibration is the system employed in all the Cromwell receivers, so that the forthcoming European shuffle will not necessitate any modifications to the sets themselves. The necessity for re-plotting the tuning positions applies, of course, to all sets, whether commercial or home constructed, but in any case, it is not a difficult job. What is probably the best method is to pick out, say, half a dozen stations that you can be certain of recognising at various parts of the dial, and then to fill in the gaps with the aid of station guide afterwards.

### DECCA GRAMOPHONE CO., LTD.

Sets affected: Models 280, 350, 300, 430, 480 and 550.

Sets not affected: All models previous to season 1933/34.



# and the New

that will cause owners the minimum amount of inconvenience when the Lucerne Plan becomes effective. The dials of the first three sets mentioned above are marked simply in degrees, the dials of the remainder being split up into both wavelengths and degrees. With sets of this type it is interesting to note that not only will there be the old stations to re-locate, but several new ones as well which are to be inaugurated when the plan becomes virtually "law."

It is only this year that the Decca Gramophone Co., Ltd. has started to mark the dials of their sets with the names of stations, and in consequence all models previous to 1933/34 will be unaffected by the revision.

In the case of their latest models, however, the dials of all of which bear both names and wavelengths, a new scale is available to meet the new conditions, and the cost is 2s. 6d. For all practical purposes, the method of fixing is identical with the instructions given under the heading of Brunswick Ltd., and readers concerned are asked to refer back to that paragraph.

### EDGE RADIO LTD.

Sets affected: None.  
Sets not affected: Drummer B.4, Drummer R.B.4, Drummer M.S.6, Drummer R.M.S.6, and R.M.S.6A.

In the happy position of being comparative newcomers to the radio industry, Edge Radio Ltd. were able to anticipate the present position, and to avoid the use of any dial-marking system which might involve alteration at a later date. Nobody, of course, could overcome the shifting of station positions, but with an accurately calibrated wavelength scale, the shuffle should cause very little inconvenience.

THE NEW	STATION	THE OLD
373.1	Scottish Regional	376.4
377.4	Lwow	381
382.2	Leipzig	389.6
386.6	Toulouse P.T.T.	255.1
391.1	Midland Regional	398.9
395.8	Katowice	408
400.5	Marseilles	315
400.5	Viipuri	291
405.4	Munich	533
415.5	Kiev	1034.5
420.8	Rome	441
426.1	Stockholm	436
431.7	Paris P.T.T.	447.1
437.3	Belgrade	429.7
443.1	Sottens	403
449.1	North Regional	480
455.9	Langenberg	473
465.9	Lyons	465.8
470.2	Prague	488.6
483.9	Brussels No. 1	509.2
506.8	Vienna	517.2
522.6	Mühlacker	360.5
531	Palermo	539.5
531	Athlone	413
536.6	Beromünster	459
549.5	Budapest	550.5
559.7	Bolzano	368.1
559.7	Wilno	566
569.3	Ljubljana	574.7

note that not only will there be the old stations to re-locate, but several new ones as well which are to be inaugurated when the plan becomes virtually "law."

### FERRANTI, LTD.

Sets affected: Arcadia Consolette, Companionette and Console, and Gloria Consolette, Clock Consolette, Console and Companion.

Sets not affected: Lancastra Parva, Magna, and Radiogram.

Although several of Ferranti's famous sets are affected by the alterations, it is not the intention of the makers to produce new scales until there is reasonable assurance that stations are to "stay put." The temporary inaccuracies in the station naming, however, is not, in this case, a very serious matter since the dial of every set affected is also calibrated in wavelength.

When the new scales are available, the question of fitting is, comparatively, an easy one. The chassis in each case has first to be removed from the cabinet by undoing the four screws through the bottom of the cabinet, and it will then be seen that the scale is held in place by several small screws which can readily be removed with a screw-driver. When about to fit the new dial, first tune the set to a powerful transmission, the name of which is known, and taking care not to allow the

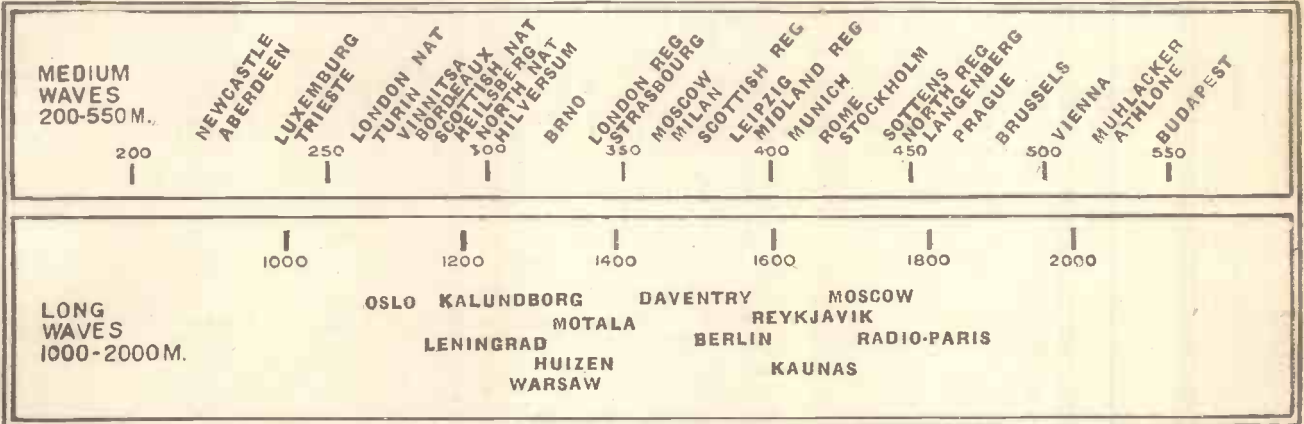

### ELDECO RADIO LTD.

Sets affected: None.  
Sets not affected: S.H.6 (portable), and Eldeco Stenode.

Portable receivers, as a general rule, are constructed in such a compact way that to attempt to change the tuning scale is a particularly intricate job. For that reason, it is fortunate for owners of the Eldeco S.H.6 portable that the dial is marked simply in degrees. Owners of the Eldeco Stenode, too, can count their blessings in that the dial of this particular model is marked only in wavelengths and degrees. Nothing apart from re-location of stations will be necessary with either set.

### FARADAY ALL-WAVE WIRELESS LTD.

Sets affected: None.  
Sets not affected: The S.620L. (A.C. and D.C. models).

This is one of the few commercial receivers that covers the complete band from 15-2,000 metres, and according to the maker's details, each wavelength is capable of separate calibration. The dial, which is accurate to 1 metre for medium and long waves, and to .1 metre for short waves, is actually marked in wavelengths, and with such a high degree of accuracy the change-over should cause no inconvenience whatsoever.

### FAUDELS, LTD.

Sets affected: None.  
Sets not affected: Coronet Three, Coronet Class B Three, Coronet Class B Four, Coronet A.C. Superbet Five, Coronet Superbet Seven, and Coronet A.C. Superbet Five Radiogram.  
The Coronet range of receivers is another one

1107	Moscow No. 2	1115
1145	Lahti	1796
1186	Oslo	1083
1224	Leningrad	857
1261	Kalundborg	1153.8
1304	Warsaw	1411
1345	Kharkov	368.1
1345	Huizen	1875
1389	Motala	1378
1442	Minsk	1105
1500	Daventry	1554.4
1571	Berlin	1635
1639	Reykjavik	1200
1639	Kaunas	1935
1639	Ankara	1538
1714	Moscow No. 1	1481
1796	Radio Paris	1725
1875	Brasov	—

spindle to rotate, carefully move the dial round one way or the other until the name of the station coincides with the slot through which the dial is illuminated from behind. That done, the fixing screws can then be carefully tightened.

### GAMBRELL RADIO, LTD.

Sets affected: None.  
Sets not affected: Models R.N.A.C., R.N.D.C., R.4 A.C., G.3 A.C., G.3 D.C., R.3 A.C., R.3 D.C., F.A.C., F.D.C., and the 7/8-valve Superbet.

No structural alterations of any description will be necessary to any of the receivers in the Gambrell range, for all of them, with the exception of the 7/8-valve Super, are fitted with dials marked in degrees. The 7/8 Super has wavelengths on the dial in addition to degrees. The only essential to owners of sets of this type is an authentic and reliable guide to the new wavelengths, and that is given on the centre pages of this supplement.

### GENERAL ELECTRIC CO., LTD.

Sets affected: Models B.C.3335, B.C.3336, B.C.3355, B.C.3340, B.C.3480, B.C.3484, B.C.3440, B.C.3441, B.C.3445, B.C.3446, B.C.3442, B.C.3443, B.C.3447, B.C.3448, B.C.3449, B.C.3445, B.C.3443.

Sets not affected: B.C.3140, B.C.3240, B.C.3241, B.C.3245, B.C.3345, B.C.3130, B.C.3161, B.C.3360, and all models previous to 1931/32.

The G.E.C. range of receivers is indeed an extensive one, but as was to be expected of this enterprising organisation, arrangements have been made for new scales to be supplied for practically every one of their sets that are affected. For the B.C.3335



# BETWEEN FIVE AND SIX MILLION SETS ARE

and the B.C.3336, the procedure for the changing of scales is as follows:

First remove the control knobs by slackening off the necessary grub screws, and the back of the cabinet by unscrewing the two milled thumb screws near the top. Two circular pads will be found just inside the back of the set, one on either side of the cabinet on a level with the top deck of the chassis. Against these press two bolts, each held fixed by two locknuts, one on either side plate of the chassis. Slacken the locknuts and screw each bolt inwards as far as possible. Next withdraw the two bolts which hold the front part of the chassis to the inside of the cabinet. (These are located on either side of the plate supporting the loudspeaker.) To complete the removal of the chassis, turn the set face downwards on some sort of padded batten to avoid damage to the projecting spindles, unscrew the four fixing bolts at the bottom of the cabinet, and then, if you once again stand the set upright you will find it easily possible to withdraw the chassis.

If you now refer to the lower sketch on the last page of this supplement, you will see that the tuning indicator is held in position by twelve small rivets. The old indicator, complete with frame, must be removed by bending up the ends of the rivets at the back of the indicator. The new one can then be placed in position and, by means of the twelve new rivets that are supplied with it, fixed firmly on the frame. The frame is then replaced on the chassis, after which the chassis can be put back in the cabinet.

## B.C.3358 and B.C.3340.

For the B.C.3358 and the B.C.3340, the procedure for the changing of the tuning indicator is exactly the same as for the set described above, but a slightly different procedure is necessary for the removal of the chassis.

In addition to removing the back and the control knobs, it is also necessary in this case to remove the cleats holding the loudspeaker cable form and leads from mains plug. Next turn the set face downwards, taking care not to damage the projecting spindles, and withdraw the four chassis fixing bolts from the bottom of the cabinet. To remove the chassis, stand the set upright once again, lift it slightly to clear the two locating pins, and withdraw. Sufficient slack has been left on the speaker cable form to allow the chassis to be withdrawn.

In the case of the B.C.3480 and B.C.3483 receivers, the method recommended for the removal of the chassis is as follows. First pull off the four knobs at the front of the panel, and the one at the back, and then remove the back of the set. With the back off, the next job is to remove the clip which holds the loudspeaker cable form to the



R.I. have kept to wavelength calibration, as seen by this close-up of the dial of the Madrigal three-valve A.C. table model. This set needs no modification.



side of the cabinet. If you now remove the four chassis holding down bolts from the underside of the cabinet (underside of the deck in the B.C.3484), and pull out the speaker cable form plug from its socket, it will be found that the chassis can be removed entirely.

The changing of the actual scale is a very simple matter, and if you refer to the diagram on this page, you will see exactly how it is done. By removing the six screws numbered from 1 to 6, it will be found that the tuning indicator comes right away.

The removal of the chassis in the B.C.3440, B.C.3441, B.C.3445 and B.C.3446 for the purposes of changing the scale should be undertaken as follows: First remove the four knobs on the front by pulling them off (there are no grub screws), and take off the back of the set. Since enough slack has been left on the speaker cable to enable the chassis to be withdrawn, for its removal, it is simply necessary to remove the four chassis holding down bolts on the underside of the cabinet.

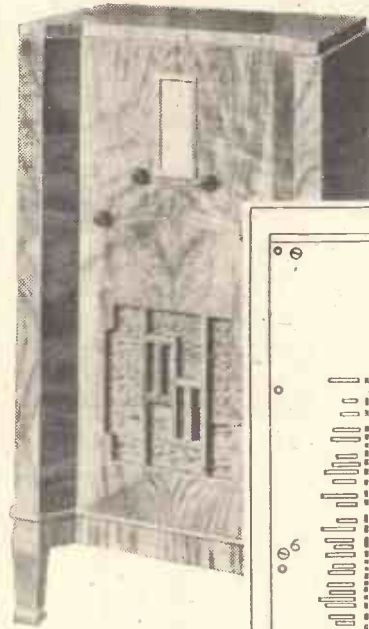

All the necessary directions for altering the tuning scale of this G.E.C. receiver—the Console Cabinet Superhet for A.C. Mains—are given in our Supplement, and the sketch of the scale shown here indicates the main features. Very elaborate plans have already been made by the G.E.C. to ensure that all their sets shall be suitable for the new wavelength conditions which come into force on January 15th.

A sketch showing all the necessary details for the replacement of the tuning indicator is shown on page 795. Unscrew the two screws marked, remove old indicator, and fix the new one in position by means of the same two screws.

Exactly the same procedure should be adopted for the B.C.3442, B.C.3443, B.C.3444, B.C.3448, and B.C.3449, except that in these cases the chassis holding down bolts are underside of the deck.

The prices of the new scales for all the sets have been fixed at 2s. 6d., and they are available from the makers.

## GRAMPIAN REPRODUCERS LTD.

Sets affected: None.

Sets not affected: The Kew Model and the Richmond Model.

The only two sets in the Gramplan range, the Kew and the Richmond models, will not be affected since the dials of both are calibrated only in degrees and wavelengths.

## HACKER, H., & SONS.

Sets affected: Models E.P.46, E.K.46, and E.1012. Sets not affected: Models E.L.42, 42 Console and the 35 Console.

The cost of the new dials for the three sets that are affected in the range produced by H. Hacker & Sons is 2s. 6d. We understand from the makers

that the replacement could easily be undertaken by the user, but in any case, appointed stockists will be in a position to undertake the work for a nominal charge.

## HART COLLINS LTD.

Sets affected: None.

Sets not affected: Passport 3-valve, Passport 5-valve and Passport 7-valve.

All sets in the Hart Collins range prior to 1933 are calibrated in degrees, but the new season's models have dials marked in wavelengths. None of the sets will be affected by the change-over except to the extent of re-plotting the tuning positions—a task that can be best undertaken by reference to our guide on pages 796 and 797.

## HIGGS (GT. BRITAIN) LTD.

Sets affected: Magnex Receiver and Radiogram, and the Exponential Five.

Sets not affected: The remainder of the range.

Owners of Higgs' sets will be interested to learn that the makers are working on an entirely new dial to be released on January 15th, which will employ a system of calibration in both station names and wavelengths. For this reason, it is not proposed to take any action with regard to the revision until the new dial is released.

## HIS MASTER'S VOICE.

H.M.V. receivers are listed on the opposite page and the manufacturers are making special arrangements to ensure that owners of their instruments at present fitted with station and wavelength scales will be able to use them under the new conditions.

Temporary measures are suggested at first until the broadcast band has "settled down" once more, and so for the next six months special cards only will be available, free of charge, these being followed later by new tuning dial strips at a nominal price for fixing in place of the existing scales.

On the cards will be a replica of the present station dial for each instrument and, side by side with it, a sketch of the dial based on the Lucerne Plan. This simple reference will show the listener the new position of any desired station on his scale.

Many of the H.M.V. receivers, as can be seen from the list, are not affected by the change in wavelengths other than by the fact that the stations will come in at different readings than they do at present. In each case a simple table of wavelengths and dial readings can soon be compiled by the owner of the set.

## HUSTLER, SIMPSON & WEBB (AERODYNE RECEIVERS).

Sets affected: None.

Sets not affected: Swift, Kestrel, Finch, Eagle, Swan, Falcon, Cardinal Radiogram.

Of these receivers the first two have scales marked in degrees, while the others have wavelength calibrations. Thus it will be seen that the dials themselves need no alteration to enable them to cope perfectly with the new wavelengths.

To enable rapid searching and station identification to be carried out, however, we would advise owners to draw up a graph of their dial readings against wavelengths so that they can see at a glance exactly where they are on the dials.

In some instances the change in a station's wavelength is very considerable, and without some ready means of position-finding it may take a long time before a given station is found on the dials.

## KOLSTER BRANDES.

Sets affected: None.

Sets not affected: K.B.888, 666, 444, 333, 354, 364, Hika Portable.

All the Kolster Brandes' receiver designs sail through the alterations in wavelength unscathed. With one exception they are wavelength calibrated,

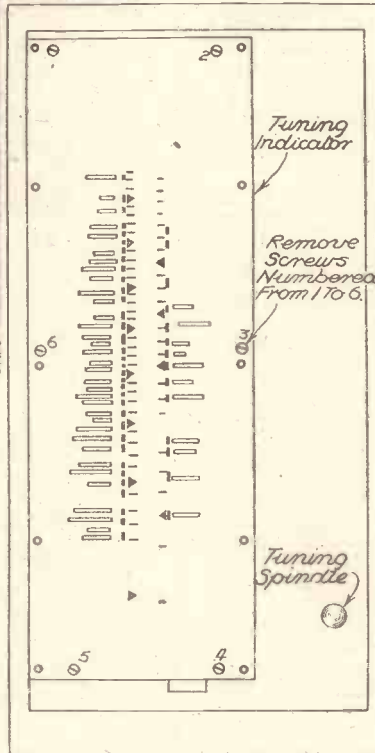

# AFFECTED BY THESE WAVELENGTH CHANGES

with no station names on the dials. The one exception is the Hika Portable, which has the scale marked in degrees.

So, here again, no structural alteration, not even the changing of a scale, has to be carried out when on January 15th the general post of the European ether takes place. Just a list of the various favourite stations and the new positions on the dials, found by experiment, will suffice to provide complete ease of station-finding after that date. Very easy, and quite readily carried out after a few hours' listening with a notebook and a copy of the programmes.

### LISSEN LTD.

Sets affected: None.  
Sets not affected: Models 8020, 8001, 8007, 8012, 8014, 8033, 8051, 8060, 8055, 8039, 8019, 8030, 8005.

With few exceptions, all the Lissen receiver scales are wholly marked either in degrees or are wavelength calibrated so that no change of scale is needed where this firm's products are concerned. The exceptions concern such receivers as have one or two prominent stations marked by initials, such as L.R. for London Regional.

These initials can readily be ignored, or without much trouble painted out with white paint, or covered with small pieces of paper. New positions can then be marked, if desired, by ink or black paper letters. Such a change can hardly be deemed an important alteration, so that Lissen Ltd. are not issuing any new dials or celluloid strips for their sets.

The same remarks apply to Lissen receivers not listed above—those that are not now current, and have been discontinued, though some may still be in the hands of listeners. And, of course, it applies also to kit receivers for home-construction.

### MAJESTIC.

Sets affected: None.  
Sets not affected: Models 49, 66, and previously issued receivers and radiograms.

Kilocycle calibration of all Majestic receivers makes them impervious to all wavelength shuffles. Whether stations go up or down in wavelength, i.e. down or up in frequency, matters not at all as far as Majestic set owners are concerned, provided that the aforesaid stations remain within the wide range of wavelengths covered by these sets.

A home-made calibration chart, however, with the new positions of the broadcasters on it will greatly assist in picking out your programmes after Sunday, Jan. 14th, for at first the whole waveband will seem rather strange, and the failure of certain stations to come in at their usual positions on the tuning scale will inevitably be disconcerting.

But no alteration to the set will be required, so that the upset caused by the new "Plan" will be very slight. In making out the new chart of stations it must not be forgotten that it should be done in kilocycles against dial readings, and not wavelengths, for if the latter are used the list will be very trying to use with the kilocycle-marked scales of the Majestic receivers.

### MANUFACTURERS ACCESSORIES CO. LTD.

Sets affected: None.  
Sets not affected: "Macovox" Universal 5, Super 5, Super 4, Select 3.

Once again, the Lucerne Plan does not affect broadcast reception except inasmuch as new wavelengths have to be remembered, for "Macovox" receivers are all calibrated in wavelengths. Tuning can, therefore, be carried out with the same ease as previously, it being borne in mind that possibly some of the erstwhile receivable stations may have been so changed in their wavelengths that they are no longer covered by the band width of the receiver.

Whether or no any of the favourite programmes are likely to be lost for this cause can be checked up in a few moments by reference to the new wavelength list given in this Supplement and the maximum and minimum wavelengths shown on the dial of the receiver. It is unlikely, however,

that anything important will suffer except those stations who are relegated from solus frequencies to those of a "common waveband."

### MARCONIPHONE.

Sets affected: Models 276, 291, 290, 260, 272, 274.  
Sets not affected: Models 254, 271, 283, 255, 253, 248, 252.

In the Marconiphone range about half of the receivers are affected by the new changes, inas-

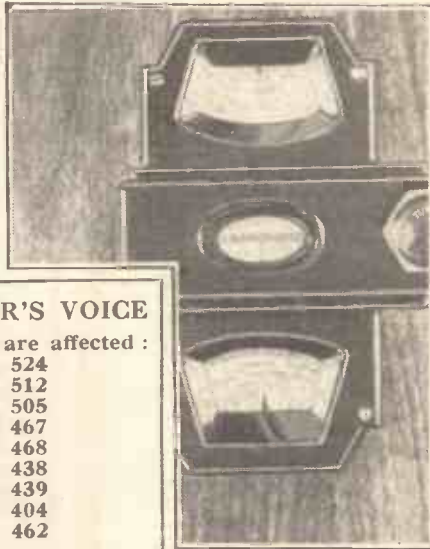

### HIS MASTER'S VOICE

Receivers that are affected:

- Model 524
- Model 512
- Model 505
- Model 467
- Model 468
- Model 438
- Model 439
- Model 404
- Model 462

Unaffected H.M.V. Sets:

- Model 532
- Model 523
- Model 470
- Model 436
- Model 531
- Model 521
- Model 522
- Model 435
- Model 459
- Model 459MC.

The H.M.V. preparations for the Lucerne Plan are dealt with in the text of this Supplement.

The H.M.V. Superhet Auto-radiogram Seven showing a close-up of the tuning scales. Special cards have been prepared for owners of this set, so that the new wavelengths can be correlated with the readings on the receiver.

much as they have scales marked in station names as well as wavelengths. The fact that wavelength calibration is included will enable owners to carry on with but little inconvenience after Jan. 14th until such time as the wavelength muddle is duly sorted out and made permanent, when new scales will be provided through Marconiphone dealers for fitting to the receivers.

These will be available at a nominal figure, and will be easy to fit, though it is advisable to let the dealer carry out the alteration in all cases.

In the interim Marconiphone are issuing, free of charge, charts which represent identical reproductions of the present tuning dials, showing the changes which are being made by the Lucerne Plan. These will meet the needs of the immediate change to a great extent, and will help to tide over the period till the final settling down of the stations takes place.

### McMICHAEL RADIO LTD.

Sets affected: None.  
Sets not affected: Twin Supravox A.C., Twin Supravox D.C., Duplex Mains 4, Super 5 Class B, Lodex 5 Class B, Cabinet Portable type D.S., Duplex 4 (suitcase model).

As all McMichael receivers are not only wavelength calibrated, but also go down to 200 metres and well up the scale, very little is likely to be missed by owners of models of this make.

Even Bournemouth and Plymouth listeners, whose stations are to be round the 203-metre mark after January 14th, can rest assured that their set will "get down" if they are among those listed above.

This "getting down" property is going to be an important feature in many receivers, for listeners to low wavelength relay locals are going to have a bad time if their sets are not going to cover the new frequencies.

And if a commercial set will not "go down," then there is usually an end to the matter, it cannot be altered like many of the home-constructor designs.

### MURPHY RADIO LTD.

Sets affected: None.  
Sets not affected: Models B.4, A.3, A.3.A, B.5, A.4, D.4, A.3.

As you will have judged, by consideration of this Supplement, those of you who have read through it, the majority of British radio firms have gone wholly out for wavelength calibration of receiver tuning scales. They have ignored for the most part station naming, and in view of the forthcoming alterations—which are pretty drastic—they are to be congratulated.

Was it chance or foresight that led Murphy, among the others, to eschew station-named dials, for this form of calibration is undoubtedly popular and convenient. Most people would probably rather pick out a station on the dial than have to look up its wavelength and then tune in by that.

However, the wavelength sets have hit the nail on the head this time, for as they constitute the bulk of the set market they have saved the listening public, and their manufacturers, a great deal of trouble.

The Lucerne Plan need have no terrors for those with Murphy sets, for clear wavelength markings are features of these original designs, and station finding under the new régime is going to be very easy.

### PHILCO.

Sets affected: None.  
Sets not affected: Five Star Baby Grand, Five Star Concert Grand, Three Star Baby Grand, Transitone (Car Radio), Models 247, 56, 245 (Baby Grand), 256, 71X., 71X.L., 56 and 248 E.L. ("Lowboy.")

Shadow tuning is advertised as a big feature in Philco receivers, but at the present moment a feature of bigger importance is the fact that all Philco sets are calibrated in frequency (kilocycles), and so remain accurate no matter what station wavelength alterations may take place.

To assist in logging stations any Philco dealer will give you a special station-finder chart which lists the various stations as found on the Philco dials.

This chart, made up-to-date for use after Jan. 14th, should be of the utmost assistance to Philco set owners for it tells them at a glance exactly where to look for any broadcaster that comes within their range. It means complete freedom from worry concerning the possible effects of the Lucerne arrangement, for there are to be no effects on owners of any of the receivers designated above.

### PHILIPS LAMPS LTD.

Sets affected: None.  
Sets not affected: Models 630A., 630C., 634A., 634C., 639A.

The unique Philips calibration system has nullified the wavelength changes, for no matter

The Model P/B Pye Portable, like almost all the other Pye types, will need a new scale when the Lucerne wavelength plan comes into operation. The makers are supplying the necessary scales at a charge of 2/6d. each, and these may be fitted by any Pye service agent.



On the other hand, the changing of the scales is not a difficult matter and can quite successfully be carried out at home in accordance with the very clear details provided with each scale. For the convenience of Pye owners, these instructions are printed on the next page.

If the instructions are carefully followed, your Pye change-over will take only a very short time.

# WHY NOT FIT THE NEW SCALE YOURSELF?

how the stations are to shift about, the dials on the receivers will need no changing.

Micrometer dials are fitted to the Philips receivers, and to cover these after January 15th all that will be necessary is a new station chart. This is to be provided free by Philips on receipt of particulars of the set—type number, registration number, and the number of the old chart.

Applications for the charts can be made at once, and a special form is available for the purpose. This can be obtained from Philips dealers, or direct from Messrs. Philips Lamps, Ltd., 145, Charing Cross Road, London, W.C.2.



Station names are included in the scale of this Varley A.P.29, but the change-over is easily carried out, the necessary particulars being given on the following page.

The word "Charts" should be clearly written across the left-hand corner of the envelope containing the request. There is no need to wait till January 15th for the new chart. It can be obtained now, and held in readiness for that date.

## PORTADYNE RADIO.

Sets Affected : Models S.A.C., S.B.  
Sets not Affected : Model P.B.

The Portadyne receiver, Model P.B, is calibrated in wavelengths, so that Lucerne does not upset the tuning dial of this type. It is otherwise, however, with the other two models, which, in addition to wavelengths, have station positions marked on their dials.

It is felt by the manufacturers, however, that although January 15th sees the start of the wavelength shuffle, it will not necessarily see the end of it. In other words, alterations and revisions will be required before the ether settles down again to an ordered state of affairs.

Stations will probably continue to move about for some time after the main change, and that being the case, Portadyne Radio are not yet preparing any new scales for fitting to their station-calibrated receivers. When the final wavelengths have been decided new scales will be made, and the question of the necessary alterations will be gone into.

## PYE RADIO LTD.

Sets Affected : Models P/B., E/B., P/AC., E/AC., E/DC., E/RG/AC., S., G/AC., G/DC., G/B., O/B.

Sets not Affected : Model K.

The last-named Pye set is calibrated in wavelengths, and so escapes any need for alteration, for only principal stations are indicated on the dial. The others, however, have to have new scales to enable them to conform to the new wavelengths, being calibrated in wavelengths and station names.

Alteration is quite easy, however, and can be carried out at home or by a Pye service agent, who will be entitled to charge a small amount for fitting. The new scales will cost 2s. 6d. But as the alteration is simple, many will wish to do it themselves, and Pye will be pleased to supply the necessary instructions with the dials. Here is the method of fitting undertaken in the cases of the P/B. and P/AC. models:

The chassis is removed from the cabinet in accordance with the instructions in "Service Notes"; the pilot lamp holder is unscrewed, and the calibrated dial is removed after the fixing screw has been released.

Place the new dial in position on the gang spindle, and then place the rotor vanes of the condenser fully in mesh. Take special care that the vanes on both sides of the centre spindle are flush with the stators.

To do this, take two strips of metal, 1½-in. wide,

the ends of which are straight, and place one on either side of the centre spindle across the vanes so that these are now fully in mesh.

Hold the vanes in this position with the strips of metal, and adjust the dial spindle so that the centre line coincides with both the indicators. Fasten the dial in this position. Then replace the lampholder and the chassis in the cabinet.

## RADIO GRAMOPHONE DEVELOPMENT LTD.

Sets Affected : None.

Sets not Affected : Models 701 702, 901, 1201.

A deliberate policy chosen by R.G.D. is that of using only wavelength calibrations on all their receivers. The result is, therefore, that January 15th will not be noticed by R.G.D. set users to any great extent. Stations will still be tuned in according to wavelength, but they will "appear" on different positions of the scale from formerly. That is all that will happen.

This is a great advantage, for the alteration of the scales of some of the giant R.G.D. radio-

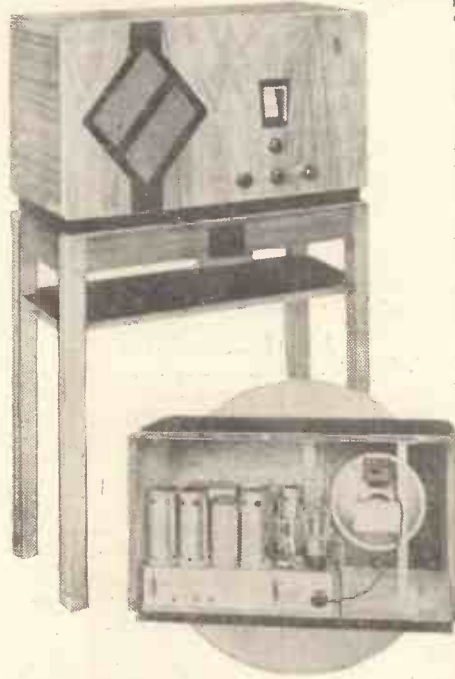

The K.B.666 is unaffected by the shuffle, so that owners of this receiver have nothing to worry about.

grams might well prove a difficult task for any but a skilled radio engineer. No R.G.D. receiver owner need take the slightest notice of the new wavelengths, therefore, save to note on what wavelengths his favourite stations are scheduled to transmit.

## RADIO INSTRUMENTS LTD.

Sets Affected : None.

Sets not Affected : Madrigal 6-valve Super Radiogram, 3-valve A.C., Class B.4.

The above three receivers and R.I. sets of earlier design sail through the turbulent ether of January 15th without trouble. Radio Instruments is another of the firms who, have always kept to degree or wavelength calibration in view of possible upheavals of the type of the Lucerne Plan.

Madrigal receivers of all classes will still read accurately, no matter what the wavelength of the station you want to receive, provided, of course, that it falls within the scope of the tuning of the particular set.

Those examples of R.I. workmanship listed above are all wavelength-calibrated and so they will need not even a recharting of the dial, for any station can be found by reference to its wavelength and the setting of the receiver dial accordingly.

Where older sets having degree-marked dials are concerned, it is advisable, as already pointed out, to draw a dial-reading-wavelength graph so that the new position of the stations can readily be found, by reference to the tuning curve thus obtained.

Such a chart can readily be drawn by noting the positions of a few of the well-known transmissions.

## REES MACE MANUFACTURING CO. LTD.

Sets Affected : None.

Sets not Affected : Radiogram de-Luxe, Gnome S.G., 4 Portable, Universal A.C.-D.C., Universal Radiogram.

Of the four sets marketed by this firm, three are marked in degrees (two of which are also wavelength-calibrated) and the fourth is marked in wavelengths only. So obviously the question of dial alteration to meet the new wavelength requirements does not arise.

The "Gnome" S.G.4 Portable, calibrated in degrees only, will need a dial-reading-wavelength chart in order that stations can be found quickly, but if owners of it have not one they can easily make it themselves from a few readings taken from well-known transmitters.

The other three sets need no such aid to tuning, for they are wavelength-calibrated and so any station should easily be found by reference to the list of stations and their wavelengths. After January 15th they will appear at different dial readings from the present positions, but apart from that no change will be noticed. Certainly no structural or dial alterations will have to be carried out on Rees Mace receivers.

## REGENTONE LTD.

Sets Affected : Superhet Console, Superhet Six, Band-Pass Four, A.C. or D.C.-Quadradyne.

Sets not Affected : None.

Regentone Ltd. market five sets in all, counting the two versions of the Band-Pass Four, and all of them are calibrated with station names. Accordingly on January 15th the scales will need replacing by new ones showing the fresh positions of stations.

This is an easy task, and can be carried out at home, or by Regentone appointed stockists. In this case it is possible that a small charge will be made, according to circumstances.

The change-over from one scale to another is simplicity itself, and need take only a few minutes. This ease is obtained because the possibilities of wavelength alterations were realised when the sets were designed, and so the scales were designed accordingly.

We give a sketch showing the three main portions of the scale, the metal frame "A," the scale itself, "B," and the transparent mica cover "C." This latter fits over the tuning scale and is held away from it by about ¼-inch by the spacing washers on the bolts. "D." The indicating needle moves in the space between B and C.



Ferranti have given full details for the conversion of their Georgia Console (illustrated here).

To change the scale the following procedure is adopted: Remove the two screws "E" on the back of the wave-scale assembly, when the latter will come away complete from the drive. This obviates removing the chassis of the set from its cabinet.

Now remove the four screws, "D" when the transparent mica covering "C" will come away with the old tuning scale "B." The new scale is put in place instead of the old one, and the reverse process results in the set being satisfactorily changed for the new conditions.

## SIX-SIXTY RADIO CO. LTD.

Sets Affected : Type 332.

Sets not Affected : Super 5.

The Six-Sixty Super 5 is calibrated in wavelengths only, so the Lucerne Plan will not affect

# WE TELL YOU HOW TO DO IT!

the design of this receiver. It will, however, upset the calibration (or rather the full calibration) of Type 332. This has a scale marked not only in metres, kilocycles and degrees, which would be unaffected by the change, but also in station names.

The alteration of the scale is easily carried out by the set owner by the simple expedient of removing four screws holding the escutcheon to the cabinet—when the scale is simple to remove.

New scales are not at the moment available, Six-Sixty holding the matter in abeyance until the new wavelengths have been tried and some sort of finality is reached. When they do issue a scale, however, which will be as soon as is reasonably safe from likelihood of further alterations, it will cost but a nominal sum.

Till that time owners of Type 332 will be able to carry on quite successfully by ignoring the station names on the dial and using the wavelength calibration.

### SUNBEAM ELECTRIC LTD.

Sets affected. None.

Sets not affected. Models M./30, M./34, W./35, W.L./35, W.T./43, B./37, B./40, B.L./40.

Owners of Sunbeam sets have nothing to worry about in connection with the wavelength upheaval. All the receivers made by this firm are calibrated in wavelengths only, so that picking out the stations with their changed frequencies will be just as easy—from the point of view of finding on the dial—as it was before they moved wavelength.

At first, of course, the new positions on the dial will seem strange, but if the wavelengths given in the press against the stations names are duly noted there should be no trouble whatever.

No dial changes or alterations to the sets will have to be made.

### TANNOY PRODUCTS LTD.

Sets affected. None.

All the Tannoy Products receivers are designed with a rather unusual form of calibration that does away with the need for structural modifications when wavelength changes take place.

The dial is directly calibrated in 9-kilocycle channels, which are numbered. The customer is provided with a blue print indicating the stations operating on the numbered channels, from which he can readily select any transmission he may require.

With the new wavelengths in operation it is necessary, of course, to have fresh blue prints showing the new positions of the stations, and these prints have been prepared so that there need be no delay in set operation when the change-over occurs.

Those desirous of the new prints should apply to their Tannoy dealers, giving full details concerning their sets—type and number, etc.—or direct to Tannoy Products Ltd., Canterbury Grove, West Norwood, London, S.E.27.



A new dial can be obtained for the Ekco Super-heterodyne S.H.5 (above), and full details for fitting it are given in the Supplement.

### TELSEN ELECTRIC CO. LTD.

Sets affected. None.

Sets not affected. Models 464, M.30 (Golden Voice), 343, Air Marshal, 470, 474.

No alteration of dials or scales is necessary with Telsen receivers, which are all calibrated in wavelengths, with the exception of "Air Marshal" and Model 343, which are fitted with degree markings only. As a matter of fact Models

470 and 474 are calibrated in wavelengths and also marked in degrees.

The two sets marked in degrees only will need some form of home calibration—a tuning graph, or some list of stations and dial readings—in order that it can be used successfully for station searching, otherwise when the wavelength change-over occurs the owner will be lost when he comes to try to find some wanted programme.

The other Telsen receivers will be just as easy to use after the change as before, for the wavelength calibration will enable stations to be found very quickly.

### ULTRA ELECTRIC LTD.

Sets affected. Tiger Superbet (battery), Tiger Superhet A.C. and D.C., Panther, Lynx A.C. and D.C.

Sets not affected. None.

The above "latest models" of the Ultra Range are all affected by the wavechanging owing to the fact that station names, as well as wavelengths, are marked on the tuning scales. Some of last season's sets, too, will be similarly upset, and Ultra have got the matter in hand in a business-like manner.

New drums are being supplied to bring the sets up to date, and these are easily fitted by unscrewing four bolts holding the chassis to the cabinet, removing chassis, and undoing the drum-dial grub screw.

This enables the drum to be taken off, when a new one can be fitted. A station is then tuned in, identified, and the new drum is rotated to agree



Free charts for the affected Marconi receivers, of which this 274 is one, are available, and these will be followed later by new scales that can easily be fitted.

with the station. The grub screw can then be tightened up and the chassis replaced.

The new drums cost a small amount and can be obtained from Ultra dealers. They will not be available direct from the makers, who no doubt would prefer Ultra set owners to allow the dealer to do the fitting.

### UNITED RADIO MANUFACTURERS.

Sets affected: Models E, T, T.2B, F, A.P., S.E., S.B.

Sets not affected: Models H., H./M.C., D.3, D.3M.C. A very marked difference lies between the first and second list of models of United Radio Manufacturers sets. The types H., H./M.C., D.3, D.3M.C. have dials marked in degrees only, while the other types are marked with station names and wavelengths.

Owners of the first types will find that a new wavelength dial-reading chart made out at home will do all that is required in the way of aiding station finding, but those who possess the remaining models will need new scales if the sets are to be fully up to date.

New dials are available for the purpose, and cost 2s., post free. They can be fitted by the dealer from whom the set was purchased, or in the cases of the smaller models, at home. In large sets it is best to let the dealer do the fitting.

The dials are secured by two screws, so that their alteration is not at all a difficult matter. The

photograph shows how easily the change-over can be made.

### VARLEY LTD.

Sets affected: Models A.P.26, A.P.27, A.P.28, A.P.29, A.P.30, A.P.31, A.P.32, A.P.33.

Sets not affected: A.P.46, A.P.48, A.P.50, A.P.52, A.P.54.

Many of the Varley range of receivers are calibrated in wavelengths, but eight of the older designs of that company will be affected, as they

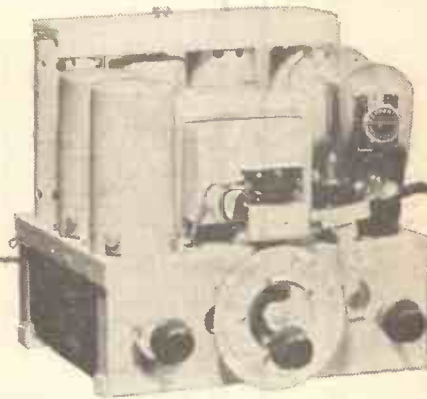

The small screws that hold the dial in position on this Ferranti Arcadia can be seen in this illustration of the chassis.

are fitted with station-name dials. These sets are listed above.

They can easily be altered to meet the requirements of the Lucerne Plan, and new scales are to be available for the purpose.

The method of changing is as follows: Unscrew the two wood screws holding the V-shaped escutcheon plate on the front of set, and on turning the dial round away from you the screws holding the scale-slips in position will be visible.

Unscrew and replace the old scales and replace the paper slip, with its celluloid covering in position, by passing over the top of the drum and pulling it under the bottom of the drum, refixing the screws after pulling the slip tight. The slots allow some movement to get the scales in correct position.

The new Varley models—A.P.46, 48, 50, 52 and 34—are already calibrated for the new wavelength plan, and so have been listed above as "sets not affected."

★ ★ ★

The following details concern firms whose reports on the effects of the wavelength change were obtained too late to be incorporated in alphabetical order in the Supplement.

### OSTAR-GANZ.

Sets affected. None.

Sets not affected: Universal High-mu Three, Universal High-mu Four, Universal High-mu Four Midget, Universal Five-Valve Super, Universal Seven-Valve Stenode Super, Universal Radiogram.

These receivers are fitted with full-voltage mains valves and are suitable for use in either D.C. or A.C. electricity supplies without any alteration. They are calibrated in wavelengths only, so that the Lucerne Plan will not affect their operation other than in the alteration of positions in which the various stations come in on the dials.

The wavelength ranges of these sets is stated to be 200-500 metres and 800-1,950 metres, so that the British stations relegated to 203-5 metres should easily be received. Athlone, however, will be lost when it goes up to its new wavelength above 500 metres.

### SLEKTUN PRODUCTS, LTD.

Sets affected. None.

Sets not affected. R & R. All-Electric Twin A.C., R & R. Class B Three.

Both these sets employ dials marked in degrees which obviate any possibility of trouble due to any wavelength shuffle as far as stations within the scope of the set are concerned.

Certain stations will move outside the scope of wavelength bands of the sets, owing to the new frequency positioning; but this is unavoidable, and few commercial sets are, we believe, available which will cover the whole gamut of wavelengths from below 200 to 2,000 metres.

The wavelength shifting may also have a slight effect on the strength at which some stations are received, so that set owners in general must not be

# EVERYTHING READY FOR THE BIG SHUFFLE

surprised if some transmitters can be heard better than before, on January 15th, and some are reduced in strength.

### WATES RADIO, LTD.

Sets affected: Futura D.C. Table Model, Futura A.C. Table Model, Futura D.C. Receiver, Futura A.C. Receiver, Futura D.C. Console, Futura A.C. Console, Futura D.C. Radiogram, Futura A.C. Radiogram.

Sets not affected: None.

These eight receivers are calibrated in wavelengths and have also the positions of the principal stations marked on the dials. To the extent that

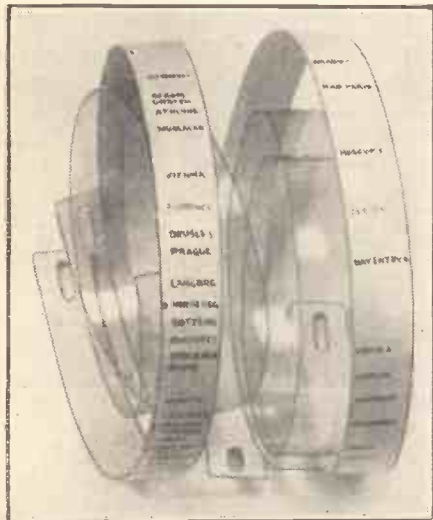

The dial ribbons for the Varley receiver range A.P. 28-33 inclusive. Full details for fitting are given.

these positions will be wrong, therefore, the sets are affected by the wavelength changes, though the use of the receivers will not be upset if the wavelength scale is referred to.

The Wates receivers, then, will not by any means be out of date, and it is suggested that the station names can easily be blanked out—covered with pieces of white paper—and new positions marked by cutting out the names of the stations in the box on this page and pasting them on the tuning scale.

This procedure is recommended to all who have sets with just a few principal stations marked on the dials, and the type in which the names are set has been chosen as being suitable for the purpose in the majority of cases.

The employment of a few station names on a wavelength-calibrated dial greatly assists in the tuning of the set, especially by members of the family who only use the receiver for programmes from a few stations.

### DARIO RECEIVERS (Impex Electrical, Ltd.)

Sets affected: None.  
Sets not affected: Regional Receiver, Regional de Luxe, Europa Receiver, All-Electric Regional A.C. and D.C.

The dials of the Dario receivers are marked in degrees, so that here again no inconvenience will be encountered by listeners on January 15th. As we have advised before, it is desirable that a chart of some sort be made by owners of these sets so that the finding of the various stations shall be simplified.

With degrees only on the dial it is often extremely difficult to find transmissions when they change considerably in wavelength, as will occur in many instances when the new scheme comes into operation.

### HAYNES RADIO.

Sets affected: None.  
Sets not affected: Class B Three, Class B Four, Quality Receiver, A.C. Ferrocart Three, A.C. Superheterodyne, D.C. Superheterodyne.

All Haynes receivers are normally fitted with tuning scales marked in degrees, though wavelength-calibrated dials are available at an extra charge of 1s. 6d. In either case the wavelength changes will not upset the operation of these receivers, so that owners of Haynes sets have nothing to worry about.

## YOUR LOCAL STATION. How the dial reading is affected by the change.

### BOURNEMOUTH:

Moves from 288.5 to 203.5 metres. Listeners to the Bournemouth station will find quite an appreciable difference in dial reading when the Lucerne Plan comes into operation. Bournemouth in the future will have the same wavelength as Plymouth, and it will be found in most sets right at the bottom of the dial.

### PLYMOUTH:

Moves from 218.5 to 203.5 metres. The same remarks apply to Plymouth as to Bournemouth, since these two stations are on the common wavelength of 203.5 metres.

### ABERDEEN:

Moves from 214.3 to 222.6 metres. With the new wavelength of 222.6 metres, Aberdeen is now on one of the international common waves. The change-over will simply mean that the station will be received a few degrees higher up.

### LONDON AND WEST NATIONALS:

Move from 261.6 to 261.1 metres. The change in the wavelength of these stations is so very small that the alteration in tuning position will hardly be noticeable.

### BELFAST:

Moves from 242.3 to 267.4 metres. The 25-metre increase in the wavelength of Belfast will make an appreciable difference to its tuning position. It may be as much as 10 degrees higher up the scale, but, in any case, it is far from being a serious alteration.

### SCOTTISH NATIONAL:

Moves from 288.5 to 285.7 metres. The slight decrease in the wavelength of the Scottish National station will make little if any difference to the position at which it is tuned in.

### NORTH NATIONAL:

Moves from 301.5 to 298.2 metres. When the change takes place, Northern listeners will find their National station just a degree or so farther down the dial.

### WEST REGIONAL:

Moves from 309.9 to 307.1 metres. The 3-metre difference in the setting of the West Regional station will hardly be noticeable on the dial, and for all practical purposes the change will make no difference.

### LONDON REGIONAL:

Moves from 356 to 342.1 metres. The change in dial reading of the London Regional will certainly be noticeable, but is unlikely to cause any inconvenience.

### SCOTTISH REGIONAL:

Moves from 378.4 to 373.1 metres. Here, again, the change will be barely noticeable, and the station will be found only just a fraction below the setting at which it has always been received.

### MIDLAND REGIONAL:

Moves from 398.9 to 391.1 metres. On most scales the 8-metre difference, between the new and the old wavelengths will only represent a matter of a few degrees.

### NORTH REGIONAL:

Moves from 480 to 449.1 metres. The change in wavelength of the North Regional represents one of the biggest British moves, with the exception of Daventry 5-X X.

### DAVENTRY:

Moves from 1554.4 to 1500 metres. There is every indication that the new wavelength will completely avoid heterodyning.

In the preceding columns we have endeavoured to tell how the various commercial receivers will be affected on January 15th, when the new wavelength schedule begins, giving details of the alterations where necessary for dial and scale recalibration. But there remain one or two things to be said in general about the alterations that have to be carried out on some of the commercial sets.

In the first place, it is advisable to let the dealer assist you in any case where there is appreciable doubt about how the alterations are to be made. Some sets are a little bit awkward in their design when it comes to changes of this nature, and the

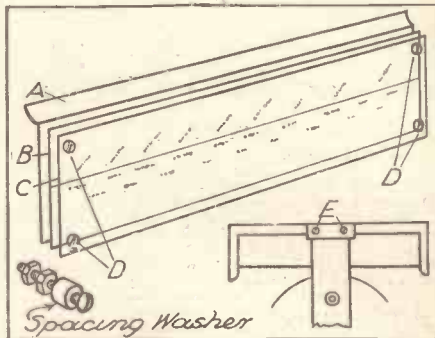

The Regentone scale is fitted between a metal back and the mica shield shown above. This sketch illustrates the details given in the text.

unmechanically inclined may find the task a bit baffling if the set under modification is particularly difficult to get at.

Whatever the set, however, if it is of the mains variety you must be sure you disconnect the mains completely before even examining the inside to see how the dials or scales are removed. In the same way batteries must be disconnected from battery receivers before a like procedure is commenced.

If these precautions are not carried out you may do a considerable amount of damage to the receiver or the valves. It should be remembered, however, that all sets are completely harmless, from the point of view of shocks, if they are disconnected from their batteries or the mains.

### CHECKING THE READINGS.

After the dials have been fitted, especially where drum dials are concerned, or where there is a certain amount of slack allowed in the fitting for adjustment purposes, a trial run of the set should be undertaken to check up the readings.

Tune in a powerful station that you know—the local will do—and then reduce the volume by means of the volume control, keeping the station tuned dead in all the time. Then check up the wavelength or the position of the reading of that station on your newly fitted dial or scale.

If this is not correct adjust the scale or dial by a slight movement of same until the position is found where the correct station name comes under the pointer when the given station is tuned in.

Unless this check-up is undertaken you will find that distant transmissions are difficult to pick up, for with a wrongly aligned scale the tuning will be inaccurately calibrated, and the identification of broadcasters will be rendered wrong.

After the scales and dials have been fitted, be careful to tighten up every nut and screw that you have had to slack, and any others that may come to your notice as requiring tightening.

The greatest care must be taken when the sets are being removed from their chassis (where such a step is necessary) that no leads attached to fixtures in the cabinet, such as the loudspeakers, are broken or dragged loose. Gentleness is essential to success where anything of this nature is concerned.

In most cases it will be advisable to remove the valves before taking the set out of the cabinet, for it is easy to knock a valve during the process, and these are components that do not react kindly to such treatment.

Incidentally, screwdrivers and pliers should not be allowed to poke into the vanes of variable condensers, nor on the diaphragms of loudspeakers in the process of dismantling a receiver.

It sounds absurd to mention these things, probably, but these accidents are not so unusual as may be imagined, for when one is taking a set to pieces in a hurry, as most of us do at some time or other, it is easy to be careless, and one slip of the nature outlined above may do irreparable damage.

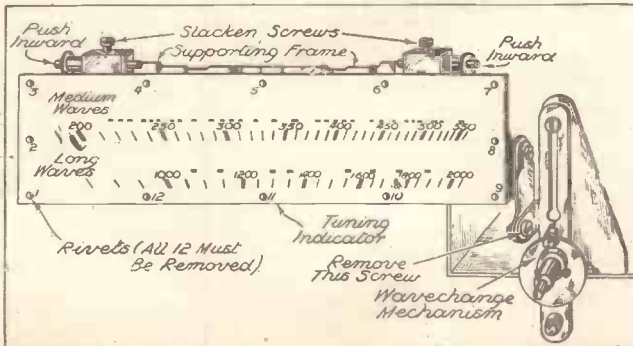

Twelve rivets hold the scale of the G.E.C. "Gala" receiver, which comes under the heading of "affected receivers."

# "No Tears with a PILOT AUTHOR KIT"

# PETO-SCOTT EVERYTHING RADIO—CASH C.O.D. or EASY TERMS

Peto-Scott are pioneers in Radio and Television. Our Service to the British Public was introduced in 1919, and during 14 years of Solid Service and Satisfaction we have established a reputation for fair dealing that defies competition. Customers in all parts of the globe come to us regularly for all their radio requirements Sets, Kits of all descriptions, Part Kits, Miscellaneous

Components, Speakers, Eliminators and Accessories. Purchases can be made for Cash, C.O.D., or on Easy Payments. WE DEAL WITH YOU DIRECT—Peto-Scott's Easy Way System with its strict privacy and no third party collections—will bring radio to your home by convenient monthly payments. Send list for quotation; no obligation.

## PETO-SCOTT S.T.500 WALNUT CONSOLETTTE



Regd. Design No. 787,710

**25/-**

An outstanding example of cabinet craftsmanship. Hand French polished. Veneered Macassar and Walnut finish by experts. Cash or C.O.D. 25/-. Carr. and Packing, 2/6 extra, or 6/- Deposit and 4 monthly payments of 6/- (including carriage and packing). Baffle-Baseboard Assembly, 3/6 extra. Specified PETO-SCOTT TABLE CABINET. CASH or C.O.D., 19/6, or 6/- Deposit and 3 monthly payments of 6/- (including carriage and packing).

SEND FOR 1934 CABINET CATALOGUE.

## D.B. THREE

**KIT "A"** Author's Kit of first specified parts, including PETO-SCOTT Ready-Drilled Panel and "Metaplex" Baseboard, but less Valves and Cabinet. CASH or C.O.D. Carriage Paid. Or 12 monthly payments of 9/3 **£5-0-0**

**KIT "B"**  
As for Kit "A" but with Set of Specified Valves only. CASH or C.O.D. Carriage Paid. **£6-18-0**  
Send only 12/6.  
Balance in 11 monthly payments of 12/6.

**KIT "C"**  
As for Kit "B" but with PETO-SCOTT Table Cabinet, as specified. CASH or C.O.D. Carriage Paid. **£7-13-0**  
Send only 14/-.  
Balance in 11 monthly payments of 14/-.

## UNITY-TWO

**KIT "A"** Author's Kit of first specified parts, including PETO-SCOTT Ready-Drilled Panel and "Metaplex" Baseboard, but less Valves and Cabinet. CASH or C.O.D. Carriage Paid. Or 12 monthly payments of 4/3 **£2-7-0**

## VOL-PEN

**KIT "A"** Author's Kit of first specified parts, including Metaplex Chassis and PETO-SCOTT Ready-Drilled Ebonite Panel, but less Valves and Cabinet. CASH or C.O.D. Carriage Paid **£4-17-6** Or 12 monthly payments of 9/-.  
SEND FOR DETAILED LIST OF PARTS FOR ALL THE ABOVE SETS.

## S.T.500

**KIT "A"** Comprising Mr. John Scott-Taggart's Kit of FIRST SPECIFIED Components, including Telsen "Class B" Output Choke, Peto-Scott "Metaplex" Baseboard and Ready-drilled Panel and Terminal-Strip. Less Valves and Cabinet. With FULL-SIZE Blue Print and copy "Popular Wireless," Oct. 21st Cash or C.O.D. Carriage Paid, **£5-5-0** or 12 monthly payments of 9/6.

**KIT "B"**  
As Kit "A," but including 4 Specified Valves. Cash or C.O.D. Carriage Paid, **£7-10-3** or 12 monthly payments of 13/9.

**KIT "GT"**  
As Kit "B," but including Peto-Scott Specified Walnut Table Cabinet. Cash or C.O.D. Carriage Paid, **£8-9-9** or 12 monthly payments of 15/6.

**KIT "CC"** As Kit "B" including Peto-Scott Specified Walnut Console Cabinet. Complete with Baffle Baseboard Assembly, but less Speaker. Cash or C.O.D. Carriage Paid **£8-18-9** Or 12 monthly payments of 16/3.  
If Peto-Scott Permanent Magnet Speaker required add 19/6 to Cash Price or add 1/6 to each monthly payment.

## FINISHED INSTRUMENTS

**"S.T.500,"** complete in Peto-Scott Walnut Table Cabinet, exact to Mr. John Scott-Taggart's FIRST Specification. Aerial Tested. Complete with Valves. Cash or C.O.D. Carriage Paid, **£10-0-0** or 12 monthly payments of 18/3.

**"S.T.500,"** complete in Peto-Scott Walnut Console Cabinet, exact to specification. With Peto-Scott Moving-Coil Speaker. Complete with Valves. Ready to Play. Aerial Tested. **£11-5-0** Cash or C.O.D. Carriage Paid, or 12 monthly payments of 21/-.

## CONVERT YOUR S.T.400 to S.T.500



With Free Copy "POPULAR WIRELESS" and OFFICIAL BLUE PRINT.

**YOURS FOR 5/-**  
BALANCE IN 8 MONTHLY PAYMENTS OF 5/3

Peto-Scott S.T.500 Conversion Kit comprises all FIRST SPECIFIED parts required to convert your S.T.400 to the new S.T.500, including output choke, but less valve. CASH or C.O.D. Carriage Paid, 42/-.  
H.P. TERMS: Complete Kit with Valve, 12 monthly payments of 5/3.

PETO-SCOTT CO. LTD., 77, CITY RD., LONDON, E.C.1. Tel.: Clerkenwell 9406/7.  
West End Showrooms; 62, High Holborn, London, W.C.2. Tel.: Holborn 3248.

Dear Sirs,—Please send me CASH/C.O.D./H.P. for which I enclose £.....d. CASH/H.P. Deposit.  
NAME.....  
ADDRESS.....  
P.W., 8/1/34.

## 1934 WALNUT ADAPTAGRAM



38 in. high, 22 in. wide, 15 1/2 in. deep. Speaker Compartment: 17 in. by 19 in. by 14 in.

**YOURS FOR 8/3**

CONVERT YOUR EXISTING SET INTO A MODERN RADIOGRAM

As illustrated, Cash or C.O.D. Carriage 2/6 extra. Or 8/3 Deposit and 11 monthly payments of 5/9 (Carriage paid). IN OAK OR MAHOGANY NO EXTRA. Special drillings or other special cut-out designs add 3/- extra to cash price or 3d. to each monthly payment. Direct from Factory. NO MIDDLEMAN'S PROFITS. Built by master-craftsmen of the piano trade. Real inlaid walnut, mortised, tenoned. French polished. With motor-board ready to take your set, speaker and power equipment. Plain front or venetian panels, 14 in. by 7 in., 16 in. by 7 in., 18 in. by 8 in. Baffle-board, 3/6 extra.

**NEW GARRARD MODEL 202A.** 12-in. turn-Send table. Electric motor for A.C. mains. Cash 6/- or C.O.D. Carriage Paid 12/10/0. Balance in 8 monthly payments of 6/- only

**NEW ROLA CLASS "B" PERMANENT MAGNET MOVING-COIL SPEAKER AND AMPLIFIER,** with valve and input transformer. Two models: A, for PM2B, PD220, and 220B; B, for 240B, HP2 (state which when ordering). Cash or only C.O.D. Carriage Paid, 13/11/0. Balance in 11 monthly payments of 6/6.

## IMPORTANT

Order from PETO-SCOTT any separate items for the S.T.500. We specialise in, and carry the largest stocks in the country of all FIRST SPECIFIED PARTS. Delivery from stock. Therefore you KNOW that you are certain of receiving the parts Mr. John Scott-Taggart chose. WE DO NOT SUBSTITUTE. Send Cash or C.O.D. Orders over 10/- all Post Charges Paid. Easy Terms on orders over £2. GREAT BRITAIN ONLY.

## S.T.500 STRUCTAKIT



With Free Copy "POPULAR WIRELESS" and OFFICIAL BLUE PRINT.

**7/6**  
CASH OR C.O.D.

Comprising Peto-Scott Baseboard with Metaplex Section; Ready-Drilled Panel and Terminal Strip; S.T.500 Screen; B.H.C. Mounting Bracket.

# TESTED AND FOUND-

Being leaves from the Technical Editor's Notebook

## A "HOME MIKE"

GREAT fun can be had with a small microphone used in conjunction with a wireless set, especially at parties. But I hope "P.W." readers will not use this stunt in the way an American was recently reported to have done.

He caused "news" announcements to be made, such as: "It is reported that a committee is to be formed to investigate the affairs of the 'XYZ' corporation, serious allegations having been made against it." And of course, the manager of the "XYZ" concern would be one of his guests during the coming through of the spoof news bulletin.

On one occasion one of his guests left hurriedly and committed suicide because he believed one of these "joke" announcements to be genuine.

However, there is plenty of scope for good, healthy fun which will cause laughter and hurt nobody's feelings. Also, of course, a "home mike" has definite valuable uses. For instance, it can be used as a detector of baby crying or to enable a sick person to communicate his or her needs to other people in the house.

I've used a small mike for similar purposes in my home for years, and wouldn't be without it. All that has to be done is to join it to the set in much the same way as a pick-up is sometimes connected.

But the ordinary mike requires a battery and a transformer, which is rather a nuisance.

However, the Scientific Supply Stores, of Newington Causeway London, S.E.1, have produced a "Home Mike" which needs no such extras of this nature. It is as self-contained as a pick-up.

And it is quite a simple matter to connect it to a set. All that has to be done is to remove the detector valve, replace it after a special disc connector has been slipped into position and make a connection to the earth terminal or chassis.

The mike is quite sensitive, and in my opinion the quality it gives is superior to the average small mike response.

Given moderately careful use, it is not at all difficult to "put into" the loudspeaker something that can easily pass as "official" announcements; though whether or not the speaker can mislead his listeners into thinking he is one of the B.B.C.



One of the most important features of the Scientific Supply Stores microphone is the fact that it needs no battery or transformer. Simply slip the adaptor disc under the detector valve, join the second lead to earth—and there you are!

announcers depends upon his own individual elocutionary accomplishments. Anyway, if he can speak "quite nicely," this particular home mike will go a long way towards emulating B.B.C. standards!

## IGRANIC TUBULAR CONDENSERS

It is permissible for any firm to say of its goods that they are "marvellous," "stupendous," "better than anything hitherto accomplished," and so on, because eulogy of this kind is a matter of opinion. Maybe the originators of such phrases are not always sincere in their protestations, but that can be neither proved nor disproved.

But I fancy the present-day radio public, or at least the home constructor, pays little heed to mere words. Facts are required—definite claims which can be judged and considered in comparison with precedents and standard practices.

No amount of verbal colouration could equal in impressiveness the following simple, straightforward description of the Igranitic Tubular Type Fixed Condensers, which appears in the Igranitic catalogue:

"These condensers are constructed of high-conductivity copper strips interwound with a transparent insulating material of high specific inductive capacity. They are guaranteed to be within 5 per cent of their rated capacity, and each condenser is

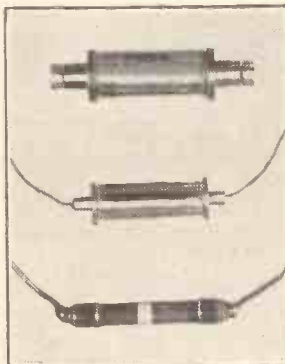

Igranitic tubular condensers need no "drum-beating" to extol their advantages. They sell at the ridiculously low price of 6d. and have proved themselves first-class components.

tested to withstand 1,000 volts (R.M.S.) A.C. Small and compact, they are easily connected, screw terminals and wire ends being provided, no special mounting base being necessary, the condenser being supported by the connecting wires. Supplied in the following sizes: .0001 mfd., .0003 mfd. and .001 mfd."

Such restraint is characteristic of Igranitic, and I hope the policy produces the full reward it deserves. But I very much doubt it!

However, I have yet to give point to my words. This Igranitic Tubular Condenser carries a rating and test guarantee which at once places it right at the head of its class. What is the price? Two and sixpence? Two shillings? Would it be dear at one and six?

The price is 6d. for the .0001 mfd. and the .0003 mfd., and 8d. for the .001 mfd. And it is one of the neatest pieces of work which has come my way for a long time.

When it is remembered that retailers and wholesalers have to take their shares of that 6d. or 8d., it amazes one that such prices can be possible.

True, the condensers are very small, but compared with those black lozenges that used to sell as condensers at 2s. 6d. and more, they are miracles of cunning design and sound workmanship. There you are: it is quite obvious Igranitic don't need to beat a drum—they can safely leave that for others to do for them!

I must mention, in conclusion, that I have tested and used some of these Igranitic Tubulars, and found them to be first-class little components in every way.

## THE WEARITE 7-PIN VALVE HOLDER

There have been a few seven-pin valve holders come my way which take seven-pin valves very effectively. Others have tended either to grip the valve like a vicious trap or to take it so loosely that inefficient contacts result.

It is largely a mechanical problem, this accommodation of a compacted group of seven pins. And I consider one of the most successful of all solutions is to be found in the Wearite seven-pin valve holder for chassis mounting which is illustrated on this page.

A valve slides into it with wonderful smoothness, and good contact is made at every pin.

The scheme that ensures this satisfactory effect is an ingenious but very simple one. The actual contacts are made by the brass grips that are extensions of the appropriate soldering tags.

But around each brass contact grip is a steel spring piece that ensures an entirely satisfactory and smooth springiness that brass alone could not give.

It is a first-class valve holder, cleverly designed and very well made.

I RECENTLY had an opportunity of running my fingers over the controls of Clarke's "Atlas A.4" Receiver, and I must confess that if this is an example of what can be done by using pentode valves throughout, then very definitely I am all in favour.

As a matter of fact, I believe that Clarke's, in the design of their "A.4," were among the first, if not actually the first, firm to produce a set with the circuit sequence of pentode variable-mu S.G., pentode detector and power pentode output, and not only is it a pleasing combination to handle, it definitely does bring in the stations.

The calibration of the dial in both wavelengths and station names is another weakness of mine. I hope I am not getting



Weekly jottings of interest to buyers.

lazy in my old age, but to me, at any rate, there is always something tremendously satisfying about being able to recognise stations as I go along without having to wait for announcements or without having to refer to a list of stations.

I'm talking of commercial sets, of course. If it happens to be a

set that I have built myself, then I view the matter entirely differently, for half the joy is in finding out for one's self exactly what it will do. But so far as commercial designs are concerned, where every effort is made to cater for the maiden aunt just as much as for the non-technical male folk, station naming, in my opinion, is a most desirable practice.

However, to come back to the "A.4," it  
(Continued on page 806.)



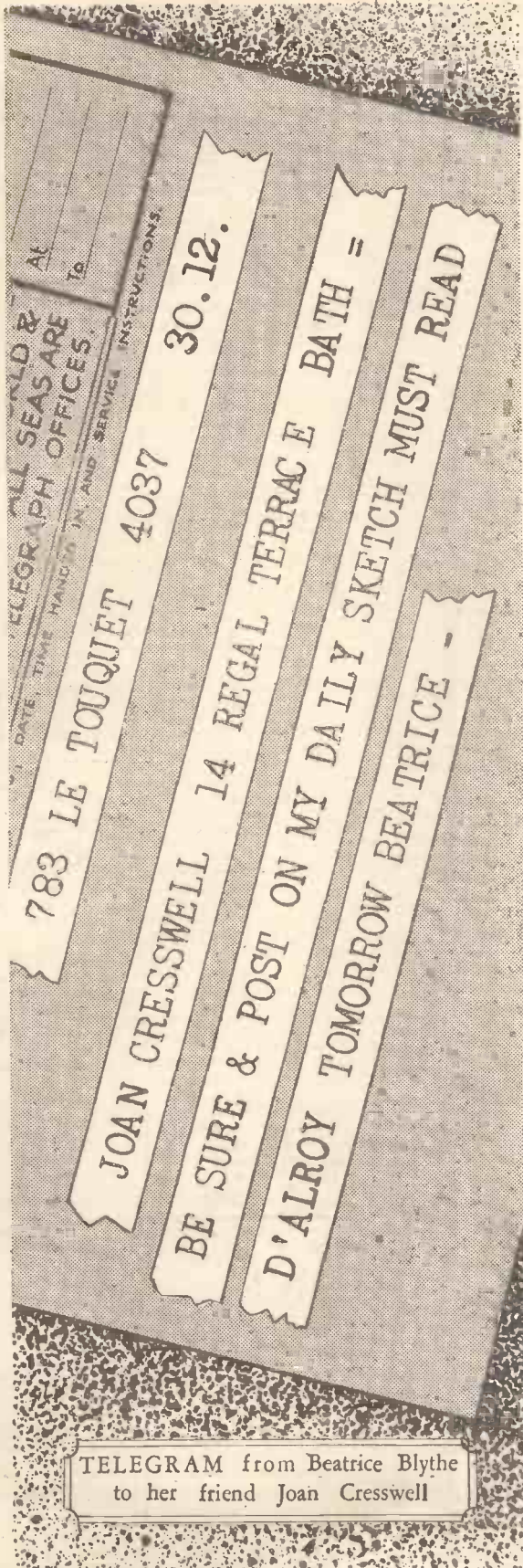

# Why is GROSVENOR the longest-lived battery in the World?

Firstly . . . . . The zinc cells are the cause of 99% of battery failures. By the Grosvenor MERCURY process, these vital cells are guarded—scientifically protected against corrosion and deterioration.

Secondly . . . . . So long do these MERCURY-protected cells last that Grosvenor fill them with extra chemicals to use them up. Every Grosvenor battery is crammed to the limit with this abundant extra long-lived power.

That is why it is no idle claim, but a scientific certainty that Grosvenor are the longest-lived batteries in the world—the batteries that give you more for your money. Insist on Grosvenor next time, and test this for yourself!

**NEXT TIME  
PLUG INTO  
THE BATTERY-**

Ⓞ GROSVENOR Mercury Batteries are made for every Radio need from 5/6 to 20/-. Ask also for Grosvenor Miscanlite Electric Torchies, strong and attractively coloured, from 1/-.



**-THAT GIVES  
YOU MORE**

GROSVENOR ELECTRIC BATTERIES, LIMITED,  
2-3, White Street, E.C.2. Telephone: METropolitan 6856 (3 lines).

When you renew your **rectifier**, change it for the **last time . . .**

Change now to  
**WESTINGHOUSE  
METAL RECTIFIERS**  
and obviate periodical renewal.

THE WESTINGHOUSE BRAKE & SAXBY SIGNAL CO., LTD.,  
82, YORK ROAD, KING'S CROSS, LONDON, N.1.

## WATTS DISSIPATION SIMPLY EXPLAINED

A short article of practical interest  
to all home constructors.

THE newcomer to wireless is often puzzled by the terms "watts dissipation," "watts rating," "I<sup>2</sup>R loss" and the like.

Now consider the diagram. We have here a resistance in the plate circuit of a detector valve used for decoupling purposes, and of a value of about 25,000 ohms. We are, of course, aware that this valve may take from 1 to 10 milliamps., varying in accordance with its oscillating condition.

Every electrical engineer is familiar with the I<sup>2</sup>R loss, as it is called, because it means that power is lost owing to the resistance of his circuits. Therefore, he tries to keep this resistance as low as possible.

From Ohm's Law we know that  $I = \frac{E}{R}$ ,  $R = \frac{E}{I}$ , and  $E = I \times R$ . Now, power in

watts is equal to the voltage across the resistance, multiplied by the current flowing in this resistance, and equals  $I \times E$ . Seeing that  $E = I \times R$ , we can substitute  $I \times R$  for  $E$ , thereby finding that the power or heating effect is  $I \times I \times R = I^2R$ .

This power is all dissipated in heat. Assuming, for simplicity, that the detector

takes 1 milliamp.—in other words,  $\frac{1}{1,000}$  ampere—we get from the formula  $I^2R$  the figures  $\frac{1 \times 1 \times 25,000}{1,000 \times 1,000} = .025$  watts to be dissipated in heat.

Now consider what happens when the valve takes 10 milliamps. From our formula we find  $\frac{10 \times 10 \times 25,000}{1,000 \times 1,000} = 2.5$  watts,

which goes to show the importance of the watts rating method of choosing a resistance. A resistance which would dissipate 2.5 watts would have to be made on much more substantial lines than one that would need to dissipate only .025 watts.

For those interested, the actual heat developed may be calculated from the formula: heat in calories = .24 I<sup>2</sup>Rt, where I = amperes, R = resistance of the circuit and t = the time in seconds.

Although the heat generated in this way is very small in wireless receivers, it has, nevertheless, to be taken into account, otherwise the element of the resistance would possibly burn out.

## WHERE THE WATTS GO

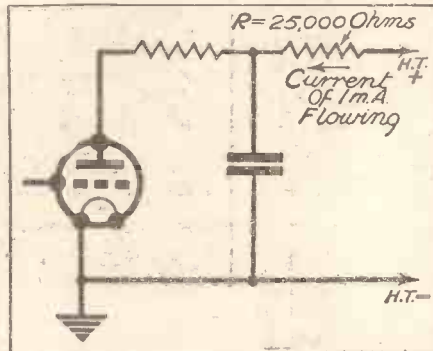

This simple circuit clearly shows how watts dissipation takes place.

and if you study it carefully in conjunction with the much simplified diagram which I give, you will have mastered an important part of the process of television.

## THE LISTENER'S NOTEBOOK

(Continued from page 788.)

Apart from an experimental service for housewives, a morning item under the heading of "News from the Markets" and a Saturday evening discussion on matters of topical interest, there seems little else that is new.

Mind you, I don't scorn the old, for the old embraces many of the interests of a large listening public.

It has happened again. I've long wondered how broadcasters can resist the temptation to address a private remark to their own kith and kin when broadcasting. When we heard it done the other week we were shocked, of course, and thousands of tongues began wagging simultaneously.

Personally, I think it is remarkable that it hasn't happened more often. I have never broadcast a word, though I nearly did once.

I remember finding myself alongside a B.B.C. van on the top of which Mr. H. M. Abrahams was sitting engaged in a running commentary of an Oxford and Cambridge relay meeting. Lord Burrell sat with him, deeply engrossed in all that was going on. Lord Burrell wasn't there in any official capacity—that was obvious. But it was evident from the look on his face that he wanted to talk into that microphone. And I did, too.

Actually neither of us did, though I did produce the biggest of my characteristic coughs in the hope that it would be recognised by friends of mine, who I knew were listening in. It wasn't recognised.

It would be a difficult job if one had to decide who was the most successful broadcast speaker for the year 1933. A number of speakers could be eliminated straightway, but the remaining stages of this process of elimination would be rather ticklish.

If I ultimately decided it was Mr. Howard Marshall, I wonder how many people would agree with me. I should arrive at this decision, I think, chiefly because Mr. Marshall has spoken on a diversity of topics, and always brilliantly.

## THE MIRROR OF THE B.B.C.

(Continued from page 788.)

of the L.M.S., Sir Josiah Stamp, have been urging on Sir John Reith the national importance and the value to listeners of sustained attention to travel and holiday problems.

I hear that the overtures have been successful. It remains to be seen whether the intention will be translated in terms of acceptable entertainment.

### Imperial Airways Birthday.

The B.B.C. has ambitious plans for calling attention to the tenth anniversary of Imperial Airways, which falls early in April. In addition to the usual speeches and news items there will be a special programme, given probably in the second week of April. This will take the form of a picture in sound of the progress of Civil Flying. It is interesting to note that Major Woods Humphrey, Managing Director of Imperial Airways, and Sir John Reith have been friends since they served a common engineering apprenticeship before the war.

### Memorial to J. C. Stobart.

The name of John Clark Stobart, B.B.C. Director of Educational and Religious Broadcasting, who died in May last, is to be perpetuated in a cot and memorial tablet in the Children's Ward of Charing Cross Hospital. The cot will be dedicated by the Rev. Pat. McCormick and the tablet unveiled by Mrs. J. H. Whitley at a short broadcast ceremony in the hospital on January 12th, at 5.15.

## THE LINK BETWEEN

(Continued from page 804.)

is certainly a set that ought not to be overlooked by anyone contemplating the purchase of a new commercial set, and, so far as appearance is concerned, it is definitely in keeping with the modern trend. I like it, and I am convinced that it is going to make a hit.

Here's to 1934 and to all the prospects that it holds in store for even better and cheaper radio! None of us can forecast accurately at this juncture what the future trend of developments is likely to be, but at least I'm prepared to bet my shoes (sorry, I don't wear boots!) that, whatever it is, "P.W." will be out first with the news. Just you wait and see! And now back into harness once again.

### Postmen, Beware!

My heart is always inclined to go out to the great army of that most welcome fraternity—the postmen—whenever Mullard's bring out a new catalogue.

I know that whenever I have included one of their catalogues in our postcard literature service we have been simply inundated with applications; in fact, in one instance the number of requests for Mullard literature created a record. What it must be like in Mullard's literature department, I shudder to think. Such is fame.

But that is just by the way. The main thing is that the third edition of Mullard's Rapid Valve Guide, which contains all the very latest additions to their famous range, is now available, and may be had free for the asking through the medium of our postcard service. It's just a nice convenient size for the waistcoat pocket, and, as usual, it contains a most handy table of valve equivalents. Take my tip and let us have your postcard at once. The (No. 70.) demand is sure to be heavy.

## OUR POSTCARD SERVICE.

Applications for trade literature mentioned in these columns can be made through "P.W." by quoting the reference number given at the end of the paragraph. Just send a postcard to G. T. Kelsey, at Tallis House, Tallis Street, E.C.4. Any literature described during the past four weeks may be applied for in this way—just quote the number or numbers.

## TELEVISION

### Breaking Up the Picture

(Continued from page 784.)

one of the earliest of these devices, and is still quite widely used for the purpose.

It consists of a thin sheet-metal disc of considerable size, say 18 in. or 2 ft. in diameter, and mounted upon a spindle at its centre so that it can be spun like a wheel. This is actually done, and it is driven at a high speed by an electric motor.

Near the edge of the disc a series of small holes is punched, in the form of a spiral, so that each hole is placed a trifle nearer to the centre of the disc than the previous one in the series. The complete spiral is so planned that it exactly fills the circumference of the disc.

### Across the Screen.

Now imagine that we have placed a screen of suitable material on one side of the disc and a bright light on the other. Light will pass through the holes and fall on the screen, producing bright spots thereon. If we now set the disc running the spots will stream across the screen one at a time, each tracing a line just beside that swept by the previous one.

At each revolution of the disc the spots will cover the whole surface of the screen if the spiral is correctly planned, and then in the next revolution they will begin again and sweep it once more, repeating the process as long as the disc is kept running.

There you have the outline of the business,

## MAKING A START ON SHORT WAVES

Some First Experiences

I WAS shown, for the first time, the power of covering distances by means of short waves, one summer evening about four and a half years ago. My main set at that time was the first type of Cossor "Melody-Maker," but for head-phone listening I had made up from junk of a previous set a single valver using swinging-coil reaction.

The valve very conveniently worked with a flash-lamp battery.

After having read some articles on short waves, and fired with the ambition to get down to low wavelengths, I plugged in coils of about 15 turns and, on tuning, came on a very strong carrier. This proved to be, in the light of later knowledge, a ship-to-shore 'phone station on 170 metres.

The speech was in German, and too loud to be comfortable. I thought, of course, at that time it could not be higher than 60 metres.

"A Proper Set."

Convinced now of the possibilities of short-wave work, the next thing to do was to get a proper set. The Adaptor idea appealed to me very much.

I liked the "Antipodes," but not being very expert then in the manipulation of ebonite, I did not see how I was going to make the coil. However, a correspondent in "P.W." described an Adaptor he was using.

This appeared easy to build, and not many parts were required, so I got busy. A .0005 variable condenser was taken to bits and double-spaced, and an old five-plate vernier unearthed. I had now the tuning and reaction condensers; the coils were spirals of 16-gauge wire, tied with string to strips of ebonite.

The panel, which had seen service as many things in the past, was really a number of holes held together by bits of ebonite. Great attention was paid to the spacing of parts, and at bends the wiring described graceful semi-circles.

Trying Out The Adaptor.

When all was finished, I plugged the Adaptor, by means of an old valve base, into the detector socket of the "Cossor," but on turning the knobs heard not a sound. I tried all sorts of things, but could get no oscillation whatever. Thinking the baseboard too small for adequate spacing, I bought a bigger one and rebuilt the whole thing. Still not a sound.

Then I thought of a power valve for detector, but still no results. Then, having a "brain-wave," I plugged into the second valve holder on the broadcast set, and at once heard the now familiar chirping of Morse. Apparently the resistance for the R.C. stage had been cutting down too much of the H.T. to the plate of the detector valve.

Results with this little set were quite good, although the necessity for long extension handles was soon very evident. W2XAF was heard very strongly.

And so, once having made a start, I went on, and now have three or four short-wavers.

V. H. B.



Modern

design

plus

unequaled

performance

Type 9200—Test volts  
650 D.C. Wkg. volts  
250 D.C.

1 mfd. 2/6

2 mfd. 3/6

4 mfd. 7/-

1. True non-inductive type of construction.
2. Available in various grades for working voltages from 300-900 D.C. peak.
3. Adequate factor of safety for each.
4. New method of fixing to chassis.
5. Aluminium containers with moulded bakelite top of distinctive appearance to match other components.
6. Takes up minimum amount of space on chassis.

# DUBILIER CONDENSERS

DUBILIER CONDENSER CO. (1925) LTD., DUCON WORKS, VICTORIA RD., N. ACTON, LONDON, W.3

THE ENGINEERING DEPARTMENT OF THE POST OFFICE offers attractive openings as Probationary Inspectors to young men (aged 17-23) who are interested in Engineering. No experience is required. Commencing salary £209 per year. Details of open Entrance Examination from B.I.E.T. (Dept. 568), 29, Oxford Street, W.1.

LOUD SPEAKERS REPAIRED, 4/-  
(Blue Spot a Speciality, 5/-.)  
Transformers and Moring Coils quoted for. 24-Hour Service. Trade Discount. Clerkenwell 9069.  
E. MASON, 44, EAST ROAD (nr. Old Street Tube Station). LONDON. N.1.

## ADD 50/- WEEKLY TO YOUR EARNINGS

by charging accumulators in your spare time. Complete Plant incorporating Westinghouse Rectifiers, to charge 105 cells weekly

Trade Price £4:4:0 or 8/- monthly  
A.C. Mains only Send for descriptive booklet  
MAINS' POWER RADIO, LTD., ROMFORD, ESSEX

WE invite readers to support our Advertisers—care being taken to accept only announcements of reputable firms!

All applications for Advertising Space in POPULAR WIRELESS

should be addressed to the Advertisement Department, John Carpenter House, John Carpenter Street, London, E.C.4. Phone CITY 0202.

# RADIOTORIAL

The Editor will be pleased to consider articles and photographs dealing with all radio subjects, but cannot accept responsibility for manuscripts or photos. Every care will be taken to return MSS. not accepted for publication. A stamped and addressed envelope must be sent with every article.

All Editorial communications should be addressed to the Editor, POPULAR WIRELESS, Tallis House, Tallis Street, London, E.C.4.

All inquiries concerning advertising rates, etc., to be addressed to the Advertisement Offices, John Carpenter House, John Carpenter St., London, E.C.4.

The constructional articles which appear from time to time in this journal are the outcome of research and experimental work carried out with a view to improving the technique of wireless reception. As much of the information given in the columns of this paper concerns the most recent developments in the radio world, some of the arrangements and specialties described may be the subjects of Letters Patent, and the amateur and the trader would be well advised to obtain permission of the patentees to use the patents before doing so.

## VALVES FOR THE "S.T.500"

N. T. H. (Winslow).—"If it is specially important to get the valves right, please give the makes recommended and the type of valve for each valve holder.

"Also which Class B valve did Mr Scott-Taggart himself use?"

The list of recommended valves was given in the original article (Oct. 21st number of "P.W."), and is as follows:

In the Mullard range: (V.1) P.M.12 A; (V.2) P.M.2 DX; (V.3, Driver) P.M.2 A; (V.4, Class B) P.M.2 B.

Cossor valves, arranged in the same order, are: 220 S.G.; 210 Det.; 215 P.; 220 B.

In the Osram range we have: S.22; H.L.2; L.P.2; B.21.

In the Mazda range: S. 215 B; H.L.2; P.220; P.D.220.

Marconi valves (arranged like the others in valve holder numerical order) are: S.22; H.L.2; L.P.2; and B.21.

The Class B valve used in the original set was of the B.21 type, the driver being an L.P.2.

## WHEN WRITING TO THE TECHNICAL QUERIES DEPARTMENT.

Owing to the heavy rush the Technical Queries staff are finding it difficult to keep pace with the demands made upon them. Every effort is made to give replies promptly, but this is difficult unless the letters sent by readers are clearly written, with the symptoms stated, causes tried, etc., as briefly and clearly as possible.

If several questions arise they should be enumerated separately. Clear writing, on only one side of the paper, and clear statements will help us to help you with the least possible delay.

## CRACKLING NOISES—CAUSES AND CURES.

C. W. (Oxford).—"About six months ago you gave a friend of mine some valuable hints on crackling and noises of that kind, suggestions on how to trace, etc.

"I should be very pleased to have this information if you can oblige."

Crackles and similar noises may be due to a defect in the receiver, in the aerial, earth or batteries, or to atmospheric disturbances or interference due to electrical machinery.

A brief test may be applied to the receiver by disconnecting the aerial and earth leads, and if the noise then ceases it may fairly safely be assumed that the receiver is in order.

It should be noted that this does not mean that the aerial and earth themselves are in order, and it is advisable to examine the lead-in wires, insulators, and the joint between the earth lead and water-pipe or earth tube.

The intensity of the noise caused by atmospheric disturbances varies from time to time. It is less in winter than in summer.

Interference caused by electrical apparatus is often similar to an "atmospheric" background, and may be picked up by the aerial or earth. In all mains receivers it comes in through the mains wiring.

It is often found that a really efficient earth connection, consisting of a larger earth tube in moist ground, with a connecting lead not over seven or eight feet long, is of very great help. A long earth lead or a connection to a gas- or water-pipe, which is some considerable distance from the ground, is usually very ineffective, and in extreme cases no difference can be detected when this is disconnected from the receiver.

Gas-pipe earths should never be used. Sometimes, when an efficient earth is unobtainable, a counter-poise may be used instead.

This should be nearly as possible a replica of the aerial, erected at a height of ten or twelve feet, just as much care being exercised over its insulation as over that of the aerial.

In cases where the interference may be coming via the mains it may be found that some form of H.F. filter in the mains leads is of assistance.

With A.C. receivers, two fixed condensers of 1- to 2-mfd. capacity and high-test voltage may be connected in series across the mains leads, the centre point of the two condensers being connected to earth.

Special mains H.F. chokes are marketed by several manufacturers, and one of these may be connected in series with each mains lead, the condensers being connected across the mains leads on the receiver side.

In general, where interference due to electrical apparatus is thought to be the cause of the trouble, we would suggest that you write to the B.B.C., Broad-



## FOR BETTER RADIO

The constructor is sometimes tempted not to bother with screens, especially around coil units which are metal-covered by their makers. But good screening is vital to good results.

### USING ADDITIONAL SCREENING

With modern high-magnification valves even the wiring to such units can cause unwanted interaction. In fact, the long wire to the anode (terminal on bulb) of a screened-grid valve is frequently metal-covered on this account.

So if the designer specifies a screen in addition to existing screening it is unwise to ignore his recommendation.

casting House, London, W.1, giving details of the trouble, as the B.B.C. and the Post Office are doing everything possible to remedy this trouble.

Crackling due to a fault in the receiver may be due, amongst other things, to bad switch contacts, defective components or valves, bad wiring connections or faulty batteries. The spring contacts of the wavechange and on-off switches should be examined to make sure that a firm, springy grip is made, and if the contacts appear dirty they should be cleaned carefully with very fine sand-paper.

The valve pins should be cleaned, and care should be taken to see that they fit tightly in the valve holder sockets. In some cases the internal connections of valve holders develop faults, and it is worth while examining these. The various joints, terminals and insulated wires in the receiver should all be looked over and remade or tightened up where necessary.

## "P.W." PANELS, No. 151.—RENNES, FRANCE.

This station is not so popular with listeners as some of the other French stations, one of the reasons being that it has used the wavelength of 271.5 metres, immediately under Turin.

The Italian programme has tended to blot out the Rennes transmissions. But on January 15th Rennes will change to 288.5 metres, where it will be sandwiched between Heilsberg (above) and the Scottish National and Bournemouth (below).

Rennes usually closes down with the Marseillaise and "Bon soir," etc. Man announcer. Power, 1.3 kilowatts.

## THE ELECTRON FLOW INSIDE A VALVE.

C. M. (Manchester).—"Your 'Radio Step-by-Step' reminds me of a question that has always puzzled me, and which I have never seen answered in 'P.W.'"

"It is this: As it must take an electron a definite time (however fast it goes) to travel from filament to anode of a valve, would not this time factor prevent the valve from acting at very, very high frequencies?"

The speed of an electron travelling in an electric field varies, to some extent and between certain limits, proportionally to the strength of that field. The greater the velocity of electrons the greater the number that will arrive at a certain point—such as the anode of a valve—in a certain time. And thus the greater the current. (For current is the flow of electrons.)

If we can raise and lower the strength of the governing field a million times a second we should successively increase and decrease the rate of flow,—in other words, the current—a million times a second. It would not matter if the particular electrons arriving at the anode had done the whole journey from filament to anode or not.

Thus the velocity of an electron as such has nothing to do with the problem. What really matters is that its velocity can be changed with extreme rapidity. And, owing to the electron's remarkable tractability, currents of extremely high frequencies can be generated inside the valve.

## tone control on the "APEX."

H. P. (Southampton).—"When turning the tone control ('P.W.' Apex) I find that it does not control the volume at all."

The tone control of the "Apex" or of other similar receivers is not intended to control volume. Tone and volume are two entirely different things.

On the "Apex" the alteration of the aerial coupling enables the volume to be regulated to some extent (fuller details next week).

The tone control, however, enables the relative proportions of high- and low-note reproduction to be varied to suit personal preference.

And it enables heterodyne whistles, which are sometimes evident when receiving distant stations, to be suppressed.

## GRID BIAS FOR THE NEWER VARIABLE-MU VALVES.

L. C. (Burnsley).—"My 'Airsprite' fulfilled all your claims, but, nevertheless, there is one respect in which it is different from the set you described: the grid bias on the V.M. valve.

"If I give the valve the full sixteen volts G.B. on the G.B.—I lead it won't work, although the book says 'maximum negative voltage.' But it is perfect with only about four and a half volts. Why is that?"

Simply because you are using a newer type of multi-mu valve, of the kind known as "short base."

The original valves required much more grid bias to get the same effect. And with one of the newer types you do not need such a high maximum negative grid-bias voltage.

Instead of using a 16-volt battery, one of 9 volts, or perhaps less, is capable of covering your requirements with such a multi-mu valve.

## JOINING AN OLD H.T. BATTERY IN SERIES WITH A NEW ONE.

S. L. (Portsmouth).—"To settle a bit of an argument, will you back up my claim that it is O.K. to connect an old H.T. battery in series with the new one under certain circumstances?"

"I admit I was wrong in my first contention, which was that it was correct to do so for a pentode. Results have proved that there is immediate distortion.

"But I feel sure that I have seen it stated in 'P.W.' that an old battery need not be

(Continued on next page.)

## RADIOTORIAL QUESTIONS AND ANSWERS

(Continued from previous page.)

thrown away immediately, but can be joined in with the new one so as not to waste it."

Oh, no! Not long ago we pointed out how an old H.T. battery could be employed, under certain conditions, to give strictly limited service. We cannot, however, support your contention, because it is never advisable to join it in series with a new battery. To do so merely ties the new battery down to the old one's inferiority.

### REGULATION OF FADING BY AUTOMATIC VOLUME CONTROL.

F. D. D. (Sowerby, Yorks).—"My interest in the how-it-works side has never abated, and I still like to read explanations of the way in which the small set functions, although I have now become the proud possessor of a seven-valve superhet, with automatic volume control.

"Incidentally, this latter is a wonderful feature, and it 'holds' Heilsberg or other similar powerful and distant stations at

### DON'T DELAY!

No more tokens will appear in "P.W." for Mr. Scott-Taggart's presentation wireless book

### THE MANUAL OF MODERN RADIO

If you have not already sent in your Gift Voucher, containing 8 tokens and accompanied by the necessary remittance according as to whether you have reserved the Standard or the De Luxe Edition, then you should

### DO IT NOW!

Please note that if you have sent in your Voucher and do not receive your copy of the Manual within a fortnight, you should send a post-card giving the date of posting the Voucher and the number of the Postal Order. The address is POPULAR WIRELESS, Presentation Book Department (G.P.O. Box 184a), Cobb's Court, Broadway, London, E.C.4.

steady volume, enabling me to enjoy a concert from there with a little trouble from fading as there is from Moorside Edge.

"I notice, however, that it does not always 'come off' with complete success. For instance, on Sunday afternoon I was pleased to find Turin coming in at fine volume, although it was not four o'clock and quite daylight.

"A little later and this station had faded right out, with only the faintest suggestion of a programme in the background. For curiosity I kept the adjustment untouched, and later he came back again very strongly.

"To check up if the set was working properly on other stations I tuned in several foreigners, all proving as usual. But Turin continued to be uncertain right up to half-past five, at which time I had to go out.

"Is it usual for automatic control to fail on certain stations in that way?

It is common to find that A.V.C. will not control all stations with equal efficiency, because their ratios of minimum to maximum strengths vary widely.

Its task is a difficult one. Comparing Heilsberg with Turin, for example, it may be that there is always a measurable input from Heilsberg to your aerial, even during daylight. And when the station "fades in" its strength compares with that of a local.

Turin, on the other hand, may also "come up like a local" at its best. But when conditions are unfavourable it fades out from your aerial to a much weaker degree than Heilsberg ever reaches.

Thus your automatic volume control can adequately compensate for all the variations it finds in the programme strength from Heilsberg. But it is unable to do so in the case of Turin, because from that station the variations between minimum and maximum strengths are so much greater.

### HOW MANY DECIBELS?

J. O. (Cardiff).—"The book says that in comparing strengths of two sets the trained ear can only just hear a difference of one decibel. And an improvement is not worth while unless it results in a change of several decibels.

"Then it says: 'The number of decibels =  $10 \log_{10} (P1/P2)$ , where P1 and P2 are the two powers. What does that mean?"

Decibels and logs are hardly popular wireless subjects! But the formula can be explained briefly as follows:

The expression within the brackets is easily understood. It is the ratio of the two powers.

To take an example: If P1 equals 25 and P2 equals 5, the ratio is simply 25 over 5, which equals 5.

The formula would then be simplified to read: No. of decibels =  $10 \log_{10} 5$ .

The expression " $\log_{10} 5$ " signifies the common logarithm; and, as perhaps you know, a logarithm is a sort of number that stands for another number.

The common log of a number may be found in a suitable table of logs. And such a table shows that the common log of 5 is .6990.

We thus find that, simplified still further, our equation means No. of decibels =  $10 \times .6990$ , which equals approximately 7.

So that in this instance the difference in power is about 7 decibels.

### THE NEW MULTIPLE VALVES.

R. G. F. (Merton).—"Desiring a list of the receiving valves now on the market, I was particularly interested in the paragraph entitled 'The New Multiple Valves' in your December 30th number. But I am disappointed to find that the book referred to, 'The Wireless and Gramophone Trader Year Book and Diary for 1934,' is not available to the general public. Can you help me?"

We regret that the item to which you refer indicated that the "Year Book" could be purchased by all. Actually, of course, it is only supplied to those in the trade. However, you will find a list of valves such as you desire in the "Wireless World" Diary for 1934.

## BEHIND THE SCENES OF RADIO

UNTIL quite recently radio has been the one form of popular entertainment which has lacked its own "Who's Who." This state of affairs has now been amply remedied, and among the books which have arrived to reveal to listeners the intimate lives of their broadcasting favourites, Mr. Sydney Moseley's "WHO'S WHO IN BROADCASTING" (Pitman, 3s. 6d.) is especially welcome.

Mr. Moseley has filled his 150 pages in a painstaking and entertaining manner. Although one may feel some disappointment that among the 600 people mentioned such essentially radio names as Doris Arnold, Leslie Bridgewater, Clapham and Dwyer and John Tilley have no place, this is in part atoned for by the inclusion of many people whose work for radio does not always receive its fair share of appreciation.

Mr. F. X. J. Abraham, assistant maintenance engineer-in-charge at Chelmsford; Capt. Donisthorpe, of the G.E.C.; Mr. Eric Gill, the sculptor; Mr. Gorham, the editor of the "Radio Times," are four names taken at random. It is right that their widely varying services to broadcasting should have due recognition. In doing this Mr. Moseley has scanned a very wide scene.

T. R.

# Ground Wave..

## the Secret of War-time Radio

In the Great War, the Ground Wave system enabled signals to be heard clearly through static and enemy interference. The EMET ensures perfect reception through an earth connection only, free from interfering noises picked up by ordinary aerials. Fit an EMET for better and clearer reception.

# EMET

## GROUND AERIAL



NO OUTSIDE  
AERIAL  
REDUCES  
STATIC NOISE  
INCREASES  
SELECTIVITY  
SAVES  
EXPENSE

The  
Ultra  
Modern  
Aerial.

COMPLETELY  
SHIELDED  
to prevent  
pick-up of  
interference

The EMET is a fully shielded aerial—the latest development in noise-free radio. The EMET takes less than a minute to fix to your set. Simply connect the two wires to your usual Aerial and Earth Terminals, and your earth lead to the terminal provided. Fully tested and guaranteed. Sent post free

FREE TRIAL

POST COUPON

THE EMET COMPANY

6, Rutherford Street, NEWCASTLE-ON-TYNE.

Send one EMET Ground Aerial. I enclose 5/- and if not satisfied I can return it within 5 days from dispatch date and my money will be refunded in full.

Name .....

Address .....



# CLASS "B" MAINS UNITS

Heayberd Class "B" Mains Units are the only satisfactory models on the market. They employ the Cossor Neon Stabiliser Tube, thus enabling absolutely constant voltage regulation between 5 and 50 ma. A.C. MODEL. Output: 130 v. at 5-50 ma. Tappings. H.T.1, variable S.G., 40/100 v. H.T.2, 100 v. H.T.3, 130 v.

PRICE 97/6

The D.C. MODEL has the same output and tappings. Price 55/-

Fill in the coupon below and send with 3d. in stamps for 36-p. booklet describing these Units and packed with hints, tips, and circuit diagrams.

Mr. .... P.W. ....

**F.C. HEYBERD & CO.**  
10, FINSBURY ST EC2  
*One Minute From Moorgate Station.*

## EASY TERMS PROMPT DELIVERY

Any Amplion, Blue Spot, Baker, Celestion, Epoch, Ferranti, Grampian, Igranic, Lamplugh, Magnavox, Ormond, R & A, Rola, Sonochorde or W.B. Speaker supplied.

Send 5/- only

and pay balance by monthly instalments. No references. Entirely private and confidential.

**KITS, PARTS, SETS, ELECTRIC CLOCKS ON EASY TERMS.**

Send for Catalogue and List of 83 Speakers.  
**TURNADGE & PARTNERS, LTD.,**  
107, Fleet Street, London, E.C.4.  
Telephone: Central 1903.

## Engineers' Guide

Containing the widest choice of engineering courses in the world. Quality for a well-paid post in Engineering by studying at home with The T.I.G.B. Become an A.M. I.C.E., A.M. I. Mech. E., A.M. I. E. E., etc. Training until Successful is Guaranteed for the one fee. WRITE NOW for "The Engineers' Guide to Success," stating branch, post or you to

**THE TECHNOLOGICAL INSTITUTE OF GT. BRIT.**  
26, Temple Bar House, London, E.C.4.

Founded 1917. 19,000 Successes



**To Success**

PLEASE be sure to mention "Popular Wireless" when communicating with Advertisers. Thanks!

# THAT CHRISTMAS DAY PROGRAMME!

Telling listeners of the vast and almost unbelievable amount of work involved in the preparation of what might appear, by the smoothness of its execution, to have been a comparatively simple hour's programme.

BY ONE WHO HELPED TO ORGANISE IT.

IN the projected arrangements for the final week of 1933 appeared some weeks ago the single line, "Special Programme: 'Absent Friends': 2 o'clock." It was followed by the curt information that at 3 o'clock His Majesty the King would address the Empire from his home at Sandringham. No doubt by the time you read these lines you will have heard that programme, and perhaps you will have looked at the billing in the "Radio Times" and said to yourself: "An hour's work on Christmas Day! That is rather hard lines on some of the chaps at Broadcasting House," and you would have thought no more about it.

### A Matter of Organisation.

But it is probably true that for about fifty people those four words, "Special Programme: 'Absent Friends,'" have formed the background of their activities, and even more of their thoughts, for well over two months. The more sceptical among you no doubt believe that the most part, if not all, of this programme was a fake. You will have read the words "Bermuda," "Ottawa," "a lighthouse off the Northumbrian Coast," "Bedwas Pit," and so forth, and you will give the B.B.C. credit for a good deal of ingenuity in production and stage-management.

But actually this programme was far more a matter of organisation and engineering than it was a production in the truest sense of that word. The programme had, certainly, a producer in charge. One of the special programme producers of the Drama Department was the focal point of the whole business; in his hands was the preparation of the original script and on his shoulders lay the ultimate responsibility.

But like all the best broadcasting work, this particular programme was no single individual's true credit or responsibility.

It was the outcome of weeks of the most intensely co-operative thought and action. Practically no branch of the Corporation's organisation was not called in—if not for active assistance, for invaluable advice. In the first instance, it was decided that the co-operation of the broadcasting organisations of the Dominions, on the one hand, and of our own Regional stations, on the other, was essential.

### Altered by the People on the Spot.

The Empire Department, therefore, had to make contact with the Dominions to discover how they would co-operate, to send them their parts of the programme in skeleton in such a form that the people on the spot could easily alter them for purposes of exactitude—whereas the skeleton had to be accurate from our point of view from that of timing—and finally to arrange for a test to be heard from each of the Dominions and Colonies concerned.

In the second place, meetings were

held which were attended by the various Regional programme directors, with the Director of Entertainment in the chair. At these meetings it was decided as to what share each Region should take in the programme according to the original scheme laid out, and the Regions were asked to make suggestions for the presentation of particularly telling items. The Regional programme directors had then the responsibility of preparing individually their sections of the final script, and, once they were approved, of rehearsing them and timing them. Meanwhile, the Outside Broadcast Department was being called upon to arrange for such relays as those from the bottom of the mine, the lighthouse, York Minster and the church at Bredon:

While all these multifarious activities were proceeding it must not be forgotten that the business of broadcasting had to go on, and that the engineering staff, in addition to carrying out their normal duties, were suddenly faced with the enormous task of finding time and lines for the reception of tests from Ottawa or New Zealand, or arranging rehearsals—during which the producer of the programme, sitting at the dramatic control panel, instead of speaking to half a dozen studios, could speak simultaneously to half a dozen Regions.

### Enthusiasts Demanding Hot Milk.

In addition, a special speaker for a London studio, to be backed by an elaborate sequence of sound effects, had to be separately rehearsed. The Administration Branch had to be cajoled into providing extra money for a programme of this magnitude and expense. The canteen found itself frequently faced at two o'clock in the morning by haggard enthusiasts demanding hot milk after exchanging the time of night with their opposite numbers in Bombay or Cape Town. A very high official had to be rehearsed for the introduction of His Majesty, and the Outside Broadcast Director had to make his own special arrangements for the climax of the programme at Sandringham.

It is occasionally fashionable nowadays to sneer at the team spirit and to refer to it as an outmoded product of the Kipling decade. Without that team spirit exemplified in practice a thing like the "Absent Friends" programme would be completely impossible. Strict adherence to departmental practice or hierarchical views would wreck the whole show in ten minutes. Fifty or sixty people were engaged in nothing more dramatically exciting than the handling of an excessively difficult job in which no single mistake could be allowed and in which every second had its own absolute importance—a job which, in the words of the programme itself, "covers the Seven Seas and the Five Continents."

Well, I hope you enjoyed it!

# TECHNICAL NOTES

Some diverse and informative jottings about interesting aspects of radio.

By Dr. J. H. T. ROBERTS, F.Inst.P.

## How Much Amplification?

PEOPLE often wonder, especially newcomers to radio, why we should content ourselves with sets of what we might call medium sensitivity, with all manner of refinements, in order to get distant stations.

On the face of it, why not simply pile on lots and lots of amplification and get the same result that way, irrespective of any refinements in design or manipulation?

## Signal Strength v. Background.

At first sight you might imagine that there was room for almost any amount of amplification, and that if you used a sufficient number of valves you ought to be able to get pretty well anything under the sun. The fact is that—quite apart from difficulties incidental to piling on of amplification—we are limited by the ratio of "signal" strength to background noise and interference. If you have an extremely sensitive set you will pick up not only the "signal" which you want, but all kinds of static and the various interferences which are classed under the term "background."

chance of getting the station you want fairly free from background, and this is why, in the case of many distant stations, it is so much easier to get decent reception at night than during the day. So you see that piling on the agony in the shape of extra stages of amplification is not quite so simple as it looks.

## Matching.

Before leaving this point, I must mention that the question of sensitivity also depends on the speaker, and should point out that this again is bound up with the suitability of the speaker itself to the output stage of the receiver. This brings in the question of the *matching* of the output stage and the speaker, but I have dealt with that before in these Notes.

## Care in Ganging.

I need hardly mention that when you are building a "ganged" receiver it is better to gang the condensers on a fairly weak signal, so as to avoid any complications at this point. Having once got the ganging right, you will easily be able to tell, if anything goes wrong later on, whether this is due to loss of sensitivity in the valves or failure of any other component.

## Pick-up Points.

Talking about gang-condenser sets, there is another point which I should like to mention relating to the use of a pick-up with a set of this kind. You will sometimes find that when you connect the pick-up to such a receiver the ganging will be upset owing to the capacity across the grid circuit—introduced by the pick-up, with its associated wiring, switch, etc.

This upset in the ganging may show itself in the form of a reduction in the *sensitivity* or even in the *selectivity*. It is, therefore, a good plan, when

you connect a pick-up to a ganged receiver, to go over the trimming condenser across the detector coil and see whether this does not require some slight readjustment. I should mention that you are more likely to notice this effect when a screen-grid valve is used in the detector position than when an ordinary three-electrode valve is used, owing to the difference in damping between the S.G. valve and the ordinary type.

## Leads and Whistles.

Another point to bear in mind when connecting your pick-up to a receiver is that the pick-up leads should be as short as possible, and, if necessary, shielded leads should be used. In the latter case it will be necessary to connect the metal covering or braiding of the leads to earth, but I do not advise their use if it can be avoided.

(Continued on next page.)

## STABILISING PUSH-PULL VALVES

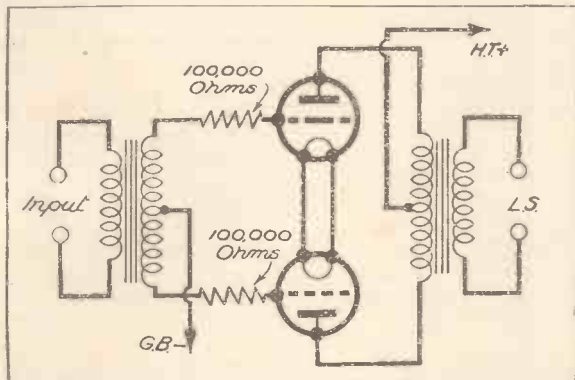

The best position for stabilising resistances in a push-pull arrangement of output valves is shown in the accompanying diagram, which is of the conventional push-pull circuit with input and output transformers. The input transformer secondary and the output transformer primary are centre-tapped, and stopping resistances of 100,000 ohms are inserted in the two grid leads.

## Not from the Same Source.

Now, unfortunately, these background noises do not originate at the same distance as the desired station. In fact, it is fairly true to say that they have little or no relationship to the desired "signal" at all. Some of the disturbing noises may come from quite close at hand, whilst others are due to electrical atmospheric conditions occurring at places between the receiver and the transmitting station, and at all sorts of other places as well. If too much amplification has to be used to bring up the desired "signal" it means that the background will be amplified out of all proportion, so that the "signal," although received, will not be worth listening to.

## Day-and-Night Reception.

It becomes necessary, therefore, to wait for conditions which give you a reasonable

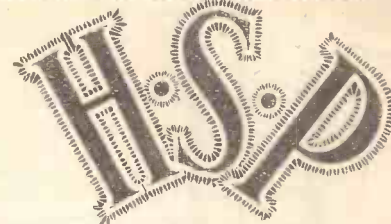

## The Changed Wave Lengths do not affect this set. . . .

Whilst other users are suffering inconvenience and expense by the change in wave lengths, H.S.P. owners are happy with a set that requires no change or expense. We thought of all this when we built the set.

**H.S.P. RADIOGRAM with AUTO RECORD CHANGER.** The only British instrument of its kind at the price.

All mains . . . A.C. or D.C. . . fitted Garrard Auto Record Changer playing eight tunes . . . circuit comprises 1 H.F. Screened Grid Stage, power pentode detector, special pentode output and indirectly heated rectifier.

**25**  
GNS.



Please send me FREE literature

Name.....

Address.....

WRITE IN PENCIL

**H.S.P. WIRELESS COMPANY, LANGFORD WORKS, WESTON-SUPER-MARE.**

## RADIO SUPPLIES

Send your list of Radio needs for our quotation. Kits, Parts Sets, etc. Everything in Radio stocked, prompt delivery, 7 days' approval. Catalogue free. Taylex & Standard Wet H.T. replacements stocked.

**P. TAYLOR, 2, GROVE ROAD, BALHAM, S. W. 12**



## OPENINGS for ENGINEERS

Never before has engineering offered such magnificent chances. With the rise of the depression, the industry is literally teeming with first-

class opportunities. Our 250-page Hand-book, "ENGINEERING OPPORTUNITIES," shows where the opportunities lie, and the easiest way to prepare for them. The Hand-book gives details of A.M.I.Mech.E., A.M.I.E.E., A.M.I.C.E., G.P.O., etc., Exams., outlines Home-Study Courses in all branches of Civil, Mech., Elec., Motor, Radio and "Talkie" Engineering, Building, etc., and explains our unique Employment Dept. Send for this valuable Hand-book to-day—FREE! **British Institute of Engineering Technology, 101, Shakespeare House, 29, Oxford St., London, W. 1**

Write for Illustrated Catalogue of **RADIO-GRAMPHONE CABINETS** of exclusive modern design, made by craftsmen in highly figured Oak, Walnut, or Mahogany, post free. **REMARKABLE VALUE** Cabinets made to order a speciality. **Makor**, under licence of the **HOWE BOX BAFFLE** Recommended by the B.B.C. Full details on request. **GILBERT** Cabinet Makor. Estimates Free. **SWINDON** Estd. 1866.

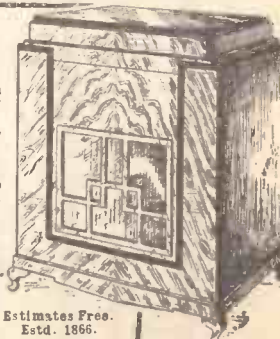

PLEASE be sure to mention "Popular Wireless" when communicating with Advertisers. Thanks!

## YOU CAN TAKE IT FROM ME!

### THAT ELECTRADIX BARGAIN SALE LIST Will Save You Pounds



**THE DIX-MIPANTA METER**

THREE ranges of volts: 0.75, 0.150, 0.300. Used for

MILLIAMPS reads 0.12 m/a., and 0.75 m/a.  
The Dix-Mipanta. In black bakelite case. Measures only 2½ in. x 2½ in. A 2-guinea Tester.

Complete in case with pair of test leads and plugs - 19/6 Leaflet gives full information.

**REPAIRS.** We have a staff of expert workmen for meter and electrical repairs at low prices.

## HOME BROADCASTER

Why not be your own Announcer? This No. 11 Home Mike at 5/6 is a new design. Solid bakelite case, back terminals. Fine, robust and excellent reproduction. Can be used with any radio set for home broadcasting.

**YOUR PARTY WOULD BE INCOMPLETE WITHOUT A HOME RADIO MIKE.**



Only 5/6

Your visit to our Showrooms is welcomed.

**ELECTRADIX RADIOS**  
218, UPPER THAMES STREET, E.C.4



## Something Really NEW!

### MY STORY, by Mick the Miller

THEY say I am the most famous Greyhound that ever chased an electric hare round the track. Perhaps I am—but do you know that I was once actually condemned to death? I lived, however, and eventually won the greyhounds' greatest race. For the first time I have revealed my life-story in this issue of PICTORIAL WEEKLY. I hope you will buy a copy on Friday and read it. It has been thrilling to me—and I believe you will find it exciting, too. Incidentally, I am proud to have it published in the fine, all-photogravure PICTORIAL WEEKLY. It's a winner for 2d.—and I know one when I see it.

Until next Friday,  
Mick the Miller.

## PICTORIAL WEEKLY

On Sale Fri., Jan. 5th - 2d.

## TECHNICAL NOTES

(Continued from previous page.)

as they tend to increase the capacity and reduce the sensitivity. Any trouble due to lack of shielding of the leads or to the leads being too long will generally manifest itself by a whistle in the loudspeaker.

**Transformer Input Better.**

If you are obliged to use long leads it is worth considering a transformer input from the pick-up to the amplifier, this transformer being, of course, adjacent to the amplifier, *not* to the pick-up, so that the pick-up leads in effect become the short leads connecting the secondary of the transformer to the amplifier. This transformer may have an even ratio of 1 to 1, or sometimes it is better to use a small step-up, such as 1 to 2 or even 1 to 3, the smaller winding being the one connected to the pick-up.

## FURTHER TRIBUTES TO "S.T. 500"

(Continued from page 787.)

### PECKHAM

"54 STATIONS AT L.S. STRENGTH."  
[From C. Lockwood, Holbeck Row, Peckham, S.E.15.]

"I thank you for the 'S.T.500.' I can get 54 stations on it at L.S. strength. Thanking you for all S.T. sets."

### SWINDON

"STATIONS ROLL-IN."

[From A. W. Smith, 25, Whitehead Street, Swindon, Wilts.]

"Very many thanks for the 'S.T.500.' It is sheer delight to operate and listen to such a fine set.

"I built the 'S.T.400,' and that was a fine set, and had thoughts of adding Class B to it when along came the very thing I had been waiting for—the 'S.T.500'! Class B in a perfect combination.

"What glorious volume and depth of tone this set pours forth!

"I have not completed my log yet, but the stations roll in one after the other with exquisite ease of tuning.

"The aerial reaction is a gift most precious for distant stations that would normally be a whisper. How much we listeners owe to S.T. for entertainment in radio that makes reproduction so lifelike and full of vitality!

"I could let my pen run away in praise of this (to use your own phrase) 'racing-model' receiver. "I also operate on the D.C. mains with an Ekco unit, and everything is all right.

"I conclude with a song of praise and thanksgiving to you, J. S.-T., and to 'Popular Wireless' as the medium by which the 'way how' was made possible. Selectivity, quality, volume are perfect. THANKS."

### KILBURN

"THANKS!"

[From F. E. Morris, 12, Esmond Road, Kilburn, London, N.W.6.]

"Your 'S.T.500' is already the 'Talk of the Town,' and home constructors are busy 'Night and Day' building it. Even old 'Lazybones' across the way is thinking of making it. I said 'Don't Blame Me,' if you can't obtain the parts, as this set is certainly causing 'The Last Round-Up' of wireless fans.

"Many people have heard mine and said 'Isn't It Heavenly?' Even 'Tea for Two' loses its attraction when the 'S.T.500' is in action, and many wireless widows are already murmuring 'Lover, Come Back to Me.'

"It is only 'Once in a Blue Moon' that home constructors are as lucky as this, and I would once more say 'Thanks.'"

### WORTHING

"A VERY FINE SET INDEED."

[From F. R. Gotelee, White Lodge, Mill Road, Worthing.]

"When 'S.T.400' first appeared I read all about it. I then deducted 50 per cent from what you said, and decided it was worth building. Having built it and tried it, I found it was 100 per cent up on what you said it was!

"I have now added the extra parts and turned it into the 'S.T.500.' This is a very fine set indeed, and well worth doing, and easier, if anything, to operate. The valves I had on hand were Mullard P.M.12,

P.M.2DX., P.M.2A, so I added P.M.2B to keep to the same range, using 4 volts grid bias on driver valve only."

## SUFFOLK

"ABSOLUTE SATISFACTION."

[From J. Case, "The Croft," Reydun, Nr. Southwold, Suffolk.]

"Just a brief letter of thanks for giving me such a magnificent set as the 'S.T.500.'

"I was not a reader of 'Popular Wireless,' Advertisement of 'S.T.500.' Purchase of copy of 'P.W.' Instant decision to build due to previous experience of 'S.T.300' and consequent faith in Scott-Taggart. Absolute satisfaction.

"'S.T.500' certainly has that little extra something. Now regular reader of that wonderful journal, 'P.W.'

"Thank you, Mr. Scott-Taggart."

## PORTSMOUTH

"ALL ONE COULD WISH FOR."

[From R. W. Putnam, 3, Malins Road, Portsmouth, Hants.]

"I must first apologise for making an alteration to your great 'S.T.400,' a set which gave me every satisfaction, but the 'balanced-phase double reaction' of your 'S.T.500' tempted me to make the alteration, and perhaps there are more '400' owners who would like to try the following:

The cost is very small: '00035 reaction distributor condenser replaced by '0005 Littos; '00004 aerial coupler retained; automatic reaction equaliser removed from set; both reaction circuits and H.F. end of set rewired to include the 'phase-reverser' component.

"The result was all one could wish for in smooth reaction on both circuits, with perfect stability, allowing for greater sensitivity, whilst still retaining the excellent selectivity of the set. Many thanks for the balanced-phase double reaction. Wishing you every success."

## WESTGATE-ON-SEA

"WHAT BEAUTIFUL STRENGTH!"

[From J. Rowling, Hockeridge Cottage, Canterbury Road, Westgate-on-Sea, Kent.]

"I had meant to write to you many times when your '400' was giving exceptionally good results, but have never seemed to manage it. Now that I have converted it into the '500,' it's really marvellous.

"I still have the original screen-grid valve which has been in constant use for over twelve months, and I have the set on early and late: before breakfast very often, then again at dinner time, and again from 4.30 onwards all the week. Sunday, of course, it's on practically all day.

"There seems to be nothing lacking in the way of reserve power, for I have a job cutting her down at times. I have a very ordinary inside aerial in the roof of a bungalow, but results are marvellous. Stations tumbling over each other to get in all round the dial, and what beautiful strength!—no case of a little whisper in the far distance.

"I have had dozens of friends and acquaintances in to hear it, and every one is agreed that he has never heard a set to come near it. That is about both the '400' and the '500.'

"As long ago as 1925 I had one of your sets—the 'Elstree Six'—and that was a set, too! I lived within a mile of Bournemouth studio in the days when she was a pretty powerful station and swamped all other stations. But the 'Elstree Six' soon showed her where she got out. The '500' is in the old 'Elstree Six' cabinet, and a bit of it holding the gramophone motor to complete the radiogram.

"I have had an offer for the '500' as she stands, and am undecided as to whether I shall build another '500' for myself, or the 'Super-Six' you describe in the December 'Wireless Constructor,' or even the 'Olympia Radiogram.' The only thing I am decided about is that it will definitely be one of yours. "Thanking you and wishing you all success."

## REDDITCH

"AMPLIFICATION IS STAGGERING."

[From W. F. Cave, 74, Rectory Road, Redditch, Worcs.]

"I have no doubt that you are quite tired by now of reading the various forms of congratulation you have received in respect of the 'S.T.500.'

"I should, however, like to refer to the letter of October 25th, from the 'P.W.' Query Department, when it was agreed that the combination of your high-frequency and detector circuit, arranged on 'S.T.500' lines, would be eminently satisfactory with a normal low-frequency amplifier following it. This suggestion I put forward for the reason that I had a H.T. eliminator and did not wish to use Class B valves.

"I am writing now to inform you that this set has been completed, and the results entirely confirm the claims that you have made, and I beg to convey my heartiest congratulations for having developed a circuit for home constructors that will give such magnificent results. I am able to select just what station I please, and the amplification is staggering; tone excellent.

"The control given by the aerial coupler, combined with its reaction, followed by the anode coupler and its reaction, enables one to obtain very sharp tuning and to vary the volume with perfect ease—to some extent far beyond expectation."



# POPULAR WIRELESS

THE FIRST AND FOREMOST RADIO WEEKLY FOR THE CONSTRUCTOR & AMATEUR EXPERIMENTER

Scientific Adviser: SIR OLIVER LODGE, F.R.S.  
 Technical Editor: C. V. DOWDING, Associate I.E.E.  
 Assistant Editor: P. ROBERT BIRD.

Managing Editor:  
 N. F. EDWARDS.

Chief Radio Consultant: P. P. ECKERSLEY  
 Assistant Editor: A. JOHNSON-RANDALL  
 Chief of Research: K. D. ROGERS.

"ANTI-BATCH"  
 "DISINFECTING ADAMS"  
 G. POTTER, M.P.  
 "HAPPY DAYS"

## RADIO NOTES & NEWS

EXCITING BROADCAST  
 STRAIGHT FROM BUSH  
 "SOME" EARTH  
 THE "CONVERTER"

### The Complete Listener.

I HEARD of a Christmas present to a man who has just retired from business and is likely to have to spend a considerable time in his armchair. I regard it as a work of art.

A good superhet; loudspeaker extension to bedroom; remote-control "switch off"; "Radio Times" cover; book about composers, another about musical instruments, another about broadcasters, another about the principles of wireless—and a year's subscription to "P.W." If that little lot isn't a masterpiece of organisation, what is?

### The Anti-Batch Movement.

FROM a contemporary I lift this story about Arthur Catterall, the well-known violinist and B.B.C. Symphony Orchestra leader. Having been delayed in a train by fog, he jumped into a taxi and asked to be driven to Broadcasting House. But the driver sternly eyed the violin case.

"Are you one of those blokes who play in the Batch Cantabriges?" he asked. Mr. Catterall admitted that he was. "Then come out of my cab," ordered the driver. "You can blinking well walk." I hope the story is not apocryphal, for it is good enough to be true.

### Round the Home Fire.

I GET a great deal of private fun from my observation of the attitude of some of the lady members of my family towards certain programme items.

Here's a sample: I told them that I wished to hear Rutherford lecture on the disintegration of the atom. "Adam who?" inquired one charmer. "It all sounds very queer—this disinfecting!" said another. "Besides," said the first, "it's no good disinfecting one atom; they multiply fearfully."

And after the lecture: "How can you be taken in so? Bombarding something too small to see and then saying that he hit it?"

### Cuthbert Seldom Clicks.

ANOTHER endearing trait of my family is their skill at being always out of phase with me *vis-à-vis* the radio. They really like radio, regarding it as an essential of life; but when I begin to rub my hands and chirp brightly about some unusually plummy programme, the dears wish to play bridge or the piano.

Yet should I suggest giving the B.B.C. the go-by on some very Bach-y evening they are sure to say that they feel like "a

that St. Stephen's is the place where his kind most do congregate.

Anyhow, I begrudge the M.P.'s this crowning exclusivity. They are paid £400 a year for belonging to the most exclusive club in the world, so why should they be presented with the sole rights of one of the funniest, yet most refined, humorists alive?

### Probably the Right Idea.

A BRIGHT lad of fifteen summers—and half a Rugby season—who is home from school for the "hols." is privileged to use my radio-set. Last "hols." he used to scour the U.K. and Europe for dance bands, but something has happened to the lad—possibly some heavy lecturer has injected iron and gall into his mind.

Anyhow, after listening to a particularly "hot" piece, he remarked, "Pooh! call that dance music? Why, the only thing that could dance to that would be a skeleton on a string!" And was he far wrong?

### Taxi Radio In New York.

ON one day last month there were about 15,000 taxis in New York fitted with radio sets. The next day they were forbidden to ply for hire until their radio sets had been removed. The police took that drastic action as a result of an accident in which a mere pedestrian was knocked down by a taxi which was playing "Happy Days are Here Again."

There are going to be wigs on the green about it, too, for the radio taxi has "caught on" with the public—and the taxi owners have invested £100,000 in the receivers. Knock down a jay-walker?—oh, forget it! But muck up £100,000?—hi, where is the militia?

### The March Plays Up.

GOOD for Marconi! Instead of giving his lovely Marchesa an "old master," or a framed picture of Mussolini by

(Continued on next page.)

## THE MAN

PERFECT RECEPTION

BEHIND

MATCHED RADIO

## THE REGIONAL SCHEME

A 1934 TRIUMPH

DESIGNS

THE RECEIVER FOR ALL

## YOUR NATIONAL SET

SEE PAGE 820 FOR FULL DETAILS

spot or two of kilocycles." There is something to be said in favour of telephones after all.

### Gillie's Little Joke.

GILLIE POTTER is credited with the intention of trying to enter Parliament, but I hope he will forgive me if I express my preference for regarding the report as one of his best jokes.

It would be just like Gillie to suggest that the House is the proper place—the risible home—for a popular comedian: to insinuate

# MAKING SURE OF GOOD RADIO RECEPTION

moonlight, or an egg-cosy worked with her initials, the regular fellow just went plump and ordered a Marconiphone radiogramophone for her. I can imagine him saying—more or less: "Here's a bit of the old firm."

And for Baby Marconi there was a wonderful bow-wow, woolly and cuddly, which barks and blinks and wags its tail—almost like a junior partner!

### Vive le Sport!

IT is perhaps but a natural result of French broadcasting that the listening French public has by its complaints driven the programme builders to such extremities that they produce items such as snail races. I learn that listeners actually bet on the performance of these creatures, and that prizes are awarded also.

One would imagine that a running commentary on a snail race must be deadly dull, and that the people who listen to it must be bored beyond measure; but I have too much respect for French mentality to suppose that this dreary sport is other than a bit of fun introduced purely as a "stunt."

### Watts In a Name?

IS it unbounded optimism which has caused the "U.S. Radio and Television Corporation" to change its name to "General Household Utilities Company"? Can home television be so near? By the way, the Radio Editor of the great Associated Press, thinking ahead for television, sees for that art more scope for indoor than for outdoor productions.

Moreover, he inclines to the opinion that it will be necessary to have matinée and evening television shows instead of continuous transmissions. Guess he's right, but that the problem will not arise here for years and ye-ars.

### Ex-Cannibals Take Up Radio.

I HEAR that an Australian radio company employs natives on its stations as engine-starters, greasers, chauffeurs and telegraph messengers. The "boys" are usually picked straight from the bush, and some have been cannibals, though they will not admit the fact.

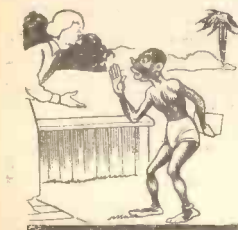

They are successful on routine work, but weak in celebration: so much so that if one has to deliver a radio message to a Mr. Brown, and Mr. Brown has gone to Europe, the messenger will not let Mrs. Brown have

the message! Quite right. It might be from some other "fella Mary."

### Solomon's Tricycle.

THIS title looks anachronistic until you realise that I am referring to the pianist Solomon. It would appear that this maestro is quite human, a fact at which I rejoice.

When he was but eight years old, in 1911, he played some highbrow music at the Queen's Hall, and when someone handed a tricycle up to the platform our prodigy was so little embarrassed that he mounted it at once and rode victoriously off the platform, knocking down two violinists en route.

### America On Medium Waves.

SEE page 718, "P.W.," December 16th. This subject is bringing us some interesting replies, and one of the best is from W. W. W. (Exeter), who states that five years' observations indicate to him that the U.S.A. comes in best during times of full moon, and that N. and S. America are seldom receivable equally well on one and the same night.

his right shoulder. One over the left would have been a blessed relief!

But, joking apart, I may say that a close examination of the footprint (for the monster has only one foot) proves that the "monster" is a one-legged radio critic trying to find Sir J. Reith's grandfather's birthplace with a view to a snappy biography.

### The "Earth" Magnificent.

I HAVE just read, with amusement, mingled with admiration, about the "earth" which has been deposited—*le mot juste*—by a man in Wellington, N.Z.: a six-foot hole, then ashes, then old papers, then two ten-foot sheets of corrugated iron, more papers, more ashes, and the whole topped off with about two stone of salt.

Pity he does not say what politics the papers profess! It's little matters of detail like that . . . Anyhow, he forgot to include the iron bedstead, so he has fallen short of perfection after all. After all that salt!



## SHORT WAVES

Listeners on short wavelengths are said to have heard bad language from trawlers.

"Heaven help the listeners-in on such a night!" as the trawler-men say. "Punch."

"There, darling, look what a nice present I've bought for you—the latest type of radiogram. Cheap, too; only a pound a month."

"Really! How many months?" "Answers." "Gracious! I forgot to ask."

Once people who talked to themselves were thought to be evincing the first signs of insanity.

Nowadays they are known as radio lecturers.

Radio Fan: "What sort of a set has Brown got?"

Second ditto: "Well, it's the sort of set that doesn't need a radio log—all it needs is a splinter."

### TIME SIGNALS.

I need not tune the wireless in	At six, as sure as I'm alive.
To get right time each day;	I hear the milkman's feet. . . .
An early broadcast will begin	And when the evening comes around
Down our suburban way.	Each gate-click well I know.
The paper boy at half-past five	As weary husbands, homeward bound,
Slams gates all down the street;	Into their havens go.
	A. M. F. ("Answers").

### DISILLUSIONED.

The gramophone enthusiast who went to a big city radio store because they advertised a "Record" sale.

We hear that a talk on angling will shortly be broadcast. Presumably this will be on a long wave-length.

He confirms that the locality of the receiver is an important factor. For example, he gets WENR (Chicago) very well, but cannot hear Canadian medium-wavers; whereas his friend in London has precisely the opposite luck.

He has noticed, too, that if he begins to hear America as early as 11.30 p.m. he is in for a good spell of reception. I should be glad to have the experiences of others on these points.

### That Loch Ness Monster.

NO journalist dare omit a reference to the fair unknown who is labelled the "Loch Ness Monster." Therefore I may reveal the fact that I was travelling on that loch in the glorious summer of 1933 and found that the only available monster was a steward who continually spat over

making sure is that which is reported from Sydney, N.S.W. Thus runs the tale:

A rich breeder of sheep applied to the N.S.W. Supreme Court for an injunction to restrain a bank from making payments to his daughter, who had "done a guy" and married someone, although she was under 21 years of age. The injunction was granted, and, in addition, leave to serve it by broadcasting.

Very refreshing! In this country the court would still be searching Magna Charta with a microscope for precedents, etc.



# A NEW RADIO STABILISER

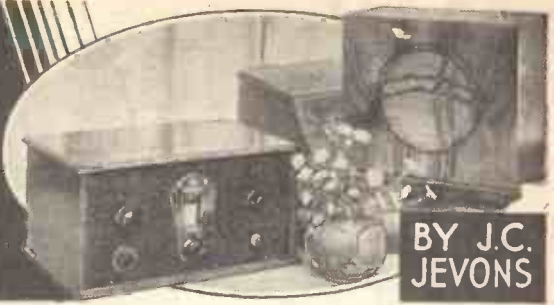

BY J.C. JEVONS

Constant H.T. voltage, unvaried by changing anode current, is essential to perfect valve operation. In this article our contributor shows how the theoretically ideal mains unit can very nearly be obtained in practice.

ACCORDING to Ohm's Law, the voltage drop in a circuit is measured by the product of the current and the resistance through which it flows. Applying this rule to the type of H.T. eliminator shown in Fig. 1, it is clear that neither of the two tapping points marked H.T.2 and

2 or 3 milliamps at one moment to as much as 30 or 40 milliamps at the next.

Obviously, one cannot expect to get the best from a valve if the plate and screen-grid voltages fluctuate in this erratic fashion. In fact, special ballasting tubes of the neon-lamp type are already on the market specially designed for Class B eliminators.

spite of subsequent changes in current.

One could therefore replace the potentiometer P in Fig. 1 by two or more discharge tubes, K, K1, connected in series, as shown in Fig. 3, each tube being designed to drop, say, 100 volts. Once the tubes "strike" and start to conduct, the voltage supply to the valves in the set will remain at a steady value, no matter what load is being taken.

The "glow-gap divider" is a more convenient adaptation of the same idea. Instead of using separate tubes, a number of extra electrodes, A—E, are inserted in the same bulb, as indicated in Fig. 5, and each electrode is tapped off directly to the appropriate valve in the set (Fig. 4).

## THE USUAL SCHEME

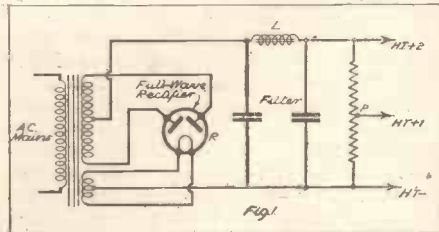

With a power pack, using this circuit, it is impossible to obtain constant anode voltage with variable anode current.

## Degrees of Ionisation

In the ideal eliminator unit the voltages at the various tapping points should "stay put" under all operating conditions, as is the case with the new "glow-gap divider." This is a gas-filled tube—of the neon-lamp type—which has the peculiar property of being able to pass an increasing amount of current under a steady applied voltage.

The resistance of a metallic conductor, as distinct from a gaseous one, follows Ohm's Law and remains the same for all values of

## Spacing-the Electrodes

The tube contains neon mixed with certain rare gases up to a pressure of a few centimetres of mercury. By suitably shaping and spacing the electrodes inside the tube an input of, say, 280 volts can be "dropped" in equal steps of 70 volts between each electrode. Once the input voltage has been divided in this way it will remain "anchored" for any current load up to 50 or 60 milliamps.

If fewer tapping points are required, one or more of the electrodes can be short-circuited without interfering with the action of the rest. One "gap" is generally used to provide grid bias.

Fig. 5 is a section through the actual electrode assembly of a five-pin "glow-gap divider" tube.

H.T.1 will, in practice, deliver a steady voltage to the set—as, of course, they should if the valves are to operate properly.

For instance, as the current taken by the set rises, the potential drop through the internal resistance of the rectifier R and across the smoothing choke L will also increase, thus reducing the voltage available at the point H.T.2. The same also applies to the point H.T.1, except that the voltage there is further influenced by the resistance of the potential divider P.

## Very Pronounced Variations

In the ordinary way the voltage at H.T.2 may change, say, from 250 volts when the set is taking 10 milliamps to 180 volts as the load rises to 30 milliamps. In the case of Class B or Q.P.P. amplifiers, where the H.T. consumption is very small during the quiescent periods, the possible voltage variations will be still more pronounced, since the load may change from

## CONSTANT VOLTAGE



Fig. 2 illustrates the voltage regulation possible with the use of a stabiliser, while Fig. 5 shows the arrangement of the "gaps" in the new "divider."

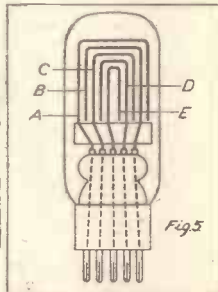

current, so that the voltage drop increases with the current, and vice versa.

In the case of a gas-filled tube, however, the internal resistance depends upon the degree of ionisation of the contained gas. This, in turn, is affected by the amount of current passing through, and so one is up against a somewhat complex state of affairs.

## Adaptable to Different Conditions

In short, a gas-filled tube does not obey Ohm's Law. It has the power of "adapting" itself to different conditions, so that—within certain limits—the voltage across anode and cathode remains independent of the amount of current passing through the tube.

As shown in the curve of Fig. 2, the tube starts to discharge current at what is called the striking voltage, marked S. As the current increases, the voltage at first starts to fall (negative resistance), but almost immediately rises to a steady value, which then remains substantially the same in

## Acts as a Filter

The action of the "glow-gap divider" may be compared to that of a "floating" battery. It supplies constant voltages to the set, irrespective either of changes in the load or of fluctuations in the mains supply. A further advantage is that it helps to filter the rectified supply current by automatically absorbing the "ripple" components.

## TAKING TAPPINGS

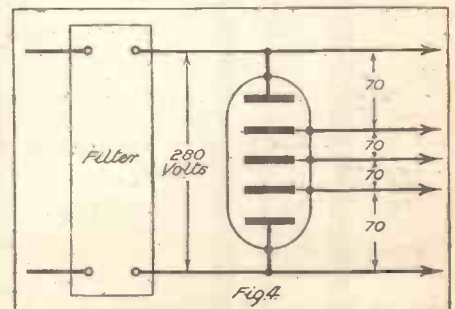

Three tappings of voltages can be achieved with the new "glow-gap divider."

## A BETTER METHOD

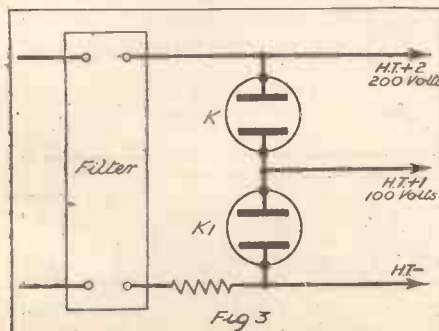

A valuable method of obtaining constant "main" and "tapped" voltages from a mains unit.

# Short Wave Notes

Notes of interest concerning stations and conditions on the short-wave band, written in an entertaining manner by the foremost expert in short-wave practice.

I WONDER what 1934 has in store for the short-wave enthusiast. It *should* be an extremely interesting year, chiefly on account of the fact that we are certainly well on the rising part of the curve of that terrible eleven-year cycle. I make no apology for bringing the subject up, so great is its importance to us.

### None Of Us' Has Given Up.

Consider what has happened. All the evidence we can collate goes to show that short-wave reception conditions follow the outline of the well-known sunspot cycle, which occurs over a period of eleven years. This was at its last peak in 1927, which was, undoubtedly, a very fine year for short-wave reception. The next peak is due in 1938, with the "trough," naturally, occurring during 1932 or 1933.

Well, we have survived the "trough" without much difficulty. We have moaned about bad conditions and unreliable reception, but none of us has given up. Now everything in the garden's lovely again, and we have to look forward to a gradual but steady improvement in short waves for five years or so. A pleasant prospect, especially as our knowledge of the subject and the apparatus at our disposal has improved beyond all recognition!

I wish all these new short-wave broadcast stations wouldn't make such a habit of rushing about and changing places like clowns at a circus. Identification is becoming a nightmare nowadays. I can't possibly invite Cousin Charles round to hear Sydney on Sunday morning for fear that it might turn out to be a Portuguese station that has exchanged wavelengths with him, or something of the sort. And, as for all these new Venezuelan and Colombian stations—well, South America is very much in evidence these days.

### A Little Luck and Perseverance.

How many readers, I wonder, realise that Colombian broadcasting stations are to be found now on 51.49, 51.2, 49.6, 48.5, 47, 46.5, 42.3, 41.6 and 40.5 metres? It's a fact—there are no fewer than nine of them between 40 and 52 metres. I am not pretending that they are all heard regularly over here; but they are on the air, and with a little luck and plenty of perseverance many of them may be picked up.

The best ones to look for are Bogota (H J 3 A B F) on 48.5 metres and Barranquilla (H J 1 A B B) on 46.5 metres. A friend of mine, the complete inefficiency of whose receiver is almost proverbial, has found both of these stations.

The North Americans have not been too good recently, with the usual exceptions of

W 3 X L (46.69 metres) and W 3 X A L (16.87 metres). W 2 X A D and W 8 X K have both been good at times, but very unreliable.

J. B. M. (Glasgow) has heard a station on 49.3 metres that he believes to be St. John's, Canada (V E 9 B J). I don't think many British listeners have bagged this Canadian as yet. V E 9 G W on 49.22 metres, of course, seems to be heard by everyone. V E 9 C S (Vancouver) is quite another story. Has *anyone* reading these notes ever heard him?

Several readers have reported a Brazilian station on about 36.65 metres. According to J. B. M., this is the Radio Club of Brazil's station (P S K). Officially this is not a broadcasting station, but when I have heard

## RADIO AIDS THE "FILMS"



A short-wave transmitting set, weighing only twenty-five pounds, in use at an American film studio. It is employed on large "sets," where its portability is of great advantage and saves the fixing of numerous points for "line" telephones.

him he has been very near it! He is, of course, right outside the legitimate short-wave broadcast bands, being about halfway between two of them.

E A R 5 8 is another of these "hybrid" stations. He is located at Tenerife, and works on 41.6 metres, which is in the *amateur* band, if you please, and yet he is listed as a broadcasting station. I wonder what the Spanish and Canary Island "hams" have to say to that.

The famous station at Riobamba, Ecuador, known as "El Prado," is now

listed as working on 45.31 metres. Just below him, on 45 metres, is another station in Ecuador—H C 2 R L. I am told that "El Prado" only works on Thursdays at present and is not active until the small hours. H C 2 R L, however, has been logged at midnight on Sundays, and appears to be a good station.

Here's yet another "bag" for someone. Meet the Dominican Republic, Central America, represented by the station H I - 1 A on 47.8 metres approximately. And, for the super-ambitious, Kuala Lumpur, Malay States (Z G' E), works on 48.92 metres, and can be heard (weather permitting!) between 1 p.m. and 3.30 p.m.

All these newcomers are providing a splendid incentive to us to brush up our super-sets and to start record breaking again. There has never been a more opportune time for novices to "break in" on short waves than the present.

### Jump In Right Away.

Over a hundred stations are available to the owner of a decent receiver; eighty of them are in localities that one would probably never hear in a lifetime if one didn't use short waves. The gear is simple to make and—well, not so simple to operate. But that's all the more fun.

If anyone reading these notes is at present "on the brink," let me make an earnest appeal to him to take his courage in both hands and jump in right away. The bite of the short-wave bug is exceedingly venomous, but it's considerably more pleasant than influenza, and the effects last for ever.

It would do my readers good to be able to read some of the letters that I receive occasionally from people who have just got right into the hang of short-wave work. "Why did I ever keep out of it for so long?" asks P. T. R. (Northampton).

"If I had only known what I was missing during those three years when I fiddled about on the broadcast bands and called short-wavers a crowd of nitwits, I would have gone up the highest chimney in the neighbourhood and proclaimed a public apology!"

### Sailing an Uncharted Sea.

Although the wording of that one is rather original, it expresses the spirit of letters that reach me every day.

Short-wave work *is* worth while, but, like most things that are worth while, it is not all plain sailing at first. It must feel like sailing an uncharted sea to be twiddling the knobs of one's first short-waver, without any experience at first hand of what it's all about. I wish I could grasp that thrill again, but I have got to the blasé stage, and it requires the ultra-shorts to get me all excited.

W. L. S.

## WHAT OUR READERS ARE SAYING

An appreciation of the "A.T.B. All-Wave Three."

The Editor, POPULAR WIRELESS.

Dear Sir,—Having from time to time built some of the designs issued by your journal and found them quite good, particularly the "Comet" and the "Cosmic-3," the latter a distinct advance on anything previously attempted, when the "A.T.B. All-Wave-Band 3" was issued I decided to build it. The results are all you claim for it. The A.T.B. makes handling easier and certainly imparts quality into the set. Which is another winner for "P.W."

Yours truly,

S. H. SOUTHARD.

310, Copnor Road, Copnor, Portsmouth.

G.P. KENDALL B.Sc. ON

TELEVISION

# METHODS OF LIGHT CONTROL

SO far we have been content just to assume that it was possible in some way to produce at the receiver a beam of light which could be made to vary in brightness in sympathy with the impulses coming in from the transmitter.

We have not asked how this process of light modulation is achieved, because we wanted first to learn how the received picture is built up with the aid of a single spot of light flying about on the screen.

One of the television engineer's problems is to obtain light and shade to correspond with the scene transmitted. In this week's section of our Television Survey Mr. Kendall tells how it is done, and of the difficulties which have to be overcome.

We have now got a pretty good idea as to how that important process is carried out by one typical method, and it is time to consider this modulation business.

We have by no means exhausted the subject of scanning methods, of course, but at present I am only aiming at a general survey of principles. Greater detail must come later.



Here is an excellent example of what a Kerr cell looks like. In this particular model (made by Mervyn Sound & Vision Co., Ltd.) the terminals for the electrical input are at the top. They are each connected to a set of plates, like condenser vanes, the whole assembly being immersed in nitro-benzol, which thus acts as the dielectric.

The reader will already have realised that in television we pick up from the transmitter a series of impulses which vary in strength in such a way as to represent the light and shade of each part of the picture. The problem is to produce a beam of light which varies in brightness in exact accordance with those impulses.

### The Gas-filled Lamp.

One simple way of doing it is to put the received impulses into a powerful amplifier whose output goes to a neon lamp. If the "signals" are made strong they will cause the lamp to light, and variation in them will produce corresponding brilliance alteration in the light.



This method is easy to understand, and it is quite practical within certain limits. It has advantages in the way of simplicity and cheapness, and it is still used a good deal in simple televiewers.

Unfortunately, however, its limitations are considerable, and so it is tending to give way to improved methods. Probably its greatest drawback is that, under normal conditions, it gives only a small amount of light, so that it is not possible to get a really bright picture of any size.

It is not ordinarily possible to use the projection method at all with a neon

reproducer. If the attempt were made in such a system as I showed in my sketch last week, for example, the picture on the screen would be too faint to be of value.

### A Small Image.

It is generally necessary for the observer to place his eye in the position where I showed a screen, and look directly at the neon through the holes in the scanning disc as they go by. He then sees the picture appear on the surface of the disc,

The great feature of an article on Television from the pen of G. P. Kendall is the easy-to-understand language he employs. You read with such keen interest that unconsciously you come to share his mastery of this fascinating subject.

built up in the usual way by the scanning action of the holes, each of which produces a bright spot crossing the picture area.

The resulting picture is quite bright under good conditions; but, of course, it is small and difficult for more than one

## HOW ILLUMINATION IS VARIED

To build up a television picture our local source of light must fluctuate instantaneously, from the mere glow that corresponds with shadows to the bright light of full illumination. In some systems the lamp itself does this, the neon tube being the outstanding example. But there are highly interesting possibilities in the use of a steady source of bright light, which is then "moulded" or modulated by the incoming television impulses.

The huge neon tube depicted below was specially developed for the reception of television in a gas. Under operating conditions it gets so hot that water-cooling of the anodes is necessary! A fluctuating pinkish light appears around the central rectangle whilst the tube is in operation.



THE LATEST WATER-COOLED NEON "MONSTER"



This back view of a Baird Televisor shows a lamp of the neon type in position. Unlike the huge affair shown in the adjacent column, it is suitable for home use. When the television receiver is in action, the cover is replaced over the lamp, to prevent escape of light from the back, and the terminals also are screened off on account of the high voltages used.

person to see at a time. Something can be done to overcome this drawback by placing a large lens in such a position as to magnify the image, but even then the method is rather limited in its applications.

The recent tendency, therefore, has been largely to abandon the attempt to make the received picture impulses themselves generate the actual light required for the reproduction of the picture. Instead, a strong local source of light is used, such as a 100-watt lamp, and the beam from this is controlled by the picture impulses with

(Continued on next page.)

# G. P. KENDALL, B.Sc., CONTINUES HIS TELEVISION REVIEW

(Continued from previous page.)

the aid of a device which can be regarded as a "light valve."

This is a very important process, for it is one of the methods which made possible for the first time a television receiver of quite reasonable simplicity that yet could throw a picture of considerable brightness upon a little screen so as to be seen with ease by a number of persons.

## Concentrated Illumination.

In view of its importance I think it will be as well if we spend a little time upon this method of arranging a television receiver and study its working in some detail.



First, there is the local source of light, and this is usually a lamp of what is called the projector type, which has a small, concentrated filament emitting a lot of light from a very small area.

This is necessary for good results, because our next requirement, we shall find, is a system of lenses to produce a narrow but intense beam of light able to make its way through the very small apertures in the light-valve device. Such a sharply focused beam can only be got when the light source is very small in size.

## Modulating The Light.

Now about this light-valve affair. Let us first see what we want it to do, and then perhaps we shall find it easier to understand how the gadget actually does its job. What we want is a device through which we can pass our beam of light to be controlled or "modulated" in exact accordance with the variations in the incoming picture impulses.

To be more explicit, we want it to make the beam of light vary in brightness in exact sympathy with the incoming signals, and so it is evident that we do indeed want a sort of tap or valve which can be operated electrically, allowing more or less light to get through according to the voltage applied to it.

We can dismiss right away all ideas of any sort of mechanical device with actual moving parts, because the frequencies dealt with in television are far too high for such a scheme to be practical.

Now let us see how a light valve can be arranged *without* the use of mechanical working parts, taking for our example the "Kerr cell," which plays such an important part in television nowadays. This device depends for its working upon the phenomenon of "polarisation" of light, which, I'm afraid, is a rather abstruse subject.

Let me try to put it very simply. Imagine that a beam of ordinary light consists of vibrations in all directions across the main direction of travel of the beam. Now suppose we put this beam through a device which will only allow to pass those vibrations which are in one particular direction and stops all the others. The result is called a beam of polarised light.

Next imagine that we put another of these special devices so that the polarised beam has to try to pass through this one also. Here we begin to notice some very interesting things happening.

If the polarising axis of the second device is in the same direction as that of the first one the light will get through, while if the axis is turned to a certain angle the polarised beam will be stopped, and we shall find that we

## FOR BETTER VIEWING

In the television receiver shown above the image is rather small, so the designer has arranged for a large lens to be let into the front of the cabinet. In this way several people can see the received picture at once, but of course the size of the lens cannot be extended indefinitely on account of the effect on the detail of the picture.

## MANY REFLECTORS

The close-up of a mirror drum (below) comes from Germany. Optical science has always been specially well developed there, and television apparatus is now being evolved in great profusion and with very considerable success. This particular model was developed some years ago for reception purposes, and it will be seen that the drive is an electric motor.

cannot see through the system, although both parts of it appear to the eye quite transparent when examined separately!

These polarising devices are called "Nicol prisms," and they consist of little pieces of a certain mineral crystal cut to a special shape. They have long been used by the mineralogist for his special purposes, but it was only comparatively recently that it was discovered that they provided the basis for a light valve of a highly effective kind for television work, which I shall describe in detail next week.



## Practical Hints on Upkeep.

**E**XCELLENT as the mirror drum is from the optical point of view, it must be confessed that it does require a little more care and attention than the scanning disc. It must be kept scrupulously clean, and some precautions are desirable to ensure that the individual adjustments of the mirrors are not upset in use.

Cleaning may seem an obvious point, but it must be done with care, lest the fine surface of a good mirror be injured. For safety always use a piece of really clean and soft chamois leather. Before you start *always* shake the leather perfectly free from dust.

Prevention is better than cure, so always try to keep a mirror drum closed in and protected from dust as much as you can. Remember that the less you clean it the better, so try to keep it from *getting* dusty.

## Precautions to Take.

To preserve the adjustment of the mirrors the first point is to use great care in cleaning; do not rub heavily, but run the leather over them with a very light touch indeed. Never handle a mirror drum roughly.

The other important precaution to maintain the accuracy of setting is to see that the drum is not subjected to great variations of temperature.

Never put it near a fire, and if the driving motor is enclosed under the same cover it is usually as well to provide some means of ventilation. This is not always necessary, for some motors run very cool, but the point should not be forgotten.

The possibility of heat from the projection lamp should be borne in mind, too.

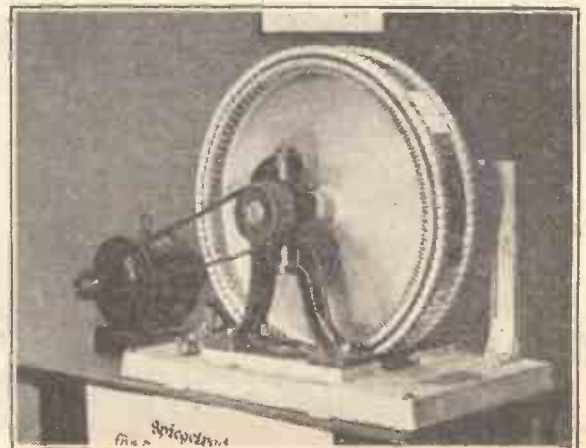



In a recent issue of "P.W." we published a letter from Dr. J. Robinson in which this well-known scientist joined issue with our Chief Radio Consultant over the matter of Stenodes and the elimination of interference. This week P. P. Eckersley returns to the fray with an interesting explanation of his earlier remarks and a contention that, except in special circumstances, you cannot eliminate interference from other stations without impairing quality.

I SEE in "P.W." of Dec. 16th that Dr. Robinson, inventor of the Stenode and enemy of the side-band, takes me to task because I have stated in "P.W." that it is impossible to find a solution for the biggest problem of wireless—"the multiplication of stations to any limits."

He is glad to find my scepticism embraces the obiter dicta of Westinghouse as well as Robinson. He says I am an obscurantist, defying progress, discouraging the young idea. The Stenode, he says, is excellent, it eliminates all sorts of interferences, and he resents what seems to him my attempt to eliminate it with a gesture. Why, the Stenode, he says, has had a government report written about it!—but he does not give the findings of that report.

The last thing I want to do is to avoid my responsibilities, but I know that I am right in all I say. I know, however, that the written and the spoken word is liable to misinterpretation, and one may thereby do an unconscious injustice to someone or something. Take the case in point.

**Detector Demodulation.**

Dr. Robinson thinks that I coupled his name with that of Westinghouse when I wanted to convey the fact that the Westinghouse Company had fallen into the same errors as other distinguished people. No! Westinghouse himself never defied the side-band theory.

I think, too, that Dr. Robinson should have full credit for reviving an idea, peculiarly applicable to broadcast technique, when he took up the subject of tone correction where it had been left and applied it conscientiously to broadcast receiver design. To get good detector demodulation selectivity you want to have the largest possible ratio of signal voltage due to wanted to signal voltage due to unwanted carrier. And nothing does this better than very sharply tuned circuits.

Dr. Robinson was one of the first to point out the necessity for detector demodulation in these terms.

**A Matter of Degree.**

The question rests not as a matter of principle, but as a matter of degree. Granted you get selectivity by sharply tuned circuits, do you not also cut off the upper side-bands? Why, yes! Dr. Robinson admits it, because he has an audio output with a rising characteristic. So the result is a straight characteristic. But the question is: straight, yes, but how far?

With a very selective circuit you get to

a point where the upper side-band = 0, and the audio amplification, therefore, has to be infinity. What you get as a result, is nearly 0, because that is much easier than getting infinite magnification!

**Straight-line Response.**

The question about the Stenode, or any ode and dyne or ish, or any name you like, is just this:

Suppose we set up the receiver. Suppose we take a voltmeter and connect it across that receiver's loudspeaker coil itself, you get with a moving-coil speaker about 1 volt.

Then, supposing we are very, very nice to the B.B.C. and say to them, "Sirs,

**SYDNEY BROADCASTING**

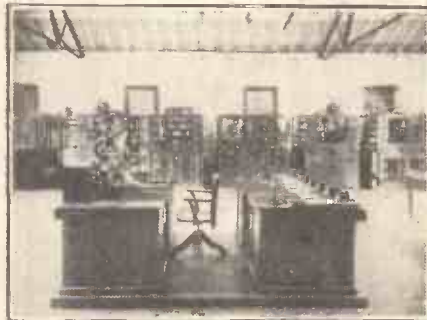

Photo by Marconi's Wireless Telegraph Co., Ltd. A view of the transmitting room and control panels at the Pennant Hills station at Sydney. This station is used for broadcasting between Australia and England, and was used as part of the Empire link in the recent Christmas Day programme.

would you kindly modulate Brookman's Park transmitter, with equal intensity, from 30 cycles up to 10,000 cycles? Don't over-modulate ever, but keep the aerial currents modulated the same for every frequency, and let us know as you go what frequency you are on." Then we tune in the receiver under test to Brookman's Park, and we watch that voltmeter.

From the deep mumble, up into the contralto, through the treble off the end of the piano, past the birds and piccolos and past the harmonics, right up to the bats! If that needle reads the same at any frequency, and if, at any frequency, the reading of that needle is proportional between limits to the B.B.C. input, then that set will give lovely, lovely quality. It may achieve selectivity or it may not. If it is a very selective receiver it cannot give perfect quality.

Any set (except those which use shielded

down leads, e.g. a Kolster Brandes) which eliminates interference will eliminate some of that wanted voltmeter deflection I talked about. Any set which sees that voltmeter fall off is losing you quality.

It may have to do this because of side-band jamming and the silly state of Europe, etc., etc. The Stenode, like every other receiver, has to cut—but the question is, at what frequency?

All design is compromise. You cannot have all that spectrum. There is not a set in the world which does. The compromise is always between selectivity and sensitivity.

Tone correction is an excellent way of solving a part of the problem. But it is only part of the problem. The best way to eliminate all interference is to switch off the set; one way to eliminate some interference is to cut off the side-bands.

**A Good Principle.**

We who know the side-band theory, who use it every day, who are faced with its inevitable consequences, get a trifle worried when there is claimed for an excellent piece of technological development "a revolutionary new principle."

No! the Stenode embodies a good principle—is it not used in every set to-day which has tuned circuits and a pentode valve?—but certain examples of it embody, so it seems to me, too much of a good principle. And you can have too much of a good thing—too much, indeed, of courage, if that means defying the fundamental laws of physics.

\*-----\*

"THE FINEST THREE-PENNYWORTH."

\*-----\*

The Editor, POPULAR WIRELESS.

Dear Sir,—I feel I must congratulate you on the very excellent weekly, POPULAR WIRELESS. Only quite recently I commenced to read this very interesting and informative journal, being attracted by your "Economy" Three and Four sets, which undoubtedly do what you people claim for them. I read quite a lot of "wireless matter," and can assure you that, in my opinion, your "super" is very aptly named and certainly does give the amateur every encouragement to build, experiment, etc.

Your circuits should certainly appeal to the man with modest means (we in this great industrial area should know), and perhaps, by way of a suggestion, may I write that very often the deciding factor of building or altering a set is the cost?

May you continue to give us what surely must be the finest threepennyworth of its kind each week!

Yours truly,  
W. LUXTON.

12, Soudan Road, Stockport.

# Free NEXT WEEK Free

**A VALUABLE MULTI-PURPOSE TOOL**

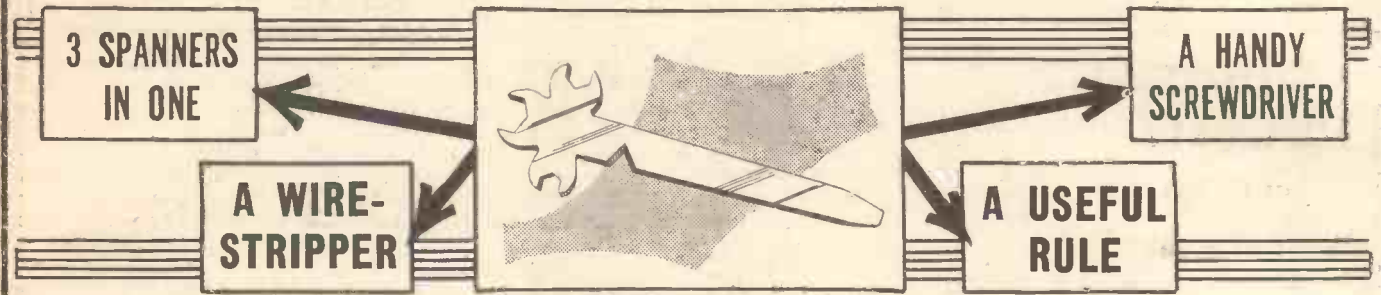

Also  
**FIRST  
 DETAILS  
 OF A  
 GREAT  
 NEW  
 SET**



Entirely Novel—  
**A NATIONAL  
 RECEIVER  
 FOR  
 EVERY  
 HOME**



*The Engineer who Designed  
 Your B.B.C. Station  
 Designed this Set for You!*



# FOR EVERYBODY

For BATTERIES

For A.C. MAINS

For D.C. MAINS

For RADIO

For RECORDS

**YOUR BEST PROGRAMME**

*is from an*  
**Eckersley-built Station**

**YOUR BEST RECEPTION**

will be on

**THE NATIONAL 3**

*Designed by P. P. ECKERSLEY*

Among the **TECHNICAL FEATURES** it embodies:—

**OHMIC CONTROL**

An entirely new and amazingly successful method of achieving up-to-date selectivity.

Also acts as effective volume control.

**INDUCTIVELY COUPLED AERIAL**

To suit different conditions and for overall sensitivity.

**SIMPLIFIED SWITCHING**

For instantaneous change from one waveband to the other.

**INTERVALVE H.F. TRANSFORMER COUPLING**

To ensure efficient transference of amplified input to the detector.

**SCREENED-GRID VALVE**

For stable radio-frequency magnification, and securing wide choice of alternative programmes.

**CUMULATIVE GRID RECTIFICATION**

P. P. Eckersley says "You can do no better."

**GANGED TUNING**

Achieves the ease of operation essential for a truly national set.

**DIFFERENTIAL REACTION**

Constancy of tuning adjustment and smooth retroaction effects

are among the benefits conferred by this method.

**DOUBLE DECOUPLING**

This prevents instability and is specially advantageous when the H.T. Battery has lost its first youth.

**TRANSFORMER - COUPLED L.F. STAGE**

For maximum amplification on the low-frequency side.

**SELF-BIASED PENTODE**

In addition to its economy, the output valve provides the high-note compensation required for quality reception.

The "P.W."

# NATIONAL THREE

FOR YOU!

IT IS  
**INEXPENSIVE**

IT IS  
**EASY TO MAKE**

in Next Week's

# POPULAR WIRELESS

Order Now. 3d.

THOSE who were counting on any changes in the B.B.C. Board of Governors at the end of 1933 will be equally disappointed if they look for these at the end of 1934. The Chairman, Mr. Whitley, will not complete his normal term of office until December 31st, 1936; Mr. Harold Brown's term is the same as that of the Chairman; Mr. Norman, the Vice-Chairman, Lord Bridgeman and Mrs. Mary Agnes Hamilton will not finish their five years until December 31st, 1937—that is, twelve months after the new charter and licence have been introduced.

Thus, unless the Government decides to add two members to the Board of Governors, as it is entitled to do at any time under Order-in-Council, there will be two changes at the end of 1936 and three at the end of 1937.

#### Further "Housing" Troubles.

The congestion at Broadcasting House gets worse. Also there are alarming signs that some of the studios are not efficient for their purposes. Altogether the "housing problem" is giving the Board of Governors no little or subsiding anxiety. I hear of inquiries and investigations and of reports asked for in a few weeks' time. It is perhaps fortunate that the investigation is undertaken from within rather than being imposed from without.

#### B.B.C. Finance.

Behind the campaign to take for the Treasury a still larger share of licence revenue is a thinly veiled attempt to cripple the B.B.C. and to force it still farther into the realm of private trading. If the campaign succeeds, the B.B.C. will be forced to seek revenue from expanding publishing activities, which is certainly not desirable.

The real problem is not to reduce the money available, but rather to let the B.B.C. have more licence revenue and restrain it from invading the field of private enterprise, such as publishing. In 1932 a profit of over £320,000 was made out of publications by the B.B.C. This money was diverted from the publishing industry, and the microphone was the potent instrument of diversion.

#### S. P. B. Mais in America.

Mr. Mais, now back from his "Modern Columbus" tour of America, has become

### THE MIRROR OF THE B.B.C.

## NO CHANGES IN THE BOARD

Congestion at Broadcasting House—More Raids on Licence Revenue?—Fees for Broadcast Talkers.

REFLECTIONS BY O.H.M.

the subject of remarkable comment and controversy on the other side of the Atlantic. Mr. Mais is alleged to have neglected the social side of his tour to the extent of avoiding certain official functions in his honour.

I gather that the task of handling his job properly would have been quite impossible if Mr. Mais had accepted anything like even the most important of the invitations proffered. As for his broadcasts, American opinion is enthusiastic; indeed, rather more so than British opinion. It is understood that Broadcasting House, although appreciative, had several "points" to make to Mr. Mais.

#### Programme Officials on a World Tour.

Referring again to my exclusive advance announcement of the world tour of Messrs. Eckersley and Siepmann, Entertainment

## A VERSATILE PRODUCER



Martyn C. Webster, who was transferred to Birmingham at the end of last year as Director of Light Entertainment, was previously chief announcer in Scotland before coming to London as the youngest of the Broadcasting House producers.

## THE LISTENER'S NOTEBOOK

Comment and criticism on recent radio entertainment and on programme personalities of the moment.

presentation. Which only goes to prove there is a large public for these performances.

Isn't there some authority or other that presents a certificate to the best amateur society of the year? Just as a prize band sometimes broadcasts after the contest, why not the prize society after the award? Rival societies would love such a broadcast, if only to compare talent.

What tremendous encouragement the B.B.C. would be giving to amateur dramatic activity in the country! In every branch of art the amateur is indispensable. The professional needs him as much as anyone.

The B.B.C. might also discover

fresh talent. The B.B.C., we are told, is always in search of talent. Didn't Mr. Eric Maschwitz spend his Christmas holiday on the hunt?

It might be argued, of course, that the amateur actor is only good locally, i.e. he wouldn't find audiences outside his own district as charitable as those within it. Well, I'm not so sure!

Father Walke has a band of locals in Cornwall who don't call for charity, anyhow. The Nativity play they put on at Christmas should have satisfied the crabbier critic.

And I venture to think it would be the same with many an amateur dramatic society. Anyhow, it's worth thinking about.

The Modern Columbus has accom-

and Talks Directors of the B.B.C., I now hear that these gentlemen will do a good deal of broadcasting and public speaking, particularly in the United States and the Dominions.

Mr. Eckersley does not care much for public speaking, and for him it will be an ordeal; Mr. Siepmann, on the other hand, is a practised orator. I

hope, however, he does not deal with his audiences in quite the patronising way in which the other night he told the British listening public about the Spring Talks.

He said something about there being a fair sprinkling of fools in his audience, and he had little else but contempt for those listeners who wrote criticising programmes. This is not quite the attitude that will "go over" in America!

#### Mrs. Borrett's Broadcasting Future.

When Mrs. Borrett, the ex-B.B.C. announcer, was in the public eye, great pains were taken at Broadcasting House to emphasise how she was to be used regularly as an artiste. There was talk of regular play engagements, Children's Hours and so on. There does not seem to be much alacrity in applying these promises now.

#### The Payment of Speakers.

The B.B.C. naturally tries to get its talkers, eminent and obscure, at the lowest possible figure. There is no standard fee. But now that more people come to the microphone, talkers are beginning to compare notes, with some amusing results.

For instance, I hear that Mr. Churchill (who is appearing in the "Whither Britain?" series) was told that another speaker in the same series was offered about four times as much as he! I wonder if broadcast talkers will ever get together into a protective organisation to secure uniform treatment?

#### Sir John Deals Direct.

When the new organisation of the B.B.C. was started in September last the plan was to protect Sir John Reith, the Director-General, from the necessity of any contact with the staff apart from the two Controllers. I understand this worked for a time, but that it is now breaking down. Sir John is dealing direct with whomsoever he likes; which is probably a good thing for the broadcasting service.

THE studio broadcast of "The Mikado" whetted my appetite for more of these Gilbert and Sullivan treasures. The D'Oyly Carte Company are the exponents *par excellence* of these. Indeed, they ought to be, for they do nothing else. But there are numerous amateur societies who annually put on a good show.

Unfortunately a lot of these societies, although they put on a presentable show, are hard put to it to meet the expenses involved. There is too often an adverse balance, or whenever the show is in aid of local charities there's precious little for charity.

So I would suggest a broadcast-relay or two of these amateur productions. The B.B.C. would (or ought to be) glad to make up the deficiency in box-office takings.

That a broadcast of these amateur productions would be popular there is no question. Almost every town in the country possesses its amateur dramatic society—and many villages, too.

The keenest rivalry exists between these societies. One society will often travel miles to see another society's

plished his voyage of discovery. Has he discovered much? Frankly, I've been disappointed. Although there was never a shortage of information, it was never quite the sort of information I wanted or expected.

Though I find it difficult to describe the type of information I did expect, there wasn't much about Mr. Mais' subject-matter that one would associate with a discovery.

After all, America isn't an unknown country (wasn't it discovered in 1492?), and Mr. Mais was too content to give us stuff that had reached us years ago.

Then, again, reception was never good. This wasn't Mr. Mais' fault. At times it was thoroughly bad. Transatlantic relays aren't worth the large expenses they entail if these broadcasts are specimens of the best that can be done at the moment.

It is a great pity that a few people thought the "bells of Bethlehem" a fake. There always have been sceptics, and there always will be. But the B.B.C. must see to it that they never offer the smallest grounds for scepticism.

(Continued on page 838.)

# Recommended WRINKLES

## FOR HAIR-LINE TUNING.

MANY constructors will have escutcheon plates with no protection from dust for the dial. I have found the following extremely useful: Obtain a developed negative from any photographic chemist and, after cleaning, draw carefully down centre of same a straight line with a pen, to form a hair-line. Stick, with secotine,

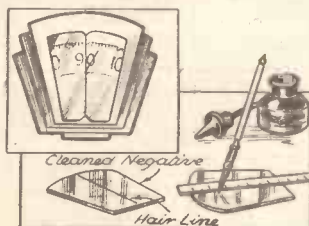

A line marked with a pen on a photographic negative simplifies tuning.

the negative behind the escutcheon, keeping the hair-line in the centre. This will be found to protect the dial from becoming dirty and also give accurate readings.

## IMPROVING SWITCH CONTACTS.

VERY often the crackles heard in a mains set are due to the presence of faulty electric light switches in the house. Usually an offending switch will make particularly loud crackles in the receiver when it is switched on and off.

Sometimes the following treatment will prove surprisingly effective in removing crackling noises.

First turn the supply off at the main switch. This is very important. Next remove the cover of the offending tumbler switch, and, with the switch in the off position, bend closer together the spring sides of the contact into which the "knife" part of the switch fits. Before replacing cover see that the switch is still able to "close" properly.

Treat in this way all the switches you suspect.

## FIXING GRUB SCREWS.

ON occasions one comes across a condenser dial in which the fixing screw has broken away from the thread in the bakelite, so making the dial useless.

A cure for this is to procure or make a metal band to fit the dial hub, as shown in sketch. Drill a hole in the band, and solder a brass nut (same thread as grub screw) over the hole; then replace band over the hub.

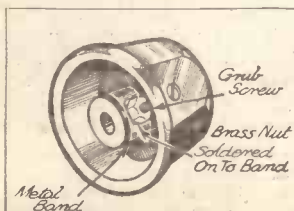

Old dials in which the grub screw is useless need not be thrown away.

To make sure of the dial not slipping file a flat on the condenser spindle.

## "CALIBRATING" A PRESET CONDENSER.

PRESET condensers are now widely used to control selectivity, and are usually successful except in one respect: there is no means of telling how far out, or in, the knob has been turned. It is very easy to make calibration possible in the following manner:

Turn the knob as far out as possible without its coming out of the con-

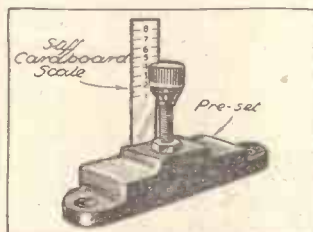

"Calibrating" a preset with a scale makes selectivity control easier.

as an amplifier, thus providing the extra stage needed.

Very often, however, it will be found that only a small extra input is needed to load up the Class B valve sufficiently. This can be provided by joining another transformer in circuit between the pick-up and driver valve.

An ordinary intervalve component will be satisfactory, although the higher its ratio the better.

The volume control is connected across the pick-up in the usual manner, one end of its resistance and the slider going to the two primary terminals of the extra L.F. transformer. That part of the potentiometer between the slider and the end of the resistance element that goes to the primary is actually across the primary, but since it is never likely to be at a very low value it will not affect the high notes.

## A SPEAKER CONE.

I HAVE found the following has proved a very efficient speaker cone: Cut and gum a cone to desired size from a piece of hot, pressed drawing-paper; then cut out of soft leather a circular washer of 2 in. width and suitable to fix by strong glue 1/4 in. all round the edge of the cone. Give the paper, both sides, several coats of

raw-cut and press round with the fingers. This makes very neat angles

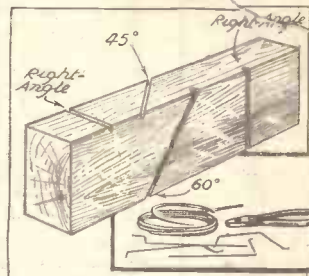

Neat angle bends are made by this method and the insulating material is not broken.

and obviates any cracking or breaking of the insulating material, which is often damaged by the jaws of the pliers when they are used.

## CUTTING COIL SLOTS.

THOSE who make their own coils will know the difficulty of making slots in ribbed formers. Usually the width of slot made by a cut with a single hacksaw blade cut is not wide enough.

The method adopted for widening such slots is usually to file them out wider or to make another cut with the hacksaw close to the first cut. But in many cases such methods often result in too wide a slot.

When that is the case the following idea will be found of considerable value. Instead of only one blade being fitted to the hacksaw frame, two are put on side by side.

The two blades must, of course, be of the same length and similar type, otherwise the holes in them will not come at the same points, and they will not both be tensioned to the same degree by the hacksaw frame.

They may both be put in to cut in the same direction, or they may be reversed so that one cuts when the saw is pushed forward and the other when it is pulled back.

## PREVENTING SPLITS.

WHEN screwing panels to plywood baseboards, or when nailing pieces of plywood together, it is not uncommon for the wood to split. The likelihood of splits can be reduced

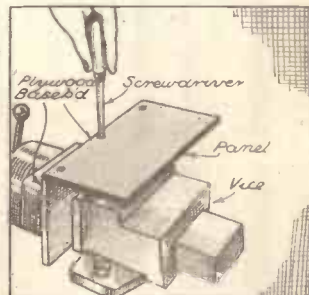

Holding wooden baseboards in a vice prevents the wood splitting when inserting screws.

considerably by drilling a small hole first of all, but by far the best scheme is to grip the work in a vice, as illustrated in the accompanying diagram.

## ONE GUINEA FOR THE BEST WRINKLE!

Readers are invited to send a short description, with sketch, of any original and practical radio idea. Each week £1 ls. will be paid for the best Wrinkle from a reader, and others published will be paid for at our usual rates.

Each hint must be on a separate sheet of paper, written on one side of the page only. Address your hints to the Technical Editor, "Popular Wireless," Tallis House, Tallis Street, E.C.4, marking the envelope "Recommended Wrinkles."

Will readers please note that the Editor cannot, in any circumstances, guarantee to return rejected Wrinkles, and that payment for published hints is not made until ten days after they appear?

The best Wrinkle in the January 6th issue was sent by Mr. A. J. Symons, "Colong," Beaumont Avenue, West Hyde, New South Wales, Australia, to whom a guinea is being awarded.

denser; then take a piece of thin, stiff cardboard as long as from the bottom of the condenser to the top of the knob and about two centimetres wide.

Then turn the knob as far in as it will go, and from the top of it in that position to the top of the cardboard mark the cardboard on each edge facing the condenser, in millimetres.

Then stick the cardboard to the side of the condenser, so that the knob has a central position on the cardboard. Having both sides calibrated makes it possible to read the scale more accurately from any angle.

## INCREASING THE INPUT.

CLASS B amplification is particularly attractive for use in a battery outfit for record reproduction alone. But in many instances it will be found that sufficient amplification is not obtained from the driver and Class B valves alone, and one may be faced with the addition of another stage, which tends to spoil the simplicity of the scheme.

The reason for the apparently small degree of amplification given by the two valves is that the driver does not act as a voltage amplifier like an ordinary stage. For one thing it is generally coupled by a step-down transformer instead of a step-up one, and it has to provide power to the Class B valve.

In a radiogram the difficulty is simple to overcome, because when working on pick-up the detector valve can be used

French polish or shellac with a brush.

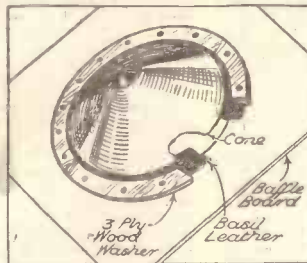

A soft leather washer is used for mounting the cone.

To fix the cone to baffle board, I used a large 3-ply wooden ring to hold the leather washer, with screws every 2 in.

## BENDING WIRES.

WHEN wiring up a set with Glazite or similar insulated wire, get a piece of hard wood about 5" or 6 in. long 2 in. wide and 1/2 in. thick. In this, with a tenon saw, make cuts as illustrated about 1/4 in. deep.

To bend the wire place in the suitable

# TESTED AND FOUND-

Being leaves from the Technical Editor's Notebook

## RADIO RECEPTION

A NUMBER of readers have asked me for my opinion regarding certain of the several small aerial-substitute gadgets which are now on sale. Some of these are claimed to give superior results to the best outdoor aerials.

Now, although it is as well to avoid being too dogmatic in radio matters, I feel bound to say that I do not believe it possible for a small device used indoors to give more than a proportion of the performance of an efficient outdoor aerial.

Indeed, I have not yet encountered one which is able even to equal a fair extended wire indoor aerial. But in those cases where a "money-back-if-not-satisfied" policy rules, the purchaser has at least the opportunity of trying an interesting experiment, and is safeguarded against a fruitless outlay if, under his particular conditions, he is not satisfied.

## UTILITY MICRO DISC DIAL

An extract from the 1933-34 Wilkins and Wright catalogue:

"At first blush the discerning reader may find a chuckle in the fact that on the preceding page we virtually say that a straight-line dial is the common-sense method, and follow up that remark by illustrating the dial shown on this page. But our reasoning is perfectly sound: we realise that not everyone will like the unconventional appearance of the straight-line dials, so we retain in our range the best of the standard range."

That appeals to me both for its divergence from the usual rather dry style adopted by catalogue compilers, and from its bold acceptance of the fact that many of us constructors are decidedly conventional in our tastes.

However, if the Utility Micro Disc Dial, to a description of which the above words are an introduction, is conventional in general form, it embodies attractive features of its own which lift it above the ordinary.

What specially appeals to me is the way in which



Although the makers describe this Utility Micro Disc Dial as "conventional," it possesses many attractive features of its own.

the scale inclines back and makes for easy viewing. A vertical scale is sometimes almost invisible in the black recesses of a small escutcheon deeply moulded.

The dial is fitted with both a direct and a good slow-motion drive which contributes a fine control giving a ratio of 50 to 1. This enables an extremely close adjustment to be made, for it works beautifully and renders it just the kind of dial for the modern superhet, or for any set for that matter.

This Utility Micro Disc Dial, with bevel disc (as above described), costs 8s. 6d. There is a flat disc model available from 8s., but, in my opinion, 6d. extra is a small price to pay for the refinement.

## PRISMS FOR TELEVISION

I notice a lamentable tendency on the part of practically all television writers to avoid explanations of light polarisation. Yet it can be explained quite simply, and as it is a very vital process in some television systems the constructor ought to be told about it.



Messrs. Wilburn have been able to provide a pair of prisms not using Iceland Spar for the low price of 17s. 6d.

However, Mr. Kendall has not side-stepped the issue in his "P.W." television article this week, and I have never known him not to be well equipped with easy-to-understand descriptions of even the most abstruse scientific subjects, but in its application to television light polarisation it is highly important.

Before I describe a new piece of apparatus that I have to hand, I must, in the meantime, say a few words on the subject myself, or you will be unable to appreciate my remarks.

I want you to think of light as consisting of vibrations in both horizontal and vertical planes. Certain shaped crystals, often of Iceland Spar, have the power to prevent the passage of any light waves except those in the one definite plane.

Visualise an Iceland Spar prism as a narrow slot. You can twist it round so that it will cut off either the vertical or horizontal vibrations.

Obviously, if the light is directed through two such devices, and the one is turned so that it stops the vertical vibrations and the other so that the horizontal vibrations are cut out, then no light at all will get through.

A Kerr cell is a device which will twist light vibrations out of their plane in accordance with the degree of electrical charges imposed on it.

Clearly, then, if a Kerr cell is placed between two polarising prisms arranged normally to prevent all light passing, this twisting effect will result in a certain amount of light getting through.

Thus we have a means of changing electrical impulses into light variations.

Iceland Spar, in suitable condition for the purpose, is expensive material, but Messrs. Wilburn & Co. (makers of Peak Condensers) have been able to design suitable prisms not using Iceland Spar for retelling at 17s. 6d. per pair, and that is, of course, very much cheaper than the cheapest "Nicol" prisms, as the Iceland Spar variety are styled.

I expect you will have gathered that one test for such prisms is to take a pair and see how closely they can be adjusted to provide a complete exclusion of light.

It is not fair to hold them up against a very bright light, because in actual fact the efficiency of their functioning for practical purposes is given by the ratio of full light to "light leakage."

And in this respect I consider that, in the circumstances, these Peak Prisms are definitely good, and they appear to me to be likely to last, and that is more than can now be said of a pair of Iceland Spar prisms I purchased a few years ago.

Both are now so discoloured that neither alone will let much light through in either plane! And I cannot remember that in linearity they ever had much on these Peaks.

## A NEW BULGIN SWITCH

For the preceding five minutes before penning these words I have been operating a new Bulgin switch. Just clicking it over from the one side to the other.

This three-point Bulgin switch (intended for wave change or on/off work) is particularly noteworthy for its perfect action, a speciality of all Bulgin switches.

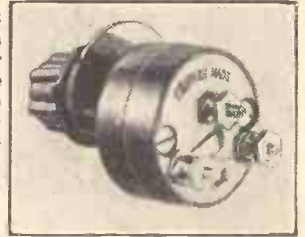

You who are regular readers of "P.W." will know why. You will be well aware by now that if there is one thing that fascinates me beyond most others it is that kind of perfect action that is now almost traditional to a Bulgin switch.

In my egotistical moments I like to think that I have done no little towards the elimination of those early atrocities which used to masquerade as switches, though I must make it plain that Bulgin's entry into the switch market was, if my memory serves me right, in itself something of a revolutionary character. Anyway, I do know they have never listed any switches that were not above criticism.

This newest Bulgin switch is a small rotary having the same click-over action as their admirable toggles.

It is of the 3-point type suitable for wave-changing, and for on-off control when it is desired also to switch a grid-bias battery on and off additionally to L.T.

At 2s. this Bulgin switch represents excellent value for money, and that it is first class in design and construction almost goes without saying.



Weekly jottings of interest to buyers.

WHENEVER the name of Cossor comes up one is apt automatically to associate it with a very famous range of valves and an almost equally famous range of sets. But the activities of this enterprising organisation do not end there by any means, and although the other products for which they are responsible are perhaps not quite so widely known, they are none the less efficient.

I try never to let an opportunity pass for bringing to the notice of "P.W." readers anything that is likely to make for better radio, and it is because I believe that the components and accessories which are produced "under the sign of the eagle" so worthily uphold the prestige of the name they bear that I desire particularly to bring them to your notice.

Cossors, in addition to valves and sets, make loudspeakers, H.T. and G.B. batteries, L.T. accumulators, an L.F. transformer, a

(Continued on page 836.)



# For the new wave- lengths

**SLOT AERIAL FILTER**  
the invention of  
a World-famous  
Designer

## **SLOT** **AERIAL FILTER**

Neat, Simple, Efficient.  
Knob Control. Complete  
with nickelled cut-out  
switch and terminals in  
one handsome unit.  
Smaller than a matchbox.  
Well-finished in polished  
Bakelite.

A crowded Ether... Stations a hair's-breadth apart... overlapping increasingly difficult to avoid. SLOT solves the problem! SLOT is a mighty atom—smaller than a matchbox, but wonderfully efficient. SLOT separates those

Stations, makes Selectivity needle-keen, reduces interference without reducing volume. SLOT adapts your set to the new wavelengths. Fit SLOT to your lead-in, it takes but a moment and improves reception for good.

**NO OTHER SELECTIVITY UNIT CAN DO WHAT SLOT DOES.**

# 2/6

Obtainable from all Dealers  
or post free from sole  
manufacturers.

*A  
new*

# **GRAHAM FARISH PRODUCT**



Advertisement of GRAHAM FARISH LTD., MASONS HILL, BROMLEY, KENT.

Export Office: 11/12 Fenchurch Street, E.C.3.

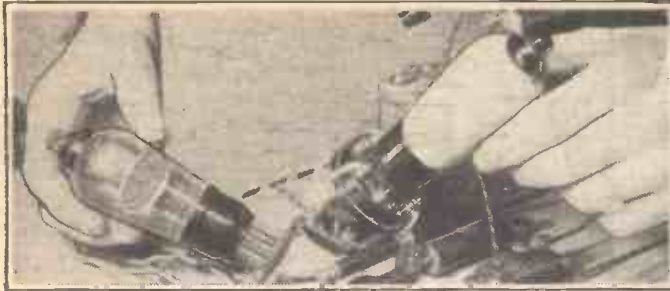

# Making a SCREEN-PENTODE ADAPTOR

WE are so used to the wonderful tetrode or screen-grid H.F. amplifier after the years it has been with us that we find it difficult to picture radio reception without it. Since the days when the early horizontal type of 6-volt S.G. valve made its appearance from the Marconi-Osram factories we have grown to look

something that will do all the S.G. valve will do, and then "some": a valve that is capable of providing better amplification, greater stability in itself and which will cost no more.

The newcomer is the H.F. pentode, or screen pentode, as it is often called, and it really is a wonderful valve. As H.F. amplifier (fixed or variable- $\mu$ ), as detector in an ordinary receiver or as a "mixer" (first detector) in a superhet the screen pentode is capable of providing a noticeable improvement over the performance of the tetrode.

In order to enable readers of "P.W." who want to compare the new pentode with their ordinary multi- $\mu$  S.G. valves we have designed a simple valve holder adaptor which will take the pentode and enable it to be plugged straight into the S.G. valve holder without any circuit alterations being necessary in the set.

## TERMINAL CONNECTIONS

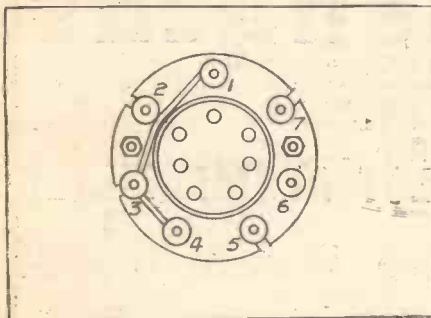

The terminals in this diagram have been numbered for reference purposes. The actual holders are not so marked by the manufacturers, the terminals being left blank.

upon it as an efficient, and therefore permanent, leader of the team of valves which constitutes our receiver.

But the time is drawing near when we shall have to say good-bye to the vigorous friend that has guided so many programmes from aerial towards speaker, for the days of the S.G. valve as we now know it—the screen-grid tetrode—are numbered.

### Providing Better Amplification.

Not because of any falling-off in its effectiveness (all through the years it has been steadily improved), but because something has arrived to take its place—

## FEW CONNECTIONS



An ordinary seven-pin valve holder is used for the upper portion of the adaptor, mounted on a circular piece of ebonite bearing four pins.

### Its First Form.

The first introduction we had to the new arrival was in its A.C. form—a five-pin indirectly-heated mains valve, obtainable in either multi- $\mu$  or "straight" variety; but it has advanced since then, and from the same stable that produced the screen tetrode we have the first release of a battery multi- $\mu$  screen pentode—the VP21.

In very many battery sets using multi- $\mu$  screen-grid valves it is possible *theoretically*

Progress in radio is steadily being maintained, as witness the various improvements that have been made in the design of valves. The latest H.F. valve is the battery screen pentode, a seven-pin amplifier with wonderful capabilities. Here is an adaptor that will enable you to plug the new valve straight into your four-pin S.G. holder without any alteration to the set's wiring.

to substitute screen pentodes without any change whatever in anything but the results. In other sets better screening, because of the increased amplification, is required to make the *theoretical* change-over possible.

We have put "*theoretical*" in italics for a definite reason—to emphasise the fact that it must not be confused with *practical*. The mains screen pentode of the five-pin variety can both theoretically and practically be substituted in many sets for the five-pin mains tetrode; but in the case of the battery screen pentode the makers have seen fit to use a *seven-pin* base, making it impossible for the valve to be plugged into the standard four-pin holder which supports the battery tetrode.

### Separate Connections.

The reason for the seven-pin base is that the makers wanted to bring both the suppressor grid (the one nearest the anode) and the metallised coating of the valve out to separate pins. This is useful in certain circuits, but is not required for ordinary straight H.F. amplification.

## THE UNDER SIDE

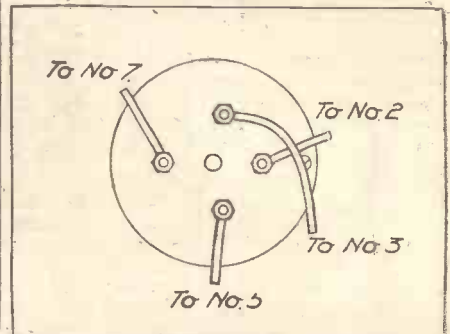

This diagram shows how the connections from the four-pin base are taken to the seven-pin holder above it.

The idea is quite simple, being merely the fixing of a standard seven-pin valve holder on to a base fitted with four pins, the wiring between the two being carried out on the adaptor.

### One Pin is Not Used.

It may be difficult to see at first how it is possible to reduce seven pins to four, but it must be remembered that although the pentode has seven pins, one of these is dummy, leaving six connections only. Of these one is to the suppressor grid and another to the coating on the bulb of the valve. The remaining four are made up of two filaments, screen and control grids.

(Continued on page 840.)

## THE FOUR PINS

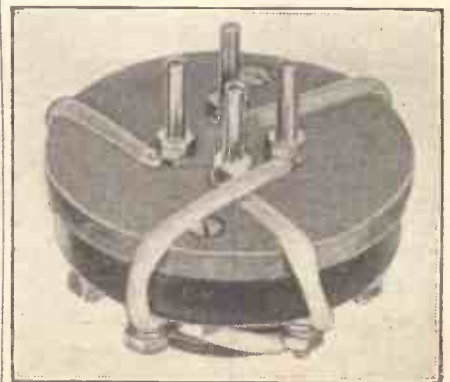

How the ebonite disc, with its four pins, is fixed to the seven-pin valve holder. The grid pin is in the foreground connected to No. 2 on the valve holder.

OUR SPECIAL  
SUPPLEMENT for  
BEGINNERS

# RADIO STEP-BY- STEP



ONE of the difficulties which confront the beginner when he seeks electrical knowledge is that of visualising what is actually happening in an electrical circuit.

When water flows into a tank or along a pipe, the movement of the water is clearly visible. For this reason the water pipe or tank form very convenient analogies for current flow and pressure.

### Another Electrical Property.

Those who are following this series will remember that we used the garden hose to illustrate both current and voltage. Similarly, the water tower was helpful in explaining the action of a condenser.

### THEORETICAL SYMBOLS

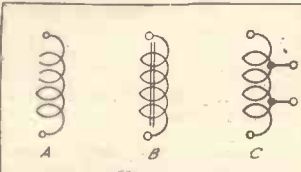

The three theoretical symbols show "A," a coil with an air core such as a simple solenoid winding; "B," an iron-cored choke; and "C," a tapped inductance having an aircore.

Now we are going to bring in a further analogy to assist in grasping another electrical property. Inductance is a word which is used just as freely as those other vitally important electrical factors—voltage, current, resistance and capacity. But what is it?

We know that when a voltage is applied to the two ends of a length of wire (conductor) a current will flow along that wire. This is perfectly true, but there is something else that we haven't yet discussed.

### Starting from Zero.

Although the current flows through the circuit formed by the wire, it takes an appreciable time to build up to its maximum value. If, for example, the final value of this current is one ampere it doesn't actually start off at this figure. On the contrary, it starts from zero, reaching its final value in a certain definite time.

The time taken is small—so small that if we insert a measuring instrument in the circuit we form the impression that the final value is attained simul-

taneously with the application of the voltage.

Moreover, the current does not drop to zero instantaneously with the removal of the driving force (voltage). It dies away gradually, taking a certain time to fall to zero, just as it did to reach its maximum value.

You have all seen a flywheel. Now a flywheel possesses inertia.

occurs at the instant of breaking the switch contacts. This is due to the inductance of the wiring. In a circuit of very high inductance the sudden breaking of a circuit will cause a considerable amount of energy to be liberated.

This energy is similar to the mechanical force exerted by a flywheel when an attempt is

magnetic field, and we showed that the lines of force due to this field could induce electricity in a neighbouring conductor at the instant of starting and stopping the current flow, or if for any reason the current varied so as to produce a change in the magnetic field.

But we did not explain that the magnetic field could also induce a current in its own conductor. Take, for example, a coil of wire. When a current commences to flow through the coil the magnetic lines of force due to the current thread their way through the coil and in doing so cut the adjacent turns.

### Henries and Micro-Henries.

This produces a voltage which opposes the building up of the current in the wire. In the same way, when the current is suddenly stopped, the lines of force collapse back on the coil, and in doing so induce voltages which tend to maintain the current flow.

Hence an iron core, by providing an easy path for the magnetic lines, increases their effect and so produces a higher inductance.

The unit of inductance is the henry; hence we hear of iron-cored apparatus having an inductance of so many henries. In radio work this unit is too large for some purposes, so the milli-henry, or one-thousandth of a henry, is used instead. There is also the micro-henry, or one-millionth of a henry.

A tuning coil of the type used on the medium broadcast wave-band generally has an inductance in the neighbourhood of 300 micro-henries and an H.T. smoothing choke an inductance of from 20-40 henries.

### SIMILAR TO INERTIA

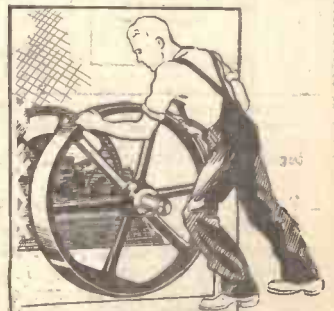

Inductance is analogous to inertia in mechanics, and can be likened to the difficulty of starting and stopping a flywheel.

## THE MEANING OF INDUCTANCE

It requires a considerable time to get up speed, and dislikes being set in motion. Once it has started it shows an equal dislike to stopping. In fact, our flywheel goes on running even after the driving force has been removed, and if you attempt to stop it you will find it no easy matter.

The inertia of the flywheel—that is, its objection to being suddenly started or stopped—is analogous to inductance. Inductance, in other words, is an electrical property that

made suddenly to stop it. Such a procedure might result in serious damage to the flywheel mounting or to the person trying to stop it from turning, depending upon the speed and mass of the wheel.

### INCREASING THE VALUE

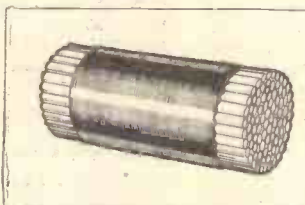

The inductance of a coil of wire is considerably increased by winding it upon an iron core.

The energy liberated during the breaking of a circuit will similarly depend upon its inductance and force or electrical power in that circuit.

Inductance can be added to a circuit by winding up a wire into a coil. A straight conductor or wire has some inductance, however short may be its length, but by winding the same wire into a spool its inductance is increased considerably.

### A Change in the Field.

It is increased still more by winding the wire upon an iron core, a fact from which you will gather that inductance is closely allied to the building up and collapsing of a magnetic field.

As we explained in a previous article, the effect of current flow along a wire is to produce a

### WOUND IN A COIL

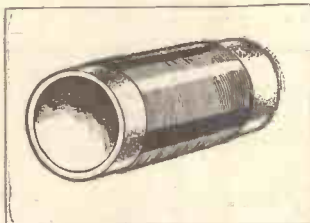

Inductance can be added to a circuit by winding a length of wire into a coil. The type of coil shown above is a solenoid.

resists change. It tends to stop the flow of an electrical current, and it also tries to keep the current flowing once it has started, just as the flywheel goes on turning when the force which drives it has been removed. Moreover, inductance tends to resist any alteration in the value of the current when it is already flowing.

Perhaps, you have noticed that in switching off a circuit, as, say, the mains, a small spark

Special Beginner's Supplement—2.

**CHOKE**

A coil designed to offer a high impedance to alternating currents.

**H.F. Chokes.**

These usually have air cores, though in some cases iron cores are now employed. As it is the purpose of an H.F. choke to present a high resistance to high-frequency currents, it is necessary that its capacity should be kept within reasonably low limits. This is generally done by sectionising the winding.

It is advantageous in some cases to reduce the external magnetic field of an H.F. choke. One method of doing this is to wind it binocularly—that is, in two complete sections, the windings on each being in opposite directions. Alternatively, the choke is provided with a metal shield.

H.F. chokes used in reaction circuits do not necessarily always have to assume the high efficiency needed for a choke used in the anode circuit of an S.G. valve. For these and certain superheterodyne circuits H.F. chokes of comparatively high inductance and very low self-capacity are needed.

A special form of construction is required for H.F. chokes intended to be employed in mains-filter circuits. They must be wound with wire able to carry the relatively high current, and good insulation and efficient heat-dispersing qualities are needed.

**SIMPLE ADDITION**

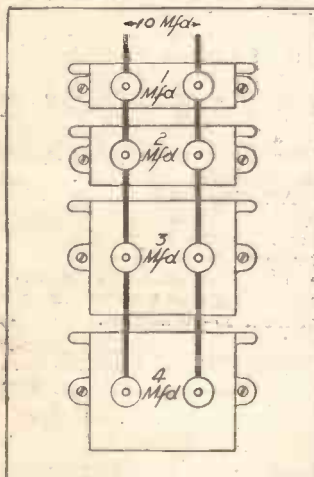

The total capacity of condensers coupled in parallel (as in this diagram) is easily found by adding together the individual capacities of the separate condensers.

**L.F. Chokes.**

These are invariably wound on iron cores. They are adapted to numerous purposes, and for these different types are made. But all L.F. chokes should conform to these requirements: (1) They should have as low an ohmic resistance as possible and

(2) should possess a reasonably low self-capacity.

L.F. chokes used in mains-smoothing circuits are rated to carry specific maximums of currents. These ought not to be exceeded, or harmful heating effects may be caused.

The inductance of an L.F. choke tends to vary as with varying currents passed through it. An inductance of 50 henries at one or two milliamperes may fall to as low as 10 or so henries at 30 milliamperes in some cases.

Care should be taken that the desired inductance is achieved at the current normally to be passed through the component. A constancy of inductance within limits can be obtained by including an air-gap in the choke's magnetic circuit, but this method of construction is not favoured by all manufacturers.

Chokes specifically intended

tuning complexity of the set. But nowadays tuned H.F. couplings are welcomed because of the greater selectivity they contribute to the set as a whole.

There are still, of course, special applications of choke coupling, such as in certain superhet systems, which cannot be criticised on the above scores.

Also the choke coupling of a loudspeaker to an output valve is a standard practice.

**CONDENSER**

A device consisting of a pair or pairs of metal plates for storing electrical energy. The simplest form of condenser comprises two pieces of metal separated by air or some other non-conductive substance.

This separating or insulating medium is known as the dielectric.

The capacity of a condenser

thus we have:  $\frac{1}{C} = \frac{25}{12}$

$$C = \frac{12}{25} = .48 \text{ mfd.}$$

You will observe that when condensers are connected in series the resultant capacity is less than that of the smallest condenser. This is an invariable rule that is worth remembering.

We are dealing with the various types of condensers under their separate headings—By-pass Condenser, Electrolytic Condenser, Fixed Condenser, Ganged Condenser, etc.—but there are a few further remarks to make concerning them of a general character.

A condenser offers resistance to the flow of alternating current (it constitutes a definite barrier to the flow of direct current), and this resistance is known as reactance. The reactance of a condenser is measured in ohms and varies as with the capacity of the condenser and the frequency of the current. The smaller the capacity and the lower the frequency the greater the reactance.

Inductance, very much unrequired at times, may be present in fixed condensers of certain forms of construction.

Parallel resistance will be present in the form of leakage through the insulation of a condenser, and must be kept as low as possible. The insulation of a condenser can cause losses of electrical energy, and air is the best insulator from this point of view.

**CONDENSER MICROPHONE.**

A microphone which is in effect a condenser, one plate of which is vibrated by the air waves. The resultant variation of capacity is then communicated to an external and amplifying circuit.

# RADIO TERMS

Wireless simply explained in a readable and easily-referred-to manner.

By G. V. DOWDING, Associate I.E.E.

for inter-valve coupling, or for output filters may not be suitable for mains-circuit smoothing.

L.F. chokes can be used instead of L.F. transformers for coupling output valves to loudspeakers. (See Auto-Transformer.)

**CHOKE COUPLING**

An alternative to L.F. transformer or resistance-capacity coupling between valves. It is not now widely favoured, for it has little advantage over resistance coupling, except that owing to the lower ohmic resistance of the choke there will be a smaller H.T. voltage loss, but no voltage step-up is possible, as in the case of transformer coupling.

H.F. choke coupling (also known as aperiodic or untuned coupling) was at one time frequently used in portable sets, for it enabled the amplification of another valve or valves to be gained without adding to the

(which is reckoned in microfarads, for this is the practical unit of capacity) depends upon three factors: (1) The area of the plates; (2) the distance between the plates; (3) the dielectric constant of the material separating the plates.

The greater the plate area, the closer the two sets of plates, and the higher the dielectric constant the greater the capacity.

When condensers are connected in parallel the resultant capacity is the sum of the individual capacities.

A 1 mfd., 2 mfd., 3 mfd. and 4 mfd. joined together in parallel (See Fig.) give a capacity of 10 mfd.

Condensers

in series obey this formulæ:

$$\frac{1}{C} = \frac{1}{C_1} + \frac{1}{C_2} + \frac{1}{C_3}, \text{ etc., etc.}$$

Taking the same values as with our previous example:

$$\frac{1}{C} = \frac{1}{1} + \frac{1}{2} + \frac{1}{3} + \frac{1}{4}$$

**NOT IN FAVOUR**

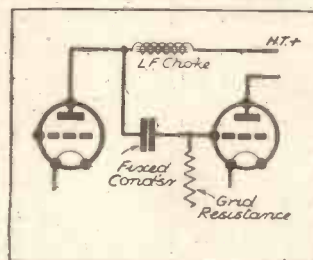

An L.F. choke can be used as an alternative to resistance-capacity coupling, as shown in the circuit section above, but its advantages are not sufficient to put its use in general favour.

**BY FORMULA**

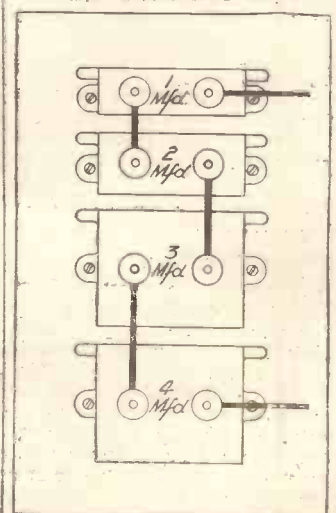

When condensers are joined in series, as they are here, a formula enters into the calculation of their total capacity. The method of calculation is given on this page.



# FOR EVERY SET — there's a PILOT AUTHOR KIT CASH — C.O.D. — or H.P.

## NEW 1934 RADIO

Originators of Kits of Parts in 1919, we supply all your Radio needs CASH, C.O.D., or EASIWAY. Our Customers are invited to take advantage of our Technical Service or call for Demonstration at our Showrooms, 77, City Road, London, E.C.1, or 62, High Holborn, London, W.C.2.



**FIRST WITH THE GOODS**

Any PROPRIETARY LINE advertised in this paper is readily obtainable from PETO-SCOTT subject to manufacturer's delivery. CASH, C.O.D., or H.P.

**IF IT'S MADE—WE STOCK IT!**

- W.B. EQUILUDE EXTENSION SPEAKER** Send 4/6  
with adjustable Switch, Chassis and Equilude Unit for perfect matching. Cash or C.O.D. Carriage Paid, £1/13/6. only
- Balance in 7 monthly payments of 4/8.
- R & A. MULTEX EXTENSION SPEAKER** for Commercial or Home-Built Receivers, past or present, no matter what the circuit. Chassis Model. Cash or C.O.D. Carriage Paid, £1/10/0. Send 4/- only
- Balance in 7 monthly payments of 4/-.
- EPOCH CLASS B COMBINATION SPEAKER**, a complete Class B Adapter, carefully balanced to give superb quality with colossal volume. Complete with Class B Valve. Cash or C.O.D. Carriage Paid, £3/3/6. Send 5/9 only
- Balance in 11 monthly payments of 5/9.
- ATLAS G.A.26**, for Mains, Class B and Q.P.P. Four tappings: 60/80, 50/90, 120, 150, 25 m/A. Cash or C.O.D. Carriage Paid, £2/19/6. Send 6/- only
- Balance in 10 monthly payments of 6/-.

### HOME BROADCASTER

Broadcast through your own set with the G.E.C. Microphone. Works of your set with only a 3-volt Dry Battery. Complete with 25 feet of Flex. Cash or C.O.D. Carriage Paid, £1/1/0. Send 2/6 only

Balance in 6 monthly payments of 3/6.

- GARRARD ELECTRIC MOTOR A.C.4**, with 12-in. Turntable. Cash or C.O.D. Carriage Paid £2/2/6. Send 5/9 only
- Balance in 7 monthly payments of 5/9.
- B.T.H. MINOR PICK-UP AND TONE ARM** Cash or C.O.D. Carriage Paid, £1/1/0. Send 4/6 only
- Balance in 4 monthly payments of 4/6.

Send for "HOW TO BUILD A SHORT-WAVE RECEIVER," complete with FREE full-size Blue Print; of KELSEY SHORT-WAVE ADAPTOR.

- PETO-SCOTT P.M. MOVING-COIL SPEAKER** Input Transformer. For Power or Pentode, complete with Transformer. Cash or C.O.D. Carriage Paid, 19/6. Send 2/6 only
- Balance in 5 monthly payments of 4/-.
- NEW LISSEN SKYSCRAPER FOUR ALL-WAVE CHASSIS MODEL**, in Sealed Carton. Cash or C.O.D. Carriage Paid, £5/12/6. Send 10/3 only
- Balance in 11 monthly payments of 10/3.
- ROLA F6P.M. PERMANENT MAGNET MOVING-COIL SPEAKER**, with input Transformer. Cash or C.O.D. Carriage Paid, £2/9/6. Send 6/- only
- Balance in 8 monthly payments of 6/-.
- BLUE SPOT 99P.M. PERMANENT MAGNET MOVING-COIL SPEAKER**. Complete with tapped input Transformer. Cash or C.O.D. Carriage Paid, £2/19/6. Send 6/- only
- Balance in 10 monthly payments of 6/-.

## PETO-SCOTT S.T.500 WALNUT CONSOLETTA



Regd. Design No. 787,010

An outstanding example of cabinet craftsmanship. Hand French polished, Veneered Macassar and Walnut finish by experts. Cash or C.O.D. 25/- Carr. and Packing, 2/6 extra, or 6/- Deposit and 4 monthly payments of 6/- (including carriage and packing). Baffle-Baseboard Assembly, 3/6 extra. Specified PETO-SCOTT TABLE CABINET, CASH or C.O.D. 19/6, or 6/- Deposit and 3 monthly payments of 6/- (including carriage and packing).

**25/-**

SEND FOR 1934 CABINET CATALOGUE.

### D.B. THREE

**KIT "A"** Author's Kit of First Specified Parts, including PETO-SCOTT Ready-Drilled Panel and "Metaplex" Baseboard, but less Valves and Cabinet. CASH or C.O.D. Carriage Paid **£5-0-0**

Or 12 monthly payments of 9/3.

**KIT "B"** As for Kit "A," but with Set of Specified Valves only. CASH or C.O.D. Carriage Paid, **£6-18-0**

Send only 12/6.  
Balance in 11 monthly payments of 12/6.

**KIT "C"** As for Kit "B," but with PETO-SCOTT Table Cabinet, as specified. CASH or C.O.D. Carriage Paid, **£7-13-0**

Send only 14/-.  
Balance in 11 monthly payments of 14/-.

### UNITY-TWO

**KIT "A"** Author's Kit of first specified parts, including PETO-SCOTT Ready Drilled Panel and "Metaplex" Baseboard, but less Valves and Cabinet. CASH or C.O.D. Carriage Paid, **£2-7-0**

Or 12 monthly payments of 4/3.

### VOL-PEN

**KIT "A"** Author's Kit of first specified parts, including "Metaplex" Chassis and PETO-SCOTT Ready-Drilled Ebonite Panel, but less Valves and Cabinet. CASH or C.O.D. Carriage Paid, **£4-17-6**

Or 12 monthly payments of 9/-.

SEND FOR DETAILED LIST OF PARTS FOR ALL THE ABOVE SETS.

**IMPORTANT** Order from PETO-SCOTT any separate items for the S.T.500. We specialise in, and carry the largest stocks in the country of all FIRST SPECIFIED PARTS. Delivery from stock. Therefore you KNOW that you are certain of receiving the parts Mr. John Scott-Taggart chose. WE DO NOT SUBSTITUTE. Send Cash or C.O.D. Orders over 10/- all Post Charges Paid GREAT BRITAIN ONLY. Easy Terms on orders over £2. H.P. Terms are NOT available to Irish or Overseas Customers.

PETO-SCOTT CO. LTD., 77, CITY RD., LONDON, E.C.1. Tel.: Clerkenwell 9406/7.  
West End Showrooms: 62, High Holborn, London, W.C.2. Tel.: Holborn 3248.

Dear Sirs,—Please send me CASII/C.O.D./H.P. for which I enclose £.....d. CASH/H.P. Deposit.

NAME.....  
ADDRESS.....  
P.W., 13/1/34.

## S.T.500

**KIT "A"** Comprising Mr. John Scott-Taggart's Kit of FIRST SPECIFIED Components, including Telsen "Class B" Output Choke, Peto-Scott "Metaplex" Baseboard and Ready-drilled Panel and Terminal Strip. Less Valves and Cabinet. With FULL-SIZE Blue Print and copy "Popular Wireless," Oct. **£5-5-0**

21st. Cash or C.O.D. Carriage Paid.

or 12 monthly payments of 9/6.

**KIT "B"** As Kit "A," but including 4 Specified Valves. Cash or C.O.D. Carriage Paid, **£7-10-3**

or 12 monthly payments of 13/9.

**KIT "CT"** As Kit "B," but including Peto-Scott Specified Walnut Table Cabinet. Cash or C.O.D. Carriage Paid, **£8-9-9**

or 12 monthly payments of 15/6.

**KIT "CC"** As Kit "B," including Peto-Scott Specified Walnut Console Cabinet. Complete with Baffle Baseboard Assembly, but less Speaker. Cash or C.O.D. Carriage Paid **£8-18-9**

Or 12 monthly payments of 16/3.

If Peto-Scott Permanent Magnet Speaker required add 19/6 to Cash Price or add 1/6 to each monthly payment.

### FINISHED INSTRUMENTS

**"S.T.500,"** complete in Peto-Scott Walnut Table Cabinet, exact to Mr. John Scott-Taggart's FIRST Specification. Aerial Tested. Complete with Valves. Cash or C.O.D. Carriage Paid, **£10-0-0**

or 12 monthly payments of 18/3.

**"S.T.500,"** complete in Peto-Scott Walnut Console Cabinet, exact to specification. With Peto-Scott Moving-Coil Speaker. Complete with Valves. Ready to Play. Aerial Tested. Cash or C.O.D. Carriage Paid, **£11-5-0**

or 12 monthly payments of 21/-.

### CONVERT YOUR S.T.400 to S.T.500

With Free Copy "POPULAR WIRELESS" and OFFICIAL BLUE PRINT.

**YOURS FOR 5/-**

Balance in 8 monthly payments of 5/3.

Peto-Scott S.T.500 Conversion Kit comprises all FIRST SPECIFIED parts required to convert your S.T.400 to the new S.T.500, including output choke, but less valve. CASH or C.O.D. Carriage Paid, 42/-.

H.P. TERMS. Complete Kit with Valve, 12 monthly payments of 5/3.

### EXCLUSIVELY SPECIFIED



IN ALL "POPULAR WIRELESS" SETS  
The only METALLISED BOARD of its kind. See the TRADE MARK on each BASEBOARD and CHASSIS. Easily drilled and perfect soldering. Made only by PETO-SCOTT, obtainable from all dealers. In case of difficulty send direct to PETO-SCOTT.

ANY ITEM SUPPLIED SEPARATELY—ORDERS OVER 10/- SENT C.O.D. CARRIAGE AND POST CHARGES PAID

# CHINA'S BIG BROADCASTER

CHINA has never previously been on the map as far as radio listeners are concerned, as in the various provinces of China there have only been very limited power stations. Most of these stations have been run half-their transmitting time for the benefit of the European population, but the programmes have not yet been much worth hearing. Moreover, the power of these local transmitters has ranged from only between a half to 2 kilowatts, and it has been quite impossible to hear these in this country.

Now that the Telefunken Company have installed a new 75-kilowatt (aerial power) transmitter at Nanking, this station can be considered a "possible."

Even if you cannot log Radio Nanking you will be interested in this description of the station, as it is really an eye-opener in the Westernisation of the Chinese.

## An Interesting Station.

The station was built by Telefunken under the order of the Nanking Government, and the working wavelength of 440 metres was arbitrarily chosen.

Radio Nanking is an interesting station, as it consists of three entirely separate buildings. The station generates its own power, and one building is given over entirely to the 600-h.p. Diesel engines. The transmitter proper is contained in the second, while the third is mainly taken up by a large studio and by the subsidiary amplifier gear and the charging arrangements.

The broadcaster is occupied for a small period every day by Government telegraph transmissions. The power is then increased, but for ordinary broadcast work, which takes up the major part of the day, the aerial power is 75 kilowatts on 440 metres. There is a modulation depth of 70 per cent, and as the whole transmitter is quartz-crystal controlled there is no appreciable frequency variation.

A feature of Radio Nanking is the pair of lattice masts, each just over 300-feet high. These masts are built under contract for the Telefunken firm and closely resemble those at a number of German stations. The masts are spaced apart about an eighth of a mile, and a five-wire T-shaped aerial, with a cage down-lead, is carried between the masts.

## Main Studio.

The main studio building and entrance hall are very imposing and governmental, and in striking contrast to the surrounding agricultural country just outside Nanking. The main buildings are brick-faced with white stone, and there is an impressive concrete drive up to the front entrance. There is a small office overlooking the



The Telefunken engineers have recently completed a big station at Nanking, so this must now be put on the logs of keen long-distance listeners. Here is a description of the main studio and transmitting gear by our Special Correspondent.

entrance, but, with this exception, all the station buildings are single storey.

The main studio is very Western. It is a double-height building, nearly 50 feet long, and has two windows for control-rooms, in addition to a third window up near the ceiling communicating with the balcony. Double-glass windows communicate with the outside world, but as all the walls are lagged with sound-proof material no noise can enter the studios.

## European Furnishings.

The whole place is cooled, which is essential, during the middle of the day. Two fans are carried from the ceiling, but these are so quiet-running that the microphones (there are six of them) do not pick up any mechanical noise. The furnishing of this main studio is carried out in the customary European fashion. There are microphone stands all connected to boxes for the microphone leads, reading desks, light indicator switches and an additional ventilation wall vent.

The transmitter hall is just as spacious.

## THE NEW RADIO BUILDING AT NANKING

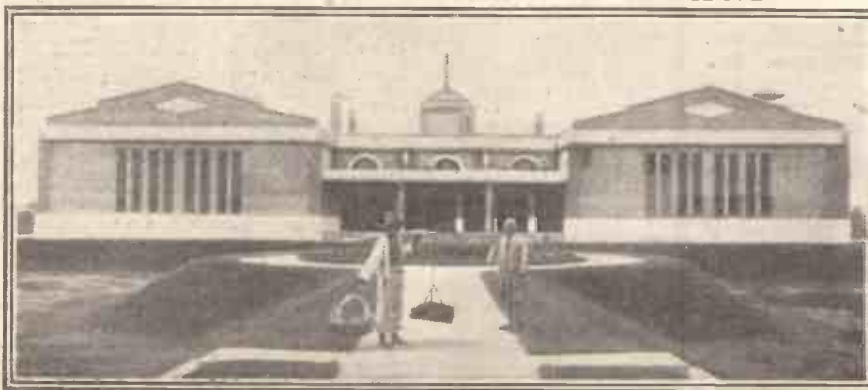

The Nanking Broadcasting station, with its towering masts, and situated in the midst of the great plains of China, forms a striking contrast to the surrounding agricultural country. The new station operates on a wavelength of 440 metres with a power of 75k.w.

The Telefunken apparatus is of the very latest type, and is built up in the usual fashion of this concern, there being no complete apparatus racks, each screening coil and valve stage being on insulated pads, and the wiring between the stages is carried out in the open.

In the final stages of the transmitter each water-cooled valve is individually supported, and its controls are brought out to large car-type steering-wheels, so that the operator need not get too close to the high-frequency parts.

## Duplicate Crystal Control.

There is one sloping control desk carrying the usual anode-circuit master controls, indicator lights and main switches. All the direct current regulation is done from this control panel, while the tuning is done with the car-type steering-wheels. The usual safety cords are put round in high-voltage parts of the transmitter, and the tuning can be adjusted without high-voltage danger.

The entire quartz-crystal control apparatus is in duplicate, so that if one crystal breaks down another can immediately be brought into use. This duplication also enables the wavelength to be changed very quickly, if necessary, but only one crystal is normally kept working. As usual, it is enclosed in a thermostat-controlled oven, and the first stages of the crystal oscillator are in duplicate.

Right in the centre of the transmitter is an electric indicator board, worked from the control desk. The wording of this is in English, and enables the operator at the controls to see at once on which stages the high-tension supply is connected. This indicator board is worked by relays from the main control.

Cooling water is pumped separately to each stage by motor-driven rotary pumps, and all the power for these pumps and the other subsidiary apparatus is provided by the 600-h.p. Diesel engine in the adjacent power-house. This engine is direct-coupled to an alternator which supplies the whole A.C. power for Radio Nanking. The water pumps and other small motors work direct off the A.C. supply, and this locally generated power is

stepped up and rectified for the direct-current high-tension transmitter supply.

## The Switchboard.

In the switchboard-room of Radio Nanking there is a panel controlling the converters for each section of the transmitter, the high-tension motor-generators, the filament supply to the transmitting valves, etc.

The studio control switches are in this room, and the tone is checked by a pilot loudspeaker.

# SHORT WAVES



# FOR QUALITY

By  
M. G. SCROGGIE, B.Sc., A.M.I.E.E.

THIS wonderful radio progress, in spite of all the talk about it, is really in a left-stick. As Eckersley shows, the achievements of engineers are rendered largely null and void by the apportioners of Europe's ether at Lucerne and at other comfortable resorts before it. The fact remains that real quality, as good as technicians are able and willing—more than willing—to give it, is impossible so long as the wavelengths of stations are crowded together as they are.

### It Isn't Good Enough!

If great progress in technique had not been made during the last few years reception wouldn't even be tolerable. As

The present overcrowded state of the long and medium wavebands will undoubtedly have to be relieved sooner or later; and below our contributor gives his views on this matter, and shows how the ultra-short waves could be used to advantage.

What is to be done? If some of the musicians are given notice to quit there will be such a riot trying to decide who is to stay that the whole street will be thrown into confusion and the residents left in a worse plight than before. Meanwhile, more pianists are continually joining the crowd while the others are arguing about it.

The only way out that treats all alike is to cut off the top octave or two of each piano and let its owner play as well as he can on what is left. At the best it won't be real piano music, but perhaps it is preferable to bedlam.

The illustration is not perfect, of course. One would have to suppose that the residents had some means of listening to one pianist at a time (more or less).

### More Room Necessary.

But to continue: some of the more enlightened residents decide that they cannot tolerate this clipped music any longer, and they scout around and find some lovely long streets with next to nobody in them. Here they can accommodate

an extended long waveband. To have really good reproduction it is necessary to have two or three times the compass of musical notes; but let that go just now.

There are, at the present moment, nearly twice as many stations trying to crowd into those two wavebands. The result is that not only have we to accept reproduction that is not as good as it might easily be, but in addition there are all sorts of troubles—whistling, growling, fading, distortion—caused by stations on common wavelengths. These troubles will almost certainly increase under the new Lucerne Plan—the more so because of the all-round increase in the range of receivers.

### Using A Common Wave.

The synchronising of two high-power stations—the London and the West Nationals—has seemed to work quite well up to the present, but there is already evidence that it is not a very happy arrangement during the hours of darkness. It is, of course, quite easy to understand how two stations giving different programmes on the same wavelength can be as bad as two speakers at a time in one meeting—actually a great deal worse than that—but it may not be quite clear to everybody why there should be any trouble when both stations are relaying the same programme; and, even so, what daylight and darkness have got to do with it.

Our street-piano analogy doesn't help us here, but perhaps you can think of two people each holding one end of a rope and waving it up and down. They send waves along the rope, which may be taken to represent the ether waves sent out from two broadcasting stations. Each is waving his end exactly in time with the other, but

(Continued on next page.)

## A SEVEN-METRE TRANSMITTER

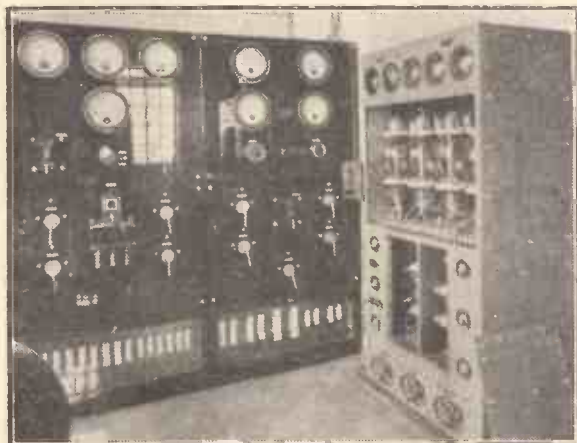

At the moment the B.B.C. are carrying out experiments on the ultra-short waves with a view to employing these for television and possibly local broadcast services. Above you see the modulator unit of the Broadcasting House ultra-short-wave transmitter. The transmitter employs a power of approximately one kilowatt.

things are, broadcast reproduction can be quite pleasing to most people, just because they have never heard anything better. But it isn't good enough.

And, in spite of all the wonderful ways that number-eight hats have thought out in order to make the best of a bad situation, it seems as near to a certainty as anything can be in this twentieth century that realistic reproduction never will be a marketable proposition, or even a possibility, so long as there is a nine-kilocycle separation.

### A Simple Illustration.

Many of you know quite well why this is so. Imagine a streetful of piano artistes. Each has a full-size piano, with 7½ octaves, about five feet long. But the street is not long enough for them all to get their pianos in line, and the neighbouring streets belong to Government officials, shipping magnates and representatives of the Services, who won't tolerate street music.

thousands of pianos—twenty feet long if they want them. Let's go!

Those who have understood this parable know what I mean. If each broadcasting station is allowed to transmit musical notes (which go to the building up of every sort of speech or noise as well as music) up to 4,500 vibrations or cycles per second before encroaching on the stance of the next broadcaster in wavelength there is room for 112 stations to transmit at once on separate wavelengths in the medium waveband and about 15 more on

## THE WEST REGIONAL STATION

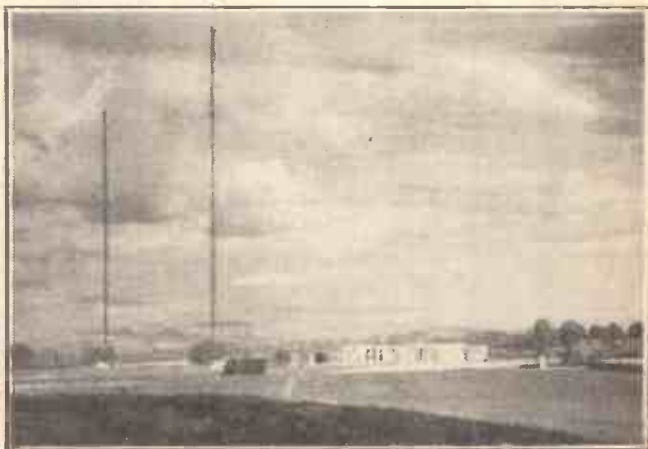

Above you see a view of the West Regional station. It is one of the recent additions to the medium waves, and one of its transmitters—West National—shares a common place in the ether with London National.

## SHORT WAVES FOR QUALITY

(Continued from previous page.)

at some points along the rope the waves arrive together, giving a bigger up-and-down motion, or they may arrive in opposition, giving weaker reception: perhaps even cancelling out altogether.

Very close up to either end the effect of the distant rope-shaking is negligible, but in the middle parts it is a toss-up whether the effect is better or worse as a result of getting two sets of waves at once. That may be likened to daylight conditions. Only those about midway between London and Watchet find themselves any differently off under those particular conditions.

But under cover of darkness a state of affairs exists that is difficult to imitate with any imaginary rope. The famous Heaviside layer, and perhaps a few other layers up in the sky that people are steadily naming after themselves, reflect the waves back on to the earth—waves that haven't been weakened by keeping one leg, so to speak, on the ground.

### The Effect of Slight Variations.

The result of this is that people just out of London suddenly find themselves getting as strong a wave from the West as from Brookmans Park (Fig. 1). Whether they will be pleased about that or not depends entirely on whether the West wave boosts the local one or washes it out.

Even if it happens to do the right thing at this moment the Heaviside layer (or

one of his mates) is sure to give a slight wriggle and deflect the new arrival on to somebody else, miles away, leaving London to carry on without assistance.

Worse still, the slightest change in the wavelength of one station compared with that of the other reverses the whole situation, so that what helped now hinders (Fig. 2). The knowledge that people in other districts who were previously hindered are now helped is not likely to be much consolation.

You may have read that the wavelengths of the two stations are kept very steady. So they are: wonderfully steady.

## THE REFLECTING LAYER

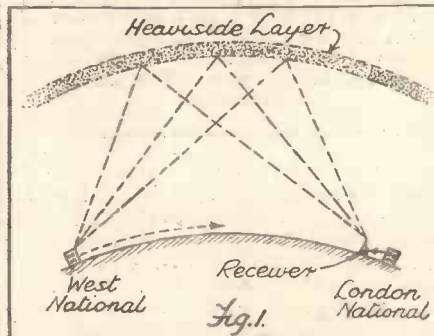

This diagram illustrates how the famous Heaviside layer reflects the sky-wave of a station earthwards and enables great distances to be covered.

But in half an hour's programme each station sends out about 2,000,000,000 waves. If one of them makes a mistake and sends out 2,000,000,001 waves it is enough to turn joy to sadness!

Even if they keep *exactly* in step it still doesn't get over the fact that in some places the two sets of waves cancel out. Mere fading, such as is caused by the shifting reflections of the Heaviside layer, can be overcome by using automatic volume control. But not a complete cancellation.

### Five-Metre Possibilities.

You might think it a very satisfactory achievement to keep two transmitting stations, 150 miles apart, synchronised in wavelength to within one part in a million. That is what happened one night during a programme, and it sounded more tremulant than the most emotional cinema organ extant.

You see, the West National was alternately adding and subtracting its contribution; hence the "wobble." Within 20 miles of either station the distant transmission is relatively too weak to make this effect noticeable in daylight. But after dark it is sometimes very noticeable indeed.

Fortunately, this is only a temporary arrangement so far as the B.B.C. transmitters are concerned. But the time is coming when there will be very few stations left in Europe with a wavelength to call their own.

Where are the empty streets? There is a very long one between 5 and 8 metres. It looks very short, stated like that. The shorter the wave, however, the higher the frequency; actually there is room for 2,500 stations, all with a separate wavelength, according to the Lucerne spacing. But we have condemned that as a bad spacing—a barrier to good reproduction.

With 2½ times as much elbow room, 1,000 can still be accommodated—enough to keep Europe going for a time.

But the beauty of the thing is that these very short waves never come back again from the Heaviside layer, so we don't get reception from them at 500 miles as strong as at 5; or silly results of that sort that lead to troublesome interference by far-distant stations. So if 1,000 stations is too few—and it might be, in view of the restricted range—there is no objection to using the same wavelengths many times over for other stations.

### Stimulating High-Quality Reproduction.

Just think of the stimulus it would give to the production of high-quality loud-speakers, amplifiers, microphones—all throttled under the present system. And it wouldn't mean the end of long-distance listening, for the present wavelengths could still be used. Then there is television, which is even more cramped by this overcrowding.

Of course, there are difficulties. Short waves are freakish. But, then, that is just what was said of 100 metres, 50 metres, 30 metres—and now they are in regular use for all sorts of purposes! All power to the people who are finding out by actual trial what 5 metres can do! Theory alone has too often been proved unsafe!

## REPLACING PENTODES WITH POWER VALVES

Some advice to those who wish to use a power valve in a set designed for pentode output.

**A**LTHOUGH it is not possible, without some alteration to the set, to use a pentode in a receiver designed for power valves, it is a fairly easy matter to use a power valve in place of a pentode.

In the case of battery sets it is necessary only to make sure that the power valve to be substituted takes approximately the same H.T. current, and that the right amount of grid bias is provided. It is also advisable to see that the flex lead that originally was connected to the side terminal on the pentode does not make contact with any other part of the set.

### Insulate the Unused Lead.

If you want to be really safe it might be as well to wrap a small piece of insulating tape around this lead. Of course, the set may be one in which a five-pin pentode is used, in which case there will be no need to worry about any flex lead.

If your receiver works from the mains you will have to be more careful. Not only will the H.T. consumption of the two valves have to be the same, but it will be necessary also to make sure that the two types require the same amount of grid bias. This is necessitated by the fact that the grid bias is supplied automatically by a fixed resistance inside the set.

Still another point to watch in the case of mains-operated sets is to make sure that the filaments of the two valves are of the same type. By this is meant that if the pentode is indirectly heated the power valve must be likewise. The same remarks apply to directly-heated pentodes. F. B.

## AN EXPLANATION

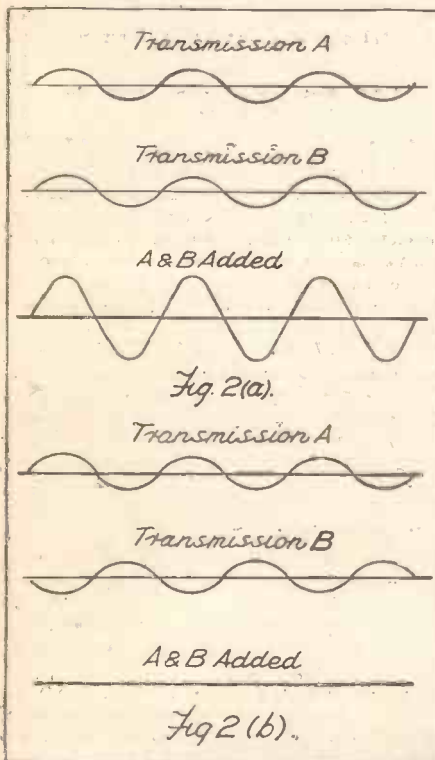

With the aid of this diagram Mr. Scroggie describes the effect of two transmitters working on a common wave. If the two sets of waves arrive in phase their effects will be added, as in Fig. 2(a), while if they arrive out of phase they will tend to cancel out, as in Fig. 2 (b).



# SELECTING FIXED CONDENSERS

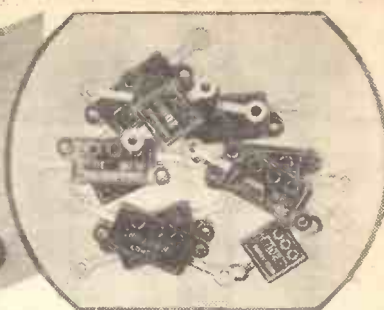

**T**HE diversity of fixed condensers now available must tend to confuse the set constructor. A short summary of the best uses of the various types may therefore prove helpful.

So far as the smaller fixed condensers, such as grid condensers, are concerned, it is usual and desirable to use only the mica dielectric type. This includes all condensers up to .01 mfd.

In some cases, such as the coupling condenser of a resistance-capacity stage, a mica condenser up to .1 mfd. or even larger capacity may be required.

However, excepting this particular use, condensers over .01-mfd. capacity rarely need to be mica type.

### The Effect of Inductance.

Fixed condensers with paper dielectrics and having capacities between .1 and 8 mfd. are obtainable in various types. In general these can be classed as "non-inductive" and "ordinary" paper condensers.

The "ordinary" paper condenser is made by rolling a sheet of paper between two sheets of tinfoil. This method of construction is quite satisfactory, except that it causes a considerable self-inductance.

### SMALL VALUES



Small condensers, such as those used for grid circuits, are usually of the mica type. As a rule they are obtainable in values up to .01 mfd.—or higher for special purposes.

This property causes these condensers to offer an appreciable impedance to high-frequency currents, although at low frequencies this effect is practically negligible.

Therefore inductive condensers should not be used in high-frequency stages for decoupling, the non-inductive type being utilised.

The ordinary "rolled-foil" paper condenser will, however, be quite satisfactory in any part of the L.F. circuit, as will also the non-inductive type.

Electrolytic condensers having capacities up to 50 or 100 mfd., and rated to work at comparatively low voltages, have recently become available. These are quite cheap and are comparable in size to large mica condensers.

As the working voltage is usually between 12 and 50, their main use is as bias-resistance shunt condensers in mains-operated sets. It is important that these condensers be connected in circuit correctly, as they are polarised.

Condensers of the paper type should be used for L.F. decoupling, loudspeaker feeds or

Those apparently unimportant components—the fixed condensers—are not quite so innocuous as they may seem to the uninitiated. The careful choice of fixed condensers is as important as the selection of any other component in a receiver, as this article sets out to prove.

the reservoir and voltage-doubler condensers of A.C. H.T. supply units.

High-voltage electrolytic condensers offer the advantages of high capacity, small size and relatively low cost. This type of condenser offers a fairly high impedance at frequencies above about 300 cycles. Also the A.C. voltage applied to these condensers must be low.

In consequence of these points this type of condenser should only be used as the main smoothing condensers in a mains-supply unit—that is, the condensers connected across the H.T. supply on the side of the choke farthest from the rectifier.

### Correct Connections Essential.

As with the low-voltage type, the high-voltage electrolytic condensers must be connected correctly so far as polarity is concerned. A reversal of the connections may destroy electrolytic condensers.

It will be appreciated that the use of this type of condenser in a D.C. mains set or H.T. unit may not be advisable, owing to the possibility of reversing the polarity when connecting the mains supply.

A special "non-polarised" electrolytic condenser is supplied by one maker, for use in D.C. mains circuits and this will of course be entirely satisfactory.

Apparently some difficulty is frequently

experienced in determining the voltage rating of the fixed condensers required. In most battery-operated sets condensers rated at 200-volts working voltage will be quite satisfactory.

It may be mentioned that the test voltage of a condenser has no definite relation to the working voltage. Unfortunately, some condenser manufacturers only quote the test voltage of their condensers.

### Safe Working Voltage.

In this case it is fairly safe to assume that the safe D.C. working voltage of the condenser is half the test voltage. In certain positions in A.C. mains apparatus a considerable A.C. voltage may be applied in addition to a D.C. voltage.

For this reason it is wise to err on the safe side when choosing condensers for A.C. mains sets or H.T. supply units.

The additional cost of a higher-voltage condenser is comparatively little, and is an insurance against breakdown or short life.

C. R.

## BELOW 50 METRES

Practical hints from a reader for those who experiment with the higher frequencies.

**Q**UITE often a short (say 15 ft.) perpendicular aerial is the best for reception.

Just arrange a wooden support to project from the house-top at the required height and bring the aerial straight to a downstairs window.

A very small vernier condenser of one plate in parallel with an aerial tuning condenser sometimes works astounding wonders in the matter of easy tuning. It is possible to make this from a variety of standard condensers which one may have on hand by just slipping away the plates; arrange a pigtail contact for the moving plate, if possible.

### A Screening Tip.

Screen the baseboard with copper-foil or aluminium, and the panel as well if it can be done. Use a fairly thick board on top of the screen, so that one does not have to worry about accidental shorts and mounting components off the screen.

Try a variable grid condenser of .0003-.00025 mfd., and keep all leads as short as can be managed. A metallised valve is useful as detector, and if L.F. is wanted experiment with resistance-capacity coupling with an output filter. If "head capacity" is present insert a short-wave H.F. choke in the positive telephone lead.

J. R.

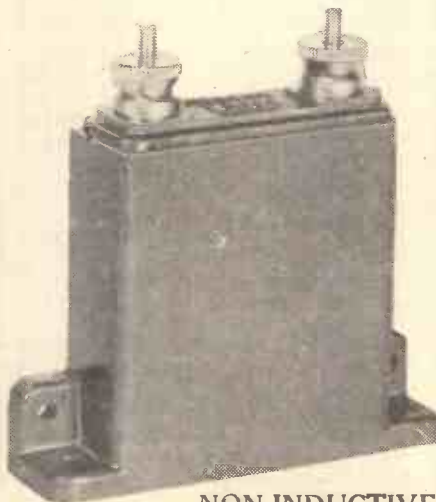

NON-INDUCTIVE

An example of a non-inductive condenser with a capacity of 1 mfd.: a type suitable for inclusion in both H.F. and L.F. circuits.

# RADIOTORIAL

The Editor will be pleased to consider articles and photographs dealing with all radio subjects, but cannot accept responsibility for manuscripts or photos. Every care will be taken to return MSS. not accepted for publication. A stamped and addressed envelope must be sent with every article.

All Editorial communications should be addressed to the Editor, POPULAR WIRELESS, Tallis House, Tallis Street, London, E.C.4.

All inquiries concerning advertising rates, etc., to be addressed to the Advertisement Offices, John Carpenter House, John Carpenter St., London, E.C.4. The constructional articles which appear from time to time in this journal are the outcome of research and experimental work carried out with a view to improving the technique of wireless reception. As much of the information given in the columns of this paper concerns the most recent developments in the radio world, some of the arrangements and specialties described may be the subjects of Letters Patent, and the amateur and the trader would be well advised to obtain permission of the patenters to use the patents before doing so.

## QUESTIONS AND ANSWERS

### CONTROLLING THE VOLUME OF THE "P.W." "APEX."

C. J. H. (Fallowfield).—“What is the best method of reducing the volume on the local station programme without incurring much trouble or cost?”

“The set is the ‘Apex’, built up from your paper, October 1st, 1932.”

For a set of the “Apex” type there is nothing to beat a small condenser in the aerial lead for inexpensive control of volume.

All you need is one of the solid dielectric type of condensers which has a shunting position, with a maximum capacity which is about 0005 mfd.

It can easily be mounted in the space to the left of the first wave-change switch, where it does not spoil the appearance of the panel. One terminal of the new condenser then takes the lead from the aerial-coil unit (the lead which formerly joined that component to the series aerial condenser at the back of the baseboard).

The other terminal of the new condenser then runs across the baseboard direct to the series aerial condenser in question, thus bringing the new condenser permanently into the aerial circuit.

### TRIALS AND TROUBLES WITH TUNING COILS.

A great many of the faults which have been puzzling readers of late appear to be coil faults. This is probably quite an accident, because normally a coil unit is a remarkably trouble-free piece of apparatus.

One of the sufferers is T. G. A., of Attercliffe, and his own account of his troubles is both amusing and instructive. He says:

“Although it was during the season of goodwill and all that, I cursed the whole thing up hill, down dale and on the level. For it worked like the perfect set on the medium waves, but it sulked like the deuce on the long waves. Not a whisper could I get.

“Switch all right?” says you. Yessir! That switch, the wiring to the switch, the panel on which that switch was mounted, the connections to that switch—in fact, everything about that darned switch seemed to be PERFECT.

“I got a pal in to look it over, and the fool laughed so much because all our remedies and suggestions failed that in the end I chucked him out!

“As it proved, the bit of a dust-up with him did me good, because I sat down to get my wind back, and in thinking it over I came to the conclusion that it must be the coil unit, although I had already had it out twice.

“It was, by heck! And about the artfullest fault you ever needed to make you tear your whiskers out in handfuls.

“It was like this: the aerial terminal lead goes to the 5 terminal on the K.G.O. coil, as you know, and the switching joins the 5 either to long or medium-wave tapping.

“At least, it does in 999,999 cases out of 1,000,000. But I was Bill Muggins the Millionth!

“On my coil the long-wave spring underneath the base looked just as good as the other side, but I found that although the switch moved the spring, it did not press the two contacts together.

“So, on long waves, all I had been doing was bringing the aerial to the 5 terminal and letting it stop there! ‘No-connection-with-the-coil-next-door’ sort of thing! (Talk about leading a horse to the water and then not making him drink!)



TRIMMING GANGED CONDENSERS.

Usually each section is provided with a small “trimmer” condenser, and this must be adjusted correctly when the set is built and then left alone.

Trimming instructions should always be regarded as important, and carried out carefully. The overall sensitivity of the set will be greatly reduced if the set is not correctly “trimmed.”

### FOR BETTER RADIO

The great convenience of unified tuning for several circuits is often off-set by a failure to get full value from each of the circuits in question. Such an arrangement must be kept “in trim.”

“You can guess what happened when I had put it right, because the aerial is pretty good, and when that switch did its job properly and hitched the aerial to the set, it gave the old loudspeaker something to think about, I can tell you.

“And, to render my triumph complete, that fool of a pal of mine came back to laugh at me again. But by that time it was roaring out on Kalundborg like the Loch Ness monster, and when he heard it he admitted that it was better than his own set could do.

### “P.W.” PANELS, No. 152, REYKJAVIK, ICELAND.

Under the new wavelength plan coming into operation on January 15th, 1934, Reykjavik is to occupy the wavelength of 1,639 metres—theoretically a better one than 1,200 metres, where it now works.

But it will still be a difficult station to receive in this country, because its new wavelength will be shared with Kaunas and Ankara. Moreover, the projected Madrid long-waver is also to work on 1,639 metres when it comes into operation.

Reykjavik has a lady announcer, and the name is given as “Utvarpostod-Islandsi Reykjavik.” The power is 16 kilowatts, and distance (from London) 1,175 miles.

“So now all is merry and bright, as they say on the Christmas cards; and I must wish you and the ‘P.W.’ technical hounds, and all the poor blighters who have impossible faults to find, a very happy New Year.”

### DIRECT RECEPTION FROM BOSTON, U.S.A., ON MEDIUM WAVES.

All readers who are out for the reception of American programmes will be interested in this report from “Ether Searcher.”

Writing from Bunrannoch House, Kinloch-Rannoch, Perthshire, he says:

“Last night—or, rather, 12.45 a.m.—I ‘netted’ a transatlantic broadcast from Boston. The loudspeaker would not take it forth, so I had to resort to the phones.

“In this locality, at that time, atmospherics were really bad, but I managed to hear not so badly.

“I do not know what your ‘report’ of this particular station will be, but I distinctly heard a male announcer, in rich Yank vernacular, state that ‘this is the end of the concert given by kind permission of the Commissioners of the Boston Fire Department,’ and that any listener who had heard the programme, or any who had not, could tune in next Tuesday about the same time, and they would hear another broadcast from the same source.

“I am almost certain that he named the station as Radio Boston, W B B A, or some other letters sounding identical.

“It may have been W D D A because, as I mentioned before, atmospherics were really bad.

“I wonder if any other ‘P.W.’-ite ether searcher heard this station on December 22nd at the time I mention. It did not close down then, but the concert from the Fire Department ended about 12.55 a.m.

### LOCATING THE STATION

“Is there the faintest possibility that you could publish this letter, or part thereof, so that any of your readers may read it and have a try at locating it? As near as I can make it, the nearest station to it is our own National, the home station being about 5 degrees away from it.

“The set is rather an ancient circuit, and my aerial coil has about 45 turns, with a reaction of approx. 60.

“I had just replaced my detector with a new Mullard P.M.2D.X., and it may have been this that enabled me to hear this particular fellow from over the water. Please enlighten me per return as to the real name of the station and other particulars.”

We think the answer to “Ether Searcher’s” problem is definitely W B Z A, Boston.

This station works on 990 kilocycles (approx. 301 metres) on a power of only 1 kilowatt—the same as that employed by Aberdeen.

W B Z A is situated in Boston, Mass., with the studio in Springfield, and is usually linked with its big brother, W B Z, also of Boston.

The interesting thing for the DX (long-distance) listener to note is that “Ether Searcher” thought the call-sign was “W B B A,” whereas it was actually W B Z A. We have often pointed out how this kind of thing happens, but here is the explanation again for the benefit of all would-be “Transatlantics.”

It is all a matter of pronunciation. The Americans never pronounce “Z” as we do; they say “Zee” instead of “Zed.”

So what the announcer said in this instance was “W B Z A,” pronounced the American way, which is “W B Zee A.” Naturally enough, it sounds to us more like “W B B A” than what we should call “W B Zed A.”

(Continued on next page.)

## RADIOTORIAL QUESTIONS AND ANSWERS

(Continued from previous page.)

### The "S.T.500" For Records.

R. Y. (Pentonville).—"We have decided on the 'S.T.500,' but want to use it for gramophone as well as wireless.

"My reason for writing is to know if you have published anything about changing it over in your paper. If so, what new parts are necessary? Please say which 'P.W.' number, and how much for it?"

Full details of the manner in which you can use an "S.T.500" as a radiogram were given in the November 25th issue of "P.W." No. 599.

If this cannot be obtained locally you can apply to the publishers, The Amalgamated Press, Ltd., Back Number Dept., Bear Alley, Farringdon Street, London, E.C.4. The price is 4d. per copy, post free.

The new parts required are:

- (a) 1 radiogram switch, Wearite type I.23.
- (b) 1 50,000-ohm potentiometer, preferably of the log-law type.
- (c) 1 pick-up.
- (d) 1 small single-cell battery, giving 1½ volts, or a tapping on a separate grid-bias battery.

### WHEN AERIAL REACTION ON THE "S.T.500" APPEARS TO BE REVERSED.

R. N. (Middlesbro').—"I find that the aerial reaction on my 'S.T.500' works correctly on the long waves, but on the medium

### IS YOUR SET BEHAVING ITSELF?

Perhaps your switching doesn't work properly? Or some mysterious noise has appeared and is spoiling your radio reception? Or one of the batteries seems to run down much faster than formerly?

Whatever your radio problem may be, remember that the Technical Query Department is thoroughly equipped to assist our readers, and offers its unrivalled service.

Full details, including scale of charges, can be obtained direct from the Technical Query Dept., POPULAR WIRELESS, The Fleetway House, Farringdon Street, London, E.C.4.

A postcard will do. On receipt of this an Application Form will be sent to you post free immediately. This application will place you under no obligation whatever, but, having the form, you will know exactly what information we require to have before us in order to solve your problems.

**LONDON READERS, PLEASE NOTE:** Inquiries should NOT be made by phone or in person at Fleetway House or Tallis House.

waveband the application of reaction to the aerial reduces the volume instead of giving an increase.

"Can you explain why? And what should be done about that?"

It is just possible, though not very probable, that your symptoms are due to a reversed reaction winding on the aerial coil.

You can check this quite easily for yourself. All you have to do is to change over the connections to terminals 1 and 6 on the aerial coil.

In other words, you must take lead 61 to terminal 1 and take lead 10 to terminal 6.

This will remedy the fault if it is due to an incorrectly wound coil.

If, however, after the above test, the coil proves to be in order, the probability is that you are using the controls incorrectly.

Remember that the application of reaction is largely used when it is desired to increase the selectivity.

In such circumstances both the anode and the aerial couplers should be set to fairly low values—that is, left of the half-way position. It is not satisfactory to attempt to increase selectivity merely by increasing reaction without corresponding reduction of one or both the couplers.

On the medium wavelengths it is rarely necessary to use more than a little of the available movement of the aerial coupler, from the full-left position.

With this low value of aerial coupling and a moderate degree of anode coupling you will probably find that the application of the aerial reaction has the desired effect.

An important point to remember about operation is that the tuning dials must be slightly readjusted when any alteration of coupler or reaction control is made.

Finally, for the full details on these and similar points about working, we would refer you to Mr. Scott-Taggart's article, "The 'S.T. 500' in Action." It appeared in "P.W." dated November 11th, 1933.

# A SUPREME COMPLIMENT from a GREAT TECHNICIAN



Captain P. P. Eckersley, the Engineer who gave Britain the Regional Stations—of world-wide reputation as pioneer technician and a sound, fearless critic—has, in specifying a W.B. Microlode as first choice in his 'National Three' paid to W.B. designers and factory executives the highest compliment possible. There are vital reasons for his choice. Perfect matching to the receiver, due to the unique 'Microlode' feature, gives better balance of tone. The unique 'Mansfield' magnet, 30 per cent stronger than a good cobalt steel magnet of equal weight, gives better sensitivity and wonderfully crisp attack. Most of the "Great Names in Radio" have endorsed with enthusiasm the 'Microlode' speakers. Since their introduction, they have been made the first or sole specification in practically every important constructor set. Hear the difference a 'Microlode' will make to your set. It will amaze you!



**'MICROLODE'**  
Moving-Coil Speaker  
MODEL PM4A - - 42/-  
Write for the new folder

Whiteley Electrical Radio Co. Ltd. (Dept. P), Radio Works, Mansfield, Notts.

Sole Agents in Scotland: Radiovision Ltd., 233, St. Vincent Street, Glasgow, C.2.  
Sole Agents in I.F.S.: Kelly & Shiel, Ltd., 47, Fleet Street, Dublin.



# EASY TERMS

The very latest Radio Sets, Loud-speakers, and Kits supplied on the lowest monthly terms. Strict privacy. Prompt delivery. All Carriage Paid. Price List FREE.

## AVOMINOR

Universal testing meter (Delivery from stock). Every fault in a receiver can be quickly traced. A first-class instrument. Cash or C.O.D. £2.0.0, or 5/- with order and 7 monthly payments of 5/6.

**SET OF THREE VALVES**—Cossor, Mullard or Mazda. 1 Screen Grid, 1 Detector, 1 Power. Cash or C.O.D. £1.11.3, or 5/- with order and 6 monthly payments of 5/-.

All types of A.C. valves also supplied.

**New ATLAS MODEL CA25 H.T. ELIMINATOR.** Output 25 milliamps. 4 Tappings. Cash price £2.19.8, or 5/- with order and 11 monthly payments of 5/6.

## BLUE SPOT PRODUCTS

### MOVING COIL CHASSIS

29PM 5/- with order & 6 monthly payments of 5/2  
 45PM 5/- " " " " " " " " 5/6  
 99PM 5 " " " " " " " " 5/6

### MOVING COIL CABINET SPEAKERS

22PM 5/- with order & 9 monthly payments of 5/-  
 62PM 6/3 " " " " " " " " 6/3

### PICK-UP MODEL 33

5/- with order and 6 monthly payments of 5/8  
 To avoid delay, will customers kindly send first payment with order!

Estd. 1925 **THE LONDON RADIO SUPPLY COMPANY** 'Phone: 1977  
 National

**LONDON RADIO SUPPLY COMPANY**  
 11, OAT LANE NOBLE STREET LONDON, E.C.2

**\*8.v. AFTER 14 MONTHS' USE.**  
 Amazing tribute to Standard Leclanche Battery.



L. K. Reading, writes:—  
 "My present Battery I put up in Sept., 1932, fourteen months' going every day on a 3-v. set, and still kicks up 80-v." An extract from one of hundreds of similar letters showing how Standard Wet Battery solves H.T. problem for good. Keeps up to voltage amazingly, improves tone; annual replenishment at small cost gives you constant pure H.T. year in, year out. 120-v. 12,500 m.a. £2 complete, carriage paid. Invest now. Please write for details. All Standard Battery Spares Supplied.

**THE WET H.T. BATTERY CO. (P.W.),**  
 26, Lisie Street, London, W.C.2. Gerrard 6121.

**RADIO SUPPLIES**  
 Send your list of Radio needs for our quotation. Kits, Parts, Sets, etc. Everything in Radio stocked, prompt delivery. 7 days' approval. Catalogue free. Taylex & Standard Wet H.T. replacements stocked.  
**P. TAYLOR, 9, GROVE ROAD, BALHAM, S.W.12**

**Piano Tone RADIO GRAM CABINETS**  
 as supplied to B.B.C.

**65/- Polished Cabinet for 35/-**  
 No Middle Profits!  
 Famous maker offers finest Radio Furniture. As supplied to B.B.C. A Quality and Value impossible to better. Beautifully hand polished. **GUARANTEED Piano Tone Acoustically.**  
 Trial Very Delightful You! (Cash or 10/- Monthly.)  
**LIST FREE! From Makers—**

**PICKETT'S**  
 Piano Tone  
 Cabinet (P.W.) Works, Albion Rd., Bexleyheath, Br. London

All applications for Advertising Space in **POPULAR WIRELESS** should be addressed to the Advertising Department, John Carpenter House, John Carpenter Street, London, E.C.4. 'Phone: CITY 0202.

## THE LINK BETWEEN

(Continued from page 824.)

gramophone pick-up, a volume control and a series of plugs and jacks, and without exception the prices are extremely reasonable.

All these items are made the subject of a special Cossor leaflet which is available free for the asking through the medium of our postcard literature scheme. Incidentally, I notice that the leaflet also contains details of radiogram conversion kits for the all-electric "Melody Maker," (No. 71.) model 347.

### Not What The Doctor Ordered!

If you dropped sixteen pounds dead weight bang on the top of one of your valves I've no doubt that you would make tracks for a dust-pan and brush without waiting to survey the consequences!

Well, well, is it not surprising how one is apt to take things for granted? There's no telling what these modern valves will stand up to. Take, for instance, the case of Mr. Miller, of Plymouth, an ardent "P.W."-ite and the proud possessor of an "S.T.500."

He had been in the habit of keeping his loud-speaker on a shelf above the set until one day it fell off and crowned good and properly the Marconi output valve in his set. And to his amazement, when he went to gather up the pieces, he found that the valve was still intact and working away merrily

### CAN YOU BEAT IT?



When the loudspeaker, which can be seen on the shelf, fell on the Marconi power valve below its fret was broken, but the valve remained intact and is still working as well as ever.

while the fret of his loudspeaker was shattered beyond recognition. And the fret, so Mr. Miller tells us, was made from 3-in. oak! Can anyone beat that? It is certainly a striking tribute to the strength and rigidity of Marconi valves, but it isn't one of those little parlour tricks that can be performed *ad lib.* For that reason it is recommended that the coal-hammer should still be used for its legitimate purpose!

### Off The Beaten Track.

Mr. H. de A. Donisthorpe, of the G.E.C., who is generally regarded as one of the radio industry's live wires, had some illuminating observations to make at the recent Schoolboys' Exhibition on the important subject of "Wireless as a Career."

His comments were made the subject of a special record which was broadcast to the enthusiastic crowds every afternoon, and, from what I gather,

### OUR POSTCARD SERVICE.

Applications for trade literature mentioned in these columns can be made through "P.W." by quoting the reference number given at the end of the paragraph. Just send a postcard to G. T. Kelsey, at Tallis House, Tallis Street, E.C.4. Any literature described during the past four weeks may be applied for in this way—just quote the number or numbers.

it proved to be an extremely popular feature among the younger generation.

One is prompted to wonder why the B.B.C. doesn't do something of this sort. After all, the industry offers practically unlimited scope to the right types of youngsters, but the main difficulty at the moment seems to be in knowing how best to go about it.

### Hello, Mike!

Do you want a really good laugh? I've just had one, and, believe me, it wasn't the aftermath of "Hogmanay" celebrations, for I welcomed 1934 in the land of Nod.

The fact of the matter is that I have just seen a copy of Regentone's excellent publication entitled "Hello, Mike," and that accounts for everything. It's a most amusing publication in which popular broadcast celebrities are cleverly caricatured.

Why not let me arrange for a copy to be sent to your home? It is available free for the asking through our postcard literature scheme, and I'll wager my brand-new double-diode-triode (No. 72) to a crystal detector that you enjoy it!

## LISTEN TO THESE NEXT WEEK!

Outstanding items selected from the programmes for the week ending January 20th.

- Sunday January 14**  
 National: "Two Gentlemen of Verona": a play by William Shakespeare, to be produced by Lance Sieveking.  
 Regional: A concert of music by the Guards' Band for those who like Military Band items.
  - Monday January 15**  
 National: "Away to the Hills": a new radio musical comedy, by C. Denis Freeman and Mark H. Lubbock, a combination which never fails to succeed. To be repeated on the Regional wave on Tuesday.  
 Midland Region: A Pageant of Staffordshire.  
 Scottish Region: Excerpts from the pantomime, "Puss in Boots," relayed from the New Metro-pole Theatre, Glasgow. Great fun, this!
  - Tuesday January 16**  
 National: "Ghosts": a play by Henrik Ibsen adapted for broadcasting. (To be repeated on the Regional wave on Thursday.)  
 Regional: "Away to the Hills": repeat performance of a new musical comedy.  
 West Region: A concert of Negro Music. An unusual programme which should succeed.
  - Wednesday January 17**  
 Midland Region: "From the Musical Comedies": a bright concert of light music relayed from Droitwich Spa.  
 North Region: Excerpts from "Cinderella," relayed from the Palace Theatre, Manchester. This is always worth listening to.
  - Thursday January 18**  
 Regional: "Ghosts": repeat performance of Ibsen's "strong meat" for lovers of radio drama.  
 West Region: "Aerial Tour in the Black Mountains": a local feature in which the brilliant young Gloucestershire novelist, John C. Moore, takes a leading part.
  - Friday January 19**  
 Regional: "Songs from the Shows": a welcome revival of the John Watt series, dealing this week with the Shaftesbury Theatre. All the popular "stars" of this feature will appear. (To be repeated on the National wave on Saturday afternoon.)  
 West Region: A programme of Sir Landon Ronald's music.
  - Saturday January 20**  
 National: "Songs from the Shows": a matinee performance of Friday night's Shaftesbury Theatre show for those who listen on Saturday afternoons.  
 North Region: Variety programme relayed from the Argyle Theatre, Birkenhead. These relays usually provide the best broadcast variety in the country.
- NOTE.** On and after Monday, January 15th, the British stations will be heard on their new wavelengths.



## A REVOLUTIONARY NEW VALVE

A DEVELOPMENT that may revolutionise radio valve construction, at any rate in the power class, is shortly being introduced to the British public at the Physical and Optical Society Exhibition in London on January 11th—the day after this issue of "P.W." appears on the book-stalls.

We have all become familiar with the nickel and molybdenum electrodes, especially the molybdenum anodes, in valves, and even with the carbonised anodes in the cases of high-power dissipation valves. But these anodes are likely to be completely superseded, especially in large valves, by a type of plate that at first sight appears an impossibility.

### Heat Dissipation.

The material used is graphite. It is recognised, of course, that the high-power amplifying valve has to have (1) a large anode to give good heat dissipation, and (2) one that is carbonised to prevent proton emission, which would take place from the metal if a layer of carbon (well ingrained in the metal) were not provided. This emission would bombard the filament and speedily render the valve useless.

New metal anodes get very hot on bombardment with the electrons that are the life stream of the valve, and the higher the power dissipation of the valve, the greater the heat that has to be got rid of at the anode. It's a nuisance, but there it is—or was.

Was, because graphite has shown the way to obtain an electrode that does not get very hot, owing to its good heat-radiating properties, and which has intrinsically the "non-proton" quality we require.

### Very Much Cooler.

So on January 11th Ediswan are showing the first British graphite anode valve—the ES.75H. It is a big fellow—like the present ES.75H.—and is for power address work, for it dissipates 75 watts in the anode circuit.

The molybdenum anode of the "old" ES.75H. reaches a temperature of 800–1,000° Centigrade—the graphite anode of the new valve runs at only 300–400 degrees for the same wattage dissipation.

But this valve is probably only the forerunner of smaller valves with similar anodes, and we may reasonably expect to hear of 25-watters (like the P.P.5/400), in the not too far distant future taking advantage of the new anode.

This, by the way, in the ES.75H. is made up of two plates, or moulds, of graphite about  $\frac{1}{8}$ -in. thick, clamped together to form a more or less conventionally shaped electrode.

The main trouble experienced with the new type of anodes—namely, obtaining efficient valve evacuation—has, I believe, been successfully overcome by the Ponders End Research laboratories, and we can look forward to seeing some very interesting samples of the new design.

K. D. R.

# FINEST VALUE IN MAINS SWITCHES

ALL RATED 250 VOLTS

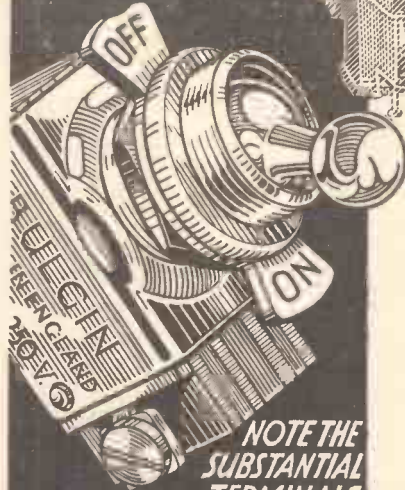

NOTE THE SUBSTANTIAL TERMINALS

LIST No. S.80 1/6

IT IS ESSENTIAL to use only the best. Bulgin Mains Toggle Switches are more widely specified and used than other makes because they have no equals in value, efficiency, reliability and safety. They all have smart snap-action.

LIST No. S.80. Single-pole ON-OFF up to 3A. at 250 v. 1/6

List No.	Description	Price
S.81.	Single-pole changeover .. ..	1/9
S.82.	Double-pole ON-OFF .. ..	2/3
S.87.	Three-point ON-OFF .. ..	1/9
S.87A.	Four-point ON-OFF .. ..	1/9
S.88.	Double-pole ON-OFF .. ..	2/6
S.89.	Double-pole changeover .. ..	3/-
S.98.	Double-pole double-throw .. ..	2/3

(Various current ratings, see pages 6, 7 Catalogue No. 153 "P.")



A. F. BULGIN & CO. LTD., ABBEY RD., BARKING, ESSEX.  
 Phone: Grange Wood 3266 & 7.  
 London Showrooms:  
 9, 10, 11, Cursitor Street, Chancery Lane, E.C.4.  
 Telephone: Holborn 2072.

G.P.O. Engineering Dept. (No experience required.) Commence £4 per week. Age 17-23. Excellent prospects. Free details of entrance Exam. from B.I.E.T. (Dept. 568), 31, Oxford Street, W.1.

**LOUD SPEAKERS REPAIRED, 4/-**  
 (Blue Spot a Specialty, 5/-)  
 Transformers and Headphones, 4/-, Eliminators, Mains Transformers and Moving Coils quoted for. 24-Hour Service. Trade Discount. Clerkenwell 9069.  
 E. MASON, 44, EAST ROAD (nr. Old Street Tube Station), LONDON, N.1.

**Micromesh**  
 THE MODERN VALVE  
 Literature and prices on request.  
 Standard Telephones & Cables Ltd.  
 St. Chad's Place, 361, Gray's Inn Rd., W.C.1  
 Terminus 6285

## EASY TERMS PROMPT DELIVERY

Any Amplion, Blue Spot, Baker, Celestion, Epoch, Ferranti, Gramplain, Igranic, Lamplugh, Magnavox, Ormond, R & A, Rola, Sonochorde, or W.B. Speaker supplied.

Send 5/- only

and pay balance by monthly instalments. No references. Entirely private and confidential.

**KITS, PARTS, SETS, ELECTRIC CLOCKS ON EASY TERMS.**

Send for Catalogue and List of 83 Speakers.

**TURNADGE & PARTNERS, LTD.,**  
 107, Fleet Street, London, E.C.4.

Telephone: Central 1903.

## MODERN RADIOGRAM CABINETS ON H.P. TERMS

We invite readers to support our Advertisers—care being taken to accept only announcements of reputable firms!



CASH PRICE 69/6 OR C.O.D.

### Specifications of Two Models in our Range.

**"Westminster."**  
 3' 3" high, 2' 6" wide, 1' 4" deep.  
 Made to take all makes of pick-ups, turntables, motor and speakers; also sets up to 18" X 8". Holes will be drilled, or vignettes, free of charge. Side cupboards will take both 10" and 12" records. Complete with chromium handles and guaranteed clock. Supplied in walnut, oak and mahogany at one price.

H.P. Terms: Deposit 15/-. 6 monthly payments of 10/6.

**"Windsor."**  
 3' 3" high, 2' 6" wide; 1' 4" deep.  
 Taking all accessories as "Westminster" model except clock and side cupboards. Both models are fitted with hinged motor-boards. Supplied in walnut, oak and mahogany at one price.

H.P. Terms: Deposit 10/-. 6 monthly payments of 6/-.  
 Carriage Paid.



CASH PRICE 42/- OR C.O.D.

**W. S. WILKIN**  
 NELSON MEWS, SOUTHEND, ESSEX.

Phone: 4330.

Catalogue Free.

PLEASE be sure to mention "Popular Wireless" when communicating with Advertisers. Thanks!

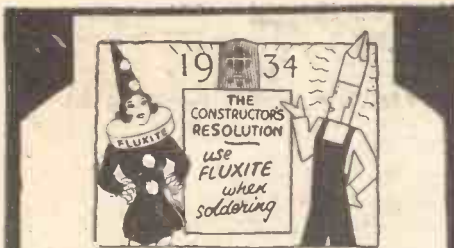

"We're Fluxite and Solder—the reliable pair; Famous for Soldering—known everywhere!"

A NEW RESOLUTION is oft hard to keep—But IF you keep THIS one—REPAIRS will be cheap!

See that Fluxite and Solder are always by you in the house—garage—workshop—anywhere where simple, speedy Soldering is needed.

ALL MECHANICS WILL HAVE  
**FLUXITE**  
IT SIMPLIFIES ALL SOLDERING

All Ironmongers sell Fluxite in tins: 4d., 8d., 1s. 4d., and 2s. 8d. Ask to see the FLUXITE POCKET SOLDERING SET—complete with full instructions—7s. 6d. Ask also for our leaflet on HARDENING STEEL with Fluxite.

FLUXITE LTD. (Dept. 324), Rotherhiths, S.E. 16

FOR ALL REPAIRS!



Best allowance made on your old set or parts in exchange for new radio goods.

Sets and parts bought for Cash.  
R. WIGFIELD, Furlong Road, Goldthorpe, Yorks.

**INVENTORS.** Your ideas may be worth royalties if submitted to manufacturers—but apply for your PATENT first. Write for my FREE "INVENTORS' POCKET-BOOK," explaining how to patent inventions. Submit particulars in confidence for free expert advice.—EDWIN V. AXE, A.I.M.E., 27, Chancery Lane, London.

MAKE YOUR SET SUPER SELECTIVE

**VARIAL**  
gives aeriels every desired degree of selectivity, cutting out interference from other stations. Fixed in a moment on any set on any aerial with no alterations. Can be supplied already attached to a coil of Superial.

The only self-contained variable aerial.

100 ft.	75 ft.	50 ft.	The world's most selective aerial.
4/6	3/6	2/9	

**INVISIBLE AERIALS**  
Run Superial through ELECTRON INSULATOR PINS and have the ONLY efficient indoor or invisible aerial. OAK, MAHOGANY, BLACK. Six in a box. **6d.**

THE NEW LONDON ELECTRON WORKS, LTD., 19, East Ham, E.6.

PLEASE be sure to mention "POPULAR WIRELESS" when communicating with Advertisers. THANKS!

THE LISTENER'S NOTEBOOK

(Continued from page 822.)

I am urged to repeat this warning by the appearance of yet another letter deploring the B.B.C.'s engagement of a Continental band (the Café Colette) while so many British musicians are on the dole (or words to that effect).

The Café Colette may be the B.B.C.'s biggest joke, but it is also one of its biggest mistakes. There's no doubt that on the first appearance of this band thousands of listeners were fooled.

And although we've been told many times now what the Café Colette band is, there are still listeners who remain unenlightened. When at last they do find out there will be more expressions of annoyance.

The point is that it is so easy, now that distance is of small account in radio, for listeners to be fooled. On no account must there be a lack of confidence between the B.B.C. and its subscribers.

I am among those who welcome the swing-over to the sweeter sort of dance music, especially when the words of the songs are really humorous. Henry Hall's programme of dance music on Christmas Day was first-rate in this respect. It contributed largely to the fun of the party at which I was.

Expecting the same thing on Boxing Night, we were terribly disappointed. We suffered the first five numbers in silence, but such a shadow of gloom came over the house that we were forced to switch off.

If you keep your programmes of music, Henry, you might look up Boxing Day's programme, note the first five numbers, and bury them deep down into the earth.

Turning to talks, I think the most outstanding one of recent weeks was the P.M.G.'s on the 1934 programme of the G.P.O. And the P.M.G. was making his debut at the microphone too! It says very little for the difficulty of the art of broadcasting when a novice can master it at once. Perhaps broadcasters are born and not made.

FROM ENTHUSIASTIC READERS

THE "UNITY TWO."

The Editor, POPULAR WIRELESS.  
Dear Sir,—I must give vent to my feelings and tell you how much I appreciate the publication of that little two-valver, the "Unity Two." I am fairly new to the ranks of the home constructors, but in my short time I have built three of your big sets, including "S.T.500."

With the "Unity Two" I was absolutely amazed. I received three local stations at very good strength and twenty foreigners at loudspeaker volume.

Thank you so much for this set, and do please give us some more.  
Yours faithfully,  
JOHN BRYDEN.  
36, First Avenue, Netherlee, Glasgow, S.4.

THE "ECONOMISER" — AND OTHER MATTERS.

The Editor, POPULAR WIRELESS.  
Dear Sir,—It's some months since I wrote you last, so I now offer many thanks for the article on the "H.T. Economiser Unit." It is a great boon: all that you claim. I built it these holidays, with the new Igranic non-inductive condensers and their spaghetti resistances (using two 100,000 mfd. in series to obtain the 200,000 mfd. value), and of course the Westector.

All this I obtained direct from both firms, who were most prompt in delivery—all we seem to stock in Swindon is the relay.

(It might interest your technicians to know that by inserting a pair of phones between aerial and earth I can pick up the relay by induction, although their two programme wires are at right angles to my aerial and 80 feet away and at front of house with aerial at back. I have picked it up at greater distances than this. By adding a two-valve L.T. amplifier I can use loudspeaker, and have done so at various times for at least two and a half years. Their chief engineer said it was impossible till I proved it by an actual demonstration.)

On Christmas Day, at 11.12 p.m., I received Pittsburg (U.S.A.), K D K A, 306 m. They were just starting sports news, and I plainly heard their call-sign—K D K A. It was rather faint, with a slight fading, and the West Regional interfered a bit; this was on my old S.G., det. and L.T. plus the Economiser unit and using plug-in coils and speaker.

Before I conclude may I express my praise for Scott-Taggart's "Manual of Modern Radio"? I received it on the Friday, and I only posted forms on the Wednesday. Most prompt!

Wishing you all a prosperous New Year.  
Yours truly,  
G. W. DICKSON.  
28, Dryden Street, Swindon, Wilts.

TECHNICAL NOTES

Some diverse and informative jottings about interesting aspects of radio.

By Dr. J. H. T. ROBERTS, F.Inst.P.

Wireless in Nature.

I DARE say you know that there is a theory that certain types of insects are able to communicate with one another over considerable distances by means of radio impulses sent out and received through these microscopic whiskers carried on their heads.

It is, I am told, a common experiment to liberate a moth in a district where the species was not previously known, and in a very short time other moths will be attracted in considerable numbers, the theory being, as I say, that the moths are able to communicate with one another by radio impulses.

This may be nothing more than a pretty story, but, however that may be, the Gartheb'k aerial, which I referred to recently, is based on a similar design, and from what I understand from the inventor is a very efficient pick-up of radio signals.

Battery Economy.

It is funny how people's shopping methods differ. Personally, I have a habit of always going for the better article, whatever it may be, although some of my friends tell me that this is merely extravagance. But I do not think it is, because I always think that if you buy a good article, even though you pay a bit more, you have got something worth having; in other words, it is in the nature of an investment, whereas if you buy a cheap and trashy article it is ten to one you throw it away before long and in the end buy a better one—which you might just as well have done at first and saved the extra cost of the cheap one.

You may be wondering what this has to do with wireless. These remarks are prompted by the habit which so many people seem to have of buying cheap and trashy high-tension batteries which hardly last any time at all—in fact, with some of the batteries on the market they haven't even a respectable shelf life, and are already pretty well on the sick list before you buy them.

Check Up on the Year.

There are a number of thoroughly sound and reliable British-made batteries on the market, and I would strongly advise you to go in for one of these next time you are requiring a new H.T. battery and not to be misled into getting a cheap one which is really much more expensive in the long run.

The trouble is that few people really check up how long a battery lasts and how much they spend on batteries in the course of a year. If they did this carefully and methodically, even for one year, they would realise that they were spending far more per annum on the cheap batteries than they would be on good ones.

Automatic Volume Control.

I still get letters from readers about automatic volume control and asking all sorts of queries as to how it can be fitted to

(Continued on next page.)

## TECHNICAL NOTES

(Continued from previous page.)

different types of set, and so on. There is no doubt that A.V.C. is a great advantage, since it levels out a good deal of the fading which otherwise troubles you and it prevents the set from being overloaded with a heavy incoming signal.

### Obtaining Accurate Tuning.

Many of these queries are from owners of battery sets and the fitting of A.V.C. to these is not too easy, but I will deal with this more fully in some later notes.

There is a point with regard to automatic volume control which is not often made clear: which is that with this arrangement it is not at all easy to judge by the ear when the circuits are at resonance; in other words, when they are accurately tuned. You will readily see that it is the very operation of the automatic volume control itself which prevents you from judging in this way.

Consequently, some kind of visual tuning indicator is necessary, and one of the simplest arrangements is the use of an

the Class B amplification system gives you a low current on the average.

This means that the load on the H.T. source is correspondingly reduced, so, in short, you get practically mains results with battery drive. You know, of course, that this Class B arrangement should be used with a special transformer, and you should not try to use an ordinary transformer for the purpose.

### The Popularity of the Catkin.

Talking about valves, it is surprising how the metal Catkin valves have caught on. The principle of the Catkin valve is the substitution of a metal container for the usual glass one, this metal container forming the anode of the valve. Some people seem to think that the Catkin is an entirely different valve from the ordinary types. Well, of course, it is different in the way which I have just mentioned, but in general it has the usual characteristics and can be used in place of ordinary glass valves, assuming the characteristics to be more or less the same.

### Less Risk of Instability.

The A.C. Catkin valves can be used for H.F. and L.F. amplification, also for the detector stage and power stage.

There are several important advantages from the method by which these valves are made, and one is that they embody, as it were, their own screening, so that the danger of instability is much less than with valves of the ordinary type. Another point is that when used in the detector stage there is less liability to microphonic vibration.

### Television Progress.

There seems to be quite a lot of activity in the various television camps in different parts of the world these days, and although television is still "around the corner," apparently it isn't the same corner.

The trend of television experiment lately seems to be in the direction of televising cinematograph films instead of an actual scene. This, of course, is not true television—or rather I should say it is not what the public expect of television—since the image is seen at the receiving end some time after the events have actually taken place.

Television, as the man in the street understands the term, means showing events at a distance, when they are actually happening, in the same way as he would see them with the naked eye if he were on the spot, or through a telescope if he were only a relatively short distance away.

### "After the Event."

This dodge of photographing the events on to a cinematograph film, developing the film and then televising the same, renders the process considerably less difficult, although goodness knows there are still plenty of technical difficulties left to contend with.

As you know, television pictures so far suffer from smallness in size, flicker, and blurring and indistinctness of the image, which is often about as decipherable as a medical man's signature. In order to improve the definition it is desirable to have additional radio channels, and this, in view of the already congested state of the ether so far as the broadcast region is concerned, practically means that recourse

(Continued on next page.)

## S.G. VALVE DECOUPLING

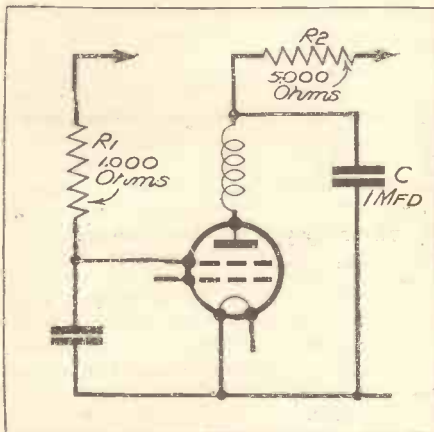

The above diagram shows how an S.G. valve may be decoupled. The screen resistance R1 may be 1,000 ohms or less, whilst the anode resistance R2 should be about 5,000 ohms. An anode condenser C, of 1 mfd. or more, should be connected in circuit also. The screen circuit will usually have a by-pass condenser already connected.

illuminated dial, or rather an illuminated portion of the dial, in the centre of which is the tuning indicator.

### Push-Pull Points.

Although the great advantages of the push-pull arrangement for getting maximum volume output are so well known, there have been until recently certain difficulties in the way of using this arrangement for battery sets. The main difficulty is that the anode current in the ordinary arrangement is apt to be much too heavy for H.F. batteries, which accordingly run only a short life, whilst another point is the difficulty of getting the effective matching of the two valves.

### Valve-Matching.

With the coming of the Class B valves, however, these difficulties were done away with, because, in the first place, the two parts of the Class B valve are properly matched—thus saving you the labour of getting matched valves for yourself—whilst

## Easy Terms

### Strict Privacy Guaranteed

—we deal with you direct

### W.B.P.M. 4 MICROLODE MOVING COIL SPEAKER

SEND FOR IT ON 7 DAYS' TRIAL

With Switch-controlled Multi-ratio input transformer. Send 2/6 for 7 days' trial. If approved, balance in 2 monthly payments of 5/6. Cash or C.O.D. Carriage Paid, 42/-.  
W.B.P.M. 6. Send only 2/6, balance in 8 monthly payments of 4/3. Cash or C.O.D. 32/6.



### ATLAS ELIMINATOR

SEND FOR IT ON 7 DAYS' TRIAL

C.A. 25 for A.C. Mains. Class B and Q.P.P. 4 tappings: 60/80, 50/90, 120, 150, 25 m.a.

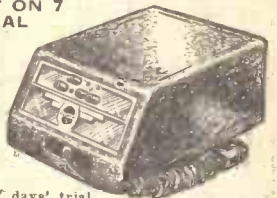

Send only 3/6 for 7 days' trial. Balance in 11 monthly payments of 5/6. Cash or C.O.D. Carriage Paid, £219/6.

### N.T.S. CLASS 'B' SPEAKER-AMPLIFIER

SEND FOR IT ON 7 DAYS' TRIAL

Gives seven times the volume. Ready assembled, with Class B Valve and N.T.S. Permanent Magnet Moving-Coil Speaker. Send only 5/- for 7 days' trial. If approved, balance in 11 monthly payments of 5/6. Cash or C.O.D. Carriage Paid, £219/6.



### NEW BLUE SPOT CLASS 'B' OUTPUT STAGE

SEND FOR IT ON 7 DAYS' TRIAL

With Class B Output Valve (less speaker). Send only 2/6 for 7 days' trial. If approved, send further 1/6. Balance in 11 monthly payments of 4/-. Cash or C.O.D. Carriage Paid, £23/6.

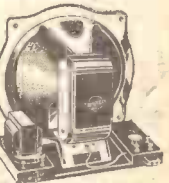

### N.T.S. CLASS 'B' SPEAKER

SEND FOR IT ON 7 DAYS' TRIAL

Gives perfect reproduction. With input transformer for power or pentode. Send 2/6 for 7 days' trial. If approved, pay balance in 5 monthly payments of 4/6. Cash or C.O.D. Carriage Paid, 22/6. Also model for Power or Pentode. Same Price and Terms.

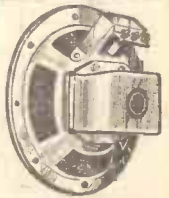

Please state type required.

## New Times Sales Co.

56, LUDGATE HILL, LONDON, E.C.4.

Dear Sirs:

(a) Please send me.....

(b) I enclose Cash/Deposit.....

NAME.....

ADDRESS.....

F.W. 13/1/34.



## PROFESSOR A.M. LOW

We have pleasure in announcing that Prof. A. M. Low, the eminent Engineering Scientist, has accepted the post of Principal to the B.I.E.T. It is impossible to over-emphasise the importance of this event and the tremendous advantages all connected with the Institute will enjoy as a result of the Professor's appointment. We urge you, this New Year, to let us show you how we can help you, how we can alter your entire outlook and earning power, whatever your age or experience. Send to-day for

### "ENGINEERING OPPORTUNITIES."

This 256-page Handbook is full of unusual information. Among other things, it gives details of the B.Sc., A.M.I.C.E., A.M.I.Mech.E., A.M.I.E.E., L.I.O.B., G.P.O., Matric., etc. Exams., outlines modern Home-Study Courses in all branches of Civil, Mech., Elec., Motor, Aero., Radio Engineering, Building, Neon Lighting, etc., and explains the activities of our Employment Dept. No engineer can afford to be without the information contained in this unique Handbook. Send for your copy now—FREE and post free.

BRITISH INSTITUTE OF ENGINEERING TECHNOLOGY, 101, SHAKESPEARE HOUSE, 29, OXFORD STREET W.I.

## EASY PAYMENTS

"There's no place like HOLMES."

The first firm to supply Wireless parts on easy payments. Nine years advertiser in "Popular Wireless." Thousands of satisfied customers.

We recommend

## EPOCH SPEAKERS

	De.	Monthly
	Price	Payments
SUPER DWARF P.M. ...	23/6	4/4 5 of 4/4
20th CENTURY P.M. ...	35/-	4/10 7 of 4/10
11-in. SUPER P.M. ...	45/-	4/11 9 of 4/11
B5 P.M. ...	84/-	7/8 11 of 7/8

LISSEN Skycraper 4 Kit	112/6	10/-	11 of 10/3
TELSEN 325 Star Kit	39/6	5/5	7 of 5/5
EXIDE H.T. Accu. 120-v.	60/-	6/-	9 of 6/8
ATLAS Eliminator C.A.25	59/6	5/-	11 of 5/6
BLUE SPOT 29P.M.	35/-	4/10	7 of 4/10
E.T.H. Pick-up Vol. Con.	25/-	4/8	5 of 4/8

Parts for any Kit Set. Any make of Speaker.

New Goods Obtained for Every Order.

Send us a list of the parts you require and the payments that will suit your convenience, and we will send you a definite quotation. Anything Wireless.

H. W. HOLMES, 29, FOLEY STREET, Great Portland Street, London, W.1.

Phone: Museum 1414.



## THE HOME BROADCASTER

A New Practical Home Mike for 5/6. Wireless Broadcasting at Home.

A solo mike for hand or stand in fine bakelite case, with back terminals, front metal grille. New and finely finished. Only 5/6.

5/6

## THE DIX-MIPANTA VEST-POCKET TESTER

A wonderfully versatile moving-iron multi-range meter for service on A.C. jobs. No projecting terminals. Three ranges of volts: 0.75, 0.150, 0.300. Used for milliamps reads: 0.125 m/A., and 0.75 m/A. In black bakelite case. Measures only 2 1/2 in. by 2 1/2 in.

A two-guinea tester for 19/0

Complete in case, with pair of test leads and plugs.

A 1,000 other Bargains in our January Sale List "P," post free

## ELECTRADIX RADIOS

218 UPPER THAMES ST., LONDON, E.C.4

Telephone: CITY 0191.

## TECHNICAL NOTES

(Continued from previous page.)

must be made to short waves. If an unlimited number of short-wave lengths were available the television problem would be much simplified.

### Short-wave Possibilities.

Quite recently it has been suggested to transmit on very short wavelengths of something under 8 metres, and if such short waves are used it means that the transmission can only be made over a comparatively short distance of a few miles.

This more or less rules out the scheme of radiating short-wave television from a small number of high-power transmitters; on the other hand, it suggests the establishment of a considerable number of short-wave television transmitting stations all over the country, with only a few miles separating them.

According to this way of looking at the matter, the requirements of ordinary broadcasting seem to be diametrically opposed to those of short-wave television, and in view of the fact that broadcasting is now so fundamentally established and is of such greater importance it will be interesting to see how the requirements of television can ultimately be met.

### L.F. Decoupling.

If you are using a battery-driven receiver, especially with low-frequency amplification, you will almost certainly find the need for decoupling—if not at first, at any rate as soon as your high-tension battery begins to run down. The symptoms that decoupling is needed are L.F. oscillation and motor-boating. These troubles are due to feedback effects, owing to the connection—the indirect connection, that is—between the detector and low-frequency anodes.

### Feed-back Effects.

I mentioned that this feed-back effect is more noticeable when the H.T. battery is beginning to run down, and this is because the resistance of the battery increases so that the low-frequency currents in the detector-anode circuit cannot get to earth as readily as they should.

When the H.T. battery is a new one, of low internal resistance, there is a ready path to earth for these audio-frequency currents; but this path becomes more and more difficult as the internal resistance of the H.T. battery increases, and so the tendency to "feed-back" gradually increases.

The way to get over this is to put a resistance (15,000 ohms) in the anode circuit and then to connect a condenser (about 2 mfd.) between the end of the resistance adjacent to the anode and the earth.

## MAKING A SCREEN-PENTODE ADAPTOR

(Continued from page 826.)

The anode connection, as in the case of the tetrode, is on the top of the bulb.

For ordinary H.F. amplification it is not necessary to make separate use of the individual connections to the suppressor grid and to the metallised coating. Both these elements can be earthed. In other words, they can be connected to the negative

filament pin. This then leaves four separate connections to go to the four pins.

We have, therefore, connected these common points to the filament pin of the special base that corresponds with the normal negative pin of the standard S.G. valve—that is, the pin to which the metal coating is usually taken. If the set is wired up correctly for a metallised S.G. valve the metal coating of the pentode and the suppressor grid will automatically be correctly connected to L.T. — when the adaptor is plugged into the set.

### Simplicity of Construction.

The actual construction and wiring of the adaptor are shown in the illustrations. It is merely a seven-pin valve holder screwed on to a suitably shaped piece of ebonite into which in correct positions are screwed four valve pins, obtainable at any radio dealer's. The shanks of these pins where they protrude above the nuts are filed down, and the nuts themselves are countersunk so that there is no danger of any short circuit between the pins and the underparts of the seven-pin valve holder.

The connections are made with ordinary wire and sleeving, and the job is done. With the pentode in the seven-pin side of the adaptor and the latter plugged into the S.G. valve holder of the set one is enabled very easily and rapidly to compare the two types of valves.

G. W.

## BRINGING THEM TO LIFE

"Stereoscopic" Radio Reception.

"I WONDER what he is like?" How often that query follows the announcement of a radio artiste! And, indeed, it is a natural human desire to know as much as possible about the people we hear on the radio.

The impersonality of broadcasting is something to which we have not become accustomed even after eleven years of it, and we readily grasp any opportunity of getting more "in the know" concerning the people in the programmes.

The B.B.C. tells us little about our friends of the ether; but the new illustrated "WHO'S WHO" ON THE WIRELESS, recently published at 6d., admirably supplies this deficiency of knowledge.

### An Excellent Book.

In this remarkable book over 300 biographies—written in easy style, and not just dry-as-dust statistics—of popular broadcasters are provided, accompanied by a large number of photographs.

Intimate details that bring all these radio stars to life enable owners of this handy book to listen to the broadcast programmes with greatly increased enjoyment. Such knowledge of the artistes as is given by "WHO'S WHO" ON THE WIRELESS is essential to full appreciation of the radio fare provided by the B.B.C., and it is not an exaggeration to say that it acts like a stereoscopic camera in bringing our radio artistes from relative unreality into bold living relief.

The book is excellent value and indispensable to the discriminating listener.

D. K.

FREE! THE "MULTI-TOOL" FREE!  
A combined Spanner, Screwdriver, Rule and Wire-Stripper

PRICE 3<sup>D</sup>

# Popular Wireless

REGISTERED AT THE G.P.O. AS A NEWSPAPER

Vol. XXIV, No. 607, January 20th, 1934.



## ECKERSLEY DESIGNED YOUR LOCAL STATION

### He NOW Designs YOUR SET

### At last! MATCHED RADIO

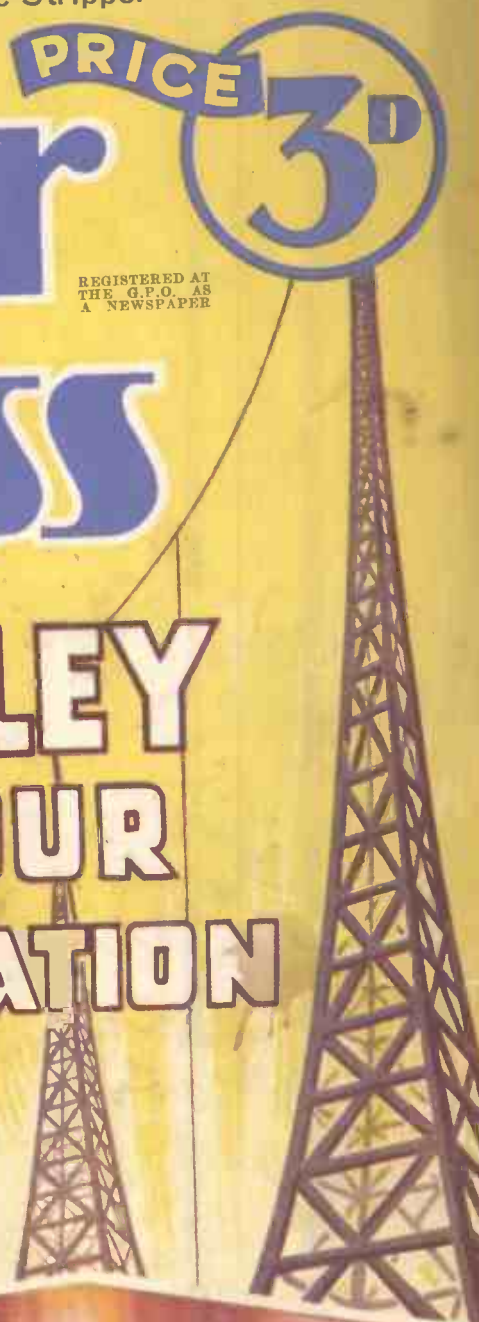



to tell the TRUTH  
the WHOLE TRUTH  
AND NOTHING BUT THE TRUTH!

Unshakable testimony! Irrefutable accuracy! You want *that* kind of evidence of radio faults and efficiency; but can you be sure of it?—Yes, with the AvoMinor, but with nothing less. Let that be clear—the AvoMinor is ACCURATE, and to a degree unapproached by any other combination testing instrument at anywhere near its price.

**THE AVOMINOR**  
TRADE MARK  
TELLS THE WHOLE TRUTH

**10**  
TESTING INSTRUMENTS  
IN  
**ONE**



Test *everything* with the AvoMinor. Test circuits, valves, components, batteries and eliminators. Test with ease and with unparalleled, indisputable accuracy, with the AvoMinor. It is a moving coil combination measuring instrument giving **TEN different** ranges of readings in milliamps, volts and ohms, on one scale and with only one pair of leads. It is a younger brother of the famous Avometer, the insistent choice of leading technical experts and service engineers throughout the world.

No other instrument in the world (except the Avometer itself) makes so many tests with such a high degree of precision. It is an expert's precision instrument designed by specialists to provide expert's testing facilities for the intelligent radio "fan." It is **THE ONE** instrument for you!

Dimensions:  
4" x 3" x 1 1/2".  
Complete in handsome case with pair of leads and interchangeable crocodile clips and testing prods.

**40%**

**DEFERRED TERMS** if desired. Write for particulars

Nothing less than the AvoMinor will give you the dependable accuracy you need. Ask your radio dealer, or write for fully descriptive pamphlet.

**MILLIAMPS**

0-6 milliamps  
0-30 milliamps  
0-120 milliamps

**VOLTS**

0-6 volts  
0-120 volts  
0-300 volts

**OHMS**

0-10,000 ohms  
0-60,000 ohms  
0-1,200,000 ohms  
0-3 megohms

The total resistance of the AvoMinor is 100,000 ohms. Full scale deflection is obtained with a consumption of only 3 milliamps.

BRITISH MADE  
AND OWNED.

THE AUTOMATIC COIL WINDER & ELECTRICAL EQUIPMENT CO., LTD.,  
WINDER HOUSE, DOUGLAS ST., LONDON, S.W.1. Telephone: Victoria 3405-7

# FIRST CHOICE!

## CELESTION

*The Very Soul of Music*

### LOUDSPEAKERS

*Mr. P. P. ECKERSLEY'S*

**FIRST CHOICE**

for the "NATIONAL  
ECKERSLEY THREE"

Again—Celestion Loudspeakers have been chosen. Mr. P. P. Eckersley has personally carried out tests which fully justify his recommendation of the Celestion Speaker. The Cobalt steel magnets incorporated in Celestion Moving-Coil Loudspeakers are accurately proportioned. Large enough to be **AMAZINGLY SENSITIVE EVEN ON SMALL INPUTS**—small enough to reduce magnetic leakage to a minimum. As a result, Celestion Loudspeakers are much more efficient than many with magnets of considerably larger external dimensions. It is such attention to detail that Celestion owe their unrivalled popularity and supremacy.

*Ask your dealer to demonstrate Celestion in either chassis or cabinet form.*

PPM 9 Chassis Model - - - £1 : 15 : 0

PPM 19 Chassis Model - - - £2 : 7 : 6

CELESTION LTD., LONDON ROAD, KINGSTON-ON-THAMES

London Showrooms: 106, Victoria Street, S.W.1

**FOREMOST NAME IN SOUND REPRODUCTION**

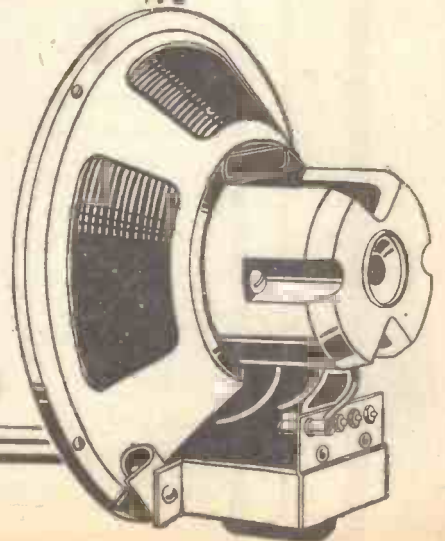

FURTHER OFFER  
OF OUR GREAT

**£1-1-0 Presentation  
Volume**



THE  
MANUAL  
OF  
MODERN  
RADIO  
SCOTT-TAGGART

THE MANUAL  
OF  
MODERN RADIO

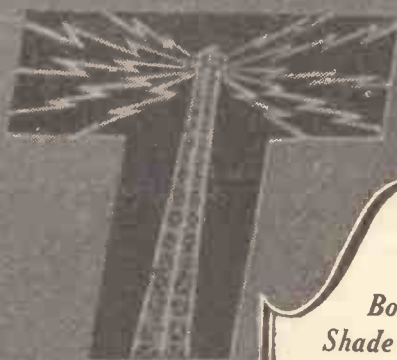

JOHN SCOTT-TAGGART

*Superbly  
Bound in a Rich  
Shade of Green Cloth  
with Silken Finish  
and containing*

**36 CHAPTERS  
424 PAGES**

*Over*  
**500 DIAGRAMS  
AND CIRCUITS**

*Complete Dictionary  
of Wireless Terms*

**40 PAGES OF  
ART PLATES**

*Thousands of Facts  
and Explanations*



ALL-PATENTED



# SEND IN YOUR APPLICATION NOW . . . AN ENORMOUS DEMAND IS ANTICIPATED

# THE GREATEST WIRELESS BOOK YET PUBLISHED

So many applications have been received from readers who failed to take advantage of our previous offer of Scott-Taggart's great radio masterpiece that we have decided to provide our readers with a further opportunity to obtain this superb volume on bargain terms.

But this will be the last opportunity! The **MANUAL OF MODERN RADIO** has been acclaimed as the finest all-round book on radio yet offered to the public. Elsewhere in this issue we publish letters of appreciation from prominent personalities in the radio world and of delighted readers.

Every radio enthusiast needs this book; it is a sure guide to knowledge and success in everything connected with the technical side of wireless, written by a man whose qualifications are unrivalled, the greatest living expert in set designing to-day.

Three-quarters of a million copies of John Scott-Taggart's books have been bought by the wireless public!

It is seven years since Mr. John Scott-Taggart has found time to write a wireless book. His "Manual of Modern Radio" is a monumental work—a landmark in the literature of wireless technique. Within its pages he has brought the whole art of radio reception and the use of valves.

The Manual is "red hot" as regards recent developments. If you are interested in such things as H.F. Pentodes, Iron-Core Coils, the Double-Diode Pentode, Cathode-Injector

systems, Metal Detectors, Class B Amplification, the Capehart Circuit, Metal Valves, Quiet Automatic Volume Control, the Pentagrid—here in this book will you find all you want to know.

But if, on the other hand, you are a novice who would like to know a little about "how the wheels go round," here again is the book for you. Scores of circuit diagrams are duplicated in pictorial form to help the beginner, and it has been assumed that the reader knows nothing whatever about electricity or science. All one needs is the ability to read.

"The Manual of Modern Radio" will occupy an honoured place on your bookshelf. Beautifully bound in green cloth and printed in clear type, it will form a treasure-house of facts and advice from which to draw upon.

A massive volume (completely devoid, of course, of any advertising matter), which would ordinarily be sold at a guinea, can become yours for a purely nominal expenditure, but only if you act at once.

Every word of the Manual is newly written by John Scott-Taggart, and every diagram has been specially prepared solely for this great compendium of the radio knowledge of to-day.

Our offer of John Scott-Taggart's "Manual of Modern Radio" is the bargain of a radio lifetime. We urge you to seize the opportunity now. Fill in your reservation form **AT ONCE**.

## What to do

Look carefully at the two forms on this page. First of all you must write your name and address on Form 1, which is just an ordinary label, on which you must stick a 3d stamp. Then fill in Form 2, which is your reservation form. Then send these two forms to **POPULAR WIRELESS**. When they are received in our office, you will be sent a Gift Voucher on which to qualify for your "Manual of Modern Radio."

There are six spaces on this Gift Voucher on which you will have to stick six Gift Tokens cut from **POPULAR WIRELESS** for six consecutive weeks. The token will be found at the bottom left-hand corner of the last page of the text. When this gift Voucher is complete—i.e., after six weeks—you are asked to send a P.O. for 2/9 (2/6 with 3d. stamp attached). This 2/9 is to cover the cost of carriage and delivery to your door, cardboard container for packing, and insurance. "The Manual of Modern Radio" can only be supplied to readers who complete the necessary Gift Voucher.

As this volume is only available to regular readers, if you have not placed a regular order for **POPULAR WIRELESS** you must do so at once. Overseas readers are not eligible.



3d. Stamp must be affixed here by YOU

Name.....

Full Address.....



## POST AT ONCE RESERVATION FORM

Applicants must complete label on left and affix halfpenny stamp in space provided. Fill in this Reservation Form and send with label to:

**POPULAR WIRELESS Presentation Book Dept. (G.P.O. Box No. 184a), Cobb's Court, Broadway, London, E.C.4.**

I hereby apply for GIFT VOUCHER and request you to reserve for me in accordance with your special offer the presentation "Manual of Modern Radio." I have given a standing order, to my newsagent, to supply POPULAR WIRELESS regularly each week.

Reader's Name.....  
(State Mr., Mrs. or Miss)

Full Address.....

Reader's Signature.....

Newsagent.....

Address.....

**PLEASE WRITE IN CAPITAL LETTERS. YOU MUST FILL IN LABEL ON LEFT and send with the Reservation Form in unsealed envelope bearing halfpenny stamp.**

For Office Use



# THREE NATIONAL USES FOR WESTECTORS

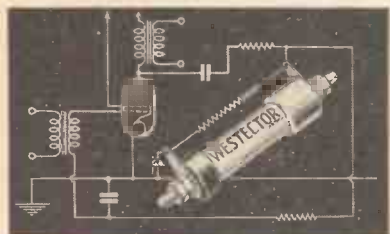

## BATTERY ECONOMY

Used as a battery economiser, the Westector enables a large output to be obtained from a battery set without using special equipment, and is applicable to any type of receiver.

## AUTOMATIC VOLUME CONTROL



Usually the introduction of Automatic Volume Control necessitates complicated alterations. But even delayed A.V.C. may be obtained in a simple manner with the Westector.

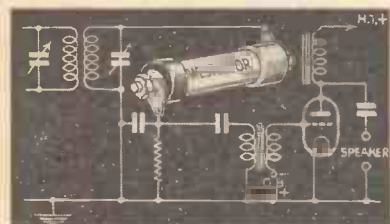

## HIGH-QUALITY DETECTION

When used as the second detector in a Superheterodyne, the Westector gives straight line rectification with distortionless detection, and it is almost impossible to overload it.

*You will want to know more about this useful component. It is incorporated in many commercial receivers, A.V.C. Units, etc. A 3d. stamp to Dept. P.W. will bring you full details—a copy of our booklet "The All Metal Way, 1934."*

THE WESTINGHOUSE BRAKE & SAXBY SIGNAL CO. LTD.,  
82, YORK ROAD, KING'S CROSS, LONDON, N.1.

# In 1934

find your stations in the clearest and most easily read wireless page of any daily newspaper.

Wireless owners especially appreciate Daily Sketch. For it is the great *modern* newspaper for the young-minded — men and women, both enjoy it—as its information is so *practical*—so easy to follow.



*ABOVE all, they enjoy those magnificently produced exclusive news-pictures that almost talk as they show you the world at a glance.*

# DAILY SKETCH

The Premier Picture Newspaper,

Make it a habit... order it NOW

# CAPTAIN ECKERSLEY chooses a

Trust the men who know—and follow their lead. You can bet your bottom dollar that when a designer with Capt. Eckersley's reputation makes an exclusive specification he is dead certain that nothing better exists.

And Capt. Eckersley is not alone in singling out Radiophone components as the most reliable in quality and performance. Nearly all first class sets use Radiophone components, and thousands of constructors have proved their very marked superiority.

Take no chance with your present set. Build RIGHT at the outset by using Radiophone components. Then you can be sure of first class results, absolute accuracy and a quality that has no equal. Fill in the coupon below and get full details and prices post free by return.

**SPECIFIED EXCLUSIVELY for the P.W. "NATIONAL ECKERSLEY THREE"**

British Radiophone 3 gang condenser (Type 604) with Slow Motion Dial (Type 711). Price complete **28/-**



## RADIOPHONE CONDENSER for Popular Wireless "NATIONAL ECKERSLEY THREE"

**Send this to-day**

**RADIOPHONE**  
MATCHED PERFECTION

To **BRITISH RADIOPHONE LTD.**, Aldwych House, London, W.C.2.  
Please send me Illustrated Catalogues of Radiophone Products.

Name..... Address.....

P.W. 12.



KINGS  
OF THE  
AIR

EFFICIENCY

UNIFORMITY

DEPENDABILITY



Cossor 2-volt Screened Grid Valves

Type	Fila-ment Amps.	Anode Volts	Imped.	Amp. Factor	Mutual Conduc-tance m.a./v.	Price
*215 S.G.	.15	120-150	300,000	330	1.10	15/6
*220 S.G.	.2	120-150	200,000	320	1.60	15/6
*220 V.S.G.	.2	120-150	110,000	—	1.60	15/6
*220 V.S.	.2	120-150	400,000	—	1.60	15/6

Cossor A.C. Mains Screened Grid Valves

Type	Purpose	Imped.	Amp. Factor	Mutual Conduc-tance m.a./v.	Price
**MSG-HA	Super H.F. Amp'n.	500,000	1,000	2.0	17/6
*41 MSG	Super H.F. Amp'n.	400,000	1,000	2.5	17/6
**MSG-LA	Super H.F. Amp'n.	200,000	750	3.75	17/6
**MMSG	Variable-Mu	200,000	—	2.5	17/6
**MS/PB-J-A	H.F. Pentode	—	—	4.0	17/6
**MS/PEN	H.F. Pentode	—	—	2.8	17/6
**MVS/PEN	Variable-Mu H.F. Pentode	—	—	2.2	17/6

The above Valves have Indirectly Heated Cathode, 4 Volts, 1 Amp.

Cossor D.C. Mains Screened Grid Valves

**DVSG	Variable-Mu	—	—	2.5	17/6
**DS/PEN	H.F. Pentode	—	—	2.3	17/6
**DVS/PEN	Variable-Mu H.F. Pentode	—	—	2.0	17/6

The above Valves have Indirectly Heated Cathode, 16 Volts, 0.25 Amp.

\*These Valves available with or without Metallised Bulbs.

† Characteristics measured at 1.5 grid volts.

\*\* Stocked with Metallised Bulb only.

In common with all other types of Cossor Valves, Cossor Screened Grids are fitted with the famous Mica Bridge. This method of construction ensures strict adherence to characteristics, uniform efficiency and long and dependable service. By fitting a Cossor Screened Grid Valve to your S.G. Receiver you can very considerably improve its performance. Your Dealer will tell you the type you need.

# COSSOR SCREENED GRID VALVES

## NEW STATION CHART!

Get one of the new Cossor Station Charts which gives the revised wavelengths, etc., of over 80 foreign stations and has space for entering your own dial readings, price 2d. from your Dealer or write to A. C. Cossor Ltd., Melody Dept., Highbury Grove, London, N.5, enclosing 2d. stamp

To A. C. COSSOR LTD., Melody Dept., Highbury Grove, London, N.5  
Please send me free of charge, a copy of the Cossor 72-page Wireless Book.

Name.....

Address.....

**B.V.33** P.W. 20/1/34.....

# POPULAR WIRELESS

THE FIRST AND FOREMOST RADIO WEEKLY FOR THE CONSTRUCTOR & AMATEUR EXPERIMENTER

Scientific Adviser: SIR OLIVER LODGE, F.R.S.  
 Technical Editor: G. V. DOWDING, Associate I.E.E.  
 Assistant Editor: P. ROBERT BIRD.

Managing Editor:  
 N. F. EDWARDS.

Chief Radio Consultant: P. P. ECKERSLEY.  
 Assistant Editor: A. JOHNSON-RANDALL.  
 Chief of Research: K. D. ROGERS.

PLAYING RECORDS  
 BATTERY DATA  
 GOOD FELLOWS  
 GRANITE "EARTH"

## RADIO NOTES & NEWS

HEALING RADIO  
 PRIVATE LIVES  
 LOOKING AT LEGS  
 CHILD ACTORS

### Public Gramophone Performances.

THIS month discussions are taking place between the gramophone record manufacturers and the Performing Right Society about the future licence position regarding the performance of records in public.

On the one hand, the manufacturers seek to have the conditions for record users as easy as possible; on the other, the P.R.S. aims at protecting the rights of its members by implementing the legal decisions which have been given in its favour in the recent test cases. May the spirit of compromise preside over their deliberations!

### The Future of Home Construction.

ONCE again I have observed here and there in the Press a faint effort to provoke discussion on the subject of the future of home construction. Of course, one might as well discuss the future of gardening; but, if there be any doubt whether home radio has a future, let it be dispelled at once by the fact that it is growing in popularity and importance, steadily, all over the world.

The keen schoolboy tinkerer of to-day will be the scientifically trained experimenter of to-morrow; and just as amateurs did so much to explore the now familiar short-wave field, so they may yet be the pioneers of the television system of the future.

### Budapest's China Cup.

IT is quite exciting to read the newspapers' accounts of Budapest's new 120-kw. station, whose 997-foot-high, cigar-shaped, 580-ton mast stands on a "china cup" about a yard in diameter and three inches thick.

But surely, if 580-ton weight, or, to be more accurate, 471 tons—for we will deduct the weight of the stays, etc.—if 471 tons does not smash the cup it must poke it into the earth unless some other foundation be provided.

Incidentally, I may mention that this type of mast base is not new in principle, for one of the masts at Nauzen used to rest on a sphere of glass the size of which I do not remember.

### The "Chloride Chronicle."

I HAVE received a copy of that bright and informative "Chloride Chronicle and Exide News," and am pleased to note that the technical article by the Chief Engineer of the Chloride Electrical Storage Co. maintains its excellence.

Forty of these have now appeared, and when completed will form, I should think, an exhaustive treatise on storage batteries, much of the data they contain being absent from the text-books.

The "Letter-Bag Problems" feature is probably a lifebelt to many a desperate

Mr. D. L. Lewis, a "P.W." reader, of 2, Commercial Street, Hyde, has made me an honorary member, and before he reads this he will have heard from me. I should be deeply gratified if 10,000 or so of you would send him a penny postage for a card so that you can see what the club does. Will you, please?

### Radio and the Beyond.

I HAVE been asked whether I think that by the agency of radio we shall gain some knowledge of the supernatural world.

Considering that we have already mastered some of the secrets of that intangible medium, the ether, which may be the very primal stuff of the universe and all it contains, I should not be surprised if the path to glimpses of the supernatural were via the ether.

But I prefer to believe that the human spirit can develop into something which reveals the non-material universe more clearly than any electrical device.

### Earths in the Diamond Fields.

LEAVING the higher regions and descending to earth, we come down whack upon about the worst "earth" in the world; or almost the worst—namely, that of the Consolidated Diamond Mines of South West Africa, Ltd., at their station at Luderitzbucht. It is of solid granite, with sand pockets! Hence they have to use a counterpoise.

In the days before counterpoises were so well developed I worked on a station which was built on volcanic rock. We laid the earth-plates on the rock, weighted them down with a brick apiece and used to spend our spare time in scraping up little pockets of earth to cover them up.

### "P.W." in India.

A WELCOME letter from P. B. S. (S. Coorg, India) illustrates clearly how "P.W." helps to ensure the future of home-radio even in the places remote from civilisation.

This reader lives where there is no electric supply, cinema, theatre or other facilities for contact with the world of men elsewhere, yet he considers that by the aid

(Continued on page 890.)



**THIS VALUABLE WORK**

May still be obtained by regular readers of **POPULAR WIRELESS**

For Full Details of

**OUR NEW OFFER**

Turn to pages 842 and 843

battery user or charging-station proprietor. The magazine costs only twopence; the company bears the cost of printing and publishing, and gives the proceeds to the Chloride Sick Club.

### Ariel and the "Rooters."

FOR the second year in succession I have received a card of membership of the "Old Original Rooters' Club," whose object is to get together money for hospitals, poor children, blind babies and other worthy objects of sympathy coupled with practical help. Evidently this is a concourse of genial good fellows. Headquarters at the Star Hotel, George Street, Hyde

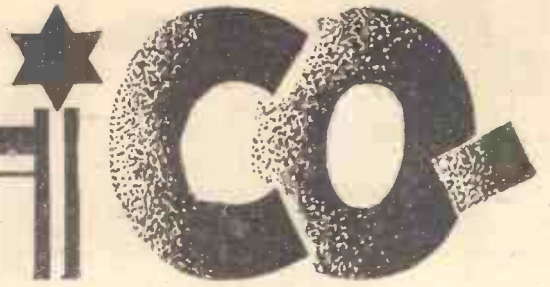

**P.P.E.**  
**DESIGNED THE**  
**REGIONAL**  
**STATIONS**



# ORDINATION



**HE NOW  
DESIGNS  
YOUR SET**



# Eckersley

## THE GENIUS BEHIND THE REGIONAL SCHEME

**PETER PENDLETON ECKERSLEY** is one of the few eminent men who do not like being written about. In all the thousands of words he has contributed to "P.W." he has rarely referred to his own achievements. And if they do crop up, as sometimes they must, he always makes light of them.

Even when you know him well enough to talk to you constantly come against this same unusual barrier. You find he is a brilliant talker unless you try to make him talk about himself. That is his one dumb subject.

In chatting with him you soon discover the true cosmopolitan touch. He has been all over the world, and evidently thinks no more of a trip to Warsaw than you or I of a trip to Wembley.

But he never gives you an inkling of the reasons for his world-wide rambles. You never get a hint of the foreign-government invitations that have come to him because of his professional pre-eminence. He simply will not talk about himself.

So it is at the risk of offending him that I intend to do something that has not been done before: to draw the veil and set out in print facts which have rarely been made public—facts to do with the development of the art of broadcasting.

Everyone knows to-day that Great Britain is the foremost radio nation in Europe. With our six-million-or-so licensed

**B.B.C.'S FIRST  
CHIEF ENGINEER**

### A BRIEF REVIEW of the romantic career of Britain's Greatest Wireless Technician By "ARIEL"

listeners we are the envy of all our radio neighbours.

We have those twin-programme facilities—dual National and Regional entertainments—which all other countries desire. Our high-power broadcasting stations cover the whole country with a network of alternative entertainments.

And, remember, it has all come into being in the last few crowded years. Broadcasting arrived quite suddenly, a surprise from the scientists.

There was no precedent for it—only a pressing need. There was no accumulated experience to draw on—only the urgent national desire that the new art should be made available to every home in the country.

So somebody had to grapple quickly with the problems it presented. Someone had to cater for those crowding aeri-als: to conjure up the kilo-watts.

To engineer the entertainment of the whole nation we needed a blend of visionary and hard-headed expert. And, luckily for British broadcasting, we found him in the person of P. P. Eckersley.

Before joining the B.B.C. in 1923 he was in the Experimental Section Designs Department of Marconi's Wireless Telegraph Co., Ltd. (He was head of that department long before he was thirty!)

And already he had made a great name in the development of radio technique and rendered brilliant service in the war. One of the problems he had been up against was that of deriving power for its wireless on an aeroplane in flight. He quickly developed methods in which the generator was wind-driven as the plane roared through the air.

Another interesting war-time job of his was that of assisting Major Fuller, who was exploring the possibilities of doing "sound-ranging" by radio. And also they were deputed to produce a secret telephone

system, but, of course, there is no information available about that.

It was about this time that "P. P. E." gave the first demonstration of a system to operate duplex telephony when using the one aerial for both reception and transmission. And a little later he designed, in collaboration with C. E. Prince, the first aircraft wireless telephone set.

The first big transmitting station which he designed was a specially interesting one—the ground transmitter for aircraft at Croydon. And that idea of his for single-aerial duplex telephony working led to his being called upon to design a set on those lines having a range of fifty miles.

They said that if he could, it would be the first of its kind in existence. Shortly after they had to knock out the "if" and admit that he had produced the goods.

Naturally enough, these achievements did not go unnoticed. Early in life

**EUROPE'S DELEGATE  
TO RADIO  
WORLD CONFERENCE**

Eckersley was a marked man, sure to be in the running as candidate for any big job in the fascinating walk of

life which he followed.

And that is how the public got to know him. For the post-war public was highly interested in all "this wireless business" that was being talked about, and it was clamouring for a broadcasting service so that it could listen-in.

The very first broadcasting station to give regular programme service in Great Britain was erected at Writtle, near Chelmsford. It was a huge success.

But instead of the smooth, slick efficiency of the machinery we have to-day there was a glamorous air of pioneering about it all. And instead of a proper announcer the Engineer-in-charge used to talk to his listeners, so that soon everybody got to know his name—P. P. Eckersley, of course!

It seemed inevitable that he should be chosen as the B.B.C.'s first Chief

**FARADAY AND  
KEITH LECTURER**

Engineer. Upon him fell the responsibility of technical development—what stations should be built, where they should be placed, how they should be connected, by whom they should be run.

He shouldered the technical side during those first critical years. Under his guidance it rapidly became the best broadcasting service in the world.

You will appreciate that it was not only his technical ability that counted. He has far more than that.

As the B.B.C.'s Chief Engineer his task was to cover this country with broadcasting. And in carrying out that task he showed the sure touch of genius. "On long waves and

(Continued on next page.)

**DESIGNED  
WORLD'S FIRST  
"TWIN" STATION**

visionary and hard-headed expert. And, luckily for British broadcasting, we found him in the person of P. P. Eckersley.

**DESIGNED  
FIRST AIRCRAFT  
GROUND STATION**

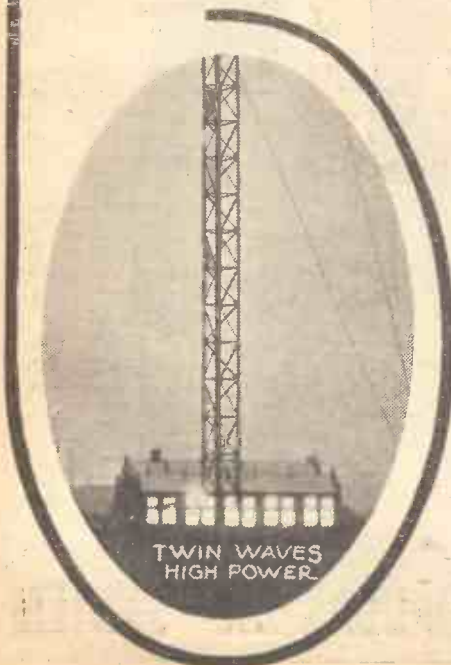



**ECKERSLEY —  
THE GENIUS BEHIND THE  
REGIONAL SCHEME**

(Continued from previous page.)

medium waves, by main station and relay, he fed the broadcast programmes to British aerials with a success that rapidly won world-wide acknowledgment.

To that rare quality that we call Vision he also allies his sheer technical brilliance.

It was as a visionary that he conceived the Regional Scheme for providing us with alternative programmes. After which, the practical side of him got busy on the details for carrying it out, with the result that Britain owns the only twin-wave two-programmes-simultaneously broadcasting service in the world.

(All Europe envies us this service. In Germany there is no Hamburg National and Regional. There is just Hamburg—take it or leave it! And the same with the other countries.)

From triumph on the national scale he went on to international success. He was European delegate to the World Wireless

**CONSULTANT B.B.C.,  
SWISS GOVT., ETC.**

Conference at Washington, and he again represented Europe at The Hague in 1929.

He is adviser to governments, and he

**CONTRIBUTOR TO  
ENCYCLOPEDIA  
BRITANNICA**

thinks in terms of whole continents. It was he who first suggested the formation of an international union of broadcasters to study all problems relating to a European Wavelength Plan.

(The technical bases then proposed are now universally accepted. But it was Eckersley who showed the way.)

And always, contrasted with the spectacular scope of his work, there is his awe-inspiring concentration on technical knowledge. He writes learned papers for the Institution of Electrical Engineers that you and I can't read at all. But you will find them in the Journal of the I.E.E. And, moreover, you will find them marked, years in succession, with the words "Premium Prize Awarded."

**B.B.C. DELEGATE  
N.R. CONVENTION**

It is the life ambition of many a famous man to write a paper for the I.E.E. But it appears to be just a spare-time occupation for P. P. Eckersley.

He has also contributed to the "Encyclopedia Britannica" and delivered both Keith and Faraday Lectures! He has broadcast from most of the important stations of the world.

His name will always be associated with technical achievements of which the man in the street knows nothing, but which the radio engineer regards as masterly. Although broadcasting is but a young science, its debt to Eckersley is overwhelming, and on the increase.

Take, for example, his paper on the design of aerials for broadcast transmission—a piece of work involving the opening up of a whole new vista of quantitative measurement. Detail by detail he accumulated new evidence of reception-range all over this country, and then analysed his mass of material. The facts which emerged were vital facts, and he outlined them in one of his scientific papers with definite and precise statement.

At that time they were new, but they became text-book truths, now accessible to every radio engineer. And though listeners everywhere benefit from this, very

sound like an exciting enterprise, but it was. For it was an accomplishment the importance of which only an idealist could conceive, and which only a leading technician could carry out.

It aptly illustrates his strongest characteristics—the blending of imaginative idealism with the finger-tip knowledge of the born engineer.

I ought to give you some brief chronological outline of his technical achievements. But it simply can't be done unless one writes a book. (And I can only hope

**INITIATED  
SYNCHRONISED  
WAVELENGTHS**

entertainment benefits, day after day, from the Eckersley Touch. (You will certainly never learn of it from his pen!)

I should like to examine his allegiance to those two democratic ideals—quality and service. His aim is, The Best—and he wants it for all.

Most of all I should like to speculate on what the future holds for him—and for us. He is still only a young man, full of enthusiasms. He is still going forward, though that disarming diffidence about his own achievements makes it impossible to foretell his future.

To-day his appointments as consulting engineer give him an absolutely unique international reputation. He holds a staggering variety of advisory positions of the highest responsibility.

Governments and giant corporations the world over retain his services, among them being the B.B.C.; the Swiss Federal Government; Cunard Steamship Co., Ltd.; Marconi's Wireless Telegraph Co., Ltd.; Legal Insurance Co., Ltd.; Middlesbrough Municipal Corporation; Westinghouse Electric International Co. and numerous other of the most important British and foreign concerns.

I must emphasise again that the facts I am giving are but a part of the story. There must be much at which I am unable to guess!

And yet so reticent is he that what I have now been able to disclose about "P. P. E.'s" activities may mar a friendship that I value greatly.

But it will have been worth it if Carlyle was right when he said: "We cannot look, however imperfectly, upon a great man without gaining something by him."

**PIONEERED  
LONG-WAVE  
BROADCASTING**

that if ever I write a biography it will be Eckersley's.)

If I had the space I would tell you how your broadcast

**RAN ALL  
BRITAIN'S FIRST  
BROADCASTS**



**Peter Pendleton Eckersley**

few will ever realise how much of their enjoyment is due to Eckersley's work.

Equally important to you and me was his analysis of the broadcast-frequency spectrum. Having visualised far in advance the problems of quality transmission in an overcrowded ether, he tackled the heart of the problem. Before Europe had grown her crop of high-powered transmitters, he pinned down the precise facts about carrier-wave separation and quality.

The estimation of exact details of kilocycle allocation and so forth may not

**CONCEIVED B.B.C.  
REGIONAL SCHEME**

**HOW BRITAIN BUILT UP HER UNIQUE BROADCASTING SYSTEM**

# A NATIONAL SET

**UNIQUE  
DESIGN**

**ADAPTABLE  
TO ANY AERIAL**

**EASY TO  
HANDLE**

**STANDARD  
COMPONENTS**

**I** SOMETIMES take tea with the Editor. We talk of this and that and the other. We review the position. We argue rather fiercely about the relative merits of American and European methods of broadcasting. We see in the new international wave-length plan the failure of bureaucracy and the stupidity of ultra-nationalism.

We touch on the later developments of the receiving set.

## How It All Began.

One day he said to me: "You know, there ought to be a national set."

"What," I said, "do you mean by that—one that, if exported, will explode?"

No; he didn't mean that. He meant a set which represented the best of standard practice, which could be adapted to all and every condition of reception, and which would not cost more than the average listener could reasonably afford.

"Are you not," I said, "just describing any nationally advertised set?"

"I want something different from that," he continued. "I want something for our readers: something which will simplify reception, as you, in your Regional scheme, simplified transmission; and yet . . ."

**P.P. ECKERSLEY**

*Introduces his  
Latest Design*

It ended by my agreeing to try to design something to a specification—a specification prepared by the Editor and his technical staff, and those associated with "P.W.," who know all the ins and outs of the trade and what components can be procured and which are good and which are—not so good, and so on and so forth.

## The Best of Modern Practice.

The specification is something like this: A receiving set which represents the best of modern practice, which can be adapted to modern conditions of listening, which is easy to handle, and so has the fewest possible number of adjustments. A set which, for reasons of battery consumption, must not use more than three valves, and which must use standard components procurable by the ordinary buyer.

In fact, nothing tricky. I became excited.

I have always held that the multi-adjustment-stunt-circuit set is no more than a toy, giving the user the same thrill as would be given by any ordinary commercial puzzle.

A wireless set should be adaptable to public service; it shouldn't require ultra-skillful operation, nor should it, by oscillating continuously, be a nuisance to everyone else.

So, because I hope my whole technical life has been and is bound up with public-service work and not with "stunts," I intend to do what the Editor suggested and to design the "National Eckersley Three."

I will tell you my thought processes. First, I said I should have three valves. I insist on three tuned circuits.

It is criminal these days to put out a design with less than three circuits, unless, of course, you depart from a national-set conception and rely upon the skilled user's skilful skill.

Three tuned circuits, three valves. I take it we can have either (a) det. and 2 L.F.'s; (b) 1 H.F., 1 det. and 1 L.F.; (c) 2 H.F.'s, 1 det.; (d) 1 H.F., 1st det. and oscillator, 2nd det.

## Much To Recommend It.

The detector and two L.F. circuit is always a joy; it has so much to recommend it. You can make it "all-wave" so easily. Ultra-short, short, medium, long, ultra-long.

It's only a question of a tuner. Well, when I say "only" I mean

**FOR  
QUALITY  
RECEPTION  
EVERYWHERE**

**OHMIC CONTROL  
OF SELECTIVITY**

**EXTREMELY SENSITIVE**

**SIMPLIFIED  
SWITCHING**

**UNIFIED  
TUNING**

the problem is easier than if one or more of the tuned circuits is bound up with an H.F. valve.

But the disadvantages, to my mind, outweigh the advantages now that the high-frequency circuit is so much "tamer" than it used to be. Mark you, two or three years ago this was the best set for the sort of purpose we have at present in mind, as witness its tremendous sale and popularity. To-day its disadvantages are too numerous to countenance in view of the improvements made elsewhere.

## Rectification of Weak "Signals."

In the first place, most detector curves are "curvey" for weak "signals." A too-weak "signal" means, with a "det. and 2 L.F.," a distorted result, however much you may amplify after the detector.

Then, if you use modern big-lift valves, they will be liable to "pong" and give audio feed-back.

If I only wanted to listen to a local station and had a big aerial, and at minimum a field strength of 5 millivolts per meter to play with, a det. and L.F. should be my choice. But we are designing a national set adaptable to all sorts and conditions of listening.

*The Evolution of Our Special Three-Valve Receiver*

# FOR EVERYBODY

**REASONABLE  
PRICE**

**ONLY 3  
VALVES**

**OHMIC  
CONTROL**

**FOR 1934  
CONDITIONS**

Then, again, the det. and 2 L.F.'s only work really well when intensive retroaction is applied. This may also be true of many other types of sets forced to live in Economy Street; but with the det. and 2 L.F.'s you have to "react into the aerial."

And I know that nothing would be farther from your intentions than that. As the author of the original "don't-do-it" campaign it would perhaps be inconsistent of me to advocate a "must-do-it" set!

Now let us think of (c)—2 H.F.'s and det. Terribly attractive!

You can get three high-frequency circuits in easily. You can use a pentode detector and combine detector and low-frequency amplification in one.

The filtration to separate the H.F. and the L.F. is easy. The straightness of the detector characteristic is remarkable.

that supers, to give good quality, cannot be designed; I only say that they take a lot of watching!

**A Good, Stable Combination.**

If I can find more time, perhaps one day we may have another look at a three-valve super. It's attractive, but at the moment too ambitious for a national set.

So, at long last, we fall back upon the good old stable, straightforward H.F., det. and audio, the commonest type of set in the world,

and the one which is seldom properly designed because it always "works"—i.e. makes a noise.

I have tried to design a three-valve set within the limitations of the regulations that I must use

**THE AIM  
WAS  
BETTER  
RADIO**

You have an automatic-frequency-characteristic compensation because you use a pentode. But you do not get pentode distortion.

Alas! in spite of all this, we have to abandon it because, for a home-constructed job, using most any valves and most any components, it could never be made sufficiently stable for home use.

Most elaborate screening is necessary, and the tuning up of the circuits is a matter of touch and experience rather than an easily described and understood process. No! Alas! Good-bye!

The superhet (d) is an interesting speculation. I tried it—as, indeed, I tried all the above-described circuits.

Briefly, my objection to the super is simply this: that the conditions of first detector and oscillation are "tricky." I do not say

public-service set. It is a set which will stay on the table and give you programmes, not an hysterical, stunted, screaming, fleckle puzzle—amusing as is the latter to those who like that form of amusement.

*P. P. Eckersley*

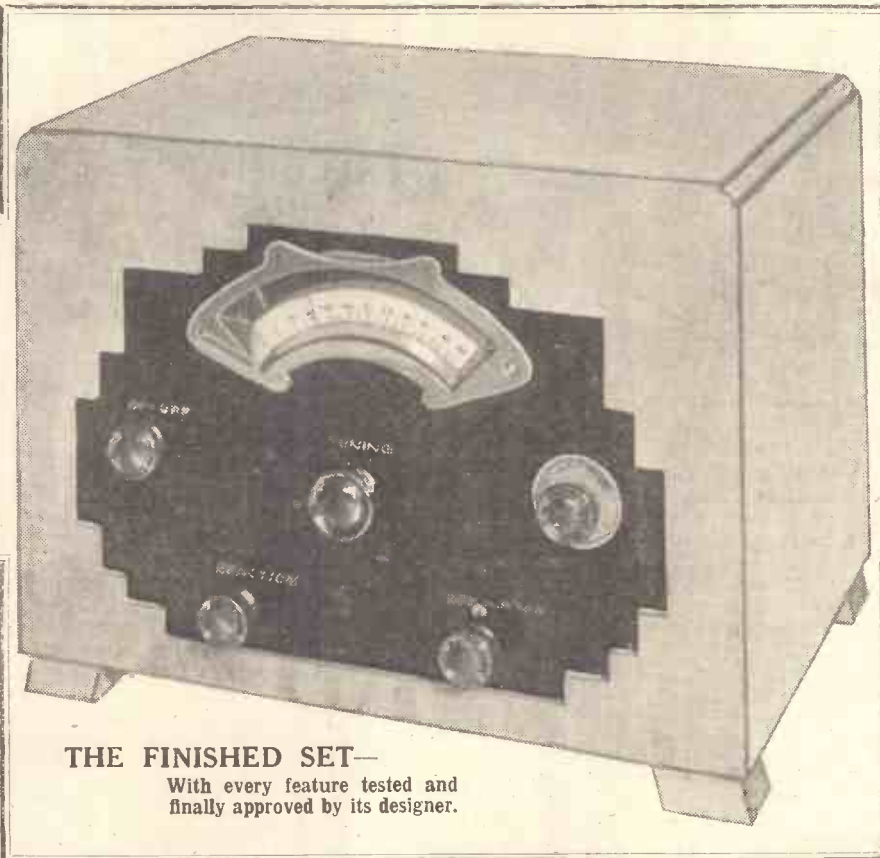

**THE FINISHED SET—**  
With every feature tested and finally approved by its designer.

**THE  
RESULT  
IS  
BETTER  
RADIO**

standard components, make it for a reasonable price and yet compete with modern requirements.

It has been great fun. I think the result is an excellent result.

Here is a set based upon ordinary knowledge, but adapted by me to have each part a part of a whole—a balanced, sane and

**Described by Britain's Greatest Radio Technician**

# THE NATIONAL ECKERSLEY THREE

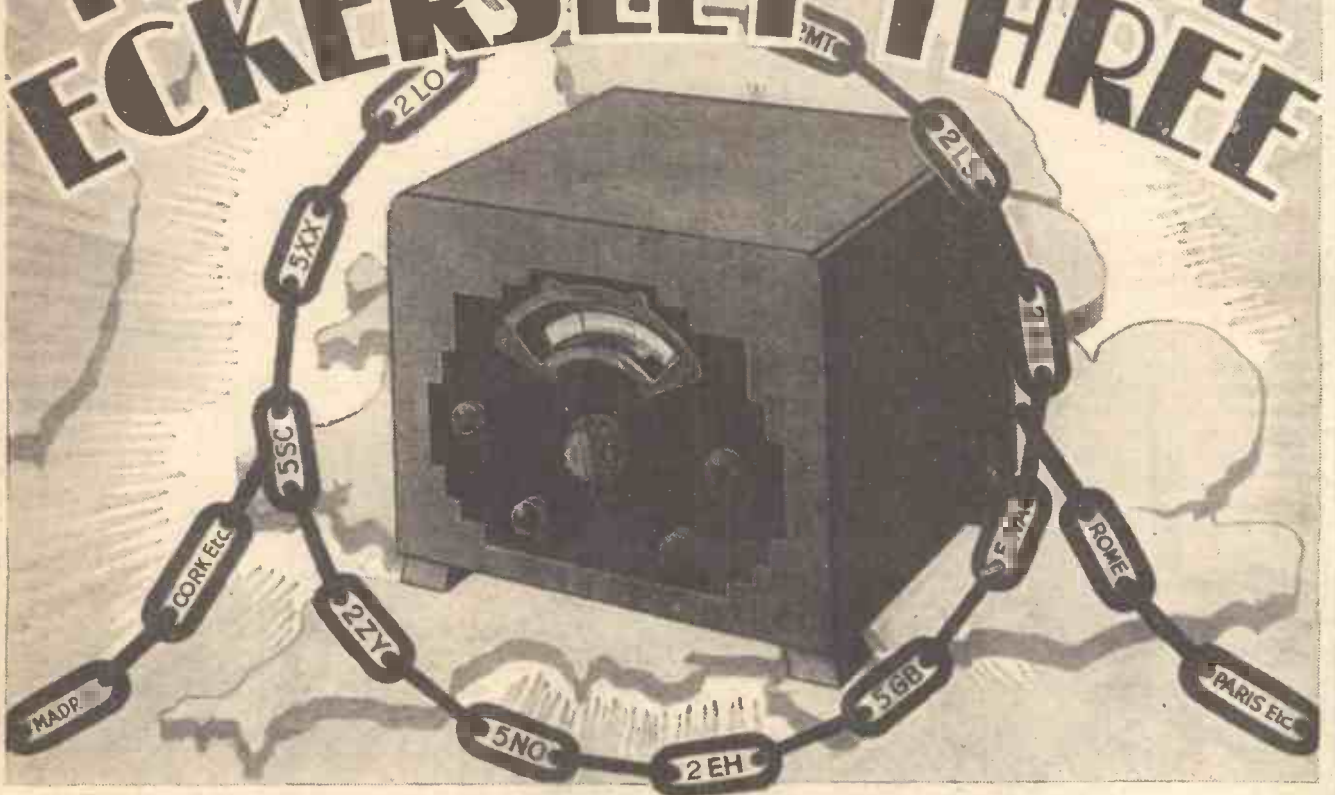

I HAVE already given you my reasons for choosing, for a "National" set, the conventional valve combination H.F., det. and audio (low frequency). Such a set, so it seems to me, is a balanced set, capable of being robust enough for the many uses it may be put to, and yet sensitive enough for the needs of the modern listener, who is rightly not content with only the local station.

The paramount question of to-day is to get sufficient selectivity without ruining the quality.

#### Fine Quality of Locals.

If we use two circuits and intensive retroaction we must get different quality for every different adjustment of retroaction, which different adjustment must be made for every different circumstance. With three circuits and purposeful retroaction on one circuit only we do approximate to a more uniform performance.

Moreover, we tend to get better quality the more powerful the station, and this is sane, because it is the powerful station

which is not jammed and which, therefore, can be well reproduced.

Three circuits are a minimum requirement of to-day and represent an excellent compromise.

#### The Band-pass Theory.

A lot of designers who use one H.F. valve and three tuned circuits use the first two tuned circuits as a band-pass circuit; that is, they couple these circuits by reactance—i.e. an inductance, or a capacity, or both.

Now, the exponents of band-pass theory say that theirs is the right technique because, with band-pass, the high-frequency circuits are equally responsive over a wide band of (side-band) frequencies, and therefore give better quality than those which "cut off" the side-bands.

#### Two Important Facts.

In saying this they neglect two facts: (1) That a pentode valve has a frequency characteristic which gives high-note predominance over low, and high-frequency circuits, if peak tuned, give a frequency

characteristic which gives low notes predominance over high.

Thus the association of peak-tuned high frequency with pentode output can be made to give, provided the designer is skilful, something more nearly approximating to a straight-line overall-frequency characteristic than the band-pass circuits, associated, as they often are, with a pentode.

The second fact (2) is that a band-pass circuit does not "tune" on the carrier-wave. Its tune point is ambiguous, and it is, therefore, particularly if retroaction is present, ambiguous in its behaviour and extremely difficult to adjust.

#### The Best Arrangement.

My arrangement of resistance coupling, combining peak tuning and pentode output, is by far the best compromise.

The way in which my three circuits are combined in the "National" set is shown in the theoretical diagram.

The resistance R is the important component. It couples the circuits when these are at the same point of tune. It achieves

DESIGNED BY **P.P. ECKERSLEY**  
ORIGINATOR OF THE REGIONAL SCHEME OF BRITISH BROADCASTING

# Inaugurating a New Standard of Success

"peak" tuning. The resistance is variable. Now, the resistance is quite novel. The "Eckersley Tuner" had resistance coupling applied to "parallel-tuned circuits"; the "National Eckersley Three" has a resistance coupling applied to series-tuned circuits.

The resistance R is both a selectivity and volume control.

If the resistance is very large the selectivity of the arrangement is less, and is equal to the selectivity of one tuned circuit only. If the resistance is very small the selectivity is the selectivity of two completely dissociated circuits—as, for instance, two circuits coupled by a valve. Thus if one circuit has a selectivity represented by 6 decibels at 9,000 cycles off tune, then, with a large coupling resistance, the two circuits will give only this performance.

But if the resistance is small, then the selectivity of the arrangement is represented by 12 decibels at 9,000 cycles (twice as much), and we are really getting all the selectivity we can.

A further use of the resistance is that of a volume control. When the resistance is small you get least volume and most selectivity. But you then use retroaction on the final circuit and get sensitivity and selectivity.

For the local station you keep the resistance smaller still; but, after a certain

constant and best, and the resistance acts as a volume control—clever!

A pentode output valve, with its rising response for the higher audio-frequencies, gives just that automatic tone compensation necessary for good quality. Now, having given you the general ideas, let me go on to the particularities of the set described in this article.

Firstly: Do, please, use the components which are specified. It is not that I think the components specified are superlatively better than other components; it is that they are adapted best to the design.

Messrs. X's plugs in a Y car are excellent, but Z's plugs are hopeless. In the W car it is vice versa—Z's plugs are lovely, X's awful.

So in designing anything you use the components of a design; you do not haphazardly make a collection of bits, screw them together, wire them up and just

## ★.....★ LINE UP YOUR SET WITH THE REGIONAL STATIONS! ★.....★

The Engineer who gave Britain its unique chain of twin-wave high-power broadcasting stations here describes the ideal home-built set for receiving their programmes.

Tuned by a single knob, it will select your programme with incisive finality.

The man who planned and provided our broadcasting stations is unquestionably the foremost authority on British radio.

**HE DESIGNED THIS SET FOR YOU.**

point, it cannot increase selectivity beyond a maximum possible, and so you loosen the reaction and keep the resistance small, and you get excellent quality.

In fact, if the resistance is large the first variation is a selectivity control. After it has become small selectivity remains

## SIMPLICITY!

Note the few controls—the clean lines of the design—the clear base-board.

These denote ease of construction and efficiency of operation.

## ECONOMY!

Only three valves—but quality reception of scores of powerful programmes.

The distance-getting powers of the receiver are remarkable.

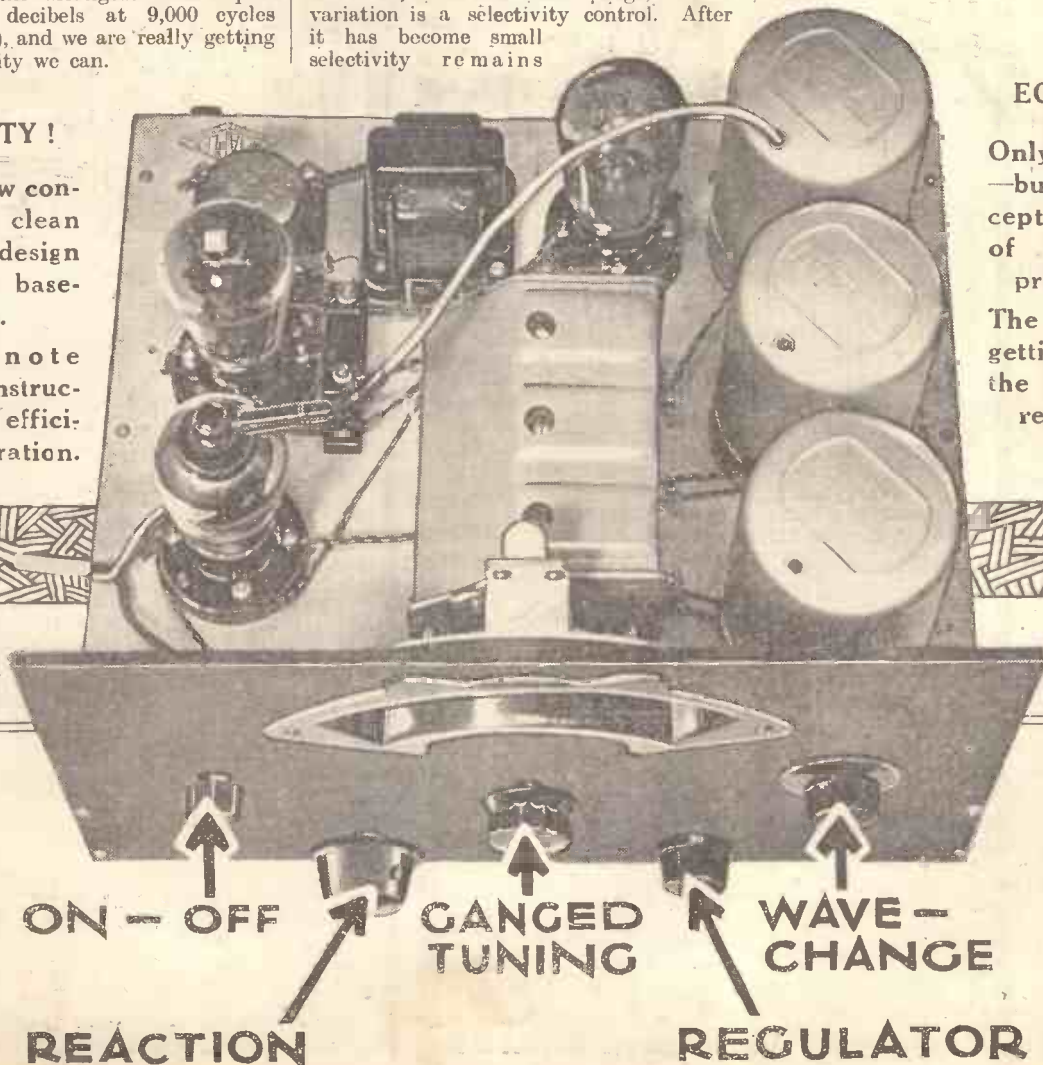

# Components & Alternatives for the National Set

Tick  
off  
each  
item  
below

Tick  
off  
each  
item  
below

- |  |   |
|--|---|
| <ul style="list-style-type: none"> <li>1 British Radiophone 3-gang .0005-mfd. tuning condenser, type 604.</li> <li>1 British Radiophone slow-motion drive for above, type 711.</li> <li>1 Set 3 Telsen matched screened coils, type W288, or Colvern K.G.O., N.G.O., K.G.R.</li> <li>3 W.B. large type 5-pin valve holders, or Benjamin, Telsen, Lissen, Graham Farish.</li> <li>1 Lissen Hypernik L.F. transformer, or Telsen, Varley, R.I.</li> <li>1 Graham Farish screened H.F. choke, type H.M.S., or Telsen, Bulgin, Wearite.</li> </ul> | <ul style="list-style-type: none"> <li>1 Graham Farish 300-ohm <math>1\frac{1}{2}</math>-watt type Ohmite resistance with horizontal holder.</li> <li>1 Lissen 1-meg. grid leak with wire ends, or Varley, Dubilier, Bulgin.</li> <li>1 Dubilier .1-mfd. tubular fixed condenser, type 4404, or T.C.C., Graham Farish.</li> </ul> |
|--|---|



- |  |  |
|--|--|
| <ul style="list-style-type: none"> <li>1 Graham Farish .0003-mfd. differential reaction condenser, or Polar, Telsen, J.B., British Radiogram.</li> <li>1 Graham Farish 2-mfd. fixed condenser, or T.C.C., Telsen.</li> <li>2 T.C.C. 2-mfd. fixed condensers, type 50, or Graham Farish, Telsen.</li> <li>1 Igranic 20-ohm. variable resistance, type WYPAD.</li> <li>1 Dubilier 100-ohm resistance, 1-watt type, or Graham Farish, Bulgin (with wire ends or terminals).</li> <li>1 Graham Farish 100,000-ohm <math>1\frac{1}{2}</math>-watt type Ohmite resistance with horizontal holder, or Ferranti.</li> <li>1 Graham Farish 30,000-ohm <math>1\frac{1}{2}</math>-watt type Ohmite resistance with horizontal holder, or Ferranti.</li> <li>1 Graham Farish 5,000-ohm <math>1\frac{1}{2}</math>-watt type Ohmite resistance with horizontal holder, or Ferranti.</li> </ul> | <ul style="list-style-type: none"> <li>1 Dubilier .0002-mfd. fixed condenser, type 620, or T.C.C., Lissen, Graham Farish, Telsen.</li> <li>1 British Radiogram rotary QMB on-off switch, type No. 51, or Bulgin.</li> <li>1 Clix S.G. anode connector, or Belling-Lee, Bulgin.</li> <li>4 Clix indicating terminals, or Bulgin, Belling-Lee, Igranic.</li> <li>2 Belling-Lee wander-plugs, or Igranic, Clix, Bulgin.</li> <li>1 Belling-Lee wander-fuse.</li> <li>2 Clix accumulator spades, or Belling-Lee, Ealex.</li> <li>1 Peto-Scott Metaplex chassis, 12 in. x 10 in. x <math>2\frac{1}{2}</math> in., with terminal strips.</li> <li>1 Peto-Scott ebonite, panel 12 in. x 8 in., or Goltone, Permcol, Wearite.</li> <li>1 Set British Radiogram matched knobs.</li> <li>2 Coils British Radiophone "push-back" wire.</li> <li>1 Peto-Scott cabinet.</li> <li>Screened wire, flex, screws, etc. (Peto-Scott).</li> </ul> |
|--|--|

# Eckersley Tells You Exactly Why and How to Build It

expect perfection! On the other hand, this is not universally true—obviously it could not be. So treat the specification carefully, as carefully as I have done.

Note that the coils and the variable condenser specified must be used. The choice of the type of coupling resistance was fixed by the fact that it was the only one available; otherwise there is nothing very subtle about a variable resistance!

Make sure that the 2-mfd. condensers mounted on the underside of the chassis are of the universal mounting type. I have used Metaplex for the chassis.

### A Logical Layout.

Metaplex is metallised wood. It is just an obviously good idea, because it screens as it takes screws, as it holds things together!

The use of a chassis—which allows components to be mounted above and below the baseboard—enables a more logical layout of components, and also makes it possible to construct the set in a much smaller compass.

It is sometimes thought that wiring tends to become complicated if a chassis is used, but in this case it certainly is not so, because the holes through which the

Having collected together the necessary and correct components, or, better still, having purchased a complete kit of parts from one of the firms who specialise in this

The escutcheon itself is not used. Note that the same procedure should be adopted in mounting the wavechange escutcheon.

**SUITABLE VALVES for the NATIONAL ECKERSLEY THREE.**

Make.	S.G.	Detector.	Output.
Cossor ..	220S.G.	210H.F.	220H.P.T.
Mullard ..	P.M.12A.	P.M.1 H.L.	P.M.22A.
Mazda ..	S.215A.	H.L.2	Pen.220
Marconi ..	S.24	H.L.2	P.T.2
Osram ..	S.24	H.L.2	P.T.2

**FOR ALL-THE-YEAR-ROUND RESULTS**

## THE PLACING OF THE PANEL CONTROLS

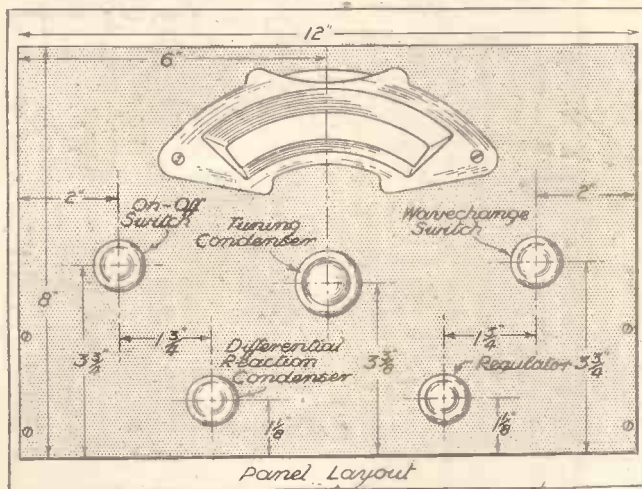

From the sketch above you will see exactly where each control is placed on the panel for easy operation. For the close-up of the coils on the right the screens have been removed to show you the sheer simplicity of their connections

business, the actual construction may be started.

First of all, the panel should be marked out and drilled. With the aid of the front-of-panel diagram and the templates, supplied with the various component, no difficulty should be encountered in doing this.

The hole for the escutcheon of the tuning control is preferably cut out with a fretsaw. Failing this, a keyhole saw, a tool which practically everybody possesses, may be used.

### Selectivity Control.

Drill two holes, in opposite corners of the piece to be cut out, large enough to take the blade of the saw. The two adjacent sides can then be cut from each hole.

The selectivity control is mounted by means of

two screws. Having drilled the spindle hole, the escutcheon should be placed in position and the holes for the fixing screws marked.

The diameters of the various holes for control spindles are as follows:

On-off switch,  $\frac{1}{8}$  in.; wavechange switch,  $\frac{1}{8}$  in.; and fixing holes for same,  $\frac{1}{4}$  in.

Reaction condenser,  $\frac{3}{8}$  in.; selectivity control,  $\frac{1}{4}$  in.; and fixing holes for same,  $\frac{1}{4}$  in.

The dimensions for the tuning condenser drive are given on the template supplied with same.

### Mounting the Components.

It only remains now to drill the holes for fixing the panel to the chassis. There are two holes on either side of the panel,  $\frac{1}{8}$  in. from the respective edges.

The two bottom holes are  $\frac{1}{2}$  in. from the bottom of the panel, and the two upper holes 1 in. above these. These holes should be drilled and countersunk to take No. 4 wood screws.

When all the drilling has been done the panel can be put on one side until it is required for attaching to the chassis.

A start can now be made on the chassis. The components on the underside of the chassis should be mounted first. This includes mounting the aerial and earth and loudspeaker terminals to the terminal strips, which are already drilled to take them.

(Continued on page 860.)

various leads pass are all numbered in the diagrams. In fact, the wiring is much simpler and easier to do.

The chassis is supplied ready made up, with the terminal strips already attached and drilled to take the terminals.

Do not attempt to make up a wooden chassis and cover it with metal foil. Not only is this a very difficult job, but the result will probably be very disappointing from the point of view of appearance. Unless the metal covering is absolutely complete, the set may refuse to work, as several connections are made to the chassis

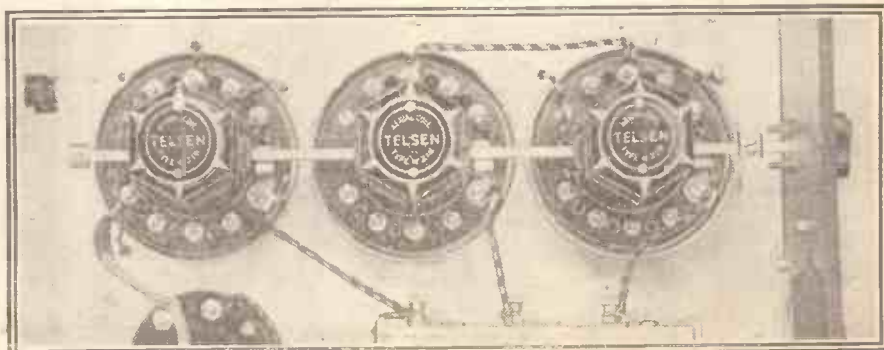

THE THREE SCREENED DUAL-WAVE COILS.

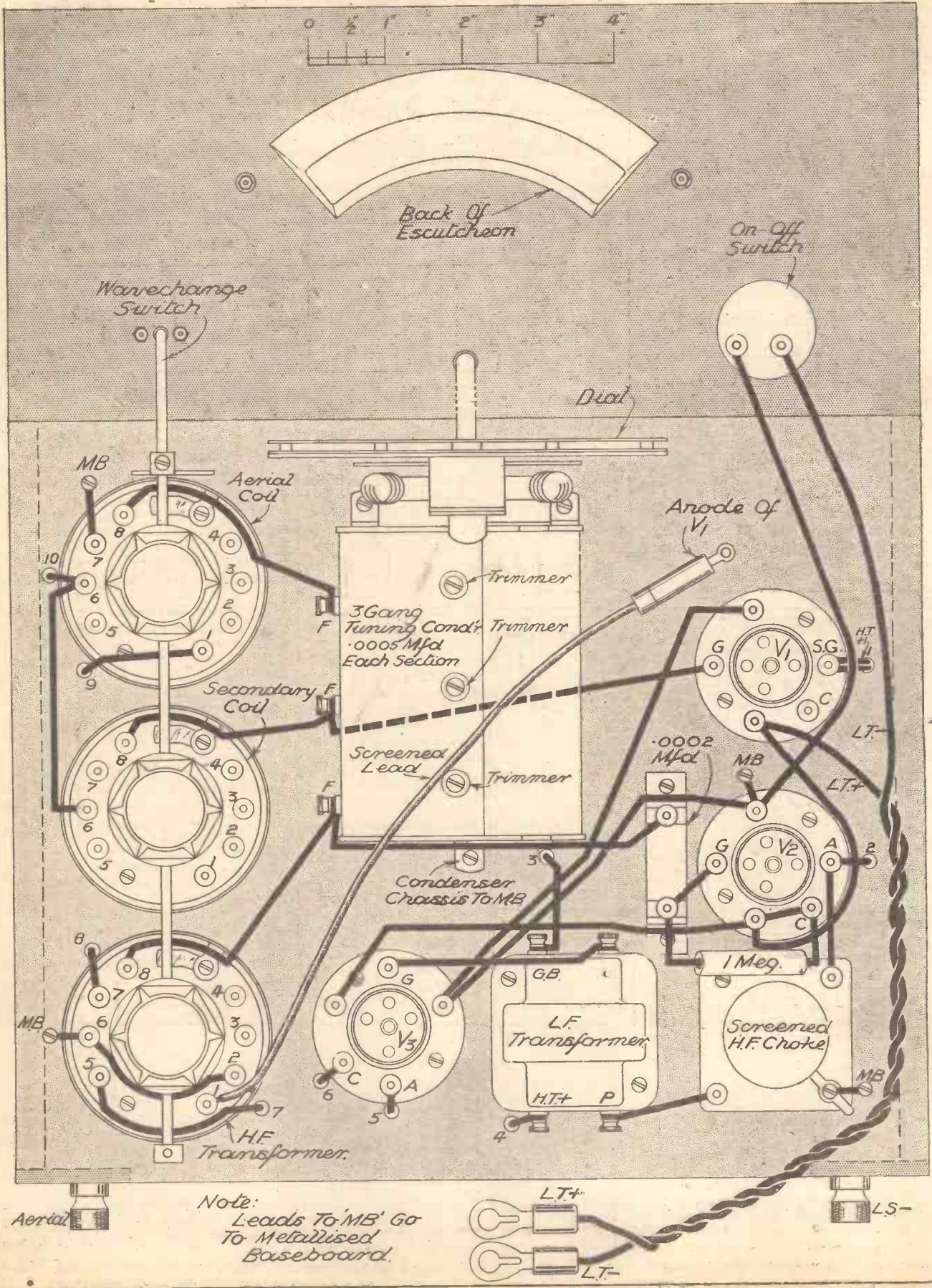



# How to Wire Up Your National Eckersley Three

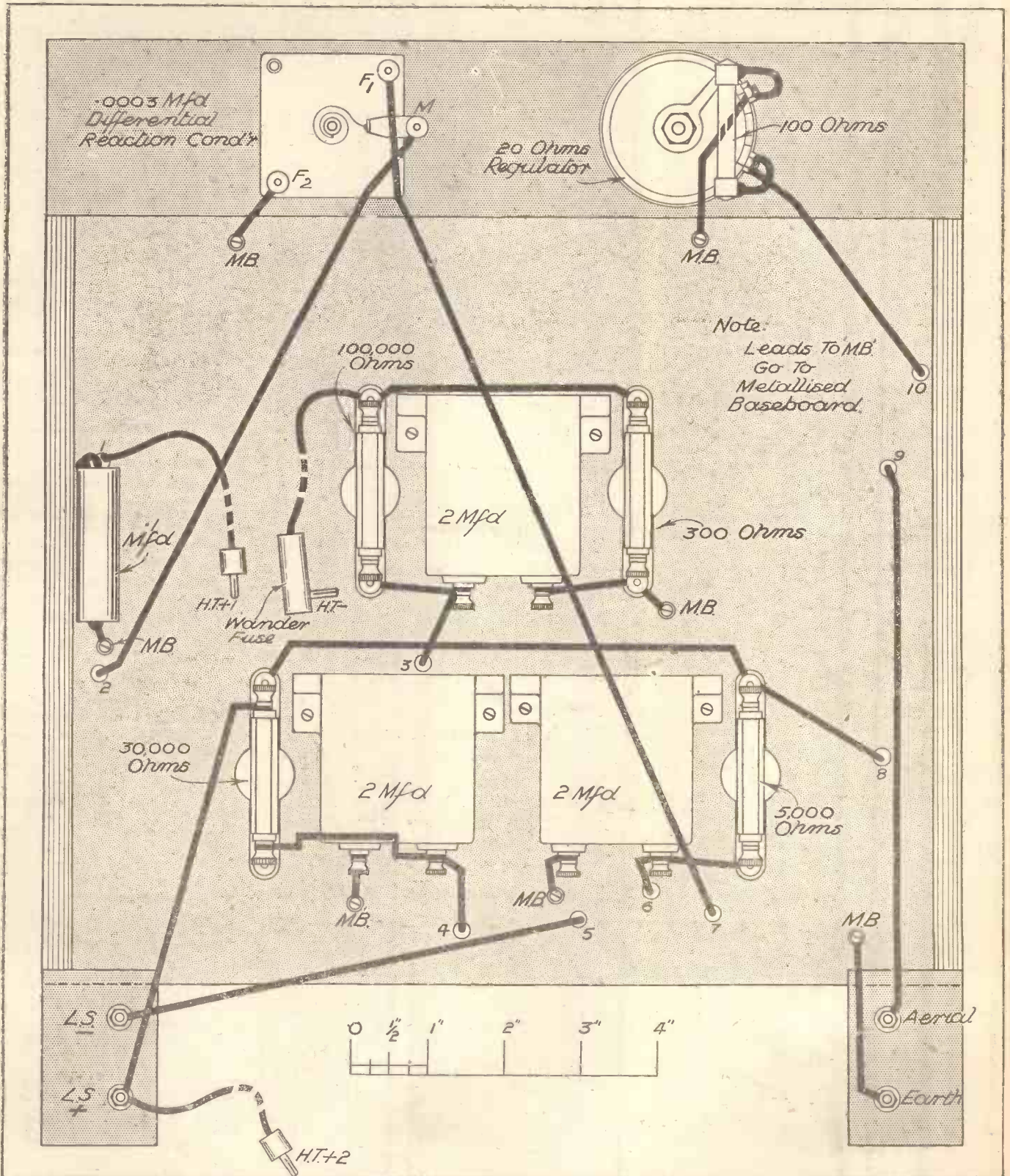

On the previous page we give the above chassis wiring diagram as the set appears when looked at from the back. The heavy black lines denote where the wires go, but note that one of them (dotted) passes underneath the 3-gang tuning condenser. For the actual "run" of the wires from point to point see also the photographs. Above we have the wiring below the baseboard as seen when the set, held front and back, is turned completely over. The holes in the baseboard are numbered so that you can follow the run of each wire that passes through the chassis.

## Its Sheer Simplicity Marks a Great Design

Make sure that all the components are in the correct positions. It is advisable to place a piece of thin card under each of the four resistance holders to prevent any possibility of short circuits.

Before the wire-ended .1 mfd. is mounted a hole should be drilled,  $\frac{3}{8}$  in. from the side and  $3\frac{1}{2}$  in. from the front of the chassis. One wire end of the condenser is passed through this hole, being insulated with a short length of sleeving.

Now turn the chassis the right way up and commence operations on the top.

### All in Line.

Draw a pencil line down the centre of the chassis from front to back. Now draw two more lines on either side and parallel to this and 4 in. from it.

Another line must now be drawn parallel to and 2 in. from the back of the chassis. The panel must now be placed in position (but not fixed) so that the tuning condenser can be correctly positioned.

The rear fixing foot of the condenser should fall on the central pencil line, and the tuning dial should just not touch the back of the escutcheon. The panel may now be removed and the condenser fixed in that position.

The coils are mounted so that the left-hand pencil line (from the back of the set) passes through their centres, and the line drawn parallel to the back of the chassis passes through the centre of the rear coil or H.F. transformer.

This same line also passes through the centres of the V3 valve holder, the L.F. transformer and the H.F. choke. The remaining line (on the right) passes through the centres of the V1 valve holder, the V2 valve holder and the H.F. choke.

### Easy to Wire.

When all the components have been mounted the eight holes through which the various wires pass should be drilled. If these are drilled at this point when all the components are mounted, it is more certain that they will be in the correct positions.

Before starting the wiring the panel must be fitted to the chassis with No. 4 countersunk wood screws,  $\frac{3}{8}$  in. long. It is best to run a small drill through first, and then the wood will not split.

The wiring can now be started. It is shown by the black lines in the diagrams, and it will be noticed that several leads are taken to the chassis and fixed by a wood screw. Washers should be used here and preferably round-headed screws, otherwise it will be almost impossible to hold the wire down.

The underside wiring should be done first, and this includes the wires which go through the chassis to the various points on top. It is a good plan to mark off

The screened lead which connects the anode of the screened-grid valve to No. 1 on the H.F. transformer should have its ends finished off by slipping over a short length of rubber tubing or binding with insulating tape. This will

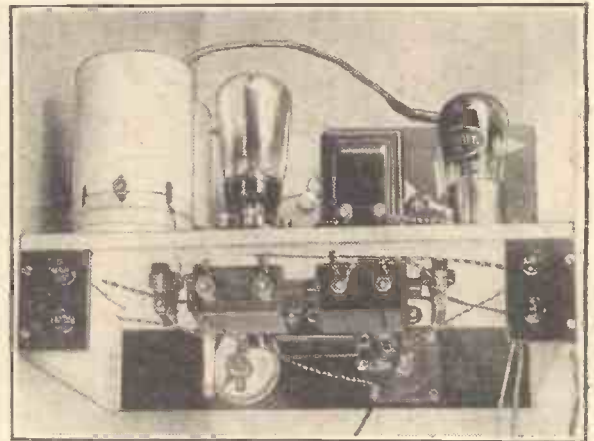

### AS SEEN FROM THE BACK

The arrangement of the components above and below the raised baseboard is one reason for the constructional simplicity achieved. The main components have plenty of room on the upper surface, and those below can be placed just where they are wanted to make wiring as short as possible.

## RECOMMENDED ACCESSORIES

**LOUDSPEAKER.**—Celestion, W.B., Rola, Blue Spot, R. & A., Ferranti, H.M.V., Amplion, Marconiphone, Cossor, G.E.C.

**BATTERIES.**—H.T. 120 volts: Lissen, G.E.C., Ever Ready, Siemens, Pertrix, Ediswan, Drydex, Marconiphone, Grosvenor, Hellesens or Block H.T. accumulators.

**L.T. 2 volts:**

Block, Lissen, Pertrix, G.E.C., Ediswan, Exide, Oldham.

**AERIAL AND EARTH EQUIPMENT.**—Electron "Superial,"

Goltone "Akrite."

British Radiophone "Receptru" down-lead.

Bulgin Lightning switch.

Graham Farish "Filt" earthing device.

prevent the screening from slipping down.

One more word about the construction. In the list of components are specified Colvern coils as alternatives to those used by me in the building of this set.

These coils are electrically the same as Telsen, but they are somewhat differently mounted and have their terminals differently marked. This means that the connections shown on the wiring diagram require slight modification.

### Very Simple Alterations.

The alterations are given on page 899 so that those who decide to use Colvern instead of Telsen should refer to that page for full details of the coil connections.

Having completed the wiring, it is only necessary to connect the wander-plugs and wander-fuse to the H.T. leads and the accumulator spades to the L.T. leads, and the set is ready to go on test.

And so I wish you good luck and good signals!

Remember, it's not a gadget set, not a wild and woolly roarer and oscillator. A "National" set for national use.

And, within the limits set by practical considerations, it has been designed, not thrown together. If you will do your part I shall feel proud of our co-operation.

P. P. E.

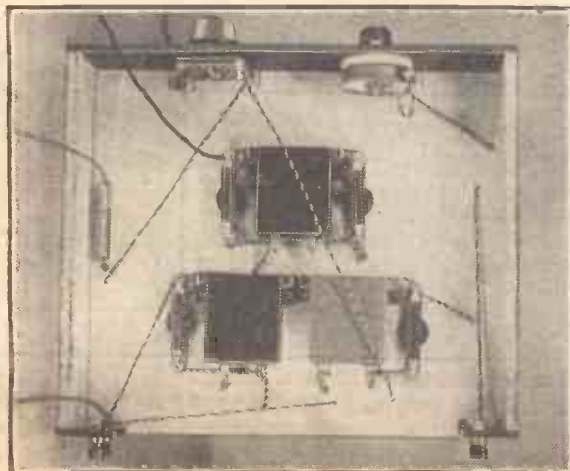

Compare this picture with the wiring diagram on page 859 if you are in doubt; as to any of the under-baseboard connections. In the set there are many leads going direct to the metal baseboard, and this accounts for the fact that the wiring looks unusually simple when the number of components is taken into consideration. The values of all the resistances, condensers, etc., will be found on the diagrams on pages 858 and 859.

the leads in the diagram as you put them on the set.

Provided that the filaments are wired first on the top of the chassis, it is immaterial in what order the rest of the set is wired, provided that you remember to mark off as you go.

## RUN IT FROM THE MAINS!

As described here, the "National Eckersley Three" is in battery-driven form, but the set

**CAN BE OPERATED FROM A.C. OR D.C. SUPPLY.**

The conversion is amazingly easy, and next week we show how the receiver is immediately rendered ready for A.C. operation. The following week we shall deal with the D.C. mains modifications.

# A SUPREME COMPLIMENT from a GREAT TECHNICIAN



**Captain P. P. Eckersley, the Engineer who gave Britain the Regional Stations—of world-wide reputation as pioneer technician and a sound, fearless critic—has, in specifying a W.B. Microloode as first choice in his "National Three" radio-gramophone, paid to W.B. designers and factory executives the highest compliment possible.**

There are vital reasons for his choice ● Perfect matching to the receiver, due to the unique "Microloode" feature, gives better balance of tone ● The unique "Mansfield" magnet, 30 per cent, stronger than a good cobalt steel magnet of equal weight, gives better sensitivity and wonderfully crisp attack.

Most of the "great names in radio" have appeared under whole-hearted tributes to the revolutionary performance of this great range of speakers. Since their introduction a "Microloode" has been specified either solely or as author's first choice in practically every important constructor set ● **You should hear the difference a "Microloode" will make to your set: it will amaze you!**

## "MICROLOODE"

Moving-Coil Speaker,  
MODEL PM4A - - 42/-



Write NOW for the new W.B. folder of "MICROLOODE" speakers.

Whiteley Electrical Radio Co., Ltd. (Dept. P), Radio Works,  
Sole Agents in Scotland: Radiovision Ltd., 233 St. Vincent St., Glasgow, C.2  
Sole Agents in I.F.S.: Kelly and Shiel, Ltd., 47 Fleet Street, Dublin.

*Announcing* the new  
**TELSEN**  
**G.S.**  
**TRANSFORMERS**

— specified for the "*National Eckersley Three*"

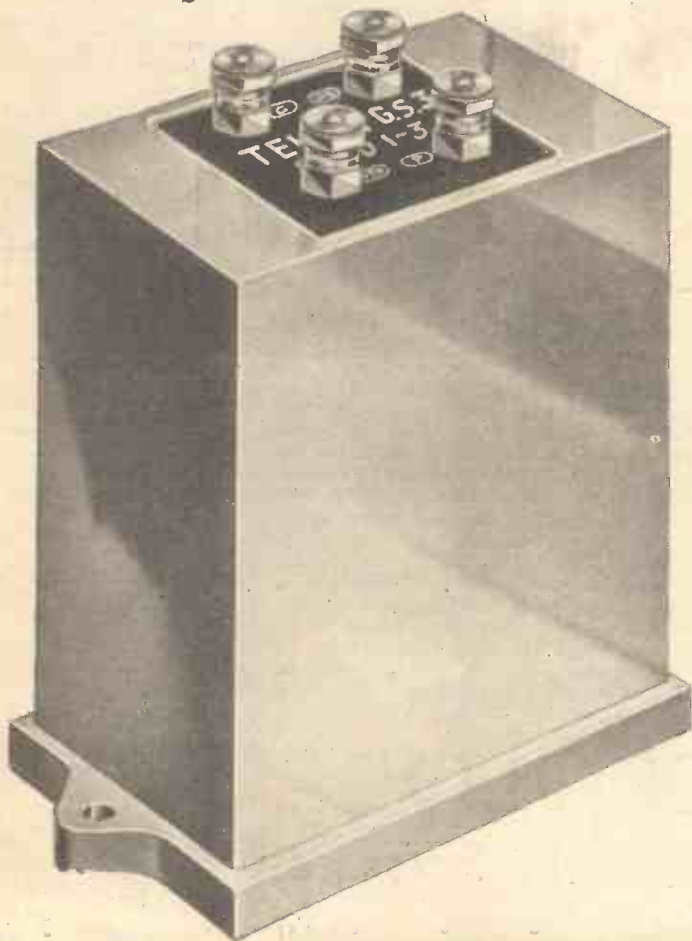

**L**ONG scientific research by Telsen technicians has now resulted in the introduction of the wonderful G.S.3 and G.S.5 Transformers. These new types incorporate special spaced layer windings and non-hygroscopic impregnation greatly in advance of other designs. They also ensure an exceptionally good frequency characteristic, surpassing that of other directly-fed anode transformers costing far more. A silican steel alloy core of ample dimensions is provided, ensuring an extremely high inductance without saturation, when the primary is passing the normal anode current of detector valves. The new G.S.3 and G.S.5 Transformers will carry a D.C. primary current up to 5 m.a. and are therefore suitable for connecting directly into the anode circuit of detector valves.

G.S.3 (Ratio 3-1)  
 G.S.5 (Ratio 5-1)

**8'6**

**TELSEN COVER EVERY TRANSFORMER REQUIREMENT**

ANNOUNCEMENT OF THE TELSEN ELECTRIC CO. LTD., ASTON, BIRMINGHAM

# Eckersley Tells You HOW IT WORKS—

Everyone likes to know how and why his set works as it does, but it is seldom that a foremost authority on set design tells the public interestingly of the circuit considerations one by one.

That is exactly what P. P. Eckersley does in this fascinating survey of the features of his "National Three."

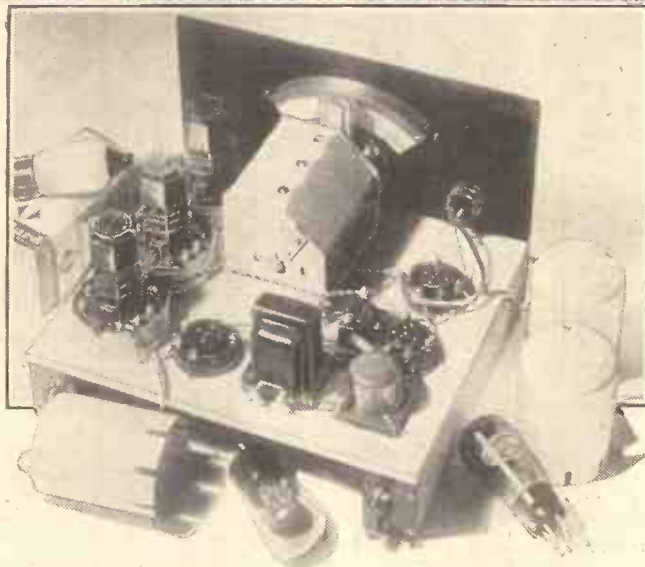

The set builder is here shown that each circuit consideration, important in itself, must also line up with the final conception and assist the overall result.

The new method of ohmic coupling is explained in brief detail, and the inferiority of a band-pass-pentode combination to that employed in this design is clearly demonstrated.

LET us take the pictures one by one, and so understand better the workings of the "National Eckersley Three."

The aerial is inductively coupled. Very well. Why?

Well, there are two ways of

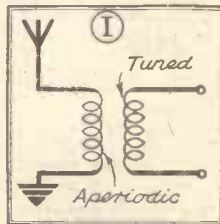

**INDUCTIVE COUPLING**  
To suit different aerial conditions and achieve the maximum sensitivity.

capacity coupling the size of the aerial is a little influential, or, if that difficulty is eliminated, the overall sensitivity is not very good.

For tuned-series circuits, as in Fig. II, inductive coupling is much the best.

NOW, in Fig. II we see the ingenious resistance (ohmic) coupling. A voltage is induced in the coil  $L_1$  from the aerial. There is a circuit from earth through  $C_1$  and through  $L_1$ .

Then the circuit divides and the currents can pass either through  $R$  or through  $L_2$  and  $C_2$ .

Now, if the signal coming down the aerial is in resonance with  $C_1$ ,  $L_1$  and  $C_2$ ,  $L_2$  ( $C_1$ ,  $L_1 = C_2$ ,  $L_2$ ), then the

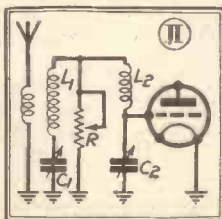

**OHMIC CONTROL**  
Acts as an unusually effective selectivity device and also as volume control on the local station.

coupling the aerial —one by a small capacity on to the top of a tuned circuit and the other as shown in Fig. I.

Capacity coupling is quite good if the first tuned circuit goes direct to the grid or if parallel-resistance coupling is used as in the "Eckersley Tuner"; but with path through  $L_2$ ,  $C_2$  is of low impedance compared with  $R$ .

But if the signals are out of tune they find  $L_2$ ,  $C_2$  a high impedance, but  $R$  is as before, and so they are all drained off down  $R$ . The arrangement is selective.  $R$  is a selectivity control when  $R$  is greater than a certain amount and a volume control afterwards.

**A "THREE-CIRCUIT" SET**

**SENSITIVE** enough to receive what is worth while;  
**SELECTIVE** enough to separate that which is wanted from that which is not;  
**SMALL** enough not to litter a room; and  
**SIMPLE ENOUGH FOR THE NATION TO HANDLE.**

It is, I think, a very practical arrangement. You can keep a constant selectivity between  $R$  and retroaction at all frequencies. The arrangement is not a band-pass device.

FIG. IV is just to see if we understand about H.F. magnification. Taken in conjunction with Fig. III I think the best thing to say is that the coil makers have spent a lot of time and money in evolving something which is both stable and practical.

They have designed this for me and for you, and I should be an idiot if, just for the sake of being "original," I pretended they didn't know as much about it as I did.

would like a fatter filament and a higher high tension.

IN Fig. IX you will see "decoupling" to prevent motor-boating in case the H.T. battery is getting old. This reduces the voltage on the anode of the detector.

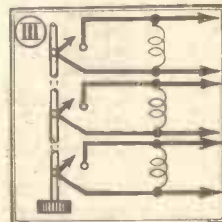

**GANGED SWITCHING**  
For rapid change-over from medium to long waves, and vice versa.

If your batteries are new or if you are feeling you would like to boost the quality a bit, try a higher high tension for the detector—perhaps by shorting the primary decoupling resistance of Fig. IX.

But don't tell anyone I told you to if the thing starts motor-boating. Safety first for the designer, but he is in the know to the extent of letting you do a little experimenting!

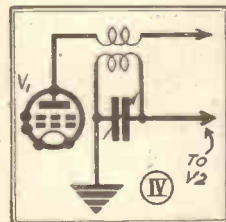

**H.F. INTERVALVE COUPLING**  
An H.F. transformer is employed.

DIFFERENTIAL retroaction in Fig. VIII is just a dodge to keep tuning constant and retroaction smooth. It works, and it is obvious

(Continued on next page.)

# ECKERSLEY TELLS YOU HOW IT WORKS

(Continued from previous page.)

why it works, and I'm not going to insult you by padding things out. No doubt you've used differential retroaction before, but don't overdo it!

**W**E adopt ganging (Fig. VII) because the days of multi-controls are over. (Our pet octopus, which we used to train to operate nine knobs—controlling interdependent quantities—died only a few weeks ago after seeing a set with 18 knobs!)

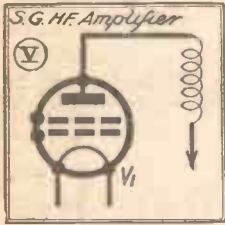

**GANGED TUNING**

The single control operates the aerial, tuned-grid and tuned-secondary circuits.

is the way in which it automatically "tone compensates." I have so often explained to "P.W." readers in my "Eckersley Explains" columns that the magnification of a high-impedance valve is in proportion to the impedance in its anode circuit, if that impedance is less than the valve impedance.

A loudspeaker-transformer impedance rises and rises and rises as the frequency goes up (to certain limits). And so the pentode mag. goes up and up and up.

But (and particularly with my resistance coupling, which is selective because it increases the carrier-wave of the wanted station in relation to the carrier-wave of the unwanted—the essence of selectivity) the high-frequency circuits drop the magnification of the higher (side-band) frequencies. So the rising characteristic of the pentode compensates for the

**N**OW for the pentode (Fig. XI.). In the depths of my— But we've had enough of that. This is a design to a specification. We can't have every-

In fact, one feature of the pentode which strongly recommends its use

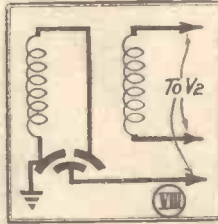

**DIFFERENTIAL REACTION**  
For constancy of tuning and smooth retroaction effects.

falling characteristics of the high-frequency circuits, and the overall characteristic of the balanced and designed set is constant.

It is foolish, in this connection to use band-pass and pentode, because the band-pass is flat and the pentode rises.

The whole point of selectivity is to get detector demodulation selectivity, and this is done best by peak, not band-pass, tuning.

The pentode is self-biased—a little trick to get away from the need for more batteries—a simplification used a great deal in the design of valve apparatus of all sorts:

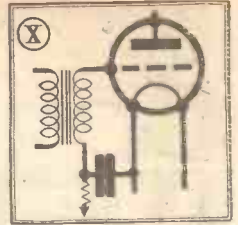

**L.F. TRANSFORMER COUPLING**  
For maximum voltage amplification.

**N**OW you know, in bits, how it works. A three-circuit set, a three-valve set,

a balanced set, a stable set; sensitive enough for receiving what is worth while receiving, selective enough to separate that worth-while transmission which is wanted from that which is not.

Small enough not to litter a room, simple enough for the nation to handle. So set it up and see. So many s's mean so much more top.—And top is quality. The set is intended to be on top.

But the proof of the receiver is in the listening. And you who construct my National set will see immediately you get it going what I have been driving at. The set is intended to give just those things you have always wished for.

**A**ND in Fig. X we adopt a transformer.

Of course, in the depths of my purist soul I'm against transformers. But what am I to do?

Wireless transmission is a compromise to-day. So wireless reception hasn't any need of gold paint!

And as we must cut off a bit—better a clean bit than a dirty all—well, the transformer is an admirable filter. Besides, it gives you more sensitivity.

Don't think I'm being sarcastic. I think, for this ubiquitous set, that the transformer is essential, and I think that I've chosen a very good one.

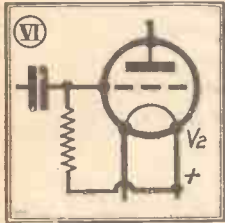

**SCREENED-GRID H.F. VALVE**  
Ensures stable magnification of the radio-frequency input from the aerial.

## THE ECKERSLEY NATIONAL THREE—

**T**HIS impression of the set, as seen by our draughtsman, shows in practical form many of the points referred to by P. P. Eckersley in his description of how the set works.

The inductive aerial coupling is enclosed in the aerial section of the coil unit—namely, the one nearest the panel. From this unit one lead goes through the base-board to the regulator which governs the ohmic coupling.

The central coil unit contains the L2 winding, which is connected to the grid of the S.G. valve. Separate coil shielding ensures that the magnitude of the radio-frequency voltage developed across L2 is governed by the resistance of the regulator.

The high-frequency transformer is con-

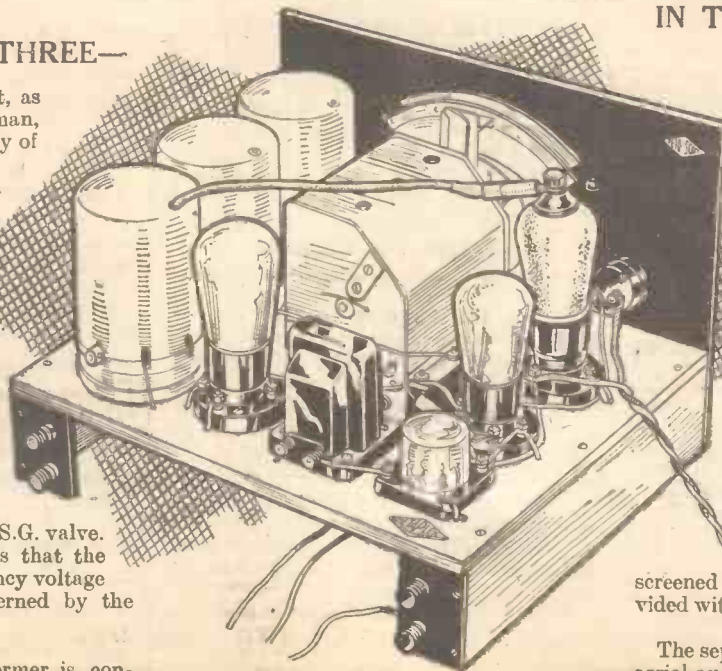

## IN THEORY AND IN PRACTICE

tained in the third section of the coil unit, and it is to the primary of this that the lead from the S.G. anode is taken.

The projection on this coil unit indicates where the switch-rod terminates. It is controlled from the panel, and greatly simplifies the operation of wave-changing.

The pentode, V.3, is the valve standing between this third coil-unit section and the L.F. transformer, and the detector is beside the S.G. valve, with the screened condenser, each section being provided with a trimmer.

The separate small terminal blocks carry aerial and earth and loudspeaker terminals.

# SLOT

## AERIAL FILTER



The "SLOT" Aerial Filter is the only satisfactory method of adapting your receiver to the new wavelengths. It enables your set to pick up stations on the lower broadcast wavelength that many sets cannot get without its aid.

"SLOT" increases selectivity—reduces interference and overlapping.

"SLOT" enables you to get the maximum from your receiver.

"SLOT" costs but a trifle—it is fitted in two minutes and will improve reception for good.

**2** EACH

**FREE!**

A STATION TUNING-CHART showing all the NEW WAVELENGTHS will be presented Free with every SLOT purchased.

USE

# GRAHAM FARISH PRODUCTS

for NATIONAL ECKERSLEY 3

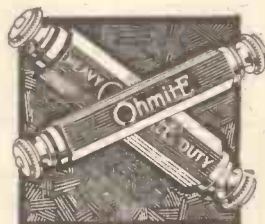

OHMITE RESISTANCES, 1/3 watts 1/6, 2/3 watts 2/3

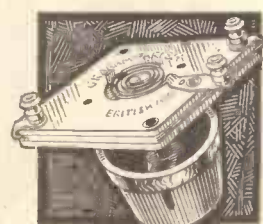

LITLQS DIFFERENTIAL CONDENSER Price 2/- each



NON-INDUCTIVE CONDENSERS 1/2 mfd., 1/6 1 mfd., 2/- 1 mfd., 1/9 2 mfd., 3/-

ALSO SPECIFIED.—H.M.S. Screened H.F. Choke, GRAHAM FARISH Horizontal Resistance Holders and the BOOSTER Unit.\*

\*See advertisement on page 899, this issue.

Obtainable from all Dealers or post free from Sole Manufacturers:  
**GRAHAM FARISH LTD., MASONS HILL, BROMLEY, KENT**

**The NATIONAL  
ECKERSLEY  
THREE**

SPECIALLY DESIGNED FOR  
**POPULAR WIRELESS**  
by **P.P. ECKERSLEY**  
PATENTED - STRICTLY COPYRIGHT

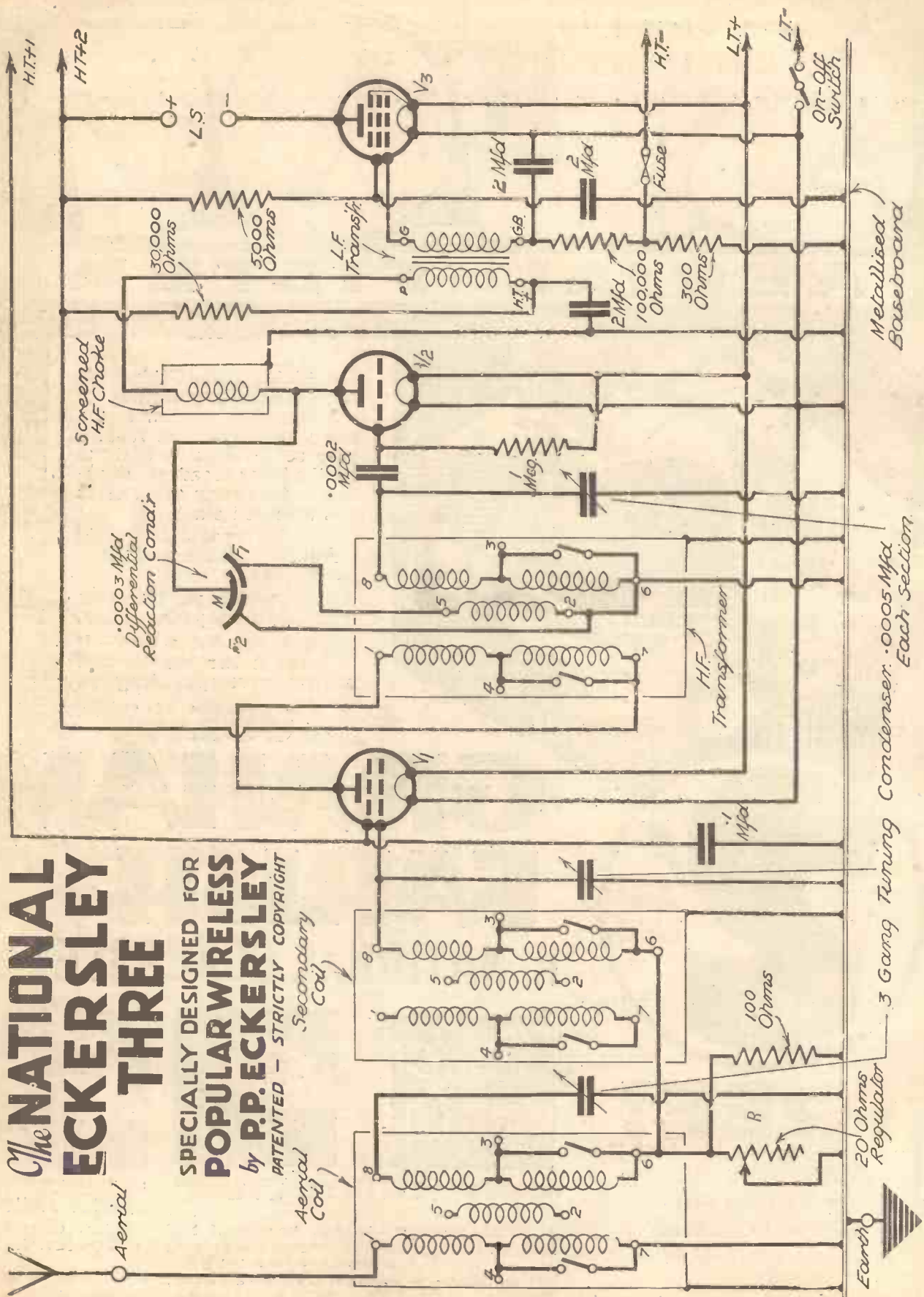

Aerial

20 Ohms Regulator

3 Gang Tuning Condenser .0005 Mfd Each Section

100 Ohms

1 Mfd

H.F. Transformer

1 Meg

0.0002 Mfd

Screened H.F. Choke

0.0003 Mfd Differential Reaction Condenser

30,000 Ohms

5,000 Ohms

L.F. Transformer

2 Mfd

100,000 Ohms

500 Ohms

2 Mfd

Fuse

HT+

HT-

LT+

LT-

On-Off Switch

Metallised Baseboard

Earth

Secondary Coil

Aerial Coil



## Everything arranged for CONSTRUCTIONAL SIMPLICITY

The photograph immediately below shows the practical form of the Regulator, which alone would make the National Eckersley Three a noteworthy design. It gives an entirely new method of ohmic control exactly suited to 1934 conditions. Close-ups of the wiring of the three valve holders are also seen below.

To the right is a view of the coils with one of the screens removed. This photo illustrates how the shielded lead to the anode of the S.G. valve is arranged.



## BALANCED DESIGN

The symmetrical panel arrangement is symbolical of the balanced and co-ordinated design.

The set is delightfully easy to handle, all the tuning being done by the one central control.

Apart from switches, the only other controls are the Regulator and reaction.

Both of these are unnecessary for ordinary reception, but they afford a remarkably pleasing elasticity of control when foreign programmes are desired.

# The NATIONAL ECKERSLEY RADIOGRAM

"WHAT you want when you want it"  
—given by a gramophone.

"No records to change, continuous performance, alternative programmes"—given by the wireless.

"What you want when you want it: continuous performance, alternative programmes"—given by the wireless gramophone.

\* \* \*

So obviously you ought to make the "National Three" complete by using the "three" part as the radio part and adding a gramophone and using the "two" part!

## An Adaptable Circuit.

One of the reasons why I rejected other combinations of three valves allowed for in the specification was that they none of them adapted themselves so well to radio-gramophone technique as the H.F., det. and "one-note" combination.

One of the more serious compromises, however, is that the pentode output valve has a rising frequency characteristic—or, if you like, it cuts out bass. The gramophone (to some extent) does the same.

Pick-ups have different characteristics. The quality-minded will do little experiments with resistances across the secondary of the intervalve transformer or will use condensers to connect across the pick-up terminals.

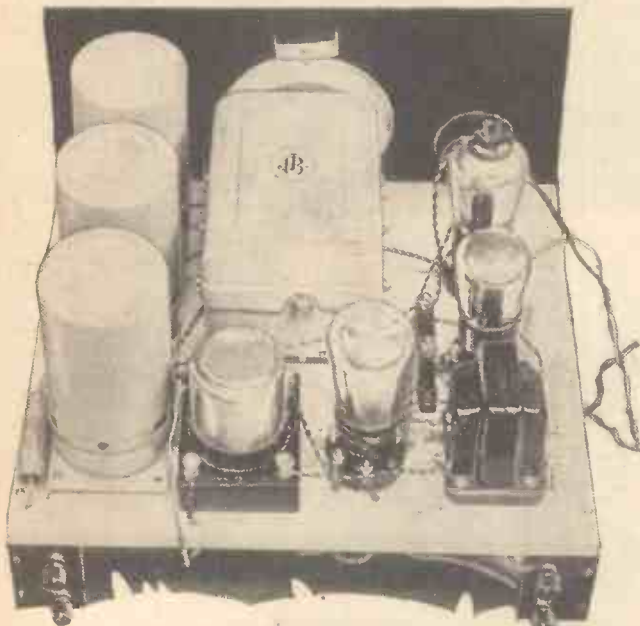

This rear view of the Eckersley Radiogram clearly shows its general resemblance to the National Three. The economiser unit, placed close to one of the screened coils, ingeniously enables a great saving of H.T. current to be effected, thus bringing continuous quality reproduction within the reach of every constructor.

P. P. Eckersley

—who gave Britain its broadcasting stations—designed this set for YOU.

The model he describes here is battery-run, but is also simple to convert for either A.C. or D.C. operation, so wherever you live you can be sure it is ideal for providing continuous entertainment from

## RADIO or RECORD

But he must remember that you don't bring up bass—you cut down treble; the result is the same as regards quality, but not as regards volume: another way of saying you cannot have something for nothing.

### "The Best of Both Worlds."

The gramophone record becomes more and more important as wireless "develops." Even the B.B.C. have recognised this, and they frequently "broadcast gramophone records." (Which is a curious but perfectly understood sentence.)

But they do not always broadcast the records you want to listen to. On the other hand you have a nice announcer or the ever-casual Mr. Stone to change the records for you. But as I keep on saying, you can make the best of both worlds if you have both radio and gramophone.

There is a point concerning records and needles which I don't often see emphasised. A steel needle wears out records.

A record played

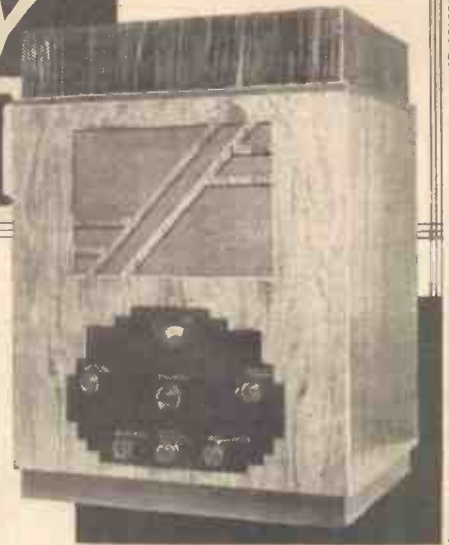

two or three times by a steel needle loses the finest edge of quality—you would need a good pick-up, amplifier, and ear to detect it, but it has been detected.

But these fibre, thorn, or wood needles are worn out by the record, they don't wear out the record. And it's easier to replace needles than to replace records.

On the other hand, you get a different quality according to the needle you use for a given pick-up.

### Quality Standards.

I don't mean that you get a worse quality if you use this or that type. You have so many variables.

The pick-up, the amplifier, the needle, the loudspeaker, the record, all subscribe differently to the result. And my word don't records vary!

I use a gramophone a great deal as a standard of quality—we have to be very careful to choose records which are standards of quality.

### THE "NATIONAL RADIOGRAM" ACCESSORIES

**BATTERIES.**—H.T., 120 volts: Ediswan, Lissen, Marconiphone, G.E.C., Ever Ready, Pertrix, Siemens, Drydex, Hellestons, Grosvenor or Block H.T. Accumulators.

**G.B.:** 16½ volts, Drydex, Ever Ready, Siemens, Lissen, Pertrix, Marconiphone.

**L.T.:** 2 volts, Block, Ediswan, Lissen, Pertrix, G.E.C., Exide, Oldham.

**AERIAL AND EARTH EQUIPMENT.**—Electron "Superial," Gohone "Akrita," British Radiophone "Receptru" downlead, Bulgin lightning switch, Graham Farish "Flt" earthing device.

Of course, a record doesn't record many frequencies above 5,000 to 6,000 cycles/sec. But the radio set, unless the signal is overwhelmingly strong and local, cannot go much above 4,000 cycles/sec.

And all design is compromise. So that with your "National Three" I doubt if you get much above 4,000. It's no good giving you mush.

Better a clean something than an attempt at perfection and a result in mush. So the gramophone will be just as good and may even be better than the radio.

(Continued on next page.)

## THE NATIONAL ECKERSLEY RADIOGRAM

(Continued from previous page.)

You can make it better and better by playing about with tone correctors. I would suggest a tone corrector which is a resistance and a condenser connected in series across the loudspeaker.

### THE VALVES FOR THE ECKERSLEY RADIOGRAM

Make.	S.G.	Detector.	Output.
Cossor	220S.G.	210H.F.	220P.T.
Mullard	P.M.12A	P.M.1H.L.	—
Mazda	S.215A.	H.L.2	Pen.220A.
Marconi	S.24	H.L.2	—
Osram	S.24	H.L.2	—
Hivac	S.G.210	H.210	—
Tungsram	S.220	H.R.210	—

You might see if you can better suit your gramophone by using such a corrector, which might be left out when the radio comes along.

You see I cannot lay down hard and

fast rules because my design is not absolutely rigid—we have to allow you some latitude in components.

What I say is that you will get a thoroughly good and solid result, but, depending upon the interaction of the different quantities involved in different components, you can improve that result. Moreover, you can improve it for your satisfaction and for no one else's.

### The Listeners' Taste.

I so frequently get asked, "What set shall I buy?"

People think I am being unkind or unwilling when I give what appears to them to be evasive replies. But how can I tell people what set to buy when the result you get from sets pleases or fails to please in terms of the listeners' taste in noise.

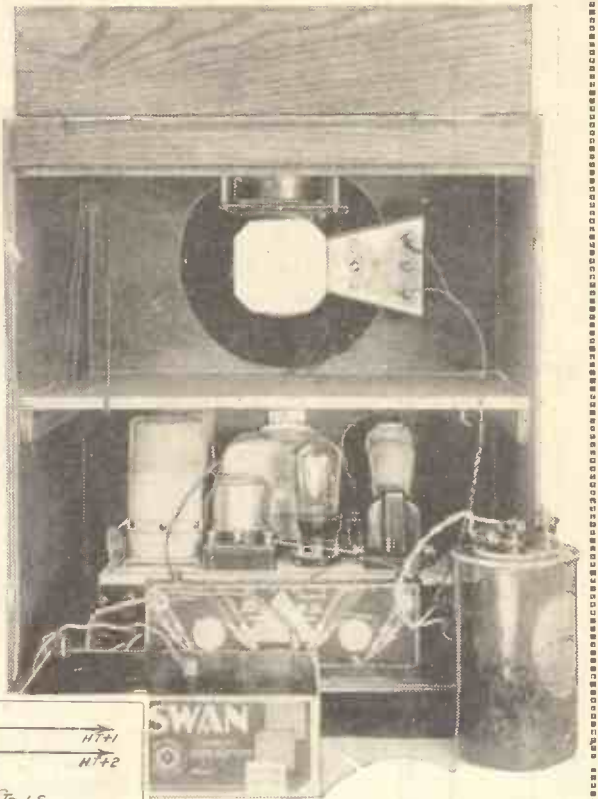

### COMPACTLY ARRANGED

A view from the back showing the ample space provided for batteries, and the general arrangement of the set. The accumulator and H.T. battery are housed in the compartment which is immediately above the chassis, and in which can be seen the loudspeaker and clockwork motor.

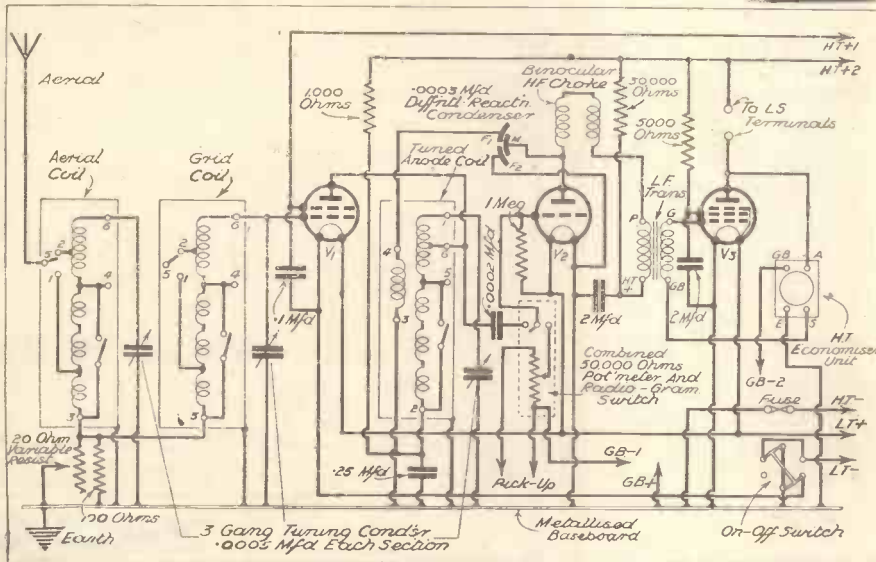

### SOME NOTABLE DETAILS OF THIS NOVEL DESIGN.

Ohmic coupling, evolved by P. P. Eckersley for "P.W." readers, and introduced to the public in this week's issue, controls the volume and selectivity of the input to the S.G. valve. Beneath V<sub>2</sub> will be seen the combined potentiometer and radiogram switch, whilst the H.T. economiser unit is shown connected in circuit to the right.

In addition to this latter, which greatly reduces battery costs, the set is well decoupled at all appropriate points. Note, also, that the rotation of the on-off switch breaks the filament circuit of the S.G. valve when on "Gramophone"—another feature for economical upkeep.

One person likes a quality the other finds unsatisfactory. We use the "art" of reproduction and—"de gustibus non disputandum." At least it's much better not to discuss matters of art with people of no taste.

### "A Grand Opportunity."

So I say to you here is a grand opportunity with this radiogram to get something near to what you want. Next week you will get the constructional details. I have given you the framework, and the walls, and the foundation of the building. It is your hobby and I hope you delight to do the "decoration."

## THE PARTS TO USE AND THE MAKES TO CHOOSE

- 1 J.B. 3-gang .0005-mfd. tuning condenser, "Nugang," type A.
- 1 Colvern 3-gang coil unit, type K.G.O., K.G.O., K.G.R. or Telsen W.238.
- 3 Benjamin 5-pin valve holders, or Lissen, W.B., Telsen, Graham Farish.
- 1 Lissen Hypernik L.F. transformer, or Telsen, Varley, R.I.
- 1 Amplion binocular H.F. choke, or Telsen, Graham Farish.
- 1 Graham Farish .0003-mfd. differential reaction condenser, or J.B., Polar, Telsen, British Radiogram.
- 1 Graham Farish 2-mfd. fixed condenser, or T.C.C., Telsen.
- 1 T.C.C. 2-mfd. fixed condenser, type 50, or Graham Farish, Telsen.
- 1 Dubilier 25-mfd. tubular fixed condenser, type 4406, or T.C.C., Graham Farish.
- 1 Dubilier 1-mfd. tubular fixed condenser, type 4404, or T.C.C., Graham Farish.
- 1 T.C.C. .0002-mfd. fixed condenser, type 34, or Dubilier, Telsen, Lissen, Graham Farish.
- 1 Lissen 1-meg. grid leak with wire ends, or Dubilier, Varley, Bulgin.
- 1 Graham Farish 30,000-ohm 1½-watt type "Ohmite" resistance with horizontal holder, or Ferranti.
- 1 Graham Farish 5,000-ohm 1½-watt type "Ohmite" resistance with horizontal holder, or Ferranti.
- 1 Graham Farish 1,000-ohm 1½-watt type "Ohmite" resistance with horizontal holder.
- 1 Graham Farish H.T. Economiser Units type T.P.
- 1 Westinghouse "Westector" metal rectifier, type W.4.

- 1 Dubilier 100-ohm 1-watt type resistance, or Graham Farish, Bulgin, Varley (with wire ends or terminals).
- 1 Igranic 20-ohm variable resistance, type WYPAD.
- 1 Bulgin switch, type S.110.
- 1 Bulgin 50,000-ohm potentiometer with 3-point change-over switch, type V.S.36.
- 1 Clix S.G. anode connector, or Belling-Lee, Bulgin.
- 4 Belling-Lee indicating terminals, or Bulgin, Igranic, Clix.
- 5 Belling-Lee wander-plugs, or Clix, Bulgin, Igranic.
- 1 Belling-Lee wander-fuse.
- 2 Clix accumulator spades, or Bulgin, Belling-Lee, Eelex.
- 1 Peto-Scott Metaplex chassis, 12 in. x 10 in. x 2½ in., with terminal strips.
- 1 Peto-Scott ebonite panel, 12 in. x 8 in., or Goltone, Permcold, Wearite.
- 1 Set British Radiogram matched knobs.
- 1 Peto-Scott cabinet.
- 2 Coils British Radiophone "push-back" wire.
- Flex, screws, etc. (Peto-Scott).
- 1 Harlie gramophone pick-up, model 65, or Cosmocord Standard No. 2, Marconi, Columbia.
- 1 Garrard single-spring gramophone motor with 7-in. handle, type No. 20, or Collaro.
- 1 W.B. Microlode loudspeaker chassis, type P.M.2a, or suitably sized R. & A., Rola, Blue Spot, Celestion, Amplion.

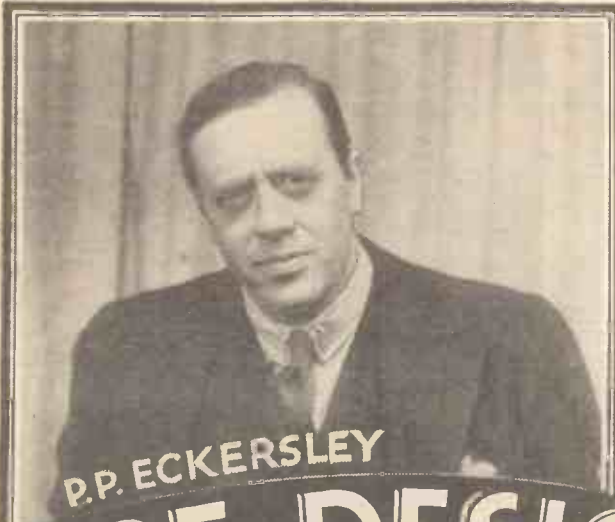

P.P. ECKERSLEY

1919

DESIGNED  
BRITAIN'S  
FIRST  
AIRCRAFT  
GROUND  
STATION  
AT CROYDON



# P.P.E. DESIGNS

REGIONAL SCHEME



1923

CONCEIVED THE  
REGIONAL SCHEME  
OF BRITISH  
BROADCASTING  
NOW PUT INTO  
PRACTICE AND  
GIVING ALTERNATIVE  
PROGRAMMES

1929

TV  
BR



THE WORLD'S FIRST  
WAVELENGTH HIGH  
STATION (BROOKMANS)

ALSO

THE FIRST  
LOW-POWER  
DUPLEX  
WIRELESS  
TELEPHONE  
SET USING  
SAME AERIAL  
FOR  
RECEPTION &  
TRANSMISSION

DUPLEX TELEPHONY

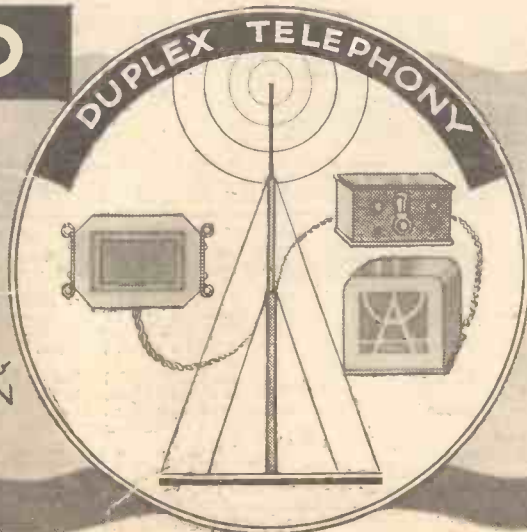

ALSO

DESIGNED FIRST  
EFFICIENT  
LARGE-OUTPUT  
AMPLIFIER  
FOR RE-  
DIFFUSION  
OF  
PROGRAMMES

WIRED WIRELESS

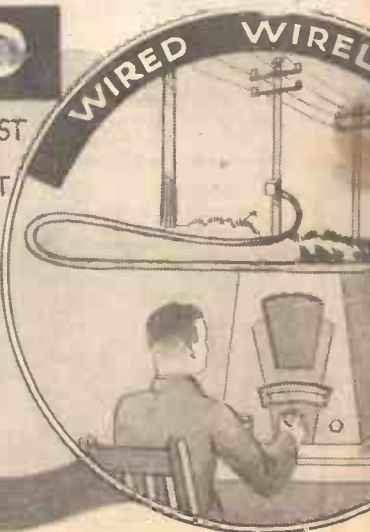

**1922**

**EXPERIMENTAL BROADCASTING**

RAN FIRST  
REGULAR  
BROADCASTING  
STATION IN  
BRITAIN AT  
WRITTLE  
(2 M.T.) NEAR  
ELMSFORD



**1923**

PIONEERED  
INTRODUCTION  
OF LONG WAVE  
HIGH-POWER  
BROADCASTING  
TECHNIQUE



**TWIN — WAVE  
BROADCASTING**

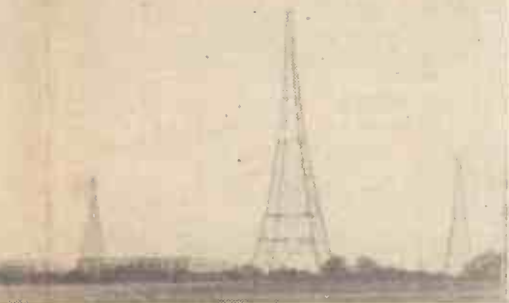

**THE MOST SUCCESSFUL TWIN-  
HIGH-POWER BROADCASTING  
TOWER AT WANS PARK, LONDON**

**ALSO**

DISTRIBUTION OF  
A MAIN  
PROGRAMME—  
BY LOCAL  
RELAY STATIONS

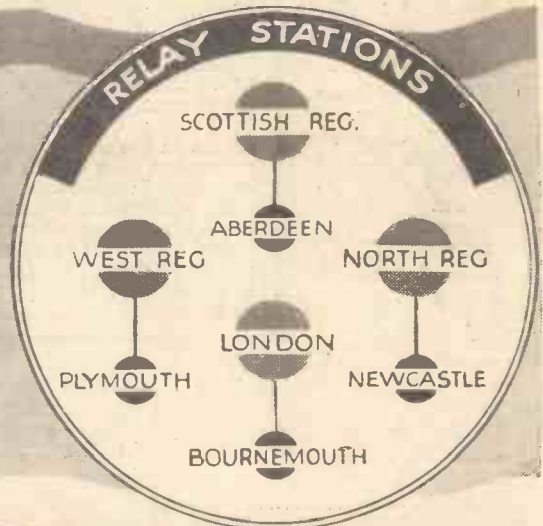

**1934 HIS LATEST  
THE NATIONAL  
ECKERSLEY THREE**

**AND**

SEVERAL  
BROADCASTING  
STATIONS  
PLACED ON  
THE SAME  
WAVELENGTH  
(NOW  
COMMON  
PRACTICE)

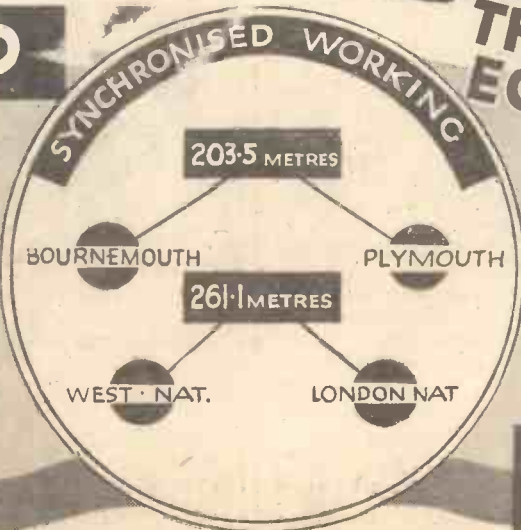

**ECONOMY** is a much-abused word. The world hasn't made up its mind whether to economise or spend. But while you probably want to spend money on things which give you pleasure, you don't want to spend money on waste.

The high-tension battery wears out. It is a consumable store. It runs down partly of its own sweet will and partly because it has to work for a living.

## HOW TO FIT AN ECONOMISER UNIT

If you give it less work to do it will, like you, live longer—up to a point. The days of its age, work or no work, are numbered.

An Economiser is a clever little thing which costs a bit at first and then pays for itself over and over again by saving battery power—saving money otherwise spent on waste. And it doesn't spoil the quality or performance of the set.

In principle it works by making a little tiny bit of the audio currents put the right amount of negative on the grid of the wasteful valve, which is, before the audio currents arrive, biased back so as only to absorb a very little current from the battery.

It's a sort of Class B, Q.P.P., X.Y.Z. idea without some of the snags incidental to these schemes.

### A Simple Scheme.

The scheme of operation can be outlined in a few words. From A on the  $V_3$  valve holder (see sketch), audio-frequency voltages are taken to the A terminal on the Economiser unit.

Inside this they go through a resistance, and then to another resistance which has a

## THE NATIONAL ECKERSLEY THREE CUTTING THE H.T. COSTS

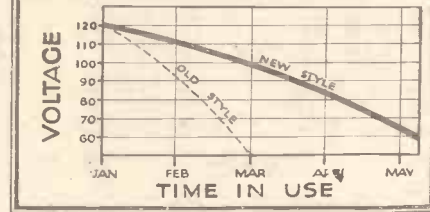

Full details of a simple fitment that is easily mounted—now or later—on to the National Eckersley Three, for the purpose of approximately halving the H.T. running expenses.

### AN ENTIRELY OPTIONAL REFINEMENT

As far as quality and range are concerned, the results on your National Eckersley Three are not affected by the scheme described here. But it means a tremendous lot to the length of life of your high-tension battery. So you are recommended to read this page, in which P. P. Eckersley himself describes the device in his own illuminative style.

You can then decide whether to fit it to the set straight away or bear it in mind as a possible future refinement.

Its installation is a matter of but a few minutes, either when the set is built or after you have had it in use.

And it has the great advantage that you can, if desired, use a much "bigger" output valve than is otherwise possible with a small H.T. battery, with all the attendant improvements in results.

rectifier (metal) in parallel with it, on their way to the G.B. terminal.

The rectifier "shorts" the parallel resistance for one half-cycle of alternation and lets all the current go through the resistance on the other. So you get currents flowing sensibly in only one direction in the resistance in parallel with the rectifier.

You will then appreciate, if you work it all out slowly, how the resistance in parallel with the rectifier behaves like a battery connected reversely to the real grid-bias battery.

### Automatic Adjustment.

If, then, the audio is strong the rectifier and resistance partly cancel the negative on the grid given by the grid-bias battery; if the audio is weak or non-existent you get full grid negative and very little anode current.

The thing adjusts itself automatically. I think it is very clever.

Here's the way to fit it to the National Eckersley Three.

Remove the 2-mfd. condenser, which is in the centre of the underside of the chassis. Remove also the resistances (300 ohms and 100,000 ohms) on either side of this condenser. Remove also all leads attached to these components, and connect H.T.-lead

to chassis. (The automatic bias is now no more.)

Now prepare the Economiser. There is a double holder under this unit which takes a 50,000 resistance (1½-watt "Ohmite") and the W.4 Westector (purchased separately).

Make sure that the Westector is inserted the right way round. The negative side (black) goes to the clip to which the terminal marked G.B. is connected.

Mount the Economiser on a piece of wood 5½ in. x 3 in. x ¾ in. This is shown clearly in diagram. The whole is then mounted beside the L.F. transformer and screwed on to the chassis from the underside. This is made clear in the photograph.

"A" terminal of Economiser is connected to the anode terminal of  $V_3$ ; "S" terminal to G.B. terminal of L.F. transformer; "E" terminal to chassis and G.B.+ lead; "G.B." terminal to G.B.—lead.

## DOUBLES THE LIFE OF YOUR H.T.B.

I want to tell you, now that you've fitted it, that you can use a big valve with it, which valve would otherwise have killed your H.T. in no time. A Mazda Pen.220A or Cossor 220P.T. would do well, and you should use 120 volts of H.T. and about 15–16.5 volts grid negative with such valves.

### Greater Volume.

The larger valve will mean greater volume without distortion and a greater margin of safety for peak passages.

Who's afraid of the big H.T. When you use Economise? Use a valve like the old P.T.—He—he—he—he—!

## WHERE THE WIRES GO

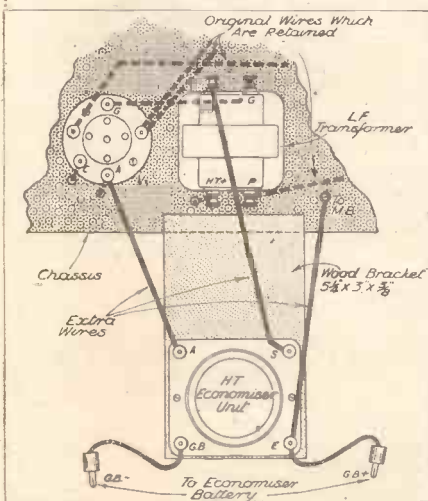

The new wires are those shown in heavy black lines, the original wiring of the transformer and valve holder being depicted by the dotted lines.

The dimensions of the small wooden panel are also given, so this small sketch makes clear the whole above-baseboard operation of fitting the unit.

To the right is a picture of the small extra panel with the H.T. Economiser mounted in position upon it. It is screwed to the baseboard near the transformer, as shown, and the necessary few alterations to the connections are fully described in the article on this page. A 50,000 ohm resistance and Westector are carried in the base, being fitted before the Economiser is screwed down.

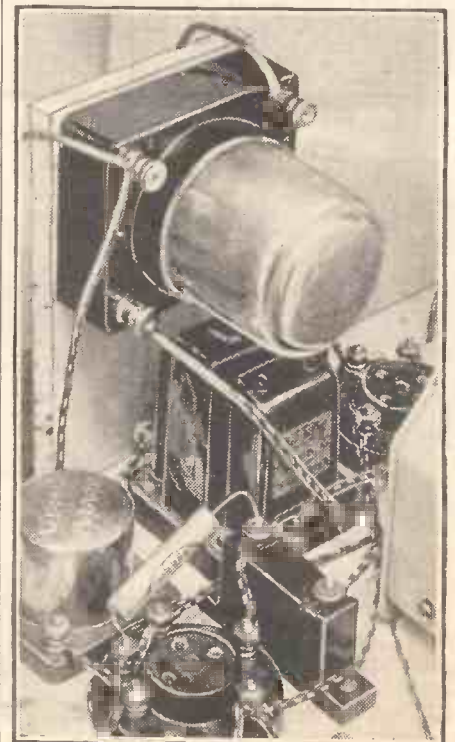



# ECKERSLEY NATIONAL THREE



The Pilot Kit SERVICE was founded in 1919.

## PILOT AUTHOR KIT EXACT TO SPECIFICATION

See the PILOT on the carton. It's a real guarantee.

### PETO-SCOTT CABINETS Exclusively Specified



TABLE MODEL.

This handsome walnut-polished cabinet was specially designed by PETO-SCOTT at the request of "Popular Wireless" to house the Eckersley National 3. Constructed throughout in first-quality material and beautifully finished by hand french-polishing macassar veneer set the seal of the piano trade. Cash or C.O.D.

17/6

Packing and Carriage, 2/6 extra.



RADIOGRAM MODEL.

Another exclusive and delightful cabinet by PETO-SCOTT, also specially designed at the request of "Popular Wireless" for the Eckersley National Radiogram. The beautiful walnut finish and handsome contrasting macassar veneer set the seal of perfection in cabinet design on this latest Peto-Scott production. Cash or C.O.D.

47/6

Packing and Carriage, 2/6 extra.

H.P., 7/6 Deposit and 9 monthly payments of 5/3. Loudspeaker Baffle Baseboard Assembly if required, 3/6 extra. State size of hole required when ordering.

#### FINISHED INSTRUMENTS

PETO-SCOTT are manufacturing the Eckersley National 3 and the Eckersley National Radiogram as finished instruments. Built exactly to specification as detailed on this page. Carefully assembled by experts, and every instrument aerial tested on actual Broadcast before despatch.

PRICES ON APPLICATION.

### CASH - C.O.D. £ 5 - 10 - 0

These are the Parts the Author used

1	British Radiophone 3-gang, type 604	1	0	0
1	British Radiophone S.M. drive, type 711	1	8	6
1	Set of Telsen screened coils, type W.288	1	2	6
3	W.E. large type 5-pin valve holders	...	...	...
1	Lissen Hypernik I.F. transformer	12	6	6
1	Graham Farish H.F. choke, type H.M.S.	12	6	6
1	Graham Farish 0003-mfd. differential	2	0	0
1	Graham Farish 2-mfd. fixed condenser	3	0	0
2	T.C.C. 2-mid. fixed condensers, type 50	7	0	0
1	Igranic 20-ohm resistance, type WYPAD	2	0	0
1	Dubilier 100-ohm resistance, 1-watt type	1	0	0
1	Graham Farish 100,000-ohms 1 1/2-watt type Ohmite resistance with horizontal holder	2	0	0
1	Graham Farish 30,000-ohms 1 1/2-watt type Ohmite resistance with horizontal holder	2	0	0
1	Graham Farish 5,000-ohms 1 1/2-watt type Ohmite resistance with horizontal holder	2	0	0
1	Peto-Scott 300-ohm 1 1/2-watt type Ohmite resistance with horizontal holder	2	0	0
1	Lissen 1-meg. grid leak with wire ends	1	0	4
1	Dubilier 1-mfd fixed condenser, type 4404	1	4	0
1	Belling-Lee wander plugs	1	4	0
1	British Radiogram on-off switch, No. 51	2	0	0
1	Clix S.G. anode connector	1	4	0
4	Clix indicating terminals	1	0	4
2	Belling-Lee wander plugs	1	0	4
1	Belling-Lee wander fuse	1	0	0
2	Clix accumulator spades	1	4	0
1	Peto-Scott Metaplex chassis, 12" x 10" x 2 1/2", with terminal strips	3	6	0
1	Peto-Scott onbrite panel, 12" x 8", ready drilled	3	0	0
5	British Radiogram matched knobs	2	0	0
1	Peto-Scott connecting wire, screened wire, fixing screws, etc.	2	6	0
				"KIT "A," CASH OR C.O.D. £5 10 0

OR YOURS FOR

10/-

and 11 monthly payments of 10/-  
KIT "A" Author's Kit of first specified parts including READY-DRILLED PANEL and METAPLEX chassis assembly, but less valves and cabinet, Cash or C.O.D. £5:10:0  
Carriage paid ... .. £5:10:0  
or 12 monthly payments of 10/-

ACCESSORIES.  
5 Mullard valves as specified 1 19 0  
1 Peto-Scott table cabinet (Carr. 2/6 extra) 19 6

#### KIT "B"

As Kit "A," but including set of specified valves, but less cabinet, Cash or C.O.D. Carriage paid,

£7:9:0  
or 12 monthly payments of 13/9

#### KIT "C"

As Kit "A," but including valves and cabinet, as illustrated, Cash or C.O.D. Carriage paid,

£8:6:6  
or 12 monthly payments of 15/3

## ECKERSLEY NATIONAL RADIOGRAM

These are the Parts the Author used

1	J.B. tuning condenser, Nugang A	1	2	6
1	Colvern 3-gang coil unit, K.G.O., K.G.O. K.G.R.	1	8	6
3	Benjamin 5-pin valve holders	12	6	6
1	Lissen Hypernik transformer	12	6	6
1	Amplion Binocular H.F. choke	2	0	0
1	Graham Farish 0003-mfd. diff.	2	0	0
1	Graham Farish 2-mfd. condenser	3	0	0
1	T.C.C. 2-mid. fixed condenser	1	6	0
1	Dubilier 25-mfd. condenser, type 4406	1	4	0
1	Dubilier 1-mfd. condenser, type 4404	1	4	0
1	T.C.C. 0002-mfd. condenser, type 34	1	3	0
1	Lissen 1-meg. grid leak with wire ends	1	0	0
1	Graham Farish 50,000-ohm Ohmite resistance with horiz. holder	2	0	0
1	Graham Farish 1,000-ohm Ohmite resistance with horiz. holder	2	0	0
1	Graham Farish 5,000 Ohmite resistance with horizontal holder	2	0	0
1	Graham Farish H.T. economiser unit	7	6	0
1	Westinghouse Westector, type W.4	7	6	0
1	Dubilier 100-ohm 1-watt resistance	1	0	0
1	Igranic 20-ohm resist. type WYPAD	2	0	0
1	Bulgin switch, type S110	2	6	0
1	Bulgin potentiometer, type V.S.36	5	0	0
1	Clix S.G. anode connector	1	4	0
4	Belling-Lee type B. terminals	1	0	0
5	Belling-Lee wander plugs	1	0	0
1	Belling-Lee wander fuse	1	0	0
2	Clix accumulator spades	1	4	0
1	Peto-Scott Metaplex chassis, 12" x 10" x 2 1/2", with terminal strips	3	6	0
1	Peto-Scott Panel, 12" x 8", ready drilled	3	0	0
6	British Radiogram matched knobs	2	4	0
2	Coils connecting wire, screws, flex, etc.	2	6	0
				"KIT "A," CASH OR C.O.D. £6 10 0

KIT "A" Author's Kit of first specified parts including READY-DRILLED PANEL and METAPLEX chassis assembly, but less valves, cabinet, speaker and gramophone equipment. Cash or C.O.D. Carriage paid, £6:10:0  
or 12 monthly payments of 12/-

#### KIT "B"

As Kit "A," including valves, but less speaker, cabinet and gramophone equipment. Cash or C.O.D. Carriage paid,

£8:9:0  
or 12 monthly payments of 15/6.

#### KIT "C"

As Kit "A," including valves, cabinet and PETO-SCOTT gramophone equipment but less speaker. Cash or C.O.D. Carriage paid,

£12:14:6  
or 12 monthly payments of 23/3.

With Peto-Scott Permanent Magnet Moving-coil Speaker, if required, add 19/6 to Cash Price or 1/9 to each monthly payment.

#### PETO-SCOTT GRAMO. EQUIPMENT.

1	Peto-Scott "Eckersley Radiogram" cabinet	£	s.	d.
1	Peto-Scott combined shelf and baffle	2	3	6
1	British Radiogram pick-up	17	6	0
1	Edison Bell double spring motor with 7" handle	17	0	0

**IMPORTANT**—Parts, Kits, Miscellaneous Components, Finished Receivers or Accessories for Cash, C.O.D., or H.P. on our own System of Easy Payments. Send us a list of your wants. We will quote you by return. Easy Terms on orders over £2. CASH or C.O.D. orders value over 10/- sent Carriage and Post Charges Paid. GREAT BRITAIN ONLY. H.P. Terms are NOT available to Irish or Overseas customers.

PETO-SCOTT CO. LTD., 77, CITY RD., LONDON, E.C.1. Tel.: Olerkenwell 9406/7.  
West End Showrooms: 62, High Holborn, London, W.C.2. Tel.: Holborn 3248.

Dear Sirs,—Please send me CASH/C.O.D./H.P. \_\_\_\_\_  
for which I enclose £.....s.....d. CASH/H.P. Deposit.  
NAME.....  
ADDRESS.....  
P.W., 20/1/34.

ANY ITEM SUPPLIED SEPARATELY—ORDERS OVER 10/- SENT C.O.D. CARRIAGE AND POST CHARGES PAID

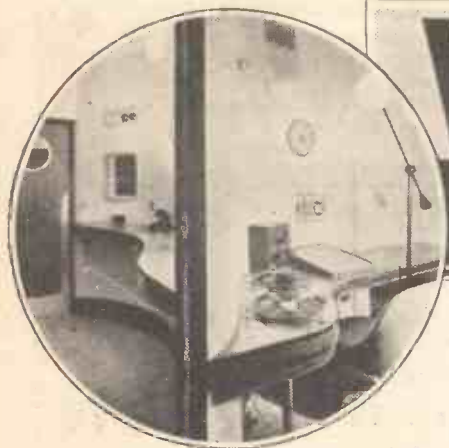

# WHAT IT IS LIKE TO BE AN ANNOUNCER

The first article written by the first British lady announcer in which she vividly describes some of her experiences at Broadcasting House.

ON July 24th, 1933, I sat in a studio at Broadcasting House, known as 4B, clutching the little grey reading desk feverishly with both hands. I was waiting to make my first announcement and wishing I had never been foolhardy enough to think I could be an announcer.

Exactly four months later, on November 24th, I sat in the same studio, trying to swallow a lump in my throat about the size of an egg, waiting to say "Good-night" for the last time. And when I had done so I put my head down and fairly soaked that reading desk with tears!

Partly I was crying at the loss of my job, which I had loved so well, and partly at leaving behind me all the real friends I had made during those four months, both in Broadcasting House and outside among the listening public.

I can never pay enough tribute to the kindness and friendliness shown me by everyone there. Everybody did their best—and a good best at that—to make my job as easy and pleasant as possible.

Perhaps I ought to say a special word about my co-announcers. If my appoint-

always knew that; and in the eyes of those far more competent to judge than I am the experiment was a failure. But I was, naturally, bitterly disappointed. I loved my work, and I believed, and do still, that there is endless scope for a woman announcer, and that sooner or later the B.B.C. will have, not one, but two or three.

There are various programmes that need

waiting for the result of an appeal that one is sending out into the air. I remember one night "S O S-ing," as we call it, to a man on board a trawler somewhere in the North Sea that his baby was dangerously ill; I had a terrible longing to say: "I do hope you'll find it better." But that would never have done!

## Adaptability of Mind.

There are some things, however, that a woman should not deal with. Announcing fat-stock prices, for instance, football results and even the news seem to me to be definitely a man's job. And I say this in spite of the fact that a great many of my letters of appreciation came from ardent racing enthusiasts who liked the pace at which I read the racing results! Against that, though, I had several letters from members of my own sex asking me if I considered it "decent or womanly" to be heard reading the football results!

The announcer's job teaches one various lessons, and perhaps the first is adaptability of mind. In most walks of life one deals with more or less the same type of person for a large part of each day. But the announcer may go from announcing a cabinet minister or a bishop, via a Spanish tango band to a variety show, and from there to read the news. And so his mind becomes, and keeps, very supple from this constantly varied work.

One very important part of the announcer's job is getting the right angle on announcing. This takes time, because at first such a large

part of one's mind is occupied with the technical side of the work, pressing buttons, watching for red, green or white lights, not forgetting various technical announcements one has to make—"This programme is also being radiated on G.S.F.—F for fortune"—for instance, and so on.

Only when this becomes second nature can one begin to realise one's audience  
(Continued on page 892.)



## FEMININE INDIGNATION.

Several women listeners wrote to Mrs. Borrett during her spell of announcing to ask whether she thought it "decent or womanly" to be heard reading the football results!

Racing and football results, says Mrs. Borrett (inset), are better dealt with by a male announcer, while certain programmes, such as romantic plays, light music and household talks, should be announced by a woman's voice.



a woman's voice—for instance, the announcements at the beginning, and even more at the end, of romantic plays; certain light musical programmes, as well as



An exclusive article by the first B.B.C.

Lady Announcer

MRS. GILES BORRETT

ment was a shock to them—and I fancy it must have been—they never showed it by word or deed. They made every effort to teach me my job thoroughly, and put themselves out quite a lot to do so.

I started the job feeling very much like a new girl at school, distinctly embarrassed at the thought of invading the sanctity of the announcers' hitherto bachelor room. But they put me at my ease immediately, and I do believe they were as sorry when I left as—well, as they said they were!

I have absolutely no sense of grievance at my dismissal. I was an experiment: I

such obvious things as talks, especially intended for women listeners, on house-keeping and kindred topics.

There is a school of thought which says S O S messages sound better when given by a woman's voice, though I am not sure that I agree with this myself. Men's voices, like their hearts, can be just as sympathetic as any woman's. No announcer becomes mechanical over those S O S messages. It is impossible not to think of the anxious relatives and friends



# C H O S E N

**FOR THE NATIONAL ECKERSLEY "3"  
AND NATIONAL ECKERSLEY RADIOGRAM**



*Specified for both the "National Echersley 3" and "National Echersley Radiogram": 1 Colvern 3-gang coil unit, type K.G.O., K.G.O., K.G.R.*

*Price 8/6 complete.*



*Ferrocart coils, Colvern's latest achievement, are the most outstanding advancement in coil construction. Write for Radio List No. 12, telling you all about them. Many enthusiasts have found it of great interest. Post free, on request.*

*Colvern Ltd., Romford, Essex.  
London Wholesale Office:  
150, King's Cross Road, W.C.1.*

Specified by Mr. P. P. Eckersley for his "National 3" and "National Radiogram" . . . the choice of experts everywhere . . . Colvern are the finest and most accurate coils made. Built to the highest standard of engineering precision, every coil is thoroughly tested and guaranteed. Make certain of the best results . . . use Colvern Coils. Types and prices are given on the left.

## COLVERN COILS

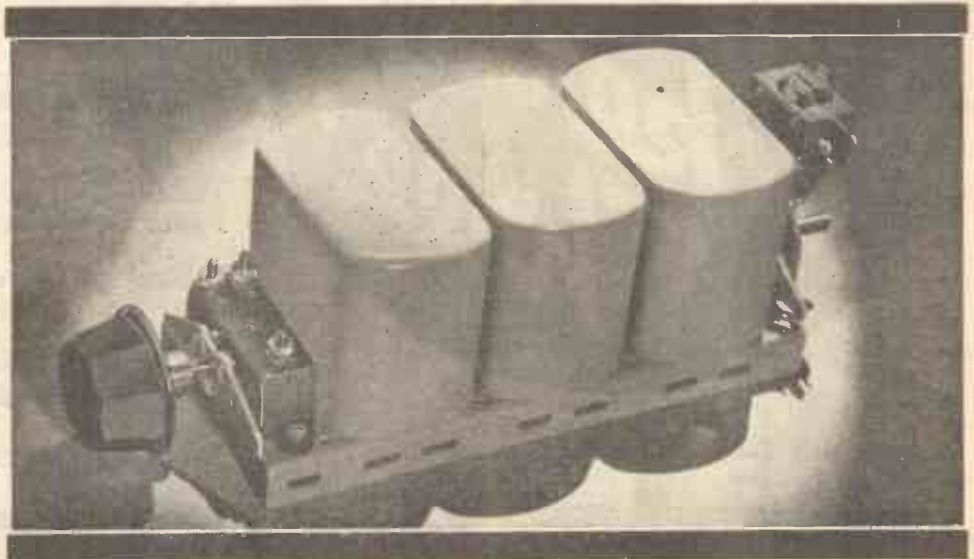

*Made under licence from the patentee, Hans Vogt.*

**MAKERS OF THE FAMOUS  
F e r r o c a r t**

# Your complete TELSEN SHOPPING LIST

for the



ONLY 100% perfect components can give you perfect results from your "P.W. National Eckersley Three." By using throughout your set the *tested* Telsen Components featured on this Shopping List, you can be sure of *matched efficiency* and the high standard of performance of which the brilliant circuit is capable.

Tear out this list of all the Telsen Components you need for your "P.W. National Eckersley Three" and take it with you for reference at your radio dealer's.

- |  |      |
|--|------|
| 1 Telsen Triple Ganged<br>Condenser (with dust cover)      | 22/6 |
| 1 set Telsen Triple-Matched<br>Screened Coils              | 21/6 |
| 3 Telsen 5-pin Solid Type<br>Valveholders @ 8d. each       | 2/-  |
| 1 Telsen G.S.3 L.F.<br>Transformer                         | 8/6  |
| 1 Telsen Standard Screened<br>H.F. Choke                   | 3/6  |
| 1 Telsen .0003 Differential<br>Reaction Condenser          | 2/6  |
| 3 Telsen 2mfd. 500 volt test<br>Paper Condensers @ 3/- ea. | 9/-  |
| 1 Telsen 100,000 ohm<br>Resistor                           | 1/-  |
| 2 Telsen 30,000 ohm<br>Resistors @ 1/- each                | 2/-  |
| 1 Telsen 5,000 ohm Resistor                                | 1/-  |
| 1 Telsen 1 megohm Grid Leak                                | 1/-  |
| 1 Telsen Grid Leak Holder ..                               | 6d.  |
| 1 Telsen .1 mfd. Small<br>Tubular Condenser                | 1/6  |
| 1 Telsen .0002 mfd. Fixed<br>Mica Condenser                | 1/-  |

**TELSEN FOR EVERYTHING IN RADIO**

ANNOUNCEMENT OF THE TELSEN ELECTRIC CO. LTD., ASTON, BIRMINGHAM

# MORE PRAISE FOR THE S.T. MANUAL

From PROFESSOR E. V. APPLETON, F.R.S.

One of the most notable features of modern journalism is the high technical standard of the popular wireless papers. What we may call "the average electrical knowledge per head of population" has increased enormously during the last ten years, and I have no hesitation in attributing this progress largely to the influence of the wireless journals. They teach the amateur that enthusiasm is not enough, and that a keener pleasure can be his when knowledge and understanding are added.

Mr. Scott-Taggart's book seems to me admirably suited to assist in our general electrical education. It is attractively written and is illustrated by most excellent diagrams. It is thoroughly up to date, and gives a full account of the remarkable progress in valve and circuit technique which has taken place during the last eighteen months.

From W. W. BURNHAM (Chairman of the Radio Manufacturers' Association).

I have now had an opportunity of reading through this book. It is certainly some time since a book has appeared from the pen of Mr. Scott-Taggart, but a study of this work shows that he has not lost his fluent style and knack of explaining radio problems in a manner which makes them easily understood by the average radio listener.

I am pleased to note that the book is right up to date, because it generally happens that this is not the case with text-books, probably owing to the delay between the date they are written and the date they are published.

I think that the chapter on "Decoupling Devices and Filters" is particularly well done, the copious diagrams making the action of these devices perfectly clear.

I think that 541 diagrams must be nearly a record for a book of this size.

I think that this book is perhaps the best of its class, and every radio enthusiast who is not content to turn a knob, but would like to know why, ought to make a New Year's resolution to get hold of a copy of this book somehow.

From P. P. ECKERSLEY, M.I.E.E.

Mr. Scott-Taggart has a truly encyclopedic knowledge. The practice of radio—or electronics, as one prefers to call the whole art—is becoming more and more extensive. The cataloguing, even, of the bits and pieces which go to make up circuits is an undertaking itself; but when, in addition to that, we have Scott-Taggart's gift of writing, coupled with his knowledge, something is produced which is, in the best sense of the word, "useful."

"The Manual of Modern Radio" is unique in its own field, and I can confidently urge readers to grasp this opportunity of obtaining it.

Below we give a selection of messages we have received from famous personalities in the Radio and Electrical World in praise of Mr. John Scott-Taggart's "The Manual of Modern Radio." Full details as to how you can secure a copy of this famous work will be found on another page.

From Dr. J. H. T. ROBERTS, F.Inst.P.

Mr. Scott-Taggart has put us all still further into his debt by the publication of his latest book, "The Manual of Modern Radio." It is written in extremely clear and simple style, and is a veritable mine of information on the modern developments of radio technique. Such a Manual was badly wanted by the vast radio public, and no one was better fitted to provide it than the author.

I had the pleasure to be associated with "S.-T." in the early days, when he was pioneering in radio publications, and was amazed then—as I have continued to be ever since—at the quantity of his energy and the

So many new devices are employed in these receivers that it is important to have a book which describes them, and it will now be possible, without elaborate filing systems, to turn up accounts of Automatic Volume Control, Variable-mu Valves, Second Channel Elimination, Decoupling System and various other devices.

For the student this is very useful, and whilst making him understand what is happening in wireless design to-day it will also prepare him for future developments.

From PHILIP R. COURSEY, B.Sc., M.I.E.E. (Technical Director, Dubilier Condenser Co., Ltd.).

The new Manual written by Mr. Scott-Taggart, which has been issued by The Amalgamated Press, is an attractive volume. The author has set himself a task of no small magnitude in preparing such a book with a wide range of appeal.

The non-technical reader can find in it simple explanations of the elements of radio reception, while those who require detailed information about recent developments—such, for example, as Quiescent A.V.C. applied to superheterodyne receivers—can find it explained with clearly drawn diagrams. A number of photographic illustrations also adds to the general interest. The book should, I think, be much appreciated.

From the Managing Director of A. C. Cossor, Ltd.

"The Manual of Modern Radio" should provide a very ready source of information to those users of radio sets who are desirous of knowing more of their technical design and construction.

From the Editor of the "Broadcaster."

I am very much obliged to you for giving me an opportunity of seeing Scott-Taggart's "The Manual of Modern Radio," which I understand has been specially written to interest those amateurs who are anxious to know something of the technicalities of radio, and which you are so generously presenting to the regular readers of "Popular Wireless."

A simple explanation of the complicated technique of radio is a difficult thing for the listener to acquire. I think that Mr. Scott-Taggart has produced a handbook which should succeed in persuading many thousands to take a keener interest in the fascinating technical story of modern radio communication.

(Continued on next page)

From Dr. JAMES ROBINSON (Inventor of the Stenode).

It was a happy thought of The Amalgamated



The photograph above is of Prof. E. V. Appleton, F.R.S., while to the left is W. W. Burnham (Chairman of the R.M.A.), and to the right, Phillip R. Coursey, B.Sc., M.I.E.E., of the Dubilier Condenser Company. Below is Dr. J. H. T. Roberts, F.Inst.P.



THE MIRROR OF THE B.B.C.

## THOSE SUNDAY PROGRAMMES

Test Mobilisation?—Attack on Monetary Policy—Meeting of Departmental Heads.

REFLECTIONS BY O. H. M.

ANOTHER agitation is about to start in Parliament on the subject of Sunday programmes. The B.B.C. will be urged to provide longer and lighter programmes and more decisive alternatives. As it is felt that direct representations will be useless, pressure will be resorted to. Sir Kingsley Wood, the P.M.G., is believed to be privately in favour of these reforms.

The Press generally would like them if only because they would offer more formidable opposition to Continental sponsored programmes that now have a practical monopoly of the British Sunday radio audience.

### Great Internal Activity.

There are apparently well-founded rumours of unusual internal activity in the B.B.C. An emergency series of conferences and meetings is being held. Sir John Reith is seeing members of the staff both in groups and separately. What does this mean or portend? It has all the symptoms of a "test mobilisation."

I would not be surprised if it has to do with a rehearsal for a national emergency, caused either by internal commotion or external war. Whitehall has always looked upon the B.B.C. as perhaps the greatest potential mainstay of "law and order" in any crisis.

### B.B.C. Finance.

The attack on B.B.C. finance and financial methods is spreading. One reason, of course, is the secrecy with which the subject is surrounded. The Postmaster-General's annual report to Parliament on the B.B.C. provides only the sketchiest outline of the broadcasting business, and the balance-sheet is of the shortest.

I believe it is generally agreed that Sir John Reith is one of the greatest, if not the greatest, financial administrator in the country to-day; but his persistent refusal to tell us all about it causes wonder and resentment.

I am sure Sir John could give a broadcast talk which would clear up most doubts and anxieties. For example, he could easily dispose of the rumour that he is considering reducing the amount of money to be spent on programmes in order to provide new offices for Regional directors.

### The Programme Board Restored.

The old Control Board of the B.B.C. having disappeared with reorganisation, it

(Continued on page 900.)

## MORE PRAISE FOR THE S.-T. MANUAL

(Continued from previous page.)

From the Radio Editor of the "Daily Mail."

To the amateur radio enthusiast who finds difficulty in coping with complicated technicalities, Mr. John Scott-Taggart's book, "The Manual of Modern Radio," will come as a god-send. For it is written in a clear, simple style that wins and holds the interest of the seeker after knowledge.

I recommend any listener who is apt to boast, "Oh, of course, I do not know anything at all about the technical side of broadcasting!" to get this generously filled handbook. He will soon voluntarily eat his words.

From the Radio Correspondent of the "Daily Telegraph."

Mr. John Scott-Taggart has a happy way of anticipating the difficulties of the student. Consequently his work is shorn of bewildering irrelevances and remains a lucid exposition of radio from fundamentals to the latest developments.

Radio amateurs are indebted to the enterprise which places such a comprehensive production at their disposal. There must be exceedingly few who will not profit from its study.

From the Radio Correspondent of the "News-Chronicle."

I have read "The Manual of Modern Radio" with the greatest interest. Mr. Scott-Taggart is to be congratulated upon the production of a book which will be of inestimable value to the wireless amateur.

## THEY PROMISED NOT TO MARRY—BUT...!



When the "Southern Sisters" radio trio was formed the three girls promised each other that they would not marry. They kept their promise until the eve of last Christmas, when Betty Havell, the soprano (seen next to her husband), married Dr. G. Knight. The trio, however, will carry on as usual.

From the Principal of the Wireless College, Colwyn Bay.

I have had an opportunity of reading "The Manual of Modern Radio" by Mr. Scott-Taggart, and must say that in placing such a work on the market you will be supplying a long-felt need. It will, obviously, interest and instruct many in the technicalities of radio who would normally not be either able or willing to devote the time and study to obtain an equivalent knowledge of the subject by the usual methods.

From S. R. Mullard.

I think "The Manual of Modern Radio" is a wonderful piece of work, and it should be of great value to the listener with a slight knowledge of electricity.

It will also be of value as a reference book in any library.

(Continued on page 893.)

## THE LISTENER'S NOTEBOOK

Though we do not necessarily associate ourselves with 'all the remarks expressed in this feature, readers will be interested this week in our contributor's criticisms of broadcast plays and his opinions of some of the new talks.

THE custom is now well established to divide broadcast music into the two classes of trivial and otherwise. The use of the terms highbrow and lowbrow is rather out of favour at the moment, though the expressions are still to be heard. On the other hand, broadcast plays are usually considered as a whole, calling for the same sort of listening, while Shakespeare, du Garde Peach and Lord Dunsany are bunched together and labelled dramatists whose plays are broadcast by the B.B.C.

I am not a little surprised at this attitude towards radio drama, as I see clearly a line of demarcation between stage plays adapted for the microphone and those specially written for that medium. The result of much listening to these plays has forced me to the conclusion that, whereas the adapted plays have always a good story to tell, the specially written ones have, with rare exceptions, no story at all.

Mr. du Garde Peach's earlier radio plays

I number among the rare exceptions referred to above. But his latest work, "Meet Mrs. Beeton," is a perfect specimen of the typical broadcast play about nothing. I noticed with interest that he called "Meet Mrs. Beeton" a culinary comedy. I imagine the stress is on culinary, for comedy it wasn't—at least, as I understand comedy. A culinary effort would have been a more appropriate appellation, as it must have been an effort to write on so trivial a theme a play that was to take an hour to unfold.

I am fond of quoting "The Green Goddess," broadcast some long time ago now, because of its excellent story. The retelling of this story afterwards was well worth the time it took, and this was considerable. To tell the story of "Meet Mrs. Beeton" would take seconds only and not arouse the smallest interest either.

It didn't matter in the slightest that there were three changes in the advertised cast, announced, incidentally, after the performance. Such a story could have been told by anyone. But had the play been one of the other category I would have resented such changes very strongly. This practice must not be allowed to grow. "I would listen to anything John Somebody or Jeanne

(Continued on page 900.)

# NATIONAL ECKERSLEY III



## NATIONAL DE LUXE KIT

The guaranteed Constructors' kit for those who insist on the best only.

**£5 : 17 : 6**

**SPECIFICATION :**

- |   |               |
|---|---------------|
| 1 J.B. Linatune 3-gang '0005-mfd. tuning condenser with straight-line illuminated slow-motion drive and screening cover | £ s. d.       |
| 1 set matched Colvern coils, types KGO, KGO, KGR  | 1 7 6         |
| 3 W.B. large type 5-pin valve holders   | 1 8 6         |
| 1 R.I. special New Hypermu L.F. transformer   | 2 6           |
| 1 Wearite screened H.F. choke, type HFP   | 15 6          |
| 3 Dubilier, type 9200, non-inductive fixed condensers, 2 mfd.   | 3 6           |
| 1 Igranic 20-ohm variable resistance, type WYPAD  | 10 6          |
| 4 Erie resistances with horizontal holders—100,000, 30,000, 5,000, and 300 ohms   | 2 0           |
| 1 Erie 100-ohm resistance with wire ends  | 5 0           |
| 1 Erie 1-meg. grid leak with wire ends  | 1 0           |
| 1 Dubilier 1-mfd. tubular condenser, type 4404  | 1 0           |
| 1 Dubilier '0002 fixed condenser, type 670  | 1 4           |
| 1 Bulgin Rotary Radiogram switch, type S.85   | 1 0           |
| 1 Belling-Lee anode connector   | 1 6           |
| 1 Belling-Lee wander fuse with H.T. fuse  | 2             |
| 4 Belling-Lee indicating terminals  | 1 0           |
| 2 Belling-Lee indicating wander plugs   | 1 0           |
| 2 Belling-Lee accumulator spades  | 3             |
| 1 "ACE" metal-sprayed screened chassis with terminal strips   | 4             |
| 1 "ACE" walnut ebonite panel 12" x 8" drilled to specification  | 3 0           |
| 1 Set walnut knobs for matching panel   | 5 6           |
| 2 Coils push-back wire  | 1 6           |
| Screened wire, flex, screws, etc.   | 3             |
| 1 Graham Farish '0003-mfd. differential reaction condenser  | 1 3           |
| Constructional copy of "Popular Wireless"   | 2 0           |
|   | <b>Gratis</b> |
| "ACE" De Luxe National Kit A  | 5 17 6        |
| 3 Valves to specification   | 1 19 0        |
| "ACE" De Luxe National Kit B  | 7 16 6        |

**"ACE" DE LUXE CABINETS**

- |   |        |
|---|--------|
| National Table Type in solid Oak                                    | 1 15 0 |
| National Console Type in solid Oak                                  | 2 2 0  |
| National Special Radiogram Cabinet in solid Oak, Walnut or Mahogany | 6 6 0  |

## NATIONAL ECKERSLEY RADIOGRAM

ACE DE LUXE KIT "A" **£6 : 17 : 6**

ACE DE LUXE KIT "B" **£8 : 16 : 6**

Similar specification to National De Luxe III Kit with extra components as specified, for battery economiser and Radiogram.

## MARCUS



## OVERTON



Still the best Four-Valve Class B constructors' Kit. Read these letters:—

From Robson & Nesbitt, Humshaugh.  
To Marcus, Overton Radio Limited.  
We received your kit for S.T. 500 Pth. and assembled same on 9th without any trouble, which speaks well for your kit. The completed job is perfect, including tuning and tone. I have had friends to hear same, six of these wireless fans, who are going to sell theirs cheap and build the S.T. 500; two of these people have electric sets, which speak still better for the circuit and your kit.—Yours very satisfied,  
W. NESBITT.

From J. W. Squires, 40B, Old Kent Rd., London.  
To Marcus, Overton Radio Limited.  
I have to record my appreciation of your prompt service in the despatch of the S.T. 500 receiver a week or so ago. It is a splendid receiver in every respect. The selectivity is very good, the volume immense, and the tone is exceptionally fine. This, I feel sure, must be the result of using the highest quality components. It certainly outshines any manufactured main set I have heard for general performance. It is indeed a De Luxe receiver, and I shall certainly not hesitate to advise my friends to place their business with you. With best wishes for the future.—Yours faithfully,  
J. W. SQUIRES.

And the price of the complete guaranteed De Luxe Kit "A" is **£5:12:6** or with four tested valves **£7:17:9**

- ACCESSORIES.**  
Any Radio or Electrical material can be supplied to order. Send specification of requirements for suggestions and quotations. Our service is free and unbiased.
- |   |        |
|---|--------|
| Harle gramophone pick-up, No. 65  | 18 0   |
| Blue Spot gramophone pick-up, No. 33, with volume control               | 1 15 0 |
| Garrard No. 20 single spring motor                                      | 1 17 0 |
| Garrard Junior B double spring gramophone turntable with automatic stop | 1 15 6 |
| W. B. PM4A Microloide speaker   | 2 2 0  |
| W. B. PM5X Microloide speaker   | 1 13 6 |
| Blue Spot 39PM speaker  | 2 19 6 |
| M.P.R. eliminator for A.C. mains  | 2 10 0 |
| M.P.R. eliminator for D.O. mains  | 1 10 0 |
| Sound Sales speaker (recommended)                                       | 2 0 0  |
- SPECIAL "ACE" Class B unit** with valve; a quality job giving real punch with exceptional tone (sent on 7 days' approval against cash with order) ... 2 2 0

To Marcus, Overton Radio Limited, 62, Borough High Street, London Eridge, S.E.1.  
Phone: HOP 4431.

Please supply immediately:—  
Name: .....  
Address: .....  
(Block Letters, please.) P.W., 20/1/34.  
**TRADE SUPPLIED.**



## NATIONAL STANDARD KIT

The guaranteed Constructors' kit for those who want the best at least cost.

**£4 : 14 : 0**

**SPECIFICATION :**

- |   |               |
|---|---------------|
| 1 J.B. Nugang condenser, type A, '0005-mfd. 3-gang with disc drive              | £ s. d.       |
| 1 Set Colvern coils, type KGO, KGO, KGR   | 1 0 6         |
| 3 W.B. large type 5-pin valve holders   | 1 8 6         |
| 1 R.I. Difeed L.F. transformer  | 2 6           |
| 1 Wearite screened H.F. choke   | 7 6           |
| 1 Graham Farish '0003-mfd. differential reaction condenser                      | 2 0           |
| 3 Dubilier 2-mfd. condensers, type BS   | 7 6           |
| 1 Igranic 20-ohm variable resistance, type WYPAD                                | 2 0           |
| 1 Erie 100-ohm resistance with wire ends  | 1 0           |
| 4 Erie Resistances with horizontal holders—100,000, 30,000, 5,000, and 300 ohms | 5 0           |
| 1 Erie 1-meg. grid leak with wire ends  | 1 0           |
| 1 Dubilier 1-mfd. tubular condenser, type 4404                                  | 1 4           |
| 1 Dubilier '0002-mfd. condenser, type 670                                       | 1 0           |
| 1 Bulgin Rotary Radiogram switch, type S.85                                     | 1 6           |
| 1 Belling-Lee anode connector   | 2             |
| 4 Belling-Lee indicating terminals  | 1 0           |
| 2 Belling-Lee indicating wander plugs   | 3             |
| 1 Belling-Lee wander fuse with H.T. fuse  | 1 0           |
| 2 Belling-Lee accumulator spades  | 4             |
| 1 "ACE" metal sprayed screened chassis with terminal strips                     | 3 0           |
| 1 "ACE" black ebonite panel, 12 in. x 8 in., drilled to specification           | 3 0           |
| 2 Coils push-back connecting wire   | 8             |
| Screened wire, flex, screws, etc.   | 3             |
| Constructional copy of "Popular Wireless"                                       | <b>Gratis</b> |
| "ACE" Standard National Kit A   | 4 14 0        |
| 3 Valves to specification   | 1 19 0        |
| "ACE" Standard National Kit B   | 6 13 0        |

**"ACE" STANDARD CABINETS**

- |  |        |
|--|--------|
| National Table type in Walnut finish       | 15 0   |
| National Console type in Walnut finish     | 1 7 6  |
| National Radiogram in Oak or Walnut finish | 3 10 0 |

## NATIONAL ECKERSLEY RADIOGRAM

ACE STANDARD KIT "A" **£5:16:0**

ACE STANDARD KIT "B" **£7:15:0**

Similar specification to National Standard III Kit with extra components for battery economiser and Radiogram.

**INSIST ON "ACE" MATCHED AND SEALED KITS. THE BEST MADE**

# Who Will Write a Radio Play for Children?

(Continued from page 847.)

of "P.W." he is probably in advance of many city dwellers.

As a doctor P. B. S. may indeed with justice feel that radio is his domain as much as medicine, for, as "P.W." has recorded, radio is entering more and more into the development of the art of healing. P. B. S.'s inquiries are receiving attention, though I cannot promise that we shall publish all the articles which he suggests.

## SHORT WAVES

Teacher (to geography class): "What was Columbus trying to find in 1492?"  
Bright Pupil: "A short-wave hook-up to India."—"Radio News."

"They say in America that the Petting Rule holds good for radio."  
"What on earth do they mean?"  
"Well, you get the best results in the dark."

### My Indian Bloodhound.

BESIDES being a doctor and a radio "fan," P. B. S. is developing into one of those bloodhounds of whose like I have often written in awe. They trail a dropped comma or other small slip with noses down and tails up, baying beautifully. What a compliment to a paper, to be read so thoroughly!

Well, P. B. S. is shaping well and will become a veritable *dhole* if he perseveres; but the particular quarries he mentions are, I think, hardly worth his skill. Time may remedy the omissions, P. B. S., if you wait.

Be a *yogi* as well as a medicine man, and stare fixedly at each successive number of "P.W."

### Slight Irrelevancies.

IN some of the letters which readers are good enough to address to me I come across the strangest questions, often quite irrelevant to radio. "If you throw a kitten into the air feet first, on coming to a standstill ready to return it turns over very quickly. How?" Pure presence of mind, laddie!

Here's another: "Why is your firm's telegraphic address 'Mistitled, Cent, London'?" Certainly we should be mistitled "cent." We are the whole gold dollar!

Finally: "I should be glad to know your favourite toast." By all means! Done evenly on both sides; thin and hot.

### They Hear Them Eat!

BLESS me shoul! If the U.S.A. is not nearing delirium point in its efforts to be amused by radio! I have reported some fairly good examples, but that which follows must assuredly take the quinine tablet.

Station WICC actually broadcast a plate-to-plate spaghetti-eating contest. Twenty guzzlers lined up, and as the stuff disappeared the station director told

the "story"—in itself a great feat, I think.

The winner finished five platefuls in twelve minutes and received two cases of spaghetti as his prize. Well, well!



### Stars Off-Stage.

WITH the exception of those who are the victims of next-door's non-stop loudspeaker it is fairly correct to say that one half of the world knows not how the other half amuses itself.

I am moved to this aphorism on learning that Layton's hobby is cooking, whilst that of his partner, Johnstone, is philosophical reading.

Then consider the inimitable Gillie Potter, who is an expert on Church history; or George Robey, the maker of choice violins. A man has to be pretty clever, or even well read, nowadays to be a successful humorist.

### The B.B.C. Couldn't Do It.

HERE is the story of the triumph of the "sound-effects" department of Station WOR (U.S.A.). For the purposes of a playlet they required to broadcast the sounds made by glasses on a saloon counter, and although they tried X" combinations of boards, liquids and glasses, the real touch just would not come.



Then some genius blandly suggested that glasses on a real counter might sound like glasses on a counter—so they moved a bar into the studio. And lo! the result was exactly like glasses on a counter. But just imagine a bar in a B.B.C. studio!

### "Leg Show" by Television.

THOSE forward-reaching Americans are steadily, albeit painfully, plodding after television as an amusement. As a sample of what is being done I may mention the football match which was "news-reeled" by cinema-camera and then televised three hours later.

The crowd, ground markings and other details were clearly seen, but of the players—their legs only! However, if on the next occasion the ball is also seen, there will be the essential parts of a football game.



### The Lucky Singer.

MISS DESIREE ELLINGER, who charmed us last month, is a lucky as well as a lovely lady. A great traveller, she has been held up by bandits on the Trans-Siberian Railway, she has crashed in an aeroplane and has experienced a typhoon in the China sea, on which occasion, I gather, her ship was fighting for seventeen hours in the Limoon Pass, which leads into Hong Kong Harbour.

That must have been a "super" typhoon, for I shall never forget the four hours which I had in that narrow gut of water during a typhoon—the only time in my life when

I put down my pipe and looked wistful. But then I was smoking ship's plug!

### News from Nowhere.

S.S., of one of H.M. ships-o'-war, addresses me from the blue, described as an East Indies commission. Hard indeed is the lot of S.S.! In fourteen months he has heard part of an Empire programme three times—once intelligibly. For the rest he has to be content with weather, news and fat-stock prices in three languages.



Called in at Nairobi on a shore-trip, but would not "gate-crash" the station. They would have welcomed you, boy! Promises Technical Staff ruby eye of Indian idol for design of A.C. radiogram, 3-4 valves, with aerial—but he can have my set, ready made, on those terms. All the best for 1934, S.S., and thanks for your cheery screed!

### A New Outlet for Youth.

IS there any important significance in the discovery by American radio play producers that the youthful actor is more adept and effective before the microphone than the adults?

They say that the kids project themselves in their parts more readily and show an apprehension of the technical side ("fade out," etc.) superior to that of more mature persons.

As a result the pay of the children often works out to as much as \$250 (a little less than £50) per week, which, it is said, is rarely equalled by an adult.

### Will the B.B.C. Try Them?

NOW here, it seems to me, is a fine chance for the B.B.C. to engage in a bit of research in order to check the experience of the Americans. And if what I have stated above is confirmed there is an opportunity for employing young people who otherwise might be dole demoralised.

It should, however, be recollected that all

## ON THE AIR

"Wireless knows no boundaries," acclaims an expert.

We wonder if he has ever tried to smuggle his portable set across the Continent!

"London will broadcast 'The Fog'..." Thanks, we've already had enough of the real thing.

children are born actors and actresses, as may be observed from their play; but often the inspiration vanishes when school begins, and the heavenly innocence of the child is partly masked by the social veneer.

Again, the child's voice demands a child's part, so that new plays must be written. Who will write a play entirely for child actors?

ARIEL.

MAKE  
YOUR  
BATTERY  
SET GIVE  
YOU THE  
VOLUME  
OF A  
MAINS  
SET !



If you want to get Mains volume from an ordinary battery set, replace your power valve with a Lissen Power Pentode, type P.T.2A. Immediately you will notice a tremendous increase in volume on all stations, a new brilliance of tone, a power in your set that will amaze you. There is no need to alter your receiver at all. Simply replace your existing power valve with a Lissen Power Pentode and you get the extra power immediately. It does not increase the current consumption of your set, yet it gives you an output that will drive a moving-coil speaker at full volume and with that characteristic Lissen pentode tone which puts a genuine verve into stringed instruments, blare into brass, majesty in the organ and sincerity in the human voice.

FOR Q.P.P. OUTPUT!

Use two of these Lissen P.T.2A Valves for Q.P.P. output—they are the ONLY valves for which you will require no expensive electrical measuring instrument in order to obtain exact matching. All Lissen P.T.2A valves are sent out matched. The exact voltage required is printed on each valve, so that all you have to do is to set the wander plugs on the H.T. battery to the voltage indicated on the valve, in order to secure perfect Q.P.P. output.

USE A POWER PENTODE  
**LISSEN**  
P.T.2A  
POWER - PENTODE

ASK FOR  
LISSEN  
P.T.2A

12/6

Send for full particulars, telling you how to build a modern Q.P.P. receiver, to LISSEN LIMITED, Worples Road, Isleworth, Middlesex.

WE CONTINUE

# P.W.'s COMPLETE SURVEY OF MODERN TELEVISION

By G. P. KENDALL

I'M afraid I ended my article rather abruptly last week when I was just starting to tell you how the Kerr cell works. However, you will remember that I had explained the important polarising effects which can be obtained with the aid of the devices called Nicol prisms, and now we must see how we can take advantage of them to achieve a light-control effect.

### How the Kerr Cell Works.

This is how it is done: Two Nicol prisms are placed in the beam of light from the local lamp, set at such angles that the polarised beam from the first just fails to get through the second. Between the two another gadget is placed called a Kerr cell, so that the light passes through this also.

Now, the Kerr cell is a device which is capable of modifying the plane of polarisation of a beam of polarised light passing through it. It does so, moreover, to a varying degree, according to the electrical voltage applied to certain points in the cell.

What it does, in effect, is to turn the plane of polarisation of the beam coming through the first Nicol so that a little light begins to make its way through the second Nicol. It does this to an extent depending on the voltage applied to it, so that the light getting through the whole assembly varies

spreading out in the form of a long cone of very gradual taper.

This is not at all what we

require, for our final object is a sharply focused spot of light on the screen. We must evidently take steps to convert our diverging beam into a converging one once more, and this means that we must insert another lens in the system at some point after the light valve.

Then we must also make provision for directing the beam of modulated light through the scanning apparatus and finally leading it to the receiving screen. Practical considerations usually involve the use of sundry mirrors for these purposes, and in this connection I should like to offer a hint to those who may intend to embark on experimental work later on with this particular system.

### Avoiding Losses.

In the course of such work it is often tempting to overcome all sorts of difficulties by leading the light beam here and there through the apparatus with the aid of lots of mirrors, but the temptation is one to resist. No mirror is 100-per-cent efficient, and every time you add one to the system you lose a little light.

Seeing, when far beyond the range of visibility, is a fascinating scientific problem which few writers can do justice to. But G. P. Kendall is an outstanding exception, as you will agree when you have read this intensely interesting description of the latest light-control methods.

which the light passes. When electrical voltages are applied to the two sets of plates, which are insulated from each other, the polarising effects are produced in the liquid.

The liquid, you will understand, acts as the dielectric of the condenser, and it is the dielectric strain produced therein which sets up the optical effects. To secure the strongest possible action the beam of light is made to pass through the spaces between the plates, which are interleaved very much like those of a variable condenser when it is set to its maximum capacity.

Naturally, a certain amount of auxiliary apparatus is needed in a practical receiver in addition to the light valve itself, as I hinted last week.

### A Very Thin Ray.

In the case of a Kerr cell system we obviously require first a lamp as a source of light, as I have already mentioned, and then we want a lens or combination of lenses to pick up as much light from that lamp as possible, and focus it down to a tiny, but intense, pencil small enough to get through the necessarily very small opening in the light valve.

This pencil of light is usually arranged to come to an actual point as it goes through the Kerr cell, so when it emerges therefrom it will be diverging again, i.e.



Dr. E. F. W. ALEXANDERSON.

according to the voltage impressed on the cell.

Here, then, we have our light-valve action, and all we have to do is to apply the picture impulses to the terminals of the cell to get the modulated beam we need for picture building.

I'm afraid it's rather a headachy subject, but I think that if you will now go back and read my description over again you will get quite a good grasp of its general principles.

Having done that, you will just want an outline of the construction of the Kerr cell, and then we can leave the subject of light control for a while. Briefly, then, the cell consists of an assembly of spaced-out plates just like those of a condenser, immersed in a liquid called nitro-benzol, through



DENES VON MIHALY.

Try therefore, so to arrange your gear that you can get the beam to the necessary places with the minimum number of mirrors, and thus get as bright

an image as possible.

These points are chiefly of importance in connection with the "mirror drum" scanner. With the perforated disc type it is usually easy to arrange a straight-through light path, but the Kerr cell is not often used with this kind of scanner.

Finally I must emphasise the utmost importance of accuracy in mounting all the parts of a television receiver. Mechanical weaknesses are as fatal to good results as electrical faults, and every care has to be taken to avoid such shortcomings.

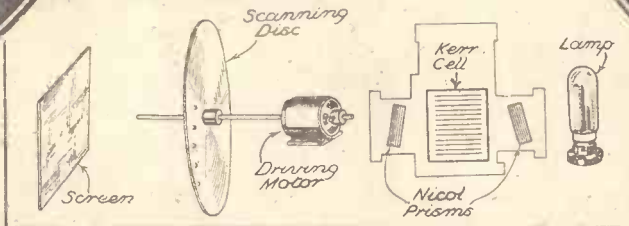

### TWISTING A BEAM OF LIGHT

The lamp (right) is made to give a brilliant light which is focused and passed through the Kerr cell and scanning disc to the receiving screen. But the light can only pass the Kerr cell in accordance with the varying impulses impressed on this from the distant television transmitter, which thus controls the illumination of the screen.

Dr. Alexanderson is one of the foremost television pioneers in America, while Von Mihaly has been responsible for many outstanding developments in the same science in Europe.



# TELSEN SCREENED COILS



*Exclusively specified*  
FOR THE P. W.  
*"National Eckersley Three"*

**C**APTAIN ECKERSLEY knows! And it is because he *knows* that he has specified and used TELSEN Triple-Matched Screened Coils in his latest triumph. There can be no more eloquent tribute to their lasting efficiency—the ultimate attainable in a perfectly shielded inductance of moderate dimensions. Follow his lead. Insist on TELSEN wherever coils are concerned.

TELSEN TRIPLE MATCHED SCREENED COILS . . . . . **21/6**  
TELSEN TWIN MATCHED SCREENED COILS . . . . . **14/6**  
TELSEN SINGLE SCREENED COIL . . . . . **7/-**

## TELSEN COVER EVERY COIL REQUIREMENT

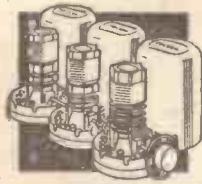

TELSEN SUPERHET COILS  
Type S.330 21/6

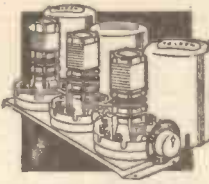

TELSEN BAND PASS & OSCILLATOR COIL UNIT  
21/6



TELSEN IRON CORED COILS  
Single 8/6  
Twin matched 17/-  
Triple matched 25/6

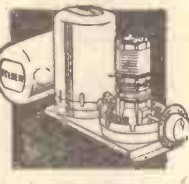

TELSEN BAND PASS COIL UNIT  
14/6



TELSEN DUAL RANGE AERIAL COIL  
7/6



TELSEN H.F. TRANSFORMER COIL  
5/6



TELSEN OSCILLATOR COIL  
7/6

**TELSEN FOR EVERYTHING IN RADIO**  
ANNOUNCEMENT OF THE TELSEN ELECTRIC CO. LTD., ASTON, BIRMINGHAM

You lose 33 $\frac{1}{3}$ %

reception with **dry batteries**  
Study the graph. Weigh up the  
saving that **"Half the Bulk"**  
**Plateless H.T. Accumulators**

would produce. Dry battery voltage falls continually.  
A Block H.T. accumulator maintains full voltage throughout its charge. Roughly this gives you 33 $\frac{1}{3}$ % more at full voltage (which is vital to proper reproduction). Moreover, having no "plates," a Block H.T. is not much bigger than a full-capacity dry battery—or half the bulk of the old style H.T. accumulator. Complete in beautiful bakelite casket with handle.

**INTERMEDIATE TAPPINGS ARE NOW FITTED.**

V O L T S	1 <sup>st</sup> month	2 <sup>nd</sup> month	3 <sup>rd</sup> month
120		<b>'BLOCK' ACCUMULATOR</b> <i>DRY BATTERY</i>	
<b>GOOD RECEPTION</b>			
100			
<b>POOR RECEPTION</b> Internal resistance rising. Falling-off in Bass notes.			
80			
<b>BAD RECEPTION</b> High internal resistance. No reaction. No Bass notes. LF Oscillation. Motor-boating			
0			



**RELATIVE COSTS.**

Even one year's supply of 60-v. dry batteries would practically pay for a 37/6 Block H.T. Accumulator. Thereafter the Block H.T. costs nothing but a shilling or two for re-charging!

**SPECIFIED**  
for the  
**NATIONAL**  
**ECKERSLEY**  
**3**

60 v. 5000 m.a.h. 14 $\frac{1}{2}$ " x 4 $\frac{1}{2}$ ", 37/6. 30 v., 21/-.

**HALVE your L.T. re-charging !**

Why re-charge your L.T. every ten days or so? A Block L.T. takes up no more space than your present 40 a.h. type—and gives 80 a.h.; lasts twice as long per charge! Free from all the weaknesses of the old plate type. 80 a.h., 2v., 11/6



BLOCK BATTERIES LTD., BY-PASS ROAD, BARKING, ESSEX.



If there is one speaker which stands out above all others for faithfulness in reproduction and full tonal volume it is the Amplion P.M. speaker. When you consider that Amplion speakers are made by expert sound technicians to suit all the characteristics of modern set design, you will understand why so many leading designers are using Amplion exclusively in their sets, and why Mr. Eckersley in "The National Three" also recommends the Amplion P.M. Moving-Coil Speaker.

Equal popularity is enjoyed by Amplion components, here again the Amplion Binocular H.F. choke is specified. Ensure success, use Amplion components and speakers in both these important constructional details.

- Binocular H.F. Choke.....Price 4/6
- "Audiola" Moving-Coil Speaker 9" cone ..... 49/6
- "M.C.22" Moving-Coil Speaker 7" cone.....39/6

*Both models-fitted with all purpose universal transformer.*



Amplion, (1932) Ltd., 82/84, Rosoman Street, London, E.C.1.

# The ONLY Battery Set



## MODEL 74

7-STAGE SUPER-HET WITH BAND-PASS TUNING

WALNUT FINISH ★  
13 Gns.

or 12 monthly payments of £1.5s.

BLACK & CHROMIUM ★  
14 Gns.

or 12 monthly payments of £1.7s.

★ There are also All-Electric Models for A.C. or D.C. Mains incorporating DELAYED AUTOMATIC VOLUME CONTROL. Also available in handsome Console Cabinet 18 Gns. or 12 monthly payments of £1. 14. 9.

with . . .

- CLASS 'B' OUTPUT
- DETACHABLE FRET, interchangeable silk — exclusive to EKCO.
- UNEXCELLED STATION-RANGE PERFORMANCE.
- Moving-Coil Speaker.
- Magnificent Bakelite Cabinet.
- One-knob tuning.
- Station scale with NAMES and wave-lengths.
- Local-distant switch.
- Light-beam and shadow station indicator.
- Combined on-off switch and volume control for radio and gramophone.
- Gramophone pick-up sockets controlled by switch.
- External speaker connections.

# EKCO RADIO

at **13** GNS.

Consult your dealer or post coupon now!

To  
 E.K. COLE Ltd., Dept. A.15, EKCO Works, Southend-on-Sea  
 A full-coloured folder will be sent to you free on receipt of this coupon  
 NAME .....

ADDRESS .....

OUR SPECIAL SUPPLEMENT for BEGINNERS

RADIO STEP-BY-STEP



WHY is it that the thirst for radio knowledge is so often quenched by the fear of formulae? It is true that some of the more intricate calculations in radio do require the services of the skilled mathematician, but, on the other hand, there are plenty of useful practical calculations that can be worked out even though you may not be a mathematical juggler.

Don't fight shy of figures and formulae. Those in common use are invariably quite simple and merely look difficult.

Not Really Difficult.

Suppose you were reading an article or a chapter in a radio text-book and suddenly came across an expression like this:

$$Z = \sqrt{R^2 + (2\pi fL - \frac{1}{2\pi fC})^2}$$

or this:

$$L = 2l (2.3026 \log_{10} \frac{4l}{d} - 2.853)$$

What would you do? Probably a great many of you would pass on to something else and give the "highbrow" stuff a miss.

Now, in the Step-by-Step series we want to tell you something about formulae and to show you how to work them out without the necessity of having to take an extensive course in maths. All "dry-as-dust" treatment will be eliminated, and we shall confine ourselves to those processes that are of real practical value to the radio enthusiast.



A HOSE ANALOGY

Here is a helpful analogy. The trickle of water from the hose is due to lack of pressure or excessive pipe resistance. It illustrates an electrical circuit in which only a small current can flow, owing to inadequate voltage or high resistance.

Mathematicians have a habit of using various letters and symbols with the object of achieving greater simplicity. In other words, they employ a kind of shorthand, and it is this which the beginner tends to find so confusing.

For instance, we often see a number with another one tacked on to the top right-hand corner. To take a practical case, we have 10<sup>2</sup>. This is called "ten squared," or "ten to the power of two." Boiled down, it simply means that the number 10 has to be multiplied by itself—i.e. 10 × 10, which is equal to 100.

THE FASCINATION OF FIGURES

Hence, 10<sup>2</sup> is another way of writing 100. The method is very useful in dealing with large numbers. A thousand would be written 10<sup>3</sup> (i.e. 10 cubed), and a million as 10<sup>6</sup> (ten to the sixth). The power, or exponent, as it is also called, merely tells you how many times you have to multiply the number by itself. A million is ten multiplied by itself six times.

Sometimes the power has a minus sign in front—e.g. 10<sup>-2</sup>. This is another method of writing one-hun-

dredth or  $\frac{1}{100}$ . 10<sup>-3</sup> is the same as  $\frac{1}{1,000}$  (one-thousandth), and 10<sup>-6</sup> is one-millionth.

Now, engineers and mathematicians also use letters of the alphabet to represent numbers. Perhaps one of the simplest instances we can take is Ohm's Law, which we explained in an earlier article.

Ohm's Law.

Ohm's Law says that the current flowing in a circuit is equal to the voltage or pressure divided by the resistance. It is expressed in the form:

$$I = \frac{E}{R}$$

I, E and R represent numbers, the symbol "=" is the same thing as saying "is equal to," and the horizontal line separating E and R tells you that E has to be divided by R.

Taking a practical example, we will assume that E is 100 volts and R is 50 ohms.

Then  $I = \frac{100}{50}$  or I, the current in amps, is equal to 2. (This is assuming the current flowing to be D.C.)

Or perhaps we want to work out the volts dropped or lost when a certain current flows through a resistance. The question of voltage drop is very important. For example, you

might have a mains unit giving a voltage of 150, which, although suitable for supplying some of the valves in your set, is nevertheless too high for others.

Suppose the detector only requires 100 volts on its anode. Then you would have to drop 50 of the 150 volts in order to supply the valve with the 100 volts it requires.

To do this a resistance would have to be inserted in series with the high-tension connection going to the anode of the valve.

The valve makers will tell you how much current the valve takes at 100 volts. Sup-

pose it is 4 milliamperes ( $\frac{4}{1,000}$  of an ampere).

Now, Ohm's Law can also be written in the form  $\frac{V}{I} = R$ ,

where V is the voltage dropped in the resistance and I the current in amperes. R is the unknown resistance that we have to find.

In this particular case the voltage to be dropped is 50 and the current is  $\frac{4}{1,000}$  of an amp. So  $\frac{50}{\frac{4}{1,000}}$ , or 50 divided by  $\frac{4}{1,000}$ , is the little sum that we have to work out.

$\frac{50}{\frac{4}{1,000}}$  is the same as 50,000 divided by 4 (moving the decimal point three places to the right and adding three noughts to the top number). This gives an answer of 12,500 ohms, and

is the value of the resistance R which we must insert in circuit to reduce the 150-volts supply to 100 volts at the anode of the detector valve.

Finding Voltage Drop.

If we already know the current flowing (in amps.) and the resistance we can find the voltage drop simply by multiplying the current and resistance together. The equation or expression is written  $V = I \times R$ . It could be written as  $V = I \times R$ , but for convenience the multiplication sign × is generally omitted.

So when you see two letters such as I and R written like this: —IR—you will know that one has to be multiplied by the other. Taking as an example the sum we have just done, we see that IR=12,500 multiplied by  $\frac{4}{1,000}$ , which is equal to 50. If you don't wish to be bothered by the decimal all you have to do is to multiply 12,500 by  $\frac{4}{1,000}$ . That is, multiply the 12,500 by 4 and divide the answer by 1,000. The result is just the same in both cases.

So you see these little sums are perfectly simple when they are tackled in a practical manner. It is true that the formulae given at the beginning of this article are somewhat more involved, but actually they are no more difficult than Ohm's Law in its simplest form. But we must leave our further explanations for the next article on the subject.

HIGH PRESSURE



The good flow of water due to adequate supply pressure and low pipe resistance can be likened to a circuit having a high voltage and low resistance. In an alternating current circuit the inductance and capacity have to be considered as well as resistance.

HOW MANY AMPS?

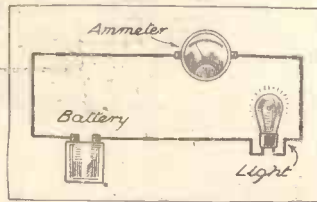

In practice, the current flowing in a circuit is generally measured with an ammeter. But it can also be found by Ohm's Law provided the voltage of the supply (in this case the battery) and the resistance (or impedance) are known.

# Telsen H.F. CHOKES AND CONDENSERS



**TELSEN SCREENED H.F. CHOKES**  
 These new Chokes have been very carefully designed so that their efficiency is consistently high over the whole of the waveband for which they are intended. They are small and compact and the metal screen, which is connected to an earthing terminal, entirely prevents interaction with other components.



- TELSEN ALL-WAVE SCREENED H.F. CHOKES 5/6
- TELSEN STANDARD SCREENED H.F. CHOKES 3/6
- SHORT WAVE SCREENED H.F. CHOKES 3/6
- Standard H.F. Choke - - 2/6
- Short Wave H.F. Choke - 3/-
- Binocular H.F. Choke - 4/6

**TELSEN REACTION CONDENSERS**

Entirely re-designed. Now incorporate several valuable improvements with no increase in price, the whole unit being also now enclosed in a strong dustproof bakelite case. Supplied complete with knob.

Capacity	Price
'0003 mfd. . . . .	2/6
'00015 .. . . .	2/6
'0001 .. . . .	2/6
'00075 .. . . .	2/6
'0005 .. . . .	2/6

**TELSEN DIFFERENTIAL CONDENSERS**

Similar in design and construction to the reaction condensers. Supplied complete with knob.

Capacity	Price
'0003 mfd. . . . .	2/6
'00015 .. . . .	2/6
'0001 .. . . .	2/6

**TELSEN AERIAL SERIES CONDENSER With Switch**

Built on similar lines to the new reaction condensers, providing an ideal selectivity and volume control. Supplied complete with knob.

Max. Cap.	Price
'0003 mfd. . . . .	2/6

Special Beginner's Supplement—2.

**COILS**

Practically all modern tuning coils are wound in single-layer solenoid fashion, in so far, at least, as their medium-wave windings are concerned.

A typical "aerial coil" has medium-wave, long-wave and reaction windings. Additionally, there may be a primary winding for the aerial circuit (Fig. 1a). In other cases the aerial is connected to a tapping, the position in the winding of which determines the selectivity of the arrangement within limits.

A coil unit for intervalve coupling sometimes has both primary and secondary medium- and long-wave windings, and can then be used as an H.F. transformer.

To achieve reasonable efficiency a tuning coil must be of low H.F. resistance, and it is to obtain this that recourse is often made to stranded wire in its winding.

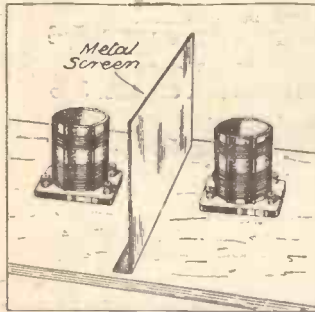

Fig. 1. A metal screen should be used to separate two unshielded coils in a circuit.

The object of utilising special iron cores in tuning coils is to obtain the desired inductance with a minimum of wire and so achieve a low H.F. resistance. Additionally, because the coil itself can be made much smaller screening can be applied with less consequent loss, owing to the greater distance between coil and shield that can be obtained while still retaining reasonable overall dimensions.

When a screen (shield or "can," as it may alternatively be called) is added to a coil the

**AERIAL CIRCUIT**

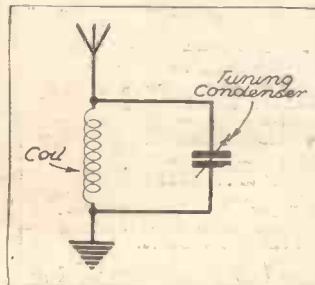

Fig. 3. The arrival of a wave in an ordinary aerial circuit sets up a current which goes round and round the circuit, growing less in strength at each journey.

coil's inductance will be affected, and in a properly designed screened coil this effect is taken into account. Iron will increase the inductance, but aluminium or any other non-magnetic metal will reduce it. This will, of course, affect the "wave-range" of the coil.

Two or more unshielded coils used in different valve

# RADIO TERMS

Wireless simply explained in a readable and easily-referred-to manner.

By G. V. DOWDING, Associate I.E.E.

stages should be placed so that they do not tend to couple unduly. A partition screen (Fig. 1) can be used, but it is generally advisable to supplement this by placing the coils in such a way that their magnetic fields do not tend to link (Fig. 2).

The range of wavelengths a coil will cover depends upon the capacity range of the variable condenser used with it.

For ordinary broadcasting ranges it is usual to employ a variable condenser having a maximum capacity of .0005 mfd. To maintain a good electrical balance of inductance and capacity it is not desirable generally to exceed this.

**WAVE-CHANGE COILS**

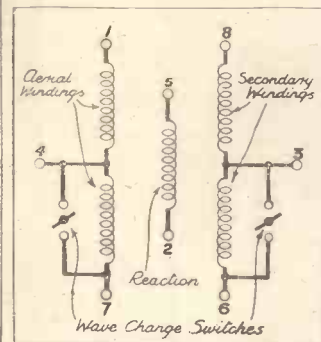

Fig. 1a. A typical dual-range coil shown in theoretical form. The diagram clearly shows the three main sections.

To cover the wide waveband of about 200 to 2,000 metres occupied by broadcasting stations it is therefore necessary to employ two values of inductance.

These can be obtained either by switching a long-wave coil in series with the smaller medium-wave coil, or by using two entirely separate coils.

The former method is the one most widely adopted.

**CONDUCTOR.**

Any substance which offers a relatively low resistance to electrical currents. It is very difficult to determine where the line between a very poor insulator and a very poor conductor can be drawn. The fact is there is no such thing as a perfect insulator. All substances are to some extent

The "arrival" of its first wave sets up a current in the circuit, and if there were no following waves this current would tear backwards and forwards around the circuit, growing less and less in strength with each succeeding oscillation.

"The rate at which the oscillations die away indicates the damping of the circuit. The oscillations die away because energy is spent in overcoming resistance, and the greater the resistance in the circuit the greater the damping (Fig. 5).

This resistance can be in the form of ohmic resistance (in the

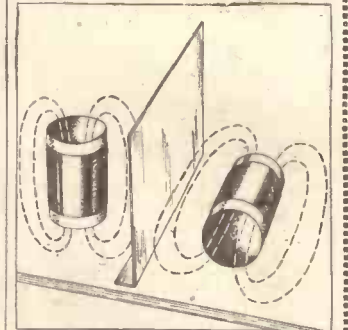

Fig. 2. To complement the effects of a screen the coils should be placed so that their magnetic fields do not tend to link.

conductors in the literal sense, though in practice no difficulty is found in making arbitrary distinctions.

**CONTINUOUS CURRENT**

An alternative description for direct current.

**COULOMB**

A unit of quantity in electricity equalling one ampere flowing for one second.

**COUNTERPOISE**

An alternative to the ordinary earth connection, comprising a wire or wires insulated from earth and arranged under the aerial.

**COUPLING**

When a change of current in PREVENTING BOOM

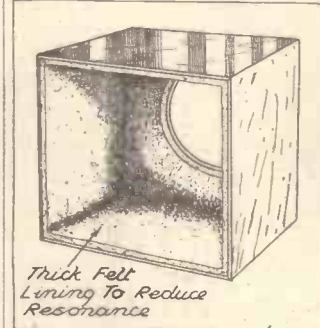

Fig. 4. The lining of a loudspeaker cabinet tends to reduce vibration at certain frequencies.

one circuit produces an electromotive force in another, then it is said that there is coupling between them.

**CURRENT**

The flow of electricity. The unit of electrical flow is the ampere.

**DAMPING**

When a circuit is tuned to a particular frequency, currents of that frequency are able to oscillate in it. For example, take an ordinary aerial tuning circuit tuned to the frequency of one particular broadcasting station (Fig. 3).

wire of a coil, etc.) or a resistance based on the energy drawn from the circuit by all forms of losses in coils and condensers, etc.—dielectric losses, for instance.

The damping determines the selectivity of a circuit. The less the damping the greater the selectivity.

Mechanical and acoustic damping is encountered in the loudspeaker. Anything which tends to restrict the mechanical oscillatory motion of a loudspeaker armature or diaphragm constitutes damping.

Diaphragm and loudspeaker cabinets tend to have natural resonant frequencies, frequencies at which they will vibrate more freely than others. Damping by means of special damping or absorbent material can be employed to eliminate, or at least reduce, such an effect (Fig. 4).

**WASTED ENERGY**

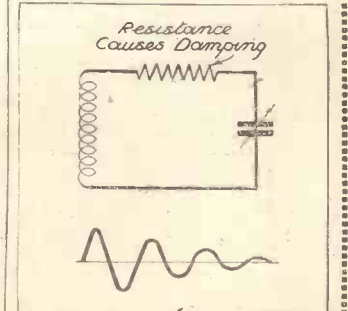

Fig. 5. This shows how a current going round the circuit of Fig. 3 expends energy on overcoming the resistance of the circuit, and so grows weaker and weaker.

# NICORE

## A. V. C. UNIT



**AND  
THE**

The Varley Nicore automatic volume control unit can be fitted to any receiver having one or more variable- $\mu$  S.G. valves. Connected immediately after the detector valve (second detector with Superhets) in place of the H.F. choke. Easily inserted into the circuit, only four connections being necessary.

**B.P.27 - - - - - 15/6      D.P.44 - - 15/6**

# Varley

(Proprietors: Oliver Peel Control Ltd.)

*Write to us to-day for full particulars of the whole range of Varley Components*

# POWER PUNCHER

Advert. of Oliver Peel Control Ltd., Kingsway House, 103, Kingsway, W.C.2. 'Phone: Holborn 5303



The new Varley "Power Puncher" is easily incorporated in most battery sets. Gives greater volume with lower H.T. current. Requires no special transformers or valves.

# GARRARD

## QUALITY PRODUCTS



AT small cost you can convert your set into a modern radio-gram with all the advantages of gramophone reproduction with radio amplification. Garrard Motor, turntable, combined pick-up and tone-arm, needle-cups (and volume control if required), are fitted to a bronzed-steel unit plate which ensures simplicity of fitting.

Electric models are suitable for 100 to 130, and 200 to 250-volt mains, and spring models are unusually silent in operation.

- A.C.4 "Garrard" Electric Radio-gram Unit - - 75/-
- No. 10B. "Garrard" Double Spring Radio-gram Unit 81/9
- No. 202A. "Garrard" Electric Radio-gram Unit - - 81/9
- Universal "Garrard" Electric Radio-gram Unit - - 128/6

*Write for full particulars:*

**GARRARD ENGINEERING AND MANUFACTURING CO. LTD.**  
SWINDON, WILTS; 17, GRAFTON STREET, LONDON, W.  
Swindon 534 & 535 (2 lines.)      Regent 7596.

## WHAT SET IS YOURS?

**FOR EVERY SET ON THE MARKET THERE IS A SUPER-LIFE GROSVENOR BATTERY.**

For instance, is yours a

**PYE**

There is a Super-Life Grosvenor for every Pye Model. Ask your dealer.

Whatever the make, you would get the *most* out of your set with a Grosvenor Battery. A Grosvenor would give it just the silent super-abundant power it needs—and lasts far longer than any battery you have ever had. The Grosvenor MERCURY process is the secret; guarding against corrosion and enabling the cells to be hydraulically crammed with *extra* chemicals. Next time, insist on a Grosvenor. Specified for the National Eckersley 3.

or, if yours is a

**McMICHAEL**

- PYE G.B.1. Ask for Grosvenor DBA. 475 (159 + 9 v.) 17/6
- PYE P.B. Ask for Grosvenor SR. 590 (130½ + 4½ v.) 17/6
- McMICHAEL Duplex 4. Ask for Grosvenor DBA. 395 (120 v.) 14/-
- McMICHAEL Class B.5. Ask for Grosvenor SR. 490 (99 + 7½ v.) 16/-

your dealer has a Super-Life Grosvenor made specially for your set.

*Mercury-protected cells make it  
The Longest-Lived Battery  
in the World"*



**GROSVENOR ELECTRIC BATTERIES LTD., 2-3, White St., E.C.2.**  
Works: Watford, Herts.      Telephone: METropolitan 6866 (3 lines).

# TESTED AND FOUND?

Being leaves from the Technical Editor's Notebook

## THE "MITE" GANG CONDENSER

SOME of the very best work in the whole of the radio industry is being done by the condenser makers. As a matter of fact, this seems to have been the case for years.

I suppose the reason is that, as condenser-design problems are largely mechanical problems, there has been a tendency for highly skilled mechanical engineers to drift towards that sphere of radio and for mechanical and electrical engineering to go more hand in hand than with some of the other branches.

A most attractive example of the achievement of modern condenser manufacture is the Utility "Mite" Gang.

It is only a third or quarter the size of a standard model, but is equal in every way to the larger ones. I place it among the very best pieces of work I have encountered.

Two patterns are available, one having a die-cast and the other a pressed-steel frame, the prices being the same in each case, i.e. 12s. 6d. for the two-gang and 19s. for the three-gang.

Why, then, you may well ask, have these two patterns? The idea appears to be this: With the die-cast frame the minimum dimensions can be obtained, but not the extremely high degree of accuracy that is possible with the somewhat larger, but still quite, small pressed-steel frame.

The die-cast pattern is very satisfactory, and I should say is well up to average standards in the above respect and superior to them in others.

I haven't space to describe the many outstanding features of this Utility "Mite" Gang Condenser, but you will find them all detailed in an interesting manner in the current Wilkins & Wright, Ltd., catalogue.

If you do not happen to possess a copy I would advise you to write to Utility Works, Birmingham, for one, although I am aware that in giving you this good advice I am trespassing on our Mr. Kelsey's ground!



One of the greatest advantages of the Utility "Mite" gang condenser is its small size. In efficiency it is in every way equal to a larger condenser.

## A BIG CELESTION SPEAKER

During the past few years the general tendency in industry has been to provide the consumer with as much as possible at the lowest price. And

such has been the keenness of competition that prices have been in many instances too low to show good profits.

Now, that is all very nice for us consumers—up to a point. So long as this policy could be maintained by feeding on capital we got excellent value for our money and only a relatively few suffered.

But a fundamentally uneconomic structure is bound in the long run to bring individual and collective disaster. One by one the various industries seemed to recognise this and took steps to put their houses in order. And, to cut my economic preamble short, we are largely by this means just managing to creep back from the edge of the precipice.

A radio by-product of the afore-mentioned scramble to give buyers bigger and better bargains was the flood of inexpensive moving-coil loudspeakers, which, by the way, still persists, though I believe their production is now on a quite solid economic basis owing to improved methods of production.

But, surrounded by a score or more of different makes of these real-value-for-money instruments, I recently found myself asking a question. Would or would not there be a market for a really hot-stuff moving-coil loudspeaker? I mean a loudspeaker designed and made regardless of cost.

Giving full credit where credit is due, I will at once admit that there are on the market "senior" types which are really splendid productions. Nevertheless, I have had the impression that, given a good price to work to, say twelve to fifteen guineas or more for the bare unit alone, the industry could now present something quite marvellous, though the doubt remains that many could, after all, afford or even desire such a luxury.

Anyway, this thought of mine drifted along to Celestions, and the result is that they have sent me one of their Auditorium units to try, Model A.C. 38.

This is not quite the kind of instrument I had in mind for it is a public-address model, not a speaker for the home. However, I presume it has been sent to me to show just what can be done when mass and power restrictions are removed.

It was with great interest that I tested this big Celestion unit, and I must mention in passing that it took us about three hours to arrange suitable conditions under which it could be operated, for our laboratory, though fairly large, is neither a lecture-hall nor a wide-open space. Remember that this big Celestion is not a junior P.M., but a speaker suitable for a cinema.

(Continued on page 892.)

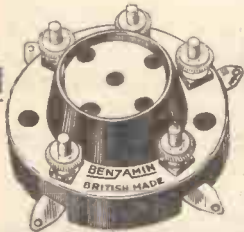

# 3

**BENJAMIN 5-PIN VALVEHOLDERS**

**SPECIFIED FOR THE "NATIONAL ECKERSLEY THREE"**

Because they ensure perfect valve contact and because they are so neat in assembly Benjamin Five-pin valveholders have been used by Mr. Eckersley in this great Public set.

Take advantage of his long experience: use Benjamin, too, in every set you build. 5-Pin . . . .

**Price 10d. each**

# BENJAMIN

**ELECTRIC LTD.,  
Tariff Road, Tottenham.**

## ELECTRADIX RADIOS HOME BROADCASTER



A New, Practical Home Mike for 5/6. Wireless Broadcasting at Home.

A solo mike for hand or stand in fine bakelite case, with back terminals, front metal grille. New and finely finished. 5/6 Only

### THE DIX-ONEMETER

The ideal of multi-range, moving-coil meters. Built to first-grade British Engineering Standard. Fifty ranges in one meter. Measures microamps to 20 amps., millivolts to 1,000 volts, 50 ohms to megohms. Six terminals; two clear scales, mirror, and knife-edge pointer for accurate reading. Complete in case, 60/-

**TRU-TWIN CAMERASCOPES, BROWNS',** double lens, folding, 2/-; **CHASSIS** for Set Builders: All-Metal Base C' axis, fitted 2 valve holders, all drilled for Brownie components, 3/8; **Loudspeaker** Fret Silk, 12 in. X 12 in., 1/-; 24 in. X 24 in., 3/-.

**THE BATTERY SUPERSEDER** makes H.T. from your L.T. 2-volt battery, rectified and smoothed. Gives 3 tappings and lasts indefinitely. A boon to those who are not on the mains. Reduced from £3/15/- New and Guaranteed, 37/6.

**PARCELS** of experimental odd magnets, wire chokes, condensers, switches, terminals, etc., post free, 10 lbs. 7/-; 7 lbs., 5/-; 1,000 other Bargains in New Sale List "M.E."



1,000 other Bargains in our January Sale List "P,"  
**ELECTRADIX RADIOS**  
218 UPPER THAMES ST., LONDON, E.C.4  
Telephone: Central 4611.

## FOR THE NEW WAVE LENGTHS! COMPLETE THE JOB

CHANGE YOUR PRESENT AERIAL for an **AIRCLIPSE** Auto-Inductive AERIAL



Have a selective aerial as well as a selective set! You get amazing clarity with this modern aerial. It banishes "mush" because it filters all incoming signals. It adjusts your set to present conditions. You get more stations because you hear them all separately—each programme crystal clear. Unsightly masts and wires are disposed of. Lightning danger is gone. Your set is made portable. Not just another gadget, Airclipse is new and improved in principle.

\* "Delighted" writes a user.

"My receiver has always been exceptionally good, but with your new patent, it is even better. The result is more than I expected—it does all that it claims to do."

A. W. T., Plumstead, S.E. 18.  
At all dealers, but if any difficulty order direct.

# 5/-

FOR A.C. MAINS & BATTERY SETS

**AIRCLIPSE LIMITED**  
182 Vauxhall Bridge Rd. London, S.W.1.



**CHEAPER  
POWER  
FOR  
BATTERY SETS**



THE BEST BATTERY EVER BUILT NOW COSTS YOU LESS

*The* **INCOMPARABLE  
FULL O' POWER**  
'POWER' TYPE *Triple Capacity*  
RADIO BATTERIES

Advanced scientific methods of manufacture enable these exceptional reductions to be made.

Made by **SIEMENS** specialists in battery manufacture for over 60 years.

● Write for free booklet 667 of up-to-date battery information to address below.

	OLD PRICE	NEW PRICE	OLD PRICE	NEW PRICE
V.4 60 volt.	17/-	8/6	V.6 108 volt.	20/- 15/-
V.5 45 volt.	9/-	7/6	V.8 120 volt.	24/- 17/6

Agents: **SIEMENS ELECTRIC LAMPS AND SUPPLIES LIMITED, 38/39, Upper Thames Street, London, E.C.4.**



Smoke  
**PLAYER'S  
AIRMAN  
MIXTURE**

The finest mixture  
at **10<sup>D</sup>** per oz

ALSO PLAYER'S 'AIRMAN' NAVY CUT  
DE LUXE AT 1.1<sup>D</sup> PER OZ.

PA 32



Meet Your  
Favourite  
**RADIO  
STARS!**

One of the curious things about radio is that it puts you on friendly terms, as it were, with a host of clever folk whom you have never seen — whom you possibly never will see.

You have listened to their voices so very often during the eleven or so years of broadcasting that you cannot but feel that you know them well. And yet—what are they like? You must have often wondered.

No need to wonder any longer. Here they are—over three hundred of them—assembled to meet you in the pages of **WHO'S WHO ON THE WIRELESS**. Dance Band Leaders, Comedians, Singers, Entertainers, Critics, Commentators—the whole team are lined up to say "How do!"

Over 300  
**BIOGRAPHIES**  
& Numerous Portraits  
of Famous Stars.

6<sup>D</sup>. At all Newsagents, etc.

**WHO'S WHO  
ON THE WIRELESS**

## TESTED AND FOUND

(Continued from page 890.)

When we did get it going its performance was thrilling, the response being wonderfully balanced through the whole scale.



The A.C.38 speaker has a 38-watt field supplied from a 65-watt rectifying and smoothing unit incorporated in the chassis.

Radio music stepped up by a twenty-watt outfit failed to load it to its limits (it will take 25 watts safely), and the closest approach to realism of reproduction was attained that we have heard.

As a demonstration of Celestion's mastery of their art the test was one hundred per cent complete.

### PETO-SCOTT CABINETS

During the past month or two, Peto-Scott have designed quite a number of special cabinets for various of our sets. And the latest examples of their work are to be seen in the photos of the National Eckersley Three.

At least the excellent forms adopted will be evident but not the finer details of craftsmanship and finish.

These can be seen to their full advantage only in the real thing. The Radiogram model particularly is one of the best pieces of radio cabinet work which we have encountered. Although it is unusually substantial, this quality is skillfully hidden by its artistic lines.

The finish is magnificent, there being a high polish on flawless surfaces. For really high-class cabinets

at prices within the reach of all, Peto-Scott have certainly set an extremely high standard.

I must mention that the above paragraphs are quite spontaneous on my part. You see it so often happens that upon the cabinet depends at least, to some extent, the dimensions of success achieved by a set.

In this present instance (I am referring to our Great National set described in this issue) Messrs. Peto-Scott have done their part, as before, in grand style and it is in acknowledgment of this that I have penned the foregoing words.

## WHAT IT IS LIKE TO BE AN ANNOUNCER

(Continued from page 874.)

and grasp one's exact function in the scheme of things: a friendly voice to make the bridge between artiste and listener, to prepare the listener to like the artiste and make the artiste feel happy and at home in the studio so that he or she goes to the microphone feeling that there are a crowd of friends "at the other end," if I may express it like that.

At first the silent studios and the silent artistes waiting behind one make one very self-conscious. One feels that they are noticing one's every mistake. Only when one realises that they are far too occupied with what they are going to do to regard one as more than an introduction to their performance: only when one is completely at home with both studio and microphone can one begin to come to a friendly understanding with the unseen audience. It is important, too, to picture the different kinds of people listening to all the various types of programmes at all the various times of day.

To take a few examples: The ardent musicians, who listen nightly to the promenade concerts and who only want to know what will be played. Or the young people listening to the light evening programmes, who would like one to be rather chatty. Or the invalids, to whom the ordinary daytime programmes come as a welcome break in their monotony.

Letters help one in this, of course. I had one once from an old lady of 70 who had not been out of her room for 30 years and listened to the morning service every day. She told me that the way I said "Good-morning" made her feel "all comfortable." I always remembered that. And lest I should get bored with the morning weather forecast "at dictation speed" I had a charming letter from the skipper of a tramp steamer in the North Sea, saying: "Please go on reading the forecast as slow as you do now, as I have no shorthand." The thought of that skipper in his often-pitching steamer kept my speed at super-dictation! I hope he was pleased.

"A Happy Time."

And, of course, in case one should get conceited, there are always the people who write and say: "Get off the air! You've a loud, vulgar and ill-educated voice."

It was a happy time for me. I made many mistakes—probably all that the men announcers have ever made and some of my own. One thing, however, never happened to me. The engineers never sent down a message after my news reading: "Dirty background noises caused by announcer's shirtfront creaking!"



# SPECIFIED FOR THE "ECKERSLEY NATIONAL RADIO-GRAM"

J. B. NUGANG type "A"

A rigid chassis that is all one piece—so strong that there can never be the slightest distortion in use. Trimmers to each stage operated by external starwheels. Special rotor bearings ensure permanent accuracy and give remarkably free movement.

Nugang type "A"—complete with Disc Drive and fully screened - - 22/6



## PRECISION INSTRUMENTS

Advertisement of Jackson Bros. (London) Ltd., 72, St. Thomas Street, London, S.E.1.

Telephone: HOp 1837

## MORE PRAISE FOR THE S.T. MANUAL

(Continued from page 878.)

From C. C. PATERSON, O.B.E., M.Inst.C.E., M.I.E.E., F.Inst.P. (Research Laboratories, General Electric Co., Ltd.)

The technique of wireless reception has moved so rapidly during the past two years that many who were once expert have failed to hold the pace, whilst those who come to it anew and would fain understand it, hold-back in alarm at its complication. To all such, this book will come as a godsend.

Those who are really expert do not always realise, as have the promoters of this book, the value to the industry of an understanding public. They are doing a great service by interpreting to the intelligent public the present state of this vital and fascinating branch of free-electron engineering.

From CAPTAIN de A. DONISTHORPE (of The General Electric Co., Ltd.)

I have just completed reading that very excellent text-book, "The Manual of Modern Radio," by John Scott-Taggart, and must compliment you on its production.

It is of particular interest to me, as I have known Scott-Taggart since his first association with radio.

### ANOTHER GREAT OPPORTUNITY

to obtain a copy of Mr. John Scott-Taggart's magnificent presentation book

"THE MANUAL OF MODERN RADIO"

is given to regular readers of "POPULAR WIRELESS" this week.

Please turn to pages 847 and 848.

I can say that I have not seen a more complete text-book in years and one that will appeal to both amateur and professional alike. I like it because it is right up to date, and in these days of such tremendous strides in radio design it is a hard matter to keep pace with the rate of progress; and at the same time the fundamental principles are there for those who wish to refer to them.

From the CHIEF ENGINEER, (Technical Department, H.M.V.)

"The Manual of Modern Radio" is a well compiled treatise dealing with all phases of radio reception, and will fill a gap in radio literature. It should be in the hands of all persons who intend to take the sale and service of radio receivers seriously and efficiently.

From V. Z. de FERRANTI, Esq., (Managing Director, Ferranti, Ltd.)

I am sure "The Manual of Modern Radio" by John Scott-Taggart will be of interest to the radio amateur, and will help in the education of the public.

From CAPT. H. J. ROUND, M.C., M.I.E.E., (the famous radio pioneer and late Chief of Research of the Marconi Co.)

This is a very comprehensive manual of broadcast radio circuits, bringing together in an interesting way a large amount of information up till now only obtainable by much searching.

Mr. Scott-Taggart should be congratulated on his fine effort."

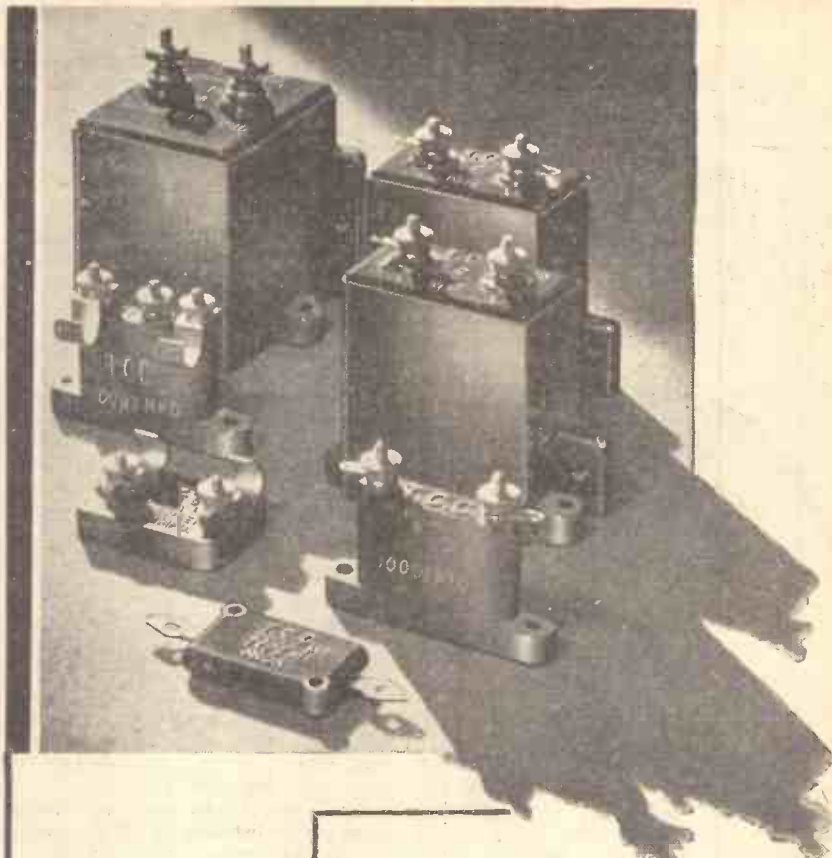

# T.C.C.

ALL-BRITISH  
CONDENSERS

are

## PEDIGREE CONDENSERS

Thoroughbred—of sound stock—a line that goes back twenty-seven years . . . more than a quarter of a century's research—unmixed by other activities—always condensers. And so . . . development, year by year keeping just ahead of radio's needs.

That is what T.C.C. stands for — what backs each and every T.C.C. Condenser you buy. Any of the group of popular T.C.C. Condensers illustrated—or the latest electrolytic, or a block condenser, they are reliable—dependable.

Insist on T.C.C. and be *sure*.

The Telegraph Condenser Co. Ltd.,  
Wales Farm Road, N. Acton, W.3.

# THE SUPREME VALVE

but at **ECONOMY** prices

The Tungram Note, correcting youthful impudence: "Now perhaps you can FEEL that there's something unusual about the amplification factor of our new Tungram Symphonic Valves!"



## OLD SETS RE-VITALISED BY TUNGSRAM'S NEW SYMPHONIC VALVES

New life from your old set—without change of circuit! Re-vitalise your set to-day with Tungram Symphonic Valves! Specially designed, after months of research, to improve the volume, quality and sensitivity of old A.C. sets! Inexpensive, too.



### THE SYMPHONIC A.C. RANGE INCLUDES

- Symphonic Screen Grid AS 4120
- Symphonic V.M. Screen Grid AS 4125
- Symphonic H.F. Pentode HP 4100
- Symphonic V.M. H.F. Pentode HP 4105
- Symphonic Detector AR 4101
- Symphonic Multi Grid Output APP 4120

Ask your Dealer or write our Technical Dept.

# TUNGSRAM

## BARIUM VALVES

Tungram Electric Lamp Works (Gl. Brit.) Ltd, 72 Oxford St., W.3

TAS/TU26

# RADIOTORIAL

The Editor will be pleased to consider articles and photographs dealing with all radio subjects, but cannot accept responsibility for manuscripts or photos. Every care will be taken to return MSS. not accepted for publication. A stamped and addressed envelope must be sent with every article.

All Editorial communications should be addressed to the Editor, POPULAR WIRELESS, Tallis House, Tallis Street, London, E.C.4.

All inquiries concerning advertising rates, etc., to be addressed to the Advertisement Offices, John Carpenter House, John Carpenter St., London, E.C.4.  
The constructional articles which appear from time to time in this journal are the outcome of research and experimental work carried out with a view to improving the technique of wireless reception. As much of the information given in the columns of this paper concerns the most recent developments in the radio world, some of the arrangements and specialities described may be the subjects of Letters Patent, and the amateur and the trader would be well advised to obtain permission of the patentees to use the patents before doing so.

## QUESTIONS AND ANSWERS

### WHEN THE NATIONALS CLOSE DOWN.

W. H. (Nr. Cheddar).—"Is it right that the B.B.C. is going to close down all the National stations later on in the year?"

No, they certainly won't do that. But when the new long-waver at Droitwich is completed it will not be necessary to repeat that programme in certain districts, so there will be some rearrangement of "National" wavelengths.

### IF THE LOCAL STATION IS HEARD ON LONG WAVES.

J. N. (Bournemouth).—"It was perfect when we lived near Petersfield, but now we have moved to Bournemouth the long waves are spoilt because we can hear Bournemouth all the time below about 50 on the dial.

"I was telling my mate about this, and he suggested I should write in to you, because he thought you had brought out a scheme to stop it, about a couple of years ago, when it was very troublesome.

"If that can be done it would be a great saving, as there is nothing wrong with the set, and it seems a pity to have to get a new one on top of moving expenses, just because we are nearer to a B.B.C. station."

Break-through of medium wavelength transmissions on the long waves is unfortunately experienced quite frequently in these days of high-powered stations, unless specially selective coil units or circuits are employed.

The trouble can usually be remedied by the application of the Contradyné system. This was originally

The Lissen Anti-break-through choke can be used in exactly the same way as the extra coil referred to, and it has the advantage that it is a compact little component.

### "TO SAVE HAVING TO CHANGE THE PLUG-IN COILS."

W. S. (Epping).—"What I am aiming to do is to save having to change the plug-in coils every time I go over to the long waves, or come back to medium waves after listening to a long-wave station.

"The set is an old one, you will guess—as a matter of fact, it was made from one of your early blue prints, and although the blue print has gone west—the set is still going strong.

"The only trouble is this perpetual pulling out one pair of coils and putting in the others.

"As there is plenty of room near the present coils, can I put the others somewhere reasonably close and have a switch or a couple of switches to 'put in' or 'take out' long-wave coils?"

"The coils I use are: reaction 150 and aerial 200 for long waves; reaction 50 and aerial 40 for medium."

"Two spare coil holders for baseboard mounting are already in my possession, and the switches I could probably rake out of the junk box. So if you can give me a method of doing it I am ready to try."

It should be very easy, if you have space, to mount the second pair of coils so that they do not couple with the first pair. We suggest that when fitting the holders you line them up at right angles to the other pair, to reduce this risk to a minimum.

The alterations to the wiring are very easy, the idea being to break the present coil-wiring to enable the long-wave coils to be inserted in series with the medium-wave coils. Then the respective long- or

### "P.W." PANELS, No. 153.—RIGA.

The new wavelength scheme has moved Riga from 525.8 metres down to 238.5 metres, and the full effect upon reception in this country has yet to be determined. It was infrequently received upon this old wavelength.

Like some of the other north-east-of-Europe stations when Riga was heard it was often at considerable strength. There is a woman announcer, who calls the station "Re-ga," and closes down with "Ar Labu Nakti" (Good-night).

The distance from London is 1,042 miles. Power employed, 15 kilowatts.

described in "P.W." some time ago, and has been widely copied.

Essentially it consists of connecting a fairly large coil in series with the lead-in when receiving long-wave programmes.

The coil may be one of the plug-in type, of about 150 size. Or it may be home made, and consist of a hank-winding of 100 or 150 turns of 26 or 28 D.C.C. wire, wound on a former 2½ or 3 in. in diameter.

An ordinary on-off switch should be connected across the ends of the coil, so that when changing over to medium waves the coil can be short-circuited by merely placing the switch in the "on" position.

It is rather important to note that the proper working of the method depends, to some extent, upon there being no coupling between the original coils of the set and the added (Contradyné) coil. For this reason it is advisable to mount the coil, whether plug-in or hank-wound, outside the set, and well away from the cabinet if the other coils are close up against this.

medium-wave coil holders are cut out when not required by means of a switch across each.

You will require two switches of the single-pole, double-throw type, or else one of the double-pole, double-throw type, each half of this latter being used as a separate coil switch.

To explain the method we will describe the alteration to the reaction-coil wiring in detail. If you then treat the aerial-coil wiring in the same way, on the lines described above, you will achieve your object.

After the new coil holder has been mounted in position, with the switch near, the connection to the old reaction coil has to be removed from one side of its holder, and taken to the corresponding side of the new coil holder. Then the two vacant terminals on the coil holders are joined together by an extra lead.

In addition, this extra lead has to be connected to the "mid-point" of the switch. In other words, the

(Continued on next page.)

# DUBILIER CONDENSERS

The ultra modern  
Paper Condenser  
specified by the  
leading modern  
designers for up-  
to-date constructors

## TYPE 9200.

Test Volts  
650 D.C.  
Max Peak Volts  
300 D.C.  
W.kg. Volts  
250 D.C.



### PRICES

1 mfd. 2/6  
2 mfd. 3/6  
4 mfd. 7/-

### OUTSTANDING FEATURES

True non-inductive construction.  
New easy-fixing method.  
Aluminium containers with moulded bakelite tops.  
Occupy minimum space on base-board.

The following Dubilier Condensers and Resistances are specified for the National Eckersley Three:

- 1 100 ohm Resistance—one watt type.
- 1 1 mfd Tubular Condenser—Type 4404.
- 1 .0032 mfd Condenser—Type 620.

The following Condensers and Resistances are specified for the National Eckersley Radiogram:

- 1 100 ohm Resistance—one watt type.
- 1 .25 mfd Tubular Condenser—Type 4406.
- 1 .1 mfd Condenser—Type 4404.

# DUBILIER CONDENSERS

DUBILIER CONDENSER CO. (1925) LTD.  
Decon Works, Victoria Rd., North Acton, London, W. 3

## RADIOTORIAL QUESTIONS AND ANSWERS

(Continued from previous page.)

contact of this switch is to be joined to both the coil holders.

And all you have to do to complete the reaction switch connections is to run a lead from one of its outer terminals to one reaction coil holder on the side not already connected to the switch; and similarly with the other outer switch terminal, which should be joined to the remaining reaction coil holder, also on the side not already joined to the switch.

When this has been done you will see that when the switch is over to one side it connects right across one of the coils, thus leaving only the other coil in action. And if the switch on the other pair of coils is made to do the same you have the circuit exactly as it was originally.

By throwing over the switches you immediately change over to the other wayband, the unwanted pair of coils being "shorted" out of circuit by the movement of the switch arms. Thus all the coils are permanently in the set, but one pair is always switched out when the other pair is in use.

If you find reaction effects are not obtained, try reversing the leads to the reaction coil holder. Or if reaction is too fierce, try increasing the distance between the reaction coil holder and its fellow aerial coil holder.

### BETTER RADIO



Many of the components of the modern radio receiver are encased in metal screens to prevent feed-back, and sometimes the screens themselves give rise to puzzling symptoms.

Generally the screens should be earthed, and failure to ensure this may result in instability. When they are earthed care must be taken that H.T. leads, etc., are well insulated from the screens, or battery leakage and crackling noises may arise.

If a shielded component is recommended for a particular design it is generally inadvisable to attempt the use of a similar but unshielded component instead.

**USING SHIELDED COMPONENTS.**

### BAD SWITCHING DUE TO POOR CONTACT WITH METAL BASEBOARD.

The following helpful letter from E. F. (Stalybridge) deals interestingly with a fault that is frequently cropping up, according to our correspondence. We quote it as written, but would point out that in addition to failure to get medium-wave results, this particular fault often causes queer tuning and reaction effects as well.

Here is an extract from E. F.'s letter:

"Long-wave programmes were good, but the set would not go on medium waves at all. So my first idea was to examine the wavechange contacts. All perfectly good, and the switching 'in' and 'out' going with a good hefty click which ought to have satisfied anybody. All the same, there was nothing doing on medium waves except very weak stuff mixed with long-wave programmes. I put in another coil of the same make, borrowed from a friend. It worked well on his set, but was no better than my own on my set.

"Just to make sure, I got him to fit my coil on his set. Perfect, first go, so that proved it was not the coil. I then thought I might have made a silly mistake with the connections to the wavechange, but they were just the same as on the diagram. Just as I was giving up in desperation, I noticed that the lead from one switch arm to the metal baseboard ended there in a dirty-looking joint. So I cleaned it up and

(Continued on next page.)

# Easy Terms

Strict Privacy Guaranteed  
—we deal with you direct

## W.B.P.M. 4 MICROLODE MOVING-COIL SPEAKER

SENT ON 7 DAYS' TRIAL  
With switch-controlled multi-ratio Input Transformer. Send only 5/- for 7 days' trial. If approved, balance in 8 monthly payments of 5/3. Cash or O.O.D. Carriage Paid, £2/2/0.

W.B.P.M.6. Send only 2/6, balance in 8 monthly payments of 4/3. Cash or O.O.D. Carriage Paid, £1/12/6.



## ROLA CLASS 'B' SPEAKER-AMPLIFIER

SENT ON 7 DAYS' TRIAL  
Complete Class B Amplifying Unit, with Valve and Rola P.M. Moving-coil Speaker. Send only 5/- for 7 days' trial. If approved, balance in 11 monthly payments of 6/3. Cash or O.O.D. Carriage Paid, £3/11/0.

ROLA F.R.6 P.M. Class B Speaker. Send only 5/-, balance in 8 monthly payments of 4/6. Cash or O.O.D. Carriage Paid, £1/19/6.



## TELSEN ELIMINATOR

SENT ON 7 DAYS' TRIAL  
Model W.346. 150 volts at 28 m.a. S.G. and Detector tapping. Send only 2/6 for 7 days' trial. If approved, send further 2/6. Balance in 17 monthly payments of 6/-, Cash or O.O.D. Carriage Paid, £4/17/6.

Model W.346. 150 volts at 28 m.a. S.G. and Detector tapping. Send only 2/6 for 7 days' trial. If approved, send further 2/6. Balance in 17 monthly payments of 6/-, Cash or O.O.D. Carriage Paid, £4/17/6.



## N.T.S. CLASS 'B' SPEAKER

SENT ON 7 DAYS' TRIAL  
Complete with Input Transformer. Send only 2/6 for 7 days' trial. If approved, balance in 5 monthly payments of 4/6. Cash or O.O.D. Carriage Paid, £1/2/6.

CLASS B Model. Same Price and Terms. When ordering, state which type required.

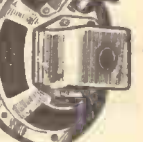

## N.T.S. PICK-UP

Frequency response 80-5,000 cycles. Bakelite head. Florentine bronze finish. Complete with lead and arm support.

SENT ON 7 DAYS' TRIAL  
Send only 2/6 for 7 days' trial. If approved, balance in 4 monthly payments of 4/3. Cash or O.O.D. Carriage Paid, 17/6.

Send only 2/6 for 7 days' trial. If approved, balance in 4 monthly payments of 4/3. Cash or O.O.D. Carriage Paid, 17/6.

## New Times Sales Co.

56, LUDGATE HILL, LONDON, E.C.4.

Dear Sirs:

(a) Please send me.....

(b) I enclose Cash/Deposit.....

NAME.....

ADDRESS.....

P.W. 20/1/34.



Get **FREE**  
Details To-day  
OF THIS AMAZING  
NEW AERIAL SYSTEM

# EMET GROUND AERIAL



**NO OUTSIDE  
AERIAL  
REDUCES  
STATIC NOISE  
INCREASES  
SELECTIVITY  
SAVES  
EXPENSE**

The  
Ultra  
Modern  
Aerial.

**COMPLETELY  
SHIELDED  
to prevent  
pick-up of  
Interference**

**GROUND WAVE . . .  
the Secret of Successful  
War-time Wireless . . .**

In the Great War, the Ground Wave system enabled signals to be heard clearly through static and enemy interference. The EMET ensures perfect reception through an earth connection only, free from interfering noises picked up by ordinary aeriels. Fit an EMET for better and clearer reception.

**FOR  
DETAILS  
AND  
FREE  
TRIAL  
OFFER / POST COUPON**

The EMET takes less than a minute to fix to your set. Simply connect the two wires to your usual Aerial and Earth Terminals and your earth lead to the terminal provided. Fully tested and guaranteed. Sent post free, 5/-. Money refunded if not satisfied.

## THE EMET COMPANY

6, Rutherford Street, NEWCASTLE-ON-TYNE.

Please send me, without any obligation, full details of the EMET Ground Aerial and your FREE TRIAL offer.

Name.....

Address.....

P.W.....



Weekly jottings of interest to buyers.

WHAT is perhaps the best indication of the popularity of "P.W.'s" post-card literature scheme is the number of readers who make use of it. We like it. The more the merrier is our motto, for it enables us to carry out our main object in life, which is to be of service to our readers.

But the task of ensuring as near as possible a "return-of-post" service does not get easier as the numbers increase, and in order to reach that ideal state of affairs it is imperative that the whole system should run smoothly and efficiently.

Please Write Clearly.

Recently a card found its way to my desk and the name and address of the sender were written in such a way that nothing short of a magician could possibly have sorted it out. I even took it into our Research Department in the hope that they might be able to throw some light on the subject, for they seem to have a happy knack of sorting out most things.

Result: signature bearing strong resemblance to certain Greek characters, but unable to determine whether the gent signed himself in microfarads or ohms, and were not quite certain as to which were the Alpha and Omega of his name. And I am supposed to read it!

To get down to brass tacks, it would help considerably to keep the wheels oiled if future applicants would just be good enough to see that their cards are legible.

Fortunately the percentage of "bad boys" is small. All the same, just one illegible card is sufficient slightly to interrupt the service, and as the effect is cumulative, the delay soon mounts up.

'Nuff said! I know that henceforth my readers, all of whom I regard as my friends, will just take that tiny bit more care which will prevent me from going permanently cross-eyed. Thanks a lot, as they say.

It's There, But You Can't See It.

Item number one this week is invisible. I'm sorry; I am not trying wilfully to be funny, but it just happens to be a fact. You see, it happened like this:

A certain friend of mine wanted a set, last word in efficiency, dozens of stations and all the rest of it, but he wasn't going to have an unsightly aerial about the place at any price. Said he didn't believe that I could fix up an aerial in any way that would be invisible, and as I am always partial to winning a packet of cigarettes I took up the challenge.

I am enjoying the smokes. I had previously seen a demonstration of the Pix Invisible Aerial, and I had been impressed at the time with the merits of the idea, so that the rest was easy.

It is made simply in the form of an adhesive tape which can be stuck down to

(Continued on next page.)

# PETO-SCOTT EVERYTHING RADIO - CASH C.O.D. or EASY TERMS TRIUMPH! PETO-SCOTT

PERMANENT-MAGNET MOVING-COIL  
1934 EXTENSION SPEAKER

In Beautiful Walnut Cabinet.

Yours for

**5/-**

down

Balance in  
7 monthly  
payments  
of 5/6.

CASH for C.O.D.  
Carriage Paid.

**39/6**



In addition to the extraordinary wide range of output ratios — 30, covering the requirements of every type of home-constructed and factory-built set, old or

new—the PETO-SCOTT EXTENSION SPEAKER is built with an inclined baffle, supported on felt cushions which completely eliminate all resonance and boom, enhancing the already perfect tonal balance. Complete with Combined Volume Control and Switch. Obtainable only direct from PETO-SCOTT. Speaker only (less cabinet) Cash or C.O.D. Carriage Paid 29/6 or yours for 4/- down and 7 monthly payments of 4/-.

DESIGNED WITH 30 RATIOS

SUITABLE OUTPUT FOR 1001 RECEIVERS.

FOR POWER—SUPER-POWER—PENTODE—CLASS "B"—IN FACT EVERY TYPE OF OUTPUT VALVE KNOWN. Alterations to ratio readily made without removing Speaker or back of cabinet. See inset illustration.

NEW BLUE SPOT 29P.M. PERMANENT MAGNET MOVING-COIL SPEAKER. With input transformer. Cash or C.O.D. Carriage Paid, £1/12/6. Balance in 6 monthly payments of 5/- only

ROLA 6P.M. PERMANENT MAGNET MOVING-COIL SPEAKER, with input transformer, Cash or C.O.D. Carriage Paid, £2/9/6. Balance in 8 monthly payments of 6/- only

Balance in 8 monthly payments of 6/-

## NEW TELSEN 323

LATEST TELSEN KIT RELEASE. Less Send  
Valves. Cash or C.O.D. Carriage Paid, 5/-  
29/6. only

Balance in 5 monthly payments of 5/3. only

TELSER 323 KIT with set of 3 Valves. Send  
Cash or C.O.D. 6/-  
Carriage Paid, £2/15/6. only

Balance in 9 monthly payments of 6/- only

PETO-SCOTT CO., 77 City Rd., London, E.C.1  
Telephone: Clerkenwell 9406/7.

West End Showrooms: 62, High Holborn,  
London, W.C.1. Telephone: Holborn 3248.

Dear Sirs,

(a) Please send me.....

(b) I enclose Cash/Deposit.....

NAME.....

ADDRESS.....

P.W. 20/1/34

SEND FOR QUOTATION BY RETURN OF POST



## 50, 25 or 15 ma. at 150v. from D.C.

HERE is a good and reliable mains unit for D.C. mains. If you are running your set from H.T. batteries, you are taking the dearest and most troublesome way. Get a Heayberd Mains Unit—no need to worry about your supply being changed to A.C., because these units are specially made to be converted.

MODEL H.D.C.150. TRIPLE ADJUSTABLE OUTPUTS: 50, 25 or 15 ma. at 150v. Tappings: 40-100v. Variable S.G. 80-130v. PRICE 55/- Variable, 150 fixed. A.C. Units also supplied.

Fill in coupon and send NOW with 3d. in stamps for 36-p. booklet describing all types of Mains Units, and showing how to build your own.

..... POST NOW.....  
 Mr.....  
 Address..... P.W.

**F.C. HEYBERD & CO**  
 10, FINSBURY ST EC2  
*One Minute From Moorgate Station.*

## LOUD SPEAKERS REPAIRED 4/-

(Blue Spot a Speciality, 5/-)  
 Transformers and Headphones, 4/-, Eliminators, Mains Transformers and Moving Coils quoted for. 24-Hour Service, Trade Discount. Clerkenwell 9069.  
 E. MASON, 44, EAST ROAD (nr. Old Street Tube Station), LONDON, N.1.

## ENGINEERING OPPORTUNITIES 250 PAGES Free

Never before has engineering offered such magnificent chances. With the rise of the depression, the industry is literally teeming with first-class opportunities. Our 250-page Hand-book "ENGINEERING OPPORTUNITIES" shows where the opportunities lie, and the easiest way to prepare for them. The Hand-book gives details of A.M.I.Mech.E., A.M.I.E.E., A.M.I.C.E., G.P.O., etc. Exams., outlines Home-Study Courses in all branches of Civil, Mech., Elec., Motor, Radio and "Talkie" Engineering, Building etc., and explains our unique Employment Dept. Send for this valuable Hand-book to-day—FREE!  
 British Institute of Engineering Technology, 101, Shakespeare House, 29, Oxford St., London W.1

## RADIO SUPPLIES

Send your list of Radio needs for our quotation. Kits, Parts, Sets, etc. Everything in Radio stocked, prompt delivery. 7 days' approval. Catalogue free. Taylex & Standard Wet H.T. replacements stocked.  
 P. TAYLOR, 9, GROVE ROAD, BALHAM, S.W.12

Write for Illustrated Catalogue of RADIO-GRAM-PHONE CABINETS of exclusive modern design. Made by craftsmen in highly figured Oak, Walnut, or Mahogany, post free. REMARKABLE VALUE Cabinets made to order a speciality. Make, under licence, of the HOWE BOX BAFFLE Recommended by the B.B.C. Full details on request.  
**GILBERT**  
 Cabinet Maker  
**SWINDON**  
 Estimates Free. Estd. 1896.



## THE LINK BETWEEN

(Continued from previous page.)

practically anything, and which leaves no traces when it is removed. A 30-ft. length of Pix Invisible Aerial (which costs 2s.) stuck down to the top of the picture rail is practically impossible to detect, and it certainly does do its job.

"A.V.C." (Adherents Vary Considerably).

Human psychology is very strange at times. People read about A.V.C., they get all enthusiastic and try it, and then, when it does precisely what it is supposed to do, they seem to feel that they have been done.

Automatic volume control is a very fine scheme, but what everybody seems to overlook is the fact that it affects the local stations as well as the distant ones. Why is it that so many people like to be able to blow off the roof on the local stations, even though they could never listen comfortably to such a volume?

It's rather like the man with a very powerful car in London. Although he is

## ANOTHER FREE GIFT!

Every reader of POPULAR WIRELESS will receive next week yet another magnificent free gift!

With each copy of POPULAR WIRELESS next Wednesday there will be given away a fine 32-page book, priced at sixpence, and entitled:—

## "1000 UP-TO-DATE RADIO HINTS AND TIPS."

There is sure to be a bigger-than-usual demand for next week's POPULAR WIRELESS, so ORDER YOUR COPY TO-DAY.

probably never able to exceed more than about twenty miles an hour, he just likes to feel that his car has got it in it to do seventy or eighty.

However, that is just by the way. The main fact is that Varleys have now brought out a new delayed automatic volume control unit for fitting to existing sets in which the volume level is controllable. Full details, together with helpful circuit diagrams are given in a special Varley leaflet which is available through the medium of our postcard literature (No. 73).

## OUR POSTCARD SERVICE

Applications for trade literature mentioned in these columns can be made through "P.W." by quoting the reference number given at the end of the paragraph. Just send a postcard to G. T. Kelsey, at Tallis House, Tallis Street, E.C.4. Any literature described during the past four weeks may be applied for in this way—just quote the number or numbers.

## WIRELESS SUPPLIES

Let us supply your RADIO wants. Any single part, kit, or set, etc. We pay carriage. Seven days approval. We supply, FREE, one of our PATENT BAFFLE BOARDS with any speaker bought from us.—Electa Wire Gram 97, Sussex Road, Brixton, London, S.W.9.

## GUARANTEED REPAIRS

Repairs, overhauling of every description carried out by experts. Send us particulars of your requirements for FREE QUOTATION.  
 S.T.400 converted to S.T.500. ... 47/6  
 All extra components as specified.  
 UNIT REPAIR SERVICE, 18, Paltanay St., London, N.1

# UNIVERSE 1934 PICK-UP



## SPECIFIED BY Popular Wireless for the "ECKERSLEY THREE"

STANDARD MODEL No. 2. Output 4 volts—average 2 volts. Base can be used in any position. Pick-up reel cannot go out of adjustment (part applied for). Ball-catch swivel head for easy changing. In attractive brown bakelite moulded case. Complete with connecting leads. PRICE 18/6

If your dealer does not stock Universe 1934 Pick-ups, write us direct for illustrated folder

COSMOCORD Ltd. Dept. P.W. Universe Works, Enfield, Middx. 'Phone Enfield 3646.

# "TONASTAT" SOLVES THE QUESTION

Of giving to your set just that added selectivity which makes such a wonderful difference in the clarity of reproduction. Minimises overlap of nearby stations, cuts down whistle interference. Suits from a single valver to a super set.

Simple to use. Easy to connect. A circuit to suit your set is shown on instruction leaflet; "P" supplied with every "Tonastat."

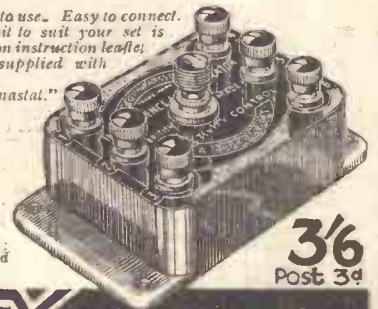

'Phone Enfield 2823.

3/6 Post 3d

## TAYLOR PRODUCTS Co

32, QUEENSWAY, PONDER'S END, MDX.

## MAKE A RADIOGRAM OR GRAMOPHONE

Our 64-page Illustrated List for 3d. will tell you how and show you a great variety of Spring and Electric Motors, Turntables, Tone-arms, Soundboxes, Horns, Loudspeakers, Pick-ups, Cabinets, bins, idlers, door-latches, knobs, handles, and catches. Also Receivers, Kits, complete Gramophones, accessories, springs, needles and repair parts at lowest prices; wholesale or retail (Established 30 Years.)  
 The Recent Fittings Co (P.W.), 120 Old St. London E.C.1.

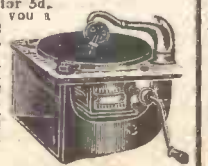

PLEASE be sure to mention "Popular Wireless" when communicating with Advertisers. Thank!



**EASY TERMS PROMPT DELIVERY**

Any Amplion, Blue Spot, Baker, Celebration, Epoch, Ferranti, Grampian, Igranic, Lamplugh, Magnavox, Ormond, R & A, Rola, Sonochorde or W.B. Speaker supplied.

Send 5/- only

and pay balance by monthly instalments. No references. Entirely private and confidential.

**A Universal Loud Speaker for every purpose**



We Strongly Recommend the R & A "Multex"

Chassis Model . . . . 30/-  
Cabinet Model . . . . 45/-

either sent on trial for 5/-, balance by small monthly payments if satisfied.

**"BA" Multex COSSOR MELODY MAKER KITS**

Battery Model 342 . . . . £7 2 6  
or 12 payments of 13/6

**LISSEN KITS**

Skyscraper 3 . . . . £4 9 6  
or 12 payments of 8 3

**KITS, PARTS, VALVES, ELECTRIC CLOCKS ON EASY TERMS.**

Send for Catalogue and List of 83 Speakers. **TURNADGE & PARTNERS, LTD.,** 107, Fleet Street, London, E.C.4. Telephone: Central 1903.

G.P.O. Engineering Dept. (No experience required.) Commence £4 per week. Age 17-23. Excellent prospects. Free details of entrance Exam. from B.I.E.T. (Dept. 568), 31, Oxford Street, W.1.

**ADD 50/- WEEKLY TO YOUR EARNINGS**

by charging accumulators in your spare time. Complete Plant incorporating Westinghouse Rectifiers, to charge 105 cells weekly

Trade Price £4:4:0 or 8/- monthly

A.C. Mains only Send for descriptive booklet **MAINS' POWER RADIO, LTD., ROMFORD, ESSEX**

**YOU ARE WANTED ON THE SHORT WAVES**

Short-wave reception with any receiver with the new remarkable **UNIT RADIO** short-wave unit. IDEAL for use with the S.T.500. Complete unit sent for 5/- down. Send for illustrated leaflet. Cash or C.O.D. **37/6**  
**UNIT RADIO, 12, Fultney St., London, N.1.**

**Engineers' Guide**

Containing the widest choice of engineering courses in the world. Qualify for a well-paid post in Engineering by studying at home with The T.I.C.B. Become an A.M.I.C.E., A. M. I. Mech E., A. M. I. E. E., etc. Training until Successful is Guaranteed for the one fee. WRITE NOW for "The Engineers' Guide to Success," stating branch, post or qualification that interests you to

THE TECHNOLOGICAL INSTITUTE OF GT. BRIT. 26, Temple Bar House, London, E.C.4.

Founded 1917. 19,000 successes



**To Success** 152 PAGES

PLEASE be sure to mention "Popular Wireless" when communicating with Advertisers. Thanks!

**LISTEN TO THESE NEXT WEEK!**

Outstanding items selected from the programmes for the week ending January 27th.

**Monday January 22**

National: Bertha Philharmonic Concert. A genuine Continental relay of a world-famous orchestra.  
Regional: "From One Band to Another," a novelty presentation of contrasted dance music, making a sensible alternative.

Midland Region: Three Short Plays. Two old favourites, "The Monkey's Paw" and "Five Birds in a Cage" will be included in this triple bill.

**Tuesday January 23**

National: "The Kentucky Minstrels," another revival of an old black-faced minstrel show, brought up-to-date (repeated on the Regional wave on Wednesday).

Scottish Region: An excerpt from "1934," relayed from the Empress Playhouse, Glasgow. Scottish relays are usually worth hearing.

**Wednesday January 24**

National: "Trent's Last Case." The first of the Dramatic Director's new series of "full-of-action" radio plays. Listen to this.

Regional: "The Kentucky Minstrels." Repeat performance of a genuine nigger minstrel show.

**Thursday January 25**

Regional: "Robert Burns." A celebration of the 175th anniversary of the Scottish poet's birth, relayed appropriately from Scotland.

North Region: Variety Programme, a relay from the Empire Theatre, Middlesbrough. These northern outside broadcasts make excellent listening.

Scottish Region: "Robert Burns." Scotland's national celebration, relayed to-night to London Regional listeners from the Western House, Ayr.

**Friday January 26**

Regional: "Songs from the Shows." The second in the 1934 series of these universally popular entertainments. John Watt has chosen Drury Lane for this week's material (to be repeated on the National wave on Saturday afternoon).

Midland Region: "Dancing Round Europe." A popular programme of dance music relayed from Nottingham.

Belfast: "Trailers." A satire, burlesquing previews, is the best description of an amusing new revue for Northern Ireland listeners.

**Saturday January 27**

National: "Songs from the Shows." A matinee repeat performance of Friday night's Drury Lane programme. A good show at a good time of day.

Regional: Transatlantic Debate. Oxford University speakers will argue with members of Chicago University across 3,000 miles of ocean.

**ALTERNATIVE COILS FOR THE NATIONAL ECKERSLEY THREE**

Here are the details for the mounting and connection of the Colvern coils specified as alternatives to those used by the designer of the "National Eckersley Three."

The Colvern coils should be mounted so that one K.G.O. coil is next to the panel, followed by the other K.G.O., and then the K.G.R. In addition to original components, a .25-mfd. tubular fixed condenser, with wire ends, is required.

Connections are as follows:  
K.G.O. nearer panel: 5 to aerial terminal; 6 to fixed vanes of first section of tuning condenser; 3 to terminal nearer chassis of variable selectivity control resistance, and to 3 on second K.G.O. coil; 6 on which is connected to fixed vanes of middle section of tuning condenser, and from this point to grid of V.1. 6, on K.G.R. coil to terminal, nearer panel, of 0002-mfd. grid condenser.

Flex lead from same terminal of this condenser to anode of V.1. The remaining connections to K.G.R. are: 2 via chassis to terminal, nearer panel, of 5000-ohm resistance, and also to .25-mfd. tubular condenser, the other end of which is connected to chassis; 1 to fixed vanes of rear section of tuning condenser; 3 to chassis; 4 to F.1. of differential reaction condenser.

Note: With Colvern coils the wavechange switch hole in the panel will be 4 1/4 inches from the bottom, and the on-off switch position should be raised to correspond.



**Specified for the NATIONAL ECKERSLEY RADIOGRAM**

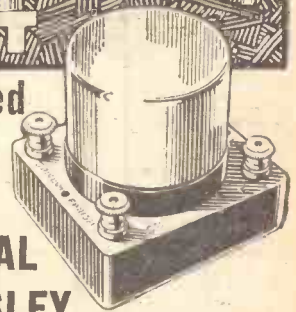

THE NATIONAL ECKERSLEY RADIOGRAM utilises the "BOOSTER" Unit and so enables super power valves to be employed with an actual saving of H.T. current.

If your receiver is extravagant of H.T. current you cannot do better than follow the lead of this eminent designer and obtain Mains power volume from your normal H.T. battery.

The correct BOOSTER Unit for the NATIONAL ECKERSLEY RADIOGRAM is Type T.P.

**7/6**

**A GRAHAM FARISH PRODUCT**

Write for leaflet B.P.1. to Sole Makers—**GRAHAM FARISH LTD., BROMLEY, KENT.**

**The TERMINAL for the "NATIONAL ECKERSLEY THREE"**

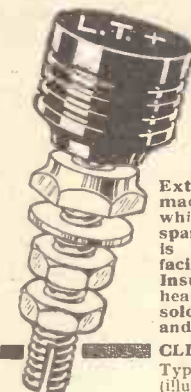

Extremely robust and soundly made. Hexagonal shoulder, which, by being held with a spanner while the nut behind is made tight, greatly facilitates mounting. Insulated and non-removable head. Provision for secure, solderless connection. Clear and easily read markings.

**CLIX PANEL TERMINAL**  
Type B . . . 4d. Type A 2 1/2d. (illustrated)

**THE DESIGNER ALSO SPECIFIES CLIX SPADE TERMINALS**

Positive metal-to-metal wiring is fully protected from creeping acid by a specially designed collar. Corrosion is impossible. Contact is perfect.

Large size, Nickel-plated or lead-coating . . . . 2d.  
Small size, Nickel plated . . . . 1 1/2d.

Latest Leaflet "P" sent on request.



**LECTRO LINX Ltd., 79a Rochester Row, S.W.1**

# THE MIRROR OF THE B.B.C.

(Continued from page 878.)

is good to know that the still older Programme Board has been restored.

This is a weekly meeting of those actually in charge of the service in all its important departments. Col. Dawnay, the new programme chief, presides, and is supported by Mr. Roger Eckersley, Director of Entertainment; Mr. Charles Siepmann, Director of Talks; Mr. Iremonger, Director of Religion; Mr. Lindsay Wellington, Director of Presentation; Captain Cecil Graves,

## THE "MULTI-TOOL"

The Editor regrets that owing to the nature of the free gifts in this issue it is not possible to include them in copies forwarded to OVERSEAS READERS

Director of Empire and Foreign Broadcasting; and three or four others.

### "The Immortal Memory."

Broadcasting is going to assist Scotsmen at home or in exile to pay their tribute to the great Robert Burns on Thursday, January 25th. We need say little about the poet (Scotsmen will do all the talking about him until the last kilt has ceased to waggle).

It is sufficient to give the broad details of the radio celebrations of Burns Night, in which the B.B.C. is collaborating with the Ayr Burns Club, whose proceedings will be relayed from the Western House, Ayr, where the club is meeting that evening.

### Eisteddfod Prizes.

The B.B.C. is offering two prizes each of twenty guineas for radio drama writing at next year's Royal National Eisteddfod of Wales, which is to be held at Neath in August.

One is for a short play in English dealing with any aspect in Welsh life, and the other for a short play in Welsh. Consolation prizes will be awarded in each case if, in the opinion of the adjudicator, the best play submitted fails to attain the required standard.

Failure to win the full awards must surely be taken as a failure of the B.B.C.'s present policy to devote so much of the West Regional transmissions to Welsh interests.

As usual, the offer of these prizes is causing discontent in the west country, and people are already saying that prizes should also be offered for west country plays.

To which the B.B.C. replies that it would do so if there was a west country festival equivalent to the National Eisteddfod of Wales.

### TO REGULAR READERS

The Editor regrets that, owing to extreme pressure on space, three of the "P.W." features—"Eckersley Explains," "Short Wave Notes" and "Recommended Wrinkles"—have been unavoidably held over this week.

# THE LISTENER'S NOTEBOOK

(Continued from page 878.)

What's-her-name is in," is a frequent confession. Illness or the like is another matter, but no other reason should be considered adequate for breaking a contract.

The fact that Commander Stephen King-Hall has reached the 152nd talk of a series, and is still absorbingly interesting speaks, well for both the series and the speaker. The way in which he can crowd an explanation of President Wilson's fourteen points, the three million unemployed, the Zoo and an exhibition into a talk lasting barely twenty minutes, and all without a suggestion of rush, is really masterly.

I fancy Stephen is aware that numberless grown-ups are given to eavesdropping while this children's talk is on. It is only because this is so that one can justify his trying to explain the significance of the three million unemployed, etc., for the tiny-tots among his listeners oughtn't to care for any of these things.

A remark in a recent news bulletin intrigued me no end. It was from the report of the death of Lord Churchill. It was this: "To our younger listeners he will

## NEXT WEEK

Further details about the NATIONAL ECKERSLEY THREE  
Also  
Eckersley's NATIONAL THREE FOR A.C. MAINS

Buy your "P.W." on Wednesday

be best remembered as being the Chairman of the G.W.R. Co." Why younger listeners? Perhaps someone will enlighten me.

"Mr. Pewter Works it Out" is a very promising new series, judging from the opening talk. It is typically A. P. Herbert. A point, however, seems to have escaped Mr. Herbert's notice. Mr. Pewter is a great reader of newspapers and a listener to wireless talks. My conception of Mr. Pewter at present is that he may be a great reader of newspapers, but he certainly isn't a listener to wireless talks. If he were, he couldn't be guilty of those gross mispronunciations of words that broadcasting has now made household. If wireless has done anything to further popular education, nowhere is it more apparent than in the correct way the likes of Mr. Pewter (and Florrie) use and pronounce a vocabulary that their fathers were wont only to see. C. B.



# L.F. CHOKES

In a Class alone.

Registered Design No. 773746.

A splendid range of reliable low frequency chokes built strictly to specifications given. Finished in frosted aluminium; for chassis or baseboard mounting. Insulated terminals.

List No.	STANDARD L.F. CHOKES.	Price
L.F.16	20 h. at 20 m.a. 700 ohms approx.	7/6
L.F.20	32 h. at 15 m.a. 900 ohms approx.	7/6
POWER L.F. CHOKES.		
L.F.14	20 h. at 50 m.a. 400 ohms approx.	10/6
L.F.15	32 h. at 30 m.a. 600 ohms approx.	10/6
L.F.18	10 h. at 60 m.a. 320 ohms approx.	10/6
PENTODE CT. L.F. CHOKE.		
L.F.17	50 h. at 25 m.a. 1,000 ohms approx.	11/6
SUPER POWER L.F. CHOKE.		
L.F.21	15 h. at 100 m.a. 450 ohms approx.	15/6

SEND FOR 80 p. CATALOGUE No. 153 "P."  
Enclose 2d. postage.



TELEPHONE: GRANGEWOOD 3366. *The Choice of Critics* TELEPHONE: GRANGEWOOD 3367

A. F. BULGIN & Co., Ltd., ABBEY RD., BARKING, ESSEX.  
London Showrooms: 9, 10, 11, Cursitor St., Chancery Lane, E.C.4

"S.T." MANUAL 1 TOKEN

# AN OPEN LETTER TO EVERY OWNER OF A BATTERY SET

CONTRACTORS TO H.M. ADMIRALTY, INDIA OFFICE, WAR OFFICE, G.P.O. AND THE LEADING HOME AND OVERSEAS RAILWAYS.



REGISTERED



MANUFACTURERS OF EVERYTHING ELECTRICAL.



Cable Address: POLYPHASE, LONDON.  
Codes: NEW STANDARD LOMBARD, WESTERN UNION (5 LETTER EDITION) AND A.S.C. (15<sup>TH</sup> EDITION) AND PRIVATE.

Telegraphic Address: ELECTRICITY, WESTCENT, LONDON.

Telephone (LONDON) TEMPLE BAR 8000 (170 LINES)

SPECIAL TRIMMERS UP TO 8 IN. TEMPLE BAR 2051.

HEAD OFFICE:  
**Magnet House,**  
Kingsway, LONDON, W.C.2.

January 1934

Dear Listener

Is your set one of these - OSRAM MUSIC MAGNET 3 - OSRAM MUSIC MAGNET FOUR - OSRAM FOUR (NEW MUSIC MAGNET) or any "Kit" set or PORTABLE receiver using one or more screen-grid valves? If so, this letter is addressed to you.

We have a new member added to our large family who is a specialist in the art of rejuvenation, he is a screen-grid valve called S23. OSRAM S23 gives increased strength of tuning (Sensitivity with Stability) clearer reception of stations on adjacent wavelengths (Improved Selectivity) and for such a performance the smallness of his account for H.T. consumption is surprising (low anode and Screen currents). His price is 15'6, and you will find it is the smallest specialist fee you will ever have paid.

Yours Sincerely  
**OSRAM VALVES**

# Any Intelligent Man or Woman CAN Make These and Make Money

## Made at Home for 2/3—Sold at 6/-—PROFIT 3/9

**£5 per Week—  
5 Hours a Day!**



Dear Sirs,  
I am writing to let you know how well I am progressing.

I started 15 months ago with 30s. worth of chemicals. I made £4. 11s. 11d. profit in the first five weeks and

now have stock and plant valued at £40. All my chemicals I buy in bulk, so that I can make as much as 200 per cent. profit. The last five weeks' business has brought me in £25 7s. 6d., working 5 hours a day

These excellent results are due to your kind assistance at all times.

(Sgd.) E. W. Edwards.

(Original can be seen.)

### MASS PRODUCTION EXPECTED

Dear Sir,

I have managed to get into the Trade, although I did not look for it as I started too late in the Season. However, I have had trial orders from all the Ironmongers here and all are very pleased and there are no complaints.



I am looking forward to contracts from the same sources this next season, and I hope to be able to go in for mass production gear.

I am very pleased I took up your proposition and in my humble opinion there isn't a better product on the market. I have had all the other kinds through my hands and have dissected them all, and I know they are all inferior.

Yours faithfully,

(Sgd.) Allan L. Litt-Wilson.

(Original can be seen.)



## Many People LIKE YOU Have Doubled Their Incomes!

Let us introduce you to genuine, honest spare-time work in the comfort of your home at which men and women to-day are making handsome profits regularly—week in and week out.

By simply posting the Coupon below you can learn at once how you can BUILD UP PRESENT and FUTURE PROSPERITY. You can commence on your kitchen table in a spare room or outhouse. The work is clean, safe, pleasant and quite simple. It is the making of our Patented Radio Appliances. The demand for these Appliances is so enormous that it runs into MILLIONS.

Help us to supply this demand and help yourself to the profits. You can make anything up to £300 a year this self-same way. Think what you could do with all those extra £'s. Why, it means freedom, independence, and a definite "knock-out blow" to Financial Worry and Trade Depression.

The wonderful part of it is that you need not have the slightest previous experience or technical knowledge. There is no expensive "plant" to buy. Only a few small hand tools and presses, most of which you can make yourself at trifling cost. And you are not "tied" in any way whatever. Your profits are only limited by the amount of time you choose to devote to the work.

N.B.—The originals of these and other testimonials may be inspected at our offices at any reasonable time.

Send this Form for  
**FREE Instructions**  
**How to Start** →

### SELL AS FAST AS CAN MAKE

Gentlemen,  
I am very pleased with the excellent service you give and also the quality of the goods.

My spare time has been very limited, but I am satisfied that I am getting full value for my money.

The product sells as fast as I can make it. (Sgd.) Norman Stockwell.

(Original can be seen.)



### STRAIGHTFORWARD

Dear Sir,

I thank you for your straightforward and easy process. I think it is one of the best hobbies that anyone could take up.

(Signed)  
F. J. Herbert.

(Original can be seen.)



### We GUARANTEE you PROFIT

and, if necessary, we will take sufficient of your output off your hands to ensure it, provided only that your work comes up to the easily attained standard of efficiency—we undertake to continue your training FREE as long as required. Start now. The market is unlimited and cannot possibly become overcrowded. It is A GOOD, CLEAN, HONEST, STRAIGHT-FORWARD BUSINESS, which will help you to become your own "Master."

**ONE MAN  
EARNED  
£960  
IN  
SPARE  
TIME**

## £'s COUPON

To Mr. V. ENGLAND-RICHARDS,  
THE ENGLAND-RICHARDS CO., LTD.,  
1144, King's Lynn, Norfolk.

Sir,—Please send me at once, and FREE, full details as to how I can Make a Patented Radio Speciality for 2s. 3d. to retail from 6s. to 7s. 6d. and Make Money at Home in my spare time: also Large Broadsheet of Fully Illustrated Original Testimony from those already making Big Money. I enclose 2d. stamps for postage.

Print your name and address boldly in capital letters on a plain sheet of paper and pin this coupon to it.

"Popular Wireless," 20/1/34.

**£6**  
A WEEK in a  
**Business of Your Own**



# VALVES for clear reception!

● Once you have fitted your set out with the new 1934 Dario Valves, you will say that you never knew what clear reception was before. The improvement is like moving from the back of the gallery to the front of the stalls. Dario Valves are sturdy too, which, with their reasonable prices, makes them the most economical on the market.

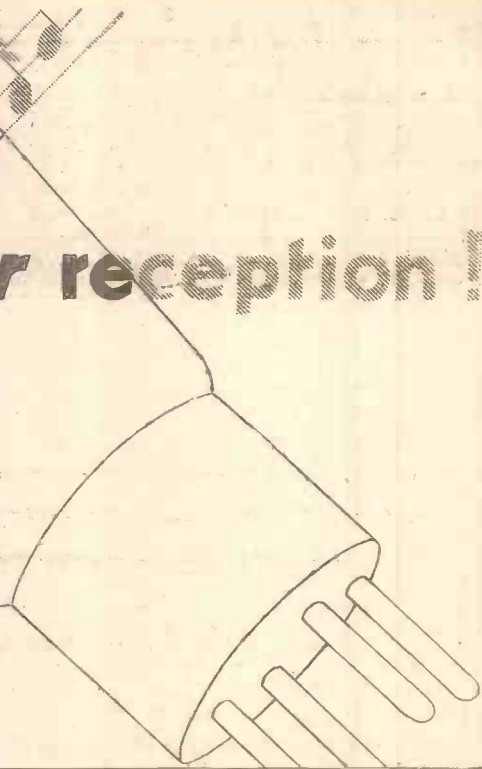

**EVERY NEW TYPE AND IMPROVEMENT**

## 2 Free Blueprints

# THE REMARKABLE LINACORE



*3-valve circuit  
equal to a Superhet*



**COUPON**

By sending this coupon NOW you will receive free a blueprint of an ideal battery or mains model "LINACORE" circuit, which from 3 valves will give you results equal to a "Superhet." Enclose 2d. only for postage, and state which.

For battery receivers type BPB (as illustrated) **69/6**  
For Mains receivers type BPM - - -

To Jackson Bros. (London) Ltd.,  
72, St. Thomas' Street; London, S.E.1.

Please send Free Blueprint of { Mains Model  
(Delete one not required) { Battery Model

I enclose 2d. in stamps for postage.

NAME .....  
ADDRESS .....  
P.W. ....



Nothing so splendid as the spirit of pageantry!

AS REPRODUCED BY THE POWER OF A

**LISSEN H.T. BATTERY**

# POPULAR WIRELESS

THE FIRST AND FOREMOST RADIO WEEKLY FOR THE CONSTRUCTOR & AMATEUR EXPERIMENTER

Scientific Adviser: SIR OLIVER LODGE, F.R.S.

Technical Editor: G. V. DOWDING, Associate, I.E.E.

Assistant Editor: P. ROBERT BIRD.

Managing Editor:

N. F. EDWARDS.

Chief Radio Consultant: P. P. ECKERSLEY.

Assistant Editor: A. JOHNSON-RANDALL.

Chief of Research: K. D. ROGERS.

**BLIND CONSTRUCTORS  
A "STAR" READER  
HE DOESN'T LIKE 'EM  
NOT OF THE B.B.C.**

## RADIO NOTES & NEWS

**THE MOT JUSTE  
A "PICK-ME-UP"  
ANTI-JAZZ  
WIRELESS & WEATHER**

### My Good Resolution.

AS a rule, I make only bad or indifferent New Year's resolutions; they are the more easily retained unbroken. I have, however, made one good one (which will mortify some of you), namely, that I will not during 1934 allow myself to be further involved with iron bedsteads. Surely no radio journalist has ever been so bedevilled with such monstrous contraptions as "Ariel."

And yet I have on hand at least six contributions from readers bearing on the subject, including one which suggests the aperiodic coupling of one of the brutes to an "S.T.500." Dash it, I'll be sleeping on the mat soon!

### "P.W.'s" Double Rôle.

IT appears from a charming letter by E. L. van der G. (Amsterdam) that "P.W." not only helps its readers to become wirelessly wise, but, in addition, is the means of helping foreigners to learn English. Mr. van der G. is a "star" of foreign readers, having subscribed from our No. 26, about eleven years ago.

Judging from his letter, we seem to have taught him the language very well, though I am bound to say that the Dutch are notably clever as polylinguists. We all appreciate his letter and hope that he will preach "P.W." both in Holland and his native Java.

### Learning Radio by Braille.

HERE'S an inspiring fact: The blind, having become interested in radio, are now inquiring for information about its theory. The demand has become important enough for the National Institute to put in hand a Braille edition of a popular work on the subject, which will be sold at a third of its cost of production.

Probably there will eventually grow up a body of blind "home constructors"; Captain Ian Fraser, M.P., has already demonstrated that such manual work is quite possible.

### Reception in France.

THE B.B.C. states that since the London and West National wavelengths were synchronised people in the south of France have complained of inability to

receive the London National programmes. These programmes were received last winter all over the Continent.

However, a substitute may be found in the North National, working on 296.2 metres, which is successfully received on the Continent at night. In any case, all should be well when Droitwich gets to work on long waves, so the south of France must possess its soul in patience until the summer.

### OUTSTANDING CONTRIBUTORS TO THIS WEEK'S ISSUE

SIR OLIVER LODGE, F.R.S.

"All About Sound and Radio Waves" page 921

P. P. ECKERSLEY, M.I.E.E.

"The National Three for A.C." page 911

Dr. J. H. T. ROBERTS, F.Inst.P.

"Technical Notes" page 938

Britain's leading radio technicians write for "POPULAR WIRELESS"

### The "Ayes" Have It.

AMONGST the statistics dished up by the B.B.C. there is a scrap of news which is a sufficient answer to the class of critics—Press and private—who represent the B.B.C. as a failure and almost a public scandal.

Of the 80,000 to 100,000 letters on the subject of the programmes which the B.B.C. receives yearly there are twenty which express or imply satisfaction with the B.B.C.'s efforts, to every one which expresses or implies the reverse.

That is an unmistakable vote of confidence, and I hope that those who gravely wag their shock beards and pretend that they represent the wrath of a united nation will cut out the "sensation stuff" and be fair.

### No Claque for Cantor.

EDDIE CANTOR, the sloe-eyed film comedian—who is also a very popular broadcaster—has fallen heavily upon studio audiences and is going to do something about it. He doesn't like their clapping and laughter (nor do we), and he doesn't need their presence. In fact, Eddie declares that the comedians who insist upon an audience in the studio are actuated only by vanity.

All the same, considering that in America huge studios have been built with accommodation for audiences, I believe that the protest will fall upon unsympathetic ears.

### Record-Changer Wanted.

A SOUTH PERTH reader of five months' standing (keep it up, sir!), whose name is, appropriately, Lamb, but whose initials might be A. H. or G. H. or what have you, writes inquiring for the latest type of record-changer.

If he cannot get one which will play each side consecutively, up to a total of about eight records—and I fear he cannot—then he will be content with one which will play a series through and then play the reverse sides.

I am passing his inquiry to our "trade" specialist, but should be glad if any interested manufacturer would reply direct to Mr. Lamb. Address: 38, Strickland Street, South Perth, W. Australia.

### Attenuated Answers.

S. N. V. (Darlington).—You are a nice man in spite of the fact that you write with the poker—or something. The reply is, an aerial with a free end is a better absorber of electro-magnetic energy than a loop or frame aerial.

L. J. F. (Taunton).—No, sir, you have lost your halfpenny—for I am not of the B.B.C. Lucky for them, isn't it?

### A Radio Society Note.

I HAVE received the spring, 1934, fixture card of the Croydon Radio Society, and it is a peacherino—as Henry Ford called Thomas Edison.

This go-ahead Croydon gang are in the middle of a New Year drive for members and their Hon. Sec., Mr. E. L. Cumbers, 14,

(Continued on next page.)

# THE SPIRITUAL HOME OF TELEVISIONISTS

(Continued from previous page.)

Campden Road, S. Croydon, will be pleased to send a fixture card and details of membership to any interested comrades who will apply to him.

### Bothering the Bacteria.

**A**FTER the burglars, the bacteria! Having made the lives of the crooks miserable, radio is now to be devoted to doing things to the life-cycles of bacteria, and the instrument with which this is to be done was exhibited by Marconi's at the Physical Society Exhibition early this month.

The "ultra-high-frequency magnetron oscillation generator," which will be used for treating "cultures" with concentrated H.F. fields, is a valve with two half-cylindrical anodes. When it is placed in a strong magnetic field it will, at a critical value of such field, deliver oscillations at the natural frequency of an oscillatory circuit connected to it.

The H.F. circuit supplied consists of a variable condenser, across which can be placed a series of inductances to cover the necessary frequency range.

### "Thugs of the B.B.C."

**A**CCORDING to a Halifax newspaper, Mr. Roy Henderson was very outspoken about broadcasting during a speech at a recent musical festival. "Wire-

less is doing its best to try to kill amateur effort."

That can mean only that the B.B.C. is conscientiously trying to discourage people from singing and playing without payment. Is that so? Again:



"We are being throttled by wireless." So the B.B.C. are a lot of thugs, too!

And doubtless the B.B.C. distributes poisoned sugar-sticks to kid reciters! People with strong feelings about a matter close to their hearts ought nevertheless to cultivate the art of using the *mot juste*, if only as amateurs.

### Stopping "Motor-boating."

**F**H. (Denholme) made a "straight" det. and 2 L.F. which "motor-boated" splendidly—only that and nothing more.

Fred then found that by holding the output terminals of the second transformer he could stop the noise and get his local station better than with his "S.T.300." He then reversed the same transformer, and now it is working "as well as any straight set I have heard." How and wherefore? says Fred.

### Less L.F. Amplification.

**W**HAT Fred probably achieved by both kinds of monkeying he describes was the damping of the circuit so much that he is now getting little more

than one stage of L.F. amplification. He can take his output from the first transformer now and probably notice but little difference.

Or he can connect the second transformer properly, reduce the grid leaks to a half or a quarter megohm and try the effect of various resistances, ranging from 100,000 ohms upwards, across the primary or secondary.

### A Thoughtful Wife.

**W**E all know of the sweet creatures who buy men's gifts, and with the best will in the world go wrong through sheer ignorance. (Books, tobacco, ties, etc.) But

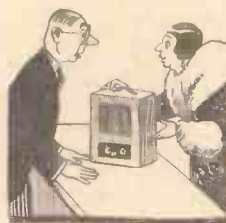

what a charming wife that must have been who called on a Reading dealer on Christmas Eve with a portable gramophone and complained of its "tinny" performance.

Her husband, she said, had objected to it, and so she thought it might be improved if it were fitted with a "pick-me-up"! One wonders whether she ordered a pint or a quart size.

### New Radio-Telly Branch.

**I**AM very pleased to hear that my county, Kent, is now invested with a branch of the Anglo-American Radio and Television Society. I hope that Kent will rally to this society and become the country's star branch.

A stamped, addressed envelope to the Secretary, Mr. E. Ingleton, "The Haven," Chalk, nr. Gravesend, will elicit full particulars. Now, Kentishmen and Men of Kent, "do me proud" and make



attention to detail which distinguishes a Sicilian vendetta.

Indeed, it is reported that the practitioners in Baden-Baden during 1933 applied anti-interference devices to electrically heated pillows, hair cutters, hair driers, vacuum cleaners and massage machines, besides flat irons. How on earth did they overlook flashlamps?

### But What Was the Music?

**B**RIDLING with self-satisfaction, the National Broadcasting Corporation (U.S.A.) announces that music consumed 67.4% of its 1933 programme time; literature, drama and talks, 17.9%; news, 3.1%; hens' and kids' programmes, 4.7%; and religion, 1.8%.

The N.B.C. "calculates" that 21.15% of the total, including music, was occupied by programmes of an educational nature. Yes, but just what was that music? One man's music is another guy's pain in the neck.

### Like Us, After All.

**I**T is of interest to survey the results of a poll of likes and dislikes about American radio which was taken by the "Literary Digest," for they seem to me to show that the American listener is at heart much the same as the British.

Hearken to this! For jazz, 518; against, 10,876. For crooners, 64; against, 9,636. For political speeches, 838; against, 1,002. For saxophones, 12; against, 252. And so on and so forth.

### Retrospect—First Glance.

**R**ECENTLY I found the first volume (1911) of the "Marconigraph," the world's first radio magazine, and here are some of the "Notes and News" of those days in brief: Telegrams to ships via Poldhu, *three shillings a word*. Reception of wireless signals from Havana in aeroplane flying over Palm Beach.

Radio station opened on Cocos Island. A few years later it brought the Sydney to fight the Emden! Article about his trip as wireless operator with the Newfoundland sealing fleet, by Mr. E. T. Fisk—now chief of Australia's wireless industry.

### Retrospect—Second Glance.

**R**EPORT from U.S.A. that a New York engineer had accelerated the growth of strawberries by 41 days by some radio device not disclosed.

Old controversy, "Does wireless affect climate?" already going strong. Flammarion, world-famous astronomer, takes matter very seriously and predicts cold and wet year as result of radio. But 1911 was particularly hot and dry. Question not yet settled; just like the weather!

ARIEL

## SHORT WAVES

One of the pronunciation experts at the B.B.C. has listed twelve ways of saying "Yes."

We understand that this does not include the popular "Qualte" and "That's raite."

"The average radio receiver contains approximately 1,500 POUNDS, including the last-screw and lug and other minute parts," says the "New Haven Evening Register" of America. Quite a little gold mine.

"The only sane way to use a broadcast receiving set is to shut it off except when something is on which one wants to hear," we read in an electrical paper.

But that would be such waste of 10s. a year.

### A VERY GOOD WISH.

May you never have an SOS  
To cause the least alarm;  
The forecast for your every day  
Be "weather fair and warm";  
And may the plays and talks of life  
Always entertain you:

It's symphonies and vaudevilles  
Never bore or pain you;  
And when at last the programme's done  
And you shut off your set,  
May joy be yours that this has been  
The gladdest New Year yet!

(From a card received from an overseas reader.)

Gravesend the spiritual home of televisionists!

### The Thorough Teuton.

**F**ROM an official report it is learned that the stamping out of interference with radio caused by electrical devices is taking place in Germany with the loving



More  
About

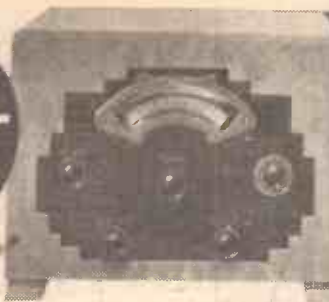

# THE NATIONAL ECKERSLEY 3

**A**LL sorts of little points occur to me. Without thought of order let me spill them out as lightly as accumulator acid flows on to the carpet—but with less consequent damage, I hope.

Batteries! Batteries! Well, unfortunately many of us have got to use them.

The set "takes" 11 m./a. So the battery must give the set what it takes or the set will be half-starved. It's not economical to use cheap foods, and it's not economical to feed a set from a doubtful source.

The normal H.T. battery-discharge rate should be, then, above 11 m./a. and, in reason, the higher above the better. That may cost more in capital, but within limits less in revenue, and it certainly will give greater pleasure.

#### Screening-Grid Voltage.

And do not forget that the current taken by the S.G. valve greatly depends upon the voltage applied to its screens. This must lie between 60 and 80 volts, so put (H.T. + 1) into a hole equal to or more than 60, or equal to or less than 80, and, just for saving current, the lower the better.

But balance up performance against economy. And note that this figure, 60-80, means volts, not labels—beware of an old battery.

All the above advice applies to all types of valves.

I do not support the type of advertising

★.....★  
**The construction of this entirely unique design was fully described last week, and here are further practical points about the set in use, with details of voltages, batteries, and trimming the tuning condenser.**  
**P. P. ECKERSLEY,**  
**ORIGINATOR OF BRITAIN'S REGIONAL SCHEME OF BROADCASTING,**  
 designed this public-service set to provide you with continuous radio entertainment from British and foreign stations.  
 ★.....★

which extols a valve because it is alleged to give by itself perfect quality or range or power.

A valve by itself is just a glass bottle on legs. But, provided the circuits round the valve are properly designed, a bad valve can ruin everything.

Equally bad circuits round a good valve.

will ruin everything. But in the case of the "National Three" the circuits are all right. Be sure, then, that the valves are worthy of the circuits!

And to this end use only those specified. If you do not, then, particularly in the case of the output valve which uses "free grid-bias" circuits, you will be inviting trouble.

Fuse: I think fuses are essential. I wish I could be persuaded to use them more!

You who are much wiser than I will use the 150 m./a. type. Do not fear that these are too much on the heavy side—they will do all they are meant to do in protecting your filaments, and they are more robust and reliable than the 60 m./a. type.

#### Care of the Accumulator.

Accumulator: This may be all right for the old hands. But the neophyte should see that "Vaseline"—"your friend in a hundred troubles"—is included in his list for the accumulator terminals. Vaseline prevents acid spray getting on to the metal of the terminals and so stops the growth of that ugly, messy, highly coloured sponge which too often adorns the uncared-for accumulator.

(Continued on next page.)



#### TRIMMED TUNING.

Putting the final touches to the detector's grid circuit before the set is brought into action. Once made, this adjustment does not need alteration.



INSERTING THE DETECTOR

On a following page you will find a list of the types and makes of valves recommended for each position.

### THE BEST ACCESSORIES TO EMPLOY

**LOUDSPEAKER.**—Celestion, W.B., Rola, Blue Spot, R. & A., Ferranti, H.M.V., Amplion, Marconiphone, Cossor, G.E.C.

**BATTERIES.**—H.T. 120 volts: Lissen, G.E.C., Ever Ready, Siemens, Pertrix, Ediswan, Drydex, Marconiphone, Grosvenor, Hellesens or Block H.T. accumulators.

L.T. 2 volts: Block, Lissen, Pertrix, G.E.C., Ediswan, Exide, Oldham.

**AERIAL AND EARTH EQUIPMENT.**—Electron "Superial," Goltone "Akrite," British Radiophone "Receptru" download, Bulgin Lightning Switch, Graham Farish "Filt" earthing device.



## UNIQUE—

This view, taken at Brookmans Park, shows the two adjacent control desks—one for London National, on 261.1 metres, and the other for London Regional, on 342.1 metres. Usually, broadcasting transmitters are placed as far apart as possible, though, when two are serving the same area, it is a great advantage to be able to combine them under one roof. The twin-wave high-power broadcasting station idea was considered impracticable until Eckersley proved, by the success of the British Regionals, that all the technical objections could be overcome.

(Continued from previous page.)

Do what every good experimenter does before putting the valves in their holders: be sure that the voltages getting to the holders are the correct ones.

A pocket-lamp bulb is a qualitative voltmeter for the L.T. If it blows up it shows that the H.T. is where it shouldn't be. Better than blowing up a valve.

I suppose you will be using moving-coil loudspeakers, but, if you are not, get a pentode choke and instructions how to connect it up, so that the loudspeaker shall be "matched" to the valve and the proper H.T. shall be applied to that valve's anode.

I have told you, all this time, that the set is designed. So it is, and the rising pentode characteristic offsets the falling H.T. characteristics for a few average loudspeakers.

But loudspeakers are different one from another. Even a good loudspeaker may be unsuited to a good set. A design uses compatible components.

If your loudspeaker is incompatible to the set, use a tone corrector. A simple form of tone corrector consists in a network connected across the loudspeaker. In its simplest form this is a resistance in series with a condenser.

### Resistance and Condenser Values.

There are so many variables that I cannot give you hard and fast rules or hard and fast values. Try resistances between 5,000 and 20,000 ohms and condensers between 0.005 and 0.01 mfd.

Designed by

## FULL PARTICULARS OF ALL THE PARTS REQUIRED TO MAKE THE "NATIONAL ECKERSLEY THREE"

- |  |  |
|--|--|
| 1 British Radiophone 3-gang .0005-mfd. tuning condenser type 604.                                      | 1 Graham Farish 300-ohm 1½-watt type Ohmite resistance with horizontal holder.             |
| 1 British Radiophone slow-motion drive for above, type 711.  | 1 Lissen 1-meg. grid leak with wire ends, or Varley, Dubilier, Bulgin.                     |
| 1 Set 3 Telsen matched screened coils, type W288, or Colvern K.G.O., K.G.O., K.G.R.                    | 1 Dubilier .1-mfd. tubular fixed condenser, type 4404, or T.C.C., Graham Farish.           |
| 3 W.B. large type 5-pin valve holders, or Benjamin, Telsen, Lissen, Graham Farish.                     | 1 Dubilier .0002-mfd. fixed condenser, type 620, or T.C.C., Lissen, Graham Farish, Telsen. |
| 1 Lissen Hypernik L.F. transformer, or Telsen Type G.S. 5, Varley, R.I.                                | 1 British Radiogram rotary QMB on-off switch, type No. 51, or Bulgin.                      |
| 1 Graham Farish screened H.F. choke, type H.M.S., or Telsen, Bulgin, Wearite.                          | 1 Clix S.G. anode connector, or Belling-Lee, Bulgin.                                       |
| 1 Graham Farish .0003-mfd. differential reaction condenser, or Polar, Telsen, J.B., British Radiogram. | 4 Clix indicating terminals, or Bulgin, Belling-Lee, Igranic.                              |
| 1 Graham Farish 2-mfd. fixed condenser, or T.C.C., Telsen.   | 2 Belling-Lee wander-plugs, or Igranic, Clix, Bulgin.                                      |
| 2 T.C.C. 2-mfd. fixed condensers, type 50, or Graham Farish, Telsen.                                   | 1 Belling-Lee wander-fuse.   |
| 1 Igranic 20-ohm variable resistance, type WYPAD.  | 2 Clix accumulator spades, or Belling-Lee, Eelex.  |
| 1 Dubilier 100-ohm resistance, 1-watt type, or Graham Farish, Bulgin (with wire ends or terminals).    | 1 Peto-Scott Metaplex chassis, 12 ins. x 10 ins. x 2½ in., with terminal strips.           |
| 1 Graham Farish 100,000-ohm 1½-watt type Ohmite resistance with horizontal holder, or Ferranti.        | 1 Peto-Scott ebonite panel, 12 in. x 8 in., or Goltone, Permco!, Wearite.                  |
| 1 Graham Farish 30,000-ohm 1½-watt type Ohmite resistance with horizontal holder, or Ferranti.         | 1 Set British Radiogram matched knobs.   |
| 1 Graham Farish 5,000-ohm 1½-watt type Ohmite resistance with horizontal holder, or Ferranti.          | 2 Coils British Radiophone "push-back" wire.   |
|  | 1 Peto-Scott cabinet.  |
|  | Screened wire, flex, screws, etc. (Peto-Scott).  |

The larger the condenser or the lower the resistance the less the top.

This tone corrector removes top. All correctors remove something; no corrector can put something in. So only use a tone corrector if you have too much (pentode) top.

I know that the dial light is terribly attractive. On the other hand, it takes current. So it's *not* connected normally. But you can do what you like about it—leave it in permanently, put in a switch to switch it on when you want it (but not always when the set is on), or just leave it out.

**Some Points to Watch.**

Suppose the set doesn't work when you connect it up. I assure you it will be your fault. Therefore it is very unlikely that you need read this. But just in case.

**Batteries:** Are they really giving their volts right up to the terminals? Internal disconnections are possible. If found, short out the break with wander-plugs.

**Coil Cans Cut Connections, see?** But see that they haven't, or that they haven't bared insulation and shorted a voltage to earth.

The regulator coupling resistance must be a resistance, not a short. Disconnect it and see if it was shorting.

ganged tuning condenser are accurately matched, it does not follow that the three-tuning circuit will be in step. The stray capacities in the wiring and the inter-electrode capacity of the valves account for this.

Consequently each section of the ganged tuning condenser is provided with a trimmer.

The most-satisfactory way of adjusting these is as follows:

Screw down each trimmer as far as it will go. Now turn back each one a complete revolution. Tune in a fairly weak station at the lower end of the medium wave-band, with the selectivity control set for maximum selectivity.

Increase the reaction for maximum signal strength, and then adjust the two trimmers nearer the panel for loudest signals.

When this has been done all the circuits will be in tune.



**WHICH VALVES TO CHOOSE AND USE**

Make.	S.G.	Detector	Output.
Cossor	220S.G.	210 H.F.	220 H.P.T.
Mullard	P.M.12A.	P.M.1 H.L.	P.M.22A
Mazda	S.215A.	H.L.2	Pen. 220
Marconi	S.24	H.L.2	P.T.2
Osram	S.24	H.L.2	P.T.2

**MAKES AND TYPES FOR BEST RESULTS**

—EFFICIENT

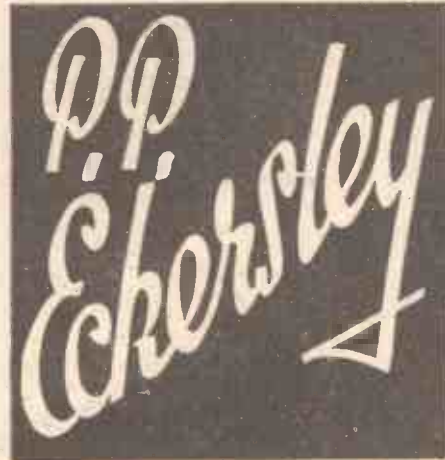

Metallised valves have conducting glass which connects to earth. Any lively and wanted voltage will disappear if it touches the valve globe; e.g. the anode connector of V.1 (the H.F. valve) mustn't be shorting on to the metallised part of the valve.

**A Local-distant Switch.**

If suddenly signals shout so shockingly that you cannot even, by means of the regulator, cut them down, you are very close to a powerful station. Fit a local-distant switch, which in the local position shunts the aerial and earth terminals by a resistance of the order of 100 ohms.

I usually take off the main aerial and connect instead a few feet of flex to the aerial terminal. I then get as much or as little signal as I like by twisting the flex more or less round the aerial.

When I want the full signal I join them metallicly; when I want a soft signal I leave them capacitously embraced. It's cheap and not particularly nasty.

Although the coils are all of exactly the same inductance, and all sections of the

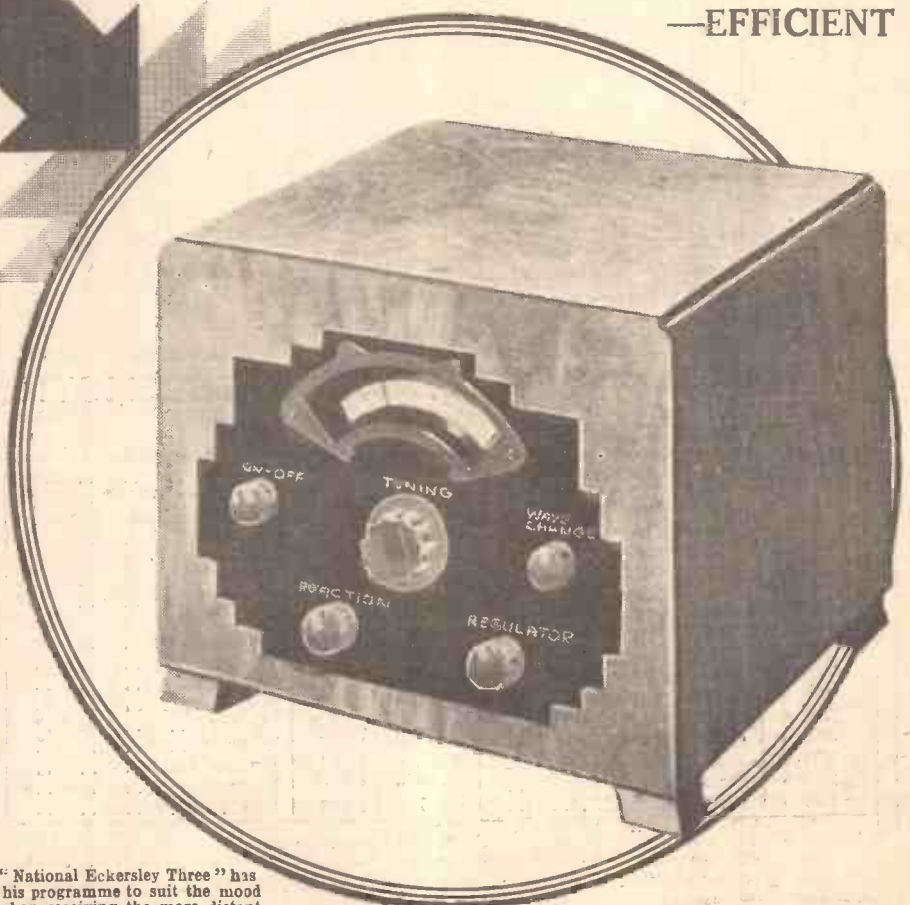

Although it is a one-knob-tuning receiver, the "National Ekersley Three" has an enormous range, enabling its owner to select his programme to suit the mood of the moment. Reaction is only necessary when receiving the more distant stations, and the Regulator gives effective and smooth control of volume and selectivity.

# THE OPEN OF RADIO

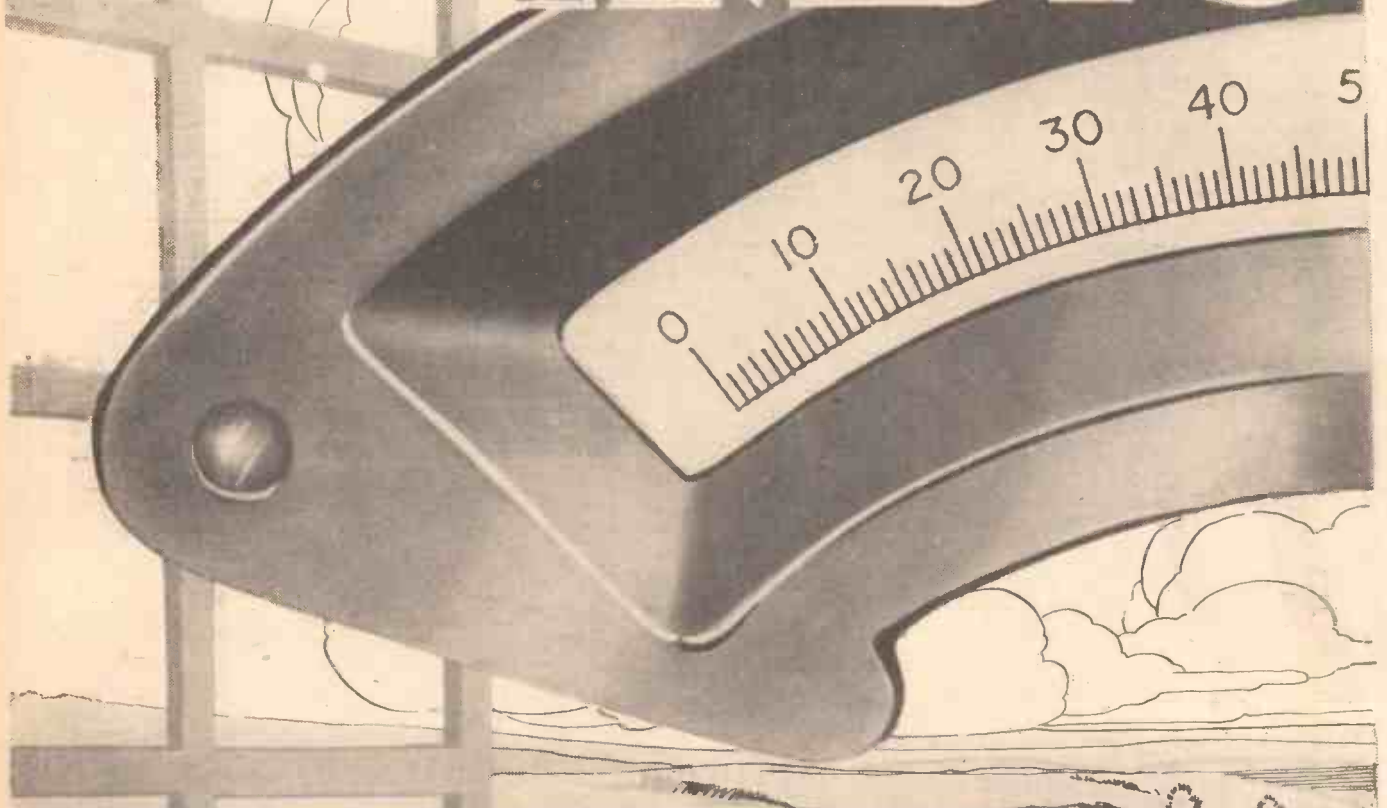

## WHERE TO FIND THE NEW WAVELENGTHS —

New Wavelength	Name of Station	Dial Reading	New Wavelength	Name of Station	Dial Reading
222.6	Aberdeen	7.5	209.9	Cork	4
318.8	Algiers	32	1500	Daventry 5 X X	54
531	Athlone	89	1571	Deutschlandsender	59
274	Barcelona	19.5	222.6	Dublin	7.5
283.3	Bari	22	491.8	Florence	79.5
267.4	Belfast	18.5	251	Frankfurt	14.5
356.7	Berlin	42.5	304.3	Genoa	28
539.6	Beromunster	91.5	243.7	Gleiwitz	12.5
278.6	Bordeaux	21	318.8	Goteborg	32
203.5	Bournemouth	2.5	331.9	Hamburg	35.4
298.8	Bratislava	26.5	291	Heilsberg	24.5
315.8	Breslau	31.2	301.5	Hilversum	27.5
325.4	Brno	34	265.3	Horby	18
483.9	Brussels I	78	1345	Huizen	41
321.9	" II	33	1261	Kalundborg	34
212.6	Bucharest	5	395.8	Katowice	54.5
549.5	Budapest	95.5	1145	Lahti	27

DIAL POSITIONS OF ALL THE PRINCIPAL STATIONS —

# WINDOW THE WORLD

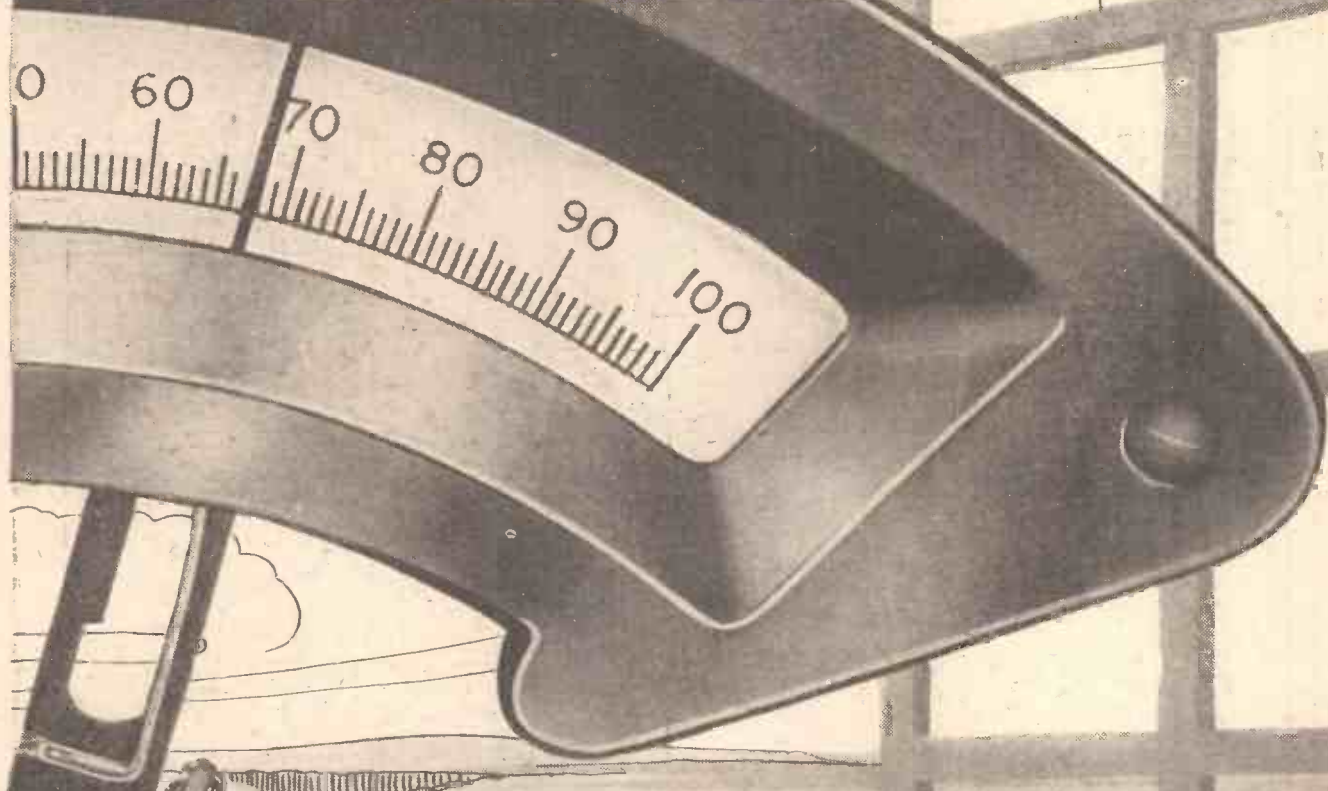

## —ON YOUR NATIONAL ECKERSLEY THREE

New Wavelength	Name of Station	Dial Reading	New Wavelength	Name of Station	Dial Reading
455.9	Langenberg	70.25	1186	Oslo	30
382.2	Leipzig	50	431.7	Paris (P T T.)	64
247.3	Lille	13.5	203.5	Plymouth	2.5
261.1	London National	17	470.2	Prague	74.5
342.1	„ Regional	38.5	1796	Radio Paris	77.5
377.4	Lwow	49	420.8	Rome	61
463	Lyons	72.5	285.7	Scottish National	23
293.5	Madrid No. 2	25	373.1	„ Regional	48
391.1	Midland Regional	53	443.1	Sottens	67
368.6	Milan	46	349.2	Strasbourg	40.5
259.1	Moravska Ostrava	16.5	499.2	Sundsvall	82
1714	Moscow (Komintern)	70.5	386.6	Toulouse	51.5
522.6	Muhlacker (Stuttgart)	88	245.5	Trieste	13
405.4	Munich	57	263.2	Turin	17.5
209.9	Newcastle	4	506.8	Vienna	83
296.2	North National	26.25	261.1	West National	17
449.1	„ Regional	68.5	307.1	„ Regional	28.5

—Under the Wavelength Scheme Initiated on January 15, 1934

The Above-Baseboard  
Wiring Plan of  
P. P. Eckersley's  
National Three  
for A.C.

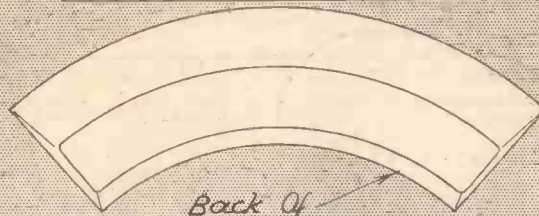

To GB Socket  
On Mains Unit

Slider

Combined  
5000 Ohms Potmeter  
& On-Off Switch

To Switch  
Plug On  
Mains  
Unit

Dial

Wavechange  
Switch

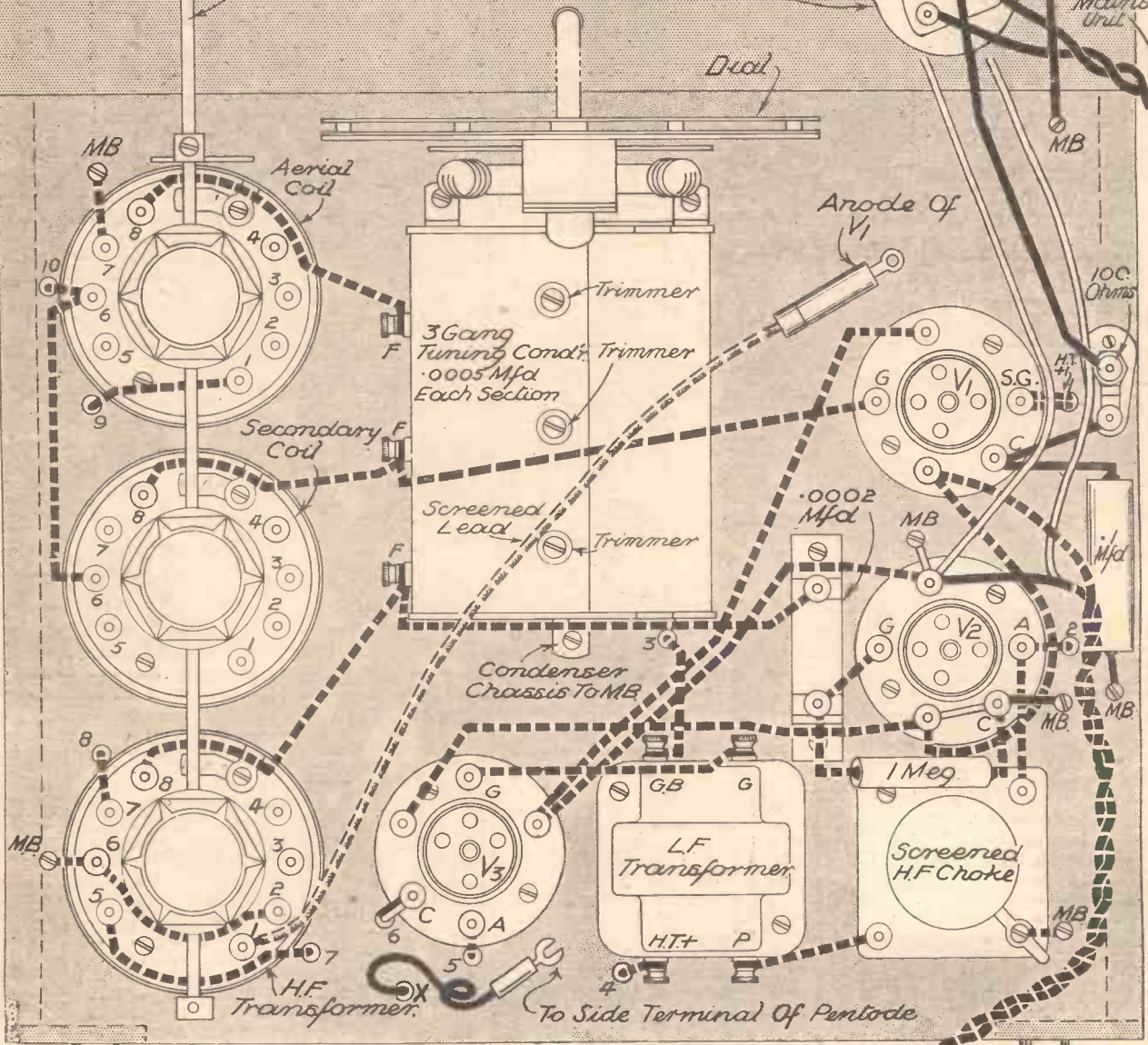

Note:  
Leads To 'MB' Go  
To Metallized  
Baseboard





# How the National Eckersley Three is Converted to A.C.

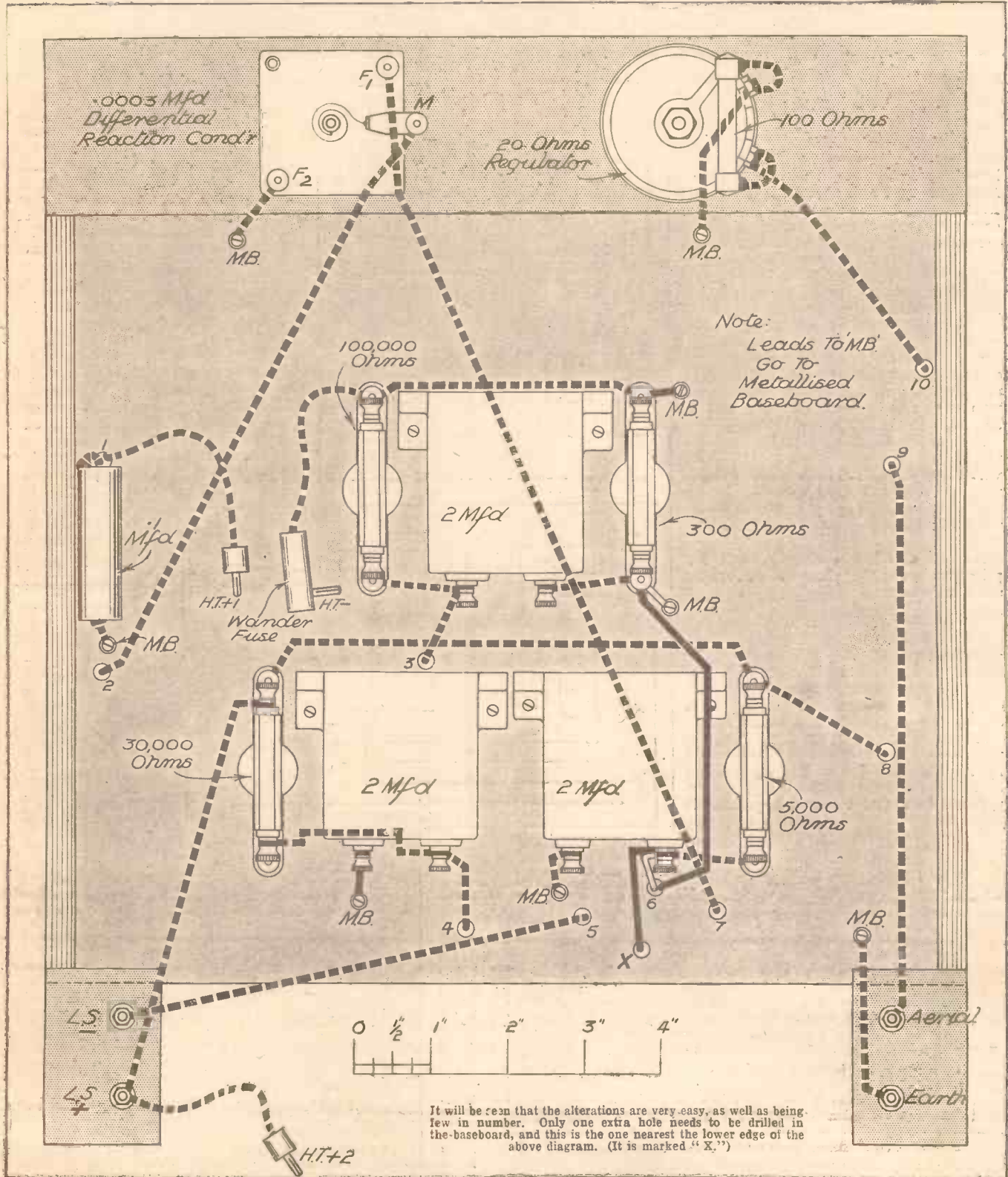

On this page and page 910 the few alterations to wiring are clearly indicated, the heavy dotted lines showing the original wiring which is left unaltered. The full black lines show new wiring. Old wires which must be removed are shown "hollow," as double lines. (Examples of all three classes will be seen connected to the lower terminal of the 300-ohm resistance near the centre of the page.)



## ECKERSLEY'S NATIONAL THREE FOR A.C.

(Continued from page 911.)

This will be connected to the side terminal of the output pentode valve.

Now remove lead joining 300-ohm resistance to chassis, and connect same terminal of 300-ohm resistance via hole 6 to cathode of V.3.

Connect the remaining terminal of this resistance to chassis.

### The Volume Control.

Reverting once more to the top of the chassis, the on-off switch is removed and replaced by the combined potentiometer and on-off switch, and the vertical holder for the 100-ohm resistance is screwed in position.

These new components are all shown clearly in the photograph and diagram.

The cathode terminal of V.1 is connected to the terminal of the resistance holder, and also to one wire end of a .1-mfd. tubular fixed condenser. The remaining wire end of the condenser is connected to the chassis.

The top terminal of the resistance must be connected to the centre terminal of the potentiometer. (Referring to the wiring diagram, it will be seen that there are three

terminals on the top of the potentiometer.)

Connect the right-hand terminal to the chassis, and the left-hand terminal to a length of single flex, about eighteen inches long. Connect a length of twin flex about the same length to the switch terminals of the potentiometer.

The socket which connects to the switch plug on mains unit should be attached to the other end of the twin flex. The mains leads must be connected to the socket portion of the mains plug and fuses.

The receiver and mains unit are now ready to be connected up. The positions

for the L.T. leads and H.T. leads are obvious. The single-flex lead from the potentiometer has a wander-plug attached (Continued on page 938.)

## FEW PARTS AND EASY WIRING

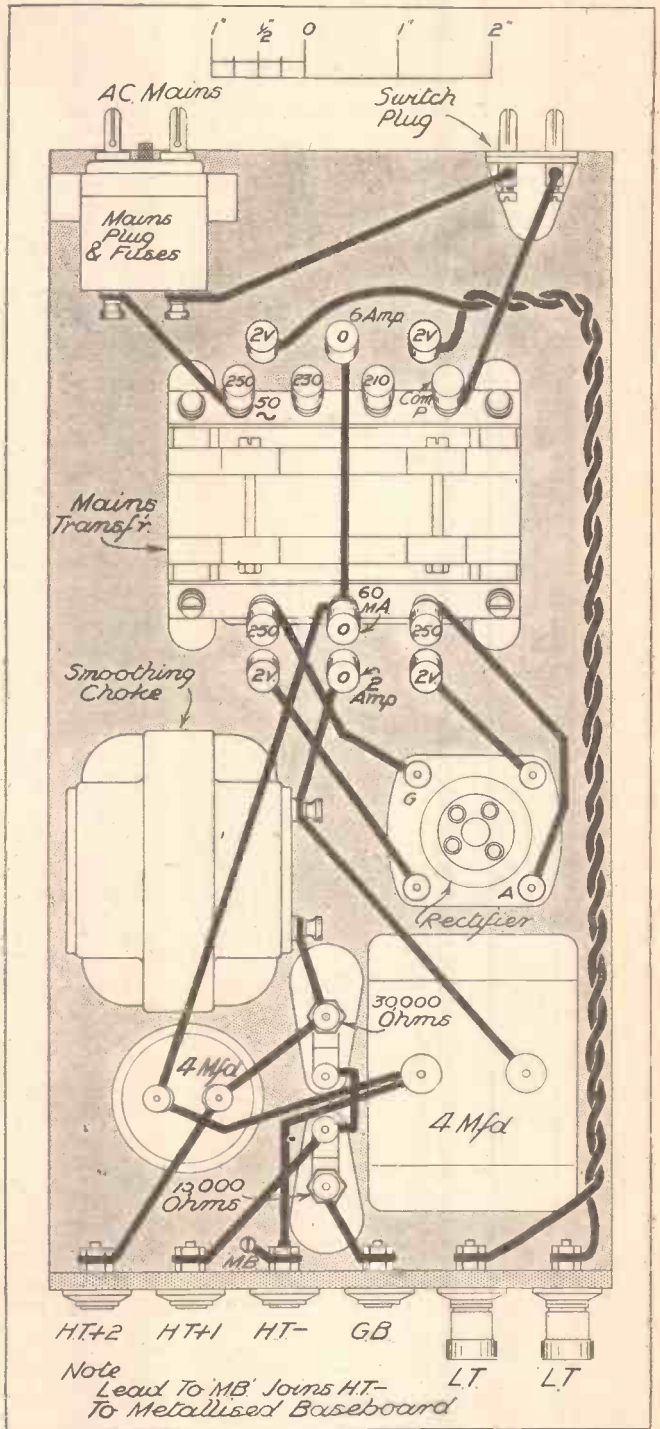

Full details for the placing of the components are given by this diagram of the A.C. unit, drawn to the scale above it. The heavy black lines, as usual, denote the wiring, which, though relatively easy and straightforward, should be carried out with care.

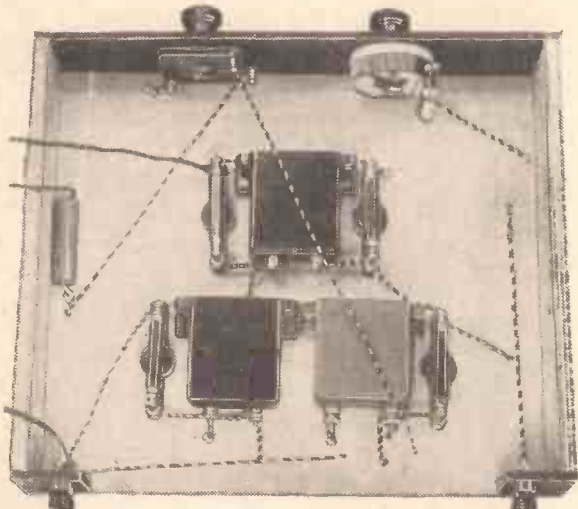

UNDER THE BASEBOARD. A close-up of the altered wiring.

## THE A.C. VALVES TO USE

Make	S.G.	Detector	Output
Cossor	M.V.S.G.	41M.H.L.	M.P./Pen.
Mullard	M.M.4V.	354V.	Pen.4V.
Mazda	A.C./S.1V.M.	A.C./H.L.	A.C. Pen.
Osram	V.M.S.4B.	M.H.4	M.P.T.4
Marconi	V.M.S.4B	M.H.4	M.P.T.4

## COMPONENTS FOR THE A.C. UNIT

- 1 R.I. mains transformer, type E.Y.30.
- 1 Lissen smoothing choke, type L.N.5301, or Wearite, type H.T.12.
- 1 T.C.C. 4-mfd. fixed condenser, type 80, or Dubilier.
- 1 Dubilier 4-mfd. fixed condenser, type 9200/9201.
- 1 Benjamin 4-pin valve holder, "Vibrolder" type, or W.B., Telsen, Lissen.
- 1 Graham Farish 30,000-ohm 1 1/2-watt "Ohmite" resistance in vertical holder.

- 1 Graham Farish 15,000-ohm 1 1/2-watt "Ohmite" resistance in vertical holder.
- 4 Igranic "Indigraph" sockets, or Clix, Bulgin, Belling-Lee.
- 2 Igranic "Indigraph" terminals, or Belling-Lee, Bulgin, Clix.
- 1 Bulgin combined mains plug and fuses, type F.15.
- 1 Belling-Lee mains plug, type 1042, or Bulgin, Goltone.
- 1 Peto-Scott "Metaplex" baseboard, 12 in. x 6 in.
- 1 Peto-Scott terminal strip, 6 in. x 1 1/2 in.
- 1 Coil of British Radiophone "Push-back" wire.

RECTIFIER VALVE: 1 Mullard I.W.2, or Mazda UU.60/250.

# THE NATIONAL ECKERSLEY RADIOGRAM

LAST week I told you of the many merits of this radio-gramophone design, so I can now proceed to describe the actual building of it.

Well, that's enough of preamble. Let us cut the cackle, etc.

Firstly, about components. I have to repeat what I have said in other articles: that where we give no alternative component makers it isn't because other manufacturers are dumb, but because we have a

design, and very often a design is only suited by one component.

You can have a carburettor suitable for one engine and quite unsuitable for another. The carburettor is part of the design of an engine; it cannot be judged just by itself as a carburettor.

In other cases a single manufacturer named in a list means that no other manufacturer manufactures the component. (That's an easy one.)

**How-to-make particulars of the magnificent self-contained radio-gramophone which was introduced to our readers last week. It will be seen that construction is quite a straightforward matter, and remarkably simple considering the power and entertainment possibilities of this unique receiver design.**

**By P. P. ECKERSLEY.**



Getting nearer to the details, we begin, and emphasise:

The two 2-mfd. condensers on the underside of the chassis must be of the universal mounting type. Of course, if any of the makes specified are used they will be satisfactory.

You can save yourself an enormous amount of trouble if you simply buy a kit from a kit-set manufacturer. You are then bound to have everything—even down to screws!

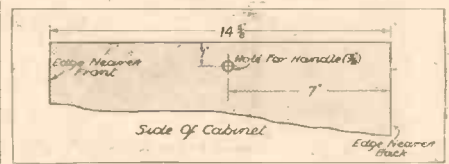
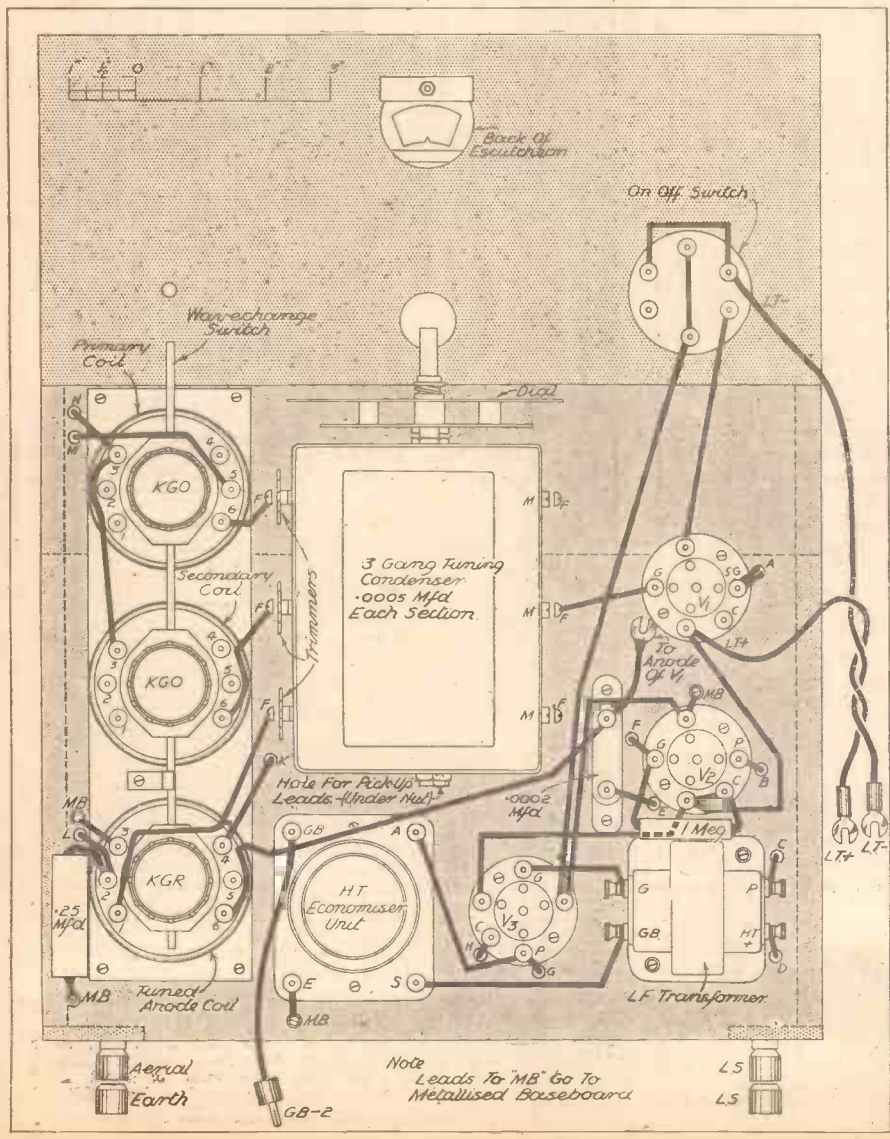

**THE HOLE FOR THE HANDLE.**  
From the dimensions given above you can see exactly where the cabinet should be drilled.

So I assume you have all the ambition and all the bits. Now to help you put them together.

The first thing to do is to mark out the panel. This will be easy if you use the front of the panel diagram and the template supplied with the tuning condenser.

The hole for the tuning-dial escutcheon can be cut out by means of an extending centre bit or a fret saw. Failing either of these, a key-hole saw can be used. (Most

*(Continued on next page.)*

- RADIOGRAM ACCESSORIES**
- BATTERIES.**—H.T., 120 volts: Ediswan, Lissen, Marcomphone, G.E.C., Ever Ready, Petrix, Siemens, Drydex, Hellesens, Grosvenor.
  - G.B. 10½ volts: Drydex, Ever Ready, Siemens, Lissen, Petrix, Marcomphone.
  - L.T., 2 volts: Block, Ediswan, Lissen, Petrix, G.E.C., Exide, Oldham.
  - AERIAL AND EARTH EQUIPMENT.**—Electron "Superial," Goltone "Akrite," British Radiophone "Receptra" downlead, Bulgin lightning switch, Graham Farish "Filt" earthing device.

The whole of the above-baseboard wiring is shown in this diagram. Wires to components below the baseboard pass through holes in it, these being lettered "A," "B," "C," etc., to correspond with similar letters on the under-baseboard wiring diagram which appears on a following page.

# THE NATIONAL ECKERSLEY RADIOGRAM

(Continued from previous page.)

people who "make things" have these. The sizes of the holes for mounting the various panel components are as follows: On-off switch,  $\frac{5}{8}$  in. Reaction condenser,  $\frac{3}{8}$  in. Wavechange switch,  $\frac{1}{2}$  in. Combined volume control and radiogram switch,  $\frac{3}{8}$  in. Mark out the holes for the selectivity

control by means of the escutcheon supplied with it. The hole for the spindle is  $\frac{1}{16}$  in., and those for the fixing holes  $\frac{1}{8}$  in.—these must be counter-sunk.

The necessary details regarding the holes for the tuning condenser-drive-escutcheon and condenser from the template supplied with it.

These drilling details show the exact positions of the various controls on the front of the panel.

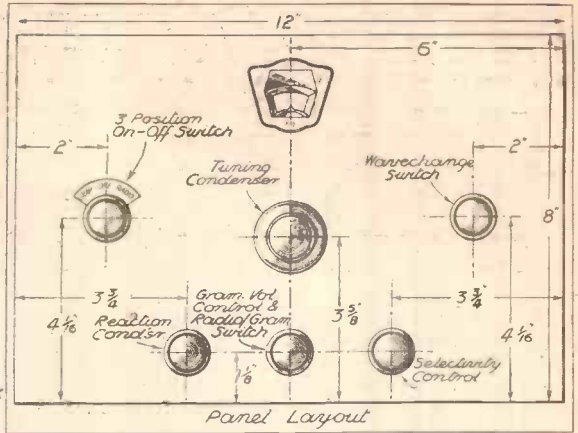

## THE NATIONAL ECKERSLEY RADIOGRAM COMPONENTS

- 1 J.B. 3-gang .0005-mfd. tuning condenser. "Nugang," type A.
- 1 Colvern 3-gang coil unit, type K.G.O., K.G.O. K.G.R., or Telsen W.238.
- 3 Benjamin 5-pin valve holders, or Lissen, W.B., Telsen, Graham Farish.
- 1 Lissen Hypernik L.F. transformer, or Telsen, type G.S.5, Varley, R.I.
- 1 Amplion binocular H.F. choke, or Telsen, Graham Farish.
- 1 Graham Farish .0003 mfd. differential reaction condenser or J.B., Polar, Telsen, British Radiogram.
- 1 Graham Farish 2-mfd. fixed condenser, or T.C.C., Telsen.
- 1 T.C.C. 2-mfd. fixed condenser, type 59, or Graham Farish, Telsen.
- 1 Dubilier 25-mfd. tubular fixed condenser, type 4496, or T.C.C., Graham Farish.
- 1 Dubilier 1-mfd. tubular fixed condenser, type 4404, or T.C.C., Graham Farish.
- 1 T.C.C. .0002-mfd. fixed condenser, type 34, or Dubilier, Telsen, Lissen, Graham Farish.
- 1 Lissen 1-meg. grid leak with wire ends, or Dubilier, Varley, Bulgin.
- 1 Graham Farish 30,000-ohm  $\frac{1}{2}$ -watt type "Ohmite" resistance with horizontal holder, or Ferranti.
- 1 Graham Farish 5,000-ohm  $\frac{1}{2}$ -watt type "Ohmite" resistance with horizontal holder, or Ferranti.
- 1 Graham Farish 1,000-ohm  $\frac{1}{2}$ -watt type "Ohmite" resistance with horizontal holder.
- 1 Graham Farish H.T. Economiser Unit, type T.P.
- 1 Westinghouse "Westector" metal rectifier, type W.A.

- 1 Dubilier 100-ohm 1-watt type resistance or Graham Farish, Bulgin, Varley (with wire-ends or terminals).
- 1 Igranic 20-ohm variable resistance, type WYPAD.
- 1 Bulgin switch, type S.110.
- 1 Bulgin 50,000-ohm potentiometer with 3-point change-over switch, type V.S.36.
- 1 Clix S.G. anode connector, or Belling-Lee, Bulgin.
- 4 Belling-Lee indicating terminals, type R, or Bulgin, Igranic, Clix.
- 5 Belling-Lee wander-plugs, or Clix, Bulgin, Igranic.
- 1 Belling-Lee wander-fuse.
- 2 Clix accumulator spades, or Bulgin, Belling-Lee, Eelex.
- 1 Peto-Scott Metaplex chassis, 12 in. x 10 in. x 23 in., with terminal strips.
- 1 Peto-Scott ebonite panel, 12 in. x 8 in., or Goltone, Permoil, Wearite.
- 1 Set British Radiogram matched knobs.
- 1 Peto-Scott cabinet.
- 2 Coils British Radiophone "push-back" wire.
- Flex, screws, etc. (Peto-Scott).
- 1 Harile gramophone pick-up model 65, or Cosmocord Standard No. 2, Marconi, Columbia.
- 1 Garrard single-spring gramophone motor with 7-in. handle, type No. 29, or Collaro.
- 1 W.B. Microloide loudspeaker chassis, type P.M.4a, or suitably sized R. & A., Rola, Blue Spot, Celestion, Amplion.

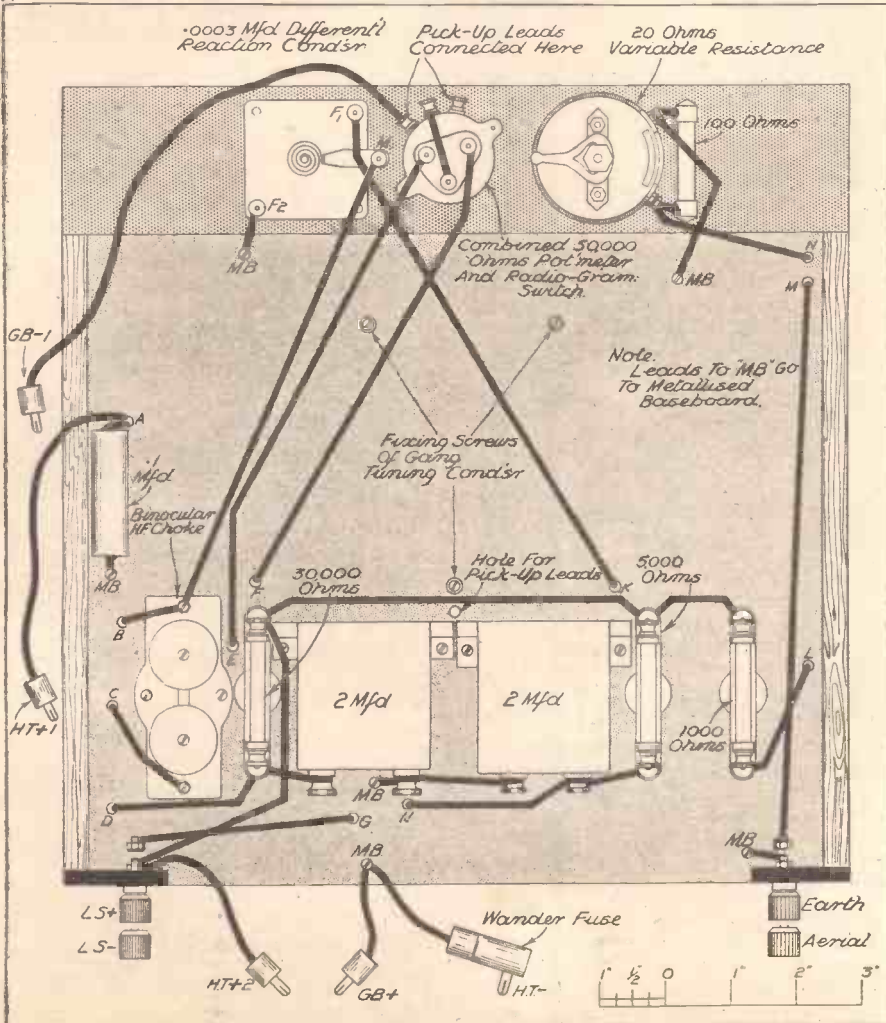

Having mounted the components on the panel, it can be put aside for the time being and a start can be made on the chassis.

This is supplied with the terminal strips already mounted and drilled, so start with the terminals. Draw a faint pencil line down the centre of the underside of the chassis from back to front and parallel to the sides.

Under the Baseboard.

The two 2-mfd. condensers are now mounted one on either side of this line and

### THE VALVES REQUIRED

Make.	S.G.	Detector.	Output.
Cossor	220S.G.	210H.F.	220P.T.
Mullard	P.M.12A	P.M.1H.L.	—
Mazda	S.215A.	H.L.2	Pen.220A.
Marconi	S.24	H.L.2	—
Osram	S.24	H.L.2	—
Hivac	S.G.210	H.210	—
Tungram	S.220	H.R.210	—

six inches from the front. The H.F. choke and the three resistance holders are all mounted in line with the condensers.

Make sure that all these components are in their correct places, otherwise they might get in the way when drilling the holes through which leads pass from underside to top of chassis.

One of these holes is drilled from the underside. It will be used to pass through

(Continued on page 934.)

The components underneath the baseboard on the lower part of the panel are here shown wired together. As in the preceding diagram, the connections to the metal baseboard are shown terminating on it, and marked "M.B."

THE MIRROR OF THE B.B.C.

THROUGH AMERICAN EYES

No Titles for Broadcasting House—"News Reel" Fades  
Out—Advertising and Entertainment—Spanish Barn.

REFLECTIONS BY O. H. M.

I HEAR the B.B.C. has become an acute bone of contention in the United States. This has happened through a series of debates in high schools on the desirability or otherwise of the Americans substituting the B.B.C. system for the sponsored programme system which they have at present.

A great number of high schools are involved, and it has become apparent, as the debates proceed, that the case for the B.B.C. system is being so strongly supported that a turn may be given to public opinion dangerous to American broadcasters. So strenuous efforts are being put forth to catch up the lost ground.

There is, in some cases, active and almost offensive anti-B.B.C. and anti-British propaganda. My feeling is that American opinion is not likely to be deviated by such panic tactics. Anyway, the debates assume a greater importance than was ever expected, and the ultimate analysis of their results will be awaited with interest all over the world.

"Honours" Disappointments.

The absence of all B.B.C. names from the New Year's Honour List has caused a good deal of heart-burning at Broadcasting House. It has been known that several names have been put up time and again, but without result. Only Sir John Reith and Sir Charles Cargill have so far been recognised.

I wonder if the promotion of Sir Kingsley Wood to the Cabinet will have any effect on the next series of recommendations from the B.B.C. Governors for Royal recognition in the Birthday List.

Malcolm Frost in Canada.

Malcolm Frost, the enterprising and adventurous young B.B.C. "bagman" of recorded programmes, reports good progress in the United States and Canada. In the latter country he has linked up with the Canadian Marconi Company through its Sales Manager.

After visiting the Pacific Coast of the United States, Mr. Frost will return by way of the Antipodes, where there are

some loose ends of his business to be tied up.

The End of Anonymity.

As I exclusively forecast recently, the pressure of facts has forced the B.B.C. to depart from its rigid rule of anonymity for members of its staff. Already the rule had been endangered through important



TWO "FIRST BROADCASTS"

On the left is Seymour Hicks as "Scrooge" in "A Christmas Carol," during his first broadcast appearance at the end of last year.

Below, a young visitor to the Schoolboys' Exhibition becomes an announcer for a few minutes on the B.B.C. Stand.



and constant exceptions. There was a time when only the Governors and the Director-General could be mentioned by name. Then conductors, producers, and staff artistes became known to the public by name.

Several ineffectual attempts were made to turn back the clock. But growing public interest and the legitimate insistence of journalism have won out. Anonymity is dead. A final attempt may be made to continue to apply it to announcers, but this will likewise fail.

Mystery of the News Bulletins.

What has happened about the ambitious projects for enlivening the News Bulletins? Mr. Lionel Fielden, to whom was entrusted the working out of the Saturday night "news reel," seems to be engaged on other things, and the news reel is no more—at least, in its vivid form. I have

"time," stating that he was in close personal touch with Mr. Whitley, the Chairman.

Those who believe in this sort of thing  
(Continued on page 934.)

It seems a pity that, just when there are one or two bright little dance numbers going, all the dance bands, light orchestras, cinema organs, variety artistes, and gramophone records should conspire to kill them straightway. Fleeting indeed is the fame and fortune of a sweet melody dance number!

I am thinking particularly of "Without That Certain Thing," Henry Hall, the Grand Theatre, Blackburn, Billy Cotton, Christopher Stone and the Trocadero Cinema Orchestra all did it recently within an hour or two of one another.

This repetition at nausum must be expected, I suppose, by those listeners who have time enough on their hands to do some continuous listening

Such has been the case with me lately. Yet I was glad of the opportunity to listen to a few musical combinations that I knew only by name. The Trocadero Cinema Orchestra, directed by Alfred Van Dam, impressed me no end.

Obviously a smaller orchestra than the Commodore Grand, it yet possesses much in common with Joseph

THE LISTENER'S NOTEBOOK

Frank comments on recent programmes and on microphone personalities of the moment.

Muscant's boys. This is good praise, for the Commodore has few rivals.

I liked the Coventry Hippodrome Orchestra, too. This is perhaps because I didn't care much for the Leeds University midday concert that preceded it, and still less the gramophone recital of some symphonies that followed.

It wasn't Handel's Alcina Suite that displeased me. On the contrary, I liked it. But "Summer Night on the River," by Delius, and

Symphony No. 5, etc., by Sibelius (which I thought would never end), were just a nightmare. I despair of ever understanding such music.

I was disappointed not to hear Jack Hylton. Incidentally, I stayed in purposely to hear him. I didn't think the excuse for his non-appearance was very convincing either. "A prior continental engagement." Had Mr. Hylton forgotten this when he fired up with the B.B.C.?

You must keep a diary, Jack!

Billy Cotton stepped into the breach. I can't say I like all Billy's arrangements and orchestrations. Some of his tunes are badly mutilated. What I do like about him is that he has a good pianist and he uses him. I mean, as a soloist.

I wish his crooner—Teddie Foster—wouldn't strain his larynx trying to imitate Louis Armstrong. It's a beastly noise, even if the imitation reaches perfection.

(Continued on page 932.)

# TELSEN SCREENED COILS



*Exclusively specified*  
FOR THE P. W.  
*"National Eckersley Three"*

**C**APTAIN ECKERSLEY knows! And it is because he *knows* that he has specified and used **TELSEN Triple-Matched Screened Coils** in his latest triumph. There can be no more eloquent tribute to their lasting efficiency—the ultimate attainable in a perfectly shielded inductance of moderate dimensions. Follow his lead. Insist on **TELSEN** wherever coils are concerned.

TELSEN TRIPLE MATCHED SCREENED COILS . . . . .	<b>21/6</b>
TELSEN TWIN MATCHED SCREENED COILS . . . . .	<b>14/6</b>
TELSEN SINGLE SCREENED COIL . . . . .	<b>7/-</b>

## TELSEN COVER EVERY COIL REQUIREMENT

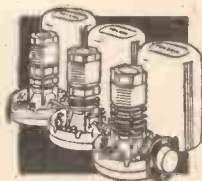

TELSEN SUPERHET COILS  
Type S.330 21/6

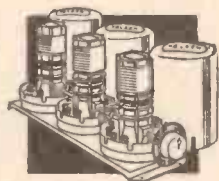

TELSEN BAND PASS & OSCILLATOR COIL UNIT  
21/6

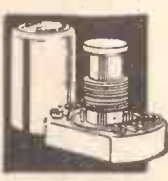

TELSEN IRON CORED COILS  
Single 8/6  
Twin matched 17/-  
Triple matched 25/6

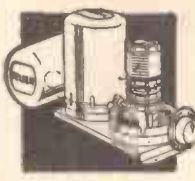

TELSEN BAND PASS COIL UNIT  
14/6



TELSEN DUAL RANGE AERIAL COIL  
7/6



TELSEN H.F. TRANSFORMER COIL  
5/6

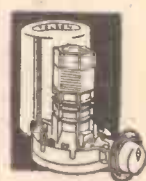

TELSEN OSCILLATOR COIL  
7/6

**TELSEN FOR EVERYTHING IN RADIO**  
ANNOUNCEMENT OF THE TELSEN ELECTRIC CO. LTD., ASTON, BIRMINGHAM

# Short Wave Notes

News and comments by radio's foremost short-wave expert.

**T**HE International DX-ers' Alliance announces the following special programmes for short-wave listeners:

From CP5 (La Paz, Bolivia), 49.3 metres, on January 27th, 6.30-7.30 a.m.; from PA0 ASD on January 28th, 4-6 a.m.; and from VE9CS, Vancouver, 49.43 metres, also on January 28th, from 7.30-9 a.m.

The transmission from Vancouver is unusually interesting, and I venture to suggest that there are very few listeners in this country who have heard that station. The Mozambique station, CR7AA, is giving a special transmission on February 4th, from 2-4 a.m.

For the benefit of the lucky ones who do hear CR7AA, his full address is Box 183, Lourenco Marques, Mozambique, Africa.

## The Competitive Spirit.

I make no secret of the fact that I am all in favour of these short-wave clubs and associations. They certainly foster the competitive spirit that makes for keenness and efficiency. I am rather worried about what the position will be if too many new ones crop up, but I suppose there are still plenty of "unattached" listeners!

V. C. S. (Southport) sends in a log and inquires about the possibility of obtaining QSL's or verifications from short-wave broadcasting and commercial stations. Well, V. C. S., most of the broadcasters will

send some sort of acknowledgment if your report is of any value to them; but I am led to believe that far too many short-wave reception reports are absolutely useless to the people concerned owing to lack of details and inaccuracy.

If you ever do an outstanding bit of reception, keep a careful log of what you hear, together with notes on conditions at the time, wavelength of the station, items heard, fading, etc., and post it off, and you will generally receive some sort of verification.

But please don't send anything to high-power commercial telephony stations, ships' operators and the like—they are already driven out of their wits by the volume of reports which, however carefully they may have been made out, are really quite useless to them.

## 5-Metre Transmission.

V. C. S. would like to get in touch with anyone in his locality who is interested in 5-metre work from the transmitting point of view. His full address is V. C. Slight (2 BPA), 46, Talbot Street, Southport.

W. G. M. (Southampton) sends in an interesting letter and log. Like most of us who listen to the amateurs, he has been finding the 40-metre band the most interesting. "20" has been supremely unreliable, although very good at times. "80" doesn't produce much DX, but is nevertheless quite amusing.

W. G. M. can't find Nairobi on 49.5 metres, and is beginning to worry about his set. I should think the trouble is a "dead spot" for that part of the world, as the rest of the log seems good enough. His philosophical attitude towards short-wave work is worth quoting: "If the signals you want aren't there, just listen to those that are,

and have patience." You certainly won't get far without the latter quality. It is essential to all short-wave work.

## Is It Oslo?

For the benefit of readers who are worried about the "mystery" station between 42 and 45 metres, may I say that I think it is the Oslo short-wave relay to the northern parts of Norway? Can any readers confirm this?

May I publicly thank J. B. M. (Glasgow) for his New Year's gift of an ear syringe? I don't know whether he thinks I may need

## 180-LINE TELEVISION



Denes von Mihaly, a Hungarian, has invented the new mechanical television receiver seen here to handle the German standard pictures of 180 lines and 25 frames a second.

it before or after my bouts of intensive listening.

W. G. B. (Carshalton) has made up my one-valver in an attaché-case, and has had it out in all weathers, including snow. That's real enthusiasm!

W.L.S.

**N**OT so long ago Mr. Richard Haigh, English manager of H.M.V., expressed the opinion that the public was showing a renewed interest in "good" music. By this I presume he meant music as opposed to dance or "jazz" rhythm, which, by the majority of musical critics, is not included among the "good."

Anyhow, the 1934 releases by H.M.V. show a remarkable degree of support for their manager's words, for three works of serious type are included. The list is not exactly highbrow, but the more classical minded will be well pleased.

Leading off, we have an almost complete recording of Strauss' delightful "Der Rosenkavalier"—13 double-sided twelve-inches (DB2060-72). It is a recording worthy of plenty of praise, for it is the successful result of three years' patient endeavour and waiting.

During this period many experiments have been made, but until a few months ago it had not been possible to get together the chief artistes—Lotte Lehmann, Maria Olszewska, Elisabeth Schumann, and Richard Mayer—in Vienna so that they could record with the famous Vienna Philharmonic Orchestra. When the time came £10,000 worth of recording apparatus was sent out specially from England to the Konzerthaus of Vienna, where the records were made.

## By the Boy Violinist.

Next I must draw your attention to the second of the "good" musical items—and it is really good, too. Yehudi Menuhin, the boy violinist genius, has made four discs of Lalo's "Symphonie Espagnole" with the Orchestra Symphonique de Paris (DB1999-2002).

Though called a symphony, the work is really a concerto, and it has a strong Spanish tang, though written by a Frenchman. The conductor, by the way, was Georges Enesco—once Menuhin's teacher, though the pupil has since outshone the master.

Number three in the "high-class section" is Chopin's "Fantasie in F Minor," by Alfred Cortot (DB2031-2).

All the Gilbert and Sullivan operas have been recorded in "authentic" (D'Oyly Carte) form; I believe, by H.M.V. for some time, with the exception of one, which has just been done in abridged form to complete the whole of the Gilbert and Sullivan works on disc. This opera is "The Sorcerer," and its recording was done under the supervision of Mr. Rupert D'Oyly Carte. The numbers are B8054-9.

The ever-popular "Song of the Flea," beloved by

## ROUND THE RECORDS

Selections and recommendations from the most recent issues for the benefit of the radiogram enthusiast.

Chaliapin, has again been recorded. This time the singer is Lawrence Tibbett, who will be remembered for his "Cuban Love Song" among other recordings.

He has given an outstanding performance of the song, with its depiction of the adventures of the flea that went to Court. On the face of it the story of the song is humorous and unusual, but it is given added piquance when one realises that the composer, Moussorgsky, was satirising the Russian prime minister of the time.

Moussorgsky was the illegitimate son of a Russian prince, I believe, and as a Government clerk bitterly resented the favours which the prime minister granted his friends. This topical song of last century has now become a classic (DB1945).

One of the most tuneful ballads we have had lately is "Her Name is Mary," and lovers of this haunting melody will be interested in its sequel, "I Still Love Mary," which has just been released, sung by Derek Oldham on B8087. I am one who does not quite favour the sequel idea in music—it so often places too heavy a handicap on the successor if it follows a real hit. But I must leave you to form your own opinions in this case.

Incidentally, "Mary" is the wife of a cinema organist who chose this way of expressing his affection.

How many of you realised that Peter Dawson, that veteran vocalist, was also a composer and song writer? Well, he is, under the name of McCall, and he has just sung two of his own compositions on an H.M.V. disc. The items are naturally fully suitable for his fine voice, and are called "Westward Ho" and "Song of the Drum."

And now from "good" to—dance music! Good dance music, too! Ray Noble and his orchestra give

us a taste of modern but melodious orchestration in "My Song Goes Round the World" and "Song Without Words" (B6438).

"Without That Certain Thing" is excellently played by Jack Jackson and his orchestra on B6436—leading us a trifle nearer the "hotness" of the American bands. These latter break out this month in the form of the King of Jazz (Paul Whiteman and his orchestra) and Cab Calloway and his Cotton Club orchestra—a coloured band of world-wide renown and due to visit this country in March.

"Cab" is recording exclusively for H.M.V. now, and his first numbers are among the January releases—"Evenin'" and "Harlem Hospitality." The disc is B6437, and the effect—well, it's "hot."

Sixpence a tune! And a full ten-inch one at that! This is the offer of Rex records, which have earned for themselves an enviable reputation for value among gramophiles. A gramophone is, of course, a gramophone lover. The derivation of the word is probably (?) from "gramo" (gramophone) and "philo" meaning "I file," and harking back to the days when all true gramophone "fans" used fibre needles, necessitating a great deal of filing. Oh yeah! But it will do quite well—won't it?—the word is genuine if the derivation is not exactly accurate.

## Some Good-Value D'ses.

For the princely sum of one shilling you have the choice of records by Jay Wilbur and his band, Lew Sylva and his band, Val Rossing—one time Henry Hall's vocalist—Bob and Alf Pearson, Sandy Powell, Leslie Holmes, Leslie Sarony and so on. The latest film hits are available, such as "The Winds in the West" and "We'll all go Riding on a Rainbow," from *Aunt Sally*; "My Hat's on the Side of my Head," from *Jack Aho*; "Shadow Waltz," from *Gold Diggers of 1933*; "Night and Day," from the musical play *Gay Divorce*; and "Thanks," from Bing Crosby's film, *Too Much Harmony*.

Sandy Powell's efforts as (1) a Stowaway and (2) in *The Shipwreck*, in his record, "Sandy Goes to Sea," will delight thousands. It's wonderful how he keeps it up.

The "Rex" list is well worth looking carefully through—it contains a wide variety, from the new boy singer, Master Joe Petersen, to Wurlitzer items played by Charles D. Smart.

K.D.R.

# Exide's NEW idea!



## "Battery Time"

—tells you  
in time  
the time  
to recharge

# Exide

## "INDICATOR" BATTERY

When the Exide 'Indicator' says 'Full' the battery *is* full—and that's that. When the 'Indicator' hand approaches 'Empty' it is time to get the battery recharged—and that's *that*. The great point about the Exide 'Indicator' is that with it you always know where you stand. It puts an end to uncertainty. It puts an end to the risk of being let down by a run-down battery. The Exide Batteries already equipped with this invention are the "D" types listed below. You'll know which battery to get next time.

### PRICES WITH 'INDICATORS'

Type DTG-C	2 volt	20 a.h.	5/-
" DFG-C	"	45 "	9/-

★ These prices do not apply to the Irish Free State.

Exide Batteries are obtainable in sizes to suit every set from Exide Service Stations and all reputable dealers. Exide Service Stations give service on every make of battery.

Exide Batteries, Exide Works, Clifton Junction, near Manchester. Branches: London Manchester, Birmingham, Bristol, Glasgow, Dublin, Belfast

R49

# THE BIG SHUFFLE

The greatest wavelength "general post" the world has known took place when the Lucerne Plan came into operation on the night of January 14th-15th. In this article Mr. K. D. Rogers describes how the change-over was carried out and its effect on British listeners.

**PIONEER** in organised broadcasting, Britain took the lead in the wavelength shuffle that was carried out on the night of January 14th-15th. And a graceful gesture was made by allowing her youngest station—the Scottish Regional—to commence.

As you are all probably aware, the whole of Europe was supposed to close down at 11 o'clock on the Sunday night, and then the various stations were to come on the air one at a time on their new frequencies.

I sat up to listen to them. And so did a number of engineers in the frequency-listening posts at Brussels and Tatsfield.

Sharp on eleven all the stations closed down—with the exception of some twenty or thirty of them! The B.B.C. had long been silent—since about 10.40—but punctuality did not seem to be a strong continental virtue. No. Eleven o'clock heard them still going strong—dance music here; opera there; a mixed bag of Morse, heterodyne and jazz (which was which, I wonder?) somewhere else.

## A Minor Tragedy.

Athlone had vanished. He must have gone early, for I did not hear a trace of him when I switched on at 10.30. And as my normal household set does not go quite up to 531 metres (his new wavelength), I am afraid I shall not hear much of him again. One of the minor tragedies of the Lucerne Plan, for I enjoyed Athlone, and I expect many of you will be in the same boat.

By eleven-ten many more stations had closed down, though Fécamp was still going hard and strong, assisted by a medley of heterodynes, on his 225.9-metre wave. He seemed reluctant to move.

Round about eleven-fifteen all modulation was silent—except Fécamp and one or two others—though a number of carriers were on. The long waves, too, were deserted. Then, bang on 50 degrees on my set a voice came through; "This is the Scottish Regional transmitter testing." A nice voice with a wee-breath o' Bonnie Scotland in its accent. The youngest of the B.B.C. stations had opened the proceedings.

## The Continual Announcements.

How tired that chap must have become announcing the same words every few seconds for minutes on end while Brussels checked his frequency! He could not roam the dial, as I did, for other fry (of which Fécamp was still the only one) while the monotonous business went on.

At 11.23 the Midland Regional took up the refrain, while a most varied assortment of tickings, bird chirpings, songs and breathings floated over the ether.

Scores of stations were impatiently waiting to begin, with their waves on and weird background noises creeping through.

Then good, hearty strokes of a gong—Radio Strashourg. Not coming over very well, but of good quality. He was followed,

despite the scare of fire experienced an hour previously, by Leipzig. From subsequent reports it seems lucky that the famous German station was able to "take the air" at all, for a serious fire was reported to have started in the mast an hour before the change-over was due to take place.

Fire or no fire, however, there he was with "Hier ist Leipzig," and merrily playing gramophone records and badly heterodyned at first. Followed a piano (badly tuned) between Leipzig and the still-running carrier of the Scottish Regional, but no announcement.

## After Three-Quarters of an Hour.

After three-quarters of an hour of it four stations had tested, and it looked as if the change-over of the two hundred odd would take a matter of days—not hours. There may have been some small-powered relays testing as well during that time, but no others were heard on my set.

Lafayette, fading badly, was the next, and incidentally the first, to give his wavelength. And was he heterodyned? Another station just below him also came on,

## ONE OF THE GIANTS

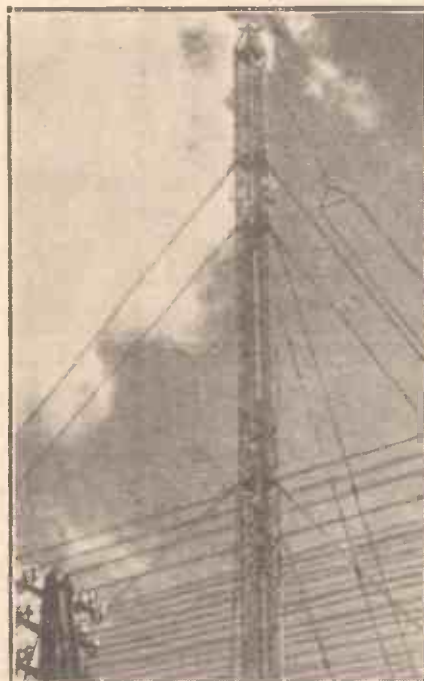

A photographic impression of one of the huge masts of Deutschlandsender, whose wavelength was shifted on January 15th to 1571 metres.

but did not announce—very helpful! A second unidentified station—I could not catch his announcement—arrived at 75 degrees on the dial and hurriedly carried out his tests.

And so it went on, with the Fécamp medley ever grinding out its distorted and

fading cacophony on 225.9 metres. It was all very orderly, very cut and dried and very monotonous.

So we wandered on through the wavelengths, the London Regional being next and regaling us with a long reading of the history of International Rugger. I particularly liked the remark concerning the Welsh "particianship." But no wavelength announcement. Apparently we British, and the Germans too, regard such an addition to the other statements as a reflection on the accuracy of the station's tuning. The French religiously gave the wavelength, but not so ourselves.

## On the Long Waves.

The Scottish National and an Italian took up the tale, followed by a "pirate" French station, who announced in English that next week he would be on 222.6 metres. The wavelength at the time was a bit above that.

At about 12.25 a.m. more long-wave carriers came on, but with no modulation, save that of Radio-Paris announcing the wavelengths of Bordeaux, Fécamp, Toulouse and others. At this time, too, the real hard work of the change-over made itself evident. A great deal of heterodyning had been occurring round Leipzig, and so the German and the Scottish Regional came on again and did some slight frequency shifting. Evidently the wavelengths were not to Brussels' liking.

Followed Berlin on 356.7 metres with a lively Viennese waltz—a treat after the solid British announcements. Then Belfast; then more nightingales below 260 metres—no announcement; more Fécamp, and the North National on 296.2.

Things were going a bit faster; but at 1.30 a.m. very few stations seemed to have been checked. Paris was still busy announcing odds and ends, and the ether was becoming more and more filled with unmodulated carriers.

## Still On in the Morning.

Still the change-over went remorselessly on. London National, West National, Germans, French, Italians came on and said their pieces and were silent again. How sorry I felt for those Brussels and Tatsfield fellows, just listening—listening and checking! All through the night.

As I fell asleep at 3 a.m. I was thinking of them; and at 7.30, when I switched on again to hear Radio-Paris still discussing the Lucerne Plan, though nearly all other stations were silent, including Fécamp at last, I thought of them again. I bet they don't want another general shuffle for some time!

And how does the plan work? Well, at the time of writing, it is a bit early to judge, for there will be minor changes as experience shows where trouble occurs.

Luxembourg looks like being a troublesome black sheep in the European family, for he has calmly annexed Warsaw's official wavelength of 1,304 metres. Just where Warsaw is going remains to be seen, unless Luxembourg kindly decides to move owing to unsatisfactory results.

An hour or so of listening subsequent to the change-over naturally showed up a number of problems that required solving, but they will probably have been straightened out by the time you read this.

For instance, Eiffel Tower has so far not

(Continued on page 936.)



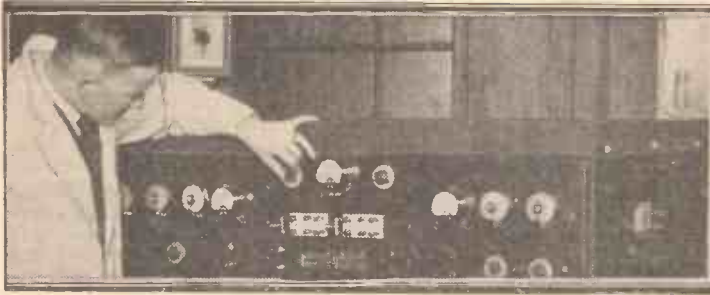

# ALL ABOUT SOUND and RADIO WAVES

By SIR OLIVER LODGE F.R.S.

**O**SCILLATIONS are of many different kinds, and when they occur in a medium they must produce waves. But the kind of wave produced depends on the medium in which the oscillations occur; if there is no medium there are no waves.

Think of any rhythmic motion, say the motion of a fan. As the fan moves slowly through the air, the air in front has time to get round to the back of the fan, and the result is no sound. When it is moved more quickly, the air in front is condensed, i.e. the pressure is increased a trifle, and the air behind rarefied, or the pressure diminished a corresponding amount, while it is moving forward; while on the return journey these effects are reversed.

The condensation when it occurs is transmitted by the air, and travels at a rate depending on that medium, and similarly with the rarefaction. The condensations and rarefactions are feeble when produced by even the rapid movements of a fan, since most of the air escapes from compression and runs round to the back.

### Compression and Rarefaction.

Moreover, the compression and the rarefaction are simultaneously produced, at no great distance from each other, and accordingly their effect at a distance is very small, even when the motion is rapid and when the surface is considerable.

Even with rapid motion, when the surface is small, as in the case of a stretched string vibrating, very little wave motion is produced, and therefore it is inaudible at a distance. But if the string is attached to something with a considerable surface, the vibrations are communicated to that surface and imparted to the air, and the sound is heard. If both ends of the string are fixed to a sound-board, then the string becomes a musical instrument.

The rate of vibration or pitch depends on the oscillating body. The transmission to a distance by wave depends on the properties of the medium. If there is no medium, the result is silence; a vibrating body in a vacuum cannot be heard, though all the other conditions are supplied.

### Depends on the Medium.

The velocity of propagation also depends on the medium and on nothing else. A sudden compression communicated to the air, as by a pop-gun, is conveyed about a thousand feet in a second. This velocity is called the velocity of sound, and it varies with the state of the medium and its temperature. At 60° Fahrenheit it has been measured as 1,120 ft., which we may take as the average.

Now when the sound is produced by an oscillation, if the oscillating body makes a hundred complete excursions in a second it would have travelled in the 1/100th part of a second 112 ft., which distance is called

matter to propagate it, and it gradually dissipates itself in the matter and becomes extinct. If the disturbance is very violent, the air is warmed infinitesimally as a result of the quenching of the sound.

If the sound in its passage enters another medium, say another gas, a little will be reflected at the boundary; but most of it goes on, at a rate depending on the new medium, and with a wavelength altered to correspond. But the ratio of velocity to wavelength remains unaltered—that is, the pitch or frequency remains constant at the rate at which it was produced.

Consequently, though the sound reaches the ear through different media, it does not alter in pitch. Nor does a steady wind or motion of the medium alter the pitch, although it lengthens the distance at which the sound travels in one second, and accordingly lengthens the wavelength in the same proportion.

### Differences in Pitch.

So the pitch is unaltered by that. If, however, there are gusts it would blow the sound at one moment more rapidly towards the ear, and at another moment slacken the pace. So the pitch would not remain steady, but will rise and fall slightly, giving a wailing sound.

If there is relative motion between the sound and the hearer, the pitch will also change. If the observer is moving towards the source, he will receive the waves of constant wavelength more rapidly than they otherwise would come, and therefore the pitch he hears will be higher than that of the sounding body; while if he is receding from it, it will be lower.

If it is the sounding body which is moving towards the stationary hearer the waves will be crowded up on one side, and spread out on the other. They travel only at a speed depending on the medium, which is unaltered.

### Have You Heard This?

Accordingly the waves will be shorter and the hearer will receive more waves per second than if there had been no redistribution. The pitch all round a sounding body will remain on the average constant; but the wavelength, and therefore the pitch, will depend on the direction in which the sound is travelling.

Thus a change of pitch will result in either case; it is called a Doppler effect, being first observed and accounted for by Herr Doppler in the last century.

It is easily noticed, as on a railway or in a motor-car. The horn sounds shriller when the two cars are approaching, then it drops,

(Continued on next page.)

\*.....\*

High among the achievements of our distinguished contributor is his work on waves and wave-motion, and in this article he writes vividly of sound and of some of the wave-principles which underlie radio reception. Sir Oliver's gift of clear exposition is world-known, and we have pleasure in presenting this excellent example to the readers of "POPULAR WIRELESS."

\*.....\*

the wavelength, and depends on the medium.

The frequency of oscillation depends on the sounding body; the frequency in this case is 100 a second. In that time it has produced 100 waves end to end. They

### OUR SCIENTIFIC ADVISER

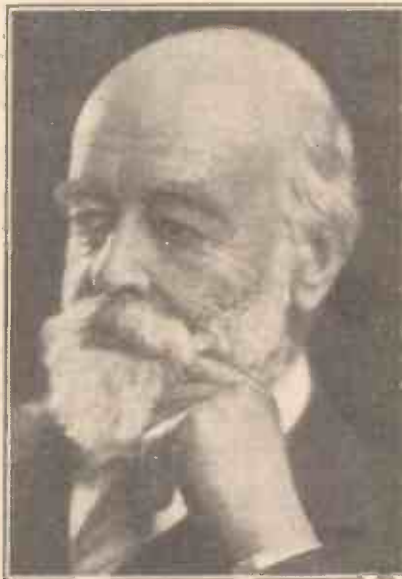

Sir Oliver Lodge is often affectionately called "The Grand Old Man of Radio." He will be 83 this year, and during his lifetime has contributed many vital developments to wireless technique, including the invention of tuning.

therefore stretch a distance of 1,120 ft. corresponding to the velocity of sound.

Thus every oscillation in the air tends to produce sound of a certain pitch depending on the frequency of vibration, and a certain wavelength is also generated, depending on this frequency and on the rate at which the atmosphere transmits it.

Sound spreads out in all directions; it does not go beyond the atmosphere; it cannot get out into vacuum; it requires

## ALL ABOUT SOUND AND RADIO WAVES

(Continued from previous page.)

something like a semi-tone, in pitch when they are receding, the amount of rise or fall depending on the relative velocity of the two cars.

When the two cars are moving at the same rate in the same direction one behind the other, there is no change of pitch. When everything is steady, the number of waves received per second must depend on how many are emitted per second, and the two numbers will correspond.

All our examples have been taken from

### WHAT ARE WAVES ?



Waves on the surface of water are not very good examples of wave-motion, especially when they are breaking on a shore. But, as Sir Oliver Lodge shows, they have many points of interest to the student of wave-motion.

## IN PRAISE OF "THE MANUAL OF MODERN RADIO"

A further selection of letters from experts which arrived too late for inclusion last week.

From Dr. W. H. ECCLES, F.R.S.

I THANK you for the copy of Mr. Scott-Taggart's book "The Manual of Modern Radio." I have looked through it with the greatest interest; it is a remarkable collection of practically all the technical developments of recent years in radio receivers, and in allied apparatus such as radio-gramophones.

Progress in wireless devices and circuits has been very great in the past five years, and even for the expert it is a constant struggle to keep up to date; for the amateur it must be almost impossible. But this book does a great deal to bring the amateur nearer the expert, for it is right up to the moment, and is written in clear and concise language. I think that readers who start with a sufficient groundwork will find it a valuable instructor and a safe guide to further studies.

From R. FERGUSON (Joint General Manager, Marconi International Marine Communications Co., Ltd.).

I WAS very pleased to receive a copy of Mr. Scott-Taggart's book "The Manual of Modern Radio." From a cursory examination it would appear to be well up to the standard of Mr. Scott-Taggart's usual technical work, and should prove of real help to those anxious to master the fundamentals of radio technique.

sound so far, for that is the simplest kind of oscillation. But one might produce an oscillation in other ways, say by raising and lowering the surface of water, as by a disk on it.

When you raise the disk, an elevation is produced which travels away at a certain rate, depending on the properties of the water; and when lowered the hollow tends to fill up, and that also is transmitted.

But now there is a complication, for the rate of travel of the wave is not independent of the wavelength; that is, the velocity of water waves depends upon the pitch. If you vibrate slowly or comparatively slowly, the waves will be long and will travel more rapidly. Hence these water waves, which to the eye are most familiar, and can be seen travelling along, are really more complicated.

But there is no condensation or rarefaction in that case; the rate of travel depends on the force of gravity—that is, on something outside the medium; but the direction of the oscillation is perpendicular to the direction of travel, one being vertical and the other being horizontal.

#### Transverse Waves.

The waves are what are called transverse, instead of being longitudinal. Nevertheless, the frequency of the oscillation multiplied by the wavelength gives the speed of travel in this case as in the other.

This dependence of velocity on wavelength and frequency is inevitable in all cases of waves. The wavelength represents the distance which the pulse travels in one

oscillation, and that is not always independent of the frequency of the oscillation.

The two independent things are the frequency and the velocity. The wavelength is the ratio of the two.

The velocity depends on many adventitious circumstances, principally the intensity of gravity and the density of the liquid. But it depends in a subordinate degree on the depth of the vessel in which the liquid is contained. The further consideration of transverse waves and the question of ether waves, we must leave for the next article on this subject.

### USING A REFLECTOR

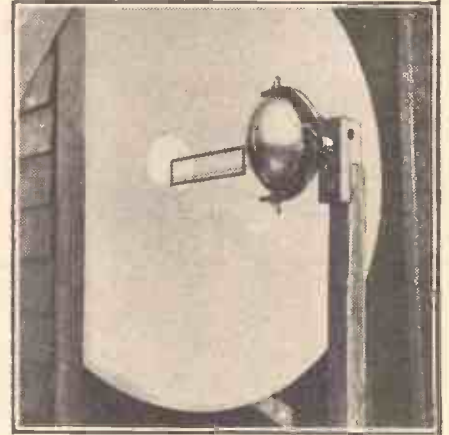

Electro-magnetic (wireless) waves can be reflected and so concentrated into a beam, this reflector being one of those used for micro-wave communication across the English Channel.

From the Manager of the London Radio College.

WE thank you for the copy of "The Manual of Modern Radio," by John Scott-Taggart. We have given this book a very close study and we are frankly of the opinion that the subject has never before been put so clearly to "the man in the street."

The absence of complicated formulae and the simplicity of the language in which it is written make it an ideal work for all those who are interested in radio, but who have not the time nor the inclination to study the deeper technicalities of the science. We feel sure that the book has only to become more widely known to receive a ready appreciation from the radio public.

## ACCUMULATOR SAFETY HINTS

Suggestions which will enable the accumulator user to guard against the damage which sulphuric acid can cause.

ALTHOUGH the latest types of accumulators are much safer and far less liable to spill their contents than the types which were in general use a few years ago, the highly corrosive nature of the electrolyte makes every accumulator a potential source of risk unless suitable precautions are taken.

When a cell is returned from the charging station (where sulphuric acid is sometimes splashed about pretty freely on the charging bench), there are almost certain to be some traces of acid remaining on the outside of the glass or celluloid case.

These traces of liquid tend to strengthen as the water evaporates, and if the acid which remains is allowed to come into contact with a polished surface, a table-cover, curtain or any other material of that sort, a good deal of damage may be done.

Risk of damage can be reduced by standing the accumulator on a glass-topped tray or on one of the special vulcanised trays sold for the purpose. Even a plain sheet of thick glass is quite effective as a means of protecting the surface of the table-top or wireless cabinet.

#### Neutralising the Acid.

Another good idea is to keep handy a cloth soaked in a strong alkaline solution—such as soda or ammonia—and make a point of wiping the outside of the accumulator case with this rag each time it is returned from the charging station.

Where the accumulator stands on a table near a window, care should be taken to see that the window-curtains do not brush over the top of the cell, if they sway in a draught from the window.

I have seen a curtain badly damaged through this cause, a hole about six inches in diameter being produced by acid-spray.

When testing the S.G. of the electrolyte with a hydrometer there is always a risk of splashing or spilling a few drops "overboard." It is advisable, therefore, to keep a suitable alkali handy to neutralise any acid that is accidentally scattered abroad.

Finally, it is wisest never to clean up an accumulator when you have a cut or graze on one of your hands. Not only will acid make such a wound very painful, but the danger of poisoning due to the presence of lead in the acid must be remembered. K.



# ECKERSLEY NATIONAL THREE



The Pilot Kit SERVICE was founded in 1919.

## PILOT AUTHOR KIT EXACT TO SPECIFICATION

See the PILOT on the carton. It's a real guarantee.

LATEST TELSEN KIT RELEASE. Less Valves. Cash or C.O.D. Carriage Paid, 29/6. Balance in 5 monthly payments of 5/3.

TELSEN 323 KIT with set of three Valves. Cash or C.O.D. Carriage Paid, £2/15/6. Balance in 9 monthly payments of 6/-.

NEW LISSEN SKYSCRAPER FOUR ALL-WAVE CHASSIS MODEL. Complete Kit comprises all components, including set of Lissen Valves. Cash or C.O.D. Carriage Paid, £5/12/6. Balance in 11 monthly payments of 10/3.

PETO-SCOTT PERMANENT MAGNET MOVING-COIL SPEAKER

Power or Pentode  
Complete with input transformer. Balance in 5 monthly payments of 4/-.

Cash or C.O.D. 19/6  
Carriage Paid.

2/6 DOWN.

NEW BLUE SPOT PERMANENT MAGNET MOVING-COIL SPEAKER 4.5 P.M. With input transformer. Cash or C.O.D. Carriage Paid, £2/5/0. Balance in 7 monthly payments of 6/-.

BLUE SPOT 99 P.M. PERMANENT MAGNET MOVING-COIL SPEAKER. Complete with tapped input transformer. Cash or C.O.D. Carriage Paid, £2/19/6. Balance in 10 monthly payments of 6/.

NEW W.B. P.M.4A. MICROLODE PERMANENT MAGNET SPEAKER, complete with switch-controlled multi-ratio input transformer. Cash or C.O.D. Carriage Paid, £2/2/0. Balance in 7 monthly payments of 5/9.

NEW ROLA CLASS "B" PERMANENT MAGNET MOVING-COIL SPEAKER AND AMPLIFIER. Complete with valve and input transformer. Two Models "A" for P.M.2B. P.D.220 and 220 B. "B" for 240 B. and HP. 2 (state which when ordering). Cash or C.O.D. Carriage Paid, £3/11/0. Balance in 11 monthly payments of 6/6.

ROLA F.R.6 P.M.23 CLASS "B" SPEAKER with input transformer, Cash or C.O.D. Carriage Paid, £1/19/6. Balance in 9 monthly payments of 4/6.

**BARGAIN**

**PHILCO 5-VALVE BALANCED SUPER-HETERODYNE**

LOWBOY (CONSOLE) MODEL 56.

All Electric; seven tuned circuits with single dial control. Gives amazing performance with new economy in operating costs. Duo wavelengths; no leak between bands. Illuminated dial, no reaction; chassis and tuning condenser floating on rubber. Oversize, energised M.C. Speaker with large baffle-board gives exquisite, full tone. Beautiful cabinet in Walnut and Oriental woods with rich inlays. Height, 39 1/2".

22 GNS. OUR PRICE 12 GNS.

or 18 Monthly payments of 18/6.

COLLARO "POST-A-LETTER" RECORD CHANGER. Converts your set to a Radiogram immediately, incorporating Empire self-starting induction motor, and No. 20 Pick-up. Chassis Model. Cash or C.O.D. Carriage Paid, £6/18/6. Balance in 11 monthly payments of 12/9.

B.T.H. SENIOR PICK-UP AND TONE ARM WITH VOLUME CONTROL. Cash or C.O.D. Carriage Paid, £1/17/6. Balance in 7 monthly payments of 5/-.

ATLAS G.A.25, for Mains, Class "B" and Q.P.P., four tappings: 60/80, 50/90, 120, 150, 25 m.A. Cash or C.O.D. Carriage Paid, £2/19/6. Balance in 10 monthly payments of 6/-.

### CASH - C.O.D.

£5 - 10 - 0

KIT "A" Author's Kit of first specified parts including READY-DRILLED PANEL and METAPLEX chassis assembly, but less valves and cabinet, Cash or C.O.D. £5:10:0 Carriage Paid or 12 monthly payments of 10/-

KIT "B" As Kit "A" but including set of specified valves, but less cabinet, Cash or C.O.D. Carriage Paid, £7:9:0 or 12 monthly payments of 13/9

KIT "C" As Kit "A" but including valves and cabinet as illustrated, Cash or C.O.D. Carriage Paid, £8:6:6 or 12 monthly payments of 15/3

### ECKERSLEY NATIONAL RADIOGRAM KIT "A"

Author's Kit of first specified parts including READY-DRILLED PANEL and METAPLEX chassis assembly, but less valves, cabinet, speaker and gramophone equipment. Cash or C.O.D. Carriage Paid, £6:10:0 or 12 monthly payment of 12/-

KIT "B" As Kit "A," including valves, but less speaker, cabinet and gramophone equipment. Cash or C.O.D. Carriage Paid, £8:9:0 or 12 monthly payments of 15/6.

KIT "C" As Kit "A," including valves, cabinet and PETO-SCOTT gramophone equipment, but less speaker. Cash or C.O.D. Carriage Paid, £12:14:6 or 12 monthly payments of 23/3.

With Peto-Scott Permanent Magnet Moving-coil Speaker, if required, add 19/6 to Cash Price or 1/9 to each monthly payment.

### KIT-BITS You pay the Postman. We pay post charges on all orders over 10/- GT. BRITAIN ONLY.

	£	s.	d.
1 British Radiophone 3-gang, type 604	1	0	6
1 British Radiophone S.M. drive, type 711	1	8	6
1 Set of Telsen screened coils, type W.288	1	1	6
1 Lissen Hypernik L.F. transformer	12	6	
2 T.C.C. 2-mfd. fixed condensers, type 50	7	0	
3 Mullard valves as specified	1	19	0
1 Peto-Scott table cabinet (Carr. 2/C extra)	19	6	

### KIT-BITS You pay the Postman. We pay all post charges on orders over 10/- GT. BRITAIN ONLY.

	£	s.	d.
1 J.B. tuning condenser, Nugent A	1	2	6
1 Colvern 3-gang coil, K.G.O., K.G.O., K.G.R.	1	8	6
1 Graham Parish H.T. economiser unit	7	6	
1 Westinghouse Westector, type W.4	7	6	
1 British Radiogram pick-up	17	6	
1 Edison Bell double spring motor, 7" handle	17	0	

## PETO-SCOTT CABINETS Exclusively Specified.



**TABLE MODEL.**  
This handsome walnut-polished cabinet was specially designed by PETO-SCOTT at the request of "Popular Wireless" to house the Eckersley National 3. Constructed throughout in first-quality material and beautifully finished by hand french-polishing macassar veneer set the seal of the piano trade. Cash or C.O.D. 17/6 Packing and Carriage, 2/6 extra.



**RADIOGRAM MODEL.**  
Another exclusive and delightful cabinet by PETO-SCOTT, also specially designed at the request of "Popular Wireless" for the Eckersley National Radiogram. The beautiful walnut finish and handsome contrasting macassar veneer set the seal of perfection in cabinet design on this latest Peto-Scott production. Cash or C.O.D. 47/6 Packing and Carriage, 2/6 extra.

**IMPORTANT—Parts, Kits, Miscellaneous Components, Finished Receivers or Accessories for Cash, C.O.D., or H.P. on our own System of Easy Payments.** Send us a list of your wants. We will quote you by return. Easy Terms on orders over £2. Cash or C.O.D. orders value over 10/- sent Carriage and Post Charges Paid. GREAT BRITAIN ONLY. H.P. Terms are NOT available to Irish or Overseas customers.

PETO-SCOTT CO. LTD., 77, CITY RD., LONDON, E.C.1  
West End Showrooms: 62, High Holborn, London, W.C.2. Tel.: Clerkenwell 9406/7. Tel.: Holborn 3248.

Dear Sirs,—Please send me CASH/C.O.D./H.P. for which I enclose £.....d. CASH/H.P. Deposit.

NAME.....  
ADDRESS.....

P.W., 27/1/34.

**50% reduction in H.T.  
and prolonged battery life**

In addition to its other advantages just consider the resultant economy of the "Power Puncher." For example, in an average 3-valve set (1 S.G. Detector and Small Pentode) you save 50% of H.T. consumption. In other words you save at least one H.T. battery renewal per year and in some cases two. Write to us for the new Varley Catalogue — it is FREE.

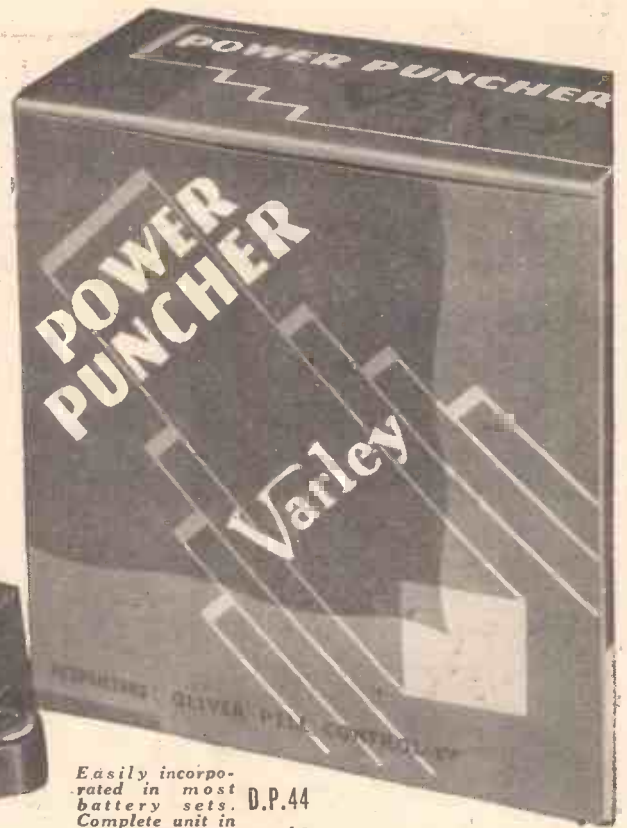

Easily incorporated in most battery sets. Complete unit in its self—Requires no extra rectifier or resistances.

D.P.44  
15/6

**Varley**  
(Proprietors: Oliver Pell Control Ltd)

Advertisement of Oliver Pell Control Ltd., Kingsway House, 103, Kingsway, London, W.C.2. Phone: Hol. 5303

**THE WIRELESS CONSTRUCTOR**

A SPECIAL ARTICLE describing **THE "FERRO-POWER" FIVE**

*A four-stage quality receiver capable of an undistorted output of over seven thousand milliwatts.*

FEBRUARY NUMBER IS ON SALE EVERYWHERE

PRICE **6** D.

FEATURED THIS MONTH **The S.T. SUPER AS A RADIOGRAM**

*Details of an extremely easy and inexpensive conversion for this magnificent receiver.*

**OTHER CONTRIBUTIONS INCLUDE**

Some New "Duo" Circuits From My Armchair  
Looking After Records  
Some Wireless Cabinet Woods

Questions I Am Asked  
B.B.C. News  
The New Wavelengths  
Getting Foreigners on a Portable, etc., etc.

GET A COPY TO-DAY

**THE WIRELESS CONSTRUCTOR**



# RADIO STEP-BY-STEP

OUR SPECIAL  
SUPPLEMENT for  
BEGINNERS

### CYCLE

One complete alternation of current from zero to max. in one direction and back to zero, then to max. and back to zero in the other direction. Also applied to one complete wave in the ether.

### D.C.

Direct current. This is current which flows in one direction only.

### D.C.C.

Double-cotton covered.

### DISTORTION.

Any deviation from the original wave form of the speech or music picked up by the broadcast microphone that occurs in the voyage to the listener's loud-speaker.

### DRIVER TRANSFORMER.

The transformer used to couple the driver valve and a Class B valve. Fundamentally it is similar to a normal L.F. transformer, but its specification is subject to special requirements. Its ratio depends upon the valves used, but usually lies between 1 and 1.5 to 1, and it has a centre-tapped secondary.

Owing to the fact that current flows in the grid circuits of a Class B valve, the secondary winding of a driver (or Class B) transformer must have a comparatively low resistance.

### DRIVER VALVE.

The valve which precedes a stage of Class B amplification. Must be of the power type, for a Class B stage is power, not voltage, operated.

### DECIBEL.

The bel is the "transmission unit," but is too large for practical purposes; therefore a tenth part of it, the decibel (db.), is used.

The decibel is an extremely useful unit, enabling calculations of power outputs of amplifiers, etc., quickly to be made on a comparative basis.

It does not by itself express a quantity, but indicates the ratio existing between two voltages or powers. It is, in fact, a unit of loss and gain. A certain voltage is fed into an amplifier and arrives at the output magnified; the ratio between the two voltages can be expressed in decibels. The power output from an amplifier is increased from X milliwatts to Y milliwatts; the gain can be stated in decibels.

The foremost advantage is that the decibel bears a direct relation to the sensitivity of the ear. The difference in two powers differing by 1 db. is just discernible by the ear.

Also decibels can be added. One amplifier may have a voltage gain of 50 and another into which it feeds a voltage gain of 75. To express the total effect necessitates multiplication (50 x 75) and a clumsily large figure. But with the transmission unit method it is only necessary to add the decibel gains of the amplifiers.

### DETECTOR.

A device for rectifying high-frequency current. There are three types of detector. The most widely used is the valve, but many crystal detectors are still in use. Then there is the metal rectifier, which is a specialised version of the metal rectifier used for rectifying mains alternating current.

### DIELECTRIC.

A substance having an extremely high electrical resistance such as mica, ebonite, etc.,

satisfactory for low-frequency circuits may impose serious dielectric losses in a high-frequency circuit in certain circumstances.

### DIODE.

A valve in which only two elements, an anode and cathode (filament), are used. Diodes are sometimes used as detectors and frequently figure in automatic volume control circuits. In the latter case they are often combined in the one bulb with triodes and pentodes.

### DIRECT RAY.

The term applied to the waves which are emitted by a wireless transmitting station parallel to the surface of the earth.

### DIRECTIONAL AERIAL.

An aerial that transmits or receives better in the one direction than any other direction.

### EARTH CONNECTION.

The earth is as important as the aerial in wireless telephony. The best earth connection for a radio set is undoubtedly a good buried earth. This can take the form of a tube of metal or a metal plate embedded in damp soil. When the soil is dry extensive watering or the use of a chemical earth which attracts and condenses moisture is to be recommended.

An efficient alternative is to make contact with a water-pipe, but a soldered joint is to be advised, one perfectly made by a plumber.

The lead from the earth terminal of the set to the earth tube or plate or water-pipe should be kept as short as possible. It need not be insulated.

In the case of a D.C. set an earth will be automatically provided by the mains themselves, and often little advantage is gained by using an ordinary earth connection in addition. But if one is used it should be ascertained that either internally or externally there is a series fixed condenser to prevent the mains from being led out via the H.T. and H.T. minus circuit connections to earth.

Frequently the positive main to a house is one which is earthed by the power-supply authorities, and, obviously, to introduce a negative mains earth too would cause a short circuit.

(Continued on next page.)

# RADIO TERMS

Wireless simply explained in a readable and easily-referred-to manner.

By G. V. DOWDING, Associate, I.E.E.

We have said that the decibel indicates a ratio. Strictly it should be used only for defining power ratios, and is ten times the common logarithm of the ratio of the two powers.

Supposing the power output of an amplifier is increased from 200 to 1,000 milliwatts. The ratio of gain is  $\frac{1,000}{200} = 5$ . The common logarithm of 5 is .6990, and that is .7 for all practical purposes. Ten times .7 is 7, and that is the decibel gain achieved. Increasing the power from 200 to 1,000 milliwatts is equivalent to a 7 decibels gain.

In the case of current or voltage the resistances across which the voltages exist or through which the currents traverse must be taken into account. When these resistances are equal for both voltages or both currents they cancel out

and used for separating the plates of a condenser.

### DIELECTRIC CONSTANT.

A constant based on air as unity which indicates the effect of the insulating substance between its plates on the capacity of a condenser. This constant is known as the specific inductive capacity.

The dielectric constant or specific inductive capacity of air is, as we have said, 1. That of mica is 6. Therefore, given the same area of plates and distance of separation, a mica condenser will have 6 times the capacity of an air condenser.

### DIELECTRIC LOSS.

The loss occasioned by the absorption of energy in a dielectric when a potential difference is applied across it.

This loss increases as with increases of frequency. A condenser construction that is

### THREE WIRE SYSTEM

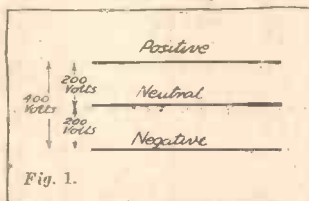

Fig. 1.

The object of this system is to provide two voltages, one for factories, trams, etc., and one for household use, from the same set of wires.

electric when a potential difference is applied across it.

This loss increases as with increases of frequency. A condenser construction that is

Special Beginners' Supplement—Page 2.

The "earthing of a positive" occurs in what is known as the three-wire system.

The object of this system is to provide two voltages—a high one for factories, trams, etc., and a lower one for household services.

Three wires leave the power station—a negative, a positive and the neutral. Connection to the positive and negative gives the full voltage, say 400 (see Fig. 1); but when neutral is used with either positive or negative 200 volts is provided.

Clearly, the neutral, which is earthed, is positive in regard to the negative wire. One side of a street may be served in this way, with a neutral and negative, while the other side has the neutral and positive, in which latter case the neutral becomes for practical purposes a normal earthed negative.

**EARTH POTENTIAL.**

Theoretically there are presumed to be no differences of potential between different parts of the earth, which is, therefore, presumed to be of zero potential. Actually this is not the case, but the potential differences in at least localised areas are generally negligible.

The metal chassis, coil screens and other parts of a set which are connected to the L.T. negative-H.T. negative "earth line" are said to be at earth potential, although this condition, which is desirable for them if stability in the set is to be achieved, does not necessarily exist in the ab-

sence of a good connection to the earth itself.

**EBONITE.**

A hard rubber compound. Sulphur is added to the rubber, which is then subjected to a heat- and - pressure process. Ebonite is black, can be given a good polish and is an excellent insulator. But it cracks or chips fairly easily and is liable to warp. If subjected to strong sunlight, the sulphur in it tends to oxidise and produce discoloration. Ebonite should be worked with metal-working tools.

**EDDY CURRENTS.**

Currents produced in metal that comes within the influence of a varying magnetic field. The metal is heated, and therefore energy is dissipated.

The wasteful effects of eddy currents in the core of an L.F. transformer or choke are minimised by breaking the core into thin sheets or laminations, each of which is insulated by means of an insulating varnish.

But even this would not suffice in a high-frequency component, for the higher the frequency the larger the eddy currents. Therefore the iron of an iron-cored tuning coil is powdered, and the particles electrically separated by means of a filling material.

**ELECTROLYTE.**

The sulphuric acid or other solution used in an accumulator. It is generally sulphuric acid, but there are accumulators in which an alkaline solution is employed.

**ELECTROLYTIC CONDENSER.**

A condenser which is formed by an electrolytic action. It generally consists of two electrodes (plates) of aluminium immersed in an ammonium-phosphate solution. When a voltage is applied across these plates hydrogen is released from the solution and forms an insulating skin over the surface of one of the plates (Fig. 2).

This action is styled polarisation. A condenser is thus constituted, with the solution acting as one plate and the aluminium electrode, over which the insulating film has been formed, as the other plate.

The film is extremely thin, and so a very high capacity results, with a relatively small electrode area.

A steady voltage across the terminals of the condenser must be maintained, or the condenser ceases to act as such.

A small current—the leakage or polarising current—flows the whole time through the condenser while it is working.

When used in a smoothing circuit the fluctuations impressed across an electrolytic condenser must form only a proportion of the total current.

It is necessary to connect up an electrolytic condenser a certain way round, and so its terminals are generally marked "positive" and "negative" to ensure a correct connection. In the case of a tubular metal-cased electrolytic condenser for chassis mounting the metal

casing is the negative connection.

The "wet" type, in which a liquid is used, needs to be vertically mounted; but the "dry" type, in which a paste replaces the solution, can be mounted in any position.

Electrolytic condensers of

**HIGH CAPACITY**

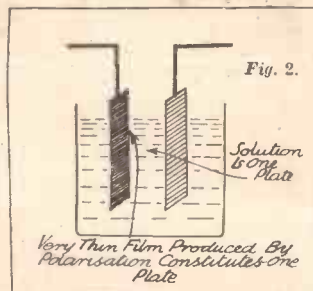

Fig. 2. Illustrating the action of an electrolytic condenser. This type of condenser must be connected the right way round.

only a few cubic inches in size, having capacities up to 1,000 mfd., are made, and high-voltage types of the more usual 4 and 8 mfd. and other such capacities are readily obtainable.

While it is not reasonable to expect an electrolytic condenser to last for ever (any more than can an ordinary type), a useful life of some years is possible.

**ELECTRIC FIELD.**

A field of influence extending around an electrified body which causes an attraction or repulsion of other electrified bodies.

**FIGURES—FACTS—AND FORMULAE**

**Simplifying the mathematics of radio.**

LAST week, in the article dealing with the practical application of Ohm's Law ("The Fascination of Figures"), the examples which we gave were only applicable to direct-current circuits. Earlier in this series we learnt that direct current (D.C.) differs from alternating current (A.C.), inasmuch as D.C. never changes in direction, whereas A.C. is constantly changing both in strength and direction.

This difference between the two forms of electricity necessitates a slight modification to the expression  $I = \frac{E}{R}$ . In direct-

current circuits we have only to consider the effect of R, the resistance. The existence of inductance in series with a source of D.C. has no result upon the steady flow of current, and the presence of a condenser (capacity) in one of the connections from the supply source acts as a definite barrier to any electricity flowing.

**A Different Story.**

But when we are dealing with A.C. the story is very different. The current flow is definitely dependent on inductance and capacity. When either or both properties are present in measurable quantities they have to be taken into account in any expressions involving A.C. current flow and voltage.

The resistive effect of the capacity and inductance is generally denoted by the letter X and is called the reactance. Sometimes X is also used to denote the reactance of inductance or capacity singly; but it is better to write  $X_L$  for the inductive reactance and  $X_C$  for

the capacity reactance. In this way we learn to regard the letter X by itself as standing for the total reactance due to a combination of inductance and capacity.

So far we have said nothing about resistance. This property, however, is of primary importance in alternating-current circuits just as it is in D.C. circuits.

Thus, while in the case of direct current the only thing that impedes or resists current flow is the resistance, in an A.C. circuit resistance capacity and inductance have to be taken into consideration and allowance made for their effects in alternating-current calculations. **Combined Properties.**

The combination of these three properties is called the impedance. Impedance is expressed as so many ohms in the same way as resistance by itself and is denoted by the letter Z.

The impedance of a circuit is not just the sum of the resistance and reactance. If it were many formulæ would be much easier to work out.

Actually we find that Z, the impedance, is equal to the square root of the resistance squared plus the reactance squared.

This can be written as

$$Z = \sqrt{R^2 + X^2}$$

We mentioned last week that a power simply means "multiplied by itself so many times." Hence  $R^2$  is R multiplied by R, and  $X^2$  is X multiplied by X. The symbol  $\sqrt{\quad}$  means

the square root of everything under the horizontal line, and a square root of a number is that number which, multiplied by itself, gives the given number.

Thus,  $\sqrt{9}$  is equal to 3,

because three times three equals the given number, which in this case is nine.

The square root of 16 is 4 ( $\sqrt{16} = 4$ ), or, to put it another way,  $4^2$  (four squared) is equal to 16.

The square root of a number may also be written  $16^{\frac{1}{2}}$  instead of  $\sqrt{16}$ . Both methods

mean the same thing. Next week we shall take you a step further in simplified radio mathematics.

**IMPEDING THE FLOW**

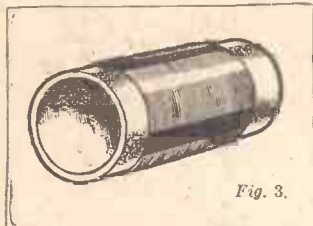
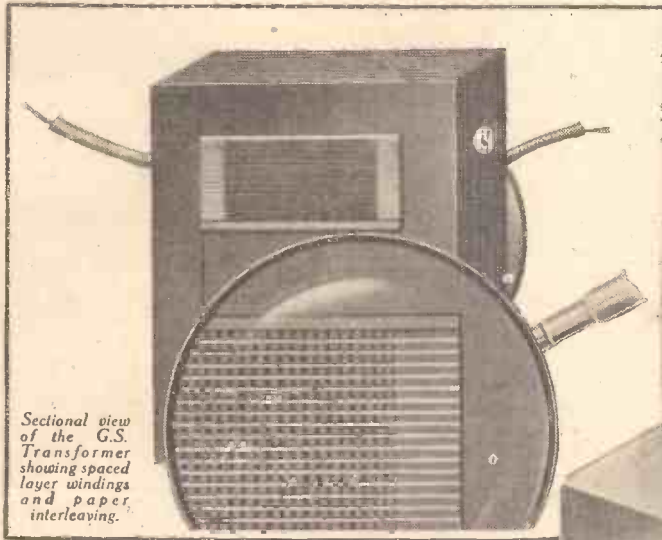

Fig. 3.

When a circuit contains an inductance in series with the source of supply the effect is to impede the flow of an alternating current. The inductance of the circuit is increased by wire wound into a coil and is further increased by the presence of an iron core.

# TELSEN G.S. TRANSFORMERS

specified for the "P.W.  
National  
Eckersley  
Three!"



Sectional view of the G.S. Transformer showing spaced layer windings and paper interleaving.

**T**HE new TELSEN G.S. TRANSFORMERS represent the result of long scientific research by Telsen technicians. They incorporate spaced layer windings and non-hygroscopic impregnation, and possess an exceptionally good frequency characteristic. A silicon steel alloy core of ample dimensions ensures an extremely high inductive capacity without saturation when the primary is passing the normal anode current of detector valves. They will carry a D.C. primary current up to 5 m.a. and can therefore be connected directly into the anode circuit of detector valves.

G.S.3  
(ratio 3-1)

G.S.5  
(ratio 5-1)

**8/6**

TELSEN D.R. TRANSFORMERS, designed and constructed on the same principles, are the first parallel-fed transformers with an absolutely STRAIGHT LINE characteristic. Shorted turns or breakdowns due to large magnetic surges are absolutely eliminated, the inductance being also enormously increased by the use of a special nickel iron alloy core of very high permeability — that of the D.R.3, for instance, being, no less than 150 henries!

D.R.3  
(ratio 3-1)

D.R.5  
(ratio 5-1)

**8/6**

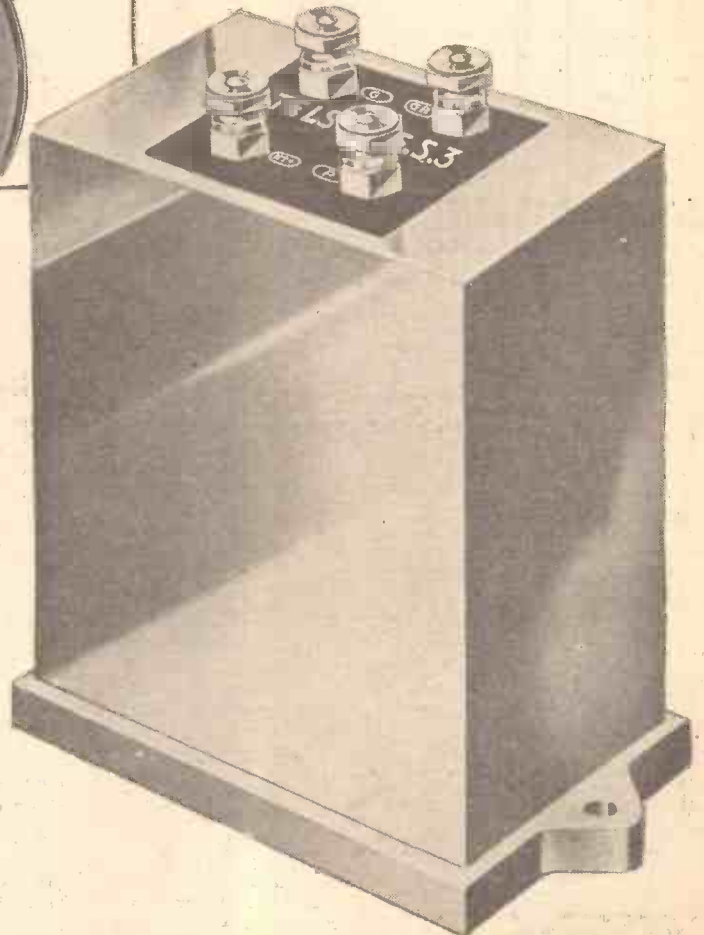

**TELSEN COVER EVERY TRANSFORMER REQUIREMENT**  
ANNOUNCEMENT OF TELSEN ELECTRIC CO. LTD., ASTON, BIRMINGHAM

# TESTED AND FOUND?

Being leaves from the Technical Editor's Notebook

## A NEW EXIDE INDICATOR BATTERY

LET me draw your attention to one of the most important L.T. battery developments of this decade. At least, that is what I consider the Exide Indicator accumulator to be.

Its special feature, beyond being an Exide product (for every Exide manufacture has general special features), is that it embodies an entirely original Indicator.

This tells you the condition of the cell at a glance. A large hand gradually moves over from the plainly inscribed word "Full" to "Half," and finally to "Empty," as the cell is discharged, so at any time and without reference to meters or hydrometers you know definitely how the cell stands.

The importance of this ingenious system of self-indication to the average listener cannot be over-estimated. It is easy enough to say that much the same thing can be done with coloured beads, and so it can; but apart from the fact that words always convey more than symbols to the inexpert there is this vital point to bear in mind: with the Exide Indicator the relative condition of the cell at any particular moment is plainly to be seen.

The discharge of the cell is indexed by the large hand moving around a plainly marked arc terminating with "Empty" and with the "half-way" condition clearly displayed. Any intermediate condition such as "Three-quarters discharged and a quarter to go" can just as easily be read off as if it, too, were described in lettering.

In a zinc water tank you not only note how much the level of the water has fallen, but also how much remains if you want closely to check the contents. That is why a glass gauge, or, better still, a glass tank, is more satisfactory when you are engaged in such inquiries, because you get full-scale vision.

It is perhaps not so much a question of accurate measurement as of ethical satisfaction!

Any way, whatever it is, it is there, and that is why the Exide Indicator is so satisfying. It is a big enough step to get the words "Full," "Half" and "Empty" to provide automatic and immediate indication of the cell's condition, but it is doubly a triumph to be able to show as well every gradation of intermediate condition at a glance.

It should also be noted that this Exide Indicating Battery is no complicated construction of flimsy mechanical and chemical elements. The whole thing is magnificent in its robust simplicity. That indicating hand won't stick or play tricks—of that you can be certain. And there is no reason why it should, for, despite its complete originality, the idea is straightforward enough.

And, in any case, if there is one firm connected with radio who make almost a fetish of reliability and service that firm is surely Exide.

It is merely a unique application of the hydrometer principle, and the Indicator works by giving visual indication of the specific gravity of the acid. That is the beauty of the scheme from a technical point of view. There aren't any wheels and works behind that easy-to-see hand; it moves up or falls merely because the buoyancy of the acid alters.

I've charged and discharged my sample of this Exide Indicator Battery several times just for the pleasure of watching it "do its stuff," and each time my opinion of Exide in general and their latest product in

particular has risen several degrees, high though it has always been in the past.

There is a lot more that I would like to say about this wonderful Indicator Battery. For instance, I am tempted to write at length on the advantages and virtues of making new things available to the public at prices competitive with their existing and less novel rivals (this new Exide accumulator sells at a surprisingly low figure) instead of the all-too-frequent practice of placing a price on mere novelty.

I would also like to say quite a bit more about the Exide Indicator Battery in action, but I have already exceeded the space normally devoted to a single new component or accessory.

However, I have no doubt that Exide themselves have some interesting literature for circulation, and so I will urge "P.W." readers to write to Exide Batteries, of 137, Victoria Street, London, S.W.1, if they want to know anything further about the battery, and I am sure they will.

## RESISTANCE-FED TRANSFORMER COUPLING

The dimensions of the Igranite Resistance-Fed Transformer Coupling Unit, illustrated on this page, are 2½ in. × 1½ in. × 2½ in. It comprises a high-grade L.F. transformer having a primary inductance



This compact unit is made by the Igranite Electric Co., Ltd., of 149, Queen Victoria Street, London, E.C.4, at the remarkably low price of 10s. 6d.

of about one hundred henries, decoupling and feed resistances and a coupling condenser.

And on test the unit evinces a response of exceptional uniformity. Superior, in fact, to that of any normal high-class transformer.

Yes, there is certainly a strong case for "parallel feeding" when it is carried out in the manner of this Igranite unit. The quality of resistance-capacity coupling is obtained, together with satisfactory amplification, for the unit has a step-up ratio of 1 to 4½.

It is also internally screened, so that it can be inserted into a compact layout without fear of interaction.

Another good point is that the decoupling

resistance can be cut out if not required. I have heard it said that complete resistance-fed coupling units do not sell as readily as the separate parts needed for the method. This would be hard to believe of this Igranite component, for it costs only 10s. 6d. and is a particularly neat and compact component.

Bearing these facts in mind, as well as the saving in wiring it allows, one can hardly see the justification for the alternative of purchasing the separate parts, for that is likely to be a more expensive procedure into the bargain.

## THE J.B. "LINACORE"

A week or two ago I observed that a large proportion of the best examples of high-class engineering in the radio industry emanates from the condenser makers.

The truth of this is amply borne out by that new product of Jackson Bros., the J.B. "Linacore."

This is indeed a superb piece of work. And it is the better example of the point because it extends beyond the highly specialised nucleus that constitutes the main manufactures of this noted concern.

The "Linacore" is a complete band-pass assembly. I nearly used either the word "unit" or "tuner," but neither is sufficiently descriptive, for the "Linacore" is considerably more than fifty per cent of a set!

It embodies three iron-cored coils and a three-gang condenser arranged to provide three tuned circuits in most up-to-date band-pass formation.

The tuning control is calibrated in wavelengths (200-550 and 800-2,000 metres). There is a reaction control and a switch providing on-off, wavechange and radio gram switching.

All these controls are grouped so that actually there are only two main panel knobs, each with a second concentrically placed.

Some idea of the neatness and compactness of the whole assembly can be gathered from the accompanying photo, but this cannot show the first-class workmanship and finish.

But note the straight-line tuning scale giving full vision and easy and accurate readings.

The most obvious advantages of a complete assembly of this nature are that of compactness and the facility with which a high-grade set can be made with it, even by the novice; but in addition an exceptional efficiency is achieved by the expert design and matching of the component parts.

Band-passing can be very disappointing when unsuitable elements are employed, but this J.B.



The J.B. "Linacore" is almost a complete receiver in itself as the photograph shows.

"Linacore" exemplifies the principle at its very best.

After testing a set in which it formed the integral and greater part, I am able to say definitely that it is just the thing for the constructor desirous of coping with the 1934 ether with the minimum of expense and trouble.

In conclusion, readers should note that Jackson Bros., of 72, St. Thomas Street, London, S.E.1, are circulating some interesting literature and a free blue print of a "Linacore" set. This ought to be secured by all radio enthusiasts.



Weekly jottings of interest to Buyers by G. T. KELSEY.

FOR years moulded bakelite cabinets for wireless receivers were my pet aversions. I just could not stand the look of them at any price; and if anybody said, "It's got a bakelite cabinet," a more than usually blank look would be radiated from my countenance—see how modest the lad is!—and my enthusiasm would be somewhere in the neighbourhood of freezing point.

Rather strange that I should now have one in my own home—one, incidentally, of which I am more than a little proud. To be quite honest, in my case I think it was the chromium touch that finally pushed the pendulum hard over, for the moment I saw the modernistic black and chromium exterior of the Ekco Model 74 receiver I had a strong impulse to break the tenth commandment on the spot.

I think it must have been the old school tie that saved me on that occasion, but anyway, I've got one now, and when I tell you that it works as well as it looks, so to speak, you will understand the reason for my enthusiasm.

(Continued on page 935.)



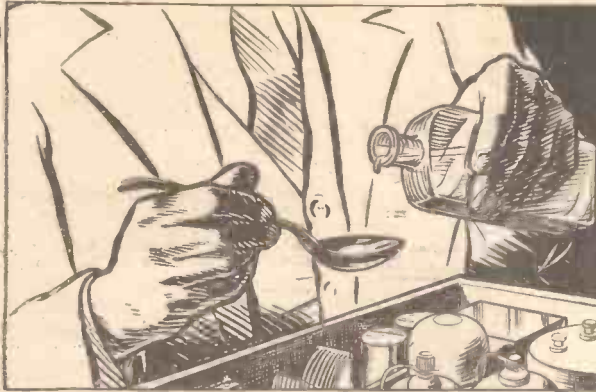

**Give your set a tonic**  
**Fit "Radio Record"—the quality**  
**valve. You will be amazed at the**  
**difference in your reception.**

If you are troubled with whistling, crackling, howling, etc., the "Radio Record" D.L.2. (battery-operated) really non-microphonic Detector Valve will eliminate these interferences.

**COMPLETE RANGE OF 2-VOLT AND A.C. MAINS VALVES**



- BATTERY HEATED VALVES**
- D.L.2. Special non-microphonic Detector.
  - Hr.2. High Frequency Amplifier.
  - L.2. Low Frequency Amplifier.
  - L.P.2. Low Consumption small power (also for Q.P.P.)
  - P.2. Power (suitable in and L.F. stage).
  - S.P.2. Super Power.
  - P.T.2. Poly electrode output.
  - S.2. Screen-Grid H.F. Amplifier and Det.

- INDIRECTLY HEATED A.C. VALVES.**
- AC.HL. A.C. Detector and Triode Amplifier.
  - AC/S. "A.C." Screen-Grid H.F.
  - AC/V.S. A.C. Variable-Mu.
  - AC/PT. A.C. Polytrode.
  - AC/P. A.C. Power.

- RECTIFYING VALVE**
- FW350. Full Wave Rectifier (output 350 volts 150 milliamperes).

Prices from

**3'9**

Obtainable from all Wireless Dealers or any of Messrs. Currys Ltd. Branches.

**RECORD RADIO LTD.**

ELDON ST. HOUSE, 2-3, ELDON ST., LONDON, E.C.2. Tel: Bishopgate 1301

An **AMPLION** because—

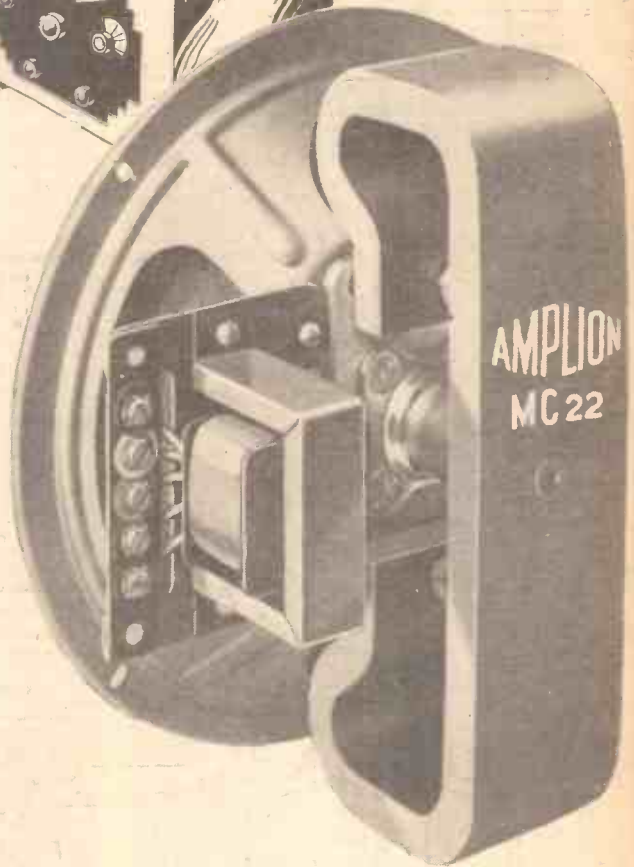
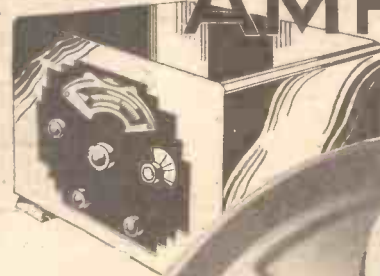

There is no other speaker which has achieved and maintained a reputation as high as that of the Amplion P.M. Speaker. The outstanding merits of this new speaker are its consistent performance, its wonderful faithfulness in reproduction and its ability to handle volume without distortion. Designed to suit the characteristics of modern receivers, it is the practical result of our highly experienced technical staff, and Mr. Eckersley considers it worthy and recommends it for his "National Three."

Amplion reputation is further enhanced by a range of quality components; here again Mr. Eckersley chose an Amplion Binocular H.F. Choke. His judgment is shared by many other well-known designers as well as by numerous manufacturers of receivers. You too can ensure success in receiver construction by asking and receiving from your local dealer "AMPLION."

"M.C.22" Moving-Coil Speaker 7" cone.... Price 39/6

"Audiola" Moving-Coil Speaker 9" cone.... Price 49/6

Both models fitted with all-purpose Universal transformer.

Binocular H.F. Choke..... Price 4/6

**—AMPLION—**

Telephone: Clerkenwell 5140-1.

Amplion (1932) Ltd., 82/84, Rosoman Street, London, E.C.1.

**YOU CAN TAKE IT FROM ME!**

THAT ELECTRADIX BARGAIN SALE LIST

Will Save You Pounds

**THE HOME BROADCASTER**

Why not be your own Announcer?

This No. 11 Home Mike at 5/6 is a new design. Solid bakelite case, back terminals. Fine, robust and excellent reproduction. Can be used with any radio set for home broadcasting. Only 5/6



**ELECTRADIX RADIOS**  
 218, UPPER THAMES ST., E.O.4  
 Telephone. Central 4611.

**WATCH YOUR L.T.**

Keep it well up with a "Varsity" Battery Charger. Type "A" Tantalum Rect., 1-amp., complete parts, 7/6. Type "B" do., 1-amp., 10/6. Type "C" Westinghouse Rectifier, 1-amp., complete ready to plug-in, 12/6. Type "D" do., 1-amp., 2, 4, or 6 volts, complete in metal case, 17/6. Other chargers up to £8. Transformer and Choke Stampings, Bobbins, etc., stocked in great variety.

**FROST RADIO CO., 21, Red Lion Street, E.C.1**

**WE INVITE READERS to support our Advertisers—care being taken to accept only announcements of reputable firms!**

# RADIOTORIAL

The Editor will be pleased to consider articles and photographs dealing with all radio subjects, but cannot accept responsibility for manuscripts or photos. Every care will be taken to return MSS. not accepted for publication. A stamped and addressed envelope must be sent with every article.

All Editorial communications should be addressed to the Editor, POPULAR WIRELESS, Tallis House, Tallis Street, London, E.C.4.

All inquiries concerning advertising rates, etc., to be addressed to the Advertisement Offices, John Carpenter House, John Carpenter St., London, E.C.4.  
The constructional articles which appear from time to time in this journal are the outcome of research and experimental work carried out with a view to improving the technique of wireless reception. As much of the information given in the columns of this paper concerns the most recent developments in the radio world, some of the arrangements and specialities described may be the subjects of Letters Patent, and the amateur and the trader would be well advised to obtain permission of the patentees to use the patents before doing so.

## QUESTIONS AND ANSWERS

### RECEIVING AMERICAN STATIONS ON THE MEDIUM WAVELENGTHS—INTERESTING EXPERIENCES OF "P.W." READERS.

The great interest aroused by "Ether Searcher's" letter in "Radiatorial" of "P.W.," dated January 13th, has resulted in a host of letters dealing with the direct reception of American broadcasting stations in this country. These have proved again that "P.W." readers, using their ordinary sets, can tune in programmes from stations three thousand and more miles away with amazing ease.

There is the case of Mr. T. E. Barnes, for instance. Writing from 18, Pall Mall, Chorley, Lancashire, he tells of a before-breakfast experience that must want a lot of beating. Here is an extract from his letter:

"On the morning of December 29th I switched set on and slowly turned the dials searching, at 7.15 a.m. I heard music. I waited for his call.

"He gave it as W 8 X O, testing a new 500,000-watt transmitter on W L W's wavelength, 720 kc. (418 metres). One of the numbers played was 'Somewhere in the West.' He was asking for reports on the transmission.

"He also said he had had a report from Tennessee with a cigar in! Which, he said, a previous well-known announcer had almost asked someone to oblige him with. I have kept wondering if any other 'P.W.' reader had the same experience as me."

Mr. Barnes goes on to say "He was still carrying on the programme at 8.15 a.m., only it had gone low. At 9 a.m. it was only a whisper."

All this was on a four-valver, and Mr. Barnes is certainly to be congratulated on his enterprise in getting such tremendous range at an hour when most of us think our sets are useless.

Another correspondent tells of success at his first attempt as follows:

"On the night of December 28th I made my first attempt to secure America, and had W T I C (Hartford, Connecticut) on the loudspeaker. Fairly good strength, but atmospheric bad at times.

"I made a second attempt on January 7th, between 1 and 3 a.m., and on certain I had five stations, and one was 'Ether Searcher's' W B Z. I heard 'This is W B B and W B B A, the Westinghouse stations of the National Broadcasting Company.'

"I also heard him mention Boston. I also had W T I C, also W T A I, giving a Saturday night Jamboree. Also one on practically the same wavelength as Scottish Regional. Did not get call-sign, but said 'National Broadcasting Co.'; and another 10 degrees below."

(NOTE.—Mr. Barnes made the same mistake as "Ether Searcher" in thinking that the call was W B B (and W B B A) instead of W B Z (and W B Z A). See the original reply to "Ether Searcher," January 13th, in "P.W.")

Another specially interesting letter was from Mr. J. Kyle, of 30, Waterside Street, Irvine, Ayrshire. He certainly knows an American station when he hears one, as the following extract from his letter convincingly shows:

"Have just got January 13th issue of 'P.W.' and read letter of 'Ether Searcher' regarding reception of Boston, U.S.A., on December 22nd. I also received this programme.

"A copy of my log for that evening might be interesting to you. I have lived in Winnipeg for six years, and just came home recently.

"I am well acquainted with nearly all the large Yankee stations and often sit up late to see how many of them I can log.

"I think I can give you something that very few have had the good fortune to hear. Well, here is the log in question:

"December 22nd.—W B Z A (Boston, Mass.), W B I S (Boston, Mass.), W T I C (Hartford, Conn.), W T A M (Cleveland, Ohio), W E A F (New York, N.Y.), W P Y (Atlantic City, N.J.), X E R (Villa Acuna, Mexico).

"X E R on 410.7 metres comes in just above Athlone's old wavelength. I knew the station immediately I heard the call letters in Mexican or Spanish before I heard the English announcer, and it was quite a thrill I can assure you.

"I used to get this station in Winnipeg very strongly, and could almost give you one of John R. Brinkley's medical sermons off by heart. I suppose you know that the Federal Radio Commission of the U.S. refused him permission to raise the power of his station in Kansas, and so he went over the border and built X E R, which, I suppose, is about the most powerful station in the world—100,000 watts.

(Continued on next page.)



# SLOT

## AERIAL FILTER



Now you can adapt your Receiver to the new Wave-lengths simply, quickly. Just fit a SLOT Aerial Filter on or near your Set, connect to the Aerial lead-in . . . the job is done. And what an improvement! Keener Selectivity. No interference. No overlapping. SLOT is small but a giant in action, it brings in Stations that many Sets cannot otherwise receive, especially on the lower broadcast waves; it gives you the very finest reception of which your set is capable. It lasts a life-time—yet it costs but 2/-.

**FREE**  
A STATION TUNING-CHART showing all the NEW WAVELENGTHS will be presented Free with every SLOT purchased.

Ask your dealer for SLOT to-day or obtain it direct, post free.

**Advt. of GRAHAM FARISH LTD.,**

# RADIOTORIAL QUESTIONS AND ANSWERS

(Continued from previous page.)

"He still talks from his studio in Kansas over land-wire to Mexico, and incidentally obliterates quite a few of the weaker Yankees."

One of the best letters we received starts off: "I have never wrote to you before, although I am a regular reader of your paper, and not being a good scholar . . ." But this reader then goes on to give some results that many a high-brow school-master would give anything to equal.

Mr. H. Tyne, of 8, Walham Avenue, Fulham, says: "I have built a few of your sets, also the 'S.T.300' and '400.' I built the '500' a week after it was published, and it is the goods."

"My aerial is 25 ft. long and the earth wire 50 ft. long, owing to being at top of the house, but the results are wonderful."

"I have not got the 'P.W.' with me now; I left it on my lorry. But about that station in your last (January 13th) issue, the Boston Fire Department. I picked it up this morning, Sunday, January 14th, and this is what was read out: 'Boston (W B V), a symphony orchestra.' After that there was a weather report and also the time. The words spoken were Standard time 15.10."

"By my clock it was 3.10 a.m. Dial readings on 'S.T.500' were 60/65."

"After that a talk on amateur tennis, peppermint guns, and then an organ recital."

(Note again that this reader got caught by American pronunciation, as explained in the original letter to "Ether Searcher." It was not W B V, but W B Z that he heard. And the last letter of the call-sign sounded like V, because the Americans always pronounce Z as "Zee," and not "Zed," as we pronounce it.)

We could go on with more interesting extracts from letters on this subject, but enough has already been said to show how great are the possibilities of transatlantic reception on medium waves.

We shall be particularly interested to hear of our readers' success in this direction on the "National Eckersley Three," because P. P. Eckersley himself has confessed to surprise at what his three-valver can do in the way of long-distance reception. And no matter how accustomed you are to the wonders of radio there is always a real thrill to be had out of an announcement that you hear in your own home the moment it is being spoken on the other side of the Atlantic Ocean, 3,000 miles or so away.

## DRIVER VALVE FOR THE "S.T.500."

T. S. C. C. (Blackpool).—"I do not wish to go against Mr. Scott-Taggart's recommendations, but here is just one small change I should like to make in my choice of valves for the 'S.T.500.'

"It is the type of driver valve. He advises a small power valve for this, but I would like to try to make do with an L.21, with a



FOR  
BETTER  
RADIO

### WHEN TERMINALS ARE CLOSE TOGETHER.

It often happens that faults occur in sets with closely adjacent terminals because the wiring to these is not carried out with sufficient care.

If flex connections are used they must have no stray metallic "whiskers" to bridge across to adjacent wires or terminals. And particular care must be taken of any soldering tags.

Sometimes these are long enough to swing round and touch another conductor which should not be connected thus, and many puzzling "shorts" have been traced to such accidental contact.

special driver transformer to go with it, if necessary, to get the same results.

"Please ask him if this will be O.K., and what ratio transformer he recommends?"

We are afraid you did not read the "S.T.500" articles very carefully. T. S. C. C., or you would never have referred to such a modification as "just one small change." It is anything but that.

Referring to the various combinations of driver valve, transformer, etc., Mr. Scott-Taggart—after asking readers to follow his lead if they wished to get results like his own—gave the following very definite information about the driver valve.

He said: "The small power valve, L.P.2, takes more current and costs 1s. 9d. more than the L.21. The power output of the small power valve is about twice that of the L.21. Quality is also considerably better."

"As regards the overall results, you will get half as much again out of your Class B valve if you use the small power valve L.P.2."

"The maximum you can get with H.T. up to 150 volts is 1,500 milliwatts with the L.21, as against 2,300 milliwatts with the L.P.2, which I advise."

"On the score of sensitivity, power output and quality I very definitely prefer the L.P.2 and B.21 combination. Nevertheless, I feel that many of the public will lean towards the L.21. And they will be wrong."

"There will be lots of temptations to use apparatus different from what I advise. But if you fall for it you must accept the responsibility."

"I give you alternative choices, but reluctantly. You are probably not in a position to experiment with all sorts of combinations as I have done. I have no intention of throwing the responsibility on your shoulders and leave you stranded at a cross-road, uncertain which of several apparently attractive roads to follow."

"I definitely tell you what I think is best. In this case I prefer the L.P.2."

We think you must agree, T. S. C. C., that nothing could be plainer, and it would be an unnecessary bother and waste of time to ask Mr. Scott-Taggart for his recommendation on the subject.

## TO MAKE YOUR OWN COILS FOR THE "S.T.500."

Several readers have pointed out that there must be many who, like themselves, prefer to make their own coils, and have expressed a wish for constructional details of the coils for the "S.T.500."

Nearly all the necessary information will be found in the August, 1932, issue of "The Wireless Constructor." There instructions were given for making a pair of "S.T.300" coils, which are almost identical. In fact, the "S.T.300 and "S.T.500" anode coils are

(Continued on next page.)

# For the New Wavelengths

USE  
**GRAHAM FARISH**  
PRODUCTS FOR THE  
**NATIONAL ECKERSLEY 3**

**EACH**

OHMITE RESISTANCES,  
1 1/2 watts 1/6  
3 watts 2/3

LITLOS DIFFERENTIAL CONDENSER  
Price 2/- each

NON-INDUCTIVE CONDENSERS  
1/2 mfd., 1/8 1 mfd., 2/-  
1/3 mfd., 1/9 2 mfd., 3/-

BOOSTER UNIT . . . . . 7/6

L.M.S. CHOKE . . . . . 4/6

**MASON'S HILL - BROMLEY - KENT**

## RADIOTORIAL QUESTIONS AND ANSWERS

(Continued from previous page.)

identical in every particular, so the description applies exactly.

Moreover, the "S.T.300" aerial coil only requires a small reaction winding to be added to adapt it for the "S.T.500." But it is very important to get the number of turns, direction of winding, etc., right, or otherwise results will not be satisfactory.

This is how it is done, for the home-made coil in question. (But note that these instructions do not apply to all "S.T. 300" coils. They would be wrong, for instance, for the Colvern type aerial coil.)

On the home-made coil, constructed in accordance with the details in the August "Wireless Constructor," we require an extra 14½ turns of 36 S.W.G. single-silk-covered

anti-clockwise direction, looking from the top of the coil.

Note.—Readers who may desire to obtain the back number of "The Wireless Constructor" referred to, and who find difficulty in getting it through a local newsagent, should write direct to the publishers:

The Amalgamated Press, Ltd.,  
Back Number Department,  
Bear Alley,  
Farringdon Street,  
London, E.C.4.

(The cost of a back number of "The Wireless Constructor" is 8½d., post free.)

### Building a Transmitter.

"JARROW" (no address forwarded).—"I thought of making a small transmitter and receiver for the little man of the house, but the details I had of same can't be found."

"Being a regular reader of POPULAR WIRE-

### "P.W." PANELS, No. 154.—ROME.

One of Europe's most popular stations, Rome works on 420.8 metres with a power of 50 kilowatts. Occasionally a man announcer is heard, but generally "Radio Roma" is announced by a lady.

The station is linked with Naples (called "Napoli" in Italian), and is famed for its excellent operatic broadcasts.

The closing words are "Fine della trasmissione" (end of transmission), followed by "Buona notte" (Good night). The closing tunes are the Royal Italian March and Fascist Hymn.

wire to form a new winding between the medium-wave and long-wave windings.

This single-hank is wound in the same position on the former of this aerial coil as is the reaction winding on the anode-coil former, i.e. in a slot exactly the same distance above the long-wave-winding slots.

The new winding starts at No. 1 terminal and ends at No. 6 terminal. It is wound in an

LESS for years, I thought I would ask your help in the matter."

"Such a set would interfere with neighbouring receivers, so it is illegal.

It is possible for bona fide experimenters to obtain a transmitting licence from the Postmaster-General, but this entails skill in the Morse code and a certain technical knowledge. So we are afraid your youngster will have to wait till he is grown up enough for this before he can take an active part in wireless transmitting experiments.

## THE LISTENER'S NOTEBOOK

(Continued from page 916.)

Harry Roy also has a crooner with a weakness for Louis Armstrong. Harry Roy is rich in crooners—he has three of them. One of them ought certainly to be muzzled, for he dominates everything when he holds forth:

Crooners should be kept under control. I like Henry Hull's pair just because they fit in so properly with the rest of the band.

I'm afraid I've very definite likes and dislikes where dance music is concerned. I view with dismay the large number of terrible comedy numbers that dance bands put over these days. On the other hand, some of these comedy numbers are first rate. I've little use either for the sort of tune that sweeps continents, as Christopher Stone puts it. And the hot stuff! Ugh! If you want a classic specimen of what I mean let me commend you to a number called "Can You Take It?" played, I think, by Fletcher Henderson and his Orchestra. It's a record.

The best thing in the way of plays so far this year happened in a Children's Hour. It was a little thing called "The French Prisoner," by Sybil Clark. I don't know the cast that did it—there were five of them: a grandfather, grandson and daughter, a military sergeant, and a French prisoner called Gaston de St. Croix. Every part was well played. "The French Prisoner" wouldn't disgrace an evening programme.

If this particular Children's Hour is typical of the fare provided for children, then there's little room for grumbling. Peter's reading of the adventures of Eustace, with the appropriate farmyard noises, was a clever piece of work, and must have delighted the smaller ones, for whom, according to Mac, the story was specially intended.

Congratulations to Mr. T. A. Waterhouse, of Birmingham, on his excellent talk on pike-fishing, and more particularly on his exposition of the angler's philosophy. This was an invigorating talk, free from affectation or any absurd microphone manner.

Also to Mary Cadbury (soprano) from the Western Studio. She has a lovely voice and knows a good song or two. Her only fault—common to many sopranos, unfortunately—is that one cannot catch her words. C.B.

# A SUPREME COMPLIMENT from a GREAT TECHNICIAN



Captain P. P. Eckersley, the Engineer who gave Britain the Regional Stations—of world-wide reputation as pioneer technician and a sound, fearless critic—has, in specifying a W.B. Microlode as first choice in his "National Three" radio-gramophone, paid to W.B. designers and factory executives the highest compliment possible.

There are vital reasons for his choice. Perfect matching to the receiver, due to the unique "Microlode" feature, gives better balance of tone. The unique "Mansfield" magnet, 30 per cent stronger than a good cobalt steel magnet of equal weight, gives better sensitivity and wonderfully crisp attack.

Most of the "great names in radio" have appeared under whole-hearted tributes to the revolutionary performance of this great range of speakers. Since their introduction a "Microlode" has been specified either solely or as author's first choice in practically every important constructor set. You should hear the difference a "Microlode" will make to your set: it will amaze you!



## "MICROLODE"

PM6 32/6 PM4A 42/- MOVING-COIL SPEAKER  
PM2A 79/6 PM1A 120/- MODEL PM4A - - - 42/-

Whiteley Electrical Radio Co., Ltd., Dept. P, Radio Works, Mansfield, Notts.

Sole Agents in Scotland: Radiovision Ltd., 233 St. Vincent St., Glasgow, C.2.

Sole Agents in I.F.S.: Kelly and Shiel, Ltd., 47 Fleet Street, Dublin.



# SPECIFIED FOR THE NATIONAL ECKERSLEY '3'

## and the National Eckersley Radiogram

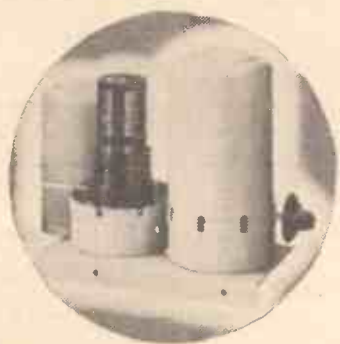

*Specified for both the "National Eckersley 3" and "National Eckersley Radiogram": 1 Colvern 3-gang coil unit, type K.G.O., K.G.O., K.G.R.*

*Price 28/6 complete.*

Specified by Mr. P. P. Eckersley for his "National 3" and "National Radiogram" . . . the choice of experts everywhere . . . Colvern are the finest and most accurate coils made. Built to the highest standard of engineering precision, every coil is thoroughly tested and guaranteed. Make certain of the best results . . . use Colvern Coils. Types and prices are given on the left.

# COLVERN COILS



*Ferrocarril coils, Colvern's latest achievement, are the most outstanding advancement in coil construction. Write for Radio List No. 12, telling you all about them. Many enthusiasts have found it of great interest. Post free, on request.*

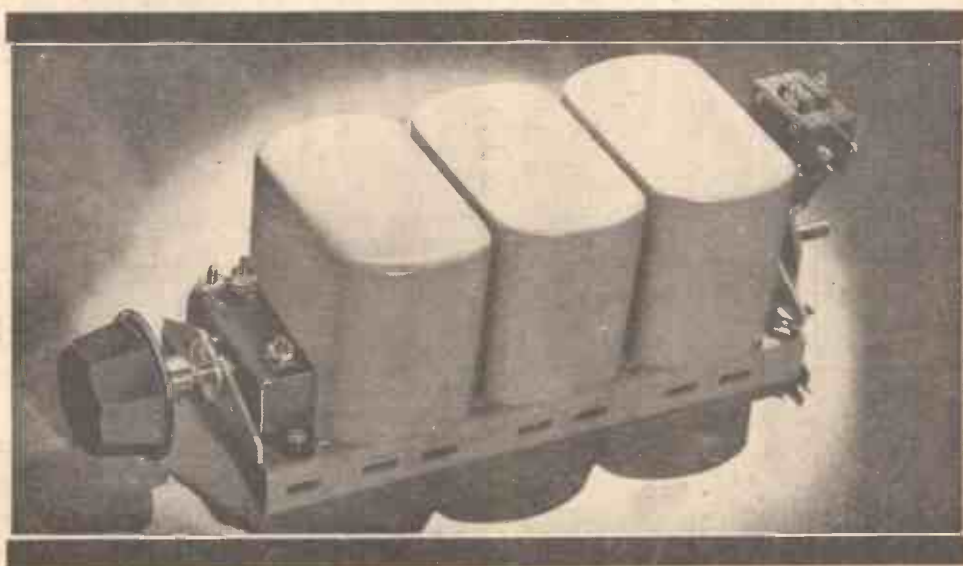

*Made under licence from the patentee, Hans Vogt.*

Colvern Ltd., Romford, Essex.  
London Wholesale Office:  
150, King's Cross Road, W.C.1.

# MAKERS OF THE FAMOUS Ferrocarril

# DUBILIER RESISTANCES

There are  
over 7,000,000  
Dubilier  
Resistances in  
constant use by  
British Listeners

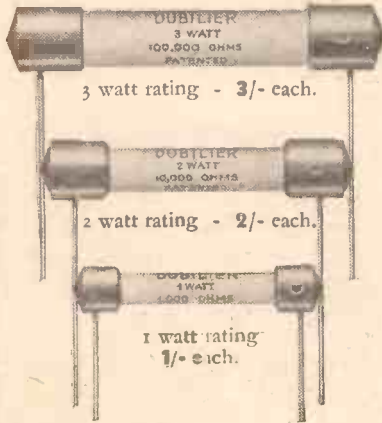

Each one  
conclusive proof  
of  
Dubilier's  
outstanding  
Reliability

# DUBILIER RESISTANCES

DUBILIER CONDENSER CO. (1925) LTD.  
Ducon Works, Victoria Rd., North Acton, London, W. 3

## THE MIRROR OF THE B.B.C.

(Continued from page 916.)

are deluded. There will be no sponsored programmes for at least ten years, and probably not then.

### "Mike" in an Historic Barn.

Down on the "English Riviera," at Torre Abbey, Torquay, is a building known as the Spanish barn; from where the Torquay Municipal Orchestra's concert is to be relayed for West Regional listeners on Monday evening, January 29th.

The barn—the old tithe barn of the Abbey and built at the end of the twelfth century—received its name from the fact that after the "bust up" with the Spanish Armada in Torbay on June 22nd, 1588, nearly four hundred of the crew of one of the Spanish galleons were imprisoned in the barn.

Subsequently the barn was used as a coach house and stables, but it has now been restored to its original appearance.

## THE NATIONAL ECKERSLEY RADIOGRAM

(Continued from page 915.)

one wire of the .1-mfd. condenser. It is 2 1/4 in. from the front and 1/8 in. from the side.

A 1/8-in. drill should be used. Slip a length of insulating sleeving over the wire end of this condenser to prevent its shorting on the chassis.

Before mounting the components on the top of chassis note that there are three leads going to the "F" terminals of the tuning condenser on one side. These leads should be attached first of all—that on the rear terminal is six inches long and those on the other two four inches long.

The positions of the above-baseboard components are clearly shown in the diagram and after the parts have been mounted the wiring can be carried out. The order in which it is done does not matter very much. It is perhaps rather easier to wire the underside first. It is advisable to mark off each wire on the diagram as it is put on the set. Slip a piece of insulating sleeving over the wire end of the .25-mfd. condenser where it enters the rear coil can.

Do not try to mount the loudspeaker to its baffle by two screws. Put them all in.

Before putting motor-board back, loudspeaker must be placed in position; otherwise it will foul the motor and will not go in the cabinet.

Next week in "On the Air with The National Eckersley Three" details of battery voltages, and other practical data concerning the operation of the Eckersley National Radiogram, will be given. Also the connections for the use of Telsen instead of Colvern coils will be explained.

## LISTEN TO THESE NEXT WEEK!

Outstanding items selected from the programmes for the week ending February 3rd.

### Sunday January 28

National: Orchestral Concert from Bournemouth. An excellent chance for National listeners to hear the splendid fare provided by Sir Dan Godfrey.

### Monday January 29

National: "Florodora." You recently enjoyed the broadcast version of a modern musical comedy, "No, No, Nanette!" Here is a chance to hear Leslie Stuart's old favourite via the microphone. Ivy St. Helier and Charles Mayhew are playing in this (to be repeated on the Regional wave on Wednesday).

West Regional: A Percy Fletcher programme. English light music given its proper place in the evening's entertainment.

### Tuesday January 30

National: "Wild Decembers." Clemence Dane's successful stage show adapted for the microphone. Regional: A modern dance music programme. If you like dance music, listen to this. If you don't, you'll know what to avoid!

Belfast: "Shubertlode." An orchestral programme which speaks for itself.

### Wednesday January 31

Midland Regional: "You will hear . . ." An interesting programme of current Midland theatre music. A novelty event of which the Midland Region provides many.

North Regional: Variety programme relayed from the Empire Theatre, York.

### Thursday February 1

Regional: "The King's Tryall." A reconstruction of the trial of Charles I, written and produced by Peter Creswell. This will probably be the first of several such programmes.

Belfast: "The Retroscope." Backwards into the past in a new play by Wilson Guy.

### Friday February 2

National: "Songs from the Shows." No. 3 of the new 1934 series (produced by John Watt) deals with the Vaudeville Theatre. (To be repeated on the Regional wave on Saturday afternoon.)

### Saturday February 3

National: The usual Saturday night variety programme.

Regional: A performance of Mozart's "The Magic Flute" for open lovers.

North Regional: A relay of part of the pantomime "Cinderella" (very popular this year) from the Theatre Royal, Leeds.

## FOR PICK-UP AND MOTOR

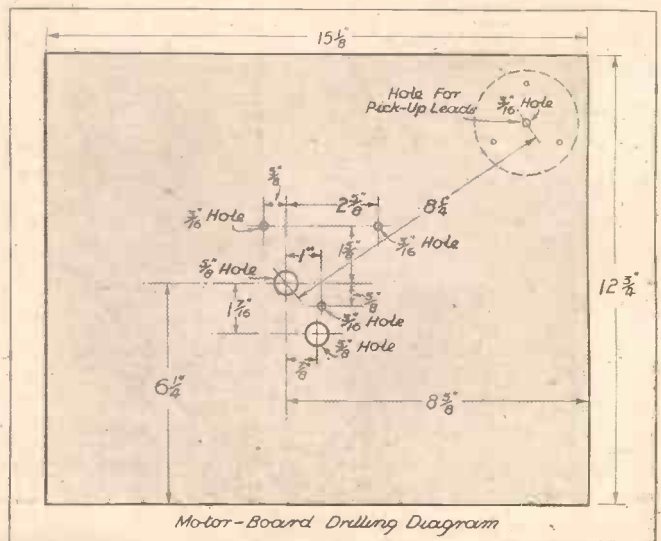

The details of the drilling for the motor board are clearly shown in the diagram. The board should be removed from the cabinet for the fitting of motor and pick-up.

## THE LINK BETWEEN

(Continued from page 928.)

As a matter of fact, Ekco's have done some really Spartan work in the design and production of bakelite cabinets, and it is true to say of their Model 74 receiver that it is one of the most-talked-of sets of the season. What a difference between these modern ones of Ekco's and the older types of bakelite cabinets in general which used to give me such a pain in the neck!

If you are fond of figures it may interest you to know that in the production of these attractively modern cabinets something approaching 10,000 units of electricity are used every day in the Southend works of Messrs. E. K. Cole. Fourteen hydraulic presses, each one weighing over 100 tons and standing 35 feet high from its base, are working almost incessantly to cope with the demand.

I can't say that I'm surprised. After all, it is still true that a thing of beauty is a joy for ever, and Mrs. "Link Between" is dead nuts on the beauty aspect!

### Answers To Correspondents (Perhaps!)

"Dear Sir,—What load shall I put in the anode circuit of my last valve?" to which I am prompted to reply: "What's the matter with a 'Microlode'?" That is because I've just seen Mr. Taylor, the "electric" sales manager of W.B., and with unbounded enthusiasm such as he possesses for what is undoubtedly a fine range of speakers, it is inevitable that I, too, should have become infected.

As a matter of fact, I don't wonder at his enthusiasm. The modern range of W.B. speakers, and especially the "Microlodes," are first-class instruments, and that is not just an airy statement without adequate substantiation. P. P. E., I noticed, used one in his "National Radiogram," and there is no need, I feel, to dwell upon the significance of that. In the half-dozen speakers of various makes that I

### AT THE EKCO WORKS



One of the giant hydraulic presses that are used in the Ekco Factory for moulding bakelite cabinets.

could name as being the most outstanding instruments of the present day, W.B. would certainly qualify for one of those positions.

### A Two That Was Minus.

On page 875 of last week's issue there appeared an advertisement for the Colvern Coils specified by P.P.E. for his National Sets, in which the price of the coils was inadvertently given as 8s. 6d. instead of 28s. 6d.! Most of you, I know, will have spotted the misprint, but in case there should be any reader who is not familiar with Colvern Coils, my reference to the matter will, I hope, clear up any little misunderstandings.

### A Telsen Note.

Several readers have written in to ask which of the many transformers in the Telsen range is most suited for the Eckersley National Set. I understand from the technical folk that the one that was actually tested in the set was the new G.S.5. Will interested readers kindly note?

### Of Special Interest.

I have just been examining a blue print of the famous J.B. "Linacore" battery three kit set, and I must admit that I am most impressed. It seems to me to be one of the most simple commercial kit sets to construct that I have ever seen, and it is certainly a thoroughly modern design. Readers may be interested to know that if they write to Jackson Brothers, 72, St. Thomas' Street, London Bridge S.E.1, mentioning "P.W." and enclosing a 2d. stamp for postage, a copy of the blue print will be sent free of charge. It is well worth having.

## HAVE A CAPSTAN! - YOU'LL LIKE IT BETTER



Plain or Cork Tipped

10 FOR 6<sup>d</sup>  
20 FOR 11<sup>1</sup>/<sub>2</sub><sup>d</sup>

## THERE'S NO BETTER VALUE

Issued by The Imperial Tobacco Company (of Great Britain and Ireland), Ltd.

C.S. 429 F.

### EDEN RADIO

CONDENSERS for NATIONAL  
ECKERSLEY THREE and  
RADIOGRAM.

- 1 Mfd. Tubular, 6d. Post 1½d.
- 25 " " 9d. " 1½d.
- 2 " Std., 1/3 " 2d.

All British. Guaranteed 12 months.

**EDEN RADIO,**  
11, Eden St., London, N.W.1

**RADIO GRAM CABINETS**  
*As supplied to B.B.C.*

**65/- Polished Cabinet for 35/-**  
No Middle Profits!

Famous maker offers finest Radio Furniture. As supplied to B.B.C. A Quality and Value impossible to better. Beautifully hand polished! **GUARANTEED** Piano Tone Acoustically.

Trial Will Delight You! (Cash or 10/- Monthly.)

LIST FREE! From Makers—

**PICKETT'S**  
*Piano Tone*

Cabinet (P.W.) Works, Albion Rd. Bexleyheath, Nr. London

★ PLEASE be sure to mention "Popular Wireless" when communicating with Advertisers. Thanks! ★





## TWO NEW VALVES

Details of new multi-electrode amplifiers.

I HAVE just had three most interesting little parcels of valves. Two contained samples of a new battery output type—from the Marconi and Osram Valve Companies respectively, while the other, from a source I cannot mention at the moment, contained a new development for the H.F. section of the receiver. Both types of valves are of absorbing interest, and are as completely different in characteristics as it is possible to imagine.

Let me consider the battery valve first. This is a new valve for Q.P.P. output. You thought Q.P.P. (quiescent push-pull) was dead? Not a bit of it. Many of the best commercial sets employ it, though the trouble of matching the two pentodes let it be beaten by the positive-drive type of Class B (for Q.P.P. is really Class B), where the home constructor was concerned.

The new valve, however, does away with the need of matching—it is already matched in its two sections, and is, briefly, two P.T.2 pentodes in one glass envelope.

Gives 1,000 Milliwatts.

Known as the Q.P.21 this valve is capable of providing up to 1,000 milliwatts of undistorted output power with a grid-bias voltage of—10.5, and an H.T. of 150 volts. With these figures the total quiescent H.T. current (including screen current) is only 2.6 milliamps, and the estimated mean H.T. battery current is 6 milliamps. Pretty economical, isn't it?

The valve is of the seven-pin type in the new "anti-pong bulb," and at present is not yet priced. In the price decided lies the secret of its future success—or failure—of course. If a reasonable figure, say 20s. to 25s., is chosen, then a Q.P.P. set with the new Q.P.21 should work out cheaper to build than a Class B set of the positive-drive type, say the makers, and the new valve should become very popular. I rather agree there, for the quality obtainable with properly matched transformers is really very good, and, of course, there is no need for a driver stage.

For Superhets.

The third parcel, from the "hush-hush" source, contained an advance specimen of an A.C. Heptode, for use as a mixer and oscillator for superhets. The whole process is done electronically inside the valve, which has five "grids," cathode, anode, and, of course, heater.

One of the "grids" is used as an anode for the oscillator, working at 150 volts H.T., while the main anode is used in the mixing (or first detector) operation. The valve is tantamount to a screened-grid mixer plus a triode oscillator.

It has, of course, a 4-volt heater and takes 1 amp. A.C. The inner and outer screens are connected together and require 100 volts max. H.T. K.D.R.

### "P.W.'s" Television Survey.

The Editor regrets that owing to extreme pressure on space the special Television feature by G. P. Kendall has been unavoidably held over this week.

# UNIVERSAL DISTANT CONTROL RELAY

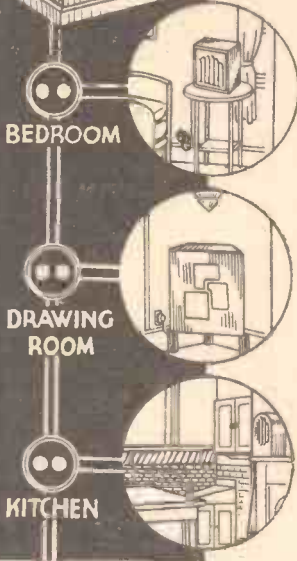
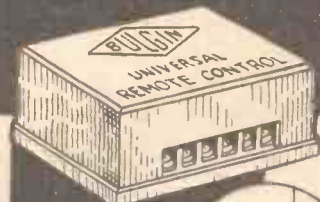

## FOR BATTERY or MAINS SETS!!

This new invention switches the Radio "Off" or "On" from any room in the house, and can be applied to any make of receiver.

The relay is operated by neat bakelite pushes. The wiring, which is similar to an electric bell installation, can be carried out by any home constructor or the local electrician.

UNIVERSAL DISTANT CONTROL UNIT  
List No. R.C.10...25/- Complete

BAKELITE CONTROL PUSHES 2/- Each  
No delicate mechanism to get out of order. Costs nothing to maintain, as it operates on momentary current.

SEND FOR 80p. CATALOGUE, No. 153P, GIVING FULL DETAILS. ENCLOSE 2d. POSTAGE.



Telephone: Grange Wood 3266

Telephone: Grange Wood 3267

A. F. BULGIN & Co., Ltd., ABBEY ROAD, BARKING, ESSEX  
London Showrooms: 9, 10, 11, Cursitor St., Chancery Lane, E.C.4. Telephone: Holborn 2072

## A COMPLETE TELEVISION RECEIVER FOR 77/6!

DO YOU KNOW A COMPLETE SET OF COMPONENTS COSTS ONLY 77/6?

Kit includes—Electric Motor (any voltage), Variable Resistance, G.E.C. Neon Tube, Scanning Disc, Lenses, Etc. Carriage Paid.

Experiment in this Fascinating Field—  
Wonderful Results from any Type of Three-Valve Receiver!

A. SHEARMAN,  
17/19 VAN DIEMAN'S RD.,  
CHELMSFORD.  
'Phone 412.

### YOU ARE WANTED ON THE SHORT WAVES

Short-wave reception with any receiver with the new remarkable UNIT RADIO short-wave unit. IDEAL for use with the S.T.500. Complete unit sent for 5/- down. Send for illustrated leaflet. Cash or C.O.D. 37/6  
UNIT RADIO. 12, Pultney St., London, N.1.

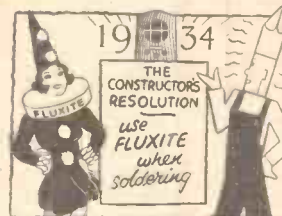

"We're Fluxite and Solder— the reliable pair ; Famous for Soldering— known everywhere!"

A NEW RESOLUTION is oft hard to keep— But IF you keep THIS one— REPAIRS will be cheap!

See that Fluxite and Solder are always by you in the house—garage—workshop—anywhere where simple, speedy Soldering is needed.

ALL MECHANICS WILL HAVE

# FLUXITE

IT SIMPLIFIES ALL SOLDERING

All Ironmongers sell Fluxite in tins: 4d., 8d., 1s. 4d., and 2s. 8d. Ask to see the FLUXITE POCKET SOLDERING SET—complete with full instructions—7s. 6d. Ask also for our leaflet on HARDENING STEEL with Fluxite.

FLUXITE LTD (Dept. 324), Rotherhiths, S.E.16

## FOR ALL REPAIRS!



All applications for Advertising Space in POPULAR WIRELESS should be addressed to the Advertising Department, John Carpenter House, John Carpenter Street, London, E.C.4.

'Phone: Central 8080.

# ECKERSLEY'S NATIONAL THREE FOR A.C.

(Continued from page 913.)

to it, and is connected to the socket on the mains unit marked G.B. The switch leads from the receiver are connected to the switch plug on the mains unit.

A list of valves is given elsewhere. These are all of the indirectly-heated type, requiring 4 volts across their heaters. This is supplied by the mains transformer in the mains unit.

It will be seen that there are two 4-volt windings. The one labelled 4 volts 6 amps. supplies the heaters of the valves in the receiver, whilst the other, giving 4 volts 2 amps., supplies the heater of the rectifier valve in the mains unit.

### Output Valve Biasing.

Provided that the valves specified are used, the results will be equally good, whatever make is chosen.

Other valves must not be used. Results may be satisfactory, but it is more likely that they will be very disappointing. Stick to the valves that have actually been tested in the set, and you can be confident that the results will be equal to those obtained with the original set.

There is just one point regarding the biasing resistance of the output valve. This is the 300-ohm resistance under the chassis. For all except the Mullard valve this remains unaltered. With this valve, however, it must be changed to a value of 350 ohms.

Now for the construction of the A.C. mains unit.

Having collected together the necessary components, they should first be mounted on the Metaplex baseboard. The mains plug and fuses and the switch plug must be mounted exactly as in the diagram, their centres being 1 in. from the respective sides of the baseboard.

This is to ensure that the metal cover of the unit will not foul either of the plugs. The terminal strip is drilled as follows:

All the holes are  $\frac{1}{2}$  in. down from the top of the strip. The two end ones are each  $\frac{1}{2}$  in. in from the respective ends of the strip. The remaining holes are drilled at intervals of 1 in.

### "Indirectly-heated"

No special precautions have to be taken in the wiring, except to make certain that this follows the diagram and that the insulation of the wire is such that there is no risk of its breaking down.

By far the safest way is to use the wire specified. Not only is this very pleasant to use, but it is also perfectly safe.

When the wiring is complete, the rectifier is inserted and the metal cover may be put on. This becomes earthed automatically to the metallised baseboard, thus making it shock-proof.

The rectifier valve is of the indirectly-heated cathode type, and, as it takes approximately the same time to heat up as the valves in the receiver, the full H.T. is not applied until the receiver valve cathodes reach their maximum temperature.

Not only does this preserve the valves, but also the condensers in the smoothing and decoupling circuits which are prevented from having too high a voltage applied to them.

# TECHNICAL NOTES

Some diverse and informative jottings about interesting aspects of radio.

By Dr. J. H. T. ROBERTS, F.Inst.P.

### Push-Push Amplification.

SEVERAL readers have written to me on the question—which I mentioned in these Notes a week or two back—of the high-tension supply when using Class B or Q.P.P. amplification. You will remember I pointed out that the current consumption with these new forms of amplification is not always so small as you might imagine, and that in consequence it was often desirable to use a heavy-duty H.T. battery (assuming you are using batteries) rather than one of the "standard" type, or one of small cells.

### Large Total Current.

When you come to think of it you have your screen-grid H.F. amplifiers at 2 to 3 milliamps each, whilst multi- $\mu$  screen-grids will probably use considerably more than this, as much as  $3\frac{1}{2}$  or 4 milliamps each. You have to add to this the low-frequency side, whilst the output valve may be accounting for quite a large percentage of the total current.

Taking all this into consideration, you will see that with an ordinary so-called "standard" H.T. battery the load is really too great, and the sudden rushes of current, which arise with the Class B or Q.P.P. amplifier, cannot be properly catered for by the battery.

### The Internal Resistance.

Another point which is often overlooked, altogether apart from any question of Class B or any other form of amplification, is the fact that, with a battery of inadequate capacity, not only does the voltage fall very rapidly, but the resistance increases; in fact, this increase in the internal resistance is often a more important item than the actual fall in voltage.

If a battery of nominal 120 volts falls to an actual voltage of, say, 100 this is not in itself a very serious matter; it all depends, of course, on the circuit and upon whether the voltage values used are critical, but, at a pinch, it can be put right by connecting a small battery in series with the bigger one.

### Causes Bad Distortion.

But the question of the internal resistance is another matter altogether, and this cannot be remedied by another battery in series. With Class B or Q.P.P. the internal resistance becomes particularly important because of the fact that, on the average, you are using a relatively small current, but often you get these sudden rushes which may be quite large.

If the battery cannot stand up to these rushes of current you will get bad distortion, and you may get disgusted with the arrangement and throw away the battery. There must be lots of standard-capacity H.T. batteries thrown away because of the rise in the internal resistance rather than the drop in the terminal voltage.

(Continued on next page.)

# MATCHED AND TESTED KITS FOR ECKERSLEY'S NATIONALS

## DE LUXE KITS

The guaranteed Constructors' Kits for those who insist on the best only. For detailed specification see page 879 "Popular Wireless" 20th Jan., 1934.

**NATIONAL III (Battery Model)**  
 Kit "A" £5 - 17 - 6  
 Kit "B" £7 - 16 - 6

**NATIONAL III (A.C. Mains Model)**  
 Kit "A" (including mains unit) £9 - 12 - 0  
 Kit "B" (including mains unit, valves, and rectifier) £12 - 14 - 0

**NATIONAL RADIO-GRAM (Battery Model)**  
 Kit "A" £6 - 17 - 6  
 Kit "B" £8 - 16 - 6

**S.T. 500 (Class B Battery Model)**  
 Kit "A" £5 - 12 - 6  
 Kit "B" £7 - 17 - 9

Any Radio or Electrical material can be supplied to your order. Send specifications of requirements for suggestions and quotations. Our advice is free and unbiased. Demonstrations Daily.

**MARCUS, OVERTON RADIO LTD.,**  
 62, BOROUGHS HIGH STREET,  
 LONDON BRIDGE, S.E.1.

Phone: Hop 4431. Trade supplied.

## STANDARD KITS

The guaranteed Constructors' Kits for those who want the best at least cost. For detailed specification see page 879 "Popular Wireless" 20th Jan., 1934.

**NATIONAL III (Battery Model)**  
 Kit "A" £4 - 14 - 0  
 Kit "B" £6 - 13 - 0

**NATIONAL RADIO-GRAM (Battery Model)**  
 Kit "A" £5 - 16 - 0  
 Kit "B" £7 - 15 - 0

### NATIONAL III A.C. Mains Unit.

SPECIFICATION	£	s.	d.
1 E.I. R.Y.30 mains transformer	1	10	0
1 Wearite smoothing choke, H.T.13	12	6	0
2 Dabiller 4-mfd. condensers, type LEC	13	6	0
1 W.B. 4-pin valve holder	6	6	0
1 Erie resistance with holder, 50,000 ohms	1	3	0
1 Erie resistance with holder, 15,000 ohms	1	3	0
4 Belling-Lee sockets, type 1070	1	3	0
2 Belling-Lee terminals	6	6	0
1 Bulgin mains plug and fuses, F.15	3	0	0
1 "ACE" metal-sprayed screened baseboard	1	6	0
1 "ACE" terminal strip, 6" x 1 1/2"	1	9	0
1 Coil pushback wire	1	6	0
Screws, twin mains flex, etc.	1	7	0

1 Mullard I.W.2 rectifying valve ... 3 7 6  
 Complete kit with valve ... 4 0 0  
 Or assembled and tested ready for use ... 4 10 0

### Extra Components for A.C. Version.

£	s.	d.
1 Bulgin 5,000-ohm potentiometer with switch YS.29	4	6
1 Dabiller tubular condenser, type 4404	1	4
1 Erie 100-ohm resistance with holder	1	3
3 A.C. mains valves to specification	2	9

**EASY TERMS PROMPT DELIVERY**

Any Amplion, Blue Spot, Baker, Celestion, Epoch, Ferranti, Grampian, Igranic, Lamplugh, Magnavox, Ormond, R & A, Rola, Sonochorde or W.B. Speaker supplied.

Send 5/- only

and pay balance by monthly instalments. No references. Entirely private and confidential.

**ECKERSLEY III KITS**

- Standard Kit £4/15/0  
or 12 payments of 8/5.
- With Valves £6/14/0  
or 12 payments of 12/3.
- Specified Kit £5/10/0  
or 12 payments of 10/-.
- With Valves £7/9/0  
or 12 payments of 13/8.

**MANUFACTURERS' KITS**

- Cossor 342 12 monthly payments of 13/6
- Lissen 3. 12 monthly payments of 8/3
- Lissen 4 12 monthly payments of 10/6
- Telsen 323 6 monthly payments of 5/3
- With Valves 10 monthly payments of 6/-

**KITS, PARTS, VALVES, ELECTRIC CLOCKS ON EASY TERMS.**

Send for List of 83 Speakers and state requirements.  
**TURNADGE & PARTNERS, LTD.,**  
107, Fleet Street, London, E.C.4.  
Telephone: Central 1903.

**RADIO DEMONSTRATORS.** Evening work. Required most parts of the country. Amateurs with spare time considered. Write Westminster National Supplies Ltd., 16, Old Swan Lane, London, E.C.4.

**'TONASTAT' SOLVES THE QUESTION**

Of giving to your set just that added selectivity which makes such a wonderful difference in the clarity of reproduction. Minimises overlap of nearby stations, cuts down whistle interference. Suits from a single valver to a super set.

Simple to use. Easy to connect. A circuit to suit your set is shown on instruction leaflet "P" supplied with every "Tonastat."

The "Tonastat" is another product for Universal use and is of even greater value than the famous "TONAX CONE ADAPTOR" which we also produced, and the sales of which have already passed the Million mark.

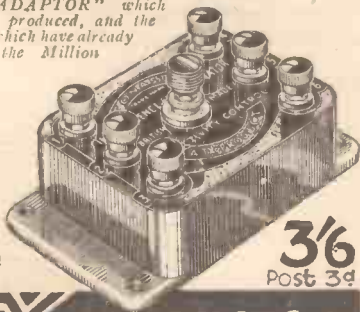

Phone: Epsford 2823.

3/6 Post 3d

**TX PRODUCTS Co**

32 QUEENSWAY FONDERS END MDX.

PLEASE be sure to mention "Popular Wireless" when communicating with Advertisers. Thanks!

**TECHNICAL NOTES**

(Continued from previous page.)

**Battery v. Mains Sets.**

I wonder what is the ratio of battery sets to mains sets? This is a question which is often asked, and you get the most astonishing variations of opinion on it. Some people say that there is still a great preponderance of battery-set users, whilst, on the other hand, the mains people back their favourite with ever-increasing confidence.

At any rate, whatever the actual figures may be, there is no doubt that there is an enormous number of people using battery sets; in a large percentage of cases this is because they have no electric supply available and are, therefore, obliged to use a battery receiver; but in a good many cases also people who have the electric supply use a battery set for preference, or perhaps have a mains set and a battery set. Designs for battery sets always "go down well" when published in "P.W.," and that in itself is a proof of their popularity.

**A Fair Comparison.**

Talking about battery sets, you may remember that some time ago I said something in this column about the actual cost of the current supply from the H.T. battery as compared with the current obtained from the mains in a mains receiver. According to a simple calculation, it was quite easy to see that the actual current for the H.T. battery worked out at a good deal more than the current from the mains. Several readers, however, have written to me to say that, whilst this may be true, it is hardly the right way to look at the thing, because the actual cost of the H.T. current is only one of many items. They maintain that for a fair comparison one should take into account the advantages of the battery set, such as low first cost, small depreciation and cost of replacements, and so on.

**The Relative Advantages.**

This, of course, is quite true, and when I made the comparison between mains current and battery current I was not seeking to draw any invidious distinction, but was only working out what appeared to be rather an interesting little arithmetical sum.

We all know, of course, that the actual cost of battery current is a relatively small item (incidentally, it is made even smaller if you use the well-known types of British-made batteries instead of certain inferior ones which unfortunately find their way on the market from somewhere), and, in any case, against this we have to set the advantages of the battery set which I have just mentioned above.

He would be a brave man who started a full-blown controversy (which I certainly don't intend to do) on the comparative advantages of mains receivers and battery receivers, since each type has such an army of supporters!

No doubt I shall now get a lot of letters from battery users throwing stones at the mains people, and vice versa—which will all be very interesting.

**Increasing the Volume.**

Most constructors are from time to time intrigued with the idea of increasing output volume, and there are all sorts of ways in which this can be done. One method

(Continued on next page.)

HIGH IN QUALITY

**ECKERSLEY TELLS YOU the valves to use**

**HIVAC 10'6**  
S.G. 210

**HIVAC 4'6**  
H. 210

**RADIOGRAM OR RECEIVER**

results will be up to standard for those who use the valves recommended.

Your dealer can supply HIVAC. If slightest delay, order direct.

Write Dept. "P."

HIVAC

THE SCIENTIFIC VALVE

LOW IN PRICE

British made by the  
**HIGH VACUUM VALVE CO., LTD.**  
113-117, Farringdon Rd., London, E.C.1.  
Telephone: Clerkenwell 7557.

**EASY PAYMENTS**

"There's no place like HOLMES."

The first firm to supply Wireless parts, on easy payments. Nine years advertiser in "Popular Wireless." Thousands of satisfied customers.

We recommend

EPOCH SPEAKERS

		De-posit	Monthly
		Payments	Payments
SUPER DWARF P.M. ...	23/6	4/4	5 of 4/4
20th CENTURY P.M. ...	35/-	4/10	7 of 4/10
11-in. SUPER P.M. ...	45/-	4/11	9 of 4/11
B5 P.M. ...	84/-	7/8	11 of 7/8

LISSEN Skyscraper 4 Kit 112/6 10/- 11 of 10/3  
TELSEN 325 Star Kit ... 39/6 5/5 7 of 5/5  
EXIDE H.T. Accu. 120-v. 60/- 6/- 9 of 6/8  
ATLAS Eliminator C.A.25 59/6 5/- 11 of 5/6  
BLUE SPOT 29P.M. ... 35/- 4/10 7 of 4/10  
B.T.H. Pick-up Vol. Con. 25/- 4/8 5 of 4/8

Parts for any Kit Set. Any make of Speaker.

**New Goods Obtained for Every Order.**

Send us a list of the parts you require and the payments that will suit your convenience, and we will send you a definite quotation. Anything Wireless.

**H. W. HOLMES, 29, FOLLEY STREET,**  
Great Portland Street, London, W.1.  
Phone: Museum 1414.

G.P.O. Engineering Dept. (No experience required.) Commence £4 per week. Age 17-23. Excellent prospects. Free details of entrance Exam. from B.I.E.T. (Dept. 568), 31, Oxford Street, W.1.

**600 Extra-Selected Dutch Bulbs for 10/- (10/6 c.o.d.), free destination (carriage and duty paid by us):** 300 Gladioli, 100 Montbretias, 50 Anemones, 50 Ranuncules, 50 Clover of Happiness, 25 Lilies, 25 Begonias.

**M. WALRAVEN & Co.,**  
Kerkstraat 23, Hillegom, HOLLAND.

PLEASE be sure to mention "Popular Wireless" when communicating with Advertisers. Thanks!



## HERE'S YOUR 1934 RADIO GUIDE!

Have you got the Heayberd 1934 Handbook?—if not, get it NOW. Contains all useful information on how to run your radio from the mains. Fifteen blueprints showing how to build your own mains unit or battery charger, etc. Two pages of helpful radio hints for all amateurs. You must have this handbook if you wish to be in front with 1934 mains working.

Cut out this advertisement, write your name in the margin, and send with 3d. in stamps for your copy.

**F. C. HEAYBERD & CO.,**  
10, FINSBURY STREET, E.C.2. P.W.

### RADIO SUPPLIES

Send your list of Radio needs for our quotation. Kits, Parts, Sets, etc. Everything in Radio stocked, prompt delivery, 7 days' approval. Catalogue free. Taylex & Standard Wet H.T. replacements stocked.  
**P. TAYLOR, 9, GROVE ROAD, BALHAM, S.W.12**

## MAKE YOUR SET SUPER SELECTIVE

**VARIABLE** 16

gives aeriels every desired degree of selectivity, cutting out interference from other stations. Fixed in a moment on any set on any aerial with no alterations. Can be supplied already attached to a coil of Superial.

The only self-contained variable aerial.

100 ft.	75 ft.	50 ft.	The world's most
4/6	3/6	2/9	selective aerial.

**INVISIBLE AERIALS**

Run Superial through ELECTRON INSULATOR PINS and have the ONLY efficient indoor or invisible aerial. OAK, MAHOGANY, BLACK. Six in a box. 6d.

**THE NEW LONDON ELECTRON WORKS, LTD.,**  
19 East Ham, E.6.

### WIRELESS SUPPLIES

Let us supply your RADIO wants. Any single part, kit or set, etc. We pay carriage. Seven days approval. We supply, FREE, one of our PATENT Baffle Boards with any speaker bought from us.—Electa Wire Gram, 97, Sussex Road, Brixton, London, S.W.9.

## OPENINGS for ENGINEERS

**250 Pages Free**

Never before has engineering offered such magnificent chances. With the rise of the depression, the industry is literally teeming with first-class opportunities. Our 250-page Hand-book, "ENGINEERING OPPORTUNITIES" shows where the opportunities lie, and the easiest way to prepare for them. The Hand-book gives details of A.M.I.Mech.E., A.M.I.E.E., A.M.I.C.E., G.P.O., etc. Exams., outlines Home-Study Courses in all branches of Civil, Mech., Elec., Motor, Radio and "Talkie" Engineering, Building, etc., and explains our unique Employment Dept. Send for this valuable Hand-book to-day—FREE! British Institute of Engineering Technology, 101, Shakespeare House, 29, Oxford St., London, W.1

## TECHNICAL NOTES

(Continued from previous page.)

which appears to be the simplest is to use so-called power-grid detection. Perhaps it is the very name which is apt to deceive people into the belief that on changing over to power-grid detection they are going to get "power" results at once.

By the way, the term "power valve" has been responsible for much misapprehension on the part of amateurs, and really it is—or, at any rate, may be—quite misleading. The power valve is only a "power" component in so far as its power-handling capacity goes, and there are many cases where a power valve is used without the expected results.

### Power-Grid Detection.

Power-grid detection also gives you a power handling rather than a power-producing capacity. As you no doubt know, the circuit which is used is the same as the ordinary grid-leak detector arrangement,

example, is being received, it may quite well be that the power-grid arrangement is doing no good.

### What You Must Consider.

So what you have to consider is whether with your aerial (and the strength of station received), and with your S.G. high-frequency amplifying arrangements, you are delivering to the detector an amount of power which is more than it can handle without distortion. If the power is well within the capacity of the detector the best thing you can do is to leave it alone; but if, on the other hand, it is being overloaded, then it is worth while to consider changing over to the power-grid arrangement. But don't make the mistake that so many people make of altering your detector components and anode voltage, and then thinking that *ipso facto* you will get a great increase in output volume.

Are you in  
difficulty  
with your  
**National  
Eckersley Three?**  
or  
**The Change-over  
in Wavelengths?**  
or  
**Anything Else  
Radio?**

If so, Consult

The National Radio Service Company  
(Chairman: P. P. Eckersley, M.I.E.E.),  
15/16, Alfred Place, Tottenham Court  
Road, London, W.C.1  
Muscum 7651.

Write for explanatory literature  
and details of special offer to  
readers of "Popular Wireless."

## CLASS "B" MAINS UNITS

using entirely new  
voltage regulator

CONSTANT OUTPUT 130v.  
AT ALL CURRENTS UP TO 55 MILLIAMPS.  
Tappings: 60/80 S.C., 80/100 DET.  
130v. POWER.

### IDEAL FOR S.T.500!

Model B.A.55, attractive appearance, high quality, very compact, for A.C. Mains - - **88/6**  
send NOW for full description, illustrations, regulation curve, etc.

**THE BRITISH MAINS UNIT CO., CROMWELL  
HOUSE, HIGH HOLBORN, W.C.1.**

## NEXT WEEK

**P. P. ECKERSLEY M.I.E.E.**  
tells you more about his latest  
and greatest receiver in an  
article entitled:  
**"On the Air with the  
National Eckersley  
Three."**

---

**NOEL ASHBRIDGE B.Sc., M.I.E.E.**  
Chief Engineer of the B.B.C.,  
writes authoritatively on:  
**"Broadcasting Quality"**

---

**Make sure of a copy of  
"POPULAR WIRELESS"  
by placing an order to-day**

but different values of grid leak and condenser are used. As a rule, these values are much lower, the value of the leak being usually about a quarter of a megohm, whilst for the condenser a value of .0001 mfd. is often used.

The point I want to bring out is, however, that merely changing over to these lower values of grid leak and condenser does not mean that you are going to get power results from the circuit. The essential point about the power-grid detector is that it works on a different part of the characteristic curve, and for this it is important that a high anode voltage should be applied to it.

### The Question of Distortion.

The power-grid detector arrangement, when properly operated, will handle more volume than the ordinary detector without distortion, but obviously it cannot handle volume unless that volume is supplied to it, either by reason of extra H.F. amplification or by a larger aerial input. Unless there is sufficient high-frequency amplification, or unless a powerful local station, for